

The Washington County Department of Education met in regular session on August 8, 2024 at 5:30 PM in the Central Office. Attendance is as follows: **Present:** Annette Buchanan, Mary Beth Dellinger, Keith Ervin, Chad Fleenor, David Hammond, Gregg Huddleston, Mike Masters, Whitney Riddle, Vince Walters..

Vince Walters - prayer  
Mary Beth Dellinger - Lead the Pledge

Chad Fleenor moved for approval of the meeting minutes, as presented. Gregg Huddleston seconded the motion which carried on roll call vote:  
Annette Buchanan: yes, Mary Beth Dellinger: yes, Keith Ervin: yes, Chad Fleenor: yes, David Hammond: yes, Gregg Huddleston: yes, Mike Masters: yes, Whitney Riddle: yes, Vince Walters: yes

First Band and Trust donated \$2,500.00 to Washington County Schools.  
Chad Fleenor moved for approval of the meeting agenda. Vince Walters seconded the motion which carried on roll call vote:  
Annette Buchanan: yes, Mary Beth Dellinger: yes, Keith Ervin: yes, Chad Fleenor: yes, David Hammond: yes, Gregg Huddleston: yes, Mike Masters: yes, Whitney Riddle: yes, Vince Walters: yes

Mr. Boyd announced upcoming meetings.

September meeting:  
Election of officers, organizational meeting, and new board members.

Enrollment numbers change daily. Mr. Huddleston asked for comparison of last school year. Mr. Ervin also asked about kindergarten enrollment. Mr. Boyd explained the numbers are down, but normally the numbers go up in the first week of school.

David Hammond Made the motion to approve. Gregg Huddleston seconded the motion which carried on roll call vote:  
Annette Buchanan: yes, Mary Beth Dellinger: yes, Keith Ervin: yes, Chad Fleenor: yes, David Hammond: yes, Gregg Huddleston: yes, Mike Masters: yes, Whitney Riddle: yes, Vince Walters: yes

Todd and Ginger of Lewis Group Architects gave updates on the stadium renovations.

Chad Fleenor moved approval as submitted. Whitney Riddle seconded the motion which carried on roll call vote:

Annette Buchanan: yes, Mary Beth Dellinger: yes, Keith Ervin: yes, Chad Fleenor: yes, David Hammond: yes, Gregg Huddlestone: yes, Mike Masters: yes, Whitney Riddle: yes, Vince Walters: yes

Chad Fleenor moved for approval as submitted. Whitney Riddle seconded the motion which carried on roll call vote:

Annette Buchanan: yes, Mary Beth Dellinger: yes, Keith Ervin: yes, Chad Fleenor: yes, David Hammond: yes, Gregg Huddlestone: yes, Mike Masters: yes, Whitney Riddle: yes, Vince Walters: yes

Gray Elementary Cabinets

School Nutrition Equipment

Food Purchased for entire year.

NETCO - Membership Fees for School Nutrition

College Board Exams 1 of 3 for High Schools

The fee covers all students

Daniel Boone Exams and Fees

Chad Fleenor Moved approval as submitted. David Hammond seconded the motion which carried on roll call vote:

Annette Buchanan: yes, Mary Beth Dellinger: yes, Keith Ervin: yes, Chad Fleenor: yes, David Hammond: yes, Gregg Huddlestone: yes, Mike Masters: yes, Whitney Riddle: yes, Vince Walters: yes

Chad Fleenor moved approval as submitted. David Hammond seconded the motion which carried on roll call vote:

Annette Buchanan: yes, Mary Beth Dellinger: yes, Keith Ervin: yes, Chad Fleenor: yes, David

Hammond: yes, Gregg Huddleston: yes, Mike Masters: yes, Whitney Riddle: yes, Vince Walters: yes

Chad Fleenor moved for approval as submitted. David Hammond seconded the motion which carried on roll call vote:

Annette Buchanan: yes, Mary Beth Dellinger: yes, Keith Ervin: yes, Chad Fleenor: yes, David Hammond: yes, Gregg Huddleston: yes, Mike Masters: yes, Whitney Riddle: yes, Vince Walters: yes

Annette Buchanan - discussion of fees per student or as a whole Chad Fleenor moved for approval as submitted. Annette Buchanan seconded the motion which carried on roll call vote:

Annette Buchanan: yes, Mary Beth Dellinger: yes, Keith Ervin: yes, Chad Fleenor: yes, David Hammond: yes, Gregg Huddleston: yes, Mike Masters: yes, Whitney Riddle: yes, Vince Walters: yes

Chad Fleenor moved for approval as submitted. Annette Buchanan seconded the motion which carried on roll call vote:

Annette Buchanan: yes, Mary Beth Dellinger: yes, Keith Ervin: yes, Chad Fleenor: yes, David Hammond: yes, Gregg Huddleston: yes, Mike Masters: yes, Whitney Riddle: yes, Vince Walters: yes

Mr. Boyd requests to formerly approve all schools except UH to the Community Eligibility Program. Mary Beth Dellinger moved to approve all schools (except UH) for CEP. Chad Fleenor seconded the motion which carried on roll call vote:

Annette Buchanan: yes, Mary Beth Dellinger: yes, Keith Ervin: yes, Chad Fleenor: yes, David Hammond: yes, Gregg Huddleston: yes, Mike Masters: yes, Whitney Riddle: yes, Vince Walters: yes

Dr. Adams, along with Jeremy Moore's recommendation, asked the board to proceed with Mueller Master Bids, LLC.

Chad Fleenor move approval to accept bid of \$44,760 to Mueller Master Bids, LLC for SCES project. Annette Buchanan seconded the motion which carried on roll call vote:

Annette Buchanan: yes, Mary Beth Dellinger: yes, Keith Ervin: yes, Chad Fleenor: yes, David Hammond: yes, Gregg Huddleston: yes, Mike Masters: yes, Whitney Riddle: yes, Vince Walters: yes

The 2 vans that were approved were sold. Dr. Adams found one. He made a request to purchase a Ford van, found in Murfreesboro.

. Whitney Riddle moved to approve purchase of Ford Van from Murfreesboro Ford per state contract. Chad Fleenor seconded the motion which carried on roll call vote:

Annette Buchanan: yes, Mary Beth Dellinger: yes, Keith Ervin: yes, Chad Fleenor: yes, David Hammond: yes, Gregg Huddleston: yes, Mike Masters: yes, Whitney Riddle: yes, Vince Walters: yes

No action requested, Mr. Boyd included all the information to the commission.

Mr. Ervin requests setting a price for the sound systems at the high schools. Dr. Adams stated that the bid opening would be on Friday, August 16th, at 9:00 A.M. Vince Walters moved to authorize release of bids and authorize the executive committee review and approve best bid.

Gregg Huddleston seconded the motion which carried on roll call vote:

Annette Buchanan: yes, Mary Beth Dellinger: yes, Keith Ervin: yes, Chad Fleenor: yes, David Hammond: yes, Gregg Huddleston: yes, Mike Masters: yes, Whitney Riddle: yes, Vince Walters: yes

Board members discussed the responsibility of payment. Whitney Riddle moved to bid paving of parking lot at Crossroads Christian Church as part of agreement to continue use of the area by DBHS for events. Chad Fleenor seconded the motion which carried on roll call vote:

Annette Buchanan: yes, Mary Beth Dellinger: yes, Keith Ervin: yes, Chad Fleenor: yes, David Hammond: yes, Gregg Huddlestone: yes, Mike Masters: yes, Whitney Riddle: yes, Vince Walters: yes

Keith Ervin moved to table. Gregg Huddlestone seconded the motion which failed on roll call vote:

Chad Fleenor: no, David Hammond: no, Mike Masters: no, Whitney Riddle: no, Vince Walters: no, Annette Buchanan: yes, Mary Beth Dellinger: yes, Keith Ervin: yes, Gregg Huddlestone: yes  
Vince Walters Move to postpone action. Mary Beth Dellinger seconded the motion which carried on roll call vote:

Chad Fleenor: no, David Hammond: no, Mike Masters: no, Whitney Riddle: no, Annette Buchanan: yes, Mary Beth Dellinger: yes, Keith Ervin: yes, Gregg Huddlestone: yes, Vince Walters: yes

Chad Fleenor move to amend the amount from \$1,500,000 to \$2,200,000.00. Whitney Riddle seconded the motion which carried on roll call vote:

Keith Ervin: no, Mike Masters: no, Whitney Riddle: no, Annette Buchanan: yes, Mary Beth Dellinger: yes, Chad Fleenor: yes, David Hammond: yes, Gregg Huddlestone: yes, Vince Walters: yes

Chad Fleenor Counter with the amended amount. Whitney Riddle seconded the motion which carried on roll call vote:

Annette Buchanan: no, Keith Ervin: no, Mary Beth Dellinger: yes, Chad Fleenor: yes, David Hammond: yes, Gregg Huddlestone: yes, Mike Masters: yes, Whitney Riddle: yes, Vince Walters: yes

David Hammond, thanks to Ms. Dellinger for her years of service.

Keith Ervin, It's been an honor to serve with you.

Gregg Huddlestone, I appreciate Ms. Dellinger for her guidance on my decision to run for school board.

Whitney Riddle, It has been a privilege and an honor to serve on the board with Ms. Dellinger.

Chad Fleenor, I appreciate Ms. Dellinger. You have been a great asset to the board.

Vince Walters, It has been a delight to work with Ms. Dellinger.

Annette Buchanan, Thank you for all the service you have given us. Glad I have you as a life-long friend.

Mike Masters, I agree with everyone. I have enjoyed serving with you.

Mary Beth Dellinger, Thank you all.

Washington County Schools  
 Monthly Enrollment Report  
 As of 08/02/2024

School	-2	-1	0	1	2	3	4	5	6	7	8	9	10	11	12	Total
Boones Creek Elementary School	15	24	86	110	93	99	86	103	88	91	74	0	0	0	0	869
Daniel Boone High School	0	0	0	0	0	0	0	0	0	0	0	313	282	294	292	1181
David Crockett High School	0	0	0	0	0	0	0	0	0	0	0	312	290	303	276	1181
Fall Branch Elementary School	0	2	23	33	26	27	39	28	28	23	40	0	0	0	0	269
Gray Elementary School	0	16	62	57	56	57	54	65	58	55	57	0	0	0	0	537
Grandview Elementary School	3	26	76	62	71	62	69	62	52	70	70	0	0	0	0	623
Jonesborough Elementary School	0	4	60	115	102	110	112	90	99	96	119	0	0	0	0	907
Lamar Elementary School	0	24	42	43	52	48	33	37	50	45	43	0	0	0	0	417
Ridgeview Elementary School	5	7	51	66	96	82	86	72	91	103	81	0	0	0	0	740
South Central Elementary School	0	0	10	24	17	25	26	18	13	20	18	0	0	0	0	171
Sulphur Springs Elementary School	0	0	33	35	38	47	37	55	42	45	40	0	0	0	0	372
University School	0	0	21	20	19	20	25	47	52	52	52	85	82	84	77	636
West View Elementary School	0	0	24	29	31	32	30	40	29	33	31	0	0	0	0	279
Tennessee Virtual Learning Academy												6	8	11	14	39
Total Enrollment as of 08/02/2024																8221

## Field Trip Report

<b>School</b>	<b>Date of Trip</b>	<b>Destination</b>	<b>Teacher/Class</b>
DBHS	7/12/2024	Hamblen County Great Smokey Mountain Youth Livestock Fair, Walters State Expo Center in White Pine	Leann Turner
DBHS	7/25/2024	Greene County Fair Beef Cattle Show July 25th-27th; 109 Jeff Woods Memorial Dr, Greeneville, TN 37745	Leann Turner
DCHS	10/25/2024	Storytelling Center (Jonesborough) Concert: Dovie Thomason	Earlene Hopkins/International Club
DCHS	10/4/2024	International Storytelling Festival	Ms. Earlene Hopkins/French/International Club
WVES	8/31/2024	University of Tennessee	Laura Arredondo coach
GVES	8/31/2024	UT Knoxville Football stadium	Coach- Christina Huester
DCHS	8/30/2024	International Storytelling Center (Jonesborough), Simon Brooks	Ms. Earlene Hopkins/French/International Club
DCHS	8/16/2024	Appalachian Fair	J. Gourley
DCHS	8/16/2024	Black Sheep Farm - 8/16, Cocke County Fair Sheep Show 8/17	Ford - Ag- 9-12
DCHS	8/22/2024	Appalachian Fair Sheep Show	Ford - Ag - 9-12
DBHS	8/21/2024	Appalachian Fairgrounds	Cathy Reynolds
DBHS	8/22/2024	Appalachian Fairgrounds	Michelle Phillips, Health Science leaders and HOSA leaders, 11 and 12
DBHS	8/8/2024	SS, RV and Gray Schools	Scott Blanton/band/9-12
DBHS	8/9/2024	Fall Branch and Boones Creek schools	Scott Blanton
RVES	8/8/2024	SS, RV and Gray schools	Scott Blanton
RVES	8/9/2024	Fall Branch and Boone Creek Elementary	Scott Blanton
SSES	8/8/2024	SS, RV and Gray schools	Scott Blanton
SSES	8/9/2024	Fall Branch and Boones Creek schools	Scott Blanton
RVES	12/6/2024	Ridgeview to Barter Theater to Golden Corral (Bristol, VA) to Ridgeview	Jackson 5th Grade

Monthly Personnel Report

JULY 2024

Employee	Disposition/New	School, Position	Effective Date	Replacing
Richard "Rick" Peters	New Hire	Gray, 7th Grade Math Teacher	7/29/2024	Christine Lewis
Holly Walters	New Hire/Rehire	Lamar, 1st grade Teacher	7/29/2024	Katelyn Dugger
Heather Griffith	New Hire	Lamar, SPED IA	8/5/2024	Kaley Holden
Blake Dugger	New Hire	Gray, PE Teacher	7/29/2024	John Ryan
Heather Constable	New Hire/Interim	Lamar, Interim 1st Grade Teacher	7/29/2024	Caitlin Alban
Patricia "Trish" Looney	New Hire	Gray, SPED Teacher	7/29/2024	Kathryn Schneider
Danny Adams	New Hire	System-wide, Maintenance	7/8/2024	Vacant Position
Michelle Knight	New Hire	SS, 6-8 Science Teacher	7/29/2024	Amanda Natale
Cynthia Duncan	New Hire	System-wide, Behavior Intervention Specialist	7/29/2024	New FTA-IDEA
Robert Roller	New Hire	DBHS, Math Teacher	7/29/2024	Alexandra Johnson
Amy Johnson	New Hire	System-wide, SPED Consulting/Lead Teacher	7/29/2024	
Shanna Boyd	New Hire	DBHS, Assistant Cheerleading Coach	7/9/2024	Ashley Giacometti
Tika Wimer	New Hire	District Office, Custodian	7/22/2024	Jeanene McCurry
Brooke Sergent	New Hire	GV, Head Cross Country Coach	7/10/2024	Art Jacquez
Emily Koelling	New Hire	BCE, PE Teacher (Position transferred from WV to BCE)	7/29/2024	Jennifer Taylor
Danielle Porcho	New Hire	DBHS, English Teacher	7/29/2024	Heather Easterling
Lucas Stinson	New Hire	JES, 8th grade Teacher	7/29/2024	James Howerton
May Manookian	New Hire	System-wide, School Psychologist	7/29/2024	Christie Teilmann
Dominic Anslow	New Hire	JES, Math Teacher	7/29/2024	Lessa Gregg
Amy Mikelbank	New Hire	School Nutrition, PT Cook	8/5/2024	Sarah Heltzel
Rachel Gray	New Hire	Transportation, Bus Driver	7/15/2024	Ongoing Need
Reid Sanders	New Hire	Interim Gray, PE	7/29/2024	Brooke Echevarria
Stella Perkins	New Hire	School Nutrition, PT Cook	8/5/2024	Amanda Carver
Wes Dulaney	New Hire	GV, Head Softball Coach	7/16/2024	Sam Tarlton
Ashley Burgin	New Hire	JES, IA	8/5/2024	Robin Boyd
Savannah Wills	New Hire	SACC, Caregiver	7/16/2024	Ongoing Need
Zoe Doshier	New Hire	US, SPED Teacher	7/18/2024	New position
Stacey Estes	New Hire	RV, School Counselor	7/29/2024	Clanci Tipton
Clara Faye Rutledge	New Hire	DCHS, English Teacher	7/29/2024	
Michael Riddle	New Hire	Maintenance, HVAC Technician	7/29/2024	Jeremy Moore
Steven Jones	New Hire	Transportation, Bus Driver	7/22/2024	Ongoing Need
Emily Manis	New Hire	JES, 5th Grade Math & Science	7/29/2024	Kelly Coakley
Jennifer Fair	New Hire	DCHS, Health Science Teacher	7/29/2024	Leslie Britton
Charity Roberts	New Hire	FB, 6-8 Grade Science and Social Studies Teacher	7/29/2024	Matthew Haren
Debra Saults	New Hire/Rehire	SC, Sped IA	8/5/2024	New position
Teakemue "TK" Hill	New Hire	Southside, Middle School Asst. Football Coach	7/23/2024	Mike Tisor
David Hallatt	New Hire	Transportation, Bus Driver	7/24/2024	Ongoing Need
Monica Dauksch	New Hire	Gray, Art Teacher	7/29/2024	Janice Flynn
Mitchell Calvin	New Hire	DBHS, CTE Teacher	7/29/2024	New position
Sandrine Thermoz-Lorcieri	New Hire	DBHS, Spanish Teacher	7/29/2024	Shantall Raines
Janice Flynn	Rehire	FB, Interim Art Teacher	7/29/2024	Amber Pugh
Reagan Metz	New Hire	JES, Interim 3rd grade	7/29/2024	Sarah Drew
Jordan Landers	New Hire	RV, SPED Tacher	7/29/2024	Kristen Lane
Brandon Woods	New Hire	DBHS, Assistant Band	7/29/2024	New Position
Benjamin "Ben" Barr	New Hire	DCHS, Sped Teacher	7/29/2024	Matthew Williams

Monthly Personnel Report

JULY 2024

Heather Miller	New Hire	GV, 5th Grade Teacher	7/29/2024	Emmy Day
Ivy Blaser	New Hire	SS, Music Teacher	7/29/2024	Mickey Murray
Andrea Stapleton	New Hire	JES, Sped Teacher	7/29/2024	Abigail Carr
Courtney Laporta	New Hire	BCE, Interim 1st Grade Teacher	7/29/2024	Jill Arnold
Paul "Xavier" Painter	New Hire/Rehire	Maintenance, Maintenance Worker	7/29/2024	Vacant position
Robert Micklewright	New Hire	School Nutrition, PT Cook	8/5/2024	Kaley Holden
Mason Mounger	New Hire/Rehire	Maintenance, PT Grounds	7/29/2024	Josh Thomas
Shauna Slemp	New Hire	FB, Music Teacher	7/29/20024	Patricia Abbott
Samantha Richardson	New Hire	SACC, Caregiver	7/29/2024	Michael Stanton
Janice Byrum	New Hire	GV, SPED Teacher	7/29/2024	Emily Marshall
Amanda Greer	New Hire	BCE, 5th Grade Teacher	7/29/2024	Penny Cox/Amy Shipley
Amanda Boyle	New Hire	DBHS, SPED Teacher	7/29/2024	John Good
April Roberts	New Hire	Transportation, Bus Driver	7/30/2024	Ongoing Need
Rhonda Neal	New Hire	SACC, Caregiver	7/30/2024	Ongoing Need
Brittany Blevins	New Hire	School Nutrition, PT Cook	7/30/2024	Kalyn McDonald
Abigail "Abbie" Bowlin	New Hire	SACC, Caregiver	8/5/2024	Ongoing Need
Timothy "Tim" Campbell	New Hire/Rehire	Asbury, Pt Teacher 120 day contract	7/29/2024	Tanner Moon
Logan Shelton	New Hire	Lamar, 5th Grade	7/31/2024	Holly Moffitt
Matthew Childers	New Hire	Northside, Middle School Soccer Coach	8/1/2024	Sarah Steadman
Hallie Schumaker	New Hire	SACC, Caregiver	8/15/2024	Ongoing Need
Kelly Ollis	New Hire	JES, Title IA	8/5/2024	New Position
Levi Summers	New Hire	DCHS, IA	8/5/2024	Ron Sillmon
Jenna Smith	Transfer	from GV, SPED IA to GV, Gen Ed IA	8/5/2024	Yvonne Hicks
Michael Mitchell	Transfer	from SACC, Caregiver to DCHS, ISS IA	8/5/2024	Savannah Lusk
Michael "Brian" Miller	Transfer	from DCHS, Asst Baseball Coach to DCHS Head Baseball Coach	7/26/2024	Spence Street
Kelly Bowman	Transfer	from SACC, Caregiver to School Nutrition, PT Cook	8/5/2024	Caitlynn Taylor
Nathaniel Patterson	Transfer	from DBHS, SPED IA to DBHS, Workplace Readiness Specialist	8/5/2024	Mackenzie Sewigert
Ashley Broyles	Transfer	from SC IA, to SC Data Clerk	7/22/2024	Frances Broyles
Misty Chisholm	Transfer	from GES, Data Clerk to BCE, Custodian	7/24/2024	Charlene Crouch
Austin Barnett	Transfer	from SACC Caregiver to BCE, SACC Site Director/IA	8/5/2024	Cade Gray
Joshua Thomas	Transfer	from PT Maintenance Grounds to FT Maintenance Grounds	7/3/2024	Vacant Position
Emily Marshall	Transfer	from GV SPED teacher to System-wide, SPED Consulting/Lead Teacher PreK-8	7/29/2024	New FTE position
Donna Sims	Transfer	from Substitute to UH, PT SPED IA	7/8/2024	Casey Lovelace
Amanda Elliott	Transfer	from DCHS, SPED Teacher to DCHS, Graduation Coach	7/1/2024	Charlie Conner
Laranda Sells	Transfer	from RV, SACC Site Director/IA to RV, SPED IA	8/5/2024	Kirsten Montgomery
Ty Gray	Transfer	from SACC Caregiver to RV, SACC Site Director/IA	8/5/2024	Laranda Sells
Tim Anderson	Transfer	from DCHS, Teacher to DCHS, SPED Teacher	7/29/24	Amanda Elliott
Julie Pearce	Transfer	from JES, Data Clerk to JES, IA/OA	8/5/2024	
Kelly Williams	Transfer	from Substitute to RV, IA	8/5/2024	Misty Childers
Jessica Knight	Transfer	from Gray, 6th grade teacher to SC, School Counselor	7/29/2024	Chase Byrd
Mickey Murray	Transfer	from SS, Music Teacher to DBHS, Assistant Band Director 11mo employee	7/29/2024	Zac Austin
Viviana Farmer	Transfer	from sub to BCE, Library IA	8/5/2024	Madison Williams

Monthly Personnel Report

JULY 2024

Vanessa Noblet	Transfer	from sub to DBHS, Workplace Readiness Specialist	8/5/2024	Christopher Steger
Christopher Steger	Transfer	from DBHS, Workplace Readiness Specialist to DBHS, Driver's Ed Teacher	7/29/2024	Kylie Shearer
Dovie Bright	Transfer	from sub to System-wide, ESL Intake Coordinator	7/29/2024	New position
Janice "Holly" Moffitt	Transfer	from Lamar 5th Grade to SSm 5th Grade Teacher	7/30/2024	Rachel Reynolds
Robert Waddill	Transfer	Transportation, Bus Driver	08/05/2024	Transfer from full-time driver to Sub. Driver
Rachel Reynolds	Resignation	SS, 3rd Grade	7/23/2024	
Amanda Boyle	Resignation	JES, SPED IA	6/21/2024	
Tasha Hyatt	Resignation	School Nutrition, PT Cook	7/11/2024	
Mary Sluss	Resignation	School Nutrition, PT Cook	2/8/2024	
Sunnie Shelton	Resignation	School Nutrition, PT Cook	5/24/2024	
Abigail Carr	Resignation	JES, SPED Teacher	6/27/2024	
Savanna Lusk	Resignation	DCHS, ISS IA	7/12/2024	
Charlie Dugger	Resignation	Lamar, PreK SPED Teacher	7/11/2024	
Emmy Day	Resignation	GV, 5th Grade Teacher	7/16/2024	
Robert Waddill	Resignation	Transportation, Bus Driver		will remain a sub driver
Amy Shipley	Retirement	BCE, 5th Grade	07/01/2024	
Fran Broyles	Retirement	Data Clerk, South Central	7/1/2024	
Johnathan Hyatt	Requested Leave	DBHS, Custodian	effective 7/10/2024 thru estimated 7/29/2024	
Darrin Sherfey	Requested Leave	DBHS, Custodian	effective 7/1/2024 thru estimated 7/29/2024	
McKenzie Sewell	Requested Leave	DBHS, HS Math Teacher	effective 9/2/2024 through estimated 12/20/2024	
Cheryl Richardson	Requested Leave	WV, Teacher	effective 7/30/2024 through estimated 8/16/2024	
Jessica Ford	Requested Leave	JES, Kindergarten Teacher	effective 9/27/2024 through estimated 12/20/2024	
Jeanene McCurry	Requested Leave	District Office, Custodian	effective 8/1/24 through 8/31/2024	

Intent to Apply/Research	Grants Writer/Manager's Report	<b>August 2024</b>						
<b>Bureau of Justice STOP School Violence Grant</b>	Grant submitted June, 2024	Announcement of the winners will be around October 1, 2024.						
<b>Researching grant for planting trees</b>	Working with the Operations Department. Provide shade trees to elementary school campuses.							
<b>Researching grants for Communication boards for playgrounds</b>	Working with the Student Support Services Department. The goal is to assist students with disabilities by providing labeled images on a communication board during physical breaks at the playground area.							
Grants Awarded								
Grants Managed								
<b>FY 2025 - CTE Perkins Reserve</b>	Awarded <b>\$50,000</b> for Daniel Boone CTE program in connection with Culinary ARTS and certain populations						Will assist CTE Director with any needs in managing the grant.	
<b>ETSU SLICE - SL Partnership STEM LITERACY COMPUTATION IN EDUCATION WITH SCHOOL LEADERS</b>	<b>ETSU federal government grant we have partnered</b>	Currently processes quotes and POs for procurements of the minigrants for participating schools' teams. Total award is appx. \$81,000 in materials, equipment, and supplies.	I am the Co-PI-LEA CONTACT for Washington County	Financial reimbursements invoices and execution of purchases with schools' classroom minigrants that will be provided at the end of year 2 grant term and any other needs that may occur.				
<b>LEAPS PROGRAM</b>	Start new school year	UPDATED EPLAN BUDGET \$75,000	Provide all necessary documentation into Department of Human Services Child Care Provider Portal to renew the SCES LEAPS site for continuing service	Help with any grant related to personnel, data reporting, purchases and attend meetings with the state department.				
<b>ISM Grant</b>	Continue supporting CTE Director as needed. Will help write FY25 grant and budget.	Assist CTE Director when needed	Note: schools involved in this grant were awarded (allocated FY2023) BCE \$500,000, DB \$1,000,000, DC \$1,000,000, FB \$200,000, GV \$500,000, Gray \$500,000, JES \$500,000, RV \$500,000, SC \$200,000, SS \$500,000, University \$1,000,000, WV \$500,000					
<b>ARP 2.0 Homeless Grant</b>	Grant will end Dec. 2024	In collaboration with Director of Attendance and Chief Students Supports Officer.		Providing purchasing and documentation support.	HELP WITH REPORTING	help with any grant related reimbursement request documentation		

## **Monthly Facility Tracker reports**

All Locations -

<https://facilitytracker.app-garden.com/Woms/PublicAnalytic/Index?guid=af78549c-6e53-41e9-afec-dd4d8bfa815d>

WVES -

<https://facilitytracker.app-garden.com/Woms/PublicAnalytic/Index?guid=7061e70d-ee81-4bbe-a0a9-333ee6630ce4>

SSES -

<https://facilitytracker.app-garden.com/Woms/PublicAnalytic/Index?guid=82641ccd-b40b-406e-9593-f1f5d6d454ea>

SCES -

<https://facilitytracker.app-garden.com/Woms/PublicAnalytic/Index?guid=f4112e8b-ace7-42c8-83ce-ce7cca700d0a>

RVES -

<https://facilitytracker.app-garden.com/Woms/PublicAnalytic/Index?guid=abece4e4-3aaf-4e20-afb9-e7a4b253e7ea>

LES -

<https://facilitytracker.app-garden.com/Woms/PublicAnalytic/Index?guid=03c462a1-53fd-429c-8d8a-862353a095d4>

JMS -

<https://facilitytracker.app-garden.com/Woms/PublicAnalytic/Index?guid=047f5116-d265-4220-bca1-d51fd1f24df6>

JES -

<https://facilitytracker.app-garden.com/Woms/PublicAnalytic/Index?guid=3c2e5fd0-4dc5-4a44-b1a8-7ff0bc15c27e>

GES -

<https://facilitytracker.app-garden.com/Woms/PublicAnalytic/Index?guid=ef3d7048-0b99-4548-9f31-04632f0fae84>

GVES -

<https://facilitytracker.app-garden.com/Woms/PublicAnalytic/Index?guid=e2b27430-f9cb-4618-8958-f37a78a60a75>

FBES -

<https://facilitytracker.app-garden.com/Woms/PublicAnalytic/Index?guid=b9027fb8-5461-4cad-a2ca-4cd8a33ecfbe>

DCHS -

<https://facilitytracker.app-garden.com/Woms/PublicAnalytic/Index?guid=88424530-f628-46ae-8852-1a2d40bc9785>

DBHS -

<https://facilitytracker.app-garden.com/Woms/PublicAnalytic/Index?guid=1f5402fa-95ef-4b85-bc13-1b2a390eadd8>

BCES -

<https://facilitytracker.app-garden.com/Woms/PublicAnalytic/Index?guid=475154ae-7197-4f43-8ec4-6b9764458>

[b84](#)

Midway -

<https://facilitytracker.app-garden.com/Woms/PublicAnalytic/Index?guid=ec7f00ea-3b78-41db-9542-060401a41>

[1e6](#)

Bus Garage -

<https://facilitytracker.app-garden.com/Woms/PublicAnalytic/Index?guid=13f0ab1b-e7e9-4a01-bbeb-9b2d5181fb5f>

Warehouse -

<https://facilitytracker.app-garden.com/Woms/PublicAnalytic/Index?guid=7da489ac-1553-4a46-a0ac-27646726a003>

Central Office -

<https://facilitytracker.app-garden.com/Woms/PublicAnalytic/Index?guid=fbf02e24-8b01-46d9-98d1-a5e123581838>

Please let Jerry Day know when (if) approved

Washington County Department of Education  
School Educational **OVERNIGHT** Trip Authorization\*

RECEIVED

AUG 01 2024

BY: KR

Date of Request July 23 School DCHS Trip Date Dec 19 22

Estimated time of departure 8:00am and return 10:00pm total time away 4 days

Destination (include location) Hilton Head South Carolina

Teacher \_\_\_\_\_ Class \_\_\_\_\_ Grade \_\_\_\_\_

Chaperones Thomas Gouge  
Jerry Day  
Makail Gouge

Number of Students Involved 12

Estimated Total Miles (both ways) of Trip \_\_\_\_\_

Bus Driver/Number We will rent vans Bus Driver/ Number \_\_\_\_\_

Will Chaperones have a list (roll) that they are responsible for? Yes

As you plan the trip, will all children be given instructions as to what they should do if they become separated (lost) from the group? Yes

Will you have on file parental release forms signed by parents or legal guardians? Yes

Explain the educational value of the trip: Elite Basketball Tournament  
For National Ranked Teams by invitation only

Total Cost Estimate \$ 3000.00

Plans for meeting the costs Funds already secured by school account  
and booster club.

Transportation cost for educational trips shall be calculated in the following manner:

- \$16.00 per hour for driver (2 hour minimum)
- \$ 3.15 per hour to cover fixed charges (SS, retirement, etc.)
- \$19.15 total to be remitted to the central office per hour

Reimbursement for the bus and fuel shall be made at the rate of \$.75 per mile.

\*Refer to Board Policy 4.302

[Signature]  
Principal's Signature

7/29/24  
Date

BY WC SUPERINTENDENT [Signature]

08-01-24  
Date

Superintendent's Signature

Date Approved by the Board of Education \_\_\_\_\_

**PURCHASING DEPARTMENT**  
**WASHINGTON COUNTY BOARD OF EDUCATION**

Purchase Order **Nº 1238**  
 Date Issued **07-01-24**  
 Appropriation No. **72310399**  
 Dept. **Administration**  
 School

**PURCHASE ORDER**

**TO**  
**A Better Way Athletics**

Deliver to **WASHINGTON COUNTY BOARD OF EDUCATION**  
 Address **405 WEST COLLEGE STREET**  
**JONESBOROUGH, TN 37659**

Via

Articles on this order must be charged to account of

**NOTICE TO VENDOR**

1. Purchase order **MUST** bear two signatures in order to be valid.
2. Purchase order number **MUST** appear on all invoices submitted for payment.
3. Mail **TWO** copies of your invoice promptly to:

**Washington County Board of Education**  
**405 West College Street**  
**Jonesborough, TN 37659**  
**Telephone (423) 753-1105**

ARTICLES OR SERVICES	CODE	QUANTITY & UNIT	UNIT PRICE	TOTAL
(Unless otherwise stated all prices F.O.B. Destination)				
<b>Annual Subscription Fee</b>				
<b>GRAND TOTAL - INCLUDING ALL ATTACHED PAGES</b>				<b>\$ 12,000<sup>00</sup></b>

**SUBJECT TO THE FOLLOWING CONDITIONS**

1. All packages, cartons or other containers must be plainly marked with the purchase order number.
2. The right is reserved to purchase in the open market and to charge the difference to the Vendor in the event that deliveries are not made at the time specified in the bid and on this order.
3. Whenever a delivery is rejected, the Vendor shall be notified and be given the reason for the rejection. All rejected deliveries shall be held at the Vendor's risk and he shall bear the expense of removal.
4. Acceptance of this order includes acceptance of all terms, prices, delivery, instructions, specifications and conditions stated.
5. The county is not liable for Federal excise tax or state sales tax.
6. Each shipment and/or each purchase order should be covered by separate invoice.

**IMPORTANT: INVOICES AND PACKAGES MUST BEAR PURCHASE ORDER NUMBER**

<b>VENDOR'S COPY</b>	There is an otherwise unincumbered balance to the credit of the proper appropriation, allotment or fund to meet the expenditure covered by this purchase.	APPROVED:
	Authorized Signature	Purchasing Agent

**A Better Way Athletics, LLC**

10710 Midlothian Tpke Ste 300  
North Chesterfield, VA 23235  
US



**INVOICE**

BILL TO  
Washington County Schools  
405 West College Street  
Jonesborough, TN 37659 USA

INVOICE 1141  
DATE 07/01/2024  
TERMS Net 30  
DUE DATE 07/31/2024

ACTIVITY	DESCRIPTION	QTY	RATE	AMOUNT
Annual Fee	Subscription Term: July 1, 2024 - June 30, 2025	1	12,000.00	12,000.00

Please remit payment to A Better Way Athletics, LLC at:  
10710 Midlothian Tpke  
Suite 300  
North Chesterfield, VA 23235

BALANCE DUE

**\$12,000.00**

Federal EIN #: 87-2452442

For billing related questions, please contact [billing@abetterwayathletics.com](mailto:billing@abetterwayathletics.com).

Payment pending Board  
approval @ July 11, 2024  
regular BOB mtg

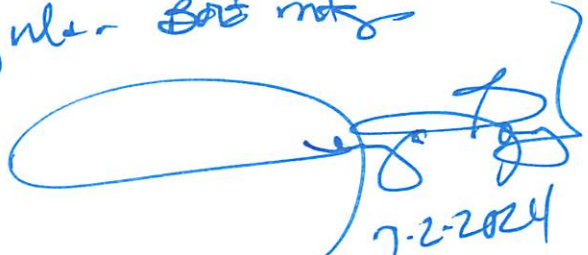

7-2-2024

**PURCHASING DEPARTMENT**  
**WASHINGTON COUNTY BOARD OF EDUCATION**

Purchase Order **Nº 2458**

Date Issued **7/9/2024**

Appropriation No. **722 50399**

Dept. **Technology**

School **System-wide**

**PURCHASE ORDER**

TO **Hapara Renewal**  
**Cordance Operations LLC**

Deliver to **WCDE - C. Fullbright**

Address

Via

Articles on this order must be charged to account of

**NOTICE TO VENDOR**

1. Purchase order **MUST** bear two signatures in order to be valid.
2. Purchase order number **MUST** appear on all invoices submitted for payment.
3. Mail **TWO** copies of your invoice promptly to:

**Washington County Board of Education**  
**405 West College Street**  
**Jonesborough, TN 37659**  
**Telephone (423) 753-1105**

ARTICLES OR SERVICES	CODE	QUANTITY & UNIT	UNIT PRICE	TOTAL
(Unless otherwise stated all prices F.O.B. Destination)				
Access to the web filter module which provides district with AI based internet filtering + control  * See att. Quote *  Sub starts: <u>7/1/24 - 6/30/25</u>		8,100.00		\$ 76,964.18
<b>GRAND TOTAL - INCLUDING ALL ATTACHED PAGES</b>				\$ 76,964.18

**SUBJECT TO THE FOLLOWING CONDITIONS**

1. All packages, cartons or other containers must be plainly marked with the purchase order number.
2. The right is reserved to purchase in the open market and to charge the difference to the Vendor in the event that deliveries are not made at the time specified in the bid and on this order.
3. Whenever a delivery is rejected, the Vendor shall be notified and be given the reason for the rejection. All rejected deliveries shall be held at the Vendor's risk and he shall bear the expense of removal.
4. Acceptance of this order includes acceptance of all terms, prices, delivery, instructions, specifications and conditions stated.
5. The county is not liable for Federal excise tax or state sales tax.
6. Each shipment and/or each purchase order should be covered by separate invoice.

**IMPORTANT: INVOICES AND PACKAGES MUST BEAR PURCHASE ORDER NUMBER**

*Handwritten signature*

**VENDOR'S COPY**

There is an otherwise unincumbered balance to the credit of the proper appropriation, allotment or fund to meet the expenditure covered by this purchase.

Authorized Signature

APPROVED:

Purchasing Agent



Hapara, a business unit of Cordance Operations LLC

# QUOTE

Washington County School District (TN)

**Attention To:**

Heath Bailey

405 W COLLEGE ST  
Jonesborough, TN 37659  
United States

**Issued by:**

Beth Still

beth.still@hapara.com

**Please make PO out to the following:**

Cordance Operations LLC

16W Martin Street  
Raleigh, NC 27601  
United States

**Quote Date**

7/8/2024

**Quote Number**

00022847

Description	Quantity	Sales Price	Total Price
Recurring access to the Monitoring module which provides oversight into a student's online activity			
Order for Washington County School District (TN)	8,100.00	USD 4.00	USD 30,034.80
Your subscription runs from July 1, 2024 to June 30, 2025.			
Recurring access to the Web Filter module which provides district with AI based internet filtering and control			
Order for Washington County School District (TN)	8,100.00	USD 4.50	USD 33,789.15
Your subscription runs from July 1, 2024 to June 30, 2025.			
Recurring access to the Wellness module which provides mental health alerts and web monitoring			
Order for Washington County School District (TN)	8,100.00	USD 1.75	USD 13,140.23
Your subscription runs from July 1, 2024 to June 30, 2025.			
<b>Total Price</b>			<b>USD 76,964.18</b>

Due Date 7/30/2024

Thank you so much for letting us provide you with a quote for our services. The quote is valid for 60 days from the date of the quote ("Quote Date" above).

Please note that this quote does not include any applicable sales tax.

If you have any questions regarding pricing, please feel free to contact the sales representative who issued the email (the email is at the top of the quote).

Your purchase of our services is governed by and subject to the Terms of Service found by clicking [here](#).

Please email this Quote with your signature and your Purchase Order to your Hapara representative.

Agreed and accepted on behalf of the above-named customer:

By: \_\_\_\_\_, Authorized Signatory



Hapara, a business unit of Cordance Operations LLC

Name: \_\_\_\_\_

Date: \_\_\_\_\_

Contact Details     Please email Purchase Order to [beth.still@hapara.com](mailto:beth.still@hapara.com)

# Request for Taxpayer Identification Number and Certification

**Give Form to the  
requester. Do not  
send to the IRS.**

▶ Go to [www.irs.gov/FormW9](http://www.irs.gov/FormW9) for instructions and the latest information.

Print or type.  
See Specific Instructions on page 3.

<b>1</b> Name (as shown on your income tax return). Name is required on this line; do not leave this line blank. <b>Cordance Operations LLC</b>	
<b>2</b> Business name/disregarded entity name, if different from above <b>Hapara, Inc.</b>	
<b>3</b> Check appropriate box for federal tax classification of the person whose name is entered on line 1. Check only <b>one</b> of the following seven boxes.  <input type="checkbox"/> Individual/sole proprietor or single-member LLC <input type="checkbox"/> C Corporation <input type="checkbox"/> S Corporation <input type="checkbox"/> Partnership <input type="checkbox"/> Trust/estate  <input checked="" type="checkbox"/> Limited liability company. Enter the tax classification (C=C corporation, S=S corporation, P=Partnership) ▶ <b>P</b> <small>Note: Check the appropriate box in the line above for the tax classification of the single-member owner. Do not check LLC if the LLC is classified as a single-member LLC that is disregarded from the owner unless the owner of the LLC is another LLC that is <b>not</b> disregarded from the owner for U.S. federal tax purposes. Otherwise, a single-member LLC that is disregarded from the owner should check the appropriate box for the tax classification of its owner.</small>  <input type="checkbox"/> Other (see instructions) ▶	<b>4</b> Exemptions (codes apply only to certain entities, not individuals; see instructions on page 3):  Exempt payee code (if any) _____  Exemption from FATCA reporting code (if any) _____  <small>(Applies to accounts maintained outside the U.S.)</small>
<b>5</b> Address (number, street, and apt. or suite no.) See instructions. <b>16W Martin Street</b>	Requester's name and address (optional)
<b>6</b> City, state, and ZIP code <b>Raleigh, NC 27601</b>	
<b>7</b> List account number(s) here (optional)	

## Part I Taxpayer Identification Number (TIN)

Enter your TIN in the appropriate box. The TIN provided must match the name given on line 1 to avoid backup withholding. For individuals, this is generally your social security number (SSN). However, for a resident alien, sole proprietor, or disregarded entity, see the instructions for Part I, later. For other entities, it is your employer identification number (EIN). If you do not have a number, see *How to get a TIN*, later.

**Note:** If the account is in more than one name, see the instructions for line 1. Also see *What Name and Number To Give the Requester* for guidelines on whose number to enter.

<b>Social security number</b>													
<table style="width: 100%; border-collapse: collapse;"> <tr> <td style="width: 25px; height: 25px; border: 1px solid black;"></td> <td style="width: 25px; height: 25px; border: 1px solid black;"></td> <td style="width: 25px; height: 25px; border: 1px solid black;"></td> <td style="width: 25px; height: 25px; border: 1px solid black;"></td> <td style="width: 25px; height: 25px; border: 1px solid black;"></td> <td style="width: 25px; height: 25px; border: 1px solid black;"></td> <td style="width: 25px; height: 25px; border: 1px solid black;"></td> <td style="width: 25px; height: 25px; border: 1px solid black;"></td> <td style="width: 25px; height: 25px; border: 1px solid black;"></td> <td style="width: 25px; height: 25px; border: 1px solid black;"></td> <td style="width: 25px; height: 25px; border: 1px solid black;"></td> <td style="width: 25px; height: 25px; border: 1px solid black;"></td> </tr> </table>													
<b>or</b>													
<b>Employer identification number</b>													
<table style="width: 100%; border-collapse: collapse;"> <tr> <td style="width: 25px; height: 25px; border: 1px solid black; text-align: center;">8</td> <td style="width: 25px; height: 25px; border: 1px solid black; text-align: center;">6</td> <td style="width: 25px; height: 25px; border: 1px solid black; text-align: center;">-</td> <td style="width: 25px; height: 25px; border: 1px solid black; text-align: center;">1</td> <td style="width: 25px; height: 25px; border: 1px solid black; text-align: center;">9</td> <td style="width: 25px; height: 25px; border: 1px solid black; text-align: center;">0</td> <td style="width: 25px; height: 25px; border: 1px solid black; text-align: center;">2</td> <td style="width: 25px; height: 25px; border: 1px solid black; text-align: center;">5</td> <td style="width: 25px; height: 25px; border: 1px solid black; text-align: center;">2</td> <td style="width: 25px; height: 25px; border: 1px solid black; text-align: center;">9</td> </tr> </table>	8	6	-	1	9	0	2	5	2	9			
8	6	-	1	9	0	2	5	2	9				

## Part II Certification

Under penalties of perjury, I certify that:

1. The number shown on this form is my correct taxpayer identification number (or I am waiting for a number to be issued to me); and
2. I am not subject to backup withholding because: (a) I am exempt from backup withholding, or (b) I have not been notified by the Internal Revenue Service (IRS) that I am subject to backup withholding as a result of a failure to report all interest or dividends, or (c) the IRS has notified me that I am no longer subject to backup withholding; and
3. I am a U.S. citizen or other U.S. person (defined below); and
4. The FATCA code(s) entered on this form (if any) indicating that I am exempt from FATCA reporting is correct.

**Certification instructions.** You must cross out item 2 above if you have been notified by the IRS that you are currently subject to backup withholding because you have failed to report all interest and dividends on your tax return. For real estate transactions, item 2 does not apply. For mortgage interest paid, acquisition or abandonment of secured property, cancellation of debt, contributions to an individual retirement arrangement (IRA), and generally, payments other than interest and dividends, you are not required to sign the certification, but you must provide your correct TIN. See the instructions for Part II, later.

<b>Sign Here</b>	Signature of U.S. person ▶	Date ▶ <b>5/1/2023</b>
------------------	----------------------------	------------------------

## General Instructions

Section references are to the Internal Revenue Code unless otherwise noted.

**Future developments.** For the latest information about developments related to Form W-9 and its instructions, such as legislation enacted after they were published, go to [www.irs.gov/FormW9](http://www.irs.gov/FormW9).

### Purpose of Form

An individual or entity (Form W-9 requester) who is required to file an information return with the IRS must obtain your correct taxpayer identification number (TIN) which may be your social security number (SSN), individual taxpayer identification number (ITIN), adoption taxpayer identification number (ATIN), or employer identification number (EIN), to report on an information return the amount paid to you, or other amount reportable on an information return. Examples of information returns include, but are not limited to, the following.

- Form 1099-INT (interest earned or paid)

- Form 1099-DIV (dividends, including those from stocks or mutual funds)
  - Form 1099-MISC (various types of income, prizes, awards, or gross proceeds)
  - Form 1099-B (stock or mutual fund sales and certain other transactions by brokers)
  - Form 1099-S (proceeds from real estate transactions)
  - Form 1099-K (merchant card and third party network transactions)
  - Form 1098 (home mortgage interest), 1098-E (student loan interest), 1098-T (tuition)
  - Form 1099-C (canceled debt)
  - Form 1099-A (acquisition or abandonment of secured property)
- Use Form W-9 only if you are a U.S. person (including a resident alien), to provide your correct TIN.

*If you do not return Form W-9 to the requester with a TIN, you might be subject to backup withholding. See What is backup withholding, later.*

By signing the filled-out form, you:

1. Certify that the TIN you are giving is correct (or you are waiting for a number to be issued),
2. Certify that you are not subject to backup withholding, or
3. Claim exemption from backup withholding if you are a U.S. exempt payee. If applicable, you are also certifying that as a U.S. person, your allocable share of any partnership income from a U.S. trade or business is not subject to the withholding tax on foreign partners' share of effectively connected income, and
4. Certify that FATCA code(s) entered on this form (if any) indicating that you are exempt from the FATCA reporting, is correct. See *What is FATCA reporting*, later, for further information.

**Note:** If you are a U.S. person and a requester gives you a form other than Form W-9 to request your TIN, you must use the requester's form if it is substantially similar to this Form W-9.

**Definition of a U.S. person.** For federal tax purposes, you are considered a U.S. person if you are:

- An individual who is a U.S. citizen or U.S. resident alien;
- A partnership, corporation, company, or association created or organized in the United States or under the laws of the United States;
- An estate (other than a foreign estate); or
- A domestic trust (as defined in Regulations section 301.7701-7).

**Special rules for partnerships.** Partnerships that conduct a trade or business in the United States are generally required to pay a withholding tax under section 1446 on any foreign partners' share of effectively connected taxable income from such business. Further, in certain cases where a Form W-9 has not been received, the rules under section 1446 require a partnership to presume that a partner is a foreign person, and pay the section 1446 withholding tax. Therefore, if you are a U.S. person that is a partner in a partnership conducting a trade or business in the United States, provide Form W-9 to the partnership to establish your U.S. status and avoid section 1446 withholding on your share of partnership income.

In the cases below, the following person must give Form W-9 to the partnership for purposes of establishing its U.S. status and avoiding withholding on its allocable share of net income from the partnership conducting a trade or business in the United States.

- In the case of a disregarded entity with a U.S. owner, the U.S. owner of the disregarded entity and not the entity;
- In the case of a grantor trust with a U.S. grantor or other U.S. owner, generally, the U.S. grantor or other U.S. owner of the grantor trust and not the trust; and
- In the case of a U.S. trust (other than a grantor trust), the U.S. trust (other than a grantor trust) and not the beneficiaries of the trust.

**Foreign person.** If you are a foreign person or the U.S. branch of a foreign bank that has elected to be treated as a U.S. person, do not use Form W-9. Instead, use the appropriate Form W-8 or Form 8233 (see Pub. 515, *Withholding of Tax on Nonresident Aliens and Foreign Entities*).

**Nonresident alien who becomes a resident alien.** Generally, only a nonresident alien individual may use the terms of a tax treaty to reduce or eliminate U.S. tax on certain types of income. However, most tax treaties contain a provision known as a "saving clause." Exceptions specified in the saving clause may permit an exemption from tax to continue for certain types of income even after the payee has otherwise become a U.S. resident alien for tax purposes.

If you are a U.S. resident alien who is relying on an exception contained in the saving clause of a tax treaty to claim an exemption from U.S. tax on certain types of income, you must attach a statement to Form W-9 that specifies the following five items.

1. The treaty country. Generally, this must be the same treaty under which you claimed exemption from tax as a nonresident alien.
2. The treaty article addressing the income.
3. The article number (or location) in the tax treaty that contains the saving clause and its exceptions.
4. The type and amount of income that qualifies for the exemption from tax.
5. Sufficient facts to justify the exemption from tax under the terms of the treaty article.

**Example.** Article 20 of the U.S.-China income tax treaty allows an exemption from tax for scholarship income received by a Chinese student temporarily present in the United States. Under U.S. law, this student will become a resident alien for tax purposes if his or her stay in the United States exceeds 5 calendar years. However, paragraph 2 of the first Protocol to the U.S.-China treaty (dated April 30, 1984) allows the provisions of Article 20 to continue to apply even after the Chinese student becomes a resident alien of the United States. A Chinese student who qualifies for this exception (under paragraph 2 of the first protocol) and is relying on this exception to claim an exemption from tax on his or her scholarship or fellowship income would attach to Form W-9 a statement that includes the information described above to support that exemption.

If you are a nonresident alien or a foreign entity, give the requester the appropriate completed Form W-8 or Form 8233.

## Backup Withholding

**What is backup withholding?** Persons making certain payments to you must under certain conditions withhold and pay to the IRS 24% of such payments. This is called "backup withholding." Payments that may be subject to backup withholding include interest, tax-exempt interest, dividends, broker and barter exchange transactions, rents, royalties, nonemployee pay, payments made in settlement of payment card and third party network transactions, and certain payments from fishing boat operators. Real estate transactions are not subject to backup withholding.

You will not be subject to backup withholding on payments you receive if you give the requester your correct TIN, make the proper certifications, and report all your taxable interest and dividends on your tax return.

**Payments you receive will be subject to backup withholding if:**

1. You do not furnish your TIN to the requester,
2. You do not certify your TIN when required (see the instructions for Part II for details),
3. The IRS tells the requester that you furnished an incorrect TIN,
4. The IRS tells you that you are subject to backup withholding because you did not report all your interest and dividends on your tax return (for reportable interest and dividends only), or
5. You do not certify to the requester that you are not subject to backup withholding under 4 above (for reportable interest and dividend accounts opened after 1983 only).

Certain payees and payments are exempt from backup withholding. See *Exempt payee code*, later, and the separate Instructions for the Requester of Form W-9 for more information.

Also see *Special rules for partnerships*, earlier.

## What is FATCA Reporting?

The Foreign Account Tax Compliance Act (FATCA) requires a participating foreign financial institution to report all United States account holders that are specified United States persons. Certain payees are exempt from FATCA reporting. See *Exemption from FATCA reporting code*, later, and the Instructions for the Requester of Form W-9 for more information.

## Updating Your Information

You must provide updated information to any person to whom you claimed to be an exempt payee if you are no longer an exempt payee and anticipate receiving reportable payments in the future from this person. For example, you may need to provide updated information if you are a C corporation that elects to be an S corporation, or if you no longer are tax exempt. In addition, you must furnish a new Form W-9 if the name or TIN changes for the account; for example, if the grantor of a grantor trust dies.

## Penalties

**Failure to furnish TIN.** If you fail to furnish your correct TIN to a requester, you are subject to a penalty of \$50 for each such failure unless your failure is due to reasonable cause and not to willful neglect.

**Civil penalty for false information with respect to withholding.** If you make a false statement with no reasonable basis that results in no backup withholding, you are subject to a \$500 penalty.

**Criminal penalty for falsifying information.** Willfully falsifying certifications or affirmations may subject you to criminal penalties including fines and/or imprisonment.

**Misuse of TINs.** If the requester discloses or uses TINs in violation of federal law, the requester may be subject to civil and criminal penalties.

## Specific Instructions

### Line 1

You must enter one of the following on this line; **do not** leave this line blank. The name should match the name on your tax return.

If this Form W-9 is for a joint account (other than an account maintained by a foreign financial institution (FFI)), list first, and then circle, the name of the person or entity whose number you entered in Part I of Form W-9. If you are providing Form W-9 to an FFI to document a joint account, each holder of the account that is a U.S. person must provide a Form W-9.

**a. Individual.** Generally, enter the name shown on your tax return. If you have changed your last name without informing the Social Security Administration (SSA) of the name change, enter your first name, the last name as shown on your social security card, and your new last name.

**Note: ITIN applicant:** Enter your individual name as it was entered on your Form W-7 application, line 1a. This should also be the same as the name you entered on the Form 1040/1040A/1040EZ you filed with your application.

**b. Sole proprietor or single-member LLC.** Enter your individual name as shown on your 1040/1040A/1040EZ on line 1. You may enter your business, trade, or "doing business as" (DBA) name on line 2.

**c. Partnership, LLC that is not a single-member LLC, C corporation, or S corporation.** Enter the entity's name as shown on the entity's tax return on line 1 and any business, trade, or DBA name on line 2.

**d. Other entities.** Enter your name as shown on required U.S. federal tax documents on line 1. This name should match the name shown on the charter or other legal document creating the entity. You may enter any business, trade, or DBA name on line 2.

**e. Disregarded entity.** For U.S. federal tax purposes, an entity that is disregarded as an entity separate from its owner is treated as a "disregarded entity." See Regulations section 301.7701-2(c)(2)(iii). Enter the owner's name on line 1. The name of the entity entered on line 1 should never be a disregarded entity. The name on line 1 should be the name shown on the income tax return on which the income should be reported. For example, if a foreign LLC that is treated as a disregarded entity for U.S. federal tax purposes has a single owner that is a U.S. person, the U.S. owner's name is required to be provided on line 1. If the direct owner of the entity is also a disregarded entity, enter the first owner that is not disregarded for federal tax purposes. Enter the disregarded entity's name on line 2, "Business name/disregarded entity name." If the owner of the disregarded entity is a foreign person, the owner must complete an appropriate Form W-8 instead of a Form W-9. This is the case even if the foreign person has a U.S. TIN.

### Line 2

If you have a business name, trade name, DBA name, or disregarded entity name, you may enter it on line 2.

### Line 3

Check the appropriate box on line 3 for the U.S. federal tax classification of the person whose name is entered on line 1. Check only one box on line 3.

IF the entity/person on line 1 is a(n) . . .	THEN check the box for . . .
• Corporation	Corporation
• Individual • Sole proprietorship, or • Single-member limited liability company (LLC) owned by an individual and disregarded for U.S. federal tax purposes.	Individual/sole proprietor or single-member LLC
• LLC treated as a partnership for U.S. federal tax purposes, • LLC that has filed Form 8832 or 2553 to be taxed as a corporation, or • LLC that is disregarded as an entity separate from its owner but the owner is another LLC that is not disregarded for U.S. federal tax purposes.	Limited liability company and enter the appropriate tax classification. (P= Partnership; C= C corporation; or S= S corporation)
• Partnership	Partnership
• Trust/estate	Trust/estate

### Line 4, Exemptions

If you are exempt from backup withholding and/or FATCA reporting, enter in the appropriate space on line 4 any code(s) that may apply to you.

#### Exempt payee code.

- Generally, individuals (including sole proprietors) are not exempt from backup withholding.
- Except as provided below, corporations are exempt from backup withholding for certain payments, including interest and dividends.
- Corporations are not exempt from backup withholding for payments made in settlement of payment card or third party network transactions.
- Corporations are not exempt from backup withholding with respect to attorneys' fees or gross proceeds paid to attorneys, and corporations that provide medical or health care services are not exempt with respect to payments reportable on Form 1099-MISC.

The following codes identify payees that are exempt from backup withholding. Enter the appropriate code in the space in line 4.

- 1—An organization exempt from tax under section 501(a), any IRA, or a custodial account under section 403(b)(7) if the account satisfies the requirements of section 401(f)(2)
- 2—The United States or any of its agencies or instrumentalities
- 3—A state, the District of Columbia, a U.S. commonwealth or possession, or any of their political subdivisions or instrumentalities
- 4—A foreign government or any of its political subdivisions, agencies, or instrumentalities
- 5—A corporation
- 6—A dealer in securities or commodities required to register in the United States, the District of Columbia, or a U.S. commonwealth or possession
- 7—A futures commission merchant registered with the Commodity Futures Trading Commission
- 8—A real estate investment trust
- 9—An entity registered at all times during the tax year under the Investment Company Act of 1940
- 10—A common trust fund operated by a bank under section 584(a)
- 11—A financial institution
- 12—A middleman known in the investment community as a nominee or custodian
- 13—A trust exempt from tax under section 664 or described in section 4947

The following chart shows types of payments that may be exempt from backup withholding. The chart applies to the exempt payees listed above, 1 through 13.

IF the payment is for . . .	THEN the payment is exempt for . . .
Interest and dividend payments	All exempt payees except for 7
Broker transactions	Exempt payees 1 through 4 and 6 through 11 and all C corporations. S corporations must not enter an exempt payee code because they are exempt only for sales of noncovered securities acquired prior to 2012.
Barter exchange transactions and patronage dividends	Exempt payees 1 through 4
Payments over \$600 required to be reported and direct sales over \$5,000 <sup>1</sup>	Generally, exempt payees 1 through 5 <sup>2</sup>
Payments made in settlement of payment card or third party network transactions	Exempt payees 1 through 4

<sup>1</sup> See Form 1099-MISC, Miscellaneous Income, and its instructions.

<sup>2</sup> However, the following payments made to a corporation and reportable on Form 1099-MISC are not exempt from backup withholding: medical and health care payments, attorneys' fees, gross proceeds paid to an attorney reportable under section 6045(f), and payments for services paid by a federal executive agency.

**Exemption from FATCA reporting code.** The following codes identify payees that are exempt from reporting under FATCA. These codes apply to persons submitting this form for accounts maintained outside of the United States by certain foreign financial institutions. Therefore, if you are only submitting this form for an account you hold in the United States, you may leave this field blank. Consult with the person requesting this form if you are uncertain if the financial institution is subject to these requirements. A requester may indicate that a code is not required by providing you with a Form W-9 with "Not Applicable" (or any similar indication) written or printed on the line for a FATCA exemption code.

A—An organization exempt from tax under section 501(a) or any individual retirement plan as defined in section 7701(a)(37)

B—The United States or any of its agencies or instrumentalities

C—A state, the District of Columbia, a U.S. commonwealth or possession, or any of their political subdivisions or instrumentalities

D—A corporation the stock of which is regularly traded on one or more established securities markets, as described in Regulations section 1.1472-1(c)(1)(i)

E—A corporation that is a member of the same expanded affiliated group as a corporation described in Regulations section 1.1472-1(c)(1)(i)

F—A dealer in securities, commodities, or derivative financial instruments (including notional principal contracts, futures, forwards, and options) that is registered as such under the laws of the United States or any state

G—A real estate investment trust

H—A regulated investment company as defined in section 851 or an entity registered at all times during the tax year under the Investment Company Act of 1940

I—A common trust fund as defined in section 584(a)

J—A bank as defined in section 581

K—A broker

L—A trust exempt from tax under section 664 or described in section 4947(a)(1)

M—A tax exempt trust under a section 403(b) plan or section 457(g) plan

**Note:** You may wish to consult with the financial institution requesting this form to determine whether the FATCA code and/or exempt payee code should be completed.

### Line 5

Enter your address (number, street, and apartment or suite number). This is where the requester of this Form W-9 will mail your information returns. If this address differs from the one the requester already has on file, write NEW at the top. If a new address is provided, there is still a chance the old address will be used until the payor changes your address in their records.

### Line 6

Enter your city, state, and ZIP code.

## Part I. Taxpayer Identification Number (TIN)

**Enter your TIN in the appropriate box.** If you are a resident alien and you do not have and are not eligible to get an SSN, your TIN is your IRS individual taxpayer identification number (ITIN). Enter it in the social security number box. If you do not have an ITIN, see *How to get a TIN* below.

If you are a sole proprietor and you have an EIN, you may enter either your SSN or EIN.

If you are a single-member LLC that is disregarded as an entity separate from its owner, enter the owner's SSN (or EIN, if the owner has one). Do not enter the disregarded entity's EIN. If the LLC is classified as a corporation or partnership, enter the entity's EIN.

**Note:** See *What Name and Number To Give the Requester*, later, for further clarification of name and TIN combinations.

**How to get a TIN.** If you do not have a TIN, apply for one immediately. To apply for an SSN, get Form SS-5, Application for a Social Security Card, from your local SSA office or get this form online at [www.SSA.gov](http://www.SSA.gov). You may also get this form by calling 1-800-772-1213. Use Form W-7, Application for IRS Individual Taxpayer Identification Number, to apply for an ITIN, or Form SS-4, Application for Employer Identification Number, to apply for an EIN. You can apply for an EIN online by accessing the IRS website at [www.irs.gov/Businesses](http://www.irs.gov/Businesses) and clicking on Employer Identification Number (EIN) under Starting a Business. Go to [www.irs.gov/Forms](http://www.irs.gov/Forms) to view, download, or print Form W-7 and/or Form SS-4. Or, you can go to [www.irs.gov/OrderForms](http://www.irs.gov/OrderForms) to place an order and have Form W-7 and/or SS-4 mailed to you within 10 business days.

If you are asked to complete Form W-9 but do not have a TIN, apply for a TIN and write "Applied For" in the space for the TIN, sign and date the form, and give it to the requester. For interest and dividend payments, and certain payments made with respect to readily tradable instruments, generally you will have 60 days to get a TIN and give it to the requester before you are subject to backup withholding on payments. The 60-day rule does not apply to other types of payments. You will be subject to backup withholding on all such payments until you provide your TIN to the requester.

**Note:** Entering "Applied For" means that you have already applied for a TIN or that you intend to apply for one soon.

**Caution:** A disregarded U.S. entity that has a foreign owner must use the appropriate Form W-8.

## Part II. Certification

To establish to the withholding agent that you are a U.S. person, or resident alien, sign Form W-9. You may be requested to sign by the withholding agent even if item 1, 4, or 5 below indicates otherwise.

For a joint account, only the person whose TIN is shown in Part I should sign (when required). In the case of a disregarded entity, the person identified on line 1 must sign. Exempt payees, see *Exempt payee code*, earlier.

**Signature requirements.** Complete the certification as indicated in items 1 through 5 below.

**1. Interest, dividend, and barter exchange accounts opened before 1984 and broker accounts considered active during 1983.** You must give your correct TIN, but you do not have to sign the certification.

**2. Interest, dividend, broker, and barter exchange accounts opened after 1983 and broker accounts considered inactive during 1983.** You must sign the certification or backup withholding will apply. If you are subject to backup withholding and you are merely providing your correct TIN to the requester, you must cross out item 2 in the certification before signing the form.

**3. Real estate transactions.** You must sign the certification. You may cross out item 2 of the certification.

**4. Other payments.** You must give your correct TIN, but you do not have to sign the certification unless you have been notified that you have previously given an incorrect TIN. "Other payments" include payments made in the course of the requester's trade or business for rents, royalties, goods (other than bills for merchandise), medical and health care services (including payments to corporations), payments to a nonemployee for services, payments made in settlement of payment card and third party network transactions, payments to certain fishing boat crew members and fishermen, and gross proceeds paid to attorneys (including payments to corporations).

**5. Mortgage interest paid by you, acquisition or abandonment of secured property, cancellation of debt, qualified tuition program payments (under section 529), ABLE accounts (under section 529A), IRA, Coverdell ESA, Archer MSA or HSA contributions or distributions, and pension distributions.** You must give your correct TIN, but you do not have to sign the certification.

**What Name and Number To Give the Requester**

For this type of account:	Give name and SSN of:
1. Individual	The individual
2. Two or more individuals (joint account) other than an account maintained by an FFI	The actual owner of the account or, if combined funds, the first individual on the account <sup>1</sup>
3. Two or more U.S. persons (joint account maintained by an FFI)	Each holder of the account
4. Custodial account of a minor (Uniform Gift to Minors Act)	The minor <sup>2</sup>
5. a. The usual revocable savings trust (grantor is also trustee) b. So-called trust account that is not a legal or valid trust under state law	The grantor-trustee <sup>1</sup> The actual owner <sup>1</sup>
6. Sole proprietorship or disregarded entity owned by an individual	The owner <sup>3</sup>
7. Grantor trust filing under Optional Form 1099 Filing Method 1 (see Regulations section 1.671-4(b)(2)(i)(A))	The grantor*
For this type of account:	Give name and EIN of:
8. Disregarded entity not owned by an individual	The owner
9. A valid trust, estate, or pension trust	Legal entity <sup>4</sup>
10. Corporation or LLC electing corporate status on Form 8832 or Form 2553	The corporation
11. Association, club, religious, charitable, educational, or other tax-exempt organization	The organization
12. Partnership or multi-member LLC	The partnership
13. A broker or registered nominee	The broker or nominee

For this type of account:	Give name and EIN of:
14. Account with the Department of Agriculture in the name of a public entity (such as a state or local government, school district, or prison) that receives agricultural program payments	The public entity
15. Grantor trust filing under the Form 1041 Filing Method or the Optional Form 1099 Filing Method 2 (see Regulations section 1.671-4(b)(2)(i)(B))	The trust

<sup>1</sup> List first and circle the name of the person whose number you furnish. If only one person on a joint account has an SSN, that person's number must be furnished.

<sup>2</sup> Circle the minor's name and furnish the minor's SSN.

<sup>3</sup> You must show your individual name and you may also enter your business or DBA name on the "Business name/disregarded entity" name line. You may use either your SSN or EIN (if you have one), but the IRS encourages you to use your SSN.

<sup>4</sup> List first and circle the name of the trust, estate, or pension trust. (Do not furnish the TIN of the personal representative or trustee unless the legal entity itself is not designated in the account title.) Also see *Special rules for partnerships*, earlier.

\*Note: The grantor also must provide a Form W-9 to trustee of trust.

Note: If no name is circled when more than one name is listed, the number will be considered to be that of the first name listed.

**Secure Your Tax Records From Identity Theft**

Identity theft occurs when someone uses your personal information such as your name, SSN, or other identifying information, without your permission, to commit fraud or other crimes. An identity thief may use your SSN to get a job or may file a tax return using your SSN to receive a refund.

To reduce your risk:

- Protect your SSN,
- Ensure your employer is protecting your SSN, and
- Be careful when choosing a tax preparer.

If your tax records are affected by identity theft and you receive a notice from the IRS, respond right away to the name and phone number printed on the IRS notice or letter.

If your tax records are not currently affected by identity theft but you think you are at risk due to a lost or stolen purse or wallet, questionable credit card activity or credit report, contact the IRS Identity Theft Hotline at 1-800-908-4490 or submit Form 14039.

For more information, see Pub. 5027, Identity Theft Information for Taxpayers.

Victims of identity theft who are experiencing economic harm or a systemic problem, or are seeking help in resolving tax problems that have not been resolved through normal channels, may be eligible for Taxpayer Advocate Service (TAS) assistance. You can reach TAS by calling the TAS toll-free case intake line at 1-877-777-4778 or TTY/TDD 1-800-829-4059.

**Protect yourself from suspicious emails or phishing schemes.** Phishing is the creation and use of email and websites designed to mimic legitimate business emails and websites. The most common act is sending an email to a user falsely claiming to be an established legitimate enterprise in an attempt to scam the user into surrendering private information that will be used for identity theft.

The IRS does not initiate contacts with taxpayers via emails. Also, the IRS does not request personal detailed information through email or ask taxpayers for the PIN numbers, passwords, or similar secret access information for their credit card, bank, or other financial accounts.

If you receive an unsolicited email claiming to be from the IRS, forward this message to [phishing@irs.gov](mailto:phishing@irs.gov). You may also report misuse of the IRS name, logo, or other IRS property to the Treasury Inspector General for Tax Administration (TIGTA) at 1-800-366-4484. You can forward suspicious emails to the Federal Trade Commission at [spam@uce.gov](mailto:spam@uce.gov) or report them at [www.ftc.gov/complaint](http://www.ftc.gov/complaint). You can contact the FTC at [www.ftc.gov/idtheft](http://www.ftc.gov/idtheft) or 877-IDTHEFT (877-438-4338). If you have been the victim of identity theft, see [www.IdentityTheft.gov](http://www.IdentityTheft.gov) and Pub. 5027.

Visit [www.irs.gov/IdentityTheft](http://www.irs.gov/IdentityTheft) to learn more about identity theft and how to reduce your risk.

## Privacy Act Notice

Section 6109 of the Internal Revenue Code requires you to provide your correct TIN to persons (including federal agencies) who are required to file information returns with the IRS to report interest, dividends, or certain other income paid to you; mortgage interest you paid; the acquisition or abandonment of secured property; the cancellation of debt; or contributions you made to an IRA, Archer MSA, or HSA. The person collecting this form uses the information on the form to file information returns with the IRS, reporting the above information. Routine uses of this information include giving it to the Department of Justice for civil and criminal litigation and to cities, states, the District of Columbia, and U.S. commonwealths and possessions for use in administering their laws. The information also may be disclosed to other countries under a treaty, to federal and state agencies to enforce civil and criminal laws, or to federal law enforcement and intelligence agencies to combat terrorism. You must provide your TIN whether or not you are required to file a tax return. Under section 3406, payers must generally withhold a percentage of taxable interest, dividend, and certain other payments to a payee who does not give a TIN to the payer. Certain penalties may also apply for providing false or fraudulent information.

**PURCHASING DEPARTMENT**  
**WASHINGTON COUNTY BOARD OF EDUCATION**

**PURCHASE ORDER**

Purchase Order **Nº 2514**

Date Issued **7/16/24**

Appropriation No. **41E71100-499**

Dept. **Academics**

School **DCHS**

**TO**

**N I E T**

Deliver to **David Crockett High School**

Address **684 Old St Rt 34**

Via **Jonesborough, TN 37659**

Articles on this order must be charged to account of

**NOTICE TO VENDOR**

1. Purchase order **MUST** bear two signatures in order to be valid.
2. Purchase order number **MUST** appear on all invoices submitted for payment.
3. Mail **TWO** copies of your invoice promptly to:

**Washington County Board of Education**  
**405 West College Street**  
**Jonesborough, TN 37659**  
**Telephone (423) 753-1105**

**10-3580**

ARTICLES OR SERVICES (Unless otherwise stated all prices F.O.B. Destination)	CODE	QUANTITY & UNIT	UNIT PRICE	TOTAL
Onsite or Virtual Coaching & Support		14	\$2,750	
<b>GRAND TOTAL - INCLUDING ALL ATTACHED PAGES</b>				<b>\$38,500<sup>w</sup></b>

**SUBJECT TO THE FOLLOWING CONDITIONS**

1. All packages, cartons or other containers must be plainly marked with the purchase order number.
2. The right is reserved to purchase in the open market and to charge the difference to the Vendor in the event that deliveries are not made at the time specified in the bid and on this order.
3. Whenever a delivery is rejected, the Vendor shall be notified and be given the reason for the rejection. All rejected deliveries shall be held at the Vendor's risk and he shall bear the expense of removal.
4. Acceptance of this order includes acceptance of all terms, prices, delivery, instructions, specifications and conditions stated.
5. The county is not liable for Federal excise tax or state sales tax.
6. Each shipment and/or each purchase order should be covered by separate invoice.

**IMPORTANT: INVOICES AND PACKAGES MUST BEAR PURCHASE ORDER NUMBER**

**VENDOR'S COPY**

There is an otherwise unincumbered balance to the credit of the proper appropriation, allotment or fund to meet the expenditure covered by this purchase.

Authorized Signature

APPROVED:

Purchasing Agent



NATIONAL INSTITUTE FOR  
EXCELLENCE IN TEACHING

### Statement of Work

<b>Project:</b> 2024-25 NIET Support for Washington County SD- David Crockett High School		<b>Project ID:</b> ID-3580
<b>Partner:</b> Washington County School District		<b>Date:</b> July 15, 2024
<b>Primary Contact Name:</b> Ashley Davis	<b>Phone:</b> 423-753-1150	<b>Email:</b> keysa@wcde.org
<b>Secondary Contact Name:</b> Josh Davis	<b>Phone:</b> 423-753-1150	<b>Email:</b> davisj2@wcde.org
<b>Scope:</b> Washington County School District - David Crockett High School has requested NIET support services for the 2024-25 school year. Support to include fourteen (14) days of onsite/virtual training and support. The support will continue the focus from 2023-24 around collective leadership, collaborative learning, instructional excellence, and reflective culture. Total cost is \$38,500.00 inclusive of travel. This agreement is effective immediately and will continue through June 30, 2025; additional details are outlined on appendix A. The parties acknowledge and agree that the General Terms and Conditions along with the additional details outlined in Appendix A are hereby incorporated into this Statement of Work.		
<b>Authorized Representative Name</b>	<b>Date</b>	<b>Authorized Representative Signature</b>
<u>National Institute for Excellence in Teaching</u> Molly Kwas Chief Financial Officer	July 15, 2024	
<u>Washington County School District</u> Name: Title:		

## GENERAL TERMS AND CONDITIONS

These General Terms and Conditions ("General Terms and Conditions") are applicable to any Services (as defined below) provided by the National Institute for Excellence in Teaching, a nonprofit, public benefit corporation ("NIET") as retained and subscribed pursuant to the "Statement of Work" ("SOW", and together with these General Terms and Conditions, the "Agreement") therein as the Client.

### 1. THE SERVICES

- a. Provision of the Services. Pursuant to the Statement of Work, NIET has agreed to provide Client with services as described in the Statement of Work, (the "Services"). The Services may be provided to Client in person or virtually by NIET personnel, by granting access to NIET's Data Management System (the "Portal"), or as more fully set forth in the Statement of Work. All references herein to "Client" shall refer to Client and its affiliates that are receiving the Services pursuant hereto.
- b. Performance Standard. NIET will perform the Services in a professional manner, using personnel having a level of skill in the area commensurate with the requirements of the Services to be performed. NIET shall use commercially reasonable efforts to maintain the timeliness of the delivery of the Services.
- c. Use of Services. Client agrees that (i) it will not knowingly use the Services in contravention of any laws or regulations, (ii) it will use the Services in accordance with the instructions and reasonable policies established by NIET from time to time and communicated to Client and (iii) it will use the Services only for internal purposes. Client will not provide, directly or indirectly, any of the Services or any portion thereof to any third-party.
- d. Client Responsible for Compliance with Laws. Client (and not NIET) will be responsible (i) for compliance by Client with all laws and governmental regulations affecting its employees (including labor regulations (e.g., time and attendance) and collective bargaining agreements, and (ii) for any use Client may make of the Services to assist in complying with laws and governmental regulations, including qualifying for and obtaining grants or complying with any related audits.
- e. Web-Based Services. Client understands that a portion of the Services supplied by NIET hereunder are delivered over the Internet and the reliability of the Internet is beyond the reasonable control of NIET. Therefore, although NIET makes reasonable efforts to ensure the accuracy and reliability of such Services, neither NIET nor any third party supplier guarantees such accuracy or reliability, and Client acknowledges that NIET, its employees, agents, contractors, sub-contractors and other third party suppliers will not be held liable for any damages suffered or incurred by Client or any other person or entity arising out of (a) any fault, interruption or delay in any service supplied to Client, (b) out of any inaccuracy, error or omission in any Service supplied to Client, (c) any loss of data, or (d) any reliance upon any Service supplied to Client however such faults, interruptions, delays, inaccuracies, errors or omissions arise, unless due to NIET's gross negligence or willful misconduct.

### 2. FEES; TAXES

- a. Late Cancellation. In the event that NIET is scheduled to deliver Services and for reasons unrelated to Section 8.e., the Client cancels within seventy-two (72) hours, NIET will charge for the delivery of Services as outlined in the Statement of Work.
- b. Fees. Client shall pay NIET for the Services in the amount and at the time set forth in the Statement of Work. Client will pay all invoices, if any, in full within thirty (30) days of invoice date. If Client fails to pay any amount due hereunder, whether by acceleration or otherwise, Client, on written demand, shall pay interest at the rate of 1.5% (or the maximum allowed by law if less) on such past due amount from the due date thereof until the payment date. Client shall reimburse NIET for any expenses incurred, including interest and reasonable attorney fees, in collecting amounts due NIET hereunder.

### 3. INTELLECTUAL PROPERTY

- a. Ownership of Proprietary Rights. All rubrics, trainings, support materials, software applications, manuals, reports, studies, and related documentation made available, directly or indirectly, by NIET to Client, including without limitation the Portal and all manuals, reports, studies and similar material created by NIET, as part of the Services (collectively, the "NIET Products") are the exclusive property of NIET or the third parties from whom NIET has secured the rights to such NIET Product. All rights, title and interest in or to any copyright, trademark, service mark and other proprietary right relating to the NIET Products and the related logos, product names, etc. are reserved. The use of any software included in, or supplied by NIET for use with, the NIET Products, shall be governed by the license agreement delivered with such software. Neither Client nor any recipient shall: (i) alter or remove from any NIET Product or associated documentation any proprietary, copyright, trademark or trade secret legend, or (ii) attempt to decompile, disassemble or reverse engineer the NIET Product or other confidential and proprietary information.
- b. NIET Infringement Indemnity. NIET will defend Client in any suit or cause of action alleging that the NIET Products, as provided by NIET and used in accordance with the terms of this Agreement, infringe upon any United States copyright, trade secret, or other proprietary right of a third party. NIET will pay damages assessed, including reasonable attorneys' fees, against Client in any such suit or cause of action, provided that, (i) NIET is promptly notified in writing of such a suit or cause of action, (ii) NIET controls any negotiations or defense and Client assists NIET as reasonably required by

NIET, and (iii) Client takes all reasonable steps to mitigate any potential damages that may result. The foregoing infringement indemnity will not apply and NIET will not be liable for any damages assessed in any suit or cause of action whereby Client is required to indemnify NIET pursuant to Section 3.c. below. If any NIET Product is held or believed to infringe on any third-party's intellectual property rights, NIET may, in its sole discretion, (a) modify the NIET Product to be non-infringing, (b) obtain for Client a license to continue using such NIET Product, or (c) if neither (a) nor (b) are practical, terminate this Agreement as to the infringing NIET Product and return to Client any unearned fees paid by Client to NIET in advance. This Section 3.b. states NIET's entire liability and Client's exclusive remedies for infringement of intellectual property rights of any kind.

- c. **Client Infringement Indemnity.** To the extent permitted by State law, Client will defend NIET against, and pay damages assessed in, any suit or cause of action alleging that the NIET Products infringe upon any United States copyright, trade secret, or other proprietary right of a third party, to the extent that any such suit or cause of action results from (i) any alteration, change, modification and /or enhancement of the NIET Products made by Client or any third party on behalf of Client without NIET's express permission; (ii) Client's use of the NIET Products in combination with any hardware, software or other materials not expressly authorized by NIET, or use of other than the most current release of the NIET Products that results in a claim or action for infringement that could have been avoided by use of the current release, (iii) use of the NIET Products after Client has been notified that the NIET Products infringe upon the intellectual property rights of a third party, or (iv) use by Client of unmodified NIET Products after Client has been informed of modifications that would avoid claims of infringement.

#### 4. GENERAL PROVISIONS

- a. **Protection of Client Files.** NIET will take reasonable precautions to prevent the loss of or alteration to Client's data files in NIET's possession, but NIET does not undertake to guarantee against any such loss or alteration. NIET will maintain a record retention policy and may from time to time, in its sole discretion, modify or amend such policy. However, NIET is not and will not be, Client's official record keeper. Accordingly, Client will, to the extent it deems necessary, keep copies of all source documents of the information delivered to NIET.
- b. **Confidential Information.** All Confidential Information disclosed hereunder will remain the exclusive and confidential property of the disclosing party. The receiving party will not disclose the confidential information of the disclosing party and will use at least the same degree of care, discretion and diligence in protecting the Confidential Information of the disclosing party as it uses with respect to its own confidential information. The receiving party will limit access to Confidential Information to its employees and authorized agents with a need to know and will instruct such persons to keep such information confidential. Notwithstanding the foregoing, (i) NIET may use information collected in the Portal for its noncommercial research purposes and (ii) the receiving party may disclose Confidential Information to the extent necessary to comply with any law, rule, regulation or ruling applicable to it and to the extent necessary to enforce its rights under this Agreement.

#### 5. LIMITATION OF LIABILITY

This Section 5 sets forth the full extent of NIET's liability for damages resulting from this Agreement or the Services rendered or to be rendered hereunder, regardless of the form in which such liability or claim for damages may be asserted, and sets forth the full extent of Client's remedies. NIET and Client acknowledge that the fees for the Services to be provided hereunder reflect the allocation of risk set forth in this Section 5.

- a. **Client Responsibility.** Client will be responsible for (i) the consequences of any instructions Client may give to NIET, (ii) Client's failure to use the Services in the manner prescribed by NIET, and (iii) Client's failure to supply accurate and timely information.
- b. **Errors and Omissions.** NIET's sole liability to Client or any third party for claims of any type or character arising from errors or omissions in the Services that are caused by NIET shall be to correct the affected Client training, product, study, report or material, as the case may be. Upon the request of Client, NIET will correct any error or omission made by NIET in connection with the Services at no additional charge to Client.
- c. **Limit on Monetary Damages.** Notwithstanding anything to the contrary contained in this Agreement (other than and subject to its indemnity obligations pursuant to Section 3.b, above), NIET's liability under this Agreement for damages (monetary or otherwise) under any circumstances for claims of any type or character made by Client or any third party arising from or related to the Services will be limited in each instance to the lesser of (i) the amount of actual damages incurred by Client or, (ii) NIET's charges for the affected Services; provided however, that NIET's aggregate liability hereunder in any calendar year will not exceed the fees collected from Client by NIET during the previous twelve (12) months. NIET will issue Client a credit(s) equal to the applicable amount and any such credit(s) will be applied against future Services. The foregoing limitation shall not apply to actual damages incurred by Client as a direct result of the criminal acts of NIET or any of its employees.
- d. **No Consequential Damages.** NEITHER NIET NOR CLIENT WILL BE RESPONSIBLE FOR SPECIAL, INDIRECT, INCIDENTAL, CONSEQUENTIAL, OR OTHER SIMILAR DAMAGES THAT THE OTHER PARTY MAY INCUR OR EXPERIENCE IN CONNECTION WITH THIS AGREEMENT OR THE SERVICES, HOWEVER CAUSED AND UNDER WHATEVER THEORY OF LIABILITY, EVEN IF SUCH PARTY HAS BEEN ADVISED OF THE POSSIBILITY OF SUCH DAMAGES.

#### 6. TERM AND TERMINATION

- a. **Term.** NIET or Client may terminate the Statement of Work as provided therein. The Terms of this General Terms and

Confidential and Proprietary

Conditions shall survive the termination of the Statement of Work, as applicable.

- b. Post-Termination Services. If the parties agree to any post termination services, such as transition services, the Agreement shall continue to with respect to such Services to the extent not expressly contradicted by any such post-termination agreement.
- c. Post-Termination Data. If requested by Client within 6 months of the termination of the Statement of Work, NIET shall deliver Portal reports to Client in, at NIET's election, an Excel or PDF format. Client may request within 6 months of the termination of the Statement of Work Portal reports in another format, or raw data, and NIET will attempt to accommodate Client at a fee to be mutually agreed upon by the parties.

#### 7. **DISCLAIMER OF WARRANTIES**

EXCEPT AS EXPRESSLY SET FORTH IN THIS AGREEMENT, NIET EXPRESSLY DISCLAIMS ALL EXPRESS AND IMPLIED WARRANTIES, INCLUDING ANY IMPLIED WARRANTIES OF MERCHANTABILITY, TITLE, ACCURACY, INTEGRATION OR FITNESS FOR A PARTICULAR PURPOSE, NON-INFRINGEMENT, NON-INTERRUPTION OF USE, AND FREEDOM FROM PROGRAM ERRORS WITH RESPECT TO THE SERVICES, THE NIET PRODUCTS, ANY CUSTOM PROGRAMS CREATED BY NIET OR ANY THIRD-PARTY SOFTWARE DELIVERED BY NIET.

#### 8. **GENERAL**

- a. Assignment. Neither party may assign this Agreement without the prior written consent of the other.
- b. Inducement. Client has not been induced to enter into this Agreement by any representation or warranty not set forth in this Agreement. This Agreement contains the entire agreement of the parties with respect to its subject matter. This Agreement shall not be modified except in writing and signed by NIET and Client.
- c. Independent Contractor Status. Each party and its employees are independent contractors in relation to the other party with respect to all matters arising under this Agreement. Nothing herein shall be deemed to establish a partnership, joint venture, association, or employment relationship between the parties.
- d. Third Party Beneficiaries. Nothing in this Agreement creates, or will be deemed to create, third party beneficiaries of or under this Agreement. NIET has no obligation to any third party by virtue of this Agreement.
- e. Force Majeure. Any party hereto will be excused from performance under this Agreement for any period of time that the party is prevented from performing its obligations hereunder as a result of an act of God, war, earthquake, civil disobedience, pandemic, court order, labor dispute, or other cause beyond the party's reasonable control.
- f. Governing Law. This Agreement shall be governed, construed, and enforced according to the laws of the State of Tennessee, without giving effect to principles of conflicts of laws.
- g. Notices. Notices sent to either party shall be effective when delivered in person, by mail, or by email to the address or email address, as the case may be, set forth in the Statement of Work. For mail, notice shall be effective one (1) day after being sent by overnight courier, or two (2) days after being sent by first class mail postage prepaid. For email, notice shall be effective upon receipt acknowledgement from the recipient.

### Appendix A

Name	Description	Quantity	Price	Extended Cost
Onsite/Virtual Coaching and Support	Through onsite or virtual coaching and support, educators work alongside NIET specialists to transfer and apply best practices into unique individual school settings. NIET's strengths-based coaching and support focuses on reflection and the effective implementation of key concepts and strategies learned through NIET trainings (e.g. instructional excellence, effective professional learning, leadership teams, observation and feedback, evaluation, teacher leadership, curriculum alignment). Specific focus areas will be determined in consultation with the district partners.	14	\$2,750.00	\$38,500.00
<b>TOTAL</b>			<b>\$38,500.00</b>	

*Please note: NIET issues invoices on a monthly basis for support outlined in this Statement of Work. NIET invoices in half and full day increments based on direct hours of support. For 3 or fewer hours, a half-day will be invoiced. For more than 3 hours, a full-day will be invoiced. This Statement of Work is valid for 60 days from the date hereof, and becomes binding if signed and delivered by both parties during that period.*

**PURCHASING DEPARTMENT  
WASHINGTON COUNTY BOARD OF EDUCATION**

Purchase Order No. **2576**

Date Issued **7/16/24**

Appropriation No. **72250399**

Dept. **Technology**

School **S-wide**

**PURCHASE ORDER**

**TO Raptor Technologies  
Renewal**

**Deliver to WCDE - C. Fullbright**

Address

Via

Articles on this order must be charged to account of

**NOTICE TO VENDOR**

1. Purchase order **MUST** bear two signatures in order to be valid.
2. Purchase order number **MUST** appear on all invoices submitted for payment.
3. Mail **TWO** copies of your invoice promptly to:

**Washington County Board of Education  
405 West College Street  
Jonesborough, TN 37659  
Telephone (423) 753-1105**

ARTICLES OR SERVICES (Unless otherwise stated all prices F.O.B. Destination)	CODE	QUANTITY & UNIT	UNIT PRICE	TOTAL
Emergency Management Software License		14	\$699.60	\$9,794.40
Raptor Visitor Management Annual Access Fee Start Date: 9/1/24 End Date: 8/31/25 *Renewal Notice Att.*		14	\$660.00	\$9,240.00
<b>GRAND TOTAL - INCLUDING ALL ATTACHED PAGES</b>				<b>\$19,034.40</b>

**SUBJECT TO THE FOLLOWING CONDITIONS**

1. All packages, cartons or other containers must be plainly marked with the purchase order number.
2. The right is reserved to purchase in the open market and to charge the difference to the Vendor in the event that deliveries are not made at the time specified in the bid and on this order.
3. Whenever a delivery is rejected, the Vendor shall be notified and be given the reason for the rejection. All rejected deliveries shall be held at the Vendor's risk and he shall bear the expense of removal.
4. Acceptance of this order includes acceptance of all terms, prices, delivery, instructions, specifications and conditions stated.
5. The county is not liable for Federal excise tax or state sales tax.
6. Each shipment and/or each purchase order should be covered by separate invoice.

**IMPORTANT: INVOICES AND PACKAGES MUST BEAR PURCHASE ORDER NUMBER**

*Handwritten initials/signature*

**VENDOR'S COPY**

There is an otherwise unincumbered balance to the credit of the proper appropriation, allotment or fund to meet the expenditure covered by this purchase.

Authorized Signature

**APPROVED:**

Purchasing Agent



**Renewal Notice**

<b>Date</b>	7/1/2024
<b>Renewal #</b>	84818
<b>Start Date</b>	9/1/2024
<b>End Date</b>	8/31/2025

**"Protect Every Child, Every School, Every Day"**

**Bill To:**

Washington County School District  
Accounts Payable  
405 West College Street  
Jonesborough TN 37659

**Ordered By:**

Washington County School District (TN)

<b>Terms</b>
RN N60

Description	Qty	Price	Amount
One (1) Emergency Management Software License	14	\$699.60	\$9,794.40
Raptor Visitor Management Annual Access Fee	14	\$660.00	\$9,240.00

<b>Subtotal</b>	\$19,034.40
<b>Tax Total</b>	\$0.00
<b>Total</b>	\$19,034.40

[Click Here for Inquiries or to Send Purchase Orders](#)

Remit Checks to:

Raptor Technologies, LLC  
Dept 141  
PO Box 4458  
Houston, TX 77210-4458

Please reference invoice number(s) on all check payments.



**PURCHASING DEPARTMENT**  
**WASHINGTON COUNTY BOARD OF EDUCATION**  
**FEDERAL PROJECTS FUND**  
**PURCHASE ORDER**

Purchase Order **35501**  
 Date Issued **7/10/24**  
 Appropriation No. **72220-524(900)**  
 Dept. **SpEd**  
 School **CO**

TO **EPS Operations, LLC**  
**4800 Hampden Ln. Suite 560**  
**Bethesda, MD 20814**

Deliver to **Washington County Department of Education**  
 Address **405 W. College St.**  
**Jonesborough, TN 37659**  
 Via **Jacki Wolfe**

**NOTICE TO VENDOR**

- 1. Purchase order number MUST appear on all invoices submitted for payment.**
- 2. Mail TWO copies of your invoice promptly to:**  
 Washington County Board of Education  
 405 West College Street  
 Jonesborough, Tennessee 37659  
 Telephone (423) 753-1105

on or before

Articles on this order must be charged to account of

ITEM NO.	ARTICLES OR SERVICES	CODE	QUANTITY & UNIT	UNIT PRICE	TOTAL
	(Unless otherwise stated all prices F.O.B. Destination)				
	Spire Initial onsite Prof Dev Day		1	3,250	3,250
	Spire Refresher onsite prof dev		1	3,250	3,250
	Spire Support coaching day		+ <sup>AH</sup> 5	3,250	<del>3,250</del> <sup>AH</sup> 16,250
<b>GRAND TOTAL - INCLUDING ALL ATTACHED PAGES</b>					<b>22,750</b>

**SUBJECT TO THE FOLLOWING CONDITIONS**

- All packages, cartons or other containers must be plainly marked with the purchase order number.
- The right is reserved to purchase in the open market and to charge the difference to the Vendor in the event that deliveries are not made at the time specified in the bid and on this order.
- Whenever a delivery is rejected, the Vendor shall be notified and be given the reason for the rejection. All rejected deliveries shall be held at the Vendor's risk and he shall bear the expense of removal.
- No changes in or cancellations of this purchase order shall be recognized by the Vendor unless authorized by special form issued by the Purchasing Agent.
- Acceptance of this order includes acceptance of all terms, prices, delivery, instructions, specifications and conditions stated.
- The county is not liable for Federal excise tax or state sales tax.
- Each shipment and/or each purchase order should be covered by separate invoice.

**IMPORTANT: INVOICES AND PACKAGES MUST BEAR PURCHASE ORDER NUMBER**

**VENDOR'S COPY**

There is an otherwise unincumbered balance to the credit of the proper appropriation, allotment or fund to meet the expenditure covered by this purchase.

Authorized Signature

APPROVED:

Purchasing Agent



**EPS Operations, LLC**  
4800 Hampden Ln., Suite 560  
Bethesda, MD 20814

Tax ID Number: 92-1780143

**Quote**  
**#QU007409**  
Created: 5/16/2024  
Expires: 7/31/2024



**Our physical and mailing address has changed! Please update your records.**  
Our previous address was EPS Operations, LLC | P.O. Box 3000 | Nashua, NH 03061  
Our remit-to address is unchanged: EPS Operations, LLC | P.O. Box 713265 | Chicago, IL 60677-1265

**Bill To**  
WASHINGTON CO SCHOOL DISTRICT  
405 W COLLEGE ST  
JONESBOROUGH TN 37659  
United States

**Ship To**  
WASHINGTON CO SCHOOL DISTRICT  
405 W COLLEGE ST  
JONESBOROUGH TN 37659  
United States

**Prepared For:**  
Contact Name: Jacki Wolfe  
Contact Email: wolfej@wcde.org  
Contact Phone: (423) 753-1100  
Customer Account: 0138969  
Contract Number:

**Your Sales Contact**

Patti Walker

**Email**

patti.walker@epslearning.com

**Phone**

Notes:

Qty	Item	ISBN	Description	Unit Price	Amount
1	2001980		SPIRE INITIAL ONSITE PROF DEV DAY	\$3,250.00	\$3,250.00
1	2001981		SPIRE REFRESHER ONSITE PRO DEV	\$3,250.00	\$3,250.00
5	2001976		SPIRE SUPPORT COACHING DAY	\$3,250.00	\$16,250.00

**Special Delivery Instructions (Please complete)**

Lift Gate Truck Required:  Inside Delivery Required:

Shipping Instructions:

Pack List Notes:

**Subtotal** \$22,750.00  
**Shipping & Handling** \$0.00  
**Tax Total** \$0.00

**Total** \$22,750.00

To accept and place an order using this quote

**By Email**

Send this signed and dated quote with your purchase order number to orders@epslearning.com

**By Phone**

Call our Customer Care team at 800-225-5750 Monday-Friday between 8:00am and 5:30pm ET

Please send a copy of your PO with this quote acceptance.

Signature: \_\_\_\_\_

Name: \_\_\_\_\_

Date: \_\_\_\_\_

Purchase Order Number: \_\_\_\_\_

*Jacki Wolfe*  
*Jacki Wolfe*  
*5.28.2024*  
*PO after July 1, 2024*

Budget Detail

Line Item Total:

Account Number: 72220 - Support Services/Special Education Program

Line Item Number: 524 - In-Service / Staff Development

Strategic Plan: Educators

CCEIS:

Optional Program Code:

Location Code: Washington County (900)

Quantity:

Cost:

Professional Learning for personnel supporting SWD (i.e. LRP, TAASE, CEC, BoysTown, SPIRE, etc.) - allocation will cover registration, travel per diems, lodging, and materials.

Line Item Total:

Account Number: 72220 - Support Services/Special Education Program

Line Item Number: 790 - Other Equipment

Strategic Plan: Educators

CCEIS:

Optional Program Code:

Location Code: Washington County (900)

Quantity:

Cost:

Line Item Total:

Equipment for special education personnel (i.e. printer ink/toner, assessment devices, printers, scanners, etc.)

Session Timeout  
(Hide Timer)  
00:29:25

Total for filtered Budget Details:

Total for all other Budget Details:

Total for all Budget Details:

Adjusted Allocation:

Remaining:

[Return](#)



Mr. Joshua Davis  
 Secondary curriculum  
 Washington Co School District -TN  
 405 W College St  
 Jonesborough, TN 37659-1009  
 United States

**Quote Number:** 269426-2  
**Quote Creation Date:** 07-29-2024  
**Quote Expiration Date:** 09-30-2024

**Quote Release:** 2

TN Thinking Mathematically print + digital  
 Price Quote Summary

Solution	Base Amount	Total
<b>Blitzer: Thinking Mathematically</b>	\$ 17,593.40	\$ 17,593.40
<b>MyMathLab</b>	\$ 9,969.30	\$ 9,969.30
<b>Solution Subtotal</b>	<b>\$ 27,562.70</b>	<b>\$ 27,562.70</b>
	<b>Shipping &amp; Handling</b>	<b>\$ 1,495.44</b>
	<b>Total</b>	<b>\$ 29,058.14</b>

Price Quote Detail

ISBN	Description	Price	Charged Qty	Total Charged
<b>Blitzer: Thinking Mathematically</b>				
<b>Blitzer, Thinking Mathematically 8th edition ©2023</b>				
9780135347171	THINKING MATHEMATICALLY: SUPPLEMENTAL LESSON FOR [TENNESSEE DEPARTMENT OF EDUCATION]	24.97	110	\$2,746.70
9780137605798	Blitzer, Thinking Mathematically, 8e ©2023 NASTA Student Edition	134.97	110	\$14,846.70
	<b>Blitzer, Thinking Mathematically 8th edition ©2023 Subtotal</b>			<b>\$ 17,593.40</b>
	<b>Blitzer: Thinking Mathematically Subtotal</b>			<b>\$ 17,593.40</b>
<b>MyMathLab</b>				
<b>MyMathLab for School from Pearson</b>				

ISBN	Description	Price	Charged Qty	Total Charged
9780132962377	MyMathLab® for School 1yr - Digital Delivery Access	52.47	190	\$9,969.30
<b>MyMathLab for School from Pearson Subtotal</b>				<b>\$ 9,969.30</b>
<b>MyMathLab Subtotal</b>				<b>\$ 9,969.30</b>
<b>Solution Subtotal</b>				<b>\$ 27,562.70</b>
<b>Shipping and Handling</b>				<b>\$ 1,495.44</b>
<b>Total</b>				<b>\$ 29,058.14</b>

## Savvas Learning Company LLC Terms and Conditions

**To place your order** please submit a copy of this price quote with your Purchase Order, include the Quote Number on your Purchase Order, and include any other required documentation. You may send the order documents using an electronic form **or** by mail. Please submit your PO and price quote via one of the following methods:

**Online:** <https://support.savvas.com/support/s/customerserviceus>

**Mail:** PO Box 6820, Chandler, AZ 85246

Savvas does not accept Credit Card information via postal mail, facsimile, or email. Credit Card information will only be accepted via phone, eCommerce, or OASIS. For questions regarding your order please call Customer Service: 1-800-848-9500.

**Price quote:** This is a price quote for the customer's convenience only, and not an offer to contract. All quotes are subject to review and final acceptance by an authorized representative of Savvas at its offices. Savvas reserves the right to correct typographical, computational or other errors. Savvas' standard payment terms are net 30 days unless otherwise specified. All pricing is in US Dollars unless otherwise specified. Pricing calculations use multiple decimal places to determine the most accurate extended pricing but are represented in standard currency format.

**Shipping & handling** charges (where applicable) are shown on the quote. S&H rates quoted are for standard ground transportation and may not reflect account contracted rates. If expedited shipping is requested, actual charges may be higher. For orders picked up at the Savvas warehouse by the customer or a third party carrier contracted by the customer, a 2% handling charge will be applied to shippable items. The 2% charge will appear on the customer proposal and invoice as a S&H charge.

**Taxes:** All pricing in this quote is exclusive of any applicable sales, use or other similar taxes or duties. The customer is responsible for any such taxes or duties that may apply; if the customer is tax exempt, evidence of such tax exemption must be provided. Estimated tax may be provided solely for customer convenience. The amount indicated is only an estimate and is intended to be helpful for budgeting purposes. The actual amount of sales tax assessed at the time of invoicing may be more or less.

**Platforms:** Savvas, and any third party for which Savvas serves as the sales agent or distributor, reserve the right to change and/or update technology platforms, including possible edition updates to customers during the term of access. Customers will be notified of any change prior to the beginning of the new school year.

**Damaged & Defective Products:** If a print product, or the print component of a blended (print & digital) product, is received in damaged or defective condition, Savvas will issue a credit or replacement at no charge to the customer if the customer promptly (no later than 120 days) returns the damaged or defective product. Customers must report missing product immediately upon receipt.

**Return Policy:** Returns (other than damaged or defective products) are subject to the following conditions: (a) materials must be returned to Savvas at the customer's expense in new, unused condition, suitable for resale by Savvas (note that any barcoding, stickering, stamping or similar marking on any print materials renders them unsuitable for resale); (b) materials must be returned within six (6) months from the date of purchase; (c) the customer must obtain a Return Materials Authorization ("RMA") from Savvas prior to returning the materials, and must ship the materials back to Savvas within thirty days of receiving the RMA; (d) all materials sold in a set or package must be returned complete as originally sold; and (e) any materials provided by Savvas to the customer on a no-charge basis in consideration of the customer's purchase must be returned in proportion to the purchased materials that are being returned for a credit. A restocking fee of 3% may be applied to credits over \$1,000. Savvas' return policy does not apply to science lab kits or trade publication novels, which are sold on a non-returnable basis.

**Consumable Worktexts:** Subsequent year consumable worktexts will ship each year on the anniversary of the original order date for the duration of their license. Worktexts will ship to the location listed on the original order. Quantities for each grade level and title will remain consistent each year. Changes to quantities of titles previously ordered, shipping location changes, or any other changes to consumable worktext shipments must be made 4 weeks prior to shipment date. (the anniversary of the original order date unless changed). Changes can be made on the Subscription Worktext Site:

<https://worktext-subscriptions.savvas.com>

**Annual subscriptions for iLit and Successmaker Only:** Savvas' iLit and Successmaker products (and no others) automatically renew on the anniversary date of the original purchase and will be invoiced accordingly unless otherwise specified.

**Technical support services** are included with purchase of Savvas digital products.

online help: <https://support.savvas.com/support/s/k12-curriculum-support-form>

phone: 1-800-848-9500

**Professional Services:** Professional Services: All paid services must be delivered within twelve (12) months of the order date of those services. Any unused services expire at the end of such twelve (12) month period, unless otherwise specified in contract terms. Any cancellation made with less than 72 hours' notice will result in a cancellation fee equal to the full price of the event. MySavvasTraining is included with purchase of products (<https://mysavvastraining.com>).

**PURCHASING DEPARTMENT**  
**WASHINGTON COUNTY BOARD OF EDUCATION**

PURCHASE ORDER

Purchase Order **№ 2599**  
 Date Issued **07-25-24**  
 Appropriation No. **71100449**  
 Dept. **INSTRUCTION**  
 School

TO  
**SAVVAS**

**NOTICE TO VENDOR**

1. Purchase order **MUST** bear two signatures in order to be valid.
2. Purchase order number **MUST** appear on all invoices submitted for payment.
3. Mail **TWO** copies of your invoice promptly to:

**Washington County Board of Education**  
**405 West College Street**  
**Jonesborough, TN 37659**  
**Telephone (423) 753-1105**

Deliver to **WASHINGTON COUNTY BOARD OF EDUCATION**  
 Address **405 WEST COLLEGE STREET**  
**JONESBOROUGH, TN 37659**  
 Via

Articles on this order must be charged to account of

ARTICLES OR SERVICES	CODE	QUANTITY & UNIT	UNIT PRICE	TOTAL
(Unless otherwise stated all prices F.O.B. Destination)				
<b>MATH TEXTBOOKS</b>				
<b>GRAND TOTAL - INCLUDING ALL ATTACHED PAGES</b>				<b>\$ 29,058.14</b>

**SUBJECT TO THE FOLLOWING CONDITIONS**

1. All packages, cartons or other containers must be plainly marked with the purchase order number.
2. The right is reserved to purchase in the open market and to charge the difference to the Vendor in the event that deliveries are not made at the time specified in the bid and on this order.
3. Whenever a delivery is rejected, the Vendor shall be notified and be given the reason for the rejection. All rejected deliveries shall be held at the Vendor's risk and he shall bear the expense of removal.
4. Acceptance of this order includes acceptance of all terms, prices, delivery, instructions, specifications and conditions stated.
5. The county is not liable for Federal excise tax or state sales tax.
6. Each shipment and/or each purchase order should be covered by separate invoice.

**IMPORTANT: INVOICES AND PACKAGES MUST BEAR PURCHASE ORDER NUMBER**

VENDOR'S COPY

There is an otherwise unincumbered balance to the credit of the proper appropriation, allotment or fund to meet the expenditure covered by this purchase.

---

Authorized Signature

APPROVED:

---

Purchasing Agent



**Mower #1** Lazer Z E Series 60"; Cut, Motor: 801V KW; Machine Hours: 1500;  
Fair/Good Condition  
Works as it should; Needs oil change; SN: 408859397



Additional Pictures of Mower #1



**Mower #2 Laser Z E Series 60" Cut; Motor: 801V KW; Machine Hours: 910; Fair/ Good Condition; Works as should; Needs Oil Change; SN: 408687269**



Additional Pictures of Mower #2



**Mower #3** Ferris Walk Behind 36" Cut; 541VW; Machine Hours: 100; Condition: Good; Needs Oil Change; Works as it should



**Mower #4 Kubota Z725 60" Cut; Motor: 801V KW; Machine Hours: 1,520; Fair Condition; Works as it should; Needs oil change, needs pulleys and bearings; SN: 14326**



Additional Pictures of Mower #4



**Mower #5** Lazer Z E Series 72" cut; Motor: 801V KW; Machine Hours: 1480; Fair/Good Condition; Works as it should; Needs oil change; Comes with Grass Flap; SN 408688101



Additional Pictures of Mower #5



**Mower #6** Lazer Z S-Series 60" Cut; Motor: 801V KW; Machine Hours: 1530; Good Condition; Needs Oil Change; Comes with grass flap; SN: 401290417



**Mower #7** Lazer Z E-Series 52" Cut; Motor: 751V KW; Machine Hours: 640; Good Condition; Works as should; Needs Oil Change; Comes with grass Flap; SN: 412378586



Additional Pictures of Mower #7



**Mower #8** Lazer Z Batwing 96" Cut; Motor: Yamnar Diesel Engine; Machine Hours: 1200;  
Fair/Good Condition; Needs Oil Change; Rear Grass Discharge



Additional Pictures of Mower #8



**Mower #9** Lazer Z E-Series 60" Cut; Motor: 801V KW; Machine Hours: 580; Good Condition; Works as it should; Needs Oil Change; SN: 411490683



Additional Pictures of Mower #9



Roland XR-640 Large Format Solvent Printer. You can print on vinyl or banner material.  
Has not been run in approximately 8 Years



Additional Pictures of Roland XR-640 Printer

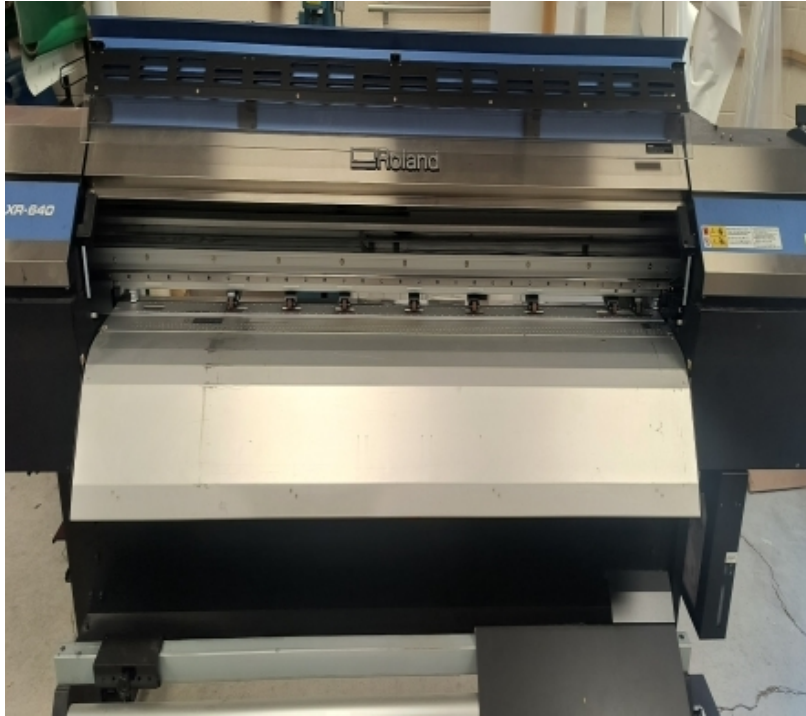

Additional Pictures of Roland XR-640 Printer

## Annual Vehicle Authorization Report 2024-2025 School Year

<u>Vehicle Number</u>	<u>Employee Name</u>	<u>Employee Assignment</u>	<u>Need for 24 hour access</u>	<u>One-way mileage home</u>
<u>Truck #116 2024 Silverado 1500</u>	Tony Roberts	Transportation Supervisor	Breakdowns or to drive bus	15 miles one-way
<u>Truck #117 2024 Silverado 1500</u>	Lynn Archer	Support Supervisor for Transportation	Breakdowns or to drive bus	3 miles one-way
<u>Truck #20 1993 Dodge Ram</u>	James Brewer	Bus Mechanic	Breakdowns or to drive bus	14 miles one-way
<u>Truck #42 2021 Chevy Silverado</u>	William Meneses	Bus Mechanic	Breakdowns or to drive bus	3 miles one-way
<u>Truck #42 2021 Chevy Silverado</u>	Adam Tipton	Bus Mechanic	Breakdowns or to drive bus	16 miles one-way
<u>Truck #9 2021 Chevy Silverado</u>	Lee Archer	Bus Mechanic	Breakdowns or to drive bus	4 miles one-way
<u>Truck #2 2006 Dodge Ram</u>	Jamie Brooks	Bus Mechanic	Breakdowns or to drive bus	20 miles one-way
<u>Truck #26 2020 Silverado 1500</u>	Jeremy Moore	Maintenance Supervisor	On call for system-wide emergencies	14 miles one-way
<u>Truck #45 2021 Chevy Silverado</u>	Logan Clark	Ground Maintenance	Sporting events (nights/weekends)	5 miles one-way
<u>Van #105 2023 Ford Van</u>	Vince Swiney	Technology	Alarm/Security Checks System-wide	27 miles one-way
<u>Truck #119 2024 Chevy Silverado</u>	Joe Lyons	Technology	Alarm/Security Checks System-wide	7 miles one-way
<u>Van #100 2020 Ford Transit Van</u>	Jeff Carver	Foodservice	Freezer/Security Checks System-wide	20 Miles one-way

<u>Truck #3 2006</u> <u>Chevy 1500</u>	Dale Scott	DCHS Security Guard	Grounds work and security	Lives on Campus
<u>Truck #52 2017</u> <u>Ford F-150</u>	Michelle Stallard	Maintenance	Occasional Use	22 Miles one-way



INSPIRE BUSINESS INTERIORS

# DANIEL BOONE H.S.

Cafeteria Renovation



# CAFETERIA PLAN

INSPIRE BUSINESS INTERIORS

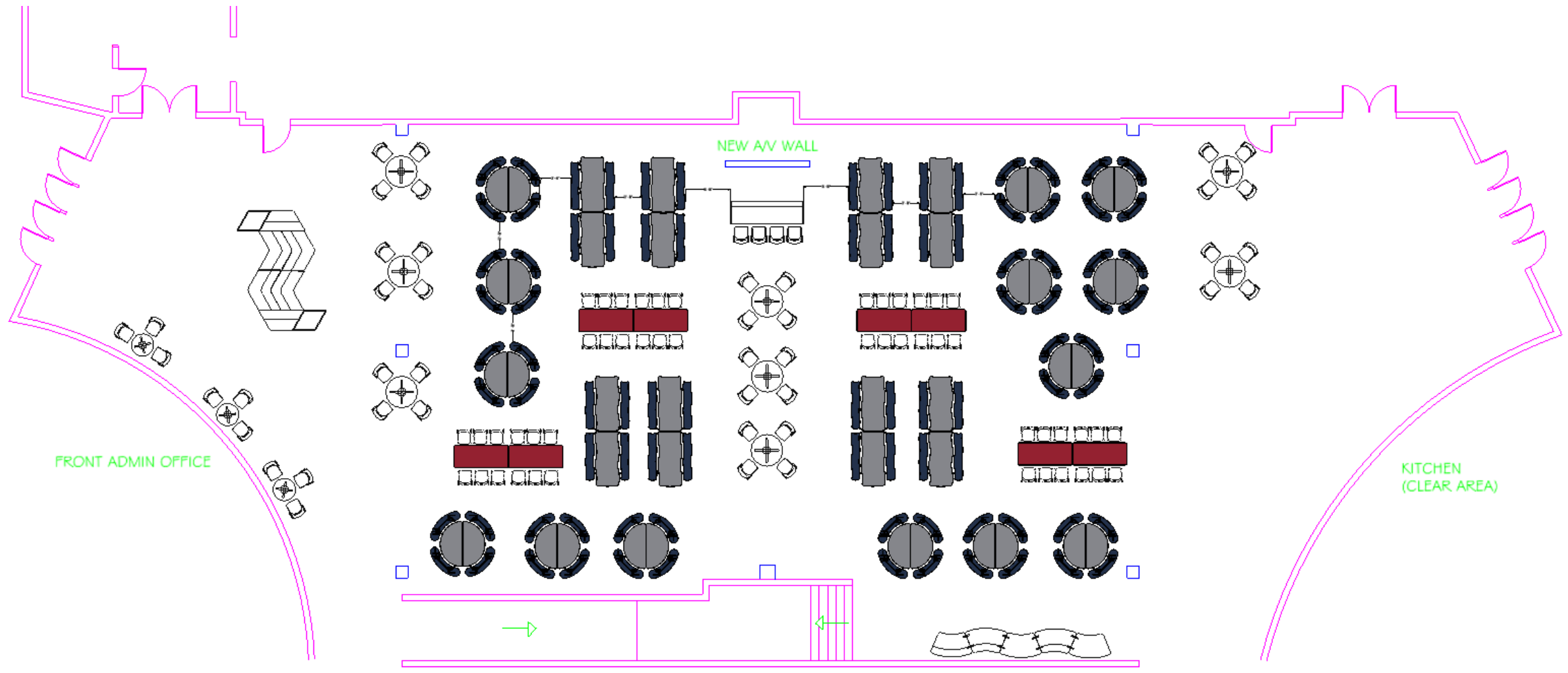

# CAFETERIA

INSPIRE BUSINESS INTERIORS



HON Cherry Shell



Wilsonart Mushroom



Wilsonart North Sea



Wilsonart Candy Apple



NPS Mobile Bench Table



HON Smartlink Chair



NPS Mobile Bench Table



# CAFETERIA

INSPIRE BUSINESS INTERIORS

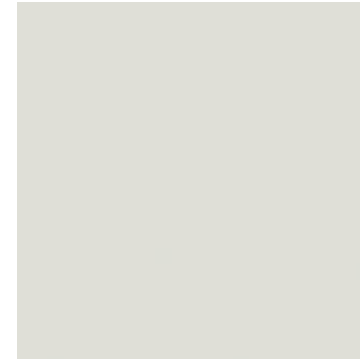

HON Loft Shell

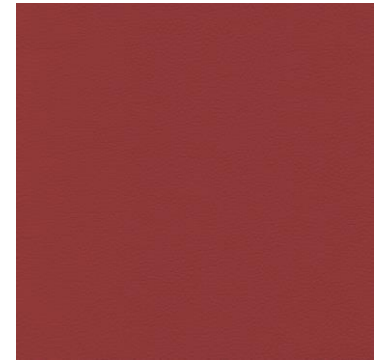

HON Contourett Red



HON Skyline Walnut

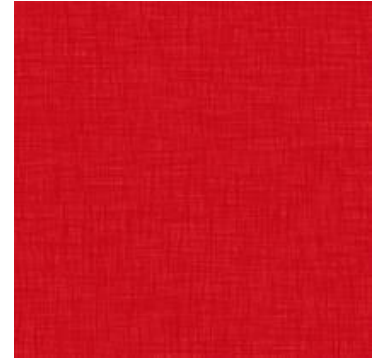

Wilsonart Candy Apple



HON Preside Table



HON Smartlink Chair



NPS Mobile Bench Table



# CAFETERIA

INSPIRE BUSINESS INTERIORS

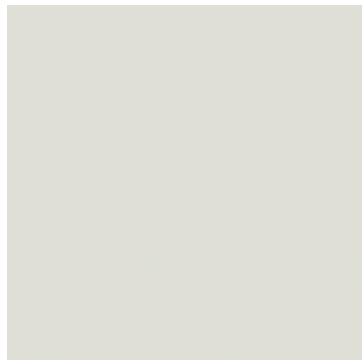

HON Loft Shell

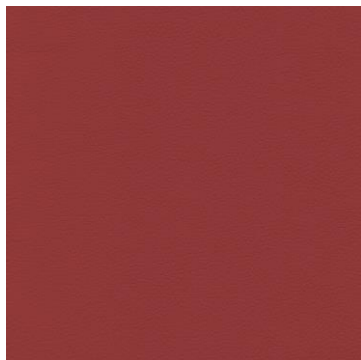

HON Contourett Red



HON Skyline Walnut

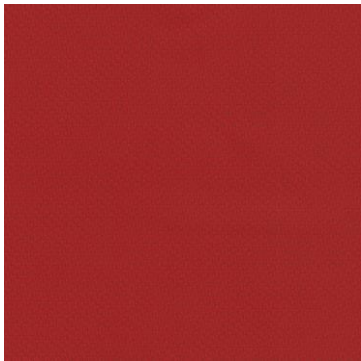

HON Bradbury Gala



HON Preside Table



HON Smartlink Chair



NPS Mobile Bench Table



# CAFETERIA

INSPIRE BUSINESS INTERIORS

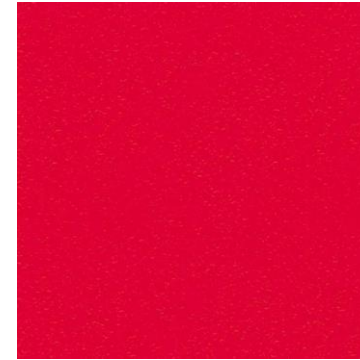

HON Cherry Shell



Wilsonart Mushroom



Wilsonart North Sea

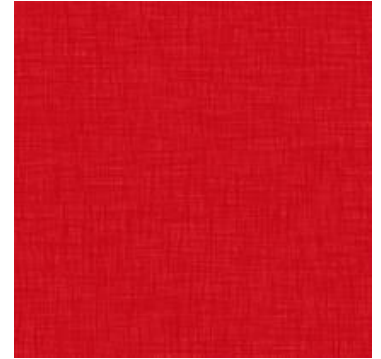

Wilsonart Candy Apple



NPS Mobile Bench Table



HON Smartlink Chair



NPS Mobile Bench Table



# CAFETERIA- BUDGET



INSPIRE BUSINESS INTERIORS

Budget for Furniture as Shown on Plan:

Loose Seating/ Lounge

\$42,500.00

High Density Seating

\$72,000.00

\*Pricing based on current list pricing as of June 2024. Priced per OMNIA cooperative purchasing contract #R191804

\*\*Pricing may fluctuate based on final layouts, furniture specifications, and finishes chosen. PO to be based on finalized quote.





 Inspire Business Interiors  
 (423)-282-5400  
 itisor@inspirebusinessinteriors.com



# THANK YOU

<https://www.inspirebusinessinteriors.com/>



**PURCHASING DEPARTMENT**  
**WASHINGTON COUNTY BOARD OF EDUCATION**

Purchase Order **No 2673**

Date Issued **8/6/24**

Appropriation No. **141-E-71100-722-002**

Dept. **ISM**

School **DBHS**

**PURCHASE ORDER**

**TO** Inspire Business Interiors

**litishor@inspirebusinessinteriors.com**

Deliver to **Daniel Boone High School**

Address **1440 Suncrest Dr.  
Gray, TN 37615**

Via **Stephanie Gray**

Articles on this order must be charged to account of

**NOTICE TO VENDOR**

- 1. Purchase order MUST bear two signatures in order to be valid.**
- 2. Purchase order number MUST appear on all invoices submitted for payment.**
- 3. Mail TWO copies of your invoice promptly to:**

**Washington County Board of Education  
405 West College Street  
Jonesborough, TN 37659  
Telephone (423) 753-1105**

ARTICLES OR SERVICES	CODE	QUANTITY & UNIT	UNIT PRICE	TOTAL
(Unless otherwise stated all prices F.O.B. Destination)				
woose seating / Lounge				\$42,500.00
High density seating				\$72,000.00
Omnia #R191804				
<b>GRAND TOTAL - INCLUDING ALL ATTACHED PAGES</b>			<b>NTE</b>	<b>\$150,000.00</b>

**SUBJECT TO THE FOLLOWING CONDITIONS**

1. All packages, cartons or other containers must be plainly marked with the purchase order number.
2. The right is reserved to purchase in the open market and to charge the difference to the Vendor in the event that deliveries are not made at the time specified in the bid and on this order.
3. Whenever a delivery is rejected, the Vendor shall be notified and be given the reason for the rejection. All rejected deliveries shall be held at the Vendor's risk and he shall bear the expense of removal.
4. Acceptance of this order includes acceptance of all terms, prices, delivery, instructions, specifications and conditions stated.
5. The county is not liable for Federal excise tax or state sales tax.
6. Each shipment and/or each purchase order should be covered by separate invoice.

**IMPORTANT: INVOICES AND PACKAGES MUST BEAR PURCHASE ORDER NUMBER**

**VENDOR'S COPY**

There is an otherwise unincumbered balance to the credit of the proper appropriation, allotment or fund to meet the expenditure covered by this purchase.

Authorized Signature

**APPROVED:**

Purchasing Agent

KH



- [ePlan Home](#)
- [Search](#)
- [Reports](#)
- [Inbox](#)
- [Planning](#)
- [Monitoring](#)
- [Funding](#)
- [Data and Information](#)
- [Reimbursement Requests](#)
- [Project Summary](#)
- [LEA Document Library](#)
- [Address Book](#)
- [TDOE Resources](#)
- [Help for Current Page](#)
- [Contact TDOE](#)
- [ePlan Sign Out](#)

Hale, Brad

**Production**

Session Timeout  
[\(Hide Timer\)](#)  
 00:24:30

### Budget Detail

Washington County (900) Public District - FY 2024 - Innovative School Models (ISM) - Rev 9 - Innovative School Models

[Return](#)

Filtering - 9 out of 166 Budget Details match selected filters

[Show All / Clear All](#)

Account Number	Line Item Number	Location Code	Tags	Narrative
71100 - Regular Instru...	All	All	No Options Selected	No Options Selected

[Download Budget Data](#)

<< First < Previous | 1 | Next > Last >> Items 1-9 out of 9

Items/Page: 10

**Budget Detail**

**Account Number:** 71100 - Regular Instruction Program

**Line Item Number:** 722 - Regular Instruction Equipment

**Priority Area:** Career Exploration

**Optional Program Code:**

**Location Code:** Boones Creek Elementary (900-0020)

**Quantity:**

**Cost:**

**Line Item Total:**

**Narrative Description**

SY 24 CTE/STEM Lab furniture and instructional equipment such as but not limited to: Tables, desks, chairs, computers, iPads, printers

**Account Number:** 71100 - Regular Instruction Program

**Line Item Number:** 722 - Regular Instruction Equipment

**Priority Area:** CTE Programs of Study

**Optional Program Code:**

**Location Code:** Daniel Boone High School (900-0037)

**Quantity:**

**Cost:**

**Line Item Total:**

Revision 6 5/29/24: 71100-722 line item added to purchase computers, tables/desks, chairs, etc. to support the addition of the digital arts program of study.

Revision 7 6/18/14: Added \$110,000 from line 71300-730 to enhance DBHS SBE cafe/school store by purchasing equipment/furniture/enhance seating capacity to foster student awareness and use of the SBE school cafe space

**Account Number:** 71100 - Regular Instruction Program

**Line Item Number:** 722 - Regular Instruction Equipment

**Priority Area:** Career Exploration

**Optional Program Code:**

**Location Code:** Grandview Elementary School (900-0050)

**Quantity:**

**Cost:**

**Line Item Total:**

SY24 CTE/STEM Lab furniture and Instructional Equipment such as but not limited to: tables, desks, chairs, computers, ipads, printers apple TV, Kindle

**Account Number:** 71100 - Regular Instruction Program

**Line Item Number:** 722 - Regular Instruction Equipment

**Priority Area:** Career Exploration

SY24 Regular Instruction Equipment to be purchased such as but is not limited to: tables, desks, chairs, computers, iPads, printers that have a life span of one year or more.

Optional Program Code:  
 Location Code: Gray Elementary School (900-0055)  
 Quantity: 1.00  
 Cost: \$25,000.00  
 Line Item Total: \$25,000.00

Account Number: 71100 - Regular Instruction Program  
 Line Item Number: 722 - Regular Instruction Equipment  
 Priority Area: Career Exploration

Optional Program Code:  
 Location Code: Jonesborough Elementary School (900-0070)  
 Quantity: 1.00  
 Cost: \$50,000.00  
 Line Item Total: \$50,000.00

Account Number: 71100 - Regular Instruction Program  
 Line Item Number: 722 - Regular Instruction Equipment  
 Priority Area: Career Exploration

Session Timeout  
 (Hide Timer)  
 00:24:30

Optional Program Code:  
 Location Code: Lamar Elementary (900-0075)  
 Quantity: 1.00  
 Cost: \$25,000.00  
 Line Item Total: \$25,000.00

Account Number: 71100 - Regular Instruction Program  
 Line Item Number: 722 - Regular Instruction Equipment  
 Priority Area: Career Exploration

Optional Program Code:  
 Location Code: Ridgeview Elementary School (900-0080)  
 Quantity: 1.00  
 Cost: \$30,000.00  
 Line Item Total: \$30,000.00

Account Number: 71100 - Regular Instruction Program  
 Line Item Number: 722 - Regular Instruction Equipment  
 Priority Area: Career Exploration

Optional Program Code:  
 Location Code: Sulphur Springs Elementary (900-0095)  
 Quantity: 1.00  
 Cost: \$25,000.00  
 Line Item Total: \$25,000.00

Account Number: 71100 - Regular Instruction Program  
 Line Item Number: 722 - Regular Instruction Equipment

FY 24 Instruction Equipment and furniture such as but not limited to:  
 Tables, desks, chairs, computers, ipads, Apple TV, Kindle  
 Revision 2: \$10,000 added from deleted line item 76100-399 because no capital improvements were needed due to new school building. SY23-24 furniture items will be purchased for Paxton/Patterson College and Career Ready Labs.  
 Revision 3 (3/11/24): \$3,700 added from 71300-730. Paxton Patterson quote was more than expected.  
 Revision 4 (3/15/24): \$5,300 added from 71300-429. More furniture requested

SY24 Regular Instruction Equipment to be purchased such as but is not limited to:  
 tables, desks, chairs, computers, iPads, printers, etc.

SY24 Regular Instruction Equipment to be purchased such as but is not limited to:  
 tables, desks, chairs, computers, iPads, printers, etc.

FY24 Instruction Equipment and Furniture items such as but not limited to:  
 tables, desks, chairs, computers, iPads, Printers, Apple TV, Kindle

FY24 Instruction Equipment and Furniture items such as but not limited to:  
 tables, desks, chairs, computers, iPads, printers, Apple TV, Kindle



INSPIRE BUSINESS INTERIORS



# DANIEL BOONE H.S.

Cafeteria & Library Renovation



# CAFETERIA PLAN

INSPIRE BUSINESS INTERIORS

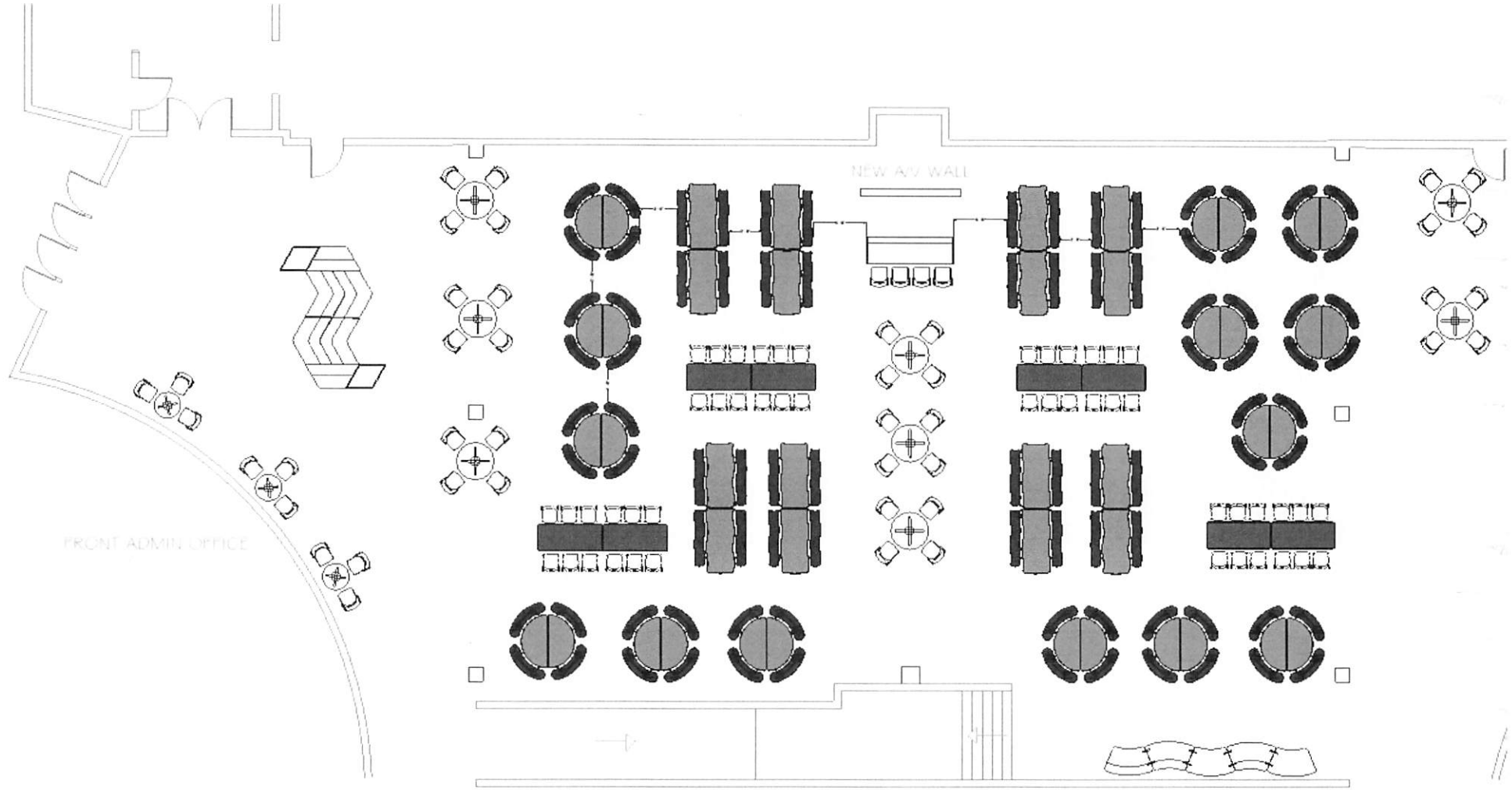

# CAFETERIA



INSPIRE BUSINESS INTERIORS

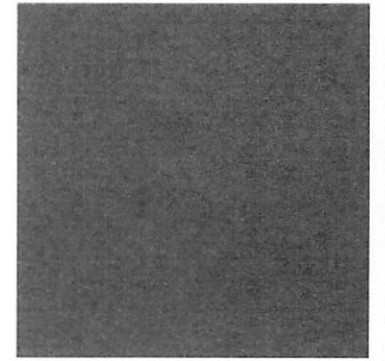

HON Cherry Shell

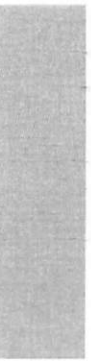

Wilsonart North Sea

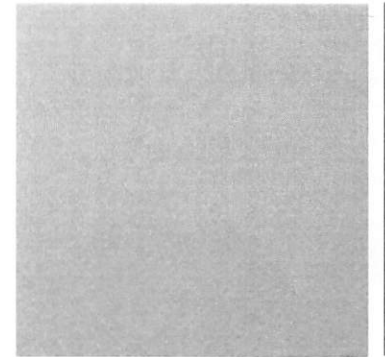

Wilsonart North Sea



HON Cherry Shell



NPS Mobile Bench Table



HON Smartlink Chair



# CAFETERIA

INSPIRE BUSINESS INTERIORS

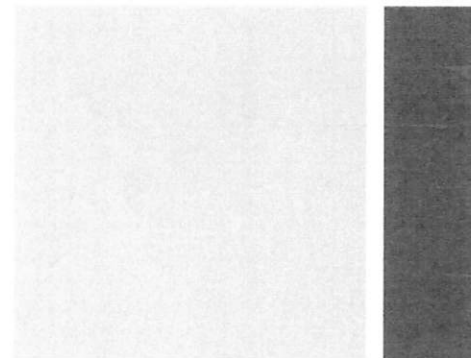

HON Loft Shell

HON

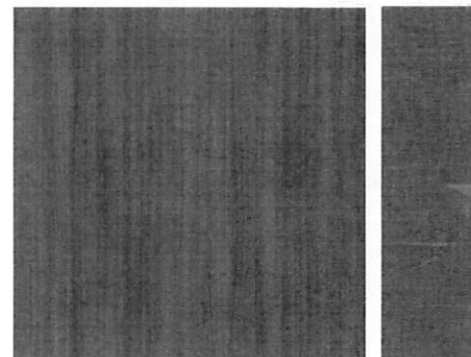

HON Skyline Walnut

Wilson



HON Preside Table

HON Smartlink Chair



# CAFETERIA



INSPIRE BUSINESS INTERIORS

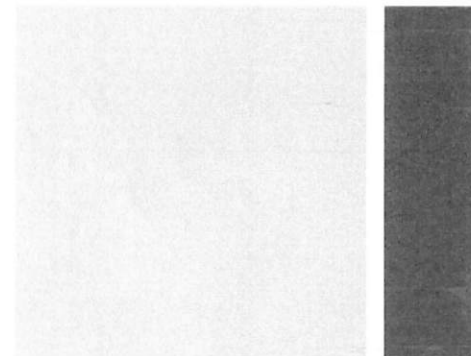

HON Loft Shell

HON

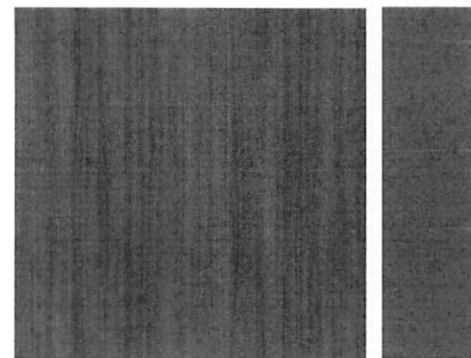

HON Skyline Walnut

HON



HON Preside Table

HON Smartlink  
Chair



# CAFETERIA

INSPIRE BUSINESS INTERIORS

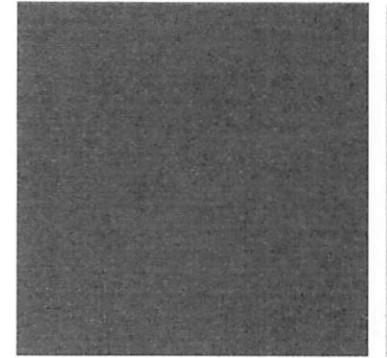

HON Cherry Shell



Wilsonart

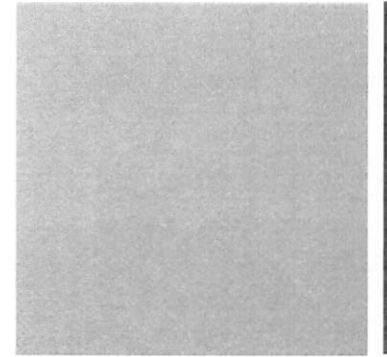

Wilsonart North Sea



Wilsonart



NPS Mobile Bench Table



HON Smartlink Chair



# CAFETERIA- BUDGET



INSPIRE BUSINESS INTERIORS

Budget for Furniture as Sh  
Loose Seating/ Lounge  
\$42,500.00  
High Density Seating  
\$72,000.00

\*Pricing based on current  
2024. Priced per OMNIA  
purchasing contract #R19  
\*\*Pricing may fluctuate ba  
furniture specifications, and  
to be based on finalized qu





Insf  
(42  
itisor

INSPIRE BUSINESS INTERIORS

# THANK YOU

<https://www.inspirebusinessinteriors.com/>



Proposal for  
**Washington County Board of Education**

Prepared by



07/30/2024  
PROJECT: 168018  
Westview Elementary School



800-438-2780 | [cunninghamrec.com](http://cunninghamrec.com)

Hello!

We are excited for the opportunity to work with you on your upcoming exciting new playground project! For almost 60 years, Cunningham Recreation has designed and built thousands of playgrounds for children of all ages and all abilities. We partner with municipalities, schools, architects and youth organizations to plan, design and build their vision from the ground-up.

Cunningham Recreation is the exclusive representative for GameTime park and playground equipment in North Carolina, South Carolina, Virginia, West Virginia, Arkansas, Kansas, Missouri, Illinois, Oklahoma, Texas, Tennessee, Iowa, Nebraska, North Dakota, South Dakota, Delaware, Maryland, and DC.

The following pages will provide greater detail about our proposal(s), more information on Cunningham Recreation and GameTime and how we can meet the goals of your project.

Please reach out with any questions or additional details. I look forward to working with you.

Sincerely,



Maggie Webb  
Sales Associate  
423-762-2843  
[maggie@cunninghamrec.com](mailto:maggie@cunninghamrec.com)



# About Cunningham Recreation and GameTime



Since 1929, GameTime has been a pioneer in the commercial playground equipment industry. GameTime has continued to bring meaningful research around the importance of play to the design, engineering, manufacture, and delivery of play equipment. GameTime Play Equipment's work has elevated industry standards on safety, physical and mental development, inclusion, and intergenerational interaction.

GameTime play systems, site furnishings and amenities are constructed from the highest quality materials and are backed by the industry's best warranty and customer service. Equipment is manufactured to meet current ASTM, CPSC and ADA guidelines for playground safety and accessibility.

For almost 60 years, Cunningham Recreation has been providing commercial park and playground equipment from design to construction. We are proud to serve as GameTime Play Equipment's exclusive representative in North Carolina, South Carolina, Virginia, West Virginia, Arkansas, Kansas, Missouri, Illinois, Oklahoma, Tennessee, Texas, Iowa, Nebraska, North Dakota, South Dakota, Delaware, Maryland, and DC.

Cunningham Recreation has adequate coverage in each territory to ensure our customers receive professional assistance and excellent customer service.

## Range of Installation and Services

GameTime holds an ISO 9001 certification, which validates our high-quality manufacturing standards and our commitment to excellence in the design, production, installation, inspection and testing of our products. Our ISO 14001 certification supports our dedication to environmental sustainability and our commitment to eliminating waste, implementing recycling practices in our manufacturing facility, and offering recycled and recyclable products to our customers.

Cunningham Recreation specializes in complete park and playground solutions. We offer a full range of commercial park and play equipment for children of all ages and all abilities, and we have completed thousands of installations.

Cunningham Recreation offers a variety of resources and design approaches for planning and maintaining parks and playgrounds.



Both Cunningham Recreation and GameTime are considered leaders in the playground industry. Why not partner with a leader? Our research, design principles, innovative products and available resources are at your disposal.



## SIGNATURE PROJECTS



### Goodlettsville Elementary School – Metro Nashville Public Schools, Tennessee

This project utilizes our PrimeTime line of equipment to provide maximum play value at an affordable cost. This playground includes multiple slides and climbers along with balancing activities and swings to provide fun, developmentally appropriate play activities for children of all abilities.

Total Cost: \$100,000

### Beech Street – Clarksville, Tennessee

Beech Street Park is an inclusive play space that was designed to offer a wide range of play experiences. The turf surfaced park consist of swings, a net feature, and a main structure that includes ramps, panels, and slides. The goal was to design a park that provides fair, comfortable, active, and safe play experience for all children.

Total Cost: \$230,000



### BlueCross Healthy Place at Barfield Crescent Park – Murfreesboro, Tennessee

The BlueCross Healthy Place at Barfield Crescent Park is a space that provides opportunity for communities to get to know one another and enjoy healthy activity. This space encourages multi-generational play experiences and includes poured in place surfacing, an inclusive playground and adult fitness equipment.

Total Cost: \$750,000



# Westview Elementary Limestone, TN

Design • Build • PLAY!

## Modular PrimeTime Play Structure

Blue Decks

Blue Plastics/Tubes/Roof

Blue Uprights

Orange Accents

Blue HDPE

Blue/White 2C HDPE



# Westview Elementary Limestone, TN

Design • Build • PLAY!

Modular PowerScape Play Structure  
Blue Decks  
Blue Plastics/Tubes  
Blue Uprights  
Orange Accents  
Black Cabling  
Blue HDPE  
Blue/White 2C HDPE



# Westview Elementary Limestone, TN

Separate Swing Area  
Swing Frame: Blue



Main Playground Swings  
Swing Frame: Blue

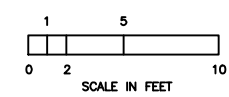
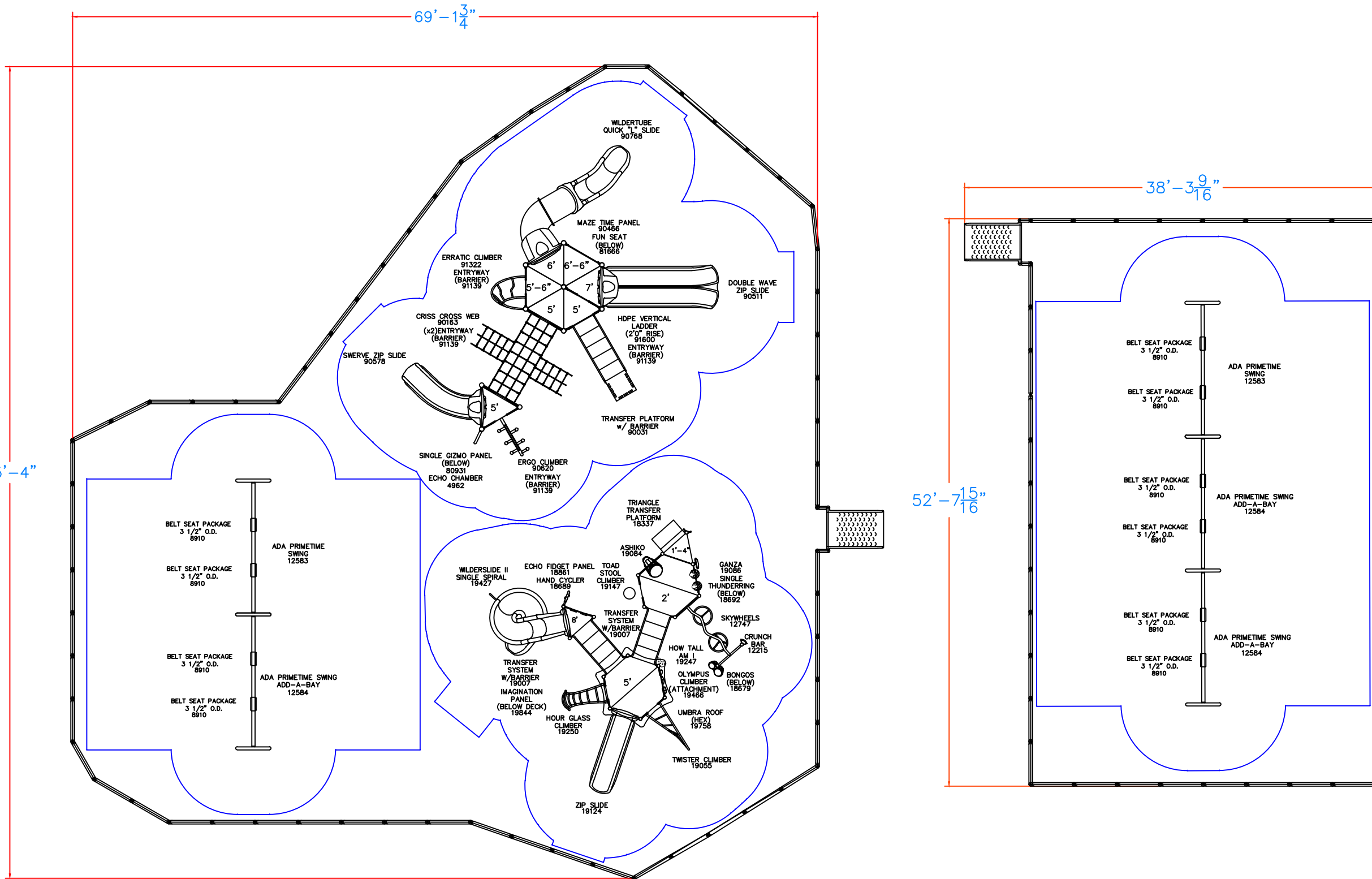

Washington County Board of Education  
Westview Elementary School  
Limestone, TN  
Representative  
Cunningham Recreation

This play equipment is recommended for children ages 5-12

Minimum Area Required:  
Scale:  
This drawing can be scaled only when in an 11" x 17" format

**IMPORTANT:** Soft resilient surfacing should be placed in the use zones of all equipment, as specified for each type of equipment, and at depths to meet the critical fall heights as specified by the U.S. consumer Product Safety Commission, ASTM standard F 1487 and Canadian Standard CAN/CSA-Z-614

Drawn By: HS/TCV  
Date: 07/29/2024  
Drawing Name: 168018-01-02



GameTime c/o Cunningham Recreation  
 PO Box 240981  
 Charlotte, NC 28224  
 800.438.2780  
 704.525.7356 FAX

07/30/2024  
 Quote #  
 168018-01-02

## Westview Elementary School, Grant CWO

Washington County Board of Education  
 Attn: Jarrod Adams  
 405 West College Street  
 Jonesborough, TN 37659  
 UNITED STATES  
 Phone: 423-753-1112  
 adamsj@wcde.org

Ship to Zip 37681

Quantity	Part #	Description	Unit Price	Amount
1	RDU	GameTime - Modular PrimeTime Play Structure for Ages 5-12 [Basic: _____] [Accent: _____] [SkyWheel: _____] [Deck:Pvc: _____] [RotoPlastic: _____] [2ColorHDPE: _____] [HDPE: _____] [Roof: _____] [Roof2: _____]	\$57,144.00	\$57,144.00
		(4) 12023 -- 3 1/2" Uprt Ass'Y Alum 8'		
		(1) 12024 -- 3 1/2" Uprt Ass'Y Alum 9'		
		(4) 12025 -- 3 1/2" Uprt Ass'Y Alum 10'		
		(6) 12077 -- 3 1/2" Uprt Ass'Y Alum 15'		
		(1) 12215 -- Crunch Bar Prime Time		
		(1) 12747 -- 1'-6"/2'-0" Skywheel Attch-2 Whls		
		(1) 18201 -- 36" Tri Punched Deck P/T		
		(1) 18337 -- 36" Tri Transfer Platform		
		(1) 18679 -- Bongos		
		(1) 18689 -- Hand Cyclcr		
		(1) 18692 -- Single Thunder Ring		
		(6) 18832 -- Umbra Roof Extemsion 2'		
		(1) 18861 -- Echo Fidget Panel		
		(2) 19007 -- Transfer System W/Barrier (3' Rise)		
		(1) 19055 -- Twister (5' & 5'-6")		
		(1) 19084 -- Ashiko		
		(1) 19086 -- Ganza		
		(1) 19124 -- Straight Zip Slide (5')		
		(1) 19147 -- Toad Stool		
		(1) 19247 -- How Tall Am I		
		(1) 19250 -- Hour Glass (3' Thru 5')		
		(2) 19289 -- Two Piece Hex Deck		
		(1) 19427 -- Single Spiral		
		(1) 19466 -- Olympus Climber - 5'0 thru 6'0 attac		
		(1) 19758 -- Umbra Hex roof		



GameTime c/o Cunningham Recreation  
 PO Box 240981  
 Charlotte, NC 28224  
 800.438.2780  
 704.525.7356 FAX

07/30/2024  
 Quote #  
 168018-01-02

## Westview Elementary School, Grant CWO

Quantity	Part #	Description	Unit Price	Amount
		(6) 19762 -- Umbra Roof Plug		
		(1) 19844 -- Imagination Panel		
		(3) G12069 -- 3 1/2"Uprt Ass'Y Galv 14'		
1	RDU	GameTime - Modular PowerScape Play Structure for Ages 5-12 [Deck:Pvc:_____] [Basic:_____] [RotoPlastic:_____] [Tube:_____] [Accent:_____] [Cabling:_____] [2ColorHDPE:_____] [HDPE:_____]	\$54,839.00	\$54,839.00
		(1) 4962 -- Echo Chamber		
		(7) 80001 -- 49"Tri Punched Steel Deck		
		(1) 80931 -- Single Gizmo Panel		
		(1) 81666 -- Fun Seat		
		(1) 90031 -- 5' Transfer Platform W/Barrier		
		(1) 90163 -- 4'/5' Criss Cross Web		
		(1) 90269 -- 11' Upright, Alum		
		(1) 90270 -- 12' Upright, Alum		
		(4) 90271 -- 13' Upright, Alum		
		(1) 90466 -- Maze Panel, Above Dk		
		(1) 90511 -- 7'/7'-6" Double Wave Zip Slide		
		(1) 90578 -- Swerve Slide		
		(1) 90620 -- Ergo Climber (5'-0" & 5'-6")		
		(1) 90768 -- 6' Wildertube Quick 'L' Reverse		
		(1) 153655 -- 30 Deg Elbow Sec 30" Dia		
		(1) 153844 -- 90 Deg Elbow Sec 30" Dia		
		(1) 160682 -- Tube Support 81 13/16"Lg		
		(1) 203582 -- Tube Entrance Section		
		(1) 205962 -- Straight Section		
		(1) 205963 -- Curved Left Section		
		(1) 206179 -- Exit Section		
		(1) 207772 -- Wilder Tube Section		
		(1) 208853 -- Footbuck 28 3/8"Lg		
		(1) 208857 -- Hdw-Wildertube Quick "S"		
		(5) 91139 -- Entryway - Barrier		
		(1) 91322 -- Erratic Climber 5'6"-6'6"		
		(1) 91600 -- HDPE Vertical Ladder 2'0"		
		(3) G90269 -- 11' Upright, Galv		



GameTime c/o Cunningham Recreation  
 PO Box 240981  
 Charlotte, NC 28224  
 800.438.2780  
 704.525.7356 FAX

07/30/2024  
 Quote #  
 168018-01-02

## Westview Elementary School, Grant CWO

Quantity	Part #	Description	Unit Price	Amount
		(1) G90270 -- 12' Upright, Galv		
1	RDU	GameTime - Two Bay Primetime Swings [Basic:_____]	\$4,589.00	\$4,589.00
		(4) 8910 -- Belt Seat 3 1/2"Od(8910)		
		(1) 12583 -- Ada Primetime Swing Frame, 3 1/2" Od		
		(1) 12584 -- Ada Primetime Swing Aab, 3 1/2" Od		
1	RDU	GameTime - Three Bay Primetime Swings [Basic:_____]	\$6,524.00	\$6,524.00
		(6) 8910 -- Belt Seat 3 1/2"Od(8910)		
		(1) 12583 -- Ada Primetime Swing Frame, 3 1/2" Od		
		(2) 12584 -- Ada Primetime Swing Aab, 3 1/2" Od		
2	4858	GameTime - Access Playcurb-W/Adap	\$820.00	\$1,640.00
101	4862	GameTime - 12" Playground Border	\$83.00	\$8,383.00
1	178749	GameTime - Owner's Kit	\$89.00	\$89.00
270	EWf	GT-Impax - Engineered Wood Fiber Safety Surfacing (CY)- <ul style="list-style-type: none"> <li>• Play Area: 3,758 Sq.Ft.</li> <li>• Swing Area: 1,680 Sq.Ft.</li> <li>• Thickness (Compacted): 12"</li> </ul>	\$21.50	\$5,805.00
1	2024 GT- Grant	MISC - 2024 Matching Funds Grant- <b>Grant Rules and Limitations:</b> To qualify for up to 100% matching grant, list price of the qualifying playground system must exceed \$75,000, and payment in full must accompany your order. For play systems with a list price of less than \$75,000 and greater than \$25,000 with payment in full, GameTime playground grants are available with matching funds up to 80%. For play systems that exceed \$25,000, and purchased with credit terms, matching funds are available up to 65%. Matching funds are subject to rounding rules and may vary based on qualified purchase. No other offer, discount, or special programs can be used with this grant program. This special matching fund offer applies to PowerScape®, PrimeTime®, Xscape®, and Modern City® systems only. Up to 50% matching funds for select outdoor fitness equipment, including THRIVE®, Challenge Course, KidCourse, and The Stadium®. VistaRope®, freestanding net structures, TuffForms, Landmark Design, GTSymphony freestanding, other freestanding play products, and Play On! non-system events are not eligible for funding. <b>All applications must be received and validated by the project administrator by October 18, 2024.</b> GameTime reserves the right to decline any application for a GameTime grant. <b>GameTime will accept grant orders until October 25, 2024,</b> or until all eligible funds are disbursed, whichever comes first. <b>Customer must be able to receive order by December 31, 2024, subject to transportation availability.</b> GameTime reserves the right to terminate this offer at any time without notice. GameTime playground grants can only be applied to additional GameTime purchases and only in conjunction with the original purchase. Standard policies and warranties as listed in the 2024 GameTime Playground Design Guide apply. Freight and applicable sales tax are extra and not included. Other terms and restrictions may apply. Contact your local GameTime representative for complete details.		
Contract: OMNIA #2017001134			<b>Sub Total</b>	\$139,013.00
			<b>Discount</b>	(\$58,427.79)
			<b>Freight</b>	\$5,164.00
			<b>Total</b>	<b>\$85,749.21</b>



GameTime c/o Cunningham Recreation  
PO Box 240981  
Charlotte, NC 28224  
800.438.2780  
704.525.7356 FAX

07/30/2024  
Quote #  
168018-01-02

## Westview Elementary School, Grant CWO

### Comments

**\*To receive Grant Cash With Order pricing, payment in full, via check, must be received with order.**

**\* Materials only quotation. This pricing does not include any offloading or installation of equipment or safety surfacing.**

**\* Taxes, if applicable, will be applied at the time of invoice. Please provide a copy of your tax exempt certificate to avoid the addition of taxes.**

### GAMETIME - TERMS & CONDITIONS:

- **PRICING:** Due to volatile economic demand, pricing is valid for 30 days. Pricing is subject to change. Request updated pricing when purchasing from quotes more than 30 days old.
- **TERMS OF SALE:** For equipment & material purchases, Net 30 days from date of invoice for governmental agencies and those with approved credit. All others, full payment for equipment, taxes and freight up front. Balance for services & materials due upon completion or as otherwise negotiated upon credit application review. Pre-payment may be required for equipment orders totaling less than \$5,000. Payment by VISA, MasterCard, or AMEX is accepted (**If you elect to pay by credit card, GameTime charges a 2.50% processing fee that is assessed on the amount of your payment. This fee is shown as a separate line item and included in the total amount charged to your credit card. You have the option to pay by check, ACH or Wire without any additional fees.**). Checks should be made payable to Playcore Wisconsin, Inc. d/b/a GameTime unless otherwise directed. **Any order exceeding \$300,000 will require progress payments during the course of completion.**
- **CREDIT APPLICATION:** Required for all non-governmental agencies and those entities who have not purchased from GameTime within the previous twelve calendar months.
- **FINANCE CHARGE:** A 1.5% monthly finance charge (or maximum permitted by law) will be added to all invoices over 30 days past due.
- **CASH WITH ORDER DISCOUNT:** Orders for GameTime equipment paid in full at time of order via check or electronic funds transfer (EFT) are eligible for a 3% cash-with-order (CWO) discount.
- **ORDERS:** All orders shall be in writing by purchase order, signed quotation or similar documentation. Purchase orders must be made out to Playcore Wisconsin, Inc. d/b/a GameTime.
- **FREIGHT CHARGES:** Shipments shall be F.O.B. destination. Freight charges prepaid and added separately.
- **SHIPMENT:** **Standard Lead time is 10-12 weeks** (some items may take longer) after receipt and acceptance of purchase order, credit application, color selections and approved drawings or submittals.
- **PACKAGING:** All goods shall be packaged in accordance with acceptable commercial practices and marked to preclude confusion during unloading and handling.
- **RECEIPT OF GOODS:** Customer shall coordinate, receive, unload, inspect and provide written acceptance of shipment. Any damage to packaging or equipment must be noted when signing delivery ticket. If damages are noted, receiver must submit a claim to Cunningham Recreation within 15 Days. Receiver is also responsible for taking inventory of the shipment and reporting any concealed damage or discrepancy in quantities received within 60 days of receipt.
- **RETURNS:** Returns are only available on shipments delivered within the last 60 days. A 25% (min.) restocking fee will be deducted from any credit due. Customer is responsible for all packaging & shipping charges. Credit is based on condition of items upon return. All returns must be in unused and merchantable condition. GameTime reserves the right to deduct costs associated with restoring returned goods to merchantable condition. Uprights & custom products cannot be returned.
- **TAXES:** Sales tax is shown as a separate line item when included. A copy of your tax exemption certificate must be submitted at time of order or taxes will be added to your invoice.

### SUPPLY ONLY:

- All items are quoted supply only.
- Installation services are not included.
- Customer is responsible for coordinating delivery, receipt, unloading, and inventory equipment.
- Missing or damaged equipment must be reported within 60 days of delivery.



GameTime c/o Cunningham Recreation  
PO Box 240981  
Charlotte, NC 28224  
800.438.2780  
704.525.7356 FAX

07/30/2024  
Quote #  
168018-01-02

## Westview Elementary School, Grant CWO

**ACCEPTANCE OF QUOTATION:**

*Acceptance of this proposal indicates your agreement to the terms and conditions stated herein.*

Accepted By (printed): \_\_\_\_\_ Title: \_\_\_\_\_

Telephone: \_\_\_\_\_ Fax: \_\_\_\_\_

P.O. Number: \_\_\_\_\_ Date: \_\_\_\_\_

Purchase Amount: **\$85,749.21**

SALES TAX EXEMPTION CERTIFICATE #: \_\_\_\_\_

(PLEASE PROVIDE A COPY OF CERTIFICATE)

\_\_\_\_\_  
Salesperson's Signature

\_\_\_\_\_  
Customer Signature

**BILLING INFORMATION:**

Bill to: \_\_\_\_\_

Contact: \_\_\_\_\_

Address: \_\_\_\_\_

Address: \_\_\_\_\_

City, State: \_\_\_\_\_ Zip: \_\_\_\_\_

Tel: \_\_\_\_\_ Fax: \_\_\_\_\_

E-mail: \_\_\_\_\_

**SHIPPING INFORMATION:**

Ship to: \_\_\_\_\_

Contact: \_\_\_\_\_

Address: \_\_\_\_\_

Address: \_\_\_\_\_

City, State: \_\_\_\_\_ Zip: \_\_\_\_\_

Tel: \_\_\_\_\_ Fax: \_\_\_\_\_

E-mail: \_\_\_\_\_



GameTime c/o Cunningham Recreation  
 PO Box 240981  
 Charlotte, NC 28224  
 800.438.2780  
 704.525.7356 FAX

07/30/2024  
 Quote #  
 168018-02-02

## Westview Elementary School - Installation and Site Work

Washington County Board of Education  
 Attn: Jarrod Adams  
 405 West College Street  
 Jonesborough, TN 37659  
 UNITED STATES  
 Phone: 423-753-1112  
 adamsj@wcde.org

**Ship to Zip** 37659

Quantity	Part #	Description	Unit Price	Amount
1	INSTALL	MISC - Grading to Level Playground	\$3,925.00	\$3,925.00
1	INSTALL	MISC - Installation of Equipment, per quote #168018-01-02	\$52,000.00	\$52,000.00
1	INSTALL	MISC - Installation of Playcurbs, per quote #168018-01-02	\$1,375.00	\$1,375.00
1	INSTALL	MISC - Installation of EWF Safety Surfacing, per quote #168018-01-02	\$2,400.00	\$2,400.00
Contract: OMNIA #2017001134			<b>Sub Total</b>	\$59,700.00
<b>Total</b>				<b>\$59,700.00</b>

**Comments**

\* Site must be clear, level, free of obstructions, and accessible. Site should permit installation equipment access. Purchaser shall be responsible for unknown conditions such as buried utilities, tree stumps, bedrock or any concealed materials or conditions that may result in additional costs.

\* Taxes, if applicable, will be applied at the time of invoice. Please provide a copy of your tax exempt certificate to avoid the addition of taxes.



GameTime c/o Cunningham Recreation  
PO Box 240981  
Charlotte, NC 28224  
800.438.2780  
704.525.7356 FAX

07/30/2024  
Quote #  
168018-02-02

## Westview Elementary School - Installation and Site Work

### GAMETIME - TERMS & CONDITIONS:

- **PRICING:** Due to volatile economic demand, pricing is valid for 30 days. Pricing is subject to change. Request updated pricing when purchasing from quotes more than 30 days old.
- **TERMS OF SALE:** For equipment & material purchases, Net 30 days from date of invoice for governmental agencies and those with approved credit. All others, full payment for equipment, taxes and freight up front. Balance for services & materials due upon completion or as otherwise negotiated upon credit application review. Pre-payment may be required for equipment orders totaling less than \$5,000. Payment by VISA, MasterCard, or AMEX is accepted (**If you elect to pay by credit card, GameTime charges a 2.50% processing fee that is assessed on the amount of your payment. This fee is shown as a separate line item and included in the total amount charged to your credit card. You have the option to pay by check, ACH or Wire without any additional fees.**). Checks should be made payable to Playcore Wisconsin, Inc. d/b/a GameTime unless otherwise directed. **Any order exceeding \$300,000 will require progress payments during the course of completion.**
- **CREDIT APPLICATION:** Required for all non-governmental agencies and those entities who have not purchased from GameTime within the previous twelve calendar months.
- **FINANCE CHARGE:** A 1.5% monthly finance charge (or maximum permitted by law) will be added to all invoices over 30 days past due.
- **CASH WITH ORDER DISCOUNT:** Orders for GameTime equipment paid in full at time of order via check or electronic funds transfer (EFT) are eligible for a 3% cash-with-order (CWO) discount.
- **ORDERS:** All orders shall be in writing by purchase order, signed quotation or similar documentation. Purchase orders must be made out to Playcore Wisconsin, Inc. d/b/a GameTime.
- **FREIGHT CHARGES:** Shipments shall be F.O.B. destination. Freight charges prepaid and added separately.
- **SHIPMENT: Standard Lead time is 10-12 weeks** (some items may take longer) after receipt and acceptance of purchase order, credit application, color selections and approved drawings or submittals.
- **PACKAGING:** All goods shall be packaged in accordance with acceptable commercial practices and marked to preclude confusion during unloading and handling.
- **RECEIPT OF GOODS:** Customer shall coordinate, receive, unload, inspect and provide written acceptance of shipment. Any damage to packaging or equipment must be noted when signing delivery ticket. If damages are noted, receiver must submit a claim to Cunningham Recreation within 15 Days. Receiver is also responsible for taking inventory of the shipment and reporting any concealed damage or discrepancy in quantities received within 60 days of receipt.
- **RETURNS:** Returns are only available on shipments delivered within the last 60 days. A 25% (min.) restocking fee will be deducted from any credit due. Customer is responsible for all packaging & shipping charges. Credit is based on condition of items upon return. All returns must be in unused and merchantable condition. GameTime reserves the right to deduct costs associated with restoring returned goods to merchantable condition. Uprights & custom products cannot be returned.
- **TAXES:** Sales tax is shown as a separate line item when included. A copy of your tax exemption certificate must be submitted at time of order or taxes will be added to your invoice.

### INSTALLATION CONDITIONS:

- **ACCESS:** Site should be clear, level and allow for unrestricted access of trucks and machinery.
- **STORAGE:** Customer is responsible for providing a secure location to off-load and store the equipment during the installation process. Once equipment has delivered to the site, the owner is responsible should theft or vandalism occur unless other arrangements are made and noted on the quotation.
- **FOOTER EXCAVATION:** Installation pricing is based on footer excavation through earth/soil only. Customer shall be responsible for unknown conditions such as buried utilities (public & private), tree stumps, rock, or any concealed materials or conditions that may result in additional labor or materials cost.
- **UTILITIES:** Installer will contact 811 to locate all public utilities prior to layout and excavation of any footer holes. Owner is responsible for locating any private utilities.
- **ADDITIONAL COSTS:** Pricing is based on a single mobilization for installation unless otherwise noted. Price includes ONLY what is stated in this quotation. If additional site work or specialized equipment is required, pricing is subject to change.



GameTime c/o Cunningham Recreation  
PO Box 240981  
Charlotte, NC 28224  
800.438.2780  
704.525.7356 FAX

07/30/2024  
Quote #  
168018-02-02

## Westview Elementary School - Installation and Site Work

### ACCEPTANCE OF QUOTATION:

Acceptance of this proposal indicates your agreement to the terms and conditions stated herein.

Accepted By (printed): \_\_\_\_\_ Title: \_\_\_\_\_

Telephone: \_\_\_\_\_ Fax: \_\_\_\_\_

P.O. Number: \_\_\_\_\_ Date: \_\_\_\_\_

Purchase Amount: **\$59,700.00**

SALES TAX EXEMPTION CERTIFICATE #: \_\_\_\_\_

(PLEASE PROVIDE A COPY OF CERTIFICATE)

\_\_\_\_\_  
Salesperson's Signature

\_\_\_\_\_  
Customer Signature

### BILLING INFORMATION:

Bill to: \_\_\_\_\_

Contact: \_\_\_\_\_

Address: \_\_\_\_\_

Address: \_\_\_\_\_

City, State: \_\_\_\_\_ Zip: \_\_\_\_\_

Tel: \_\_\_\_\_ Fax: \_\_\_\_\_

E-mail: \_\_\_\_\_

### SHIPPING INFORMATION:

Ship to: \_\_\_\_\_

Contact: \_\_\_\_\_

Address: \_\_\_\_\_

Address: \_\_\_\_\_

City, State: \_\_\_\_\_ Zip: \_\_\_\_\_

Tel: \_\_\_\_\_ Fax: \_\_\_\_\_

E-mail: \_\_\_\_\_

# MATERIAL COLOR OPTIONS

METAL	PLASTIC	HDPE	2 COLOR HDPE
Black	Champagne	Black	Black/White
Starlight Black		Dolphin Gray	Gray/Black
Metallic	Beige		White/Black
White		Brown	Brown/White
Vanilla	Green		
Champagne		Chartreuse	Spring Green/White
Beige	Spring Green		
Brown		Azure	Sky Blue/White
Bronze	Blue		
Dark Green		Periwinkle	Purple/White
Green	Royal Purple		
Sage		Burgundy	Red/White
Ice Butter	Red		
Ice Mint		Orange	Yellow/Black
Chartreuse	Yellow		
Spring Green			
Ocean			
Azure			
Sea Mist			
Sky Blue			
Blue			
Periwinkle			
Royal Purple			
Burgundy			
Red			
Orange			
Butterscotch			
Yellow			

Actual colors may differ from the images represented here. Contact your local GameTime representative for sample materials.

# MATERIAL COLOR OPTIONS

## SHADE FABRIC

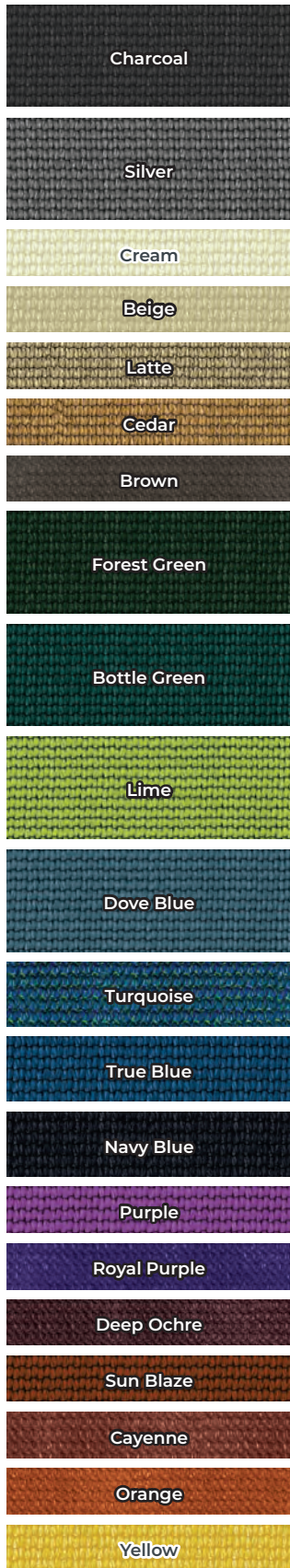

## VISTAROPETM STANDARD

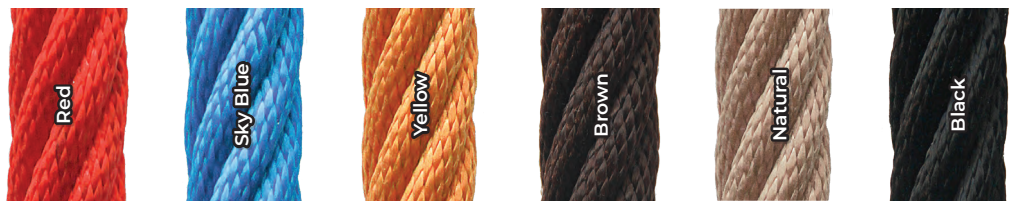

## VISTAROPETM CUSTOM

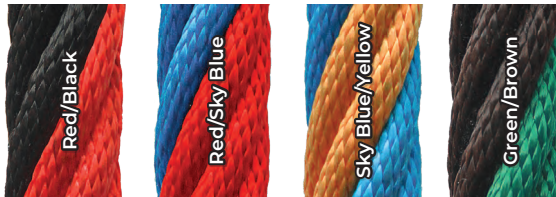

\*Colors for VistaRope products only. All standard GameTime ropes are black.

## SPECIAL ROCK

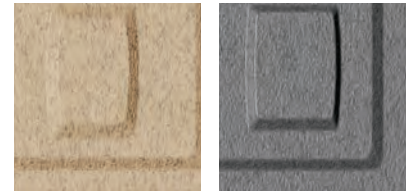

Sandstone

Deep Granite

## WALLCANO® HANDHOLDS



Red

Green

Blue

Beige

## SITE RECYCLED PLASTIC LUMBER

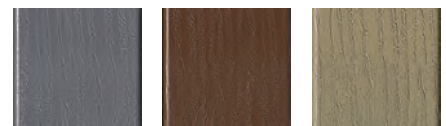

Gray

Tudor

Sand

## DECKS

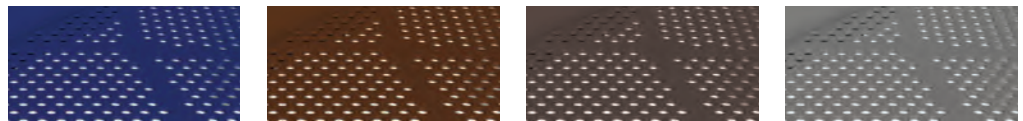

Blue

Brown

NEW! Chocolate

Gray

**PURCHASING DEPARTMENT**  
**WASHINGTON COUNTY BOARD OF EDUCATION**

PURCHASE ORDER

Purchase Order **No 2499**  
 Date Issued **07-01-24**  
 Appropriation No. **76100799**  
 Dept.  
 School **DBHS & DCHS**

**NOTICE TO VENDOR**

1. Purchase order **MUST** bear two signatures in order to be valid.
2. Purchase order number **MUST** appear on all invoices submitted for payment.
3. Mail **TWO** copies of your invoice promptly to:

**Washington County Board of Education**  
 405 West College Street  
 Jonesborough, TN 37659  
 Telephone (423) 753-1105

**TO**  
 Bur-Wil Construction  
 Bristol TN 37621

Deliver to **DBHS/DCHS**  
 Address  
 Via

Articles on this order must be charged to account of

ARTICLES OR SERVICES	CODE	QUANTITY & UNIT	UNIT PRICE	TOTAL
(Unless otherwise stated all prices F.O.B. Destination)				
Stadium Upgrades * Washington County Government as paid the first 3.4M. * The <del>total</del> below \$4,887,000 is the approved Board <del>portion</del> Portion. Project approved by BOE (10-17-2024)				
<b>GRAND TOTAL - INCLUDING ALL ATTACHED PAGES</b>			\$ 4,887,000.00	

**SUBJECT TO THE FOLLOWING CONDITIONS**

1. All packages, cartons or other containers must be plainly marked with the purchase order number.
2. The right is reserved to purchase in the open market and to charge the difference to the Vendor in the event that deliveries are not made at the time specified in the bid and on this order.
3. Whenever a delivery is rejected, the Vendor shall be notified and be given the reason for the rejection. All rejected deliveries shall be held at the Vendor's risk and he shall bear the expense of removal.
4. Acceptance of this order includes acceptance of all terms, prices, delivery, instructions, specifications and conditions stated.
5. The county is not liable for Federal excise tax or state sales tax.
6. Each shipment and/or each purchase order should be covered by separate invoice.

**IMPORTANT: INVOICES AND PACKAGES MUST BEAR PURCHASE ORDER NUMBER**

**VENDOR'S COPY**

There is an otherwise unincumbered balance to the credit of the proper appropriation, allotment or fund to meet the expenditure covered by this purchase.

Authorized Signature

**APPROVED:**

Purchasing Agent



2024 July 25

Mr. Brad Hale, Chief Financial Officer  
Washington County Schools  
405 W College Street  
Jonesborough, TN 37659

**RE: Washington County Schools (WCS) Athletic Upgrades – Phase 1**  
**Daniel Boone High School + David Crockett High School**  
**Gray, TN Jonesborough, TN**  
**LGA # 22043**

Application and Certificate for Payment No. 07

Dear Mrs. Hale:

Please find attached one (1) digital copy of APPLICATION AND CERTIFICATE FOR PAYMENT NO. 07 for the above referenced project. We have reviewed the application and to the best of our knowledge, information, and belief find that the amount requested appears to be reasonable and appropriate to the Work accomplished. Therefore, we recommend payment in the amount of **\$2,683,751.19**. Please make payment directly to the Construction Manager and enclose a copy of the application with their payment.

We have not made an independent examination of the Contractor's records nor verified whether subcontractors, persons, suppliers, vendors, or other entities with whom the Contractor may have agreements relative to this project have been paid and our recommendation does not constitute a representation that such accounts have, in fact, been paid. We have not inventoried any stored materials for which payment has been requested. We have relied entirely on the Contractor's representations made in the attached Application and Certificate for Payment and our observations of the Work as the basis for our recommendation.

Please do not hesitate to contact our office if you have any questions.

Sincerely,

A handwritten signature in black ink that reads 'Ginger Azpurua'.

Ginger Azpurua

Cc: Jarrod Adams, WCS Chief Operations Office  
Jerry S. Boyd, WCS Superintendent  
Todd Morris, BurWil Construction Co  
Paul M. McCall, LGA

## Application and Certificate for Payment

Invoice No. 13569

<b>TO OWNER:</b> Washington Co. Board of Education 405 W. College Street Jonesborough, TN 37659	<b>PROJECT:</b> Washington Co Athletic Upgrade	<b>APPLICATION NO:</b> 7 <b>PERIOD TO:</b> 6/30/2024 <b>CONTRACT FOR:</b> <b>CONTRACT DATE:</b> <b>PROJECT NOS:</b> 352-203-05 /	<b>Distribution to:</b> OWNER <input type="checkbox"/> ARCHITECT <input type="checkbox"/> CONTRACTOR <input type="checkbox"/> FIELD <input type="checkbox"/> OTHER <input type="checkbox"/>
<b>FROM CONTRACTOR:</b> BurWil Construction Company, Inc. P. O. Box 637 Bristol, TN 37621	<b>VIA ARCHITECT:</b>		

### CONTRACTOR'S APPLICATION FOR PAYMENT

Application is made for payment, as shown below, in connection with the Contract. AIA Document G703™, Continuation Sheet, is attached.

1. ORIGINAL CONTRACT SUM .....	\$	8,287,000.00
2. NET CHANGE BY CHANGE ORDERS .....	\$	186,721.98
3. CONTRACT SUM TO DATE (Line 1 ± 2) .....	\$	8,473,721.98
4. TOTAL COMPLETED & STORED TO DATE (Column G on G703) .....	\$	6,078,555.11
5. RETAINAGE:		
a. <u>5.00</u> % of Completed Work (Column D + E on G703)	\$	<del>303,927.75</del>
b. _____ % of Stored Material (Column F on G703)	\$	_____
Total Retainage (Lines 5a + 5b, or Total in Column I of G703) .....	\$	303,927.75
6. TOTAL EARNED LESS RETAINAGE .....	\$	5,774,627.36
(Line 4 minus Line 5 Total)		
7. LESS PREVIOUS CERTIFICATES FOR PAYMENT .....	\$	3,090,876.17
(Line 6 from prior Certificate)		
8. CURRENT PAYMENT DUE .....	\$	2,683,751.19
9. BALANCE TO FINISH, INCLUDING RETAINAGE .....	\$	2,699,094.62
(Line 3 minus Line 6)		

CHANGE ORDER SUMMARY	ADDITIONS	DEDUCTIONS
Total changes approved in previous months by Owner	\$	\$
Total approved this month	\$	\$
<b>TOTAL</b>	<b>\$</b>	<b>\$</b>
NET CHANGES by Change Order	\$	

**CAUTION: You should sign an original AIA Contract Document, on which this text appears in RED. An original assures that changes will not be obscured.**

AIA Document G702™ – 1992. Copyright © 1953, 1963, 1965, 1971, 1978, 1983 and 1992 by The American Institute of Architects. All rights reserved. **WARNING: This AIA® Document is protected by U.S. Copyright Law and International Treaties. Unauthorized reproduction or distribution of this AIA® Document, or any portion of it, may result in severe civil and criminal penalties, and will be prosecuted to the maximum extent possible under the law.** Purchasers are permitted to reproduce ten (10) copies of this document when completed. To report copyright violations of AIA Contract Documents, e-mail The American Institute of Architects' legal counsel, [copyright@aia.org](mailto:copyright@aia.org).

The undersigned Contractor certifies that to the best of the Contractor's knowledge, information and belief the Work covered by this Application for Payment has been completed in accordance with the Contract Documents, that all amounts have been paid by the Contractor for Work for which previous Certificates for Payment were issued and payments received from the Owner, and that current payment shown herein is now due.

**CONTRACTOR:** BurWil Construction Company, Inc.  
By: Will H. Famerus, CEO Date: July 15, 2024  
State of: Tennessee

County of: Sullivan  
Subscribed and sworn to before me this Fifteenth day of July, 2024

Notary Public: Janice L. Hubble  
My commission expires: 10/25/2026

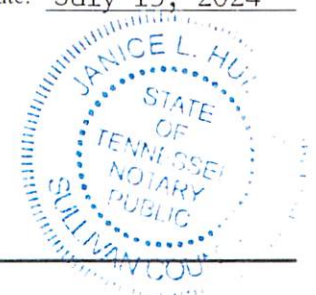

### ARCHITECT'S CERTIFICATE FOR PAYMENT

In accordance with the Contract Documents, based on on-site observations and the data comprising this application, the Architect certifies to the Owner that to the best of the Architect's knowledge, information and belief the Work has progressed as indicated, the quality of the Work is in accordance with the Contract Documents, and the Contractor is entitled to payment of the AMOUNT CERTIFIED.

AMOUNT CERTIFIED ..... \$ 2,683,751.19  
(Attach explanation if amount certified differs from the amount applied. Initial all figures on this Application and on the Continuation Sheet that are changed to conform with the amount certified.)

**ARCHITECT:**  
By: Janice L. Hubble Date: 07/25/2024

This Certificate is not negotiable. The AMOUNT CERTIFIED is payable only to the Contractor named herein. Issuance, payment and acceptance of payment are without prejudice to any rights of the Owner or Contractor under this Contract.



# AIA Document G703™ – 1992

## Continuation Sheet

AIA Document G702™-1992, Application and Certificate for Payment, or G732™-2009, Application and Certificate for Payment, Construction Manager as Adviser Edition, containing Contractor's signed certification is attached.  
 In tabulations below, amounts are in US dollars.  
 Use Column I on Contracts where variable retainage for line items may apply.

APPLICATION NO: 7  
 APPLICATION DATE: 6/30/2024  
 PERIOD TO: 6/30/2024  
 ARCHITECT'S PROJECT NO: 352-203-05

A ITEM NO.	B DESCRIPTION OF WORK	C SCHEDULED VALUE	D WORK COMPLETED		F MATERIALS PRESENTLY STORED (Not in D or E)	G		H BALANCE TO FINISH (C - G)	I RETAINAGE (If variable rate)
			FROM PREVIOUS APPLICATION (D + E)	THIS PERIOD		TOTAL COMPLETED AND STORED TO DATE (D+E+F)	% (G ÷ C)		
01-00	GENERAL REQUIREMENTS								
01-01	General Conditions	590,241.57	210,000.00	100,000.00		310,000.00	52.52	280,241.57	15,500.00
01-02	Building Permit	4,000.00	8,000.00	-4,000.00		4,000.00	100.00		200.00
01-03	Payment & Performance Bond	56,650.00	56,650.00			56,650.00	100.00		2,832.50
01-04	Daniel Boone Testing Allowance	10,000.00	8,218.00	1,343.40		9,561.40	95.61	438.60	478.07
01-05	David Crockett Testing Allowance	10,000.00	7,921.00	2,079.00		10,000.00	100.00		500.00
01-06	Daniel Boone Contingency								
01-07	David Crockett Contingency								
02-00	DANIEL BOONE								
02-01	DB Selective Demolition	62,000.00	62,000.00			62,000.00	100.00		3,100.00
02-02	DB Site Grading/Site Utilities	307,975.55	207,234.00	45,000.00		252,234.00	81.90	55,741.55	12,611.70
02-03	DB Paving, Striping & Parking Signage	45,323.40						45,323.40	
02-04	DB Concrete Sidewalks/Steps	217,843.25						217,843.25	
02-05	DB Fencing	34,000.00						34,000.00	
02-06	DB Concrete	387,766.88	395,674.26	-7,907.38		387,766.88	100.00		19,388.34
02-07	DB Masonry	326,185.27	310,000.00			310,000.00	95.04	16,185.27	15,500.00
02-08	DB Misc Steel	72,872.50	15,000.00	15,000.00		30,000.00	41.17	42,872.50	1,500.00
02-09	DB Steel Allowance	10,000.00						10,000.00	
02-10	DB Rough Carpentry	13,562.50	8,000.00	5,000.00		13,000.00	95.85	562.50	650.00
02-11	DB Millwork	21,000.00						21,000.00	
02-12	DB Roofing	38,000.00		10,000.00		10,000.00	26.32	28,000.00	500.00
02-13	DB Sealants & Caulking	12,400.00						12,400.00	
02-14	DB Doors, Frames & Hardware	43,648.00	13,000.00	8,000.00		21,000.00	48.11	22,648.00	1,050.00
02-15	DB Coiling Counter Doors	10,000.00						10,000.00	
	GRAND TOTAL								

**CAUTION:** You should sign an original AIA Contract Document, on which this text appears in RED. An original assures that changes will not be obscured.

### Continuation Sheet

AIA Document G702™ 1992, Application and Certificate for Payment, or G732™ 2009, Application and Certificate for Payment, Construction Manager as Adviser Edition, containing Contractor's signed certification is attached.  
 In tabulations below, amounts are in US dollars.  
 Use Column F on Contracts where variable retainage for line items may apply.

APPLICATION NO: 7  
 APPLICATION DATE: 6/30/2024  
 PERIOD TO: 6/30/2024  
 ARCHITECT'S PROJECT NO: 352-203-05

ITEM NO	DESCRIPTION OF WORK	SCHEDULED VALUE	WORK COMPLETED		MATERIALS PRESENTLY STORED <i>(Not in D or E)</i>	G		BALANCE TO FINISH <i>(C - G)</i>	RETAINAGE <i>(If variable rate)</i>
			FROM PREVIOUS APPLICATION <i>(D + E)</i>	THIS PERIOD		TOTAL COMPLETED AND STORED TO DATE <i>(D + E + F)</i>	%		
02-16	DB Metal Studs/Drywall	1,234.00	45,000.00	-43,766.00		1,234.00	100.00		61.70
02-17	DB Flooring	4,000.00						4,000.00	
02-18	DB Painting	119,926.00		60,000.00		60,000.00	50.03	59,926.00	3,000.00
02-19	DB Toilet Partitn,Accs&Fire Ex	42,567.80						42,567.80	
02-20	DB Signage	46,000.00	23,000.00			23,000.00	50.00	23,000.00	1,150.00
02-21	DB Grandstands	1,216,520.00		1,216,520.00		1,216,520.00	100.00		60,826.00
02-22	DB Plumbing	240,000.00	95,000.00	75,000.00		170,000.00	70.83	70,000.00	8,500.00
02-23	DB HVAC	105,000.00		65,000.00		65,000.00	61.90	40,000.00	3,250.00
02-24	DB Electrical	681,673.00	494,000.00	45,000.00		539,000.00	79.07	142,673.00	26,950.00
03-00	DAVID CROCKETT								
03-01	DC Selective Demolition	50,500.00	50,000.00	500.00		50,500.00	100.00		2,525.00
03-02	DC Site Grading/Site Utilites	289,275.00	195,000.00	45,000.00		240,000.00	82.97	49,275.00	12,000.00
03-03	DC Pvng, Stripe&Prkng Signage	66,000.00						66,000.00	
03-04	DC Concrete Sidewalks/Steps	38,930.00						38,930.00	
03-05	DC Fencing	48,000.00						48,000.00	
03-06	DC Concrete	255,547.83	269,856.60	-14,308.77		255,547.83	100.00		12,777.39
03-07	DC Masonry	280,765.00	210,000.00	40,000.00		250,000.00	89.04	30,765.00	12,500.00
03-08	DC Misc Steel	29,190.00	5,000.00	5,000.00		10,000.00	34.26	19,190.00	500.00
03-09	DC Steel Allowance	10,000.00						10,000.00	
03-10	DC Rough Carpentry	13,000.00		9,000.00		9,000.00	69.23	4,000.00	450.00
03-11	DC Millwork	20,125.00						20,125.00	
03-12	DC Roofing	40,000.00		35,000.00		35,000.00	87.50	5,000.00	1,750.00
03-13	DC Sealants & Caulking	12,600.00						12,600.00	
03-14	DC Doors, Frames, & Hardware	43,058.50	15,000.00	7,500.00		22,500.00	52.25	20,558.50	1,125.00
	GRAND TOTAL								

**CAUTION: You should sign an original AIA Contract Document, on which this text appears in RED. An original assures that changes will not be obscured.**

## Continuation Sheet

AIA Document G702™-1992, Application and Certificate for Payment, or G732™-2009, Application and Certificate for Payment, Construction Manager as Adviser Edition, containing Contractor's signed certification is attached.  
 In tabulations below, amounts are in US dollars.  
 Use Column I on Contracts where variable retainage for line items may apply.

APPLICATION NO: 7  
 APPLICATION DATE: 6/30/2024  
 PERIOD TO: 6/30/2024  
 ARCHITECT'S PROJECT NO: 352-203-05

A ITEM NO.	B DESCRIPTION OF WORK	C SCHEDULED VALUE	D WORK COMPLETED		F MATERIALS PRESENTLY STORED <i>(Not in D or E)</i>	G		H BALANCE TO FINISH <i>(C - G)</i>	I RETAINAGE <i>(If variable rate)</i>
			FROM PREVIOUS APPLICATION <i>(D + E)</i>	THIS PERIOD		TOTAL COMPLETED AND STORED TO DATE <i>(D + E + F)</i>	% <i>(G - C)</i>		
03-15	DC Coiling Counter Doors	10,000.00						10,000.00	
03-16	DC Metal Studs/Drywall	2,041.00		2,041.00		2,041.00	100.00		102.05
03-17	DC Flooring	4,000.00						4,000.00	
03-18	DC Painting	123,114.00		65,000.00		65,000.00	52.80	58,114.00	3,250.00
03-19	DC Toilet Partitn,Accs&Fire Ex	42,814.93						42,814.93	
03-20	DC Signage	43,000.00		23,000.00		23,000.00	53.49	20,000.00	1,150.00
03-21	DC Grandstands	1,215,990.00		800,000.00		800,000.00	65.79	415,990.00	40,000.00
03-22	DC Plumbing	250,000.00	75,000.00	75,000.00		150,000.00	60.00	100,000.00	7,500.00
03-23	DC HVAC	105,000.00		65,000.00		65,000.00	61.90	40,000.00	3,250.00
03-24	DC Electrical	750,381.00	475,000.00	75,000.00		550,000.00	73.30	200,381.00	27,500.00
GRAND TOTAL		8,473,721.98	3,253,553.86	2,825,001.25		6,078,555.11	71.73	2,395,166.87	303,927.75

**CAUTION: You should sign an original AIA Contract Document, on which this text appears in RED. An original assures that changes will not be obscured.**

**PURCHASING DEPARTMENT**  
**WASHINGTON COUNTY BOARD OF EDUCATION**

Purchase Order **No 2676**  
 Date Issued **7/31/2024**  
 Appropriation No. **72620499**  
 Dept. **Maintenance**  
 School **Gray**

**PURCHASE ORDER**

**TO** Preston Woodworking  
 Rolling Hills Drive  
 Johnson City, TN 37604

Deliver to Gray Elementary  
 Address 755 Gray Station Rd.  
 Via Gray, TN 37615

**NOTICE TO VENDOR**

1. Purchase order **MUST** bear two signatures in order to be valid.
2. Purchase order number **MUST** appear on all invoices submitted for payment.
3. Mail **TWO** copies of your invoice promptly to:

Washington County Board of Education  
 405 West College Street  
 Jonesborough, TN 37659  
 Telephone (423) 753-1105

Articles on this order must be charged to account of

ARTICLES OR SERVICES	CODE	QUANTITY & UNIT	UNIT PRICE	TOTAL
(Unless otherwise stated all prices F.O.B. Destination)				
Classroom Plastic Laminates Countertops				\$12,941
*BOE approved at 4/4/2024 Meeting				
<b>GRAND TOTAL - INCLUDING ALL ATTACHED PAGES</b>				<b>\$12,941</b>

**SUBJECT TO THE FOLLOWING CONDITIONS**

1. All packages, cartons or other containers must be plainly marked with the purchase order number.
2. The right is reserved to purchase in the open market and to charge the difference to the Vendor in the event that deliveries are not made at the time specified in the bid and on this order.
3. Whenever a delivery is rejected, the Vendor shall be notified and be given the reason for the rejection. All rejected deliveries shall be held at the Vendor's risk and he shall bear the expense of removal.
4. Acceptance of this order includes acceptance of all terms, prices, delivery, instructions, specifications and conditions stated.
5. The county is not liable for Federal excise tax or state sales tax.
6. Each shipment and/or each purchase order should be covered by separate invoice.

**IMPORTANT: INVOICES AND PACKAGES MUST BEAR PURCHASE ORDER NUMBER**

<b>VENDOR'S COPY</b>	There is an otherwise unincumbered balance to the credit of the proper appropriation, allotment or fund to meet the expenditure covered by this purchase.	APPROVED:
	Authorized Signature	Purchasing Agent



PRICE INQUIRY FORM

VENDOR	DESCRIPTION OF ITEM FOR PRICE COMPARISON	PRICE QUOTED
Firm <u>Preston Woodworking</u> Address <u>120 Rolling Hills Dr. JC TN 37604</u> Person Contacted _____ <u>(423) 928-9331</u> Date <u>6/6/24</u>	Cabinets for Gray Elementary 1 <sup>st</sup> Grade Classrooms	\$12,941 <del>1</del>
Firm <u>Cabinets Direct LLC</u> Address <u>125 E. Jackson Blvd</u> Person Contacted _____ <u>brownbbass@hotmail.com</u> Date <u>5/30/24</u>	lr	\$ 24,848 <sup>00</sup>
Firm <u>Appalachian Cabinets</u> Address _____ Person Contacted _____ Date _____	lr	No Quote

Name of person obtaining inquiry Jarrod Adams



Agenda Item Details

Show Agenda

Meeting: April 4, 2024 at 5:30 PM - WASHINGTON COUNTY BOARD OF EDUCATION

Public Comment Period

There shall be a public comment period for each meeting with actionable items on the agenda, with the exception of teacher disciplinary hearings. Comments shall be limited to topics listed on the agenda. The total public comment period shall be for no more than three (3) minutes. If an individual wishes to address the Board, he/she shall sign up on the form provided before the beginning of the board meeting to request time to speak. Each speaker shall be given no more than (3) minutes. Delegations must select only one individual to speak on their behalf unless otherwise determined by the Board. Board Policy 1.609 Appeals to and Appearances Before the Board

Agenda Item: XI.F. Replacement of laminate countertops and cabinets at Gray Elementary; \$12,176.00; No funding source identified

Agenda Item Type: Action Item

Action(s):

Motion carried:

Mary Beth Dellinger proceed with cabinets. David Hammond seconded the motion which carried on roll call vote:

- Gregg Huddlestone: yes
Mike Masters: yes
Whitney Riddle: yes
Vince Walters: no
Keith Ervin: yes
Annette Buchanan: yes
Mary Beth Dellinger: yes
Chad Fleenor: no
David Hammond: yes

Attachments:

- Inspire - Gray Elementary\_(1)
Download Original File

Last Modified by Jennifer Moore on March 27, 2024 at 11:08 AM

Tennessee School Boards Association
525 Brick Church Park Drive
Nashville, TN 37207
(615) 815-3900 | (800) 448-6465

Copyright © 2015-2024. Sparq Data Solutions Inc. - All Rights Reserved.

Questions? Comments? Contact TSBA!

Privacy Policy

Terms and Conditions of Use



Quote Increased by \$765



# PRESTON

---

## WOODWORKING

---

720 Rolling Hills Drive, Johnson City, TN 37604 Phone (423) 928-9331 Fax (423) 928-3958

Date: July 31, 2024  
To: Washington County Schools  
Attn: Wanda Rowland  
From: Greg Smith  
Re: Gray Elementary School  
Includes: Quote

Classrooms – 4 Total  
Plastic Laminate Cabinets and Countertops  
(Layout based on provided drawing and field measurements)  
Installation

\$ 12,941

Note:

- Please call with any questions.
- Shop drawings to be provided with approved quote.
- Demolition of existing casework is not included in quote.
- Sinks to be provided by others.

Cabinets Direct, LLC  
125 E. Jackson Blvd. STE6  
Jonesborough, TN 37659  
423-791-3851  
brownbbass@hotmail.com

# Estimate



### ADDRESS

Washington Co. Dept. of Education  
405 West College Street  
Jonesborough, TN 37659

### SHIP TO

Washington Co. Dept. of Education  
Gray Elementary  
Gray, TN

ESTIMATE #	DATE	EXPIRATION DATE
	05/30/2024	07/01/2024

	DESCRIPTION	AMOUNT
Commercial Cabinets	Melamine Cabinets For 1st Grade Class Room, With Laminate Finish, 3 Mill Edge Banding On All Doors And Drawers. All Cabinets And Countertops For 2-Right And 2-Left Hand Units	23,600.00
Hardware	Stock Knobs	128.00
Installation	Installation and Delivery	1,120.00
	TOTAL	<b>\$24,848.00</b>

Accepted By

Accepted Date



## Fwd: Quote

1 message

**Kelli Hauldren** <hauldrenk@wcde.org>  
To: Jarrod ADAMS <adamsj@wcde.org>

Wed, Jun 5, 2024 at 5:42 AM



**Kelli Hauldren, M.Ed.**  
CTE Supervisor, Washington County Schools

423-753-1100 | [www.wcde.org](http://www.wcde.org) | [hauldrenk@wcde.org](mailto:hauldrenk@wcde.org)  
405 W College Street Jonesborough, TN 37659

Create your WiseStamp [email signature](#)

----- Forwarded message -----

From: **Appalachian Cabinets, LLC** <[appalachiancabinets@gmail.com](mailto:appalachiancabinets@gmail.com)>  
Date: Wed, May 8, 2024 at 10:11 AM  
Subject: Re: Quote  
To: Kelli Hauldren <[hauldrenk@wcde.org](mailto:hauldrenk@wcde.org)>

Thank you for letting us know.

On Wed, May 8, 2024 at 10:10 AM Kelli Hauldren <[hauldrenk@wcde.org](mailto:hauldrenk@wcde.org)> wrote:  
Jacob and Shelly,

Thanks for getting back to us quickly about cabinets for Daniel Boone High School. I have spoken with our Chief Operations Officer and Washington County Schools is not able to pay until a job is complete. I understand this does not work with your company policy. I appreciate your responsiveness to our request. Thanks so much for your time. I hope you all have a great week!

Thanks,

--



**Kelli Hauldren, M.Ed.**  
CTE Supervisor, Washington County Schools

423-753-1100 | [www.wcde.org](http://www.wcde.org) | [hauldrenk@wcde.org](mailto:hauldrenk@wcde.org)  
405 W College Street Jonesborough, TN 37659

Create your WiseStamp [email signature](#)

<b>REQ DATE</b>
<b>07/11/2024</b>

## Washington County Schools Nutrition

405 West College Street  
 Jonesborough, TN 37659  
 423-753-1107  
 nutrition@wcde.org

<b>REQUISITION NUMBER</b>
<b>1430250016</b>

VENDOR KEY : DOUGLAS 000  
 SHIP DATE : 07/11/2024  
 FISCAL YEAR : 2024-2025  
 ENTERED BY : RAINSPAU001

PRINTED 08/01/2024

**VENDOR:**  
 DOUGLAS EQUIPMENT  
 301 NORTH STREET  
 BLUEFIELD, WV 24701

**SHIP TO:**  
 Washington County Schools - Food Service  
 405 W COLLEGE ST  
 JONESBOROUGH, TN 37659

ATTN: PAULETTE RAINS

QUANTITY	UNIT	DESCRIPTION OF ITEMS OR MATERIALS	UNIT PRICE	AMOUNT
1		hot pass thru for lamar	13914.23000	13,914.23
ACCOUNT SUMMARY (FOR INTERNAL USE)				
		ACCOUNT NUMBER	ACCOUNT AMOUNT	
		143 E 73100 710 000 00041 000	13,914.23	
			<b>PAGE TOTAL</b>	13,914.23
			<b>TOTAL</b>	13,914.23

This is a Requisition and not an official Purchase Order.  
 The District is not financially responsible for the  
 unauthorized purchases made with a Requisition.

# DOUGLAS EQUIPMENT

Restaurant & Food Store  
Equipment

# Quote

05/09/2024

**Project:**  
#55642 Washington County  
Schools, TN

**From:**  
Douglas Equipment  
Corey Mann  
301 North St.  
Bluefield, WV 24701-4048  
304-327-0149

Job Reference Number: 27832

\*\*\*PLEASE ADD 3% FOR CREDIT CARD PURCHASES\*\*\*  
 \*\*\*INCLUDES DROP SHIPPING UNLESS NOTED  
 OTHERWISE\*\*\*  
 \*\*\*NET 30 ON CASH OR CHECK PURCHASES\*\*\*  
 \*\*\*DOES NOT INCLUDE STATE SALES TAX WHERE  
 APPLICABLE\*\*\*  
 \*\*\*PLEASE ADD 125.00 IF LIFTGATE IS REQUIRED\*\*\*  
 \*\*\*SHIPPING INCLUDED\*\*\*  
 \*\*\*<OPTIONAL> ITEMS ARE NOT INCLUDED IN THE PRICE  
 ADD THE AMOUNT IN THE LEFT COLUMN FOR ACCURATE  
 PRICING\*\*\*

Item	Qty	Description	Sell	Sell Total
1	1 ea	<b>PASS-THRU HEATED CABINET</b>  Traulsen Model No. AHF132WP-HHG Spec-Line Heated Cabinet, Pass-thru, one-section, stainless steel exterior, aluminum interior, standard depth cabinet, half-height glass doors, with EZ-Clean Gaskets, (3) clear coated adjustable shelves per section, microprocessor controls, 6' adjustable stainless steel legs, NSF, UL	\$13,914.23	\$13,914.23
	1 ea	6-year parts & labor, standard. Visit <a href="http://www.traulsen.com">www.traulsen.com</a> for details		
	1 ea	208/115v/60/1-ph, 7.8 amps, standard		
	1 ea	Thermometer side door: hinged on right, standard		
	1 ea	Rear door hinged on left		
	10 ea	Universal tray slide - per pair		
	1 ea	Credit for standard coated shelf, deduct		

*Paulette Rains*

Item	Qty	Description	Sell	Sell Total
			ITEM TOTAL:	\$13,914.23
			Total	\$13,914.23

- PRICING VALID FOR 30 DAYS
  - PLEASE ADD 3% FOR CREDIT CARD PURCHASES
  - DOES NOT INCLUDE STATE SALES TAX WHERE APPLICABLE
  - SHIPPING INCLUDED BASED OFF OF THE QUANTITY AND LOCATION REQUESTED.
- IF ORDER REFLECTS A DIFFERENT QUANTITY OR LOCATION,  
PRICE IS SUBJECT TO CHANGE AT CUSTOMERS EXPENSE.*

Acceptance: \_\_\_\_\_ Date: \_\_\_\_\_

Printed Name: \_\_\_\_\_

Project Grand Total: \$13,914.23



Project \_\_\_\_\_  
 AIA # \_\_\_\_\_ SIS # \_\_\_\_\_  
 Item # \_\_\_\_\_ Quantity \_\_\_\_\_ C.S.I. Section 114000

SPEC LINE - R/A SERIES

## A-Series

Pass-Thru Heated Cabinet Model  
 32" Deep, Glass Door, W-Width

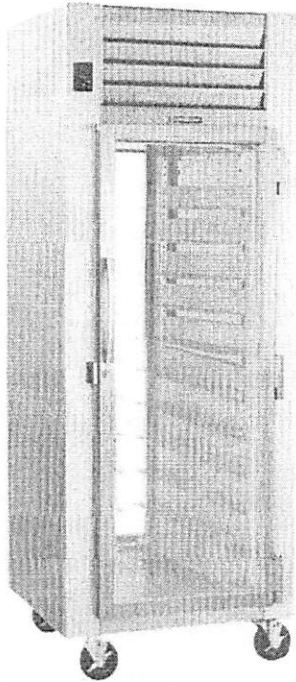

### STANDARD PRODUCT FEATURES

- Traulsen's Smart Control with LED Display
- Stainless Steel Exterior/Anodized Aluminum Interior
- Ducted Fan Air Distribution System
- Standard Operating Temperature Range 140-180°F
- ON/OFF Switch Located on Control Face
- Full or Half-Height Glass Door(s) with Locks
- Stainless Steel Vertical Door Handles
- Self-Closing Doors with Stay Open Feature at 120 Degrees
- Standard Door Hinging F & R: 132WP = Right (other hingings available)
- Automatically Activated LED Lights
- Stainless Steel Breaker Caps
- Three Adjustable, Coated Wire Shelves Per Section, Supported on Pilasters (factory installed)
- Magnetic Snap-In EZ-Clean Door Gasket(s)
- Stainless Steel One-Piece Louver Assembly - Front & Rear
- 9' Cord & Plug Attached
- Set of (4) 6" High Adjustable Stainless Steel Legs

### ACCESSORIES & OPTIONS

- #1 Type Trayslides to Accommodate either (1) 18" x 26" or (2) 14" x 18" Pans
- #4 Type Trayslides to Accommodate 18 to 19 Levels for 18" x 26" Pans
- Universal Type Trayslides to Accommodate Either (1) 18" x 26" or (2) 12" x 20" or (2) 14" x 18" Pans
- Additional Coated Wire or Optional Stainless Steel Shelves
- EZ-Change Interiors (#1, universals, universal heavy-duty trayslides & shelves)
- EZ-Open Foot Pedal (full height doors only)
- Locking Hasps (padlocks supplied by others)
- 115/60/1 or 208-230/60/1 Voltage
- Export 220/50/1 Voltage
- Kool Klad Exterior Laminate Decor
- Set of (4) 4 1/8" or 6" High Casters in Lieu of Legs
- Other Support Options: 4 1/2" High Base or 6" High Kickplate (for use with standard legs)
- Fluorescent Lights
- Prison/Correctional Facility Options



Intertek



This unit is listed to the applicable UL, CSA and NSF Standards by an approved NRTL. Consult the factory or unit's data plate for approval information.

### AVAILABLE CONFIGURATIONS

#### A-Series Models

AHF132WP-FHG  
 AHF132WP-HHG

#### Door(s)

Full Height Glass  
 Half Height Glass

**- GUARANTEED FOR LIFE CAM-LIFT HINGES**

Approved by \_\_\_\_\_ Date \_\_\_\_\_ Approved by \_\_\_\_\_ Date \_\_\_\_\_



# A-Series

Pass-Thru Heated Cabinet Model  
32" Deep, Glass Door, W-Width

MODEL  
AHF132WP-HHG

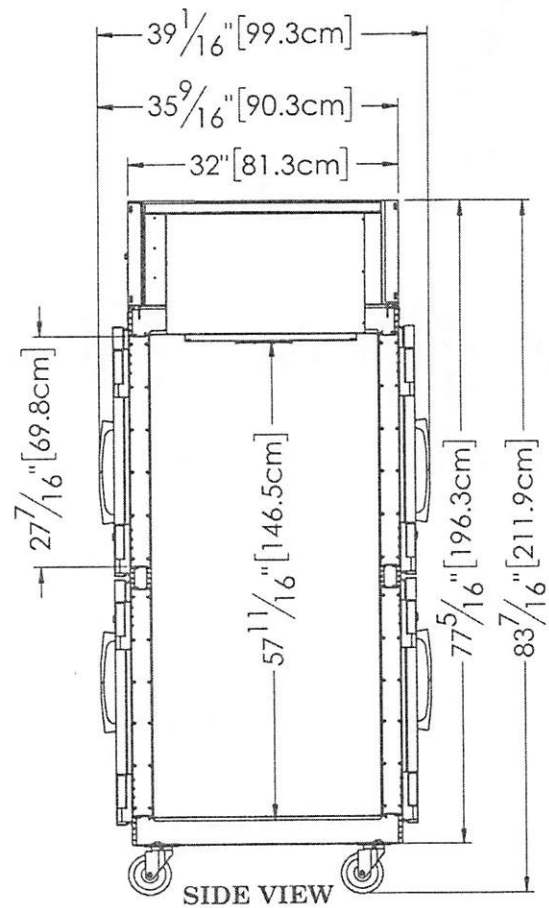
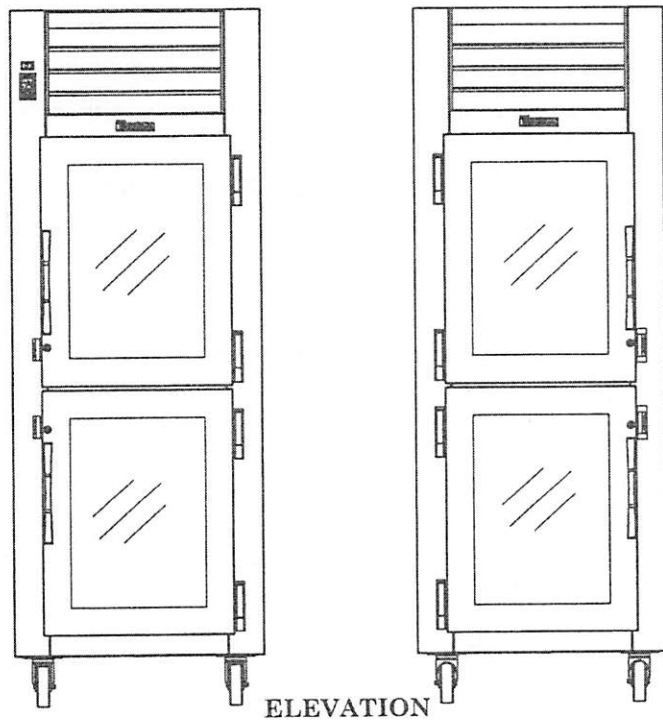
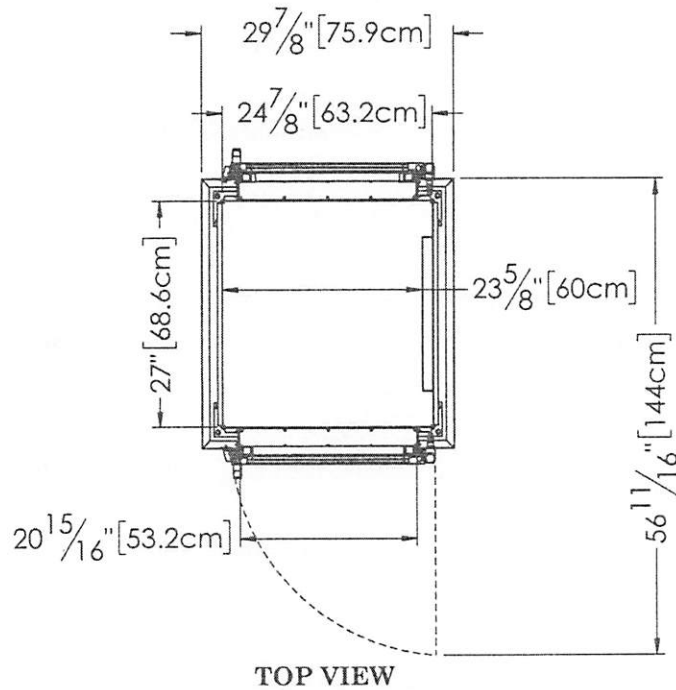

CAD and/or Revit Files Available

<https://traulsen.kclcad.com/>

R/A SERIES

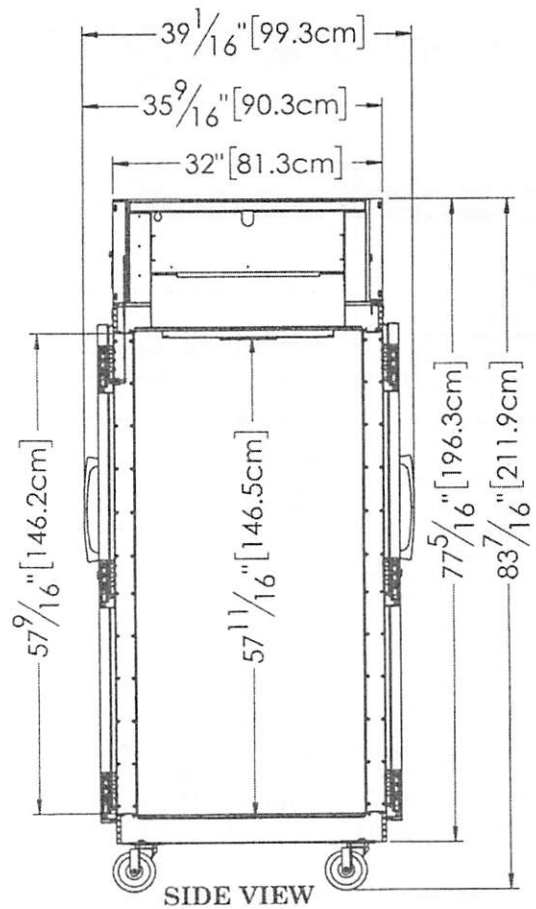
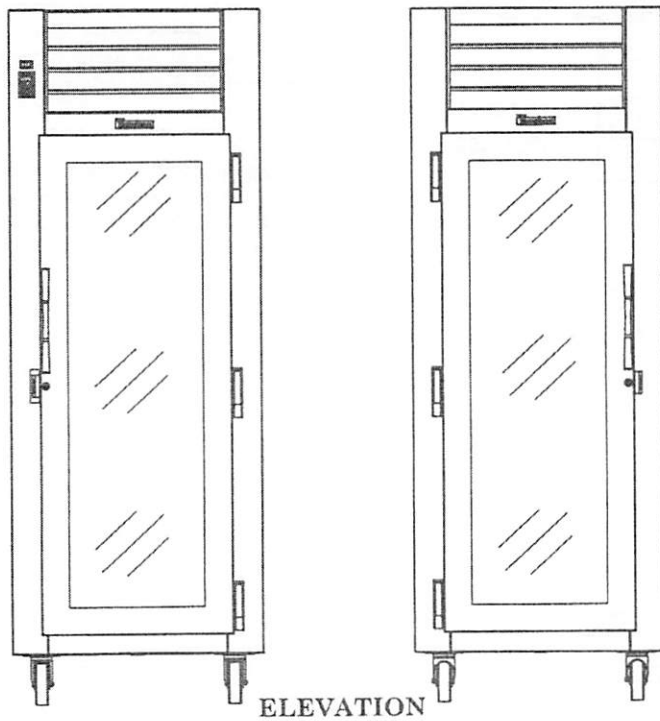
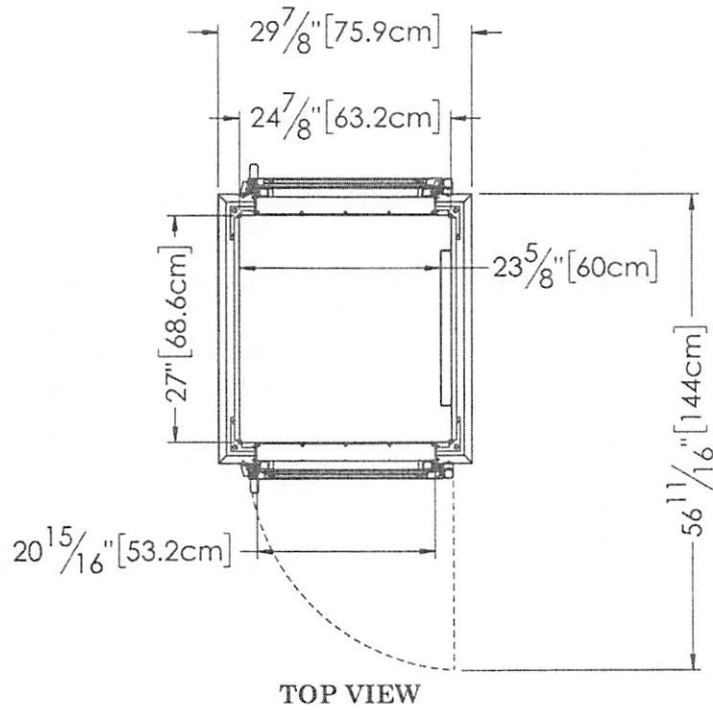

CAD and/or Revit Files Available

<https://traulsen.kclcad.com/>

## MODEL

AHF132WP-HHG  
AHF132WP-FHG

MODELS	AHF132WP
<b>DIMENSIONAL DATA</b>	
Net capacity cu. ft.	24.86 (704 cu l)
Length - overall in.	29 7/8" (75.9 cm)
Depth - overall in.	39 1/16" (99.3 cm)
Depth - over body in.	32" (81.3 cm)
Depth - door open 90° in.	56 1/16" (144 cm)
Clear door width in. <sup>1</sup>	20 15/16" (53.2 cm)
Clear half-door height in.	27 7/16" (69.8 cm)
Clear full-door height in.	57 9/16" (146.2 cm)
Height - overall on 6" legs	83 7/16" (211.9 cm)
No. Standard Shelves	3
Shelf area sq. ft. <sup>2</sup>	13.46 (1.25 sq. m)
<b>ELECTRICAL DATA</b>	
Voltage <sup>3</sup>   Plug	208-230/115/60/1   NEMA L14-20P or NEMA 5-20P
Wattage @ 208V	2000
Full Load Amperes	8.2
<b>SHIPPING DATA</b>	
Length - Crated in.	48" (121.9 cm)
Depth - Crated in.	42" (106.7 cm)
Height - Crated in.	85" (215.9 cm)
Volume - Crated cu. ft.	99.17 (2808.2 cu l)
Weight - Crated lbs.	429 (194.6 kg)

**NOTES:** Figures in parentheses reflect metric equivalents.

- Please note that the available cabinet width narrows for 5 7/8" from the top of the door frame to 20 15/16" in order to allow for the heater fans.
- Area of standard shelf compliment only, does not include storage area of additional shelves or available on cabinet bottom.
- Heater is capable of operation from 208V to 230V as supplied standard. Actual amp figure will change at any voltage other than 208V.

When ordering please specify: Voltage, Hinging, and Options

Equipped with one NEMA L14-20P Plug  
(1 section models @ 208V only)



Equipped with one NEMA 5-20P Plug  
(1 section models @ 115V only)



## EQUIPMENT SPECIFICATIONS

### CONSTRUCTION, HARDWARE, INSULATION

The cabinet exterior front, one piece sides & louver assembly are made from heavy-gauge stainless steel. The interior is constructed of anodized aluminum. The exterior top & bottom are made from heavy-gauge galvanized steel. Included is a set of four adjustable 6" stainless steel legs.

Doors have a gasket-protecting metal door pan, removable plug cylinder locks & guaranteed for life gravity action, self-closing glide hinges that stay open at 120 degrees. An external switch is included to activate interior LED lighting. The gasket design simplifies cleaning & enhances longevity. Anti-condensate heaters are located behind each door opening. The unit has seamless, polished metal corners & vertical stainless steel handles. The cabinet is insulated with high density, non-CFC, foamed in place polyurethane.

### HEATING SYSTEM

The unit uses a low watt density, serpentine-style heater. Low velocity air is forced evenly across its large surface area to move heat through a down-air distribution duct without drying product. A vent is included at the top of the cabinet for positive humidity control. A 9' cord & plug are provided.

### CONTROL

Traulsen's Smart Control features advanced control algorithms & sophisticated diagnostic capabilities to optimize performance. Utilizing Smart Sensors, it adapts the operation of the heating system to a variety of environments & usage patterns. The Smart Control also offers a complete set of visual alarms designed to alert the user to critical events such as power outages or a prolonged door opening. In the event of an alarm, a dedicated Alarm LED will illuminate, informing the user of the critical event and duration.

### INTERIOR

The interior includes three factory installed pilaster-mounted, full-width coated wire shelves per section with no large gaps. Each shelf can support up to 225 lbs. Factory installed optional trayslides may be purchased in combination with, or in lieu of these.

### WARRANTY

6-Year Parts & Labor Warranty

CONTINUED PRODUCT DEVELOPMENT MAY NECESSITATE SPECIFICATION CHANGES WITHOUT NOTICE.



# Quote

05/08/2024

**Project:**  
 Washington Co- Lamar School Traulsen  
 Lamar School  
 3261 Hwy 81 South  
 Jonesborough, TN 37659

**From:**  
 Strategic Equipment, LLC  
 Heidi Keller  
 3011 Industrial Parkway East  
 Knoxville, TN 37921  
 (865)545-5222 (contact)  
 (865)522-4448 (Fax)

Thank you for allowing TriMark the opportunity to provide pricing. Please be aware in this very unstable market; manufacturers are experiencing delays, pricing increases and additional freight surcharges and storage fees. *As such, quotes will remain in effect for 30 days.* TriMark reserves the right to make any corrections or adjustments due to cost increases, market fluctuations, supply chain disruptions, tariffs, third party supplier changes in cost, general contractor delays, or any other factors outside of TriMark's control at any time prior to delivery. We apologize for the inconvenience.

For all custom fabricated equipment, exhaust hoods, walk-in coolers/freezers, and all items requiring owner selections of colors or laminate finishes, these prices are current estimates. We will re-quote those items based on the manufacturers' prices in effect at the time when field measurements can be taken and/or color/laminate selections are made by the owner. This policy also applies to all items of standard manufacture that cannot be shipped immediately upon fabrication to an owner's or general contractor's facility.

Item	Qty	Description
1	1 ea	<b>PASS-THRU HEATED CABINET</b> Model No. AHF132WP-HHG Spec-Line Heated Cabinet, Pass-thru, one-section, stainless steel exterior, aluminum interior, standard depth cabinet, half-height glass doors, with EZ-Clean Gaskets, (3) clear coated adjustable shelves per section, microprocessor controls, 6' adjustable stainless steel legs, NSF, UL
	1 ea	6-year parts & labor, standard. Visit <a href="http://www.traulsen.com">www.traulsen.com</a> for details
	1 ea	208/115v/60/1-ph, 7.8 amps, standard
	1 ea	Thermometer side door: hinged on right, standard
	1 ea	Rear door hinged on left
	10 ea	Universal tray slide - per pair
	1 ea	Credit for standard coated shelf, deduct
	1 ea	<b>INSTALLATION</b> Deliver, uncrate, set in place. Remove and dispose of old Pass Thru REUSE trim Plug in and make sure unit is working

**ITEM TOTAL:**

Total

**Sales Quote**

**Sales Quote Number: 624645**

Page: 1

**KaTom Restaurant Supply, Inc.**  
**305 Katom Dr.**  
**KODAK, TN 37764**

<b>Sales Quote Date:</b> 5/8/2024	<b>Due Date:</b> 5/23/2024	<b>Ship Date:</b> 5/8/2024
<b>Customer ID:</b> 12768	<b>Contact:</b> Caitlin Shew	<b>SalesPerson:</b> Christian Clark
<b>Cust. Phone:</b> (423) 753-1107	<b>Cust. Fax:</b> (423) 753-1111	<b>Quote Expires:</b>
kitec@wcde.org		

**Sell**  
**To:** Washington County School  
 Caitlin Shew  
 School Food Service  
 405 W College Street  
 JONESBOROUGH, TN 37659  
 USA

**Ship**  
**To:** Washington County School  
 Caitlin Shew  
 School Food Service  
 405 W College Street  
 JONESBOROUGH, TN 37659  
 USA

<b>Terms</b> NET 15	<b>Ext Doc No.</b>	<b>Your Reference</b>	<b>Ship Via</b>	<b>Loc Code</b> KODAK	<b>Loc Phone</b>	<b>Loc Fax</b>
------------------------	--------------------	-----------------------	-----------------	--------------------------	------------------	----------------

<u>Blueprint No.</u>	<u>Number</u>	<u>Description</u>	<u>Quantity</u>	<u>Unit</u>	<u>Unit Price</u>	<u>Total Price</u>
	206-AHF132WPHHG208	CABINET HEAT PASS GLASS 208V Must Ship LTL Free Shipping to Customer	1	EA	14,204.36	14,204.36

**Website: katom.com      Phone: (800) 541-8683      Fax: (800) 821-9130**

This office will follow up with you within 24 hours to ensure you received this quotation. Quotation must be signed below to be official.

**Submitted by:** \_\_\_\_\_ **Accepted by:** \_\_\_\_\_

Subtotal: 14204.36  
 S, H, & I: 0  
 Total Sales Tax: 0  
 Total: 14204.36

Federal and/or State tax laws may apply at the time of invoicing.

**BY PLACING YOUR ORDER, YOU ACKNOWLEDGE AND AGREE THAT YOU HAVE READ AND AGREE TO BE BOUND BY KATOM'S POLICIES AND PROCEDURES STANDARD TERMS AND CONDITIONS, POLICIES AND PROCEDURES, INCLUDING BUT NOT LIMITED TO THE KATOM PRIVACY POLICY, RETURN POLICY, SHIPPING POLICY, AND TERMS AND CONDITIONS (WHICH INCLUDE DISCLAIMERS AND LIMITATIONS OF KATOM'S LIABILITY, AS WELL AS A PROVISION WHEREBY YOU AGREE TO ARBITRATE ALL DISPUTES), LOCATED AT WWW.KATOM.COM/POLICY (COLLECTIVELY, THE "TERMS"). PLEASE CALL 1-800-541-8683 TO OBTAIN A PHYSICAL OR E-MAIL COPY OF THE TERMS. THE TERMS ARE ALSO AVAILABLE BY SCANNING THE QR CODE IN THE BOTTOM RIGHTHAND CORNER OF THIS QUOTE WITH THE CAMERA OF YOUR MOBILE DEVICE. IF YOU DO NOT AGREE TO BE BOUND BY ALL PROVISIONS OF THE TERMS, YOU MUST NOTIFY KATOM WITHIN TEN (10) DAYS OF RECEIPT OF THIS QUOTE AND IMMEDIATELY REJECT AND RETURN ALL GOODS TO KATOM. YOUR USE OF THE GOODS, OR YOUR FAILURE TO REJECT AND RETURN THE GOODS TO KATOM WITHIN TEN (10) DAYS, SHALL CONSTITUTE ACCEPTANCE OF ALL TERMS.**





# Quote

05/08/2024

**Project:**  
**Washington Co- Lamar School Traulsen**  
**Lamar School**  
**3261 Hwy 81 South**  
**Jonesborough, TN 37659**

**From:**  
**Strategic Equipment, LLC**  
**Heidi Keller**  
**3011 Industrial Parkway East**  
**Knoxville, TN 37921**  
**(865)545-5222 (contact)**  
**(865)522-4448 (Fax)**

Thank you for allowing TriMark the opportunity to provide pricing. Please be aware in this very unstable market; manufacturers are experiencing delays, pricing increases and additional freight surcharges and storage fees. ***As such, quotes will remain in effect for 30 days.*** TriMark reserves the right to make any corrections or adjustments due to cost increases, market fluctuations, supply chain disruptions, tariffs, third party supplier changes in cost, general contractor delays, or any other factors outside of TriMark's control at any time prior to delivery. We apologize for the inconvenience.

For all custom fabricated equipment, exhaust hoods, walk-in coolers/freezers, and all items requiring owner selections of colors or laminate finishes, these prices are current estimates. We will re-quote those items based on the manufacturers' prices in effect at the time when field measurements can be taken and/or color/laminate selections are made by the owner. This policy also applies to all items of standard manufacture that cannot be shipped immediately upon fabrication to an owner's or general contractor's facility.

Item	Qty	Description	
1	1 ea	<b>PASS-THRU HEATED CABINET</b> Model No. AHF132WP-HHG Spec-Line Heated Cabinet, Pass-thru, one-section, stainless steel exterior, aluminum interior, standard depth cabinet, half-height glass doors, with EZ-Clean Gaskets, (3) clear coated adjustable shelves per section, microprocessor controls, 6' adjustable stainless steel legs, NSF, UL	
	1 ea	6-year parts & labor, standard. Visit <a href="http://www.traulsen.com">www.traulsen.com</a> for details	
	1 ea	208/115v/60/1-ph, 7.8 amps, standard	
	1 ea	Thermometer side door: hinged on right, standard	
	1 ea	Rear door hinged on left	
	10 ea	Universal tray slide - per pair	
	1 ea	Credit for standard coated shelf, deduct	
	1 ea	INSTALLATION Deliver, uncrate, set in place. Remove and dispose of old Pass Thru REUSE trim Plug in and make sure unit is working	
			<b>ITEM TOTAL: \$16,732.20</b>
			<b>Total \$16,732.20</b>



Conditions-of-Sale.pdf . which are incorporated herein by reference and shall govern. The parties specifically agree that no signature shall be required in order for this Quote or its applicable terms and conditions to be deemed legally binding and enforceable on Customer where the intent to be so bound can be inferred (including by acceptance or retention of products or services), notwithstanding contrary requirements under any law.

**Any tax or similar fees shown in this Quote are an estimate only.**

Florida Refrigeration License # CAC1821900

Austin	Beaumont	Houston	Lewisville
TACLB52729R	TACLA35912C	TACLA108388C	TACLB16860C

Regulated by the Texas Department of Licensing and Regulation, P.O. BOX 12157,  
Austin, Texas, 1-800-803-9202. [www.tdlr.texas.gov](http://www.tdlr.texas.gov)

I understand, agree to and accept the above terms and conditions.

<i>REQ DATE</i>
<b>07/18/2024</b>

## Washington County Schools Nutrition

405 West College Street  
 Jonesborough, TN 37659  
 423-753-1107  
 nutrition@wcde.org

<i>REQUISITION NUMBER</i>
<b>1430250021</b>

VENDOR KEY : NETCO 000  
 SHIP DATE : 07/18/2024  
 FISCAL YEAR : 2024-2025  
 ENTERED BY : HARTGCHL000

PRINTED 08/01/2024

VENDOR:  
 NETCO  
 100 E MAPLE ST  
 JOHNSON CITY, TN 37601

SHIP TO:  
 Washington County Schools - Food Service  
 405 W COLLEGE ST  
 JONESBOROUGH, TN 37659

ATTN: CHLOE HARTGROVE

QUANTITY	UNIT	DESCRIPTION OF ITEMS OR MATERIALS	UNIT PRICE	AMOUNT
1		BLANKET PO NETCO 24-25 SY	204521.35000	204,521.35
		ACCOUNT SUMMARY (FOR INTERNAL USE)		
		ACCOUNT NUMBER	ACCOUNT AMOUNT	
		143 E 73100 399 000 00000 000	204,521.35	
			<b>PAGE TOTAL</b>	204,521.35
			<b>TOTAL</b>	204,521.35

This is a Requisition and not an official Purchase Order.  
 The District is not financially responsible for the  
 unauthorized purchases made with a Requisition.

<i>REQ DATE</i>
<b>07/18/2024</b>

## Washington County Schools Nutrition

405 West College Street  
 Jonesborough, TN 37659  
 423-753-1107  
 nutrition@wcde.org

<i>REQUISITION NUMBER</i>
<b>1430250020</b>

VENDOR KEY : NETCO 000  
 SHIP DATE : 07/18/2024  
 FISCAL YEAR : 2024-2025  
 ENTERED BY : HARTGCHL000

PRINTED 08/01/2024

VENDOR:  
 NETCO  
 100 E MAPLE ST  
 JOHNSON CITY, TN 37601

SHIP TO:  
 Washington County Schools - Food Service  
 405 W COLLEGE ST  
 JONESBOROUGH, TN 37659

ATTN: CHLOE HARTGROVE

QUANTITY	UNIT	DESCRIPTION OF ITEMS OR MATERIALS	UNIT PRICE	AMOUNT
1		NETCO CD FEE FOR 24-25	13817.43000	13,817.43
		ACCOUNT SUMMARY (FOR INTERNAL USE)		
		ACCOUNT NUMBER	ACCOUNT AMOUNT	
		143 E 73100 399 000 00000 000	13,817.43	
			<b>PAGE TOTAL</b>	<b>13,817.43</b>
			<b>TOTAL</b>	<b>13,817.43</b>

This is a Requisition and not an official Purchase Order.  
 The District is not financially responsible for the  
 unauthorized purchases made with a Requisition.

**PURCHASING DEPARTMENT**  
**WASHINGTON COUNTY BOARD OF EDUCATION**

Purchase Order **Nº 2682**  
 Date Issued **08-05-24**  
 Appropriation No. **71100499-0017**  
 Dept. **Instruction**  
 School **University**

**PURCHASE ORDER**

**TO**  
*The College Board*  
*New York NY 10087*

Deliver to *University School*  
 Address *Johnson City TN 37614*  
 Via

**NOTICE TO VENDOR**  
 1. Purchase order **MUST** bear two signatures in order to be valid.  
 2. Purchase order number **MUST** appear on all invoices submitted for payment.  
 3. Mail **TWO** copies of your invoice promptly to:  
**Washington County Board of Education**  
**405 West College Street**  
**Jonesborough, TN 37659**  
**Telephone (423) 753-1105**

Articles on this order must be charged to account of

ARTICLES OR SERVICES	CODE	QUANTITY & UNIT	UNIT PRICE	TOTAL
(Unless otherwise stated all prices F.O.B. Destination)				
<i>AP Exams and Fees</i>				
<b>GRAND TOTAL - INCLUDING ALL ATTACHED PAGES</b>				<b>\$ 23,769.00</b>

**SUBJECT TO THE FOLLOWING CONDITIONS**

1. All packages, cartons or other containers must be plainly marked with the purchase order number.
  2. The right is reserved to purchase in the open market and to charge the difference to the Vendor in the event that deliveries are not made at the time specified in the bid and on this order.
  3. Whenever a delivery is rejected, the Vendor shall be notified and be given the reason for the rejection. All rejected deliveries shall be held at the Vendor's risk and he shall bear the expense of removal.
  4. Acceptance of this order includes acceptance of all terms, prices, delivery, instructions, specifications and conditions stated.
  5. The county is not liable for Federal excise tax or state sales tax.
  6. Each shipment and/or each purchase order should be covered by separate invoice.
- IMPORTANT: INVOICES AND PACKAGES MUST BEAR PURCHASE ORDER NUMBER**

<b>VENDOR'S COPY</b>	There is an otherwise unincumbered balance to the credit of the proper appropriation, allotment or fund to meet the expenditure covered by this purchase.	APPROVED:
	_____ Authorized Signature	_____ Purchasing Agent



Customer Number 125447  
 AI Code 431000  
 Invoice # A251254471  
 Date 05/23/2024  
 Terms Upon Receipt  
 PO Number  
 Admin Year AP2024

141E 71100-499 - 00017

**Bill To**  
 University School  
 68 Martha Culp Dr  
 Johnson City, TN 37614  
 United States of America  
  
 ATTN: Heidi Campbell  
 Email: campbellhe@etsu.edu

DESCRIPTION	QUANTITY	UNIT PRICE	AMOUNT
Used AP Examinations	277	\$89.00	\$24,653.00
Used AP Capstone Examinations	14	\$137.00	\$1,918.00
AP Unused Examination or Cancellation Fee	6	\$40.00	\$240.00
AP College Board Fee Reduction - Capstone	3	-\$36.00	-\$108.00
AP College Board Fee Reduction - Non-Capstone	36	-\$36.00	-\$1,296.00
TN subsidy for fee-reduced students (Capstone)	3	-\$30.00	-\$90.00
TN subsidy for fee-reduced students	36	-\$30.00	-\$1,080.00
Niswonger Subsidy for Full Priced Students for Standard Exams	5	-\$89.00	-\$445.00
Niswonger Subsidy for Fee Reduced Priced Students for Standard Exams	1	-\$23.00	-\$23.00
<b>SUB-TOTAL</b>			<b>\$23,769.00</b>
<b>SHIPPING &amp; HANDLING</b>			<b>\$0.00</b>
<b>TAX</b>			<b>\$0.00</b>
<b>NET TOTAL</b>			<b>\$23,769.00</b>
<b>CREDITS</b>			<b>\$0.00</b>
<b>PAYMENTS</b>			<b>\$0.00</b>
<b>CURRENT NET BALANCE</b>			<b>\$23,769.00</b>

Customer Number: 125447      Invoice # A251254471      Invoice Total: \$23,769.00

You must reference your invoice number when submitting the payment.  
 Checks should be payable to "College Board" and made payable in US dollars drawn on a US Bank.

College Board  
 P.O. Box 30171  
 New York, NY 10087-0171  
 Federal Tax ID: 13-1623965

<b>Balance Due:</b>	<b>\$23,769.00</b>
---------------------	--------------------

Please make checks payable to "College Board"  
 For questions, contact Customer Service at:  
 Phone: 877-274-6474 Email: apexams@info.collegeboard.org

## Brad Hale

---

**From:** Honeycutt, Dustin G. <HONEYCUTTDG@mail.etsu.edu> on behalf of Honeycutt, Dustin G.  
**Sent:** Monday, June 10, 2024 12:15 PM  
**To:** Brad Hale  
**Subject:** [EXTERNAL] Your 2024 AP Exam Invoice is attached  
**Attachments:** 431000\_125447\_1063\_A251254471\_05232024.pdf

Brad,

I hope you had a great weekend!

Just making sure this is going to be paid from WCDE?

Thanks!

Dustin

---

**From:** Brad Hale <haleb@wcde.org>  
**Sent:** Thursday, May 30, 2024 12:20 PM  
**To:** Paul MASTERS <mastersp@wcde.org>; Honeycutt, Dustin G. <HONEYCUTTDG@mail.etsu.edu>  
**Subject:** FW: [EXTERNAL] Your 2024 AP Exam Invoice is attached

Dustin,

If we took care of this last year then yes we should take care of this again this year unless there was some type of one-year agreement to pay.

Paul,

See where this was paid for last year.

**W. Brad Hale, MBA**  
*Chief Financial Officer*  
*Washington County Department of Education*  
(W) 423-753-1105  
(F) 423-753-1114

---

**From:** Honeycutt, Dustin G. [mailto:[HONEYCUTTDG@mail.etsu.edu](mailto:HONEYCUTTDG@mail.etsu.edu)]  
**Sent:** Thursday, May 30, 2024 10:49 AM  
**To:** Brad Hale <haleb@wcde.org>  
**Subject:** FW: [EXTERNAL] Your 2024 AP Exam Invoice is attached

Brad,

I hope you are doing well today! Last year WCDE took care of this invoice for us, will WCDE be paying this for us this year?

Thanks!

Dustin Honeycutt  
University School  
423-439-8431

---

**From:** Campbell, Heidi E <[CAMPBELLHE@mail.etsu.edu](mailto:CAMPBELLHE@mail.etsu.edu)>  
**Sent:** Friday, May 24, 2024 9:40 AM  
**To:** Honeycutt, Dustin G. <[HONEYCUTTDG@mail.etsu.edu](mailto:HONEYCUTTDG@mail.etsu.edu)>  
**Subject:** FW: [EXTERNAL] Your 2024 AP Exam Invoice is attached

---

**From:** [noreply@corpsys.collegeboard.org](mailto:noreply@corpsys.collegeboard.org) <[noreply@corpsys.collegeboard.org](mailto:noreply@corpsys.collegeboard.org)>  
**Sent:** Friday, May 24, 2024 9:06 AM  
**To:** Campbell, Heidi E <[CAMPBELLHE@mail.etsu.edu](mailto:CAMPBELLHE@mail.etsu.edu)>  
**Subject:** [EXTERNAL] Your 2024 AP Exam Invoice is attached

Dear Customer,

Your 2024 AP Exam invoice is attached. Please review and submit payment by June 15, 2024, following the instructions included on the invoice. *Note: Payment must be made in U.S. dollars and drawn on a U.S. bank.*

To view your account details, go to the Packing List and Invoice page in AP Registration and Ordering, ([myap.collegeboard.org](http://myap.collegeboard.org)). Please note the packing list will only be stored for 120 days.

If you have any questions regarding your bill, please contact AP Services for Educators at 877-274-6474 or via the contact form: [cb.org/apeducatorinquiry](http://cb.org/apeducatorinquiry).

Accounts Receivable  
College Board  
11955 Democracy Drive 20190

Attachment: 431000\_125447\_1063\_A251254471\_05232024.pdf

*The [EXTERNAL] tag in the subject line identifies emails that do NOT originate from an ETSU person or service. Please exercise caution when handling emails from external sources. Any email that is unsolicited and requires you to take immediate action, appears to be forged or is PHISHING for information can be verified by emailing the ITS Help Desk.*

**PURCHASING DEPARTMENT**  
**WASHINGTON COUNTY BOARD OF EDUCATION**

Purchase Order **No 3397** WBH  
 Date Issued **8/8/24** <sup>72130-322</sup>  
 Appropriation No. **METHODS**  
 Dept. **Academics**  
 School **DBHS**

**PURCHASE ORDER**

**TO**  
**College Board**  
 Deliver to **Panici Boone High School**  
 Address **1440 Suncrest Dr**  
 Via **Johnson City, TN 37615**  
 Articles on this order must be charged to account of

**NOTICE TO VENDOR**

1. Purchase order **MUST** bear two signatures in order to be valid.
2. Purchase order number **MUST** appear on all invoices submitted for payment.
3. Mail **TWO** copies of your invoice promptly to:

**Washington County Board of Education**  
 405 West College Street  
 Jonesborough, TN 37659  
 Telephone (423) 753-1105

ARTICLES OR SERVICES <small>(Unless otherwise stated all prices F.O.B. Destination)</small>	CODE	QUANTITY & UNIT	UNIT PRICE	TOTAL
Used AP Exams		241	\$89	\$21,440
AP unused Exams or cancel. Fee		25	\$40	\$1,000
<b>GRAND TOTAL - INCLUDING ALL ATTACHED PAGES</b>				<b>\$22,440</b>

**SUBJECT TO THE FOLLOWING CONDITIONS**

1. All packages, cartons or other containers must be plainly marked with the purchase order number.
2. The right is reserved to purchase in the open market and to charge the difference to the Vendor in the event that deliveries are not made at the time specified in the bid and on this order.
3. Whenever a delivery is rejected, the Vendor shall be notified and be given the reason for the rejection. All rejected deliveries shall be held at the Vendor's risk and he shall bear the expense of removal.
4. Acceptance of this order includes acceptance of all terms, prices, delivery, instructions, specifications and conditions stated.
5. The county is not liable for Federal excise tax or state sales tax.
6. Each shipment and/or each purchase order should be covered by separate invoice.

**IMPORTANT: INVOICES AND PACKAGES MUST BEAR PURCHASE ORDER NUMBER**

VENDOR'S

There is an otherwise unincumbered balance to the credit of the proper appropriation, allotment or fund to meet the expenditure covered by this purchase.

**APPROVED:**



Customer Number 125450  
 AI Code 431015  
 Invoice # A251254501  
 Date 05/27/2024  
 Terms Upon Receipt  
 PO Number  
 Admin Year AP2024

**Bill To**

Daniel Boone High School  
 1440 Suncrest Dr  
 Johnson City, TN 37615  
 United States of America

ATTN: McKenzi Ferguson  
 Email: fergusonm@wcde.org

DESCRIPTION	QUANTITY	UNIT PRICE	AMOUNT
Used AP Examinations	241	\$89.00	\$21,449.00
AP Unused Examination or Cancellation Fee	25	\$40.00	\$1,000.00
<b>SUB-TOTAL</b>			<b>\$22,449.00</b>
<b>SHIPPING &amp; HANDLING</b>			<b>\$0.00</b>
<b>TAX</b>			<b>\$0.00</b>
<b>NET TOTAL</b>			<b>\$22,449.00</b>
<b>CREDITS</b>			<b>\$0.00</b>
<b>PAYMENTS</b>			<b>\$0.00</b>
<b>CURRENT NET BALANCE</b>			<b>\$22,449.00</b>

PURCHASE CONTROL STAMP  
 WASHINGTON COUNTY BOARD OF EDUCATION

Received By: Al Woodard Date: 8/8/24

Approved for Payment By: [Signature]

Date Approved: 8/8/24

Fund Charged: 141 E 71100449

Customer Number: 125450

Invoice # A251254501

Invoice Total: \$22,449.00

You must reference your invoice number when submitting the payment.

Checks should be payable to "College Board" and made payable in US dollars drawn on a US Bank.

College Board  
 P.O. Box 30171  
 New York, NY 10087-0171  
 Federal Tax ID: 13-1623965

<b>Balance Due:</b>	<b>\$22,449.00</b>
---------------------	--------------------

Please make checks payable to "College Board"  
 For questions, contact Customer Service at:  
 Phone: 877-274-6474 Email: apexams@info.collegeboard.org



Customer Number 125450  
 AI Code 431015  
 Invoice # A251254501  
 Date 05/27/2024  
 Terms Upon Receipt  
 PO Number  
 Admin Year AP2024

<b>Bill To</b>
Daniel Boone High School 1440 Suncrest Dr Johnson City, TN 37615 United States of America
ATTN: McKenzi Ferguson Email: fergusonm@wcde.org

DESCRIPTION	QUANTITY	UNIT PRICE	AMOUNT
Used AP Examinations	241	\$89.00	\$21,449.00
AP Unused Examination or Cancellation Fee	25	\$40.00	\$1,000.00
<b>SUB-TOTAL</b>			\$22,449.00
<b>SHIPPING &amp; HANDLING</b>			\$0.00
<b>TAX</b>			\$0.00
<b>NET TOTAL</b>			\$22,449.00
<b>CREDITS</b>			\$0.00
<b>PAYMENTS</b>			\$0.00
<b>CURRENT NET BALANCE</b>			\$22,449.00

Customer Number: 125450

Invoice # A251254501

Invoice Total: \$22,449.00

You must reference your invoice number when submitting the payment.

Checks should be payable to "College Board" and made payable in US dollars drawn on a US Bank.

College Board  
 P.O. Box 30171  
 New York, NY 10087-0171  
 Federal Tax ID: 13-1623965

<b>Balance Due:</b>	<b>\$22,449.00</b>
---------------------	--------------------

Please make checks payable to "College Board"  
 For questions, contact Customer Service at:  
 Phone: 877-274-6474 Email: apexams@info.collegeboard.org





**PURCHASING DEPARTMENT**  
**WASHINGTON COUNTY BOARD OF EDUCATION**

**PURCHASE ORDER**

Purchase Order **№ 2321**  
 Date Issued **07-01-24**  
 Appropriation No. **72710729**  
 Dept. **TRANSPORTATION**  
 School

**TO**  
**MERCEDES-BENZ OF NASHVILLE**

**NOTICE TO VENDOR**

1. Purchase order **MUST** bear two signatures in order to be valid.
2. Purchase order number **MUST** appear on all invoices submitted for payment.
3. Mail **TWO** copies of your invoice promptly to:

**Washington County Board of Education**  
 405 West College Street  
 Jonesborough, TN 37659  
 Telephone (423) 753-1105

Deliver to **WASHINGTON COUNTY BOARD OF EDUCATION**  
 Address **405 WEST COLLEGE STREET**  
**JONESBOROUGH, TN 37659**  
 Via

Articles on this order must be charged to account of

ARTICLES OR SERVICES	CODE	QUANTITY & UNIT	UNIT PRICE	TOTAL
(Unless otherwise stated all prices F.O.B. Destination)				
<b>2023 MERCEDES-BENZ SPRINTER 2500</b>		<b>2</b>	<b>\$ 57,946.55</b>	
<b>* STATE CONTRACT # 80121 *</b>				
<b>GRAND TOTAL - INCLUDING ALL ATTACHED PAGES</b>				<b>\$ 115,843.10</b>

**SUBJECT TO THE FOLLOWING CONDITIONS**

1. All packages, cartons or other containers must be plainly marked with the purchase order number.
2. The right is reserved to purchase in the open market and to charge the difference to the Vendor in the event that deliveries are not made at the time specified in the bid and on this order.
3. Whenever a delivery is rejected, the Vendor shall be notified and be given the reason for the rejection. All rejected deliveries shall be held at the Vendor's risk and he shall bear the expense of removal.
4. Acceptance of this order includes acceptance of all terms, prices, delivery, instructions, specifications and conditions stated.
5. The county is not liable for Federal excise tax or state sales tax.
6. Each shipment and/or each purchase order should be covered by separate invoice.

**IMPORTANT: INVOICES AND PACKAGES MUST BEAR PURCHASE ORDER NUMBER**

<b>VENDOR'S COPY</b>	There is an otherwise unincumbered balance to the credit of the proper appropriation, allotment or fund to meet the expenditure covered by this purchase.	<b>APPROVED:</b>
	Authorized Signature	Purchasing Agent

# Mercedes-Benz of Nashville

Date: 10/18/2023  
 Salesperson: Pat Pointer  
 Manager: Kirt Kuhn

FOR INTERNAL USE ONLY

**BUSINESS NAME** WASHINGTON COUNTY SCHOOL DISTRICT 1 Home Phone: (423) 426-5473  
**CONTACT** \_\_\_\_\_

Address : JONESBOROUGH, TN 37659 Work Phone: \_\_\_\_\_  
WASHINGTON

E-Mail : robertst@wcde.org Cell Phone: (423) 753-1172

**VEHICLE**

Stock # : PT152347 New / Used : New VIN : W1Y40CHY4PT152347 Mileage: 6  
 Vehicle : 2023 Mercedes-Benz Sprinter 2500 Color : 29147/White  
 Type : High Roof 4-Cyl M2CA7G

**TRADE IN**

Payoff : \_\_\_\_\_ VIN : \_\_\_\_\_ Mileage: \_\_\_\_\_  
 Vehicle : \_\_\_\_\_ Color : \_\_\_\_\_  
 Type : \_\_\_\_\_

<b>Sonic Price</b>	<u>58,634.00</u>
Discount	<u>799.00</u>
Rebate	<u>1,000.00</u>
Adjusted Price	<u>56,835.00</u>
_____	_____
_____	_____
_____	_____
_____	_____
<b>Total Purchase</b>	<u>56,835.00</u>
<b>Fair Market Value</b>	_____
<b>Trade Difference</b>	_____
<b>Doc Fee</b>	<u>799.00</u>
<b>Tax</b>	<u>.00</u>
<b>Non Tax Fees</b>	<u>312.65</u>
<b>Net Price</b>	<u>57,946.65</u>
<b>Trade Payoff</b>	_____
<b>Cash Deposit</b>	<u>.00</u>
<b>Balance</b>	<u>57,946.65</u>

Purchaser's Signature \_\_\_\_\_ Accepted for MB of Nashville \_\_\_\_\_

Co-Purchaser's Signature \_\_\_\_\_

This worksheet is not valid unless signed and accepted by an authorized official of Mercedes-Benz of Nashville and approved by a lending institution, if any, of Buyer's or Seller's choice as to any deferred balance. Processing Fee represents Dealer's recovery of administrative overhead expenses plus profit. In the event the buyer rejects the contract after acceptance by Mercedes-Benz of Nashville and financing (if any has been approved), seller may apply deposit to cover its reasonable costs, but seller waives no other remedies. Buyer certifies to be 18 years of age or older.

*State Contract # 80121*

## Brad Hale

---

**From:** Jarrod ADAMS <adamsj@wcde.org> on behalf of Jarrod ADAMS  
**Sent:** Tuesday, June 11, 2024 4:00 PM  
**To:** Brad Hale  
**Cc:** Jennifer Moore  
**Subject:** Re: FW: Sprinter 170 gas

State Contract #80121

Dr. Jarrod Adams  
Chief Operations Officer  
Washington County Department of Education

On Tue, Jun 11, 2024, 3:42 PM Brad Hale <[haleb@wcde.org](mailto:haleb@wcde.org)> wrote:

Jarrold,

Do we have a State Contract # for this purchase or is this from a Purchasing Cooperative?

Otherwise we have to bid this out for the new fiscal year unless I get different instructions from the State Auditors.

**W. Brad Hale, MBA**

*Chief Financial Officer*

*Washington County Department of Education*

(W) 423-753-1105

(F) 423-753-1114

**From:** Jennifer Moore [mailto:[moorej@wcde.org](mailto:moorej@wcde.org)]  
**Sent:** Tuesday, June 11, 2024 3:19 PM  
**To:** Brad Hale <[haleb@wcde.org](mailto:haleb@wcde.org)>  
**Subject:** Fwd: Sprinter 170 gas

----- Forwarded message -----

From: **Jarrold ADAMS** <[adamsj@wcde.org](mailto:adamsj@wcde.org)>

Date: Tue, Jun 11, 2024 at 3:18 PM

Subject: Fwd: Sprinter 170 gas

To: Jennifer Moore <[moorej@wcde.org](mailto:moorej@wcde.org)>

For Board workshop...

Dr. Jarrod Adams

Chief Operations Officer

Washington County Department of Education

----- Forwarded message -----

From: **Tony Roberts** <[robertst@wcde.org](mailto:robertst@wcde.org)>

Date: Tue, Jun 11, 2024 at 6:31 AM

Subject: Fwd: Sprinter 170 gas

To: Jarrod ADAMS <[adamsj@wcde.org](mailto:adamsj@wcde.org)>

----- Forwarded message -----

From: **Pointer, Patrick** <[Patrick.Pointer@mercedesbenzofnashville.com](mailto:Patrick.Pointer@mercedesbenzofnashville.com)>

Date: Mon, Jun 10, 2024 at 7:45 PM

Subject: Sprinter 170 gas

To: Tony Roberts <[robertst@wcde.org](mailto:robertst@wcde.org)>

At the moment there are 2 170 white gas available. The quote would be the same as the attached, but \$2,000 less due to MSRP. Please give me a call. Thanks.

Best Regards,

**-Pat**

---

Pat Pointer, CV Manager  
Mercedes-Benz Sprinter Nashville  
Franklin, TN

615.807.0058

--

Thank you,

Tony Roberts

Washington County Schools

Transportation Supervisor

--

***Jennifer D. Moore***

***Executive Assistant***

Washington County Schools

405 West College Street

Jonesborough, TN 37659

(423)753-1100



**WASHINGTON**  
COUNTY SCHOOLS

INSPIRE ★ STRIVE ★ THRIVE

Mr. Jerry S. Boyd  
Superintendent

405 W. College St.  
Jonesborough, TN 37659  
Phone (423) 753-1100

TO: Jerry Boyd, Superintendent

FROM: Jarrod Adams, Chief Operations Officer

DATE: July 22, 2024

SUBJECT: Vans for the School Nutrition Department

Eddie's Auto Sales  
Church Hill, TN

2022 Ford Transit  
49,046 miles  
\$44,995

2021 Ford Transit  
65,772 miles  
\$39,995

2015 Ford Transit  
28,443 miles  
\$38,995

Board of Directors

Annette Buchanan  
Mary Beth Dellinger  
Keith Ervin

Chad Fleenor  
David Hammond  
Gregg Huddlestone

Mike Masters  
Whitney Riddle  
Vince Walters



3600 Henson Road, Knoxville, TN 37921  
tel: (865) 588-4320 • fax: (865) 588-4111  
e-mail: info@baselineLLC.com

www.baselineLLC.com

www.baselinellc.com

### PROPOSAL

TO: Logan Clark Washington County Schools 405 W. College Street Jonesborough, TN 37659  Email: clarkl@wcde.org	JOB NAME: Boones Creek baseball/softball facility  LOCATION: Boones Creek Road  PHONE: 423 470-3674 DATE: 2/28/2024
---	--

We hereby submit specifications and estimates for:

### Boones Creek Fields Synthetic Turf Maintenance

Field Cleaning and Decompaction: Baseline will decompact each field using tined decompaction equipment to loosen compacted infill and cause fibers to stand up. A magnet will also remove metal debris in the field. This process also cleans the field of loose fibers and other debris.

Baseline will conduct an infill depth check to determine rubber infill depth prior to addition of new rubber particles. We will visually inspect the field for loose seams and edges with special attention to inlays (hash marks, numbers, logos, etc.). Baseline will also check high use areas for extra wear to determine if any replacement is needed.

Rubber infill installation: Based on measurements and testing Baseline will add rubber as needed to enhance GMAX testing. The field will be groomed upon completion. Volume of rubber to be added will be a function of infill depth and how much rubber the field will hold.

Baseline will repair or replace damaged pitcher's stride area or batter's boxes as necessary. Replacement assumes normal wear and tear.

Lastly Baseline will produce a written report detailing work done and issues addressed.

Total cost for all four fields per year.

**WE PROPOSE TO PERFORM THE ABOVE NAMED WORK FOR THE SUM OF: \$8,500.00**

year after completion unless otherwise specified. Payment in full to be made upon completion of the described work; 1 1/2% interest per month will be applicable to any unpaid balance ten days after the invoice date.

Valid Through: 90 days

Submitted by: *Will Ferguson*  
Will Ferguson

**Acceptance of Proposal-** The above prices, specifications, and conditions are satisfactory and are hereby accepted. Empire Corporation of TN, Inc. is authorized to do the work as specified. Payment will be made as outlined above.

DATE OF ACCEPTANCE: \_\_\_\_\_ SIGNATURE: \_\_\_\_\_





# Estimate

Limestone  
 3800 Hwy 11-E  
 Limestone TN 37681  
 423-257-8310

**Date** 7/22/2024  
**Estimate #** 63143  
**Expires** 8/21/2024  
**Exp. Close** 7/22/2024  
**PO #** BOONES CREEK ELEMENT...  
**Shipping Method** JD METALS TRUCK - NO CH...

**Bill To**  
 WASHINGTON CO. DEPT. OF EDUCATION  
 405 WEST COLLEGE STREET  
 CENTRAL OFFICE  
 JONESBOUROUGH TN 37659

**Ship To**  
 WASHINGTON CO. DEPT. OF EDUCATION  
 405 WEST COLLEGE STREET  
 CENTRAL OFFICE  
 JONESBOUROUGH TN 37659

Item Code	Description	Specifications	Quantity	SQ.	U/M	Rate	Amount
FASTFRAME PACKA...	BUILDING FOR BOONES CREEK ELEMENTARY:  25X40X10 STEEL BUILDING 4/12 PITCH NO OVERHANGS 2-9X8 GARAGE DOORS 1-3068 STEEL ENTRY DOOR ROOF INSULATION INCLUDED ALL PANELS, TRIMS, AND ACC. INSTALLATION INCLUDED 4" CONCRETE PAD INCLUDED  (THIS IS AN ESTIMATE ONLY AND SUBJECT TO CHANGE BY FINAL BUILDING DETAILING)  (EXCAVATION NOT INCLUDED BUT CAN BE ADDED UPON SITE INSPECTION)		1		EA	33,000...	33,000.00

	<b>Subtotal</b>	33,000.00
<b>Shipping Cost (JD METALS TRUCK - NO CHARGE)</b>		0.00
	<b>Total</b>	<b>\$33,000.00</b>

# **Specifications for Stadium Public Address Systems**

*Daniel Boone High School - 1440 Suncrest Dr. Gray, TN 37615*

*David Crockett High School - 684 Old State Rt. 34 Jonesborough, TN 37659*

## **Article I - Qualifications**

- a) Bidder shall have no less than 10 years experience in the design, installation and maintenance of Public Address and Sound Systems.
- b) Bidder shall have no less than 10 years experience in the areas of Football Stadium and related Athletic Facility Public Address and Sound Systems.

## **Article II - Requirements**

- a) Bidder shall be required to have and maintain while on the project, no less than \$1,000,000 of liability insurance.
- b) Bidder shall be required to respond within 24 hours of a report of an equipment failure or other report of a problem with the systems.
- c) Bidder shall be required to warranty all equipment and labor for a minimum of one year commencing from the date of completion.

## **Article III - Scope of Work**

- a) Bidder shall design, furnish and install a Public Address System including but not limited to: Speakers, Amplifiers, Preamplifiers, Equalizers etc. so as to provide audio coverage for the Home Side bleachers with no more than 1% degradation of articulation. System shall also provide audio coverage for the Visitor Side bleachers so as to provide audio coverage with no more than 5% degradation of articulation.
- b) Bidder shall furnish and install:
  - 1 Wireless Lapel Microphone (referee)
  - 1 Wireless Handheld Microphone (staff)
  - 1 Wired Desktop Microphone with push to talk (announcer)
  - 1 Multimedia Unit with compact disc player, media device connection and Bluetooth capabilities.

- c) Bidder shall also furnish and install a supplemental Sound System for the purpose of providing audio coverage for the concourse areas behind the press box and under bleacher areas.
- d) Bidder shall furnish and install an Amplifier with 70-volt output that provides enough power for a minimum of four 30 watt multi-tap 70 volt paging horns.
- e) Bidder shall install a minimum of two 30 watt multi-tap 70 volt paging horns attached to the rear side of the press box.
- f) Bidder shall install a minimum of two 30 watt multi-tap 70 volt paging horns in the under bleacher area.
- g) Bidder shall install a separate volume control for each of the two concourse areas.
- h) Bidder shall integrate the supplemental sound system with the main Public Address System so that all audio generated will be broadcast through the Supplemental System.

#### **Article IV - Completion and Training**

- a) Bidder shall provide training for each Athletic Director and appropriate staff members at the sites upon completion of the Systems.
- b) Bidder shall provide a Certificate of Completion and Certification to each Athletic Director at each site.



Name of Event:	
Contact Person:	
Contact' s Email:	Phone #
Date of Event:	Time of Event:
Rooms/Resources Requested:	
Setup Date:	Setup Time:

At Crossroads Christian Church, we love to share our facilities with our neighbors and community. In return, we ask for your courtesy in following these guidelines while on our campus. Crossroads is a Christian organization, and usage of the facilities must be done in such a way that it respects the values of our organization.

### General Campus Guidelines

- Your event or activity should only use the space or spaces previously agreed upon. This includes the gym stage.
- Please do not use any type of adhesive or tacks on the walls or stage.
- Please do not leave doors propped open unless it is to carry in supplies for your event.
- An adult should supervise children at all times, and they should not be allowed to wander through the facilities.
- You are responsible for movement and setup of tables/chairs for events on our campus. Please clean tables and chairs after use.
- If you are borrowing chairs and tables from Crossroads, you will need to provide people to load and unload them. Please make sure tables/chairs have been cleaned after use.
- Do not park on any grassy areas or drive on concrete walkways.
- Do not drive onto any of the recreational fields.
- Use of alcoholic beverages and illegal drugs are prohibited on campus.
- Music choices should be free of offensive language and content.
- Smoking and vaping are not allowed in any building on campus.
- Spray glue cannot be used inside any building on campus.
- Spray paint cannot be used inside any building, on outside concrete, or in the parking lot.
- Take all supplies with you each time you use the campus. Supplies should not be stored on campus.
- Please understand that we reserve the right to cancel major events in the case of an emergency.
- Please understand that we reserve the right to cancel weekly/monthly-scheduled events in the case of an emergency or church-related event.

## TECH USE

- Use of the house sound system or projection system will require hiring a technician from the Crossroads Worship Arts Team at a rate of \$25/hour.
- A Fender Passport portable sound system with microphone can be reserved and used free of charge. The system is stored in the room to the right of the stage.
- Musical and sound equipment (including the piano) should only be used if previously agreed upon.

## GYMNASIUM

- The stage area is not to be used unless previously agreed upon.
- You are responsible for your own setup and cleanup. Please only use tables agreed upon, as they may be reserved for another group.
- Use a chair dolly to move groups of chairs. There are dollies in the table storage closet to the left of the stage. Please don't drag them across the floor.
- Please do not stand or climb on the stacked chairs.
- Following your event, stack chairs six high. Use a chair dolly to move chairs to sides of the gym. **Please do not stand or sit on stacked chairs.**
- Empty trash containers and put new liners in each container. Trash liners are on the kitchen counter. Take all trash to the dumpster located in the gravel parking area at the front of the campus.
- Wipe down tables. Return tables to the original location.
- Mop up spills. Sweep gym floor and entrance lobby. Cleaning supplies, mops, vacuum, and dust mops are located in the back of the restroom/storage room to the right of the stage.
- Check restrooms. Empty trash. A new liner will be provided to put in the can. Flush all toilets. Turn off lights.
- If stage curtains are used, please do not hang anything from bars or pin anything to curtains.
- Please do not pin or hang anything from the Connect Center.
- No food or drinks on the stage.
- Use restrooms in the lobby instead of restrooms on each side of the stage. These are storage areas.
- **Please do not use any type of adhesive or tacks on the walls or stage.**

## KITCHEN

- Sweep and mop up spills.
- Empty trash and replace liners. Liners are on the counter. Take trash to the dumpster.

- Wash any dishes or utensils used and put them away.
- Leave used dishtowels in the sink.
- Please take all leftover food.
- Please do not store any of your supplies in the kitchen cabinets or pantry.
- The Crossroads kitchen is only a warming kitchen. It is essential that you turn on the stove hood fan as well as the box fan located on top of the freezer when using the regular oven or the convection oven.

## **CLASSROOMS AND LOWER AUDITORIUM IN MAIN BUILDING**

- After use, reset room to its original layout.
- Empty trash can and take to the dumpster. A new liner will be provided to put in the can. Please empty bathroom trash as well.
- Sweep or vacuum floor and wipe down tables. Cleaning supplies, brooms, mops, and vacuum are located in the storage closet of Room 103.
- Clean off whiteboards.
- Check restrooms to make sure all toilets have been flushed and turn off lights.
- Please do not store your supplies in the classrooms or storage closets.
- Please do not use any type of adhesive or tacks on the walls.

## **NURSERY**

- Empty all trash and take trash to the dumpster. A new liner will be provided to put in the can.
- Check that toilet has been flushed.
- Wipe all surfaces with the Clorox wipes provided.
- Sanitize used toys with Clorox wipes provided and put all toys away.
- Please do not use any type of adhesive or tacks on the walls.

## **CHILDREN' S MINISTRY BUILDING**

- Reset rooms to the original setup.
- Wipe down tables.
- Clean off the whiteboards.
- Empty trash and take to the dumpster. A new liner will be provided to put in the can.
- Sweep and wipe up any spills.
- Check restrooms. Empty trash. Flush all toilets. Turn off lights.
- Please do not store your supplies in any rooms or storage areas of the building.
- The helium tank and copier are only to be used for church-related events.
- Please do not use any type of adhesive or tacks on the walls.

## STUDENT MINISTRY BUILDING

- Empty trash and replace liners. Liners are in the kitchen area. Take trash to the dumpster.
- Please do not any type of adhesive or tacks on the walls.
- Please do not move the soundboard.
- Sweep and clean up any spills.
- Wash, dry, and put away any dishes or utensils used.
- Leave wet dishtowels hanging over the sink area.
- Return tables to the storage closet.
- Reset the room to the original position.
- Please do not store your supplies in the main room, kitchen, or storage closets.
- Take all leftover food.
- Check restrooms. Empty trash. New liners are in the kitchen area. Flush all toilets. Turn off lights.
- Stage or stage equipment should not be used unless previously agreed upon.

## RECREATION FIELDS

- Do not drive onto fields.
- Do not park on fields.
- Pick up trash and empty trash in the dumpster located near the campus entrance.
- Please move equipment off of the field after use.

Kingsport, TN 37663

# Estimate

Phone # 423-323-8197

6/21/2024

Fax # 423-323-8704



18105

Contract Submitted To:	ATTN:	
WA County Schools Jeremy Moore 1300 Suncrest Dr Gray, Tn, 37615	E-mail:	
	Job Name	
	Location	

Description	Total
Approx. 18,986 Square Feet of Fine Grade removing 6" of material and replacing with: 4" Compacted Base Stone 2" Compacted Surface Mix  ** No other milling, hauling, utility relocation, digging, striping, or materials included. ** Only one mobilization per phase included. Additional will require a change order. ** No permits or testing included.	105,497.00
Stripe lot per plans.	783.00
Remove Existing curb.	2,500.00

Asphalt Clause: Pricing quoted herein is based on Liquid Asphalt Index Pricing from our supplier for the date of quote. per liquid ton. Due to volatility in oil markets, pricing is subject to change, and will be adjusted at time of placement.

**Exclusions/Disclaimers:**

- As a standard anything not specifically listed above or addressed in this section shall be considered excluded regardless of plan specs Including "Incidentals".
- Testing, Permits, Fees, Bonds, Demolition, Heavy Grading Layout, ThermoPlastic, Manhole and/or Grating Adjustments, Staking Layout are excluded from this quote
- Traffic control; anything beyond two (2) flagmen is excluded
- No Signage is included in this quote unless specifically stated above
- Rock Clause (will be additional charge if there is rock to be removed)
- Sub-Grade to be within +/- 0.1 of required grade

We propose to furnish labor, equipment, and materials to complete work listed in a professional, workmanlike manner according to standard industry practices. Payment is due at time of service. Accounts not paid within 30 days are subject to an 18% monthly finance charge. Should legal proceedings become necessary to collect payment, customer is responsible for court costs and our attorney fees.

Thank you for the opportunity to earn your business!

Authorized Signature: \_\_\_\_\_

Terms

**Total** \$108780.00

I/We hereby accept the terms set forth in this quote and authorize BRACKEN PAVING, to perform the aforementioned work.

\_\_\_\_\_

## PARKING LOT LEASE AGREEMENT

This Agreement is entered into this the \_\_\_\_ day of \_\_\_\_\_, ~~2023-2024~~ by and between the Washington County Board of Education (hereinafter, “ the School Board”) and ~~the Board of Elders for~~ Crossroads Christian Church (hereinafter, “the Church”) and sets forth the terms and conditions governing the School Board’s lease of the Church’s parking lot.

**1. General Terms.** For the initial sum of \_\_\_\_\_, ~~\$250,000.00~~, paid by the School Board to the Church on or before ~~June 30, 2023~~ March 31, 2024, and thereafter, on July 1 for each year of this lease, the annual sum of one dollar (\$1.00), the Church does hereby grant to the School Board a non-exclusive right to use the Church’s parking lot for the purpose of overflow parking from Daniel Boone High School. This lease shall be renewed automatically and annually ~~run~~ through June 30, 2048 ~~2049~~, unless prior notice to terminate the lease is given by either party at least one month prior to renewal. This lease ~~and~~ may be renewed beyond 2048 ~~2049~~ by the agreement of both the School Board and the Church.

**2. Conditions.** The Church shall have the right to establish reasonable requirements on the use of the parking lot, such as designating specific areas to park, and the School Board shall cooperate in good faith with the Church to respect the Church’s ownership of the property. Any activity on the leased property shall be in accordance with the Church’s acceptable use policy and any conduct outside this policy may result in termination of the contract.

**3. Maintenance.** The Church shall be exclusively responsible for any maintenance and upkeep of the parking lot, and the Church specifically waives any claim for contribution toward the maintenance and upkeep of the lot made necessary, in whole or part, by the School Board’s use. It is understood and agreed that the initial sum set forth in Paragraph 1 above is intended to compensate the Church in advance for any wear and tear on the lot occasioned by the School Board’s use.

**4. Insurance and indemnity.** It is understood and agreed by and between the School Board and the Church that this parking lot is unsecured and that there is no way to monitor access to it. Accordingly, both parties understand and agree that it is their responsibility to carry appropriate insurance on their own property, and the Church would require that the School Board continue to carry at least \$1 million of general liability per occurrence and \$32 million in the aggregate and that the Church be named as an additional insured party and provide the Church with a certificate of insurance annually. and both parties disclaim any duty to indemnify the other except to the extent that Tennessee law may require otherwise.

**IN WITNESS WHEREOF**, we have set our hands:

\_\_\_\_\_  
Mike Masters,

Chairman of the Board

Washington County Board of Education

\_\_\_\_\_  
Jamie Hunigan,

Chairman, Board of Elders

Crossroads Christian Church