

Board of Education Regular Meeting

Monday, August 12, 2024 8:00 PM

Board Room, 1301 Centennial Avenue, Utica, NE 68456-0187

Mark Avery: Present
Bryce Borchers: Present
Doug Cast: Present
Lana Hoffschneider: Present
Jason Richters: Present
Derek Tomes: Present

1. MEETING CALL TO ORDER	Speaker (s) : Board President
1.1. Reading of Public Meeting Notice	Speaker (s) : Board President
1.1.1. Open Meetings Act	Speaker (s) : Board President
1.2. Roll Call	Speaker (s) : President Richters
1.2.1. Action to Excuse Board Member(s) if Necessary	Speaker (s) : President Richters
1.3. Centennial Public School Mission Statement: Empower, Challenge, and Support Every Student, Every Day.	
1.4. Pledge of Allegiance	Speaker (s) : President Richters
1.5. Consent Agenda Action(s) : Motion to approve consent agenda as presented Passed with a motion by Derek Tomes and a second by Lana Hoffschneider. Voting Detail: Mark Avery: Yea Bryce Borchers: Yea Doug Cast: Yea Lana Hoffschneider: Yea Jason Richters: Yea Derek Tomes: Yea Voting Summary: Yea: 6, Nay: 0	Speaker (s) : President Richters
1.5.1. Consider Minutes of Previous Meeting and Their Approval	Speaker (s) : Board President
1.5.2. Consider General Fund and Activity Fund Bills and Their Approval	Speaker (s) : Board President
1.5.3. Consider Activity Accounts and Treasurer's Report	Speaker (s) : Board President
1.6. Public Forum	Speaker (s) : Board President
1.6.1. Public forum: This is an opportunity for members of the public to speak to items on the agenda or items of concern to the public. If you are not part of the presentation of an agenda	Speaker (s) : Board President

item, you need to speak now. Thank you for your participation.

2. ACTION ITEMS

Speaker (s) : Board President

2.1. DISCUSS, REVIEW, AND CONSIDER APPROVAL OF POLICIES 6003-6012, 5001, & 5055

Action(s) :

Motion to approve policies 6003-6012, 5001, 5055 as presented Passed with a motion by Doug Cast and a second by Derek Tomes.

Voting Detail:

Mark Avery: Yea
Bryce Borchers: Yea
Doug Cast: Yea
Lana Hoffschneider: Yea
Jason Richters: Yea
Derek Tomes: Yea

Voting Summary: Yea: 6, Nay: 0

2.2. DISCUSS, REVIEW, AND CONSIDER APPROVAL OF ITEMS TO BE DECLARED AS SURPLUS FOR IMMEDIATE SALE OR DISPOSAL

Speaker (s) : SUPT. FORD

Action(s) :

Motion to declare items as surplus for immediate sale or disposal as presented Passed with a motion by Mark Avery and a second by Lana Hoffschneider.

Voting Detail:

Mark Avery: Yea
Bryce Borchers: Yea
Doug Cast: Yea
Lana Hoffschneider: Yea
Jason Richters: Yea
Derek Tomes: Yea

Voting Summary: Yea: 6, Nay: 0

2.3. DISCUSS, REVIEW AND CONSIDER APPROVAL OF BID FOR A SCHOOL BUS

Speaker (s) : SUPT. FORD

Action(s) :

Motion to approve the bid proposal from Thomas Buses as presented Passed with a motion by Mark Avery and a second by Bryce Borchers.

Voting Detail:

Mark Avery: Yea
Bryce Borchers: Yea
Doug Cast: Yea
Lana Hoffschneider: Yea
Jason Richters: Yea
Derek Tomes: Yea

Voting Summary: Yea: 6, Nay: 0

2.4. DISCUSS, REVIEW AND CONSIDER AGREEMENT WITH

Speaker (s) : SUPT.

PRAIRIE ROOTS FOR THE 2024-2025 SCHOOL YEAR

FORD

Action(s) :

Motion to approve the proposed agreement with Prairie Roots for the 2024-2025 school year Passed with a motion by Lana Hoffschneider and a second by Mark Avery.

Voting Detail:

Mark Avery: Yea
Bryce Borchers: Yea
Doug Cast: Yea
Lana Hoffschneider: Yea
Jason Richters: Yea
Derek Tomes: Yea

Voting Summary: Yea: 6, Nay: 0

2.5. DISCUSS, REVIEW, AND CONSIDER APPROVAL OF 2024-2025 ACTIVITIES BUDGET

Speaker (s) : SUPT. FORD

Action(s) :

Motion to approve the 2024-2025 Activities Budget as presented Passed with a motion by Derek Tomes and a second by Mark Avery.

Voting Detail:

Mark Avery: Yea
Bryce Borchers: Yea
Doug Cast: Yea
Lana Hoffschneider: Yea
Jason Richters: Yea
Derek Tomes: Yea

Voting Summary: Yea: 6, Nay: 0

2.6. DISCUSS, REVIEW, AND CONSIDER APPROVAL OF THE PURCHASE OF KITCHEN EQUIPMENT - COMBI OVEN

Speaker (s) : SUPT. FORD

Action(s) :

Motion to approve the purchase of the Combi Oven from Sysco as presented Passed with a motion by Lana Hoffschneider and a second by Derek Tomes.

Voting Detail:

Mark Avery: Yea
Bryce Borchers: Yea
Doug Cast: Yea
Lana Hoffschneider: Yea
Jason Richters: Yea
Derek Tomes: Yea

Voting Summary: Yea: 6, Nay: 0

3. DISCUSSION ITEMS

Speaker (s) : Board President

3.1. NASB DISTRICT MEETING PLANNING

Speaker (s) : SUPT. FORD

3.2. SUPERINTENDENT'S REPORT - FINANCIAL INFORMATION, LEGISLATIVE UPDATE, JOB DESCRIPTION

3.3. EDRISING NATIONAL CONFERENCE REPORT

4. ADJOURN

Speaker (s) : Board
President

Action (s) :

Motion to adjourn at 10:12 pm Passed with a motion by Doug Cast and a second by Derek Tomes.

Voting Detail:

Mark Avery: Yea

Bryce Borchers: Yea

Doug Cast: Yea

Lana Hoffschneider: Yea

Jason Richters: Yea

Derek Tomes: Yea

Voting Summary: Yea: 6, Nay: 0

Board Secretary

York News-Times



Publication Name:

York News-Times

Publication URL:

www.yorknewstimes.com

Publication City and State:

York, NE

Publication County:

York

Notice Popular Keyword Category:

Notice Keywords:

centennial

Notice Authentication Number:

202408081355515162931

2726237997

Notice URL:

[Back](#)

Notice Publish Date:

Saturday, July 20, 2024

Notice Content

Notice is hereby given that a meeting of the Board of Education of Centennial Public School, District 67-R, will be held at 8:00 p.m. on the 12th day of August, 2024, in the Board of Education Room of the Centennial School, Utica, Nebraska, which meeting will be open to the public. An agenda, kept continuously current, is available for public inspection on the school website and at the office of the superintendent. By: Bryce Borchers, Secretary Centennial Public School Board of Education Meeting Summary July 8, 2024 Meeting was called to order at the conclusion of hearings. All board members present. Action Items: --Approve consent agenda --Approve updates/addition to policies 2006, 2008, 2009, 3000.1, 3004.1, 3011, 3017, 3053, 3059, 4053, 4011, 5004, 5005, 5008, 5035, 5049, 6024, 6031, 6036, 6038, 6040-6043 as presented. --Approve policies 5057-5067 and 6001-6002 as presented --Approve 2024-25 teacher handbook as presented --Approve 2024-25 student handbooks as presented --Designate the York News-Times, Lincoln Journal Star or the Omaha World-Herald as the newspapers of record for the 2024-25 school year Discussion Items: --Superintendent's Report-Financial Documents, Professional Development Calendar, Legislative Update --Review milk and fuel bids --FBLA National Conference Report --Budget workshop planning Meeting adjourned at 9:58 p.m. July 20, 2024 COL-NE-1600011 ZNEZ

[Back](#)

Board of Education Special Meeting

Monday, July 29, 2024 8:00 PM

Board Room, 1301 Centennial Avenue, Utica, NE 68456-0187

Mark Avery: Present
Bryce Borchers: Present
Doug Cast: Present
Lana Hoffschneider: Present
Jason Richters: Present
Derek Tomes: Present

1. MEETING CALL TO ORDER

Speaker (s) : CHR.
RICHTERS

1.1. Reading of Public Meeting Notice

Speaker (s) : CHR.
RICHTERS

1.2. Open Meetings Act

Speaker (s) : CHR.
RICHTERS

1.3. Roll Call

Speaker (s) : CHR.
RICHTERS

1.4. PLEDGE OF ALLEGIANCE

2. Public Forum

2.1. Public forum: This is an opportunity for members of the public to speak to items on the agenda or items of concern to the public. If you are not part of the presentation of an agenda item, you need to speak now. Thank you for your participation.

3. DISCUSSION ITEM(S)

3.1. BUDGET WORK SESSION

4. ADJOURN

Action(s) :

Motion to adjourn at 9:42pm. This motion, made by Doug Cast and seconded by Derek Tomes, Passed.

Voting Detail:

Mark Avery: Yea
Bryce Borchers: Yea
Doug Cast: Yea
Lana Hoffschneider: Yea
Jason Richters: Yea
Derek Tomes: Yea

Voting Summary: Yea: 6, Nay: 0

Board Secretary

Board of Education Regular Meeting

Monday, July 8, 2024 Regular Board Meeting - to begin after the conclusion of both hearings.

Board Room, 1301 Centennial Avenue, Utica, NE 68456-0187

Mark Avery: Present
Bryce Borchers: Present
Doug Cast: Present
Lana Hoffschneider: Present
Jason Richters: Present
Derek Tomes: Present

1. MEETING CALL TO ORDER	Speaker (s) : Board President
1.1. Reading of Public Meeting Notice	Speaker (s) : Board President
1.1.1. Open Meetings Act	Speaker (s) : Board President
1.2. Roll Call	Speaker (s) : President Richters
1.2.1. Action to Excuse Board Member(s) if Necessary	Speaker (s) : President Richters
1.3. Centennial Public School Mission Statement: Empower, Challenge, and Support Every Student, Every Day.	
1.4. Pledge of Allegiance	Speaker (s) : President Richters
1.5. Consent Agenda Action(s) : Motion to approve Consent Agenda Passed with a motion by Derek Tomes and a second by Lana Hoffschneider. Voting Detail: Mark Avery: Yea Bryce Borchers: Yea Doug Cast: Yea Lana Hoffschneider: Yea Jason Richters: Yea Derek Tomes: Yea Voting Summary: Yea: 6, Nay: 0	Speaker (s) : President Richters
1.5.1. Consider Minutes of Previous Meeting and Their Approval	Speaker (s) : Board President
1.5.2. Consider General Fund and Activity Fund Bills and Their Approval	Speaker (s) : Board President
1.5.3. Consider Activity Accounts and Treasurer's Report	Speaker (s) : Board President
1.5.4. Designation of banks with deposits of funds	Speaker (s) : SUPT. FORD
1.5.5. Appointment of School Legal Counsel	
1.6. Public Forum	Speaker (s) : Board

President

1.6.1. Public forum: This is an opportunity for members of the public to speak to items on the agenda or items of concern to the public. If you are not part of the presentation of an agenda item, you need to speak now. Thank you for your participation.

Speaker (s): Board
President

2. **ACTION ITEMS**

Speaker (s): Board
President

2.1. DISCUSS, REVIEW AND CONSIDER 2024-2025 POLICY UPDATES

Action(s):

Motion to approve policy updates/additions to the following policies: 2006, 2008, 2009, 3003.1, 3004.1, 3011, 3017, 3053, 3059, 4053, 4011, 5004, 5005, 5008, 5035, 5049, 6024, 6031, 6036, 6039, 6040, 6041, 6042, and 6043 as presented Passed with a motion by Doug Cast and a second by Derek Tomes.

Voting Detail:

Mark Avery:	Yea
Bryce Borchers:	Yea
Doug Cast:	Yea
Lana Hoffschneider:	Yea
Jason Richters:	Yea
Derek Tomes:	Yea

Voting Summary: Yea: 6, Nay: 0

2.2. DISCUSS, REVIEW, AND CONSIDER POLICIES 5057-5067; 6001-6002

Speaker (s): SUPT.
FORD

Action(s):

Motion to approve policies 5057-5067; 6001-6002 as presented Passed with a motion by Bryce Borchers and a second by Lana Hoffschneider.

Voting Detail:

Mark Avery:	Yea
Bryce Borchers:	Yea
Doug Cast:	Yea
Lana Hoffschneider:	Yea
Jason Richters:	Yea
Derek Tomes:	Yea

Voting Summary: Yea: 6, Nay: 0

2.3. DISCUSS, REVIEW, AND CONSIDER APPROVAL OF 2024-2025 TEACHER HANDBOOKS

Speaker (s): SUPT.
FORD

Action(s):

Motion to approve the 2024-2025 teacher handbook as presented Passed with a motion by Doug Cast and a second by Derek Tomes.

Voting Detail:

Mark Avery:	Yea
Bryce Borchers:	Yea

Doug Cast: Yea
Lana Hoffschneider: Yea
Jason Richters: Yea
Derek Tomes: Yea

Voting Summary: Yea: 6, Nay: 0

2.4. DISCUSS, REVIEW, AND CONSIDER APPROVAL OF 2024-2025 STUDENT HANDBOOKS **Speaker (s):** SUPT. FORD

Action(s):

Motion to approve the 2024-2025 student handbooks as presented Passed with a motion by Derek Tomes and a second by Lana Hoffschneider.

Voting Detail:

Mark Avery: Yea
Bryce Borchers: Yea
Doug Cast: Yea
Lana Hoffschneider: Yea
Jason Richters: Yea
Derek Tomes: Yea

Voting Summary: Yea: 6, Nay: 0

2.5. DISCUSS, REVIEW, AND CONSIDER DESIGNATION OF NEWSPAPERS OF RECORD

Action(s):

Motion to designate the York News Times, Lincoln Journal Star, or the Omaha World Herald as the newspapers of record for the 2024-2025 school year Passed with a motion by Mark Avery and a second by Lana Hoffschneider.

Voting Detail:

Mark Avery: Yea
Bryce Borchers: Yea
Doug Cast: Yea
Lana Hoffschneider: Yea
Jason Richters: Yea
Derek Tomes: Yea

Voting Summary: Yea: 6, Nay: 0

3. **DISCUSSION ITEMS** **Speaker (s):** Board President

3.1. SUPERINTENDENT'S REPORT-FINANCIAL DOCUMENTS, PROFESSIONAL DEVELOPMENT CALENDAR, LEGISLATIVE UPDATE **Speaker (s):** SUPT. FORD

3.2. REVIEW MILK AND FUEL BIDS

3.3. FBLA NATIONAL CONFERENCE REPORT

3.4. BUDGET WORKSHOP PLANNING

4. **ADJOURN** **Speaker (s):** Board President

Action(s):
Motion to adjourn at 9:58pm Passed with a motion

by Doug Cast and a second by Lana Hoffschneider.

Voting Detail:

Mark Avery: Yea

Bryce Borchers: Yea

Doug Cast: Yea

Lana Hoffschneider: Yea

Jason Richters: Yea

Derek Tomes: Yea

Voting Summary: Yea: 6, Nay: 0

Board Secretary

Board of Education - Student Fees Hearing - Meeting to follow Parent Involvement Hearing

Monday, July 8, 2024 8:00 PM

Board Room, 1301 Centennial Avenue, Utica, NE 68456-0187

Mark Avery: Present
Bryce Borchers: Present
Doug Cast: Present
Lana Hoffschneider: Present
Jason Richters: Present
Derek Tomes: Present

1. MEETING CALL TO ORDER	Speaker (s): CHR. RICHTERS
1.1. Reading of Public Meeting Notice	Speaker (s): CHR. RICHTERS
1.2. Open Meetings Act	Speaker (s): CHR. RICHTERS
1.3. Roll Call	Speaker (s): CHR. RICHTERS
2. STUDENT FEES POLICY REVIEW	
3. INVITE AND CONSIDER ANY PUBLIC COMMENTS AND SUGGESTIONS THAT WOULD LEAD TO AN IMPROVED POLICY	
4. ADJOURN	
Action(s):	Motion to adjourn at 8:10pm. This motion, made by Mark Avery and seconded by Bryce Borchers, Passed.
Voting Detail:	
Mark Avery:	Yea
Bryce Borchers:	Yea
Doug Cast:	Yea
Lana Hoffschneider:	Yea
Jason Richters:	Yea
Derek Tomes:	Yea
Voting Summary:	Yea: 6, Nay: 0

Board Secretary

Board of Education Hearing - Parent Involvement

Monday, July 8, 2024 8:00 PM

Board Room, 1301 Centennial Avenue, Utica, NE 68456-0187

Mark Avery: Present
Bryce Borchers: Present
Doug Cast: Present
Lana Hoffschneider: Present
Jason Richters: Present
Derek Tomes: Present

1. MEETING CALL TO ORDER	Speaker (s) : CHR. RICHTERS
1.1. Reading of Public Meeting Notice	Speaker (s) : CHR. RICHTERS
1.2. Open Meetings Act	Speaker (s) : CHR. RICHTERS
1.3. Roll Call	Speaker (s) : CHR. RICHTERS
2. PARENT AND GUARDIAN INVOLVEMENT IN EDUCATION PRACTICES POLICY REVIEW	
3. INVITE AND CONSIDER ANY PUBLIC COMMENTS AND SUGGESTIONS THAT WOULD LEAD TO AN IMPROVED POLICY	
4. ADJOURN	
Action(s) : Motion to adjourn at 8:07 pm. This motion, made by Lana Hoffschneider and seconded by Derek Tomes, Passed.	
Voting Detail:	
Mark Avery:	Yea
Bryce Borchers:	Yea
Doug Cast:	Yea
Lana Hoffschneider:	Yea
Jason Richters:	Yea
Derek Tomes:	Yea
Voting Summary: Yea: 6, Nay: 0	

Board Secretary

Activity Fund Balance Report - Detail - Exclude Encumbrances

07/2024 - 07/2024

Regular; Beginning Month 07/2024; Processing Month 07/2024; Accounts to Include Accounts with Activity; Fund Number 05

Fund: 05 ACTIVITIES FUND

Chart of Account Number			Chart of Account Description			Entity Name	Expenses	Revenues	Balance Change	Balance
Entry Date	JR	Reference #	Check Acct	Check #	Description					
05 704			Fund Balance			*Previous Balance				(6,276.38)
						*Ending Balance:	0.00	0.00	0.00	(6,276.38)
05 704 0003			ATHLETICS FUND BALANCE			*Previous Balance				(76,945.12)
05 704 0003			ATHLETICS FUND BALANCE							
05 1790 0003			ATHLETICS							
07/05/2024	CR	17834			David City ck - Dist Track	Wagner, Jenny	0.00	100.00		
07/05/2024	CR	17837			jh track meet	Wagner, Jenny	0.00	985.00		
07/05/2024	CR	17838			dist track	Wagner, Jenny	0.00	600.00		
07/05/2024	CR	17839			hats/golf balls	Wagner, Jenny	0.00	234.00		
07/05/2024	CR	17850			royal publishing ck - dist track	Wagner, Jenny	0.00	200.00		
07/05/2024	CR	17852			H. Kube's sponsorship All-Star GBB	Wagner, Jenny	0.00	100.00		
05 5200 0003			ATHLETIC TRANSFER FROM DISTRICT FUND							
07/05/2024	CR	17855			Athl Fund Txfr from Dist Fund	Richters, Nancy	0.00	20,000.00		
07/30/2024	CR	17857			athl fund	Richters, Nancy	0.00	10,000.00		
05 2900 610 000 0 000 0003			ATHLETICS SUPPLIES							
07/23/2024	CD	925797776 - 2	5	45625	Athletic Supplies	BSN SPORTS LLC	304.18	0.00		
07/23/2024	CD	1PCR-6KQV-J314	5	45629	Track Supplies	AMAZON CAPITAL SERVICES	314.81	0.00		
07/30/2024	CD	N003291575	5	45640	Patches	JOSTENS INC.	165.95	0.00		
07/30/2024	CD	20240730	5	45642	All-Star Games	Capital One	273.06	0.00		
07/30/2024	CD	S1472109.001-2	5	45644	supplies	PYRAMID SCHOOL PRODUCTS	138.57	0.00		
05 2900 810 000 0 000 0003			ATHLETICS DUES AND FEES							
07/15/2024	CD	20240715	5	45621	Golf Entry Fee	Crete High School	100.00	0.00		
05 2900 890 000 0 000 0003			ATHLETICS MISC EXPENSE							
07/09/2024	CD	20240805	5	45618	FB Jersey Reimbursement	Fehlhafer, Trevor	50.00	0.00		
07/30/2024	CD	20240730	5	45647	NSIAAA Fees	Centennial General Fund	208.00	0.00		
07/30/2024	CD	20240730	5	45647	State Speech Hotel Rooms	Centennial General Fund	267.00	0.00		
07/30/2024	CD	20240730	5	45647	state dance meal	Centennial General Fund	211.95	0.00		
07/30/2024	CD	20240730	5	45647	State Wrestling	Centennial General Fund	56.67	0.00		
05 704 0003			ATHLETICS FUND BALANCE			*Current Activity				30,128.81
						*Ending Balance:	2,090.19	32,219.00	0.00	(46,816.31)
05 704 0050			CONCESSIONS FUND BALANCE			*Previous Balance				33,180.62
05 704 0050			CONCESSIONS FUND BALANCE							
07/30/2024	GJ				Conc to BA 5/9		0.00	0.00	(651.62)	
07/30/2024	GJ				Conc to Staff (Dist Events) 5/9		0.00	0.00	(651.62)	
07/30/2024	GJ				District Events to Conc. for Dist Track		0.00	0.00	297.12	
05 1790 0050			CONCESSIONS							
07/05/2024	CR	17847			centennial Elem. ck	Klanecky, Nikki	0.00	63.86		
07/10/2024	CR	AUTO			Conc. sales	Square Inc.	0.00	69.23		
07/17/2024	CR	AUTO			Conc. sales	Square Inc.	0.00	5.64		
07/24/2024	CR	AUTO			Conc. sales	Square Inc.	0.00	67.23		

Activity Fund Balance Report - Detail - Exclude Encumbrances

07/2024 - 07/2024

Regular; Beginning Month 07/2024; Processing Month 07/2024; Accounts to Include Accounts with Activity; Fund Number 05

Fund: 05 ACTIVITIES FUND

Chart of Account Number			Chart of Account Description			Entity Name	Expenses	Revenues	Balance Change	Balance
Entry Date	JR	Reference #	Check Acct	Check #	Description					
07/31/2024	CR	AUTO			Conc. Sales	Square Inc.	0.00	83.42		
05 2900 610 000 0 000 0050					CONCESSIONS SUPPLIES					
07/30/2024	CD	311	5	45638	Pizza	BRONCO SPUR	752.00	0.00		
07/30/2024	CD	20240730	5	45639	Pop for conc. inside/outside	Chesterman Company	1,290.36	0.00		
07/30/2024	CD	310	5	45637	Pizza	BRONCO SPUR	618.00	0.00		
07/30/2024	CD	20240730	5	45646	Concession Supplies	CASH-WA DISTRIBUTING CO	1,077.84	0.00		
05 704 0050					CONCESSIONS FUND BALANCE	*Current Activity				(4,454.94)
						*Ending Balance:	3,738.20	289.38	(1,006.12)	28,725.68
05 704 0052					BRONCO STORE FUND BALANCE	*Previous Balance				1,420.29
05 704 0052					BRONCO STORE FUND BALANCE					
05 2900 890 000 0 000 0052					BRONCO STORE MISC EXPENSE					
07/30/2024	CD	20240730	5	45647	NHS membership & pins	Centennial General Fund	2.75	0.00		
07/30/2024	CD	20240730	5	45647	PBIS reward lunch	Centennial General Fund	52.67	0.00		
05 704 0052					BRONCO STORE FUND BALANCE	*Current Activity				(55.42)
						*Ending Balance:	55.42	0.00	0.00	1,364.87
05 704 0053					MARKET 67 FUND BALANCE	*Previous Balance				1,127.96
05 704 0053					MARKET 67 FUND BALANCE					
05 1790 0053					MARKET 67					
07/01/2024	CR	AUTO			sales	Square Inc.	0.00	30.86		
07/12/2024	CR	AUTO			Market 67 sales	Square Inc.	0.00	57.55		
05 704 0053					MARKET 67 FUND BALANCE	*Current Activity				88.41
						*Ending Balance:	0.00	88.41	0.00	1,216.37
05 704 0054					BRONCO CLOSET FUND BALANCE	*Previous Balance				930.90
05 704 0054					BRONCO CLOSET FUND BALANCE					
05 2900 610 000 0 000 0054					BRONCO CLOSET SUPPLIES					
07/30/2024	CD	20240730	5	45647	Kohl's purchase	Centennial General Fund	96.49	0.00		
05 704 0054					BRONCO CLOSET FUND BALANCE	*Current Activity				(96.49)
						*Ending Balance:	96.49	0.00	0.00	834.41
05 704 0055					BRONCO COFFEE & CREATIONS FUND BALANCE	*Previous Balance				45.38
						*Ending Balance:	0.00	0.00	0.00	45.38
05 704 0056					SUMMER CAMPS FUND BALANCE	*Previous Balance				3,854.92
05 704 0056					SUMMER CAMPS FUND BALANCE					
07/30/2024	GJ				Summer Camps to VB		0.00	0.00	(1,000.00)	
05 704 0056					SUMMER CAMPS FUND BALANCE	*Current Activity				(1,000.00)
						*Ending Balance:	0.00	0.00	(1,000.00)	2,854.92
05 704 0057					PBIS FUND BALANCE	*Previous Balance				(1,016.14)

Activity Fund Balance Report - Detail - Exclude Encumbrances

07/2024 - 07/2024

Regular; Beginning Month 07/2024; Processing Month 07/2024; Accounts to Include Accounts with Activity; Fund Number 05

Fund: 05 ACTIVITIES FUND

Chart of Account Number		Chart of Account Description				Entity Name	Expenses	Revenues	Balance Change	Balance
Entry Date	JR	Reference #	Check Acct	Check #	Description					
05 704 0103						DISTRICT EVENTS FUND BALANCE				
05 704 0103						DISTRICT EVENTS FUND BALANCE				
07/30/2024	GJ				District Events to Conc. for Dist Track		0.00	0.00	(297.12)	
07/30/2024	GJ				Conc to Staff (Dist Events) 5/9		0.00	0.00	651.62	
05 1750 0103						DISTRICT EVENTS POP MACHINE				
07/30/2024	CR	17858			Coca-Cola	Wagner, Jenny	0.00	65.82		
05 1790 0103						DISTRICT EVENTS				
07/05/2024	CR	17842			senior grad gift cards	Wagner, Jenny	0.00	1,173.00		
05 2900 610 000 0 000 0103						DISTRICT EVENTS SUPPLIES				
07/30/2024	CD	310	5	45637	Pizza	BRONCO SPUR	56.00	0.00		
05 2900 890 000 0 000 0103						DISTRICT EVENTS MISC EXPENSE				
07/30/2024	CD	20240730	5	45647	Credit Card Charges	Centennial General Fund	417.99	0.00		
05 704 0103						DISTRICT EVENTS FUND BALANCE				
						*Current Activity				1,119.33
						*Ending Balance:	473.99	1,238.82	354.50	25,009.43
05 704 0104						BOYS BASKETBALL FUND BALANCE				
05 704 0104						BOYS BASKETBALL FUND BALANCE				
05 1790 0104						BOYS BASKETBALL				
07/05/2024	CR	17835			youth bbb camp	Scholl, Cam	0.00	550.00		
07/05/2024	CR	17836			team camp	Scholl, Cam	0.00	5,850.00		
07/09/2024	CR	17860			summer checks	Scholl, Cam	0.00	325.00		
07/22/2024	CR	17862			summer checks	Scholl, Cam	0.00	75.00		
05 2900 352 000 0 000 0104						BOYS BASKETBALL OFFICIALS				
07/01/2024	CD	20240805	5	45609	BBB summer league & assigner	Scheel, Ken	150.00	0.00		
07/01/2024	CD	20240805	5	45610	BBB summer league official	Moore, James	75.00	0.00		
07/01/2024	CD	20240805	5	45611	BBB summer league official	Holtz, Heath	75.00	0.00		
07/01/2024	CD	20240805	5	45612	BBB summer league official	Mastel, Noah	75.00	0.00		
07/01/2024	CD	20240805	5	45613	BBB summer league official	Benes, Adam	75.00	0.00		
07/01/2024	CD	20240805	5	45614	BBB summer league official	Meyer, Bragan	75.00	0.00		
05 2900 610 000 0 000 0104						BOYS BASKETBALL SUPPLIES				
07/11/2024	CD	S 33557	5	45620	T-shirts camp	Heath Sports & Tees	649.16	0.00		
05 2900 890 000 0 000 0104						BOYS BASKETBALL MISC EXPENSE				
07/01/2024	CD	20240805	5	45615	BBB Summer League Clock	Nisly, Mike	300.00	0.00		
07/30/2024	CD	20240730	5	45643	Fuel Mileage for Summer Camps	CENTRAL VALLEY AG	53.38	0.00		
05 704 0104						BOYS BASKETBALL FUND BALANCE				
						*Current Activity				5,272.46
						*Ending Balance:	1,527.54	6,800.00	0.00	3,966.16
05 704 0105						CROSS COUNTRY FUND BALANCE				
						*Previous Balance				333.90
						*Ending Balance:	0.00	0.00	0.00	333.90
05 704 0106						FOOTBALL FUND BALANCE				
						*Previous Balance				1,594.05

Activity Fund Balance Report - Detail - Exclude Encumbrances

07/2024 - 07/2024

Regular; Beginning Month 07/2024; Processing Month 07/2024; Accounts to Include Accounts with Activity; Fund Number 05

Fund: 05 ACTIVITIES FUND

Chart of Account Number			Chart of Account Description			Entity Name	Expenses	Revenues	Balance Change	Balance
Entry Date	JR	Reference #	Check Acct	Check #	Description					
05 704 0106					FOOTBALL FUND BALANCE					
05 2900 610 000 0 000 0106					FOOTBALL SUPPLIES					
07/09/2024	CD	20240805	5	45617	FB Gear for Fundraising	BSN SPORTS LLC	781.95	0.00		
05 2900 890 000 0 000 0106					FOOTBALL MISC EXPENSE					
07/30/2024	CD	20240730	5	45643	Fuel Mileage for Summer Camps	CENTRAL VALLEY AG	186.14	0.00		
05 704 0106					FOOTBALL FUND BALANCE					
						*Current Activity				(968.09)
						*Ending Balance:	968.09	0.00	0.00	625.96
05 704 0107					GIRLS BASKETBALL FUND BALANCE					(1,687.94)
						*Previous Balance				
05 704 0107					GIRLS BASKETBALL FUND BALANCE					
05 1790 0107					GIRLS BASKETBALL					
07/05/2024	CR	17840			team camp	Kloke, Eric	0.00	2,100.00		
07/05/2024	CR	17845			camp VB/GBB	Anstine, Alex	0.00	40.00		
07/05/2024	CR	17849			camp	Kloke, Eric	0.00	300.00		
05 2900 890 000 0 000 0107					GIRLS BASKETBALL MISC EXPENSE					
07/30/2024	CD	20240730	5	45643	Fuel Mileage for Summer Camps	CENTRAL VALLEY AG	149.15	0.00		
05 704 0107					GIRLS BASKETBALL FUND BALANCE					
						*Current Activity				2,290.85
						*Ending Balance:	149.15	2,440.00	0.00	602.91
05 704 0108					GOLF FUND BALANCE					(342.69)
						*Previous Balance				
05 704 0108					GOLF FUND BALANCE					
05 1790 0108					GOLF					
07/05/2024	CR	17841			camp	Scholl, Cam	0.00	279.00		
05 704 0108					GOLF FUND BALANCE					
						*Current Activity				279.00
						*Ending Balance:	0.00	279.00	0.00	(63.69)
05 704 0109					SOFTBALL FUND BALANCE					1,101.52
						*Previous Balance				
05 704 0109					SOFTBALL FUND BALANCE					
05 2900 610 000 0 000 0109					SOFTBALL SUPPLIES					
07/23/2024	CD	217949	5	45627	SB Camp Tees	RBS ACTIVEWEAR	533.36	0.00		
07/23/2024	CD	20240723	5	45628	Jacket	BSN SPORTS LLC	82.54	0.00		
05 704 0109					SOFTBALL FUND BALANCE					
						*Current Activity				(615.90)
						*Ending Balance:	615.90	0.00	0.00	485.62
05 704 0115					TRACK FUND BALANCE					372.73
						*Previous Balance				
						*Ending Balance:	0.00	0.00	0.00	372.73
05 704 0116					VOLLEYBALL FUND BALANCE					4,446.07
						*Previous Balance				
05 704 0116					VOLLEYBALL FUND BALANCE					
07/30/2024	GJ				Summer Camps to VB		0.00	0.00	1,000.00	
05 1790 0116					VOLLEYBALL					
07/05/2024	CR	17845			camp VB/GBB	Anstine, Alex	0.00	40.00		
07/05/2024	CR	17848			league	Anstine, Alex	0.00	400.00		

Activity Fund Balance Report - Detail - Exclude Encumbrances

07/2024 - 07/2024

Regular; Beginning Month 07/2024; Processing Month 07/2024; Accounts to Include Accounts with Activity; Fund Number 05

Fund: 05 ACTIVITIES FUND

Chart of Account Number			Chart of Account Description			Entity Name	Expenses	Revenues	Balance Change	Balance
Entry Date	JR	Reference #	Check Acct	Check #	Description					
07/16/2024	CR	17861			summer vb	Anstine, Alex	0.00	3,300.00		
07/23/2024	CR	17863			summer check	Anstine, Alex	0.00	400.00		
05 2900 352 000 0 000 0116					VOLLEYBALL OFFICIALS/JUDGES					
07/29/2024	CD	20240805	5	45630	VB summer league official	KLANECKY, NICOLE ANN	200.00	0.00		
07/29/2024	CD	20240805	5	45631	VB summer league official	Saunders, Cambria	200.00	0.00		
07/29/2024	CD	20240805	5	45632	VB summer league official	Green, Krislyn	200.00	0.00		
07/29/2024	CD	20240805	5	45633	VB summer league official	WAGNER, JENNY RAYE	100.00	0.00		
07/29/2024	CD	20240805	5	45634	VB summer league official	KUCERA, MCKENNA ANN	50.00	0.00		
07/29/2024	CD	20240805	5	45635	VB summer league official	Luebbe, Kate	50.00	0.00		
05 2900 610 000 0 000 0116					VOLLEYBALL SUPPLIES					
07/23/2024	CD	925868092	5	45622	Volleyball Shirts	BSN SPORTS LLC	1,356.80	0.00		
07/23/2024	CD	925978837	5	45623	Range Pack Pullover	BSN SPORTS LLC	67.42	0.00		
07/23/2024	CD	925950848	5	45624	VB gear	BSN SPORTS LLC	292.52	0.00		
05 2900 810 000 0 000 0116					VOLLEYBALL DUES AND FEES					
07/08/2024	CD	20240805	5	45616	Concordia Team Camp	CONCORDIA UNIVERSITY	2,500.00	0.00		
07/09/2024	CD	20240805-0001	5	45619	JV camp	CONCORDIA UNIVERSITY	300.00	0.00		
05 704 0116					VOLLEYBALL FUND BALANCE	*Current Activity				(176.74)
						*Ending Balance:	5,316.74	4,140.00	1,000.00	4,269.33
05 704 0117					WRESTLING FUND BALANCE	*Previous Balance				2,552.32
05 704 0117					WRESTLING FUND BALANCE					
05 1790 0117					WRESTLING					
07/05/2024	CR	17856			change from summer camp food	Payne, Phil	0.00	97.43		
05 2900 890 000 0 000 0117					WRESTLING MISC EXPENSE					
07/30/2024	CD	20240730	5	45643	Fuel Mileage for Summer Camps	CENTRAL VALLEY AG	95.77	0.00		
05 704 0117					WRESTLING FUND BALANCE	*Current Activity				1.66
						*Ending Balance:	95.77	97.43	0.00	2,553.98
05 704 0118					BASEBALL FUND BALANCE	*Previous Balance				7.16
05 704 0118					BASEBALL FUND BALANCE					
07/30/2024	GJ				Conc to BA 5/9		0.00	0.00	651.62	
05 704 0118					BASEBALL FUND BALANCE	*Current Activity				651.62
						*Ending Balance:	0.00	0.00	651.62	658.78
05 704 0119					GIRLS WRESTLING FUND BALANCE	*Previous Balance				783.72
						*Ending Balance:	0.00	0.00	0.00	783.72
05 704 0204					JH BOYS BASKETBALL FUND BALANCE	*Previous Balance				18.35
						*Ending Balance:	0.00	0.00	0.00	18.35
05 704 0207					JH GIRLS BASKETBALL FUND BALANCE	*Previous Balance				1,588.82
						*Ending Balance:	0.00	0.00	0.00	1,588.82
05 704 0215					JH TRACK FUND BALANCE	*Previous Balance				271.10

Activity Fund Balance Report - Detail - Exclude Encumbrances

07/2024 - 07/2024

Regular; Beginning Month 07/2024; Processing Month 07/2024; Accounts to Include Accounts with Activity; Fund Number 05

Fund: 05 ACTIVITIES FUND

Chart of Account Number		Chart of Account Description			Entity Name	Expenses	Revenues	Balance Change	Balance
Entry Date	JR	Reference #	Check Acct	Check #	Description				
						0.00	0.00	0.00	271.10
05 704 0216					JH VOLLEYBALL FUND BALANCE				36.23
					*Previous Balance				36.23
					*Ending Balance:	0.00	0.00	0.00	36.23
05 704 0301					ART FUND BALANCE				19.59
					*Previous Balance				19.59
					*Ending Balance:	0.00	0.00	0.00	19.59
05 704 0302					BAND TRIP FUND BALANCE				8,649.05
					*Previous Balance				8,649.05
					*Ending Balance:	0.00	0.00	0.00	8,649.05
05 704 0303					DANCE/CHEER FUND BALANCE				(398.07)
05 704 0303					DANCE/CHEER FUND BALANCE				
05 2900 610 000 0 000 0303					DANCE/CHEER SUPPLIES				
07/23/2024	CD	0000006	5	45626	Cheer T-shirts	HoHuHa Designs	154.00	0.00	
05 704 0303					DANCE/CHEER FUND BALANCE				(154.00)
					*Current Activity				(154.00)
					*Ending Balance:	154.00	0.00	0.00	(552.07)
05 704 0305					FBLA FUND BALANCE				(5,066.27)
05 704 0305					FBLA FUND BALANCE				
05 1790 0305					FBLA				
07/05/2024	CR	17855			NLC expenses	Richters, Nancy	0.00	6,446.00	
05 704 0305					FBLA FUND BALANCE				6,446.00
					*Current Activity				6,446.00
					*Ending Balance:	0.00	6,446.00	0.00	1,379.73
05 704 0306					FCCLA FUND BALANCE				2,506.29
					*Previous Balance				2,506.29
					*Ending Balance:	0.00	0.00	0.00	2,506.29
05 704 0307					FFA FUND BALANCE				34,578.19
05 704 0307					FFA FUND BALANCE				
05 1790 0307					FFA				
07/05/2024	CR	17843			metal	Podliska, Holly	0.00	214.00	
07/05/2024	CR	17843			rest of metal deposit	Podliska, Holly	0.00	0.80	
07/05/2024	CR	17844			plant sale	Podliska, Holly	0.00	924.00	
07/05/2024	CR	17855			overpayment on invoice	Richters, Nancy	0.00	221.00	
05 1920 0307					FFA DONATIONS				
07/30/2024	CR	17859			donation	Podliska, Holly	0.00	300.00	
05 2900 610 000 0 000 0307					FFA SUPPLIES				
07/30/2024	CD	310	5	45637	Pizza	BRONCO SPUR	144.00	0.00	
05 2900 890 000 0 000 0307					FFA MISC EXPENSE				
07/30/2024	CD	20240730	5	45645	FFA Reimbursement	LUETTEL, HOLLY ANNE	382.35	0.00	
05 704 0307					FFA FUND BALANCE				1,133.45
					*Current Activity				1,133.45
					*Ending Balance:	526.35	1,659.80	0.00	35,711.64

Activity Fund Balance Report - Detail - Exclude Encumbrances

07/2024 - 07/2024

Regular; Beginning Month 07/2024; Processing Month 07/2024; Accounts to Include Accounts with Activity; Fund Number 05

Fund: 05 ACTIVITIES FUND

Chart of Account Number		Chart of Account Description			Entity Name	Expenses	Revenues	Balance Change	Balance
Entry Date	JR	Reference #	Check Acct	Check #	Description				
05 704 0308					MUSICAL FUND BALANCE				8,213.46
					*Previous Balance				8,213.46
					*Ending Balance:	0.00	0.00	0.00	8,213.46
05 704 0309					NHS FUND BALANCE				225.74
					*Previous Balance				225.74
05 704 0309					NHS FUND BALANCE				
05 2900 610 000 0 000 0309					NHS SUPPLIES				
07/30/2024	CD	20240730	5	45647	NHS membership & pins	Centennial General Fund	225.74	0.00	
05 704 0309					NHS FUND BALANCE				(225.74)
					*Current Activity				(225.74)
					*Ending Balance:	225.74	0.00	0.00	0.00
05 704 0311					ONE ACT FUND BALANCE				1,221.00
					*Previous Balance				1,221.00
					*Ending Balance:	0.00	0.00	0.00	1,221.00
05 704 0312					QUIZ BOWL FUND BALANCE				749.24
					*Previous Balance				749.24
					*Ending Balance:	0.00	0.00	0.00	749.24
05 704 0313					SHOW CHOIR FUND BALANCE				(6,751.95)
					*Previous Balance				(6,751.95)
					*Ending Balance:	0.00	0.00	0.00	(6,751.95)
05 704 0314					SPEECH FUND BALANCE				653.14
					*Previous Balance				653.14
					*Ending Balance:	0.00	0.00	0.00	653.14
05 704 0315					STUDENT COUNCIL FUND BALANCE				2,809.99
					*Previous Balance				2,809.99
05 704 0315					STUDENT COUNCIL FUND BALANCE				
05 1750 0315					STUDENT COUNCIL POP MACHINE				
07/30/2024	CR	17858			Coca-Cola	Wagner, Jenny	0.00	36.74	
05 2900 610 000 0 000 0315					STUDENT COUNCIL SUPPLIES				
07/30/2024	CD	310	5	45637	Pizza	BRONCO SPUR	98.00	0.00	
05 704 0315					STUDENT COUNCIL FUND BALANCE				(61.26)
					*Current Activity				(61.26)
					*Ending Balance:	98.00	36.74	0.00	2,748.73
05 704 0316					UNIFIED ACTIVITIES FUND BALANCE				205.90
					*Previous Balance				205.90
					*Ending Balance:	0.00	0.00	0.00	205.90
05 704 0317					ISTRUMENTAL MUSIC				(3,739.74)
					*Previous Balance				(3,739.74)
05 704 0317					ISTRUMENTAL MUSIC				
05 1790 0317					ISTRUMENTAL MUSIC				
07/05/2024	CR	17855			JH Music Festivals	Richters, Nancy	0.00	249.00	
05 704 0317					ISTRUMENTAL MUSIC				249.00
					*Current Activity				249.00
					*Ending Balance:	0.00	249.00	0.00	(3,490.74)
05 704 0318					VOCAL MUSIC FUND BALANCE				(1,119.62)
					*Previous Balance				(1,119.62)
05 704 0318					VOCAL MUSIC FUND BALANCE				

Activity Fund Balance Report - Detail - Exclude Encumbrances

07/2024 - 07/2024

Regular; Beginning Month 07/2024; Processing Month 07/2024; Accounts to Include Accounts with Activity; Fund Number 05

Fund: 05 ACTIVITIES FUND

<u>Chart of Account Number</u>		<u>Chart of Account Description</u>				<u>Entity Name</u>	<u>Expenses</u>	<u>Revenues</u>	<u>Balance Change</u>	<u>Balance</u>
<u>Entry Date</u>	<u>JR</u>	<u>Reference #</u>	<u>Check Acct</u>	<u>Check #</u>	<u>Description</u>					
05 1790 0318					VOCAL MUSIC					
07/05/2024	CR	17855			Dist Music Contest	Richters, Nancy	0.00	120.00		
05 704 0318					VOCAL MUSIC FUND BALANCE	*Current Activity			120.00	
						*Ending Balance:	0.00	120.00	0.00	
05 704 0319					MIDDLE SCHOOL QUIZ BOWL FUND BALANCE	*Previous Balance			1,381.86	
05 704 0319					MIDDLE SCHOOL QUIZ BOWL FUND BALANCE					
05 2900 610 000 0 000 0319					MIDDLE SCHOOL QUIZ BOWL SUPPLIES					
07/30/2024	CD	1QKM-FMQ7-7QQD	5	45636	Middle School Quiz Bowl supplies	AMAZON CAPITAL SERVICES	111.72	0.00		
05 704 0319					MIDDLE SCHOOL QUIZ BOWL FUND BALANCE	*Current Activity			(111.72)	
						*Ending Balance:	111.72	0.00	0.00	
05 704 0320					FCA FUND BALANCE	*Previous Balance			274.62	
						*Ending Balance:	0.00	0.00	0.00	
05 704 0321					EdRISING FUND BALANCE	*Previous Balance			376.35	
05 704 0321					EdRISING FUND BALANCE					
05 2900 890 000 0 000 0321					EdRISING MISC EXPENSE					
07/30/2024	CD	20240730	5	45641	metro passes in DC	LUEBBE, JESSICA	180.00	0.00		
05 704 0321					EdRISING FUND BALANCE	*Current Activity			(180.00)	
						*Ending Balance:	180.00	0.00	0.00	
05 704 0322					CLOSE UP FUND BALANCE	*Previous Balance			0.00	
						*Ending Balance:	0.00	0.00	0.00	
05 704 0401					CLASS 2021 FUND BALANCE	*Previous Balance			613.27	
						*Ending Balance:	0.00	0.00	0.00	
05 704 0403					CLASS 2023 FUND BALANCE	*Previous Balance			0.00	
						*Ending Balance:	0.00	0.00	0.00	
05 704 0405					CLASS 2024 FUND BALANCE	*Previous Balance			0.00	
						*Ending Balance:	0.00	0.00	0.00	
05 704 0406					CLASS 2025 FUND BALANCE	*Previous Balance			2,933.48	
05 704 0406					CLASS 2025 FUND BALANCE					
05 1790 0406					CLASS 2025					
07/05/2024	CR	17855			diplomas	Richters, Nancy	0.00	291.90		
05 2900 610 000 0 000 0406					CLASS 2025 SUPPLIES					
07/30/2024	CD	20240730	5	45647	Prom Supplies	Centennial General Fund	43.82	0.00		
05 704 0406					CLASS 2025 FUND BALANCE	*Current Activity			248.08	

Activity Fund Balance Report - Detail - Exclude Encumbrances

07/2024 - 07/2024

Regular; Beginning Month 07/2024; Processing Month 07/2024; Accounts to Include Accounts with Activity; Fund Number 05

Fund: 05 ACTIVITIES FUND

<u>Chart of Account Number</u>		<u>Chart of Account Description</u>				<u>Entity Name</u>	<u>Expenses</u>	<u>Revenues</u>	<u>Balance Change</u>	<u>Balance</u>
<u>Entry Date</u>	<u>JR</u>	<u>Reference #</u>	<u>Check Acct</u>	<u>Check #</u>	<u>Description</u>					
						*Ending Balance:	43.82	291.90	0.00	3,181.56
05 704 0407					CLASS 2026 FUND BALANCE	*Previous Balance				2,172.08
05 704 0407					CLASS 2026 FUND BALANCE					
05 1790 0407					CLASS 2026					
07/05/2024	CR	17853			Kona Ice/Travelin Tom's Coffee cks	Klanecky, Nikki	0.00	345.00		
05 704 0407					CLASS 2026 FUND BALANCE	*Current Activity				345.00
						*Ending Balance:	0.00	345.00	0.00	2,517.08
05 704 0408					CLASS 2027 FUND BALANCE	*Previous Balance				407.36
						*Ending Balance:	0.00	0.00	0.00	407.36
05 704 0702					CHROMEBOOK ASSURANCE FUND BALANCE	*Previous Balance				2,898.95
05 704 0702					CHROMEBOOK ASSURANCE FUND BALANCE					
05 1740 0702					CHROMEBOOK ASSURANCE FEE					
07/03/2024	CR	AUTO			CB Assurance pd by CC on FinalForms	FinalForms Stripe, Transfer	0.00	20.00		
07/05/2024	CR	AUTO			CB Assurance pd by CC on FinalForms	FinalForms Stripe, Transfer	0.00	20.00		
07/10/2024	CR	AUTO			CB Assurance pd by CC on FinalForms	FinalForms Stripe, Transfer	0.00	20.00		
07/12/2024	CR	AUTO			CB Assurance pd by CC on FinalForms	FinalForms Stripe, Transfer	0.00	20.00		
07/17/2024	CR	AUTO			CB Assurance pd by CC on FinalForms	FinalForms Stripe, Transfer	0.00	40.00		
07/18/2024	CR	AUTO			CB Assurance pd by CC on FinalForms	FinalForms Stripe, Transfer	0.00	20.00		
07/19/2024	CR	AUTO			CB Assurance pd by CC on FinalForms	FinalForms Stripe, Transfer	0.00	20.00		
07/23/2024	CR	AUTO			CB Assurance pd by CC on FinalForms	FinalForms Stripe, Transfer	0.00	40.00		
07/24/2024	CR	AUTO			CB Assurance pd by CC on FinalForms	FinalForms Stripe, Transfer	0.00	20.00		
07/25/2024	CR	AUTO			CB Assurance pd by CC on FinalForms	FinalForms Stripe, Transfer	0.00	20.00		
07/26/2024	CR	AUTO			CB Assurance pd by CC on FinalForms	FinalForms Stripe, Transfer	0.00	140.00		
07/29/2024	CR	AUTO			CB Assurance pd by CC on FinalForms	FinalForms Stripe, Transfer	0.00	120.00		
05 1790 0702					CHROMEBOOK ASSURANCE					
07/05/2024	CR	17851			CB repair - O. Naber	Tesar, Dan	0.00	10.00		
05 704 0702					CHROMEBOOK ASSURANCE FUND BALANCE	*Current Activity				510.00
						*Ending Balance:	0.00	510.00	0.00	3,408.95
05 704 0704					JH YEARBOOK FUND BALANCE	*Previous Balance				(1,083.08)

Activity Fund Balance Report - Detail - Exclude Encumbrances

07/2024 - 07/2024

Regular; Beginning Month 07/2024; Processing Month 07/2024; Accounts to Include Accounts with Activity; Fund Number 05

Fund: 05 ACTIVITIES FUND

Chart of Account Number		Chart of Account Description			Entity Name	Expenses	Revenues	Balance Change	Balance
Entry Date	JR	Reference #	Check Acct	Check #	Description				
						0.00	0.00	0.00	(1,083.08)
05 704 0705					LIBRARY FUND BALANCE				240.21
						0.00	0.00	0.00	240.21
05 704 0706					SCIENCE FUND BALANCE				890.81
						0.00	0.00	0.00	890.81
05 704 0707					WEIGHT ROOM FUND BALANCE				8,214.80
						0.00	0.00	0.00	8,214.80
05 704 0708					YEARBOOK FUND BALANCE				6,670.18
05 704 0708					YEARBOOK FUND BALANCE				
05 2900 610 000 0 000 0708					YEARBOOK SUPPLIES				
07/30/2024	CD	20240730	5	45647	Yearbooks & team/group photos	Centennial General Fund	1,207.83	0.00	
05 704 0708					YEARBOOK FUND BALANCE				(1,207.83)
									5,462.35
05 704 0709					SHOP/TECH FUND BALANCE				2,319.10
						0.00	0.00	0.00	2,319.10
05 704 0710					CHESS CLUB FUND BALANCE				161.09
						0.00	0.00	0.00	161.09
05 704 0800					CENTENNIAL CHOICE FUND BALANCE				15,992.57
05 704 0800					CENTENNIAL CHOICE FUND BALANCE				
05 1790 0800					CENTENNIAL CHOICE				
07/05/2024	CR	17846			KN Farms & C Ehlers cks	Wagner, Jenny	0.00	430.00	
07/05/2024	CR	17854			ham. patties - centennial lunch fund	Richters, Nancy	0.00	128.00	
05 704 0800					CENTENNIAL CHOICE FUND BALANCE				558.00
									16,550.57
05 704 0801					DISTRICT REIMBURSEMENT FUND BALANCE				(916.34)
						0.00	0.00	0.00	(916.34)
05 704 0900					GENERAL FUND BALANCE				5,231.81
05 704 0900					GENERAL FUND BALANCE				
05 1750 0900					GENERAL (CEA) POP MACHINE				
07/30/2024	CR	17858			Coca-Cola	Wagner, Jenny	0.00	54.42	
05 2900 610 000 0 000 0900					GENERAL SUPPLIES				
07/30/2024	CD	1708200115522	5	11	Deposit Books for activity fund	DELUXE SMALL BUSINESS	195.56	0.00	
05 704 0900					GENERAL FUND BALANCE				(141.14)

Activity Fund Balance Report - Detail - Exclude Encumbrances

07/2024 - 07/2024

Regular; Beginning Month 07/2024; Processing Month 07/2024; Accounts to Include Accounts with Activity; Fund Number 05

Fund: 05 ACTIVITIES FUND

Chart of Account Number

Chart of Account Description

Entry Date JR Reference # Check Acct Check # Description

Entity Name

Expenses

Revenues

Balance Change

Balance

*Ending Balance:

195.56

54.42

0.00

5,090.67

Fund Total: 05

17,870.50

57,862.90

0.00

121,509.03

Register Report

6/1/2024 through 7/31/2024

Date	Account	Num	Description	Memo	Category	Tag	Tax ...	Clr	Amount
BALANCE 5/31/2024									33,907.11
6/5/2024	Elementary	7054	...Printing Center USA		[Pictures]	year book			R-103.51
				Amount left to p...	[Fundraiser]	year book			R-31.41
6/27/2024	Elementary	7055	Amazon Capital Services	Elem. Supplies f...	[Supplies Grant]	supplies			R-1,679.15
7/11/2024	Elementary	884563	Bayer	Donation for 2025	[Camp Invention]	Camp Invention			R8,600.00
6/1/2024 - 7/31/2024									6,785.93
BALANCE 7/31/2024									40,693.04
TOTAL INFLOWS									8,600.00
TOTAL OUTFL...									-1,814.07
NET TOTAL									6,785.93

<u>Vendor Name</u>		<u>Vendor Description</u>	<u>Amount</u>
Checking	1		
Checking	1	Fund: 01 GENERAL FUND	
ALICAP		INSURANCE	238,994.00
ALL COPY PRODUCTS, INC		SUPPLIES	3,374.99
AMAZON CAPITAL SERVICES		SUPPLIES	4,728.17
ARNOLD MOTOR SUPPLY		AUTO PARTS	116.64
BARGEN, JENNIFER		REIMBURSEMENT	120.27
BEAVER HARDWARE		FACILITY SUPPLIES	69.93
BEL-CON REFUSE			40.00
BLACK HILLS ENERGY		NATURAL GAS	342.59
BREITKREUTZ, JESSICA		REIMBURSEMENT	104.69
BULK BOOKSTORE		BOOKS	129.85
BUTLER COUNTY		ELECTION FEES	100.00
Capital One Trade Credit		SUPPLIES	532.00
Capital One		SUPPLIES	153.16
CDW GOVERNMENT, INC		TECHNOLOGY	770.00
CENTENNIAL ACTIVITY FUND		DISTRICT REIMBURSEMENT	76,500.00
CENTENNIAL DEPRECIATION FUND		TRANSFER	170,000.00
CENTRAL NEBRASKA REHABILITATION SERVICES		PHYSICAL THERAPY	2,532.13
CENTRAL VALLEY AG		FUEL	1,594.93
CENTURY HOUSE CHIROPRACTIC INC.			87.00
COLUMN SOFTWARE PBC			115.13
CROWNE PLAZA KEARNEY		LODGING	419.85
CULLIGAN OF CRETE		SUPPLIES	134.25
DAS STATE ACCOUNTING		TELEPHONE	267.63
DATAVIZION			75.64
EASY TIME CLOCK, INC		CLOUD SOFTWARE	101.00
ESU 6			10,610.88
ESU COORDINATING COUNCIL		FEES	294.50
GRAINGER		FACILITY SUPPLIES	213.26
GUMDROP BOOKS		BOOKS	2,000.00
H & S PLUMBING AND HEATING		PLUMBING	408.16
HALI, MCBRIDE			28.48
HD SUPPLY		FACILITY SUPPLIES	2,165.44
HIRERIGHT LLC		PHYSICAL/TESTING	81.55
INNOVATIVE OFFICE SOLUTIONS, LLC		COMPUTER HARDWARE	5,652.47
INSIGHT PUBLIC SECTOR, INC		TECHNOLOGY	1,432.35
INSPIRA		FEES	200.00
J.W. Pepper & Son, Inc.		MUSIC	637.49
JAYMAR BUSINESS FORMS INC		SUPPLIES	317.24
JOURNEY EDUCATION		SOFTWARE	4,306.00
KONICA MINOLTA PREMIER FINANCE		COPIER LEASE	468.43
KOPCHOS SANITATION, INC		SERVICES	782.50
Kosek, Niki			14.38
LIEDTKE, BONITA		REIMBURSEMENT	615.00
MATHESON TRI-GAS INC		WELDING SUPPLIES	570.41
MCCORMICK'S HEATING & AIR CONDITIONING		HVAC MAINTENANCE	7,926.73

<u>Vendor Name</u>	<u>Vendor Description</u>	<u>Amount</u>
MEMORIAL HEALTH CARE SYSTEMS	PHYSICALS	35.00
MIDWEST DOOR AND HARDWARE	REAPIRS/MAIN	36.90
MY CENTRAL SUPPLY		1,191.52
NATIONAL ART & SCHOOL SUPPLIES, INC	SUPPLIES	3,249.87
NE COUNCIL OF SCHOOL ADMIN	FEES	1,110.00
NEBRASKA CENTRAL EQUIPMENT, INC	BUS PARTS/SUPPLIES	451.85
NEBRASKA SAFETY CENTER	BUS DRIVER CLASS	7,350.00
NORRIS PUBLIC POWER DISTRICT	ELECTRICTY	12,872.48
NORTH PRINTING & OFFICE SUPPLY	SUPPLIES	358.60
NORTHWEST EVALUATION ASSOCIATION	STAFF DEV	6,427.50
NOTABLE, INC	WEB/CLOUD	1,685.25
PANKOKE, PEGGY	CENSUS	615.00
PAPER TIGER SHREDDING	SERVICES	60.00
POTTER REPAIR	AUTO REPAIR	2,454.13
PYRAMID SCHOOL PRODUCTS	SUPPLIES	185.76
S & S WORLDWIDE	SUPPLIES	250.88
SOFTWARE UNLIMITED INC	BUSINESS OFFICE SOFTWARE	5,050.00
TEACHER INNOVATION, INC	SUBSCRIPTION	800.00
TEACHING STRATEGIES, LLC	TEXTBOOKS	660.00
TRUCK CENTER COMPANIES	BUS REPAIRS	104.69
UNITE PRIVATE NETWORKS, LLC	WAN FIBER	2,092.36
VERIZON CONNECT		360.05
VERIZON WIRELESS	CELL PHONES	60.08
VILLAGE OF UTICA	WATER/SEWER	1,268.70
WINDSTREAM	TELEPHONE	533.20
YAMBER, DANA	REIMBURSEMENT	285.00
YORK NEWS TIMES	ADV/PRINTING	68.62
ZITO BUSINESS	INTERNET SERVICE	121.69

Fund Total: 589,868.25

Checking Account Total: 589,868.25

August 2024 Board Meeting						
July 2024 Bank Statements		CENTENNIAL PUBLIC SCHOOL TREASURER'S REPORT				
FUND	BANK	TYPE OF INVESTMENT		AMOUNT	INT. REC.	
Lunch Fund	First Bank of Utica	Checking		<u>\$14,937.15</u>		
				Total	\$14,937.15	
Depreciation Fund	Farmers & Merchants	MMA		<u>\$34,014.21</u>	\$9.80	
				Total	\$34,014.21	
Unemployment Ins.	Cornerstone Bank	CD		\$60,061.75	\$331.54	
	Cornerstone Bank	MMA		<u>\$7,503.73</u>	<u>\$6.27</u>	
				Total	\$67,565.48	\$337.81
Building Fund	First Bank of Utica	Building Fund		\$591,075.29	\$1,195.65	
		Bond Fund		<u>\$782,318.02</u>	<u>\$264.99</u>	
				Total	\$1,373,393.31	\$1,460.64
General Account	York State, Gresham	CD		\$191,896.46	\$805.03	
	First Bank of Utica	PayFlex Acct		<u>\$19,620.76</u>		
				Total	\$211,517.22	\$805.03
	First Bank of Utica	Checking		<u>\$2,862,959.52</u>	\$1,468.03	
		General Fund Total	\$3,074,476.74			
		Total Invested All Accounts Combined		<u>\$4,564,386.89</u>		
		Total amount invested at Farmers & Merchants	\$34,014.21			
		Total amount invested at First Bank of Utica	\$4,270,910.74			
		Total amount invested at Cornerstone Bank, Waco	\$67,565.48			
		Total amount invested at York State, Gresham	<u>\$191,896.46</u>			
		Total Invested	\$4,564,386.89			

Activity Fund Balance Report - Summary - Exclude Encumbrances

08/2024 - 08/2024

Regular; Beginning Month 08/2024; Processing Month 08/2024; Accounts to Include Accounts with Activity; Fund Number 05

Fund: 05 ACTIVITIES FUND

<u>Chart of Account Number</u>	<u>Chart of Account Description</u>	<u>Beginning Balance</u>	<u>Expenses</u>	<u>Revenues</u>	<u>Balance Change</u>	<u>Balance</u>
05 704	Fund Balance	(6,276.38)	0.00	0.00	0.00	(6,276.38)
05 704 0003	ATHLETICS FUND BALANCE	(46,816.31)	0.00	0.00	0.00	(46,816.31)
05 704 0050	CONCESSIONS FUND BALANCE	28,725.68	0.00	0.00	0.00	28,725.68
05 704 0052	BRONCO STORE FUND BALANCE	1,364.87	0.00	0.00	0.00	1,364.87
05 704 0053	MARKET 67 FUND BALANCE	1,216.37	0.00	0.00	0.00	1,216.37
05 704 0054	BRONCO CLOSET FUND BALANCE	834.41	0.00	0.00	0.00	834.41
05 704 0055	BRONCO COFFEE & CREATIONS FUND BALANCE	45.38	0.00	0.00	0.00	45.38
05 704 0056	SUMMER CAMPS FUND BALANCE	2,854.92	0.00	0.00	0.00	2,854.92
05 704 0057	PBIS FUND BALANCE	(1,016.14)	0.00	0.00	613.27	(402.87)
05 704 0103	DISTRICT EVENTS FUND BALANCE	25,009.43	0.00	0.00	0.00	25,009.43
05 704 0104	BOYS BASKETBALL FUND BALANCE	3,966.16	0.00	0.00	0.00	3,966.16
05 704 0105	CROSS COUNTRY FUND BALANCE	333.90	0.00	0.00	0.00	333.90
05 704 0106	FOOTBALL FUND BALANCE	625.96	0.00	0.00	0.00	625.96
05 704 0107	GIRLS BASKETBALL FUND BALANCE	602.91	0.00	0.00	0.00	602.91
05 704 0108	GOLF FUND BALANCE	(63.69)	0.00	0.00	0.00	(63.69)
05 704 0109	SOFTBALL FUND BALANCE	485.62	0.00	0.00	0.00	485.62
05 704 0115	TRACK FUND BALANCE	372.73	0.00	0.00	0.00	372.73
05 704 0116	VOLLEYBALL FUND BALANCE	4,269.33	0.00	0.00	0.00	4,269.33
05 704 0117	WRESTLING FUND BALANCE	2,553.98	0.00	0.00	0.00	2,553.98
05 704 0118	BASEBALL FUND BALANCE	658.78	0.00	0.00	0.00	658.78
05 704 0119	GIRLS WRESTLING FUND BALANCE	783.72	0.00	0.00	0.00	783.72
05 704 0204	JH BOYS BASKETBALL FUND BALANCE	18.35	0.00	0.00	0.00	18.35
05 704 0207	JH GIRLS BASKETBALL FUND BALANCE	1,588.82	0.00	0.00	0.00	1,588.82
05 704 0215	JH TRACK FUND BALANCE	271.10	0.00	0.00	0.00	271.10
05 704 0216	JH VOLLEYBALL FUND BALANCE	36.23	0.00	0.00	0.00	36.23
05 704 0301	ART FUND BALANCE	19.59	0.00	0.00	0.00	19.59
05 704 0302	BAND TRIP FUND BALANCE	8,649.05	0.00	0.00	(8,649.05)	0.00
05 704 0303	DANCE/CHEER FUND BALANCE	(552.07)	0.00	0.00	0.00	(552.07)
05 704 0305	FBLA FUND BALANCE	1,379.73	0.00	0.00	0.00	1,379.73
05 704 0306	FCCLA FUND BALANCE	2,506.29	0.00	0.00	0.00	2,506.29
05 704 0307	FFA FUND BALANCE	35,711.64	0.00	0.00	0.00	35,711.64
05 704 0308	MUSICAL FUND BALANCE	8,213.46	0.00	0.00	0.00	8,213.46
05 704 0309	NHS FUND BALANCE	0.00	0.00	0.00	0.00	0.00
05 704 0311	ONE ACT FUND BALANCE	1,221.00	0.00	0.00	0.00	1,221.00
05 704 0312	QUIZ BOWL FUND BALANCE	749.24	0.00	0.00	0.00	749.24
05 704 0313	SHOW CHOIR FUND BALANCE	(6,751.95)	0.00	0.00	4,158.69	(2,593.26)

Activity Fund Balance Report - Summary - Exclude Encumbrances

08/2024 - 08/2024

Regular; Beginning Month 08/2024; Processing Month 08/2024; Accounts to Include Accounts with Activity; Fund Number 05

Fund: 05 ACTIVITIES FUND

<u>Chart of Account Number</u>	<u>Chart of Account Description</u>	<u>Beginning Balance</u>	<u>Expenses</u>	<u>Revenues</u>	<u>Balance Change</u>	<u>Balance</u>
05 704 0314	SPEECH FUND BALANCE	653.14	0.00	0.00	0.00	653.14
05 704 0315	STUDENT COUNCIL FUND BALANCE	2,748.73	0.00	0.00	0.00	2,748.73
05 704 0316	UNIFIED ACTIVITIES FUND BALANCE	205.90	0.00	0.00	0.00	205.90
05 704 0317	ISTRUMENTAL MUSIC	(3,490.74)	0.00	0.00	3,490.74	0.00
05 704 0318	VOCAL MUSIC FUND BALANCE	(999.62)	0.00	0.00	999.62	0.00
05 704 0319	MIDDLE SCHOOL QUIZ BOWL FUND BALANCE	1,270.14	0.00	0.00	0.00	1,270.14
05 704 0320	FCA FUND BALANCE	274.62	0.00	0.00	0.00	274.62
05 704 0321	EdRISING FUND BALANCE	196.35	0.00	0.00	0.00	196.35
05 704 0322	CLOSE UP FUND BALANCE	0.00	0.00	0.00	0.00	0.00
05 704 0401	CLASS 2021 FUND BALANCE	613.27	0.00	0.00	(613.27)	0.00
05 704 0403	CLASS 2023 FUND BALANCE	0.00	0.00	0.00	0.00	0.00
05 704 0405	CLASS 2024 FUND BALANCE	0.00	0.00	0.00	0.00	0.00
05 704 0406	CLASS 2025 FUND BALANCE	3,181.56	0.00	0.00	0.00	3,181.56
05 704 0407	CLASS 2026 FUND BALANCE	2,517.08	0.00	0.00	0.00	2,517.08
05 704 0408	CLASS 2027 FUND BALANCE	407.36	0.00	0.00	0.00	407.36
05 704 0702	CHROMEBOOK ASSURANCE FUND BALANCE	3,408.95	0.00	0.00	0.00	3,408.95
05 704 0704	JH YEARBOOK FUND BALANCE	(1,083.08)	0.00	0.00	1,083.08	0.00
05 704 0705	LIBRARY FUND BALANCE	240.21	0.00	0.00	0.00	240.21
05 704 0706	SCIENCE FUND BALANCE	890.81	0.00	0.00	0.00	890.81
05 704 0707	WEIGHT ROOM FUND BALANCE	8,214.80	0.00	0.00	0.00	8,214.80
05 704 0708	YEARBOOK FUND BALANCE	5,462.35	0.00	0.00	(1,083.08)	4,379.27
05 704 0709	SHOP/TECH FUND BALANCE	2,319.10	0.00	0.00	0.00	2,319.10
05 704 0710	CHESS CLUB FUND BALANCE	161.09	0.00	0.00	0.00	161.09
05 704 0800	CENTENNIAL CHOICE FUND BALANCE	16,550.57	0.00	0.00	0.00	16,550.57
05 704 0801	DISTRICT REIMBURSEMENT FUND BALANCE	(916.34)	0.00	0.00	0.00	(916.34)
05 704 0900	GENERAL FUND BALANCE	5,090.67	0.00	0.00	0.00	5,090.67
Fund Total: 05		<u>121,509.03</u>	<u>0.00</u>	<u>0.00</u>	<u>0.00</u>	<u>121,509.03</u>

Account Balances - As of 8/8/2024

Account	8/8/2024 Balance
Bank Accounts	
Elementary	35,207.83
Reading Classic	0.00
Savings	3,007.18
TOTAL Bank Accounts	38,215.01
Liability Accounts	
BACKPACK	-12,823.23
Books	-953.84
Boxtops	-1,685.84
Camp Invention	-8,600.00
Fundraiser	-8,897.55
General	-2,137.03
Girls on the Run	-363.94
Pictures	0.00
Polk Grant	0.00
Supplies Grant	-1,439.30
TOTAL Liability Accounts	-36,900.73
OVERALL TOTAL	1,314.28

KSB SCHOOL LAW

6000 Series M E M O R A N D U M

The 6000 series of policies address curricular and academic issues. We provide a description of the policies in the paragraphs below. Many of the policies in this series will apply without modification, but each one should be reviewed carefully to make sure that it conforms to your school district's practices.

Policy 6001. School Organization. We have two separate versions of Policy 6001 contained in this document. They define the school as organized in either K-6 and 7-12 or K-5, 6-8, and 9-12 schools. **You must select the version of this policy to describe how your board has organized your school district and delete the other option.**

Policy 6002. School Calendar. This is a standard policy about the school calendar. We believe it is best practice for the administrative team to propose the calendar. Some schools involve the teachers and/or parent organizations in creating the calendar. If that is your practice, we will be happy to help you revise this policy, although we believe that is not best practice.

Policy 6003. Instructional Program. This is a standard policy about the instructional program. You must fill in the number of instructional hours in the first paragraph.: The hours shown above are the minimum number of instructional hours for each corresponding grade as required by Nebraska law and NDE regulation. They may be, but are not required to be, adjusted upward at the board's discretion.

Policy 6004. Curriculum Development. This is a standard policy about curriculum development. Please note that this policy expressly places on principals the responsibility to ensure that teachers are teaching the curriculum and likewise places responsibility on the superintendent to hold principals accountable for implementation of the curriculum.

Policy 6005. Academic Credits and Graduation. This policy is the placeholder where the board should insert its standards for academic credits and graduation.

Policy 6006. Commencement Ceremony. This policy contains two options regarding the commencement ceremony. One permits a student who is within a specified number of credits to participate in the ceremony without receiving a diploma. The second permits all seniors to participate in the ceremony. **You must select one option and delete the other.**

Policy 6007. Senior Recognition. This policy addresses recognition of academic achievement by graduating seniors. The board should fill in the standards that the district uses. Note that you are not required to follow any particular process for recognizing academic achievement of graduating students.

Policy 6008. Class Rank. This policy addresses class rank. It is not required by state law, but this is always a politically charged issue. We have highlighted areas where the board should exercise its discretion to set standards. This is another area where school districts vary widely in their past practice. Please let us know if you would like our assistance in creating a policy which describes your board's decisions in this area.

Policy 6009. Grade Placement and Academic Credits of Transfer Students. This policy sets forth the criteria for determining the grade placement of transfer students, and addresses what credits the district will accept from both accredited and from exempt (home) schools.

Policy 6010. Special Education Identification, Evaluation and Verification. This policy guarantees the district will comply with the rules and protocols of the Nebraska Department of Education and the United States Department of Education identifying, evaluating, verifying and serving students who may be entitled to rehabilitation or special education services.

Policy 6011. Fire Instruction and Prevention. This policy states that the district will provide regular periods of fire instruction and will observe State Fire Day as required by statute.

Policy 6012. Flag Display and Patriotic Observances. This policy confirms the state statute requiring that the district display the U.S. and state flags. It also implements the requirements of Rule 10 related to the recitation of the pledge of allegiance.

Policy 6013. Teaching Controversial Issues. This policy addresses the teaching of controversial issues and sets forth criteria for teachers to follow when teaching or leading discussions.

Policy 6014. School Attendance on Days of Scheduled Activities. This policy requires students to attend regularly scheduled classes on days when they participate in any student activity. Be sure to check with your secondary administrators to determine what their current practice is related to student absences and school activities. If your district has a different practice let us know and we can help you update this policy.

Policy 6015. Summer School. This policy authorizes the school district to conduct a summer school program for students who need remedial help and for enrichment purposes. Your board will need to decide if it will allow a student who retakes a course in the summer to replace a lower grade earned during the regular school year for purposes of class rank. These can become sensitive political issues, so your board should also consult with your secondary administrative team to receive their input on this issue.

Policy 6016. Homebound and Off-Campus Instruction. This policy addresses homebound and other forms of off-campus instruction. Although the majority of students who are served in these settings are students with some sort of disability, there are times when a general education student is not able to attend school for a prolonged period but is not legally disabled. When special education students are placed in a homebound or off-campus setting, the board should be mindful that it is the student's IEP team and not the administration or board of education that determines the details of that placement.

Policy 6017. Homework. Although not legally required, many boards of education would like to have a broad policy statement on the value of homework. Some boards also want to place restrictions on the amount of work assigned by teachers overall or on Wednesday nights. We are aware that with the advent of flipped classrooms and 1:1 programs, the entire concept of homework is in flux. Again, your board should discuss its unique approach to this issue and let us know if you would like our assistance in crafting a customized policy.

Policy 6018. Grades. This is a standard policy on issuing grades. For special education law purposes, it is important that the board have a standard interval during which the school will communicate grades and academic progress to general education students.

Policy 6019. [Intentionally Left Blank]

Policy 6020. Multicultural Education. This is a standard policy on fostering and developing an appreciation and understanding of the racial, ethnic and cultural heritage of all students. Rule 10 requires that the board

receive an annual report on the multicultural education program. This policy places the responsibility for delivering that report on the superintendent.

Policy 6021. District Criteria for Selecting Evaluators to be Used for Special Education. This policy is required by Rule 51 of the Nebraska Department of Education. This policy can be no more restrictive than the criteria you would apply when seeking your own evaluations. Please review and update the highlighted paragraph in consultation with your special education staff and providers to ensure that it accurately reflects the boundaries you would recognize for the school district's own evaluations, noting where certain specialized assessments or evaluations will require travel outside the generally applicable geographical area.

Policy 6022. [Intentionally Left Blank]

Policy 6023. [Intentionally Left Blank]

Policy 6024. [Intentionally Left Blank]

Policy 6025. Student Cell Phone and Other Electronic Devices. The pendulum of school policy on banning or allowing students to possess and use cell phones at school continues to swing. This policy attempts to capture what we believe most schools do related to this issue by providing several options. They range from a fairly flexible version that permits students to use phones outside of class time, to options that require students to use devices like Yondr bags or an outright ban on having cell phones at school. Please review the options and the paragraphs within the option you choose to ensure it aligns with your school's preference. We are more than happy to help you tweak any of the options or create a new one that aligns with your practices.

Policy 6026. Emergency Dismissal. This policy gives the superintendent or his/her designee the responsibility for determining whether and when to cancel or dismiss extracurricular activities because of inclement weather or emergency conditions.

Policy 6027. Field Trips. This is a standard policy on field trips. Note that this policy requires principal approval for in-state field trips and board approval for out-of-state field trips. If your district follows a different protocol be sure to review this policy or reach out to one of the KSB attorneys to revise it for you. Also be sure to share this policy with all staff and volunteers who supervise student trips.

Policy 6028. The Extracurricular Activities Program. This is a standard policy about the purposes and governance of extracurricular programs. Please

note the highlighted sentence which states that the superintendent assigns extracurricular sponsorship. We strongly believe that this is best practice. A few school boards persist in appointing coaches and other activity sponsors at the board level. If that is your practice, you should modify this sentence accordingly.

Policy 6029. Activity Trips. This policy governs transportation and conduct on activity trips.

Policy 6030. Public Appearances of School Groups. This policy addresses school groups making public appearances. We have had a few issues over the years in which students have performed at political rallies or similar events that could create the public perception that a district officially supports a candidate or ballot issue. There is also the possibility that a school group is asked to perform at an event that could create political headaches for the board. Like singing the national anthem at a lingerie football league game. In order to avoid these problems, this policy requires that building principals approve the public performance of any student group.

Policy 6031. Emergency Exclusion Procedure. This policy governs the procedure for extending an emergency exclusion under the Student Discipline Act. It is required if a school district ever wishes to extend a student's emergency exclusion beyond an initial 5-day period. This has become an increasingly important policy, so administrators should be familiar with the procedures in this policy.

The law requires the process for an extended emergency exclusion to be substantially similar to the process for long-term discipline, including notice and an opportunity for a hearing. However, the statutes also permit the school to modify its emergency exclusion process to account for the tight timelines involved in providing due process during emergency exclusion extensions. Our policy takes advantage of that necessary flexibility, but administrators will still need to be on top of these shortened timelines any time they propose to extend an emergency exclusion beyond 5 days.

Policy 6032. Constitution Day Education. This policy meets the statutory requirement for observing Constitution Day on September 17th.

Policy 6033. Seclusion and Restraint. The restraint and seclusion of students has been the subject of national attention and lawsuits. This policy provides definitions, guidelines, procedures, and staff requirements. You should review this policy carefully with your staff and ensure it is wholly consistent with your present practices.

Policy 6034. Concussion Awareness. This policy meets the requirements of Nebraska law and outlines each school's obligations for compliance with those requirements for student concussions. It requires training for all coaches, notifications to families, and "return to learn" protocols as adopted by NDE. We have included applicable forms, and if you have forms you use already we would be happy to review them. You should review these requirements in detail even if you make no changes to this policy.

Policy 6035. Athletic Contest Participation by Sixth Graders. Section 004.02C of Rule 10 allows schools to include sixth grades students in interscholastic athletic competitions involving seventh and eighth grade students when (1) combined enrollment for seventh and eighth grade becomes fewer than 12 boys or 12 girls and (2) if the school board or local governing body has a policy regulating participation for sixth graders. This is the recommended policy.

Policy 6036. Reading Instruction and Intervention Services. The Nebraska Reading Improvement Act expresses the Unicameral's intent that all students in public schools be able to read at or above grade level by third grades. In order to meet this goal, school boards are required to develop policies to facilitate reading instruction and intervention services to address student reading needs, including, but not limited to, dyslexia. Beginning with the 2019-20 school year, schools will be required to administer reading assessments approved by NDE three times per school year to all students in kindergarten through third grade. Schools will also be required to provide supplemental reading intervention programs to students identified with reading deficiencies to ensure that they are reading at or above grade level by the end of third grade. This policy addresses all of the requirements of the Act.

Policy 6037. Selection and Review of Library Materials. We want to be clear that this policy is *optional*. Many districts have functioned for decades without a policy covering the procurement and review/challenges to library materials. However, we also know that in times of political pressure, it may help to have a process laid out for how materials are selected and then later challenged by concerned individuals. Within the policy, we have laid out 3 options for the selection of library materials and 2 options for review of those materials when someone has a concern. We also place limits on who can make such a request, how many items can be challenged at once, and how often items can be challenged. You should review the policy and its options carefully before deciding if you want to adopt it at all, and if you do, which option best suits the preferences of your board and administration. You can also elect to eliminate either the selection section or the review section and use only the other portion of the policy. For example, many schools are

satisfied with their current library material selection practices utilized by their librarians/media specialists, but they like having a clear policy to use when an individual wants a library material removed or restricted. If that makes sense to you, you can simply delete the selection section and keep the review section—or vice-versa. We have also included forms for individuals who wish to challenge a library material and a draft response letter you can use to create a response after the challenged material is reviewed. Those are in the 5000 series forms.

Most importantly, we want to make clear that this policy applies only to library materials. Core curricular materials and curriculum-related supplements are not intended to be covered by this policy. Those are covered elsewhere, such as in your parent involvement policy, and parent and patron rights to access those materials are governed by state and federal law. We also do not want patrons or parents to believe they can challenge actual curriculum materials—in most cases, they can review but cannot opt-out or ask for those to be removed. That is generally true regardless of the reason for their objection—religious, political, or otherwise.

Policy 6038. Artificial Intelligence. This is an optional policy. We have received questions from several clients about a board policy on the extent to which students may permissibly use artificial intelligence tools “AI Tools” (such as ChaptGPT and other chatbots) in connection with school assignments. This policy lays out (1) the board’s approval of using AI Tools in connection with academic assignments, and (2) details the minimum requirements and expectations for such use.

Under this policy, teachers are responsible for determining the extent to which a student may permissibly use AI Tools in connection with any specific assignment and the policy imposes certain minimum requirements that students using such tools must meet (including disclosure and proper attribution). Please note that the criteria laid out in this policy are not in response to legal requirements. Rather, this policy provides a practical framework for your teaching staff to consider whether and how AI Tools can and should be used in connection with school assignments. The policy also clarifies that student use of AI Tools should be consistent with expectations of academic honesty when using other sources of information. If the board is inclined to adopt this policy (or a version of it), we strongly encourage the board to consult with the administration (who may work with the teaching staff) to ensure that the framework and expectations are consistent with the teaching practices.

Policy 6039. Repeat of Grade at Parent-Guardian Request. This policy implements the state law requirements that permits parents to request their

child repeat grades K-4 based on academic needs, absenteeism, or illness, and repeat a grade in 5-12 based on absenteeism. The policy places certain timelines on parents to make the requests at the end of the school year they would like to repeat. This is because the 3 reasons for K-4 and 1 reason for 5-12 repetitions are tied to a school year. We also require the initial request to be submitted to the building principal so that the principal can provide the superintendent with all of the information on things like attendance that will be needed to respond to the request. Please note that many of the headlines implied parents get sole discretion on grade repetition, but that is just not true. For a K-4 or 5-12 student to repeat a grade, they must meet the applicable criteria. The process also includes NDE reporting requirements and use of a form created by NDE.

Policy 6040. Prekindergarten (Preschool or Early Childhood) Program. Schools are not required to have Pre-K programs. If you do have one, state law permits school-operated Pre-K programs some flexibility in determining how many years students may attend preschool and flexibility for prioritizing which students schools want to attend. It also allows capacity limitations. This policy is designed to set up the framework for you to use if your school has a Pre-K program. It highlights those areas you'll need to fill in to account for how you run your program, which ages of students you prioritize, and capacity limitations. If you don't have a Pre-k program run by your school, don't adopt this policy and just leave 6040 as "Intentionally Left Blank."

Policy 6041. Malcolm X Day Education. May 19th is Malcolm X Day in Nebraska, and state law requires schools to hold suitable exercises and learning opportunities in recognition of Malcolm X on that date (similar to Veterans Day). This policy addresses this requirement and explains how schools must celebrate the day if May 19 happens to fall on a weekend. Interestingly, the implementing legislation was silent on what schools must do if some or all students are already done with the school year by May 19, which is a real possibility in years where there are few snow days. Our policy is also silent, because we interpret the Unicameral's silence to mean you only need to have a Malcolm X Day service if school is in session.

Policy 6042. Projection Maps. Whether it was a nod of deference to the hit 2000s TV show "The West Wing" or the effectiveness of map makers lobbyists, state law now limits the use of Mercator projection maps in schools. This policy (required by law) lays out the limited circumstances in which you can still use a Mercator projection map standing alone or within a textbook, and it generally requires you to use a Gall-Peters projection map or AuthaGraph projection map at the same time. Thank goodness for "local" control.

Policy 6043. Mapping Data. State law provides for grant funding and authority for schools to create and share school building/property mapping data with public safety agencies like law enforcement. From a public safety perspective, this allows more efficient response in the event of a crisis situation. However, in order to take advantage of the grant funding and ability to share this data with safety officials, you must have a policy that meets the requirements of the implementing legislation. This policy lays those out.

5001 Compulsory Attendance and Excessive Absenteeism

Required Attendance

Every person residing in the school district who has legal or actual charge or control of any child who is of mandatory attendance age shall cause that child to attend a public or private school regularly unless the child has graduated from high school or has been allowed to disenroll pursuant to this policy.

Mandatory Attendance Age

All children who are or will turn six years old before January 1 of the current school year are of mandatory attendance age. Children who have not turned eighteen years of age are of mandatory attendance age.

Exceptions

This policy does not apply when attendance is made impossible or impracticable by severe weather conditions or by the **temporary mental or physical** illness of the student or a child whom the student is parenting.

A child who will not reach age 7 before January 1 of the current school year may be excused from mandatory attendance if the child's parent or guardian completes an affidavit affirming that alternative educational arrangements have been made for the child. A copy of the required affidavit is attached to this policy.

Discontinuing Enrollment – 5 Year Old Students

The person seeking to discontinue the enrollment of a student who will not reach six years of age prior to January 1 of the current school year shall submit a signed, written request and to the superintendent using the form which is attached to this policy. The school district may request written verification or documentation that the person signing the form has legal or actual charge or control of the student. The school district shall discontinue the enrollment of any student who satisfies these requirements. Any student whose enrollment is discontinued under this subsection shall not be eligible to reenroll in this school district until the beginning of the following school year unless otherwise required by law.

Discontinuing Enrollment – 16 and 17 Year Old Students

Only children who are at least 16 years of age may be disenrolled from the district. The person seeking to discontinue the child's enrollment shall submit a signed, written request and submit it to the superintendent using the form which is attached to this policy. The district will follow the procedures outlined on the attached form in considering requests to disenroll.

Only children disenrolling to attend ~~a non-accredited~~ **an exempt** school may be exempt from this policy. The person with legal or actual charge or control of the child must provide the superintendent with a copy of the signed request submitted to the State Department of Education for attending ~~non-accredited~~ **exempt** schools. The superintendent may confirm the validity of the submission with the State Department of Education.

Attendance Officer

Each building principal is designated as an attendance officer for the district. Each building principal, at his or her discretion, may delegate these responsibilities to any other qualified individual. The attendance officer is responsible for enforcing the provisions of state law relating to compulsory attendance. This responsibility includes but is not limited to filing a report with the county attorney of the county in which a student resides. Compensation for the duties of attendance officer is included in the salary for the superintendent or designee.

Excused Absences

Absences should be cleared through the Principal's office in advance whenever possible. An absence or tardy, even by parental approval, may not be excused. All absences, except for illness and/or death in the family, require advance approval. An absence for any of the following reasons will be excused, provided the required procedures have been followed:

- (A) Attendance at a funeral for a member of the immediate family (parents, siblings, and grandparents),
- (B) Physical or mental illness which causes a student to be absent from school (A doctor's note will be required after four consecutive days absent for illness OR if the school nurse sent the student home), NOTE: Just because a student visited the school nurse does not mean that going home will be excused.
- (C) Medical appointments which require student to be absent from school,

(with note from doctor or dentist to verify excuse)

(D) Court appearances that are required by a court order and the student is not responsible for needing to be in court,

(E) School sponsored activities which require students to be absent from school,

(F) Family trips in which student accompanies parent(s)/legal guardian(s) IF AND ONLY IF the following conditions are met: 1) approval by the principal in advance; 2) the student communicates with all of his/her teachers prior to the trip and makes mutually agreed upon plan with each teacher for completing work prior to the trip and/or setting due dates for work that can be completed upon the student's return to school; 3) successfully meeting all deadlines for schoolwork set forth in condition #2.

(G) Severe Weather

(H) Suspensions and Expulsions

(I) Other absences which have received prior approval from the Principal.

Excessive Absenteeism

When a student receives 5 unexcused absences or the hourly equivalent in any semester, the Attendance Officer will follow the handbook procedure for addressing barriers to the student's attendance.

When a student is absent more than twenty days per year or the hourly equivalent and any portion of the absences is unexcused, the Attendance Officer may/must file a report with the county attorney of the county in which the student resides. For example, if the student accumulates 23 days of excused absences due to documented illness and is tardy one time, the Attendance Officer may/must file a report with the appropriate county attorney.

Making Up Absences (Optional – Remove or revise based on your District's practices.)

When a student receives 10 unexcused absences or the hourly equivalent in any semester, the student shall be required to make up those absences through attendance in detention, summer detention, or Saturday school. Absences shall be made up at a rate of 30 minutes per missed class period.

Adopted on: 7/10/2017

Revised on: 7/11/2022

Reviewed on: 4/11/2022, 2-12-2024

5055

Enrollment in Kindergarten

A child must reach the age of five on or before July 31st of the calendar year to be enrolled in kindergarten. The school district will enroll a child who will reach the age of five between August 1st and October 15th of the year of enrollment if the parent or guardian requests such enrollment and provides an affidavit stating:

- (a) the child attended kindergarten in another jurisdiction in the current school year; or
- (b) the family anticipates relocating to another jurisdiction that would allow admission within the current year; or
- (c) the child has demonstrated through recognized assessment procedures approved by the board that he or she is capable of performing the work of kindergarten.

The recognized assessment procedure approved by the board is the administration of the Wechsler Preschool and Primary Scale of Intelligence -Third Edition and the Stanford-Binet: Fifth Edition to measure cognitive ability, the Woodcock-Johnson Tests of Achievement and the Wechsler Individual Achievement Test for academic achievement, and the Beery Visual Motor Integration Test for visual-fine motor skills, all of which are administered by an ESU 6 psychologist.

The board delegates to the elementary principal responsibility for determining whether the conditions of this policy have been met. In order to enroll in kindergarten early, students must achieve a score of at least "Meets Requirements" in all four areas (Cognitive, Early Academics Reading, Early Academics Math, and Fine Motor).

Each year, the district will have a kindergarten Enrollment and Assessment Period ("Assessment Period"). Parents or guardians whose child is a legal resident of the district wishing to enroll pursuant to this policy must complete all requirements for enrollment no later than the end of the Assessment Period. The assessment request and parent questionnaire must be completed and returned to the District no later than May 20th of the spring before fall enrollment to allow summer assessment to be completed.

Parents or guardians of students who become legal residents of the district after the Assessment Period, and thus were unable to participate in the Assessment Period,

must contact the elementary principal about registering and/or scheduling a time for assessment.

Adopted on: _____

Revised on: _____

Reviewed on: _____



Memorandum

DATE: August 12th, 2024

TO: Centennial Board of Education

FROM: Seth Ford, superintendent

SUBJECT: Surplus Property

As per Board Policy #3019, the following items need to be declared surplus so that we may sell, recycle, or otherwise dispose of them.

- 40 - 2"x6"x16' boards previously used for concrete forms
- 2 sets of 4 gym lockers - Small Gym Locker Room



2025 IC Bus, CE Series 65-2

PB110

Dash Air Conditioning

Underfloor Luggage Compartments, Interior Racks

LED Exterior Lights, LED Headlights, LED Domes

Tire Pressure Monitor System

Safety-Star Premium Package

Appearance Package

36 Month/50,000 Extended Warranty

Sales Proposal For:

Cornhusker Int'l Stock Bus

Presented By:

CORNHUSKER INTERNATIONAL TRUCKS, INC

May 02, 2023

Prepared For:

Cornhusker Int'l Stock B Russ Folts
3131 Cornhusker Hwy
Lincoln, NE 68504-1593
(402)331 - 8801
Reference ID: 2025 65-2

Presented By:

CORNHUSKER INTERNATIONAL
TRUCKS, INC
R
ussell Folts 3131
CORNHUSKER
HIGHWAY
LINCOLN NE 68504 -
(402)466-8461

Thank you for the opportunity to provide you with the following quotation on a new IC Corporation vehicle. I am sure the following detailed specification will meet your operational requirements, and I look forward to serving your business needs.

**Model
Profile
2025 CE
SCHOOL
BUS
(PB110)**

AXLE CONFIG:

4X2

APPLICATION:

School Transportation

MISSION:

Requested GVWR: 27500. Calc. GVWR: 29800
Calc. Start / Grade Ability: 26.39% / 2.07% @ 55 MPH
Calc. Geared Speed: 88.6 MPH

DIMENSION:

Wheelbase: 254.00, CA: N/A, Axle to Frame: 152.00

ENGINE, DIESEL:

{Cummins B6.7 250} EPA 2021, 250HP @ 2400 RPM, 660 lb-ft Torque @ 1600 RPM, 2600 RPM
Governed Speed, 250 Peak HP (Max), School Bus Only

TRANSMISSION, AUTOMATIC:

{Allison 2500 PTS} 6th Generation Controls, Wide Ratio, 6-Speed with Double Overdrive, Less
PTO Provision, Less Retarder, with 33,000-lb GVW and GCW Max, School Bus
Omit Item (Clutch & Control)

CLUTCH:

AXLE, FRONT NON-DRIVING:

{Dana Spicer E-1002IR} I-Beam Type, 10,000-lb Capacity

AXLE, REAR, SINGLE:

{Dana Spicer S140} Single Reduction, 19,800-lb Capacity, 190 Wheel Ends Gear Ratio: 5.57

TIRE, FRONT:

(2) 11R22.5 Load Range H R89 ALL POSITION (PIRELLI), 501 rev/mile, 75 MPH, All-Position

TIRE, REAR:

(4) 11R22.5 Load Range H R89 CS (PIRELLI), 494 rev/mile, 75 MPH, Drive

SUSPENSION, REAR, SINGLE:

19,800-lb Capacity, Two Stage Vari-Rate Springs

PAINT:

Cab schematic 100NB

Location 1: 4421, School Bus Yellow (Std)

Chassis schematic N/A

Description

Base Chassis, Model CE SCHOOL BUS with 254.00 Wheelbase, N/A CA, and 152.00 Axle to Frame.

BODY PLANS

BODY, BUS Conventional; 78" Headroom, 31'11" Body Length, 71 Passenger, 254 WB

BODY PLAN, NON-SPECIAL NEEDS for CE, 31' 11" Body Length, 65 Passenger, 254" WB, DM0048A000

BODY PLAN, APPROVED VARIATION Number 001

AXLE CONFIGURATION

AXLE CONFIGURATION {Navistar} 4x2

ENGINE

ENGINE, DIESEL {Cummins B6.7 250} EPA 2021, 250HP @ 2400 RPM, 660 lb-ft Torque @ 1600 RPM, 2600 RPM Governed Speed, 250 Peak HP (Max), School Bus Only

CARB EMISSION WARR COMPLIANCE Federal, Does Not Comply with CARB Emission Warranty

CARB IDLE COMPLIANCE Federal, Does Not Comply with California Clean Air Idle Regulations

EMISSION, CALENDAR YEAR {Cummins B6.7} EPA, OBD and GHG Certified for Calendar Year 2023

RADIATOR Aluminum, 2-Row, Down Flow, Front to Back System, 640 SqIn Louvered, with 383 SqIn Charge Air Cooler, Includes In-Tank Oil Cooler

Includes

: RADIATOR HOSES Premium, Rubber

FAN DRIVE {Warner Electric FC550} On/Off Type, Electronically Activated and Controlled

Includes

: FAN Nylon

AIR CLEANER Single Element, Fire Retardant Media

ANTI-FREEZE Red, Extended Life Coolant; To -40 Degrees F/ -40 Degrees C, Freeze Protection

BLOCK HEATER, ENGINE {Phillips} 120V/750W, for Cummins ISB/B6.7 Engines

Includes

: BLOCK HEATER SOCKET Receptacle Type; Mounted in Center Through Front Bumper

CRUISE CONTROL Electronic

OIL PAN 15 Quart Capacity, For Cummins ISB/B6.7 Engines

THROTTLE, HAND CONTROL Electronic

TRANSMISSION

TRANSMISSION, AUTOMATIC {Allison 2500 PTS} 6th Generation Controls, Wide Ratio, 6-Speed with Double Overdrive, Less PTO Provision, Less Retarder, with 33,000-lb GVW and GCW Max, School Bus

NEUTRAL AT STOP OMIT

SHIFT CONTROL PARAMETERS {Allison} 1000 or 2000 Series Transmissions, Performance Programming

TRANSMISSION OIL Synthetic; 20 thru 28 Pints

TRANSMISSION SHIFT CONTROL Column Mounted Stalk Shifter, for Allison 1000 & 2000 Series Transmission

Description
CLUTCH

CLUTCH Omit Item (Clutch & Control)

REAR AXLES, SUSPENSIONS

AXLE, REAR, SINGLE {Dana Spicer S140} Single Reduction, 19,800-lb Capacity, 190 Wheel Ends . Gear Ratio: 5.57

SUSPENSION, REAR, SINGLE 19,800-lb Capacity, Two Stage Vari-Rate Springs

SHOCK ABSORBERS, REAR (2)

FRONT AXLES

AXLE, FRONT NON-DRIVING {Dana Spicer E-1002IR} I-Beam Type, 10,000-lb Capacity

FRONT SUSPENSIONS

SUSPENSION, FRONT, SPRING Parabolic Taper Leaf, Shackle Type, 10,000-lb Capacity, with Shock Absorbers

Includes

: SPRING PINS Rubber Bushings, Maintenance-Free

CABS, COWLS, BODIES

COWL Flat Back

AIR CONDITIONER with Integral Heater and Defroster

CAB INTERIOR TRIM Classic, for Day Cab

GAUGE CLUSTER Base Level; English with English Electronic Speedometer

Includes

: GAUGE CLUSTER DISPLAY: Base Level (3" Monochromatic Display), Premium Level (5" LCD Color Display); Odometer, Voltmeter, Diagnostic Messages, Gear Indicator, Trip Odometer, Total Engine Hours, Trip Hours, MPG, Distance to Empty/Refill for

: GAUGE CLUSTER Speedometer, Tachometer, Engine Coolant Temp, Fuel Gauge, DEF Gauge, Oil Pressure Gauge, Primary and Secondary Air Pressure or Auxiliary Air Pressure (if Air Equipped)

: WARNING SYSTEM Low Fuel, Low DEF, Low Oil Pressure, High Engine Coolant Temp, Low Battery Voltage (Visual and Audible), Low Air Pressure, Primary and Secondary (if Air Equipped)

GAUGE, DEF FLUID LEVEL

GAUGE, OIL TEMP, AUTO TRANS for Allison Transmission

HEATER SHUT-OFF VALVES (2) Ball Valve Type

INSTRUMENT PANEL Wing Panel

IP CLUSTER DISPLAY On Board Diagnostics Display of Fault Codes in Gauge Cluster

MONITOR, TIRE PRESSURE System Gives Warning that Tire Pressure is Below Set Pressure, Monitors Tire Pressure of Each Tire with Temperature Compensation, Data Displayed in the LCD of the Cluster, for 4x2 Axle Configuration, Does Not Include Lift Axles or Spare Wheels

WINDSHIELD Three Piece, Bonded, with Shaded Band

FRAMES

FRAME RAILS High Strength Low Alloy Steel (50,000 PSI Yield); 10.125" x 3.062" x 0.312" (257.2mm x 77.8mm x 8.0mm); 489.2" (12425mm) Maximum OAL

BUMPER, FRONT Contoured, Steel, Painted Gloss Black, Severe Duty

Description

CROSSING GATE, FRONT Omit Item
CROSSMEMBER, REAR, AF (2)
TOW HOOK, FRONT (2) Frame Mounted
TOW HOOK, REAR (2) Mounted on Lower Rail Flange
WHEELBASE RANGE 254" (645cm) Only

BRAKES

BRAKE SYSTEM, HYDRAULIC {Wabco} Split System, with Automatic Adjustment and Four Channel ABS
TRACTION CONTROL, HYDRAULIC Automatic; Hydraulic Brake System, with Electronic Stability Control
BRAKE, PARKING {Bosch} DSSA Type, 12" x 3"; for Hydraulic Brake Chassis; Foot Operated in Cab; Differential Mounted
BRAKES, FRONT {Meritor Quadraulic} Hydraulic Disc Type, with Four 70mm Diameter Pistons, 12,000-lb Capacity
DUST SHIELDS, FRONT BRAKE for Hydraulic Brakes
BRAKES, REAR {Meritor Quadraulic} Hydraulic Disc Type, with Four 70mm Diameter Pistons, 21,000-lb Capacity per Axle
DUST SHIELDS, REAR BRAKE for Hydraulic Brakes
GVWR LIMITATION FOR BUS with Hydraulic Brakes, Limited to 29,800-lbs Maximum to meet FMVSS 105 Requirements, for Conventional Bus
PARKING BRAKE INTERLOCK Parking Brake Cannot be Released Until Ignition Switch is in "ON" Position and Service Brake Pedal is Applied, Use with Hydraulic Brake Chassis Only

STEERING

STEERING GEAR {Sheppard M100} Power
STEERING COLUMN Tilting
STEERING WHEEL 4-Spoke; 18" Dia., Black Leather Wrapped

DRIVELINES

DRIVELINE SYSTEM {Dana Spicer} SPL100, for 4x2/6x2
PROPSHAFT GUARD

EXHAUST SYSTEMS

EXHAUST SYSTEM Horizontal Aftertreatment System, Frame Mounted Under Right Rail, for Single Long Horizontal Tail Pipe
ENGINE EXHAUST BRAKE for Cummins ISB/B6.7/ISL/L9 Engine with Variable Vane Turbo Charger
TAIL PIPE (1) Horizontal, Long, Exits Left Side Through Bumper

ELECTRICAL SYSTEMS

ELECTRICAL SYSTEM 12-Volt, Standard Equipment

Includes

: HAZARD SWITCH Push On/Push Off, Located on Instrument Panel to Right of Steering Wheel
: HEADLIGHT DIMMER SWITCH Integral with Turn Signal Lever
: MISCELLANEOUS FEATURES Modular, Loom Protected, Grommets in all Applicable Body Openings, Assembled in Computer Assisted Fixture which Verifies Continuity and Correct Assembly Prior to Installation
: PARKING LIGHT Integral with Front Turn Signal and Rear Tail Light

Description

: STARTER SWITCH Electric, Key Operated
: TURN SIGNAL SWITCH Self-Cancelling with Lane Change Feature
: TURN SIGNALS, FRONT Includes Reflectors and Auxiliary Side Turn Signals, Solid State Flashers; Flush Mounted
: WINDSHIELD WIPER SWITCH 2-Speed with Wash and Intermittent Feature (5 Pre-Set Delays), Integral with Turn Signal Lever
: WIRING, CHASSIS Color Coded and Continuously Numbered

ALTERNATOR {Leece-Neville BLP4024N} Brushless, 12 Volt, 325 Amp Capacity, Pad Mount, with Remote Sense

BATTERY BOX Steel, with Powder Coat Sliding Tray, 25.25" Wide, for Standard Batteries, 1-3 Battery Capacity, Mounted Left Side Behind Front Axle Perpendicular to Frame Rail

BATTERY DISCONNECT SWITCH {Cole-Hersee 75920-06} 300 Amp, Disconnects Charging Circuits, Locks with Padlock, Battery Box Mounted

BATTERY SYSTEM {Fleetrite} Maintenance-Free, (3) 12-Volt 1980CCA Total, Top Threaded Stud

BRAKE WARNING INDICATOR Light and Audible Alarm; Parking Brake/Motion Warning System for Engaged Parking Brake

BK WARN IND,PARK BK NOT SET Visual and Audible Alarm, Active Upon Ignition Off and Parking Brake Not Set, Reminder to Set Parking Brake

CIRCUIT BREAKERS Manual-Reset (Main Panel) SAE Type III with Trip Indicators, Replaces All Fuses

COLLISION MITIGATION SYSTEM Omit

HEADLIGHT WARNING BUZZER Sounds When Head Light Switch is on and Ignition Switch is in "Off" Position

HEADLIGHTS LED, with Daytime Running Lights, Automatic Twilight Controlled

HEADLIGHTS ON W/WIPERS Headlights Will Automatically Turn on if Windshield Wipers are turned on

HORN, ELECTRIC (2) Trumpet Style

INDICATOR, LOW COOLANT LEVEL with Audible Alarm

RADIO AM/FM/USB Input/Auxiliary Input, Includes Wiring and Antenna, with Public Address System

STARTING MOTOR {Mitsubishi Electric Automotive America 90P47} 12-Volt, with Soft-Start

TELEMATICS SYSTEM {ZONAR SYSTEMS V3} Installation Package, Less System; Includes Power Connector, J1939 Datalink Connector, Stop Arm and Entrance Door Inputs, Located Inside Dash Center Panel for Customer Installed Zonar V3 Module

TURN SIGNALS, FRONT Dual Face, LED, Amber/Amber, Mounted on Top of Fender, Used with Standard Flush Mounted Front Turn Signal, Side Marker Lamps, Parking Lights and Reflectors

FRONT END

FRONT END Tilting, Fiberglass, with Three Piece Construction, Dual Air Intakes

GRILLE Molded in Black, with Chrome Surround

HOOD TILT ASSIST {EASY TILT} Mechanical

LOGOS EXTERIOR Model Badges

LOGOS EXTERIOR, ENGINE Badges

SPEEDOMETER, TOOLS, MISC

CHASSIS PAINT Full Chassis

COMMUNICATIONS MODULE Telematics Device with Over the Air Programming; Includes Five Year Data Plan and International 360

MUD FLAPS, FRONT WHEELS (2) Rubber, Mounted on Fender Extension

PAINT SCHEMATIC, PT-1 Single Color, Design 100

Description

Includes

: PAINT SCHEMATIC ID LETTERS "NB"

PAINT TYPE Urethane, One or Two Colors, Other than Imron or International.

PROMOTIONAL PACKAGE 7 Year Unlimited Miles/km Warranty, Limited Time Program for Allison 2500 Series Transmission on School and Commercial Buses (Supplied directly through Allison)

FUEL TANKS

FUEL TANK Top Draw, Steel, Rectangular, 65 US Gal (246L), Includes Protective Cage, Mounted Between Frame Rails and Behind Rear Axle

DEF TANK 16.5 US Gal (62.5L) Capacity, Frame Mounted Outside Right Rail, Behind 0 Bow

FUEL/WATER SEPARATOR {Racor 400 Series,} 12 VDC Electric Heater, Includes Pre-Heater, with Primer Pump, Includes Water-in-Fuel Sensor

LOCATION FUEL/WATER SEPARATOR Mounted Under Hood, Left Side, Above Front Axle

WHEELS, TIRES - FRONT

WHEELS, FRONT {Accuride 51408} DISC; 22.5x8.25 Rims, Powder Coat Steel, 2-Hand Hole, 10-Stud, 285.75mm BC, Hub-Piloted, Flanged Nut, with Steel Hubs

(2) TIRE, FRONT 11R22.5 Load Range H R89 ALL POSITION (PIRELLI), 501 rev/mile, 75 MPH, All-Position

WHEELS, TIRES - REAR

WHEELS, REAR {Accuride 51408} DUAL DISC; 22.5x8.25 Rims, Powder Coat Steel, 2-Hand Hole, 10-Stud, 285.75mm BC, Hub-Piloted, Flanged Nut, with Steel Hubs

(4) TIRE, REAR 11R22.5 Load Range H R89 CS (PIRELLI), 494 rev/mile, 75 MPH, Drive

BODY FEATURES

BUMPER, REAR Painted, 12" High, 3/16"

Thick SUPPORTS, REAR BUMPER Bolted to Frame BODY, REAR Includes Emergency Door BOWS, ROOF 14 ga., One Piece Construction

Includes

: BOWS, ROOF Positioned Floor Line to Floor Line, Threaded Through Roof Strainers and Drip Rail

FASTENERS, HEADLINER Rivets

FLOOR, BODY with Wheel Wells

HANDLE, ASSIST Windshield Side Mounted, Left and Right, Chrome

HEADLINER, BODY Conventional; 25'11"-35'08" Body Length, Perforated Full Length with Sound Insulation Full Length

LIGHT BARS Plastic

LINING, SIDE INTERIOR, LOWER Embossed Steel, Clear Coated

RAILS, WRAP-AROUND Just Below Window Line

RUB RAILS, BODY (4) Conventional; Steel, 31'2", 31'11", 32'8", 33'5", 34'2", 34'11", 35'8" Body Lengths, Includes Snow Rail

Includes

: RUB RAILS Full Length, Primer Coated (Both Sides), Attached to Body without Cuts or Splices

Description

SEALER Extra; Sidewall to Floor, In Wheel Pocket Area, and Rear Wall to Floor

SEALER, ADDITIONAL Water-proof Sealer on all Floor Covering Seams

SIDE SHEET, BODY, EXTERIOR Conventional, 16ga., Smooth, 31'2", 31'11", 32'8", 33'5", 34'2", 34'11", 35'8" Body Lengths

SKIRT, BODY Conventional, 20", 16ga., 31'2", 31'11", 32'8", 33'5", 34'2", 34'11", 35'8" Body Lengths

Includes

: SKIRT, BODY Extra Smooth Steel Supported by Floor Gussets

STEP, FRONT ENTRANCE DOOR 27 1/4" Depth; 14ga Steel, Formed Treads, Naviflex Finish

TIE DOWNS, BODY Grade 8 Bolts, Every Body Section

Includes

: TIE DOWNS, BODY with Formed Tab that Fits into Floor Structure to Prevent Turning

COVER, REAR DOOR INSIDE HANDLE Partial Coverage

DOOR, ENTRANCE, FRONT Electric, Outward Opening, with Single Pane Glass

FASTENERS, REAR DOOR Lag Screws, Rear Door To Body

HANDLE, ASSIST, ENTRANCE DOOR Outside Entrance

HANDLE, EXTERIOR, REAR Emergency Door; Chrome

HOLD BACK, REAR DOOR Stationary, No Cables, with Plastic Cover

KEYS ALIKE, LOCKS Entrance Door, 545 Keys

LATCH, REAR DOOR One Point Slide Bar, Cam Operated, with One Inch Stroke

LOCK, ENTRANCE DOOR in External Release, with Key

LOCK, REAR DOOR with Ignition Starter Interlock

COMPARTMENT, DRIVER STORAGE Bin, Sized to Hold Three Ring Binder, Includes (1) USB-A Port and (1) USB-C Port

COMPARTMENT, LUGGAGE, LT MID 91" x 24" x 22"

Includes

: HINGES Rubber

: LATCH, T-HANDLE, LOCKING Stainless Steel

COMPARTMENT, LUGGAGE, RT MID 87" X 24" X 22"

Includes

: HINGES Rubber

: LATCH, T-HANDLE, LOCKING Stainless Steel

HOLD DOWN, BATTERY For (2) Standard Size Batteries

LUGGAGE RACK, INTERIOR Tubular, Below Light Bar, 20 Bow

WASTE CONTAINER Removable, Located in Driver Area

INSULATION, ROOF/SIDES/BULKHEAD 1.5"

NOISE REDUCTION, DRIVER FLOOR Insulation Covering Complete Driver Floor Area

NOISE REDUCTION, ROOF BOW Conventional; Insulation, 31'2", 31'11", 32'8", 33'5", 34'2", 34'11", 35'8" Body Lengths

UNDERCOAT, BODY Fire Resistant, Water Based, TT-C-730 Spec

Includes

: UNDERCOATING Performed Before and After Mounting on Chassis

**Vehicle Specifications
2025 CE SCHOOL BUS
(PB110)**

May 02,
2023

Description

UNDERCOAT, FLOOR/STEPWELL/SIDES for Engine Noise Reduction

BODY CERTIFICATION TAG Metal

BODY TAG, METAL Capacity to Include the Total Number of Passengers

LETTERS, BATTERY COMPARTMENT (01) Decal; "Battery"; 1" Black Letters, Centered on Standard Battery Box

LETTERS, CAPACITY 2" Black Decal, (1) Place, with Bus Number, For the State of Nebraska

LETTERS, DEF, I.D. Decal; "DEF ONLY", 1" Black, on DEF Filler Door

LETTERS, DOOR, REAR Decals; "EMERGENCY DOOR", 2" Black Letters Inside and Outside

LETTERS, FUEL I.D. Decal; "DIESEL FUEL", 2" Black, Adjacent to Fuel Filler Door

LETTERS, HEADER Decal; "WATCH YOUR STEP", 1" Black, Above Windshield

LETTERS, E/E WINDOW, LEFT (2) Decal Sets, "EMERGENCY EXIT", Black Inside and Outside

LETTERS, E/E WINDOW, RIGHT (2) Decal Sets, "EMERGENCY EXIT", Black, Inside and Outside

LETTERS, SCHOOL BUS FRONT/REAR Decal; "SCHOOL BUS"; with 8" Black Reflective Letters, 3M Fluorescent Diamond Grade, Yellow On Front and Rear Cap

LETTERS, STEPWELL Decal, "WATCH YOUR STEP", 2.5" Black, Behind Door on Step Riser

LOGO, ROOF LINE Decal; Wing and Shield, First Body Section, Above Driver Window and Entrance Door Over Driver Window and Entrance Door

OPERATING INSTRUCTIONS, REAR Decal, Inside Rear Emergency Door

PAINT COLOR, BODY EXTERIOR 4421 School Bus Yellow

PAINT COLOR, BODY INTERIOR 9384 Spring White

PAINT COLOR, BUMPER Rear, 0001 Canyon Black

PAINT COLOR, RUB RAILS 0001 Canyon Black

PAINT FLASHER BACKGRD 0001 Canyon Black

PAINT HOOD AND FENDER To Match Body Exterior

PAINT, RUB RAIL Flange to Flange

PAINT STREAMER On Roof, Both Sides 1" Above Drip Rail, 0001 Canyon Black

PAINT, WINDOW BOW CAPS 0001 Canyon Black, Side Only

SEAL, RUB RAILS Top Edge, All Rails

STRIPING, BUMPER (4) Decal, Non-contrasting, Front and Rear

STRIPING, E/E WINDOW, LEFT {3M} (02) Perimeter, 1" Yellow Fluorescent Diamond Grade

STRIPING, E/E WINDOW, RIGHT {3M} (02) Perimeter, 1" Yellow Fluorescent Diamond Grade

STRIPING, PERIMETER, REAR Emergency Door, 1" Yellow Reflective

STRIPING, REAR END {3M} 2" Yellow Fluorescent Diamond Grade

STRIPING, ROOF HATCH, FRONT {3M} Decal, Perimeter, 1" Yellow Fluorescent Diamond Grade

STRIPING, ROOF HATCH, REAR {3M} Decal, Perimeter, 1" Yellow Fluorescent Diamond Grade

STRIPING, SEATLINE {3M} 2" Yellow Fluorescent Diamond Grade

WIRING DIAGRAM Schematic, Electrical

Description

Includes

: ACCESS PANEL for Wiring Diagram Schematic Located on Inside of Electrical Panel Door, Below Driver Window

SUB FLOOR, PLYWOOD Conventional; B-C Exterior Grade, Less Sealed Edges, 5/8", 5 Ply, for 31'2",31'11",32'8",33'5", 34'2", 34'11", 35'8" Body Lengths

DISARM, POST TRIP INSPECTION Button Located on Light Bar at Rear of Bus

MONITOR, POST TRIP INSPECTION {Leave No Student Behind} Accessory Controlled, with Push Button Alarm Disable at Rear of Bus Prompts Driver to Walk to Back of Bus to Disable Alarm

SWITCH, LOCATION Steering Wheel; Includes Master Flasher, Flasher On/Off, Red Override, and Door Control

Includes

: SWITCH, STEERING WHEEL, LIGHT Includes Illuminated Switches

BODY FEATURES

WINDOW, DRIVER Storm

COLOR, WINDOW FRAME, PASS Passenger Window, Natural Aluminum Finish

WINDOW, E/E, LEFT (2) Vertical Hinge

WINDOW, E/E, RIGHT (2) Vertical Hinge

WINDOW, PASSENGER, TINT Conventional; 28% Light, Laminated Glass, 78" Headroom, with 31'2", 31'11", 32'8", 33'5", 34'2", 34'11", 35'8" Body Lengths

WINDOW, SASH (20) 27" Sections, 9"x 23" Opening

WINDOW, STOPS 12" Opening, Only with 78" Headroom

AISLE POSITION Center, for balanced seating

FLOOR COVERING, COLOR Blue

FLOOR COVERING, TRIM Aluminum

FLOOR COVERING, TYPE {Koroseal} All Body Lengths

STEP TREADS {Koroseal} Pebble White Nosing Only, with Non-Metal Backing, used with Formed Treaded Steps

WHEEL POCKET COVER Plastic, ABS

FAN, DEFOG LEFT CENTER 6.50" Diameter, Black, Mounted Left of Center Post, 2-Speed Switch in Panel

FAN, DEFOG RIGHT CENTER 6.50" Diameter, Black, Mounted Over Windshield, 6" Right of Centerline, 2 Speed Switch in Panel

HEATER, PASS, LT MIDSHIP 1ST 84,500 BTU

Includes

: AIR FILTER

HEATER, PASS, LT REAR 84,500 BTU

Includes

: AIR FILTER

HEATER, STEPWELL with Fixed Angle Louver to Door Glass

HEATER, WATER PUMP {2 MPU 12} Self Priming, Metal Housing

ROOF HATCH, FRONT {Specialty Hybrid Adv H1975-025-191-0F} Emergency Exit with Outside Release, Alarm, English Decals

ROOF HATCH, REAR {Specialty Hybrid Adv H1975-025-191-0F} Emergency Exit with Outside Release, Alarm, English Decals

ROOF VENT, FRONT Static

Description

ARM REST, DRIVER Left and Right

SEAT, DRIVER {Sears Atlas II} Air Suspension with Suspension Cover, Heated, Adjustable Air Lumbar, Adjustable Shocks, Seat Tilt 12 Degree Back Recline

Includes

: SEAT BELT, DRIVER Adjustable D-Loop Seat Belt, Single Locking Retractor

UPHOLSTERY, BARRIER, TYPE (1-2) Prevaill, 42 oz.

UPHOLSTERY, DRIVER SEAT, COLOR Drivers Seat, Graphite

UPHOLSTERY, DRIVER SEAT, STYLE Plain, with Cloth Insert

UPHOLSTERY, DRIVER SEAT, TYPE Synthetic Leather

BARRIER, CRASH, AFT ENTRY DOOR 39", 2 Leg

BARRIER, CRASH, AFT DRIVER 39", 1 Leg

HAND RAIL, ENTRANCE DOOR, AFT Dual Height Stainless Steel, Upper Rail 1.25" OD 28" Above Floor, Lower Rail 1" OD

HAND RAIL, ENTRANCE DOOR, FWD Dual Height Stainless Steel, Upper Rail 1.25" OD 28" Above Floor, Lower Rail 1" OD

PANEL, MODESTY, AFT ENTR DOOR Mounted Under Barrier

PANEL, MODESTY, AFT OF DRIVER Mounted Under Barrier

SHIELD, COURTESY, AFT/DRIVER 0

SEAT BELT, DRIVER, COLOR with Blaze Orange Seat Belt Webbing

SEAT BACK, PASSENGER High Back

SEAT,26",WALL,LT (01)

SEAT,39",WALL,LT (10)

SEAT,39",WALL,RT (11)

UPHOLSTERY, PASS SEATS, COLOR Blue, for Seats, Barriers and Head Bumpers

UPHOLSTERY, PASS SEATS, TYPE Prevaill, 42 oz.; for (21-22) Seats

CUSHION, SEAT 15" Depth

SHOULDER RAILS, PADDED Conventional Bus; with 31'2", 31'11", 32'8", 33'5", 34'2", 34'11", 35'8" Body Lengths

UPHOLSTERY, SEAT, STITCHING Single

BODY FEATURES

ALARM, BACKING {Ecco #850} 112 dB

CIRCUIT, PROTECTION Breakers, Manual Reset in Lieu of Fuses

FLASHER SYSTEM (8) Warning Lights, 8-Lamp System, Electronic Relay Flasher, Sequential Operation, Red Lights Activate after Amber Lights, Lights Deactivate with Door Closing

HOOD, WARNING LAMP (4) Black, 8-Lamp System, One Hood Above Two Lights

LIGHT, ENTRY DOOR {Sound Off/OptiLuxx} LED; 4" Oval; Light Mounted in Skirt Behind Entrance Door, Wired To Step Light

LIGHT, EXTERIOR, CHECK Automatically Activates Lights for Pre Trip Inspection

LIGHT, INDIC, WARNING LIGHTS Red and Amber

Includes

Description

: LIGHTS, WARNING Indicator Located in Instrument Cluster

LIGHT, STEP {Sound Off/OptiLuxx} 4" Round LED, White, Wired to Clearance Lights, Operated by Entrance Door

LIGHT, STROBE LED, Specialty Man. Co. 845-4020-100, Low Profile, Double Flash, 4.50" High

LIGHTS, BACK UP (2) {Sound Off/OptiLuxx} LED, 7" Round Clear

LIGHTS, CLUSTER {Truck Lite 07045A & 07045R} LED; Amber Front and Red Rear

LIGHTS, DIRECTIONAL, REAR (2) {Sound Off/OptiLuxx} LED, 7" Round Amber

LIGHTS, DIRECTIONAL, SIDE {Sound Off/OptiLuxx} (2) Slim-Line LED Armored, Amber, (1) Each Side First Section Aft Entrance Door

LIGHTS, DOME LED, Rectangular Recessed Type, Two Full Rows, for 29'08", 30'05", 31'02", 31'11", 32'08", 33'05" Body Lengths

LIGHTS, DOME, DRIVER (1) LED, Rectangular, Mounted in Light Bar in Ceiling, with Separate Switch

LIGHTS, MARKER, FRONT & REAR LED, Flush Mount, Amber Front and Red Rear

LIGHTS, MARKER, SIDE, INTERMED LED, Amber, Flush Mount, Intermediate, Centered, Required for Units 30 Foot or Longer

LIGHTS, STOP (2) {Sound Off/OptiLuxx} and Tail; 7" Round LED, Red

LIGHTS, TAIL, LICENSE PLATE (2) 4" Red with Light Window

LIGHTS, WARNING (8) {Sound Off/OptiLuxx} (4) 7" Round Red Flashing LED and (4) 7" Round Amber Flashing LED, 2 Front, 2 Rear Each Color

SPEAKERS AND WIRING (8) Flush Mounted In Light Bar

STOP ARM, FRONT Electric, Composite Blade, 18" Octagon, Double Sided, 1/2" White Border, Hi Intensity Grade, Strobing LED Lights

STOP ARM, LEFT REAR Electric, Composite Blade, 18" Octagon, Single Sided, 1/2" White Border, Hi Intensity Grade, Strobing LED Lights

SWITCH, DOME LIGHTS, SPLIT Front and Rear Operated with Separate 2 Position Switch, Quantity of Lights Split Equally

SWITCH, MASTER FLASHER Omit Master Flasher Switch, 8-Lamp System

SWITCH, NOISE SUPPRESSION Actuator Legend States, "NOISE SUPP ", for Separate Solenoid, with Red Switch in Panel

SWITCH, REAR DOOR BUZZER for Emergency Door

WIRING MOD, DOME LIGHTS Mounted in Ceiling

MIRROR, CROSS VIEW, EXTERIOR (2) {Rosco High Definition} Black, Heated, with LED Downlit Front Lighting

MIRROR, INSIDE 6" x 30", Clear Safety Glass, Metal Back, Round Corners

MIRROR, REAR VIEW, EXTERIOR {Rosco Open-View ES} Black, Motorized Head, Heated, Remote, Non-Detent

VISOR, INTERIOR, DRIVER LEFT 10" X 27" for Driver's Window

VISOR, INTERIOR, LEFT FRONT 6" x 30", Transparent, For Left Windshield

COMPARTMENT ABOVE DRIVER Left of the Driver

Includes

: COMPARTMENT ABOVE DRIVER Compartment Size: 39" x 10" x 10"

: HINGES Piano Type

FIRE EXTINGUISHER 5 lb 3A-40BC Minimum, with Flexible Hose and Metal Nozzle

FIRE EXTINGUISHER, FRONT LOC Located Behind Driver Seat

HINGE, COMPARTMENT Spring Lock Type, for Driver Overhead Storage Compartment

KIT, BODY FLUID Nebraska

Description

KIT, FIRST AID Metal; 24 Unit, Spec State
LATCH, COMPARTMENT Locking, for Overhead Storage Compartment
LOCATION, BODY FLUID KIT on Bulkhead
LOCATION, FIRST AID KIT Right Side Front Bulkhead with Screws
PADDING COMPART ABOVE DRIVER Window; Safety Equipment Compartment, with Cutout for Dome Light
REFLECTORS, REAR (2) 3", Red, Adhesive Back
REFLECTORS, SIDE, FRONT (2) 3", Amber; Adhesive Back, 1 Aft Drivers Window Left, 1 Aft Entrance Door Right
REFLECTORS, SIDE, INTERMEDIATE (2) 3" Amber, 1 Each Side, Below The Third Rub Rail From the Top, Adhesive Back
REFLECTORS, SIDE, REAR (2) 3", Red, Adhesive Back
SAFETY TRIANGLES Warning Reflectors, Mounted on Floor Between Driver Seat and Drivers Crash Barrier/Stanchion/Partition
CUTTER, SEAT BELT {TIE TECH Safecut} for Cutting Seat Belts
CUTTER, SEAT BELT, LOCATION Mounted on Panel Left of Driver
DEF FILLER DOOR with Locking Latch
FENDERS, RUBBER, REAR (2)
FUEL FILLER DOOR with Non-Locking Latch
FUEL FILLER PIPE Low Profile Neck Cap and Vent Hosing, for Use with Right Side Fill for Between the Rail Fuel Tanks, for Above the Floor Fuel Fill, for 25 GPM Fill Rate Only
INSPECTION PLATE Fuel Sending Unit 8" x 8" Steel
MUD FLAPS, REAR WHEELS (2) Rubber
STATE OF OPERATION Nebraska

Services Section:

WARRANTY

WARRANTY Standard for CE, RE, BE School Bus Models, Effective with Vehicles Built March 1, 2017 or Later, CTS-3304H
SERVICES, TOWING {Navistar} Service Call to 24-Month/Unlimited Mileage to the Nearest IC Bus Dealer for Navistar Warrantable Failure as Contract Defined; Includes Engine Failure if Supplier Declines Tow Coverage & ESC Supplied thru Navistar; \$550 (USA) Maximum Benefit per Incident
SRV CONTRACT, EXT VEH COVERAGE {Navistar} To 36-Month/50,000 Miles (80,000 km), Covers 100% Parts and Labor; Includes Body; Excludes Extending Warranty for Engine, Transmission, Perforation or Corrosion of Cab/Cowl Structure and Paint

BODY FEATURES

WARRANTY 5-Year, Limited

PROPOSAL

2025 Blue Bird Vision
65 Passengers

School bus

Created for: Centennial Public Schools

The quote is valid for: **60 days.**

Delivery: **4 to 6 Months**



Quote ID #: 226268



2025 **Blue Bird Vision**
65 PASSENGERS



**Safe-Durable-Quality
Construction**

Chassis

- Bright Yellow Exterior
- Chrome Grill and Black Bumpers
- Dual Rear Wheels
- 273 in. Wheelbase
- Cummings B6.7 Diesel 240HP @ 560LB
- 750 W Engine Block Heater
- Transmission Oil Cooler
- 240 Amp Alternator
- Rear Spring Suspension
- Front Soft-Tek Spring Susp
- Real Axle Ratio- 5.29
- Driver's seat- Air, Heated, Arm Rests, Lumbar
- Electronic Allison 6 Speed Transmission
- Hydraulic Brakes with ABS
- Odometer
- Power steering
- Cruise Control 75 MPH
- Fuel tank Capacity 100 Gal
- 50-State Emissions System
- Radio (AM-FM-PA) Premium
- Dual Intermittent Wipers 18"
- Tires- Kumho 11R22.5 Mud
- Two group 31 batteries
- 700 CCA on batteries
- Tilt steering column
- Overall Length: 33' 03"



Purpose built Blue Bird OEM chassis.



Cummings B6.7 240HP @ 560 LB FT Torque



Allison 6-Speed select shift transmission.

Blue Bird Body

- 77 In. Headroom
- 128 In. Exterior Height
- 90.75 In. Interior Width
- 96 In. Exterior Width
- 27 In. Manual Dual Entry Doors with Clear 72" Tall Glass
- Stainless Steel Grab Rail, LH side & RH side
- Step Well Lights
- Identification- Clearance and Directional Lights
- Exterior Heated Mirrors
- Grey Color Flooring
- Decals: Emergency Exits
- Roof Vents Located Front & Rear.
- Tinted Windows with 4 Pushouts
- Body Undercoating/Wax Premium
- Driver Overhead Storage
- 3m Body Reflectors
- Battery Disconnect

*A larger **More-View** glass minimizes the A-pillar blind spot while improving visibility of the loading area.*

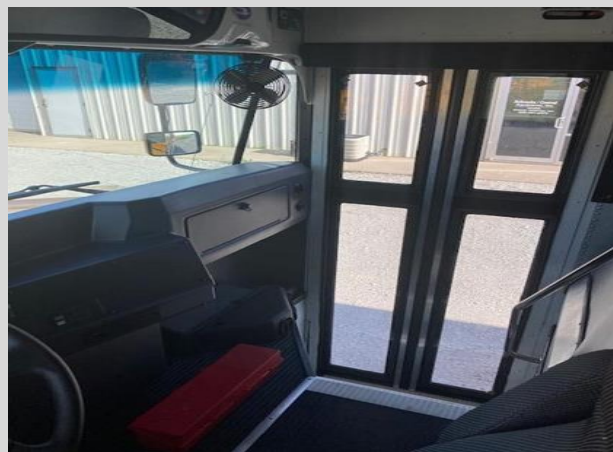

Combined exterior mirrors(convex & standard) (Optional Heated mirror W/ Timer) 7 X 10 in. / 7X 6 in. (black brackets)



Premium student seating with increased durability.



BLUE BIRD STANDARD FEATURES

Standard backup camera

Blue Bird provides a backup camera system as standard equipment on our Vision buses, which allows drivers the ability to see a live video feed while the bus is in reverse.



Body electrical control panel

- The body electrical control panel is located underneath the center of the dash.
- Every circuit is protected by ATO® typefuses; 80-amp relay.
- Electrical diagram supplied at delivery.

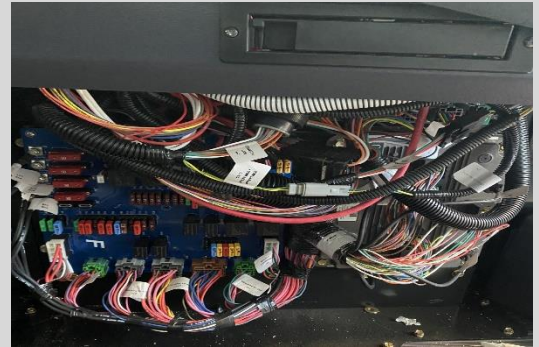

Bumper/Headlights

- The Vision's front bumper is the largest in the school bus industry. At 15" tall on both corners and 25% larger than the other school bus makes, it provides added protection and safety.

- Headlights with integrated turn signals and clear lens technology make regular maintenance and beam alignment easier than ever.



Emergency package (FEDERAL SPECS) includes:

- Triangles (3)
- Body Fluid Kit
- First Aid Kit
- Fire Extinguisher, 5lb.



Blue Bird Optional Features

- Heated Remote Controlled Mirror, w/ 15-minute Timer.
- Acoustic Headlining Spray Full Length
- National Driver's Seat Air/Heat/Lumbar/Premium
- Wiper Blades, All Weather, 18 inches
- Auxiliary Fan, Upper Right
- Auxiliary Fan, Upper Left
- Blue Fire Block Seating material
- Dual 50K Heaters, Stepwell 50K,12K Drivers
- Parcel Racks
- Fender flares
- Drivers overhead locking storage
- Electronic Stability Control
- Exterior NSBY Yellow
- Driver seat armrests
- Sun visors for driver
- Driver cup holder



2025 Blue Bird Vision

65 PASSENGERS

CHECK HERE FOR LEASE

BODY, OPTIONS AND CHASSIS \$ 124,000.00

YOUR NET PURCHASE PRICE \$ 124,000 - pricing valid for 60 days

PREPAYMENT OPTIONS:

100%: \$ _____ Prepayment Discount, Deduct..... < \$1000.00 >

Please check the box & sign here if you would like to take advantage of our pre-pay discount.

Sign Here: _____

OPTIONAL EQUIPMENT: n/a

1.	5 Year Cummings Diesel Engine Warranty	Included	
2.	5 Year Allison Transmission Warranty	Included	
3.	Parcel Racks	Included	
4.	Heated/Remote Mirrors Cross View Eye Max	Included	
5.	Back Up Camera	Included	
6.	Seat color is currently "Blue"	Included	

ACCEPTANCE FOR (School or Organization):

SIGNATURE:

PRINTED:

TITLE:

DATE:

By: Jamie Egger

Date: 10/12/2023

ESTIMATED COMPLETION DATE: 4 to 6 months

ADD 30 EXTRA DAYS FOR AIR CONDITIONING

ALL RESPONSIBILITIES OF OWNERSHIP AND LIABILITY ARE TRANSFERRED TO CUSTOMER AT DELIVERY ~ TERMS: NET CASH ON DELIVERY

PROPOSAL

2025 Blue Bird Vision
65 Passengers

School bus

Created for: Centennial Public Schools

The quote is valid for: **60 days.**

Delivery: **10 to 12 Months**



Quote ID #: 226285



2025 **Blue Bird Vision**

65 PASSENGERS



**Safe-Durable-Quality
Construction**

Chassis

- Bright Yellow Exterior
- Chrome Grill and Black Bumpers
- Dual Rear Wheels
- Ford 7.3-Liter 350HP "Godzilla"
- 273 in. Wheelbase
- 750 W Engine Block Heater
- Transmission Oil Cooler
- 240 Amp Alternator
- Rear Spring Suspension
- Front Soft-Tek Spring Susp
- Real Axle Ratio- 5.29
- Driver's seat- Air, Heated, Arm Rests, Lumbar
- Electronic Ford 6 Speed
- Hydraulic Brakes with ABS
- Odometer
- Power steering
- Cruise Control 75 MPH
- Fuel tank Capacity 98 Gal
- 50-State Emissions System
- Radio (AM-FM-PA) Premium
- Dual Intermittent Wipers 18"
- Tires- Kumho 11R22.5 Mud
- Two group 31 batteries
- 700 CCA on batteries
- Tilt steering column
- Overall Length: 33' 03"



Purpose built Blue Bird OEM chassis.



Ford 7.3 Liter 350HP Godzilla ROUSH Engine



Ford 6R140 6-Speed select shift transmission.

Blue Bird Body

- **77 In.** Headroom
- **128 In.** Exterior Height
- **90.75 In.** Interior Width
- **96 In.** Exterior Width
- **27 In.** Manual Dual Entry Doors with Clear 72" Tall Glass
- Stainless Steel Grab Rail, LH side & RH side
- Step Well Lights
- Identification- Clearance and Directional Lights
- Exterior Heated Mirrors
- Grey Color Flooring
- Decals: Emergency Exits
- Roof Vents Located Front & Rear.
- Tinted Windows with 4 Pushouts
- Body Undercoating/Wax Premium
- Driver Overhead Storage
- 3m Body Reflectors
- Battery Disconnect



*A larger **More-View** glass minimizes the A-pillar blind spot while improving visibility of the loading area.*

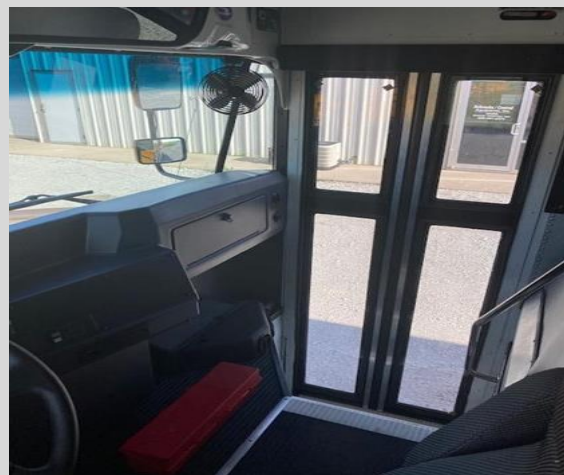

Combined exterior mirrors(convex & standard) (Optional Heated mirror W/ Timer) 7 X 10 in. / 7X 6 in. (black brackets)



Premium student seating with increased durability.



BLUE BIRD STANDARD FEATURES

Standard backup camera

Blue Bird provides a backup camera system as standard equipment on our Vision buses, which allows drivers the ability to see a live video feed while the bus is in reverse.



Body electrical control panel

- The body electrical control panel is located underneath the center of the dash.
- Every circuit is protected by ATO® typefuses; 80-amp relay.
- Electrical diagram supplied at delivery.

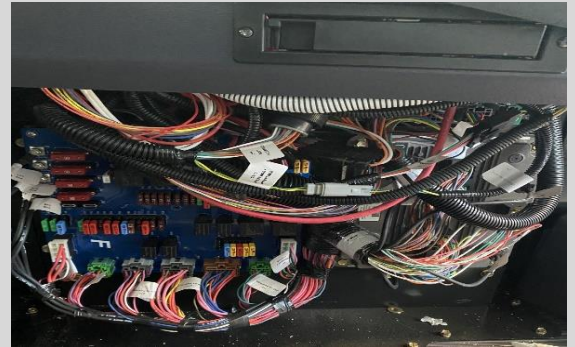

Bumper/Headlights

- The Vision's front bumper is the largest in the school bus industry. At 15" tall on both corners and 25% larger than the other school bus makes, it provides added protection and safety.

- Headlights with integrated turn signals and clear lens technology make regular maintenance and beam alignment easier than ever.



Emergency package (FEDERAL SPECS) includes:

- Triangles (3)
- Body Fluid Kit
- First Aid Kit
- Fire Extinguisher, 5lb.



Blue Bird Optional Features

- Heated Remote-Controlled Mirror, w/ 15-minute Timer.
- Acoustic Headlining Spray Full Length
- National Driver's Seat Air/Heat/Lumbar/Premium
- Student Check System (Blue Bird)
- Auxiliary Fan, Upper Right
- Auxiliary Fan, Upper Left
- White Roof Coating
- Dual 50K Heaters, Stepwell 50K, 12K Drivers
- Parcel Racks
- Fender Flares
- Drivers Overhead Locking Storage
- Electronic Stability Control
- Exterior NSBY Yellow
- Driver Seat Armrests
- Sun Visors For Driver
- Roush Performance Built In

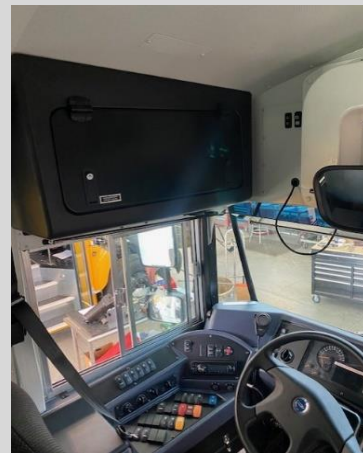

2025 Blue Bird Vision

65 PASSENGERS

CHECK HERE FOR LEASE

BODY, OPTIONS AND CHASSIS \$ 133,775.00

YOUR NET PURCHASE PRICE \$ 133,775 - pricing valid for 60 days

PREPAYMENT OPTIONS:

100%: \$ _____ Prepayment Discount, Deduct..... < \$1000.00 >

Please check the box & sign here if you would like to take advantage of our pre-pay discount.

Sign Here: _____

OPTIONAL EQUIPMENT:

1.	5 Year Ford Roush Engine Warranty	Included	
2.	5 Year Ford Roush Transmission Warranty	Included	
3.	Parcel Racks	Included	
4.	Heated/Remote Mirrors Cross View Eye Max	Included	
5.	Back Up Camera	Included	
6.	Valeo In-Wall Front & Rear High Efficiency Roof Top A/C	Add	\$10,100.00

ACCEPTANCE FOR (School or Organization):

SIGNATURE:

PRINTED:

TITLE:

DATE:

By: Jamie Egger

Date: 10/12/2023

ESTIMATED COMPLETION DATE: 10 to 12 months

ADD 30 EXTRA DAYS FOR AIR CONDITIONING

ALL RESPONSIBILITIES OF OWNERSHIP AND LIABILITY ARE TRANSFERRED TO CUSTOMER AT DELIVERY ~ TERMS: NET CASH ON DELIVERY



PROPOSAL FOR:
CENTENNIAL PUBLIC SCHOOLS

2025 THOMAS SAF-T-LINER C2 SCHOOL BUS
65 Passenger w/Maximum Seat Spacing

2025 FREIGHTLINER/THOMAS SAF-T-LINER C2

PURCHASE PRICE.....\$124,035.00

Body Model 311TS

Quote valid until November 15, 2023

Approximate delivery: 18 months

OPTIONAL: AIR CONDITIONING.....add...\$10,120.00

-Note: This is the same as your last bus.

-126,000 BTU system with rear in wall evaporator above emergency door and front side mount evaporator.

-Dual TM-21 compressors.

-Roof Top condensers to protect from mud and snow.

-Additional automotive style driver's air integrated into dash vents.

OPTIONAL: AIR SUPPLY.....add...\$1080.00

-Engine mounted air compressor and AD-9 heated air dryer

-Provided for operation of air ride driver's seat and air operated entrance door.

Corey Sundberg

10/16/2023

Corey Sundberg
Truck Center Companies

Date

AIR INTAKE

Donaldson PowerCore air cleaner with 32,000 mile /24 month service intervals. Air intake warmer

AIR RESTRICTION INDICATOR

Engine compartment mounted air restriction indicator

ALTERNATOR

Leece Neville 240 AMP 12 Volt pad mounted with automatic spring-loaded tensioner

AXLES

10,000 LB Set Back Single Front includes oil lubed hubs

21,000 LB Single Rear Axle

Magnetic rear axle drain and fill plug. Ratio 5.22 Geared to run 78 MPH

BACK-UP CAMERA

4.3" monitor built into the driver's mirror to display area behind bus when shifted into reverse.

BARRIERS

(2) 39" barriers covered with Proform fire block and right side modesty panel.

BATTERIES

Triple (3) Alliance 2280 CCA- skirt mounted battery box with slide out tray frame mounted. Battery cut-off switch included.

BODY PANELS

Exterior 20 gauge galvanized- Interior 22 gauge Galvalume from belt line to seat rail

BRAKES

Bosch hydraulic brake package, disc brakes front and rear, foot pedal actuated rear drum parking brake.

BUMPER

Heavy duty front swept back style matching the hood shape. Rear bumper is 1.6 times stronger than triple profile bumpers. Bumper is formed in shape of roadside guardrail and is tucked into side skirts to prevent catching. 3/16" plate steel with .5369 sq. in. section modulus.

CHILD CHECK

Requires driver to walk to the back of the bus to check for children left on bus at the end of the route or activity trip.

COOLING SYSTEM

805 sq. in. aluminum core radiator equipped with Mylar tank for easy coolant level visibility. All radiator hoses are Gates heavy-duty hoses with constant torque spring clamps. Long life coolant protected to -40 (5 years/150, 00 miles) 25" cooling fan with 9 nylon blades with viscous fan clutch. Low coolant sensor light

CONSTRUCTION

Eight ply rubber body to frame insulators on each cross member. Double bolted body to frame clips. Stamped one-piece wheel wells to reduce dust and water leaks. 14 gauge Galvalume U shaped side skirt reinforcements. Two crash rails installed between interior and exterior roof panels. Roof bows extend below floor line. Interior floor bumper 2" steel plate. Rear body 14 gauge reinforcements. Dual 16 gauge Galvaneel roof rail stringers. Closed section, box type, rear corner post design. Automotive style firewall. Header system achieves 1100 lb. push out force for each window

CRUISE CONTROL

Switches dash mounted

DASH GAUGES

Speedometer, Odometer, Tachometer, Hour meter, Voltmeter, Oil pressure, Fuel, Trip meter, Ammeter, Water temperature, Transmission temperature, High-low beam indicator, turn signal indicators, low coolant light, low oil pressure or high coolant temperature warning light and buzzer

DIAGNOSTICS

SAE 9 pin diagnostics interface connector mounted under dash, electronic engine integral warning and derate protection system

Dash mounted diagnostic panel for electrical system

Multi-plex electronics

DRIVER'S COMMAND CENTER

Mounted left of driver with up to 24 rocker switches with LED backlighting for electrical equipment with rheostat control switch. Side-mounted driver's storage compartment. Dual USB charging outlets for cell phone.

DRIVELINE

SPL 100 Dana Spicer main drive line has computerized angle alignment. Lubed for life splines that are booted to prevent contamination from water and road debris. Iron flywheel housing.

ELECTRICAL SYSTEM

12-volt system with color-coded and numbered wiring with matched weatherproof connectors. All that passes through metal is grommeted. ECMs are chassis frame mounted. Automatic circuit breakers protected by solid-state technology. Switches are rocker type design and provide "Smart Switch" technology that can be repositioned without rewiring or reprogramming.

ENGINE

Cummins ISB 6.7 Liter (250 HP - 660 LB/FT torque) turbo diesel
750 watt block heater w/ plug in mounted in bumper, heated fuel/water separator w/ primer.

ENTRANCE & REAR DOORS

Toggle switch, electric operated outward opening with vandal lock system installed. Four inch header pad installed above door. 86" high clear opening. Stainless steel assist hand rail at entrance steps. Rear door is located in center rear with 32" x 23" top glass and 32" x 14" bottom glass with protective shields to keep hands and fingers away from sliding components.

ESC

Electronic Stability Control is a federally mandated computerized technology that improves a vehicle's stability by detecting and reducing loss of traction and skidding.

EXHAUST

Single right hand horizontal muffler with horizontal tail pipe

FENDERETTES

Mounted over rear wheel wells

FLOOR COVERING

Plywood floor with heavy-duty black vinyl covering. All floor seam separations sealed and covered with durable rustproofed metal stripping. Cove molding along the wall. Molded rubber wheel housing covers. Rubber covered entrance step also have white nosing installed. Entire floor is sealed with adhesives

FRAME

Dual C channel main frames, full length made of 5/16" x 3" x 10 1/8" steel frame 50,000 PSI, powder coated finish. Class 8 truck type 7.5 "x 33.5" reinforced cross members. Tow hooks front and rear

FUEL TANK

100 gallon capacity safety mounted between frame rails and behind rear axle with protective cage and rear skid plate gives added protection against damage in the event the vehicle is backed over an object. Includes hinged/locking fuel tank door.

GLOVE BOX & STORAGE

Large glove box located above driver. Floor mounted clipboard and storage bin.

GVWR (Gross Vehicle Weight Rating)

30,000 lbs.

HEATERS/DEFROSTER

93,000 BTU left front heater/defroster, 53,000 BTU step well, 84,000 BTU rear left side, 50,000 BTU mid bus. Automotive style 4-speed front heater dash vents with automotive style electronic dash mounted controls. Bergstrom booster heat pump, removable filters, shut off ball type valves. Full width ducted air for windshield, driver's window and entrance door glass. (2) Defroster fans mounted over driver's window and windshield mounted on an overhead adjustable track

HEADROOM

78" Interior height

HOOD

Sloping hood design for over the hood visibility at 11 ft. Splashguards are hood mounted for easy engine access. Grill is removable for easy serviceability and hood includes integrated plenum with two expulsion valves to remove moisture and contaminants

HORNS

Dual electric with center steering wheel activation

INSULATION/NOISE REDUCTION PACKAGE

1.5 "Fiberglass in ceiling, bulkheads, walls, 2" thick fire resistant thermo-bonded polyester insulation in rafter cavities, sound abatement package, and undercoating.
Acoustic ceiling full length of bus body.

LETTERING

As required by Federal and State requirements in black block lettering including capacity, CENTENNIAL PUBLIC SCHOOLS in 6" black letters. Unit numbers as needed. Yellow reflective striping as required by state regulations.

LIGHTS

Halogen extended life headlights with daytime running lights, driver's dome light on separate switch, dual row of dome lights on separate switch with rheostat control LED Clearance/Marker- red rear/amber rear, back-up- clear, stop/tail- red at belt line. Warning-halogen eight lamp warning system flush mounted. LED Marker/Cluster-Per FMVSS with shields, strobe light. Step well-hooded step light, skirt mounted entrance door light, step light switch. Side mounted turn signals on fender and side panels

MANUALS

Printed operator's maintenance manual including electrical troubleshooting guide, web based service and parts access. Line set ticket

MIRRORS

Rosco 7" X 10" **heated/self-defrosting** rear view mirrors with **Remote Control**; Rosco Hawkeye heated cross-over mirrors with tripod bracket. Interior 6' x 30" with rubber padded edges

MUD FLAPS

HD Front and rear

PAINT

Exterior painted National School Bus Yellow with black trim using lead free urethane PPG paint, interior painted light gray, undercoated chassis.

Roof Painted White

PARCEL RACKS

Interior tubular parcel racks above passenger windows on both sides with padded ends.

RADIO

AM/FM with PA and 6 roof mounted speakers

ROOF HATCHES

(2) roof hatches installed in self-sealing pre-cut panels

RUB RAILS

Four (4) exterior side rub rails located at window level, seat level, floor, level, and bottom skirt. Seat rail is one piece formed to length, 14 gauge Galvalume. Sealed with Saf-T-Bond structural adhesive.

SAFETY EQUIPMENT

(2) Nebraska first aid kits, one mounted front and one at rear of bus. 5 lb chemical type fire extinguisher, moisture proof body fluid clean up kit, triangle safety kit.

SAFETY SOLENOID SWITCH

Single switch for complete shutdown of all heaters and radio at railroad crossings

SAF-T-VUE WINDOWS

Upper and lower pane 352 square inches, located in front of the entrance door to provide vision of the blind spot by the right front wheel without the use of a mirror.

SEAT/DRIVER

National high back **HEATED - AIR RIDE** adjustable seat, with dedicated electric compressor, three point retractable shoulder harness, dual armrests, and adjustable lumbar support.

SEAT/PASSENGER

(21) 39" & (1) 26" passenger seats covered with 42 oz. Proform leatherette fire block material and pivot cushion for cleaning with powder-coated frames

STEERING

TRW TAS-55 with full power steering. Gear driven hydraulic pump. 19" diameter padded **full floating tilt/telescoping** steering wheel.

STOP ARM

Power electrically operated stop arm with wind guard. Highly reflective and equipped with **high intensity LED lights**. Controlled by an electric switch and door operation in conjunction with 8 lamp warning system

SUSPENSION

9,000 lb. taper leaf with maintenance free rubber bushings and spring wear pads
21,000 lb. taper leaf with maintenance free rubber bushings and spring wear pads

TIRES

(2) Hankook 11R22.5 front - 14 ply
(4) Hankook 11R22.5 M/S rear - 14 ply

TRANSMISSION

Allison 2500 PTS 6-speed automatic O/D with Fuel Sense

VENTILATOR

Static type, non-closable

WHEELBASE

259"

WHEELS

22.5 x 8.25-painted black 10-hole hub piloted. Chicago Rawhide oil wheel seals

WIPERS

Bottom mounted overlapping automotive style wipe pattern

WINDOWS

ABS automotive grade technology 12" high x25" wide opening split sash tempered glass. **All side and rear passenger windows tinted, bonded, and banded.** Four-tinted tempered push out windows; all interior and exterior window frames are flat black.

WINDSHIELD

Automotive style one piece, bonded, and curved, slanted to reduce glare and breakage and provide maximum vision. The tinted safety plate laminated glass provides 3362 square inches of windshield area.

WINDSHIELD WIPERS

Electric, intermittent 5 speed heavy duty wet arm wipers. Bottom mounted overlapping automotive style pattern resulting in 1537 square inches of wiped windshield for safety. Wiper motor is accessible for service under engine hood.

WINTER FRONT COVER

Snap on yellow cover for grill

WARRANTY

Thomas/Freightliner comes standard with a 3 year/50,000 mile bumper to bumper warranty....the best in the industry!

Base: Limited 3 year bumper to bumper

Body: Limited 5 years on body

Engine: Limited 5 year/100,000 miles

Transmission: Limited 7 years/unlimited miles

Axles: Limited 5 years/unlimited includes king pins

Bus Proposal Comparisons										
Brand	Fuel Type	Passengers	Wheelbase	Tank Size	Length	Warranty	Backup Camera	Price	DERA Grant Amount	Total Cost
Blue Bird	Diesel	65	273 in.	100 Gal.	33'3"	5 Year	Included	\$124,000	\$28,500	\$95,500
Thomas	Diesel	65	259 in.	100 Gal	37'3"	3 Year (Engine 5, Transmission 7)	Included	\$124,035	\$28,500	\$95,535
International	Diesel	65	254 in.	65 Gal.	31'11"	3 year/50,000 miles	\$2,800	\$133,350	\$28,500	\$104,850
Blue Bird	Propane	65	273 in.	98 Gal.	33'3"	5 Year	Included	\$133,775	\$35,000	\$98,775

**AGREEMENT BETWEEN
CENTENNIAL PUBLIC SCHOOLS AND PRAIRIE ROOTS CHILD
DEVELOPMENT CENTER LLC**

THIS AGREEMENT is made and entered into by and between the Board of Education of Centennial Public Schools, legally known as Seward County School District No. 80-0567, (referred to respectively herein as the "Board of Education" and the "School District") and The Prairie Roots Child Development Center, LLC ("Prairie Roots Child Development Center"), referred to herein collectively as "Party" or "Parties."

WHEREAS, the Board of Education considers it to a benefit to the communities, School District, staff, and students to have a before and after school program ("Program") available to them; and

WHEREAS, the Board of Education believes that the presence of the Program and the availability of its services provided by Prairie Roots Child Development Center will make the School District more attractive to parents, will enhance the enrollment of the School District, and will improve the viability of the School District;

NOW, THEREFORE, in consideration of the mutual covenants herein contained, it is agreed by the parties hereto as follows:

1. **Leased Premises.** The School District leases the following described property (the "Leased Premises") to Prairie Roots Child Development Center to operate the Program: a gymnasium, known as the "small gym"; the cafeteria and kitchen areas; the parking lot for use of parent parking; the playground facilities of the School District outside of the regular school day; and any other School District facilities agreed to in writing by the Superintendent as requested by Prairie Roots Child Development Center.
2. **Use of Leased Premises.** Prairie Roots Child Development Center shall use the Leased Premises for the operation of the Program. The Program provides, but is not limited to, the following activities: Adult supervised,

out-of-school time, discovery center for Kindergarten through 6th Grade. Prairie Roots Child Development Center shall not use the Leased Premises for any other purpose other than those of the Program without the prior consent of the Superintendent and, if required by Nebraska law, the Board of Education. Prairie Roots Child Development Center understands and agrees that it will not exercise the rights granted to it by the School District in such a way as to interfere with or adversely affect (1) any other property of the School District or (2) the operation and control of any of the curriculum or other programs of the School District. Prairie Roots Child Development Center will not permit the Leased Premises to be used in any manner contrary to the educational interests of the School District. Based on this Agreement, the School District will not require Prairie Roots Child Development Center to complete its general facility use agreement.

3. **Priority for School District Personnel.** In consideration of obtaining the Leased Premises, Prairie Roots Child Development Center shall give priority of enrollment in the Program to students already attending the School District.
4. **Priority in the Event of Conflicts.** If there is a conflict in the scheduling or use of the Leased Premises or other School District facilities being used by Prairie Roots Child Development Center, the School District shall have priority regarding their use. The School District Superintendent or Superintendent's designee will give as much advance notice as possible to Prairie Roots Child Development Center in the event of a conflict, but the School District is under no obligation to provide notice prior to taking control of the Leased Premises or any other property of the School District. The School District agrees that in the event of a conflict, the Superintendent will provide alternative space for Prairie Roots Child Development Center to operate the Program to the extent it is available and can be used safely and consistently with the other obligations provided for in this Agreement; however, the School District is under no obligation to provide such a

backup facility if none is available.

5. **Control and Supervision.** Prairie Roots Child Development Center shall be solely responsible for the supervision and safety of the children whom it serves, its employees, its volunteers, and the parents and other persons who visit or in any way participate in the Program. Prairie Roots Child Development Center shall exercise that degree of control and supervision as is necessary for the effective management and use of the Leased Premises. Such control and supervision may include the enforcement of rules and regulations for the safety of persons who visit or use the Leased Premises.
6. **Furniture, Equipment and Supplies.** Prairie Roots Child Development Center shall provide all supplies necessary for its operation of the Program. Prairie Roots Child Development Center may ask the Superintendent, in writing, for use of School District property other than the Leased Premises, such as equipment and furniture. Upon the written approval of the Superintendent or Superintendent's designee, Prairie Roots Child Development Center may use such property pursuant to the terms governing use of the Leased Premises and any other obligations under this Agreement, including any other rules, regulations, or restrictions put in place by the Superintendent, as amended from time to time without prior notice to Prairie Roots Child Development Center.
7. **Use of Leased Premises by Other Persons or Organizations.** Prairie Roots Child Development Center may not allow other parties not subject to this Agreement to use the Leased Premises. Prairie Roots Child Development Center will abide by school policies and resolutions in operating the Program, and will require all persons using the Leased Premises for the benefit of the Program to comply with such policies or resolutions. These policies and resolutions may be amended from time to time, without notice, by the Board of Education or the School District's administration, and it is the responsibility of Prairie Roots Child Development Center to adhere to

them.

8. **Maintenance and Repair.** Prairie Roots Child Development Center shall be responsible for the general upkeep and cleaning of the Leased Premises during and after their use for the Program. Prairie Roots Child Development Center shall at all times maintain the Leased Premises in good condition subject to such reasonable standards and directives as the Board of Education or the School District administration may adopt from time to time. Prairie Roots Child Development Center will comply with such standards of maintenance and cleaning and will always return the Leased Premises and any other property of the School District back to the School District in the condition it was provided to Prairie Roots Child Development Center.
9. **Licensure.** Prairie Roots Child Development Center will be solely responsible for applying for, obtaining, and maintaining all necessary licenses, accreditations, and approval for operating the Program, including compliance with all applicable federal and state applications, requirements, laws, and regulations, including rules and regulations of enforcement agencies. Prairie Roots Child Development Center will provide the School District with proof of licensure and ability to operate the Program within 30 days of the first date of this Lease Term. If Prairie Roots Child Development Center fails to provide proof of licensure and operability, the School District may cancel this Agreement immediately upon written notice to the Director.
10. **Utilities.** The School District shall provide and pay for the electricity, heat, water, and sewer, for the Leased Premises.
11. **Access to Leased Premises.** The School District grants to Prairie Roots Child Development Center the right of access across its property for purposes of access to the Leased Premises at any times necessary to conduct the Program agreed to herein, and will also permit such access to all other persons who are authorized by Prairie Roots Child Development

Center to use the Leased Premises for purposes of the Program. Prairie Roots Child Development Center's responsibilities applying to the Leased Premises under this Agreement apply to all other property which is accessed pursuant to this provision.

12. **Term.** This Agreement shall remain in full force and effect from August 15, 2024 to July 31st, 2025 ("Lease Term"), unless sooner terminated or modified by mutual agreement of the parties. The Lease Term may be extended for any further term or terms as the parties may from time to time mutually agree. Upon termination of this Agreement, the rights of Prairie Roots Child Development Center shall terminate and all rights granted to Prairie Roots Child Development Center hereunder shall revert to the School District.
13. **Cost of the Lease.** In consideration of the benefits to the School District, the cost for the Lease Term shall be one dollar (\$1.00). The cost for future terms, if any, will be negotiated by the Board of Education and the Program.
14. **Alterations.** Prairie Roots Child Development Center shall not remodel, alter, or change the Leased Premises without the prior written consent of the Superintendent. Prior to making any alteration, permanent or temporary, requiring the School District's consent, Prairie Roots Child Development Center shall submit plans for such alteration to the School District for the School District's review and approval. Costs relating to any alteration to the Leased Premises by Prairie Roots Child Development Center with the consent of the School District shall be paid by Prairie Roots Child Development Center unless the School District and the Program otherwise agree in writing.
15. **Signs.** Prairie Roots Child Development Center must obtain the School District's prior written consent before installing any sign on the school building or the Leased Premises. All signs shall comply with all applicable local, state, and federal laws and ordinances and the requirements and

directives of the Board of Education and School District administration.

16. **Ownership.** The Leased Premises and all improvements relating thereto, including any replacement thereof, shall at all times be and remain the sole and exclusive property of the School District. Prairie Roots Child Development Center shall have no right, title, or interest therein or thereto; provided, however, the personal property belonging to Prairie Roots Child Development Center or its employees or volunteers located on the Leased Premises shall remain the property of Prairie Roots Child Development Center or the individual owner.
17. **School District's Personal Property.** Any personal property of the School District which is used by Prairie Roots Child Development Center shall remain the property of the School District.
18. **Termination and Events of Default.** Either Party will be in default under this Agreement, entitling the non-defaulting Party to terminate this Agreement, (1) if either Party breaches or otherwise fails to perform or satisfy any agreement, obligation, term, covenant, condition or provision set forth herein or arising hereunder ("Event of Default") and the Event of Default is not cured within thirty (30) days after receiving written notice from the non-defaulting Party, or (2) if such Event of Default cannot reasonably be cured within such thirty (30) day period, the defaulting Party fails to commence to cure within thirty (30) days after receiving written notice and does not fully cure within a reasonable time after commencing.
 - a. Upon the occurrence of an Event of Default, either Party may, in addition to any other remedy or right given by law, terminate this Agreement by delivery of written notice of such termination to the other Party, which delivery shall cease the Agreement immediately. If the School District elects to terminate the Agreement as provided in this paragraph, Prairie Roots Child Development Center shall forfeit all rights relating to the Leased Premises.

- b. No remedy herein conferred upon or reserved to the Parties is intended to be exclusive of any other remedy herein or any remedy provided or permitted by law; but each shall be cumulative, shall be in addition to every other remedy given hereunder or now or hereafter existing at law or in equity or by statute, and may be exercised concurrently, independently or successively.

19. Assignment. Prairie Roots Child Development Center shall not assign any rights in this Agreement without the express written consent of the Board of Education.

20. Insurance. Prairie Roots Child Development Center shall maintain, at its sole cost and expense, liability insurance to protect against liability incident to the use of or resulting from any accident occurring in, on, or about the Leased Premises. The minimum coverage under such insurance shall be \$2,000,000. Prairie Roots Child Development Center agrees to cause the School District to be named as an additional insured on the policy described in this paragraph, and shall take any other action which is necessary and effective to obtain a waiver of subrogation from the insurer such that neither Prairie Roots Child Development Center nor the School District shall be liable to the insurer for negligence.

21. Program's Use of Parking Lot. Prairie Roots Child Development Center shall have the use of the parking lot which adjoins the Leased Premises. Prairie Roots Child Development Center may permit those persons using the Leased Premises for purposes of the Program to use the School District's parking lot at such times as the lot, or some portion thereof, is not required for school functions or activities, subject to the conditions that the School District shall retain priority with respect to the use of the lot, and the School District may prescribe reasonable rules pertaining to use of the lot by Prairie Roots Child Development Center and its invitees.

22. Entirety of Agreement and Amendments. Both Parties have read the entirety of this Agreement, fully understand its terms and conditions, and agree

that this Agreement constitutes the entire agreement, and that no representations, promises, agreements or undertakings, written or oral, not herein contained shall be of any force or effect. This Agreement may only be amended by mutual written agreement of the School District and Prairie Roots Child Development Center.

23. Yearly Review. The School District and Prairie Roots Child Development Center shall review the terms of this Agreement on or before August 1st, 2024 and any other time as they may choose.

THE PRAIRIE ROOTS CHILD DEVELOPMENT CENTER, LLC and
CENTENNIAL PUBLIC SCHOOLS

By:  By: _____

Prairie Roots CDC

Centennial Public School

Authorized Representative

President, Board of Education

Dated 7/25/24, 2024. Dated _____, 2024.

CENTENNIAL ATHLETIC BUDGET REPORT 2024-2025

RECEIPTS

SPORT	2019-2020	2020-2021	2021-2022	2022-2023	2023-2024
Softball	\$686.00 (4 Home Games)	\$1,997.00 (8 Home Games)	\$1,492.00 (5 Home Games)	\$949.00 (6 Home Games)	\$1,999.00 (8 Home Games)
Volleyball	\$5,130.25	\$5,678.00	\$5,710.21	\$6,793.00	\$8,053.00
Gate	\$4,385.25 (12 Home Games)	\$4,988.00 (14 Home Games)	\$4,935.21 (10 Home Games)	\$5,958.00 (15 Home Games)	\$7,053.00 (15 Home Games)
Tournament Entries	\$745.00	\$690.00	\$775.00	\$835.00	\$1,000.00
Football	\$6,910.00 (7 Home Games)	\$7,612.00 (8 Home Games)	\$7,072.00 (7 Home Games)	\$7,407.00 (6 Home Games)	\$5,937.00 (7 Home Games)
Basketball	\$7,462.00	\$7,287.00	\$8,026.00	\$10,351.80	\$7,111.00
Gate	\$7,212.00 (22 Home Games)	\$7,157.00 (23 Home Games)	\$7,726.00 (20 Home Games)	\$10,166.80 (24 Home Games)	\$7,011.00 (20 Home Games)
Tournament Entries	\$250.00	\$130.00	\$300.00	\$185.00	\$100.00
Wrestling	\$4,008.00	\$3,431.00	\$4,599.10	\$5,679.00	\$8,728.00
Gate	\$2,518.00 (4 Home Meets)	\$1,976.00 (6 Home Meets)	\$3,109.10 (4 Home Meets)	\$4,234.00 (5 Home Meets)	\$5,978.00 (6 Home Meets)
Tournament Entries	\$1,490.00	\$1,455.00	\$1,490.00	\$1,445.00	\$2,750.00
Track	\$0.00	\$2,360.00	\$2,978.00	\$2,480.00	\$3,680.00
Tournament Entries		\$2,360.00 (4 Home Meets)	\$2,360.00 (3 Home Meets)	\$2,480.00 (2 Home Meets)	\$3,680.00 (2 Home Meets)
Pole Vault Pole Rental			\$618.00		
Baseball				\$1,105.00 (6 Home Games)	\$905.00 (7 Home Games)
All-Sports Passes/Posters	\$4,930.00	\$3,430.00	\$3,790.00	\$780.00	\$4,677.00
Miscellaneous	\$951.67 (\$500 Unified Bowling Grant)	\$1,708.23 (\$350 Special Olympics Grant)	\$2,427.47 (\$300 Unified Bowling Grant)	\$2,121.42 (\$550 Special Olympics Grant)	\$3,170.63 (\$900 Unified Bowling Grant)
TOTAL	\$30,077.92	\$33,503.23	\$36,094.78	\$37,666.22	\$44,260.63

EXPENDITURES

SPORT	2020-2021 BUDGET	2020-2021 SPENT	2021-2022 BUDGET	2021-2022 SPENT	2022-2023 BUDGET	2022-2023 SPENT	2023-2024 BUDGET	2023-2024 SPENT	2024-2025 BUDGET
Softball	\$6,587.00	\$5,770.10	\$3,163.00	\$3,055.78	\$6,383.00	\$3,731.95	\$3,548.52	\$7,481.21	\$11,049.00
Volleyball	\$8,532.31	\$8,487.64	\$4,837.00	\$4,490.70	\$6,565.00	\$8,104.82	\$6,903.88	\$8,008.88	\$11,454.00
Football	\$13,209.28	\$15,376.76	\$13,132.88	\$12,981.63	\$26,798.50	\$20,412.21	\$38,803.54	\$41,249.89	\$19,000.00
Cross Country	\$2,500.00	\$1,854.00	\$1,050.00	\$836.21	\$1,100.00	\$802.92	\$1,050.00	\$1,294.01	\$1,450.00
Unified Bowling	\$275.00	\$273.14	\$475.00	\$267.83	\$500.00	\$178.70	\$500.00	\$811.56	\$1,125.00
Girls Basketball	\$5,486.79	\$5,135.94	\$7,526.33	\$9,138.01	\$5,865.00	\$6,239.68	\$5,899.00	\$6,149.00	\$6,642.00
Boys Basketball	\$5,579.62	\$5,550.51	\$7,384.34	\$7,604.28	\$6,044.00	\$7,698.84	\$6,172.00	\$6,120.84	\$7,100.00
Wrestling	\$7,565.75	\$5,794.65	\$6,854.88	\$5,455.48					
Boys Wrestling					\$12,923.00	\$13,753.04	\$7,531.00	\$9,073.56	\$10,815.00
Girls Wrestling					\$10,650.00	\$8,455.93	\$6,800.00	\$3,038.14	\$11,870.00
Track	\$7,150.00	\$5,919.05	\$8,445.50	\$4,718.43	\$6,260.00	\$5,996.39	\$8,026.00	\$9,075.69	\$6,444.00
Golf	\$1,700.00	\$1,577.00	\$1,925.00	\$1,969.91	\$3,075.00	\$11,193.56	\$2,175.00	\$2,289.00	\$3,275.00
Baseball					\$16,761.00	\$16,825.17	\$3,089.48	\$11,375.62	\$5,958.00
Training Room	\$1,528.07	\$1,522.49	\$1,429.40	\$941.50	\$1,197.35	\$2,863.43	\$1,036.51	\$3,838.32	\$4,963.00
General Athletics	\$39,935.00	\$31,220.25	\$39,882.56	\$27,716.04	\$47,500.00	\$41,934.71	\$44,870.00	\$37,503.02	\$47,345.00
Activities (ESports, Quiz Bowl, One Act, Speech, Dance, Cheer, Yearbook)			\$4,000.00	\$217.72	\$5,500.00	\$3,810.44	\$5,500.00	\$3,654.60	\$7,000.00
TOTAL	\$100,048.82	\$88,481.53	\$100,105.89	\$79,175.80	\$151,621.85	\$152,001.79	\$141,904.93	\$150,963.34	\$155,490.00
	2020-2021	2021-2022	2022-2023	2023-2024	2024-2025				
BEGINNING BALANCE 8/1	\$16,221.81	-\$11,784.82	-\$1,479.05	-\$8,156.90	\$28,000.00				
ESTIMATED TOTAL REVENUE	\$32,000.00	\$35,000.00	\$40,000.00	\$40,000.00	\$40,000.00				
FINAL RECEIPTS	\$33,503.23	\$36,094.78	\$37,666.22	\$44,260.63					
GENERAL FUND SUPPORT	\$51,827.01	\$65,105.89	\$113,100.90	\$101,904.93	\$88,840.00				
ESTIMATED TOTAL EXPENSES	\$100,048.82	\$100,105.89	\$151,621.85	\$141,904.93	\$155,490.00				
FINAL TOTAL SPENT	\$88,481.53	\$79,175.80	\$152,001.79	\$150,963.34					

2023 VOLLEYBALL BUDGET				2024 VOLLEYBALL BUDGET			
QUANTITY	ITEM	PRICE ESTIMATE	ACTUAL SPENT	QUANTITY	ITEM	PRICE	TOTAL
1	Coaching Clinics	\$150.00	\$0.00	1	Coaching Clinics	\$150.00	\$150.00
1	AccuSpike	\$600.00	\$600.00	1	Ball Cart	\$500.00	\$500.00
2	Baden Volleyballs	\$134.00	\$134.00	4	Baden Volleyballs	\$76.00	\$304.00
1	Tachikara Hammock Cart	\$245.00	\$245.00	15	Baden Practice Volleyballs	\$46.00	\$690.00
4	36 Game Scorebooks	\$36.00	\$36.00	6	36 Game Scorebooks	\$11.00	\$66.00
5	Kneepads	\$84.90	\$84.90	2	Kneepads	\$18.00	\$36.00
1	Low Profile Cones	\$3.98	\$3.98	2	Electronic Whistles	\$16.00	\$32.00
1	Officials (Varsity, JV, and JH)	\$5,000.00	\$6,250.00	1	Coaching Board	\$10.00	\$10.00
1	Entry Fees	\$350.00	\$325.00	2	Ball Needles	\$1.00	\$2.00
1	Miscellaneous	\$300.00	\$330.00	1	AVCA Coaches Membership	\$90.00	\$90.00
				1	Set of 15 Nike Home Uniforms	\$1,110.00	\$1,110.00
	TOTAL	\$6,903.88	\$8,008.88	1	Set of 15 Nike Away Uniforms	\$1,035.00	\$1,035.00
				1	Set of 6 Nike Libero Uniforms	\$429.00	\$429.00
				1	Official Assigning Fee	\$350.00	\$350.00
				1	Officials (Varsity, JV, and JH)	\$6,000.00	\$6,000.00
				1	Entry Fees	\$350.00	\$350.00
				1	Miscellaneous	\$300.00	\$300.00
					TOTAL		\$11,454.00

2023 FOOTBALL BUDGET				2024 FOOTBALL BUDGET			
QUANTITY	ITEM	PRICE ESTIMATE	ACTUAL SPENT	QUANTITY	ITEM	PRICE	TOTAL
1	Reconditioning of Helmets/Shoulder Pads	\$2,500.00	\$3,543.00	1	Reconditioning of Helmets/Shoulder Pads	\$3,000.00	\$3,000.00
8	Revo Speed Flex Helmets	\$3,320.00	\$4,398.88	4	Revo Speed Flex Helmets	\$415.00	\$1,660.00
1	Nike Uniforms	\$17,778.54	\$17,788.54	4	Tackle Wheels	\$340.00	\$1,360.00
1	Mouthguards	\$45.00	\$45.00	1	FB Bench	\$1,400.00	\$1,400.00
8	Shoulder Pads	\$1,440.00	\$1,831.93	3	Shoulder Pads	\$185.00	\$555.00
8	Girdles	\$216.00	\$243.14	8	Girdles	\$37.00	\$296.00
10	Scrimmage Vests	\$180.00	\$180.00	10	Scrimmage Vests	\$22.00	\$220.00
15	Kneepads	\$90.00	\$90.00	5	Kneepads	\$7.00	\$35.00
5	Nike Black Towels	\$50.00	\$50.00	5	Nike Black Towels	\$14.00	\$70.00
5	Handwarmers	\$110.00	\$110.00	1	2 Sideline Coach Pads	\$2,128.00	\$2,128.00
1	Nike Practice Jerseys	\$1,550.00	\$1,608.22	8	Blue Fox 40 Whistles	\$9.00	\$72.00
8	Blue Fox 40 Whistles	\$28.00	\$56.00	4	Ball Needles	\$1.00	\$4.00
1	Ground Zero Tee	\$16.00	\$16.00	4	Wilson TD JH Footballs	\$50.00	\$200.00
8	Gameballs	\$680.00	\$704.92	1	Coaching Clinics	\$200.00	\$200.00
1	Scheduling Fee for Officials	\$200.00	\$242.00	1	Scheduling Fee for Officials	\$200.00	\$200.00
1	Field Paint and Equipment	\$2,000.00	\$1,735.45	1	Field Paint and Equipment	\$2,500.00	\$2,500.00
1	Officials (Varsity, JV, and JH)	\$4,000.00	\$3,640.00	1	Officials (Varsity, JV, and JH)	\$4,500.00	\$4,500.00
1	Down Markers	\$1,000.00	\$1,040.25	1	Decals	\$300.00	\$300.00
1	Headsets	\$3,000.00	\$3,000.00	1	Miscellaneous	\$300.00	\$300.00
1	Decals	\$300.00	\$352.00				
1	Miscellaneous	\$300.00	\$574.56 (Coaching Clinics, Binders)		TOTAL		\$19,000.00
	TOTAL	\$38,803.54	\$41,249.89				

2023 CROSS COUNTRY BUDGET				2024 CROSS COUNTRY BUDGET			
QUANTITY	ITEM	PRICE ESTIMATE	ACTUAL SPENT	QUANTITY	ITEM	PRICE	TOTAL
1	Entry Fees	\$600.00	\$1,090.00	1	Entry Fees	\$1,000.00	\$1,000.00
1	State Meet Expenses	\$250.00	\$204.01	1	State Meet Expenses	\$250.00	\$250.00
1	Miscellaneous	\$200.00	\$0.00	1	Miscellaneous	\$200.00	\$200.00
	TOTAL	\$1,050.00	\$1,294.01		TOTAL		\$1,450.00

2023 UNIFIED BOWLING BUDGET					2024 UNIFIED BOWLING BUDGET			
QUANTITY	ITEM	PRICE ESTIMATE	ACTUAL SPENT		QUANTITY	ITEM	PRICE	TOTAL
1	Polos	\$175.00	\$150.00	(Unified Bowling Shirts)	1	Polos	\$500.00	\$500.00
1	Entry Fees	\$125.00	\$95.00		1	Black Pants	\$200.00	\$200.00
1	Miscellaneous	\$200.00	\$566.56	(Meals for Students)	1	Entry Fees	\$125.00	\$125.00
					1	Miscellaneous	\$300.00	\$300.00
	TOTAL	\$500.00	\$811.56			TOTAL		\$1,125.00
GRANT = \$900.00								
					GRANT = \$300.00			

2023-2024 GIRLS BASKETBALL BUDGET				2024-2025 GIRLS BASKETBALL BUDGET			
QUANTITY	ITEM	PRICE ESTIMATE	ACTUAL SPENT	QUANTITY	ITEM	PRICE	TOTAL
12	Baden Basketballs	\$804.00	\$804.00	12	Baden Basketballs	\$90.00	\$1,080.00
1	SlipNott Refill Sheets	\$35.00	\$35.00	1	Set of 15 Nike Alternative Uniforms	\$500.00	\$500.00
5	Scorebooks	\$35.00	\$35.00	4	Scorebooks	\$8.00	\$32.00
1	Coaching Clinics	\$100.00	\$0.00	5	Ball Needles	\$1.00	\$5.00
1	Officials (Varsity, JV, Reserve, and JH)	\$4,500.00	\$5,275.00	1	Coaching Clinics	\$100.00	\$100.00
1	Entry Fees	\$125.00	\$0.00	1	Officials (Varsity, JV, Reserve, and JH)	\$4,500.00	\$4,500.00
1	Miscellaneous	\$300.00	\$0.00	1	Entry Fees	\$125.00	\$125.00
				1	Miscellaneous	\$300.00	\$300.00
	TOTAL	\$5,899.00	\$6,149.00		TOTAL		\$6,642.00

2023-2024 BOYS BASKETBALL BUDGET				2024-2025 BOYS BASKETBALL BUDGET			
QUANTITY	ITEM	PRICE ESTIMATE	ACTUAL SPENT	QUANTITY	ITEM	PRICE	TOTAL
6	Baden Basketballs	\$402.00	\$402.00	10	Baden Basketballs	\$90.00	\$900.00
2	Ankle Braces	\$90.00	\$43.84	1	Set of 15 Nike Alternate Uniforms	\$500.00	\$500.00
5	Scorebooks	\$35.00	\$35.00	5	Scorebooks	\$8.00	\$40.00
1	Slipnot Refills	\$35.00	\$35.00	1	NBCA Coaches Membership for Staff	\$85.00	\$85.00
1	NBCA Coaches Membership for Staff	\$85.00	\$85.00	1	Coaching Clinics	\$100.00	\$100.00
1	Coaching Clinics	\$100.00	\$80.00	1	Officials (Varsity, JV, Reserve, and JH)	\$5,000.00	\$5,000.00
1	Officials (Varsity, JV, Reserve, and JH)	\$5,000.00	\$5,275.00	1	Entry Fees	\$175.00	\$175.00
1	Entry Fees	\$125.00	\$165.00	1	Miscellaneous	\$300.00	\$300.00
1	Miscellaneous	\$300.00	\$0.00				
					TOTAL		\$7,100.00
	TOTAL	\$6,172.00	\$6,120.84				

2023-2024 BOYS WRESTLING BUDGET				2024-2025 BOYS WRESTLING BUDGET			
QUANTITY	ITEM	PRICE ESTIMATE	ACTUAL SPENT	QUANTITY	ITEM	PRICE	TOTAL
1	3 Gallons of Mat Cleaner & Disinfectant	\$153.00	\$153.00	1	Set of 15 Uniforms	\$1,200.00	\$1,200.00
1	48 Rolls of Mat Tape	\$528.00	\$528.00	1	Set of 15 Championship Singlets	\$1,050.00	\$1,050.00
1	Scale Calibration	\$200.00	\$0.00	1	48 Rolls of Mat Tape	\$770.00	\$770.00
1	Coaches Membership	\$100.00	\$75.00	1	Scale Calibration	\$200.00	\$200.00
1	Wrestling Assessor	\$100.00	\$160.00	3	Containers of Body Wipes	\$10.00	\$30.00
1	Officials (Varsity, JV, and JH)	\$3,500.00	\$3,500.00	3	Sets of Headgear	\$30.00	\$90.00
1	Trackwrestling Fees	\$250.00	\$100.00	3	Gallons of Mat Cleaner	\$75.00	\$225.00
1	Entry Fees	\$1,200.00	\$1,520.00	1	Coaches Clinic	\$100.00	\$100.00
1	State Meet Expenses	\$1,200.00	\$2,690.06	1	Wrestling Assessor	\$100.00	\$100.00
1	Miscellaneous	\$300.00	\$347.50 (InBody Scale)	1	Officials (Varsity, JV, and JH)	\$3,500.00	\$3,500.00
				1	Trackwrestling Fees	\$250.00	\$250.00
	TOTAL	\$7,531.00	\$9,073.56	1	Entry Fees	\$1,500.00	\$1,500.00
				1	State Meet Expenses	\$1,500.00	\$1,500.00
				1	Miscellaneous	\$300.00	\$300.00
					TOTAL		\$10,815.00

2023-2024 GIRLS WRESTLING BUDGET				2024-2025 GIRLS WRESTLING BUDGET				
QUANTITY	ITEM	PRICE ESTIMATE	ACTUAL SPENT	QUANTITY	ITEM	PRICE	TOTAL	
1	Coaches Clinic	\$100.00	\$0.00	1	Coaches Clinic	\$100.00	\$100.00	
1	24 Rolls of Mat Tape	\$250.00	\$596.64	3	Containers of Body Wipes	\$10.00	\$30.00	
1	Officials (Varsity, JV, and JH)	\$3,500.00	\$1,500.00	3	Sets of Headgear	\$30.00	\$90.00	
1	Trackwrestling Fees	\$250.00	\$0.00	1	Set of 20 Uniforms	\$1,600.00	\$1,600.00	
1	Entry Fees	\$1,200.00	\$594.00	1	Set of 20 Championship Singlets	\$1,400.00	\$1,400.00	
1	State Meet Expenses	\$1,200.00	\$0.00	1	Set of 20 JH Uniforms	\$1,200.00	\$1,200.00	
1	Miscellaneous	\$300.00	\$347.50	1	InBody Scale	\$500.00	\$500.00	
					1	Coaches Clinic	\$100.00	\$100.00
	TOTAL	\$6,800.00	\$3,038.14		1	Wrestling Assessor	\$100.00	\$100.00
					1	Officials (Varsity, JV, and JH)	\$3,500.00	\$3,500.00
					1	Trackwrestling Fees	\$250.00	\$250.00
					1	Entry Fees	\$1,200.00	\$1,200.00
					1	State Meet Expenses	\$1,500.00	\$1,500.00
					1	Miscellaneous	\$300.00	\$300.00
					TOTAL		\$11,870.00	

2024 GOLF BUDGET				2025 GOLF BUDGET			
QUANTITY	ITEM	PRICE ESTIMATE	ACTUAL SPENT	QUANTITY	ITEM	PRICE	TOTAL
1	Practice Rounds	\$300.00	\$365.00	1	Practice Rounds	\$300.00	\$300.00
1	Tournament Balls	\$500.00	\$564.00	1	Tournament Balls	\$500.00	\$500.00
1	Sandy Meadows Membership & Fees	\$655.00	\$655.00	1	Set of 10 Golf Polos	\$500.00	\$500.00
1	Entry Fees	\$400.00	\$555.00	1	Set of 10 Golf 1/4 Zips	\$500.00	\$500.00
1	Green Fees for Districts	\$120.00	\$150.00	1	Sandy Meadows Membership & Fees	\$655.00	\$655.00
1	Miscellaneous	\$200.00	\$0.00	1	Entry Fees	\$500.00	\$500.00
				1	Green Fees for Districts	\$120.00	\$120.00
				1	Miscellaneous	\$200.00	\$200.00
	TOTAL	\$2,175.00	\$2,289.00				
					TOTAL		\$3,275.00

2024 BASEBALL BUDGET				2025 BASEBALL BUDGET			
QUANTITY	ITEM	PRICE ESTIMATE	ACTUAL SPENT	QUANTITY	ITEM	PRICE	TOTAL
3	Dozen Baden Baseballs	\$255.00	\$257.94	3	Dozen Baden Baseballs	\$85.00	\$255.00
4	Line Up Cards	\$28.00	\$10.82	4	Line Up Cards	\$7.00	\$28.00
1	Dozen Whiffle Balls	\$6.48	\$6.48	1	Dozen Whiffle Balls	\$8.00	\$8.00
1	Umpires (Varsity and JV)	\$2,000.00	\$2,580.00	2	Dozen Pitching Machine Balls	\$70.00	\$140.00
1	Baseball Hats	\$500.00	\$832.14	1	Helmet Decals	\$150.00	\$150.00
1	Indoor Batting Cage	\$2,500.00	\$2,665.00	1	Tennis Balls	\$57.00	\$57.00
1	Miscellaneous	\$300.00	\$5,023.24	1	Bases	\$20.00	\$20.00
			(Pitching Mound, L Screen, Pitching Machine, Baseball Pants)	1	Umpires (Varsity and JV)	\$2,500.00	\$2,500.00
	TOTAL	\$5,589.48	\$11,375.62	1	Indoor Batting Cage	\$2,500.00	\$2,500.00
				1	Miscellaneous	\$300.00	\$300.00
					TOTAL		\$5,958.00

2023-2024 ACTIVITIES BUDGET				2024-2025 ACTIVITIES BUDGET			
QUANTITY	ITEM	PRICE ESTIMATE	ACTUAL SPENT	QUANTITY	ITEM	PRICE	TOTAL
1	Play Production	\$3,500.00	\$1,705.28	1	Play Production	\$3,500.00	\$3,500.00
	Books				Books		
	Royalty				Royalty		
	Licensing Fees				Licensing Fees		
	Costumes		\$325.95		Costumes		
	Set				Set		
	State Expenses		\$299.82		State Expenses		
	Dues for One Act				Dues for One Act		
	Registrations				Registrations		
1	Speech	\$1,000.00		1	Speech	\$1,500.00	\$1,500.00
	Entry Fees		\$144.00		Entry Fees		
	State Expenses		\$267.00		State Expenses		
1	eSports	\$500.00	\$136.91	1	eSports	\$500.00	\$500.00
1	Quizbowl	\$500.00		1	Quizbowl	\$500.00	\$500.00
1	Miscellaneous		\$775.64 (State Dance, Button Machine)	1	State Cheer & Dance	\$500.00	\$500.00
				1	Miscellaneous	\$500.00	\$500.00
	TOTAL	\$5,500.00	\$3,654.60		TOTAL		\$7,000.00

REVENUE		EXPENDITURES					
NSAA	\$9,309.00	NSAA	\$5,598.36	(State Qualifiers, Sub-District/District Games, Hosting Sub-District/District Events)			
SNC	\$10,211.00	SNC	\$3,836.60	(VB, BB, & WR)			
Concessions	\$508.97	Awards	\$94.80				
Vending	\$344.32	Hospitality	\$3,457.94				
		Students & Staff	\$4,963.08				
TOTAL	\$20,373.29	TOTAL	\$17,950.78				
TOTAL GAINED	\$2,422.51						

Project:
 Centennial Public Schools- Combi
 Oven 6/17/24
 1301 Centennial Ave.
 Utica, Ne 68456

From:
 Sysco Lincoln
 Lance Breitkreutz
 900 Kingbird Rd.
 Lincoln, NE 68512-1299
 (402)423-1031
 (402)421-5360 (Contact)

Job Reference Number: 574871

Item	Qty	Description	Sell	Sell Total
1.1	1 ea	COMBI OVEN, GAS	\$18,623.00	\$18,623.00
		 <p>RATIONAL Model No. ICC 10-HALF NG 120V 1 PH (LM200DG) (CD2GRRRA.0000270 iCombi Classic® 10-Half Size Combi Oven, natural gas, (10) 13" x 18" sheet pan or (10) 12" x 20" steam pan or (10) 1/1 GN pan capacity, digital color display screen with push button control, (3) manual operating modes: steam, convection & combination, temperature range 85° to 572°F, (100) program slots, core temperature probe, retractable hand shower, 5-speed fan, (4) automatic cleaning programs, integrated care system, 83,500 BTU, 120v/60/1-ph, 6 ft. cord, 0.9 kW, IPX5, cCSAus, NSF</p>		
	1 ea	NOTE: All discounts subject to approval by manufacturer		
	1 ea	2 years parts and labor, 5 years steam generator warranty		
	1 ea	9999.4104 K-12 Extended Warranty: Extends the warranty for 12 months beyond the Original Equipment Warranty to 3 years parts and labor. (NET)		
	1 ea	CAP Chef Assistance Program, a RATIONAL certified Chef conducts 4 hours/location specialized application training with personnel, no charge		
	1 ea	9999.2211 RCI RATIONAL Certified Installation, new certified installation for each individual gas table-top iCombi on a stand or counter, 100 miles (200 round-trip) included. (Do not use for Combi-Duo, See attached installation flyer for details) THIS ITEM IS NON-DISCOUNTABLE, USA ONLY (NET)		
	1 ea	8720.1560US Installation Kit, for gas iCombi/SCC/CMP 101G (120/60/1ph); gas iCombi/SCC/CMP 62G (208-240/60/1ph); gas iCombi/SCC/CMP 61G (120/60/1ph) THIS ITEM IS NON-DISCOUNTABLE, USA ONLY (NET)		
	1 ea	1900.1154US Water Filtration Single Cartridge System, for any iVario, single Combi model, or XS or half-size Combi-Duos, includes: (1) single head with pressure gauge, R95-CL filter & filter installation kit		

Item	Qty	Description	Sell	Sell Total
1 ea		9999.2271 RCI RATIONAL Certified Installation, additional installation cost for a RATIONAL Water Filter System is available when purchased with Certified Installation of RATIONAL unit THIS ITEM IS NON-DISCOUNTABLE, USA ONLY (NET)		
1 ea		NOTE: The RATIONAL Water Filtration Systems helps provide consistent high quality water to your RATIONAL cooking systems. The patented carbon block technology reduces the effects of sediment, chloramines and chlorine while providing the required flow rates		
1 ea		56.01.535 Active Green Cleaner Tabs, for all iCombi Pro/Classic, 150 pieces/bucket (minimum order quantity- 2 ea, unless ordered with a unit) (NET)		
1 ea		56.00.562 Care Tabs, bucket of 150 packets for all iCombi Pro/Classic models and SelfCooking Center® units from 10/2008, with CareControl - Serial SG, SH or SI series (minimum order quantity: 2pcs, unless ordered with a unit) (NET)		
1 ea		60.31.086 Stand II Stationary Oven Stand, 26-3/8"H, (14) supporting rails, side panels and top closed, rear panel open, stainless steel construction, for iCombi 6- and 10-half size Classic/Pro		
1 ea		60.75.773 Heat Shield, for left side panel, type 10-half size Pro/Classic, 2"W, stainless steel construction		
5 ea		6010.1101 Gastronorm Grid Shelf, 1/1 size, 12-3/4" x 20-7/8", stainless steel		
5 ea		6019.1150 CombiFry Basket, 1/1 GN, 12-3/4" x 20-7/8"		
			ITEM TOTAL:	\$18,623.00
			Total	\$18,623.00

Prices Good Until: 01/01/0001

Above prices are for equipment to be drop ship delivery, not uncrated, not installed, unless otherwise noted in the quote. Mechanical and electrical connections are to be by other trades. Mechanical and/or electrical parts, cords, etc., not furnished by factory as a part of the standard equipment and needed for final connections furnished by other trades. Faucets, disposers, control panels, etc to be installed by tradesmen. Customer is responsible to adhere to all local codes. Permits required by local codes and laws are the responsibility of others. Quote is good for 30 days. Price Does Not Include Sales Tax, unless noted.

Purchaser agrees to purchase and pay for the above described property. All deliveries are contingent upon delays caused by strikes, backorders, carriers, or other causes beyond the reasonable control of Sysco-Lincoln. All orders are subject to approval of the home office of Sysco-Lincoln. All terms submitted by purchaser which are different from the terms hereof are expressly rejected.

Purchaser grants to Sysco-Lincoln a purchase money security interest in the property and proceeds thereof to secure the purchase price and interest due hereunder. Until default, purchaser may possess and use the property and shall (a) keep the property in good repair; (b) insure the property against loss by fire or casualty with a company acceptable to Sysco-Lincoln naming Sysco-Lincoln as loss payee; and (c) pay all taxes and assessments thereon when due. Purchaser shall not (a) sell or transfer said property without written consent of Sysco-Lincoln; or (b) remove the property from its original location. Upon default in payment or any other terms hereof, Sysco-Lincoln shall be entitled to declare all obligations to be immediately due and to take immediate possession of the property for sale pursuant to the Uniform Commercial Code. Purchaser shall execute one or more Financing Statements filed at the request of Sysco-Lincoln. This Agreement may also be filed as a Financing Statement.

In the event this application is approved, as collateral security for the prompt and complete payment and performance of all of Customer's present or future indebtedness, obligations and liabilities to Sysco (the "Obligations"), Customer hereby grants to Sysco a continuing security interest in, and mortgage to, to the following (the "Collateral"): all (i) goods, including, without limitation, all goods now or hereafter delivered on credit to Customer pursuant to this Credit Agreement, and more fully described on invoices issued to Customer by Sysco, (ii) inventory, (iii) equipment; (iv) instruments, (iv) chattel paper, (v) documents, (vi) accounts, (vii) accounts receivable, (viii) general intangibles, (ix) deposit accounts, (x) investment property, and (xi) payment intangibles in which Customer now has or hereafter acquires any right or interest, and the proceeds, insurance proceeds and products thereof, together with all books and records, customer lists, credit files, computer files, programs, printouts and other computer materials and records related thereto.

The following are payment arrangements which can be used to comply with Sysco Corporate policy (all subject to approval) on purchases totaling \$5,000 or more. All orders require a signature:

_____ Obtain full payment in advance;

_____ Obtain an "Irrevocable Standby Letter of Credit" for the full amount, including tax. Note on Staged equipment: Bank agrees to release 90% on all equipment staged in Sysco Lincoln's insured warehouse on the next monthly billing cycle. The 10% balance will need to be paid on satisfactory receipt of goods. Sysco Lincoln will make every attempt to not bring equipment into our warehouse any earlier than will be required on-site. However, in order to facilitate not having construction delays, the equipment needs to be staged.

_____ Obtain 50% down payment and the balance due on the customer's established food terms; Note on Staged Equipment: Purchaser agrees to provide 50% down to initiate equipment order. Purchaser agrees to pay an additional 40% (up to 90% if monies were applied at time of order) on all equipment staged in Sysco Lincoln's insured warehouse on the next monthly billing cycle. The 10% balance will need to be paid on satisfactory receipt of goods. Sysco Lincoln will make every attempt to not bring equipment into our warehouse any earlier than will be required on-site. However, in order to facilitate not having construction delays, the equipment needs to be staged.

Supply & Equipment sales of \$5,000 or more will be considered on a secured basis, which requires the completion of a UCC-1 Financing Statement and a Security Agreement.

Acceptance: _____ Date: _____

Printed Name: _____

Project Grand Total: \$18,623.00



Datasheet

iCombi® Classic 10-half size E/G



Capacity

- > Ten (10) Half-size sheet pans or Ten (10) Steam table pans or Ten (10) 1/1 GN accessories
- > Removable standard hinging rack with 2 5/8 inch rack spacing (68 mm)
- > Large selection of accessories for various cooking procedures, such as grilling, braising or baking
- > For use with 1/1, 1/2, 2/3, 1/3 GN accessories and optional baker's standard accessories (400 x 600 mm)

Combi-steamer mode

- > Steaming 86 °F - 266 °F
- > Convection 86 °F - 572 °F
- > Combination of steam and convection 86 °F - 572 °F

ClimaPlus

- > Climate management – humidity measurement and control
- > Humidity setting in 10-% increments

Description

- > Combi-steamer in accordance with DIN 18866 for most cooking methods used in commercial kitchens for optional use of steam and convection, individually, one after the other, or combined.

Ventilation approvals: The electrical appliance conforms to the EPA 202 test in accordance with ANSI/NFPA 96 "Ventilation Control and Fire Protection of Commercial Cooking Operations" Refer to UL Listing KNLZ.E148536 (America) or KNLZ7.E148536 (Canada).

Unit description and functions

Cooking functions

- > ClimaPlus: The active climate management in the cooking cabinet, which constantly measures and controls the humidity and guarantees effective dehumidification, combined with high productivity, cooking quality and low energy consumption. Humidity can be adjusted in increments of 10% and monitored via the digital display for precise manual cooking
- > Dynamic air circulation in the cooking cabinet through 2 reversing high-performance fan propellers with five fan speeds that can be programmed manually. The optimal energy yield results in excellent uniformity and short cooking times.
- > High-performance steam generator for optimal steaming performance even at low temperatures below 212°F
- > Integrated, maintenance-free fat separation system without an additional fat filter
- > Cool-down function for quick cooling of the cooking cabinet via a fan propeller
- > Core temperature measurement via core temperature probe and optional positioning aid (accessories)
- > Delta-T cooking for extremely gentle preparation with minimal cooking losses
- > Digital temperature display, can be set to °C or °F, displays target and actual values
- > Cooking cabinet humidity and time displayed digitally; displays target and actual values
- > Individual programming of up to 100 single or multi-stage cooking programs with up to 12 steps
- > Individual adjustment of the cooking parameters time, temperature and humidity for a program step during ongoing operation
- > Easy transfer of cooking programs to other cooking systems via USB stick.
- > Integrated hand shower with automatic retraction and switchable spray/jet function
- > Energy-saving, long-lasting LED lighting in the cooking cabinet, with excellent color fidelity to allow quick determination of cooking progress
- > No-charge 4-hour RATIONAL certified chef assistance program

Occupational and operating safety

- > Electronic safety temperature limiter for steam generator and convection heating
- > Integrated fan wheel brake
- > Use of Active Green cleaning tabs and Care tabs (solid cleaning agent) for ideal occupational safety levels
- > HACCP data memory and output via USB
- > Tested according to national and international standards for unsupervised operation
- > Maximum tray height must not exceed 63 inch when using a RATIONAL stand
- > Ergonomic door handle with right- / left-handed door opening and swing-shut function

Networking

- > Integrated, IP-protected USB interface for local data exchange
- > Optional integrated IP-protected Ethernet interface
- > Optional integrated Wi-Fi interface (incl. Ethernet interface)

Cleaning and care

- > Automatic, water pressure-independent cleaning and maintenance system for cooking cabinet and steam generator
- > Care system: Automatic cleaning and descaling of the steam generator
- > 4 cleaning programs of varying degrees for unsupervised cleaning, including overnight
- > Easy and intuitive operation of the cleaning programs: Display of the selected cleaning program, the recommended quantity of tabs and the remaining cleaning time
- > Safe ending of the cleaning in the event of a power failure with no cleaning agent left in the cooking cabinet
- > Use of phosphate and phosphorous-free Active Green cleaner tabs and care tabs
- > Hygienic setup flush with the counter without feet for easy and safe cleaning
- > Unit door with rear-ventilated double glass panel and hinged inner pane for easy cleaning

- > Inside and outside material: stainless steel DIN 1.4301 / ASTM 304, seamless hygienic cooking cabinet with rounded corners and optimized air flow
- > Glass and stainless steel surfaces allow easy, safe external cleaning; IPX5-class protection against spraying water in all directions

Operation

- > 4.3 inch TFT color display and softkeys for easy and intuitive operation. Operating modes and functions are visually highlighted
- > Easy operation and exact settings through a central dial with push function
- > Acoustic prompts and visual messages when user action is required
- > Recirculating hoods (accessories) with situational adjustment of extraction power and service message transmission.

Installation, maintenance and environment

- > Professional installation by RATIONAL-certified technicians recommended
- > Fixed waste water connection conforming to SVGW requirements is permitted
- > Adaptation to the installation site (height above sea level) through automatic calibration
- > Operation without water softener and without additional manual descaling possible
- > Installation flush with the floor and wall through connection in the base area *
- > Double-pane glass door with heat reflective special coating for minimal energy losses
- > Service diagnostic system with automatic service message display
- > Regular maintenance is recommended. Maintenance according to manufacturer recommendations available from RATIONAL service partners
- > Energy efficiency in accordance with ENERGY STAR tested and passed. Published at www.energystar.gov
- > 2-year RATIONAL warranty including parts, labor, and travel and 5-year steam generator warranty**
- > * See the installation or planner manual for details
- > ** Terms and conditions apply, see manufacturer warranty statement at www.rational-online.com

Options

- > Hinging rack and air baffle for baker's standard accessories (400 x 600 mm)
- > Cooking cabinet door, left-hinged
- > MarineLine – ship version
- > SecurityLine – prison / security version
- > MobilityLine - mobile version (available to order as a separate accessory)
- > HeavyDutyLine – particularly resilient version
- > Integrated fat drain
- > Mobile oven rack package
- > Safety door lock
- > Protection for control panel
- > Lockable control panel
- > Integrated, IP-protected Ethernet interface
- > Integrated Wi-Fi interface (incl. Ethernet interface)

Technical specifications

Dimensions and weights

Dimensions (W x H x D)	
Cooking system (body)	33 1/2 x 39 7/8 x 30 1/2 inches
Cooking system (total)	33 1/2 x 41 7/8 x 33 1/8 inches
Cooking system with packaging	36 3/4 x 49 1/4 x 37 5/8 inches
Maximum working height of top level*	≤ 5 ft. 2 7/8 inches

*when using a corresponding RATIONAL stand

Weights	
Maximum load size per level	33 lb
Maximum total load capacity	99 lb
Weight - electric unit without packaging	271 lb
Weight - electric unit with packaging	317 lb
Weight - gas unit without packaging	315 lb
Weight - gas unit with packaging	362 lb

Electrical connection conditions

Voltage 3 ph 208 V / 240 V	
Connected loads - electric	18.9 kW
Steam power	18 kW
Convection power	18 kW
Breaker	60 A
Running AMPS	52.5 A (208 V) / 60.4 A (240 V)
Cable diameter	AWG 4 140°F
Voltage 3 ph 440 V / 480 V	
Connected loads - electric	18.9 kW
Steam power	18 kW
Convection power	18 kW
Breaker	30 A
Running AMPS	24.8 A (440 V) / 29 A (480 V)
Cable diameter	AWG 8 140°F

Not supplied with cable connection

Connected loads - gas

Natural gas G20	
Nominal heat load, total	83500 BTU
Nominal heat load, Steam mode	76000 BTU
Nominal heat load, Hot Air mode	83500 BTU
Required connection flow pressure	6.5 – 10 inch w.c.
Liquid gas	
Nominal heat load, total	82000 BTU
Nominal heat load, Steam mode	74500 BTU
Nominal heat load, Hot Air mode	82000 BTU
Required connection flow pressure	10 – 15 inch w.c.

3/4" NPT with 3/4" gas shut off

Additional gas types and voltages available on request

Connected loads - gas

Voltage 2 AC 208 V	
Connected loads - gas	0.9 kW
Breaker	15 A

RCD Type	B
Voltage 1 NAC 120 V	
Connected loads - gas	0.9 kW
Breaker	15 A
RCD Type	B

All gas units are supplied with a 6 ft cord.

Connection conditions water

Water inlet (pressure hose), each	3/4"
Water pressure (flow pressure), each	14.5-87.0 psi
Water drain, each	2" OD
Maximum flow rate per cooking system	3.17 gal/min

Water quality requirements

Untreated water can be 0 to 24.5 gr/gal (0 to 420ppm) hardness. We do not recommend treated water hardness < 5 gr/gal (86ppm) because the water could be corrosive. Sodium ion exchangers are not recommended; H+ Ion exchange systems are recommended. Water that does not meet the following minimum standards will require the proper conditioning

Contaminant	Water Requirements	If > than recommended
Sand / Particles	< 15 µm	Particle filter
Chlorine (Cl ₂)	< 0.12 gr/gal (0.2 ppm)	Active carbon filter
Chloride (Cl ⁻)	< 4.68 gr/gal (80 ppm)	RO

Connected loads - exhaust air and thermal load

Latent heat load	3269 BTU
Sensible heat emission	4344 BTU
Sound level (electric)	55 dBA
Sound level (gas)	60 dBA

Connection loads - data

LAN data interface	RJ45
WiFi data interface	IEEE 802.11 a/g/n

Minimum distances at installation

Clearance Requirements

To facilitate servicing, we recommend leaving a 20" (500 mm) gap on the left-hand side of the unit. If there is not 20" (500 mm) left side clearance available, provisions for moving the unit to the left for service access must be made. Such provisions include, but are not limited to, having quick connections (water, gas, etc.) and lengthened electrical connections with flexible cords.

If there are no external heat sources acting on the unit, there should be at least 2" (50 mm) of clearance on either side of the unit. The back of the unit can be mounted flush with the wall.

If a high temperature heat source is on the left side of the unit, clearance of at least 14" (350 mm) must be maintained on the left-hand side. This clearance may be reduced to 2" (50 mm) if a heat shield is used (see accessories).

Recommended clearance from unobstructed rear exhaust pipes and any surface collecting grease or flammable material; 16" (400 mm) gas, 10" (254 mm) electric. It is recommended to have a hood overhang of 6" (150 mm) to 18" (450 mm) at the front of the unit and 6" (150 mm) on the sides if installed at the end of the cooking line. Please refer to the Installation Manual for additional technical data and for instructions on installation and setup.

Installation conditions

> Observe all local and country-specific standards and regulations regarding the installation and operation of industrial cooking appliances. The local standards and regulations for interior ventilation systems must also be taken into account.

Approvals



NSF Certification

iCombi Pro (LM100) and iCombi Classic (LM200) are NSF-certified, shown on the NSF list.

Technical drawing, electrical

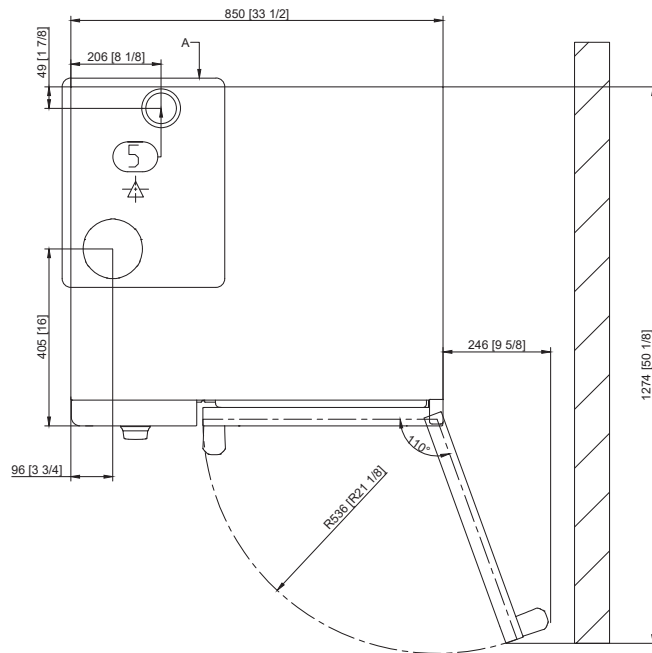
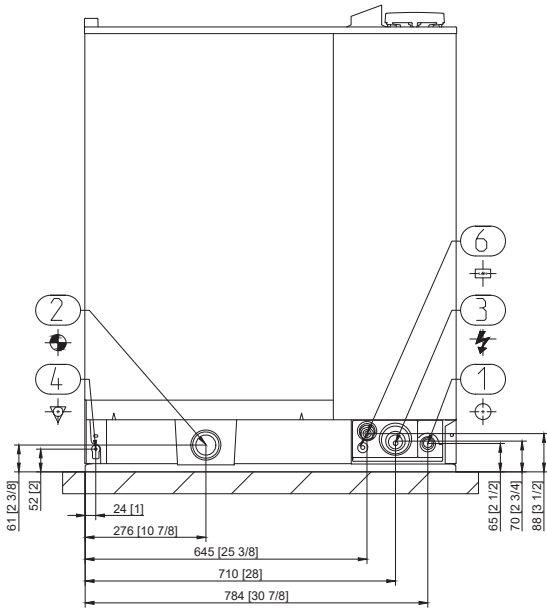
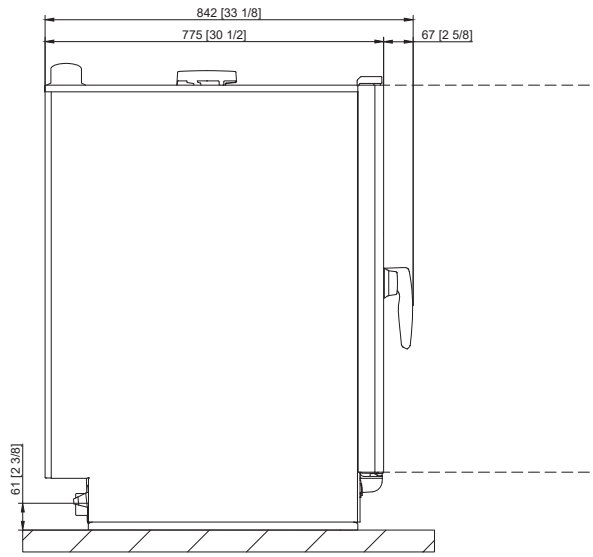
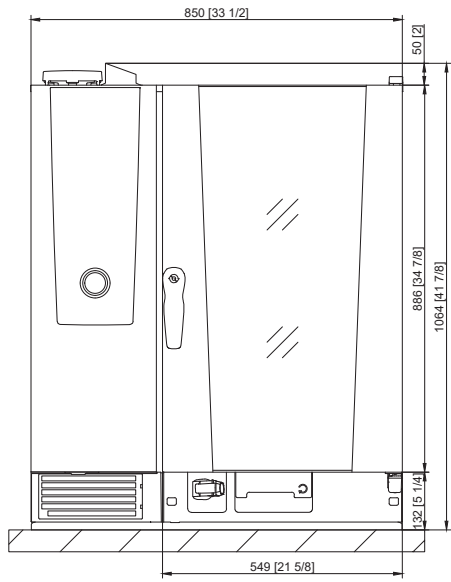

1	Water inlet
2	Water drain
3	Electrical connection
4	Equipotential bonding
5	Ventilation pipe
6	Ethernet interface

Technical drawing, gas

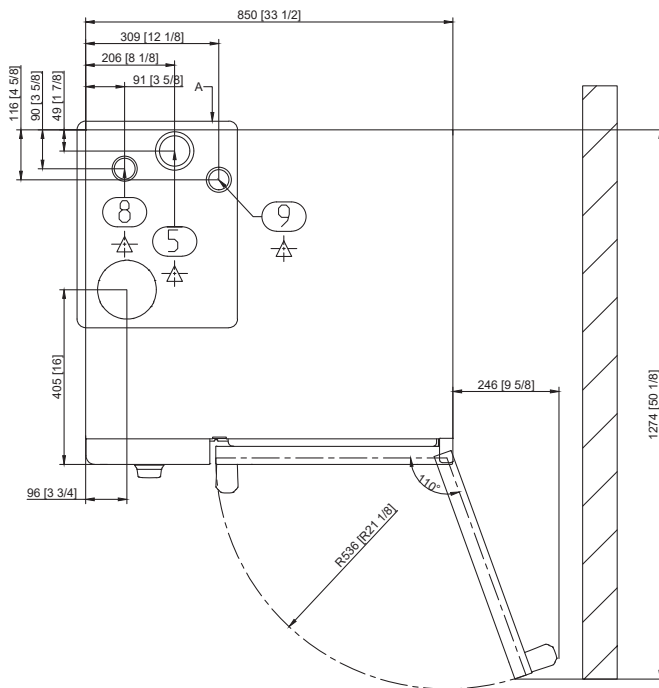
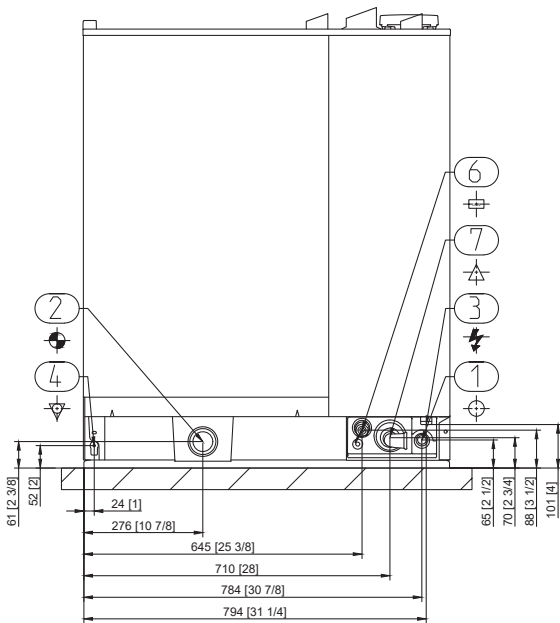
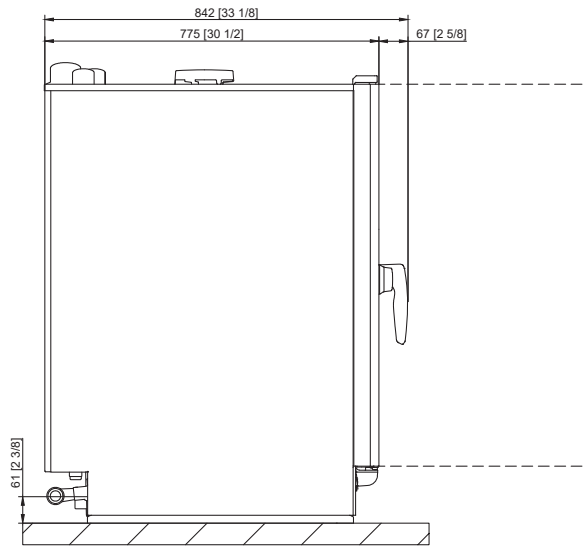
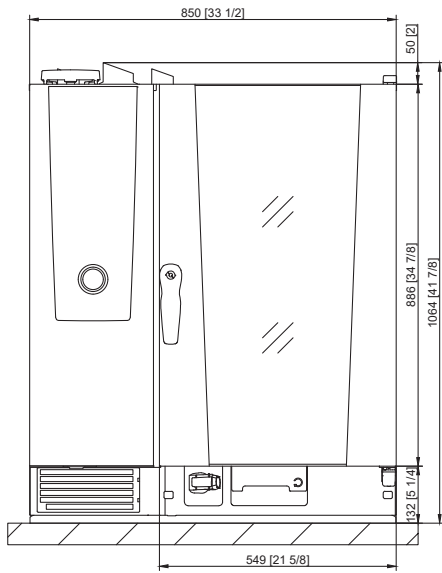

1	Water inlet
2	Water drain
3	Electrical connection
4	Equipotential bonding
5	Ventilation pipe
6	Ethernet interface
7	Gas connection
8	Exhaust pipe gas (steam)
9	Exhaust pipe gas (convection)

Datenblatt, Version 20 - 11/2/2021 10:53 AM - We reserve the right to make technical changes.

Accessories

Accessories	Item number
RATIONAL Active Green cleaning agent tabs – guarantee the best cleaning performance	Item no. 56.01.535
RATIONAL Care tabs – effectively prevent limescale deposits	Item no. 56.00.562
Condensation breaker – diverts steam and vapors to an existing exhaust air system Sizes 6-half size, 10-half size, 6-full size and 10-full size	Item no. 60.72.592
Run-in rail for mobile rack and mobile plate rack Size 6-half size, 10-half size	Item no. 60.75.115
Finishing system for banquets Size 10-half size, 26 plates	Item no. 60.11.629
Finishing system for banquets Size 10-half size, 32 plates	Item no. 60.11.628
Mobile oven rack and mobile plate oven rack – for simple loading outside the cooking system	See Cooking Systems and Accessories catalog
Hinging racks – Size 10-half size	Item no. 8 racks 60.11.547
Heat shield – for installing a unit near a heat source, e.g. a grill - Size 10-half size	Item no. left side 60.75.773 Item no. right side 60.75.771
Mobile catering stand - especially for heavy mobile catering usage	Item no. 60.31.164
Stackable Combi-Duo kit Size 6-half size E/G on Size 6-half size E or Size 10-half size E	Item no. 60.73.991
Transport trolley for mobile rack and mobile plate rack - height-adjustable - Sizes 6-full size, 10-full size	Item no. 60.75.606
Transport trolley for mobile rack and mobile plate rack - standard - Sizes 6-half size, 10-half size	Item no. 60.74.000
UltraVent recirculating hood - for Size 6-half size, 10-half size electric units only	Item no. 60.67.179
UltraVent Plus recirculating hood - for Size 6-half size, 10-half size electric units only	Item no. 60.76.177
Stands are available in various versions - standard, with casters, or with anchorable stainless steel feet	See Cooking Systems and Accessories catalog
RATIONAL USB stick – to securely transfer cooking programs and HACCP data	Item no. 42.00.162
RATIONAL Single Water Filter - for all single models and Combi-Duo XS/XS, 6-half size/6-half size and 6-half size/10-half size	Item no. 1900.1154US

We offer a wide range of cooking accessories to help you achieve ideal cooking results; for more information, please consult our accessories brochure, ask your dealer, or visit www.rational-online.com

Planner	RATIONAL AG
	1701 Golf Road, Suite C-120, Commercium Rolling Meadows, IL 60008 Toll Free: 888-320-7274 Fax: 847-755-9583 Email: info@rational-online.com Visit us on the internet: www.rational-online.com



Installation Kit

Article no. 8720.1560US

The RATIONAL Installation Kit ensures that the installer has all the essential connection materials on hand at the time of install. Not all parts are used in every installation.

Gas RATIONAL Combi Oven 6-half size G (120v/60/1ph) or (208v/60/1ph)

Gas RATIONAL Combi Oven 10-half size G (120v/60/1ph) or (208v/60/1ph)

Gas RATIONAL Combi Oven 6-full size (208-240v/60/1ph)

The Installation Kit for the above models includes:

1	ea	Gas Connector Hose, 3/4" NPT connection, 48" long, stainless steel braid with Plastic coat exterior, brass push to connect quick disconnect coupling, for castered equipment with cable strain relief
1	ea	90 degree black iron elbows, 3/4" NPT
2	ea	90 degree black iron street elbows, 1" NPT
1	ea	18" long × 3/4" NPT black iron pipe
1	ea	10" long × 3/4" NPT black iron pipe
1	ea	8" long × 3/4" NPT black iron pipe
1	ea	Close nipple 3/4" NPT black iron pipe
2	ea	45 degree black iron elbows, 3/4" NPT
2	ea	2" Minnies
1	ea	3/4" minnies
2	ea	3/4" Water Connector Hose, 5/8" ID, 3/4" female hose thread both ends, 60" long rubber coated, NSF approved
1	ea	Male union 3/4" × 3/4" MHT
2	ea	90 deg Fresh water elbow
8	feet	2" copper pipe (two 4' pieces)
2	ea	2" copper pipe 90 degree elbow
1	ea	2" copper pipe T fitting
2	ea	2" copper pipe 45 degree elbow
1	ea	2" copper pipe 90 degree elbow female to male
1	ea	2" copper pipe 90 degree long sweep
1	ea	2" copper pipe coupling
1	ea	Receptacle NEMA 6-15R 15A-250V
1	ea	NEMA 6-15R cover plate single junction box
1	ea	NEMA 6-15P
1	ea	NEMA 5-15P

Please note that installation kits are non-discountable.

Water Filtration Products.



R195-CLX



R195-CLX

RATIONAL Water Filtration Products Model R195-CLX single cartridge water filtration system helps provide consistent high quality water for your RATIONAL combi by reducing the effects of sediment, chloramines, chlorine, taste & odor while providing the required flow rates for any single Combi model or Combi-Duo models 6-half size/6-half size or 6-half size/10-half size or XS/XS.

Product Benefits

- › Carbon block technology effectively reduces chloramines, chlorine, taste, and odor for better equipment protection.
- › NSF Standard 42 and FDA CFR-21 compliant materials.
- › Sanitary Quick Change (SQC) encapsulated cartridge design allows for fast and easy cartridge change-outs with ¼" turn.
- › ½" FNPT horizontal inlet and outlet ports allow direct or easily adaptable connections to existing plumbing lines.

Model Number	Article No.	Reduction Claims	Nominal Micron Rating	Capacity	Replacement Cartridge	Service Flow Rate
R195-CLX	1900.1154US	Chlorine, Taste and Odor Chloramines	5.0 ¹	54,000 gallons (204,412 liters)	R95-CLX 1900.1155US	5 gpm (18.92 lpm) 1.5 gpm (5.68 lpm)

¹ NSF Certified for Particulate Reduction



Visit www.nsf.org for the claims associated with products that are NSF listed.

Water Filtration Products.



R195-CLX

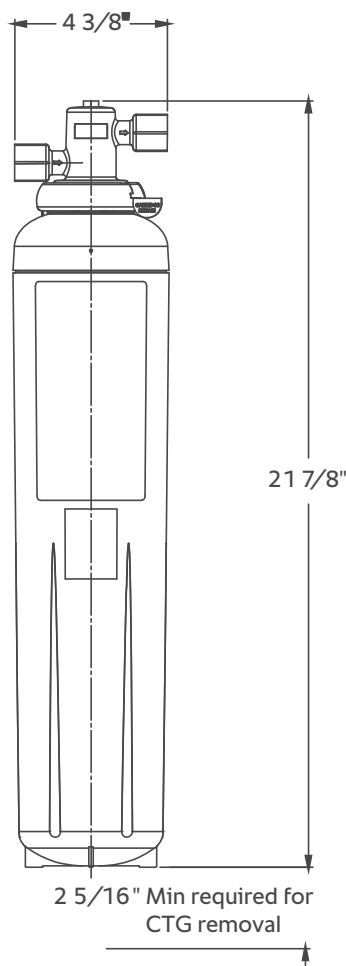

Application Guide

- › Any single RATIONAL combi
- › XS/XS Combi-Duo
- › 6-half size/6-half size Combi-Duo
- › 6-half size/10-half size Combi-Duo

Important: Installation Tips

These installation tips are for informational purposes only and are not intended to be used as actual installation instructions. Caution: To reduce the risk associated with property damage due to water leakage:

- › Read and follow Use Instructions before installation and use of this system.
- › Installation and use must comply with all state and local plumbing codes.
- › Protect from freezing, remove filter cartridge when temperatures are expected to drop below 40°F (4.4°C).
- › Do not install on hot water supply lines. The maximum operating water temperature of this filter system is 100°F (37.8°C).
- › Water pressure range- minimum 25 to maximum 80 psi (172-552 kPa). If your water pressure exceeds 80 psi (552 kPa), you must install a pressure limiting valve. Contact a plumbing professional if you are uncertain how to check your water pressure.
- › Do not install where water hammer conditions may occur. If water hammer conditions exist you must install a water hammer arrester. Contact a plumbing professional if you are uncertain how to check for this condition.
- › The disposable filter cartridge must be replaced every 12 months, at the rated capacity or sooner if a noticeable reduction in flow rate occurs.

Warning

To reduce the risk associated with the ingestion of contaminants: Do not use with water that is microbiologically unsafe or of unknown quality without adequate disinfection before or after the system.

RATIONAL recommends regularly scheduled maintenance and replacement of the filter cartridge(s) in order for the product to perform as advertised/sold. RATIONAL shall not be liable for system failures due to improper maintenance.

Limited Warranty

RATIONAL warrants this Product will be free from defects in material and manufacture for five (5) years from the date of purchase: The filter cartridge or filter membrane is warranted to be free from defects in material and manufacture for one (1) year. This warranty does not cover failures resulting from abuse, misuse, alteration or damage not caused by RATIONAL Water Filters or failure to follow installation and use instructions. No warranty is given as to the service life of any filter cartridge or membrane as it will vary with local water conditions and water consumption. RATIONAL MAKES NO OTHER WARRANTIES OR CONDITIONS, EXPRESS OR IMPLIED, INCLUDING, BUT NOT LIMITED TO, ANY IMPLIED WARRANTY OR CONDITION OF MERCHANTABILITY OR FITNESS FOR A PARTICULAR PURPOSE OR ANY IMPLIED WARRANTY OR CONDITION ARISING OUT OF A COURSE OF DEALING, CUSTOMER OR USAGE OF TRADE. If the Product fails to satisfy this Limited Warranty during the warranty period, RATIONAL will replace the Product or refund your Product purchase price. This warranty does not cover labor. The remedy stated in this paragraph is Customer's sole remedy and RATIONAL exclusive obligation. For additional information, see the entire Limited Warranty located in the product Installation and Operating Instruction Manual.

Limitation of Liability. RATIONAL will not be liable for any loss or damage arising from this RATIONAL product, whether direct, indirect, special, incidental, or consequential, regardless of the legal theory asserted, including warranty, contract, negligence or strict liability. Some states and countries do not allow the exclusion or limitation of incidental or consequential damages, so the above limitation or exclusion may not apply to you.

RATIONAL USA

1701 Golf Road
Suite C-120, Commerceum
Rolling Meadows, IL 60008

Tel. 888-320-7274 (Toll Free)
Fax 847-755-9583

info@rational-online.us
rationalusa.com



[Chef's Deal](#) > [Cooking Equipment](#) > [Commercial Ovens](#) > [Commercial Combi Ovens](#) > RATIONAL ICC 10-HALF NG 208/240V 1 PH (LM200DG) Half Size Gas Combi Oven W/ 10 Pans, Dial Controls, Steam Generator, 83.500 BTU

RATIONAL ICC 10-HALF NG 208/240V 1 PH (LM200DG) Half Size Gas Combi Oven w/ 10 Pans, Dial Controls, Steam Generator, 83.500 BTU

SKU RAT-ICC 10-HALF NG 208/240V 1 PH (LM200DG) ★★★★★ | [Like this product? Write a Review!](#)



The image above may not exactly represent the product

FREE SHIPPING **PRICE MATCH** **FINANCING AVAILABLE**

\$18,120.00

[Login](#) or [Add to Cart](#) to See Our Price

Net 30 or as low as 329.01/mo with Credit Key [Apply Now](#)

[Call or Chat](#)

Add extended warranty from CPS [Learn More](#)

None	1 YEARS + \$143.99	2 YEARS + \$237.99	3 YEARS + \$322.99	4 YEARS + \$523.99
------	-----------------------	-----------------------	-----------------------	-----------------------

Print Page Email Page Add to Wishlist Compare

Resources





RATIONAL ICC 10-HALF NG 208/240V 1 PH (LM200DG) Specs

Brand	RATIONAL
Model Number	ICC 10-HALF NG 208/240V 1 PH (LM200DG)
Weight	350 lbs
Width	33.5"
Depth	30.5"
Height	39.9"
Power Type	gas
Installation Type	countertop
Size	half size



Steam Type	steam generator
Control Type	dial control
Pan Capacity (13" x 18")	10
Pan Capacity (12" x 20")	10
G/N Pan Capacity	10 1/1

Brand



[View all RATIONAL](#)

Rational Combi Ovens iCombi® Classic 10-Half Size E/G

Description

Combi-steamer in accordance with DIN 18866 for most cooking methods used in commercial kitchens for optional use of steam and convection, individually, one after the other, or combined.

Ventilation approvals: The electrical appliance conforms to the EPA 202 test in accordance with ANSI/ NFPA 96 "Ventilation Control and Fire Protection of Commercial Cooking Operations" Refer to UL Listing KNLZ.E148536 (America) or KNLZ7.E148536 (Canada).

Cooking Functions:

- ClimaPlus: The active climate management in the cooking cabinet, which constantly measures and controls the humidity and guarantees effective dehumidification, combined with high productivity, cooking quality and low energy consumption. Humidity can be adjusted in increments of 10% and monitored via the digital display for precise manual cooking
- Dynamic air circulation in the cooking cabinet through 2 reversing high-performance fan propellers with five fan speeds that can be programmed manually. The optimal energy yield results in excellent uniformity and short cooking times.
- High-performance steam generator for optimal steaming performance even at low temperatures below 212°F
- Integrated, maintenance-free fat separation system without an additional fat filter
- Cool-down function for quick cooling of the cooking cabinet via a fan propeller
- Core temperature measurement via core temperature probe and optional positioning aid (accessories)
- Delta-T cooking for extremely gentle preparation with minimal cooking losses
- Digital temperature display, can be set to °C or °F, displays target and actual values
- Cooking cabinet humidity and time displayed digitally; displays target and actual values
- Individual programming of up to 100 single or multi-stage cooking programs with up to 12 steps
- Individual adjustment of the cooking parameters time, temperature and humidity for a program step during ongoing operation
- Easy transfer of cooking programs to other cooking systems via USB stick.
- Integrated hand shower with automatic retraction and switchable spray/jet function
- Energy-saving, long-lasting LED lighting in the cooking cabinet, with excellent color fidelity to allow quick determination of cooking progress
- No-charge 4-hour RATIONAL certified chef assistance program

Capacity:

- Ten (10) Half-size sheet pans or Ten (10) Steam table pans or Ten (10) 1/1 GN accessories
- Removable standard hinging rack with 2 5/8 inch rack spacing (68 mm)
- Large selection of accessories for various cooking procedures, such as grilling, braising or baking
- For use with 1/1, 1/2, 2/3, 1/3 GN accessories and optional baker's standard accessories (400 x 600 mm)



Combi-steamer Mode:

- Steaming 86 °F - 266 °F
 - Convection 86 °F - 572 °F
 - Combination of steam and convection 86 °F - 572 °F
-

ClimaPlus:

- Steaming 86 °F - 266 °F
 - Convection 86 °F - 572 °F
 - Combination of steam and convection 86 °F - 572 °F
-

Options:

- Hinging rack and air baffle for baker's standard accessories (400 x 600 mm)
 - Cooking cabinet door, left-hinged
 - MarineLine – ship version
 - SecurityLine – prison / security version
 - MobilityLine - mobile version (available to order as a separate accessory)
 - HeavyDutyLine – particularly resilient version
 - Integrated fat drain
 - Mobile oven rack package
 - Safety door lock
 - Protection for control panel
 - Lockable control panel
 - Integrated, IP-protected Ethernet interface
 - Integrated Wi-Fi interface (incl. Ethernet interface)
-

From The Manufacturer

(CD2GRRA.0000271) iCombi Classic® 10-Half Size Combi Oven, natural gas, (10) 13" x 18" sheet pan or (10) 12" x 20" steam pan or (10) 1/1 GN pan capacity, digital color display screen with push button control, (3) manual operating modes: steam, convection & combination, temperature range 85° to 572°F, (100) program slots, core temperature probe, retractable hand shower, 5-speed fan, (4) automatic cleaning programs, integrated care system, 83,500 BTU, 208/240v/60/1-ph, 6 ft. cord, 0.9 kW, IPX5, cCSAus, NSF





**RESTAURANT
SUPPLY.com**

855-838-1010
Speak with a real person

Shop All

Search

Cart

Sign in and enjoy Member Exclusive Pricing Order History & Tracking 30-Day Lowest Price Match Guaranteed

New to RestaurantSupply.com? [Create Account](#)

My Lists Top Brands Foodservice Designs Gift Cards Financing < 30-Day Lowest Price Match Guaranteed >

855-838-1010

Speak with a real person

Home > Restaurant Equipment > Commercial Cooking Equipment > Steamers Combi Ovens and Steam Kettles > Gas Combination Ovens

Rational ICC 10-HALF NG 120V 1 PH (LM200DG) (CD2GRRR.0000270 ICombi Classic® 10-Half Size Combi Oven

Rational ICC 10-HALF NG 120V 1 PH (LM200DG) (CD2GRRR.0000270 ICombi Classic® 10-Half Size Combi Oven

Item: #384496 MFG: #ICC 10-HALF NG 120V 1 PH (LM200DG)



Specification

Manufacturer	RATIONAL
Model Number	ICC 10-HALF NG 120V 1 PH (LM200DG)
Manufacturer Part #	ICC 10-HALF NG 120V 1 PH (LM200DG)
Type	Countertop
Steam Type	Steam Generator
Control Type	Mechanical Controls
Height	39.9"
Width	33.5"
Depth	30.5"
Weight	350 lbs
NSF Approved	Yes



Rational ICC 10-HALF NG 120V 1 PH (LM200DG) (... #384496

Details

Reviews

\$18,120.00 /Each



IPX5 Approved	Yes
---------------	-----

[Cutsheet](#)

[R195-CL Water Filtration](#)

[Wearable Parts](#)

[Care Products](#)

[Pre-Sale Checklist](#)

[Unit And Accessories Catalog](#)

[Installation Kit 1560](#)

[Certified Installation](#)

[Security Spec Sheet](#)

[R295-CL Water Filtration](#)

[Warranty Sheet](#)

[Pre-Sale Checklist](#)

Description

RATIONAL, ICC 10-HALF NG 120V 1 PH (LM200DG), (CD2GRRA.0000270 iCombi Classic® 10-Half Size Combi Oven, natural gas, (10) 13" x 18" sheet pan or (10) 12" x 20" steam pan or (10) 1/1 GN pan capacity, digital color display screen with push button control, (3) manual operating modes: steam, convection & combination, temperature range 85° to 572°F, (100) program slots, core temperature probe, retractable hand shower, 5-speed fan, (4) automatic cleaning programs, integrated care system, Ethernet interface, 83, 500 BTU, 120v/60/1-ph, 6 ft. cord, 0.9 kW, IPX5, cCSAus, NSF

Because this item is not stocked in our warehouse, processing, transit times and stock availability will vary. If you need your items by a certain date, please contact us prior to placing your order. Expedited shipping availability may vary. We cannot guarantee that this item can be cancelled off of the order or returned once it is placed.



NSF Listed
This item meets the standards imposed by NSF International, which focuses on public safety, health, and the environment.



CSA_C_US
This item meets the standards imposed by the Canadian Standards Association (CSA) for use in the United States of America and Canada.



Proposition 65
Proposition 65 requires the state to maintain and update a list of chemicals known to the state to cause cancer or reproductive toxicity.

Free Shipping

\$18,120.00 / Each

[Login for Details](#)

Net 30 or as low as \$1676/month [Prequalify](#)  [Credit Key](#) [For Business](#)

1	ADD TO CART
---	--------------------

Shipping

Lead time varies; contact our team with your ZIP code for more info.

(10) 13" x 18" sheet pan or (10) 12" x 20" steam pan or (10) 1/1 GN pan capacity



Rational ICC 10-HALF NG 120V 1 PH (LM200DG) (...
#384496

Details
Reviews

\$18,120.00

/Each

(4) automatic cleaning programs

(CD2GRRA.0000270 iCombi Classic® 10-Half Size Combi Oven

Natural gas



[View all \(Rational\)](#)

Be the first to review this product

[WRITE THE FIRST REVIEW](#)

What do you want to know about this product?

[ASK A QUESTION](#)

Other Products from this Line



Blodgett Combi BCX-14G
DBL_LP 40 7/8" Wide
Double Stack Liquid

Propane

[ADD TO CART](#)



Blodgett Combi BCX-14G
SGL_LP 40 7/8" Wide
Single Liquid Propane

Propane

[ADD TO CART](#)



Blodgett Combi BX-14G
DBL_LP 40-7/8" Wide
Double Stack Liquid

Propane

[ADD TO CART](#)



Blodgett Combi BX-1
SGL_LP 40-7/8" Wide
Single Liquid Prop

Propane

[ADD TO CART](#)

Find Related Categories

[Gas Combination Ovens](#)

Recently Viewed



Rational ICP 10-FULL NG 208/240V
1 PH (LM100EG)
(CE1GRRA.0000240) iCombi Pro@...

[About Us](#) [Blog](#) [Shipping/Receiving](#) [Payment Methods](#) [Terms](#) [Privacy](#) [Returns](#) [Financing](#)
[Overstock](#) [Scratch & Dent](#) [Clearance](#)



[Subscribe](#)



Rational ICC 10-HALF NG 120V 1 PH (LM200DG) (... #384496

[Details](#)

[Reviews](#)

\$18,120.00 /Each





DRAFT
SUPERINTENDENT OF SCHOOLS
JOB DESCRIPTION

DEPARTMENT: Administration

JOB TITLE: Superintendent of Schools

REQUIREMENTS:

1. Education Level: A Master's degree with a minimum of 60 graduate hours in educational administration or educational leadership, completion of an educational specialist, doctoral program, or other state-approved program for the preparation of a superintendent, and a one-semester internship in an approved or accredited school system.
2. Certification/Endorsement: A valid Nebraska Administrative and Supervisory Certificate with a superintendent endorsement.
3. Attendance: Performance of this position requires daily attendance except when granted leave by district policy, an employment agreement, the board, or when otherwise provided by law.
4. Other Requirements:
 - A. Possess and demonstrate strong communication (written and oral), motivational, and organizational skills.
 - B. Utilize effective data-based problem-solving skills.
 - C. Possess and demonstrate effective collaboration skills.
 - D. Possess and demonstrate qualities of sound judgment, independent thinking, and educational leadership.
 - E. Skillful in conflict resolution.
 - F. Skillful in human relations; ability to deal with a diversity of people.
 - G. Ability to organize, prioritize, and function under pressure and time constraints.
 - H. Participate in workshops, seminars, conferences, and/or advanced course work which further advance knowledge of current trends in school administration.
 - I. Possess an excellent memory and the ability to deal with more than one person or item at one time.
 - J. Such alternatives to the above qualifications as the Board of Education may find appropriate and acceptable

REPORTS TO: Board of Education

RECEIVES GUIDANCE FROM: Board of Education, School District Legal Counsel

EVALUATED BY: Board of Education

SUPERVISES: All school employees

ESSENTIAL FUNCTIONS AND PERFORMANCE RESPONSIBILITIES: The Superintendent is hired by and shall report directly to the board of education. The superintendent will be the chief administrative officer of the board of education and shall keep the board informed on important issues. The board delegates to the superintendent the general power and authority to make necessary decisions to ensure the efficient and effective operations of the school. The Superintendent must also:

1. Assist the board in developing and adopting school district policies.
2. Enforce school district policies.
3. Prepare board meeting agendas in consultation with the board president.
4. Attend all board meetings unless excused by the board.
5. Provide information to the board so that it can take any necessary or desired action.
6. Make recommendations to the board as directed or requested.
7. Ensure that board decisions are executed.
8. Create or recommend educational standards and goals.
9. Maintain the school's accreditation.
10. Review, evaluate, and make recommendations regarding the school's curriculum, teaching methods, and programs.
11. Establish the school calendar and time schedules in consultation with the board.
12. Enforce discipline and attendance laws, rules, regulations, and policies.
13. Ensure that the school's mission and goals are adequately reflected in the educational program and school operations.
14. Maintain and act as the custodian of school district records.
15. Issue press releases related to all education matters, policies, procedures, or school related incidents or events.
16. Arrange for appropriate or necessary student and staff in-service training.
17. File, or cause to be filed, all reports and other documents requested or required by local, state, or federal agencies.
18. Use his or her own discretion and best professional judgment on matters not addressed by the law, district policy, and board directive.
19. Direct and evaluate the performance of school district administrators, and other staff members as appropriate.
20. Mentor and encourage professional growth of administrators and all staff.
21. Work professionally, appropriately, and as needed with school district contractors such as auditors, architects, attorneys, and other similarly situated individuals or entities.
22. Conduct meetings with the board, contractors, school employees, students, patrons, or others to address school related matters.
23. Represent the district in collective bargaining negotiations.
24. Appear as the district's representative (or appoint a district representative) for various school-related events as necessary or appropriate.
25. Prepare, present, and file an annual school budget, subject to the approval of the board at the annual budget hearing.
26. Hire and fire classified staff.
27. Make recommendations to the school board regarding the hiring and firing of certificated staff members.
28. Show good character, mental health, and emotional control.
29. Demonstrate tactfulness and a pleasant manner.

30. Demonstrate an open mind, tolerance, and poise.
31. Display a sense of humor.
32. Maintain positive relations and display enthusiasm with students, colleagues, parents, and other community members and groups.
33. Be punctual and efficient in meeting all assignments.
34. Stay informed of new developments, ideas, and events in the administrative field.
35. Demonstrate a commitment to the profession and its code of ethics.
36. Identify strengths, limitations, needs, etc. through self-evaluation activities.
37. Demonstrate proper and professional use of employee policies.
38. Continue professional growth through reading, course work, or membership and participation in professional organizations.
39. Know, understand, apply, enforce, and follow all school district policies, procedures, and handbooks.
40. Maintain appropriate certifications and training hours as required.
41. Maintain and secure any confidential records or inquiries.
42. Perform any other duty required by state or federal law or regulation.
43. Performs other duties as assigned.

PHYSICAL REQUIREMENTS:

This position requires the individual to regularly talk or hear. The individual may be frequently required to walk, stand, sit, use hands for fine manipulation, handle or feel and reach with hands and arms. The individual may occasionally lift and/or move students or assist in moving students who can weigh 200 pounds or more. The individual may occasionally climb stairs.

	Never (0%)	Occasional (1-32%)	Frequent (33-66%)	Constant (67%)
Standing		X		
Walking		X		
Sitting			X	
Bending/Stooping		X		
Reaching/Pushing		X		
Climbing		X		
Driving		X		
Lifting(50# max)		X		
Manual Dexterity Tasks (Specify:)				

WORKING CONDITIONS: Inside the school building primarily in an air conditioned building. May require trips outside of the school building.

I have carefully reviewed this job description and affirm the following (please initial):

___ To the best of my knowledge, I CAN fulfill all the requirements, responsibilities, and training aspects set out in this document.

___ To the best of my knowledge, I CANNOT fulfill all the requirements, responsibilities, and training aspects set out in this document.

Use this space for any comments:

Employee Name (Print)

Employee Signature

	Revenue	Payroll Totals	Bill Totals	Expense Totals	Revenue/Expense Differential
September					
20-21	\$1,305,737	\$475,820	\$242,571	\$718,391	\$587,346
21-22	\$1,400,580	\$588,442	\$153,833	\$742,275	\$658,305
22-23	\$1,563,086	\$638,324	\$225,472	\$863,796	\$699,290
23-24	\$1,697,991	\$660,804	\$195,350	\$856,154	\$841,837
Average	\$1,491,848	\$590,848	\$204,307	\$795,154	\$696,694
October					
20-21	\$506,008	\$587,674	\$127,043	\$714,717	-\$208,709
21-22	\$476,870	\$643,689	\$104,862	\$748,551	-\$271,681
22-23	\$515,470	\$641,805	\$102,588	\$744,392	-\$228,922
23-24	\$506,570	\$673,151	\$110,037	\$783,188	-\$276,618
Average	\$501,230	\$636,580	\$111,132	\$747,712	-\$246,482
November					
20-21	\$145,732	\$581,408	\$111,904	\$693,312	-\$547,580
21-22	\$129,756	\$608,501	\$215,170	\$823,671	-\$693,915
22-23	\$122,074	\$635,248	\$114,671	\$749,918	-\$627,844
23-24	\$227,218	\$679,291	\$130,518	\$809,809	-\$582,591
Average	\$156,195	\$626,112	\$143,066	\$769,178	-\$612,983
December					
20-21	\$114,690	\$566,956	\$92,587	\$659,543	-\$544,853
21-22	\$275,182	\$596,356	\$114,068	\$710,424	-\$435,242
22-23	\$185,764	\$621,091	\$95,341	\$716,432	-\$530,668
23-24	\$257,104	\$661,685	\$224,987	\$886,672	-\$629,568
Average	\$208,185	\$611,522	\$131,746	\$743,268	-\$535,083
January					
20-21	\$1,054,783	\$550,335	\$108,849	\$659,184	\$395,599
21-22	\$1,690,334	\$580,961	\$124,153	\$705,114	\$985,220
22-23	\$1,724,396	\$585,495	\$120,330	\$705,825	\$1,018,571
23-24	\$1,997,702	\$641,898	\$172,062	\$813,960	\$1,183,742
Average	\$1,616,804	\$589,672	\$131,349	\$721,021	\$895,783
February					
20-21	\$918,255	\$559,130	\$87,330	\$646,460	\$271,795
21-22	\$922,640	\$605,566	\$133,808	\$739,374	\$183,267
22-23	\$1,209,231	\$607,215	\$157,257	\$764,472	\$444,759
23-24	\$1,242,662	\$629,631	\$78,824	\$708,455	\$534,207
Average	\$1,073,197	\$600,385	\$114,305	\$714,690	\$358,507
March					
20-21	\$589,949	\$555,260	\$89,282	\$644,542	-\$54,592
21-22	\$305,057	\$599,437	\$95,671	\$695,108	-\$390,051
22-23	\$392,202	\$605,397	\$135,111	\$741,726	-\$349,524
23-24	\$464,150	\$655,712	\$170,809	\$826,521	-\$362,371
Average	\$437,840	\$603,952	\$122,718	\$726,974	-\$289,135
April					
20-21	\$815,295	\$583,512	\$96,815	\$680,327	\$134,968
21-22	\$799,070	\$594,898	\$139,819	\$734,717	\$64,353
22-23	\$938,788	\$611,829	\$191,483	\$803,312	\$135,476
23-24	\$518,048	\$619,944	\$220,399	\$840,343	-\$143,212
Average	\$767,800	\$602,546	\$162,129	\$764,675	\$47,896
May					
20-21	\$1,690,128	\$598,668	\$100,856	\$699,524	\$990,604
21-22	\$2,030,275	\$603,899	\$117,669	\$721,568	\$1,308,707
22-23	\$1,946,599	\$614,708	\$106,911	\$721,619	\$1,224,979
23-24	\$2,646,217	\$691,606	\$142,307	\$833,913	\$1,812,304
Average	\$2,078,305	\$627,220	\$116,936	\$744,156	\$1,334,149
June					
20-21	\$865,361	\$550,119	\$112,314	\$662,433	\$202,929
21-22	\$710,439	\$578,502	\$145,767	\$724,269	-\$13,830
22-23	\$835,327	\$595,109	\$215,470	\$810,580	\$24,748
23-24	\$772,068	\$621,572	\$126,636	\$748,208	\$204,752
Average	\$795,799	\$586,325	\$150,047	\$736,372	\$104,650
July					
20-21	\$110,638	\$509,851	\$180,007	\$689,858	-\$579,221
21-22	\$84,305	\$519,122	\$263,775	\$782,897	-\$698,592
22-23	\$127,337	\$525,701	\$155,067	\$680,768	
23-24	\$280,620	\$546,113	\$142,646	\$688,759	
Average	\$150,725	\$525,197	\$185,374	\$710,571	-\$638,906
August					
20-21	\$162,558	\$505,218	\$310,232	\$815,450	-\$652,891
21-22	\$236,606	\$504,895	\$144,109	\$649,004	-\$412,398
22-23	\$89,966	\$532,878	\$488,582	\$1,021,460	
23-24		\$575,304	\$589,868	\$1,165,172	
Average	\$163,043	\$529,574	\$383,198	\$912,771	-\$532,645

	2023-2024 Disbursements					
Month	Total Expenditures	Cumulative Spent	% of Budget	Average % of Budget	Cum. % of Budget Spent	Average % Spent
September	\$856,154	\$856,154	8.56%	8.69%	8.56%	8.69%
October	\$783,188	\$1,639,342	7.83%	8.21%	16.40%	16.90%
November	\$809,809	\$2,449,152	8.10%	8.53%	24.50%	25.43%
December	\$886,672	\$3,335,824	8.87%	7.73%	33.37%	33.16%
January	\$813,960	\$4,149,784	8.14%	7.64%	41.51%	40.80%
February	\$708,455	\$4,858,239	7.09%	8.14%	48.60%	48.94%
March	\$826,521	\$5,684,760	8.27%	7.78%	56.87%	56.72%
April	\$840,343	\$6,525,103	8.41%	8.33%	65.27%	65.05%
May	\$833,913	\$7,359,016	8.34%	7.82%	73.61%	72.87%
June	\$748,208	\$8,107,224	7.48%	8.31%	81.10%	81.18%
July	\$688,759	\$8,795,983	6.89%	7.94%	87.99%	89.12%
August	\$1,165,172	\$9,961,155	11.66%	10.88%	99.64%	100.00%
2023-24 Budgeted Disbursements	\$9,996,811					
	Cumulative:					
	September	October	November	December	January	February
Projected Expenses	\$868,723	\$1,689,461	\$2,542,189	\$3,314,943	\$4,078,699	\$4,892,439
Actual Expenses	\$856,154	\$1,639,342	\$2,449,152	\$3,335,824	\$4,149,784	\$4,858,239
Difference	\$12,568	\$50,119	\$93,037	-\$20,881	-\$71,085	\$34,201
	March	April	May	June	July	August
Projected Expenses	\$5,670,191	\$6,502,926	\$7,284,676	\$8,115,411	\$8,909,158	\$9,996,811
Actual Expenses	\$5,684,760	\$6,525,103	\$7,359,016	\$8,107,224	\$8,795,983	\$9,961,155
Difference	-\$14,569	-\$22,177	-\$74,340	\$8,187	\$113,175	\$35,656

