

Regular Meeting of the Grand Island Board of Education

The regular meeting of the Board of Education of Grand Island in the County of Hall in the State of Nebraska was convened and called to order by President Bonnie Hinkle in open and public session on Thursday, December 8, 2016 at 6:30 PM at the the Kneale Administration Building - Board Room, 123 S Webb Road, Grand Island, NE 68802, the usual meeting place of said Board. Notice of the meeting was given in advance thereof by publication in the Grand Island Independent, the School District's designated method of giving notice. Notice of the meeting was also given in advance to all members of the Board of Education. All proceedings hereafter shown were recorded while the convened meeting was open to the attendance of the public.

ROLL CALL:

Attendance Taken at 6:30 PM.

Lisa Albers:	Absent
Carlos Bárcenas:	Present
Dan Brosz:	Present
Terry Brown:	Present
Lori Coen:	Absent
Kelly Enck:	Present
Brian Exstrum:	Present
Roger Harms:	Present
Bonnie Hinkle:	Present
Heidi Schutz:	Present

AGENDA

1. CALL TO ORDER

2. ROLL CALL

3. MISSION STATEMENT

4. CONSENT AGENDA

1. Minutes from the December 5, 2016 Special Board Meeting

2. Minutes from the November 10, 2016 Regular Meeting

3. Claims, as submitted

4. Bid Proposals as submitted

5. Staff Adjustments as submitted

6. **Treasurer's Report as submitted**
7. **Policy 6461 - Classified Staff Suspension, on Final Read**
8. **Policy 6462 - Dismissal of "At Will" Status Staff Member, on Final Read**
9. **Policy 6511 - Classified Staff Assignments and Transfers, on Final Read**
10. **Policy 6711 - Classified Staff Performance Appraisal, on Final Read**
11. **Policy 7150 - Academic Freedom, on First Read**
12. **Policy 7160 - Citizenship, on First Read**
13. **Policy 7210 - School Calendar, on First Read**
14. **Grant Report Update**
15. **Change Orders as Documented**
16. **Approval of Agenda as submitted**

5. SPECIAL RECOGNITION

1. **Holiday Card Contest Winners**

6. PUBLIC FORUM

7. OATH OF OFFICE

1. **Oath of Office for newly appointed board member, Kelly Enck**
2. **Signing of the Board Operating Principles by Board Member Kelly Enck**
3. **Attendance**

8. INFORMATION ITEMS

1. **Campus Highlights - Featuring West Lawn Elementary**
2. **Campus Highlights - Featuring Seedling Mile Elementary**
3. **Campus Highlights - Featuring GISH SIP Team**
4. **2017-2018 Traditional Calendar**

5. Nebraska Education Profile Report

6. Student Representative Report

7. NASB Conference Report Out

8. Construction Update

9. Superintendent Report

9. ACTION ITEMS

1. GIEA 2018-2019 Bargaining Agent Proposal

2. Resolution on QCPUF Project

3. 2015-2016 Audit Report

4. Shannon Builders Contract

10. COMMITTEE REPORTS

1. Finance and Facilities Committee, including possible action recommendation.

2. Teaching and Learning Committee

3. Policy Committee

4. Public Relations / Personnel Committee

5. Grand Island Public Schools Foundation Report

6. Legislative Committee

7. NASB Board of Directors Report

8. GNSA

11. EXECUTIVE SESSION for Possible Real Estate Transactions, Superintendent Evaluation, and Personnel Negotiations

12. RECONVENE FROM EXECUTIVE SESSION

13. APPROVAL OF ANY ACTION DEEMED NECESSARY AS A RESULT OF EXECUTIVE SESSION

14. **OLD BUSINESS**

15. **NOTIFICATION OF UPCOMING BOARD MEETINGS**

1. **January 16, 2017 - Regular Board Meeting, 6:30 P.M.**

16. **ADJOURNMENT**

Michelle L Simmons, Recording Secretary

Robin R. Dexter, Secretary to the Board

1. CALL TO ORDER	Board President
2. ROLL CALL	
3. MISSION STATEMENT	
4. CONSENT AGENDA	Board President
1. Minutes from the November 10, 2016 Regular Meeting	
2. Claims, as submitted	
3. Bid Proposals as submitted	
4. Staff Adjustments as submitted	
5. Treasurer's Report as submitted	
6. Policy 6461 - Classified Staff Suspension, on Final Read	
7. Policy 6462 - Dismissal of "At Will" Status Staff Member, on Final Read	
8. Policy 6511 - Classified Staff Assignments and Transfers, on Final Read	
9. Policy 6711 - Classified Staff Performance Appraisal, on Final Read	
10. Policy 7150 - Academic Freedom, on First Read	
11. Policy 7160 - Citizenship, on First Read	
12. Policy 7210 - School Calendar, on First Read	
13. Grant Report Update	
14. Change Orders as Documented	
15. Approval of Agenda as submitted	
5. SPECIAL RECOGNITION	
1. Holiday Card Contest Winners	Dr. Grover
6. PUBLIC FORUM	
7. OATH OF OFFICE	
1. Oath of Office for newly appointed board member, ??	Dr. Dexter
2. Signing of the Board Operating Principles by Board Member ????	Dr. Dexter
8. INFORMATION ITEMS	
1. Campus Highlights - Featuring West Lawn Elementary	DW Holley, Tracy Morrow, Aleta Thomas, Amelia Nicolaus, Diana Martinez, Brissa Borjas
2. Campus Highlights - Featuring Seedling Mile Elementary	Charity LaBrie and staff members
3. Campus Highlights - Featuring GISH SIP Team	Gordon Bye, Patti Bennett, and Maggie Mintken
4. 2017-2018 Traditional Calendar	Dr. Dexter
5. Nebraska Education Profile Report	Mr. McDowell
6. Student Representative Report	Mr. Erick Estevez
7. NASB Conference Report Out	Board members
8. Construction Update	Mr. Petsch
9. Superintendent Report	Dr. Grover
9. ACTION ITEMS	
1. GIEA 2018-2019 Bargaining Agent Proposal	Mr. Stelk
2. Resolution on QCPUF Project	Mr. Harden

3. 2015-2016 Audit Report	Mr. Harden
4. Shannon Builders Contract	Mr. Petsch
10. COMMITTEE REPORTS	
1. Finance and Facilities Committee, including possible action recommendation.	Mr. Brown
2. Teaching and Learning Committee	Mr. Exstrum
3. Policy Committee	Mrs. Schutz
4. Public Relations / Personnel Committee	Mrs. Hinkle
5. Grand Island Public Schools Foundation Report	Dr. Brosz
6. Legislative Committee	Mr. Harden
7. NASB Board of Directors Report	Mrs. Schutz
8. GNSA	Mr. Harden
11. EXECUTIVE SESSION for Possible Real Estate Transactions, Superintendent Evaluation, and Personnel Negotiations	
12. RECONVENE FROM EXECUTIVE SESSION	
13. APPROVAL OF ANY ACTION DEEMED NECESSARY AS A RESULT OF EXECUTIVE SESSION	
14. OLD BUSINESS	
15. NOTIFICATION OF UPCOMING BOARD MEETINGS	
1. January 16, 2017 - Regular Board Meeting, 6:30 P.M.	
16. ADJOURNMENT	

**NOTICE OF
BOARD WORK SESSION AND
SPECIAL BOARD MEETING
HALL COUNTY
SCHOOL DISTRICT #002
Grand Island, Nebraska**

Notice is hereby given that a training work session will be held by the Board of Education of Hall County School District #002, Grand Island, Nebraska, on Monday, December 5, 2016 from 5:30 p.m. until 6:30 p.m., at the Kneale Administration Building, 123 South Webb Road, Grand Island, Nebraska, which work session will be open to the public. The Work Session will be immediately followed at 6:30 p.m. by a special board meeting. An agenda for such meeting, kept continuously current, is available for inspection at the Office of the Superintendent.

Robin R. Dexter, Secretary

28

*BOE Work session
& special meeting
Dec 5, 2016*

Published Nov 28, 2016

**NOTICE OF
REGULAR BOARD MEETING
HALL COUNTY
SCHOOL DISTRICT #002
GRAND ISLAND, NEBRASKA**

Notice is hereby given that a meeting of the Board of Education of Hall County School District #002, A.K.A. Grand Island Public Schools, Grand Island, Nebraska, will be held on Thursday, December 8, 2016 at 6:30 PM at the Kneale Administration Building, 123 South Webb Road, Grand Island, Nebraska, which meeting will be open to the public. An agenda for such meeting, kept continuously current, is available for inspection at the Office of the Superintendent.

Dr. Robin R. Dexter, Secretary

29

*BOE
Regular meeting
Dec 8, 2016*

Published Nov 29, 2016

SPECIAL MEETING OF THE GRAND ISLAND BOARD OF EDUCATION

The special meeting of the Board of Education of Grand Island in the County of Hall in the State of Nebraska was convened and called to order by President Bonnie Hinkle in open and public session, on December 05, 2016 6:30 PM at the Kneale Administration Building - Board Room, 123 South Webb Road, Grand Island, Nebraska, the usual meeting place of said Board.

Notice of the meeting was given in advance thereof by publication in the *Grand Island Independent*, the School District's designated method of giving notice. Notice of the meeting was also given in advance to all members of the Board of Education. All proceedings hereafter shown were recorded while the convened meeting was open to the attendance of the public.

ROLL CALL:

Attendance Taken at 6:30 PM:

Present Board Members:

Carlos Barcenas
Dan Brosz
Terry Brown
Lori Coen
Brian Exstrum
Roger Harms
Bonnie Hinkle
Heidi Schutz

Absent Board Members:

AGENDA:

1. CALL TO ORDER

2. ROLL CALL

3. MISSION STATEMENT

Discussion:

The Mission Statement was read by Mr. Terry Brown

4. PUBLIC FORUM

5. INFORMATION ITEMS

5.1. Interview of Joshua Brown - Candidate for Ward A Board vacancy

Discussion:

The interview for Joshua Brown, 325 Ponderosa Dr., began at 6:31 P.M. and ended at 6:48 PM - during which time board members asked a set of pre-selected, standardized questions.

5.2. Interview of Kim Jensen - Candidate for Ward A Board vacancy

Discussion:

The interview for Kim Jensen, 2207 Woodridge Lane, began at 6:48 P.M. and ended at 6:59 PM - during which time board members asked a set of pre-selected, standardized questions.

5.3. Interview of John Gillespie - Candidate for Ward A Board vacancy

Discussion:

The interview for John Gillespie, 3916 Partridge Cir., began at 6:59 P.M. and ended at 7:08 PM - during which time board members asked a set of pre-selected, standardized questions.

5.4. Interview of Kelly Enck - Candidate for Ward A Board vacancy

Discussion:

The interview for Kelly Enck, 4133 Fleetwood Rd., began at 7:08 P.M. and ended at 7:21 PM - during which time board members asked a set of pre-selected, standardized questions.

5.5. Interview of Susan Milner - Candidate for Ward A Board vacancy

Discussion:

The interview for Susan Milner, 3217 Woodridge Blvd., began at 7:26 P.M. and ended at 7:36 PM - during which time board members asked a set of pre-selected, standardized questions.

5.6. Interview of Chad Smith - Candidate for Ward A Board vacancy

Discussion:

The interview for Chad Smith, 347 Redwood Rd., began at 7:44 P.M. and ended at 7:58 PM - during which time board members asked a set of pre-selected, standardized questions.

5.7. Interview of Philip Ramsel- Candidate for Ward A Board vacancy

Discussion:

The interview for Philip Ramsel, 3118 Brentwood Dr., began at 7:59 P.M. and ended at 8:13 PM - during which time board members asked a set of pre-selected, standardized questions.

5.8. Interview of Jay Wren - Candidate for Ward A Board vacancy

Discussion:

The interview for Jay Wren, 3012 Brentwood Way, began at 8:15 P.M. and ended at 8:23 PM - during which time board members asked a set of pre-selected, standardized questions.

5.9. Interview of Yolanda Nuncio - Candidate for Ward A Board vacancy

Discussion:

The interview for Yolanda Nuncio, 4362 Manchester Rd., began at 8:28 P.M. and ended at 8:44 PM - during which time board members asked a set of pre-selected, standardized questions.

6. ACTION ITEMS

6.1. Selection of Candidate for Ward A Board Seat Vacancy

Discussion:

Following Roberts Rule of Order guidelines, prospective BOE member is nominated by motion and second, then electronic vote
BOE member is appointed by majority vote

Motion Failed: The recommendation to appoint Joshua Brown for Ward A failed with a motion by Roger Harms and a second by Lori Coen.

Lisa Albers	Absent
Carlos Barcenass	No
Dan Brosz	Yes
Terry Brown	No
Lori Coen	Yes
Brian Exstrum	No
Roger Harms	Yes
Bonnie Hinkle	No
Heidi Schutz	No

Motion Passed: Recommendation for Kelly Enk passed with a motion by Brian Exstrum and a second by Dan Brosz.

Lisa Albers	Absent
Carlos Barcenass	No
Dan Brosz	Yes
Terry Brown	Yes
Lori Coen	Yes
Brian Exstrum	Yes
Roger Harms	No
Bonnie Hinkle	Yes
Heidi Schutz	Yes

7. RECESS - to notify Ward A candidates

8. RECONVENE FROM RECESS

9. UPDATE ATTENDANCE

Present Board Members:

Carlos Barcenass
Dan Brosz
Terry Brown
Lori Coen
Brian Exstrum
Roger Harms
Bonnie Hinkle

Absent Board Members:

Discussion:

Heidi Schutz left at 9:20pm

10. INFORMATION ITEMS Continued

10.1. Interview of Timothy Mayfield - Candidate for Ward B Board vacancy

Discussion:

The interview for Timothy Mayfield, 2516 Cochin St., began at 9:20 P.M. and ended at 9:38 PM - during which time board members asked a set of pre-selected, standardized questions.

10.2. Interview of Heidi Schutz - Candidate for Ward B Board vacancy

Discussion:

The interview for Heidi Schutz, 2408 Cottonwood Rd., began at 9:39 P.M. and ended at 9:51 PM - during which time board members asked a set of pre-selected, standardized questions.

11. ACTION ITEMS Continued

11.1. Selection of Candidate for Ward B Board Seat Vacancy

Discussion:

Following Roberts Rule of Order guidelines, prospective BOE member is nominated by motion and second, then electronic vote.

BOE member is appointed by majority vote.

Motion Failed: Recommend Tim Mayfield for Ward B BOE member that will be vacant on January 5, 2017. The appointment would be effective January 16, 2017 failed with a motion by Lori Coen and a second by Terry Brown.

Lisa Albers	Absent
Carlos Barcenás	No
Dan Brosz	No
Terry Brown	Yes
Lori Coen	Yes
Brian Exstrum	No
Roger Harms	No
Bonnie Hinkle	Yes
Heidi Schutz	Absent

Motion Passed: Recommend Heidi Schutz for Ward B BOE education seat vacant on January 5, 2017. The appointment would be effective January 16, 2017 passed with a motion by Dan Brosz and a second by Roger Harms.

Lisa Albers	Absent
Carlos Barcenás	Yes
Dan Brosz	Yes
Terry Brown	Yes
Lori Coen	Abstain
Brian Exstrum	Yes
Roger Harms	Yes
Bonnie Hinkle	Yes
Heidi Schutz	Absent

12. OLD BUSINESS

13. NOTIFICATION OF UPCOMING BOARD MEETINGS

13.1. December 8, 2016 - Regular Board Meeting, 6:30 P.M.

Discussion:

13.2. January 16, 2017 - Regular Board Meeting, 6:30 P.M.

Discussion:

14. ADJOURNMENT

Discussion:

All business having been completed, the meeting was adjourned at 10:18p.m.

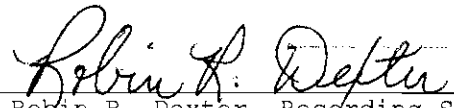

Robin R. Dexter, Recording Secretary



Robin R. Dexter, Secretary to the Board

REGULAR MEETING OF THE GRAND ISLAND BOARD OF EDUCATION

The regular meeting of the Board of Education of Grand Island in the County of Hall in the State of Nebraska was convened and called to order by President Bonnie Hinkle in open and public session, on November 10, 2016 at 6:30 PM at The Kneale Administration Building - Board Room, 123 South Webb Road, Grand Island, Nebraska, the usual meeting place of said Board.

Notice of the meeting was given in advance thereof by publication in the *Grand Island Independent*, the School District's designated method of giving notice. Notice of the meeting was also given in advance to all members of the Board of Education. All proceedings hereafter shown were recorded while the convened meeting was open to the attendance of the public.

ROLL CALL:

Attendance Taken at 6:30 PM:

Present Board Members: Dan Brosz, Terry Brown, Lori Coen, Brian Exstrum, Roger Harms, Bonnie Hinkle, Heidi Schutz, Jennifer Worthington

Absent Board Members: Carlos Barcenas

AGENDA:

1. CALL TO ORDER

2. ROLL CALL

3. MISSION STATEMENT

The Mission Statement was read by Mrs. Worthington.

4. CONSENT AGENDA

Motion Passed: The recommendation to approve the Consent Agenda as submitted passed with a motion by Terry Brown and a second by Heidi Schutz.

Carlos Barcenas	Absent
Dan Brosz	Yes
Terry Brown	Yes
Lori Coen	Yes
Brian Exstrum	Yes
Roger Harms	Yes
Bonnie Hinkle	Yes
Heidi Schutz	Yes
Jennifer Worthington	Yes

4.1. Minutes from the October 13, 2016 regular meeting

4.2. Claims, as submitted

4.3. Bid Proposals as submitted

- 4.4. Staff Adjustments as submitted**
- 4.5. Treasurer's Report as submitted**
- 4.6. Policy 6461 - Classified Staff Suspension, on First Read**
- 4.7. Policy 6462 - Dismissal of "At Will" Status Staff Member, on First Read**
- 4.8. Policy 6511 - Classified Staff Assignments and Transfers, on First Read**
- 4.9. Policy 6711 - Classified Staff Performance Appraisal, on First Read**
- 4.10. Grant Report Update**
- 4.11. Change Orders as Documented**
- 4.12. Approval of Agenda as submitted**

5. SPECIAL RECOGNITION

5.1. Roots and Shoots Student Recognition

Each year, the NEBRASKAland Foundation selects 10 to 15 entries in the Education Department to be honored at Statehood Day in the Capitol Rotunda. The entries will be on display in the Rotunda that morning and also at the Statehood Day Dinner the following evening. The students whose entries were selected and their parents and teachers will be invited to the morning event where the students will receive special recognition. The event is usually on the Friday closest to March 1, 2017. Judi Harper, Education Director at the Nebraska State Fair, will honor our winning community service projects by presenting checks and two awards from the NEBRASKAland Foundation.

5.2. Teagan Cheetsos & Carley Pool in recognition of 1st Place - GIPS Roots & Shoots (elementary- current high school) - Community Service Project. Also selected by the NEBRASKAland Foundation for the 2017 Statehood Day Showcase.

5.3. Kaden Kuusela & Anahi Mendoza-Perez in recognition of 1st Place - Secret Kindness Agents - Elementary Community Service Project. Also selected by the NEBRASKAland Foundation for the 2017 Statehood Day Showcase.

5.4. Mariah Cobler, Briannah Kutschkau, and Rayle Ostermeier in recognition of 2nd Place - Little Free Library - Elementary Community Service Project.

5.5. Elena Martinez & Hamilton Sazo Bolanos in recognition of 3rd Place - Urban Park Rangers - Elementary Community Service Project.

5.6. Eli Anson & Levy Mejia Aguilera in recognition of 3rd Place - Adopt-a-Cat - Elementary Community Service Project.

5.7. Jennifer Worthington with thanks, and in recognition of 13 years of service on the Grand Island Public Schools Board of Education

Jennifer Worthington with thanks, and in recognition of 13 years of service on the Grand Island Public Schools Board of Education. Jennifer was appointed to the Board of Education to fill a vacancy after Mr. Yost resigned. She took her oath of office December 1, 2003. Jennifer served as Vice President of the Board in 2009 and then served as President of the board for 5 years from 2010 through 2014. We wish her the best as she moves on to her next professional adventure.

6. PUBLIC FORUM

None

7. INFORMATION ITEMS

7.1. Announcement of Board of Education Vacancies

Mrs. Hinkle reviewed the current openings and vacancies on the Board of Education. At the present time, and following the election results this week, the Board will be in a position of needing to appoint a new member from Ward A and a new member from Ward B. The Ward A opening is due to board member Worthington accepting an employment position within the district administration. Hence her resignation from the board will be required. The opening in Ward B was created when there was no filing for the seat through the election process. Both openings will be advertised and will follow the appointment process.

7.2. Campus Highlights - Featuring Wasmer Elementary

Mrs. Godfrey, Melissa Sears and a four 2nd grade HAL students from Wasmer Elementary presented on Young Authors. The 2nd grade HAL students had written their own books and had their books published. Each presented their book and told of their processes.

7.3. Campus Highlights - Featuring Skills Academy

Julie Fessenden and staff from Skills Academy presented on Stronger Through Relationships. They told the stories of the kids that they serve - their student's goals, improvements and accomplishments.

7.4. Campus Highlights - Featuring Newell Elementary

Mr. Rinaldi, Carrie Whitcome (counselor) and 5th grade students from Newell Elementary presented on the Youth Leadership Conference they attended in Kearney. Student speakers were Aiden, Samantha, Cassidy, and Sophia. They each gave their thoughts on the leadership skills they learned at the conference.

7.5. Entry Plan Update / Summary

Dr. Grover gave an update on her Entry Plan that was originally approved by the Board in July. The entry plan was to cover her first 90 days in the district and the progress made. These results and findings that she gathered would then lead the district into a strategic planning process going forward. Dr. Grover reviewed the many meetings and conversations held while gathering input and data. The information not only reflected what items worked well in the district but also what areas offer opportunities for improvement.

7.6. High School Visioning, DMC Update

Dr. Dexter presented an update on the high school visioning process and the information gathered to date. She reminded the board that this is not a purchase of a product but rather it is a process to review our needs and goals. An outline of times, goals, and planned committee actions was presented.

7.7. Strategic Planning Update - Croft & Joftus

The team from Croft and Joftus reviewed the work that has been done thus far, along with the information gathered to date. Future schedules and plans were presented and discussed as well.

7.8. GIEA 2018-2019 Bargaining Agent Proposal

The Grand Island Education Association ("GIEA") requests that the school board of Grand Island Public Schools take action to recognize GIEA as exclusive bargaining agent for all the District's non-supervisory, certificated employees for the 2018-2019 contract year.

7.9. Information on QCPUF Project

During the 2016 Legislative session the Qualified Capital Purpose Undertaking Fund (QCPUF) was modified in several ways including, but not limited to, the following: the area of indoor air quality projects was removed and life safety hazards was added to the "qualified" projects, the maximum levy was reduced from 5.2 to 3.0, and projects can only be for existing facilities. To that end administration began a review of projects that meet the current and revised definition of a 'qualified' project. The attached listing is being presented with the intent of seeking a Board of Education Resolution during the December 2016 meeting calling for the issuance of QCPUF bonded indebtedness in an amount not to exceed \$4.5 million to be paid from the maximum levy.

7.10. 2015-2016 Audit Report

Per current state statute Nebraska school districts are required to have an independent audit conducted annually. Grand Island Public Schools contracts with the independent audit firm of Almquist, Maltzahn, Galloway, & Luth, P.C. to conduct the annual audit. Mr. Virgil Harden, Executive Director of Business will give an executive overview of the 2015 - 2016 audit report and answer questions Board members might have. An action item to accept and place the 2015 - 2016 audit report on file will appear on the December 2016 meeting agenda. Additionally, the audit report is posted on the District's web site along with past years reports .

7.11. Shannon Builders Contract

Mr. Petsch updated the Board on the need to amend the contract with independent contractor Steve Shannon. The contract amendment will be placed on the December 2016 Board meeting for approval.

7.12. Student Representative Report

Student representative Estevez will be representing GISH at the State NASB Conference next week. - The GISH music department successfully presented "In the Hights" musical. - Fall sports are concluding and winter sports are beginning. For those not in sports, GISH has 35 clubs for students to get involved in ... and the winter months are the best time for many of these. Students are also able to get involved with the recent blood drive. - This week students focused on the election voting process and how to vote in the future. - A Latino symposium was held at UNL and Mr. Gilbertson took students to Lincoln to participate. - The veterans parade was held this year in honor of our veterans. The past two years the parade was not held due to weather conditions. This might be the last year we hold the parade due to the Veterans home being moved to Kearney.

7.13. Construction Update

Mr. Petsch reported on all the various bond projects. All are on schedule and progressing as anticipated.

7.14. Superintendent Report

Dr. Grover addressed the transition process for the Jefferson and Stolley Park construction time frame. A Question and Answer response document will be posted for review by the early part of December.

8. ACTION ITEMS

8.1. FY 2017-2018 Budget Calendar

Annually the District practice is to review and adopt a budget calendar for the subsequent fiscal year in order to properly communicate, plan, and administer the various duties associated with the budget cycle. The Facilities and Finance Committee has reviewed the attached fiscal year 2017 - 2018 budget calendar for adoption and the full Board of Education reviewed the calendar at their October meeting.

Motion Passed: The recommendation that the Board approve the 2017-2018 budget planning calendar as presented passed with a motion by Terry Brown and a second by Jennifer Worthington.

Carlos Barcenas	Absent
Dan Brosz	Yes
Terry Brown	Yes
Lori Coen	Yes
Brian Exstrum	Yes
Roger Harms	Yes
Bonnie Hinkle	Yes
Heidi Schutz	Yes
Jennifer Worthington	Yes

8.2. Follett Resource Manager

Follett Resource Manager is a web-based inventory management platform that will help us know where all of our instructional resources are located. The advanced inventory tracking capabilities in Resource Manager will help us to monitor our instructional resources and make resource purchases based on data. The quote includes the software and onsite bar coding and system setup.

Motion Passed: The recommendation that the board approve the purchase of the Follett Resource Manager inventory management platform as presented passed with a motion by Dan Brosz and a second by Heidi Schutz.

Carlos Barcenas	Absent
Dan Brosz	Yes
Terry Brown	Yes
Lori Coen	Yes
Brian Exstrum	Yes
Roger Harms	Yes
Bonnie Hinkle	Yes
Heidi Schutz	Yes

Jennifer Worthington Yes

9. COMMITTEE REPORTS

9.1. Finance and Facilities Committee, including possible action recommendation.

Mr. Brown gave the Finance and Facilities Committee Report covering the major items discussed and under consideration by said committee. A copy of the minutes from the last meeting are available and on file. The next meeting will be held November 29th.

9.2. Teaching and Learning Committee

Mrs. Coen gave the Teaching and Learning Committee Report covering the major items discussed and under consideration by said committee. A copy of the minutes from the last meeting are available and on file. The next meeting will be held December 6th.

9.3. PR/Personnel Committee

Mr. Harms gave the Personnel Committee Report covering the major items discussed and under consideration by said committee. A copy of the minutes from the last meeting are available and on file. The next meeting will be held December 6th.

9.4. Policy Committee

Dr. Brosz gave the Policy Committee Report covering the major items discussed and under consideration by said committee. A copy of the minutes from the last meeting are available and on file. The next meeting will be held December 8th.

9.5. Grand Island Public Schools Foundation Report

Dr. Brosz reported for the GIPS Foundation. The 2nd round of Mini-Grants will be awarded the 2nd week of December. The audit report was received and will be reviewed at the next meeting. The crowd funding site is set to go live before the end of November. There will also be "30 days of Thanks" campaign throughout November as well.

9.6. Legislative Committee and GNSA Report

Mr. Harden gave the Legislative Committee Report. First Five of Nebraska held a meeting in Kearney yesterday. Harden, Grover and McDowell attended discussions on PK / early education. GNSA organizes next week during the state NASB conference.

9.7. NASB Board of Directors Report

None

10. EXECUTIVE SESSION for the purpose of discussing potential real estate transactions, personnel negotiations, and superintendent evaluation.

The Board convened to Executive Session at 8:54 p.m.

Motion Passed: The recommendation for the Board to convene to executive session for the purpose of discussing potential real estate transactions, personnel negotiations, and superintendent evaluation passed with a motion by Terry Brown and a second by Dan Brosz.

Carlos Barcenas

Absent

Dan Brosz	Yes
Terry Brown	Yes
Lori Coen	Yes
Brian Exstrum	Yes
Roger Harms	Yes
Bonnie Hinkle	Yes
Heidi Schutz	Yes
Jennifer Worthington	Yes

11. RECONVENE FROM EXECUTIVE SESSION

The Board reconvened from Executive Session at 9:42 p.m.

Motion Passed: The recommendation that the Board reconvene from executive session passed with a motion by Terry Brown and a second by Heidi Schutz.

Carlos Barcenias	Absent
Dan Brosz	Yes
Terry Brown	Yes
Lori Coen	Yes
Brian Exstrum	Yes
Roger Harms	Yes
Bonnie Hinkle	Yes
Heidi Schutz	Yes
Jennifer Worthington	Yes

12. APPROVAL OF ANY ACTION DEEMED NECESSARY AS A RESULT OF EXECUTIVE SESSION

12.1. Real Estate

Motion Passed: The recommendation that the Board authorize the President to sign the Agreement for Sale and Purchase of Real Estate For Lot Four (4), Block Thirteen (13) in Wallichs Addition to the City of Grand Island, Hall County, Nebraska, more commonly known as 1419 W 7th Street for the amount of \$148,200 to be paid from any legally available funding source passed with a motion by Terry Brown and a second by Brian Exstrum.

Carlos Barcenias	Absent
Dan Brosz	Yes
Terry Brown	Yes
Lori Coen	Yes
Brian Exstrum	Yes
Roger Harms	Yes
Bonnie Hinkle	Yes
Heidi Schutz	Yes
Jennifer Worthington	Yes

12.2. Superintendent Evaluation Form Approval

Motion Passed: The recommendation to approve the superintendent evaluation form as presented passed with a motion by Jennifer Worthington and a second by Dan Brosz.

Carlos Barcenas	Absent
Dan Brosz	Yes
Terry Brown	Yes
Lori Coen	Yes
Brian Exstrum	Yes
Roger Harms	Yes
Bonnie Hinkle	Yes
Heidi Schutz	Yes
Jennifer Worthington	Yes

12.3. Acceptance of Worthington Resignation

Motion Passed: The recommendation that the board regretfully accept the resignation of Jennifer Worthington effective November 28, 2016 passed with a motion by Terry Brown and a second by Dan Brosz.

Carlos Barcenas	Absent
Dan Brosz	Yes
Terry Brown	Yes
Lori Coen	Yes
Brian Exstrum	Yes
Roger Harms	Yes
Bonnie Hinkle	Yes
Heidi Schutz	Yes
Jennifer Worthington	Yes

13. OLD BUSINESS

None

14. NOTIFICATION OF UPCOMING BOARD MEETINGS

14.1. December 5, 2016 - Superintendent Evaluation Training - 5:30 P.M.

14.2. December 5, 2016 - Special Meeting - Candidate Interviews, 6:30 P.M.

14.3. December 8, 2016 - Regular Board Meeting, 6:30 P.M.

15. ADJOURNMENT

All business having been completed, the meeting was adjourned at 9:45 p.m.

Betty L. Wagner, Recording Secretary

Robin R. Dexter, Secretary to the Board

Grand Island Public Schools

Claims Listing

December 8, 2016

<u>Check Number</u>	<u>Payee</u>	<u>Description</u>	<u>Amount</u>
51421	United States Postal Service	Postage	\$1,220.00
51422	Ramla Bakari	Miscellaneous Expense	\$60.00
51423	Almquist Maltzahn Galloway & Luth	Accounting and Auditing	\$1,206.00
51424	Barbara Pujol	Miscellaneous Expense	\$90.00
51425	Cornerstone Counseling PC	Professional Services	\$1,100.00
51426	David L Klein	Travel Expense	\$55.08
51427	Gabby Escalante Manzano	Miscellaneous Expense	\$30.00
51428	Grand Island Utilities Dept	Electricity	\$9,821.58
51429	Jennyfer Perez Veliz	Miscellaneous Expense	\$90.00
51430	Leslie Mateo	Miscellaneous Expense	\$60.00
51431	Lindsay Montanez	Miscellaneous Expense	\$60.00
51432	Maria Ramirez Galindo	Miscellaneous Expense	\$30.00
51433	Sams Club Direct	Miscellaneous Expense	\$763.68
51434	Selena Ramirez	Miscellaneous Expense	\$60.00
51435	West Music Co	Supplies	\$349.70
51436	Wholeness Healing Center PC	Employee Assistance Plan	\$7,875.00
51437	First Bankcard Center/Visa	Supplies	\$1,775.62
51438	First Bankcard Center/Visa	Dues and Fees	\$121.72
51439	First Bankcard Center/Visa	Supplies	\$654.02
51440	First Bankcard Center/Visa	Miscellaneous Expense	\$236.80
51441	First Bankcard Center/Visa	Travel Expense	\$3,132.45
51442	First Bankcard Center/Visa	Supplies	\$596.54
51443	First Bankcard Center/Visa	Miscellaneous Expense	\$216.96
51444	First Bankcard Center/Visa	Travel Expense	\$25.00
51445	First Bankcard Center/Visa	Supplies	\$152.38
51446	First Bankcard Center/Visa	Travel Expense	\$144.48
51447	First Bankcard Center/Visa	Dues and Fees	\$3,636.47
51448	First Bankcard Center/Visa	Dues and Fees	\$4,669.10
51449	First Bankcard Center/Visa	Supplies	\$531.90
51450	First Bankcard Center/Visa	Travel Expense	\$239.97
51451	First Bankcard Center/Visa	Supplies	\$506.63
51452	First Bankcard Center/Visa	Supplies	\$157.06
51453	First Bankcard Center/Visa	Supplies	\$1,238.20
51454	First Bankcard Center/Visa	Computer Hardware	\$688.39
51455	First Bankcard Center/Visa	Supplies	\$995.00
51456	First Bankcard Center/Visa	Travel Expense	\$287.62
51457	First Bankcard Center/Visa	Periodicals	\$191.90
51458	First Bankcard Center/Visa	Travel Expense	\$255.74
51459	First Bankcard Center/Visa	Advertising and Printing	\$40.00
51460	First Bankcard Center/Visa	Library and Reference Books	\$28.46
51461	First Bankcard Center/Visa	Supplies	\$17.07
51462	First Bankcard Center/Visa	Supplies	\$338.00
51463	First Bankcard Center/Visa	Contracted Services	\$302.00
51464	First Bankcard Center/Visa	Operational Purchases	\$441.09
51465	First Bankcard Center/Visa	Supplies	\$102.35
51466	First Bankcard Center/Visa	Travel Expense	\$13,678.36
51467	First Bankcard Center/Visa	Library and Reference Books	\$22.22
51468	First Bankcard Center/Visa	Library and Reference Books	\$97.97
51469	First Bankcard Center/Visa	Supplies	\$27.21
51470	First Bankcard Center/Visa	Supplies	\$24.75
51471	First Bankcard Center/Visa	Supplies	\$54.35

Grand Island Public Schools

Claims Listing

December 8, 2016

<u>Check Number</u>	<u>Payee</u>	<u>Description</u>	<u>Amount</u>
51472	First Bankcard Center/Visa	Library and Reference Books	\$1,287.51
51473	First Bankcard Center/Visa	Travel Expense	\$1,920.21
51474	First Bankcard Center/Visa	Supplies	\$60.33
51475	First Bankcard Center/Visa	Computer Software	\$652.34
51476	Food Distribution Program	Nutrional Services Warehouse	\$44,475.97
51477	Grand Island Independent	Advertising and Printing	\$4,417.50
51478	Grand Island Public Schools	Miscellaneous Expense	\$168.85
51479	First Bankcard Center/Visa	Travel Expense	\$819.23
51480	First Bankcard Center/Visa	Supplies	\$10.97
51481	First Bankcard Center/Visa	Periodicals	\$638.66
51482	Grand Island Independent	Advertising and Printing	\$570.90
51483	Cline Williams Wright Johnson	Legal Services	\$826.00
51484	Clint Simmons	Travel Expense	\$124.74
51485	eSchool Solutions	Contracted Services	\$13,938.60
51486	Grand Island Physical Therapy	Professional Services	\$18,017.78
51487	Hiland Dairy Foods Company LLC	Milk	\$14,266.36
51488	Interstate All Battery Center	Supplies	\$28.95
51489	JP Boiler Service LLC	Contracted Services	\$2,548.00
51490	Kelly Supply Co	Supplies	\$709.88
51491	Kriz-Davis Company	Supplies	\$4,745.58
51492	Matheson Tri Gas Inc	Supplies	\$38.80
51493	Menards	Supplies	\$1,122.25
51494	Midwest Heating & A/C Co	Furniture and Equipment	\$1,688.70
51495	MRL Crane & Equipment Rental	Contracted Services	\$315.00
51496	O Keefe Elevator Co Inc	Contracted Services	\$168.00
51497	Pan-O-Gold Baking Co	Food	\$6,019.00
51498	Shannonbuilders / Construction Mgt LLC	Building Acquisition and Improvement	\$134.46
51499	Sherwin Williams Company	Supplies	\$488.47
51500	SupplyWorks	Custodial Warehouse	\$9,375.23
51501	Grand Island Abstract Escrow & Title Co.	Site Acquisition Improvement	\$1,000.00
51502	Beulah Miner	Travel Expense	\$32.40
51503	Bonnie Haase	Travel Expense	\$11.34
51504	Carolyn Arends	Travel Expense	\$31.32
51505	Deb Woitaszewski	Travel Expense	\$5.14
51506	Evelyn R Seim	Travel Expense	\$26.68
51507	Helen Batenhorst	Travel Expense	\$18.04
51508	Jeanne Koehn	Travel Expense	\$27.54
51509	LaJina M Dunning	Travel Expense	\$47.25
51510	LeAnn Masat	Travel Expense	\$8.10
51511	Pamela L Morriss	Travel Expense	\$6.75
51512	Pamela Rivera	Travel Expense	\$29.75
51513	Tara Fieldgrove	Travel Expense	\$29.16
51514	Teresa Abuwisha	Travel Expense	\$14.58
51515	Theresa McCarthy	Travel Expense	\$52.65
51516	Theresa Olsufka	Travel Expense	\$19.44
51517	First Bankcard Center/Visa	Paper Products or Chemicals	\$216.62
51518	Grand Island Utilities Dept	Electricity	\$12,567.81
51519	Grand Island Utilities Dept	Electricity	\$38,297.84
51520	Grand Island Utilities Dept	Electricity	\$13,285.18
51521	Grand Island Utilities Dept	Electricity	\$25,891.53
51522	Grand Island Utilities Dept	Electricity	\$6,427.44

Grand Island Public Schools

Claims Listing

December 8, 2016

<u>Check Number</u>	<u>Payee</u>	<u>Description</u>	<u>Amount</u>
51523	Interstate All Battery Center	Supplies	\$243.77
51524	Jerrys Sheet Metal	Supplies	\$64.00
51525	Johnson Hardware	Supplies	\$430.00
51526	Kelly Supply Co	Supplies	\$21.43
51527	Kriz-Davis Company	Supplies	\$3,668.25
51528	Matheson Tri Gas Inc	Supplies	\$36.50
51529	Menards	Supplies	\$393.97
51530	Mid-Nebraska Disposal Inc	Refuse	\$102.53
51531	Midwest Hydraulic	Repairs and Maintenance	\$517.50
51532	Mosaic at Bethphage Village	Pupil Services	\$4,324.74
51533	NAPA Auto Parts of Grand Island	Supplies	\$146.60
51534	Nebraska Fire Sprinkler Corp	Contracted Services	\$2,972.00
51535	NMC Exchange LLC	Contracted Services	\$366.14
51536	O Hara Plumbing Co Inc	Contracted Services	\$765.92
51537	One Source	Professional Services	\$653.00
51538	Platte Valley Communications	Supplies	\$1,550.00
51539	Protex Central Inc	Contracted Services	\$278.35
51540	Reams Sprinkler Supply Co	Supplies	\$1,002.62
51541	Ricks Fertilizing LLC	Contracted Services	\$324.00
51542	Roberts Pump & Supply Co	Supplies	\$344.06
51543	Safety-Kleen Corporation	Contracted Services	\$520.00
51544	Sams Club Direct	Food	\$1,891.39
51545	Sapp Bros Petroleum Inc	Supplies	\$1,864.00
51546	Shaun Shepardson	Contracted Services	\$300.00
51547	Sheffield Tree Service	Contracted Services	\$400.00
51548	Sherwin Williams Company	Supplies	\$382.64
51549	Standard Battery Inc	Supplies	\$482.80
51550	State Glass Inc	Contracted Services	\$666.48
51551	Steele Law Office	Legal Services	\$7,066.00
51552	Stetson Building Products Inc	Supplies	\$203.04
51553	SupplyWorks	Custodial Warehouse	\$9,919.79
51554	Office Depot	Supplies	\$3,819.56
51555	Super Saver	Supplies	\$1,746.07
51556	Super Saver Five Points	Supplies	\$2,439.71
51557	First Bankcard Center/Visa	Dues and Fees	\$1,510.56
51558	Fleet Service	Gas and Oil	\$725.71
51559	Fleet Service	Gas and Oil	\$1,603.09
51560	Fleet Service	Gas and Oil	\$1,510.49
51561	Fleet Service	Gas and Oil	\$1,225.82
51562	Grand Island Utilities Dept	Electricity	\$6,741.45
51563	Julia Cook	Professional Services	\$625.00
51564	Verizon Wireless	Miscellaneous Expense	\$186.09
51565	Verizon Wireless	Distance Education and Telecommunications	\$162.32
51566	Kenneth DeFrank	Travel Expense	\$145.04
51567	Nebraska Department of Education	Travel Expense	\$150.00
51568	School Library Journal	Periodicals	\$88.99
51569	Stoneware Inc	Computer Software	\$40,650.00
51570	Thompson Company	Nutrional Services Warehouse	\$9,770.10
51571	Verizon Wireless	Distance Education and Telecommunications	\$957.79
51572	Emely Martin	Miscellaneous Expense	\$90.00
51573	Cristobal Pedro	Miscellaneous Expense	\$60.00

Grand Island Public Schools

Claims Listing

December 8, 2016

<u>Check Number</u>	<u>Payee</u>	<u>Description</u>	<u>Amount</u>
51574	Five Points Bank	Supplies	\$503.50
51575	Grand Island Independent	Advertising and Printing	\$6,125.25
51576	Brown Transfer Company	Furniture and Equipment	\$337.62
51577	Grand Island Utilities Dept	Electricity	\$16,450.44
51578	Grand Island Utilities Dept	Electricity	\$2,964.89
51579	Jennifer Renee Shorter	Travel Expense	\$504.75
51580	Julia Cook	Miscellaneous Expense	\$562.50
51581	Elisa Pablo Aguilar	Miscellaneous Expense	\$30.00
51582	Leah Michel	Travel Expense	\$66.96
51583	Midamerica Books	Library and Reference Books	\$736.85
51584	Nebraska U C Fund	Unemployment Compensation	\$41.82
51585	US Postal Service (Neopost POC)	Postage	\$8,000.00
51586	Senior High School Petty Cash	Supplies	\$277.03
51587	Daniel Phillips	Travel Expense	\$111.24
51588	Dayana Hernandez	Miscellaneous Expense	\$60.00
51589	Fairfield Inn & Suites	Miscellaneous Expense	\$296.95
51590	Jason Folkerts	Contracted Services	\$1,400.00
51591	CenterPoint Energy Services Inc	Natural Gas	\$15,619.86
51592	DAS State Accounting - Central Finance	Distance Education and Telecommunications	\$238.96
51593	Abante Marketing	Supplies	\$79.04
51594	Ace Hardware	Supplies	\$410.76
51595	Advance Auto Parts	Supplies	\$294.07
51596	Agricultural Service	Supplies	\$5,085.00
51597	Alicia Rae Glaser	Travel Expense	\$40.01
51598	All Star Auto Glass of Grand Island	Repairs and Maintenance	\$54.95
51599	Alma Rawlings	Miscellaneous Expense	\$30.00
51600	Alpha Rehabilitation PC	Pupil Services	\$1,010.12
51601	Amalia Barber	Travel Expense	\$18.68
51602	Amanda Mancini-Marshall	Travel Expense	\$52.75
51603	Amber High	Supplies	\$114.70
51604	Amber Northup	Supplies	\$21.56
51605	American Fence Co Western Ne	Supplies	\$102.90
51606	Amy Hanna	Miscellaneous Expense	\$18.90
51607	Amy L Boyer	Supplies	\$17.44
51608	Andrew Rinaldi	Travel Expense	\$45.36
51609	Angela Runquist	Supplies	\$86.75
51610	Annalien Gonzalez de la Vega	Supplies	\$91.58
51611	Apperson Inc	Supplies	\$799.57
51612	Apple Computer Inc	Supplies	\$49.00
51613	April Franzen	Supplies	\$11.46
51614	Aramark Uniform Services	Contracted Services	\$413.75
51615	Aron Zumaya	Miscellaneous Expense	\$90.00
51616	Ashley Beckman	Supplies	\$28.76
51617	Awards Plus	Supplies	\$340.87
51618	B & H Photo-Video Inc	Audio Visual Materials	\$594.00
51619	Barnes And Noble Bookstore	Supplies	\$982.56
51620	Becky Gdowski	Travel Expense	\$95.90
51621	Best Buy Business Account	Supplies	\$99.98
51622	Bethany J Eash	Mileage to Parents	\$158.76
51623	Blick Art Materials	Supplies	\$5,328.53
51624	Bonnie Hummel	Travel Expense	\$124.25

Grand Island Public Schools

Claims Listing

December 8, 2016

<u>Check Number</u>	<u>Payee</u>	<u>Description</u>	<u>Amount</u>
51625	Bosselman Energy Inc	Supplies	\$75.95
51626	Bouncy Bands LLC	Supplies	\$164.45
51627	Brackers Good Earth Clays Inc	Supplies	\$1,067.40
51628	Brenda Anderson	Travel Expense	\$48.87
51629	Brian Kort	Travel Expense	\$54.00
51630	Broad Reach	Library and Reference Books	\$450.36
51631	Brooke Wentzlaff	Travel Expense	\$47.63
51632	Builders Warehouse	Supplies	\$12.72
51633	Capstone	Web Based Software	\$2,080.50
51634	Caroline George	Travel Expense	\$81.64
51635	Carrie L Kolar	Supplies	\$52.84
51636	Carrie Whitcomb	Travel Expense	\$45.36
51637	Catherine Cure	Travel Expense	\$36.07
51638	Cgsmusic	Contracted Services	\$520.85
51639	Chelsey Jo Hansen	Travel Expense	\$20.52
51640	Cheryl Russell	Supplies	\$31.96
51641	Christina Cox	Mileage to Parents	\$49.25
51642	Christina Davis	Travel Expense	\$13.28
51643	Cindy Beaman	Travel Expense	\$30.19
51644	Cintia Longoria	Supplies	\$25.67
51645	City of Grand Island	Refuse	\$180.83
51646	Claudia Aguilar	Travel Expense	\$60.48
51647	Colleen Friesen	Travel Expense	\$42.76
51648	Communications Engineering	Supplies	\$4,540.00
51649	Computer Hardware	Furniture and Equipment	\$6,120.00
51650	Comstock Corporation	Travel Expense	\$1,000.00
51651	Consolidated Concrete Co	Supplies	\$466.69
51652	Constance L Palu	Travel Expense	\$41.47
51653	Construction Rental	Contracted Services	\$412.50
51654	Construction Specialties Inc	Supplies	\$1,854.00
51655	Copycat Instant Printing	Supplies	\$798.00
51656	Copycat Instant Printing-Kearney	Supplies	\$386.60
51657	Craig Homecare	Pupil Services	\$7,201.06
51658	Cross Dillon Tire	Supplies	\$197.87
51659	Crystal M Zint-Roznik	Contracted Services	\$1,162.25
51660	Culligan of Grand Island	Contracted Services	\$130.10
51661	Dan Petsch	Travel Expense	\$86.40
51662	Dan Prickett	Travel Expense	\$40.33
51663	Daniel Phillips	Travel Expense	\$124.57
51664	Daria Pierorazio	Travel Expense	\$254.71
51665	Dawn Deuel-Rutt	Travel Expense	\$139.69
51666	Demco	Supplies	\$666.85
51667	Denise Wolfe	Travel Expense	\$82.94
51668	Diamond Vogel Paint	Supplies	\$234.53
51669	Discount School Supply Order Dept	Supplies	\$175.55
51670	Donald McQuown	Miscellaneous Expense	\$510.00
51671	E-stroyed LLC	Computer Hardware	\$1,220.00
51672	Eakes Office Solutions	Furniture and Equipment	\$6,507.37
51673	Ebsco Subscription Services	Periodicals	\$103.85
51674	EdTechTeam Inc	Supplies	\$216.00
51675	EdTechTeam, Inc	Miscellaneous Expense	\$216.00

Grand Island Public Schools

Claims Listing

December 8, 2016

<u>Check Number</u>	<u>Payee</u>	<u>Description</u>	<u>Amount</u>
51676	Educational Service Unit 10	Computer Software Maintenance	\$16,306.70
51677	Egan Supply Company	Custodial Warehouse	\$2,416.00
51678	Elizabeth K Lewis	Travel Expense	\$28.35
51679	Elizabeth Reich	Travel Expense	\$67.71
51680	Ellison Educational Equipment Inc	Supplies	\$65.75
51681	Emily Roemmich	Travel Expense	\$20.52
51682	Engaging Technologies LLC	Supplies	\$2,764.00
51683	Erin Brooks	Supplies	\$19.74
51684	Estella Abuelsheikh	Miscellaneous Expense	\$60.00
51685	ESU Coordinating Council	Miscellaneous Expense	\$30.00
51686	Fastenal	Supplies	\$69.57
51687	Father Flanagan's Boys' Home	Professional Services	\$4,043.91
51688	Flinn Scientific	Supplies	\$408.40
51689	Follett School Solutions Inc	Library and Reference Books	\$2,573.07
51690	Fun Express LLC	Supplies	\$41.91
51691	Gabriela Garcia	Mileage to Parents	\$120.96
51692	Garrett Tires & Treads	Repairs and Maintenance	\$821.05
51693	Geri Pagel	Travel Expense	\$11.07
51694	Gina Lamm	Contracted Services	\$32.38
51695	Gonzalez Vanessa	Miscellaneous Expense	\$60.00
51696	Grand Island Little Theatre Inc	Miscellaneous Expense	\$550.00
51697	Grand Island Physical Therapy	Professional Services	\$39,612.23
51698	Grand Island Public Schools Nutrition Sv	Supplies	\$1,160.33
51699	Great Lakes Sports	Supplies	\$345.49
51700	Gustave A Larson Company	Supplies	\$960.50
51701	H L Flake Co LTD	Supplies	\$223.84
51702	Head Start Family Dev Program	Contracted Services	\$7,277.00
51703	Heather Parker-Evans	Travel Expense	\$483.38
51704	Heinemann Publishing	Library and Reference Books	\$635.25
51705	Helgoth's Pumpkin Patch	Dues and Fees	\$280.00
51706	Holiday Express	Contracted Pupil Transportation	\$15,530.00
51707	Home Depot The	Supplies	\$234.00
51708	Hotsy Equipment Co	Supplies	\$1,035.29
51709	Idea Bank Marketing	Contracted Services	\$224.00
51710	Jaime Wattier	Travel Expense	\$11.50
51711	Jami White	Travel Expense	\$59.99
51712	Jane Gloor	Supplies	\$92.47
51713	Jeanna Randall	Supplies	\$132.78
51714	Jennifer Badura	Travel Expense	\$28.62
51715	Jennifer Leitschuck	Travel Expense	\$54.21
51716	Jenny Lynn Rother	Travel Expense	\$223.12
51717	Jeremy McFarland	Travel Expense	\$46.33
51718	Jerome Dubas	Supplies	\$1,325.27
51719	Jessica McDowell	Travel Expense	\$20.19
51720	John Hirschman	Travel Expense	\$15.01
51721	Johnson Hardware	Supplies	\$25,256.70
51722	Joni Mayfield	Travel Expense	\$670.46
51723	Journeyed-Microsoft LAR	Computer Software	\$57.43
51724	Juana Gomez	Travel Expense	\$711.18
51725	Julia Cook	Library and Reference Books	\$188.10
51726	Julie Armstrong	Supplies	\$13.88

Grand Island Public Schools

Claims Listing

December 8, 2016

<u>Check Number</u>	<u>Payee</u>	<u>Description</u>	<u>Amount</u>
51727	Julie Fessenden	Travel Expense	\$70.84
51728	Julie M Markvicka	Travel Expense	\$33.69
51729	JW Pepper Son Inc	Supplies	\$386.44
51730	Kadar H Mohamed	Miscellaneous Expense	\$60.00
51731	Karisa Dubbs	Travel Expense	\$74.25
51732	Karma L Krajewski	Travel Expense	\$50.22
51733	Katherine Donahoo	Miscellaneous Expense	\$7.34
51734	Kathryn Olson	Travel Expense	\$41.14
51735	Kathy Hancock	Travel Expense	\$162.10
51736	Katie Ramsey	Travel Expense	\$41.00
51737	Kayla Wiarda	Supplies	\$27.96
51738	Kelly Herlick	Travel Expense	\$36.01
51739	Kendra Hansen	Travel Expense	\$35.53
51740	Kenton Naylor	Travel Expense	\$220.33
51741	Keo Rea Eileen Leiser	Supplies	\$118.56
51742	Kimberly Luthy	Supplies	\$33.64
51743	Kip Ramsey	Travel Expense	\$110.70
51744	Kristin Watson	Travel Expense	\$38.29
51745	Kucirek Engineering Inc	Building Acquisition and Improvement	\$8,690.35
51746	Lakeshore Learning Materials	Supplies	\$30.58
51747	Laminator.Com	Supplies	\$3,546.00
51748	Laser Works	Supplies	\$28.50
51749	Laurie Anderson	Travel Expense	\$7.02
51750	Leah Michel	Miscellaneous Expense	\$125.71
51751	Learning A-Z	Web Based Software	\$2,053.95
51752	Lenovo Inc	Computer Hardware	\$625.00
51753	Lew Cole	Travel Expense	\$89.59
51754	Lookout Books	Library and Reference Books	\$396.22
51755	Loretta Pishna	Travel Expense	\$21.92
51756	Lynn Bender	Travel Expense	\$7.07
51757	Maria Trejo Guerrero	Travel Expense	\$27.00
51758	Marilyn Berven	Supplies	\$5.99
51759	Marla Rischling	Travel Expense	\$81.05
51760	Marty Markvicka	Travel Expense	\$21.06
51761	MasteryConnect Inc	Web Based Software	\$1,700.00
51762	Matheson Tri Gas Inc	Supplies	\$21.70
51763	McGraw-Hill School Education	Textbooks	\$54,902.87
51764	Meg Trout	Travel Expense	\$18.20
51765	Megan L Jaixen	Professional Services	\$5,315.43
51766	Melanie Malone	Travel Expense	\$26.08
51767	Melissa Anderson	Supplies	\$101.47
51768	Melissa Winter	Travel Expense	\$90.28
51769	Melody A Pebley	Travel Expense	\$33.80
51770	Menards	Supplies	\$1,235.96
51771	Michella Honas	Travel Expense	\$65.34
51772	Michelle E Anderson	Supplies	\$73.96
51773	Michelle Foster	Mileage to Parents	\$24.19
51774	Mid-Nebraska Disposal Inc	Refuse	\$4,059.70
51775	Midamerica Books	Library and Reference Books	\$938.59
51776	Midwest Special Instruments	Contracted Services	\$573.00
51777	Miguel Baeza Aguilera	Miscellaneous Expense	\$60.00

Grand Island Public Schools

Claims Listing

December 8, 2016

<u>Check Number</u>	<u>Payee</u>	<u>Description</u>	<u>Amount</u>
51778	Mosaic at Bethphage Village	Pupil Services	\$12,416.85
51779	Movie Licensing USA	Contracted Services	\$313.00
51780	MSC Industrial Supply Co Inc	Supplies	\$1,366.97
51781	National Association for Gifted Children	Miscellaneous Expense	\$2,596.00
51782	Natl. Assn. of Educational Procurment	Dues and Fees	\$620.00
51783	NCECBVI	Pupil Services	\$373.00
51784	Nebraska Council of School Administrator	Dues and Fees	\$435.00
51785	Nebraska Scientific	Supplies	\$1,705.15
51786	Nebraskalink LLC	Contracted Services	\$1,793.00
51787	Neil Berger	Travel Expense	\$20.19
51788	Networkfleet Inc.	Repairs and Maintenance	\$1,853.75
51789	Nichole Nesvara	Travel Expense	\$92.88
51790	Nicole Brandt	Travel Expense	\$1.62
51791	Northwestern Energy	Natural Gas	\$57.98
51792	NSASSP Region IV Principals	Dues and Fees	\$20.00
51793	O Neill Transportation & Equipment LLC	Building Acquisition and Improvement	\$8,800.00
51794	Olsson Associates	Building Acquisition and Improvement	\$1,822.40
51795	Omaha World-Herald Newspaper In Educatio	Periodicals	\$51.15
51796	Oriental Trading Company	Supplies	\$195.78
51797	Orkin Pest Control	Contracted Services	\$891.00
51798	Outdoor Recreation Products	Supplies	\$5,125.00
51799	Paper Tiger Shredding Inc	Refuse	\$240.00
51800	Patricia Van Pelt	Supplies	\$52.36
51801	Pearson Clinical Assessment	Supplies	\$58.30
51802	Penn State Industries	Supplies	\$790.70
51803	Penny Brown	Supplies	\$41.43
51804	PESI Inc	Miscellaneous Expense	\$66.94
51805	Pitsco Inc	Supplies	\$46.95
51806	Placke Melons	Supplies	\$85.00
51807	Positive Promotions Inc	Supplies	\$495.10
51808	Pro-Ed	Supplies	\$61.60
51809	Productivity Inc	Supplies	\$1,185.12
51810	Projector Superstore Inc	Supplies	\$402.00
51811	Quality Industrial Sewing Machine	Supplies	\$210.00
51812	Quill Corporation	Supplies	\$1,003.56
51813	Rachael E Caskey	Mileage to Parents	\$214.27
51814	Rachel Pischnotte	Travel Expense	\$20.19
51815	Randi Pennell	Travel Expense	\$32.07
51816	Really Good Stuff Inc	Supplies	\$765.84
51817	Rebecca Carstensen	Supplies	\$18.00
51818	Renee Engel	Travel Expense	\$159.62
51819	Riverside Technologies Inc	Computer Hardware	\$368.00
51820	Robin Dexter	Travel Expense	\$29.90
51821	Rons Music	Supplies	\$79.95
51822	Rose Zlomke	Travel Expense	\$8.75
51823	Safety-Kleen Corporation	Supplies	\$265.86
51824	Sarah K Henry	Travel Expense	\$117.01
51825	Savannah Kok	Travel Expense	\$34.56
51826	School Health Corporation	Supplies	\$213.96
51827	School Zone Publishing Company Inc	Supplies	\$102.64
51828	Shanna Gannon	Travel Expense	\$41.20

Grand Island Public Schools

Claims Listing

December 8, 2016

<u>Check Number</u>	<u>Payee</u>	<u>Description</u>	<u>Amount</u>
51829	Sherri Frisbie	Pupil Services	\$206.28
51830	Smart Apple Media	Library and Reference Books	\$174.60
51831	Stan Dancer	Supplies	\$43.89
51832	Summit Professional Education LLC	Dues and Fees	\$379.98
51833	Super Duper Publications	Supplies	\$75.80
51834	Suyapa Gonzalez	Supplies	\$101.30
51835	T-Shirt Engineers	Miscellaneous Expense	\$510.00
51836	Tara Peterson	Travel Expense	\$54.00
51837	Tawana Grover	Travel Expense	\$340.20
51838	Teacher Innovations, INC	Computer Software	\$151.20
51839	Teachers Lounge	Supplies	\$99.75
51840	Teresa Dunning	Supplies	\$9.49
51841	Terri Jensen	Library and Reference Books	\$36.13
51842	Theresa Beck	Travel Expense	\$113.94
51843	Theresa Lynn Bougger	Travel Expense	\$37.96
51844	Time For Kids	Supplies	\$178.40
51845	Tom Dinsdale Chevrolet Cadillac	Repairs and Maintenance	\$1,920.44
51846	Tom Haney Plaster & Stucco Co	Contracted Services	\$1,450.00
51847	Toni Palmer	Travel Expense	\$32.02
51848	Tonya Papineau	Travel Expense	\$133.05
51849	Toofast Supply	Supplies	\$2,210.83
51850	Tool Barn Rentals Inc	Contracted Services	\$85.00
51851	Travas G Wright	Travel Expense	\$27.49
51852	Tri City Sign Company	Contracted Services	\$338.85
51853	Tri-Cities Group Inc.	Contracted Services	\$132.46
51854	Trisys Inc	Computer Hardware	\$4,198.00
51855	Tumbleweed Press Inc	Web Based Software	\$2,095.80
51856	Tyler Technologies Inc	Computer Software	\$500.00
51857	UniFirst Corporation	Contracted Services	\$990.05
51858	Unite Private Networks LLC	Computer Software	\$24,516.15
51859	Violin Shop In Lincoln Inc	Supplies	\$622.50
51860	Western Psychological Services	Supplies	\$495.00
51861	Wiper Towel Service	Contracted Services	\$594.25
51862	Yandas Music	Miscellaneous Expense	\$79.00
51863	Yellow Dog Networks Inc	Computer Hardware	\$1,080.00
51864	B & H Photo-Video Inc	Operational Purchases	\$194.78
51865	Beulah Miner	Travel Expense	\$37.26
51866	Bonnie Haase	Travel Expense	\$15.87
51867	Brenmar Company Inc	Nutrional Services Warehouse	\$2,319.92
51868	Carolyn Arends	Travel Expense	\$34.45
51869	Cheryl Harpham	Food	\$12.72
51870	Chesterman Company	Food	\$975.20
51871	Crystal Rainforth	Travel Expense	\$56.37
51872	Culligan of Grand Island	Contracted Services	\$510.80
51873	Deb Woitaszewski	Travel Expense	\$19.27
51874	Evelyn R Seim	Travel Expense	\$16.14
51875	Fisher Fixture Company	Operational Purchases	\$1,189.44
51876	Grand Island Independent	Advertising and Printing	\$275.50
51877	Greenberg Fruit Company	Produce	\$18,792.43
51878	Helen Batenhorst	Travel Expense	\$22.78
51879	Hiland Dairy Foods Company LLC	Milk	\$36,822.18

Grand Island Public Schools

Claims Listing

December 8, 2016

<u>Check Number</u>	<u>Payee</u>	<u>Description</u>	<u>Amount</u>
51880	Jeanne Koehn	Travel Expense	\$34.02
51881	LaJina M Dunning	Travel Expense	\$29.70
51882	LeAnn Masat	Travel Expense	\$6.58
51883	Lisa Moss	Food	\$61.68
51884	Lisandra Gutierrez Garcia	Travel Expense	\$17.82
51885	Loffredo Fresh Produce	Produce	\$871.00
51886	Mary Flores	Travel Expense	\$58.42
51887	Mid-Nebraska Disposal Inc	Refuse	\$396.40
51888	Midwest Restaurant Supply LLC	Contracted Services	\$3,020.73
51889	Office Depot	Supplies	\$77.55
51890	Pamela Kay Tunks	Food	\$22.44
51891	Pamela L Morriss	Travel Expense	\$2.70
51892	Pamela Rivera	Travel Expense	\$34.45
51893	Pan-O-Gold Baking Co	Food	\$10,065.58
51894	Pepsi-Cola Company	Food	\$232.30
51895	Platinum Packaging Group	Nutrional Services Warehouse	\$254.94
51896	Sams Club Direct	Food	\$272.02
51897	Super Saver	Food	\$41.23
51898	Tara Fieldgrove	Travel Expense	\$32.40
51899	Teresa Abuwisha	Travel Expense	\$18.46
51900	Theresa McCarthy	Travel Expense	\$28.35
51901	Theresa Olsufka	Travel Expense	\$21.38
51902	Thompson Company	Nutrional Services Warehouse	\$85,828.07
51903	Wholesale Produce Supply LLC	Produce	\$2,862.00
ACH	Lacy Construction Company	Building Acquisition and Improvement	\$566,082.60
ACH	Lacy Construction Company	Building Acquisition and Improvement	\$246,102.70
ACH	Chief Construction Company	Building Acquisition and Improvement	\$210,403.09
ACH	Cross & Joftus LLC	Contracted Services	\$40,000.00
		November Claims	\$2,047,250.84
		November 16, 2016 Payroll	\$7,440,516.33
			<u>\$9,487,767.17</u>

Kneale Administration Building

Dan O. Petsch

Director of Buildings and Grounds



November 28, 2016

RE: Proposals Received for Installation of Cooling Tower Replacement
@ West Lawn Elementary School

ESTIMATE:
\$40,000

BUDGET:
Depreciation Fund

PROPOSALS GIVEN TO:

Jerry's Sheet Metal

Island Indoor Climate

PROPOSALS RECEIVED:

Supplier	Cost to Install	Bond Cost	Total Cost
Jerry's Sheet Metal	\$38,700	\$450	\$39,150
Island Indoor Climate	\$39,500	\$600	\$40,100

RECOMMENDATION:

It is recommended to approve the proposal from Jerry's Sheet Metal for a total cost of \$39,150. This project will be funded through the Depreciation Fund.

Dan O. Petsch

Director of Buildings and Grounds

**GRAND ISLAND PUBLIC SCHOOLS
Grand Island, Nebraska**

**STAFF ADJUSTMENT
December 8, 2016**

Certified New Hires

<u>Name</u>	<u>Assignment/Building</u>	<u>Effective</u>	<u>Degree/ Level</u>	<u>College/ University</u>	<u>Replaces/ Reason</u>
Nicole Brandt	Resource/CNSSP/.50 FTE/ Wasmer/.50 FTE/Newell	11/14/16	BA-02	UNK	R. Soto's FTE/Approved by Board
Jennifer Worthington	Chief of Innovation and Engagement Officer/ 1.0 FTE/Admin. Bldg.	12/05/16	MA	Doane College	Approved by Board

New Hire/Extra Standard Assignment

<u>Name</u>	<u>Extra-Standard Assignment</u>	<u>Effective</u>	<u>Replaces/Reason</u>
Russell Harvey	Middle School Girls Basketball/Walnut	11/15/16	L. Westover
Johnathon Mottl	Middle School Wrestling/Walnut	11/15/16	Due to increased number of participants

Classified New Hires

<u>Name</u>	<u>Assignment/Building</u>	<u>FTE</u>	<u>Starting Date</u>	<u>Replaces/Reason</u>
Michelle Adams	Paraeducator/CNSSP/Newell	.88	11/14/16	Student need
Kent Bennett	Assistant Custodian/Westridge	1.0	11/23/16	J. Smith
Maria Garcia	ELL Paraeducator/Lincoln Noon Monitor/Lincoln	.81 .19	11/08/16	R. Perez Reyes
Lorie Motley	Crossing Guard/Stolley Park	.31	11/28/16	P. Hill
Jane Poole	Instructional Support Coordinator/Senior	1.0	11/28/16	G. Schuller
Melody Wentling	Paraeducator/Jefferson	.38	11/03/16	Student need

Certified Resignations

<u>Name</u>	<u>Assignment/Building</u>	<u>Reason</u>	<u>Effective</u>
NONE			

Certified Extra Standard Resignations

<u>Name</u>	<u>Assignment/Building</u>	<u>Reason</u>	<u>Effective</u>
NONE			

Classified Resignations

<u>Name</u>	<u>Assignment/FTE/Building</u>	<u>Reason</u>	<u>Effective</u>
Alan Aguilar	Yard Worker/1.0 FTE/Admin. Bldg.	End of season	11/17/16
Brianna Anderson	Preschool Paraeducator/1.0 FTE/Early Learning Center	New position	12/02/16
Lori Arriola	Food Service Assistant/.50 FTE/Senior	Personal	12/02/16
Elmer Behring	Yard Worker/1.0 FTE/Admin. Bldg.	End of season	10/28/16
Randy Curran	Yard Worker/1.0 FTE/Admin. Bldg.	End of season	10/26/16
Jeanie Fisher	Skills Academy Paraprofessional/CNSSP/.94 FTE/ Dodge	New position	11/10/16
Johnny Garcia	Assistant Custodian/1.0 FTE/Senior	Personal	12/06/16
Dean Hollister	Yard Worker/1.0 FTE/Admin. Bldg.	End of season	10/28/16
Kodi Lewis	Secretary to Elementary Principal/1.0 FTE/Dodge	New position	11/28/16
Shane Moritz	Assistant Custodian/.50 FTE/Newell	Personal	11/18/16
Jerry Smith	Assistant Custodian/1.0 FTE/Westridge	Retirement	11/25/16
Diane Smutny	Secretary Human Resources/1.0 FTE/Admin. Bldg.	End of season	10/26/16
Veronica Villazana Sandoval	Paraeducator/.88 FTE/Gates	Personal	10/28/16

Certified Changes

<u>Name</u>	<u>Former Assignment</u>	<u>New Assignment</u>	<u>Effective</u>	<u>Replaces/Reason</u>
Cindy Beaman	Mathematics Coach/1.0 FTE/ Admin. Building	Curriculum Coordinator/ Mathematics/1.0 FTE plus 10 extended days/Admin. Bldg.	08/15/16	Change in assignment
Katie Ramsey	Science Coach/1.0 FTE/ Admin. Building	Curriculum Coordinator/ Science/1.0 FTE plus 10 extended days/Admin. Bldg.	08/15/16	Change in assignment

Certified Changes/Extra Standard Assignments

<u>Name</u>	<u>Former Assignment</u>	<u>New Assignment</u>	<u>Effective</u>	<u>Replaces/Reason</u>
NONE				

Classified Changes

<u>Name</u>	<u>Former Assignment</u>	<u>New Assignment</u>	<u>Effective</u>	<u>Replaces/Reason</u>
Mary Flores	Nutrition Services Supervisor/ 1.0 FTE/Admin. Bldg.	Secretary to Elementary Principal/1.0 FTE/Dodge	11/18/16	K. Lewis
Patricia Hill	Crossing Guard/.31 FTE/ Stolley Park/Noon Monitor/ .19 FTE/Shoemaker	Noon Monitor/.19 FTE/ Shoemaker	11/28/16	Employee request

Classified Changes (cont.)

<u>Name</u>	<u>Former Assignment</u>	<u>New Assignment</u>	<u>Effective</u>	<u>Replaces/Reason</u>
Gregg Kemp	Assistant Custodian/1.0 FTE/ Senior	Custodian Night Supervisor/ 1.0 FTE/Senior	11/08/16	D. Webben
Brenda Lambert	Piano Accompanist/.39 FTE/ Westridge	Piano Accompanist/.38 FTE/ Westridge	10/05/16	D. Scheel
Kara Rieger	Piano Accompanist/.44 FTE/ Senior/.56 FTE/Barr	Piano Accompanist/1.0 FTE/ Barr	08/05/16	Approved by Board
Debra Scheel	Piano Accompanist/.38 FTE/ Westridge	Piano Accompanist/.39 FTE/ Westridge	10/05/16	B. Lambert

Certified Special Assignment

<u>Name</u>	<u>Additional Assignment</u>	<u>Effective</u>	<u>Replaces/Reason</u>
Chad Ackerson	MS Core Team Leader Stipend/Westridge	08/15/16	C. Campbell
Melissa Beberniss	MS Core Team Leader Stipend/Westridge	08/15/16	P. Van Pelt
Grant Hiebner	MS Core Team Leader Stipend/Westridge	08/15/16	C. Larsen
Ashley Hilger	MS Core Team Leader Stipend/Westridge	08/15/16	8th Grade Team Leader

Certified Special Assignment (cont.)

<u>Name</u>	<u>Additional Assignment</u>	<u>Effective</u>	<u>Replaces/Reason</u>
Kyle Nabity	MS Core Team Leader Stipend/Westridge	08/15/16	J. Sorensen
Loria Lei Thunker	MS Core Team Leader Stipend/Westridge	08/15/16	D. Lindsey & K. Stutzman

Certified Special Assignment Resignations

<u>Name</u>	<u>Assignment/Building</u>	<u>Reason</u>	<u>Effective</u>
Clista Campbell	MS Core Team Leader Stipend/Westridge	Personal	05/23/16
Cheryl Larsen	MS Core Team Leader Stipend/Westridge	Personal	05/23/16
Derek Lindsey	MS Core Team Leader Stipend/.50 FTE/ Westridge	Personal	05/23/16
Janet Sorensen	MS Core Team Leader Stipend/Westridge	Personal	05/23/16
Kirk Stutzman	MS Core Team Leader Stipend/.50 FTE/ Westridge	Personal	05/23/16
Patricia Van Pelt	MS Core Team Leader Stipend/Westridge	Personal	05/23/16

The Superintendent recommends adoption of the Staff Adjustment on the consent agenda

Grand Island Public Schools

Fund Balances

Fiscal Year: 2016-2017

Month: October

Year: 2016

Fund Type:

Include Cash Balance

FY End Report

<u>Fund</u>	<u>Description</u>	<u>Beginning Balance</u>	<u>Revenue</u>	<u>Expense</u>	<u>Transfers</u>	<u>Fund Balance</u>
01	General	\$25,463,270.07	\$21,843,674.62	(\$14,369,663.84)	\$0.00	\$32,937,280.85
02	Depreciation	\$3,188,685.55	\$0.00	(\$297,077.66)	\$0.00	\$2,891,607.89
03	Employee Benefit	\$2,962,662.39	\$3.98	\$0.00	\$0.00	\$2,962,666.37
04	Contingency	\$1,015,236.18	\$2.71	\$0.00	\$0.00	\$1,015,238.89
05	Activities	\$1,579,795.71	\$226,152.70	(\$449,377.95)	\$0.00	\$1,356,570.46
06	School Lunch	\$768,681.40	\$537,871.70	(\$1,225,927.03)	\$0.00	\$80,626.07
07	Bond	\$6,668,557.04	\$2,044,007.55	\$0.00	\$0.00	\$8,712,564.59
08	Special Building	\$27,341,188.52	\$98,149.55	(\$3,011,100.76)	\$0.00	\$24,428,237.31
09	Qualified Capitol Purpose Undertaking	\$423,170.90	\$169,365.83	\$0.00	\$0.00	\$592,536.73
10	Cooperative	\$1,057,783.77	\$38.41	(\$2,709,429.96)	\$0.00	(\$1,651,607.78)
12	Student Fee	\$0.00	\$0.00	\$0.00	\$0.00	\$0.00
Grand Total:		\$70,469,031.53	\$24,919,267.05	(\$22,062,577.20)	\$0.00	\$73,325,721.38

End of Report

6461 CLASSIFIED STAFF SUSPENSION

Classified staff shall perform their assigned jobs, respect and follow Board policy, and obey the law. The superintendent or designee is authorized to suspend a classified staff member with or without pay if there exists a potential safety risk to students or staff, a potential for disruption of the educational environment, and/or insubordination. Any action to terminate would be taken before the Board through the consent agenda.

Policy Adopted: ???.???.??

6462 DISMISSAL OF "AT WILL" STATUS STAFF MEMBER

The Grand Island Public Schools believes staff should perform their jobs, respect board policy, and obey the law. Staff who are considered "at will" employees are not entitled to due process. This means the employment relationship may be terminated by either the employee or the employer at any time, with or without notice, and with or without cause. The employment relationship is not for any set period of time, and the district may alter or modify the employment status, employment hours, or job duties at the districts discretion with or without notice or cause. It shall be the responsibility of the superintendent or designee to manage the dismissal of an "at will" staff member.

All staff who are not covered under a labor contract or are not afforded due process rights, are considered "at will" staff. This means the superintendent, or designee, or the staff member may end the employment relationship at any time, with or without notice, and with or without cause. An "at will" employee may not be terminated on the basis of race, color, religion, veteran status, national origin, ethnicity, sex or gender, sexual orientation, marital status, pregnancy, childbirth or related medical condition, age, intellectual or physical disability, or other protected status.

Legal Reference: Neb. Statute 79-828 and 79-829

Policy Adopted: ??.??.??

6511 CLASSIFIED STAFF ASSIGNMENTS AND TRANSFERS

Determining the assignment of classified staff is the responsibility and sole discretion of the superintendent or designee. In making such assignments, each year the superintendent or designee shall consider the qualifications of each classified staff and the needs of the school district.

A transfer may be initiated by the staff member, the principal, or the superintendent or designee. The superintendent or designee approves or denies the transfer request.

It shall be the responsibility of the superintendent or designee to assign classified staff and report such assignments to the board. The Board approves transfers through the consent agenda.

Policy Adopted: ???.???.??

6711 CLASSIFIED STAFF PERFORMANCE APPRAISAL

Appraisal of classified staff on their skills, abilities, and competence shall be an ongoing process supervised by the superintendent or designee. The goal of the appraisal of classified staff shall be to maintain classified staff who meet or exceed the Grand Island Public Schools standards of performance, to clarify each classified staff member's role, to ascertain the areas in need of improvement, to clarify the immediate priorities of the GIPS, and to develop a working relationship between the administrators and other employees. Classified staff are evaluated within the first 30 days their probationary period of employment; evaluated again no later than 90 days of their probationary period of employment; and evaluated annually for the duration of their employment.

Policy Adopted: ???.???.??

7150 ACADEMIC FREEDOM

The Grand Island Public Schools believes students should have an opportunity to reach their own decisions and beliefs about conflicting points of view. Academic freedom is the opportunity of licensed employees and students to study, investigate, present, interpret, and discuss facts and ideas relevant to the subject matter of the classroom and appropriate to and in good taste with the maturity and intellectual and emotional capacities of the students.

It shall be the responsibility of the teacher to refrain from advocating partisan causes, sectarian religious views, or biased positions in the classroom or through teaching methods. Teachers are not discouraged from expressing personal opinions as long as students are aware it is a personal opinion and students are allowed to reach their own conclusions independently. It shall be the responsibility of the principal to ensure academic freedom is allowed but not abused in the classroom.

~~7150 ACADEMIC FREEDOM~~

~~Academic freedom is essential to the fulfillment of the purposes of the Grand Island Public Schools. Democracy is a way of life that prizes alternatives. Alternatives mean that people must make choices. Wisdom with which to make choices can come only if there is freedom of speech, of press, of assembly, and of teaching. These protect the people in their right to hear, to read, to discuss, and to reach judgments according to individual conscience. Responsible self-government is impossible without the possession and exercise of these rights.~~

~~Training for effective citizenship has historically been accepted as one of the major goals of the public school system. An instructional program that is developed to achieve this purpose places great emphasis upon teaching about our American heritage: the rights, the privileges, and the responsibilities we enjoy as citizens.~~

~~Freedom to learn is part of the heritage of every American child. It rests upon four essentials:~~

- ~~1. The right to study and discuss significant issues: social, economic, political and philosophical.~~
- ~~2. The right of access to publications or statements that have a bearing on the issue.~~
- ~~3. The right to study and discuss all sides of the issue in an atmosphere free from compulsion with the teacher's point of view clearly identified as such.~~
- ~~4. The right to reach and express an opinion that may be different from that of other members of the class and that of the teacher.~~

~~Freedom to teach is part of the heritage of every American teacher. It rests upon five essential rights of the teacher:~~

- ~~1. To select teaching materials suited to the maturity level of the pupils and conducive to deeper understanding and more critical thinking concerning the questions being explored.~~
- ~~2. To direct the attention of students to significant current questions and to promote the exchange of ideas upon them.~~
- ~~3. To conduct classes in a climate of free speech, critical thinking and independent judgment.~~
- ~~4. To participate in community affairs on the same basis as other citizens.~~

GRAND ISLAND PUBLIC SCHOOLS

- ~~5. To exemplify through behavior with students the essence of wholesome, constructive citizenship in his/her willingness to examine all sides of an issue. In discharging this responsibility, the teacher will assist students in capturing the spirit of academic freedom necessary for survival of a free society.~~

~~Grand Island teachers will be protected from censorship or restraint which unreasonably interferes with their obligation to expose students to controversial issues and to help students express their own views on such issues.~~

Policy Adopted 3-5-84

Policy Reviewed: 4-2-03

Policy Reviewed: ???.???.??

7160 CITIZENSHIP

Being a citizen of the United States, of Nebraska and of the school district community entitles students to special privileges and protections as well as requiring the students to assume civic, economic and social responsibilities and to participate in their country, state and school district community in a manner that entitles them to keep these rights and privileges.

As part of the education program, students shall have an opportunity to learn about their rights, privileges, and responsibilities as citizens of this country, state and school district community. As part of this learning opportunity students shall be instructed in the elements of good citizenship and the role quality citizens play in their country, state and school district community, the value of active participation and the practice of civil discourse. Instruction will also be aimed at developing patriotism, recognizing patriotic holidays and a reverence for the flag, developing an understanding of our nation's history and its constitution, and gaining an understanding of the dangers and fallacies of other forms of government.

Legal Reference: Nebraska Statute 79-724

~~An informed, loyal, just and patriotic citizenry is necessary to a strong, stable, just and prosperous America. Such a citizenry necessitates that every member thereof be fully acquainted with the nation's history, that he/she be in full accord with our form of government, and fully aware of the liberties, opportunities, and advantages of which we are possessed and the sacrifices and struggles of those through whose efforts these benefits were gained. Since youth is the time most susceptible to the acceptance of principles and doctrines that will influence men throughout their lives, it is one of the first duties of our educational system to so conduct activities, choose its textbooks, and arrange its curriculum in such a way that the love of liberty, justice, democracy, and America will be instilled in the heart and mind of the youth of the state.~~

~~Legal Reference: 79-724~~

Policy Adopted 3-5-84

Policy Revised 5-8-03

Policy Revised: ???.???.??

GRAND ISLAND PUBLIC SCHOOLS

7210 SCHOOL CALENDAR

The school calendar shall accommodate the education program of the school district. The school calendar shall accommodate instruction for a minimum of 1,080 hours for students in grades nine through twelve, 1,032 hours for students in grades one through eight, and 400 hours for students in kindergarten. The school calendar shall include, but need not be limited to, days for student instruction, professional learning, school improvement, teacher planning and preparation, vacation days, and parent/teacher conferences.

The academic school year for students including teacher workdays is considered to include a minimum of one-hundred and eighty-seven days in the school calendar.

Special education students may attend school on a school calendar different from that of the regular education program consistent with their Individualized Education Program.

The board, in its discretion, may excuse graduating seniors from up to five days of instruction after the school district requirements for graduation have been met. The board may also excuse graduating seniors from making up days missed due to inclement weather if the student has met the school district's graduation requirements.

It shall be the responsibility of the superintendent or designee to develop the school calendar for recommendation, approval, and adoption by the board annually.

The board may amend the official school calendar when the board considers the change to be in the best interests of the school district's education program.

Legal Reference: Neb. Statute 79-211
 NDE Rule 10.012.01B

~~The school year for elementary grades other than kindergarten shall consist of the time equivalent to at least one thousand thirty-two instructional hours. For secondary students the time equivalent shall be one thousand eighty instructional hours. The minimum time equivalent for kindergarten shall be four hundred instructional hours per year.~~

~~References: — NE. Rev. Stat. 79-101 Title 92, NAC, Chapter 10~~

Policy Adopted: 3/5/84
Policy Revised: 2/5/96
Policy Revised: ???.???.??

Dr. Robin Dexter
Associate Superintendent

December 10, 2016 Board of Education Grant Report

Grants Awarded:

8th Grade Campus Visits – Barr Middle School

This grant funded through EducationQuest Foundation is to support Barr Middle School's 8th Grade Campus Visits.
\$750.00

Field Trip to a Christmas Carol – Barr Middle School

This Nebraska Arts Council grant (\$1000) will fund transportation for students to attend the GISH play *A Christmas Carol*.

Grants in progress:

Nebraska Innovation Grant Program – Personalized Learning to be Career and College Ready

Grant funds (2.5 million) will support teacher's knowledge and skill to increasing the academic and work-based learning competencies of students through creativity, innovation, and engagement activities that capitalizes on authentic transition from education to the workforce so that all students are prepared to successfully function and compete in college and the technological 21st century workforce. (EGT, Mr. Trevino)

Nebraska Innovation Network – Satellite Community Makerspace

GIPS is pursuing strategies to engage educators, communities, business and industry leaders, and students in personally-relevant STEM (Science, Technology, Engineering, Math) based learning that leads to the development of knowledge and skills through technology rich experiences. GIPS supports the opportunity to collaborate with the City of Grand Island Public Library and UNL local extension educator to:

- Promote the Makerspace to entrepreneurs that can work alongside students to create and invent.
- Promote the space and the learning activities.

America's Promise Grant

The America's Promise grant, targets educational programs that lead to careers, which are in demand by area employers, and offers courses tuition free. The America's Promise Job Driven Grant Program relies on leveraging relationships, removing barriers and giving job-driven educational opportunities. GIPS supports CCC in applying for this grant and will promote student participation.

123 South Webb Road • Grand Island, NE 68802-4904
308 385-5900 • Fax 308 385-5949 • rdexter@gips.org • www.gips.org

Every Student, Every Day, a Success

GIPS Barr Middle School Additions and Alterations
Change Order Listing

		Totals	% of Total			
	Original Contract	\$12,073,300	100.75586%			
	Total Change Orders Amount and as a % of Total Spending	(\$90,573)	-0.75586%			
	Grand Total	\$11,982,727	100.00000%			
	CHANGE ORDERS AS A PERCENTAGE OF ORIGINAL CONTRACT		-0.75019%			



AIA[®]

Document G701[™] – 2001

Change Order

PROJECT <i>(Name and address):</i>	CHANGE ORDER NUMBER: 003	OWNER: <input checked="" type="checkbox"/>
ADDITIONS AND ALTERATIONS	DATE: October 19, 2016	ARCHITECT: <input checked="" type="checkbox"/>
BARR MIDDLE SCHOOL		CONTRACTOR: <input checked="" type="checkbox"/>
GRAND ISLAND PUBLIC SCHOOLS		FIELD: <input type="checkbox"/>
GRAND ISLAND, NEBRASKA		OTHER: <input type="checkbox"/>
TO CONTRACTOR <i>(Name and address):</i>	ARCHITECT'S PROJECT NUMBER: 14179	
LACY CONSTRUCTION CO.	CONTRACT DATE: August 14, 2015	
PO BOX 188	CONTRACT FOR: General Construction	
GRAND ISLAND, NE 68802-0188		

THE CONTRACT IS CHANGED AS FOLLOWS:

(Include, where applicable, any undisputed amount attributable to previously executed Construction Change Directives)

Item 1: PR #006: Remove duplex receptacles and replace with quad receptacles.	ADD	\$1,335.00
Item 2: PR #007: Delete (3) LE9 lintels at each level of Stair B-1 and provide lintel for door E147B.	NO CHANGE	
Item 3: PR #009R: Changes to concrete flooring, electrical and door hardware.	ADD	\$24,193.00
Item 4: PR #012: Add new gypsum board bulkhead along north wall of Cafeteria C110.	ADD	\$1,474.00
Item 5: PR #013: Revise entry to Mechanical Room A105.	ADD	\$8,105.00
Item 6: PR #016: Add roof drain in existing roof over Mech. Rm. C111 and provide new gyp. bd. bulkhead along west wall of C110.	ADD	\$2,700.00
Item 7: PR #019: Add concrete, dumpster pad & pipe ballards.	ADD	\$7,670.00
TOTAL ADD THIS CHANGE ORDER		\$45,477.00

The original Contract Sum was	\$	12,073,300.00
The net change by previously authorized Change Orders	\$	(136,050.00)
The Contract Sum prior to this Change Order was	\$	11,937,250.00
The Contract Sum will be increased by this Change Order in the amount of	\$	45,477.00
The new Contract Sum including this Change Order will be	\$	11,982,727.00

The Contract Time will be unchanged by zero (0) days.

The date of Substantial Completion as of the date of this Change Order therefore is unchanged.

NOTE: This Change Order does not include changes in the Contract Sum, Contract Time or Guaranteed Maximum Price which have been authorized by Construction Change Directive until the cost and time have been agreed upon by both the Owner and Contractor, in which case a Change Order is executed to supersede the Construction Change Directive.

NOT VALID UNTIL SIGNED BY THE ARCHITECT, CONTRACTOR AND OWNER.

CANNON MOSS BRYGGER & ASSOC.
ARCHITECT (Firm name)

208 N. PINE ST., SUITE 301
GRAND ISLAND, NE 68801

ADDRESS

BY (Signature)

JAMES R. BRISNEHAN
(Typed name)

10-21-16
DATE

LACY CONSTRUCTION COMPANY
CONTRACTOR (Firm name)

PO BOX 188
GRAND ISLAND, NE 68802-0188

ADDRESS

BY (Signature)

CHRISTOPHER WISSING
(Typed name)

10/24/16
DATE

HALL CO. SCHOOL DISTRICT 2
OWNER (Firm name)

PO BOX 4904
GRAND ISLAND, NE 68802-4904

ADDRESS

BY (Signature)

DAN O. PETSCH
(Typed name)

11/9/16
DATE



Contract Change Proposal

Contractor Proposal Number Six

Project: Barr Middle School Additions & Renovations Date: 8-Mar-16
 Owner: Grand Island Public Schools
 Architect: Cannon Moss Brygger & Architects
 Arch # 14179

Description:

In the rooms with ceiling-mounted projectors, an additional duplex receptacle is required to power the HDMI extenders provided by the Owner. In each room, revise the ceiling-mounted duplex receptacle to a double duplex receptacle (and provide the appropriate wall plate.) Rooms affected are A103, A106, A114, A116, B102, B133, C110, C125, C126, C127, D100, D115, D120, E114, E118, E119, E120, E123, E126, E138, E139, E141, E142, A204, and A205.
 as per attached CMBA's Proposal Request #6 dated 12/21/2015

Pricing Summary:

A. Contractor Cost

Supervision	50.00
Labor	0.00
Material	0.00
Equipment	0.00
Sub-total A.	50.00

B. Subcontractor Cost

Electrical	O'Hara	1,150.00
Sub-total B.		1,150.00
Sub-total, A. + B.		1,200.00
Bond and Insurance		13.20
Sub-total		1,213.20
Contractor O, H & P @10%		121.32

Grand Total, C. P. # Six

\$1,335

This Change affects project completion by 0 calendar days.

Respectfully submitted, Chris Wissing, Project Manager

Proposal



O'Hara Plumbing Co., Inc.
P.O. Box 1038
Grand Island, NE 68802-1038
(308) 382-0765
Fax (308) 382-5166
Email: oharaplumbing@hamilton.net

PROPOSAL SUBMITTED TO LACY CONSTRUCTION		PHONE	DATE 3-9-2016
STREET		JOB NAME BARR MIDDLE SCHOOL	
CITY, STATE, ZIP CODE		JOB LOCATION GRAND ISLAND NE	
ARCHITECT	DATE OF PLANS		JOB PHONE

We hereby submit specifications and estimates for: **CHANGE ORDER #260**

JOB:

Project: Barr Middle School PR #260
Barr Middle School
Change Order Number: CO6796-3

WORK DESCRIPTION: All material and labor to remove the duplex receptacle and and replace with quad receptacles.

OTHER INFORMATION:

MIDDELTON ELECTRIC TOTAL	\$1,095.00
OHARA 5% MARKUP	\$55.00
TOTAL	\$1,150.00

WE PROPOSE hereby to furnish material and labor – complete in accordance with above specifications, for the sum of:

ONE THOUSAND ONE HUNDRED AND FIFTY AND NO 100 Dollars (**\$1,150.00**).

Payment to be made as follows:

All material is guaranteed to be as specified. All work to be completed in a workmanlike manner according to standard practices. Any alteration or deviation from above specifications involving extra costs will be executed only upon written orders, and will become an extra charge over and above the estimate. All agreements contingent upon strikes, accidents or delays beyond our control. Owner to carry fire, tornado and other necessary insurance. Our workers are fully covered by Workman's Compensation Insurance.

Authorized Signature: _____ **BJ OHARA** _____

Note: This proposal may be withdrawn by us if not accepted within 30 days.

ACCEPTANCE OF PROPOSAL – The above prices, specifications and conditions are satisfactory and are hereby accepted. You are authorized to do the work as specified. Payment will be made as outlined above.

Date of Acceptance: _____

Signature: _____

Signature: _____

Middleton Electric Inc.

2716 W. Old Hwy 30
Grand Island, NE 68803
Phone: 308-382-2550
Fax: 308-382-3442

Change Order

3/3/2016

TO:

O'Hara Plumbing
3320 W Old Hwy 30

Grand Island, NE

JOB:

Project: Barr Middle School PR #260
Barr Middle School
Change Order Number: CO6796-3

WORK DESCRIPTION: All material and labor to remove the duplex receptacle and and replace with quad receptacles.

OTHER INFORMATION:

The total amount of this Change Order is: **\$1,095.00**

Sincerely,

MATT TREFFER

Material		
Non-Quoted		\$139.34
Quotes		0.00
Sales Tax (0.00%)		0.00
Total Material		\$139.34
Labor		
Direct (18.11 hours @ \$44.85)		\$812.23
0		0.00
Total Labor		\$812.23
0		\$0.00
0		0.00
0		0.00
Job Subtotal (Prime Cost)		\$951.57
Overhead (0.00%)		0.00
Profit (15.00%)		142.74
Job Total		\$1,094.31
Actual Bid Price		\$1,095.00
Material to Direct Labor ratio: 0.15		
Prime Cost per square foot		\$0.00
Job Total per square foot		\$0.00
Actual Bid Price per square ft		\$0.00
Labor cost per square foot		\$0.00
Labor hours per square foot		0.00
Gross Profit %		13.10
Gross Profit \$		\$143.43
Net Profit %		13.10



Kucirek Engineering, Inc.

7587 Main Street
Omaha, NE 68127
(402) 951-0022

PROPOSAL REQUEST (PR)

PROJECT: Grand Island Public Schools **PROJECT NO.:** 14179 (KEI No. 15001)
Barr Middle School
Grand Island, Nebraska **PR NO.:** 06

OWNER: Grand Island Public Schools **DATE:** December 21, 2015

ARCHITECT: Cannon Moss Brygger
Architects

CONTRACTOR: Lacy Construction Company

These proposal request items are added to and shall become a part of the Construction Documents dated June 12, 2015.

The contractor will be required to furnish or delete, as the case may be, all materials, labor, equipment, and supervision required to properly execute the work described herein.

The contractor and all subcontractors shall incorporate all items noted in the proposal request into the original drawings and specifications for this project.

ELECTRICAL

ITEM E1: Refer to Project Drawings – Sheets E2.01, E2.02, E2.03, E2.04, E2.05, and E2.06

1. In the rooms with ceiling-mounted projectors, an additional duplex receptacle is required to power the HDMI extenders provided by the Owner. In each room, revise the ceiling-mounted duplex receptacle to a double duplex receptacle (and provide the appropriate wall plate). Rooms affected are A103, A106, A114, A116, B102, B133, C110, C125, C126, C127, D100, D115, D120, E114, E118, E119, E120, E123, E126, E138, E139, E141, E142, A204, and A205.



Contract Change Proposal

Contractor Proposal Number Seven

Project: Barr Middle School Additions & Renovations Date: 1-Jun-16
 Owner: Grand Island Public Schools
 Architect: Cannon Moss Brygger & Architects
 Arch # 14179

Description:

Delete (3) LE9 lintels that occur at each level of Stair B-1.
 Provide lintel for door E147B, per attached email from Olsson Associates
 as per attached CMBA's Proposal Request #7 dated 2/9/2016

Pricing Summary:

A. Contractor Cost

Supervision	0.00
Labor	0.00
Material	0.00
Equipment	0.00
Sub-total A.	0.00

B. Subcontractor Cost

Structural Steel	Donner Steel	0.00
	Sub-total B.	0.00
	Sub-total, A. + B.	0.00
	Bond and Insurance	0.00
	Sub-total	0.00
	Contractor O, H & P @10%	0.00

Grand Total, C. P. # Seven

\$0

This Change affects project completion by 0 calender days.

Respectfully submitted, Chris Wissing, Project Manager



CANNON MOSS BRYGGER ARCHITECTS
208 N PINE STREET, SUITE 301 • GRAND ISLAND, NE 68801 • (P) 308.384.4444

REQUEST FOR PROPOSAL (RFP) – No. 7

PROJECT: ADDITIONS AND ALTERATIONS TO BARR MIDDLE SCHOOL

PROJECT #: 14179

DATE: February 9, 2016

TO: Chris Wissing

COMPANY: Lacy Construction Company

FROM: Matthew Bennett

COMPANY: CANNON MOSS BRYGGER ARCHITECTS

Provide a cost breakdown in accordance with the contract documents for the proposed changes to the contract as described below and on any attachments transmitted here within. This is not an authorization to proceed. If approved, the changes will be included in a forthcoming change order.

1. Delete (3) "LE9" lintels, that occur at each level of Stair B-1.
 - a. Per the attached detail, all masonry will be removed from the door opening. (See keynote #10 identifying masonry demolition for door opening at Stair B-1 on A2.02, A2.06, A2.07).
 - b. The bottom and exposed side of the existing concrete floor slab will be painted.
 - c. The painting of the steel lintel (Keynote #12 on A2.18, A2.23, A2.24) is no longer needed.
2. Provide lintel for door E147B, per attached email from Olsson Associates.

Attachments: RFP7.1 Stair B-1 Ceiling Detail, Email from Olsson Associates

CC: Dan Petsch, GIPS; Jim Brisnehan, CMBA; Chris Spilinek, OA

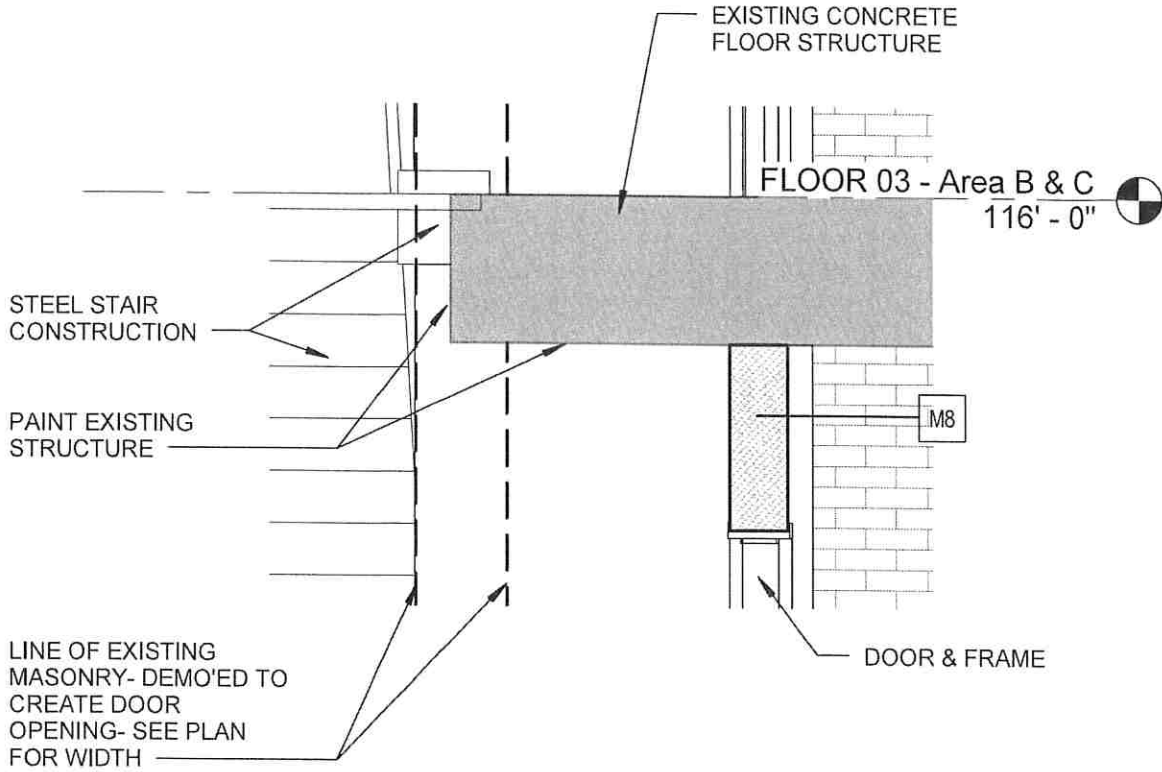

NOTE: OCCURS @ ALL 3 FLOORS OF STAIR B-1

1 CLG. @ STAIR B-1
 1/2" = 1'-0"

© 2016 CMB. Permission to reproduce all or part of this drawing is hereby granted for the limited purpose of construction of this project or showing. Unauthorized copying, storage or reproduction without written permission of Cannon Moss Brygger & Associates is prohibited by copyright law.

ADDITIONS AND ALTERATIONS TO BARR GRAND ISLAND, NEBRASKA 602 W. STOLLEY PARK RD. 68801		 CANNON MOSS BRYGGER ARCHITECTS 208 N PINE STREET, SUITE 301 GRAND ISLAND, NE 68801	CLG. STL. @ STAIR B-1	RFP7.1
PROJECT: 14179	DATE: 2/9/2016			

Matthew Bennett

From: Chris Spilinek <cspilinek@olssonassociates.com>
Sent: Monday, February 08, 2016 8:38 AM
To: Jim Brisnehan; Matthew Bennett
Subject: RE: E147B

Jim & Shannon,

It would be the same as the L2 lintel on the east side of the corridor.

Chris

Chris R. Spilinek, P.E. | Structural/Project Engineer | Olsson Associates
201 East 2nd Street | P.O. Box 1072 | Grand Island, NE 68802
TEL 308.384.8750 | DIR 308.398.2975 | FAX 308.384.8752

From: Jim Brisnehan [<mailto:brisnehan.j@cmbaarchitects.com>]
Sent: Friday, February 05, 2016 2:09 PM
To: Matthew Bennett <bennett.m@cmbaarchitects.com>; Chris Spilinek <cspilinek@olssonassociates.com>
Subject: FW: E147B

Chris please answer this question...does this just work off the misc. lintel schedule?

JIM R. BRISNEHAN AIA
PRINCIPAL ARCHITECT

CANNON MOSS BRYGGER ARCHITECTS
208 N Pine Street, Suite 301
Grand Island, NE 68801
(P) 308.384.4444 ext 2025

WWW.CMBAARCHITECTS.COM



The information contained in this communication may be confidential, and is intended only for the use of the recipient(s) named above. If the reader of this message is not the intended recipient, you are hereby notified that any dissemination, distribution, or copying of this communication, or any of its contents, is strictly prohibited. If you have received this communication in error, please return it to the sender immediately and delete the original message and any copy of it from your computer system.

From: Shannon Walker [<mailto:shannon.walker@lacygc.com>]
Sent: Friday, February 05, 2016 1:51 PM
To: Jim Brisnehan; cspilinek@olssonassociates.com; Chris Wissing; Todd Kleint
Subject: E147B

Jim,

E147B on A5.01 is listed as following type 16 head detail. Head detail 16 on A5.03 shows a CMU wall. We are going to need a lintel at this location. The load bearing beams that Chris corrected at Vestibule 147 do not sit above this door. Please review and supply us with a size and PR for this lintel.

Thanks

Shannon

Lacy Construction

Chris Wissing

From: Jason Alvarez <jalvarez@donnersteelworks.com>
Sent: Wednesday, March 09, 2016 5:47 PM
To: Chris Wissing
Subject: Barr - PR 7

Chris,

We had not additional cost associated with PR 7. The PR deleted lintels, but added a double lintel at E147B. The cost ends up being a wash, so no change for us.

Thanks,

Jason Alvarez
Senior Project Manager
Donner Steel Works
PH: 402-438-0241 ext. 200
FX: 402-438-0214

DONNER
STEEL WORKS



Contract Change Proposal

Contractor Proposal Number Nine (Revised)

Project: Barr Middle School Additions & Renovations Date: 2-Aug-16
 Owner: Grand Island Public Schools
 Architect: Cannon Moss Brygger & Architects
 Arch # 14179

Description:

Make all changes to concrete flooring, electrical, and door hardware as per attached CMBA's Proposal Request #9 dated 4/7/2016 (Barrier One not figured in this exposed concrete floor)

Pricing Summary:

A. Contractor Cost

Supervision		50.00
Labor		1,004.00
Material		650.00
Equipment		50.00
	Sub-total A.	<u>1,754.00</u>

B. Subcontractor Cost

Door Hardware	Johnson HW	2,714.00
Electrical	O'Hara	17,286.00
	Sub-total B.	<u>20,000.00</u>

	Sub-total, A. + B.	<u>21,754.00</u>
	Bond and Insurance	239.29
	Sub-total	<u>21,993.29</u>
	Contractor O, H & P @10%	2,199.33

Grand Total, C. P. # Nine (Revised)

\$24,193

This Change affects project completion by 0 calender days.

Respectfully submitted, Chris Wissing, Project Manager



CANNON MOSS BRYGGER ARCHITECTS
 208 N PINE STREET, SUITE 301 • GRAND ISLAND, NE 68801 • (P) 308.384.4444

REQUEST FOR PROPOSAL (RFP) – NO. 9

PROJECT: ADDITIONS AND ALTERATIONS TO BARR MIDDLE SCHOOL

PROJECT #: 14179

DATE: April 7, 2016

TO: Chris Wissing

COMPANY: Lacy Construction Company

FROM: Matthew Bennett

COMPANY: CANNON MOSS BRYGGER ARCHITECTS

Provide a cost breakdown in accordance with the contract documents for the proposed changes to the contract as described below and on any attachments transmitted here within. This is not an authorization to proceed. If approved, the changes will be included in a forthcoming change order.

Per RFI #9:

1. The service entrance conductors and conduits do not enter the main disconnect underground as depicted on the drawings. Instead they enter into an adjacent section that is being removed as a part of the demolition phase of the project. In order to serve the new electrical gear, the existing feeders will need to be extended. Provide pricing for all necessary concrete removal, installation of in-ground box with cover, splicing of existing feeders with new conductors, installation of additional conduits, replacement of concrete, etc. Along with the proposal, please provide submittals for the in-ground box and splicing materials.
2. In order to protect the new electrical gear from existing piping routed overhead, provide pricing to install a sheet metal gutter underneath the piping in question. The gutter shall be 1'-0" wider than piping in both directions, and shall extend 1'-0" past the edge of the electrical gear. The gutter shall have a 2" lip at the edge to prevent spillage. Route drain from gutter to nearest floor drain. *Pipes were removed. Not Required*
3. Per discussion at the site, the existing door between Boiler Room D105 and Mechanical Room E148 should be removed. In addition to the new hardware already specified for Door E148A, the following hardware should be added to the door:

1 EA RIM EXIT 99NL X 990NLR 26D RHR ACTIVE LEAF	VON DUPRIN
1 EA RIM EXIT 99EO 26D LHR INACTIVE LEAF	VON DUPRIN
1 EA REM MULLION KR4954-STAB-MT54 X 689	VON DUPRIN
1 EA MORTISE CYL 26-091 36-079 025 626	SCHLAGE
1 EA RIM CYLINDER 20-057 X 36-079 037 626	SCHLAGE

The existing lock and flushbolts will need to be removed from the door, and the door reworked to accept the new hardware.

FAX

Date April 20, 2016

Number of pages including cover sheet 1

TO: LACY CONST CO
ATTN: CHRIS WISSING

RE: PR #9 BARR SCHOOL CHANGE ORDER
REPLACE HDWE PR DRS # E148A

Phone:

Fax:

FROM: John A. Spencer, AHC
Johnson Hardware co.
2705 W Hwy 30, Ste # 3
Grand Island, Ne 68803

Phone 308-381-4366

Cell 402-461-7869

Fax 308-381-4365

CC:

(E-MAIL)JSPENCER
@JHCOMAHA.COM

REMARKS: Urgent For your review Reply ASAP Please Comment

WE ARE PLEASED TO QUOTE YOU ON THE FOLLOWING:

1 EA 99NL EXIT DEVICE
1 EA 99EO EXIT DEVICE
1 EA KR4954 STAB MT54 KEY REM MULLION
1 EA 26-092 MORTISE CYL
1 EA 20-057 RIM CYL

ALL FOR SUM OF \$ 2,714.00 FOB TRUCKS, JOBSITE + TAX

EXCLUDE SALES AND USE TAX: INSTALLATION.

THANKS

JOHN

Proposal



O'Hara Plumbing Co., Inc.
 P.O. Box 1038
 Grand Island, NE 68802-1038
 (308) 382-0765
 Fax (308) 382-5166
 Email: oharaplumbing@hamilton.net

PROPOSAL SUBMITTED TO LACY CONSTRUCTION		PHONE	DATE 6/21/2016
STREET		JOB NAME BARR MIDDLE SCHOOL	
CITY, STATE, ZIP CODE		JOB LOCATION GRAND ISLAND NEBRASKA	
ARCHITECT	DATE OF PLANS		JOB PHONE

We hereby submit specifications and estimates for: **RFP #9**

JOB:

Project: T-M Pricing for service changes
 Barr Middle School
 Change Order Number: CO6796-7

WORK DESCRIPTION: All Time and Material to relocate the incoming service conduits and cables from thier existing location to the main breaker compartment of the new switchgear

OTHER INFORMATION: Concrete cutting and patching by others

The total amount of this Change Order is: **\$16,462.00**

~~6' x 3' 24 gauge drip pan 2" tall with 3/4" gal nipple~~

MATERIAL	\$250.00
LABOR	\$450.00
TOTAL	\$700.00

OHARA CONDENSATION DRAIN	\$125.00
LABOR	\$130.00
TOTAL	\$255.00

MIDDELTON TOTAL	\$16,462.00
JERRYS SHEETMETAL	\$700.00
OHARA MARK UP	\$859.00 <i>824</i>
TOTAL	\$18,021.00

17,286.00

CONDENSATION ~~-\$255.00-~~
TOTAL \$18,276.00

\$17,286.00

WE PROPOSE hereby to furnish material and labor – complete in accordance with above specifications, for the sum of:

~~EIGHTEEN THOUSAND TWO HUNDRED SEVENTY SIX AND NO 100~~ Dollars (~~\$18,276.00~~). **\$17,286**

Payment to be made as follows:

All material is guaranteed to be as specified. All work to be completed in a workmanlike manner according to standard practices. Any alteration or deviation from above specifications involving extra costs will be executed only upon written orders, and will become an extra charge over and above the estimate. All agreements contingent upon strikes, accidents or delays beyond our control. Owner to carry fire, tornado and other necessary insurance. Our workers are fully covered by Workman’s Compensation Insurance.

Authorized Signature: BJ OHARA

Note: This proposal may be withdrawn by us if not accepted within 30 days.

ACCEPTANCE OF PROPOSAL – The above prices, specifications and conditions are satisfactory and are hereby accepted. You are authorized to do the work as specified. Payment will be made as outlined above.

Date of Acceptance: _____

Signature: _____

Signature: _____

Middleton Electric Inc.

2716 W. Old Hwy 30
Grand Island, NE 68803
Phone: 308-382-2550
Fax: 308-382-3442

Change Order

6/14/2016

TO:

O'Hara Plumbing
3320 W Old Hwy 30

Grand Island, NE

JOB:

Project: T-M Pricing for service changes
Barr Middle School
Change Order Number: CO6796-7

WORK DESCRIPTION: All Time and Material to relocate the incoming service conduits and cables from their existing location to the main breaker compartment of the new switchgear

OTHER INFORMATION: Concrete cutting and patching by others

The total amount of this Change Order is: **\$16,462.00**

Sincerely,

MATT TREFFER

Middleton Electric Inc
 Bar Middle School : T-M Pricing for service changes
 Totals (Summary) - Bid Summary: Default

Material	
Non-Quoted	
Quotes	\$9,523.64
Sales Tax (0.00%)	1,630.00
Total Material	0.00
Labor	\$11,153.64
Direct (85.00 hours @ \$44.85)	
0	\$3,812.25
Total Labor	0.00
0	\$3,812.25
0	\$0.00
0	0.00
0	0.00
Job Subtotal (Prime Cost)	\$14,965.89
Overhead (0.00%)	0.00
Profit (10.00%)	1,496.59
Job Total	\$16,462.48
Actual Bid Price	\$16,462.00
Material to Direct Labor ratio: 0.75	
Prime Cost per square foot	\$0.00
Job Total per square foot	\$0.00
Actual Bid Price per square ft	\$0.00
Labor cost per square foot	\$0.00
Labor hours per square foot	0.00
Gross Profit %	9.09
Gross Profit \$	\$1,496.11
Net Profit %	9.09

IT SERIES 

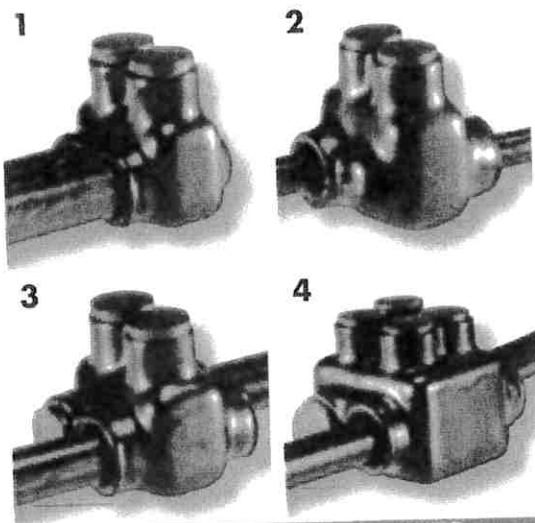

Insul-Tap connectors are suitable for connecting two wires. For sizes 3/0 AWG and smaller, they are available in two styles - with wires being connected from the same side of the connector (Figure 1) or opposite sides of the connector (Figure 2).

For sizes 250 MCM and larger, they are provided with open wire entry ports on both sides of the connector (Figure 3), which allows for access from either side. This style is supplied with removable access plugs to close the entry port not being utilized.

Abrasion and chemical resistant. UV rated. Will not support combustion. Cold temperature rated to -45°C. Dual rated for use with copper and/or aluminum cables. 600 volts. 90°C. To receive the material in bags, add "-B" to the catalog number.

Not recommended for fine-stranded, flexible wire. See Polaris Grey™ Series page 88.

CATALOG NO.	UPC CODE	FIGURE	WIRE RANGE	(INCHES)			HEX SIZE	CARTON QTY.	WEIGHT LBS. EA
				LENGTH	HEIGHT	WIDTH			
IT-4	95001	1	4-14	1.07	1.50	1.12	slotted	12	.06
ITO-4	95002	2	4-14	1.07	1.50	1.25	slotted	12	.06
IT4-A	95021	1	4-14	1.07	1.5	1.12	1/8	12	.06
IT4-S	95000	not pictured	4-14	0.7	1.5	1.12	slotted	12	.03
IT-1/0	95003	1	1/0-14	1.62	1.75	1.62	3/16	6	.13
ITO-1/0	95004	2	1/0-14	1.62	1.75	1.75	3/16	6	.13
IT-3/0	95005	1	3/0-6	1.84	1.87	1.75	1/4	6	.19
ITO-3/0	95006	2	3/0-6	1.84	1.87	1.87	1/4	6	.19
IT04-A	78924	2	4-14	1.07	1.5	1.25	1/8	12	.06
IT-250	95007	3	250-6	2.12	2.13	2.31	5/16	6	.24
IT-350	95008	3	350-6	2.47	2.44	2.50	5/16	4	.39
IT-500	95009	3	500-4	2.87	2.94	2.81	5/16	4	.53
IT-600††	78944	3	600-6	3.24	3.05	2.94	5/16	4	.80
IT-750*	95010	3	750-250	3.48	3.50	3.50	3/8	2	.94
ITH-750	92640	4	750-250	3.48	3.50	4.50	5/16	2	1.75

†† 600 Series are AL7CU and 75°C *Not UL Listed

ISR SERIES 

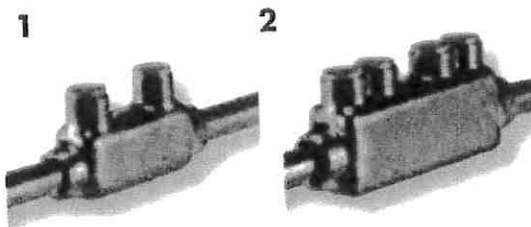

ISR Series connectors are suitable for connecting two wires in-line. Insulated with high dielectric strength plastisol and molded for precise fit. Supplied with removable access plugs over the hex screw.

Abrasion and chemical resistant. UV rated. Will not support combustion. Cold temperature rated to -45°C. Dual rated for use with copper and/or aluminum cables. 600 volts. 90°C. Not recommended for use with extra-flexible cables. See Polaris Grey™ Series page 88.

UPC NO.	UPC. NO	FIGURE	WIRE RANGE	(INCHES)			HEX SIZE	CARTON QTY.	WEIGHT LBS. EA
				LENGTH	HEIGHT	WIDTH			
ISR-1/0	95101	1	1/0-14	3.25	1.48	.90	3/16	4	.15
ISR-250	95102	1	250-6	4.00	1.90	1.19	5/16	4	.34
ISR-350	95103	1	350-6	4.47	2.20	1.32	5/16	2	.51
ISR-500	95104	1	500-4	4.62	3.00	1.62	5/16	2	.72
ISR-600††	78945	1	600-6	5.83	3.05	1.57	5/16	2	1.0
ISRH-750	92645	2	750-250	7.25	3.25	1.75	5/16	2	1.85

†† 600 Series are AL7CU and 75°C

48" x 48" VAULT ASSEMBLY

36" & 48" DEPTHS



POLYMER CONCRETE **ARMORCAST PRODUCTS COMPANY**

A6001433



LISTED
FILE #E364252

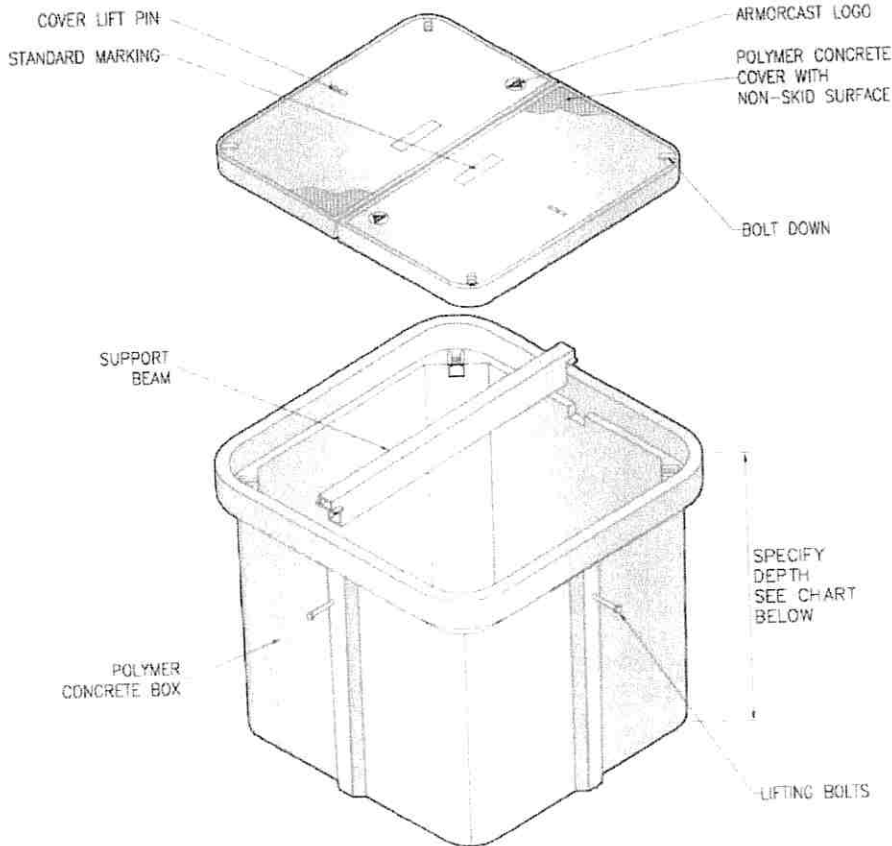

POLYMER CONCRETE VAULTS & MANHOLES

48"W x 48"L VAULT ASSEMBLIES Specify Depth Below

DESCRIPTION	NOMINAL SIZE W x L x D	LOAD RATING	ANSI TIER	PART NUMBER	APPROX. WEIGHT	PALLET QTY.
Vault & Cover Assembly	48" x 48" x 36"	10K	8	A6001433APCX36	740 lbs.	1
	48" x 48" x 36"	20K	15 / 22	A6001433TAPCX36 / A6001433HDAPCX36	740 lbs.	1
Vault & Cover Assembly	48" x 48" x 48"	10K	8	A6001433APCX48	855 lbs.	1
	48" x 48" x 48"	20K	15 / 22	A6001433TAPCX48 / A6001433HDAPCX48	855 lbs.	1

COMPONENTS

DESCRIPTION	NOMINAL SIZE W x L x D	LOAD RATING	ANSI TIER	PART NUMBER	APPROX. WEIGHT	PALLET QTY.
Replacement Covers	48" x 48" 2 pc.	10K	8	A6001434	163 lbs.	20
	48" x 48" 2 pc.	20K	15 / 22	A6001434T / A6001434HD	163 lbs.	20
Replacement Boxes	48" x 48" x 36"	10K / 20K	22	A6001433PCX36	415 lbs.	1
	48" x 48" x 48"	10K / 20K	22	A6001433PCX48	525 lbs.	1
Extension	48" x 48" x 6"	10K / 20K	222	A6001433PCX6	180 lbs.	5
Extension	48" x 48" x 9"	10K / 20K	222	A6001433PCX12	300 lbs.	5

- Vaults are Open Bottom, also available with Split Base or Solid Bottoms.
- For sizes not shown please contact Armorcast Products for more information.

THIS PRODUCT IS LISTED TO APPLICABLE UL STANDARDS AND REQUIREMENTS BY UL.

www.armorcastprod.com

Tel: (818) 982-3600 Fax: (818) 982-7742



ARMORCAST PRODUCTS COMPANY

48" x 48" VAULT ASSEMBLY STANDARD DIMENSIONS

POLYMER CONCRETE

A6001433



LISTED

FILE #E364252

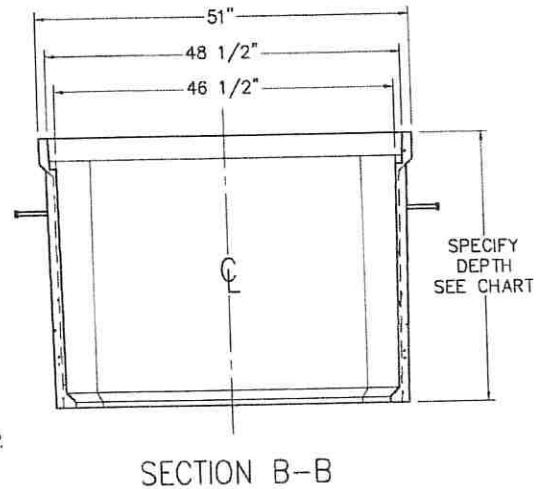
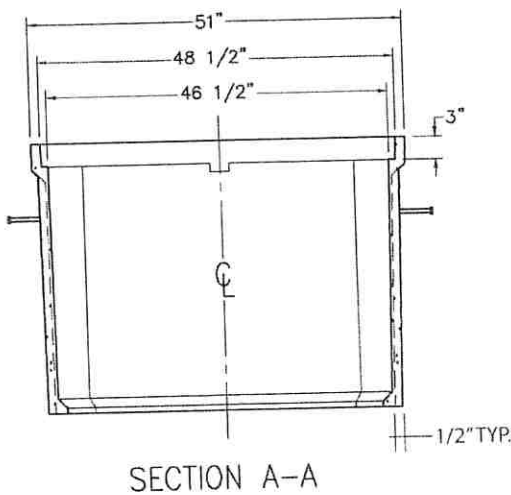
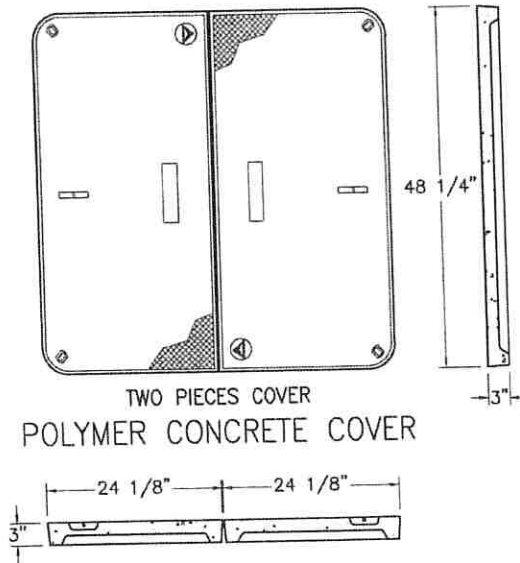
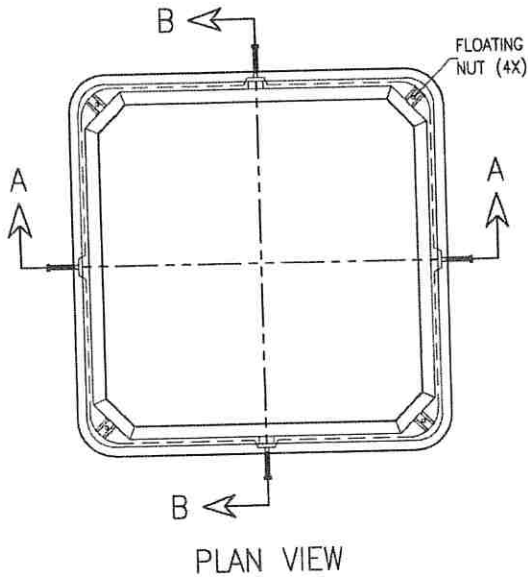

POLYMER CONCRETE
VAULTS & MANHOLE

Armorcast Products Company reserves the right to update or discontinue product information at any time without notice.

THIS PRODUCT IS LISTED TO APPLICABLE UL STANDARDS AND REQUIREMENTS BY UL.

www.armorcastprod.com

Tel: (818) 982-3600 Fax: (818) 982-7742



Contract Change Proposal

Contractor Proposal Number Twelve

Project: Barr Middle School Additions & Renovations Date: 21-Jun-16
 Owner: Grand Island Public Schools
 Architect: Cannon Moss Brygger & Architects
 Arch # 14179

Description:

Add a new gypsum board bulkhead as shown on the attached drawing, along the North wall of Cafeteria C110. Coordinate the width of the bulkhead with the width required for the ductwork and hydronic piping to be concealed. The bottom of the bulkhead is to be a minimum of 4" below the bulkhead currently shown on the west wall of this space. As shown, the bulkhead is to extend to the west wall of C110 and is to overlap the curved bulkhead at the east side of the space. The gypsum board is to be finished per the Specifications, and painted PT-6. Coordinate the routing of all ductwork, hydronic piping, conduit, sprinkler lines, etc., that may be in this area and below the acoustic ceiling, to run within this bulkhead. as per CMBA's Request for Proposal #12, dated June 9, 2016

Pricing Summary:

A. Contractor Cost

Supervision		50.00
	Sub-total A.	50.00

B. Subcontractor Cost

Drywall	Essink	1,275.00
Painting	GSC	0.00
	Sub-total B.	1,275.00

	Sub-total, A. + B.	1,325.00
	Bond and Insurance	14.58
	Sub-total	1,339.58
	Contractor O, H & P @10%	133.96

Grand Total, C. P. # Twelve

\$1,474

This Change affects project completion by 0 calender days.

Respectfully submitted, Chris Wissing, Project Manager



CANNON MOSS BRYGGER ARCHITECTS
208 N PINE STREET, SUITE 301 • GRAND ISLAND, NE 68801 • (P) 308.384.4444

REQUEST FOR PROPOSAL (RFP) – NO. 12

PROJECT: ADDITIONS AND ALTERATIONS TO BARR MIDDLE SCHOOL

PROJECT #: 14179

DATE: June 9, 2016

TO: Chris Wissing

COMPANY: Lacy Construction Company

FROM: Matthew Bennett

COMPANY: CANNON MOSS BRYGGER ARCHITECTS

Provide a cost breakdown in accordance with the contract documents for the proposed changes to the contract as described below and on any attachments transmitted here within. This is not an authorization to proceed. If approved, the changes will be included in a forthcoming change order.

1. Add a new gypsum board bulkhead as shown on the attached drawing, along the north wall of Cafeteria C110. Coordinate the width of the bulkhead with the width required for the ductwork and hydronic piping to be concealed. The bottom of the bulkhead is to be a minimum of 4" below the bulkhead currently shown on the west wall of this space. As shown, the bulkhead is to extend to the west wall of C110 and is to overlap the curved bulkhead at the east side of this space.
2. The gypsum board is to be finished per the Specifications, and painted PT-6.
3. Coordinate the routing of all ductwork, hydronic piping, conduit, sprinkler lines, etc., that may be in this area and below the acoustic ceiling, to run within this bulkhead.



DATE: 06-12-15
PROJECT: 14179

REFLECTED CEILING PLAN - FIRST FLOOR - AREA C

ADDITIONS AND ALTERATIONS TO BARR MIDDLE SCHOOL
GRAND ISLAND, NEBRASKA
602 W. STOLLEY PARK RD. 68801

SHEET
A2.19

GENERAL NOTES

- 1. REFER TO THE GENERAL NOTES FOR THE REFLECTED CEILING PLAN FOR THE FIRST FLOOR FOR THE REFLECTED CEILING PLAN.
- 2. REFER TO THE GENERAL NOTES FOR THE REFLECTED CEILING PLAN FOR THE FIRST FLOOR FOR THE REFLECTED CEILING PLAN.
- 3. REFER TO THE GENERAL NOTES FOR THE REFLECTED CEILING PLAN FOR THE FIRST FLOOR FOR THE REFLECTED CEILING PLAN.

KEYNOTES

- 1. REFER TO THE GENERAL NOTES FOR THE REFLECTED CEILING PLAN FOR THE FIRST FLOOR FOR THE REFLECTED CEILING PLAN.
- 2. REFER TO THE GENERAL NOTES FOR THE REFLECTED CEILING PLAN FOR THE FIRST FLOOR FOR THE REFLECTED CEILING PLAN.
- 3. REFER TO THE GENERAL NOTES FOR THE REFLECTED CEILING PLAN FOR THE FIRST FLOOR FOR THE REFLECTED CEILING PLAN.
- 4. REFER TO THE GENERAL NOTES FOR THE REFLECTED CEILING PLAN FOR THE FIRST FLOOR FOR THE REFLECTED CEILING PLAN.
- 5. REFER TO THE GENERAL NOTES FOR THE REFLECTED CEILING PLAN FOR THE FIRST FLOOR FOR THE REFLECTED CEILING PLAN.
- 6. REFER TO THE GENERAL NOTES FOR THE REFLECTED CEILING PLAN FOR THE FIRST FLOOR FOR THE REFLECTED CEILING PLAN.
- 7. REFER TO THE GENERAL NOTES FOR THE REFLECTED CEILING PLAN FOR THE FIRST FLOOR FOR THE REFLECTED CEILING PLAN.
- 8. REFER TO THE GENERAL NOTES FOR THE REFLECTED CEILING PLAN FOR THE FIRST FLOOR FOR THE REFLECTED CEILING PLAN.
- 9. REFER TO THE GENERAL NOTES FOR THE REFLECTED CEILING PLAN FOR THE FIRST FLOOR FOR THE REFLECTED CEILING PLAN.
- 10. REFER TO THE GENERAL NOTES FOR THE REFLECTED CEILING PLAN FOR THE FIRST FLOOR FOR THE REFLECTED CEILING PLAN.
- 11. REFER TO THE GENERAL NOTES FOR THE REFLECTED CEILING PLAN FOR THE FIRST FLOOR FOR THE REFLECTED CEILING PLAN.
- 12. REFER TO THE GENERAL NOTES FOR THE REFLECTED CEILING PLAN FOR THE FIRST FLOOR FOR THE REFLECTED CEILING PLAN.
- 13. REFER TO THE GENERAL NOTES FOR THE REFLECTED CEILING PLAN FOR THE FIRST FLOOR FOR THE REFLECTED CEILING PLAN.
- 14. REFER TO THE GENERAL NOTES FOR THE REFLECTED CEILING PLAN FOR THE FIRST FLOOR FOR THE REFLECTED CEILING PLAN.
- 15. REFER TO THE GENERAL NOTES FOR THE REFLECTED CEILING PLAN FOR THE FIRST FLOOR FOR THE REFLECTED CEILING PLAN.
- 16. REFER TO THE GENERAL NOTES FOR THE REFLECTED CEILING PLAN FOR THE FIRST FLOOR FOR THE REFLECTED CEILING PLAN.
- 17. REFER TO THE GENERAL NOTES FOR THE REFLECTED CEILING PLAN FOR THE FIRST FLOOR FOR THE REFLECTED CEILING PLAN.
- 18. REFER TO THE GENERAL NOTES FOR THE REFLECTED CEILING PLAN FOR THE FIRST FLOOR FOR THE REFLECTED CEILING PLAN.
- 19. REFER TO THE GENERAL NOTES FOR THE REFLECTED CEILING PLAN FOR THE FIRST FLOOR FOR THE REFLECTED CEILING PLAN.
- 20. REFER TO THE GENERAL NOTES FOR THE REFLECTED CEILING PLAN FOR THE FIRST FLOOR FOR THE REFLECTED CEILING PLAN.

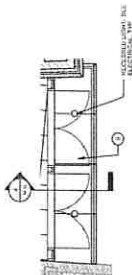

2 AREA C - SOFFIT DETAIL

KEY PLAN



PROFESSIONAL SEAL

REVISIONS

NO.	DATE	DESCRIPTION

1 FLOOR D1 - AREA C REFLECTED CEILING PLAN

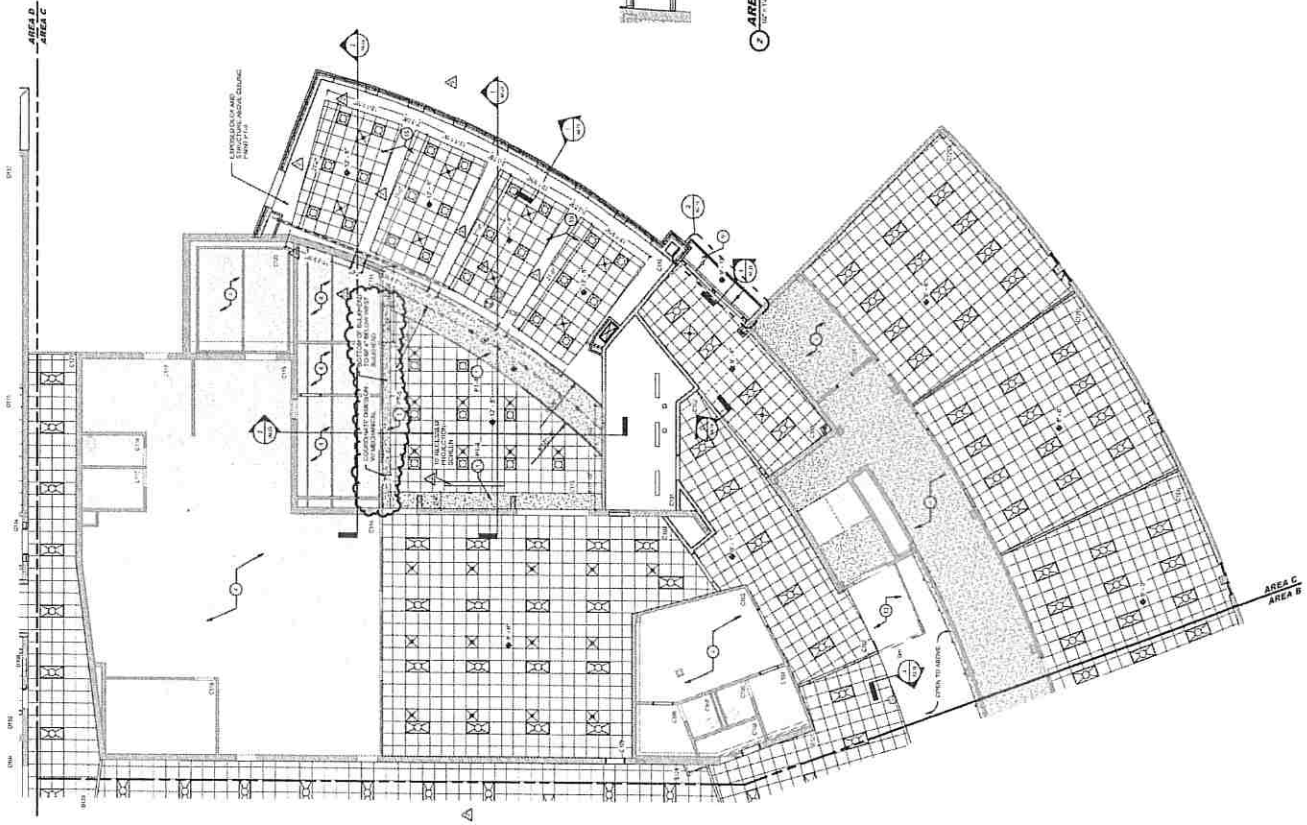

BASE AND REFLECTED CEILING LIGHTS OF FIBERS IN ROOM 1119 ARE SHOWN PERMANENTLY. THESE LIGHTS ARE REQUIRED TO REMAIN. MODIFY AND REQUIRED TO ACCORDANCE WITH CONSTRUCTION IS GOOD PRACTICE OF ROOM.



1706 S. Holland Dr.
Grand Island, NE 68803
Phone: 308-384-8617
Fax: 308-384-8620
rob@essink.biz

CHANGE ORDER

Number: Two

Date: 6-10-16

Submitted to:

Lacy Construction Co.
Attn: Chris Wissing
P.O. Box 188
Grand Island, NE 68802-0188
384-2866

Project:

Barr Middle School
Grand Island, NE

Job No.

Date of Existing Contract:

9-29-15

Per PR11

Provide material and labor to install 5/8" abuse resistant drywall at wall between kitchen and mechanical room.

ADD THE SUM OF: \$740.00

Per PR12

Provide material and labor to install bulkhead across north end of cafeteria with 3 5/8" metal studs and 5/8" abuse resistant drywall.

ADD THE SUM OF: \$1,275.00

TOTAL ADD: \$2,015.00

We agree hereby to make the change(s) specified above at this price:	\$ 2,015.00
PREVIOUS CONTRACT AMOUNT:	\$176,440.00
REVISED CONTRACT AMOUNT:	\$178,455.00

DATE:

June 10, 2016



Rob Supencheck – Vice President

Date of acceptance _____

Signature _____
(CONTRACTOR/OWNER)



Contract Change Proposal

Contractor Proposal Number Thirteen

Project: Barr Middle School Additions & Renovations Date: 2-Aug-16
 Owner: Grand Island Public Schools
 Architect: Cannon Moss Brygger & Architects
 Arch # 14179

Description:

Revise entry to Mechanical Room A105
 as per CMBA's Request for Proposal #13, dated July 8, 2016

Pricing Summary:

A. Contractor Cost

Supervision	50.00
Labor	335.00
Material	281.00
Equipment	0.00
Sub-total A.	666.00

B. Subcontractor Cost

Masonry	Summit	3,105.00
Structural steel	Donner	288.00
Door & Hardware	Johnson HW	2,339.00
Floor Coverings	Floors Inc.	551.00
Acoustic Ceilings	T-C Ceilings	100.00
Painting	GSC	239.00
Sub-total B.		6,622.00

Sub-total, A. + B.	7,288.00
Bond and Insurance	80.17
Sub-total	7,368.17
Contractor O, H & P @10%	736.82

Grand Total, C. P. # Thirteen

\$8,105

This Change affects project completion by 0 calender days.

Respectfully submitted, Chris Wissing, Project Manager

Lag Breakdown

	M	L	S
Remove 1 door Frame	20	50	
Clean up Exist Jamb	30	50	
Set 1 hollow Metal Door FM	10	60	
Grout Frame	35	50	
Add labor for panic Device		25	
Fits Stopping at top of wall 17'4"	30	30	
<hr/>			
Rebar for Masonry	100	20	
Drill 8 rebar holes	16	24	
Epoxy 8 holes	40	16	
Layout		10	
	281	335	

TELEPHONE BID

LACY CONSTRUCTION CO.
715 SOUTH CLARK
GRAND ISLAND, NE.

DATE: 8/2/16

PROJECT: Barr Middle School

FIRM: Summit Masonry

BID GIVEN BY: Jim PHONE: _____

DESCRIPTION AMOUNT

Masonry for PR# 13 Revised

234 block \$ 1.50 \$ 351

42 Sacs Grout 5.50 \$ 231

25 Sacs Mortar 5.50 \$ 137.50

15 pc. Wire 3.00 \$ 45

Labor @ \$ 10 /block \$ 2340.00

\$ 3,104.50

Quote \$ 3,105.00

ADDENDUMS: _____

TIME: _____

DONNER

STEEL WORKS

3900 Industrial Avenue
Lincoln, NE 68504

Change Proposal Request

Phone #	(402)438-0241
Fax #	(402)438-0214

Date	Quote #
7/14/2016	1722

Name / Address
Lacy Construction 3356 Old Hwy 30 P.O. Box 188 Grand Island, NE 68802



Quote by:	Project
	533-15 Barr

Description	Total
PR #13 Supply 'LL' Lintel at New Door A105A --L4x3 1/2x1/4 (2 at opening) Material Labor Shipping Sales Tax	 73.00T 65.00T 150.00T 0.00
Total	\$288.00

FAX

Date July 15, 2016

Number of pages including cover sheet 1

TO: LACY CONST CO
ATTN: CHRIS WISSING

RE: GIPS BARR FRP # 13/ PR # 13A

Phone:

Fax:

FROM: John A. Spencer, AHC
Johnson Hardware co.
2705 W Hwy 30, Ste # 3
Grand Island, Ne 68803

Phone 308-381-4366

Cell 402-461-7869

Fax 308-381-4365

CC:

(E-MAIL)JSPENCER
@JHCOMAHA.COM

REMARKS: Urgent For your review Reply ASAP Please Comment

WE ARE PLEASED TO QUOTE YOU ON THE FOLLOWING:

MAKE CHANGES TO DOOR OPENING # 105A

1 EA NEW HM FRAME 4070 X 8 ¾ JD \$376.00

1 EA NEW WOOD 45 MIN 4070 FLUSH DR \$739.00

1 EA VON DUPRIN FIRE RATED RIM EXIT W/ LEVER TRIM \$1,139.00

1 EA SCHLAGE REC CORE CYLW/BLOCK RING \$85.00

TOTAL REQUESTED CO \$2,339.00

FOB TRUCKS, JOBSITE

**NOTE PER MY PHONE CONVERSATION WITH MATT BENNETT WILL NEED NEW WOOD DOOR CAN NOT REWORK OR MAKE LARGE CUTOUT IN FIELD FOR EXIT DEVICE PREP IN WOOD DOOR.

EXCLUDE SALES AND USE TAX: INSTALLATION.

THANKS

JOHN



VISION | EXPERTISE | RESULTS

CHANGE ORDER REQUEST

July 18, 2016

PROJECT: BARR MIDDLE SCHOOL
CONTRACTOR: LACY CONSTRUCTION
CONTACT: CHRIS WISSING

Listed below is the cost to provide and install RF-1, RF-4, and RB-1 to the new door alcove at Corridor A107 per RFP #13.

Materials:	\$402.00
Labor:	\$99.00
O/P 10%	\$50.00
Total: ADD (+)	\$551.00

Acceptance

Date

Printed Name

P.O. #

Sincerely,

Brent Kunz

T-C Ceilings, Inc.
3236 Bachman St. PO Box 879
Grand Island, NE 68802

(308) 389-4954 Office
(308) 384-3998 Fax

July 15, 2016

Lacy Construction
Grand Island, NE

Attn: Estimator

RE: Barr Middle School Additions and Alterations
Grand Island, NE

ACOUSTICAL CEILINGS

Request for Proposal #13 Revised

ADD \$100.00

Add this amount to provide and install additional ceilings in the Alcove as shown on the RFP#13R documents.

Please call if any questions.

Scot Fletcher
sfletcher@tcceilings.com

All quotes not signed & returned within 45 days of quote will have to be re-quoted. Acceptance of quotes- the above prices & conditions are satisfactory and are hereby accepted.

Date of acceptance

Signature

TELEPHONE BID

LACY CONSTRUCTION CO.
715 SOUTH CLARK
GRAND ISLAND, NE.

DATE: _____

PROJECT: Bass Middle School

FIRM: GSC Unlimited

BID GIVEN BY: _____ PHONE: _____

DESCRIPTION AMOUNT

Paint for PR # 13 revised.

$18'-8" \times 12'-0" = 224 \text{ Sq Ft}$

$16'-0" \times 10'-0" = 160 \text{ Sq Ft}$

$384 \text{ Sq Ft} \times .70 = \$ 269$ Walls

~~$5' \times 6'-0"$~~

$5'-8" \times 7'-4" = 42 \text{ Sq Ft} \times .70 = (\$ 30)$ Ceiling

$\$ 239.00$

ADDENDUMS: _____

TIME: _____



CANNON MOSS BRYGGER ARCHITECTS
208 N PINE STREET, SUITE 301 • GRAND ISLAND, NE 68801 • (P) 308.384.4444

REQUEST FOR PROPOSAL (RFP) – NO. 13 REVISED

PROJECT: ADDITIONS AND ALTERATIONS TO BARR MIDDLE SCHOOL

PROJECT #: 14179

DATE: July 1, 2016 (Revised 7/8/16)

TO: Chris Wissing

COMPANY: Lacy Construction Company

FROM: Matthew Bennett

COMPANY: CANNON MOSS BRYGGER ARCHITECTS

Provide a cost breakdown in accordance with the contract documents for the proposed changes to the contract as described below and on any attachments transmitted here within. This is not an authorization to proceed. If approved, the changes will be included in a forthcoming change order.

The work described in this RFP is in response to the email from Shannon Walker, dated June 30, 2016, regarding the comments from the Electrical Inspector.

1. Per revised sheet A2.08 (attached), existing door opening at the south wall of Mechanical Room A105, will remain as is. The hollow metal frame is to be removed, and the wall patched as required.
2. Provide new 8" CMU wall construction as shown on revised drawing. New wall construction is to have a 1-Hour fire-resistance rating. Install new door frame into new opening. Rework door as required for new hardware configuration. New CMU to be finished and painted the same as the adjacent wall, as identified on the Room Finish Schedule. Provide resilient base on both sides of new walls to match adjoining rooms.
3. Provide panic hardware for door A105A. Remaining hardware items already provided, to be reused.
4. Extend floor finish of Corridor A107 into new door alcove.
5. Provide APC-1 in new alcove at 9'-6" AFF.

Attachments: Revised Sheet A2.08, dated July 8, 2016.

END OF RFP #13.



DATE: 06-13-15
PROJECT: 14175

AREA A' - FIRST FLOOR PLAN

ADDITIONS AND ALTERATIONS TO BARR MIDDLE SCHOOL
GRAND ISLAND, NEBRASKA
802 W. STOLLEY PARK RD. 68801

PROJECT A2.08

GENERAL NOTES

- A UNLESS OTHERWISE SPECIFIED, ALL MATERIALS SHALL BE AS SHOWN ON THE DRAWING.
- B ALL WORK SHALL BE ACCORDING TO THE LATEST EDITIONS OF THE NATIONAL ELECTRICAL CODE AND THE NATIONAL MECHANICAL CODE.
- C DISTRIBUTION PANELS SHALL BE INSTALLED IN ACCORDANCE WITH THE NATIONAL ELECTRICAL CODE AND THE NATIONAL MECHANICAL CODE.
- D DO NOT OBTAIN CONTRACTOR'S PERMISSION TO REMOVE OR ALTER EXISTING WORK UNLESS SPECIFICALLY NOTED ON THE DRAWING.
- E ALL WORK SHALL BE ACCORDING TO THE LATEST EDITIONS OF THE NATIONAL ELECTRICAL CODE AND THE NATIONAL MECHANICAL CODE.
- F ALL WORK SHALL BE ACCORDING TO THE LATEST EDITIONS OF THE NATIONAL ELECTRICAL CODE AND THE NATIONAL MECHANICAL CODE.
- G ALL WORK SHALL BE ACCORDING TO THE LATEST EDITIONS OF THE NATIONAL ELECTRICAL CODE AND THE NATIONAL MECHANICAL CODE.
- H ALL WORK SHALL BE ACCORDING TO THE LATEST EDITIONS OF THE NATIONAL ELECTRICAL CODE AND THE NATIONAL MECHANICAL CODE.
- I ALL WORK SHALL BE ACCORDING TO THE LATEST EDITIONS OF THE NATIONAL ELECTRICAL CODE AND THE NATIONAL MECHANICAL CODE.
- J ALL WORK SHALL BE ACCORDING TO THE LATEST EDITIONS OF THE NATIONAL ELECTRICAL CODE AND THE NATIONAL MECHANICAL CODE.
- K ALL WORK SHALL BE ACCORDING TO THE LATEST EDITIONS OF THE NATIONAL ELECTRICAL CODE AND THE NATIONAL MECHANICAL CODE.
- L ALL WORK SHALL BE ACCORDING TO THE LATEST EDITIONS OF THE NATIONAL ELECTRICAL CODE AND THE NATIONAL MECHANICAL CODE.
- M ALL WORK SHALL BE ACCORDING TO THE LATEST EDITIONS OF THE NATIONAL ELECTRICAL CODE AND THE NATIONAL MECHANICAL CODE.
- N ALL WORK SHALL BE ACCORDING TO THE LATEST EDITIONS OF THE NATIONAL ELECTRICAL CODE AND THE NATIONAL MECHANICAL CODE.
- O ALL WORK SHALL BE ACCORDING TO THE LATEST EDITIONS OF THE NATIONAL ELECTRICAL CODE AND THE NATIONAL MECHANICAL CODE.
- P ALL WORK SHALL BE ACCORDING TO THE LATEST EDITIONS OF THE NATIONAL ELECTRICAL CODE AND THE NATIONAL MECHANICAL CODE.
- Q ALL WORK SHALL BE ACCORDING TO THE LATEST EDITIONS OF THE NATIONAL ELECTRICAL CODE AND THE NATIONAL MECHANICAL CODE.
- R ALL WORK SHALL BE ACCORDING TO THE LATEST EDITIONS OF THE NATIONAL ELECTRICAL CODE AND THE NATIONAL MECHANICAL CODE.
- S ALL WORK SHALL BE ACCORDING TO THE LATEST EDITIONS OF THE NATIONAL ELECTRICAL CODE AND THE NATIONAL MECHANICAL CODE.
- T ALL WORK SHALL BE ACCORDING TO THE LATEST EDITIONS OF THE NATIONAL ELECTRICAL CODE AND THE NATIONAL MECHANICAL CODE.

KEYNOTES

- 1. FINISH: VENEER
- 2. FINISH: CARPET
- 3. FINISH: PAINT
- 4. FINISH: CERAMIC TILE
- 5. FINISH: GRANITE
- 6. FINISH: STAINLESS STEEL
- 7. FINISH: BRASS
- 8. FINISH: ALUMINUM
- 9. FINISH: WOOD GRAIN
- 10. FINISH: POLYURETHANE
- 11. FINISH: ENAMEL
- 12. FINISH: GLOSS
- 13. FINISH: MATTE
- 14. FINISH: SMOOTH
- 15. FINISH: TEXTURED
- 16. FINISH: RIBBED
- 17. FINISH: PERFORATED
- 18. FINISH: SLIGHTLY RIBBED
- 19. FINISH: BLENDED
- 20. FINISH: COMBINATION

WALL TYPES

- 1. MASONRY WALL (SEE SPECIFICATIONS)
- 2. CONCRETE WALL (SEE SPECIFICATIONS)
- 3. BLOCK WALL (SEE SPECIFICATIONS)
- 4. GYP/COR PLASTER (SEE SPECIFICATIONS)
- 5. GYP BOARD (SEE SPECIFICATIONS)
- 6. GYP BOARD WITH FIBERGLASS INSULATION (SEE SPECIFICATIONS)
- 7. GYP BOARD WITH FOAM INSULATION (SEE SPECIFICATIONS)
- 8. GYP BOARD WITH MINERAL WOOL INSULATION (SEE SPECIFICATIONS)
- 9. GYP BOARD WITH POLYSTYRENE INSULATION (SEE SPECIFICATIONS)
- 10. GYP BOARD WITH POLYURETHANE INSULATION (SEE SPECIFICATIONS)
- 11. GYP BOARD WITH POLYISOCYANURATE INSULATION (SEE SPECIFICATIONS)
- 12. GYP BOARD WITH POLYETHYLENE GLYCOL INSULATION (SEE SPECIFICATIONS)
- 13. GYP BOARD WITH POLYISOBUTYLENE INSULATION (SEE SPECIFICATIONS)
- 14. GYP BOARD WITH POLYURETHANE MOISTURE BARRIER (SEE SPECIFICATIONS)
- 15. GYP BOARD WITH POLYURETHANE VAPOR BARRIER (SEE SPECIFICATIONS)
- 16. GYP BOARD WITH POLYURETHANE SOUND BARRIER (SEE SPECIFICATIONS)
- 17. GYP BOARD WITH POLYURETHANE FIRE RATING (SEE SPECIFICATIONS)
- 18. GYP BOARD WITH POLYURETHANE SOUND AND FIRE RATING (SEE SPECIFICATIONS)
- 19. GYP BOARD WITH POLYURETHANE SOUND, FIRE AND VIBRATION RATING (SEE SPECIFICATIONS)
- 20. GYP BOARD WITH POLYURETHANE SOUND, FIRE, VIBRATION AND IMPACT RATING (SEE SPECIFICATIONS)

ASSEMBLY TYPES

- 1. SINGLE GLASS (SEE SPECIFICATIONS)
- 2. DOUBLE GLASS (SEE SPECIFICATIONS)
- 3. TINTED GLASS (SEE SPECIFICATIONS)
- 4. LOW-E GLASS (SEE SPECIFICATIONS)
- 5. WARM EDGE GLASS (SEE SPECIFICATIONS)
- 6. GASEOUS FILL GLASS (SEE SPECIFICATIONS)
- 7. INSULATED GLASS (SEE SPECIFICATIONS)
- 8. TRIPLE GLASS (SEE SPECIFICATIONS)
- 9. QUARTZ FILL GLASS (SEE SPECIFICATIONS)
- 10. ARGON FILL GLASS (SEE SPECIFICATIONS)
- 11. KRYPTON FILL GLASS (SEE SPECIFICATIONS)
- 12. XENON FILL GLASS (SEE SPECIFICATIONS)
- 13. NEON FILL GLASS (SEE SPECIFICATIONS)
- 14. HELIUM FILL GLASS (SEE SPECIFICATIONS)
- 15. AIR FILL GLASS (SEE SPECIFICATIONS)
- 16. VACUUM GLASS (SEE SPECIFICATIONS)
- 17. POLYMER GLASS (SEE SPECIFICATIONS)
- 18. ORGANIC GLASS (SEE SPECIFICATIONS)
- 19. INORGANIC GLASS (SEE SPECIFICATIONS)
- 20. METAL GLASS (SEE SPECIFICATIONS)

LOCKER TYPES

- 1. LOCKER WITH DOOR (SEE SPECIFICATIONS)
- 2. LOCKER WITH LOCK (SEE SPECIFICATIONS)
- 3. LOCKER WITH HANDLE (SEE SPECIFICATIONS)
- 4. LOCKER WITH KICKER (SEE SPECIFICATIONS)
- 5. LOCKER WITH STRAPS (SEE SPECIFICATIONS)
- 6. LOCKER WITH HOOKS (SEE SPECIFICATIONS)
- 7. LOCKER WITH SHOES (SEE SPECIFICATIONS)
- 8. LOCKER WITH BENCH (SEE SPECIFICATIONS)
- 9. LOCKER WITH MIRROR (SEE SPECIFICATIONS)
- 10. LOCKER WITH LIGHT (SEE SPECIFICATIONS)
- 11. LOCKER WITH VENTILATION (SEE SPECIFICATIONS)
- 12. LOCKER WITH INSULATION (SEE SPECIFICATIONS)
- 13. LOCKER WITH SOUND BARRIER (SEE SPECIFICATIONS)
- 14. LOCKER WITH FIRE RATING (SEE SPECIFICATIONS)
- 15. LOCKER WITH IMPACT RATING (SEE SPECIFICATIONS)
- 16. LOCKER WITH VIBRATION RATING (SEE SPECIFICATIONS)
- 17. LOCKER WITH MOISTURE BARRIER (SEE SPECIFICATIONS)
- 18. LOCKER WITH VAPOR BARRIER (SEE SPECIFICATIONS)
- 19. LOCKER WITH SOUND AND FIRE RATING (SEE SPECIFICATIONS)
- 20. LOCKER WITH SOUND, FIRE AND VIBRATION RATING (SEE SPECIFICATIONS)

PROFESSIONAL SEAL

NO.	REVISION	DATE

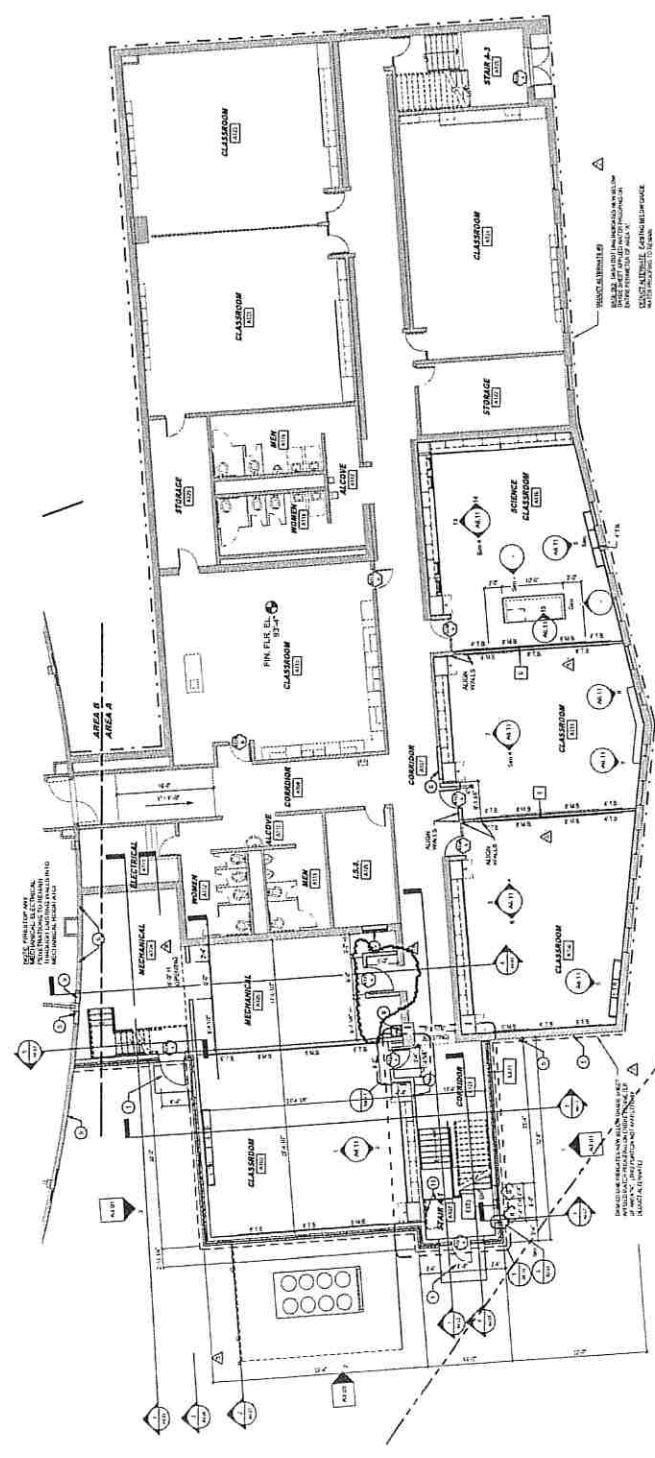

FLOOR 01 - Area A

KEY PLAN

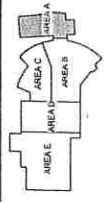



DATE: 06-12-15
PROJECT: 14179

REFLECTED CEILING PLAN - AREA A

ADDITIONS AND ALTERATIONS TO BARR MIDDLE SCHOOL
GRAND ISLAND, NEBRASKA
602 W. STOLLEY PARK RD. 68801

ASHT A2.17

GENERAL NOTES

- A. EXISTING CONDITIONS SHALL BE SHOWN AS DASHED LINES UNLESS OTHERWISE NOTED.
- B. ALL DIMENSIONS ARE UNLESS OTHERWISE NOTED.
- C. ALL DIMENSIONS ARE UNLESS OTHERWISE NOTED.
- D. ALL DIMENSIONS ARE UNLESS OTHERWISE NOTED.

KEYNOTES

- 1. SEE KEY PLAN
- 2. ALL DIMENSIONS ARE UNLESS OTHERWISE NOTED.
- 3. ALL DIMENSIONS ARE UNLESS OTHERWISE NOTED.
- 4. ALL DIMENSIONS ARE UNLESS OTHERWISE NOTED.
- 5. ALL DIMENSIONS ARE UNLESS OTHERWISE NOTED.
- 6. ALL DIMENSIONS ARE UNLESS OTHERWISE NOTED.
- 7. ALL DIMENSIONS ARE UNLESS OTHERWISE NOTED.
- 8. ALL DIMENSIONS ARE UNLESS OTHERWISE NOTED.
- 9. ALL DIMENSIONS ARE UNLESS OTHERWISE NOTED.
- 10. ALL DIMENSIONS ARE UNLESS OTHERWISE NOTED.
- 11. ALL DIMENSIONS ARE UNLESS OTHERWISE NOTED.
- 12. ALL DIMENSIONS ARE UNLESS OTHERWISE NOTED.
- 13. ALL DIMENSIONS ARE UNLESS OTHERWISE NOTED.
- 14. ALL DIMENSIONS ARE UNLESS OTHERWISE NOTED.
- 15. ALL DIMENSIONS ARE UNLESS OTHERWISE NOTED.
- 16. ALL DIMENSIONS ARE UNLESS OTHERWISE NOTED.
- 17. ALL DIMENSIONS ARE UNLESS OTHERWISE NOTED.
- 18. ALL DIMENSIONS ARE UNLESS OTHERWISE NOTED.
- 19. ALL DIMENSIONS ARE UNLESS OTHERWISE NOTED.
- 20. ALL DIMENSIONS ARE UNLESS OTHERWISE NOTED.

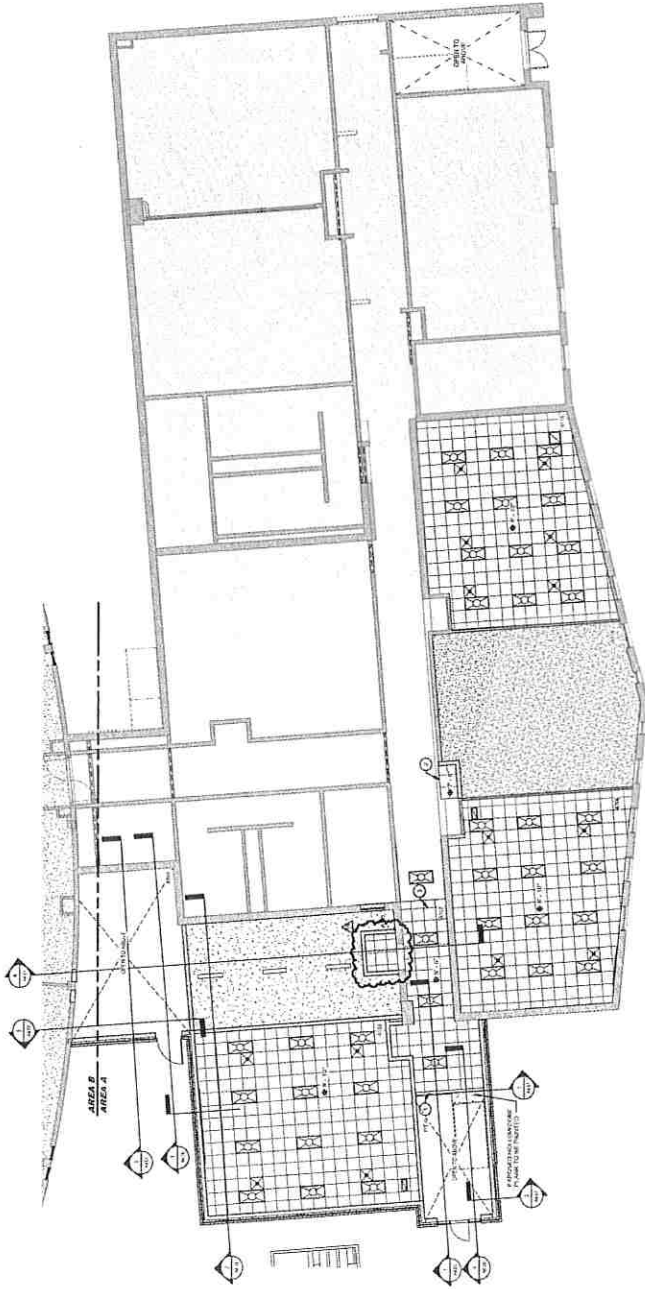

1 FLOOR 01 - Area A REFLECTED CEILING PLAN

PROFESSIONAL SEAL

REVISIONS

NO.	DESCRIPTION	DATE

KEY PLAN

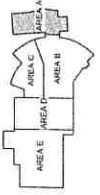

ASHT A2.17



Contract Change Proposal

Contractor Proposal Number Sixteen

Project: Barr Middle School Additions & Renovations Date: 4-Oct-16
 Owner: Grand Island Public Schools
 Architect: Cannon Moss Brygger & Architects
 Arch # 14179

Description:

Add roof drain in existing roof over Mech Room C111. Provide new 3" piping thru east wall of room C111 and tie into already installed roof drain line in NW corner of Cafeteria C110. Provide new gypsum board bulkhead to conceal roof drain piping along west wall of C110. The bottom of the new bulkhead is to align with the bottom of the bulkhead along the north wall outside of C111. Bulkhead to be tight to new drain line, and occur behind the cross bracing. Gypsum board to be finished and painted the same as the remainder of the bulkhead this new portion will tie into. as per CMBA's Request for Proposal #16, dated August 2, 2016

Pricing Summary:

A. Contractor Cost

Supervision	50.00
Labor	100.00
Material	78.00
Sub-total A.	228.00

B. Subcontractor Cost

Roofing	Tri-Cities Group	130.00
Steel Studs & Drywall	Essink	1,240.00
Plumbing	O'Hara Plumbing	830.00
Sub-total B.		2,200.00

Sub-total, A. + B.	2,428.00
Bond and Insurance	26.71
Sub-total	2,454.71
Contractor O, H & P @10%	245.47

Grand Total, C. P. # Sixteen

\$2,700

This Change affects project completion by 0 calender days.

Respectfully submitted, Chris Wissing, Project Manager

3356 West Old Highway 30 PO Box 188 Grand Island NE 68802-0188
 Business Phone 308-384-2866 Toll Free 800-321-5229 Fax 308-384-2883

www.lacygc.com



CANNON MOSS BRYGGER ARCHITECTS

208 N PINE STREET, SUITE 301 • GRAND ISLAND, NE 68801 • (P) 308.384.4444

REQUEST FOR PROPOSAL (RFP) – NO. 16

PROJECT: ADDITIONS AND ALTERATIONS TO BARR MIDDLE SCHOOL

PROJECT #: 14179

DATE: August 2, 2016

TO: Chris Wissing

COMPANY: Lacy Construction Company

FROM: Matthew Bennett

COMPANY: CANNON MOSS BRYGGER ARCHITECTS

Provide a cost breakdown in accordance with the contract documents for the proposed changes to the contract as described below and on any attachments transmitted here within. This is not an authorization to proceed. If approved, the changes will be included in a forthcoming change order.

1. Add roof drain in existing roof over Mechanical Room C111. Provide new 3" piping through east wall of room C111 and tie into already installed roof drain line in NW corner of Cafeteria C110.
2. Provide new gypsum board bulkhead to conceal roof drain piping along west wall of C110. The bottom of the new bulkhead is to align with the bottom of the bulkhead along the north wall outside of C111. Bulkhead to be tight to new drain line, and occur behind the cross bracing. Gypsum board to be finished and painted the same as the remainder of the bulkhead this new portion will tie into.

END OF RFP #16.

PROPOSAL
Tri-Cities Group Inc.
Roofing Contractors
P. O. Box 909
GRAND ISLAND, Nebraska 68802
877-290-2224
(308) 384-7230
Fax (308) 384-7260

PROPOSAL SUBMITTED TO Lacy Construction	PHONE 308-384-2866	DATE 08/06/2016
STREET 3356 W. Old Hwy. 30	JOB NAME Barr Middle School. Proposal request #16	
CITY, STATE and ZIP CODE Grand Island, NE 68803	JOB LOCATION Same	

We hereby submit specifications and estimates for:

Proposal request #16.

1. Remove the existing EPDM, roof insulation and ballast rock at new drain location.
2. Reinstall the existing Insulation, install new EPDM after the new drain is installed and flash into the existing roof system.
3. Re-distribute the ballast rock.

We propose to furnish material and labor – complete in accordance with above specifications, for the sum of: \$130.00

One hundred and thirty dollars.

Payment to be made as follows:

If material is guaranteed to be as specified. All work to be completed in a workmanlike manner according to standard practices. Any alteration or deviation from above specifications involving extra costs will be executed only upon written orders, and will become an extra charge over and above the estimate. All agreements contingent upon strikes, accidents or delays beyond our control. Owner to carry fire, tornado and other necessary insurance. Our workers are fully covered by worker's compensation insurance.

Acceptance of Proposal: The above prices, specifications and conditions are satisfactory and are hereby accepted. You are authorized to do the work as specified. Payment will be made as outlined above.

Date of Acceptance: _____

Authorized Signature *Gene Schacher*
Gene Schacher

NOTE: This proposal may be withdrawn by us if not accepted with 10 days.

Signature _____
Signature _____

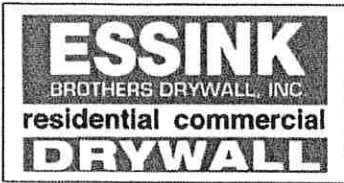

1706 S. Holland Dr.
Grand Island, NE 68803
Phone: 308-384-8617
Fax: 308-384-8620
rob@essink.biz

CHANGE ORDER

Number: Three

Date: 7-27-16

Submitted to:
Lacy Construction Co.
Attn: Chris Wissing
P.O. Box 188
Grand Island, NE 68802-0188
384-2866

Project:
Barr Middle School
Grand Island, NE

Job No.
1167

Date of Existing Contract:
9-29-15

Per RFI 34

Furnish material and labor to install metal studs, high impact drywall to cover precast at vestibule C100.

MATERIAL	\$ 496.00
LABOR	\$ 922.00
SUBTOTAL	\$1,418.00
10% PROFIT	\$ 142.00
TOTAL	\$1,560.00

Per RFI 5

Furnish material and labor to install metal studs, high impact drywall to cover roof drain at cafeteria.

MATERIAL	\$ 402.00
LABOR	\$ 725.00
SUBTOTAL	\$1,127.00
10% PROFIT	\$ 113.00
TOTAL	\$1,240.00

TOTAL ADD: \$2,800.00

Proposal



O'Hara Plumbing Co., Inc.
P.O. Box 1038
Grand Island, NE 68802-1038
(308) 382-0765
Fax (308) 382-5166
Email: oharaplumbing@hamilton.net

PROPOSAL SUBMITTED TO LACY CONSTRUCTION		PHONE	DATE 9/19/16
STREET		JOB NAME BARR JUNIOR HIGH	
CITY, STATE, ZIP CODE		JOB LOCATION GRAND ISLAND NEBRASKA	
ARCHITECT	DATE OF PLANS		JOB PHONE

We hereby submit specifications and estimates for: **PROPOSAL REQUEST 16**

AREA C ROOF DRAIN

1-3"ROOF DRAIN	\$134.00
1-3"X-HEAVY NO HUB	\$6.00
3-3"PVC 90	\$15.00
1-3"ST 45	\$5.00
1-6"X3" WYE	\$35.00
20'-3" PVC	\$28.00
3-HANGERS	\$30.00
1-PIPE LABELS	\$10.00
TOTAL	\$263.00
10% MARK UP	\$27.00
TOTAL	\$290.00

MATERIAL	\$290.00
INSULATION	\$200.00
LABOR	\$340.00
TOTAL	\$830.00

WE PROPOSE hereby to furnish material and labor – complete in accordance with above specifications, for the sum of:

EIGHT HUNDRED AND THIRTY AND NO 100

Dollars (\$830.00).

Payment to be made as follows:

All material is guaranteed to be as specified. All work to be completed in a workmanlike manner according to standard practices. Any alteration or deviation from above specifications involving extra costs will be executed only upon written orders, and will become an extra charge over and above the estimate. All agreements contingent upon strikes, accidents or delays beyond our control. Owner to carry fire, tornado and other necessary insurance. Our workers are fully covered by Workman's Compensation Insurance.

Authorized Signature: _____ **BJ OHARA** _____

Note: This proposal may be withdrawn by us if not accepted within 30 days.

ACCEPTANCE OF PROPOSAL – The above prices, specifications and conditions are satisfactory and are hereby accepted. You are authorized to do the work as specified. Payment will be made as outlined above.

Date of Acceptance: _____

Signature: _____

Signature: _____



Contract Change Proposal

Contractor Proposal Number Nineteen

Project: Barr Middle School Additions & Renovations Date: 1-Sep-16

Owner: Grand Island Public Schools

Architect: Cannon Moss Brygger & Architects

Arch # 14179

Description:

Add Concrete, dumpster pad, and pipe ballards as per drawing supplied by CMBA.

as per CMBA's Request for Proposal #19, dated September 1,, 2016

Pricing Summary:

A. Contractor Cost

Supervision	50.00
Labor	2,403.00
Material	4,369.00
Equipment	75.00
Sub-total A.	6,897.00

B. Subcontractor Cost

	0.00
	0.00
Sub-total B.	0.00
Sub-total, A. + B.	6,897.00
Bond and Insurance	75.87
Sub-total	6,972.87
Contractor O, H & P @10%	697.29

Grand Total, C. P. # Nineteen

\$7,670

This Change affects project completion by 0 calender days.

Respectfully submitted, Chris Wissing, Project Manager



CANNON MOSS BRYGGER ARCHITECTS
208 N PINE STREET, SUITE 301 • GRAND ISLAND, NE 68801 • (P) 308.384.4444

REQUEST FOR PROPOSAL (RFP) – NO. 19

PROJECT: ADDITIONS AND ALTERATIONS TO BARR MIDDLE SCHOOL

PROJECT #: 14179

DATE: September 6, 2016 (Revised September 26, 2016)

TO: Chris Wissing

COMPANY: Lacy Construction Company

FROM: Matthew Bennett

COMPANY: CANNON MOSS BRYGGER ARCHITECTS

Provide a cost breakdown in accordance with the contract documents for the proposed changes to the contract as described below and on any attachments transmitted here within. This is not an authorization to proceed. If approved, the changes will be included in a forthcoming change order.

1. Provide pricing for the construction of the dumpster pad and site work as previously discussed at the Construction Meeting.

END OF RFP #19.

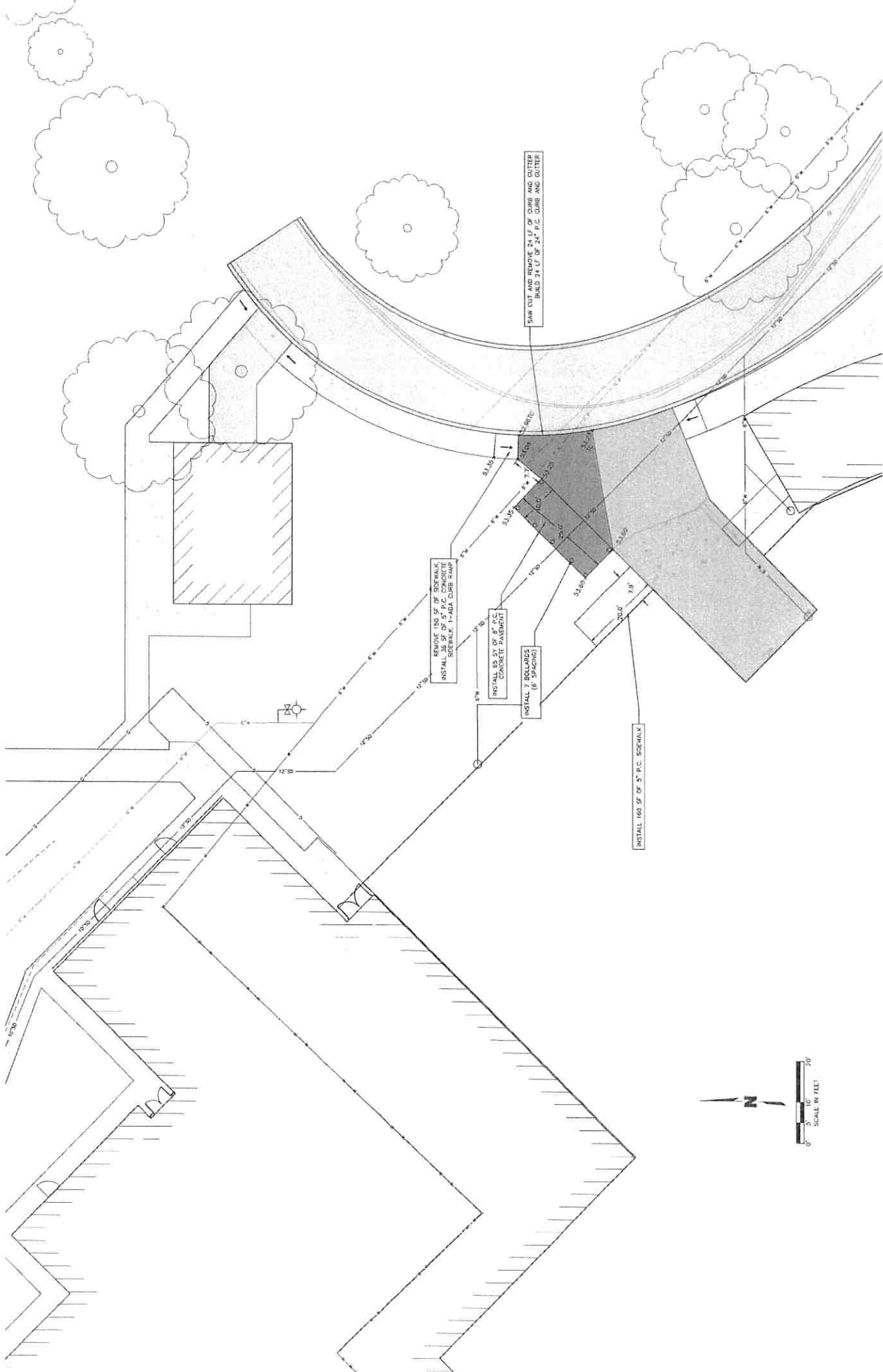

SAW OUT AND REMOVE 24' L' OF CURB AND OUTER BUILD 24' L' OF 24" P.C. CURB AND OUTER

REMOVE 120 SF OF SIDEWALK
INSTALL 38 SF OF 5" P.C. CONCRETE SIDEWALK 1-ADA CURB RAMP

INSTALL 65 SF OF 8" P.C. CONCRETE PAVEMENT

INSTALL 7 BOLLARDS (8 SPACING)

INSTALL 100 SF OF 5" P.C. SIDEWALK

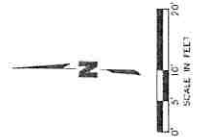

PR# 19
Barr Middle School

201

9154

2403

75

Sitework

			4cyds		
	Grade for pavy & walks				
160	20'-0" x 8'-0" x 0'-5"		3 cyds		
250	26'-0" x 10'-0" x 0'-8"		6 cyds		
263	26'-3" x 20'-0" x 0'-8" x 1/2		7 cyds		
170	6'-0" x 20'-0" x 0'-8"		3 cyds		
	7 Pipe Ballards	/sr		1190	350
	Saw cut 12 LF Walk	/	12		12
	Saw cut 24 LF Curb	/	24		24
	Remove 150 Sq Ft Walk	/			38
	Remove 20 LF Curb	/			20
	Haul off concrete rubble 3	/10			30
	Grab out 18 cyds dirt	/5			90
	Grade for 800 Sq Ft Paving	/20			160
	Misc. Sitework	/		50	50
	Excavate 7 pipe ballards	/20			140
	Haul off 22 cyds dirt	/8			176
	83 LF Conc Walks	3 ⁸⁵ / ₂₀		255	60
	632 LF Conc. Paving	24 ⁸⁵ / ₂₀		2040	480
	112 CF Conc. Pipe Ballards	5 ⁸⁵ / ₂₀		425	100
	Form 830 Sq Ft Conc.	/	25		208
	Finish 830 Sq Ft Conc.	/			208
	Cure 830 Sq Ft Conc.	/		59	42
	100 LF Exp JT	/		75	25
	Saw cut 90 LF Conc.	/	90		90
	Misc. Conc.	/	50	50	100

GIPS GISH 100 Wing Remodel
Change Order Listing

Change Order Number	Date	Change Order Explanation	Amount	Current Contract Amount	Date Approved Supv. Bldgs & Grnds	Date Approved Fac/Fin Committee	Date Approved Board of Ed.
		Original Contract Amount		2,267,000.00			
001	7/1/2016	Item 1: Painting of exposed ceilings - NOT APPROVED	0.00	2,267,000.00			
001	7/1/2016	Item 2: Door 134A changes	0.00	2,267,000.00			
001	7/1/2016	Item 3: Existing HVAC penetrations - NOT APPROVED	0.00	2,267,000.00			
001	7/1/2016	Item 4: Doors 135A and 145A changes - NOT APPROVED	0.00	2,267,000.00			
001	7/1/2016	Item 5: Existing waste piping	1,288.10	2,268,288.10			
001	7/1/2016	Item 6: Remove overhead door jambs - NOT APPROVED	0.00	2,268,288.10			
001	7/1/2016	Item 7: Doors 135A and 145A changes	1,056.00	2,269,344.10			
001	7/1/2016	Item 8: Painting of CPI storage ceilings	594.00	2,269,938.10	7/22/2016	8/2/2016	8/11/2016
002	8/30/2016	Item 1: CPI wall changes	1,287.00	2,271,225.10			
002	8/30/2016	Item 2: RFP 007 Signage modifications	(3,151.77)	2,268,073.33			
002	8/30/2016	Item 3: RFP 006 Window changes	1,937.49	2,270,010.82			
002	8/30/2016	Item 4: PT-5 Paint changes	165.00	2,270,175.82	9/21/2016	10/4/2016	10/13/2016
003	10/31/2016	Item 1: Additional Drywall work	3,608.00	2,273,783.82			
003	10/31/2016	Item 2: Existing EIFS caulking	1,272.48	2,275,056.30			
003	10/31/2016	Item 3: Reconnect existing exhaust fan	1,306.80	2,276,363.10			
003	10/31/2016	Item 4: Roof drain modifications	(5,164.20)	2,271,198.90			
003	10/31/2016	Item 5: Toilets 106 and 107 modifications	(244.00)	2,270,954.90			
003	10/31/2016	Item 6: Stain bulkhead - NOT APPROVED	0.00	2,270,954.90	11/28/2016		
			Totals	% of Total			
		Original Contract	\$2,267,000	99.82585%			
		Total Change Orders Amount and as a % of Total Spending	\$3,955	0.17415%			
		Grand Total	\$2,270,955	100.00000%			
		CHANGE ORDERS AS A PERCENTAGE OF ORIGINAL CONTRACT		0.17446%			



AIA[®]

Document G701[™] – 2001

Change Order

PROJECT (Name and address): SENIOR HIGH 100 WING REMODEL GRAND ISLAND PUBLIC SCHOOLS GRAND ISLAND, NEBRASKA	CHANGE ORDER NUMBER: 003 DATE: October 31, 2016	OWNER: <input checked="" type="checkbox"/> ARCHITECT: <input checked="" type="checkbox"/> CONTRACTOR: <input checked="" type="checkbox"/> FIELD: <input type="checkbox"/> OTHER: <input type="checkbox"/>
TO CONTRACTOR (Name and address): CHIEF CONSTRUCTION CO. PO BOX 2078 GRAND ISLAND, NE 68802-2078	ARCHITECT'S PROJECT NUMBER: 15113 CONTRACT DATE: April 15, 2016 CONTRACT FOR: General Construction	

THE CONTRACT IS CHANGED AS FOLLOWS:

(Include, where applicable, any undisputed amount attributable to previously executed Construction Change Directives)

Item 1: Additional Drywall Work	ADD \$3,608.00
Item 2: Existing EIFS Caulking	ADD \$1,272.48
Item 3: RFP 009 Reconnect Existing Exhaust Fan	ADD \$1,306.80
Item 4: RFP 005 Roof Drain Modifications	DEDUCT (\$5,164.20)
Item 5: RFP 010 Toilets 106 & 107 Modifications	DEDUCT (\$244.00)
Item 6: Stain Bulkhead	NOT APPROVED
TOTAL ADD THIS CHANGE ORDER	\$779.08

The original Contract Sum was	\$	2,267,000.00
The net change by previously authorized Change Orders	\$	3,175.82
The Contract Sum prior to this Change Order was	\$	2,270,175.82
The Contract Sum will be increased by this Change Order in the amount of	\$	779.08
The new Contract Sum including this Change Order will be	\$	2,270,954.90

The Contract Time will be unchanged by zero (0) days.

The date of Substantial Completion as of the date of this Change Order therefore is unchanged.

NOTE: This Change Order does not include changes in the Contract Sum, Contract Time or Guaranteed Maximum Price which have been authorized by Construction Change Directive until the cost and time have been agreed upon by both the Owner and Contractor, in which case a Change Order is executed to supersede the Construction Change Directive.

NOT VALID UNTIL SIGNED BY THE ARCHITECT, CONTRACTOR AND OWNER.

<u>CANNON MOSS BRYGGER & ASSOC.</u> ARCHITECT (Firm name)	<u>CHIEF CONSTRUCTION COMPANY</u> CONTRACTOR (Firm name)	<u>HALL CO. SCHOOL DISTRICT 2</u> OWNER (Firm name)
208 N. PINE ST., SUITE 301 GRAND ISLAND, NE 68801 ADDRESS	PO BOX 2078 GRAND ISLAND, NE 68802-2078 ADDRESS	PO BOX 4904 GRAND ISLAND, NE 68802-4904 ADDRESS
 BY (Signature)	 BY (Signature)	 BY (Signature)
BRADLEY C. KISSLER (Typed name)	ROGER BULLINGTON (Typed name)	DAN O. PETSCH (Typed name)
10/31/16 DATE	8/11/16 DATE	DATE



GENERAL CONTRACTORS
A SUBSIDIARY OF CHIEF INDUSTRIES, INC.

DESIGN BUILD PROFESSIONALS

Change Order Request

COR Number: 013

Date: 8/31/2016

Project Number: 16LB005

Contract Date: 4/15/2016

To:	Project:
GRAND ISLAND PUBLIC SCHOOLS Michael S. Kneale Admin Building 123 S Webb Road, P.O. Box 4904 Grand Island NE 68802-4904	GIPS Senior High 100 Wing Remodel DIV20 2124 N. Lafayette Ave. Grand Island NE 68803

Description of Change:

Add for material, labor, and equipment to install 6" metal studs, R-19 insulation, 5/8" F.S. drywall fire taped to close off separation between penthouse and rooms 120, 132, and 135 per RFI 16 and reviewed COR 003.

Add for material, labor and equipment to install additional drywall and repair existing finish on backside of room 134 wall per reviewed COR 003.

Essink = \$3,280.00

SUB-TOTAL = \$3,280.00

10% Mark-up = \$328.00

\$3,608.00

Proposed Contract Amount of this Change Order

3,608.00

Accepting this Change Order Request indicates that it should be converted to an Owner Change Order and incorporated as part of the original contract.

Accepted By:

Owner (Owner's Representative)

By (Signature)

Printed Name

Date

3935 Westgate Road
P.O. Box 2078 (MAILING)
Grand Island, NE 68802-2078
Phone 308-389-7222
Fax 308-389-7393

INTERNET: <http://www.chiefconstruction.us>
EMAIL: construction@chiefind.com

4400 E. 39th Street
P.O. Box 848 (MAILING)
Kearney, NE 68848-0848
Phone 308-238-2755
Fax 308-238-2759



1706 S. Holland Dr.
Grand Island, NE 68803
Phone: 308-384-8617
Fax: 308-384-8620
rob@essink.biz

CHANGE ORDER

Number: Three

Date: 10-18-16

Submitted to:

Chief Construction Co.
Attn: Lance Bachman
P.O. Box 2078
Grand Island, NE 68802-2078
308-389-7222

Project:

GIPS Senior High
100 Wing Remodel
Grand Island, NE

Job No.

1161

Date of Existing Contract:

4-26-16

SECOND REVISION

Work completed on a time and material basis per Lance Bachman

- 1) Rooms 120, 113, 132 and 134 – Install 6" metal stud wall, R-19 insulation, 5/8" F.S. drywall fire taped.

DETAIL OF LABOR HOURS: 7-1-16 (5 hours), 7-6-16 (16.5 hours), 7-11-16 (19 hours), 7-15-16 (11.5 hours).

LABOR 52 MAN HOURS	\$2,340.00
MATERIAL	\$ 420.00
ADD	<u>\$2,760.00</u>

- 2) Room 134 – Patch outlets, repair existing finish on backside of wall.

DETAIL OF LABOR HOURS: 7-21-16 (5 hours).

LABOR 5 MAN HOURS	\$225.00
MATERIAL	<u>\$ 35.00</u>
ADD	\$260.00

3) Room #144 – Patch and repair existing wall finishes.

DETAIL OF LABOR HOURS: 7-7-16 (5 hours)

LABOR 5 MAN HOURS	\$225.00
MATERIAL	<u>\$ 35.00</u>
	\$260.00

DATE:
October 18, 2016

Rob Supencheck – Vice President

Date of acceptance _____

Signature _____
(CONTRACTOR/OWNER)



GENERAL CONTRACTORS
A SUBSIDIARY OF CHIEF INDUSTRIES, INC.

DESIGN BUILD PROFESSIONALS

Change Order Request

COR Number: 003

Date: 6/13/2016

Project Number: 16LB005

Contract Date: 4/15/2016

To:	Project:
GRAND ISLAND PUBLIC SCHOOLS Michael S. Kneale Admin Building 123 S Webb Road, P.O. Box 4904 Grand Island NE 68802-4904	GIPS Senior High 100 Wing Remodel DIV20 2124 N. Lafayette Ave. Grand Island NE 68803

Description of Change:

Add for material, labor, and equipment to install 6" metal studs, R-19 insulation, 5/8" F.S. drywall fire taped to close off sparation between penthouse and 120, 132, and 135 per RFI 16.

Essink = \$1,650.00

SUB-TOTAL = \$1,650.00

10% Mark-up = \$165.00

TOTAL COR = \$1,815.00

Proposed Contract Amount of this Change Order

1,815.00

Accepting this Change Order Request indicates that it should be converted to an Owner Change Order and incorporated as part of the original contract.

Accepted By:

General Contractor to proceed with work on a time and material basis. Scope of work shall be as discussed with architect and owner at the job site.

Owner (Owner's Representative)

By (Signature)

Printed Name

Date

2107 S. North Road
P.O. Box 2078 (MAILING)
Grand Island, NE 68802-2078
Phone 308-389-7222
Fax 308-389-7393

INTERNET: <http://www.chiefconstruction.us>
EMAIL: construction@chiefind.com

4400 E. 39th Street
P.O. Box 848 (MAILING)
Kearney, NE 68848-0848
Phone (308) 238-2755
Fax (308) 389-6704



GIPS - Senior High 100 Wing Remodel

REQUEST FOR INFORMATION

To: Brad Kissler
Cannon Moss Brygger Architects
208 N Pine Street
Grand Island, NE 68801

RFI #: 16
Date: 6/8/2016
Job: 15113
Phone: 308-384-4444

Urgency: Standard

CC: Tim Ruzicka

Subject: Existing HVAC Ductwork Penetrations

Drawing: A2.01 & M0.01

Spec Section: 092900 & 092216

Cost Impact: T.B.D.

Schedule Impact: T.B.D.

Request:

Date Required: 6/10/2016

At the penthouse level where existing ductwork was removed for existing Heat Pumps 7 & 9 there are several openings in the existing framing and drywall. Are these openings to remain open or are they to be repaired?

Requested By: Lance Bachman

Response:

Openings into the penthouse where existing ductwork was removed are to be patched and repaired to match existing.

Answered by
CANNON MOSS BRYGGER ARCHITECTS

Date: 06/09/2016

Company



GENERAL CONTRACTORS
 A SUBSIDIARY OF CHIEF INDUSTRIES, INC.
 DESIGN BUILD PROFESSIONALS

Change Order Request

COR Number: 014
Date: 9/2/2016
Project Number: 16LB005
Contract Date: 4/15/2016

To:	Project:
GRAND ISLAND PUBLIC SCHOOLS Michael S. Kneale Admin Building 123 S Webb Road, P.O. Box 4904 Grand Island NE 68802-4904	GIPS Senior High 100 Wing Remodel DIV20 2124 N. Lafayette Ave. Grand Island NE 68803

Description of Change:

Add to remove existing caulking at all EIFS exterior surfaces and replace with new caulking. Caulk color to be "Limestone". Caulking of new EIFS patches is not included in this cost as this was included in base bid. Approximately 241 LF of caulking removal and replacement is included, see attached Sheet A3.01 with takeoff locations and quantities.

Stutzman Sealants = \$1,156.80

SUB-TOTAL = \$1,156.80

10% Mark-Up = \$115.68

TOTAL COR = \$1,272.48

Proposed Contract Amount of this Change Order

1,272.48

Accepting this Change Order Request indicates that it should be converted to an Owner Change Order and incorporated as part of the original contract.

Accepted By:

 Owner (Owner's Representative)

 By (Signature)

 Printed Name

 Date

3935 Westgate Road
 P.O. Box 2078 (MAILING)
 Grand Island, NE 68802-2078
 Phone 308-389-7222
 Fax 308-389-7393

INTERNET: <http://www.chiefconstruction.us>
 EMAIL: construction@chiefind.com

4400 E. 39th Street
 P.O. Box 848 (MAILING)
 Kearney, NE 68848-0848
 Phone 308-238-2755
 Fax 308-238-2759

Bachman, Lance

From: Nicole Stutzman <stutzmansealants@aol.com>
Sent: Thursday, September 29, 2016 9:33 AM
To: Bachman, Lance
Subject: Re: GISH 100 Wing Remodel - Existing Caulk Removal and Re-Caulk

Yes, that will be fine.

Thanks!

Brandon

-----Original Message-----

From: Bachman, Lance <lance.bachman@chiefind.com>
To: Nicole Stutzman <stutzmansealants@aol.com>
Sent: Wed, Sep 28, 2016 3:22 pm
Subject: RE: GISH 100 Wing Remodel - Existing Caulk Removal and Re-Caulk

Brandon,

We looked at this closer with the Owner and Architect and it turns out there is more like 241 LF of caulking that needs removed and replaced. Am I safe to assume the revised price would be \$1,156.80 (\$4.80/LF x \$241 LF)?

Let me know.

Thanks,

Lance Bachman | Project Manager

Chief Construction Company | chiefconstruction.build
Office:308.389.7403 | Cell:402.694.8980

From: Nicole Stutzman [<mailto:stutzmansealants@aol.com>]
Sent: Wednesday, August 31, 2016 10:04 AM
To: Bachman, Lance <lance.bachman@chiefind.com>
Subject: Re: GISH 100 Wing Remodel - Existing Caulk Removal and Re-Caulk

To cut out and reseal approximately 310 LF using Dow 790 Silicone Sealant - Bid: \$1,488.50.

Please let me know if you have any questions.

Thanks!

Brandon Stutzman
402.314.1023

-----Original Message-----

From: Bachman, Lance <lance.bachman@chiefind.com>
To: Nicole Stutzman <stutzmansealants@aol.com>

Sent: Mon, Aug 29, 2016 10:48 am

Subject: GISH 100 Wing Remodel - Existing Caulk Removal and Re-Caulk

Brandon,

The exterior of this building has some existing EIFS on it, see attached pictures. The Architect is wanting us to remove and provide new caulking at the perimeter of these locations. Would you be able to work me up a price to remove the existing caulk and caulk with new caulk? I estimate approximately, 310 LF. The color should be Sandstone.

Thanks,

Lance Bachman | Project Manager

Chief Construction Company | chiefconstruction.build
308.389.7403

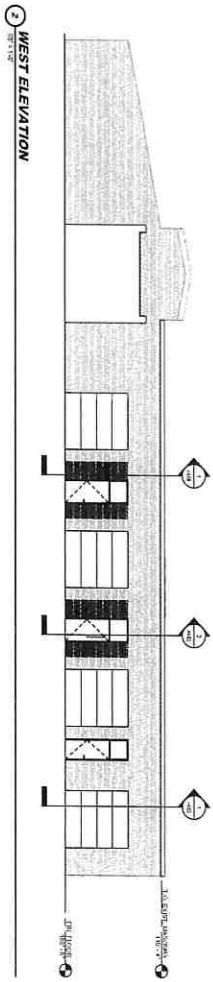
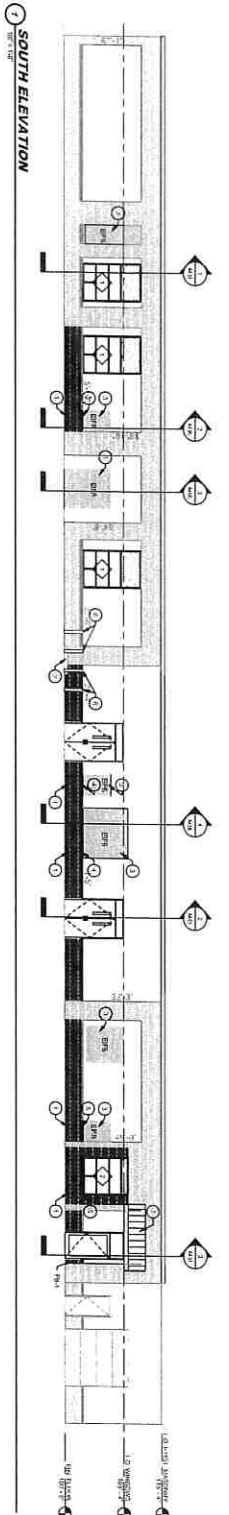

GENERAL NOTES

- A. EXISTING CONDITIONS SHALL BE MAINTAINED UNLESS SPECIFICALLY NOTED OTHERWISE.
- B. MATERIALS AND METHODS SHALL BE AS SHOWN OR AS NOTED OTHERWISE.
- C. ALL WORK SHALL BE DONE IN ACCORDANCE WITH THE LATEST EDITIONS OF THE BUILDING CODES AND SPECIFICATIONS.
- D. ALL WORK SHALL BE DONE IN ACCORDANCE WITH THE LATEST EDITIONS OF THE BUILDING CODES AND SPECIFICATIONS.

KEYNOTES

- 1. EXISTING CONDITIONS SHALL BE MAINTAINED UNLESS SPECIFICALLY NOTED OTHERWISE.
- 2. MATERIALS AND METHODS SHALL BE AS SHOWN OR AS NOTED OTHERWISE.
- 3. ALL WORK SHALL BE DONE IN ACCORDANCE WITH THE LATEST EDITIONS OF THE BUILDING CODES AND SPECIFICATIONS.
- 4. ALL WORK SHALL BE DONE IN ACCORDANCE WITH THE LATEST EDITIONS OF THE BUILDING CODES AND SPECIFICATIONS.

SCALE: 1/8"=1'-0" EXTERIOR ELEVATIONS
 Note: Elevations in feet unless otherwise noted. All dimensions are to finished surfaces unless otherwise noted.

SEAL
 REGISTERED PROFESSIONAL ARCHITECT
 STATE OF ILLINOIS
 NO. 0123456789
 EXPIRES 12/31/2017

REVISIONS

NO.	DATE	DESCRIPTION

IF THIS DRAWING IS NOT TO SCALE



DATE: 03/18/2016
 PROJECT: 15113

EXTERIOR ELEVATIONS

SENIOR HIGH 100 WING REMODEL
 GRAND ISLAND PUBLIC SCHOOLS
 2124 N. LAFAYETTE, GRAND ISLAND, NE

PROJECT: A3.01

Bachman, Lance

From: Brad Kissler <kissler.b@cmbaarchitects.com>
Sent: Wednesday, August 24, 2016 1:50 PM
To: Bachman, Lance
Cc: Shane Labenz; Ruzicka, Tim
Subject: RE: GISH 100 Wing Remodel - Caulking Colors

Color will be "Sandstone". We are expecting new caulking around the entire perimeter at each location since all EIFS exterior surfaces are getting a new finish coat.

BRADLEY C. KISSLER AIA
PRINCIPAL ARCHITECT

CANNON MOSS BRYGGER ARCHITECTS
208 N Pine Street, Suite 301
Grand Island, NE 68801
(P) 308.384.4444 ext 2024

WWW.CMBAARCHITECTS.COM



The information contained in this communication may be confidential and is intended only for the use of the recipient(s) named above. If the reader of this message is not the intended recipient, you are hereby notified that any dissemination, distribution, or copying of this communication, or any of its contents, is strictly prohibited. If you have received this communication in error, please return it to the sender immediately and delete the original message and any copy of it from your computer system.

From: Bachman, Lance [<mailto:lance.bachman@chiefind.com>]
Sent: Monday, August 22, 2016 12:04 PM
To: Brad Kissler
Cc: Shane Labenz; Ruzicka, Tim
Subject: RE: GISH 100 Wing Remodel - Caulking Colors

It will be the "Dow Corning 795" product that will be used for all Exterior Building Joints.

Lance Bachman | Project Manager

Chief Construction Company | chiefconstruction.build
308.389.7403

From: Brad Kissler [<mailto:kissler.b@cmbaarchitects.com>]
Sent: Monday, August 22, 2016 11:58 AM
To: Bachman, Lance <lance.bachman@chiefind.com>
Cc: Shane Labenz <labenz.s@cmbaarchitects.com>; Ruzicka, Tim <Tim.Ruzicka@chiefind.com>
Subject: RE: GISH 100 Wing Remodel - Caulking Colors

We would likely end up picking the same color but I think it would be best if we selected the color, that way we won't have an issue if we end up not liking the color you or your sub might select. We still have the samples if you can tell me which product we are selecting from.

Thanks,

BRADLEY C. KISSLER AIA
PRINCIPAL ARCHITECT

CANNON MOSS BRYGGER ARCHITECTS



GENERAL CONTRACTORS
A SUBSIDIARY OF CHIEF INDUSTRIES, INC.

DESIGN BUILD PROFESSIONALS

Change Order Request

COR Number: 015
Date: 9/14/2016
Project Number: 16LB005
Contract Date: 4/15/2016

To:	Project:
GRAND ISLAND PUBLIC SCHOOLS Michael S. Kneale Admin Building 123 S Webb Road, P.O. Box 4904 Grand Island NE 68802-4904	GIPS Senior High 100 Wing Remodel DIV20 2124 N. Lafayette Ave. Grand Island NE 68803

Description of Change:

Add for material, labor, and equipment to reconnect existing exhaust fan located in Electrical 131 per RFP-009.

Tri-Cities = \$125.00
 Jerry's Sheet Metal = \$1,063.00

 SUB-TOTAL = \$1,188.00
 Markup (10%) = \$118.80

 TOTAL COR = \$1,306.80

Proposed Contract Amount of this Change Order 1,306.80

Accepting this Change Order Request indicates that it should be converted to an Owner Change Order and incorporated as part of the original contract.

Accepted By:

Owner (*Owner's Representative*)

By (*Signature*)

Printed Name

Date

3935 Westgate Road
 P.O. Box 2078 (MAILING)
 Grand Island, NE 68802-2078
 Phone 308-389-7222
 Fax 308-389-7393

INTERNET: <http://www.chiefconstruction.us>
 EMAIL: construction@chiefind.com

4400 E. 39th Street
 P.O. Box 848 (MAILING)
 Kearney, NE 68848-0848
 Phone 308-238-2755
 Fax 308-238-2759

PROPOSAL
Tri-Cities Group Inc.
Roofing Contractors
P. O. Box 909
GRAND ISLAND, Nebraska 68802
877-290-2224
(308) 384-7230
Fax (308) 384-7260

PROPOSAL SUBMITTED TO Chief Construction	PHONE 308-389-7222	DATE 09/07/2016
STREET 3935 Westgate Rd.	JOB NAME 100 Wing (RFP #009)	
CITY, STATE and ZIP CODE Grand Island, NE 68803	JOB LOCATION GIPS Senior High	

We hereby submit specifications and estimates for:

(RFP #009)

Flash new exhaust pipe into the new EPDM roof system.

We propose to furnish material and labor – complete in accordance with above specifications, for the sum of: \$125.00
One hundred twenty five dollars. -----
Payment to be made as follows:
Net 30 days from completion:

All material is guaranteed to be as specified. All work to be completed in a workmanlike manner according to standard practices. Any alteration or deviation from above specifications involving extra costs will be executed only upon written orders, and will become an extra charge over and above the estimate. All agreements contingent upon strikes, accidents or delays beyond our control. Owner to carry fire, tornado and other necessary insurance. Our workers are fully covered by worker's compensation insurance.

Acceptance of Proposal: The above prices, specifications and conditions are satisfactory and are hereby accepted. You are authorized to do the work as specified. Payment will be made as outlined above.

Date of Acceptance: _____

Authorized Signature Gene Schacher
Gene Schacher

NOTE: This proposal may be withdrawn by us if not accepted with 10 days.

Signature _____
 Signature _____

JERRY'S

SHEET METAL ■ HEATING ■ COOLING

907 W. Oklahoma • PO Box 484 • Grand Island, NE 68802 • Phone: 308-384-2881

Chief Construction

GISH 100 wing PR #9

6" pipe and elbows	\$ 75.00
6" Cone Flashing	\$ 45.00
6" Vent pipe cap	\$ 35.00
JSM Labor 8 x \$55.00	\$ 440.00
JSM 15%	\$ 90.00
Middleton Electric	\$ 360.00
JSM 5%	\$ 18.00

Total cost to vent existing exhaust fan through the roof \$ 1,063.00

We do not include the roofing work.



HEATING

LENNOX COOLING

Middleton Electric Inc.

2716 W. Old Hwy 30
Grand Island, NE 68803
Phone: 308-382-2560
Fax: 308-382-3442

Change Order

9/14/2016

TO:

Chief Construction
2107 S. North Road

Grand Island, NE 68803

JOB:

Project: PR#09
GIPS Senior High 100 Wing
Change Order Number: CO679885-1

WORK DESCRIPTION: All material and labor to connect the existing exhaust fan in EElectrical 131 that was disconnected during demo process

OTHER INFORMATION:

The total amount of this Change Order is: **\$360.00**

Sincerely,

MATT TREFFER

Material		
Non-Quoted		
Quotes		\$52.68
Sales Tax (0.00%)		0.00
Total Material		0.00
Labor		\$52.68
Direct (6.12 hours @ \$44.85)		
0		\$274.48
Total Labor		0.00
0		\$274.48
0		\$0.00
0		0.00
Job Subtotal (Prime Cost)		0.00
Overhead (0.00%)		\$327.16
Profit (10.00%)		0.00
Job Total		32.72
		\$359.88
Actual Bid Price		\$360.00
Material to Direct Labor ratio: 0.16		
Prime Cost per square foot		
Job Total per square foot		\$0.00
Actual Bid Price per square ft		\$0.00
Labor cost per square foot		\$0.00
Labor hours per square foot		\$0.00
Gross Profit %		0.00
Gross Profit \$		9.12
Net Profit %		\$32.84
		9.12



CANNON MOSS BRYGGER ARCHITECTS

208 N PINE STREET, SUITE 301 • GRAND ISLAND, NE 68801 • (P) 308.384.4444

REQUEST FOR PROPOSAL (RFP- 009)

PROJECT: GRAND ISLAND PUBLIC SCHOOLS
SENIOR HIGH 100 WING REMODEL

PROJECT #: 15113

DATE: 08/24/2016

TO: LANCE BACHMAN

COMPANY: CHIEF CONSTRUCTION

FROM: BRAD KISSLER

COMPANY: CANNON MOSS BRYGGER ARCHITECTS

Provide a cost breakdown in accordance with the contract documents for the proposed changes to the contract as described below and on any attachments transmitted here within. This is not an authorization to proceed. If approved, the changes will be included in a forthcoming change order.

1. Refer to Kucirek Engineering, Inc. PR #09, dated August 24, 2016 for changes. See attached sheet.

CC: DAN PETSCH, GRAND ISLAND PUBLIC SCHOOLS



**Kucirek Engineering,
Inc.**

7587 Main Street
Omaha, NE 68127
(402) 951-0022

PROPOSAL REQUEST (PR)

PROJECT:

GRAND ISLAND
SENIOR HIGH 100 WING REMODEL
GRAND ISLAND, NEBRASKA

PR NO: PR 09

DATE OF ISSUANCE: 8-24-16

OWNER:

Dan Petsch
Grand Island Public Schools

PROJECT NO: KEI #15007

ARCHITECT:

Cannon Moss Brygger & Associates, P.C.
Grand Island, NE 68803

CONTRACTOR:

Lance Bachman
Chief Construction

The Work shall be carried out in accordance with the following supplemental instructions issued in accordance with the Contract Documents.

DESCRIPTION:

Existing exhaust fan located in Electrical 131 has had electrical connection removed. Electrical contractor shall reconnect exhaust fan to existing location (disconnect/breaker). Mechanical contractor shall discharge exhaust fan duct up thru roof and provide discharge roof cap. Existing exhaust fan is 1/12 HP and 120 V.

ATTACHMENTS:



GENERAL CONTRACTORS
A SUBSIDIARY OF CHIEF INDUSTRIES, INC.

DESIGN BUILD PROFESSIONALS

Change Order Request

COR Number: 016

Date: 7/6/2016

Project Number: 16LB005

Contract Date: 4/15/2016

To:	Project:
GRAND ISLAND PUBLIC SCHOOLS Michael S. Kneale Admin Building 123 S Webb Road, P.O. Box 4904 Grand Island NE 68802-4904	GIPS Senior High 100 Wing Remodel DIV20 2124 N. Lafayette Ave. Grand Island NE 68803

Description of Change:

Roof drain modifications per RFP-005.

O'Neill Transportation & Equipment = (\$345.00)
 Chief Construction Self-Performed Concrete = (\$590.20)
 Concrete: 3.3 CY x \$94.00/CY = \$310.20
 Labor: 2 Workers x 4 HR x \$35.00/HR = \$280.00
 Jerry's Sheetmetal = (\$4,229.00)

TOTAL COR = (\$5,164.20)

Proposed Contract Amount of this Change Order

(5,164.20)

Accepting this Change Order Request indicates that it should be converted to an Owner Change Order and incorporated as part of the original contract.

Accepted By:

Owner (Owner's Representative)

By (Signature)

Printed Name

Date

3935 Westgate Road
 P.O. Box 2078 (MAILING)
 Grand Island, NE 68802-2078
 Phone 308-389-7222
 Fax 308-389-7393

INTERNET: <http://www.chiefconstruction.us>
 EMAIL: construction@chiefind.com

4400 E. 39th Street
 P.O. Box 848 (MAILING)
 Kearney, NE 68848-0848
 Phone 308-238-2755
 Fax 308-238-2759

Bachman, Lance

From: patoneill2075@gmail.com on behalf of Pat O'Neill <pat@oneillwr.com>
Sent: Tuesday, September 20, 2016 5:01 PM
To: Bachman, Lance
Subject: Re: GISH 100 Wing Remodel - Updated RFP-005 Pricing

I gave a credit of \$990.00 but we ended up doing half of the work for \$495.00 and a mobilization which I figured at \$150.00 for a total cost of \$645.00 which leaves a deduct of \$345.00.

Thanks,

Pat

Patrick C. O'Neill
O'Neill Wood Resources
O'Neill Transportation and Equipment
PO Box 2202 Grand Island, NE 68802
Office 308-384-1690 Fax 308-381-1697
cell 308-380-6032

On Wed, Sep 14, 2016 at 2:21 PM, Bachman, Lance <lance.bachman@chiefind.com> wrote:

Pat,

You had previously given me a credit for the attached old copy of RFP-005. This was recently revised to the attached updated copy. Can you please look at your number again and let me know where you are at with the revisions?

Let me know if you have any questions.

Thanks,

Lance Bachman | Project Manager

Chief Construction Company | chiefconstruction.build
Office: 308.389.7403 | Cell: 402.694.8980

Bachman, Lance

From: patoneill2075@gmail.com on behalf of Pat O'Neill <pat@oneillwr.com>
Sent: Wednesday, June 29, 2016 4:06 PM
To: Bachman, Lance
Subject: Re: GISH 100 Wing Remodel - Roof Drain Piping Modification

The deduct would be to not cut and break out approximately 90 lineal feet of trench two feet wide. There is no savings for mobilization because I still have to mobilize all the same equipment to cut out for the stoops. The saving is for actual work not performed.

Demo saw, blade, gas \$180
Saw cut labor 8 hours at \$45 - \$360
Two hour mini-ex \$200.00
Two hours roll off truck \$250.00

Total deduct of \$990.00

Thanks,

Pat

Patrick C. O'Neill
O'Neill Wood Resources
O'Neill Transportation and Equipment
PO Box 2202 Grand Island, NE 68802
Office 308-384-1690 Fax 308-381-1697
cell 308-380-6032

On Wed, Jun 29, 2016 at 12:06 PM, Bachman, Lance <lance.bachman@chiefind.com> wrote:

Pat,

Can you get me a credit for not having to cut and remove the exterior concrete due to this change?

Thanks,

Lance Bachman | Project Manager

Chief Construction Company | chiefconstruction.build
308.389.7403

Bachman, Lance

From: BJ O'Hara <bjohara@hamilton.net>
Sent: Wednesday, September 28, 2016 11:33 AM
To: Bachman, Lance
Cc: KC
Subject: Re: GISH 100 Wing Remodel - Updated RFP-005 Pricing

Price is the same

BJ O'Hara
O'Hara Plumbing
3821 Arch Ave.
Grand Island Ne 68803
bjohara@hamilton.net
308-382-0765 Office
308-382-5166 Fax

From: Bachman, Lance
Sent: Wednesday, September 14, 2016 2:22 PM
To: mailto:bjohara@hamilton.net
Cc: KC
Subject: GISH 100 Wing Remodel - Updated RFP-005 Pricing

BJ,

You had previously given me a credit for the attached old copy of RFP-005. This was recently revised to the attached updated copy. Can you please look at your number again and let me know where you are at with the revisions?

Let me know if you have any questions.

Thanks,

Lance Bachman | Project Manager

Chief Construction Company | chiefconstruction.build
Office:308.389.7403 | Cell:402.694.8980

Proposal



O'Hara Plumbing Co., Inc.
P.O. Box 1038
Grand Island, NE 68802-1038
(308) 382-0765
Fax (308) 382-5166
Email: oharaplumbing@hamilton.net

PROPOSAL SUBMITTED TO JERRY SHEETMETAL		PHONE	DATE 7/18/2016
STREET		JOB NAME GRAND ISLAND SENIOR HIGH	
CITY, STATE, ZIP CODE		JOB LOCATION GRAND ISLAND NEBRASKA	
ARCHITECT	DATE OF PLANS		JOB PHONE

We hereby submit specifications and estimates for: **PROPOSAL REQUEST #05**

DEDUCT ROOF DRAIN PIPING IN E.L.L. ROOMS THAT GOES TO OUTSIDE MANHOLE AND TIE INTO EXISTING ROOF DRAIN PIPING

MATERIAL	\$660.00
LABOR	\$800.00
PIPE INSUALTION	\$480.00
UTILITIES	\$2,289.00
TOTAL DEDUCT	\$4,229.00

WE PROPOSE hereby to furnish material and labor – complete in accordance with above specifications, for the sum of:

FOUR THOUSAND TWO HUNDRED AND TWENTY NINE AND NO 100 _____ Dollars (\$4,229.00).

Payment to be made as follows:

All material is guaranteed to be as specified. All work to be completed in a workmanlike manner according to standard practices. Any alteration or deviation from above specifications involving extra costs will be executed only upon written orders, and will become an extra charge over and above the estimate. All agreements contingent upon strikes, accidents or delays beyond our control. Owner to carry fire, tornado and other necessary insurance. Our workers are fully covered by Workman's Compensation Insurance.

Authorized Signature: **BJ OHARA**

Note: This proposal may be withdrawn by us if not accepted within **30** days.

ACCEPTANCE OF PROPOSAL – The above prices, specifications and conditions are satisfactory and are hereby accepted. You are authorized to do the work as specified. Payment will be made as outlined above.

Date of Acceptance: _____

Signature: _____

Signature: _____



CANNON MOSS BRYGGER ARCHITECTS
208 N PINE STREET, SUITE 301 • GRAND ISLAND, NE 68801 • (P) 308.384.4444

REQUEST FOR PROPOSAL (RFP- 005)

PROJECT: GRAND ISLAND PUBLIC SCHOOLS
SENIOR HIGH 100 WING REMODEL

PROJECT #: 15113

DATE: 09/14/2016

TO: LANCE BACHMAN

COMPANY: CHIEF CONSTRUCTION

FROM: BRAD KISSLER

COMPANY: CANNON MOSS BRYGGER ARCHITECTS

Provide a cost breakdown in accordance with the contract documents for the proposed changes to the contract as described below and on any attachments transmitted here within. This is not an authorization to proceed. If approved, the changes will be included in a forthcoming change order.

1. Refer to Kucirek Engineering, Inc. Updated PR #05, dated September 13, 2016 for changes. See attached drawings.

CC: DAN PETSCH, GRAND ISLAND PUBLIC SCHOOLS



Kucirek Engineering, Inc.

7587 Main Street
Omaha, NE 68127
(402) 951-0022

PROPOSAL REQUEST (PR)

PROJECT: Grand Island Public Schools **PROJECT NO.:** 15113 (KEI No. 15007)
100 Wing Remodel
Grand Island, Nebraska **PR NO.:** UPDATED 05

OWNER: Grand Island Public Schools **DATE:** SEPTEMBER 13, 2016

ARCHITECT: Cannon Moss Brygger
Architects

CONTRACTOR: Chief Construction

These proposal request items are added to and shall become a part of the Construction Documents dated March 18, 2016.

The contractor will be required to furnish or delete, as the case may be, all materials, labor, equipment, and supervision required to properly execute the work described herein.

The contractor and all subcontractors shall incorporate all items noted in the proposal request into the original drawings and specifications for this project.

MECHANICAL

ITEM M1: Refer to Project Drawings – Sheets P1.02

1. CONNECTION TO EXISTING ROOF DRAIN SHALL BE VIA 5" NEW ROOF DRAIN.

See P1.02 sheet replacement.

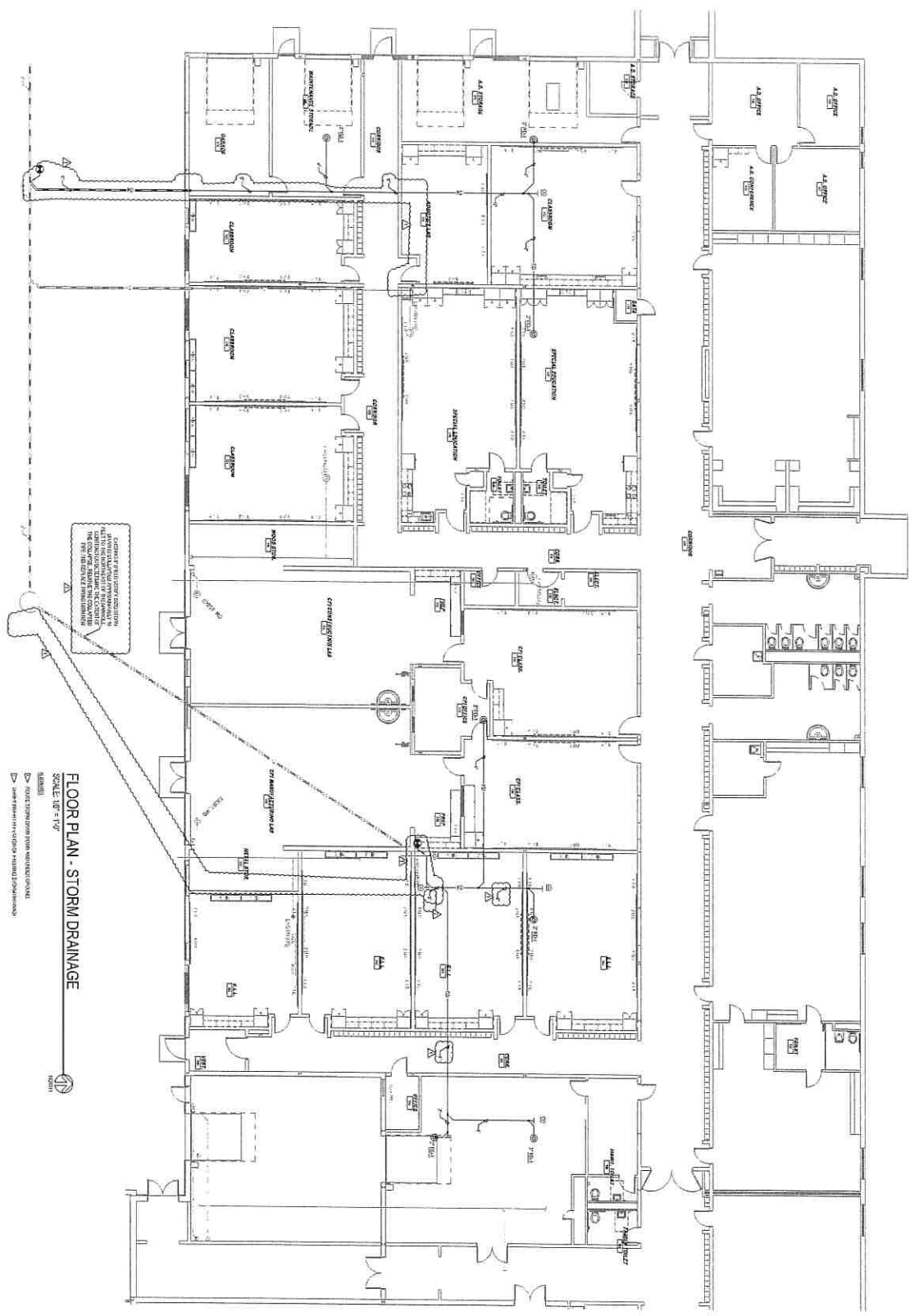

FLOOR PLAN - STORM DRAINAGE
 SCALE: 1/8" = 1'-0"
 NORTH

- LEGEND
- STORM DRAIN FROM RECEPTION AREA
 - STORM DRAIN FROM CLASSROOMS
 - STORM DRAIN FROM GYMNASIUM
 - STORM DRAIN FROM CAFETERIA

REGISTERED PROFESSIONAL ENGINEER
K E
 CONSULTING ENGINEERS
 1000 WEST 10TH AVENUE, SUITE 100
 DENVER, COLORADO 80202
 PHONE: 303.733.8800
 FAX: 303.733.8801
 WWW: KEENGINEERS.COM

SEAL

REVISIONS

NO.	DATE	DESCRIPTION
1	03/18/2016	ISSUE FOR PERMIT
2	03/18/2016	ISSUE FOR PERMIT
3	03/18/2016	ISSUE FOR PERMIT



IF THIS DRAWING IS NOT 20% COMPLETE, IT IS NOT TO SCALE.





GENERAL CONTRACTORS
A SUBSIDIARY OF CHIEF INDUSTRIES, INC.

DESIGN BUILD PROFESSIONALS

Change Order Request

COR Number: 017

Date: 9/30/2016

Project Number: 16LB005

Contract Date: 4/15/2016

To:	Project:
GRAND ISLAND PUBLIC SCHOOLS Michael S. Kneale Admin Building 123 S Webb Road, P.O. Box 4904 Grand Island NE 68802-4904	GIPS Senior High 100 Wing Remodel DIV20 2124 N. Lafayette Ave. Grand Island NE 68803

Description of Change:

Plumbing modifications to Toilets 106 & 107 per RFP 010.

O'Neill Transportation & Equipment = \$0.00
Chief Construction Self-Performed Concrete = \$0.00
Jerry's Sheetmetal = (\$244.00)

TOTAL COR = (\$244.00)

Proposed Contract Amount of this Change Order

(244.00)

Accepting this Change Order Request indicates that it should be converted to an Owner Change Order and incorporated as part of the original contract.

Accepted By:

Owner (Owner's Representative)

By (Signature)

Printed Name

Date

3935 Westgate Road
P.O. Box 2078 (MAILING)
Grand Island, NE 68802-2078
Phone 308-389-7222
Fax 308-389-7393

INTERNET: <http://www.chiefconstruction.us>
EMAIL: construction@chiefind.com

4400 E. 39th Street
P.O. Box 848 (MAILING)
Kearney, NE 68848-0848
Phone 308-238-2755
Fax 308-238-2759

Proposal



O'Hara Plumbing Co., Inc.
P.O. Box 1038
Grand Island, NE 68802-1038
(308) 382-0765
Fax (308) 382-5166
Email: oharaplumbing@hamilton.net

PROPOSAL SUBMITTED TO JERRY SHEETMETAL		PHONE	DATE 10/19/2016
STREET		JOB NAME SENIOR HIGH 100 WING	
CITY, STATE, ZIP CODE		JOB LOCATION GRAND ISLAND NEBRASKA	
ARCHITECT	DATE OF PLANS		JOB PHONE

We hereby submit specifications and estimates for: **RFP #010**

MATERIAL	\$49.00
FLOOR DRAIN	\$25.00
LABOR	\$170.00
TOTAL DEDUCT	-\$244.00

WE PROPOSE hereby to furnish material and labor – complete in accordance with above specifications, for the sum of:

TWO HUNDRED FOURTY FOUR AND NO 100

Dollars (**\$244.00**).

Payment to be made as follows:

All material is guaranteed to be as specified. All work to be completed in a workmanlike manner according to standard practices. Any alteration or deviation from above specifications involving extra costs will be executed only upon written orders, and will become an extra charge over and above the estimate. All agreements contingent upon strikes, accidents or delays beyond our control. Owner to carry fire, tornado and other necessary insurance. Our workers are fully covered by Workman's Compensation Insurance.

Authorized Signature: **BJ OHARA**

Note: This proposal may be withdrawn by us if not accepted within **30** days.

ACCEPTANCE OF PROPOSAL – The above prices, specifications and conditions are satisfactory and are hereby accepted. You are authorized to do the work as specified. Payment will be made as outlined above.

Date of Acceptance: _____

Signature: _____

Signature: _____



CANNON MOSS BRYGGER ARCHITECTS

208 N PINE STREET, SUITE 301 • GRAND ISLAND, NE 68801 • (P) 308.384.4444

REQUEST FOR PROPOSAL (RFP- 010)

PROJECT: GRAND ISLAND PUBLIC SCHOOLS
SENIOR HIGH 100 WING REMODEL

PROJECT #: 15113

DATE: 09/20/2016

TO: LANCE BACHMAN

COMPANY: CHIEF CONSTRUCTION

FROM: BRAD KISSLER

COMPANY: CANNON MOSS BRYGGER ARCHITECTS

Provide a cost breakdown in accordance with the contract documents for the proposed changes to the contract as described below and on any attachments transmitted here within. This is not an authorization to proceed. If approved, the changes will be included in a forthcoming change order.

1. Refer to Kucirek Engineering, Inc. PR #010, dated September 19, 2016 for changes. See attached sheets.

CC: DAN PETSCH, GRAND ISLAND PUBLIC SCHOOLS



Kucirek Engineering, Inc.

7587 Main Street
Omaha, NE 68127
(402) 951-0022

PROPOSAL REQUEST (PR)

PROJECT: Grand Island Public Schools **PROJECT NO.:** 15113 (KEI No. 15007)
100 Wing Remodel
Grand Island, Nebraska **PR NO.:** 010

OWNER: Grand Island Public Schools **DATE:** September 19, 2016

ARCHITECT: Cannon Moss Brygger
Architects

CONTRACTOR: Chief Construction

These proposal request items are added to and shall become a part of the Construction Documents dated March 18, 2016.

The contractor will be required to furnish or delete, as the case may be, all materials, labor, equipment, and supervision required to properly execute the work described herein.

The contractor and all subcontractors shall incorporate all items noted in the proposal request into the original drawings and specifications for this project.

MECHANICAL

ITEM M1: Refer to Project Drawings – Sheets P1.01

1. Updated sanitary piping in Family Toilet 107 and Maint. Toilet 106. Deleted floor drains in these rooms.

See P1.01 sheet replacement.

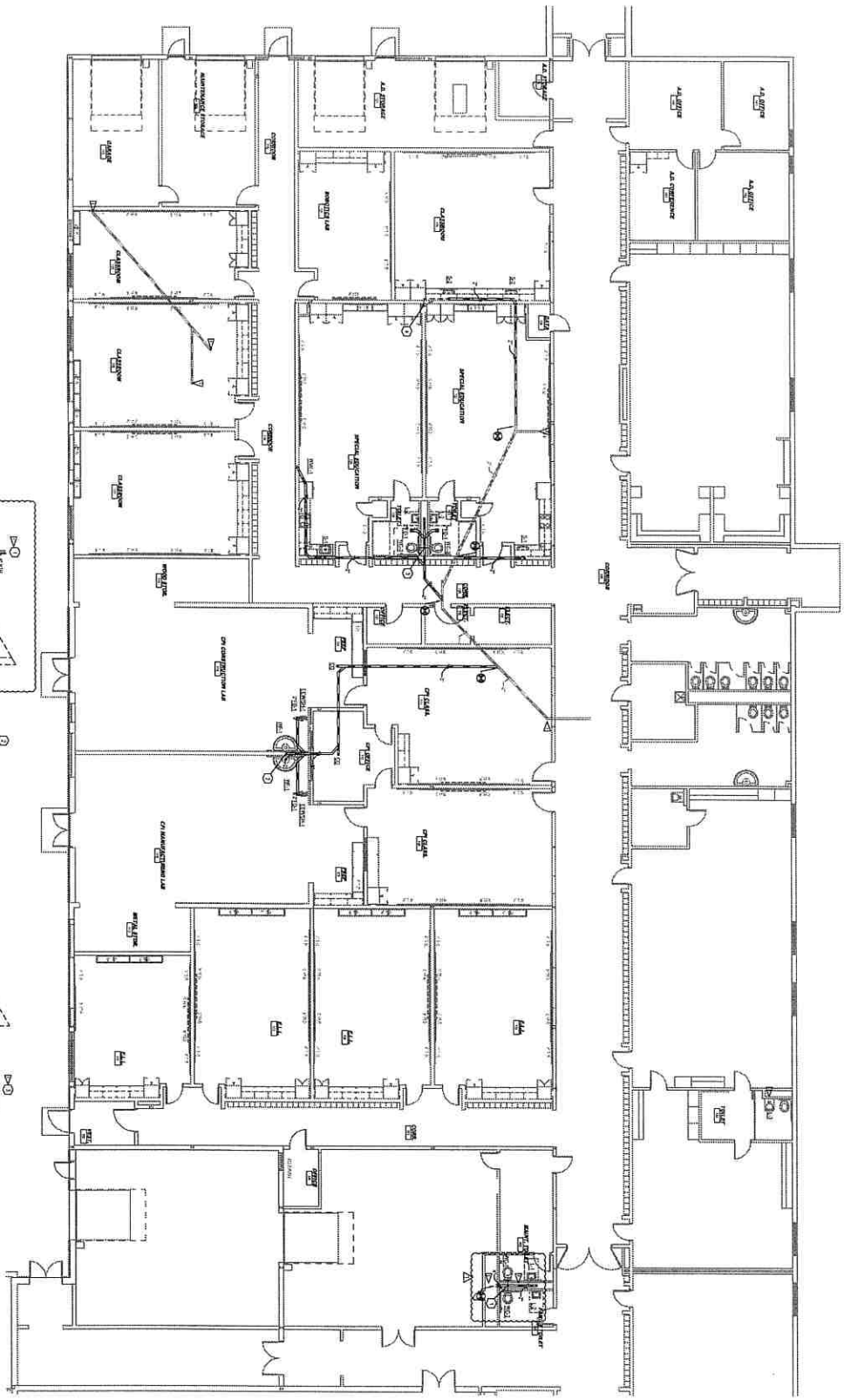

FLOOR PLAN - SANITARY WASTE AND VENT

SCALE: 1/8" = 1'-0"

- ▶ TYPICAL ROOM SCHEDULE INDICATED
- ▶ SANITARY WASTE LINE INDICATED BY SOLID LINE WITH ARROW
- ▶ VENT LINE INDICATED BY DASHED LINE
- ▶ ROOM NUMBER INDICATED BY NUMBER IN CIRCLE
- ▶ DOOR SWINGS INDICATED BY ARC
- ▶ WINDOW LOCATIONS INDICATED BY SHORT DASHED LINE
- ▶ ALL DIMENSIONS ARE IN FEET AND INCHES
- ▶ ALL DIMENSIONS ARE TO FACE UNLESS NOTED OTHERWISE
- ▶ ALL DIMENSIONS ARE TO CENTER UNLESS NOTED OTHERWISE
- ▶ ALL DIMENSIONS ARE TO FACE UNLESS NOTED OTHERWISE
- ▶ ALL DIMENSIONS ARE TO CENTER UNLESS NOTED OTHERWISE
- ▶ ALL DIMENSIONS ARE TO FACE UNLESS NOTED OTHERWISE
- ▶ ALL DIMENSIONS ARE TO CENTER UNLESS NOTED OTHERWISE

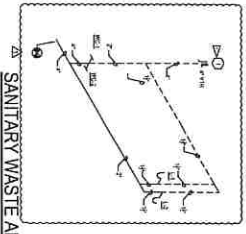

SANITARY WASTE AND VENT RISER DIAGRAM

NO SCALE

- ▶ SANITARY WASTE LINE INDICATED BY SOLID LINE WITH ARROW
- ▶ VENT LINE INDICATED BY DASHED LINE

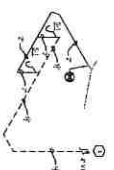
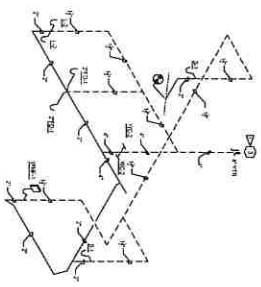

SEAL



REVISIONS

NO.	DATE	DESCRIPTION
1	03/18/2016	ISSUED FOR PERMIT



IF THIS DRAWING IS NOT SEPA-CF IT IS NOT TO SCALE





GENERAL CONTRACTORS
A SUBSIDIARY OF CHIEF INDUSTRIES, INC.

DESIGN BUILD PROFESSIONALS

Change Order Request

COR Number: 018

Date: 10/16/2016

Project Number: 16LB005

Contract Date: 4/15/2016

To:	Project:
GRAND ISLAND PUBLIC SCHOOLS Michael S. Kneale Admin Building 123 S Webb Road, P.O. Box 4904 Grand Island NE 68802-4904	GIPS Senior High 100 Wing Remodel DIV20 2124 N. Lafayette Ave. Grand Island NE 68803

Description of Change:

Add to prep, protect the surrounding finishes, stain, and finish the install wood bulkhead in CPI Construction Lab 115 per Owner/Architect request. Stain color to be selected by Architect.

GSC = \$4,250.00

SUB-TOTAL = \$4,250.00

Mark-up (10 %) = \$425.00

TOTAL COR = \$4,675.00

Proposed Contract Amount of this Change Order

4,675.00

Accepting this Change Order Request indicates that it should be converted to an Owner Change Order and incorporated as part of the original contract.

Accepted By:

Owner (Owner's Representative)

By (Signature)

Printed Name

Date

3935 Westgate Road
P.O. Box 2078 (MAILING)
Grand Island, NE 68802-2078
Phone 308-389-7222
Fax 308-389-7393

INTERNET: <http://www.chiefconstruction.us>
EMAIL: construction@chiefind.com

4400 E. 39th Street
P.O. Box 848 (MAILING)
Kearney, NE 68848-0848
Phone 308-238-2755
Fax 308-238-2759

Bachman, Lance

From: greg cramer <gscathome@gmail.com>
Sent: Tuesday, October 11, 2016 8:06 AM
To: Bachman, Lance
Subject: Sr High wood bulkhead

Follow Up Flag: Follow up
Flag Status: Flagged

Lance

To prep,protect the surrounding finishes,stain and finish the installed wood bulkhead would be \$4250.00

Thanks Greg

1. CALL TO ORDER	Board President
2. ROLL CALL	
3. MISSION STATEMENT	
4. CONSENT AGENDA	Board President
1. Minutes from the November 10, 2016 Regular Meeting	
2. Claims, as submitted	
3. Bid Proposals as submitted	
4. Staff Adjustments as submitted	
5. Treasurer's Report as submitted	
6. Policy 6461 - Classified Staff Suspension, on Final Read	
7. Policy 6462 - Dismissal of "At Will" Status Staff Member, on Final Read	
8. Policy 6511 - Classified Staff Assignments and Transfers, on Final Read	
9. Policy 6711 - Classified Staff Performance Appraisal, on Final Read	
10. Policy 7150 - Academic Freedom, on First Read	
11. Policy 7160 - Citizenship, on First Read	
12. Policy 7210 - School Calendar, on First Read	
13. Grant Report Update	
14. Change Orders as Documented	
15. Approval of Agenda as submitted	
5. SPECIAL RECOGNITION	
1. Holiday Card Contest Winners	Dr. Grover
6. PUBLIC FORUM	
7. OATH OF OFFICE	
1. Oath of Office for newly appointed board member, ??	Dr. Dexter
2. Signing of the Board Operating Principles by Board Member ????	Dr. Dexter
8. INFORMATION ITEMS	
1. Campus Highlights - Featuring West Lawn Elementary	DW Holley, Tracy Morrow, Aleta Thomas, Amelia Nicolaus, Diana Martinez, Brissa Borjas
2. Campus Highlights - Featuring Seedling Mile Elementary	Charity LaBrie and staff members
3. Campus Highlights - Featuring GISH SIP Team	Gordon Bye, Patti Bennett, and Maggie Mintken
4. 2017-2018 Traditional Calendar	Dr. Dexter
5. Nebraska Education Profile Report	Mr. McDowell
6. Student Representative Report	Mr. Erick Estevez
7. NASB Conference Report Out	Board members
8. Construction Update	Mr. Petsch
9. Superintendent Report	Dr. Grover
9. ACTION ITEMS	
1. GIEA 2018-2019 Bargaining Agent Proposal	Mr. Stelk
2. Resolution on QCPUF Project	Mr. Harden

3. 2015-2016 Audit Report	Mr. Harden
4. Shannon Builders Contract	Mr. Petsch
10. COMMITTEE REPORTS	
1. Finance and Facilities Committee, including possible action recommendation.	Mr. Brown
2. Teaching and Learning Committee	Mr. Exstrum
3. Policy Committee	Mrs. Schutz
4. Public Relations / Personnel Committee	Mrs. Hinkle
5. Grand Island Public Schools Foundation Report	Dr. Brosz
6. Legislative Committee	Mr. Harden
7. NASB Board of Directors Report	Mrs. Schutz
8. GNSA	Mr. Harden
11. EXECUTIVE SESSION for Possible Real Estate Transactions, Superintendent Evaluation, and Personnel Negotiations	
12. RECONVENE FROM EXECUTIVE SESSION	
13. APPROVAL OF ANY ACTION DEEMED NECESSARY AS A RESULT OF EXECUTIVE SESSION	
14. OLD BUSINESS	
15. NOTIFICATION OF UPCOMING BOARD MEETINGS	
1. January 16, 2017 - Regular Board Meeting, 6:30 P.M.	
16. ADJOURNMENT	

2111–BOARD OPERATING PRINCIPLES

We believe that the welfare of our community, state, and nation is directly impacted by our educational system. We believe that each child should receive the best possible education relative to his or her abilities, interests, and potentialities. To this end, we believe that Board decisions regarding complex problems of organization, curricular offerings, and financial support should be made in terms of what is best for the student and by extension, the community, state, and nation.

In order to assure maximum efforts toward this goal, the Board believes high ethical standards on the part of all Board members must be maintained in all personal and public activities. The following Operating Principles serve to guide individual board member interaction as we carry out the duties and responsibilities of board members, as well as to provide information to the public concerning the duties and responsibilities of the Board of Education as a collective whole.

I. Educational Advocate

Statement: We are advocates for successful and equitable opportunities for all students consistent with the mission statement of Grand Island Public Schools. As educational advocates, we are to assure that the schools are well run, but we are not to run the schools.

*Every Student, Every Day A Success
Within the school district of Grand Island*

- *Every student will be taught to read, write, and communicate effectively; solve problems; acquire and apply knowledge; and demonstrate mastery through performance to the best of the student's abilities;*
- *Every student will be treated with fairness and dignity;*
- *Every student will experience a sense of belonging, contribution, and success; and*
- *Every student will develop responsibility and show respect for others as well as oneself.*

In educating students, we teach hearts as well as minds.

II. Process for Addressing Public and Board Issues

Public

Statement: We will encourage the public to use the chain of command to address concerns in the following manner:

- A. Listen to the individual's concern.
- B. Explain that the board and administrative team have established a process for handling concerns starting with the immediate person responsible.
 1. Encourage the person to follow the established chain of command. Ask if he or she has discussed the issue with the person immediately responsible (for example, a teacher or coach).
 2. If so, ask if he or she has discussed the issue with the supervisor of the individual (for example, the Principal or Activities Director).
 3. If so, ask if he or she has discussed the issue with the Superintendent.
 4. Assure the person that the Superintendent will be informed of a significant complaint. However, affirm the chain of command procedure must be followed.
- C. Significant complaints will be reported to the Superintendent by the board member.

Board Member

Statement: We believe as an individual board member we have no individual power, and our power comes from being a part of a group of nine. When concerns are raised, there is a proper protocol to follow in response to the concern. The protocol is as follows:

- A. The Superintendent will be notified of issues which are causing concern of the board member, including individual or collected board concerns regarding staff or district operations.

- B. The Superintendent will be the recipient of appropriate information regarding issues needing investigation (i.e., names of people making complaints, specific instances regarding the complaint, etc.).
- C. If we have concerns about another board member:
 - The concern should first be shared personally with the board member.
 - If a resolution is not reached between the two board members, concerns will be directed to the Board President.
 - There may be times the resolution will require a discussion with the entire Board of Education in an Executive Session.

III. Meeting Format

Statement: We will conduct our meetings in accordance with the Nebraska Open Meeting Laws and in an orderly fashion.

Board Meetings

- A. Board meeting agendas will be developed cooperatively with the Board President, Vice-President, and Superintendent after receiving committee input. An individual board member may request that an item be added to the agenda.
- B. Issues will be presented as an informational item without a vote occurring to allow for full consideration and thought by board members.
 1. The vote on the issue will follow in the next month's meeting.
 2. There may be instances when an issue must be presented and voted on at the same monthly meeting.
- C. Executive Session will be used **ONLY** as necessary and consistent with Nebraska Open Meeting Laws.
- D. We welcome input from the public during the scheduled Public Forum period of each board meeting. Patrons are requested to complete the "Request to address the Board" form and follow guidelines included on the form. The form is posted outside the doors to the Boardroom.
- E. Each board meeting during the academic year will have a portion of the meeting devoted to a segment on student success within the district.
- F. We will maintain a student board member program.

Board of Education Committees

- A. Standing committees will be established to allow issues to be reviewed in great length, so the regular monthly meetings are run efficiently and timely. The committees are:
 1. Personnel
 2. Policy Review
 3. Facilities and Finance
 4. Americanism (Teaching & Learning)
- B. The district will establish and maintain additional committees as needed to include:
 1. Legislative
 2. Calendar
 3. Grand Island Education Foundation
 4. Extra Standards
 5. Labor Relations
 6. Public Relations
 7. Safety

The Board President will ask for interested participants, and provide opportunities for all board members to participate in these additional committees.
- C. Ad Hoc committees will be appointed as needed. The Board President will ask for interested participants, and provide opportunities for all board members to participate in Ad Hoc committees.
- D. All board committee agendas and minutes will be posted to the Board Committee folder in First Class (email system) for all board members to view.
- E. The committees do not have power to take formal action on issues without a full vote of the Board of Education.

- F. Non-committee board members wishing to attend specific committee meetings will make their request through the Superintendent's office.
- G. Board committees will report regularly at Board of Education meetings to ensure that information discussed in committee is made public.
- H. Committees will:
 - 1. Receive input from administration staff assigned to the particular committee.
 - 2. Seek opportunities to receive input prior to formulating recommendations.
 - 3. Analyze and organize collected data.
 - 4. Develop multiple options, which include potential impact on finance, facilities, and staff.
 - 5. Present the options to the Board of Education with a recommendation.

Small Group Meetings with the Superintendent and Board Members

- A. Each board member will have an opportunity to meet with the Superintendent and no more than three other board members on a monthly basis. The small group meetings will not violate the Open Meetings law.
- B. The meetings are intended to provide additional detail to board members about issues both negatively and positively impacting Grand Island Public Schools. No decision making will occur in the small group meetings.
- C. Summaries of the small group meetings will be shared with all board members to assure all board members receive the same information.

IV. Planning and Goal Setting

Statement: We will set direction for the District by:

- A. A comprehensive planning process which includes at least one annual session in the areas of 1.) Student achievement, 2.) Budget and 3.) Facilities.
- B. A comprehensive annual goal setting process that will form the basis for specific actions and results within the district.

V. Board Leadership

Statement: We believe effective team leadership is important for the positive progress of the Grand Island Public Schools system.

- A. Board President and Board Vice-President Positions
 - 1. The positions of Board President and Board Vice-President shall be elected annually at the January Board of Education meeting.
 - 2. Within two days following the November board meeting, the current Board President and Board Vice-President will notify the Board Secretary and the Board of Education of their interest and willingness to be considered for re-election of their positions.
 - 3. Board members interested in being considered for Board President or Board Vice-President shall make their intentions known to the Board Secretary and the Board of Education on or before December 1st.
 - 4. All board members expressing an interest in the positions will be subject to nomination for office at the January meeting.
 - 5. The Board Secretary will facilitate the election process at the January meeting.
- B. The Board President will:
 - 1. Manage the affairs of the Board of Education and
 - a. Ensure all board members are provided with the same information at approximately the same time on all issues.
 - b. Ensure all board members are provided the opportunity to represent the Board of Education equally at official school, community, state and national functions.
 - c. Monitor compliance with Operating Principles.
 - d. Plan and participate in orientation sessions for new board members.
 - 2. Establish the monthly agenda in conjunction with the Board Vice-President and Superintendent
 - 3. Assign working board committees annually after the January meeting and after soliciting areas of interests from the board members.

4. Monitor compliance with legal requirements to Open Meetings laws.
 5. Attend stakeholder meetings as determined by the Superintendent.
 6. Sign documents as legally required and approved by the Board of Education.
 7. Sign graduation diplomas.
 8. Serve as ex-officio member of standing committees of the Board, and be available to substitute on any committee with an impending absence.
 9. Conducts the semi-annual performance evaluation of the Superintendent, compiling and communicating results.
 10. Be the spokesperson for the Board of Education when called upon, including media inquiries.
 11. Serve on the Labor Relations Committee or designate Board Vice-President.
 12. Communicate Board of Education annual goals to the public.
- C. Board Vice-President will:
1. Plan and participate in orientation sessions for new board members.
 2. Meet monthly with the Board President and Superintendent to plan meeting agendas.
 3. Serve as Board President in all capacities in the absence of the Board President.
- D. Board Members (including President & Vice-President) will:
1. Attend all school board meetings.
 2. Attend and participate in meetings on assigned committees.
 3. Attend special meetings/functions of the district as requested or required (for example, graduation, specific school programs, etc).
 4. Represent the Board of Education at official school, community, state and national functions.
 5. Read and study all necessary documentation prior to discussion on issues or action items.
 6. Participate in continual professional development and attendance at NASB, NSBA, and other national conferences or meetings as agreed upon by the Board.
 7. Personally uphold these operating principles, and hold fellow board members accountable.
- E. The Board of Education team will:
1. Hire and evaluate the Superintendent's performance. The Superintendent is the only employee the Board oversees.
 2. Establish policy.
 3. Establish a budget to reflect/support board goals.
 4. Establish goals for the District.

VI. Board of Education Collaboration

Statement: We will formulate and express decisions as a body of nine speaking with one voice.

- A. We each have the freedom, opportunity, and responsibility to express his or her own beliefs about quality education.
- B. We will listen to diverse opinions. We recognize and appreciate the diverse backgrounds and experiences of other board team members which lend themselves to unique individual perspectives on issues.
- C. We must maintain the appropriate balance between being a board member and a parent, spouse, employee, or friend by not utilizing our positions as board members to influence decisions on a personal level.
- D. We will be governed by the same rules that apply to all Grand Island Public Schools district employees with regards to access to and utilization of Grand Island Public Schools district resources.
- E. We will not utilize our position to gain access to confidential information that is not made available to all board members or is not necessary for the board member to have to complete their duties.
- F. While we all have a personal point of view, our decisions will be based on the best interests of students.
- G. We will engage only in designated meetings and not in "meetings before the meetings" or "meetings after the meetings".

H. We will channel personal requests for information through the Superintendent's office.

I have read this policy and will adhere to statements of ethics and the Board Operating principles.

Board Member

Date

Policy Adopted : 10-5-00
Policy Revised: 7-10-03
Policy Revised: 1-11-07
Policy Revised: 10.14.2010



**2017-2018 STAFF
Traditional Calendar**

Elementary: 8 a.m. - 3:05 p.m.
Students dismissed at 2 p.m. Wednesdays
for teacher prep and planning

Middle: 8 a.m. - 3:30 p.m.
Students dismissed at 2 p.m. on first
Wednesday monthly for prof. learning

GISH: 8 a.m. - 3:20 p.m.
Students dismissed at 2 p.m. on first
Wednesday monthly for prof. learning

Distribution of days

	K-5	6-12
Student	173.5	173.5
Teacher	187	187
Conferences	3	3
Teacher prep	5.5	4
Prof. learning <i>(District/building, CIA, School Imp.)</i>	5	6.5

Quarter end dates
Oct. 20; Dec. 20 (82 student days)
March 1; May 24 (91.5 student days)

Trimester end dates
Nov. 9 (57 student days)
Feb. 16 (56 student days)
May 24 (60.5 student days)

Make-up days
May 24, May 25, May 29, May 30

2018-19 registration

TBA

Calendar legend

12	No school for staff
24	No school for students
18	Parent-Teacher Conferences
24	2 p.m. dismissal elementary
4	2 p.m. dismissal all students

AUGUST				
Mon	Tues	Wed	Thurs	Fri
	1	2	3	4
7	8	9	10	11
14	15	16	17	18
21	22	23	24	25
28	29	30	31	

AUGUST
9-11 New staff
14..... District Welcome/
Bldg prof. learning
15..... District CIA
16..... Teacher prep/planning
17..... K-5, 6, 9 students (2 p.m.)
18..... K-12 (2p.m.)

SEPTEMBER				
Mon	Tues	Wed	Thurs	Fri
				1
4	5	6	7	8
11	12	13	14	15
18	19	20	21	22
25	26	27	28	29

SEPTEMBER
1..... District prof. learning (a.m.)
Bldg prof. learning (p.m.)
4..... No School: Labor Day

OCTOBER				
Mon	Tues	Wed	Thurs	Fri
2	3	4	5	6
9	10	11	12	13
16	17	18	19	20
23	24	25	26	27
30	31			

OCTOBER
9-11 PTC (p.m.)
12..... PTC (a.m.)
Prep/planning (p.m.)
13..... Teacher comp day

NOVEMBER				
Mon	Tues	Wed	Thurs	Fri
		1	2	3
6	7	8	9	10
13	14	15	16	17
20	21	22	23	24
27	28	29	30	

NOVEMBER
10..... K-5 prep/planning
6-12 CIA (a.m.)
6-12 Collaborative
prep/planning (p.m.)
22-24.... No School:
Fall break

DECEMBER				
Mon	Tues	Wed	Thurs	Fri
				1
4	5	6	7	8
11	12	13	14	15
18	19	20	21	22
25	26	27	28	29

DECEMBER
21..... Bldg prof. learning (a.m.)
District prof. learning (p.m.)
22-31 .. No school: Winter break
(through Jan. 2)

JANUARY				
Mon	Tues	Wed	Thurs	Fri
1	2	3	4	5
8	9	10	11	12
15	16	17	18	19
22	23	24	25	26
29	30	31		

JANUARY
1..... No School: Winter break
2..... Teacher prep/planning
3..... K-12 staff, students return

FEBRUARY				
Mon	Tues	Wed	Thurs	Fri
			1	2
5	6	7	8	9
12	13	14	15	16
19	20	21	22	23
26	27	28		

FEBRUARY
5-7 PTC (p.m.)
8..... PTC (a.m.)
Prep/planning (p.m.)
9..... Teacher comp day

MARCH				
Mon	Tues	Wed	Thurs	Fri
			1	2
5	6	7	8	9
12	13	14	15	16
19	20	21	22	23
26	27	28	29	30

MARCH
2..... Bldg prof. learning (a.m.)
K-5 Prep/planning (p.m.)
6-12 Collaborative
prep/planning (p.m.)
5-9 No School: Spring Break
30..... No School: Easter Break

APRIL				
Mon	Tues	Wed	Thurs	Fri
2	3	4	5	6
9	10	11	12	13
16	17	18	19	20
23	24	25	26	27
30				

APRIL
2..... No School: Easter Break

MAY				
Mon	Tues	Wed	Thurs	Fri
	1	2	3	4
7	8	9	10	11
14	15	16	17	18
21	22	23	24	25
28	29	30	31	

MAY
13..... GISH Graduation
24..... Students' last day (11:30 a.m.)
K-12 Bldg prof. learning
25..... K-12 Teacher prep/planning

October 6, 2016

Bonnie Hinkle, President
Grand Island Public Schools Board of Education

Dear Ms. Hinkle:

The Grand Island Education Association continues to represent the bargaining unit covered by the 2016-17 Master Agreement and is recognized as the exclusive bargaining agent for negotiations for the 2017-18 contract year.

The Association requests that Grand Island Public Schools recognize the Association as the exclusive bargaining agent for the 2018-19 contract year for the unit it presently represents.

Please direct your response to the undersigned.

Sincerely,



Deb Gnuse, President
Grand Island Education Association

THIS COVER PAGE CONTAINS CERTAIN INFORMATION FOR QUICK REFERENCE ONLY. IT IS NOT A SUMMARY OF THIS ISSUE. INVESTORS MUST READ THE ENTIRE OFFICIAL STATEMENT TO OBTAIN INFORMATION ESSENTIAL TO THE MAKING OF AN INFORMED INVESTMENT DECISION.

**NEW ISSUE
BOOK-ENTRY-ONLY**

**NOT RATED
BANK QUALIFIED**

In the opinion of Gilmore & Bell, P.C., Bond Counsel to the District, under existing law and assuming continued compliance with certain requirements of the Internal Revenue Code of 1986, as amended (the "Code"), (1) the interest on the Bonds (including any original issue discount properly allocable to an owner thereof) is excludable from gross income for federal income tax purposes, and is not an item of tax preference for purposes of the federal alternative minimum tax imposed on individuals and corporations, (2) the interest on the Bonds is exempt from income taxation by the State of Nebraska and (3) the Bonds are "qualified tax-exempt obligations" within the meaning of Section 265(b)(3) of the Code. See "TAX MATTERS" in this Official Statement.

\$4,695,000*
HALL COUNTY SCHOOL DISTRICT 0002
IN THE STATE OF NEBRASKA
(Grand Island Public Schools)
Limited Tax Building Bonds
Series 2016

Dated: Date of Delivery

Due: December 15, as shown below

BOKF, National Association, Lincoln, Nebraska is the Paying Agent and Registrar. Interest is payable beginning June 15, 2017 and semiannually thereafter on December 15 and June 15 of each year. The Bonds are issuable in fully registered form and, when initially issued, will be registered in the name of Cede & Co., as nominee of The Depository Trust Company, New York, New York ("DTC"), which will act as securities depository for the Bonds. Purchases of the Bonds will be made in book-entry-only form, in the principal amount of \$5,000 or any integral multiple thereof, through brokers and dealers who are, or who act through, DTC participants. Beneficial owners of the Bonds will not receive physical delivery of bond certificates so long as DTC or a successor securities depository acts as the securities depository with respect to the Bonds. So long as DTC or its nominee is the registered owner of the Bonds, payments of the principal or redemption price of and interest on the Bonds will be made directly to DTC. Disbursement of such payments to DTC participants is the responsibility of DTC and disbursement of such payments to the beneficial owners is the responsibility of DTC participants. For terms relating to Bond principal and interest payments made to DTC or its nominee or in the event that the use of book-entry form is discontinued, see the caption "THE BONDS" herein.

The Bonds are being issued for the purpose of (a) paying the costs of removal of actual or potential environmental hazards, accessibility barriers, life safety code violations, life safety hazards or mold abatement and prevention in buildings of the District, all in accordance with the provisions of Section 79-10,110.02, R.R.S. Neb., as amended, (the "Act") and (b) paying certain costs of issuance for the Bonds.

The Bonds and other outstanding bonds issued pursuant to the Act and certain other applicable statutes are payable from ad valorem taxes, not to exceed three cents (\$0.030) per one hundred dollars of taxable valuation, on all taxable property located in the District. The Bonds are not general obligations of the District, may not be paid from any portion of its general funds, and are secured solely by the District's irrevocable pledge of amounts received from the levy of the limited tax described above. See the captions "SECURITY" and "NEBRASKA DEVELOPMENTS RELATED TO BUDGETS AND TAXATION" herein.

MATURITY SCHEDULE*

<u>Maturing December 15,</u>	<u>Amount</u>	<u>Interest Rate</u>	<u>Price</u>	<u>CUSIP</u>	<u>Maturing December 15,</u>	<u>Amount</u>	<u>Interest Rate</u>	<u>Price</u>	<u>CUSIP</u>
2018	\$285,000				2023	\$320,000			
2019	290,000				2024	325,000			
2020	295,000				2025	830,000			
2021	305,000				2026	855,000			
2022	310,000				2027	880,000			

The Bonds are callable in whole or in part anytime on or after the fifth anniversary of the date of original issue*, at par plus accrued interest to the date fixed for redemption. See the caption "THE BONDS – Optional Redemption" herein.

The Bonds are offered when, as and if issued and received by the Underwriter, subject to the approval of legality by Gilmore & Bell, P.C., Omaha, Nebraska, Bond Counsel to the District, and certain other conditions. It is expected that the Bonds will be available for delivery through The Depository Trust Company in New York, New York, on or about December 23, 2016*.

*Preliminary, subject to change



This Preliminary Official Statement and the information contained herein are subject to completion or amendment. These securities may not be sold, nor may offers to buy be accepted, prior to the time the Official Statement is delivered in final form. Under no circumstances shall this Preliminary Official Statement constitute an offer to sell or the solicitation of an offer to buy, nor shall there be any sale of these securities in any jurisdiction in which such offer, solicitation or sale would be unlawful prior to registration or qualification under the securities laws of such jurisdiction.

FORWARD-LOOKING STATEMENTS

This Official Statement contains statements which should be considered “forward-looking statements,” meaning they refer to possible future events or conditions.

The achievement of certain results or other expectations contained in such forward-looking statements involve known and unknown risks, uncertainties and other factors which may cause actual results, performance or achievements described to be materially different from any future results, performance or achievements expressed or implied by such forward-looking statements. The School District does not expect or intend to issue any updates or revisions to those forward-looking statements if or when its expectations change or events, conditions or circumstances on which such statements are based occur or fail to occur.

These securities have not been registered with the Securities and Exchange Commission by reason of the provisions of sections 3(a)(2) and 3(a)(4) of the Securities Act of 1933, as amended. The registration or qualification of these securities in accordance with applicable provisions of securities laws of the states in which these securities have been registered or qualified and the exemption from registration or qualification in other states shall not be regarded as a recommendation thereof. Neither these states nor any of their agencies have passed upon the merits of the securities or the accuracy or completeness of this official statement. Any representation to the contrary may be a criminal offense.

No dealer, broker, salesman or other person has been authorized by the District or the Underwriter to give any information or to make any representations with respect to the Bonds, other than those contained in this Official Statement, and if given or made, such other information or representations must not be relied upon as having been authorized by any of the foregoing. This Official Statement does not constitute an offer to sell or the solicitation of an offer to buy, nor shall there be any sale of the Bonds by any person in any jurisdiction in which it is unlawful for such other person to make such offer, solicitation or sale. This Official Statement is not to be construed as a contract with the purchasers of the Bonds. Statements contained in this Official Statement which involve estimates, forecasts or matters of opinion, whether or not expressly so described herein, are intended solely as such and are not to be construed as representations of fact. The information set forth herein has been obtained from the District and other sources which are believed to be reliable, but is not guaranteed as to accuracy or completeness by, and is not to be construed as a representation by, the Underwriter. The information and expressions of opinion herein are subject to change without notice and neither the delivery of this Official Statement nor any sale made hereunder shall, under any circumstances, create any implication that there has been no change in any of the information set forth herein since the date hereof.

**HALL COUNTY SCHOOL DISTRICT 0002
(GRAND ISLAND PUBLIC SCHOOLS)
HALL COUNTY, NEBRASKA**

**123 South Webb Road
Grand Island, Nebraska 68802**

Board of Education

Bonnie Hinkle, President
Terry Brown, Vice President
Carlos Barcenas, Member
Dan Brosz, Member
Lori Coen, Member
Roger Harms, Member
Brian Exstrum, Member
Heidi Schutz, Member
Kelly Enck, Member

Administrative Officers

Dr. Tawana Grover, Superintendent
Dr. Robin Dexter, Associate Superintendent
Virgil Harden, Chief Financial Officer

BOND COUNSEL

Gilmore & Bell, P.C.
Omaha, Nebraska

UNDERWRITER

D.A. Davidson & Co.
Omaha, Nebraska

REGISTRAR AND PAYING AGENT

BOKF, National Association
Lincoln, Nebraska

TABLE OF CONTENTS

	<u>Page</u>
INTRODUCTION	1
THE BONDS	1
General Description.....	1
Optional Redemption.....	2
Notice of Redemption; Effect of Redemption	2
Authority	3
Security	3
Book-Entry-Only System.....	4
Book-Entry System Risk Factors	6
SOURCES & USES OF FUNDS.....	7
DEBT SERVICE SCHEDULE.....	7
NEBRASKA DEVELOPMENTS RELATED TO BUDGETS AND TAXATION	8
General.....	8
Budget and Levy Limitations	8
State Aid.....	9
Motor Vehicle Taxes	9
Additional Considerations	9
BONDHOLDERS’ RISKS	9
CONTINUING DISCLOSURE	10
TAX MATTERS	10
LEGAL OPINION.....	12
FINANCIAL STATEMENTS	13
LITIGATION.....	13
MISCELLANEOUS.....	13
UNDERWRITING	13
APPROVAL OF LEGAL PROCEEDINGS	13
APPENDIX A – INFORMATION CONCERNING THE DISTRICT	
APPENDIX B –AUDITED FINANCIAL STATEMENTS	
APPENDIX C – CONTINUING DISCLOSURE UNDERTAKING	

OFFICIAL STATEMENT

\$4,695,000*
HALL COUNTY SCHOOL DISTRICT 0002
IN THE STATE OF NEBRASKA
(Grand Island Public Schools)
Limited Tax Building Bonds, Series 2016

INTRODUCTION

This Official Statement, including the cover page and the Appendices hereto, sets forth certain information in connection with the offering of \$4,695,000* Hall County School District 0002 (Grand Island Public Schools) in the State of Nebraska (the “District”) Limited Tax Building Bonds, Series 2016 (hereinafter sometimes referred to as the “Bonds”) dated as of date of delivery. The Bonds will be issued pursuant to a resolution duly passed and adopted by the Board of Education of the District (the “Board”) on December 8, 2016 (the “Resolution”).

The Bonds are being issued for the purposes of (a) paying the costs of removal of actual or potential environmental hazards, accessibility barriers, life safety code violations, life safety hazards or mold abatement and prevention in buildings of the District, (the “Project”) all in accordance with the provisions of Section 79-10,110.02, R.R.S. Neb., as amended and (b) paying certain costs of issuance for the Bonds. See “THE BONDS—Authority” herein.

The Bonds are payable from ad valorem taxes, not to exceed three cents (\$0.030) per one hundred dollars of taxable valuation, on all taxable property located in the District, which the District may levy for the purpose of financing or refinancing the costs of the Project. The Bonds are not general obligations of the District, may not be paid from any portion of its general funds, and are secured solely by the District’s irrevocable pledge of amounts received from the levy of the limited tax described above. See the captions “THE BONDS - Security” and “NEBRASKA DEVELOPMENTS RELATED TO BUDGETS AND TAXATION” herein.

THE BONDS

General Description

The Bonds are being issued as current interest-bearing bonds, which bear an original issue date issue as of the date of delivery. Interest on the Bonds is payable beginning June 15, 2017 and semiannually thereafter on December 15 and June 15 of each year (each an “Interest Payment Date”). Interest will be paid from the date of original issue or most recent Interest Payment Date, whichever is later, until maturity or earlier redemption. The Bonds will bear interest at the rates and become due at the times set forth on the inside cover page of this Official Statement. The Bonds will be issued in fully registered book-entry-only form (see the caption “THE BONDS—Book-Entry-Only System” herein) in denominations of \$5,000 or any integral multiple thereof, not exceeding the amount maturing in a given year.

Interest on the Bonds will be paid by BOKF, National Association, Lincoln, Nebraska, as registrar and paying agent with respect to the Bonds (the “Registrar”), by check or draft mailed to the registered

* Preliminary; subject to change.

owners at their registered addresses, both as shown on the registration books of the Registrar as of the close of business on the fifteenth day immediately preceding the Interest Payment Date (the "Record Date"). So long as DTC (hereinafter defined) or its nominee is the registered owner of the Bonds, payment of the principal or redemption price thereof and interest thereon will be made directly to DTC. Principal of and premium, if any, due on the Bonds at maturity or earlier date of redemption shall be paid on presentation and surrender of the Bonds at the office of the Registrar.

Upon surrender to the Registrar for cancellation, any Bond or Bonds may be transferred or exchanged for another Bond or Bonds of like aggregate principal amount in any authorized denomination, having the same maturity and bearing the same rate of interest as the Bond or Bonds surrendered. The Registrar is not required to transfer or exchange any Bond during the period from any Record Date until the immediately succeeding Interest Payment Date or to transfer any Bond which has been called for redemption, whether in whole or in part, for a period of 30 days immediately preceding the date fixed for redemption. So long as the Bonds are in book-entry only form the procedures of DTC govern transfers.

In the event that payments of interest due on the Bonds on any Interest Payment Date are not timely made, such interest shall cease to be payable to the registered owners as of the Record Date for such Interest Payment Date and shall be payable to the registered owners as of a special date of record for payment of such defaulted interest as shall be designated by the Registrar whenever moneys for the purpose of paying such defaulted interest become available.

Optional Redemption

The Bonds are subject to redemption at the option of the District at any time on or after the fifth anniversary of the date of original issue, in whole or in part, in integral multiples of \$5,000 within a maturity, at a redemption price equal to the principal amount thereof, together with the interest accrued thereon to the date fixed for redemption.

Notice of Redemption; Effect of Redemption

Notice of the call for redemption, identifying the Bonds or portions thereof to be redeemed, shall be given by the Registrar to the registered owners of the Bonds to be redeemed at their registered addresses as shown on the registration books maintained by the Registrar, by first class mail, postage prepaid, not less than 30 days prior to the date fixed for redemption. Failure to give notice to any particular registered owner or any defect in the notice given to such owner shall not affect the validity of the proceedings calling the Bonds or the redemption of any Bonds for which proper notice has been given.

If notice of redemption has been properly given and moneys for payment are available on the redemption date, the Bonds so called for redemption shall, on the redemption date, become due and payable and shall cease to bear interest and shall cease to be entitled to any lien, benefit or security under the Resolution and the owners of the Bonds so called for redemption shall have no rights under the Resolution except to receive payment of the redemption price plus accrued interest to the date fixed for redemption from funds deposited with the Registrar by the District.

Authority

The Bonds are being issued pursuant to the provisions of Section 79-10,110.02, R.R.S. Neb., as amended, to pay a portion of the costs of the Project. The Bonds are issued pursuant to the Resolution duly passed and adopted by the Board of Education of the District.

Security

The Bonds are not general obligations of the District, may not be paid from any portion of its general funds, and are secured solely by the District's irrevocable pledge of amounts received from the levy of the limited tax described herein.

Section 79-10,110.02, R.R.S. Neb., as amended (the "Act"), permits the District to issue bonds to pay the amounts necessary to be expended to remove actual or potential environmental hazards, accessibility barriers, life safety code violations, life safety hazards or mold in buildings of the District, as described in the Act, and to levy property taxes in the manner set forth in the Act, not to exceed three cents (\$0.030) per one hundred dollars of taxable valuation on the taxable property of the District, as may be necessary to cover debt service on such bonds and certain other outstanding bonds and pay such amounts necessary.

The District may levy such tax in the District for no more than ten years with respect to the Bonds. Subject to such limitation, the District is required annually to include in its budget an amount sufficient to enable it to meet its obligations under the Resolution. See the caption "NEBRASKA DEVELOPMENTS RELATED TO BUDGETS AND TAXATION" and "APPENDIX A" for further discussion on taxation and the District's budgetary process.

As of the date of this Official Statement, the District presently has outstanding its Limited Tax Refunding Building Bonds, Series 2015 (the "2015 Limited Tax Bonds") which are payable from and secured by the limited tax authorized under the Act. Neither the Act nor the Resolution limits the ability of the District to issue additional obligations secured by a pledge of the revenues derived from the limited tax described in the Act, except that the levy for all such obligations – including the Bonds and the 2015 Limited Tax Bonds – may not exceed three cents (\$0.030) per one hundred dollars of such taxable valuation, and that the tax with respect to any single obligation may not be levied for more than ten years. While the District does not currently anticipate issuing additional obligations payable from such tax levy, no assurance can be given that the District will not elect to do so prior to the final maturity of the Bonds.

The 2016-17 assessed valuation of all taxable property located in the District is \$3,050,120,816. A levy of three cents (\$0.030) per one hundred dollars of such taxable valuation is approximately \$915,036. As shown in the columns under the heading "DEBT SERVICE SCHEDULE", the amount required to pay principal and interest on the Bonds in fiscal year 2027 – the year in which the debt service on all outstanding limited tax bonds is the greatest – is expected to be approximately \$895,000*. Based on such 2016-17 taxable valuation, the limited tax authorized by the Act would, if all taxes levied at the maximum permissible rate were actually received by the District, cover the estimated debt service requirements for such year by approximately 1.02 times.*

The Act states that the District may exceed the maximum levy of three cents per one hundred dollars of taxable valuation authorized in any year in which (i) the taxable valuation of the District is lower than the taxable valuation in the year in which the District last issued bonds pursuant to the Act and (ii) such maximum levy is insufficient to meet the combined annual principal and interest obligations for all bonds issued pursuant to the Act and Section 79-10,110, R.R.S. Neb., as amended. The amount

* Preliminary; subject to change.

generated from a district's levy in excess of three cents per one hundred dollars of taxable valuation must not exceed the combined annual principal and interest obligations for such bonds minus the amount generated by levying three cents per one hundred dollars of taxable valuation.

Book-Entry Only System

The Bonds will be available to the ultimate purchasers in global book-entry form only, in the principal amount of \$5,000 or integral multiples thereof. Purchasers of the Bonds will not receive certificates representing their interests in the Bonds purchased, except as described below.

The following description of the procedures and record-keeping with respect to beneficial ownership interests in the Bonds, payment of interest and other payments on the Bonds to Participants (as hereinafter defined) or Beneficial Owners (as hereinafter defined) of the Bonds, confirmation and transfer of beneficial ownership interests in the Bonds and other related transactions by and between DTC, Participants and Beneficial Owners of the Bonds, is based solely on information furnished by DTC to the District for inclusion in this Official Statement. Accordingly, the District and the Registrar do not make any representations concerning these matters, and the Beneficial Owners of the Bonds should not rely on the following information with respect to such matters, but should instead confirm the same with the Participants from whom they purchased the Bonds.

The Depository Trust Company ("DTC"), New York, NY, will act as securities depository for the Bonds. The Bonds will be issued as fully-registered securities registered in the name of Cede & Co. (DTC's partnership nominee) or such other name as may be requested by an authorized representative of DTC. One fully-registered Bond certificate will be issued for each separate maturity of the Bonds, each in the aggregate principal amount of such maturity, and will be deposited with DTC.

DTC, the world's largest depository, is a limited-purpose trust company organized under the New York Banking Law, a "banking organization" within the meaning of the New York Banking Law, a member of the Federal Reserve System, a "clearing corporation" within the meaning of the New York Uniform Commercial Code, and a "clearing agency" registered pursuant to the provisions of Section 17A of the Securities Exchange Act of 1934. DTC holds and provides asset servicing for over 3.5 million issues of U.S. and non-U.S. equity issues, corporate and municipal debt issues, and money market instruments (from over 100 countries) that DTC's participants ("Direct Participants") deposit with DTC. DTC also facilitates the post-trade settlement among Direct Participants of sales and other securities transactions in deposited securities, through electronic computerized book-entry transfers and pledges between Direct Participant's accounts. This eliminates the need for physical movement of securities certificates. Direct Participants include both U.S. and non-U.S. securities brokers and dealers, banks, trust companies, clearing corporations and certain other organizations. DTC is a wholly-owned subsidiary of The Depository Trust & Clearing Corporation ("DTCC"). DTCC is the holding company for DTC, National Securities Clearing Corporation and Fixed Income Clearing Corporation, all of which are registered clearing agencies. DTCC is owned by the users of its regulated subsidiaries. Access to the DTC system is also available to others such as both U.S. and non-U.S. securities brokers and dealers, banks, trust companies, and clearing corporations that clear through or maintain a custodial relationship with a Direct Participant, either directly or indirectly ("Indirect Participants"). DTC has a Standard & Poor's rating of AA+. The DTC Rules applicable to its Participants are on file with the Securities and Exchange Commission. More information about DTC can be found at www.dtcc.com and at www.dtc.org.

Purchases of the Bonds under the DTC system must be made by or through Direct Participants, which will receive a credit for the Bonds on DTC's records. The ownership interest of each actual purchaser of each Bond ("Beneficial Owner") is in turn to be recorded on the Direct and Indirect Participants' records. Beneficial Owners will not receive written confirmation from DTC of their purchase. Beneficial Owners

are, however, expected to receive written confirmations providing details of the transaction, as well as periodic statements of their holdings, from the Direct or Indirect Participant through which the Beneficial Owner entered into the transaction. Transfers of ownership interests in the Bonds are to be accomplished by entries made on the books of Direct and Indirect Participants acting on behalf of Beneficial Owners. Beneficial Owners will not receive certificates representing their ownership interests in Bonds, except in the event that use of the book-entry system for the Bonds is discontinued.

To facilitate subsequent transfers, all Bonds deposited by Direct Participants with DTC are registered in the name of DTC's partnership nominee, Cede & Co., or such other name as may be requested by an authorized representative of DTC. The deposit of Securities with DTC and their registration in the name of Cede & Co. or such other DTC nominee do not effect any change in beneficial ownership. DTC has no knowledge of the actual Beneficial Owners of the Bonds; DTC's records reflect only the identity of the Direct Participants to whose accounts such Bonds are credited, which may or may not be the Beneficial Owners. The Direct and Indirect Participants will remain responsible for keeping account of their holdings on behalf of their customers.

Conveyance of notices and other communications by DTC to Direct Participants, by Direct Participants to Indirect Participants, and by Direct Participants and Indirect Participants to Beneficial Owners will be governed by arrangements among them, subject to any statutory or regulatory requirements as may be in effect from time to time. Beneficial Owners of Bonds may wish to take certain steps to augment the transmission to them of notices of significant events with respect to the Bonds, such as redemptions, tenders, defaults, and proposed amendments to the documents relating to the Bonds. For example, Beneficial Owners of Bonds may wish to ascertain that the nominee holding the Bonds for their benefit has agreed to obtain and transmit notices to Beneficial Owners. In the alternative, Beneficial Owners may wish to provide their names and addresses to the Registrar and request that copies of notices be provided directly to them.

Redemption notices shall be sent to DTC. If less than all of the Bonds within a maturity are being redeemed, DTC's practice is to determine by lot the amount of the interest of each Direct Participant in such issue to be redeemed.

Neither DTC nor Cede & Co. (nor any other DTC nominee) will consent or vote with respect to Bonds unless authorized by a Direct Participant in accordance with DTC's MMI Procedures. Under its usual procedures, DTC mails an Omnibus Proxy to the District (or the Registrar) as soon as possible after the record date. The Omnibus Proxy assigns Cede & Co.'s consenting or voting rights to those Direct Participants to whose accounts Bonds are credited on the record date (identified in a listing attached to the Omnibus Proxy).

Redemption proceeds, principal, and interest payments on the Bonds will be made to Cede & Co., or such other nominee as may be requested by an authorized representative of DTC. DTC's practice is to credit Direct Participants' accounts upon DTC's receipt of funds and corresponding detail information from the Registrar, on payable date in accordance with their respective holdings shown on DTC's records. Payments by Participants to Beneficial Owners will be governed by standing instructions and customary practices, as is the case with securities held for the accounts of customers in bearer form or registered in "street name," and will be the responsibility of such Participant and not of DTC nor its nominee, the Registrar or the District, subject to any statutory or regulatory requirements as may be in effect from time to time. Payment of redemption proceeds, principal, and interest payments to Cede & Co. (or such other nominee as may be requested by an authorized representative of DTC) is the responsibility of the Registrar (from funds provided by the District), disbursement of such payments to Direct Participants will be the responsibility of DTC, and disbursement of such payments to the Beneficial Owners will be the responsibility of Direct and Indirect Participants.

DTC may discontinue providing its services as depository with respect to the Bonds at any time by giving reasonable notice to the District or the Registrar. Under such circumstances, in the event that a successor depository is not obtained, certificates for the Bonds are required to be printed and delivered.

The District may decide to discontinue use of the system of book-entry transfers through DTC (or a successor securities depository). In that event, certificates for the Bonds will be printed and delivered to DTC.

The information under this subcaption concerning DTC and DTC's book-entry system has been obtained from sources that the District believes to be reliable, but the District takes no responsibility for the accuracy thereof.

The District and the Registrar will not have any responsibility or obligation to Participants, to Indirect Participants or to any Beneficial Owner with respect to (i) the accuracy of any records maintained by DTC, any Direct Participant or any Indirect Participant; (ii) the payment by DTC or any Direct Participant or Indirect Participant of any amount with respect to the principal or redemption price of or interest on the Bonds; (iii) any notice which is permitted or required to be given to bondholders under the Resolution; (iv) the selection by DTC or any Direct or Indirect Participant of any person to receive payment in the event of a partial redemption of the Bonds; or (v) any consent given or other action taken by DTC as Bondholder.

The information included under this subcaption, other than in this paragraph, the preceding paragraph hereof and the first two full paragraphs under this subcaption, has been provided by DTC. No representation is made by the District or the Registrar as to the accuracy or adequacy of such information provided by DTC or as to the absence of material adverse changes in such information subsequent to the date hereof. The Beneficial Owners of the Bonds will rely on DTC Participants or Indirect Participants for timely payments and other notices and for otherwise making available to the Beneficial Owners the rights of a bondholder. No assurances can be given, in the event of the bankruptcy or insolvency of DTC or the Direct Participant or Indirect Participant through which a Beneficial Owner holds beneficial interest in the Bonds, that payment will be made by DTC, the Direct Participant or the Indirect Participant on a timely basis.

Book-Entry System Risk Factors

Beneficial Owners of the Bonds may experience some delay in their receipt of distributions of principal of, and interest on, the Bonds since such distributions will be forwarded by the Registrar to DTC and DTC will credit such distributions to the accounts of its Participants, which will thereafter credit them to the accounts of the Beneficial Owners either directly or indirectly through Indirect Participants.

Since transactions in the Bonds can be effected only through DTC, its Direct Participants, Indirect Participants and certain banks, the ability of a Beneficial Owner to pledge any Bonds to persons or entities that do not participate in the DTC system, or otherwise to take actions in respect of such Bonds, may be limited due to lack of physical certificate. Beneficial Owners will not be recognized by the Registrar as registered owners for purposes of the Resolution, and Beneficial Owners will be permitted to exercise the rights of registered owners only indirectly through DTC and its Participants. For the rights of Beneficial Owners with respect to the District's continuing disclosure obligation, see "APPENDIX C".

SOURCES AND USES OF FUNDS

Sources of Funds

Principal of the Bonds: \$ _____
 TOTAL: \$ _____

Uses of Funds

Deposit to Construction Fund: \$ _____
 Costs of Issuance and Underwriting: _____
 TOTAL: \$ _____

DEBT SERVICE SCHEDULE

Fiscal Year Ending August 31	2015 Limited Tax Bonds Debt Service	Limited Tax Building Bonds, Series 2016*			Limited Tax Bonds Total Debt Service
		Principal	Interest	Total	
2017	\$491,211.25				
2018	487,811.25	\$285,000			
2019	488,105.00	290,000			
2020	487,155.00	295,000			
2021	489,998.75	305,000			
2022	486,605.00	310,000			
2023	487,160.00	320,000			
2024	486,927.50	325,000			
2025	490,820.00	830,000			
2026		855,000			
2027		880,000			
2028					
TOTAL:	<u>\$4,395,793.75</u>	<u>\$4,695,000</u>			

*Preliminary, subject to change

NEBRASKA DEVELOPMENTS RELATED TO BUDGETS AND TAXATION

General

The system of assessing and taxing personal property by the State of Nebraska (the “State”) for purposes of local ad valorem taxation for support of local political subdivisions, including the District, has from time to time been the object of controversy, legal challenges, constitutional initiative petitions and legislative action.

The District’s principal sources of revenue for its general fund are local property taxes and State Aid. Local property taxes constitute the District’s largest revenue sources, but are subject to certain limitations as discussed below. State Aid for each school district is determined annual based on student adjustment weightings and a variety of other factors including taxable valuations and per-student costs.

Budget and Levy Limitations

The Nebraska Legislature has imposed budget limitations and property tax restrictions on Nebraska political subdivisions, including public school districts, intended to reduce the level of property taxation and expenditures in the State. Budget limitations relating to school districts (Section 79-1023 *et seq.*, Reissue Revised Statutes of Nebraska, as amended, and related sections, the “Budget Limitations”) limit the growth in general fund expenditures for school districts. Tax levy limitations (Section 77-3442 *et seq.*, Reissue Revised Statutes of Nebraska, as amended, and related sections, the “Levy Limitations”) provide for an overall limitation on tax rates levied by school districts. The Budget Limitations, because they apply only to general fund expenditures, do not limit budgeting of expenditures for debt service on bonded indebtedness, nor do they limit building fund and certain other special fund expenditures. The Levy Limitations provide for an express exclusion from the limitations for property tax levies relating to bonded indebtedness. **The Bonds are not general obligations of the District, may not be paid from any portion of its general funds, and are secured solely by the District’s irrevocable pledge of amounts received from the levy of the limited tax described herein.**

Under the Budget Limitations, a school district may not increase its general fund operating expenditures more than its allowable growth rate established each year by the Nebraska Department of Education. A school district’s allowable growth rate ranges from the basic allowable growth rate (which is equal to the base limitation set forth in Section 77-3446, Reissue Revised Statutes of Nebraska, as amended) and 3% above the base limitation. The base limitation is currently set at 2.5%. The base limitation is subject to modification from year to year by the Nebraska Legislature. The specific growth rate for each school district is to be calculated based upon student population, certain cost factors and target budget levels established by the Nebraska Department of Education. The Budget Limitations are part of the system for determining aid from the State and are to be enforced through the office of the Auditor of Public Accounts of the State and the Nebraska Department of Education. State Aid may be withheld from governmental units which fail to comply. *Such budgetary limitations do not apply to, among other things, revenue pledged to retire bonded indebtedness, such as the Bonds.* Under the Levy Limitations the rates for levying property taxes have been limited for each type of governmental unit in the State. The rate of levy for school districts, such as the District, may not levy more than \$1.05 per one hundred dollars (\$100) of taxable value. *Any tax levied to pay the principal of and interest on the Bonds will not be subject to the Levy Limitations.* State Aid amounts fluctuate from year to year based upon factors set in the related statutes, and the District’s State Aid amount could decrease in future years.

Section 79-10,120, R.R.S. Neb. 2008, authorizes a building fund tax levy of not to exceed 14 cents on each one hundred dollars of taxable valuation. Funds collected from this tax levy may be used solely acquiring, constructing, erecting, altering, equipping and furnishing school buildings and additions

thereto for elementary and high school grades. The District has utilized this levy in the past. Under current statutes such levying authority is subject to the Levy Limitations, but is not included within the budgeted expenditure limitations provided for in the Budget Limitations. Funds collected from the building fund levy may **not** be used to pay the principal of and interest on the Bonds.

State Aid

State Aid is funded through the collection of statewide sales and income taxes. Legislative enactments in recent years have both increased and decreased the amounts of funds available for State Aid to school districts, as well as established and revised procedures and formulae for the distribution of State Aid to school districts. For more information on the District's State Aid receipts, see "APPENDIX A: FINANCIAL INFORMATION CONCERNING THE DISTRICT: Sources of Revenue" herein.

Motor Vehicle Taxes

State law allocates to each school district 60% of the motor vehicle taxes and fees (less a 1% county treasurer collection fee) arising from motor vehicles within the school district. Motor vehicle valuations are not included in the District's property tax base, and the District, like other taxing subdivisions, receives distributions of taxes collected by Hall County. State law further requires school districts to deposit such distributions of taxes into their general funds, and such moneys are not available to repay bonded indebtedness, including the Bonds.

Additional Considerations

The future methods for providing for financing cities, schools and other local units may be altered depending upon future actions taken by voters of the State under initiative and referendum provisions of the Nebraska constitution, future actions of the Nebraska Legislature and future decisions of Nebraska state and federal courts.

BONDHOLDERS' RISKS

The Bonds are payable from ad valorem taxes upon the taxable property in the District, subject to the limitations as set forth in the Act. The following items, among others, however, should be considered by potential investors:

1. Bonds Not Rated. The Bonds have not been rated or reviewed by any rating agency and it is not expected that any rating will be applied for. The absence of a rating may limit the market for reselling the Bonds because certain institutional and other investors limit their purchases to securities which have received a rating.

2. Limitation of Rights Upon Insolvency. The United States Bankruptcy Code enables debtors, including school districts, which are insolvent to obtain relief through petition and plan which may result in the modification or delay of payments to creditors, including bondholders. In the event of any insolvency upon the part of the District, the holders of the Bonds would be treated as general creditors of the District along with other unsecured claimants. The extent to which the exception from limitations upon overall tax rates provided for in existing legislation, including the Tax Limitations and the Budget Limitations (see "NEBRASKA DEVELOPMENTS RELATED TO BUDGETS AND TAXATION"), might entitle bondholders to be treated as a separate class or otherwise given priority over other unsecured claimants is a matter that would be subject to future determinations of Nebraska state and federal courts interpreting and applying both state law and the United States Bankruptcy Code. Procedures under the Bankruptcy Code or other insolvency laws could result in delays in payment and modifications of

payment rights. The State of Nebraska has authorized its political subdivisions to seek relief under the United States Bankruptcy Code by statute.

3. Nebraska Developments Related to Budgets and Taxation. The Nebraska Legislature has taken actions designed to reduce the reliance of local governmental units on property taxation. For a discussion of such changes, see “NEBRASKA DEVELOPMENTS RELATED TO BUDGETS AND TAXATION.”

4. Proposed Tax Legislation. President Obama has released legislative and budget proposals that would, among other things, subject interest on tax-exempt bonds to a federal income tax for taxpayers with incomes above certain thresholds. Additional proposals affecting tax-exempt interest may be considered from time to time which could limit the availability of or eliminate federally tax-exempt interest on tax-exempt bonds. Neither house of Congress has passed any such proposal, and it is not possible to predict whether President Obama’s, or another proposal with similar effects, will be enacted into law. If enacted into law, such a proposal could affect the value or marketability of tax-exempt bonds and bondholders’ tax liability. Prospective purchasers of the Bonds should consult their own tax advisors regarding the impact of any change in law on the Bonds.

CONTINUING DISCLOSURE

In accordance with the requirements of Rule 15c2-12 (the “Rule”) promulgated by the Securities and Exchange Commission, the District has agreed in the Resolution to provide the continuing disclosure information as set forth in “APPENDIX C” to this Official Statement.

Compliance with Prior Continuing Disclosure Undertakings

During the past five years the District has failed to comply with its prior undertakings under the Rule as follows:

- The District did not file its audited financial statements and operating data as required by certain of its prior undertakings under the Rule for fiscal years ended August 31, 2011, 2012 and 2013.
- The District failed to timely file notices of rating changes with respect to certain of its outstanding bond issues which occurred in calendar years 2009 through 2014, but filed notice of such rating changes in October, 2014. The District believes this information was disseminated or available through other sources.

TAX MATTERS

The following is a summary of the material federal and State of Nebraska income tax consequences of holding and disposing of the Bonds. This summary is based upon laws, regulations, rulings and judicial decisions now in effect, all of which are subject to change (possibly on a retroactive basis). This summary does not discuss all aspects of federal income taxation that may be relevant to investors in light of their personal investment circumstances or describe the tax consequences to certain types of owners subject to special treatment under the federal income tax laws (for example, dealers in securities or other persons who do not hold the Bonds as a capital asset, tax-exempt organizations, individual retirement accounts and other tax deferred accounts, and foreign taxpayers), and, except for the income tax laws of the State of Nebraska, does not discuss the consequences to an owner under any state, local or foreign tax laws. The summary does not deal with the tax treatment of persons who purchase the

Bonds in the secondary market. Prospective investors are advised to consult their own tax advisors regarding federal, state, local and other tax considerations of holding and disposing of the Bonds.

Opinion of Bond Counsel

In the opinion of Gilmore & Bell, P.C., Bond Counsel to the District, under the law existing as of the issue date of the Bonds:

Federal and Nebraska Tax Exemption. The interest on the Bonds (including any original issue discount properly allocable to an owner thereof) is excludable from gross income for federal income tax purposes and is exempt from income taxation by the State of Nebraska.

Alternative Minimum Tax. Interest on the Bonds is not an item of tax preference for purposes of computing the federal alternative minimum tax imposed on individuals and corporations, but is taken into account in determining adjusted current earnings for the purpose of computing the alternative minimum tax imposed on certain corporations.

Bank Qualification. The Bonds are “qualified tax-exempt obligations” for purposes of Section 265(b)(3) of the Code.

Bond counsel’s opinions are provided as of the date of the original issue of the Bonds, subject to the condition that the District comply with all requirements of the Code that must be satisfied subsequent to the issuance of the Bonds in order that interest thereon be, or continue to be, excludable from gross income for federal income tax purposes. The District has covenanted to comply with all such requirements. Failure to comply with certain of such requirements may cause the inclusion of interest on the Bonds in gross income for federal and Nebraska income tax purposes retroactive to the date of issuance of the Bonds. Bond Counsel is expressing no opinion regarding other federal, state or local tax consequences arising with respect to the Bonds but has reviewed the discussion under the heading “TAX MATTERS.”

Other Tax Consequences

[Original Issue Discount. For federal income tax purposes, original issue discount (“OID”) is the excess of the stated redemption price at maturity of a Bond over its issue price. The issue price of a Bond is the first price at which a substantial amount of the Bonds of that maturity have been sold (ignoring sales to bond houses, brokers, or similar persons or organizations acting in the capacity of underwriters, placement agents, or wholesalers). Under Section 1288 of the Code, OID on tax-exempt bonds accrues on a compound basis. The amount of OID that accrues to an owner of a Bond during any accrual period generally equals (1) the issue price of that Bond, plus the amount of OID accrued in all prior accrual periods, multiplied by (2) the yield to maturity on that Bond (determined on the basis of compounding at the close of each accrual period and properly adjusted for the length of the accrual period), minus (3) any interest payable on that Bond during that accrual period. The amount of OID accrued in a particular accrual period will be considered to be received ratably on each day of the accrual period, will be excludable from gross income for federal income tax purposes, and will increase the owner’s tax basis in that Bond. Prospective investors should consult their own tax advisors concerning the calculation and accrual of OID.]

[Original Issue Premium. If a Bond is issued at a price that exceeds the stated redemption price at maturity of the Bond, the excess of the purchase price over the stated redemption price at maturity constitutes “premium” on that Bond. Under Section 171 of the Code, the purchaser of that Bond must amortize the premium over the term of the Bond using constant yield principles, based on the purchaser’s

yield to maturity. As premium is amortized, the owner's basis in the Bond and the amount of tax-exempt interest received will be reduced by the amount of amortizable premium properly allocable to the owner. This will result in an increase in the gain (or decrease in the loss) to be recognized for federal income tax purposes on sale or disposition of the Bond prior to its maturity. Even though the owner's basis is reduced, no federal income tax deduction is allowed. Prospective investors should consult their own tax advisors concerning the calculation and accrual of bond premium.]

Sale, Exchange or Retirement of Bonds. Upon the sale, exchange or retirement (including redemption) of a Bond, an owner of the Bond generally will recognize gain or loss in an amount equal to the difference between the amount of cash and the fair market value of any property received on the sale, exchange or retirement of the Bond (other than in respect of accrued and unpaid interest) and such owner's adjusted tax basis in the Bond. To the extent a Bond is held as a capital asset, such gain or loss will be capital gain or loss and will be long-term capital gain or loss if the Bond has been held for more than 12 months at the time of sale, exchange or retirement.

Reporting Requirements. In general, information reporting requirements will apply to certain payments of principal, interest and premium paid on the Bonds, and to the proceeds paid on the sale of the Bonds, other than certain exempt recipients (such as corporations and foreign entities). A backup withholding tax will apply to such payments if the owner fails to provide a taxpayer identification number or certification of foreign or other exempt status or fails to report in full dividend and interest income. The amount of any backup withholding from a payment to an owner will be allowed as a credit against the owner's federal income tax liability.

Collateral Federal Income Tax Consequences. Prospective purchasers of the Bonds should be aware that ownership of the Bonds may result in collateral federal income tax consequences to certain taxpayers, including, without limitation, financial institutions, property and casualty insurance companies, individual recipients of Social Security or Railroad Retirement benefits, certain S corporations with "excess net passive income," foreign corporations subject to the branch profits tax, life insurance companies, and taxpayers who may be deemed to have incurred or continued indebtedness to purchase or carry or have paid or incurred certain expenses allocable to the Bonds. Bond Counsel expresses no opinion regarding these tax consequences. Purchasers of Bonds should consult their tax advisors as to the applicability of these tax consequences and other federal income tax consequences of the purchase, ownership and disposition of the Bonds, including the possible application of state, local, foreign and other tax laws.

LEGAL OPINION

The approving opinion of Gilmore & Bell, P.C., Omaha, Nebraska, Bond Counsel to the District, will affirm, among other things, that the Bonds have been authorized and issued in accordance with the Constitution and statutes of the State of Nebraska and constitute valid and legally binding obligations of the District, and that the District has power and is obligated to levy ad valorem taxes for the payment of the Bonds and the interest thereon upon all the property within the District subject to taxation by the District without limitation as to rate or amount. The rights of the holders of the Bonds and the enforceability thereof may be subject to bankruptcy, insolvency, reorganization, moratorium and other laws for the relief of debtors.

FINANCIAL STATEMENTS

The financial statements of the District, as of and for the year ended August 31, 2016, included in "APPENDIX B" to this Official Statement, have been audited by Almquist, Maltzahn, Galloway & Luth, Certified Public Accountants, as stated in their report appearing herein.

LITIGATION

The District will, upon delivery of the Bonds, certify that there is no litigation pending affecting the validity of the Bonds as of the date of delivery.

MISCELLANEOUS

All estimates and assumptions herein have been made on the basis of information available and are believed to be reliable, but no representations whatsoever are made that such estimates or assumptions are current or will be realized. So far as any statements herein involve matters of opinion, whether or not expressly stated, they are intended merely as such and not as representations of fact.

UNDERWRITING

D.A. Davidson & Co., the Underwriter of the Bonds, has agreed, subject to certain conditions, to purchase the Bonds from the District at an aggregate price of \$_____, which purchase price takes into account accrued interest of \$-0-, underwriter's discount of \$_____, as set out in the Resolution authorizing the Bonds, and to make a public offering of the Bonds. The Underwriters have advised the District that the Bonds may be offered and sold to certain dealers (including dealers depositing the Bonds into investment trusts) at prices lower than the initial public offering prices set forth on the cover of this Official Statement and that such public offering prices may be changed from time to time.

Although the Underwriters expect to maintain a secondary market in the Bonds after the initial offering, no guarantee can be given concerning the future existence of such a secondary market or its maintenance by the Underwriters or others.

APPROVAL OF LEGAL PROCEEDINGS

Legal matters incident to the authorization and issuance of the Bonds are subject to the unqualified approving opinion of Gilmore & Bell, P.C., Bond Counsel.

The information hereinabove set forth, and that which follows in the Appendices, should not be construed as representing all of the conditions affecting the District or the Bonds.

HALL COUNTY SCHOOL DISTRICT
0002 (GRAND ISLAND PUBLIC SCHOOLS),
IN THE STATE OF NEBRASKA

APPENDIX A
INFORMATION CONCERNING THE DISTRICT

APPENDIX A

INFORMATION CONCERNING THE DISTRICT

GENERAL AND ECONOMIC INFORMATION

Location and Size

Hall County School District 0002 (Grand Island Public Schools) in the State of Nebraska (the “District”) is a Class III school district and political subdivision organized and existing under Sections 79-102 and 79-407, Reissue Revised Statutes of Nebraska, as amended. The District is located in Hall County, Nebraska, in the east central portion of the State of Nebraska. The District encompasses approximately 9.1 square miles and has an estimated population as of 2015 of 51,440, which constitutes approximately 83% of the population of Hall County. The District includes all of the property within the corporate limits of Grand Island, Nebraska. The District also includes surrounding unincorporated areas in Hall County located in the vicinity of Grand Island, Nebraska.

Government and Organization

The District is organized as a Class III school district under Sections 79-102 and 79-407, Reissue Revised Statutes of Nebraska, as amended. The District is governed by a nine-member Board of Education. The members of the Board are elected by the voters of the District for four-year staggered terms. All Board members are elected at-large and serve without compensation. The Board is responsible for all policy decisions. The President of the Board is elected by the Board from among its members for a term of one year and has no regular administrative duties. The Secretary and Treasurer are appointed by the Board and may or may not be members of the Board.

The Board of Education appoints the Superintendent of Schools who is the chief administrative officer of the District responsible for carrying out the policies set by the Board. Additional members of the administrative staff are appointed by the Board of Education upon recommendation by the Superintendent.

Enrollment History

<u>School Year</u>	<u>Enrollment</u>
2016-17	9,775
2015-16	9,601
2014-15	9,553
2013-14	9,313
2012-13	9,098

Source: Nebraska Department of Education

Services and Utilities

Electric service, sanitary sewers and water within Grand Island are provided by city-owned utilities. Northwestern Public Service Company provides natural gas service and CenturyLink and Verizon operate communication systems.

Transportation

Grand Island's transportation facilities are a contributing factor in the continued growth of the City. Grand Island is a thoroughfare for Union Pacific and Burlington Northern-Santa Fe railroads, with daily freight service to commercial and industrial locations. Highway access to the city is from Interstate 80, one of the country's main east/west arteries, as well as U.S. Highways 2, 30, 34, and 281. Central Nebraska Regional Airport provides daily inbound and outbound flights to Denver and scheduled nonstop service to Phoenix/Mesa, Arizona and Las Vegas, Nevada. The airport also has facilities for air freight and private aircraft services. A taxi firm provides 24-hour service, seven days a week. The 124th Air Cavalry Squadron's Chinook Helicopter Base is located just east of the airport and serves over 225 cavalry and aviation maintenance National Guard soldiers.

Financial Institutions

There are sixteen banks, credit unions and savings and loan offices in Grand Island.

Health Care

St. Francis Medical Center with 159 licensed beds (not including 25 beds in a nursing home-type unit) provides modern facilities serving the community and surrounding area. Saint Francis sees nearly 8,000 inpatients each year. A nine-story patient tower was completed in 2007 at a cost of \$60 million. A medical office complex located adjacent to the hospital has approximately 150 doctors, dentists and other medical specialists available to meet health manpower needs. The City provides ambulance service with advanced life systems and fully qualified paramedics. Emergency responders are able to respond in an average of five minutes anywhere in the city.

Communications

The Grand Island Daily Independent offers daily newspaper service. A weekly advertising newspaper serves a regional area. There are five television stations and sixteen radio stations within a forty-mile radius of the City. Cable television service is offered within the City.

Recreational Facilities

The public park system consists of eighteen regional parks and twelve neighborhood parks each offering a variety of facilities throughout the 700 acres they encompass. A seven-acre water park comprised of a wave pool, four 150 to 170-foot water slides and numerous water-based play features are the flagship of the City's aquatics facilities. In 2012, the Community Redevelopment Authority of the City issued its Redevelopment Revenue Bonds (Lincoln Park Pool Project – Limited Tax Pledge), Series 2012, for the purpose of paying costs of a replacement swimming pool facility in the City's Lincoln Park area. The replacement pool opened in 2013. Other recreational facilities include the Community field house that offers indoor soccer, basketball, volleyball, flag football, baseball/softball training, batting cages and a children's playground. For the shooting enthusiast trap, skeet and sporting clay ranges, 50 yard through 600 yard rifle/pistol ranges and an 11 pad campground have been developed at the former Cornhusker Army Ammunition Plant site on land owned by the City. Additionally, an eighteen hole, par seventy-two championship golf course is provided for the public to enjoy. The recreation division offers a full slate of activities including basketball, volleyball, soccer, tennis and flag football leagues, a summer playground program, swimming lessons, children's theater and many other recreational activities that are offered throughout the year. Fonner Park provides pari-mutuel horse racing, the County Fair, livestock shows and special events. Husker Harvest Days, a major agricultural exposition, is located on a permanent site west of the City. The YMCA-YWCA Complex has a variety of recreational programs, and the adjacent Grand Generation Center is the focal point of Grand Island's senior citizen programs.

Under the terms of LB 1116 enacted in 2008, the Nebraska State Fair was transferred from Lincoln, Nebraska, to a \$40 million home in Fonner Park in Grand Island. Under LB 1116, a contribution to the costs in the amount of \$8,500,000 was required to be made by or on behalf of the City. Of that contribution, \$5,062,500 in original principal amount was provided by lease purchase financing.

ECONOMIC ACTIVITY

Business and Industry

There are approximately 75 manufacturing plants in Grand Island and Hall County, producing a variety of products on various scales of operation. The city's industry is principally related to agri-business, irrigation and agricultural equipment. The following are the principal private industrial employers in the area:

<u>Firm</u>	<u>Business</u>	<u>No. of Employees</u>
JBS Swift	Food Processing	3,300
CHI Health St. Francis	Health Care	1,370
Grand Island Public Schools	Government	1,250
Chief Industries	Manufacturing	1,000
CNHI (Case New Holland)	Manufacturing	950
Hornady Manufacturing	Manufacturing	750
City of Grand Island	Government	496
McCain Foods, USA	Food Processing	420
Principal Financial Group	Financial Services	425
Bosselman Enterprises	Real Estate Investment	391

Source: Grand Island Area Economic Development Corporation

Employment

The State of Nebraska Department of Labor, reports the following labor force data for Hall County for selected years:

<u>Year</u>	<u>Labor Force</u>	<u>Employment</u>	<u>Hall County Unemployment Rate</u>	<u>Nebraska Unemployment Rate</u>
2016	31,588	30,539	3.3%	3.1%
2015	31,633	30,668	3.1	2.7
2014	32,000	30,997	3.1	2.5
2013	34,348	33,122	3.6	3.9
2012	34,035	32,752	3.8	4.0

Source: Nebraska Department of Labor, Labor Market Information, Local Area Unemployment Statistics

DEBT STRUCTURE

The following table summarizes certain financial information concerning the District. This information should be reviewed in conjunction with the information contained in this section and the excerpts of financial statements of the District in **APPENDIX B** hereto.

Hall County School District 0002

2016 Assessed Valuation		\$3,050,120,816
Outstanding General Obligation Debt:		
9/28/2011	\$2,980,000	
3/15/2012 [±]	\$19,370,000	
12/1/2014 [±]	<u>\$50,630,000</u>	
	\$72,980,000	\$72,980,000
Outstanding Limited Tax Obligation Debt:		
2/9/2015*	\$4,025,000	
12/30/2016 (this issue)	<u>\$4,695,000</u> **	
	\$8,720,000	\$8,720,000
Total Direct Debt		<u>\$81,700,000</u>
Estimated Population (2015)		51,440
Per Capita Direct Debt		<u>\$1,588</u>
Ratio of Direct Debt to Assessed Valuation		2.68%
Overlapping and Underlying General Obligation Debt (Indirect Debt)		\$16,604,940
Total Direct and Indirect General Obligation Debt		<u>\$98,304,940</u>
Per Capita Direct and Indirect Debt		<u>\$1,911</u>
Ratio of Direct Debt and Indirect G.O. Debt to Assessed Valuation		3.22%

Overlapping Debt

Hall County

Taxable Valuation (2016)		\$5,486,356,592
G.O. Bonds (\$15,730,000 [±] ; 55.60% applicable to District)		\$8,745,880

Airport Authority

Taxable Valuation (2016)		\$5,486,356,592
G.O. Bonds (\$14,135,000 [±] ; 55.60% applicable to District)		\$7,859,060

Underlying Debt

City of Grand Island

Taxable Valuation (2016)		\$2,933,977,196
G.O. Bonds (100% applicable to District)		\$0
Lease Purchase Agreements		\$4,776,371
Revenue Debt (Not payable from property taxes)		\$148,725,000

The District has never defaulted on the payment of any of its debt obligations.

*Does not include bonds maturing 12/15/2016.

**Preliminary, subject to change.

Debt Service Requirements

General Obligation. The following schedule shows the estimated yearly principal and interest requirements for all outstanding general obligation debt of the District, including the Bonds being issued:

Fiscal Year Ending August 31	Outstanding GO Bonds	Outstanding Limited Tax Bonds*	Total Outstanding Bonded Debt Service*
2017	\$ 5,630,810.00	\$549,790.39	\$6,180,600.39
2018	5,463,826.25	610,418.75	6,074,245.00
2019	4,432,343.75	893,432.50	5,325,776.25
2020	5,457,200.00	892,592.50	6,349,792.50
2021	5,456,525.00	894,876.25	6,351,401.25
2022	5,453,600.00	895,177.50	6,348,777.50
2023	5,447,762.50	893,735.00	6,341,497.50
2024	5,450,050.00	895,860.00	6,345,910.00
2025	5,449,950.00	896,365.00	6,346,315.00
2026	4,396,650.00	894,330.00	5,290,980.00
2027	2,377,050.00	894,891.25	3,271,941.25
2028	2,377,050.00	<u>893,640.00</u>	3,270,690.00
2029	2,377,050.00		2,377,050.00
2030	2,377,050.00		2,377,050.00
2031	5,224,050.00		5,224,050.00
2032	6,503,850.00		6,503,850.00
2033	6,507,525.00		6,507,525.00
2034	6,503,525.00		6,503,525.00
2035	6,503,350.00		6,503,350.00
2036	6,503,650.00		6,503,650.00
2037	6,502,750.00		6,502,750.00
2038	6,507,625.00		6,507,625.00
2039	6,503,125.00		6,503,125.00
2040	<u>6,503,625.00</u>		<u>6,503,625.00</u>
TOTAL:	<u>\$125,909,992.50</u>	<u>\$10,105,109.14</u>	<u>\$136,015,101.64</u>

*Preliminary, subject to change; includes 2015 Limited Tax Bonds and the bonds being offered herein.

FINANCIAL INFORMATION CONCERNING THE DISTRICT

Accounting, Budgeting and Auditing Procedures

The District follows a cash system of accounting in conformity with the requirements of Nebraska law. Under this system, financial data is recorded on a cash basis with revenues and expenses being recognized only as cash is received or disbursed. Receivables, payables and accrued expenses are not recorded. Cash transactions are recorded in the following funds which the District is required to maintain for the accounting of all school moneys:

- General Fund
- Depreciation Fund
- Employee Benefit Fund
- Contingency Fund
- Activities Fund
- School Lunch Fund
- Bond Fund
- Special Building Fund
- Qualified Capitol Purpose Undertaking Fund
- Cooperative Fund

The Treasurer of the District is responsible for handling all moneys of the District and administering the above funds. All moneys received by the District from whatever source are credited to the appropriate fund. Moneys may be disbursed from such funds by the Treasurer only for the purpose for which they are levied, collected or received and all checks must be signed by the President of the Board of Education and the Treasurer.

The Superintendent, with input from his staff, principals and interested community groups, prepares a recommended budget and submits it to the Board, which may modify it. The Board adopts a budget which is submitted along with the Annual Financial report to the State of Nebraska Department of Education. The budget is designated as the Official Budget and governs the general operations for the fiscal year unless amended by the Board. The budget process begins in January and is passed at the regular Board of Education meeting in August. Under applicable statutes limitations are imposed upon increases which may be made in the District's general fund budget from year to year. See the caption "NEBRASKA DEVELOPMENTS RELATED TO BUDGETS AND TAXATION" herein. The District's fiscal year is September 1 through August 31. The budget lists estimated receipts by funds and sources and estimated disbursements by funds and purposes and includes a statement of the rate of levy per hundred dollars of assessed valuation required to raise each amount shown on the budget as coming from District taxes.

The District's principal sources of revenue for its general fund are local property taxes and state aid. State aid is allocated to school districts based upon statutory formulas which take into consideration taxable valuations, student population, per student costs and a variety of other factors. The District's current budget is governed by the provisions of the "Budget Limitations" (as described and defined below) which are discussed under the heading "*NEBRASKA DEVELOPMENTS RELATED TO BUDGETS AND TAXATION.*" The "Levy Limitations" (as described and defined below), also discussed under the heading "*NEBRASKA DEVELOPMENTS RELATED TO BUDGETS AND TAXATION,*" will limit the tax levies for subsequent fiscal years thereafter. Such limitations do not affect the District's ability to levy and collect taxes sufficient to pay the principal of and interest on the Bonds.

The financial records of the District are audited annually by a firm of independent certified public accountants in accordance with generally accepted accounting standards. In recent years, the annual audit

has been performed by Almquist, Maltzahn, Galloway, and Luth, Grand Island, Nebraska. A copy of the annual audit for the fiscal year ended August 31, 2016, is included in this Official Statement at **APPENDIX B**. A summary of significant accounting policies of the District is contained in the Notes accompanying the financial statements in the **APPENDIX B**. Financial statements for earlier years are available for examination in the District’s office.

Sources of Revenue

The District finances its operations through the local property tax levy, state aid, federal grant programs and miscellaneous sources. Debt service is financed solely through local property taxes. For the fiscal year ended August 31, 2016 the District received its revenue from various sources as follows, and the District anticipates the sources of revenue will remain substantially same for the fiscal year ending August 31, 2017:

<u>Source</u>	<u>Amount</u>
Receipts:	
Charges for services	\$ 14,635,356
Operating grants	13,343,256
Capital grants	184,294
Property and other taxes	40,962,269
State aid	47,430,924
Interest income	326,847
Other	<u>2,410,870</u>
Total receipts	\$ 119,293,816

The local property taxes provide the only source of funds payable into the Bond Fund. Such taxes are levied and collected by the County as hereinafter described. See “PROPERTY TAX INFORMATION CONCERNING THE DISTRICT – Tax Collection Record.”

Summary of Receipts, Expenditures and Fund Balances

The following summary statement of cash receipts, disbursements and changes in fund balances of the District for the five fiscal years ended August 31, 2016, has been obtained from the District’s annual audit reports prepared by Almquist, Maltzahn, Galloway, and Luth, independent Certified Public Accountants. The audited financial statements of the District for the fiscal year ended August 31, 2016, and the report of said Certified Public Accountants with respect thereto are included in **APPENDIX B** of this Official Statement. The audited financial statements for earlier years with reports by the Certified Public Accountants are available for examination in the District’s office. The statement set forth below should be read in conjunction with the other financial statements and notes appertaining hereto set forth in **APPENDIX B** of this Official Statement and the financial statements on file at the District’s office.

PROPERTY TAX INFORMATION

Current Assessed Valuation

All taxable real and personal property within the District is assessed annually by the County Assessor. The current total assessed valuation for 2016 of all taxable tangible property situated in the District is \$3,050,120,816 which represents a 3.82% increase over the prior year.

History of Property Valuations

The total assessed valuation of all taxable tangible property situated in the District has been as follows:

<u>Year</u>	<u>District 0002</u>	<u>City of Grand Island</u>	<u>Hall County</u>
2016-2017	\$3,050,120,816	\$2,933,977,196	\$5,486,356,592
2015-2016	2,938,020,328	2,831,663,760	5,182,755,879
2014-2015	2,763,011,452	2,658,635,505	4,758,657,256
2013-2014	2,669,698,545	2,574,553,789	4,258,409,140
2012-2013	2,609,831,071	2,517,067,460	4,022,486,241

Property Tax Levies and Collections

Taxes are levied annually on or before November 1. Real Property taxes and personal property taxes are due December 31 with the first half delinquent May 1 and the second half delinquent September 1.

Tax Collection Record

The following table sets forth available tax collection information for the District for the last five years.

<u>Tax Year Ended December 31</u>	<u>Taxes Levied</u>	<u>Amount Collected</u>	<u>% Collected</u>
2015-16	\$37,348,025.92	\$31,354,739.62	85.53%
2014-15	\$35,870,757.99	\$31,024,521.97	86.49%
2013-14	\$32,538,781.53	\$29,895,326.70	91.88%
2012-13	\$32,116,079.18	\$30,879,348.56	96.15%
2011-12	\$31,239,749.16	\$29,877,015.94	95.64%

Tax Rates

The following table shows the District's total tax levies including debt service (per \$100 of assessed valuation) for each of the last five fiscal years:

School Year Ended	Total Levy
<u>August 31</u>	
2015-16	\$1.2786
2014-15	1.3036
2013-14	1.2211
2012-13	1.2338
2011-12	1.1986

Major Property Taxpayers

Listed below are the ten largest taxpayers in the Grand Island Public School District as reported by the Hall County Assessor.

<u>Taxpayer</u>	<u>2016 Taxable Value</u>
Conagra Beef Company & JBS USA, LLC (Swifts)	\$ 43,698,574
CNH America, LLC & New Holland Inc.	34,853,280
Union Pacific Railroad Co.	32,990,948
Conestoga Mall 2002 LLC	24,840,895
Wal-Mart Real Estate	22,527,484
O'Conner Residential, LLC	13,101,099
Northwestern Corporation	12,200,728
TS12 LLC	11,785,583
Thayer, Janice M.	11,573,927
Dinsy LLC	10,654,369

Source: Hall County Assessor

Future Borrowing Plans

At a special election held September 9, 2014, \$69,900,000 was approved by a majority of the voters at said special election held in the District. The District issued \$51,215,000 of said authorization on December 1, 2014. The District plans to issue the remaining bonds within the next two years.

APPENDIX B
AUDITED FINANCIAL STATEMENTS

APPENDIX C

CONTINUING DISCLOSURE UNDERTAKING

APPENDIX C

FORM OF CONTINUING DISCLOSURE UNDERTAKING

The District is executing and delivering a Continuing Disclosure Undertaking for the benefit of the owners and Beneficial Owners of the Bonds and in order to assist the Underwriter in complying with Rule 15c2-12 of the Securities and Exchange Commission (the “**Rule**”). The District is the only “obligated person” with responsibility for continuing disclosure.

Annual Reports

Pursuant to the Continuing Disclosure Undertaking, the District shall, not later than **nine months** after the end of the District’s fiscal year, provide to the Municipal Securities Rulemaking Board (the “**MSRB**”) the following financial information and operating data (the “**Annual Report**”):

(a) The audited financial statements of the District for the prior fiscal year, prepared on the cash basis, which is a comprehensive basis of accounting other than the accounting principles generally accepted in the United States. If audited financial statements are not available by the time the Annual Report is required to be filed, the Annual Report shall contain unaudited financial statements in a format similar to the financial statements contained in the final Official Statement relating to the Bonds, and the audited financial statements shall be filed in the same manner as the Annual Report promptly after they become available.

(b) Updates as of the end of the fiscal year of the following financial information and operating data contained in APPENDIX A of the Official Statement in substantially the same format contained in this Official Statement:

- (i) GENERAL AND ECONOMIC INFORMATION: Enrollment History
- (ii) DEBT STRUCTURE: Hall County School District 0002: Assessed Valuation
- (iii) DEBT STRUCTURE: Hall County School District 0002: Outstanding General Obligation Debt
- (iv) DEBT STRUCTURE: Hall County School District 0002: Outstanding Limited Tax Obligation Debt

Material Event Notices

No later than 10 business days after the occurrence of any of the following events, the District shall give, or cause to be given to the MSRB, through EMMA, notice of the occurrence of any of the following events with respect to the Bonds (“**Material Events**”):

- (1) principal and interest payment delinquencies;
- (2) non-payment related defaults, if material;
- (3) unscheduled draws on debt service reserves reflecting financial difficulties;
- (4) unscheduled draws on credit enhancements reflecting financial difficulties;
- (5) substitution of credit or liquidity providers, or their failure to perform;
- (6) adverse tax opinions; the issuance by the Internal Revenue Service of proposed or final determinations of taxability, Notices of Proposed Issue (IRS Form 5701-TEB) or other material notices or determinations with respect to the tax status of the Bond, or other material events affecting the tax status of the Bonds;
- (7) modifications to rights of bondholders, if material;
- (8) bond calls, if material, and tender offers;
- (9) defeasances;
- (10) release, substitution or sale of property securing repayment of the Bonds, if material;
- (11) rating changes;

- (12) bankruptcy, insolvency, receivership or similar event of the Issuer;
- (13) the consummation of a merger, consolidation, or acquisition involving the Issuer or the sale of all or substantially all of the assets of the Issuer, other than in the ordinary course of business, the entry into a definitive agreement to undertake such an action or the termination of a definitive agreement relating to any such actions, other than pursuant to its terms, if material; and
- (14) appointment of a successor or additional trustee or the change of name of the trustee, if material.

The District may, from time to time, appoint or engage a Dissemination Agent to assist it in carrying out its obligations under the Continuing Disclosure Undertaking, and may discharge any such Agent, with or without appointing a successor Dissemination Agent. The Dissemination Agent shall not be responsible in any manner for the content of any notice or report prepared by the District pursuant to the Continuing Disclosure Undertaking.

Notwithstanding any other provision of the Continuing Disclosure Undertaking, the District may amend the Continuing Disclosure Undertaking and any provision of the Continuing Disclosure Undertaking may be waived, provided Bond Counsel or other counsel experienced in federal securities law matters provides the District with its opinion that the undertaking of the District, as so amended or after giving effect to such waiver, is in compliance with the Rule and all current amendments thereto and interpretations thereof that are applicable to the Continuing Disclosure Undertaking.

In the event of a failure of the District to comply with any provision of the Continuing Disclosure Undertaking, any owner or Beneficial Owner of the Bonds may take such actions as may be necessary and appropriate, including seeking mandamus or specific performance by court order, to cause the District to comply with its obligations under the Continuing Disclosure Undertaking. A default under the Continuing Disclosure Undertaking shall not be deemed an event of default under the Resolution, and the sole remedy under the Continuing Disclosure Undertaking in the event of any failure of the District to comply with the Continuing Disclosure Undertaking shall be an action to compel performance.

Electronic Municipal Market Access System (EMMA)

All Annual Reports and notices of Material Events required to be filed by the District or the Dissemination Agent pursuant to the Continuing Disclosure Undertaking must be submitted to the MSRB through the MSRB's Electronic Municipal Market Access system ("EMMA"). EMMA is an internet-based, online portal for free investor access to municipal bond information, including offering documents, material event notices, real-time municipal securities trade prices and MSRB education resources, available at www.emma.msrb.org. Nothing contained on EMMA relating to the District or the Bonds is incorporated by reference in this Official Statement.

Grand Island Public Schools

QCPUF Project List
Fiscal Year 2016 - 2017

DESCRIPTION OF PROJECT	BUILDING	AMOUNT	SUB TOTAL
Upgrade fire alarm system w/voice evacuation	Newell	\$120,000	
Upgrade fire alarm system w/voice evacuation	Gates	\$120,000	
Upgrade fire alarm system w/voice evacuation	Dodge	\$150,000	
Upgrade fire alarm system w/voice evacuation	Starr	\$120,000	
Upgrade fire alarm system w/voice evacuation	Howard	\$120,000	
Upgrade fire alarm system w/voice evacuation	Knickrehm	\$175,000	
Upgrade fire alarm system w/voice evacuation	Lincoln	\$120,000	
Upgrade fire alarm system w/voice evacuation	Seedling Mile	\$125,000	
Upgrade fire alarm system w/voice evacuation	Wasmer	\$150,000	
Upgrade fire alarm system w/voice evacuation	West Lawn	\$120,000	
Upgrade fire alarm system w/voice evacuation	Grand Island Senior High	\$200,000	
Upgrade fire alarm system w/voice evacuation	Early Learning Center	\$80,000	
Upgrade fire alarm system w/voice evacuation	Success Academy	\$20,000	
Upgrade fire alarm system w/voice evacuation	Indra House	\$20,000	
Upgrade fire alarm system w/voice evacuation	Kneale Administration Building	\$175,000	\$1,815,000
DESCRIPTION OF PROJECT	BUILDING	AMOUNT	
Replace fire alarm system w/voice evacuation	Walnut	\$175,000	\$175,000
DESCRIPTION OF PROJECT	BUILDING	AMOUNT	
Install fire sprinkler system	Newell	\$130,000	
Install fire sprinkler system	Gates	\$110,000	
Install fire sprinkler system	Starr	\$90,000	
Install fire sprinkler system	Knickrehm	\$130,000	
Install fire sprinkler system	Seedling Mile	\$80,000	
Install fire sprinkler system	West Lawn	\$125,000	
Install fire sprinkler system	Early Learning Center	\$110,000	\$775,000
DESCRIPTION OF PROJECT	BUILDING	AMOUNT	
Asbestos floor abatement and replacement	Newell	\$85,000	
Asbestos floor abatement and replacement	Dodge	\$45,000	\$130,000
DESCRIPTION OF PROJECT	BUILDING	AMOUNT	
Revise door knobs to ADA levers	Walnut	\$80,000	
Revise door knobs to ADA levers	Gates	\$35,000	\$115,000
DESCRIPTION OF PROJECT	BUILDING	AMOUNT	
Install elevator to second floor	Kneale Administration Building	\$750,000	
Install elevator to second floor	GISH Memorial Stadium	\$750,000	\$1,500,000
MISCELLANEOUS EXPENSES	BUILDING	AMOUNT	
Costs of Issuance and Other Capitalized Expenses	-	\$215,000	\$215,000
	Grand Total		\$4,725,000

December 8, 2016
Grand Island, Nebraska

A regular meeting of the Board of Education (the “**Board**”) of Hall County School District 0002 (Grand Island Public Schools) in the State of Nebraska (the “**District**”) was held at 6:30 p.m., December 8, 2016, in the Board Room, Kneale Administration Building, 123 South Webb Road, in Grand Island, Nebraska, the same being open to the public and preceded by advance publicized notice duly given in strict compliance with the provisions of the Open Meetings Act, Chapter 84, Article 14, Reissue Revised Statutes of Nebraska, as amended, as set forth on **Exhibit A** attached hereto stating (a) the date, time and place of the meeting; (b) that an agenda for the meeting, kept continuously current, was available for public inspection in the offices of the Superintendent; and (c) that the meeting would be open to the attendance of the public. Each member of the Board was also given advance notice of the meeting as acknowledged on **Exhibit B** attached hereto. Additionally, reasonable efforts were made to provide advance notice of the date, time, and place of the meeting to all news media requesting the same.

The President, _____, presided, and the Secretary, _____, recorded the proceedings. The meeting was called to order and on roll call the following Board Members were present: _____
_____.

The following Board Members were absent: _____. A quorum being present and the meeting duly convened, the following proceedings were had and done while the meeting was open to the attendance of the public. The President publicly announced the location of a current copy of the Nebraska Open Meetings Act posted in the meeting room for access by the public.

Board Member _____ introduced a resolution (the “**Resolution**”) and moved its passage by the Board. Board Member _____ seconded the motion to pass the Resolution. On roll call vote, the following Board Members voted in favor of the passage of the Resolution: _____
_____; the following Board Members voted against

the passage of the Resolution: _____; the following Board Members were absent or did not vote: _____. The passage of the Resolution having been agreed upon by a majority of the Board, the President declared the Resolution passed and signed the Resolution in the presence of the Board, and the Secretary attested to the passage of the Resolution by also signing the same. A true and complete copy of the Resolution is attached hereto as **Exhibit C.**

* * * * *

(Other Proceedings)

* * * * *

There being no further business to come before the meeting, on motion duly made, seconded and carried by unanimous vote, the meeting was adjourned.

_____, Secretary
Hall County School District 0002
(Grand Island Public Schools)
in the State of Nebraska

EXHIBIT A

AFFIDAVIT OF PUBLICATION OF NOTICE OF MEETING

**ACKNOWLEDGEMENT OF RECEIPT OF
ADVANCE NOTICE OF MEETING**

**ACKNOWLEDGMENT OF RECEIPT OF
ADVANCE NOTICE OF MEETING**

We, the undersigned, constituting all of the members of the Board of Education (the “**Board**”) of Hall County School District 0002 (Grand Island Public Schools) in the State of Nebraska (the “**District**”), hereby acknowledge having received advance notice of the special meeting of the Board and the agenda for the same held at 6:30 p.m., December 8, 2016, in the Board Room, Kneale Administration Building, 123 South Webb Road, in Grand Island, Nebraska.

DATED: _____, 2016.

Board Member

Board Member

Board Member

Board Member

Board Member

Board Member

Board Member

Board Member

Board Member

I hereby certify that _____ was/were absent from the meeting but that, to my personal knowledge, he/she/they received advance notice of the meeting.

Secretary

BOND RESOLUTION

RESOLUTION

“BE IT RESOLVED BY THE BOARD OF EDUCATION OF HALL COUNTY SCHOOL DISTRICT 0002, IN THE STATE OF NEBRASKA, AS FOLLOWS:

Section 1. The President and Board of Education (the “Board”) of Hall County School District 0002, in the State of Nebraska (the “District”), hereby find and determine as follows:

(a) The Board hereby finds and determines that certain actual or potential environmental hazards, accessibility barriers, life safety code violations, life safety hazards or mold, each as defined or described in Section 79-10,110.02, R.R.S. Neb., as amended, (the “Act”) exist in a public school building of the District and certain expenditures are needed for removal of such actual or potential environmental hazards and accessibility barriers, and correction of life safety code violations and life safety hazards and abatement of mold, all as defined or described in the Act, in a public school building of the District; that modifications for such removal of such actual or potential environmental hazards and accessibility barriers, and correction of life safety code violations and life safety hazards and abatement of mold (together, the “Project”) are necessary; that attached to this Resolution as Exhibit “A” is an itemized estimate of the amounts necessary to be expended for such Project (the “Estimate”); and that under the terms of the Act such Estimate may be presented to the County Clerk of Hall County, Nebraska, on or before September 20, 2017;

(b) The following matters are hereby determined:

(i) The Project as described in Section 1(a) above and more particularly described on the itemized estimate attached hereto as Exhibit “A” are hereby designated as the projects for which the tax levy provided for by the Act will be expended.

(ii) The Project does not include abatement projects related to the acquisition of new property, the construction of a new building, the expansion of an existing building, or the remodeling of an existing building for purposes other than the Project.

(iii) The District does not anticipate receipt of any issuance proceeds or other funds related to the Project.

(iv) The tax permitted to be levied pursuant to the Act will be expended to pay debt service on the bonds issued to pay all or a portion of the costs for the projects as referred to in (a) above.

(v) To pay the principal or redemption price of and interest on the Bonds (herein defined and authorized), the District estimates that it will be required to levy an annual tax based on the District’s current valuation of approximately 3.0 cents per one hundred dollars of valuation on all the taxable property of the District to be collected in each of the years beginning in 2017 (to be collected in 2018) and ending in 2026 (to be collected in 2027). Subject to the limitation in the Act, the tax hereby agreed to be levied shall be an amount sufficient to provide for the payment of principal and interest on the

bonds herein authorized as the same fall due in accordance with the terms of this resolution (the "Resolution").

(c) The Superintendent of the District is hereby directed to deliver the Estimate and a copy of this Resolution to the County Clerk of The County of Hall, in the State of Nebraska, by no later than September 20, 2017 in pursuance of the Act.

(d) The District has outstanding on the date of adoption of the Resolution its Limited Tax Refunding Building Bonds, Series 2015, outstanding in the principal amount of \$4,025,000, which were issued under the Act (the "Outstanding Bonds"); that the taxable valuation of all the taxable property for the District as most recently determined is \$2,938,020,328; that the District is permitted, pursuant to the Act, to levy a tax of not to exceed 3 cents per one hundred dollars of taxable valuation on all the taxable property of the District for the purposes of paying principal and interest on the bonds herein authorized and that such tax, when collected, will be sufficient to pay the principal of and interest on the bonds of this issue and the Outstanding Bonds as and when the same become due.

(e) All conditions, acts and things required to exist precedent to the issuance of the District's Limited Tax Building Improvement Bonds, Series 2016, in the principal amount of not to exceed \$4,725,000 (the "Bonds"; or, individually, a "Bond") under the terms of the Act to exist do exist and have been done as required by law.

Section 2. There shall be and there is hereby ordered issued the negotiable bonds of this District to be designated as its "Limited Tax Building Improvement Bonds, Series 2016" in the aggregate principal amount of not to exceed Four Million Seven Hundred Twenty-five Thousand Dollars (\$4,725,000) with said Bonds coming due on such dates and in such amounts and bearing interest at the rates per annum as shall be determined in a written designation (the "Designation") signed by the Superintendent, President or Secretary of the District (the "Authorized Officers") on behalf of the Board and which may be agreed to by D.A. Davidson & Co. (the "Underwriter"), which Designation may also determine mandatory redemption provisions (if any), and pricing terms as set forth in Section 12 below, all within the following limitations:

1. the aggregate principal amount of the Bonds shall not exceed \$4,725,000, provided, however, such amount may be increased as necessary to the extent the Bonds are sold at a net original issue discount;
2. the longest maturity of the Bonds may not be later than December 15, 2027;
3. the true interest cost on the Bonds shall not exceed 3.50% per annum;
4. two or more of the principal maturities may be combined and issued as "term bonds" and the Authorized Officer may determine the mandatory sinking fund payments and mandatory redemption amounts. Any Bonds issued as "term bonds" shall be redeemed at a redemption price equal to 100% of the principal amount thereof plus accrued interest thereon to the date of redemption and may be selected for redemption by any random method of selection determined appropriate by the Paying Agent and Registrar (as hereinafter designated) or by the Depository (as hereinafter designated).

The Authorized Officers (or any one of them) are hereby authorized to make such determinations on behalf of the Board and to evidence the same by execution and delivery of the Designation and such

determinations, when made and agreed to by the Underwriter, shall constitute the action of the Board without further action of the Board.

The Bonds shall be issued in fully registered form in the denomination of \$5,000 or any integral multiple thereof. The date of original issue for the Bonds shall be the date of delivery thereof. Interest on the Bonds, at the respective rates for each maturity, shall be payable semiannually on June 15 and December 15 of each year, commencing June 15, 2017 (or such other dates as may be determined in the Designation; each of said dates an "Interest Payment Date") and the Bonds shall bear such interest from the date of original issue or the most recent Interest Payment Date, whichever is later. The interest due on each Interest Payment Date shall be payable to the registered owners of record as of the close of business on the fifteenth day immediately preceding the next Interest Payment Date (the "Record Date"), subject to the provisions of Section 4 hereof. The Bonds shall be numbered from R-1 upwards in the order of their issuance. No Bond shall be issued originally or upon transfer or partial redemption having more than one principal maturity. The initial bond numbering and principal amounts for each of the Bonds issued shall be designated by the District's Treasurer as directed by the initial purchaser thereof. Payments of interest due on the Bonds prior to maturity or earlier redemption shall be made by the Paying Agent and Registrar, as designated pursuant to Section 3 hereof, by mailing a check or draft in the amount due for such interest on each Interest Payment Date to the registered owner of each Bond, as of the Record Date for such Interest Payment Date, to such owner's registered address as shown on the books of registration as required to be maintained in Section 3 hereof. Payments of principal and unpaid interest accrued thereon due at maturity or at any date fixed for redemption prior to maturity shall be made by said Paying Agent and Registrar to the registered owners upon presentation and surrender of the Bonds to said Paying Agent and Registrar. The District and said Paying Agent and Registrar may treat the registered owner of any Bond as the absolute owner of such Bond for the purpose of making payments thereon and for all other purposes and neither the District nor the Paying Agent and Registrar shall be affected by any notice or knowledge to the contrary, whether such Bond or any installment of interest due thereon shall be overdue or not. All payments on account of interest or principal made to the registered owner of any Bond in accordance with the terms of this Resolution shall be valid and effectual and shall be a discharge of the District and said Paying Agent and Registrar, in respect of the liability upon the Bonds or claims for interest to the extent of the sum or sums so paid.

Section 3. The Treasurer of the District or a bank or trust company as determined by an Authorized Officer shall be designated as (a) paying agent for the payment of principal of and interest on the Bonds and (b) bond registrar with respect to the registration, transfer and exchange of Bonds (the "Paying Agent and Registrar"). If a bank or trust company is designated as Paying Agent and Registrar, the District is authorized to enter into the Bond Registrar and Paying Agent Agreement (the "Paying Agent and Registrar Agreement") dated the date of its execution and delivery between the District and the Paying Agent and Registrar in substantially the form determined by an Authorized Officer in accordance with the provisions of Section 2(b) (a copy of which shall be filed in the records of the District). An Authorized Officer is authorized to execute the Paying Agent and Registrar Agreement with such changes therein as such official deems appropriate, for and on behalf of and as the act and deed of the District. The District shall have the right to remove and replace the Paying Agent and Registrar in accordance with the terms of the Paying Agent and Registrar's Agreement. The Paying Agent and Registrar shall keep and maintain for the District books for the registration and transfer of the Bonds at its designated office (the "Designated Office"). The names and registered addresses of the registered owner or owners of the Bonds shall at all times be recorded in such books. Any Bond may be transferred pursuant to its provisions at the principal office of said Paying Agent and Registrar by surrender of such Bond for cancellation, accompanied by a written instrument of transfer, in form satisfactory to said Paying Agent and Registrar, duly executed by the registered owner in person or by such owner's duly authorized agent, and thereupon the Paying Agent and Registrar on behalf of the District will deliver at its Designated Office (or send by registered mail to the transferee owner or owners thereof at such transferee owner's or

owners' risk and expense), registered in the name of the transferee owner or owners, a new Bond or Bonds of the same interest rate, aggregate principal amount and maturity. To the extent of the denominations authorized for the Bonds by this Resolution, one Bond may be transferred for several such Bonds of the same interest rate and maturity, and for a like aggregate principal amount, and several such Bonds may be transferred for one or several such Bonds, respectively, of the same interest rate and maturity and for a like aggregate principal amount. In every case of transfer of a Bond, the surrendered Bond shall be canceled and destroyed. All Bonds issued upon transfer of the Bonds so surrendered shall be valid obligations of the District evidencing the same obligations as the Bonds surrendered and shall be entitled to all the benefits and protection of this Resolution to the same extent as the Bonds upon transfer of which they were delivered. The District and said Paying Agent and Registrar shall not be required to transfer any Bond during any period from any Record Date until its immediately following Interest Payment Date or to transfer any Bond called for redemption for a period of 30 days next preceding the date fixed for redemption.

Section 4. In the event that payments of interest due on the Bonds on an Interest Payment Date are not timely made, such interest shall cease to be payable to the registered owners as of the Record Date for such Interest Payment Date and shall be payable to the registered owners of the Bonds as of a special date of record for payment of such defaulted interest as shall be designated by the Paying Agent and Registrar whenever monies for the purpose of paying such defaulted interest become available.

Section 5. If the date for payment of the principal of or interest on the Bonds shall be a Saturday, Sunday, legal holiday or a day on which banking institutions in the city where the Designated Office of the Paying Agent and Registrar is located are authorized by law or executive order to close, then the date for such payment shall be the next succeeding day which is not a Saturday, Sunday, legal holiday or a day on which such banking institutions are authorized to close, and payment on such day shall have the same force and effect as if made on the nominal date of payment.

Section 6. The Bonds shall be subject to redemption, in whole or in part, prior to maturity at any time on or after the fifth anniversary of the date of original issue thereof (or such other date as may be determined in the Designation), at the principal amount thereof plus accrued interest to the date fixed for redemption. The District may select the Bonds to be redeemed in its sole discretion but the Bonds shall be redeemed only in principal amounts of \$5,000 or integral multiples thereof. Any Bond or Bonds redeemed in part only shall be surrendered to the Paying Agent and Registrar in exchange for a new Bond or Bonds evidencing the unredeemed principal thereof. Notice of optional redemption of any Bonds shall be given at the direction of the District by said Paying Agent and Registrar by mail not less than 30 days prior to the date fixed for redemption, first class, postage prepaid, sent to the registered owner of such Bond at said owner's registered address. Such notice shall designate the Bond or Bonds to be redeemed by maturity or otherwise, the date of original issue and the date fixed for redemption and shall state that such Bond or Bonds are to be presented for prepayment at the Designated Office of said Paying Agent and Registrar. In case of any Bond partially redeemed, such notice shall specify the portion of the principal amount of such Bond to be redeemed. No defect in the mailing of notice for any Bond shall affect the sufficiency of the proceedings of the District designating the Bonds called for redemption or the effectiveness of such call for Bonds for which notice by mail has been properly given and the District shall have the right to direct further notice of redemption for any such Bond for which defective notice has been given.

Section 7. The Bonds shall be in substantially the following form:

**UNITED STATES OF AMERICA
STATE OF NEBRASKA
LIMITED TAX BUILDING IMPROVEMENT BOND
SERIES 2016
OF
HALL COUNTY SCHOOL DISTRICT 0002
(GRAND ISLAND PUBLIC SCHOOLS)**

No. R-

<u>Interest Rate</u>	<u>Maturity Date</u>	<u>Date of Original Issue</u>	<u>CUSIP</u>
%	_____, 20__	_____, 2016	514028 ____

**Registered Owner: Cede & Co.
13-2555119**

Principal Amount:

KNOW ALL PERSONS BY THESE PRESENTS: That Hall County School District 0002, in the State of Nebraska (the "District"), hereby acknowledges itself to owe and for value received promises to pay to the Registered Owner specified above, or registered assigns, the Principal Amount specified above in lawful money of the United States of America on the Maturity Date specified above with interest thereon to maturity (or earlier redemption) from the Date of Original Issue or most recent interest payment date, whichever is later, at the Interest Rate per annum specified above payable semiannually on June 15 and December 15 of each year, commencing June 15, 2017 (each of said dates an "Interest Payment Date"). Said interest shall be computed on the basis of a 360-day year consisting of twelve 30-day months. The principal hereof due at maturity or upon redemption prior to maturity, together with unpaid interest accrued thereon, is payable upon presentation and surrender of this Bond at the principal corporate trust office of _____, the Paying Agent and Registrar. Interest on this Bond due prior to maturity or earlier redemption will be paid on each Interest Payment Date by a check or draft mailed by the Paying Agent and Registrar to the registered owner of this Bond, as shown on the books of record maintained by the Paying Agent and Registrar, at the close of business on the fifteenth day immediately preceding the next Interest Payment Date, to such owner's address as shown on such books and records. Any interest not so timely paid shall cease to be payable to the person entitled thereto as of the record date such interest was payable, and shall be payable to the person who is the registered owner of this Bond (or of one or more predecessor bonds hereto) on such special record date for payment of such defaulted interest as shall be fixed by the Paying Agent and Registrar whenever monies for such purpose become available.

The District, however, reserves the right and option of redeeming bonds of this issue maturing on or after _____, 20__, in whole or in part, on _____, 20__, or at any time thereafter, at the principal amount thereof plus accrued interest to the date fixed for redemption. The District may select the bonds to be redeemed in its sole discretion but bonds shall be redeemed only in principal amounts of \$5,000 or integral multiples thereof. Notice of such redemption shall be given by mail, sent to the registered owner of any bond called for redemption at said registered owner's address in the manner provided in the resolution authorizing said bonds.

This Bond is one of an issue of fully registered bonds of the total principal amount of _____ Dollars (\$_____), of even date and like tenor except as to denomination, date of maturity and rate of interest, which were issued by said District for the purpose of paying the cost of removal of actual or potential environmental hazards, accessibility barriers, life

safety code violations, life safety hazards or mold abatement and prevention in buildings of the District, all in accordance with the provisions of Section 79-10,110.02, R.R.S. Neb., as amended (“Section 79-10,110.02”). Said bond is issued pursuant to a resolution duly adopted by the Board of Education of the District (the “Resolution”).

If the date for payment of the principal of or interest on this Bond shall be a Saturday, Sunday, legal holiday or a day on which banking institutions in the city where the designated corporate trust office of the Paying Agent and Registrar is located are authorized by law or executive order to close, then the date for such payment shall be the next succeeding day which is not a Saturday, Sunday, legal holiday or a day on which such banking institutions are authorized to close, and payment on such day shall have the same force and effect as if made on the nominal date of payment.

This Bond is transferable by the registered owner or such owner’s attorney duly authorized in writing at the designated corporate trust office of the Paying Agent and Registrar upon surrender and cancellation of this Bond, and thereupon a new bond or bonds of the same total principal amount and interest rate and maturity will be issued to the transferee as provided in the Resolution subject to the limitations therein prescribed. The District, the Paying Agent and Registrar and any other person may treat the person in whose name this Bond is registered as the absolute owner hereof for the purpose of receiving payment hereof and for all other purposes and shall not be affected by any notice to the contrary, whether this Bond be overdue or not.

This Bond shall not be valid and binding on the District until authenticated by the Paying Agent and Registrar.

IT IS HEREBY CERTIFIED AND WARRANTED that all conditions, acts and things required by law to exist or to be done precedent to and in the issuance of this Bond did exist, did happen and were done and performed in regular and due form and time as required by law and that the indebtedness of this District, including this Bond, does not exceed any limitation imposed by law. The District agrees that it shall cause to be levied and collected annually a special levy of taxes, subject to the limitation set forth in Section 79-10,110.02, on all the taxable property in said District for the purpose of paying and sufficient to pay the principal of and interest on this Bond as and when such principal and interest become due. **THIS BOND IS A LIMITED OBLIGATION OF THE DISTRICT PAYABLE SOLELY FROM TAXES LEVIED FROM YEAR TO YEAR PURSUANT TO SECTION 79-10,110.02 AND THE SINKING FUND ACCUMULATED FROM SUCH TAXES.**

AS PROVIDED IN THE RESOLUTION REFERRED TO HEREIN, UNTIL THE TERMINATION OF THE SYSTEM OF BOOK-ENTRY-ONLY TRANSFERS THROUGH THE DEPOSITORY TRUST COMPANY, NEW YORK, NEW YORK (TOGETHER WITH ANY SUCCESSOR SECURITIES DEPOSITORY APPOINTED PURSUANT TO THE RESOLUTION, “DTC”), AND NOTWITHSTANDING ANY OTHER PROVISIONS OF THE RESOLUTION TO THE CONTRARY, A PORTION OF THE PRINCIPAL AMOUNT OF THIS BOND MAY BE PAID OR REDEEMED WITHOUT SURRENDER HEREOF TO THE PAYING AGENT AND REGISTRAR. DTC OR A NOMINEE, TRANSFEREE OR ASSIGNEE OF DTC OF THIS BOND MAY NOT RELY UPON THE PRINCIPAL AMOUNT INDICATED HEREON AS THE PRINCIPAL AMOUNT HEREOF OUTSTANDING AND UNPAID. THE PRINCIPAL AMOUNT HEREOF OUTSTANDING AND UNPAID SHALL FOR ALL PURPOSES BE THE AMOUNT DETERMINED IN THE MANNER PROVIDED IN THE RESOLUTION.

UNLESS THIS BOND IS PRESENTED BY AN AUTHORIZED OFFICER OF DTC TO THE PAYING AGENT AND REGISTRAR FOR (A) REGISTRATION OF TRANSFER OR EXCHANGE OR (B) PAYMENT OF PRINCIPAL, AND ANY BOND ISSUED IN REPLACEMENT HEREOF OR

SUBSTITUTION HEREOF IS REGISTERED IN THE NAME OF DTC AND ANY PAYMENT IS MADE TO DTC OR ITS NOMINEE, ANY TRANSFER, PLEDGE OR OTHER USE HEREOF FOR VALUE OR OTHERWISE BY OR TO ANY PERSONS IS WRONGFUL BECAUSE ONLY THE REGISTERED OWNER HEREOF, DTC OR ITS NOMINEE, HAS AN INTEREST HEREIN.

IN WITNESS WHEREOF, the Board of Education of said District has caused this Bond to be executed on behalf of the District by being signed by the President and Secretary of the Board of Education of the District, both of which signatures may be facsimile signatures, all as of the Date of Original Issue specified above.

HALL COUNTY SCHOOL DISTRICT 0002
IN THE STATE OF NEBRASKA

By: (Sample – Do Not Sign)
President

ATTEST

(Sample – Do Not Sign)
Secretary

CERTIFICATE OF AUTHENTICATION

This Bond is one of the bonds authorized by the Resolution of the Board of Education of Hall County School District 0002, in the State of Nebraska, described in the foregoing bond.

_____,
Paying Agent and Registrar

By: _____
Authorized Signature

(Form of Assignment)

For value received _____
hereby sells, assigns and transfers unto _____ (Social
Security or Taxpayer I.D. No. _____) the within bond and hereby irrevocably constitutes and
appoints _____, attorney, to transfer the same on the books
of registration in the designated corporate trust office of the within mentioned Paying Agent and Registrar
with full power of substitution in the premises.

Dated: _____

Registered Owner(s)

Signature Guaranteed

By: _____

Authorized Officer(s)

Note: The signature(s) on this Assignment **MUST CORRESPOND** with the name(s) as written on the
face of the within bond in every particular, without alteration, enlargement or any change whatsoever, and
must be guaranteed by a commercial bank or a trust company or by a firm having membership on the
New York, Midwest or other stock exchange.

* * * * *

Section 8. Said Bonds shall be executed on behalf of the District by the President and Secretary of the Board who shall sign the same in their official capacity, both of which signatures are hereby authorized to be facsimile signatures. The Bonds shall be issued initially as “book-entry-only” bonds under the services of The Depository Trust Company (the “Depository”), with one typewritten bond per maturity being issued to the Depository. In such connection the President and Secretary shall deliver a Letter of Representations in the form required by the Depository (which may be in the form of a blanket letter, including any such letter previously executed and delivered), for and on behalf of the District, which shall govern matters with respect to registration, transfer, payment and redemption of the Bonds. With respect to the issuance of the Bonds as “book-entry-only” bonds, the following provisions shall apply:

(a) The District and the Paying Agent and Registrar shall have no responsibility or obligation to any broker-dealer, bank or other financial institution for which the Depository holds Bonds as securities depository (each, a “Bond Participant”) or to any person who is an actual purchaser of a Bond from a Bond Participant while the Bonds are in book-entry form (each, a “Beneficial Owner”) with respect to the following:

(i) the accuracy of the records of the Depository, any nominees of the Depository or any Bond Participant with respect to any ownership interest in the Bonds,

(ii) the delivery to any Bond Participant, any Beneficial Owner or any other person, other than the Depository, of any notice with respect to the Bonds, including any notice of redemption, or

(iii) the payment to any Bond Participant, any Beneficial Owner or any other person, other than the Depository, of any amount with respect to the Bonds. The Paying Agent and Registrar shall make payments with respect to the Bonds only to or upon the order of the Depository or its nominee, and all such payments shall be valid and effective fully to satisfy and discharge the obligations with respect to such Bonds to the extent of the sum or sums so paid. No person other than the Depository shall receive an authenticated Bond, except as provided in (e) below.

(b) Upon receipt by the Paying Agent and Registrar of written notice from the Depository to the effect that the Depository is unable or unwilling to discharge its responsibilities, the Paying Agent and Registrar shall issue, transfer and exchange Bonds requested by the Depository in appropriate amounts. Whenever the Depository requests the Paying Agent and Registrar to do so, the Paying Agent and Registrar will cooperate with the Depository in taking appropriate action after reasonable notice (i) to arrange, with the prior written consent of the District, for a substitute depository willing and able upon reasonable and customary terms to maintain custody of the Bonds or (ii) to make available Bonds registered in whatever name or names as the Beneficial Owners transferring or exchanging such Bonds shall designate.

(c) If the District determines that it is desirable that certificates representing the Bonds be delivered to the ultimate beneficial owners of the Bonds and so notifies the Paying Agent and Registrar in writing, the Paying Agent and Registrar shall so notify the Depository, whereupon the Depository will notify the Bond Participants of the availability through the Depository of bond certificates representing the Bonds. In such event, the Paying Agent and Registrar shall issue, transfer and exchange bond certificates representing

the Bonds as requested by the Depository in appropriate amounts and in authorized denominations.

(d) Notwithstanding any other provision of this Resolution to the contrary, so long as any Bond is registered in the name of the Depository or any nominee thereof, all payments with respect to such Bond and all notices with respect to such Bond shall be made and given, respectively, to the Depository as provided in the Letter of Representations.

(e) Registered ownership of the Bonds may be transferred on the books of registration maintained by the Paying Agent and Registrar, and the Bonds may be delivered in physical form to the following:

(i) any successor securities depository or its nominee; or

(ii) any person, upon (A) the resignation of the Depository from its functions as depository or (B) termination of the use of the Depository pursuant to this Section and the terms of the Paying Agent and Registrar's Agreement.

(f) In the event of any partial redemption of a Bond unless and until such partially redeemed bond has been replaced in accordance with the provisions of this Resolution, the books and records of the Paying Agent and Registrar shall govern and establish the principal amount of such bond as is then outstanding and all of the Bonds issued to the Depository or its nominee shall contain a legend to such effect.

If for any reason the Depository is terminated or resigns and is not replaced, the District shall immediately provide a supply of printed bond certificates for issuance upon the transfers from the Depository and subsequent transfers or in the event of partial redemption. In the event that such supply of certificates shall be insufficient to meet the requirements of the Paying Agent and Registrar for issuance of replacement certificates upon transfer or partial redemption, the District agrees to order printed an additional supply of such certificates and to direct their execution by manual or facsimile signatures of its then duly qualified and acting President and Secretary. In case any officer whose signature or facsimile thereof shall appear on any Bond shall cease to be such officer before the delivery of such bond (including such certificates delivered to the Paying Agent and Registrar for issuance upon transfer or partial redemption), such signature or such facsimile signature shall nevertheless be valid and sufficient for all purposes the same as if such officer or officers had remained in office until the delivery of such bond. The Bonds shall not be valid and binding on the District until authenticated by the Paying Agent and Registrar.

Section 9. After being executed by the President and Secretary of the Board, said Bonds shall be delivered to the Treasurer of the District who shall be responsible therefor under his/her official bond, and he/she shall cause the same to be delivered to the Paying Agent and Registrar for registration and authentication. The Secretary of the District is directed to make and certify a transcript of the proceedings of the District precedent to the issuance of said Bonds, a copy of which shall be delivered to the initial purchaser of said Bonds. The District's Treasurer shall maintain a record of information with respect to said Bonds as required under Section 10-140, R.R.S. Neb. 2012, as amended, and shall cause said record of information to be filed in the office of the Auditor of Public Accounts.

Section 10. The Board shall cause to be levied and collected annually a special levy of taxes, pursuant to and within the limitations set forth in the Act, on all the taxable property in the District for the purpose of paying and sufficient to pay the principal of and interest on the Bonds as and when such principal and interest become due according to the terms thereof and the terms of this Resolution. In accordance with

the determinations set forth in Section 1 of this Resolution, such tax levied to pay principal and interest on the Bonds and the taxes levied to pay principal and interest on the Outstanding Bonds, together shall not exceed 3 cents per one hundred dollars of valuation on all the taxable property of the District in each such year, all in accordance with the Act. In accordance with the Act, there is hereby created a “2016 Limited Tax Building Improvement Bond Project Account” (herein, the “2016 Account”). All taxes levied and collected by the District for the Bonds in accordance with this Section 10 shall be deposited in the 2016 Account and are hereby pledged for the prompt payment of the Bonds, both principal and interest, as the same fall due.

Section 11. The District’s obligations under this Resolution and the liens, pledges, covenants, and agreements of the District herein made or provided for, shall be fully discharged and satisfied as to the Bonds, and any such bonds shall no longer be deemed outstanding hereunder if such bonds shall have been purchased and canceled by the District, or when payment of the principal of and interest thereon to the respective date of maturity or redemption (a) shall have been made or caused to be made in accordance with the terms thereof; or (b) shall have been provided for by depositing with the Paying Agent and Registrar or with a national or state bank having trust powers, or trust company, in trust solely for such payment (i) sufficient money to make such payment and/or (ii) direct general obligations (including obligations issued or held in book entry form on the books of the Department of Treasury of the United States of America) of or obligations the principal and interest of which are unconditionally guaranteed by the United States of America (herein referred to as “U.S. Government Obligations”) in such amount and bearing interest payable and maturing or redeemable at stated fixed prices at the option of the holder as to principal, at such time or times, as will ensure the availability of sufficient money to make such payment; provided, however, that with respect to any Bond to be paid prior to maturity, the District shall have duly called such bond for redemption and given notice of such redemption as provided by law or made irrevocable provision for the giving of such notice. Any money so deposited with such bank or trust company or with the Paying Agent and Registrar may be invested or reinvested in U.S. Government Obligations at the direction of the District, and all interest and income from U.S. Government Obligations in the hands of such bank or trust company or Paying Agent and Registrar in excess of the amount required to pay principal of and interest on the Bonds for which such monies or U.S. Government Obligations were deposited shall be paid over to the District as and when collected. The District reserves the right to issue refunding bonds and provide for the investment of the proceeds thereof in accordance with this Section 11 for purposes of providing for the payment of principal and interest on the Bonds herein authorized.

Section 12. Upon execution, registration and authentication of the Bonds, the Paying Agent and Registrar is authorized to deliver them to the Underwriter, as initial purchaser of the Bonds, upon receipt of 98.80% of the principal amount of the Bonds (or such other amount as may be determined in the Designation), plus accrued interest, if any, to date of payment and delivery thereof. The District’s Treasurer is hereby authorized to deliver said Bonds to the Underwriter, as initial purchaser of said Bonds, upon payment in full of the purchase price thereof. Said initial purchaser shall have the right to direct the registration of said Bonds and the denominations thereof within each maturity subject to the restrictions of this Resolution. The Authorized Officers (or any one of them) are hereby authorized to execute the Bond Purchase Agreement related to the Bonds, which Bond Purchase Agreement may serve as the written Designation of the District. The net proceeds of the Bonds shall be applied solely to pay costs of the Project upon order of the Board. Costs of issuance for the Bonds may be paid from proceeds of the Bonds. Such purchaser and its agents, representatives and counsel (including bond counsel for the Bonds) are hereby authorized to take such actions on behalf of the District as are necessary to effectuate the closing of the issuance and sale of the Bonds, including, without limitation, authorizing the release of the Bonds by the Depository at closing. The officers of the District, or any one or more of them are hereby further authorized to take any and all actions deemed necessary or appropriate in connection with the issuance and sale of the Bonds.

Section 13. The District hereby covenants with the purchasers and holders of the Bonds herein authorized that it will make no use of the proceeds of said issue, including monies held in any sinking fund for the payment of principal and interest on said Bonds, which would cause said Bonds to be arbitrage bonds within the meaning of Sections 103 and 148 and other related sections of the Internal Revenue Code of 1986, as amended, (the “Code”) and further covenants to comply with said Sections 103 and 148 and related sections and all applicable regulations thereunder throughout the term of said issue. The District hereby covenants and agrees to take all actions necessary under the Code to maintain the tax exempt status (as to taxpayers generally) of interest payable on the Bonds herein authorized, including execution of a Federal Tax Certificate to be dated the date of issuance of the Bonds. An Authorized Officer is hereby authorized to make any certifications and designation with respect to status of the Bonds under Section 265 of the Code as he or she deems appropriate.

Section 14. The Authorized Officers are hereby authorized to review, approve, deem final and deliver on behalf of the District a Preliminary Official Statement and a Final Official Statement with respect to the Bonds, all in accordance with Rule 15c2-12 promulgated by the Securities and Exchange Commission.

Section 15. The District hereby (a) authorizes and directs that an Authorized Officer execute and deliver, on the date of issue of the Bonds, a continuing disclosure undertaking (the “Continuing Disclosure Undertaking”) in such form as shall be satisfactory to the District and in compliance with Rule 15c2-12 promulgated by the Securities and Exchange Commission, and (b) covenants and agrees that it will comply with and carry out all of the provisions of the Continuing Disclosure Undertaking. Notwithstanding any other provision of this Resolution, failure of the District to comply with the Continuing Disclosure Undertaking shall not be considered an event of default hereunder; however, any Participating Underwriter (as such term is defined in the Continuing Disclosure Undertaking) or any Beneficial Owner or any Registered Owner of a Bond (as such terms are defined in the Continuing Disclosure Undertaking) may take such actions as may be necessary and appropriate, including seeking mandamus or specific performance by court order, to cause the District to comply with its obligations under this section.

Section 16. The officers of the District, or any one or more of them, including the President, Vice President and Secretary of the Board and the Superintendent are hereby authorized to execute and deliver any and all certificates and documents and to take any and all actions determined appropriate in connection with the issuance and sale of the Bonds.

[The remainder of this page intentionally left blank.]

Section 17. This Resolution shall be in force and take effect from and after its passage.

Secretary

President

EXHIBIT "A"

ITEMIZED ESTIMATE

See attached.

Grand Island Public Schools QCPUF Project List Fiscal Year 2016 - 2017

DESCRIPTION OF PROJECT	BUILDING	AMOUNT	SUB TOTAL
Upgrade fire alarm system w/voice evacuation	Newell	\$120,000	
Upgrade fire alarm system w/voice evacuation	Gates	\$120,000	
Upgrade fire alarm system w/voice evacuation	Dodge	\$150,000	
Upgrade fire alarm system w/voice evacuation	Starr	\$120,000	
Upgrade fire alarm system w/voice evacuation	Howard	\$120,000	
Upgrade fire alarm system w/voice evacuation	Knickrehm	\$175,000	
Upgrade fire alarm system w/voice evacuation	Lincoln	\$120,000	
Upgrade fire alarm system w/voice evacuation	Seedling Mile	\$125,000	
Upgrade fire alarm system w/voice evacuation	Wasmer	\$150,000	
Upgrade fire alarm system w/voice evacuation	West Lawn	\$120,000	
Upgrade fire alarm system w/voice evacuation	Grand Island Senior High	\$200,000	
Upgrade fire alarm system w/voice evacuation	Early Learning Center	\$80,000	
Upgrade fire alarm system w/voice evacuation	Success Academy	\$20,000	
Upgrade fire alarm system w/voice evacuation	Indra House	\$20,000	
Upgrade fire alarm system w/voice evacuation	Kneale Administration Building	\$175,000	\$1,815,000
DESCRIPTION OF PROJECT	BUILDING	AMOUNT	
Replace fire alarm system w/voice evacuation	Walnut	\$175,000	\$175,000
DESCRIPTION OF PROJECT	BUILDING	AMOUNT	
Install fire sprinkler system	Newell	\$130,000	
Install fire sprinkler system	Gates	\$110,000	
Install fire sprinkler system	Starr	\$90,000	
Install fire sprinkler system	Knickrehm	\$130,000	
Install fire sprinkler system	Seedling Mile	\$80,000	
Install fire sprinkler system	West Lawn	\$125,000	
Install fire sprinkler system	Early Learning Center	\$110,000	\$775,000
DESCRIPTION OF PROJECT	BUILDING	AMOUNT	
Asbestos floor abatement and replacement	Newell	\$85,000	
Asbestos floor abatement and replacement	Dodge	\$45,000	\$130,000
DESCRIPTION OF PROJECT	BUILDING	AMOUNT	
Revise door knobs to ADA levers	Walnut	\$80,000	
Revise door knobs to ADA levers	Gates	\$35,000	\$115,000
DESCRIPTION OF PROJECT	BUILDING	AMOUNT	
Install elevator to second floor	Kneale Administration Building	\$750,000	
Install elevator to second floor	GISH Memorial Stadium	\$750,000	\$1,500,000
MISCELLANEOUS EXPENSES	BUILDING	AMOUNT	
Costs of Issuance and Other Capitalized Expenses	-	\$215,000	\$215,000
	Grand Total		\$4,725,000

SOURCES AND USES OF FUNDS

**HALL COUNTY SCHOOL DISTRICT 0002
(GRAND ISLAND PUBLIC SCHOOLS)
LIMITED TAX BUILDING BONDS, SERIES 2016
\$4.510M Project Fund, Wrap Ser. 2015 LTGOs, Cap. Int. to 12/15/17
Assumes BQ, Non-Rated, 2026 Final Maturity
[Preliminary -- for discussion only]**

Dated Date	12/23/2016
Delivery Date	12/23/2016

Sources:

<hr/>	
Bond Proceeds:	
Par Amount	4,695,000.00
<hr/>	
	4,695,000.00
<hr/> <hr/>	

Uses:

<hr/>	
Project Fund Deposits:	
Project Funds	4,510,000.00
Other Fund Deposits:	
Capitalized Interest Fund (to 12/15/17)	119,882.89
Delivery Date Expenses:	
Cost of Issuance	7,042.50
Underwriter's Discount	<u>56,340.00</u>
	63,382.50
Other Uses of Funds:	
Bond Rounding Amount	1,734.61
<hr/>	
	4,695,000.00
<hr/> <hr/>	

REVENUE AND DEBT SERVICE

HALL COUNTY NEBRASKA SCHOOL DISTRICT 0002 (GRAND ISLAND PUBLIC SCHOOLS) LIMITED TAX AGGREGATE NET DEBT SERVICE -- ACTUAL MATURITY DATES

	ANNUAL ASSESSED VALUE	LEVY \$0.030 (beg. '18)	Semiannual Revenue Avail. for D/S	SERIES 2015 LTGO Net Debt Svc	Proposed SER. 2016 LTGO Net Debt Svc \$4.695M Par \$4.510M Proj	TOTAL Semiannual Debt Service	TOTAL Fiscal Year Annual Debt Service	Annual Surplus	Cum. Surplus
6/15/2016	2,938,020,328	\$0.0172	253,264	33,796		33,796		219,468	219,468
8/31/2016				-			33,796		
12/15/2016		\$0.0172	253,264	458,796		458,796		(205,532)	13,935
6/15/2017	3,050,120,816	\$0.0163	248,087	32,415	-	32,415		215,672	229,607
8/31/2017				-	-		491,211		
12/15/2017		\$0.0163	248,087	457,415	-	457,415		(209,329)	20,278
6/15/2018	3,050,120,816	\$0.030	457,518	30,396	61,304	91,700		365,818	386,097
8/31/2018				-	-		549,115		
12/15/2018		\$0.030	457,518	460,396	346,304	806,700		(349,182)	36,915
6/15/2019	3,050,120,816	\$0.030	457,518	27,709	59,024	86,733		370,786	407,700
8/31/2019				-	-		893,433		
12/15/2019		\$0.030	457,518	462,709	349,024	811,733		(354,214)	53,486
6/15/2020	3,050,120,816	\$0.030	457,518	24,446	56,414	80,860		376,658	430,144
8/31/2020				-	-		892,593		
12/15/2020		\$0.030	457,518	469,446	351,414	820,860		(363,342)	66,802
6/15/2021	3,050,120,816	\$0.030	457,518	20,553	53,464	74,016		383,502	450,304
8/31/2021				-	-		894,876		
12/15/2021		\$0.030	457,518	470,553	358,464	829,016		(371,498)	78,806
6/15/2022	3,050,120,816	\$0.030	457,518	16,053	50,109	66,161		391,357	470,163
8/31/2022				-	-		895,178		
12/15/2022		\$0.030	457,518	476,053	360,109	836,161		(378,643)	91,520
6/15/2023	3,050,120,816	\$0.030	457,518	11,108	46,466	57,574		399,944	491,464
8/31/2023				-	-		893,735		
12/15/2023		\$0.030	457,518	481,108	366,466	847,574		(390,056)	101,408
6/15/2024	3,050,120,816	\$0.030	457,518	5,820	42,466	48,286		409,232	510,640
8/31/2024				-	-		895,860		
12/15/2024		\$0.030	457,518	490,820	367,466	858,286		(400,768)	109,872
6/15/2025	3,050,120,816	\$0.030	457,518		38,079	38,079		419,439	529,312
8/31/2025					-		896,365		
12/15/2025		\$0.030	457,518		868,079	868,079		(410,561)	118,751
6/15/2026	3,050,120,816	\$0.030	457,518		26,251	26,251		431,267	550,018
8/31/2026					-		894,330		
12/15/2026		\$0.030	457,518		881,251	881,251		(423,733)	126,285
6/15/2027	3,050,120,816	\$0.030	457,518		13,640	13,640		443,878	570,163
8/31/2027					-		894,891		
12/15/2027		\$0.030	457,518		893,640	893,640		(436,122)	134,041
6/15/2028	3,050,120,816		-		-	-		-	134,041
8/31/2028							893,640		
			10,153,063	4,429,590	5,589,433	10,019,023	10,019,023	134,041	

BOND PRICING

**HALL COUNTY SCHOOL DISTRICT 0002
(GRAND ISLAND PUBLIC SCHOOLS)
LIMITED TAX BUILDING BONDS, SERIES 2016
\$4.510M Project Fund, Wrap Ser. 2015 LTGOs, Cap. Int. to 12/15/17
Assumes BQ, Non-Rated, 2026 Final Maturity
[Preliminary -- for discussion only]**

Bond Component	Maturity Date	Amount	Rate	Yield	Price
Serial Bond:					
	12/15/2018	285,000	1.600%	1.600%	100.000
	12/15/2019	290,000	1.800%	1.800%	100.000
	12/15/2020	295,000	2.000%	2.000%	100.000
	12/15/2021	305,000	2.200%	2.200%	100.000
	12/15/2022	310,000	2.350%	2.350%	100.000
	12/15/2023	320,000	2.500%	2.500%	100.000
	12/15/2024	325,000	2.700%	2.700%	100.000
	12/15/2025	830,000	2.850%	2.850%	100.000
	12/15/2026	855,000	2.950%	2.950%	100.000
	12/15/2027	880,000	3.100%	3.100%	100.000
		4,695,000			

Dated Date	12/23/2016	
Delivery Date	12/23/2016	
First Coupon	06/15/2017	
Par Amount	4,695,000.00	
Original Issue Discount		
Production	4,695,000.00	100.000000%
Underwriter's Discount	-56,340.00	-1.200000%
Purchase Price	4,638,660.00	98.800000%
Accrued Interest		
Net Proceeds	4,638,660.00	

BOND SUMMARY STATISTICS

HALL COUNTY SCHOOL DISTRICT 0002
(GRAND ISLAND PUBLIC SCHOOLS)
LIMITED TAX BUILDING BONDS, SERIES 2016
\$4.510M Project Fund, Wrap Ser. 2015 LTGOs, Cap. Int. to 12/15/17
Assumes BQ, Non-Rated, 2026 Final Maturity
[Preliminary -- for discussion only]

Dated Date	12/23/2016
Delivery Date	12/23/2016
First Coupon	06/15/2017
Last Maturity	12/15/2027
Arbitrage Yield	2.772600%
True Interest Cost (TIC)	2.948510%
Net Interest Cost (NIC)	2.783471%
All-In TIC	2.970690%
Average Coupon	2.783471%
Average Life (years)	7.762
Weighted Average Maturity (years)	7.762
Duration of Issue (years)	6.953
Par Amount	4,695,000.00
Bond Proceeds	4,695,000.00
Total Interest	1,014,315.39
Net Interest	1,070,655.39
Bond Years from Dated Date	36,440,666.67
Bond Years from Delivery Date	36,440,666.67
Total Debt Service	5,709,315.39
Maximum Annual Debt Service	894,891.25
Average Annual Debt Service	520,079.34
Underwriter's Fees (per \$1000)	
Average Takedown	
Other Fee	12.000000
Total Underwriter's Discount	12.000000
Bid Price	98.800000

Bond Component	Par Value	Price	Average Coupon	Average Life	Average Maturity Date	PV of 1 bp change
Serial Bond	4,695,000.00	100.000	2.783%	7.762	09/26/2024	3,197.15
	4,695,000.00			7.762		3,197.15

	TIC	All-In TIC	Arbitrage Yield
Par Value	4,695,000.00	4,695,000.00	4,695,000.00
+ Accrued Interest			
+ Premium (Discount)			
- Underwriter's Discount	-56,340.00	-56,340.00	
- Cost of Issuance Expense		-7,042.50	
- Other Amounts			
Target Value	4,638,660.00	4,631,617.50	4,695,000.00
Target Date	12/23/2016	12/23/2016	12/23/2016
Yield	2.948510%	2.970690%	2.772600%

BOND DEBT SERVICE

HALL COUNTY SCHOOL DISTRICT 0002
(GRAND ISLAND PUBLIC SCHOOLS)
LIMITED TAX BUILDING BONDS, SERIES 2016
\$4.510M Project Fund, Wrap Ser. 2015 LTGOs, Cap. Int. to 12/15/17
Assumes BQ, Non-Rated, 2026 Final Maturity
[Preliminary -- for discussion only]

Period Ending	Principal	Coupon	Interest	Debt Service	Annual Debt Service
06/15/2017			58,579.14	58,579.14	
08/31/2017					58,579.14
12/15/2017			61,303.75	61,303.75	
06/15/2018			61,303.75	61,303.75	
08/31/2018					122,607.50
12/15/2018	285,000	1.600%	61,303.75	346,303.75	
06/15/2019			59,023.75	59,023.75	
08/31/2019					405,327.50
12/15/2019	290,000	1.800%	59,023.75	349,023.75	
06/15/2020			56,413.75	56,413.75	
08/31/2020					405,437.50
12/15/2020	295,000	2.000%	56,413.75	351,413.75	
06/15/2021			53,463.75	53,463.75	
08/31/2021					404,877.50
12/15/2021	305,000	2.200%	53,463.75	358,463.75	
06/15/2022			50,108.75	50,108.75	
08/31/2022					408,572.50
12/15/2022	310,000	2.350%	50,108.75	360,108.75	
06/15/2023			46,466.25	46,466.25	
08/31/2023					406,575.00
12/15/2023	320,000	2.500%	46,466.25	366,466.25	
06/15/2024			42,466.25	42,466.25	
08/31/2024					408,932.50
12/15/2024	325,000	2.700%	42,466.25	367,466.25	
06/15/2025			38,078.75	38,078.75	
08/31/2025					405,545.00
12/15/2025	830,000	2.850%	38,078.75	868,078.75	
06/15/2026			26,251.25	26,251.25	
08/31/2026					894,330.00
12/15/2026	855,000	2.950%	26,251.25	881,251.25	
06/15/2027			13,640.00	13,640.00	
08/31/2027					894,891.25
12/15/2027	880,000	3.100%	13,640.00	893,640.00	
08/31/2028					893,640.00
	4,695,000		1,014,315.39	5,709,315.39	5,709,315.39

NET DEBT SERVICE

**HALL COUNTY SCHOOL DISTRICT 0002
(GRAND ISLAND PUBLIC SCHOOLS)
LIMITED TAX BUILDING BONDS, SERIES 2016
\$4.510M Project Fund, Wrap Ser. 2015 LTGOs, Cap. Int. to 12/15/17
Assumes BQ, Non-Rated, 2026 Final Maturity
[Preliminary -- for discussion only]**

Date	Principal	Interest	Total Debt Service	Capitalized Interest Fund (to 12/15/17)	Net Debt Service	Annual Net D/S
06/15/2017		58,579.14	58,579.14	58,579.14		
08/31/2017						
12/15/2017		61,303.75	61,303.75	61,303.75		
06/15/2018		61,303.75	61,303.75		61,303.75	
08/31/2018						61,303.75
12/15/2018	285,000	61,303.75	346,303.75		346,303.75	
06/15/2019		59,023.75	59,023.75		59,023.75	
08/31/2019						405,327.50
12/15/2019	290,000	59,023.75	349,023.75		349,023.75	
06/15/2020		56,413.75	56,413.75		56,413.75	
08/31/2020						405,437.50
12/15/2020	295,000	56,413.75	351,413.75		351,413.75	
06/15/2021		53,463.75	53,463.75		53,463.75	
08/31/2021						404,877.50
12/15/2021	305,000	53,463.75	358,463.75		358,463.75	
06/15/2022		50,108.75	50,108.75		50,108.75	
08/31/2022						408,572.50
12/15/2022	310,000	50,108.75	360,108.75		360,108.75	
06/15/2023		46,466.25	46,466.25		46,466.25	
08/31/2023						406,575.00
12/15/2023	320,000	46,466.25	366,466.25		366,466.25	
06/15/2024		42,466.25	42,466.25		42,466.25	
08/31/2024						408,932.50
12/15/2024	325,000	42,466.25	367,466.25		367,466.25	
06/15/2025		38,078.75	38,078.75		38,078.75	
08/31/2025						405,545.00
12/15/2025	830,000	38,078.75	868,078.75		868,078.75	
06/15/2026		26,251.25	26,251.25		26,251.25	
08/31/2026						894,330.00
12/15/2026	855,000	26,251.25	881,251.25		881,251.25	
06/15/2027		13,640.00	13,640.00		13,640.00	
08/31/2027						894,891.25
12/15/2027	880,000	13,640.00	893,640.00		893,640.00	
08/31/2028						893,640.00
	4,695,000	1,014,315.39	5,709,315.39	119,882.89	5,589,432.50	5,589,432.50

NET DEBT SERVICE

**HALL COUNTY SCHOOL DISTRICT 0002
(GRAND ISLAND PUBLIC SCHOOLS)
LIMITED TAX BUILDING BONDS, SERIES 2016
\$4.510M Project Fund, Wrap Ser. 2015 LTGOs, Cap. Int. to 12/15/17
Assumes BQ, Non-Rated, 2026 Final Maturity
[Preliminary -- for discussion only]**

Period Ending	Principal	Interest	Total Debt Service	Capitalized Interest Fund (to 12/15/17)	Net Debt Service
08/31/2017		58,579.14	58,579.14	58,579.14	
08/31/2018		122,607.50	122,607.50	61,303.75	61,303.75
08/31/2019	285,000	120,327.50	405,327.50		405,327.50
08/31/2020	290,000	115,437.50	405,437.50		405,437.50
08/31/2021	295,000	109,877.50	404,877.50		404,877.50
08/31/2022	305,000	103,572.50	408,572.50		408,572.50
08/31/2023	310,000	96,575.00	406,575.00		406,575.00
08/31/2024	320,000	88,932.50	408,932.50		408,932.50
08/31/2025	325,000	80,545.00	405,545.00		405,545.00
08/31/2026	830,000	64,330.00	894,330.00		894,330.00
08/31/2027	855,000	39,891.25	894,891.25		894,891.25
08/31/2028	880,000	13,640.00	893,640.00		893,640.00
	4,695,000	1,014,315.39	5,709,315.39	119,882.89	5,589,432.50

TAX LEVY REPORT -- NET DEBT SERVICE

**HALL COUNTY SCHOOL DISTRICT 0002
(GRAND ISLAND PUBLIC SCHOOLS)
LIMITED TAX BUILDING BONDS, SERIES 2016
\$4.510M Project Fund, Wrap Ser. 2015 LTGOs, Cap. Int. to 12/15/17
Assumes BQ, Non-Rated, 2026 Final Maturity
[Preliminary -- for discussion only]**

Date	Debt Service	Less Fund Earnings & Draws	Net Levy	Assessed Valuation	Levy (cts per \$100)
08/31/2017	58,579.14	-58,579.14		3,050,120,816	
08/31/2018	122,607.50	-61,303.75	61,303.75	3,050,120,816	0.002010
08/31/2019	405,327.50		405,327.50	3,050,120,816	0.013289
08/31/2020	405,437.50		405,437.50	3,050,120,816	0.013293
08/31/2021	404,877.50		404,877.50	3,050,120,816	0.013274
08/31/2022	408,572.50		408,572.50	3,050,120,816	0.013395
08/31/2023	406,575.00		406,575.00	3,050,120,816	0.013330
08/31/2024	408,932.50		408,932.50	3,050,120,816	0.013407
08/31/2025	405,545.00		405,545.00	3,050,120,816	0.013296
08/31/2026	894,330.00		894,330.00	3,050,120,816	0.029321
08/31/2027	894,891.25		894,891.25	3,050,120,816	0.029340
08/31/2028	893,640.00		893,640.00	3,050,120,816	0.029299
	5,709,315.39	-119,882.89	5,589,432.50		

AGGREGATE NET DEBT SERVICE

**HALL COUNTY SCHOOL DISTRICT 0002
(GRAND ISLAND PUBLIC SCHOOLS)
LIMITED TAX BUILDING BONDS, SERIES 2016
\$4.510M Project Fund, Wrap Ser. 2015 LTGOs, Cap. Int. to 12/15/17
Assumes BQ, Non-Rated, 2026 Final Maturity
[Preliminary -- for discussion only]**

Date	Debt Service	Less Fund Earnings & Draws	Other Net Debt Service	Total	Annual Total
08/31/2017	58,579.14	-58,579.14	491,211.25	491,211.25	491,211.25
08/31/2018	122,607.50	-61,303.75	487,811.25	549,115.00	549,115.00
08/31/2019	405,327.50		488,105.00	893,432.50	893,432.50
08/31/2020	405,437.50		487,155.00	892,592.50	892,592.50
08/31/2021	404,877.50		489,998.75	894,876.25	894,876.25
08/31/2022	408,572.50		486,605.00	895,177.50	895,177.50
08/31/2023	406,575.00		487,160.00	893,735.00	893,735.00
08/31/2024	408,932.50		486,927.50	895,860.00	895,860.00
08/31/2025	405,545.00		490,820.00	896,365.00	896,365.00
08/31/2026	894,330.00			894,330.00	894,330.00
08/31/2027	894,891.25			894,891.25	894,891.25
08/31/2028	893,640.00			893,640.00	893,640.00
	5,709,315.39	-119,882.89	4,395,793.75	9,985,226.25	9,985,226.25

TAX LEVY REPORT -- AGGREGATE NET DEBT SERVICE

**HALL COUNTY SCHOOL DISTRICT 0002
(GRAND ISLAND PUBLIC SCHOOLS)
LIMITED TAX BUILDING BONDS, SERIES 2016
\$4.510M Project Fund, Wrap Ser. 2015 LTGOs, Cap. Int. to 12/15/17
Assumes BQ, Non-Rated, 2026 Final Maturity
[Preliminary -- for discussion only]**

Date	Debt Service	Less Fund Earnings & Draws	Other Net Debt Service	Net Levy	Assessed Valuation	Levy (cts per \$100)
08/31/2017	58,579.14	-58,579.14	491,211.25	491,211.25	3,050,120,816	0.016105
08/31/2018	122,607.50	-61,303.75	487,811.25	549,115.00	3,050,120,816	0.018003
08/31/2019	405,327.50		488,105.00	893,432.50	3,050,120,816	0.029292
08/31/2020	405,437.50		487,155.00	892,592.50	3,050,120,816	0.029264
08/31/2021	404,877.50		489,998.75	894,876.25	3,050,120,816	0.029339
08/31/2022	408,572.50		486,605.00	895,177.50	3,050,120,816	0.029349
08/31/2023	406,575.00		487,160.00	893,735.00	3,050,120,816	0.029302
08/31/2024	408,932.50		486,927.50	895,860.00	3,050,120,816	0.029371
08/31/2025	405,545.00		490,820.00	896,365.00	3,050,120,816	0.029388
08/31/2026	894,330.00			894,330.00	3,050,120,816	0.029321
08/31/2027	894,891.25			894,891.25	3,050,120,816	0.029340
08/31/2028	893,640.00			893,640.00	3,050,120,816	0.029299
	5,709,315.39	-119,882.89	4,395,793.75	9,985,226.25		

**HALL COUNTY SCHOOL DISTRICT #2
(GRAND ISLAND PUBLIC SCHOOLS)
GRAND ISLAND, NEBRASKA**

**FINANCIAL STATEMENTS AND
SUPPLEMENTARY INFORMATION**

August 31, 2016

TABLE OF CONTENTS

	Page
INDEPENDENT AUDITOR’S REPORT	3
MANAGEMENT’S DISCUSSION AND ANALYSIS	6
FINANCIAL STATEMENTS - MODIFIED CASH BASIS	
Government-wide Financial Statements	
Statement of Net Position	14
Statement of Activities	15
Fund Financial Statements	
Balance Sheet - Governmental Funds	16
Reconciliation of the Balance Sheet - Governmental Funds to the Statement of Net Position	17
Statement of Receipts, Disbursements, and Changes in Fund Balances - Governmental Funds	18
Reconciliation of the Statement of Receipts, Disbursements, and Changes in Fund Balances - Governmental Funds to the Statement of Activities	19
Statement of Net Position - Proprietary Fund	20
Reconciliation of the Statement of Net Position - Proprietary Fund to the Government-wide Statement of Net Position	21
Statement of Receipts, Disbursements, and Changes in Fund Net Position - Proprietary Fund	22
Reconciliation of the Statement of Receipts, Disbursements, and Changes in Fund Net Position - Proprietary Funds to the Statement of Activities	23
Statement of Net Position - Fiduciary Funds	24
Notes to Financial Statements	25
SUPPLEMENTARY AND OTHER INFORMATION	
Budgetary Comparison Schedules	
General Fund	58
Special Building Fund	59
Depreciation Fund	60
Qualified Capital Purpose Fund	61
Cooperative Fund	62
Bond Fund	63

TABLE OF CONTENTS, Continued

	Page
SUPPLEMENTARY AND OTHER INFORMATION, continued	
Combined Balance Sheet - Other Governmental Funds	64
Combined Statement of Receipts, Disbursements, and Changes in Fund Balances - Other Governmental Funds	65
Statements of Cash Receipts, Disbursements, and Fund Balance - Fiduciary Funds - Activity Fund	66
Student Fees Fund	76
Statement of Accounts with County Treasurers - Hall and Merrick County Treasurers	77
Comparative Statistical Data and Graphs	78
SINGLE AUDIT REPORTS	
Schedule of Expenditures of Federal Awards	83
Independent Auditor's Report on Internal Control Over Financial Reporting and on Compliance and Other Matters Based on an Audit of Financial Statements Performed in Accordance With <i>Government Auditing Standards</i>	85
Independent Auditor's Report on Compliance For Each Major Program and on Internal Control Over Compliance Required by the Uniform Guidance	87
Schedule of Findings and Questioned Costs	89
Summary Schedule of Prior Audit Findings	90



INDEPENDENT AUDITOR'S REPORT

Board of Education
Hall County School District #2
Grand Island, Nebraska

Report on the Financial Statements

We have audited the accompanying financial statements of the governmental activities – modified cash basis, the business-type activities – modified cash basis, the aggregate discretely presented component unit – accrual basis, each major fund – modified cash basis, the aggregate remaining fund information – modified cash basis, and the fiduciary funds – modified cash basis of Hall County School District #2 as of and for the year ended August 31, 2016, and the related notes to the financial statements, which collectively comprise the School District's financial statements as listed in the table of contents.

Management's Responsibility for the Financial Statements

Management is responsible for the preparation and fair presentation of the financial statements in accordance with the modified cash basis of accounting described in Note A; this includes determining that the modified cash basis of accounting is an acceptable basis for the preparation of the financial statements in the circumstances. Management is also responsible for the design, implementation, and maintenance of internal control relevant to the preparation and fair presentation of financial statements that are free from material misstatement, whether due to fraud or error.

Auditor's Responsibility

Our responsibility is to express opinions on these financial statements based on our audit. We conducted our audit in accordance with auditing standards generally accepted in the United States of America and the standards applicable to financial audits contained in *Government Auditing Standards*, issued by the Comptroller General of the United States. Those standards require that we plan and perform the audit to obtain reasonable assurance about whether the financial statements are free from material misstatement.

An audit involves performing procedures to obtain audit evidence about the amounts and disclosures in the financial statements. The procedures selected depend on the auditor's judgment, including the assessment of the risks of material misstatement of the financial statements, whether due to fraud or error. In making those risk assessments, the auditor considers internal control relevant to the entity's preparation and fair presentation of the financial statements in order to design audit procedures that are appropriate in the circumstances, but not for the purpose of expressing an opinion on the effectiveness of the entity's internal control. Accordingly, we express

SHAREHOLDERS

Robert D. Almquist
Phillip D. Maltzahn
Terry T. Galloway
Marcy J. Luth
Heidi A. Ashby
Christine R. Shenk
Michael E. Hoback
Joseph P. Stump
Kyle R. Overturf

no such opinion. An audit also includes evaluating the appropriateness of accounting policies used and the reasonableness of significant accounting estimates made by management, as well as evaluating the overall presentation of the financial statements.

We believe that the audit evidence we have obtained is sufficient and appropriate to provide a basis for our audit opinions.

Opinions

In our opinion, the financial statements referred to above present fairly, in all material respects, the respective financial position of the governmental activities – modified cash basis, the business-type activities – modified cash basis, the aggregate discretely presented component unit – accrual basis, each major fund – modified cash basis, the aggregate remaining fund information – modified cash basis, and the fiduciary funds – modified cash basis of Hall County School District #2, as of August 31, 2016, and the respective changes in financial position, thereof for the year then ended in accordance with the basis of accounting described in Note A.

Basis of Accounting

We draw attention to Note A of the financial statements, which describes the basis of accounting. The financial statements of the primary government are prepared on the modified cash basis of accounting, which is a basis of accounting other than accounting principles generally accepted in the United States of America. Our opinion is not modified with respect to that matter.

Other Matters

Other Information

Our audit was conducted for the purpose of forming opinions on the financial statements that collectively comprise Hall County School District #2's financial statements. The management's discussion and analysis and supplementary and other information as listed in the table of contents are presented for purposes of additional analysis and are not a required part of the financial statements. The schedule of expenditures of federal awards is presented for purposes of additional analysis as required by Title 2 U.S. *Code of Federal regulations* (CFR) Part 200, *Uniform Administrative Requirements, Cost Principles, and Audit Requirements for Federal Awards*, and is also not a required part of the financial statements.

The management's discussion and analysis, budgetary comparison schedules, combining nonmajor fund financial statements, fiduciary fund statements, and the schedule of expenditures of federal awards are the responsibility of management and were derived from and relate directly to the underlying accounting and other records used to prepare the financial statements. Such information has been subjected to the auditing procedures applied in the audit of the financial statements and certain additional procedures, including comparing and reconciling such information directly to the underlying accounting and other records used to prepare the financial statements or to the financial statements themselves, and other additional procedures in accordance with auditing standards generally accepted in the United States of America. In our opinion, the supplementary information described in the first sentence of this paragraph and the

schedule of expenditures of federal awards are fairly stated, in all material respects, in relation to the financial statements as a whole.

The county treasurer statement of receipts and disbursements and the comparative statistical data and graphs have not been subjected to the auditing procedures applied in the audit of the financial statements and, accordingly, we do not express an opinion or provide any assurance on them.

Other Reporting Required by *Government Auditing Standards*

In accordance with *Government Auditing Standards*, we have also issued our report dated October 27, 2016, on our consideration of Hall County School District #2's internal control over financial reporting and on our tests of its compliance with certain provisions of laws, regulations, contracts, and grant agreements and other matters. The purpose of that report is to describe the scope of our testing of internal control over financial reporting and compliance and the results of that testing, and not to provide an opinion on internal control over financial reporting or on compliance. That report is an integral part of an audit performed in accordance with *Government Auditing Standards* in considering Hall County School District #2's internal control over financial reporting and compliance.

Amquist, Malthe
Galloway & Lath, P.C.

Grand Island, Nebraska
October 27, 2016

**HALL COUNTY SCHOOL DISTRICT #2 (Grand Island Public Schools)
MANAGEMENT'S DISCUSSION AND ANALYSIS
For The Year Ended August 31, 2016**

MANAGEMENT'S DISCUSSION AND ANALYSIS

This section of Grand Island Public Schools' annual financial report presents management's discussion and analysis (MD&A) of the District's financial performance during the fiscal year ended August 31, 2016. Please read the MD&A in combination with the entire financial report, which immediately follows this section. For information on the Grand Island Education Foundation, Inc. component unit included in these financial statements, please see the separate audit report for the Foundation.

FINANCIAL HIGHLIGHTS

- The District decreased its governmental funds cash reserves by \$20.2 million, with the Special Building Fund cash reserves making up \$21.1 million of the decrease. The difference represents the overall increase in cash reserves for the remaining governmental funds of \$0.9 million.
- General Fund revenues were \$95.3 million, \$0.5 million more than expenses.
- General Fund operational costs were \$94.8 million, a 5.7 percent increase, primarily due to increased spending for instruction.
- Major capital improvement projects were completed to further ensure viable, clean, safe and secure facilities:
 - Purchased new mowers for the grounds department
 - Replaced track surface and upgraded security cameras at Westridge Middle School
 - Removed and replaced over \$75,000 worth of heat pumps at various buildings
 - Replaced several building roofs due to major hail storm damage in prior years
 - Added to and upgraded Engleman playground to ADA accessible
 - New carpet in Knickrehm modular and restroom flooring in main building
 - Purchased three new vehicles for the overall District fleet

**HALL COUNTY SCHOOL DISTRICT #2 (Grand Island Public Schools)
MANAGEMENT'S DISCUSSION AND ANALYSIS
For The Year Ended August 31, 2016**

- Various HVAC systems upgrades and maintenance across District
- During the 2015-2016 school year construction on all seven of the \$69.9 million September 9, 2014 bond issue projects were as follows:
 - Engleman Elementary School Addition - completed
 - Shoemaker Elementary School — Additions and renovations - completed
 - Starr Elementary School — All new construction - in progress
 - Barr Middle School — Additions and renovations - in progress
 - GISH 100 Wing Renovation — Completed Phase I, Phase II & III - in progress
 - Jeffersen Elementary — All new construction - in design and development
 - Stolley Park Elementary — All new construction - in design and development
- Grand Island Public Schools student enrollment increased from the prior year. The official (last Friday in September) pre-kindergarten through twelfth grade student count of 9,895, up from 9,698 in 2015, represents a 2.0 percent increase from the prior year and an overall three-year increase of 3.6 percent.

OVERVIEW OF THE FINANCIAL STATEMENTS

This audited annual financial report consists of three sections: management's discussion and analysis (MD&A) [this section], the financial statements, and supplementary and other information. The financial statements include two kinds of statements that present different views of the District:

- The first two statements are *district-wide financial statements* that provide both *short-term* and *long-term* information about the District's *overall* financial status. The remaining statements are *fund financial statements* that focus on *individual parts* of the

**HALL COUNTY SCHOOL DISTRICT #2 (Grand Island Public Schools)
MANAGEMENT'S DISCUSSION AND ANALYSIS
For The Year Ended August 31, 2016**

District, reporting the District's operations in *more detail* than the district-wide statements.

- The *governmental funds statements* show how basic services such as regular and special education were financed in the *short-term* as well as what remains for future spending.
- *Proprietary funds* statements offer *short-* and *long-term* financial information about the activities the District operates *like a business*, such as Nutrition Services.
- *Fiduciary funds* statements provide information about the financial relationships in which the District acts solely as a trustee or agent for the benefit of others.

The financial statements also include notes that explain some of the information in the statements and provide more detailed data. The statements are followed by a section of supplementary and other information that further explains and supports the financial statements with a comparison of the District's budget for the year and various other supporting schedules and statements.

FINANCIAL ANALYSIS OF THE DISTRICT AS A WHOLE

Net Position

The District's combined net position was higher on August 31, 2016 than it was the year before, increasing 0.9 percent to \$89.2 million. This improvement in the District's financial position came from its governmental activities, the net position of which increased \$0.4 million to \$86.7 million. The net position of the District's business-type activities increased \$0.4 million to \$2.5 million.

**HALL COUNTY SCHOOL DISTRICT #2 (Grand Island Public Schools)
MANAGEMENT'S DISCUSSION AND ANALYSIS
For The Year Ended August 31, 2016**

A summary of the District's assets, liabilities, and net position follows:

	August 31, <u>2016</u>	August 31, <u>2015</u>	Increase (Decrease)
Assets:			
Current assets	\$ 68,889,236	\$ 88,880,036	\$ (19,990,800)
Capital assets	<u>100,145,897</u>	<u>82,610,159</u>	<u>17,535,738</u>
Total assets	<u>169,035,133</u>	<u>171,490,195</u>	<u>(2,455,062)</u>
Liabilities:			
Current liabilities	3,391,221	3,764,693	(373,472)
Long-term liabilities	<u>76,406,327</u>	<u>79,305,000</u>	<u>(2,898,673)</u>
Total liabilities	<u>79,797,548</u>	<u>83,069,693</u>	<u>(3,272,145)</u>
Net position:			
Net investment in capital assets	45,980,443	47,539,523	(1,559,080)
Restricted for:			
Debt service	6,668,557	6,484,838	183,719
Building additions/ improvements	1,709,105	467,673	1,241,432
Qualified capital purposes	423,171	392,581	30,590
Unrestricted	34,456,319	33,535,887	920,432
Total net position	<u>\$ 89,237,595</u>	<u>\$ 88,420,502</u>	<u>\$ 817,093</u>

Governmental Activities

Revenues for the District's governmental activities were \$119.3 million, while total expenses were \$118.9 million. The increase in net position for governmental activities was \$0.4 million in 2016.

The decrease in cash reserves for the year ended August 31, 2016 was due primarily to the Special Building Fund using \$21.7 million of bond proceeds received in the prior year for building construction costs. Cash reserves for the Special Building Fund decreased \$21.1 million.

Strong economic growth, as measured by investment in real estate and building, coupled with aggressive reassessment practices, led to a 6.3 percent increase in property valuation. This contributed in General Fund tax asking increasing \$1.8 million (6.3 percent).

The cost of all governmental activities this year was \$118.9 million. Federal and State governments subsidized certain programs with grants and contributions (\$13.3 million). Most of the District's costs (\$90.8 million), however, were financed by District and State taxpayers. This portion of governmental activities was financed with \$41.0 million in property taxes and \$47.4 million of unrestricted State Aid based on the Statewide Education Aid Formula.

HALL COUNTY SCHOOL DISTRICT #2 (Grand Island Public Schools)
MANAGEMENT'S DISCUSSION AND ANALYSIS
For The Year Ended August 31, 2016

A comparison of governmental activities' receipts and expenses follows:

	Years Ended August 31,		Increase (Decrease)
	<u>2016</u>	<u>2015</u>	
Receipts:			
Charges for services	\$ 14,635,356	\$ 14,900,112	\$ (264,756)
Operating grants	13,343,256	12,508,231	835,025
Capital grants	184,294	-	184,294
Property and other taxes	40,962,269	38,788,352	2,173,917
State aid	47,430,924	44,100,172	3,330,752
Investment income (loss)	326,847	(110,620)	437,467
Other	2,410,870	7,842,659	(5,431,789)
Total receipts	119,293,816	118,028,906	1,264,910
Expenses:			
Instruction	66,177,631	60,791,608	5,386,023
Support services:			
Pupils	3,637,766	3,545,362	92,404
Staff	2,794,775	3,136,654	(341,879)
General Administration	1,653,830	1,545,748	108,082
School Administration	4,118,464	3,978,218	140,246
Business	484,964	578,155	(93,191)
Building and grounds	8,182,159	9,254,999	(1,072,840)
Pupil transportation	518,030	490,064	27,966
State categorical programs	420,877	461,599	(40,722)
Federal programs	5,626,046	5,299,055	326,991
Summer School	66,797	66,614	183
Activity Fund support	239,500	391,855	(152,355)
CNSSP program	16,447,536	16,647,349	(199,813)
Interest expense	3,203,750	2,290,902	912,848
Depreciation	5,349,153	5,743,051	(393,898)
Total expenses	118,921,278	114,221,233	4,700,045
Increase in net position	\$ 372,538	\$ 3,807,673	\$ (3,435,135)

**HALL COUNTY SCHOOL DISTRICT #2 (Grand Island Public Schools)
MANAGEMENT'S DISCUSSION AND ANALYSIS
For The Year Ended August 31, 2016**

Business-type Activities

Revenues of the District's business-type activities increased 7.9 percent to \$5.7 million, and expenses also increased 6.7 percent to \$5.5 million.

Food services revenues exceeded expenses by \$0.2 million.

FINANCIAL ANALYSIS OF THE DISTRICT'S FUNDS

As the District completed the year, its governmental funds reported combined fund balances of \$68.1 million, \$20.2 million less than last year's ending fund balances of \$88.3 million.

The General Fund had \$0.5 million more revenues than expenditures for the year. The Special Building Fund had \$21.1 million less revenues than expenditures for the year, accounting for most of the decrease in governmental fund balances.

As mentioned, the business-type activities revenue exceeded expenses. In addition to the district-wide financial statements, food services are reported in greater detail in the proprietary funds statements.

General Fund Budgetary Highlights

The District's budget for the General Fund anticipated that revenue and expenditures would be equal. Actual expenditures exceeded revenues by \$0.5 million for the year. Actual revenues were \$12.7 million lower than expected. The actual expenditures were \$13.2 million below budget, due primarily to a \$7.8 million favorable variance in instructional services.

CAPITAL ASSETS AND DEBT ADMINISTRATION

Capital Assets

By the end of 2016, the District had invested \$182.1 million in a broad range of capital assets, including land, buildings, athletic/sports facilities and computer and audio-visual equipment. The net book value after depreciation was \$100.1 million at August 31, 2016.

The amount represents a net increase of \$17.5 million or 21.2 percent from last year. (More detailed information about capital assets can be found in Note E to the financial statements.) Total depreciation expense for the year was \$5.5 million, while building improvements and additions to equipment and furniture amounted to \$23.0 million.

Construction in progress totaled \$27.6 million at August 31, 2016. This balance consists of \$3.0 million of construction in progress on the Engleman building addition, \$6.9 million of construction in progress on the Shoemaker building addition, \$10.7 million of construction in progress on the Starr new building, \$5.8 million of construction in progress on the Barr building

**HALL COUNTY SCHOOL DISTRICT #2 (Grand Island Public Schools)
MANAGEMENT’S DISCUSSION AND ANALYSIS
For The Year Ended August 31, 2016**

addition, \$1.1 million of construction in progress on the Senior High wing renovation, and \$0.1 million of construction in progress on architectural costs for various future building projects.

Long-term Debt

At year end, the District had \$79.8 million (principal only) in General Obligation Bonds and other debt outstanding – a decrease of 3.9 percent from last year – as shown in the table below. (More detailed information about the District’s long-term liabilities is presented in Note F to the financial statements.)

<u>Fund</u>	<u>Balance at</u> 8/31/2016	<u>Balance at</u> 8/31/2015	<u>\$ Change</u> Increase (Decrease)	<u>% Change</u> Increase (Decrease)
General	\$ 492,548	\$ 94,693	\$ 397,855	420.2 %
Bond	74,950,000	77,885,000	(2,935,000)	(3.8)
Qualified	4,025,000	4,445,000	(420,000)	(9.4)
Total governmental	<u>\$ 79,467,548</u>	<u>\$ 82,424,693</u>	<u>\$ (2,957,145)</u>	(3.6)
Nutrition	<u>\$ 330,000</u>	<u>\$ 645,000</u>	<u>\$ (315,000)</u>	(48.8)

FACTORS BEARING ON THE DISTRICT’S FUTURE

- The District will continue to pay for improvements to facilities through the use of the Special Building Fund, Qualified Capital Purpose Fund, and General Fund, along with the appropriate use of near-term and long-term debt instruments and/or lease purchase arrangements.
- The end of fiscal year 2016 marked the end of a one-year agreement with the District’s recognized local teachers union, the Grand Island Education Association (GIEA). A new negotiated agreement was reached during the 2015-2016 fiscal year for the 2016-2017 fiscal year.
- The City of Grand Island continues to annex land in response to economic growth within the community of Grand Island. In large measure, Grand Island Public Schools’ boundaries follow the City of Grand Island’s boundaries. However, the Grand Island Public Schools are mandated by State law to meet and negotiate in good faith over several specific factors with other Districts that are affected by the annexation process. When annexation occur, this process is ongoing with Hall County School District 40-0082-000

**HALL COUNTY SCHOOL DISTRICT #2 (Grand Island Public Schools)
MANAGEMENT'S DISCUSSION AND ANALYSIS
For The Year Ended August 31, 2016**

dba Northwest Public Schools, a Class III school district that lies, in part, within Grand Island Public Schools' boundaries.

- The District realized increased revenue from state aid and a relatively modest 3.82 percent valuation growth. However, that revenue growth is just enough to cover increased cost due to the impact of negotiated salaries, health care including PPACA, additional staffing needs due to enrollment growth and programming needs, and general inflationary trends.
- During the 2015-2016 fiscal year, the District undertook an intense internal review of both our Limited English Proficiency (LEP) and Poverty plans in an effort to maximize educational opportunities for our community's neediest children who are at-risk of failing.
- Tax Increment Financing (TIF) projects are becoming more frequent and larger within the Grand Island community (\$30+ million for a new hospital). The impact on the District is both positive and negative in the near and long term. Grand Island Public Schools will continue to seek understanding and express our concerns regarding the use of TIF for residential projects that place additional burden on the District's resources.

CONTACTING THE DISTRICT'S FINANCIAL MANAGEMENT

This audited financial report is designed to provide the District's stakeholders (i.e., citizens, taxpayers, customers, investors and creditors) with a general overview of the District's finances and to demonstrate the District's accountability for the money it receives. If you have any questions about this report or need additional information, please feel free to contact the following school official:

Mr. Virgil D. Harden, RSBA
Chief Financial Officer

Grand Island Public Schools
123 South Webb Road
P.O. Box 4904
Grand Island, NE 68802-4904

(308) 385-5900 x144
(308) 385-5949 – facsimile

vharden@gips.org – e-mail

**GRAND ISLAND PUBLIC SCHOOLS
GRAND ISLAND, NEBRASKA**

STATEMENT OF NET POSITION - MODIFIED CASH BASIS

August 31, 2016

	Primary Government			Component Unit (Accrual Basis)
	Governmental Activities	Business-type Activities	Total	
ASSETS				
Current assets:				
Cash and investments (notes A6 and C)	\$ 24,981,495	\$ 768,681	\$ 25,750,176	\$ 5,630,193
Cash restricted for building projects (note C)	27,260,898	-	27,260,898	-
Cash restricted for debt service (note C)	4,992,928	-	4,992,928	-
Cash restricted for qualified capital purpose undertakings (note C)	284,194	-	284,194	-
Cash with County Treasurers (note D)	10,601,040	-	10,601,040	-
Current portion of pledges receivable (note O)	-	-	-	55,628
Interest receivable	-	-	-	19
Total current assets	68,120,555	768,681	68,889,236	5,685,840
Noncurrent assets:				
Noncurrent portion of pledges receivable (note O)	-	-	-	29,874
Cash surrender value life insurance	-	-	-	13,191
Capital assets (notes A5 and E):				
Land	2,864,997	-	2,864,997	-
Construction in progress	27,572,037	-	27,572,037	-
Buildings	129,706,820	2,549,132	132,255,952	-
Furniture and equipment	17,675,581	1,692,468	19,368,049	-
Less: Accumulated depreciation	(79,783,751)	(2,131,387)	(81,915,138)	-
Net capital assets	98,035,684	2,110,213	100,145,897	-
Total noncurrent assets	98,035,684	2,110,213	100,145,897	43,065
Total assets	166,156,239	2,878,894	169,035,133	5,728,905
LIABILITIES				
Current liabilities:				
Long-term debt due within one year (note F):				
Capital lease payable	96,221	-	96,221	-
Certificates of participation	-	330,000	330,000	-
Limited tax obligation bonds payable	425,000	-	425,000	-
General obligation bonds payable	2,540,000	-	2,540,000	-
Accounts payable	-	-	-	50,253
Scholarships and grants payable	-	-	-	384,226
Payroll taxes payable	-	-	-	546
Total current liabilities	3,061,221	330,000	3,391,221	435,025
Long-term liabilities, net of current portion (note F):				
Capital lease payable	396,327	-	396,327	-
Certificates of participation	-	-	-	-
Limited tax obligation bonds payable	3,600,000	-	3,600,000	-
General obligation bonds payable	72,410,000	-	72,410,000	-
Scholarships and grants payable	-	-	-	783,758
Total long-term liabilities	76,406,327	-	76,406,327	783,758
Total liabilities	79,467,548	330,000	79,797,548	1,218,783
NET POSITION				
Net investment in capital assets	44,200,220	1,780,213	45,980,433	-
Restricted for:				
Debt service	6,668,557	-	6,668,557	-
Building additions/improvements	1,709,105	-	1,709,105	-
Qualified capital purposes	423,171	-	423,171	-
Scholarships and programs	-	-	-	3,708,730
Unrestricted	33,687,638	768,681	34,456,319	801,392
Total net position	\$ 86,688,691	\$ 2,548,894	\$ 89,237,585	\$ 4,510,122

See notes to financial statements.

**GRAND ISLAND PUBLIC SCHOOLS
GRAND ISLAND, NEBRASKA**

STATEMENT OF ACTIVITIES - MODIFIED CASH BASIS

For the year ended August 31, 2016

<u>Functions/Programs</u>	<u>Expenses</u>	<u>Charges for Services</u>	<u>Program Receipts Operating Grants and Contributions</u>
Primary government:			
Governmental activities:			
Instruction	\$ 66,177,631	\$ -	\$ 5,457,911
Support services:			
Pupils	3,637,766	-	-
Staff	2,794,775	-	-
General administration	1,653,830	-	-
School administration	4,118,464	-	-
Business	484,964	-	-
Building and grounds	8,182,159	-	-
Pupil transportation	518,030	-	-
State categorical programs	420,877	-	481,432
Federal programs	5,626,046	-	5,611,595
Summer school	66,797	-	-
Activity Fund support	239,500	-	-
CNSSP program	16,447,536	14,635,356	1,792,318
Interest on long-term debt	3,203,750	-	-
Depreciation - unallocated	5,349,153	-	-
	118,921,278	14,635,356	13,343,256
Business-type activities:			
Nutrition services	5,126,537	1,231,820	4,393,018
Depreciation	115,009	-	-
Total business-type activities	5,241,546	1,231,820	4,393,018
Total primary government	\$ 124,162,824	\$ 15,867,176	\$ 17,736,274
Component unit:			
Grand Island Education Foundation, Inc.	\$ 1,661,748	\$ 74,355	\$ 1,159,529

See notes to financial statements.

Capital Grants and Contributions	Net (Expenses) Receipts and Changes in Net Position			Component Unit (Accrual Basis)
	Primary Government		Total	
	Governmental Activities	Business-type Activities		
\$ -	\$ (60,719,720)		\$ (60,719,720)	
-	(3,637,766)		(3,637,766)	
-	(2,794,775)		(2,794,775)	
-	(1,653,830)		(1,653,830)	
-	(4,118,464)		(4,118,464)	
-	(484,964)		(484,964)	
184,294	(7,997,865)		(7,997,865)	
-	(518,030)		(518,030)	
-	60,555		60,555	
-	(14,451)		(14,451)	
-	(66,797)		(66,797)	
-	(239,500)		(239,500)	
-	(19,862)		(19,862)	
-	(3,203,750)		(3,203,750)	
-	(5,349,153)		(5,349,153)	
184,294	(90,758,372)		(90,758,372)	
-	-	\$ 498,301	498,301	
-	-	(115,009)	(115,009)	
-	-	383,292	383,292	
\$ 184,294	(90,758,372)	383,292	(90,375,080)	
\$ -				\$ (427,864)
General receipts:				
Taxes:				
Property	36,103,376	-	36,103,376	-
Motor vehicle	3,362,686	-	3,362,686	-
Other taxes	1,496,207	-	1,496,207	-
Fines and licenses	988,589	-	988,589	-
State aid	47,430,924	-	47,430,924	-
State apportionment	1,412,281	-	1,412,281	-
Investment income (loss)	326,847	226	327,073	221,768
Unrealized gain on investments	-	-	-	350,900
Other	10,000	61,027	71,027	-
Total general receipts	91,130,910	61,253	91,192,163	572,668
Change in net position	372,538	444,545	817,083	144,804
Net position - August 31, 2015	86,316,153	2,104,349	88,420,502	4,365,318
Net position - August 31, 2016	\$ 86,688,691	\$ 2,548,894	\$ 89,237,585	\$ 4,510,122

**GRAND ISLAND PUBLIC SCHOOLS
GRAND ISLAND, NEBRASKA**

**BALANCE SHEET - GOVERNMENTAL FUNDS -
MODIFIED CASH BASIS**

August 31, 2016

	<u>General Fund</u>	<u>Depreciation Fund</u>	<u>Bond Fund</u>
ASSETS			
Cash and investments	\$ 16,757,127	\$ 3,188,686	\$ 4,992,928
Cash with County Treasurers	<u>8,706,143</u>	<u>-</u>	<u>1,675,629</u>
Total assets	<u><u>\$ 25,463,270</u></u>	<u><u>\$ 3,188,686</u></u>	<u><u>\$ 6,668,557</u></u>
LIABILITIES AND FUND BALANCES			
Liabilities	\$ -	\$ -	\$ -
Fund balances:			
Restricted for:			
Debt service	-	-	6,668,557
Building additions/improvements	-	-	-
Qualified capital purposes	-	-	-
Assigned for:			
Capital outlay	-	3,188,686	-
Employee benefits	-	-	-
Contingencies	-	-	-
CNSSP	-	-	-
Unassigned	<u>25,463,270</u>	<u>-</u>	<u>-</u>
Total fund balances	<u><u>25,463,270</u></u>	<u><u>3,188,686</u></u>	<u><u>6,668,557</u></u>
Total liabilities and fund balances	<u><u>\$ 25,463,270</u></u>	<u><u>\$ 3,188,686</u></u>	<u><u>\$ 6,668,557</u></u>

See notes to financial statements.

Special Building <u>Fund</u>	Qualified Capital Purpose <u>Fund</u>	Cooperative <u>Fund</u>	Other Governmental <u>Funds</u>	Total Governmental <u>Funds</u>
\$ 27,260,898	\$ 284,194	\$ 1,057,784	\$ 3,977,898	\$ 57,519,515
80,291	138,977	-	-	10,601,040
<u>\$ 27,341,189</u>	<u>\$ 423,171</u>	<u>\$ 1,057,784</u>	<u>\$ 3,977,898</u>	<u>\$ 68,120,555</u>
\$ -	\$ -	\$ -	\$ -	\$ -
-	-	-	-	6,668,557
27,341,189	-	-	-	27,341,189
-	423,171	-	-	423,171
-	-	-	-	3,188,686
-	-	-	2,962,662	2,962,662
-	-	-	1,015,236	1,015,236
-	-	1,057,784	-	1,057,784
-	-	-	-	25,463,270
<u>27,341,189</u>	<u>423,171</u>	<u>1,057,784</u>	<u>3,977,898</u>	<u>68,120,555</u>
<u>\$ 27,341,189</u>	<u>\$ 423,171</u>	<u>\$ 1,057,784</u>	<u>\$ 3,977,898</u>	<u>\$ 68,120,555</u>

**GRAND ISLAND PUBLIC SCHOOLS
GRAND ISLAND, NEBRASKA**

**RECONCILIATION OF THE BALANCE SHEET - GOVERNMENTAL FUNDS
TO THE STATEMENT OF NET POSITION**

August 31, 2016

Total fund balances - governmental funds \$ 68,120,555

Amounts reported for *governmental activities* in the statement of net position are different because:

Capital assets used in governmental activities are not financial resources and therefore are not reported as assets in governmental funds. The cost of the assets is \$177,819,435, and the accumulated depreciation is \$79,783,751. 98,035,684

Long-term liabilities, including bonds payable, are not due and payable in the current period and therefore are not reported as liabilities in the funds. Long-term liabilities at year end consist of:

Capital leases payable	\$ (492,548)	
Limited tax obligation bonds payable	(4,025,000)	
General obligation bonds payable	<u>(74,950,000)</u>	<u>(79,467,548)</u>

Total net position - governmental activities \$ 86,688,691

See notes to financial statements.

**GRAND ISLAND PUBLIC SCHOOLS
GRAND ISLAND, NEBRASKA**

**STATEMENT OF RECEIPTS, DISBURSEMENTS, AND CHANGES
IN FUND BALANCES - GOVERNMENTAL FUNDS -
MODIFIED CASH BASIS**

For the year ended August 31, 2016

	General <u>Fund</u>	Depreciation <u>Fund</u>	Bond <u>Fund</u>
RECEIPTS			
Taxes:			
Property	\$ 28,155,562	\$ -	\$ 5,759,466
Motor vehicle	3,362,686	-	-
Homestead exemption	1,106,050	-	226,335
Pro-rate motor vehicle	91,407	-	14,337
Carline	22,080	-	4,488
Property tax credit	1,197,706	-	238,075
Fines and licenses	988,589	-	-
Tuition	-	-	-
State aid and grants	54,730,498	-	-
Federal grants	5,663,646	-	-
Investment income (loss)	3,352	1,119	11,041
Transfers from other funds	-	1,000,000	-
Other	10,000	-	-
Total receipts	<u>95,331,576</u>	<u>1,001,119</u>	<u>6,253,742</u>
DISBURSEMENTS			
Instruction	67,265,920	-	-
Support services:			
Pupils	3,637,766	-	-
Staff	2,800,978	-	-
General administration	1,653,830	-	-
School administration	4,118,464	-	-
Business	616,434	-	-
Building and grounds	7,808,942	-	-
Pupil transportation	518,030	-	-
State categorical programs	420,877	-	-
Federal programs	5,648,502	-	-
Summer school	66,797	-	-
Transfer to other funds	239,500	-	-
Capital outlay	-	809,508	-
Debt service			
Principal	-	-	2,935,000
Interest	-	-	3,132,923
CNSSP expenditures	-	-	-
Other	-	-	2,100
Total disbursements	<u>94,796,040</u>	<u>809,508</u>	<u>6,070,023</u>
Excess (deficiency) of receipts over disbursements	535,536	191,611	183,719
Fund balances - August 31, 2015	<u>24,927,734</u>	<u>2,997,075</u>	<u>6,484,838</u>
Fund balances - August 31, 2016	<u>\$ 25,463,270</u>	<u>\$ 3,188,686</u>	<u>\$ 6,668,557</u>

See notes to financial statements.

<u>Special Building Fund</u>	<u>Qualified Capital Purpose Fund</u>	<u>Cooperative Fund</u>	<u>Other Governmental Funds</u>	<u>Eliminations</u>	<u>Total Governmental Funds</u>
\$ 242,224	\$ 478,973	\$ -	\$ -	\$ -	\$ 34,636,225
-	-	-	-	-	3,362,686
10,635	18,335	-	-	-	1,361,355
319	1,643	-	-	-	107,706
212	366	-	-	-	27,146
11,516	19,854	-	-	-	1,467,151
-	-	-	-	-	988,589
-	-	14,635,357	-	-	14,635,357
-	-	-	-	-	54,730,498
-	-	1,792,318	-	(1,792,318)	5,663,646
288,755	147	-	22,433	-	326,847
-	-	-	-	(1,000,000)	-
-	-	-	-	-	10,000
<u>553,661</u>	<u>519,318</u>	<u>16,427,675</u>	<u>22,433</u>	<u>(2,792,318)</u>	<u>117,317,206</u>
-	-	-	-	(1,000,000)	66,265,920
-	-	-	-	-	3,637,766
-	-	-	-	-	2,800,978
-	-	-	-	-	1,653,830
-	-	-	-	-	4,118,464
-	-	-	-	-	616,434
-	-	-	-	-	7,808,942
-	-	-	-	-	518,030
-	-	-	-	-	420,877
-	-	-	-	(1,792,318)	3,856,184
-	-	-	-	-	66,797
-	-	-	-	-	239,500
21,679,202	-	-	-	-	22,488,710
-	420,000	-	-	-	3,355,000
-	68,328	-	-	-	3,201,251
-	-	16,447,536	-	-	16,447,536
-	400	-	9,185	-	11,685
<u>21,679,202</u>	<u>488,728</u>	<u>16,447,536</u>	<u>9,185</u>	<u>(2,792,318)</u>	<u>137,507,904</u>
(21,125,541)	30,590	(19,861)	13,248	\$ -	(20,190,698)
<u>48,466,730</u>	<u>392,581</u>	<u>1,077,645</u>	<u>3,964,650</u>		<u>88,311,253</u>
<u>\$ 27,341,189</u>	<u>\$ 423,171</u>	<u>\$ 1,057,784</u>	<u>\$ 3,977,898</u>		<u>\$ 68,120,555</u>

**GRAND ISLAND PUBLIC SCHOOLS
GRAND ISLAND, NEBRASKA**

**RECONCILIATION OF THE STATEMENT OF RECEIPTS, DISBURSEMENTS,
AND CHANGES IN FUND BALANCES - GOVERNMENTAL FUNDS
TO THE STATEMENT OF ACTIVITIES**

For the year ended August 31, 2016

Total net change in fund balances - governmental funds	\$ (20,190,698)
---	------------------------

Amounts reported for *governmental activities* in the statement of activities are different because:

Capital outlays are reported in governmental funds as expenditures.

However, in the statement of activities, the cost of those assets is allocated over their estimated useful lives as depreciation expense.

This is the amount by which capitalized capital outlay (\$22,955,244) exceeded depreciation expense (\$5,349,153) and assets issued under capital lease obligations (\$501,329) during the period.

17,104,762

Repayment of long-term debt is an expenditure in the governmental funds, but the repayment reduces long-term liabilities in the statement of net position. Principal payments consist of:

Capital leases	\$ 103,474	
Limited tax obligation bonds	420,000	
General obligation bonds	2,935,000	3,458,474

Change in net position of governmental activities	\$ <u>372,538</u>
--	--------------------------

See notes to financial statements.

**GRAND ISLAND PUBLIC SCHOOLS
GRAND ISLAND, NEBRASKA**

**STATEMENT OF NET POSITION - PROPRIETARY FUND -
MODIFIED CASH BASIS**

August 31, 2016

	<u>Nutrition Fund</u>
ASSETS	
Cash	\$ 768,681
LIABILITIES	<u>-</u>
NET POSITION	
Unrestricted	<u><u>\$ 768,681</u></u>

See notes to financial statements.

**GRAND ISLAND PUBLIC SCHOOLS
GRAND ISLAND, NEBRASKA**

**RECONCILIATION OF THE STATEMENT OF NET POSITION - PROPRIETARY
FUND TO THE GOVERNMENT-WIDE STATEMENT OF NET POSITION**

August 31, 2016

Total net position - proprietary fund	\$ 768,681
Amounts reported for <i>business-type activities</i> in the statement of net position are different because:	
Capital assets used in business-type activities are not financial resources and therefore are not reported as assets in proprietary funds. The cost of the assets is \$4,241,600, and the accumulated depreciation is \$2,131,387.	2,110,213
Long-term liabilities, including bonds payable, are not due and payable in the current period and therefore are not reported as liabilities in the funds. Long-term liabilities at year end consist of:	
Certificates of participation	<u>(330,000)</u>
Total net position - business-type activities	<u><u>\$ 2,548,894</u></u>

See notes to financial statements.

**GRAND ISLAND PUBLIC SCHOOLS
GRAND ISLAND, NEBRASKA**

**STATEMENT OF RECEIPTS, DISBURSEMENTS, AND CHANGES
IN FUND NET POSITION - PROPRIETARY FUND -
MODIFIED CASH BASIS**

For the year ended August 31, 2016

	<u>Nutrition Fund</u>
Operating receipts:	
Lunch sales	\$ 1,231,820
State sources	35,688
Federal sources	3,911,151
USDA commodities	446,179
Other	61,027
Total operating receipts	5,685,865
Operating disbursements:	
Salaries and employee benefits	2,203,805
Contracted services	88,293
Food and food service supplies	2,794,935
Capital outlay	54,234
Debt service	
Principal	315,000
Interest	16,831
Other	13,095
Total operating disbursements	5,486,193
Operating receipts in excess of disbursements	199,672
Nonoperating receipts:	
Investment income	226
Increase in net position	199,898
Net position - August 31, 2015	568,783
Net position - August 31, 2016	\$ 768,681

See notes to financial statements.

**GRAND ISLAND PUBLIC SCHOOLS
GRAND ISLAND, NEBRASKA**

**RECONCILIATION OF THE STATEMENT OF RECEIPTS, DISBURSEMENTS,
AND CHANGES IN FUND NET POSITION - PROPRIETARY FUNDS
TO THE STATEMENT OF ACTIVITIES**

For the year ended August 31, 2016

Total increase in net position - proprietary fund	\$ 199,898
Amounts reported for <i>business-type activities</i> in the statement of activities are different because:	
Capital outlays are reported in proprietary fund as expenditures. However, in the statement of activities, the cost of those assets is allocated over their estimated useful lives as depreciation expense. This is the amount by which capitalized capital outlay (\$44,656) was exceeded by depreciation expense (\$115,009) during the period.	(70,353)
Repayment of long-term debt is an expenditure in the proprietary fund, but the repayment reduces long-term liabilities in the statement of net position.	<u>315,000</u>
Change in net position of business-type activities	<u><u>\$ 444,545</u></u>

See notes to financial statements.

**GRAND ISLAND PUBLIC SCHOOLS
GRAND ISLAND, NEBRASKA**

**STATEMENT OF NET POSITION - FIDUCIARY FUNDS -
MODIFIED CASH BASIS**

August 31, 2016

	<u>Agency Funds</u>
ASSETS	
Cash	\$ 1,579,796
LIABILITIES	
For the obligations of student activities	1,579,796
For the obligations of student fees	-
Total liabilities	<u>1,579,796</u>
NET POSITION	<u><u>\$ -</u></u>

See notes to financial statements.

**GRAND ISLAND PUBLIC SCHOOLS
GRAND ISLAND, NEBRASKA**

NOTES TO FINANCIAL STATEMENTS

August 31, 2016

NOTE A – SUMMARY OF SIGNIFICANT ACCOUNTING POLICIES

A summary of the District’s significant accounting policies consistently applied in the preparation of the accompanying financial statements follows.

1. Reporting Entity

Grand Island Public Schools is a tax-exempt political subdivision and a Class III school district of the State of Nebraska. The District has considered whether any other organizations should be included in the reporting entity based upon the significance of the operational or financial relationship with the District and has concluded that the Grand Island Education Foundation, Inc. is a component unit. The Foundation exists exclusively for the benefit of the District. The component unit information was obtained from separately audited financial statements, which can be obtained by contacting the Grand Island Education Foundation, Inc.

The Grand Island Education Foundation, Inc. is a non-profit organization, which is engaged primarily in raising funds for extracurricular and academic purposes in the Grand Island area. Support is received primarily through contributions and fundraising programs. As a non-profit organization, the Grand Island Education Foundation, Inc. is exempt from income taxes in accordance with the Internal Revenue Code Section 501(c)(3).

2. Basis of Presentation

On September 1, 2002, the School District adopted the provisions of Statement No. 34 of the Governmental Accounting Standards Board, “Basic Financial Statements – and Management’s Discussion and Analysis – for State and Local Governments.” Effective September 1, 2010 the District adopted GASB Statement No. 54 regarding classification of governmental fund balances. Fund balances are classified as follows:

Nonspendable-Amounts that cannot be spent either because they are not in a spendable form or because they are legally or contractually required to be maintained intact.

Restricted-Amounts that can be spent only for specific purposes because of state or federal laws or externally imposed conditions by grantors or creditors.

Committed-Amounts that can be used only for specific purposes determined by a formal action by School Board resolution.

**GRAND ISLAND PUBLIC SCHOOLS
GRAND ISLAND, NEBRASKA**

NOTES TO FINANCIAL STATEMENTS, Continued

August 31, 2016

NOTE A – SUMMARY OF SIGNIFICANT ACCOUNTING POLICIES, continued

2. Basis of Presentation, continued

Assigned-Amounts that are designated by the Superintendent for a specific purpose but are not spendable until a budget ordinance is passed by the School Board.

Unassigned-All amounts not included in other spendable classifications.

The details of the fund balances are included in the Governmental Funds Balance Sheet (page 16). Restricted funds are used first as appropriate. Assigned Funds are reduced to the extent that expenditure authority has been budgeted by the School Board or the Assignment has been changed by the Superintendent. Decreases to fund balance first reduce Unassigned Fund balance; in the event that Unassigned Fund Balance becomes zero, then Assigned and Committed Fund Balances are used in that order.

The District's financial statements consist of government-wide financial statements, including a statement of net position and a statement of activities, and fund financial statements, which provide a more detailed level of financial information.

Government-wide Financial Statements – The statement of net position and the statement of activities display information about the District as a whole. These statements include the nonfiduciary financial activities of the District. The effect of interfund activity has been eliminated from these statements. These statements report those activities of the District that are governmental (i.e., generally supported by taxes and intergovernmental revenues) and business-type (i.e., generally supported by fees for service). Fiduciary funds are not included in the government-wide financial statements.

The statement of net position presents the financial position of the District's governmental and business-type activities at year end. The statement of activities presents a comparison between direct expenses and program revenues for each program or function of the District's governmental and business-type activities. Direct expenses are those that are specifically associated with a service, program, or department and therefore clearly identifiable to a particular function. Program revenues include charges paid by the recipient of the goods or services offered by the program and grants and contributions (including related investment earnings) that are restricted to meeting the operational or capital requirements of a particular program. Revenues that are not classified as program revenues are presented as general revenues of the District. The comparison of direct expenses with program revenues identifies the extent to which each function is self-financing or draws from the general revenues.

**GRAND ISLAND PUBLIC SCHOOLS
GRAND ISLAND, NEBRASKA**

NOTES TO FINANCIAL STATEMENTS, Continued

August 31, 2016

NOTE A – SUMMARY OF SIGNIFICANT ACCOUNTING POLICIES, continued

2. Basis of Presentation, continued

Fund Financial Statements – The District maintains fund accounting in order to aid financial management and to demonstrate legal compliance. Fund financial statements are designed to present financial information of the District at a more detailed level.

Separate financial statements are provided for governmental funds, proprietary funds, and fiduciary funds, even though the latter are excluded from the government-wide financial statements. Major individual governmental funds and major individual proprietary funds are reported as separate columns in the fund financial statements.

Proprietary funds are used to account for the School District's business-type activities. Proprietary funds distinguish operating receipts and disbursements from nonoperating items. Operating receipts and disbursements generally result from providing services and producing and delivering goods in connection with a proprietary fund's principal ongoing operations. All receipts and disbursements not meeting this definition are reported as nonoperating receipts and disbursements. The Nutrition Fund is considered a proprietary fund.

Fiduciary funds report assets held in a trustee or agency capacity for others and therefore cannot be used to support the School District's own programs. The Activity Fund and Student Fees Fund are fiduciary funds.

3. Basis of Accounting/Measurement Focus

The financial statements of the District have been prepared on the modified cash basis of accounting in that capital assets are capitalized and depreciated under the government-wide measurement focus and long-term liability proceeds and payments do not affect the statement of activities (but are instead carried on the statement of net position) under the government-wide measurement focus. This basis recognizes assets, liabilities, net position, revenues and expenses when they result from cash transactions with a provision for depreciation. This basis is a comprehensive basis of accounting other than accounting principles generally accepted in the United States of America.

As a result of the use of this modified cash basis of accounting, certain assets and their related revenues (such as accounts receivable and revenue for billed or provided services not yet collected) and certain liabilities and their related expenses (such as accounts payable and expenses for goods or services received but not yet paid, and accrued expenses and liabilities) *are*

**GRAND ISLAND PUBLIC SCHOOLS
GRAND ISLAND, NEBRASKA**

NOTES TO FINANCIAL STATEMENTS, Continued

August 31, 2016

NOTE A – SUMMARY OF SIGNIFICANT ACCOUNTING POLICIES, continued

3. Basis of Accounting/Measurement Focus, continued

not recorded in these financial statements. Accordingly, the financial statements and supplemental schedules are not intended to present financial position and results of operations in conformity with accounting principles generally accepted in the United States of America.

The measurement focus establishes the basis of accounting. The basis of accounting determines when transactions are recorded in the financial records and reported in the financial statements. Differences between the government-wide financial statements and the fund financial statements arise in the recording of capital assets, the recognition of depreciation, and the recording of long-term liabilities. Governmental fund financial statements therefore include reconciliation with brief explanations to better identify the relationship between the government-wide financial statements and the governmental fund financial statements.

The government-wide financial statements are prepared using the economic resources measurement focus and the modified cash basis of accounting, as are the proprietary fund and fiduciary fund financial statements. Proceeds from the issuance of long-term debt increase liabilities and payment of long-term debt reduces liabilities. Capital assets are capitalized and depreciation is recognized over the estimated lives of the related assets.

The governmental fund financial statements are prepared using a flow of current financial resources measurement focus and the modified cash basis of accounting. Proceeds from issuance of long-term debt are recognized when received and payment of long-term debt principal is reported as an expenditure when paid. Capital asset purchases are recorded as expenditures and depreciation is not recognized.

Proprietary funds distinguish operating revenues and expenses from nonoperating items. Operating revenues and expenses generally result from providing services in connection with a proprietary fund's principal ongoing operations.

The Grand Island Education Foundation, Inc. (component unit) uses the accrual basis of accounting, whereby revenues are recognized as earned and expenses are recognized as incurred.

**GRAND ISLAND PUBLIC SCHOOLS
GRAND ISLAND, NEBRASKA**

NOTES TO FINANCIAL STATEMENTS, Continued

August 31, 2016

NOTE A – SUMMARY OF SIGNIFICANT ACCOUNTING POLICIES, continued

4. Fund Types

Governmental Funds – Governmental fund reporting focuses on the sources, uses, and balances of current financial resources. Expendable assets are assigned to the various governmental funds according to the purposes for which they are to be used. Current liabilities are assigned to the fund from which they will be paid. The difference between governmental fund assets and liabilities is reported as fund balance. The following are the District's major governmental funds:

General Fund: This fund is the operating fund of the District. It is used to account for all financing resources except those required to be accounted for in other funds.

Special Building Fund: Accounts for taxes levied and other revenue specifically maintained for future building and equipment purchases.

Depreciation Fund: Set up for the replacement of capital assets.

Bond Fund: Accounts for the accumulation of resources for, and the payment of, principal, interest, and fiscal charges on general obligation long-term debt.

Qualified Capital Purpose Fund: Accounts for taxes levied and other revenue specifically maintained for hazard abatement and handicapped accessibility renovations.

Cooperative Fund: Accounts for the Central Nebraska Supportive Service Program, which provides special education services to Grand Island Public Schools and other participating school districts, and other cooperative agreements.

The other governmental funds include:

Contingency Fund: Set up to fund uninsured losses and legal fees incurred by the District for defense against possible losses.

Employee Benefit Fund: The Employee Benefit Fund is a reserve for unemployment claims.

Proprietary Funds – Proprietary funds include enterprise funds. Enterprise funds account for ongoing organizations and activities, which are similar to those often found in the private sector. The measurement focus is upon the determination of change in net position. The District's only proprietary fund is the following fund:

**GRAND ISLAND PUBLIC SCHOOLS
GRAND ISLAND, NEBRASKA**

NOTES TO FINANCIAL STATEMENTS, Continued

August 31, 2016

NOTE A – SUMMARY OF SIGNIFICANT ACCOUNTING POLICIES, continued

4. Fund Types, continued

Proprietary Funds, continued

Nutrition Fund: Accounts for the operations of the District's nutrition program.

Fiduciary Funds – Fiduciary fund reporting focuses on net position and changes in net position. The District's fiduciary funds consist of the following:

Activity Fund: This fund is used to account for assets held by the District in a trustee/agency capacity for various school organizations and activities.

Student Fees Fund: This fund is used to account for student fees collected from students by the District in a trustee capacity for extracurricular activities, post-secondary education, and summer or night school.

5. Capital Assets

General capital assets are those assets not specifically related to activities reported in the proprietary funds. These assets generally result from expenditures in the governmental funds. These assets are reported in the governmental activities column of the government-wide statement of net position, but are not reported in the fund financial statement of assets, liabilities, and fund balances - governmental funds.

Proprietary fund capital assets result from expenditures in the Nutrition Fund. These assets are reported in the business-type activities column of the government-wide statement of net position, but are not reported in the fund financial statement of net position.

The District has a \$5,000 capitalization threshold. Capital assets are recorded at cost (or estimated historical cost) and updated for additions and retirements during the year. Donated capital assets are recorded at their estimated fair value as of the date received. Improvements are capitalized; the cost of normal maintenance and repairs that do not add to the value of the asset or materially extend an asset's life are not.

The District does not possess any material amounts of infrastructure capital assets, such as sidewalks and parking lots. Such items are considered to be part of the cost of buildings or other improvable property.

**GRAND ISLAND PUBLIC SCHOOLS
GRAND ISLAND, NEBRASKA**

NOTES TO FINANCIAL STATEMENTS, Continued

August 31, 2016

NOTE A – SUMMARY OF SIGNIFICANT ACCOUNTING POLICIES, continued

5. Capital Assets, continued

Capital assets not being depreciated include land and construction in progress. Improvements are depreciated over the remaining useful lives of the related capital assets. Since surplus assets are sold for an immaterial amount when declared as no longer needed for public school purposes, no salvage value is taken into consideration for depreciation purposes. Depreciation is computed using the straight-line method over the estimated useful life of the asset. The District has established estimated useful lives as follows:

<u>Description</u>	<u>Estimated Useful Lives in Years</u>
Buildings	30
Furniture and Equipment (including vehicles and computer equipment)	5

6. Investments and Cash Pools

The District maintains an investment pool that is available for use by all funds. The pool consists of an interest-bearing sweep account and Wells Fargo money market funds. Each fund's equity in this pool is included in investments. The District also maintains a pooled checking account for the District's disbursements. Each fund's equity in this pool is included in cash. In addition, other cash and investments are separately held by the Bond Fund, Special Building Fund, Employee Benefit Fund, Contingency Fund, Activity Fund and Student Fees Fund.

Investments are carried at fair value. Fair value of the equity in the Nebraska School District Liquid Asset Fund Plus is the same as the value of the pool shares determined using the fair value of each pool's underlying investment portfolio.

Investment earnings include interest income and the net change for the year in the fair value of investments carried at fair value. Investment income earned in the pooled accounts is allocated to the participating funds in proportion to the average balances in each fund. Other investment income is assigned to the funds with which the related investment asset is associated.

**GRAND ISLAND PUBLIC SCHOOLS
GRAND ISLAND, NEBRASKA**

NOTES TO FINANCIAL STATEMENTS, Continued

August 31, 2016

NOTE A – SUMMARY OF SIGNIFICANT ACCOUNTING POLICIES, continued

6. Investments and Cash Pools, continued

The Grand Island Education Foundation, Inc., follows the Financial Accounting Standards Board (FASB) Codification regarding *Accounting for Certain Investments Held by Not-for-Profit Organizations*. Under FASB Codification guidance, investments in marketable securities with readily determinable fair values and all investments in debt securities are reported at their fair values in the statement of financial position. Unrealized gains and losses are included in the change in net position. Investment income and gains restricted by a donor are reported as increases in unrestricted net position if the restrictions are met (either by passage of time or by use) in the reporting period in which the income and gains are recognized.

7. Net Position

Net position represents the difference between assets and liabilities. Net investment in capital assets consists of capital assets, net of accumulated depreciation, reduced by the outstanding balances of any borrowings used for the acquisition, construction, or improvement of those assets. Net position is reported as restricted when there are limitations imposed on its use either through the enabling legislation adopted by the District or through external restrictions imposed by creditors, grantors, or laws or regulations of other governments. The District applies restricted resources when an expense is incurred for purposes for which both restricted and unrestricted net position are available.

8. Estimates

The preparation of financial statements in conformity with the modified cash basis of accounting used by the District requires management to make estimates and assumptions that affect the reported amounts of assets and liabilities and disclosure of contingent assets and liabilities at the date of the financial statements and the reported amounts of revenues and expenses during the reporting period. Actual results could differ from those estimates.

9. Contributions

The component unit accounts for contributions in accordance with the recommendations of the FASB Codification regarding *Accounting for Contributions Received and Contributions Made*. In accordance with FASB Codification guidance, contributions received are recorded as unrestricted, temporarily restricted, or permanently restricted support, depending on the existence and/or nature of any donor restrictions.

**GRAND ISLAND PUBLIC SCHOOLS
GRAND ISLAND, NEBRASKA**

NOTES TO FINANCIAL STATEMENTS, Continued

August 31, 2016

NOTE A – SUMMARY OF SIGNIFICANT ACCOUNTING POLICIES, continued

9. Contributions, continued

All other donor-restricted support is reported as an increase in temporarily or permanently restricted net position depending on the nature of the restriction. When a restriction expires (that is, when a stipulated time restriction ends or purpose restriction is accomplished), temporarily restricted net position is reclassified to unrestricted net position and reported in the statement of activities as net position released from restrictions.

10. Pledges Receivable

Unconditional pledges receivable for the component unit are recognized as revenues in the period received and as assets, decreases of liabilities, or expenses depending on the form of the benefits received. Conditional promises to give are recognized when the conditions on which they depend are substantially met.

NOTE B – BUDGET PROCESS AND PROPERTY TAXES

The District is required by state law to adopt annual budgets for all funds. The supplementary information presents budgets for the General Fund, Depreciation Fund, Bond Fund, Special Building Fund, Qualified Capital Purpose Undertaking Fund and Cooperative Fund (the major governmental funds). Each budget is presented on the cash basis of accounting, which is consistent with the requirements of the state budget act.

State Statutes of the Nebraska Budget Act provide the prescribed budget practices and procedures that governing bodies are required to follow. The amounts that may be budgeted for certain specific funds are subject to various expenditures and/or tax levy limitations.

The following procedures are followed in establishing the budgetary data reflected in the financial statements:

1. As of August 1, or shortly thereafter, Administration of the District prepares a proposed operating budget for the fiscal year commencing the following September 1. The operating budget includes proposed expenditures and the means of financing them.
2. Public hearings are conducted to obtain taxpayer comments.

**GRAND ISLAND PUBLIC SCHOOLS
GRAND ISLAND, NEBRASKA**

NOTES TO FINANCIAL STATEMENTS, Continued

August 31, 2016

NOTE B – BUDGET PROCESS AND PROPERTY TAXES, continued

3. Prior to the budget filing date, the budget is legally adopted by the Board of Education through passage of a resolution.
4. Total actual expenditures may not legally exceed the Total Budget of Expenditures. Appropriations for expenditures lapse at year end and any revisions require a public hearing and Board approval.
5. The county clerk certifies a preliminary property tax rate for each fund of the School District which levied property taxes in the county the previous year. For school systems with multiple school districts, the county clerk certifies to each school district the combined valuation of the school system and the proportion of valuation of each district. The county clerk also certifies the preliminary levies based on the combined valuation and the amount requested for the school system for the prior year. The preliminary levy shall be the final levy unless the School Board passes, by a majority vote, a resolution setting a levy at a different amount. For school systems with multiple school districts, the School Board of the Class III school district, or kindergarten through grade twelve district, shall have the authority to set the tax rate for the school system.
6. The property tax requirement resulting from the budget process is utilized to establish the tax levy in accordance with the procedures discussed above, which attaches as an enforceable lien on property within the District as of January 1. Taxes are due as of that date. One-half of the real estate taxes due January 1 become delinquent after the following May 1, with the second one-half becoming delinquent after September 1.

The assessed value at August 31, 2015, upon which the 2016 levy was based was \$2,938,020,328.

The tax levy per \$100 of assessed valuation of taxable property for the year ended August 31, 2016, was as follows:

General Fund	\$ 1.0400
Bond Fund	0.2086
Special Building Fund	0.0100
Qualified Capital Purpose Fund	<u>0.0173</u>
	<u>\$ 1.2759</u>

**GRAND ISLAND PUBLIC SCHOOLS
GRAND ISLAND, NEBRASKA**

NOTES TO FINANCIAL STATEMENTS, Continued

August 31, 2016

NOTE C – CASH AND INVESTMENTS

Cash

At August 31, 2016, the carrying value of the District's deposits was \$59,867,992 and the bank balance was \$61,211,625. For reporting purposes, the collateral on the School District bank deposits is classified in these categories:

1. Insured or collateralized with securities held by the School District or by its agent in the School District's name.
2. Collateralized with securities held by the pledging financial institution's trust department or agent in the School District's name.
3. Uncollateralized or collateralized with securities held by the pledging financial institution, or by its trust department or agent, but not in the School District's name.

As of August 31, 2016, all of the bank deposits exceeded FDIC insurance and collateral by \$404,089 at one financial institution. All securities are held by the pledging financial institution, but not in the School District's name.

Cash for the School District at August 31, 2016 consisted of the following:

Cash on hand	\$ 11,096
Demand deposits	9,348,685
Wells Fargo interest-bearing sweep account	11,643,580
Total cash	<u><u>\$ 21,003,361</u></u>

Investments

For reporting purposes the School District's investments, which are carried at market value, consisted of the following at August 31, 2016:

**GRAND ISLAND PUBLIC SCHOOLS
GRAND ISLAND, NEBRASKA**

NOTES TO FINANCIAL STATEMENTS, Continued

August 31, 2016

NOTE C – CASH AND INVESTMENTS, continued

Investments, continued

Nebraska Liquid Asset Fund:	
General Fund	\$ 4,246,270
Bond Fund	4,990,543
Contingency Fund	1,015,236
Employee Benefit Fund	2,980,498
Building Fund	25,632,084
Total investments	<u><u>\$ 38,864,631</u></u>

The Nebraska Liquid Asset Fund is similar in nature to an open-end mutual fund designed specifically for Nebraska school entities, investing only in those securities allowable for such entities under Nebraska Law; and, as such, is not considered a security for purposes of categorization of credit risk as provided in GASB Statement No. 3. A portion (\$25,367,534) of the Building Fund account is an NLAF Managed Account consisting of the following holdings as of August 31, 2016:

	<u>Market Value</u>	<u>Cost Basis</u>	<u>Unrealized Gain (Loss)</u>
NLAF Managed Account:			
US Treasury Bonds/Notes	\$ 899,754		
Federal Agency Bonds/Notes	16,484,679		
Commercial Paper	7,983,101		
Total managed account	<u><u>\$25,367,534</u></u>	<u><u>\$25,572,134</u></u>	<u><u>\$ (204,600)</u></u>

Investment income (loss) for the Special Building Fund consisted of the following for the year ended August 31, 2016:

Interest income	\$ 15,070
Managed account interest income	479,034
Realized loss on investments	(30,683)
Unrealized loss on investments	(174,666)
Total investment income (loss)	<u><u>\$ 288,755</u></u>

**GRAND ISLAND PUBLIC SCHOOLS
GRAND ISLAND, NEBRASKA**

NOTES TO FINANCIAL STATEMENTS, Continued

August 31, 2016

NOTE C – CASH AND INVESTMENTS, continued

Summary of Carrying Values

The carrying values of cash and investments shown above are included in the fund financial statements at August 31, 2016, as follows:

Carrying value	
Cash	\$ 21,003,361
Investments	38,864,631
Cash and investments	<u>\$ 59,867,992</u>

Included in the following fund financial statements captions:

Statement of Net Position - Governmental Activities	
Cash and investments	\$ 24,981,495
Cash restricted for building projects	27,260,898
Cash restricted for debt service	4,992,928
Cash restricted for qualified capital purposes	284,194
Statement of Net Position - Business-type Activities	
Cash	768,681
Statement of Net Position - Fiduciary Funds	
Activity Fund - Cash	<u>1,579,796</u>
	<u>\$ 59,867,992</u>

**GRAND ISLAND PUBLIC SCHOOLS
GRAND ISLAND, NEBRASKA**

NOTES TO FINANCIAL STATEMENTS, Continued

August 31, 2016

NOTE C – CASH AND INVESTMENTS, continued

Component Unit

The carrying values of cash and investments for the Grand Island Education Foundation, Inc. is made up of the following at August 31, 2016:

Carrying value:		
Cash		\$ 387,590
Certificates of deposit		46,711
Investments		5,195,892
Cash and investments		<u>\$ 5,630,193</u>

Investments are stated at fair value at August 31, 2016, and consist of mutual funds as follows:

	<u>Market Value</u>	<u>Cost Basis</u>	<u>Unrealized Gain (Loss)</u>
Mutual funds:			
Income Fund of America - Class A	\$ 3,734,601	\$ 3,223,798	\$ 510,803
Capital World Growth & Income - Class A	458,373	360,189	98,184
America Balanced Fund	10,286	7,800	2,486
American Capital World Growth & Income	7,477	7,212	265
Total mutual funds	<u>4,210,737</u>	<u>3,598,999</u>	<u>611,738</u>
Common stock:			
Abbvie Inc	230,760	181,587	49,173
Eli Lilly & Co	167,552	117,329	50,223
Johnson & Johnson	284,029	162,445	121,584
Microsoft	302,814	162,371	140,443
Total common stock	<u>985,155</u>	<u>623,732</u>	<u>361,423</u>
Total	<u>\$ 5,195,892</u>	<u>\$ 4,222,731</u>	<u>\$ 973,161</u>

**GRAND ISLAND PUBLIC SCHOOLS
GRAND ISLAND, NEBRASKA**

NOTES TO FINANCIAL STATEMENTS, Continued

August 31, 2016

NOTE D – FUNDS HELD BY COUNTY TREASURERS

The following receipts were held by County Treasurers for the School District at August 31, 2016. The receipts were transferred subsequent to the fiscal year ended August 31, 2016.

General Fund	\$ 8,706,143
Bond Fund	1,675,629
Building Fund	80,291
Qualified Capital Purpose Fund	138,977
Total cash with County Treasurers at August 31, 2016	\$10,601,040

NOTE E – CAPITAL ASSETS

Capital asset balances and activity for the year ended August 31, 2016, were as follows:

	Balance August 31, <u>2015</u>	<u>Additions</u>	<u>Deletions</u>	<u>Reclass</u>	Balance August 31, <u>2016</u>
<u>Governmental activities:</u>					
Capital assets not being depreciated:					
Land	\$ 2,508,627	\$ 356,370	\$ -	\$ -	\$ 2,864,997
Construction in progress	7,122,839	20,540,565	-	(91,367)	27,572,037
Capital assets being depreciated:					
Buildings	128,675,308	940,145	-	91,367	129,706,820
Furniture and equipment:					
Vehicles	2,517,284	31,583	-	-	2,548,867
Computer equipment	5,338,032	638,054	(159,387)	-	5,816,699
Equipment	10,187,419	448,527	(1,325,931)	-	9,310,015
Total furniture and equipment	18,042,735	1,118,164	(1,485,318)	-	17,675,581
Total capital assets	156,349,509	22,955,244	(1,485,318)	-	177,819,435
Less accumulated depreciation:					
Buildings	(61,807,084)	(3,667,337)	-	-	(65,474,421)
Furniture and equipment:					
Vehicles	(2,360,612)	(97,743)	-	-	(2,458,355)
Computer equipment	(4,032,371)	(461,097)	159,387	-	(4,334,081)
Equipment	(7,719,849)	(1,122,976)	1,325,931	-	(7,516,894)
Total furniture and equipment	(14,112,832)	(1,681,816)	1,485,318	-	(14,309,330)
Total accumulated depreciation	(75,919,916)	(5,349,153)	1,485,318	-	(79,783,751)
Net capital assets	\$ 80,429,593	\$ 17,606,091	\$ -	\$ -	\$ 98,035,684

**GRAND ISLAND PUBLIC SCHOOLS
GRAND ISLAND, NEBRASKA**

NOTES TO FINANCIAL STATEMENTS, Continued

August 31, 2016

NOTE E – CAPITAL ASSETS, continued

Included in governmental activities equipment are copiers under capital lease arrangements with a cost of \$501,329 and accumulated depreciation of \$50,133 at August 31, 2016.

Construction in progress at August 31, 2016, consists of \$2,999,376 on the Engleman building addition project, \$6,882,772 on the Shoemaker building addition project, \$25,000 on the Stolley Park building design, \$10,730,157 on the Starr building project, \$83,561 on the Jefferson building design, \$5,752,579 on the Barr building addition project, and \$1,098,592 on the Senior High wing renovation. Additional details on construction commitments are provided in Note M.

	Balance August 31, <u>2015</u>	<u>Additions</u>	<u>Deletions</u>	Balance August 31, <u>2016</u>
<u>Business-type activities:</u>				
Capital assets being depreciated:				
Buildings	\$ 2,549,132	\$ -	\$ -	\$ 2,549,132
Furniture and equipment:				
Vehicles	313,789	-	-	313,789
Computer equipment	67,805	29,439	-	97,244
Equipment	1,266,218	15,217	-	1,281,435
Total furniture and equipment	<u>1,647,812</u>	<u>44,656</u>	<u>-</u>	<u>1,692,468</u>
Total capital assets	4,196,944	44,656	-	4,241,600
Less accumulated depreciation:				
Buildings	(449,091)	(84,971)	-	(534,062)
Furniture and equipment:				
Vehicles	(292,841)	(13,965)	-	(306,806)
Computer equipment	(52,785)	(4,742)	-	(57,527)
Equipment	(1,221,661)	(11,331)	-	(1,232,992)
Total furniture and equipment	<u>(1,567,287)</u>	<u>(30,038)</u>	<u>-</u>	<u>(1,597,325)</u>
Total accumulated depreciation	<u>(2,016,378)</u>	<u>(115,009)</u>	<u>-</u>	<u>(2,131,387)</u>
Net capital assets	<u>\$ 2,180,566</u>	<u>\$ (70,353)</u>	<u>\$ -</u>	<u>\$ 2,110,213</u>

**GRAND ISLAND PUBLIC SCHOOLS
GRAND ISLAND, NEBRASKA**

NOTES TO FINANCIAL STATEMENTS, Continued

August 31, 2016

NOTE F – LONG-TERM LIABILITIES

Long-term liability balances and activity for the year ended August 31, 2016, were as follows:

	Balance August 31, <u>2015</u>	<u>Proceeds</u>	<u>Principal Payments</u>	Balance August 31, <u>2016</u>	Due Within One <u>Year</u>
<u>Business-type activities:</u>					
Certificates of participation	\$ 645,000	\$ -	\$ (315,000)	\$ 330,000	\$ 330,000
<u>Governmental activities:</u>					
Capital lease payable	\$ 94,693	\$ 501,329	\$ (103,474)	\$ 492,548	\$ 96,221
Limited tax obligation bonds	4,445,000	-	(420,000)	4,025,000	425,000
General obligation bonds	77,885,000	-	(2,935,000)	74,950,000	2,540,000
Total governmental long-term liabilities	<u>\$ 82,424,693</u>	<u>\$ 501,329</u>	<u>\$ (3,458,474)</u>	<u>\$79,467,548</u>	<u>\$ 3,061,221</u>

Payments on the capital lease payable are made by the General Fund. The general obligation bonds are paid by the Bond Fund. The limited tax obligation bonds are paid by the Qualified Capital Purpose Fund.

Detail of the Nutrition Fund Certificates of Participation follows:

Issuer: Hall County School District 002 (Grand Island, Nebraska, School District)

Purpose: Central kitchen equipment/remodeling

Amount: \$2,125,000

Dated: October 15, 2009

Interest Rate: 1.10 - 3.00%

Principal Due: September 15 and March 15, commencing September 15, 2010 through September 15, 2016.

Interest Due: March 15 and September 15, commencing March 15, 2010 through September 15, 2016.

**GRAND ISLAND PUBLIC SCHOOLS
GRAND ISLAND, NEBRASKA**

NOTES TO FINANCIAL STATEMENTS, Continued

August 31, 2016

NOTE F – LONG-TERM LIABILITIES, continued

Detail of the Nutrition Fund Certificates of Participation follows, continued:

<u>Fiscal Year</u>	<u>Coupon Rate</u>	<u>-----September 15-----</u>		<u>-----March 15-----</u>		<u>Total Payments</u>	<u>Principal Balance</u>
		<u>Principal</u>	<u>Interest</u>	<u>Principal</u>	<u>Interest</u>		
2016-2017	3.00%	<u>\$ 330,000</u>	<u>\$ 4,950</u>	<u>\$ -</u>	<u>\$ -</u>	<u>\$ 334,950</u>	\$ 330,000 -

Detail of the General Obligation Bonds follows:

General Obligation Bonds – 2005

Issuer: Hall County School District 002 (Grand Island, Nebraska, School District)

Purpose: Constructing a new middle school and constructing a six-classroom addition and improvements for both the existing Barr Middle School and the existing Walnut Middle School.

Amount: \$19,950,000

Dated: November 1, 2005

Interest Rate: 3.45 - 5.0%

Principal Due: December 15 commencing 2009 to 2025

Interest Due: December 15 and June 15 commencing 2006 to 2025

Callable: December 15, 2015

During the year ended August 31, 2012, the District made provision for the payment, discharge and defeasance of \$18,815,000 of the outstanding obligations of the Series 2005 General Obligation Bonds by depositing sufficient funds in trust. These funds were used to purchase direct obligations of the United States of America which, together with the interest to be earned on such obligations, will be sufficient for the payment of the principal and interest on the defeased bonds. Consequently, all of such bonds are deemed to be paid and discharged.

**GRAND ISLAND PUBLIC SCHOOLS
GRAND ISLAND, NEBRASKA**

NOTES TO FINANCIAL STATEMENTS, Continued

August 31, 2016

NOTE F – LONG-TERM LIABILITIES, continued

Detail of the General Obligation Bonds follows, continued:

General Obligation Bonds – 2011

Issuer: Hall County School District 002 (Grand Island, Nebraska, School District)

Purpose: Refunding Series 2003 bonds

Amount: \$9,995,000

Dated: September 28, 2011

Interest Rate: 0.45 - 1.75%

Principal Due: December 1 commencing 2011 to 2018

Interest Due: December 1 and June 1 commencing 2011 to 2018

Callable: September 28, 2016

A schedule of the remaining bond principal and interest attributable to the 2011 issue follows:

<u>Fiscal Year</u>	<u>Coupon Rate</u>	-----December 1----- <u>Principal</u>	<u>Interest</u>	June 1 <u>Interest</u>	<u>Total Payments</u>	<u>Principal Balance</u>
						\$ 4,950,000
2016-2017	1.20%	\$ 1,970,000	\$ 34,903	\$ 23,082	\$ 2,027,985	2,980,000
2017-2018	1.45%	1,995,000	23,082	8,619	2,026,701	985,000
2018-2019	1.75%	985,000	8,619	-	993,619	-
		<u>\$ 4,950,000</u>	<u>\$ 66,604</u>	<u>\$ 31,701</u>	<u>\$ 5,048,305</u>	

**GRAND ISLAND PUBLIC SCHOOLS
GRAND ISLAND, NEBRASKA**

NOTES TO FINANCIAL STATEMENTS, Continued

August 31, 2016

NOTE F – LONG-TERM LIABILITIES, continued

Detail of the General Obligation Bonds follows, continued:

General Obligation Bonds – 2012

Issuer: Hall County School District 002 (Grand Island, Nebraska, School District)

Purpose: Refunding the Series 2005 and 2008 bonds

Amount: \$21,340,000

Dated: March 15, 2012

Interest Rate: 2.0 - 4.0%

Principal Due: December 15 commencing 2012 to 2025

Interest Due: December 15 and June 15 commencing 2012 to 2025

Callable: December 15, 2021

A schedule of the remaining bond principal and interest attributable to the 2012 issue follows:

<u>Fiscal Year</u>	<u>Coupon Rate</u>	-----December 15-----		<u>June 15</u>	<u>Total</u>	<u>Principal</u>
		<u>Principal</u>	<u>Interest</u>	<u>Interest</u>	<u>Payments</u>	<u>Balance</u>
						\$ 19,370,000
2016-2017	2.00%	\$ 400,000	\$ 328,613	\$ 324,612	\$ 1,053,225	18,970,000
2017-2018	2.00%	415,000	324,613	320,462	1,060,075	18,555,000
2018-2019	2.00%	425,000	320,463	316,212	1,061,675	18,130,000
2019-2020	3.00%	2,485,000	316,213	278,937	3,080,150	15,645,000
2020-2021	3.00%	2,560,000	278,938	240,537	3,079,475	13,085,000
2021-2022	3.00%	2,635,000	240,538	201,012	3,076,550	10,450,000
2022-2023	3.40%	2,715,000	201,013	154,700	3,070,713	7,735,000
2023-2024	4.00%	2,820,000	154,700	98,300	3,073,000	4,915,000
2024-2025	4.00%	2,935,000	98,300	39,600	3,072,900	1,980,000
2025-2026	4.00%	1,980,000	39,600	-	2,019,600	-
		<u>\$ 19,370,000</u>	<u>\$ 2,302,991</u>	<u>\$ 1,974,372</u>	<u>\$ 23,647,363</u>	

**GRAND ISLAND PUBLIC SCHOOLS
GRAND ISLAND, NEBRASKA**

NOTES TO FINANCIAL STATEMENTS, Continued

August 31, 2016

NOTE F – LONG-TERM LIABILITIES, continued

Detail of the General Obligation Bonds follows, continued:

General Obligation Bonds – 2014

Issuer: Hall County School District 002 (Grand Island, Nebraska, School District)

Purpose: Five year construction plan at seven schools

Amount: \$51,215,000

Dated: December 1, 2014

Interest Rate: 3.0 - 5.0%

Principal Due: December 15 commencing 2015 to 2039

Interest Due: December 15 and June 15 commencing 2015 to 2039

Callable: December 15, 2024

A schedule of the remaining bond principal and interest attributable to the 2014 issue follows:

<u>Fiscal Year</u>	<u>Rate</u>	<u>Principal</u>	<u>Interest</u>	<u>Interest</u>	<u>Payments</u>	<u>Balance</u>
						\$ 50,630,000
2016-2017	3.00%	\$ 170,000	\$ 1,191,075	\$ 1,188,525	\$ 2,549,600	50,460,000
2017-2018		-	1,188,525	1,188,525	2,377,050	50,460,000
2018-2019		-	1,188,525	1,188,525	2,377,050	50,460,000
2019-2020		-	1,188,525	1,188,525	2,377,050	50,460,000
2020-2021		-	1,188,525	1,188,525	2,377,050	50,460,000
2021-2022		-	1,188,525	1,188,525	2,377,050	50,460,000
2022-2023		-	1,188,525	1,188,525	2,377,050	50,460,000
2023-2024		-	1,188,525	1,188,525	2,377,050	50,460,000
2024-2025		-	1,188,525	1,188,525	2,377,050	50,460,000
2025-2026		-	1,188,525	1,188,525	2,377,050	50,460,000
2026-2027		-	1,188,525	1,188,525	2,377,050	50,460,000
2027-2028		-	1,188,525	1,188,525	2,377,050	50,460,000
2028-2029		-	1,188,525	1,188,525	2,377,050	50,460,000
2029-2030		-	1,188,525	1,188,525	2,377,050	50,460,000
2030-2031	5.00%	2,920,000	1,188,525	1,115,525	5,224,050	47,540,000
2031-2032	4.00%	4,360,000	1,115,525	1,028,325	6,503,850	43,180,000
2032-2033	5.00%	4,565,000	1,028,325	914,200	6,507,525	38,615,000
2033-2034	5.00%	4,795,000	914,200	794,325	6,503,525	33,820,000
2034-2035	4.00%	5,015,000	794,325	694,025	6,503,350	28,805,000
2035-2036	4.00%	5,220,000	694,025	589,625	6,503,650	23,585,000
2036-2037	5.00%	5,460,000	589,625	453,125	6,502,750	18,125,000
2037-2038	5.00%	5,745,000	453,125	309,500	6,507,625	12,380,000
2038-2039	5.00%	6,035,000	309,500	158,625	6,503,125	6,345,000
2039-2040	5.00%	6,345,000	158,625	-	6,503,625	-
		<u>\$ 50,630,000</u>	<u>\$ 23,887,700</u>	<u>\$ 22,696,625</u>	<u>\$ 97,214,325</u>	

**GRAND ISLAND PUBLIC SCHOOLS
GRAND ISLAND, NEBRASKA**

NOTES TO FINANCIAL STATEMENTS, Continued

August 31, 2016

NOTE F – LONG-TERM LIABILITIES, continued

Detail of the Limited Tax Obligation Bonds follows:

Limited Tax Obligation Bonds - 2014

Issuer: Hall County School District 002 (Grand Island, Nebraska, School District)

Purpose: Refinancing the 2009 Build America Bonds

Amount: \$4,445,000

Dated: February 9, 2015

Interest Rate: 0.35 – 2.40%

Principal Due: December 15 commencing 2015 to 2024

Interest Due: December 15 and June 15 commencing 2015 to 2024

A schedule of the remaining bond principal and interest attributable to the 2015 issue follows:

<u>Fiscal Year</u>	<u>Coupon Rate</u>	-----December 15-----		<u>June 15</u>	<u>Total</u>
		<u>Principal</u>	<u>Interest</u>	<u>Interest</u>	<u>Payments</u>
2016-2017	0.65%	\$ 425,000	\$ 33,796	\$ 32,415	\$ 491,211
2017-2018	0.95%	425,000	32,415	30,396	487,811
2018-2019	1.25%	430,000	30,396	27,709	488,105
2019-2020	1.50%	435,000	27,709	24,446	487,155
2020-2021	1.75%	445,000	24,446	20,553	489,999
2021-2022	2.00%	450,000	20,553	16,052	486,605
2022-2023	2.15%	460,000	16,052	11,108	487,160
2023-2024	2.25%	470,000	11,108	5,820	486,928
2024-2025	2.40%	485,000	5,820	-	490,820
		<u>\$ 4,025,000</u>	<u>\$ 202,295</u>	<u>\$ 168,499</u>	<u>\$ 4,395,794</u>

**GRAND ISLAND PUBLIC SCHOOLS
GRAND ISLAND, NEBRASKA**

NOTES TO FINANCIAL STATEMENTS, Continued

August 31, 2016

NOTE F – LONG-TERM LIABILITIES, continued

Detail of the Capital Lease follows:

Capital Lease

On August 11, 2016, the School District entered into a 60-month capital lease for district copiers and printers expiring in 2021. The principal balance due on this lease was \$492,548 at August 31, 2016, and it bears interest of 2.04 percent. Monthly principal and interest payments of \$8,781 are due commencing August 11, 2016 through July 11, 2021.

Remaining principal and interest due on the capital lease are:

<u>Fiscal Year</u>	<u>Capital Leases</u>		<u>Total</u>
	<u>Principal</u>	<u>Interest</u>	
2016-2017	\$ 96,221	\$ 9,151	\$ 105,372
2017-2018	98,202	7,170	105,372
2018-2019	100,224	5,148	105,372
2019-2020	102,288	3,084	105,372
2020-2021	95,613	978	96,591
	<u>\$ 492,548</u>	<u>\$ 25,531</u>	<u>\$ 518,079</u>

Combined long-term debt service requirements at August 31, 2016, are:

<u>Year Ended August 31,</u>	<u>Governmental Activities</u>			<u>Business-type Activities</u>		
	<u>Principal</u>	<u>Interest</u>	<u>Total</u>	<u>Principal</u>	<u>Interest</u>	<u>Total</u>
2017	\$ 3,061,221	\$ 3,166,172	\$ 6,227,393	\$ 330,000	\$ 4,950	\$ 334,950
2018	2,933,202	3,123,807	6,057,009	-	-	-
2019	1,940,224	3,085,597	5,025,821	-	-	-
2020	3,022,288	3,027,439	6,049,727	-	-	-
2021	3,100,613	2,942,502	6,043,115	-	-	-
2022-2026	14,950,000	13,199,526	28,149,526	-	-	-
2027-2031	2,920,000	11,812,250	14,732,250	-	-	-
2032-2036	23,955,000	8,566,900	32,521,900	-	-	-
2037-2041	23,585,000	2,432,125	26,017,125	-	-	-
	<u>\$ 79,467,548</u>	<u>\$ 51,356,318</u>	<u>\$130,823,866</u>	<u>\$ 330,000</u>	<u>\$ 4,950</u>	<u>\$ 334,950</u>

**GRAND ISLAND PUBLIC SCHOOLS
GRAND ISLAND, NEBRASKA**

NOTES TO FINANCIAL STATEMENTS, Continued

August 31, 2016

NOTE G – PENSION PLAN

Plan Description

Hall County School District #2 contributes to the Nebraska School Employees Retirement System, a cost-sharing multiple-employer defined benefit pension plan administered by the Nebraska Public Employees Retirement System (NPERS). NPERS provides retirement and disability benefits to plan members and beneficiaries. The School Employees Retirement Act establishes benefit provisions.

In 1945, the Nebraska Legislature enacted the law establishing a retirement plan for school employees of the State. During the NPERS fiscal year ended June 30, 2015, there were 266 participating school districts. These were the districts that had contributions during the fiscal year. All regular public school employees in Nebraska, other than those who have their own retirement plans (Class V school districts, Nebraska State Colleges, University of Nebraska, Community Colleges), are members of the plan.

Normal retirement is at age 65. The monthly benefit is equal to the greater of the following: 1) the sum of a savings annuity, which is the actuarial equivalent of the member's accumulated contributions and a service annuity equal to \$3.50 per year of service; or 2) the average of the three 12-month periods of service as a school employee in which such compensation was the greatest, multiplied by total years of creditable service, multiplied by a formula factor of two percent, and an actuarial factor based on age.

For an employee who became a member on or after July 1, 2013, the monthly benefit is equal to the greater of the following: 1) the sum of a savings annuity, which is the actuarial equivalent of the member's accumulated contributions and a service annuity equal to \$3.50 per year of service; or 2) the average of the five 12-month periods of service as a school employee in which such compensation was the greatest, multiplied by total years of creditable service, multiplied by a formula factor of two percent, and an actuarial factor based on age.

Benefit calculations vary with early retirement. Employees' benefits are vested after five years of plan participation or when termination occurs at age 65 or later.

For school employees who became members prior to July 1, 2013, the benefit paid to a retired member or beneficiary receives an annual cost of living adjustment, which is increased by the lesser of the percentage change in the Consumer Price Index for Urban Wage Earners and Clerical Workers or two and one-half percent. The current benefit paid to a retired member or beneficiary is adjusted so that the purchasing power of the benefit being paid is not less than 75 percent of the purchasing power of the initial benefit.

**GRAND ISLAND PUBLIC SCHOOLS
GRAND ISLAND, NEBRASKA**

NOTES TO FINANCIAL STATEMENTS, Continued

August 31, 2016

NOTE G – PENSION PLAN, continued

Plan Description, continued

For school employees who became members on or after July 1, 2013, the benefit paid to a retired member or beneficiary receives an annual cost of living adjustment, which is increased by the lesser of the percentage change in the Consumer Price Index for Urban Wage Earners and Clerical Workers or one percent.

For the District's year ended August 31, 2016, the District's total payroll for all employees was \$68,116,773. Total covered payroll was \$65,848,888. Covered payroll refers to all compensation paid by the District to active employees covered by the Plan.

Contributions

The State's contribution is based on an annual actuarial valuation. In addition, the State contributes an amount equal to two percent of the compensation of all members. This contribution is considered a nonemployer contribution since school employees are not employees of the State. The employee contribution was equal to 9.78 percent from July 1, 2014, to June 30, 2015 (and from July 1, 2015 through August 31, 2016). The school district (employer) contribution is 101 percent of the employee contribution. The District's contribution to the Plan for its year ended August 31, 2016, was \$6,504,421.

Pension Liabilities

At June 30, 2015 the District had a liability of \$32,985,617 for its proportionate share of the net pension liability. (This liability is not recorded in the accompanying modified cash basis financial statements.) The net pension liability was measured as of June 30, 2015, and the total pension liability used to calculate the net pension liability was determined by an actuarial valuation as of that date. The NPERS School Plan was 89.86% funded as of June 30, 2015 based on actuarial calculations comparing total pension liability to the plan fiduciary net position. The District's proportion of the net pension liability was based on a projection of the District's long-term share of contributions to the pension plan relative to the projected contributions of all participating entities, actuarially determined. At June 30, 2015, the District's proportion was 3.028716 percent, which was a decrease of 0.03154 percent from its proportion measured as of June 30, 2014.

For the year ended June 30, 2015, the District's allocated pension expense was \$(845,502).

**GRAND ISLAND PUBLIC SCHOOLS
GRAND ISLAND, NEBRASKA**

NOTES TO FINANCIAL STATEMENTS, Continued

August 31, 2016

NOTE G – PENSION PLAN, continued

Actuarial Assumptions

The total pension liability in the June 30, 2015 actuarial valuation was determined using the following actuarial assumptions, applied to all periods included in the measurement:

Price Inflation	3.25 percent
Wage Inflation	4.00 percent
Salary increases, including wage inflation	4.00-9.00 percent
Cost-of-Living Adjustment	Members hired before July 1, 2013: 2.50% with a floor benefit equal to 75% purchasing power of original benefit. Members hired on/after July 1, 2013: 1.00% with no floor benefit
Long-term Rate of Return, net of investment expense, including price inflation	8.00 percent
Municipal Bond Index Rate	4.35 percent
Year FNP is Projected to be Depleted	N/A
Single Equivalent Int. Rate, net of investment expense, including price inflation	8.00 percent

The School Plan’s pre-retirement mortality rates were based on the 1994 Group Annuity Mortality Table, projected to 2015 using scale AA, set back one year (sex distinct with 55 percent of male rates for males and 40 percent of female rates for females).

The School Plan’s post-retirement rates were based on the 1994 Group Annuity Mortality Table, projected to 2015 using Scale AA, set-back one year (sex distinct).

The School Plan’s disability mortality rates were based on the 1983 Railroad Retirement Board Disabled Annuitants Morality (unisex).

The actuarial assumptions used in the July 1, 2014, valuations for the School plan is based on the results of the most recent actuarial experience study, which covered the five year period ending June 30, 2011. The experience study report is dated August 20, 2012.

**GRAND ISLAND PUBLIC SCHOOLS
GRAND ISLAND, NEBRASKA**

NOTES TO FINANCIAL STATEMENTS, Continued

August 31, 2016

NOTE G – PENSION PLAN, continued

Actuarial Assumptions, continued

The long-term expected real rate of return on pension plan investments was based upon the expected long-term investment returns provided by a consultant of the Nebraska Investment Council, who is responsible for investing the pension plan assets. The return assumptions were developed using a building-block method in which best-estimate ranges of expected future real rates of return (expected returns, net of pension plan investment expense and inflation) are developed for each major asset class. These ranges are combined to produce the long-term expected rate of return by weighting the expected future real rates of return by the target asset allocation percentage and by adding expected inflation. Best estimates of geometric real rates of return for each major asset class included in the pension plans' target asset allocation as of first quarter 2016, (see the discussion of the pension plan's investment policy) are summarized in the following table:

Asset Class	Target Allocation	Long-Term Expected Real Rate of Return*
US Equity	29.0%	4.4%
Non-US Equity	13.5%	5.2%
Global Equity	15.0%	4.8%
Fixed Income	30.0%	2.1%
Private Equity	5.0%	6.7%
Real Estate	7.5%	4.4%
Total	100.0%	

*Geometric mean, net of investment expenses.

Discount Rate

The discount rate used to measure the Total Pension Liability at both June 30, 2014 and June 30, 2015, was 8 percent. The discount rate is reviewed as part of the actuarial experience study, which was last performed for the period July 1, 2006, through June 30, 2011. The actuarial experience study is reviewed by the NPERS Board, which must vote to change the discount rate.

**GRAND ISLAND PUBLIC SCHOOLS
GRAND ISLAND, NEBRASKA**

NOTES TO FINANCIAL STATEMENTS, Continued

August 31, 2016

NOTE G – PENSION PLAN, continued

Discount Rate, continued

The projection of cash flows used to determine the discount rate assumed that contributions from plan members will be made at the current contribution rate and contributions from employers and nonemployers will be made at the contractually rates, actuarially determined. Based on those assumptions, the pension plans’ fiduciary net position was projected to be available to make all projected future benefit payments of current plan members. Therefore, the long-term expected rate of return on pension plan investments was applied to all periods of projected benefit payments to determine the total pension liability. The projected future benefit payments for all current plan members were projected through 2114.

Sensitivity of the District’s Proportionate Share of the Net Pension Liability to Changes in the Discount Rate.

The following presents the District’s proportionate share of the net pension liability calculated using the discount rate of 8.0 percent, as well as what the District’s proportionate share of the net pension liability would be if it were calculated using a discount rate that is 1-percentage-point lower (7.0 percent) or 1-percentage-point higher (9.0 percent) than the current rate:

	Discount rate	District's proportionate Share of net pension liability
1% decrease	7.0%	\$74,895,842
Current discount rate	8.0%	\$32,985,617
1% increase	9.0%	\$ (1,865,809)

Plan Fiduciary Net Position

Detailed information about the Plan’s fiduciary net position is available in the separately issued Nebraska Public Employees Retirement Systems Plan financial report. NPERS issues a publicly available financial report that includes financial statements and required supplementary information for NPERS. That report may be obtained by writing the NPERS, P.O. Box 94816, Lincoln, NE 68509-4816, by calling 1-800-245-5715 or via the internet at http://www.auditors.nebraska.gov/APA_Reports.

**GRAND ISLAND PUBLIC SCHOOLS
GRAND ISLAND, NEBRASKA**

NOTES TO FINANCIAL STATEMENTS, Continued

August 31, 2016

NOTE H – ANNEXATION

As a result of the City of Grand Island annexation ordinances, the Grand Island School District acquired portions of School Districts #3, #30, and #38 as of August 15, 1985. With District #3, an arrangement was made to split tax receipts from the annexed area until the 1994-95 school year subject to a per pupil cost limitation. Students in the annexed area born before the date of annexation attended District #3; those born after the date of annexation could, until the 2004-2005 school year, attend the school of their choice. Subsequent to the 2004-2005 school year, all students in the annexed area attend Grand Island Public Schools unless they use enrollment options or enroll in private schools.

NOTE I – RISK MANAGEMENT

The School District is exposed to various risks of losses related to torts; thefts of, damage to, and destruction of assets; errors and omissions; injuries to employees; and natural disasters. The School District maintains commercial insurance coverage covering each of the above risks of loss. Management believes that the coverage is adequate to preclude any significant uninsured risk of exposure to the School District.

Settled claims in the past three years have not exceeded the coverages.

Deposits and Investments

Custodial Credit Risk. For an investment, custodial credit risk is the risk that, in the event of the failure of the counterparty, the School District will not be able to recover the value of its investment or collateral securities that are in the possession of an outside party. All of the underlying securities for the School District's investments at August 31, 2016 are held in the name of the School District. The underlying securities consist of a Wells Fargo interest-bearing sweep account, Wells Fargo Money Market Funds, and Nebraska Liquid Asset Funds.

Interest Rate Risk. As a means of limiting its exposure to fair value losses arising from rising interest rates, the School District's investment policy requires that market conditions and investment securities be analyzed to determine the maximum yield to be obtained and to minimize the impact of rising interest rates. The Nebraska Liquid Asset Fund certificate of deposit maturities and managed account investments are as follows:

<u>Maturity Date by Month</u>	<u>Amount</u>
September 2016	\$ 2,304,030
November 2016	3,756,133
December 2016	5,275,514
February 2017	2,050,316
April 2017	2,001,978

**GRAND ISLAND PUBLIC SCHOOLS
GRAND ISLAND, NEBRASKA**

NOTES TO FINANCIAL STATEMENTS, Continued

August 31, 2016

NOTE I – RISK MANAGEMENT, continued

Deposits and Investments, continued

Interest Rate Risk, continued

May 2017	619,138
June 2017	5,595,244
July 2017	500,245
August 2017	6,798,216
October 2017	2,604,433
December 2017	2,302,516
February 2018	2,301,017
March 2018	<u>899,754</u>
	<u>\$ 37,008,534</u>

Credit Risk. Credit risk is the risk that the issuer or other counterparty to an investment will not fulfill its obligations. The School District’s investments consist of certificates of deposit, a Wells Fargo interest-bearing sweep account, Wells Fargo Money Market Funds, and Nebraska Liquid Asset Funds, minimizing credit risk associated with the School District’s investment portfolio.

Concentration of Credit Risk. The School District’s investment policy places no limit on the amount that may be invested in any one issuer. At August 31, 2016, the School District’s deposits consisted of the following:

<u>Financial Institution</u>	<u>Amount</u>
Wells Fargo Bank	\$ 19,417,469
Nebraska Liquid Asset Fund	38,864,631
Five Points Bank	<u>1,574,796</u>
	<u>\$ 59,856,896</u>

**GRAND ISLAND PUBLIC SCHOOLS
GRAND ISLAND, NEBRASKA**

NOTES TO FINANCIAL STATEMENTS, Continued

August 31, 2016

NOTE I – RISK MANAGEMENT, continued

Deposits and Investments, continued

Foreign Currency Risk. This risk relates to adverse effects on the fair value of an investment from changes in exchange rates. The School District's investments had no exposure to foreign currency risk and the School District held no investments denominated in foreign currency at August 31, 2016.

NOTE J – INTERFUND ACTIVITY

The School District transferred \$239,500 from the General Fund to the Activity Fund during the year ended August 31, 2016, for annual activities support.

The following transfers were also made from the General Fund during the year ended August 31, 2016. These transfers between governmental funds were eliminated from the totals presented on page 18.

<u>Fund Receiving Transfer</u>	<u>Amount</u>	<u>Purpose</u>
Cooperative Fund	\$ 1,792,318	Federal grants
Depreciation Fund	<u>1,000,000</u>	Future purchases
	<u>\$ 2,792,318</u>	

NOTE K – OPERATING LEASE

On July 21, 2011, the School District entered into a new operating lease with Eakes for service and supplies on copiers and printers. The monthly payment under this contract is \$11,935. The payments are due commencing July 21, 2011 through May 21, 2016.

Payments made under the operating lease totaled \$107,414 for the year ended August 31, 2016.

**GRAND ISLAND PUBLIC SCHOOLS
GRAND ISLAND, NEBRASKA**

NOTES TO FINANCIAL STATEMENTS, Continued

August 31, 2016

NOTE L – SECTION 125 PLAN

The District has a Section 125 Cafeteria Plan for the benefit of its employees. At August 31, 2016, the Section 125 checking account had a balance of \$201,936. The balance of unclaimed employee funds for the plan year as of August 31, 2016, was \$84,196. The \$117,740 remaining cash balance represents prior-year employee forfeitures.

NOTE M – CONSTRUCTION COMMITMENTS

At August 31, 2016, the District had the following commitments on construction projects:

<u>Description</u>	<u>Contractual Commitments</u>	Amount Paid on <u>Contracts</u> <u>as of 8/31/16</u>	<u>Remaining Commitment</u>	Expected Completion <u>Date</u>
Engleman building addition	\$ 2,651,491	\$ 2,646,491	\$ 5,000	December 2016
Barr architectural fees	284,100	255,690	28,410	November 2017
Barr building addition	11,937,250	4,754,297	7,182,953	November 2017
Barr asbestos abatement	73,000	40,000	33,000	November 2017
Shoemaker architectural fees	155,747	153,411	2,336	April 2017
Shoemaker building construction	6,420,644	6,074,541	346,103	April 2017
Starr precast concrete	189,460	170,514	18,946	August 2017
Starr architectural fees	845,308	760,787	84,521	August 2017
Starr building construction	16,585,643	9,351,189	7,234,454	August 2017
Starr engineering fees	311,087	264,424	46,663	August 2017
Starr landscaping & sprinklers	72,047	-	72,047	August 2017
Starr environmental controls	238,980	11,950	227,030	August 2017
Jefferson architectural fees	625,692	37,514	588,178	August 2019
Jefferson engineering fees	200,000	-	200,000	August 2019
Stolley Park architectural fees	672,155	388,700	283,455	August 2019
Stolley Park engineering fees	225,000	101,250	123,750	August 2019
Senior High architectural fees	158,237	137,137	21,100	December 2016
Senior High engineering fees	78,172	-	78,172	December 2016
Senior High building renovation	2,269,938	864,568	1,405,370	December 2016
	<u>\$ 43,993,951</u>	<u>\$ 26,012,463</u>	<u>\$ 17,981,488</u>	

/

**GRAND ISLAND PUBLIC SCHOOLS
GRAND ISLAND, NEBRASKA**

NOTES TO FINANCIAL STATEMENTS, Continued

August 31, 2016

NOTE N – CONTINGENCIES

The District is involved in pending lawsuits and claims on matters containing allegations relating to discrimination, personal injury, negligence and treatment of students. No provision has been made in the financial statements for any loss that might arise in the event of an unfavorable outcome of these matters. District management estimates that such litigation and claims will ultimately be resolved without material financial liability to the District in excess of applicable insurance coverage. However, events could occur in the near term that would change this estimate materially.

NOTE O – PLEDGES RECEIVABLE

For the year ended August 31, 2016, the component unit considered pledges receivable to be fully collectible; accordingly, no allowance for uncollectible pledges was recorded.

Pledges receivable activity for the year ended August 31, 2016, is as follows:

Pledges receivable at beginning of year	\$ 548,585
New pledges	103,285
Less: Collections	<u>(566,368)</u>
Pledges receivable at end of year	<u><u>\$ 85,502</u></u>

Pledges outstanding at August 31, 2016, are expected to be collected as follows:

Receivable in less than one year	\$ 55,628
Receivable in one to five years	<u>29,874</u>
	<u><u>\$ 85,502</u></u>

NOTE P – SUBSEQUENT EVENTS

Management has evaluated subsequent events through October 27, 2016, the date on which the financial statements were available for issue.

SUPPLEMENTARY AND OTHER INFORMATION

**GRAND ISLAND PUBLIC SCHOOLS
GRAND ISLAND, NEBRASKA**

**BUDGETARY COMPARISON SCHEDULE -
GENERAL FUND**

Year ended August 31, 2016

	Budget (Original and Final)	Actual	Variances - Actual Over (Under) Final Budget
RECEIPTS			
Taxes:			
Property	\$ 30,249,872	\$ 28,155,562	\$ (2,094,310)
Motor vehicle	3,500,000	3,362,686	(137,314)
Homestead exemption	-	1,106,050	1,106,050
Pro-rate motor vehicle	95,000	91,407	(3,593)
Carline	20,000	22,080	2,080
Property tax credit	-	1,197,706	1,197,706
Fines and licenses	910,000	988,589	78,589
ESU and other county receipts	10,000,000	-	(10,000,000)
State aid and grants	56,219,128	54,730,498	(1,488,630)
Federal grants	7,000,000	5,663,646	(1,336,354)
Interest	6,000	3,352	(2,648)
	-	10,000	10,000
Total receipts	108,000,000	95,331,576	(12,668,424)
EXPENDITURES			
Instructional services	75,110,000	67,265,920	(7,844,080)
Support services:			
Pupil	3,775,000	3,637,766	(137,234)
Instructional staff	4,100,000	2,800,978	(1,299,022)
General administration	1,665,000	1,653,830	(11,170)
School administration	4,100,000	4,118,464	18,464
Business	860,000	616,434	(243,566)
Building and grounds	10,000,000	7,808,942	(2,191,058)
Pupil transportation	585,000	518,030	(66,970)
Community services	10,000	-	(10,000)
State categorical grants	420,000	420,877	877
Federal programs	7,000,000	5,648,502	(1,351,498)
Summer school	75,000	66,797	(8,203)
Transfer to other funds	300,000	239,500	(60,500)
	108,000,000	94,796,040	(13,203,960)
Total expenditures	108,000,000	94,796,040	(13,203,960)
RECEIPTS OVER (UNDER) EXPENDITURES	\$ -	535,536	\$ 535,536
Fund balances - August 31, 2015		24,927,734	
Fund balances - August 31, 2016		\$ 25,463,270	

**GRAND ISLAND PUBLIC SCHOOLS
GRAND ISLAND, NEBRASKA**

**BUDGETARY COMPARISON SCHEDULE -
SPECIAL BUILDING FUND**

Year ended August 31, 2016

	Budget (Original and <u>Final</u>)	<u>Actual</u>	Variances - Actual Over (Under) Final <u>Budget</u>
RECEIPTS			
Taxes:			
Property	\$ 290,851	\$ 242,224	\$ (48,627)
Homestead exemption	-	10,635	10,635
Pro-rate motor vehicle	949	319	(630)
Carline	300	212	(88)
Property tax credit	-	11,516	11,516
Investment income (loss)	1,500	288,755	287,255
Other	<u>6,400</u>	<u>-</u>	<u>(6,400)</u>
Total receipts	300,000	553,661	253,661
EXPENDITURES			
Capital outlay	<u>50,000,000</u>	<u>21,679,202</u>	<u>(28,320,798)</u>
RECEIPTS OVER (UNDER) EXPENDITURES	<u>\$ (49,700,000)</u>	(21,125,541)	<u>\$ 28,574,459</u>
Fund balances - August 31, 2015		<u>48,466,730</u>	
Fund balances - August 31, 2016		<u>\$ 27,341,189</u>	

**GRAND ISLAND PUBLIC SCHOOLS
GRAND ISLAND, NEBRASKA**

**BUDGETARY COMPARISON SCHEDULE -
DEPRECIATION FUND**

Year ended August 31, 2016

	Budget (Original and <u>Final</u>)	<u>Actual</u>	Variances - Actual Over (Under) Final <u>Budget</u>
RECEIPTS			
Interest	\$ 3,000	\$ 1,119	\$ (1,881)
Transfer from General Fund	<u>250,000</u>	<u>1,000,000</u>	<u>750,000</u>
Total receipts	253,000	1,001,119	748,119
EXPENDITURES			
Capital outlay	<u>2,000,000</u>	<u>809,508</u>	<u>(1,190,492)</u>
RECEIPTS OVER (UNDER) EXPENDITURES	<u><u>\$ (1,747,000)</u></u>	191,611	<u><u>\$ 1,938,611</u></u>
Fund balances - August 31, 2015		<u>2,997,075</u>	
Fund balances - August 31, 2016		<u><u>\$ 3,188,686</u></u>	

**GRAND ISLAND PUBLIC SCHOOLS
GRAND ISLAND, NEBRASKA**

**BUDGETARY COMPARISON SCHEDULE -
QUALIFIED CAPITAL PURPOSE FUND**

Year ended August 31, 2016

	Budget (Original and <u>Final</u>)	<u>Actual</u>	Variances - Actual Over (Under) Final <u>Budget</u>
RECEIPTS			
Taxes:			
Property	\$ 501,462	\$ 478,973	\$ (22,489)
Homestead exemption	-	18,335	18,335
Pro-rate motor vehicle	-	1,643	1,643
Carline	1,000	366	(634)
Property tax credit	-	19,854	19,854
Interest	<u>2,538</u>	<u>147</u>	<u>(2,391)</u>
Total receipts	505,000	519,318	14,318
EXPENDITURES			
Capital outlay	31,865	-	(31,865)
Debt service:			
Principal	420,000	420,000	-
Interest	81,462	68,328	(13,134)
Other	<u>1,673</u>	<u>400</u>	<u>(1,273)</u>
Total expenditures	<u>535,000</u>	<u>488,728</u>	<u>(46,272)</u>
RECEIPTS OVER (UNDER) EXPENDITURES	<u>\$ (30,000)</u>	30,590	<u>\$ 60,590</u>
Fund balances - August 31, 2015		<u>392,581</u>	
Fund balances - August 31, 2016		<u>\$ 423,171</u>	

**GRAND ISLAND PUBLIC SCHOOLS
GRAND ISLAND, NEBRASKA**

**BUDGETARY COMPARISON SCHEDULE -
COOPERATIVE FUND**

Year ended August 31, 2016

	<u>Budget (Original)</u>	<u>Budget (Final)</u>	<u>Actual</u>	Variances - Actual Over (Under) Final <u>Budget</u>
RECEIPTS				
Tuition	\$ 15,320,000	\$ 15,820,000	\$ 14,635,357	\$ (1,184,643)
Federal grants	<u>2,500,000</u>	<u>2,500,000</u>	<u>1,792,318</u>	<u>(707,682)</u>
Total receipts	17,820,000	18,320,000	16,427,675	(1,892,325)
EXPENDITURES				
CNSSP Instruction	<u>18,000,000</u>	<u>18,500,000</u>	<u>16,447,536</u>	<u>(2,052,464)</u>
RECEIPTS OVER (UNDER) EXPENDITURES	<u>\$ (180,000)</u>	<u>\$ (180,000)</u>	(19,861)	<u>\$ 160,139</u>
Fund balances - August 31, 2015			<u>1,077,645</u>	
Fund balances - August 31, 2016			<u>\$ 1,057,784</u>	

**GRAND ISLAND PUBLIC SCHOOLS
GRAND ISLAND, NEBRASKA**

**BUDGETARY COMPARISON SCHEDULE -
BOND FUND**

Year ended August 31, 2016

	Budget <u>(Original)</u>	Budget <u>(Final)</u>	<u>Actual</u>	Variances - Actual Over (Under) Final <u>Budget</u>
RECEIPTS				
Taxes:				
Property	\$ 6,067,922	\$ 6,067,922	\$ 5,759,466	\$ (308,456)
Homestead exemption	-	-	226,335	226,335
Pro-rate motor vehicle	11,000	11,000	14,337	3,337
Carline	452	452	4,488	4,036
Property tax credit	-	-	238,075	238,075
Interest	<u>1,000</u>	<u>2,000</u>	<u>11,041</u>	<u>9,041</u>
Total receipts	6,080,374	6,081,374	6,253,742	172,368
EXPENDITURES				
Debt service:				
Principal	2,935,000	2,935,000	2,935,000	-
Interest	3,132,923	3,132,923	3,132,923	-
Other fees	<u>2,077</u>	<u>3,077</u>	<u>2,100</u>	<u>(977)</u>
Total expenditures	<u>6,070,000</u>	<u>6,071,000</u>	<u>6,070,023</u>	<u>(977)</u>
RECEIPTS OVER (UNDER)				
EXPENDITURES	<u>\$ 10,374</u>	<u>\$ 10,374</u>	183,719	<u>\$ 173,345</u>
Fund balances - August 31, 2015			<u>6,484,838</u>	
Fund balances - August 31, 2016			<u>\$ 6,668,557</u>	

**GRAND ISLAND PUBLIC SCHOOLS
GRAND ISLAND, NEBRASKA**

**COMBINED BALANCE SHEET - OTHER GOVERNMENTAL FUNDS -
MODIFIED CASH BASIS**

August 31, 2016

	<u>Contingency Fund</u>	<u>Employee Benefit Fund</u>	<u>Total</u>
ASSETS			
Cash and investments	<u>\$ 1,015,236</u>	<u>\$ 2,962,662</u>	<u>\$ 3,977,898</u>
FUND BALANCES			
Assigned for:			
Employee benefits	\$ -	\$ 2,962,662	\$ 2,962,662
Contingencies	<u>1,015,236</u>	<u>-</u>	<u>1,015,236</u>
Total fund balances	<u>\$ 1,015,236</u>	<u>\$ 2,962,662</u>	<u>\$ 3,977,898</u>

**GRAND ISLAND PUBLIC SCHOOLS
GRAND ISLAND, NEBRASKA**

**COMBINED STATEMENT OF RECEIPTS, DISBURSEMENTS, AND
CHANGES IN FUND BALANCES - OTHER GOVERNMENTAL FUNDS -
MODIFIED CASH BASIS**

For the year ended August 31, 2016

	<u>Contingency Fund</u>	<u>Employee Benefit Fund</u>	<u>Total</u>
RECEIPTS			
Interest on investments	\$ 6,039	\$ 16,394	\$ 22,433
DISBURSEMENTS			
Unemployment benefits	-	9,185	9,185
RECEIPTS OVER DISBURSEMENTS	6,039	7,209	13,248
Fund balances - August 31, 2015	1,009,197	2,955,453	3,964,650
Fund balances - August 31, 2016	<u>\$ 1,015,236</u>	<u>\$ 2,962,662</u>	<u>\$ 3,977,898</u>

**GRAND ISLAND PUBLIC SCHOOLS
GRAND ISLAND, NEBRASKA
STATEMENT OF CASH RECEIPTS, DISBURSEMENTS, AND FUND BALANCE -
FIDUCIARY FUNDS - ACTIVITY FUND**

Year ended August 31, 2016

	Beginning <u>Balance</u>	Receipts and <u>Transfers In</u>	Disbursements and <u>Transfers Out</u>	Ending <u>Balance</u>
0000 Nondepartmental				
Assistant Superintendent:				
Central Nebraska Health Department Grant	\$ 109	\$ -	\$ 109	\$ -
Executive Director of Information Technology:				
Sale and Purchase of Computers	41,660	14,725	7,296	49,089
iPad Service Contracts and Repairs	55,498	55,193	37,304	73,387
Executive Director of Business:				
Developmental League	10,000	7,800	7,800	10,000
Total Nondepartmental	<u>\$ 107,267</u>	<u>\$ 77,718</u>	<u>\$ 52,509</u>	<u>\$ 132,476</u>
0916 Administration:				
Assistant Superintendent - Curriculum:				
CCC - AP Courses	\$ 123,862	\$ 54,405	\$ 45,631	\$ 132,636
General	-	9,017	6,026	2,991
Homeless - Supplies	85	-	85	-
Parent Navigator	-	11,790	3,260	8,530
Textbook replacement	1,287	-	1,287	-
Assistant Superintendent - Student Services:				
5K Run/Walk	5,665	15,492	10,673	10,484
ILP - Special Education Senior	3,519	1,232	4,751	-
Courtesy	740	-	-	740
General	28,321	480	4,103	24,698
GIMC - Emergency Relief	1,367	-	-	1,367
Multicultural Club	200	-	-	200
Wal-Mart Grant	99	-	-	99
Classroom Mini Grants	159	12,400	12,400	159
Daugherty Grant	(7,249)	195,000	184,294	3,457
Director - Business:				
General	334,053	274,414	129,414	479,053
Theater tickets	104	-	104	-
Total Administration	<u>\$ 492,212</u>	<u>\$ 574,230</u>	<u>\$ 402,028</u>	<u>\$ 664,414</u>
0918 CNSSP:				
Assistant Superintendent:				
Circle of Friends	\$ -	\$ 4,000	\$ 2,966	\$ 1,034
Director - Student Services:				
Baasch Trust	16,615	-	-	16,615
Patty Lundeen Galraith Fund	66	-	-	66
Transitional living program	1,630	-	-	1,630
Courtesy	621	681	681	621
Special projects	7,962	1,150	-	9,112
Suicide Prevention Project	5,849	2,555	-	8,404
Total CNSSP	<u>\$ 32,743</u>	<u>\$ 8,386</u>	<u>\$ 3,647</u>	<u>\$ 37,482</u>
0926 Early Learning Center:				
Building Principal:				
Courtesy	\$ 300	\$ 4,833	\$ 4,607	\$ 526
General	1,225	1,199	1,199	1,225
Grant - NDE	-	-	2,042	(2,042)
Total Early Learning Center	<u>\$ 1,525</u>	<u>\$ 6,032</u>	<u>\$ 7,848</u>	<u>\$ (291)</u>

**GRAND ISLAND PUBLIC SCHOOLS
GRAND ISLAND, NEBRASKA**

**STATEMENT OF CASH RECEIPTS, DISBURSEMENTS, AND FUND BALANCE -
FIDUCIARY FUNDS - ACTIVITY FUND, Continued**

Year ended August 31, 2016

	Beginning <u>Balance</u>	Receipts and <u>Transfers In</u>	Disbursements and <u>Transfers Out</u>	Ending <u>Balance</u>
<u>1903 Newell Elementary:</u>				
Building Principal:				
Courtesy	\$ 1,494	\$ 858	\$ 1,058	\$ 1,294
General	9,164	21,822	19,035	11,951
PTA or PTO	-	639	639	-
Student Council	1,347	958	1,097	1,208
Total Newell Elementary	<u>\$ 12,005</u>	<u>\$ 24,277</u>	<u>\$ 21,829</u>	<u>\$ 14,453</u>
<u>1904 Gates Elementary:</u>				
Building Principal:				
Courtesy	\$ 1,470	\$ 40	\$ 40	\$ 1,470
General	2,034	5,214	5,713	1,535
Student Council	2,327	1,071	1,061	2,337
Total Gates Elementary	<u>\$ 5,831</u>	<u>\$ 6,325</u>	<u>\$ 6,814</u>	<u>\$ 5,342</u>
<u>1905 Dodge Elementary:</u>				
Building Principal:				
Facility rental	\$ 25	\$ -	\$ -	\$ 25
General	8,775	5,637	8,183	6,229
MCREL ELA project	2,176	-	-	2,176
PTA or PTO	760	4,924	-	5,684
Student Council	1,405	-	752	653
Total Dodge Elementary	<u>\$ 13,141</u>	<u>\$ 10,561</u>	<u>\$ 8,935</u>	<u>\$ 14,767</u>
<u>1906 Starr Elementary:</u>				
Building Principal:				
Character Education	\$ 767	\$ 510	\$ 235	\$ 1,042
Courtesy	22	-	-	22
General	45,522	8,171	6,405	47,288
PTA	155	335	-	490
Total Starr Elementary	<u>\$ 46,466</u>	<u>\$ 9,016</u>	<u>\$ 6,640</u>	<u>\$ 48,842</u>
<u>1907 Howard Elementary:</u>				
Building Principal:				
Action for Healthy Kids	\$ 162	\$ -	\$ -	\$ 162
Grade 4	317	-	-	317
Courtesy	883	-	-	883
Facility rental	2,652	-	-	2,652
General	5,001	8,412	6,131	7,282
Lounge	89	-	-	89
PTA or PTO	4,173	161	114	4,220
Popcorn sales	59	-	-	59
Student Council	206	-	147	59
Dollar General Literacy Foundation Grant	2,619	1,214	1,009	2,824
Total Howard Elementary	<u>\$ 16,161</u>	<u>\$ 9,787</u>	<u>\$ 7,401</u>	<u>\$ 18,547</u>

**GRAND ISLAND PUBLIC SCHOOLS
GRAND ISLAND, NEBRASKA**

**STATEMENT OF CASH RECEIPTS, DISBURSEMENTS, AND FUND BALANCE -
FIDUCIARY FUNDS - ACTIVITY FUND, Continued**

Year ended August 31, 2016

	Beginning <u>Balance</u>	Receipts and <u>Transfers In</u>	Disbursements and <u>Transfers Out</u>	Ending <u>Balance</u>
<u>1908 Jefferson Elementary:</u>				
Building Principal:				
Books	\$ 2,642	\$ -	\$ -	\$ 2,642
Facility rental	151	-	-	151
General	8,367	59	469	7,957
Grade 4	1,507	-	-	1,507
Lounge	245	-	-	245
PTA or PTO	8,568	-	-	8,568
Moonshell Arts Grant	59	-	59	-
Total Jefferson Elementary	<u>\$ 21,539</u>	<u>\$ 59</u>	<u>\$ 528</u>	<u>\$ 21,070</u>
<u>1909 Knickrehm Elementary:</u>				
Building Principal:				
Courtesy	\$ 788	\$ 85	\$ 313	\$ 560
Garden Club	243	-	13	230
General	6,989	3,193	5,145	5,037
PTA or PTO	16	-	-	16
Student Council	1,660	3,240	4,215	685
Total Knickrehm Elementary	<u>\$ 9,696</u>	<u>\$ 6,518</u>	<u>\$ 9,686</u>	<u>\$ 6,528</u>
<u>1910 Lincoln Elementary:</u>				
Building Principal:				
Class pictures	\$ 809	\$ -	\$ -	\$ 809
Courtesy	282	-	61	221
Field trips	16	-	16	-
General	2,199	6,929	7,767	1,361
Student Council	1,816	281	695	1,402
Total Lincoln Elementary	<u>\$ 5,122</u>	<u>\$ 7,210</u>	<u>\$ 8,539</u>	<u>\$ 3,793</u>
<u>1911 Seedling Mile Elementary:</u>				
Building Principal:				
Courtesy	\$ 13	\$ -	\$ -	\$ 13
Facility rental	417	-	-	417
General	5,743	211	527	5,427
PTA or PTO	15,647	17,947	20,047	13,547
Student Council	7	256	263	-
Total Seedling Mile Elementary	<u>\$ 21,827</u>	<u>\$ 18,414</u>	<u>\$ 20,837</u>	<u>\$ 19,404</u>
<u>1912 Stolley Park Elementary:</u>				
Building Principal:				
Character Education	\$ 210	\$ -	\$ 137	\$ 73
Facility rental	1,134	-	-	1,134
General	8,280	3,390	2,833	8,837
Library/media	7	235	242	-
Total Stolley Park Elementary	<u>\$ 9,631</u>	<u>\$ 3,625</u>	<u>\$ 3,212</u>	<u>\$ 10,044</u>

**GRAND ISLAND PUBLIC SCHOOLS
GRAND ISLAND, NEBRASKA**

**STATEMENT OF CASH RECEIPTS, DISBURSEMENTS, AND FUND BALANCE -
FIDUCIARY FUNDS - ACTIVITY FUND, Continued**

Year ended August 31, 2016

	Beginning <u>Balance</u>	Receipts and <u>Transfers In</u>	Disbursements and <u>Transfers Out</u>	Ending <u>Balance</u>
<u>1914 Wasmer Elementary:</u>				
Building Principal:				
Courtesy	\$ 566	\$ -	\$ 4	\$ 562
General	2,817	14,657	8,968	8,506
MCREL ELA project	4,262	-	-	4,262
Grant - AAA	1	-	1	-
Total Wasmer Elementary	<u>\$ 7,646</u>	<u>\$ 14,657</u>	<u>\$ 8,973</u>	<u>\$ 13,330</u>
<u>1915 West Lawn Elementary:</u>				
Building Principal:				
Adopt-A-School	\$ 3,635	\$ -	\$ 12	\$ 3,623
Character education	770	2,737	51	3,456
Courtesy	129	-	103	26
Facility rental	33	-	33	-
General	6,843	2,079	1,999	6,923
Math Fact Success	-	492	492	-
Museum Madness	-	4,258	2,258	2,000
PTA/PTO/PAB	3,695	19,678	18,785	4,588
HAL playground project	90	-	90	-
Popcorn sales	736	424	35	1,125
Total West Lawn Elementary	<u>\$ 15,931</u>	<u>\$ 29,668</u>	<u>\$ 23,858</u>	<u>\$ 21,741</u>
<u>1923 Shoemaker Elementary:</u>				
Building Principal:				
Grade 4	\$ 263	\$ 76	\$ 339	\$ -
Grade 5	98	-	-	98
Courtesy	538	-	101	437
Facility rental	4,520	-	-	4,520
General	2,813	12,317	7,140	7,990
PTA or PTO	7,922	21,942	20,148	9,716
Total Shoemaker Elementary	<u>\$ 16,154</u>	<u>\$ 34,335</u>	<u>\$ 27,728</u>	<u>\$ 22,761</u>
<u>1924 Engleman Elementary:</u>				
Building Principal:				
Character Education	\$ -	\$ 591	\$ -	\$ 591
Courtesy	-	193	82	111
General	4,591	1,234	1,032	4,793
Total Engleman Elementary	<u>\$ 4,591</u>	<u>\$ 2,018</u>	<u>\$ 1,114</u>	<u>\$ 5,495</u>

**GRAND ISLAND PUBLIC SCHOOLS
GRAND ISLAND, NEBRASKA**

**STATEMENT OF CASH RECEIPTS, DISBURSEMENTS, AND FUND BALANCE -
FIDUCIARY FUNDS - ACTIVITY FUND, Continued**

Year ended August 31, 2016

	<u>Beginning Balance</u>	<u>Receipts and Transfers In</u>	<u>Disbursements and Transfers Out</u>	<u>Ending Balance</u>
<u>5900 Senior High:</u>				
Building Principal:				
Embroidery class projects	\$ 1,813	\$ -	\$ 504	\$ 1,309
Facility rental	18,307	17,859	35,166	1,000
Fellowship of Christian Athletes	300	-	-	300
Fines	27,076	14,417	1,795	39,698
Friends of Rachel	517	-	-	517
General	5,016	1,954	5,126	1,844
Groundwater Festival	219	-	-	219
Hulagan's	233	-	-	233
Planner	14,877	1,896	16,773	-
Pop	1,605	263	-	1,868
GISH Staff Project	2,411	2,032	1,172	3,271
Iams Company Grant	1,000	-	-	1,000
Grant - \$50 to Fail	-	2,621	650	1,971
Gay-Straight Alliance	409	-	-	409
Total Building Principal	73,783	41,042	61,186	53,639
Activities Director:				
Art Department - Fees	-	1,852	1,164	688
Astronomy Club	129	-	-	129
Band	37	24,770	24,807	-
Cheerleaders	620	56,682	57,302	-
Cheerleaders - clinic	1,354	10,562	11,916	-
Class of Seniors	50	15,434	15,484	-
Counseling Dept.	2,217	126	-	2,343
Courtesy	15	50	65	-
Culinary Arts	117	-	-	117
Debate	219	200	166	253
Drama	11	4,265	2,991	1,285
FBLA	500	-	500	-
Faculty study	3	-	3	-
Foreign language	3	-	3	-
General	3,155	-	3,155	-

**GRAND ISLAND PUBLIC SCHOOLS
GRAND ISLAND, NEBRASKA**

**STATEMENT OF CASH RECEIPTS, DISBURSEMENTS, AND FUND BALANCE -
FIDUCIARY FUNDS - ACTIVITY FUND, Continued**

Year ended August 31, 2016

	<u>Beginning Balance</u>	<u>Receipts and Transfers In</u>	<u>Disbursements and Transfers Out</u>	<u>Ending Balance</u>
<u>5900 Senior High, continued:</u>				
Activities Director, continued:				
Ind. Tech Lab	628	-	-	628
International Club	10	-	10	-
Islander	224	31,108	31,332	-
Islander wrestling	76	14,697	14,773	-
JROTC	4,606	5,329	3,129	6,806
JROTC - Clinic	7,230	4,232	7,281	4,181
Key Club	94	190	284	-
Library/media	2,894	234	-	3,128
European Explorers	4,983	2,261	7,244	-
Math Fund	3	-	3	-
Multicultural Club	204	-	-	204
National Honor Society	406	154	560	-
NSAA	26,911	59,597	61,134	25,374
One-act plays	1,500	1,500	-	3,000
Orchestra	1,403	4,457	5,008	852
Physical education	6,339	5,211	11,550	-
Robotics	29	1,525	1,554	-
SADD	462	1,183	108	1,537
Science	44	290	236	98
Speech	927	12,023	10,981	1,969
Spirit Set	12,682	20,670	22,765	10,587
Spring musical	89	47,239	47,328	-
Student Council	7,797	15,007	16,283	6,521
Telephone	1	-	1	-
Testing	1,624	540	717	1,447
Trap team	56	-	56	-
Vocal music	2,171	1,006	909	2,268
Vocal - Show Choir	68	19,884	19,952	-
Vocational	161	-	-	161
Gay-Straight Alliance	4,126	-	-	4,126
Athletics	3,347	172,497	156,385	19,459
Weight program	50	241	291	-

**GRAND ISLAND PUBLIC SCHOOLS
GRAND ISLAND, NEBRASKA**

**STATEMENT OF CASH RECEIPTS, DISBURSEMENTS, AND FUND BALANCE -
FIDUCIARY FUNDS - ACTIVITY FUND, Continued**

Year ended August 31, 2016

	<u>Beginning Balance</u>	<u>Receipts and Transfers In</u>	<u>Disbursements and Transfers Out</u>	<u>Ending Balance</u>
<u>5900 Senior High, continued:</u>				
Activities Director, continued:				
Summer clinic - boys BB	2,056	24,620	22,741	3,935
Summer clinic - girls BB	3,871	12,006	14,743	1,134
Summer clinic - volleyball	6,027	17,714	8,808	14,933
Summer clinic - football	20,035	53,986	42,170	31,851
Senior High soccer clinic	7,435	14,971	21,896	510
Softball clinic	574	15,660	10,940	5,294
Summer clinic - track	75	4,423	4,498	-
Summer clinic - swimming	176	10,377	9,200	1,353
Summer clinic - tennis	4,178	283	2,759	1,702
Summer clinic - boys soccer	32	9,082	9,114	-
Cross country	96	6,523	6,433	186
Cross country clinic	640	909	582	967
Youth football	13,157	10,635	9,531	14,261
Football	947	38,743	36,874	2,816
Baseball	86	57,395	57,481	-
Golf clinic - boys & girls	57	1,486	-	1,543
Golf - girls	11	6,933	6,944	-
Softball	47	15,125	15,172	-
Tennis - boys	38	5,424	5,462	-
Volleyball	90	12,739	12,829	-
Wrestling	334	50,894	51,228	-
Basketball - boys	84	15,763	14,020	1,827
Basketball - girls	184	15,914	12,247	3,851
Basketball - intramural - boys	2,148	1,000	154	2,994
Swimming	1,323	13,230	14,553	-
Track	22	30,334	30,356	-
Golf - boys	82	7,994	8,076	-
Tennis - girls	75	8,088	8,163	-
Soccer	95	14,968	15,063	-
Total Activities Director	<u>163,550</u>	<u>1,012,235</u>	<u>989,467</u>	<u>186,318</u>
Total Senior High	<u>\$ 237,333</u>	<u>\$ 1,053,277</u>	<u>\$ 1,050,653</u>	<u>\$ 239,957</u>

**GRAND ISLAND PUBLIC SCHOOLS
GRAND ISLAND, NEBRASKA**

**STATEMENT OF CASH RECEIPTS, DISBURSEMENTS, AND FUND BALANCE -
FIDUCIARY FUNDS - ACTIVITY FUND, Continued**

Year ended August 31, 2016

	Beginning <u>Balance</u>	Receipts and <u>Transfers In</u>	Disbursements and <u>Transfers Out</u>	Ending <u>Balance</u>
<u>5901 Barr Middle School:</u>				
Building Principal:				
Art	\$ 236	\$ -	\$ -	\$ 236
Band	589	465	65	989
6th Grade	9,534	-	-	9,534
7th Grade	772	50	-	822
8th Grade	2,024	6,844	4,924	3,944
Concessions	22	7,158	6,373	807
Courtesy	356	-	273	83
Exploratory - Purple	302	-	-	302
Drama	1,697	-	-	1,697
Equipment and Facility Rental	-	481	-	481
Fundraiser	342	-	-	342
General	13,607	790	984	13,413
Hulas - Student Store	102	-	-	102
Library/media	340	4,415	3,232	1,523
Physical education	71	-	-	71
Student Council	2,313	843	1,250	1,906
Vocal Music	1,180	10,013	8,939	2,254
Washington D.C. trip	1,659	1,365	1,691	1,333
Athletics	13,062	57,201	66,247	4,016
Total Barr Middle School	<u>\$ 48,208</u>	<u>\$ 89,625</u>	<u>\$ 93,978</u>	<u>\$ 43,855</u>

**GRAND ISLAND PUBLIC SCHOOLS
GRAND ISLAND, NEBRASKA**

**STATEMENT OF CASH RECEIPTS, DISBURSEMENTS, AND FUND BALANCE -
FIDUCIARY FUNDS - ACTIVITY FUND, Continued**

Year ended August 31, 2016

	<u>Beginning Balance</u>	<u>Receipts and Transfers In</u>	<u>Disbursements and Transfers Out</u>	<u>Ending Balance</u>
<u>5902 Walnut Middle School:</u>				
Building Principal:				
Art	\$ 6,651	\$ 185	\$ -	\$ 6,836
Band	2,922	-	-	2,922
Character Education	27	-	3	24
Team 6A	1,920	3,479	2,526	2,873
Team 6B	4	809	813	-
Team 6C	280	-	82	198
Team 7A	1,338	1,413	1,445	1,306
Team 7B	657	558	564	651
Team 8A	560	2,248	2,220	588
Team 8B	11	324	335	-
Concessions	1,462	18,157	6,719	12,900
Courtesy	194	1,074	1,268	-
Facility rental	356	50	-	406
Future Fisherman Grant	2,301	-	692	1,609
Fundraiser	8,494	-	1,225	7,269
General	29,087	19,744	20,838	27,993
Home Economics	7,451	988	866	7,573
Library/media	853	1,843	1,111	1,585
Memory	6,184	3,833	4,145	5,872
Newcomers	1,425	1,313	797	1,941
Orchestra	4,296	2,731	1,673	5,354
PTA/PTO/PAB	689	38	23	704
Physical education	17,676	893	1,984	16,585
Financial literacy	1,500	3,495	4,318	677
Southard Grant	1,562	3,500	3,951	1,111
Staff inservice	579	-	14	565
Vocal music	8,742	1,116	1,988	7,870
Washington D.C. trip	2,921	22,056	24,977	-
Fuel Up to Play 60 Grant	89	-	89	-
Grant - Wells Fargo	1,855	-	444	1,411
Athletics	888	63,768	61,091	3,565
Total Walnut Middle School	<u>\$ 112,974</u>	<u>\$ 153,615</u>	<u>\$ 146,201</u>	<u>\$ 120,388</u>

**GRAND ISLAND PUBLIC SCHOOLS
GRAND ISLAND, NEBRASKA**

**STATEMENT OF CASH RECEIPTS, DISBURSEMENTS, AND FUND BALANCE -
FIDUCIARY FUNDS - ACTIVITY FUND, Continued**

Year ended August 31, 2016

	Beginning <u>Balance</u>	Receipts and <u>Transfers In</u>	Disbursements and <u>Transfers Out</u>	Ending <u>Balance</u>
<u>5925 Westridge Middle School:</u>				
Building Principal:				
Character education	\$ 205	\$ -	\$ 1	\$ 204
Concessions	6,106	13,861	6,444	13,523
Courtesy	189	428	405	212
Facility rental	1,476	618	-	2,094
General	875	14,956	13,425	2,406
Grade 6	555	1,604	1,801	358
Grade 7	1,497	1,077	2,092	482
Grade 8	1,525	3,052	3,442	1,135
Hula's - Student Store	56	202	-	258
Memory Book	3,400	9,315	3,538	9,177
Music	-	3,819	3,055	764
Washington D.C. trip	360	795	1,155	-
Athletics	6,452	51,927	44,776	13,603
Total Westridge Middle School	<u>\$ 22,696</u>	<u>\$ 101,654</u>	<u>\$ 80,134</u>	<u>\$ 44,216</u>
<u>5930 - Career Pathways Institute:</u>				
Building Principal:				
CCC Equipment Fund	\$ -	\$ 13,516	\$ -	\$ 13,516
Construction Project	16,623	236,788	210,748	42,663
FBLA	248	7,056	6,753	551
Fundraising	846	557	1,403	-
General	2,400	309	2,380	329
Family & Consumer Science	4,588	-	-	4,588
Medical Pathways - HOSA	40	2,122	2,162	-
Skills U.S.A.	355	19,270	19,625	-
Automotive	4,063	-	-	4,063
Manufacturing	3,041	-	-	3,041
Construction	1,404	145	118	1,431
Total Career Pathways Institute	<u>\$ 33,608</u>	<u>\$ 279,763</u>	<u>\$ 243,189</u>	<u>\$ 70,182</u>
<u>5940 - Success Academy:</u>				
Building Principal:				
General	<u>\$ -</u>	<u>\$ 2,905</u>	<u>\$ 1,905</u>	<u>\$ 1,000</u>
TOTAL ACTIVITY FUND	<u>\$ 1,294,307</u>	<u>\$ 2,523,675</u>	<u>\$ 2,238,186</u>	<u>\$ 1,579,796</u>

**GRAND ISLAND PUBLIC SCHOOLS
GRAND ISLAND, NEBRASKA**

**STATEMENT OF CASH RECEIPTS, DISBURSEMENTS, AND FUND BALANCE -
FIDUCIARY FUNDS - STUDENT FEES FUND**

Year ended August 31, 2016

	<u>Beginning Balance</u>	<u>Receipts and Transfers In</u>	<u>Disbursements and Transfers Out</u>	<u>Ending Balance</u>
<u>Extracurricular:</u>				
5900 Senior High - Extracurricular Activities	\$ 24,571	\$ 2,105	\$ 26,676	\$ -
5901 Barr Middle School	5,758	25	5,783	-
5902 Walnut Middle School	4,337	125	4,462	-
5925 Westridge Middle School	<u>10,064</u>	<u>-</u>	<u>10,064</u>	<u>-</u>
Total Student Fees	<u>\$ 44,730</u>	<u>\$ 2,255</u>	<u>\$ 46,985</u>	<u>\$ -</u>

**GRAND ISLAND PUBLIC SCHOOLS
GRAND ISLAND, NEBRASKA**

**STATEMENT OF ACCOUNTS WITH COUNTY TREASURERS -
HALL AND MERRICK COUNTY TREASURERS**

**Year ended August 31, 2016
(Unaudited)**

	General <u>Fund</u>	Bond <u>Fund</u>	Building <u>Fund</u>	Qualified Capital Purpose <u>Fund</u>
Balance - August 31, 2015	\$ 7,940,628	\$ 1,733,132	\$ 4,503	\$ 157,318
Receipts:				
Property taxes	28,365,520	5,804,871	244,625	482,624
Motor vehicle tax	3,362,686	-	-	-
Homestead allocation	1,106,050	226,335	10,635	18,335
Pro-rate motor vehicle	91,407	14,337	319	1,643
In-lieu-of tax	15,268	3,011	143	245
Interest	64,375	14,415	118	1,324
Carline	22,080	4,488	212	366
Motor vehicle rental surcharge	17,824	-	-	-
Property tax credit	<u>1,197,706</u>	<u>238,075</u>	<u>11,516</u>	<u>19,854</u>
Total receipts	<u>34,242,916</u>	<u>6,305,532</u>	<u>267,568</u>	<u>524,391</u>
Total to be accounted for	42,183,544	8,038,664	272,071	681,709
Disbursements:				
To School District	33,169,975	6,300,203	189,118	537,512
Treasurers' fees	<u>307,426</u>	<u>62,832</u>	<u>2,662</u>	<u>5,220</u>
Total disbursements	<u>33,477,401</u>	<u>6,363,035</u>	<u>191,780</u>	<u>542,732</u>
Balance - August 31, 2016	<u><u>\$ 8,706,143</u></u>	<u><u>\$ 1,675,629</u></u>	<u><u>\$ 80,291</u></u>	<u><u>\$ 138,977</u></u>

**GRAND ISLAND PUBLIC SCHOOLS
GRAND ISLAND, NEBRASKA**

COMPARATIVE STATISTICAL DATA FROM ANNUAL FINANCIAL REPORTS

**For the years ended August 31, 2016 - 2007
(Unaudited)**

	<u>2016</u>	<u>2015</u>	<u>2014</u>	<u>2013</u>
Assessed Value of School District	\$ 2,938,020,328	\$ 2,763,011,452	\$ 2,669,698,545	\$ 2,609,831,071
Current Property Tax				
Budgeted - General Fund	\$ 30,555,426	\$ 28,735,319	\$ 27,764,878	\$ 27,142,256
Average Daily Attendance (ADA)	8,644	8,457	8,325	8,229
Average Daily Membership (ADM)	9,129	8,959	8,783	8,613
Total Value of Plant and Contents	\$ 350,000,000	\$ 338,000,000	\$ 331,400,000	\$ 320,000,000
Annual Depreciation of Plant and Contents (3% of Value)	\$ 10,500,000	\$ 10,140,000	\$ 9,942,000	\$ 9,600,000
Total Adjusted Current Expense	<u>88,016,770</u>	<u>83,011,060</u>	<u>82,668,629</u>	<u>78,091,496</u>
Total Annual Cost	\$ 98,516,770	\$ 93,151,060	\$ 92,610,629	\$ 87,691,496
Annual Cost Per Pupil - ADA	\$ 11,398	\$ 11,015	\$ 11,124	\$ 10,656
Annual Cost Per Pupil - ADM	\$ 10,791	\$ 10,398	\$ 10,545	\$ 10,181

MISCELLANEOUS DATA - At Annual Cost Per Pupil (ADM)

RECEIPTS

Local	\$ 3,456	\$ 3,346	\$ 3,246	\$ 3,477
County	108	99	98	93
State	6,258	5,963	5,969	6,140
Federal	620	527	577	850
Other	<u>-</u>	<u>-</u>	<u>-</u>	<u>-</u>
Total Receipts for Year	10,442	9,935	9,890	10,560

EXPENDITURES

Instruction	7,368	6,829	6,936	6,631
Support Services	705	768	751	756
Administration	700	695	676	663
Operation and Maintenance of Plant	855	959	1,246	1,369
Pupil Transportation	57	55	57	58
State/Federal/Other	<u>698</u>	<u>700</u>	<u>740</u>	<u>849</u>
Total Expenditures for Year	<u>10,383</u>	<u>10,006</u>	<u>10,406</u>	<u>10,326</u>

RECEIPTS OVER (UNDER)

EXPENDITURES PAID	<u>\$ 59</u>	<u>\$ (71)</u>	<u>\$ (516)</u>	<u>\$ 234</u>
--------------------------	--------------	----------------	-----------------	---------------

<u>2012</u>	<u>2011</u>	<u>2010</u>	<u>2009</u>	<u>2008</u>	<u>2007</u>
\$ 2,550,512,664	\$ 2,486,056,518	\$ 2,440,165,438	\$ 2,373,367,840	\$ 2,301,668,487	\$ 2,272,247,311
\$ 26,525,344	\$ 24,860,565	\$ 24,401,650	\$ 23,733,678	\$ 21,750,778	\$ 21,472,738
8,139	8,014	7,962	7,732	7,440	7,279
8,489	8,407	8,368	8,140	7,869	7,705
\$ 300,000,000	\$ 290,600,000	\$ 280,000,000	\$ 265,500,000	\$ 228,956,290	\$ 228,956,000
\$ 9,000,000	\$ 8,718,000	\$ 8,400,000	\$ 7,965,000	\$ 6,868,689	\$ 6,868,680
75,716,339	66,545,710	67,998,067	68,938,142	60,197,822	55,246,013
\$ 84,716,339	\$ 75,263,710	\$ 76,398,067	\$ 76,903,142	\$ 67,066,511	\$ 62,114,693
\$ 10,409	\$ 9,391	\$ 9,595	\$ 9,947	\$ 9,014	\$ 8,533
\$ 9,979	\$ 8,953	\$ 9,130	\$ 9,448	\$ 8,523	\$ 8,062
\$ 3,373	\$ 3,143	\$ 3,253	\$ 3,169	\$ 3,046	\$ 3,109
125	94	89	97	92	110
6,018	5,840	5,467	5,455	5,033	4,732
1,129	1,817	1,427	650	854	837
-	-	2	94	1	-
10,645	10,894	10,238	9,465	9,026	8,788
6,833	5,660	5,945	6,343	5,769	5,335
705	711	682	706	708	730
689	750	720	711	686	689
1,273	885	870	930	856	709
54	47	46	39	35	33
883	2,417	1,869	878	944	873
10,437	10,470	10,132	9,607	8,998	8,369
\$ 208	\$ 424	\$ 106	\$ (142)	\$ 28	\$ 419

**GRAND ISLAND PUBLIC SCHOOLS
GENERAL FUND RECEIPTS
Years Ended August 31,**

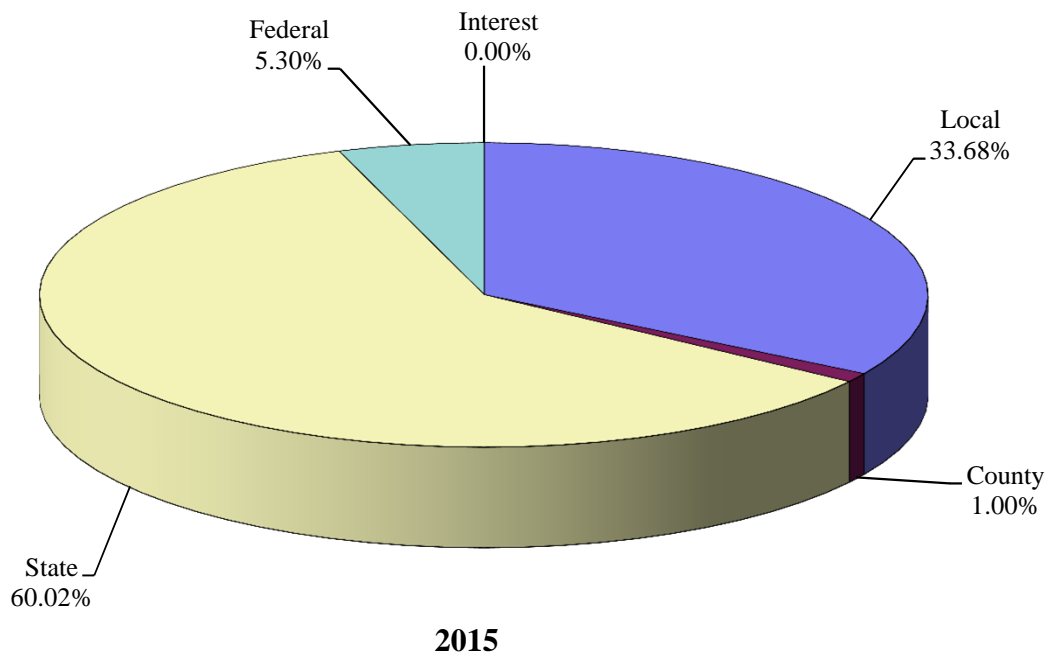
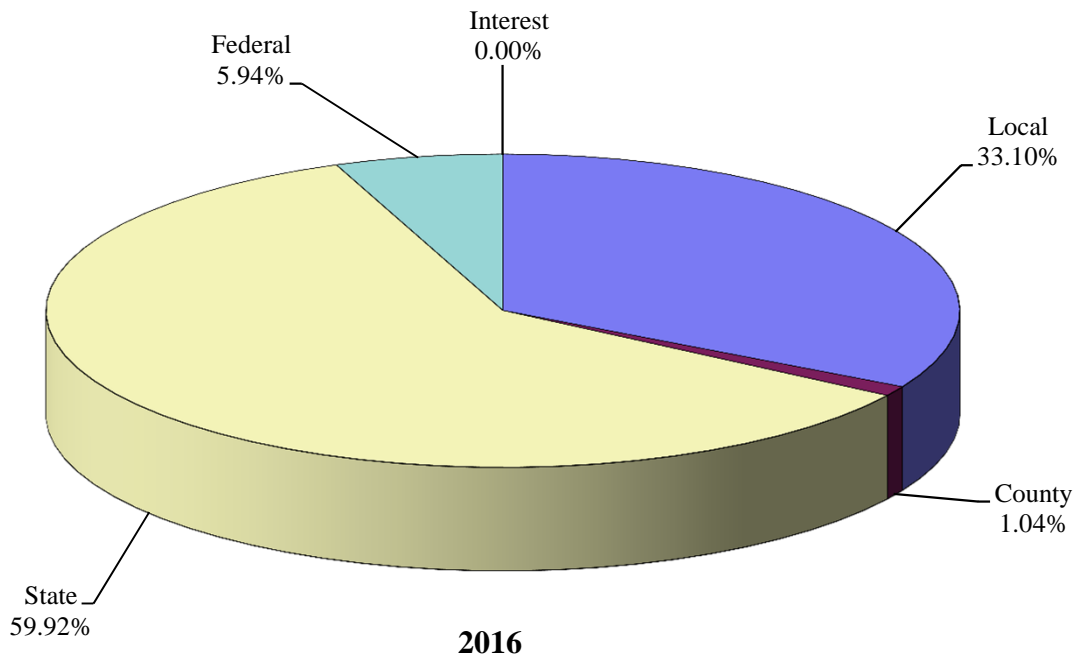

**GRAND ISLAND PUBLIC SCHOOLS
GENERAL FUND EXPENDITURES
Years Ended August 31,**

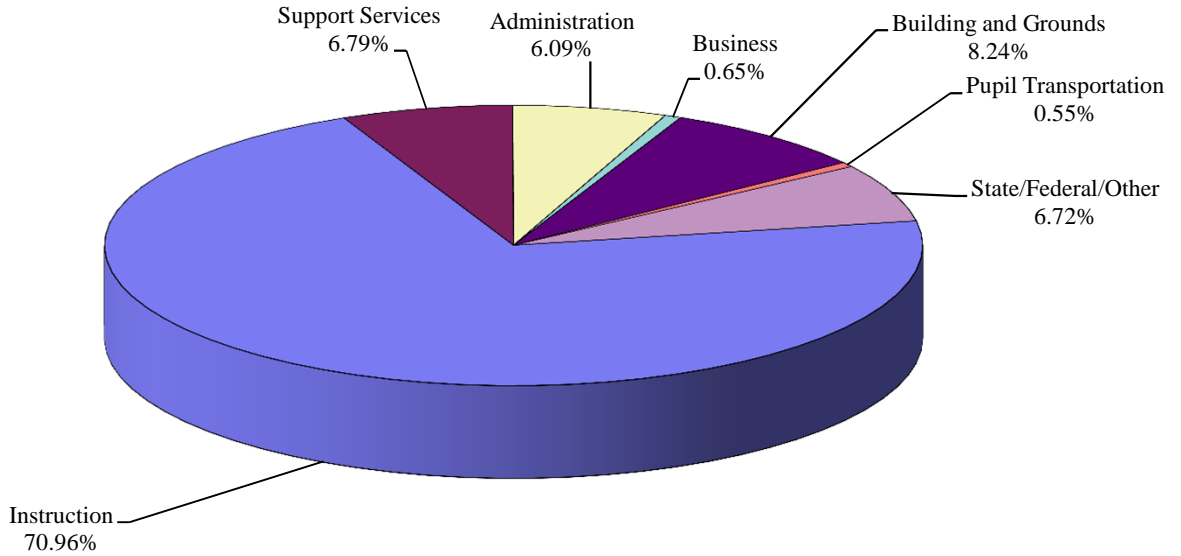

2016

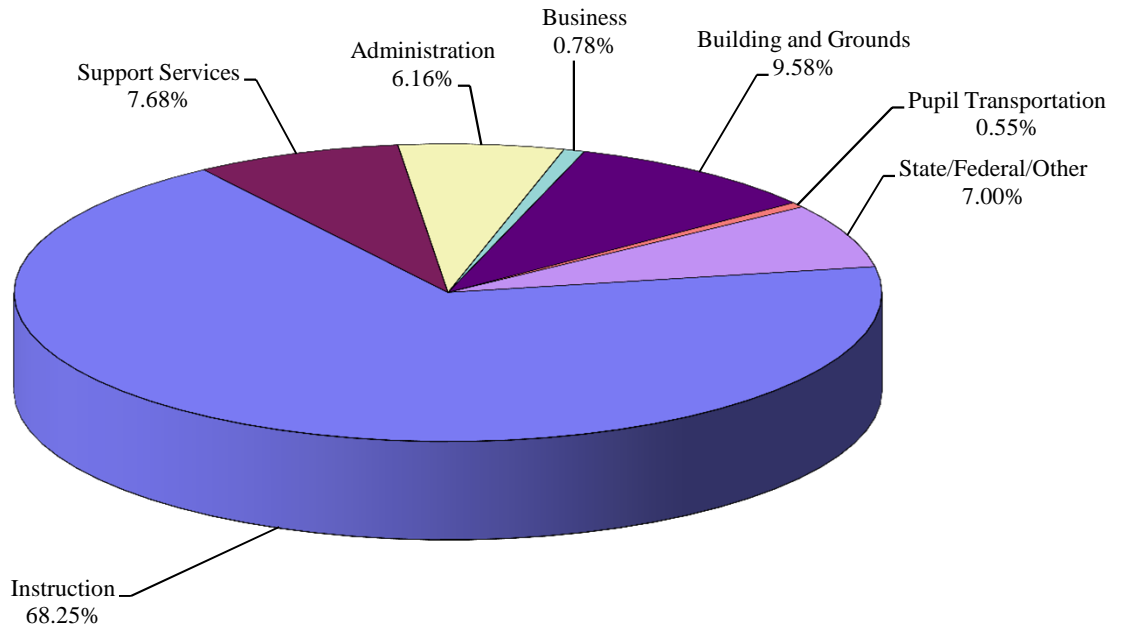

2015

**GRAND ISLAND PUBLIC SCHOOLS
BUDGETED PROPERTY TAX PER STUDENT - GENERAL FUND
Years Ended August 31, 2006 through 2016**

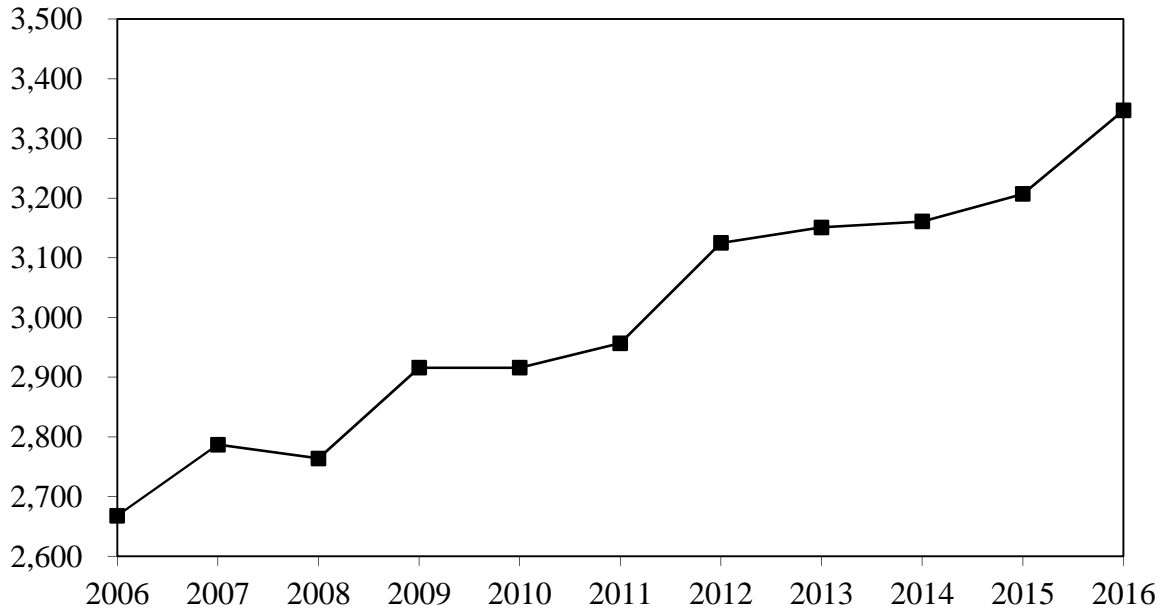

**ANNUAL COST PER STUDENT
Years Ended August 31, 2006 through 2016**

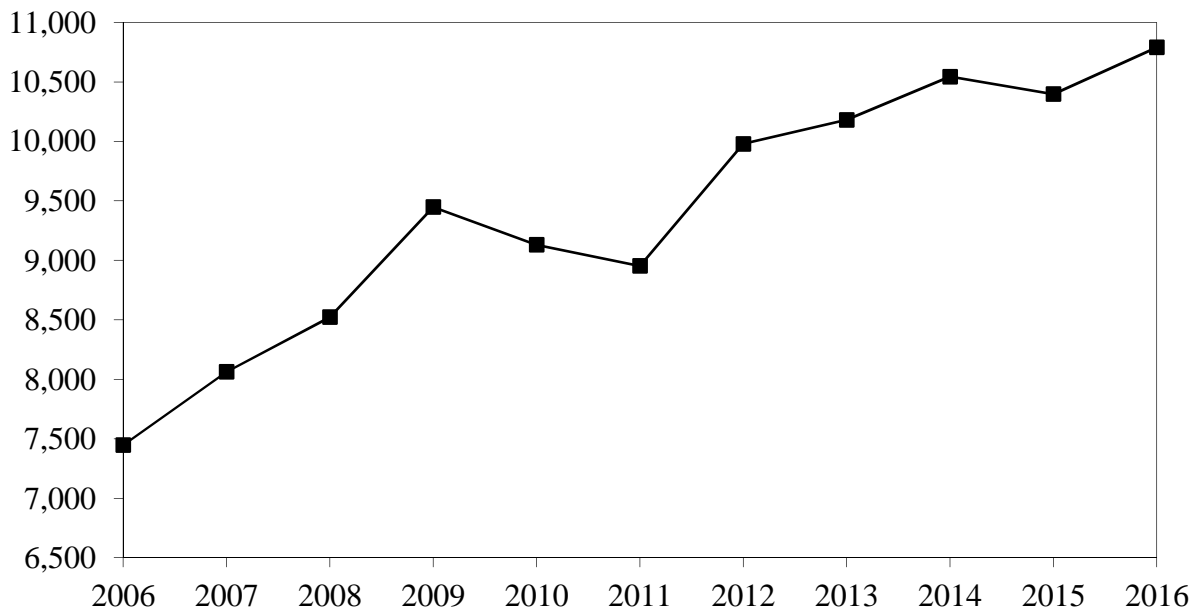

**GRAND ISLAND PUBLIC SCHOOLS
AVERAGE DAILY MEMBERSHIP
Years Ended August 31, 2006 through 2016**

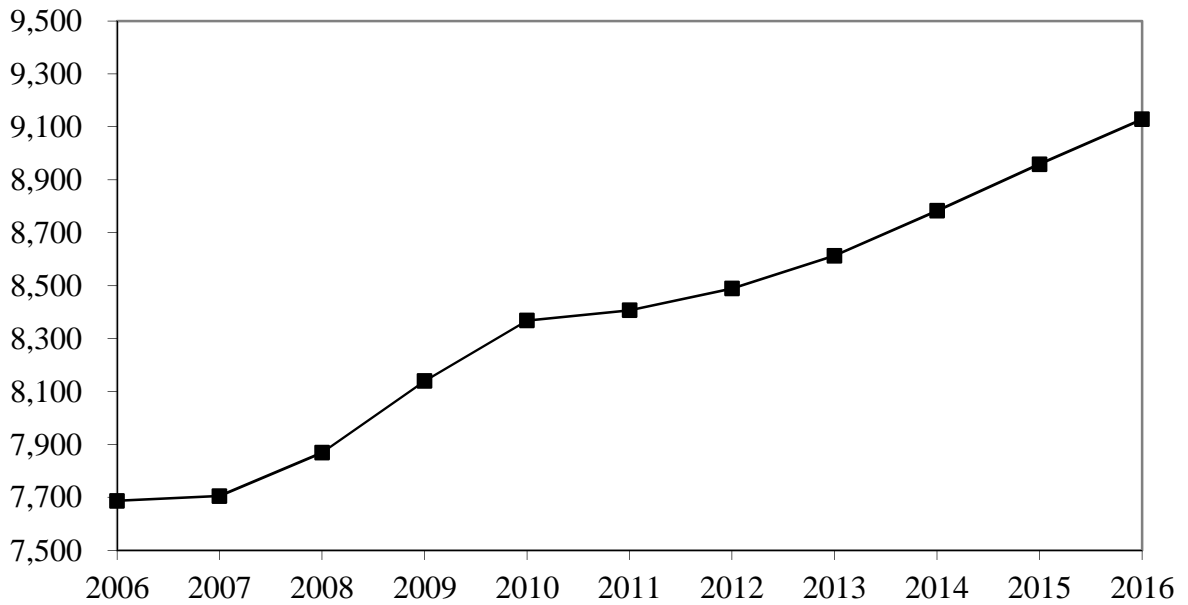

**ASSESSED VALUE PER STUDENT
Years Ended August 31, 2006 through 2016**

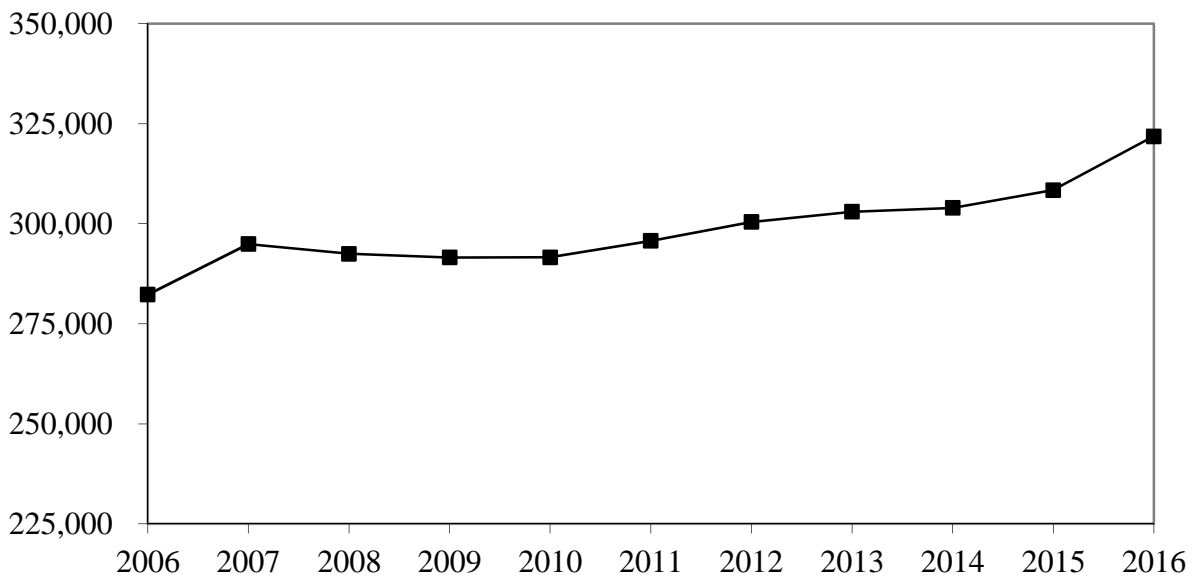

SINGLE AUDIT REPORTS

**GRAND ISLAND PUBLIC SCHOOLS
GRAND ISLAND, NEBRASKA**

SCHEDULE OF EXPENDITURES OF FEDERAL AWARDS

Year ended August 31, 2016

<u>Federal Grantor and Program Title</u>	<u>Federal CFDA Number</u>	<u>Subrecipient Grant Number</u>	<u>Expenditures</u>
<u>Department of Education</u>			
Passed Through Nebraska Department of Education:			
Special Education (IDEA) Cluster:			
Special Education - Below Age Five	84.173	40-0002-000	\$ 29,150
Special Education - Below Age Five (IDEA, Part B)	84.027	40-0002-000	1,933,247
Total Special Education (IDEA) Cluster			<u>1,962,397</u>
Title I	84.010	40-0002-000	1,685,942 *
Migrant Education - Basic State Grant Program	84.011	40-0002-000	239,461
Infants and Toddlers with Disabilities - Preschool			
Interagency Grant	84.181	40-0002-000	21,167
Perkins Basic Grant	84.048	40-0002-000	103,072
Education for Homeless Children and Youth	84.196	40-0002-000	22,302
Title II - Part A	84.367	40-0002-000	284,435
Title III - Immigrant Education	84.365	40-0002-000	298,707
Total Department of Education			<u>4,617,483</u>
<u>Department of Agriculture</u>			
Child Nutrition Cluster:			
Passed Through Nebraska Department of Education:			
National School Lunch Program	10.555	40-0002-000	3,675,143 *
Summer Food Program for Children	10.559	40-0002-000	90,136 *
Total Child Nutrition Cluster passed through Nebraska Department of Education			<u>3,765,279</u>
Passed Through Nebraska Department of Health and Human Services:			
National School Lunch Program	10.555	47-6003169	446,179 *
Total Child Nutrition Cluster			<u>4,211,458</u>
Passed Through Nebraska Department of Education:			
Child and Adult Care Food Program	10.558	40-0002-000	16,065
Fruit and Vegetable Program	10.582	40-0002-000	129,807
Total Department of Agriculture			<u>4,357,330</u>
<u>Department of Health and Human Services</u>			
Passed Through Nebraska Department of Health and Human Services:			
Medical Assistance Programs (Medicaid)	93.778	47-6003169	253,970
Total Expenditures of Federal Awards			<u><u>\$ 9,228,783</u></u>

*Major Programs

**GRAND ISLAND PUBLIC SCHOOLS
GRAND ISLAND, NEBRASKA**

SCHEDULE OF EXPENDITURES OF FEDERAL AWARDS, Continued

Year ended August 31, 2016

NOTE A - BASIS OF PRESENTATION

The accompanying schedule of expenditures of federal award includes the federal grant activity of Grand Island Public Schools and is presented on the cash basis of accounting. The information in this schedule is presented in accordance with the requirements of the Uniform Guidance.

Grand Island Public Schools did not elect to use the 10% de minimis indirect cost rate.

NOTE B - FOOD DONATION PROGRAM

Nonmonetary assistance is reported in the schedule at the fair market value of the commodities received and disbursed.



**INDEPENDENT AUDITOR'S REPORT ON INTERNAL CONTROL
OVER FINANCIAL REPORTING AND ON COMPLIANCE
AND OTHER MATTERS BASED ON AN AUDIT OF FINANCIAL
STATEMENTS PERFORMED IN ACCORDANCE WITH
GOVERNMENT AUDITING STANDARDS**

SHAREHOLDERS

Robert D. Almquist
Phillip D. Maltzahn
Terry T. Galloway
Marcy J. Luth
Heidi A. Ashby
Christine R. Shenk
Michael E. Hoback
Joseph P. Stump
Kyle R. Overturf

To the Board of Education
Grand Island Public Schools
Grand Island, Nebraska

We have audited, in accordance with the auditing standards generally accepted in the United States of America and the standards applicable to financial audits contained in *Government Auditing Standards* issued by the Comptroller General of the United States, the financial statements of the governmental activities, the business-type activities, the aggregate discretely presented component unit, each major fund, the aggregate remaining fund information and the fiduciary funds of Hall County School District #2 as of and for the year ended August 31, 2016, and the related notes to the financial statements, which collectively comprise the School District's financial statements, and have issued our report thereon dated October 27, 2016. Our report on the financial statements disclosed that, as described in Note A to the financial statements, the School District prepares its primary government financial statements on a prescribed basis of accounting that demonstrates compliance with the modified cash basis and budget laws of Nebraska, which is a comprehensive basis of accounting other than accounting principles generally accepted in the United States of America.

Internal Control Over Financial Reporting

In planning and performing our audit of the financial statements, we considered Hall County School District #2's internal control over financial reporting (internal control) to determine the audit procedures that are appropriate in the circumstances for the purpose of expressing our opinions on the financial statements, but not for the purpose of expressing an opinion on the effectiveness of the District's internal control. Accordingly, we do not express an opinion on the effectiveness of Hall County School District #2's internal control.

A deficiency in internal control exists when the design or operation of a control does not allow management or employees, in the normal course of performing their assigned functions, to prevent, or detect and correct misstatements on a timely basis. *A material weakness* is a deficiency, or a combination of deficiencies, in internal control such that there is a reasonable possibility that a material misstatement of the

entity's financial statements will not be prevented, or detected and corrected on a timely basis. A *significant deficiency* is a deficiency, or a combination of deficiencies, in internal control that is less severe than a material weakness, yet important enough to merit attention by those charged with governance.

Our consideration of internal control over financial reporting was for the limited purpose described in the first paragraph of this section and was not designed to identify all deficiencies in internal control that might be material weaknesses or significant deficiencies. Given these limitations, during our audit, we did not identify any deficiencies in internal control that we consider to be material weaknesses. However, material weaknesses may exist that have not been identified.

Compliance and Other Matters

As part of obtaining reasonable assurance about whether Hall County School District #2's financial statements are free of material misstatement, we performed tests of its compliance with certain provisions of laws, regulations, contracts and grant agreements, noncompliance with which could have a direct and material effect on the determination of financial statement amounts. However, providing an opinion on compliance with those provisions was not an objective of our audit and, accordingly, we do not express such an opinion. The results of our tests disclosed no instances of noncompliance or other matters that are required to be reported under *Government Auditing Standards*.

Purpose of this Report

The purpose of this report is solely to describe the scope of our testing of internal control and compliance and the results of that testing, and not to provide an opinion on the effectiveness of the entity's internal control or on compliance. This report is an integral part of an audit performed in accordance with *Government Auditing Standards* in considering the entity's internal control and compliance. Accordingly, this communication is not suitable for any other purpose.

*Anguist, Malthalm,
Galloway & Luth, P.C.*

Grand Island, Nebraska
October 27, 2016

**INDEPENDENT AUDITOR'S REPORT ON COMPLIANCE FOR EACH
MAJOR PROGRAM AND ON INTERNAL CONTROL OVER COMPLIANCE
REQUIRED BY THE UNIFORM GUIDANCE**

To the Board of Education
Grand Island Public Schools
Grand Island, Nebraska

SHAREHOLDERS

Robert D. Almquist
Phillip D. Maltzahn
Terry T. Galloway
Marcy J. Luth
Heidi A. Ashby
Christine R. Shenk
Michael E. Hoback
Joseph P. Stump
Kyle R. Overturf

Report on Compliance for Each Major Federal Program

We have audited Hall County School District #2's compliance with the types of compliance requirements described in the *OMB Compliance Supplement* that could have a direct and material effect on each of the District's major federal programs for the year ended August 31, 2016. Hall County School District #2's major federal programs are identified in the summary of auditor's results section of the accompanying schedule of findings and questioned costs.

Management's Responsibility

Management is responsible for compliance with federal statutes, regulations, and the terms and conditions of its federal awards applicable to its federal programs.

Auditor's Responsibility

Our responsibility is to express an opinion on compliance for each of Hall County School District #2's major federal programs based on our audit of the types of compliance requirements referred to above. We conducted our audit of compliance in accordance with auditing standards generally accepted in the United States of America; the standards applicable to financial audits contained in *Government Auditing Standards*, issued by the Comptroller General of the United States; and the audit requirements of Title 2 U.S. *Code of Federal Regulations* Part 200, *Uniform Administrative Requirements, Cost Principles, and Audit Requirements for Federal Awards* (Uniform Guidance). Those standards and the Uniform Guidance require that we plan and perform the audit to obtain reasonable assurance about whether noncompliance with the types of compliance requirements referred to above that could have a direct and material effect on a major federal program occurred. An audit includes examining, on a test basis, evidence about the District's compliance with those requirements and performing such other procedures as we considered necessary in the circumstances.

We believe that our audit provides a reasonable basis for our opinion on compliance for each major federal program. However, our audit does not provide a legal determination of Hall County School District #2's compliance.

Wealth Management, LLC Registered Investment Advisor, is affiliated with Almquist, Maltzahn, Galloway & Luth, P.C.
and offers wealth management and investment advisory services.

1203 W 2nd Street
PO Box 1407
Grand Island, NE 68802
Ph. 308-381-1810
Fax 308-381-4824
Email: cpa@gicpas.com

A PROFESSIONAL
CORPORATION

Opinion on Each Major Federal Program

In our opinion, Hall County School District #2 complied, in all material respects, with the types of compliance requirements referred to above that could have a direct and material effect on each of its major federal programs for the year ended August 31, 2016.

Report on Internal Control over Compliance

Management of Hall County School District #2 is responsible for establishing and maintaining effective internal control over compliance with the types of compliance requirements referred to above. In planning and performing our audit of compliance, we considered the District's internal control over compliance with the types of requirements that could have a direct and material effect on each major federal program to determine the auditing procedures that are appropriate in the circumstances for the purpose of expressing an opinion on compliance for each major federal program and to test and report on internal control over compliance in accordance with the Uniform Guidance, but not for the purpose of expressing an opinion on the effectiveness of internal control over compliance. Accordingly, we do not express an opinion on the effectiveness of the District's internal control over compliance.

A deficiency in internal control over compliance exists when the design or operation of a control over compliance does not allow management or employees, in the normal course of performing their assigned functions, to prevent, or detect and correct, noncompliance with a type of compliance requirement of a federal program on a timely basis. *A material weakness in internal control over compliance* is a deficiency, or combination of deficiencies, in internal control over compliance, such that there is a reasonable possibility that material noncompliance with a type of compliance requirement of a federal program will not be prevented, or detected and corrected, on a timely basis. *A significant deficiency in internal control over compliance* is a deficiency, or a combination of deficiencies, in internal control over compliance with a type of compliance requirement of a federal program that is less severe than a material weakness in internal control over compliance, yet important enough to merit attention by those charged with governance.

Our consideration of internal control over compliance was for the limited purpose described in the first paragraph of this section and was not designed to identify all deficiencies in internal control over compliance that might be material weaknesses or significant deficiencies. We did not identify any deficiencies in internal control over compliance that we consider to be material weaknesses. However, material weaknesses may exist that have not been identified.

The purpose of this report on internal control over compliance is solely to describe the scope of our testing of internal control over compliance and the results of that testing based on the requirements of the Uniform Guidance. Accordingly, this report is not suitable for any other purpose.

Almgvist, Malahahn.
Galloway & Luth, P.C.

Grand Island, Nebraska
October 27, 2016

**GRAND ISLAND PUBLIC SCHOOLS
GRAND ISLAND, NEBRASKA**

SCHEDULE OF FINDINGS AND QUESTIONED COSTS

Year ended August 31, 2016

1. A summary of auditor's results:
 - (i) Unmodified opinions were issued on all opinion units of Grand Island Public Schools as of August 31, 2016 and for the year then ended.
 - (ii) The audit did not disclose any significant deficiencies in the internal control of Grand Island Public Schools.
 - (iii) The audit did not disclose any noncompliance which is material to the financial statements of Grand Island Public Schools.
 - (iv) The audit did not disclose any significant deficiencies in the internal control over major programs for Grand Island Public Schools.
 - (v) An unmodified opinion was issued on compliance for major programs.
 - (vi) The audit did not disclose any audit findings which we are required to report under 2 CFR section 200.516(a).
 - (vii) Major Programs: Child Nutrition Cluster - CFDA #10.555 (National School Lunch Program) and #10.559 (Summer Food Program for Children), and Title I – CFDA #84.010.
 - (viii) The dollar threshold used to distinguish between Type A and Type B programs was \$750,000.
 - (ix) Grand Island Public Schools did not qualify as a low-risk auditee.
2. Findings relating to the financial statements which are required to be reported in accordance with GAGAS.

None
3. Findings and questioned costs for Federal awards which shall include audit findings as defined in 2 CFR section 200.516(a).

None

**GRAND ISLAND PUBLIC SCHOOLS
GRAND ISLAND, NEBRASKA**

SUMMARY SCHEDULE OF PRIOR AUDIT FINDINGS

Year ended August 31, 2016

Program

Findings for the year ended August 31, 2015

There were no prior audit findings.

Amendment To
Construction Management
Independent Contractor Agreement

This Amendment ("Amendment") is entered into and effective this 5th day of January, 2017, by and between Shannonbuilders/ Construction Management, LLC ("Construction Manager") and Hall County School District 2 a/k/a Grand Island Public Schools ("GIPS"), collectively, "the parties".

WHEREAS, GIPS and Construction Manager desire to extend for a term of one additional year the Construction Management Independent Contractor Agreement between the parties dated January 5, 2015; and

WHEREAS, GIPS and Construction Manager desire to define the compensation for Construction Manager's services under the Construction Management Independent Contractor Agreement.

NOW, THEREFORE, in consideration of the covenants and agreements contained herein, the parties agree as follows:

1. TERM. This Amendment shall be in effect for one year commencing January 5, 2017, and terminating January 4, 2018, during which time all terms and provisions of the Construction Management Independent Contractor Agreement between the parties dated January 5, 2015, shall remain in full force and effect except as specifically modified by this Amendment.

2. COMPENSATION. As compensation, Construction Manager shall be paid a fixed fee in the amount of One Hundred Seventeen Thousand Eight Hundred Dollars and 00/100 cents, (\$117,800). Payment shall be made in equal monthly installments. GIPS shall not be responsible for federal, state and local taxes derived from the Construction Manager's income or for the withholding and/or payment of any federal, state and local income and other payroll taxes, worker's compensation, disability benefits or other legal requirements applicable to the Construction Manager. The Construction Manager shall be responsible for the payment of the aforementioned payments.

By: Steve Shannon
Steve Shannon, Member
Shannonbuilders/ Construction Management, LLC

By: _____
Bonnie Hinkle, President,
Board of Education, Hall County School District 2,
a/k/a Grand Island Public Schools, "GIPS"