

HICKMAN COUNTY BOARD OF EDUCATION
REGULAR BOARD MEETING---April 13, 2026

The Hickman county Board of Education met on April 13, 2026, at 6:30 PM in Central Office - Room 203.

Present: Tabitha Cude, Jane Herron, Tim Hobbs, Doug Lane, Christy Mays, Pippa Taylor, Brandon Tidwell.

I. Call To Order

II. Public Comment

Citizens that would like an opportunity to speak to the Board of Education during public comment should sign up on the sheet provided at the meeting location. Anyone desiring to speak on any subject may speak for 3 minutes without prior school board notification. The sign-up sheet will be available from 5:30 p.m. - 6:30 p.m.

III. Moment of Silence

IV. Pledge of Allegiance

V. Agenda for April 13, 2026

Motion to approve the amended Agenda for April 13, 2026 (add X.M).

Motion made by Doug Lane.

Motion seconded by Tabitha Cude.

Motion Result: Passed

Tabitha Cude: Yea

Jane Herron: Yea

Tim Hobbs: Yea

Doug Lane: Yea

Christy Mays: Yea

Pippa Taylor: Yea

Brandon Tidwell: Yea

Yea: 7, Nay: 0

VI. Regular Meeting Minutes for March 2, 2026

Moti.

Motion made by Tabitha Cude.

Motion seconded by Pippa Taylor.

Motion Result: Passed

Tabitha Cude: Yea

Jane Herron: Yea

Tim Hobbs: Yea

Doug Lane: Yea

Christy Mays: Yea

Pippa Taylor: Yea

Brandon Tidwell: Yea

Yea: 7, Nay: 0

Motion to approve Regular Meeting Minutes for March 2, 2026.

Motion made by Jane Herron.

HICKMAN COUNTY BOARD OF EDUCATION
REGULAR BOARD MEETING---April 13, 2026

Motion seconded by Pippa Taylor.

Motion Result: Passed

Tabitha Cude: Yea
Jane Herron: Yea
Tim Hobbs: Yea
Doug Lane: Yea
Christy Mays: Yea
Pippa Taylor: Yea
Brandon Tidwell: Yea

Yea: 7, Nay: 0

VII. Special Called Session Minutes for March 17, 2026

Motion to approve Special Called Session Minutes for March 17, 2026.

Motion made by Jane Herron.

Motion seconded by Pippa Taylor.

Motion Result: Passed

Tabitha Cude: Yea
Jane Herron: Yea
Tim Hobbs: Yea
Doug Lane: Yea
Christy Mays: Yea
Pippa Taylor: Yea
Brandon Tidwell: Yea

Yea: 7, Nay: 0

VIII. Special Recognition

A. Employee of the Month

B. Certificate Presentation to TSBA SCOPE Conference Delegates

IX. Consent Agenda Items

Motion to approve Consent Agenda Items.

Motion made by Doug Lane.

Motion seconded by Jane Herron.

Motion Result: Passed

Tabitha Cude: Yea
Jane Herron: Yea
Tim Hobbs: Yea
Doug Lane: Yea
Christy Mays: Yea
Pippa Taylor: Yea
Brandon Tidwell: Yea

Yea: 7, Nay: 0

A. Board Chair's Report

1. Chair's Countersigned Warrants

B. Personnel Report

HICKMAN COUNTY BOARD OF EDUCATION
REGULAR BOARD MEETING---April 13, 2026

C. Financial Report

D. Attendance Report

X. Items Requiring Board Action

A. Trip Request

1. HCHS TN Strong

Motion to approve HCHS TN Strong.

Motion made by Doug Lane.

Motion seconded by Tabitha Cude.

Motion Result: Passed

Tabitha Cude: Yea

Jane Herron: Yea

Tim Hobbs: Yea

Doug Lane: Yea

Christy Mays: Yea

Pippa Taylor: Yea

Brandon Tidwell: Yea

Yea: 7, Nay: 0

2. EHHS Cheer Camp

Motion to approve EHHS Cheer Camp.

Motion made by Jane Herron.

Motion seconded by Pippa Taylor.

Motion Result: Passed

Tabitha Cude: Yea

Jane Herron: Yea

Tim Hobbs: Yea

Doug Lane: Yea

Christy Mays: Yea

Pippa Taylor: Yea

Brandon Tidwell: Yea

Yea: 7, Nay: 0

B. 2026-2027 Attendance Zones

Motion to approve 2026-2027 Attendance Zones.

Motion made by Doug Lane.

Motion seconded by Tabitha Cude.

Motion Result: Passed

Tabitha Cude: Yea

Jane Herron: Yea

Tim Hobbs: Yea

Doug Lane: Yea

Christy Mays: Yea

Pippa Taylor: Yea

Brandon Tidwell: Yea

Yea: 7, Nay: 0

HICKMAN COUNTY BOARD OF EDUCATION
REGULAR BOARD MEETING---April 13, 2026

C. TSBA 2027 Membership Dues

Motion to approve TSBA 2027 Membership Dues.

Motion made by Jane Herron.

Motion seconded by Pippa Taylor.

Motion Result: Passed

Tabitha Cude: Yea

Jane Herron: Yea

Tim Hobbs: Yea

Doug Lane: Yea

Christy Mays: Yea

Pippa Taylor: Yea

Brandon Tidwell: Yea

Yea: 7, Nay: 0

D. Hickman County Chamber of Commerce Dues

The historical \$50-per-school fee from 12-15 years ago has been replaced by an employee rate.

Motion to continue as members of the Hickman County Chamber of Commerce by paying the Dues.

Motion made by Tabitha Cude.

Motion seconded by Christy Mays.

Motion Result: Passed

Jane Herron: Abstain (With Conflict)

Tabitha Cude: Yea

Tim Hobbs: Yea

Doug Lane: Yea

Christy Mays: Yea

Pippa Taylor: Yea

Brandon Tidwell: Yea

Yea: 6, Nay: 0, Abstain (With Conflict): 1

E. Appoint all Board Members to the Budget Committee

Motion to Appoint all Board Members to the Budget Committee.

Motion made by Tabitha Cude.

Motion seconded by Doug Lane.

Motion Result: Passed

Tabitha Cude: Yea

Jane Herron: Yea

Tim Hobbs: Yea

Doug Lane: Yea

Christy Mays: Yea

Pippa Taylor: Yea

Brandon Tidwell: Yea

Yea: 7, Nay: 0

F. Bid - Intercom Maintenance and Repair Provider for 8 Schools

Motion to approve the Bid - Intercom Maintenance and Repair Provider for 8 Schools.

Motion made by Jane Herron.

Motion seconded by Brandon Tidwell.

Motion Result: Passed

HICKMAN COUNTY BOARD OF EDUCATION
REGULAR BOARD MEETING---April 13, 2026

Tabitha Cude: Yea
Jane Herron: Yea
Tim Hobbs: Yea
Doug Lane: Yea
Christy Mays: Yea
Pippa Taylor: Yea
Brandon Tidwell: Yea

Yea: 7, Nay: 0

G. Bid - Automotive Class Training Equipment for HCHS

Motion to approve Bid - Automotive Class Training Equipment for HCHS (Georgia Education Solutions).

Motion made by Doug Lane.

Motion seconded by Tabitha Cude.

Motion Result: Passed

Tabitha Cude: Yea
Jane Herron: Yea
Tim Hobbs: Yea
Doug Lane: Yea
Christy Mays: Yea
Pippa Taylor: Yea
Brandon Tidwell: Yea

Yea: 7, Nay: 0

H. Bid - TN State Category 1 E-Rate Mini-Bid Process

Motion to approve TN State Category 1 E-Rate Mini-Bid Process.

Motion made by Christy Mays.

Motion seconded by Pippa Taylor.

Motion Result: Passed

Tabitha Cude: Yea
Jane Herron: Yea
Tim Hobbs: Yea
Doug Lane: Yea
Christy Mays: Yea
Pippa Taylor: Yea
Brandon Tidwell: Yea

Yea: 7, Nay: 0

1. Network Services

I. Bid - TN State Category 2 E-Rate Mini-Bid Process

Motion to approve TN State Category 2 E-Rate Mini-Bid Process.

Motion made by Jane Herron.

Motion seconded by Brandon Tidwell.

Motion Result: Passed

Tabitha Cude: Yea
Jane Herron: Yea
Tim Hobbs: Yea
Doug Lane: Yea

HICKMAN COUNTY BOARD OF EDUCATION
REGULAR BOARD MEETING---April 13, 2026

Christy Mays: Yea
Pippa Taylor: Yea
Brandon Tidwell: Yea

Yea: 7, Nay: 0

1. Internal Connection

2. MIBS (Managed Internet Broadband Services)

Motion to approve MIBS (Managed Internet Broadband Services).

Motion made by Tabitha Cude.

Motion seconded by Pippa Taylor.

Motion Result: Passed

Tabitha Cude: Yea

Jane Herron: Yea

Tim Hobbs: Yea

Doug Lane: Yea

Christy Mays: Yea

Pippa Taylor: Yea

Brandon Tidwell: Yea

Yea: 7, Nay: 0

J. Budget Amendments

Motion to approve Budget Amendments 30, 31, and 32.

Motion made by Doug Lane.

Motion seconded by Christy Mays.

Motion Result: Passed

Tabitha Cude: Yea

Jane Herron: Yea

Tim Hobbs: Yea

Doug Lane: Yea

Christy Mays: Yea

Pippa Taylor: Yea

Brandon Tidwell: Yea

Yea: 7, Nay: 0

K. OPEB

Have the classified and non-classified paid the same amount...employee before 2015 – different tiers for different services.

Motion to table OPEB.

Motion made by Brandon Tidwell.

Motion seconded by Tabitha Cude.

Motion Result: Tabled

Tabitha Cude: Yea

Jane Herron: Yea

Tim Hobbs: Yea

Doug Lane: Yea

Christy Mays: Yea

Pippa Taylor: Yea

Brandon Tidwell: Yea

HICKMAN COUNTY BOARD OF EDUCATION
REGULAR BOARD MEETING---April 13, 2026

Yea: 7, Nay: 0

L. Board Policies

1. Revised Board Policy 1.108 (2nd Reading)

Motion to approve Revised Board Policy 1.108 (2nd Reading).

Motion made by Doug Lane.

Motion seconded by Tabitha Cude.

Motion Result: Passed

Tabitha Cude: Yea

Jane Herron: Yea

Tim Hobbs: Yea

Doug Lane: Yea

Christy Mays: Yea

Pippa Taylor: Yea

Brandon Tidwell: Yea

Yea: 7, Nay: 0

2. Revised Board Policies 1.804, 2.400, 5.114, 5.1151, 5.200, 5.201, 5.202, 5.302, 5.400, 5.403, 5.606, NEW 5.608, 5.800, 6.411 - 1st Reading

Motion to approve Revised Board Policies 1.804, 2.400, 5.114, 5.1151, 5.200, 5.201, 5.202, 5.302, 5.400, 5.403, 5.606, NEW 5.608, 5.800, 6.411 - 1st Reading.

Motion made by Doug Lane.

Motion seconded by Jane Herron.

Motion Result: Passed

Tabitha Cude: Yea

Jane Herron: Yea

Tim Hobbs: Yea

Doug Lane: Yea

Christy Mays: Yea

Pippa Taylor: Yea

Brandon Tidwell: Yea

Yea: 7, Nay: 0

3. Board Policies Review 2.401--2.703

Motion to approve Board Policies Review 2.401--2.703.

Motion made by Christy Mays.

Motion seconded by Jane Herron.

Motion Result: Passed

Tabitha Cude: Yea

Jane Herron: Yea

Tim Hobbs: Yea

Doug Lane: Yea

Christy Mays: Yea

Pippa Taylor: Yea

Brandon Tidwell: Yea

Yea: 7, Nay: 0

M. HCHS Agreement from APEX Bank

HICKMAN COUNTY BOARD OF EDUCATION
REGULAR BOARD MEETING---April 13, 2026

Motion to approve HCHS Agreement from APEX Bank.

Motion made by Doug Lane.

Motion seconded by Jane Herron.

Motion Result: Passed

Tabitha Cude: Yea

Jane Herron: Yea

Tim Hobbs: Yea

Doug Lane: Yea

Christy Mays: Yea

Pippa Taylor: Yea

Brandon Tidwell: Yea

Yea: 7, Nay: 0

XI. Discussion

A. FY2025 Internal School Funds Audit

B. Budget FY27 Update

Working sessions for April 29, Wednesday...6pm

C. Transportation - Seatbelt Safety

XII. Announcements

A. Regular Board Meeting for May 4, 2026 - this meeting will be held in the Library at HCHS due to Teacher of the Year recognitions and awards.

XIII. Closing Comments

A. Legislative Representative

B. Board Chair, Board Members, Student Representatives, and Interim Director of Schools

XIV. Adjourn

Motion to adjourn.

Motion made by Tabitha Cude.

Motion seconded by Jane Herron.

Motion Result: Passed

Tabitha Cude: Yea

Jane Herron: Yea

Tim Hobbs: Yea

Doug Lane: Yea

Christy Mays: Yea

Pippa Taylor: Yea

Brandon Tidwell: Yea

Yea: 7, Nay: 0

DOUG LANE
2059 Lake Drive, Centerville, TN 37033

PIPPA TAYLOR
6585 Oak Hill Rd., Lyles, TN 37098

TIM HOBBS
9220 Old Bon Aqua Rd., Bon Aqua, TN 37025

TABITHA CUDE
4141 Lewis Rd., Centerville, TN 37033



CHRISTY MAYS
450 Hwy. 50, Centerville, TN 37033

SHERRI BAKER
9037 E 40 Rd., Bon Aqua, TN 37025

JANE HERRON
PO Box 13, Nunnally, TN 37137

Dr. Belinda Anderson
Interim Director of Schools
115 Murphree Avenue
Centerville, TN 37033

The Hickman County Board of Education will meet in regular session on Monday, April 13, 2026 at 6:30 p.m. in RM 203 of the Central Office Complex.

- I. Call to Order
- II. Public Comment
Citizens that would like an opportunity to speak to the Board of Education during public comment should sign up on the sheet provided at the meeting location. Anyone desiring to speak on any subject may speak for 3 minutes without prior school board notification. The sign-up sheet will be available from 5:30 p.m. - 6:30 p.m.
- III. Moment of Silence
- IV. Pledge of Allegiance
- V. Agenda for April 13, 2026
- VI. Regular Meeting Minutes for March 2, 2026
- VII. Special Called Session Minutes for March 17, 2026
- VIII. Special Recognition
 - A. Employee of the Month—Dr. Tabitha Cude
 - B. Certificate Presentation to TSBA SCOPE Conference Delegates—Christy Mays
- IX. Consent Agenda Items
 - A. Board Chair's Report
 1. Chair's Countersigned Warrants
 - B. Personnel Report
 - C. Financial Report
 - D. Attendance Report
- X. Items Requiring Board Action
 - A. Trip Requests
 1. HCHS TN Strong—Sponsor and Students
 2. EHHS Cheer Camp—Coach and Cheer Captains
 - B. 2026-2027 Attendance Zones—Transportation Director
 - C. TSBA 2027 Membership Dues—Board Chair
 - D. Hickman County Chamber of Commerce Dues—Board Chair
 - E. Appoint all Board Members to the Budget Committee—Board Chair
 - F. Bid – Intercom Maintenance and Repair Provider for 8 Schools—Derek Newsom

- G. Bid – Automotive Class Training Equipment for HCHS—Jennifer Turpin/Derek Newsom
- H. Bid – TN State Category 1 E-Rate Mini-Bid Process—Technology Coordinator
 - 1. Network Services
- I. Bid – TN State Category 2 E-Rate Mini-Bid Process—Technology Coordinator
 - 1. Internal Connection
 - 2. MIBS (Managed Internet Broadband Services)
- J. Budget Amendments—Business Officer
- K. OPEB—Business Officer
- L. Board Policies
 - 1. Revised Board Policy 1.108 (2nd Reading)—Board Chair
 - 2. Revised Board Policies 1.804, 2.400, 5.114, 5.1151, 5.200, 5.201, 5.202, 5.302, 5.400, 5.403, 5.606, NEW 5.608, 5.800, 6.411 – 1st Reading—Misty Shelton
 - 3. Board Policies Review 2.401—2.703—Misty Shelton

- XI. Discussion
 - 1. FY2025 Internal School Funds Audit—Business Officer
 - 2. Budget FY27 Update—Business Officer
 - 3. Transportation-Seatbelt Safety—Board Chair and Transportation Director

- XII. Announcements
 - A. Regular Board Meeting for May 4, 2026 (this meeting will be held in the Library of HCHS due to Teacher of the Year recognitions and awards—Board Chair

- XIII. Closing Comments
 - A. Legislative Representative—Christy Mays
 - B. Board Chair, Board Members, Student Representatives, and Interim Director of Schools

- XIV. Adjourn

HICKMAN COUNTY BOARD OF EDUCATION
REGULAR BOARD MEETING---March 2, 2026

The Hickman county Board of Education met on March 2, 2026, at 6:30 PM in Central Office - Room 203.

Present: Tabitha Cude, Jane Herron, Tim Hobbs, Doug Lane, Christy Mays, Pippa Taylor.

I. Call To Order

II. Public Comment

Citizens that would like an opportunity to speak to the Board of Education during public comment should sign up on the sheet provided at the meeting location. Anyone desiring to speak on any subject may speak for 3 minutes without prior school board notification. The sign-up sheet will be available from 5:30 p.m. - 6:30 p.m.

III. Moment of Silence

IV. Pledge of Allegiance

V. Agenda for March 2, 2026

Motion to approve the Agenda for March 2, 2026 with changes on the agenda.

Motion made by Christy Mays.

Motion seconded by Doug Lane.

Motion Result: Passed

Tabitha Cude: Yea

Jane Herron: Yea

Tim Hobbs: Yea

Doug Lane: Yea

Christy Mays: Yea

Pippa Taylor: Yea

Yea: 6, Nay: 0

VI. Special Called Session Minutes for February 7, 2026

Motion to approve Special Called Session Minutes for February 7, 2026.

Motion made by Tabitha Cude.

Motion seconded by Pippa Taylor.

Motion Result: Passed

Tabitha Cude: Yea

Jane Herron: Yea

Tim Hobbs: Yea

Doug Lane: Yea

Christy Mays: Yea

Pippa Taylor: Yea

Yea: 6, Nay: 0

VII. Regular Meeting Minutes for February 9, 2026

Motion to approve the Regular Meeting Minutes for February 9, 2026.

Motion made by Pippa Taylor.

Motion seconded by Christy Mays.

Motion Result: Passed

HICKMAN COUNTY BOARD OF EDUCATION
REGULAR BOARD MEETING---March 2, 2026

Tabitha Cude: Yea
Jane Herron: Yea
Tim Hobbs: Yea
Doug Lane: Yea
Christy Mays: Yea
Pippa Taylor: Yea
Yea: 6, Nay: 0

VIII. Special Recognition

A. Employee of the Month

IX. Consent Agenda Items

Motion to approve Consent Agenda Items.

Motion made by Doug Lane.

Motion seconded by Tabitha Cude.

Motion Result: Passed

Tabitha Cude: Yea
Jane Herron: Yea
Tim Hobbs: Yea
Doug Lane: Yea
Christy Mays: Yea
Pippa Taylor: Yea
Yea: 6, Nay: 0

A. Board Chair's Report

1. Chair's Countersigned Warrants

B. Personnel Report

C. Financial Report

D. Attendance Report

E. Family Engagement Policy and School-Parent Compacts for Title I Schools

X. Information

A. School Based Therapy

Motion to approve the MOU Mercy Tennessee as a school based therapy program that is faith based.

Motion made by Doug Lane.

Motion seconded by Tim Hobbs.

Motion Result: Passed

Tabitha Cude: Yea
Jane Herron: Yea
Tim Hobbs: Yea
Doug Lane: Yea
Christy Mays: Yea
Pippa Taylor: Yea
Yea: 6, Nay: 0

HICKMAN COUNTY BOARD OF EDUCATION
REGULAR BOARD MEETING---March 2, 2026

XI. Items Requiring Board Action

A. Trip Requests

1. HCHS Volleyball Trip Request

Motion to approve the HCHS Volleyball Trip Request.

Motion made by Doug Lane.

Motion seconded by Tabitha Cude.

Motion Result: Passed

Tabitha Cude: Yea

Jane Herron: Yea

Tim Hobbs: Yea

Doug Lane: Yea

Christy Mays: Yea

Pippa Taylor: Yea

Yea: 6, Nay: 0

2. HCHS JROTC 7th Brigade Drill Competition Request

Motion to approve HCHS JROTC 7th Brigade Drill Competition Request.

Motion made by Tabitha Cude.

Motion seconded by Pippa Taylor.

Motion Result: Passed

Tabitha Cude: Yea

Jane Herron: Yea

Tim Hobbs: Yea

Doug Lane: Yea

Christy Mays: Yea

Pippa Taylor: Yea

Yea: 6, Nay: 0

3. EHHS Senior Trip Request

Motion to approve EHHS Senior Trip Request.

Motion made by Tim Hobbs.

Motion seconded by Christy Mays.

Motion Result: Passed

Tabitha Cude: Yea

Jane Herron: Yea

Tim Hobbs: Yea

Doug Lane: Yea

Christy Mays: Yea

Pippa Taylor: Yea

Yea: 6, Nay: 0

B. Approve the Distance Learning and Telemedicine (DLT) Grant

Motion to Approve the Distance Learning and Telemedicine (DLT) Grant.

Motion made by Christy Mays.

Motion seconded by Tabitha Cude.

Motion Result: Passed

Tabitha Cude: Yea

HICKMAN COUNTY BOARD OF EDUCATION
REGULAR BOARD MEETING---March 2, 2026

Jane Herron: Yea
Tim Hobbs: Yea
Doug Lane: Yea
Christy Mays: Yea
Pippa Taylor: Yea
Yea: 6, Nay: 0

C. Approve Resolution 26-1 for DLT Agency Relationship.
Motion to Approve Resolution 26-1 for DLT Agency Relationship.
Motion made by Doug Lane.
Motion seconded by Christy Mays.
Motion Result: Passed

Tabitha Cude: Yea
Jane Herron: Yea
Tim Hobbs: Yea
Doug Lane: Yea
Christy Mays: Yea
Pippa Taylor: Yea
Yea: 6, Nay: 0

D. Budget Amendments
Motion to approve Budget Amendment 29.
Motion made by Tabitha Cude.
Motion seconded by Pippa Taylor.
Motion Result: Passed

Tabitha Cude: Yea
Jane Herron: Yea
Tim Hobbs: Yea
Doug Lane: Yea
Christy Mays: Yea
Pippa Taylor: Yea
Yea: 6, Nay: 0

E. Board Policies

1. Revised Board Policy 1.901 (2nd Reading)
Motion to approve Revised Board Policy 1.901 (2nd Reading).
Motion made by Doug Lane.
Motion seconded by Tabitha Cude.
Motion Result: Passed

Tabitha Cude: Yea
Jane Herron: Yea
Tim Hobbs: Yea
Doug Lane: Yea
Christy Mays: Yea
Pippa Taylor: Yea
Yea: 6, Nay: 0

HICKMAN COUNTY BOARD OF EDUCATION
REGULAR BOARD MEETING---March 2, 2026

2. Board Policies Review - 1.803--2.400

Motion approve Board Policies Review - 1.803--2.400.

Motion made by Doug Lane.

Motion seconded by Tabitha Cude.

Motion Result: Passed

Tabitha Cude: Yea

Jane Herron: Yea

Tim Hobbs: Yea

Doug Lane: Yea

Christy Mays: Yea

Pippa Taylor: Yea

Yea: 6, Nay: 0

F. Board Member Resignation Letter

Motion to approve Board Member Resignation Letter.

Motion made by Tabitha Cude.

Motion seconded by Jane Herron.

Motion Result: Passed

Tabitha Cude: Yea

Jane Herron: Yea

Tim Hobbs: Yea

Doug Lane: Yea

Christy Mays: Yea

Pippa Taylor: Yea

Yea: 6, Nay: 0

G. Director of Schools Contract

Motion to approve Director of Schools Contract.

Motion made by Tim Hobbs.

Motion seconded by Jane Herron.

Motion Result: Passed

Tabitha Cude: Yea

Jane Herron: Yea

Tim Hobbs: Yea

Doug Lane: Yea

Christy Mays: Yea

Pippa Taylor: Yea

Yea: 6, Nay: 0

H. Consultant Discussion

The position as a consultant will begin on April 6, 2026, for Mrs. Tidwell.

XII. Announcements

A. Regular Board Meeting for April 13, 2026

XIII. Closing Comments

A. Legislative Representative

HICKMAN COUNTY BOARD OF EDUCATION
REGULAR BOARD MEETING---March 2, 2026

B. Board Chair, Board Members, Student Representatives and Interim Director
of Schools

XIV. Adjourn

Motion to adjourn.

Motion made by Doug Lane.

Motion seconded by Christy Mays.

Motion Result: Passed

Tabitha Cude: Yea

Jane Herron: Yea

Tim Hobbs: Yea

Doug Lane: Yea

Christy Mays: Yea

Pippa Taylor: Yea

Yea: 6, Nay: 0

HICKMAN COUNTY BOARD OF EDUCATION
SPECIAL CALLED SESSION---March 17, 2026

The Hickman county Board of Education met on March 17, 2026, at 6:30 PM in Central Office - Room 203.

Present: Tabitha Cude, Jane Herron, Tim Hobbs, Doug Lane, Christy Mays, Pippa Taylor.**Absent:** Tabitha Cude.**Present:** Tabitha Cude.

I. Call To Order

II. Agenda for March 17, 2026

Motion to approve the Agenda for March 17, 2026.

Motion made by Jane Herron.

Motion seconded by Pippa Taylor.

Motion Result: Passed

Tabitha Cude: Yea

Jane Herron: Yea

Tim Hobbs: Yea

Doug Lane: Yea

Christy Mays: Yea

Pippa Taylor: Yea

Yea: 6, Nay: 0

III. Items Requiring Board Action

A. Approve Incoming Director of Schools to be a Consultant from April 1, 2026--May 31, 2026

Motion to Approve Incoming Director of Schools to be a Consultant from April 1, 2026--May 31, 2026.

Motion made by Jane Herron.

Motion seconded by Tim Hobbs.

Motion Result: Passed

Doug Lane: Nay

Christy Mays: Nay

Tabitha Cude: Yea

Jane Herron: Yea

Tim Hobbs: Yea

Pippa Taylor: Yea

Yea: 4, Nay: 2

B. Trip Requests

1. JAG National Conference

JAG National Conference for permission to compete in the speech competition.

Motion made by Tabitha Cude.

Motion seconded by Christy Mays.

Motion Result: Passed

Tabitha Cude: Yea

Jane Herron: Yea

Tim Hobbs: Yea

HICKMAN COUNTY BOARD OF EDUCATION
SPECIAL CALLED SESSION---March 17, 2026

Doug Lane: Yea
Christy Mays: Yea
Pippa Taylor: Yea
Yea: 6, Nay: 0

2. HCHS JROTC

Motion to approve HCHS JROTC Mountain Man Memorial March Initiative.

Motion made by Doug Lane.

Motion seconded by Pippa Taylor.

Motion Result: Passed

Tabitha Cude: Yea
Jane Herron: Yea
Tim Hobbs: Yea
Doug Lane: Yea
Christy Mays: Yea
Pippa Taylor: Yea
Yea: 6, Nay: 0

IV. Adjourn

Motion to adjourn.

Motion made by Jane Herron.

Motion seconded by Christy Mays.

Motion Result: Passed

Tabitha Cude: Yea
Jane Herron: Yea
Tim Hobbs: Yea
Doug Lane: Yea
Christy Mays: Yea
Pippa Taylor: Yea
Yea: 6, Nay: 0

Certificate of Achievement

Presented by the Tennessee School Boards Association to

Kitty Bates

representing

Hickman County

for serving with distinction as a delegate to the

Student Congress on Policies in Education

on Tuesday, March 3, 2026



TSBA Executive Director



TSBA President

Certificate of Achievement

Presented by the Tennessee School Boards Association to

Makayla Cathey

representing

Hickman County

for serving with distinction as a delegate to the

Student Congress on Policies in Education

on Tuesday, March 3, 2026



TSBA Executive Director



TSBA President

Certificate of Achievement

Presented by the Tennessee School Boards Association to

Ryker Hicks

representing

Hickman County

for serving with distinction as a delegate to the
Student Congress on Policies in Education
on Tuesday, March 3, 2026



TSBA Executive Director



TSBA President

Certificate of Achievement

Presented by the Tennessee School Boards Association to

Caydence Strauss-Bierlair

representing

Hickman County

for serving with distinction as a delegate to the

Student Congress on Policies in Education

on Tuesday, March 3, 2026



TSBA Executive Director



TSBA President

Bank Name **Bank Number**
Cafeteria 143

<u>Payment Number</u>	<u>Vendor Name</u>	<u>Vendor ID</u>	<u>Payment Date</u>	<u>Cash Account</u>	<u>Amount</u>
43000737	American Fidelity Assurance Co	636	02/26/2026	143- -11140	\$1,557.47
43000738	Ameritas Life Insurance Corp.	7442	02/26/2026	143- -11140	\$81.42
43000739	Beam Insurance Administrators LLC	7435	02/26/2026	143- -11140	\$428.41
43000740	Hickman Co Trustee	2722	02/26/2026	143- -11140	\$1,790.02
43000741	Hickman County Trustee	2937	02/26/2026	143- -11140	\$18,109.31
43000742	Ivey Mechanical Company. LLC	8795	02/26/2026	143- -11140	\$16,107.92
43000743	Tennessee Farmers Life Insurance	5297	02/26/2026	143- -11140	\$25.00
143 Total:					<u>\$38,099.55</u>
Bank Total:					<u>\$38,099.55</u>
Bank Payment Count:					7

Hickman County Finance
 Payment Register By Account Control

Bank Name **Bank Number**
 General Purpose 141

<u>Payment Number</u>	<u>Vendor Name</u>	<u>Vendor ID</u>	<u>Payment Date</u>	<u>Cash Account</u>	<u>Amount</u>
41004380	American Fidelity Administrative Services, LLC	802	02/26/2026	141- -11140	\$563.55
41004381	American Paper & Twine Company	797	02/26/2026	141- -11140	\$81.40
41004382	Anderson, Belinda	8051	02/26/2026	141- -11140	\$341.04
41004383	Williams, Charles	9241	02/26/2026	141- -11140	\$155.00
41004384	Daugherty, Tonya	7288	02/26/2026	141- -11140	\$37.15
41004385	Dickson Electric System	1806	02/26/2026	141- -11140	\$38,199.34
41004386	Foam Crete, Inc.	8904	02/26/2026	141- -11140	\$6,466.10
41004387	Hickman Co Solid Waste Man.	2746	02/26/2026	141- -11140	\$3.60
41004388	Hickman Co Trustee	2722	02/26/2026	141- -11140	\$1,050.00
41004389	Hickman Co. General Sessions	2858	02/26/2026	141- -11140	\$839.58
41004390	Hickman County Trustee	2937	02/26/2026	141- -11140	\$385,763.43
41004391	Hull, Ronald	7447	02/26/2026	141- -11140	\$37.15
41004392	Lumen/Centurylink	4577	02/26/2026	141- -11140	\$111.76
41004393	Main Street Emporium	7541	02/26/2026	141- -11140	\$661.50
41004394	Maury County General Sessions	3800	02/26/2026	141- -11140	\$654.48
41004395	Mcleod, Tavia	4080	02/26/2026	141- -11140	\$49.30
41004396	Metropolitan Life	3677	02/26/2026	141- -11140	\$120.00
41004397	Burkheart, Michelle	9242	02/26/2026	141- -11140	\$128.50
41004398	NHA	7338	02/26/2026	141- -11140	\$1,815.00
41004399	Quill, LLC	4574	02/26/2026	141- -11140	\$219.18
41004400	William Sawyer	9244	02/26/2026	141- -11140	\$68.15
41004401	Tennessee Child Support Receipting Unit	1312	02/26/2026	141- -11140	\$791.00
41004402	Tennessee Farmers Life Insurance	5297	02/26/2026	141- -11140	\$925.00
41004403	Tn Dept. Of Labor & Workforce	92	02/26/2026	141- -11140	\$120.00
41004404	Water Authority Of Dickson Co.	5874	02/26/2026	141- -11140	\$624.80
41004405	Youth Town of Tennessee, Inc.	6951	02/26/2026	141- -11140	\$2,160.00
141 Total:					\$441,986.01
Bank Total:					\$441,986.01
Bank Payment Count:					26

Bank Name **Bank Number**
 Federal 142

<u>Payment Number</u>	<u>Vendor Name</u>	<u>Vendor ID</u>	<u>Payment Date</u>	<u>Cash Account</u>	<u>Amount</u>
42001068	Hickman County Trustee	2937	02/26/2026	142-010-11140	\$3,253.77
142-010 Total:					\$3,253.77
42001067	American Paper & Twine Company	797	02/26/2026	142-101-11140	\$1,628.00
42001068	Hickman County Trustee	2937	02/26/2026	142-101-11140	\$10,942.19
42001070	Scholastic, Inc.	4871	02/26/2026	142-101-11140	\$2,743.22
142-101 Total:					\$15,313.41
42001068	Hickman County Trustee	2937	02/26/2026	142-170-11140	\$1,537.72
142-170 Total:					\$1,537.72
42001068	Hickman County Trustee	2937	02/26/2026	142-201-11140	\$1,533.51
142-201 Total:					\$1,533.51
42001068	Hickman County Trustee	2937	02/26/2026	142-601-11140	\$610.32
142-601 Total:					\$610.32
42001068	Hickman County Trustee	2937	02/26/2026	142-801-11140	\$278.40
142-801 Total:					\$278.40
42001068	Hickman County Trustee	2937	02/26/2026	142-901-11140	\$11,583.26
42001069	Gabriel Ortiz Sanches	9243	02/26/2026	142-901-11140	\$94.25
42001071	Tennessee Farmers Life Insurance	5297	02/26/2026	142-901-11140	\$30.00
142-901 Total:					\$11,707.51
42001068	Hickman County Trustee	2937	02/26/2026	142-911-11140	\$255.92
142-911 Total:					\$255.92
Bank Total:					\$34,490.56
Bank Payment Count:					5

Bank Name Bank Number
General Purpose 141

<u>Payment Number</u>	<u>Vendor Name</u>	<u>Vendor ID</u>	<u>Payment Date</u>	<u>Cash Account</u>	<u>Amount</u>
41004406	County Of Hickman Misc Acct	1633	03/02/2026	141- -11140	\$55,718.92
41004407	Gross, Debbie	2675	03/02/2026	141- -11140	\$112.01
41004408	McManus, Christy	8120	03/02/2026	141- -11140	\$242.44
41004409	Rietveld, Stephanie	993	03/02/2026	141- -11140	\$1,400.00
41004410	Soliant Health, LLC	8569	03/02/2026	141- -11140	\$3,765.15
41004411	Town Of Centerville	5315	03/02/2026	141- -11140	\$2,993.45
141 Total:					\$64,231.97
Bank Total:					\$64,231.97
Bank Payment Count:					6

<u>Bank Name</u>	<u>Bank Number</u>
Federal	142

<u>Payment Number</u>	<u>Vendor Name</u>	<u>Vendor ID</u>	<u>Payment Date</u>	<u>Cash Account</u>	<u>Amount</u>
42001072	County Of Hickman Misc Acct	1633	03/02/2026	142-901-11140	\$390.19
142-901 Total:					\$390.19
Bank Total:					\$390.19
Bank Payment Count:					1

Bank Name **Bank Number**
General Purpose 141

<u>Payment Number</u>	<u>Vendor Name</u>	<u>Vendor ID</u>	<u>Payment Date</u>	<u>Cash Account</u>	<u>Amount</u>
41004412	Ace Hardware	635	03/05/2026	141- -11140	\$482.30
41004413	Allegra Print & Imaging	650	03/05/2026	141- -11140	\$44.63
41004414	Haines, Amanda	9148	03/05/2026	141- -11140	\$1,560.00
41004415	American Fidelity Assurance	637	03/05/2026	141- -11140	\$11,641.81
41004416	American Fidelity Assurance Co	636	03/05/2026	141- -11140	\$79,987.82
41004417	American Fidelity Assurance Co	652	03/05/2026	141- -11140	\$6,305.00
41004418	Bon Aqua Lyles Utility Distric	851	03/05/2026	141- -11140	\$2,714.80
41004419	Brewer, Robert G.	7665	03/05/2026	141- -11140	\$116.00
41004420	Carter, David	1639	03/05/2026	141- -11140	\$162.40
41004421	County Of Hickman Misc Acct	1633	03/05/2026	141- -11140	\$185,118.02
41004422	Cross, Emily	1744	03/05/2026	141- -11140	\$162.40
41004423	Dotson, Cecily	1895	03/05/2026	141- -11140	\$103.68
41004424	Duley, L.C.S.W., Joe	1814	03/05/2026	141- -11140	\$2,307.50
41004425	Ed's Supply, Inc.	2103	03/05/2026	141- -11140	\$45.53
41004426	Gallaher & Associates, Inc.	7285	03/05/2026	141- -11140	\$2,632.53
41004427	Hermitage Hall	2916	03/05/2026	141- -11140	\$1,020.00
41004428	Hibbs, Polly	3038	03/05/2026	141- -11140	\$34.80
41004429	Hickman County Trustee	2937	03/05/2026	141- -11140	\$206.43
41004430	Lumber Yard, The	3652	03/05/2026	141- -11140	\$66.24
41004431	Matrix Mechanical Solutions, LLC	7974	03/05/2026	141- -11140	\$9,308.43
41004432	Meriwether Lewis Electric Coop.	3694	03/05/2026	141- -11140	\$42,665.30
41004433	Minge, Amy R.	3723	03/05/2026	141- -11140	\$9,360.00
41004434	Plumbmaster, Inc.	4379	03/05/2026	141- -11140	\$232.60
41004435	SSC Service Solutions Compass Group USA, Inc.	4832	03/05/2026	141- -11140	\$61,838.58
41004436	Herrera, Tammy	8538	03/05/2026	141- -11140	\$40.60
41004437	Town Of Centerville	5315	03/05/2026	141- -11140	\$26,057.97
41004438	TreviPay-Walmart	8999	03/05/2026	141- -11140	\$44.69
41004439	United Farm & Home Co-op	2769	03/05/2026	141- -11140	\$41.69
41004440	Waverly Glass Inc.	5863	03/05/2026	141- -11140	\$3,020.75
41004441	Whitaker, Wesley	7554	03/05/2026	141- -11140	\$171.83
141 Total:					\$447,494.33
Bank Total:					\$447,494.33
Bank Payment Count:					30

Hickman County Finance
Payment Register By Account Control

Bank Name Bank Number
Federal 142

<u>Payment Number</u>	<u>Vendor Name</u>	<u>Vendor ID</u>	<u>Payment Date</u>	<u>Cash Account</u>	<u>Amount</u>
42001075	County Of Hickman Misc Acct	1633	03/05/2026	142-010-11140	\$399.81
42001076	Mayberry, Kimberly D.	4108	03/05/2026	142-010-11140	\$150.08
142-010 Total:					\$549.89
42001073	Amazon	727	03/05/2026	142-101-11140	\$3,524.50
42001074	American Fidelity Assurance Co	636	03/05/2026	142-101-11140	\$1,241.10
42001075	County Of Hickman Misc Acct	1633	03/05/2026	142-101-11140	\$2,443.30
42001077	Nasco Early Learning	4124	03/05/2026	142-101-11140	\$57.72
42001078	New Precision Technology, LLC	9240	03/05/2026	142-101-11140	\$263.11
42001079	Quill, LLC	4574	03/05/2026	142-101-11140	\$45.66
42001080	School Specialty	1433	03/05/2026	142-101-11140	\$128.64
142-101 Total:					\$7,704.03
42001075	County Of Hickman Misc Acct	1633	03/05/2026	142-170-11140	\$367.36
142-170 Total:					\$367.36
42001074	American Fidelity Assurance Co	636	03/05/2026	142-201-11140	\$356.40
42001075	County Of Hickman Misc Acct	1633	03/05/2026	142-201-11140	\$303.60
142-201 Total:					\$660.00
42001075	County Of Hickman Misc Acct	1633	03/05/2026	142-601-11140	\$118.51
142-601 Total:					\$118.51
42001075	County Of Hickman Misc Acct	1633	03/05/2026	142-901-11140	\$1,033.33
142-901 Total:					\$1,033.33
Bank Total:					\$10,433.12
Bank Payment Count:					8

<u>Bank Name</u>	<u>Bank Number</u>
Cafeteria	143

<u>Payment Number</u>	<u>Vendor Name</u>	<u>Vendor ID</u>	<u>Payment Date</u>	<u>Cash Account</u>	<u>Amount</u>
43000744	County Of Hickman Misc Acct	1633	03/05/2026	143- -11140	\$9,886.18
43000745	Town Of Centerville	5315	03/05/2026	143- -11140	\$155.95
143 Total:					\$10,042.13
Bank Total:					\$10,042.13
Bank Payment Count:					2

Bank Name **Bank Number**
 Cafeteria 143

<u>Payment Number</u>	<u>Vendor Name</u>	<u>Vendor ID</u>	<u>Payment Date</u>	<u>Cash Account</u>	<u>Amount</u>
43000746	Fitts, Connie S.	185	03/09/2026	143- -11140	\$221.13
43000747	Gordon Food Service, Inc.	2488	03/09/2026	143- -11140	\$82,835.09
43000748	Murfreesboro Pure Milk Co, Inc.	7552	03/09/2026	143- -11140	\$1,366.80
43000749	Optimus Pest Solutions	47	03/09/2026	143- -11140	\$240.00
43000750	Pepsi Cola	6726	03/09/2026	143- -11140	\$1,917.25
43000751	Prairie Farms Dairy	18	03/09/2026	143- -11140	\$15,429.04
43000752	Prince Hardware, LLC	4321	03/09/2026	143- -11140	\$269.78
43000753	SNA Depository	4878	03/09/2026	143- -11140	\$14.00
43000754	Volco	5841	03/09/2026	143- -11140	\$3,897.49
143 Total:					<u>\$106,190.58</u>
Bank Total:					<u>\$106,190.58</u>
Bank Payment Count:					9

Bank Name **Bank Number**
 General Purpose 141

<u>Payment Number</u>	<u>Vendor Name</u>	<u>Vendor ID</u>	<u>Payment Date</u>	<u>Cash Account</u>	<u>Amount</u>
41004442	A Dirty Job	665	03/09/2026	141- -11140	\$2,100.00
41004443	Amazon	727	03/09/2026	141- -11140	\$990.03
41004444	AT & T	7542	03/09/2026	141- -11140	\$240.72
41004445	Barnes & Noble College Booksellers, LLC	1211	03/09/2026	141- -11140	\$799.98
41004446	Bennett & DeCamp PLLC	8071	03/09/2026	141- -11140	\$1,470.00
41004447	Bluegrass Computer Systems,LLC	1030	03/09/2026	141- -11140	\$2,508.00
41004448	Brewer Chemicals & Equip, LLC	861	03/09/2026	141- -11140	\$420.00
41004449	Cdw Government Inc.	1275	03/09/2026	141- -11140	\$9,338.00
41004450	Central States Bus Sales, Inc.	1326	03/09/2026	141- -11140	\$2,331.05
41004451	Choice Automotive Equipment LLC	9236	03/09/2026	141- -11140	\$600.65
41004452	Cummins, Inc.	1749	03/09/2026	141- -11140	\$31.16
41004453	Foam Crete, Inc.	8904	03/09/2026	141- -11140	\$11,240.32
41004454	Hermitage Hall	2916	03/09/2026	141- -11140	\$240.00
41004455	Hickman County Trustee	2937	03/09/2026	141- -11140	\$4,430.73
41004456	Howard Industries, Inc.	2866	03/09/2026	141- -11140	\$15,892.00
41004457	O'Reilly Auto Parts	4265	03/09/2026	141- -11140	\$520.90
41004458	Optimus Pest Solutions	47	03/09/2026	141- -11140	\$750.00
41004459	Prince Hardware, LLC	4321	03/09/2026	141- -11140	\$4,098.18
41004460	Soliant Health, LLC	8569	03/09/2026	141- -11140	\$2,091.75
41004461	Tartan Oil, LLC	9005	03/09/2026	141- -11140	\$690.00
41004462	Town Of Centerville	5315	03/09/2026	141- -11140	\$15,626.68
41004463	Unifirst Corp.	5758	03/09/2026	141- -11140	\$548.56
141 Total:					\$76,958.71
Bank Total:					\$76,958.71
Bank Payment Count:					22

Bank Name	Bank Number
Federal	142

<u>Payment Number</u>	<u>Vendor Name</u>	<u>Vendor ID</u>	<u>Payment Date</u>	<u>Cash Account</u>	<u>Amount</u>
42001081	Educate America, LLC	9252	03/09/2026	142-101-11140	\$497.00
42001082	Howard Industries, Inc.	2866	03/09/2026	142-101-11140	\$14,055.00
42001084	Really Good Stuff, LLC	4606	03/09/2026	142-101-11140	\$639.68
42001085	Rochester 100 Inc.	4736	03/09/2026	142-101-11140	\$1,032.75
142-101 Total:					\$16,224.43
42001082	Howard Industries, Inc.	2866	03/09/2026	142-601-11140	\$3,570.00
142-601 Total:					\$3,570.00
42001083	Paxton Patterson	8235	03/09/2026	142-801-11140	\$308.50
142-801 Total:					\$308.50
Bank Total:					\$20,102.93
Bank Payment Count:					5

Bank Name **Bank Number**
 General Purpose 141

<u>Payment Number</u>	<u>Vendor Name</u>	<u>Vendor ID</u>	<u>Payment Date</u>	<u>Cash Account</u>	<u>Amount</u>
41004464	Amazon	727	03/12/2026	141- -11140	\$1,269.75
41004465	AT & T	7542	03/12/2026	141- -11140	\$58.91
41004466	Holloway, Megan M	8708	03/12/2026	141- -11140	\$37.15
41004467	Hobbs, Kara	6361	03/12/2026	141- -11140	\$454.69
41004468	McCaleb, Rachel	7746	03/12/2026	141- -11140	\$112.38
41004469	Monica Ogles PT	7756	03/12/2026	141- -11140	\$2,515.28
41004470	Rj Young Company	4691	03/12/2026	141- -11140	\$4,391.55
41004471	Roman A/V, LLC.	7045	03/12/2026	141- -11140	\$750.00
41004472	Tanner, Katelyn	6315	03/12/2026	141- -11140	\$100.78
41004473	Tennessee Bureau Of Investigation	5491	03/12/2026	141- -11140	\$50.00
41004474	The King's Daughter's School	7928	03/12/2026	141- -11140	\$5,250.00
41004475	TreviPay-Walmart	8999	03/12/2026	141- -11140	\$1,440.74
41004476	Verizon Wireless	5823	03/12/2026	141- -11140	\$68.04
41004477	Visa	8268	03/12/2026	141- -11140	\$64.79
41004478	Youth Town of Tennessee, Inc.	6951	03/12/2026	141- -11140	\$2,280.00
41004479	Zayo Education	2141	03/12/2026	141- -11140	\$2,137.68
141 Total:					\$20,981.74
Bank Total:					\$20,981.74
Bank Payment Count:					16

Bank Name Bank Number
 Federal 142

<u>Payment Number</u>	<u>Vendor Name</u>	<u>Vendor ID</u>	<u>Payment Date</u>	<u>Cash Account</u>	<u>Amount</u>
42001093	Rj Young Company	4691	03/12/2026	142-010-11140	\$254.12
142-010 Total:					\$254.12
42001086	Amazon	727	03/12/2026	142-101-11140	\$1,800.60
42001087	Elevate Your Classroom, LLC	8652	03/12/2026	142-101-11140	\$200.00
42001091	Marenem, Inc.	8293	03/12/2026	142-101-11140	\$2,497.33
42001092	Quill, LLC	4574	03/12/2026	142-101-11140	\$967.78
42001093	Rj Young Company	4691	03/12/2026	142-101-11140	\$189.48
142-101 Total:					\$5,655.19
42001090	Knowbuddy Resources	9237	03/12/2026	142-601-11140	\$523.53
142-601 Total:					\$523.53
42001088	Freeman Lumber Company	2325	03/12/2026	142-801-11140	\$621.94
42001089	Turpin, Jennifer	5444	03/12/2026	142-801-11140	\$306.24
142-801 Total:					\$928.18
42001094	Wilson, Anita	7954	03/12/2026	142-901-11140	\$1,296.00
142-901 Total:					\$1,296.00
Bank Total:					\$8,657.02
Bank Payment Count:					9

<u>Bank Name</u>	<u>Bank Number</u>
Cafeteria	143

<u>Payment Number</u>	<u>Vendor Name</u>	<u>Vendor ID</u>	<u>Payment Date</u>	<u>Cash Account</u>	<u>Amount</u>
43000755	Pace, Karen	9259	03/12/2026	143- -11140	\$37.15
43000756	Rj Young Company	4691	03/12/2026	143- -11140	\$336.83
143 Total:					\$373.98
Bank Total:					\$373.98
Bank Payment Count:					2

Bank Name	Bank Number
General Purpose	141

<u>Payment Number</u>	<u>Vendor Name</u>	<u>Vendor ID</u>	<u>Payment Date</u>	<u>Cash Account</u>	<u>Amount</u>
41004480	County Of Hickman Misc Acct	1633	03/13/2026	141- -11140	\$6,805.57
41004481	Hickman Co Trustee	2722	03/13/2026	141- -11140	\$265,887.79
141 Total:					\$272,693.36
Bank Total:					\$272,693.36
Bank Payment Count:					2

Bank Name Bank Number
Federal 142

<u>Payment Number</u>	<u>Vendor Name</u>	<u>Vendor ID</u>	<u>Payment Date</u>	<u>Cash Account</u>	<u>Amount</u>	
42001095	Hickman Co Trustee	2722	03/13/2026	142-010-11140	\$150.20	
					142-010 Total:	\$150.20
42001095	Hickman Co Trustee	2722	03/13/2026	142-101-11140	\$1,231.05	
					142-101 Total:	\$1,231.05
42001095	Hickman Co Trustee	2722	03/13/2026	142-170-11140	\$82.70	
					142-170 Total:	\$82.70
42001095	Hickman Co Trustee	2722	03/13/2026	142-201-11140	\$150.20	
					142-201 Total:	\$150.20
42001095	Hickman Co Trustee	2722	03/13/2026	142-801-11140	\$82.70	
					142-801 Total:	\$82.70
42001095	Hickman Co Trustee	2722	03/13/2026	142-901-11140	\$2,568.64	
					142-901 Total:	\$2,568.64
42001095	Hickman Co Trustee	2722	03/13/2026	142-911-11140	\$82.70	
					142-911 Total:	\$82.70
					Bank Total:	\$4,348.19
					Bank Payment Count:	1

Bank Name **Bank Number**
 General Purpose 141

<u>Payment Number</u>	<u>Vendor Name</u>	<u>Vendor ID</u>	<u>Payment Date</u>	<u>Cash Account</u>	<u>Amount</u>
41004482	ASMS, LLC	646	03/16/2026	141- -11140	\$781.00
41004483	AT & T	7542	03/16/2026	141- -11140	\$165.89
41004484	CPR Savers	1401	03/16/2026	141- -11140	\$1,832.00
41004485	Ferrellgas	7446	03/16/2026	141- -11140	\$1,703.77
41004486	Interpreters Unlimited, Inc.	6501	03/16/2026	141- -11140	\$187.50
41004487	Roman A/V, LLC.	7045	03/16/2026	141- -11140	\$200.00
41004488	Soliant Health, LLC	8569	03/16/2026	141- -11140	\$2,091.75
41004489	Stellar Therapy Services, LLC	8260	03/16/2026	141- -11140	\$6,387.50
41004490	The Brook Center Therapy Solutions, LLC	8659	03/16/2026	141- -11140	\$3,020.00
41004491	TK Elevator Corporation	7327	03/16/2026	141- -11140	\$3,922.08
41004492	Town Of Centerville	5284	03/16/2026	141- -11140	\$3,880.11
41004493	Trane U.S. Inc	5383	03/16/2026	141- -11140	\$258.96
41004494	Vasion, Inc.	9255	03/16/2026	141- -11140	\$5,130.00
41004495	Walk-In Medical Clinic Linden, LLC	6040	03/16/2026	141- -11140	\$170.00
141 Total:					\$29,730.56
Bank Total:					\$29,730.56
Bank Payment Count:					14

Bank Name	Bank Number
Federal	142

<u>Payment Number</u>	<u>Vendor Name</u>	<u>Vendor ID</u>	<u>Payment Date</u>	<u>Cash Account</u>	<u>Amount</u>
42001096	Amazon	727	03/16/2026	142-101-11140	\$2,096.05
42001098	Grassroots Workshops	9251	03/16/2026	142-101-11140	\$411.60
42001100	Rochester 100 Inc.	4736	03/16/2026	142-101-11140	\$970.00
42001101	Willow Lane Education	3529	03/16/2026	142-101-11140	\$453.03
142-101 Total:					\$3,930.68
42001099	IXL Learning	3199	03/16/2026	142-601-11140	\$3,281.25
142-601 Total:					\$3,281.25
42001097	Freeman Lumber Company	2325	03/16/2026	142-801-11140	\$949.82
142-801 Total:					\$949.82
Bank Total:					\$8,161.75
Bank Payment Count:					6

Bank Name **Bank Number**
General Purpose 141

<u>Payment Number</u>	<u>Vendor Name</u>	<u>Vendor ID</u>	<u>Payment Date</u>	<u>Cash Account</u>	<u>Amount</u>
41004496	Amazon	727	03/19/2026	141- -11140	\$631.73
41004497	American Fidelity Administrative Services, LLC	802	03/19/2026	141- -11140	\$563.55
41004498	American Fidelity Assurance	637	03/19/2026	141- -11140	\$11,762.93
41004499	American Fidelity Assurance Co	636	03/19/2026	141- -11140	\$77,826.01
41004500	American Fidelity Assurance Co	652	03/19/2026	141- -11140	\$6,305.00
41004501	Ameritas Life Insurance Corp.	7442	03/19/2026	141- -11140	\$2,999.90
41004502	AT & T	7542	03/19/2026	141- -11140	\$355.31
41004503	Beam Insurance Administrators LLC	7435	03/19/2026	141- -11140	\$10,046.58
41004504	CNB Computers USA, Inc.	6586	03/19/2026	141- -11140	\$918.00
41004505	Dickson Electric System	1806	03/19/2026	141- -11140	\$34,733.78
41004506	Fellowship Construction	2295	03/19/2026	141- -11140	\$58,186.82
41004507	First Farmers & Merchants Bank	8074	03/19/2026	141- -11140	\$3,062.46
41004508	Kelsan, Inc.	3379	03/19/2026	141- -11140	\$3,493.63
41004509	Pace Analytical National	2230	03/19/2026	141- -11140	\$756.00
41004510	Porter, Savannah	8555	03/19/2026	141- -11140	\$240.00
41004511	Quill, LLC	4574	03/19/2026	141- -11140	\$94.31
41004512	Swope Educational Consulting	5203	03/19/2026	141- -11140	\$3,800.00
41004513	TreviPay-Walmart	8999	03/19/2026	141- -11140	\$85.62
141 Total:					\$215,861.63
Bank Total:					\$215,861.63
Bank Payment Count:					18

Hickman County Finance
Payment Register By Account Control

Bank Name Bank Number
Federal 142

<u>Payment Number</u>	<u>Vendor Name</u>	<u>Vendor ID</u>	<u>Payment Date</u>	<u>Cash Account</u>	<u>Amount</u>
42001102	Amazon	727	03/19/2026	142-101-11140	\$563.58
42001104	Ameritas Life Insurance Corp.	7442	03/19/2026	142-101-11140	\$39.76
42001106	Guilford Publications, Inc.	9250	03/19/2026	142-101-11140	\$812.00
42001107	Lakeshore Learning	3463	03/19/2026	142-101-11140	\$1,155.79
42001108	Woodburn Press	6615	03/19/2026	142-101-11140	\$539.55
142-101 Total:					\$3,110.68
42001105	Beam Insurance Administrators LLC	7435	03/19/2026	142-170-11140	\$563.95
142-170 Total:					\$563.95
42001104	Ameritas Life Insurance Corp.	7442	03/19/2026	142-201-11140	\$36.00
42001105	Beam Insurance Administrators LLC	7435	03/19/2026	142-201-11140	\$126.98
142-201 Total:					\$162.98
42001103	American Fidelity Assurance Co	636	03/19/2026	142-401-11140	\$4.68
142-401 Total:					\$4.68
42001102	Amazon	727	03/19/2026	142-811-11140	\$141.15
142-811 Total:					\$141.15
42001103	American Fidelity Assurance Co	636	03/19/2026	142-901-11140	\$3,827.46
42001104	Ameritas Life Insurance Corp.	7442	03/19/2026	142-901-11140	\$208.76
42001105	Beam Insurance Administrators LLC	7435	03/19/2026	142-901-11140	\$658.12
142-901 Total:					\$4,694.34
Bank Total:					\$8,677.78
Bank Payment Count:					7

Bank Name **Bank Number**
 General Purpose 141

<u>Payment Number</u>	<u>Vendor Name</u>	<u>Vendor ID</u>	<u>Payment Date</u>	<u>Cash Account</u>	<u>Amount</u>
41004514	Amazon	727	03/23/2026	141- -11140	\$186.88
41004515	Anderson, Belinda	8051	03/23/2026	141- -11140	\$360.62
41004516	Carter, Kristen B.	1768	03/23/2026	141- -11140	\$37.15
41004517	Dean Oil Co., Inc.	1985	03/23/2026	141- -11140	\$41,196.16
41004518	Ferrellgas	7446	03/23/2026	141- -11140	\$705.29
41004519	Kelsan, Inc.	3379	03/23/2026	141- -11140	\$3,497.77
41004520	Main Street Media of TN	2718	03/23/2026	141- -11140	\$450.00
41004521	Oriental Trading Co., Inc.	6258	03/23/2026	141- -11140	\$255.44
41004522	Quill, LLC	4574	03/23/2026	141- -11140	\$253.07
41004523	Really Good Stuff, LLC	4606	03/23/2026	141- -11140	\$23.74
41004524	Republic Service, LLC #840	4739	03/23/2026	141- -11140	\$4,739.85
41004525	Soliant Health, LLC	8569	03/23/2026	141- -11140	\$1,882.58
41004526	TreviPay-Walmart	8999	03/23/2026	141- -11140	\$198.38
41004527	Water Authority Of Dickson Co.	5874	03/23/2026	141- -11140	\$1,870.30

141 Total: \$55,657.23

Bank Total: \$55,657.23

Bank Payment Count: 14

Bank Name Bank Number
 Federal 142

<u>Payment Number</u>	<u>Vendor Name</u>	<u>Vendor ID</u>	<u>Payment Date</u>	<u>Cash Account</u>	<u>Amount</u>
42001109	Amazon	727	03/23/2026	142-010-11140	\$1,273.02
142-010 Total:					\$1,273.02
42001109	Amazon	727	03/23/2026	142-101-11140	\$2,323.81
42001110	Pittman, Demarkus	9276	03/23/2026	142-101-11140	\$640.90
42001111	Quill, LLC	4574	03/23/2026	142-101-11140	\$2,128.56
42001112	Cathey, Vince	9230	03/23/2026	142-101-11140	\$326.25
142-101 Total:					\$5,419.52
Bank Total:					\$6,692.54
Bank Payment Count:					4

Bank Name Bank Number
Cafeteria 143

<u>Payment Number</u>	<u>Vendor Name</u>	<u>Vendor ID</u>	<u>Payment Date</u>	<u>Cash Account</u>	<u>Amount</u>
43000757	American Fidelity Assurance Co	636	03/23/2026	143- -11140	\$1,557.47
43000758	Ameritas Life Insurance Corp.	7442	03/23/2026	143- -11140	\$81.42
43000759	Beam Insurance Administrators LLC	7435	03/23/2026	143- -11140	\$428.41
43000760	Hickman Co Trustee	2722	03/23/2026	143- -11140	\$1,790.02
43000761	Hickman County Trustee	2937	03/23/2026	143- -11140	\$18,515.27
43000762	Tennessee Farmers Life Insurance	5297	03/23/2026	143- -11140	\$25.00
143 Total:					\$22,397.59
Bank Total:					\$22,397.59
Bank Payment Count:					6

Bank Name **Bank Number**
General Purpose 141

<u>Payment Number</u>	<u>Vendor Name</u>	<u>Vendor ID</u>	<u>Payment Date</u>	<u>Cash Account</u>	<u>Amount</u>
41004528	Amazon	727	03/26/2026	141- -11140	\$123.96
41004529	Centerville Elementary School	1540	03/26/2026	141- -11140	\$750.00
41004530	Centerville Intermediate School	8949	03/26/2026	141- -11140	\$750.00
41004531	CPR Savers	1401	03/26/2026	141- -11140	\$539.00
41004532	East Hickman Elementary School	2098	03/26/2026	141- -11140	\$750.00
41004533	East Hickman High School	2113	03/26/2026	141- -11140	\$750.00
41004534	East Hickman Intermediate School	2213	03/26/2026	141- -11140	\$750.00
41004535	East Hickman Middle School	2201	03/26/2026	141- -11140	\$750.00
41004536	Four Seasons Outdoors & Sports	2334	03/26/2026	141- -11140	\$1,404.00
41004537	Gordon Food Service, Inc.	2488	03/26/2026	141- -11140	\$32.52
41004538	Harvill, Nancy	2758	03/26/2026	141- -11140	\$6,254.15
41004539	Hickman Co Trustee	2722	03/26/2026	141- -11140	\$2,424.10
41004540	Hickman Co. General Sessions	2858	03/26/2026	141- -11140	\$839.58
41004541	Hickman County High School	2917	03/26/2026	141- -11140	\$750.00
41004542	Hickman County Middle School	2957	03/26/2026	141- -11140	\$750.00
41004543	Hickman County Trustee	2937	03/26/2026	141- -11140	\$391,518.53
41004544	Learning Labs, Inc.	8780	03/26/2026	141- -11140	\$3,686.00
41004545	Lumen/Centurylink	4577	03/26/2026	141- -11140	\$0.84
41004546	Matlock Clements, P.C.	8774	03/26/2026	141- -11140	\$35,000.00
41004547	Metropolitan Life	3677	03/26/2026	141- -11140	\$120.00
41004548	Tennessee Child Support Receipting Unit	1312	03/26/2026	141- -11140	\$791.00
41004549	Tennessee Farmers Life Insurance	5297	03/26/2026	141- -11140	\$925.00
41004550	TreviPay-Walmart	8999	03/26/2026	141- -11140	\$924.06
41004551	Virco, Inc.	5830	03/26/2026	141- -11140	\$3,640.04

141 Total: \$454,222.78

Bank Total: \$454,222.78

Bank Payment Count: 24

Bank Name Bank Number
Federal 142

<u>Payment Number</u>	<u>Vendor Name</u>	<u>Vendor ID</u>	<u>Payment Date</u>	<u>Cash Account</u>	<u>Amount</u>
42001115	Hickman County Trustee	2937	03/26/2026	142-010-11140	\$3,253.77
42001116	Hudgins, Jennifer Thrasher	3019	03/26/2026	142-010-11140	\$130.50
142-010 Total:					\$3,384.27
42001113	Amazon	727	03/26/2026	142-101-11140	\$3,941.36
42001115	Hickman County Trustee	2937	03/26/2026	142-101-11140	\$10,942.31
42001117	Poster Studio Express	9260	03/26/2026	142-101-11140	\$4,995.00
142-101 Total:					\$19,878.67
42001115	Hickman County Trustee	2937	03/26/2026	142-170-11140	\$1,537.70
142-170 Total:					\$1,537.70
42001115	Hickman County Trustee	2937	03/26/2026	142-201-11140	\$1,533.51
142-201 Total:					\$1,533.51
42001115	Hickman County Trustee	2937	03/26/2026	142-601-11140	\$610.32
142-601 Total:					\$610.32
42001114	Hickman Co Board Of Ed.	2734	03/26/2026	142-801-11140	\$3,059.97
42001115	Hickman County Trustee	2937	03/26/2026	142-801-11140	\$278.42
142-801 Total:					\$3,338.39
42001115	Hickman County Trustee	2937	03/26/2026	142-901-11140	\$11,810.90
42001118	Scholastic, Inc.	4871	03/26/2026	142-901-11140	\$316.26
42001119	Tennessee Farmers Life Insurance	5297	03/26/2026	142-901-11140	\$30.00
42001120	Western Psychological Service	6042	03/26/2026	142-901-11140	\$81.40
142-901 Total:					\$12,238.56
42001115	Hickman County Trustee	2937	03/26/2026	142-911-11140	\$255.92
142-911 Total:					\$255.92
Bank Total:					\$42,777.34
Bank Payment Count:					8

*wrong amount
check
re-written
on 3/27/25
D. Breece*

<u>Bank Name</u>	<u>Bank Number</u>
Cafeteria	143

<u>Payment Number</u>	<u>Vendor Name</u>	<u>Vendor ID</u>	<u>Payment Date</u>	<u>Cash Account</u>	<u>Amount</u>
43000763	Jimenez, Carolyn	9280	03/26/2026	143- -11140	\$37.15
143 Total:					\$37.15
Bank Total:					\$37.15
Bank Payment Count:					1

Bank Name Bank Number
 General Purpose 141

<u>Payment Number</u>	<u>Vendor Name</u>	<u>Vendor ID</u>	<u>Payment Date</u>	<u>Cash Account</u>	<u>Amount</u>
41004552	American Fidelity Assurance	637	03/27/2026	141- -11140	\$11,668.41
41004553	American Fidelity Assurance Co	636	03/27/2026	141- -11140	\$78,781.96
41004554	American Fidelity Assurance Co	652	03/27/2026	141- -11140	\$5,833.00
41004555	Ameritas Life Insurance Corp.	7442	03/27/2026	141- -11140	\$3,152.10
41004556	Beam Insurance Administrators LLC	7435	03/27/2026	141- -11140	\$11,463.24
41004557	Keller, Cole	7743	03/27/2026	141- -11140	\$381.87
141 Total:					<u>\$111,280.58</u>
Bank Total:					<u>\$111,280.58</u>
Bank Payment Count:					6

Bank Name Bank Number
Federal 142

<u>Payment Number</u>	<u>Vendor Name</u>	<u>Vendor ID</u>	<u>Payment Date</u>	<u>Cash Account</u>	<u>Amount</u>
* 42001121	Amazon	727	03/27/2026	142-101-11140	\$3,940.31
42001123	Ameritas Life Insurance Corp.	7442	03/27/2026	142-101-11140	\$19.88
142-101 Total:					\$3,960.19
42001122	American Fidelity Assurance Co	636	03/27/2026	142-201-11140	\$118.80
42001123	Ameritas Life Insurance Corp.	7442	03/27/2026	142-201-11140	\$18.00
142-201 Total:					\$136.80
42001122	American Fidelity Assurance Co	636	03/27/2026	142-901-11140	\$1,395.98
42001123	Ameritas Life Insurance Corp.	7442	03/27/2026	142-901-11140	\$104.38
42001124	Beam Insurance Administrators LLC	7435	03/27/2026	142-901-11140	\$329.06
142-901 Total:					\$1,829.42
42001122	American Fidelity Assurance Co	636	03/27/2026	142-911-11140	\$926.12
142-911 Total:					\$926.12
Bank Total:					\$6,852.53
Bank Payment Count:					4

<u>Bank Name</u>	<u>Bank Number</u>
General Purpose	141

<u>Payment Number</u>	<u>Vendor Name</u>	<u>Vendor ID</u>	<u>Payment Date</u>	<u>Cash Account</u>	<u>Amount</u>
41004558	County Of Hickman Misc Acct	1633	04/06/2026	141- -11140	\$243,075.52
41004559	Town Of Centerville	5315	04/06/2026	141- -11140	\$1,365.57
141 Total:					\$244,441.09
Bank Total:					\$244,441.09
Bank Payment Count:					2

<u>Bank Name</u>	<u>Bank Number</u>
Cafeteria	143

<u>Payment Number</u>	<u>Vendor Name</u>	<u>Vendor ID</u>	<u>Payment Date</u>	<u>Cash Account</u>	<u>Amount</u>
43000764	County Of Hickman Misc Acct	1633	04/06/2026	143- -11140	\$10,461.14
143 Total:					\$10,461.14
Bank Total:					\$10,461.14
Bank Payment Count:					1

Bank Name **Bank Number**
 Federal 142

<u>Payment Number</u>	<u>Vendor Name</u>	<u>Vendor ID</u>	<u>Payment Date</u>	<u>Cash Account</u>	<u>Amount</u>
42001125	County Of Hickman Misc Acct	1633	04/06/2026	142-010-11140	\$399.81
142-010 Total:					\$399.81
42001125	County Of Hickman Misc Acct	1633	04/06/2026	142-101-11140	\$2,443.30
142-101 Total:					\$2,443.30
42001125	County Of Hickman Misc Acct	1633	04/06/2026	142-170-11140	\$367.36
142-170 Total:					\$367.36
42001125	County Of Hickman Misc Acct	1633	04/06/2026	142-201-11140	\$303.60
142-201 Total:					\$303.60
42001125	County Of Hickman Misc Acct	1633	04/06/2026	142-601-11140	\$118.51
142-601 Total:					\$118.51
42001125	County Of Hickman Misc Acct	1633	04/06/2026	142-901-11140	\$1,423.52
142-901 Total:					\$1,423.52
Bank Total:					\$5,056.10
Bank Payment Count:					1

Bank Name **Bank Number**
General Purpose 141

<u>Payment Number</u>	<u>Vendor Name</u>	<u>Vendor ID</u>	<u>Payment Date</u>	<u>Cash Account</u>	<u>Amount</u>
41004560	Amazon	727	04/07/2026	141- -11140	\$2,800.43
41004561	AT & T	7542	04/07/2026	141- -11140	\$240.72
41004562	Bennett & DeCamp PLLC	8071	04/07/2026	141- -11140	\$1,460.50
41004563	Bon Aqua Lyles Utility Distric	851	04/07/2026	141- -11140	\$4,133.22
41004564	Carter, David	1639	04/07/2026	141- -11140	\$208.80
41004565	Gordon Food Service, Inc.	2488	04/07/2026	141- -11140	\$23.34
41004566	McCaleb, Rachel	7746	04/07/2026	141- -11140	\$60.18
41004567	Mccaleb, Susan	4081	04/07/2026	141- -11140	\$36.16
41004568	Meriwether Lewis Electric Coop.	3694	04/07/2026	141- -11140	\$41,317.92
41004569	Quill, LLC	4574	04/07/2026	141- -11140	\$515.23
41004570	Sweetwater Sound, LLC	5119	04/07/2026	141- -11140	\$229.00
41004571	Herrera, Tammy	8538	04/07/2026	141- -11140	\$52.20
41004572	Tanner, Katelyn	6315	04/07/2026	141- -11140	\$131.96
41004573	Town Of Centerville	5315	04/07/2026	141- -11140	\$16,185.30
41004574	TreviPay-Walmart	8999	04/07/2026	141- -11140	\$603.35
41004575	Whitaker, Wesley	7554	04/07/2026	141- -11140	\$208.80
141 Total:					<u>\$68,207.11</u>
Bank Total:					\$68,207.11
Bank Payment Count:					16

<u>Bank Name</u>	<u>Bank Number</u>
Federal	142

<u>Payment Number</u>	<u>Vendor Name</u>	<u>Vendor ID</u>	<u>Payment Date</u>	<u>Cash Account</u>	<u>Amount</u>
42001126	Mayberry, Kimberly D.	4108	04/07/2026	142-010-11140	\$327.70
142-010 Total:					\$327.70
42001127	NCS Pearson Inc.	4359	04/07/2026	142-901-11140	\$65.70
142-901 Total:					\$65.70
Bank Total:					\$393.40
Bank Payment Count:					2



DOUG LANE
2059 Lake Drive, Centerville, TN 37033

PIPPA TAYLOR
6585 Oak Hill Rd., Lyles, TN 37098

TIM HOBBS
9220 Old Bon Aqua Rd., Bon Aqua, TN 37025

TABITHA CUDE
4141 Lewis Rd., Centerville, TN 37033

CHRISTY MAYS
450 Hwy. 50, Centerville, TN 37033

SHERRI BAKER
9037 E 40 Rd., Bon Aqua, TN 37025

JANE HERRON
PO Box 13, Nunnely, TN 37137

Dr. Belinda Anderson
Interim Director of Schools
115 Murphree Avenue
Centerville, TN 37033

Memorandum

To: Board Members
From: Dr. Belinda Anderson
Date: 4/6/2026
Re: April Personnel Report

Leave of Absence

Professional

Support Staff

Hiring

Professional

Support Staff

*Cooper Mays
LaQuisha Waters

Volunteer Asst. Baseball Coach
EHHS Part-Time Assistant

Resignation

Professional

Preston Hall
Mike Cook
Ryan Harrison

EHMS Golf Coach
HCMS Girls' Soccer Coach
HCMS Golf Coach

Support Staff

Retirement

Professional

Support Staff

Transfers

Professional

Support Staff

Appointment

Professional

Support Staff

Open Positions

www.hickmank12.org

Click On Employment Opportunities

*Denotes a relationship under board policy 1.108. Applicants are qualified for the positions

Hickman County Finance
 Summary Financial Statement
 March 2026

141 General Purpose School		Year-To-Date			Month-To-Date		
Account	Description	Budget Estimate	Actual	% of Budget	Estimate Avg/Mth	Actual	% of Avg
Revenues							
40110	Current Property Tax	2,773,333.00	(2,817,873.47)	101.61%	231,111.08	(120,636.82)	52.20%
40120	Trustee's Collections - Prior Year	75,000.00	(63,178.48)	84.24%	6,250.00	(14,056.67)	224.91%
40125	Trustee's Collections - Bankruptcy	500.00	(47.03)	9.41%	41.67	(6.85)	16.44%
40130	Cir Clk/Clk & Master Collections-Pr Yr	40,000.00	(17,031.09)	42.58%	3,333.33	(1,234.49)	37.03%
40140	Interest And Penalty	15,000.00	(9,660.40)	64.40%	1,250.00	(3,614.64)	289.17%
40161	Payments In Lieu Of Taxes - T. V. A.	3,500.00	(1,877.32)	53.64%	291.67	(208.59)	71.52%
40162	Payments In Lieu Of Taxes-Local	6,000.00	(6,000.00)	100.00%	500.00	0.00	0.00%
40210	Local Option Sales Tax	2,975,000.00	(2,412,707.51)	81.10%	247,916.67	(266,034.87)	107.31%
40270	Business Tax	45,000.00	(13,573.90)	30.16%	3,750.00	(1,432.81)	38.21%
41110	Marriage Licenses	1,300.00	(988.00)	76.00%	108.33	(95.00)	87.69%
43570	Receipts From Individual Schools	30,000.00	(10,258.33)	34.19%	2,500.00	(3,140.00)	125.60%
43582	Community Service Fees - Adults	200.00	(5.00)	2.50%	16.67	0.00	0.00%
44120	Lease/Rentals/PPP	7,500.00	(1,685.00)	22.47%	625.00	(1,265.00)	202.40%
44170	Miscellaneous Refunds	30,000.00	(41,138.10)	137.13%	2,500.00	(10,503.26)	420.13%
44530	Sale Of Equipment	15,000.00	0.00	0.00%	1,250.00	0.00	0.00%
44560	Damages Recovered From Individuals	3,000.00	(360.00)	12.00%	250.00	0.00	0.00%
44570	Contributions & Gifts	20,000.00	(27,025.00)	135.13%	1,666.67	(2,000.00)	120.00%
44990	Other Local Revenues	30,000.00	0.00	0.00%	2,500.00	0.00	0.00%
46175	On-Behalf Contributions For OPEB	40,000.00	0.00	0.00%	3,333.33	0.00	0.00%
46510	Tennessee Investment in Student	25,081,234.00	(20,328,225.64)	81.05%	2,090,102.83	(2,503,823.70)	119.79%
46515	Early Childhood Education	445,000.00	(237,677.33)	53.41%	37,083.33	(58,151.31)	156.81%
46520	School Food Service	22,000.00	(16,839.13)	76.54%	1,833.33	(16,839.13)	918.50%
46550	Driver Education	10,000.00	0.00	0.00%	833.33	0.00	0.00%
46590	Other State Education Funds	818,936.60	(578,936.60)	70.69%	68,244.72	0.00	0.00%
46610	Career Ladder Program	37,500.00	(18,644.38)	49.72%	3,125.00	0.00	0.00%
46790	Other Vocational	1,601,845.29	(66,580.74)	4.16%	133,487.11	0.00	0.00%
46851	State Revenue Sharing -T.V.A.	220,000.00	(99,092.62)	45.04%	18,333.33	0.00	0.00%
46980	Other State Grants	59,525.19	0.00	0.00%	4,960.43	0.00	0.00%
46990	Other State Revenues	100,000.00	(192,702.71)	192.70%	8,333.33	(24,087.84)	289.05%
47143	Special Education - Grants To States	16,574.12	0.00	0.00%	1,381.18	0.00	0.00%
47640	Rotc Reimbursement	65,000.00	(41,389.08)	63.68%	5,416.67	(6,898.18)	127.35%
48990	Other	4,000.00	(36,856.17)	921.40%	333.33	(321.26)	96.38%
49700	Insurance Recovery	0.00	(70,594.97)	0.00%	0.00	(67,475.22)	0.00%
49800	Transfers In	10,000.00	0.00	0.00%	833.33	0.00	0.00%
	Total Revenues	34,601,948.20	(27,110,948.00)	78.35%	2,883,495.68	(3,101,825.64)	107.57%
Expenditures							
71100	Regular Instruction Program	(17,320,800.60)	12,726,317.94	73.47%	(1,443,400.05)	1,655,617.95	114.70%

Hickman County Finance
 Summary Financial Statement
 March 2026

141 General Purpose School		Year-To-Date			Month-To-Date		
Account	Description	Budget Estimate	Actual	% of Budget	Estimate Avg/Mth	Actual	% of Avg
71150	Alternative Instruction Program	(317,021.00)	144,381.20	45.54%	(26,418.42)	21,967.49	83.15%
71200	Special Education Program	(3,752,982.12)	2,146,820.08	57.20%	(312,748.51)	279,506.70	89.37%
71300	Career and Technical Education	(1,974,778.43)	693,018.80	35.09%	(164,564.87)	85,276.30	51.82%
72110	Attendance	(225,221.00)	112,586.04	49.99%	(18,768.42)	12,049.05	64.20%
72120	Health Services	(970,868.99)	543,632.92	55.99%	(80,905.75)	66,592.01	82.31%
72130	Other Student Support	(1,249,822.00)	744,626.90	59.58%	(104,151.83)	91,831.15	88.17%
72210	Regular Instruction Program	(1,709,956.00)	907,800.09	53.09%	(142,496.33)	109,258.14	76.67%
72220	Special Education Program	(550,492.00)	323,431.77	58.75%	(45,874.33)	40,587.93	88.48%
72230	Career and Technical Education	(221,945.22)	114,355.29	51.52%	(18,495.44)	12,481.02	67.48%
72250	Technology	(559,224.00)	392,121.75	70.12%	(46,602.00)	44,634.94	95.78%
72290	Other Programs	(35,000.00)	30,497.82	87.14%	(2,916.67)	0.00	0.00%
72310	Board Of Education	(697,742.00)	547,055.28	78.40%	(58,145.17)	47,791.39	82.19%
72320	Director Of Schools	(338,617.00)	177,891.77	52.53%	(28,218.08)	11,689.49	41.43%
72410	Office Of The Principal	(2,116,218.00)	1,192,557.86	56.35%	(176,351.50)	133,945.13	75.95%
72510	Fiscal Services	(50,000.00)	0.00	0.00%	(4,166.67)	0.00	0.00%
72610	Operation Of Plant	(2,704,798.00)	1,997,583.66	73.85%	(225,399.83)	207,789.89	92.19%
72620	Maintenance Of Plant	(1,441,028.19)	887,304.79	61.57%	(120,085.68)	44,508.61	37.06%
72710	Transportation	(2,006,898.00)	1,189,692.15	59.28%	(167,241.50)	155,439.29	92.94%
72810	Central And Other	(318,544.00)	89,124.87	27.98%	(26,545.33)	18,981.85	71.51%
73100	Food Service	(46,696.00)	0.00	0.00%	(3,891.33)	0.00	0.00%
73300	Community Services	(114,189.00)	58,061.23	50.85%	(9,515.75)	7,692.45	80.84%
73400	Early Childhood Education	(535,338.00)	299,296.09	55.91%	(44,611.50)	36,259.04	81.28%
76100	Regular Capital Outlay	(1,623,892.64)	522,929.90	32.20%	(135,324.39)	72,489.60	53.57%
	Total Expenditures	(40,882,072.19)	25,841,088.20	63.21%	(3,406,839.35)	3,156,389.42	92.65%
Total	141 General Purpose School	(6,280,123.99)	(1,269,859.80)	-20.22%	(523,343.67)	54,563.78	10.43%

142 School Federal Projects		Year-To-Date			Month-To-Date		
Account	Description	Budget Estimate	Actual	% of Budget	Estimate Avg/Mth	Actual	% of Avg
Revenues							
44170	Miscellaneous Refunds	0.00	0.00	0.00%	0.00	0.00	0.00%
47131	Vocational Educ - Basic Grants To	123,906.21	(35,521.58)	28.67%	10,325.52	0.00	0.00%
47141	Title 1 Grants To Local Educ Agencies	1,305,024.91	(567,669.31)	43.50%	108,752.08	(76,276.28)	70.14%
47143	Special Education - Grants To States	1,085,813.68	(502,049.08)	46.24%	90,484.47	(136,463.70)	150.81%
47145	Special Education Preschool Grants	53,018.44	(13,686.47)	25.81%	4,418.20	(3,910.42)	88.51%
47146	English Language Acquisition Grants	0.00	(35,776.33)	0.00%	0.00	0.00	0.00%
47148	Rural Education	84,010.08	(24,555.14)	29.23%	7,000.84	0.00	0.00%
47189	Eisenhower Prof Development State	238,626.68	(59,182.60)	24.80%	19,885.56	(10,253.05)	51.56%
47309	COVID-19 Grant D	74,500.00	0.00	0.00%	6,208.33	0.00	0.00%
47401	American Rescue Plan Act Grant #1	0.00	0.00	0.00%	0.00	0.00	0.00%
47590	Other Federal Through State	136,548.80	0.00	0.00%	11,379.07	0.00	0.00%
Total Revenues		3,101,448.80	(1,238,440.51)	39.93%	258,454.07	(226,903.45)	87.79%
Expenditures							
71100	Regular Instruction Program	(875,779.05)	548,841.46	62.67%	(72,981.59)	93,464.48	128.07%
71200	Special Education Program	(814,441.23)	393,908.65	48.37%	(67,870.10)	49,779.28	73.34%
71300	Career and Technical Education	(105,851.73)	55,008.91	51.97%	(8,820.98)	15,496.98	175.68%
72130	Other Student Support	(31,585.87)	16,635.29	52.67%	(2,632.16)	3,842.81	145.99%
72210	Regular Instruction Program	(935,379.28)	439,664.20	47.00%	(77,948.27)	68,763.58	88.22%
72220	Special Education Program	(306,890.89)	171,178.24	55.78%	(25,574.24)	23,475.17	91.79%
72230	Career and Technical Education	(5,240.17)	645.53	12.32%	(436.68)	306.24	70.13%
72710	Transportation	(26,280.58)	10,150.10	38.62%	(2,190.05)	2,263.15	103.34%
Total Expenditures		(3,101,448.80)	1,636,032.38	52.75%	(258,454.07)	257,391.69	99.59%
Total	142 School Federal Projects	0.00	397,591.87	100.00%	0.00	30,488.24	0.00%

143 Central Cafeteria		Year-To-Date			Month-To-Date		
Account	Description	Budget Estimate	Actual	% of Budget	Estimate Avg/Mth	Actual	% of Avg
Revenues							
43521	Lunch Payments - Children	0.00	(675.65)	0.00%	0.00	(96.25)	0.00%
43522	Lunch Payments - Adults	22,000.00	(16,778.49)	76.27%	1,833.33	(2,400.70)	130.95%
43523	Income From Breakfast	2,500.00	(2,405.88)	96.24%	208.33	(123.00)	59.04%
43525	A La Carte Sales	265,000.00	(160,105.24)	60.42%	22,083.33	(24,664.31)	111.69%
43570	Receipts From Individual Schools	0.00	0.00	0.00%	0.00	0.00	0.00%
44110	Investment Income	1,000.00	(112.62)	11.26%	83.33	(9.61)	11.53%
44170	Miscellaneous Refunds	0.00	0.00	0.00%	0.00	0.00	0.00%
47111	USDA School Lunch Program	1,800,000.00	(1,247,162.69)	69.29%	150,000.00	(184,845.51)	123.23%
47113	Breakfast	750,000.00	(472,488.34)	63.00%	62,500.00	(77,729.36)	124.37%
47114	USDA - Other	0.00	(6,289.92)	0.00%	0.00	(841.68)	0.00%
	Total Revenues	2,840,500.00	(1,906,018.83)	67.10%	236,708.33	(290,710.42)	122.81%
Expenditures							
73100	Food Service	(2,957,934.00)	2,352,197.46	79.52%	(246,494.50)	160,786.61	65.23%
	Total Expenditures	(2,957,934.00)	2,352,197.46	79.52%	(246,494.50)	160,786.61	65.23%
Total	143 Central Cafeteria	(117,434.00)	446,178.63	379.94%	(9,786.17)	(129,923.81)	-

School District: Hickman County District No. 410 Date 04/06/26 Month of School
 School Name: Centerville Intermediate School No. 007 No. of Days In Session: 20
 Prepared By: Phone: Begin Date: 03/01/26 End Date: 03/31/26

Grade	Net Enrollment to Date			End of Month Membership	Average Daily Attendance	Average Daily Membership
	Male	Female	Total			
K					.0000	.0000
01					.0000	.0000
02					.0000	.0000
03	53	55	108	116	108.1500	116.0500
04	41	54	95	106	96.9000	105.2000
05	57	48	105	112	100.5500	111.5000
06					.0000	.0000
07					.0000	.0000
08					.0000	.0000
09					.0000	.0000
10					.0000	.0000
11					.0000	.0000
12					.0000	.0000
K-12	151	157	308	334	305.6000	332.7500
GRAND TOTAL	151	157	308	334	305.6000	332.7500



Hickman County Schools Trip Request

Name of School: HCHS

Name of Club/Group: TN Strong

Trip Requested: Youth Summit

Purpose: To equip students with confidence to reach out to peers about tobacco use

Date and Time frame: July 19-21

Number of students: 12-16

agenda attached

Number of Chaperones: Male 1 Female 1-2

Mr. Griego
Megan Bailey
Sennie Morley

Costs associated: 0

Attachments (any information or permission slips that are sent home with students)

Has the cafeteria been notified? N/A Number of Lunches needed? N/A

How will the students travel? state provided transportation

Is a transportation request attached if system transportation is needed? N/A

state pays
for vans
to be
Rented

Signature of person requesting the trip [Signature]

Signature of Principal Rodney Emerson

Signature of Instructional Supervisor [Signature] 4/7/26

Signature of Director of Schools _____

*Per Hickman County Board of Education policy 4.302, any requested trip that has an out-of-state destination and/or is planned for overnight must have prior approval by the Board of Education.

2025/2026 Hickman Co. High School
Request for Field Trip

This form is to be completed for ALL field trips, including academic or athletic competitions at any level. It must be filled out completely at least one month before the field trip, including a roster and an itinerary from the time you leave until you return.

If the field trip is approved, you will fill out the District Field Trip Request.

- This request is for a National or State Competition
- This request is for an athletic competition
- This request is for an academic event.
- CTSO Career Development Events

OTHER

Teacher's name: Griego Subject Area: TN Strong

How is this trip an integral part of an approved course of study?

Provides students with the knowledge & confidence to help reduce the tobacco & vape use of students in HC

Before this field trip, the class will be involved in the following preliminary activities to prepare for this trip:

TN Strong members participate in anti-tobacco & vape activities

Follow-up activities for this unit will include the following activities:

Students will develop new ways to reach their peers.

What is the Date of the Trip? July 19-21 Departure Time? 9am Return Time? 4pm

Will a substitute be required? NO Have you completed the subform on Google Classroom? NO

What are the plans for the students who are not going on the trip?

N/A

Have you notified the cafeteria if you will need sack lunches or if your students will not be present for lunch? N/A

Do you need a transportation form? N/A

Have you notified Mrs. Plunkett to place it on the calendar? N/A

Do you have your student authorization to attend field trip form ready for other teachers to sign? N/A

Principal Approval: Roby Emons Date: 4-6-26

CTE Director Approval: N/A Date: _____

**TNStrong Youth Summit
Chattanooga, TN
July 19-21, 2026**

Students at HCfS are invited to attend the 2026 Youth Summit in Chattanooga TN. Approximately 21.6% of Tennessee high school students vape, more than double the national rate of roughly 10%. TNStrong works to discourage the use of vapes and tobacco usage by encouraging their peers to live healthy, clean lives. The Youth Summit helps students build the knowledge, skills, and confidence to lead the fight.

Over the course of this three-day conference, students will have the opportunity to hear from leading tobacco prevention experts as well as network with like-minded peers from across the state. The goal is that students will depart feeling fueled and equipped to reach peers and adults in the continuing effort to protect people from the harmful effects of tobacco use.

Students will stay at a hotel close to the Chattanooga convention center. All accommodations, transportation, and meals are provided by TNStrong. 1 male and at least 1 female HC employee will chaperone the event. Given time and availability, students may also be allowed to visit Chattanooga historical sites and attractions.

<https://www.tn.gov/health/health-program-areas/ttnw/tennessee-tobacco-program/tn-strong/tnstrong-youth-summit.html>

Current students showing interest.

Kathryn Qualls	Zachery Yeager
Olivia Ashley	Preston Carden
Jasmine Simmons	Lalayla Haney
Chevy Brown	Morgan Forshee
Destiny Workman	Carson Vaughn
Johnny Chapman	Kyra Decaney
Jose Ocampo	Vivianne Fralick
Kayleigh Fralick	
Izzy Pillars	

Agenda

Sunday - Jul 19, 2026

- 9:00 meet at HCHS
- 9:30 Departure
- 1:00 Chattanooga experience
- 3-4:00
 - Hotel Check-in
 - Conference center check-in
- 4:00 - 7:30
 - Dinner
 - Chaperone Meeting
 - Summit Kick-Off
- 8:00pm - 10:00pm - Youth Summit Scavenger Hunt / City Tour

Monday July 20

- 8:00am - 7:30pm - Break out sessions and Activities
- 8:00pm - 10:00pm - Youth Summit Scavenger Hunt / City Tour

Tuesday July 21

- 7:30 am - Hotel Check out
- 8:00 - 12:30 Youth Summit Breakout sessions and Activities
- 1:00 - Depart Chattanooga
- Chattanooga Experience



Hickman County Schools Board Agenda Item Request

Date: April 11, 2026

Name of School: East Hickman High School

Item Request: cheer camp @ Vanderbilt

Explanation:

Our cheer team is wanting to travel to UCA
cheer camp @ Vanderbilt University June 1-3, 2026.
We're asking for permission to do so.

Attachments (if necessary and appropriate):

Signature of Person requesting to be placed on the agenda:

Rebecca Campbell + cheer captains

Signature of Building Principal:

[Handwritten Signature]

BA
APR 07 2026

It is the recommendation of the Interim Director of Schools that the boundaries for the school zones remain the same as originally drawn for the 2007-2008 school year and that the Attendance Zone Review Committee remain active for the 2026-2027 school year.



Invoice

P.O. Box 440011
 Nashville, TN 37244-0011

Phone: (615) 815-3908 Fax: (615) 815-3911
 Email: bweinstein@tsba.net

Date	Invoice #
3/13/2026	41978

Bill To
Hickman County Board of Education Attn: Finance 115 Murphree Avenue Centerville, TN 37033

P.O. No.

Description	Qty	Rate	Amount
TSBA 2027 Membership Dues	1	6,344.00	6,344.00
Total			\$6,344.00
Payments/Credits			\$0.00
Balance Due			\$6,344.00

Please make checks payable to:
 Tennessee School Boards Association,
 Attention Finance Department.



Invoice

Hickman County Chamber of Commerce

P.O. Box 126
Centerville, TN 37033
USA

Bill to

Hickman County School System
Centerville, TN 37033
United States

Invoice number INV-1390**Invoice date** March 21, 2026**Due date** March 28, 2026**Total** \$775.00[Pay for this invoice online](#)

PRODUCTS & SERVICES	QTY	UNIT PRICE	AMOUNT
251+ Employees	1	\$775.00	\$775.00
March 21, 2026 - March 21, 2027			

Subtotal	\$775.00
Total	\$775.00

All fees are listed in USD and are subject to sales tax (as applicable).

Invitation to Bid

The Hickman County Finance Office is accepting sealed bids for an intercom maintenance and repair provider to 8 schools.

Bid documents with specifications are online at www.hickmank12.org/request-for-proposal.

Sealed bids must be mailed or delivered to the Hickman County Finance Office, 114 North Central Avenue, Suite 203, Centerville, TN 37033 and clearly marked on the outside of the envelope with "School Intercoms" by March 10, 2026, 10:00 AM. Bids will be opened on March 10, 2026, 10:00 AM at the above address.

Hickman County Board of Education reserves the right to accept or reject any and all bids or parts of bids and to waive any informalities that would prevent the acceptance of a better bid.

Present Penny Rochelle
Misty Weems

Bid Received

Townsend Systems, LLC

Trip Charge 200.00

Labor 95.⁰⁰/tech 65.⁰⁰/helper

Pricing List Price Less Discount 25%

Please complete the following:

Answers provided here must be valid for a minimum of 60 days from the bid opening date.

Experience and Qualifications

Years experience servicing public schools or other public entities 64 years

Years experience servicing intercom systems 64 years

Qualifications, training, and certifications of service personnel: Telecom, Rauland
Boyer, Telcenter, Valcom, Alphone, Visiplex, Telcom

Are you familiar with the systems and equipment being used by Hickman County Schools? _____

Responsiveness and Service Capabilities

Will you respond to calls to schedule service within 1 business day? yes

Are you licensed and insured to work in Tennessee? yes

Pricing Structure

Minimum charge/Trip charge \$ 200.00

Hourly Labor Rate \$ 95.00 /HR Tech \$ 65.00 /HR Helper

Travel Costs, if not part of minimum 0

Equipment Pricing Method List Price Less Discount 25 % (discount or markup)
(e.g., list price less discount, markup percentage of wholesale cost)

Please provide at least three (3) references from K-12 schools or other publicly funded facilities

School/Organization: Henry County schools

Contact Person: JAMIE Kemp

Phone Number: 731-642-3530

School/Organization: Henderson County schools

Contact Person: Reece Blair

Phone Number: 731-307-8295

School/Organization: JACKSON MADISON County school

Contact Person: Chris Johnson

Phone Number: 731-267-6834

School/Organization: Lake County schools

Contact Person: Lacy Stokes

Phone Number: 731-253-6601

School/Organization: Fayette County schools

Contact Person: Mike Kac

Phone Number: 901-465-5260

School/Organization: South Panola schools

Contact Person: Jeff Dandy

Phone Number: 662-209-5439

Hickman County Government

Conflict of Interest Disclosure Form

The County Financial Management System of 1981 contains the most stringent conflict of interest provisions. TCA §5-21-121 provides:

- (a) The director, purchasing agent, members of the committee, members of the county legislative body or other officials, employees, or members of the board of education or highway commission shall not be financially interested or have any personal beneficial interest, either directly or indirectly, in the purchase of any supplies, materials, equipment or contractual services for the county.
- (b) No firm, corporation, partnership, association or individual furnishing any such supplies, materials, equipment or contractual services, shall give or offer, nor shall the director or purchasing agent or any assistant or employee accept or receive directly or indirectly from any person, firm, corporation, partnership or association to whom any contract may be awarded, by rebate, gift or other otherwise, any money or other things of value whatsoever, or any promise, obligation or contract for future reward or compensation.

Date: 3/9/26 Name: Van Nash

Please describe below any relationships, transactions, positions you hold (volunteer or otherwise), or circumstances that you believe could contribute to a conflict of interest:

I have no conflict of interest to report.

I have the following conflict of interest to report (please specify any boards or committees you (and/or your spouse) sit on, the name of your employer and any businesses you or your spouse may own.

I hereby certify that the information set forth above is true and complete to the best of my knowledge.

Date: 3/9/26 Signature: Van Nash

COLLUSION AMONG BIDDERS

The bidder submitting the competitive bid which is attached to this statement, for the purpose of certifying the facts pertaining to the existence of collusion among bidders and between bidders and municipal officials or employees, as well as facts pertaining to the giving or offering of things of value to government personnel in return for special consideration in the letting of any contract pursuant to the bid to which this statement is attached.

1. Bidder is fully aware of the facts and circumstances surrounding the making of the bid to which this statement is attached and has been personally and directly involved in the proceedings leading to the submission of such bid; and
2. neither the bidder nor anyone subject to the bidder's direction or control has been a party;
 - a. to any collusion among bidders in restraint of freedom of competition by agreement to bid at a fixed price or to refrain from bidding,
 - b. to any collusion with any municipal official or employee as to quantity, quality or price in the prospective contract, or as to any other terms of such prospective contract, nor
 - c. in any discussions between bidders and any municipal official concerning exchange of money or other things of value for special consideration in the letting of a contract.
3. no officer or employee of HCS either directly or indirectly, owns any interest in the bidder's business.

NON-BOYCOTT OF ISRAEL

Concerning the Non-Boycott of Israel Act (TCA 12-4-1 et seq.), by submission of this bid/quote/proposal, each supplier and each person signing on behalf of any supplier certifies, and in the case of a joint bid/quote/proposal, each party thereto certifies as to its own organization, under penalty of perjury, that to the best of its knowledge and belief that each supplier is not boycotting Israel pursuant to § 12-4-1 and will not during the term of any award. Note: Applicable only to contracts of \$250,000 or more and to suppliers with 10 or more employees.

ACKNOWLEDGEMENT

The undersigned hereby acknowledges receipt of these affidavits and certifies that the submittal in response to this solicitation is in full compliance with the listed requirements. Failure to properly acknowledge issues concerning the above is grounds for bid rejection and may subject the signer to penalties as directed by the appropriate laws.

SIGNATURE OF AUTHORIZED AGENT Vern Deak

Subscribed and sworn to before me this 9th day of March, 2026.

Signature of Notary Public Carolyn M. McAuley

My Commission Expires 12/20/2026



This Acknowledgment must be completed, signed by an authorized agent, notarized and submitted with bid documents.

Invitation to Bid

The Hickman County Finance Office is accepting sealed bids for new Automotive Class Training Equipment for Hickman County High School.

Bid documents with specifications are online at www.hickmank12.org/request-for-proposal.

Sealed bids must be mailed or delivered to the Hickman County Finance Office, 114 North Central Avenue, Suite 203, Centerville, TN 37033 and clearly marked on the outside of the envelope "Auto Class Trainers" by March 26, 2026, 2:00 PM. Bids will be opened on March 26, 2026, 2:00 PM at the above address.

Hickman County Board of Education reserves the right to reject any, all or parts of bids, and to waive any technicalities in the bidding and to award each item to different bidders or all items to a single bidder.

Present Penny Rochelle
Misty Wams

Bids Rec'd

ATECH TRAINING INC.

Georgia Educational Solutions LLC

Please see attached

MAR 05 2026

BA

GENERAL TERMS AND CONDITIONS OF SEALED BIDS

**THESE ITEMS APPLY TO AND BECOME A PART OF THE BID NO EXCEPTIONS TO
THESE TERMS & CONDITIONS WILL BE CONSIDERED**

1. Sealed bids must be mailed or hand delivered to the Hickman County Finance Office at 114 North Central Ave, Suite 203, Centerville, TN 37033 and clearly marked on the outside of the envelope “**Auto Class Trainers**” before 2:00 PM on March 26, 2026, at which time sealed bids will be opened at the address listed above. Proposals submitted by fax or electronic mail will not be accepted.
2. No bidder may withdraw their proposal for a period of sixty (60) days after the date and hour set for the opening of bids.
3. Any exceptions or deviations from written specifications shall be shown in writing and attached to the bid form.
4. Affidavit Acknowledgement **MUST be signed, notarized, and returned** with the bid.
5. HCS reserves the right to reject any, all or parts of bids, and to waive any technicalities in the bidding and to award each item to different bidders or all items to a single bidder.
6. Questions about this bid should be directed to Derek Newsom,
derek.newsom@hickmank12.org.

Equipment Specifications

All trainers need to be mobile. Please ensure that pricing reflects all additional parts for mobility.

Description	Model	Price	Courseware included?	If no, courseware price
ABS/TCS Trainer	<u>1432</u>	<u>\$16900.00</u>	Yes or No	\$ _____
Charging System Trainer	<u>812C</u>	<u>\$11400.00</u>	Yes or No	\$ _____
4 Cyl Engine Performance Trainer	<u>650 4CYL GM</u>	<u>\$48500.00</u>	Yes or No	\$ _____
Drum/Disk Brake Trainer	<u>400</u>	<u>\$13800.00</u>	Yes or No	\$ _____
Shipping Charges		<u>\$1480.00</u>		

Estimated delivery time after receipt of order 90 days.

Please include a cut/information sheet for each trainer with sealed bid.

All equipment shall be warrantied for at least 1 year from the date of receipt.

Hickman County Schools are exempt from sales tax. A tax exempt form will be provided when the purchase order is submitted.

BIDDER INFORMATION SHEET

Full Name of Bidder: Atech Training INC

Legal Identity
(Corporation, Partnership, Individual, etc.) _____

Address 12290 Chandler Drive Walton, KY 41094

Telephone 888-738-9924

Fax 859-485-7299

Taxpayer Identification Number _____

Contact Person Amanda Godsey

Phone 859-485-7229 ext 108

Email agodsey@atechtrainig.com

AFFIDAVIT ACKNOWLEDGEMENT

AMERICANS WITH DISABILITIES ACT

Bidder shall take the necessary actions to ensure its facilities and employment practices are in compliance with the applicable requirements of the Americans with Disabilities Act. Any costs of such compliance will be the sole responsibility of the bidder.

DRUG FREE WORKPLACE REQUIREMENTS

Private employers with five or more employees desiring to contract for construction services attest that they have a drug free workplace program in effect in accordance with Tennessee Code Annotated Section 50-9-112.

IRAN DIVESTMENT ACT

Under the Iran Divestment Act, T.C.A. §§ 12-12-101--12-12-113, political subdivisions in Tennessee are prohibited from entering into any procurement or contract over \$1,000 with a person who engages in investment activities in Iran. The state's chief procurement officer is required under T.C.A. § 12-12-106 to create a list of persons who engage in investment activities in Iran. Any person who is on the list is ineligible to contract with any political subdivision of this state, and any such contract is declared void ab initio under § 12-12-110. On or after July 1, 2016, every bid or proposal submitted to a political subdivision where competitive bidding is required must contain the following statement, submitted by the bidder under penalties of perjury:

"By submission of this bid, each bidder and each person signing on behalf of any bidder certifies, and in the case of a joint bid each party thereto certifies as to its own organization, under penalty of perjury, that to the best of its knowledge and belief that each bidder is not on the list created pursuant to § 12- 12-106."

COLLUSION AMONG BIDDERS

The bidder submitting the competitive bid which is attached to this statement, for the purpose of certifying the facts pertaining to the existence of collusion among bidders and between bidders and municipal officials or employees, as well as facts pertaining to the giving or offering of things of value to government personnel in return for special consideration in the letting of any contract pursuant to the bid to which this statement is attached.

1. Bidder is fully aware of the facts and circumstances surrounding the making of the bid to which this statement is attached and has been personally and directly involved in the proceedings leading to the submission of such bid; and
2. neither the bidder nor anyone subject to the bidder's direction or control has been a party;
 - a. to any collusion among bidders in restraint of freedom of competition by agreement to bid at a fixed price or to refrain from bidding,

- b. to any collusion with any municipal official or employee as to quantity, quality or price in the prospective contract, or as to any other terms of such prospective contract, nor
 - c. in any discussions between bidders and any municipal official concerning exchange of money or other things of value for special consideration in the letting of a contract.
3. no officer or employee of HCS either directly or indirectly, owns any interest in the bidder's business.

NON-BOYCOTT OF ISRAEL

Concerning the Non-Boycott of Israel Act (TCA 12-4-1 et seq.), by submission of this bid/quote/proposal, each supplier and each person signing on behalf of any supplier certifies, and in the case of a joint bid/quote/proposal, each party thereto certifies as to its own organization, under penalty of perjury, that to the best of its knowledge and belief that each supplier is not boycotting Israel pursuant to § 12-4-1 and will not during the term of any award. Note: Applicable only to contracts of \$250,000 or more and to suppliers with 10 or more employees.

The undersigned hereby acknowledges receipt of these affidavits and certifies that the submittal in response to this solicitation is in full compliance with the listed requirements. Failure to properly acknowledge issues concerning the above is grounds for bid rejection and may subject the signer to penalties as directed by the appropriate laws.

SIGNATURE OF AUTHORIZED AGENT Amanda Lindsey

Subscribed and sworn to before me this 9 day of March 2026

Signature of Notary Public Shannon Barth

My Commission Expires 5/17/2027

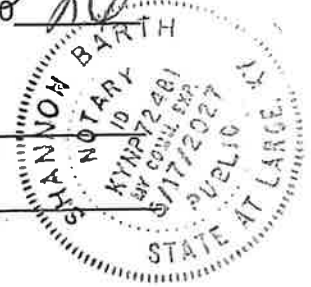

The Affidavits Acknowledgment must be completed, signed by an authorized agent and notarized and submitted with bid documents

Hickman County Government

Conflict of Interest Disclosure Form

The County Financial Management System of 1981 contains the most stringent conflict of interest provisions. TCA §5-21-121 provides:

(a) The director, purchasing agent, members of the committee, members of the county legislative body or other officials, employees, or members of the board of education or highway commission shall not be financially interested or have any personal beneficial interest, either directly or indirectly, in the purchase of any supplies, materials, equipment or contractual services for the county.

(b) No firm, corporation, partnership, association or individual furnishing any such supplies, materials, equipment or contractual services, shall give or offer, nor shall the director or purchasing agent or any assistant or employee accept or receive directly or indirectly from any person, firm, corporation, partnership or association to whom any contract may be awarded, by rebate, gift or otherwise, any money or other things of value whatsoever, or any promise, obligation or contract for future reward or compensation.

Date: 03/09/2026 Name: Amanda Godsey

Please describe below any relationships, transactions, positions you hold (volunteer or otherwise), or circumstances that you believe could contribute to a conflict of interest:

I have no conflict of interest to report.

I have the following conflict of interest to report (please specify any boards or committees you (and/or your spouse) sit on, the name of your employer and any businesses you or your spouse may own.

I hereby certify that the information set forth above is true and complete to the best of my knowledge.

Date: 3/9/2020

Signature:

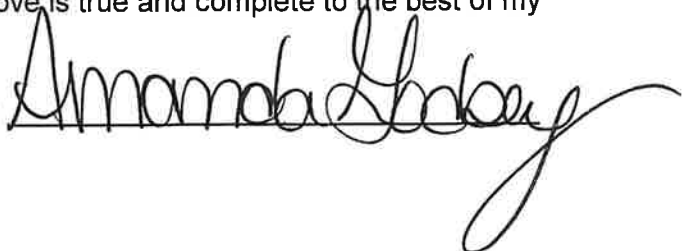

GENERAL TERMS AND CONDITIONS OF SEALED BIDS

THESE ITEMS APPLY TO AND BECOME A PART OF THE BID NO EXCEPTIONS TO THESE TERMS & CONDITIONS WILL BE CONSIDERED

1. Sealed bids must be mailed or hand delivered to the Hickman County Finance Office at 114 North Central Ave, Suite 203, Centerville, TN 37033 and clearly marked on the outside of the envelope "**Auto Class Trainers**" before 2:00 PM on March 26, 2026, at which time sealed bids will be opened at the address listed above. Proposals submitted by fax or electronic mail will not be accepted.
2. No bidder may withdraw their proposal for a period of sixty (60) days after the date and hour set for the opening of bids.
3. Any exceptions or deviations from written specifications shall be shown in writing and attached to the bid form.
4. Affidavit Acknowledgement **MUST** be **signed, notarized, and returned** with the bid.
5. HCS reserves the right to reject any, all or parts of bids, and to waive any technicalities in the bidding and to award each item to different bidders or all items to a single bidder.
6. Questions about this bid should be directed to Derek Newsom, derek.newsom@hickmank12.org.

BIDDER INFORMATION SHEET

Full Name of Bidder: **Georgia Educational Solutions, LLC**

Legal Identity

(Corporation, Partnership, Individual, etc.): **C - Corporation**

Address: **6246 Rosecommon Drive / Peachtree Corners, GA 30092**

Telephone: **Cell: (678) 488-4954**

Fax: **N/A**

Taxpayer Identification Number: **#27-3528750**

Contact Person: **Mark Jones**

Phone: **Cell: (678) 488-4954**

Email: **Mark@gaedsolutions.com**

AFFIDAVIT ACKNOWLEDGEMENT

AMERICANS WITH DISABILITIES ACT

Bidder shall take the necessary actions to ensure its facilities and employment practices are in compliance with the applicable requirements of the Americans with Disabilities Act. Any costs of such compliance will be the sole responsibility of the bidder.

DRUG FREE WORKPLACE REQUIREMENTS

Private employers with five or more employees desiring to contract for construction services attest that they have a drug free workplace program in effect in accordance with Tennessee Code Annotated Section 50-9-112.

IRAN DIVESTMENT ACT

Under the Iran Divestment Act, T.C.A. §§ 12-12-101--12-12-113, political subdivisions in Tennessee are prohibited from entering into any procurement or contract over \$1,000 with a person who engages in investment activities in Iran. The state's chief procurement officer is required under T.C.A. § 12-12-106 to create a list of persons who engage in investment activities in Iran. Any person who is on the list is ineligible to contract with any political subdivision of this state, and any such contract is declared void ab initio under § 12-12-110. On or after July 1, 2016, every bid or proposal submitted to a political subdivision where competitive bidding is required must contain the following statement, submitted by the bidder under penalties of perjury:

"By submission of this bid, each bidder and each person signing on behalf of any bidder certifies, and in the case of a joint bid each party thereto certifies as to its own organization, under penalty of perjury, that to the best of its knowledge and belief that each bidder is not on the list created pursuant to § 12- 12-106."

COLLUSION AMONG BIDDERS

The bidder submitting the competitive bid which is attached to this statement, for the purpose of certifying the facts pertaining to the existence of collusion among bidders and between bidders and municipal officials or employees, as well as facts pertaining to the giving or offering of things of value to government personnel in return for special consideration in the letting of any contract pursuant to the bid to which this statement is attached.

1. Bidder is fully aware of the facts and circumstances surrounding the making of the bid to which this statement is attached and has been personally and directly involved in the proceedings leading to the submission of such bid; and
2. neither the bidder nor anyone subject to the bidder's direction or control has been a party;
 - a. to any collusion among bidders in restraint of freedom of competition by agreement to bid at a fixed price or to refrain from bidding,

- b. to any collusion with any municipal official or employee as to quantity, quality or price in the prospective contract, or as to any other terms of such prospective contract, nor
 - c. in any discussions between bidders and any municipal official concerning exchange of money or other things of value for special consideration in the letting of a contract.
3. no officer or employee of HCS either directly or indirectly, owns any interest in the bidder's business.

NON-BOYCOTT OF ISRAEL

Concerning the Non-Boycott of Israel Act (TCA 12-4-1 et seq.), by submission of this bid/quote/proposal, each supplier and each person signing on behalf of any supplier certifies, and in the case of a joint bid/quote/proposal, each party thereto certifies as to its own organization, under penalty of perjury, that to the best of its knowledge and belief that each supplier is not boycotting Israel pursuant to § 12-4-1 and will not during the term of any award. Note: Applicable only to contracts of \$250,000 or more and to suppliers with 10 or more employees.

The undersigned hereby acknowledges receipt of these affidavits and certifies that the submittal in response to this solicitation is in full compliance with the listed requirements. Failure to properly acknowledge issues concerning the above is grounds for bid rejection and may subject the signer to penalties as directed by the appropriate laws.

SIGNATURE OF AUTHORIZED AGENT _____

Mark [unclear]

Subscribed and sworn to before me this _____ day of _____, 20 _____.

14th day of *March*, 20 *26*

Signature of Notary Public _____

[Signature]

My Commission Expires _____

11/17/2026

The Affidavits Acknowledgment must be completed, signed by an authorized agent and notarized and submitted with bid documents





Georgia Educational Solutions, LLC

6246 Rosecommon Drive
Peachtree Corners, GA 30092
Cell: (678) 488-4954
EIN: 27-3528750
Contact: Mark Jones

Attn: Mr. Derek Newson



CONSULAB

<https://www.consulab.com/>

CONSULAB

Quotation

To: Name	Mr. Larry Rochelle	Date	3/14/2026
Title	Automotive Instructor	Quotation Number	300273
College	Hickman County High School	Quote valid for one full year	
Address	1645 Bulldog Blvd. Centerville, TN 30733	All prices are FOB Destination	
Work	(931) 729-3616	Terms Net 30 days	
Email	Larry.Rochelle@hickmank12.org	Sole source in Tennessee	
		Cc: Angie Osborne	

Qty	Item #	Description	Cost (US\$)	Total (US\$)
A5 Brakes				
1	EM-122-HN02	Disc & Drum ABS Brake Trainer w/ Faults	\$18,250.00	\$18,250.00
1	EM-1200-122	Vinyl dust cover	\$475.00	\$475.00
		<i>An entire fleet of these amazing trainers can be seen at SkillsUSA Nationals in Atlanta, as well as World Skills 2026 in Singapore with ConsuLab contributing Judges and future innovations for all ASE areas through 2030!</i>		
		A note about this first trainer:		
1	EM-123-4HN02	Disc & Drum Brake Trainer (Non ABS) w/ Faults	\$10,975.00	\$10,975.00
1	EM-1200-123	Vinyl dust cover	\$475.00	\$475.00
A6 Electrical/Electronic Systems				
1	EM-200-19	Cutaway Starting System Trainer	\$3,250.00	\$3,250.00
		<i>Note: Currently, ConsuLab does not offer a pure Alternator trainer. Instead, ConsuLab teaches this area (in depth) via their Engine Performance Series Trainers</i>		
A8 Engine Performance - Our top Contender:				
1	EM-140S-GM06A	GM Chevy Cruz 1.4L Engine Bench with Student Learning Platform	\$45,450.00	\$45,450.00
	Includes:	ConsuLink (TM) Student Learning Platform Stop/Start Technology AC System Technology Coolant flow sight glass Secondary Key w/ programming Vinyl dust cover		
	It's Unique!	<i>There's nothing quite like it anywhere else in the World!</i>		
Training and Support				
1	56099-5	Basic training via MS Teams with a ConsuLab Educational Specialist All technical support via phone, email and MS Teams		INC
0	56099	Optional, In-Person Training (Per day) with an ASE Master Technician / Educational Specialist from ConsuLab	\$3,500.00	\$0.00

Curriculum Access: For complete access to all associated Curriculum Pack materials and specifications, please register for your **customer login** here:

[Customer Space](#)

Depending upon the trainer, this can include:

-93 Operation Manual



Georgia Educational Solutions, LLC

6246 Rosecommon Drive
Peachtree Corners, GA 30092
Cell: (678) 488-4954
EIN: 27-3528750
Contact: Mark Jones

Attn: Mr. Derek Newson

Derek.Newson@hickmank12.org



CONSULAB

<https://www.consulab.com/>

CONSULAB

Quotation - EXPANDED (Wish List)

To: Name	Mr. Larry Rochelle	Date	3/14/2026
Title	Automotive Instructor	Quotation Number	300273-EXP
College	Hickman County High School	Quote valid for one full year	
Address	1645 Bulldog Blvd. Centerville, TN 30733	All prices are FOB Destination	
Work	(931) 729-3616	Terms Net 30 days	
Email	Larry.Rochelle@hickmank12.org	Sole source in Tennessee	
		Cc: Angie Osborne	

Qty	Item #	Description	Cost (US\$)	Total (US\$)
A5 Brakes				
1	EM-122-HN02	Disc & Drum ABS Brake Trainer w/ Faults	\$18,250.00	\$18,250.00
1	EM-1200-122	Vinyl dust cover	\$475.00	\$475.00
	A note about this first trainer: <i>An entire fleet of these amazing trainers can be seen at SkillsUSA Nationals in Atlanta, as well as World Skills 2026 in Singapore with ConsuLab contributing Judges and future innovations for all ASE areas through 2030!</i>			
1	EM-123-4HN02	Disc & Drum Brake Trainer (Non ABS) w/ Faults	\$10,975.00	\$10,975.00
1	EM-1200-123	Vinyl dust cover	\$475.00	\$475.00
New Innovation in A5 Brakes - Inspired by Toyota:				
	EM-123-TY05	Brake Trainer for Hydraulic Diagnostics	\$27,225.00	
	EM-1200-123	Vinyl dust cover		
	It's Unique! <i>There's nothing quite like it anywhere else in the World!</i>			
A6 Electrical/Electronic Systems				
1	EM-200-19	Cutaway Starting System Trainer	\$3,250.00	\$3,250.00
	<i>Note: Currently, ConsuLab does not offer a pure Alternator trainer. Instead, ConsuLab teaches this area (in depth) via their Engine Performance Series Trainers</i>			
A8 Engine Performance - Our top Contender:				
1	EM-140S-GM06A	GM Chevy Cruz 1.4L Engine Bench with Student Learning Platform	\$45,450.00	\$45,450.00
	Includes: ConsuLink (TM) Student Learning Platform Stop/Start Technology AC System Technology Coolant flow sight glass Secondary Key w/ programming Vinyl dust cover			
	It's Unique! <i>There's nothing quite like it anywhere else in the World! A Hyundai Version is also available</i>			
Alternatives in A8 Engine Performance				
	EM-140C-TY02A	Toyota Corola 1.8L Engine Trainer w/ AC (2014-18)	\$39,950.00	
	EM-254	Manual Fault Box		
	EM-250-2C	Custom programmable fault box		
	EM-140-21	Secondary key for engine bench		
	EM-1200-141	Vinyl dust cover for engine stand		
	EM-330-1	GM Fuel Injection and Engine Management System Trainer	\$20,618.00	



Disc & drum ABS brake trainer + faults

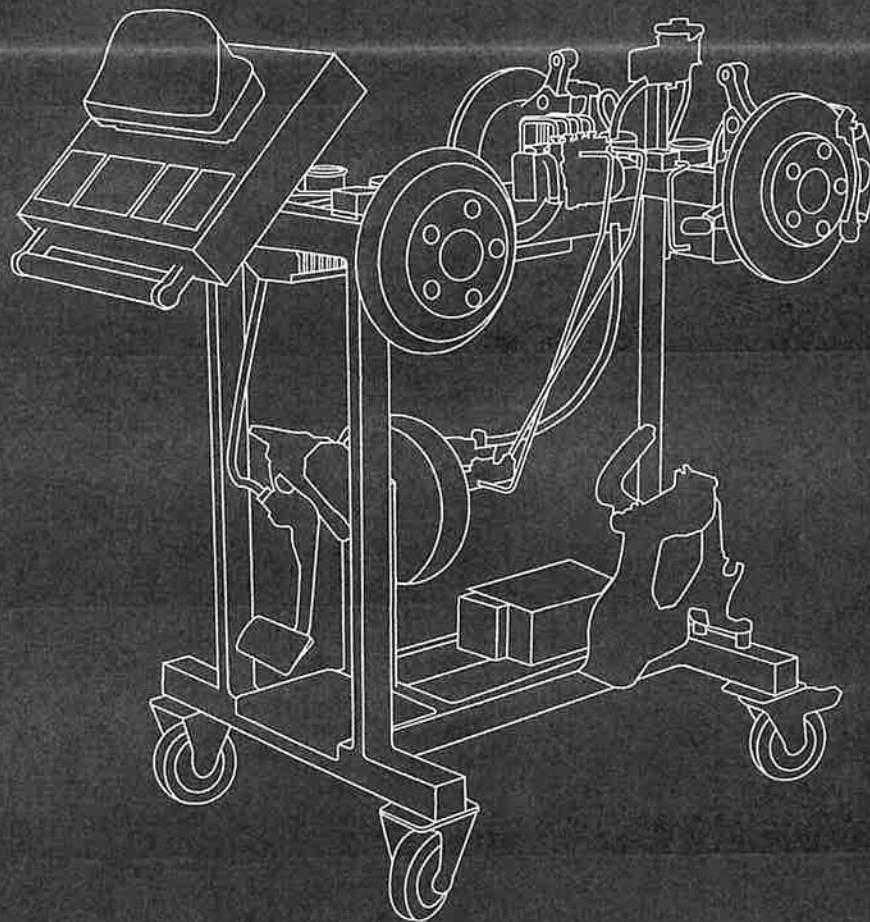

EM-123-4HN02_052746



Disc & drum brake trainer + faults

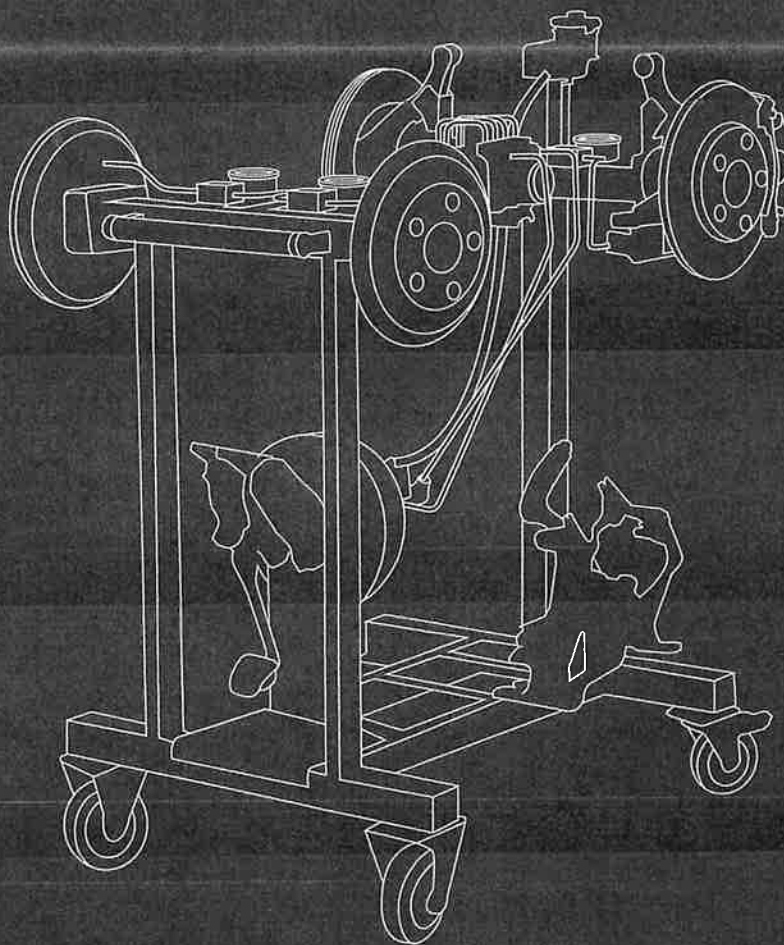

EM-200-19_052932



Cutaway starting system trainer

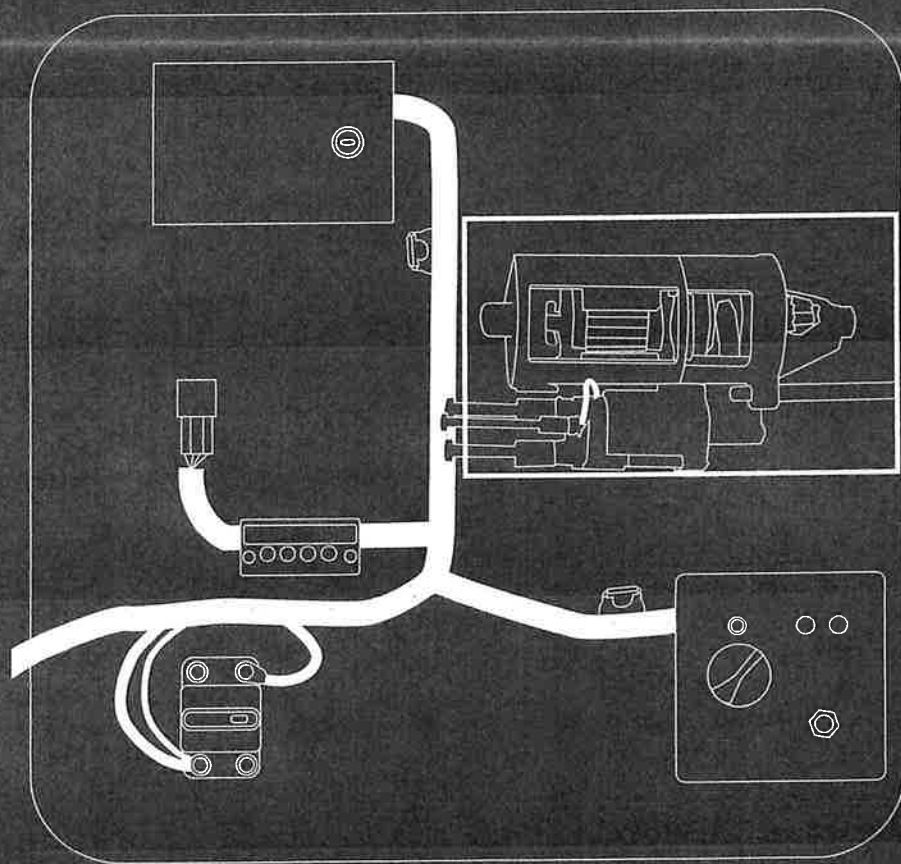

Rev 2024/03

EM-140S-GM06A_053338



ConsuLink GM 1.4L Engine trainer, AC & Stop-Start

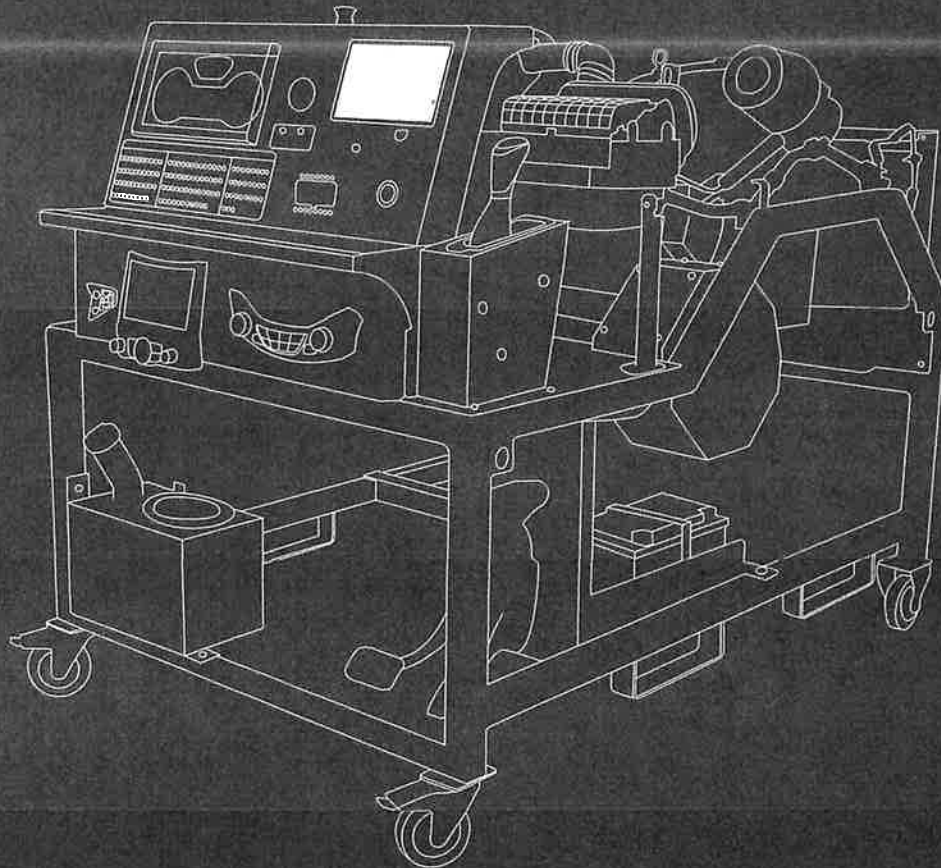

Rev 2023/09



The first ConsuLab engine bench to ever have 2 pedals, brake and accelerator. You can now do stall tests and load the engine; you can perform a basic "road test" within your classroom going up to 20mph which allows Stop-Start to function ! Combine this with the new ConsuLink™ student learning platform to enhance student engagement and use this bench to teach advanced driveability, engine performance and HVAC (air conditioning).

WHAT IS CONSULINK™?

ConsuLink™ changes the way that you and your students interact with our products. Instead of relying on switches and dials to turn on and off and adjust faults or different scenarios with the engine bench, they are now accessible through a touchscreen on the front of the trainer.

Student benefits

Through ConsuLink™ students gain access to safety warnings, component locator, wiring schematics, basic operating instructions, **Case Studies** and more. The students can autonomously activate each case study which will automatically adjust the engine bench to the preset parameters, give them the customer complaints and instructions on what to do, thus liberating instructor time. Students can proceed through these case studies on their own and bring the results to you their instructor. They bring their scan tool, service info, multimeter/oscilloscope, and their desire to learn, and ConsuLink™ will help with the rest!

Teacher benefits

ConsuLink™ holds all the information necessary to make teaching with the engine bench easy, once you enter your teacher pin or unlock it with the provided access key, you gain access to the answer keys to all the student case studies, you also gain access to numerous lessons with pre-selected fault values instructions, basic lesson plan, types of demonstrations that can be done, all **vetted out and proven by our team to save you time**. You gain access to faulted schematics, the ability to create your own case studies (through manual fault insertion), along with all the other information available through the student menus.

EDUCATIONAL ADVANTAGES

- Perform a basic "road test" in your classroom and demonstrate the **Stop-Start** and engine auto-stop features. By attaining all the **enabled criteria** you can force the engine to **auto-stop** at a "red light/stop sign". You can then demonstrate all the different disable criteria that turns the system off.
- Equipped with **OEM HVAC system** and dash controls.
- Tablet-based ConsuLink™ Student Learning Platform designed to enhance student engagement.
- Trainer touchscreen can be mirrored to a TV or projector via HDMI out port.
- Stall test can be performed by depressing both accelerator and brake pedals simultaneously, this can be used to demonstrate loading the engine and for **misfire detection**.
- OEM Instrument panel with all indicator lights
- **ECM Break Out Box** matching OEM circuit pin identification with 2mm test receptacles
- Engine systems respond to inserted faults with real world symptoms, OEM DTC's, scan tool data-stream PID changes and check engine light operation
- A **DLC** (datalink connector) **Break Out Box** specifically designed for use in educational environments with robust 2mm test pins and LED activity indicators for all 16 pins of a standard OBDII DLC





DOUG LANE
2059 Lake Drive, Centerville, TN 37033

PIPPA TAYLOR
6585 Oak Hill Rd., Lyles, TN 37098

TIM HOBBS
9220 Old Bon Aqua Rd., Bon Aqua, TN 37025

TABITHA CUDE
4141 Lewis Rd., Centerville, TN 37033



CHRISTY MAYS
450 Hwy. 50, Centerville, TN 37033

SHERRI BAKER
9037 E 40 Rd., Bon Aqua, TN 37025

JANE HERRON
PO Box 13, Nunnely, TN 37137

Dr. Belinda Anderson
Interim Director of Schools
115 Murphree Avenue
Centerville, TN 37033

DATE: March 23, 2026

TO: Hickman County Schools Technology Department / Interested Vendors

FROM: Tim Hobbs, Chairman of the Hickman County Board of Education

SUBJECT: AUTHORIZATION TO INITIATE TN STATE CATEGORY 1 E-RATE MINI-BID PROCESS

Statement of Permission

I, **Tim Hobbs**, acting in my capacity as Chairman of the Hickman County Board of Education, hereby grant the school district and its designated representatives permission to proceed with all necessary procedures to procure funding through the **Tennessee State Category 1 E-Rate Mini-Bid process**.

Purpose and Deadline

This authorization is provided to ensure the district remains in compliance with the **April 1st, 2026**, E-Rate filing deadline. Initiating these procedures immediately is vital for securing the federal and state discounts required for the district's telecommunications and internet infrastructure.

Acknowledgment of Board Authority and Local Funding

It is understood by all parties that while this authorization allows the procurement process to begin, the following conditions apply:

- This action is a preliminary step taken specifically to meet strict regulatory and state deadlines.
- The results of the mini-bid and the proposed funding plan will be presented to the **Hickman County Board of Education** as a whole during the scheduled meeting on **April 13th, 2026**.
- Final approval, the legal authority to enter into any resulting contracts, and the allocation of necessary local matching funds remain strictly subject to the vote and approval of the full Board.

Signature: _____

Tim Hobbs Chairman, Hickman County Board of Education

Tennessee Educational Broadband Consortium
Multiple Award Schedule
State Master Contract Order Form

This agreement ("Agreement") is entered into between **Hickman County School District** ("Customer") and **Zayo Education** ("Service Provider"), for E-Rate **Category 1** or **Category 2** purchases. For good and valuable consideration, including the mutual promises contained herein, Customer orders from the Service Provider the services identified below and/or in Attachment A to this Agreement ("Service"). Customer and Service Provider agree that the Service shall be provided pursuant to the rates, charges, terms and conditions set forth in SWC 400 Zayo Broadband Services ("Master Contract").

Service Ordered by Customer:

IDENTIFY REQUESTED SERVICE(S) HEREIN AND/OR IN ATTACHMENT A

The selected Service period is **(July 1, 2026 – June 30, 2031)** unless otherwise agreed upon in writing, the Service period shall commence upon service installation.

Requested Service Commencement Date(s): July 1, 2026

If this Agreement is cancelled or terminated prior to Service Installation, cancellation charges will apply as set forth in the Master Contract (if applicable).

Customer may seek Universal Service Fund funding pursuant to the rules and regulations associated with the E-Rate program.

Customer further warrants and represents that Customer is authorized to enter into this Agreement and to order Service pursuant to the Master Contract. There are no other terms and conditions allowed pursuant to this agreement other than those present in the underlying State Master Contract. Customer further warrants and represents that this Agreement complies with all applicable procurement laws and/or requirements.

This Agreement is effective when executed by Customer. Submission of a quote at the request of the Customer constitutes the Service Provider's intent to proceed upon acceptance of the Customer. This Agreement is subject to and controlled by the provisions of the State Master Contract, including any amendments as may be made from time to time.

Customer Name:

Accepted by [VENDOR NAME]:

Print Name: Belinda Anderson

Print Name: _____

By: Belinda Anderson

By: _____

Title: Interim Director of Schools

Title: _____

Date: MAR 20 2026

Date: _____

ATTACHMENT A

Quantity Name of Product or Service

Hickman County School District	HICKMAN COUNTY	E-Rate Funding Year 2026			[Attachment A] TEBC Mini-Bid Service/Equipment List				
BIDDER INFORMATION: (to be completed by vendor)	Company Name:	Zayo Education, LLC							
	Company SPIN (498 ID):	143030857							
	Contact Name:	Ali Johnson							
	Contact E-mail:	ali.johnson@zayo.com							
	Contact Phone:	(781) 556-1365							
To Be Completed by Applicant					To Be Completed by Vendor				
School/Building Name (Tip > incl. all service locations)	TEBC Product Category	Bundled or Standalone?	Speed/Capacity (Tip > incl. all speed increments for which you want pricing)	Quantity	MRC (per circuit)	NRC (installation, make-ready costs, etc.)	Ineligible Services (description)	Ineligible Costs	Annual Cost (incl. 12-months MRC+NRC+ineligible costs)
Hickman County District Office (IA+FW)	C1 Broadband	Bundled	7 Gbps / 10 Gbps	1	\$4,600 / \$5,125	\$ -	N/A	\$ -	\$55,200 / \$61,500
Hickman County District	C1 Broadband	Bundled	7 Gbps / 10 Gbps	1	\$4,600 / \$5,125	\$ -	N/A	\$ -	\$55,200 / \$61,500

Updated: 12/15/2025

*This is not a contract. The SMC Order Form is to memorialize that a mini-bid was conducted to select a service provider from the multiple award State Master Contracts – Tennessee Education Broadband Consortium (TEBC) for specific products/services. No additional terms and conditions can be added to this document, per the TEBC Master Contracts.

[Attachment F] SMC Order Form

Office (IA+FW)									
Centerville Elementary School	C1 Broadband	Bundled	10 Gbps	1	\$550	\$ -	N/A	\$ -	\$6,600
Centerville Intermediate School	C1 Broadband	Bundled	10 Gbps	1	\$550	\$ -	N/A	\$ -	\$6,600
Hickman County Middle School	C1 Broadband	Bundled	10 Gbps	1	\$550	\$ -	N/A	\$ -	\$6,600
Hickman County High School	C1 Broadband	Bundled	10 Gbps	1	\$550	\$ -	N/A	\$ -	\$6,600
East Hickman Elementary School	C1 Broadband	Bundled	10 Gbps	1	\$1,350	\$ -	N/A	\$ -	\$16,200
East Hickman Intermediate School	C1 Broadband	Bundled	10 Gbps	1	\$550	\$ -	N/A	\$ -	\$6,600
East Hickman Middle School	C1 Broadband	Bundled	10 Gbps	1	\$550	\$ -	N/A	\$ -	\$6,600
East Hickman High School	C1 Broadband	Bundled	10 Gbps	1	\$1,350	\$ -	N/A	\$ -	\$16,200
Hickman County District Office	C1 Broadband	Bundled	10 Gbps	1	\$1,250	\$ -	N/A	\$ -	\$15,000

Updated: 12/15/2025

**This is not a contract. The SMC Order Form is to memorialize that a mini-bid was conducted to select a service provider from the multiple award State Master Contracts – Tennessee Education Broadband Consortium (TEBC) for specific products/services. No additional terms and conditions can be added to this document, per the TEBC Master Contracts.*

PEPPM Mini-Bid Bid Request Template

Hickman County School District HICKMAN COUNTY E-Rate Funding Year 2026

[Attachment A] TEBC Mini-Bid Service/Equipment List

BIDDER INFORMATION: (to be completed by vendor)	Company Name:	Tennessee Independent Telecommunications Group, LLC dba IRIS Networks
	Company SPIN (498 ID):	143051188
	Contact Name:	Karen Goodwin
	Contact E-mail:	erate@irisnetworksusa.com
	Contact Phone:	865-300-6942

To Be Completed by Applicant					To Be Completed by Vendor				
School/Building Name (Tip > incl. all service locations)	TEBC Product Category	Bundled or Standalone?	Speed/Capacity (Tip > incl. all speed increments for which you want pricing)	Quantity	MRC	NRC (installation, make-ready costs, etc.)	Ineligible Services (description)	Ineligible Costs	Annual Cost (incl. 12-months MRC+NRC+ineligible costs)
Centerville Elementary School	C1 Broadband	Bundled	10 Gbps	1	\$1,315.00	\$0	N/A	N/A	\$15,780.00
Centerville Intermediate School	C1 Broadband	Bundled	10 Gbps	1	\$1,315.00	\$0	N/A	N/A	\$15,780.00
Hickman County Middle School	C1 Broadband	Bundled	10 Gbps	1	\$1,315.00	\$0	N/A	N/A	\$15,780.00
Hickman County High School	C1 Broadband	Bundled	10 Gbps	1	\$1,315.00	\$0	N/A	N/A	\$15,780.00
East Hickman Elementary School	C1 Broadband	Bundled	10 Gbps	1	\$1,315.00	\$0	N/A	N/A	\$15,780.00
East Hickman Intermediate School	C1 Broadband	Bundled	10 Gbps	1	\$1,315.00	\$0	N/A	N/A	\$15,780.00
East Hickman Middle School	C1 Broadband	Bundled	10 Gbps	1	\$1,315.00	\$0	N/A	N/A	\$15,780.00
East Hickman High School	C1 Broadband	Bundled	10 Gbps	1	\$1,315.00	\$0	N/A	N/A	\$15,780.00
Hickman County District Office	C1 Broadband	Bundled/Internet with Managed Firewall	10 Gbps	1	\$3,875.00	\$0	N/A	N/A	\$46,500.00

\$172,740.00

Please see the "site list" tab for building addresses.

Tip > [E-Rate Funding Year for Category 1: July 1-June 30]. TEBC Contracts cover FY2026-FY2030

Term of Service: July 1, 2026 - June 30, 2031

*Vendors are only permitted to submit mini-bids for product categories that are included in their original catalogs in response to RFQ #33101-26006FAS5

*By submitting a quote in response to the Customer's request, and if selected, the Service Provider agrees to abide the Terms and Conditions of the referenced SMC and proceed with the project accordingly, subject to coordination with the Customer.

*Order may be cancelled if E-Rate and/or local budget approval is not secured.

Hickman County is looking for 10 Gbps Internet Access for all sites in the school district.

MAR 20 2026

PEPPM Mini-Bid Bid Request Template

Hickman County School District HICKMAN COUNTY E-Rate Funding Year 2026

[Attachment A] TEBC Mini-Bid Service/Equipment List

BIDDER INFORMATION: (to be completed by vendor)	Company Name:	United Data Technologies
	Company SPIN (498 ID):	143054389
	Contact Name:	Chad Arnold
	Contact E-mail:	carold@udtonline.com
	Contact Phone:	615-305-0243

To Be Completed by Applicant					To Be Completed by Vendor				
School/Building Name <small>(Tip > incl. all service locations)</small>	TEBC Product Category	Bundled or Standalone?	Speed/Capacity <small>(Tip > incl. all speed increments for which you want pricing)</small>	Quantity	MRC	NRC <small>(installation, make-ready costs, etc.)</small>	Ineligible Services <small>(description)</small>	Ineligible Costs	Annual Cost <small>(incl. 12-months MRC+NRC+ineligible costs)</small>
Internet Access without Basic Firewall - End Site to UDT POP/Internet									
Centerville Elementary School	C1 Broadband	Bundled	10 Gbps	1	\$ 2,500.00	\$ -	None	\$ -	\$ 30,000.00
Centerville Intermediate School	C1 Broadband	Bundled	10 Gbps	1	\$ 2,500.00	\$ -	None	\$ -	\$ 30,000.00
Hickman County Middle School	C1 Broadband	Bundled	10 Gbps	1	\$ 2,500.00	\$ -	None	\$ -	\$ 30,000.00
Hickman County High School	C1 Broadband	Bundled	10 Gbps	1	\$ 2,500.00	\$ -	None	\$ -	\$ 30,000.00
East Hickman Elementary School	C1 Broadband	Bundled	10 Gbps	1	\$ 2,500.00	\$ -	None	\$ -	\$ 30,000.00
East Hickman Intermediate School	C1 Broadband	Bundled	10 Gbps	1	\$ 2,500.00	\$ -	None	\$ -	\$ 30,000.00
East Hickman Middle School	C1 Broadband	Bundled	10 Gbps	1	\$ 2,500.00	\$ -	None	\$ -	\$ 30,000.00
East Hickman High School	C1 Broadband	Bundled	10 Gbps	1	\$ 2,500.00	\$ -	None	\$ -	\$ 30,000.00
Hickman County District Office	C1 Broadband	Bundled	10 Gbps	1	\$ 2,500.00	\$ -	None	\$ -	\$ 30,000.00

Please see the "site list" tab for building addresses.

\$270,000
With Firewall \$378,000

Tip > [E-Rate Funding Year for Category 1: July 1-June 30]. TEBC Contracts cover FY2026-FY2030
Term of Service: July 1, 2026 - June 30, 2031

- *Vendors are only permitted to submit mini-bids for product categories that are included in their original catalogs in response to RFQ #33101-26006FAS5
- *By submitting a quote in response to the Customer's request, and if selected, the Service Provider agrees to abide the Terms and Conditions of the referenced SMC and proceed with the project accordingly, subject to coordination with the Customer.
- *Order may be cancelled if E-Rate and/or local budget approval is not secured.

Hickman County is looking for 10 Gbps Internet Access for all sites in the school district.

UDT Notes -

Service provided in pricing template above is Internet Access without Hosted Basic Firewall for all sites in the district direct to UDT POP and Internet Access
All network traffic is routed first to the UDT POP and then to final destination including traffic destined for another district school or office

Internet Access service with Hosted Basic Firewall direct to POP/Internet is available as follows:

10 Gbps Internet Access direct to POP/Internet with Hosted Basic Firewall \$ 3,500.00 MRC per site

BA
MAR 20 2026

PEPPM Mini-Bid Bid Request Template

Alternate Network Options -

UDT has available a lit fiber solution utilizing underlying local dark fiber that connects each school site directly to the district office
 This service is priced with the following options

Internet Access from District Office	10 Gbps	\$	4,000.00	MRC
Internet Access from District Office with Hosted Basic Firewall	10 Gbps	\$	5,500.00	MRC
Dual Internet Access from District Office (2 circuits)	10 Gbps	\$	4,725.00	MRC per circuit
Dual Internet Access from District Office (2 circuits) with Hosted Basic Firewall	10 Gbps	\$	6,225.00	MRC per circuit
Data Transport - WAN - End Site Service to District Office	10 Gbps	\$	1,550.00	MRC per site
Dual WAN End Site to District Office (2 circuits)	10 Gbps	\$	1,812.50	MRC per site per circuit

Example Configuration including Internet Access with Hosted Basic Firewall

Internet Access with Hosted Basic Firewall	District Office	10 Gbps	\$	5,500.00	MRC
Data transport - WAN to District Office	8 End Sites	10 Gbps	\$	12,400.00	MRC
Total			\$	<u>17,900.00</u>	MRC

Example Configuration including Dual Internet Access with Hosted Basic Firewall

Dual Internet Access with Hosted Basic Firewall	District Office	2 x 10 Gbps	\$	12,450.00	MRC
Data transport - WAN to District Office	8 End Sites	10 Gbps	\$	12,400.00	MRC
Total			\$	<u>24,850.00</u>	MRC

Example Configuration including Dual Internet Access with Hosted Basic Firewall and Dual WAN

Dual Internet Access with Hosted Basic Firewall	District Office	2 x 10 Gbps	\$	12,450.00	MRC
Data Transport - WAN Aggregation service to District Office	2 WAN Aggregation circuits	10 Gbps	\$	3,100.00	MRC
Dual Data transport - WAN to District Office	8 End Sites	2 x 10 Gbps	\$	29,000.00	MRC
Total			\$	<u>41,450.00</u>	MRC

 MAR 20 2026

PEPPM Mini-Bid Bid Request Template

Hickman County School District HICKMAN COUNTY E-Rate Funding Year 2026

[Attachment A] TEBC Mini-Bid Service/Equipment List

BIDDER INFORMATION: (to be completed by vendor)	Company Name:	Zayo Education, LLC
	Company SPIN (498 ID):	143030857
	Contact Name:	Ali Johnson
	Contact E-mail:	ali.johnson@zayo.com
	Contact Phone:	(781) 556-1365

To Be Completed by Applicant					To Be Completed by Vendor				
School/Building Name (Tip > incl. all service locations)	TEBC Product Category	Bundled or Standalone?	Speed/Capacity (Tip > incl. all speed increments for which you want pricing)	Quantity	MRC (per circuit)	NRC (installation, make-ready costs, etc.)	Ineligible Services (description)	Ineligible Costs	Annual Cost (incl. 12-months MRC+NRC+ineligible costs)
Hickman County District Office (IA+FW)	C1 Broadband	Bundled	7 Gbps / 10 Gbps	1	\$4,600 / \$5,125	\$ -	N/A	\$ -	\$55,200 / \$61,500
Hickman County District Office (IA+FW)	C1 Broadband	Bundled	7 Gbps / 10 Gbps	1	\$4,600 / \$5,125	\$ -	N/A	\$ -	\$55,200 / \$61,500
Centerville Elementary School	C1 Broadband	Bundled	10 Gbps	1	\$550	\$ -	N/A	\$ -	\$6,600
Centerville Intermediate School	C1 Broadband	Bundled	10 Gbps	1	\$550	\$ -	N/A	\$ -	\$6,600
Hickman County Middle School	C1 Broadband	Bundled	10 Gbps	1	\$550	\$ -	N/A	\$ -	\$6,600
Hickman County High School	C1 Broadband	Bundled	10 Gbps	1	\$550	\$ -	N/A	\$ -	\$6,600
East Hickman Elementary School	C1 Broadband	Bundled	10 Gbps	1	\$1,350	\$ -	N/A	\$ -	\$16,200
East Hickman Intermediate School	C1 Broadband	Bundled	10 Gbps	1	\$550	\$ -	N/A	\$ -	\$6,600
East Hickman Middle School	C1 Broadband	Bundled	10 Gbps	1	\$550	\$ -	N/A	\$ -	\$6,600
East Hickman High School	C1 Broadband	Bundled	10 Gbps	1	\$1,350	\$ -	N/A	\$ -	\$16,200
Hickman County District Office	C1 Broadband	Bundled	10 Gbps	1	\$1,250	\$ -	N/A	\$ -	\$15,000

\$210,000

with Firewall

\$229,155

with Firewall &

Content Filter

\$229,200

Please see the "site list" tab for building addresses.

Tip > [E-Rate Funding Year for Category 1: July 1-June 30]. TEBC Contracts cover FY2026-FY2030

Term of Service: July 1, 2026 - June 30, 2031

*Vendors are only permitted to submit mini-bids for product categories that are included in their original catalogs in response to RFQ #33101-26006FAS5

*By submitting a quote in response to the Customer's request, and if selected, the Service Provider agrees to abide the Terms and Conditions of the referenced SMC and proceed with the project accordingly, subject to coordination with the Customer.

*Order may be cancelled if E-Rate and/or local budget approval is not secured.

Hickman County is looking for 10 Gbps Internet Access for all sites in the school district.

Pricing Footnotes

- In accordance with Zayo Education's TEBC Catalog Pricing, additional Internet Access and Wide Area Network (WAN) service options are available in the items listed in the pricing catalog, as well as more granular increments based on the per 1Mbps or per 1Gbps rates. Discounts will be applied commensurate with the pricing listed above based on pricing and availability.
- Upgrade pricing is subject to fiber availability and/or order.
- As part of this procurement, Zayo Education will extend service coverage to any newly established or existing sites requiring Internet, WAN or resilient connectivity during the contract period, subject to mutually agreed terms and pricing.
- Demarcation point relocation services are available upon request. Pricing for such moves will be determined on a case-by-case basis, and is not included in the standard scope of this proposal.
- As part of this procurement, Zayo Education understands that network operations or hand site relocation services may be required over the term of the contract, should the customer

Managed Basic Firewall

Tier	Monthly Recurring Cost
0-100 Mbps	\$100
101-500 Mbps	\$200
501-1000 Mbps	\$300
1001-5000 Mbps	\$1,750
5001-10000 Mbps	\$2,000
10001-50000 Mbps	\$3,000
50001-200000 Mbps	\$4,000
200001-250000 Mbps	\$5,000

Managed Basic Firewall Pricing Footnotes

- Zayo Education requires the customer to have Zayo Managed Internet Access as part of this product solution and to meet certain specifications.
- Managed Basic Firewall pricing is based on the Internet speed from the aggregation point.
- Managed Basic Firewall pricing is based on a no-contract one-year term.
- Managed Basic Firewall is eligible for E-Rate funding.
- Additional required taxes, if applicable, will be charged according to the province or territory to which the service is delivered.

BA

MAR 20 2026

PEPPM Mini-Bid Bid Request Template

These services are provided as a service to our customers. We reserve the right to change or discontinue these services at any time without notice. These services are provided on an "as-is" basis and we do not warrant their availability or performance. Zayo Education agrees to provide these services under the terms and conditions outlined in this contract.

Optional Services

Managed Services

Managed Connectivity

- Managed Internet Access
- Managed WAN

Managed Cybersecurity

- Unified Threat Management
- Managed Firewall
- Managed DDoS Protection

Managed Communications

- VoIP, Unified Communications (UCaaS)
- SIP Trunking, Audio Conferencing, Fax over IP, & Toll-Free Service

Managed Edge

- Managed WiFi/LAN
- Secure Service Edge (SSE)
- SD-WAN

Network Connectivity

Ethernet

Dedicated Internet Access

IP Transit

CloudLink

IP VPN and E-LAN

DDoS Protection

Fiber & Transport

Dark Fiber

Wavelengths

Private Networks

Mobile Infrastructure

Please speak with your Account Manager for additional details and quotes.

Additional IPv4 Address Space*

IP Block Size	Available Customer IPs	1st Additional Block	2nd Additional Block	3rd Additional Block	4th Additional Block
10/24	1,048,576	1,048,576	1,048,576	1,048,576	1,048,576
10/22	104,857.6	104,857.6	104,857.6	104,857.6	104,857.6
10/20	10,485.76	10,485.76	10,485.76	10,485.76	10,485.76
10/18	1,048.576	1,048.576	1,048.576	1,048.576	1,048.576
10/16	65,536	65,536	65,536	65,536	65,536
10/14	4,096	4,096	4,096	4,096	4,096
10/12	256	256	256	256	256
10/10	16	16	16	16	16

DDoS Protection Standard Pricing

Bandwidth Range	12-month Term	24-month Term	36-month Term	60-month Term
10-50 Mbps	\$400	\$375	\$350	\$275
50-100 Mbps	\$700	\$650	\$600	\$475
100-200 Mbps	\$1,200	\$1,100	\$1,000	\$775
200-500 Mbps	\$2,200	\$2,000	\$1,800	\$1,375
500-1,000 Mbps	\$4,200	\$3,800	\$3,400	\$2,575
1,000-2,000 Mbps	\$8,200	\$7,400	\$6,600	\$5,075
2,000-5,000 Mbps	\$16,200	\$14,600	\$13,000	\$9,875
5,000-10,000 Mbps	\$32,200	\$29,000	\$25,800	\$19,675
10,000-20,000 Mbps	\$64,200	\$58,000	\$51,800	\$39,375
20,000-50,000 Mbps	\$128,200	\$116,000	\$103,800	\$78,750
50,000-100,000 Mbps	\$256,200	\$232,000	\$207,600	\$157,500
100,000-200,000 Mbps	\$512,200	\$464,000	\$415,600	\$315,000
200,000-500,000 Mbps	\$1,024,200	\$928,000	\$831,200	\$630,000
500,000-1,000,000 Mbps	\$2,048,200	\$1,856,000	\$1,662,400	\$1,260,000
1,000,000-2,000,000 Mbps	\$4,096,200	\$3,712,000	\$3,324,800	\$2,520,000
2,000,000-5,000,000 Mbps	\$8,192,200	\$7,424,000	\$6,649,600	\$5,040,000
5,000,000-10,000,000 Mbps	\$16,384,200	\$14,848,000	\$13,299,200	\$10,080,000
10,000,000-20,000,000 Mbps	\$32,768,200	\$29,696,000	\$26,598,400	\$20,160,000
20,000,000-50,000,000 Mbps	\$65,536,200	\$59,392,000	\$52,396,800	\$39,360,000
50,000,000-100,000,000 Mbps	\$131,072,200	\$118,784,000	\$104,793,600	\$78,720,000

Unified Threat Management Features

Tier	Monthly Recurring Cost
Basic	\$1,000
Standard	\$2,000
Advanced	\$4,000
Enterprise	\$8,000

Optional Content Filtering

Service	Monthly Fee Per Site
Content Filtering	\$500

Content Filtering Pricing Footnotes

- Content filtering is available for all sites.
- Content filtering is available for all sites and is not available for all sites.
- Content filtering is available for all sites and is not available for all sites.
- Content filtering is available for all sites and is not available for all sites.
- Content filtering is available for all sites and is not available for all sites.

Secure Service Edge (SSE) Feature

Product	Price per User per Year - Less than 1000 users	Price per User per Year - More than 1000 users
Next-Generation Secure Web Gateway	\$1,000	\$500
Secure Service Edge	\$1,000	\$500
Secure Service Edge Private Access (ZTNA, SWG, CASP, and Cloud)	\$1,000	\$500

Multi-Factor Authentication Optional Add-On

User License Quantity	MSRP
1	\$100
25	\$2,500
50	\$5,000
100	\$10,000
250	\$25,000
500	\$50,000
1000	\$100,000
2500	\$250,000
5000	\$500,000
10000	\$1,000,000

CloudLink Pricing

Bandwidth Range (Mbps)	Monthly (12 Month Term)
1-100	\$100

IPv4 Address Pricing Footnotes

- No charge for IPv4 address space currently.
- Customer unable to use IPv4 address space currently will be charged for IPv4 address space.
- Additional IPv4 address space is required to support a request for additional IPv4 address space.
- Up to a 25% increase in the number of IPv4 addresses is allowed. The cost is calculated based on the number of additional IPv4 addresses requested. Plus, a 25% increase in the number of IPv4 addresses requested will result in a 25% increase in the cost of the IPv4 address space.
- Prices are subject to change based on IPv4 address availability or other market factors.
- May vary depending on the IP address block.
- Additional requirements may apply, if applicable, will be charged separately to the provider necessary to verify the IPv4 address is delivered.

DDoS Protection Pricing Footnotes

BA
MAR 20 2026

Tennessee Educational Broadband Consortium
Multiple Award Schedule
State Master Contract Order Form

This agreement ("Agreement") is entered into between **Hickman County School District** ("Customer") and **Zayo Education** ("Service Provider"), for E-Rate **Category 1** or **Category 2** purchases. For good and valuable consideration, including the mutual promises contained herein, Customer orders from the Service Provider the services identified below and/or in Attachment A to this Agreement ("Service"). Customer and Service Provider agree that the Service shall be provided pursuant to the rates, charges, terms and conditions set forth in SWC 400 Zayo Broadband Services ("Master Contract").

Service Ordered by Customer:

IDENTIFY REQUESTED SERVICE(S) HEREIN AND/OR IN ATTACHMENT A

The selected Service period is **(July 1, 2026 – June 30, 2031)** unless otherwise agreed upon in writing, the Service period shall commence upon service installation.

Requested Service Commencement Date(s): July 1, 2026

If this Agreement is cancelled or terminated prior to Service Installation, cancellation charges will apply as set forth in the Master Contract (if applicable).

Customer may seek Universal Service Fund funding pursuant to the rules and regulations associated with the E-Rate program.

Customer further warrants and represents that Customer is authorized to enter into this Agreement and to order Service pursuant to the Master Contract. There are no other terms and conditions allowed pursuant to this agreement other than those present in the underlying State Master Contract. Customer further warrants and represents that this Agreement complies with all applicable procurement laws and/or requirements.

This Agreement is effective when executed by Customer. Submission of a quote at the request of the Customer constitutes the Service Provider's intent to proceed upon acceptance of the Customer. This Agreement is subject to and controlled by the provisions of the State Master Contract, including any amendments as may be made from time to time.

Customer Name:

Accepted by [VENDOR NAME]:

Print Name: Belinda Anderson

Print Name: _____

By: Belinda Anderson

By: _____

Title: Interim Director of Schools

Title: _____

Date: MAR 20 2026

Date: _____

ATTACHMENT A

Quantity Name of Product or Service

Hickman County School District	HICKMAN COUNTY	E-Rate Funding Year 2026			[Attachment A] TEBC Mini-Bid Service/Equipment List				
BIDDER INFORMATION: (to be completed by vendor)	Company Name:	Zayo Education, LLC							
	Company SPIN (498 ID):	143030857							
	Contact Name:	Ali Johnson							
	Contact E-mail:	ali.johnson@zayo.com							
	Contact Phone:	(781) 556-1365							
To Be Completed by Applicant					To Be Completed by Vendor				
School/Building Name (Tip > incl. all service locations)	TEBC Product Category	Bundled or Standalone?	Speed/Capacity (Tip > incl. all speed increments for which you want pricing)	Quantity	MRC (per circuit)	NRC (installation, make-ready costs, etc.)	Ineligible Services (description)	Ineligible Costs	Annual Cost (incl. 12-months MRC+ NRC+ineligible costs)
Hickman County District Office (IA+FW)	C1 Broadband	Bundled	7 Gbps / 10 Gbps	1	\$4,600 / \$5,125	\$ -	N/A	\$ -	\$55,200 / \$61,500
Hickman County District	C1 Broadband	Bundled	7 Gbps / 10 Gbps	1	\$4,600 / \$5,125	\$ -	N/A	\$ -	\$55,200 / \$61,500

Updated: 12/15/2025

*This is not a contract. The SMC Order Form is to memorialize that a mini-bid was conducted to select a service provider from the multiple award State Master Contracts – Tennessee Education Broadband Consortium (TEBC) for specific products/services. No additional terms and conditions can be added to this document, per the TEBC Master Contracts.

[Attachment F] SMC Order Form

Office (IA+FW)									
Centerville Elementary School	C1 Broadband	Bundled	10 Gbps	1	\$550	\$ -	N/A	\$ -	\$6,600
Centerville Intermediate School	C1 Broadband	Bundled	10 Gbps	1	\$550	\$ -	N/A	\$ -	\$6,600
Hickman County Middle School	C1 Broadband	Bundled	10 Gbps	1	\$550	\$ -	N/A	\$ -	\$6,600
Hickman County High School	C1 Broadband	Bundled	10 Gbps	1	\$550	\$ -	N/A	\$ -	\$6,600
East Hickman Elementary School	C1 Broadband	Bundled	10 Gbps	1	\$1,350	\$ -	N/A	\$ -	\$16,200
East Hickman Intermediate School	C1 Broadband	Bundled	10 Gbps	1	\$550	\$ -	N/A	\$ -	\$6,600
East Hickman Middle School	C1 Broadband	Bundled	10 Gbps	1	\$550	\$ -	N/A	\$ -	\$6,600
East Hickman High School	C1 Broadband	Bundled	10 Gbps	1	\$1,350	\$ -	N/A	\$ -	\$16,200
Hickman County District Office	C1 Broadband	Bundled	10 Gbps	1	\$1,250	\$ -	N/A	\$ -	\$15,000

Updated: 12/15/2025

**This is not a contract. The SMC Order Form is to memorialize that a mini-bid was conducted to select a service provider from the multiple award State Master Contracts – Tennessee Education Broadband Consortium (TEBC) for specific products/services. No additional terms and conditions can be added to this document, per the TEBC Master Contracts.*

DOUG LANE
2059 Lake Drive, Centerville, TN 37033

PIPPA TAYLOR
6585 Oak Hill Rd., Lyles, TN 37098

TIM HOBBS
9220 Old Bon Aqua Rd., Bon Aqua, TN 37025

TABITHA CUDE
4141 Lewis Rd., Centerville, TN 37033



CHRISTY MAYS
450 Hwy. 50, Centerville, TN 37033

SHERRI BAKER
9037 E 40 Rd., Bon Aqua, TN 37025

JANE HERRON
PO Box 13, Nunnally, TN 37137

Dr. Belinda Anderson
Interim Director of Schools
115 Murphree Avenue
Centerville, TN 37033

DATE: March 23, 2026

TO: Hickman County Schools Technology Department / Interested Vendors

FROM: Tim Hobbs, Chairman of the Hickman County Board of Education

SUBJECT: AUTHORIZATION TO INITIATE TN STATE CATEGORY 2 E-RATE MINI-BID PROCESS

Statement of Permission

I, **Tim Hobbs**, acting in my capacity as Chairman of the Hickman County Board of Education, hereby grant the school district and its designated representatives permission to proceed with all necessary procedures to procure funding through the **Tennessee State Category 2 E-Rate Mini-Bid process**.

Purpose and Deadline

This authorization is provided to ensure the district remains in compliance with the **April 1st, 2026**, E-Rate filing deadline. Initiating these procedures immediately is vital for securing the federal and state discounts required for the district's telecommunications and internet infrastructure.

Acknowledgment of Board Authority and Local Funding

It is understood by all parties that while this authorization allows the procurement process to begin, the following conditions apply:

- This action is a preliminary step taken specifically to meet strict regulatory and state deadlines.
- The results of the mini-bid and the proposed funding plan will be presented to the **Hickman County Board of Education** as a whole during the scheduled meeting on **April 13th, 2026**.
- Final approval, the legal authority to enter into any resulting contracts, and the allocation of necessary local matching funds remain strictly subject to the vote and approval of the full Board.

Signature: _____

Tim Hobbs Chairman, Hickman County Board of Education

Tennessee Educational Broadband Consortium
Multiple Award Schedule
State Master Contract Order Form

This agreement ("Agreement") is entered into between Hickman County School District ("Customer") and Central Technologies ("Service Provider"), for E-Rate Category 2 purchases. For good and valuable consideration, including the mutual promises contained herein, Customer orders from the Service Provider the services identified below and/or in Attachment A to this Agreement ("Service"). Customer and Service Provider agree that the Service shall be provided pursuant to the rates, charges, terms and conditions set forth in 33104-00420 Central Technologies.

Service Ordered by Customer:

IDENTIFY REQUESTED SERVICE(S) HEREIN AND/OR IN ATTACHMENT A

The selected Service period is Internal Connections (July 1, 2026 – June 30, 2031). Unless otherwise agreed upon in writing, the Service period shall commence upon service installation.

Requested Service Commencement Date(s): July 1, 2026

If this Agreement is cancelled or terminated prior to Service Installation, cancellation charges will apply as set forth in the Master Contract (if applicable).

Customer may seek Universal Service Fund funding pursuant to the rules and regulations associated with the E-Rate program.

Customer further warrants and represents that Customer is authorized to enter into this Agreement and to order Service pursuant to the Master Contract. There are no other terms and conditions allowed pursuant to this agreement other than those present in the underlying State Master Contract. Customer further warrants and represents that this Agreement complies with all applicable procurement laws and/or requirements.

This Agreement is effective when executed by Customer. Submission of a quote at the request of the Customer constitutes the Service Provider's intent to proceed upon acceptance of the Customer. This Agreement is subject to and controlled by the provisions of the State Master Contract, including any amendments as may be made from time to time.

Customer Name:

Print Name: Belinda Anderson

By: Belinda Anderson

Title: Interim Director of Schools

Date: MAR 24 2026

Accepted by [VENDOR NAME]:

Print Name: _____

By: _____

Title: _____

Date: _____

ATTACHMENT A

Quantity Name of Product or Service

Hickman County School District E-Rate Funding Year 2026 [Attachment A] TEBC Mini-Bid Service/Equipment List

BIDDER INFORMATION: (to be completed by vendor)	Company Name:	Central Know-It-All Computer Systems
	Hickman SPN (499 ID):	14110000
	Contact Name:	John Walker
	Contact E-mail:	central@know-it-all.com
	Contact Phone:	847-424-7244

To Be Completed by Applicant						To Be Completed by Vendor				
School/Building Name (optional)	TEBC Product Category	Preferred Manufacturer Name (or Equivalent)	Description	Model Number (SKU)	Estimated Quantity	Price/Unit	Extended Price (quantity x unit price)	E-Rate eligible % of SKU	Extended Eligible Cost (unit price x % eligibility)	
Hickman County School District	Software	Aruba	HPE Aruba Networking Central AP Foundation 5 year Subscription E-STU	Q275542F	349	\$180	\$62,820	100%	\$62,820	
Hickman County School District	Software	Aruba	HPE Aruba Networking Central Switch Class 2 Foundation 5 year Subscription E-STU	Q275542F	20	\$560	\$11,200	100%	\$11,200	
							\$78,620		\$ 78,620	

Compatibility/Interoperability Requirements
 If vendors are bidding an "equivalent" product line that is different than what is listed in Column G, the product must be equivalent in quality and functionality, and must be fully interoperable and compatible with the applicant's existing equipment/systems which are as follows:
Applicant: List below what existing equipment/software/systems any proposed equivalent equipment must be fully compatible with:

Term of Service: April 1, 2026 - September 30, 2027 (may be extended to match E-Rate fiscal year and extensions)
 *Vendors are only permitted to submit mini-bids for product categories that are included in their original catalogs in response to RFQ #23101-28000(FASJ)
 *By submitting a quote in response to the Customer's request, and accepted, the Service Provider agrees to abide the Terms and Conditions of the referenced SMC and proceed with this project accordingly, subject to coordination with the Customer.
 *Order may be cancelled if Rate and/or local budget approval is not secured.

 MAR 24 2026

Tennessee Educational Broadband Consortium
Multiple Award Schedule
State Master Contract Order Form

This agreement ("Agreement") is entered into between Hickman County School District ("Customer") and Central Technologies ("Service Provider"), for E-Rate Category 2 purchases. For good and valuable consideration, including the mutual promises contained herein, Customer orders from the Service Provider the services identified below and/or in Attachment A to this Agreement ("Service"). Customer and Service Provider agree that the Service shall be provided pursuant to the rates, charges, terms and conditions set forth in 33104-00420 Central Technologies.

Service Ordered by Customer:

IDENTIFY REQUESTED SERVICE(S) HEREIN AND/OR IN ATTACHMENT A

The selected Service period is MIBS (July 1, 2026 – June 30, 2031). Unless otherwise agreed upon in writing, the Service period shall commence upon service installation.

Requested Service Commencement Date(s): July 1, 2026

If this Agreement is cancelled or terminated prior to Service Installation, cancellation charges will apply as set forth in the Master Contract (if applicable).

Customer may seek Universal Service Fund funding pursuant to the rules and regulations associated with the E-Rate program.

Customer further warrants and represents that Customer is authorized to enter into this Agreement and to order Service pursuant to the Master Contract. There are no other terms and conditions allowed pursuant to this agreement other than those present in the underlying State Master Contract. Customer further warrants and represents that this Agreement complies with all applicable procurement laws and/or requirements.

This Agreement is effective when executed by Customer. Submission of a quote at the request of the Customer constitutes the Service Provider's intent to proceed upon acceptance of the Customer. This Agreement is subject to and controlled by the provisions of the State Master Contract, including any amendments as may be made from time to time.

Customer Name:

Accepted by [VENDOR NAME]:

Print Name: Belinda Anderson

Print Name: _____

By: Belinda Anderson

By: _____

Title: Interim Director of Schools

Title: _____

Date: MAR 24 2026

Date: _____

ATTACHMENT A

Quantity Name of Product or Service

Name of Applicant: [Redacted] E-Rate Funding Year 2025 [Attachment A] TEBC Mini-Bid Service/Equipment List

BIDDER INFORMATION: To be completed by vendor	Company Name:	Central Educational Technology
	Company SPIN #/E-Proc ID#:	14170000
	Contact Name:	John Wilson
	Contact Email:	john.wilson@central-tech.com
	Contact Phone:	865 4242266

To Be Completed by Applicant						To Be Completed by Vendor	To Be Completed by Vendor
School/Building Name (optional)	TEBC Product Category	Manufacturer Name	Description (leased equipment or Applicant owned)	Model Number (SKU)	Estimated Quantity	E-Rate eligible % of SKU	
	MIBS	ARUBA	Switch	Aruba 2930M Series Core Switch	0	100%	
		ARUBA	SWITCH	Aruba 2930V3200F	55	100%	
		ARUBA	SWITCH	Aruba 6300M	9	100%	
		ARUBA	AP	AP 275 555	360	100%	
		ARUBA	AP	AP 325	10	100%	
			Monthly Recurring Cost:		\$ 2,000	Year 1 Annual:	\$ 24,000
						*To Be Completed by Vendor	Years 2-5 Annual: \$9,000

Compatibility/Interoperability Requirements
 If vendors are bidding an "equivalent" product line that is different than what is listed in Column C, the products must be equivalent in quality and functionality, and must be fully interoperable and compatible with the applicant's existing equipment/systems which are as follows:

BA
 MAR 24 2026

Hickman County Board of Education
Budget Amendment 30
General Purpose (141)
April 13, 2026

Account	Description	Debit	Credit	Justification
49700 - -	Insurance Recovery	\$ 64,055.14		EHHS Gym Floor Damage
76100 - 799 -	Other Capital Outlay		\$64,055.14	
46790	Other CTE Revenue	58,820.30		TCAT Revenue
71300 - 599 -	Other Charges		58,820.30	
TOTALS		<u>\$ 122,875.44</u> <u>\$ 122,875.44</u>		

Approved:

Attest:

Board Chair

Dr. Belinda Anderson

Hickman County Board of Education
Budget Amendment 31
General Purpose (141)
April 13, 2026

Account	Description	Debit	Credit	Justification
73400 - 499 -	Other Supplies	\$ 500.00		Adjustment to VPK
73400 - 355 -	Travel		500.00	
72110 - 499 -	Other Supplies	900.00		To cover travel for training for new SIS program
72110 - 524 -	In-Service	900.00		
72110 - 355 -	Travel		1,800.00	
TOTALS		<u>\$ 2,300.00</u>	<u>\$ 2,300.00</u>	

Approved:

Attest:

Board Chair

Dr. Belinda Anderson

Hickman County Board of Education
Budget Amendment 32
Federal Programs (Fund 142)
April 13, 2026

Account	Description	Debit	Credit	Justification
72710 - 146 - - 801	Bus Drivers	\$ 780.58		To bring CTE Perkins into agreement with ePlan
71300 - 499 - - 801			\$ 780.58	
TOTALS		\$ 780.58	\$ 780.58	

Approved:

Attest:

Board Chair

Dr. Belinda Anderson

Account Activity Summary
Hickman
01/01/2026 - 03/31/2026

<i>Beginning Value - Investment Account</i>	\$	3,177,451.24
<i>Beginning Value - Alternative Invest. Acct.</i>	\$	303,165.77
Total Beginning Value ^{1 See Definitions}	\$	3,480,617.01
Additions ²		
Contributions ³	\$	-
Dividends & Interest ⁴	\$	28,438.01
Withdrawals ⁵		
TSBA Fee ⁶	\$	(2,175.39)
MS Fees ⁷	\$	(2,277.53)
System Distributions ⁸	\$	-
Unadjusted Investment Earnings ⁹	\$	(105,192.74)
<i>Ending Value - Investment Account</i>	\$	3,009,342.04
<i>Ending Value - Alternative Invest. Acct.</i>	\$	390,067.32
Total Ending Value ¹⁰	\$	3,399,409.36

Definitions:

1. **Beginning Value:** The total account value at the start of business on the first day of the specified reporting period.
2. **Additions:** All credits to the account in which total account value is increased within the specified reporting period.
3. **Contributions:** The sum of total cash deposits and/or other asset transfers into the Morgan Stanley account from outside of the Morgan Stanley account and by instruction of the client within the specified reporting period.
4. **Dividends and Interest:** The sum of all dividend, interest, and capital gain payments credited to the account and those in the which settlement date lies within the specified reporting period. **NOTE:** Any dividend, interest, or capital gain distribution in which a settlement date lies outside of the reporting period or in which was included in the beginning value will not be included 'Dividends and Interest' total for the period.
5. **Withdrawals:** The sum of total cash and/or other asset transfers out of the Morgan Stanley account to any other account whether inside or outside of the firm.
6. **TSBA Fee:** The fee calculated by instruction of the client and is based on the account value at the end of business on the last day of the prior quarter.
7. **MS Fees:** The sum of all quarterly fees charged by Morgan Stanley and any adjustments made to this charge within the specified reporting period in which client is in agreement for investment advisory and brokerage services provided.
8. **System Distributions:** The sum of any distributions to the beneficiary (public school system) of the GASB 45 Trust within the specified reporting period.
9. **Unadjusted Investment Earnings:** The earnings of asset investments in the Morgan Stanley account unadjusted for any fees charged or withdrawals in the account by instruction of Morgan Stanley or the client and within the specified reporting period.
10. **Ending Value:** The Account Value at the end of business on the last day of the specified reporting period.

The information and data contained in this report are from sources considered reliable, but their accuracy and completeness is not guaranteed. This report has been prepared for illustrative purposes only and is not intended to be used as a substitute for monthly transaction statements you receive on a regular basis from Morgan Stanley Smith Barney LLC. Please compare the data on this document carefully with your monthly statements to verify its accuracy. The Company strongly encourages you to consult with your own accountants or other advisors with respect to any tax questions.

Account Contribution Summary
Hickman
01/01/2026 - 03/31/2026

ACTIVITY DATE	ACTIVITY	DESCRIPTION		TYPE
		Total Deposits	0.00	

The information and data contained in this report are from sources considered reliable, but their accuracy and completeness is not guaranteed. This report has been prepared for illustrative purposes only and is not intended to be used as a substitute for monthly transaction statements you receive on a regular basis from Morgan Stanley Smith Barney LLC. Please compare the data on this document carefully with your monthly statements to verify its accuracy. The Company strongly encourages you to consult with your own accountants or other advisors with respect to any tax questions.

Account Dividend & Interest Summary
Hickman
01/01/2026 - 03/31/2026

ACTIVITY DATE	ACTIVITY	DESCRIPTION		TYPE
01/02/2026	Dividend	PGIM SHORT-TERM CORP BOND Z	644.48	Cash
01/02/2026	Dividend	PGIM TOTAL RETURN BOND Z	1,065.48	Cash
01/02/2026	Dividend	BLACKROCK HIGH EQ INCOME INST	2,177.68	Cash
01/02/2026	Dividend	JOHN HANCOCK BOND I	2,504.10	Cash
01/02/2026	Dividend	JANUS HENDERSON MLT SEC INC I	1,817.21	Cash
01/05/2026	Dividend	CION ARES DIVERSIFIED CREDIT U	1,101.86	Cash
01/30/2026	Cashless Dividend	BLACKSTONE BCRED	989.61	Cash
01/30/2026	Interest Income	MORGAN STANLEY PRIVATE BANK NA	24.10	Cash
01/30/2026	Interest Income	MORGAN STANLEY BANK N.A.	4.25	Cash
02/02/2026	Dividend	PGIM SHORT-TERM CORP BOND Z	645.82	Cash
02/02/2026	Dividend	PGIM TOTAL RETURN BOND Z	1,038.15	Cash
02/02/2026	Dividend	BLACKROCK HIGH EQ INCOME INST	1,756.57	Cash
02/02/2026	Dividend	JOHN HANCOCK BOND I	1,709.18	Cash
02/02/2026	Dividend	JANUS HENDERSON MLT SEC INC I	1,477.52	Cash
02/03/2026	Dividend	CION ARES DIVERSIFIED CREDIT U	1,109.07	Cash
02/27/2026	Cashless Dividend	BLACKSTONE BCRED	996.89	Cash
02/27/2026	Interest Income	MORGAN STANLEY PRIVATE BANK NA	11.59	Cash
03/02/2026	Dividend	PGIM SHORT-TERM CORP BOND Z	578.48	Cash
03/02/2026	Dividend	PGIM TOTAL RETURN BOND Z	945.91	Cash
03/02/2026	Dividend	BLACKROCK HIGH EQ INCOME INST	1,900.64	Cash
03/02/2026	Dividend	JOHN HANCOCK BOND I	1,699.90	Cash
03/02/2026	Dividend	JANUS HENDERSON MLT SEC INC I	1,411.45	Cash
03/03/2026	Dividend	CION ARES DIVERSIFIED CREDIT U	1,008.38	Cash
03/11/2026	Dividend	VICTORYSHARES FREE CASH FLOW	77.61	Cash
03/20/2026	Dividend	ISHARES CORE S&P U.S. GROWTH	229.69	Cash
03/20/2026	Dividend	ISHARES CORE S&P U.S. VALUE	349.72	Cash
03/25/2026	Cashless Dividend	BREIT CL S-2	142.54	Cash
03/27/2026	Cashless Dividend	BLACKSTONE BCRED	1,004.81	Cash
03/31/2026	Interest Income	MORGAN STANLEY PRIVATE BANK NA	15.32	Cash
		Total Dividends and Interest	28,438.01	

The information and data contained in this report are from sources considered reliable, but their accuracy and completeness is not guaranteed. This report has been prepared for illustrative purposes only and is not intended to be used as a substitute for monthly transaction statements you receive on a regular basis from Morgan Stanley Smith Barney LLC. Please compare the data on this document carefully with your monthly statements to verify its accuracy. The Company strongly encourages you to consult with your own accountants or other advisors with respect to any tax questions.

*Account Fee Summary
Hickman
01/01/2026 - 03/31/2026*

ACTIVITY DATE	ACTIVITY	DESCRIPTION		TYPE
01/08/2026	Service Fee	ADV FEE 01/01-01/31	-485.76	Cash
01/12/2026	CASH TRANSFER	FUNDS TRANSFERRED	-2,175.39	Cash
01/21/2026	Service Fee	NET PLATFORM FEE	0.00	Cash
01/28/2026	Account Fee	BER10 PLACE FEE	-440.00	Cash
01/28/2026	Account Fee	BDP69 PLACE FEE	-440.00	Cash
02/06/2026	Service Fee	ADV FEE 02/01-02/28	-431.56	Cash
03/06/2026	Service Fee	ADV FEE 03/01-03/31	-480.21	Cash
		Total Withdrawals	-4,452.92	

***Cash Balance Includes Cash, Bank Deposits, MMF Balance, and Unsettled Cash.**

Unless otherwise indicated, this information is not intended to be a substitute for the official account statements that you receive from us. This information is approximate and subject to adjustment, updating and correction and is for illustrative and general reference purposes only. We are not responsible for any clerical, computational or other inaccuracies, errors or omissions. We obtain market values and other data from various standard quotation services and other sources, which we believe to be reliable. However, we do not warrant or guarantee the accuracy or completeness of any such information. The values that you actually receive in the market for any investment may be higher or lower than the values reflected herein. To the extent there are any discrepancies between your official account statement and this information, you should rely on the official account statement. This information should not be considered as the sole basis for any investment decision. The Bank Deposit Program (BDP) is a cash sweep feature whereby clients can choose to have their available free credit balances automatically deposited into interest bearing, FDIC-insured deposit accounts at up to three banks ("Program Banks"): (1) Morgan Stanley Bank, N.A. and/or Morgan Stanley Private Bank, National Association (together, the "Morgan Stanley Banks"), or (2) Citibank, N.A. The Program Banks are FDIC members. Morgan Stanley Smith Barney LLC ("Morgan Stanley") is a registered broker-dealer, not a bank. Morgan Stanley and the Morgan Stanley Banks are affiliates. Unless specifically disclosed to you in writing, other investments and services offered to you through Morgan Stanley are not insured by the FDIC, are not deposits of or other obligations of, or guaranteed by, the Program Banks and involve investment risks, including possible loss of principal amount invested.

External Assets - Certain assets listed in this view are based upon information provided by you, your client or other external sources and are not part of accounts that you manage at Morgan Stanley. Assets not held with Morgan Stanley may not be covered by SIPC protection or by additional protection under Morgan Stanley's excess insurance coverage plans. Morgan Stanley may include information about these external assets in this view solely as a service to you, and Morgan Stanley is not responsible for the accuracy of any information provided by external sources, including but not limited to, you, your client or another financial institution. You are responsible for ensuring the accuracy of such information. Generally, any financial institution that holds securities is responsible for year-end reporting (Internal Revenue Service (IRS) Form 1099) and separate periodic statements, which may vary from Morgan Stanley's information due to different tax reporting periods.

The information and data contained in this report are from sources considered reliable, but their accuracy and completeness is not guaranteed. This report has been prepared for illustrative purposes only and is not intended to be used as a substitute for monthly transaction statements you receive on a regular basis from Morgan Stanley Smith Barney LLC. Please compare the data on this document carefully with your monthly statements to verify its accuracy.

The Company strongly encourages you to consult with your own accountants or other advisors with respect to any tax questions.

Hickman County Board of Education

Descriptor Term: Nepotism	Descriptor Code: 1.108	Issued Date: 09/19/23
	Rescinds: 1.108	Issued: 03/06/23

~~Whenever a person is considered by the director of schools for initial employment and that person is related to a member of the Board or the Director of Schools, employment shall not be allowed. Should a need arise to hire a "relative" of the Director or Board member, the Director can bring the matter to the Board in session which will require an affirmative simple majority roll call vote.~~

Whenever a person is considered by the director of schools for initial employment or transfer in the system and that person is related to a member of the Board, the director of schools, an administrator in the system, a county commissioner, or any appointed or elected county official, the relationship shall be publicly made known to the Board prior to the employment of such person.¹

If a member of the Board has a relative who is an employee in the system, prior to voting on any matter of business that may have an effect upon the employment of the relative, the member shall declare such relationship. In making such a declaration, the member shall certify that his/her vote on the pending matter will be in the best interest of the school system.¹

Two (2) or more employees who are relatives shall not be within the same line of supervision.

This shall not apply to any person within such a relationship who has been regularly employed by the Board prior to the inception of this relationship, adoption of this policy or board member's election and/or Director's appointment.

For purposes of this policy, the terms "related to" and "relative" include the following relationships: spouse, parent, parent-in-law, child, son-in-law, daughter-in-law, grandparent, grandchild, brother, sister, uncle, aunt, nephew, niece, or any person who resides in the same household.²

Legal References

1. TCA 49-2-202(a)(3)
2. TCA 49-2-202(a)(3)(B)

Cross References

Supervision 5.108
Assignment/Transfer 5.115



Misty Shelton
VPK Supervisor/Licensure Coordinator/Board Policies
Hickman County Schools
115 Murphree Avenue
Centerville, Tennessee 37033

To: School Board Members
From: Misty Shelton
Date: April 2026

1st reading:

1.804 – Alcohol & Drugs in the Workplace

This updated policy contains a provision on examinations based on reasonable suspicion.

2.400 Revenue- Due to the federal government's decision to discontinue production of pennies, the Tennessee Comptroller of the Treasury has issued guidance regarding payment practices. TSBA has recommended changes that are reflected in their model policy.

5.114 – Personnel Files

This updated policy clarifies that disciplinary action is part of an employee's personnel file.

5.1151 – Telework During Emergencies

This policy has been updated to clarify that telework outside of emergency situations is not permitted.

5.200-5.202 – Separation Practices for Employees

These policies include a provision for alternative work assignments instead of suspension without pay

5.302 – Sick Leave

This updated policy includes a provision for verifying absences of five days or longer. Additionally, it contains a provision regarding suspected misuse.

5.400 – Personnel Health Examinations/Communicable Diseases

This policy includes a new provision on providing options for employees who may be ill.

5.403 – Drug & Alcohol Testing for Employees

This updated policy contains new information on best practices for reasonable suspicion testing.

5.606 – Political Activities

This change includes a prohibition on using district-owned property for filming political content.

931-729-3391 ext. 2226

misty.shelton@hickmank12.org

fax 931-729-3834



NEW 5.608 – Tutoring for Pay

This updated policy includes a more detailed provision on tutoring arrangements.

5.800 – Director of Schools

This updated policy includes provisions clarifying the Director's personnel responsibilities.

6.411 Student Wellness- The State Board of Education recently made updates to its Coordinated School Health Program Policy. These revisions were made to align State Board language with statutory requirements and reflect the current practices and needs of school districts. TSBA has recommended changes that are reflected in their model policy.

Up for Review:

- 2.401 Gifts and Bequests
- 2.402 Investment Earnings
- 2.403 Surplus Property Sales
- 2.404 School Support Organizations
- 2.500 Deposit of Fund
- 2.600 Bonded Employees
- 2.601 Fundraising Activities
- 2.700 Accounting System
- 2.701 Financial Reports and Records
- 2.702 Inventories
- 2.703 Audits

Thank you for your careful consideration of these policies.

931-729-3391 ext. 2226

misty.shelton@hickmank12.org

fax 931-729-3834

Hickman County Board of Education

Descriptor Term: Alcohol & Drugs in the Workplace	Descriptor Code: 1.804	Issued Date: 03/02/26
	Rescinds: 1.804	Issued: 02/05/24

General

Any employee who violates the terms of this policy shall be subject to disciplinary action, including but not limited to, suspension, dismissal, and/or referral for prosecution.¹

The Director of Schools shall be responsible for providing a copy of this policy to all school district employees.

DEFINITIONS

“Workplace” shall include any school building or any school premise; any school-owned or any other school-approved vehicle used to transport students to and from school or school activities; and off-school property during any school-sponsored or school approved activity, event, or function.

“Illegal drugs” shall include any narcotic drug, hallucinogenic drug, amphetamine, barbiturate, marijuana, or any other controlled substance as defined by federal law.²

“Unauthorized drugs” shall include, but are not limited to, inhalants; any designer, synthetic, derivative, analogous, or “look-alike” substances that are manufactured, designed, or intended to resemble and/or mimic the effects of illegal drugs; any legally prescribed drugs being used in a manner for which they were not intended or prescribed including, but not limited to, the use of prescription drugs prescribed for another individual; and any lawful substances that could result in impairment of physical or mental capacity that is threatening to the health or safety of the employee or others.³

“Alcohol” shall include, but is not limited to, spirits, liquor, wine, beer, and any liquid containing alcohol as defined by state and federal law.⁴

ALCOHOL & DRUG-FREE WORKPLACE

No employee while on or in the workplace shall unlawfully manufacture, distribute, dispense, possess, use, or be under the influence of any illegal or unauthorized drugs¹ or any alcohol.⁵

PHYSICAL EXAMINATION/SCREENING BASED UPON REASONABLE SUSPICION

Whenever the Director, or his/her authorized designee reasonably suspects that an employee’s work performance or on-the-job behavior may have been affected in any way by illegal drugs or alcohol or that an employee has otherwise violated this policy, Alcohol & Drugs in the workplace, the employee may be required to submit a breath and/or urine sample for drug and alcohol testing as detailed in Policy 5.403 Drug & Alcohol Testing for Employees.

Legal References

1. [Drug Free Workplace Act of 1988, 41 USCA § 8103; 34 CFR §§ 84.205 – 84.215](#)
2. [21 USCA § 812](#)
3. [TCA 49-5-1003\(b\)\(16\), \(17\), \(18\)](#)
4. [TCA 57-4-102; 26 USCA § 5002](#)
5. [TCA 39-17-715](#)

Cross References

Supervision 5.108
Drug & Alcohol Testing for Employees 5.403
Drug-Free Schools 6.307

Hickman County Board of Education

Descriptor Term Revenues	Descriptor Code: 2.400	Issued Date: 03/02/26
	Rescinds: 2.400	Issued: 12/04/23

1 *General*

2 Any money collected by any school shall be documented by a written receipt.

3 The schools may receive funds collected from activities and for events held at or in connection with
4 the school, including contracts with other schools for interschool events. To be included in this
5 accounting are all monies collected from lunch rooms, athletics, entertainments, school clubs, fees,
6 concessions and all fundraising activities. Each principal shall determine the reconciliation method to
7 be used for all events which require a ticket.¹

8 The purchase of items intended for resale for profit through the schools shall be subject to sales tax
9 based on the purchase price to the vendor providing the service or item. Resale items not intended to
10 generate a profit shall be determined by the principal.

FEES

12 School fees are to be kept to a minimum and may be expended only for the purposes for which they
13 were collected. The school shall not require any student to pay a fee to the school for any purpose,
14 except as authorized by the Board. No fees shall be required of any student as a condition to attend the
15 school or use its equipment.² School fees shall be waived for students who receive free or reduced-
16 price lunches.³ No student will be penalized for non-payment of any materials fee.

EXTENDED SCHOOL PROGRAM

18 Extended school funds shall be collected at the individual schools and receipted and deposited in the
19 school bank account. The principal shall report the collections and pay the Board by school check.⁴

FINES

21 A student will be held responsible for the cost of replacing any materials or property which the student
22 loses or damages,⁵ including textbooks, library books, equipment and buildings. All money collected
23 as fines shall be placed in the systemwide school fund.

TUITION INCOME

25 Tuition collected from non-resident students shall be placed in the systemwide school fund.

1 RENTAL INCOME

2 The principal will collect and remit to the central office all money received for use of a particular
3 school facility or other school property.

4 GRANTS

5 Grants for educational purposes made available by the state and/or federal government may be sought
6 by the school system but only when the conditions of their availability are in harmony with the
7 purposes and policies of the Board and the laws of the state and county. Principals may apply for and
8 receive grants, but funds must be recorded in a separate restricted fund account.⁴

9 COLLECTION OF FUNDS THROUGH ONLINE PAYMENT⁶

10 Approved district staff may utilize Linqconnect.com for electronic transactions. The Director of
11 Schools/designee shall determine when this type of transaction may be utilized on a case-by-case basis.
12 At the individual school level, the principal shall oversee the collection of funds and submit a plan that
13 includes the following:

- 14 1. Adequate supporting documentation for the electronic collection method including a plan to
15 provide a total daily receipt summary;
- 16 2. Methods of providing receipts to payers;
- 17 3. Information on maintaining and inspecting any voided receipts; and
- 18 4. How daily electronic collections shall be reconciled with the total daily receipt summary and
19 who will be assigned to complete this task.

20 Processing fees for these transactions shall be charged.

21 The Director of School/designee shall establish adequate internal controls to ensure compliance with
22 the Tennessee Internal School Funds Manual.

23 **ROUNDING IN CASH TRANSACTIONS**

24 Due to the discontinuance of the penny, rounding procedures shall be utilized in cash transactions.
25 This applies to collections of all cash funds received by the district.

26 Cash transactions shall be rounded to the nearest \$0.05. The following rounding method shall be
27 utilized:

- 28 • Amounts ending in \$0.01 or \$0.02 shall be rounded down
- 29 • Amounts ending in \$0.03 or \$0.04 shall be rounded up
- 30 • Amounts ending in \$0.06 or \$0.07 shall be rounded down
- 31 • Amounts ending in \$0.08 or \$0.09 shall be rounded up

1

The Director of Schools/designee shall monitor implementation to ensure compliance with accounting standards and state law.

)



Legal References

1. [TCA 49-2-110\(a\); *Internal School Funds Manual, Section 5-4*](#)
2. [TCA 49-6-3001\(a\); TCA 49-2-110\(c\)](#)
3. [TCA 49-2-114](#)
4. [*Internal School Funds Manual, Section 4-32, 4-33*](#)
5. [TCA 37-10-101, 102](#)
6. [*Internal School Funds Manual, Section 5-8*](#)

Cross References

Fundraising Activities 2.601
Student Activity Funds Management 2.900
Food Service Management 3.500
Textbooks and Instructional Materials 4.400
Compensation Guides & Contracts 5.110
Attendance of Non-Resident Students 6.204
Student Fees and Fines 6.709

Hickman County Board of Education

Descriptor Term: Personnel Records	Descriptor Code: 5.114	Issued Date: 12/09/24
	Rescinds: 5.114	Issued: 11/07/22

The director of schools or his designee(s) shall be authorized to maintain personnel records and to permit inspection of the same. The following personnel records shall be maintained for all employees as appropriate:

1. Employee applications and contracts;
2. Professional certificates and other documents required by state and federal laws and regulations;¹
3. Evaluations;
4. Cumulative information files:
 - a. Age
 - b. Experience
 - c. Qualifications
 - d. Salary
 - e. Physical exams
 - f. Sex
 - g. Race
 - h. Names of schools and grades taught
5. INS Form I-9.²
6. Disciplinary action, as appropriate and any response from the employee.

The following guidelines shall be followed:

1. Information contained in personnel records shall be limited to job-related matters;
2. The director of schools shall be responsible for notifying all employees of the types of records kept and uses made of such records;
3. Employees shall be granted an opportunity to respond in writing to material placed in records;
4. Employee records are public records, except medical records, and shall be open for inspection during regular business hours;³
5. In accordance with federal law, the district shall release information regarding the professional qualifications and degrees of teachers and the qualifications of paraprofessionals to parents upon request for any teacher or paraprofessional who is employed by a school receiving Title I funds and who provides instruction to their child at that school.⁴

6. Members of the public may not obtain the home telephone number, personal cell phone number, bank account information, social security number, residential street address, or driver license information (except where driving or operating a vehicle is considered to be a part of the employee's duties), of an employee or of the immediate family members or household members of an employee, unless release of this information is expressly authorized by the employee.⁵
7. A record of the person inspecting and the date of inspection shall be recorded; and
8. Copies of records may be made under rules determined by the director of schools.⁶

Legal References

1. [TCA 49-2-301\(b\)\(1\)\(M\)](#)
2. [Immigration Reform and Control Act of 1986, Pub. L. No. 99-603, 100 Stat. 3359](#)
3. [TCA 10-7-503, 504](#)
4. [20 USCA § 6312\(e\)\(1\)](#)
5. [TCA 10-7-504\(f\)\(1\); TCA 10-7-504\(a\)\(23\)](#)
6. [TCA 10-7-506; TCA 49-2-301\(b\)\(1\)\(AA\)](#)

Cross References

Teacher Effect Data 5.1141

Hickman County Board of Education

	Descriptor Term: Telework During Emergencies	Descriptor Code: 5.1151	Issued Date: 12/09/24
		Rescinds: 5.1151	Issued: 11/07/22

General

Teleworking is a work arrangement where designated employees are allowed to perform their normal duties and responsibilities through the use of hardware and software at an alternate location from their normal work site.

The Director of Schools may require an employee to telework if the duties and responsibilities of the position are required during times of emergency. An employee's participation in the program will be determined by the length and duration of the emergency and will be both initiated and ended at the discretion of the supervisor and/or the Director of Schools. **Telework outside of times of emergency is not permitted.**

WORK ENVIRONMENT

Employees approved for telework shall maintain a dedicated and safe work environment.

An employee who teleworks shall not allow anyone other than district employees to utilize district provided services or equipment. Employees shall keep remote work and information confidential, in accordance with district policies, procedures, and applicable privacy laws.

Cross References

Emergency Closings 1.8011

Hickman County Board of Education

Descriptor Term: Separation Practices for Tenured Teachers	Descriptor Code: 5.200	Issued Date: 02/03/25
	Rescinds: 5.200	Issued: 12/05/22

1 **ALTERNATIVE WORK ASSIGNMENT**

2 During an investigation of any accusations that may lead to further disciplinary action, the Director of
3 Schools or his/her designee, may choose to reassign the impacted employee to a different work
4 location and/or duties. This alternative work assignment would last until the investigation is complete
5 and any findings are used to determine what, if any, further action is necessary. Alternative work
6 assignments may be designated in lieu of suspending an employee without pay, as deemed appropriate
7 by the Director of Schools or his/her designee.

8 **SUSPENSION PENDING AN INVESTIGATION ¹**

9 The director of schools may suspend a teacher at any time that may seem necessary, pending
10 investigation or final disposition of a case before the board or an appeal. If the matter under investigation
11 is not the subject of an ongoing criminal investigation or a department of children's services
12 investigation, and if no charges for dismissal have been made, a suspension pending investigation shall
13 not exceed ninety (90) days in duration. Under no circumstances shall the director of schools suspend a
14 teacher with pay. If vindicated or reinstated, the teacher shall be paid full salary for the period of
15 suspension.

16 **SUSPENSION OF THREE DAYS OR LESS ^{2,3}**

17 A director of schools/designee may suspend a teacher for incompetence, inefficiency, neglect of duty,
18 unprofessional conduct and insubordination. Before an employee is suspended he/she shall be: (1)
19 provided with written notice, including the reasons for the suspension along with an explanation of the
20 evidence; (2) given an opportunity to respond to the director at a conference, if requested within five
21 (5) days; and (3) given a written decision of the suspension within ten (10) days. Both parties may be
22 represented by counsel at the conference, which shall be recorded.

23 Under no circumstances shall a director of schools suspend a tenured teacher with pay. If reinstated, the
24 tenured teacher shall be paid full salary for the period of suspension, unless suspension without pay is
25 deemed to be an appropriate penalty.

26 **DISMISSAL OR SUSPENSIONS GREATER THAN THREE DAYS⁴**

27 The Board shall maintain a list of qualified individuals who have indicated a willingness to act as
28 impartial hearing officers, as defined under Tennessee law.

29 When charges are made against a tenured teacher, charging the teacher with offenses which may justify
30 dismissal or a suspension greater than three days, the charges shall be made in writing, specifically stating
31 the offenses which are charged and shall be signed by the party or parties making the charges.

1 If, in the opinion of the Board, the charges are of such nature as to warrant the release or a suspension
2 greater than three days of the teacher, the director of schools shall give the teacher a written notice of
3 this decision, a copy of the charges against the teacher, and a copy of a form provided by the
4 Commissioner of Education advising the teacher of his/her legal duties, rights and recourse.

5 A tenured teacher who has been given notice of charges against him/her may within thirty (30) days after
6 receipt of notice give written notice to the director of schools of his/her request for a hearing.

7 The director of schools shall, within five (5) days after receipt of request, assign a hearing officer from
8 the list maintained by the Board.

9 The hearing officer shall notify the parties, or their attorney, of the officer's assignment and direct the
10 parties or the attorneys for the parties, or both, to appear before the hearing officer for simplification of
11 issues and the scheduling of the hearing. That hearing shall be set no later than thirty (30) days following
12 receipt of the initial request for a hearing. In the discretion of the hearing officer, all or part of any
13 prehearing conference may be conducted by telephone if each participant has an opportunity to
14 participate, be heard, and to address proof and evidentiary concerns. The hearing officer is empowered
15 to issue appropriate orders and to regulate the conduct of the proceedings.

16 Either party may appeal to the Board of Education an adverse ruling by giving written notice of appeal
17 within ten (10) working days of the hearing officer's delivery of the hearing officer's written findings
18 and conclusions. The director of schools shall prepare a copy of the proceedings, including all transcripts
19 and evidence, documentary or otherwise, and transmit the same to the Board within twenty (20) days of
20 the receipt of the notice of appeal.

21 The Board shall hear the appeal on the record, and no new evidence may be submitted by either party.
22 The appealing party may appear before the Board to argue why the adverse ruling should be over-turned.
23 In no event should such argument last more than fifteen (15) minutes, unless the Board should vote to
24 extend additional time. At the conclusion of the hearing, any member of the Board may vote to sustain
25 the decision of the Hearing officer, send the record back for additional evidence, revise the penalty or
26 reverse the decision. The Board shall render its decision within ten (10) working days after the
27 conclusion of the hearing. In the event that the decision of the Board is appealed to the Chancery court,
28 the Board shall transmit the entire record prepared by the director and reviewed by the Board to the
29 Chancery court for its review.

30 RESIGNATION

31 A teacher shall give the director of schools notice of resignation at least thirty (30) days before the
32 effective date of the resignation. A teacher who fails to give such notice, in the absence of justifiable
33 extenuating circumstances, shall forfeit all tenure status. The Board may waive the thirty (30) days'
34 notice requirement and permit a teacher to resign in good standing.⁵

35 The conditions under which it is permissible to break a contract with the Board are as follows:⁶

- 36 1. The incapacity on the part of the teacher to perform the contract as evidenced by the certified
37 statement of a physician approved by the Board;

1 2. The release by the Board of the teacher from the contract which the teacher has entered into with
2 the Board.

3 Any teacher on leave shall notify the director of schools in writing at least thirty (30) days prior to the
4 date of return if the teacher does not intend to return to the position from which he/she has taken leave.
5 Failure to render such notice may be considered a breach of contract.⁷

6 Upon a breach of contract, the Board, upon a motion recorded in its minutes, may file a complaint with
7 the State Board of Education and request the suspension of a teacher's certificate. After the State Board
8 of Education has provided the teacher an opportunity for defense during a hearing, the State Board of
9 Education may suspend the certificate for no less than thirty (30) and no more than three hundred sixty-
10 five (365) days.⁸

11 **RETIREMENT**

12 Retirement shall mean a termination of services under conditions which will allow the employee to draw
13 benefits from retirement plans and/or social security benefits. Employees eligible for retirement benefits
14 may elect to retire at any age according to the provisions of the retirement system.

15 Central office personnel shall assist employees in securing retirement benefits; however, it shall be the
16 responsibility of the retiring employee to provide verification of eligibility in writing from TCRS to the
17 central office. It shall be the responsibility of the retiring employee to file for benefits.

Legal References

1. [TCA 49-5-511\(a\)\(3\)](#)
2. [TCA 49-2-301\(b\)\(1\)\(EE\)](#), [TCA 49-5-512\(d\)](#)
3. [TCA 49-5-511\(a\)\(2\)](#)
4. [TCA 49-5-511; 512; 513](#)
5. [TCA 49-5-508\(a\)](#)
6. [TCA 49-5-508\(c\)](#)
7. [TCA 49-5-706](#)
8. [TCA 49-5-411\(b\)](#)

Cross References

- Public Hearings 1.401
- Teacher Tenure 5.117
- Recommendations and File Transfers 5.203

Hickman County Board of Education

Descriptor Term: Separation Practices for Non-Tenured Teachers	Descriptor Code: 5.201	Issued Date: 02/03/25
	Rescinds: 5.201	Issued: 12/05/22

1 **ALTERNATIVE WORK ASSIGNMENT**

2 During an investigation of any accusations that may lead to further disciplinary action, the Director of
3 Schools or his/her designee, may choose to reassign the impacted employee to a different work
4 location and/or duties. This alternative work assignment would last until the investigation is complete
5 and any findings are used to determine what, if any, further action is necessary. Alternative work
6 assignments may be designated in lieu of suspending an employee without pay, as deemed appropriate
7 by the Director of Schools or his/her designee.

8 **SUSPENSION PENDING AN INVESTIGATION¹**

9 The director of schools may suspend a teacher at any time that may seem necessary, pending
10 investigation or final disposition of a case before the board or an appeal. If the matter under investigation
11 is not the subject of an ongoing criminal investigation or a department of children's services
12 investigation, and if no charges for dismissal have been made, a suspension pending investigation shall
13 not exceed ninety (90) days in duration. Under no circumstances shall the director of schools suspend a
14 non-tenured teacher with pay. If vindicated or reinstated, the non-tenured teacher shall be paid full salary
15 for the period of suspension.

16 **SUSPENSION OF THREE DAYS OR LESS²**

17 A director of schools/designee may suspend a teacher for incompetence, inefficiency, neglect of duty,
18 unprofessional conduct and insubordination. Before an employee is suspended he/she shall be: (1)
19 provided with written notice, including the reasons for the suspension along with an explanation of the
20 evidence; (2) given an opportunity to respond to the director at a recorded conference, if requested within
21 five (5) days; and (3) given a written decision of the suspension within ten (10) days. Both parties may
22 be represented by counsel at the conference, which shall be recorded.

23 **DISMISSAL OR SUSPENSION GREATER THAN THREE DAYS²**

24 The director of schools may dismiss or suspend for more than three days any non-tenured teacher **during**
25 **the contract year** for incompetence, inefficiency, insubordination, improper conduct or neglect of duty
26 after giving the non-tenured teacher, in writing, due notice of the charges.

27 The director of schools shall give the non-tenured teacher an opportunity for a full and complete hearing
28 before an impartial hearing officer.

29 The Board will appoint an impartial hearing officer to conduct such hearings. The hearing officer will
30 hear the case and the employee shall have the right to:

- 1 1. be represented by counsel;
- 2 2. call and subpoena witnesses;
- 3 3. examine all witnesses; and
- 4 4. require that all testimony be given under oath.

5 Factual findings and decisions in all dismissal cases shall be reduced to written form and delivered to the
6 affected employee within ten (10) working days following the close of the hearing. The employee may
7 appeal the decision to the Board within ten (10) working days of the hearing officer rendering the written
8 decision to the employee. Written notice of appeal to the Board shall be given to the director of schools.
9 Within twenty (20) days' of receipt of notice, the director shall prepare a copy of the proceedings,
10 transcript, documentary and other evidence presented and provide the Board a copy of the same.

11 The Board shall hear the appeal. No new evidence shall be introduced. The non-tenured teacher may
12 appear in person or be represented by counsel and argue why the decision should be modified or reversed.
13 The Board shall take one of the following actions:

- 14 1. sustain the decision;
- 15 2. send the record back if additional evidence is necessary; or
- 16 3. revise the penalty or reverse the decision.

17 Before any decision to dismiss is made, a majority of the membership of the Board shall concur in
18 sustaining the charges. The Board shall render a decision on the appeal within ten (10) working days
19 after the conclusion of the hearing.

20 The director of schools shall also have the right to appeal any adverse ruling by the Hearing Officer in
21 same manner as the non-tenured teacher.

22 Within twenty (20) days after receipt of notice of the decision of the Board, either party may appeal to
23 the chancery court in the county where the school system is located. The Board shall provide the entire
24 record of the hearing to the court.

25 **NONRENEWAL**

26 Non-tenured teachers are subject to the same rules and regulations and are entitled to the privileges of
27 employment enjoyed by tenured teachers except that they have no claim upon continuing employment
28 or tenure protections.

29 The principal is responsible for discussing deficiencies as part of the evaluation process with the non-
30 tenured teacher and providing assistance for overcoming these deficiencies.

31 The director of schools is under no obligation to re-employ non-tenured teachers at the end of their con-
32 tract period. If the director of schools determines not to renew the contract of a non-tenured teacher, the
33 following action shall be taken:

- 34 1. The Board shall be notified at the next regular board meeting; and
- 35 2. Written notice of non-renewal shall be sent to the teacher by certified mail or overnight carrier,
36 or by email within five (5) business days following the last instructional day for the school

1 year.³ If the reason for nonrenewal is due only to a loss of funding for the position, then the
2 notice shall include a statement listing it as the cause for nonrenewal.⁴

3 RESIGNATION

4 A teacher shall give the director of schools notice of resignation at least thirty (30) days before the
5 effective date of the resignation.⁵ The Board may waive the thirty (30) days-notice requirement and
6 permit a teacher to resign in good standing.

7 The conditions under which it is permissible to break a contract with the Board are as follows:⁶

- 8 1. The incapacity on the part of the teacher to perform the contract as evidenced by the certified
9 statement of a physician approved by the Board;
- 10 2. The release by the Board of the teacher from the contract which the teacher has entered into with
11 the Board.

12 Any teacher on leave shall notify the director of schools in writing at least thirty (30) days' prior to the
13 date of return if the teacher does not intend to return to the position from which he/she has taken leave.
14 Failure to render such notice may be considered a breach of contract.⁷

15 Upon a breach of contract, the Board, upon a motion recorded in its minutes, may file a complaint with
16 the State Board of Education and request the suspension of a teacher's certificate. After the State Board
17 of Education has provided the teacher an opportunity for defense during a hearing, the State Board of
18 Education may suspend the certificate for no less than thirty (30) and no more than three hundred sixty-
19 five (365) days.⁸

20 RETIREMENT

21 Retirement shall mean a termination of services under conditions which will allow the employee to draw
22 benefits from retirement plans and/or social security benefits.

23 Employees eligible for retirement benefits may elect to retire at any age according to the provisions of
24 the retirement system. Central office personnel shall assist employees in securing retirement benefits;
25 however, it shall be the responsibility of the retiring employee to provide verification of eligibility in
26 writing from TCRS to the central office. It shall be the responsibility of the retiring employee to file for
27 benefits.

28 *(Note: Nonrenewal of non-tenured teachers after the contract year is not suspension or dismissal and*
29 *does NOT follow the suspension/dismissal procedures outlined in this policy. Rather, nonrenewal of*
30 *non-tenured teachers after the contract year follows the nonrenewal procedures outlined in this policy.)*

Legal References

1. [TCA 49-5-511\(a\)\(3\)](#)
2. [TCA 49-2-301\(b\)\(1\)\(EE\)](#); [TCA 49-5-512](#)
3. [TCA 49-5-409](#)
4. [TCA 49-5-409\(b\)\(2\)](#)
5. [TCA 49-5-508](#)

Cross References

- Public Hearings 1.401
Teacher Tenure 5.117
Recommendations and File Transfers 5.203

6. [TCA 49-5-411\(a\)](#)
7. [TCA 49-5-706](#)
8. [TCA 49-5-411\(b\)](#)

Hickman County Board of Education

Descriptor Tenn: Separation Practices for Non-Certified Employees	Descriptor Code: 5.202	Issued Date: 02/03/25
	Rescinds: 5.202	Issued: 12/05/22

1 **ALTERNATIVE WORK ASSIGNMENT**

2 During an investigation of any accusations that may lead to further disciplinary action, the Director of
3 Schools or his/her designee, may choose to reassign the impacted employee to a different work location
4 and/or duties. This alternative work assignment would last until the investigation is complete and any
5 findings are used to determine what, if any, further action is necessary. Alternative work assignments
6 may be designated in lieu of suspending an employee without pay, as deemed appropriate by the Director
7 of Schools or his/her designee.

8 **SUSPENSION**

9 A director of schools/designee may suspend an employee at any time when deemed necessary.¹

10 Under no circumstances shall a director of schools suspend an employee with pay. If reinstated, the
11 employee shall be paid full salary for the period of suspension, unless suspension without pay is deemed
12 to be an appropriate penalty.

13 **DISMISSAL**

14 All non-certified (classified) employees are employed at the will of the director. The director of schools
15 may dismiss any non-certified employee during the contract year for any reason.

16 **RESIGNATION**

17 Support personnel shall give the immediate supervisor written notice of resignation at least two (2) weeks
18 (ten (10) working days) in advance of the effective date of voluntary termination. The ten (10) working
19 days may be waived by the director of schools for justifiable reason.

20 The immediate supervisor shall forward copies the day received to the director of schools' office. The
21 payroll office will prepare final payment for the next appropriate scheduled pay day.

22 **RETIREMENT**

23 Retirement shall mean a termination of services under conditions which will allow the employee to draw
24 benefits from retirement plans and/or social security benefits.

25 Employees eligible for retirement benefits may elect to retire at any age according to the provisions of
26 the retirement system.

- 1 Central office personnel shall assist employees in securing retirement benefits; however, it shall be the
- 2 responsibility of the retiring employee to provide verification of eligibility in writing from TCRS to the
- 3 central office. It shall be the responsibility of the retiring employee to file for benefits.

- 4 Employees who retire under TCRS may be employed up to one hundred twenty (120) days per year
- 5 without loss of retirement benefits.²

Legal References

1. [TCA 49-2-301\(b\)\(1\)\(EE\), \(FF\)](#)
2. [TCA 8-36-805](#)

Cross References

Recommendations and File Transfers 5.203

Hickman County Board of Education

Descriptor Term: Sick Leave	Descriptor Code: 5.302	Issued Date: 02/03/25
	Rescinds: 5.302	Issued: 12/05/22

LICENSED PERSONNEL

The time allowed for sick leave for professional personnel shall be one (1) day for each month employed during the school year and shall accumulate for an unlimited number of days.¹

Sick leave shall be defined as: illness of a teacher from natural causes or accident, quarantine, or illness or death of a member of the immediate family of a teacher, including the teacher's wife or husband, parents, grandparents, children, grandchildren, brothers, sisters, mother-in-law, father-in-law, daughter-in-law, son-in-law, brother-in-law, and sister-in-law.²

A signed statement listing the cause of absence shall be provided by the employee on forms furnished by the director of schools and shall promptly be given to the immediate supervisor in support of all claims for sick leave pay. A falsified statement shall be grounds for dismissal. An employee absent for five (5) consecutive working days shall submit a doctor's statement verifying illness or injury of the employee or immediate family member.

Frequent use and/or suspected misuse of sick leave by an employee are sufficient grounds for requiring a physician's certificate stating the reason for absence.

A certificate from the physician on forms furnished by the Board may be required in support of any claim for sick leave pay.

In case of doubt, the Board of Education shall have final authority as to who is entitled to leave under this section and the time for which the leave may be allowed.

A teacher in need of sick leave shall be allowed to use unearned sick leave up to the amount of days which such teacher may accumulate during the remainder of the school year in which he is employed. Such advance use of sick leave shall be charged to sick leave accumulated in the same school year.

Upon termination of the employment of such teacher-before-such-days are earned or at the end of the school year, there shall be deducted from the final salary of each teacher an amount based on his daily rate of pay sufficient to cover the excess sick leave days used by him and if such final salary is insufficient for this purpose the teacher shall be liable for reimbursement of any amount in excess of his final salary.

The principal shall notify the director of schools' office at once if an employee is sick beyond the limit of his/her sick leave accumulation. The substitute teacher, beyond this point, must have a certificate or permit and must be paid according to the state salary scale.

Permanent, cumulative sick leave records for each active professional employee shall be kept in the director of schools' office.

A teacher, upon employment, may transfer his/her accumulated sick leave from another Tennessee school system, provided that the director of schools of the system in which the accumulated leave was held provides notarized verification.³

SUPPORT PERSONNEL

Sick leave shall be the same for support personnel as for certified employees.

The time allowed (days earned) for sick leave shall be one (1) day for each month an employee is employed except bus drivers, who shall earn one half (1/2) day for each month employed.

Sick leave shall be cumulative for all earned days not used.

At the termination of the employment of any employee, all unused sick leave accumulated by the employee shall be terminated.

The immediate supervisor may require a physician's certificate stating the reason for absence.

Frequent and misuse of sick leave by an individual are sufficient grounds for requiring a physician's certificate stating the reason for absence.

A teacher, upon employment, may transfer his/her accumulated sick leave from another Tennessee school system, provided that the director of schools of the system in which the accumulated leave was held provides notarized verification.

Legal References

1. [TCA 49-5-710\(a\)\(1\)](#)
2. [TRR/MS 0520-01-02-.04\(2\)](#)
3. [TCA 49-5-710\(a\)\(5\)](#)

Cross References

Workers' Compensation 3.602
Orientation and Probation 5.107
Short Term Leaves of Absence 5.300
Family and Medical Leave 5.305
Physical Assault Leave 5.307

Hickman County Board of Education

Descriptor Term: Personnel Health Examinations / Communicable Diseases	Descriptor Code: 5.400	Issued Date: 04/07/25
	Rescinds: 5.400	Issued: 03/06/26

All employees, prior to entering service, shall present a certificate showing a satisfactory health record.¹ Employees shall inform the director of schools whenever they contract a contagious or communicable disease.

No employee who has any communicable disease shall perform his/her duties in any location where such might endanger the health of school children. The Board shall require any employee to submit to a physical examination by a physician whenever there is reason to believe that the employee has any communicable disease.²

~~The director of schools shall reassign or suspend any employee who is suspected of having a communicable disease which might endanger the health of children,~~ The Director of Schools shall reassign an employee to alternate duties, place employee on administrative leave with pay, or temporarily remove employee from the school setting who is suspected of having a communicable disease which might endanger the health of students, pending investigation and final disposition of the case before the Board.

To assist the Board in making final disposition of the case, the director of schools may refer the case to the County Health Office or other medical experts.

The Board shall use the written report to determine the employment status of the employee.

Legal References

1. [TCA 49-5-404](#)
2. [TCA 49-2-203\(b\)\(2\)](#); [TCA 49-5-710\(a\)\(7\)](#)

Cross References

Section 504 and ADA Grievance Procedures 1.802
Suspension/Dismissal 5.200-5.202

Hickman County Board of Education

Descriptor Term: Drug & Alcohol Testing for Employees	Descriptor Code: 5.403	Issued Date: 04/07/25
	Rescinds: 5.403	Issued: 03/06/23

REASONABLE SUSPICION DRUG TESTING

~~Trained supervisors have the responsibility to observe and document the cause for reasonable suspicion and when appropriate, refer the matter to the director of schools/designee. It is not the supervisor's responsibility to attempt diagnosis. All information, facts and circumstances leading to and supporting this suspicion should be included in a written report detailing the basis for the suspicion. After the report is filed, the employee should be notified.~~

If a supervisor observes or receives a report of conduct suggesting a potential violation of Policy 1.804, Alcohol & Drugs in the Workplace, the supervisor shall promptly inform the Director/designee. Upon reasonable suspicion that an employee's job performance or behavior may be impaired by illegal drugs, including improper use of prescribed drugs, or alcohol, the Director/designee may require the employee to undergo drug or alcohol testing.

An employee who is required to submit to drug or alcohol testing based upon reasonable suspicion and refuses shall be charged with insubordination, and necessary procedures will be taken to terminate the employee in accordance with board policy, and state law, where applicable.

An employee who tests positive on a reasonable suspicion test will be in violation of this policy and subject to termination.

The Director or his/her authorized designee are the only individuals in the district authorized to make the determination that reasonable suspicion or cause exists to order a drug screen and are the only individuals who may order an employee to submit to a drug screen.

Two types of cases for which reasonable suspicion procedures may be invoked are:

1. Chronic Case: Deteriorating job performance or changes in personal traits characteristics where the use of alcohol or drugs may be reasonably suspected as the cause.

Acute Case: Appearing in a specific incident or observation to then be under the present influence of alcohol or drugs, or investigation of an accident where the use of alcohol or drugs is reasonably suspected to be a contributing cause

Any employee may be required to submit to substance screening if the following conditions exist: (list is not inclusive)

1. Observed use, possession or sale of illegal drugs and/or use, possession, sale, or abuse of

alcohol and/or prescription drugs.

2. Apparent physical state of impairment of motor functions.
3. Marked changes in personal behavior not attributed to other factors.
4. Employee involvement in or contribution to an accident where the use of alcohol or drugs is reasonably suspected or employee involvement in a pattern of repetitive accidents whether or not they involve actual or potential injury.
5. Violation of criminal statutes involving the use of illegal drugs, alcohol or prescription drugs and/or violations of drug statutes.

TESTING FOR CDL EMPLOYEES

All drivers and applicants for driver positions who are required to hold a Commercial Drivers License (CDL) to perform their job function must adhere to the requirements of this policy and all procedures relating to this policy.¹

The use, possession, sale, purchase or transfer of any controlled substances except medically prescribed drugs on school property, while on school business or while operating school vehicles and equipment is prohibited. Drinking alcoholic beverages during working hours, four (4) hours before reporting to work or having any measurable amount of alcohol in his/her system during working hours is prohibited, whether on or off school property. Working hours include all breaks. Off-duty use of drugs and alcohol is prohibited to the extent that it affects driver's attendance or performance and his/her ability to pass required DOT alcohol and controlled substance tests. Any violation of this policy is grounds for termination as employee of the Board and possible legal prosecution.

The use of any prescription drug that could affect the central nervous system or one that would impair reaction time shall be reported to the director of schools/director of transportation. Notice shall be given of non-prescription (over-the-counter) drugs being taken on a regular basis. The notice shall include the duration of ingestion and the possible side effects.

Procedures

The execution and enforcement of this policy will follow set procedures to screen bodily fluids, conduct breath testing, and/or search all employee/applicants for alcohol and drug use, and those employees suspected of violating this policy who are involved in a reportable accident or who are periodically or randomly selected. The procedures are designed not only to detect violations of this policy, but also to ensure fairness to each employee. Disciplinary action will be taken as necessary.

Implementation

The director of schools/director of transportation is authorized to implement this policy and procedures for the drug testing program, including a periodic review of the program to address any problems, changes and/or revisions of it, maintenance of all records required by the federal regulations, and

determination upon Board approval of how the program will be accomplished, whether in-house, contracted or by consortium.

Dissemination

The director of schools/director of transportation shall be responsible for communicating this policy and the procedures to all employees affected by this policy and shall be accountable for its consistent enforcement.² The director of schools/director of transportation is designated to answer questions about this policy, procedures and all other matters involved in alcohol and controlled substance testing of CDL drivers and the reasonable suspicion testing of all other employees.

Legal References

1. [Omnibus Transportation Employee Testing Act of 1991, 49 USCA § 5331](#)
2. [49 CFR § 382.601](#)

Cross References

Alcohol & Drugs in the Workplace 1.804

Hickman County Board of Education

Descriptor Term: Staff Community Relations	Descriptor Code: 5.606	Issued Date: 03/03/25
	Rescinds: 5.606	Issued: 02/06/23

COMMUNITY ACTIVITIES

In their relationship with community groups, an effort should be made by all employees to make school life a part of community life. Employees should know the community, its influence and its opportunities for students as well as for themselves.

Employees have a right to express their views on any issue, but must in each case make clear that the view expressed is not the official view of the Board or school system.

POLITICAL ACTIVITIES

Employees may, on their own time, campaign for or against any candidate or referendum, but they shall not use ~~the schools, the classroom~~ district owned property or system position for political forum nor engage in any political promotion or solicitation during school hours. District owned property includes, but is not limited to: all buildings, signage, message boards, telephonic equipment, electronic equipment, and email accounts. District-owned property, including school buildings, district offices, and other facilities, shall not be used as a location for filming or recording content intended for political promotion or solicitation. Employees shall not use audio or video messages to engage in any political promotion or solicitation during school hours.!

Any employee who intends to campaign for an elective public office which infringes upon a contracted agreement shall present a proposed solution to the Board for consideration. The essential element to be determined by the Board is whether the activities proposed by the employee are consistent with his services to the school system and the best interests of education.

Leave to hold legislative office shall be granted for whatever period may be required but shall be granted without pay.

Cross References

Legal References

1. [TCA 49-6-2009](#)

Board-Community Relations 1.500

News Releases, News Conferences & Interviews

1.503 Advertising & Distribution of Materials in

Schools 1.806

Hickman County Board of Education

Monitoring: Review: Annually, in February	Descriptor Term: Tutoring for Pay	Descriptor Code: 5.608	Issued Date:
		Rescinds:	Issued:

Any teacher may enter into an agreement with parent(s)/guardian(s) for tutoring children for a fee, but this practice shall be limited to those children whom the teacher is not currently exercising teaching, administrative, or supervisory responsibility.¹ No private teaching or tutoring shall be done during the hours of the regular school day.

Any teacher who enters into a private tutoring agreement with a parent/guardian does so as an independent actor and not as an agent of the school district. The school district shall not be liable for any claims, damages, or liabilities arising from or related to private tutoring services provided by a school employee. The teacher providing such tutoring services shall assume full responsibility and liability, and agrees to indemnify and hold harmless the school district, its board members, administrators, and employees from any and all claims, demands, actions, or causes of action arising out of or in connection with such services.

Legal References

1. [TCA 49-5-1003\(b\)\(11\)](#)

Cross Reference

- Community Use of School Facilities 3.206
 Non-School Employment 5.607

Hickman County Board of Education

	Descriptor Term: Director of Schools	Descriptor Code: 5.800	Issued Date: 04/07/25
		Rescinds: 5.800	Issued: 02/06/23

The director of schools shall be the chief executive officer of the school system and shall have, under the direction of the Board, general supervision of all the public schools, personnel and departments of the school system. The director of schools is responsible for the management of the schools under the Board's policies and is accountable to the Board.¹ The Director of Schools is the only employee directly employed by the Board of Education. All other employees of the district are employed, supervised, and managed under the authority of the Director of Schools.¹

The Director of Schools is charged by the Board with the responsibility to oversee and manage all personnel matters within the district, consistent with applicable laws, regulations, and Board policies. This includes hiring, assignment, evaluation, discipline, and dismissal of employees, as well as the delegation of such duties as appropriate.² ~~The director of schools, at his/her discretion, may delegate any of his/her duties to other school personnel.~~

Legal References

1. [TCA 49-2-301\(a\)](#)
2. [TCA 49-2-301\(e\)](#)

Hickman County Board of Education

Descriptor Term: Student Wellness	Descriptor Code: 6.411	Issued Date: 09/08/25
	Rescinds: 6.411	Issued: 07/07/25

1 The Hickman County Board recognizes the value of proper nutrition, physical activity, and other
2 health conscious practices and the impact that such practices have on student academic achievement,
3 health, and wellbeing. In order to provide an environment conducive to overall student wellness, this
4 policy shall be followed by all schools in the Hickman County School District.¹

5 **COMMITMENT TO COORDINATED SCHOOL HEALTH**

6 All schools shall implement CDC's Coordinated School Health approach to managing new and existing
7 wellness-related programs and services in schools and the surrounding community based on State law
8 and State Board of Education CSH Standards and Guidelines. The district's coordinated school health
9 coordinator shall be responsible for overseeing compliance with State Board of Education CSH
10 Standards and Guidelines in the school district.

11 **SCHOOL HEALTH ADVISORY COUNCIL^{2,3}**

12 An advisory council shall be established to serve as a resource to school sites for implementing
13 policies and programs and develop an active working relationship with the county health council. The
14 council shall consist of individuals representing the school and community, including parents, students,
15 teachers, school administrators, health professionals, school food service representatives, and members
16 of the public. The primary responsibilities of the council include but are not limited to:

- 17 1. Developing, implementing, monitoring, reviewing and as necessary, making recommendations
18 as to physical activity and nutrition;
- 19 2. Ensuring all schools within the district create and implement an action plan related to all
20 School Health Index modules;
- 21 3. Ensuring results of the action plan are annually reported to the council; and,
- 22 4. Ensuring school level results include measures of progress on each indicator of the School
23 Health Index.

24 The State Board of Education's Coordinated School Health and Physical Education Policies shall be
25 used as guidance by the Council to make recommendations. The Hickman County School Board may
26 consider recommendations of the Council in making policy changes or revisions.

27 Additionally, each school will have a Healthy School Team that is representative of all eight (8)
28 components of the CSH program. The team members shall consist of the principal, teachers, staff,
29 students, parents, and community members with at least half of the team members being non-school
30 personnel.² ~~consisting of teachers, students, parents, and administrators.~~² The Team shall hold Healthy

1 School Team meetings during the school year to assess needs and oversee planning and
2 implementation of school health efforts.

3 The director of schools/designee will ensure compliance with the school Wellness Policy, to include an
4 assessment of the implementation of the Wellness Policy and the progress made in attaining the policy
5 goals. The assessment will be made available to the public.

6 **COMMITMENT TO NUTRITION**

7 All schools within the Hickman County District shall participate in and are committed to offering
8 school meals that are consistent with the USDA child nutrition programs, which may include but not
9 be limited to, the National School Lunch Program, the School Breakfast Program, the Summer Food
10 Service Program, and the After School Snack Program.^{4,5,6}

11 Meals shall be accessible to all students in a non-stigmatizing manner. ~~Students will be given 10~~
12 ~~minutes of breakfast and 20 minutes after sitting down for lunch.~~ Students will be given adequate time
13 to enjoy healthy meals and relax in a pleasant environment. Good nutritional habits shall be
14 encouraged. All food including vending machines, fundraising items, and concessions must meet
15 guidelines set forth by the Healthy, Hunger-free Kids Act, 2010, Smart Snacks in Schools.^{4,5,6} Schools
16 shall follow the State Child Nutrition Program limit on days in which non-healthy foods may be used
17 for fundraisers.

18 It is the intent of the Hickman County School District to protect and promote student's health by
19 permitting advertising and marketing for only those foods and beverages that are permitted to be sold
20 on the school campus, consistent with the District's wellness policy. Food and beverage marketing is
21 defined as advertising and other promotions in schools. Food and beverage marketing often includes an
22 oral, written, or graphic statements made for the purpose of promoting the sale of a food or beverage
23 product made by the producer, manufacturer, seller, or any other entity with a commercial interest in
24 the product.

25 All foods offered on the school campus may meet or exceed the USDA Smart Snacks in School
26 nutrition standards including through: celebrations and parties, classroom snacks brought by parents,
27 rewards, and incentives. School cafeterias prohibit the sale of caffeinated energy drinks.

28 The school principal/designee shall be responsible for overseeing the school district's compliance with
29 the State Board of Education Rules and Regulations for sale of food items in the school district.^{2,5,6}

30 **DISTRICT GOALS**

31 The Hickman County District will promote healthy nutrition through various activities, including
32 nutrition related newsletters, informational links on the district website, healthy eating posters and
33 bulletin boards in dining areas, and informational booths at various community functions. Nutrition
34 Education will be offered as part of a standards based program designed to provide students with the
35 knowledge and skills needed to promote and protect their health as outlined in the State Board of
36 Education Health Education and Lifetime Wellness Standards. District nutrition goals, and
37 measurement of their effectiveness, are updated annually in the state Coordinated School Health
38 report. Nutrition education will discourage teachers from using high fat, sugar, and sodium foods as
39 rewards and encourage students to start each day with a healthy breakfast. If a district engages in food

1 or beverage marketing, all marketing shall comply with the Smart Snacks in School nutrition
standards.⁶

3 **COMMITMENT TO PHYSICAL ACTIVITY AND PHYSICAL EDUCATION⁷**

4 The board recognizes that physical activity is extremely important to the overall health of a child.
5 Schools shall support and promote physical activity. Physical activity may be integrated into any areas
6 of the school program.

7 Physical Education classes shall be offered as part of a standards based program designed to provide
8 developmentally appropriate moderate to vigorous physical activity as an integral part of the class. All
9 physical education classes shall comply with the State Board of Education's Physical Education
10 Standards.

11 Unstructured physical activity periods shall be offered in addition to the school district's physical
12 education program. Elementary school students shall receive a minimum of forty (40) minutes of
13 physical activity each full school day. Middle and high school students shall receive a minimum of
14 ninety (90) minutes of physical activity each full school week.

15 Physical activity will be conducted outside if weather permits. The following activities shall not be
16 considered physical activity: walking to and from class, time spent on an electronic device, and time
17 spent in a physical education class.

18 Schools shall continue to offer after school sports and activities. Physical activity shall not be
19 employed as a form of discipline. Physical activity shall not be withheld from a student as a form of
20 punishment.

21 **COMMITMENT TO CURRICULUM³**

22 All applicable courses of study should be based on State-approved curriculum standards.

23 **SCHOOL HEALTH INDEX³**

24 All schools within the district shall annually administer a baseline assessment on each of the
25 recommended School Health Index modules. Results shall be submitted to the School Health Advisory
26 Council and reported to the State Department of Education.

27 **COMPLIANCE⁸**

28 The superintendent/designee will ensure compliance with the school Wellness Policy, to include an
29 assessment of the implementation of the Wellness Policy and the progress made in attaining policy
30 goals.

31 *Recordkeeping*

32 Coordinated School Health will retain records to document compliance with the requirements of the
33 wellness policy.

1 *Annual Notification of Policy*

2 Coordinated School Health will inform families and the public each year of information about the
3 wellness policy, including updates and implementation status. This information will be made to the
4 public via district website and/or district wide communications, and actively encourage their
5 involvement.

6 *Triennial Progress Assessments*

7 Every three years, Coordinated School Health will evaluate compliance with the wellness policy to
8 assess the implementation of the policy and include:

- 9
- 10 • Compliance with the wellness policy
 - 11 • How the wellness policy compares to the wellness policy assessment tool
 - 12 • Description of the progress made in attaining the goals of the wellness policy, which are the
annual goals found in the Coordinated School Health annual report.

13 The School Health Coordinator is responsible for managing the triennial assessment. The School
14 Health Advisory Council and the individual schools will monitor schools' compliance with the
15 wellness policy. Coordinated School Health will inform families and community members of the
16 availability of the triennial assessment via district website and/or district-wide communications.

17 *Revisions and Updating the Policy*

18 The School Health Advisory Council will update or modify the wellness policy based on the results of
19 the annual School Health Index and triennial assessments. The wellness policy will be assessed and
20 updated as indicated at least every three years, following the triennial assessment. The District will
21 notify the public about the content of or any updates to the wellness policy annually through the
22 district website and/or district-wide communications.

23 *Community Involvement, Outreach, and Communications*

24 The District is committed to being responsive to community input. Hickman School District will
25 actively communicate with representatives of the School Health Advisory Council and others can
26 participate in the development, implementation, and periodic review and update of the wellness policy
27 through a variety of means appropriate for the district.

Legal References

1. [TCA 49-6-1022](#)
2. [State Board of Education Policy 4.204](#)
3. [State Board of Education Policy 4.206](#)
4. [42 USCA § 1758b; TRR/MS 0520-01-06-.04](#)
5. [TRR/MS 0520-01-06](#)
6. [7 CFR § 210; 7 CFR § 220](#)
7. [TCA 49-6-1021; Public Acts of 2025, Chapter No. 306](#)
8. [7 CFR § 210.31\(f\)](#)

Cross References

Student Suicide Prevention 6.415

Hickman County Board of Education

	Descriptor Term: Gifts and Bequests	Descriptor Code: 2.401	Issued Date: 02/05/24
		Rescinds: 2.401	Issued: 02/07/22

1 *General*

2 The director of schools is authorized to accept gifts to the school system and may designate others to
3 accept gifts for particular schools in behalf of the Board.¹ The Board will officially express
4 appreciation to the donor and all major gifts will be reported to the Board and publicly announced.

5 In instances where the director of schools or his designee doubts the appropriateness or usefulness of
6 an offered gift, the gift may be declined or the matter referred to the Board.

7 In accepting gifts and donations, the following guidelines shall be followed:

- 8 1. Unless otherwise expressly specified in writing, all property contributed, given, or otherwise
9 placed on school premises shall for all intents and purposes be a gift and shall become school
10 system property subject to the same controls and regulations that govern the use of other
11 school-owned property.
- 12 2. Contributions of equipment or services that may involve major costs for installation,
13 maintenance, or initial or continuing financial commitments from school funds shall be
14 presented by the director of schools' office for Board consideration and approval.
- 15 3. Because of difference in economic resources available to various schools, and for other
16 reasons, the purchase of equipment on a matching fund basis (part of cost provided by an
17 individual or organization and part by the Board shall not be encouraged.
- 18 4. Individuals or organizations wanting to contribute supplies or equipment will consult with
19 school officials about the feasibility of accepting such contributions prior to the solicitation of
20 funds or the making of budgetary appropriations.
- 21 5. A list of supplies and equipment which have been contributed shall be reported to the Board by
22 the director of schools' office annually.
- 23
24
25
26

Legal References

1. TCA 49-6-2006(a)

Cross References

Staff Conflict of Interest 5.601
Staff Gifts and Solicitations 5.605
Student Gifts 6.710

Hickman County School System

Gifts and Bequests

2.401AP

Hickman County Schools

Record of Gifts and Bequests

Item	Name of Donor	Estimated Value

Hickman County Board of Education

	Descriptor Term: Investment Earnings	Descriptor Code: 2.402	Issued Date: 02/05/24
		Rescinds: 2.402	Issued: 02/07/22

1 *Individual Schools*

2 The building principal, with consent of the director of schools, is authorized to invest excess funds of
 3 the school in savings accounts.¹ Interest earned on general fund accounts shall be credited to general
 4 fund revenue. Interest earned on restricted fund accounts shall be credited to revenue in each restricted
 5 account.

6 School food service funds shall be kept separate from other school funds and interest earned on food
 7 service fund deposits shall be credited to food service revenue.

8 All funds shall be deposited into accounts fully protected by sufficient collateral.

Legal References

1. Tennessee Internal School Uniform Accounting Policy Manual; Section 6-1

Cross References

- Deposit of Funds 2.500
 Food Service Management 3.500

Hickman County Board of Education

Descriptor Term: Surplus Property Sales	Descriptor Code: 2.403	Issued Date: 07/07/25
	Rescinds: 2.403	Issued: 08/05/24

1 The Director of Schools shall prepare a list of unusable items for Board approval.¹ The list shall contain
2 the following information: name of item, date of purchase, and reason for disposal (vehicles will list VIN
3 and mileage).

4 All unusable items shall be sold to the highest bidder after advertising in a newspaper of general
5 circulation at least seven (7) days prior to the sale.² Notice shall also be published on a news and
6 information website in accordance with state law.³ The sales will occur via online auction in accordance
7 with state law.²

8 Surplus property which has no value or has a value of less than five hundred dollars (\$500) may be
9 disposed of without the necessity of bids. In order for such disposal without bids, the Director of Schools
10 and the Board Chair shall agree in written form that the property is of no value or is of less value than
11 five hundred dollars (\$500).⁴

12 If reasonable attempts to dispose of surplus properties fail to produce monetary return to the district, the
13 Board shall approve other methods of disposal.⁵

14 Surplus equipment will be auctioned off (i.e. Gov.planet) by the district whenever it becomes available.
15 The Board shall approve all surplus equipment prior to disposal. Buses will be stored in a secured
16 location until they are sold.

17 **DISPOSITION OF EQUIPMENT PURCHASED WITH FEDERAL DOLLARS⁶**

18 When equipment that was purchased with federal dollars is no longer needed for the original project or
19 program or for other activities currently or previously supported by a federal agency, disposition of the
20 equipment shall be made as follows:

- 21 1. Items of equipment with a current per-unit fair market value of less than \$10,000 may be
22 retained, sold, or otherwise disposed of with no further obligation to the awarding agency; or
23
- 24 2. Items of equipment with a current per unit fair market value in excess of \$10,000 may be
25 retained or sold, and the awarding agency shall have a right to an amount calculated by
26 multiplying the current market value or proceeds from sale by the awarding agency's share of
27 the equipment.
28

Legal References

1. [TCA 49-6-2006\(b\)\(3\); TCA 49-6-2208](#)
2. [TCA 49-6-2007\(b\)](#)
3. [Public Acts of 2024, Chapter No. 793; Public Acts of 2025, Chapter No. 105](#)
4. [TCA 49-6-2007\(d\)](#)
5. [TCA 12-2-403\(a\)](#)
6. [2 CFR § 200.313\(e\)](#)

Cross References

Duties of Officers 1.201
Inventories 2.702
Textbooks and Instructional Materials 4.400

Hickman County School System

News and Information Website for Legal Notices

2.403.2AP

When a legal notice is required to be published in a newspaper of general circulation, whether by state law or board policy, the notice shall also be published on a news and information website.

To be classified as a news and information website, the following criteria shall apply to the website:

1. Has a URL;
2. Has been published continuously for the previous twelve-month period;
3. Has been published using recognized standards of professional journalism;
4. Must have content revised on a regular basis not less than three (3) times per week;
5. Has a fixed title or name and date lines and complies with and abides by all copyright laws;
6. Does not serve primarily as a platform to promote the interests or opinions of a special interest group, individual, or cause;
7. Is principally devoted to the dissemination of local or general news with at least fifty percent (50%) of all editorial content reported being original, excluding advertisements;
8. Exists and is registered pursuant to state law with the Secretary of State;
9. Must have an office of publication based in the county in which the notice is required to be published;
10. Is available and open to the public where business is transacted during usual business hours;
11. Maintain a telephone number and email listing; and
12. Includes in each updated publication the contact information of the news and information website.

To ensure compliance, the District shall publish any legal notice on the <https://hickmancountytimes.com/> website.

Hickman County Board of Education

Descriptor Term: School Support Organizations	Descriptor Code: 2.404	Issued Date: 02/05/24
	Rescinds: 2.404	Issued: 02/07/22

1 INTRODUCTION

2 Only a group or organization that has entered into a written cooperative agreement with the Board may
3 use the name, mascot, or logo of a school or the school district to solicit or raise money, materials,
4 property, securities, services, or other things of value.¹

5 A civic organization operating concessions or parking at school-sponsored events is not a school support
6 organization subject to this policy.

7 REPORTING AND RECORDS

8 The director or the director's designee shall annually post a list of organizations that are recognized as
9 school support organizations on the school district's web site.

10 Any forms, annual reports, or financial statements submitted shall be open to public inspection as a
11 public record.

12 PROCEDURES

13 The director shall create procedures to oversee the relationship between the Board and any school
14 support organization. These procedures shall include, at a minimum, the following:

- 15 1. Any agreement between the Board and a school support organization shall be in writing and
16 signed by the director or the director's designee and an authorized agent of the school support
17 organization seeking authorization. This agreement shall contain, at a minimum, the following
18 provisions:
 - 19 a. An agreement to abide by any policies and procedures regarding school support
20 organizations; and,
 - 21 b. An agreement to indemnify the Board, the director and all other agents of the local
22 education agency for the actions of the school support organization.
- 23 2. Prior to entering into any agreement, a school support organization shall submit the following
24 to the director or the director's designee:²
 - 25 a. Documentation confirming the school support organization's status as a nonprofit
26 organization, foundation, or a chartered member of a nonprofit organization or foundation;
27
 - 28 b. A written statement of the goals and objectives of the group or organization;
29
 - 30
 - 31
 - 32

- 1 c. The principal contact telephone and address, as well as the telephone number, address, and
2 position of each officer of the group or organization; and,
3
- 4 d. A copy of the school support organization's written policy specifying reasonable
5 procedures for accounting, controlling, and safeguarding any money, materials, property,
6 securities, services, or other things of value collected or disbursed by it.
- 7 3. The director shall designate a date prior to the beginning of the regular school year for the
8 school support organization to submit a form to the director or the director's designee which
9 verifies the information previously provided by the school support organization is correct or, if
10 the information is no longer correct, that date shall be the deadline for any corrections.³
- 11 4. The school support organization shall abide by all applicable Federal, State and local laws,
12 ordinances and regulations in its activities.
- 13 5. The school support organization shall maintain a copy of its charter, bylaws, minutes, and
14 documentation of its recognition as a nonprofit organization.
- 15 6. The school support organization shall maintain financial records for a period of at least four (4)
16 years.
- 17 7. The school support organization shall operate within the applicable standards and guidelines set
18 by a related state association, if applicable, and shall not promote, encourage or acquiesce in
19 any violation of student or team eligibility requirements, conduct codes or sportsmanship
20 standards.
- 21 8. The school support organization's officers shall ensure that school support organization funds
22 are safeguarded and are spent only for purposes related to the stated goals and objectives of the
23 organization.
- 24 9. The school support organization shall obtain the approval of the director or the director's
25 designee before undertaking any fundraising activity. The director or the director's designee
26 shall consider, at a minimum, the following when approving or denying a request by a school
27 support organization to engage in a fundraising activity:⁴
- 28 a. Whether the fundraising activity, as scheduled, conflicts with the fundraising activity of the
29 school district or an individual school within that district; and,
30
- 31 b. Whether the fundraising activity is consistent with the goals and mission of the school or
32 school district.
- 33 10. The school support organization shall provide access to all books, records, and bank account
34 information for the school support organization to officials of the local school board, local
35 school principal, or auditors of the office of the comptroller of the treasury upon request.
- 36 11. A school representative cannot act as a treasurer or bookkeeper for a school support
37 organization, or be a signatory on the checks for a school support organization. A majority of

1 the voting members of any school support organization board should not be composed of
2 school representatives.⁵

3 The director may enact procedures to suspend or revoke the authorization of any school support
4 organization for a failure to abide by the policies and procedures regarding school support
5 organizations.

6 OPERATION OF A SCHOOL BOOKSTORE

7 The principal of a school may enter into an agreement with a recognized school support organization
8 for the operation of a bookstore located on school grounds, which makes direct sales to students and
9 faculty, pursuant to procedures promulgated by the director. These procedures shall provide, at a
10 minimum, the following:

- 11 1. One hundred percent (100%) of the profits of the operation of the bookstore are used for
12 support of the school; and
- 13 2. The school support organization provides the school with the relevant collection documentation
14 that would have been required pursuant to the provisions of the manual produced under § 49-2-
15 110 for student activity funds.⁶

16 The director may provide such other procedures and forms as he or she deems necessary.

17 CONCESSIONS AND PARKING

18 The principal of a school may agree to allow an authorized school support organization to operate and
19 collect money for a concession stand or parking at a related school academic, arts, athletic, or social
20 event on school property without the prior approval of the director or director's designee. Any money
21 payable to the school pursuant to the agreement with the principal will be considered school support
22 group funds and not student activity funds if the school support organization provides the school with
23 the relevant collection documentation required by the student activity funds manual produced by the
24 State.

Legal References

1. TCA 49-2-604(a)
2. TCA 49-2-604(b)(1)
3. TCA 49-2-604(b)(1)(B)
4. TCA 49-2-604(b)(2)
5. TCA 49-2-604(g)
6. TCA 49-2-110

Hickman County School System

School Support Organization

2.404AP

School Support Organizations Administrative Procedures

1. Any agreement between the Board and a school support organization shall be in writing and signed by the director or the director's designee and an authorized agent of the school support organization seeking authorization. This agreement shall contain, at a minimum, the following provisions: a. An agreement to abide by any policies and procedures regarding school support organizations; and, b. An agreement to indemnify the Board, the director and all other agents of the local education agency for the actions of the school support organization.
2. Prior to entering into any agreement, a school support organization shall submit the following to the director or the director's designee:
 - a. Documentation confirming the school support organization's status as a nonprofit organization, foundation, or a chartered member of a nonprofit organization or foundation;
 - b. A written statement of the goals and objectives of the group or organization;
 - c. The principal contact telephone and address, as well as the telephone number, address, and position of each officer of the group or organization; and,
 - d. A copy of the school support organization's written policy specifying reasonable procedures for accounting, controlling, and safeguarding any money, materials, property, securities, services, or other things of value collected or disbursed by it.
3. School Support Organizations will submit a list of current officers and bank statements annually by July 1 and attend financial training provided by the school system in order to remain active and to be considered for the approval of fundraisers.
4. The school support organization shall abide by all applicable Federal, State and local laws, ordinances and regulations in its activities.
5. The school support organization shall maintain a copy of its charter, bylaws, minutes, and documentation of its recognition as a nonprofit organization.
6. The school support organization shall maintain financial records for a period of at least four (4) years.
7. The school support organization shall operate within the applicable standards and guidelines set by a related state association, if applicable, and shall not promote, encourage or acquiesce in any violation of student or team eligibility requirements, conduct codes or sportsmanship standards.
8. The school support organization's officers shall ensure that school support organization funds are safeguarded and are spent only for purposes related to the stated goals and objectives of the organization.
9. The school support organization shall obtain the approval of the director or the director's designee before undertaking any fundraising activity. The director or the director's designee shall consider, at a minimum, the following when approving or denying a request by a school support

organization to engage in a fundraising activity:

Whether the fundraising activity, as scheduled, conflicts with the fundraising activity of the school district or an individual school within that district; and,

a. Whether the fundraising activity is consistent with the goals and mission of the school or school district.

10. The school support organization shall provide access to all books, records, and bank account information for the school support organization to officials of the local school board, local school principal, or auditors of the office of the comptroller of the treasury upon request.

11. A school representative cannot act as a treasurer or bookkeeper for a school support organization or be a signatory on the checks for a school support organization. A majority of the voting members of any school support organization board should not be composed of school Representatives.

Hickman County Board of Education

	Descriptor Term: Deposit of Funds	Descriptor Code: 2.500	Issued Date: 03/11/24
		Rescinds: 2.500	Issued: 02/07/22

1 *Central Office*

2 All income payable to the Board will be deposited with the county trustee, who will credit it to the
3 appropriate account.¹

4 *Individual Schools*

5 All money collected at the building level must be cleared through the principal's office.

6 The principal shall deposit funds daily if possible, but no later than three (3) days after being received.²

7 Deposit slips will be filed along with other permanent records. Each deposit slip must show the
8 various receipt numbers. The total amount of deposit shall be shown on the last receipt deposited.

9 Monies collected at the building level must be deposited to no more than three bank accounts:³

- 10 1. General School Fund/Restricted Accounts;
11
12 2. School Food Service; and
13
14 3. Savings.

Legal References

1. TCA 8-11-104
2. *Internal School Funds Manual*, Sections 4-20, 6-1, 6-2
3. *Internal School Funds Manual*, Section 4-2, 4-3, 6-1, 6-2

Cross References

Investment Earnings 2.402
Student Activity Funds Management 2.900
Food Service Management 3.500

Hickman County Board of Education

	Descriptor Term: Bonded Employees	Descriptor Code: 2.600	Issued Date: 03/11/24
		Rescinds: 2.600	Issued: 02/07/22

1 *General*

2 The director of schools and all other employees who handle school monies shall be bonded in order to
3 indemnify the school system against the loss of any funds.¹

4 The Board shall determine the amount of the bond, giving consideration to the total amount of money
5 and/or property that is handled in each school.²

Legal References

1. TCA 8-19-101 through 103; TCA 49-2-110(a)(1)
2. *Internal School Funds Manual*, Section 4-19

Hickman County Board of Education

Descriptor Term: Fundraising Activities	Descriptor Code: 2.601	Issued Date: 12/04/23
	Rescinds: 2.601	Issued: 02/07/22

1 *Individual Schools*

2 The schools shall avoid exploiting students, whether by advertising or otherwise promoting products or
3 services, soliciting funds or information, or securing participation in non-school related activities and
4 functions. At the same time, schools shall inform and assist students in learning about programs,
5 activities or information which may be of help or service to them. To attempt a fair balance, the following
6 general guidelines will apply:¹

- 7 1. Fundraising activities shall be authorized by the Board and shall be for the purpose of
8 supplementing funds for established school programs and not for supplanting funds which are
9 the responsibility of the public.
10
- 11 2. Fundraising companies and other salespersons shall obtain permission in writing from the
12 director of schools' office to visit the schools.
13
- 14 3. Any commission payable by companies will be paid in the form of reduced prices to the
15 students, or paid into the activity fund of the school for use by the school. No school employee
16 shall personally benefit from any fundraising activity.
17
- 18 4. The principal must obtain written approval from the director of schools or designee for all
19 fundraising activities that involve the participation of the general student population in the
20 marketing process of the fundraising effort. All other fundraising activities must have written
21 approval from the principal and comply with all administrative procedures issued by the
22 director of schools. The authorization request shall contain the following information:²
23
 - 24 a. A list of the proposed fundraising activities;
 - 25 b. Purpose of the fundraising activity;
 - 26 c. Proposed uses of funds raised;
 - 27 d. Expected student involvement in fundraising activity (school-wide or individual class or
28 club); and
 - 29 e. Margin of profit and how it is to be paid to the school.
- 30
- 31 5. The director of schools shall determine whether or not the activity will benefit the school,
32 contribute to the welfare of the student body and supplement, not replace, funds necessary to
33 fulfill the board's required contributions.
34
- 35 6. The director of schools will inform the Board of any approved fundraising activity.
36 Authorization requests and the director's letter of approval shall be provided to the Board
37 before the fundraising activity is implemented.

- 1 7. Students will not be excused from a regular class to participate in a fundraising activity. No
2 grade in a subject or course will be affected by a student's participation in a fundraising
3 activity.
4
- 5 8. No quotas will be imposed on students involved and their efforts will be voluntary. Students
6 who do not participate in fundraising activities will not be punished or discriminated against in
7 any way.
8
- 9 9. Principals shall submit an annual report on fundraising activity to the director of schools and to
10 the Board which will indicate the gross amount of funds raised and the net profit realized.

11 This policy shall not be construed as preventing a teacher from using instructional or informational
12 materials even though the materials might include reference to a brand, product or a service.

13 **LOTTERIES**

14 No fundraising activity shall be conducted which distributes prizes or makes awards to winners from
15 among purchasers of chances by means of tickets or otherwise through a random drawing or other
16 random selection process.³

17 **ONLINE FUNDRAISING**

18 Individual schools may establish school-wide online fundraising accounts. The accounts must meet all
19 fundraising requirements established by the board and the *Internal School Uniform Accounting Policy*
20 *Manual*. The principal/designee of each school shall have access to the established fundraising account
21 to ensure all funds are properly accounted for, and the information is recorded in the school's
22 accounting records by the designated personnel. Online fundraising shall not be used on behalf and for
23 the benefit of an outside party.

24 Employees shall not engage in online fundraising in their official capacity as district employees nor
25 make any reference to non-school sponsored fundraisers, online or otherwise, that would lead another
26 to believe such activity is an approved school fundraiser.

27 **FUNDRAISING FOR NONEDUCATIONAL PURPOSES⁴**

28 On approval of the principal, an employee may be authorized to raise and use funds for the following
29 noneducational purposes:

- 30 1. Bereavement support;
31
32 2. Award recognition;
33
34 3. Employee morale;
35
36 4. Banquets; or
37
38 5. Other situations at the principal's discretion.

- 1 These funds shall be derived from vending machine revenue, donations, or charitable organizations.
- 2 The Director of Schools shall develop administrative procedures regarding the receipt, disbursement,
- 3 accounting, and auditing of these noneducational funds. The Director of Schools shall ensure that the
- 4 procedures are consistent with board policy and state law and disseminate them to all employees.
- 5 **RECORDKEEPING¹**
- 6 The Director of Schools/designee shall ensure that the appropriate records are maintained for each
- 7 fundraising activity and shall be responsible for collecting and maintaining the appropriate documents
- 8 that show the approving, tracking, and monitoring of each fundraising activity from beginning to end.

Legal References

1. *Tennessee Internal School Uniform Accounting Policy Manual*, Section 4-30, 4-31
2. *Tennessee Internal School Uniform Accounting Policy Manual*, Section 4-32
3. Tenn. Att'y Gen. Op. No. 03-049 (Apr. 22, 2003)
4. TCA 49-2-134

Cross References

Revenues 2.400
School Support Organization 2.404
Audits 2.703
Vendor Relations 2.809
Student Activity Funds Management 2.900
Staff Gifts and Solicitations 5.605
Gifts 6.710

Hickman County School System

Fundraising Activities

2.601AP

Fundraising Activities

Fundraisers serve the purpose of supplementing programs and not supplanting what is required of the Board of Education. Fundraising activities must be requested and approved by the Principal and the Director of Schools. Fundraiser requests must be approved and submitted in the packet for the Board of Education prior to the monthly board meeting. Fundraisers must be approved and submitted to the board of education prior to commencing in the fundraising activity.

In May of each year, principals shall submit an account of fundraising for the school for the year to the Director of Schools.

Hickman County Board of Education

	Descriptor Term: Accounting System	Descriptor Code: 2.700	Issued Date: 04/08/24
		Rescinds: 2.700	Issued: 02/07/22

1 *Central Office*

2 The director of schools shall maintain a system of accounting, arranged according to the regulations
3 prescribed by the Commissioner of Education, which provide a detailed and accurate account of all
4 receipts and disbursements of the schools.¹

5 *Individual Schools*

6 The Board authorizes each respective school under its jurisdiction to receive activity and other internal
7 funds, such as athletic ticket money, school lunch funds and school class funds. The Board shall hold
8 each principal responsible for the management of all internal accounts under his/ her jurisdiction in
9 accordance with the Tennessee Internal School Uniform Accounting Policy Manual.²

Legal References

1. TCA 49-2-301(b)(1)(D); TCA 49-3-316(a)(1)
2. TCA 49-2-110(d)

Cross References

Petty Cash Accounts 2.801
Student Activity Funds Management 2.900

Hickman County Board of Education

	Descriptor Term: Financial Reports and Records	Descriptor Code: 2.701	Issued Date: 04/08/24
		Rescinds: 2.701	Issued: 02/07/22

1 **FINANCIAL REPORTS**

2 *Central Office*

3 The Executive Committee shall submit to the Board at each regular Board meeting a report of all business
4 transacted since the last regular meeting.¹

5 A report indicating all receipts and expenditures will be given quarterly to the County Commission.²
6 Each report will show the amount of the annual appropriation, the amount expended by account to date,
7 the amount encumbered and the free balance in each account.

8 The director of schools shall submit monthly financial reports to the Board and to state and federal
9 agencies as required.

10 *Individual Schools*

11 Each principal shall submit to the director of schools at the end of each calendar month on a prescribed
12 form the receipts, expenditures and cash balance of all accounts under his jurisdiction.³ These reports
13 shall be made available to the Board at its request.

14 **FINANCIAL RECORDS**

15 *General*

16 The director of schools shall maintain all financial records as required by regulation and applicable state
17 and federal law. The Board, from time to time, may determine to extend the retention time for certain
18 records.⁴

Legal References

1. TCA 49-2-206(b)(5)
2. TCA 49-2-301(b)(1)(Q)
3. *Internal School Funds Manual*, Section 3-5
4. *Internal School Funds Manual*, Section 4-24

Cross References

- School District Records 1.407
Food Service Management 3.500

Hickman County Board of Education

	Descriptor Term: Inventories	Descriptor Code: 2.702	Issued Date: 04/08/24
		Rescinds: 2.702	Issued: 02/07/22

1 *General*

2 The director of schools shall establish an accurate inventory procedure for all school real and personal
3 (e.g., material and equipment) property, and this system shall be implemented at each school facility.
4 Equipment is defined as all items with a unit cost of \$5,000.00 or more and a minimum useful life
5 expectancy of three years (including freight and installation charges)*. Minor sensitive equipment is
6 defined as having a value of \$100.00 to \$5,000.00 (technology equipment and related support
7 equipment). Administrative personnel shall ensure that a physical count of all such property is taken at
8 the end of each fiscal year, and this inventory shall be properly entered on the appropriate records for
9 accounting purposes.¹

10 Each school shall maintain a complete inventory with a duplicate maintained in the central office.

11 **EQUIPMENT PROCURED WITH FEDERAL DOLLARS²**

12 The director shall establish procedures for administrators to follow which meet all federal
13 accountability guidelines, including guidelines for the purchasing, inventorying, security and
14 disposition of all equipment purchased with federal funds.

Legal References

1. *Internal School Funds Manual*, Section 4-21 -
Section 4-23
2. 2 CFR § 200.313

Cross References

Surplus Property Sales 2.403
Security 3.205
Equipment & Supplies Management 3.300

* As defined by Tennessee Department of General Services

Hickman County School System

Inventories

2.702AP

Inventory Procedures

Equipment Procedures

Equipment is defined as all items with a unit cost of \$5,000.00 or more and a minimum useful life expectancy of three years. Freight charges and installation cost should be included as a cost of equipment. Sensitive minor equipment is defined as items purchased with a cost of between \$100.00 and \$4,999.99. This include sensitive items such as computers, external computer peripherals, etc.

Hickman County Board of Education

	Descriptor Term: Audits	Descriptor Code: 2.703	Issued Date: 04/08/24
		Rescinds: 2.703	Issued: 02/07/22

1 *General*

2 An audit of all fiscal accounts, including accounts and records of all school student activity funds, shall
3 be made by a certified public accountant following the end of each fiscal year.¹

4 The director of schools shall furnish or make copies of the audit available to the proper authorities as
5 prescribed by law.²

6 When an administrative change occurs during the fiscal year and the position is responsible for the
7 expenditure of funds, a special audit of accounts involved shall be conducted. The special audit shall
8 be as extensive as the Board may determine.

9 **AUDIT FINDINGS³**

10 A corrective action plan shall be developed to address any findings on the annual audit. The plan shall
11 include the following:

- 12 1. Name(s) of the individual responsible for implementing the plan;
13 2. The correct action taken or planned; and
14 3. Anticipated completion date.

15 The plan shall be submitted to the Office of the Comptroller of the Treasury.

Legal References

1. TCA 49-2-112; TCA 49-2-110(a)
2. TRR/MS 0520-01-02-.13(3)(d)
3. TCA 9-3-407

Cross References

- Fundraising Activities 2.601
Student Activity Funds Management 2.900



AGREEMENT FOR EXCLUSIVE SPONSORSHIP AND DEPOSITS

Prepared for:

Robyn Emerson, Principal
Hickman County High School
1645 Bulldog Blvd.
Centerville, TN 37033

Created By:

Apex Bank
314 N. Public Square
Centerville, TN 37033

This agreement has been entered into as of _____ between the following entities, Apex Bank and Hickman County High School; the mutual agreement is as follows:

Hickman County High School will open and continually operate in good standing all banking-related accounts for the duration of this agreement, and Apex Bank will provide Hickman County High School the following:

	<u>Estimated Value</u>
• Summit Business Checking Accounts	
o Interest bearing at 0.20%	\$ 100
• Waive all fees / Free Checks (first year)	\$ 500
• \$1,500 first year donation	\$1,500
o \$1,000 years 2-5	
• 120 cases of Apex labelled water	\$2,880
o to be sold at school events	
• Apex Bank Kick-for-Cash	\$ 500
o 1 home football game (Homecoming)	
o \$500 prize	
• \$250 to student & \$250 to school (make)	
• \$500 to school (miss)	
• Apex Bank Hoop-for Cash	\$ 500
o 1 home basketball game (Homecoming)	
o \$500 prize	
• \$250 to student & \$250 to school (make)	
• \$500 to school (miss)	
• Year 1 - High School Football Team Scoreboard donation of (10 Season agreement per Coach Patrick Smith)	\$26,500

Year 1 estimated donation: \$5,980 + \$26,500 Football Scoreboard

Years 2 – 5 estimated donations: \$5,480 per year

Total estimated donations over the 5-year agreement: \$54,400

The parties further agree as follows:

1. The term of this agreement is for 5 years, beginning _____ and expiring on _____.
2. It is also agreed that Hickman County High School will fully transition full banking account relationship to Apex Bank no later than August 1, 2026.
3. No other financial institutions may be displayed on / under the scoreboards of any sports facility at Hickman County High School throughout the term of this agreement.
4. The Apex Bank Logo will be displayed:
 - Rights to place signage on / under the scoreboard on the football field
 - Rights to place signage on / under the scoreboard in the school gymnasium
 - Rights to place signage on / under all remaining scoreboards on campus
 - Rights to place logo on scrolling LED sign in front of school or "Thank you to our corporate sponsor Apex Bank" on scrolling LED sign in front of school – if approved by school attorney
5. During all football games, the continuation of "Apex Bank First Down" at no additional charge through the term of this agreement.
6. Exclusive rights to provide Apex Bank Kick-for-Cash at the homecoming football game.
7. Exclusive rights to provide Apex Bank Hoop-for-Cash at the homecoming basketball game.
8. Coordinate with the principal to arrange an on-site visit to meet with teachers and staff.
9. Flex classes throughout the year with students.
10. All Hickman County High School accounts will be held at Apex Bank through the term of this agreement.
11. When available, Hickman County High School agrees to exclusively offer Apex labeled water for sale in its concession stands throughout campus. Water will be furnished by Apex Bank at no charge.

Hickman County High School does hereby agree to release, acquit, and forever discharge Apex Bank from any and all claims, actions, causes of action, lawsuits, damages, liabilities, obligations, warranties, agreements, rights, costs, expenses, attorneys' fees, judgments, claims, counterclaims, cross claims, and demands of any nature whatsoever, in any way relating to the subject matter of the Agreement, including damage to person or property.

Authorized representatives from Hickman County High School and Apex Bank do hereby agree to enter into this agreement by signing below.

Robyn Emerson, Principal
Hickman County High School
Date: _____

Marcy Tindle
Apex Bank
Date: _____

Account Opening Documentation:

- Proof of EIN
- Letter from Principal stating Apex Bank has permission to open account
- List of all signers on accounts
 - Two forms of ID on all signers
 - Driver's License
 - SS Card, Voters Registration Card, Health Insurance Card, etc

Exhibit 1

PROPOSED FUNDRAISING ACTIVITIES

Fund/account name Sunshine Committee

Proposed fundraising activities: Selling drinks and chips as a
snack part after T-camp on Monday April 20, Tuesday April 21
and Monday 29 April

Purposed Uses of funds raised
~~to help staff~~ to help staff appreciation support

Expected student involvement (school-wide or specific school organization) _____

School-wide

Method by which school will receive profit percentage of sales

Requested by Amber J. Redden ^{P.E. Teacher}
Sunshine Committee ^{Teacher} Date 3-10-26
Name/Title

Approved by Kathy Dick Date 3-10-26
Principal

Approved by Belinda Anderson Date MAR 11 2026
Director of Schools*

*The Director of Schools must approve all fundraising activities that involve the participation of the general student population in the marketing process of the fundraising effort.

PROPOSED FUNDRAISING ACTIVITIES

Fund/Account Name: _____

Proposed Fundraising Activities: 8th grade format
Sell tickets for 8th grade dance

Proposed Uses of Funds Raised: 8th grade dance supplies

Expected Student Involvement (school-wide or specific school organization):

· School wide

Method by which school will receive profit: Cash or check

Requested by (Name/Title): Shayna Scoggins Date: 3/16/26

Approved by (Principal): Jana Willis Date: 3-16-26

Approved by (Director of Schools): Belinda De Date: MAR 16 2026

PROPOSED FUNDRAISING ACTIVITIES

Fund/Account Name: P.E.

Proposed Fundraising Activities: MAY 19 All day student basketball
tournament; will happen during school hours

Proposed Uses of Funds Raised: organizers, P.E. equip,
basketballs, racks, football, disc golf, etc

Expected Student Involvement (school-wide or specific school organization):

Students participants + observers;
volunteers

Method by which school will receive profit: cash

Requested by (Name/Title): Preston Hall P.E Date: 2-25-26

Approved by (Principal): [Signature] Date: 2-25-26

Approved by (Director of Schools): [Signature] Date: FEB 26 2026

PROPOSED FUNDRAISING ACTIVITIES

Fund/account name GIRLS BASKETBALL + BOYS BASKETBALL

Proposed fundraising activities: SPONSORS FOR 26-27 SEASON
SPONSORS WILL GO ON THE HONOR

Purposed Uses of funds raised

Practice Jerseys, Equipment + Gear

Expected student involvement (school-wide or specific school organization)

Girls Basketball + Boys Basketball

Method by which school will receive profit Cash or Check

Requested by Ron Puckel / LCAAA Date 3/23/26
Name/Title

Approved by Jana S. Shiggins Date 3/25/26
Principal

Approved by Belinda DeLoe Date MAR 25 2026
Director of Schools*

* The Director of Schools must approve all fundraising activities that involve the participation of the general student population in the marketing process of the fundraising effort.

FUNDRAISER AUTHORIZATION FORM

School HCHS

Fund/club/class account Volleyball 601

Expected timeframe of fundraiser June 3-5 2026

Proposed fundraising activities Kids Volleyball Camp

Method of fundraising (e.g., in-person, crowdfunding, etc.) In-person

Proposed uses of funds raised* Team Camp Fees

Expected student involvement (school-wide or specific school organization)
Community

Method by which school will receive profit Cash/check

Requested by Rachel Hudgins/Head Coach Date 3-23-26
Name/Title

Approved by Roby Emarich Date 3-23-26
Principal

Approved by Belinda Anderson Date MAR 24 2026
Director of Schools**

* Any change in proposed uses of funds raised must be approved by the Director of Schools

** The Director of Schools must approve all fundraising activities that involve the participation of the general student population in the marketing process of the fundraising effort.

FUNDRAISER AUTHORIZATION FORM

School Hickman County High School

Fund/club/class account Boys Soccer

Expected timeframe of fundraiser February 23rd - March 9th

Proposed fundraising activities Venmo calendar
Cash/Check calendar

Method of fundraising (e.g., in-person, crowdfunding, etc.) In-person

Proposed uses of funds raised* Jersey expenses, paying referees,
transport to away games

Expected student involvement (school-wide or specific school organization)
Specific School organization (Boys soccer)

Method by which school will receive profit Cash or Check

Requested by Lucas Istre / Head Coach,
Boys Soccer Date 2/13/26
Name/Title

Approved by [Signature] Robyn Emerson Date 2-24-26
Principal

Approved by [Signature] Belinda Anderson Date FEB 25 2026
Director of Schools**

* Any change in proposed uses of funds raised must be approved by the Director of Schools

** The Director of Schools must approve all fundraising activities that involve the participation of the general student population in the marketing process of the fundraising effort.

PROPOSED FUNDRAISING ACTIVITIES



East Hickman High School
7700 Hwy 7, Lyles, TN 37098
Phone 931-670-1366 Fax 931-670-1039

Fund/Account Name East Hickman Volleyball Team

Account Number _____

Proposed fundraising activities: Double Good Popcorn, Nuts.com, Serve-a-thon, Volleyball Calendar

Purposed Uses of funds raised: Volleyball equipment, concessions, paying the refs, volleyball tournaments

Expected Student involvement (school-wide or specific school organization): East Hickman Volleyball Team

Method by which school will receive profit: Checks, cash

Requested by: Maya Nichols (Horner)/ Head Volleyball Coach 04/06/2026

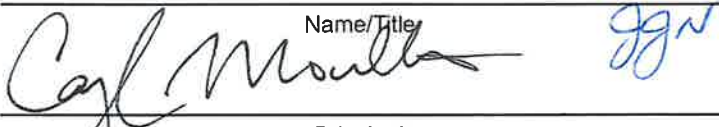
Approved by:  4/6/26
Name/Title Date

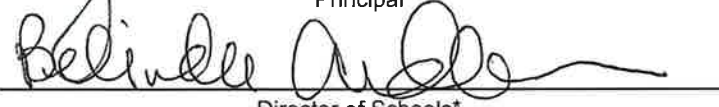
Approved by:  APR 06 2026
Principal Date
Director of Schools*

* The Director of Schools must approve all fundraising activities that involve the participation of the general student population in the marketing process of the fundraising effort.

PROPOSED FUNDRAISING ACTIVITIES



East Hickman High School
7700 Hwy 7, Lyles, TN 37098
Phone 931-670-1366 Fax 931-670-1039

Fund/Account Name Theater

Account Number 806

Proposed fundraising activities: Spring Play "Check, Please" after-school and during-school performances

Purposed Uses of funds raised: Funding future theatre performances

Expected Student involvement (school-wide or specific school organization): Student actors and crew members

Method by which school will receive profit: Ticket Sales

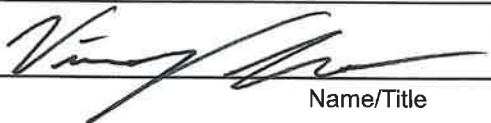
Requested by:  Theatre Teacher 3/17/26
Name/Title Date

Acknowledge by:  Bookkeeper 3-17-26
Date

Approved by:  Principal 3-17-26
Date

Approved by:  Director of Schools* MAR 18 2026
Date

* The Director of Schools must approve all fundraising activities that involve the participation of the general student population in the marketing process of the fundraising effort.

PROPOSED FUNDRAISING ACTIVITIES



East Hickman High School
7700 Hwy 7, Lyles, TN 37098
Phone 931-670-1366 Fax 931-670-1039

Fund/Account Name East Hickman Tennis Account

Account Number _____

Proposed fundraising activities: Tennis event for National Tennis Month

Purposed Uses of funds raised: Uniforms, travel & equipment

Expected Student involvement (school-wide or specific school organization): School wide

Method by which school will receive profit: Check

Requested by: Robin G. Main Head Tennis Coach
Name/Title

3-8-26
Date

Acknowledge by: [Signature]
Bookkeeper

3-10-26
Date

Approved by: [Signature]
Principal

3-10-26
Date

Approved by: [Signature]
Director of Schools*

MAR 12 2026
Date

* The Director of Schools must approve all fundraising activities that involve the participation of the general student population in the marketing process of the fundraising effort.

PROPOSED FUNDRAISING ACTIVITIES



East Hickman High School
7700 Hwy 7, Lyles, TN 37098
Phone 931-670-1366 Fax 931-670-1039

Fund/Account Name CTE Animal Science

Account Number 859

Proposed fundraising activities: Mrs. Field's Cookie Dough Fundraiser - Online
~ 2 weeks after approval

Purposed Uses of funds raised: to pay for field trip to TN Equine Hospital &
Equine Performaxx @ The Jackle Center for Equine Science
class

Expected Student involvement (school-wide or specific school organization): students in classes
~ 31 students

Method by which school will receive profit: check will be mailed to school at the
conclusion of the sale

Requested by: Kenda Polk - Animal/Vet. Science Teacher 3/11/26
Name/Title Date

Acknowledge by: [Signature] 3/1/26
Bookkeeper Date

Approved by: [Signature] 3/10/26
Principal Date

Approved by: [Signature] MAR 12 2026
Director of Schools* Date

* The Director of Schools must approve all fundraising activities that involve the participation of the general student population in the marketing process of the fundraising effort.

PROPOSED FUNDRAISING ACTIVITIES



East Hickman High School
7700 Hwy 7, Lyles, TN 37098
Phone 931-670-1366 Fax 931-670-1039

Fund/Account Name Football

Account Number 601

Proposed fundraising activities: East Hickman Discount Card, made by us to promote local businesses

Purposed Uses of funds raised: jerseys, field maintenance, football operations

Expected Student involvement (school-wide or specific school organization): Football team will sell discount cards

Method by which school will receive profit: selling discount cards for \$20, we will purchase cards before selling. Making \$19 on each card

Requested by: Brett Lovett / Teacher
Name/Title

3/13/26
Date

Acknowledge by: [Signature]
Bookkeeper

3/13/26
Date

Approved by: [Signature]
Principal

3/13/26
Date

Approved by: Belinda Adde
Director of Schools*

MAR 13 2026
Date

* The Director of Schools must approve all fundraising activities that involve the participation of the general student population in the marketing process of the fundraising effort.

PROPOSED FUNDRAISING ACTIVITIES



East Hickman High School
7700 Hwy 7, Lyles, TN 37098
Phone 931-670-1366 Fax 931-670-1039

Fund/Account Name East Hickman Tennis Account

Account Number _____

Proposed fundraising activities: Tennis event for National Tennis Month

Purposed Uses of funds raised: uniforms, travel & equipment

Expected Student involvement (school-wide or specific school organization): School wide

Method by which school will receive profit: Check

Requested by: Robin Gilman Head Tennis Coach 3-8-26
Name/Title Date

Acknowledge by: [Signature] 3-10-26
Bookkeeper Date

Approved by: [Signature] 3-10-26
Principal Date

Approved by: [Signature] MAR 11 2026
Director of Schools* Date

* The Director of Schools must approve all fundraising activities that involve the participation of the general student population in the marketing process of the fundraising effort.