

HICKMAN COUNTY BOARD OF EDUCATION
REGULAR BOARD MEETING---May 2, 2022

The Hickman county Board of Education met on May 2, 2022, at 7:00 PM in Room 203 of the Central Office Building.

Call To Order

Moment of Silence

Pledge of Allegiance

Approval of April 4, 2022 Regular Board Meeting Minutes

Approval of Agenda

Special Recognition

Employee of the Month

CES Teacher of the Year

EHES Teacher of the Year

CIS Teacher of the Year

EHIS Teacher of the Year

EHMS Teacher of the Year

HCMS Teacher of the Year

EHHS Teacher of the Year

HCHS Teacher of the Year

Hickman County Grades PK-4 Teacher of the Year

Hickman County Grades 5-8 Teacher of the Year

Hickman County Grades 9-12 Teacher of the Year

District Championship Recognition

Communications to the Board

Director's Report

Financial Report

ESSER Updates

Administrative Reports

SCOPE Conference

HICKMAN COUNTY BOARD OF EDUCATION
REGULAR BOARD MEETING---May 2, 2022

OPEB Quarterly Report

Director of Schools Evaluation

Board of Education Self-Evaluation

Items Requiring Board Action

Trip Requests

HCHS Basketball Camp

EHHS International Bridge Building Competition

EHHS FBLA National Conference

EHHS Football Camp

EHMS Boys Basketball

ESSER Plan Revisions

Transportation Capital Purchase

Budget Amendments

Athletic Practice During The School Day

EHHS Cafeteria HVAC Purchase

Chromebook Bid

Student Chromebook Management Bid

Chromebook Charging Cart Bid

School Security Camera Systems Bid

Cognia Accreditation

2022-2023 141, 143 Budgets

Revised Board Policy 3.3001 (1st Reading)

Revised Board Policy 1.102 (2nd Reading)

Revised Board Policy 6.206 (2nd Reading)

Board Policy Review 4.100-4.212

Announcements

Adjourn

Monday, April 4, 2022
REGULAR BOARD MEETING MINUTES

The Hickman County Board of Education met in regular session on Monday, April 4, 2022, at 7:00 p.m. in Room 203 of the Central Office building. School board members in attendance at the meeting were Chair Amy Bryant, Ron Gammons, Jane Herron, Tim Hobbs, and Vance Willis. Jim Hudgins and Steve Gianakos were absent from the meeting.

Chair Amy Bryant asked the group to observe a moment of silence.

Chair Amy Bryant led the group in the Pledge of Allegiance.

Jane Herron made a motion to approve the minutes from the meeting held on March 7, 2022. Ron Gammons seconded the motion.

Monday, March 7, 2022
REGULAR BOARD MEETING MINUTES

The Hickman County Board of Education met in regular session on Monday, March 7, 2022, at 7:00 p.m. in Room 203 of the Central Office building. School board members in attendance at the meeting were Chair Amy Bryant, Ron Gammons, Steve Gianakos, Jane Herron, Tim Hobbs, and Vance Willis. Jim Hudgins was absent from the meeting.

Chair Amy Bryant asked the group to observe a moment of silence.

Chair Amy Bryant led the group in the Pledge of Allegiance.

Steve Gianakos made a motion to approve the minutes from the board meeting on February 7, 2022. Jane Herron seconded the motion. On a voice vote, the motion was approved 6-0.

Vance Willis made a motion to approve the agenda. Ron Gammons seconded the motion.

The Hickman County Board of Education will meet in regular session on Monday, February 7, 2022, at 7:00 p.m. in room 203 of the Central Office Building. A work session will be held at 6:00 p.m. before the board meeting in Room 203.

- I. Call to Order
- II. Moment of Silence
- III. Pledge of Allegiance
- IV. Approval of December 6, 2021 Regular Board Meeting Minutes
- V. Approval of January 18, 2022 Special Called Board Meeting Minutes
- V. Approval of Agenda
- VI. Special Recognition
 - A. Employee of the Month
 - 1. December 2021--Vance Willis
 - 2. January 2022--Amy Bryant
 - 3. February 2022--Jim Hudgins
 - B. SCOPE Conference Students and Chaperones--Director of Schools
- VII. Communications to the Board
 - A. TSBA OPEB Quarterly Statement--Board Chair

- B. Director's Report--Director of Schools
 - C. Financial Report--Business Officer
 - D. ESSER Updates--ESSER Manager
 - E. Final Audit Contract--Director of Schools
 - F. 2022-2023 Budget Calendar--Director of Schools
- VIII. Items Requiring Board Action
- A. Trip Requests
 - 1. HCHS JROTC--Sponsor and Students
 - 2. EHHS FCCLA--Sponsor and Students
 - 3. EHHS FBLA--Sponsor and Students
 - 4. EHHS HOSA--Sponsor and Students
 - B. Event Requests
 - 1. EHHS Prom--Sponsor and Students
 - 2. HCHS Prom--Sponsor and Students
 - 3. HCHS JROTC--Sponsor and Students
 - 4. HCHS Boys Soccer--Coach and Players
 - C. Budget Amendments--Business Officer
 - D. Amended Fund Balance--Director of Schools
 - E. ESSER Public Health and Safety Plan--Director of Schools
 - F. Federal Grants Update--Director of Schools
 - G. School Bus Bid--Transportation Director
 - H. Revised Board Policy 5.701(1st Reading)--Director of Schools
 - I. Revised Board Policy 6.313 (1st Reading)--Director of Accountability
 - J. Board Policy Review 2.100-2.804--Director of Accountability
- XI. Announcements
- XII. Adjourn

On a voice vote, the motion was approved 6-0.

Michelle Bates was recognized by Tim Hobbs as the March Employee of the Month.

Michelle Gilbert announced that Kara Hobbs had been recognized as the South Central Region Coordinated School Health Coordinator of the Year.

Steve Gianakos made a motion to approve the Director's Report. Jane Herron seconded the motion.

Memorandum

To: Board Members
 From: Michelle Gilbert
 Date: January 25, 2022
 RE: February Director's Report

Leave of Absence

Professional

Michael Beem	FMLA (January 11, 2022-February 8, 2022)
Todd Collins	FMLA (December 15, 2022-January 31, 2022)
Charles Thompson	FMLA (January 3, 2022-January 31, 2022)
Kendra Mayberry	FMLA (March 7, 2022-May 13, 2022)
Allie Sue Hughes	FMLA (February 7, 2022-April 29, 2022)

Support Staff

Hiring

Professional

Brandy Mayberry	CES Special Education Teacher
Ben Bentley*	HCHS Teacher

Barry Jones
Lori Lanham
Support Staff
Anna Spears
Tiwana Booker

HCHS Teacher
HCHS Teacher

CIS Special Education Assistant
CIS Special Education Assistant

Resignation

Professional
Melissa Istre
Lynne Anderson
Jessica Cook
Support Staff

HCHS Teacher
CES Special Education Teacher
EHMS Teacher

Retirement

Professional
Support Staff

Transfers

Professional

Support Staff

Hope Clark
Stephanie Bodine
McKensy Patrick

EHES Full Time Sp Ed Assistant to Part-Time
EHES Part-Time Sp Ed Assistant to Full Time
EHES Part-Time SP Ed Assistant to Full Time

Appointment

Professional
Support Staff
Tommy McClanahan
Noah Nicholson

HCMS Volunteer Assistant Softball Coach
HCMS Volunteer Assistant Softball Coach and
Baseball Coach

Open Positions

1 Secondary Personal Finance/ Economics Position
2 Secondary Math Positions
2 Secondary Science Positions
1 Spanish Position
1 Special Education Position
1 Speech Language Position
1 Behavior Support Position
Bus Drivers

* Denotes a relationship under board policy 1.108. Applicants are qualified for the positions.

On a voice vote, the motion was approved 6-0.

Ron Gammons made a motion to approve the financial report as presented. Tim Hobbs seconded the motion. On a voice vote, the motion was approved 6-0.

Vance Willis made a motion to approve the ESSER update. Steve Gianakos seconded the motion. On a voice vote, the motion was approved 6-0.

Tim Hobbs made a motion to approve the EHHS FFA overnight trip request to the state convention on March 27-30, 2022, in Gatlinburg, TN, for 6 students. Ron Gammons seconded the motion. On a voice vote, the motion was approved 6-0.

Ron Gammons made a motion to approve the HCHS FFA overnight trip request to the state convention on March 27-30, 2022, in Gatlinburg, TN. Tim Hobbs seconded the motion. On a voice vote, the motion was approved 6-0.

Steve Gianakos made a motion to approve budget amendments 24-26 and to approve the correction made to budget amendment 20. Jane Herron seconded the motion.

<u>Aye</u>	<u>Nay</u>	<u>Pass</u>	<u>Absent</u>
------------	------------	-------------	---------------

Amy Bryant
Ron Gammons
Steve Gianakos
Jane Herron
Tim Hobbs

Jim Hudgins

Vance Willis

On a roll call vote, the motion was approved 6-0-1.

Ron Gammons made a motion to approve the bid for Systems Liquidation to purchase 30 laptops at a total of \$12,870.00. Amy Bryant seconded the motion.

<u>Aye</u>	<u>Nay</u>	<u>Pass</u>	<u>Absent</u>
------------	------------	-------------	---------------

Amy Bryant
Ron Gammons
Steve Gianakos
Jane Herron
Tim Hobbs

Jim Hudgins

Vance Willis

On a roll call vote, the motion was approved 6-0-1.

Ron Gammons made a motion to approve the transition of a school van to be used for transportation purposes for public events at the request of Coordinated School Health and Project AWARE. Tim Hobbs seconded the motion. On a voice vote, the motion was approved 6-0.

The Hickman County School system interviewed 4 candidates for architect services for the projects outlined in the approved ESSER application. Two candidates were recommended to present information to the board of education members during a scheduled meeting on March 7, 2022. One candidate withdrew prior to the meeting. Steve Gianakos made a motion to select Lyle Cook Martin as the architect for the projects. Tim Hobbs seconded the motion.

<u>Aye</u>	<u>Nay</u>	<u>Pass</u>	<u>Absent</u>
------------	------------	-------------	---------------

Amy Bryant
Ron Gammons
Steve Gianakos
Jane Herron

Tim Hobbs

Jim Hudgins

Vance Willis

On a roll call vote, the motion was approved 6-0.

Tim Hobbs made a motion to approve the 2022-2023 attendance zones to remain the same as in previous years. Ron Gammons seconded the motion. On a voice vote, the motion was approved 6-0.

Vance Willis made a motion to approve revised board policy 5.701 on second reading. Steve Gianakos seconded the motion.

<u>Aye</u>	<u>Nay</u>	<u>Pass</u>	<u>Absent</u>
Amy Bryant			
Ron Gammons			
Steve Gianakos			
Jane Herron			
Tim Hobbs			

Jim Hudgins

Vance Willis

On a voice vote, the motion was approved 6-0.

Steve Gianakos made a motion to approve revised board policy 6.313 on second reading. Jane Herron seconded the motion. On a voice vote, the motion was approved 6-0.

Amy Bryant made a motion to approve the review and update of board policies 3.100-3.220. Steve Gianakos seconded the motion. On a voice vote, the motion was approved 6-0.

Steve Gianakos made a motion to approve the updated COVID-19 protocols and procedures. Jane Herron seconded the motion. On a voice vote, the motion was approved 6-0.

The budget work sessions scheduled for April 4 and April 18 (if needed) were announced.

An announcement was made regarding the CTE banquet that is scheduled for March 12, 2022, at 10:00 a.m. at the fellowship hall at Fairfield Church of Christ.

The meeting was adjourned at 7:32 p.m.

On a voice vote, the motion was approved 5-0.

Ron Gammons made a motion to approve the agenda. Tim Hobbs seconded the motion.

The Hickman County Board of Education will meet in regular session on Monday, April 4, 2022, at 7:00 p.m. in room 203 of the Central Office Building. A work session will be held at 6:00 p.m. before the board meeting in Room 203.

- I. Call to Order
- II. Moment of Silence
- III. Pledge of Allegiance

- IV. Approval of March 7, 2022 Regular Board Meeting Minutes
- V. Approval of Agenda
- VI. Special Recognition
 - A. Employee of the Month--Steve Gianakos
 - B. Student Recognition of ACT 29 and above--High School Principals
- VII. Communications to the Board
 - A. Director's Report--Director of Schools
 - B. Financial Report--Business Officer
 - C. ESSER Updates--ESSER Manager
 - D. Facility Use Request--Parent
- VIII. Items Requiring Board Action
 - A. Trip Requests
 - 1. EHHS Senior Class--Sponsor and Students
 - 2. HCHS TNStrong Conference--Sponsor and Students
 - 3. EHHS Culinary Arts Jr. Chef Competition--Sponsor and Students
 - B. EHES Job Share Request for 2022-2023--EHES Principal and K-12 Supervisor
 - C. CIS Job Share Request for 2022-2023--CIS Principal and K-12 Supervisor
 - D. Budget Amendments--Business Officer
 - E. Hygiene Paper Products Bid--Maintenance Director
 - F. School Mowing Services Bid--Maintenance Director
 - G. School Patch & Paving Services Bid--Maintenance Director
 - H. School Parking Lot Striping Services Bid--Maintenance Director
 - I. Yearly School System Technology Service Plan Bid--Technology Coordinator
 - J. Best for All Grant--Director of Schools
 - K. Revised Board Policy 1.102 - (1st Reading)--Director of Accountability
 - L. Revised Board Policy 6.206 - (1st Reading)--Director of Accountability
 - M. Board Policy Review 3.300--3.602 --Director of Accountability
- IX. Announcements
- X. Adjourn

On a voice vote, the motion was approved 5-0.

Beth Robinson was recognized by Amy Bryant as the Employee of the Month for April.

The Board of Education recognized students that achieved an ACT score of 29 and above:
 HCHS: Houston Hudgins, John Jacobs, Sara True
 EHHS: Kyla O'Guin, Amelia Reed, Kayla Dungee

Ron Gammons made a motion to accept the Director's Report. Jane Herron seconded the motion.

Memorandum

To: Board Members
 From: Michelle Gilbert
 Date: March 22, 2022
 RE: April Director's Report

Leave of Absence

Professional
Support Staff
 Maria Kennedy
 Kayla Pardue

Hiring

Professional

Lynne Anderson
Samuel McGreevy
Gabrielle Horner
Joseph Slaughter
Amber Walker
Support Staff
Jennifer Kinney
Staci Conner
Natalie Greene

EHES Special Education Teacher
EHMS Teacher
EHES Teacher
EHES/EHIS Physical Education Teacher
CES SLP Interim

Substitute Teacher
Substitute Teacher
Substitute Teacher

Resignation

Professional
Scott Hannah

ALC Teacher

Support Staff

Retirement

Professional
Support Staff

Transfers

Professional
Support Staff

Appointment

Professional
Support Staff
Robin Gilliam

EHHS Tennis Coach

Open Positions

2 Secondary Math Positions
2 Secondary Science Positions
1 Spanish Position
1 Special Education Position
1 Speech Language Position
1 Behavior Support Position
Bus Drivers

* Denotes a relationship under board policy 1.108. Applicants are qualified for the positions.

On a voice vote, the motion was approved 5-0.

Ron Gammons made a motion to accept the financial report. Tim Hobbs seconded the motion. On a voice vote, the motion was approved 5-0.

Vance Willis made a motion to accept the ESSER update. Amy Bryant seconded the motion. On a voice vote, the motion was approved 5-0.

Mr. Eugene Berry spoke to the Board of Education concerning a Facility Use Request. He was concerned that his request had not been approved. Michelle Gilbert informed the board members the only outstanding issue for the application was the school employee that was needed to supervise while the facility was in use.

Ron Gammons made a motion to approve a trip request for the EHHS senior class to travel to Dollywood on May 11, 2022. Tim Hobbs seconded the motion. On a voice vote, the motion was approved 5-0.

Vance Willis made a motion to approve a trip request for the HCHS TN Strong to attend a conference from June 5-7, 2022. Jane Herron seconded the motion. On a voice vote, the motion was approved 5-0.

Ron Gammons made a motion to approve the trip request for EHHS Culinary Arts to attend the Junior Chef Competition at MTSU on April 27-28, 2022. Tim Hobbs seconded the motion. On a voice vote, the motion was approved 5-0.

Ron Gammons made a motion to approve the job share requests from East Hickman Elementary School for the 2022-2023 school year. Vance Willis seconded the motion. On a voice vote, the motion was approved 5-0.

Tim Hobbs made a motion to approve the job share request from Centerville Intermediate School for the 2022-2023 school year. Ron Gammons seconded the motion. On a voice vote, the motion was approved 5-0.

Amy Bryant made a motion to approve budget amendments 27-29. Ron Gammons seconded the motion.

<u>Aye</u>	<u>Nay</u>	<u>Pass</u>	<u>Absent</u>
Amy Bryant			
Ron Gammons			
			Steve Gianakos
Jane Herron			
Tim Hobbs			
			Jim Hudgins
Vance Willis			

On a roll call vote, the motion was approved 5-0-0-2

Ron Gammons made a motion to approve the award of the hygiene paper products bid for 2022-2023 to Kelsan. They were the lowest bid. Jane Herron seconded the motion.

<u>Aye</u>	<u>Nay</u>	<u>Pass</u>	<u>Absent</u>
Amy Bryant			
Ron Gammons			
			Steve Gianakos
Jane Herron			
Tim Hobbs			
			Jim Hudgins
Vance Willis			

On a roll call vote, the motion was approved 5-0-0-2

Amy Bryant made a motion to approve the award of the mowing bid for 2022-2023 to Petty and Sons Mowing. Ron Gammons seconded the motion.

<u>Aye</u>	<u>Nay</u>	<u>Pass</u>	<u>Absent</u>
Amy Bryant			
Ron Gammons			Steve Gianakos
Jane Herron			
Tim Hobbs			Jim Hudgins
Vance Willis			

On a roll call vote, the motion was approved 5-0-0-2

Vance Willis made a motion to approve the schools patch and paving services for 2022-2023 to Sessions Paving. Tim Hobbs seconded the motion.

<u>Aye</u>	<u>Nay</u>	<u>Pass</u>	<u>Absent</u>
Amy Bryant			
Ron Gammons			Steve Gianakos
Jane Herron			
Tim Hobbs			Jim Hudgins
Vance Willis			

On a roll call vote, the motion was approved 5-0-0-2

Tim Hobbs made a motion to approve the award of the school parking lot striping and painting bid to Sessions. They were the low bid. Ron Gammons seconded the motion.

<u>Aye</u>	<u>Nay</u>	<u>Pass</u>	<u>Absent</u>
Amy Bryant			
Ron Gammons			Steve Gianakos
Jane Herron			
Tim Hobbs			Jim Hudgins
Vance Willis			

On a roll call vote, the motion was approved 5-0-0-2

Ron Gammons made a motion to approve the award of the technology services contract for \$45,000.00 for 2022-2023 to Bluegrass. Jane Herron seconded the motion.

<u>Aye</u>	<u>Nay</u>	<u>Pass</u>	<u>Absent</u>
Amy Bryant			
Ron Gammons			Steve Gianakos
Jane Herron			

Tim Hobbs

Jim Hudgins

Vance Willis

On a roll call vote, the motion was approved 5-0-0-2

Ron Gammons made a motion to approve the spending plan and submission of the Best for All Grant for \$200,000.00. Tim Hobbs seconded the motion.

<u>Aye</u>	<u>Nay</u>	<u>Pass</u>	<u>Absent</u>
Amy Bryant			
Ron Gammons			Steve Gianakos
Jane Herron			
Tim Hobbs			Jim Hudgins
Vance Willis			

On a roll call vote, the motion was approved 5-0-0-2

Ron Gammons made a motion to approve revised board policy 1.102 on first reading. Amy Bryant seconded the motion. On a voice vote, the motion was approved 5-0.

Vance Willis made a motion to approve revised board policy 6.206 on first reading. Tim Hobbs seconded the motion. On a voice vote, the motion was approved 5-0.

Amy Bryant made a motion to approve the review and update of board policies 3.300-3.602. Vance Willis seconded the motion. On a voice vote, the motion was approved 5-0.

Michelle Gilbert announced that the Board of Education would hold a work session for the 2022-2023 school budgets on Monday, April 18, 2022, at 6:00 p.m. at the Central Office.

The meeting was adjourned at 7:57 p.m.



AMY BRYANT

9589 S. Lick Creek Rd., Lyles, TN 37098

RONALD GAMMONS

6419 Rice Ln., Lyles, TN 37098

TIM HOBBS

9220 Old Bon Aqua Rd., Bon Aqua, TN 37025

JIM HUDGINS

1297 E. Grinders Switch Rd., Centerville, TN 37033

JANE HERRON

1222 Hwy. 100., Centerville, TN 37033

STEVE GIANAKOS

9792 Dogwood Dr., Bon Aqua, TN 37025

VANCE WILLIS

2868 Hwy 48 N., Nunnely, TN 37137

Michelle Gilbert

Director of Schools

115 MURPHREE AVENUE

CENTERVILLE, TN 37033

The Hickman County Board of Education will meet in regular session on Monday, May 2, 2022, at 7:00 p.m. in the library of Hickman County High School. A work session will be held at 6:00 p.m. in the library of Hickman County High School .

- I. Call to Order
- II. Moment of Silence
- III. Pledge of Allegiance
- IV. Approval of April 4, 2022 Regular Board Meeting Minutes
- V. Approval of Agenda
- VI. Special Recognition
 - A. Employee of the Month--Jane Herron
 - B. CES Teacher of the Year--Jim Hudgins
 - C. EHES Teacher of the Year--Vance Willis
 - D. CIS Teacher of the Year--Jane Herron
 - E. EHIS Teacher of the Year--Ron Gammons
 - F. EHMS Teacher of the Year--Steve Gianakos
 - G. HCMS Teacher of the Year--Tim Hobbs
 - H. EHHS Teacher of the Year--Amy Bryant
 - I. HCHS Teacher of the Year--Jim Hudgins
 - J. Hickman County Grades PK-4 Teacher of the Year--Vance Willis
 - K. Hickman County Grades 5-8 Teacher of the Year--Jane Herron
 - L. Hickman County Grades 9-12 Teacher of the Year--Ron Gammons
 - M. District Championship Recognition--Amy Bryant
- VII. Communications to the Board
 - A. Director's Report--Director of Schools
 - B. Financial Report--Business Officer
 - C. ESSER Updates--ESSER Manager
 - D. Administrative Reports--Director of Schools
 - E. SCOPE Conference--SCOPE Attendees
 - F. OPEB Quarterly Report--Director of Schools
 - G. Director of Schools Evaluation--Board Chair
 - H. Board of Education Self-Evaluation--Board Chair
- VIII. Items Requiring Board Action
 - A. Trip Requests
 1. HCHS Basketball Camp--Principal

2. EHHS International Bridge Building Competition--Sponsor and Students
 3. EHHS FBLA National Conference--Sponsor and Students
 4. EHHS Football Camp--Coach and Players
 5. EHMS Boys Basketball Camp--Coach and Players
- B. ESSER Plan Revisions--Director of Schools
 - C. Transportation Capital Purchase--Director of Transportation
 - D. Budget Amendments--Business Officer
 - E. Athletic Practice During the School Day--Deputy Superintendent
 - F. EHHS Cafeteria HVAC Purchase--Maintenance Director
 - G. Chromebook Bid--Business Officer
 - H. Student Chromebook Management Bid--Business Officer
 - I. Chromebook Charging Cart Bid--Business Officer
 - J. School Security Camera Systems Bid--Business Officer
 - K. Cognia Accreditation--Director of Schools
 - L. 2022-2023 141, 143 Budgets--Director of Schools
 - M. Revised Board Policy 3.3001 - (1st Reading)--Director of Accountability
 - N. Revised Board Policy 1.102 - (2nd Reading)--Director of Accountability
 - O. Revised Board Policy 6.206 - (2nd Reading)--Director of Accountability
 - P. Board Policy Review 4.100-4.212 --Director of Accountability
- IX. Announcements
- X. Adjourn



AMY BRYANT
9589 S. Lick Creek Rd., Lyles, TN 37098

RONALD GAMMONS
3419 Rice Ln., Lyles, TN 37098

TIM HOBBS
9220 Old Bon Aqua Rd., Bon Aqua, TN 37025

JIM HUDGINS
1297 E. Grinders Switch Rd., Centerville, TN 37033

JANE HERRON
1222 Hwy 100., Centerville, TN 37033

STEVE GIANAKOS
9792 Dogwood Dr., Bon Aqua, TN 37025

VANCE WILLIS
2868 Hwy 48 N., Nunnely, TN 37137

Michelle Gilbert
Director of Schools
115 MURPHREE AVENUE
CENTERVILLE, TN 37033

Memorandum

To: Board Members
From: Michelle Gilbert
Date: April 22, 2022
RE: May Director's Report

Leave of Absence

Professional

Sandie Luna

April 11-May 20, 2022 (FMLA)

Support Staff

Hiring

Professional

Support Staff

Brenda Lynch

Ashanti Reynolds

Dina Binkley

EHMS Bookkeeper

Food Service

Food Service

Resignation

Professional

Tommy Stanley

Charles Price

HCHS Business Teacher/Head Girls Basketball Coach

HCHS JROTC Instructor

Support Staff

Patti Edwards

Food Service

Retirement

Professional

Pam Mitchell Clark

Don Qualls

EHHS/HCHS Art (end of 2021-2022 year)

Career Technical Education Director (June 30, 2022)

Support Staff

Transfers

Professional

Support Staff

Appointment

Professional

Support Staff

Open Positions

2 Secondary Math Positions
2 Secondary English Positions
2 Secondary Science Positions
1 Spanish Position
1 Special Education Position
1 Speech Language Position
1 Behavior Support Position
Bus Drivers

* Denotes a relationship under board policy 1.108. Applicants are qualified for the positions.



Administrative Reports
2020-2021 Teacher Evaluation Data

Level of Effectiveness Scores

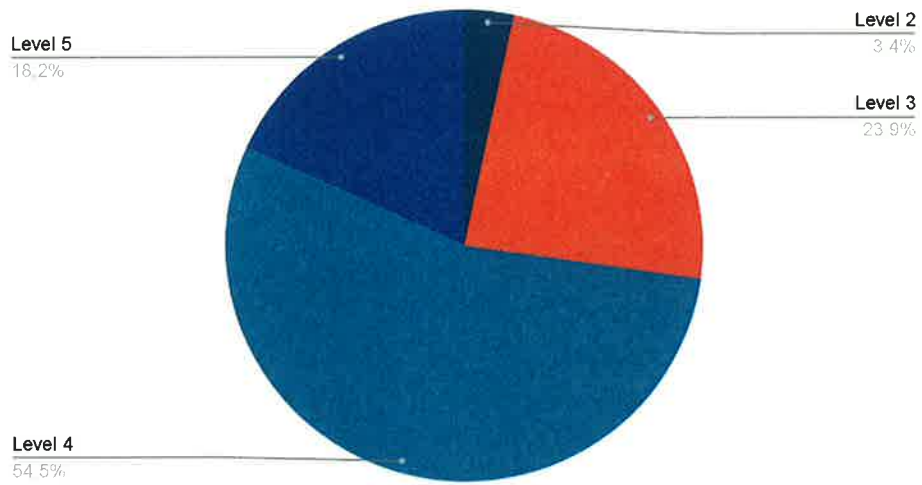

2020-2021 Administrator Evaluation Data

Level of Effectiveness Scores

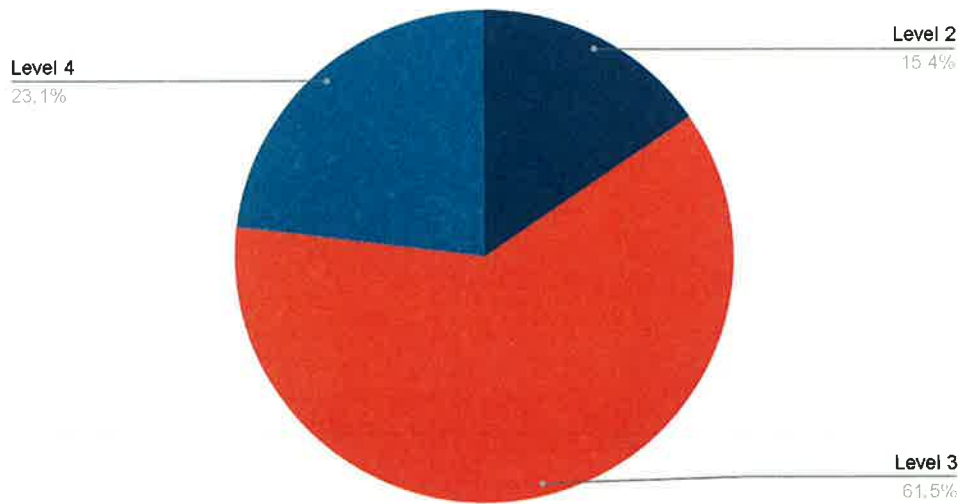

Account Activity Summary
Hickman
1/1/2022 - 3/31/2022

<i>Beginning Value - Investment Account</i>	\$	2,730,925.40
<i>Beginning Value - Alternative Invest. Acct.</i>	\$	152,411.40
Total Beginning Value ^{1 See Definitions}	\$	2,883,336.80
<i>Additions</i> ²		
Contributions ³	\$	-
Dividends & Interest ⁴	\$	10,629.58
<i>Withdrawals</i> ⁵		
TSBA Fee ⁶	\$	(1,802.09)
MS Fees ⁷	\$	(1,172.93)
System Distributions ⁸	\$	-
<i>Unadjusted Investment Earnings</i> ⁹	\$	(158,136.52)
<i>Ending Value - Investment Account</i>	\$	2,623,921.15
<i>Ending Value - Alternative Invest. Acct.</i>	\$	108,933.69
Total Ending Value ¹⁰	\$	2,732,854.84

Definitions:

1. **Beginning Value:** The total account value at the start of business on the first day of the specified reporting period.
2. **Additions:** All credits to the account in which total account value is increased within the specified reporting period.
3. **Contributions:** The sum of total cash deposits and/or other asset transfers into the Morgan Stanley account from outside of the Morgan Stanley account and by instruction of the client within the specified reporting period.
4. **Dividends and Interest:** The sum of all dividend, interest, and capital gain payments credited to the account and those in the which settlement date lies within the specified reporting period. **NOTE:** Any dividend, interest, or capital gain distribution in which a settlement date lies outside of the reporting period or in which was included in the beginning value will not be included 'Dividends and Interest' total for the period.
5. **Withdrawals:** The sum of total cash and/or other asset transfers out of the Morgan Stanley account to any other account whether inside or outside of the firm.
6. **TSBA Fee:** The fee calculated by instruction of the client and is based on the account value at the end of business on the last day of the prior quarter.
7. **MS Fees:** The sum of all quarterly fees charged by Morgan Stanley and any adjustments made to this charge within the specified reporting period in which client is in agreement for investment advisory and brokerage services provided.
8. **System Distributions:** The sum of any distributions to the beneficiary (public school system) of the GASB 45 Trust within the specified reporting period.
9. **Unadjusted Investment Earnings:** The earnings of asset investments in the Morgan Stanley account unadjusted for any fees charged or withdrawals in the account by instruction of Morgan Stanley or the client and within the specified reporting period.
10. **Ending Value:** The Account Value at the end of business on the last day of the specified reporting period.

The information and data contained in this report are from sources considered reliable, but their accuracy and completeness is not guaranteed. This report has been prepared for illustrative purposes only and is not intended to be used as a substitute for monthly transaction statements you receive on a regular basis from Morgan Stanley Smith Barney LLC. Please compare the data on this document carefully with your monthly statements to verify its accuracy. The Company strongly encourages you to consult with your own accountants or other advisors with respect to any tax questions.

Account Contribution Summary
Hickman
1/1/2022 - 3/31/2022

ACTIVITY DATE	ACTIVITY	DESCRIPTION		TYPE
		Total Deposits	0.00	

The information and data contained in this report are from sources considered reliable, but their accuracy and completeness is not guaranteed. This report has been prepared for illustrative purposes only and is not intended to be used as a substitute for monthly transaction statements you receive on a regular basis from Morgan Stanley Smith Barney LLC. Please compare the data on this document carefully with your monthly statements to verify its accuracy. The Company strongly encourages you to consult with your own accountants or other advisors with respect to any tax questions.

Account Dividend & Interest Summary
Hickman
1/1/2022 - 3/31/2022

ACTIVITY DATE	ACTIVITY	DESCRIPTION		TYPE
01/03/2022	Dividend	PGIM SHORT DUR HIGH YLD OPP FD	263.52	Cash
01/03/2022	Dividend	PGIM SHORT-TERM CORP BOND Z	859.66	Cash
01/03/2022	Dividend	BLACKROCK HIGH EQ INCOME INST	1,045.58	Cash
01/03/2022	Dividend	PUTNAM FLOATING RATE INC Y	326.47	Cash
01/04/2022	LT Cap Gain	BLACKROCK HIGH EQ INCOME INST	725.38	Cash
01/05/2022	Dividend	ISHARES CORE MSCI EAFE ETF	232.55	Cash
01/18/2022	Dividend	PERFORMANCE TRUST STRAT BD I	255.95	Cash
01/31/2022	Dividend	NEUBERGER BERMAN NEXT GEN FUND	131.00	Cash
01/31/2022	Dividend	NEUBERGER BERMAN NEXT GEN FUND	132.00	Cash
01/31/2022	Interest Income	MORGAN STANLEY PRIVATE BANK NA	0.39	Cash
01/31/2022	Interest Income	MORGAN STANLEY PRIVATE BANK NA	0.06	Cash
01/31/2022	Interest Income	MORGAN STANLEY BANK N.A.	0.62	Cash
02/01/2022	Dividend	PGIM SHORT-TERM CORP BOND Z	874.30	Cash
02/01/2022	Dividend	BLACKROCK HIGH EQ INCOME INST	733.47	Cash
02/01/2022	Dividend	PUTNAM FLOATING RATE INC Y	331.92	Cash
02/16/2022	Dividend	PERFORMANCE TRUST STRAT BD I	526.30	Cash
02/28/2022	Dividend	NEUBERGER BERMAN NEXT GEN FUND	164.80	Cash
02/28/2022	Interest Income	MORGAN STANLEY PRIVATE BANK NA	0.03	Cash
02/28/2022	Interest Income	MORGAN STANLEY PRIVATE BANK NA	0.68	Cash
02/28/2022	Interest Income	MORGAN STANLEY BANK N.A.	0.10	Cash
03/01/2022	Dividend	PGIM SHORT-TERM CORP BOND Z	804.03	Cash
03/01/2022	Dividend	BLACKROCK HIGH EQ INCOME INST	888.96	Cash
03/01/2022	Dividend	PUTNAM FLOATING RATE INC Y	311.81	Cash
03/16/2022	Dividend	PERFORMANCE TRUST STRAT BD I	364.33	Cash
03/29/2022	Dividend	VANGUARD INDEX FDS S&P 500 ETF	355.79	Cash
03/30/2022	Dividend	ISHARES CORE S&P U.S. GROWTH	356.97	Cash
03/30/2022	Dividend	ISHARES CORE S&P U.S. VALUE	783.10	Cash
03/31/2022	Dividend	NEUBERGER BERMAN NEXT GEN FUND	159.10	Cash
03/31/2022	Interest Income	MORGAN STANLEY PRIVATE BANK NA	0.01	Cash
03/31/2022	Interest Income	MORGAN STANLEY PRIVATE BANK NA	0.61	Cash
03/31/2022	Interest Income	MORGAN STANLEY BANK N.A.	0.09	Cash
		Total Dividends and Interest	10,629.58	

The information and data contained in this report are from sources considered reliable, but their accuracy and completeness is not guaranteed. This report has been prepared for illustrative purposes only and is not intended to be used as a substitute for monthly transaction statements you receive on a regular basis from Morgan Stanley Smith Barney LLC. Please compare the data on this document carefully with your monthly statements to verify its accuracy. The Company strongly encourages you to consult with your own accountants or other advisors with respect to any tax questions.

*Account Fee Summary
Hickman
1/1/2022 - 3/31/2022*

ACTIVITY DATE	ACTIVITY	DESCRIPTION		TYPE
01/07/2022	Service Fee	ADV FEE 01/01-01/31	-412.20	Cash
01/11/2022	CASH TRANSFER	FUNDS TRANSFERRED	-1,802.09	Cash
01/19/2022	Service Fee Adj	NET PLATFORM CREDIT	0.07	Cash
02/07/2022	Service Fee	ADV FEE 02/01-02/28	-365.40	Cash
03/07/2022	Service Fee	ADV FEE 03/01-03/31	-395.40	Cash
		Total Withdrawals	-2,975.02	

***Cash Balance Includes Cash, Bank Deposits, MMF Balance, and Unsettled Cash.**

Unless otherwise indicated, this information is not intended to be a substitute for the official account statements that you receive from us. This information is approximate and subject to adjustment, updating and correction and is for illustrative and general reference purposes only. We are not responsible for any clerical, computational or other inaccuracies, errors or omissions. We obtain market values and other data from various standard quotation services and other sources, which we believe to be reliable. However, we do not warrant or guarantee the accuracy or completeness of any such information. The values that you actually receive in the market for any investment may be higher or lower than the values reflected herein. To the extent there are any discrepancies between your official account statement and this information, you should rely on the official account statement. This information should not be considered as the sole basis for any investment decision. The Bank Deposit Program (BDP) is a cash sweep feature whereby clients can chose to have their available free credit balances automatically deposited into interest bearing, FDIC-insured deposit accounts at up to three banks ("Program Banks"): (1) Morgan Stanley Bank, N.A. and/or Morgan Stanley Private Bank, National Association (together, the "Morgan Stanley Banks"), or (2) Citibank, N.A. The Program Banks are FDIC members. Morgan Stanley Smith Barney LLC ("Morgan Stanley") is a registered broker-dealer, not a bank. Morgan Stanley and the Morgan Stanley Banks are affiliates. Unless specifically disclosed to you in writing, other investments and services offered to you through Morgan Stanley are not insured by the FDIC, are not deposits of or other obligations of, or guaranteed by, the Program Banks and involve investment risks, including possible loss of principal amount invested. External Assets - Certain assets listed in this view are based upon information provided by you, your client or other external sources and are not part of accounts that you manage at Morgan Stanley. Assets not held with Morgan Stanley may not be covered by SIPC protection or by additional protection under Morgan Stanley's excess insurance coverage plans. Morgan Stanley may include information about these external assets in this view solely as a service to you, and Morgan Stanley is not responsible for the accuracy of any information provided by external sources, including but not limited to, you, your client or another financial institution. You are responsible for ensuring the accuracy of such information. Generally, any financial institution that holds securities is responsible for year-end reporting (Internal Revenue Service (IRS) Form 1099) and separate periodic statements, which may vary from Morgan Stanley's information due to different tax reporting periods.

The information and data contained in this report are from sources considered reliable, but their accuracy and completeness is not guaranteed. This report has been prepared for illustrative purposes only and is not intended to be used as a substitute for monthly transaction statements you receive on a regular basis from Morgan Stanley Smith Barney LLC. Please compare the data on this document carefully with your monthly statements to verify its accuracy. The Company strongly encourages you to consult with your own accountants or other advisors with respect to any tax questions.



Hickman County Director of Schools Evaluation Results

**Amy Bryant, Chairman
Ronald Gammons
Steve Gianakos
Jane Herron
Tim Hobbs
Jim Hudgins
Vance Willis**

April 2022

2022 Hickman County Director of Schools Overall Evaluation Score

Section I Qualitative:

Appendix A: Administrator Survey $4.35 \times 42\% = 1.83$

Appendix B: Board Observational Data $3.87 \times 33\% = 1.28$

Section II Quantitative:

Appendix C: Achievement of Board Goals/Strategic Plan $3.63 \times 25\% = 0.91$

Overall Evaluation Score: 4.02

2022 Hickman County Director of Schools Evaluation Results		
Evaluation Numbers	Appendix A - Administrators' Perceptions of Director's Performance	Rating Out of 5
1	The director develops clear expectations.	4.19
2	The director models good communication skills.	4.06
3	The director is knowledgeable about the curriculum.	4.63
4	The director ensures that funds are spent wisely.	4.44
5	The director holds me accountable for my job responsibilities.	4.31
6	The director supports professional learning activities for teachers and administrators.	4.56
7	The director maintains positive relationships with administrators.	4.31
8	The director enforces board policy in a fair and consistent manner.	4.50
9	The director ensures the safety of students and school personnel.	4.44
10	The director administers the schools in accordance with state laws.	4.56
11	The director has an effective plan to recruit effective employees.	3.94
12	The director takes an active leadership role in the instructional improvement.	4.44
13	The director evaluates my performance in a fair and consistent manner.	4.13
14	The director interacts effectively with system employees.	4.25
15	The director is accessible to administrators.	4.25
16	The director develops good staff morale and loyalty to the system.	4.31
17	The director works effectively with the school board.	4.50
18	The director involves administrators as much as possible in decision-making.	4.31
19	The director listens to suggestions from the administrative staff.	4.31
20	The director demonstrates a caring attitude.	4.63
Administrator Survey Average:		4.35

Hickman County Director of Schools Evaluation 2022

Appendix A - Administrators' Perceptions of Director's Performance

Additional Comments

- Michelle Gilbert is THE BEST superintendent! She does what is in the best interest of our students, staff, and community!
- The survey seems to indicate that the board would like to have a director of schools who is knowledgeable of the P-12 curriculum, has professional communication skills, uses feedback from stakeholders, is fiscally responsible, is in compliance with state and federal laws, leads instructional improvement, supports professional development of current staff, takes steps to ensure a safe learning/working environment, builds working relationships with commissioners, understands the culture of the district/county, and genuinely cares about students/families/staff/community. No one is perfect, but you have all these things in your current director of schools. In addition, your director of schools has experience that can only come from doing the job. If there are areas/duties where you think performance can be improved, I hope you are able to provide actionable steps towards those improvements and clear expectations for future performance. I appreciate that this process gives employees the opportunity to provide feedback, but I hope as board members you are also getting into classrooms, cafeterias, buses, extracurricular programs, tutoring programs, CTE programs, ball games, and commissioner meetings to see the successes and challenges first-hand.
- Mrs. Gilbert has created positive change to the work environment of our school system. She allows administrators to make decisions that are based on what is best for students at all times. She treats everyone fairly and creates a positive work environment.
- I feel Michelle is very Honest and sincere Director and strives to make our system to be the best we can be. In my opinion she does an outstanding job, considering the wage constraints in the areas of support staff. There needs to be a outside third party consultant survey done to do a comparable wage report and then work in a yearly steps over 3 years to get all personal to a surrounding competitive rate that will promote retention and quality. I feel the district does a great job of with certified teachers and conservative fiscally responsible operations. The across the board "support staff" wages is the one area lacking that needs more balance and consistency in wages. Although this falls under the Director of Schools job responsibility, the mindset of the Board is the "leading influence" in correcting this issue.
- Mrs. Gilbert loves our school system! She has devoted her life to the work of educating the children of Hickman County. She wants the very best for our students, teachers, admin, and community.

2022 Hickman County Director of Schools Results		
Evaluation Numbers	Appendix B - Board Observational Data	Rating Out of 5
	BOARD RELATIONSHIPS: Goal 1	
1.1	Keeps all board members informed on issues, needs and operation of the school system, including employment, promotion and dismissal of personnel.	3.57
1.2	Offers professional advice to the board on items requiring board action, with appropriate recommendations based on thorough study and analysis.	3.86
1.3	Maintains a high degree of understanding and respect between staff and the board.	4.00
1.4	Recommends policies to the board that comply with state law and State Board of Education and Tennessee Department of Education rules and regulations; that protect the security and integrity of the district infrastructure and the data it contains; and that protect the rights and confidentiality of staff and students.	4.00
1.5	Interprets and executes the intent of board policy through the development of administrative procedures.	3.86
1.6	Seeks and accepts constructive criticism of work from the board.	4.00
1.7	Supports board policy and actions to the public and staff.	4.14
1.8	Refrains from criticism of members of the board.	4.00
1.9	Goes immediately and directly to the board when he/she feels an honest, objective difference of opinion exists between him/her and any or all members of the board, in an earnest effort to resolve such difference immediately.	3.86
1.10	Bases position with regard to matters discussed by the board upon principle, and is willing to maintain that position without regard for its popularity until an official position has been reached, after which time the superintendent supports the decision of the board, as long as he/she remains in its employ.	4.00
	Average	3.93

2022 Hickman County Director of Schools Results		
	COMMUNITY RELATIONSHIPS: Goal 2	
2.1	Is an effective spokesperson for the school system.	4.14
2.2	Builds public support for the school district.	4.29
2.3	Develops cooperative relationships with the news media.	4.14
2.4	Uses information about family and community concerns, expectations, and needs regularly.	4.00
2.5	Secures available community resources to help the school district solve problems and achieve goals.	3.86
2.6	Establish partnerships with area businesses, institutions of higher education, and community groups to strengthen programs and support school district goals.	4.14
2.7	Recognizes and values diversity.	3.86
2.8	Uses public resources and funds appropriately and wisely.	3.86
	Average	4.04

2022 Hickman County Director of Schools Results		
	STAFF AND PERSONNEL RELATIONSHIPS: Goal 3	
3.1	Develops good staff morale and loyalty to the system.	3.14
3.2	Treats all personnel fairly.	3.71
3.3	Delegates authority to staff members appropriately.	3.71
3.4	Demonstrates use of system and staff evaluation data for personnel policies, decision-making, promotion of career growth and professional development.	4.00
3.5	Offers professional development that is focused on student learning consistent with the school districts vision and goals.	4.00
3.6	Considers diversity in developing learning experiences.	3.80
3.7	Uses technologies in teaching and learning.	4.00
3.8	Recognizes staff for their professional achievements.	4.00
3.9	Models learning for staff.	3.67
3.10	Provides shared leadership and decision-making opportunities for staff that promotes a climate of collaboration and collegiality.	3.80
	Average	3.78

2022 Hickman County Director of Schools Results		
	FACILITIES AND FINANCE: Goal 4	
4.1	Demonstrates knowledge of school facilities and develops a process that builds internal and public support for facility needs, including bond issues and capital improvement plans.	3.71
4.2	Ensures the maintenance of school property and the safety of personnel and property.	4.00
4.3	Meets and works collaboratively with the Board and appropriate staff to determine priorities for budgeting and the effective allocation of space and human resources.	4.00
4.4	Provides accurate and timely reports to the board on the financial condition of the school system.	4.14
4.5	Develops and monitors long-range plans for school and district technology and information systems and makes informed district decisions about computer hardware and software and staff developing needs while allocating resources consistent with district plan.	3.86
4.6	Demonstrates budget management including financial forecasting, planning, cash flow management, account auditing and monitoring and oversees the district's fiduciary responsibilities.	3.86
4.7	Establishes and sustains partnerships with community agencies to provide additional resources to support the social and emotional growth and development of at-risk students.	4.20
	Average	3.97

2022 Hickman County Director of Schools Results		
	VISION: Goal 5	
5.1	Works effectively with board, staff, and community to develop long-range strategic plans.	4.00
5.2	Initiates communication and facilitates cooperation and collaboration among staff regarding the district's mission, curriculum and program initiatives.	3.83
5.3	Keeps board and community informed of progress towards long-range goals.	3.57
5.4	Clearly articulates system's vision, mission and priorities to community and media.	3.83
5.5	Ensures that the vision shapes the educational programs, plans, and activities.	3.83
5.6	Uses assessment data related to student learning to develop the school district vision and goals.	3.67
5.7	Seeks and obtains needed resources to support the implementation of the school district mission and goals.	4.00
5.8	Monitors, evaluates and advises the vision, mission, and implementation plans regularly.	3.43
	Average	3.77

2022 Hickman County Director of Schools Results		
	STUDENT ACHIEVEMENT: Goal 6	
6.1	Develops, implements, promotes and monitors continuous improvement in student achievement by using a variety of appropriate techniques.	3.86
6.2	Applies effective methods of providing, monitoring, evaluating and reporting student achievement.	3.57
6.3	Establishes curriculum planning to anticipate occupational trends and school-to-career needs.	3.67
6.4	Provides equitable access for students and staff to technologies that facilitate productivity and enhance learning.	3.71
6.5	Involves faculty and stakeholders in enhancement and renewal of curriculum to ensure alignment of curriculum, instruction and assessment.	3.20
6.6	Reviews analyses of student academic achievement through standardized test results and other academic sources.	3.71
6.7	Applies and communicates qualitative and quantitative findings to identify strengths and weaknesses in programs and practices in order to ensure continuous improvement.	4.00
6.8	Develops, monitors and assesses district and school improvement plans, including the regular review and analysis of district's test scores by school and sub-groups.	3.71
6.9	Formulates plan to assess appropriate teaching methods and classroom management strategies for all learners.	3.67
6.10	Works collaboratively with members of the staff in using student achievement data to determine relevant professional development opportunities.	3.57
6.11	Meets with principals regularly to provide feedback on goal achievement and to assess ongoing school improvement efforts.	3.80
6.12	Reviews, reports and reacts appropriately to state accountability measures.	3.86
6.13	Identifies, clarifies and addresses barriers to student learning.	3.83
6.14	Recognizes and celebrates student accomplishments.	3.71
	Average	3.71

2022 Hickman County Director of Schools Results		
	MANAGEMENT AND OPERATIONS: Goal 7	
7.1	Ensures that operational plans and procedures to achieve the vision and goals of the school district are in place.	3.86
7.2	Manages time to maximize attainment of organizational goals.	3.71
7.3	Identifies potential problems and opportunities.	3.57
7.4	Confronts and resolves problems in a timely manner.	3.71
7.5	Aligns financial, human, and material resources to the goals of school district.	3.57
7.6	Solicits staff input to discuss issues and to promote effective problem-framing and problem-solving skills.	3.80
7.7	Demonstrates professional and effective conflict resolution skills.	3.71
7.8	Uses effective group-process and consensus building skills.	3.80
7.9	Participates in professional learning that is aligned with strategic plan and enhances leadership skills.	3.71
7.10	Implements and enforces school district code of conduct and appropriate and effective disciplinary policies, procedures and programs in a timely and consistent manner.	3.57
7.11	Promotes a climate of trust and teamwork within the district.	3.43
7.12	Clearly communicates expectations regarding behavior and procedures for handling disciplinary problems to students, staff, parents and other members of the community.	3.57
7.13	Establishes procedures and practices for dealing with emergencies such as weather, threats to the school, student violence and trauma.	4.00
	Average	3.69

2022 Hickman County Director of Schools Results		
	INTEGRITY, FAIRNESS AND ETHICS: Goal 8	
8.1	Demonstrates values, beliefs, and attitudes that inspire others to higher levels of performance.	3.86
8.2	Serves as a role model.	4.00
8.3	Accepts responsibility for school operations.	4.00
8.4	Uses the influence of the office to enhance the educational program rather than for personal gain.	4.14
8.5	Treats people fairly, equitably, and with dignity and respect.	4.00
8.6	Protects the rights and confidentiality of students and staff.	4.00
8.7	Demonstrates appreciation for and sensitivity to the diversity in the school community.	4.00
8.8	Expects and promotes that others in the school community will demonstrate integrity and exercise ethical behavior throughout the district.	4.14
8.9	Fulfills legal and contractual obligations.	3.86
8.10	Applies laws and procedures fairly, wisely, and considerately.	3.86
8.11	Maintains the physical and emotional wellness necessary to meet the responsibilities of the position.	3.57
	Average	3.95

2022 Hickman County Director of Schools Results		
	POLITICAL/SOCIAL/CULTURAL CONTEXT: Goal 9	
9.1	Ensures that the environment in which schools operate is influenced on behalf of students and their families.	4.00
9.2	Ensures that the school community works within the framework of policies, laws, and regulations enacted by local, state, and federal authorities.	3.86
9.3	Ensures that lines of communication are developed with decision-makers outside the school community.	3.83
9.4	Promotes and expects a district-based climate of tolerance, acceptance and civility.	3.86
9.5	Establishes a culture that encourages responsible risk-taking while requiring accountability for results.	4.00
9.6	Ensures that there is ongoing dialogue with representatives of diverse community groups.	4.20
	Average	3.96
	Board Observational Data Average:	3.87

2022 Hickman County Director of Schools Evaluation Results - Appendix B

Appendix B - Board Observational Data	Average
Board Relationships	3.93
Community Relationships	4.04
Staff and Personnel Relationships	3.78
Facilities, Finance and Human Resources	3.97
Vision	3.77
Student Achievement	3.71
Management and Operations	3.69
Integrity, Fairness and Ethics	3.95
Political/Social/Cultural Context	3.96
AVERAGE:	3.87

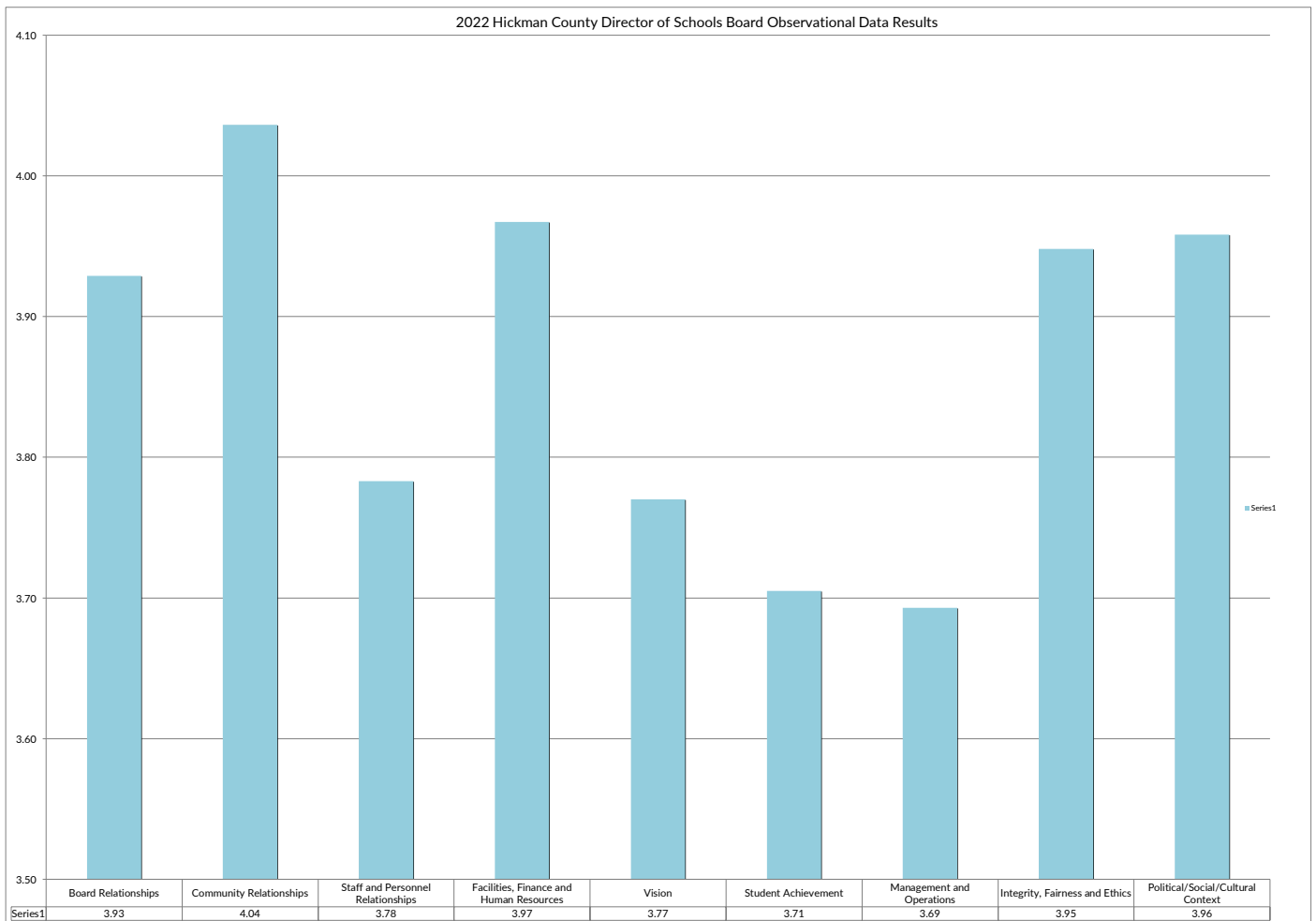

2022 Hickman County Director of Schools Evaluation Results		
Objective Numbers	Appendix C - Annual Objectives	Rating Out of 5
	Performance Objective 1: Ensure that there is a continuous improvement plan for student achievement and growth.	
1.1	Ensure the improvement plan is clear and data-based.	3.71
1.2	Examine data, set goals and stay the course or initiate change as necessary.	3.57
1.3	Resources are clearly aligned with improvement plan.	3.57
	Average	3.62
	Performance Objective 2: Develop a school district strategic plan.	
2.1	Annual and long-range goals, along with measurable objectives and strategies, have been established with input from Board, staff and community members.	3.57
2.2	A district-wide vision has been created with input from Board and staff.	3.86
	Average	3.72
	Performance Objective 3: Evaluate the organizational structure of the district and reorganize as necessary to achieve maximum effectiveness.	
3.1	The reorganization of personnel and a revised organizational chart has been developed.	3.50
3.2	If necessary, a fiscal review with budgetary recommendations.	3.57
	Average	3.54
	Performance Objective 4: Develop a comprehensive plan to promote school system and increase parent and community involvement.	
4.1	Promotional tools for the school system have been developed.	3.67
4.2	Development of tools to increase parent and community involvement in reopening of school system during pandemic.	3.57
4.3	Created new approaches to engage with parents and community partners throughout school year due to pandemic.	4.00
	Average	3.75

2022 Hickman County Director of Schools Evaluation Results		
	Performance Objective 5: Work with the school board to develop and implement an annual plan for promoting school system and increasing communication and support with the county commission/city council.	
5.1	The board adopts an annual agenda for promotion, which includes activities, which the board and/or the Director will complete during the year. The plan must include activities to build support from the County Commission/City Council.	3.29
	Average	3.29
	Performance Objective 6: Develop a budget for the school board as outlined in school policies, activities in the school board annual agenda, and guidelines established by the State Department of Education.	
6.1	A budget document has been formulated using procedures required by school board policies, activities in the school board annual agenda, and guidelines established by the State Department of Education.	3.86
6.2	Budget documents were developed to serve the school system's needs for additional funding from government bodies due to pandemic.	3.71
	Average	3.79
	Performance Objective 7: Ensure the Board's annual agenda is developed and implemented.	
7.1	Evidence that annual agenda items referencing the Director of Schools have been completed or are ongoing and nearing completion.	3.71
	Average	3.71
	Performance Objective 8: Provide and promote activities that give the school board an opportunity to review its effectiveness and improve the relationship between individual school board members, and the school board as a whole with the Director of Schools.	
8.1	Information regarding improvement activities such as workshops, clinics, conventions, board retreats, etc.	3.50
8.2	A self-evaluation instrument that reviews school board effectiveness and allows for each school board member to make recommendations and suggestions for improvement has been distributed to the Board for their review.	3.71
	Average	3.61
	Performance Objective Average:	3.63

2022 Hickman County Director of Schools Evaluation Results - Appendix C

Appendix C - Annual Objectives	Average
Objective 1	3.62
Objective 2	3.72
Objective 3	3.54
Objective 4	3.75
Objective 5	3.29
Objective 6	3.79
Objective 7	3.71
Objective 8	3.61
AVERAGE:	3.63

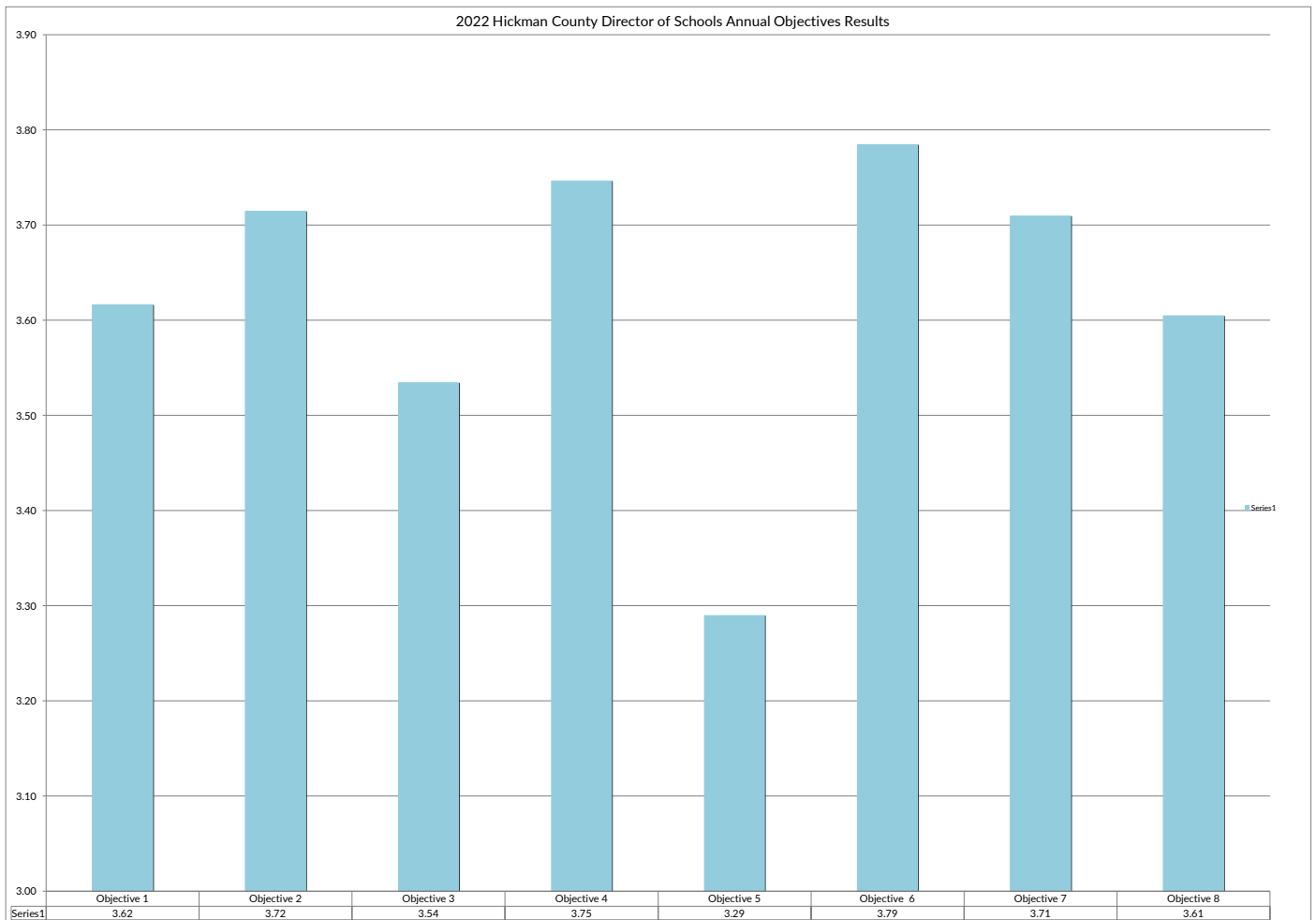

Hickman County Director of Schools Evaluation 2022

Appendix B & C – Board Observational Data & Achievement of Board Goals/Strategic Plan

[Additional Comments](#)

- Michele does a great job and loves her job, staff, and most of all the students. There are times when something is on the agenda that we may be aware of, but she will make sure that we know prior to the mtg. it would be good to get this information ahead of time.



Hickman County School Board Self-Evaluation 2021-2022

Questions Responses 4 Settings

4 responses



Accepting responses

Summary

Question

Individual

Board Meetings Section -- The board has sufficient time and opportunity to review the agenda and supporting materials before a board meeting



4 responses

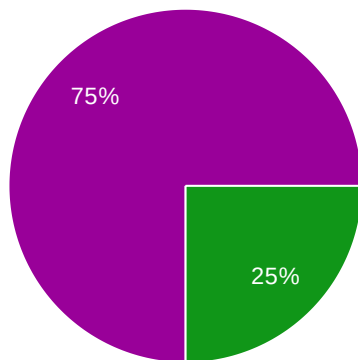

- Strongly Disagree
- Disagree
- Neutral
- Agree
- Strongly Agree

How important is this to me: "The board has sufficient time and opportunity to review the agenda and supporting materials before a board meeting"?



4 responses

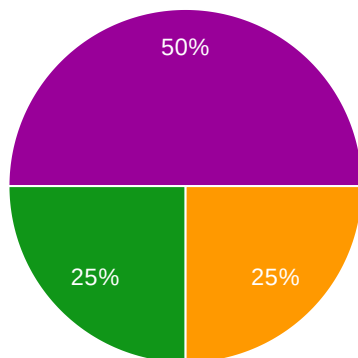

- Not important
- Somewhat Important
- Important
- Very Important
- Essential

The board encourages participation by each board member.



4 responses

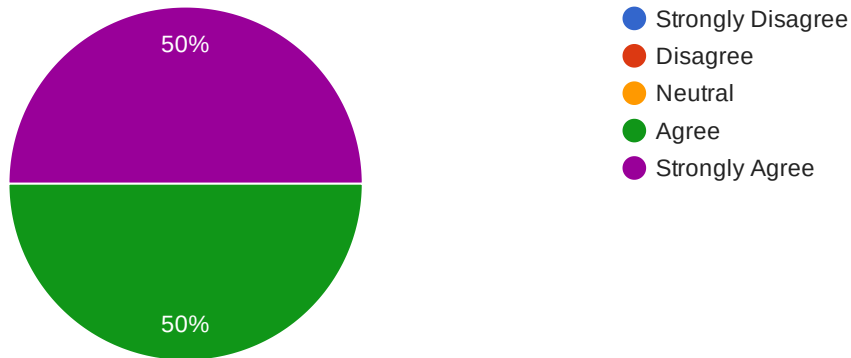

How important is this to me: "The board encourages participation by each board member."?



4 responses

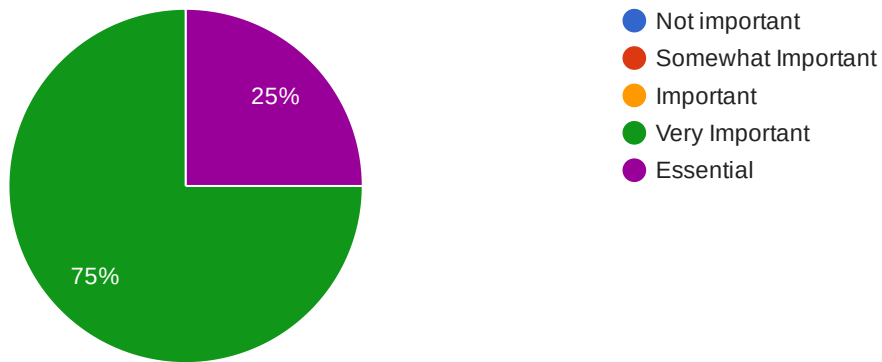

Board members come to meetings prepared to focus on discussion issues and keep comments relevant and brief.



4 responses

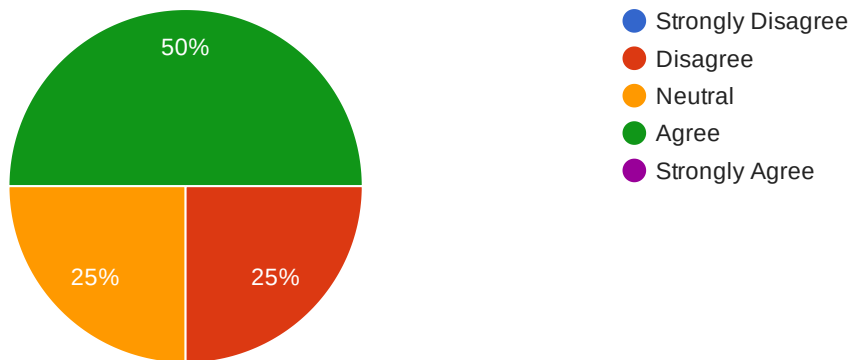

How important is this to me: "Board members come to meetings prepared to focus on discussion issues and keep comments relevant and brief."?



4 responses



All board members are routinely familiar with the agenda materials and are ready to discuss and decide important items.



4 responses

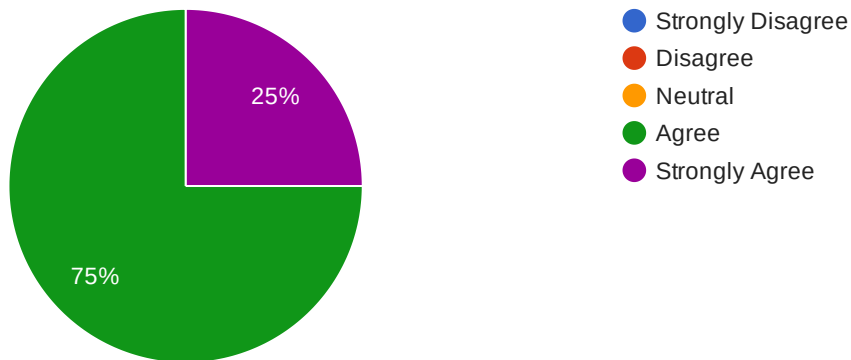

How important is this to me: "All board members are routinely familiar with the agenda materials and are ready to discuss and decide important items."?



4 responses

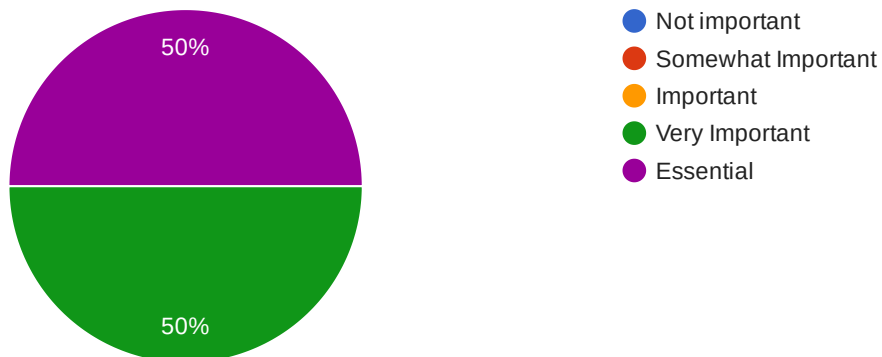

Adequate background information on issues to come before the board is routinely provided in advance of the board meeting.



4 responses

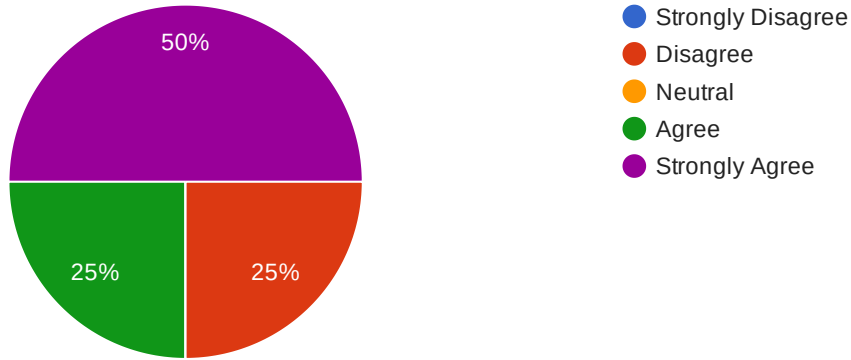

How important is this to me: "Adequate background information on issues to come before the board is routinely provided in advance of the board meeting."?



4 responses

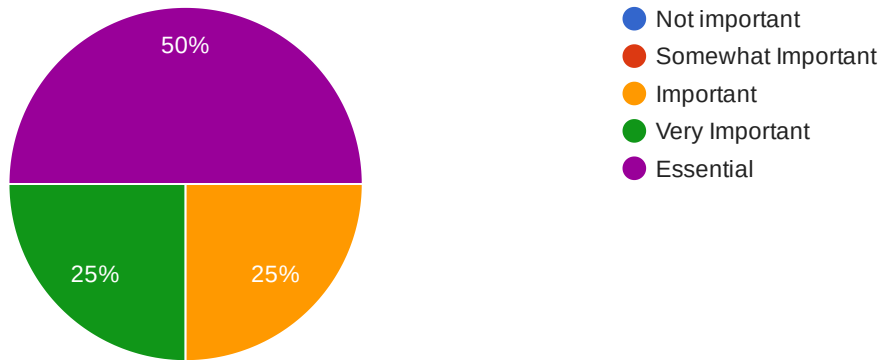

The board weighs all decisions in terms of what is best for the students of the school system.



4 responses

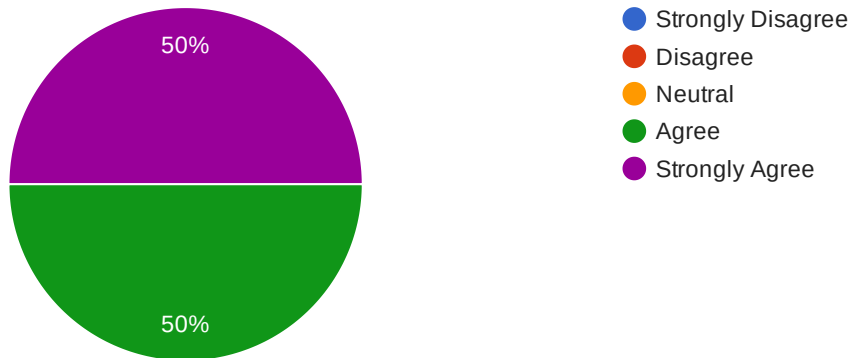

How important is this to me: "The board weighs all decisions in terms of what is best for the students of the school system."?



4 responses

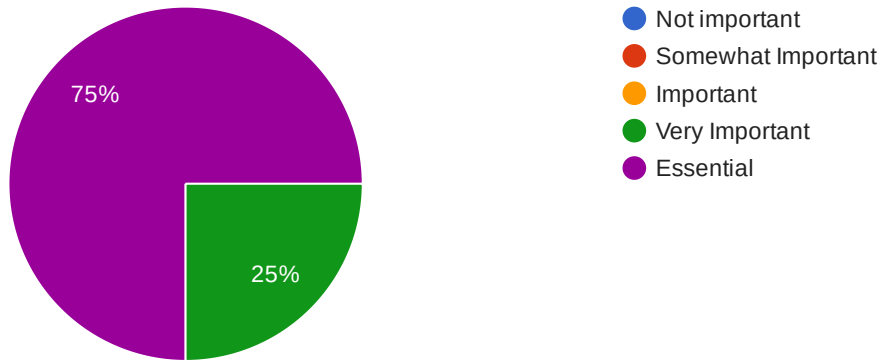

Team Building Section -- The board is able to disagree on matters and still maintain an attitude of mutual respect and trust.



4 responses

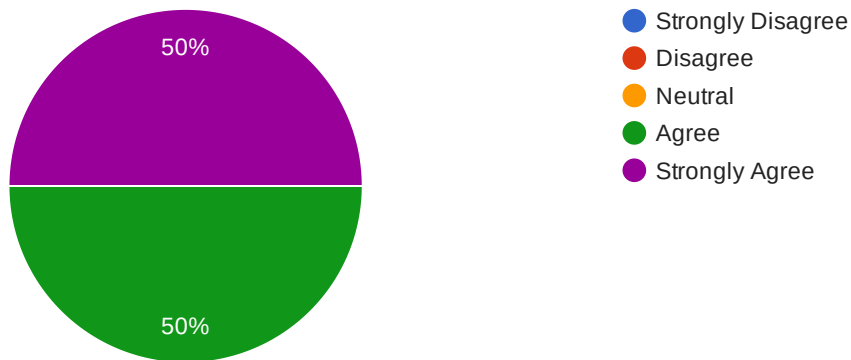

How important is this to me: "The board is able to disagree on matters and still maintain an attitude of mutual respect and trust."?



4 responses

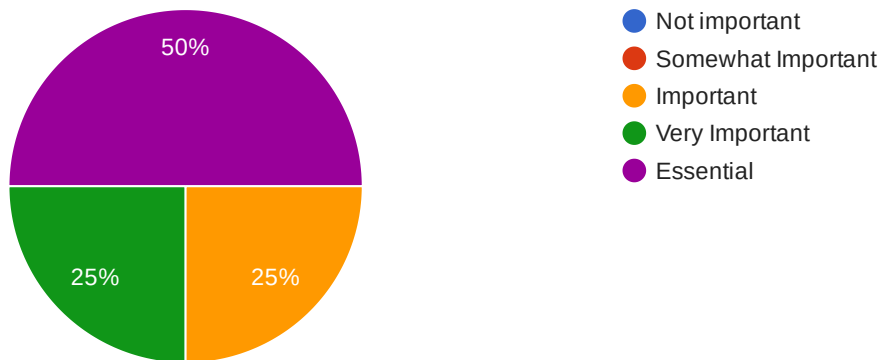

The board is open and honest with each other, as well as administrators, and is able to maintain an attitude of mutual trust and respect.



4 responses

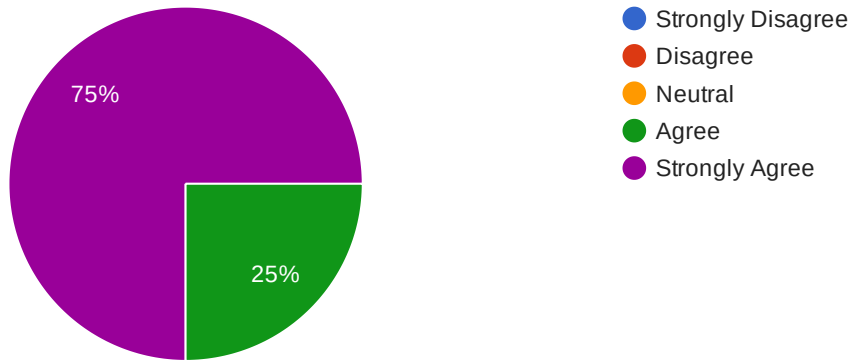

How important is this to me: "The board is open and honest with each other, as well as administrators, and is able to maintain an attitude of mutual trust and respect."?



4 responses

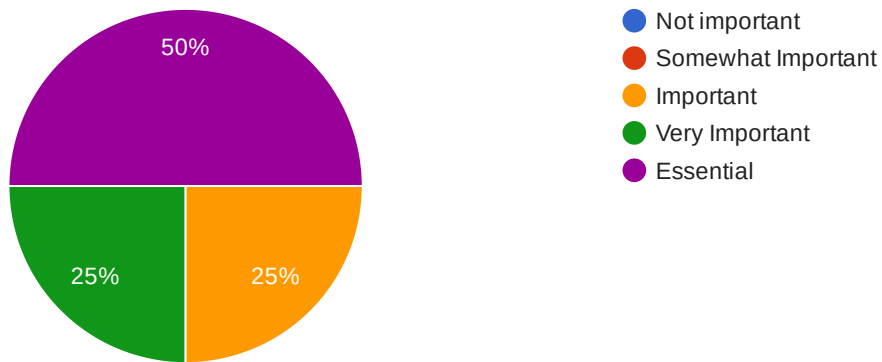

The district has a planned program to orient newly-elected board members.



4 responses

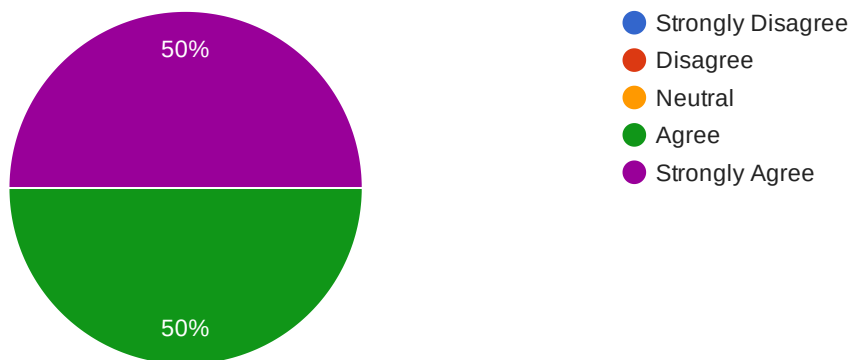

How important is this to me: "The district has a planned program to orient newly-elected board members."?



4 responses

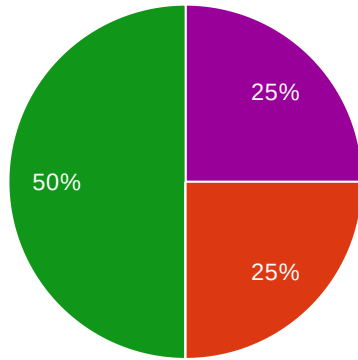

- Not important
- Somewhat Important
- Important
- Very Important
- Essential

Once a decision has been made, all members respect the decision and the board speaks with one voice.



4 responses

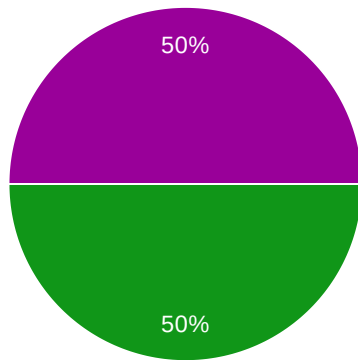

- Strongly Disagree
- Disagree
- Neutral
- Agree
- Strongly Agree

How important is this to me: "Once a decision has been made, all members respect the decision and the board speaks with one voice."?



4 responses

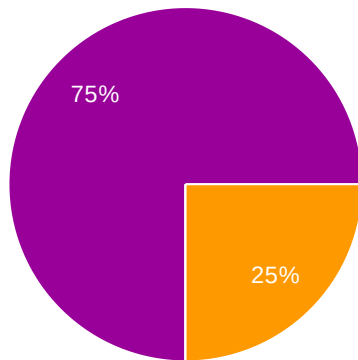

- Not important
- Somewhat Important
- Important
- Very Important
- Essential

Board members do not attempt to individually speak on behalf of the board or commit the board.



4 responses

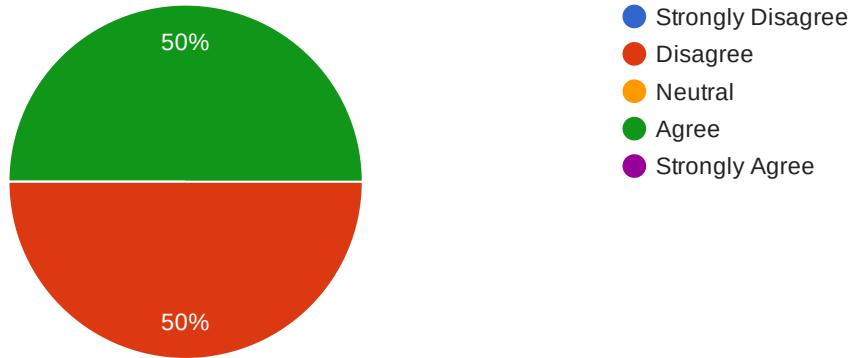

How important is this to me: "Board members do not attempt to individually speak on behalf of the board or commit the board."?



4 responses

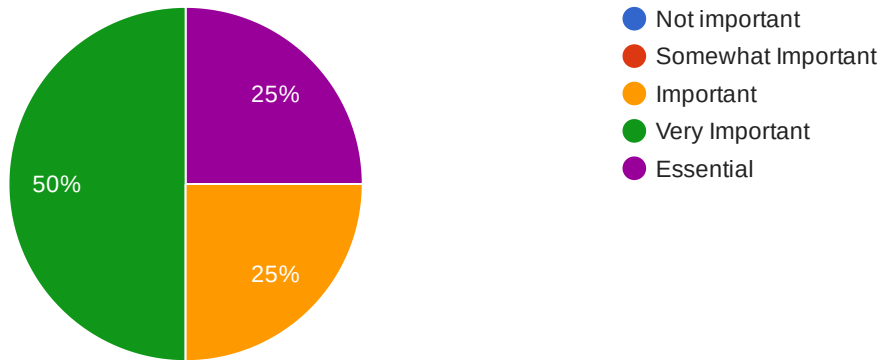

Board/Director of Schools/Staff Relations -- The board and the Director of Schools trust and respect one another.



4 responses

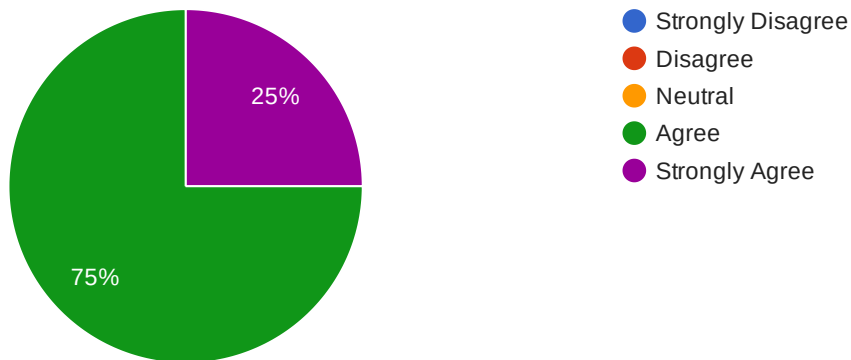

How important is this to me: "The board and the Director of Schools trust and respect one another."?



4 responses

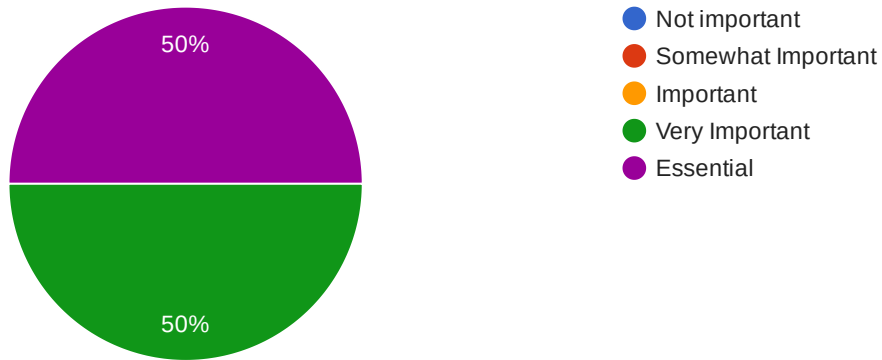

Each member of the board understands and respects the distinction between the board's responsibilities and the director of schools's duties.



4 responses

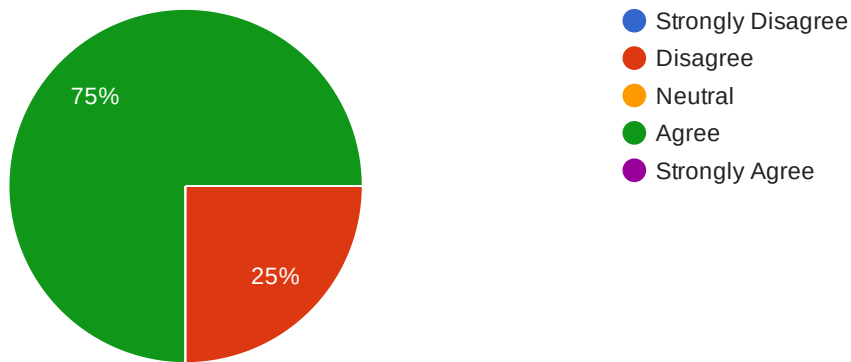

How important is this to me: "Each member of the board understands and respects the distinction between the board's responsibilities and the director of schools's duties."?



4 responses

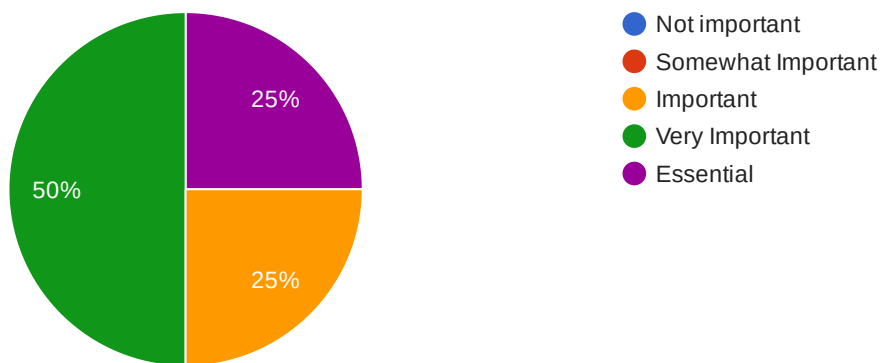

Our board and director of schools agree on how complaints or concerns to board members should be handled.



4 responses

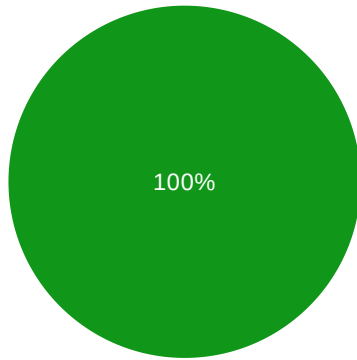

- Strongly Disagree
- Disagree
- Neutral
- Agree
- Strongly Agree

How important is this to me: "Our board and director of schools agree on how complaints or concerns to board members should be handled."?



4 responses

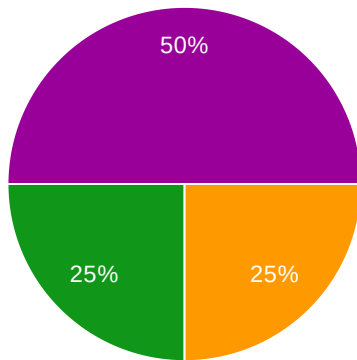

- Not important
- Somewhat Important
- Important
- Very Important
- Essential

Board members work to avoid surprises by sharing concerns or questions with the superintendent in advance of the board meeting.



4 responses

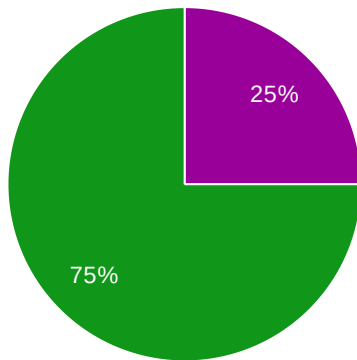

- Strongly Disagree
- Disagree
- Neutral
- Agree
- Strongly Agree

How important is this to me: "Board members work to avoid surprises by sharing concerns or questions with the superintendent in advance of the board meeting."?



4 responses

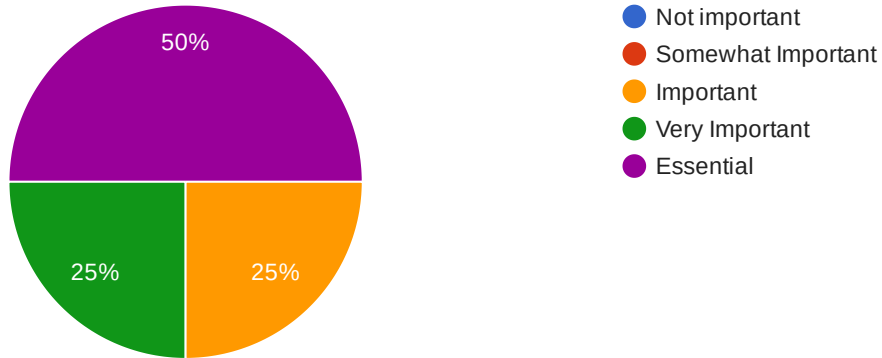

The Director of Schools is given direction by the board as a whole rather than by individual members.



4 responses

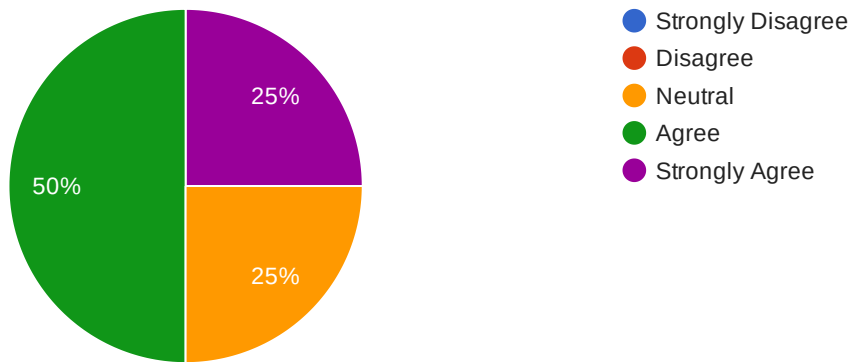

How important is this to me: "The Director of Schools is given direction by the board as a whole rather than by individual members."?



4 responses

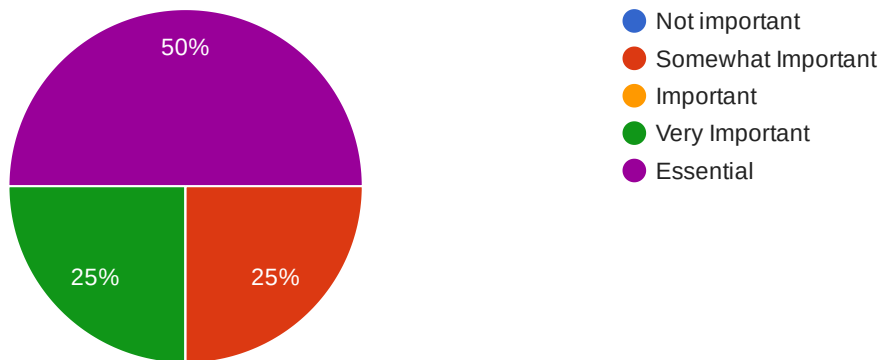

The board recognizes staff accomplishments.



4 responses

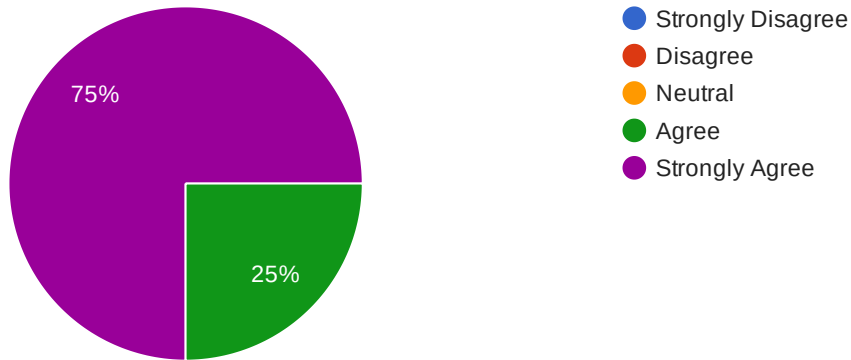

How important is this to me: "The board recognizes staff accomplishments."?



4 responses

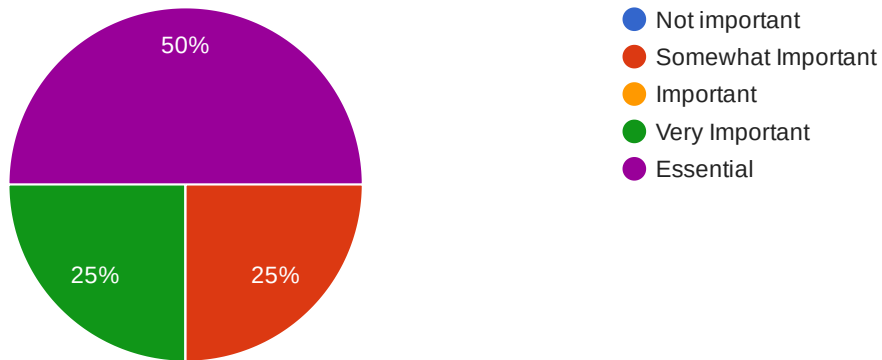

Individual board members avoid making excessive personal requests from staff.



4 responses

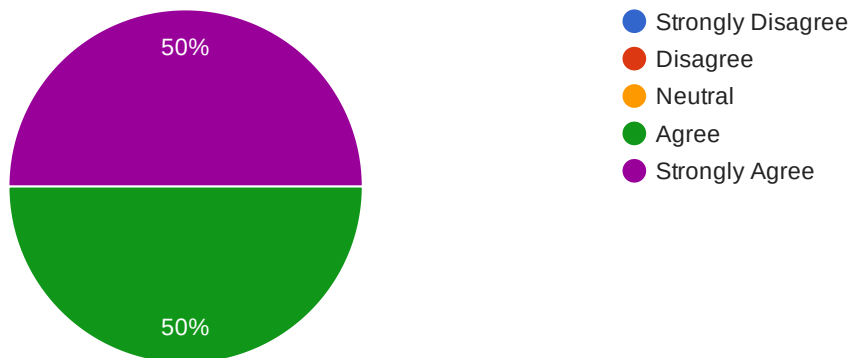

How important is this to me: "Individual board members avoid making excessive personal requests from staff."?



4 responses

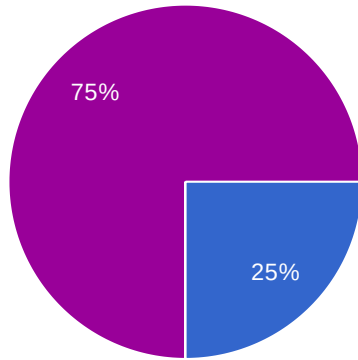

- Not important
- Somewhat Important
- Important
- Very Important
- Essential

Board members are respectful to other board members, administrators, staff, and visitors.



4 responses

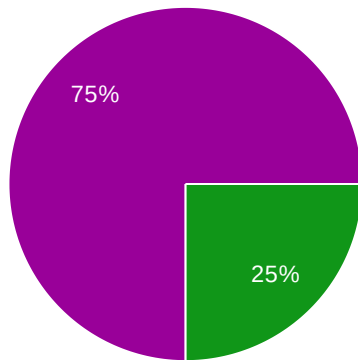

- Strongly Disagree
- Disagree
- Neutral
- Agree
- Strongly Agree

How important is this to me: "Board members are respectful to other board members, administrators, staff, and visitors."?



4 responses

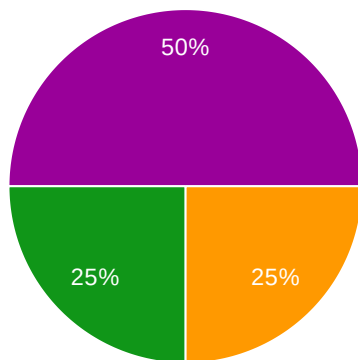

- Not important
- Somewhat Important
- Important
- Very Important
- Essential

Board members direct complaints and requests to the Director of Schools rather than attempting to solve them directly.



4 responses

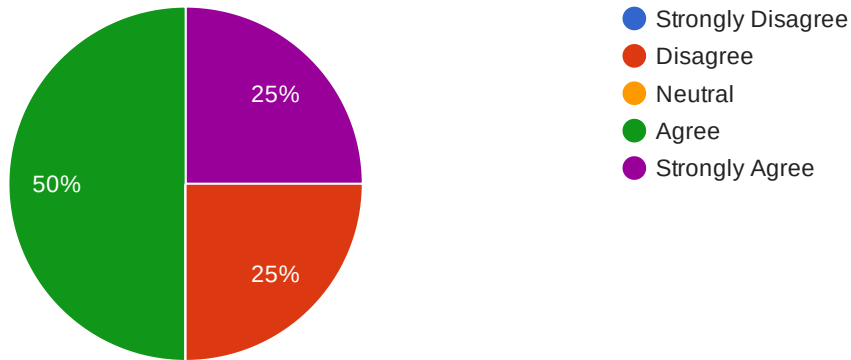

How important is this to me: "Board members direct complaints and requests to the Director of Schools rather than attempting to solve them directly."?



4 responses

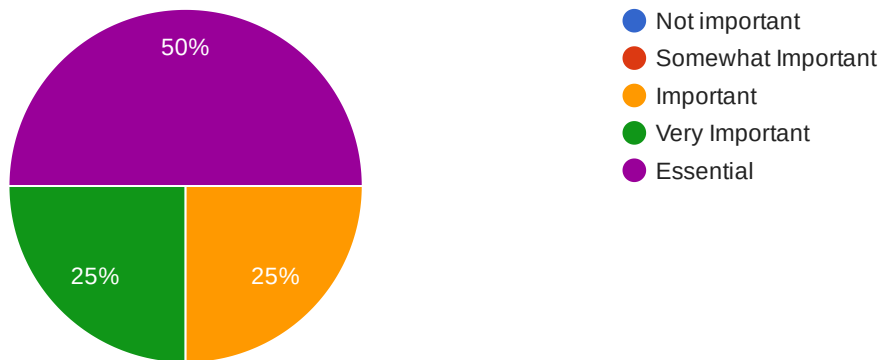

The board ensures that an effective evaluation system is in place for the director of schools and all employees.



3 responses

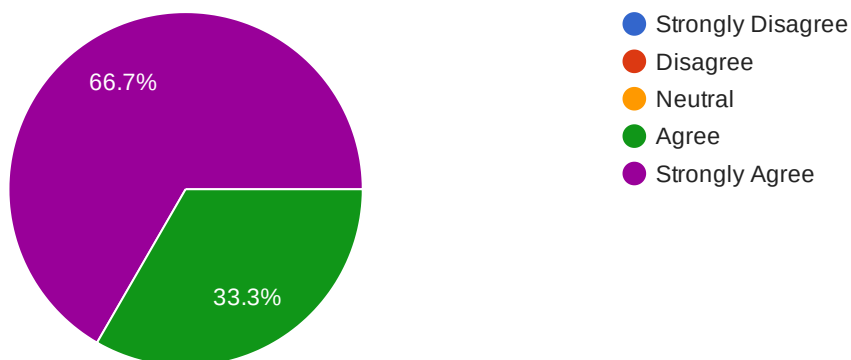

How important is this to me: "The board ensures that an effective evaluation system is in place for the director of schools and all employees."?



4 responses



Vision/Planning -- A vision/mission statement for the district exists and is periodically reviewed by the board and widely disseminated in the district.



4 responses

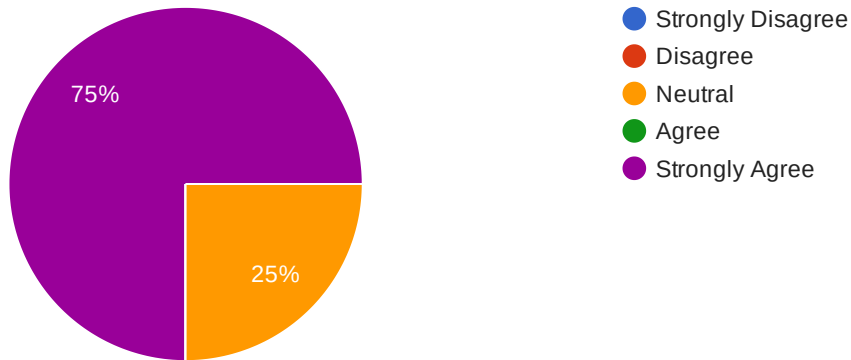

How important is this to me: "A vision/mission statement for the district exists and is periodically reviewed by the board and widely disseminated in the district."?



4 responses

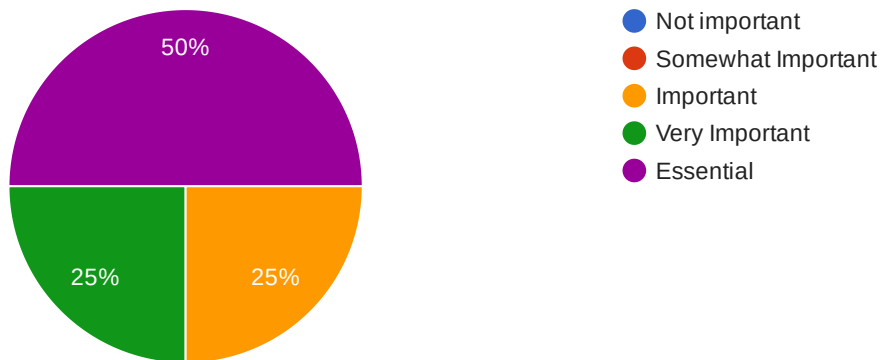

The vision reflects community priorities.



4 responses

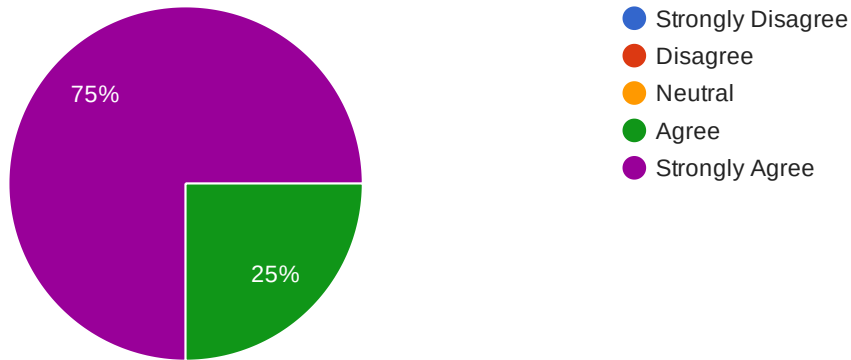

How important is this to me: "The vision reflects community priorities."?



4 responses

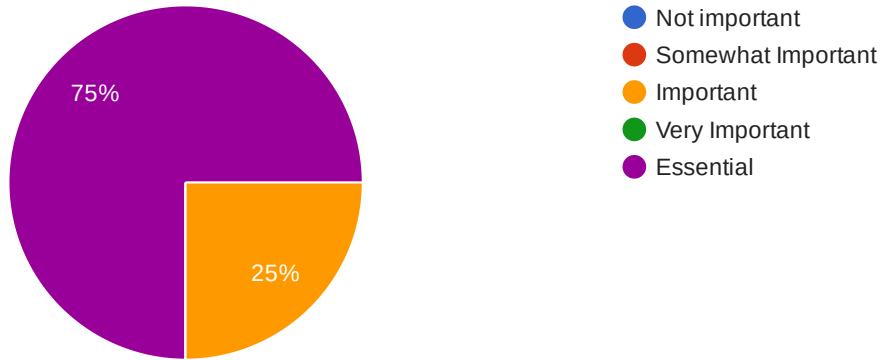

Discussion of major items before the board routinely includes consideration of their impact on meeting district goals.



4 responses

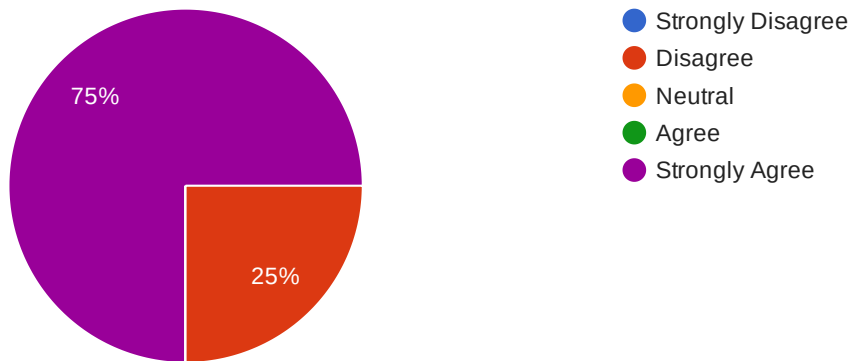

How important is this to me: "Discussion of major items before the board routinely includes consideration of their impact on meeting district goals."?



4 responses



The Director's evaluation considers how well the director has addressed the district goals.



4 responses

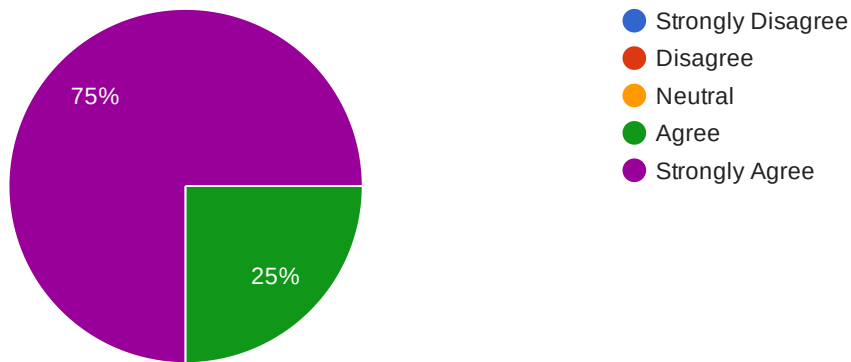

How important is this to me: "The Director's evaluation considers how well the director has addressed the district goals."?



4 responses

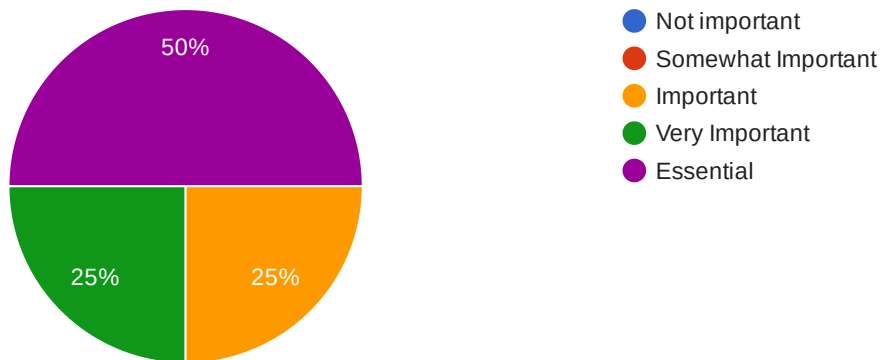

The board emphasizes setting and monitoring district goals, instead of how staff should achieve these goals.



4 responses

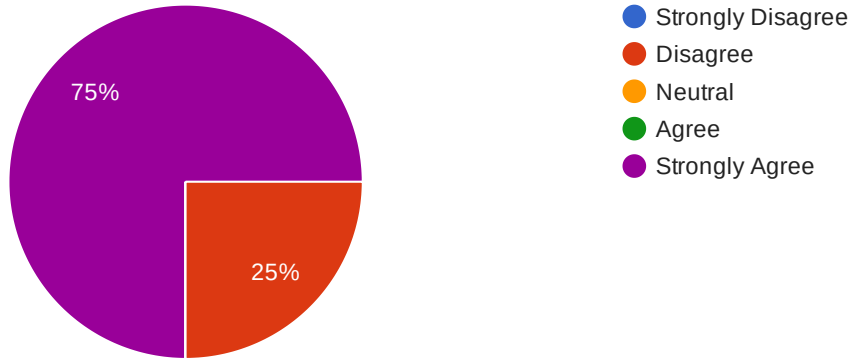

How important is this to me: "The board emphasizes setting and monitoring district goals, instead of how staff should achieve these goals."?



4 responses

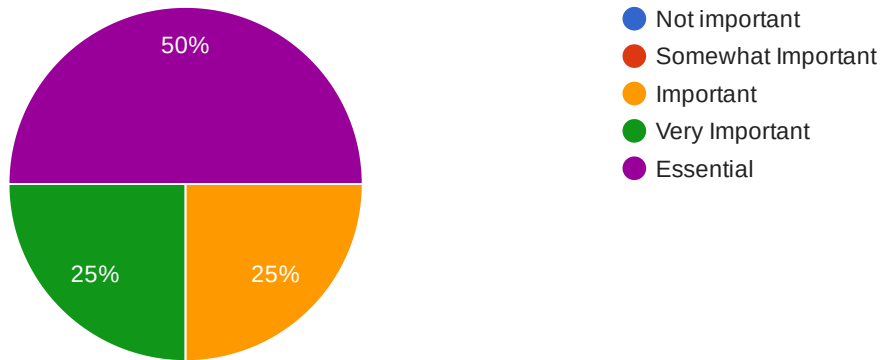

The board does not get bogged down discussing operation details of the district or schools.



4 responses

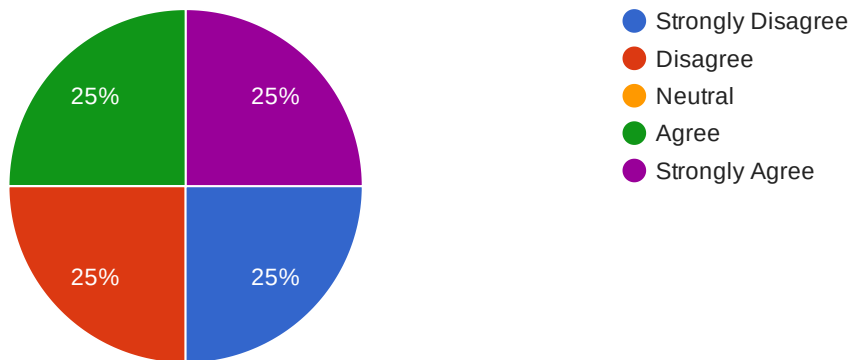

How important is this to me: "The board does not get bogged down discussing operation details of the district or schools."?



4 responses

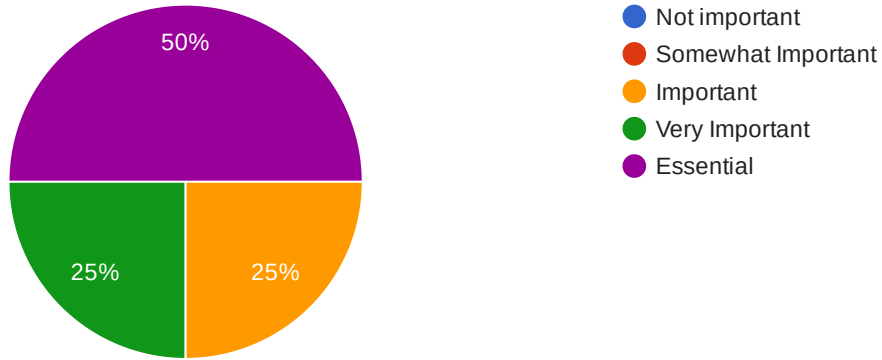

The board regularly solicits input from the community when establishing the future vision of the district.



4 responses

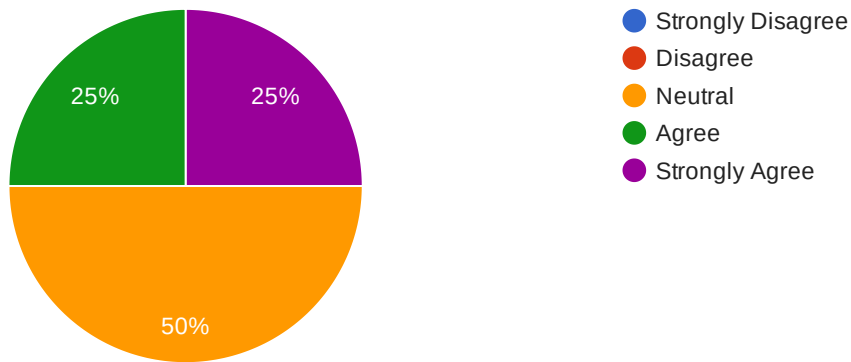

How important is this to me: "The board regularly solicits input from the community when establishing the future vision of the district."?



4 responses

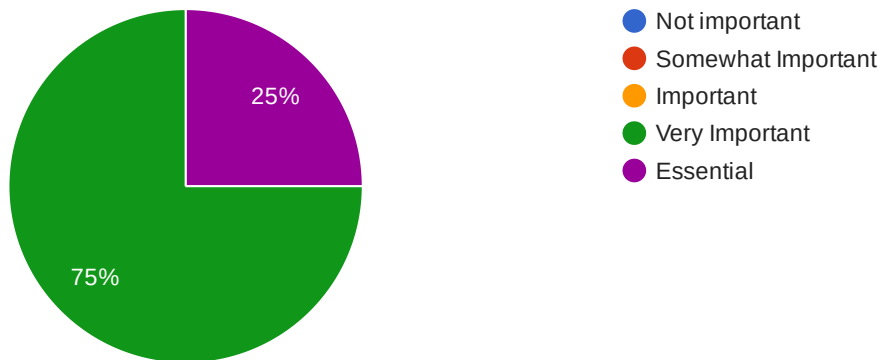

Our board sets policies needed for the operation of the school district.



4 responses

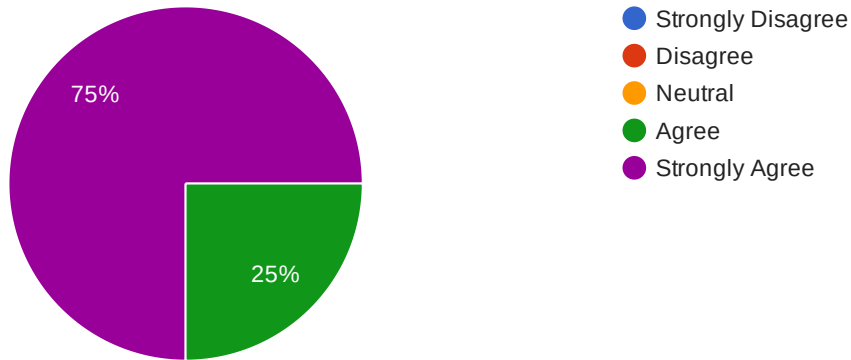

How important is this to me: "Our board sets policies needed for the operation of the school district."?



4 responses

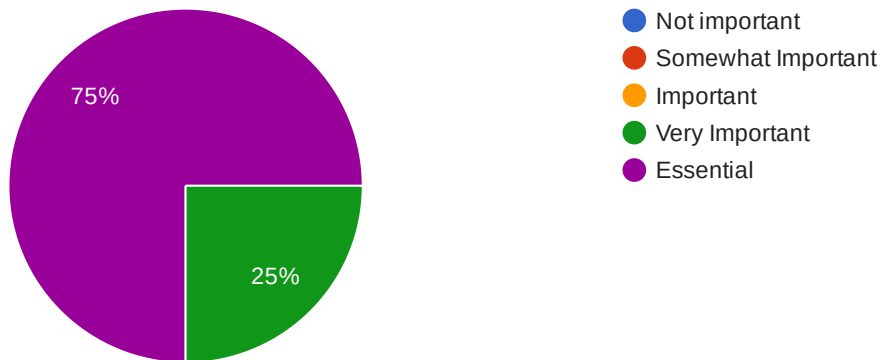

Before adopting a policy which affects them, our board actively seeks the input of employees, students and community members.



4 responses

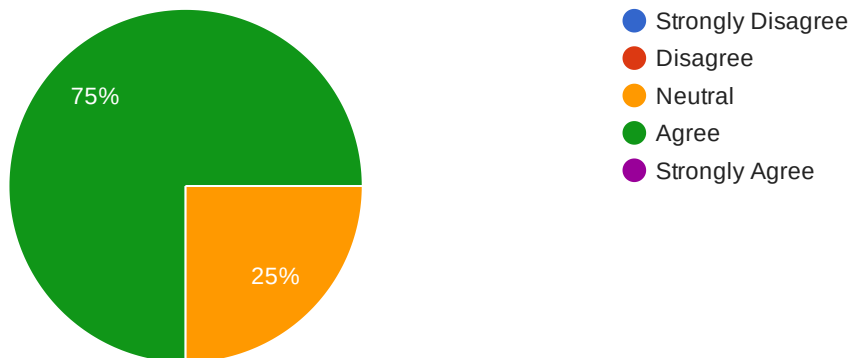

How important is this to me: "Before adopting a policy which affects them, our board actively seeks the input of employees, students and community members."?



4 responses

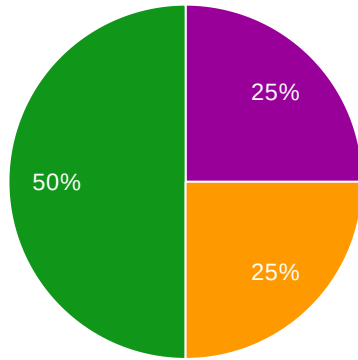

- Not important
- Somewhat Important
- Important
- Very Important
- Essential

Board policies are administered consistent with the intent of the policy.



4 responses

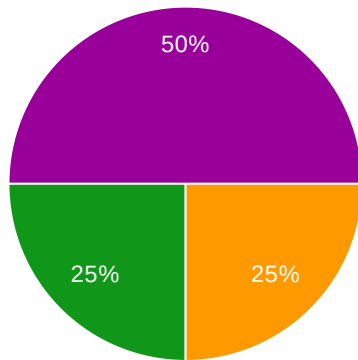

- Strongly Disagree
- Disagree
- Neutral
- Agree
- Strongly Agree

How important is this to me: "Board policies are administered consistent with the intent of the policy."?



4 responses

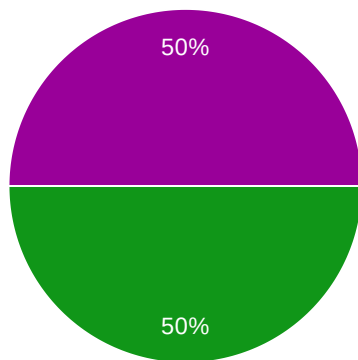

- Not important
- Somewhat Important
- Important
- Very Important
- Essential

The board has developed an ongoing system to review and update all policies annually.



4 responses

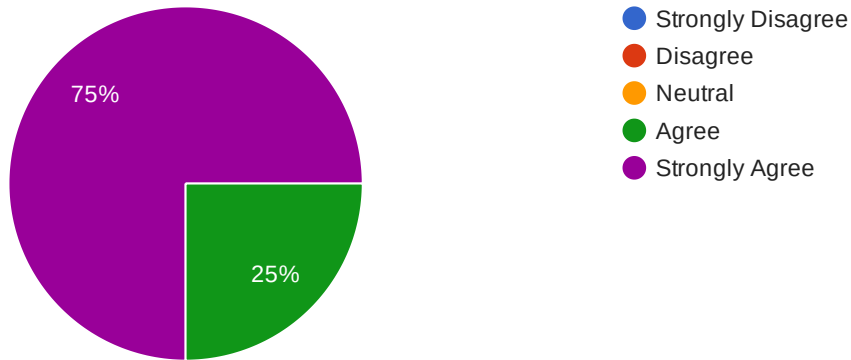

How important is this to me: "The board has developed an ongoing system to review and update all policies annually."?



4 responses

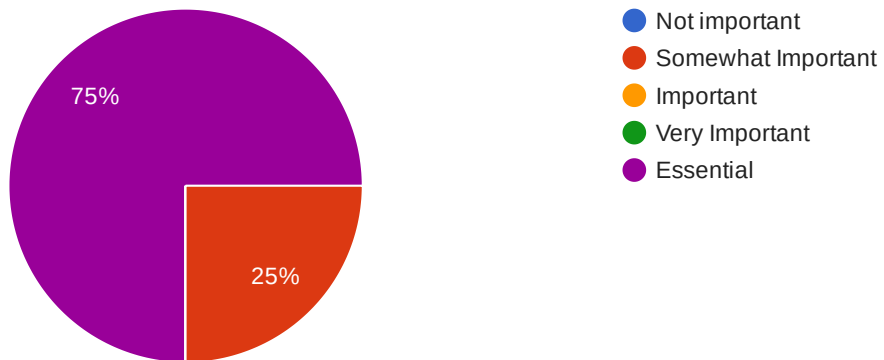

Student Achievement -- The board holds itself ultimately responsible for high achievement by all students.



4 responses

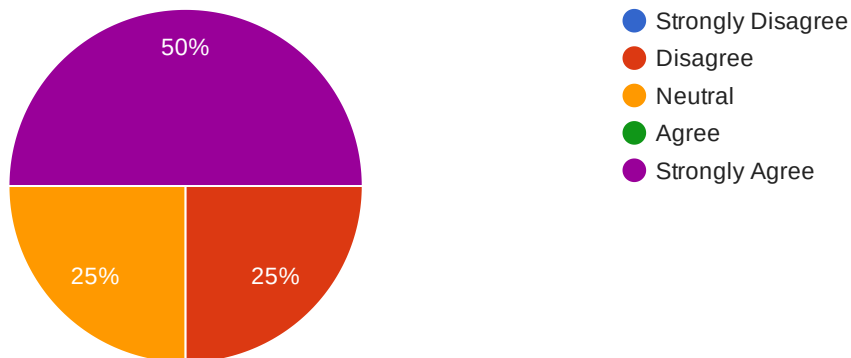

How important is this to me: "The board holds itself ultimately responsible for high achievement by all students."?



4 responses

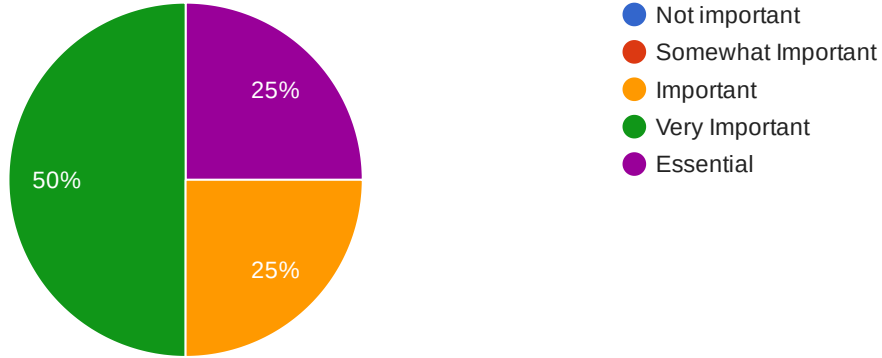

The board regularly examines data to determine where achievement gaps exist and how much progress is being made to reduce those gaps.



4 responses

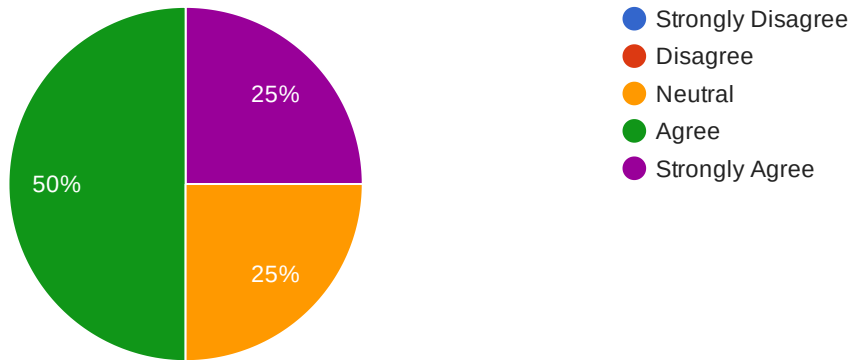

How important is this to me: "The board regularly examines data to determine where achievement gaps exist and how much progress is being made to reduce those gaps."?



4 responses

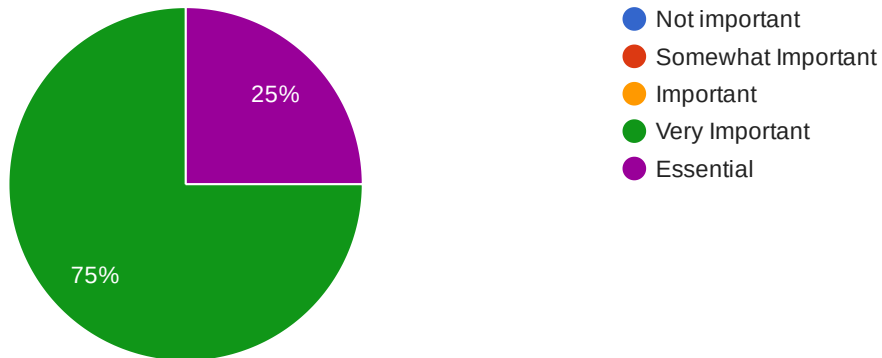

The board provides a quality educational program imposing high individual academic standards for each student.



3 responses

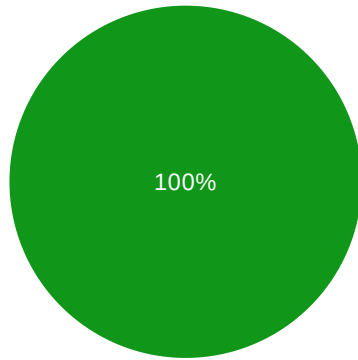

- Strongly Disagree
- Disagree
- Neutral
- Agree
- Strongly Agree

How important is this to me: "The board provides a quality educational program imposing high individual academic standards for each student."?



4 responses

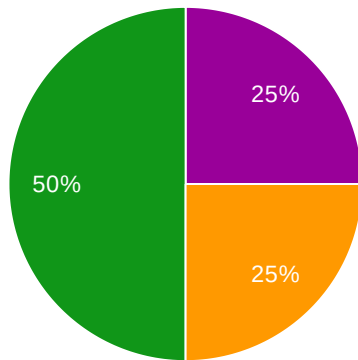

- Not important
- Somewhat Important
- Important
- Very Important
- Essential

Student academic performance is regularly presented to the board.



4 responses

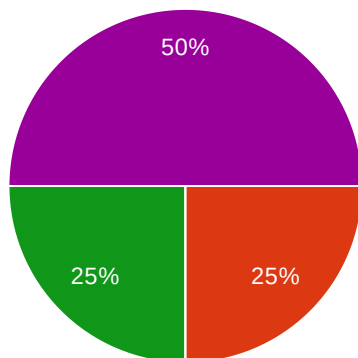

- Strongly Disagree
- Disagree
- Neutral
- Agree
- Strongly Agree

How important is this to me: "Student academic performance is regularly presented to the board."?



4 responses

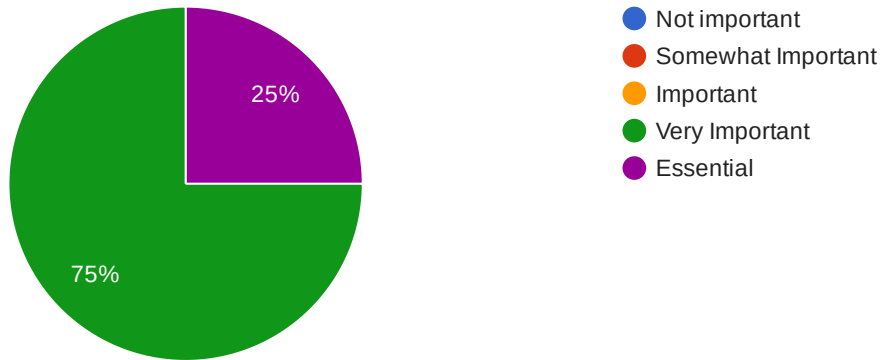

The board regularly recognizes student accomplishments at board meetings.



4 responses

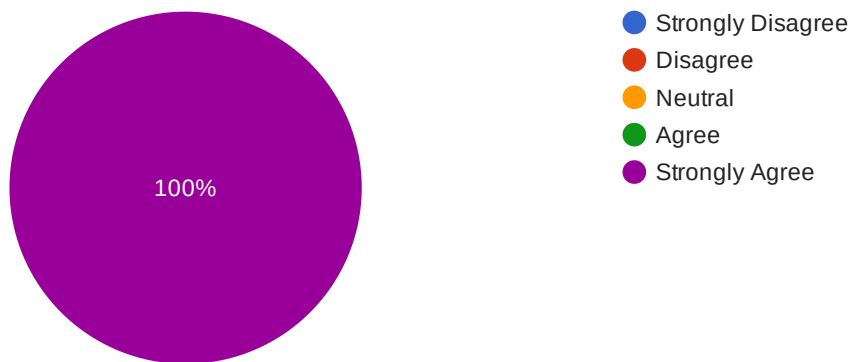

How important is this to me: "The board regularly recognizes student accomplishments at board meetings."?



4 responses

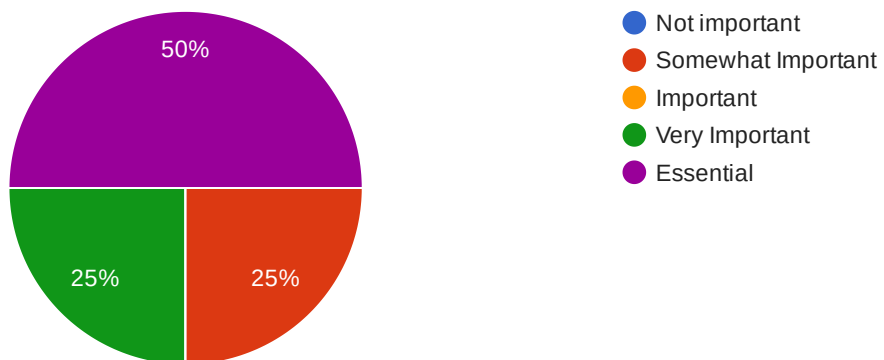

Community Relations -- The board provides for involvement of the public in the operating of our schools.



4 responses

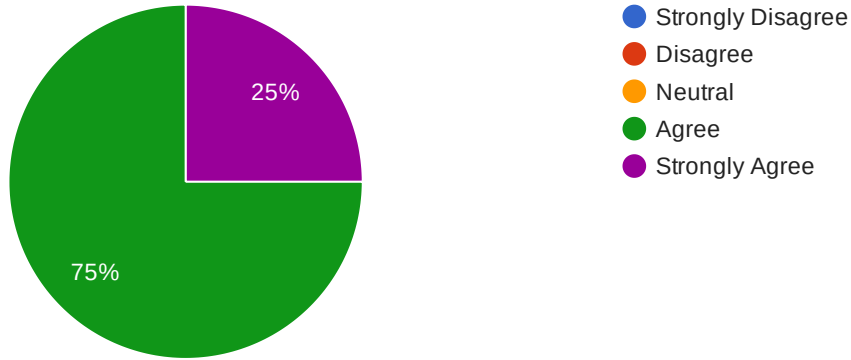

How important is this to me: "The board provides for involvement of the public in the operating of our schools."?



4 responses

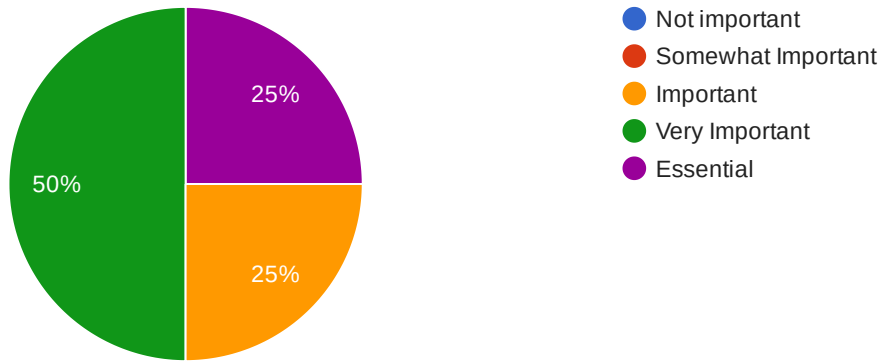

Our board actively promotes the school district to the public.



4 responses

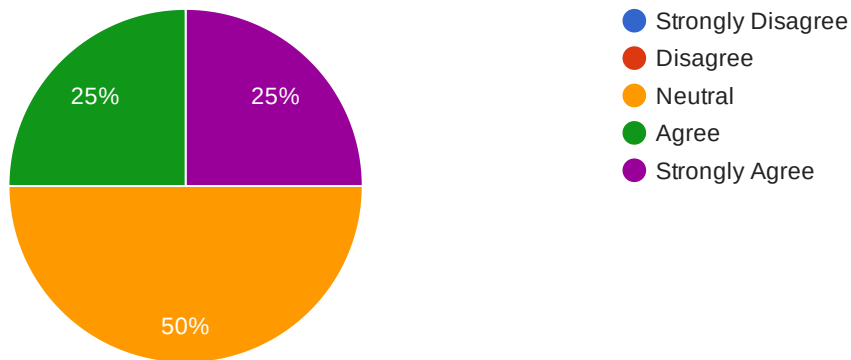

How important is this to me: "Our board actively promotes the school district to the public."?



4 responses

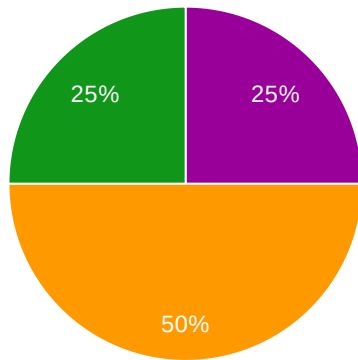

- Not important
- Somewhat Important
- Important
- Very Important
- Essential

Our board is accountable to the community.



4 responses

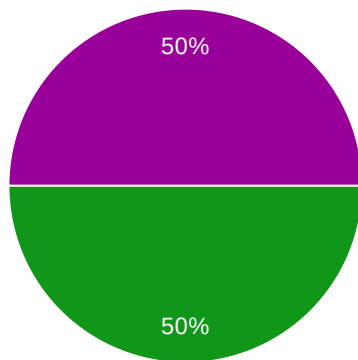

- Strongly Disagree
- Disagree
- Neutral
- Agree
- Strongly Agree

How important is this to me: "Our board is accountable to the community."?



4 responses

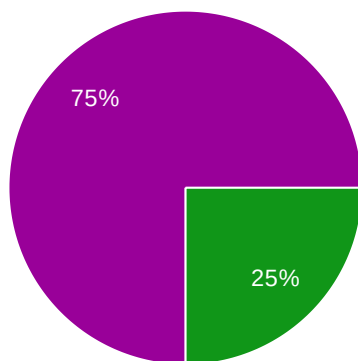

- Not important
- Somewhat Important
- Important
- Very Important
- Essential

Our school board is respected by the community.



4 responses

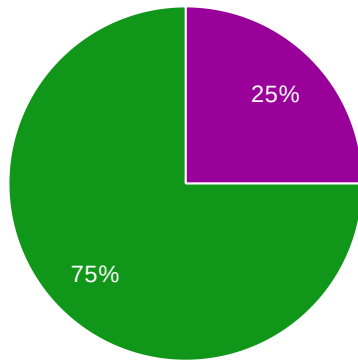

- Strongly Disagree
- Disagree
- Neutral
- Agree
- Strongly Agree

How important is this to me: "Our school board is respected by the community."?



4 responses

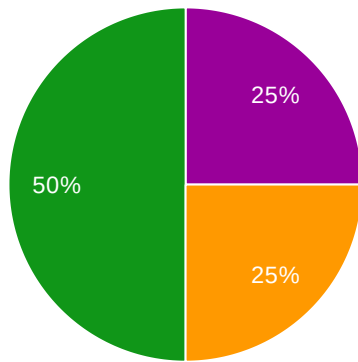

- Not important
- Somewhat Important
- Important
- Very Important
- Essential

The board refrains from committing to a position on an issue before all relevant facts are present.



4 responses

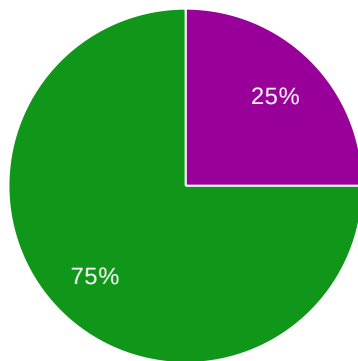

- Strongly Disagree
- Disagree
- Neutral
- Agree
- Strongly Agree

How important is this to me: "The board refrains from committing to a position on an issue before all relevant facts are present."?



4 responses

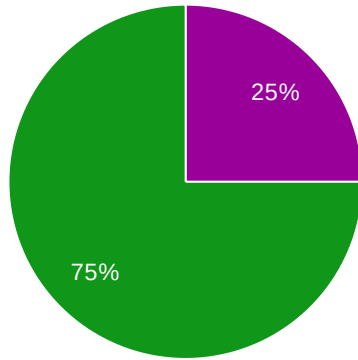

- Not important
- Somewhat Important
- Important
- Very Important
- Essential

Members of the board refrain from speaking for the board on issues on which the board has no official position.



4 responses

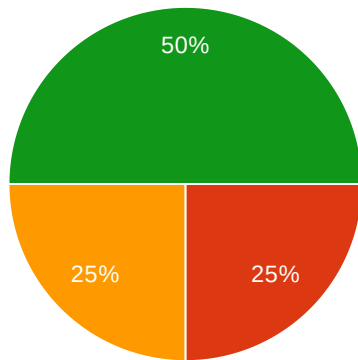

- Strongly Disagree
- Disagree
- Neutral
- Agree
- Strongly Agree

How important is this to me: "Members of the board refrain from speaking for the board on issues on which the board has no official position."?



4 responses

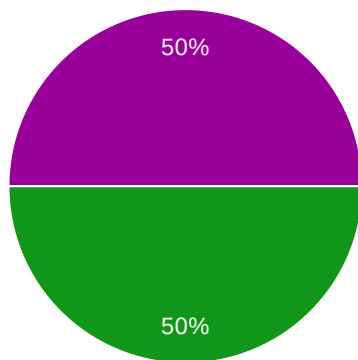

- Not important
- Somewhat Important
- Important
- Very Important
- Essential

Advocacy - Our board takes the initiative to establish and maintain positive personal relationships with other locally-elected officials/funding body.



4 responses

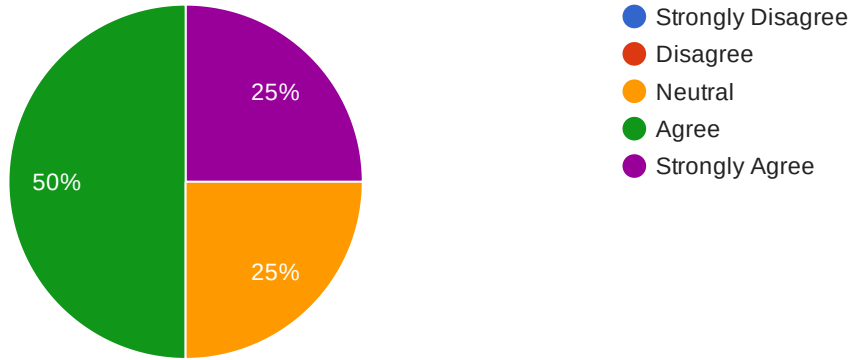

How important is this to me: "Our board takes the initiative to establish and maintain positive personal relationships with other locally-elected officials/funding body.?"



4 responses

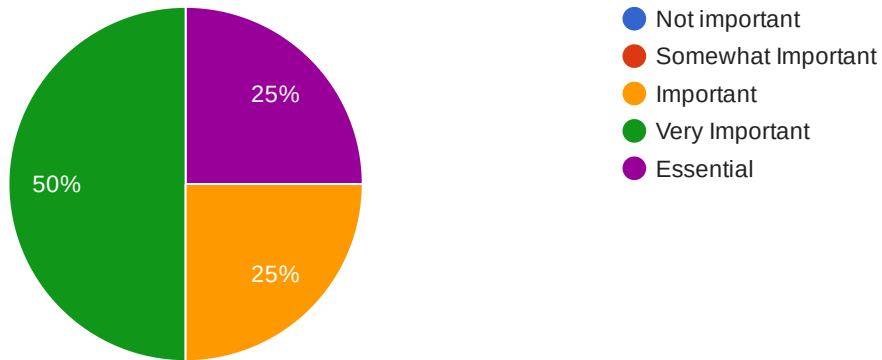

Our board strives to keep local officials up-to-date on board activities and school district needs.



4 responses

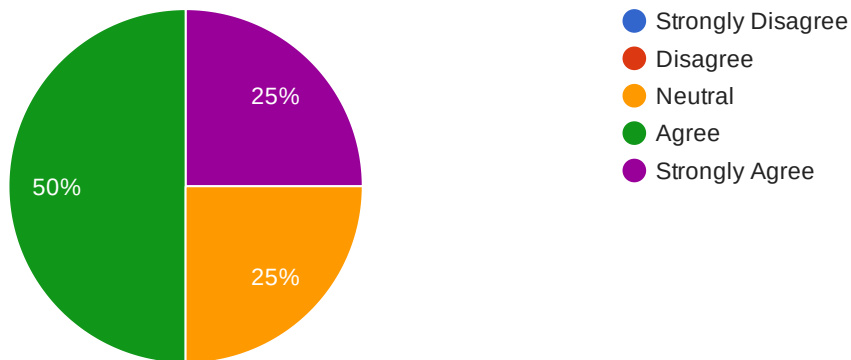

How important is this to me: "Our board strives to keep local officials up-to-date on board activities and school district needs."?



4 responses

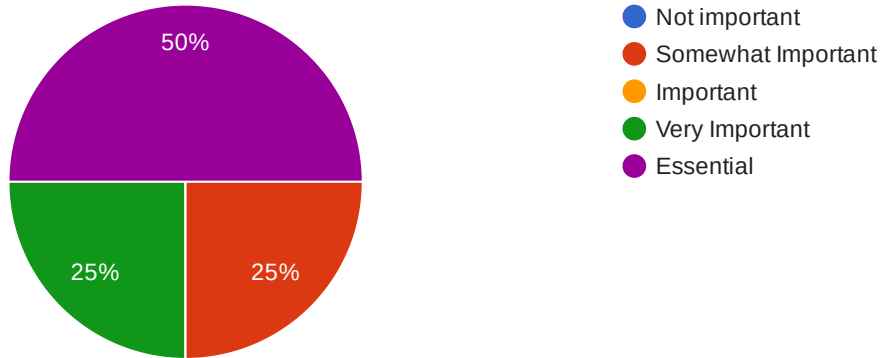

Our board understands the need to influence statewide legislation and works diligently to develop a positive relationship with local members of the General Assembly.



4 responses

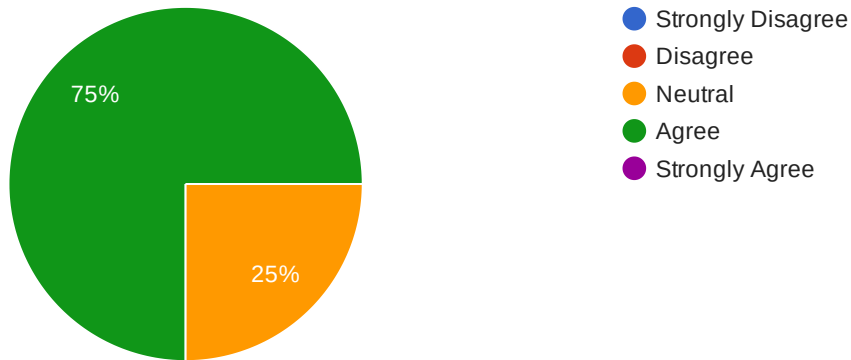

How important is this to me: "Our board understands the need to influence statewide legislation and works diligently to develop a positive relationship with local members of the General Assembly."?



4 responses

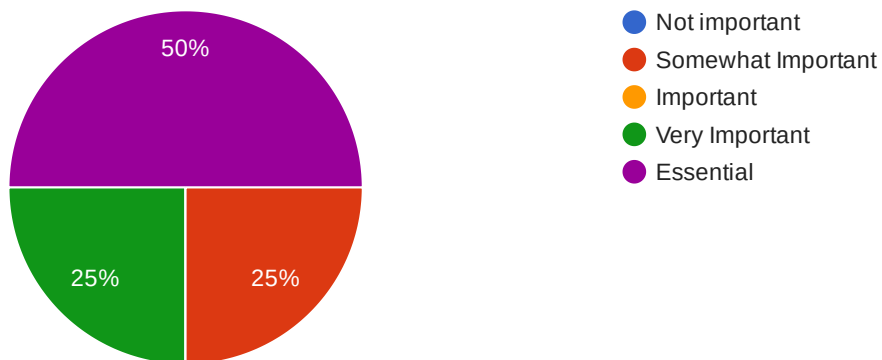

Our board, collectively and individually, regularly contacts legislators regarding their position on important legislation.



4 responses

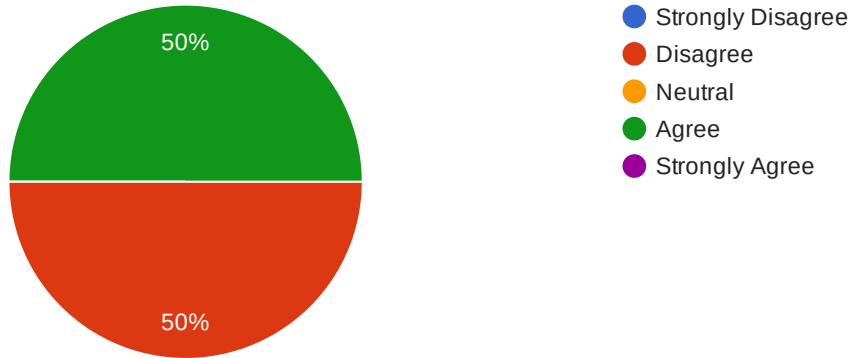

How important is this to me: "Our board, collectively and individually, regularly contacts legislators regarding their position on important legislation."?



4 responses

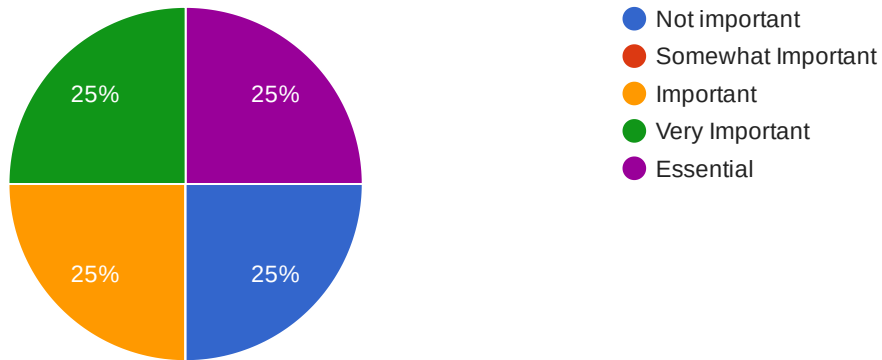

Our board is represented at TSBA's Day on the Hill meeting.



4 responses

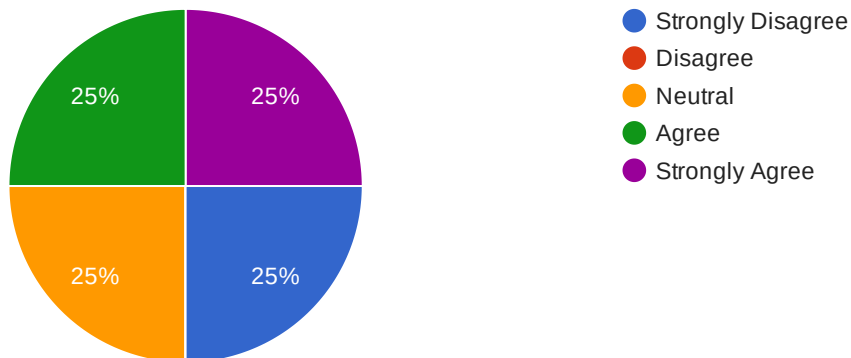

How important is this to me: "Our board is represented at TSBA's Day on the Hill meeting."?



4 responses

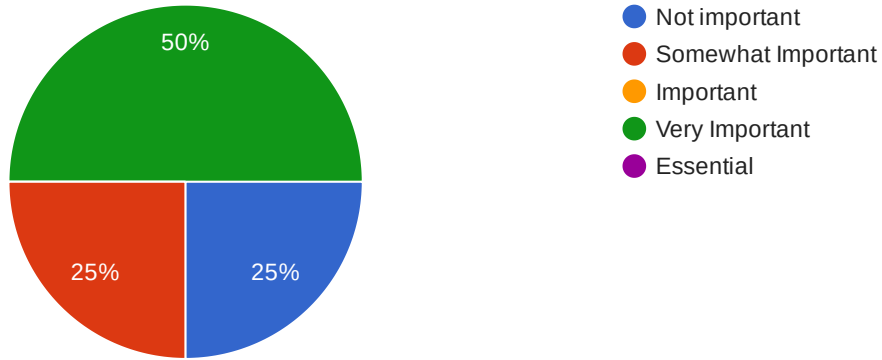

Budget/Finance -- The board understands the basic principles of school finance, including state, federal and local sources of revenue.



4 responses

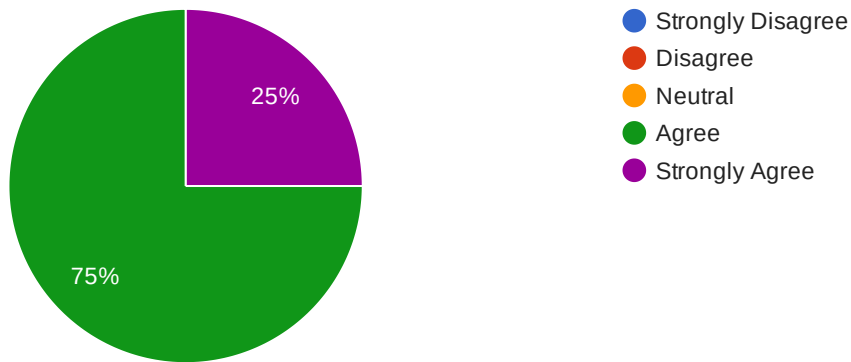

How important is this to me: "The board understands the basic principles of school finance, including state, federal and local sources of revenue."?



4 responses

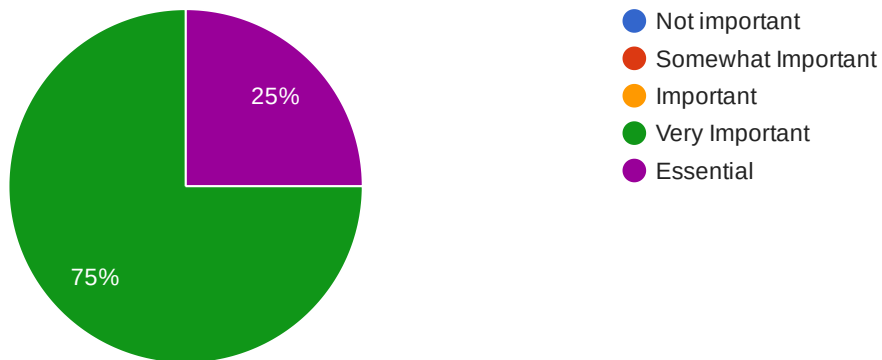

The budget reflects the strategic plan and supports the district's goals and objectives for student achievement and citizenship.



4 responses

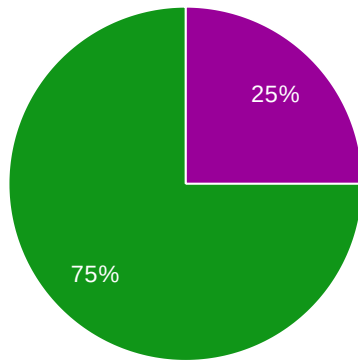

- Strongly Disagree
- Disagree
- Neutral
- Agree
- Strongly Agree

How important is this to me: "The budget reflects the strategic plan and supports the district's goals and objectives for student achievement and citizenship."?



4 responses

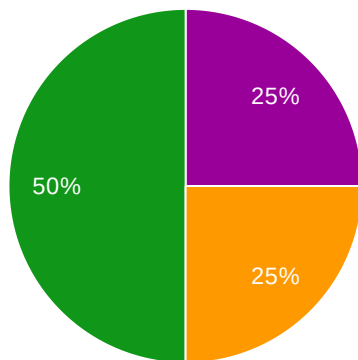

- Not important
- Somewhat Important
- Important
- Very Important
- Essential

The budget reflects the district's vision and mission.



4 responses

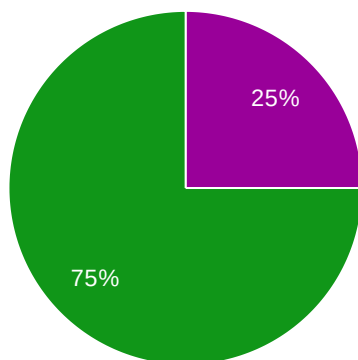

- Strongly Disagree
- Disagree
- Neutral
- Agree
- Strongly Agree

How important is this to me: "The budget reflects the district's vision and mission."?



4 responses

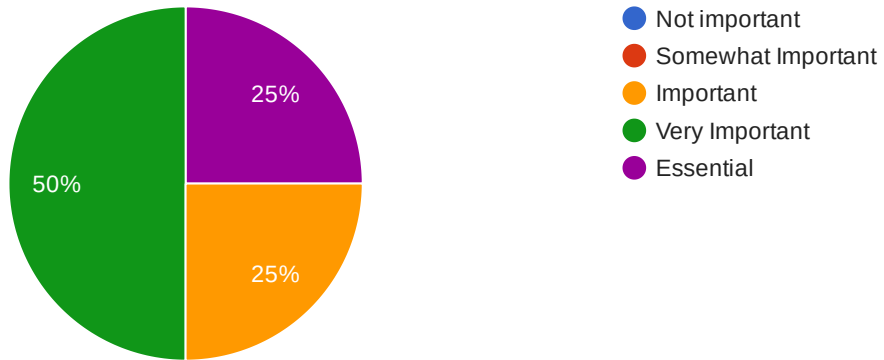

The board requires proper accountability for the expenditure of school district funds.



4 responses

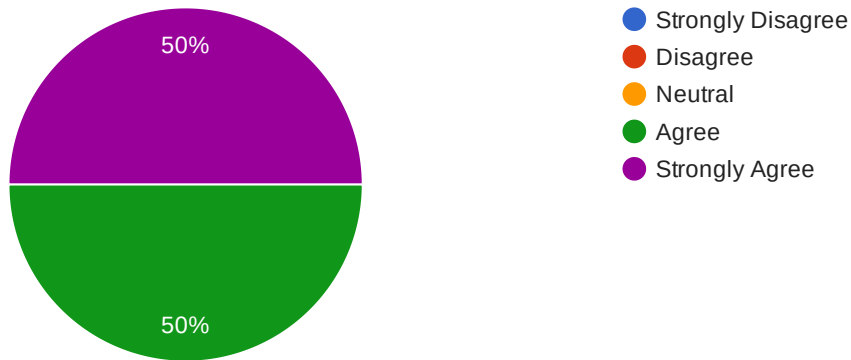

How important is this to me: "The board requires proper accountability for the expenditure of school district funds."?



4 responses

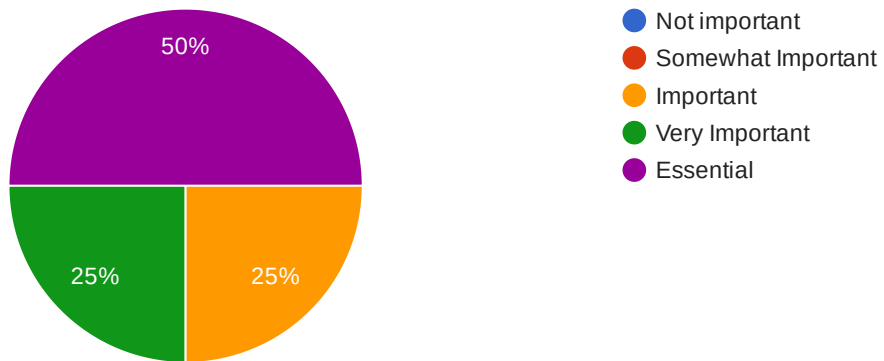

Please enter your name below.

4 responses

Vance Willis

Jane Herron

Amy Bryant

Steve Gianakos



Hickman County Schools Board Agenda Item Request

Date:

4/6/22

Name of School:

Hickman County High School

Item Request:

Bethel Team Camp (Basketball)

Explanation:

- Requesting permission to travel and stay overnight at Bethel for our basketball team camp.

- June 13, 14, 15

Attachments (if necessary and appropriate):

Signature of Person requesting to be placed on the agenda:

Thomas W. Stanley

Signature of Building Principal:

Jill Rice



Hickman County Schools Trip Request

Name of School: East Hickman High School

Name of Club/Group: CRAVE

Trip Requested: May 6-9 International Bridge Building Competition

Purpose: International Bridge Building Contest
Stem-Physics

Date and Time frame: May 6-9

Number of Students: 1

Number of Chaperones: Male Female 1

Costs associated: hotel, airfare, transportation

Attachments (any information or permission slips that are sent home with students)

Has the cafeteria been notified? N/A Number of Lunches needed? N/A

How will students travel? air travel

Is a transportation request attached if system transportation is needed? N/A

Signature of person requesting the trip Kathy Dick

Signature of Principal Amberley Williams

Signature of Instructional Supervisor Kathy Dick

*Per Hickman County Board of Education policy 4.302, any requested trip that has an out-of-state destination and/or is planned for overnight must have prior approval by the Board of Education.

04/15/2016 11:34 FAX



Hickman County Schools Board Agenda Item Request

Date: April 12, 2022

Name of School: EHHS

Item Request: Request to travel to Chicago

Explanation: for the FBLA National Conference

See attached

Attachments (if necessary and appropriate):

See attached

Signature of Person requesting to be placed on the agenda:

Cindi Morgan

Signature of Building Principal:

Kimberly Williams

To: Michelle Gilbert and School Board

From: Cindi Morgan, EHHS FBLA Advisor

Date: April 12, 2022

RE: FBLA National Conference

I am requesting to be put on the May School Board Agenda in order to be granted permission for
qualifying students to attend the FBLA National Conference. This is an overnight trip to
Chicago, IL on June 28-July 2. Two teams of students, 4 in total, have qualified for and will
attending the conference and will be accompanied by myself, my husband and some parents.
I will drive a school van as transportation for the students.

Details are as follows:

- Advisor: Cindi Morgan
- Dates: June 28 - July 2
- Cost:

- Hotel Rooms 3 rooms x 4 nights @ \$309/night
- Conference Registration 12 x \$93
- **Total**

\$3,708.00
 \$980.00
\$4,688.00

- Funding will be provided by the EHHS FBLA account and CTE account (Don Qualley).
 Students will be responsible for paying for their food.



Hickman County Schools Board Agenda Item Request

Date: 4/14/22
Name of School: East Hickman High School
Item Request: EHHS Football Camp

Explanation:

We are requesting to have our football
camp (overnight) at the high school. The
dates are from July 17th - July 21st.
We will need the use of the Social Studies/English
hallway for rooms to sleep in. We will use 4 separate
lockers for showers. We will need the cafeteria
for breakfast, lunch, & dinner.

Attachments (if necessary and appropriate):

Signature of Person requesting to be placed on the agenda:

Chris [Signature]

Signature of Building Principal:

Kimberly Williams



Hickman County Schools Board Agenda Item Request

Date: 26 April 2022

Name of School: East Hickman Middle School

Item Request: Overnight Basketball Camp

Explanation: Seeking approval for Boys Varsity Basketball team to attend an overnight camp at Freed-Hardeman.

Camp dates 01 June 2022 - 02 June 2022

Attachments (if necessary and appropriate):

Signature of Person requesting to be placed on the agenda:

[Signature]

Signature of Building Principal or Director of Schools:

[Signature]



ESSER Revisions
May 2022

Activity	Cost	Recurring?
2 Nurses for summer camp	\$11,000.00	no
Instructional Supplies for summer camp grades 6-8	\$5,200.00	no
1 Teacher for summer camp grades 6-8	\$5,500.00	no
1 Educational Assistant for summer camp grades 6-8	\$2,750.00	no
2 books/student for summer camp grades 6-8	\$4,300.00	no



Steven George
Director of Transportation
115 Murphree Avenue
Centerville, Tn 37033

I am requesting to purchase the Hunter HDE 32 Heavy Duty Wheel Balancer from the 450 Tire and Tubes line item currently standing at \$22,289.91 unencumbered balance. This unit is sold and serviced by the same company we have bought a tire changer from and have received great service. The HDE 32 wheel balancer has two unique features that will increase life and wear of the tire. Firstly, the TDC Laser System shows exactly the placement of the wheel weight. Secondly, the load bar which will measure the runout and Match-mounting the high spot on a tire to the low spot on a rim makes the assembly roll as smoothly as possible. Runout-related vibration is minimized, ensuring a smoother ride and longer tire life.

Neither of the other units quoted have the load bar feature or the capability to track performances as the HDE 32 unit. Neither of the other units have the support system as the HDE 32. We realize there are lower quotes but none offer the quality, durability or features as the Hunter HDE 32 Wheel Balancer.



EQUIPMENT PROPOSAL / SALES AGREEMENT

Prepared on 4/12/2022 by Dustin Thomas

Submitted to:

Hickman County Bus Garage
115 Murphree Ave
Centerville, Tn 37033

Quoted through:

CENTRAL TENNESSEE LIFT &
EQUIP
1203 GREENSWARD AVENUE
LEBANON, TN 37087



HDE32

19,393.82

Heavy Duty Elite Balancer with No touch Laser System and TDC Laser

Learn more and see it in action!

<https://www.hunter.com/wheel-balancers/hd-elite/>

HD Elite Balancer

- For Heavy Duty applications up to 500lbs and 52" diameter
- Fits passenger car and light truck applications
- No-touch laser vision cameras systems
- Diagnostic load roller allows ForceMatching to optimize runout and match dual assemblies
- SmartWeight(R) Better Balance & Saves Excess Weight
- Integrated Power Wheel Lift – 500lb capacity
- Automatic Wheel Runout Measurement
- Automatic Centering Check ensures wheels are properly centered
- TDC Laser System,
- Factory Installation and Training
- Made in USA



Prices subject to change without notice.	Subtotal	\$19,393.82
--	----------	-------------

This proposal is good through 05/12/2022

Total investment	\$19,393.82
------------------	-------------

Proposal includes installation and on-site training by a Hunter Technical Representative.

Electrical and compressed air connections to equipment are not included on this quotation.

Estimated delivery:

This Proposal was Prepared for

Legal Name of Business

Hickman County Bus Garage

Billing Address

115 Murphree Ave

City, State Zip

Centerville, Tn 37033

Main Contact

Main Phone Number

X

Approval

Items on this Proposal

1 HDE32

Your Local Hunter Team



James Alcorn II
Business Consultant
Columbia, TN 38401-7539
(615) 691-0005
j.a.alcorn2@gmail.com



Wade, Ryan
Technical & Training Representative
Hohenwald, TN
(931) 306-7149
thehuntermedic@gmail.com



Funk, Eric
Regional Manager
(615) 829-2094
efunk@hunter.com



Dustin Thomas
CENTRAL TENNESSEE LIFT &
EQUIP
615-504-8639
Dustin1204@gmail.com

Total investment (Cash / Check)

\$19,393.82

All software pre-installed on, or subsequently released by Hunter for, Hunter equipment is licensed pursuant to the Hunter Engineering Company End User License Agreement(EULA) accompanying such software. A copy of the EULA is available upon request. By placing an order for, purchasing, or using Hunter equipment, you acknowledge and agree to be legally bound by the EULA, which is hereby incorporated by reference.

HD Elite Balancer

The world's #1 heavy-duty diagnostic balancer

**AUTOMATIC WHEEL
MEASUREMENTS!**

**MADE
IN USA**
HUNTER ENGINEERING COMPANY ST. LOUIS, MO



HD Elite Balancer quickly measures runout with every balance

EXCLUSIVE

Unmatched Speed!



- ✓ Measure runout and balance faster than any traditional balancer!

PATENTED

Laser Vision System



- ✓ Eliminate error opportunities
- ✓ More information in less time



OPTIONAL | PATENTED

Diagnostic Load Roller



- ✓ Roller detects high spot of tire and allows matching
- ✓ Measures entire contact patch for accurate results



 Designates features requiring diagnostic load roller.

EXCLUSIVE

Most durable shaft in the industry



MADE IN USA
 HUNTER ENGINEERING COMPANY ST. LOUIS, MO

PATENTED

Automatic CenteringCheck®



- ✓ Ensures proper centering
- ✓ Eliminates setup errors

PATENTED

eCal Auto-Calibration

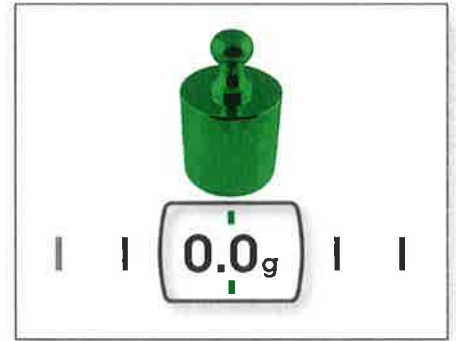

- ✓ True "self-calibration"
- ✓ No operator input required

PATENTED

Enhanced SmartWeight®



- ✓ Even better balance
- ✓ Maximum efficiency
- ✓ More single weight solutions

STANDARD

Touchscreen Interface



- ✓ Intuitive interface
- ✓ Quickly train new technicians



STANDARD

Wheel Lift



- ✓ Easily lifts wheel assemblies up to 500 lbs
- ✓ Aids proper mounting

Balance Any Size Wheel



- ✓ Services cars and light trucks
- ✓ Uses standard adaptors



HD Elite Balancers help eliminate wheel-related vibration and increase tire life



1 An Unknown Force Vibrates the Spindle



Customer complains about strong vehicle vibrations.

Vibration is transferred from the wheel, through the steering column to the customer.

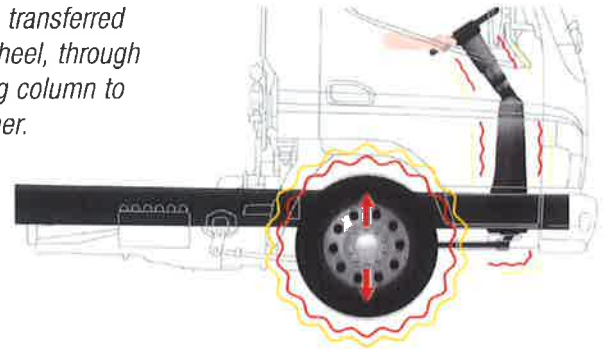

2 Specialized Sensors Measure the Assembly



Roller contacts wheel surface

The HD Elite balancer automatically measures runout (eccentricity) of a tire and wheel assembly.

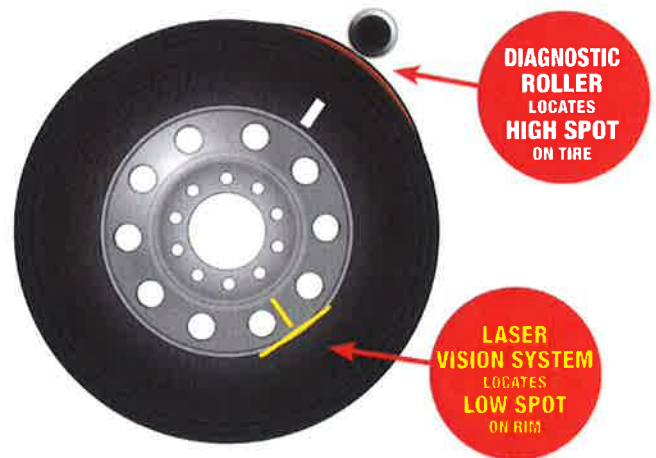

DIAGNOSTIC ROLLER LOCATES HIGH SPOT ON TIRE

LASER VISION SYSTEM LOCATES LOW SPOT ON RIM

The roller measures the entire contact patch of the tire, detecting if the assembly is out of round.

3 Match-Mounting Cancels the Vibration



Match-mounting the high spot on a tire to the low spot on a rim makes the assembly roll as smoothly as possible.



RUNOUT MINIMIZED

Runout-related vibration is minimized, ensuring your customer a smoother ride and longer tire life.

Matching dual assemblies to maximize tire life

Opposing High Spots

Dual tire assemblies with aligned high spots behave like single assemblies with runout. Marking and installing wheels with high spots 180 degrees opposed makes the dual assembly more round than the two assemblies alone.

- ✓ Reduces Vibration
- ✓ Increases Tire Life

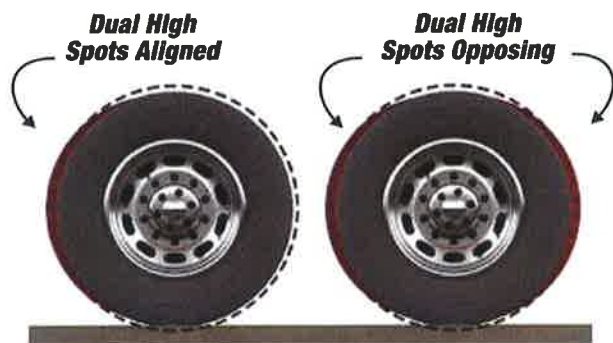

Unequal Load on Duals

Mismatched diameters on dual tires causes the larger tire to carry more load, thus generating more heat and reducing tire life. The lesser diameter tire may develop premature tire wear due to slippage relative to the road surface.

- ✓ Increases Tire Life

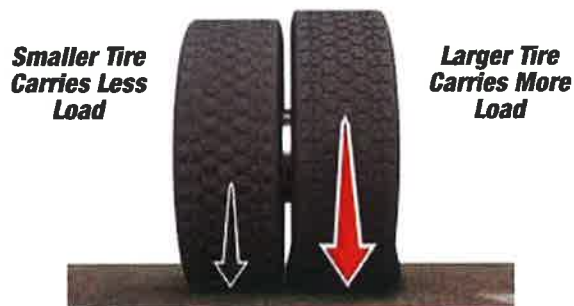

SmartWeight® reduces labor costs and service time

- ✓ Provides better balance
- ✓ Maximizes productivity
- ✓ Minimizes weight usage
- ✓ Reduces labor costs

Saves Labor Time

SmartWeight® reduces “floor-to-floor” cycle time on more than 30% of wheels balanced by optimized use of a single weight to achieve the best possible balance.

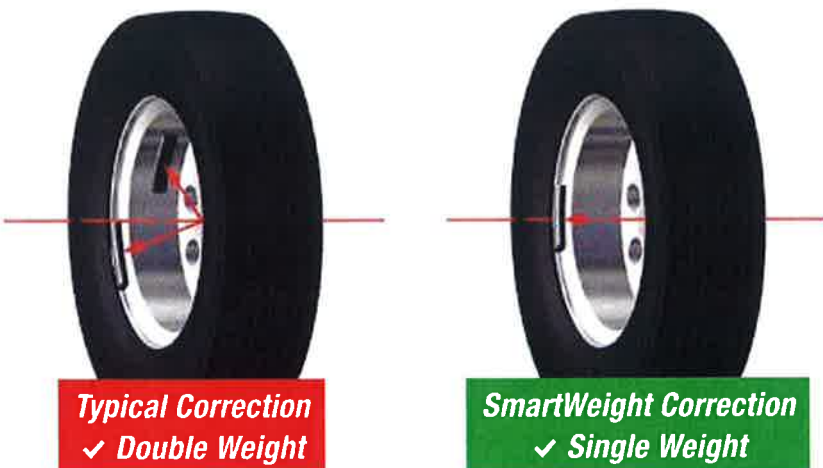

View your savings LIVE!

- ✓ Track your weight savings

Watch your investment grow

Investment Return	
ForceMatch and SmartWeight Savings	
Best Remaining Full Concrete Payback (est.)	0.0
ForceMatch and SmartWeight Savings Payback To Date (%)	112.89%

- ✓ See weight and labor savings based on **your** shop's numbers

HD Elite vision technology unlocks more benefits in less time!

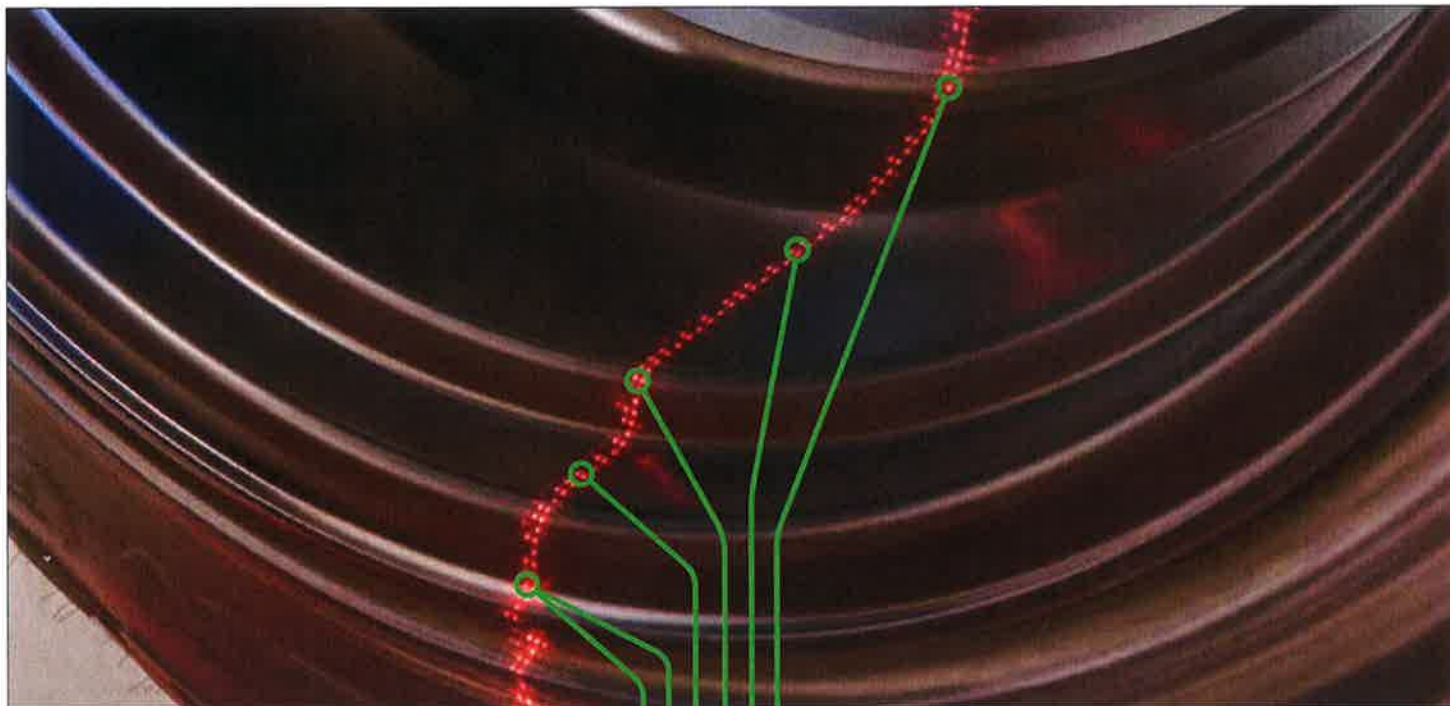

Wheel dimensions

AUTOMATIC



Automatically determines weight plane locations

Weight mode

AUTOMATIC



Selects clip or tape weight usage, if desired

Rim runout

AUTOMATIC



Calculates force-match solution

Spoke location

AUTOMATIC



Automatically hides tape weights behind spokes

SmartWeight® optimized

AUTOMATIC



Allows more single weight solutions

Rim profiled

AUTOMATIC



Creates three-dimensional model of the rim



Reduce operator error

- ✓ Automatically measures wheel dimensions
- ✓ Automatically selects weight mode
- ✓ Automatically measures rim runout

Optional Equipment

Configurations Without Diagnostic Load Roller

- ✓ Maintains all superior balancing features
- ✓ Eliminates diagnostic roller benefits
- ✓ Reduces overall package price



HDE11 shown

Popular Equipment Accessories



PATENTED

HammerHead® Top-Dead-Center Laser

- ✓ Greater weight placement accuracy to avoid mistakes
- ✓ More single-spin balances improve productivity and shop profitability
- ✓ Overhead LED light illuminates work area



Color Printer*

- ✓ Help sell premium service
- ✓ Explain results to customer



* Printer model may vary from pictured

 Available as a field-installed option.

STANDARD

Convenient Storage Options

Adaptor tree conveniently stores oversized balancer accessories.



Specifications*



HDE33 shown

Power requirements	196-253V, 10 amp, 50/60 Hz, 1 ph NEMA L6-20P plug included
Air supply requirements	100-175 psi (7-12 bar)
Capacity	
Rim width	1.5 in to 19.5 in (38 mm to 495 mm)
Rim diameter	10 in to 30 in (254 mm to 762 mm)*
ALU	7.5 in to 38 in (191 mm to 965 mm)*
Max. tire diameter	52 in (1321 mm)
Max. tire width	19.5 in (495 mm)
Max. tire weight	500 lbs (227 kg)
Min. tire diameter for roller application	26 in (660 mm)
Imbalance resolution	± 0.05 oz (1.0 g)
Placement accuracy	512 positions, ± 0.35°
Balancing speed	100 rpm
Motor	Programmable drive system and DC motor

* Extreme wheel sizes may require manual data entry.

Model Overview



	HDE33	HDE32	HDE11	HDE10
Diagnostic Load Roller	✓	✓		
TDC Laser System	✓	✓		
Ink Jet Print w/Storage	✓		✓	
Width (W)	75.75 in 1924 mm	71 in 1803 mm	75.75 in 1924 mm	71 in 1803 mm
Height (H)	88 in 2223 mm	88 in 2223 mm	80.5 in 2045 mm	80.5 in 2045 mm
Depth (D)	73.5 in 1867 mm	73.5 in 1867 mm	73.5 in 1867 mm	73.5 in 1867 mm
Weight	824 lb 374 kg	804 lb 365 kg	762 lb 346 kg	742 lb 337 kg

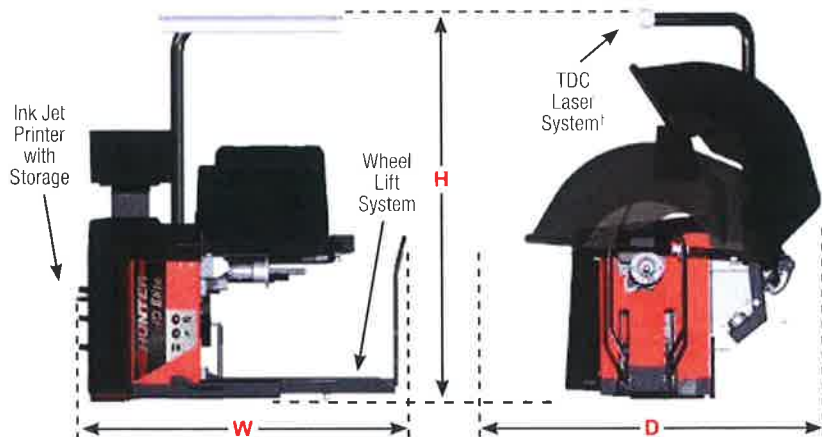

Because of continuing technological advancements, specifications, models and options are subject to change without notice. Printer may differ from versions shown throughout brochure images.

The HD Elite Wheel Balancer is a Class 1 laser product.

CLASS 1 LASER PRODUCT
IEC 60825-1 ed. 2 2007 USA
EN/IEC 60825-1 ed. 3 2014 non-USA



Be sure to check out other Hunter literature for more quality products from Hunter Engineering.

† When equipped with the TDC system, the balancer is a Class 2M laser product.

LASER RADIATION - DO NOT STARE INTO THE BEAM OR VIEW DIRECTLY WITH OPTICAL INSTRUMENTS. Viewing the laser output with magnifiers or related optical instruments within a distance of 100 mm from the laser aperture may pose an eye hazard



LASER LIGHT
DO NOT VIEW DIRECTLY WITH OPTICAL INSTRUMENTS (MAGNIFIERS)
CLASS 1M LASER PRODUCT
635-670nm (39mW CW)
CLASSIFIED PER IEC 60825-1, ED. 1.2, 2011-01

HUNTER Engineering Company

www.hunter.com



[Home](#) > [Tire Changers & Wheel Balancers](#) > [Wheel Balancers](#) > [Corghi EyeLight Plus Automatic Diagnostic Wheel Balancer](#)

Corghi EyeLight Plus Automatic Diagnostic Wheel Balancer

IN STOCK SKU EYELIGHT

GUARANTEED LOWEST PRICE: \$19,345.00

Regular Price: ~~\$20,760.00~~

\$534 / mo

INCLUDES FREE SHIPPING*

Qty

[Add to Cart](#)

- OR -

Check out with **PayPal**

Corghi Eyclight Plus Automatic Diagnostic Wheel Balancer | Touchless | Diagnostic Performance Series

The Corghi Eyclight Plus guarantees high productivity and high profitability. Launch and diagnosis times have improved by 40% compared to the previous version. Touchscreen & Contactless, automatic, quick and works without touching the wheel. Touchscreen monitor diagnostic wheel balancer with contactless size detection, automatic wheel clamping system, automatic guard opening, complete wheel diagnosis and drift problem solution. Fast, accurate, reliable and easy-to-use.



[Description](#)

[Features and Specs](#)

[Accessories/Options](#)

[More Information](#)

[Reviews](#)

Description



Corghi Eyclight Plus Automatic Diagnostic Wheel Balancer | Touchless | Diagnostic Performance Series

The Corghi Eyclight Plus guarantees high productivity and high profitability. Launch and diagnosis times have improved by 40% compared to the previous version. Touchscreen & Contactless, automatic, quick and works without touching the wheel. Touchscreen monitor diagnostic wheel balancer with contactless size detection, automatic wheel clamping system, automatic guard opening, complete wheel diagnosis and drift problem solution. Fast, accurate, reliable and easy-to-use.

Fully Automatic

No manual operation is required from the operator. Launch and diagnosis times were reduced by 40% compared to the previous version. Eyclight Plus is among the fastest diagnostic balancers on the world market.

Touchscreen Interface

The graphic interface and touchscreen technology simplify and speed up operations and work programme selection.

Artificial Vision and Dimension Measurement with Contactless System

Without any intervention by the operator, EYELIGHT PLUS uses a professional quality video camera and advanced Corghi patented artificial vision technology to acquire and process the wheel image, and identify the balancing planes. Simultaneously, two high precision laser sensors measure the dimensions of the wheel in total autonomy and with no physical contact (Contactless System) in just a few seconds.

Automatic Positioning and LED Illuminator

At the end of the spin cycle, the wheel is braked and brought automatically into the balancing position (RPA). The integrated LED illuminator illuminates the work area to facilitate wheel cleaning and application of the counterweights.

Adhesive Counterweight Application

The internal point laser indicates the correct position for applying the adhesive counterweights with absolute precision.

Complete Wheel Diagnosis

The diagnostic programme measures the following parameters automatically:

- a) Radial and lateral wheel run-out (1st harmonic and peak-to-peak), to calculate the optimum mounting position for the tire on the wheel and solve the common problem of road vibration
- b) wheel drift, which causes the vehicle to pull constantly to one side of the road when driving in a straight line
- c) tread depth, in 3 areas of the tire

Intelligent Positioning Lite

A special vehicle tyre set diagnostic tool for checking run-out and imbalance. Once all the wheels are memorised, EM9980C suggests their best placement on the vehicle placement of the wheels themselves on the vehicle for maximum comfort and safety.

Weight Management and Opt Flash

Special suite of programmes including LESS WEIGHT, which cuts job times (20%) and reduces the quantity of counterweights used (30%), for more cost-effective, environmentally friendly operation.

Minimises road noise by allowing the operator to alter the position of the tyre on the wheel in order to optimise quietness.

Hidden Weight Automatic

New 'Hidden Weight Automatic' programme to divide the external side balancing adhesive weight into two equivalent weights hidden behind the spokes. A completely autonomous operation.

Slanted Front & Automatically Opening Compact Wheel Guard

Slanted front for easier operator access to interior of wheel.

Compact wheel guard (patent pending), designed to allow installation of the wheel balancer against a wall and accommodate wheels with diameters up to 44" (1,118 mm). Opens automatically to speed up jobs and save time.

HPC High Precision Collet

In addition to the 4 centering cones, Eyclight Plus is equipped, as standard, with the 'High Precision Collets' kit for an optimal centering of the wheel. The kit consists of 8 double-sided, low-taper axle boxes made of high-strength steel. The new cabinet now provides special lateral housings to collect the kit and always keep the work area tidy.

Multifunction (One-Touch) Button and Weight Tray

One-Touch multifunction button - Makes the selection of work programmes simpler and quicker.

Ergonomic and functional weight holder top with large trays for different types of counterweights and tools.

Rear Spray Guard Panel

Rear splash guard panel with slots for additional accessories.

Electronic Wheel Clamping

New electromechanical system which reduces working times and increases centring precision.

Features and Specs

Features

- Fully Automatic
- Touchscreen Interface
- Computer Vision
- Wheel Dimension with Contactless System
- Automatic Positioning and LED Illuminator
- Intelligent Positioning Lite
- LaserLine Pointer for Application of Counterweights
- Complete Wheel Diagnosis
 - Radial and Lateral Wheel Run-Out
 - Wheel Drift
 - Tread Depth
 - Tyre Conicity
- Automatic Compact Wheel Guard
- Multifunction (One-Touch) Button
- Automatic Wheel Clamping
- Weight Management
- Hidden Weight Automatic

- Opt Flash
- Easy Calibration
- Variable Speed Cycle
- 3 Operators
- Ergonomic and Functional Weight Tray
- Slanted Front and Compact Wheel Guard

Specifications

- Power Supply Voltage: 230V / 1ph / 50hz, 115V / 1ph/ 60hz
- Total Power Absorption: 700 W
- Balancing Speed: 75-85-98 rpm
- Max. Unbalance Value Calculated: 999 g
- Resolution: 1-5 g
- Average Measurement Time: 7 s
- Shaft Diameter: 40 mm / 1.57"
- Rim Diameter Setting Range: 1"-35"
- Rim Diameter Measurement Range: 10"-32"
- Max. Wheel Width (with Guard): 23.6" / 600 mm
- Max. Wheel Diameter (with Guard): 44" / 1118 mm
- Max. Wheel/Machine Distance: 10.82" / 275 mm
- Max. Wheel Weight: 165.3 lbs. / 75 kg
- Machine Weight: 436.5 lbs. / 198 kg

Accessories/Options

Related Products

Check items to add to the cart or

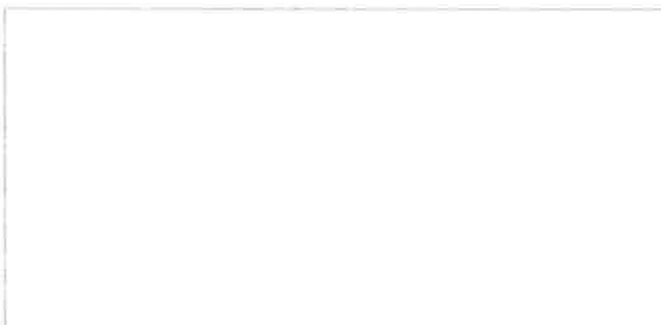



Corghi 8-21100141 Light Truck Cone Kit

GUARANTEED LOWEST PRICE: \$635.00

~~Regular Price: \$789.00~~

Add to Cart



More Information

more [Corghi EyeLight Wheel Balancer Brochure \(.pdf\)](#)

CORGHI EYELIGHT - Diagnostic Line Wheel Balancer (EN)



CORGHI EYELIGHT - Diagnostic Line Wheel Balancer



EYELight - Automechanika 2014



CORGHI - Autopromotec 2015 - EyeLight



Reviews

Browse for more products in the same category as this item:



Call toll Free
844-524-9058
for specials of the day
Mon-Sat 6AM-6PM Pacific Standard Time

We Accept checks and credit cards



Most orders ship in 1-3 business days

DISCOUNTS FOR ALL FIRST TIME BUYERS ON CERTAIN PRODUCTS

Call toll Free
844-524-9058
for specials of the day
Mon-Sat 6AM-6PM Pacific Standard Time

We Accept checks and credit cards



Most orders ship in 1-3 business days

DISCOUNTS FOR ALL FIRST TIME BUYERS ON CERTAIN PRODUCTS

Excellent



Based on 497 reviews

SHOP BY CATEGORY

BENDPAK BANG FOR THE BUCK SALE

ACCESSORIES

BUS AND TRUCK EQUIPMENT

PARTS WASHERS

SPECIAL OFFERS

CAR LIFT

AIR COMPRESSORS

AUTO BODY

4.8 
Google Customer Reviews



Coats 6450-2DK Heavy Duty Wheel Balancer Kit

Autel
\$16,563.00

Financing as low as \$501.91/month
[Click here to apply!](#)

 (No reviews yet)

[Write a Review](#)

Shipping: Free Shipping

Quantity:

[ADD TO CART](#)

[ADD TO WISH LIST](#)

BENDPAK LIFTS

AC EQUIPMENT

CHALLENGER LIFTS

BRAKE LATHES

COATS TIRE EQUIPMENT

ATLAS EQUIPMENT

CORGHI USA

3 IN 1 COMBO DEALS

DANNMAR EQUIPMENT

MAXJAX

BENDPAK EXHAUST PIPE BENDERS

FORWARD LIFTS

AUTOMOTIVE LIFTS

DIAGNOSTIC SCANNERS

LUBRICATION EQUIPMENT

MOTORCYCLE EQUIPMENT

BENDPAK PIPE BENDERS

SHOP



Overview

Reviews

PRODUCT DESCRIPTION

Coats 6450-2D (K) Heavy-Duty Balancer Kit

Kit Includes:

- 6450-2D | Wheel Balancer (*Your Choice of 1PH or 3PH*)
- 8143935 | Lug Centered Budd Plate Adapter
- 8109877 | Hub Centered Budd Adapter
- 575 | Wheel Lift

Take control of your toughest jobs with Coats heavy duty wheel balancers. Our full line of heavy duty balancers are proven performers, and are some of the most robust wheel balancers you can buy. They also come standard with loads of features that make your job faster and easier.

From the first push of a button, you're in complete control. Load wheel parameters and automatically index the wheel to the weight positions. And with the Stop and Lock feature, you can lock the spindle firmly in place at the weight location for easier, more accurate weight installation. Coats heavy duty balancers also come standard with an AC Vector Drive motor, which shaves 20 seconds off a typical 22.5" wheel spin. And with the laser Tape-A-Weight weight placement capability, you'll achieve more one-spin balances than ever before.

It all adds up to making your toughest balancing jobs faster and easier, for years to come.

The Coats 6450 Series is a huge step forward. Bar none, one of the best Heavy-Duty Balancers in the business.

Features:

- Powerful 1.5 HP direct drive motor shaves 20 seconds off a typical 22.5" spin
- Static on screen provides simultaneous display of static and dynamic data and identifies any excess residual static imbalance.

4.8 ★★★★★
Google
Customer Reviews

TIRE CHANGERS

WORKBENCHES

RANGER TIRE EQUIPMENT

TRANSMISSION EQUIPMENT

TUXEDO EQUIPMENT

HOFMANN

WHEEL BALANCER AND TIRE CHANGER COMBOS

WHEEL SERVICE

WHEEL BALANCERS

ATLAS WHEEL BALANCERS

Coats Wheel Balancers

CORGHI USA

HOFMANN

Ranger Wheel Balancers

Tux Equipment Wheel Balancers

- DCS ensures the 6450 is the most accurate heavy duty balancer in car/light truck mode on the market, like two balancers in one.
- Laser weight placement for 3 parameter auto data entry in tape modes
- 500 lbs Met Lab / UL approved
- Designed for front line, high-volume balancing
- Easy-to-read LED readouts

Static on Screen Display | Simultaneous display of static and dynamic data identifies any excess residual static imbalance

Laser Guided Operation | Pinpoints accurate Tape-A-Weight placements

Direct Drive | Coats direct drive wheel balancers feature a uniquely designed dynamic section (the system that senses and reports vibration to the balancer). Our direct drive system integrates the balancer's robust motor and spindle into a single, factory pre-balanced assembly with ZERO noise that can result in balancing errors.

Specifications:

- Model | 6450-2D
- Drive System | Direct
- Tire Diameter | 52"
- Rim Width | 20"
- Maximum Tire Weight | 500 lbs (UL)
- Self Calibrating | Yes
- On Screen Calibration Directions | Yes
- Auto Data Entry | 2 Parameter
- Stop On Top | No
- Auto Indexing | No
- Operator A & B | Yes
- Match Mount | Yes
- Motor Size | 1.5 hp Direct
- Cycle Time | R11 22.5 (200 lb) 18 sec.
- Cones | 2 Auto, 2 Light Truck
- Ounce/Gram Selectable | Yes
- Adapter Storage | Side Pegs
- Direct Weight Placement | Yes
- Monitor/Display | LED w/ Text Instruction Box
- Balancing Modes | 11
- Shaft Diameter | 2" (51 mm)
- Resolution Displayed | .01 oz.
- Accuracy | .01 oz.
- Round Off | 1/4 - 1/2 - 2 oz.
- Footprint | 72" w x 62" d
- Shipping Weight | 1,100 lbs
- 220v/1ph @ 60hz | 850645002

SHOP BY BRAND

BendPak

Danger
4.8 ★★★★★
Google
Customer Reviews

Tux Equipment

- 220v/3ph @60hz | 850645003

Coats

Included Adapter Kits:

Robinair

- 4 Cone Set / Range: 2.44" - 6.95"

CAR LIFT

Optional Adapter Kits *(Sold Separately)*:

ideal

- 8109877 | Hub Centered Budd Cone Kit / Range: 8.52" - 8.89"
- 8113043 | Deep Offset Plate Set (3) / Range: 4.922", 6.693", 4.561" and 4.766"
- [85009086 | HD Balancer Chuck with Plate](#) / Range: 8" - 12"
- 8110785 | Dayton Standard Center Adapter / Range: 20" - 22.5"
- 8110786 | Extension Kit for Standard Adapter / Range: 24.5" - 26"
- 8143935 | Stud Piloted Budd Adapter / Range: 22.5" and 24.5"

Dannmar
Equipment

Corghi

[View all Brands](#)

YOU MAY ALSO LIKE...



Autel MS906BT MaxiSys Automotive Diagnostic Scanner/Code Reader w/ECU



\$1,250.00

Financing as low as
\$37.88/month
[Click here to apply!](#)

ADD TO CART



AUTEL AULMAS20T MA600 All Systems: Frame, Calibration Cmpnts, MS909 Tablet and



\$24,800.00

Financing as low as
\$751.52/month
[Click here to apply!](#)

ADD TO CART

AUTEL AULMAS20 Complete ADAS Mobile Target System No Tablet



\$23,300.00

Financing as low as \$706.06/month
Click here to apply!

ADD TO CART

AUTEL AULAS20T Skip to the beginning of the images gallery Autel ADAS Standard Frame All



\$26,900.00

Financing as low as \$815.15/month
Click here to apply!

ADD TO CART

RECOMMENDED

COATS 6450-3D Heavy-Duty Truck Wheel



\$13,188.00

Financing as low as \$399.64/month
Click here to apply!

ADD TO CART

Coats 885 Wheel Balancer - 40mm



\$4,111.00

Financing as low as \$124.58/month
Click here to apply!

ADD TO CART

Hofmann geodyna™ 980L Heavy-Duty



\$12,300.00

Financing as low as \$372.73/month
Click here to apply!

ADD TO CART

COATS 6450-2D



\$12,460.00

Financing as low as \$377.58/month
Click here to apply!

ADD TO CART

JOIN OUR MAILING LIST for special offers!

Email

JOIN

Contact Us

1317 north San Fernando
blvd #225
Burbank, ca 91504
844-524-9058

Accounts & Orders

Wishlist
Login or Sign Up
Shipping & Returns
Sitemap

Quick Links

About Us
Contact Us
Blog
Manufacture Shipping
Policies
Apply for Financing

Recent Blog Posts



DISCOVER



PayPal

VISA

VISA
Checkout



© 2022 Automotize Equipment Specialists | Sitemap

4.8 ★★★★★

Google
Customer Reviews

Hickman County Board of Education
 Budget Amendment 30
 Fund 142 - Federal Programs
 May 2, 2022

Account	Description	Debit	Credit	Justification	
71200 - 163 - - 930	Educational Assistants	\$ 28,047.92		Using ESSER 1 funds to provide 1 Teacher, Educational Asst, 2 Nurses and Supplies & Materials	
71200 - 201 - - 930	Social Security	1,041.60			
71200 - 212 - - 930	Medicare	243.60			
71100 - 116 - - 930	Teacher		\$ 4,800.00		
71100 - 163 - - 930	Educational Assistants		2,400.00		
71100 - 201 - - 930	Social Security		446.40		
71100 - 204 - - 930	State Retirement		759.12		
71100 - 212 - - 930	Medicare		104.40		
71100 - 429 - - 930	Instructional Supplies		5,200.00		
71100 - 499 - - 930	Other Supplies & Materials		4,300.00		
72120 - 131 - - 930	Medical Personnel		9,600.00		
72120 - 201 - - 930	Social Security		595.20		
72120 - 204 - - 930	State Retirement		988.80		
72120 - 212 - - 930	Social Security		139.20		
	TOTALS	\$ 29,333.12	\$ 29,333.12		

Approved:

Attest:

Amy Brvant

Michelle Gilbert

Hickman County Board of Education
 Budget Amendment - 31
 Fund 142 - Federal Programs
 May 2, 2022

Account	Description	Debit	Credit	Justification
47309 - - - 955	Revenue	\$ 80,000.00		Early Literacy Network
72210 - 399 - - 955	Other Contracted Services		\$ 80,000.00	
47307 - - - 938	Revenue	200,000.00		Best for All District Grant
71100 - 722 - - 938	Regular Instruction Equipment		122,000.00	
72130 - 130 - - 938	Social Workers		45,000.00	
72130 - 201 - - 938	Social Security		2,790.00	
72130 - 204 - - 938	State Retirement		4,500.00	
72130 - 207 - - 938	Medical Insurance		8,000.00	
72130 - 212 - - 938	Medicare		652.50	
72130 - 790 - - 938	Other Equipment		17,057.50	
TOTALS		\$ 280,000.00	\$ 280,000.00	

Approved:

Attest:

Amy Bryant

Michelle Gilbert

Hickman County Board of Education
 Budget Amendment - 32
 Fund 141 - General Purpose
 May 2, 2022

Account	Description	Debit	Credit	Justification
46590 - - SLC		\$ 226,909.59		
46590 - - BC		93,040.55		
46590 - - SMC		64,831.31		
46590 - - LCT		60,935.26		
71100 - 116 - SLC	Teachers		\$ 108,000.00	
71100 - 163 - SLC	Assitants		32,000.00	
71100 - 201 - SLC	Social Security		10,710.00	
71100 - 204 - SLC	State Retirement		14,838.36	
71100 - 429 - SLC	Instructional Supplies		11,200.00	
71100 - 499 - SLC	Other Supplies		10,800.00	
72210 - 189 - SLC	Other Salaries & Wages		1,600.00	
72210 - 201 - SLC	Social Security		122.40	
72210 - 204 - SLC	State Retirement		164.80	
73100 - 165 - SLC	Cafeteria Personnel		19,200.00	
73100 - 201 - SLC	Social Security		1,468.80	
73100 - 204 - SLC	State Retirement		2,112.00	
73100 - 422 - SLC	Food Supplies		14,693.23	
71100 - 116 - BC	Teachers		57,600.00	
71100 - 163 - BC	Assitants		16,800.00	
71100 - 201 - BC	Social Security		5,690.88	
71100 - 204 - BC	State Retirement		7,785.84	
71100 - 429 - BC	Instructional Supplies		2,667.90	
72210 - 189 - BC	Other Salaries and Wages		800.00	
72210 - 201 - BC	Social Security		61.20	
72210 - 204 - BC	State Retirement		82.40	
73100 - 422 - BC	Food Supplies		1,552.33	
71100 - 116 - SMC	Teachers		21,600.00	
71100 - 163 - SMC	Assitants		6,400.00	
71100 - 201 - SMC	Social Security		2,142.00	
71100 - 204 - SMC	State Retirement		3,000.00	
71100 - 429 - SMC	Instructional Supplies		14,636.14	
71100 - 499 - SMC	Other Supplies		2,700.00	
71100 - 599 - SMC	Other Charges		2,700.00	
72610 - 328 - SMC	Janitorial Services		8,805.57	
73100 - 165 - SMC	Cafeteria Personnel		2,400.00	
73100 - 201 - SMC	Social Security		183.60	
73100 - 204 - SMC	State Retirement		264.00	
72710 - 146 - LCT	Bus Drivers		28,000.00	
72710 - 189 - LCT	Other Salaries and Wages		4,000.00	
72710 - 201 - LCT	Social Security		2,450.90	
72710 - 204 - LCT	State Retirement		5,440.00	
72710 - 412 - LCT	Diesel Fuel		20,000.00	
72710 - 599 - LCT	Other charges		1,044.36	
	TOTALS	\$ 445,716.71	\$ 445,716.71	Budget Amendment for Reimbursements related to Summer Learning Camps (SLC); Bridge Camp (BC); STREAM Mini Camps (SMC); Learning Camps Transportation (LTC)

Approved:

Attest:

Amy Bryant

Michelle Gilbert

Hickman County Board of Education
Budget Amendment - 33
Fund 141 - General Purpose
May 2, 2022

Account	Description	Debit	Credit	Justification
71100 - 189 -	Other Salaries & Wages	60,900.00		To properly record Differentiated Pay Expenditures
72610 - 189 - DP	Other Salaries & Wages		60,900.00	
73100 - 201 -	Social Security	4,100.00		
73100 - 201 - DP	Social Security		4,100.00	
73100 - 442 -	Propane	15,000.00		To cover overages in Gasoline
72710 - 425 -	Gasoline		15,000.00	
TOTALS		\$ 80,000.00	\$ 80,000.00	

Approved:

Attest:

Amy Bryant

Michelle Gilbert

Invitation to
Bid

The Hickman County Finance Office is accepting sealed bids for Chromebook Units and Chrome OS Management Service License.

Bid with specifications are online at: www.hickmank12.org/request-for-proposal.

All bidders will be required to submit a conflict of interest disclosure form that can be obtained at www.hickmank12.org/request-for-proposal.

Sealed bids must be mailed or delivered to the Hickman County Finance Office, 114 North Central Avenue, Suite 203, Centerville, TN 37033 and clearly marked on the outside of the envelope "Chromebooks and Chrome Management Licenses". Bids will be opened on Monday, April 25th, 2022 at 10:00 a.m. in the Finance Office.

The Hickman County Board of Education reserves the right to accept or reject any and all bids or parts of bids and to waive any informalities that would prevent the acceptance of a better bid.

Present Penny Mayberry
Misty Weaver

Riverside Technologies	316.00
Trafara	377.40
Hypertec Direct	331.74
Viva city Tech	310.00
System Liquidation	271.00
Howard Technology	327.00
Arey Jones	314.45

PASSION. CREATIVITY. STRATEGYPK

RTI[®]

RIVERSIDE TECHNOLOGIES, INC.

105 Gateway Drive | North Sioux City, SD 57049

Request for Proposal

Chromebook Units and Chrome OS Management Service License

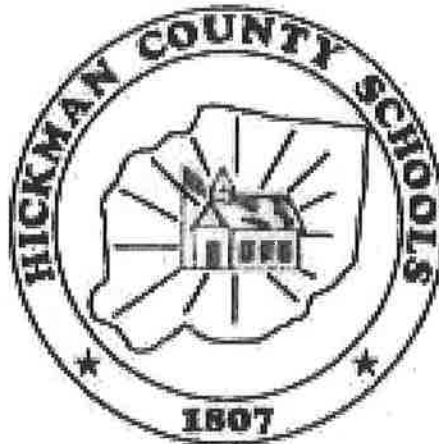

Hickman County Schools

114 North Central Ave Suite 203
Centreville, TN 37033

April 14, 2022

Hickman County Schools
114 North Central Ave Suite 203
Centreville, TN 37033

Dear Brad Gilbert,

Riverside Technologies, Inc. (RTI) is pleased to provide Hickman County Schools with the following response to Request for Proposal - Chromebook Units and Chrome OS Management Service License. We are confident that our Chromebook solution provided by our education solution team will exceed your expectations for affordability, quality, performance and customer support.

Driven by passion, creativity and teamwork, RTI is committed to providing you with the best hardware and customer service possible. With years of experience in engineering, technology support, Chromebook deployments, and customer service your account management team stands ready to assist you. RTI has deployed over 150,000 Chromebooks successfully for multiple school districts across the United States. RTI can provide the following services to Hickman County Schools:

- **Asset Tagging/Reporting:** RTI labels each system with an identification tag. Your Asset Management information is detailed in a report that includes: bar-coded asset numbers, computer manufacturer, model number, serial number and any other custom information requested.
- **Green Delivery:** RTI removes all packaging materials and disposes of, or recycles the materials. RTI bulk ships your orders in our custom shipping container that minimizes waste, is easily collapsible and recyclable.
- **Google Enrollment:** RTI sets up your Chromebook to have the most up to date operating system and software.

We are aware that you are selecting a partner who has provided outstanding customer service, professionalism, advanced technical ability and premium product. We look forward to collaboration with your business and employees to make a difference in Hickman County Schools! Please do not hesitate to reach out with any questions to Todd Butters at (866) 804-4388 ext. 1427. We appreciate the opportunity to do business with you!

Sincerely,



Kevin Heiss
President
Riverside Technologies, Inc.
Cell | 712-490-9981
kevinh@lrti.com

Invitation to
Bid

The Hickman County Finance Office is accepting sealed bids for Chromebook Units and Chrome OS Management Service License.

Bid with specifications are online at: **www.hickmank12.org/request-for-proposal**.

All bidders will be required to submit a conflict of interest disclosure form that can be obtained at www.hickmank12.org/request-for-proposal.

Sealed bids must be mailed or delivered to the Hickman County Finance Office, 114 North Central Avenue, Suite 203, Centerville, TN 37033 and clearly marked on the outside of the envelope "Chromebooks and Chrome Management Licenses". Bids will be opened on Monday, April 25th, 2022 at 10:00 a.m. in the Finance Office.

The Hickman County Board of Education reserves the right to accept or reject any and all bids or parts of bids and to waive any informalities that would prevent the acceptance of a better bid.

Bid Specifications for Chromebooks:

Chrome OS

14 inch screen (non-touch) preferred

4 GB RAM preferred

16 GB Hard Drive Size Preferred

Wireless Compatible

USB and HDMI ports available

Headphone Jack

Prices are to include shipping and handling charges for delivery, asset tagging/configuration. Chromebooks should be named and enterprise enrolled to the proper school in Google Admin Console as determined by Hickman County Schools.

Any color choice is determined by Hickman County Schools.

12 month support warranty for Chromebook

Questions should be directed to Brad Gilbert, Technology Coordinator, via e-mail at brad.gilbert@hickmank12.org

No exact number of chromebooks being ordered is available at this time. A price breakout dependent on quantity purchased will be accepted. Bid prices are expected to be good for one year unless noted otherwise in the bid.

Hickman County Government

Conflict of Interest Disclosure Form

The County Financial Management System of 1981 contains the most stringent conflict of interest provisions. TCA §5-21-121 provides:

- (a) The director, purchasing agent, members of the committee, members of the county legislative body or other officials, employees, or members of the board of education or highway commission shall not be financially interested or have any personal beneficial interest, either directly or indirectly, in the purchase of any supplies, materials, equipment or contractual services for the county.
- (b) No firm, corporation, partnership, association or individual furnishing any such supplies, materials, equipment or contractual services, shall give or offer, nor shall the director or purchasing agent or any assistant or employee accept or receive directly or indirectly from any person, firm, corporation, partnership or association to whom any contract may be awarded, by rebate, gift or other otherwise, any money or other things of value whatsoever, or any promise, obligation or contract for future reward or compensation.

Date: 4/14/2022 Name: Kevin Heiss

Please describe below any relationships, transactions, positions you hold (volunteer or otherwise), or circumstances that you believe could contribute to a conflict of interest:

I have no conflict of interest to report.

I have the following conflict of interest to report (please specify any boards or committees you (and/or your spouse) sit on, the name of your employer and any businesses you or your spouse may own.

I hereby certify that the information set forth above is true and complete to the best of my knowledge.

Date: 4/14/2022 Signature: 



Riverside Technologies, Inc. (RTI)

Your Complete IT Source

Riverside Technologies Inc. (RTI) is the next generation of an IT service provider. Beyond specializing in IT solutions—managed services, IT hardware, warehouse services, and technology deployment—we add our blend of passion, creativity, and teamwork. We understand your unique challenges, develop creative solutions, and provide unmatched responsiveness. RTI is **trusted** throughout the nation and across various industries for being a **complete IT source**.

1:1 Solutions

Tailored for You

Excellent equipment and trusted partnerships backed by RTI's expert customization.

Managed Services

Filling the Gaps

An extension of your IT department, we hit your sweet spot, from simple IT support to complete outsourcing.

Enterprise Solutions

Maximize Your ROI

Our start-to-finish solutions will help maximize your IT investment and achieve your business goals.

Customization

Make a Statement

Customization solutions from RTI will create a complete, branded solution that makes a statement.

Integration

Bring It All Together

No headaches, hassles, or wasted time. We'll make the integration process as seamless as possible.

Deployment

Nailing the Details

Attention to detail is critical. We'll handle the little things to ensure ongoing success for your organization.

Education

Smart Student Solutions

Simple, end-to-end answers to designing, integrating, and managing learning environments.

Managed Print

Free Up Resources

Focus on your business and let RTI manage and optimize your printers and copiers.

Assessments

Evolve Your IT

Our certified IT engineers complete various invaluable, industry-leading assessments.



Hickman County School District Chromebooks and Chrome Management Licenses

Quote #tb081274 v1

Prepared For:
Hickman County School District
Main
Brad Gilbert
115 Murphree Ave
Centerville, TN 37033
P: 9317293391 x-2229
E: brad.gilbert@hickmank12.org

Prepared by:
Riverside Technologies
Todd Butters
748 N 109th Court
Omaha, NE 68154
P: 866.804.4388 x-1427
E: tbutters@riversidetechnologies.com

Date Issued:
04.14.2022
Expires:
05.14.2022

Contract:

Hardware		Price	Qty	Ext. Price
Hickman County Chromebooks	Hickman County Chromebooks	\$316.00	1	\$316.00
3V2U9UT#ABA	HP Chromebook 14 G7 14" Chromebook - HD - 1366 x 768 - Intel Celeron N4500 Dual-core (2 Core) - 4 GB Total RAM - 32 GB Flash Memory - Intel Chip - Chrome OS - Intel UHD Graphics - English Keyboard - 12.50 Hours Battery Run Time - IEEE 802.11ax Wireless LA		1	
				
RTSWR-T0023	Google Management Console		1	
RTWHS-T0025	Google Enrollment Service		1	
RTWHS-T0003	Asset Tag		1	
RTWHS-T0002	Green Delivery		1	
Google Support through June 2029				
			Subtotal:	\$316.00

Quote Summary	Amount
Hardware	\$316.00
Total:	\$316.00

Taxes, shipping, handling and other fees may apply. We reserve the right to cancel orders arising from pricing or other errors.



HP Chromebook 14 G7

An essential Chromebook for education and frontline work

Power through the day with the durable HP Chromebook 14 G7 and its manageable, secure, and intuitive Chrome OS. The latest Intel® Celeron® processor¹, large 14" diagonal screen, long battery life, and HP docking support² enhance productivity.



Designed for maximum productivity

- Combine dynamic features driving this 14" Chromebook with Chrome apps and easily execute tasks and workflows. Powered by the latest Intel® Celeron® processor¹, up to 8 GB memory⁸, 128 GB storage⁴, and a fast-charge battery for mastering through long days.

Ultralight and durable for long-lasting mobility

- Get a hard-wearing Chromebook at less than 19 mm (.748 in) thin. Feel confident carrying a device that undergoes MIL-STD 810H testing⁶, has reinforced USB-C® ports, and features a wipeable keyboard⁷ that withstands spills up to 350 ml (11.8 oz).

Designed for easy collaboration

- Collaborate with a narrow bezel display, optional wide-viewing angle IPS touchscreen⁸, wide-angle HD webcam, and dual mics for a better video conferencing experience. Add your display, projector, or accessories with HDMI and USB-C®.⁹
- Breathe easy with the low-maintenance, highly manageable, and secured Chrome OS. With automatic software updates through June 2029 and built-in anti-virus protection, your device is protected and up to date.¹⁶
- The perfect combination of performance, power consumption, and value handles multiple assignments smoothly and reliably with up to four processing cores to divide up the work.¹
- Undergoes MIL-STD 810H combined with HP Total Test Process to ensure this Chromebook exceeds HP durability and reliability standards—helping reduce total cost of ownership.^{6,11}
- Increase productivity without hassle. Connect to additional displays and projectors with an HDMI port that helps reduce dongle and cable clutter.
- Work from almost anywhere with a fast, reliable wireless connection. Get enhanced connectivity even on crowded wireless networks at a long range with Wi-Fi 6 WLAN module, supporting MU-MIMO and HP Extended Range Wireless LAN.^{12,13,14}
- Enjoy the freedom to unplug and work at different sites throughout the day with a long-running battery. Charge to 90% battery life in 90 minutes with HP Fast Charge.⁵
- Immerse yourself in on-screen visuals with a narrow border design that maximizes the screen's view within a smaller chassis.
- Tested for 1000 cleanings, the keyboard of this Chromebook can be wiped down using commonly available household disinfecting and cleaning wipes.⁷
- Up to 8 GB RAM and 128 GB eMMC storage options allow staff, teachers, and students to access thousands of Android applications, complete tasks, and collaborate with others.^{4,8,15}
- Keep going even in dimly lit rooms or aboard red-eye flights. With an optional illuminated keyboard, you can type comfortably in more environments.⁸

HP Chromebook 14 G7 Specifications Table



Available Operating Systems	Chrome OS™
Processor family	Intel® Celeron® processor
Available Processors ^{1,2}	Intel® Celeron® N4500 (up to 2.8 GHz burst frequency, 4 MB L3 cache, 2 cores); Intel® Celeron® N5100 (up to 2.80 GHz burst frequency, 4 MB L3 cache, 4 cores)
Maximum memory	8 GB LPDDR4X-4266 SDRAM Memory soldered down.
Internal storage	32 GB up to 64 GB eMMC 5.0 ³
Display size (diagonal, metric)	35.6 cm (14")
Display	35.6 cm (14") diagonal, FHD (1920 x 1080), IPS, anti-glare, 250 nits, 45% NTSC; 35.6 cm (14") diagonal, HD (1366 x 768), narrow bezel, anti-glare, 250 nits, 45% NTSC; 35.6 cm (14") diagonal, FHD (1920 x 1080), touch, IPS, anti-glare, 250 nits, 45% NTSC ^{6,7}
Available Graphics	Integrated: Intel® UHD Graphics ⁶
Audio	HD audio, dual speakers, dual array microphones
Wireless technologies	(HP Extended Range Wireless LAN, MU-MIMO and Chromecast support)
Expansion slots	1 microSD (Supports SD, SDHC, SDXC.)
Ports and Connectors	2 SuperSpeed USB Type-A 5Gbps signaling rate; 1 SuperSpeed USB Type-C® 5Gbps signaling rate (USB Power Delivery, DisplayPort™ 1.4); 1 headphone/microphone combo; 1 HDMI 1.4
Input devices	Spill-resistant, full-size, optional backlit, textured, flint silver Chrome keyboard ¹⁵ ; Clickpad with multi-touch gesture support, taps enabled as default;
Communications	Intel® Wi-Fi 6 AX201 (2x2) and Bluetooth® 5 combo, non-vPro®;
Camera	720p HD privacy camera ^{6,16}
Software	Chrome Education Upgrade (Sold separately); HP Classroom Manager (Sold separately) ^{9,10}
Security management	Nano Security lock slot; Google Titan C ¹¹
Fingerprint reader	Fingerprint reader not available
Power	HP Smart 45 W USB Type-C® adapter
Battery type	HP Long Life 2-cell, 47 Wh Li-ion polymer ^{12,17}
Dimensions	32.65 x 22.7 x 1.83 cm
Weight	Starting at 1.54 kg (Weight will vary by configuration.)
Energy efficiency compliance	ENERGY STAR® certified; EPEAT® 2019 registered where applicable. EPEAT® registration varies by country. See www.epeat.net for registration status by country. ¹⁴
Sustainable Impact specifications	Low Halogen; Outside box and corrugated cushions are 100% sustainably sourced and recyclable ^{18,19}
Warranty	1 year (1-1-0) limited warranty and service offering includes 1 year of parts and labor. Terms and conditions vary by country. Certain restrictions and exclusions apply.

HP Chromebook 14 G7

Accessories and services (not included)

HP Prelude Backpack 15.6



Help keep your notebook safe and your hands free while you're on the move with the durable HP 15.6 Prelude Backpack, now with a pop of color from the stylish blue interior.
Product number: 1E7D6AA

HP Wireless Premium Mouse



Create a sleek, professional, clutter-free workspace and give yourself room to move around with the HP Wireless Premium Mouse, which integrates seamlessly with your HP notebook.
Product number: 1JR31AA

HP HDMI to VGA Adapter



The HP HDMI to VGA Adapter maximizes the display functionality of your HP Ultrabook™ or Notebook PC by converting the HDMI output signal to an analog VGA input for easy connecting to an external VGA display for dual-display productivity.
Product number: H4F0ZAA

HP 3 year Next Business Day Onsite Hardware Support for Notebooks



Receive 3 years of next business day onsite HW support from an HP-qualified technician for your computing device, if the issue cannot be solved remotely.
Product number: UQ992E

HP Chromebook 14 G7

Messaging Footnotes

- ¹ Multicore is designed to improve performance of certain software products. Not all customers or software applications will necessarily benefit from use of this technology. Performance and clock frequency will vary depending on application workload and your hardware and software configurations. Intel's numbering, branding and/or naming is not a measurement of higher performance.
- ² HP docks sold separately.
- ⁴ Up to 128GB is an optional feature that must be configured at purchase. For storage drives, GB = 1 billion bytes. Actual formatted capacity is less. Up to 8.1 GB is not user accessible.
- ⁵ Recharges the battery up to 90% within 90 minutes when the system is off or in standby mode, when used with the power adapter provided with the mobile thin client, and no external devices are connected. After charging has reached 90% capacity, charging speed will return to normal. Charging time may vary +/- 10% due to System tolerance.
- ⁶ MIL-STD testing is not intended to demonstrate fitness for U.S. Department of Defense contract requirements or for military use. Test results are not a guarantee of future performance under these test conditions. Accidental damage requires an optional HP Accidental Damage Protection Care Pack.
- ⁷ The keyboards of the HP Education portfolio, including the HP Chromebook 14 G7, have been tested to 1,000 wipes to be cleaned with Windex® Original Glass & Surface Wipes and Clorox® Disinfecting Wipes with EPA Registration Number 5813-79. Do not use wipes on other surfaces of the product. See user guide for cleaning instructions.
- ⁸ Optional feature that must be configured at purchase.
- ⁹ HDMI and USB-C® cables sold separately.
- ¹¹ Test results are not a guarantee of future performance under these test conditions. Accidental damage requires an optional HP Accidental Damage Protection Care Pack.
- ¹² Wireless access point and Internet service required and sold separately. Availability of public wireless access points limited. Wi-Fi 6 (802.11ax) is backwards compatible with prior 802.11 specs. The specifications for Wi-Fi 6 are draft specifications and are not final. If the final specifications differ from the draft specifications, it may affect the ability of the notebook to communicate with other 802.11ax WLAN devices. Only available in countries where 802.11ax is supported.
- ¹³ Multiple-Input Multiple-Output (MU-MIMO) is a wireless technology that uses multiple transmitters and receivers to enhance data transfer. MIMO requires a MU-MIMO router, sold separately.
- ¹⁴ Based on internal testing vs. previous generation product with 802.11ac wireless LAN module.
- ¹⁵ Internet access required and sold separately. Some apps may require purchase.
- ¹⁶ See <https://support.google.com/chrome/a/answer/6220366?hl=en> for more information.

Technical Specifications Footnotes

- ¹ Multicore is designed to improve performance of certain software products. Not all customers or software applications will necessarily benefit from use of this technology. Performance and clock frequency will vary depending on application workload and your hardware and software configurations. Intel's numbering, branding and/or naming is not a measurement of higher performance.
- ² Processor speed denotes maximum performance mode; processors will run at lower speeds in battery optimization mode.
- ³ For storage drives, GB = 1 billion bytes. TB = 1 trillion bytes. Actual formatted capacity is less. Up to 30 GB (for Windows 10) is reserved for system recovery software.
- ⁴ Wireless access point and Internet service required and sold separately. Availability of public wireless access points limited. Wi-Fi 6 is backwards compatible with prior 802.11 specs. The specifications for Wi-Fi 6 (802.11ax) are draft and are not final. If the final specifications differ from the draft specifications, it may affect the ability of the notebook to communicate with other 802.11ax devices.
- ⁵ Chromecast must be purchased separately.
- ⁶ HD content required to view HD images.
- ⁷ Resolutions are dependent upon monitor capability, and resolution and color depth settings.
- ⁸ Based on internal testing vs. previous generation product with 802.11ac wireless LAN module.
- ⁹ HP Classroom Manager is sold separately. Control and device locking from the teacher's desktop requires purchase of HP Classroom Manager.
- ¹⁰ Chrome Education Upgrade requires one-time setup, subscription, Google Admin Console, and your organization's domain. Please see <https://support.google.com/a/answer/60216>.
- ¹¹ Lock is sold separately.
- ¹² Recharges up to 90% within 90 minutes when the system is off or in standby mode when used with the power adapter provided with the notebook. After charging has reached 90% capacity, charging will return to normal. Charging time may vary +/- 10% due to System tolerance.
- ¹³ HP Care Packs are sold separately. Service levels and response times for HP Care Packs may vary depending on your geographic location. Service starts on date of hardware purchase. Restrictions and limitations apply. For details, visit www.hp.com/go/cpc. HP services are governed by the applicable HP terms and conditions of service provided or indicated to Customer at the time of purchase. Customer may have additional statutory rights according to applicable local laws, and such rights are not in any way affected by the HP terms and conditions of service or the HP Limited Warranty provided with your HP Product.
- ¹⁴ Based on US EPEAT® registration according to IEEE 1680.1-2018 EPEAT®. Status varies by country. Visit www.epeat.net for more information.
- ¹⁵ Backlit keyboard is an optional feature.
- ¹⁶ 720p HD Privacy camera is optional and must be configured at purchase.
- ¹⁷ Actual battery Watt-hours (Wh) will vary from design capacity. Battery capacity will naturally decrease with shelf life, time, usage, environment, temperature, system configuration, loaded apps, features, power management settings and other factors.
- ¹⁸ External power supplies, power cords, cables and peripherals are not Low Halogen. Service parts obtained after purchase may not be Low Halogen.
- ¹⁹ 100% outer box packaging and corrugated cushions made from sustainably sourced certified and recycled fibers.

Sign up for updates hp.com/go/getupdated

© Copyright 2021 HP Development Company, L.P. The information contained herein is subject to change without notice. The only warranties for HP products are set forth in the express limited warranty statements accompanying such products. Nothing herein should be construed as constituting an additional warranty. HP shall not be liable for technical or editorial errors or omissions contained herein.

Intel, Celeron and Intel vPro are trademarks or registered trademarks of Intel Corporation or its subsidiaries in the United States and other countries. DisplayPort™ and the DisplayPort™ logo are trademarks owned by the Video Electronics Standards Association (VESA®) in the United States and other countries. USB Type-C® and USB-C® are registered trademarks of USB Implementers Forum. © 2020 Google LLC All rights reserved. Google and the Google Logo are registered trademarks of Google LLC.

March 2021





Riverside Technologies, Inc. (RTI)

Dedicated Team for:

Hickman County Schools

Todd Butters, Account Executive

Phone: 605-242-5028 Ext. 1427

Cell: 712-490-4910

tbutters@lrti.com

Bill Burke, Director of Sales - East

Phone: 605-242-5028 Ext. 1017

Cell: 712-223-0351

bburke@lrti.com

Tristen Morris, Customer Service Specialist

Phone: 866.804.4388 x1046

Fax: 866-812-5370

tmorris@lrti.com

Kevin Heiss, President

Phone: 605-242-5028 Ext. 1002

Cell: 712-490-9981

kevinh@lrti.com



www.RiversideTechnologies.com



866.804.4388



@ Trafera.com
2550 University Ave W Ste 315-S
Saint Paul, MN 55114
(651) 888-7922

04/20/2022

Hickman County Finance Office
Attn: Bid Administrator
114 North Central Avenue
Suite 203
Centerville, TN 37033

Chromebook and Chrome Management Licenses

To the Bid Administrator and Whom It May Concern,

Introduction

Please accept our enclosed proposal for your *Chromebooks and Chrome Management Licenses* request for quotes. Trafera is an industry leader in innovative computing solutions for schools and government agencies. In January 2021, FireFly Computers and Trinity3 Technology united as Trafera to provide the educational technology market with the latest and greatest Chromebooks and classroom technology. With over 18 years of combined experience, we bring you even better prices, greater product availability, and a wider range of products and services, all without sacrificing the fast, personalized service you deserve.

We currently do business with over 3,400 school districts and organizations across all 50 US states. Trafera is a Google for Education Premier Partner and one of the top 3 vendors of Google Chrome products worldwide. We are also an HP Power Partner and HP Authorized Services Provider.

Our team has become experts in making technology deployments painless, and we focus on providing knowledgeable, end-to-end customer support and service options to save you time, effort, and money. By offering the right technology with the right support, we drive student achievement toward a bright future.

Trafera Account Manager

At Trafera, we pride ourselves on providing the very best customer service in the technology industry. You will have direct access to your own dedicated, US-based, Trafera Account Manager who can help with everything from pre-sales questions to warranty support. This means you'll always get reliable service from someone who knows your account and can provide you with the timely assistance you deserve.



Your Trafera Account Manager:

Haley Koerner, Senior Account Manager

612-326-1810 (direct)

1-855-862-5120 x 2104 (toll-free)

651-888-7916 (fax)

haley.koerner@trafera.com

Proposal Overview

We are proposing the HP Chromebook 14 G7 Enterprise with Google Chrome Education Upgrade (Chrome Management License), White Glove Setup, Asset Tagging, MAC addresses, and free Trafera TRAILS. All products are brand new, and free FOB destination shipping with liftgate service and Trafera Green Pack is included. Our pricing will be valid for one year from the bid opening date and will be valid for any quantity purchased.

Trafera specializes in technology for K-12 education, higher education, and municipal government agencies. By focusing on these specific sectors of the technology market, we've been able to partner with customers to address specific pain points in ways other vendors can't match. Whether it's stress-free setup options, convenient warranty services, or revolutionary new ways to handle parts and repairs, Trafera is fully invested in delivering one-of-a-kind solutions to help you manage your technology faster, easier, and more pain-free.

Product Specifications

HP Chromebook 14 G7 Enterprise

- Intel Celeron N4500 Dual-Core Processor
- 4GB RAM
- 32GB Storage
- 14" HD Display
- Intel UHD Graphics
- 720p webcam
- Google AUE June 2029

FREE Technical Assistance from Trafera Engineers

At Trafera, our teams are unparalleled experts in deploying 1-to-1 Chromebooks in education. If awarded, our technical support and operations teams will be available to you by phone or email at no additional charge to answer unlimited questions about how to configure your Google Chrome Education Upgrade or tackle any troublesome issues that arise.

Premium Customizable White Glove Setup

Our Google® Certified support team has set up and configured Chrome Management settings for hundreds of thousands of Chromebooks, from large deployments of 10,000+ all the way down to small deployments of just a few dozen devices. We will work with you to go



beyond the basic white glove enrollment most vendors offer, and we'll pre-configure your Chromebooks exactly the way you want them. We can pre-assign Chromebooks to specific OUs (organizational units), apply customized desktop backgrounds, and even sort your shipments into separate groups according to OU, grade level, or school destination. Sometimes this means sorting devices onto separate pallets, but it can also be as simple as us putting a colored sticker on the outside of each box or bulk-shipped device bag that identifies its OU, building, or room designation. No other vendor goes as far as we do to provide the customization and expertise perfect for your unique District's needs. Our typical "White Glove" setup includes:

- Pre-enrolling devices in the District's G Suite (Google Apps) Domain
- Preconfiguring Wi-Fi settings for all devices, if purchased
- Updating Chrome OS to the latest stable public release
- Applying District-specific settings and customizations to each device, if desired
- Assigning subsets of devices to specific Organizational Units (OUs), if desired
- Testing devices to replace defective and DOA units before shipping
- Attaching asset tags to District specifications
- Capturing of MAC addresses
- Charging the device fully and powering it down after enrollment

Trafera Green Pack

As a "green" waste-reducing option, we offer our Trafera Green Pack. With this green shipping option, devices will be shipped to the destination in large "Gaylord-style" shipping boxes with cardboard or slotted foam dividers. These boxes accommodate approximately 240 devices. Trafera Green Pack saves time and reduces the number of technical staff required to unbox and distribute large technology orders. Trafera compresses and bundles the original packaging, and leftover boxes into re-usable cardboard bales and disposes of the materials with a local cardboard recycler.

FREE Trafera TRAILS

TRAILS (Technology, Resources, Activities, and Investigative Lessons for Schools) is a powerful library of lessons and professional learning experiences that empower teachers to transform their instruction by broadening their technology fluency. TRAILS comes in two variations: TRAIL Guides and TRAIL Mix. TRAIL Guides are thorough, rigorous courses that follow the research-based 5E Model of Instruction. They are organized into five thematic lesson units that cover multiple weeks of instruction. These lessons are tightly aligned to Next Generation Science and ISTE Standards. TRAIL Guides follow Universal Design for Learning guidelines to ensure these lessons accommodate every learner. Looking for something a little smaller? Check out TRAIL Mix! This variation offers power-packed activities, is perfect for virtual delivery, and is designed to be taught in under 45 minutes. Every TRAIL Mix activity has fun interdisciplinary



components too. When you purchase devices with Trafera, you'll have access to TRAILS, all at no charge. To create an account, visit <https://www.trafera.com/trafera-trails/>.

Resources for Success

Trafera brings you more than just products and services, we go beyond using technology hardware to drive student achievement. When you become part of our Trafera community, you're adopted into a full ecosystem of resources, guides, expert advice, insider information, social interactions, webinars, and more. The indispensable tools we bring you can help you create a technology environment where all students are connected, all staff and teachers are equipped, and every need is supported. To stay up to date on the latest resources Trafera has to offer, check out <https://www.trafera.com/shows-events/> and follow us on your social platform of choice.

Web: <https://www.trafera.com>

LinkedIn: <https://www.linkedin.com/company/traferaofficial/>

YouTube: Search Trafera

Facebook: <https://www.facebook.com/TraferaOfficial/>

Twitter: <https://twitter.com/TraferaOfficial>

Conclusion

We hope we've helped show you that our proposal provides the very best solution for your upcoming technology purchase. Please let us know if we can send any additional information or answer any questions. Thank you.

Sincerely,

Nikki Levin

Sr. VP of Operations, Trafera LLC

Hickman County Government

Conflict of Interest Disclosure Form

The County Financial Management System of 1981 contains the most stringent conflict of interest provisions. TCA §5-21-121 provides:

- (a) The director, purchasing agent, members of the committee, members of the county legislative body or other officials, employees, or members of the board of education or highway commission shall not be financially interested or have any personal beneficial interest, either directly or indirectly, in the purchase of any supplies, materials, equipment or contractual services for the county.
- (b) No firm, corporation, partnership, association or individual furnishing any such supplies, materials, equipment or contractual services, shall give or offer, nor shall the director or purchasing agent or any assistant or employee accept or receive directly or indirectly from any person, firm, corporation, partnership or association to whom any contract may be awarded, by rebate, gift or other otherwise, any money or other things of value whatsoever, or any promise, obligation or contract for future reward or compensation.

Date: 4/19/22 Name: Jim Mattson

Please describe below any relationships, transactions, positions you hold (volunteer or otherwise), or circumstances that you believe could contribute to a conflict of interest:

I have no conflict of interest to report.

I have the following conflict of interest to report (please specify any boards or committees you (and/or your spouse) sit on, the name of your employer and any businesses you or your spouse may own.

I hereby certify that the information set forth above is true and complete to the best of my knowledge.

Date: 4/19/2022 Signature: 



Bill to
Hickman County Schools
Customer No: 70338
 114 North Central Ave
 Suite 203
 Centerville TN 37033
 USA

Ship to

Quote Details
 Created: April 19, 2022
 Expiration: April 23, 2023
 Created by: Haley Koerner
 haley.koerner@trafera.com

Estimate No: E000070516

Contract
 None

Products & Services

Items and Descriptions	Overview	Notes	Qty	Unit Price	Totals
HP14 G7 CAM N4500 4G 32G 14" CHROME	HP14 G7 Chromebook - 14" HD Display (1366 x 768) - Intel Celeron N4500 Dual-Core 1.10GHz - 4 GB RAM - 32GB Flash Memory - Intel UHD Graphics - Chrome OS - WIFI + BT		1	\$338.90	\$338.90
Google Chrome Management Perpetual EDU	Google Chrome Management Perpetual EDU License		1	\$32.00	\$32.00
Trafera White Glove Under 300 Units	Trafera White Glove Under 300 Units - Pre-enrolled in Google Apps® domain - Custom themes and settings applied - Hardware functionality check - Google Console OU management		1	\$6.50	\$6.50
Trafera Asset Tags with White Glove			1	\$0.00	\$0.00
MAC Addresses with White Glove			1	\$0.00	\$0.00
Trafera Preconfigure Customer WiFi			1	\$0.00	\$0.00
TRAILS Digital Lesson Library - 1 Yr Sub	500+ powerful online resources for educators. TRAILS includes three resources: • TRAIL Guides - Thematic units aligned to NGSS Standards • TRAIL Mix - Stand alone lessons perfectly suited for face-to-face or virtual instruction • Children's Literature - Featuring "Tom the Traferatops", a fun and shy dinosaur who loves to learn with technology		1	\$0.00	\$0.00

Lift Gate on Truck *All
Shipping/Freight
Included

1 \$0.00 \$0.00

Trafera Green Packing

1 \$0.00 \$0.00

Subtotal \$377.40

Tax \$0.00

Total \$377.40

Net Terms N30

Terms and Conditions

This quote is confidential and is to be viewed solely by individuals within the organization to whom it is addressed. Unauthorized distribution or disclosure of the contents of this quote is prohibited. If you are not from the organization addressed, please notify us immediately so we can prepare a quote specific to you. Prices and availability may change without notice prior to the quote expiration date.

Questions? Contact me

Haley Koerner

haley.koerner@trafera.com



Trafera

2550 University Ave W, Suite 315 - S
St. Paul MN 55114
United States



HP Chromebook 14 G7 Enterprise

Empower your frontline with a stylish, sturdy Chromebook

Help frontline workers provide essential support with the durable and versatile 14" Chromebook for enterprise. Keep productive with a narrow-border touchscreen, long battery life, and HDMI port. Easily manage your fleet with Chrome Enterprise Upgrade.¹



Day-to-day reliability

- Get a Chromebook built for the rigors of your frontline. This device undergoes MIL-STD 810H testing² and features long battery life, a minor-spill-resistant keyboard, and reinforced ports and internal structures for durability over time.

Power and versatility in a fanless design

- Focus on your customers with a quiet, versatile device. The fanless, ultra-thin and light design with the 180° lay-flat hinge enables quality service, while the latest Intel® Celeron® processor³ and up to 128 GB eMMC⁴ supports multitasking.

Enterprise-class security and manageability

- Breathe easy with the low-maintenance, highly manageable, and secure Chrome OS with automatic software updates⁵ through June 2029. Deploy, manage, and control users, devices, and apps with Chrome Enterprise Upgrade.¹
- Breathe easy with the low-maintenance, highly manageable, and secured Chrome OS. With automatic software updates through June 2029 and built-in anti-virus protection, your device is protected and up to date.⁵
- The perfect combination of performance, power consumption, and value handles multiple assignments smoothly and reliably with up to four processing cores to divide up the work.³
- Experience seamless device integration with the included Chrome Enterprise Upgrade. Get 200+ policies for user, device, and fleet management and support for Active Directory and your VDI and enterprise mobility management solutions.^{1,7}
- Up to 8 GB RAM and 128 GB eMMC storage options allow staff, teachers, and students to access thousands of Android applications, complete tasks, and collaborate with others.^{4,8}
- Undergoes MIL-STD 810H testing combined with HP Total Test Process to ensure this enterprise Chromebook exceeds HP durability and reliability standards—helping reduce total cost of ownership.^{2,10}
- Never wonder if someone is watching you with the added peace of mind that comes from the optional integrated HP Privacy Camera. The camera's physical shutter protects users from malicious surveillance.⁸
- Work from almost anywhere with a fast, reliable wireless connection. Get enhanced connectivity even on crowded wireless networks at a long range with Wi-Fi 6 WLAN module, supporting MU-MIMO and HP Extended Range Wireless LAN.^{11,12,13}
- Tested for 1000 cleanings, the keyboard of this enterprise Chromebook can be wiped down using commonly available household disinfecting and cleaning wipes.¹⁴
- Enjoy the freedom to unplug and work at different sites throughout the day with a long-running battery. Charge to 90% battery life in 90 minutes with HP Fast Charge.¹⁵
- Immerse yourself in on-screen visuals with a narrow-border design that maximizes the screen within a small chassis. Keep going and type comfortably even in dimly lit rooms with an optional backlit keyboard.⁸

HP Chromebook 14 G7 Enterprise Specifications Table



Available Operating Systems	Chrome OS™ with Chrome Enterprise Upgrade ⁸
Processor family	Intel® Celeron® processor
Available Processors ^{1,2}	Intel® Celeron® N4500 (up to 2.8 GHz burst frequency, 4 MB L3 cache, 2 cores) Intel® Celeron® N5100 (up to 2.80 GHz burst frequency, 4 MB L3 cache, 4 cores)
Display size (diagonal)	14"
Maximum memory	8 GB LPDDR4X-4266 SDRAM Memory soldered down.
Internal storage	32 GB up to 64 GB eMMC 5.0 ³
Display ^{6,7}	14" diagonal, FHD (1920 x 1080), touch, IPS, anti-glare, 250 nits, 45% NTSC 14" diagonal, HD (1366 x 768), touch, narrow bezel, anti-glare, 250 nits, 45% NTSC 14" diagonal, HD (1366 x 768), narrow bezel, anti-glare, 250 nits, 45% NTSC 14" diagonal, FHD (1920 x 1080), IPS, anti-glare, 250 nits, 45% NTSC
Available Graphics	Integrated: Intel® UHD Graphics ⁶
Audio	HD audio, dual speakers, dual array microphones
Expansion slots	1 microSD (Supports SD, SDHC, SDXC.)
Ports and Connectors	2 SuperSpeed USB Type-A 5Gbps signaling rate; 1 SuperSpeed USB Type-C® 5Gbps signaling rate (USB Power Delivery, DisplayPort™ 1.4); 1 headphone/microphone combo; 1 HDMI 1.4
Available Keyboards ¹⁵	Spill-resistant, full-size, optional backlit, textured, flint silver Chrome keyboard
Available Pointing Devices	Clickpad with multi-touch gesture support, taps enabled as default
Communications ^{4,5,18}	(HP Extended Range Wireless LAN, MU-MIMO and Chromecast support) Intel® Wi-Fi 6 AX201 (2x2) and Bluetooth® 5 combo, non-vPro®
Camera ^{6,16}	720p HD privacy camera
Software ^{9,10}	Chrome Education Upgrade (Sold separately); HP Classroom Manager (Sold separately)
Security management ¹¹	Nano Security lock slot; Google Titan C
Fingerprint reader	Fingerprint reader not available
Power	HP Smart 45 W USB Type-C® adapter
Battery type ^{12,17}	HP Long Life 2-cell, 47 Wh Li-Ion polymer Battery is internal and not replaceable by customer. Serviceable by warranty. Fast charging 90% in 90 minutes.
Dimensions	12.85 x 8.93 x 0.72 in; 32.65 x 22.7 x 1.83 cm
Weight	Starting at 3.38 lb; Starting at 1.54 kg (Weight will vary by configuration.)
Energy efficiency compliance ¹⁴	ENERGY STAR® certified; EPEAT® 2019 registered where applicable. EPEAT® registration varies by country. See www.epeat.net for registration status by country.
Sustainable impact specifications ^{19,20}	Low Halogen; Outside box and corrugated cushions are 100% sustainably sourced and recyclable
Warranty ¹³	HP Services offers 1-year limited warranties and 90 day software limited warranty options depending on country. Batteries have a default one year limited warranty except for Long Life batteries which will have same 1-year or 3-year limited warranty as the platform. Refer to http://www.hp.com/support/batterywarranty/ for additional battery information. On-site service and extended coverage is also available. HP Care Pack Services are optional extended service contracts that go beyond the standard limited warranties. To choose the right level of service for your HP product, use the HP Care Pack Services Lookup Tool at: http://www.hp.com/go/cpc .

So, you just got
new classroom tech.
Let TRAILS help you
teach more effectively
with it.

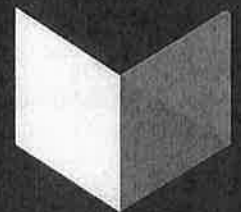

TRAILS
by TRAFERA

What is TRAILS?

TRAILS Digital Lesson Library is a powerful online resource for educators that helps connect the dots between new technology and real-world teaching experiences. Every TRAILS lesson within the library introduces a new app, tool, or concept that helps teachers build confidence in an increasingly tech-based classroom.

- ✓ Comprehensive, multi-lesson units (TRAIL Guides)
- ✓ Grab-n-go lessons (TRAIL Mix)
- ✓ Fun and engaging interdisciplinary activities

Developed by Teachers

and written by
accredited educators
passionate about
teaching with tech.

Virtual Learning Ready

and designed to work
for instruction both in
and out of the
classroom.

Carefully Aligned

to follow UDL guidelines
and ISTE standards and
peer reviewed for quality
assurance.



COMPUTER
SCIENCE

E.L.A.

MATH

SCIENCE

SOCIAL
STUDIES

ENGINEERING
& DESIGN



Empower teachers to transform instruction through tech fluency.

Do you ever think, “I have all this technology that I know I should be using with my students, but I don’t even know where to start!”? If so, you’re not alone!

TRAILS Digital Lesson Library was created by passionate educators just like you as a source of inspiration for ed-tech best practices. Every TRAILS lesson is tightly aligned to standards and packed full of fun and easy-to-use technology tools that **give your students the learning experiences they deserve.**

DIGITAL
CITIZEN-
SHIP

ART

CODING

HEALTH

PHYSICAL
EDUCATION

FOREIGN
LANGUAGE

Transform Learning Experiences.

A TRAILS learning experiences is noticeably different than a traditional lesson. It addresses learning standards in a fresh and exciting way using tools that will shape the way students learn, develop, and work throughout their education.



Broaden Teacher Tech Fluency.

Each lesson introduces new apps, tools, and ideas for building engaging classroom experiences around technology. This builds the capacity to genuinely engage students and close achievement gaps.



"We've had teachers who were paralyzed when it came to teaching with tech. With TRAILS, they were able to break out of their shells and adopt new technology enthusiastically!"

Johnny A. Hill | Educator | MA

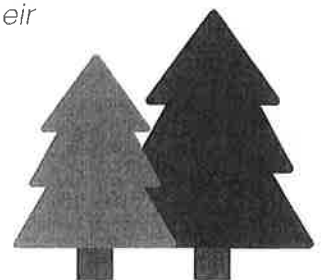

Free Demo! Give TRAILS a Try!

Share these lessons with fellow teachers to see if TRAILS is right for your school's classrooms.

TRY TRAIL Mix

Bite-sized lessons for Click or Brick

Length: Single Lesson (30-60 minutes)

These little lessons were designed to make technology use easy, approachable, and fun! Just like the real stuff, with TRAIL Mix, you can take just a small handful of tech lessons (or gobble up a whole lot!) to fuel your class' learning experiences.

[VIEW LESSON](#)

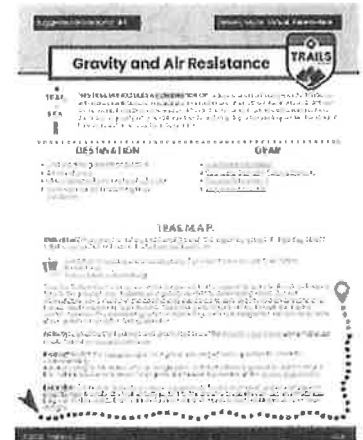

TRY TRAIL Guides

Multi-lesson learning adventures

Length: Full Unit (4-6 lessons)

These rigorous lessons follow the research based 5E Model of instruction, and are organized into 5-lesson thematic units that cover multiple weeks of instruction. TRAIL Guides are tightly aligned to Next Generation Science and ISTE Standards. Also, TRAIL Guides follow Universal Design For Learning guidelines to ensure they accommodate every learner.

[VIEW LESSON](#)

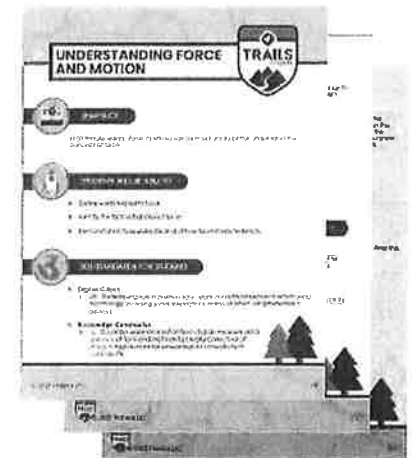



DITCH THE WASTE



TRAFERA GREEN PACK

GO GREEN WHEN YOU BUY FROM TRAFERA.

Wave good-bye to the mountain of cardboard. Instead of shipping in individual boxes, bulk-shipped devices arrive in palletized Gaylord-style boxes with slotted foam or cardboard dividers that can hold approximately 240 units each. Non-palletized options are also available for smaller bulk packaging orders.

Trafera Green Pack not only saves your hands from the pain of repeatedly opening hundreds of cardboard boxes, it also saves you the time and expense of disposing of all those empty boxes. Best of all, instead of sending them into the waste stream, we compress and bundle our leftover boxes into re-usable cardboard bails that get picked up by a local cardboard recycler.

Buying charging carts? Trafera can pre-wire the carts and ship your devices inside for a fully hands-free deployment. You may never have to touch your Chromebooks again!

Even more great solutions for your device deployment at www.trafera.com



**CONVENIENT,
ECO-FRIENDLY,
AND JUST PLAIN EASY.**

Just another reason why Trafera is the top favorite of schools everywhere for 1-to-1 student technology.

Trinity3 and FireFly are now Trafera!



TRAFERA

Support and Services



"This organization is high quality and founded on good values. They are our number 1 choice for purchasing technology as we find they present us with the best solutions, purchasing options, value and client service!"



Ramiro Salto
Serena Community UD #2, IL



In the 20+ years of being a technology coordinator for our school district, [Trafera] has been one of the best companies to work with. Their sales people are amazing. Their service and support are awesome.



Noel Erskine
Norris School District, NE



Before they ship

CHROMEBOOK FLEET SETUP

Premium White Glove

- Enroll in Google Apps domain
- Pre-configure WiFi settings
- Update Chrome OS to the latest stable release
- Basic testing to replace defective and DOA units
- Apply district specific settings and customizations
- Assign subsets of devices to specific OUs, if desired

Etching and Asset Tagging

- Customizable to your district

CARTS, CASES, AND MORE

Charging Carts and Cabinets

- Top manufacturers and models for education available
- Buy Chromebooks and Carts together for professional pre-wiring and in-cart shipping

Cases and Shells

- Devices pre-installed in cases or shells (by request)

CUSTOM SHIPPING

Bulk Packaging and Shipping

- Eco-friendly packaging saves time, money, and the pain (literally) of opening hundreds of boxes
- Paired with White Glove, it's the fastest, easiest way to distribute new devices.

trafera.com



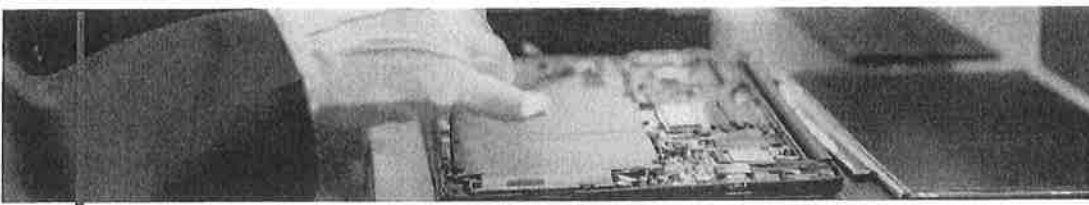

When they need repairs

WARRANTY SUPPORT

Trafera Warranties

- Single point of contact for all your warranty repair needs
- All logistics, shipping, and repairs are done by Trafera's in-house staff
- Warranty levels let you get as much or as little coverage as your school needs

Extended Warranties and Accident Damage

- Authorized Services Provider (ASP) for most manufacturers
- Fast turn-around times

Trafera Smart Ship

- Free shipping both ways for bulk-device repairs
- Convenient packaging provided, free of charge

ALTERNATIVE REPAIR OPTIONS

Trafera Smart Repair

- All the convenience of a warranty, but only pay for the repairs you need.
- Cause of breakage doesn't matter, there's no need for tracking down serial numbers, and you can use credits on any device, even if you didn't purchase it from us.
- Credits good for professional repairs and Chromebook parts

DIY Repair Kit

- Professional tools for two or more technicians to complete just about every Chromebook repair
- Get started with our free Student Repair Program Starter Guide

Chromebook Parts Store

- Online portal for finding and buying Chromebook parts

We're with you the whole time.

TRAFERA WARRANTIES



Trafera Silver Warranty

1-4 Year Warranty



Trafera Gold Warranty

1-4 Year Warranty with
Accidental Damage Protection (ADP)



Trafera Platinum Warranty

Premium 1-4 Year Warranty with
Accidental Damage Protection (ADP)



 trafera.com
 sales@trafera.com
 (651) 888-7922

Contact Trafera for more information



+



TRINITY3
TECHNOLOGY

are now...



TRAFERA



About Trafera

Bringing everything that was great about Trinity3 and FireFly together as Trafera means you'll have the undisputed industry leader in school and government technology as an advocate in your corner. As the new #1 provider of Chromebooks and classroom technology in North America, we'll be able to bring you even better prices, greater product availability, and a wider range of products and services, all without sacrificing the fast, personalized service you deserve.

Trafera is the best of both worlds, plus a whole lot more.



Your goals. **Our mission.**

Each student **connected**

- ✔ Devices & Accessories
- ✔ Software
- ✔ Security & Web Filtering
- ✔ Internet Access

Every teacher **empowered**

- ✔ Work-From-Home Solutions
- ✔ Interactive Flat Panels
- ✔ Digital Curriculum
- ✔ Professional Development
- ✔ Conferencing Tools

All needs **supported**

- ✔ Comprehensive Warranties
- ✔ Repairs
- ✔ White Glove Deployment
- ✔ Guides, Blogs, & Community
- ✔ Leasing & Buy-Backs



TRAFERA

@ trafera.com

📍 2550 University Ave W suite 315-S, St Paul, MN 55114

📞 (651) 888-7922



Hypertec Direct USA

1868 E. Broadway Rd
 Tempe, Arizona 85282
 United States
<http://www.hypertecdirect.com/>
 (P) 1-866-787-0426 (F) 480-626-9001

Customer Notes

Note that a 5% discount will be added for qty 1000

Quote # (Open)
Date Apr 19, 2022 08:43 AM MDT
Modified Date Apr 19, 2022 10:12 AM MDT
Quote # 75781 - rev 1 of 1
Description None
SalesRep Morin, Louis-Vincent (P) (+1) 418.683.2192 ext. 7208
Customer Contact

Customer

Hickman County School (HC13317)
 114 North Central Avenue, Suite 203
 Centerville, TN 37033
 United States

Bill To

Hickman County School
 114 North Central Avenue, Suite 203
 Centerville, TN 37033
 United States

Ship To

Hickman County School
 114 North Central Avenue, Suite 203
 Centerville, TN 37033
 United States

Shipping and Payment Info

Customer PO:

Special Instructions:

Terms:

Undefined

Ship Via:

FedEx Ground

Carrier Account #:

Products

#	Description	Part #	Tax Qty	Unit	Price	Total
1	Google Chrome OS Management Console License - academic	CROS-SW-DIS-EDU-NEW	Yes 1		\$32.98	\$32.98
2	Lenovo IdeaPad S145-14IWL 81MU Pentium Gold 5405U / 2.3 GHz - Win 10 Home in S mode - 4 GB RAM - 128 GB SSD - 14" 1366 x 768 (HD) - UHD Graphics - Wi-Fi 5, Bluetooth - gray IMR - kbd: US	81MU007NUS	Yes 1		\$278.76	\$278.76

Subtotal: \$311.74
 Tax (9.7500%): \$32.34
 Shipping: \$20.00
Total: \$364.08

Leasing and Extended Warranty Opportunities Available!

Hypertec Direct offers competitive leasing rates, ask us today for a quick quote. Extended warranties on our solutions are available upon request. Visit hypertecdirect.com/it-leasing-financing for more information.

Disclaimer

These prices do NOT include applicable taxes, insurance, shipping, delivery, setup fees, or any cables or cabling services or material unless specifically listed above. All prices are subject to change without notice. Supply subject to availability.

Terms and Conditions

All returns must be accompanied by original invoice and authorized RMA number

Hickman County Government

Conflict of Interest Disclosure Form

The County Financial Management System of 1981 contains the most stringent conflict of interest provisions. TCA §5-21-121 provides:

- (a) The director, purchasing agent, members of the committee, members of the county legislative body or other officials, employees, or members of the board of education or highway commission shall not be financially interested or have any personal beneficial interest, either directly or indirectly, in the purchase of any supplies, materials, equipment or contractual services for the county.
- (b) No firm, corporation, partnership, association or individual furnishing any such supplies, materials, equipment or contractual services, shall give or offer, nor shall the director or purchasing agent or any assistant or employee accept or receive directly or indirectly from any person, firm, corporation, partnership or association to whom any contract may be awarded, by rebate, gift or other otherwise, any money or other things of value whatsoever, or any promise, obligation or contract for future reward or compensation.

Date: April 18th 2022 Name: Louis-Vincent Morin

Please describe below any relationships, transactions, positions you hold (volunteer or otherwise), or circumstances that you believe could contribute to a conflict of interest:

I have no conflict of interest to report.

I have the following conflict of interest to report (please specify any boards or committees you (and/or your spouse) sit on, the name of your employer and any businesses you or your spouse may own.

I hereby certify that the information set forth above is true and complete to the best of my knowledge.

Date: April 18th 2022 Signature: 

Invitation to
Bid

The Hickman County Finance Office is accepting sealed bids for Chromebook Units and Chrome OS Management Service License.

Bid with specifications are online at: **www.hickmank12.org/request-for-proposal**.

All bidders will be required to submit a conflict of interest disclosure form that can be obtained at www.hickmank12.org/request-for-proposal.

Sealed bids must be mailed or delivered to the Hickman County Finance Office, 114 North Central Avenue, Suite 203, Centerville, TN 37033 and clearly marked on the outside of the envelope "Chromebooks and Chrome Management Licenses". Bids will be opened on Monday, April 25th, 2022 at 10:00 a.m. in the Finance Office.

The Hickman County Board of Education reserves the right to accept or reject any and all bids or parts of bids and to waive any informalities that would prevent the acceptance of a better bid.

Hickman County Government

Conflict of Interest Disclosure Form

The County Financial Management System of 1981 contains the most stringent conflict of interest provisions. TCA §5-21-121 provides:

- (a) The director, purchasing agent, members of the committee, members of the county legislative body or other officials, employees, or members of the board of education or highway commission shall not be financially interested or have any personal beneficial interest, either directly or indirectly, in the purchase of any supplies, materials, equipment or contractual services for the county.
- (b) No firm, corporation, partnership, association or individual furnishing any such supplies, materials, equipment or contractual services, shall give or offer, nor shall the director or purchasing agent or any assistant or employee accept or receive directly or indirectly from any person, firm, corporation, partnership or association to whom any contract may be awarded, by rebate, gift or other otherwise, any money or other things of value whatsoever, or any promise, obligation or contract for future reward or compensation.

Date: 04/19/22 Name: Phillip DRAUG

Please describe below any relationships, transactions, positions you hold (volunteer or otherwise), or circumstances that you believe could contribute to a conflict of interest:

I have no conflict of interest to report.

I have the following conflict of interest to report (please specify any boards or committees you (and/or your spouse) sit on, the name of your employer and any businesses you or your spouse may own.

I hereby certify that the information set forth above is true and complete to the best of my knowledge.

Date: 04/19/22 Signature: 



ATTENTION:
Hickman County School District
Brad Gilbert

FROM:
Bluegrass Computer Systems, LLC
174 Saundersville Road, Suite 501
Hendersonville, TN 37075

SUBJECT:

Request for Proposal - Chromebooks and Chrome OS Licenses

HP 14" - 4GB DDR, 32GB eMMC, Chrome OS, 1yr Warranty

- \$298 per unit

Google Chrome EDU Perpetual License

- \$38 per license

Total Price Per unit with license

- \$336

Notes

Price includes enterprise enrollment, asset tagging/configuration and delivery

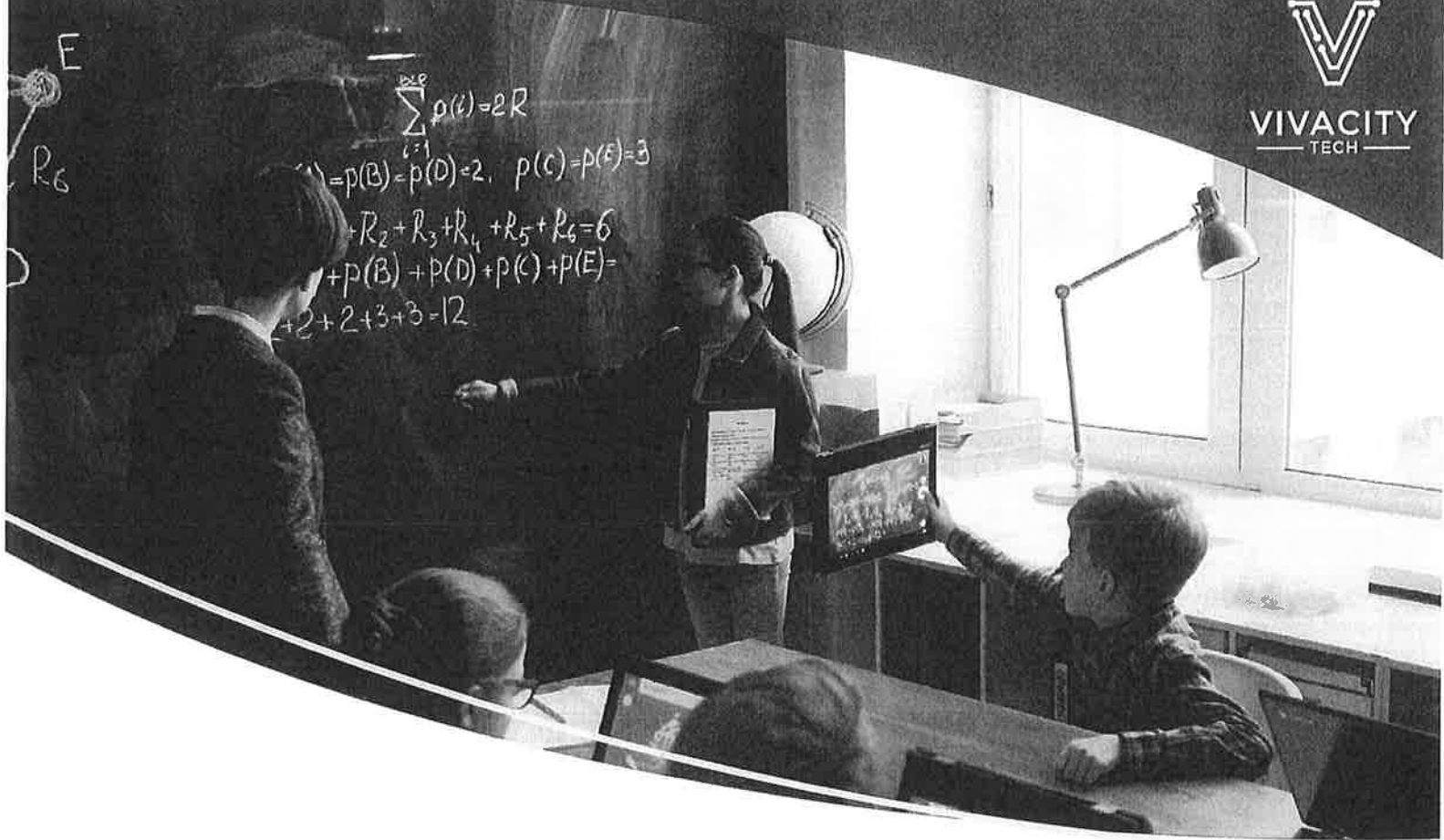

Buy Better.

Providing Mobile Device Deployment
Solutions to Schools Everywhere

Prepared For:

Hickman County Board of Education

ITB: Chromebook Units and Chrome OS Management Service License

HELLO!

THANK YOU for considering Vivacity Tech PBC as your new partner. We are confident that our team and award-winning products cannot only help you achieve your one-to-one deployment goals, but also get you the lowest cost Chromebook bundle on the market.

We've worked hard to align our products and services with our customer's needs to ensure that our solutions have a real impact on their bottom line, without compromise.

With only three years in the industry, we've made an impact in thousands of school districts across the country – ranging from 500 students to 23,000. We've built a team of problem-solvers, passionate about students' success and driven to help with all of our customers' technology needs. We look forward to doing the same for you.

INCLUDED IN THIS PACKET

- Full Quote and Requested Bid Documents
- About Vivacity Tech
- Sales Representative Bio
- Products, Services, and Repairs
- Customer Central
- Green Shipping Info
- References and Testimonials
- Greenville, SC Team

WELCOME TO VIVACITY

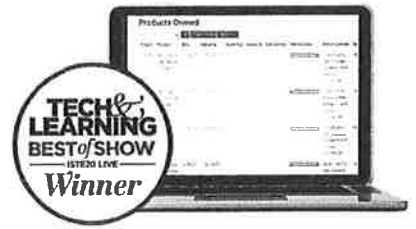

Hickman County Government

Conflict of Interest Disclosure Form

The County Financial Management System of 1981 contains the most stringent conflict of interest provisions. TCA §5-21-121 provides:

- (a) The director, purchasing agent, members of the committee, members of the county legislative body or other officials, employees, or members of the board of education or highway commission shall not be financially interested or have any personal beneficial interest, either directly or indirectly, in the purchase of any supplies, materials, equipment or contractual services for the county.
- (b) No firm, corporation, partnership, association or individual furnishing any such supplies, materials, equipment or contractual services, shall give or offer, nor shall the director or purchasing agent or any assistant or employee accept or receive directly or indirectly from any person, firm, corporation, partnership or association to whom any contract may be awarded, by rebate, gift or otherwise, any money or other things of value whatsoever, or any promise, obligation or contract for future reward or compensation.

Date: 4-20-2022 Name: Eli J. Maloley

Please describe below any relationships, transactions, positions you hold (volunteer or otherwise), or circumstances that you believe could contribute to a conflict of interest:

I have no conflict of interest to report.

I have the following conflict of interest to report (please specify any boards or committees you (and/or your spouse) sit on, the name of your employer and any businesses you or your spouse may own.

I hereby certify that the information set forth above is true and complete to the best of my knowledge.

Date: 4-20-2022 Signature: 



Vivacity Tech PBC
Chromebook Price Proposal
Hickman County School District
ITB: Chromebook Units and Chrome OS Management Service Licenses

Product and SKU	1-1000+ Units
HP 14 G7 Chromebook (3V2U9UT) Including White Glove Enrollment Services and Asset Tagging, and Green Shipping	\$279.00
Google Chrome Management License (CROSSWDISEDUNEW)	\$31.00



HP Chromebook 14 G7

An essential Chromebook for education and frontline work

Power through the day with the durable HP Chromebook 14 G7 and its manageable, secure, and intuitive Chrome OS. The latest Intel® Celeron® processor¹, large 14" diagonal screen, long battery life, and HP docking support² enhance productivity.

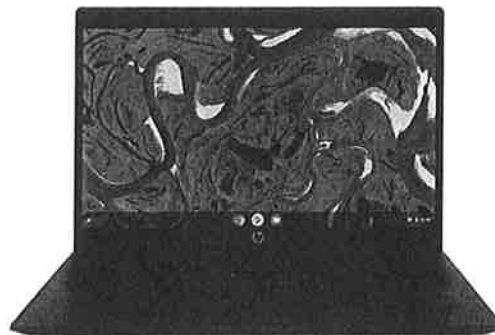

Designed for maximum productivity

- Combine dynamic features driving this 14" Chromebook with Chrome apps and easily execute tasks and workflows. Powered by the latest Intel® Celeron® processor¹, up to 8 GB memory⁸, 128 GB storage⁴, and a fast-charge battery for mastering through long days.

Ultralight and durable for long-lasting mobility

- Get a hard-wearing Chromebook at less than 19 mm (.748 in) thin. Feel confident carrying a device that undergoes MIL-STD 810H testing⁶, has reinforced USB-C® ports, and features a wipeable keyboard⁷ that withstands spills up to 350 ml (11.8 oz).

Designed for easy collaboration

- Collaborate with a narrow bezel display, optional wide-viewing angle IPS touchscreen⁸, wide-angle HD webcam, and dual mics for a better video conferencing experience. Add your display, projector, or accessories with HDMI and USB-C®.⁹
- Breathe easy with the low-maintenance, highly manageable, and secured Chrome OS. With automatic software updates through June 2029 and built-in anti-virus protection, your device is protected and up to date.¹⁶
- The perfect combination of performance, power consumption, and value handles multiple assignments smoothly and reliably with up to four processing cores to divide up the work.¹
- Undergoes MIL-STD 810H combined with HP Total Test Process to ensure this Chromebook exceeds HP durability and reliability standards—helping reduce total cost of ownership.^{6,11}
- Increase productivity without hassle. Connect to additional displays and projectors with an HDMI port that helps reduce dongle and cable clutter.
- Work from almost anywhere with a fast, reliable wireless connection. Get enhanced connectivity even on crowded wireless networks at a long range with Wi-Fi 6 WLAN module, supporting MU-MIMO and HP Extended Range Wireless LAN.^{12,13,14}
- Enjoy the freedom to unplug and work at different sites throughout the day with a long-running battery. Charge to 90% battery life in 90 minutes with HP Fast Charge.⁵
- Immerse yourself in on-screen visuals with a narrow border design that maximizes the screen's view within a smaller chassis.
- Tested for 1000 cleanings, the keyboard of this Chromebook can be wiped down using commonly available household disinfecting and cleaning wipes.⁷
- Up to 8 GB RAM and 128 GB eMMC storage options allow staff, teachers, and students to access thousands of Android applications, complete tasks, and collaborate with others.^{4,8,15}
- Keep going even in dimly lit rooms or aboard red-eye flights. With an optional illuminated keyboard, you can type comfortably in more environments.⁸

HP Chromebook 14 G7 Specifications Table



Available Operating Systems	Chrome OS™
Processor family	Intel® Celeron® processor
Available Processors ^{1,2}	Intel® Celeron® N4500 (up to 2.8 GHz burst frequency, 4 MB L3 cache, 2 cores); Intel® Celeron® N5100 (up to 2.80 GHz burst frequency, 4 MB L3 cache, 4 cores)
Maximum memory	8 GB LPDDR4X-4266 SDRAM Memory soldered down.
Internal storage	32 GB up to 64 GB eMMC 5.0 ³
Display size (diagonal, metric)	35.6 cm (14")
Display	35.6 cm (14") diagonal, FHD (1920 x 1080), IPS, anti-glare, 250 nits, 45% NTSC; 35.6 cm (14") diagonal, HD (1366 x 768), narrow bezel, anti-glare, 250 nits, 45% NTSC; 35.6 cm (14") diagonal, FHD (1920 x 1080), touch, IPS, anti-glare, 250 nits, 45% NTSC ^{6,7}
Available Graphics	Integrated: Intel® UHD Graphics ⁵
Audio	HD audio, dual speakers, dual array microphones
Wireless technologies	(HP Extended Range Wireless LAN, MU-MIMO and Chromecast support)
Expansion slots	1 microSD (Supports SD, SDHC, SDXC)
Ports and Connectors	2 SuperSpeed USB Type-A 5Gbps signaling rate; 1 SuperSpeed USB Type-C® 5Gbps signaling rate (USB Power Delivery, DisplayPort™ 1.4); 1 headphone/microphone combo; 1 HDMI 1.4
Input devices	Spill-resistant, full-size, optional backlit, textured, flint silver Chrome keyboard ¹⁵ ; Clickpad with multi-touch gesture support, taps enabled as default;
Communications	Intel® Wi-Fi 6 AX201 (2x2) and Bluetooth® 5 combo, non-vPro®;
Camera	720p HD privacy camera ^{6,16}
Software	Chrome Education Upgrade (Sold separately); HP Classroom Manager (Sold separately) ^{9,10}
Security management	Nano Security lock slot; Google Titan C ¹¹
Fingerprint reader	Fingerprint reader not available
Power	HP Smart 45 W USB Type-C® adapter
Battery type	HP Long Life 2-cell, 47 Wh Li-ion polymer ^{12,17}
Dimensions	32.65 x 22.7 x 1.83 cm
Weight	Starting at 1.54 kg (Weight will vary by configuration.)
Energy efficiency compliance	ENERGY STAR® certified; EPEAT® 2019 registered where applicable. EPEAT® registration varies by country. See www.epeat.net for registration status by country. ¹⁴
Sustainable impact specifications	Low Halogen; Outside box and corrugated cushions are 100% sustainably sourced and recyclable ^{18,19}
Warranty	1 year (1-1-0) limited warranty and service offering includes 1 year of parts and labor. Terms and conditions vary by country. Certain restrictions and exclusions apply.

HP Chromebook 14 G7

Messaging Footnotes

- ¹ MultiCore is designed to improve performance of certain software products. Not all customers or software applications will necessarily benefit from use of this technology. Performance and clock frequency will vary depending on application workload and your hardware and software configurations. Intel's numbering, branding and/or naming is not a measurement of higher performance.
- ² HP docks sold separately.
- ⁴ Up to 128GB is an optional feature that must be configured at purchase. For storage drives, GB = 1 billion bytes. Actual formatted capacity is less. Up to 8.1 GB is not user accessible.
- ⁵ Recharges the battery up to 90% within 90 minutes when the system is off or in standby mode, when used with the power adapter provided with the mobile thin client, and no external devices are connected. After charging has reached 90% capacity, charging speed will return to normal. Charging time may vary +/-10% due to system tolerance.
- ⁶ MIL-STD testing is not intended to demonstrate fitness for U.S. Department of Defense contract requirements or for military use. Test results are not a guarantee of future performance under these test conditions. Accidental damage requires an optional HP Accidental Damage Protection Care Pack.
- ⁷ The keyboards of the HP Education portfolio, including the HP Chromebook 14 G7, have been tested to 1,000 wipes to be cleaned with Windex® Original Glass & Surface Wipes and Clorox® Disinfecting Wipes with EPA Registration Number 5813-79. Do not use wipes on other surfaces of the product. See user guide for cleaning instructions.
- ⁸ Optional feature that must be configured at purchase.
- ⁹ HDMI and USB-C® cables sold separately.
- ¹¹ Test results are not a guarantee of future performance under these test conditions. Accidental damage requires an optional HP Accidental Damage Protection Care Pack.
- ¹² Wireless access point and Internet service required and sold separately. Availability of public wireless access points limited. Wi-Fi 6 (802.11ax) is backwards compatible with prior 802.11 specs. The specifications for Wi-Fi 6 are draft specifications and are not final. If the final specifications differ from the draft specifications, it may affect the ability of the notebook to communicate with other 802.11ax WLAN devices. Only available in countries where 802.11ax is supported.
- ¹³ Multiple-Input Multiple-Output (MU-MIMO) is a wireless technology that uses multiple transmitters and receivers to enhance data transfer. MU-MIMO requires a MU-MIMO router, sold separately.
- ¹⁴ Based on internal testing vs. previous generation product with 802.11ac wireless LAN module.
- ¹⁵ Internet access required and sold separately. Some apps may require purchase.
- ¹⁶ See <https://support.google.com/chrome/a/answer/6220366?hl=en> for more information.

Technical Specifications Footnotes

- ¹ MultiCore is designed to improve performance of certain software products. Not all customers or software applications will necessarily benefit from use of this technology. Performance and clock frequency will vary depending on application workload and your hardware and software configurations. Intel's numbering, branding and/or naming is not a measurement of higher performance.
- ² Processor speed denotes maximum performance mode; processors will run at lower speeds in battery optimization mode.
- ³ For storage drives, GB = 1 billion bytes, TB = 1 trillion bytes. Actual formatted capacity is less. Up to 30 GB (for Windows 10) is reserved for system recovery software.
- ⁴ Wireless access point and Internet service required and sold separately. Availability of public wireless access points limited. Wi-Fi 6 is backwards compatible with prior 802.11 specs. The specifications for Wi-Fi 6 (802.11ax) are draft and are not final. If the final specifications differ from the draft specifications, it may affect the ability of the notebook to communicate with other 802.11ax devices.
- ⁵ Chromecast must be purchased separately.
- ⁶ HD content required to view HD images.
- ⁷ Resolutions are dependent upon monitor capability, and resolution and color depth settings.
- ⁸ Based on internal testing vs. previous generation product with 802.11ac wireless LAN module.
- ⁹ HP Classroom Manager is sold separately. Control and device locking from the teacher's desktop requires purchase of HP Classroom Manager.
- ¹⁰ Chrome Education Upgrade requires one-time setup, subscription, Google Admin Console, and your organization's domain. Please see <https://support.google.com/a/answer/60216>.
- ¹¹ Lock is sold separately.
- ¹² Recharges up to 90% within 90 minutes when the system is off or in standby mode when used with the power adapter provided with the notebook. After charging has reached 90% capacity, charging will return to normal. Charging time may vary +/-10% due to system tolerance.
- ¹³ HP Care Packs are sold separately. Service levels and response times for HP Care Packs may vary depending on your geographic location. Service starts on date of hardware purchase. Restrictions and limitations apply. For details, visit www.hp.com/go/cpc. HP services are governed by the applicable HP terms and conditions of service provided or indicated to Customer at the time of purchase. Customer may have additional statutory rights according to applicable local laws, and such rights are not in any way affected by the HP terms and conditions of service or the HP Limited Warranty provided with your HP Product.
- ¹⁴ Based on US EPEAT® registration according to IEEE 1680.1-2018 EPEAT®. Status varies by country. Visit www.epeat.net for more information.
- ¹⁵ Backlit keyboard is an optional feature.
- ¹⁶ 720p HD Privacy camera is optional and must be configured at purchase.
- ¹⁷ Actual battery Watt-hours (Wh) will vary from design capacity. Battery capacity will naturally decrease with shelf life, time, usage, environment, temperature, system configuration, loaded apps, features, power management settings and other factors.
- ¹⁸ External power supplies, power cords, cables and peripherals are not Low Halogen. Service parts obtained after purchase may not be Low Halogen.
- ¹⁹ 100% outer box packaging and corrugated cushions made from sustainably sourced certified and recycled fibers.

Sign up for updates hp.com/go/getupdated

© Copyright 2021 HP Development Company, L.P. The information contained herein is subject to change without notice. The only warranties for HP products are set forth in the express limited warranty statements accompanying such products. Nothing herein should be construed as constituting an additional warranty. HP shall not be liable for technical or editorial errors or omissions contained herein.

Intel, Celeron and Intel vPro are trademarks or registered trademarks of Intel Corporation or its subsidiaries in the United States and other countries. DisplayPort™ and the DisplayPort™ logo are trademarks owned by the Video Electronics Standards Association (VESA®) in the United States and other countries. USB Type-C® and USB-C® are registered trademarks of USB Implementers Forum. © 2020 Google LLC All rights reserved. Google and the Google Logo are registered trademarks of Google LLC.

March 2021





OUR STORY

Our story began in the Spring of 2018 with a single device case and a vision to be an all-inclusive K-12 EdTech solutions provider. Today, we are privileged to serve over 2,000 school districts nationwide ranging in all sizes. How did we achieve this growth in a few short years? By doing business better.

When industry veteran and CEO, Eli Maloley, brought Vivacity Tech to life he did so by setting the foundation of the company on one solid principle: Be Better. Provide better service, better products, and better solutions at a better value; all while bettering society.

Since our inception, we've worked tirelessly to achieve this goal. We've brought all services under one roof, keeping costs low and streamlining the buyer's journey in the process. We've opened two full Chromebook repair centers, cultivated top-tier partnerships with leading Chromebook manufacturers and recently increased our customer reach with a second office in Greenville, South Carolina.

We've hired a slew of product engineers and designers to manufacture a full suite of storage solutions including smart charging carts, cabinets and device cases along with Chrome-

book accessories. We've added curriculum developers to our team and offer a Student Repair Academy giving students hands-on training and certifications to repair broken mobile devices. Finally, to round out the total one-to-one deployment package, we developed our very own award-winning asset management software, Customer Central.

We stand out for bringing unrivaled energy and innovation to the EdTech industry, giving back along the way, all for the sake of education and our customers.



MISSION

At Vivacity Tech our mission is to provide 1:1 mobile device deployment solutions with the most value. We want to be a single source EdTech solutions provider, streamlining the deployment process. It is absolutely important to us that we make the buying experience for schools everywhere vivacious.

To do this we took our first step forward by becoming a manufacturer/Value Added Reseller hybrid. Vivacity combined manufacturing, distribution, and services under one roof. This cuts the middleman out at every step bringing the lowest cost products to the customer in the most efficient way.

VALUES

1.

BE BETTER

Vivacity was founded on this notion. The goal is to strive to outperform the competition and be the best option for our customers in every way, every time. Settling is not an option.

2.

CARRY PASSION

Enjoying a profession makes it worth doing and drives better results. Everyone in our company is encouraged to find what they love and nurture those skills and ambitions.

3.

KEEP DREAMING

We live life outside of the box. Taking risks and thinking big to achieve what has yet to be done is what we strive for. No goal is unattainable.

4.

GIVE FORWARD

As the first and only PBC in the EdTech industry it is important to us that we foster the communities around us. We want our donations and our partnerships to cultivate a culture of giving and helping others.

5.

STAY VIVACIOUS

Our team members are bright, upbeat people who want to spread positivity through their work. We do away with the boring and drab and lean into fun and free spirited.

QUICK FACTS

Headquarters:
**St. Paul,
Minnesota**

100%
VIVACIOUS

Hours spent
Volunteering
3360

Second Location:
**GREENVILLE,
SOUTH CAROLINA**

2000
Districts Served

\$6000
Donated toward
scholarships

0
Boring meetings had

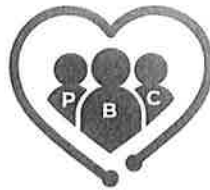

\$100,000+
IT equipment donated

35
Partner Distribution
Centers

Adding
**3 NEW SCHOOL
DISTRICT**
Customers Daily

Partnership with
**ST. PAUL RIGHT
TRACK PROGRAM**

QUICK FACTS

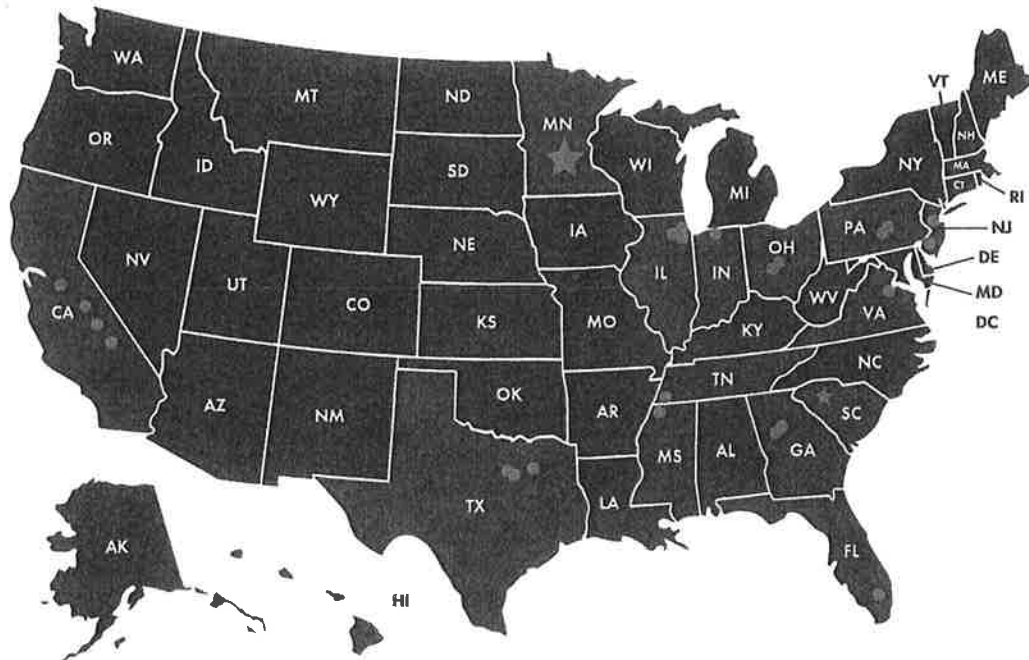



OUR TEAM

At Vivacity Tech, we're passionate about creating an inclusive company culture that values and promotes diversity. We believe a diverse workplace drives better value, better decisions and better products. To that end, we've cultivated a gender-balanced leadership team, hired diversity consultants to help ensure we stay on par with our company initiatives and established a partnership with the city of St. Paul to give under-resourced youth on-the-job training and professional development. We believe building a team from the ground up that is diverse in people, perspectives and experiences allows us to make smarter business decisions.

Public Benefit Corporations have what's called a Triple-Bottom-Line; "People, Planet, Profits" – in that order. From Professional Development allowances to robust benefits to incredible incentives, we ensure our People are taken care of. What's really cool? Our desire for excellence. The passionate, collaborative and friendly environment is tangible as we ensure our teammates succeed in doing what we do best – driving change for the better.



Megan Lokuta
Regional Sales Manager

BACKGROUND

Megan started with Vivacity Tech when it was only ten months old at the time and she had decided to change career paths. She dove into a new position and new company head first. Since starting with Vivacity Tech, Megan has proven to be an energetic and passionate sales consultant. She loves meeting new people and helping clients get the best deal while providing first rate customer service. She currently manages hundreds of accounts as the Account Executive of the North East region of the US.

EDUCATION

Megan started her professional career as an Exercise Physiologist in cardiopulmonary rehab. She obtained her Bachelors of Science and her Masters Degree from Bloomsburg University of Pennsylvania. With a passion for healing through exercise, this was the perfect place to start. After three years in the medical field, Megan decided to leave the hospital behind and change careers. This led her on the path to find Vivacity Tech.

GET TO KNOW MEGAN

Megan was born and raised in Northeastern PA, which is 10 minutes from Scranton for any Office fans. She loves anything outdoors, from snowboarding to hiking and rock climbing, to archery, fishing, boating, and four-wheeling. Traveling and exploring are her favorite, and she considers herself an exercise enthusiast. She also has a fur baby named Levi who's an Irish Doodle and her best buddy!

Contact Megan

megan@vivacitytech.com or (612) 504-7071



SOLUTIONS FROM THE START

We're your trusted partner for the long haul—before, during and after your purchase has been completed. Vivacity Tech is a national leader in 1:1 deployments for K-12 school districts. Our unique hybrid manufacturing and reselling approach allows us to deliver the smoothest, most affordable Chromebook deployments anywhere in the nation.

Deploying Chromebooks is the heart of our company, and we have specialized our services for streamlining this process. From consultation to successfully getting devices into your classroom, we offer the most value along with top-notch customer service every step of the way.

The process can be as customizable as needed. Devices can show up ready to be passed out from the box, with cases and charging carts already personalized and equipped for use. Or, if preferred, devices can arrive ready for some set up and organization before being handed to students.

Take a look into our process for turn-key 1:1 deployments.

PRE-DEPLOYMENT

1. HASSLE-FREE CONSULTATION

Our team of sales professionals meets with you to understand your school district's needs and helps determine the best deployment solutions for you.

2. ZERO-TOUCH SERVICES

With our customized in-house services, we can prepare your devices before they are shipped, allowing you to unbox and pass out devices as soon as they arrive. Our services include:



WHITE GLOVE CONFIGURATION



CUSTOM DEVICE ENGRAVING



ASSET TAGGING



HEAT TRANSFER

3. QUOTE

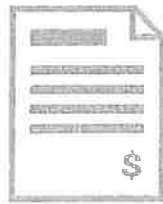

Our team can have quotes wrapped up in minutes and viewable in Customer Central or over email. Vivacity accepts purchase orders and offers quick credit checks for easy ordering.

4. ORDER

Let the fun begin! Log into Customer Central to check the status of your order every step of the way.

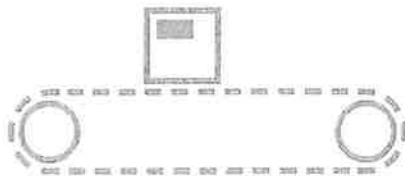

5. PRODUCTION

We'll get to work on your order and provide real-time updates on the production status in Customer Central.

6. SHIPMENT AND DELIVERY

Your shipment is on the way!



GREEN SHIPPING



QUALITY CONTROL

SERVICES PRE-DEPLOYMENT

POST-DEPLOYMENT



FREE, UNLIMITED CUSTOMER SUPPORT

In addition to having access to our full resource library and how-to videos, our certified technicians are available to help with any and all Chromebook needs.



DEVICE BUYBACKS

We buyback old, unwanted mobile devices of all makes, ages and conditions so your school district can replenish its budget and purchase new IT equipment.



SEAMLESS REPAIRS



VIVACITY REPAIR CENTER

Regardless of our pre-arranged service agreement, we've made the entire repair process as painless as possible from ticket submission to ticket tracking to repair turnaround times.



STUDENT REPAIR ACADEMY

SRA is Vivacity-developed curriculum intended to fully train students in becoming certified technicians and repair your devices in house.

SERVICES POST-DEPLOYMENT

VIVACITY TECH REPAIR CENTERS

Vivacity Tech repair centers are authorized service providers for **HP, Lenovo, Dell, Acer, ASUS, Safeware** and **Worth Ave Group**, with technicians who are highly trained. Customer Central, our asset management software, provides full visibility into the repair process. Create a repair ticket, ship the device to us for service, and monitor the status of the repair through the dashboard.

From start to finish the entire repair process including diagnostic averages at 30-45 minutes per repair. Our Bench Rate is \$15.00 per 15 minutes of diagnostic/repair. Our turn around is 1-2 business days for a standard repair so long as the parts are in stock at our repair center. If the parts are not in stock they are ordered as soon as possible and the repair is completed once the part arrives.

REPAIRS STEP BY STEP

1. DAMAGE CHROMEBOOK



We know accidents happen and that sometimes devices get damaged. No matter what the problem Vivacity will help you find the best solution for repair.

2. CREATE REPAIR TICKET IN CUSTOMER CENTRAL

Next step is to create a repair ticket. Log into Customer Central, go to the Products Owned tab and find the device that needs repair and select Submit Repair Ticket or find the device by serial number. Once the device is selected fill out the appropriate information and submit.

3. CONNECT WITH SUPPORT ABOUT SHIPPING

Our Support team will reach out once the ticket is received to discuss getting a shipping box and label sent out.

4. MAIL DEVICE TO REPAIR CENTER

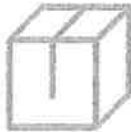

Once the device is ready to ship, put it in the mail and it will make its way to our nearest repair center.

5. TRACK WITH CUSTOMER CENTRAL

Once the device has arrived to us via mail, track its repair progress using Customer Central. See updated information about where the device is within the repair system from beginning to end and all the details in-between.

6. VIVACITY TECH REPAIRS

From start to finish the entire repair process including diagnostic averages at 30-45 minutes per repair. Our Bench Rate is \$15.00 per 15 minutes of diagnostic/repair.



7. FIXED DEVICE IS SHIPPED BACK

Repairs take 1-2 business days on average and are sent back once the device has been fixed.



8. PRICING (COSTS VARY)

Depending on the damage and what warranty coverage was chosen, the price of the repair will be invoiced and be accessible through Customer Central.

REPAIRS STEP BY STEP

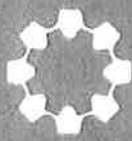

STUDENT BENEFITS

- Basic fundamentals of a computing device; including components, software, hardware and troubleshooting tactics
- Managing a healthy repair workflow including; how to create support tickets and techniques for tracking and documentation
- How to repair school issued devices to help operate a student-led repair center
- Safety and best practices of a computer technician along with proper usage of tools
- The 4C's of the 21st Century – Communication, Collaboration, Critical Thinking, and Creativity
- Customer service skills and traits of working as a team member

DISTRICT BENEFITS

- Utilize students to assist tech staff in maintaining their fleet of Chromebooks
- Minimize downtime for damaged devices
- Reduce money spent shipping devices to repair centers
- Give students a platform for hands-on learning

MODULES INCLUDE

- **FUNDAMENTALS OF COMPUTING**
Discusses concepts related to types of computers, the evolution and history of computers, operating system functions, hardware, software, Chromebook components and more.
- **BEST PRACTICES AND ESSENTIAL SKILLS OF A TECHNICIAN**
Demonstrates customer service traits and professionalism, effective communication skills, critical thinking, collaboration, leadership skills, personal safety, troubleshooting tactics, and skills to adapt to challenges.
- **REPAIR TICKET MANAGEMENT (& INTRO TO STUDENT REPAIR CENTER)**
Instruction on how to log tasks, perform diagnostics, deploy and inventory 1:1 devices, manage a healthy workflow, develop techniques for tracking and documenting tickets.
- **TROUBLESHOOTING CHROMEBOOK HARDWARE AND SOFTWARE PROBLEMS**
Demonstrates concepts related to troubleshooting methodology, performance, physical damage, touchscreens, application issues, overheating and more.
- **CHROMEBOOK REPAIR GUIDES**
In depth training on how to repair specific HP and Lenovo Chromebooks, general terminology associated with parts, and required tools needed to perform repairs.

CHROMEBOOK REPAIR GUIDES INCLUDE:

HP 11A G6	HP 11A G7	Lenovo 100e
HP 14 G5	HP 11A G8	Lenovo 500e
HP X360	HP 11 MK G9	Lenovo 300e

If your district issued device is not listed above, please let us know and we will work to include this offering in our certification program.



CUSTOMER CENTRAL

CUSTOMER CENTRAL

Customer Central is our customizable asset management software.

INVENTORY MANAGEMENT

Easily track and manage your IT assets in our user-friendly dashboard. We'll automatically upload devices you purchase from us into your Customer Central account.

REAL-TIME ORDER STATUS

View your order status in real-time. Whether your order is in preliminary stages, production or shipment, you'll have full visibility and tracking information every step of the way.

ORDER AUDIT TRAIL

Every purchase order, quote and invoice can be viewed through your Customer Central account. Our optimized dashboard allows you to keep track of every transaction you've ever made with us.

REPAIR TRACKING

Simplify your repair maintenance requests by submitting support tickets attached directly to your assets. Ship the device back to us for service and monitor the status of your repair through your dashboard.

RESOURCE LIBRARY

Easily troubleshoot repairs in-house with our full resource-library containing part specific repair videos.

USER ROLES

Give your entire team access down to the site level or limit permissions. Users can provide their team with only the dashboard they need.

CUSTOMER SUPPORT

Customer Central provides 24/7 access to your dedicated Account Manager's information and unlimited customer support.



GREEN SHIPPING

Making shipping easier for our customers and on the planet is a huge goal at Vivacity Tech. Because of this we implemented a green shipping initiative to cut down on waste, properly recycle materials, and streamline device deployment.

BENEFITS

- Saves time: Grab devices and pass them out from the box
- Affordability: At no additional cost to the customer
- Reduces original equipment manufacturer packaging waste
- Makes distributing mobile devices easier
- Convenient packaging safely ships devices and power adapters
- More sustainable solution for the environment

GREEN SHIPPING BOXES

- Capacity: 5 or 10 units fit comfortably per box
- 350 Chromebooks on 1 pallet
- Original equipment manufacturer materials are properly recycled with local recycling centers
- Optional service to send original equipment manufacturer boxes separately
- 10 Unit (in) - 22L x 14W x 11H
- 5 Unit (in) - 14L x 12W x 11H
- Packed with ❤️ in the USA



CUSTOMERS AND REACH

Vivacity Tech is a tech resource for schools and school districts all across the United States. Our Regional Sales Managers work all throughout the country to give the best service possible. We currently serve over 2,000 districts and on average add 3 school district customers each day. See the map below for a visual representation of Vivacity Tech's customer concentration and reach.

CUSTOMERS AND REACH

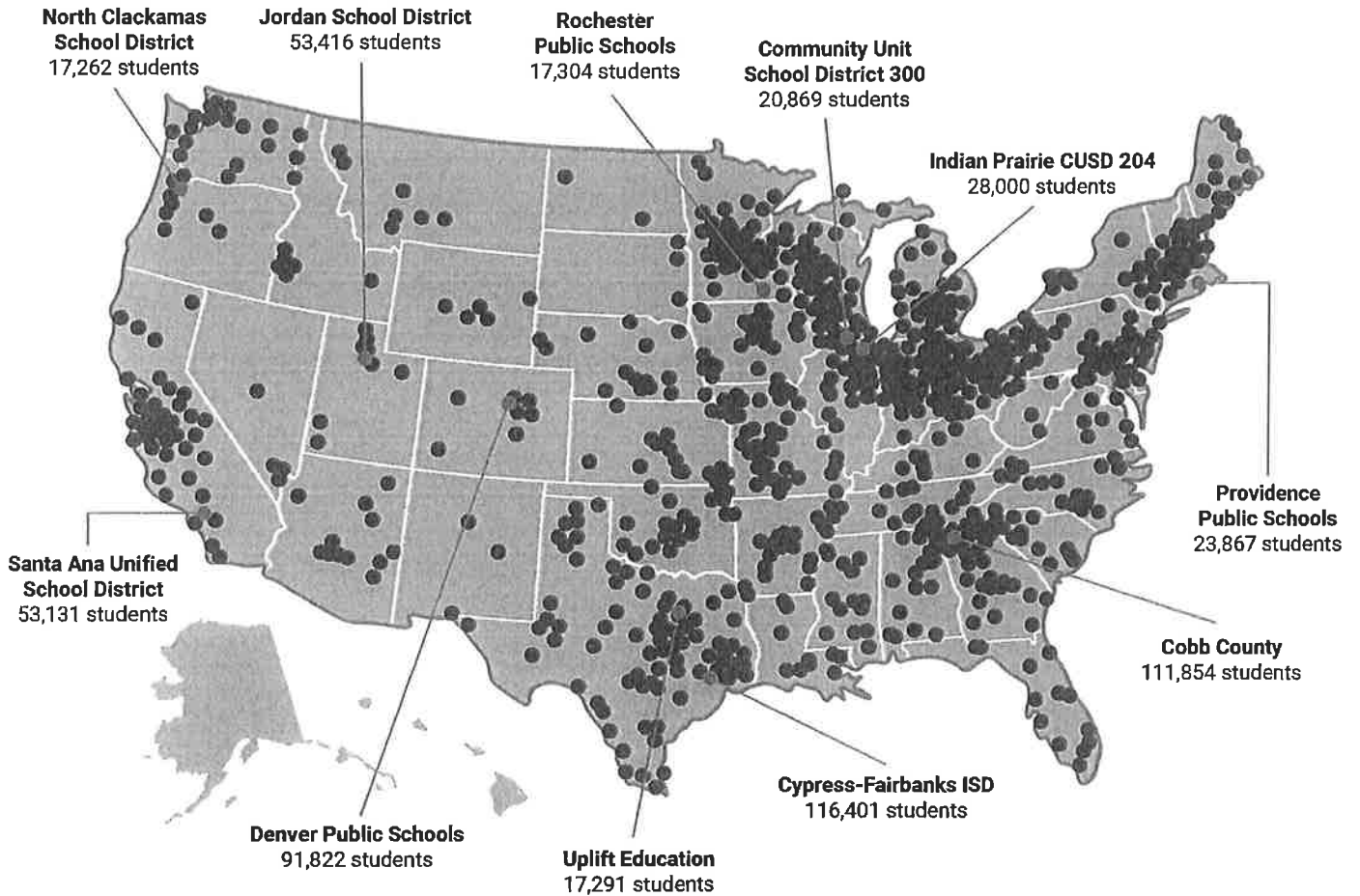



BUSINESS REFERENCES

WHITKO COMMUNITY SCHOOLS

Abby Spurlin, Device Manager

(260) 723-0594 or abby.spurlin@whitko.org

Project Overview: Whitko Community Schools purchased over 800 Chromebooks with Vivacity Tech Extended Warranties. Whitko also utilizes our free asset management software, Customer Central, and Vivacity Tech Repair Services. They have been customers with us for over 3 years.

COMMUNITY UNIT SCHOOL DISTRICT 300

Gary Krause, ADM Manager - IT/Operations

(847) 551-8331 or jgary.krause@d300.org

Project Overview: Community Unit School District 300 has purchased over 22,000 Chromebooks along with Vivacity Tech's Sidekick Carrier Cases and our Smart Charging Carts. District 300 uses our free asset management software, Customer Central and they are enrolled in our Student Repair Academy.

LENOIR CITY SCHOOLS

Chris Smallen, CTO

(865) 988-1934 or csmallen@lenoircityschools.net

Project Overview: Lenoir City Schools purchased over 1600 Chromebooks with Vivacity Tech Extended Warranties and Work-In Cases since Spring 2020. The district also utilizes our repair services.

INDIAN PRAIRIE SCHOOL DISTRICT

Brian Grinstead, Support Services Coordinator

(603) 375-3000 or brian_grinstead@ipspd.org

Project Overview: Indian Prairie School District purchased over 9,000 Chromebooks along with parts and accessories from Vivacity Tech. They chose to have White Glove service and Asset Tagging along with Green Shipping. IPSD has also taken advantage of our repair services and we have completed over 11,000 repairs for their district.



CUSTOMER TESTIMONIALS

KIM WILSON

Haralson County School District

My first experience with Vivacity started with just buying some Chromebooks for the school year. We trusted them with a few hundred Chromebooks and they delivered on all of our needs. They even had them set up and ready for students upon arrival. We were so happy with our order that we made another order for their 30 carrier smart carts to have in the classroom. They were amazing quality! Since then, I have yet to see anything better. They have the best carts, Chromebook cost, and outstanding customer service! Vivacity Tech has made my life easier and has provided for all of my students effortlessly.

THI KETHAVONG

Uplift Education

I've worked with Vivacity Tech for almost a year and a half and I have enjoyed every minute. Their customer service and satisfaction really sets them apart from other vendors! Our representative takes care of all of our Chromebook, charging cart, and case needs. She makes sure to communicate and is always available when we need her. I am looking forward to continuing to work with Vivacity for many years to come!

CARMEN WILSON

Crawford County School District

I have purchased several Chromebooks, carts, cabinets and cases from Vivacity and I am very impressed with all of the products I have received. Our sales representative is very knowledgeable and honest when selling us products. I appreciate their attention to detail and approach to giving us the best product at the best price. I particularly enjoy the 30 unit cart and the 12 unit wall cabinet from Vivacity. They are the lowest cost carts and cabinets on the market that I have seen and I am very impressed with the quality of them. Vivacity Tech is different from other EdTech companies because they have amazing products that are a great value, coupled with great customer service.

DENTON WAINWRIGHT

Taylor County School

I've enjoyed working with Vivacity Tech over the last year. They are super responsive to any request I may have. The products they manufacture are high quality and Vivacity stands behind every product they sell. They even have taken the time to listen to any product improvement ideas and implemented them when they are able. Their superior products, value, and customer service make them stand apart from other vendors I've worked with in the past.



SAY HELLO TO

VIVACITY GREENVILLE

GREENVILLE TEAM

In order to better serve our customers Vivacity Tech is branching out. Our Vivacity Greenville location in Greenville, South Carolina is an amazing opportunity to push forward in our mission to provide solutions with the best value.

This location offers a full pro-

duction center which includes in house services such as laser etching, embroidery, and white gloving. It will also serve as a full distribution center and a complete HP and Lenovo repair center.

Our team in Greenville is passionate about their work and

excited to form new partnerships. This office is filled with a diverse group of people with an immense amount of drive and experience. We are happy to be closer to our clients to be able to serve them faster, more efficiently, and more effectively.



Hickman County Finance Office
114 North Central Avenue, Suite 203
Centerville, TN 37033
Attn: Brad Gilbert, Technology Coordinator

CHROMEBOOKS & CHROME MANAGEMENT LICENSES

Index

Page 1-2	Company Profile
Page 3	Lenovo 14E Chromebook
Page 4	Delivery, Payment Terms, References

Prepared by:

Ken Kajja
System Liquidation Inc
1652 South 2nd Street
Plainfield, NJ 07063
Ph:908-668-0008 EXT:354
Toll Free: 1-833-547-4693
Fax:908-668-0088
Email: ken@systemliquidation.com
Website: www.systemliquidation.com

Company Overview

System Liquidation. is a Lenovo Authorized Business Partner and a leading provider of both new and refurbished information technology equipment. A Microsoft Authorized Gold Certified Partner and Refurbisher, we have access to millions of dollars of IT products from Tier 1 vendors like: HP, Dell, IBM, Lenovo, Samsung, and others. We have 2 warehouses-One 20,000 square foot located in New Jersey and 2nd 75,000 square foot located in Ontario, Canada. We sell our top-quality equipment to many verticals including: Government, Education, Healthcare, Manufacturers and Value-Added Resellers. System Liquidation Inc. offers a strategic approach to information technology resource management and provides a cost-effective IT solution to today's demanding marketplace. System Liquidation understands that corporate capital expenditures are continuously constrained by the ever-changing economic IT marketplace.

Background and Workforce

System Liquidation was founded in 2007 in Plainfield NJ. System Liquidation Inc and our sister company employ over 100 individuals who have a wide range of industry certifications including: MCSE's, CCNA's and A+. The number is expected to increase in the coming years. In addition to, our employee collectively has many years of relevant work experience with professional relationships within a multitude of industries. Our staff is also able to communicate in over 10 languages. This talented group of people possess post-secondary education in many fields including; Business, Computer Science, and Electronic Engineering.

Trust

We trust our customers implicitly and run our company accordingly. A good example is our warranty policy. When a customer needs to utilize the warranty, our clients simply tell us what parts are needed and we ship them. This way of thinking permeates through everything we do and the end result is that you never have to fight us to do what you want—we're always on the same side.

Deliverables & Willingness to Enter into Agreement

System Liquidation Inc. confirms that we can complete and execute the Deliverables outlined in our submission document. System Liquidation Inc. confirms that we are prepared to enter into an agreement with Hickman County Board of Education.

① kg

Financial and Business Viability

System Liquidation Inc. confirms that we have not:

- a) Declared bankruptcy or made a voluntary assignment in bankruptcy;
- b) Made a proposal under any legislation related to bankruptcy or insolvency; or,
- c) Been subject to or instituted any proceedings, arrangement, or compromise with creditors including having had a receiving and/or manager appointed to hold its assets.

Proof of Insurance

System Liquidation Inc. confirms that we are able to obtain Insurance Coverage for this assignment.

Deliverables

System Liquidation Inc. confirms that we can complete and execute the Deliverables outlined in our submission document.

Non-Collusion

System Liquidation Inc. certifies that this proposal is made without any previous understanding, agreement or connection with any person, firm, or corporation making a proposal for the same project, and is in all respects fair, without outside control, collusion, fraud, or otherwise illegal action.

Bid Compliance

System Liquidation Inc. has complied with all bid requirements and agrees to the terms and conditions as outlined in the bid document.

⑤ 

LENOVO 14E CHROMEBOOK

- AMD A4-9120C
- 1.6 GHz
- 4 GB RAM
- 32 GB eMMC
- 802.11a/b/g/n/ac, BT 4.2
- 2x USB 3.0 Ports
- 2x USB-C
- Webcam
- Micro SD Card Reader
- MIL-STD 810G Tested
- Up to 10 Hours
- White Glove Service – Google Enrollment, Asset Tags
- 1 Year Lenovo Warranty
- Brand New in the Box

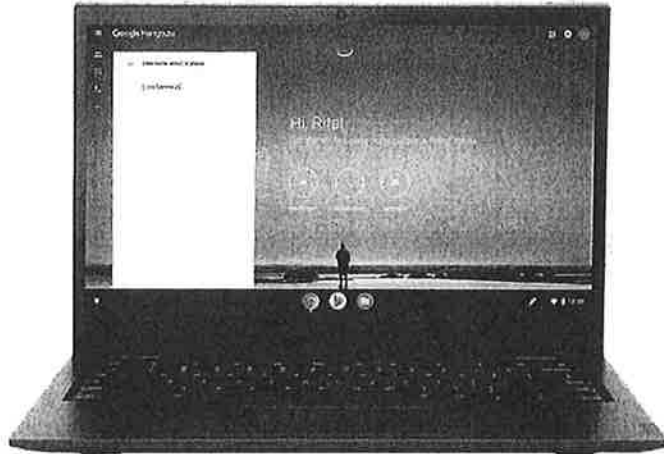

LENOVO 14E Chromebook

MFG Part Number	Description	Unit Price
81MH0006US	Lenovo 14 E Chromebook	\$227
CROSSWDISEDUNEW	Google Edu License	\$ 32
WHITE GLOVE	Enroll, Asset Tag	\$ 12
SHIPPING		NO CHARGE
TOTAL		\$271 / unit

System Liquidation
 1652, South 2nd Street
 Plainfield, NJ 07063

③

Delivery Time

System Liquidation Inc. will deliver product within 21 Days of Receipt of P.O. Product is in stock

Payment

System Liquidation will accept a Purchase order from the School District.

References

School District of Waukesha

Tim Mehling, Systems Administrator
tmehling@waukesha.k12.wi.us
262.970.1052

Royall School District

Justin Howe, Technology Director
howej@royall.k12.wi.us
608.462.2600

Arab City School District

Brian Quillin, Technology Coordinator
bquillin@arabcityschools.org
256.931.9321

Contact :

Ken Kajia

System Liquidation Inc
1652, South 2ND Street
Plainfield, NJ 07061
Ph: 908-668-0008 X 354
Fax: 908-668-0088
ken@systemliquidation.com

(4) / 19

Letter of Transmittal

April 21, 2022

Hickman County Schools
114 N Central Avenue, Suite 203
Centerville, TN 37033

RE: Chromebooks and Chrome Management Licenses

Dear: Hickman County Schools:

Howard Technology Solutions (a division of Howard Industries, Inc... **Federal ID Number 64-0466143** and SPIN 143022153) (Corporation) is pleased to offer a response to your RFP. Howard Technology Solutions has read and understands the bid and are able to provide the services requested. Howard Technology Solutions, with its 40+ years of manufacturing experience, is well versed in the manufacturing and production of technology products and services.

Howard Technology Solutions, a division of Howard Industries, Inc., was established in 1998 with our parent company being founded in 1968. Howard Technology Solutions currently employs approximately 4,531 employees. Howard Technology Solutions is driven by helping our customers understand technology products and services that could benefit their organizations.

HOWARDedu focuses solely on the needs of K-12 schools and higher education facilities, supplying them with affordable, advanced technology—everything from distance learning and interactive 21st Century classroom products to network security and storage solutions.

Howard Technology Solutions has the ability to meet all requirements of this RFP.

The office location that will serve as the main point of contact is Howard Technology Solutions at 36 Howard Dr., Ellisville, MS 39437. (Phone) 601.425.3181; (Email) bids@howardcomputers.com. Your point of contact for this RFP is: Brandey Boyd: Bids & Contract Manager, (Phone) 601.399.5831 (Fax) 601.399.5077 (Email) bboyd@howard.com.

36 Howard Drive • Ellisville, MS 39437
P.O. Box 1590 • Laurel, MS 39441

HOWARDTM
TECHNOLOGY SOLUTIONS

www.Howard.com

A Division of Howard Industries, Inc.

888.912.3151 general • 601.399.5077 fax
888.323.3151 technical support

TN K-12 Inside Sales Rep

Chris Hamm
601.399.5763
chamm@howard.com

TN K-12 Account Manager

Mike Scherer
865.507.6507
mscherer@howard.com

Sincerely,



Michelle Brady
Bid Specialist
Phone: 601.425.3181 Ext: 5772
Fax: 601.399.5077
Email: bids@howardcomputers.com

Invitation to
Bid

The Hickman County Finance Office is accepting sealed bids for Chromebook Units and Chrome OS Management Service License.

Bid with specifications are online at: **www.hickmank12.org/request-for-proposal**.

All bidders will be required to submit a conflict of interest disclosure form that can be obtained at www.hickmank12.org/request-for-proposal.

Sealed bids must be mailed or delivered to the Hickman County Finance Office, 114 North Central Avenue, Suite 203, Centerville, TN 37033 and clearly marked on the outside of the envelope "Chromebooks and Chrome Management Licenses". Bids will be opened on Monday, April 25th, 2022 at 10:00 a.m. in the Finance Office.

The Hickman County Board of Education reserves the right to accept or reject any and all bids or parts of bids and to waive any informalities that would prevent the acceptance of a better bid.

Bid Specifications for Chromebooks:

Chrome OS

14 inch screen (non-touch) preferred

4 GB RAM preferred

16 GB Hard Drive Size Preferred

Wireless Compatible

USB and HDMI ports available

Headphone Jack

Prices are to include shipping and handling charges for delivery, asset tagging/configuration. Chromebooks should be named and enterprise enrolled to the proper school in Google Admin Console as determined by Hickman County Schools.

Any color choice is determined by Hickman County Schools.

12 month support warranty for Chromebook

Questions should be directed to Brad Gilbert, Technology Coordinator, via e-mail at brad.gilbert@hickmank12.org

No exact number of chromebooks being ordered is available at this time. A price breakout dependent on quantity purchased will be accepted. Bid prices are expected to be good for one year unless noted otherwise in the bid.

Hickman County Government

Conflict of Interest Disclosure Form

The County Financial Management System of 1981 contains the most stringent conflict of interest provisions. TCA §5-21-121 provides:

- (a) The director, purchasing agent, members of the committee, members of the county legislative body or other officials, employees, or members of the board of education or highway commission shall not be financially interested or have any personal beneficial interest, either directly or indirectly, in the purchase of any supplies, materials, equipment or contractual services for the county.
- (b) No firm, corporation, partnership, association or individual furnishing any such supplies, materials, equipment or contractual services, shall give or offer, nor shall the director or purchasing agent or any assistant or employee accept or receive directly or indirectly from any person, firm, corporation, partnership or association to whom any contract may be awarded, by rebate, gift or otherwise, any money or other things of value whatsoever, or any promise, obligation or contract for future reward or compensation.

Date: 4.21.22 Name: Howard Technology Solutions
a division of Howard Industries, Inc.

Please describe below any relationships, transactions, positions you hold (volunteer or otherwise), or circumstances that you believe could contribute to a conflict of interest:

I have no conflict of interest to report.

I have the following conflict of interest to report (please specify any boards or committees you (and/or your spouse) sit on, the name of your employer and any businesses you or your spouse may own.

I hereby certify that the information set forth above is true and complete to the best of my knowledge.

Date: 4.21.22 Signature: Michelle Brady

Phone: 1.888.912.3151
 Fax: 1.601.399.5077
 Online: www.howardcomputers.com



Howard Computers
 P.O. Box 1588
 Laurel, MS 39441

Online Quotation

Quote No: CH5 1199829.00
Customer Name: Brad Gilbert
Company Name: Hickman County Schools
Quote Name: HP Chromebook with License

Quote Date: April 20, 2022
Phone Number: 9317293391
Fax Number:

Item 1

Category	Description	Qty.	Unit Price	Ext. Price
System Type:	Accessories			
1:	HP Chromebook 14 G7 - Celeron N4500 / 1.1 GHz - Chrome OS - UHD Graphics - 4 GB RAM - 32 GB eMMC - 14' 1366 x 768 (HD) - Wi-Fi 6 - jet black - kbd: US MPN: 3V2U9UT#ABA	1	\$288.00	\$288.00
2:	Google Chrome OS Management Console - License - academic MPN: CROSSWDISEDUNEW	1	\$32.00	\$32.00
3:	White Glove Services 2501+ MPN: WG5000	1	\$7.00	\$7.00
Sub-Total:				\$327.00
Shipping & Handling :				Included
Taxes:				Tax Exempt
Total for Item 1 :				\$327.00

This quote will expire May 20, 2022.
 To expedite your order, please include your quote number with your Purchase Order.

Total for all pre-configured items

Sub-Total:	\$327.00
Shipping & Handling :	Included
Taxes:	Tax Exempt
Total:	\$327.00

Notes:

Pricing and availability subject to change without notice. Packaging, Shipping, and Handling fees are not included unless specifically stated. Prices and lease payments do not include applicable taxes. Ship dates are approximations and are not guarantees. Quick ship items not available in Alaska, Hawaii, or outside the United States. Specific state laws may affect shipment of products.

Any order for kiosks must be canceled prior to 21 days from the scheduled date of shipment to avoid incurring a 50% cancellation fee. Any cancellation made within that 21-day window will automatically incur a charge equivalent to 50% of the total kiosk order being canceled.

Howard reserves the right to charge a 25% restocking fee for cancellation of a purchase order after Howard has commenced fulfillment of the order. Howard may, with notice, cancel any purchase order at any time without any liability to the Purchaser. Howard reserves the right to charge the Purchaser full purchase price for delaying shipment of a purchase order for an extended period of time which then results in the cancellation of said order.

Given the current uncertainties related to international trade, Howard hereby reserves the right to unilaterally revise the prices quoted herein in the event its manufacturing or procurement costs for such goods increase due to the imposition by the United States or any other country of new or higher tariff(s) or of any other similar tax, fee or charge.

If Purchaser fails to pay any invoice in full within the time quoted herein, Howard may, without notice, accelerate the due date of all outstanding invoices and require that all outstanding invoices, including any interest thereon, be immediately due and payable in full.

Howard's product warranties and return policies and related information, which are available at <https://www.howardcomputers.com/support/warranties.cfm> and <https://www.howardcomputers.com/support/returnpolicy.cfm>, are fully adopted and incorporated herein by reference. These may also be obtained by calling 1-888-912-3151 or emailing webmaster@howardcomputers.com.

THIS QUOTATION IS EXPRESSLY LIMITED TO, AND EXPRESSLY MADE CONDITIONAL ON, PURCHASER'S ACCEPTANCE OF THE TERMS SET FORTH OR INCORPORATED HEREIN; HOWARD OBJECTS TO ANY DIFFERENT OR ADDITIONAL TERMS.



HP Sales Central

HP Chromebook 14 G7 (3V2T8UT)

Active as of 2/25/2021



Overview

An essential Chromebook for education and frontline work

Power through the day with the durable HP Chromebook 14 G7 and its manageable, secure, and intuitive Chrome OS. The latest Intel processor¹, large 14" diagonal screen, long battery life, and HP docking support² enhance productivity.

Power through your day with the durable HP Chromebook 14 G7. It has Chrome OS with an Intel® processor¹, large screen, and long-running battery.

Designed for easy collaboration

Collaborate with a narrow bezel display with a wide-angle HD webcam and dual mics for a better video conferencing experience. Add your display, projector or accessories with HDMI and USB-C⁹.

Ultralight and durable for long-lasting mobility

Get a hard-wearing, ultra-thin Chromebook. Feel confident carrying a device that undergoes MIL-STD 810H testing⁶, has reinforced USB-C[®] ports, and features a wipeable keyboard⁷ that withstands spills up to 350 ml (11.8 oz).

Designed for maximum productivity

Combine dynamic features driving this 14" Chromebook with Chrome apps and easily execute tasks and workflows. Powered by the latest Intel® Celeron® processor¹, plenty of storage and memory, and a fast-charge battery⁵ for mastering through long days.

Specifications

Operating system

Chrome OS™

Processor family

Intel® Celeron® processor

Processor

Intel® Celeron® N4500 (up to 2.8 GHz burst frequency, 4 MB L3 cache, 2 cores)^{6,7,1}

Sustainable impact specifications

Low Halogen; Outside box and corrugated cushions are 100% sustainably sourced and recyclable

Security management

Nano Security lock slot; Google Titan C

Memory

8 GB LPDDR4x-4266 SDRAM (onboard)

Internal Storage

32 GB eMMC

Optical drive

Not included

Display

14" diagonal, HD (1366 x 768), touch, narrow bezel, anti-glare, 250 nits, 45% NTSC

Display size (diagonal)

14"

Graphics

Integrated

Graphics (integrated)

Intel® UHD Graphics

Ports

2 SuperSpeed USB Type-A 5Gbps signaling rate; 1 SuperSpeed USB Type-C® 5Gbps signaling rate (USB Power Delivery, DisplayPort™ 1.4); 1 headphone/microphone combo; 1 HDMI 1.4

Expansion slots

1 microSD

Camera

720p HD camera

Audio

HD audio, dual speakers, dual array microphones

Pointing device

Clickpad with multi-touch gesture support

Keyboard

Full-size island-style, spill and pick resistant keyboard

Wireless

Intel® AX201 Wi-Fi 6 (2x2) and Bluetooth® 5 combo, non-vPro®

Power

45 W USB Type-C™ adapter

Battery type

HP Long Life 2-cell, 47 Wh Li-ion polymer

Minimum dimensions (W x D x H)

12.85 x 8.93 x 0.72 in

Weight

Starting at 3.38 lb

UPC number

195908490869

Software included

Chrome Education Upgrade (Sold separately); HP Classroom Manager (Sold separately)⁹
¹⁰ 1

Manufacturer Warranty

HP Services offers 1-year limited warranties and 90 day software limited warranty options depending on country. Batteries have a default one year limited warranty except for Long Life batteries which will have same 1-year or 3-year limited warranty as the platform. Refer to <http://www.hp.com/support/batterywarranty/> for additional battery information. On-site service and extended coverage is also available. HP Care Pack Services are optional extended service contracts that go beyond the standard limited warranties. To choose the right level of service for your HP product, use the HP Care Pack Services Lookup Tool at: <http://www.hp.com/go/cpc>.¹³ 1

Overview

- 1 Multicore is designed to improve performance of certain software products. Not all customers or software applications will necessarily benefit from use of this technology. Performance and clock frequency will vary depending on application workload and your hardware and software configurations. Intel's numbering, branding and/or naming is not a measurement of higher performance.
- 2 HP docks sold separately.
- 5 Recharges the battery up to 90% within 90 minutes when the system is off or in standby mode, when used with the power adapter provided with the mobile thin client, and no external devices are connected. After charging has reached 90% capacity, charging speed will return to normal. Charging time may vary +/-10% due to System tolerance.
- 6 MIL-STD testing is not intended to demonstrate fitness for U.S. Department of Defense contract requirements or for military use. Test results are not a guarantee of future performance under these test conditions. Any accidental damage requires an optional HP Accidental Damage Protection Care Pack.
- 7 The keyboards of the HP Education portfolio, including the HP Chromebook 14 G7, have been tested to 1,000 wipes to be cleaned with Windex® Original Glass & Surface Wipes and Clorox® Disinfecting Wipes with EPA Registration Number 5813-79. Do not use wipes on other surfaces of the product. See user guide for cleaning instructions.
- 9 HDMI and USB-C® cables not included and sold separately.

Specifications

- 6 Multi-core is designed to improve performance of certain software products. Not all customers or software applications will necessarily benefit from use of this technology. Performance and clock frequency will vary depending on application workload and your hardware and software configurations. Intel's numbering, branding and/or naming is not a measurement of higher performance.
- 7 Intel® Turbo Boost performance varies depending on hardware, software and overall system configuration. See <http://www.intel.com/technology/turboboost/> for more information.
- 9 HP Classroom Manager is sold separately. Control and device locking from the teacher's desktop requires purchase of HP Classroom Manager.
- 10 Chrome Education Upgrade requires one-time setup, subscription, Google Admin Console, and your organization's domain. Please see <https://support.google.com/a/answer/60216>.
- 13 HP Care Packs are sold separately. Service levels and response times for HP Care Packs may vary depending on your geographic location. Service starts on date of hardware purchase. Restrictions and limitations apply. For details, visit www.hp.com/go/cpc. HP services are governed by the applicable HP terms and conditions of service provided or indicated to Customer at the time of purchase. Customer may have additional statutory rights according to applicable local laws, and such rights are not in any way affected by the HP terms and conditions of service or the HP Limited Warranty provided with your HP Product.

Detailed Specifications

Accessories

HP Sure Key Cable Lock 2L3Z2AV; HP Prelude Pro Backpack 15.6 1D4G7AV; HP USB-C Travel Hub G2 1W257AV; HP USB-C to VGA Adapter 6QK86AV; Optical Travel USB Mouse 1KL17AV

Audio

HD audio, dual speakers, dual array microphones

Battery brand

HP

Battery capacity

47

Battery capacity uom

Wh

Battery cells number

2

Battery life

Long Life

Battery life note

Battery is internal and not replaceable by customer. Serviceable by warranty. Fast charging 90% in 90 minutes.

Battery type

HP Long Life 2-cell, 47 Wh Li-ion polymer

Battery type

Li-ion polymer

Battery weight

0.42 lb

Battery weight

190 g

Bluetooth version

Bluetooth® 5.0

Brightness

250 nits

Camera

720p HD camera

Camera resolution (vertical)

720p

Camera resolution standard

HD

Code name

Bergman

Color gamut

45% NTSC

Copyright notice

© Copyright 2022 HP Development Company, L.P. The information contained herein is subject to change without notice. The only warranties for HP products and services are set forth in the express warranty statements accompanying such products and services. Nothing herein should be construed as constituting an additional warranty. HP shall not be liable for technical or editorial errors or omissions contained herein.

Datasheet photo 1

AHID/b1db65438c9df5006c34a3b184f38ea7833c4aa3

Datasheet photo 3

AHID/4f33569bc23dcb704e80417855626e0dea1fa041

Datasheet photo 4

AHID/1f2e31262cb47abb2d6f92f61ef9000cc791d185

Datasheet photo 5

AHID/e96e15d3d6c4d5301d7483303846ff4d6f0f021e

Display

14" diagonal HD touch display

Display

14" diagonal, HD (1366 x 768), touch, narrow bezel, anti-glare, 250 nits, 45% NTSC

Display bezel

narrow bezel

Display brightness

250

Display brightness uom

nits

Display footnote number

[6,7]

Display resolution (pixels)

1366 x 768

Display resolution standard

HD

Display size (diagonal)

14"

Display size (diagonal) uom

"

Display size (diagonal, imperial)

14

Display size (diagonal, metric)

35.6

Display size (diagonal, metric) uom

cm

Display surface treatment

anti-glare

Display touchscreen type

touch screen

Expansion slots

1 microSD

Expansion slots note

Supports SD, SDHC, SDXC.

Fingerprint reader

Fingerprint reader not available

Graphics

Integrated

Graphics (integrated)

Intel® UHD Graphics

Image legal disclaimer

Product image may differ from actual product

Internal Storage

32 GB eMMC

Keyboard

Full-size island-style, spill and pick resistant keyboard

Keyboard features

Pick and spill resistant

Keyboard size

Full-size

Manufacturer Warranty

HP Services offers 1-year limited warranties and 90 day software limited warranty options depending on country. Batteries have a default one year limited warranty except for Long Life batteries which will have same 1-year or 3-year limited warranty as the platform. Refer to <http://www.hp.com/support/batterywarranty/> for additional battery information. On-site service and extended coverage is also available. HP Care Pack Services are optional extended service contracts that go beyond the standard limited warranties. To choose the right level of service for your HP product, use the HP Care Pack Services Lookup Tool at: <http://www.hp.com/go/cpc>.

Memory

8 GB LPDDR4x-4266 SDRAM (onboard)

Memory and storage

8 GB memory; 32 GB eMMC storage

Minimum dimensions (W x D x H)

12.85 x 8.93 x 0.72 in

Minimum dimensions (W x D x H)

32.65 x 22.7 x 1.83 cm

Operating system

Chrome OS™

Optical drive

Not included

Pointing device

Clickpad with multi-touch gesture support

Ports

2 SuperSpeed USB Type-A 5Gbps signaling rate; 1 SuperSpeed USB Type-C® 5Gbps signaling rate (USB Power Delivery, DisplayPort™ 1.4); 1 headphone/microphone combo; 1 HDMI 1.4

Power

45 W USB Type-C™ adapter

Processor

Intel® Celeron® N4500 (up to 2.8 GHz burst frequency, 4 MB L3 cache, 2 cores)

Processor family

Intel® Celeron® processor

Processor name footnote number

[6,7]

Product brand name

HP

Product long name specifications

HP Chromebook 14 G7, 14", touch screen, Chrome OS™, HD

Product short name specifications

HP Chromebook 14 G7, 14"

Security management

Nano Security lock slot; Google Titan C

Security management footnote number

[11]

Software included

Chrome Education Upgrade (Sold separately); HP Classroom Manager (Sold separately)

Software included footnote number

[9,10]

Standard memory note

Transfer rates up to 4266 MT/s.

Storage type

eMMC

Sustainable impact specifications

Low Halogen; Outside box and corrugated cushions are 100% sustainably sourced and recyclable

Sustainable impact specifications footnote number

[18,19]

Tech spec footnote

[10] Chrome Education Upgrade requires one-time setup, subscription, Google Admin Console, and your organization's domain. Please see <https://support.google.com/a/answer/60216>.

Tech spec footnote

[11] Lock is sold separately.

Tech spec footnote

[12] Recharges up to 90% within 90 minutes when the system is off or in standby mode when used with the power adapter provided with the notebook. After charging has reached 90% capacity, charging will return to normal. Charging time may vary +/-10% due to System tolerance.

Tech spec footnote

[13] HP Care Packs are sold separately. Service levels and response times for HP Care Packs may vary depending on your geographic location. Service starts on date of hardware purchase. Restrictions and limitations apply. For details, visit www.hp.com/go/cpc. HP services are governed by the applicable HP terms and conditions of service provided or indicated to Customer at the time of purchase. Customer may have additional statutory rights according to applicable local laws, and such rights are not in any way affected by the HP terms and conditions of service or the HP Limited Warranty provided with your HP Product.

Tech spec footnote

[14] Based on US EPEAT® registration according to IEEE 1680.1-2018 EPEAT®. Status varies by country. Visit www.epeat.net for more information.

Tech spec footnote

[15] Backlit keyboard is an optional feature.

Tech spec footnote

[16] 720p HD Privacy camera is optional and must be configured at purchase.

Tech spec footnote

[17] Actual battery Watt-hours (Wh) will vary from design capacity. Battery capacity will naturally decrease with shelf life, time, usage, environment, temperature, system configuration, loaded apps, features, power management settings and other factors.

Tech spec footnote

[18] External power supplies, power cords, cables and peripherals are not Low Halogen. Service parts obtained after purchase may not be Low Halogen.

Tech spec footnote

[19] 100% outer box packaging and corrugated cushions made from sustainably sourced certified and recycled fibers.

Tech spec footnote

[2] Multicore is designed to improve performance of certain software products. Not all customers or software applications will necessarily benefit from use of this technology. Performance and clock frequency will vary depending on application workload and your hardware and software configurations. Intel's numbering, branding and/or naming is not a measurement of higher performance.

Tech spec footnote

[20] Wireless access point and internet service required and sold separately. Availability of public wireless access points limited. Wi-Fi 6 is backwards compatible with prior 802.11 specs. The specifications for Wi-Fi 6 (802.11ax) are draft and are not final. If the final specifications differ from the draft specifications, it may affect the ability of the notebook to communicate with other 802.11ax devices.

Tech spec footnote

[3] Processor speed denotes maximum performance mode; processors will run at lower speeds in battery optimization mode.

Tech spec footnote

[4] For storage drives, GB = 1 billion bytes. TB = 1 trillion bytes. Actual formatted capacity is less. Up to 30 GB (for Windows 10) is reserved for system recovery software.

Tech spec footnote

[5] Chromecast must be purchased separately.

Tech spec footnote

[6] Multi-core is designed to improve performance of certain software products. Not all customers or

software applications will necessarily benefit from use of this technology. Performance and clock frequency will vary depending on application workload and your hardware and software configurations. Intel's numbering, branding and/or naming is not a measurement of higher performance.

Tech spec footnote

[7] Intel® Turbo Boost performance varies depending on hardware, software and overall system configuration. See <http://www.intel.com/technology/turboboost/> for more information.

Tech spec footnote

[8] Based on internal testing vs. previous generation product with 802.11ac wireless LAN module.

Tech spec footnote

[9] HP Classroom Manager is sold separately. Control and device locking from the teacher's desktop requires purchase of HP Classroom Manager.

Touchscreen

Yes

Trademark information

Intel, Celeron and Intel vPro are trademarks or registered trademarks of Intel Corporation or its subsidiaries in the United States and other countries. DisplayPort™ and the DisplayPort™ logo are trademarks owned by the Video Electronics Standards Association (VESA®) in the United States and other countries. USB Type-C® and USB-C® are registered trademarks of USB Implementers Forum. © 2020 Google LLC All rights reserved. Google and the Google Logo are registered trademarks of Google LLC.

UNSPSC code

43211503

UPC number

195908490869

vPro enabled

non-vPro®

Warranty footnote number

[13]

Weight

Starting at 1.54 kg

Weight

Starting at 3.38 lb

Weight note (imperial)

Weight will vary by configuration.

Weight note (metric)

Weight will vary by configuration.

Wireless

Intel® AX201 Wi-Fi 6 (2x2) and Bluetooth® 5 combo, non-vPro®

Wireless antenna

2x2

Wireless Model

Wi-Fi 6 AX201

Wireless Note

MU-MIMO and Miracast support.

Wireless standard

Wi-Fi 6

Wireless supplier

Intel®

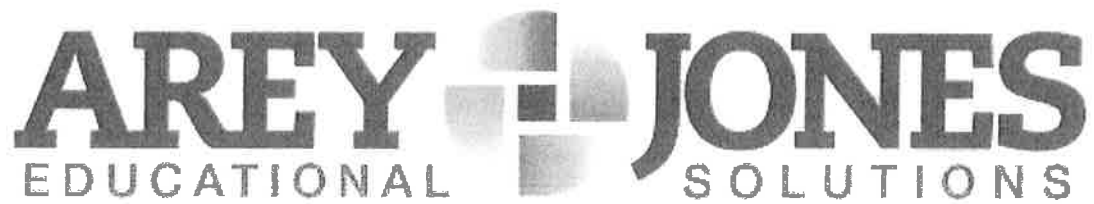

**The Hickman County Finance Office -
Chromebook Units and Chrome OS Management
Service License.**

Hickman County Government

Conflict of Interest Disclosure Form

The County Financial Management System of 1981 contains the most stringent conflict of interest provisions. TCA §5-21-121 provides:

- (a) The director, purchasing agent, members of the committee, members of the county legislative body or other officials, employees, or members of the board of education or highway commission shall not be financially interested or have any personal beneficial interest, either directly or indirectly, in the purchase of any supplies, materials, equipment or contractual services for the county.
- (b) No firm, corporation, partnership, association or individual furnishing any such supplies, materials, equipment or contractual services, shall give or offer, nor shall the director or purchasing agent or any assistant or employee accept or receive directly or indirectly from any person, firm, corporation, partnership or association to whom any contract may be awarded, by rebate, gift or otherwise, any money or other things of value whatsoever, or any promise, obligation or contract for future reward or compensation.

Date: 4-23-22 Name: Madeline Scarpella

Please describe below any relationships, transactions, positions you hold (volunteer or otherwise), or circumstances that you believe could contribute to a conflict of interest:

I have no conflict of interest to report.

I have the following conflict of interest to report (please specify any boards or committees you (and/or your spouse) sit on, the name of your employer and any businesses you or your spouse may own.

I hereby certify that the information set forth above is true and complete to the best of my knowledge.

Date: 4-23-22 Signature: 

Chromebook

Description	Qty	Unit Price	Ext. Price	Tax
3V2U9UT HP Chromebook 14 G6 Chrome OS 14" HD (1366 x 768) Non-touch display 4 GB LPDDR4 SDRAM 32 GB eMMC SSD Intel Wireless-AC 9560 2 x USB 3.1 Gen 1, HDMI, Headphone/microphone combo jack, USB-C 3.1 Gen 1 (Power Delivery/data/video) 1-year warranty	1	\$272.95	\$272.95	Y
CROS-SW-DISEDU Chrome Education Upgrade License	1	\$29.50	\$29.50	Y
HCS-AT Asset Tagging A district approved asset tag will be applied to the device A separate, matching asset tag will be applied to the label on the outside of the device's box An asset tag report will be provided to the district before delivery	1	\$1.00	\$1.00	Y
HCS-WG Chrome Enrollment Device will be unboxed, inspected, tested and turned on according to district specifications Device will be updated with latest Chrome OS The Chromebook is then enrolled into the district's G-Suite domain using district-supplied credentials Chromebooks are moved into the appropriate organizational unit (OU) if desired Key information fields such as location, notes, and asset id are populated using a toolchain we developed in-house in collaboration with District IT departments The device will be re-packed	1	\$6.00	\$6.00	Y
HCS-SHP Shipping The shipping fee is waived for orders equal or larger than 20 units	1	\$5.00	\$5.00	Y

Price Subtotal: **\$314.45**

TN 62453 Hickman County Schools RFP Chromebooks

Prepared by:

Arey Jones Educational Solutions

Matt Aaronson
(800) 998-9199
matthew.aaronson@areyjones.com

Contract:

NON-CONTRACT Non-Contract

NA

Prepared for:

Hickman County Schools - TN

,
Brad Gilbert

brad.gilbert@hickmank12.org

Quote Information:

Quote # MA062453.1

Quote Date: 04/22/2022
Expiration Date: 05/22/2022
Product Category: N/A

Quote Summary

Description	Amount
Chromebook	\$314.45

Taxable Subtotal:	\$314.45
Grand Subtotal:	\$314.45
Estimated Tax:	\$30.66
Grand Total:	\$345.11



HP Chromebook 14 G6

An essential, large-screen Chromebook for frontline workers, educators, and students

Seize your day with the durable HP Chromebook 14 G6 and its manageable, secured, and intuitive Chrome OS and Intel® processors.¹ Expand with future-ready USB-C® and HDMI, get maximum uptime from a long-running battery, and prevent remote camera hacking with the optional HP Privacy Camera.²

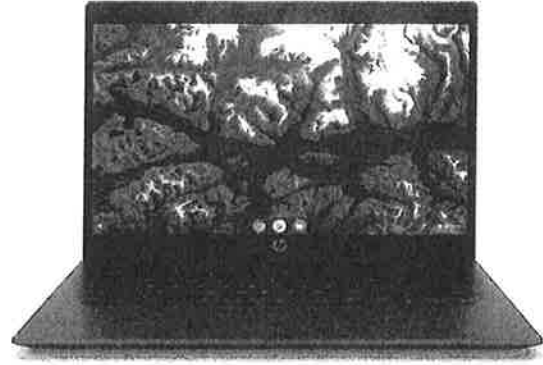

*Product image may differ from actual product

Designed for working and learning

- Master your to-do list with a 14" diagonal screen, Intel® processors¹, Chrome OS, fast-charging battery, and up to 8 GB² memory and 128 GB^{2,3} storage. Connect in dense areas with WLAN 802.11 ac⁴, MU-MIMO⁵, and HP Extended Range Wireless LAN.⁶

Built for reliability

- Get a device built for everyday wear and tear with metal corner reinforcements. It undergoes a 70 cm drop test⁷ on concrete, HP's Total Test Process⁸, and MIL-STD 810G testing.⁹ The keyboard resists spills of up to 350 ml (12 oz) of water.⁸

Designed for easy collaboration

- Collaborate in the room with an optional narrow bezel, wide viewing angle IPS screen², wide-angle HD webcam, and dual mics. Add your display, projector or accessories with HDMI and USB-C®. Navigate in low light with the optional backlit keyboard.²
- Breathe easy with the low-maintenance, highly manageable, and secured Chrome OS. With automatic software updates through June 2026 and built-in anti-virus protection, your device is safe and always up to date.¹⁰
- Unplug and work at different sites throughout the day with a long-running battery. Charge to 90% battery life in 90 minutes with HP Fast Charge.¹¹
- Select a 14" diagonal, non-touch, anti-glare HD or FHD screen, HD touchscreen or anti-glare FHD touchscreen. Each has a narrow bezel so you see more of your work.²
- Never wonder if someone is watching you with the added peace of mind that comes from the optional, integrated HP Privacy Camera. The camera's physical shutter protects users from malicious surveillance.²
- Charge your Chromebook and USB-C® accessories through the USB-C® port, or add an optional HP USB-C® dock to access your external display and USB-A accessories and connect to your wired network.¹³
- Easily deploy, manage, and control users, devices, and apps on 10s, 100s, and even 1000s of HP Chromebooks with Google's optional Chrome Enterprise Upgrade or Chrome Education Upgrade.^{2,12}
- Customize your Chromebook with the latest apps, tools, extensions and themes.¹²
- Get access to Google's G Suite of office productivity software that keeps you productive and connected to your e-mail, calendars, documents, spreadsheets, slides, and more in the cloud.¹²
- Rely on support you can trust with HP's world-class limited warranty. Extend your protection to cover accidents, travel, next-business day needs, and more with optional HP Care Pack services.¹⁴

HP Chromebook 14 G6 Specifications Table



*Product image may differ from actual product

Available Operating Systems	Chrome OS™
Processor family	Intel® Celeron® processor
Available Processors^{1,2}	Intel® Celeron® N4120 with Intel® UHD Graphics 600 (1.1 GHz base frequency, up to 2.6 GHz burst frequency, 4 MB cache, 4 cores); Intel® Celeron® N4020 with Intel® UHD Graphics 600 (1.1 GHz base frequency, up to 2.8 GHz burst frequency, 4 MB cache, 2 cores); Intel® Celeron® N4000 with Intel® UHD Graphics 600 (1.1 GHz base frequency, up to 2.6 GHz burst frequency, 4 MB cache, 2 cores)
Maximum memory	8 GB LPDDR4-2400 SDRAM Onboard memory. Supports Dual Channel Memory.
Internal storage	16 GB up to 128 GB eMMC 5.0 ³
Display size (diagonal, metric)	35.56 cm (14")
Display	14" diagonal HD SVA eDP anti-glare micro-edge WLED-backlit, 220 nits, 45% NTSC (1366 x 768); 14" diagonal FHD IPS eDP anti-glare micro-edge WLED-backlit, 250 nits, 45% NTSC (1920 x 1080); 14" diagonal HD SVA BrightView TOP micro-edge WLED-backlit touch screen, 220 nits, 45% NTSC (1366 x 768); 14" diagonal FHD SVA anti-glare TOP micro-edge WLED-backlit touch screen, 250 nits, 45% NTSC (1366 x 768) ^{7,9} 35.56 cm (14") diagonal HD SVA eDP anti-glare micro-edge WLED-backlit, 220 nits, 45% NTSC (1366 x 768); 35.6 cm (14") diagonal FHD IPS eDP anti-glare micro-edge WLED-backlit, 250 nits, 45% NTSC (1920 x 1080); 35.56 cm (14") diagonal HD SVA BrightView TOP micro-edge WLED-backlit touch screen, 220 nits, 45% NTSC (1366 x 768); 35.56 cm (14") diagonal FHD SVA anti-glare TOP micro-edge WLED-backlit touch screen, 250 nits, 45% NTSC (1366 x 768) ^{7,9}
Available Graphics	Integrated: Intel® UHD Graphics 600 ⁷ (Support HD Decode, DX12, and HDMI 1.4b.)
Audio	HD audio, dual speakers, dual array microphone
Wireless technologies	Intel® Dual Band Wireless-AC 9560 802.11a/b/g/n/ac (2x2) Wi-Fi® and Bluetooth® 5 Combo, non-vPro™ ^{5,6} ##netinterface_02_seriesfntntr## (MU-MIMO and Chromecast support)
Memory card device	1 microSD (optional)
Ports and Connectors	2 USB 3.1 Gen 1; 1 USB 3.1 Type-C® Gen 1 (Charge and video support, data transfer, power delivery); 1 Micro card reader; 1 headphone/microphone combo; 1 HDMI 1.4b ; (HDMI cable sold separately .)
Input devices	Full-size island-style Chrome keyboard, cool gray, spill resistant, optional backlit ⁸ ; Touchpad with multi-touch gesture support, taps enabled as default;
Camera	720p HD camera; HD Privacy webcam ^{7,17}
Software	Chrome Education Upgrade (Sold separately); Chrome Enterprise Upgrade (Sold separately); ¹¹
Security management	Nano Security lock slot; Google H1 Security Chip; ¹²
Fingerprint reader	Fingerprint reader not available
Power	HP Smart 45 W USB Type-C™ adapter
Battery type	HP Long Life 2-cell, 47.36 Wh Li-ion polymer
Battery life	Up to 13 hours and 30 minutes ^{13,18}
Dimensions	12.85 x 8.93 x 0.72 in 32.65 x 22.7 x 1.83 cm
Weight	Starting at 3.38 lb Starting at 1.54 kg (Weight will vary by configuration.)
Ecolabels	ENERGY STAR® certified; EPEAT® 2019 Silver ¹⁵
Sustainable impact specifications	Low halogen; TCO 8.0 Certified ¹⁶
Warranty	HP Services offers 1-year limited warranties and 90 day software limited warranty options depending on country. Batteries have a default one year limited warranty except for Long Life batteries which will have same 1-year or 3-year limited warranty as the platform. Refer to http://www.hp.com/support/batterywarranty/ for additional battery information. On-site service and extended coverage is also available. HP Care Pack Services are optional extended service contracts that go beyond the standard limited warranties. To choose the right level of service for your HP product, use the HP Care Pack Services Lookup Tool at: http://www.hp.com/go/cp .

HP Chromebook 14 G6

Accessories and services (not included)

Additional Services (Not included)



HP Care Pack

UQ990E - HP 3 year Pickup and Return Hardware Support for Notebooks;UQ996E - HP 3 year Pickup and Return Hardware Support w/Accidental Damage Protection;UQ994E - HP 3 year Next business day onsite Hardware Support w/Accidental Damage Protection

HP Chromebook 14 G6

Messaging Footnotes

- ¹ Multi-core is designed to improve performance of certain software products. Not all customers or software will necessarily benefit from use of this technology. Performance and clock frequency will vary depending on application workload and your hardware and software configurations. Intel's numbering branding and/or naming is not a measurement of higher performance.
- ² Sold separately or as an optional feature that must be configured at the time of purchase.
- ³ For storage drives, GB = 1 billion bytes. Actual formatted capacity is less. Up to 5.1 GB is reserved for system recovery software.
- ⁴ Wireless access point and internet service required and sold separately. Availability of public wireless access points limited. Wi-Fi 5 (802.11 ac) is backwards compatible with prior 802.11 specs.
- ⁵ Multiple-Input Multiple-Output (MIMO) is a wireless technology that uses multiple transmitters and receivers to enhance data transfer. MIMO requires a MU-MIMO router, sold separately.
- ⁶ Based on internal testing vs. previous generation product with 802.11ac wireless LAN module.
- ⁷ Drop test is not a guarantee of future performance under these test conditions. Any accidental damage requires an optional HP Accidental Damage Protection Care Pack.
- ⁸ HP Total Test Process testing is not a guarantee of future performance under these test conditions. Any accidental damage requires an optional HP Accidental Damage Protection Care Pack.
- ⁹ MIL STD 810H testing is not intended to demonstrate fitness for U.S. Department of Defense contract requirements or for military use. Test results are not a guarantee of future performance under these test conditions. Accidental damage requires an optional HP Accidental Damage Protection Care Pack.
- ¹⁰ See <https://support.google.com/chrome/a/answer/6220366?hl=en> for more information.
- ¹¹ Recharges the battery up to 90% within 90 minutes when the system is off or in standby mode, when used with the power adapter provided with the notebook, and no external devices are connected. After charging has reached 90% capacity, charging speed will return to normal. Charging time may vary +/-10% due to system tolerance.
- ¹² Internet access required and sold separately. Some apps may require purchase.
- ¹³ Sold separately. See product QuickSpecs for compatible HP docks.
- ¹⁴ HP Care Pack services sold separately. Service levels and response times for HP Care Packs may vary depending on your geographic location. Service starts on date of hardware purchase. Restrictions and limitations apply. For details, visit www.hp.com/go/cpc. HP services are governed by the applicable HP terms and conditions of service provided or indicated to Customer at the time of purchase. Customer may have additional statutory rights according to applicable local laws, and such rights are not in any way affected by the HP terms and conditions of service or the HP Limited Warranty provided with your HP Product.

Technical Specifications Footnotes

- ¹ Multi-core is designed to improve performance of certain software products. Not all customers or software applications will necessarily benefit from use of this technology. Performance and clock frequency will vary depending on application workload and your hardware and software configurations. Intel's numbering branding and/or naming is not a measurement of higher performance.
- ² Processor speed denotes maximum performance mode; processors will run at lower speeds in battery optimization mode.
- ³ For storage drives, GB = 1 billion bytes. Actual formatted capacity is less. Up to 8.1 GB is not user available.
- ⁴ Google Drive offer is tied to this device and is non-transferable. Not available with Chrome Enterprise Upgrade enrollment. If this device is returned, the extra storage will be revoked. In order to redeem this offer, you will need to be on Chrome OS™ 23 or later. Internet access is required and not included. Additional information about storage plan refunds, renewals, cancellations and expiration is available at the Google website: <https://support.google.com/chromebook/answer/2703646?hl=en>
- ⁵ Wireless access point and internet service required and sold separately. Availability of public wireless access points limited.
- ⁶ Multiple-Input Multiple-Output (MIMO) is a wireless technology that uses multiple transmitters and receivers to enhance data transfer. MIMO requires a MU-MIMO router, sold separately.
- ⁷ HD content required to view HD images.
- ⁸ Backlit keyboard is an optional feature.
- ⁹ Resolutions are dependent upon monitor capability, and resolution and color depth settings.
- ¹⁰ Chrome Enterprise Upgrade and Chrome Education Upgrade are sold separately and require one-time setup, subscription, Google Admin Console, and your organization's domain. Please see <https://support.google.com/a/answer/60216>.
- ¹¹ Security lock is sold separately.
- ¹² Testing conducted by HP using Google Chrome OS power_LoadTest. Battery life will vary and the maximum capacity of the battery will naturally decrease with time and usage and battery optimization activation. See <http://www.chromium.org/chromium-os/testing/power-testing> for test details.
- ¹³ HP Care Packs are sold separately. Service levels and response times for HP Care Packs may vary depending on your geographic location. Service starts on date of hardware purchase. Restrictions and limitations apply. For details, visit www.hp.com/go/cpc. HP services are governed by the applicable HP terms and conditions of service provided or indicated to Customer at the time of purchase. Customer may have additional statutory rights according to applicable local laws, and such rights are not in any way affected by the HP terms and conditions of service or the HP Limited Warranty provided with your HP Product.
- ¹⁴ Based on US EPEAT® registration according to IEEE 1680.1-2018 EPEAT®. Status varies by country. Visit www.epeat.net for more information.
- ¹⁵ External power supplies, power cords, cables and peripherals are not Low Halogen. Service parts obtained after purchase may not be Low Halogen.
- ¹⁶ HD Privacy webcam is sold separately or as an optional feature.
- ¹⁷ Battery configuration and charge capacity is optimized to improve battery health over time based upon charging patterns and temperature.

Sign up for updates hp.com/go/getupdated

About Arey Jones -

We're a leading provider of K-12 Technology Solutions. Our experience in successful partnerships with Districts nationwide means that we understand the challenges you face, and deliver products and services to aid you in reaching your goals.

Headquartered in San Diego, California, Arey Jones was founded in 1897 to serve the stationary and administrative needs of the local educational market. In 1972, Arey Jones was purchased by Broadway Typewriter Company, owned by the Scarpella Family. Since that time, the Scarpella Family has operated and expanded the business as Arey Jones Educational Solutions.

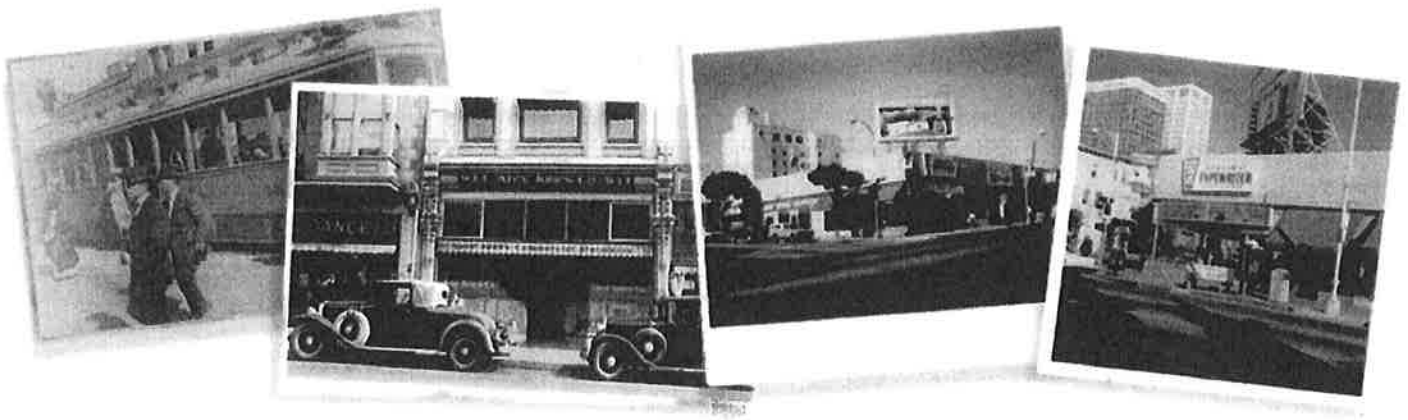

Arey Jones first location in San Diego, CA

Today, Arey Jones Educational Solutions is the premier nationwide provider of technology solutions dedicated to working exclusively with K-12 educational market. Arey Jones Educational Solutions has been involved with this business from the very beginning in the early 1990's providing hardware, software, integration, configuration, service and support. This dedication to working exclusively with the K-12 marketplace offers Arey Jones a unique qualification to meet the technology needs of Districts nationwide. Every employee within the Arey Jones company has experience working with the hundreds of School Districts around the county we have contracts with.

Part of Arey Jones extensive training for new candidates is included in our 90-day introduction organizational training all employees are required to take. This is an extensive training process that involves all departments of our organization. Experience has proven that investing in our employees training results in maintaining a high level of customer satisfaction and employee retention. Additional training provided by our partner manufacturers Lenovo, HP, Dell, Apple and many more is part of an on-going training program. This ensures that all managers and team members have the same base knowledge and are able to work together well.



Many of the managers/supervisors have all been promoted from within, and some have even been with Arey Jones since the beginning of their K-12 journey. The managers all have at least five years of experience in working with customers and suppliers in educational technology, some even having upwards of 25 years of experience. Each of the manager's teams are trained broadly, as well as specifically to their area of work. Our technicians and engineers working service and repair all have the necessary manufacturer (HP, Dell, Lenovo, Apple, and so on) certifications required to perform work. Arey Jones also requires our technicians and engineers to have other technical certifications such as A+ Certified, N+ Certified, Google for Education and Microsoft Office Certified.

From 7 am PST - 8 am PST : Arey Jones 800 number is always answered by a live personnel. We do not believe in automated systems when it comes to phone calls. At Arey Jones, you will never be directed to voicemail unless requested after speaking to our live operator. This is the service we have been holding strict to for over 50 years.

Districts we work with are offered cell phones of all department managers and staff they interact with.

Project Planning: How we accomplish RFP requirements

Arey Jones Educational Solutions works exclusively with schools and our delivery teams, installers, certified technicians, and network/systems engineers are familiar with the special circumstances of working within schools. Arey Jones' staff is sensitive to the classroom environment and the limitation schools have when receiving equipment and services. The teams of employees are in schools and administrative offices every day, and conduct themselves in a courteous, professional manner. Arey Jones will NOT subcontract any portion of this contract unless requested by the District.

In addition to the representatives and managers for your District, a specific project manager is assigned to large deployment related projects. The project manager will work together with the account representatives to ensure completeness of project. We will also assign a lead installer who will be present onsite throughout each rollout to verify all services have been complete. Arey Jones will work directly with the District, our suppliers and manufacturer partners to forecast large quantity purchase orders to ensure standard or expedited lead times on all orders. Product can be secured at the time a purchase order is received from the District.

At Arey Jones we are committed to providing cost-effective, right-sized solutions that meet your District's educational and technological goals. We also understand the occasional need to leverage and existing installed-base of equipment and are well versed with technologies such as virtual desktops (VDI) and thin-client solutions that allow the District to maximize the efficiency of their purchasing dollar. We also provide a full portfolio of server, network, and wireless solutions and can schedule sessions with our sales engineers and vendor partners, such as Intel, Lenovo, Dell, HP and others to assist the District in assembling cost-effective solutions that meet the district's needs.

All manufacturers each offer product roadmaps and information on new and upcoming models prior to manufacturer build or release date with a signed Non-Disclosure Agreement. Arey Jones works directly with the manufacturers to ensure that product roadmaps and new product releases are presented as these are available. Arey Jones also provides resources to assist the District in testing the exciting new and upcoming products within the District's specific environment.

The Executive Team and Scarpella Family believe in the value that is created in having a strong workforce that focuses on putting the customer first. Our team's commitment to our customers is responsible for the success we have in meeting the differing needs of school Districts nationwide.

Arey Jones strongly believes in the idea having qualified and well trained employees on all aspects of our business that can provide the best possibly customer service to the District at every level.

Arey Jones has a strict policy regard all background checks on employees and keeps current all necessary fingerprinting or registration for employees. We understand the importance of having trustworthy employees working with schools.

Our senior staff not only includes the executive team, but also all of our management team have been with us for over 10 years. The Scarpella family makes up the executive team, and Michael, Peter, and Mattie Scarpella have all worked in the K-12 education technology market since the late 1980's. The other members of the senior staff have between 10-20 years in K-12, and work closely with the Scarpella family in all facets of the business.

Manufacturer Relationships

Our proven track record of providing high quality service and product can be seen with our references, many of our customers have been working with us for 10-25 years. We provide them with service and support and utilize top-tier manufactures. Our relationship with these top tier manufactures allow for us to provide the District with the best options in terms of cost, and also allows for visibility into future models.

Affordability is a top concern of many Districts and at Arey Jones we make it a top priority to provide the best option for you district keeping cost in mind. Our close relationship with manufactures allow for us to have the latest technology and competitive pricing.

Our custom deployment, integration, and warranty support are tailored to meet the needs of a District both large and small. The following shows our relationship the tip-tier manufacturers.

PARTNER AND RELATIONSHIP	PARTNERSHIP LEVEL
Google for Education	Premier Level
Intel - Relationship Since 2000	Technology Provider - Platinum Level
HP - Relationship Since 1988 (as Compaq)	HP Inc. - Platinum Partner, Hewlett Packard Enterprise - Silver Partner
Lenovo - Relationship Since 1988 (as IBM)	Platinum Level
Dell - Relationship since 1989	Premier Partner: Client, Preferred Partner: Servers; Networking/Storage

Customer References

Below is a list of Arey Jones customers references available. If needed, additional available upon request.

Savannah Chatham County Public School System

Contact Information:

Edra Buckles, Director of Technology

Office: 912-395-1022

Email: Edra.buckles@sccpss.com

Wake County Public School System

Contact Information:

Kathy White, Director, Inventory Management

Office: 919-694-0135

Email: Kwhite2@wcpss.net

The School District of Manatee County

Contact Information:

Scott A. Hansen, CTO

Office: (941) 708-8770 x41062

Email: hansen2s@manateeschools.net

Mobile County Public School System

Contact Information:

David Akridge, Executive Manager of Information Technology

1 Magnum Pass, Mobile, AL 36618

Phone: 251-221-5142 ext. 6204

Email: dakridge@mcpss.com

San Diego Unified School District

Contact Information:

Torren Allen, Executive Director of Information Technology

4100 Normal Street, San Diego, CA

Phone: 619- 260-5438

Email: tallen@sandi.net

Customer References and Other Notable Experience Detail

Nothing is more important to us than the satisfaction of the Districts we work with. Included below is our customer references in detail and a few other notable Districts we provide solutions for.

1. Savannah Chatham County Public School System - GA

Arej Jones has partnered with SCCPSS for over five years and provides a turn-key solution on all desktops, laptops and Chromebooks purchased throughout the District. All Chromebooks, Desktops and Laptops are configured, asset tagged, etched, and white-glove delivered. The District also purchases Bretford carts and the deployment services we offer for carts including wiring, installation of devices, and delivery. We also have provided their warranty support for the past 3 years on both existing product and new product purchased. One of our large most recent projects was a quick deployment of 14, 000 Chromebooks.

2. Fulton County Schools - GA

Arej Jones provided Fulton County Schools with a variety of Dell systems including Desktops, Laptops, Tablets and All-In-One systems as well as their associated accessories. Custom Services for Fulton County Schools include: Imaging with custom district-provided Windows image, asset tagging and management (for large rollouts), domain join, delivery, installation and onsite warranty service.

We have worked with FCS for over 5 years and were just awarded their Teacher and Student Device bid for another contract period.

3. Wake County Public School System - NC

Arej Jones provided Wake County Public School System with a variety of services on their systems. Custom Services for the District included include: Chrome enrollment, asset tagging, engraving and management (for large rollouts), delivery, installation and onsite warranty service. Arej Jones has worked with Wake County Public Schools Systems for just over a year. In the summer of 2020 we provided services on over 50,000 Chrome devices in just 3 weeks.

4. The School District of Manatee County - FL

Arej Jones provides School District of Manatee County with a variety of HP systems including Desktops, Chromebook Laptops, Tablets and All-In-One systems as well as their associated accessories. We have worked with The School District of Manatee County for about 2 years.

Professional Service Performed: Chrome Integration Services and Delivery, Warranty Repair, Active Directory Domain Design Validation, System Center Configuration Manager Design Validation, Remote Distribution Point Setup, Chrome Management Initial Setup, On-going SCCM Support.

5. Miami Dade County Public Schools - FL

Arey Jones was awarded MDCPS Mobile Device and Services Bid with Lenovo product. Arey Jones Services has performed turn-key services for the District for over 3 years. We have deployed approximately 50,000 devices prior to this year with an additional 12,000 currently. These are Lenovo devices with full services and cart provisioning. We created a Custom SCCM-Based System imaging according to imaging specifications, includes hosting a remote SCCM DP in our configuration center via VPN.

6. Baldwin County Board of Education - AL

Arey Jones has worked with the Baldwin County Board of Education for 15 years. We have provided Lenovo and HP computers and servers to schools throughout their district with pre-configured, pre-imaged computers. We also provide the un-boxing and set-up of the computers for desktops and laptops.

1:1 Chromebook Deployment

Arey Jones has completed three phased deployment of 23,000 Lenovo Chromebook systems into the Baldwin County Public Schools. Each student in the Baldwin schools will receive a Chromebook as their personal device to use throughout the school year. These Chromebooks include full Accidental Damage Protection and are replacing an aging fleet of MacBook Air systems that are no longer under warranty or are coming off-lease. Baldwin County Public Schools expects significant multi-year cost savings from switching to the Chromebook platform.

7. Mobile County Public Schools - AL

Arey Jones is working to transition the largest school district in the state of Alabama, with 57,000 students to a 1:1 computing model based on Lenovo Chromebooks. Mobile County Schools ordered from and tasked Arey Jones to provision and deploy 35,000 Chromebook systems to be available to students in a 2 month period. Prior to this Chromebook deployment Mobile County Schools was running a Windows (primarily) and Mac (where necessary) installed base consisting of laptops, desktops, thin clients and tablets of various sorts, with a goal of achieving full 1:1 computing through BYOD. However, the rapid onset of COVID caused a paradigm shift and necessitated rapidly deploying devices for students and the district chose Arey Jones to meet that need.

8. San Diego Unified School District - CA

Arey Jones has worked with the San Diego Unified School District for over 35 years. The San Diego Unified School District (SDUSD) serves over 75,000 students, and has marked more than 150 years of service to San Diego's children. Arey Jones currently provides integration services (Acquisition, Warehousing, Delivery/Installation, Asset Tagging and Imaging) and maintenance support on all procured equipment.

Over the past year we have deployed over 40,000 new devices to the District, some with deadlines of only weeks in advance. In June 2020, San Diego Unified trusted Arey Jones to collect the remaining carts and devices, clean and bulk-package them for delivery to each school site in order to facilitate a transition to full on-line learning in at the beginning of the 2020-2021 school year. When the project concludes on 7/31/2020, Arey Jones will have collected, cleaned with lint-free cloths and 70% isopropyl alcohol and re-distributed 3,900 carts and over 60,000 devices.

9. Los Angeles Unified School District - CA

Arey Jones has worked with the Los Angeles Unified School District for over 18 years. We currently provide Dell, HP, Lenovo, Samsung, Microsoft Surface (desktops, laptops, servers, Chromebooks, tablets) warranty service for the 750+ the schools.

July 2020 - October 2021 - 280,000 devices configured, integrated and deployed

Notable Project - May 2020 -Deploy 75,000 new Chromebooks and 101,000 new iPads for 1:1 Learning in 6 weeks.

With the on-set of the COVID-19 Pandemic, LAUSD accelerated it's 1:1 digital learning initiative and purchased 75,000 new HP and Lenovo Chromebooks and 101,000 iPads. Arey Jones provided hardware, configuration/laser engraving, cleaning and deployment services for the Chromebook devices. For the iPads, Arey Jones worked with Apple to rapidly develop a deployment strategy and workflow and provision, configure, case and deploy all 101,000 iPads in 6 weeks. Arey Jones also provides next business day support for all LAUSD systems and has been doing so for 25 years

10. San Francisco Unified School District - CA

Arey Jones has partnered with San Francisco School District for the last two years and provides a turn-key solution on all desktops, laptops and Chromebooks purchased throughout the District. Arey Jones also provides the integration services on the Apple devices as well. All Chromebooks and Laptops are configured, asset tagged and tested prior to delivery.

Phase 1 and 2 Deployment Notable Project

Phase 1 - QTY 19,500 Devices Provisioned, integrated into carts, and delivered in 35 days

Phase 2 - QTY 15,000 Current

Device Support and Service Complete Catalog -

Receiving and Warehousing

Receiving, warehousing and consolidation services are provided in our local bonded and insured warehouse and fulfillment center to facilitate the creation of an installation solution that meets or exceeds all District needs. Arey Jones coordinates product deliveries from manufacturer partners selected from this RFP. This is consistent with the process Arey Jones has used for successful computing device rollouts around the country for the last two decades. All product will be stored in our secure warehouse space which allows Arey Jones to receive and store large inventories until delivery date(s) as identified by the District. Each device will be laser etched, asset tagged, enrolled/ imaged and configured at our warehouse and fulfillment center prior to delivery.

Prior to leaving our warehouse, all systems will be DOA checked and configured to District specifications. Damaged or blemished devices will be replaced from Arey Jones' stock or repaired prior to configuration.



Arey Jones' local fulfillment centers can easily accommodate the District's need to store many laptops until the scheduled delivery dates and has strict access control requirements for all personnel entering and exiting the facility

Etching -

Arey Jones can etch the District Logo, "Property of XXX", Asset Number with barcode, and Warranty expiration date. Arey Jones will supply a sample of etching for approval prior to etching the District's computers.



Arey Jones has over 20 state of the art etching machines available to the District. This allows for quicker provisioning and less hold ups in our warehouse, ultimately speeding up the overall deployment process to the District.

Windows: Imaging and Configuration

When imaging is purchased, all imaging tasks for computers delivered school sites or the District's Warehouse/Distribution Center will be performed prior to shipping in our local fulfillment centers' configuration department. This ensures that systems delivered to the District are ready to go when delivered. Arey Jones will also maintain a catalog of images developed in cooperation with the District. Our technicians can assist in the creation and development of Windows system images. We are able to accept images in a variety of standard image formats including MS Windows Image (DISM/ImageX aka WIM), Symantec Ghost and Clonezilla. We will work with the Board's technology department to support other formats as required.

Optional Site to Site VPN

Should the District wish to implement a VPN connection, Arey Jones will also be able to perform provisioning tasks such as Active Directory Domain Join or SCCM-based installations on the configuration department workbench prior to delivery. Larger school districts have also collocated MDT and SCCM remote deployment point servers in our configuration centers that link back up via VPN tunnels. Co-located servers are kept in a secure, climate controlled environment with limited physical access. Arey Jones offers this deployment server colocation service for our customers at no additional charge.

Windows: Domain Join

It is the desire of Arey Jones to perform as many tasks as possible relating to the configuration of computing devices while at our warehouse. To this end, we will work with the District to establish a VPN tunnel to perform computer naming and domain join functions. Arey Jones currently uses VPN tunnels to work with our largest customers to streamline the imaging and configuration process. If VPN setup is not possible, these functions will be shifted to the on-site installation teams.

Chrome: Device Enrollment

For our Chromebook enrollment service, Arey Jones upgrades the device to the latest version of Chrome OS available at the time the order is processed. Each Chromebook is then enrolled into the District's G-Suite domain using district-supplied credentials. Optionally, we can move Chromebooks into the appropriate organizational unit (OU) in the management console and populate key information fields such as, location, notes and asset id using a toolchain we developed in-house in collaboration with District IT departments.

Standard Cart Provisioning

We pride ourselves on neatly cable managed carts, which are still easily reconfigurable. We have worked with a variety of cart manufacturers including Anywhere, Black Box, Bretford, JAR, Lock'N'Charge, Tripp-Lite and others in both charge-only and network managed cart configurations.

Cart Refurbishing

Arey Jones Technicians can perform a full cart refurbish. This includes picking up the cart and devices onsite and bringing back to Arey Jones secured Integration Center, where Arey Jones technicians will completely clean out each cart. This includes the removal and replacement of the device power adapters.

Summer Cleaning of Student/Staff Devices

Our Summer Cleaning service is customized for each District, but generally includes the following services:

- Device Consolidation, Asset Scanning and Pickup from School Sites/Offices using secure storage totes
- Physical Cleaning and Damage Assessment
- Warranty Repairs Completed
- Non-Warranty Work Options
- System re-imaging/re-enrollment
- Systems delivered to sites using secure storage totes

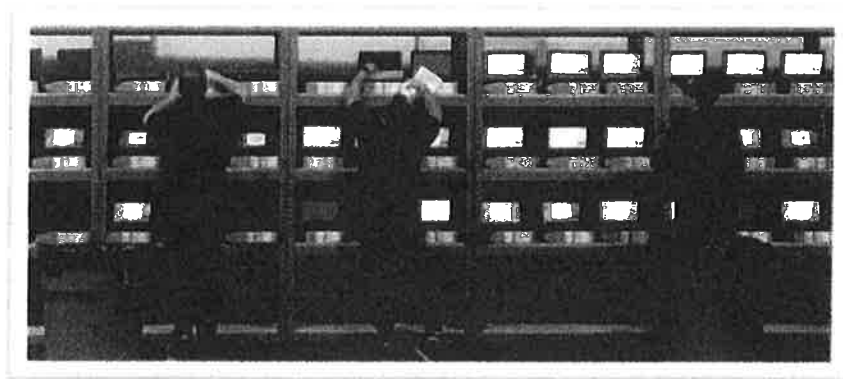

Asset Tagging

Arey Jones can add the required asset tag to the device. Our custom asset tag creation can allow for the District to specify what is needed and the reporting associated with it.

Professional Development

Arey Jones can offer countless resources to provide professional development. Our long time relationships with all manufacturers and specially Intel allow us access to top tier professional development we can then pass down to Districts. Professional development is customized to Districts nationwide by Arey Jones.

Onsite Delivery

In our pricing proposal we have provided a selection of hardware that will ship as well as a white glove services proposal. If value-added services were purchased with the device, Arey Jones will ensure that each device is student/staff ready when it is delivered to the District.

Our delivery processes remain the same whether one (1) system, 25 systems, or 2500 systems are ordered. We will deliver the system(s) to the District on our trucks that include liftgates, with our own badged personnel and we will never use common carrier freight such as United Parcel Service (UPS) or Federal Express (FedEx) for deliveries from Arey Jones.



White Glove Installation with Trash Removal

Installation performed by Arey Jones will be consistent with the procedures described in the product manual(s) and will conform to the installation procedures and specifications negotiated with and/or provided by the District prior to the time of installation. Arey Jones provides an array of flexible delivery options at no additional cost, including mutually agreeable extended delivery hours, order consolidation and custom palletization.

For the District, Arey Jones will schedule all product deliveries Monday through Friday 8:00 am-4:00 pm excluding legal holidays, or days during which the District sites are closed, provide shipping options which allow for multiple addresses, and multiple interior installation locations for each address. Deliveries shall not be performed on weekends or during designated the District holidays unless prearranged with the District. Arey Jones will coordinate all deliveries with the location administrator and/or the designated School District Project Manager to not disrupt the school site or District operations. All deliveries will be scheduled outside of outside of school start and end times to avoid delivery vehicles hindering traffic flow during high-volume traffic periods. Deliveries will also be scheduled at least 24 hours in advance of the delivery date.

Unless otherwise pre-approved by District, all orders will be shipped complete, including all required accessories that are ordered with devices and considered part of the computer order such as: mouse, keyboard, power cord, docking station, video adapters, etc.

Arey Jones requires all employees to be fingerprinted using the District's chosen fingerprinting and background check process as well as undergoing a Department of Justice background check before they are permitted to enter any school site or office on a Districts property. It is company policy that all Arey Jones personnel must sign in at the site's front office before they proceed to a classroom or office. Once they are through at the site, they are also required to sign out.

Arey Jones performs delivery using our own trucks, with lift-gate service and does not use "common carrier freight" such as United Parcel Service or Federal Express unless specifically requested for by the District. All shipments will be packaged according to district guidelines.

Invitation To Bid

The Hickman County Finance Office is accepting sealed bids for Chromebook Monitoring Software for Hickman County Schools.

Additional specifications can be found at: www.hickmank12.org/request-for-proposal.

All bidders will be required to submit a conflict of interest disclosure form that can also be found at: www.hickmank12.org/request-for-proposal.

Sealed bids must be mailed or delivered to the Hickman County Finance Office, 114 North Central Avenue, Suite 203, Centerville, TN 37033 and clearly marked on the outside of the bid envelope "Chromebook Monitoring Software". Bids will be opened on Monday, April 18th, 2022 at 10:00 A.M. in the Finance Office.

The Hickman County School District reserves the right to reject any and or all bids or proposals and to waive any informalities, which in the opinion of the school system, would prevent the acceptance of a better bid.

Present Penny Mayberry
Misty Weems

Central 18762.67 + 66,180.39

Surely 67,665.00

Aristotle 16,128.82

Light speed Systems 25,280.00

Soft Choice 66,734.00

Go Guardian 31,680.00



REQUEST FOR PROPOSAL

Hickman County Schools

“Chromebook Monitoring Software”

Bid Due Date: April 18, 2022 @ 10:00am

Central Technologies, Inc.

PO Box 30867
Knoxville, TN 37930

OR

6101 Industrial Heights Drive NW
Knoxville, TN 37909

Account Executive
Jordan Walker
jwalker@centralinc.com
Direct: 843.425.2265
Toll-Free: 800.315.4132
Fax: 865.312.8190

SPIN #: 143035655
General Contractors License #: 00067550
TN Alarm Contractors License: 2138



Hickman County Schools Evaluation Committee:

It is with great pleasure that Central Technologies, Inc submits this bid for "Chromebook Monitoring Software" for Hickman County Schools. We are very excited to have the opportunity to continue a relationship with Hickman County Schools and would be honored to be selected as your preferred partner for Chromebook Monitoring Software .

- Central Technologies will communicate with stack holders about any supply chain issues
- Central Technologies is a drug free workplace
- Central Technologies has local representation

Our staff has spent the past 17+ years helping districts successfully implement technology throughout the state of Tennessee and our certified technical personnel have completed hundreds of successful installations, all with a high degree of customer satisfaction. Our #1 goal is customer satisfaction 100% of the time with our better service and smarter solutions.

We look forward to the opportunity to partner with you on this project!

Thank you,

A handwritten signature in black ink that reads "Jordan Walker". The signature is written in a cursive, flowing style.

Jordan Walker

Senior Account Executive: Jordan Walker

Email: jwalker@centralinc.com

Direct: 843.425.2265

Toll-Free: 800.315.4132

Fax: 865.312.8190



PRICING PROPOSAL:

PART B SPECS Refer to Attached Pricing Quote

- A. Software will allow for reports on websites accessed by students, searches, etc.
- B. Ability to block/whitelist URLs as needed is preferred.
- C. Ability to track lost and stolen chromebooks using location, screenshots, etc. preferred.
- D. Ability to function with the Google Admin console to populate users and groups.
- E. Classroom management tools for teachers such as screen monitoring, viewing student screens, and controlling student devices.
- F. Ability for self-harm alerts is preferred.

LINEWISE PRODUCT GUIDE DISCOUNT - 2% off MSRP

Linewize

Description	Price	Qty	Ext. Price
LW-T3-LGW-1Y FamilyZone Local Gateway 1 Yr Subscription. 2,501-10,000 FTE	\$2,666.67	1	\$2,666.67
LW-T3-CLASS-1Y Classwize - 1 Year Subscription. Cloud managed classroom management suite. Provides screen visibility and control on Windows, Mac, and Chrome Operating Systems with cloud directory integration and school roster support. Cyber Safety included. 2,500-10,000	\$2.22	3200	\$7,104.00
LW-T3-SMGR-1Y Linewize - School Manager 1 Year Subscription. Cloud-Managed Filter and Reporter w/ built in Cyber-Safety controls. 2,500-10,000 FTE. Unlimited devices.	\$2.81	3200	\$8,992.00

Subtotal: **\$18,762.67**

 **Statement of Work**

Linewize 1 Year Subscription, Start Date TBD

Linewize

Prepared by:

Central Technologies Inc

Jordan Walker
843-425-2265
Fax 865-312-8190
jwalker@centralinc.com

Prepared for:

Hickman County Schools

115 Murphree Avenue
Centerville, TN 37033
Brad Gilbert
(931) 729-3391
brad.gilbert@hickmank12.org

Quote Information:

Quote #: 011139

Version: 1
Delivery Date: 04/15/2022
Expiration Date: 08/05/2022

Quote Summary

Description	Amount
Linewize	\$18,762.67
Total: \$18,762.67	

Taxes, shipping, handling and other fees may apply. We reserve the right to cancel orders arising from pricing or other errors.

Central Technologies Inc

Signature: 
Name: Jordan Walker
Title: Senior Account Manager
Date: 04/15/2022

Hickman County Schools

Signature: _____
Name: Brad Gilbert
Date: _____

Hickman County Government

Conflict of Interest Disclosure Form

The County Financial Management System of 1981 contains the most stringent conflict of interest provisions. TCA §5-21-121 provides:

- (a) The director, purchasing agent, members of the committee, members of the county legislative body or other officials, employees, or members of the board of education or highway commission shall not be financially interested or have any personal beneficial interest, either directly or indirectly, in the purchase of any supplies, materials, equipment or contractual services for the county.
- (b) No firm, corporation, partnership, association or individual furnishing any such supplies, materials, equipment or contractual services, shall give or offer, nor shall the director or purchasing agent or any assistant or employee accept or receive directly or indirectly from any person, firm, corporation, partnership or association to whom any contract may be awarded, by rebate, gift or otherwise, any money or other things of value whatsoever, or any promise, obligation or contract for future reward or compensation.

Date: April 12, 2022 Name: Jordan Walker

Please describe below any relationships, transactions, positions you hold (volunteer or otherwise), or circumstances that you believe could contribute to a conflict of interest:

I have no conflict of interest to report.

I have the following conflict of interest to report (please specify any boards or committees you (and/or your spouse) sit on, the name of your employer and any businesses you or your spouse may own.

I hereby certify that the information set forth above is true and complete to the best of my knowledge.

Date: April 12, 2022 Signature: *Jordan Walker*



REQUEST FOR PROPOSAL

Hickman County Schools

“Chromebook Monitoring Software”

Bid Due Date: April 18, 2022 @ 10:00am

Central Technologies, Inc.

PO Box 30867
Knoxville, TN 37930

OR

6101 Industrial Heights Drive NW
Knoxville, TN 37909

Account Executive
Jordan Walker
jwalker@centralinc.com
Direct: 843.425.2265
Toll-Free: 800.315.4132
Fax: 865.312.8190

SPIN #: 143035655
General Contractors License #: 00067550
TN Alarm Contractors License: 2138



Hickman County Schools Evaluation Committee:

It is with great pleasure that Central Technologies, Inc submits this bid for "Chromebook Monitoring Software" for Hickman County Schools. We are very excited to have the opportunity to continue a relationship with Hickman County Schools and would be honored to be selected as your preferred partner for Chromebook Monitoring Software .

- Central Technologies will communicate with stack holders about any supply chain issues
- Central Technologies is a drug free workplace
- Central Technologies has local representation

Our staff has spent the past 17+ years helping districts successfully implement technology throughout the state of Tennessee and our certified technical personnel have completed hundreds of successful installations, all with a high degree of customer satisfaction. Our #1 goal is customer satisfaction 100% of the time with our better service and smarter solutions.

We look forward to the opportunity to partner with you on this project!

Thank you,

A handwritten signature in black ink that reads "Jordan Walker". The signature is written in a cursive, flowing style.

Jordan Walker

Senior Account Executive: Jordan Walker

Email: jwalker@centralinc.com

Direct: 843.425.2265

Toll-Free: 800.315.4132

Fax: 865.312.8190



CENTRAL
Technologies, Inc.

PRICING PROPOSAL:

PART B SPECS Refer to Attached Pricing Quote

- A. Software will allow for reports on websites accessed by students, searches, etc.
- B. Ability to block/whitelist URLs as needed is preferred.
- C. Ability to track lost and stolen chromebooks using location, screenshots, etc. preferred.
- D. Ability to function with the Google Admin console to populate users and groups.
- E. Classroom management tools for teachers such as screen monitoring, viewing student screens, and controlling student devices.
- F. Ability for self-harm alerts is preferred.

SECURLY / DYKNOW PRODUCT GUIDE DISCOUNT - 2% off MSRP



Securly/Dyknow

Description	Price	Qty	Ext. Price
Dyknow Classroom Management Dyknow Classroom Management / 3300 Licenses	\$4.89	3300	\$16,137.00
Reveal by Securly Reveal by Securly / 3300 Licenses	\$1.33	3300	\$4,389.00
Securly Filter Core Securly Filter Core / 3300 Licenses	\$5.21	3300	\$17,193.00
Securly Home Securly Home / 3300 Licenses	\$1.33	3300	\$4,389.00
Securly Auditor Core Securly Auditor Core / 3300 Licenses	\$1.72	3300	\$5,676.00
Securly 24 Securly 24 / 3300 Licenses	\$5.13	3300	\$16,929.00
One time set fee One time set fee	\$1,467.39	1	\$1,467.39

Subtotal: **\$66,180.39**

▶ **Statement of Work**

Securly/Dyknow 1 Year Subscription - Start Date TBD

Securly/Dyknow

Prepared by:

Central Technologies Inc

Jordan Walker
843-425-2265
Fax 865-312-8190
jwalker@centralinc.com

Prepared for:

Hickman County Schools

115 Murphree Avenue
Centerville, TN 37033
Brad Gilbert
(931) 729-3391
brad.gilbert@hickmank12.org

Quote Information:

Quote #: 011137

Version: 1
Delivery Date: 04/15/2022
Expiration Date: 08/05/2022

Quote Summary

Description	Amount
Securly/Dyknow	\$66,180.39
Total: \$66,180.39	

Taxes, shipping, handling and other fees may apply. We reserve the right to cancel orders arising from pricing or other errors.

Central Technologies Inc

Hickman County Schools

Signature: _____



Name: Jordan Walker

Title: Senior Account Manager

Date: 04/15/2022

Signature: _____

Name: Brad Gilbert

Date: _____

Hickman County Government
Conflict of Interest Disclosure Form

The County Financial Management System of 1981 contains the most stringent conflict of interest provisions. TCA §5-21-121 provides:

- (a) The director, purchasing agent, members of the committee, members of the county legislative body or other officials, employees, or members of the board of education or highway commission shall not be financially interested or have any personal beneficial interest, either directly or indirectly, in the purchase of any supplies, materials, equipment or contractual services for the county.
- (b) No firm, corporation, partnership, association or individual furnishing any such supplies, materials, equipment or contractual services, shall give or offer, nor shall the director or purchasing agent or any assistant or employee accept or receive directly or indirectly from any person, firm, corporation, partnership or association to whom any contract may be awarded, by rebate, gift or otherwise, any money or other things of value whatsoever, or any promise, obligation or contract for future reward or compensation.

Date: April 12, 2022 Name: Jordan Walker

Please describe below any relationships, transactions, positions you hold (volunteer or otherwise), or circumstances that you believe could contribute to a conflict of interest:

I have no conflict of interest to report.

I have the following conflict of interest to report (please specify any boards or committees you (and/or your spouse) sit on, the name of your employer and any businesses you or your spouse may own.

I hereby certify that the information set forth above is true and complete to the best of my knowledge.

Date: April 12, 2022 Signature: 



Hickman County Schools

Request for Proposal
Chromebook Monitoring Software



Contents

Executive Summary	3
Qualifications of Securly	4
Solutions Overview	6
Dyknow Classroom Management	
Training and Support	18
References	20
Additional Products	22
Hickman County Documents and Signature Pages and Cost Proposal	25

Executive Summary

HickmanCounty Schools (HCS) is committed to providing a safe and secure digital environment for all students, faculty, and staff. Over the following pages, Securly will share our responses to showcase our understanding of the scope of services and requirements as set forth by HCS to procure Securly's management solutions for Chromebook management: Securly Reveal and *Dyknow Classroom Management*.

Securly acknowledges receipt of this RFP and recognizes the uniqueness of HCS and the support that is needed for the successful implementation and adoption of a unique classroom management solution designed for teachers. Securly will work to ensure a safe learning environment is in place. Working with Securly in addressing HCS needs will provide efficiencies in procurement, cost, and resources (personnel and time). This customized classroom management solution will support and enhance the student experience within and beyond school time that addresses a healthy and safe digital environment for all students

Securly is committed to being a partner with HCS to support and enhance a safe student climate for all students.

Key Contact:

Ella Sherman

Sales Manager

111 N Market Street, 4th Floor

San Jose, CA 95113

ella.sherman@securly.com

Qualifications of Securly

Securly was founded in 2012 in the heart of Silicon Valley. The founders had an extensive security background in engineering and IT products with a passion for student safety.

Recently, Securly acquired Dyknow. Dyknow has almost two decades of experience empowering educators through the effective use of technology. The company's two solutions – Classroom Management and Device Impact Measurement – allow teachers to defeat distractions in the classroom to increase student engagement and teach confidently with technology, as well as deliver powerful analytics to administrators and technology coaches that help measure the impact of school-issued devices and technology.

With Dyknow's Classroom Management solutions, Securly is now the end-to-end student safety and digital experience management platform for K–12.

With a deeply-rooted purpose and tireless commitment to innovation, we deliver a ubiquitous experience to help students learn, engage, explore, grow, and live securely.

Always connected, always protected.



Securly Headquarters

111 N. Market Street
4th Floor
San Jose, California 95113
United States

Securly HQ East

5600 77 Center Drive, Suite 350
Charlotte, North Carolina 28217
United States

Securly R&D

#101, B Wing, MCCIA Trade Towers,
S.B. Road, Pune 411016
India

Securly Operations

Margaritas 38, Zona Centro
Cancún Quintana Roo, 77500,
Mexico

Recent awards & certifications



Leadership Team



Bharath Madhusudan CRO/Co-Founder/Co-CTO

With more than a decade of enterprise security and engineering experience, including in an Architect-level role at Huawei-Symantec, combined with his operational experience and deep understanding of sales and marketing, Bharath is the right person to help lead Securly to its next level of scale. Bharath has a Masters in Computer Science from Washington University at St Louis.



Neeraj Thakar SVP of Engineering

As a patented inventor and network security veteran, Neeraj brings to Securly more than 15 years of experience building threat research teams developing solutions for malware, reverse engineering, and network security. Having designed infrastructures for malware research and security visualization tools, Neeraj shares his technology knowledge through security blogs and online media.



Scott Cohn SVP of Finance

With more than 15 years of industry and public accounting experience that began at PricewaterhouseCoopers and quickly evolved into several VP of finance roles, Scott's successful track record of helping hyper-growth start-ups outperform even their own expectations influences Securly's continued success. Scott received his BS from Santa Clara University.

Solution Overview

Dyknow Classroom Management

Dyknow Classroom Management is a powerful classroom management tool enabling teachers to take control of their online classes.

Dyknow Classroom works on Chromebooks as well as Mac and Windows devices for both school-owned (1:1) and student-owned devices (BYOD). The solution works for both in-school classes as well as remote learning or a hybrid combination of the two.

Description

Dyknow Classroom is a cloud-based classroom management tool, empowering teachers to guide and monitor online activities, keep students focused, and communicate directly with the class. Securly Classroom allows teachers to manage devices, share and lock screens, monitor student screens, and control content.

Monitor

Teachers can quickly view screens of individual students or the entire class. Students are able to immediately get on-task and stay on-task.

Manage

Dyknow Classroom is able to choose what students see, and block what they don't.

Engage

Teachers are able to send messages to students, check for their understanding, and ask questions of the content they are viewing.

Review

Once class is done, teachers can review the history of student data and all the activity they had online.

Real time Activity Monitor

Teachers now have a Real Time Activity Tracker on their dashboard, with multiple actions they can leverage to engage the classroom.

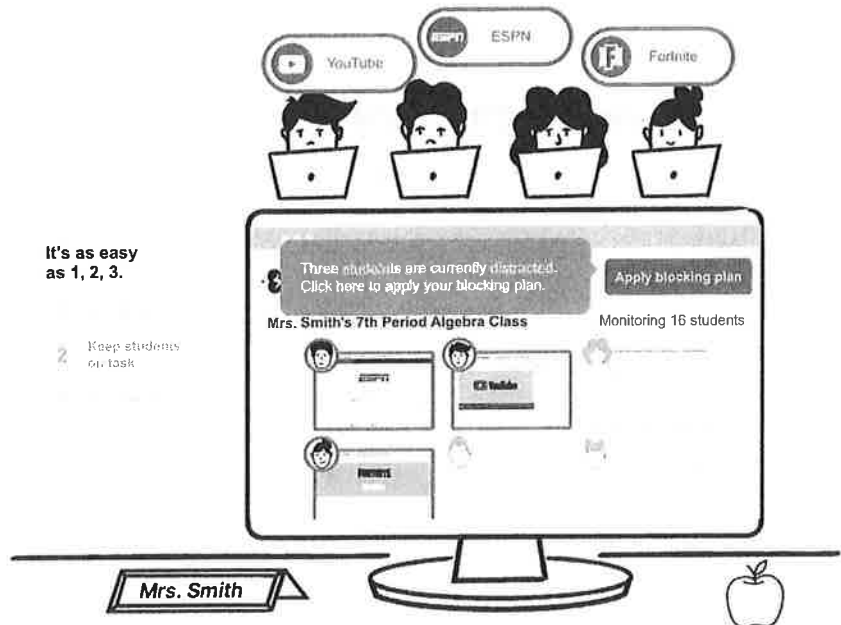

Real Time Blocking and Time-based Blocking

Teachers can block student online activity in Real Time. Also, Instead of blocking one person in real time, Dyknow Classroom offers a wide array of customizations to allow block, segmented lists, etc.

Prompt Student Action

Teachers can prompt student interaction by

- Checking Student Understanding
- Getting their Attention / Send a Message
- Send Questions

Review browsing history

Get easy access to all in-class browsing history. Teachers can check the browsing history for any of their own students at any time, while administrators have access to all student history.

Securly Reveal

While HCS is using devices that are running dozens of educational apps and licenses, you need to know which investments are actually paying off. Given the sheer volume of devices, platforms, and applications, identifying these hidden budget drains can feel like an insurmountable task. Stop-gap solutions like manual

surveys and piecing together individual reports are imperfect at best and often provide only limited insights. There has to be a better way. You'll find it in Securly Reveal.



Using data captured from student devices, Reveal will give HCS unprecedented visibility into device, website, and application analytics. HCS will be able to measure exactly how school-issued devices and technology tools are used, so you can make smarter decisions and investments backed by data. With Reveal, HCS will get complete usage data so you can know the impact of school-issued devices.

Device Impact Measurement

For Administrators and Tech Coaches to identify wasted funds by measuring how school-issued devices and technology tools are actually used.

Reveal helps Administrators:

- gain powerful device usage data to inform decisions
- reduce wasted funds
- identify budget opportunities at the school & district level

Reveal helps Tech Coaches:

- access essential data to drive tech training & PD initiatives
- identify tech-uncomfortable teachers for additional support
- export usage data on demand to support decision makers

Four Areas of Reporting with Reveal:

- Website Usage by Week

Website Usage by Week						
Top 100 Websites ↕	Students ↕	Views ↕	Percent Time ↓	Avg Viewing Time ↕	Trending ↕	
edtechguy.net	21,045	7,620,227	28.3%	4.3h	↕	
classmate.com	19,646	4,361,896	13.5%	2.2h	↕	
www.gv.com	13,329	910,161	5.0%	1.2h	↕	
www.pearson.com	20,578	2,620,273	4.0%	0.6h	↕	
www.magnify.com	6,868	418,795	3.4%	1.6h	↕	
www.pearson.com	10,466	471,794	2.7%	0.8h	↕	
www.pearson.com	9,807	412,282	2.2%	0.7h	↕	
www.pearson.com	6,931	211,711	1.4%	0.6h	↕	

- Application Usage by Week

Application Usage by Week						
Top 100 Applications ↕	Students ↕	Views ↕	Percent Time ↓	Avg Viewing Time ↕	Trending ↕	
Windows Explorer	10,869	334,454	3.0%	0.9h	↕	
Microsoft Word	7,233	582,013	2.9%	1.3h	↕	
Zoom Meeting	6,898	428,724	2.2%	1.0h	↕	
Edge	6,634	136,058	1.6%	0.7h	↕	
Microsoft PowerPoint	4,392	211,454	0.9%	0.7h	↕	
OneNote	1,367	63,488	0.6%	1.4h	↕	
Outlook	9,205	101,790	0.3%	0.1h	↕	
Outlook Web Information	4,582	18,545	0.1%	< 0.1h	↕	

- Total Students by Day

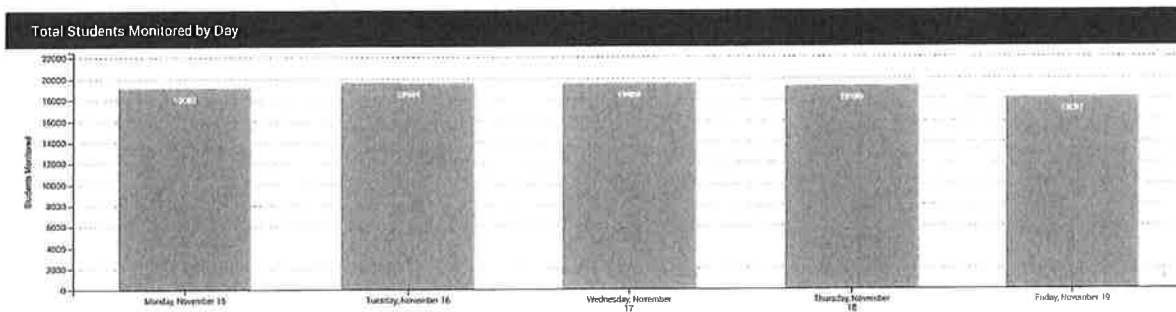

- Average Usage by Hour

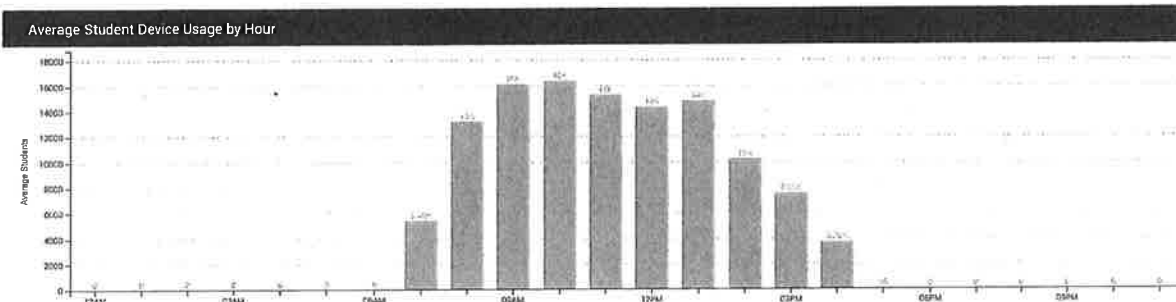

Simple Deployment

Get up and running quickly with our import manager and pre-defined data import templates.

Device Compatibility

Works on Chromebook, PC, and Mac devices and in mixed environments.

Data Security

Stores student information as de-identified data accessible only via permission set for each user role.

Data Access

Gain unrestricted access to your data, plus holistic and comprehensive reporting.

Cloud Delivery

Scale an unlimited number of wireless devices with no server requirement and absolutely no impact on your network performance.

Seamless Integration

Integrates directly with student information systems (SIS), including PowerSchool, Infinite Campus, and Skyward, to streamline implementation and ensure accurate class rostering.

Analytics & Insights

Know how many devices are being used, daily and hourly usage trends, and compare usage week-over-week and month-over-month. Track website and app usage to identify the most used — and underused — resources.

Securely Reveal Provides a Complete View of Device Usage

1 Automatic Monitoring

2 Log In from Anywhere & Access Dashboard

3 Review Data at a Glance & Export on Demand

Filter by:

- School(s)
- Report Timeframe

Review Device Impact Measurements:

- Compare week-over-week and month-over-month usage
- Spot trends in activity
- View hourly student screen time

Instantly export data

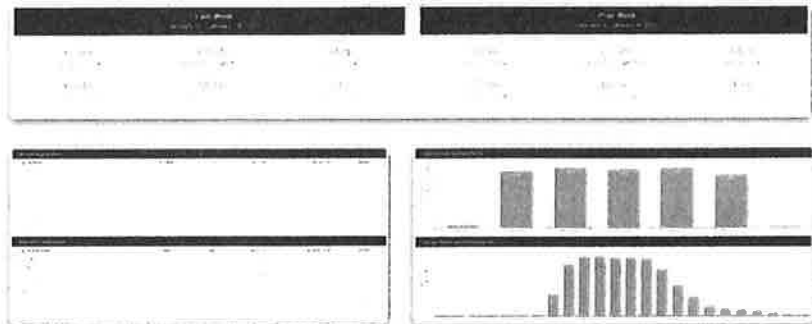

Network, Hardware, and Conversion

Securly solutions are SaaS solutions for classroom management, and “hardware” is maintained in the Cloud. Service arrangements are not required as no on-premise hardware exists within customer infrastructure . While the school will have regular correspondence from its Account Manager, our team will make Software Development Team aware of any updates with emails prior to anything going live.

Integration and conversion

Our classroom management provides direct integration (roster pull) from a variety of sources including Google Classroom, Canvas, Schoology, Classlink, and Clever. It also allows “ad-hoc” or manually created classes for special circumstances where the class is not rostered elsewhere. These are easily created by quickly browsing Google Directory to add students to the class or group.

Training and Support

<u>Training and Support</u>	<u>Yes (Y) or No (N)</u>	<u>Securly Comments</u>
Knowledgeable and capable online classroom management and student engagement monitoring solution deployment/implementation specialists to drive a successful implementation and oversee product implementation, training, and overall client support	Y	
Customer support is available 24/7 via phone, email, or online support portal with a guaranteed response of one business day after receiving notice of issue	Y	
Offers initial virtual training, training of trainers, and any refresher training as necessary	Y	Including additional training in cost proposal
Availability of the following information: <ul style="list-style-type: none"> o Guaranteed uptime o Minimal performance expectations o Bug fixing policy 	Y	
Provides a system for the District to report system bugs and product enhancement requests	Y	
Knowledgeable client support staff who are available to personally take calls and provide immediate assistance	Y	
Provides on-going reporting of client satisfaction and a clear escalation path for issue resolution	Y	
Has an online client community that provides collaboration and communication opportunities for sharing ideas, information, templates, best practices, and other resources	Y	Our "Lounge" is a great community for best practices and implementation
Maintains thorough online knowledge base; including training documents, user guides, and administration guides	Y	
Planned scheduled maintenance and product release	Y	

Being committed to students and their safety is great, but no solution is quite worth the investment without the full support and committed long-term service to its customers and schools using the solution. Securly is fully committed to making relationship building, truly customer-focused service and ongoing support a major part of its solution to any school or customer that uses us.

Securly wants to take support beyond traditional ticket-solving, to making it a great experience that is so good, you forgot you had a problem in the first place. We are committed to developing long-lasting relationships with anyone we work with, and want to partner with schools to find out what we can do better as we further our development and engagement with the K-12 education community.

Securly provides:

- No Subcontractors with implementation and service
- Phone and email support
- Support Deployment assistance and training for staff
- Feedback calls with development teams
- Caring customer-friendly support staff
- Award-winning sales support team and products (Tech & Learning December 2021)

On boarding information is provided to a Sales Engineer who builds your account on the backend. Your Deployment is scheduled by your Account Manager and Welcome Information is provided to you by introducing you to your Sales Engineer.

The Calendar Event will include a conference bridge and a download for our TeamViewer Thin Client to establish a remote session to your workstation. The first call will confirm the scope of test deployment and describe at a high level how our solutions will work in your environment.

These calls all include general step by step instruction on the Securly Web Interface, with access to additional in-depth training Webinars if necessary. A follow up call or expanded deployment is scheduled during the call or via email shortly after the original deployment if necessary.

References

Securly has grown by nearly 1000% in 5 years, raising more than \$20 million in funding to continue helping education address student safety. Securly did this by building a Customer Success Team of dedicated customer success staff that manage and nurture relationships with customers long-term. This includes periodic reviews of product adoption, student safety statistics, reports, and carefully-tracked customer satisfaction. We are committed to developing long-lasting relationships and want to partner with schools to continuously improve how we serve the needs of the K-12 education community. Our technical support is available and is unlimited.

Reference #1

Entity Name	Carrollton-Farmers Branch ISD
Entity Address	1445 N Perry Rd
Entity City, State, Zip	Carrollton, TX 75006-6134
Contact Name	Robin Stout
Contact Title	Senior Director of Digital Learning
Contact Phone	(972) 968-4339
Contact Email	stoutr@cfbisd.edu

Reference #2

Entity Name	Elgin School District U-46 (IL)
Entity Address	355 E Chicago Street
Entity City, State, Zip	Elgin, IL 60120
Contact Name	Laura Macias
Contact Title	Director of Technology

Contact Phone	(972) 968-4339
Contact Email	lauramacias@u-46.org

Reference #3	
Entity Name	Blue Valley Schools Unified School District 229 KS
Entity Address	15020 Metcalf Avenue
Entity City, State, Zip	Overland Park, KS 66223
Contact Name	Jodie Johnston
Contact Title	Digital Learning Support Analyst
Contact Phone	(913) 239-4339
Contact Email	jjohnston01@bluevalleyk12.org

Past Performance

Below is a summary of the total number of installations in the last 3 years by the year of installation and the total number of current users for the proposed system.

- 2,337 New Installs in the last 3 years.
- 676 New Installs in 2017
- 703 New Installs in 2018
- 958 New Installs in 2019
- 11 Million Students are currently being supported by Securly.

Securly has grown nearly 1000% in 5 years, and raised over \$20 million in funds to continue helping education address student safety. Securly did this by building a Customer Success Team of dedicated representatives that manage and nurture relationships with customers long term. This includes periodic reviews of product adoption, student safety stats, reports, and carefully-tracked customer satisfaction.

We are committed to developing long-lasting relationships with anyone we work with and want to partner with schools to find out what we can do better as we further our development and engagement with the K-12 education community. Our technical support is available and is unlimited.

Additional Products

The following are optional Securly products outside of the proposed solutions

Auditor

Real-time email, Google Docs, and Google Drive scanning with AI-based notifications for nudity, bullying, self-harm, and violence. Auditor is able to also monitor students on One Drive for Student Safety Issues, Self-Harm Issues, Bullying Issues and Site Safety Issues.

Auditor uses the most sophisticated AI engine in student safety to scan emails, Docs, and Drive in real-time. Get alerts based on context, not just keywords.

- **Google Docs and comments:** Live documents can be used for spreading rumors, passing notes, or penning final farewells. Auditor scans for signs of bullying, self-harm, and violence, letting you know immediately when a student is in crisis.
- **Files on Google Drive and OneDrive:** Nudity detection for files stored in Google Drive and OneDrive keeps inappropriate photos away from innocent eyes.
- **Emails and attachments:** Auditor scans Gmail and Office 365 email content for nudity in image attachments, bullying, self-harm, and violence.
- **Delegated admins:** Delegate by group or organizational unit (OU) so alerts go to the staff members closest to the student in crisis.
- **Confidence scores:** Securly's AI assigns a confidence score to every notification. You pick the confidence scores you want to get notifications for.

Create Delegated Reporting Group

Enter a Delegated Reporting Group Name*

Delegated Admin Group 1

Add User Email IDs*

admin@securlyqa1.com, hc9@securlyqa1.com, harytest@securlyqa1.com, rahulu@securlyqa1.com, kiddeight@securlyqa1.com

Tabs Displayed to Users

Flagged Auditor +

Configure Email Alerts

Filter

Send blocked activity email alerts

Send flagged activity email alerts for

Auditor

Select the email alerts for Gmail 2

Select the email alerts for G Docs 1

Category	Confidence Level	Alert Urgency
<input checked="" type="checkbox"/> Nudity	2	Immediate
<input type="checkbox"/> Violence	1	Immediate
<input type="checkbox"/> Bullying	1	Immediate

Save Group

Benefits of Auditor

- **Easy setup**
 - Covers all your devices, everywhere, across multiple platforms. Simple. Safe.
- **Sophisticated AI**
 - Analyzes all content across email, Docs, and Drive using the industry's longest-learning AI.
- **Real-time notifications**

- If a student's content shows signs of bullying, self-harm, or violence, you'll be the first to know.

24 by Securly

Our team of highly-trained specialists work with our AI to analyze flagged activity notifications— 24 hours a day, 7 days a week. A thorough risk assessment of the student is performed, identifying concerning trends and patterns. When an alert is determined to be urgent, the 24 Team follows an escalation process to notify the school.

24/7 analysis

When a flagged activity alert comes up, a thorough risk assessment is performed to identify patterns in a student's search history. Crucial signs of trouble can begin small, and commonly-overlooked clues like search history can provide a valuable virtual map into a student's mental state.

Escalation processes

Different levels of notifications and plans of action are in place for emergency situations, minimizing false alarms. Sometimes a student might just be curious about a concerning topic, while another might be desperately obsessed.

Action plans

When immediate action is needed, you will hear directly from one of our analysts. They will give you full context into the student's activity so your staff can make a well-informed decision on what to do next.

Integration with our other groundbreaking products

Pair 24 with Auditor, Filter, and Tipline for the most complete student safety solution on the market.

Filter

Keep your students safe on all devices with Securly's signature cloud-based web filter. Get full visibility into online activity, download or email reports, and receive notifications for flagged content with the most sophisticated AI engine in student safety.

Filter is iKeepSafe certified and SOC2 compliant, and specifically tailored to student data privacy legislation, including the Student Online Personal Information Protection Act (SOPIPA).

Complete online visibility

- **AI-based context analysis:** Filter monitors for signs of bullying, self-harm, and violence across social networking and web searches, going beyond keyword scanning to understand the true meaning of the phrase in context. For example, the phrase "To kill a mockingbird" may contain a concerning keyword

("kill") but is not concerning in context. When a student is suffering or looking at concerning content, you'll know.

- **Live activity feed:** Stop guessing, know your students' online activity. Our pioneering visual audit trail makes it easy to see favicons, exact searches, and video thumbnails at a glance.
- **Selective SSL decryption:** Eliminate performance issues and security concerns with our one-of-a-kind approach to filtering and decrypting secure web traffic.

AI-flagged alerts and granular reporting

- **Flagged alerts:** Analyze searches and sites visited with the longest-learning AI on the market. Our separate flagged activity feed lets you focus on the concerning trends at your school or district.
- **Delegated admins:** Delegate by group or organizational unit (OU) so alerts go to staff members closest to the student.
- **Shared reporting:** Quickly download, schedule, or email reports by OU.

Policy creation and customization

- **Parent access:** Give parents control over their child's school device when it goes home so they can view their child's online activity, "pause" the internet, and set their own filtering rules with Securly Home. When it comes to granting control for parent access, you hold the key (more information below).
- **Take-home and guest policies:** In addition to creating your own policies, customizable Take-Home and Guest policies come included with Filter to make sure the right devices and people are filtered and protected on and off-campus.
- **Policy map and custom groups:** The policy map makes it easy to move OUs from one policy to another and create custom groups* for a pre-set amount of time to allow or deny access — all without needing Google or Azure directories.

HOME

Parenting in a digital world can be hard. Securly Home makes it easier. Depending on the level of control set by the school, parents can view their child's recent searches, sites visited, and videos watched on their school-owned device. Give parents the confidence they need to take control of their child's screen time at home.

- **Parent email reports:** Every week, parents receive a snapshot of their child's online activity, directly to their inbox.
- **Parent access:** You choose what activity parents can see on their child's school-owned device. Whether it's restricted to only home activity, educational activity, or all activity, parents can check the live feed anytime with the app or web view.

- **Parental controls:** Depending on the level of control you set, parents can customize their own filtering rules when their child's school device is at home.
- **Pause internet access:** Parents can use the Home app to turn internet access on or off with a single tap when the device is away from school.
- **Flagged alerts:** Parents receive push notifications in the Home app of their child's flagged activity.
- **Offline schedules:** Parents can set offline (no internet) schedules for school devices at home. Perfect for bedtime.

Benefits

- **Easiest setup**
 - True cloud—not a combination of agents, DNS, and appliances based on device type
 - Appliances do not scale, and DNS can't do user-level policies and deep-packet inspection for safety threats
- **Most vetted and battle-hardened cloud-tech**
 - Scale-ready
- **Rich parental controls** for not just reporting, but filtering and screen-time management of take-home 1:1 devices
 - Admins get enterprise-level control over what parents can and can't do
 -

Key Technologies

Cloud-based solution: Cloud-based web filtering as an appliance replacement, for any device, anywhere.

HTTPS/SSL decryption: Securly can filter SSL traffic, providing full protection and customization as necessary, while only decrypting websites under our blocked categories, leaving other sites alone. This helps eliminate latency, and allow full scalability while taking care of HTTPS traffic.

Proxy filtering: Securly can transparently proxy a few select websites on demand, allowing us to detect cyberbullying, suicide, and violence, on social media websites such as Facebook and Twitter—while providing fast URL filtering on the rest of the traffic—any device, anywhere.

Integration with Google Authentication: All authentication via Google, including transparent AD auth for domain machines. Primarily browser-based authentication, or completely seamless on Chromebooks.

Take-home policies: Devices that go home can easily have separate policies based on location, rather than time-based roles – these policies automatically changed when the device is back on a school network.

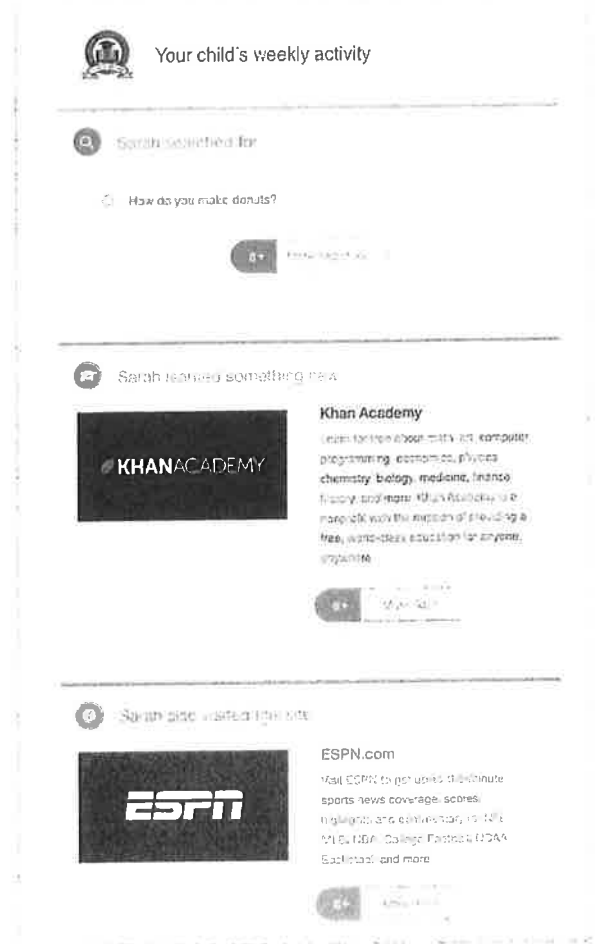

Google-enhanced SafeSearch: You can apply YouTube restricted mode and safe mode on popular search engines, and use a safer technology keeping Google images safer for younger students.

Teacher controls: Teachers that have permission can override the filter as needed.

Audit logs: Keeps a record of each instance when an admin or teacher allows a site.

Bullying and self-harm detection: Our AI helps identify inappropriate posts related to bullying or self-harm and notifies the school.

Parental integration: Parents can get involved with e-mailed activity reports or even parent portal access



CREATED BY	QUOTE DATE	CUSTOMER
ella.sherman@securly.com	04/12/2022	Hickman County Schools

Contract Term: July 1, 2022 - June 30, 2023 (1 Year)

QUOTE DETAILS			
ITEM	QTY	UNIT PRICE	TOTAL PRICE
Dyknow CM (1 year)	3300	\$5.00	\$16,500.00
<ul style="list-style-type: none">- Cloud-based classroom management tool- Monitor and manage devices in the classroom- One Time \$1500.00 set up fee			+ \$1,500.00
Reveal by Securly (1 year)	3330	\$1.36	\$4,488.00
<ul style="list-style-type: none">- Device Impact Management Reporting with analytics and insights for administration			
ADDITIONAL SOLUTIONS			
Filter Core (1 year)	3300	\$5.33	\$17,589.00
<ul style="list-style-type: none">- AI-based Web-content filtering			
Home (1 year)	3330	\$1.36	\$4,488.00
<ul style="list-style-type: none">- Parent reports, controls and filter access at home			
Auditor Core (1 year)	3300	\$1.76	\$5,808.00
<ul style="list-style-type: none">- Realtime Google Workspace monitoring			
24 by Securly (1 year)	3300	\$5.24	\$17,292.00
<ul style="list-style-type: none">- Team of specialists work with the district to analyze flagged activity notifications 24 x 7			
Total			\$67,665.00



111 N. Market Street,
#400 San Jose, CA 95113



PH: 1-855-SECURLY
FAX: 1-855-SCRLYFX



www.securly.com
sales@securly.com

Hickman County Government

Conflict of Interest Disclosure Form

The County Financial Management System of 1981 contains the most stringent conflict of interest provisions. TCA §5-21-121 provides:

- (a) The director, purchasing agent, members of the committee, members of the county legislative body or other officials, employees, or members of the board of education or highway commission shall not be financially interested or have any personal beneficial interest, either directly or indirectly, in the purchase of any supplies, materials, equipment or contractual services for the county.
- (b) No firm, corporation, partnership, association or individual furnishing any such supplies, materials, equipment or contractual services, shall give or offer, nor shall the director or purchasing agent or any assistant or employee accept or receive directly or indirectly from any person, firm, corporation, partnership or association to whom any contract may be awarded, by rebate, gift or otherwise, any money or other things of value whatsoever, or any promise, obligation or contract for future reward or compensation.

Date: 04 / 05 / 2022 Name: Mike Jolley

Please describe below any relationships, transactions, positions you hold (volunteer or otherwise), or circumstances that you believe could contribute to a conflict of interest:

I have no conflict of interest to report.

I have the following conflict of interest to report (please specify any boards or committees you (and/or your spouse) sit on, the name of your employer and any businesses you or your spouse may own.

I hereby certify that the information set forth above is true and complete to the best of my knowledge.

Date: 04 / 05 / 2022 Signature: 

TITLE Conflict of Interest for Hickman RFP
FILE NAME Conflict-of-Inter...sure-Formdocx.pdf
DOCUMENT ID e9ef4724d5d7b1e821d4a7989f1c3542babc9725
AUDIT TRAIL DATE FORMAT MM / DD / YYYY
STATUS Signed

Document History



SENT

04 / 05 / 2022
 19:09:52 UTC-7

Sent for signature to Mike Jolley (michael@securly.com) from casey@securly.com
 IP: 66.91.43.202



VIEWED

04 / 05 / 2022
 19:27:48 UTC-7

Viewed by Mike Jolley (michael@securly.com)
 IP: 174.208.226.4



SIGNED

04 / 05 / 2022
 19:28:01 UTC-7

Signed by Mike Jolley (michael@securly.com)
 IP: 174.208.226.4



COMPLETED

04 / 05 / 2022
 19:28:01 UTC-7

The document has been completed.



Request for Proposal

Student Chromebook Monitoring Software

Bid Opening: April 18th, 2022 at 10:00am

Sergeant Laboratories, Inc.
560 Lester Ave
Onalaska, WI 54650

Company Profile

Sergeant Laboratories was established in 1999 and revolutionized instructional technology with the development of AristotleK12. For school districts who prioritize student education, AristotleK12 is an ed tech management platform that provides users with advanced oversight and specialized education security. Unlike other antiquated educational systems, AristotleK12 is the only platform with agile functionality and rapid adaptability, ensuring a seamless experience for educators and students while supporting the dynamic policies of the district administration.

AristotleK12 is suitable for in-person, online, and hybrid learning situations. The product integrates classroom management, student behavior analytics/alerts, geo-location tracking, asset & utilization reporting, G-Suite automation, and student-centric filtering in a single unified platform.

Scope of Required Services

Classroom Management – Features Include but Not Limited To:

- Historical and investigative reports of individual student internet activity
- Reports for online activity while the school-owned device is at home
- A customizable block list is available to restrict access to websites that are not needed for a particular class.
- Teachers can push single or multiple URLs to student devices
- Geo-location reporting to pinpoint the location of missing or stolen devices
- Google authentication for classroom management
- Ability to integrate District data with OneRoster®, with users identified by rostered name or another customizable name
- Student screens are shared in real-time to a teacher dashboard, allowing educators to see exactly what users see
- Teachers can blank the screen on student devices
- Teachers can view, close, open, and refocus student tabs
- Student device controls limited for test administration and remote proctoring
- Screen sharing from the teacher is available for one student, some students, or all students
- At-risk student behavior can be monitored through keyword/phrase tracking and alerting, including a default list of keywords/phrases that can also be manually altered
- Real-time alerts sent for potentially dangerous behavior

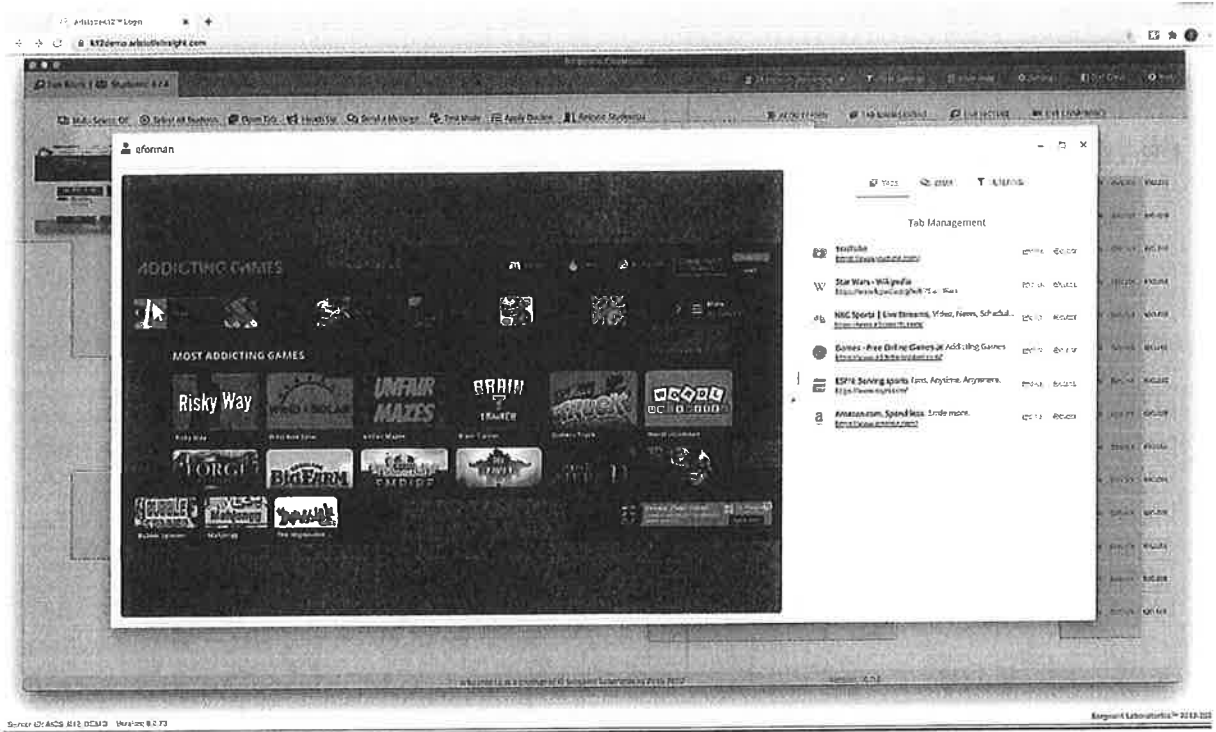

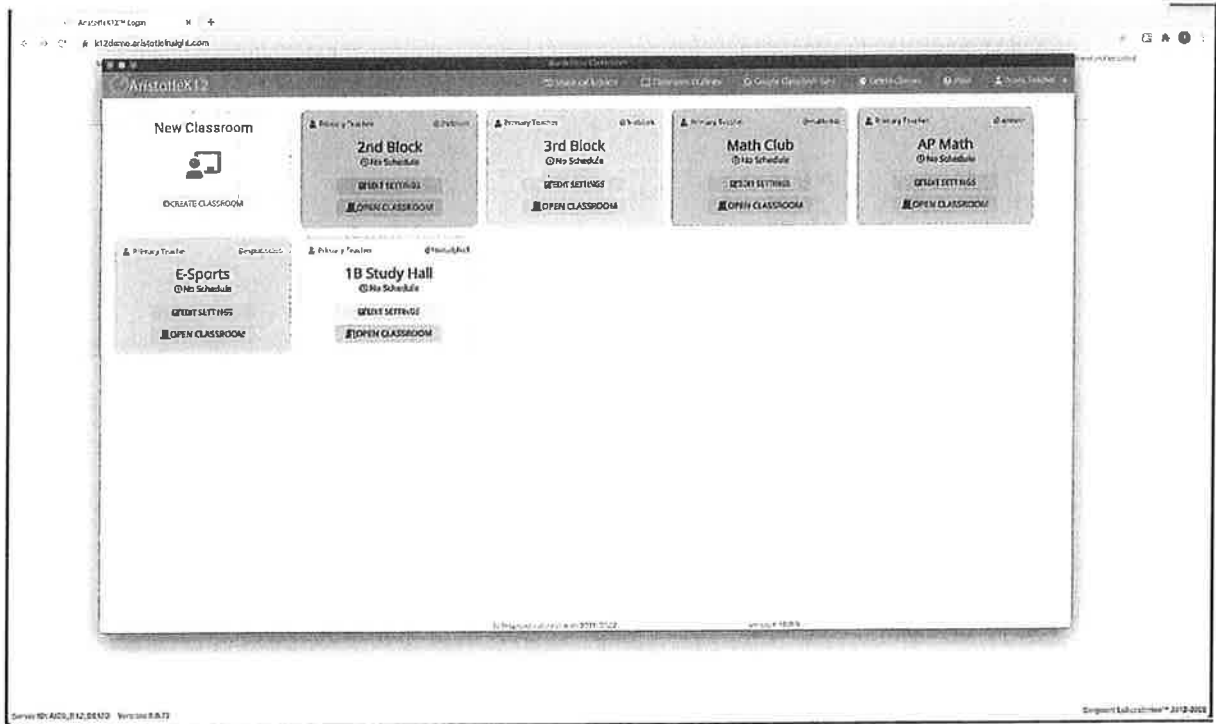

Value-Added Services

Classroom Management – Features Include but Not Limited To:

- Built in live video and audio to facilitate distance learning
- Centralized management in a cloud-hosted solution
- Multi-Device support for Windows, MAC, Chromebook, and iOS devices
- Ability to view browsing history for student devices
- Teachers can chat or message with individual students or the entire class with two-way communication

Asset Utilization & Reporting – Features Include but Not Limited To:

- Device & application inventory
- Software licensing report
- Reports for installed apps/extensions
- Monitor changes made to policies and configurations, including changes to the Google Admin Console
- Reports on the number of active computers, users, and applications
- Reports on how devices and applications are being utilized
- Parents receive reports via email containing a summary of their student's activities

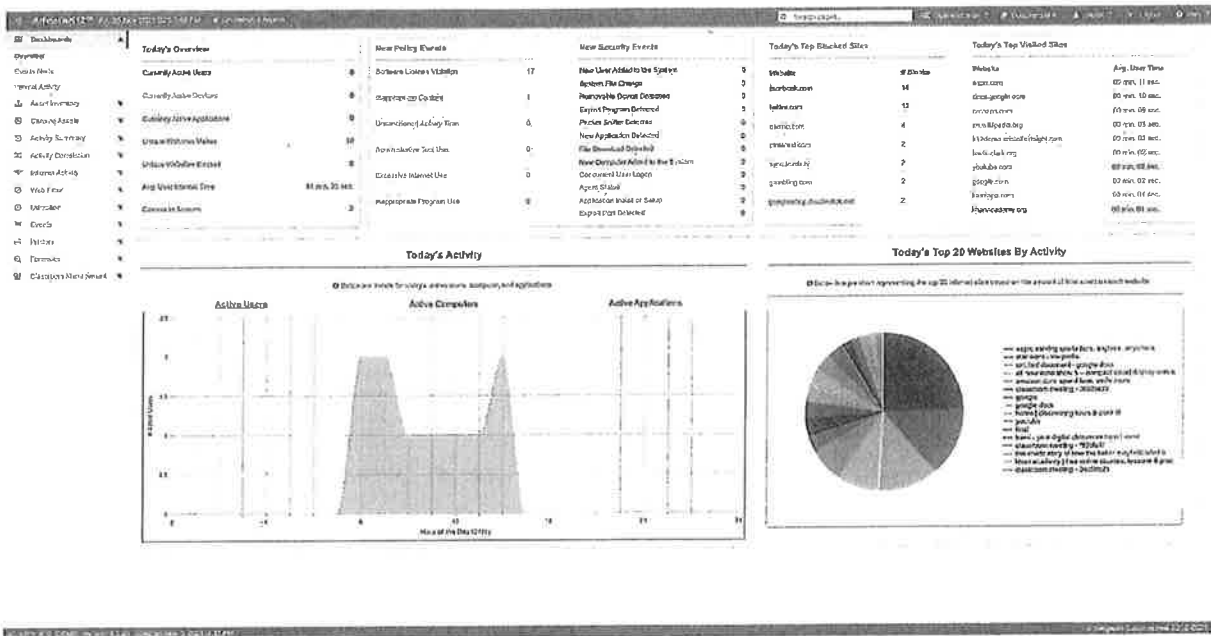

Today's Top 20 Websites By Activity

Below is a pie chart representing the top 20 internet sites based on the amount of time spent on each website.

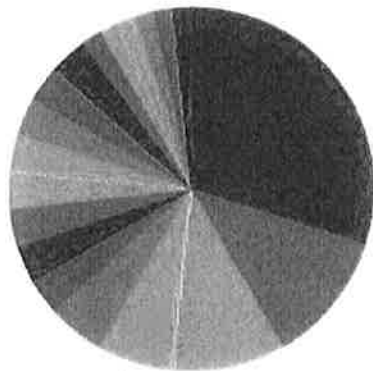

- espn: serving sports fans anytime anywhere.
- home - youtube
- final
- suicide - google search
- dictionary.com | meanings and definitions of words
- classroom meeting - 7eaab664
- pbs kids
- home | discovering lewis & clark
- classroom meeting - b2e2a1a0
- amazon.com spend less smile more
- kami - your digital classroom hero | kami
- classroom meeting - 928c508e
- netflix - watch tv shows online. watch movies online
- classroom meeting - 5c49639d
- proxy - google search
- star wars - wikipedia
- google - google search
- lewis and clark - bing
- @travdemo

Student-Centric Content Filter – Features Include but Not Limited To:

- Provide customized filtering by VLAN or subnet
- Filtering can be enabled or disabled for different groups of users to allow specific district members to bypass filtering
- Unique filter permissions can be set up with varying degrees of restrictions for different groups/users like students, teachers, and building administrators, and redefined as needed
- Apply filter controls based on time or location of student device
- Filtering can be done both on- and off-premises for Chrome devices
- Block access to websites based on both categories and specific URLs/Domains
- Block VPN sites by category
- Ability to allow or block all sections of AristotleK12 for specific users
- Alerts are created when inappropriate content is generated
- When applying filters to YouTube, educators and District staff can whitelist videos and filter content by category, video, keyword, or channel
- Safe search enforcement is available for Google, Yahoo, Bing, YouTube, and DuckDuckGo
- Selective Secure Socket Layer inspection and decryption

Block YouTube: NO Filtering: ON Safe Search: ON Comments Visible: NO Side Bar Visible: NO

YouTube Categories

Category	Blocked
	Is Yes <input type="radio"/> No <input type="radio"/>
Action/Adventure	YES
Anime/Animation	YES
Autos & Vehicles	YES
Classics	NO
Comedy	YES
Comedy	YES
Documentary	NO
Drama	NO
Education	NO
Entertainment	YES
Family	NO

YouTube Videos

Video	Blocked
	Is Yes <input type="radio"/> No <input type="radio"/>
"The Unsearchables" Chapter 23	NO
10 Moments on LOVE TV You Won't Believe Happened! Compilation	YES
Baseball in the Time of Cholera	NO
Best Female Vocal Grammy Music: Mar 2019 EDM, Trap, Dubstep, Dr&B, Electro House	YES
Bob's Burger: Linda & Bobbie	YES
Build a Web Proxy Server	YES
Ch. 4 House Playlist Releasing Summer Anime 2019	NO
ESQ No. "COLLEGE BABY" for	NO
Follow The Leader - Tutorial	NO
Greatest Sports Events 2017 Part 1 (hunny)	NO
How easy is it to capture data on public free Wi-Fi? - Gary explains	YES

Keywords to Block

Keyword/Phrase	Blocked	World Only
	Is Yes <input type="radio"/> No <input type="radio"/>	Is Yes <input type="radio"/> No <input type="radio"/>
13+	YES	NO
adult	NO	NO
adult	YES	NO
dark web	YES	NO
drugs	YES	NO
fight	YES	NO
film	YES	NO
for sale	YES	NO
for sale	YES	NO
fuck	NO	NO
gambling	YES	NO

YouTube Channels

Channel	Blocked
	Is Yes <input type="radio"/> No <input type="radio"/>
Substack	YES
Steve Sheldon	YES
CrazyRussianHacker	NO
Edgardo	NO
Fanatic	YES
Good Mystral Morning	YES
HESMORAKON	NO
Joe Sandagato	YES
Katy Krone	NO
Khan Academy	NO
Lin	NO

System Updates and Technical Support

Major releases/updates to the AristotleK12 system will be announced via email and will include release notes explaining everything that is new/different. All customers are eligible to receive training from our professional support staff and are encouraged to schedule as much training as they feel is needed when new features are released so that educators and other district staff can feel comfortable and confident with the system.

Regular communication with our customers is standard practice. Customers are contacted at least once per quarter to ensure user experience is positive, provide training & support resources, and to share developments related to feature additions. We also welcome feedback and input from customers related to feature requests.

Help files, short videos and tool tip callouts are accessible throughout the AristotleK12 platform often eliminating the need for extensive training or time spent contacting our Customer Success group.

Customer support requests are monitored with ticketing software. New tickets may be created by calling our office and speaking with a team member, or via email. Additionally, any support inquiries that exceed available staff resources at the time of the initial call will typically receive a response within two business hours.

Customer Success staff are available by phone between 8:00am-5:00pm Central Time, Monday through Friday, and the help desk email is monitored 24/7. Unlimited training and technical support are included with the AristotleK12 license. Customer Success staff may be scheduled for dedicated sessions with any member or members of the District using our calendar links.

AristotleK12 Implementation Timeline

Purchase order received

Same Day – Public IP information will be requested from District personnel. Once received, our engineers will begin the build process of a cloud server for the customer.

1-3 Business Days Later – An email will be sent that contains login credentials, a dropbox link containing device clients (if the customer has windows/mac devices), and links allowing the customer to schedule setup/system training and/or educator training.

3-10 Business Days After Ordering – Typically, customers will schedule system/setup training before scheduling educator training. During this virtual meeting, our support engineers will guide the customer through deploying device clients (chrome extensions, windows/mac agents, and proxy filter PAC file/certificate if applicable). The support engineers will also guide the customer through the data integration setup to make sure AristotleK12 is able to collect information from applicable sources such as G-suite, Active Directory, or a Student Information System. If the customer would like to receive email alerts, our support staff will also assist in getting an SMTP connection established. Once these areas have been configured, our support staff will make sure data is reporting to the system and go through an initial tour of some of the most popular reports in the system. This initial meeting is typically scheduled for 1.5 hours, and additional trainings/meetings can be scheduled whenever the customer would like.

Timeline Varies – Once the AristotleK12 system has been set up with data reporting and the device clients installed, the customer will schedule a meeting for Borderless Classroom Training (educator training). The customer may choose to have whoever will be the best contact(s) attend this virtual meeting (technology director, technology coaches, a group of educators, all educators, etc.) Customers may also choose to schedule multiple training sessions as well to ensure all necessary staff are able to receive training. During this virtual training, our educator training staff will guide the attendees through:

- How to create/sync classes (Google Classroom, SIS, a custom class)
- How to start a class (either manual start or a scheduled class)
- Tab control (closing tabs, opening tabs, and refocusing students' tabs)
- In-class filtering (class-wide filtering and individual filtering)
- Live lecture/conference (audio/video conferencing with students)
- Additional class controls (test mode, screensharing, blanking screens, etc.)

Our trained staff will also be able to help with any questions or use cases attendees have during the meeting. Once again, these meetings can be scheduled whenever the customer feels there is a need.

Implementation complete

Pricing



Price Quote

AristotleInsight

Date: 4/7/2022
 Quote #: 040722-A
 Expiration Date: 6/30/2022

Sergeant Laboratories, Inc.
 560 Lester Ave
 Onalaska, WI 54650

 Matt Vande Slunt
 (608)788-9143
 mvandeslunt@provecompliance.com

To:
 Hickman County School System
 115 Murphree Ave
 Centerville, TN 37033

 Brad Gilbert
 (931)729-3391
 brad.gilbert@hickmank12.org

Salesperson	Ship Method	Shipping Terms	Payment Terms	Due Date
			Net 30	TBD

Qty	Description	Line Total
1	AristotleK12™ Configuration Includes: -Cloud Appliance License -Agent Installer -Training -Configuration	16,128.82
	Windows/Mac Connections	
3,200	Chromebook Connections	Included
	Ipad Connections	
1	One-Year AristotleK12™ License Includes: -Updates -Phone Support -Hardware Support & Warranty -Customer Success Program	Included
<i>Subtotal</i>		\$16,128.82
<i>Sales Tax</i>		Paid by Customer
<i>Total</i>		\$16,128.82

For your convenience, this quote becomes an order upon acceptance by signature. Upon returning signed acceptance of this quote, Sergeant Laboratories will proceed with production and invoicing. Product License and Support Services Agreement acceptance required prior to system shipment.

Accepted by: _____

Reference/PO Number: _____

Please submit a copy of your organization's purchase order for processing.

Thank you for your business!

Student Data Privacy Policy

Privacy Policy: www.aristotlek12.com/student-privacy

This Privacy Policy was last updated on April 25, 2019

Sergeant Laboratories, Inc (the Company), the producer of AristotleK12 (the Product), is a technology company providing K12 education with a unified digital integration platform combining classroom device management, student user behavior analytics, asset & utilization reporting, and student centric filtering to improve learning outcomes while providing for a safer and more productive learning environment. The Company is committed to student data privacy relating to information the Product collects, stores, and reports to authorized users (Customers). Information security is a top priority of the Company.

This Privacy Policy explains how the Product collects, stores, and protects information. The Company strongly encourages Customers to read this policy and associated laws in their entirety to fully comprehend Sergeant Laboratories' policy with regard to student personal information.

What Information Does the Product Use?

The Product uses various technological safeguards to protect students and help them become responsible digital citizens. The Product collects user behavior activity the Customer may use to identify the student. The Product does not collect student personal information from sources outside the Product. Student personal information will not be used by the Company for any reason.

Student personal information collected from student use of school technology may depend on the particular settings enabled or disabled by the Customer. Depending on the enabled settings and user configurations, information that may be collected includes account information, online behavior, and location.

The Product may collect a student's school-managed account information, which includes: student's name, email, Google Profile ID, as well as any device identifiers necessary to connect a student to a particular device and settings. Depending on features and settings configured by the Customer, the Product may collect additional information, including a student's browsing history, IP address, and relevant online activity. Using the Product, a Customer may collect the geographic location of devices for the purpose of locating and recovering any device that may be unaccounted for. The Product will automatically collect certain information which may include IP address, time and date stamp, browser language and type, amount of time spent on content, login times, type of device, and settings.

The Product uses collected information to provide reports, student safety alerts, and utilization details to the Customer. The Company may view information collected by the

Product in the process of providing support services to Customers. Information collected by the Product may be used to verify compliance with applicable laws to protect our Customers.

What Does the Company Prohibit with Regard to Collected Information?

- The Company will not sell any information collected by the Product.
- The Company will not use student personal information beyond the need to support Customers for authorized educational/school purposes.
- Student Profiles will not be recorded for non-educational purposes.
- The Company will not retain student information longer than is reasonably necessary for such participation, in order to fulfill the purpose for which it was disclosed.
- The Company will not use student information for any type of behavioral targeting of advertisements towards students.
- The Company will not make any alterations to this policy without notifying Customers of said changes.

Does The Company Share Collected Information?

Student personal information will not be provided to any third party by the Company without written authorization from the Customer. Information collected by the Product is not openly accessible. Third parties requesting access must comply with this privacy policy.

The Company reserves the right to disclose information under certain circumstances. These may include: School Access, Protection of Sergeant Laboratories, Legal Requirements, or Business Transfer.

Customer access provides personnel of the school to have access to the account. The Company also supports reviews and corrections of student personal information through schools, teachers or other educational entities. If you have any questions about viewing or updating information on file, please contact your school or district.

Information may be disclosed if determined that doing so is necessary and/or appropriate to protect the Company, its rights, and safety. The Company reserves the right to disclose certain information in compliance with legal requirements such as; law enforcement or legal/regulatory processes.

In the future event of a business transfer, corporate sale, merger, reorganization, dissolution or other related event, collected information may be a part of the transferred assets. In this instance, any Company successor must be in agreement to this privacy policy and comply to the guidelines both stated here and in the Student Privacy Pledge.

How Does The Company Protect Information?

Sergeant Laboratories maintains security and student privacy as a top priority. The Company has many safeguards in order to protect student personal information. The Company prides itself on maintaining a comprehensive security program that protects the security, privacy, and integrity of student users. Only authorized personnel will be allowed access to any information. The Company works hard to prevent any unauthorized access and take precautionary measures to instill security in its Product. In the event of a security breach, Sergeant Laboratories will comply with all relevant breach laws and procedures to mend the issue and provide notification to Customers.

Sergeant Laboratories complies with FERPA, COPPA, and the Student Privacy Pledge guidelines, along with any other applicable laws. Links at the bottom of this policy are provided to these policies and law, for your convenience. The Company encourages you to read these documents to their entirety.

Will The Company Ever Change the Privacy Policy?

Sergeant Laboratories reserves the right to modify this Privacy Policy at any time without prior notice to maintain relevant procedures. Provided at the top of this policy will be the date of the most recent update for the policy. The Company will not make material changes to the Privacy Policy without providing an email notification to Customers. An option for agreement to the alterations made to the Policy will be presented to Customers. New consent will be given when the Customer continues to use the Product, after the notified change. Customer's continued use of the Product ensures agreement with the revised Privacy Policy.

Please feel free to contact Sergeant Laboratories with questions relating to this policy.

Contact Us

Sergeant Laboratories

866-748-5227

info@provecompliance.com

Additional Resources

FERPA: <https://www2.ed.gov/policy/gen/guid/fpco/ferpa/students.html>

COPPA: <https://www.ftc.gov/tips-advice/business-center/privacy-and-security/children%27s-privacy>

Student Privacy Pledge: <https://studentprivacypledge.org/>

April 6, 2022

Hickman County School District
114 North Central Avenue Ste 203
Centerville, TN 37033

Finance Office,

Sergeant Laboratories, Inc is a Minnesota Corporation based in Onalaska, Wisconsin.
Our EIN number is 39-1952680.

We are the developer and manufacturer of AristotleK12™ student computer desktop monitoring, classroom device management, filtering, and utilization reporting systems. We own all patents, have developed and own all software, and configure required server appliance hardware.

We are the original and sole source provider of AristotleK12.

If you have any questions, please contact me at: eanderholm@provecompliance.com
or (608)788-9143.

Regards,



Eric Anderholm
CEO Sergeant Laboratories

Hickman County Government Conflict of Interest Disclosure Form

The County Financial Management System of 1981 contains the most stringent conflict of interest provisions. TCA §5-21-121 provides:

- (a) The director, purchasing agent, members of the committee, members of the county legislative body or other officials, employees, or members of the board of education or highway commission shall not be financially interested or have any personal beneficial interest, either directly or indirectly, in the purchase of any supplies, materials, equipment or contractual services for the county.
- (b) No firm, corporation, partnership, association or individual furnishing any such supplies, materials, equipment or contractual services, shall give or offer, nor shall the director or purchasing agent or any assistant or employee accept or receive directly or indirectly from any person, firm, corporation, partnership or association to whom any contract may be awarded, by rebate, gift or other otherwise, any money or other things of value whatsoever, or any promise, obligation or contract for future reward or compensation.

Date: 4/6/22 Name: Matt Vande Slunt

Please describe below any relationships, transactions, positions you hold (volunteer or otherwise), or circumstances that you believe could contribute to a conflict of interest:

I have no conflict of interest to report.

I have the following conflict of interest to report (please specify any boards or committees you (and/or your spouse) sit on, the name of your employer and any businesses you or your spouse may own.

I hereby certify that the information set forth above is true and complete to the best of my knowledge.

Date: 4/11/22 Signature: 



Proposal for

Hickman County Schools

Chromebook Monitoring Software

RFP Response



Jay Patrick
Regional Success Manager
jpatrick@lightspeedsystems.com
(737) 787-2086

Contents

- Background
- Why Lightspeed Systems®?
- Enterprise-Class Partnership
- The Power of an Integrated Ecosystem
- Lightspeed Filter™
 - Lightspeed Parent Portal™
- Lightspeed Classroom Management™
- Lightspeed Alert™
- Pricing
- Conclusion



Aligned with Your Safety and Online Learning Initiatives

The schools in the community of Hickman County, Tennessee are looking for Chromebook Monitoring Software solutions that will allow them to keep their students safe online at home or on-campus.

Specifically, Hickman County Schools has identified the following requirements:

- Software will allow for reports on websites accessed by students, searches, etc.
- Ability to block/whitelist URLs as needed is preferred.
- Ability to track lost and stolen Chromebooks using location, screenshots, etc. preferred.
- Ability to function with the Google Admin console to populate users and groups.
- Classroom management tools for teachers with screen monitoring, viewing student screens, and controlling student devices.
- Ability for self-harm alerts is preferred.

Lightspeed Systems can easily meet and exceed all your requirements with our suite of solutions.

Trusted by Districts World-wide

More than 28,000 schools world-wide trust Lightspeed Systems® to protect their students, anywhere learning happens. Districts using Lightspeed solutions near you include:

- Hickman County Schools (*Lightspeed since 2017 has served as your web content filtering provider*)
- Benton County School District
- Maury County Public School District
- Henry County School District
- Bartlett City Schools
- White County School District



WHY LIGHTSPEED?

Lightspeed Systems®

The most trusted partner for online learning safety and effectiveness for every student

What Sets Lightspeed Apart?

A Proven Partner

At Lightspeed Systems®, we are committed to being a proven, trusted partner to our customers. For over 20 years, we've collaborated with our client schools and districts to tailor our solutions to the unique and ever-changing landscape of K-12 learning technology. As education finds itself in the midst of a technology revolution, with new systems, devices, and tools being implemented constantly, Lightspeed Systems helps districts ensure that their technology is safe, well-managed, and optimally functional. Lightspeed Systems works with tens of thousands of schools to maximize the safety, mobility, and effectiveness of their students' learning experience.

Committed to Privacy

Providing the safest and most effective online learning experience requires a deep and thorough approach to defense. Lightspeed Systems delivers enterprise-class software solutions and the safety net—from cloud security, first-rate tech partnerships, and customer support—to keep students protected and our clients successful. Our commitment to student and district data privacy is unrivaled. Lightspeed Systems is one of the only solutions on the market that boasts a dedicated team of data scientists, database administrators, and a data privacy team, ensuring optimal student safety and data security from the roots up. We're early signers of the Student Privacy Pledge, we're GDPR compliant across solutions and company policies, members of Student Data Privacy Consortium and IMS Global Learning Consortium, and our solutions are hosted in the secure AWS® cloud giving us a 99.9% uptime, creating the safest environment available for student data.

Visit our Trust page at: www.lightspeedsystems.com/about/trust



**STUDENT
PRIVACY
PLEDGE
SIGNATORY**



Student Data Privacy Consortium



Lightspeed Systems®

ENTERPRISE-CLASS SOFTWARE METHODOLOGY

Enterprise-Class Partnership

Lightspeed Systems® is the only company in our space that has invested in the full enterprise-class software process. This includes everything from Product Management to Product Development and touches every aspect of the company including Cloud Operations, Security, Client Services and Support. And our solutions are designed to be robust, value-driven, and scalable.

You can be confident that when you choose Lightspeed, you are choosing a company that is dedicated to and invests in world-class, enterprise software best practices.

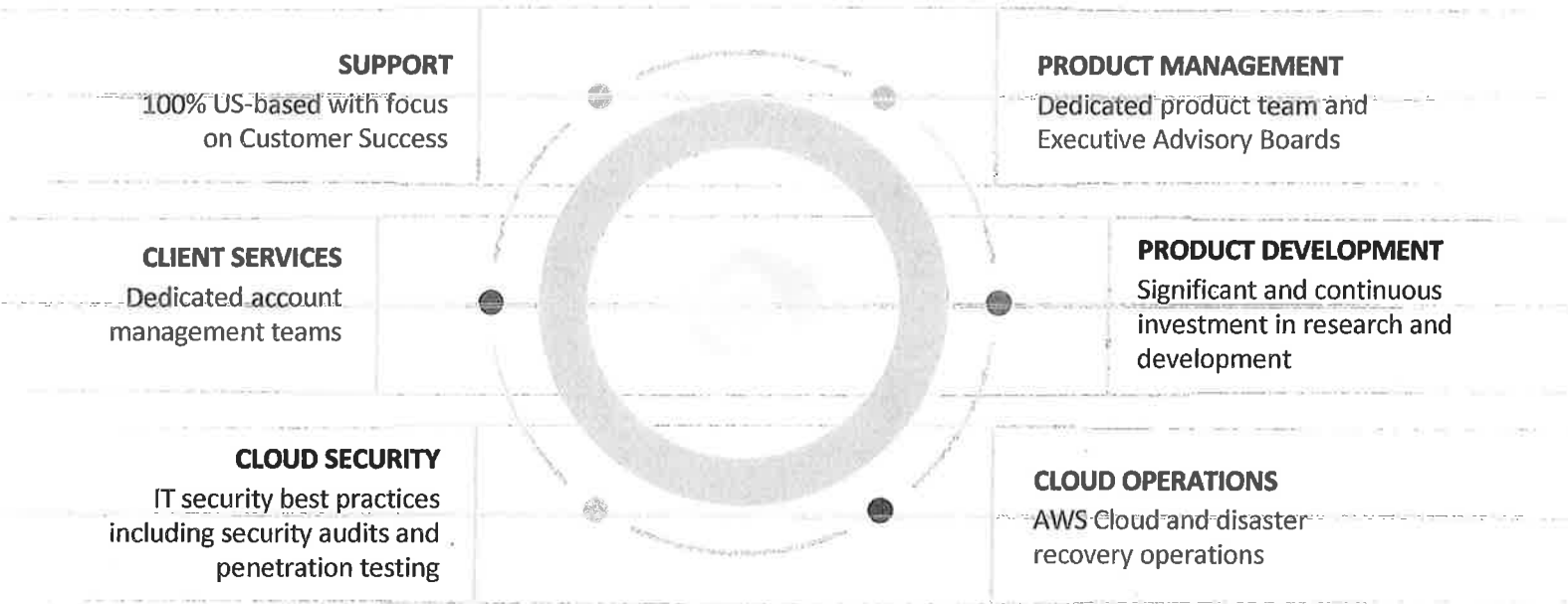

“

The impact continues to grow as a 1:1 district in a 24/7/365 fashion. Having a partner like Lightspeed gives me as a CTO piece of mind around protecting, monitoring, and now analyzing the overall student experience.

- Kyle Berger, Chief Technology Officer, Grapevine-Colleyville Independent School District

”



The Power of an Integrated Ecosystem

Lightspeed Systems® builds an ecosystem of integrated solutions that enable schools to more effectively and efficiently manage online learning.

With the Lightspeed Systems Solutions Suite, there is only one ...

- ✓ Vendor
- ✓ Contract

- ✓ Budget
- ✓ Invoice

- ✓ Account Manager
- ✓ Implementation

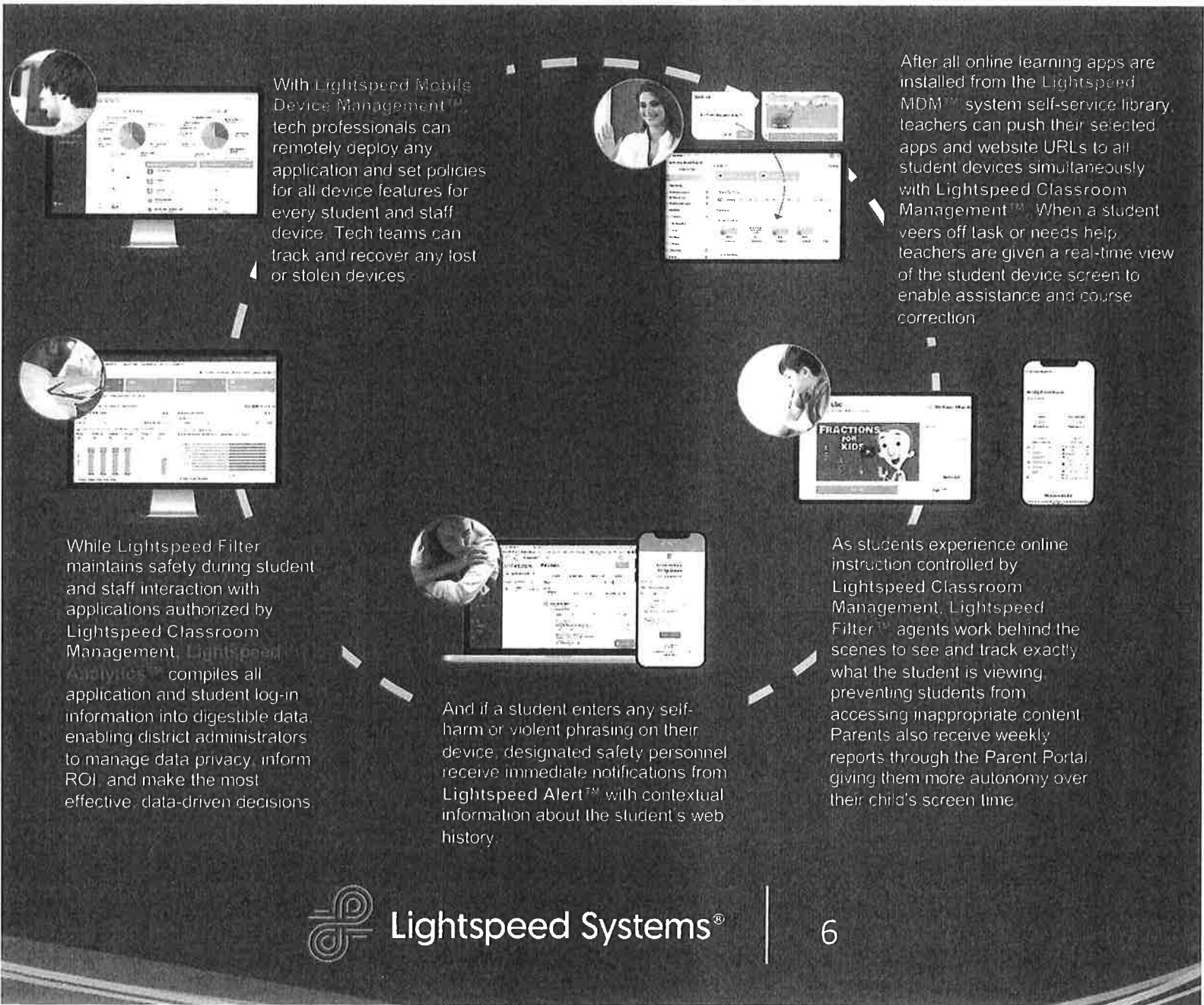



Lightspeed Filter™

Protect Students From Harmful Online Content

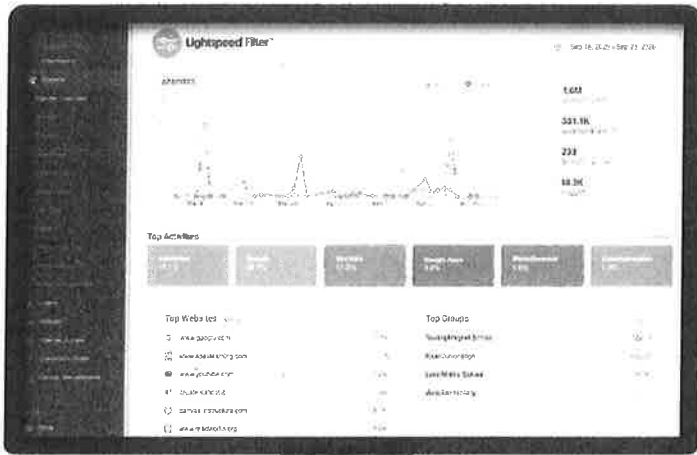

Lightspeed Filter™ is powered by the **most comprehensive database** of K-12 online content in the industry from 20 years of web indexing. Patented device-level agents leverage advanced AI to automatically block millions of inappropriate, harmful and unknown sites, images, and videos.

Ensure out-of-the-box CIPA compliance with Lightspeed Filter, the only solution on the market that employs all four key components of effective, accurate, consistent protections; dynamic, comprehensive database, always-on web crawling, advanced machine-learning, and in-house data scientists.

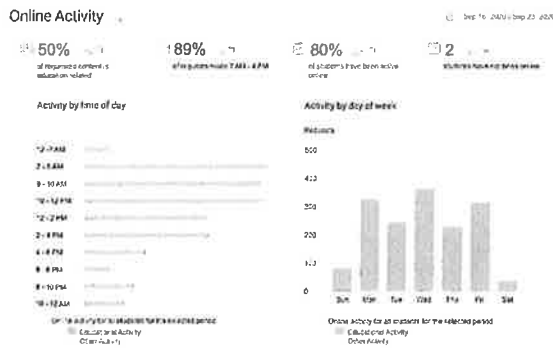

IT leaders have **visibility and insights across all student online activity** to secure safe and effective learning experiences for all students. Comprehensive, real-time reporting surfaces harmful and inappropriate internet browsing and activity to mitigate exposure and maintain compliance.

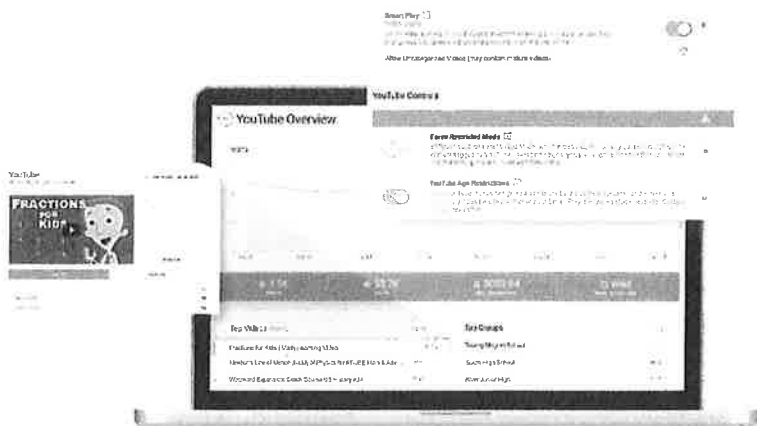

With our proprietary SmartPlay™ technology, **Lightspeed Filter makes YouTube a safe and reliable instructional tool.** Patented agents and mature database effectively block millions of inappropriate videos, thumbnails, and recommended by YouTube content. Customizable policy controls enable admins to set parameters and selectively allow and permit content—including videos and comments, by grade level, group, class, and site types—without being overly restrictive.



Lightspeed Systems®



Lightspeed Filter™

Lightspeed Parent Portal™

Empower Parents with Student Activity Insights

Whether parents are assisting students with remote lessons, serving as tech support for their children, or making sure that devices are being used appropriately, their involvement is more important than ever. The Lightspeed Parent Portal™ enhances communication by allowing guardians visibility of their child’s internet activity at home to keep them safe, focused, and observing healthy screen time allowances.

- Automate **Weekly Parent Report** emails showing number of browsed web pages, student time spent daily online, and sites most visited.
- Give parents more in-depth time-stamped data of **Student Internet Activity** with the online portal.
- Allow parents to **pause web browsing** for 1 hour, three hours, or overnight to prevent time-wasting.

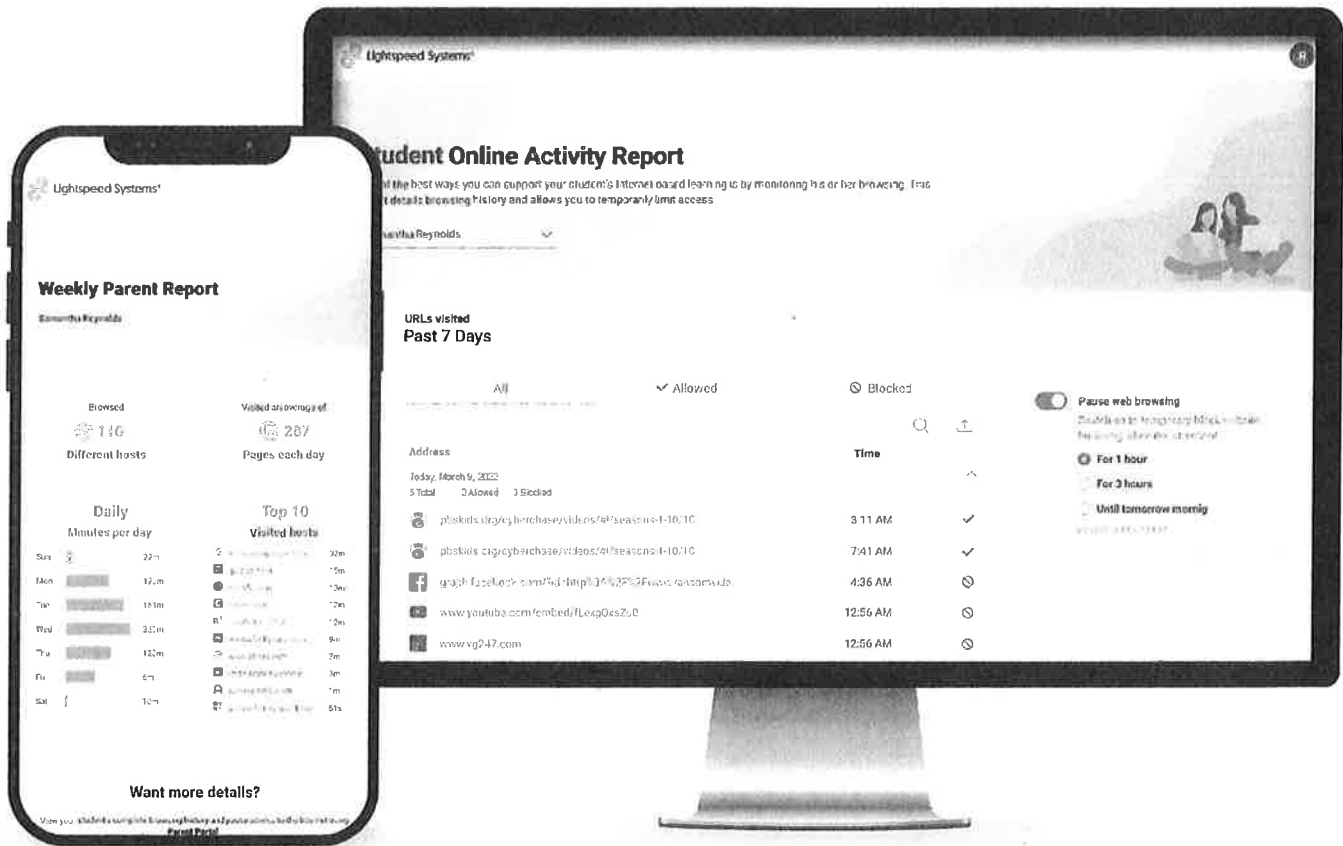

Lightspeed Systems®



Lightspeed Classroom Management™

Keep Students Engaged and Focused on Digital Learning

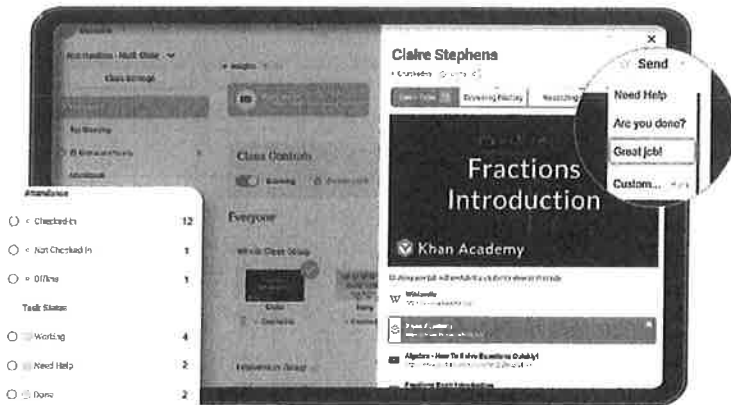

With Lightspeed Classroom Management™, teachers can keep their **students logged in, participating, and focused whether in-person or at a distance.** Advanced AI technology gives teachers **real-time visibility and control of their students' digital workspaces, status updates, and online activity.** Maintain instructional face time with students with the **Zoom integration allowing meeting launch directly from Lightspeed Classroom Management.**



Help educators maintain the necessary level of instructional control with tools to **block commonly distracting web pages and limit access to only the sites that support the lesson with just two clicks.** To maximize valuable instruction time, provide teachers the ability to **push out vetted curriculum links directly to students' screens, identify off-task behavior in real time, and reach out directly to students needing assistance.**

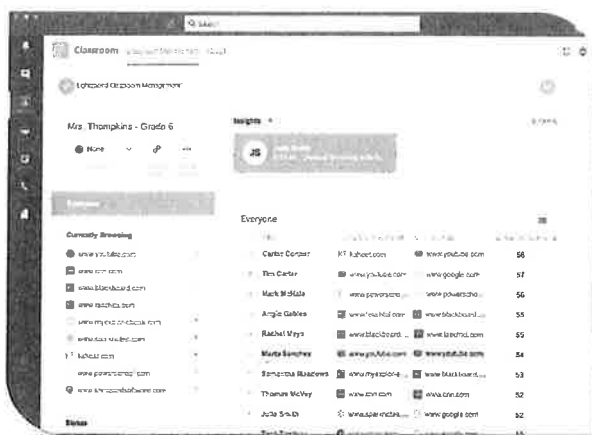

Lightspeed Classroom Management ensures every student can access instructional materials from wherever learning is taking place. With the **Microsoft® Teams integration,** educators can **access the entire Lightspeed Classroom Management software directly in the Teams platform** to provide instructional materials, maintain visibility, and keep students engaged all in one spot.





Lightspeed Alert™

Prevent Suicides, Cyberbullying, and School Violence



Lightspeed Alert™ is a critical component in student safety plans and the **prevention of self-harm, suicide, and school violence**. District administrators and their delegates are notified instantly of threats and can intervene before an incident occurs. Now with 24/7/365 human response, schools can ensure another layer of protection with Lightspeed safety specialists analyzing threats for proper escalation processes.



Lightspeed Alert uses patented, **advanced AI to monitor, interpret, and flag warning signs** in emails, Google docs, social media posts, web searches, Microsoft® Teams and Meetings chat, nearly everywhere students are interacting online.

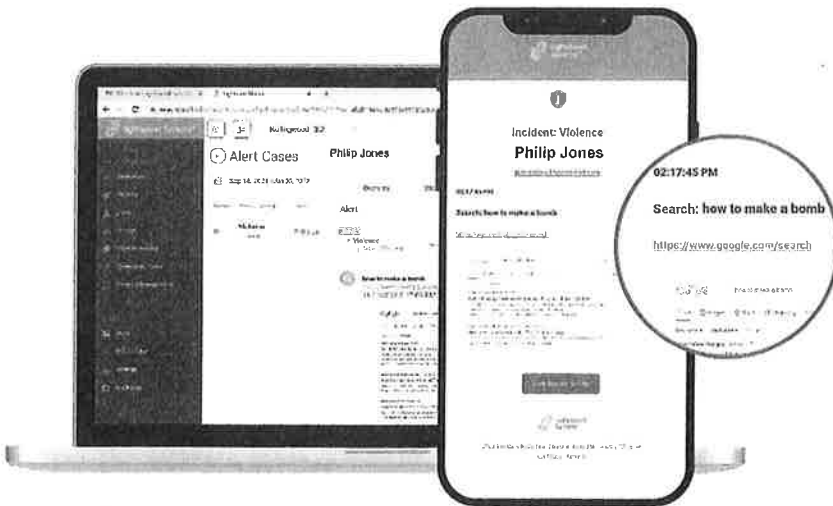

With Lightspeed Alert, **administrators gain insight into students' mental wellness**. **Activity logs** provide visibility into online activity before and after a flagged event for effective response and interventions. **Designate the appropriate personnel to receive alerts**, from safety officers to counselors to principals. **Analyze and share safety trend data** to recognize and check in with at-risk students and develop effective mental health programs.



Lightspeed Systems®

Pricing

With schools facing unknown hurdles of online learning, Lightspeed Systems® would like to extend a partnership proposal to Hickman County Schools. In the spirit of the partnership, Lightspeed Systems would like to offer Lightspeed Filter, Lightspeed Classroom Management and Lightspeed Alert to help Hickman County Schools in providing safe and effective online learning.

The table below explains our Lightspeed Systems® Solutions Suite offering.

DESCRIPTION	FEE	EXTENDED COST
3,200 x Lightspeed Filter™ (7/1/2022 – 6/30/2023)	\$4.40 / license	\$14,080.00
3,200 x Lightspeed Classroom Management™ (7/1/2022 – 6/30/2023)	\$2.00 / license	\$6,400.00
3,200 x Lightspeed Alert™ (7/1/2022 – 6/30/2023)	\$1.50 / license	\$4,800.00
Year One Total Cost		\$25,280.00
Year Two Total Cost (option year)	+5%	\$26,560.00
Year Three Total Cost (option year)	+5%	\$27,904.00

The existing Lightspeed Filter licenses currently active at Hickman County Schools are due to expire on 5/11/2022. To ensure CIPA compliance, Lightspeed has provided a prorated cost below for an extension period that bridges the expiration of your existing services and the beginning date of the RFP of 5/12/2022 through 6/30/2022.

DESCRIPTION	FEE	EXTENDED COST
3,200 x Lightspeed Filter™ (5/12/2022 – 6/30/2022)	\$0.60 / license	\$1,920.00
Prorated Extension Total Cost		\$1,920.00



IN CONCLUSION

Why Lightspeed Systems®?

At Lightspeed Systems, we are dedicated to supporting K-12 online education. Our narrow market focus has allowed us to design innovative solutions that fit the specific and growing needs of school districts. Over the years, we have evolved with you.

Our unparalleled expertise in K-12 has helped us develop the most up-to-date enterprise-class software that is easy to implement and even easier to use. And we can flexibly scale to meet customer requirements as the number of schools, students, devices, and software demands increase. Lightspeed products filter student and staff internet access, look for warning signs in student online activity, manage software across every district device, and give administrators the data they need to make effective decisions about the quality and efficiency of their students' online educational experience.

Lightspeed Systems is a trusted partner to tens of thousands of schools. Let us show you why.

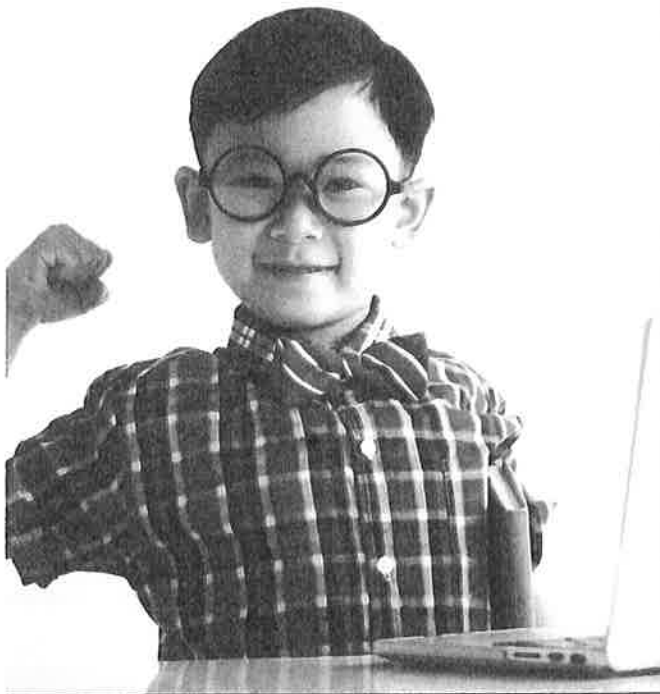

“

We like being able to partner with one vendor for multiple solutions for efficiency and data sharing. The data and functions are integrated for ease of use, and we love the concept of being able to access and integrate everything from one dashboard.

- Monika Davis,
Chief Information Officer,
DeKalb County School
District, GA

”





Lightspeed Systems®

www.lightspeedsystems.com

Contact:

Jay Patrick
Customer Success Manager
jpatrick@lightspeedsystems.com
(737) 787-2086

Hickman County Government

Conflict of Interest Disclosure Form

The County Financial Management System of 1981 contains the most stringent conflict of interest provisions. TCA §5-21-121 provides:

- (a) The director, purchasing agent, members of the committee, members of the county legislative body or other officials, employees, or members of the board of education or highway commission shall not be financially interested or have any personal beneficial interest, either directly or indirectly, in the purchase of any supplies, materials, equipment or contractual services for the county.
- (b) No firm, corporation, partnership, association or individual furnishing any such supplies, materials, equipment or contractual services, shall give or offer, nor shall the director or purchasing agent or any assistant or employee accept or receive directly or indirectly from any person, firm, corporation, partnership or association to whom any contract may be awarded, by rebate, gift or other otherwise, any money or other things of value whatsoever, or any promise, obligation or contract for future reward or compensation.

Date: 4/5/2022 Name: Lightspeed Systems

Please describe below any relationships, transactions, positions you hold (volunteer or otherwise), or circumstances that you believe could contribute to a conflict of interest:

I have no conflict of interest to report.

I have the following conflict of interest to report (please specify any boards or committees you (and/or your spouse) sit on, the name of your employer and any businesses you or your spouse may own.

I hereby certify that the information set forth above is true and complete to the best of my knowledge.

Date: 4/5/2022 Signature: 

Gregory Funk, VP Corporate Controller
on behalf of Lightspeed Systems

Hi Brad,

Securly is one of the leaders in Chromebook Monitoring Software and I am pleased to advise their products for this RFP.

As per the requested specs, I have given a breakdown of different products that cater to the mentioned requirements.

1. **Classroom Management**- Help teachers engage every student and lead class with confidence.
2. **Reveal**- Collect and analyze usage data to understand the impact of your 1:1 device program.
3. **Filter Core**- Web filtering
4. **Home**- Helps Schools partner with parents to keep students safe online.
5. **Auditor Core**- Real-time scanning of email and Docs, plus Drive and OneDrive for AI-based notifications of nudity, cyberbullying, suicide, and violence
6. **24**- A team of highly trained risk analysts, watching for warning signs around the clock

Why Softchoice

Softchoice is a large IT solutions provider in the United States and Canada. Softchoice US headquarters are located at 314 West Superior Street, Suite 400, Chicago, IL 60654. Softchoice main website is www.softchoice.com. We have been serving SLED clients for over 15 years and has a dedicated department supporting State, Local and Education clients.

We help our customers with fully funded programs like 'Asset Insight Optimization' and 'Customer Immersion Experience' to ensure they get the best 'Return on Investment'.

Thanks,

Aakash Gulati

Territory Account Executive

[\(678\) 248-1665](tel:(678)248-1665)

aakash.gulati@softchoice.com

 Softchoice



Softchoice
20 Mowat Avenue
Toronto, ON M6K 3E8

Sales/Order desk
Phone: (800) 268-7638
Fax: (800) 268-7639

Quote	Q-1016004
Date	13-Apr-2022

Quote

Ship To :
Brad Gilbert
Hickman County Schools
115 MURPHREE AVE
CENTERVILLE, TN 37033

Bill To:
Brad Gilbert
Hickman County Schools
115 MURPHREE AVE
CENTERVILLE TN
37033

Quote Prepared For	Brad Gilbert Hickman County Schools Phone: 931.729.3391 x 2229 Email: brad.gilbert@hickmank12.org
Quote Sent By	Aakash Gulati aakash.gulati@softchoice.com Phone: Fax:
Comments	

Item #	Mfg SKU #	Description	Qty	Billing Frequency	Start Date	End Date	Unit Price	Extended Price
2000677360		DYKNOW CLASSROOM MANAGEMENT	3300	Upfront	01-Jul-2022	30-Jun-2023	\$4.91	\$16,203.00
2000677401		REVEAL BY SECURLY	3300	Upfront	01-Jul-2022	30-Jun-2023	\$1.33	\$4,389.00
2000677402		SECURLY FILTER CORE	3300	Upfront	01-Jul-2022	30-Jun-2023	\$5.25	\$17,325.00

2000677403		SECURLY HOME	3300	Upfront	01-Jul-2022	30-Jun-2023	\$1.42	\$4,686.00
2000677404		SECURLY AUDITOR CORE	3300	Upfront	01-Jul-2022	30-Jun-2023	\$1.72	\$5,676.00
2000677405		SECURLY 24	3300	Upfront	01-Jul-2022	30-Jun-2023	\$5.15	\$16,995.00
2000677406		SECURLY - ONE TIME SET FEE	1				\$1,460.00	\$1,460.00
SUBTOTAL								\$66,734.00
DELIVERY: Ground - 3 to 5 days								\$0.00
State Tax								\$0.00
Local Tax								\$0.00
TOTAL								\$66,734.00
All currency in this quote is in (USD).								

Pricing, availability and special offers are subject to change at any time.

This purchase is subject to Softchoice's online terms of sale, unless you have a separate purchase agreement signed by both your company and Softchoice, in which case, that separate agreement will govern. Softchoice's terms of sale can be found at:

<https://www.softchoice.com/softchoice-terms-and-conditions-for-products>

Hickman County Government

Conflict of Interest Disclosure Form

The County Financial Management System of 1981 contains the most stringent conflict of interest provisions. TCA §5-21-121 provides:

- (a) The director, purchasing agent, members of the committee, members of the county legislative body or other officials, employees, or members of the board of education or highway commission shall not be financially interested or have any personal beneficial interest, either directly or indirectly, in the purchase of any supplies, materials, equipment or contractual services for the county.
- (b) No firm, corporation, partnership, association or individual furnishing any such supplies, materials, equipment or contractual services, shall give or offer, nor shall the director or purchasing agent or any assistant or employee accept or receive directly or indirectly from any person, firm, corporation, partnership or association to whom any contract may be awarded, by rebate, gift or other otherwise, any money or other things of value whatsoever, or any promise, obligation or contract for future reward or compensation.

Date: 13th APRIL 2022 Name: AAKASH GULATI

Please describe below any relationships, transactions, positions you hold (volunteer or otherwise), or circumstances that you believe could contribute to a conflict of interest:

I have no conflict of interest to report.

I have the following conflict of interest to report (please specify any boards or committees you (and/or your spouse) sit on, the name of your employer and any businesses you or your spouse may own.

I hereby certify that the information set forth above is true and complete to the best of my knowledge.

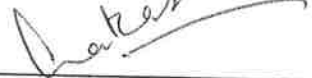
Date: 13th APRIL 2022 Signature: 



Invitation To Bid

Chromebook Monitoring Software

Hickman County Schools

Submitted By:
GoGuardian RFP Department
RFP@goguardian.com

April 18, 2022

Re: Invitation to Bid for Chromebook Monitoring Software

Dear Evaluation Committee:

We at GoGuardian¹ are excited about the opportunity to work with Hickman County Schools in support of your effort to implement Chromebook Monitoring Software. Our industry-leading solution includes flexible content filtering and the tools that teachers need to guide and monitor students online and keep them focused on their schoolwork. **We are proposing GoGuardian Admin and GoGuardian Teacher to meet your district's needs.** The benefits of GoGuardian Admin and GoGuardian Teacher Filtering include:

Single Unified Dashboard. Manage everything from a single unified dashboard.

Integrated Technology. Simplify your digital environment with integrated technology.

Real-Time Filtering. Granular content filtering that refreshes every 3 seconds.

Actionable Insights. Easily identify actionable insights across your district, classrooms, and devices.

No cost implementation and discounted training.

Having worked with some of the largest school districts in the nation, GoGuardian will empower your district and schools to help achieve your student safety goals. We support K-12 schools through powerful tools that are currently helping over 10,000 schools safely maximize the learning potential of millions of students. We believe a partnership with GoGuardian would have a tremendous impact on your students by helping your district create a safe and effective digital learning environment. Should you have any questions about this proposal, your primary point of contact at GoGuardian is:

Primary Contact Information

Emily Davis, Account Executive

(218) 428-9401 | edavis@goguardian.com

Thank you for this partnership opportunity. We look forward to sharing our solution.

Sincerely,



Brennan Petar – VP, Revenue and Strategy
GoGuardian

¹ Liminex, Inc. dba GoGuardian

GoGuardian is committed to providing solutions as described in this proposal and understands that Hickman County Schools has included its terms and conditions for incorporation into any final contract between Hickman County Schools and GoGuardian. In anticipation of further discussions with Hickman County Schools regarding this procurement, please find the standard Liminex Products Terms of Service and End User License Agreement and incorporated Product Privacy Policy available for your review at <https://www.goguardian.com/policies/eula> and <https://www.goguardian.com/policies/product-privacy>. GoGuardian respectfully requests the incorporation of these terms into any final contract between Hickman County Schools and GoGuardian. GoGuardian's exceptions to the Hickman County Schools terms are also included in our response and serve as additional points of discussion should Edulastic be considered for contract award.

Table of Contents

Scope of Work	6
GoGuardian Solution Overview	7
GoGuardian Admin	8
GoGuardian Parent App	10
Beacon Starter	11
Additional Beacon Features Available	12
GoGuardian Teacher	14
Pricing	16
Appendix A: Case Studies	17

Attachments:

Conflict of Interest Disclosure Form
Legal Exceptions

Scope of Work

Below is GoGuardian's response to Specs listed in Part B of the Invitation to Bid.

Specifications	GoGuardian Response
Software will allow for reports on websites accessed by students, searches, etc.	Yes , GoGuardian Admin offers granular reporting. Administrators can easily access usage and trends at the organizational unit level(s) to generate reports for apps, websites, google docs, and more.
Ability to block/whitelist URLs as needed is preferred.	<p>Yes, GoGuardian Admin has been used by districts to ensure student safety - keyword flagging, blocking specific URLs, and website categories.</p> <p>GoGuardian goes beyond traditional filters with our Smart Filtering solutions. Using machine learning, GoGuardian helps technology departments proactively block explicit content and proxies. For dynamic (Google Docs, comments sections, chat features) or uncategorized (new websites or blog posts), GoGuardian is able to scan the content of a page and block sites that slip past traditional filters. This ensures that students remain safe and admins are no longer playing "catch-up" blocking sites as they pop up.</p> <p>With GoGuardian Teacher, teachers can control student devices by creating controlled browsing environments (allow and block sites), freezing (locking) screens, and sending students to a specific URL.</p>
Ability to track lost and stolen chromebooks using location, screenshots, etc. preferred.	Yes , with GoGuardian Admin, District administrators can also use GoGuardian's theft recovery to help find student devices that are lost or stolen off-campus.
Ability to function with the Google Admin console to populate users	Yes , GoGuardian Admin provides on- and off-prem filtering and monitoring services in the

<p>and groups.</p>	<p>form of two custom extensions deployed to Chrome devices through the Google Admin Console cloud management system.</p>
<p>Classroom management tools for teachers such as screen monitoring, viewing student screens, and controlling student devices.</p>	<p>Yes, GoGuardian Teacher provides the ability to monitor real-time browsing (both active and open tabs) of all students and access student browsing records up to 6 months in the past. Teachers can open the resource they want to share as a tab with individual students, selected groups, or the entire class. Teachers can control student devices by creating controlled browsing environments (allow and block sites), freezing (locking) screens, and sending students to a specific URL.</p>
<p>Ability for self-harm alerts is preferred.</p>	<p>Yes, GoGuardian Beacon is designed to help identify students who are at risk of suicide, self-harm, or possible harm to others.</p> <p>Identify students engaging in suicide or self-harm content online (including through Search).</p> <p>Get alerts with context, screenshots, and past activities for faster, more-informed responses.</p> <p>GoGuardian can alert designated responders to get students help and quickly activate your school's response plan. An optional team of trained, U.S.-based safety support specialists are available to review and escalate active planning alerts 24/7. (Beacon 24/7 is an optional, additional service available to your district.)</p>

GoGuardian Solution Overview

GoGuardian Admin

GoGuardian Admin is our flagship filtering solution designed for K-12 districts that want an easier way to help keep their students safe online across a broad mix of device types, networks, and filtering policies. Our secret to making this easier is by providing a single, unified interface to help manage and monitor every device connected to your school's network.

Advanced AI that dynamically updates, saving you time

Traditional URL and keyword-based filters can sometimes indiscriminately block large portions of the internet from your teachers and students and, in turn, create extra work for your team to manage. GoGuardian's advanced Artificial Intelligence engine filters with precision, providing room for students to explore, while more accurately targeting problematic content based on context and meaning.

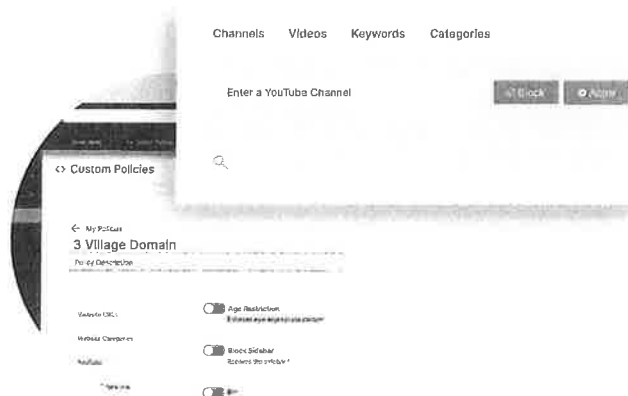

Unlike traditional static filters that require a lot of hands-on maintenance to keep updated, our AI dynamically updates to keep up with new and emerging content so that you don't have to. The result is less work for you and a more productive online experience for your students.

Better protect students from explicit content wherever it occurs

Our internal research teams have estimated that nearly 20% of all explicit content that students encounter online occurs in legitimate collaboration tools. This is news to many IT admins using traditional URL filters that can't "see" content being created and shared on the device. If your current filter only scans web pages once when they are

downloaded, you may have a problem with explicit content that you can't even see. GoGuardian's scanning engine continuously analyzes content being created, viewed, or shared in your students' browsers, helping to create a safer online experience for all.



Encourage better digital citizenship with customizable alerting options

The internet is a remarkable place with endless amounts of educational content. But it can also present many opportunities for students to make a wrong turn without fully understanding that their online behavior is distracting or inappropriate.

At GoGuardian, we believe that solutions that can notify students when they are off-task (thereby allowing them to self-correct) are more effective at changing student behavior than solutions that only block distracting content. Because of this, we provide granular filtering options to help you create customizable guardrails and alerts for students based on content types, such as YouTube and social media, as well as age group, time, or location.

When students venture beyond designated appropriate behavior, our tailored actions allow you to better enforce your district's policies, as well as encourage students to strive for better digital citizenship.

Obtain insights with intuitive and easy-to-understand reporting

GoGuardian's summary-level dashboard has data-rich graphs and easy-to-understand visualization tools right at your fingertips. This, along with customizable aggregate and

detailed activity export report options, provides a comprehensive understanding of individual student browsing behavior and trends.

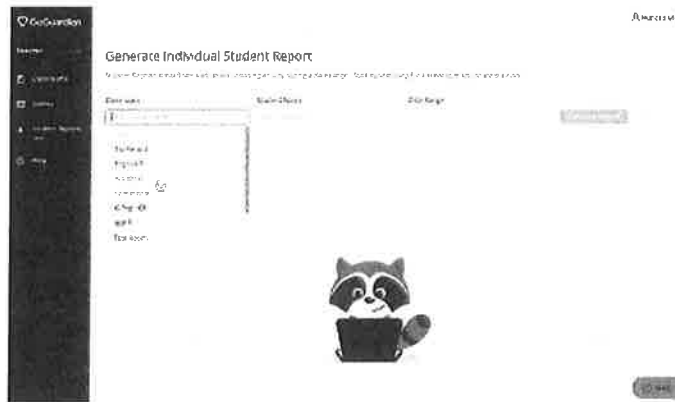

GoGuardian Parent App

GoGuardian Parent provides administrators with the ability to grant additional restriction capabilities to parents, on top of district/charter settings. "Out of School" mode provides the ability for parents to add additional filters, pause the internet, and schedule paused internet during non-school hours.

Reporting/Alerts

GoGuardian's Parent App allows parents to view the internet history of their students. Our user interface and illustrative charts quickly communicate student online activity so that parents have more visibility into their student's browsing activity. Parents have additional filtering and internet pausing controls so they can better manage their student's device usage at home.

Beacon Starter

GoGuardian Admin comes with our Beacon Starter alert functionality.

With over 90% of active suicide planning alerts occurring in Search, it is critical to have a solution that can spot warning signs wherever the student is online. Unlike other solutions that focus primarily on G-Suite or Office365, **Beacon works across all of the content that your students are creating, searching for, and consuming online.**

This includes search engines, chat, online docs, social media, email, web apps, and more. Beacon also offers the option to have a dedicated team of safety specialists review and escalate active planning alerts 24/7. These specialists operate within the U.S. and are specially trained to evaluate alerts.

Active Planning

Online behavior and/or content visited or generated by students that may demonstrate the student is actively planning their suicide, such as looking up methodologies, suicide notes, etc.

Receive alerts with context

Beacon alerts provide robust context around an event, helping you determine what caused an alert and how to take action. Alerts include screenshots up to 15 minutes before and after browsing history, the predicted phase of suicidality, historical activity, and highlighted text. You can also denote various interventions or actions taken, as well as assign risk levels for ease of review.

Activate the appropriate responders

Beacon's robust and flexible alerting system can bring in the right school responders, help notify parents after hours, and even provide students directly with resources.

Designed alongside mental health experts

Beacon was designed with the guidance of leading experts in mental health to ensure that it fits seamlessly into your school or district's suicide prevention policy.



Additional Beacon Features Available²

Beacon's model predicts what phase the content is in, such as:

Suicide Ideation

Online behavior and/or content visited or generated by a student that could indicate that a student is forming or expressing thoughts about suicide, including thoughts about their own suicide.

Self-Harm

Online behavior and/or content visited or generated by a student that may demonstrate a student's desire to harm themselves without trying to end their life.

Threats and Violence

GoGuardian Beacon Threats and Violence detection is a feature within GoGuardian Beacon that seeks to further support student safety and well-being using a machine learning model to help detect violent or threatening web searches.

GoGuardian Beacon Threats and Violence helps detect four categories of activity indicating violent or threatening web searches. In each category, Beacon is focused on finding intentional indicators of potential school safety risks. Instantaneous alerts show context, screenshots, and past activities for faster, more-informed responses.

Guns & Bombs: looks for online searches for guns and bombs inquiring about how to acquire, build, use, conceal, or transport the gun or bomb. Examples include: "How to buy a gun" but not "Water gun"

² Additional features are optional and an additional cost.

Violent Acts: looks for online searches inquiring about how to commit a violent act, how to obtain the means to commit a violent act, or expressing a desire to commit a violent act. Examples include: “How to kill my dad” but not any search text including “lyric”

Bullying: looks for online searches indicating that the user may be a victim of bullying, harassment, or threats or is seeking help to stop bullying, harassment, or threats. Examples include: “How to stop my bully” but not “bullying statistics”

Historical Acts: looks for online searches directly referencing specific school shootings or attacks, or specific perpetrators of those attacks. The name of a school or perpetrator must be included in the text. Examples include: “Columbine shooting” but not “Zodiac Killer”

Help and Support

Online behavior and/or content visited or generated by a student that may demonstrate a student is looking for help and support resources for themselves or a peer, such as hotline numbers, American Foundation for Suicide Prevention, documents, support forums, etc.

Suicide Research

Online behavior and/or content visited or generated by a student that may demonstrate a student is looking up statistics and information about suicide, as one may do for a class assignment, versus exhibiting signs of suicide ideation.

Designed alongside mental health experts

Beacon was designed with the guidance of leading experts in mental health to ensure that it fits seamlessly into your school or district's suicide prevention policy.

GoGuardian Teacher

The GoGuardian Teacher solution helps all students begin each class successfully right from the start by allowing teachers to easily distribute digital classroom lessons while blocking websites and content unrelated to the class. This process is so easy, in fact, that teachers have indicated that on average, GoGuardian recovers seven minutes of classroom teaching time per session.

GoGuardian facilitates personal interactions between teachers and students by allowing video conferencing, audio-video screen sharing, and group communication. Students can also ask questions directly to their teacher, without disturbing the rest of the class.

As a classroom session proceeds, teachers are alerted to students who are off-task and/or struggling with their lessons. Most solutions rely on URL lists to determine if students are off-task; however, GoGuardian goes far beyond this, leveraging artificial intelligence that can determine if a student is doing history homework in math class.

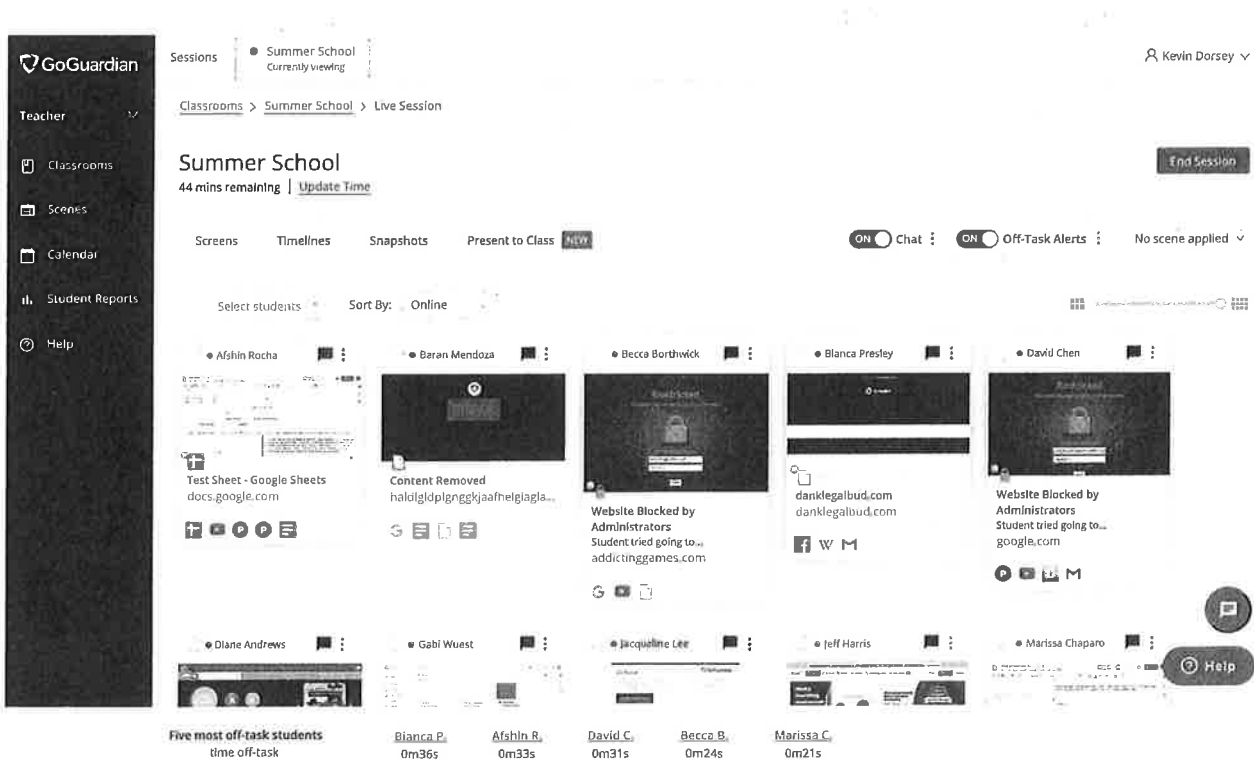

Scenes

GoGuardian Teacher gives teachers the ability to set the scene for a classroom session with an allowed website list or a blocked website list, enabling them to create custom browsing rules for students. Teachers can use this feature to block distracting sites that students continue to visit, while keeping the rest of the internet open. With GoGuardian Teacher, educators can also allow only a single website for quiz administration or to keep students focused, while blocking everything else not on the list. These custom web-browsing rules are made by the teacher with Scenes layer on top of existing filtering solutions and do not override filtering set up by an administrator.

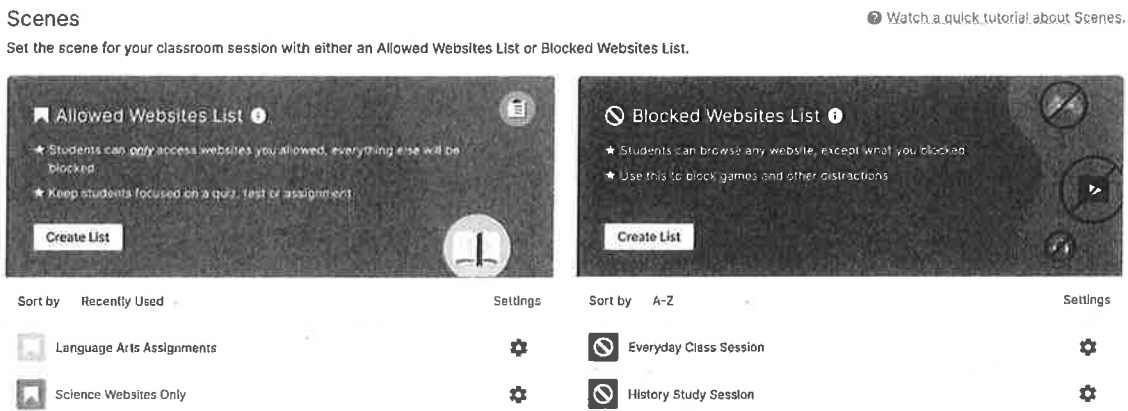

Announcements / Chat / Video Conferencing / Recording

GoGuardian Teacher allows for chat, video conferencing (additional fee), and recording through a video conferencing solution built specifically for K-12. Teachers can connect with students through audio and video calls one-on-one or in a group, all from within GoGuardian Teacher.



ORDER FORM

QUOTE # Q-202729
DATE 4/12/2022
EXPIRATION DATE 5/8/2022



Bill To

Hickman County School District (TN)
115 Murphree Ave
Centerville, Tennessee 37033
United States

Ship To

Brad Gilbert
Hickman County School District (TN)
115 Murphree Ave
Centerville, Tennessee 37033-1443
United States
9317291425
brad.gilbert@hickmank12.org

GoGuardian

Liminex, Inc. dba GoGuardian
2030 E Maple Avenue
El Segundo, California 90245
United States

Thank you for your interest in GoGuardian's products! This order form ("**Order Form**") identifies the GoGuardian products you have selected for subscription ("**Licensed Product(s)**"), the term of your initial subscription(s) to the Licensed Product(s) ("**Initial Term**"), the number of licenses included in your base subscription(s) ("**Licenses**"), as well as the fees associated with your base subscription(s), any Licenses you add to your subscription(s) during the Initial Term, and support and professional services related to the Licensed Product(s).

This Order Form, once executed by authorized representatives of Liminex, Inc. dba GoGuardian ("**GoGuardian**") on behalf of itself and its family of company Affiliates including Pear Deck, Inc. ("**Pear Deck**") and Edulastic (formally - Snapwiz, Inc. doing business as Edulastic, "**Edulastic**") and the organization listed below ("**School**," "**you**" or "**your**"), and together with the Liminex Product Terms of Service and End User License Agreement available at <http://www.goguardian.com/policies/eula> (<https://www.goguardian.com/policies/eula> (for Liminex), <https://www.peardeck.com/terms-of-service> (for Pear Deck), or <https://edulastic.com/terms-of-service> (for Edulastic) (the "Terms" and, together with this Order Form, the "Agreement"), forms a binding contract. All capitalized terms not defined in this Order Form have the meaning given to them in the Terms. In the event of any conflict between this Order Form and the Terms, the terms set forth in this Order Form will prevail, but solely with respect to this Order Form. We do not agree to any other terms, including without limitation any terms on your School's purchase order.

QTY	PART #	DESCRIPTION	Start Date	End Date	Rate	Extended
3,200	GG-ADM1Y-001500	GoGuardian Admin	7/1/2022	6/30/2023	\$4.95	\$15,840.00
3,200	GG-TCR1Y-001500	GoGuardian Teacher	7/1/2022	6/30/2023	\$4.95	\$15,840.00
TOTAL (USD):						\$31,680.00

Add-on Licenses. If during the Initial Term or during any Renewal Term, you would like to expand your base subscription(s) to include additional Licenses, please contact GoGuardian so that we can send you an additional Order Form for those 'add-on' Licenses ("**Add-Ons**"). If we do not hear from you and you deploy additional Licenses, we will send you an Order Form and invoice your Organization for subscriptions to the Add-Ons you use. Add-Ons, once deployed, will be rolled into your base subscription, and, collectively, are referred to as the "**Subscription**."

RENEWAL SUBSCRIPTION TERMS

Following the Initial Term, your Subscription (including any Add-Ons during the previous term) will automatically renew on an annual basis for successive 12-month periods (each, a "**Renewal Term**," and together with the Initial Term, the "**Term**") at GoGuardian's then-current fees (including an Innovation Increase as defined below) for such Subscription, unless you provide us with written notice of cancellation or written intent not to renew at least sixty (60) days prior to the end of the then-current Term. Your cancellation will take effect as of the last day of your then-current Term and you will not be charged for the upcoming Renewal Term. You will not be entitled to receive a refund or credit of any subscription fees paid for your then-current Term even if you elect not to use the Subscription for the remainder of that Term.

ORDER FORM

QUOTE # Q-202729
DATE 4/12/2022
EXPIRATION DATE 5/8/2022



RENEWAL FEES

GoGuardian is dedicated to improving the Licensed Products on an ongoing basis through continued innovation in research and development. For this reason, following the Initial Term, the Subscription Fee-Per License Price for each Licensed Product will be subject to an automatic fee increase equal to % above the Subscription Fee-Per License Price you paid for the Licensed Product in the previous term ("**Innovation Increase**"). Order Forms and invoicing for Renewal Terms will reflect the Innovation Increase and your renewal subscription fees will be calculated using the increased fees for the number of Licenses included in your Subscription. You agree to pay the Subscription Fees, reflecting the Innovation Increase, due for each Renewal Term as described herein, unless you decide not to renew the Subscription with GoGuardian in accordance with this Order Form.

PAYMENT

Full payment of the Total Base Subscription Fees for Initial Term is required before access to the Subscription is provided for the Initial Term. Your Organization is responsible for all payment of fees associated with any Add-Ons. Payment for all fees, including any fees for Add-Ons, is due within thirty (30) days of invoice date. Payment of the applicable Total Base Subscription Fees (including fees for any Add-Ons) for each Renewal Term is also due up front in full in advance of each Renewal Term, Your Organization is responsible for all taxes and duties unless expressly included in this Order Form.

Accepted By : _____
PO Number : _____
Date : _____

Appendix A: Case Studies

- GoGuardian Teacher: Downey Unified School District
- GoGuardian Admin: Denton Independent School District



K-12 SUCCESS STORIES

Downey Unified School District DOWNEY • CALIFORNIA

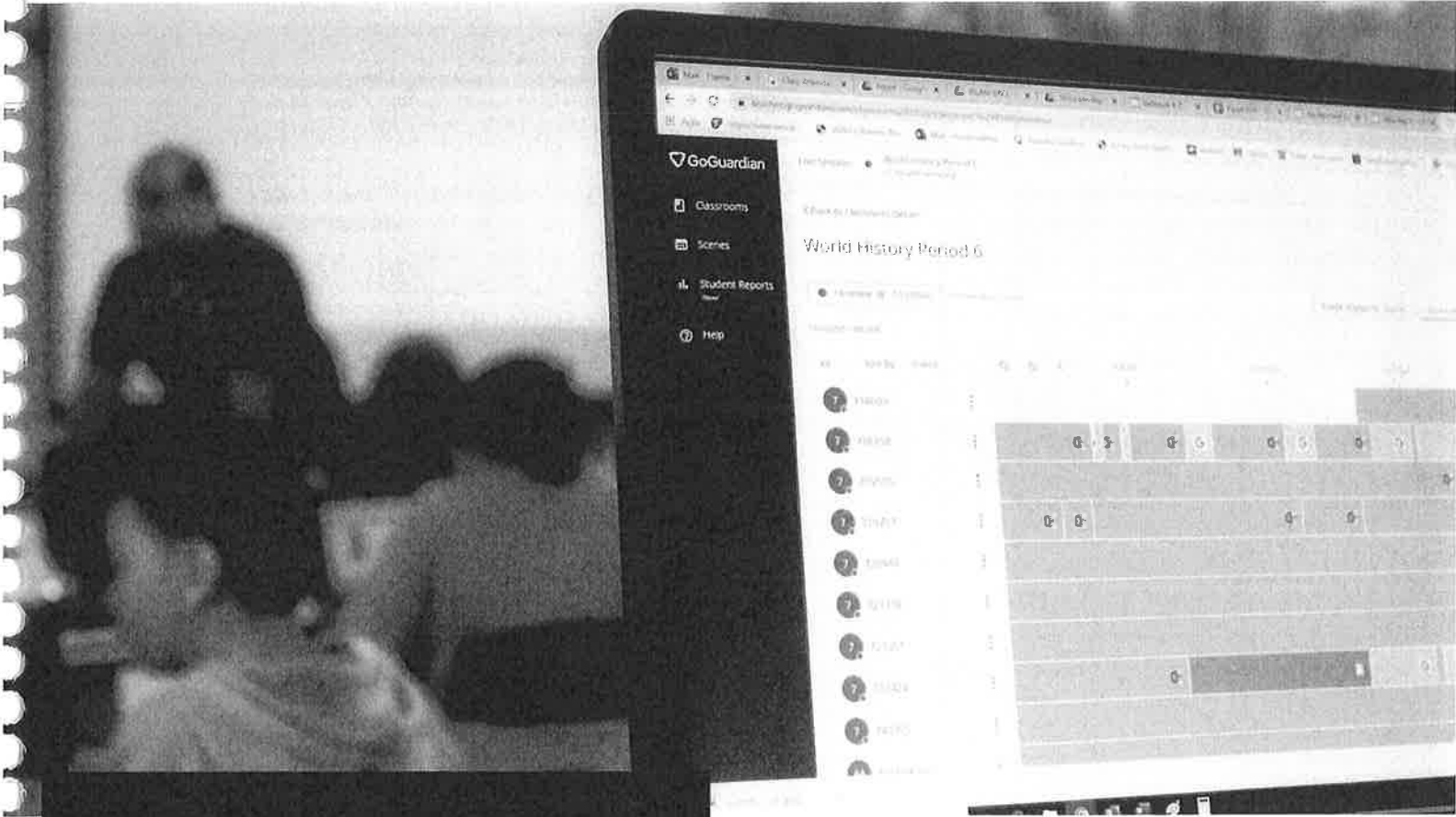

# OF SCHOOLS	20
GRADE LEVELS	Pre-K to 12
ENROLLMENT	22,000
DEVICES	10,000
PRODUCTS	Teacher

Downey USD used **GoGuardian Teacher** on Windows to **save time** and give teachers confidence in their use of school technology.

CHALLENGE

Like most districts, Josh Davis of Downey Unified School District was struggling to drive device adoption among his teachers. His intention was to provide tools that would help teachers create new and innovative lessons, but he was met with resistance and fear of the unknown.

ACTIONS

Forced to face their technology fears, DUSD had initially implemented a clunky solution that ultimately failed teachers and students, as well as wasted valuable class time. What they needed was a cross-platform program that gave teachers confidence in their devices. That was when they learned that GoGuardian was now on Windows, making it possible to work with Microsoft Education tools, such as OneNote and Edge Browser. The district chose to use GoGuardian as their complete 1:1 technology program.

RESULTS

GoGuardian Teacher allowed Downey's teachers to be confident in their use of technology in the classroom and to gain back valuable class time. Along with the increased instructional time, DUSD also saw the benefits of increased student engagement, limited distractions, and access to technology for all stakeholders.

Supercharged by a Microsoft partnership, GoGuardian enables DUSD teachers to manage their classrooms on any device, browser, or operating system. The teachers feel empowered when they use GoGuardian, and the students are better positioned to succeed more safely in the 21st century classroom.

"Our big challenge was taking that fear away from the teachers. Sometimes for teachers, they have to see it in order to understand it."

JOSH DAVIS, INSTRUCTIONAL TECHNOLOGY COACH

"Technology is not going away... Knowing that there's programs and software out there like GoGuardian that would help teachers use it safely and productively I think is a good thing."

SCOTT SCHEINER, TEACHER



Downey USD used GoGuardian Teacher on Windows to save time and give teachers confidence in their use of technology.

"It's provided so much of a safety net having the ability to just push the website out there for them streamlines things...The time that we have to work on the projects is increased."

Scott Schreiner
Teacher
Downey Unified School District

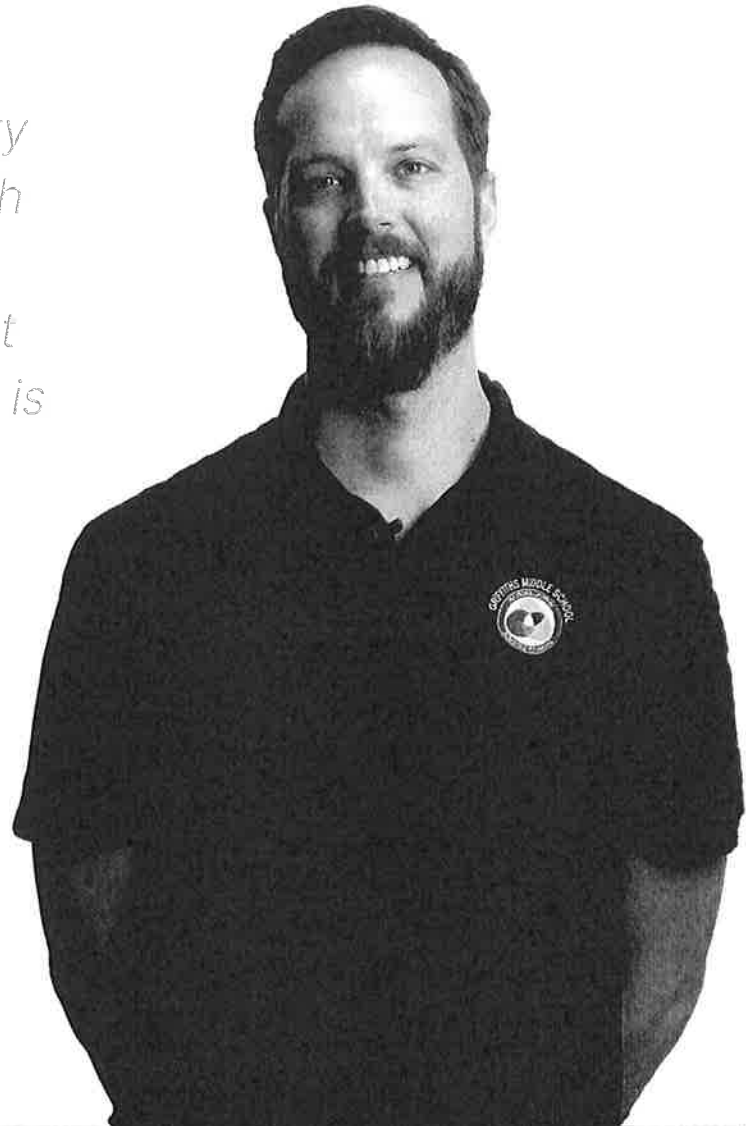

About GoGuardian Teacher

GoGuardian helps you create smart and effective digital learning environments that work any way you want them to, without surprises. We're as passionate about keeping kids safe, on-task, and engaged as you are. With GoGuardian Teacher providing a view into your students' online activity and providing you control over their devices, you can eliminate distractions, connect with students, and save time. Teach confidently with devices knowing that your students are staying focused and on-task.



Safer Students. Better learning.

GoGuardian helps thousands of K-12 schools maximize the learning potential of every student by creating safe and effective digital learning environments. Our technology products help educators inspire curiosity in the classroom, protect students from harmful or distracting content, and support student mental health.

Today, over 7+ million students are safely exploring more of the internet with the industry's most advanced device management platform. That's why GoGuardian is the fastest growing education company in the US.¹

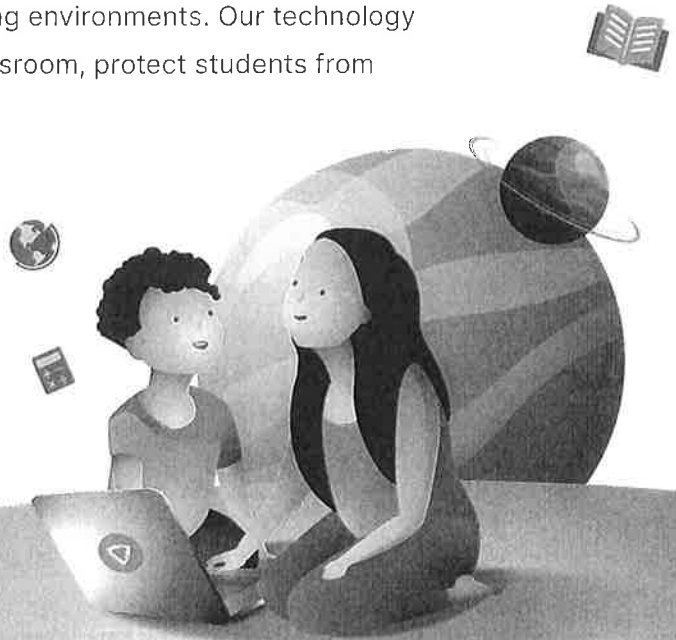

Our customers love what we do and who we do it for.

GoGuardian is superb at keeping our students on-task and engaged. Thanks for a great product, and for being so responsive to requests and suggestions.



Joy Kidd
5th Grade Teacher
Cockrell Elementary School

GoGuardian for us was a complete package. Our teachers fell in love with it within minutes and said, 'whatever you do, don't take away GoGuardian.'



Shad McGaha
Chief Technology Officer
Wichita Falls ISD

GoGuardian allowed us to open up the Internet for our students so they may explore it, learn from it, and most importantly, build smart and practical habits when it comes to using it.



Rade Obradovic
5th Grade Teacher
Duval County Public Schools

Visit goguardian.com or call us at 888 310-0410 to learn more or start your **free** trial today.

1. According to the 2018 Inc 500

INTRODUCING

The GoGuardian Suite

Unify your filtering, classroom management, and school mental health tools into a single suite. Reduce the overall complexity of your environment while streamlining your procurement and deployment process. The GoGuardian Suite helps you maximize the learning potential of your 1:1 school technology program.

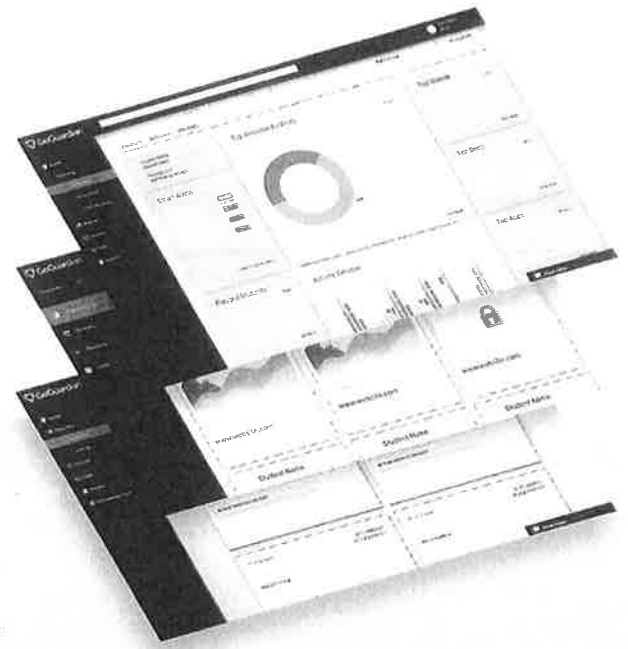

Benefits of a unified solution:

- Configure and manage everything from a single unified interface.
- Simplify your digital learning environment with integrated technology.
- Easily identify actionable insights across your district, classrooms, and devices.
- Save money through bundling.

INCLUDED IN THE SUITE:

GoGuardian Admin™

Filter and monitor any device and any OS with K-12's most powerful content filter.

GoGuardian DNS™

Keep all your BYOD users and guests on your network safe with a scalable DNS filtering solution built specifically for education.

GoGuardian Parent App™

Give parents direct access to their student's device activity and additional filtering controls from an easy-to-use mobile app.

GoGuardian Teacher™ **NEW**

Eliminate distractions and connect with students with K-12's leading classroom management software, now with video conferencing.

GoGuardian Beacon®

Proactively identify students at risk of suicide and self-harm, with an option of 24/7 escalation.

GoGuardian Fleet™

Easily deploy, manage, track, and maintain your entire Chromebook inventory across your school or district.



K-12 Success Stories

Denton Independent School District DENTON • TEXAS



# OF SCHOOLS	40
GRADE LEVELS	Kindergarten–12 TH
ENROLLMENT	29,300
CHROMEBOOKS	7,500+
PRODUCTS	Admin

Denton Independent School District's Technology Goals:

Denton Independent School District's Technology Goals: Denton ISD is focused on using technology to inspire 21st century educational skills in all of their students. Making sure students' educational experience is enhanced through the use of technology is something Denton ISD, and its technology department, strive for every day.

GoGuardian & Denton ISD: Opening Doors While Keeping Kids Safe

Expanding the Learning Potential of the Internet...with Safeguards

Denton Independent School District was growing at a rate of 800 students per year and had opened a school a year for the past ten years. Their expanding student body posed a challenge. The school district needed to ensure that every student could use their Chromebooks in the classroom to enhance learning, while also staying safe.

As Dr. Jamie Wilson, Superintendent of Schools for Denton ISD, said, "For us, the key is to ensure every student is getting both opportunity and safety through their devices. Technology has allowed us to transform how kids learn and has given them tools to innovate and create. It has also allowed us to ensure kids stay safe while exploring their passions and innovating. And that's where GoGuardian comes in..."

By using GoGuardian Admin, Denton school administrators could monitor online activity across the growing district, and help students make better choices online, giving them access to knowledge with safeguards. Dr. Wilson explained, "If a student's online activity is problematic or potentially dangerous, we can send them a gentle alert with GoGuardian. This reminds them that they're not alone online, and their actions have an impact on the greater online community. It also teaches them digital citizenship: being a good online citizen is more than being a safe Internet user—it's about being smart, aware, and having respect for yourself and others."

"GoGuardian reports on so many things: YouTube videos watched, browser activity, Chrome extensions, and Google Docs. This has been the first year that we've actually been able to manage YouTube because of GoGuardian"

Garrett Chandler
Sr. Applications Analyst
Denton ISD

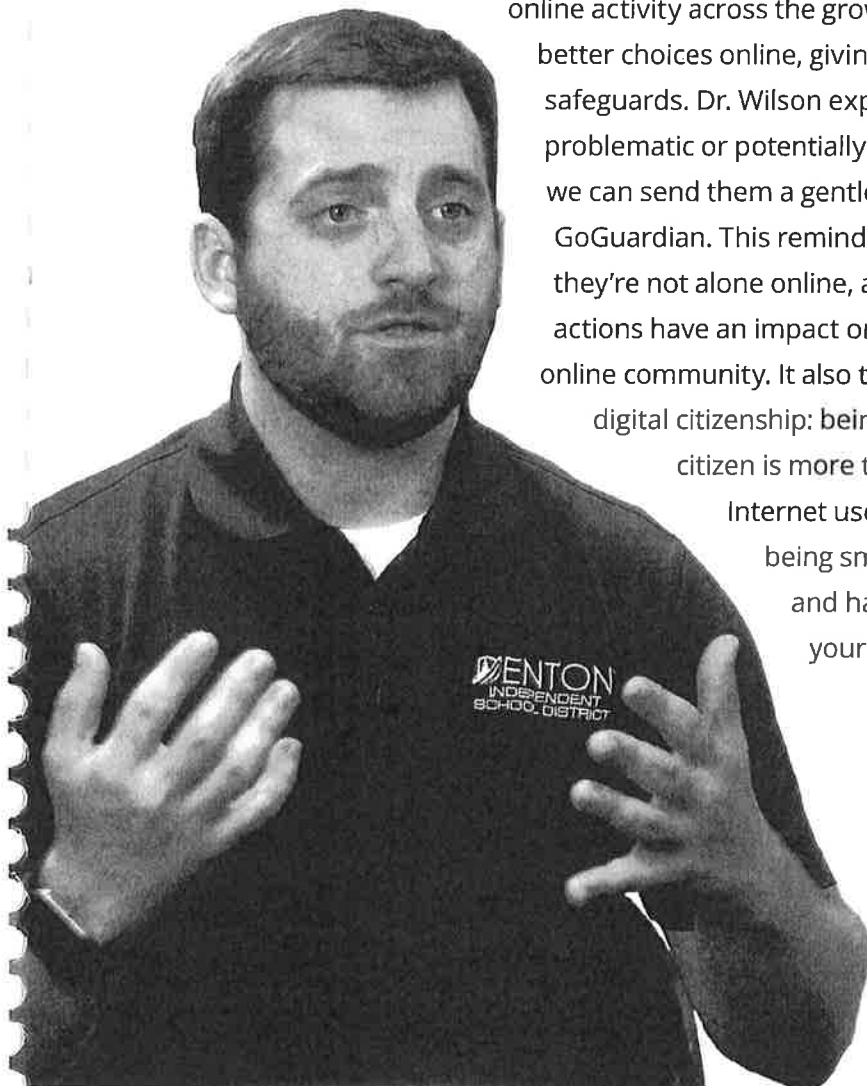

THE CHALLENGE

Transparency is crucial when it comes to ensuring the safety of students online. When Denton ISD transitioned from PCs to Chromebooks, they didn't have a software solution to monitor online activity. Student logins would authenticate them on PCs - but on Chromebooks, there was a generic account that didn't identify users. Teachers were left playing detective when they needed to report on individual student usage. This posed a tremendous challenge for student safety.

THE PLAN

As their student body continued to grow, Denton ISD needed more sophisticated, granular reporting on Chromebook usage. GoGuardian not only fulfilled this need, but also allowed administrators to monitor Chromebooks in a simple, intuitive way. This permitted Denton ISD to expand the learning potential of the internet, without compromising students' safety.

THE IMPACT

Implementing GoGuardian has improved Denton ISD's ability to impart digital citizenship and 21st-century skills to its students. Teachers use GoGuardian to show students how online communities are just like real-life communities: there are rules to follow that ensure safety and respect. GoGuardian has also given the district the ability to manage the online activity of their expanding student body in a scalable and sustainable way. With individualized monitoring and reporting, administrators receive granular feedback on each student's digital footprint. Through GoGuardian's Smart Alerts technology, the school can even send personalized messages that empower students to be better digital citizens, and stay on task. Denton ISD's success with GoGuardian led Area Superintendent Gwen Perkins to conclude,

"I would absolutely unequivocally recommend GoGuardian for any school district, regardless of the size."



Time spent off-task



Time spent on YouTube



Time spend on G-Suite

*Data is based on the 2017-18 school year as of 10/24/2017.

Write Your Own Success Story

For more information on how GoGuardian can help your district achieve better learning through technology, contact us today for a customized product demo and free trial access:

info@goguardian.com

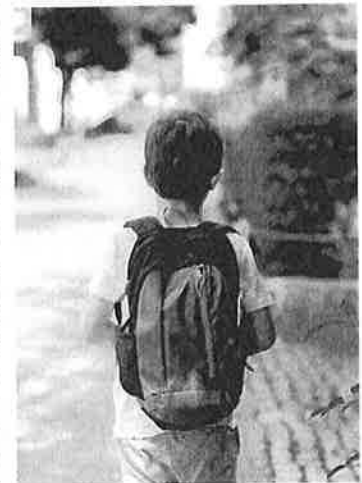
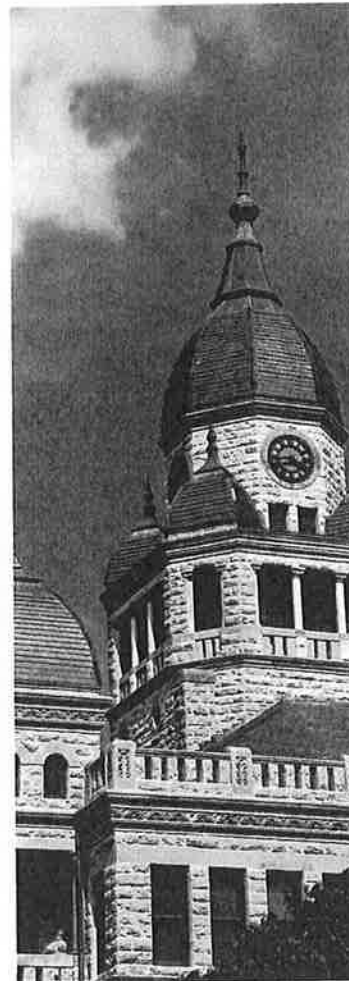

Visit goguardian.com/stories
to see additional customer success stories

Smart technology needs smart management.

As more schools implement technology programs—either through 1:1 initiatives or shared carts—the need for powerful, easy-to-use device management tools is greater than ever. From device assignment and repair tracking to web filtering and classroom management, many districts often end up using a patchwork of tools and apps to accomplish their strategic technology goals.

With a full suite of position-tailored products designed and built just for Chromebooks, GoGuardian makes it easy for school districts to manage large or small device deployments, keep their students safer online, and gain valuable insights into how their technology programs are working.



GoGuardian Admin™
Filtering & Monitoring

GoGuardian Teacher™
Classroom Management

GoGuardian Fleet™
Asset Tracking & Management



Our education technology partners:



ABOUT GOGUARDIAN

Based in Los Angeles, GoGuardian is a leader in Chromebook management solutions for K-12 school districts. GoGuardian products are used by 44,000+ educators in all fifty states, impacting millions of students and teachers every day as they use the Internet for collaboration and learning.



@goguardian

Learn More

Visit goguardian.com or call us at 888-310-0410 to start your free trial today.

Hickman County Government

Conflict of Interest Disclosure Form

The County Financial Management System of 1981 contains the most stringent conflict of interest provisions. TCA §5-21-121 provides:

- (a) The director, purchasing agent, members of the committee, members of the county legislative body or other officials, employees, or members of the board of education or highway commission shall not be financially interested or have any personal beneficial interest, either directly or indirectly, in the purchase of any supplies, materials, equipment or contractual services for the county.
- (b) No firm, corporation, partnership, association or individual furnishing any such supplies, materials, equipment or contractual services, shall give or offer, nor shall the director or purchasing agent or any assistant or employee accept or receive directly or indirectly from any person, firm, corporation, partnership or association to whom any contract may be awarded, by rebate, gift or otherwise, any money or other things of value whatsoever, or any promise, obligation or contract for future reward or compensation.

Date: 4/10/2022 Name: Brennan Petar, VP of Revenue Operations & Strategy

Please describe below any relationships, transactions, positions you hold (volunteer or otherwise), or circumstances that you believe could contribute to a conflict of interest:

I have no conflict of interest to report.

I have the following conflict of interest to report (please specify any boards or committees you (and/or your spouse) sit on, the name of your employer and any businesses you or your spouse may own.

I hereby certify that the information set forth above is true and complete to the best of my knowledge.

Date: 4/10/2022

Signature: _____

DocuSigned by:

Brennan Petar

4620A585F7DE4B3...

Hickman County School District
Centerville, TN

Request for Proposal for Chromebook Monitoring Software
Submission Deadline: April 18, 2022 10:00 AM (CDT)

Liminex, Inc. dba GoGuardian Exceptions

*******START OF CONFIDENTIAL INFORMATION EXEMPT FROM THE TENNESSEE PUBLIC RECORDS ACT*******

As a software provider dedicated to building software for K-12 schools, GoGuardian's contractual terms have been customized for educational software. We are providing GoGuardian's standard End User License Agreement (available at <https://www.goguardian.com/policies/eula> and incorporated Product Privacy Policy (available at <https://www.goguardian.com/policies/product-privacy>) (as may be amended from time to time in accordance with the terms therein) for Hickman County School District's review and to incorporate into any final contract between Hickman County School District and GoGuardian.

*******END OF CONFIDENTIAL INFORMATION EXEMPT FROM THE TENNESSEE PUBLIC RECORDS ACT*******

Invitation To Bid

The Hickman County Finance Office is accepting sealed bids for Chromebook Charging Carts for Hickman County Schools.

Additional specifications can be found at: www.hickmank12.org/request-for-proposal.

All bidders will be required to submit a conflict of interest disclosure form that can also be found at: www.hickmank12.org/request-for-proposal.

Sealed bids must be mailed or delivered to the Hickman County Finance Office, 114 North Central Avenue, Suite 203, Centerville, TN 37033 and clearly marked on the outside of the bid envelope "Chromebook Charging Carts". Bids will be opened on Monday, April 18th, 2022 at 10:30 A.M. in the Finance Office.

The Hickman County School District reserves the right to reject any and or all bids or proposals and to waive any informalities, which in the opinion of the school system, would prevent the acceptance of a better bid.

Present Penny Mayberry
Misty Weems

Bids Rec'd. and attached
Central

Blum

Riverside

School Specialty No Bid

Howard



REQUEST FOR PROPOSAL

Hickman County Schools

“Chromebook Charging Cart”

Bid Due Date: April 18, 2022 @ 10:30am

Central Technologies, Inc.

PO Box 30867
Knoxville, TN 37930

OR

6101 Industrial Heights Drive NW
Knoxville, TN 37909

Account Executive
Jordan Walker
jwalker@centralinc.com
Direct: 843.425.2265
Toll-Free: 800.315.4132
Fax: 865.312.8190

SPIN #: 143035655
General Contractors License #: 00067550
TN Alarm Contractors License: 2138

PRICING PROPOSAL:

PART B SPECS

Carts must have the ability to be moved in the schools with locking wheels preferred. YES

Carts must include the ability to be locked for security purposes. YES

Carts must have the ability to charge chromebooks while in storage. YES

Carts must have the ability to hold chromebooks with a 14 inch screen with the door shut properly. YES

Vendor can choose to bid on one or all of the following sized carts:

1. 25 slot - N/A
2. 30 slot - \$699.00
3. 36 slot - \$999.00

ANYWHERE PRODUCT GUIDE DISCOUNT - 2% off MSRP

Jordan Walker

Hickman County Government

Conflict of Interest Disclosure Form

The County Financial Management System of 1981 contains the most stringent conflict of interest provisions. TCA §5-21-121 provides:

- (a) The director, purchasing agent, members of the committee, members of the county legislative body or other officials, employees, or members of the board of education or highway commission shall not be financially interested or have any personal beneficial interest, either directly or indirectly, in the purchase of any supplies, materials, equipment or contractual services for the county.
- (b) No firm, corporation, partnership, association or individual furnishing any such supplies, materials, equipment or contractual services, shall give or offer, nor shall the director or purchasing agent or any assistant or employee accept or receive directly or indirectly from any person, firm, corporation, partnership or association to whom any contract may be awarded, by rebate, gift or other otherwise, any money or other things of value whatsoever, or any promise, obligation or contract for future reward or compensation.

Date: April 12, 2022 Name: Jordan Walker

Please describe below any relationships, transactions, positions you hold (volunteer or otherwise), or circumstances that you believe could contribute to a conflict of interest:

I have no conflict of interest to report.

I have the following conflict of interest to report (please specify any boards or committees you (and/or your spouse) sit on, the name of your employer and any businesses you or your spouse may own.

I hereby certify that the information set forth above is true and complete to the best of my knowledge.

Date: April 12, 2022 Signature: 



AC-30

Designed to charge, store and transport 15 to 30 Chromebooks or Tablets

Configurable 30 Bay Charging Cart



30 Devices



Basic Charging



Secure

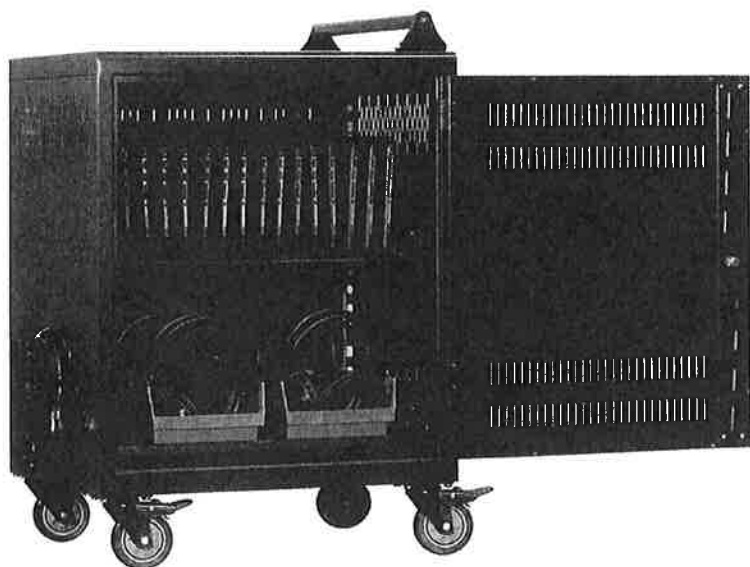
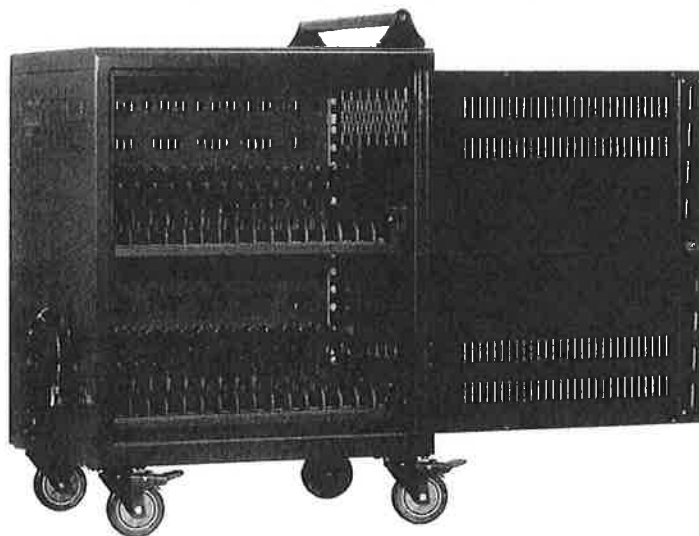

- Full Metal Construction
- 3-point Locking Door w/ Padlock Loop
- Removable Device Dividers
- Integrated Cable Management w/ Cable Clips
- Numbered Shelf Strips
- Basic Charging with 2 Power Cords
- Removable AC Adapter Baskets
- 4" Swivel / Directional / Lock Casters
- Ships Fully Assembled (except handle)
- Lifetime Frame Warranty

DIMENSIONS

Height:	34.8"
Width:	26"
Depth:	20"

CART CAPACITY

Divider Spacing:	1"
Shelf Depth:	14.5"
Shelf Height:	11.5"

WEIGHT

Product Weight:	98 lbs.
Shipping Weight:	114 lbs.

Specifications subject to change without notice.
81420

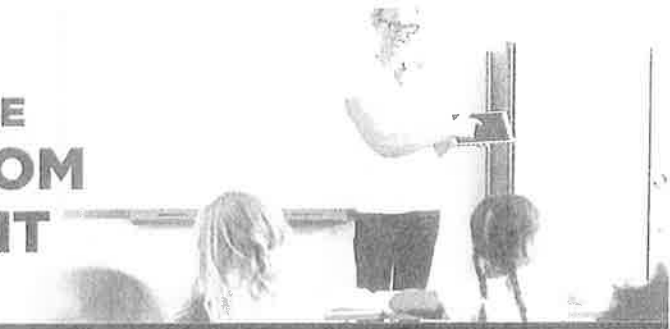

AC-PLUS

Designed to charge, store and transport up to 36 Chromebooks, Laptops or Tablets up to 14 inches

36 Bay Secure Cycle Charging Cart



36 Devices



Cycle Charging



Secure

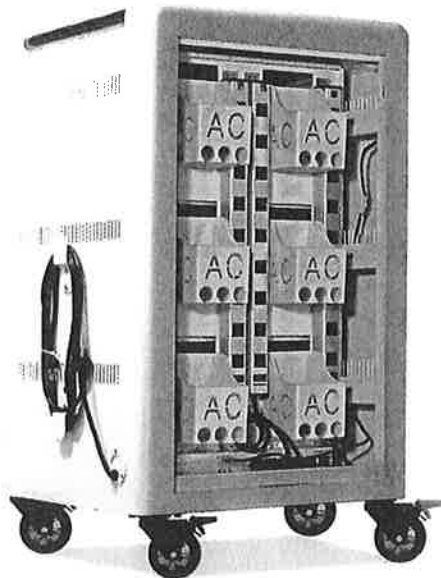

- UL Certification 60950-1
- 15 Minute Cycle Timer
- Full Metal Construction
- Rounded Top Corners
- 3-point Locking Door w/ Padlock Loop
- Removable Device Dividers
- Integrated Cable Management w/ Cable Clips
- Removable AC Adapter Baskets
- 4" Swivel / Directional / Lock Casters
- Ships Fully Assembled
- Lifetime Frame Warranty

DIMENSIONS

Height:	44.3"
Width:	25.5"
Depth:	23.7"

CART CAPACITY

Divider Spacing:	1.18"
Shelf Depth:	14.25"
Shelf Height:	10.5"

WEIGHT

Product Weight:	160 lbs.
Shipping Weight:	200 lbs.

Specifications subject to change without notice.
8520



Hickman County Schools

ITB: Chromebook Charging Carts

Due: April 18, 2022 at 10:30 A.M.



A Technology Proposal created for Hickman County Finance Office

Submitted on April 5, 2022

SUBMITTED BY Bluum USA, Inc.

Barry Masters, Account Executive

Phone Number: 647-997-6219

Fax Number: 905-946-0059

Email Address: barry.masters@bluum.com

bluum™



April 5, 2022

Hickman County Finance Office
114 North Central Avenue, Suite 203
Centerville, TN 37033

Dear Hickman County School District,

With the hyper-accelerated transition to technology-based education over the last year, educators are seeking deeper partnerships with solutions providers who can deliver more than a sale or a product. They are looking for a true partner who is vested in helping broaden access and improve learning outcomes. Bluum is that partner.

Selling technology is no longer enough. It must be accompanied by services, training, and support to empower educators and students to meet their goals. For nearly 40 years, Bluum has been a vital part of the education ecosystem. *Our vision: A future where everyone has access to a great education.*

The Bluum affiliate entities create one of the largest privately held education technology solutions providers in the U.S. We fill customer needs by providing services associated with distributors, dealers, resellers and system integrators. Bluum's comprehensive portfolio contains over 1 million products and services, many provided by industry-leading and niche manufacturers. Bluum primarily serves the education market, ranging from public pre-schools to colleges and universities, to private and charter schools and organizations. Bluum is the only technology solutions provider with a clear focus on a higher calling to spark the next generation of learning. Our market leadership position and reputation have earned numerous awards and accolades from our customers, vendors, and industry.

As a true partner, we commit to being with you every step of the way – from planning and design to purchasing, integration, and installation – and throughout the entire technology lifecycle, providing services like professional development, classroom management, and technology buyback. We help you derive the greatest benefits and maximize the overall value of your technology investments.

WHAT SETS BLUUM APART?

Our deep experience in understanding how technology is used to manage, teach, and learn helps us create differentiated solutions that are purpose-built to improve the learning landscape. Our clients benefit from:

- **Experience** – With technology and education in our DNA, our 900+ employees are committed to helping educators improve learning outcomes. Nearly 40 years of providing technology and services to educators and students have helped us master services requiring higher and more specialized skills at the level of experience unmatched by other companies.
- **Portfolio** – Bluum offers one of the largest and most comprehensive technology portfolios available – more than one million products from over 800 industry-leading manufacturers and service providers.
- **Scale & Agility** - We have made significant investments in our business to scale our customers' needs. This includes creating more exclusive and innovative solutions, increasing our coverage model across North America, and improving our negotiating ability with vendors. All enable us to have more meaningful discussions with customers about how to solve their challenges.
- **Integration Capabilities** – Our pedigree contains deep technical knowledge and expert-level collaborative technology design and integration services. This gives us the ability to plan and execute on high-end, complex technology projects and offer integration services anywhere in the U.S.



- Services – Bloom provides a complete suite of education-specific services ranging from product screening and professional development to IT asset disposition (ITAD) and product lifecycle management.
- Coverage – Bloom has coverage in every state in the U.S. and a large portion of Canada. Our ed-tech experts live and work in the areas where our clients are located and are invested in the schools they serve.
- Results - Over 20 million students use Bloom-provided technology and solutions every day.

Bloom is proud to support transformative change in education. We are confident you will find we have the right mix of experience, expertise, product, and services to support your requirements effectively. If you need more information, please contact me directly at: barry.masters@bluum.com.

I look forward to the opportunity to partner with Hickman County School District to ensure student academic achievement and empower tomorrow's leaders.

Sincerely,

Barry Masters

Account Executive

P: 647-997-6219

E: barry.masters@bluum.com

Trox + Tierney Is Now Bluum

Effective in February and March 2022, the companies comprising the Bluum brand group changed their corporate names to represent the new "Bluum" identity, pursuant to an amended and restated Certificate of Incorporation filed with their respective Secretaries of State.

New Affiliate Name	Superseded Affiliate Name	FEIN (Same as Previous)
Bluum Technology Canada, Inc.	<i>CDI Computer Dealers Inc.</i>	98-0385056
Bluum USA, Inc.	<i>Troxell Communications, Inc.</i>	86-0716114
Bluum of Minnesota, LLC	<i>Tierney Brothers, LLC</i>	41-1355993
Bluum of Texas, LLC	<i>CDI Dallas, LLC</i>	84-3269935
Bluum Integration, LLC	<i>Integrated AV Systems, LLC dba Summit Integration Systems</i>	86-0716114
Bluum (US) Corporation	<i>CDI Computers (US) Corp</i>	42-1773443

The change is only a change in name; it does not affect the ownership, management, or shareholder rights of the corporation, nor does it change any of its legal rights or obligations of any contracts, agreements or relationships that were in place prior to the change. Contracts, agreements, purchase orders, requests for quotes, and other relevant transactional documents should all be conducted under the new full corporate name of the respective entity. Previously existing contracts, agreements, purchase orders, sales orders or sales invoices are unaffected by this change, other than to correctly identify the new name that should be used from this day forward. The Bluum companies, listed above, will be identified by the same and unchanged FEINs. The names "Bluum" and "Bluum Technology," as well as their stylized logos, are trademarks licensed by Bluum USA, Inc. for its use, and the use of its affiliates, from Bluum Holdings, LLC (formerly Troxell Purchaser, LLC).

For this project, Bluum USA, Inc. will be the affiliate contracting with Hickman County Finance Office. A revised Federal Form W9 can be provided by your Account Executive, upon request

Invitation To Bid

The Hickman County Finance Office is accepting sealed bids for Chromebook Charging Carts for Hickman County Schools.

Additional specifications can be found at: www.hickmank12.org/request-for-proposal.

All bidders will be required to submit a conflict of interest disclosure form that can also be found at: www.hickmank12.org/request-for-proposal.

Sealed bids must be mailed or delivered to the Hickman County Finance Office, 114 North Central Avenue, Suite 203, Centerville, TN 37033 and clearly marked on the outside of the bid envelope "Chromebook Charging Carts". Bids will be opened on Monday, April 18th, 2022 at 10:30 A.M. in the Finance Office.

The Hickman County School District reserves the right to reject any and or all bids or proposals and to waive any informalities, which in the opinion of the school system, would prevent the acceptance of a better bid.

PART B SPECS

Carts must have the ability to be moved in the schools with locking wheels preferred.

Carts must include the ability to be locked for security purposes.

Carts must have the ability to charge chromebooks while in storage.

Carts must have the ability to hold chromebooks with a 14 inch screen with the door shut properly.

Vendor can choose to bid on one or all of the following sized carts:

1. 25 slot
2. 30 slot
3. 36 slot

Vendor can choose to price according to the amount of chromebook carts purchased. No set amount of carts to purchase is decided at this time.

Any questions can be directed via email to brad.gilbert@hickmank12.org.

OPTION 1- Trox Carts



CDI Dallas LLC
4675 E. Cotton Center Blvd. Suite 155
Phoenix, AZ 85040

Quote Number: QUO-51663-90895
Created On: 4/4/2022

HICKMAN CO SCHOOL DISTRICT

Contact: Brad Gilbert
Email: brad.gilbert@hickmank12.org
115 MURPHREE AVE
CENTERVILLE, Tennessee, 37033-1443

HICKMAN CO SCHOOL DISTRICT

BRAD GILBERT
115 MURPHREE AVE
CENTERVILLE, TN, 37033-1443

Terms: Net 30

FOB: Destination

Customer #: 51663

Expires: 5/4/2022

Trox Cart Quote

Item	Description	Sell Price	Qty	Ext. Price
1	The TROX EC32S storage and smart charging cart for 32 (Max 15") notebooks or Chromebooks, 2 fixed shelves with 16 slots on each that measure 15.4" deep and 12.2" high and 1.5" wide, angled outlets to accommodate a variety of A/C adaptors, cable management, A/C adaptor brick baskets and 4 x 5" swivel wheels. Alternate 32 Device Cart	\$775.00	1	\$775.00
				Non-Taxable
2	The TROX SC33: Storage and charging cart for 33 (Max 15.6") units, preprogramed 2nd generation solid state smart charging technology, with three pull out drawers and 5" wheels. Alternate 33 Device Cart	\$1,069.00	1	\$1,069.00
				Non-Taxable
3	WARRANTY TROX cart limited manufacturer warranty, includes electrical component coverage for 5 years, and a lifetime limited warranty on the other components of the cart.	\$0.00	1	\$0.00
				Non-Taxable
4	TROX Pre-wiring Installation Charge for PWR Bar and Cable Management for Chromebook/Notebook cart. OPTIONAL We do not supply extra wires. Please work with us to buy the cords and adapters or send us your adapters and cords and we will install them.	\$41.00	1	\$41.00
				Non-Taxable
5	SHIPPING IS FREE UNLESS LIFTGATE IS REQUIRED- SEE BELOW DOCK TO DOCK SHIPPING IS FREE.	\$75.00 *	1	\$75.00 *
				Non-Taxable

*** SHIPPING WITH LIFTGATE SERVICE IF REQUIRED:
\$75 FOR EACH SHIPMENT FOR TROX CARTS
IT DOES NOT MATTER HOW MANY CARTS PER SHIPMENT**

Subtotal \$1,960.00
Total \$1,960.00

Thank You,



BARRY MASTERS

Account Executive

O: 1-888-226-5727 #3892

C: 647-997-6219

E: Barry.Masters@bluum.com

bluum.com

NOTE: My new email is Barry.Masters@bluum.com
Please update my contact information.

TROX™

EC32S Economy Charging Cart

Designed for Chromebooks, Laptops and Tablets Up to 15.6 Inches

Looking for a simple, cost effective smart charging cart that can store and charge a variety of devices without breaking the bank? The Trox EC32S Economy Charging Cart is designed for efficiency in the classroom and for cost.

It's safe, secure and simple. Just plug it in and charge up to 32 devices simultaneously.

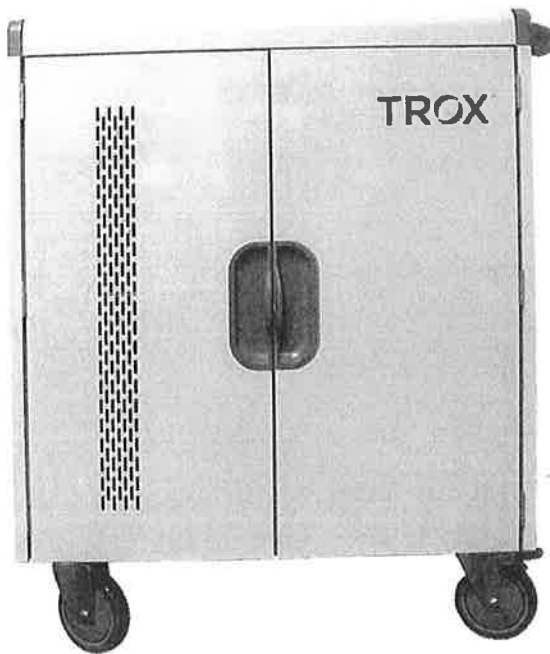

FEATURES:

- Fits most devices up to 15"*
- Compact and mobile – move anywhere with ease
- Hassle-free cable and power management system
- Easy A/C adaptor accommodation
- 3-point door locking system for security

COMPREHENSIVE WARRANTY:

Our comprehensive warranty coverage guarantees your investment is protected.

- Limited 5-year warranty on electrical
- Lifetime warranty on parts
- \$0 cost of ownership guarantee – we'll fix or replace for free**

* Fits most devices up to 15". Please check with your account executive about the best fit for your devices.

** Replacement may be with new or refurbished model of equivalent value, depending on stock.

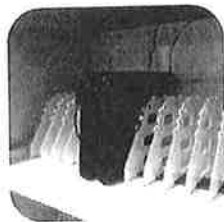
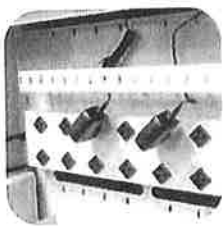

Trox has deployed over 28,000 charging carts and cabinets to schools across North America. We're a preferred choice due a rigorous manufacturing process and a \$0 cost of ownership guarantee.

TROX™

Contact your Trox account executive
or call **1.855.TROX355** | **Trox.com**



TROX™

EC32S Economy Charging Cart

Specifications

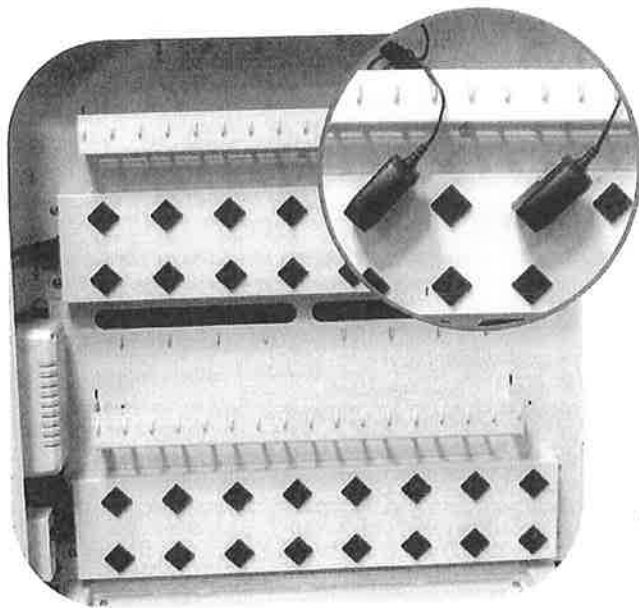

CART DIMENSIONS:

Width	Depth	Height
32"	29"	37"

SLOT SIZE:

Width	Depth	Height
1.75"	15.25"	15.5" Top Shelf 13" Bottom Shelf

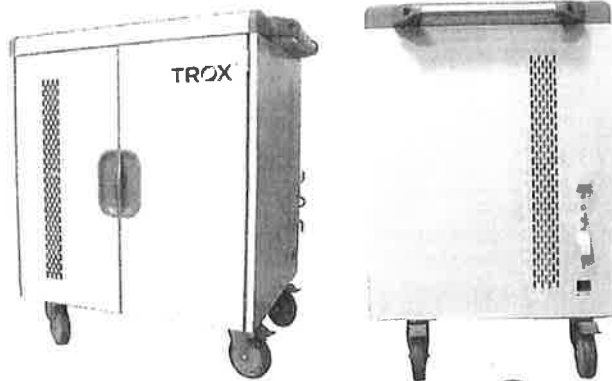

UL Approved

Device Capacity:	32
External Outlets:	0
Smart Charging:	Yes
Slide Out Shelving:	No
Cable Management:	Yes
Power Brick Holder:	Yes
Cart Weight:	114 lbs
Warranty (Parts):	Lifetime
Warranty (Electrical):	5 Year
Casters:	4 swivel, 2 locking
Caster Size:	5"
Lockable with Padlock:	Yes
Security Hook:	Yes
Color:	Grey



Save time and get your cabinet pre-wired.
Ask your account executive for details.

TROX™

Contact your Trox account executive
or call **1.855.TROX355** | Trox.com



TROX™

SC33 Smart Charging Cart

Designed for Chromebooks, Laptops and Tablets Up to 15 Inches

The Trox SC33 smart charging cart is ideal for larger classrooms. The unit is practical and compact, with slide-out shelves that make placing and removing devices easier and safer. Holding up to 33 devices, the SC33 uses the latest smart charge technology to ensure the quickest charge possible.



FEATURES:

- Fits most devices up to 15"*
- Slide out shelves make storing and charging easy
- Compact and mobile – move anywhere with ease
- Hassle-free cable and power management system
- Easy A/C adaptor accommodation
- 3-point door locking system for security
- Instant-on charge

COMPREHENSIVE WARRANTY:

Our comprehensive warranty coverage guarantees your investment is protected.

- Limited 5-year warranty on electrical
- Lifetime warranty on parts
- \$0 cost of ownership guarantee – we'll fix or replace for free**

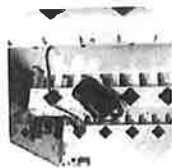

* Fits most devices up to 15". Please check with your account executive about the best fit for your devices.
** Replacement may be with new or refurbished model of equivalent value, depending on stock.

Trox has deployed over 28,000 charging carts and cabinets to schools across North America. We're a preferred choice due a rigorous manufacturing process and a \$0 cost of ownership guarantee.

TROX™

Contact your Trox account executive
or call **1.855.TROX355** | Trox.com



TROX™

SC33 Smart Charging Cart

Specifications

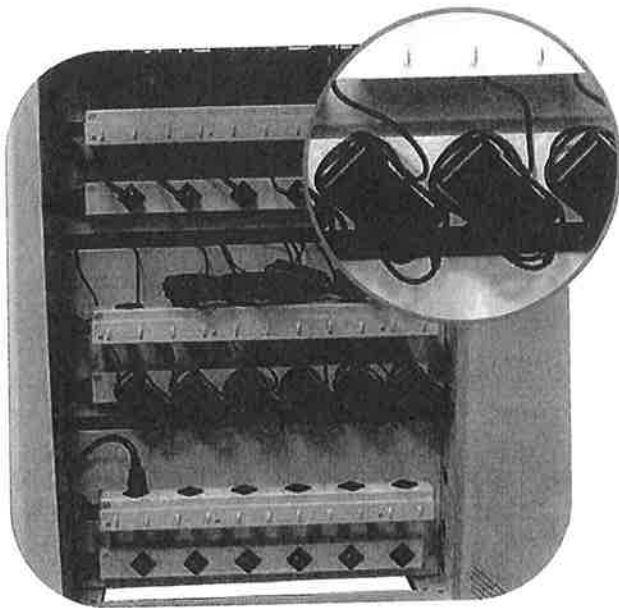

CART DIMENSIONS:

Width	Depth	Height
28.03"	24.34"	40.75"

COMPARTMENT SIZE:

Width	Depth	Height
1.34"	15.25"	10"

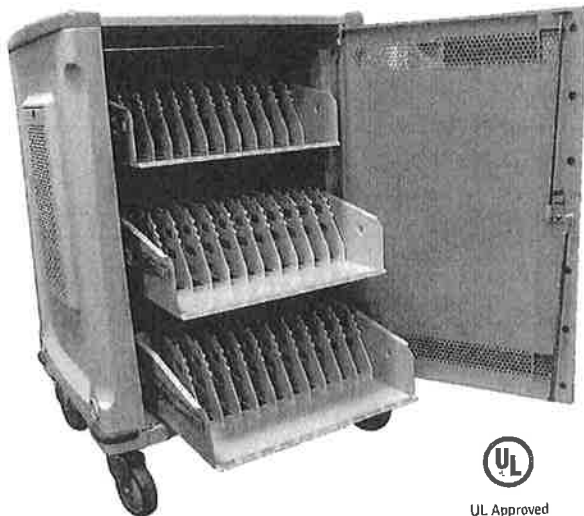

UL Approved

Device Capacity:	33
External Outlets:	3
Smart Charging:	Yes
Slide Out Shelving:	Yes
Cable Management:	Yes
Power Brick Holder:	Yes
Cart Weight:	145 lbs
Warranty (Parts):	Lifetime
Warranty (Electrical):	5 Year
Casters:	4 swivel, 2 locking
Caster Size:	5"
Lockable with Padlock:	Yes
Security Hook:	Yes
Color:	Blue



Save time and get your cabinet pre-wired.
Ask your account executive for details.

TROX™

Contact your Trox account executive
or call **1.855.TROX355** | Trox.com



OPTION 2 - Anywhere Carts



CDI Dallas LLC
 4675 E. Cotton Center Blvd. Suite 155
 Phoenix, AZ 85040

Quote Number: QUO-51663-90906
 Created On: 4/4/2022

HICKMAN CO SCHOOL DISTRICT

Contact: Brad Gilbert
 Email: brad.gilbert@hickmank12.org
 115 MURPHREE AVE
 CENTERVILLE, Tennessee, 37033-1443

HICKMAN CO SCHOOL DISTRICT

BRAD GILBERT
 115 MURPHREE AVE
 CENTERVILLE, TN, 37033-1443

Terms: Net 30 FOB: Destination Customer #: 51663 Expires: 5/4/2022

Anywhere Cart Quote

Item	Description	Sell Price	Qty	Ext.Price
1	ANYWHERE MFG#AC-VERT-24 24 Bay - Anywhere Cart Vertical 24 - Secure Charging Cabinet Alternate 24 Device Cart	\$645.00	1	\$645.00 Non-Taxable
2	ANYWHERE MFG#Anywhere Cart AC-30 30 Bay - Anywhere Cart 30 - Economical Secure Charging Cart 30 Device Cart	\$709.00	1	\$709.00 Non-Taxable
3	ANYWHERE MFG#AC-PLUS 36 Bay - Anywhere Cart AC-Plus - Secure Charging Cart with Cycle Timer 36 Device Cart	\$1,019.00	1	\$1,019.00 Non-Taxable
4	WARRANTY Lifetime limited warranty on the frame work and 5 years on electrical	\$0.00	1	\$0.00 Non-Taxable
5	SHIPPING IS FREE UNLESS LIFTGATE IS REQUIRED- SEE BELOW	\$150.00 *	1	\$150.00 * Non-Taxable
* DOCK TO DOCK SHIPPING FROM ANYWHERE CARTS IS FREE. SHIPPING WITH LIFTGATE SERVICE IF REQUIRED: \$150 FOR EACH SHIPMENT OF ANYWHERE CARTS IT DOES NOT MATTER HOW MANY CARTS PER SHIPMENT				
Subtotal				\$2,523.00
Total				\$2,523.00

Thank You,



BARRY MASTERS

Account Executive

O: 1-888-226-5727 #3892

C: 647-997-6219

E: Barry.Masters@bluum.com

bluum.com

NOTE: My new email is Barry.Masters@bluum.com
 Please update my contact information.

AC-VERT-24

Designed to charge, store and secure 24 Chromebooks, Laptops or Tablets.

24 Device Secure Charging Tower



24 Devices



Basic Charging



Secure

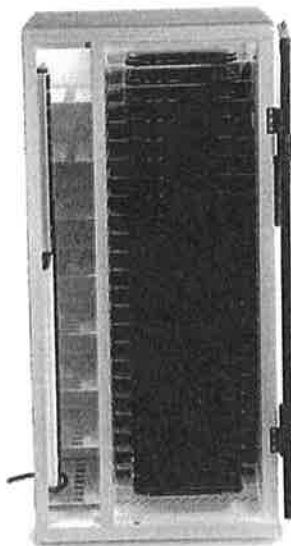
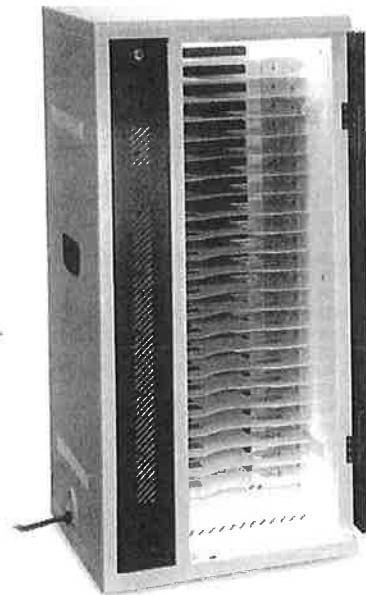

Large Capacity, Small Footprint

Using either the Wall Mount or Optional Stand, the AC-VERT-24 places devices wherever they're needed.

- Full Metal Construction
- Wall or Stand (Optional) Mountable
- 3-Point Locking Door with Padlock Loop
- Door Folds 270° To The Side
- Heavy Duty Door Hinges
- Secure Locking Power Adapter Area
- Removable AC Adapter Mounting Plates
- Ships Fully Assembled
- Lifetime Frame Warranty

Dimensions

Height: 39.5"
Width: 18"
Depth: 15"

Cabinet Capacity

of Devices: 24
Bay Width: 11"
Depth: 13.5"
Height: 1.1"

Weight

Product Weight: 77 lbs.
Shipping Weight: 82 lbs.

Specifications subject to change without notice. 010121



AC-30

Designed to charge, store and transport 15 to 30 Chromebooks or Tablets

Configurable 30 Bay Charging Cart

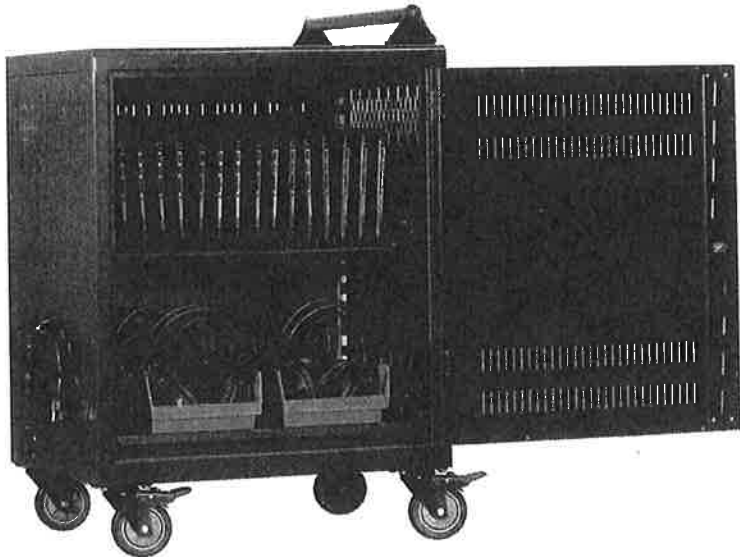
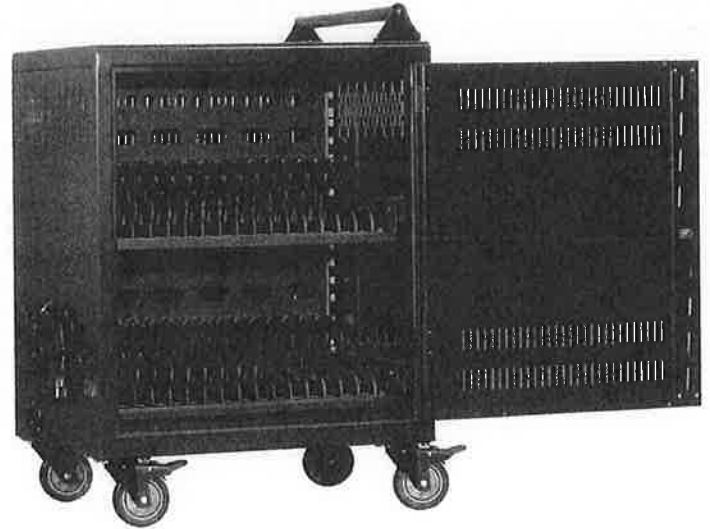

- Full Metal Construction
- 3-point Locking Door w/ Padlock Loop
- Removable Device Dividers
- Integrated Cable Management w/ Cable Clips
- Numbered Shelf Strips
- Basic Charging with 2 Power Cords
- Removable AC Adapter Baskets
- 4" Swivel / Directional / Lock Casters
- Ships Fully Assembled (except handle)
- Lifetime Frame Warranty

DIMENSIONS

Height:	34.8"
Width:	26"
Depth:	20"

CART CAPACITY

Divider Spacing:	1"
Shelf Depth:	14.5"
Shelf Height:	11.5"

WEIGHT

Product Weight:	98 lbs.
Shipping Weight:	114 lbs.

Specifications subject to change without notice.
81420



AC-PLUS

Designed to charge, store and transport up to 36 Chromebooks, Laptops or Tablets up to 14 inches

36 Bay Secure Cycle Charging Cart



36 Devices



Cycle Charging



Secure

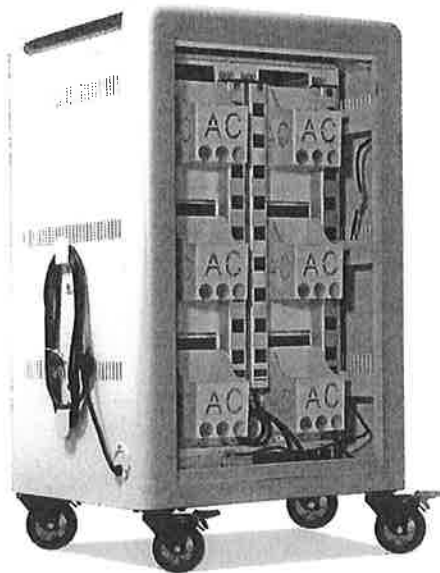

- UL Certification 60950-1
- 15 Minute Cycle Timer
- Full Metal Construction
- Rounded Top Corners
- 3-point Locking Door w/ Padlock Loop
- Removable Device Dividers
- Integrated Cable Management w/ Cable Clips
- Removable AC Adapter Baskets
- 4" Swivel / Directional / Lock Casters
- Ships Fully Assembled
- Lifetime Frame Warranty

DIMENSIONS

Height:	44.3"
Width:	25.5"
Depth:	23.7"

CART CAPACITY

Divider Spacing:	1.18"
Shelf Depth:	14.25"
Shelf Height:	10.5"

WEIGHT

Product Weight:	160 lbs.
Shipping Weight:	200 lbs.

Specifications subject to change without notice.
8320

Hickman County Government

Conflict of Interest Disclosure Form

The County Financial Management System of 1981 contains the most stringent conflict of interest provisions. TCA §5-21-121 provides:

- (a) The director, purchasing agent, members of the committee, members of the county legislative body or other officials, employees, or members of the board of education or highway commission shall not be financially interested or have any personal beneficial interest, either directly or indirectly, in the purchase of any supplies, materials, equipment or contractual services for the county.
- (b) No firm, corporation, partnership, association or individual furnishing any such supplies, materials, equipment or contractual services, shall give or offer, nor shall the director or purchasing agent or any assistant or employee accept or receive directly or indirectly from any person, firm, corporation, partnership or association to whom any contract may be awarded, by rebate, gift or other otherwise, any money or other things of value whatsoever, or any promise, obligation or contract for future reward or compensation.

Date: 4/5/2022 Name: Bluum USA, Inc.

Please describe below any relationships, transactions, positions you hold (volunteer or otherwise), or circumstances that you believe could contribute to a conflict of interest:

I have no conflict of interest to report.

I have the following conflict of interest to report (please specify any boards or committees you (and/or your spouse) sit on, the name of your employer and any businesses you or your spouse may own.

I hereby certify that the information set forth above is true and complete to the best of my knowledge.

Date: 4/5/2022 Signature: 

Corporate Resolution of Signing Authority

RESOLVED, that Erez Pikar, President and Chief Executive Officer; Dan Gerelick, Chief Financial Officer; Naipaul Sheosankar, Treasurer; Michael Fabio, Secretary and Vice President of Finance; Sarah Kydd, Chief Operating Officer; and Craig Schramm, Vice President of Business Systems are hereby authorized to sign contracts of Bluum USA, Inc. (the "Corporation") in the Corporation's name and behalf.

The undersigned hereby certifies that he is the duly elected and qualified Secretary and Vice President of Finance of the Corporation which is duly formed pursuant to the laws of the state of Delaware and that the foregoing is a true record of a resolution duly adopted at a meeting of the Board of Directors and that said meeting was held in accordance with state law and the Bylaws of the Corporation on the 23rd day of April, 2021, and that said resolution is now in full force and effect without modification or rescission.

IN WITNESS WHEREOF, I have executed my name as Secretary and Vice President of Finance and have hereunto affixed the corporate seal of the above-named Corporation this 23rd day of April, 2021.



Michael Fabio, Secretary and Vice President of Finance

COVID-19 Statement

Due to unforeseen effects of the current COVID-19 outbreak, including but not limited to decreases in manufacturer operations and shipping, governmental restrictions and tariffs, and access to necessary sites/personnel, Bluum may experience delays in receiving equipment from manufacturers.

Understand that we are in constant communication with our manufacturers and will keep you apprised of any potential changes in product availability, while working with you on solutions to mitigate downtime.

RTI®

RIVERSIDE TECHNOLOGIES, INC.

105 Gateway Drive | North Sioux City, SD 57049

Request for Proposal

Chromebook Units and Chrome OS Management Service License



Hickman County Schools

114 North Central Ave Suite 203
Centreville, TN 37033

April 14, 2022

Hickman County Schools
114 North Central Ave Suite 203
Centreville, TN 37033

Dear Brad Gilbert,

Riverside Technologies, Inc. (RTI) is pleased to provide Hickman County Schools with the following response to Request for Proposal - Chromebook Units and Chrome OS Management Service License. We are confident that our Chromebook solution provided by our education solution team will exceed your expectations for affordability, quality, performance and customer support.

Driven by passion, creativity and teamwork, RTI is committed to providing you with the best hardware and customer service possible. With years of experience in engineering, technology support, Chromebook deployments, and customer service your account management team stands ready to assist you. RTI has deployed over 150,000 Chromebooks successfully for multiple school districts across the United States. RTI can provide the following services to Hickman County Schools:

- **Asset Tagging/Reporting:** RTI labels each system with an identification tag. Your Asset Management information is detailed in a report that includes: bar-coded asset numbers, computer manufacturer, model number, serial number and any other custom information requested.
- **Green Delivery:** RTI removes all packaging materials and disposes of, or recycles the materials. RTI bulk ships your orders in our custom shipping container that minimizes waste, is easily collapsible and recyclable.
- **Google Enrollment:** RTI sets up your Chromebook to have the most up to date operating system and software.

We are aware that you are selecting a partner who has provided outstanding customer service, professionalism, advanced technical ability and premium product. We look forward to collaboration with your business and employees to make a difference in Hickman County Schools! Please do not hesitate to reach out with any questions to Todd Butters at (866) 804-4388 ext. 1427. We appreciate the opportunity to do business with you!

Sincerely,



Kevin Heiss
President
Riverside Technologies, Inc.
Cell | 712-490-9981
kevinh@lrti.com

Invitation to
Bid

The Hickman County Finance Office is accepting sealed bids for Chromebook Units and Chrome OS Management Service License.

Bid with specifications are online at: **www.hickmank12.org/request-for-proposal**.

All bidders will be required to submit a conflict of interest disclosure form that can be obtained at www.hickmank12.org/request-for-proposal.

Sealed bids must be mailed or delivered to the Hickman County Finance Office, 114 North Central Avenue, Suite 203, Centerville, TN 37033 and clearly marked on the outside of the envelope "Chromebooks and Chrome Management Licenses". Bids will be opened on Monday, April 25th, 2022 at 10:00 a.m. in the Finance Office.

The Hickman County Board of Education reserves the right to accept or reject any and all bids or parts of bids and to waive any informalities that would prevent the acceptance of a better bid.

Bid Specifications for Chromebooks:

Chrome OS

14 inch screen (non-touch) preferred

4 GB RAM preferred

16 GB Hard Drive Size Preferred

Wireless Compatible

USB and HDMI ports available

Headphone Jack

Prices are to include shipping and handling charges for delivery, asset tagging/configuration. Chromebooks should be named and enterprise enrolled to the proper school in Google Admin Console as determined by Hickman County Schools.

Any color choice is determined by Hickman County Schools.

12 month support warranty for Chromebook

Questions should be directed to Brad Gilbert, Technology Coordinator, via e-mail at brad.gilbert@hickmank12.org

No exact number of chromebooks being ordered is available at this time. A price breakout dependent on quantity purchased will be accepted. Bid prices are expected to be good for one year unless noted otherwise in the bid.

Hickman County Government

Conflict of Interest Disclosure Form

The County Financial Management System of 1981 contains the most stringent conflict of interest provisions. TCA §5-21-121 provides:

- (a) The director, purchasing agent, members of the committee, members of the county legislative body or other officials, employees, or members of the board of education or highway commission shall not be financially interested or have any personal beneficial interest, either directly or indirectly, in the purchase of any supplies, materials, equipment or contractual services for the county.
- (b) No firm, corporation, partnership, association or individual furnishing any such supplies, materials, equipment or contractual services, shall give or offer, nor shall the director or purchasing agent or any assistant or employee accept or receive directly or indirectly from any person, firm, corporation, partnership or association to whom any contract may be awarded, by rebate, gift or otherwise, any money or other things of value whatsoever, or any promise, obligation or contract for future reward or compensation.

Date: 4/14/2022 Name: Kevin Heiss

Please describe below any relationships, transactions, positions you hold (volunteer or otherwise), or circumstances that you believe could contribute to a conflict of interest:

I have no conflict of interest to report.

I have the following conflict of interest to report (please specify any boards or committees you (and/or your spouse) sit on, the name of your employer and any businesses you or your spouse may own.

I hereby certify that the information set forth above is true and complete to the best of my knowledge.

Date: 4/14/2022 Signature: 



Riverside Technologies, Inc. (RTI)

Your Complete IT Source

Riverside Technologies Inc. (RTI) is the next generation of an IT service provider. Beyond specializing in IT solutions—managed services, IT hardware, warehouse services, and technology deployment—we add our blend of passion, creativity, and teamwork. We understand your unique challenges, develop creative solutions, and provide unmatched responsiveness. RTI is **trusted** throughout the nation and across various industries for being a **complete IT source**.

1:1 Solutions

Tailored for You

Excellent equipment and trusted partnerships backed by RTI's expert customization.

Managed Services

Filling the Gaps

An extension of your IT department, we hit your sweet spot, from simple IT support to complete outsourcing.

Enterprise Solutions

Maximize Your ROI

Our start-to-finish solutions will help maximize your IT investment and achieve your business goals.

Customization

Make a Statement

Customization solutions from RTI will create a complete, branded solution that makes a statement.

Integration

Bring It All Together

No headaches, hassles, or wasted time. We'll make the integration process as seamless as possible.

Deployment

Nailing the Details

Attention to detail is critical. We'll handle the little things to ensure ongoing success for your organization.

Education

Smart Student Solutions

Simple, end-to-end answers to designing, integrating, and managing learning environments.

Managed Print

Free Up Resources

Focus on your business and let RTI manage and optimize your printers and copiers.

Assessments

Evolve Your IT

Our certified IT engineers complete various invaluable, industry-leading assessments.



Hickman County School District Chromebooks and Chrome Management Licenses

Quote #tb081274 v1

Prepared For:
Hickman County School District
Main
Brad Gilbert
115 Murphree Ave

Prepared by:
Riverside Technologies
Todd Butters
748 N 109th Court
Omaha, NE 68154

Date Issued:
04.14.2022
Expires:
05.14.2022

Centerville, TN 37033
P: 9317293391 x-2229
E: brad.gilbert@hickmank12.org

P: 866.804.4388 x-1427
E: tbutters@riversidetechnologies.com

Contract:

Hardware		Price	Qty	Ext. Price
Hickman County Chromebooks	Hickman County Chromebooks	\$316.00	1	\$316.00
3V2U9UT#ABA	HP Chromebook 14 G7 14" Chromebook - HD - 1366 x 768 - Intel Celeron N4500 Dual-core (2 Core) - 4 GB Total RAM - 32 GB Flash Memory - Intel Chip - Chrome OS - Intel UHD Graphics - English Keyboard - 12.50 Hours Battery Run Time - IEEE 802.11ax Wireless LA		1	
				
RTSWR-T0023	Google Management Console		1	
RTWHS-T0025	Google Enrollment Service		1	
RTWHS-T0003	Asset Tag		1	
RTWHS-T0002	Green Delivery		1	
Google Support through June 2029				
			Subtotal:	\$316.00

Quote Summary	Amount
Hardware	\$316.00
Total:	\$316.00

Taxes, shipping, handling and other fees may apply. We reserve the right to cancel orders arising from pricing or other errors.



HP Chromebook 14 G7

An essential Chromebook for education and frontline work

Power through the day with the durable HP Chromebook 14 G7 and its manageable, secure, and intuitive Chrome OS. The latest Intel® Celeron® processor¹, large 14" diagonal screen, long battery life, and HP docking support² enhance productivity.



Designed for maximum productivity

- Combine dynamic features driving this 14" Chromebook with Chrome apps and easily execute tasks and workflows. Powered by the latest Intel® Celeron® processor¹, up to 8 GB memory⁸, 128 GB storage⁴, and a fast-charge battery for mastering through long days.

Ultralight and durable for long-lasting mobility

- Get a hard-wearing Chromebook at less than 19 mm (.748 in) thin. Feel confident carrying a device that undergoes MIL-STD 810H testing⁶, has reinforced USB-C® ports, and features a wipeable keyboard⁷ that withstands spills up to 350 ml (11.8 oz).

Designed for easy collaboration

- Collaborate with a narrow bezel display, optional wide-viewing angle IPS touchscreen⁸, wide-angle HD webcam, and dual mics for a better video conferencing experience. Add your display, projector, or accessories with HDMI and USB-C®.⁹
- Breathe easy with the low-maintenance, highly manageable, and secured Chrome OS. With automatic software updates through June 2029 and built-in anti-virus protection, your device is protected and up to date.¹⁶
- The perfect combination of performance, power consumption, and value handles multiple assignments smoothly and reliably with up to four processing cores to divide up the work.¹
- Undergoes MIL-STD 810H combined with HP Total Test Process to ensure this Chromebook exceeds HP durability and reliability standards—helping reduce total cost of ownership.^{6,11}
- Increase productivity without hassle. Connect to additional displays and projectors with an HDMI port that helps reduce dongle and cable clutter.
- Work from almost anywhere with a fast, reliable wireless connection. Get enhanced connectivity even on crowded wireless networks at a long range with Wi-Fi 6 WLAN module, supporting MU-MIMO and HP Extended Range Wireless LAN.^{12,13,14}
- Enjoy the freedom to unplug and work at different sites throughout the day with a long-running battery. Charge to 90% battery life in 90 minutes with HP Fast Charge.⁵
- Immerse yourself in on-screen visuals with a narrow border design that maximizes the screen's view within a smaller chassis.
- Tested for 1000 cleanings, the keyboard of this Chromebook can be wiped down using commonly available household disinfecting and cleaning wipes.⁷
- Up to 8 GB RAM and 128 GB eMMC storage options allow staff, teachers, and students to access thousands of Android applications, complete tasks, and collaborate with others.^{4,8,15}
- Keep going even in dimly lit rooms or aboard red-eye flights. With an optional illuminated keyboard, you can type comfortably in more environments.⁸

HP Chromebook 14 G7 Specifications Table



Available Operating Systems	Chrome OS™
Processor family	Intel® Celeron® processor
Available Processors^{1,2}	Intel® Celeron® N4500 (up to 2.8 GHz burst frequency, 4 MB L3 cache, 2 cores); Intel® Celeron® N5100 (up to 2.80 GHz burst frequency, 4 MB L3 cache, 4 cores)
Maximum memory	8 GB LPDDR4X-4266 SDRAM Memory soldered down.
Internal storage	32 GB up to 64 GB eMMC 5.0 ³
Display size (diagonal, metric)	35.6 cm (14")
Display	35.6 cm (14") diagonal, FHD (1920 x 1080), IPS, anti-glare, 250 nits, 45% NTSC; 35.6 cm (14") diagonal, HD (1366 x 768), narrow bezel, anti-glare, 250 nits, 45% NTSC; 35.6 cm (14") diagonal, FHD (1920 x 1080), touch, IPS, anti-glare, 250 nits, 45% NTSC ^{6,7}
Available Graphics	Integrated: Intel® UHD Graphics ⁶
Audio	HD audio, dual speakers, dual array microphones
Wireless technologies	(HP Extended Range Wireless LAN, MU-MIMO and Chromecast support)
Expansion slots	1 microSD (Supports SD, SDHC, SDXC.)
Ports and Connectors	2 SuperSpeed USB Type-A 5Gbps signaling rate; 1 SuperSpeed USB Type-C® 5Gbps signaling rate (USB Power Delivery, DisplayPort™ 1.4); 1 headphone/microphone combo; 1 HDMI 1.4
Input devices	Spill-resistant, full-size, optional backlit, textured, flint silver Chrome keyboard ¹⁵ ; Clickpad with multi-touch gesture support, taps enabled as default;
Communications	Intel® Wi-Fi 6 AX201 (2x2) and Bluetooth® 5 combo, non-vPro®;
Camera	720p HD privacy camera ^{6,16}
Software	Chrome Education Upgrade (Sold separately); HP Classroom Manager (Sold separately) ^{9,10}
Security management	Nano Security lock slot; Google Titan C ¹¹
Fingerprint reader	Fingerprint reader not available
Power	HP Smart 45 W USB Type-C® adapter
Battery type	HP Long Life 2-cell, 47 Wh Li-Ion polymer ^{12,17}
Dimensions	32.65 x 22.7 x 1.83 cm
Weight	Starting at 1.54 kg (Weight will vary by configuration.)
Energy efficiency compliance	ENERGY STAR® certified; EPEAT® 2019 registered where applicable. EPEAT® registration varies by country. See www.epeat.net for registration status by country. ¹⁴
Sustainable Impact specifications	Low Halogen; Outside box and corrugated cushions are 100% sustainably sourced and recyclable ^{18,19}
Warranty	1 year (1-1-0) limited warranty and service offering includes 1 year of parts and labor. Terms and conditions vary by country. Certain restrictions and exclusions apply.

HP Chromebook 14 G7

Accessories and services (not included)

HP Prelude Backpack 15.6



Help keep your notebook safe and your hands free while you're on the move with the durable HP 15.6 Prelude Backpack, now with a pop of color from the stylish blue interior.
Product number: 1E7D6AA

HP Wireless Premium Mouse



Create a sleek, professional, clutter-free workspace and give yourself room to move around with the HP Wireless Premium Mouse, which integrates seamlessly with your HP notebook.
Product number: 1JR31AA

HP HDMI to VGA Adapter



The HP HDMI to VGA Adapter maximizes the display functionality of your HP Ultrabook™ or Notebook PC by converting the HDMI output signal to an analog VGA input for easy connecting to an external VGA display for dual-display productivity.
Product number: H4F02AA

HP 3 year Next Business Day Onsite Hardware Support for Notebooks



Receive 3 years of next business day onsite HW support from an HP-qualified technician for your computing device, if the issue cannot be solved remotely.
Product number: UQ992E

HP Chromebook 14 G7

Messaging Footnotes

- ¹ Multicore is designed to improve performance of certain software products. Not all customers or software applications will necessarily benefit from use of this technology. Performance and clock frequency will vary depending on application workload and your hardware and software configurations. Intel's numbering, branding and/or naming is not a measurement of higher performance.
- ² HP docks sold separately.
- ³ Up to 128GB is an optional feature that must be configured at purchase. For storage drives, GB = 1 billion bytes. Actual formatted capacity is less. Up to 8.1 GB is not user accessible.
- ⁴ Recharges the battery up to 90% within 90 minutes when the system is off or in standby mode, when used with the power adapter provided with the mobile thin client, and no external devices are connected. After charging has reached 90% capacity, charging speed will return to normal. Charging time may vary +/-10% due to System tolerance.
- ⁵ MIL-STD testing is not intended to demonstrate fitness for U.S. Department of Defense contract requirements or for military use. Test results are not a guarantee of future performance under these test conditions. Accidental damage requires an optional HP Accidental Damage Protection Care Pack.
- ⁶ The keyboards of the HP Education portfolio, including the HP Chromebook 14 G7, have been tested to 1,000 wipes to be cleaned with Windex® Original Glass & Surface Wipes and Clorox® Disinfecting Wipes with EPA Registration Number 5813-79. Do not use wipes on other surfaces of the product. See user guide for cleaning instructions.
- ⁷ Optional feature that must be configured at purchase.
- ⁸ HDMI and USB-C® cables sold separately.
- ⁹ Test results are not a guarantee of future performance under these test conditions. Accidental damage requires an optional HP Accidental Damage Protection Care Pack.
- ¹⁰ Wireless access point and Internet service required and sold separately. Availability of public wireless access points limited. Wi-Fi 6 (802.11ax) is backwards compatible with prior 802.11 specs. The specifications for Wi-Fi 6 are draft specifications and are not final. If the final specifications differ from the draft specifications, it may affect the ability of the notebook to communicate with other 802.11ax WLAN devices. Only available in countries where 802.11ax is supported.
- ¹¹ Multiple-Input Multiple-Output (MU-MIMO) is a wireless technology that uses multiple transmitters and receivers to enhance data transfer. MIMO requires a MU-MIMO router, sold separately.
- ¹² Based on internal testing vs. previous generation product with 802.11ac wireless LAN module.
- ¹³ Internet access required and sold separately. Some apps may require purchase.
- ¹⁴ See <https://support.google.com/chrome/a/answer/6220366?hl=en> for more information.

Technical Specifications Footnotes

- ¹ Multicore is designed to improve performance of certain software products. Not all customers or software applications will necessarily benefit from use of this technology. Performance and clock frequency will vary depending on application workload and your hardware and software configurations. Intel's numbering, branding and/or naming is not a measurement of higher performance.
- ² Processor speed denotes maximum performance mode; processors will run at lower speeds in battery optimization mode.
- ³ For storage drives, GB = 1 billion bytes. TB = 1 trillion bytes. Actual formatted capacity is less. Up to 30 GB (for Windows 10) is reserved for system recovery software.
- ⁴ Wireless access point and Internet service required and sold separately. Availability of public wireless access points limited. Wi-Fi 6 is backwards compatible with prior 802.11 specs. The specifications for Wi-Fi 6 (802.11ax) are draft and are not final. If the final specifications differ from the draft specifications, it may affect the ability of the notebook to communicate with other 802.11ax devices.
- ⁵ Chromecast must be purchased separately.
- ⁶ HD content required to view HD images.
- ⁷ Resolutions are dependent upon monitor capability, and resolution and color depth settings.
- ⁸ Based on internal testing vs. previous generation product with 802.11ac wireless LAN module.
- ⁹ HP Classroom Manager is sold separately. Control and device locking from the teacher's desktop requires purchase of HP Classroom Manager.
- ¹⁰ Chrome Education Upgrade requires one-time setup, subscription, Google Admin Console, and your organization's domain. Please see <https://support.google.com/a/answer/60216>.
- ¹¹ Lock is sold separately.
- ¹² Recharges up to 90% within 90 minutes when the system is off or in standby mode when used with the power adapter provided with the notebook. After charging has reached 90% capacity, charging will return to normal. Charging time may vary +/-10% due to System tolerance.
- ¹³ HP Care Packs are sold separately. Service levels and response times for HP Care Packs may vary depending on your geographic location. Service starts on date of hardware purchase. Restrictions and limitations apply. For details, visit www.hp.com/go/pc. HP services are governed by the applicable HP terms and conditions of service provided or indicated to Customer at the time of purchase. Customer may have additional statutory rights according to applicable local laws, and such rights are not in any way affected by the HP terms and conditions of service or the HP Limited Warranty provided with your HP Product.
- ¹⁴ Based on US EPEAT® registration according to IEEE 1680.1-2018 EPEAT®. Status varies by country. Visit www.epeat.net for more information.
- ¹⁵ Backlit keyboard is an optional feature.
- ¹⁶ 720p HD Privacy camera is optional and must be configured at purchase.
- ¹⁷ Actual battery Watt-hours (Wh) will vary from design capacity. Battery capacity will naturally decrease with shelf life, time, usage, environment, temperature, system configuration, loaded apps, features, power management settings and other factors.
- ¹⁸ External power supplies, power cords, cables and peripherals are not Low Halogen. Service parts obtained after purchase may not be Low Halogen.
- ¹⁹ 100% outer box packaging and corrugated cushions made from sustainably sourced certified and recycled fibers.

Sign up for updates hp.com/go/getupdated

© Copyright 2021 HP Development Company, L.P. The information contained herein is subject to change without notice. The only warranties for HP products are set forth in the express limited warranty statements accompanying such products. Nothing herein should be construed as constituting an additional warranty. HP shall not be liable for technical or editorial errors or omissions contained herein.

Intel, Celeron and Intel vPro are trademarks or registered trademarks of Intel Corporation or its subsidiaries in the United States and other countries. DisplayPort™ and the DisplayPort™ logo are trademarks owned by the Video Electronics Standards Association (VESA®) in the United States and other countries. USB Type-C® and USB-C® are registered trademarks of USB Implementers Forum. © 2020 Google LLC All rights reserved. Google and the Google Logo are registered trademarks of Google LLC.

March 2021





Riverside Technologies, Inc. (RTI)

Dedicated Team for:

Hickman County Schools

Todd Butters, Account Executive

Phone: 605-242-5028 Ext. 1427
Cell: 712-490-4910
tbutters@lrti.com

Bill Burke, Director of Sales - East

Phone: 605-242-5028 Ext. 1017
Cell: 712-223-0351
bburke@lrti.com

Tristen Morris, Customer Service Specialist

Phone: 866.804.4388 x1046
Fax: 866-812-5370
tmorris@lrti.com

Kevin Heiss, President

Phone: 605-242-5028 Ext. 1002
Cell: 712-490-9981
kevinh@lrti.com



www.RiversideTechnologies.com



866.804.4388



April 11, 2022

**HICKMAN COUNTY SCHOOL DISTRICT
115 MURPHREE AVE
CENTERVILLE, TN 37033-1443 US**

Attn: Purchasing

Account # 268635

Bid Number: CHROMEBOOK CHARGING CARTS

Due date: **04-18-2022, 10:30 AM**

School Specialty appreciates the opportunity to review your request for bid, however we are unable to respond at this time. We would, however, appreciate remaining on your bidders list for future opportunities.

Please use this email for future notifications: bidnotices@schoolspecialty.com

Thank you for your consideration.

Sincerely,

Sadie Baha

Sadie Baha

Letter of Transmittal

April 12, 2022

Hickman County School District
Attn: Finance Office
114 North Central Avenue, Suite 203
Centerville, TN 37033

RE: Chromebook Charging Carts

Dear: Hickman County School District:

Howard Technology Solutions (a division of Howard Industries, Inc...**Federal ID Number 64-0466143** and SPIN 143022153) (Corporation) is pleased to offer a response to your RFP. Howard Technology Solutions has read and understands the bid and are able to provide the services requested. Howard Technology Solutions, with its 40+ years of manufacturing experience, is well versed in the manufacturing and production of technology products and services.

Howard Technology Solutions, a division of Howard Industries, Inc., was established in 1998 with our parent company being founded in 1968. Howard Technology Solutions currently employs approximately 4,531 employees. Howard Technology Solutions is driven by helping our customers understand technology products and services that could benefit their organizations.

HOWARDedu focuses solely on the needs of K-12 schools and higher education facilities, supplying them with affordable, advanced technology—everything from distance learning and interactive 21st Century classroom products to network security and storage solutions.

Howard Technology Solutions has the ability to meet all requirements of this RFP.

The office location that will serve as the main point of contact is Howard Technology Solutions at 36 Howard Dr., Ellisville, MS 39437. (Phone) 601.425.3181; (Email) bids@howardcomputers.com. Your point of contact for this RFP is: Brandey Boyd: Bids & Contract Manager, (Phone) 601.399.5831 (Fax) 601.399.5077 (Email) bboyd@howard.com.

36 Howard Drive • Ellisville, MS 39437
P.O. Box 1590 • Laurel, MS 39441

HOWARDTM
TECHNOLOGY SOLUTIONS

888.912.3151 general • 601.399.5077 fax
888.323.3151 technical support

www.Howard.com

A Division of Howard Industries, Inc.

TN K-12 Inside Sales Rep

Chris Hamm
601-399-5763
chamm@howard.com

TN K-12 Account Manager

Trey Skelton
615-762-6401
tskelton@howard.com

Sincerely,



Michelle Brady
Bid Specialist
Phone: 601.425.3181 Ext: 5772
Fax: 601.399.5077
Email: bids@howardcomputers.com

Invitation To Bid

The Hickman County Finance Office is accepting sealed bids for Chromebook Charging Carts for Hickman County Schools.

Additional specifications can be found at: www.hickmank12.org/request-for-proposal.

All bidders will be required to submit a conflict of interest disclosure form that can also be found at: www.hickmank12.org/request-for-proposal.

Sealed bids must be mailed or delivered to the Hickman County Finance Office, 114 North Central Avenue, Suite 203, Centerville, TN 37033 and clearly marked on the outside of the bid envelope "Chromebook Charging Carts". Bids will be opened on Monday, April 18th, 2022 at 10:30 A.M. in the Finance Office.

The Hickman County School District reserves the right to reject any and or all bids or proposals and to waive any informalities, which in the opinion of the school system, would prevent the acceptance of a better bid.

PART B SPECS

Carts must have the ability to be moved in the schools with locking wheels preferred.

Carts must include the ability to be locked for security purposes.

Carts must have the ability to charge chromebooks while in storage.

Carts must have the ability to hold chromebooks with a 14 inch screen with the door shut properly.

Vendor can choose to bid on one or all of the following sized carts:

1. 25 slot
2. 30 slot
3. 36 slot

Vendor can choose to price according to the amount of chromebook carts purchased. No set amount of carts to purchase is decided at this time.

Any questions can be directed via email to brad.gilbert@hickmank12.org.

Hickman County Government

Conflict of Interest Disclosure Form

The County Financial Management System of 1981 contains the most stringent conflict of interest provisions. TCA §5-21-121 provides:

- (a) The director, purchasing agent, members of the committee, members of the county legislative body or other officials, employees, or members of the board of education or highway commission shall not be financially interested or have any personal beneficial interest, either directly or indirectly, in the purchase of any supplies, materials, equipment or contractual services for the county.
- (b) No firm, corporation, partnership, association or individual furnishing any such supplies, materials, equipment or contractual services, shall give or offer, nor shall the director or purchasing agent or any assistant or employee accept or receive directly or indirectly from any person, firm, corporation, partnership or association to whom any contract may be awarded, by rebate, gift or other otherwise, any money or other things of value whatsoever, or any promise, obligation or contract for future reward or compensation.

Date: 4-10-02 Name: Michelle Brady

Howard Technology Solutions
a division of Howard Industries, Inc.

Please describe below any relationships, transactions, positions you hold (volunteer or otherwise), or circumstances that you believe could contribute to a conflict of interest:

I have no conflict of interest to report.

I have the following conflict of interest to report (please specify any boards or committees you (and/or your spouse) sit on, the name of your employer and any businesses you or your spouse may own.

I hereby certify that the information set forth above is true and complete to the best of my knowledge.

Date: 4-10-02 Signature: Michelle Brady

Phone: 1.888.912.3151
 Fax: 1.601.399.5077
 Online: www.howardcomputers.com



Howard Computers
 P.O. Box 1588
 Laurel, MS 39441

Online Quotation

Quote No:	CH5 1197429.00	Quote Date:	April 11, 2022
Customer Name:	Brad Gilbert	Phone Number:	9317293391
Company Name:	Hickman County Schools	Fax Number:	
Quote Name:	Chromebook Charging Cart RFP - AC-PLUS		

Item 1

Category	Description	Qty.	Unit Price	Ext. Price
System Type: 1:	Accessories AC-PLUS 36 Bay Secure Cycle Charging Cart • UL Certification 60950-1 • 15 Minute Cycle Timer • Full Metal Construction • Rounded Top Corners • 3-point Locking Door w/ Padlock Loop • Removable Device Dividers • Integrated Cable Management w/ Cable Clips • Removable AC Adapter Baskets • 4" Swivel / Directional / Lock Casters • Ships Fully Assembled • Lifetime Frame Warranty	1	\$1,050.00	\$1,050.00
			Sub-Total:	\$1,050.00
			Shipping & Handling :	\$150.00
			Taxes:	Tax Exempt
			Total for Item 1:	\$1,200.00

This quote will expire May 11, 2022.
 To expedite your order, please include your quote number with your Purchase Order.

Total for all pre-configured items

Sub-Total:	\$1,050.00
Shipping & Handling :	\$150.00
Taxes:	Tax Exempt
Total:	\$1,200.00

Notes:

Free Dock - Dock Shipping. Lift Gate Service Requested (Fee \$150 Per Truck Shipment to Single Delivery Location).
 If shipping to multiple locations, Lift Gate fee applicable per location.

Pricing and availability subject to change without notice. Packaging, Shipping, and Handling fees are not included unless specifically stated. Prices and lease payments do not include applicable taxes. Ship dates are approximations and are not guarantees. Quick ship items not available in Alaska, Hawaii, or outside the United States. Specific state laws may affect shipment of products.

Any order for kiosks must be canceled prior to 21 days from the scheduled date of shipment to avoid incurring a 50% cancellation fee. Any cancellation made within that 21-day window will automatically incur a charge equivalent to 50% of the total kiosk order being canceled.

Howard reserves the right to charge a 25% restocking fee for cancellation of a purchase order after Howard has commenced fulfillment of the order. Howard may, with notice, cancel any purchase order at any time without any liability to the Purchaser. Howard reserves the right to charge the Purchaser full purchase price for delaying shipment of a purchase order for an extended period of time which then results in the cancellation of said order.

Given the current uncertainties related to international trade, Howard hereby reserves the right to unilaterally revise the prices quoted herein in the event its manufacturing or procurement costs for such goods increase due to the imposition by the United States or any other country of new or higher tariff(s) or of any other similar tax, fee or charge.

If Purchaser fails to pay any invoice in full within the time quoted herein, Howard may, without notice, accelerate the due date of all outstanding invoices and require that all outstanding invoices, including any interest thereon, be immediately due and payable in full.

Howard's product warranties and return policies and related information, which are available at <https://www.howardcomputers.com/support/warranties.cfm> and <https://www.howardcomputers.com/support/returnpolicy.cfm>, are fully adopted and incorporated herein by reference. These may also be obtained by calling 1-888-912-3151 or emailing webmaster@howardcomputers.com.

THIS QUOTATION IS EXPRESSLY LIMITED TO, AND EXPRESSLY MADE CONDITIONAL ON, PURCHASER'S ACCEPTANCE OF THE TERMS SET FORTH OR INCORPORATED HEREIN; HOWARD OBJECTS TO ANY DIFFERENT OR ADDITIONAL TERMS.

Phone: 1.888.912.3151
 Fax: 1.601.399.5077
 Online: www.howardcomputers.com



Howard Computers
 P.O. Box 1588
 Laurel, MS 39441

Online Quotation

Quote No: CH5 1197440.00
Customer Name: Brad Gilbert
Company Name: Hickman County Schools
Quote Name: Chromebook Charging Cart RFP - AC-30

Quote Date: April 11, 2022
Phone Number: 9317293391
Fax Number:

Item 1

Category	Description	Qty.	Unit Price	Ext. Price
System Type: 1:	Accessories AC-30 Configurable 30 Bay Charging Cart • Full Metal Construction • 3-point Locking Door w/ Padlock Loop • Removable Device Dividers • Integrated Cable Management w/ Cable Clips • Numbered Shelf Strips • Basic Charging with 2 Power Cords • Removable AC Adapter Baskets • 4" Swivel / Directional / Lock Casters • Ships Fully Assembled (except handle) • Lifetime Frame Warranty	1	\$740.00	\$740.00
Sub-Total:				\$740.00
Shipping & Handling :				\$150.00
Taxes:				Tax Exempt
Total for Item 1:				\$890.00

This quote will expire May 11, 2022.
 To expedite your order, please include your quote number with your Purchase Order.

Total for all pre-configured items

Sub-Total:	\$740.00
Shipping & Handling :	\$150.00
Taxes:	Tax Exempt
Total:	\$890.00

Notes:

Free Dock - Dock Shipping. Lift Gate Service Requested (Fee \$150 Per Truck Shipment to Single Delivery Location).
 If shipping to multiple locations, Lift Gate fee applicable per location.

Pricing and availability subject to change without notice. Packaging, Shipping, and Handling fees are not included unless specifically stated. Prices and lease payments do not include applicable taxes. Ship dates are approximations and are not guarantees. Quick ship items not available in Alaska, Hawaii, or outside the United States. Specific state laws may affect shipment of products.

Any order for kiosks must be canceled prior to 21 days from the scheduled date of shipment to avoid incurring a 50% cancellation fee. Any cancellation made within that 21-day window will automatically incur a charge equivalent to 50% of the total kiosk order being canceled.

Howard reserves the right to charge a 25% restocking fee for cancellation of a purchase order after Howard has commenced fulfillment of the order. Howard may, with notice, cancel any purchase order at any time without any liability to the Purchaser. Howard reserves the right to charge the Purchaser full purchase price for delaying shipment of a purchase order for an extended period of time which then results in the cancellation of said order.

Given the current uncertainties related to international trade, Howard hereby reserves the right to unilaterally revise the prices quoted herein in the event its manufacturing or procurement costs for such goods increase due to the imposition by the United States or any other country of new or higher tariff(s) or of any other similar tax, fee or charge.

If Purchaser fails to pay any invoice in full within the time quoted herein, Howard may, without notice, accelerate the due date of all outstanding invoices and require that all outstanding invoices, including any interest thereon, be immediately due and payable in full.

Howard's product warranties and return policies and related information, which are available at <https://www.howardcomputers.com/support/warranties.cfm> and <https://www.howardcomputers.com/support/returnpolicy.cfm>, are fully adopted and incorporated herein by reference. These may also be obtained by calling 1-888-912-3151 or emailing webmaster@howardcomputers.com.

THIS QUOTATION IS EXPRESSLY LIMITED TO, AND EXPRESSLY MADE CONDITIONAL ON, PURCHASER'S ACCEPTANCE OF THE TERMS SET FORTH OR INCORPORATED HEREIN; HOWARD OBJECTS TO ANY DIFFERENT OR ADDITIONAL TERMS.



AC-PLUS

Designed to charge, store and transport up to 36 Chromebooks, Laptops or Tablets up to 14 inches

36 Bay Secure Cycle Charging Cart



36 Devices



Cycle Charging



Secure

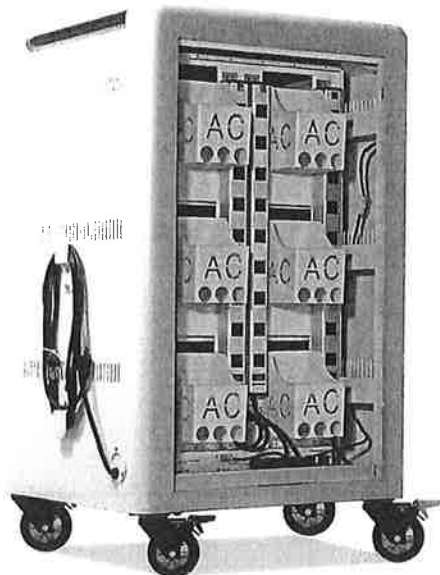

- UL Certification 60950-1
- 15 Minute Cycle Timer
- Full Metal Construction
- Rounded Top Corners
- 3-point Locking Door w/ Padlock Loop
- Removable Device Dividers
- Integrated Cable Management w/ Cable Clips
- Removable AC Adapter Baskets
- 4" Swivel / Directional / Lock Casters
- Ships Fully Assembled
- Lifetime Frame Warranty

DIMENSIONS

Height: 44.3"
Width: 25.5"
Depth: 23.7"

CART CAPACITY

Divider Spacing: 1.18"
Shelf Depth: 14.25"
Shelf Height: 10.5"

WEIGHT

Product Weight: 160 lbs.
Shipping Weight: 200 lbs.

Specifications subject to change without notice.
8320



AC-30

Designed to charge, store
and transport 15 to 30
Chromebooks
or Tablets

Configurable 30 Bay Charging Cart



30 Devices



Basic Charging



Secure

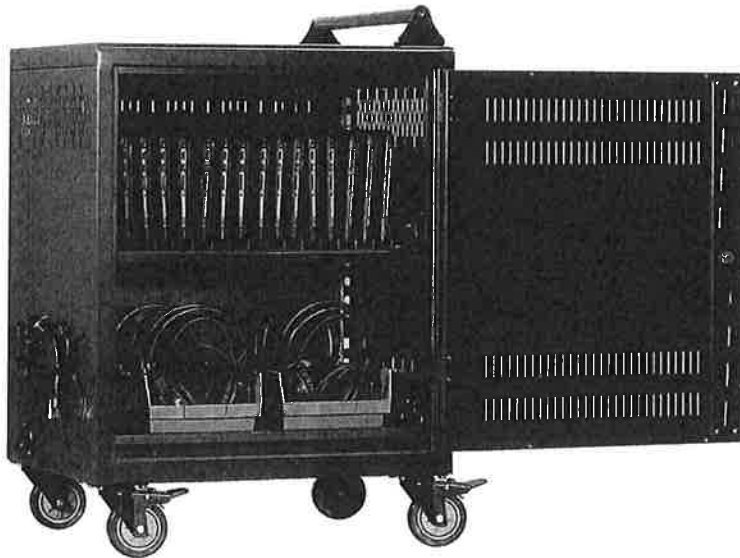
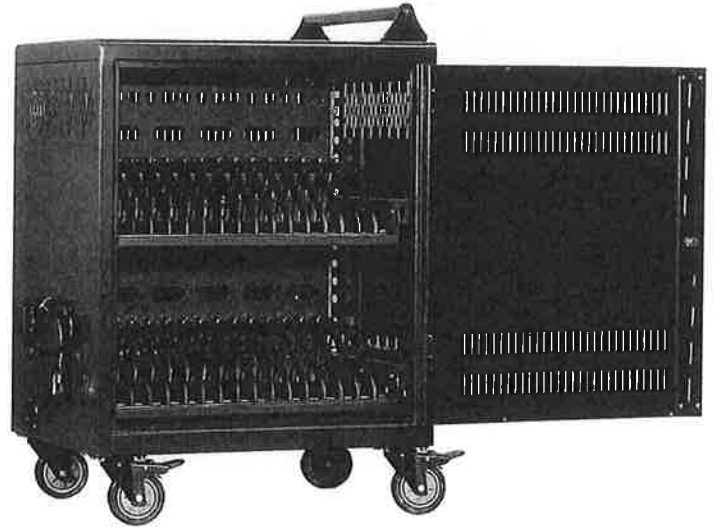

- Full Metal Construction
- 3-point Locking Door w/ Padlock Loop
- Removable Device Dividers
- Integrated Cable Management w/ Cable Clips
- Numbered Shelf Strips
- Basic Charging with 2 Power Cords
- Removable AC Adapter Baskets
- 4" Swivel / Directional / Lock Casters
- Ships Fully Assembled (except handle)
- Lifetime Frame Warranty

DIMENSIONS

Height: 34.8"
Width: 26"
Depth: 20"

CART CAPACITY

Divider Spacing: 1"
Shelf Depth: 14.5"
Shelf Height: 11.5"

WEIGHT

Product Weight: 98 lbs.
Shipping Weight: 114 lbs.

Specifications subject to change without notice.
81420

Invitation To Bid

The Hickman County Finance Office is accepting sealed bids for "School Security Camera Systems".

Specifications can be found on-line at: www.hickmank12.org/request-for-proposal.

All bidders will be required to submit a conflict of interest disclosure form that can also be obtained at: www.hickmank12.org/request-for-proposal.

Sealed Bids must be mailed or hand delivered to the Hickman County Finance Office, 114 North Central Avenue, Suite 203, Centerville, TN 37033 and clearly marked on the outside of the envelope "School Security Camera Systems". Bids will be opened on April 25th, 2022 at 10:30 a.m. in the Finance Office

The Hickman County Board of Education reserves the right to accept or reject any and all bids or parts of bids and waive any informalities that would prevent the acceptance of a better bid.

Present *Renny Mayberry*
Misty Weaver

Bluegrass Computer Systems
HCHS 10,700.00

Invitation To Bid

The Hickman County Finance Office is accepting sealed bids for "School Security Camera Systems".

Specifications can be found on-line at: www.hickmank12.org/request-for-proposal.

All bidders will be required to submit a conflict of interest disclosure form that can also be obtained at: www.hickmank12.org/request-for-proposal.

Sealed Bids must be mailed or hand delivered to the Hickman County Finance Office, 114 North Central Avenue, Suite 203, Centerville, TN 37033 and clearly marked on the outside of the envelope "School Security Camera Systems". Bids will be opened on April 25th, 2022 at 10:30 a.m. in the Finance Office

The Hickman County Board of Education reserves the right to accept or reject any and all bids or parts of bids and waive any informalities that would prevent the acceptance of a better bid.

Hickman County Government

Conflict of Interest Disclosure Form

The County Financial Management System of 1981 contains the most stringent conflict of interest provisions. TCA §5-21-121 provides:

- (a) The director, purchasing agent, members of the committee, members of the county legislative body or other officials, employees, or members of the board of education or highway commission shall not be financially interested or have any personal beneficial interest, either directly or indirectly, in the purchase of any supplies, materials, equipment or contractual services for the county.
- (b) No firm, corporation, partnership, association or individual furnishing any such supplies, materials, equipment or contractual services, shall give or offer, nor shall the director or purchasing agent or any assistant or employee accept or receive directly or indirectly from any person, firm, corporation, partnership or association to whom any contract may be awarded, by rebate, gift or otherwise, any money or other things of value whatsoever, or any promise, obligation or contract for future reward or compensation.

Date: 04/19/22 Name: Philip Draude

Please describe below any relationships, transactions, positions you hold (volunteer or otherwise), or circumstances that you believe could contribute to a conflict of interest:

I have no conflict of interest to report.

I have the following conflict of interest to report (please specify any boards or committees you (and/or your spouse) sit on, the name of your employer and any businesses you or your spouse may own.

I hereby certify that the information set forth above is true and complete to the best of my knowledge.

Date: 04/19/22 Signature: 



Scope of Work

ATTENTION:
Hickman County School District
Brad Gilbert

FROM:
Bluegrass Computer Systems, LLC
174 Saundersville Road, Suite 501
Hendersonville, TN 37075

SUBJECT:
School Security Camera Systems

Specifications/Scope of Work

- 1) Bluegrass Computer Systems acknowledges the goal of providing visualization of persons inside all school building hallways, office areas, and main entry points of Hickman County High School. And to provide visual coverage of areas currently not covered.
 - a. These points include outdoor visualization of driveway entry and exit points as well as parking for all facilities.
 - b. BCS will utilize Axis Communications Video Management System to integrate Axis cameras.

School Security Camera Systems - Hickman County Schools

Bid Form and Specifications/Scope of Work

The following Bid Form and Specifications/Scope of Work are to be used to submit bids by school.

Complete Pricing on this FORM and return with BID:

Camera Types: (cost should include any related licensing)
(All cameras must be network capable)

Camera Type	Price	Licensing
Single HD Dome Camera:	\$319	\$79
Multi-position HD Camera: (minimum of 4 views)	\$1349	\$79
HD PTZ Camera:	\$999	\$79
HD Bullet:	\$599	\$79
POE Mini Switch	\$450	

Installation and all related materials

School	Installation Cost (including all related materials)	Other related Cost (please provide specifics on a separate sheet)
Hickman County High School	\$10,700	

SPECIFICATIONS/SCOPE OF WORK

Bid can be awarded for individual schools or multiple schools

1 -- Scope of Work

1.1 Provide visualization of persons inside all school building hallways, office areas, and main entry points of the following schools: Hickman County High School. Minimum camera requirements are HD 1080p or comparable specifications. District goal is clear visualization for areas where current cameras do not provide adequate coverage.

1.2 Provide visualization of driveway entry and exit points as well as parking for all facilities as funds allow. District goal is to capture vehicle description and/or identification criteria such as license plates.

1.3 Appropriate VMS and storage should be included for each school facility, with storage located at the central office. Minimum storage capacity requirements are 30 days of storage. Accessible cloud base storage is acceptable.

1.4 Appropriate video management system (VMS) compatible with Axis Camera Station. **VMS must be network capable.**

1.5 If applicable provide VMS certification along with expiration date.

2 -- Maps and Layouts of Existing Facilities

2.1 Appointments for a walkthrough can be made by contacting Brad Gilbert at brad.gilbert@hickmank12.org. Attending a walkthrough is not mandatory. A school map of the current camera locations can be provided by request at the e-mail address above.

2.2 Any system procured and installed during the course of this contract must be in compliance with all material elements of the specifications. Any changes to must be approved by HCS and documented in writing.

2.3 Map Notes - Maps provided under this RFP are not guaranteed for scale and only provide representation for bidding purposes. Maps are not guaranteed for 100 percent accuracy as there may have been minor alterations to some facilities that may or may not affect work.

3 -- Service and Support

Proposer shall include with response a detailed explanation of all material elements regarding service and support elements of this contract including, but not limited to:

- a) VMS - Please discuss service levels for software systems including response time, escalation procedures, and preventative problem identification capabilities.
- b) Protocol and Price for Upgrades and/or Updates
- c) All Licensing Considerations
- d) All initial fees and annual subscription costs
- e) System Troubleshooting Assistance and Protocol for Rest of System including Cameras, Servers, ancillary systems.

4 -- Installation

Please discuss all pertinent elements and methodologies of installation including but not limited to:

- a) Pre-planning
- b) Sourcing/Product Acquisition
- c) Delivery/Set-up/Storage/Security
- d) Installation
- i) Schedule - Please include your understanding of working in occupied K-12 space, school hours, administration support and partnership, safety, clean-up, and potential schedule. System "Start-up", Testing, and Quality Control
- ii) All work should be completed after school hours of operation or during school breaks
- iii) Inventory list of cameras and other equipment required in an excel format. File layout to be provided at a later time.

All work and camera installs are expected to be completed by June 30th, 2022.

CONTRACTOR QUALIFICATIONS

Contractor shall submit a statement pertaining to the labor/staff that will be utilized in the performance of this contract. This statement should include experience, qualifications, training, etc.

- Tennessee State Contractor License is required
- VMS Certification - If applicable, be sure to identify which staff member(s), who will be assigned to this specific project, are certified.
- Single Point of Contact - Please identify and detail qualifications of the Single Point of Contact from your company for this contract. While HCS may interact with multiple layers of staff, contractor must provide one point of accountability for all material aspects of the contract include installation, warranty, service, etc.

Sub - Contractor

Proposer shall disclose proposed use of contract labor in relation to labor performed by company staff. If contracted labor will be used, the proposer shall detail process for acquisition, vetting, supervision, and management during length of engagement. Proposer shall also certify the warranty and back all work performed by any sub-contracted labor and to be responsible for all communication as single point of contact.

Permits - If applicable, the Contractor will be required to be in compliance with all Federal, State, City, and local laws, rules and regulations and shall be responsible for all coordination and cost associated with license(s), permits, etc.

April 12, 2022

CERTIFIED MAIL

Hickman County School System
115 Murphree Avenue
Centerville, Tennessee 37033

Dear Administrator:

This letter contains important information about your accreditation with Cognia™, expiring June 30, 2022. As you may know, AdvancED and Measured Progress are now Cognia. Cognia has made multiple attempts over the past year to contact you to schedule your reaccreditation process to maintain your accreditation status. We have thus far been unable to make contact.

To maintain your institution accreditation in accordance with *Cognia Accreditation and Certification Policies and Procedures*, you will need to provide the following information in your accreditation workspace in the Cognia Improvement Platform (<https://myjourney.cognia.org/login>) **by May 16, 2022**:

1. Performance standards worksheet with narratives and ratings
2. Evidence supporting your performance standards ratings, via direct upload into workspace or shared in a cloud storage solution such as Google Drive
3. Assurances diagnostic (found in the Diagnostics module in the Cognia Improvement Platform)

Cognia will then conduct a reaccreditation review using your submitted materials. You will be assessed the Engagement Review Fee at the time of the review. Should you fail to provide the required information by the specified time, we will be forced to drop your accreditation as of June 30, 2022, due to violation of Policy II, 2.03 and 2.04.e:

2.03 General Requirements. In order to achieve and maintain Cognia accreditation or certification, an institution or system must: a. Maintain membership in Cognia; b. Adhere to Cognia policies, Standards, and Assurances for accreditation and/or certification; c. Submit all required reports and demographic updates within prescribed timeframes; and d. Pay all required fees within prescribed timeframes.

2.04 Accreditation Requirements. In addition to the general requirements, and in order to achieve and maintain accreditation, an institution or system must: ... e. Host an Engagement Review within a timeframe established by the Cognia Accreditation Office after achieving the status of candidate and **at least once every five years thereafter.** (*emphasis added*)

Cognia is available to answer any questions you might have regarding this information and may be reached at +1.678.392.2285 or by contacting your local Cognia office by finding your local contact at <https://www.cognia.org/find-your-local-contact/>.

Sincerely,

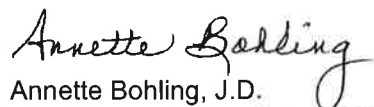

Annette Bohling, J.D.
Chief Global Accreditation Officer

HICKMAN COUNTY SCHOOLS
 FY 2023 - BUDGET SPREADSHEET

PGM	OBJ	CC	Description	FY 2020		FY 2021		FY 2022		FY 2023	
				YTD Actual	Total Budget	YTD Actual	Total Budget	YTD Actual	Projected Budget	Inc/(Dec)	
			Non-Personnel	6,127,006	(25,504,519)	6,185,706	(7,581,056)	3,900,268	9,478,416	1,897,360	824,782
			Total	28,852,216	(33,085,575)	28,452,038	(33,085,575)	20,243,212	35,807,717	2,722,142	318,459
71100			Regular Instruction Program	13,334,564	(14,601,004)	12,821,809	(14,601,004)	10,513,727	14,919,463	318,459	318,459
71150			Alternative Instruction Program	164,805	(180,671)	125,989	(180,671)	118,711	238,087	57,416	57,416
71200			Special Education Program	2,856,440	(3,194,103)	2,901,221	(3,194,103)	1,658,613	3,329,017	134,914	134,914
71300			Career and Technical Education Program	986,370	(1,260,256)	993,219	(1,260,256)	596,205	1,179,844	(80,412)	(80,412)
72110			Attendance	139,581	(174,970)	150,494	(174,970)	56,849	174,519	(451)	(451)
72120			Health Services	331,562	(386,008)	360,259	(386,008)	242,049	422,721	36,713	36,713
72130			Other Student Support	864,327	(1,020,144)	943,086	(1,020,144)	561,026	1,055,414	35,270	35,270
72210			Regular Instruction Program	1,151,499	(1,347,034)	1,217,771	(1,347,034)	681,264	1,421,957	74,923	74,923
72220			Special Education Program	112,741	(121,505)	108,706	(121,505)	65,604	125,050	3,545	3,545
72230			Career and Technical Education Program	98,706	(112,411)	104,098	(112,411)	77,534	114,679	2,268	2,268
72250			Technology	248,776	(339,567)	310,198	(339,567)	262,273	511,826	172,259	172,259
72290			Other Programs	-	(35,000)	16,404	(35,000)	19,011	35,000	-	-
72310			Board Of Education	452,705	(669,913)	434,717	(669,913)	413,716	684,913	15,000	15,000
72320			Director Of Schools	269,583	(292,764)	273,434	(292,764)	195,232	303,453	10,689	10,689
72410			Office Of The Principal	1,517,238	(1,853,785)	1,494,826	(1,853,785)	990,504	1,923,818	70,033	70,033
72510			Fiscal Services	42,235	(45,000)	43,306	(45,000)	45,000	50,000	5,000	5,000
72610			Operation Of Plant	1,871,463	(2,380,500)	1,986,947	(2,380,500)	1,567,580	2,433,500	53,000	53,000
72620			Maintenance Of Plant	972,960	(1,185,022)	989,995	(1,185,022)	567,655	1,424,070	239,048	239,048
72710			Transportation	2,189,181	(2,372,457)	1,987,016	(2,372,457)	1,403,257	2,584,422	211,965	211,965
72810			Central And Other	186,793	(257,500)	188,964	(257,500)	28,201	257,883	383	383
73100			Food Service	27,504	(35,604)	27,249	(35,604)	-	38,571	2,967	2,967
73300			Community Services	125,256	(132,316)	125,582	(132,316)	70,319	143,813	11,497	11,497
73400			Early Childhood Education	428,079	(473,041)	434,174	(473,041)	194,891	494,197	21,156	21,156
76100			Regular Capital Outlay	314,245	(450,000)	249,291	(450,000)	(249,291)	1,779,000	1,329,000	1,329,000
99100			Transfers Out	165,602	(165,000)	163,284	(165,000)	163,284	165,000	-	-
			Total	\$ 28,852,216	\$ (33,085,575)	\$ 28,452,038	\$ (33,085,575)	\$ 20,243,212	\$ 35,810,217	\$ 2,724,642	\$ 2,724,642

HICKMAN COUNTY SCHOOLS
 FY 2023 - BUDGET SPREADSHEET
 71100 - Regular Instruction Program

PGM	OBJ	CC	Description	FY 2020		FY 2021		FY 2022		FY 2023	
				YTD Actual	YTD Actual	YTD Actual	Total Budget	YTD Actual	Projected Budget	Incl/(Dec)	
			Personnel	12,819,617	12,257,005	(14,168,004)	10,355,590	14,534,327	366,323		
			Non-Personnel	514,947	564,804	(433,000)	158,137	436,000	3,000		
			Total	13,334,564	12,821,809	(14,601,004)	10,513,727	14,970,327	369,323		
71100	116		Teachers	8,250,561	8,463,690	(9,505,579)	6,185,278	9,840,000	334,421		
71100	117		Career Ladder Program	48,000	45,000	(50,000)	22,500	50,000	-		
71100	128		Homebound Teachers	-	-	(12,000)	-	12,000	-		
71100	140		Salary Supplements	282,065	303,545	(319,317)	180,936	382,852	63,535		
71100	163		Educational Assistants	352,425	333,710	(300,000)	234,598	324,240	24,240		
71100	188		Bonus Payments	368,202	-	-	-	-	-		
71100	189		Other Salaries & Wages	106,309	37,843	(150,000)	84,925	162,120	12,120		
71100	189	DP	Other Salaries & Wages	242,744	68,550	(250,000)	253,733	250,000	-		
71100	198		Non-Certified Subs	134,993	113,024	(150,000)	127,552	185,000	35,000		
71100	201		Social Security	701,546	681,440	(802,248)	498,521	838,150	35,902		
71100	201	DP	Social Security	18,184	5,139	(19,125)	18,985	19,125	-		
71100	204		State Retirement	870,696	725,288	(1,167,735)	1,196,405	1,000,000	(167,735)		
71100	207		Medical Insurance	1,377,832	1,395,542	(1,442,000)	1,552,157	1,470,840	28,840		
71100	217		Retirement - Hybrid	66,060	84,234	-	-	-	-		
71100	336		Maintenance And Repair - Equipment	4,000	8,000	(16,000)	-	16,000	-		
71100	399		Other Contracted Services	32,500	59,938	(85,000)	50,747	85,000	-		
71100	429		Instructional Supplies And	101,103	97,597	(122,000)	82,816	125,000	3,000		
71100	449		Textbooks	277,932	355,290	(100,000)	17,069	100,000	-		
71100	499		Other Supplies And Materials	9,086	7,979	(10,000)	7,505	10,000	-		
71100	722		Regular Instruction	90,326	36,000	(100,000)	-	100,000	-		
			Total	\$ 13,334,564	\$ 12,821,809	\$ (14,601,004)	\$ 10,513,727	\$ 14,970,327	\$ 369,323		

BUDGET REQUEST NARRATIVE

PGM	OBJ	DESCRIPTION
71100	140	Proposed increases in Sports Supplements total \$47,250
71100	204	Reduction in Legacy Retirement contribution from 10.3% to 8.69%
71100	217	Calculated at Year End

HICKMAN COUNTY SCHOOLS
 FY 2023 - BUDGET SPREADSHEET
 71150 - Alternative Instruction Program

PGM	OBJ	CC	Description	FY 2020 YTD Actual	FY 2021 YTD Actual	Total Budget	FY 2022 YTD Actual	FY 2023 Projected Budget	Inc./(Dec)
			Personnel	164,247	125,564	(179,171)	117,826	233,087	53,916
			Non-Personnel	559	425	(1,500)	885	2,500	1,000
			Total	164,805	125,989	(180,671)	118,711	235,587	54,916
71150	116		Teachers	98,200	70,817	(112,000)	97,999	150,000	38,000
71150	163		Educational Assistants	17,830	17,982	(19,000)	12,247	20,535	1,535
71150	188		Bonus Payments	9,100					
71150	201		Social Security	9,159	5,565	(10,022)	7,580	13,046	3,024
71150	204		State Retirement	13,014	13,620	(14,449)		17,906	3,457
71150	207		Medical Insurance	16,944	17,580	(23,700)		31,600	7,900
71150	355		Travel					2,500	2,500
71150	399		Other Contracted Services						
71150	429		Instructional Supplies	206		(500)		1,000	500
71150	499		Other Supplies	353	425	(1,000)	885	1,500	500
71150	Total			164,805	125,989	(180,671)	118,711	238,087	57,416

BUDGET REQUEST NARRATIVE

PGM	OBJ	DESCRIPTION
71150	116	
71150	163	
71150	188	
71150	201	
71150	204	
71150	207	
71150	399	
71150	429	
71150	499	

HICKMAN COUNTY SCHOOLS
 FY 2023 - BUDGET SPREADSHEET
 71200 - Special Education Program

PGM	OBJ	CC	Description	FY 2020 YTD Actual	FY 2021 YTD Actual	FY 2022 Total Budget	FY 2022 YTD Actual	Projected Budget	Inc/(Dec)
			Personnel	2,661,203	2,720,876	(2,969,103)	1,552,718	3,089,017	119,914
			Non-Personnel	195,237	180,346	(225,000)	105,895	240,000	15,000
			Total	2,856,440	2,901,221	(3,194,103)	1,658,613	3,329,017	134,914
71200	116		Teachers	1,427,939	1,524,603	(1,625,000)	1,096,687	1,695,000	70,000
71200	124		Physiological Personnel	59,478	62,790	(64,000)	42,964	68,000	4,000
71200	128		Homebound Teachers	28,031	24,263	(23,000)	939	24,175	1,175
71200	163		Educational Assistants	212,304	229,074	(317,143)	192,948	342,768	25,625
71200	171		Speech Pathologist	187,456	186,945	(214,878)	113,702	225,858	10,980
71200	188		Bonus Payments	78,800					
71200	201		Social Security	142,325	148,680	(171,668)	105,477	180,219	8,551
71200	204		State Retirement	217,004	227,122	(223,814)		216,805	(7,009)
71200	207		Medical Insurance	307,866	317,398	(329,600)		336,192	6,592
71200	399		Other Contracted Services	195,237	180,346	(225,000)	105,895	240,000	15,000
71200			Total Expenditures	2,856,440	2,901,221	(3,194,103)	1,658,613	3,329,017	134,914

BUDGET REQUEST NARRATIVE

DESCRIPTION

34 Positions

anticipated increase in cost of services based on current inflation and additional needed services

HICKMAN COUNTY SCHOOLS
 FY 2023 - BUDGET SPREADSHEET
 71300 - Career and Technical Education Program

PGM	OBJ	CC	Description	FY 2020 YTD Actual	FY 2021 YTD Actual	FY 2022 Total Budget	FY 2022 YTD Actual	Projected Budget	Inc./Dec)
			Personnel	906,481	950,552	(1,048,256)	528,108	1,039,844	(8,412)
			Non-Personnel	79,889	42,667	(212,000)	68,097	140,000	(72,000)
			Total	986,370	993,219	(1,260,256)	596,205	1,179,844	(80,412)
71300	116		Teachers	636,053	697,470	(770,000)	476,882	770,000	
71300	140		Salary	12,000	12,000	(12,000)	6,000	12,000	
71300	188		Bonus Payments	33,600					
71300	198		Non-Certified Subs	13,342	12,608	(15,000)	8,608	20,000	5,000
71300	201		Social Security	51,309	54,020	(60,971)	36,618	61,353	382
71300	204		State Retirement	76,556	80,126	(86,255)		70,380	(15,875)
71300	207		Medical	83,620	94,328	(104,030)		106,111	2,081
71300	399		Other Contracted Services	7,111	14,810	(15,000)	10,720	15,000	
71300	449		Textbooks			(100,000)	2,318	75,000	(25,000)
71300	429		Instructional						
71300	429	SS	Instructional	2,992					
71300	499		Other Supplies	13,071	12,797	(15,000)	14,763	20,000	5,000
71300	499	SS	Other Supplies			(23,000)	13,106		(23,000)
71300	599	SS				(500)			(500)
71300	730		Vocational	19,716	15,060	(32,000)	1,569	30,000	(2,000)
71300	730	SS	Vocational	37,000		(26,500)	25,621		(26,500)
71300	790		Other Equipment						
71300			Total Expenditures	986,370	993,219	(1,260,256)	596,205	1,179,844	(80,412)

BUDGET REQUEST NARRATIVE

DESCRIPTION

14 Positions

Salary Supplement for Cosmetology

JTG Annual Contract

Adoption of CTE Textbooks

HICKMAN COUNTY SCHOOLS
 FY 2023 - BUDGET SPREADSHEET
 72110 - Attendance

PGM	OBJ	CC	Description	FY 2020 YTD Actual	FY 2021 YTD Actual	Total Budget	FY 2022 YTD Actual	FY 2023 Projected Budget	Inc/(Dec)
			Personnel	116,824	123,247	(135,170)	46,318	133,403	(1,767)
			Non-Personnel	22,757	27,247	(39,800)	10,531	41,116	1,316
			Total	139,581	150,494	(174,970)	56,849	174,519	(451)
72110	105		Supervisor/Director	67,480	73,000	(77,000)	19,120	79,240	2,240
72110	162		Clerical Personnel						-
72110	189		Other Salaries & Wages	31,500	31,500	(36,894)	23,921	34,150	(2,744)
72110	201		Social Security	7,550	7,973	(8,713)	3,277	8,674	(39)
72110	204		State Retirement	10,294	10,774	(12,563)	-	11,339	(1,224)
72110	207		Medical Insurance	3,900	11,088	(15,800)	-	16,116	316
72110	331		Legal Services						-
72110	355		Travel	2,833	1,772	(5,000)	1,343	3,000	(2,000)
72110	399		Other Contracted Services	12,000	12,000	(17,000)	8,873	20,000	3,000
72110	499		Other Supplies And Materials	4,024	2,387	(2,000)	316	2,000	-
72110	524		Inservice	340	-	(1,000)	-	1,000	-
72110	719		Office Equipment				-	5,000	5,000
72110			Total Expenditures	139,921	150,494	(175,970)	56,849	180,519	4,549

BUDGET REQUEST NARRATIVE

DESCRIPTION

PGM	OBJ	DESCRIPTION
72110	105	
72110	189	
72110	201	
72110	204	
72110	207	
72110	331	
72110	355	
72110	399	Skyward
72110	499	
72110	524	
72110	719	Copier

HICKMAN COUNTY SCHOOLS
 FY 2023 - BUDGET SPREADSHEET
 72120 - Health Services

PGM	OBJ	CC	Description	FY 2020		FY 2021		FY 2022		FY 2023	
				YTD Actual	Total Budget	YTD Actual	Total Budget	YTD Actual	Projected Budget	Inc/(Dec)	
			Personnel	310,330	(357,008)	337,854	(357,008)	226,092	384,121	27,113	
			Non-Personnel	21,232	(29,000)	22,405	(29,000)	15,957	38,600	9,600	
			Total	331,562	(386,008)	360,259	(386,008)	242,049	422,721	36,713	
72120	131		Medical Personnel	135,951	(153,612)	168,229	(153,612)	130,312	161,462	7,850	
72120	189		Other Salaries & Wages	-	-	-	-	-	5,000	5,000	
72120	189	CHG	Other Salaries & Wages	101,050	(105,833)	93,069	(105,833)	80,041	115,000	9,167	
72120	201		Social Security	9,992	(11,751)	12,524	(11,751)	9,664	12,734	984	
72120	201	CHG	Social Security	7,665	(8,096)	7,055	(8,096)	6,074	8,798	701	
72120	204		State Retirement	24,648	(28,616)	25,797	(28,616)	-	31,045	2,429	
72120	204	CHG	State Retirement	-	-	-	-	-	-	-	
72120	207		Medical Insurance	31,024	(49,100)	31,180	(49,100)	-	50,082	982	
72120	355		Travel	2,980	(5,000)	3,589	(5,000)	3,691	5,000	-	
72120	399		Other Contracted Services	2,702	(4,000)	2,836	(4,000)	3,744	4,000	-	
72120	413		Drugs And Medical Supplies	3,135	(4,500)	4,251	(4,500)	3,273	4,500	-	
72120	499		Other Supplies And Materials	3,016	(3,000)	2,531	(3,000)	1,119	3,000	-	
72120	524		Inservice	1,240	(2,000)	1,113	(2,000)	394	3,000	1,000	
72120	599		Other Charges	-	(2,000)	1,100	(2,000)	1,044	9,100	7,100	
72120	735		Health Equipment	8,159	(8,500)	6,984	(8,500)	2,692	10,000	1,500	
72120			Total Expenditures	331,562	(386,008)	360,259	(386,008)	242,049	422,721	36,713	

BUDGET REQUEST NARRATIVE

DESCRIPTION

72120	131		5th Nurse Position
72120	189		Level 4 -Vaping Offense - 4 50 minute sessions per student (after school)
72120	201		
72120	204		
72120	207		
72120	355		Increase to \$5000
72120	399		4000
72120	413		
72120	499		
72120	524		Electronic Health Records 8000
72120	599		PD Pads
72120	735		

HICKMAN COUNTY SCHOOLS
 FY 2023 - BUDGET SPREADSHEET
 72210 - Regular Instruction Program

PGM	OBJ	CC	Description	FY 2020		FY 2021		FY 2022		FY 2023	
				YTD Actual	Total Budget	YTD Actual	Total Budget	YTD Actual	Projected Budget	Inc/(Dec)	
			Personnel	1,101,150	(1,256,434)	1,155,581	(1,256,434)	660,261	1,322,957	66,523	
			Non-Personnel	50,350	(90,600)	62,190	(90,600)	21,003	99,000	8,400	
			Total	1,151,499	(1,347,034)	1,217,771	(1,347,034)	681,264	1,421,957	74,923	
72210	105		Supervisor/Director	72,450	(71,970)	71,070	(71,970)	58,933	79,600	7,630	
72210	129		Librarians	339,180	(430,000)	395,670	(430,000)	293,417	451,973	21,973	
72210	161		Secretary(s)	185,931	(200,000)	200,206	(200,000)	114,140	216,160	16,160	
72210	162		Clerical Personnel	181,739	(200,000)	188,370	(200,000)	150,314	216,160	16,160	
72210	188		Bonus Payments	24,000							
72210	189		Other Salaries & Wages	-	(19,500)	-	(19,500)	113	19,500	-	
72210	201		Social Security	56,188	(70,531)	60,931	(70,531)	43,344	75,230	4,699	
72210	204		State Retirement	97,330	(101,693)	86,046	(101,693)	-	98,339	(3,354)	
72210	207		Medical Insurance	144,332	(162,740)	153,288	(162,740)	-	165,995	3,255	
72210	336		Maintenance And Repair	-	(2,500)	-	(2,500)	-	4,000	1,500	
72210	355		Travel	950	(5,000)	791	(5,000)	1,390	5,000	-	
72210	399		Other Contracted Services	7,827	(15,500)	12,733	(15,500)	14,885	16,000	500	
72210	432		Library Books/Media	4,000	(4,000)	6,360	(4,000)	-	8,000	4,000	
72210	499		Other Supplies And Materials	225	(3,600)	675	(3,600)	301	4,000	400	
72210	524		Inservice	385	(2,000)	25	(2,000)	276	2,000	-	
72210	722		Regular Instruction	6,855	(8,000)	-	(8,000)	-	10,000	2,000	
72210	790		Other Equipment	30,108	(50,000)	41,606	(50,000)	4,150	50,000	-	
			72210 Total	1,151,499	(1,347,034)	1,217,771	(1,347,034)	681,264	1,421,957	74,923	

BUDGET REQUEST NARRATIVE

PGM	OBJ	DESCRIPTION
72210	790	Safe Schools Grant

HICKMAN COUNTY SCHOOLS
 FY 2023 - BUDGET SPREADSHEET
 72220 - Special Education Program

PGM	OBJ	CC	Description	FY 2020		FY 2021		FY 2022		FY 2023	
				YTD Actual	YTD Actual	YTD Actual	Total Budget	YTD Actual	Projected Budget	Inc/(Dec)	
			Personnel	101,334	100,146	109,005	59,891	105,550	19,500	(3,456)	
			Non-Personnel	11,407	8,560	(12,500)	5,713	19,500	7,000	7,000	
			Total	112,741	108,706	(121,505)	65,604	125,050	3,545	3,545	
72220	105		Supervisor/Director	72,294	75,035	(76,691)	55,320	76,000	(691)		
72220	189		Other Salaries & Wages	4,594	1,350	(5,000)	-	5,000	-		
72220	196		In-Service Training	2,822	1,415	(3,500)	594	2,000	(1,500)		
72220	201		Social Security	5,650	5,822	(6,517)	3,977	6,350	(168)		
72220	204		State Retirement	8,450	8,844	(9,397)	-	8,300	(1,097)		
72220	207		Medical Insurance	7,524	7,680	(7,900)	-	7,900	-		
72220	336		Maintenance And Repair	4,450	2,786	(5,000)	1,057	5,000	-		
72220	355		Travel	6,957	5,774	(7,500)	4,656	7,500	-		
72220	524		In-Service PD								
			Total Expenditures	112,741	108,706	(121,505)	65,604	125,050	3,545	3,545	

BUDGET REQUEST NARRATIVE	
PGM OBJ	DESCRIPTION
72220 105	1 FTE (92% of Salary)
72220 189	
72220 196	
72220 201	
72220 204	
72220 207	
72220 336	
72220 355	
72220 524	PD - PreK Social Emotional Training (curriculum purchased), SLP Training, TASSE Training

HICKMAN COUNTY SCHOOLS
 FY 2023 - BUDGET SPREADSHEET
 72230 - Career and Technical Education Program

PGM	OBJ	CC	Description	FY 2020		FY 2021		FY 2022		FY 2023	
				YTD Actual	Total Budget	YTD Actual	Total Budget	YTD Actual	Projected Budget	Inc/(Dec)	
			Personnel	96,962	(104,411)	101,187	(104,411)	72,893	106,679	2,268	
			Non-Personnel	1,744	(8,000)	2,911	(8,000)	4,640	8,000	-	
			Total	98,706	(112,411)	104,098	(112,411)	77,534	114,679	2,268	
72230	105		Supervisor	76,280	(81,320)	79,520	(81,320)	67,767	83,960	2,640	
72230	201		Social Security	5,537	(6,221)	6,011	(6,221)	5,127	6,423	202	
72230	204		State Retirement	7,621	(8,970)	7,976	(8,970)	-	8,396	(574)	
72230	207		Medical	7,524	(7,900)	7,680	(7,900)	-	7,900	-	
72230	336		Maintenance And Repair - Equipment	1,000	(3,000)	1,220	(3,000)	1,200	3,000	-	
72230	355		Travel	322	(2,000)	988	(2,000)	454	2,000	-	
72230	499		Other Supplies	422	(3,000)	703	(3,000)	2,987	3,000	-	
72230			Total Expenditures	98,706	(112,411)	104,098	(112,411)	77,534	114,679	2,268	

BUDGET REQUEST NARRATIVE	
PGM	DESCRIPTION
72230 105	1 FTE
72230 201	
72230 204	
72230 207	
72230 336	Maintenance of CTE Equipment
72230 355	Travel by CTE Director
72230 499	Office Supplies for CTE Director

HICKMAN COUNTY SCHOOLS
 FY 2023 - BUDGET SPREADSHEET
 72250 - Technology

PGM	OBJ	CC	Description	FY 2020		FY 2021		FY 2022		FY 2023	
				YTD Actual	YTD Actual	YTD Actual	Total Budget	YTD Actual	Projected Budget	Inc/(Dec)	
			Personnel	84,089	84,476	(89,567)	60,748	100,826	11,259		
			Non-Personnel	164,687	225,722	(250,000)	201,526	411,000	161,000		
			Total	248,776	310,198	(339,567)	262,273	511,826	172,259		
72250	105		Supervisor/Director	60,000	60,000	(63,000)	53,157	68,300	5,300		
72250	189		Other Salaries & Wages	4,421	4,485	(5,000)	3,467	10,000	5,000		
72250	201		Social Security	4,703	4,697	(5,355)	4,125	5,990	635		
72250	204		State Retirement	7,065	7,394	(8,312)	-	8,636	324		
72250	207		Medical Insurance	7,900	7,900	(7,900)	-	7,900	-		
72250	336		Maintenance And Repair Services - Equipment	1,622	2,969	(4,000)	3,030	10,000	6,000		
72250	350		Internet Connectivity			(93,000)	92,786	100,000	7,000		
72250	355		Travel	150	-	(2,000)	315	2,000	-		
72250	399		Other Contracted Services	138,378	154,031	(72,000)	73,047	100,000	28,000		
72250	499		Other Supplies And Materials	435	1,413	(2,000)	298	2,000	-		
72250	722		Regular Instruction Equipment	8,417	67,308	(77,000)	32,050	97,000	20,000		
72250	722	ERATE	Regular Instruction Equipment - Erate	15,685				100,000	100,000		
72250			Total Expenditures	248,776	310,198	(339,567)	262,273	511,826	172,259		

BUDGET REQUEST NARRATIVE	
PGM	DESCRIPTION
72250 105	
72250 189	
72250 201	
72250 204	
72250 207	
72250 336	
72250 350	
72250 355	
72250 399	Potential increases in Contracted Services based on rebidding of contracts and current rate of inflation
72250 499	Increase based on replacement of 2 central office servers (could pay out of FY 2022 funds)
72250 722	Replacing Main Switch at each school - ERATE is and 80/20. Anticipated total cost of \$500,000
72250 722	ERATE

HICKMAN COUNTY SCHOOLS
 FY 2023 - BUDGET SPREADSHEET
 72310 - Board Of Education

PGM	OBJ	CC	Description	FY 2020 YTD Actual	FY 2021 YTD Actual	Total Budget	FY 2022 YTD Actual	FY 2023 Projected Budget	Inc/(Dec)
			Personnel	13,561	8,283	(26,913)	8,557	26,913	-
			Non-Personnel	439,145	426,434	(643,000)	405,159	658,000	15,000
			Total	452,705	434,717	(669,913)	413,716	684,913	15,000
72310	191		Board And Committee Members Fees	6,519	7,365	(13,000)	3,376	13,000	-
72310	196		In-Service Training	6,567	400	(12,000)	4,941	12,000	-
72310	201		Social Security	475	518	(1,913)	241	1,913	-
72310	305		Audit Services	27,500	27,500	(35,000)	27,500	35,000	-
72310	320		Dues And Memberships	32,779	17,975	(32,000)	25,732	32,000	-
72310	331		Legal Services	27,635	18,850	(40,000)	5,495	40,000	-
72310	399		Other Contracted Services	-	-	(5,000)	2,447	5,000	-
72310	506		Liability Insurance	57,982	68,610	(145,000)	74,292	145,000	-
72310	510		Trustee's Commission	121,008	128,476	(125,000)	110,761	140,000	15,000
72310	513		Workman's Compensation Insurance	167,678	155,576	(250,000)	156,390	250,000	-
72310	534		Refund To Applicant For Criminal	-	-	(1,000)	-	1,000	-
72310	599		Other Charges	4,563	9,447	(10,000)	2,543	10,000	-
			72310 Total	452,705	434,717	(669,913)	413,716	684,913	15,000

PGM	OBJ	DESCRIPTION
72310	191	
72310	196	
72310	201	
72310	305	
72310	320	
72310	331	
72310	399	
72310	506	
72310	510	
72310	513	
72310	534	
72310	599	

HICKMAN COUNTY SCHOOLS
 FY 2023 - BUDGET SPREADSHEET
 72320 - Director Of Schools

PGM	OBJ	CC	Description	FY 2020		FY 2021		FY 2022		FY 2023	
				YTD Actual	YTD Actual	YTD Actual	Total Budget	YTD Actual	Projected Budget	Inc/(Dec)	
			Personnel	247,061	249,728	249,728	(254,364)	176,710	265,053	10,689	
			Non-Personnel	22,522	23,706	23,706	(38,400)	18,522	38,400	-	
			Total	269,583	273,434	273,434	(292,764)	195,232	303,453	10,689	
72320	101		County Official/Administrative Officer	109,000	110,000	110,000	(113,000)	94,167	115,000	2,000	
72320	117		Career Ladder Program	1,000	1,000	1,000	(1,000)	-	1,000	-	
72320	161		Secretary(s)	86,616	88,273	88,273	(90,000)	70,050	96,800	6,800	
72320	189		Other Salaries & Wages								
72320	201		Social Security	14,810	15,030	15,030	(15,606)	12,391	16,279	673	
72320	204		State Retirement	23,735	23,526	23,526	(22,501)	103	23,472	971	
72320	207		Medical Insurance	11,900	11,900	11,900	(12,257)	-	12,502	245	
72320	307		Communication	499	750	750	(3,000)	2,021	3,000	-	
72320	336		Maintenance And Repair Services	14,552	16,172	16,172	(20,000)	10,119	20,000	-	
72320	348		Postal Charges	-	-	-	(1,000)	-	1,000	-	
72320	355		Travel	2,330	1,258	1,258	(3,400)	1,708	3,400	-	
72320	399		Other Contracted Services	3,075	3,050	3,050	(5,000)	950	5,000	-	
72320	435		Office Supplies	714	1,410	1,410	(2,500)	728	2,500	-	
72320	499		Other Supplies And Materials	1,352	1,065	1,065	(3,500)	2,997	3,500	-	
72320	599	SS	Other Charges - Outside Support	1,851	18,162	18,162	(17,800)	7,938	(17,800)		
			72320 Total	271,434	291,596	291,596	(310,564)	203,170	303,453	(7,111)	

BUDGET REQUEST NARRATIVE

PGM	OBJ	DESCRIPTION
72320	101	
72320	117	
72320	161	
72320	189	
72320	201	
72320	204	
72320	207	
72320	307	
72320	336	
72320	348	
72320	355	
72320	399	
72320	435	
72320	499	
72320	599	U Trust

HICKMAN COUNTY SCHOOLS
 FY 2023 - BUDGET SPREADSHEET
 72410 - Office Of The Principal

PGM	OBJ	CC	Description	FY 2020		FY 2021		FY 2022		FY 2023	
				YTD Actual	YTD Actual	YTD Actual	Total Budget	YTD Actual	Projected Budget	Inc/(Dec)	
			Personnel	1,388,731	1,329,648	(1,684,585)	919,776	1,754,618	70,033		
			Non-Personnel	128,507	165,178	(169,200)	70,727	169,200	-		
			Total	1,517,238	1,494,826	(1,853,785)	990,504	1,923,818	70,033		
72410	104		Principals	634,897	617,005	(721,600)	505,256	750,000	28,400		
72410	139		Assistant Principals	446,652	416,336	(500,000)	303,377	525,000	25,000		
72410	189		Other Salaries & Wages			(75,000)	47,447	90,000	15,000		
72410	201		Social Security	79,752	76,921	(99,190)	63,697	104,423	5,233		
72410	204		State Retirement	116,952	122,110	(143,015)	-	136,500	(6,515)		
72410	207		Medical Insurance	110,478	97,276	(145,780)	-	148,696	2,916		
72410	348		Postal Charges	-	1,600	(1,600)	-	1,600	-		
72410	355		Travel	-	3,500	(3,600)	-	3,600	-		
72410	399		Other Contracted Services	28,507	57,678	(61,600)	22,098	60,000	(1,600)		
72410	399	CES	Other Contracted Services	12,500	12,800	(12,800)	3,420	13,000	200		
72410	399	CIS	Other Contracted Services	12,500	12,800	(12,800)	5,354	13,000	200		
72410	399	EHES	Other Contracted Services	12,500	12,800	(12,800)	7,558	13,000	200		
72410	399	EHHS	Other Contracted Services	12,500	12,800	(12,800)	4,851	13,000	200		
72410	399	EHIS	Other Contracted Services	12,500	12,800	(12,800)	13,948	13,000	200		
72410	399	EHMS	Other Contracted Services	12,500	12,800	(12,800)	2,790	13,000	200		
72410	399	HCHS	Other Contracted Services	12,500	12,800	(12,800)	2,335	13,000	200		
72410	399	HCMS	Other Contracted Services	12,500	12,800	(12,800)	8,374	13,000	200		
72410	790		Other Equipment								
72410			Total Expenditures	1,517,238	1,494,826	(1,853,785)	990,504	1,923,818	70,033		

BUDGET REQUEST NARRATIVE

DESCRIPTION

72410	104		8 FTE
72410	139		8 FTE
72410	189		H.S. Athletic Director Positions
72410	201		
72410	204		
72410	207		
72410	348		
72410	355		
72410	399		Athletic Trainer Services, Copier Contracts, etc
72410	790		

HICKMAN COUNTY SCHOOLS
 FY 2023 - BUDGET SPREADSHEET
 72510 - Fiscal Services

PGM	OBJ	CC	Description	FY 2020		FY 2021		FY 2022		FY 2023	
				YTD Actual	Total Budget	YTD Actual	Total Budget	YTD Actual	Projected Budget	Inc/(Dec)	
			Personnel	-	-	-	-	-	-	-	-
			Non-Personnel	42,235	(45,000)	43,306	(45,000)	45,000	50,000	5,000	5,000
			Total	42,235	(45,000)	43,306	(45,000)	45,000	50,000	5,000	5,000
72510	105		Supervisor/Director								
72510	201		Social Security								
72510	204		State Retirement								
72510	207		Medical Insurance								
72510	399		Other Contracted Services	42,235	(45,000)	42,235	(45,000)	45,000	50,000	5,000	5,000
72510	Total			42,235	(45,000)	42,235	(45,000)	45,000	50,000	5,000	5,000

BUDGET REQUEST NARRATIVE	
PGM	DESCRIPTION
72510 399	Services/Position in the Finance Office other related fees

HICKMAN COUNTY SCHOOLS
 FY 2023 - BUDGET SPREADSHEET
 72610 - Operation Of Plant

PGM	OBJ	CC	Description	FY 2020		FY 2021		FY 2022		FY 2023	
				YTD Actual	YTD Actual	YTD Actual	Total Budget	YTD Actual	Projected Budget	Inc/(Dec)	
			Personnel								
			Non-Personnel	1,871,463	1,986,947	(2,380,500)	(2,380,500)	1,567,580	2,433,500	53,000	
			Total	1,871,463	1,986,947	(2,380,500)	(2,380,500)	1,567,580	2,433,500	53,000	
72610	307		Communication	41,730	46,030	(50,000)	(50,000)	32,652	50,000	-	
72610	399		Other Contracted Services	553,231	609,652	(710,000)	(710,000)	412,321	750,000	40,000	
72610	410		Custodial Supplies	23,269	33,306	(35,000)	(35,000)	15,738	35,000	-	
72610	415		Electricity	754,531	749,184	(915,000)	(915,000)	636,773	950,000	35,000	
72610	434		Natural Gas	77,626	100,525	(165,000)	(165,000)	78,860	200,000	35,000	
72610	454		Water And Sewer	192,042	198,618	(245,000)	(245,000)	150,357	245,000	-	
72610	499		Other Supplies And Materials	2,429	1,023	(3,500)	(3,500)	289	3,500	-	
72610	501		Boiler Insurance	7,025	5,755	(8,000)	(8,000)	7,105	10,000	2,000	
72610	502		Building And Contents Insurance	143,521	160,744	(180,000)	(180,000)	167,486	190,000	10,000	
72610	720		Plant Operation Equipment	76,060	82,111	(69,000)	(69,000)	66,000		(69,000)	
72610			Total Expenditures	1,871,463	1,986,947	(2,380,500)	(2,380,500)	1,567,580	2,433,500	53,000	

BUDGET REQUEST NARRATIVE

DESCRIPTION

72610	307		
72610	399		
72610	410		
72610	415		
72610	434		
72610	454		
72610	499		
72610	501		
72610	502		
72610	720		

Electrical Cost projected increase of approximately 5% for FY 2022-2023 (EIA est Mar 29, 2022)

EIA projections have 34% increase for 2022 over 2021 and 23% decrease for 2023. Kiplinger show futures trading 34% higher than current level

HICKMAN COUNTY SCHOOLS
 FY 2023 - BUDGET SPREADSHEET
 72710 - Transportation

PGM	OBJ	CC	Description	FY 2020		FY 2021		FY 2022		FY 2023	
				YTD Actual	YTD Actual	YTD Actual	Total Budget	YTD Actual	Projected Budget	Incl/(Dec)	
			Personnel	1,075,418	1,013,244	(1,241,901)	591,892	1,293,422	51,521		
			Non-Personnel	1,113,764	973,773	(1,130,556)	811,365	1,291,000	160,444		
			Total	2,189,181	1,987,016	(2,372,457)	1,403,257	2,584,422	211,965		
72710	105		Supervisor/Director	56,000	50,000	(60,750)	45,563	65,000	4,250		
72710	142		Mechanic(s)	79,109	73,720	(120,409)	58,690	130,138	9,729		
72710	146		Bus Drivers	601,564	554,613	(633,444)	385,460	660,000	26,556		
72710	146	SE	Bus Drivers	53,452	65,093	(68,000)	45,422	70,000	2,000		
72710	161		Secretary(s)	10,392	10,458	(12,000)	7,943	12,970	970		
72710	196		In-Service								
72710	201		Social Security	57,581	52,253	(64,425)	36,503	66,410	1,985		
72710	201	SE	Social Security	3,685	4,739	(5,202)	3,250	5,355	153		
72710	204		State Retirement	84,277	85,171	(92,891)	-	95,752	2,862		
72710	204	SE	State Retirement	5,654		(7,500)		7,721	221		
72710	207		Medical Insurance	107,424	99,700	(139,780)	-	142,576	2,796		
72710	207	SE	Medical Insurance								
72710	299		Other Fringe Benefits	16,280	7,496	(37,500)	9,062	37,500	-		
72710	335		Maintenance And Repair Services - BLDG		12,557	(5,000)		5,000	-		
72710	338		Maintenance And Repair Services - Vehicles	23,720	10,004	(25,000)	11,414	30,000	5,000		
72710	355		Travel			(2,500)		2,500	-		
72710	399		Other Contracted Services	55,802	20,221	(90,000)	33,602	55,000	5,000		
72710	412		Diesel Fuel	116,331	101,808	(200,000)	110,414	250,000	50,000		
72710	418		Equipment And Machinery Parts		81	(2,000)		2,000	-		
72710	424		Garage Supplies	2,679	1,511	(3,500)	2,510	3,500	-		
72710	425		Gasoline	21,434	18,553	(30,000)	28,216	45,000	15,000		
72710	433		Lubricants	3,195	3,506	(12,000)	3,787	12,000	-		
72710	442		Propane Gas		7,630	(88,000)	24,778	75,000	(13,000)		
72710	450		Tires And Tubes	17,733	13,603	(30,000)	3,496	30,000	-		
72710	453		Vehicle Parts	73,879	44,745	(120,000)	32,240	120,000	-		
72710	511		Vehicle And Equipment Insurance	40,157	40,183	(45,000)	43,352	50,000	5,000		
72710	524		Inservice								
72710	599		Other Charges			(40,000)	40,000	5,000	-		
72710	718		Motor Vehicles					110,000	70,000		
72710	729		Transportation Equipment	758,833	699,372	(477,556)	477,556	496,000	18,444		
72710	729		Total Expenditures	2,189,181	1,987,016	(2,372,457)	1,403,257	2,584,422	206,965		

BUDGET REQUEST NARRATIVE

DESCRIPTION

PGM OBJ

72710	146		increase sub pay from \$50 to \$65 which is approximately daily rate of new driver
72710	338		Anticipated increase in cost
72710	355		Fuel Usage Software Tracker
72710	399		To move some expenditures that were being recorded in 399
72710	412		2 Drivers Ed - Cars; 2 Vans to replace 2006 year vans
72710	599		4 Buses with Seatbelts - Current Cost from Bluebird is \$124k per bus
72710	718		
72710	729		

HICKMAN COUNTY SCHOOLS
 FY 2023 - BUDGET SPREADSHEET
 72810 - Central And Other

PGM	OBJ	CC	Description	FY 2020		FY 2021		FY 2022		FY 2023	
				YTD Actual	YTD Actual	YTD Actual	Total Budget	YTD Actual	Projected Budget	Inc/(Dec)	
			Personnel	6,020	8,636	1,420	(40,000)	1,420	40,383	383	
			Non-Personnel	180,774	180,327	26,781	(217,500)	26,781	217,500	-	
			Total	186,793	188,964	28,201	(257,500)	28,201	257,883	383	
72810	201		Social Security	-	-	101	(383)	101	383	-	
72810	207		Medical Insurance	-	-	-	-	-	-	-	
72810	210		Unemployment Compensation	6,020	8,636	-	(34,618)	-	35,000	383	
72810	299		Other Fringe Benefits	-	-	1,319	(5,000)	1,319	5,000	-	
72810	316		Contributions	133,500	140,000	-	(152,500)	-	152,500	-	
72810	399		Other Contracted Services	24,984	29,965	10,142	(35,000)	10,142	35,000	-	
72810	499		Other Supplies And Materials	3,933	60	7,203	(13,000)	7,203	15,000	2,000	
72810	499	SS	Other Supplies And Materials	13,357	10,303	8,236	(15,000)	8,236	15,000	-	
72810	599	SS	Other Charges - Outside Support	5,000	-	1,200	(2,000)	1,200	(2,000)	(2,000)	
72810	Total			186,793	188,964	28,201	(257,500)	28,201	257,883	383	

BUDGET REQUEST NARRATIVE

DESCRIPTION

PGM	OBJ
72810	201
72810	207
72810	210
72810	299
72810	316
72810	399
72810	499
72810	599

HICKMAN COUNTY SCHOOLS
 FY 2023 - BUDGET SPREADSHEET
 73100 - Food Service

PGM	OBJ	CC	Description	FY 2020		FY 2021		FY 2022		FY 2023	
				YTD Actual	YTD Actual	YTD Actual	Total Budget	YTD Actual	Projected Budget	Inc/(Dec)	
			Personnel	27,504	27,249	-	-	(35,604)	-	38,571	2,967
			Non-Personnel	-	-	-	-	-	-	-	-
			Total	27,504	27,249	27,249	(35,604)	(35,604)	-	38,571	2,967
73100	105		Supervisor/Director	23,333	23,000	23,000	(30,000)	(30,000)	-	32,500	2,500
73100	201		Social Security	1,744	1,760	1,760	(2,295)	(2,295)	-	2,486	191
73100	204		State Retirement	2,427	2,489	2,489	(3,309)	(3,309)	-	3,585	276
73100	599		Other Charges	-	-	-	-	-	-	-	-
73100	Total			27,504	27,249	27,249	(35,604)	(35,604)	-	38,571	2,967

BUDGET REQUEST NARRATIVE	
PGM	DESCRIPTION
73100 105	
73100 201	
73100 204	
73100 599	

HICKMAN COUNTY SCHOOLS
 FY 2023 - BUDGET SPREADSHEET
 73300 - Community Services

PGM	OBJ	CC	Description	FY 2020		FY 2021		FY 2022		FY 2023	
				YTD Actual	YTD Actual	YTD Actual	Total Budget	YTD Actual	Projected Budget	Inc/(Dec)	
			Personnel	120,257	122,587	(125,316)	67,336	133,813	8,497		
			Non-Personnel	5,000	2,995	(7,000)	2,983	10,000	3,000		
			Total	125,256	125,582	(132,316)	70,319	143,813	11,497		
73300	105		Supervisor/Director	31,500	31,500	(31,894)	23,921	34,150	2,256		
73300	189		Other Salaries & Wages	56,178	56,802	(58,075)	38,717	62,667	4,592		
73300	201		Social Security	6,253	6,466	(6,883)	4,699	7,406	523		
73300	204		State Retirement	9,381	9,819	(9,924)	-	10,679	755		
73300	207		Medical Insurance	16,944	18,000	(18,540)	-	18,911	371		
73300	355		Travel								
73300	499		Other Supplies And Materials	5,000	-	(5,000)	2,683	5,000	-		
73300	524		Inservice	-	-	-	-	-	-		
73300	719		Office Equipment		2,995	(2,000)	300	5,000	3,000		
73300			Total Expenditures	125,256	125,582	(132,316)	70,319	143,813	11,497		

BUDGET REQUEST NARRATIVE

PGM	OBJ	DESCRIPTION
73300	105	
73300	189	
73300	201	
73300	204	
73300	207	
73300	355	
73300	399	
73300	499	
73300	524	
73300	599	
73300	719	

HICKMAN COUNTY SCHOOLS
 FY 2023 - BUDGET SPREADSHEET
 73400 - Early Childhood Education

PGM	OBJ	CC	Description	FY 2020		FY 2021		FY 2022		FY 2023	
				YTD Actual	YTD Actual	YTD Actual	Total Budget	YTD Actual	Projected Budget	Inc/(Dec)	
			Personnel	400,231	405,542	(432,541)	174,991	453,697	21,156		
			Non-Personnel	27,847	28,632	(40,500)	19,900	40,500	-		
			Total	428,079	434,174	(473,041)	194,891	494,197	21,156		
73400	105		Supervisor/Director	36,700	39,820	(40,720)	33,933	42,100	1,380		
73400	116		Teachers	176,562	188,708	(195,800)	90,600	205,805	10,005		
73400	163		Educational Assistants	63,676	62,204	(69,200)	31,349	74,791	5,591		
73400	188		Bonus Payments	9,250							
73400	189		Other Salaries & Wages	8,841	8,970	(12,000)	6,933	12,000	-		
73400	198		Non-Certified Subs	2,432	-	(5,000)	-	5,000	-		
73400	201		Social Security	21,965	22,506	(24,306)	12,175	25,604	1,298		
73400	204		State Retirement	32,805	34,334	(35,045)	-	36,917	1,872		
73400	207		Medical Insurance	48,000	49,000	(50,470)	-	51,479	1,009		
73400	210		Unemployment Compensation								
73400	355		Travel	320	-	-	-	500	500		
73400	399		Other Contracted Services	400	457	(189)	189	2,000	1,811		
73400	429		Instructional Supplies And	11,718	10,498	(14,811)	9,984	10,500	(4,311)		
73400	499		Other Supplies And Materials	9,823	17,152	(10,500)	6,000	10,500	-		
73400	524		Inservice	1,136	125	-	-	2,000	2,000		
73400	720		Plant Operation Equipment								
73400	790		Other Equipment	4,451	400	(15,000)	3,726	15,000	-		
73400			Total Expenditures	428,079	434,174	(473,041)	194,891	494,197	21,156		

BUDGET REQUEST NARRATIVE

DESCRIPTION

PGM OBJ

HICKMAN COUNTY SCHOOLS
 FY 2023 - BUDGET SPREADSHEET
 76100 - Regular Capital Outlay

PGM	OBJ	CC	Description	FY 2020 YTD Actual	FY 2021 YTD Actual	Total Budget	FY 2022 YTD Actual	Projected Budget	FY 2023 Inc/(Dec)
			Personnel						
			Non-Personnel	314,245	249,291	(450,000)	(249,291)	1,779,000	1,329,000
			Total	314,245	249,291	(450,000)	(249,291)	1,779,000	1,329,000
76100	799		Other Capital Outlay	314,245	249,291	(450,000)	(249,291)	1,779,000	1,329,000
76100	Total			314,245	249,291	(450,000)	(249,291)	1,779,000	1,329,000

BUDGET REQUEST NARRATIVE

PGM	OBJ	DESCRIPTION

Hickman County Board of Education

Descriptor Term:

Use of Phones and Faxes

Descriptor Code:

3.3001

Issued Date:

04/04/22

Rescinds:

3.3001

Issued:

01/06/20

1 Telephones, faxes and cellular/mobile telephones funded with school district funds shall comply with
2 the following procedures:

- 3 1. Absolutely no personal and/or non-school district use is allowed.
- 4
- 5 2. Long-distance calls shall be held to a minimum and a monthly long distance log sheet must be
6 maintained for cellular/mobile telephones.
- 7
- 8 3. Official or employee must have a narrative explaining need on file with the director of schools'
9 office and the finance office for any cellular/mobile telephone.
- 10
- 11 4. The director of schools' office and the finance office reserves the right to obtain a complete list
12 of monthly calls for audit purposes.
- 13
- 14 5. The Board will not be responsible for the loss of any cellular/mobile telephones, or for damages
15 to privately owned vehicles vandalized as a result of an attempt to steal the phone.
- 16
- 17 6. Optimum rates must be obtained, through competitive bids for any cellular/mobile telephone,
18 and placed on file with the director of schools' office and finance office. If the monthly bill
19 reflects charges greater than the customary minimum monthly bill, the excess portion shall
20 become the responsibility of the employee to whom the cell phone has been issued.
- 21
- 22 7. Only the director of schools' office or designee are authorized to sign contracts for
23 cellular/mobile telephones and service.
- 24
- 25 8. The director of schools by this policy has the authority to cancel contracts for cellular/mobile
26 service, when in his/her opinion, abuse has occurred, and he/she has the authority to require
27 that identified abuse shall be reimbursed to the County.
- 28
- 29 9. Facsimile transmissions shall be for official school district business only.

Hickman County Board of Education

Descriptor Term: Board Members Legal Status	Descriptor Code: 1.102	Issued Date: 05/06/19
	Rescinds: 1.102	Issued: 03/06/17

1 The legal status of board members shall be as follows:¹

2 NUMBER

3 The Board is composed of seven (7) members. One member shall be elected from each school district,
4 each school district being composed of one (1) County Commission district.

5 QUALIFICATIONS

6 Members of the Board shall be residents ~~of and elected on a non-partisan basis~~ from districts of
7 substantially equal population,¹ and shall be citizens of recognized integrity, intelligence, and ability to
8 administer the duties of the office.² To qualify as a candidate, an individual must show proof of
9 graduation from high school or receipt of a G.E.D or HiSET. No member of the County Commission
10 nor any other County official shall be eligible for election as a member of the county Board of
11 Education.³

12 TERMS OF OFFICE

13 Members of the Board shall serve four (4) year terms.¹

14 METHOD OF ELECTION

15 Members of the Board shall be elected by qualified voters of Hickman County at the August election.

16 VACANCIES

17 Vacancies shall be declared to exist on account of death, resignation, removal from the district which
18 elected him, removal from the school system,⁵ or through due process proceedings.⁴

19 When a vacancy occurs, the unexpired term shall be filled at the next regular or special meeting of the
20 County Commission.⁵ Such appointment shall continue until the next regular election.

Legal References

1. TCA 49-2-201
2. TCA 49-2-202(a)(1); TCA 49-2-202(a)(4)
3. TCA 49-2-202(a)(2)
4. TCA 8-47-101; TCA 49-1-611; TCA 49-2-202
5. TCA 49-2-202(e)



State of Tennessee

PUBLIC CHAPTER NO. 1

THIRD EXTRAORDINARY SESSION

HOUSE BILL NO. 72

By Mr. Speaker Sexton and Representatives Cepicky, Griffey, Williams, Smith, Moody, Lafferty, Weaver, Sherrell, Cochran, Reedy, Lynn

Substituted for: Senate Bill No. 9

By Mr. Speaker McNally and Senators Bell, Niceley

AN ACT to amend Tennessee Code Annotated, Title 49, Chapter 2, relative to partisan elections for school board members.

BE IT ENACTED BY THE GENERAL ASSEMBLY OF THE STATE OF TENNESSEE:

SECTION 1. Tennessee Code Annotated, Section 49-2-201, is amended by deleting the last sentence in subdivision (a)(1) and substituting instead the following:

Elections for school board members may be conducted on a partisan or nonpartisan basis. If at least one (1) county primary board of a political party elects to conduct school board elections on a partisan basis, then a person seeking a position on any board in that county may campaign as the nominee or representative of a political party, and political parties may nominate candidates for membership on the board by any method authorized under the rules of the party or by primary election under title 2.

SECTION 2. Tennessee Code Annotated, Section 49-2-201, is further amended by deleting subsection (d) and substituting the following:

(d)

(1)

(A) Primary elections in which candidates nominated for school boards are to appear on the regular August election ballot are held on the first Tuesday in May before the August election. In the years in which an election is held for president of the United States, a political party primary for offices to be elected in the regular August election shall be held on the same day as the presidential preference primary. In such event, the qualifying deadline for independent and primary candidates is twelve o'clock (12:00) noon, prevailing time, on the date established in § 2-5-101(a)(2).

(B) Primary elections in which candidates nominated for school board are to appear on the regular November election ballot are held concurrently with the regular August election. The qualifying deadline for independent and primary candidates is twelve o'clock (12:00) noon, prevailing time, on the date established in § 2-5-101(a)(1).

(C) Primary elections in which candidates nominated for school board are to appear on a ballot other than the regular August or regular November election ballot may be held on the first Tuesday in the third month before the election. If the first Tuesday of the third month falls on a legal holiday, the election shall be held on the second Tuesday of the third month before the election. Nothing in this subdivision (d)(1)(C) requires a primary election to be held, political parties may elect to nominate candidates for membership on the board by any method authorized under the rules of the party pursuant to subdivision (a)(1).

HB72

(2) If the date for a primary election falls within ninety (90) days of an upcoming regular primary or general election being held in the jurisdiction, the commission or commissions may reset the date of the primary election to coincide with the regular primary or general election, even though this may be outside of the time period established herein. All dates dependent on the date of the election must be adjusted accordingly and any acts required to be done by these dates must be performed timely if done in accordance with the adjusted dates.

(3) The qualifying deadline for independent and primary candidates is twelve o'clock (12:00) noon, prevailing time, on the date established in § 2-5-101(a).

(4) If the county executive committee timely filed a notice with the county election commission directing the commission to hold a May primary election in 2022, then within thirty (30) days of the effective date of this act, the county executive committee may file a supplemental notice, in writing, to include school board offices to be elected in the regular August election within the county.

SECTION 3. No later than thirty (30) days after the effective date of this act, a county executive committee may direct, in writing, the county election commission to hold a primary for school board offices to be elected in the regular November 2022 election.

SECTION 4. This act takes effect upon becoming a law, the public welfare requiring it.

THIRD EXTRAORDINARY SESSION

HOUSE BILL NO. 72

PASSED: October 29, 2021



CAMERON SEXTON, SPEAKER
HOUSE OF REPRESENTATIVES



RANDY MCNALLY
SPEAKER OF THE SENATE

APPROVED this 12th day of November 2021



BILL LEE, GOVERNOR

Adopt Model Policy

Click here to choose a school board.

Monitoring: Review: Annually, in March	Descriptor Term: Transfers Within the System	Descriptor Code: 6.206	Issued Date:
		Rescinds:	Issued:

1 *General*¹

2 Each year, the Director of Schools/designee shall review the number of spaces available in each school
3 by grade, class, and program levels. This information shall be posted on the district's website along
4 with the dates of the district's open enrollment period. The open enrollment period shall last for thirty
5 (30) days and information about the number of seats available shall be posted for at least fourteen (14)
6 days prior. The Director of Schools/designee shall reserve a reasonable number of enrollment spaces at
7 each school to account for the enrollment of zoned students, siblings of students, and students who
8 have a parent/guardian employed at the school.²

9 During the district's open enrollment period each year, a parent/guardian may request that his/her child
10 attend a school within the district other than the one to which the child is zoned. The Director of
11 Schools/designee shall review such requests, and if adequate space is available, grant such transfers. If
12 the number of requests exceeds the number of available spaces, the Director of Schools/designee shall
13 implement a lottery to fill the available spaces.

The open enrollment process shall be completed before other nonresident transfers are approved.

15 **POST ENROLLMENT**¹

16 Once accepted, the student shall provide his/her own transportation to and from the school. The student
17 must maintain satisfactory attendance, behavior, and effort to remain in the new school.

18 **CHANGE IN RESIDENCE**¹

19 Students whose families transfer their residence to another school area after the first month of school
20 may complete the school year at their former school. Students who present evidence that they will
21 move during the school year and who desire to enroll in a new school in the new area may do so with
22 prior written request for a change of school area.

23 **[NOTE: Not effective in the event of a federally mandated desegregation order.]**³

Legal References

1. TCA 49-2-128
2. TCA 49-6-3113
3. 34 C.F.R. § 100.4

Cross References

Student Assignments 6.205
Homeless Students 6.503
Students in Foster Care 6.505

Hickman County Board of Education

	Descriptor Term: Transfers Within the System	Descriptor Code: 6.206	Issued Date: 01/04/21
		Rescinds: 6.206	Issued: 10/01/18

1 During the month of June each year, a parent/guardian may request that his/her child attend a school
 2 within the system other than the one to which the child is zoned.** The director of schools or his/her
 3 designee shall review such requests and, if adequate space is available, grant such transfers unless a
 4 transfer would be adverse to the best interests of the child or the school system. If granted, the student
 5 must provide his/her own transportation to and from the school.¹

6 Except within the first ten (10) days of a school year where a parent/guardian may appeal the assignment
 7 of a student to the Board,² after a student has enrolled in one (1) school within the system, he/she shall
 8 not be permitted to transfer to another unless there is a change in residence of the student's parents or
 9 guardian outside the area in which the student enrolled. Any exception to this policy must be brought
 10 before the director of schools for evaluation and decision.

11 Students whose families transfer their residence to another school area after the first month of school
 12 may complete the school year at their former school. Students who present evidence that they will move
 13 during the school year and who desire to enroll in a new school in the new area may do so with prior
 14 written request for a change of school area. The director of schools or his/her designee may grant other
 15 exceptions to this policy for good and sufficient reasons.

16 Principals shall allow credit for work transferred from other schools only when substantiated by official
 17 transcripts or successful completion of comprehensive written examinations approved, administered and
 18 graded by the principal or his/her designated representative.³

Legal References

1. TCA 49-2-128
2. TCA 49-6-3201
3. TRR/MS 0520-01-03-.03(9)

Cross References

- Student Assignments** 6.205
Homeless Students 6.503
Students in Foster Care 6.505

** Not effective in event of federally-mandated desegregation order.



State of Tennessee

PUBLIC CHAPTER NO. 479

SENATE BILL NO. 788

By Lundberg, White

Substituted for: House Bill No. 1305

By White, Hardaway, Smith, Hazlewood, Todd, Grills, Reedy, Calfee, Moody, Terry, Lynn

AN ACT to amend Tennessee Code Annotated, Title 49, Chapter 1; Title 49, Chapter 2 and Title 49, Chapter 6, relative to open enrollment.

BE IT ENACTED BY THE GENERAL ASSEMBLY OF THE STATE OF TENNESSEE:

SECTION 1. Tennessee Code Annotated, Section 49-2-128, is amended by deleting the section and substituting instead:

(a) Before the start of each school year, an LEA shall identify each school that, based on the school's capacities at the building, grade, class, and program levels, has space available to enroll and serve additional students. In determining available space at the class level, an LEA may use the class size averages specified in § 49-1-104.

(b)(1) An LEA shall post the number of spaces available for enrollment in each school by grade, class, and program levels on the LEA's website at least fourteen (14) days before the beginning of the open enrollment period under subsection (c). An LEA shall not include in the number of spaces available for enrollment under this subdivision (b)(1) the number of enrollment spaces that are reserved by the LEA pursuant to subdivision (b)(2).

(2) An LEA may reserve a reasonable number of enrollment spaces each school year from the number of spaces, if any, determined by the LEA to be available for enrollment for purposes of this section, to accommodate the potential enrollment of students who may relocate within the respective school zone, students who may have a sibling enrolled at the respective school, and students who may have a parent who teaches at the respective school.

(c) Before the start of each school year, each LEA shall conduct an open enrollment period of at least thirty (30) days during which a parent or guardian of a student residing within the LEA may apply for enrollment of the parent's or guardian's student in a school that the student is not zoned to attend. During the open enrollment period, a parent or guardian may submit an application for transfer to a school identified by the LEA as having space available to enroll and serve additional students.

(d) At the end of the open enrollment period, an LEA shall approve an application for transfer if space is available for the student at the requested school. If the number of applications for transfer to a school exceeds the number of spaces available for enrollment in the school at the building, grade, class, or program level, as identified by the LEA according to subsection (b), then the LEA shall conduct a lottery to select the students who may transfer to the school.

(e) If an LEA grants a transfer to a student, then the parent or guardian of the student is responsible for transportation to the new school. The student must maintain satisfactory attendance, behavior, and effort to remain in the new school.

(f)(1) An LEA shall not deny a student who is zoned to attend or who was enrolled in a school during the previous school year enrollment and attendance in the school.

(2)(A) An LEA shall not admit a nonresident student seeking to transfer into the LEA from outside the LEA under §§ 49-6-3104 and 49-6-3105 before all applications for transfer under subsection (c) have been acted upon according to subsection (d).

(B) Notwithstanding subdivision (f)(2)(A), an LEA may enroll a nonresident student pursuant to § 49-6-3113 before all applications for transfer under subsection (c) have been acted upon according to subsection (d).

SECTION 2. This act takes effect upon becoming a law, the public welfare requiring it, and applies to the 2022-2023 school year and each school year thereafter.

SENATE BILL NO. 788

PASSED: May 3, 2021

Randy McNally
SPEAKER OF THE SENATE

Cameron Sexton, SPEAKER
HOUSE OF REPRESENTATIVES

APPROVED this 18th day of May 2021

Bill Lee, GOVERNOR

Hickman County Board of Education

	Descriptor Term: Instructional Goals	Descriptor Code: 4.100	Issued Date: 02/03/20
		Rescinds: 4.100	Issued: 12/04/17

1 The Board approves the following broad-based instructional goals for students:

- 2 • To acquire the knowledge and attitude necessary to achieve and maintain good physical and
3 mental health;
- 4
- 5 • To develop the skills necessary to function as a self-directed person;
- 6
- 7 • To develop the capacity to cope with change through an understanding of the arts, humanities
8 and scientific processes;
- 9
- 10 • To know the principles involved in making moral and ethical choices;
- 11
- 12 • To develop the basic skills of reading, writing, computation, spelling, speaking and problem
13 solving;
- 14
- 15 • To develop a positive attitude toward learning as a lifelong endeavor;
- 16
- 17 • To learn to identify personal talents and interests, make appropriate career choices, and develop
18 career skills;
- 19
- 20 • To acquire knowledge and to develop skills in the management of personal and public
21 resources necessary for meeting obligations to self, family and society;
- 22
- 23 • To learn to act in a responsible manner;
- 24
- 25 • To learn of the rights and responsibilities of citizens of the community, state, nation and world;
26 and
- 27
- 28 • To learn to understand, respect and interact with people of different cultures, generations and
29 races.

Cross References

School District Goals 1.700

Hickman County Board of Education

	Descriptor Term: Instructional Standards	Descriptor Code: 4.101	Issued Date: 08/02/21
		Rescinds:	Issued:

1 *General*

2 The Board is charged with selection of the curriculum. No subjects or topics prohibited by state or
3 federal law shall be taught.¹ The Director of Schools shall develop administrative procedures to
4 implement this policy.

5 **STATE STANDARDS²**

6 Only Tennessee state standards shall be taught within the school district. The following are prohibited:

- 7 1. Instructional materials, textbooks, or supplemental materials created to align exclusively with
8 Common Core; or
9
10 2. Instructional materials, textbooks, or supplemental materials that are marketed or otherwise
11 identified as Common Core textbooks or instructional materials.

12 **CURRICULUM AND INSTRUCTIONAL PROGRAMMING**

13 All curriculum and instructional programming implemented in the school district shall adhere to state
14 and federal laws. District employees shall not include or promote any concepts that would violate state
15 law when providing instruction, using instructional or supplemental materials, or when implementing
16 the instructional program and curriculum.¹

17 The Director shall develop procedures to ensure that the district's instructional program complies with
18 state law.

Legal References

1. Public Acts of 2021, Chapter No. 205; Public Acts of 2021, Chapter No. 281; Public Acts of 2021, Chapter No. 471; Public Acts of 2021, Chapter No. 493
2. TCA 49-1-302(a)(8); TCA 49-1-314

Cross References

Controversial Issues 4.800
Controversial Materials 4.801

Hickman County Board of Education

	Descriptor Term: Curriculum Development	Descriptor Code: 4.200	Issued Date: 02/03/20
		Rescinds: 4.200	Issued: 12/04/17

1 Under the leadership and direction of the curriculum director, a unified curriculum shall be developed
2 within the statewide curriculum framework for the school system in each subject area, grades K-12,
3 and presented to the Board for adoption.^{1,2}

4 Teachers in each school shall participate in the systemwide development of the curriculum in their
5 appropriate subject areas. Assignments for curriculum development in the elementary grades will be
6 made by the principal.

7 The curriculum will be revised and updated regularly through in-service programs and curriculum
8 planning sessions, with changes subject to approval by the Board.

9 At least one copy of the complete curriculum shall be placed in each school. Teachers shall be given a
10 personal copy of the portion which pertains to their area of teaching. New teachers shall be given an
11 appropriate copy and briefed on its content in relation to the total curriculum.

12 Each teacher shall follow a course of study based on curriculum guides and textbooks. The prepared
13 course of study shall be reviewed annually and regularly updated and must be related to the individual
14 needs and abilities of the students.

15 Experimentation with newer concepts of curriculum design, scheduling, and instructional techniques is
16 encouraged but must have prior approval of the principal. An experimental program requires the
17 approval of the director of schools, the Board, the Commissioner of Education and the State Board of
18 Education.²

19 A course may become a permanent part of the school program after three (3) years of operation upon
20 approval of the State Board of Education.²

21 **IMPLEMENTATION**

22 The primary responsibility for the effective operation of the curriculum program and activities shall be
23 delegated to the director of schools.

24 The instructional supervisors, principals and teachers shall work cooperatively in the instructional
25 program.

26 The school principals shall be responsible for administering the established instructional programs and
27 for the development and supervision of a coordinated plan for the improvement of instruction in their
28 schools.

Legal References

1. TCA 49-1-302(a)(1)-(3), (8)
2. TRR/MS 0520-01-03-.05(1)(a); TRR/MS 0520-01-03-.05(2)

Cross References

Evaluations of Instructional Programs 4.702
In-Service & Staff Development Opportunities 5.113
Staff Rights & Responsibilities 5.600
Staff Time Schedules 5.602

Hickman County Board of Education

	Descriptor Term: <h2 style="text-align: center;">Basic Program</h2>	Descriptor Code: 4.201	Issued Date: 02/03/20
		Rescinds: 4.201	Issued: 01/06/20

1 The Board shall not discriminate on the basis of sex, race, national origin, creed, age, marital status in
 2 its educational programs or activities.

3 Pupil-teacher ratios shall not exceed the averages outlined in state law. Further, class sizes shall not
 4 exceed the maximum allowed by state law.¹

5 Curriculum material utilized shall reflect the cultural and racial diversity present in the United States
 6 and the variety of careers, roles and life-styles open to women as well as men in our society. One of the
 7 objectives of the total curriculum and teaching strategies is to reduce stereotyping and to eliminate bias
 8 on the basis of sex, race, ethnicity, religion and disability. The curriculum shall foster respect and
 9 appreciation of the cultural diversity found in our country and an awareness of the rights, duties and
 10 responsibilities of each individual as a member of a pluralistic society.²

11 The course of study in the schools shall include those subjects required by the Legislature and
 12 Tennessee State Board of Education as follows: reading, writing, spelling, arithmetic, English,
 13 geography, hygiene, sanitation, music, drawing, black history and culture, physical education, and free
 14 enterprise. Specific topics required in the schools include: nature of alcoholic drinks, narcotics and
 15 smoking of cigarettes and their effect upon the human system; history of Tennessee and its
 16 Constitution; history of the United States and its Constitution; displaying of the American flag;
 17 highway safety; and defensive driving.

18 The Board reserves the right to add additional courses and to amend the content of prescribed courses
 19 as experience and the process of curriculum development indicate the desirability of such change.³

Legal References

1. TCA 49-1-104; TRR/MS 0520-01-03-.03(3)
2. 42 USCA § 12101; 34 CFR § 106.34
3. TCA 49-6-1001 to 1034, 1201-1205, 1301, 1302

Cross References

- Graduation Requirements 4.605
- Religious Content of Courses 4.804
- Student Goals 6.100
- Student Concerns, Complaints, and Grievances 6.305

Hickman County Board of Education

	Descriptor Term: Lifetime Wellness	Descriptor Code: 4.2012	Issued Date: 02/03/20
		Rescinds: 4.2012	Issued: 12/04/17

1 Students in grades 9-12 shall complete a unit of lifetime wellness, a planned program to promote a
2 lifelong process of positive lifestyle management that seeks to integrate the emotional, social,
3 intellectual and physical dimensions of self for a longer, more productive, and higher quality of life, as
4 a requirement for graduation.¹

5 Participation in marching band or interscholastic athletics shall not be substituted for this requirement.¹

6 Members of the professional staff shall work with the county and state health departments, the welfare
7 department and members of the medical profession in promoting a program of good health for all
8 pupils. Indications of a health problems shall be reported to the principal and the parents.

9 The following topics shall be included as part of the lifetime wellness course to help students reach the
10 specified goals in the curriculum framework:

- 11 1. Disease Prevention and Control
- 12
- 13 2. Safety and First Aid
- 14
- 15 3. Mental Health
- 16
- 17 4. Nutrition
- 18
- 19 5. Substance Use/Abuse
- 20
- 21 6. Sexuality and Family Life
- 22
- 23 7. Personal Fitness and Related Skills

Legal References

1. TRR/MS 0520-01-03-.06(1)(a)(14)

Cross References

Student Drug and Alcohol Use 6.307
Acquired Immune Deficiency Syndrome (AIDS) 6.404

Hickman County Board of Education

	Descriptor Term: Family Life Education	Descriptor Code: 4.2013	Issued Date: 08/02/21
		Rescinds: 4.2013	Issued: 10/05/20

1 A family life education program shall be implemented within the school district in compliance with state
2 law.¹

3 The Board shall annually evaluate the program and shall conduct public hearings and parental
4 conferences at least once (1) each September as part of the evaluation.

5 A parent who chooses not to have a student participate in the family life education program shall
6 submit such request in writing to the director of schools. A student who is excused from family life
7 instruction shall be assigned alternative activities and shall not be penalized academically.

8 Prior to implementing the family life education curriculum, the Board shall conduct at least one (1)
9 public hearing at which the plan will be explained and parents and community members shall be given
10 the opportunity to express their opinions.

11 The goals of instruction for the family life education program shall be to:²

- 12 1. Provide accurate information about human reproduction, including conception, birth, and
13 prenatal care, with specific emphasis on the family unit and the responsibilities and consequences
14 relating to sexual activity;
- 15 2. Adapt this information to the age and grade level of students;
- 16 3. Promote, encourage and increase communication between parents and students;
- 17 4. Increase decision-making skills;
- 18 5. Offer information that will help students act responsibly;
- 19 6. Enhance and develop the student's self-esteem; and
- 20 7. Provide instruction on the prevention of dating violence.

21 Within these goals and at appropriate age and grade levels, the information presented will include:

- 22 1. Anatomy, physiology, and psychology of adolescence and sexual growth;
- 23 2. Marriage and responsibilities of family life;
- 24 3. Responsibilities of parents and child care;
- 25 4. Legal aspects of sexual conduct;
- 26 5. Self-respect, self-control, and individual differences among people;
- 27 6. Community resources;
- 28 7. Pregnancy and childbirth; and

- 1 8. Instruction on education, intervention, prevention, and treatment of: (A) child sexual abuse,
2 including such abuse that may occur in the home, in accordance with the declarations and
3 requirements of §§ 37-1-601(a) and 37-1-603(b)(3); and (B) Human trafficking in which the
4 victim is a child.
- 5 Instruction on family life education shall emphasize that abstinence from sexual relations is the only
6 method of protection that is 100% effective.
- 7 Personnel involved in instruction regarding human sexuality will conduct such instruction with
8 maturity and discretion. Personnel providing family life instruction shall receive in-service training
9 prior to presenting such instruction.

Legal References

1. TCA 49-6-1302; Public Acts of 2021, Chapter No. 290
2. TCA 49-6-1304

Hickman County Board of Education

Descriptor Term: Special Education	Descriptor Code: 4.202	Issued Date: 02/03/20
	Rescinds: 4.202	Issued: 12/04/17

1 The Board shall provide access to a free appropriate public education to all handicapped children ages
2 3- 21, inclusive, residing within the jurisdiction of the school system. The plan for implementation of
3 appropriate instruction and special education services shall be in accordance with the current Rules,
4 Regulations, and Minimum Standards of the State Board of Education,¹ and state² and federal³ law.

5 The Board shall develop and periodically update a local plan for providing special education services
6 for handicapped students. Specifically, the Board assures that:

- 7 1. All handicapped children living within the school system have available to them a free,
8 appropriate public education which emphasizes special education and related services to meet
9 their unique needs; and
- 10 2. The rights of handicapped children and their parents are protected.

11 The plan shall aim toward meeting the following objectives:

- 12 1. To carry out a comprehensive screening and assessment plan emphasizing the early
13 identification and evaluation of handicapped students.
- 14 2. To use the Individual Educational Program (IEP-Team) for reviewing assessment, formulating
15 programming, and determining placement for every handicapped student, including review of
16 proposed suspensions when appropriate, in accordance with the State Board of Education
17 Rules, Regulations, and Minimum Standards;
- 18 3. To ensure that placements are made which educate handicapped children with non-handicapped
19 to the maximum extent appropriate in the schools these children would normally attend if not
20 handicapped and with age-appropriate peers;
- 21 4. To provide each handicapped child with an individual educational program (IEP) specifically
22 designed to meet his unique needs;
- 23 5. To provide continuing evaluation of each handicapped child's progress, including at least
24 annual review of his IEP and complete re-evaluation at least every three (3) years;
- 25 6. To ensure that procedural safeguards required by state and federal laws are adhered to; and
- 26 7. To involve parents of handicapped children in a meaningful dialogue with school personnel
27 which will begin with initial referral and continue throughout the student's educational career.

Legal References

1. TRR/MS 0520-01-09
2. TCA 49-10-101 et seq.
3. Education of Individuals with Disabilities, 20 U.S.C. Sections 1400-1485; Section 504 of the Rehabilitation Act of 1973 (Note: Section 504 of the Rehabilitation Act of 1973 has been interpreted by the courts to protect individuals with contagious diseases.)

Cross References

Compulsory Attendance Ages 6.201
Alternative School Program 6.319
Student Communicable Diseases 6.403
Acquired Immune Deficiency Syndrome 6.404
Special Education Students 6.500

Hickman County Board of Education			
	Descriptor Term: Summer Instructional Programs	Descriptor Code: 4.204	Issued Date: 08/02/21
		Rescinds: 4.204	Issued: 02/03/20

1 *General*

2 The following programs will be made available to students:^{1,2}

- 3 1. Traditional summer school;
- 4
- 5 2. Learning loss bridge camps;
- 6
- 7 3. After-school learning mini camps (2021-2023); and
- 8
- 9 4. Summer learning camps (2021-2023).

10 These programs shall be organized and operated in accordance with state law as well as guidelines
 11 provided by the Tennessee Department of Education. Funding for all programming shall be provided
 12 for in the annual budget and take into account any available grants. The Board may adopt tuition rates
 13 for those students attending a traditional summer school program.³

14 **SUMMER PROGRAMMING²**

15 The Director of Schools shall present a recommended summer programming plan to the Board each
 16 year, no later than the regularly scheduled May meeting, outlining the following:

- 17 1. Courses offered;
- 18
- 19 2. Transportation;
- 20
- 21 3. Class size ratios;
- 22
- 23 4. Budget, including staff compensation;
- 24
- 25 5. School nutrition needs;
- 26
- 27 6. Staffing;
- 28
- 29 7. Enrollment criteria; and
- 30
- 31 8. Any additional necessary information.

32 **ATTENDANCE REQUIREMENTS²**

- 1 Priority students, as defined by state law, shall not be required to attend summer programs.
- 2 Local attendance requirements are listed in the administrative procedures.
- 3 The Director of Schools shall be responsible for developing administrative procedures regarding the
- 4 attendance requirements of priority students in each program.

Legal References

1. TRR/MS 0520-01-03-.03(9)
2. Public Acts of 2021, Special Legislative Session, Chapter No. 1
3. TCA 49-6-3003

Cross References

Extended Contracts 5.112

Hickman County Board of Education

	Descriptor Term: Enrollment in Advanced Courses	Descriptor Code: 4.205	Issued Date: 08/02/21
		Rescinds: 4.205	Issued: 10/05/20

1 *General*

2 Students in grades seven through twelve (7-12) may enroll in available advanced courses including, but
3 not limited to, advanced English language arts, mathematics, or science courses.¹

4 To enroll in these courses, students shall meet the following standards:

- 5 1. Honors Courses: grades and TCAP/EOC scores
- 6 2. Dual Credit Courses: grades and TCAP/EOC scores
- 7 3. Industry Certification-Aligned Courses: grades and TCAP/EOC scores
- 8 4. Dual Enrollment: grades and TCAP/EOC scores
- 9 5. Advanced Placement: grades and TCAP/EOC scores
- 10 6. Cambridge International: grades and TCAP/EOC scores
- 11 7. College Level Exam Program: grades and TCAP/EOC scores
- 12 8. International Baccalaureate: grades and TCAP/EOC scores

13 The principal of each school shall have the authority to require additional criteria for the
14 enrollment in advanced courses to fit the needs of the students within the school.

15 **NOTIFICATION¹**

16 Parent(s)/guardian(s) shall be provided written notification of a student's eligibility to enroll in
17 advanced courses. The notification shall state that a student will remain enrolled in the course unless
18 the parent/guardian timely submits a written request for removal. The Director of Schools shall
19 determine the deadline to submit the request for removal.

20 Students may also be removed from an advanced course if the student's teacher determines that the
21 student should be removed based on performance after thirty (30) days of instruction and the principal
22 approves the request to remove the student.

23 **COLLEGE LEVEL COURSES²**

24 Students may earn credit by enrolling in a postsecondary institution and taking college level courses.
25 Students who take and pass dual enrollment courses at a postsecondary institution shall have their
26 postsecondary credits accepted for high school credit as a substitution for an aligned graduation
27 requirement course.

28 These courses may be offered at the high school, postsecondary institution, or online. If not offered on
29 the high school campus, the Board shall not be responsible for transportation. Any tuition or fees due to
30 enrollment in college level courses are the responsibility of the parent(s)/guardian(s).

- 1 Grades earned in such college level courses shall be used to determine class rank, grade point average,
- 2 and class valedictorian or salutatorian.

3 **DUAL ENROLLMENT**

- 4 Students may earn credit by enrolling in a postsecondary institution and taking college level courses.
- 5 Students who take and pass dual enrollment courses at a postsecondary institution shall have their
- 6 postsecondary credits accepted for high school credit as a substitution for an aligned graduation
- 7 requirement course.³

Legal References

1. Public Acts of 2021, Chapter No. 170; State Board of Education Policy 3.301
2. TRR/MS 0520-01-03-.03(8)
3. TRR/MS 0520-01-03-.03(4)(c)

Hickman County Board of Education

	Descriptor Term: Homebound Instruction	Descriptor Code: 4.206	Issued Date: 10/04/21
		Rescinds: 4.206	Issued: 02/03/20

1 The homebound instruction program is for students who because of a medical condition are unable to
2 attend the regular instructional program.¹ The homebound instruction program shall consist of three (3)
3 hours of instruction per week for a period of time determined, on a case-by-case basis, by the district.

4 To qualify for this program, a student shall have a medical condition that will require the student to be
5 absent for a minimum of ten (10) consecutive instructional days, or for an aggregate of at least ten (10)
6 instructional days for a student who has a chronic medical condition. The student shall be certified by
7 his/her treating physician as having a medical condition that prevents him/her from attending regular
8 classes. The services provided to the homebound student shall reflect the student's capabilities and be
9 determined by the homebound instructor, after consultation with appropriate professional staff of the
10 student's assigned school.

11 Recertification shall be obtained after the expiration of each period of homebound instruction if the
12 student's physician certifies, in writing, that the student has a medical condition that prevents him/her
13 from returning to the regular instructional program.

14 **COVID-19 QUARANTINE²**

15 Students on homebound instruction who are temporarily quarantined due to a positive COVID-19 test
16 result or possible exposure to COVID-19 may participate in remote instruction during the period of
17 quarantine only.

Legal References

1. TCA 49-10-1101; TRR/MS 0520-01-02-.10
2. TRR/MS 0520-01-13-.01(d)(1)

Cross References

Alternative Credit Options 4.209
Virtual Education Program 4.212
Student Communicable Diseases 6.403
Acquired Immune Deficiency Syndrome 6.404

Hickman County Board of Education

	Descriptor Term: English Learners	Descriptor Code: 4.207	Issued Date: 02/03/20
		Rescinds: 4.207	Issued: 12/04/17

1 If the inability to speak and understand the English language excludes a student from effective
2 participation in the educational programs offered by the district, the district shall take reasonable actions
3 to provide the student equal access to its programs. Students who are English learners (“EL”) shall be
4 identified, assessed, and provided appropriate services. No child shall be admitted to or excluded from
5 any program or extra-curricular activity based on the student’s surname or EL status.¹

6 The director of schools shall evaluate the effectiveness of the district’s language assistance programs to
7 ensure EL students will acquire English proficiency and the ability to participate in the standard
8 instructional program within a reasonable period of time.

9 ENGLISH LANGUAGE INSTRUCTION PROGRAM

10 The board directs the administration to develop and implement language instruction programs that:²

- 11 1. Appropriately identify EL students in a timely, valid, and reliable manner.
- 12 2. Determine the appropriate instructional environment for EL students.
- 13 3. Provide EL students with a language assistance program that is educationally sound and proven
14 successful.
- 15 4. Annually assess the English proficiency of EL students and monitor the progress of students in
16 order to determine their readiness for standard instructional program.
- 17 5. Monitor the progress of students that have exited the EL program.

18 PARENTAL NOTIFICATION³

19 Parents of EL students shall be given notice of, and information regarding, the instructional program
20 within the first thirty (30) days of the school year, or within the first two weeks of a student being placed
21 in a language instruction educational program (LIEP). At a minimum, the notice will include the
22 following:³

- 23 1. The reason for identifying the child as an EL student;
- 24 2. The child’s level of English language proficiency, including how the level was assessed, and the
25 status of the child’s academic achievement;
- 26 3. Methods of instruction used in the program, methods of instruction in other available programs,
27 and how they differ;

- 1 4. How the program meets the educational strengths and needs of the student, and how the program
2 will help the student reach English language proficiency and meet academic standards;
- 3 5. Program exit requirements, rate of transition to a standard instructional program classroom, and
4 expected rate of high school graduation;
- 5 6. How the program meets the goals of an EL student with an IEP; and
- 6 7. Information on the parents' right to withdraw the student from the program or choose another
7 program or method of instruction if available.
- 8 Parental involvement will be encouraged and parents will be regularly apprised of their child's progress.⁴

Legal References

1. Elementary and Secondary Education Act, as amended by ESSA (Pub. L. 114-95), § 1112(e)(3)(D); State Board of Education Policy 3.207
2. Elementary and Secondary Education Act, as amended by ESSA (Pub. L. 114-95), § 3113(b)(3)(B); State Board of Education Policy 3.207
3. Elementary and Secondary Education Act, as amended by ESSA (Pub. L. 114-95), § 1112(e)(3)(A); State Board of Education Policy 3.207
4. Elementary and Secondary Education Act, as amended by ESSA (Pub. L. 114-95), § 1112(e)(3)(C); State Board of Education Policy 3.207

Hickman County Board of Education

	Descriptor Term: Adult Education Program	Descriptor Code: 4.208	Issued Date: 02/03/20
		Rescinds: 4.208	Issued: 01/08/18

- 1 An Adult Education Program shall be provided to enable students and out-of-school youth who are
2 seventeen (17) years of age and over to meet high school graduation requirements and receive a high
3 school diploma.^{1,2}
- 4 The director of schools shall appoint a member of the staff to coordinate, plan and develop the
5 program.
- 6 Written parental permission and the approval of the coordinator is required for those students under 18
7 years of age.

Legal References

1. TCA 49-6-409; TRR/MS 0520-01-02-.05

Hickman County Board of Education

	Descriptor Term: Alternative Credit Options	Descriptor Code: 4.209	Issued Date: 02/03/20
		Rescinds: 4.209	Issued: 08/05/19

1 **ONLINE COURSES**

2 High school students may earn credit to be applied toward graduation requirements by completing online
3 courses offered through agencies or institutions approved by the Board. Credit from these online courses
4 may be earned only in the following circumstances:

- 5 1. The course is not offered at the high school, or although the course is offered at the high school,
6 the student has an unavoidable scheduling conflict;
- 7 2. The course will serve as a supplement to homebound instruction;
- 8 3. The student had been served by a recognized home school during the 2018 – 2019 school year
9 and has re-enrolled in the local education agency;
- 10 4. The student has been expelled from a regular school setting, but educational services are to be
11 continued; or
- 12 5. The principal, with agreement from the student's teachers and parent(s)/guardian(s), determines
13 the student requires a differentiated or accelerated learning environment.

14 The express approval of the principal/designee shall be obtained before a student enrolls in an online
15 course. Enrollment in approved online courses will be considered on a case by case basis by the principal
16 and teachers. The school shall receive an official record of the final grade before credit toward graduation
17 will be recognized.

18 Through a supervision plan, the school shall be responsible for providing appropriate supervision and
19 monitoring of students taking online courses.

20 **COURSE ACCESS PROGRAM**

21 Students in grades seven through twelve (7-12) may participate in the statewide course access
22 program. To become eligible to participate, students shall:

- 23 1. Meet all prerequisite requirements for the course access course; and
- 24 2. Be unable to enroll in a comparable course at the student's school because:
 - 25 a. A comparable course is not offered; or
 - 26 b. A legitimate situation exists that prevents the student from enrolling in a comparable
27 course.¹
- 28

- 1 The Director of Schools shall develop administrative procedures to ensure that students and
2 parent(s)/guardian(s) are given written notice of their right to appeal any denial of a course access
3 course enrollment in a timely manner.² All appeals shall be submitted in writing to the Board within
4 ten (10) days of a denial.
- 5 After a timely appeal is made, the Board will provide written notification to the student and
6 parent(s)/guardian(s) of the time, place, and date of the hearing. The hearing shall be held no later than
7 ten (10) days after the appeal is submitted. At the hearing, the Board shall determine whether there was
8 an error in denying the student the ability to participate in the course access program.³

Legal References

1. TRR/MS 0520-01-14-.03(1)
2. TRR/M 0520-01-14-.03(7)
3. TRR/MS 0520-01-14-.03(6)

Cross References

Homebound Instruction 4.206
Grading System 4.600
Graduation Requirements 4.605

Hickman County Board of Education

	Descriptor Term: Credit Recovery	Descriptor Code: 4.210	Issued Date: 02/03/20
		Rescinds: 4.210	Issued: 01/08/18

1 **GENERAL**¹

2 The director of schools shall ensure that credit recovery facilitators receive training regarding course
3 organization, online instruction management and related technology.

4 Credit recovery teachers shall comply with all State Board of Education certification requirements.¹

5 **ADMISSION AND REMOVAL**²

6 No student shall be admitted to or otherwise enrolled in credit recovery courses unless:

- 7 1. The student's parent/guardian gives written consent for the student to enroll in the proposed
8 credit recovery course. Parents/guardians should be informed that not all postsecondary
9 institutions will accept credit recovery courses for credit and that the NCAA Clearinghouse will
10 not accept credit recovery courses for credit; and
11
- 12 2. The student has previously taken an initial, non-credit recovery section of the proposed course
13 and received a grade of at least fifty percent (50%). Students who receive a grade of below fifty
14 percent (50%) in the non-credit recovery section of the course must re-take the course.

15 If a student is seeking to recover credit for the first semester of a two-semester course, the student may
16 not receive the full credit for the course until he/she has enrolled in and passed the second semester of
17 the course and taken any applicable End of Course examinations.

18 The board shall track students enrolled in credit recovery courses as directed by the Tennessee
19 Department of Education.

20 **INSTRUCTION AND CONTENT**³

21 Credit recovery teachers shall work closely with credit recovery facilitators to correlate class content
22 and instruction.

23 The director of schools shall ensure that all credit recovery courses:

- 24 1. Align with Tennessee's current academic standards for the relevant course content area, as
25 approved by the State Board of Education; and
26
- 27 2. Differentiate instruction to address individual student growth needs based on diagnostic
28 assessment or End of Course data.

1 Students in credit recovery programs shall:

- 2 1. Complete a course skill-specific diagnostic to determine skill-specific goals;
- 3
- 4 2. Meet individual skill-specific goals in a flexible time frame as established by identified student
- 5 need; and
- 6
- 7 3. Master all individualized skill-specific goals as established by the diagnostic process in order to
- 8 earn credit.

9 **GRADES⁴**

10 Students passing credit recovery shall receive a grade of seventy percent (70%).

11 Grades awarded in credit recovery courses shall adhere to the State Board of Education's Uniform
12 Grading Policy.⁵

Legal References

1. SBOE Policy 2.103(7)(b)
2. SBOE Policy 2.103(7)(c)
3. SBOE Policy 2.103(7)(d)
4. SBOE Policy 2.103(7)(e)
5. SBOE Policy 3.301

Cross References

Grading System 4.600
Promotion and Retention 4.603

Hickman County Board of Education

	Descriptor Term: Work Based Learning Program	Descriptor Code: 4.211	Issued Date: 02/03/20
		Rescinds: 4.211	Issued: 12/04/17

- 1 Students shall have access to a system of structured work-based learning (WBL) experiences that allow
- 2 them to apply classroom theories to practical problems as well as explore career options.

- 3 The director of schools shall develop administrative procedures to govern the efficient administration
- 4 of the WBL program. Such procedures shall include, among other things, a process for evaluation and
- 5 assessment of the program to ensure that it is of high quality and meets the needs of students.¹

Legal References

1. State Board of Education Policy 2.103

Hickman County Board of Education

	Descriptor Term: Virtual Education Program	Descriptor Code: 4.212	Issued Date: 10/04/21
		Rescinds:	Issued:

1 *General*

2 The Hickman County virtual education program is a course or series of courses offered by a school
3 district to provide students a broader range of educational opportunities through the use of technology.
4 Utilizing this program is temporary and shall not replace a student's regular instructional program.¹

5 Class size ratios for the virtual education program shall comply with the requirements as outlined in
6 state law.²

7 Virtual education programs³ shall be made available to students for the following purposes:

- 8 1. Academic remediation, enrichment, or providing students access to a wider range of courses;
9
- 10 2. Continuity of educational service for students who are homebound;⁴
11
- 12 3. Continuity of educational service for students who are quarantining;⁵ and
13
- 14 4. Continuity of educational service for students enrolled in an alternative school.⁶

15 **ELIGIBILITY AND PARTICIPATION REQUIREMENTS**

16 Students shall be eligible to utilize a virtual education program if participating in one of the above
17 educational opportunities. The following factors shall also be taken into consideration when
18 determining eligibility:

- 19 1. Attendance;
20
- 21 2. Grades; and
22
- 23 3. Technology survey.
24

25 **ATTENDANCE**

26 Student attendance in the virtual education program shall adhere to the general requirements of board
27 policy 6.200 and any relevant administrative procedures.

28 Methods of confirming student attendance shall include two or more of the following:

- 1 1. Students participating in a phone call with a teacher, with parent/guardian support as
2 appropriate for the age of the student;
- 3
- 4 2. Students participating in synchronous virtual instruction;
- 5
- 6 3. Students completing work in a learning management system; or
- 7
- 8 4. Students submitting work via hard-copy or virtual formats.

9 **REMOVAL FROM VIRTUAL EDUCATION PROGRAM**

10 A student may be removed from the virtual education program or denied future enrollment in a virtual
11 education program based on disciplinary issues, attendance issues, or poor academic performance.

12 Before a student is removed based on poor academic performance, the following interventions shall
13 occur:

- 14 1. Notification of parent/guardian;
- 15
- 16 2. One-on-one assessment conducted by the principal/designee regarding any learning needs and
17 academic performance; and
- 18
- 19 3. One-on-one virtual support sessions with the student.

Legal References

1. TRR/MS 0520-01-03-.05(2)
2. TCA 49-1-104(h); State Board of Education Policy
3.206
3. TCA 49-16-101; TRR/MS 0520-01-03-.05(2)(a)
4. TRR/MS 0520-01-02-.10; TRR/MS 0520-01-09-.07
5. TRR/MS 0520-01-13-.01(1)(d)(1)
6. TRR/MS 0520-01-02-.09

Cross References

Homebound Instruction 4.206
Credit Recovery 4.210
Alternative Education 6.319

PROPOSED FUNDRAISING ACTIVITIES

Fund/account name Outdoor Playground

Proposed fundraising activities: Kona Ice Truck

Purposed Uses of funds raised Outdoor Playground supplies

Expected student involvement (school-wide or specific school organization) School-wide

Method by which school will receive profit Vendor will collect money and give school 20% of profits. All students will get a snow cone even if they don't pay. (Courtesy of the vendor)

Requested by Shelda Qualls / AP Name/Title Date 4/20/22

Approved by Jennifer Hudgin Principal Date 4/20/22

Approved by Michelle Hebert Director of Schools* Date 4/22/22

* The Director of Schools must approve all fundraising activities that involve the participation of the general student population in the marketing process of the fundraising effort.

PROPOSED FUNDRAISING ACTIVITIES

Fund/account name HCHS Cheer

Proposed fundraising activities: Calendar Sale - ^{April-} May

Purposed Uses of funds raised Uniforms, Warm-ups

Expected student involvement (school-wide or specific school organization) Cheer leaders

Method by which school will receive profit Cash, Check

Requested by Alison Stanley - Coach Date 4/13/22
Name/Title

Approved by Becky Malugi Date 4/22/22
Principal

Approved by Michelle Heibert Date 4/25/22
Director of Schools*

* The Director of Schools must approve all fundraising activities that involve the participation of the general student population in the marketing process of the fundraising effort.

PROPOSED FUNDRAISING ACTIVITIES

Fund/account name HCHS cheer

Proposed fundraising activities: Peach Sale - June

Purposed Uses of funds raised Poms, Signs, anything needed

Expected student involvement (school-wide or specific school organization) Cheerleaders

Method by which school will receive profit Cash, Check

Requested by Alison Stanley-Coach Date 4/13/22
Name/Title

Approved by Becky Malin Date 4/22/22
Principal

Approved by Michelle Hilvert Date 4/25/22
Director of Schools*

* The Director of Schools must approve all fundraising activities that involve the participation of the general student population in the marketing process of the fundraising effort.

PROPOSED FUNDRAISING ACTIVITIES

Fund/account name P.E. fund

Proposed fundraising activities: The sell of concessions on field day.

Purposed Uses of funds raised
Funds raised will be deposited in the PE account & used
for purchasing PE equipment

Expected student involvement (school-wide or specific school organization) _____
School wide

Method by which school will receive profit The selling of concession
goods.

Requested by Mason Rochelle Date 4-8-22
Name/Title

Approved by Marcy Tidwell Date 4-11-22
Principal

Approved by Michelle Hewitt Date 4/11/22
Director of Schools*

* The Director of Schools must approve all fundraising activities that involve the participation of the general student population in the marketing process of the fundraising effort.

please follow guidelines of
nutrition policy

PROPOSED FUNDRAISING ACTIVITIES



East Hickman High School
7700 Hwy 7, Lyles, TN 37098
Phone 931-670-1366 Fax 931-670-1039

Fund/Account Name

EHHS Tennis

Account Number

Proposed fundraising activities:

tennis round robin

Purposed Uses of funds raised:

purchase tennis equipment

Expected Student involvement (school-wide or specific school organization):

Students + community participation

Method by which school will receive profit:

Cash / checks

Requested by:

Robin Gilliam / tennis coach

Name/Title

4/14/22

Date

Approved by:

Kimberly Williams

Principal

4/21/22

Date

Approved by:

Michelle Hevert

Director of Schools*

4/22/22

Date

* The Director of Schools must approve all fundraising activities that involve the participation of the general student population in the marketing process of the fundraising effort.

X Bookkeeper Jeff Nordke

4-21-22 ended 4/2019

date



PROPOSED FUNDRAISING ACTIVITIES

East Hickman High School
7700 Hwy 7, Lyles, TN 37098
Phone 931-670-1366 Fax 931-670-1039

Fund/Account Name Cheerleading - Andrea Furkins

Account Number _____

Proposed fundraising activities: Shirt Sale - spirit wear (see attached)
May 2022 and August 2022

Purposed Uses of funds raised: Pay for bus rides to away
games throughout football and basketball
seasons.

Expected Student involvement (school-wide or specific school organization): Clem, middle,
and high ~~school~~ school

Method by which school will receive profit: Cash, Check

Requested by: Andrea M. Furkins / Head Coach
Name/Title

Date
4/14/22

Approved by: Kimberly Williams
Principal

Date
4/18/22

Approved by: Michelle Hebert
Director of Schools*

Date

* The Director of Schools must approve all fundraising activities that involve the participation of the general student population in the marketing process of the fundraising effort.

Apparel Order Form



Eagles Swoosh Design Short Sleeve Tee

Y Small - XL: \$15; 2X: \$17; 3X: \$18; 4X: \$19

- Y Small _____
- Y Medium _____
- Y Large _____
- Y XL _____
- Small _____
- Medium _____
- Large _____
- XL _____
- 2X _____
- 3X _____
- 4X _____

Sweatshirt

Y Small - XL: \$25; 2X: \$27; 3X: \$28; 4X: \$29

- Y Small _____
- Y Medium _____
- Y Large _____
- Y XL _____
- Small _____
- Medium _____
- Large _____
- XL _____
- 2X _____
- 3X _____
- 4X _____

Eagles Game Day Design Short Sleeve Tee

Y Small - XL: \$17; 2X: \$19; 3X: \$20; 4X: \$21

- Y Small _____
- Y Medium _____
- Y Large _____
- Y XL _____
- Small _____
- Medium _____
- Large _____
- XL _____
- 2X _____
- 3X _____
- 4X _____

Sweatshirt

Y Small - XL: \$27; 2X: \$29; 3X: \$30; 4X: \$31

- Y Small _____
- Y Medium _____
- Y Large _____
- Y XL _____
- Small _____
- Medium _____
- Large _____
- XL _____
- 2X _____
- 3X _____
- 4X _____

AMY BRYANT
9589 S. Lick Creek Rd., Lyles, TN 37098

JACKIE DEITMEN
1911 Dellmen Ln., Nunnely, TN 37137

TIM HOBBS
9220 Old Bon Aqua Rd., Bon Aqua, TN 37025

JIM HUDGINS
1297 E. Grinders Switch Rd., Centerville, TN 37033



Michelle Gilbert
SUPERINTENDENT
115 MURPHREE AVENUE
CENTERVILLE, TN 37033

JEWELL PRINCE
2439 Skyview Dr., Centerville, TN 37033

KATHY REDDEN
11379 Moss Branch Rd., Bon Aqua, TN 37025

MIKE THOMASSON
105 Hickory Trace, Lyles, TN 37098

**School Support Organization
Request For Fundraising Activities**

Organization Soar & Score Club

Proposed Fundraising Activity Free Throw Challenge

Date(s) June 4th, 2022

Location(s) East Hickman High School

Requested By Pippa Saylor
Resident/Chair of Organization

Date 4/25/2022

Recommended By Kimberly Williams
Principal

Date 4/25/2022

Approved Michelle Gilbert
Director of Schools or Designee

Date 4/27/22

Not Approved _____
Director of Schools or Designee

Date _____

X Joe Nordke
EHHS Bookkeeper

A signed copy will be mailed to the organization and forwarded to the school

PROPOSED FUNDRAISING ACTIVITIES

Fund/account name Cheerleading

Proposed fundraising activities: Calendar Sales

Purposed Uses of funds raised
Calendar sales to raise money to help with uniform cost.

Expected student involvement (school-wide or specific school organization) _____
Each Cheerleader is expected to participate

Method by which school will receive profit Cash or check

Requested by Mollie Chessor/ Cheer Coach Date 4-26-22
Name/Title

Approved by  Date 4-26-22
Principal

Approved by  Date 4/28/22
Director of Schools*

* The Director of Schools must approve all fundraising activities that involve the participation of the general student population in the marketing process of the fundraising effort.

PROPOSED FUNDRAISING ACTIVITIES

Fund/account name Cheerleading

Proposed fundraising activities: Peach Sale

Purposed Uses of funds raised
Funds are to be used to help with items and necessities that cheerleaders may need throughout
the school year.

Expected student involvement (school-wide or specific school organization) _____
Each Cheerleader is expected to participate

Method by which school will receive profit Cash or check

Requested by Mollie Chessor/ Cheer Coach Date 4-26-22
Name/Title

Approved by *Jina S. Higgins* Date 4.26.22
Principal

Approved by *Michelle Sivert* Date 4/28/22
Director of Schools*

* The Director of Schools must approve all fundraising activities that involve the participation of the general student population in the marketing process of the fundraising effort.