

HICKMAN COUNTY BOARD OF EDUCATION
REGULAR BOARD MEETING---December 7, 2020

The Hickman county Board of Education met on December 7, 2020, at 7:00 PM in Room 203 of the Central Office Building.

Call To Order

Moment of Silence

Pledge of Allegiance

Approval of November 2, 2020 Regular Meeting Minutes

Approval of Agenda

Special Recognition

Employee of the Month

Athletes Performing at the State Level

Communications to the Board

Director's Report

Financial Report

Family Resource Centers Mid-Year Report

Items Requiring Board Action

Budget Amendments

Request To Declare Surplus Property

Playground Equipment Bid Approval

Revised Board Policies - 5.200, 1.901, 4.401, 6.303, 6.405 (1st Reading)

Revised Board Policy - 5.501 (2nd Reading)

Board Policy Review - 5.605--5.803

Announcements

Board Retreat

Adjourn

Monday, November 2, 2020

REGULAR BOARD MEETING MINUTES

The Hickman County Board of Education met in regular session on Monday, November 2, 2020 at 7:00 p.m. in Room 203 of the Central Office building. School board members in attendance at the meeting were Chair Amy Bryant, Steve Gianakos, Ronald Gammons, Jane Herron and Jim Hudgins. Tim Hobbs and Vance Willis were absent.

After a moment of silence and the Pledge of Allegiance, Jim Hudgins made a motion to approve the minutes held on October 5, 2020. Ronald Gammons seconded the motion. On a voice vote, the motion was approved 5-0.

Steve Gianakos made a motion to approve the agenda for November 2, 2020. Ronald Gammons seconded the motion. On a voice vote, the motion was approved 5-0.

Jim Hudgins made a motion to approve to approve the director's report. The motion received a second from Jane Herron. On a voice vote, the motion was approved 5-0.

The financial report was present by Mike Elkins. Ronald Gammons made a motion to approve the financial report, as presented. Jim Hudgins seconded the motion. On a roll call vote Amy Bryant, Ronald Gammons, Steve Gianakos, Jane Herron, and Jim Hudgins voted aye. The motion carried 5-0.

Chair Amy Bryant presented the OPEB financial statement. A motion was made by Steve Gianakos to approve the report. Jim Hudgins seconded the motion. On a voice vote, the motion was approved 5-0.

JROTC instructor, Sgt. Riley, asked the board to approve three trips for the JROTC program. Ronald Gammons made a motion to approve the trips and it was seconded by Jim Hudgins. On a voice vote, the trips were approved 5-0.

Also, Sgt. Riley made a request that would allow the JROTC cadets a Dining-Out activity on March 27, 2021. Ronald Gammons made a motion to approve the event. Jane Herron seconded the motion. The motion was approved 5-0.

Mike Elik presented budget amendments to the board. Steve Gianakos made a motion to approve the budget amendments. Jim Hudgins seconded the motion. In a roll call vote Amy Bryant, Ronald Gammons, Steve Gianakos, Jane Herron, and Jim Hudgins voted aye. The budget amendments were approved 5-0.

Calendar Committee Chair, Julia Thomasson, presented the proposed school calendar for 2020-2021. Steve Gianakos made a motion to approve the calendar. Jim Hudgins seconded the motion. on a voice vote the motion was approved 5-0.

Don Qualls asked the board to approve two requests for splitting supplements. Ronald Gammons made a motion to approve the request. Jane Herron seconded the motion. On a roll call vote Amy Bryant, Ronald Gammons, Steve Gianakos, Jane Herron and Jim Hudgins voted aye. The motion was approved 5-0.

Mike Elkins asked the board to approve the lowest bid submitted by Firefly for the technology devices bid for 2020-2021. Jim Hudgins made the motion to approve Firefly as the winning bid for the technology devices. Ronald Gammons seconded the motion. On a roll call vote Amy Bryant, Ronald Gammons, Steve Gianakos, Jane Herron, and Jim Hudgins voted aye. The Firefly bid was approved 5-0.

Mike Elkins asked the print bid be awarded to Allegra in Dickson. Steve Gianakos made the motion to award the printing bid to Allegra. The motion was seconded by Jane Herron. On a roll call vote Amy Bryant, Ronald Gammons, Steve Gianakos, Jane Herron and Jim Hudgins vote aye. The Allegra bid was approved 5-0.

Mike Elkins also presented the school network upgrade bid and asked the board to approve BGC for that bid. Jim Hudgins made a motion to approve the bid. Ronald Gammons seconded the motion. on a roll call vote Amy Bryant, Ronald Gammons, Steve Gianakos, Jane Herron, and Jim Hudgins voted aye. The motion was approved 5-0.

Mike Plunkett presented the HVAC gym units bid. He asked that EHMS and EHES also add a unit to replace older units. He asked Trane be awarded the bid. Steve Gianakos made a motion to approved the request. Ronald Gammons seconded the motion. On a roll call vote Amy Bryant, Ronald Gammons, Steve Gianakos, Jane Herron, and Jim Hudgins voted aye. The motion was approved 5-0.

Mike Plunkett stated that no bids were received for waterproofing the foundation at the school bus garage. He did say that he had earlier received a quote from David Baker and this would not require a bid to repair. No board action was required.

Don Qualls asked the board to support a resolution be sent to the state asking for a moratorium on state standardized testing be considered for the 2020-2021 school year. Jim Hudgins made the motion to approve the board supporting a moratorium on state standardized testing for this school year. Ronald Gammons seconded the motion. On a voice vote, the motion was approved 5-0. Ronald Gammons also suggested that request be sent to our state representatives.

Mist Shelton asked the board to approve the compliance report. Jane Herron made a motion to approve the compliance report. Steve Gianakos seconded the motion. On a voice vote, the motion was approved 5-0.

Misty Shelton asked the that board policy 6.409 be approve. Ronald Gammon made a motion to approve the policy. The motion was seconded by Jim Hudgins. On a voice vote, the motion was approved 5-0.

Misty Shelton asked that board policies 5.200, 5.201, 5.202, 5.302, 5.303, 5.304, and 5.305 on second reading.

Jim Hudgins made a motion to approve the board policies on second reading. Ronald Gammons seconded the motion. on a voice vote, the motion was approved 5-0.

Misty Shelton also asked the board to approve board policies 5.4400 and 5.603 that were up for review. Jim Hudgins made a motion to approve the policies up for review (5.400 and 5.603). Ronald Gammons seconded the motion. on a voice vote the motion was approved 5-0.

No announcements were given.

Ronald Gammons made a motion to adjourn. Jim Hudgins seconded the motion. The motion passes 5-0.

The meeting was adjourned at 7:45 p.m.

AMY BRYANT

9589 S. Lick Creek Rd , Lyles, TN 37098

RONALD GAMMONS

8419 Rice Ln., Lyles, TN 37098

TIM HOBBS

9220 Old Bon Aqua Rd. Bon Aqua, TN 37025

JIM HUDGINS

1297 E. Grinders Switch Rd. Centerville, TN 37033



Michelle Gilbert

Director of Schools
115 MURPHREE AVENUE
CENTERVILLE, TN 37033

JANE HERRON

1222 Hwy 100., Centerville, TN 37033

STEVE GIANAKOS

9792 Dogwood Dr., Bon Aqua, TN 37025

VANCE WILLIS

2868 Hwy 48 N., Nunnally, TN 37137

The Hickman County Board of Education will meet in regular session on Monday, December 7, 2020, at 7:00 p.m. in Room 203 of the Central Office building. A work session will be held at 6:00 p.m. in Room 203 of the Central Office building.

- I. Call to Order
- II. Moment of Silence
- III. Pledge of Allegiance
- IV. Approval of November 2, 2020 Regular Board Meeting Minutes
- V. Approval of Agenda
- VI. Special Recognition
 - A. Employee of the Month--Steve Gianakos
 - B. Athletes Performing at the State Level--Jane Herron
- VII. Communications to the Board
 - A. Director's Report--Director of Schools
 - B. Financial Report--Business Officer
 - C. Family Resource Center Mid-Year Report--Family Resource Center Directors
- VIII. Items Requiring Board Action
 - A. Budget Amendments--Business Officer
 - B. Request To Declare Surplus Property--Director of Special Programs
 - C. Playground Equipment Bid Approval--Business Officer
 - D. Revised Board Policies 5.200, 1.901, 4.401, 6.303, 6.405 (1st Reading)--Director of Accountability
 - E. Revised Board Policy 5.501 (2nd Reading)--Director of Accountability
 - F. Board Policy Review 5.605--5.803--Director of Accountability
- IX. Announcements--Board Retreat
- X. Adjourn

Michelle Gilbert
Director of Schools
Hickman County Schools
115 Murphree Avenue
Centerville, TN 37033

Re: Recommendation for District Employee of the Month

October 22, 2020

Dear Mrs. Gilbert:

Hickman County Schools is brimming with high-quality candidates who are worthy of being honored by the Board of Education. When considering potential administrators, many names came to mind. Thinking about classroom instructors, we could rattle off several exceptional educators. The support staff in our schools always goes above and beyond its listed duties. Our coaches and assistant coaches pour out their blood, sweat, and tears for our young scholar athletes throughout the year. How would we ever choose one person to be honored as Employee of the Month?

Then we came to EHHS Athletic Director and Coach Aaron Taylor. He undoubtedly fits all the criteria of worthiness. As Athletic Director, he attends all EHHS games and most competitions countywide, and he surely participates in all district and regional meetings. At those games, home and away both, we'll see him following the team down the field from the sidelines cheering and supporting our players. He is a champion for all students, but in his role as AD, he is a true champion for Hickman County and its school system. If a player is injured, he's with the gurney and at the ambulance. He supports and comforts concerned, even angry parents--all with a gentle and compassionate, genuine spirit. We'll see him selling tickets, cutting grass, and even driving from Columbia late at night just to check the security and condition of our sporting venues. Even with all of his duties as AD, when our school needed a head basketball coach, Aaron Taylor stepped up and said, "I'll do it."

Coach Taylor's level of excellence isn't confined to the fields and courts of our athletes, though. Inside the building he is also a champion. If students aren't on track to graduate or are in situations at home which affect their academic performance, Coach Taylor is hunting them down, drawing them in, and leading them to new heights. He gives them hope. He gives them new perspectives. He gives them Eagle wings. Verily, he gives them love. Aaron Taylor takes special interest in the students who need it the most. Recently, he championed a special needs student in the ELC classroom. Coach T would spend time with this student daily, taking walks and having talks, being a friend.

No matter what he faces personally, our AD shines as an example to others. He is an Eagle soaring high. He is a Bulldog fighting for our students, our athletes, and our parents. He is a Hickmanite through and through, even when he's in Maury, Lewis, Perry, Houston, Montgomery, Williamson, Lawrence, Decatur, Stewart, Cheatham, Marshall, Dickson, Humphreys, Benton or Bedford counties. He is one of us, and we are united as one for him. Please take special consideration for this special employee and make him district Employee of the Month.

Respectfully,

Scott Angell
Beth Robinson
Priscilla Smith

East Hickman High School Staff

AMY BRYANT

9589 S. Lick Creek Rd., Lyles, TN 37098

RONALD GAMMONS

8419 Rice Ln., Lyles, TN 37098

TIM HOBBS

9220 Old Bon Aqua Rd., Bon Aqua, TN 37025

JIM HUDGINS

1297 E. Grinders Switch Rd., Centerville, TN 37033



Michelle Gilbert

Director of Schools
115 MURPHREE AVENUE
CENTERVILLE, TN 37033

JANE HERRON

1222 Hwy 100., Centerville, TN 37033

STEVE GIANAKOS

9782 Dogwood Dr., Bon Aqua, TN 37025

VANCE WILLIS

2868 Hwy 48 N., Nunnally, TN 37137

Memorandum

To: Board Members
From: Michelle Gilbert
Date: November 24, 2020
RE: December Director's Report

Leave of Absence

Professional

Elizabeth Roberson
Emily Mobley

December 14, 2020-February 21, 2021 (FMLA)

Support Staff

Hiring

Professional

Brandi Cramer

Nurse

Support Staff

Donna Roberts
Ron Hull, Jr
Amanda Cochran
Lucindi Johnston
William McDonald
Joy Randolph
Sara Brown
Matilyn Herbison
Faryn Matney
Madelyn Owens
Alex Seagraves
Jessica Simpson

Bus Driver
Mechanic
Food Service
Substitute
Substitute
Substitute
Substitute
Substitute
Substitute
Substitute
Substitute
Substitute

Resignation

Professional

Support Staff

Kaitlyn Loveless

EHMS Part-Time

Retirement

Professional

Support Staff

Transfers

Professional

Stacia Anglin

CES Assistant Principal to Alternative School Teacher

Support Staff

Appointment

Professional

Support Staff

Open Positions

1 Secondary Personal Finance/ Economics Position

1 Secondary Math Position

2 Special Education Positions

2 Secondary Science Positions

1 Alternative Learning Environment Position

Bus Drivers

*denotes a relationship under the nepotism policy 1.108

The prospective employee(s) is duly qualified to occupy the position.

Template Name: LGC Summary
 Created by: LGC

Hickman County Finance
 Summary Financial Statement
 November 2020

User:
 Date/Time:

Michael Elkins
 12/7/2020 11:01 AM
 Page 1 of 4

141 General Purpose School		Year-To-Date			Month-To-Date		
Account	Description	Budget Estimate	Actual	% of Budget	Estimate Avg/Mth	Actual	% of Avg
Revenues							
40110	Current Property Tax	3,042,197.00	(540,243.04)	17.76 %	253,516.42	(162,688.64)	64.17 %
40120	Trustee's Collections - Prior Year	100,000.00	(27,962.44)	27.96 %	8,333.33	(4,687.40)	56.25 %
40125	Trustee's Collections - Bankruptcy	0.00	(123.23)	0.00 %	0.00	(4.44)	0.00 %
40130	Clr Clk/Clk & Master Collections-Pr Yr	55,000.00	(15,440.91)	28.07 %	4,583.33	(2,394.21)	52.24 %
40140	Interest And Penalty	21,000.00	(3,000.63)	14.29 %	1,750.00	(631.91)	36.11 %
40161	Payments In Lieu Of Taxes - T. V. A.	4,000.00	(1,452.60)	36.32 %	333.33	(291.77)	87.53 %
40162	Payments In Lieu Of Taxes-Local	6,000.00	0.00	0.00 %	500.00	0.00	0.00 %
40210	Local Option Sales Tax	1,550,000.00	(720,780.14)	46.50 %	129,166.67	(175,733.65)	136.05 %
40270	Business Tax	30,000.00	(3,502.78)	11.68 %	2,500.00	(619.35)	24.77 %
40320	Bank Excise Tax	30,000.00	0.00	0.00 %	2,500.00	0.00	0.00 %
40350	Interstate Telecommunications Tax	1,500.00	0.00	0.00 %	125.00	0.00	0.00 %
41110	Marriage Licenses	1,300.00	(750.50)	57.73 %	108.33	(199.50)	184.15 %
43517	Tuition - Other	2,000.00	(2,300.00)	115.00 %	166.67	0.00	0.00 %
43570	Receipts From Individual Schools	60,000.00	(1,703.60)	2.84 %	5,000.00	0.00	0.00 %
43582	Community Service Fees - Adults	200.00	(87.00)	43.50 %	16.67	0.00	0.00 %
44120	Lease/Rentals	1,000.00	(70.00)	7.00 %	83.33	(70.00)	84.00 %
44170	Miscellaneous Refunds	40,000.00	(8,047.89)	20.12 %	3,333.33	(99.00)	2.97 %
44530	Sale Of Equipment	5,000.00	(12,422.90)	248.46 %	416.67	0.00	0.00 %
44560	Damages Recovered From Individuals	3,000.00	0.00	0.00 %	250.00	0.00	0.00 %
44570	Contributions & Gifts	15,000.00	(3,534.00)	23.56 %	1,250.00	(2,780.00)	222.40 %
46511	Basic Education Program	22,516,000.00	(9,016,751.36)	40.05 %	1,876,333.33	(2,254,187.84)	120.14 %
46515	Early Childhood Education	419,362.00	(98,283.50)	23.44 %	34,946.83	(28,861.35)	82.59 %
46520	School Food Service	22,000.00	0.00	0.00 %	1,833.33	0.00	0.00 %
46550	Driver Education	10,000.00	0.00	0.00 %	833.33	0.00	0.00 %
46590	Other State Education Funds	240,000.00	0.00	0.00 %	20,000.00	0.00	0.00 %
46591	Coordinated School Health	90,000.00	0.00	0.00 %	7,500.00	0.00	0.00 %
46594	Family Resource Centers	59,223.00	(14,805.83)	25.00 %	4,935.25	0.00	0.00 %
46610	Career Ladder Program	60,000.00	(28,381.40)	47.30 %	5,000.00	(28,381.40)	567.63 %
46851	State Revenue Sharing -T.V.A.	250,000.00	(55,120.76)	22.05 %	20,833.33	(55,120.76)	264.58 %
46980	Other State Grants	300,000.00	0.00	0.00 %	25,000.00	0.00	0.00 %
46981	Safe Schools	88,000.00	0.00	0.00 %	7,333.33	0.00	0.00 %
46990	Other State Revenues	20,000.00	(5,046.06)	25.23 %	1,666.67	0.00	0.00 %
47640	Rotc Reimbursement	60,000.00	(20,180.43)	33.63 %	5,000.00	(6,879.69)	137.59 %
48990	Other	40,000.00	(4,500.00)	11.25 %	3,333.33	(2,000.00)	60.00 %
49700	Insurance Recovery	10,000.00	0.00	0.00 %	833.33	0.00	0.00 %
49800	Transfers In	25,000.00	0.00	0.00 %	2,083.33	0.00	0.00 %
Total Revenues		29,176,782.00	(10,584,491.00)	36.28 %	2,431,398.50	(2,725,630.91)	112.10 %

Template Name: LGC Summary
 Created by: LGC

Hickman County Finance
 Summary Financial Statement
 November 2020

User:
 Date/Time:

Michael Elkins
 12/7/2020 11:01 AM
 Page 2 of 4

141 General Purpose School		Year-To-Date			Month-To-Date		
Account	Description	Budget Estimate	Actual	% of Budget	Estimate Avg/Mth	Actual	% of Avg
Expenditures							
71100	Regular Instruction Program	(14,303,581.00)	5,074,385.42	35.48 %	(1,191,965.08)	1,453,785.98	121.97 %
71150	Alternative Instruction Program	(169,526.00)	28,416.20	16.76 %	(14,127.17)	4,521.19	32.00 %
71200	Special Education Program	(3,048,933.00)	799,895.19	26.24 %	(254,077.75)	208,381.95	82.02 %
71300	Career and Technical Education	(1,104,098.00)	292,448.17	26.49 %	(92,008.17)	66,140.78	71.89 %
72110	Attendance	(155,621.00)	58,402.61	37.53 %	(12,968.42)	9,685.14	74.68 %
72120	Health Services	(362,750.00)	106,460.83	29.35 %	(30,229.17)	26,068.85	86.24 %
72130	Other Student Support	(988,313.00)	270,774.00	27.40 %	(82,359.42)	69,804.53	84.76 %
72210	Regular Instruction Program	(1,292,398.00)	339,610.04	26.28 %	(107,699.83)	80,799.90	75.02 %
72220	Special Education Program	(119,202.00)	50,430.07	42.31 %	(9,933.50)	7,974.55	80.28 %
72230	Career and Technical Education	(109,671.00)	44,696.30	40.75 %	(9,139.25)	8,097.22	88.60 %
72250	Technology	(326,901.00)	225,933.32	69.11 %	(27,241.75)	12,256.99	44.99 %
72290	Other Programs	(35,000.00)	0.00	0.00 %	(2,916.67)	0.00	0.00 %
72310	Board Of Education	(669,000.00)	283,567.92	42.39 %	(55,750.00)	15,049.94	27.00 %
72320	Director Of Schools	(283,150.00)	126,099.14	44.53 %	(23,595.83)	17,557.80	74.41 %
72410	Office Of The Principal	(1,693,269.00)	588,217.59	34.74 %	(141,105.75)	140,103.83	99.29 %
72510	Fiscal Services	(45,000.00)	0.00	0.00 %	(3,750.00)	0.00	0.00 %
72610	Operation Of Plant	(2,356,000.00)	922,736.34	39.17 %	(196,333.33)	202,122.71	102.95 %
72620	Maintenance Of Plant	(952,438.00)	395,153.04	41.49 %	(79,369.83)	36,733.65	46.28 %
72710	Transportation	(2,332,170.00)	545,701.85	23.40 %	(194,347.50)	122,859.93	63.22 %
72810	Central And Other	(253,500.00)	13,961.09	5.51 %	(21,125.00)	9,540.20	45.16 %
73100	Food Service	(28,110.00)	0.00	0.00 %	(2,342.50)	0.00	0.00 %
73300	Community Services	(132,475.00)	35,439.33	26.75 %	(11,039.58)	7,874.40	71.33 %
73400	Early Childhood Education	(453,163.00)	133,392.73	29.44 %	(37,763.58)	32,114.83	85.04 %
76100	Regular Capital Outlay	(105,000.00)	77,192.14	73.52 %	(8,750.00)	0.00	0.00 %
99100	Transfers Out	(165,000.00)	0.00	0.00 %	(13,750.00)	0.00	0.00 %
	Total Expenditures	(31,484,269.00)	10,412,913.32	33.07 %	(2,623,689.08)	2,531,474.37	96.49 %
Total	141 General Purpose School	(2,307,487.00)	(171,577.68)	-7.44 %	(192,290.58)	(194,156.54)	-100.97

Template Name: LGC Summary
 Created by: LGC

Hickman County Finance
 Summary Financial Statement
 November 2020

User: Michael Elkins
 Date/Time: 12/7/2020 11:01 AM
 Page 3 of 4

142 School Federal Projects		Year-To-Date			Month-To-Date		
Account	Description	Budget Estimate	Actual	% of Budget	Estimate Avg/Mth	Actual	% of Avg
Revenues							
44170	Miscellaneous Refunds	0.00	0.00	0.00 %	0.00	0.00	0.00 %
47131	Vocational Educ - Basic Grants To	115,977.07	(46,394.20)	40.00 %	9,664.76	0.00	0.00 %
47141	Title 1 Grants To Local Educ Agencies	1,253,193.60	(338,031.37)	26.97 %	104,432.80	(102,396.90)	98.05 %
47143	Special Education - Grants To States	1,029,540.71	(235,232.02)	22.85 %	85,795.06	(61,285.82)	71.43 %
47145	Special Education Preschool Grants	34,359.88	0.00	0.00 %	2,863.32	0.00	0.00 %
47146	English Language Acquisition Grants	73,762.00	(16,503.58)	22.37 %	6,146.83	0.00	0.00 %
47148	Rural Education	173,963.39	(9,357.63)	5.38 %	14,496.95	0.00	0.00 %
47189	Eisenhower Prof Development State	224,055.14	(31,555.06)	14.08 %	18,671.26	0.00	0.00 %
47301	ARRA Grant #1	879,730.25	(437,949.80)	49.78 %	73,310.85	(115,735.42)	157.87 %
47590	Other Federal Through State	285,000.00	(65,172.00)	22.87 %	23,750.00	0.00	0.00 %
49800	Transfers In	0.00	0.00	0.00 %	0.00	0.00	0.00 %
Total Revenues		4,069,582.04	(1,180,195.66)	29.00 %	339,131.84	(279,418.14)	82.39 %
Expenditures							
71100	Regular Instruction Program	(1,714,855.19)	694,875.84	40.52 %	(142,904.60)	68,612.61	48.01 %
71200	Special Education Program	(719,384.14)	169,530.11	23.57 %	(59,948.68)	42,055.26	70.15 %
71300	Career and Technical Education	(101,848.07)	56,907.60	55.87 %	(8,487.34)	14,165.24	166.90 %
72120	Health Services	(20,000.00)	7,676.53	38.38 %	(1,666.67)	0.00	0.00 %
72130	Other Student Support	(352,516.32)	108,067.30	30.66 %	(29,376.36)	22,143.46	75.38 %
72210	Regular Instruction Program	(593,643.11)	164,489.51	27.71 %	(49,470.26)	25,961.34	52.48 %
72220	Special Education Program	(462,790.46)	102,775.87	22.21 %	(38,565.87)	22,129.25	57.38 %
72250	Technology	(50,000.00)	0.00	0.00 %	(4,166.67)	0.00	0.00 %
72610	Operation Of Plant	(30,000.00)	800.00	2.67 %	(2,500.00)	0.00	0.00 %
72710	Transportation	(1,900.00)	0.00	0.00 %	(158.33)	0.00	0.00 %
99100	Transfers Out	(22,644.75)	0.00	0.00 %	(1,887.06)	0.00	0.00 %
Total Expenditures		(4,069,582.04)	1,305,122.76	32.07 %	(339,131.84)	195,067.16	57.52 %
Total	142 School Federal Projects	0.00	124,927.10	100.00 %	0.00	(84,350.98)	0.00 %

Template Name: LGC Summary
 Created by: LGC

Hickman County Finance
 Summary Financial Statement
 November 2020

User:
 Date/Time:

Michael Elkins
 12/7/2020 11:01 AM
 Page 4 of 4

143 Central Cafeteria		Year-To-Date			Month-To-Date		
Account	Description	Budget Estimate	Actual	% of Budget	Estimate Avg/Mth	Actual	% of Avg
Revenues							
43521	Lunch Payments - Children	240,000.00	(18,529.51)	7.72 %	20,000.00	0.00	0.00 %
43522	Lunch Payments - Adults	65,000.00	(10,885.01)	16.75 %	5,416.67	0.00	0.00 %
43523	Income From Breakfast	65,000.00	(6,566.69)	10.10 %	5,416.67	0.00	0.00 %
43525	A La Carte Sales	244,100.00	(40,255.54)	16.49 %	20,341.67	0.00	0.00 %
43570	Receipts From Individual Schools	0.00	(15,000.00)	0.00 %	0.00	(15,000.00)	0.00 %
44110	Investment Income	200.00	(81.85)	40.93 %	16.67	(12.19)	73.14 %
47111	USDA School Lunch Program	1,065,000.00	(361,994.40)	33.99 %	88,750.00	0.00	0.00 %
47113	Breakfast	480,000.00	(131,972.70)	27.49 %	40,000.00	0.00	0.00 %
47114	USDA - Other	15,000.00	(1,748.16)	11.65 %	1,250.00	(367.68)	29.41 %
	Total Revenues	2,174,300.00	(587,033.86)	27.00 %	181,191.67	(15,379.87)	8.49 %
Expenditures							
73100	Food Service	(2,174,271.00)	1,019,985.27	46.91 %	(181,189.25)	179,303.76	98.96 %
	Total Expenditures	(2,174,271.00)	1,019,985.27	46.91 %	(181,189.25)	179,303.76	98.96 %
Total	143 Central Cafeteria	29.00	432,951.41	-	2.42	163,923.89	-

Centerville Family Resource Center
Mid-year Report
December 7, 2020

Following is an account of activities the Centerville Family Resource Center has completed so far this school year:

FAMILY ENGAGEMENT

GOAL: To host student orientation for up to one hundred (100) incoming students to grades 3, 6 and 9th at Centerville Intermediate, Hickman Middle and High Schools.

ACTIVITY: 1) In July 2020, calls with the Alert Now went out to all parents of new 3rd, 6th and 9th grade students in the Centerville area inviting them to a “Virtual” Open House.
2) On Friday, July 31, 2020, Hickman County High School Guidance Department hosted a Virtual Freshman Orientation. Ninety-eight (98) students attended the virtual tour.
3) On Friday, July 31, 2020, Centerville Intermediate School hosted an Open House with seventy-eight (78) students in attendance.
4) On Friday, July 31, 2020, Hickman County Middle School hosted a Virtual Open House. Fifty (50) students attended the virtual tour.

COLLABORATION PARTNERS

GOAL: To collaborate with Centerville Elementary and Intermediate Schools and local businesses and organizations in facilitating an “Adopt-A-Class” program for up to forty 40 classrooms.

ACTIVITY: 1) Centerville Family Resource Center director began contacting businesses in person and by telephone in August, 2020 to explain the Adopt-A-Class program. The program this year would be “NO IN PERSON VISITS” due to Covid-19. Sponsors could drop off items to be given to their classrooms or zoom “visits” were made available for sponsors and their classrooms. Virtual classroom students who return to school will have a sponsor with the teacher they are assigned to upon return. A total of thirty (30) sponsors have been matched with twenty-nine (29) classrooms.

2) Several sponsors have sent you-tube videos or have had zoom presentations with their classrooms.

FAMILY TRAINING

GOAL: To sponsor Smart From the Start, “Babies At Their Best”, “Toddler Time”, and “Preschool In a Bag” programs targeting approximately ten (10) children ages 0-5 years of age who are not enrolled in any organized daycare to receive weekly educational packets throughout the school year.

ACTIVITY:

- 1) In August, 2020, fliers and application forms for Smart From the Start were supplied to the Hickman County Health Department and Hickman County Public Library. Parents were given a choice of in-person or zoom classes. For in-person classes, mask are provided for both adults and students and hand sanitizer is always available.
- 2) Two (2) babies are enrolled in the “Babies At Their Best” program.
- 3) Parents receive a monthly newsletter.
- 4) Four (4) two year old students are enrolled in Toddler Time.
- 5) Story Hour is provided every Wednesday at the Hickman County Public Library. At the end of each story hour, children are given a packet of educational worksheets to work on at home with the parent.
- 6) Five (5) students are enrolled in Preschool In a Bag and zero (0) in K-Prep.
- 7) Story Hour is provided every Tuesday, Wednesday, Thursday and Friday at the Centerville Family Resource Center office. At the end of each story hour, children are given a packet of educational worksheets to work on at home with a parent.

FAMILY SUPPORT

- GOAL:**
- 1) To sponsor a “Friday Friends” food program targeting twenty-five (25) children who are in need of food over the weekend.
 - 2) To collaborate with community leaders, civic organizations, and individuals to provide Christmas for up to seventy-five (75) children in the Centerville area schools.

- ACTIVITY:**
- 1) Fliers and referral forms were given to principals, teachers and guidance counselors explaining the “Friday Friends” program. Teachers were asked to refer any student they thought might be in need of food items over the weekend.
 - 2) Each Friday packets of easy to prepare food items are sent to the students at the elementary, intermediate, and middle schools.
 - 3) One hundred three (103) Friday Friends bags are given out each Friday for those students in need. Overall we serve forty-six (46) families.
 - 4) Donations from several local churches, Second Harvest, businesses and caring individuals help this program succeed.

- 1) Fliers were sent out to students and parents at Centerville Elementary, Centerville Intermediate, and Hickman Co. Middle School on September 25, 2020 with information about the Operation Santa Claus program.
- 2) One hundred sixty-five (165) individual names from sixty-two (62) families have requested help with Christmas. As of November 12, 2020 fourteen (14) children from five (5) families are on the waiting list.
- 3) Due to Covid-19, Operation Santa Claus will provide a drive through pick up service for gifts on Saturday, December 12, 2020.



EAST FAMILY RESOURCE CENTER

5191 TN-100

Lyles, TN 37098

Phone & Fax (931) 670-6617

Alison Stanley, Director

Becky Coleman, Supervisor

East Family Resource Center Mid-Year Report

Following is an account of activities the East Hickman Family Resource Center has completed so far this school year:

FAMILY ENGAGEMENT

GOAL: To host student orientation for up to one hundred (100) incoming students to grades 3, 6 and 9th at East Hickman Intermediate, Middle and High Schools.

ACTIVITY:

1. In July 2020, calls with the Alert Now telephone system and listing in the local newspaper went out to all parents of new 3rd, 6th and 9th grade students at East Hickman Elementary, Middle and High School. Students in 3rd and 6th grade were invited to a "Virtual" Open House and the 9th graders were invited to social distancing Open House with specific times to attend.
2. On Friday, July 31, 2020 the East Hickman Family Resource Center, in conjunction with the East Hickman High School Guidance Department, hosted a Freshman Open House. One hundred twenty-five (125) students with one parent each were able to attend the social distance Open House. Grand total was two hundred fifty (250) visitors at the school.
3. On Friday, July 31, 2020 East Hickman Middle School hosted a Sixth Grade Virtual Open House. Sixty (60) students attended the virtual tour.
4. On Friday, July 31, 2020 East Hickman Intermediate School hosted a Third Grade Virtual Open House. Sixty-five (65) students attended the virtual tour.

COLLABORATION PARTNERS

GOAL: To collaborate with East Hickman Elementary, East Hickman Intermediate and local businesses and organizations in facilitating an "Adopt-A-Class" program for up to forty (40) classrooms.

ACTIVITY:

1. East Hickman Family Resource Center director began contacting businesses in person and by telephone in August 1, 2020 to explain the Adopt-A-Class program. The program this year would be "NO IN PERSON VISITS" due to Covid 19. Sponsors could drop off items to be given to their classroom or zoom "visits" were made available for sponsors and their classroom. All in house classrooms are covered. Virtual classroom students who return to school will have a sponsor with the teacher they are assigned to upon return. A total of thirty-three (33) sponsors have been matched with thirty-three (33) classrooms. Seven (7) virtual teachers do not have a sponsor since their students are not participating as in-person students.
2. Several sponsors have sent you-tube presentations to their classrooms.

FAMILY TRAINING

GOAL: To sponsor Smart From the Start "Preschool In A Bag", "Toddler Time" and "Babies At Their Best" programs targeting approximately ten (10) children ages 0 - 5 years of age who are not enrolled in Head Start, Pre-K, or any organized daycare to receive educational materials once a week throughout the school year

ACTIVITY:

1. In August 2020, fliers and application forms for Smart from the Start were supplied to the East Hickman Library and East Hickman Elementary School. Parents were given a choice of in-person class or zoom classes and parents who wanted their children to participate were unanimous in having in-person classes. Mask are provided for both students and parents and hand sanitizer is always available. Students were assigned particular days attend to properly social distance.
2. Six (6) children are currently enrolled in the Smart From the Start Program.
3. Story Hour is provided every Tuesday, Thursday and Friday at 9:30 a.m. at the East Hickman Family Resource Center. At the end of each story hour, children are given a packet of educational worksheets to work on at home with the parent.
4. Smart From the Start is theme related. Stories, arts and crafts and individually wrapped snacks are provided.

FAMILY SUPPORT

- GOAL:**
- 1) To sponsor a "Friday Friends" food program targeting twenty-five (25) children who are in need of food over the weekend.**
 - 2) To collaborate with community leaders, civic organizations and individuals to provide Christmas for up to seventy-five (75) children in the East Hickman area.**

ACTIVITY:

1. Fliers and referral forms were given to principals, teachers and guidance counselors explaining the "Friday Friends" program. Teachers were asked to refer any student they thought might be in need of food items over the weekend.
 2. Each Friday, packets of easy to prepare food items are sent to the students at the elementary school, intermediate and middle school
 3. Fifty-nine (59) Friday Friends bags are given out each Friday for those students in need.
 4. Donations from several local churches, businesses and caring individuals help this program succeed.
 5. Second Harvest Food Pantry in Nashville donates 203 bags of food monthly to help with this project. Each January we have to re-apply for assistance for the next year.
-
1. Operation Santa Claus forms were sent home to students of all East Hickman schools the last week of September, 2020.
 2. Two hundred nineteen (219) children from eighty-five (85) families requested help with Christmas gifts.
 3. Due to Covid 19, Operation Santa Claus will provide a drive through pick up service for gifts on Saturday, December 12, 2020.

Hickman County Board of Education
 Budget Amendment No. 8
 Federal Programs (Fund 142)
 December 7, 2020

Account	Description	Debit	Credit	Justification
47303 - - 935	Revenue	60,000.00		LEA Reopening and Programmatic Supports Grant
71100 - 429 - 935	Instructional Supplies & Mat		10,000.00	
71100 - 722 - 935	Regular Instruction Equipment		50,000.00	
47590 - - 964	Revenue	181,286.99		Project Aware Carryover from Prior Year
72130 - 105 - 964	Supervisor	500.00		
72130 - 189 - 964	Other Salaries & Wages	6,200.00		
72130 - 198 - 964	Non-certified Substitutes		900.00	
72130 - 201 - 964	Social Security	443.70		
72130 - 204 - 964	State Retirement	903.76		
72130 - 207 - 964	Medical Insurance	3,900.00		
72130 - 307 - 964	Communication		19,900.00	
72130 - 355 - 964	Travel		2,400.00	
72130 - 399 - 964	Other Contracted Services		20,000.00	
72130 - 435 - 964	Office Supplies		19,500.00	
72130 499 964	Other Supplies & Materials		24,390.00	
72130 599 964	Other Charges		93,664.75	
99100 504 964	Indirect Cost		12,479.70	
TOTALS		\$ 253,234.45	\$ 253,234.45	

Approved:

Attest:

Amv Brvant

Michelle Gilbert

Hickman County Board of Education
 Budget Amendment No. 9
 Federal Programs (Fund 142)
 December 7, 2020

Account	Description	Debit	Credit	Justification
72210 - 524 - 401	In-Service	1,050.00		Adjustment to Title IV
72210 - 196 - 401	In-Service Training		1,050.00	
71100 - 722 - 601	Regular Instruction Equipment	5,948.65		
71100 - 189 - 601	Other Salaries & Wages		5,360.00	
71100 - 201 - 601	Social Security		411.00	
71100 - 204 - 601	State Retirement		324.32	
72210 - 201 - 601	Social Security	180.00		Adjustments to Title V
72210 - 204 - 601	State Retirement	466.67		
72210 - 355 - 601	Travel	10,000.00		
72210 - 189 - 601	Other Salaries & Wages		500.00	
72210 - 524 - 601	In-Service		10,000.00	
TOTALS		<u>\$ 17,645.32</u>	<u>\$ 17,645.32</u>	

Approved:

Attest:

Amy Brvant

Michelle Gilbert

Hickman County Board of Education
Budget Amendment No. 10
General Purpose (Fund 141)
December 7, 2020

Account	Description	Debit	Credit	Justification
48990	Revenue	2,000.00		MLEC Grant
71100 499 SS	Other Supplies & Materials		2,000.00	
TOTALS		<u>\$ 2,000.00</u>	<u>\$ 2,000.00</u>	

Approved:

Attest:

Amy Bryant

Michelle Gilbert



Office of Special Programs
Hickman County Board of Education
115 Murphree Avenue
Centerville, Tennessee 37033

Re: Declaration of Surplus Property

Date: November 11, 2020

Item: Canon Copier – Serial #DRL47953

Request to declare the following as Surplus Property:

Description: Cannon IR1025IF Copier

Quantity: 1

Purchased through Fund Account: 141-71100-722

Purchase Date: 9/12/2011

Reason for Declaration: Copier is in disrepair and unusable. Due to the age of the copier, software is outdated and unable to be upgraded. The company holding the maintenance agreement communicated that they have made several attempts at repairs and is unable to return copier to functional condition.

Signed,

A handwritten signature in blue ink that reads "Julia Thomasson".

Julia Thomasson
Director of Special Programs
Hickman County Schools

Attachments: Original purchase order and invoice

HICKMAN COUNTY GOVERNMENT

114 N. CENTRAL AVE., SUITE 203
 CENTERVILLE, TENNESSEE 37033
 PHONE (931) 729-6124
 FAX (931) 729-4994

COPY

Print Date
 09/02/2011

PO NUMBER	141-00013944
ORDER DATE	09/02/2011
VENDOR NUMBER	R-000107
REQUISITION NUMBER	295

ASAP

TO: RJ YOUNG COMPANY, INC
 PO BOX 40623
 NASHVILLE, TN 37204-0623

DELIVERY DATE

TERMS

DELIVER ITEMS TO:

HICKMAN CO. BOARD OF ED.
 115 MURPHREE AVE
 CENTERVILLE, TN 37033

SPECIAL INSTRUCTIONS

ORDER

ORDER/CONFIRMATION

CONFIRMATION DATE

PLACED BY

CONFIRMING TO

BY: J. THOMPSON

QUANTITY	FUND ACCOUNT NUMBER	ITEM DESCRIPTION	AMOUNT
1	141-71100-722	4 CANON IRI025IF	7,800.00

GRAND TOTAL

7,800.00

NO POSTAGE NECESSARY IF MAILED IN THE UNITED STATES
 POSTAGE WILL BE PAID BY ADDRESSEE
 HICKMAN COUNTY BOARD OF EDUCATION
 115 MURPHREE AVE
 CENTERVILLE, TN 37033

TERMS AND CONDITIONS OF PURCHASE

- 1. The goods shown on this purchase order are the property of the seller until payment in full is received by the seller.
- 2. The buyer shall be responsible for the payment of the purchase price of the goods shown on this purchase order.
- 3. The buyer shall be responsible for the payment of the purchase price of the goods shown on this purchase order.
- 4. The buyer shall be responsible for the payment of the purchase price of the goods shown on this purchase order.
- 5. The buyer shall be responsible for the payment of the purchase price of the goods shown on this purchase order.
- 6. The buyer shall be responsible for the payment of the purchase price of the goods shown on this purchase order.
- 7. The buyer shall be responsible for the payment of the purchase price of the goods shown on this purchase order.
- 8. The buyer shall be responsible for the payment of the purchase price of the goods shown on this purchase order.
- 9. The buyer shall be responsible for the payment of the purchase price of the goods shown on this purchase order.
- 10. The buyer shall be responsible for the payment of the purchase price of the goods shown on this purchase order.

TERMS AND CONDITIONS OF PURCHASE

There is an otherwise unencumbered balance to the credit of the proper appropriation, allotment or fund to meet the expenditure covered by this purchase.

APPROVED:

A. Elliott

FINANCE OFFICE

AUTHORIZED SIGNATURE



809 DIVISION STREET
 PO BOX 40623
 NASHVILLE, TENNESSEE 37204
 TOLL FREE: (800)347-1955
 P:(615)255-8551
 F:(615)726-2771

Powered By imageWORKS
 We Can Save You Time!
 Call ImageWORKS to
 set up Meter Reading
 at no additional cost!
 1-800-347-1955

**B
I
L
L
T
O**

JEAN GREGORY
 HICKMAN COUNTY SPECIAL
 ED DEPT GENERAL OFFICE
 115 MURPHREE AVE
 CENTERVILLE TN 37033-1430

INVOICE NO
 DZN502 1
INVOICE DATE
 09/28/11
TERMS: NET DUE
 UPON RECEIPT

CUSTOMER NO.	CUST. ORDER NO.	DATE ORDERED	DATE SHIPPED	SHIP VIA	REPRESENTATIVE	
551084	141-0001 3944	09/12/11	09/14/11		30SA34	DR
ORDERED	PKG	SHIPPED	PROD. NO.	DESCRIPTION	UNIT PRICE	AMOUNT
1	EA	1	ABN25F	CANON IR1025IF COPIER IR25F DRL47953 ITEM # 2586B001AA	1,950.000	1950.00
1	EA	1	NABFN1	CASSETTE FEEDING MOD N2 /IR1023 ITEM # 0859B004AA		
1		1	NAZ999	NON-SERIALIZED NOI ACCESSORIES ITEM # NON-SER NOI		
NET 10						
						SUBTOTAL
						1,950.00
						TOTAL DUE
						1,950.00

**S
H
I
P
T
O**

EAST HICKMAN MIDDLE SCHOO
 SPECIAL EDUCATION DEPT
 9414 EAST EAGLE DRIVE
 LYLES TN 37098-9709

**R
E
M
I
T
T
O**

RJ YOUNG COMPANY, INC
 P O BOX 40623
 NASHVILLE TN 37204-0623

COMMENTS:

PLEASE PAY FROM THIS INVOICE
 OVERDUE ACCOUNTS WILL BE CHARGED A LATE
 PAYMENT FEE OF 1.5% PER MONTH OR TO THE
 EXTENT OF THE LAW

Invitation to Bid

The Hickman County Finance Office is accepting sealed bids for Playground Equipment at Centerville Elementary School.

Bid with specifications are online at: www.hickmank12.org/request-for-proposal.

All bidders will be required to submit a conflict of interest disclosure form that can also be obtained at: www.hickmank12.org/request-for-proposal.

Sealed bids must be mailed or delivered to the Hickman County Finance Office, 114 North Central Avenue, Suite 203, Centerville, TN 37033 and clearly marked on the outside of the envelope "Playground Equipment - CES".

Bids will be opened on Monday, November 16, 2020 at 11:00 a.m. in the Finance Office. The Hickman County Board of Education reserves the right to accept or reject any and all bids or parts of bids and to waive any informalities that would prevent the acceptance of a better bid.

Present Penny Mayberry
Carrie Davis

Bliss Products \$11,895.00

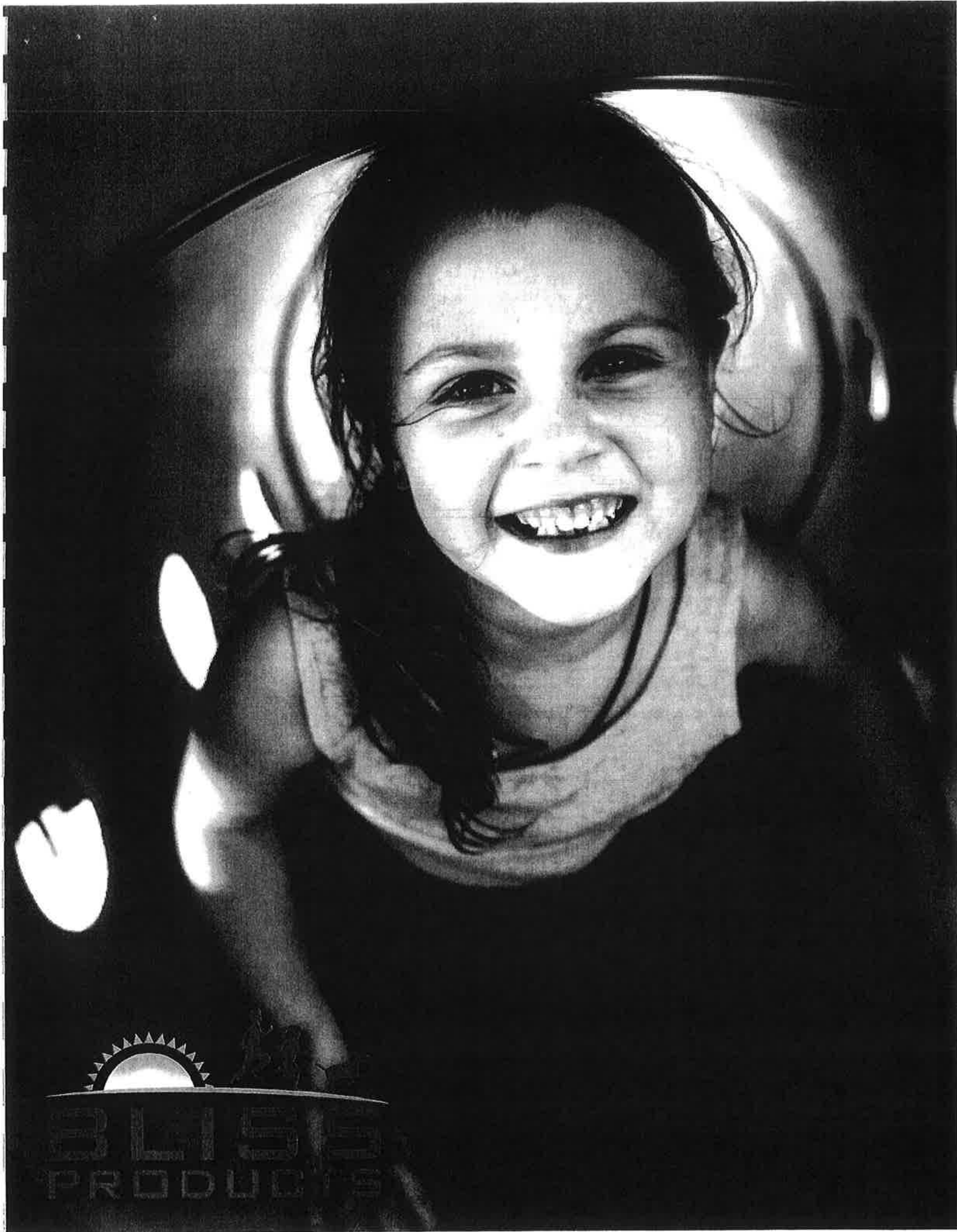

BLISS
PRODUCTS



Bliss Products and Services, Inc
 6831 S. Sweetwater Rd.
 Lithia Springs, GA 30122
 (800) 248-2547
 (770) 920-1915 Fax

Quote # **53798**

Sales Rep: Jamie Carter
 jamie@blissproducts.com
 O: (615) 472-8809
 C: (615) 804-6001

Hickman County Finance Office

Date 11/5/2020

Project Centerville
 Elementary School

Bill To

Hickman County Finance Office
 114 North Central Ave
 Suite 203
 Centerville, TN, 37033

Ship To

Hickman County Finance Office
 114 North Central Ave
 Suite 203
 Centerville, TN, 37033

Contact

Purchasing

Approximate Ship Date

Ship Via

Terms

Net 30

Vendor	Part #	Description	Qty	Unit Price	Extended Price
FN	TD-IG-N	Tuned Drums	1	\$2,795.00	\$2,795.00
FN	DUET-IG-REC	Duet	1	\$3,235.00	\$3,235.00
FN	YANZ-IG-REC	Yantzee	1	\$3,740.00	\$3,740.00
INS		Installation of Freenotes Pieces NOTE: Installation is not into concrete and does not include any concrete slab. Installation of these pieces are with concrete footers into the ground.	1	\$2,125.00	\$2,125.00

Sub Total \$11,895.00
Freight 0.00
Tax 0.00

Taxable Subtotal \$11,895.00

Financing as low as **\$295** / month may be available pending credit approval.

Grand Total \$11,895.00

Quote valid for 30 days unless otherwise noted.

Sales tax exempt certificate will be required for exemption. All orders are subject to approval and acceptance by the manufacturer. Deposits may be required. Add 3% to total for charge card transactions. Manufacturing lead times will not begin without an actual shipping address, color and mount selection, approved purchase order or fully executed contract. Customer will need to coordinate with freight carrier if unloading or inside delivery is required. Damaged or missing parts must be noted on the bill of lading at the time of delivery. A finance charge of 1.5% per month will be added to all invoices past due. Return items are subject to manufacturer's policies and may result in freight and restocking fees.

Signed quote will not be accepted for orders over \$500.

Install Conditions - Unless otherwise noted:

- Site should be clear, level and allow continuous access for delivery, materials and equipment. A space must be provided for the staging and secure storage of equipment within a reasonable distance to the jobsite.
- Installation price based on a single mobilization and unrestricted work hours. We can accommodate special requests but they may result in additional labor costs.
- Bliss will call for public locates but the customer is responsible for locating and identifying all private utilities. We are not responsible for damage to unmarked lines.
- Installation requiring footers are based on normal soil conditions. Excessive rock, coral, asphalt, foundations, pipes or other obstructions will result in additional labor costs.

- If permitting is required, customer is responsible for providing site survey. Equipment delivery and installation times will not begin until permitting is approved. Permitting fees and engineering drawings not included.
- Bliss will smooth jobsite but full site restoration (such as sod) is not included. Bliss will take every care with trees, curbs, sidewalks, fences and other site obstructions but will not be responsible for damage caused by normal installation processes.
- Removal of trash and spoils is not included. Customer responsible for providing dumpster for debris and/or an area within reasonable distance to spread spoils.
- Bliss will not be held responsible for delays due to weather.
- Customer accepts all responsibility for requests that are not in compliance with ASTM, CPSC or local building codes.

Complete Terms and Conditions can be found at <https://blissproducts.com/terms-conditions/>

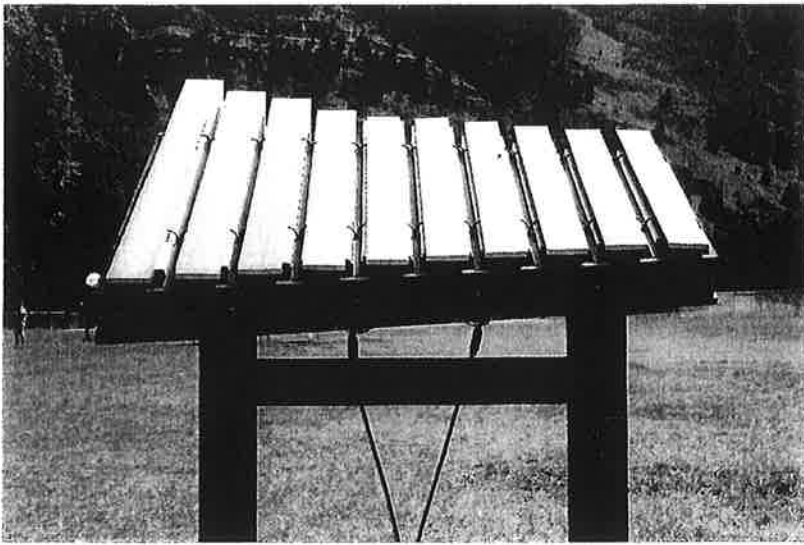

Freenotes™ Harmony Park

A PLAYCORE Company

FreenotesHarmonyPark.com | 970.375.7825

Yantzee

The color is Blue. The Yantzee is played in the Key of C Major. Please note the photos of our instruments may show slight variations of components.

A foundational piece for any instrument grouping, the low notes of the Yantzee create a rich canvas of sound for the other melodic instruments to play over. The Yantzee is an excellent accompaniment for all other Freenotes designs. The individual notes are made with resonated aluminium bars that give these low tones remarkable projection for their size.

Please see our web site for Yantzee options.

- Multigenerational
- Interactive Play
- Durable
- Sculptural
- Perfectly Tuned
- No Wrong Notes
- All Abilities, All Ages
- Everyone Can Play!



FREENOTES HARMONY PARK CREATING MUSICAL PARKS IN COMMUNITIES EVERYWHERE!

YANTZEE INSTALLATION GUIDE

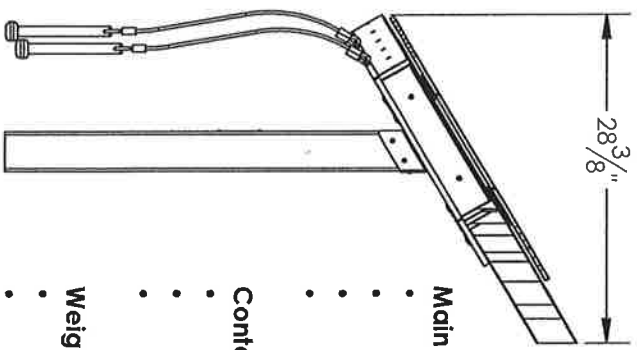
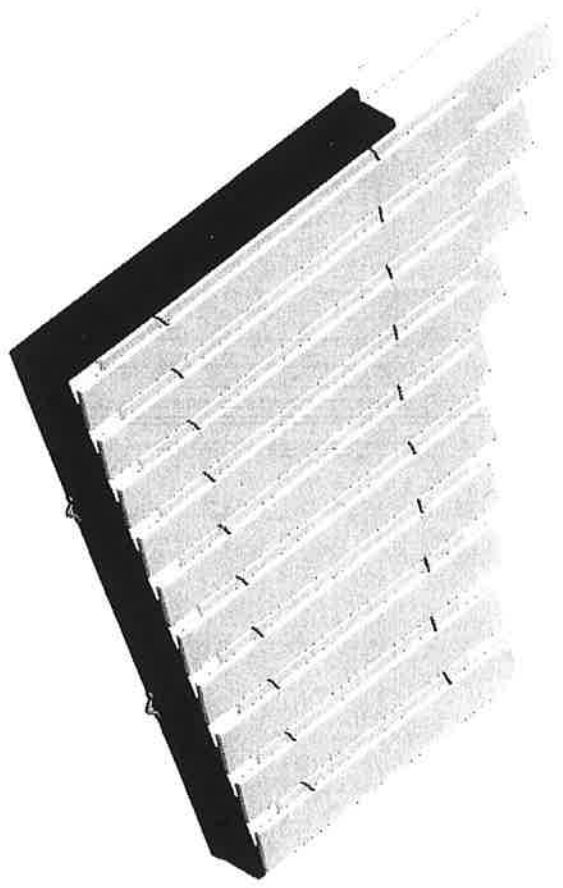
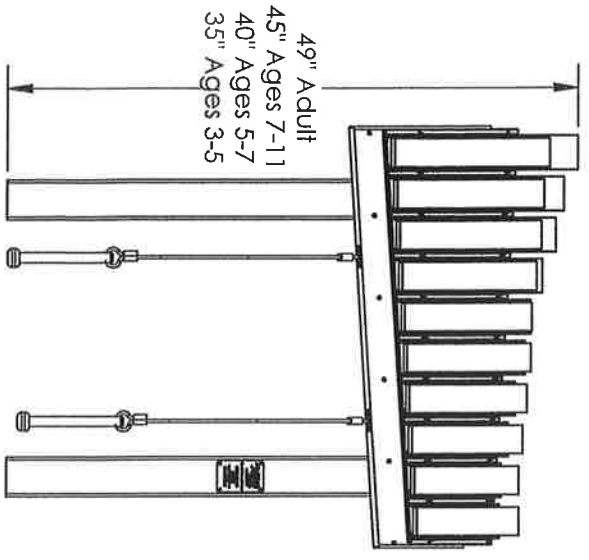
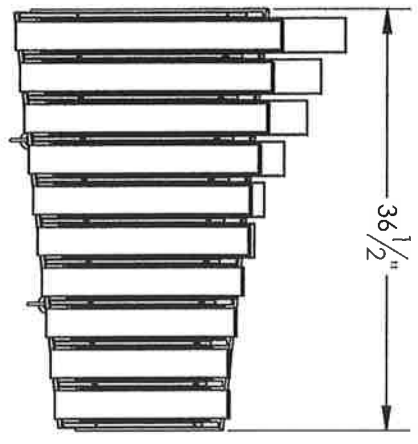

Main Features:

- A Minor Diatonic
- Recycled HDPE Frame
- Anodized Aluminum Bars & Resonators
- Stainless Steel Hardware

Contents:

- SHEET 2 - Parts List and Instrument to Post Installation
- SHEET 3 - In Ground Installation
- SHEET 4 - Surface Mount Installation

Weights:

- Instrument Weight, 79lbs.
- Boxed Instrument Weight, 90lbs.
- Boxed Posts Weight, 35-72lbs.



FREENOTES HARMONY PARK
194 BODO DRIVE, UNIT F
DURANGO CO 81303
TEL: (970) 375-7825
FAX: (970) 247-0856
WWW.FREENOTESHARMONYPARK.COM

PROPRIETARY AND CONFIDENTIAL
THE INFORMATION CONTAINED IN THIS
DRAWING IS THE SOLE PROPERTY OF
FREENOTES HARMONY PARK. ANY
REPRODUCTION IN PART OR AS A
WHOLE WITHOUT THE WRITTEN
PERMISSION OF FREENOTES HARMONY
PARK IS PROHIBITED.

TITLE:
Yantzee - Installation Guide

DWG. NO. YANZ-INSTALL

REVISION: B

SCALE: 1:16

DATE: 2/9/2018

SHEET 1 OF 4

Parts List:

ITEM NO.	PART DESCRIPTION	In Ground - Recycled Post/Qty.	In Ground - Steel Post/Qty.	Surface Mount Recycled Post/Qty.	Surface Mount Steel Post/Qty.
1	Yantzee Instrument Assembly	1	1	1	1
2	Small SS Holster	2	2	2	2
3	In Ground Recycled Post, 7/2"lg.	2	-	-	-
4	In Ground Steel Post, 7/2"lg.	-	2	-	-
5	Surface Mount Recycled Post, 3/6"lg.	-	-	2	-
6	Surface Mount Steel Post, 3/6"lg.	-	-	-	2
7	Surface Mount Base, For Recycled Post	-	-	2	-
8	#8 Flat Head Screw, 1.25"lg. SS, T15 tampo	8	8	8	8
9	#8 Button Head Screw, 1.25"lg. SS, T15 tampo	10	-	10	-
10	#10-24 Button Head Machine Screw, 1"lg. SS, T25 tampo	-	10	-	10
11	5/16" Hex Head Lag Bolt, 5"lg. SS	-	-	4	-
12	3/8"-16 Wedge Expansion Anchor, SS	-	-	8	8
13	35/64" Hex Nut Cap	-	-	8	8
14	Security Driver	1	1	1	1

Step 1: Start by mounting the Holsters to the Instrument Back with the provided #8 Flat Head Screws and Driver. The Back comes predrilled. Screw heads should be flush with the Holster surface when properly installed. Holster should also be flush along the back. Drive Screws slowly to prevent stripping.

Step 2: With two people, situate the Instrument with Holsters installed onto the Posts. Posts come predrilled and/or tapped. Fasten the Instrument to the Posts with the provided #8 Button Head Screw for Recycled Posts or #10-24 Button Head Machine Screw for Steel Posts. Drivers are provided.

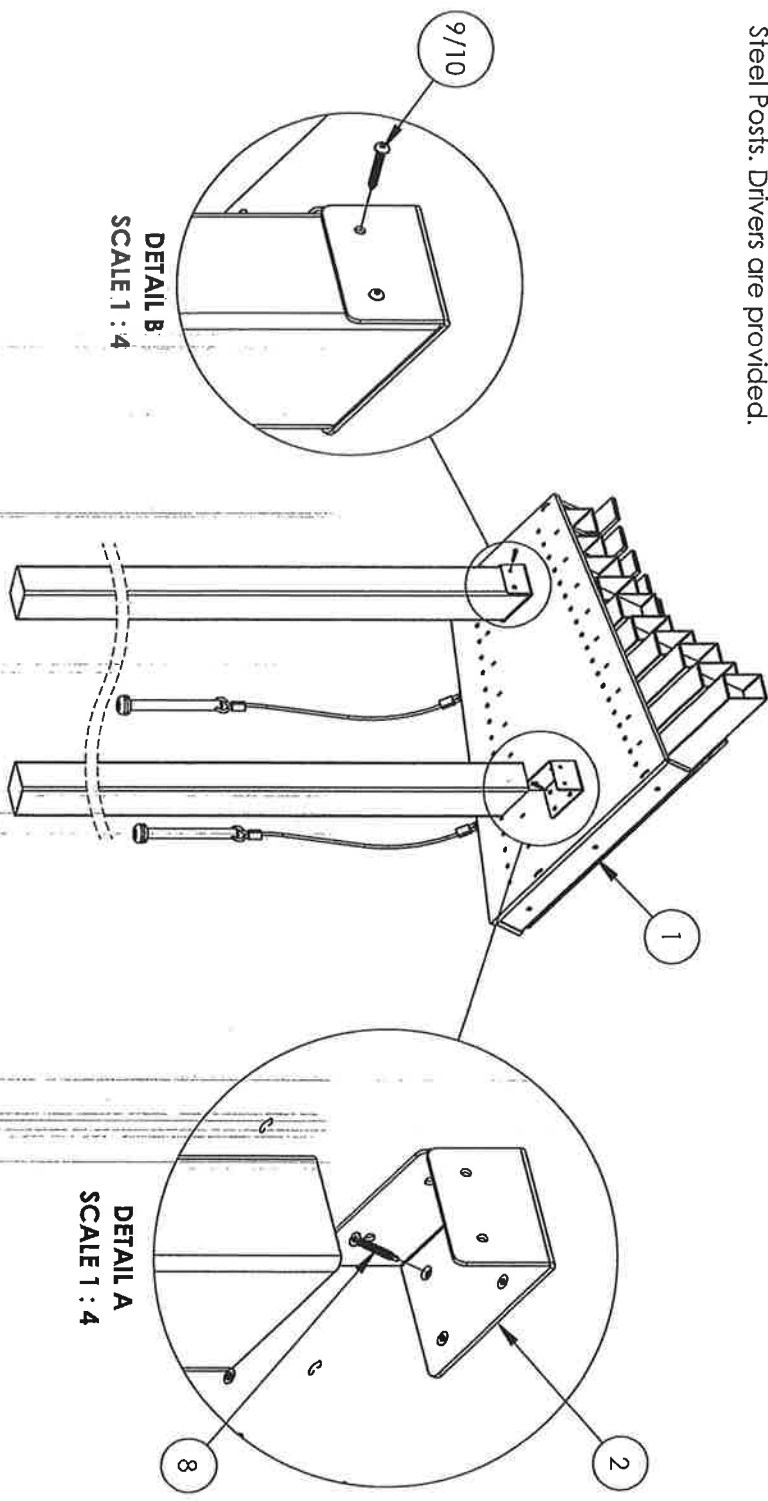

DETAIL B
SCALE 1 : 4

DETAIL A
SCALE 1 : 4



FREEMOTES HARMONY PARK
194 BODO DRIVE, UNIT F
DURANGO CO 81303
TEL: (970) 375-7825
FAX: (970) 247-0856
WWW.FREEMOTESHARMONYPARK.COM

PROPRIETARY AND CONFIDENTIAL
THE INFORMATION CONTAINED IN THIS
DRAWING IS THE SOLE PROPERTY OF
FREEMOTES HARMONY PARK. ANY
REPRODUCTION IN PART OR AS A
WHOLE WITHOUT THE WRITTEN
PERMISSION OF FREEMOTES HARMONY
PARK IS PROHIBITED.

TITLE: Parts List and Instrument to Post Installation
DWG. NO. YANZ-INSTALL

REVISION: B
SCALE: 1:16
DATE: 2/9/2018
SHEET 2 OF 4

Step 1: Excavate two 10" diameter holes, 36" deep, and 24" on center at the installation location. Contractor can modify Post to desired height. Post Length = Frost Depth (36" Recommended) + Finished Post Height

Finished Post Height Guideline: (Ages 3-5, 22") (Ages 5-7, 27") (Ages 7-11, 32") (Adult, 36")

Step 2: With two people, lower the Posts with the Instrument attached into the excavated holes.

Step 3: Verify the correct placement, levelness, and finished height of the Instrument. Check for sufficient clearance around the Instrument, a 36" perimeter around the Instrument is recommended for wheelchair accessibility.

Step 4: Last pour concrete around the posts. It is recommended to brace the instrument to hold it rigid while the concrete cures. Leave to set according to the concrete manufacturers guidelines. Approximately (6) 80lb. bags will be needed.

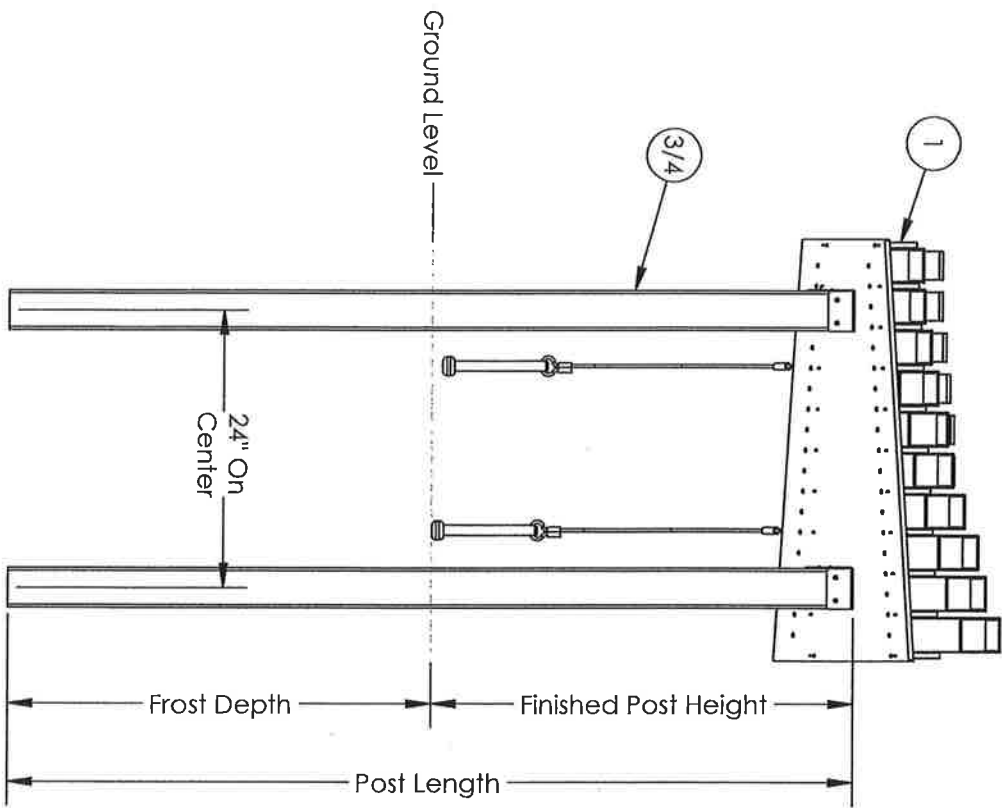

FREENOTES HARMONY PARK
194 BOBO DRIVE, UNIT F
DURANGO CO 81303
TEL: (970) 375-7825
FAX: (970) 247-0856
WWW.FREENOTESHARMONYPARK.COM

PROPRIETARY AND CONFIDENTIAL
THE INFORMATION CONTAINED IN THIS
DRAWING IS THE SOLE PROPERTY OF
FREENOTES HARMONY PARK. ANY
REPRODUCTION IN PART OR AS A
WHOLE WITHOUT THE WRITTEN
PERMISSION OF FREENOTES HARMONY
PARK IS PROHIBITED.

TITLE:
In Ground Installation

DWG. NO. YANZ-INSTALL

REVISION: B

SCALE: 1:16

DATE: 2/9/2018

SHEET 3 OF 4

Step 1: Standard height for Surface Mount Posts are 36". The Recycled Posts may be modified in the field to the following heights:
 (Ages 3-5, 22") (Ages 5-7, 27") (Ages 7-11, 32") (Adult, 36")
 The height of Surface Mount Steel Posts can not be adjusted.

Step 2: Determine installation location. Verify concrete footing is a minimum of 48" long x 24" wide x 6" thick. If the concrete pad is at an angle, steel washers are required to act as shims (Shims not provided). If there is not already an existing pad, approximately (7) 80lb. bags will be needed. Allow concrete to cure per concrete manufacturers guidelines.

Step 3 (Recycled Post Only): Install the Surface Mount Bases to the bottom of the Posts. Align the holes on the Bases with the holes on the Posts. The Bases should fit snugly around the Posts. Fasten them together with the provided 5/16" Hex Head Log Bolts.

Step 4: With two people place the Instrument Assembly with Posts attached onto the concrete pad and mark the center of the holes on the surface mount bases. After you have made your marks, set aside the Instrument in order to drill for anchor holes. With a hammer or rotary drill, drill through concrete at marked locations. Drill to a minimum depth of 4". A 3/8" masonry drill bit will be needed.

Step 5: Place the Instrument back over the drilled out holes. Insert provided anchor bolts into aligned holes. Position anchor nut so that it is flush with the top of the bolt. Pound anchor bolts into the hole until the anchor washer is flush with the surface mount bases. Tighten anchor bolts until they are snug. Cover remaining bolt sections with provided nut caps.

Step 6: Verify the correct placement, levelness, and finished height of the Instrument. Check for sufficient clearance around the Instrument, a 36" perimeter around the Instrument is recommended for wheelchair accessibility.

Step 7: If installing onto wet concrete, us the wet set anchor manufacturers guidelines for installation procedures.

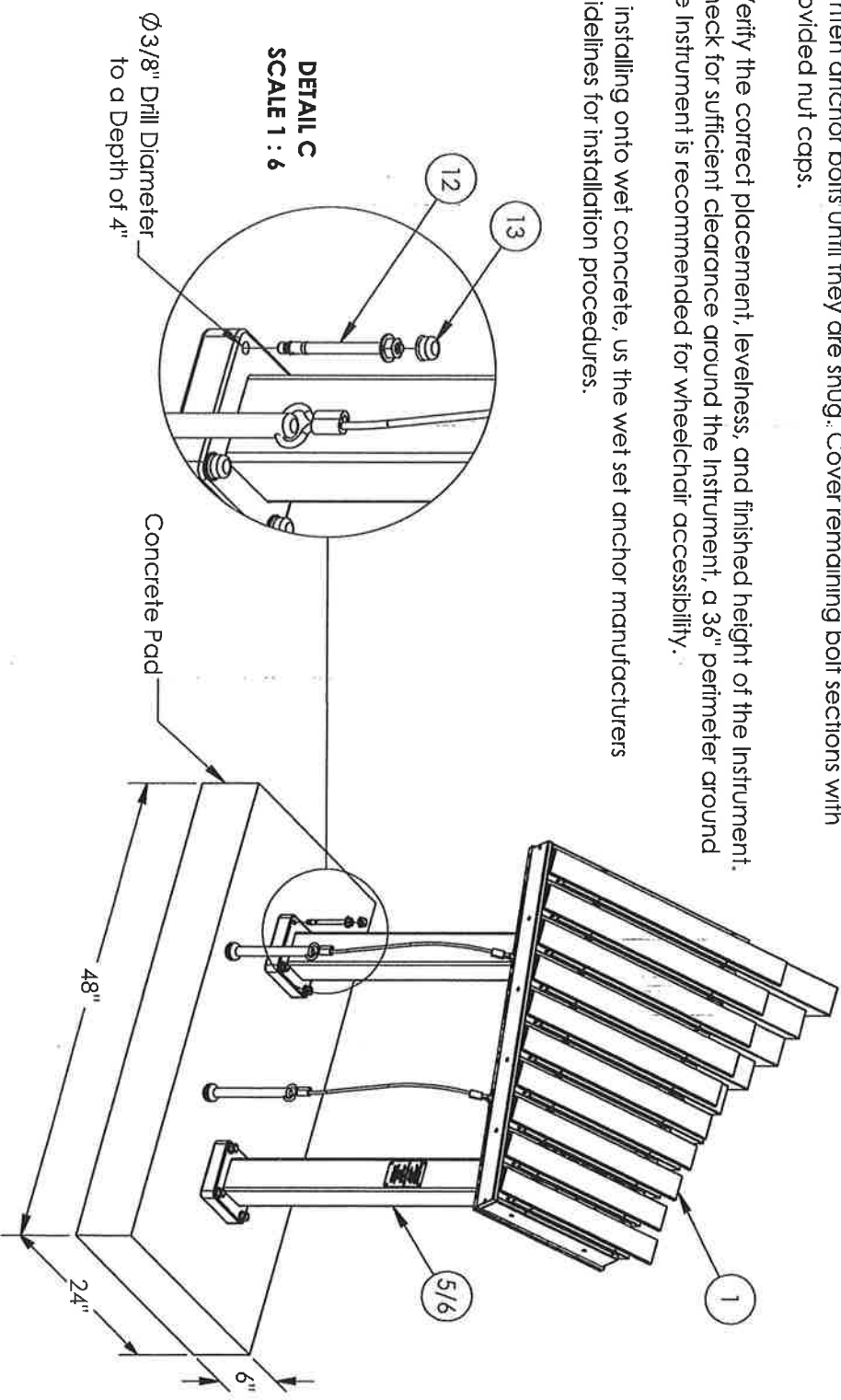

PLAYCORE Company
 FREEMOTES HARMONY PARK
 194 BODO DRIVE, UNIT F
 DURANGO CO. 81303
 TEL: (970) 375-7825
 FAX: (970) 247-0856
 WWW.FREEMOTESHARMONYPARK.COM

PROPRIETARY AND CONFIDENTIAL
 THE INFORMATION CONTAINED IN THIS
 DRAWING IS THE SOLE PROPERTY OF
 FREEMOTES HARMONY PARK. ANY
 REPRODUCTION IN PART OR AS A
 WHOLE WITHOUT THE WRITTEN
 PERMISSION OF FREEMOTES HARMONY
 PARK IS PROHIBITED.

TITLE:
 Surface Mount Installation

DWG. NO. YANZ-INSTALL

REVISION: B
 SCALE: 1:16
 DATE: 2/9/2018
 SHEET 4 OF 4

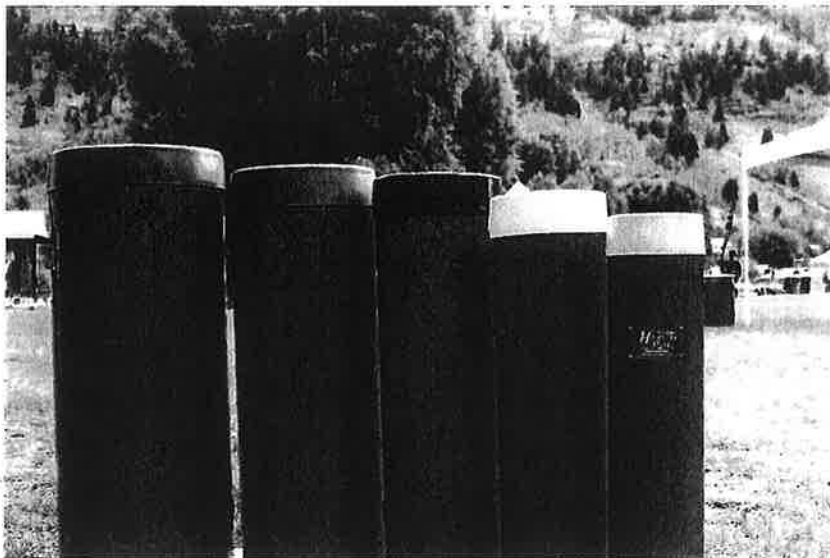

Freenotes Harmony Park™

A PLAYCORE® Company

FreenotesHarmonyPark.com | 970.375.7825

Tuned Drums

Five Tuned Drums have many options: sizes, adult and toddler; color choices, bright rainbow as well as natural lid options; installed in ground or on any surface in any arrangement; played by one or more players.

Caps are also replaceable.

Green Drums available with either rainbow or natural lid color options. Please note the photos of our instruments may show slight variations of components.

- **Multigenerational**
- **Interactive Play**
- **Durable**
- **Sculptural**
- **Perfectly Tuned**
- **No Wrong Notes**
- **All Abilities, All Ages**
- **Everyone Can Play!**

Please see our web site for Tuned Drum options.

 Listen Here
<https://www.youtube.com/watch?v=dKleRCLiB7c> 

 For more photos visit
<http://freenotesharmony.com/products/instrument-collection/tuned-drums>

 CAD Product ID
<http://freenotesharmony.com/Mom/Company/ViewProduct?productID=20&companyId=42&searchType=Itemµsite=>

FREENOTES HARMONY PARK CREATING MUSICAL PARKS IN COMMUNITIES EVERYWHERE!

TUNED DRUMS INSTALLATION GUIDE

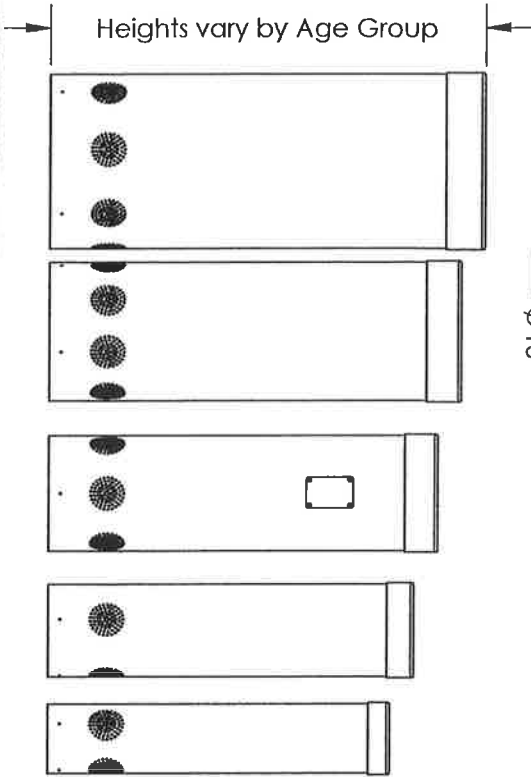
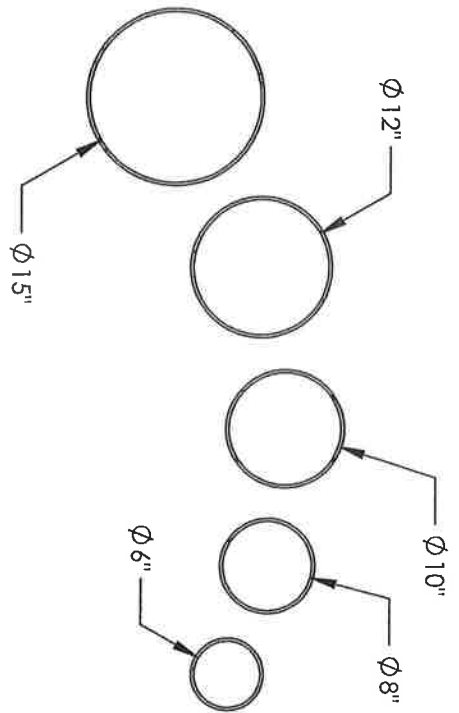

- Main Features:**
- Low to High Tuning
 - Cap Color Options

- Contents:**
- SHEET 2 - In Ground Installation w/ Parts List
 - SHEET 3 - Surface Mount Installation w/ Parts List

- Weights:**
- Instrument Total Weight, 60-84lbs.
 - Boxed Instrument Total Weight, 90-110lbs.
 - Individual Drum Weights vary per style and finished height selection

Cap Color Options:

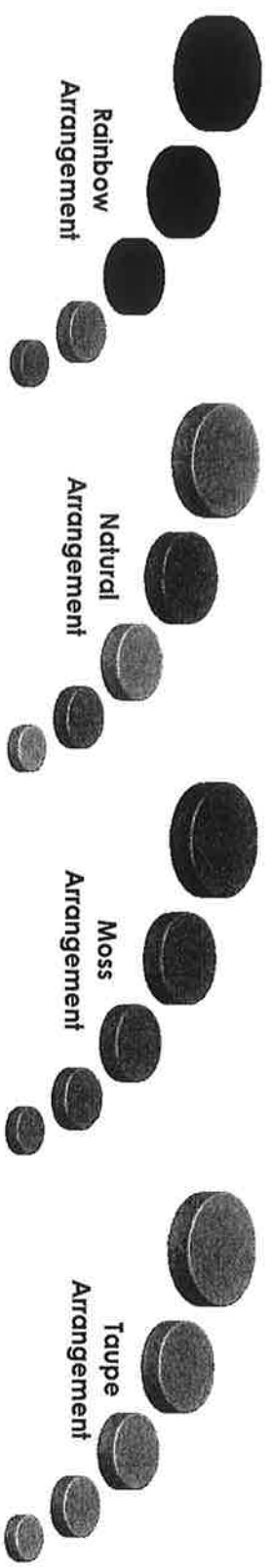

FREENOTES HARMONY PARK
194 BODO DRIVE, UNIT F
DURANGO CO 81303
TEL: (970) 375-7825
FAX: (970) 247-0856
WWW.FREENOTESHARMONYPARK.COM

PROPRIETARY AND CONFIDENTIAL
THE INFORMATION CONTAINED IN THIS
DRAWING IS THE SOLE PROPERTY OF
FREENOTES HARMONY PARK. ANY
REPRODUCTION IN PART OR AS A
WHOLE WITHOUT THE WRITTEN
PERMISSION OF FREENOTES HARMONY
PARK IS PROHIBITED.

TITLE: Tuned Drums - Installation Guide
DWG. NO. TD-INSTALL

REVISION: NA
SCALE: 1:16
DATE: 2/9/2018
SHEET 1 OF 3

Parts List:

ITEM NO.	DESCRIPTION	QTY.	NORMAL FINISHED HEIGHT	TODDLER FINISHED HEIGHT
1	Ø 15" In Ground Tuned Drum	1	37"	29"
2	Ø 12" In Ground Tuned Drum	1	35"	27.5"
3	Ø 10" In Ground Tuned Drum	1	33"	26"
4	Ø 8" In Ground Tuned Drum	1	31"	24.5"
5	Ø 6" In Ground Tuned Drum	1	29"	23"

Step 1: Arrange Drums in desired location and pattern. Drums can be laid out in any configuration desirable, but must be installed less than 3" or greater than 9" apart. **WARNING:** Between 3" and 9" there lies a chance for a child's head to get stuck. (Reference: **US Consumer Product Safety Commission, Public Playground Safety Handbook**)

Step 2: Determine border of trench for concrete pad. Trench should be a minimum of 6" deep. Concrete pad should perform under local soil and weather conditions.

Step 3: Excavate trench to required depth. Check levelness of trench then pour concrete and fill trench completely per code requirements. Immediately after the concrete has been poured, drive the Tuned Drums into the wet concrete per your chosen layout.

Step 4: The bottom edge of the Drum Bases are scalloped to assist in their installation into the concrete. Twist Drums into concrete to a depth of 5". Check for plumbness, if needed brace the Drums to keep them rigid and in place during the curing process. Leave to set according to the concretemanufacturer's guidelines.

Step 5: Check for sufficient clearance around instruments. A 36" clearance is recommended around the the entire Drum arrangement for wheelchair accessibility, however this is not required for proper function. Drums may also be installed next to a wall or in a variety of different configurations.

Step 6: Remove plastic film from drum caps if applicable.

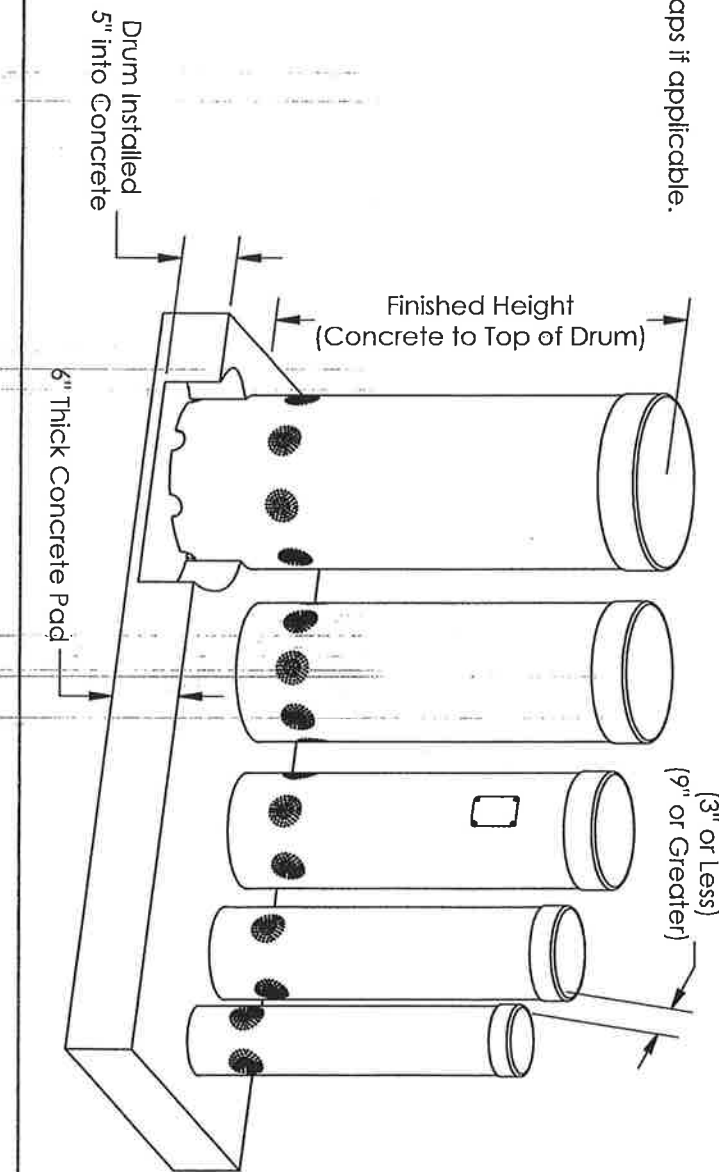

FREENOTES HARMONY PARK
 194 BODO DRIVE, UNIT F
 DURANGO CO 81303
 TEL: (970) 375-7825
 FAX: (970) 242-0856
 WWW.FREENOTESHARMONYPARK.COM

PROPRIETARY AND CONFIDENTIAL
 THE INFORMATION CONTAINED IN THIS
 DRAWING IS THE SOLE PROPERTY OF
 FREENOTES HARMONY PARK. ANY
 REPRODUCTION IN PART OR AS A
 WHOLE WITHOUT THE WRITTEN
 PERMISSION OF FREENOTES HARMONY
 PARK IS PROHIBITED.

TITLE:
 In Ground Installation with Parts List

DWG. NO. TD-INSTALL

REVISION: A
SCALE: 1:16
DATE: 2/9/2018
SHEET 2 OF 3

ITEM NO.	DESCRIPTION	QTY.	NORMAL FINISHED HEIGHT	TODDLER FINISHED HEIGHT
1	Ø 1.5" Surface Mount Tuned Drum	1	37"	29"
2	Ø 1.2" Surface Mount Tuned Drum	1	35"	27.5"
3	Ø 1.0" Surface Mount Tuned Drum	1	33"	26"
4	Ø 8" Surface Mount Tuned Drum	1	31"	24.5"
5	Ø 6" Surface Mount Tuned Drum	1	29"	23"
6	Surface Mount Anchor Disc	5	-	-
7	Ø 1/4 x 3.25" Anchor Bolt, SS	15	-	-
8	#10 Button Head Screw, 2"lg. SS, T25 tamp	20	-	-
9	Security Driver	1	-	-

Step 1: Arrange Drums in desired location and pattern. Drums can be laid out in any configuration desirable, but must be installed less than 3" or greater than 9" apart.
WARNING: Between 3" and 9" there lies a chance for a child's head to get stuck.
(Reference: US Consumer Product Safety Commission, Public Playground Safety Handbook)

Step 2: Once you have decided your layout, replace drums with the provided Anchor Discs. Mark holes on the concrete through the (3) holes on all of the Anchor Discs. Set aside Discs, drill 1/4" holes 2" into concrete at marked locations. A Ø 1/4" masonry drill bit will be needed. Contractor to provide a concrete slab that will perform under local soil and weather conditions. (If anchoring to a material other than concrete, fasteners to be provided by the customer)

Step 3: Place the Anchor Discs back over the drilled out holes. Insert provided anchor bolts into aligned holes. Position anchor nut so that it is flush with the top of the bolt. Pound anchor bolts into the hole until the anchor washer is flush with the post base. Tighten anchor bolts until they are snug.

Step 4: Install the Drums over the Anchor Discs. Pre-drill (4) 1/8" holes in a 90° cross pattern, 1" up from the bottom of the drum. Drill through both Drum and Anchor Disc. When predrilling holes, make sure they clear the previously installed anchor bolts, and that there is clearance for the 2" screws to be installed without interfering with the other drums. Secure Drums to Discs with the provided #10 Button Head Screws and Driver.

Step 5: Check for sufficient clearance around instruments. A 3/6" clearance is recommended around the the entire Drum arrangement for wheelchair accessibility, however this is not required for proper function. Drums may also be installed next to a wall or in a variety of different configurations.

Step 6: Remove plastic film from drum caps if applicable.

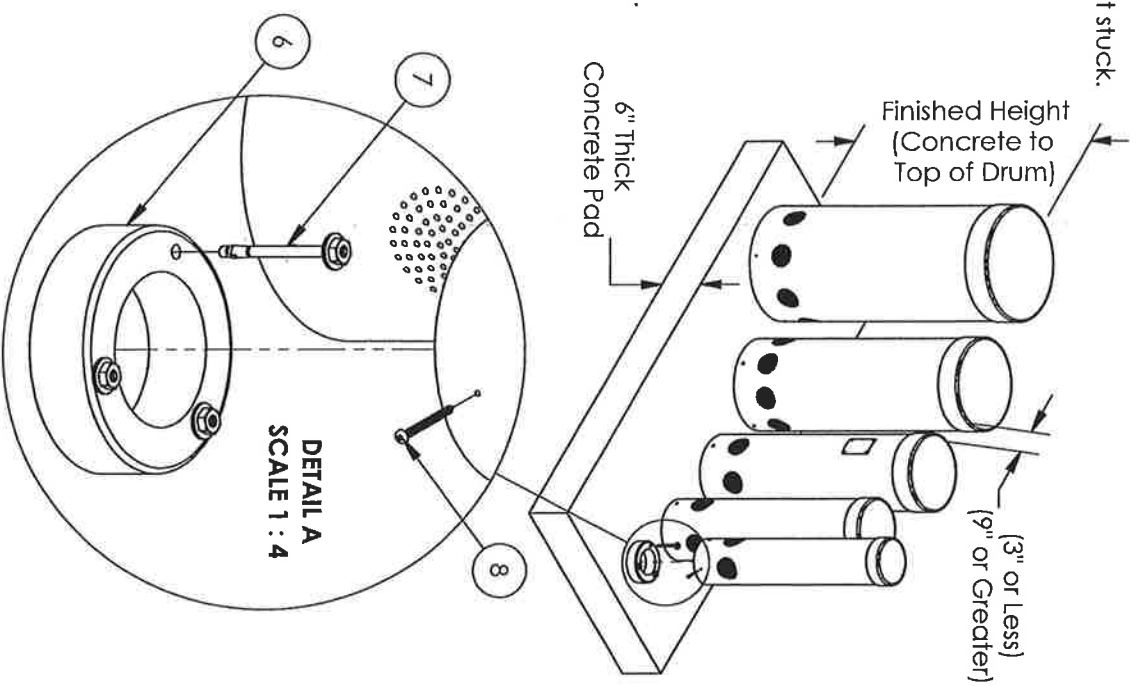

FREEMOTES HARMONY PARK
 194 BODO DRIVE, UNIT F
 DURANGO CO 81303
 TEL: (970) 375-7825
 FAX: (970) 247-2854
 WWW.FREEMOTESHARMONYPARK.COM

PROPRIETARY AND CONFIDENTIAL
 THE INFORMATION CONTAINED IN THIS DRAWING IS THE SOLE PROPERTY OF FREEMOTES HARMONY PARK. ANY REPRODUCTION IN PART OR AS A WHOLE WITHOUT THE WRITTEN PERMISSION OF FREEMOTES HARMONY PARK IS PROHIBITED.

TITLE: Surface Mount Installation with Parts List
 DWG. NO. TD-INSTALL

REVISION: A
 SCALE: 1:24
 DATE: 2/9/2018
 SHEET 3 OF 3

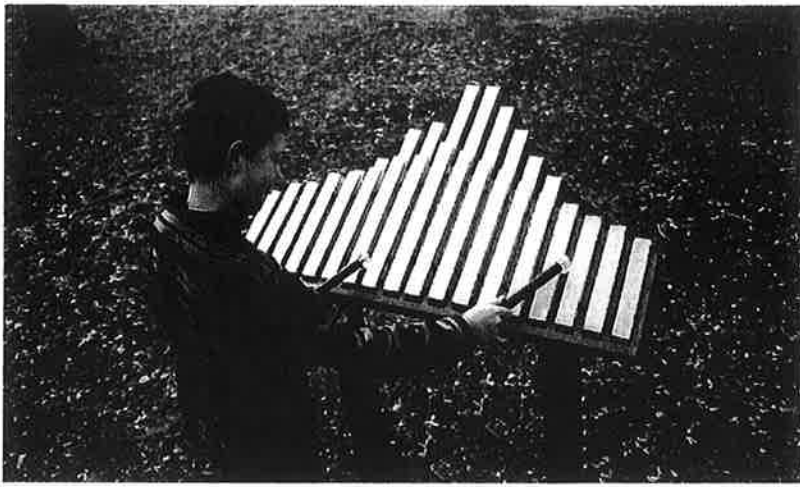

Freenotes Harmony Park™

A PLAYCORE Company

FreenotesHarmonyPark.com | 970.375.7825



The color is Blue. One side of
The Duet plays the C Major Scale while
the other side offers the A Minor Scale.
Please note the photos of our instruments
may show slight variations of components.

Duet – Our first instrument
combining keys of aluminum
and fiberglass to enhance the
playing experience. Enjoy
both sounds of delight
and rhythm at the same time
or enjoy playing with someone
and share the experience.

Please see our web site
for Duet options.

- **Multigenerational**
- **Interactive Play**
- **Durable**
- **Sculptural**
- **Perfectly Tuned**
- **No Wrong Notes**
- **All Abilities, All Ages**
- **Everyone Can Play!**



FREENOTES HARMONY PARK CREATING MUSICAL PARKS IN COMMUNITIES EVERYWHERE!

DUET INSTALLATION GUIDE

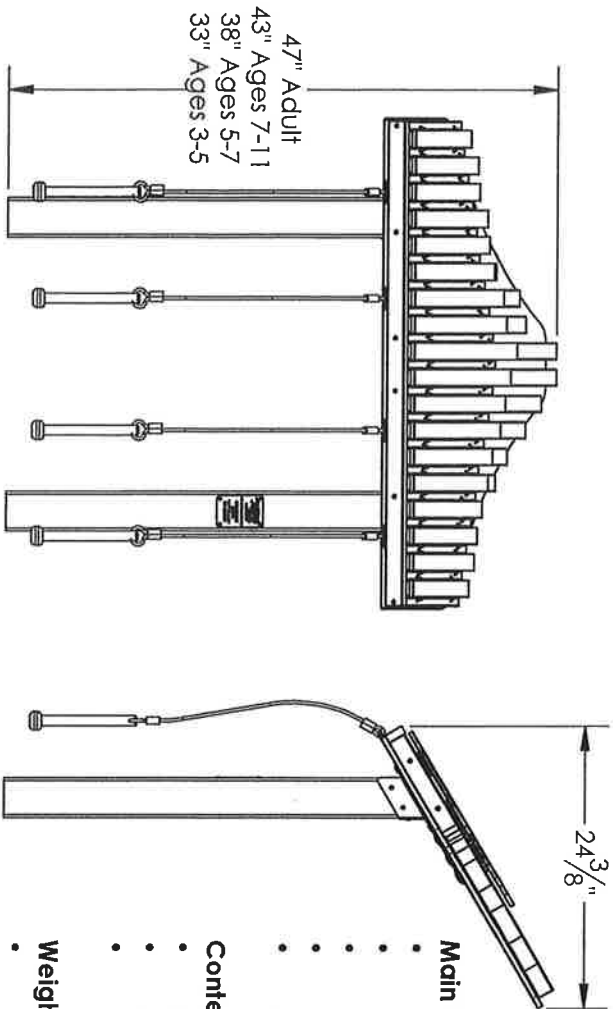
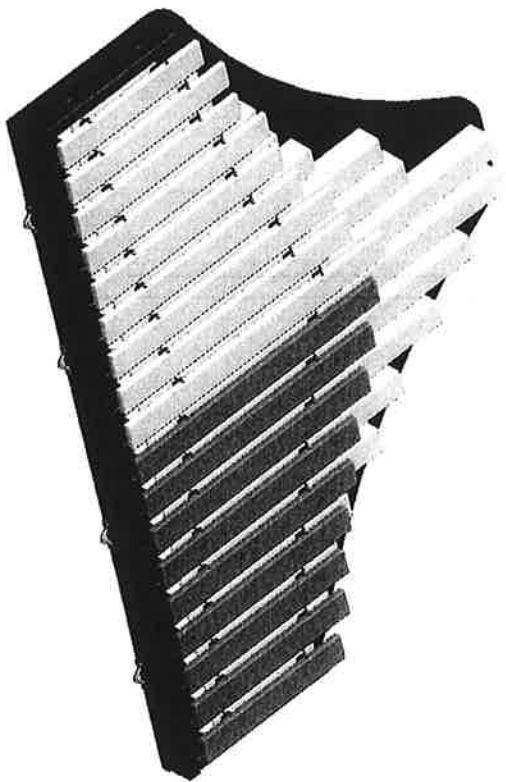
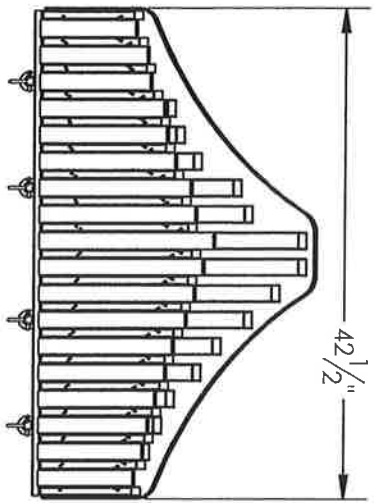

Main Features:

- (LH) A Minor / (RH) C Major Pentatonic
- Recycled HDPE Frame
- Anodized Aluminum Bars & Resonators
- Coated Fiberglass Bars
- Stainless Steel Hardware

Contents:

- SHEET 2 - Parts List and Instrument to Post Installation
- SHEET 3 - In Ground Installation
- SHEET 4 - Surface Mount Installation

Weights:

- Instrument Weight, 49lbs.
- Boxed Instrument Weight, 60lbs.
- Boxed Post Weight, 35-72lbs.



FREEMOTES HARMONY PARK
 194 BODO DRIVE, UNIT F
 DURANGO CO. 81303
 TEL: (970) 375-7825
 FAX: (970) 247-0856
 WWW.FREEMOTESHARMONYPARK.COM

PROPRIETARY AND CONFIDENTIAL
 THE INFORMATION CONTAINED IN THIS
 DRAWING IS THE SOLE PROPERTY OF
 FREEMOTES HARMONY PARK. ANY
 REPRODUCTION IN PART OR AS A
 WHOLE WITHOUT THE WRITTEN
 PERMISSION OF FREEMOTES HARMONY
 PARK IS PROHIBITED.

TITLE: Duet - Installation Guide

DWG. NO. DUET-INSTALL

REVISION: B

SCALE: 1:16

DATE: 2/9/2018

SHEET 1 OF 4

Parts List:

ITEM NO.	PART DESCRIPTION	In Ground - Recycled Post/QTY.	In Ground - Steel Post/QTY.	Surface Mount Recycled Post/QTY.	Surface Mount Steel Post/QTY.
1	Duet Instrument Assembly	1	1	1	1
2	Small SS Holster	2	2	2	2
3	In Ground Recycled Post, 72"lg.	2	-	-	-
4	In Ground Steel Post, 72"lg.	-	2	-	-
5	Surface Mount Recycled Post, 36"lg.	-	-	2	-
6	Surface Mount Steel Post, 36"lg.	-	-	-	2
7	Surface Mount Base, For Recycled Post	-	-	2	-
8	#8 Flat Head Screw, 1.25"lg. SS, T15 tamp	8	8	8	8
9	#8 Button Head Screw, 1.25"lg. SS, T15 tamp	10	-	10	-
10	#10-24 Button Head Machine Screw, 1"lg. SS, T25 tamp	-	10	-	10
11	5/16" Hex Head Lag Bolt, 5"lg. SS	-	-	4	-
12	3/8"-16 Wedge Expansion Anchor, SS	-	-	8	8
13	35/64" Hex Nut Cap	-	-	8	8
14	Security Driver	1	1	1	1

Step 1: Start by mounting the Holsters to the Instrument Back with the provided #8 Flat Head Screws and Driver. The Back comes predrilled. Screw heads should be flush with the Holster surface when properly installed. Holster should also be flush along the back. Drive Screws slowly to prevent stripping.

Step 2: With two people, situate the Instrument with Holsters installed onto the Posts. Posts come predrilled and/or tapped. Fasten the Instrument to the Posts with the provided #8 Button Head Screw for Recycled Posts or #10-24 Button Head Machine Screw for Steel Posts. Drivers are provided.

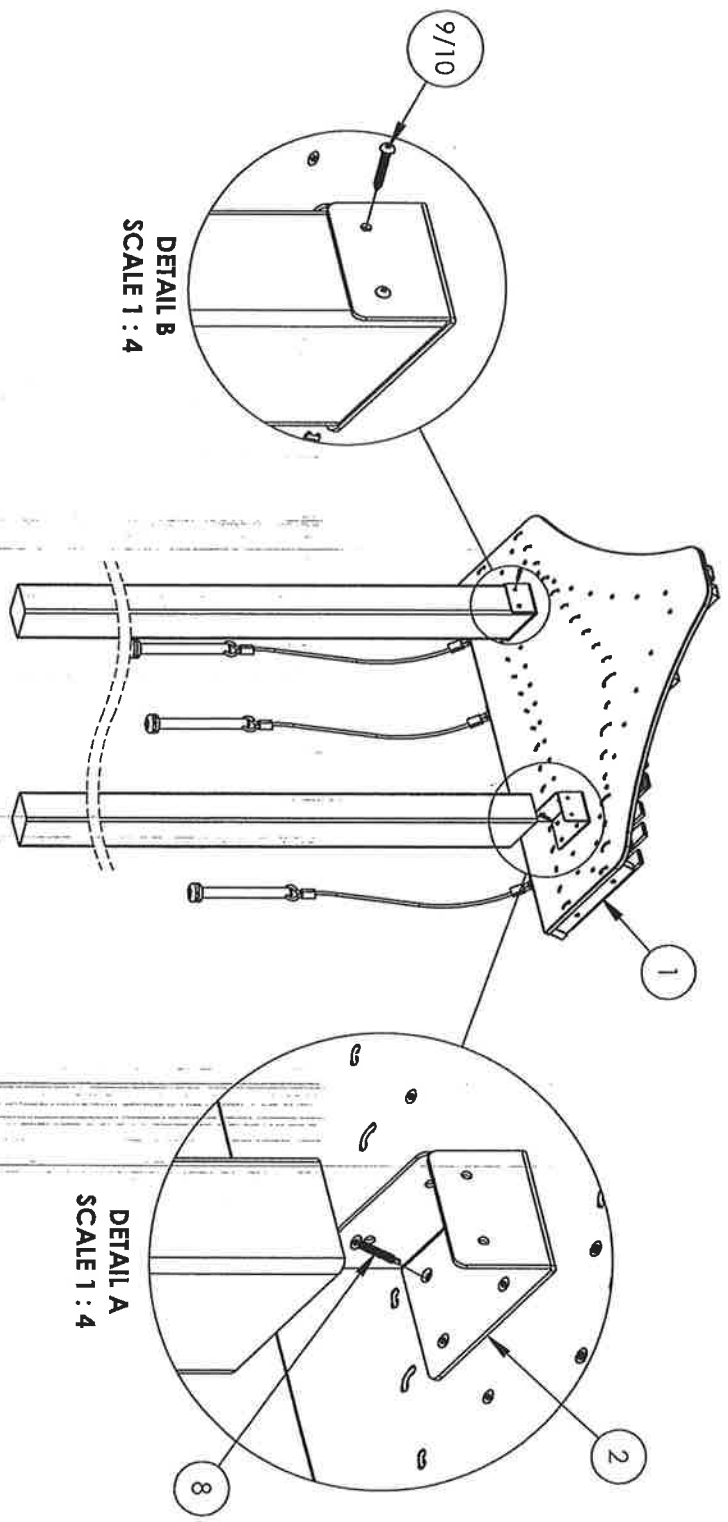

FREENOTES HARMONY PARK
194 BODO DRIVE, UNIT F
DURANGO CO 81303
TEL: (970) 375-7825
FAX: (970) 247-0856
WWW.FREENOTESHARMONYPARK.COM

PROPRIETARY AND CONFIDENTIAL
THE INFORMATION CONTAINED IN THIS
DRAWING IS THE SOLE PROPERTY OF
FREENOTES HARMONY PARK. ANY
REPRODUCTION IN PART OR AS A
WHOLE WITHOUT THE WRITTEN
PERMISSION OF FREENOTES HARMONY
PARK IS PROHIBITED.

TITLE: **Parts List and Instrument to Post Installation**
DWG. NO. **DUET-INSTALL**

REVISION: B
SCALE: 1:16
DATE: 2/9/2018
SHEET 2 OF 4

Step 1: Excavate two 10" diameter holes, 36" deep, and 25.5" on center at the installation location. Contractor can modify Post to desired height. Post Length = Frost Depth (36" Recommended) + Finished Post Height

Finished Post Height Guideline: (Ages 3-5, 22") (Ages 5-7, 27") (Ages 7-11, 32") (Adult, 36")

Step 2: With two people, lower the Posts with the Instrument attached into the excavated holes.

Step 3: Verify the correct placement, levelness, and finished height of the Instrument. Check for sufficient clearance around the Instrument, a 36" perimeter around the Instrument is recommended for wheelchair accessibility.

Step 4: Last pour concrete around the posts. It is recommended to brace the Instrument to hold it rigid while the concrete cures. Leave to set according to the concrete manufacturers guidelines. Approximately (6) 80lb. bags will be needed.

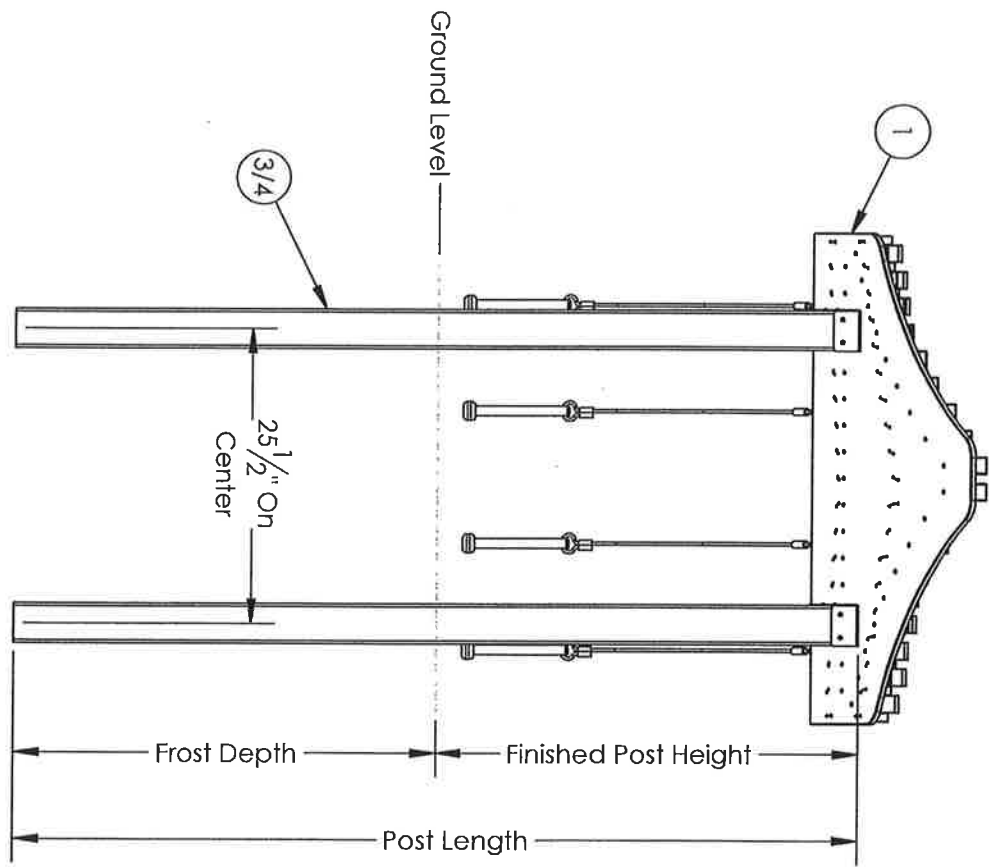

FREENOTES HARMONY PARK
 194 BODO DRIVE, UNIT F
 DURANGO, CO 81303
 TEL: (970) 375-7825
 FAX: (970) 247-0856
 WWW.FREENOTESHARMONYPARK.COM

PROPRIETARY AND CONFIDENTIAL
 THE INFORMATION CONTAINED IN THIS
 DRAWING IS THE SOLE PROPERTY OF
 FREENOTES HARMONY PARK. ANY
 REPRODUCTION IN PART OR AS A
 WHOLE WITHOUT THE WRITTEN
 PERMISSION OF FREENOTES HARMONY
 PARK IS PROHIBITED.

TITLE:
In Ground Installation

DWG. NO. DUET-INSTALL

REVISION: B

SCALE: 1:16

DATE: 2/9/2018

SHEET 3 OF 4

Step 1: Standard height for Surface Mount Posts are 36". The Recycled Posts may be modified in the field to the following heights:
 (Ages 3-5, 22") (Ages 5-7, 27") (Ages 7-11, 32") (Adult, 36")
 The height of Surface Mount Steel Posts can not be adjusted.

Step 2: Determine installation location. Verify concrete footing is a minimum of 48" long x 24" wide x 6" thick. If the concrete pad is at an angle, steel washers are required to act as shims (Shims not provided). If there is not already an existing pad, approximately (7) 80lb. bags will be needed. Allow concrete to cure per concrete manufacturers guidelines.

Step 3 (Recycled Post Only): Install the Surface Mount Bases to the bottom of the Posts. Align the holes on the Bases with the holes on the Posts. The Bases should fit snugly around the Posts. Fasten them together with the provided 5/16" Hex Head Log Bolts.

Step 4: With two people place the Instrument Assembly with Posts attached onto the concrete pad and mark the center of the holes on the surface mount bases. After you have made your marks, set aside the Instrument in order to drill for anchor holes. With a hammer or rotary drill, drill through concrete at marked locations. Drill to a minimum depth of 4". A 3/8" masonry drill bit will be needed.

Step 5: Place the Instrument back over the drilled out holes. Insert provided anchor bolts into aligned holes. Position anchor nut so that it is flush with the top of the bolt. Pound anchor bolts into the hole until the anchor washer is flush with the surface mount bases. Tighten anchor bolts until they are snug. Cover remaining bolt sections with provided nut caps.

Step 6: Verify the correct placement, levelness, and finished height of the Instrument. Check for sufficient clearance around the Instrument, a 36" perimeter around the Instrument is recommended for wheelchair accessibility.

Step 7: If installing onto wet concrete, us the wet set anchor manufacturers guidelines for installation procedures.

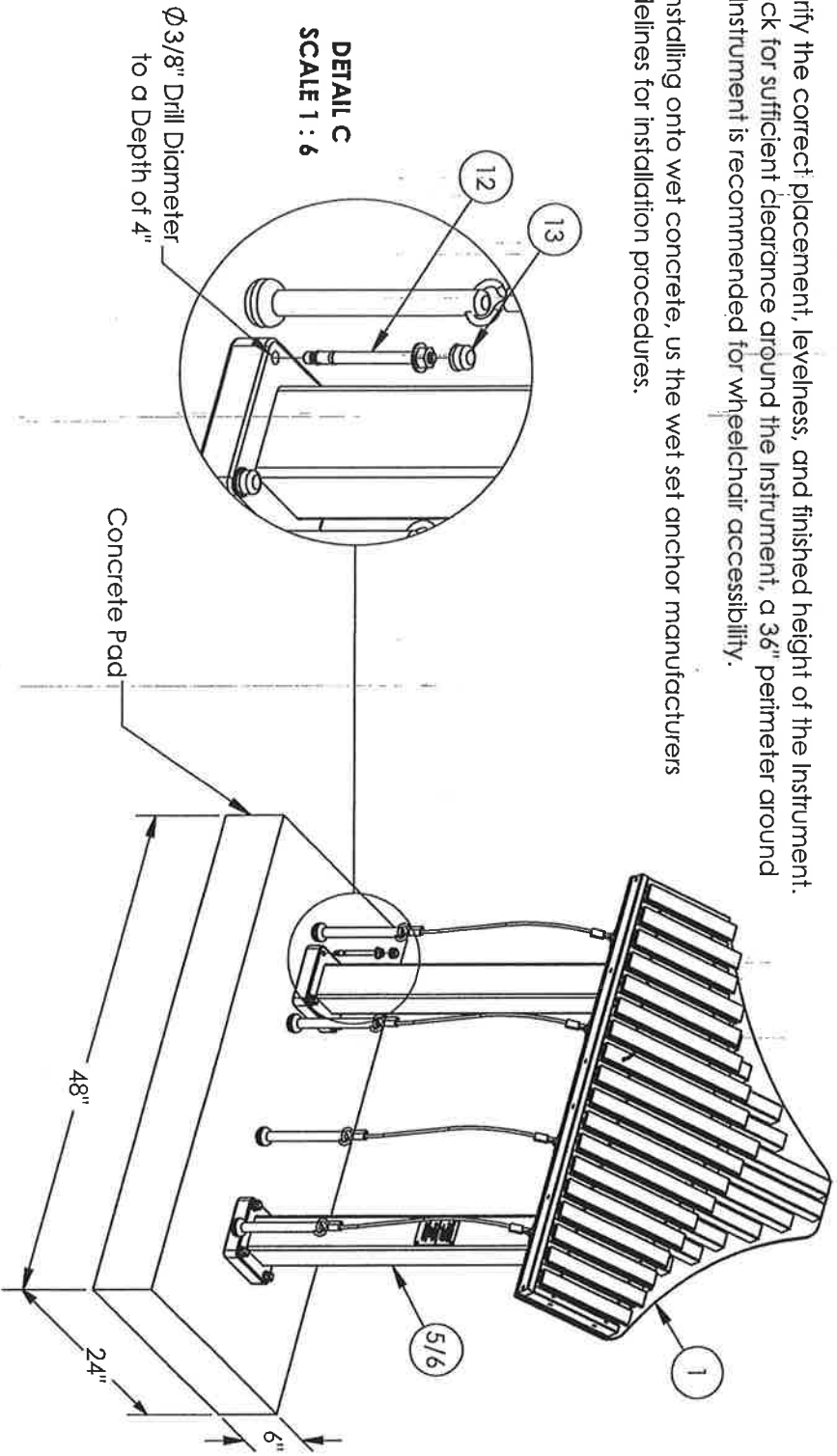



Misty Shelton
Director of Accountability
Hickman County Schools
115 Murphree Avenue
Centerville, Tennessee 37033

To: School Board Members
From: Misty Shelton
Date: December 2020

1st Reading:

5.200-Separation Practices for Tenured teachers- replace lines 8-11 of page 3 of current policy with the following wording- Teachers who retire under TCRS may be employed up to one hundred twenty (120) days per year without loss of retirement benefits. Retired teachers may substitute teach for additional days if the Director of Schools certifies in writing to the Division of Retirement that no other qualified personnel are available to substitute teach.⁹

1.901-Charter School Applications- Recent legislation that changes the charter school process will go into effect on January 1, 2021. Beginning next year, amended charter applications shall be submitted to the TN Charter School Commission. Previously, these appeals had to be submitted to the State Board of Education. TABS has updated this model policy to align with this change.

4.401- Textbooks - A new State Board of Education regulation creates a process for Boards to apply for waivers regarding textbooks and instructional materials. To take advantage of this, a Board must vote to seek a waiver to use materials that are not included on the list approved by the State Textbook Commission. TSBA has updated their model policy to include a provision on these waivers.

6.303- Interrogations and Searches- With the increase in vaping across the state, TSBA has received many questions on conducting searches in line with policy 6.303 and state law. As a result, they wanted to send out their model policy on this topic. They recommend that searches be conducted within the parameters of what is allowed under state and federal law.

6.405- Medicines- TSBA has updated their policy to clarify the process for allowing students to self-administer asthma medication during school hours.

931-729-3391 ext. 2226

misty.shelton@hickmank12.org

fax 931-729-3834

2nd Reading:

5.501- Complaints and Grievances- Add after line 17 as #1 Age Discrimination Employment Act;

Up for review:

5.605- Staff Gifts and Solicitations

5.606- Staff Community Relations

5.607- Non-School Employment

5.609- Consultants

5.610- Staff-Student Relations

5.611- Ethics

5.700- Interim Employees

5.701- Substitute Teachers- on line 13 of page 1 add **Director of Schools designee** as person preparing list of substitute teachers

5.702- Student Teachers

5.800- Director of Schools

5.801- Recruitment and Selection

5.802- Qualifications and Duties of the Director of Schools

5.803- Evaluation of the Director of Schools

Thank you in advance for your careful consideration of these policies.

931-729-3391 ext. 2226

misty.shelton@hickmank12.org

fax 931-729-3834

The Hickman County School System does not discriminate in its educational programs, activities, or employment practices on the basis of race, sex, national origin, religion, creed, age, marital status, or disability as required by Title VI of the Civil Rights Acts of 1964, Title IX of the Educational Amendments of 1972, and Section 504 of the Rehabilitation Act of 1973. All necessary accommodations are made for equitable participation by constituents without regard to race, gender, disability, economic status, or special needs as required by Section 427 of the General Education Provision Act & P. L. 107-110-NO CHILD LEFT BEHIND.

Hickman County Board of Education

Descriptor Term: Separation Practices for Tenured Teachers	Descriptor Code: 5.200	Issued Date: 11/02/20
	Rescinds: 5.200	Issued: 10/05/20

1 **SUSPENSION PENDING AN INVESTIGATION**¹

2 The director of schools may suspend a teacher at any time that may seem necessary, pending investigation or
3 final disposition of a case before the board or an appeal. If the matter under investigation is not the subject of an
4 ongoing criminal investigation or a department of children's services investigation, and if no charges for
5 dismissal have been made, a suspension pending investigation shall not exceed ninety (90) days in duration.
6 Under no circumstances shall the director of schools suspend a teacher with pay. If vindicated or reinstated, the
7 teacher shall be paid full salary for the period of suspension.

8 **SUSPENSION OF THREE DAYS OR LESS**^{2,3,4}

9 A director of schools/designee may suspend a teacher for incompetence, inefficiency, neglect of duty,
10 unprofessional conduct and insubordination. Before an employee is suspended he/she shall be: (1) provided
11 with written notice, including the reasons for the suspension along with an explanation of the evidence; (2)
12 given an opportunity to respond to the director at a conference, if requested within five (5) days; and (3) given a
13 written decision of the suspension within ten (10) days. Both parties may be represented by counsel at the
14 conference, which shall be recorded.

15 Under no circumstances shall a director of schools suspend a tenured teacher with pay. If reinstated, the tenured
16 teacher shall be paid full salary for the period of suspension, unless suspension without pay is deemed to be an
17 appropriate penalty.

18 **DISMISSAL OR SUSPENSIONS GREATER THAN THREE DAYS**⁵

19 The Board shall maintain a list of qualified individuals who have indicated a willingness to act as impartial
20 hearing officers, as defined under Tennessee law.

21 When charges are made against a tenured teacher, charging the teacher with offenses which may justify
22 dismissal or a suspension greater than three days, the charges shall be made in writing, specifically stating the
23 offenses which are charged and shall be signed by the party or parties making the charges.

24 If, in the opinion of the Board, the charges are of such nature as to warrant the release or a suspension greater
25 than three days of the teacher, the director of schools shall give the teacher a written notice of this decision, a
26 copy of the charges against the teacher, and a copy of a form provided by the Commissioner of Education
27 advising the teacher of his/her legal duties, rights and recourse.

28 A tenured teacher who has been given notice of charges against him/her may within thirty (30) days after receipt
29 of notice give written notice to the director of schools of his/her request for a hearing.

30 The director of schools shall, within five (5) days after receipt of request, assign a hearing officer from the list
31 maintained by the Board.

1 The hearing officer shall notify the parties, or their attorney, of the officer's assignment and direct the parties or
2 the attorneys for the parties, or both, to appear before the hearing officer for simplification of issues and the
3 scheduling of the hearing. That hearing shall be set no later than thirty (30) days following receipt of the initial
4 request for a hearing. In the discretion of the hearing officer, all or part of any prehearing conference may be
5 conducted by telephone if each participant has an opportunity to participate, be heard, and to address proof and
6 evidentiary concerns. The hearing officer is empowered to issue appropriate orders and to regulate the conduct
7 of the proceedings.

8 Either party may appeal to the Board of Education an adverse ruling by giving written notice of appeal within
9 ten (10) working days of the hearing officer's delivery of the hearing officer's written findings and conclusions.
10 The director of schools shall prepare a copy of the proceedings, including all transcripts and evidence,
11 documentary or otherwise, and transmit the same to the Board within twenty (20) days of the receipt of the
12 notice of appeal.

13 The Board shall hear the appeal on the record, and no new evidence may be submitted by either party. The
14 appealing party may appear before the Board to argue why the adverse ruling should be over-turned. In no
15 event should such argument last more than fifteen (15) minutes, unless the Board should vote to extend
16 additional time. At the conclusion of the hearing, any member of the Board may vote to sustain the decision of
17 the Hearing officer, send the record back for additional evidence, revise the penalty or reverse the decision. The
18 Board shall render its decision within ten (10) working days after the conclusion of the hearing. In the event
19 that the decision of the Board is appealed to the Chancery court, the Board shall transmit the entire record
20 prepared by the director and reviewed by the Board to the Chancery court for its review.

21 RESIGNATION

22 A teacher shall give the director of schools notice of resignation at least thirty (30) days before the effective date
23 of the resignation. A teacher who fails to give such notice, in the absence of justifiable extenuating
24 circumstances, shall forfeit all tenure status. The Board may waive the thirty (30) days' notice requirement and
25 permit a teacher to resign in good standing.

26 The conditions under which it is permissible to break a contract with the Board are as follows:

- 27 1. The incapacity on the part of the teacher to perform the contract as evidenced by the certified statement
28 of a physician approved by the Board;
- 29 2. The release by the Board of the teacher from the contract which the teacher has entered into with the
30 Board.⁶

31 Any teacher on leave shall notify the director of schools in writing at least thirty (30) days prior to the date of
32 return if the teacher does not intend to return to the position from which he/she has taken leave. Failure to
33 render such notice may be considered a breach of contract.⁷

34 Upon a breach of contract, the Board, upon a motion recorded in its minutes, may file a complaint with the State
35 Board of Education and request the suspension of a teacher's certificate. After the State Board of Education has
36 provided the teacher an opportunity for defense during a hearing, the Commissioner may suspend the certificate
37 for no less than thirty (30) and no more than three hundred sixty-five (365) days.⁸

38 RETIREMENT

1 Retirement shall mean a termination of services under conditions which will allow the employee to draw
 2 benefits from retirement plans and/or social security benefits. Employees eligible for retirement benefits may
 3 elect to retire at any age according to the provisions of the retirement system.

4 Central office personnel shall assist employees in securing retirement benefits; however, it shall be the
 5 responsibility of the retiring employee to provide verification of eligibility in writing from TCRS to the central
 6 office. It shall be the responsibility of the retiring employee to file for benefits.

7 Teachers who retire under TCRS may be employed up to one hundred twenty (120) days per year without loss
 8 of retirement benefits. Retired teachers may substitute teach for additional days if the Director of Schools
 9 certifies in writing to the Division of Retirement that no other qualified personnel are available to substitute
 10 teach.⁹

11 The director of schools may employ teachers retired for at least one year for full-time employment as a
 12 kindergarten through twelfth grade teacher on a year-to-year basis. Retirement benefits will not be lost or
 13 suspended under certain conditions, which include but are not limited to the following:¹⁰

- 14 1. The director of schools of the employing system must certify in writing that no other qualified
 15 individuals are available to fill the position;
- 16 2. The Commissioner of Education must certify that the employing school system serves an area that lacks
 17 qualified teachers to serve in the position to be filled;
- 18 3. The retired teacher must hold a valid license and shall not be entitled to tenure status;
- 19 4. The retired teacher shall not be eligible to accrue additional retirement benefits, accrue leave or receive
 20 medical insurance coverage; and
- 21 5. The salary paid to the retired member shall not be less than the rate of compensation set by the Board
 22 for teachers with no experience filling similar positions, nor more than eighty-five percent (85%) of the
 23 rate of compensation set by Board for teachers with comparable training and years of experience filling
 24 similar positions.

Legal References

1. TCA 49-5-511(a)(3)
2. TCA 49-2-301(b)(1)(EE), TCA 49-5-512(d)
3. TCA 49-5-511(a)(2)
4. TCA 49-5-511—513
5. TCA 49-5-508(a)
6. TCA 49-5-508(c)
7. TCA 49-5-706
8. TCA 49-5-411(b)
9. TCA 8-36-805

Cross References

- Public Hearings 1.401
 Recommendations and File Transfers 5.203

10. TCA 8-36-821

Hickman County Board of Education

Descriptor Term: Charter School Applications	Descriptor Code: 1.901	Issued Date: 11/04/19
	Rescinds: 1.901	Issued: 08/05/19

1 SCOPE

2 This policy shall apply to sponsors and potential sponsors of newly created public charter schools. It
3 shall not apply to public charter schools converted from existing public schools pursuant to TCA 49-
4 13-106(b)(2).¹

5 DEFINITION

6 A charter school shall be a public, nonsectarian, non-religious, non-home based school which operates
7 within a public school district. It shall be subject to all state and federal laws and constitutional
8 provisions prohibiting discrimination on the basis of disability, race, creed, color, gender, national
9 origin, religion, ancestry or need for special education services.

10 The purposes of charter schools are to:

- 11 1) Improve learning for all students and close the achievement gap between high and low
12 students;
- 13 2) Provide options for parents to meet educational needs of students in high priority schools;
- 14 3) Encourage the use of different and innovative teaching methods, and provide greater decision-
15 making authority to schools and teachers in exchange for greater responsibility for student
16 performance;
- 17 4) Measure performance of pupils and faculty, and ensure that children have the opportunity to
18 reach proficiency on state academic assessments;
- 19 5) Create new professional opportunities for teachers; and
- 20 6) Afford parents substantial meaningful opportunities to participate in the education of their
21 children.

27 APPLICATION PROCESS²

28 A prospective charter school sponsor shall send the Director of Schools notice of its intent sixty (60)
29 days prior to February 1st of the year preceding the year in which the proposed charter school plans to
30 begin operation as a charter school.

31 A sponsor seeking board approval of an initial charter school application shall complete the forms
32 provided by the Department of Education. The application shall provide all the information required by

1 law. The sponsor shall demonstrate that the proposed charter school meets the purpose prescribed by
2 law for the formation of a charter school, and the proposed charter school will be able to implement a
3 viable program of quality education for its students.³

4 Applications shall be submitted to the Board and Department of Education on or before 4:30 p.m. on
5 February 1st of the year preceding the year in which the proposed charter school plans to begin
6 operation as a charter school. If the 1st of February falls on a Saturday, Sunday, or holiday on which
7 the school district offices are closed, applications will be accepted on the next business day on or
8 before 4:30 p.m. Late applications will not be accepted, without exception. The sponsor shall pay an
9 application fee of \$2,500.00.²

10 **REVIEW TEAM¹**

11 If necessary, the board shall appoint a review team to assist in reviewing and evaluating charter school
12 applications. The team shall be composed of: members of the administrative staff for the district;
13 community members; and a member of the board. At the board meeting in February each year, the
14 Director of Schools shall make a recommendation to the board of which members of his administrative
15 staff should be appointed to the team. The board shall name the members of the team at its meeting in
16 March of each year. The board shall designate a chairman of the review team as the contact person for
17 answering questions about the application process and receiving applications.

18 The board shall require a procedure for receiving, reviewing and ruling on applications for the
19 establishment of charter schools. The procedure must include a timeline for the application and review
20 process. A copy of the procedure, including the review criteria, shall be available to any interested
21 party upon request.

22 The review team shall:

- 23 1) Evaluate all charter school applications based on the review criteria adopted by the board;
- 24
- 25 2) Recommend one of the following options to the board for each application: approve, reject, or
26 reject with stipulations for reconsideration; and
- 27
- 28 3) Make recommendations for revocation, renewal or non-renewal of charter contracts.

29 **APPROVAL, DENIAL OF APPLICATION⁴**

30 The board shall rule by resolution on the approval or denial of a charter application within ninety (90)
31 days of receipt of the completed application or the application shall be deemed approved by law. The
32 director of schools shall report the action taken by the board to the department of education.

33 **Approval**

34 The sponsor of a public charter school that is approved by the board shall enter into a written
35 agreement with the board, which shall be binding on the charter school's governing body. This
36 agreement, known as the charter agreement, shall be in writing signed by the sponsor and the board. In
37 the application, the sponsor must demonstrate that the proposed charter school meets the purpose
38 prescribed by law for the formation of a charter school and the proposed charter school will be and

- 1 shall include all aspects of the sponsor's approved application as well as any reporting requirements prescribed under state or federal laws.
- 3 Starting in the 2018-2019 school year, the board will receive an annual authorizer fee of three percent
4 (3%) of the annual per student state and local allocations or thirty-five thousand dollars (\$35,000),
5 whichever is less.⁵
- 6 Charter schools approved by the board of education are expected to implement the application as
7 submitted and approved. Material variations in operations from the approved application require
8 amendment pursuant to statute and the charter school agreement.
- 9 The board should not be expected to provide services to charter schools that are not requested during
10 the application process except for those services that are required under state or federal laws. Services
11 agreed to be provided to the charter schools by the board shall be provided at board actual cost. The
12 board and charter school shall execute a service contact for any additional services.
- 13 New public charter school agreements are approved for a ten-year period.⁶ The board may revoke or
14 deny renewal of a public charter school agreement for any of the reasons enumerated in TCA 49-13-
15 122.⁷
- 16 **Denial**
- 17 Upon receipt of the grounds for denial, the sponsor shall have thirty (30) days within which to submit
18 an amended application to correct the deficiencies. The board shall have thirty (30) days either to deny
or to approve the amended application or the application shall be deemed approved by law.⁴
- 20 A denial of an application by the board may be appealed by the sponsor, within ten (10) days of the
21 final decision to deny with the Tennessee Charter School Commission.⁹

Legal References

1. TCA 49-13-106; State Board of Education Policy 6.111
2. TCA 49-13-107; TCA 1-3-102; TCA 49-13-108; TRR/MS 0520-14-01
3. TCA 49-13-110
4. TCA 49-13-108; TRR/MSS 0520-14-01
5. TCA 49-13-128
6. TRR/MS 0520-14-01-06; TCA 49-13-110
7. TCA 49-13-110
8. TCA 49-13-122
9. TCA 49-13-108(b)(5)

Hickman County Board of Education

Descriptor Term: Textbooks	Descriptor Code: 4.401	Issued Date: 03/02/20
	Rescinds: 4.401	Issued: 03/05/18

1 **SELECTION**¹

2 The selection of textbooks shall be completed according to the laws and policies required by the State
3 of Tennessee and the State Textbook Commission. The responsibility for textbook selection rests with
4 the local textbook selection committees subject to approval by the Board. Use of textbooks and
5 instructional materials not on the list approved by the State Textbook Commission is permissible if the
6 Board submits a waiver to the State Board of Education and such waiver is approved. The director of
7 schools shall establish a procedure for providing citizens of the community with an opportunity to
8 examine proposed textbooks prior to their final adoption,² including public notice of time and location
9 at which textbooks may be examined. Once the proposed textbooks have been approved by the Board,
10 the director of schools shall post the list of all approved textbooks and instructional materials adopted
11 for use across the school system on the school system's website and send a copy of the list to the
12 commissioner of education.¹

13 **COMPLAINTS & RECONSIDERATION**

14 The director of schools shall develop forms and procedures to enable citizens to file complaints
15 regarding the selection or content of approved textbooks. Following the conclusion of this
16 administrative process, a complainant may appeal an outcome to the Board.

17 **DISTRIBUTION**

18 The director of schools shall designate an employee to be responsible for the purchase and distribution
19 of textbooks in each school. The principal shall be responsible for seeing that each student receives the
20 required textbooks at no cost to the student.

21 **CARE OF TEXTBOOKS**³

22 Textbooks are property of the Board and shall be returned at the end of the school year, upon
23 completion of the course or upon withdrawal from a course or school. Parents are to sign an agreement
24 stating they shall be responsible for the textbooks received and used by their children.

25 The following reimbursement schedule shall be used as a guide for collecting fines for lost or
26 destroyed books:

27	Age of Book	Amount Collected
28	1 - 2 years	100% of replacement cost
	3 - 4 years	75% of replacement cost
29	5 or more years	50% of replacement cost

1 The Board shall approve and periodically review a schedule of fines for damaged books. In cases
2 where the book is damaged to the extent it is no longer useable, the amount collected shall conform to
3 the reimbursement schedule for lost books. A fine may only be assessed in cases where the pupil or
4 parent damages, loses or defaces the textbook either through willful intent or neglect.⁴

5 Following an interview with parties and an investigation, if needed, the principal may assess the
6 appropriate fine and notify the parents in writing.

7 The principal may include with the notice a provision stating that failure to pay the fine imposed
8 within a reasonable time may result in the imposition of one of the following sanctions:³

- 9 1. Refusal to issue any additional textbooks until restitution is made;
- 10 2. Withholding of all grade cards, diplomas, certificates of progress, or transcripts until restitution
11 is made;
- 12 3. Not allowing the pupil to take interim or final examinations or to earn course credit in the
13 course for which the textbook is prescribed until restitution is made; or
- 14 4. Reducing the pupil's grade in the course for which the textbook is prescribed by one (1) letter
15 grade or ten (10) percentage points until restitution is made.

16 The principal may waive the assessment of fines when in his/her judgment the student is the victim of
17 uncontrollable circumstances and not responsible for the damages.

18 INSPECTION

19 A list textbooks used by the schools shall be revised annually by building administrators under the
20 direction of the director of schools. Textbooks shall be available for inspection by parents/guardians
21 upon request, and the director of schools shall develop procedures for the inspection of materials and
22 distribute these procedures to each principal.²

Legal References

1. TCA 49-6-2207(c), (e)-(f); TCA 49-6-2202(d)
2. 20 USCA § 1232h(a); TCA 49-6-7003
3. TCA 49-3-310(1)(B)
4. TCA 49-3-310(1)(C)

Cross References

Surplus Property Sales 2.403
Reconsideration of Instructional Materials 4.403
Controversial Materials 4.801
Student Fees and Fines 6.709

Hickman County Board of Education

Descriptor Term: Interrogations and Searches	Descriptor Code: 6.303	Issued Date: 02/04/19
	Rescinds: 6.303	Issued: 11/05/18

1 INTERROGATIONS BY SCHOOL PERSONNEL

2 School personnel have a duty to report any reasonable suspicion that a student is carrying, or has
3 carried, a weapon or is violating, or has violated, a provision of the Tennessee Drug Control Act to the
4 principal, the principal's designee or, if the principal and the principal's designee are unavailable and
5 the offense was committed on school property, to the appropriate authorities.¹

6 Students may be questioned by teachers or principals about any matter pertaining to the operation of a
7 school and/or the enforcement of its rules. Questioning must be conducted discreetly and under
8 circumstances which will avoid unnecessary embarrassment to the student being questioned. Any
9 student answering falsely, evasively or refusing to answer a proper question may be subject to
10 disciplinary action, including suspension.

11 If a student is suspected or accused of misconduct or infraction of the student code of conduct, the
12 principal may interrogate the student, without the presence of parent(s)/guardian(s) or legal custodians
and without giving the student constitutional warnings.

14 INTERROGATIONS BY POLICE (AT ADMINISTRATOR'S REQUEST)

15 If the principal has requested assistance by the police department to investigate a crime involving
16 his/her school, the police shall have permission to interrogate a student suspect in school during school
17 hours. The principal shall first attempt to notify the parent(s)/guardian(s) or legal custodians of the
18 student of the intended interrogation unless circumstances require otherwise. The interrogation may
19 proceed without attendance of the parent(s)/guardian(s) or legal custodians. The principal or his/her
20 designee shall be present during the interrogation.

21 The use of police women or female staff members is desirable in the interrogation of female students.

22 POLICE-INITIATED INTERROGATIONS

23 If the police deem circumstances of sufficient urgency to interrogate students at school for unrelated
24 crimes committed outside of school hours, the police department shall first contact the principal
25 regarding the planned interrogation, inform him/her of the probable cause to investigate within the
26 school. The principal shall make reasonable effort to notify the parent(s)/guardian(s) or legal
27 custodians of the interrogation unless circumstances require otherwise. The interrogation may proceed
28 without attendance of the parent(s)/guardian(s) or legal custodians. The principal or his/her designee
29 shall be present during the interrogation.

1 SEARCHES BY SCHOOL PERSONNEL

2 In order to ensure a safe and secure learning environment, the Director of Schools shall develop
3 procedures regarding the searching of students, lockers, vehicles, and containers which are consistent
4 with state law. The Director of Schools shall develop additional procedures to ensure compliance with
5 all of the provisions of the School Security Act of 1981.^{1,2}

6 Any principal, or his/her designee, having reasonable suspicion may search any student, place or thing
7 on school property or in the actual or constructive possession of any student during any organized
8 school activity off campus, including buses, vehicles of students or visitors (*Notice shall be posted in*
9 *the school parking lot that vehicles parked on school property by students or visitors are subject to*
10 *search for drugs, drug paraphernalia or dangerous weapons*), and containers or packages if he/she
11 receives information which would cause a reasonable belief that the search will lead to the discovery
12 of:

- 13 1. Evidence of any violation of the law;
- 14
- 15 2. Evidence of any violation of school rules or regulations or proper standards of student or
- 16 faculty conduct;
- 17
- 18 3. Any object or substance which, because of its presence, presents an immediate danger of harm
- 19 or illness to any person.

20 A student using a locker that is the property of the school system does not have the right of privacy in
21 that locker or its contents. All lockers or other storage areas provided for student use on school
22 premises remain the property of the school system and are provided for the use of students subject to
23 inspection, access for maintenance and search. *Notice shall be posted in each school that lockers and*
24 *other storage areas are school property and are subject to search.*

25 A student may be subject to physical search or a student's pocket, purse or other container may be
26 required to be emptied because of the results of a locker search, or because of information received
27 from a teacher, staff member or other student if such action is reasonable to the principal. All of the
28 following standards of reasonableness shall be met:

- 29 1. A particular student has violated policy;
- 30
- 31 2. The search could be expected to yield evidence of the violation of school policy or disclosure
- 32 of a dangerous weapon or drug;
- 33
- 34 3. The search is in pursuit of legitimate interests of the school in maintaining order, discipline,
- 35 safety, supervision and education of students;
- 36
- 37 4. The primary purpose of the search is not to collect evidence for a criminal prosecution; and
- 38 5. The search shall be reasonably related to the objectives of the search and not excessively
- 39 intrusive in light of the age of the student, as well as the nature of the infraction alleged to have
- 40 been committed.

1 School officials may conduct hand-held or walk-through metal detector checks of a student's person or
2 personal effects.

3 **USE OF ANIMALS**

4 When necessary, dogs or other animals trained to detect drugs or dangerous weapons may be used in
5 conducting searches, but the animals shall be used only to pinpoint areas which need to be searched
6 and shall not be used to search the persons of students or visitors.

7 **SEARCHES BY POLICE**

8 If public health or safety is involved, upon request of the principal who shall be present, police officers
9 may make a general search of students' lockers and desks, or students' or nonstudents' automobiles for
10 drugs, weapons or items of an illegal or prohibited nature.

11 If the principal has received reliable information which he/she believes to be true that evidence of a
12 crime or of stolen goods, not involving school property of members of the school staff or student body,
13 is located on school property and that any search for such evidence or goods would be unrelated to
14 school discipline or to the health and safety of a student or the student body, he/she shall request police
15 assistance; and procedures to obtain and execute a search warrant shall thereafter be followed.

16 Anything found in the course of the search conducted in accordance with this policy which is evidence
17 of a violation of the law or a violation of student conduct standards may be:

- 18 1. Seized and admitted as evidence in any hearing, trial, suspension or dismissal proceeding. It
19 should be tagged for identification at the time it is seized and kept in a secure place by the
20 principal or the principal's designee until it is presented at the hearing. At the discretion of the
21 principal, the items seized may be returned to the parent or guardian of a student or, if it has no
22 significant value, the item may be destroyed, but only with the express written permission of
23 the director of schools.
24
- 25 2. Any seized item may be turned over to any law enforcement officer. Any dangerous weapon or
26 drug as defined in TCA 49-6-4202 shall be turned over to an appropriate law enforcement
27 official after completion of an administrative proceeding at which its presence is reasonably
28 required.

29 Whenever the possibility of uncovering evidence of a criminal nature exists, the principal or his/her
30 designee may request the assistance of a law enforcement officer to:

- 31 1. Search any area of the school premises, any student or any motor vehicle on the school
32 premises; or
33
- 34 2. Identify or dispose of anything found in the course of a search conducted in accordance with
35 this policy.

36 The involvement of law enforcement officials is encouraged when there is reasonable cause to suspect
that criminal evidence is about to be uncovered.

1

Legal References

1.TCA 49-6-4203(b)

2.TCA 49-6-4201 et seq.; Tenn. Op. Att’y Gen. No. 14-21
(February 24, 2014)

Cross References

Traffic and Parking Controls 3.403

Procedural Due Process 6.302

Child Abuse and Neglect 6.409

Hickman County Board of Education

Descriptor Term: Medicines	Descriptor Code: 6.405	Issued Date: 12/03/18
	Rescinds: 6.405	Issued: 04/02/18

1 If under exceptional circumstances a child is required to take non-prescription or prescription
2 medication during school hours and the parent/guardian cannot be at school to administer the
3 medication, only the principal or the principal's designee will assist in self-administration of the
4 medication if the student is competent to self-administer medicine with assistance in compliance with
5 the following regulations: ¹

6 Written instructions signed by the parent will be required and will include:

- 7 1. Child's name;
- 8 2. Name of medication;
- 9 3. Name of physician;
- 10 4. Time to be self-administered;
- 11 5. Dosage and directions for self-administration (non-prescription medicines must have label
12 direction);
- 13 6. Possible side effects, if known; and
- 14 7. Termination date for self-administration of the medication.

15
16 **Students with asthma shall be permitted to self-administer prescribed, metered dosage asthma-**
17 **reliever inhalers if the additional information is provided by a parent/guardian:**

- 18
19 1. **Written statement from the prescribing health care practitioner that the student suffers from**
20 **asthma and has been instructed in self-administration; and**
- 21
22 2. **Purpose of the medication.**

23
24 **The medication shall be delivered to the principal's office in person by the parent/guardian of the**
25 **student unless the medication shall be retained by the student for immediate self-**
26 **administration.**

27 Volunteer personnel, trained by a registered nurse, may administer emergency medication to a student
28 based on that student's Individual Health Plan (IHP) or a physician's standing order. A call to 911 will
be made in the event of these emergencies.

1 The administrator/designee will:

- 2 1. Inform appropriate school personnel of the medication to be self-administered;
- 3 2. Keep written instructions from parent in student's record;
- 4 3. Keep an accurate record of the self-administration of the medication;
- 5 4. Keep all medication in a locked cabinet except medication retained by a student per physician's
- 6 order;
- 7 5. Return unused prescription to the parent or guardian only; and
- 8 6. Ensure that all guidelines developed by the Department of Health and the Department of
- 9 Education are followed.

10 The parent or guardian is responsible for informing the designated official of any change in the
11 student's health or change in medication.

12 A copy of this policy shall be provided to a parent or guardian upon receipt of a request for long-term
13 administration of medication.

14 **TRANSPORTATION OF MEDICATIONS ON SCHOOLS BUSES**

15 In an effort to ensure the safety and well-being of all students, no medications except inhalers or other
16 medications which a physician has indicated in writing should be kept on a student's person, may be
17 transported on school buses. Parents must make arrangements for delivery of medications to the school
18 that their child attends.

19 In the event that medication is sent to school on a bus in violation of this policy, the following
20 procedure will be utilized:

21 1. *First Non-Compliance Incident*

22 Parents will be contacted by phone or letter. A copy of this policy will be attached to the letter.

23 2. *Second Non-Compliance Incident*

24 A referral will be made to the Juvenile Court of Hickman County and/or the Department of
25 Children's Services for disposition of the matter.

26 **DISPOSAL OF MEDICATIONS**

1 Notification will be provided by phone call or notes sent home to parents one week prior to the end of
the school year that unused medication is remaining at school.

3 If a parent/guardian or their designee does not pick up remaining medication, disposal will occur at the
4 end of the school year by transporting to the Hickman County Sheriff's Department to be disposed of
5 properly through the Community Drug Take Back Program. Two school personnel shall be present at
6 disposal. Appropriate school personnel will be trained annually in disposal procedures. Documentation
7 shall occur regarding disposal of all medications.

8 **BLOOD GLUCOSE SELF-CHECKS²**

9 Upon written request of a parent or guardian, and if included in the student's medical management plan
10 and in the IHP, a student with diabetes shall be permitted to perform a blood glucose check or
11 administer insulin using any necessary diabetes monitoring and treatment supplies, including sharps.
12 The student shall be permitted to perform the testing in any area of the school or school grounds at any
13 time necessary. The student will report the use of the monitoring or treatment supplies to school
14 employee for proper disposal.

15 Sharps shall be stored in a secure, but accessible location, including the student's person, until use of
such sharps is appropriate.

17 Use and disposal of sharps shall be in compliance with the guidelines set forth by the Tennessee
18 Occupational Safety and Health Administration (TOSHA).

19 **STUDENTS WITH PANCREATIC INSUFFICIENCY OR CYSTIC FIBROSIS³**

20 Students diagnosed with pancreatic insufficiency or cystic fibrosis shall be permitted to carry and self-
21 administer their prescribed medication in a manner directed by a licensed healthcare provider without
22 additional assistance or direction. The Director of Schools shall develop procedures for the
23 development of both an Individualized Healthcare Plan (IHP) and an Emergency Care Plan (ECP) that
24 conforms to state law for every student with pancreatic insufficiency or cystic fibrosis that wishes to
25 self-medicate.

26 **STUDENTS WITH ADRENAL INSUFFICIENCY⁴**

27 The parent/guardian of a student diagnosed with adrenal insufficiency shall notify the school district of
28 the student's diagnosis. Once notified, the district shall observe the following procedure:

- 29 1. The district shall train school personnel who will be responsible for administering the
medication for the treatment of adrenal insufficiency and any who volunteer to administer the

- 1 medication.
- 2
- 3 2. The district shall maintain a record of all school personnel who have completed this training.
- 4
- 5 3. If a student is suffering from an adrenal crisis, a school nurse or other licensed health care
- 6 professional may administer the prescribed medication to the student. If a school nurse or other
- 7 licensed health care professional is not immediately available, trained school personnel may
- 8 administer the prescribed medication.
- 9 The director of schools shall develop procedures on the administration of medications that treat adrenal
- 10 insufficiency and recordkeeping per rules set forth by the State Board of Education.

Legal References

- 1.TCA 49-50-1602 et seq.; TRR/MS 0520-01-13-.03
- 2.TCA 49-50-1602(d)(7)
- 3.State Board of Education Policy 4.205; TRR/MS 0800-01-10
- 4.TCA 49-50-1601
- 5.TRR/MS 0520-01-13; State Board of Education Policy 4.205

Cross References

Emergency Allergy Response Plan 6.412



Misty Shelton
Director of Accountability
Hickman County Schools
115 Murphree Avenue
Centerville, Tennessee 37033

To: School Board Members
From: Misty Shelton
Date: December 2020

1st Reading:

5.200-Separation Practices for Tenured teachers- replace lines 8-11 of page 3 of current policy with the following wording- Teachers who retire under TCRS may be employed up to one hundred twenty (120) days per year without loss of retirement benefits. Retired teachers may substitute teach for additional days if the Director of Schools certifies in writing to the Division of Retirement that no other qualified personnel are available to substitute teach.⁹

1.901-Charter School Applications- Recent legislation that changes the charter school process will go into effect on January 1, 2021. Beginning next year, amended charter applications shall be submitted to the TN Charter School Commission. Previously, these appeals had to be submitted to the State Board of Education. TABS has updated this model policy to align with this change.

4.401- Textbooks - A new State Board of Education regulation creates a process for Boards to apply for waivers regarding textbooks and instructional materials. To take advantage of this, a Board must vote to seek a waiver to use materials that are not included on the list approved by the State Textbook Commission. TSBA has updated their model policy to include a provision on these waivers.

6.303- Interrogations and Searches- With the increase in vaping across the state, TSBA has received many questions on conducting searches in line with policy 6.303 and state law. As a result, they wanted to send out their model policy on this topic. They recommend that searches be conducted within the parameters of what is allowed under state and federal law.

6.405- Medicines- TSBA has updated their policy to clarify the process for allowing students to self-administer asthma medication during school hours.

931-729-3391 ext. 2226

misty.shelton@hickmank12.org

fax 931-729-3834

2nd Reading:

5.501- Complaints and Grievances- Add after line 17 as #1 Age Discrimination Employment Act;

Up for review:

5.605- Staff Gifts and Solicitations

5.606- Staff Community Relations

5.607- Non-School Employment

5.609- Consultants

5.610- Staff-Student Relations

5.611- Ethics

5.700- Interim Employees

5.701- Substitute Teachers- on line 13 of page 1 add **Director of Schools designee** as person preparing list of substitute teachers

5.702- Student Teachers

5.800- Director of Schools

5.801- Recruitment and Selection

5.802- Qualifications and Duties of the Director of Schools

5.803- Evaluation of the Director of Schools

Thank you in advance for your careful consideration of these policies.

931-729-3391 ext. 2226

misty.shelton@hickmank12.org

fax 931-729-3834

The Hickman County School System does not discriminate in its educational programs, activities, or employment practices on the basis of race, sex, national origin, religion, creed, age, marital status, or disability as required by Title VI of the Civil Rights Acts of 1964, Title IX of the Educational Amendments of 1972, and Section 504 of the Rehabilitation Act of 1973. All necessary accommodations are made for equitable participation by constituents without regard to race, gender, disability, economic status, or special needs as required by Section 427 of the General Education Provision Act & P. L. 107-110-NO CHILD LEFT BEHIND.

Hickman County Board of Education

Descriptor Term: Complaints and Grievances	Descriptor Code: 5.501	Issued Date: 11/02/20
	Rescinds: 5.501	Issued: 10/01/18

1 EMPLOYMENT-RELATED COMPLAINTS/GRIEVANCES

2 The Board believes that differences of opinions arising in the course of employment should be
3 resolved as quickly as possible and at the lowest supervisory level.

4 In instances of questions by an individual staff member concerning the interpretation of policies and
5 procedures to that staff member, administrative practices within his/her particular school, and
6 relationships with other employees, the staff member concerned must consult the administrative or
7 supervisory personnel to whom he/she is responsible. If a satisfactory resolution of the problem cannot
8 be reached after ample opportunity for consideration of the matter, the staff member concerned may
9 discuss the matter with the next level of supervision up to and including the director of schools.

10 In instances where an individual staff member feels for personal reasons that he/she cannot discuss a
11 problem with his/her immediate superior, he/she may take the problem directly to the director of
12 schools. After review of the case, the director of schools shall take action as he/she deems appropriate
and within a prompt, reasonable time shall notify all parties concerned of his decision.

14 HARASSMENT/DISCRIMINATION GRIEVANCES

15 Employees should notify any district complaint manager if they believe the Board, its employees or
16 agents have violated their rights guaranteed by the State or federal Constitution, State or federal statute
17 or board policy including:^{1,2,3}

18 1. Age Discrimination Employment Act;

19 2. Title II of the Americans with Disabilities Act⁴

20 3. Title IX of the Education Amendments of 1972⁵

21 4. Section 504 of the Rehabilitation Act of 1973⁶

22 5. Claims of sexual harassment under Title VII of the Civil Rights Act of 1964 and Title IX of the
23 Education Amendments of 1972^{7,5}

24 The complaint manager will endeavor to respond and resolve complaints without resorting to this
25 grievance procedure and, if a complaint is filed, to address the complaint promptly and equitably. The
26 right of a person to prompt and equitable resolution of the complaint shall not be impaired by the
27 person's pursuit of other remedies. Use of this grievance procedure is not a prerequisite to the pursuit
28
29
30
31

1 of other remedies and use of this grievance procedure does not extend any filing deadline related to the
2 pursuit of other remedies.

- 3 1. Filing a Complaint — An employee who wishes to avail himself or herself of this grievance
4 procedure may do so by filing a complaint with any district complaint manager. The employee
5 may request a complaint manager of the same sex. The complaint manager may assist the
6 employee in filing a grievance.
7
- 8 2. Investigation — The complaint manager will investigate the complaint or appoint a qualified
9 person to undertake the investigation on his or her behalf. The complaint and identity of the
10 complainant will not be disclosed except (1) as required by law or this policy; or (2) as
11 necessary to fully investigate the complaint; or (3) as authorized by the complainant. The
12 complaint manager shall file a written report within ten (10) days of the filing of the grievance,
13 of his or her findings with the director of schools. If a complaint of sexual harassment contains
14 allegations involving the director of schools, the written report shall be filed with the Board.
15 The director of schools shall keep the Board informed of all complaints.
16
- 17 3. Decision and Appeal — After receipt of the complaint manager's report, the director of schools
18 shall render a written decision within five (5) days of the receipt of the report which shall be
19 provided to the employee. If the employee is not satisfied with the decision, the employee may
20 appeal the decision to the Board by making a written request to the complaint manager. The
21 complaint manager shall be responsible for promptly forwarding all materials relative to the
22 complaint and appeal to the Board. Thereafter, the Board shall render within thirty (30) days
23 from the date the appeal was received, review the report and affirm, overrule or modify the
24 decision and render a written finding which shall be provided to the complainant. This
25 grievance procedure shall not be construed to create an independent right to a Board hearing.

26 **APPOINTING COMPLAINT MANAGERS**

27 The director of schools shall appoint at least two complaint managers, one of each gender. The Federal
28 Rights Coordinator may be appointed as a complaint manager. The director of schools shall insert into
29 this policy the names, addresses and telephone numbers of current complaint managers. (see note)

30 *(Note: Title IX regulations require districts to identify the name, address and telephone number of the*
31 *person who is responsible for coordinating the district's compliance efforts. A policy should not be*
32 *adopted with a person's name in it; rather, the identifying information can be added and amended as*
33 *necessary.)*

Legal References

1. Age Discrimination Employment Act, 29 USCA § 621 *et seq.*; 42 USCA §§ 6101 – 6107; 34 CFR § 110.25
2. Equal Pay Act, 29 USCA § 206(d)
3. Immigration Reform and Control Act, 8 USCA § 1324 *et seq.*
4. Americans with Disabilities Act, 42 USCA § 12101 *et seq.*
5. Title IX of the Education Amendments, 20 USCA § 1681 *et seq.*
6. Section 504 of the Rehabilitation Act, 29 USCA § 701 *et seq.*
7. Title VII of Civil Rights Act, 42 USCA § 2000e *et seq.*

Cross References

Appeals to and Appearances Before the Board 1.404
Section 504 and ADA Grievance Procedures 1.802
Equal Opportunity Employment 5.104
Discrimination/Harassment of Employees 5.500
Title IX & Sexual Harassment 6.3041

Hickman County Board of Education			
	Descriptor Term: Staff Gifts and Solicitations	Descriptor Code: 5.605	Issued Date: 10/07/19
		Rescinds: 5.605	Issued: 08/06/18

1 **GIFTS**

2 Employees of the Board shall not accept gifts from students unless the gifts are of token value only.

3 Individual employees of the Board will refrain from giving gifts to staff members who exercise
 4 administrative or supervisory jurisdiction over them, either directly or indirectly. The collection of
 5 money for group gifts is discouraged except in special circumstances such as bereavement, serious
 6 illness, or for mementos at retirement. Employees may collect money for group gifts, subject to the
 7 approval of the principal.

8 Employees are prohibited from accepting things of material value from individuals, companies or
 9 organizations doing business with the school system. Exceptions to this policy are the acceptance of
 10 minor items which are generally distributed to all by the companies through public relations programs.

11 **SOLICITATIONS**

12 No organization may solicit funds from employees within the schools. Flyers or other materials related
 13 to fund drives shall not be distributed through the schools without the written approval of the director of
 14 schools.

15 Employees will not be made responsible for the collection of any money or the distribution of any fund
 16 drive literature within the schools unless such activity has the director of schools' written approval.

Cross References

Advertising & Distribution of Materials in Schools 1.806
 Fundraising Activities 2.601
 Vendor Relations 2.809
 Staff Conflicts of Interest 5.601
 Student Gifts 6.710

Hickman County Board of Education			
	Descriptor Term: Staff Community Relations	Descriptor Code: 5.606	Issued Date: 08/06/18
		Rescinds: 5.606	Issued: 08/02/99

1 **COMMUNITY ACTIVITIES**

2 In their relationship with community groups, an effort should be made by all employees to make school
3 life a part of community life. Employees should know the community, its influence and its opportunities
4 for students as well as for themselves.

5 Employees have a right to express their views on any issue, but must in each case make clear that the
6 view expressed is not the official view of the Board or school system.

7 **POLITICAL ACTIVITIES**

8 Employees may, on their own time, campaign for or against any candidate or referendum, but they shall
9 not use the schools, the classroom or system position for political forum nor engage in any political
10 promotion or solicitation during school hours.

11 Any employee who intends to campaign for an elective public office which infringes upon a contracted
12 agreement shall present a proposed solution to the Board for consideration. The essential element to be
13 determined by the Board is whether the activities proposed by the employee are consistent with his
14 services to the school system and the best interests of education.

15 Leave to hold legislative office shall be granted for whatever period may be required but shall be granted
16 without pay.

Cross References

Board-Community Relations 1.500
News Releases, News Conferences & Interviews 1.503
Advertising & Distribution of Materials in Schools 1.806

Hickman County Board of Education			
	Descriptor Term: Non-School Employment	Descriptor Code: 5.607	Issued Date: 08/06/18
		Rescinds: 5.607	Issued: 06/04/01

1 **PROFESSIONAL PERSONNEL**

2 A given professional position may require additional hours during evenings or other times when offices
3 may be closed. Outside employment is regarded as employment for compensation which is not within
4 the duties and responsibilities of the employee's regular position with the school system.

5 An employee will not perform any duties related to an outside job during his/her regular working hours
6 or during the additional time that the responsibilities of the position require, nor will an employee use
7 any district facilities, equipment or materials in performing outside work. This includes the Board's
8 computer systems and networks and any configuration of hardware and software. The systems and
9 networks include all of the computer hardware, operating system software, stored text and data files.
10 This includes but is not limited to, electronic mail, local databases, externally accessed databases (such
11 as the Internet), CD-ROM, optical media, clip art, digital images, digitized information, communications
12 technologies, and new technologies as they become available. The Board reserves the right to have all
13 technology resource activity monitored.

14 The Board's technology resources will be used only for learning, teaching and administrative purposes
15 consistent with the Board's mission and its goals. Commercial use of the Board's system is strictly
16 prohibited.

17 When the periods of work are such that certain evenings, days or vacation periods are duty-free, the
18 employee may use such off-duty time for the purposes of remuneration, provided all the following
19 conditions are met:

- 20 1. The work in no way interferes with the degree of effectiveness of his/her work in the school
21 system;
22 2. The work in no way reflects detrimentally upon the school system or its prestige;
23 3. Such outside obligations do not prevent the individual from assuming duties required by the
24 regular position; and
25 4. The individual does not receive remuneration for work which is customarily within his/her
26 regular position.¹

27 A teacher employed full time by the Hickman County Board of Education may be employed and paid
28 by the same or another institution for additional part-time work, outside the teacher's regular hours, not
29 to exceed four hundred (400) clock hours out of any nine-month period.

30 If such additional part-time work is or includes teaching in an institution of higher education, such
31 teacher shall be limited to teaching no more than two (2) courses per quarter or semester.

1 Such employment shall be approved by the governing board of each institution or system.'

2 **SUPPORT PERSONNEL**

3 Support personnel shall not be prohibited from holding employment outside the school system so long
4 as such employment does not interfere with regular and overtime scheduled duties for the school system.

Legal References

1. TCA 49-5-410

Hickman County Board of Education

	Descriptor Term: Consultants	Descriptor Code: 5.609	Issued Date: 08/06/18
		Rescinds: 5.609	Issued: 08/02/99

- 1 Administrative and supervisory personnel may be authorized by the director of schools to make
- 2 consulting or speaking engagements of a professional nature outside the school system provided that
- 3 such commitment do not adversely affect the performance of their system assignments. Personnel may
- 4 accept honoraria in connection with these authorized out-of-system activities.

Hickman County Board of Education			
	Descriptor Term: Staff-Student Relations	Descriptor Code: 5.610	Issued Date: 08/06/18
		Rescinds: 5.610	Issued: 09/10/01

1 Staff members shall maintain professional relationships with students at all times and develop
2 wholesome and constructive relationships with them. Staff members shall be expected to regard each
3 student as an individual and to accord each student the rights and respect that is due.

4 Staff members shall promote a learning environment that encourages fulfillment of each student's
5 potential in regard to his/her program, consistent with district goals and with optimal opportunities for
6 students. This goal may be reached by adapting instruction to individual needs, by:

- 7 1. Insisting on reasonable standards of scholastic accomplishment for all students;
- 8
- 9 2. Creating a positive atmosphere in and out of the classroom;
- 10
- 11 3. Extending courtesy and respect to students; and
- 12
- 13 4. Treating all students with consistent fairness.¹

4 Staff members shall use good judgment in their relationships with students beyond their work
15 responsibilities and/or outside the school setting and shall avoid excessive informal and social
16 involvement with individual students. Any appearance of impropriety shall be avoided. Sexual
17 relationships between employees and students shall be prohibited.²

18 **INTERACTIONS**

19 Whenever any interaction is taking place between a student and a person employed by the school system,
20 and the interaction takes place behind a closed door or in an area where others are not present, the door
21 shall have a visual transparent opening, or the door shall remain open, or another school employee shall
22 be in the room.

23 All building level administrative personnel shall keep a written record of conferences with students
24 which shall include the student's name, date, time, and the nature of the discussion.

25 Whenever a student is transported by school personnel (e.g., taken home due to illness, taken home after
26 athletic practice or an athletic even) another school employee should be present.

27
28 These guidelines shall be adhered to at all times unless extenuating circumstances render them
29 impractical or impossible.

Legal References

1. TEA Code of Ethics of the Education Profession
2. TCA 39-13-506; TCA 39-13-527

Cross References

Staff Rights & Responsibilities 5.600
Ethics 5.611

Hickman County Board of Education			
	Descriptor Term: Ethics	Descriptor Code: 5.611	Issued Date: 08/06/18
		Rescinds: 5.611	Issued: 08/02/99

1 An effective educational program requires the services of men and women of integrity, high ideals and
 2 human understanding. To maintain and promote these essentials, all employees are expected to maintain
 3 high standards in their school relationships.¹ These standards include the following:

- 4 1. The maintenance of just and courteous professional relationships with student, parent(s), staff
 5 members and others;
- 6 2. The maintenance of their own efficiency and knowledge of the developments in their fields of
 7 work;
- 8 3. The transaction of all official business with the properly designated authorities of the school
 9 system;
- 10 4. The establishment of friendly and intelligent cooperation between the community and the school
 11 system;
- 12 5. The representation of the school system on all occasions that the contributions of the school
 13 system to the community are recognized;
- 14 6. The welfare of children as the first concern of the school system when placing professional
 15 personnel. The use of pressure on school officials for appointments or transfers is unethical;
- 16 7. Restraint from using school contacts and privileges to promote partisan politics, sectarian
 17 religious views or selfish propaganda of any kind;
- 18 8. The responsibility to make any criticism of other staff members or of the school system directly
 19 to the particular school administrator who has the administrative responsibility for improving the
 20 situation and then to the director of schools, if necessary; and
- 21 9. The proper use and protection of all school properties, equipment and materials.

Legal References

1. TCA 49-5-501(3)(D); TCA 49-5-1003, 1004

Cross References

- Staff Rights and Responsibilities 5.600
 Staff-Student Relations 5.610

Hickman County Board of Education			
	Descriptor Term: Interim Employees	Descriptor Code: 5.700	Issued Date: 08/06/18
		Rescinds: 5.700	Issued: 12/04/06

1 Employees shall be hired on an interim contract only when a vacancy is (created by an employee taking
 2 a leave of absence as set forth in TCA 49-5-702.)¹ Such interim employees shall be considered as
 3 temporary replacements for the remainder of the school year and the contract term will not be considered
 4 as initial employment.

5 Said positions will be filled at the discretion of the director of schools in such a manner as to cause the
 6 least disruption in the educational process for students and as quickly as possible to ensure a continuous
 7 function of the position.

8 Persons filling any temporary positions shall have no expectancy of continued employment under TCA
 9 49-5-409 or any other, but such person shall be considered for employment in filling vacancies as
 10 specified in the section dealing with initial employment. The contract of each temporary employee shall
 11 contain the following statement: *I understand that in filling a temporary position I have no expectancy
 12 of continued employment but shall be considered for initial employment to fill other vacancies.*

Legal References

1. TCA 49-2-203(a)(1)(A); TCA 49-5-702

Cross References

Long-Term Leaves of Absence 5.304

Hickman County Board of Education			
	Descriptor Term: Substitute Teachers	Descriptor Code: 5.701	Issued Date: 08/06/18
		Rescinds: 5.701	Issued: 08/07/17

1 Substitute teachers are those teachers used to replace teachers on leave or to fill temporary vacancies.^{1,2}
2 Substitute teachers may be employed and paid directly by the board of education or by a third party
3 public or private employer through an agreement between such third party employer and the board of
4 education. Substitute teachers employed by third party entities shall be subject to the same
5 unemployment benefit eligibility conditions as substitute teachers employed directly by the board of
6 education.²

7 **APPLICATION/QUALIFICATIONS**

8 Criminal history record checks and fingerprinting of applicants for substitute teaching are required.³

9 Applicants with revoked licenses or certificates according to the Department of Education shall not be
10 hired.⁴

11 Qualifications for substitute teachers shall be: (1) a high school diploma or GED; (2) attendance at an
12 orientation session.

13 A list of substitute teachers will be prepared by the [director of schools, personnel director, etc.] who
14 will maintain files which may include transcripts, credentials, recommendations and other pertinent
15 information.

16 **COMPENSATION**

17 If employed directly by the board of education, the compensation of substitute teachers shall be
18 determined annually by the Board.

19 Retired teachers serving as substitutes who do not have an active teaching license shall be paid the same
20 as a retired substitute teacher with an active teaching license. This only applies to teachers who retired
21 after July 1, 2011 through July 1, 2016.⁵

22 **CERTIFICATION**

23 When substituting for a regular teacher who has been absent for twenty (20) consecutive days, a
24 substitute teacher must possess a teaching certificate with endorsement in the discipline(s) to be taught.⁵
25 When substituting for a teacher without sick leave, the substitute shall be certified and paid according to
26 the state salary schedule.¹

27 Retired teachers may substitute one-hundred twenty (120) days per year without loss of retirement ben-
28 efits¹ and may substitute for additional days if the director of schools certifies in writing to the State
29 Board of Education that no other qualified personnel are available to substitute teach.⁷

1 EMERGENCY NEEDS

2 All teacher aides, secretaries and clerks are approved substitute teachers for use in emergency situations.
3 Emergency use shall be defined as less than a full day due to the regular or substitute teacher being
4 unable to arrive on time or remain for the full day.

5 Said substitutes shall receive the proportionate equivalent salary regular substitute teachers would
6 receive under similar circumstances or their regular salary, if higher; however, they shall not receive pay
7 for both positions at the same time.

8 TRAINING AND ORIENTATION

9 The director of schools shall be responsible for ensuring that there are appropriate training and
10 development programs for substitute teachers.

11 RESPONSIBILITIES

12 Substitute teachers shall assume the same responsibilities as the regular teacher, including, but not
13 limited to, bus duty and playground supervision.

14 RE-EMPLOYMENT/TERMINATION

15 On an annual basis, the director of schools, with input from the principals, shall determine which
16 substitute teachers performed at an acceptable level. Substitute teachers who performed below an
17 acceptable level shall not be re-employed.

18 All substitutes shall be responsible for providing correct addresses and phone numbers and for notifying
19 the principal and/or third party employer if they wish to terminate their service as substitutes.

Legal References

1. TRR/MS 0520-1-2-.04(6)
2. TCA 49-5-709
3. TCA 49-5-413(a)(2)
4. TCA 49-2-203(a)(15)
5. Public Acts of 2017, Chapter No. 387
6. TCA 49-3-312; TRR/MS 0520-01-02-.04(6)(b)
7. Public Acts of 2017, Chapter No. 287

Hickman County Board of Education

	Descriptor Term: <h2 style="text-align: center;">Student Teachers</h2>	Descriptor Code: 5.702	Issued Date: 08/06/18
		Rescinds: 5.702	Issued: 08/02/99

- 1 In an efficiently administered program of student teaching, the students are provided opportunities for
- 2 laboratory experiences in practical teaching situations under the guidance and supervision of experienced
- 3 classroom teachers, principal and supervising personnel.

- 4 The local system, in addition to rendering a much needed service to the teaching profession, has the
- 5 opportunity of observing beginning teachers and evaluating their ability and potential in applying for
- 6 vacancies when they occur.

- 7 Student teachers shall be accepted or refused by the director of schools, the principal or the supervising
- 8 teacher.

- 9 Student teachers will be expected to observe all rules and regulations established by the Board.

- 10 A student teacher shall be accorded the same protection of the laws as a certificated teacher and shall
- 11 comply with all rules and regulations of the Board and observe all duties of teachers as set forth in state
- 12 statute.¹

- 13 In addition, student teachers shall be required to fulfill all normal local responsibilities, both school and
- 14 extracurricular, and shall familiarize themselves with the policies of the Board and the school.

- 15 No classroom student shall have more than one (1) student teacher per year in a given subject. Any
- 16 exception to this policy must have prior approval from the director of schools.

- 17 The evaluation of a student teacher shall be based upon a joint agreement between the cooperating
- 18 teacher and the student's supervising teacher.

- 19 A student teacher may be asked to terminate his or her service upon the mutual consent of the principal,
- 20 the cooperating teacher and the supervising teacher at any time during the term.

Legal References

1. TCA 49-5-403(c); TCA 49-5-201

Hickman County Board of Education

	Descriptor Term: Director of Schools	Descriptor Code: 5.800	Issued Date: 08/06/18
		Rescinds: 5.800	Issued: 08/02/99

1 The director of schools shall be the chief executive officer of the school system and shall have, under
2 the direction of the Board, general supervision of all the public schools, personnel and departments of
3 the school system. The director of schools is responsible for the management of the schools under the
4 Board's policies and is accountable to the Board.¹

5
6 The director of schools, at his/her discretion, may delegate any of his/her duties to other school
7 personnel.

Legal References

1. TCA 49-2-301(a)

Hickman County Board of Education

	Descriptor Term: Director of Schools Recruitment and Selection	Descriptor Code: 5.801	Issued Date: 08/06/18
		Rescinds: 5.801	Issued: 01/11/16

1 When a vacancy occurs, the appointment of a director of schools is a function of the Board.¹ The Board
2 is responsible for finding the person it believes can most effectively translate into action the policies of
3 the Board and the goals of the community and the professional staff.

4 The Board may employ a consultant to advise and assist the Board in the search and selection process.
5 However, final selection shall rest with the Board after a thorough consideration of qualified
6 applicants. An interim director of schools appointed during the time of a search shall not become a
7 candidate unless the Board expressly permits such inclusion in the selection procedures. A board
8 member may not apply for or in any other way be considered for the position of director of schools.²

9 If the Board chooses to conduct a search to fill the position, the Board shall initially develop the
10 following:

11 1. A job description

12

13 2. A timeline

14

15 3. A process for accepting and reviewing applications

16

17 4. Selection procedures which shall include, but not be limited to, the following:³

18

19 a. The Board may invite the community, including board employees, to participate in the
20 process of selecting a director of schools. Resumes of persons interviewed by the Board
21 shall be available in the central office for public inspection.

22

23 b. The interview process for each finalist shall include meetings with various staff and
24 community groups and an interview with the entire board.

25

26 c. Candidates shall be interviewed by the Board in an open session. Only board members
27 will be allowed to ask questions during the interview.

28

29 d. The Board shall attempt to select a director by unanimous vote, but a simple majority
30 vote of the membership of the board shall be required for the appointment of a director
31 of schools.

Legal References

1. TCA 49-2-203(a)(14)
2. TCA 49-2-203(a)(1)(D)
3. TCA 49-2-203(a)(14)(B)

Hickman County Board of Education			
	Descriptor Term: Qualifications and Duties of the Director of Schools	Descriptor Code: 5.802	Issued Date: 08/06/18
		Rescinds: 5.802	Issued: 04/02/18

1 **QUALIFICATIONS**

- 2 1. A professional educator's license
3 2. A master's degree in education with a preference for a doctorate degree
4 3. Three (3) years of successful experience in school administration
5 4. Such other qualifications as the board deems desirable

6 **REPORTS TO:** The Board of Education

7 **SUPERVISES:** All administrative and supervisory personnel in the district

8 **JOB GOAL:** To provide leadership in developing and maintaining the best possible educational
9 programs and services

10 **SCOPE OF RESPONSIBILITY:** The management responsibilities of the director of schools shall
11 extend to all activities of the district, to all phases of the educational program, to all aspects of the
12 financial operation, to all facility management, and to the conduct of such other duties as may be assigned
13 by the board. The director of schools may delegate these duties together with appropriate authority but
14 may not delegate nor relinquish ultimate responsibility for results or any portion of accountability.

15 **ESSENTIAL FUNCTIONS**

16 **General Administrative**

- 17 1. Provides leadership in identification of priorities and assures that all activities reflect those
18 board-established priorities.
- 19 2. Prepares and recommends short and long-range plans for board approval and implements those
20 plans when approved.
- 21 3. Prepares, in conjunction with the board chair, agenda recommendations relative to all matters
22 requiring board action, including all facts, information, options, and reports needed to assure
23 informed decisions. Provides advice and counsel to the board on matters before it.
- 24 4. Attends all regular and special meetings of the board and keeps a complete and accurate record
25 of the proceedings of all meetings of the board and of its official acts.
- 26 5. Recommends drafts of new policies or changes to the board. Anticipates potential problems.
27 Recommends policies or courses of staff action.

- 1 6. Develops administrative procedures to implement board policy or for the items deemed
2 necessary for the efficient operation of the schools and disseminates these procedures to
3 appropriate staff.
- 4 7. Keeps the board informed regarding development in other districts or at state and national levels
5 that would be helpful to the district.
- 6 8. Ensures that all local, state, and federal standards for the health and safety of the students and
7 staff are maintained and that required reports are maintained.
- 8 9. Fulfills all statutory obligations and implements the education law of the State of Tennessee and
9 the rules and regulations of the State Board of Education.¹

10 **Financial Management**

- 11 1. Provides direction to and supervision of school business functions. Encourages development and
12 implementation of sound business practices. Continually assesses business practices to achieve
13 efficiency.
- 14 2. Prepares, annually, a budget and submits it to the board for approval. Presents approved budget
15 to the appropriate local funding body for adoption.
- 16 3. Makes appropriate written reports for the board detailing all receipts and expenditures of the
17 public school funds and submits them to the local funding body.
- 18 4. Ensures that funds are spent prudently by providing adequate control and accounting of the
19 district's financial and physical resources.

20 **Personnel Administration**

- 21 1. Establishes lines of authority which shall be approved by the board and shown on the system
22 organization chart. Lines of authority shall not restrict the practical working relationships of all
23 staff members at all levels.
- 24 2. Employs such personnel as may be necessary within the limits of budgetary provisions and
25 recommends to the board teachers who are eligible for tenure.
- 26 3. Develops recruitment procedures to assure well-qualified applicants for professional and non-
27 professional positions.
- 28 4. Assigns and transfers employees as the interest of the district may dictate and reports such action
29 to the board for information and record.
- 30 5. Holds meetings of teachers and other employees as necessary for the discussion of matters
31 concerning the welfare and improvement of the schools.
- 32 6. Communicates directly or through delegation all actions of the board relating to personnel
33 matters to all and receives employees' communications to be made to the board.

- 1 7. Evaluates principals annually.
- 2
- 3 8. Informs the Office of Educator Licensing of licensed educators who have been suspended or
- 4 dismissed, who have resigned, following allegations of conduct, including sexual misconduct,
- 5 which, if substantiated, would warrant consideration for license suspension or revocation, or
- 6 who have been convicted of a felony. The report shall be submitted within thirty (30) days of
- 7 the suspension, dismissal, or resignation or of receiving knowledge of the felony conviction.²

8 **Instructional Leadership**

- 9 1. Serves as the chief school executive. Ensures the development and maintenance of a positive
- 10 educational program designed to meet the needs of the community and to carry out the policies
- 11 of the board. Ensures that a system of thorough and efficient education, as defined by state law,
- 12 is available to all students.
- 13 2. Recommends to the board for its adoption all courses of study, curriculum guides, and major
- 14 changes in tests and time schedules to be used in the schools.
- 15 3. Oversees the timely revisions of all curriculum guides and courses of study.
- 16 4. Develops guidelines and direction for monitoring the effectiveness of existing and new
- 17 programs.
- 18 5. Conducts a periodic audit of the total school program and advises the board of recommendations
- 19 for the educational advancement of the schools.
- 20 6. Seeks out available sources for grant funding to support programs and projects.
- 21 7. Ensures that the goals of the school system are adequately reflected in its educational program
- 22 and operations.

23 **Community/Public Relations**

- 24 1. Promotes community support of the schools. Interprets district programs and services, reports,
- 25 plans, events, and activities of interest and solicits community opinions regarding school and
- 26 educational issues.
- 27 2. Identifies available community resources and links to social service agencies that support
- 28 education and healthy child development.
- 29 3. Develops strategies to promote parental involvement in their student's education and provides
- 30 opportunities for parent-teacher interaction.
- 31 4. Maintains contact and good relations with local media. Acts as the board's spokesperson.
- 32 5. Ensures that the district interests will be represented in meetings and activities of municipal and
- 33 other governmental agencies.

1 6. Represents the school system and its interests in community organizations, activities, and
2 projects.

3 **TERMS OF EMPLOYMENT:** Serves in accordance with the terms of the contract between the board
4 and the director of schools. Salary to be determined by the board. A written contract can be executed
5 with a duration up to four (4) years which may be renewed.

6 **EVALUATION:** Performance of this job will be evaluated in accordance with provisions of state law
7 and the board's policy on evaluation of the director of schools.

8 **GENERAL REQUIREMENTS:** The above statements are intended to describe the general nature and
9 level of work being performed by the person assigned to this position. They are not intended to be a
10 complete list of responsibilities, duties, and skills required of personnel so assigned.

Legal References

1. TCA 49-2-301
2. TRR/MS 0520-02-03-.09(2); Public Acts of 2018, Chapter No. 935

Cross References

Executive Committee 1.301
Administrative Procedures 1.601
Administrative Committees 1.602
Administrative Reports 1.603
School District Planning 1.701
Job Descriptions 5.103
Application and Employment 5.106
Evaluation of the Director of Schools 5.803

Hickman County Board of Education			
	Descriptor Term: Evaluation of the Director of Schools	Descriptor Code: 5.803	Issued Date: 08/06/18
		Rescinds: 5.803	Issued: 03/06/17

1 Through an annual evaluation of the director of schools,¹ the Board will strive to accomplish the
2 following:

- 3 1. Clarify the role of the director according to Board Policy 5.802;
- 4
- 5 2. Develop harmonious working relationships between the Board and the director; and
- 6
- 7 3. 3. Develop improvements in the administrative leadership of the school system.

8 The Board will develop, with the director, a set of performance objectives based on the needs of the
9 system. The performance of the director will be reviewed in accordance with these specified goals. The
10 performance objectives will be memorialized in an evaluation plan that includes, at a minimum, sections
11 regarding job performance, student achievement, relationships with staff and personnel, relationships
12 with board members, and relationships with the community.¹

13 At a time agreed to by the Board and the director, the Board will meet as a body to evaluate the director's
14 performance.

15 The following guidelines will be used in the evaluation process:

- 16 1. The director will know the standards upon which he/she will be evaluated and will be involved
17 in the development of those standards.
- 18
- 19 2. A part of the evaluation may be a composite of the evaluation by individual board members, but
20 the Board, as a whole, will meet with the director to discuss the composite evaluation.
- 21
- 22 3. The evaluation shall include a discussion of strengths as well as weaknesses.
- 23
- 24 4. Both the Board and director will prepare for the evaluation; the director will conduct a self-
25 evaluation and board members will document the evidence used in rating the director's
26 performance.
- 27
- 28 5. All documentation will be supported by objective evidence.

Legal References

1. TCA 49-2-203(a)(16)

Cross References

- Board-Director Relations 1.205
Qualifications/Duties of the Director of Schools 5.802

PROPOSED FUNDRAISING ACTIVITIES

Fund/account name Library 901

Proposed fundraising activities: Scholastic Book Fair

Purposed Uses of funds raised additional funds for library account

Expected student involvement (school-wide or specific school organization) _____

Method by which school will receive profit a percentage of total sales will go to library funds

Requested by Dereck Little Date 11-9-2020
Name/Title

Approved by Mary Tidwell Date 11-9-20
Principal

Approved by Dan Gools Date 11/9/2020
Director of Schools*

* The Director of Schools must approve all fundraising activities that involve the participation of the general student population in the marketing process of the fundraising effort.



AMY BRYANT
9589 S. Lick Creek Rd., Lyles, TN 37098

JACKIE DEITMEN
1911 Deitmen Ln., Nunnely, TN 37137

TIM HOBBS
9220 Old Bon Aqua Rd., Bon Aqua, TN 37025

JIM HUDGINS
1297 E. Grinders Switch Rd., Centerville, TN 37033

JEWELL PRINCE
2439 Skyview Dr., Centerville, TN 37033

KATHY REDDEN
11379 Moss Branch Rd., Bon Aqua, TN 37025

MIKE THOMASSON
105 Hickory Trace, Lyles, TN 37098

Michelle Gilbert
SUPERINTENDENT
115 MURPHREE AVENUE
CENTERVILLE, TN 37033

**School Support Organization
Request For Fundraising Activities**

Organization East Hickman Band & Choir Boosters

Proposed Fundraising Activity Candle Sale

Date(s) Nov 2 - Nov 30

Location(s) EHHS + EHMS

Requested By Quentin Haley
President/Chair of Organization

Date 10/29/2020

Recommended By Michael Bean
Principal

Date 10/29/20

Approved Don J. Smith
Director of Schools or Designee

Date 11/2/2020

Not Approved _____
Director of Schools or Designee

Date _____

A signed copy will be mailed to the organization and forwarded to the school



AMY BRYANT
9589 S. Lick Creek Rd., Lyles, TN 37098

JACKIE DEITMEN
1911 Deitmen Ln., Nunnally, TN 37137

TIM HOBBS
9220 Old Bon Aqua Rd., Bon Aqua, TN 37026

JIM HUDGINS
1207 E. Grinders Switch Rd., Centerville, TN 37033

JEWELL PRINCE
2438 Skyview Dr., Centerville, TN 37033

KATHY REDDEN
11370 Moss Branch Rd., Bon Aqua, TN 37026

MIKE THOMASSON
106 Hickory Trace, Lyles, TN 37098

Michelle Gilbert
SUPERINTENDENT
116 MURPHREE AVENUE
CENTERVILLE, TN 37033

School Support Organization
Request For Fundraising Activities

Organization Soar and Score Booster Club

Proposed Fundraising Activity 6th Grade Basketball Play Days

Date(s) Dec. 12th, Jan. 9th

Location(s) EHHS Gymnasium

Requested By Pippa Saylor
President/Chair of Organization

Date 10/28/20

Recommended By Niriel Beem
Principal

Date 10/28/20

Approved Don Qualk
Director of Schools or Designee

Date 11/3/2020

Not Approved _____
Director of Schools or Designee

Date _____

A signed copy will be mailed to the organization and forwarded to the school



Michelle Gilbert
SUPERINTENDENT
115 MURPHREE AVENUE
CENTERVILLE, TN 37033

AMY BRYANT
9589 S. Lick Creek Rd., Lyles, TN 37098

JACKIE DEITMEN
1911 Deltmen Ln., Nunnally, TN 37137

TIM HOBBS
9220 Old Bon Aqua Rd., Bon Aqua, TN 37025

JIM HUDGINS
1297 E. Grinders Switch Rd., Centerville, TN 37033

JEWELL PRINCE
2439 Skyview Dr., Centerville, TN 37033

KATHY REDDEN
11379 Moss Branch Rd., Bon Aqua, TN 37026

MIKE THOMASSON
105 Hickory Trace, Lyles, TN 37098

School Support Organization
Request For Fundraising Activities

Organization Soar and Score Booster Club

Proposed Fundraising Activity: Business Banners and Sponsorships

Date(s) Ongoing

Location(s) EHHS

Requested By Pippa Saylor
President/Chair of Organization

Date 10/28/20

Recommended By Michelle Bean
Principal

Date 10/28/20

Approved Don Quirk
Director of Schools or Designee

Date 11/3/2020

Not Approved _____
Director of Schools or Designee

Date _____

A signed copy will be mailed to the organization and forwarded to the school

AMY BRYANT
6589 S. Lick Creek Rd., Lyles, TN 37098



JANE HERRON
1222 Hwy. 100., Centerville, TN 37033

RONALD GAMMONS
6419 Rice Ln., Lyles, TN 37098

STEVE GIANAKOS
8792 Dogwood Dr., Bon Aqua, TN 37025

TIM HOBBS
9220 Old Bon Aqua Rd., Bon Aqua, TN 37025

VANCE WILLIS
2868 Hwy 48 N., Nunnally, TN 37137

JIM HUDGINS
1297 E. Grinders Switch Rd., Centerville, TN 37033

Michelle Gilbert
Director of Schools
115 MURPHREE AVENUE
CENTERVILLE, TN 37033

School Support Organization
Request For Fundraising Activities

Organization Soar and Score Club - Boys

Proposed Fundraising Activity 20 for \$ 20.

Date(s) Basketball season (Nov. 2020)

Location(s) East Hickman

Requested By Pippa Saylor 11/5/2020
President/Chair of Organization Date

Recommended By Michael Dean 11/5/20
Principal Date

Approved Don Judd 11/5/2020
Director of Schools or Designee Date

Not Approved _____
Director of Schools or Designee Date

** A signed copy will be mailed to the organization and forwarded to the school**

PROPOSED FUNDRAISING ACTIVITIES

Fund/account name Class of 2021 (703)

Proposed fundraising activities: Sonic drive in 10% of
Sales. 5th of ~~the~~ December ~~at~~ ~~the~~ 5-8 PM

Purposed Uses of funds raised Graduation

Expected student involvement (school-wide or specific school organization) _____
10 or less students to wear Bulldog Mascot

Method by which school will receive profit check

Requested by Charles Price Sponsor Date 4/NOV/2020
Name/Title

Approved by Ken D. Self Date 10/9/2020
Principal

Approved by Don Qualls Date 11/6/2020
Director of Schools*

* The Director of Schools must approve all fundraising activities that involve the participation of the general student population in the marketing process of the fundraising effort.

PROPOSED FUNDRAISING ACTIVITIES

Fund/account name JROTC / 069

Proposed fundraising activities: Christmas Wreaths

Purposed Uses of funds raised Pay for competitive entry fees and obstacle course repairs

Expected student involvement (school-wide or specific school organization) JROTC

Method by which school will receive profit Collect funds from sales then we will reimburse supplier for wreaths ordered.

Requested by Mary Staley ISG (K) USA Date _____
Name/Title Garry Stott Riley

Approved by Ken D. Roof Date 10/30/2020
Principal

Approved by Don Luecke Date 11/6/2020
Director of Schools*

* The Director of Schools must approve all fundraising activities that involve the participation of the general student population in the marketing process of the fundraising effort.