

HICKMAN COUNTY BOARD OF EDUCATION
REGULAR BOARD MEETING---February 3, 2020

The Hickman county Board of Education met on February 3, 2020, at 7:00 PM in Room 203 of the Central Office Building.

Call To Order

Approval of January 6, 2020 Regular Meeting Minutes

Approval of Agenda

Special Recognition

Employee of the Month

Communications to the Board

Director's Report

Financial Report

OPEB Trust Financial Statement

Items Requiring Board Action

Trip Requests

East Hickman High School FFA

Hickman County High School Girls Soccer

Hickman County High School JROTC

Hickman County High School JROTC

Hickman County High School JROTC

Hickman County High School JROTC

Hickman County High School JROTC Military Formal

Budget Amendments

School Bus Bids

Engine Replacement Proposal

EHES Job Share Request

Land for Sale behind HCMS

Revised Board Policies 6.300, 6.312 (2nd Reading)

Board Policy Review 4.100--4.211

HICKMAN COUNTY BOARD OF EDUCATION
REGULAR BOARD MEETING---February 3, 2020

Announcements - **Board Retreat scheduled for February 8, 2020 has been cancelled**

Adjourn

Monday, January 6, 2020
REGULAR BOARD MEETING MINUTES

The Hickman County Board of Education met in regular session on Monday, January 6, 2020, at 7:00 p.m. in room 203 of the Central Office building. School board members in attendance at the meeting were Chair Amy Bryant, Tim Hobbs, Steve Gianakos, Ron Gammons, and Jane Herron. Jim Hudgins and Vance Willis were absent from the meeting.

Tim Hobbs made a motion to approve the minutes from the meeting held on December 2, 2019. Steve Gianakos seconded the motion. On a voice vote the motion was approved 5-0.

Steve Gianakos made a motion to amend the agenda to add revised board policies 6.300 and 6.312 on first reading to item E. Revised Board Policies. Ron Gammons seconded the motion. On a voice vote, the motion was approved 5-0.

Ron Gammons made a motion to approve the amended agenda. Jane Herron seconded the motion.

The Hickman County Board of Education will meet in regular session on Monday, January 6, 2020, at 7:00 p.m. in Room 203 at the Central Office. A work session will be held at 6:00 p.m. in Room 203 of the Central Office.

- I. Call to Order
- II. Approval of December 2, 2019 Regular Board Meeting Minutes
- III. Approval of Agenda
- IV. Special Recognition
 - A. Employee of the Month (Amy Bryant)
- V. Communications to the Board
 - A. Director's Report—Director of Schools
 - B. Financial Report—Business Officer
- VI. Items Requiring Board Action
 - A. Trip Requests—Sponsor and Students
 - B. Budget Amendments—Business Officer
 - C. ADA Ramp at HCHS—Maintenance Director
 - D. Resolution No.19-02—Director of Schools
 - E. Revised Board Policies 6.300, 6.312 (1st reading), 4.201, 6.411 (2nd Reading)—Director of Accountability
 - F. Board Policy Review 3.300-3.602--Director of Accountability
- VII. Announcements--January 25, 2020, 8:00 a.m.-12:00 p.m. at Centerville Intermediate School
- VIII. Adjourn

On a voice vote, the motion was approved 5-0.

Steve Gianakos made a motion to accept the Director's Report. Tim Hobbs seconded the motion.

Memorandum

To: Board Members

From: Michelle Gilbert
Date: December 19, 2019
RE: January Director's Report

Leave of Absence

Professional
Support Staff

Hiring

Professional
Jennifer Lange
Support Staff

EHIS Teacher

Resignation

Professional
Support Staff
Jared Carkuff
Autumn Goltz
Lance Standridge
Deborah McCoy

HCHS In School Suspension/Asst. Football Coach
HCMS Special Education Assistant
Bus Driver
Food Service

Retirement

Professional
Support Staff

Transfers

Professional
Support Staff

Appointment

Professional
Support Staff

On a voice vote, the motion was approved 5-0.

Ron Gammons made a motion to accept the Financial Report. Jane Herron seconded the motion. On a voice vote, the motion was approved 5-0.

Steve Gianakos made a motion to approve Budget Amendment #5. Ron Gammons seconded the motion.

<u>Aye</u>	<u>Nay</u>	<u>Pass</u>	<u>Absent</u>
Amy Bryant			
Ron Gammons			
Steve Gianakos			
Jane Herron			
Tim Hobbs			

Jim Hudgins
Vance Willis

On a roll call vote, the motion was approved 5-0.

Tim Hobbs made a motion to approve the HCHS auditorium stage ADA Ramp quote from EZ Access. Steve Gianakos seconded the motion.

<u>Aye</u>	<u>Nay</u>	<u>Pass</u>	<u>Absent</u>
------------	------------	-------------	---------------

Amy Bryant
Ron Gammons
Steve Gianakos
Jane Herron
Tim Hobbs

Jim Hudgins
Vance Willis

On a roll call vote, the motion was approved 5-0.

Steve Gianakos made a motion to approve Resolution 19-02. Jane Herron seconded the motion.

Resolution No. 19-02

Guidelines to Govern the Hickman County Board of Education's GASB 45 Trust

WHEREAS, A contract with the Hickman County Education Association (HCEA) established a medical insurance premium payments for retired teachers; and

WHEREAS, The Hickman County Board of Education entered into an agreement with the Tennessee School Boards Association's GASB 45 Trust ("the Trust" or "Trust") to fund such a program; and

WHEREAS, The contract with the HCEA expired on June 30, 2014; and

WHEREAS, The Hickman County Board of Education adopted Resolution 16-01 in order to establish new rules and regulations to govern participation and expenditures relative to the Trust and its recipients; and

WHEREAS, The Hickman County Board of Education now desires to establish new rules and regulations to govern participation and expenditures relative to the Trust and its recipients from henceforth;

NOW, THEREFORE, BE IT RESOLVED by the Board of Education in Hickman County, Tennessee, assembled in regular session this 6th day of January 2020 that:

Section 1: The Trust is applicable (i.e., open to participation) to those licensed employees according to the guidelines set forth herein, who meet the following criteria:

- A. Licensed employees who were hired on or before June 30, 2015, or;
- B. Licensed employees who were employed by the Hickman County School System during the time the Trust has been in effect from its inception through June 30, 2015, and who

left the Hickman County School System and then became re-employed by the Hickman County School System on or after July 1, 2015.

Section 2: To be eligible to participate in receiving funds from the Trust, an employee must meet all of the requirements of this Resolution, must complete state and local forms at the time of filing for retirement, which must be no later than the date of the last payroll payment for the school year in which the employee is retiring.

Section 3: For those not eligible for Medicare at the time of retirement, the Board will contribute the following from the time of retirement until the retiree becomes eligible for Medicare or for a maximum of six (6) years, whichever comes first. However, if a retiring teacher has provided 35 or more years of continuous service in the Hickman County School System, premiums will be paid for a maximum of ten (10) years or until retiree becomes eligible for Medicare, whichever comes first, according to the following schedule:

- A. 30 or more years of service in Hickman County Schools
 - 1. 55% of a single policy premium
 - 2. 30% of a family policy premium

- B. 20-29 years of service in Hickman County Schools
 - 1. 45% of a single family policy premium
 - 2. 25% of a family policy premium

- C. 10-19 years of service in Hickman County Schools
 - 1. 35% of a single policy premium
 - 2. 15% of a family policy premium

Section 4: Retirees who meet the following conditions shall be eligible for reimbursement for Medicare supplement insurance in accordance with the schedule set below:

- A. Must meet State of Tennessee requirements to enroll in the State of Tennessee plan for Medicare supplement insurance:

- B. Are eligible for Medicare at the time of retirement; or

- C. Become eligible for Medicare after participating in Section 3, above;

- D. Medicare supplement payments shall be paid as a reimbursement, one time per year, in the month of December, according to the following rate schedule:
 - (i) Retirees with 30 or more years of service in the Hickman County Schools shall receive a local contribution, which when combined with the State of Tennessee contribution, shall equal 100% of premium cost.

(ii) Retirees with 20-29 years of service in the Hickman County Schools shall receive a local contribution, which, shall equal 35% of premium cost.

(iii) Retirees with 10-19 years of service in the Hickman County Schools shall receive a local contribution, which, shall equal 25% of premium cost.

Section 5: Upon exhaustion of funds in the Trust, membership in the Trust is abolished. If sufficient funds are not available to make a complete payment during any fiscal year to eligible retirees participating in the Trust, the remaining Trust funds are to be prorated and each participant will receive an equal share, with the exception if there is an odd amount, the last eligible participant, arranged alphabetically, will receive an odd amount to zero the Trust account out.

Section 6: The Board hereby ratifies and approves all Medicare supplement payments which have been made to any retirees since the expiration of the Agreement between the Board of Education and the Hickman County Education Association, subject to approval by the State of Tennessee and applicable rules and regulations.

Adopted, this 6th day of January 2020.

Action:

 5 Aye 0 Nay 0 Pass 2 Absent

Aye:

Amy Bryant
Ron Gammons
Steve Gianakos
Jane Herron
Tim Hobbs

Absent:

Jim Hudgins
Vance Willis

Adopted:

Attest:

On a roll call vote, the motion was approved 5-0.

Amy Bryant made a motion to approve revised board policies 6.300 and 6.312 on first reading. Steve Gianakos seconded the motion. On a voice vote, the motion was approved 5-0.

Jane Herron made a motion to approve revised board policies 4.201 and 6.411 on second reading. Ron Gammons seconded the motion. On a voice vote, the motion was approved 5-0.

Tim Hobbs made a motion to accept the review of board policies 3.300-3.602. Ron Gammons seconded the motion. On a voice vote, the motion was approved 5-0.

An announcement was made that a board retreat would be held on Saturday, January 25, 2020, from 8:00 a.m.-12:00 p.m. at Centerville Intermediate School.

The meeting was adjourned at 7:22 p.m.



AMY BRYANT
9589 S. Lick Creek Rd., Lyles, TN 37098

RONALD GAMMONS
6419 Rice Ln., Lyles, TN 37098

TIM HOBBS
9220 Old Bon Aqua Rd., Bon Aqua, TN 37025

JIM HUDGINS
1297 E. Grinders Switch Rd., Centerville, TN 37033

JANE HERRON
1222 Hwy. 100., Centerville, TN 37033

STEVE GIANAKOS
9792 Dogwood Dr., Bon Aqua, TN 37025

VANCE WILLIS
2868 Hwy 48 N., Nunnely, TN 37137

Michelle Gilbert
Director of Schools
115 MURPHREE AVENUE
CENTERVILLE, TN 37033

The Hickman County Board of Education will meet in regular session on Monday, February 3, 2020, at 7:00 p.m. in Room 203 at the Central Office. A work session will be held at 6:00 p.m. in Room 203 of the Central Office.

- I. Call to Order
- II. Approval of January 6, 2020 Regular Board Meeting Minutes
- III. Approval of Agenda
- IV. Special Recognition
 - A. Employee of the Month (Vance Willis)
- V. Communications to the Board
 - A. Director's Report--Director of Schools
 - B. Financial Report--Business Officer
 - C. OPEB Trust Financial Statement--Director of Schools
- VI. Items Requiring Board Action
 - A. Trip Requests--Sponsor and Students
 1. East Hickman High School FFA--Sponsor and Students
 2. Hickman County High School Girls Soccer--Coach and Players
 3. Hickman County High School JROTC--Sponsor and Students
 4. Hickman County High School JROTC--Sponsor and Students
 5. Hickman County High School JROTC--Sponsor and Students
 6. Hickman County High School JROTC--Sponsor and Students
 - B. Hickman County High School JROTC Military Formal--Sponsor and Students
 - C. Budget Amendments--Business Officer
 - D. School Bus Bids--Director of Transportation
 - E. Engine Replacement Proposal--Director of Transportation
 - F. EHES Job Share Request--Principal and Supervisor
 - G. Land for Sale behind HCMS--Director of Schools
 - H. Revised Board Policies 6.300, 6.312 (2nd Reading)--Director of Accountability
 - I. Board Policy Review 4.100-4.211--Director of Accountability
- VII. Announcements--Board Retreat scheduled for February 8, 2020 has been cancelled
- VIII. Adjourn



AMY BRYANT
9589 S. Lick Creek Rd., Lyles, TN 37098

RONALD GAMMONS
6419 Rice Ln., Lyles, TN 37098

TIM HOBBS
9220 Old Bon Aqua Rd., Bon Aqua, TN 37025

JIM HUDGINS
1297 E. Grinders Switch Rd., Centerville, TN 37033

JANE HERRON
1222 Hwy. 100., Centerville, TN 37033

STEVE GIANAKOS
9792 Dogwood Dr., Bon Aqua, TN 37025

VANCE WILLIS
2868 Hwy 48 N., Nunnely, TN 37137

Michelle Gilbert
Director of Schools
115 MURPHREE AVENUE
CENTERVILLE, TN 37033

Memorandum

To: Board Members
From: Michelle Gilbert
Date: January 28, 2020
RE: February Director's Report

Leave of Absence

Professional

Robyn Emerson
Kim Jenkins

FMLA (January 6-February 10, 2020)
FMLA (January 6-February 10, 2020)

Support Staff

Hiring

Professional

Christy Uhl
Jennifer Armstrong
Ashley Easley
Lonnie Horner

Project AWARE Student Support
Project AWARE Student Support
Project AWARE Student Support
HCHS Biology (100-day contract)

Support Staff

Tracy Rivers
Sarah Eisenhuth
Horace Dunnivant

HCHS In-School Suspension
HCMS Special Education Assistant
Substitute Bus Driver

Resignation

Professional

Support Staff

Stephanie Bodine

EHES Special Education Assistant

Retirement

Professional

Support Staff

Transfers

Professional

Support Staff

Floy Ann McCutchen
Jessie Waters
Ronnie Lewis

Substitute Bus Driver to Full Time Bus Driver
Substitute Bus Driver to Full Time Bus Driver
Substitute Bus Driver to Full Time Bus Driver

Appointment

Professional

Support Staff

Brett Lovett

HCHS Interim Head Football Coach

Open Positions

1 Music Position

1 School Counselor Position

1 Secondary Math Position

2 Special Education Positions

1 Bookkeeper Position

1 Special Education Assistant

Template Name:
Created by: LGC

Hickman County Finance
Summary Financial Statement by Fund
January 2020

User:
Date/Time:

Michael Elkins
2/2/2020 9:30 PM
Page 1 of 4

141 General Purpose School		Year-To-Date			Month-To-Date		
Account	Description	Budget Estimate	Actual	% of Budget	Estimate Avg/Mth	Actual	% of Avg
Revenues							
40110	Current Property Tax	2,965,472.00	(1,277,010.22)	43.06 %	247,122.67	0.00	0.00 %
40120	Trustee's Collections - Prior Year	100,000.00	(32,413.58)	32.41 %	8,333.33	0.00	0.00 %
40125	Trustee's Collections - Bankruptcy	0.00	(407.65)	0.00 %	0.00	0.00	0.00 %
40130	Cir Clk/Clk & Master Collections-Pr Yr	55,000.00	(5,166.17)	9.39 %	4,583.33	0.00	0.00 %
40140	Interest And Penalty	21,000.00	(4,098.03)	19.51 %	1,750.00	0.00	0.00 %
40161	Payments In Lieu Of Taxes - T. V. A.	4,000.00	(1,753.33)	43.83 %	333.33	0.00	0.00 %
40162	Payments In Lieu Of Taxes-Local	6,000.00	0.00	0.00 %	500.00	0.00	0.00 %
40210	Local Option Sales Tax	1,600,000.00	(708,285.88)	44.27 %	133,333.33	0.00	0.00 %
40270	Business Tax	30,000.00	(5,790.19)	19.30 %	2,500.00	0.00	0.00 %
40320	Bank Excise Tax	30,000.00	0.00	0.00 %	2,500.00	0.00	0.00 %
40350	Interstate Telecommunications Tax	1,500.00	0.00	0.00 %	125.00	0.00	0.00 %
41110	Marriage Licenses	1,300.00	(589.00)	45.31 %	108.33	0.00	0.00 %
43513	Tuition - Summer School	1,000.00	0.00	0.00 %	83.33	0.00	0.00 %
43517	Tuition - Other	1,000.00	(1,300.00)	130.00 %	83.33	0.00	0.00 %
43570	Receipts From Individual Schools	60,000.00	(5,876.80)	9.79 %	5,000.00	0.00	0.00 %
43582	Community Service Fees - Adults	200.00	(144.70)	72.35 %	16.67	0.00	0.00 %
44120	Lease/Rentals	1,000.00	(405.00)	40.50 %	83.33	0.00	0.00 %
44146	E-Rate Funding	15,000.00	0.00	0.00 %	1,250.00	0.00	0.00 %
44170	Miscellaneous Refunds	28,100.39	(42,235.00)	150.30 %	2,341.70	0.00	0.00 %
44530	Sale Of Equipment	5,000.00	(11,401.45)	228.03 %	416.67	0.00	0.00 %
44560	Damages Recovered From Individuals	3,000.00	(2,483.94)	82.80 %	250.00	0.00	0.00 %
44570	Contributions & Gifts	15,000.00	(7,621.00)	50.81 %	1,250.00	0.00	0.00 %
46511	Basic Education Program	22,360,000.00	(11,300,939.20)	50.54 %	1,863,333.33	0.00	0.00 %
46515	Early Childhood Education	419,362.00	(90,850.25)	21.66 %	34,946.83	0.00	0.00 %
46520	School Food Service	22,000.00	0.00	0.00 %	1,833.33	0.00	0.00 %
46550	Driver Education	10,000.00	0.00	0.00 %	833.33	0.00	0.00 %
46590	Other State Education Funds	250,000.00	0.00	0.00 %	20,833.33	0.00	0.00 %
46591	Coordinated School Health	90,000.00	0.00	0.00 %	7,500.00	0.00	0.00 %
46594	Family Resource Centers	59,223.00	(29,611.66)	50.00 %	4,935.25	0.00	0.00 %
46610	Career Ladder Program	60,000.00	(29,883.73)	49.81 %	5,000.00	0.00	0.00 %
46851	State Revenue Sharing -T.V.A.	250,000.00	(58,589.34)	23.44 %	20,833.33	0.00	0.00 %
46980	Other State Grants	50,000.00	(2,950.00)	5.90 %	4,166.67	0.00	0.00 %
46981	Safe Schools	104,023.10	0.00	0.00 %	8,668.59	0.00	0.00 %
46990	Other State Revenues	25,062.30	(5,062.30)	20.20 %	2,088.53	0.00	0.00 %
47640	Rotc Reimbursement	65,000.00	(25,801.96)	39.70 %	5,416.67	0.00	0.00 %
48990	Other	85,400.00	(16,800.00)	19.67 %	7,116.67	0.00	0.00 %
49700	Insurance Recovery	10,000.00	0.00	0.00 %	833.33	0.00	0.00 %
49800	Transfers In	25,000.00	0.00	0.00 %	2,083.33	0.00	0.00 %

Template Name:
Created by: LGC

Hickman County Finance
Summary Financial Statement by Fund
January 2020

User:
Date/Time:

Michael Elkins
2/2/2020 9:30 PM
Page 2 of 4

141 General Purpose School		Year-To-Date			Month-To-Date		
Account	Description	Budget Estimate	Actual	% of Budget	Estimate Avg/Mth	Actual	% of Avg
	Total Revenues	28,828,642.79	(13,667,470.38)	47.41 %	2,402,386.90	0.00	0.00 %
Expenditures							
71100	Regular Instruction Program	(14,023,399.39)	7,683,742.25	54.79 %	(1,168,616.62)	1,051,740.96	90.00 %
71150	Alternative Instruction Program	(170,436.00)	72,519.36	42.55 %	(14,203.00)	11,212.08	78.94 %
71200	Special Education Program	(3,074,402.00)	1,219,142.81	39.65 %	(256,200.17)	186,109.78	72.64 %
71300	Career and Technical Education	(1,150,695.00)	457,108.73	39.72 %	(95,891.25)	62,984.98	65.68 %
72110	Attendance	(157,047.00)	78,692.87	50.11 %	(13,087.25)	9,378.75	71.66 %
72120	Health Services	(362,746.00)	149,083.35	41.10 %	(30,228.83)	23,022.68	76.16 %
72130	Other Student Support	(944,221.00)	347,566.63	36.81 %	(78,685.08)	53,231.07	67.65 %
72210	Regular Instruction Program	(1,354,356.00)	475,324.63	35.10 %	(112,863.00)	74,046.09	65.61 %
72220	Special Education Program	(115,363.00)	65,337.36	56.64 %	(9,613.58)	7,551.45	78.55 %
72230	Career and Technical Education	(114,933.00)	53,978.13	46.96 %	(9,577.75)	6,874.15	71.77 %
72250	Technology	(275,049.00)	176,779.59	64.27 %	(22,920.75)	5,756.31	25.11 %
72310	Board Of Education	(670,000.00)	346,709.00	51.75 %	(55,833.33)	0.00	0.00 %
72320	Director Of Schools	(282,179.00)	158,107.15	56.03 %	(23,514.92)	17,438.06	74.16 %
72410	Office Of The Principal	(1,711,905.30)	724,109.13	42.30 %	(142,658.78)	96,056.02	67.33 %
72510	Fiscal Services	(45,000.00)	235.00	0.52 %	(3,750.00)	0.00	0.00 %
72610	Operation Of Plant	(2,313,000.00)	1,210,410.64	52.33 %	(192,750.00)	140,938.50	73.12 %
72620	Maintenance Of Plant	(1,114,193.10)	653,844.86	58.68 %	(92,849.43)	35,717.46	38.47 %
72710	Transportation	(2,112,078.00)	789,347.36	37.37 %	(176,006.50)	109,114.58	61.99 %
72810	Central And Other	(254,500.00)	33,116.36	13.01 %	(21,208.33)	9,698.13	45.73 %
73100	Food Service	(28,110.00)	20,061.91	71.37 %	(2,342.50)	5,015.48	214.11 %
73300	Community Services	(130,305.00)	53,593.89	41.13 %	(10,858.75)	7,555.24	69.58 %
73400	Early Childhood Education	(448,354.00)	182,013.67	40.60 %	(37,362.83)	29,599.35	79.22 %
76100	Regular Capital Outlay	(331,000.00)	78,718.00	23.78 %	(27,583.33)	6,500.00	23.56 %
99100	Transfers Out	(165,000.00)	0.00	0.00 %	(13,750.00)	0.00	0.00 %
	Total Expenditures	(31,348,271.79)	15,029,542.68	47.94 %	(2,612,355.98)	1,949,541.12	74.63 %
Total	141 General Purpose School	(2,519,629.00)	1,362,072.30	54.06 %	(209,969.08)	1,949,541.12	928.49 %

Template Name: LGC
 Created by:

Hickman County Finance
 Summary Financial Statement by Fund
 January 2020

User:
 Date/Time:

Michael Elkins
 2/2/2020 9:30 PM
 Page 3 of 4

142 School Federal Projects		Year-To-Date			Month-To-Date		
Account	Description	Budget Estimate	Actual	% of Budget	Estimate Avg/Mth	Actual	% of Avg
Revenues							
44170	Miscellaneous Refunds	0.00	(0.05)	0.00 %	0.00	0.00	0.00 %
47131	Vocational Educ - Basic Grants To	104,022.67	(48,126.86)	46.27 %	8,668.56	0.00	0.00 %
47141	Title 1 Grants To Local Educ Agencies	1,335,300.94	(428,242.18)	32.07 %	111,275.08	0.00	0.00 %
47143	Special Education - Grants To States	1,021,606.54	(292,593.84)	28.64 %	85,133.88	0.00	0.00 %
47145	Special Education Preschool Grants	29,322.74	(5,511.68)	18.80 %	2,443.56	0.00	0.00 %
47146	English Language Acquisition Grants	146,012.83	0.00	0.00 %	12,167.74	0.00	0.00 %
47148	Rural Education	121,540.11	(34,250.49)	28.18 %	10,128.34	0.00	0.00 %
47189	Eisenhower Prof Development State	190,954.66	(21,626.48)	11.33 %	15,912.89	0.00	0.00 %
47590	Other Federal Through State	297,265.94	(63,560.88)	21.38 %	24,772.16	0.00	0.00 %
Total Revenues		3,246,026.43	(893,912.46)	27.54 %	270,502.20	0.00	0.00 %
Expenditures							
71100	Regular Instruction Program	(1,189,907.36)	504,685.98	42.41 %	(99,158.95)	107,356.99	108.27 %
71200	Special Education Program	(605,879.15)	221,830.46	36.61 %	(50,489.93)	36,205.28	71.71 %
71300	Career and Technical Education	(84,322.67)	59,023.64	70.00 %	(7,026.89)	10,987.60	156.37 %
72130	Other Student Support	(343,444.27)	68,692.03	20.00 %	(28,620.36)	17,172.02	60.00 %
72210	Regular Instruction Program	(553,558.35)	174,516.92	31.53 %	(46,129.86)	22,387.84	48.53 %
72220	Special Education Program	(437,078.75)	134,900.40	30.86 %	(36,423.23)	20,848.80	57.24 %
72710	Transportation	(9,500.00)	266.92	2.81 %	(791.67)	184.79	23.34 %
99100	Transfers Out	(22,335.88)	0.00	0.00 %	(1,861.32)	0.00	0.00 %
Total Expenditures		(3,246,026.43)	1,163,916.35	35.86 %	(270,502.20)	215,143.32	79.53 %
Total	142 School Federal Projects	0.00	270,003.89	100.00 %	0.00	215,143.32	0.00 %

Template Name:
Created by: LGC

Hickman County Finance
Summary Financial Statement by Fund
January 2020

User:
Date/Time:

Michael Elkins
2/2/2020 9:30 PM
Page 4 of 4

143 Central Cafeteria		Year-To-Date			Month-To-Date		
Account	Description	Budget Estimate	Actual	% of Budget	Estimate Avg/Mth	Actual	% of Avg
Revenues							
43521	Lunch Payments - Children	0.00	(47,254.66)	0.00 %	0.00	0.00	0.00 %
43522	Lunch Payments - Adults	65,000.00	(22,009.98)	33.86 %	5,416.67	0.00	0.00 %
43523	Income From Breakfast	4,500.00	(19,097.04)	424.38 %	375.00	0.00	0.00 %
43525	A La Carte Sales	145,000.00	(113,848.49)	78.52 %	12,083.33	0.00	0.00 %
43570	Receipts From Individual Schools	0.00	0.00	0.00 %	0.00	0.00	0.00 %
44110	Investment Income	200.00	(89.52)	44.76 %	16.67	0.00	0.00 %
44530	Sale Of Equipment	0.00	(114.30)	0.00 %	0.00	0.00	0.00 %
46980	Other State Grants	0.00	(6,850.00)	0.00 %	0.00	0.00	0.00 %
47111	USDA School Lunch Program	1,305,000.00	(548,766.31)	42.05 %	108,750.00	0.00	0.00 %
47113	Breakfast	580,000.00	(230,900.05)	39.81 %	48,333.33	0.00	0.00 %
47114	USDA - Other	15,000.00	(6,066.76)	40.45 %	1,250.00	0.00	0.00 %
	Total Revenues	2,114,700.00	(994,997.11)	47.05 %	176,225.00	0.00	0.00 %
Expenditures							
73100	Food Service	(2,114,699.00)	1,508,315.23	71.33 %	(176,224.92)	146,391.07	83.07 %
	Total Expenditures	(2,114,699.00)	1,508,315.23	71.33 %	(176,224.92)	146,391.07	83.07 %
Total	143 Central Cafeteria	1.00	513,318.12	-	0.08	146,391.07	-

*Account Activity Summary
Hickman
09/30/2019 - 12/31/2019*

Beginning Value ^{1 See Definitions}	\$	2,184,757
<hr/>		
Additions ²		
Contributions ³	\$	-
Dividends & Interest ⁴	\$	53,341.87
Withdrawals ⁵		
TSBA Fee ⁶	\$	(1,364.11)
MS Fees ⁷	\$	(975.74)
System Distributions ⁸	\$	-
Unadjusted Investment Earnings ⁹	\$	92,437.98
<hr/>		
Ending Value ¹⁰	\$	2,328,197

Definitions:

1. **Beginning Value:** The total account value at the start of business on the first day of the specified reporting period.
2. **Additions:** All credits to the account in which total account value is increased within the specified reporting period.
3. **Contributions:** The sum of total cash deposits and/or other asset transfers into the Morgan Stanley account from outside of the Morgan Stanley account and by instruction of the client within the specified reporting period.
4. **Dividends and Interest:** The sum of all dividend, interest, and capital gain payments credited to the account and those in the which settlement date lies within the specified reporting period. **NOTE:** Any dividend, interest, or capital gain distribution in which a settlement date lies outside of the reporting period or in which was included in the beginning value will not be included 'Dividends and Interest' total for the period.
5. **Withdrawals:** The sum of total cash and/or other asset transfers out of the Morgan Stanley account to any other account whether inside or outside of the firm.
6. **TSBA Fee:** The fee calculated by instruction of the client and is based on the account value at the end of business on the last day of the prior quarter.
7. **MS Fees:** The sum of all quarterly fees charged by Morgan Stanley and any adjustments made to this charge within the specified reporting period in which client is in agreement for investment advisory and brokerage services provided.
8. **System Distributions:** The sum of any distributions to the beneficiary (public school system) of the GASB 45 Trust within the specified reporting period.
9. **Unadjusted Investment Earnings:** The earnings of asset investments in the Morgan Stanley account unadjusted for any fees charged or withdrawals in the account by instruction of Morgan Stanley or the client and within the specified reporting period.
10. **Ending Value:** The Account Value at the end of business on the last day of the specified reporting period.

The information and data contained in this report are from sources considered reliable, but their accuracy and completeness is not guaranteed. This report has been prepared for illustrative purposes only and is not intended to be used as a substitute for monthly transaction statements you receive on a regular basis from Morgan Stanley Smith Barney LLC. Please compare the data on this document carefully with your monthly statements to verify its accuracy. The Company strongly encourages you to consult with your own accountants or other advisors with respect to any tax questions.

Account Contribution Summary
Hickman
09/30/2019 - 12/31/2019

ACTIVITY DATE	ACTIVITY	DESCRIPTION		TYPE
		Total Deposits	0.00	

The information and data contained in this report are from sources considered reliable, but their accuracy and completeness is not guaranteed. This report has been prepared for illustrative purposes only and is not intended to be used as a substitute for monthly transaction statements you receive on a regular basis from Morgan Stanley Smith Barney LLC. Please compare the data on this document carefully with your monthly statements to verify its accuracy. The Company strongly encourages you to consult with your own accountants or other advisors with respect to any tax questions.

Account Dividend & Interest Summary
Hickman
09/30/2019 - 12/31/2019

ACTIVITY DATE	ACTIVITY	DESCRIPTION		TYPE
10/01/2019	Dividend	VANGUARD INDEX FDS S&P 500 ETF	417.75	Cash
10/01/2019	Dividend	PGIM SHORT-TERM CORP BOND Z	563.31	Cash
10/01/2019	Dividend	PIONEER BOND Y	412.91	Cash
10/01/2019	Dividend	NUVEEN STRATEGIC INCOME INST	432.90	Cash
10/01/2019	Dividend	PUTNAM FLOATING RATE INC Y	267.44	Cash
10/01/2019	Dividend	E V SHT DURATION GOVT INC I	86.43	Cash
10/11/2019	Dividend	BLACKROCK HIGH EQ INCOME INST	273.54	Cash
10/16/2019	Dividend	TEMPLETON GLOBAL BD FD ADV	173.68	Cash
10/31/2019	Interest Income	MORGAN STANLEY BANK N.A.	4.23	Cash
11/01/2019	Dividend	PGIM SHORT-TERM CORP BOND Z	624.76	Cash
11/01/2019	Dividend	PIONEER BOND Y	412.34	Cash
11/01/2019	Dividend	NUVEEN STRATEGIC INCOME INST	434.31	Cash
11/01/2019	Dividend	PUTNAM FLOATING RATE INC Y	257.61	Cash
11/01/2019	Dividend	E V SHT DURATION GOVT INC I	89.59	Cash
11/15/2019	LT Cap Gain	THORNBURG INTL GROWTH I	536.21	Cash
11/18/2019	Dividend	TEMPLETON GLOBAL BD FD ADV	180.69	Cash
11/29/2019	Interest Income	MORGAN STANLEY BANK N.A.	3.21	Cash
12/02/2019	Dividend	PGIM SHORT-TERM CORP BOND Z	625.45	Cash
12/02/2019	Dividend	PIONEER BOND Y	415.04	Cash
12/02/2019	Dividend	NUVEEN STRATEGIC INCOME INST	435.84	Cash
12/02/2019	Dividend	PUTNAM FLOATING RATE INC Y	248.26	Cash
12/02/2019	Dividend	E V SHT DURATION GOVT INC I	84.37	Cash
12/06/2019	Dividend	BLACKROCK HIGH EQ INCOME INST	228.60	Cash
12/06/2019	LT Cap Gain	DELAWARE SMID CAP GROWTH INST	667.30	Cash
12/12/2019	LT Cap Gain	PGIM JENNISON GROWTH Z	9,874.64	Cash
12/13/2019	Dividend	OAKMARK FUND ADVISOR	1,393.57	Cash
12/13/2019	LT Cap Gain	OAKMARK FUND ADVISOR	11,460.38	Cash
12/16/2019	Dividend	JOHN HANCOCK DISPLND VAL INST	1,907.00	Cash
12/16/2019	LT Cap Gain	JOHN HANCOCK DISPLND VAL INST	5,934.96	Cash
12/17/2019	Dividend	TEMPLETON GLOBAL BD FD ADV	409.10	Cash
12/18/2019	Dividend	T ROWE PRICE JAPAN FUND	233.91	Cash
12/18/2019	LT Cap Gain	T ROWE PRICE JAPAN FUND	9.36	Cash
12/18/2019	LT Cap Gain	VICTORY RS VALUE Y	1,374.15	Cash
12/18/2019	ST Cap Gain	T ROWE PRICE JAPAN FUND	187.13	Cash
12/18/2019	ST Cap Gain	VICTORY RS VALUE Y	74.65	Cash
12/19/2019	Dividend	DWS SMALL CAP CORE S	30.70	Cash
12/19/2019	LT Cap Gain	DWS SMALL CAP CORE S	3.77	Cash
12/20/2019	Dividend	ISHARES INC MSCI JAPAN ETF	279.95	Cash
12/20/2019	Dividend	ISHARES CORE MSCI EAFE ETF	1,851.28	Cash
12/20/2019	Dividend	ISHARES SP SMALLCAP 600 INDEX	226.71	Cash
12/20/2019	Dividend	ISHARES S&P MIDCAP 400 INDEX	101.02	Cash

12/20/2019	Dividend	ISHARES CORE S&P U.S. GROWTH	840.16	Cash
12/20/2019	Dividend	ISHARES CORE S&P U.S. VALUE	850.91	Cash
12/20/2019	Dividend	AMERICAN EUROPACIFIC GRW F2	1,582.71	Cash
12/20/2019	LT Cap Gain	AMERICAN EUROPACIFIC GRW F2	2,402.05	Cash
12/23/2019	Dividend	THORNBURG INTL GROWTH I	298.93	Cash
12/23/2019	Dividend	LAZARD EMRG MKT EQ BLEND INST	1,465.80	Cash
12/24/2019	Dividend	VICTORY RS VALUE Y	170.55	Cash
12/27/2019	Dividend	VANGUARD INDEX FDS S&P 500 ETF	459.98	Cash
12/27/2019	Dividend	VANGUARD FTSE EMERGING MARKETS	286.26	Cash
12/27/2019	Dividend	PUTNAM EQUITY INCOME Y	195.18	Cash
12/27/2019	Dividend	PIONEER BOND Y	320.11	Cash
12/27/2019	LT Cap Gain	PUTNAM EQUITY INCOME Y	1,098.08	Cash
12/30/2019	Dividend	JOHN HANCOCK MULTI FACT MID	140.31	Cash
12/31/2019	Interest Income	MORGAN STANLEY BANK N.A.	2.79	Cash
		Total Dividends and Interest	53,341.87	

The information and data contained in this report are from sources considered reliable, but their accuracy and completeness is not guaranteed. This report has been prepared for illustrative purposes only and is not intended to be used as a substitute for monthly transaction statements you receive on a regular basis from Morgan Stanley Smith Barney LLC. Please compare the data on this document carefully with your monthly statements to verify its accuracy. The Company strongly encourages you to consult with your own accountants or other advisors with respect to any tax questions.

*Account Fee Summary
Hickman
09/30/2019 - 12/31/2019*

ACTIVITY DATE	ACTIVITY	DESCRIPTION		TYPE
10/07/2019	CASH TRANSFER	FUNDS TRANSFERRED	-1,364.11	Cash
10/14/2019	Service Fee	ADV FEE 10/01-12/31	-981.46	Cash
10/16/2019	Service Fee Adj	NET PLATFORM CREDIT	5.72	Cash
		Total Withdrawals	-2,339.85	

***Cash Balance Includes Cash, Bank Deposits, MMF Balance, and Unsettled Cash.**

Unless otherwise indicated, this information is not intended to be a substitute for the official account statements that you receive from us. This information is approximate and subject to adjustment, updating and correction and is for illustrative and general reference purposes only. We are not responsible for any clerical, computational or other inaccuracies, errors or omissions. We obtain market values and other data from various standard quotation services and other sources, which we believe to be reliable. However, we do not warrant or guarantee the accuracy or completeness of any such information. The values that you actually receive in the market for any investment may be higher or lower than the values reflected herein. To the extent there are any discrepancies between your official account statement and this information, you should rely on the official account statement. This information should not be considered as the sole basis for any investment decision. The Bank Deposit Program (BDP) is a cash sweep feature whereby clients can choose to have their available free credit balances automatically deposited into interest bearing, FDIC-insured deposit accounts at up to three banks ("Program Banks"): (1) Morgan Stanley Bank, N.A. and/or Morgan Stanley Private Bank, National Association (together, the "Morgan Stanley Banks"), or (2) Citibank, N.A. The Program Banks are FDIC members. Morgan Stanley Smith Barney LLC ("Morgan Stanley") is a registered broker-dealer, not a bank. Morgan Stanley and the Morgan Stanley Banks are affiliates. Unless specifically disclosed to you in writing, other investments and services offered to you through Morgan Stanley are not insured by the FDIC, are not deposits of or other obligations of, or guaranteed by, the Program Banks and involve investment risks, including possible loss of principal amount invested.

External Assets - Certain assets listed in this view are based upon information provided by you, your client or other external sources and are not part of accounts that you manage at Morgan Stanley. Assets not held with Morgan Stanley may not be covered by SIPC protection or by additional protection under Morgan Stanley's excess insurance coverage plans. Morgan Stanley may include information about these external assets in this view solely as a service to you, and Morgan Stanley is not responsible for the accuracy of any information provided by external sources, including but not limited to, you, your client or another financial institution. You are responsible for ensuring the accuracy of such information. Generally, any financial institution that holds securities is responsible for year-end reporting (Internal Revenue Service (IRS) Form 1099) and separate periodic statements, which may vary from Morgan Stanley's information due to different tax reporting periods.

The information and data contained in this report are from sources considered reliable, but their accuracy and completeness is not guaranteed. This report has been prepared for illustrative purposes only and is not intended to be used as a substitute for monthly transaction statements you receive on a regular basis from Morgan Stanley Smith Barney LLC. Please compare the data on this document carefully with your monthly statements to verify its accuracy. The Company strongly encourages you to consult with your own accountants or other advisors with respect to any tax questions.



Hickman County Schools Board Agenda Item Request

Date: 1/20/2020

Name of School: East Hickman High School

Item Request: Ask permission to attend FFA State Convention

Explanation: Students will be attending the yearly FFA state convention in Gallatinburg, TN. The dates of attendance will be March 29th - April 1 2020. We will depart from campus Sunday morning and return Wednesday evening.

Attachments (if necessary and appropriate):

Signature of Person requesting to be placed on the agenda:

Myles High Williams Ag. ETHS

Signature of Building Principal:

Arnell Beaman



Hickman County Schools Board Agenda Item Request

Date: 14-Jan-20

Name of School: Hickman County High School

Item Requested: Resident Girls Soccer Training Camp

Explanation: HCHS Girls Soccer Coaching Staff request permission to host a

resident training camp 19- 23 July 2020 at Hickman County High School. Players will be

dropped off at HCHS the evening of 19 July and will leave the evening of 23 July.

Attachments (if necessary and appropriate):

Handouts will be provided at the meeting.

Signature of Person requesting to be placed on the agenda:

Amy Scottley

Signature of Building Principal

Ken D. Eng



Hickman County Schools Board Agenda Item Request

Date: 14-Jan-20

Name of School: Hickman County High School

Item Requested: Out-of-State Trip Request

Explanation: HCHS JROTC request permission to participate in the

JROTC Cadet Leadership Challenge (JCLC) at the Wendell Ford Regional Training Center

(Greenville, KY) 04 - 08 JUNE 2020. Approximately 7-10 Cadets will attend the training event

(2 Females, 5 Males) female chaperones are provided by the schools partnered during the

training. Females and males berth in separate bays of the same building. An instructor

rotates on duty 24 hrs a day. Cadets will participate in a physical fitness test, combat water

survival training (CWST), boat operations, land navigation, Field Leader Reaction Course

(FLRC), rappelling, and the obstacle course. This event is 100% funding by USACC.

Attachments (if necessary and appropriate):

Signature of Person requesting to be placed on the agenda:

Mary Scott Lay (ISB-12), USA

Signature of Building Principal

Ken D. Eng



Hickman County Schools Board Agenda Item Request

Date: 14-Jan-20

Name of School: Hickman County High School

Item Requested: Trip Request

Explanation: HCHS JROTC request permission to participate in the 7th Brigade

Regional Academic, Air Rifle, Drill, and Robotics competition at Fort Knox, KY on March 14th.

There is no cost for Cadets.

Attachments (if necessary and appropriate):

Signature of Person requesting to be placed on the agenda:

Mary Scott Kelly 1st Lt, USA

Signature of Building Principal

Ken A. Esf



Hickman County Schools Trip Request

Name of School: _____ HCHS _____

Name of Club/Group: _____ JROTC _____

Trip Requested: _____ North Harding HS (Fort Knox) _____

Purpose: _____ 7TH Brigade Regional Competition _____

Date and Time frame: _____ 14 March 2020 _____

Number of Students: _____ 25-30 _____

Number of Chaperones: _____ 1 (Amanda Riley) _____

Cost Associated: _____ None _____

Attachments (any information or permission slips that are sent home with students)

Has the cafeteria been notified? _____ N/A _____ Number of Lunches needed? _____

How will students travel? _____ Bus _____

Is a transportation request attached if system transportation is needed? _____ Yes _____

Signature of person requesting the trip _____ 1SG RILEY _____

Signature of Principal: _____ *Ken D. Esp* _____

Signature of instructional Supervisor _____ *Misty G. Shuttler* _____

*Per Hickman County Board of Education policy 4.302, any requested trip that has an out-of-state destination and/or is planned for overnight must have prior approval by the Board of Education.



Hickman County Schools Trip Request

Name of School: _____ HCHS _____

Name of Club/Group: _____ JROTC _____

Trip Requested: _____ Wendell Ford Training Center (Greenville, KY) _____

Purpose: _____ JROTC Cadet Leadership Challenge (JCLC) _____

Date and Time frame: _____ 04 - 08 JUNE 2020 _____

Number of Students: _____ 7 - 10 _____

Number of Chaperones: _____ 4 (Williamson County Provided) _____

Cost Associated: _____ None _____

Attachments (any information or permission slips that are sent home with students)

Has the cafeteria been notified? _____ N/A _____ Number of Lunches needed? _____

How will students travel? _____ Government Rented SUV (s) _____

Is a transportation request attached if system transportation is needed? _____ N/A _____

Signature of person requesting the trip: _____ *Doug Riley* _____ 1SG RILEY

Signature of Principal: _____ *Kevin D. Eng* _____

Signature of instructional Supervisor _____

*Per Hickman County Board of Education policy 4.302, any requested trip that has an out-of-state destination and/or is planned for overnight must have prior approval by the Board of Education.



Hickman County Schools Board Agenda Item Request

Date: 17-Jan-20

Name of School: Hickman County High School

Item Requested: Resident Raider Training Camp

Explanation: HCHS JROTC Instructor Staff request permission to host a

resident training camp 30 July - August 2nd 2020 at Hickman County High School. Raiders will b

ropped off at HCHS the evening of 30 July and will leave the afternoon of 02 AUG.

Attachments (if necessary and appropriate):

Handouts will be provided at the meeting.

Signature of Person requesting to be placed on the agenda:

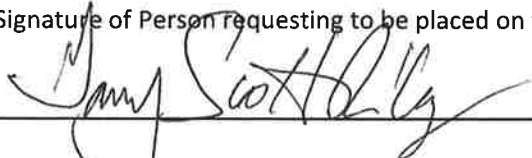

Signature of Building Principal

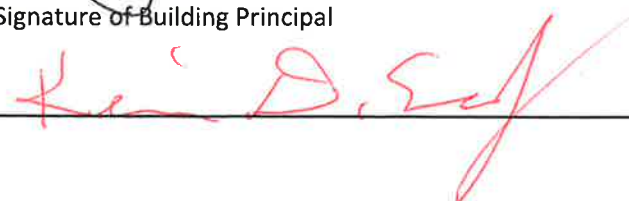



Hickman County Schools Board Agenda Item Request

Date: 14-Jan-20

Name of School: Hickman County High School

Item Requested: Military Formal & Awards Ceremony

Explanation: HCHS JROTC request permission to host a military formal event

on 02 MAY 2020 at Hickman County High School as required by Cadet Command Regulation

145-2. The event will begin at 1700hrs (5:00 pm) and will conclude by 2000hrs (8:00 pm).

During the event Cadets will engage in formal dining, prog ceremony, National & Regional

Award presentation, Class of 2020 Cord presentation, & Class of 2021 Rank Promotion.

Guest speaker TBD. Parents are permitted to attend the event. Dates will not be 21 or older.

Estimated cost is \$20-\$25 per attendee.

Attachments (if necessary and appropriate):

Signature of Person requesting to be placed on the agenda:

Young Scott Riley 156(LR), USA

Signature of Building Principal

Ken D. Euf

Hickman County Board of Education
 Budget Amendment No. 6
 General Purpose (141)
 February 3, 2020

Account	Description	Debit	Credit	Justification
71100 - 189	Other Salaries & Wages	\$ 250,000.00		
71100 - 189 - DP	Other Salaries & Wages		\$ 250,000.00	To budget into correct Object Code
71100 - 201	Social Security	19,125.00		
71100 - 201 - DP	Social Security		19,125.00	
72120 - 189	Other Salaries & Wages	102,339.00		
72120 - 189 - CHG	Other Salaries & Wages		102,339.00	To budget into correct Object Code
72120 - 189	Other Salaries & Wages	19,350.00	19,350.00	
72120 - 189 - CHG	Other Salaries & Wages			
72610 - 502	Bldg & Contents Insurance	3,000.00		To cover Boiler Insurance Expenditure
72610 - 501	Boiler Insurance		3,000.00	in excess of Budget
72620 - 418	Equipment & Machinery Parts	471.56		
72620 - 499	Other Supp & Mats		471.56	To budget for exp in Line Item
72710 - 146	Bus Drivers	65,000.00		
72710 - 146 - SE	Bus Drivers		65,000.00	
72710 - 201	Social Security	4,972.50		To budget into correct Object Code
72710 - 201 - SE	Social Security		4,972.50	
72710 - 204	State Retirement	8,957.00		
72710 - 204 - SE	State Retirement		8,957.00	
73300 - 105	Supervisor	31,500.00		
73300 - 105 - FRC	Supervisor		15,750.00	
73300 - 105 - FRE	Supervisor		15,750.00	
73300 - 189	Other Salaries & Wages	56,178.00		
73300 - 189 - FRC	Other Salaries & Wages		30,840.00	
73300 - 189 - FRE	Other Salaries & Wages		25,338.00	To budget into correct Object Code
73300 - 201	Social Security	4,297.62		
73300 - 201 - FRC	Social Security		2,359.26	
73300 - 201 - FRE	Social Security		1,938.36	
73300 - 499	Other Supplies & Mat	5,000.00		
73300 - 499 - FRC	Other Supplies & Mat		2,500.00	
73300 - 499 - FRE	Other Supplies & Mat		2,500.00	
	TOTALS	\$ 570,190.68	\$ 570,190.68	

Approved:

Attest:

Amy Bryant

Michelle Gilbert

Hickman County Board of Education
Budget Amendment No. 7
General Purpose (141)
February 3, 2020

Account	Description	Debit	Credit	Justification
48990 -	Revenue	\$ 21,000.00		Utrust Grant
72320 - 599 - SS	Other Charges		\$ 21,000.00	
	TOTALS	<u>\$ 21,000.00</u>	<u>\$ 21,000.00</u>	

Approved:

Attest:

Amy Bryant

Michelle Gilbert

Hickman County Board of Education
Budget Amendment No. 8
Food Service (143)
February 3, 2020

Account	Description	Debit	Credit	Justification
46980	Other State Grants	\$ 6,850.00		State Grant for Eq
73100 - 599	Other Charges		\$ 6,850.00	
TOTALS		<u>\$ 6,850.00</u>	<u>\$ 6,850.00</u>	

Approved:

Attest:

Amy Bryant

Michelle Gilbert

INVITATION TO BID

The Hickman County Finance Office is accepting sealed bids for school bus units. Bids for up to two (2) conventional thirty-nine (39) passenger Type C Special Equipped School Bus.

Specifications and bid requirement may be obtained from Steven George, Director of Transportation, Hickman County Schools at 931-729-3391, Ext. 2241 or by e-mail steven.george@hickmank12.org or online at www.hickmank12.org/request-for-proposal.

Sealed bids must be mailed or delivered to the Hickman County Finance Office, 114 North Central Avenue, Suite 203, Centerville, TN 37033 and clearly marked on the outside of the bid envelope "School Bus Units – 39 Passenger Type C Special Equipped." Bids will be opened on Monday, February 3, 2020 at 10:15 a.m. at the Finance Office.

The Hickman County Board of Education reserves the right to accept or reject any and all bids or parts of bids and to waive any informalities that would prevent acceptance of a better bid.

Present Penny Mayberry
Cardi Davis

Cumberland 112,028.⁰⁰

Central State 115,207.⁰⁰

Bus Sales

HICKMAN COUNTY BOARD OF EDUCATION
115 MURPHREE AVENUE
CENTERVILLE, TN 37033
931-729-3391

BID OFFER FOR UP TO TWO (2) CONVENTIONAL Thirty Nine (39) PASSENGER SPECIAL
EQUIPPED SCHOOL BUSES

TO THE HICKMAN COUNTY BOARD OF EDUCATION, CENTERVILLE, TENNESSEE:

IN RESPONSE TO YOUR INVITATION, MY COMPANY SUBMITS THE FOLLOWING BIDS ON
SCHOOL BUS. THE SCHOOL BUS SPECIFICATIONS REQUIRED BY THE TENNESSEE STATE
BOARD OF EDUCATION, AND BY YOU, AND THE CONDITIONS SET FORTH IN YOUR BID
INVITATION ARE CLEARLY UNDERSTOOD AND ARE COMPILED WITHIN THIS BID.

- A. MAKE Blue Bird MODEL & NUMBER BB CV Vision
B. BID PRICE DELIVERED F.O.B. CENTERVILLE, TENNESSEE MOUNTED AND
FULLY EQUIPPED AS SPECIFIED.

NUMBER OF BUSES	SEATING CAPACITY	UNIT PRICE	TOTAL
<u>2</u>	<u>39</u>	<u>\$115,207.00</u>	<u>\$230,414.00</u>
<u> </u>	<u> </u>	<u> </u>	<u> </u>
<u> </u>	<u> </u>	<u> </u>	<u> </u>
TOTAL BIDS ON ALL			<u>\$230,414.00</u>

INVOICE TO BE PAID IN FULL UPON COMPLETION AND PASSING INSPECTION BY STATE
OF TENNESSEE.

SIGNED

Paula Gamm

Regional Sales Manager
TITLE

Central States Bus Sales, Inc.
COMPANY
303 Business Park Drive
Lebanon, TN 37090
ADDRESS

DATE: February 3, 2020

Delivery Date: May 1, 2020 (Must be specific)

SCHOOL BUS SPECIFICATIONS

UNIT MUST MEET ALL STATE AND FEDERAL SPECIFICATIONS. PLEASE NOTE ANY DEVIATIONS BESIDE THE RESPECTIVE DESCRIPTION. ALL DEVIATIONS WILL BE CONSIDERED.

WARRANTIES: Towing to be included for life of all applicable warranties.
Three Year Bumper to Bumper
Power Train Five year or 100,000 mile warranty

CHASSIS MINIMUM REQUIREMENTS

ALTERNATOR: Must be a 240 amp minimum, 12 volt.

AXLES: Front: 12,000 # rating minimum, "I" beam type. Rear 23,000 Minimum. Both axles made by same manufacturer.

BATTERIES: 2100 CCA Minimum. Double 00 gauge battery cables. Battery compartment to have a sliding tray with stop. **With cutoff switch in battery box**

BRAKES: Dual air with Bendix anti-lock system, Front: - 16.5" x 5" x 7/8" thick, Rear: -16.5" x 7" x 7/8" thick. Air compressor to be 13.2 CFM min. Three air tanks provided with total capacity of 4,760 cu. In Bendix AD-9 air dryer.

BUMPERS: Minimum of 12" after forming front and rear steel plate bumpers. The rear bumper shall have a 14" wrap-around. Front and rear bumpers must be bolted not welded to frame with grade 8 bolts.

ENGINE: Ford 6.8L Propane Engine w/5yr Unlimited mile warranty.

FRAME: Must be one piece. No frame extension. Completely painted for rust and corrosion protection. 50,000 psi minimum.

EXHAUST: Max NOx allowed .05. **To exit rear of bus thru the bumper.**

FUEL TANK: 100 gal. Min. Sender inspection access plate. Fuel system must include 2 fuel/water separators. One spin-on type at the engine and a second filter element with see through bowl and self-venting drain. Fuel tank to have heat shields if within 12 inches of exhaust system. **Must have Interlock System, 5yr. unlimited mile warranty.**

GAUGES: Seven digit speedometer/odometer, fuel, voltmeter, oil pressure, tachometer, hour meter, coolant temperature, dual air brake gauges.
Warning systems to include: low air pressure light and buzzer, high temp./low oil pressure light and buzzer, low coolant light.

SAFETY: **Electronic Stability Control installed. Meet Colorado Rack and Kentucky Pole Test and show certification.**

SHOCKS: **Air Ride Suspension System front and rear.** Dual action piston type: two front and two rear required. 1 3/4" bore. *Air ride not available on front*

STEERING: Tilt wheel. Full power
1/9/2020

(PAGE 2)

TIRES: Tubeless radial tires as needed 11R x 22.5; 16 ply rating highway.

TOW HOOKS: Unit to be equipped with tow hooks. 2 front; 2 rear.

TRANSMISSION: Ford 6R140 6spd Automatic Transmission w/5yr unlimited mile warranty, cooling accomplished by an oil cooler mounted external from transmission, minimum capacity 1,530 BTUs per minute with external spin-on filter.

WHEELS: HUB ALIGNED 22.5 x 8.25, painted black.

WIRING: Color and number coded. Protected by blade type fuses. Resistant to heat, abrasion, and solvents.

BODY REQUIREMENTS

A/C SYSTEM: MINIMUM 120,000 BTU

COMPARTMENTS: Storage compartment to be located over windshield area. Add glove box at door in dash. Add padded arm rest with storage.

CONSTRUCTION: Body parts must be treated with zinc coating after fabrication and before assembly. Entire body surface including the floor construction shall meet FMVSS 221 in all joints.

FLOOR: Shall be 14 gauge heavily galvanized steel. They shall be welded and riveted at reinforcements. These main floor cross-members must be full width to outer sheet metal on each side of body for maximum collision protection.

ROOF BOWS: 14 gauge hat-shaped roof bows one piece from floor overhead to floor on the other side shall be used. Bows shall end upon floor overhead to floor on the other side shall be used. Bows shall end upon floor at each side for maximum rollover strength.

BODY SHEET METAL: Four 16 gauge applied rub rails plus one embossed for a total of five. Embossed rain visor over each window. Skirts to be 16 ¼" measured from the floor level. These rails to be riveted to structured bows and side panels with buck rivets. Body shall be fully undercoated, under floor, skirt panels and wheel wells prior to mounting on chassis. Rain visors to be embossed in roofing sheet metal over each window. These roof sheets shall be one piece from window top to window top on the other side for maximum strength. They shall be double lapped and secured with two rows of rivets for additional strength.

CROSSING ARM: Front bumper crossing arm equipped to be air operated

STOP SIGN: To be air operated

DOORS: Entrance: Outward opening door, air operated with Kentucky switch. 30" full opening and 1,500 sq." of glass area. Stainless steel grab rail. Rear emergency 36" x 51" to have upper and lower glass. Retainer to hold door open. **Rear door to have red stop warning lighted sign in center of door AKA rear motorist alert sign.**

1/9/2020

(PAGE 3)

FLOORING: Black rubber flooring with white colored nosing on each step. Molded rubber covers required over front and rear interior wheel-housings. Rounded rustproof molding to be installed where floor meets wall on each side.

HEADROOM: Interior headroom to be 77" full length of bus.

HEATERS: 90,000 BTU front heater/defroster, 80,000 BTU rear heater **mounted behind rear wheels.** Two 6" dash fans. Front heater to have removable filter. Rear heat with filter

INSULATION: 1 ½" thick fiberglass in roof, front, and rear. 1 ½" mineral wool blanket type insulation on sides to insure vertical integrity.

IDENTIFICATION: School system name 6" HICKMAN COUNTY SCHOOLS & 6" Numbers Front - Rear and sides

LIFT DOOR: Lift door to be mounted in the rear providing 43" wide opening. Lift must be by Ricon model, meeting the most recent standards

LIGHTS: Warning light system meeting current federal specifications. All red overhead and stop arm lights to be strobe LED lights. Side directional lights mounted on right and left. 5" back up lights, 7" tail lights. Warning lights to be hooded. Roof strobe with guard.
Interior lights: Step well light and dome lights. **All lights to be LED**

MIRRORS: Interior: 6" x 30" non-glare, adjustable. Exterior: Heated mirrors meeting federal and state standards. **Student Mirror: to have rear view camera built in.**

SUN VISOR: 6" x 30" transparent, adjustable, left above driver only.

MUD FLAPS: Unit to have front and rear mud flaps.

FENDERS: Two rubber rear fenders.

NOISE REDUCTION: This will include acoustic ceiling and plywood floor in the front two sections. Reflective padding attached to underside of engine hood to reduce engine heat and noise.

PAINT: **White Roof,** Exterior; heat cured polyurethane.

PARTS LINE REPORT: A print out of the build sheet that includes part numbers.

SAFETY: Four push out windows and two Spheros roof hatches. 1" reflective tape at floor line.

CHILD REMINDER SYSTEM: Doran

SEATS:	Seat Belt Ready Frames
Seat/Driver	Air operated with fabric and high back w/tilt Left and right arm rests
Seat/Passenger	DOT seats with brown upholstery
Seat Space	No shorter than 26" min. knee space

1/9/2020

(PAGE 3)

SEATING: 4 wheel chair positions 18+4 with 2 open positions and 2 with seats upon delivery.

SIDE PANELS: Interior - Aluminized steel side walls with mar-resistant finish.

SOLENOID: Disconnects all body circuits when ignition is turned off.

STEPWELL: Slant three step entrance.

VENTILATION: Driver's fresh air vent with dash control and static roof vent.

WINDOWS: Tinted Split sash design with latches with aluminum frames **ONLY**.

WINDSHIELD: Flat laminated safety glass or one piece bonded/tinted.

WIPERS: Wet arm type. To be equipped with intermittent.

WIRING: Color and number coded. Protected by auto resetting circuit breakers. Accessible without removing windows.

HORN/ALARMS: Dual electric horn located away from wheel splash area. 112 dbs. Back up alarm.

SAFETY EQUIPMENT: Triangle kit with case mounted in driver's area. Fire extinguisher- 5 pound mounted in driver's area First Aid Kit as well as a bio-hazard kit mounted in driver's area.

PA's and RADIOS: AM/FM CD PLAYER /PA stereo WITH AUX PORT, 4 interior speakers flush mounted. To have one flush mounted PA speaker mounted in front of cab for PA system.

CAMERA: REI HD SERIES 8 camera system - WITH 320 GB HARD DRIVE, Four Cameras on both side walls with the 180degree cameras and One camera out the front

Two Way Communication Radio: Kenwood To be installed as part of bid.

Items to be priced separately:

Engine: Cummins Diesel, in line six configuration, 220 minimum H.P. Must have minimum of 600 ft. lb. gross torque minimum. Engine Warning system. 750 watt heater. High/low idle and cruise control.

One bus is to come with Cummins Quick Serve and Cummins Insite Subscription and Engine Diagnostics Equipment.

	Diesel w/insite & equipment	\$5,500.00
Seatbelts: 3- 3 point in every seat	3-pt belts included	
Disc Brakes: On Front and Rear Axles	Air disc brakes	\$2,400.00
Suspension: Without Air Ride	Delete air suspension	(\$ 650.00)

1/9/2020

SP: 27504 BBCV 2610, 48 CAP

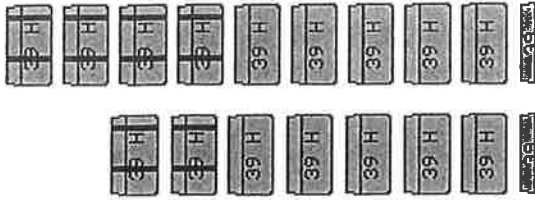

SP: 27504 BBCV 2610, 48 CAP

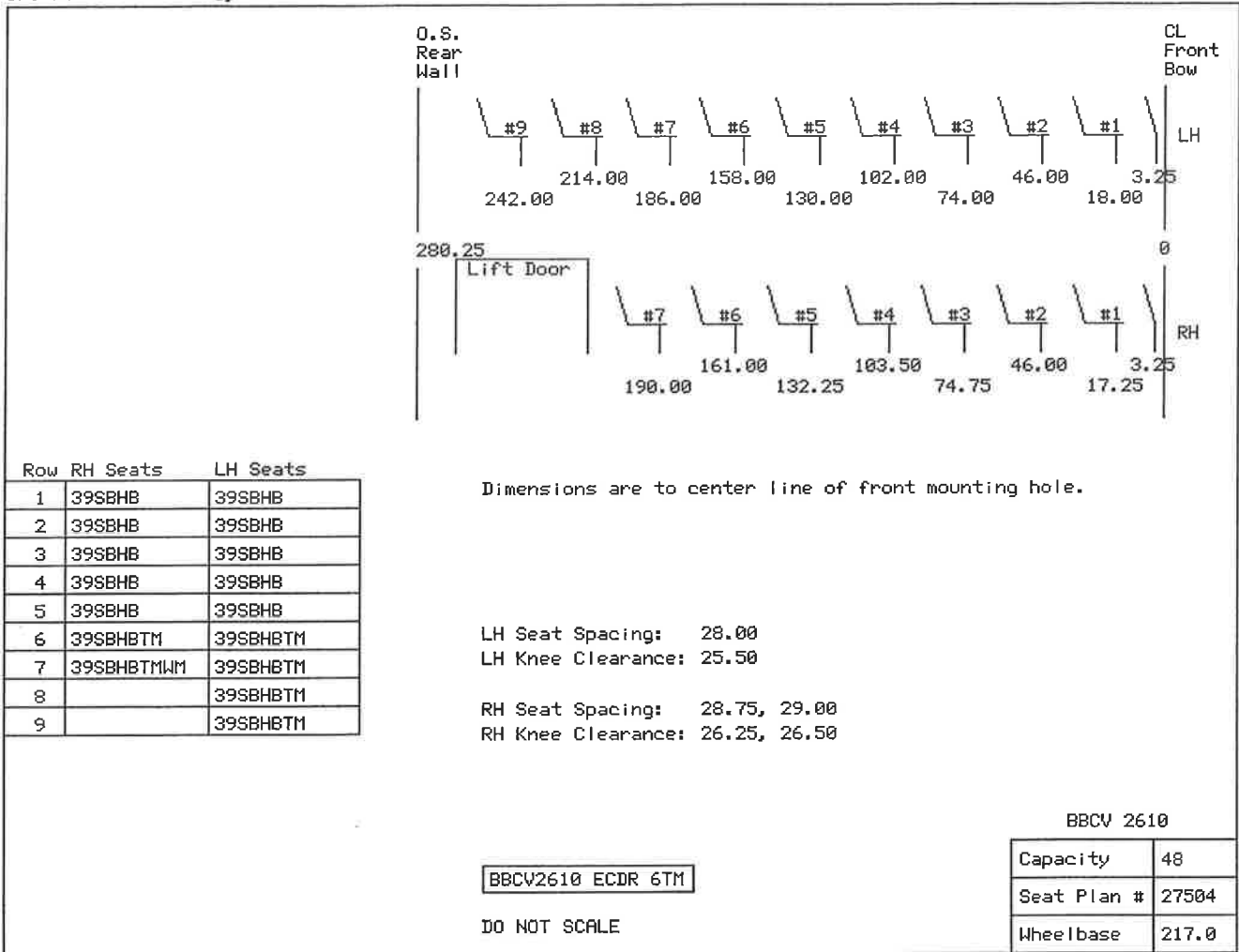



BLUE BIRD

Standard Limited Warranty

North America (U.S.A. & Canada)

Blue Bird Body Company (Blue Bird) warrants each bus to be free from defects in material and workmanship under normal use and service within the limits described below:

1. For a period of five (5) years/100,000 miles/160,000 kilometers, whichever occurs first from date of delivery to the original user, Blue Bird warrants the:
 - Chassis frame rails and cross-members to be free from defects in structural integrity (breaking or cracking).
 - Body shell (those structural metal components welded or riveted together forming floor, side walls, roof, front and rear sections) to be free from defects in structural integrity (breaking or cracking) including rust-through.
 - Interior and exterior paint adhesion to the body shell (those components forming side walls, roof, front and rear sections) and doors.
 - School bus seat frames and barrier frames to be free from defects in structural integrity (breaking or cracking).
 - Blue Bird emissions components not covered by the engine manufacturer conform with all U.S. federal emissions regulations at the time of manufacture and that they are free from defects in material or workmanship which would cause them not to meet the U.S. federal emissions regulations. Refer to the engine manufacturer's limited warranty statement for emissions warranty coverage by the engine manufacturer.
2. For a period of four (4) years/50,000 miles/80,000 kilometers, whichever occurs first from date of delivery to the original user, Blue Bird warrants the:
 - Front axle assembly, including king pins, I-beam, bushings and spindles, excluding brakes and axle ends.
 - Rear axle assembly and differential, excluding brakes and wheel ends.
3. For a period of three (3) years/36,000 miles/60,000 kilometers, whichever occurs first from date of delivery to the original user, Blue Bird warrants the:
 - Comfort Aire® Integrated air conditioner, if equipped, subject to annual service inspections.
4. For a period of two (2) years from date of delivery to the original user, Blue Bird warrants the:
 - School bus passenger and driver windows. Transit-style windows not included.
5. For a period of two (2) years/24,000 miles/40,000 kilometers, whichever occurs first from date of delivery to the original user, Blue Bird warrants the:
 - Suspension, excluding pins and bushings.
 - Driveshafts, support bearings and universal joints.
6. For a period of one (1) year/12,000 miles/20,000 kilometers, whichever occurs first from date of delivery to the original user, Blue Bird warrants:
 - All other components not covered in 1, 2, 3, 4 and 5 above, except engines, automatic transmissions, wheelchair lifts, non-Blue Bird air conditioners, tires, and batteries. The warranties of the engine, automatic transmission, wheelchair lift, non-Blue Bird air conditioners, tires, and batteries, are provided solely by, and are the responsibility of, those manufacturers and are not a part of Blue Bird's limited warranty.

Blue Bird's obligation covered in this limited warranty is limited to the repair or replacement of such parts as shall, under normal use and service, appear to have been defective in workmanship or material. This warranty is applicable to Blue Bird bus products, All American (AFE, A3RE, D3FE, D3RE) and Vision (BBCV), that are registered and operated in the United States of America, Canada, Puerto Rico, U.S. Virgin Islands, Guam, and American Samoa. The warranty period begins on the date the bus is delivered to the original user. During the warranty period, this warranty is transferable to subsequent Owners/Operators in U.S.A. or Canada.

THIS LIMITED WARRANTY IS EXPRESSLY IN LIEU OF ALL OTHER WARRANTIES EXPRESSED OR IMPLIED AND ALL OTHER OBLIGATIONS OR LIABILITIES. NO PERSON, INCLUDING SALESPERSONS, DEALERS, OR FACTORY REPRESENTATIVES OF BLUE BIRD, IS AUTHORIZED TO MAKE ANY REPRESENTATION OR WARRANTY CONCERNING BLUE BIRD PRODUCTS EXCEPT TO REFER PURCHASERS TO THIS LIMITED WARRANTY. BLUE BIRD MAKES NO WARRANTY OF MERCHANTABILITY OR FITNESS FOR A PARTICULAR PURPOSE. BLUE BIRD SHALL NOT BE LIABLE FOR INCIDENTAL OR CONSEQUENTIAL DAMAGES.

Contact your Blue Bird Dealer to obtain service for your Blue Bird bus. Your Blue Bird Dealer will help arrange for repairs by the Dealer or another qualified repair facility. Defects must be reported to a Blue Bird Dealer immediately upon discovery of the defect and within the warranty period as stated herein. Defects must be repaired immediately upon discovery of the defect and within the warranty period as stated herein. Unless authorized by the Blue Bird Dealer, repairs under this limited warranty are to be performed by the Blue Bird Dealer. It is the responsibility of the Owner/Operator to return the bus to the Blue Bird Dealer, or qualified repair facility authorized by the Blue Bird Dealer for warranty repairs. All claims for warranty repairs by other than the Blue Bird Dealer must be received by the Blue Bird Dealer not later than 30 days after the repair date. The owner/operator is responsible for operating and maintaining the bus as described in the Operator's and Service Manuals. All maintenance records should be retained by the owner/operator. Your Blue Bird Dealer will register the bus with Blue Bird and can assist with registering components that are warranted by the component manufacturers.

Limitations & Exclusions

In addition to the limitations described on the previous page, items specifically not covered include but are not limited to:

- Engines, automatic transmissions, wheelchair lifts, air conditioners (other than Blue Bird ComfortAire® system), tires, and batteries. The limited warranties for these components are provided solely by and are the responsibility of those manufacturers and are not a part of Blue Bird's limited warranty.
- Loss of use and incidental consequential expenses, including but not limited to commercial loss, loss of commercial fares, driver time or pay, lease or rental of substitute vehicle, storage, lodging, meals, telephone calls and other travel costs.
- Wear, wear-out and consumption. This warranty shall not apply to any parts or components which must be repaired, replaced or adjusted during the warranty period that are due to wear, wear-out or consumption, including but not limited to brake pads and linings, drums and rotors, wiper blades, light bulbs, filters, lubricants, fluids, belts, bearings other than those specifically covered by the limited warranty, suspension pins and bushings, batteries, worn seat covers, worn stepreads and floor covering, worn door and window seals, discharged fire extinguishers, damaged (scratches, cracks) gauge and light lenses, and tires. Wear not only include friction-type wear but can also include environmental deterioration including but not limited to surface corrosion on exhaust pipes/clamps and brake drums/rotors, as well as fading, cracking or discoloration of seat covers caused by U.V.
- Maintenance including but not limited to tightening loose fasteners, axle & wheel alignments, wheel-balancing, tightening body tie-downs, door adjustments, tightening hose clamps, and sealing/caulking windows, doors, panels, hatches and lights.
- This warranty shall not apply to any parts or components which must be repaired, replaced or adjusted during the warranty period as a result of accident damage, abnormal operation, misuse and/or abuse, including but not limited to excessive operation on unpaved, un-maintained roads, operation on cross-country trails or off-road conditions, collision, fire, vandalism, explosion, objects striking the vehicle, theft, freezing, riot, flood.
- Paint adhesion failures resulting from abrasions, atmospheric conditions, road chemicals, caustic detergents/cleaners, and/or improper maintenance. Paint adhesion failures, whether warrantable defects or non-warrantable events, that are not repaired immediately upon discovery of the failure may deteriorate the finish and/or panels underneath. Surface corrosion and/or other progressive deterioration as a result of not repairing paint failures immediately is not covered by this warranty.
- If dealers or customers have any vehicle modifications or equipment installations performed without the written approval of Blue Bird, to the extent the modifications or equipment installations adversely affect other vehicle components or performance, Blue Bird shall not accept any product liability or claims under the terms of the limited warranty. These claims become the sole responsibility of the company performing the modifications and/or installations.
- Transportation expenses to deliver the bus to a Blue Bird Dealer or nearest qualified repair facility, including but not limited to fuel, driver time/pay, mileage and towing.
- Repairs to parts or components which have been previously replaced with parts not obtained from Blue Bird or failures caused by non-Blue Bird parts or components. Rework of repairs not performed by or approved by a Blue Bird Dealer.
- Excessive labor hours, premium labor costs, overtime labor costs, local taxes. This limited warranty covers reasonable labor to perform replacement or repair.
- Defects not reported to a Blue Bird Dealer and repaired during the warranty period. Repairs are to be made immediately upon discovery of the defect.
- Damage caused by using improper or contaminated fluids, including but not limited to fuels, lubricants and coolant. Damage caused by using fluids that do not meet Blue Bird's or the Manufacturers' minimum recommendations. Damage caused by the lack of fluids and/or improper fluid maintenance.
- Using non-Blue Bird service parts. Usage of non-Blue Bird parts will affect future warranty coverage.
- Overloading beyond the normal seated and standee capacity voids all warranties.

Blue Bird reserves the right to make changes in design and changes or improvements upon its products without imposing any obligations upon itself to install the same upon products theretofore manufactured. Any suit alleging a breach of this limited warranty or of any other alleged warranty, including any claim for rescission or revocation of acceptance, must be filed within one year of breach.

Controlling Law and Severability

This Limited Warranty shall be governed by and construed in accordance with the laws of the State of Georgia, U.S.A. The owner/operator agrees and consents to the exclusive jurisdiction of the courts of the State of Georgia for all purposes regarding this Limited Warranty and further agrees and consents that venue of any action involving this Limited Warranty or any other alleged warranty, including any claim for rescission or revocation of acceptance, shall be exclusively in Peach County, Georgia. Owner/Operator hereby submits to personal jurisdiction in Peach County, Georgia and waives any objection or argument related to venue, personal jurisdiction, forum non conveniense, and/or transfer. If any portion hereof is found to be void or unenforceable, the remaining provisions of the Limited Warranty shall remain in full force and effect.

✓ INVITATION TO BID

- ✓ The Hickman County Finance Office is accepting sealed bids for school bus units. Bids for up to Two (2) conventional Thirty Nine (39) passenger Type C Special Equipped School Bus. Specifications and bid requirement may be obtained from Steven George, Director of Transportation, Hickman County Schools at 931-729-3391, Ext. 2241. Email: steven.george@hickmank12.org

- ✓ Sealed bids must be mailed or delivered to the Hickman County Finance Office, 114 North Central Avenue, Suite 203, Centerville, TN 37033 and clearly marked on the outside of the bid envelope “School Bus Units.” Bids will be opened on
February 3 at 10:15am
at the Finance Office. The Hickman County Board of Education reserves the right to accept or reject any and all bids or parts of bids and to waive any informalities that would prevent acceptance of a better bid.

BID RESULTS REQUEST

Dear School:

I apologize that my schedule did not allow me to attend today's bid opening.

May I please have the bid results returned to me sent via email, or fax?

My contact information is below.

EMAIL: AScurlock@CLTTE.com

Fax: 615-844-5326

Thank you so much and I appreciate your help,

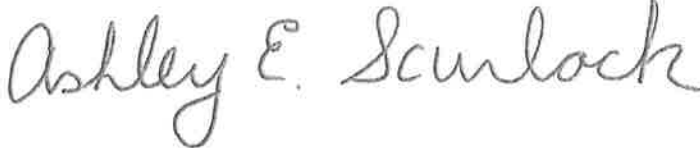

Ashley E. Scurlock

Bus Account Manager

Cumberland

1901 Lebanon Pike

Nashville, TN 37210

Cell Phone 615.598.3572

My fax line: 615-844-5326

Main Fax line: 615-829-7859

AScurlock@CLTTE.com



HICKMAN COUNTY BOARD OF EDUCATION
 115 MURPHREE AVENUE
 CENTERVILLE, TN 37033
 931-729-3391

- ✓ BID OFFER FOR UP TO TWO (2) CONVENTIONAL Thirty Nine (39) PASSENGER SPECIAL EQUIPPED SCHOOL BUSES
- ✓ TO THE HICKMAN COUNTY BOARD OF EDUCATION, CENTERVILLE, TENNESSEE:
- ✓ IN RESPONSE TO YOUR INVITATION, MY COMPANY SUBMITS THE FOLLOWING BIDS ON SCHOOL BUS. THE SCHOOL BUS SPECIFICATIONS REQUIRED BY THE TENNESSEE STATE BOARD OF EDUCATION, AND BY YOU, AND THE CONDITIONS SET FORTH IN YOUR BID INVITATION ARE CLEARLY UNDERSTOOD AND ARE COMPILED WITHIN THIS BID.

- A. MAKE IC Bus MODEL & NUMBER IC Bus PB105, CE 18+4 SPED
- B. BID PRICE DELIVERED F.O.B. CENTERVILLE, TENNESSEE MOUNTED AND FULLY EQUIPPED AS SPECIFIED.

NUMBER OF BUSES	SEATING CAPACITY	UNIT PRICE	TOTAL
<u>1 or more</u>	<u>18+4 Special Needs</u>	<u>\$112,028.00</u>	<u>\$224,056 for two</u>
_____	_____	_____	_____
_____	_____	_____	_____
TOTAL BIDS ON ALL			<u>\$224,056 for two</u>

INVOICE TO BE PAID IN FULL UPON COMPLETION AND PASSING INSPECTION BY STATE OF TENNESSEE.

SIGNED Ashley E. Scurlock
 Bus Account Manager
 TITLE
Cumberland International Trucks, Inc.
 COMPANY
1901 Lebanon Pike, Nashville, TN 37210
 ADDRESS
 DATE: Monday, February 3, 2020

Delivery Date: 180 days ARO (Must be specific)

1/9/2020

SCHOOL BUS SPECIFICATIONS

UNIT MUST MEET ALL STATE AND FEDERAL SPECIFICATIONS. PLEASE NOTE ANY DEVIATIONS BESIDE THE RESPECTIVE DESCRIPTION. ALL DEVIATIONS WILL BE CONSIDERED.

WARRANTIES: Towing to be included for life of all applicable warranties. ✓
Three Year Bumper to Bumper ✓
Power Train Five year or 100,000 mile warranty ✓

CHASSIS MINIMUM REQUIREMENTS

ALTERNATOR: Must be a 240 amp minimum, 12 volt. May need to be a 325 for AC

- ✗ **AXLES:** Front: 12,000 # rating minimum, "I" beam type. Rear 23,000 Minimum. Both axles made by same manufacturer. 10,000 front and 21,000 rear
- ✗ **BATTERIES:** 2100 CCA Minimum. Double 00 gauge battery cables. Battery 1980 (3) CCA Batteries compartment to have a sliding tray with stop. **With cutoff switch in battery box**
- ✓ **BRAKES:** Dual air with Bendix anti-lock system, Front: - 16.5" x 5" x 7/8" thick, Rear: -16.5" x 7" x 7/8" thick. Air compressor to be 13.2 CFM min. Three air tanks provided with total capacity of 4,760 cu. In Bendix AD-9 air dryer.
- ✓ **BUMPERS:** Minimum of 12" after forming front and rear steel plate bumpers. The rear bumper shall have a 14" wrap-around. Front and rear bumpers must be bolted not welded to frame with grade 8 bolts.
- ✗ **ENGINE:** Ford 6.8L Propane Engine w/5yr Unlimited mile warranty. PSI Engine
- ✓ **FRAME:** Must be one piece. No frame extension. Completely painted for rust and corrosion protection. 50,000 psi minimum.
- ✗ **EXHAUST:** Max NOx allowed .05. **To exit rear of bus thru the bumper.** NOx .13 below federal requirement of .20 Eligible for VW grant funding
- ✗ **FUEL TANK:** 100 gal. Min. Sender inspection access plate. ~~Fuel system must include 2 fuel/water separators. One spin-on type at the engine and a second filter element with see-through bowl and self-venting drain. Fuel tank to have heat shields if within 12 inches of exhaust system.~~ **Must have Interlock System, 5yr. unlimited mile warranty.**
- ✓ **GAUGES:** Seven digit speedometer/odometer, fuel, voltmeter, oil pressure, tachometer, hour meter, coolant temperature, dual air brake gauges.
Warning systems to include: low air pressure light and buzzer, high temp./low oil pressure light and buzzer, low coolant light.
- ✓ **SAFETY:** Electronic Stability Control installed. Meet Colorado Rack and Kentucky Pole Test and show certification.
- ✓ **SHOCKS:** Air Ride Suspension System front and rear. Dual action piston type: two front and two rear required. 1 3/4" bore.
- ✓ **STEERING:** Tilt wheel. Full power

1/9/2020

(PAGE 2)

✗ **TIRES:** Tubeless radial tires as needed 11R x 22.5; 16 ply rating highway. Low profile tires for flat floor

✓ **TOW HOOKS:** Unit to be equipped with tow hooks. 2 front; 2 rear.

✗ **TRANSMISSION:** Ford 6R140 6spd Automatic Transmission w/5yr unlimited mile warranty, cooling accomplished by an oil cooler mounted external from transmission, minimum capacity 1,530 BTUs per minute with external spin-on filter. Allison Transmission with 7 year warranty

✓ **WHEELS:** HUB ALIGNED 22.5 x 8.25, painted black.

✓ **WIRING:** Color and number coded. Protected by blade type fuses. Resistant to heat, abrasion, and solvents. Resettable circuit breakers per wiring request on the bid

BODY REQUIREMENTS

✓ **A/C SYSTEM:** MINIMUM 120,000 BTU

✗ **COMPARTMENTS:** Storage compartment to be located over windshield area. Add glove box at door in dash. Add padded arm rest with storage. Driver storage to the right of the driver

✓ **CONSTRUCTION:** Body parts must be treated with zinc coating after fabrication and before assembly. Entire body surface including the floor construction shall meet FMVSS 221 in all joints.

✓ **FLOOR:** Shall be 14 gauge heavily galvanized steel. They shall be welded and riveted at reinforcements. These main floor cross-members must be full width to outer sheet metal on each side of body for maximum collision protection. IC Bus construction meets and exceeds all FMVSS

✓ **ROOF BOWS:** 14 gauge hat-shaped roof bows one piece from floor overhead to floor on the other side shall be used. Bows shall end upon floor overhead to floor on the other side shall be used. Bows shall end upon floor at each side for maximum rollover strength. IC Bus construction meets and exceeds all FMVSS

✓ **BODY SHEET METAL:** Four 16 gauge applied rub rails plus one embossed for a total of five. Embossed rain visor over each window. Skirts to be 16 ¼" measured from the floor level. These rails to be riveted to structured bows and side panels with buck rivets. Body shall be fully undercoated, under floor, skirt panels and wheel wells prior to mounting on chassis. Rain visors to be embossed in roofing sheet metal over each window. These roof sheets shall be one piece from window top to window top on the other side for maximum strength. They shall be double lapped and secured with two rows of rivets for additional strength. No rain visors and IC Bus meets and exceeds all FMVSS

✓ **CROSSING ARM:** Front bumper crossing arm equipped **to be air operated**

✓ **STOP SIGN:** To be air operated

✓ **DOORS:** Entrance: Outward opening door, air operated with Kentucky switch. 30" full opening and 1,500 sq." of glass area. Stainless steel grab rail. Black hand rail
Rear emergency 36" x 51" to have upper and lower glass. Retainer to hold door open. **Rear door to have red stop warning lighted sign in center of door AKA rear motorist alert sign.**

1/9/2020

(PAGE 3)

- ✓ **FLOORING:** Black rubber flooring with white colored nosing on each step. Molded rubber covers required over front and rear interior wheel-housings. Rounded rustproof molding to be installed where floor meets wall on each side.
- ✓ **HEADROOM:** Interior headroom to be 77" full length of bus.
- ✓ **HEATERS:** 90,000 BTU front heater/defroster, 80,000 BTU rear heater **mounted behind rear wheels.** Two 6" dash fans. Front heater to have removable filter. Rear heat with filter
- ✓ **INSULATION:** 1 ½" thick fiberglass in roof, front, and rear. 1 ½" mineral wool blanket type insulation on sides to insure vertical integrity.
- ✓ **IDENTIFICATION:** School system name 6" HICKMAN COUNTY SCHOOLS & 6" Numbers Front - Rear and sides
- ✗ **LIFT DOOR:** Lift door to be mounted in the rear providing 43" wide opening. Lift must be by Ricon model, meeting the most recent standards Braun lift
- ✓ **LIGHTS:** Warning light system meeting current federal specifications. All red overhead and stop arm lights to be strobe LED lights. Side directional lights mounted on right and left. 5" back up lights, 7" tail lights. Warning lights to be hooded. Roof strobe with guard. Interior lights: Step well light and dome lights. **All lights to be LED**
- ✓ **MIRRORS:** Interior: 6" x 30" non-glare, adjustable. Exterior: Heated mirrors meeting federal and state standards. **Student Mirror: to have rear view camera built in.**
- ✓ **SUN VISOR:** 6" x 30" transparent, adjustable, left above driver only.
- ✓ **MUD FLAPS:** Unit to have front and rear mud flaps.
- ✓ **FENDERS:** Two rubber rear fenders.
- ✓ **NOISE REDUCTION:** This will include acoustic ceiling and plywood floor in the front two sections. Reflective padding attached to underside of engine hood to reduce engine heat and noise.
- ✓ **PAINT:** **White Roof,** Exterior; heat cured polyurethane.
- ✓ **PARTS LINE REPORT:** A print out of the build sheet that includes part numbers.
- ✗ **SAFETY:** Four push out windows and two Spheros roof hatches. 1" reflective tape at floor line.
Specialty Brand
- ✓ **CHILD REMINDER SYSTEM:** Doran No Child Left Behind System

- | | |
|------------------|---|
| SEATS: | Seat Belt Ready Frames |
| ✓ Seat/Driver | Air operated with fabric and high back w/tilt
Left and right arm rests |
| ✓ Seat/Passenger | DOT seats with brown upholstery |
| ✓ Seat Space | No shorter than 26" min. knee space |

(PAGE 3)

- ✓ **SEATING:** 4 wheel chair positions 18+4 with 2 open positions and 2 with seats upon delivery.
- ✓ **SIDE PANELS:** Interior - Aluminized steel side walls with mar-resistant finish.
- ✓ **SOLENOID:** Disconnects all body circuits when ignition is turned off.
- ✗ **STEPWELL:** Slant three step entrance. No slant
- ✓ **VENTILATION:** Driver's fresh air vent with dash control and static roof vent.
- ✓ **WINDOWS:** Tinted Split sash design with latches with aluminum frames **ONLY**.
- ✗ **WINDSHIELD:** Flat laminated safety glass or one piece bonded/tinted. 4 piece windshield roped in
- ✓ **WIPERS:** Wet arm type. To be equipped with intermittent.
- ✓ **WIRING:** Color and number coded. Protected by auto resetting circuit breakers.
Accessible without removing windows.
- ✓ **HORN/ALARMS:** Dual electric horn located away from wheel splash area.
112 dbs. Back up alarm.
- ✓ **SAFETY EQUIPMENT:** Triangle kit with case mounted in driver's area. Fire extinguisher- 5 pound mounted in driver's area First Aid Kit as well as a bio-hazard kit mounted in driver's area.
- ✓ **PA's and RADIOS:** AM/FM CD PLAYER /PA stereo WITH AUX PORT, 4 interior speakers flush mounted. To have one flush mounted PA speaker mounted in front of cab for PA system.
- ✓ **CAMERA: REI HD SERIES 8 camera system - WITH 320 GB HARD DRIVE, Four Cameras on both side walls with the 180degree cameras and One camera out the front**
- ✓ **Two Way Communication Radio: Kenwood** To be installed as part of bid.
- ✓ **Items to be priced separately:**
 - Engine: Cummins Diesel**, in line six configuration, 220 minimum H.P. Must have minimum of 600 ft. lb. gross torque minimum. Engine Warning system. 750 watt heater. High/low idle and cruise control.
One bus is to come with Cummins Quick Serve and Cummins Insite Subscription and Engine Diagnostics Equipment. Save \$10,000.00
- ✓ **Seatbelts:** 3- 3 point in every seat \$10,000
- ✓ **Disc Brakes:** On Front and Rear Axles \$3,000.00
- ✓ **Suspension:** Without Air Ride Save \$100.00

1/9/2020

Power Solutions International

Powering a Greener Future



PSI

8.8L PSI Low-speed | Specification Sheet

Displacement: 535cid (8.767 liters)

Compression Ratio: 10:1

Bore x Stroke: 4.350" (110.5 mm) X 4.500" (114.3 mm)

Power: Gas-LS: 270 hp (201 kW) @ 2600 rpm

Gas-HS: 501hp (374 kW) @ 4400 rpm

LP-LS: 270 hp (201 kW) @ 2600 rpm

CNG-LS: 235 hp (175 kW) @ 2600 rpm

Torque:

Gas-LS: 565 lb-ft (766 Nm) @ 1500 rpm

Gas-HS: 650 lb-ft (881 Nm) @ 3700 rpm

LP-LS: 565 lb-ft (766 Nm) @ 1500 rpm

CNG-LS: 495 lb-ft (671 Nm) @ 1500 rpm



Fuel Agnostic

Common Controls



Low Speed (LS) Torque

or

High Speed (HS) Power

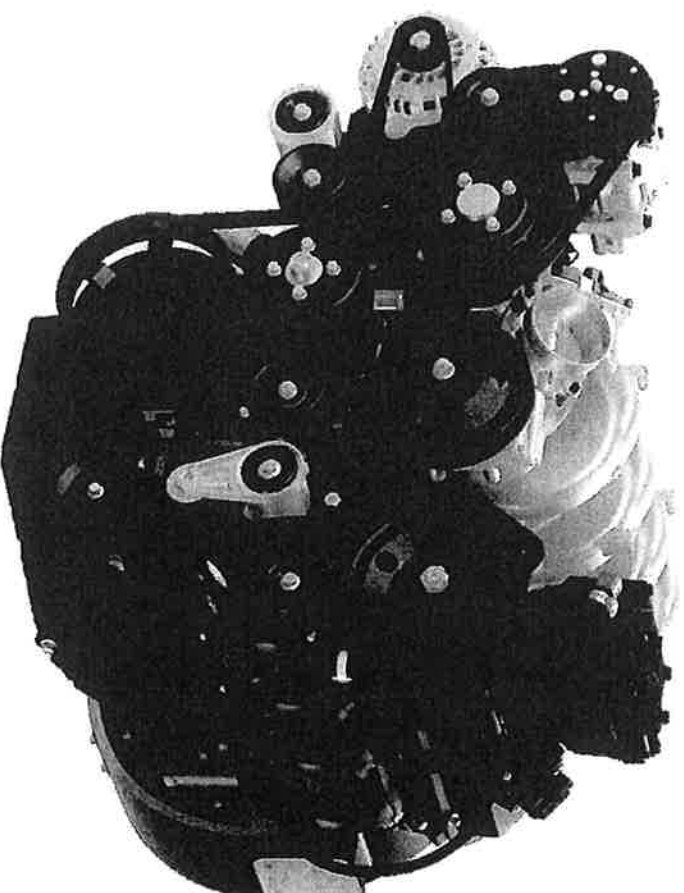

Compatible with

Allison 1000/2000/3000
transmissions

PSI

8.8L Base History

Industrial

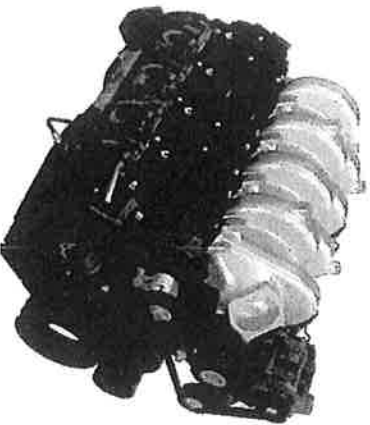

On-Highway



Major Improvements over GM 8.1L



Heads



Crankshaft



Intake

Transmission Compatibility

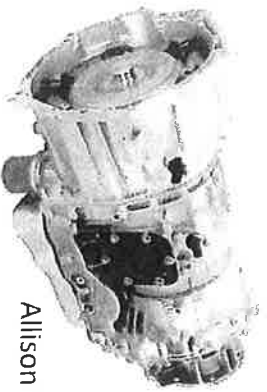

Allison 1000/2000

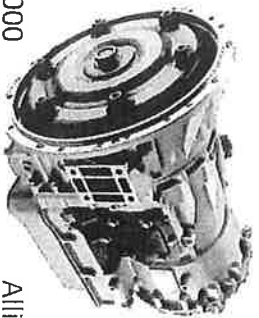

Allison 3000+

Production:

Job one:

Jan 2013

Present Build:

8-10 units per day.

Capacity:

50 units per day.

Produced to date:

2300 units (as of Jan 2014)

Engine Specs:

Displacement:

535cid (8.767 liters)

Compression Ratio:

10:1

Bore x Stroke:

4.350" (110.5 mm) X 4.500" (114.3 mm)

Improvements over GM 8.1L:

Cylinder Heads

Modernized, heavy-duty, high-low heads create fast burn to improve efficiency and reduce emissions.

Crankshaft

Forged and induction hardened steel crankshaft creates durable block capable of 1,000 ft-lb of torque

Intake Manifold

Tuned long-runner provides higher torque while special air gap design keeps engine air cooler to improve efficiency

Camshafts

Optimized camshafts for both low-speed and high speed engine operation to ensure customer expectations are met

PSI

8.8L Configuration for CE Bus

Leece Neville Pad Mount Alternator
(Standard: 320A, Options: 190-240A)

Ixetic Power Steering
Pump (LF72A)
(21 cc/rev, 160 bar)

Bendix
Tu-flo 550 Kit
(12 SCFM)

Custom
Wiring
Harness

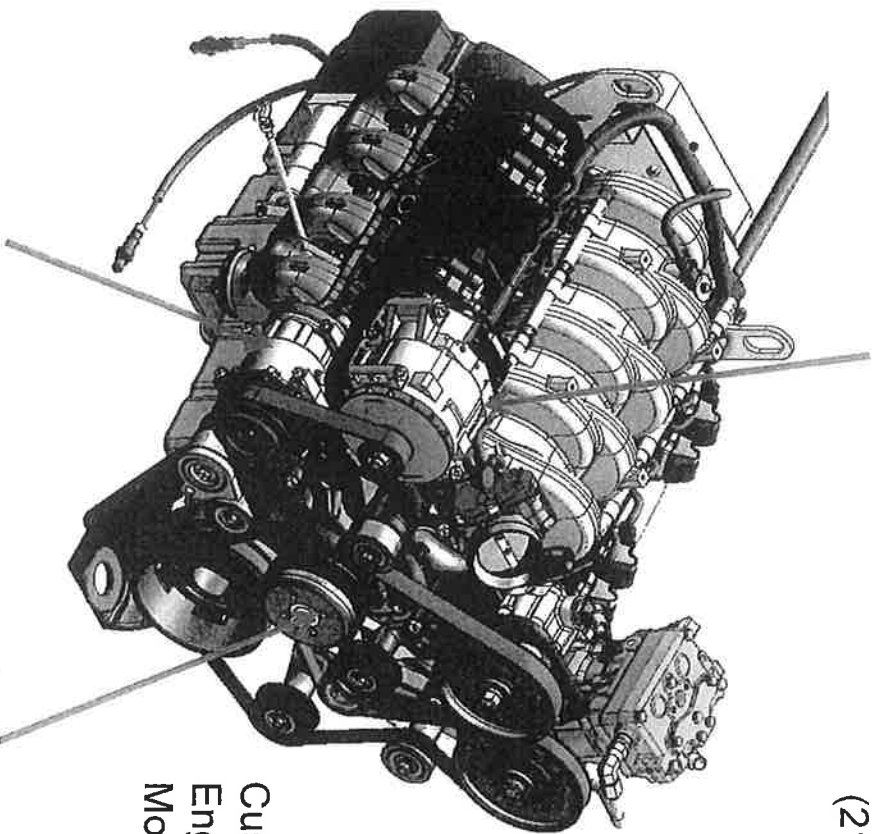

Custom
Engine
Mount

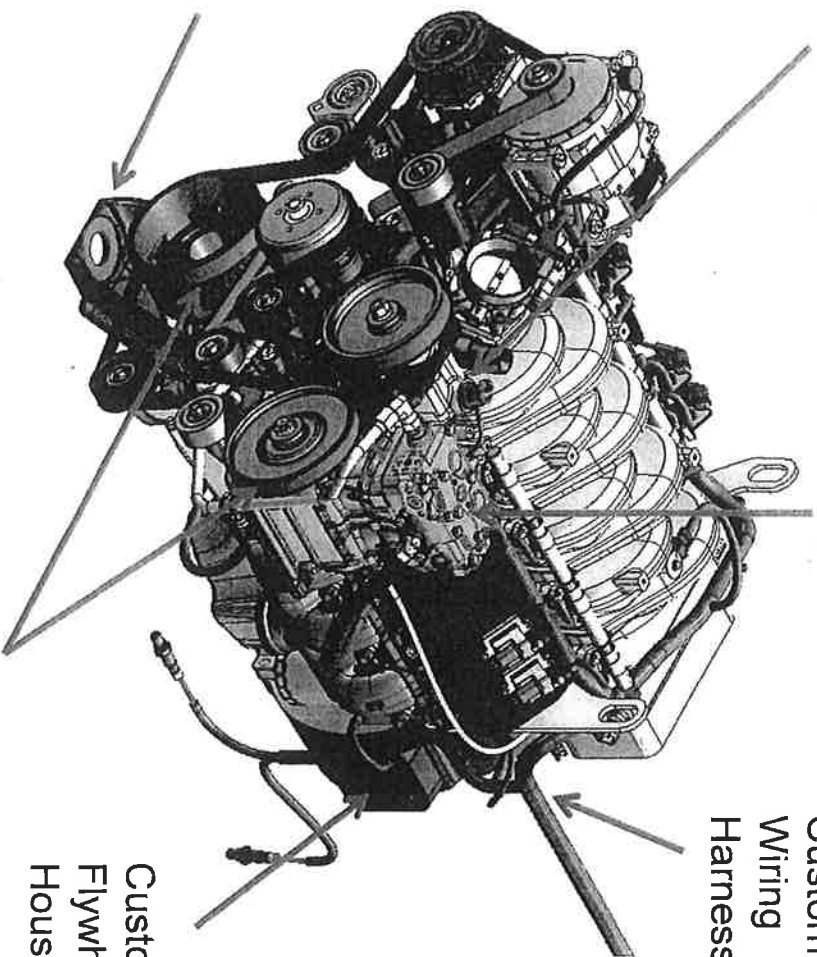

Custom
Flywheel
Housing

8-groove outer
6-groove inner

TCCL A/C Compressor
(165cc)

25" Borg Warner Fan
Borg Warner Air Sense Viscous Clutch



8.8L Propane Tank System for CE Bus

Sleepers 67.5 Gallon Tank System
with integrated pumps, valves, filters

NFFPA
Pressure Relief System
(Puffer)

Biphase
Liquid Propane Delivery Module
(LPDM)

Navistar
Fuel Fill System

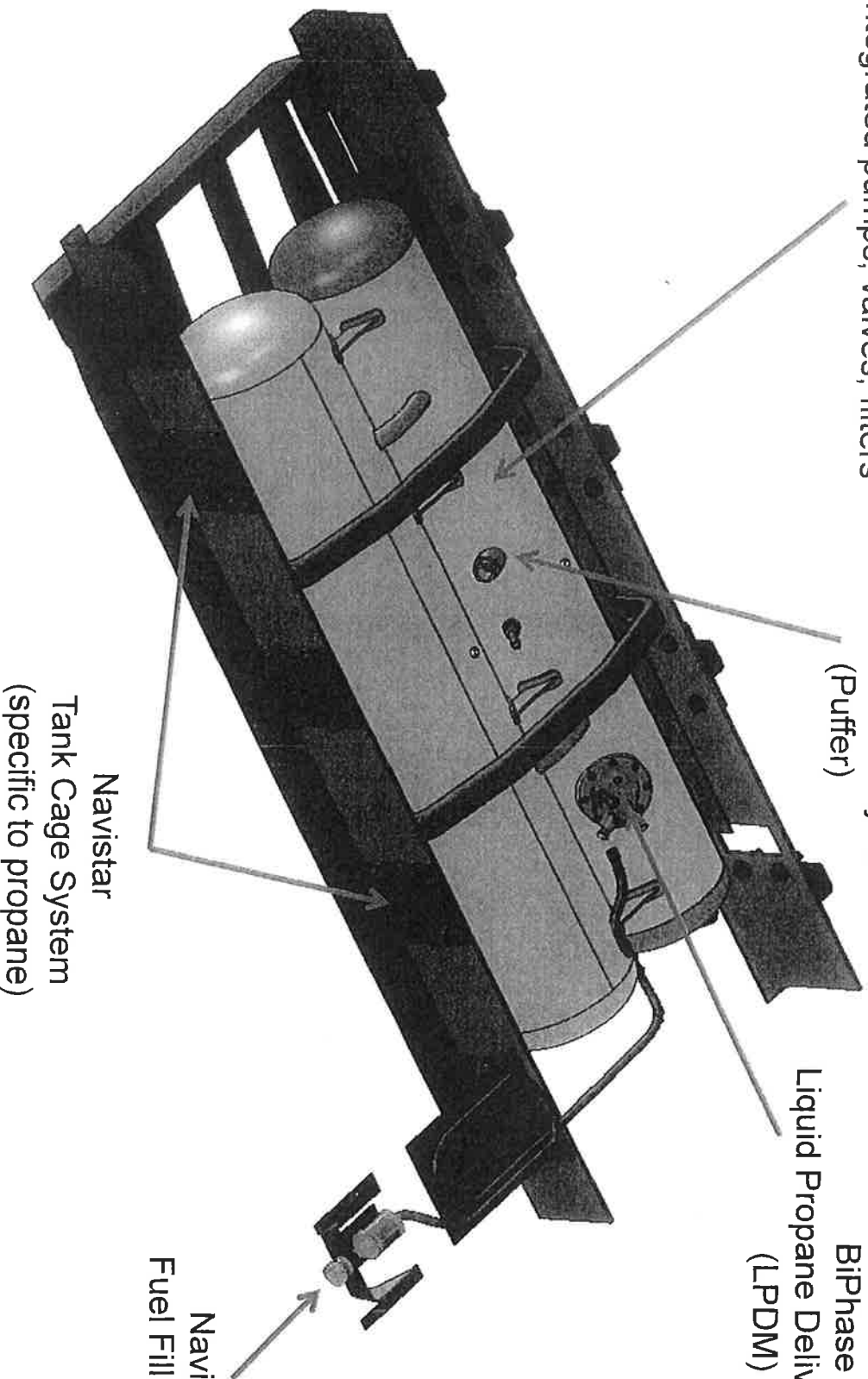

Navistar
Tank Cage System
(specific to propane)

PSI

Control Strategy

MT88 V-8 Controller

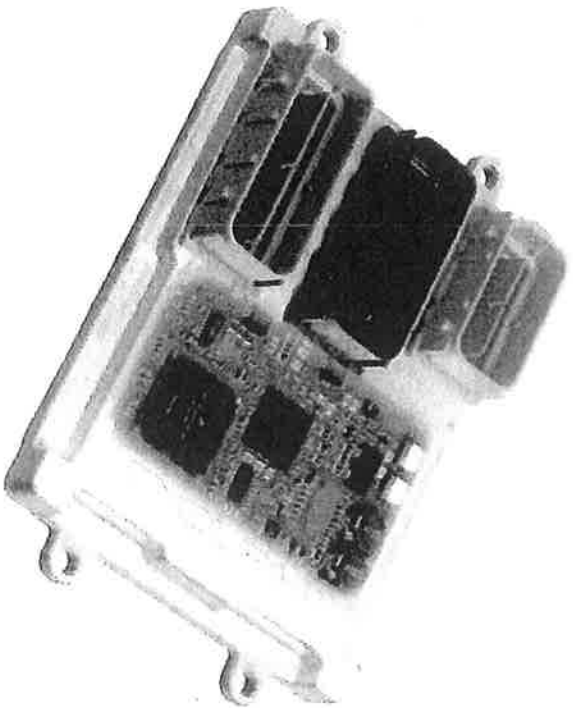

- **Certified System Software (Delphi)**
- State of the Art Torque-based controls
- Full OBD-HD Compliance
- Opportunity for customer proprietary features
- J1939 Communication
- 5-year exclusive relationship

PSI Capabilities

- Proprietary software using Delphi core
- Partnered with world class partners (e.g. Ricardo)
- In-house Engineering & Test Capabilities
 - 50+ engineers on staff and growing
 - Full CAD, CAE, CFD analysis
 - Emissions & performance calibration
- Application engineering
- Internal dyno test capabilities (2014)

mastertrak[®]
ADVANCED TELEMATICS SOLUTIONS



Technical Comparison

	PSI 8.8L V-8	Cummins ISB6.7L	GM / PI 8.0L V-8	Ford 6.8L V-10
Displacement	8.8L	6.7L	8.0L	6.8L
Horsepower	270 hp @ 2600 RPM	240 hp @ 2400	350 hp @ 4000	362 hp @ 4750
Torque	565 lb-ft @ 1500 RPM	560 lb-ft @ 1600	500 lb-ft @ 3100	457 lb-ft @ 3250
Bore / Stroke	4.35" X 4.50"	4.21" x 4.88"	4.27" x 4.25"	3.55" x 4.17"
Compression Ratio	10:1	17.3:1	9.6:1	9.2:1



Performance Comparison

Propane Torque Comparison

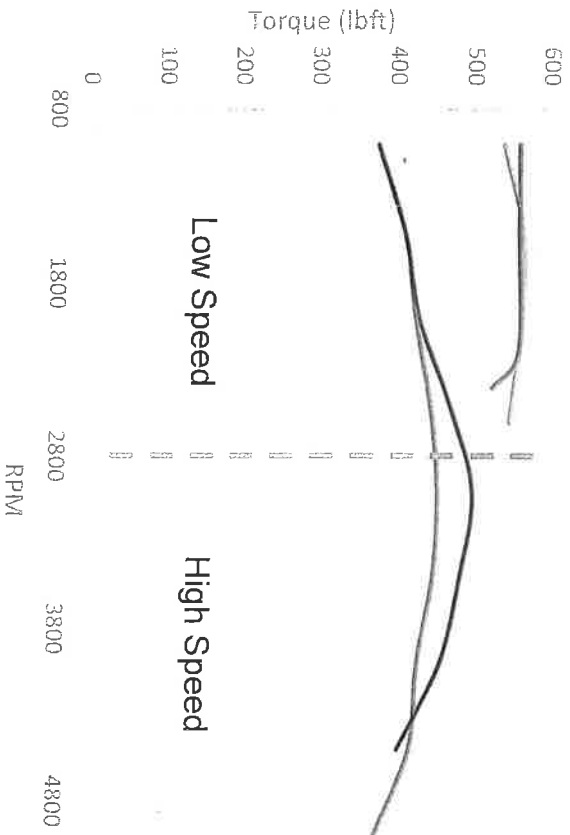

Propane Power Comparison

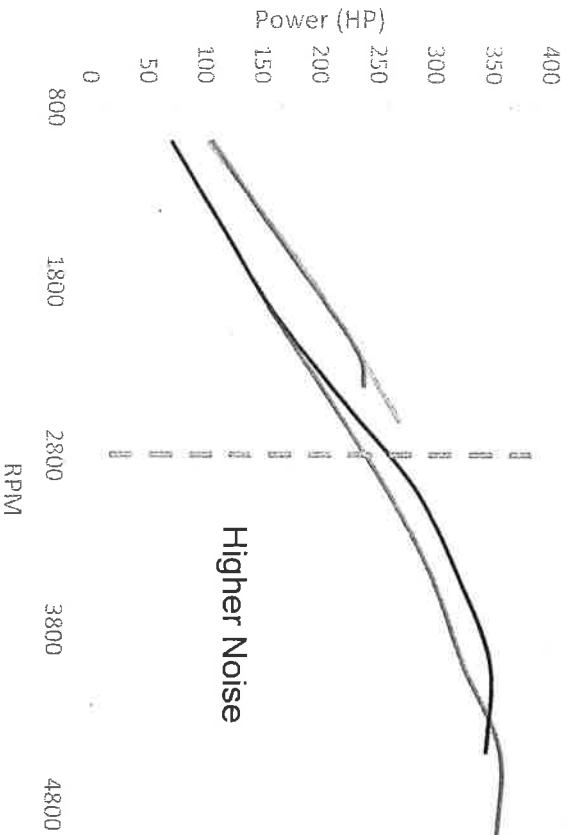

CE Series Bus Engine

ISB 240hp/560 lb-ft selected for Comparison



General Data

- ❏ MOR for all engines (CARB/EPA)
- ❏ Dedicated Application Engineering
- ❏ Common Controls Platform
- ❏ 5 Year, 100,000 Mile Engine Warranty Coverage
- ❏ Customer solutions focused
 - Parts
 - Dealer/Service training
- ❏ Advanced Engineering, Design and Test Capabilities
 - CFD, FEA, Engine Testing Lab
- ❏ Global Sourcing & Supply Chain
- ❏ Service & Warranty
 - Administered via Navistar systems
 - Leverage PSI Diagnostic Service Tool through Navistar dealers
- ❏ Integrated Telematics available

Powering a Greener Future



DIESEL & PROPANE
8.8L V-8

PURPOSE BUILT FOR THE SCHOOL BUS INDUSTRY

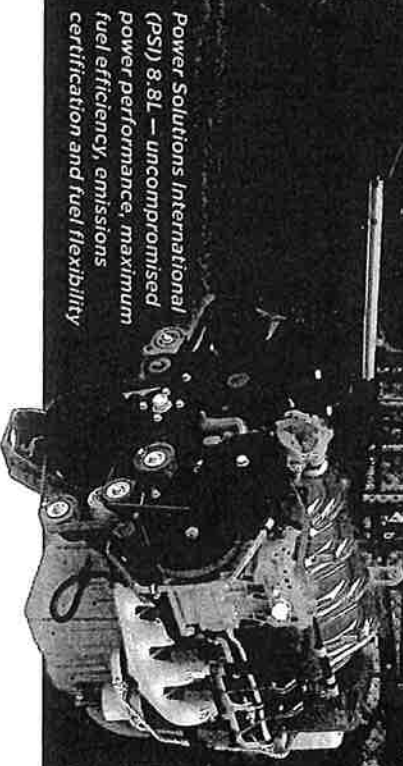

Power Solutions International (PSI) 8.8L — uncompromised power performance, maximum fuel efficiency, emissions certification and fuel flexibility



DEVELOPED FROM THE BLOCK UP TO
BE RELIABLE AND DURABLE

HEAVY-DUTY DESIGN

- Forged, induction-hardened crankshaft
- Forged rods and pistons
- Oil bath lubrication provides piston cooling
- Low engine-speed design produces less noise, heat and wear than competitor gasoline and propane engines

SERVICEABLE

- Both the engine compartment and engine provide best-in-class accessibility for easy maintenance
- Includes the industry's only one-stop warranty for gasoline and propane vehicles
- Allison Transmission 7-year/Unlimited mileage warranty
- Industry's broadest, most capable parts distribution and dealer network

ALLISON TRANSMISSIONS

- Shorter, sturdier shaft has increased durability vs. Ford
- Over 44% more clutch material vs. Ford so it holds gear and lasts longer in the toughest operation
- Heavy-duty park pawl better secures vehicle
- Same transmission used across all IC Bus[®] powertrains for ease of maintenance

POWER OF CHOICE

- Gasoline and Propane versions use same engine block providing an easy solution for mechanics and drivers of mixed fleets
- Gasoline and Propane make cold weather startup easy
- Upfront cost is lower for gasoline compared to diesel



CYLINDER HEADS

Modernized, heavy-duty, high-flow heads create fast burn to improve efficiency and reduce emissions



CRANKSHAFT

Forged and induction-hardened steel crankshaft creates durable block capable of 1,000+ ft-lb of torque



INTAKE MANIFOLD

Tuned long-runner provides higher torque and special air gap design keeps engine air cooler for improved efficiency

ENGINE COMPARISON: IC BUS® VS. BLUE BIRD

PSI 8.8L V-8

FORD 6.8L V-10

IC BUS VS	Gasoline	Propane
Displacement	8.8L	8.8L
Rated Horsepower	265 hp @ 2600	270 hp @ 2600
@ 1000 RPM	95 hp	103 hp
@ 2000 RPM	202 hp	215 hp
Rated Torque	548 lb.-ft. @ 1800	565 lb.-ft. @ 1500
@ 1000 RPM	500 lb.-ft.	540 lb.-ft.
@ 2000 RPM	530 lb.-ft.	564 lb.-ft.
Bore / Stroke	4.35" x 4.50"	4.35" x 4.50"
Compression Ratio	9.1:1	10:1

RPM / HORSEPOWER

The PSI 8.8L low engine speed design drives like a diesel, with no compromise on engine power and reliability.

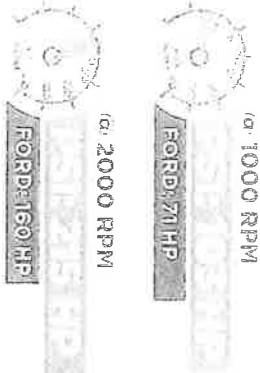

FORD 6.8L V-10	PROPANE
Displacement	6.8L
Rated Horsepower	362 hp @ 4750
@ 1000 RPM	71 hp
@ 2000 RPM	160 hp
Rated Torque	457 lb.-ft. @ 3250
@ 1000 RPM	375 lb.-ft.
@ 2000 RPM	420 lb.-ft.
Bore / Stroke	3.55" x 4.17"
Compression Ratio	9.2:1

DISPLACEMENT: | 6.8L | RATED POWER: | 362 HP | RATED TORQUE: | 457 LB-FT

WARRANTY COVERAGE — ADVANTAGE: IC BUS®

PSI POWERTRAIN:
5-year / Unlimited miles

ALLISON TRANSMISSION:
7-year / Unlimited miles

When it comes to servicing your IC Bus®, you can count on the broadest, most capable dealer network in the industry — no matter what component needs attention. In contrast, a Blue Bird customer will need to visit either Ford or Roush depending on the service requirement.

The simplicity of the IC Bus® warranty means less frustration and quicker service.

CAN I GET MY BUS SERVICED AT A BUS DEALERSHIP?

SERVICE	IC BUS	BLUE BIRD
Gasoline Engine:	YES	NO
Gasoline Fuel System:	YES	NO
Propane Engine:	YES	NO
Propane Fuel System:	YES	NO

ALLISON 2000 SERIES™ TRANSMISSION ADVANTAGE

ALLISON SHAFT

Shorter sturdier shaft has increased strength and reliability vs. Ford



ALLISON C1 CLUTCH

8.3% more clutch material vs. Ford

Better holding force and delivering more power to the drive wheels



ALLISON C5 CLUTCH

44.2% more clutch material vs. Ford

Holds 1st gear and lasts longer in the toughest operation



ALLISON PARK PAWL

Heavy-duty park pawl better secures vehicle when you need it most



www.ICBus.com

Specifications, descriptions and illustrative material in this literature are accurate as known at time of publication, but are subject to change without notice. Illustrations may include optional equipment and accessories, and may not include all standard equipment. IC Bus is a registered trademark of Navistar, Inc. BAD18005

© 2018 Navistar Inc. All rights reserved. All marks are trademarks of their respective owners. Lithographed in the United States of America.



UNITED STATES ENVIRONMENTAL PROTECTION AGENCY
2020 MODEL YEAR
CERTIFICATE OF CONFORMITY
WITH THE CLEAN AIR ACT

**OFFICE OF TRANSPORTATION
 AND AIR QUALITY**
ANN ARBOR, MICHIGAN 48105

Certificate Issued To: Power Solutions International, Inc.
 (U.S. Manufacturer or Importer)

Certificate Number: LPSIE08.8LPG-001

Effective Date:
 12/16/2019
Expiration Date:
 12/31/2020

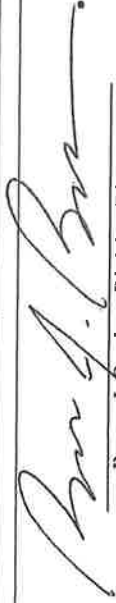
 Byron J. Bunker, Division Director
 Compliance Division

Issue Date:
 12/16/2019
Revision Date:
 N/A

Model Year: 2020

Manufacturer Type: Original Engine Manufacturer

Engine Family: LPSIE08.8LPG

Intended Service Class: Light or Medium Heavy-Duty Otto Cycle engines for all vehicles (certified for vehicles between 14,001 lbs and 33,000 lbs GVWR inclusive)

Fuel Type: Liquefied Petroleum Gas

Intended Engine Application: Vocational
Primary Test Configuration Transient Duty Cycle:
 CO2 FCL value (g/hp-hr): 536
 CO2 FEL value (g/hp-hr): 552
 N2O FEL value (g/hp-hr): 0.10
 CH4 FEL value (g/hp-hr): 0.10

Pursuant to Section 206 of the Clean Air Act (42 U.S.C. section 7525), 40 CFR Parts 86 and 1036, and subject to the terms and conditions prescribed in those provisions, this certificate of conformity is hereby issued with respect to the test engines which represent the engine family, and is subject to the terms and conditions prescribed in those provisions.

This certificate of conformity covers only those new motor vehicle engines which conform in all material respects to the design specifications that applied to those engines described in the documentation required by 40 CFR Parts 86 and 1036 and which are produced during the model year stated on this certificate of the said manufacturer, as defined in 40 CFR Parts 86 and 1036.

This certificate of conformity is conditional upon compliance of said manufacturer with the averaging, banking and trading provisions of 40 CFR Parts 86 and 1036. Failure to comply with these provisions may render this certificate void *ab initio*.

It is a term of this certificate that the manufacturer shall consent to all inspections described in 40 CFR Parts 86 and 1068 and authorized in a warrant or court order. Failure to comply with the requirements of such a warrant or court order may lead to revocation or suspension of this certificate for reasons specified in 40 CFR Parts 86 and 1036. It is also a term of this certificate that this certificate may be revoked or suspended or rendered void *ab initio* for other reasons specified in 40 CFR Parts 86 and 1036.

This certificate does not cover engines sold, offered for sale, or introduced, or delivered for introduction into commerce in the U.S. prior to the effective date of the certificate.

This certificate is issued subject to the conditions specified in 40 CFR 80.24. Catalyst-equipped vehicles designed to be operated on gasoline or flexible fuel, otherwise covered by this certificate, which are driven outside the United States, Canada, Mexico, Japan, Australia, Taiwan and the Bahama Islands will be presumed to have been operated on leaded fuel resulting in deactivation of the catalysts. If these vehicles are imported or offered for importation without retrofit of the catalyst, they will be considered not to be within the coverage of this certificate unless included in a catalyst control program operated by manufacturer or a United States Government Agency and approved by the Administrator.

Pursuant to the authority vested in California Air Resources Board by Health and Safety Code Division 26, Part 5, Chapter 2; and pursuant to the authority vested in the undersigned by Health and Safety Code Sections 39515 and 39516 and Executive Order G-19-095;

IT IS ORDERED AND RESOLVED: The engine and emission control systems produced by the manufacturer are certified as described below for use in on-road motor vehicles with a manufacturer's GVWR over 14,000 pounds. Production engines shall be in all material respects the same as those for which certification is granted.

MODEL YEAR	ENGINE FAMILY	ENGINE SIZES (L)	FUEL TYPE ¹	STANDARDS & TEST PROCEDURE	INTENDED SERVICE CLASS ²	ECS & SPECIAL FEATURES ³	DIAGNOSTIC ⁸
2020	LPSIE08.8LPG	8.8	LPG	Otto	HDO	ECM, TWC, 2HO2S(2), SFI	OBD(P)
PRIMARY ENGINE'S IDLE EMISSIONS CONTROL ⁵			ADDITIONAL IDLE EMISSIONS CONTROL ⁵				
N/A			N/A				
ENGINE (L)	ENGINE MODELS / CODES (rated power, in hp)						
8.8	LPG 270 / 8800 (270)						
¹ not applicable; GVWR=gross vehicle weight rating; 13 CCR xyz=Title 13, California Code of Regulations, Section xyz; 40 CFR 86.abc=Title 40, Code of Federal Regulations, Section 86.abc; L=liter; hp=horsepower; kw=kilowatt; hr=hour; ² CNG/LNG=compressed/liquefied natural gas; LPG=liquefied petroleum gas; E85=85% ethanol fuel; MF=multi fuel a.k.a. BF=bi fuel; DF=dual fuel; FF=flexible fuel; ³ L/M/H HDO=light/modium/heavy heavy-duty diesel; UB=urban bus; HDO=heavy duty Otto; ⁴ ECS=emission control system; TWC/O2=three-way/oxidizing catalyst; NAC=NOx adsorption catalyst; SCR-U / SCR-N=selective catalytic reduction - urea / - ammonia; WU (prefix)=warm-up catalyst; DPF=diesel particulate filter; PTOX=periodic trap oxidizer; HO2S/O2S=heated/oxygen sensor; HAFS/AFS=heated/air-fuel-ratio sensor (a.k.a. universal or linear oxygen sensor); WR-HO2S=wide range oxygen sensor; TBI=throttle body fuel injection; SFI/MFI=sequential/multi port fuel injection; DGI=direct gasoline injection; GCARB=gaseous carburetor; ID/DDI=indirect/direct diesel injection; TC/SC=turbo/super charger; CAC=charge air cooler; EGR / EGR-C=exhaust gas recirculation / cooled EGR; PAIR/AIR=pulsed/secondary air injection; SPL=smoke puff limiter; ECM/PCM=engine/powertrain control module; EM=engine modification; 2 (prefix)=parallel; (2) (suffix)=in series; ⁵ ESS=engine shutdown system (per 13 CCR 1956.8(a)(6)(A)(1)); 30g=30 g/hr NOx (per 13 CCR 1956.8(a)(6)(C)); APS=internal combustion auxiliary power system; ALT=alternative method (per 13 CCR 1956.8(a)(6)(D)); Exempt=exempted per 13 CCR 1956.8(a)(6)(B) or for CNG/LNG fuel systems; N/A=not applicable (e.g., Otto engines and vehicles); ⁸ EMD=engine manufacturer diagnostic system (13 CCR 1971); OBD(F) / (P) / (S)=full / partial / partial with a fine / on-board diagnostic;							

Following are: 1) the FTP exhaust emission standards, or family emission limit(s) as applicable, under 13 CCR 1956.8; 2) the SET and NTE limits under the applicable California exhaust emission standards and test procedures for heavy-duty diesel engines and vehicles (Test Procedures); and 3) the corresponding certification levels, for this engine family. "Diesel" CO, SET and NTE certification compliance may have been demonstrated by the manufacturer as provided under the applicable Test Procedures in lieu of testing. (For flexible- and dual-fueled engines, the CERT values in brackets [] are those when tested on conventional test fuel. For multi-fueled engines, the STD and CERT values for default operation permitted in 13 CCR 1956.8 are in parentheses.) ⁴

	NMHC		NOx		NMHC+NOx		CO		PM		HCHO	
	FTP	SET	FTP	SET	FTP	SET	FTP	SET	FTP	SET	FTP	SET
STD	0.14	*	0.20	*	*	*	14.4	*	0.01	*	0.01	*
CERT	0.10	*	0.13	*	*	*	1.9	*	0.000	*	0.002	*
NTE	*	*	*	*	*	*	*	*	*	*	*	*

⁴ g/bhp-hr=grams per brake horsepower-hour; FTP=Federal Test Procedure; SET=Supplemental emissions testing; NTE=Not-to-Exceed; STD=standard or emission test cap; FEL=family emission limit; CERT=certification level; NMHC/HC=non-methane/hydrocarbon; NOx=oxides of nitrogen; CO=carbon monoxide; PM=particulate matter; HCHO=formaldehyde;

BE IT FURTHER RESOLVED: The manufacturer has demonstrated compliance with the Greenhouse Gas Emission Standards as specified in Title 13 CCR 1956.8 and the incorporated "California Exhaust Emission Standards and Test Procedures for 2004 and Subsequent Model Heavy Duty Otto Cycle Engines and Vehicles" (HDOE Test Procedures) adopted December 27, 2000, as last amended December 19, 2018 using the 2014 model year National Heavy-Duty Engine and Vehicle Greenhouse Gas Program as specified in Section 1036.108 of the HDOE Test Procedures. The manufacturer has submitted the required information and therefore has met the criteria necessary to receive a California Executive Order based on the Environmental Protection Agency's Certificate of Conformity for the above listed engine family.

in g/bhp-hr	EPA CERTIFICATE OF CONFORMITY				PRIMARY INTENDED SERVICE CLASS			
	LPSIE08.8LPG-001				Vocational			
	CO ₂				CH ₄		N ₂ O	
	FTP	SET						
STD	627	*			0.10		0.10	
FCL	536	*			*		*	
FEL	552	*			*		*	
CERT	536	*			0.04		0.03	

⁴ g/bhp-hr=grams per brake horsepower-hour; FTP=Federal Test Procedure; SET=Supplemental emissions testing; STD = standard or emission test cap; FEL=family emission limit; FCL=family certification level; CERT=certification level; CO₂=carbon dioxide; CH₄=methane; N₂O=nitrous oxide; VOCATIONAL=vocational engine; TRACTOR=tractor engine

BE IT FURTHER RESOLVED: For the listed engine models the manufacturer has submitted the materials to demonstrate certification compliance with 13 CCR 1965 (emission control labels), 13 CCR 1971.1 (on-board diagnostic, full or partial compliance) and 13 CCR 2035 et seq. (emission control warranty).

Engines certified under this Executive Order must conform to all applicable California emission regulations.

The Bureau of Automotive Repair will be notified by copy of this Executive Order.

Executed at El Monte, California on this 10TH day of January 2020.



Allen Lyons, Chief
Emissions Certification and Compliance Division

Engine Model Summary Template

Engine Family	1.Engine Code	2.Engine Model	3.BHP@RPM (SAE Gross)	4.Fuel Rate: m/stroke @ peak HP (for diesel only)	5.Fuel Rate: (lbs/hr) @ peak HP (for diesels only)	6.Torque @ RPM (SAE Gross)	7.Fuel Rate: mm/stroke@peak torque	8.Fuel Rate: (lbs/hr)/peak torque	9.Emission Control Device Per SAE J1937
LPSIE08.8LPG	8800	LPG 270	270 @ 2600			565 @ 1500			ECM, TWC, 2HOS2(2), SFI

INVITATION TO BID

The Hickman County Finance Office is accepting sealed bids for school bus units. Bids for up to six (6) conventional seventy- eight (78) passenger school bus. Specifications and bid requirement may be obtained from Steven George, Director of Transportation, Hickman County Schools at 931-729-3391, Ext. 2241 or by e-mail at steven.george@hickmank12.org or online at www.hickmank12.org/request-for-proposal.

Sealed bids must be mailed or delivered to the Hickman County Finance Office, 114 North Central Avenue, Suite 203, Centerville, TN 37033 and clearly marked on the outside of the bid envelope "School Bus Units – 78 Passenger." Bids will be opened on Monday, February 3, 2020 at 10:00 a.m.

The Hickman County Board of Education reserves the right to accept or reject any and all bids or parts of bids and to waive any informalities that would prevent acceptance of a better bid.

Cumberland 94376.⁰⁰

Central State 98962.⁰⁰

Bus Sales

Present Renny Mayberry
Candi Oan

HICKMAN COUNTY BOARD OF EDUCATION
115 MURPHREE AVENUE
CENTERVILLE, TN 37033
931-729-3391

BID OFFER FOR UP TO SIX (6) CONVENTIONAL SEVENTY- EIGHT (78) PASSENGER
SCHOOL BUSES

TO THE HICKMAN COUNTY BOARD OF EDUCATION, CENTERVILLE, TENNESSEE:

IN RESPONSE TO YOUR INVITATION, MY COMPANY SUBMITS THE FOLLOWING
BIDS ON SCHOOL BUS. THE SCHOOL BUS SPECIFICATIONS REQUIRED BY THE
TENNESSEE STATE BOARD OF EDUCATION, AND BY YOU, AND THE CONDITIONS
SET FORTH IN YOUR BID INVITATION ARE CLEARLY UNDERSTOOD AND ARE
COMPILED WITHIN THIS BID.

- A. MAKE Blue Bird MODEL & NUMBER BB CV Vision
B. BID PRICE DELIVERED F.O.B. CENTERVILLE, TENNESSEE MOUNTED
AND FULLY EQUIPPED AS SPECIFIED.

NUMBER OF BUSES	SEATING CAPACITY	UNIT PRICE	TOTAL
<u>6</u>	<u>77</u>	<u>\$98,962.00</u>	<u>\$593,772.00</u>
_____	_____	_____	_____
_____	_____	_____	_____
TOTAL BIDS ON ALL			<u>\$593,772.00</u>

INVOICE TO BE PAID IN FULL UPON COMPLETION AND PASSING INSPECTION BY
STATE OF TENNESSEE.

SIGNED

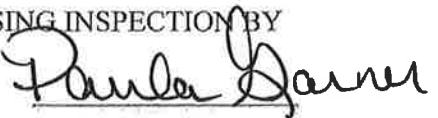

Regional Sales Manager
TITLE

Central States Bus Sales, Inc.
COMPANY
303 Business Park Drive
Lebanon, TN 37090
ADDRESS

DATE: February 3, 2020

Delivery Date: April 1, 2020 (Must be specific)

SCHOOL BUS SPECIFICATIONS

UNIT MUST MEET ALL STATE AND FEDERAL SPECIFICATIONS. PLEASE NOTE ANY DEVIATIONS BESIDE THE RESPECTIVE DESCRIPTION. ALL DEVIATIONS WILL BE CONSIDERED.

WARRANTIES: Towing to be included for life of all applicable warranties.
Three Year Bumper to Bumper
Power Train Five year or 100,000 mile warranty.

CHASSIS MINIMUM REQUIREMENTS

ALTERNATOR: Must be a 240 amp minimum, 12 volt.

AXLES: Front: 12,000 # rating minimum, "T" beam type. Rear 23,000 Minimum. Both axles made by same manufacturer.

BATTERIES: 2100 CCA Minimum. Double 00 gauge battery cables. Battery compartment to have a sliding tray with stop. **With cutoff switch in battery box**

BRAKES: Dual air with Bendix anti-lock system, Front: - 16.5" x 5" x 7/8" thick, Rear: -16.5" x 7" x 7/8" thick. Air compressor to be 13.2 CFM min. Three air tanks provided with total capacity of 4,760 cu. In. Bendix AD-9 air dryer.

BUMPERS: Minimum of 12" after forming front and rear steel plate bumpers. The rear bumper shall have a 14" wrap-around. Front and rear bumpers must be bolted not welded to frame with grade 8 bolts.

ENGINE: Ford 6.8L Propane Engine w/ 5yr unlimited mile warranty

FRAME: Must be one piece. No frame extension. Completely painted for rust and corrosion protection. 50,000 psi minimum.

EXHAUST: max NOx allowed .05. **To exit rear of bus thru the bumper.**

FUEL TANK: 100 gal. Min. Sender inspection access plate. Fuel system must include 2 fuel/water separators. One spin-on type at the engine and a second filter element with see through bowl and self-venting drain. Fuel tank to have heat shields if within 12 inches of exhaust system. **Must Have Interlock system , 5yr unlimited mile warranty**

GAUGES: Seven digit speedometer/odometer, fuel, voltmeter, oil pressure, tachometer, hour meter, coolant temperature, dual air brake gauges.
Warning systems to include: low air pressure light and buzzer, high temp./low oil pressure light and buzzer, low coolant light.

SAFETY: **Electronic Stability Control, meet Colorado Rack and Kentucky Pole Test. Show certification.**

(PAGE 2)

SHOCKS: Air Ride Suspension System front and rear. Dual action piston type: two front and two rear required. 1 3/4" bore. *Air ride not available on front*

STEERING: Tilt wheel. Full power

TIRES: Tubeless radial tires as needed 11R x 22.5; 16 ply rating highway.

TOW HOOKS: Unit to be equipped with tow hooks. 2 front; 2 rear.

TRANSMISSION: Ford 6r140 6spd Automatic Transmission w/5yr unlimited mile warranty, transmission, cooling accomplished by an oil cooler mounted external from transmission, minimum capacity 1,530 BTUs per minute with external spin-on filter.

WHEELS: HUB ALIGNED 22.5 x 8.25, painted black.

WIRING: Color and number coded. Protected by blade type fuses. Resistant to heat, abrasion, and solvents.

BODY REQUIREMENTS

COMPARTMENTS: Storage compartment to be located over windshield area. Add glove box at door in dash. Add padded arm rest with storage.

CONSTRUCTION: Entire body surface including the floor construction shall meet FMVSS 221 in all joints.

FLOOR PANELS: Shall be 14 gauge heavily galvanized steel. They shall be welded and riveted at reinforcements. These main floor cross-members must be full width to outer sheet metal on each side of body for maximum collision protection.

ROOF BOWS: 14 gauge hat-shaped roof bows one piece from floor overhead to floor on the other side shall be used. Bows shall end upon floor overhead to floor on the other side shall be used. Bows shall end upon floor at each side for maximum rollover strength.

BODY SHEET METAL: Four 16 gauge applied rub rails plus one embossed for a total of five. Embossed rain visor over each window. Skirts to be 16 1/4" measured from the floor level. These rails to be riveted to structured bows and side panels with buck rivets. Body shall be fully undercoated, under floor, skirt panels and wheel wells prior to mounting on chassis. Rain visors to be embossed in roofing sheet metal over each window. These roof sheets shall be one piece from window top to window top on the other side for maximum strength. They shall be double lapped and secured with two rows of rivets for additional strength.

CROSSING ARM: Front bumper crossing arm equipped to be air operated

STOP SIGN: To be air operated

(PAGE 3)

DOORS: Entrance: Outward opening door, air operated with Kentucky switch. 30" full opening and 1,500 sq." of glass area. Stainless steel grab rail.
Rear emergency 36" x 51" to have upper and lower glass. Retainer to hold door open. **Rear door to have red stop warning lighted sign in center of door.**

FLOORING: Black rubber flooring with white colored nosing on each step. Molded rubber covers required over front and rear interior wheel-housings. Rounded rustproof molding to be installed where floor meets wall on each side.

HEADROOM: Interior headroom to be 77" full length of bus.

HEATERS: 90,000 BTU front heater/defroster, 80,000 BTU rear heater **mounted behind rear wheels.** Two 6" dash fans. Front heater to have removable filter. Rear heat with filter

INSULATION: 1 ½" thick fiberglass in roof, front, and rear. 1 ½" mineral wool blanket type insulation on sides to insure vertical integrity.

IDENTIFICATION: School system name 6" HICKMAN COUNTY SCHOOLS & 6" Numbers Front - Rear and sides

LIGHTS: Warning light system meeting current federal specifications. All red overhead and stop arm lights to be strobe LED lights. Side directional lights mounted on right and left. 5" back up lights, 7" tail lights. Warning lights to be hooded. Roof strobe with guard.
Interior lights: Step well light and dome lights. **All lights to be LED,** light system monitor display within view of driver.

MIRRORS: Interior: 6" x 30" non-glare, adjustable. Exterior: Heated mirrors meeting federal and state standards.

SUN VISOR: 6" x 30" transparent, adjustable, left above driver only.

MUD FLAPS: Unit to have front and rear mud flaps.

FENDERS: Two rubber rear fenders.

NOISE REDUCTION: This will include acoustic ceiling and plywood floor in the front two sections. Reflective padding attached to underside of engine hood to reduce engine heat and noise.

PAINT: **White Roof** , Exterior; heat cured polyurethane.

PARTS LINE REPORT: A print out of the build sheets

SAFETY: Four push out windows and two roof hatches Spheros brand. One inch full length side reflective tape at floor line.

CHILD REMINDER SYSTEM: Doran

1/9/2020

(PAGE 4)

SEATS: **Seat Belt Ready Frames**
 Seat/Driver Air operated with brown fabric and high back w/tilt
 Left and right arm rests
 Seat/Passenger DOT seats with brown upholstery .

SIDE PANELS: Interior - Aluminized steel side walls with mar-resistant finish.

SOLENOID: Disconnects all body circuits when ignition is turned off.

STEPWELL: Slant three step entrance.

VENTILATION: Driver's fresh air vent with dash control and static roof vent.

WINDOWS: Clear split sash design with latches with aluminum frames only.

WINDSHIELD: Flat laminated safety glass or one piece bonded/tinted.

WIPERS: Wet arm type. To be equipped with intermittent.

WIRING: Color and number coded. Protected by auto resetting circuit breakers.
 Accessible without removing windows.

HORN/ALARMS: Dual electric horn located away from wheel splash area.
 112 dbs. Back up alarm.

SAFETY EQUIPMENT: Triangle kit with case mounted in driver's area. Fire extinguisher- 5
 pound mounted in driver's area First Aid Kit as well as a bio-hazard kit mounted in driver's area.

PA's and RADIOS: AM/FM CD PLAYER /PA stereo WITH AUX PORT, 4 interior speakers
 flush mounted. To have one flush mounted PA speaker mounted in front of cab for PA system.

**CAMERA: REI HD SERIES 8 camera system - WITH 320 GB HARD DRIVE, Four
 Cameras on both side walls with the 180degree cameras and One camera out the front**

Two Way Communication Radio: Kenwood To be installed as part of bid

ITEMS TO BE PRICED SEPARATELY

ENGINE: Cummins Diesel, in line six configuration, 220 minimum H.P. Must have minimum
 of 600 ft. lb. gross torque minimum. Engine Warning system. 750 watt heater. High/low idle
 and cruise control. **One bus is to come with Cummins Quick Serve and Cummins Insite
 Subscription and Engine Diagnostics Equipment.**

Diesel w/insite & equipment \$5,500.00

SEATBELT: Three seat belts to a seat 3-pt belts on 77 passenger \$8,800.00

DISC BRAKES: Air disc on both front and rear axles Air Disc brakes \$2,400.00

SUSPENSION: Without Air Ride Delete air suspension (\$ 650.00)

SP: 23922 BBCV 3310, 77 CAP

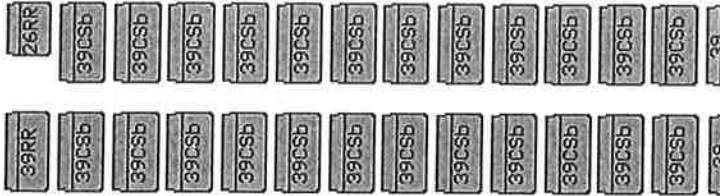

SP: 23922 BBCV 3310, 77 CAP

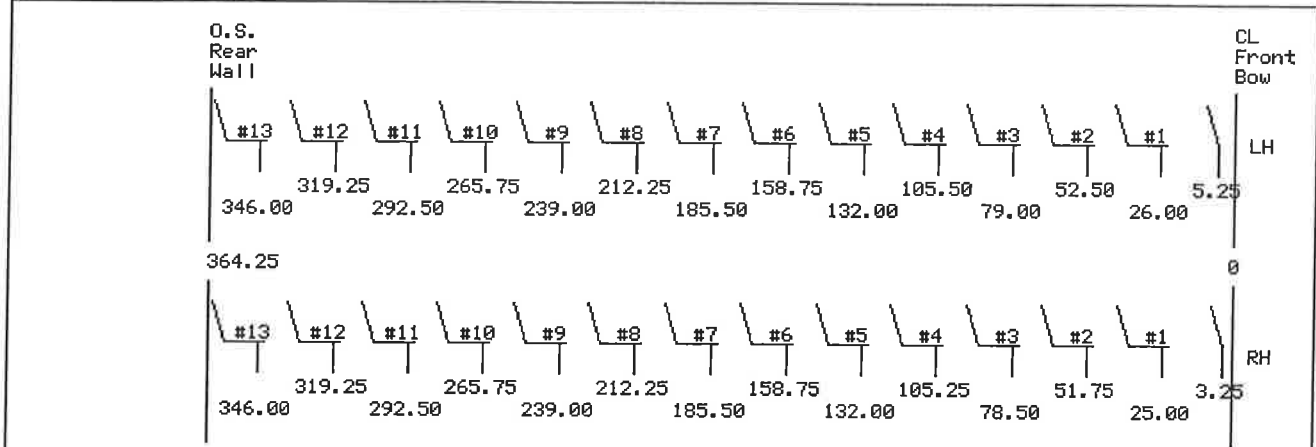

Row	RH Seats	LH Seats
1	39CNVLBR	39CNVLBR
2	39CNVLBR	39CNVLBR
3	39CNVLBR	39CNVLBR
4	39CNVLBR	39CNVLBR
5	39CNVLBR	39CNVLBR
6	39CNVLBR	39CNVLBR
7	39CNVLBR	39CNVLBR
8	39CNVLBR	39CNVLBR
9	39CNVLBR	39CNVLBR
10	39CNVLBR	39CNVLBR
11	39CNVLBR	39CNVLBR
12	39CNVLBR	39CNVLBR
13	39CNVLBRRR	26CNVLBRRR

Dimensions are to center line of front mounting hole.

LH Seat Spacing: 26.50, 26.75
 LH Knee Clearance: 24.74, 24.99
 RH Seat Spacing: 26.75
 RH Knee Clearance: 24.99

BBCV3310 NEXTGEN LBR

DO NOT SCALE

BBCV 3310	
Capacity	77
Seat Plan #	23922
Wheelbase	273.0



BLUE BIRD

Standard Limited Warranty
North America (U.S.A. & Canada)

Blue Bird Body Company (Blue Bird) warrants each bus to be free from defects in material and workmanship under normal use and service within the limits described below:

1. For a period of five (5) years/100,000 miles/160,000 kilometers, whichever occurs first from date of delivery to the original user, Blue Bird warrants the:
 - Chassis frame rails and cross-members to be free from defects in structural integrity (breaking or cracking).
 - Body shell (those structural metal components welded or riveted together forming floor, side walls, roof, front and rear sections) to be free from defects in structural integrity (breaking or cracking) including rust-through.
 - Interior and exterior paint adhesion to the body shell (those components forming side walls, roof, front and rear sections) and doors.
 - School bus seat frames and barrier frames to be free from defects in structural integrity (breaking or cracking).
 - Blue Bird emissions components not covered by the engine manufacturer conform with all U.S. federal emissions regulations at the time of manufacture and that they are free from defects in material or workmanship which would cause them not to meet the U.S. federal emissions regulations. Refer to the engine manufacturer's limited warranty statement for emissions warranty coverage by the engine manufacturer.
2. For a period of four (4) years/50,000 miles/80,000 kilometers, whichever occurs first from date of delivery to the original user, Blue Bird warrants the:
 - Front axle assembly, including king pins, I-beam, bushings and spindles, excluding brakes and axle ends.
 - Rear axle assembly and differential, excluding brakes and wheel ends.
3. For a period of three (3) years/36,000 miles/60,000 kilometers, whichever occurs first from date of delivery to the original user, Blue Bird warrants the:
 - Comfort Aire® integrated air conditioner, if equipped, subject to annual service inspections.
4. For a period of two (2) years from date of delivery to the original user, Blue Bird warrants the:
 - School bus passenger and driver windows. Transit-style windows not included.
5. For a period of two (2) years/24,000 miles/40,000 kilometers, whichever occurs first from date of delivery to the original user, Blue Bird warrants the:
 - Suspension, excluding pins and bushings.
 - Driveshafts, support bearings and universal joints.
6. For a period of one (1) year/12,000 miles/20,000 kilometers, whichever occurs first from date of delivery to the original user, Blue Bird warrants:
 - All other components not covered in 1, 2, 3, 4 and 5 above, except engines, automatic transmissions, wheelchair lifts, non-Blue Bird air conditioners, tires, and batteries. The warranties of the engine, automatic transmission, wheelchair lift, non-Blue Bird air conditioners, tires, and batteries, are provided solely by, and are the responsibility of, those manufacturers and are not a part of Blue Bird's limited warranty.

Blue Bird's obligation covered in this limited warranty is limited to the repair or replacement of such parts as shall, under normal use and service, appear to have been defective in workmanship or material. This warranty is applicable to Blue Bird bus products, All American (AFE, A3RE, D3FE, D3RE) and Vision (BBCV), that are registered and operated in the United States of America, Canada, Puerto Rico, U.S. Virgin Islands, Guam, and American Samoa. The warranty period begins on the date the bus is delivered to the original user. During the warranty period, this warranty is transferable to subsequent Owners/Operators in U.S.A. or Canada.

THIS LIMITED WARRANTY IS EXPRESSLY IN LIEU OF ALL OTHER WARRANTIES EXPRESSED OR IMPLIED AND ALL OTHER OBLIGATIONS OR LIABILITIES. NO PERSON, INCLUDING SALESPERSONS, DEALERS, OR FACTORY REPRESENTATIVES OF BLUE BIRD, IS AUTHORIZED TO MAKE ANY REPRESENTATION OR WARRANTY CONCERNING BLUE BIRD PRODUCTS EXCEPT TO REFER PURCHASERS TO THIS LIMITED WARRANTY. BLUE BIRD MAKES NO WARRANTY OF MERCHANTABILITY OR FITNESS FOR A PARTICULAR PURPOSE. BLUE BIRD SHALL NOT BE LIABLE FOR INCIDENTAL OR CONSEQUENTIAL DAMAGES.

Contact your Blue Bird Dealer to obtain service for your Blue Bird bus. Your Blue Bird Dealer will help arrange for repairs by the Dealer or another qualified repair facility. Defects must be reported to a Blue Bird Dealer immediately upon discovery of the defect and within the warranty period as stated herein. Defects must be repaired immediately upon discovery of the defect and within the warranty period as stated herein. Unless authorized by the Blue Bird Dealer, repairs under this limited warranty are to be performed by the Blue Bird Dealer. It is the responsibility of the Owner/Operator to return the bus to the Blue Bird Dealer, or qualified repair facility authorized by the Blue Bird Dealer for warranty repairs. All claims for warranty repairs by other than the Blue Bird Dealer must be received by the Blue Bird Dealer not later than 30 days after the repair date. The owner/operator is responsible for operating and maintaining the bus as described in the Operator's and Service Manuals. All maintenance records should be retained by the owner/operator. Your Blue Bird Dealer will register the bus with Blue Bird and can assist with registering components that are warranted by the component manufacturers.

Limitations & Exclusions

In addition to the limitations described on the previous page, items specifically not covered include but are not limited to:

- Engines, automatic transmissions, wheelchair lifts, air conditioners (other than Blue Bird ComfortAire® system), tires, and batteries. The limited warranties for these components are provided solely by and are the responsibility of those manufacturers and are not a part of Blue Bird's limited warranty.
- Loss of use and incidental consequential expenses, including but not limited to commercial loss, loss of commercial fares, driver time or pay, lease or rental of substitute vehicle, storage, lodging, meals, telephone calls and other travel costs.
- Wear, wear-out and consumption. This warranty shall not apply to any parts or components which must be repaired, replaced or adjusted during the warranty period that are due to wear, wear-out or consumption, including but not limited to brake pads and linings, drums and rotors, wiper blades, light bulbs, filters, lubricants, fluids, belts, bearings other than those specifically covered by the limited warranty, suspension pins and bushings, batteries, worn seat covers, worn stepreads and floor covering, worn door and window seals, discharged fire extinguishers, damaged (scratches, cracks) gauge and light lenses, and tires. Wear not only include friction-type wear but can also include environmental deterioration including but not limited to surface corrosion on exhaust pipes/clamps and brake drums/rotors, as well as fading, cracking or discoloration of seat covers caused by U.V.
- Maintenance including but not limited to tightening loose fasteners, axle & wheel alignments, wheel-balancing, tightening body tie-downs, door adjustments, tightening hose clamps, and sealing/caulking windows, doors, panels, hatches and lights.
- This warranty shall not apply to any parts or components which must be repaired, replaced or adjusted during the warranty period as a result of accident damage, abnormal operation, misuse and/or abuse, including but not limited to excessive operation on unpaved, un-maintained roads, operation on cross-country trails or off-road conditions, collision, fire, vandalism, explosion, objects striking the vehicle, theft, freezing, riot, flood.
- Paint adhesion failures resulting from abrasions, atmospheric conditions, road chemicals, caustic detergents/cleaners, and/or improper maintenance. Paint adhesion failures, whether warrantable defects or non-warrantable events, that are not repaired immediately upon discovery of the failure may deteriorate the finish and/or panels underneath. Surface corrosion and/or other progressive deterioration as a result of not repairing paint failures immediately is not covered by this warranty.
- If dealers or customers have any vehicle modifications or equipment installations performed without the written approval of Blue Bird, to the extent the modifications or equipment installations adversely affect other vehicle components or performance, Blue Bird shall not accept any product liability or claims under the terms of the limited warranty. These claims become the sole responsibility of the company performing the modifications and/or installations.
- Transportation expenses to deliver the bus to a Blue Bird Dealer or nearest qualified repair facility, including but not limited to fuel, driver time/pay, mileage and towing.
- Repairs to parts or components which have been previously replaced with parts not obtained from Blue Bird or failures caused by non-Blue Bird parts or components. Rework of repairs not performed by or approved by a Blue Bird Dealer.
- Excessive labor hours, premium labor costs, overtime labor costs, local taxes. This limited warranty covers reasonable labor to perform replacement or repair.
- Defects not reported to a Blue Bird Dealer and repaired during the warranty period. Repairs are to be made immediately upon discovery of the defect.
- Damage caused by using improper or contaminated fluids, including but not limited to fuels, lubricants and coolant. Damage caused by using fluids that do not meet Blue Bird's or the Manufacturers' minimum recommendations. Damage caused by the lack of fluids and/or improper fluid maintenance.
- Using non-Blue Bird service parts. Usage of non-Blue Bird parts will affect future warranty coverage.
- Overloading beyond the normal seated and standee capacity voids all warranties.

Blue Bird reserves the right to make changes in design and changes or improvements upon its products without imposing any obligations upon itself to install the same upon products theretofore manufactured. Any suit alleging a breach of this limited warranty or of any other alleged warranty, including any claim for rescission or revocation of acceptance, must be filed within one year of breach.

Controlling Law and Severability

This Limited Warranty shall be governed by and construed in accordance with the laws of the State of Georgia, U.S.A. The owner/operator agrees and consents to the exclusive jurisdiction of the courts of the State of Georgia for all purposes regarding this Limited Warranty and further agrees and consents that venue of any action involving this Limited Warranty or any other alleged warranty, including any claim for rescission or revocation of acceptance, shall be exclusively in Peach County, Georgia. Owner/Operator hereby submits to personal jurisdiction in Peach County, Georgia and waives any objection or argument related to venue, personal jurisdiction, forum non conveniencence, and/or transfer. If any portion hereof is found to be void or unenforceable, the remaining provisions of the Limited Warranty shall remain in full force and effect.



1901 LEBANON PIKE • NASHVILLE, TN 37210 • PHONE: 615 256-4633 • FAX: 615 255-8318

BID RESULTS REQUEST

Dear School:

I apologize that my schedule did not allow me to attend today's bid opening.

May I please have the bid results returned to me sent via email, or fax?

My contact information is below.

EMAIL: AScurlock@CLTTE.com

Fax: 615-844-5326

Thank you so much and I appreciate your help,

Ashley E. Scurlock
Bus Account Manager



1901 Lebanon Pike
Nashville, TN 37210
Cell Phone 615.598.3572
My fax line: 615-844-5326
Main Fax line: 615-829-7859
AScurlock@CLTTE.com



HICKMAN COUNTY BOARD OF EDUCATION
 115 MURPHREE AVENUE
 CENTERVILLE, TN 37033
 931-729-3391

✓ BID OFFER FOR UP TO SIX (6) CONVENTIONAL SEVENTY- EIGHT (78) PASSENGER SCHOOL BUSES

✓ TO THE HICKMAN COUNTY BOARD OF EDUCATION, CENTERVILLE, TENNESSEE:

IN RESPONSE TO YOUR INVITATION, MY COMPANY SUBMITS THE FOLLOWING BIDS ON SCHOOL BUS. THE SCHOOL BUS SPECIFICATIONS REQUIRED BY THE TENNESSEE STATE BOARD OF EDUCATION, AND BY YOU, AND THE CONDITIONS SET FORTH IN YOUR BID INVITATION ARE CLEARLY UNDERSTOOD AND ARE COMPILED WITHIN THIS BID.

- ✓ A. MAKE IC Bus MODEL & NUMBER IC Bus, PB105, CE 78 Passenger
- B. BID PRICE DELIVERED F.O.B. CENTERVILLE, TENNESSEE MOUNTED AND FULLY EQUIPPED AS SPECIFIED.

NUMBER OF BUSES	SEATING CAPACITY	UNIT PRICE	TOTAL
<u>1 or more</u>	<u>78 Passenger</u>	<u>\$94,376.00</u>	<u>\$566,256 total for 6 units</u>
_____	_____	_____	_____
_____	_____	_____	_____

TOTAL BIDS ON ALL \$566,256 total for 6 units

INVOICE TO BE PAID IN FULL UPON COMPLETION AND PASSING INSPECTION BY STATE OF TENNESSEE.

SIGNED Ashley E. Scumlock

Bus Account Manager
TITLE

Cumberland International Trucks, Inc.
COMPANY

1901 Lebanon Pike
ADDRESS

DATE: Nashville, TN 37210

Delivery Date: 150 days ARO (Must be specific)

Feb 3, 2020

✓ SCHOOL BUS SPECIFICATIONS

✓ **UNIT MUST MEET ALL STATE AND FEDERAL SPECIFICATIONS. PLEASE NOTE ANY DEVIATIONS BESIDE THE RESPECTIVE DESCRIPTION. ALL DEVIATIONS WILL BE CONSIDERED.**

✓ **WARRANTIES:** Towing to be included for life of all applicable warranties. ✓
Three Year Bumper to Bumper ✓
Power Train Five year or 100,000 mile warranty. ✓

✓ **CHASSIS MINIMUM REQUIREMENTS**

✓ **ALTERNATOR:** Must be a 240 amp minimum, 12 volt. ✓

× **AXLES:** Front: 12,000 # rating minimum, "I" beam type. Rear 23,000 Minimum. Both axles made by same manufacturer. 10,000 front and 21,000 rear

× **BATTERIES:** ~~2100~~ CCA Minimum. Double 00 gauge battery cables. Battery 1980 (3) CCA Batteries compartment to have a sliding tray with stop. **With cutoff switch in battery box**

✓ **BRAKES:** Dual air with Bendix anti-lock system, Front: - 16.5" x 5" x 7/8" thick, Rear: -16.5" x 7" x 7/8" thick. Air compressor to be 13.2 CFM min. Three air tanks provided with total capacity of ~~4,760~~ cu. In. Bendix AD-9 air dryer. 3740 cu capacity

✓ **BUMPERS:** Minimum of 12" after forming front and rear steel plate bumpers. The rear bumper shall have a 14" wrap-around. Front and rear bumpers must be bolted not welded to frame with grade 8 bolts.

× **ENGINE:** Ford 6.8L Propane Engine w/ 5yr unlimited mile warranty PSI Engine

✓ **FRAME:** Must be one piece. No frame extension. Completely painted for rust and corrosion protection. 50,000 psi minimum.

× **EXHAUST:** max NOx allowed ~~.05~~. **To exit rear of bus thru the bumper.** NOx .13 below federal requirement of .20 Eligible for VW grant funding

× **FUEL TANK:** ~~100~~ gal. Min. Sender inspection access plate. ~~Fuel system must include 2 fuel/water separators. One spin on type at the engine and a second filter element with see through bowl and self venting drain. Fuel tank to have heat shields if within 12 inches of exhaust system.~~ **Must Have Interlock system , 5yr unlimited mile warranty** 90.16 gallon @ 80%

✓ **GAUGES:** Seven digit speedometer/odometer, fuel, voltmeter, oil pressure, tachometer, hour meter, coolant temperature, dual air brake gauges.
Warning systems to include: low air pressure light and buzzer, high temp./low oil pressure light and buzzer, low coolant light.

✓ **SAFETY:** **Electronic Stability Control, meet Colorado Rack and Kentucky Pole Test. Show certification.** Collision Mitigation System as well!

(PAGE 2)

✓ **SHOCKS:** **Air Ride Suspension System front and rear.** Dual action piston type: two front and two rear required. 1 3/4" bore.

1/9/2020

- ✓ **STEERING:** Tilt wheel. Full power
- ✓ **TIRES:** Tubeless radial tires as needed 11R x 22.5; 16 ply rating highway.
- ✓ **TOW HOOKS:** Unit to be equipped with tow hooks. 2 front; 2 rear.
- × **TRANSMISSION:** Allison Transmission with 7 year warranty
~~Ford 6R140 6 spd~~ Automatic Transmission w/~~5yr~~ unlimited mile warranty, transmission, cooling accomplished by an oil cooler mounted external from transmission, minimum capacity 1,530 BTUs per minute with external spin-on filter.
- ✓ **WHEELS:** HUB ALIGNED 22.5 x 8.25, painted black.
- ✓ **WIRING:** Color and number coded. Protected by blade type fuses. Resistant to heat, abrasion, and solvents. Resettable circuit breakers per wiring request on the bid

BODY REQUIREMENTS

- × **COMPARTMENTS:** Storage compartment to be located over ~~windshield~~ area. Add ~~glove box~~ at door in dash. Add padded arm rest with storage. Driver storage to the right of the driver
- ✓ **CONSTRUCTION:** Entire body surface including the floor construction shall meet FMVSS 221 in all joints.
- ✓ **FLOOR PANELS:** Shall be 14 gauge heavily galvanized steel. They shall be welded and riveted at reinforcements. These main floor cross-members must be full width to outer sheet metal on each side of body for maximum collision protection. IC Constructions meets FMVSS
- ✓ **ROOF BOWS:** 14 gauge hat-shaped roof bows one piece from floor overhead to floor on the other side shall be used. Bows shall end upon floor overhead to floor on the other side shall be used. Bows shall end upon floor at each side for maximum rollover strength. IC Constructions meets FMVSS
- ✓ **BODY SHEET METAL:** Four 16 gauge applied rub rails plus one embossed for a total of five. Embossed rain visor over each window. Skirts to be 16 ¼" measured from the floor level. These rails to be riveted to structured bows and side panels with buck rivets. Body shall be fully undercoated, under floor, skirt panels and wheel wells prior to mounting on chassis. ~~Rain visors~~ to be embossed in roofing sheet metal over each window. These roof sheets shall be one piece from window top to window top on the other side for maximum strength. They shall be double lapped and secured with two rows of rivets for additional strength. IC Constructions meets FMVSS
No rain visors Longer 20" skirts
- ✓ **CROSSING ARM:** Front bumper crossing arm equipped to be air operated
- ✓ **STOP SIGN:** To be air operated

(PAGE 3)

- ✓ **DOORS:** Entrance: Outward opening door, air operated with Kentucky switch. 30" full opening and 1,500 sq." of glass area. ~~Stainless~~ steel grab rail. Dual Black hand rails
- ✓ Rear emergency 36" x 51" to have upper and lower glass. Retainer to hold door open. **Rear door to have red stop warning lighted sign in center of door.**

- ✓ **FLOORING:** Black rubber flooring with white colored nosing on each step. Molded rubber covers required over front and rear interior wheel-housings. Rounded rustproof molding to be installed where floor meets wall on each side.
- ✓ **HEADROOM:** Interior headroom to be 77" full length of bus. 78" headroom
- ✓ **HEATERS:** 90,000 BTU front heater/defroster, 80,000 BTU rear heater **mounted behind rear wheels.** Two 6" dash fans. Front heater to have removable filter. Rear heat with filter
- ✓ **INSULATION:** 1 ½" thick fiberglass in roof, front, and rear. 1 ½" mineral wool blanket type insulation on sides to insure vertical integrity.
- ✓ **IDENTIFICATION:** School system name 6" HICKMAN COUNTY SCHOOLS & 6" Numbers Front - Rear and sides
- ✓ **LIGHTS:** Warning light system meeting current federal specifications. All red overhead and stop arm lights to be strobe LED lights. Side directional lights mounted on right and left. 5" back up lights, 7" tail lights. Warning lights to be hooded. Roof strobe with guard. Interior lights: Step well light and dome lights. **All lights to be LED,** light system monitor display within view of driver.
- ✓ **MIRRORS:** Interior: 6" x 30" non-glare, adjustable. Exterior: Heated mirrors meeting federal and state standards.
- ✓ **SUN VISOR:** 6" x 30" transparent, adjustable, left above driver only.
- ✓ **MUD FLAPS:** Unit to have front and rear mud flaps.
- ✓ **FENDERS:** Two rubber rear fenders.
- ✓ **NOISE REDUCTION:** This will include acoustic ceiling and plywood floor in the front two sections. Reflective padding attached to underside of engine hood to reduce engine heat and noise.
- ✓ **PAINT:** **White Roof** , Exterior; heat cured polyurethane.
- ✓ **PARTS LINE REPORT:** A print out of the build sheets
- ✓ **SAFETY:** Four push out windows and two roof hatches ~~Spheres~~ brand. One inch full length side reflective tape at floor line. Specialty Brand
- ✓ **CHILD REMINDER SYSTEM:** ~~Doran~~ No Child Left Behind System

(PAGE 4)

- ✓ **SEATS:** **Seat Belt Ready Frames**
- ✓ Seat/Driver Air operated with brown fabric and high back w/tilt
Left and right arm rests Right Side Arm Rest Only
- ✓ Seat/Passenger DOT seats with brown upholstery .
- ✓ **SIDE PANELS:** Interior - Aluminized steel side walls with mar-resistant finish.

- ✓ **SOLENOID:** Disconnects all body circuits when ignition is turned off.
- ✓ **STEPWELL:** Slant three step entrance. No slant
- ✓ **VENTILATION:** Driver's fresh air vent with dash control and static roof vent.
- ✓ **WINDOWS:** Clear split sash design with latches with aluminum frames only. Tinted windows
- ✓ **WINDSHIELD:** Flat laminated safety glass or one piece bonded/tinted. 4 piece windshield roped in
- ✓ **WIPERS:** Wet arm type. To be equipped with intermittent.
- ✓ **WIRING:** Color and number coded. Protected by auto resetting circuit breakers. Accessible without removing windows.
- ✓ **HORN/ALARMS:** Dual electric horn located away from wheel splash area. 112 dbs. Back up alarm.
- ✓ **SAFETY EQUIPMENT:** Triangle kit with case mounted in driver's area. Fire extinguisher- 5 pound mounted in driver's area First Aid Kit as well as a bio-hazard kit mounted in driver's area.
- ✓ **PA's and RADIOS:** AM/FM-~~CD~~ PLAYER /PA stereo WITH AUX PORT, 4 interior speakers flush mounted. To have one flush mounted PA speaker mounted in front of cab for PA system.
No CD player on radio
- ✓ **CAMERA: REI HD SERIES 8 camera system - WITH 320 GB HARD DRIVE, Four Cameras on both side walls with the 180degree cameras and One camera out the front**
- ✓ **Two Way Communication Radio: Kenwood** To be installed as part of bid
- ✓ **ITEMS TO BE PRICED SEPARATELY**
- ✓ **ENGINE:** Cummins Diesel, in line six configuration, 220 minimum H.P. Must have minimum of 600 ft. lb. gross torque minimum. Engine Warning system. 750 watt heater. High/low idle and cruise control. **One bus is to come with Cummins Quick Serve and Cummins Insite Subscription and Engine Diagnostics Equipment.** Save \$3,000
- ✓ **SEATBELT:** Three seat belts to a seat \$10,000
- ✓ **DISC BRAKES:** Air disc on both front and rear axles \$3,000.00
- ✓ **SUSPENSION:** Without Air Ride Save \$100.00

LEFT SIDE FUEL FILL
OPTION CANNOT BE USED
WITH THIS BODY PLAN.

VERTICAL HINGED E/E
REQUIRED

SPACING IS BT1/
GEN4 COMPATIBLE

BODY PLAN

WHEELBASE 276"

PB10500, 34 FT. 11 IN., PLUS 9 RR, CAP 78, SEAT SIZE 39/39, SEAT SPACING VARIES

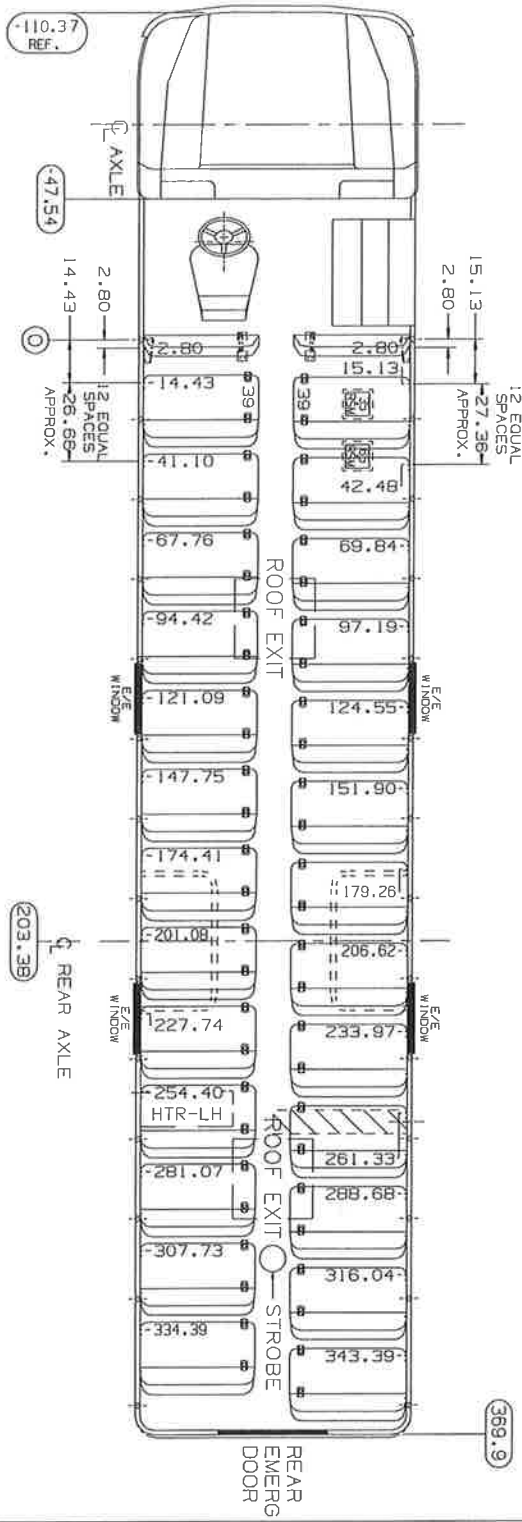

THIS UNIT CONFORMS TO APPLICABLE FMVSS

THIS DOCUMENT IS THE PROPERTY OF INTERNATIONAL TRUCK AND ENGINE CORPORATION AND IS NOT TO BE REPRODUCED OR TRANSMITTED IN ANY FORM OR BY ANY MEANS, ELECTRONIC OR MECHANICAL, INCLUDING PHOTOCOPYING, RECORDING, OR BY ANY INFORMATION STORAGE AND RETRIEVAL SYSTEM.

50000/49000

INTERNATIONAL TRUCK AND ENGINE CORPORATION	
INTERNATIONAL CONFIDENTIAL PROPRIETARY	
REFERENCE: 000	APPROX. WGS: (WEIGHT)
LINEAR MEASURE: <input type="checkbox"/> IN <input type="checkbox"/> MM	ROOF PAINT: <input type="checkbox"/> YES <input type="checkbox"/> NO
TRUCK MAKE: <input type="checkbox"/> F <input type="checkbox"/> I <input type="checkbox"/> M <input type="checkbox"/> O <input type="checkbox"/> R	TRUCK MODEL: <input type="checkbox"/> 1 <input type="checkbox"/> 2 <input type="checkbox"/> 3 <input type="checkbox"/> 4
TRUCK YEAR: 1990	TRUCK COLOR: <input type="checkbox"/> B <input type="checkbox"/> G <input type="checkbox"/> R <input type="checkbox"/> W
TRUCK MAKE: 1000	TRUCK MODEL: 40, 201, 4010
TRUCK YEAR: 91	TRUCK COLOR: E 50
BODY PLAN PB10500	
TRUCK MAKE: <input type="checkbox"/> D <input type="checkbox"/> I <input type="checkbox"/> M <input type="checkbox"/> O <input type="checkbox"/> R	TRUCK MODEL: <input type="checkbox"/> 1 <input type="checkbox"/> 2 <input type="checkbox"/> 3 <input type="checkbox"/> 4
TRUCK YEAR: 01	TRUCK COLOR: <input type="checkbox"/> B <input type="checkbox"/> G <input type="checkbox"/> R <input type="checkbox"/> W
TRUCK MAKE: <input type="checkbox"/> F <input type="checkbox"/> I <input type="checkbox"/> M <input type="checkbox"/> O <input type="checkbox"/> R	TRUCK MODEL: <input type="checkbox"/> 1 <input type="checkbox"/> 2 <input type="checkbox"/> 3 <input type="checkbox"/> 4
TRUCK YEAR: 01	TRUCK COLOR: <input type="checkbox"/> B <input type="checkbox"/> G <input type="checkbox"/> R <input type="checkbox"/> W

CLAND-330A

01

Power Solutions International

Powering a Greener Future





8.8L PSI Low-speed | Specification Sheet

Displacement: 535cid (8.767 liters)

Compression Ratio: 10:1

Bore x Stroke: 4.350" (110.5 mm) X 4.500" (114.3 mm)

Power:

Gas-LS: 270 hp (201 kW) @ 2600 rpm

Gas-HS: 501hp (374 kW) @ 4400 rpm

LP-LS: 270 hp (201 kW) @ 2600 rpm

CNG-LS: 235 hp (175 kW) @ 2600 rpm

Torque:

Gas-LS: 565 lb-ft (766 Nm) @ 1500 rpm

Gas-HS: 650 lb-ft (881 Nm) @ 3700 rpm

LP-LS: 565 lb-ft (766 Nm) @ 1500 rpm

CNG-LS: 495 lb-ft (671 Nm) @ 1500 rpm



**Fuel Agnostic
Common Controls**



Low Speed (LS) Torque

or

High Speed (HS) Power

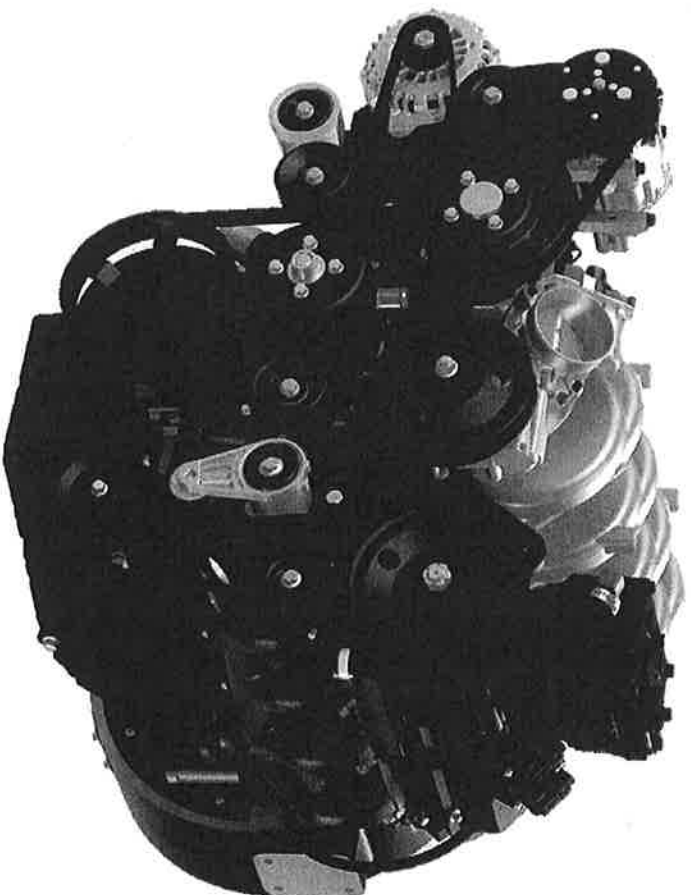

Compatible with

Allison 1000/2000/3000

transmissions

PSI

8.8L Base History

Industrial

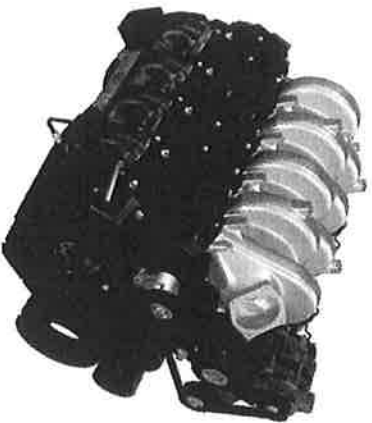

On-Highway



Major Improvements over GM 8.1L



Heads



Crankshaft



Intake

Transmission Compatibility



Allison 1000/2000

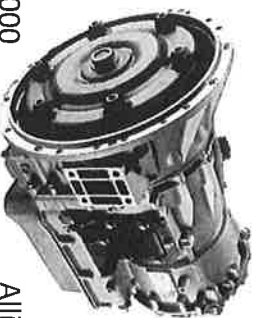

Allison 3000+

Production:

Job one:

Jan 2013

Present Build:

8-10 units per day.

Capacity:

50 units per day.

Produced to date:

2300 units (as of Jan 2014)

Engine Specs:

Displacement:

535cid (8.767 liters)

Compression Ratio:

10:1

Bore x Stroke:

4.350" (110.5 mm) X 4.500" (114.3 mm)

Improvements over GM 8.1L:

Cylinder Heads

Modernized, heavy-duty, high-low heads create fast burn to improve efficiency and reduce emissions.

Crankshaft

Forged and induction hardened steel crankshaft creates durable block capable of 1,000 ft-lb of torque

Intake Manifold

Tuned long-runner provides higher torque while special air gap design keeps engine air cooler to improve efficiency

Camshafts

Optimized camshafts for both low-speed and high speed engine operation to ensure customer expectations are met

PSI

8.8L Configuration for CE Bus

Leece Neville Pad Mount Alternator
(Standard: 320A, Options: 190-240A)

Ixetic Power Steering
Pump (LF72A)
(21 cc/rev, 160 bar)

Bendix
Tu-flo 550 Kit
(12 SCFM)

Custom
Wiring
Harness

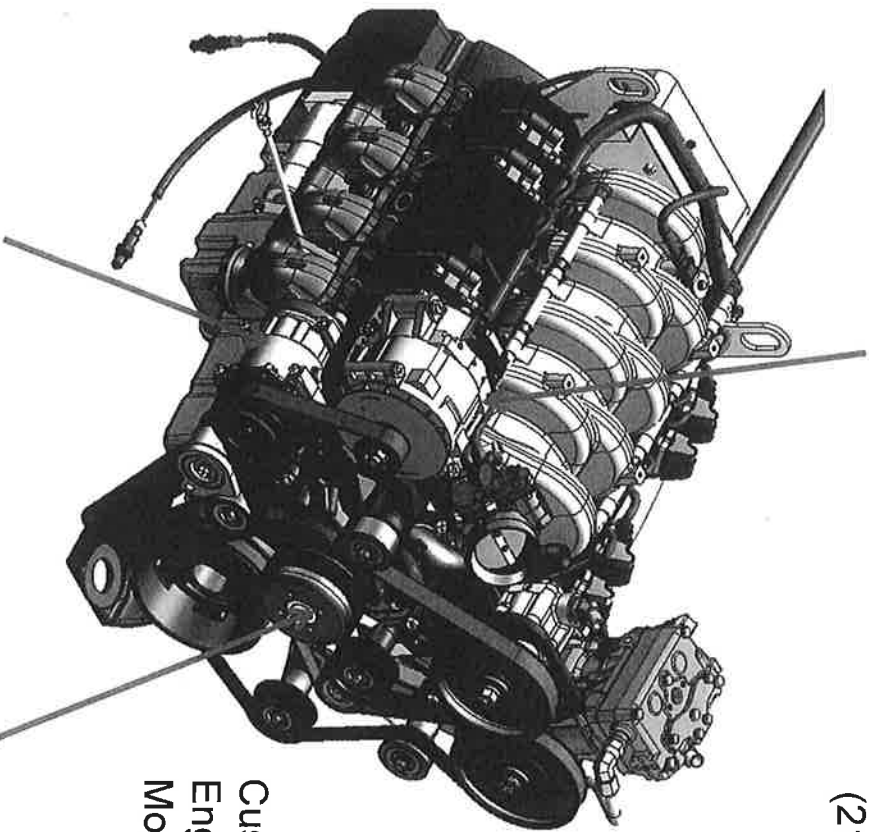

Custom
Engine
Mount

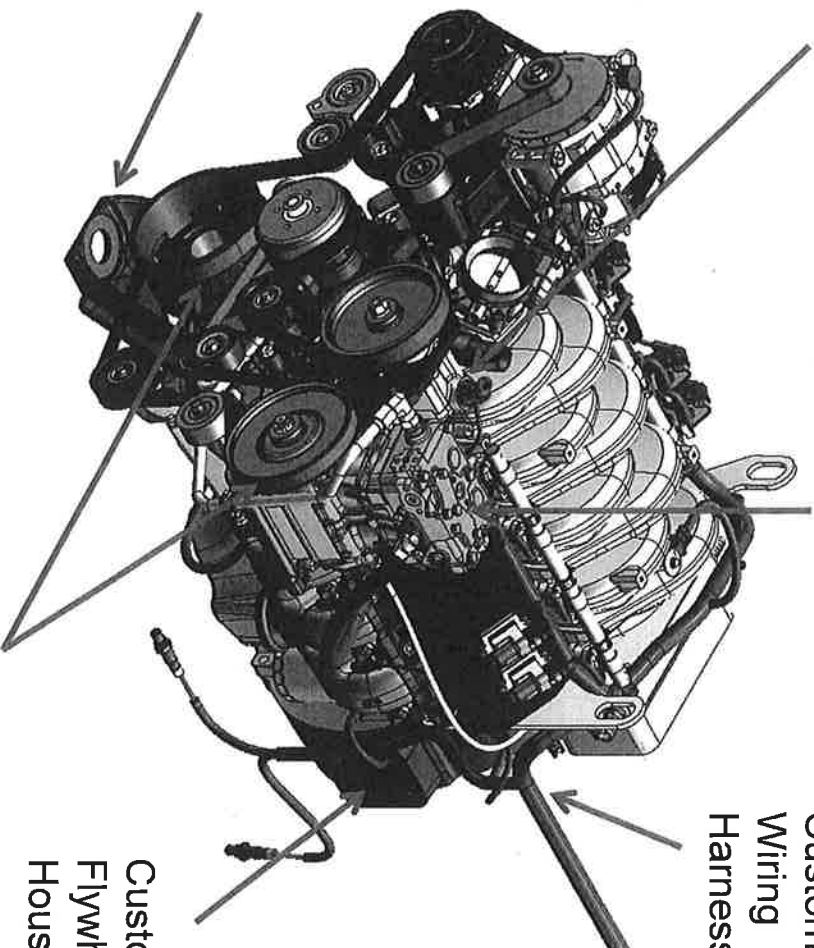

Custom
Flywheel
Housing

TCCl A/C Compressor
(165cc)

25" Borg Warner Fan
Borg Warner Air Sense Viscous Clutch

8-groove outer
6-groove inner



8.8L Propane Tank System for CE Bus

Sleepers 67.5 Gallon Tank System
with integrated pumps, valves, filters

NFPA
Pressure Relief System
(Puffer)

Biphase
Liquid Propane Delivery Module
(LPDM)

Navistar
Fuel Fill System

Navistar
Tank Cage System
(specific to propane)

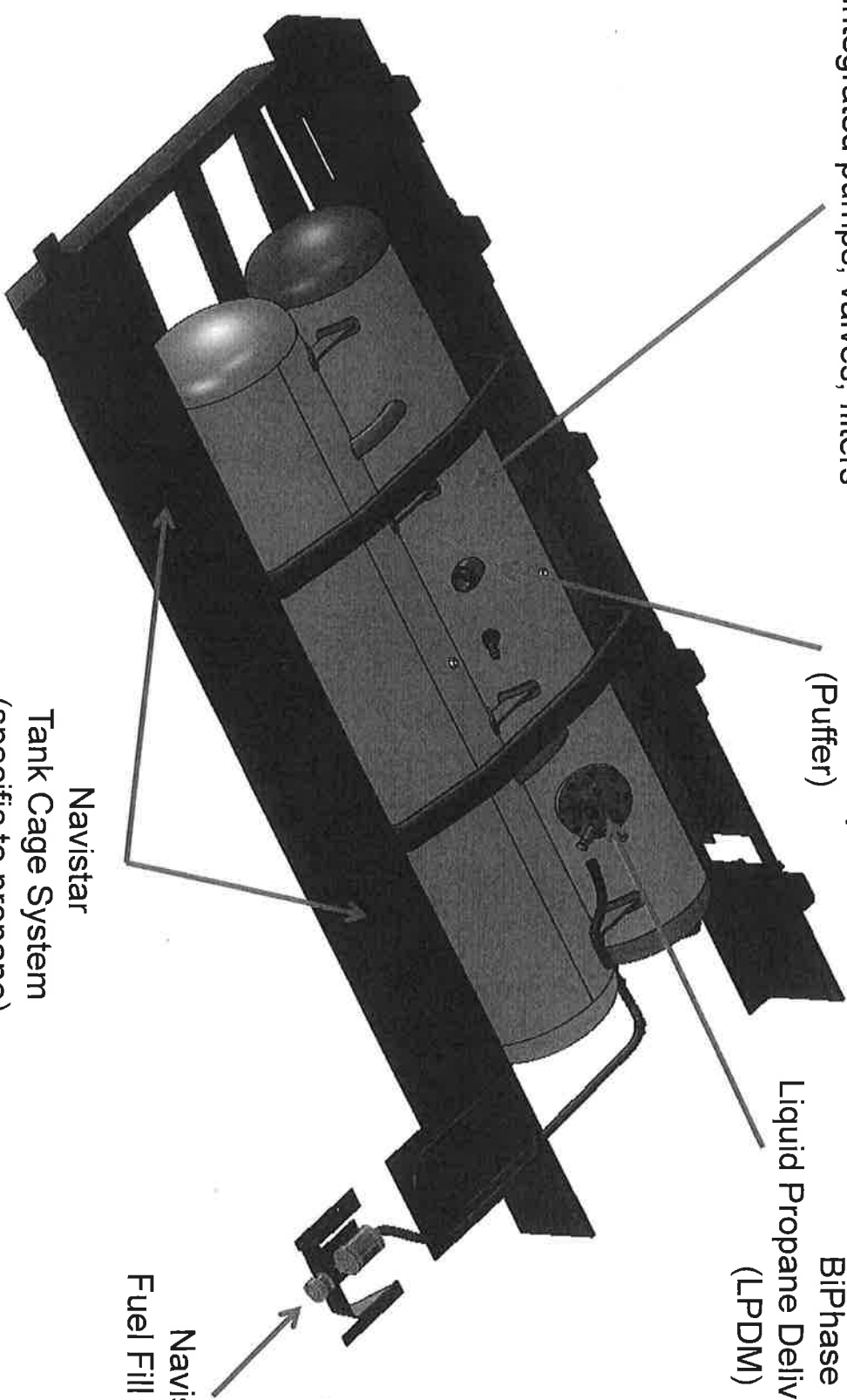

PSI

Control Strategy

MT88 V-8 Controller

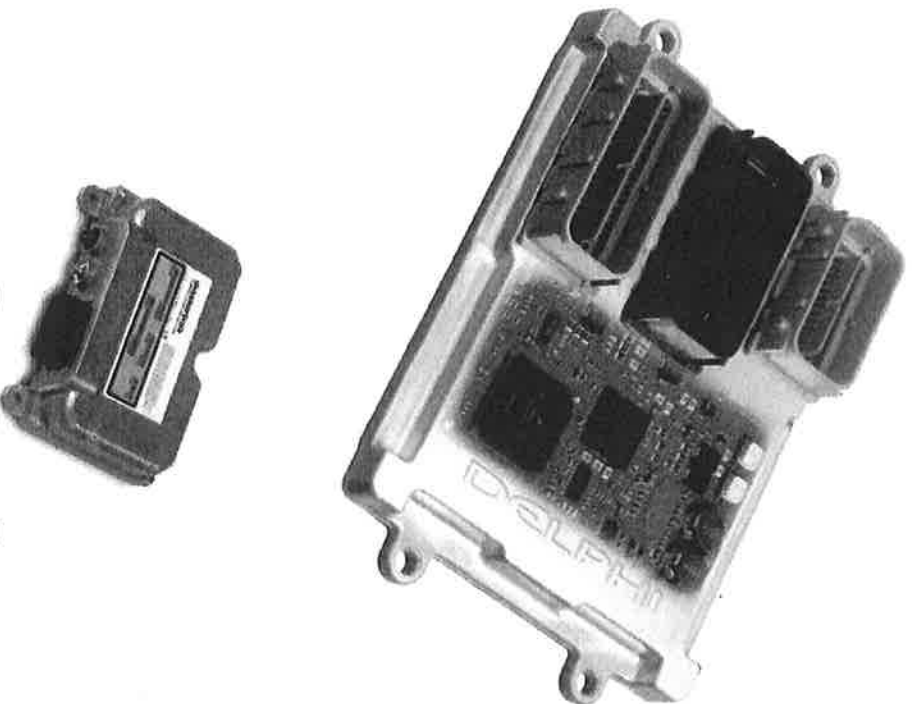

- **Certified System Software (Delphi)**
- State of the Art Torque-based controls
- Full OBD-HD Compliance
- Opportunity for customer proprietary features
- J1939 Communication
- 5-year exclusive relationship

PSI Capabilities

- Proprietary software using Delphi core
- Partnered with world class partners (e.g. Ricardo)
- In-house Engineering & Test Capabilities
 - 50+ engineers on staff and growing
 - Full CAD, CAE, CFD analysis
 - Emissions & performance calibration
 - Application engineering
 - Internal dyno test capabilities (2014)

mastertrak[®]
ADVANCED TELEMATICS SOLUTIONS



Technical Comparison

	PSI 8.8L V-8	Cummins ISB6.7L	GM / PI 8.0L V-8	Ford 6.8L V-10
Displacement	8.8L	6.7L	8.0L	6.8L
Horsepower	270 hp @ 2600 RPM	240 hp @ 2400	350 hp @ 4000	362 hp @ 4750
Torque	565 lb-ft @ 1500 RPM	560 lb-ft @ 1600	500 lb-ft @ 3100	457 lb-ft @ 3250
Bore / Stroke	4.35" X 4.50"	4.21" x 4.88"	4.27" x 4.25"	3.55" x 4.17"
Compression Ratio	10:1	17.3:1	9.6:1	9.2:1



Performance Comparison

Propane Torque Comparison

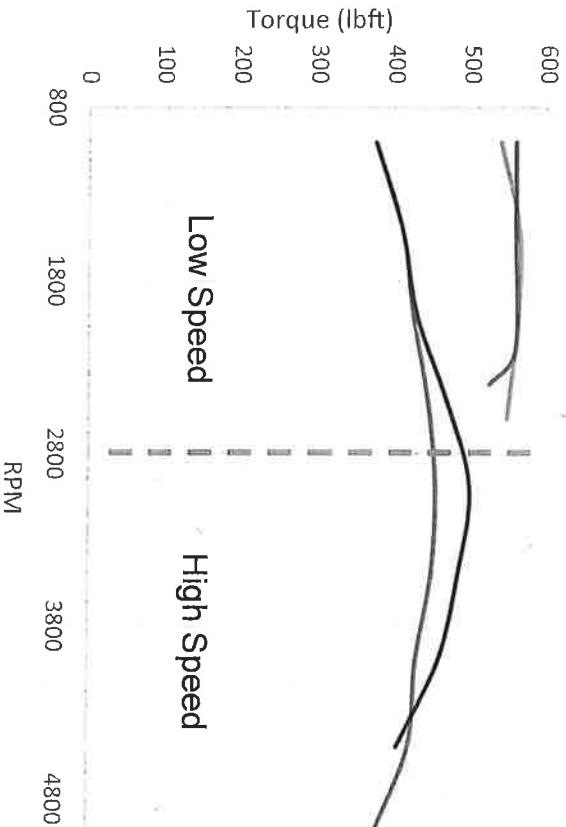

Propane Power Comparison

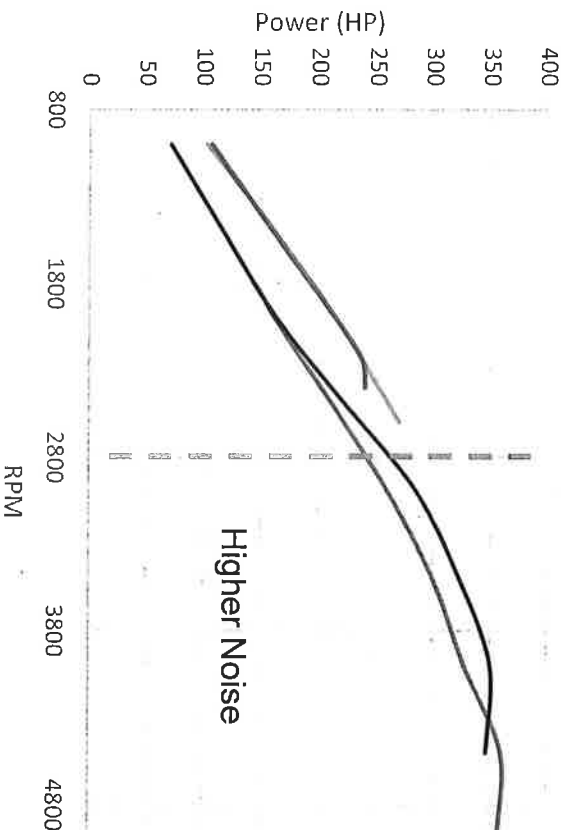

CE Series Bus Engine
ISB 240hp/560 lb-ft selected for Comparison



General Data

- **MOR for all engines (CARB/EPA)**
- **Dedicated Application Engineering**
- **Common Controls Platform**
- **5 Year, 100,000 Mile Engine Warranty Coverage**
- **Customer solutions focused**
 - **Parts**
 - **Dealer/Service training**
- **Advanced Engineering, Design and Test Capabilities**
 - **CFD, FEA, Engine Testing Lab**
- **Global Sourcing & Supply Chain**
- **Service & Warranty**
 - **Administered via Navistar systems**
 - **Leverage PSI Diagnostic Service Tool through Navistar dealers**
- **Integrated Telematics available**

Powering a Greener Future



GASOLINE & PROPANE
8.8L V-8

PURPOSE BUILT FOR THE SCHOOL BUS INDUSTRY



Power Solutions International (PSI) 8.8L — uncompromised power performance, maximum fuel efficiency, emissions certification and fuel flexibility

DEVELOPED FROM THE BLOCK UP TO
BE RELIABLE AND DURABLE

HEAVY-DUTY DESIGN

- ▶ Forged, induction-hardened crankshaft
- ▶ Forged rods and pistons
- ▶ Oil bath lubrication provides piston cooling
- ▶ Low engine-speed design produces less noise, heat and wear than competitor gasoline and propane engines

SERVICEABLE

- ▶ Both the engine compartment and engine provide best-in-class accessibility for easy maintenance
- ▶ Includes the industry's only one-stop warranty for gasoline and propane vehicles
- ▶ Allison Transmission 7-year/Unlimited mileage warranty
- ▶ Industry's broadest, most capable parts distribution and dealer network

ALLISON TRANSMISSIONS

- ▶ Shorter, sturdier shaft has increased durability vs. Ford
- ▶ Over 44% more clutch material vs. Ford so it holds gear and lasts longer in the toughest operation
- ▶ Heavy-duty park pawl better secures vehicle
- ▶ Same transmission used across all IC Bus® powertrains for ease of maintenance

POWER OF CHOICE

- ▶ Gasoline and Propane versions use same engine block providing an easy solution for mechanics and drivers of mixed fleets
- ▶ Gasoline and Propane make cold weather startup easy
- ▶ Upfront cost is lower for gasoline compared to diesel

CYLINDER HEADS

Modernized, heavy-duty, high-flow heads create fast burn to improve efficiency and reduce emissions

CRANKSHAFT

Forged and induction-hardened steel crankshaft creates durable block capable of 1,000+ ft-lb of torque

INTAKE MANIFOLD

Tuned long-runner provides higher torque and special air gap design keeps engine air cooler for improved efficiency



ENGINE COMPARISON: IC BUS® VS. BLUE BIRD

PSI 8.8L V-8 VS. FORD 6.8L V-10

PSI 8.8L V-8	GASOLINE	PROPANE
Displacement	8.8L	8.8L
Rated Horsepower	265 hp @ 2600	270 hp @ 2600
@ 1000 RPM	95 hp	103 hp
@ 2000 RPM	202 hp	215 hp
Rated Torque	548 lb.-ft. @ 1800	565 lb.-ft. @ 1500
@ 1000 RPM	500 lb.-ft.	540 lb.-ft.
@ 2000 RPM	530 lb.-ft.	564 lb.-ft.
Bore / Stroke	4.35" x 4.50"	4.35" x 4.50"
Compression Ratio	9.1:1	10:1

DISPLACEMENT: 8.8L | RATED POWER: 265-270 HP | RATED TORQUE: 548-565 LB-FT

RPM / HORSEPOWER

The PSI 8.8L low engine speed design drives like a diesel, with no compromise on engine power and reliability.

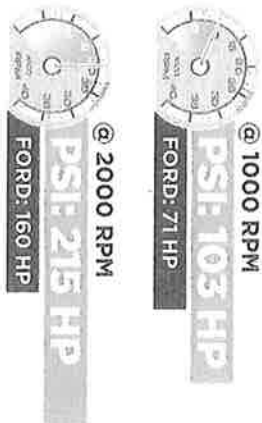

FORD 6.8L V-10	PROPANE
Displacement	6.8L
Rated Horsepower	362 hp @ 4750
@ 1000 RPM	71 hp
@ 2000 RPM	160 hp
Rated Torque	457 lb.-ft. @ 3250
@ 1000 RPM	375 lb.-ft.
@ 2000 RPM	420 lb.-ft.
Bore / Stroke	3.55" x 4.17"
Compression Ratio	9.2:1

DISPLACEMENT: 6.8L | RATED POWER: 362 HP | RATED TORQUE: 457 LB-FT

WARRANTY COVERAGE — ADVANTAGE: IC BUS®

PSI POWERTRAIN: **5-year / Unlimited miles**
 ALLISON TRANSMISSION: **7-year / Unlimited miles**

When it comes to servicing your IC Bus® you can count on the broadest, most capable dealer network in the industry — no matter what component needs attention. In contrast, a Blue Bird customer will need to visit either Ford or Roush depending on the service requirement.

The simplicity of the IC Bus® warranty means less frustration and quicker service.

CAN I GET MY BUS SERVICED AT A BUS DEALERSHIP?

SERVICE	IC BUS	BLUE BIRD
Gasoline Engine:	YES	NO
Gasoline Fuel System:	YES	NO
Propane Engine:	YES	NO
Propane Fuel System:	YES	NO

ALLISON 2000 SERIES™ TRANSMISSION ADVANTAGE

ALLISON SHAFT
 Shorter sturdier shaft has increased strength and reliability vs. Ford



ALLISON C1 CLUTCH
 8.3% more clutch material vs. Ford



Better holding force and delivering more power to the drive wheels

ALLISON C5 CLUTCH
 44.2% more clutch material vs. Ford



Holds 1st gear and lasts longer in the toughest operation

ALLISON PARK PAWL
 Heavy-duty park pawl better secures vehicle when you need it most



www.ICBus.com
 Specifications, descriptions and illustrative material in this literature are accurate at time of publication, but are subject to change without notice. Illustrations may include optional equipment and accessories, and may not include all standard equipment. IC Bus is a registered trademark of Navistar, Inc. BADI8005
 © 2018 Navistar Inc. All rights reserved. All marks are trademarks of their respective owners. Lithographed in the United States of America.



**UNITED STATES ENVIRONMENTAL PROTECTION AGENCY
2020 MODEL YEAR
CERTIFICATE OF CONFORMITY
WITH THE CLEAN AIR ACT**

**OFFICE OF TRANSPORTATION
AND AIR QUALITY
ANN ARBOR, MICHIGAN 48105**

Certificate Issued To: Power Solutions International, Inc.
(U.S. Manufacturer or Importer)

Certificate Number: LPSIE08.8LPG-001

Effective Date:
12/16/2019

Expiration Date:
12/31/2020

Byron J. Bunker, Division Director
Compliance Division

Issue Date:
12/16/2019

Revision Date:
N/A

Model Year: 2020

Manufacturer Type: Original Engine Manufacturer

Engine Family: LPSIE08.8LPG

Intended Service Class: Light or Medium Heavy-Duty Otto Cycle engines for all vehicles (certified for vehicles between 14,001 lbs and 33,000 lbs GVWR inclusive)

Fuel Type: Liquefied Petroleum Gas

Intended Engine Application: Vocational
Primary Test Configuration Transient Duty Cycle:
CO2 FCL value (g/hp-hr): 536
CO2 FEL value (g/hp-hr): 552
N2O FEL value (g/hp-hr): 0.10
CH4 FEL value (g/hp-hr): 0.10

Pursuant to Section 206 of the Clean Air Act (42 U.S.C. section 7525), 40 CFR Parts 86 and 1036, and subject to the terms and conditions prescribed in those provisions, this certificate of conformity is hereby issued with respect to the test engines which represent the engine family, and is subject to the terms and conditions prescribed in those provisions.

This certificate of conformity covers only those new motor vehicle engines which conform in all material respects to the design specifications that applied to those engines described in the documentation required by 40 CFR Parts 86 and 1036 and which are produced during the model year stated on this certificate of the said manufacturer, as defined in 40 CFR Parts 86 and 1036.

This certificate of conformity is conditional upon compliance of said manufacturer with the averaging, banking and trading provisions of 40 CFR Parts 86 and 1036. Failure to comply with these provisions may render this certificate void *ab initio*.

It is a term of this certificate that the manufacturer shall consent to all inspections described in 40 CFR Parts 86 and 1068 and authorized in a warrant or court order. Failure to comply with the requirements of such a warrant or court order may lead to revocation or suspension of this certificate for reasons specified in 40 CFR Parts 86 and 1036. It is also a term of this certificate that this certificate may be revoked or suspended or rendered void *ab initio* for other reasons specified in 40 CFR Parts 86 and 1036.

This certificate does not cover engines sold, offered for sale, or introduced, or delivered for introduction into commerce in the U.S. prior to the effective date of the certificate.

This certificate is issued subject to the conditions specified in 40 CFR 80.24. Catalyst-equipped vehicles designed to be operated on gasoline or flexible fuel, otherwise covered by this certificate, which are driven outside the United States, Canada, Mexico, Japan, Australia, Taiwan and the Bahama Islands will be presumed to have been operated on leaded fuel resulting in deactivation of the catalysts. If these vehicles are imported or offered for importation without retrofit of the catalyst, they will be considered not to be within the coverage of this certificate unless included in a catalyst control program operated by manufacturer or a United States Government Agency and approved by the Administrator.

Pursuant to the authority vested in California Air Resources Board by Health and Safety Code Division 26, Part 5, Chapter 2; and pursuant to the authority vested in the undersigned by Health and Safety Code Sections 39515 and 39516 and Executive Order G-19-095;

IT IS ORDERED AND RESOLVED: The engine and emission control systems produced by the manufacturer are certified as described below for use in on-road motor vehicles with a manufacturer's GVWR over 14,000 pounds. Production engines shall be in all material respects the same as those for which certification is granted.

MODEL YEAR	ENGINE FAMILY	ENGINE SIZES (L)	FUEL TYPE ¹	STANDARDS & TEST PROCEDURE	INTENDED SERVICE CLASS ²	ECS & SPECIAL FEATURES ³	DIAGNOSTIC ⁶
2020	LPSIE08.8LPG	8.8	LPG	Otto	HDO	ECM, TWC, 2HO2S(2), SFI	OBD(P)
PRIMARY ENGINE'S IDLE EMISSIONS CONTROL ⁵			ADDITIONAL IDLE EMISSIONS CONTROL ⁵				
N/A			N/A				
ENGINE (L)	ENGINE MODELS / CODES (rated power, in hp)						
8.8	LPG 270 / 8800 (270)						

^{*} =not applicable; GVWR=gross vehicle weight rating; 13 CCR xyz=Title 13, California Code of Regulations, Section xyz; 40 CFR 86.abc=Title 40, Code of Federal Regulations, Section 86.abc; L=liter; hp=horsepower; kw=kilowatt; hr=hour;
¹ CNG/LNG=compressed/liquefied natural gas; LPG=liquefied petroleum gas; E85=85% ethanol fuel; MF=multi fuel a.k.a. BF=bi fuel; DF=dual fuel; FF=flexible fuel;
² L/M/H HDD=light/medium/heavy heavy-duty diesel; UB=urban bus; HDO=heavy duty Otto;
³ ECS=emission control system; TWC/OC=three-way/oxidizing catalyst; NAC=NOx adsorption catalyst; SCR-U / SCR-N=selective catalytic reduction - urea / - ammonia; WU (prefix)=warm-up catalyst; DPF=diesel particulate filter; PTOX=periodic trap oxidizer; HO2S/O2S=heated/oxygen sensor; HAFS/AFS=heated/air-fuel-ratio sensor (a.k.a., universal or linear oxygen sensor); WR-HO2S=wide range oxygen sensor; TBI=throttle body fuel injection; SF/MFI=sequential/multi port fuel injection; DGI=direct gasoline injection; GCARB=gaseous carburetor; IDI/DDI=indirect/direct diesel injection; TC/SC=turbo/super charger; CAC=charge air cooler; EGR / EGR-C=exhaust gas recirculation / cooled EGR; PAIR/AIR=pulsed/secondary air injection; SPL=smoke puff limiter; ECM/PCM=engine/powertrain control module; EM=engine modification; 2 (prefix)=parallel; (2) (suffix)=in series;
⁵ ESS=engine shutdown system (per 13 CCR 1956.8(a)(6)(A)(1)); 30g=30 g/hr NOx (per 13 CCR 1956.8(a)(6)(C)); APS =internal combustion auxiliary power system; ALT=alternative method (per 13 CCR 1956.8(e)(6)(D)); Exempt=exempted per 13 CCR 1956.8(a)(6)(B) or for CNG/LNG fuel systems; N/A=not applicable (e.g., Otto engines and vehicles);
⁶ EMD=engine manufacturer diagnostic system (13 CCR 1971); OBD(F) / (P) / (S)=full / partial / partial with a fine / on-board diagnostic;

Following are: 1) the FTP exhaust emission standards, or family emission limit(s) as applicable, under 13 CCR 1956.8; 2) the SET and NTE limits under the applicable California exhaust emission standards and test procedures for heavy-duty diesel engines and vehicles (Test Procedures); and 3) the corresponding certification levels, for this engine family. "Diesel" CO, SET and NTE certification compliance may have been demonstrated by the manufacturer as provided under the applicable Test Procedures in lieu of testing. (For flexible- and dual-fueled engines, the CERT values in brackets] are those when tested on conventional test fuel. For multi-fueled engines, the STD and CERT values for default operation permitted in 13 CCR 1956.8 are in parentheses.) ⁴

	NMHC		NOx		NMHC+NOx		CO		PM		HCHO	
	FTP	SET	FTP	SET	FTP	SET	FTP	SET	FTP	SET	FTP	SET
STD	0.14	*	0.20	*	*	*	14.4	*	0.01	*	0.01	*
CERT	0.10	*	0.13	*	*	*	1.9	*	0.000	*	0.002	*
NTE	*	*	*	*	*	*	*	*	*	*	*	*

⁴ g/bhp-hr=grams per brake horsepower-hour; FTP=Federal Test Procedure; SET=Supplemental emissions testing; NTE=Not-to-Exceed; STD=standard or emission test cap; FEL=family emission limit; CERT=certification level; NMHC/HC=non-methane/hydrocarbon; NOx=oxides of nitrogen; CO=carbon monoxide; PM=particulate matter; HCHO=formaldehyde;

BE IT FURTHER RESOLVED: The manufacturer has demonstrated compliance with the Greenhouse Gas Emission Standards as specified in Title 13 CCR 1956.8 and the incorporated "California Exhaust Emission Standards and Test Procedures for 2004 and Subsequent Model Heavy Duty Otto Cycle Engines and Vehicles" (HDOE Test Procedures) adopted December 27, 2000, as last amended December 19, 2018 using the 2014 model year National Heavy-Duty Engine and Vehicle Greenhouse Gas Program as specified in Section 1036.108 of the HDOE Test Procedures. The manufacturer has submitted the required information and therefore has met the criteria necessary to receive a California Executive Order based on the Environmental Protection Agency's Certificate of Conformity for the above listed engine family.

In g/bhp-hr	EPA CERTIFICATE OF CONFORMITY		PRIMARY INTENDED SERVICE CLASS	
	LPSIE08.8LPG-001		Vocational	
	CO ₂		CH ₄	N ₂ O
	FTP	SET		
STD	627	*	0.10	0.10
FCL	536	*	*	*
FEL	552	*	*	*
CERT	536	*	0.04	0.03

⁴ g/bhp-hr=grams per brake horsepower-hour; FTP=Federal Test Procedure; SET=Supplemental emissions testing; STD = standard or emission test cap; FEL=family emission limit; FCL=family certification level; CERT=certification level; CO₂=carbon dioxide; CH₄=methane; N₂O=nitrous oxide; VOCATIONAL=vocational engine; TRACTOR=tractor engine

BE IT FURTHER RESOLVED: For the listed engine models the manufacturer has submitted the materials to demonstrate certification compliance with 13 CCR 1965 (emission control labels), 13 CCR 1971.1 (on-board diagnostic, full or partial compliance) and 13 CCR 2035 et seq. (emission control warranty).

Engines certified under this Executive Order must conform to all applicable California emission regulations.

The Bureau of Automotive Repair will be notified by copy of this Executive Order.

Executed at El Monte, California on this 10TH day of January 2020.



Allen Lyons, Chief
Emissions Certification and Compliance Division

Engine Model Summary Template

Engine Family	1.Engine Code	2.Engine Model	3.BHP@RPM (SAE Gross)	4.Fuel Rate: mm/stroke @ peak HP (for diesel only)	5.Fuel Rate: (lbs/hr) @ peak HP (for diesels only)	6.Torque @ RPM (SEA Gross)	7.Fuel Rate: mm/stroke@peak torque	8.Fuel Rate: (lbs/hr)@peak torque	9.Emission Control Device Per SAE J1939
LPSIE08.8LPG	8800	LPG-270	270 @ 2600			565 @ 1500			ECM, TWC, 2HOS2(2), SFI

Ashley E. Scurlock

Bus Account Manager

Business License Number: 00016021

Salesman Dealer License: 00091001

Imberland

1901 Lebanon Pike

Nashville, TN 37210

Cell Phone 615.598.3572

My Fax Line: 615.844.5326

Main Fax: 615.829.7859

AScurlock@CLTTE.com



AIRSTAIR COMPANY



**SEALED SCHOOL BUS BID
PLEASE DO NOT OPEN!**

Hickman County Finance Office

114 North Central Avenue,

Suite 203

Centerville, TN 37033

(931) 729-3391

Monday, February 3, 2020 @ 10:00AM

"School Bus Bid"

78 passenger Propane

INVITATION TO BID

The Hickman County Finance Office is accepting sealed bids for school bus units. Bids are for 1-2 Type A special equipped bus. Specifications and bid requirement may be obtained from Steven George, Director of Transportation, Hickman County Schools at 931-729-3391, Ext. 2241 or by email at steven.george@hickmank12.org or online at www.hickmank12.org/request-for-proposal.

Sealed bids must be mailed or delivered to the Hickman County Finance Office, 114 North Central Avenue, Suite 203, Centerville, TN 37033 and clearly marked on the outside of the bid envelope "School Bus Units – Type A Special Equipped." Bids will be opened on Monday, February 3, 2020 at 10:30 a.m. at the Finance Office.

The Hickman County Board of Education reserves the right to accept or reject any and all bids or parts of bids and to waive any informalities that would prevent acceptance of a better bid.

Cumberland No Bid

Central State \$73,893.⁰⁰
Bus Sales

Present Penny Mayberry
Candi Ows

INVITATION TO BID

The Hickman County Finance Office is accepting sealed bids for school bus units. Bids for 1-2 Type A special equipped bus. Specifications and bid requirement may be obtained from Steven George, Director of Transportation, Hickman County Schools at 931-729-3391, Ext. 2241. Email: steven.george@hickmank12.org

Sealed bids must be mailed or delivered to the Hickman County Finance Office, 114 North Central Avenue, Suite 203, Centerville, TN 37033 and clearly marked on the outside of the bid envelope "School Bus Units." Bids will be opened on

February 3 at 10:30am

at the Finance Office. The Hickman County Board of Education reserves the right to accept or reject any and all bids or parts of bids and to waive any informalities that would prevent acceptance of a better bid.

HICKMAN COUNTY BOARD OF EDUCATION

115 MURPHREE AVENUE
CENTERVILLE, TN 37033
931-729-3391

BID OFFER FOR 1 UP TO 2 BUS TYPE A UNITS.

TO THE HICKMAN COUNTY BOARD OF EDUCATION, CENTERVILLE, TENNESSEE:

IN RESPONSE TO YOUR INVITATION, MY COMPANY SUBMITS THE FOLLOWING BIDS ON SCHOOL BUSES. THE SCHOOL BUS SPECIFICATIONS REQUIRED BY THE TENNESSEE STATE BOARD OF EDUCATION, AND BY YOU, AND THE CONDITIONS SET FORTH IN YOUR BID INVITATION ARE CLEARLY UNDERSTOOD AND ARE COMPLIED WITHIN THIS BID.

- A. MAKE _____ MODEL & NUMBER _____
B. BID PRICE DELIVERED F.O.B. CENTERVILLE, TENNESSEE MOUNTED AND FULLY EQUIPPED AS SPECIFIED.

NUMBER OF BUSES	SEATING CAPACITY	UNIT PRICE	TOTAL
_____	_____	<u>No Bid</u>	<u>No Bid</u>
_____	_____	_____	_____
_____	_____	_____	_____

TOTAL BIDS ON ALL _____

INVOICE TO BE PAID IN FULL UPON COMPLETION AND PASSING INSPECTION OF STATE OF TENNESSEE.

SIGNED

Ashley E. Scudlock

Bus Account Mg.

TITLE

Cumberland

COMPANY

ADDRESS

DATE:

Feb 3, 2020

Delivery Date: _____ (Must be specific)

* PENALTY CLAUSE: THERE WILL BE A \$100.00 A DAY PENALTY, PER UNIT, ACCESSED FOR EACH DAY OVER AGREED DELIVERY DATE.

WARRANTIES: TOWING WILL BE INCLUDED FOR LIFE OF ALL APPLICABLE WARRANTIES

LIFT BUS SCHOOL BUS SPECIFICATIONS

Vehicle(s) shall be new 2020 (or later) year model front engine design.

IN ADDITION, UNIT MUST MEET ALL STATE AND FEDERAL SPECIFICATIONS.

PLEASE NOTE ANY DEVIATIONS FROM THE ABOVE SPECIFICATIONS BESIDE THE RESPECTIVE DESCRIPTION.

CHASSIS REQUIREMENTS

ALTERNATOR: 220 VOLTS

AXLES: 14,000 GVW

BATTERIES: Dual Batteries, mounted in battery compartment in body skirt. With a battery cutoff switch

BRAKES: Hydraulic anti-lock, front disc, rear drum or disc.

BUMPERS: Front steel to be supplied by chassis manufacturer. Rear to measure 3/16" x 8" high hot rolled steel with 12" wrap around

CHASSIS: GM or equivalent

CONTROLS: Following are minimum requirements:

- | | |
|--|-------------------------------------|
| a. Intermittent wipers | b. Key-type starter switch |
| c. Dimmer switch | d. Hazard switch on steering column |
| e. Self-canceling turn signal | f. Rheostat dash dimmer |
| g. Dash-mounted transmission shifter | |
| h. All accessory switches to be dash mounted, no overhead controls | |
- COOLING: Super duty cooling package, school bus package

DRIVE LINE: Steel drive shafts with protective guard around each shaft.

ENGINE: Diesel specify in what manufacturer with 5 Year/ 100,000 miles Warranty. Towing included for life of warranty on engine.

FUEL TANK: Minimum of 33 gallons

FUEL SYSTEM: Fuel system must include fuel filter/water separator.

- INSTRUMENTS:
- | | |
|------------------------------|-----------------------|
| a. Speedometer/odometer | b. Voltmeter |
| c. Fuel gauge | d. Oil pressure gauge |
| e. Coolant temperature gauge | |

LIFT BUS SPECS (PAGE 2)

- PAINT: Wheels and bumpers painted black
- SHOCKS: Heavy duty, double action piston type; two front and two rear required
- STEERING: Full power
- TIRES: Tubeless radial tires; 16 LT. 225/75R, 16E
- TRANSMISSION: 6 speed automatic with overdrive
- WHEELS: Disc type: 16"

BODY REQUIREMENTS

- A/C SYSTEM: Minimum 50,000 BTU with skirt mounted condenser;
To have front dash and rear AC in wall; skirt mounted condenser
- ACCESS: Wiring and fuse access to be inside covered by a removable panel that does not require the use of tools.
- CAMERA: To be REI 8 head dvr with 4 cameras mounted on both side walls with 180 field of vision and one out the front view
- COMPARTMENTS: Storage compartment mounted over the driver's area
- CONSTRUCTION: Must meet FMVSS 221 joint strength requirements. Floor to have a 14 gauge steel welded frame which supports an aluminum sheet floor and 5/8" Marine grade plywood floor. Roof sheets to be one piece from window to window with embossed rain visors.
- DOORS: Entrance: Outward opening door, Electric operation, 30" full opening and 1,500 sq. inch of glass area. Stainless steel grab rail.
Rear emergency to have upper and lower tinted glass.
- FLOORING: Black rubber flooring with white colored nosing on each step. Molded rubber covers required over front and rear interior wheel-housings. Rounded rustproof metal cover molding to be installed where floor meets wall on each.
- HEADROOM: Interior must have a minimum of 75" headroom at aisle.

LIFT BUS SPECS (PAGE 3)

HEATERS: Two heaters are required. Front heater / defroster. One rear wall mounted heater 40,000 BTUs.

HORNS/ALARM: Mounted in steering wheel. 112 DBS. backup alarm.

INSULATION: 1 ½” insulation in the sides and roof

IDENTIFICATION: Our school system with 6in letters lettered on both sides of bus. Numbers will be provided to the successful bidder.

LIGHTS: Eight light warning LED light system. **All lights to be LED.**

LIFT DOOR: Lift door to be mounted in the rear providing a 43” wide opening. Lift must be by Ricon model, meeting most recent standards.

MIRRORS: Interior: 6” x 16” non-glare. With rear view camera mouted in mirror view

Exterior: **To be heated. Federal spec.**

MUD FLAPS: Front mud flaps to be installed

RADIO: AM/FM/CD stereo with clock

2-WAY RADIO: Kenwood To be installed as part of bid

PAINT: School Bus Yellow with black rub rails

REFLECTIVE MARKINGS: 3 M Diamond Grade Reflective vinyl markings “SCHOOL BUS” 8” front and rear roof caps, 2” wide strip each side of bus at floor line. 1 ¾” wide strip on rear of bus at top and bottom and 2” wide strip vertically on each side of rear.

SAFETY: Spheros triple roof vent (1); Push out windows (2) FAK, FE, Flares, body fluid kit.

SEATS: Driver: Cloth, high back with reclining feature.
Passenger: Driver side seats to be 39 inches, seat belts, gray upholstery.

SEAT PLAN: 21 Passenger, with all passenger seats removable. Five wheelchair stations. **Please enclose a copy of your floor plan.**

LIFT BUS SPECS (PAGE 4)

SIDE PANELS: Interior - Aluminized steel side walls with mar-resistant finish.

SOLENOID: Must have a solenoid breaker that disconnects all body circuits when ignition is turned off.

STEPWELL: Aluminum three step entrance with 8" step riser max.

STROBE: Roof mounted strobe light with separate switch

TIE DOWNS: Wheelchair tie downs to be auto-retractable, four point plus shoulder and lap belts.
To have aluminum tracking mounted in the floor.

WINDOWS: Windows are to be aluminum split sash type. Tinted windows in side and rear glass.

WIPERS: Intermittent feature

WIRING: All body wiring shall be color coded.

CHILD REMINDER SYSTEM: Doran

WARRANTY

CHASSIS: To have 5 yr. /100,000 mile warranty. Towing included for life of warranty.

BODY: Please enclose a copy.

TRANSMISSION: Five years/unlimited mileage.

ENGINE: 5YR/100,000 mile warranty with towing for life of warranty.

HICKMAN COUNTY BOARD OF EDUCATION
115 MURPHREE AVENUE
CENTERVILLE, TN 37033
931-729-3391

BID OFFER FOR 1 UP TO 2 BUS TYPE A UNITS.

TO THE HICKMAN COUNTY BOARD OF EDUCATION, CENTERVILLE, TENNESSEE:

IN RESPONSE TO YOUR INVITATION, MY COMPANY SUBMITS THE FOLLOWING BIDS ON SCHOOL BUSES. THE SCHOOL BUS SPECIFICATIONS REQUIRED BY THE TENNESSEE STATE BOARD OF EDUCATION, AND BY YOU, AND THE CONDITIONS SET FORTH IN YOUR BID INVITATION ARE CLEARLY UNDERSTOOD AND ARE COMPLIED WITHIN THIS BID.

- A. MAKE Girardin/GM MODEL & NUMBER Micro Bird G5
B. BID PRICE DELIVERED F.O.B. CENTERVILLE, TENNESSEE MOUNTED AND FULLY EQUIPPED AS SPECIFIED.

NUMBER OF BUSES	SEATING CAPACITY	UNIT PRICE	TOTAL
<u>1</u>	<u>16+1</u>	<u>\$73,893.00</u>	<u>\$73,893.00</u>
<u> </u>	<u> </u>	<u> </u>	<u> </u>
<u> </u>	<u> </u>	<u> </u>	<u> </u>
TOTAL BIDS ON ALL			<u>\$73,893.00</u>

INVOICE TO BE PAID IN FULL UPON COMPLETION AND PASSING INSPECTION OF STATE OF TENNESSEE.

SIGNED



Regional Sales Manager
TITLE

Central States Bus Sales, Inc.
COMPANY
303 Business Park Drive
Lebanon, TN 37090
ADDRESS

DATE: February 3, 2020

Delivery Date: June 15, 2020 (Must be specific)

* PENALTY CLAUSE:

THERE WILL BE A \$100.00 A DAY PENALTY, PER UNIT, ACCESSED FOR EACH DAY OVER AGREED DELIVERY DATE.

WARRANTIES:

TOWING WILL BE INCLUDED FOR LIFE OF ALL APPLICABLE WARRANTIES

LIFT BUS SCHOOL BUS SPECIFICATIONS

Vehicle(s) shall be new 2020 (or later) year model front engine design.

IN ADDITION, UNIT MUST MEET ALL STATE AND FEDERAL SPECIFICATIONS. PLEASE NOTE ANY DEVIATIONS FROM THE ABOVE SPECIFICATIONS BESIDE THE RESPECTIVE DESCRIPTION.

CHASSIS REQUIREMENTS

- ALTERNATOR: 220 VOLTS
- AXLES: 14,000 GVW
- BATTERIES: Dual Batteries, mounted in battery compartment in body skirt. With a battery cutoff switch
- BRAKES: Hydraulic anti-lock, front disc, rear drum or disc.
- BUMPERS: Front steel to be supplied by chassis manufacturer. Rear to measure 3/16" x 8" high hot rolled steel with 12" wrap around
- CHASSIS: GM or equivalent
- CONTROLS: Following are minimum requirements:
a. Intermittent wipers
b. Key-type starter switch
c. Dimmer switch
d. Hazard switch on steering column
e. Self-canceling turn signal
f. Rheostat dash dimmer
g. Dash-mounted transmission shifter
h. All accessory switches to be dash mounted, no overhead controls
- COOLING: Super duty cooling package, school bus package
- DRIVE LINE: Steel drive shafts with protective guard around each shaft.
- ENGINE: Diesel specify in what manufacturer with 5 Year/ 100,000 miles Warranty. Towing included for life of warranty on engine.
- FUEL TANK: Minimum of 33 gallons
- FUEL SYSTEM: Fuel system must include fuel filter/water separator.
- INSTRUMENTS: a. Speedometer/odometer
b. Voltmeter
c. Fuel gauge
d. Oil pressure gauge
e. Coolant temperature gauge

LIFT BUS SPECS (PAGE 2)

PAINT: Wheels and bumpers painted black

SHOCKS: Heavy duty, double action piston type; two front and two rear required

STEERING: Full power

TIRES: Tubeless radial tires; 16 LT. 225/75R, 16E

TRANSMISSION: 6 speed automatic with overdrive

WHEELS: Disc type: 16"

BODY REQUIREMENTS

A/C SYSTEM: Minimum 50,000 BTU with skirt mounted condenser; To have front dash and rear AC in wall; skirt mounted condenser

ACCESS: Wiring and fuse access to be inside covered by a removable panel that does not require the use of tools.

CAMERA: To be REI 8 head dvr with 4 cameras mounted on both side walls with 180 field of vision and one out the front view

COMPARTMENTS: Storage compartment mounted over the driver's area

CONSTRUCTION: Must meet FMVSS 221 joint strength requirements. Floor to have a 14 gauge steel welded frame which supports an aluminum sheet floor and 5/8" Marine grade plywood floor. Roof sheets to be one piece from window to window with embossed rain visors.

DOORS: Entrance: Outward opening door, Electric operation, 30" full opening and 1,500 sq. inch of glass area. Stainless steel grab rail. Rear emergency to have upper and lower tinted glass.

FLOORING: Black rubber flooring with white colored nosing on each step. Molded rubber covers required over front and rear interior wheel-housings. Rounded rustproof metal cover molding to be installed where floor meets wall on each.

HEADROOM: Interior must have a minimum of 75" headroom at aisle.

LIFT BUS SPECS (PAGE 3)

- HEATERS: Two heaters are required. Front heater / defroster. One rear wall mounted heater 40,000 BTUs.
- HORNS/ALARM: Mounted in steering wheel. 112 DBS. backup alarm.
- INSULATION: 1 ½” insulation in the sides and roof
- IDENTIFICATION: Our school system with 6in letters lettered on both sides of bus. Numbers will be provided to the successful bidder.
- LIGHTS: Eight light warning LED light system. **All lights to be LED.**
- LIFT DOOR: Lift door to be mounted in the rear providing a 43” wide opening. Lift must be by Ricon model, meeting most recent standards.
- MIRRORS: Interior: 6” x 16” non-glare. With rear view camera mouted in mirror view
Exterior: **To be heated. Federal spec.**
- MUD FLAPS: Front mud flaps to be installed
- RADIO: AM/FM/CD stereo with clock
- 2-WAY RADIO: Kenwood To be installed as part of bid
- PAINT: School Bus Yellow with black rub rails
- REFLECTIVE MARKINGS: 3 M Diamond Grade Reflective vinyl markings “SCHOOL BUS” 8” front and rear roof caps, 2” wide strip each side of bus at floor line. 1 ¾” wide strip on rear of bus at top and bottom and 2” wide strip vertically on each side of rear.
- SAFETY: Spheros triple roof vent (1); Push out windows (2) FAK, FE, Flares, body fluid kit.
- SEATS: Driver: Cloth, high back with reclining feature.
Passenger: Driver side seats to be 39 inches, seat belts, gray upholstery.
- SEAT PLAN: 21 Passenger, with all passenger seats removable. Five wheelchair stations. **Please enclose a copy of your floor plan.**

LIFT BUS SPECS (PAGE 4)

- SIDE PANELS: Interior - Aluminized steel side walls with mar-resistant finish.
- SOLENOID: Must have a solenoid breaker that disconnects all body circuits when ignition is turned off.
- STEPWELL: Aluminum three step entrance with 8" step riser max.
- STROBE: Roof mounted strobe light with separate switch
- TIE DOWNS: Wheelchair tie downs to be auto-retractable, four point plus shoulder and lap belts.
To have aluminum tracking mounted in the floor.
- WINDOWS: Windows are to be aluminum split sash type. Tinted windows in side and rear glass.
- WIPERS: Intermittent feature
- WIRING: All body wiring shall be color coded.
- CHILD REMINDER SYSTEM: Doran

WARRANTY

- CHASSIS: To have 5 yr. /100,000 mile warranty. Towing included for life of warranty.
- BODY: Please enclose a copy.
- TRANSMISSION: Five years/unlimited mileage.
- ENGINE: 5YR/100,000 mile warranty with towing for life of warranty.



EXCEPTIONS

**HICKMAN COUNTY SCHOOLS
TYPE A Special Equipped Bus**

<i>ITEM DESCRIPTION</i>	<i>EXCEPTION</i>
A/C SYSTEM: Minimum 50,000 with skirt mounted condenser; to have front dash and rear AC in wall; skirt mounted condenser	TOTAL AC capacity is 55,000 BTU but A/C is rear ceiling mount, not in wall.
COMPARTMENTS: Storage compartment mounted over driver's area.	GLOVE BOX is located beside MORE VIEW window.

NOTE: The wheelchair restraint configuration for this bus is as shown below:

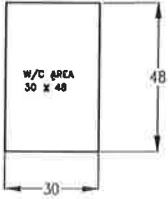

IMPORTANT NOTICE / AVIS IMPORTANT

VEHICLE CONFIGURATION AND CAPACITY ARE SUBJECT TO CHANGE TO REFLECT ANY AND ALL CHASSIS SPECIFICATIONS OF THE MODEL YEAR UTILIZED.
LA CONFIGURATION ET LA CAPACITÉ DE CE VÉHICULE SONT SUJETTES À DES MODIFICATIONS AFIN DE TENIR COMPTE DES SPÉCIFICATIONS DU CHÂSSIS DE L'ANNÉE MODÈLE UTILISÉ.

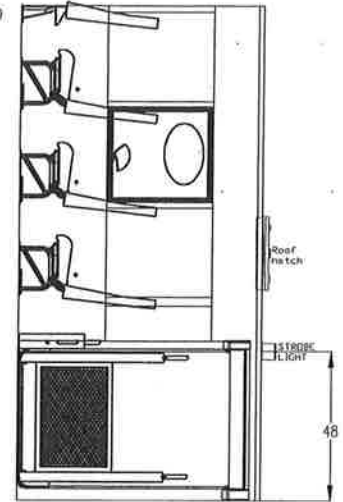
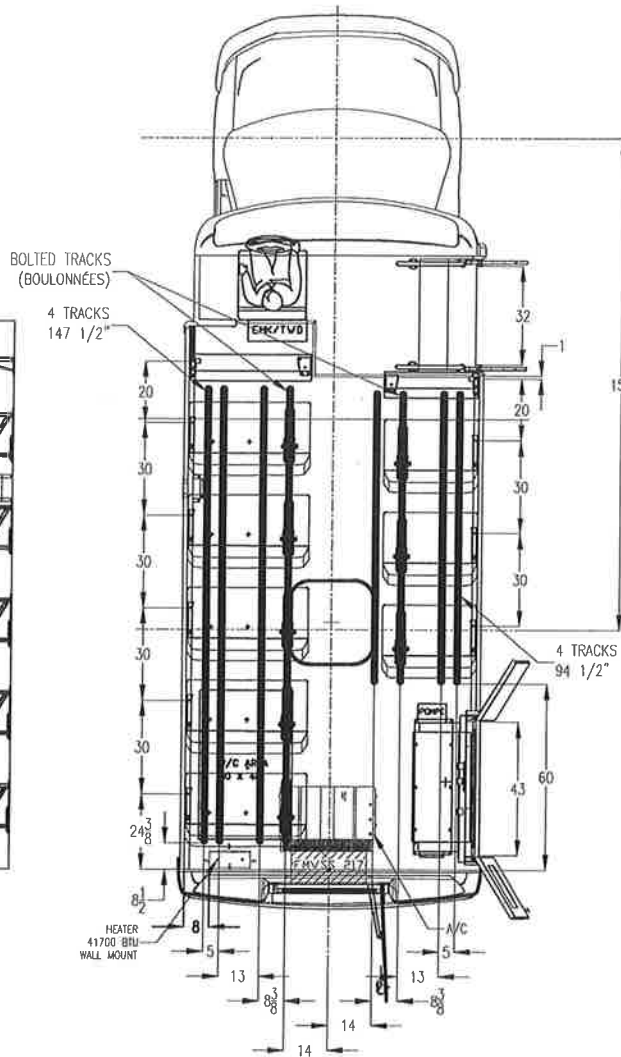
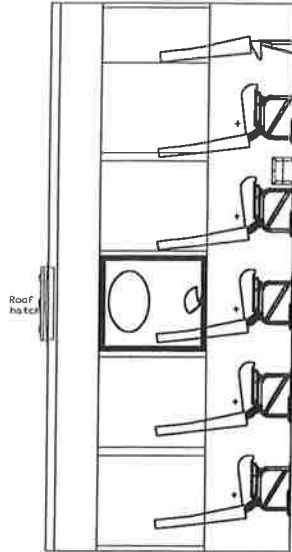

**FOR QUOTATION ONLY
POUR SOUMISSION SEULEMENT**

SEAT	DIM.	SIDE	QTY	LEG
SH-CT	39	LH	5	*
SH-CT	30	RH	3	*

Seat spacing = See drawing D.O.D.: 32"

APPROVED CONFIGURATIONS

Total ambulatory passengers:	21	Total wheel chair passengers:	0
Load cap. (pass. + cargo):	**** kg	**** lbs	

A	2019/02/18	J. M.	DRAWING CREATION
REV.	YYYY/MM/DD	BY	DESCRIPTION
Stock Number:			
Customer Approval:	Date:		

Drawn by:	J. M.	
MODEL:	UGM5 CRM WSP	
UNIT = INCHES	Drawing no.	
SCALE = DO NOT SCALE	042416	
NOTE: Any option added to this floorplan shall be approved by the Corporation Micro Bird inc technical department.		

Request For Proposal

The Hickman County Finance Office is accepting **Request for Proposal** for complete removal and replacement of a **6.0 Ford Remanufactured Engine with Dealer Backed Warranty in a 2008 E450 cutaway Special Equipped School Bus**. Additional information may be obtained from Steven George, Director of Transportation, Hickman County Schools at 931-729-3391, Ext. 2241, or by email: steven.george@hickmank12.org.

Sealed Request for Proposals must be mailed or delivered to the Hickman County Finance Office, 114 North Central Avenue, Suite 203, Centerville, TN 37033 and clearly marked on the outside of the bid envelope "School Bus Engine Replacement" Proposals will be opened on Monday, January 27, 2020 at 10:00 a.m. at the Finance Office.

The Hickman County Board of Education reserves the right to accept or reject any and all proposals and to waive any informalities that would prevent acceptance of a better proposal.

*Present Penny Mayberry
Carrie Davis*

No Bids Rec'd



Hickman County Schools Board Agenda Item Request

Date: January 10, 2020

Name of School: East Hickman Elementary School

Item Request: EHES Job Share

Explanation: Mrs. Mandy Tidwell and Mrs. Jennifer Knight are seeking approval to continue their job share position in second grade at East Hickman Elementary.

See attached proposal

Signature of Person requesting to be placed on the agenda:

Mandy Tidwell / Jennifer Knight

Signature of Building Principal:

Reigha Coble

January 10, 2020

To whom it may concern:

We are requesting a job share position for the 2020-2021 school year. The purpose of requesting this position is to enable us to spend more time at home caring for our young children, but also continuing to serve as an educator. We believe an equal balance between caring for our families and educating our students will benefit everyone involved. We are grateful to have had the opportunity to work in a job share position for the past two school years. We have attached our job share proposal which includes our plan, as well as other important information regarding a job share position. We really appreciate your consideration on this matter.

Sincerely,

Mandy Tidwell

Jennifer Knight

Logo

School Name

August
2020

Important Information

Sun	Mon	Tue	Wed	Thu	Fri	Sat
			29 JK\MT	30 JK\MT	31 JK\MT	1
2	3 JK\MT 8-10	4 Admin. JK\MT	5 JK\MT	6 JK\MT	7 JK\MT	8
9	10 JK	11 MT	12 JK	13 MT	14 JK	15
16	17 JK	18 MT	19 JK	20 MT	21 MT	22
23	24 JK	25 MT	26 JK	27 MT	28 JK	29
30	31 JK					

Logo

School Name

September
2020

Important Information

Sun	Mon	Tue	Wed	Thu	Fri	Sat
		1 MT	2 JK	3 MT	4 MT	5
6	7 No School Labor Day	8 JK/MT P.D.	9 JK	10 MT	11 JK	12
13	14 JK	15 MT	16 JK	17 MT	18 MT	19
20	21 JK	22 MT	23 JK	24 MT	25 JK	26
27	28 JK	29 MT	30 JK			

Logo

School Name

October
2020

Important Information

Sun	Mon	Tue	Wed	Thu	Fri	Sat
				1 MT	2 MT	3
4	5 JK	6 MT	7 JK	8 MT	9 JK	10
11	12 Columbus Day F A	13 L L	14 B R	15 F A	16 K	17
18	19 JK	20 MT	21 JK	22 MT	23 JK	24
25	26 JK	27 MT	28 JK	29 MT	30 MT	31 Halloween

Logo

School Name

November
2020

Important Information

Sun	Mon	Tue	Wed	Thu	Fri	Sat
1	2 JK\MT PTC 10-4	3 MT	4 JK	5 MT	6 JK	7
8	9 JK	10 MT	11 Veterans Day JK	12 MT	13 MT	14
15	16 JK	17 MT	18 JK	19 MT	20 JK	21
22	23 JK	24 MT	25 NO	26 Thanksgiving Day S C	27 HOOOL	28
29	30 JK					

Logo

School Name

December
2020

Important Information

Sun	Mon	Tue	Wed	Thu	Fri	Sat
		1 MT	2 JK	3 MT	4 JK	5
6	7 JK	8 MT	9 JK	10 MT	11 MT	12
13	14 JK	15 MT	16 JK	17 MT	18 JK\MT 8-10	19
20	21	22 8	23	24	25 Christmas	26
27	28	29	30	31		

Logo

School Name

January
2021

Important Information

Sun	Mon	Tue	Wed	Thu	Fri	Sat
					1 New Year's Day	2
3	4 JK\MT Admin.	5 MT	6 JK	7 MT	8 MT	9
10	11 JK	12 MT	13 JK	14 MT	15 JK	16
17	18 ML King's Day No School	19 MT	20 JK	21 MT	22 JK	23
24	25 JK	26 MT	27 JK	28 MT	29 JK	30
31						

Logo

School Name

February
2021

Important Information

Sun	Mon	Tue	Wed	Thu	Fri	Sat
	1 JK	2 MT	3 JK	4 MT	5 MT	6
7	8 JK	9 MT	10 JK	11 MT	12 JK	13
14	15 President's Day No School	16 MT	17 JK	18 MT	19 MT 	20
21	22 JK	23 MT	24 JK	25 MT	26 JK	27
28						

Logo

School Name

March
2021

Important Information

Sun	Mon	Tue	Wed	Thu	Fri	Sat
	1 JK	2 MT	3 JK	4 MT	5 MT	6
7	8 JK	9 MT	10 JK	11 MT	12 JK	13
14	15 JK	16 MT	17 JK	18 MT	19 MT	20
21	22 JK	23 MT	24 JK	25 MT	26 JK	27
28	29 S P	30 R I	31 M @			

Logo

School Name

April
2021

Important Information

Sun	Mon	Tue	Wed	Thu	Fri	Sat
				1 BRE	2 Good Friday AK	3
4 Easter Sunday	5 JK	6 MT	7 JK	8 MT	9 JK	10
11	12 JK	13 MT	14 JK	15 MT	16 MT	17
18	19 JK	20 MT	21 JK	22 MT	23 JK	24
25	26 JK	27 MT	28 JK	29 MT	30 MT	

Logo

School Name

May
2021

Important Information

Sun	Mon	Tue	Wed	Thu	Fri	Sat
						1
						2
						3
						4
						5
						6
						7
						8
						9
						10
						11
						12
						13
						14
						15
						16
						17
						18
						19
						20
						21
						22
						23
						24
						25
						26
						27
						28
						29
						30
						31

Mother's Day

JK

Last Day
MT

JK\MT
Admin

JK\MT
8-10

Memorial's Day



Misty Shelton
Director of Accountability
Hickman County Schools
115 Murphree Avenue
Centerville, Tennessee 37033

To: School Board Members
From: Misty Shelton
Date: February 2020

Up for Review:

- 4.100- Instructional Goals**
- 4.200- Curriculum Development**
- 4.201- Basic Program**
- 4.2012-Lifetime Wellness**
- 4.2013- Family Life Education**
- 4.202- Special Education**
- 4.203- Advanced College Placement**
- 4.204 Summer School**
- 4.206- Homebound Instruction**
- 4.207- English Learners**
- 4.208- Adult Education Program**
- 4.209- Alternative Credit Option**
- 4.210- Credit Recovery**
- 4. 211- Work Based Learning Program**

Up for 2nd reading:

- 6.300- Code of Behavior and Discipline-** Remove Lines 12-25 under punishment for Cell Phone Violations and add ***Principal discretion based on severity of violation***
- 6.312-Use of Personal Communication Devices and Electronic Devices-** Lines 15-17 should now read ***A student using a device outside these parameters shall be in violation of this policy and subject to disciplinary action.***

Thank you in advance for your careful consideration of these policies.

931-729-3391 ext. 2226

misty.shelton@hickmank12.org

fax 931-729-3834

Hickman County Board of Education

Descriptor Term: Code of Behavior and Discipline	Descriptor Code: 6.300	Issued Date: 11/05/18
	Rescinds: 6.300	Issued: 08/06/18

1 The following list of offenses and consequences is not intended to be an all-inclusive list. It is an attempt
2 to bring some consistency in the handling of student misconduct throughout the school system.

3 These school rules will apply:

- 4 1. On all school grounds and in school buses during, before or after school hours.
- 5 2. En route to and from school, including, but not limited to, on school buses.
- 6 3. At a school activity, function or event on or off campus.
- 7 4. Off campus if the conduct is potentially or actually disruptive to the school environment or its
8 educational purposes or constitutes a threat to the health, safety or welfare of either students or school
9 officials.

10 OFFENSES

PUNISHMENT

11 ZERO TOLERANCE OFFENSES

12 **Drugs:** Unlawfully possessing, acquiring, attempting
13 to acquire, using, being under the influence of, selling
14 or attempting to sell, distributing or transmitting any
15 narcotic, stimulant drug, prescription drug, barbitol or
16 legend drug, inhalants, or any other controlled
17 substance.

Mandatory 1 year expulsion

18 **Weapons:** Bringing a firearm to school or being in
19 possession of a firearm at school or knowingly
20 possessing, handling, transmitting, or using a weapon,
21 or knowingly possessing an object with the intent of
22 going armed, or use of any object in a threatening
23 or assaultive manner. Weapons include, but are not
24 limited to, firearms, BB guns, pellet guns, ammunition,
25 explosives, knives with blades of 2 1/2 inches or more

Mandatory 1 year expulsion

1 in length, switchblades, razor blades, box cutters,
2 bowie knife, hawk bill knife, or other like instruments
3 utilizing a razor blade and ice picks, daggers, slingshots,
4 leaded canes, blackjacks and knuckles.

5 **Assault:** Committing an assault which causes serious
6 bodily injury to another student or others. Acting in
7 lawful self-defense is not a violation of this rule.

Principal Discretion

8 **OTHER OFFENSES**

9 **Harassment (Intimidation/Bullying):** Conduct by a
10 student that has the purpose or effect of unreasonably
11 interfering with another student's academic development
12 or that creates an intimidating, hostile or offensive
13 learning environment.

**Up to and including a 1 year
expulsion**

14 **Harassment (Discrimination):** Any conduct that:
15 1. Unreasonable interferes with student work or
16 educational opportunities; or
17 2. Creates an intimidating, hostile or offensive
18 learning environment, where such conduct is
19 based on a person's sex, race, ethnicity or religion.

**Up to and including a 1 year
expulsion**

20 **Drug Look-A-Likes or Drug Paraphernalia:** Drug
21 look-alikes or paraphernalia shall include pills, powder
22 or any substance which gives the appearance of
23 prohibited drugs. Drug paraphernalia shall include
24 roach clips, rolling papers, pot pipes, pagers or any
25 other device or materials used with illegal substances.

5 day suspension

26 **Representation of any Substance as an Illegal Drug
27 or Controlled Substance. Other Drugs:** Possessing,
28 acquiring, attempting to acquire, using (whether by inhala-
29 tion, ingestion or injection), being under the influence of,
30 selling or attempting to sell, distributing or transmitting
31 any designer, synthetic or counterfeit drug, any illegal per-
32 formance enhancing drug, any substance that causes impair-
33 ment, any substance which is inappropriately used to alter

30 day suspension

1 the mind, mood or behavior, or any other substance used as
2 a drug. This Disciplinary Offense covers anything used as
3 a drug not covered in the Drugs section of the Zero
4 Tolerance Offenses.

5 **Smoking:** Smoking of any substance, including but not
6 limited to tobacco is prohibited. Both use (whether
7 smoking or otherwise) and possession of tobacco is
8 prohibited.

19 **Alcohol:** Possessing, acquiring, attempting to acquire,
20 consuming, being under the influence of, selling or
21 attempting to sell, distributing or transmitting alcoholic
22 beverages.

26 **Other Weapon Offenses:** A student shall not knowingly
27 possess, handle, or transmit oleoresin capsicum (pepper
28 spray), a knife with blade less than 2 1/2 inches in length
29 or a weapon replica. An exception applies to weapon
30 replicas when school authorities specifically authorize the
31 use of weapon replicas in instances such as the color guard,
32 a prop in a school play, and the like.

33 **Threats:** A threat communicated verbally or demonstra-
34 tively to inflict physical or other harm on any school

Punishment for Tobacco Use or Possession:

First Offense: 2 days in-school suspension

Second Offense: 3 days in-school suspension

Third Offense: 5 days in-school suspension

Fourth or More Offense: Suspension in addition to the foregoing, when a student is found to be in possession of tobacco, a court petition must be filed.

Punishment for non-tobacco smoking:

10 days suspension

30 days suspension or alternative school placement

First Offense: 5 day suspension or alternative school placement.

Second Offense: 10 day suspension or alternative school placement

Principal Discretion

1 employee, any other person acting in an official capacity
2 on behalf of the school, or any other student. To be a
3 violation of this rule, the threat must be one which would
4 cause a person to reasonably fear imminent bodily injury.

5 **Dress Code Violations**

First Offense: 1 day in-school
suspension or school-issued
uniform

Second or More Offenses: 1 day
in-school suspension or school-
issued uniform and parents
contacted.

12 **Cell Phone Violations**

Principal
discretion
based on
severity of
violation

~~**First Offense:** Phone confiscated
and not released to parent until the
end of the school day. As a
condition of release, parent signs
form acknowledging punishments
for further cell phone violations.~~

~~**Second Offense:** Phone
confiscated and not released to
parent until the end of last school
day of current grading period.~~

~~**Third and Subsequent Offenses:**
Phone confiscated and not released
to parent until end of last day of the
current school year.~~

26 **Damage to Property or Persons** including vandalism or
27 or damage resulting of misuse or destruction of school
28 property.

**Principal Discretion plus restitu-
tion**

29 **Fighting**

Principal Discretion

30 **Lying or Cheating**

Principal Discretion

31 **Failure to Obey Staff**

Principal Discretion

32 **Disruption of School**

Principal Discretion

1	Hazing: Any intentional or reckless act, on or off	Principal Discretion
2	school property, by a student, that endangers the mental	
3	or physical health or safety of that student, or that induces	
4	or coerces a student to endanger such student's mental or	
5	physical health or safety.	
6	Disrespect for School Employees or Other Students	Principal Discretion
7	Disruptive Behavior	Principal Discretion
8	Gambling	Principal Discretion
9	Attendance: Skipping any amount of school or	Principal Discretion
10	leaving school without permission	
11	Inappropriate Language	Principal Discretion
12	Forgery: Forging an official note to/from school	Principal Discretion
13	Littering	Principal Discretion
14	Off-Campus Criminal Behavior: Off-campus criminal	Principal Discretion
15	behavior which results in the student's being charged with	
16	a felony when the student's continued presence in school	
17	poses a danger to persons or property or disrupts the	
18	educational process.	
19	Other Off-Campus Behavior: A violation of any school	Principal Discretion
20	rule off-campus when the conduct is potentially or actually	
21	disruptive to the school environment, its educational	
22	purpose, or constitutes a threat to the health, safety, or	
23	welfare of a student or students and/or school personnel.	
24	Other Inappropriate Behavior	Principal Discretion
25	Offenses that are also Crimes: Any of the above offenses that constitute a criminal offense will be	
26	reported to local law enforcement officials.	

1 **Special Education Procedure:** The discipline of special education students is governed by federal and
2 state laws. If an offense is committed by a special education student, the federal laws may or may not
3 permit punishment as set forth above. In addition, special and different procedures must be followed
4 when an offense is committed by a special education student.

5 **Director's Right to Modify:** The director of schools has the right to modify disciplinary sanctions.
6 Such modification may only be done on a case-by-case basis considering the specific circumstances
7 surrounding the disciplinary sanction.

8 **Safe Harbor Provision:**

- 9 1. A student may approach a school official and voluntarily surrender an object, the possession of which
10 is prohibited by these rules, provided the object is one that the student could lawfully possess off
11 school grounds and is not a firearm. This safe harbor provision does not apply if a search is ongoing
12 in the school. If a student approaches a school official and voluntarily surrenders such an object,
13 then the student will not be subject to discipline under these rules. The principal will make
14 arrangements to return the object to the student's parents or legal guardian.
- 15 2. If a student discovers an illegal item such as drugs, a weapon or other contraband (e.g. tobacco,
16 alcohol) on school property, including on a school bus, the student may approach a school official
17 and report the discovery. A student shall not be in violation of the rules solely by making such a report.
18 School officials shall use discretion in determining whether the circumstances surrounding the report
19 warrant further investigation of the reporting student.

Hickman County Board of Education

Descriptor Term: Use of Personal Communication Devices and Electronic Devices	Descriptor Code: 6.312	Issued Date: 05/06/19
	Rescinds: 6.312	Issued: 01/07/19

1 Students in grades K-12 may possess personal communication devices and personal electronic devices
2 while on school property. Such devices include, but are not limited to, wearable technology such as
3 eye glasses, rings, or watches that have the capability to record, live stream, or interact with wireless
4 technology; cell phones; laptops; pagers; tablets; and mp3 players.

5 For students in grades K-5, the device must be in the off mode and must be kept in a backpack, pocket,
6 purse, or similar personal carry-all and may not be used during school hours without specific
7 permission from the principal/designee.

8 For students in grades 6-12, principals/designees will determine appropriate times when such devices
9 may be used.

10 At the direction of the teacher, and with the approval of the administration, students are encouraged to
11 bring personal electronic devices to school that support learning. Use of devices must be aligned with
12 the instruction taking place in a classroom.

13 At no time shall a student operate any device with video or picture taking capabilities in a locker room,
14 classroom, bathroom, or other location where such operation may violate the privacy rights of another
15 person. ~~A device used outside these parameters shall result in confiscation of the device until such time~~
16 ~~as it may be released to the student's parent/guardian. A student in violation of this policy is subject to~~
17 ~~disciplinary action.~~ be and

18 The student who possesses any such device shall assume responsibility for its use and care. At no time
19 shall the school be responsible for theft, loss or damage to devices that are brought on school property.

student using a device



Misty Shelton
Director of Accountability
Hickman County Schools
115 Murphree Avenue
Centerville, Tennessee 37033

To: School Board Members
From: Misty Shelton
Date: February 2020

Up for Review:

- 4.100- Instructional Goals**
- 4.200- Curriculum Development**
- 4.201- Basic Program**
- 4.2012-Lifetime Wellness**
- 4.2013- Family Life Education**
- 4.202- Special Education**
- 4.203- Advanced College Placement**
- 4.204 Summer School**
- 4.206- Homebound Instruction**
- 4.207- English Learners**
- 4.208- Adult Education Program**
- 4.209- Alternative Credit Option**
- 4.210- Credit Recovery**
- 4. 211- Work Based Learning Program**

Up for 2nd reading:

- 6.300- Code of Behavior and Discipline-** Remove Lines 12-25 under punishment for Cell Phone Violations and add ***Principal discretion based on severity of violation***
- 6.312-Use of Personal Communication Devices and Electronic Devices-** Lines 15-17 should now read ***A student using a device outside these parameters shall be in violation of this policy and subject to disciplinary action.***

Thank you in advance for your careful consideration of these policies.

931-729-3391 ext. 2226

misty.shelton@hickmank12.org

fax 931-729-3834

Hickman County Board of Education

Monitoring: Review: Annually, in November	Descriptor Term: <h2 style="margin: 0;">Instructional Goals</h2>	Descriptor Code: 4.100	Issued Date: 12/04/17
		Rescinds: 4.100	Issued: 08/02/99

- 1 The Board approves the following broad-based instructional goals for students:
- 2 • To acquire the knowledge and attitude necessary to achieve and maintain good physical and
- 3 mental health;
- 4
- 5 • To develop the skills necessary to function as a self-directed person;
- 6
- 7 • To develop the capacity to cope with change through an understanding of the arts, humanities
- 8 and scientific processes;
- 9
- 10 • To know the principles involved in making moral and ethical choices;
- 11
- 12 • To develop the basic skills of reading, writing, computation, spelling, speaking and problem
- 13 solving;
- 14
- 15 • To develop a positive attitude toward learning as a lifelong endeavor;
- 16
- 17 • To learn to identify personal talents and interests, make appropriate career choices, and develop
- 18 career skills;
- 19
- 20 • To acquire knowledge and to develop skills in the management of personal and public
- 21 resources necessary for meeting obligations to self, family and society;
- 22
- 23 • To learn to act in a responsible manner;
- 24
- 25 • To learn of the rights and responsibilities of citizens of the community, state, nation and world;
- 26 and
- 27
- 28 • To learn to understand, respect and interact with people of different cultures, generations and
- 29 races.

Cross References

School District Goals 1.700

Hickman County Board of Education

Monitoring: Review: Annually, in November	Descriptor Term: Curriculum Development	Descriptor Code: 4.200	Issued Date: 12/04/17
		Rescinds: 4.200	Issued: 06/06/05

1 Under the leadership and direction of the curriculum director, a unified curriculum shall be developed
2 within the statewide curriculum framework for the school system in each subject area, grades K-12,
3 and presented to the Board for adoption.^{1,2}

4 Teachers in each school shall participate in the systemwide development of the curriculum in their
5 appropriate subject areas. Assignments for curriculum development in the elementary grades will be
6 made by the principal.

7 The curriculum will be revised and updated regularly through in-service programs and curriculum
8 planning sessions, with changes subject to approval by the Board.

9 At least one copy of the complete curriculum shall be placed in each school. Teachers shall be given a
10 personal copy of the portion which pertains to their area of teaching. New teachers shall be given an
11 appropriate copy and briefed on its content in relation to the total curriculum.

12 Each teacher shall follow a course of study based on curriculum guides and textbooks. The prepared
13 course of study shall be reviewed annually and regularly updated and must be related to the individual
14 needs and abilities of the students.

15 Experimentation with newer concepts of curriculum design, scheduling, and instructional techniques is
16 encouraged but must have prior approval of the principal. An experimental program requires the
17 approval of the director of schools, the Board, the Commissioner of Education and the State Board of
18 Education.²

19 A course may become a permanent part of the school program after three (3) years of operation upon
20 approval of the State Board of Education.²

21 **IMPLEMENTATION**

22 The primary responsibility for the effective operation of the curriculum program and activities shall be
23 delegated to the director of schools.

24 The instructional supervisors, principals and teachers shall work cooperatively in the instructional
25 program.

26 The school principals shall be responsible for administering the established instructional programs and
27 for the development and supervision of a coordinated plan for the improvement of instruction in their
28 schools.

Legal References

1. TCA 49-1-302(a)(1)-(3), (8)
2. TRR/MS 0520-01-03-.05(1)(a); TRR/MS 0520-01-03-.05(2)

Cross References

Evaluations of Instructional Programs 4.702
In-Service & Staff Development Opportunities 5.113
Staff Rights & Responsibilities 5.600
Staff Time Schedules 5.602

Hickman County Board of Education

	Descriptor Term: <p style="text-align: center;">Basic Program</p>	Descriptor Code: <p style="text-align: center;">4.201</p>	Issued Date: <p style="text-align: center;">01/06/20</p>
		Rescinds: <p style="text-align: center;">4.201</p>	Issued: <p style="text-align: center;">12/04/17</p>

1 The Board shall not discriminate on the basis of sex, race, national origin, creed, age, marital status in
 2 its educational programs or activities.

3 Pupil-teacher ratios shall not exceed the averages outlined in state law. Further, class sizes shall not
 4 exceed the maximum allowed by state law.¹

5 Curriculum material utilized shall reflect the cultural and racial diversity present in the United States
 6 and the variety of careers, roles and life-styles open to women as well as men in our society. One of the
 7 objectives of the total curriculum and teaching strategies is to reduce stereotyping and to eliminate bias
 8 on the basis of sex, race, ethnicity, religion and disability. The curriculum shall foster respect and
 9 appreciation of the cultural diversity found in our country and an awareness of the rights, duties and
 10 responsibilities of each individual as a member of a pluralistic society.²

11 The course of study in the schools shall include those subjects required by the Legislature and
 12 Tennessee State Board of Education as follows: reading, writing, spelling, arithmetic, English,
 13 geography, hygiene, sanitation, music, drawing, black history and culture, physical education, and free
 14 enterprise. Specific topics required in the schools include: nature of alcoholic drinks, narcotics and
 15 smoking of cigarettes and their effect upon the human system; history of Tennessee and its
 16 Constitution; history of the United States and its Constitution; displaying of the American flag;
 17 highway safety; and defensive driving.

18 The Board reserves the right to add additional courses and to amend the content of prescribed courses
 19 as experience and the process of curriculum development indicate the desirability of such change.³

Legal References

1. TCA 49-1-104; TRR/MS 0520-01-03-.03(3)
2. 42 USCA § 12101; 34 CFR § 106.34
3. TCA 49-6-1001 to 1034, 1201-1205, 1301, 1302

Cross References

- Graduation Requirements 4.605
 Religious Content of Courses 4.804
 Student Goals 6.100
 Student Concerns, Complaints, and Grievances 6.305

Hickman County Board of Education

Monitoring: Review: Annually, in November	Descriptor Term: <h2 style="margin: 0;">Lifetime Wellness</h2>	Descriptor Code: 4.2012	Issued Date: 12/04/17
		Rescinds: 4.2012	Issued: 08/02/99

1 Students in grades 9-12 shall complete a unit of lifetime wellness, a planned program to promote a
 2 lifelong process of positive lifestyle management that seeks to integrate the emotional, social,
 3 intellectual and physical dimensions of self for a longer, more productive, and higher quality of life, as
 4 a requirement for graduation.¹

5 Participation in marching band or interscholastic athletics shall not be substituted for this requirement.²

6 Members of the professional staff shall work with the county and state health departments, the welfare
 7 department and members of the medical profession in promoting a program of good health for all
 8 pupils. Indications of a health problems shall be reported to the principal and the parents.

9 The following topics shall be included as part of the lifetime wellness course to help students reach the
 10 specified goals in the curriculum framework:

- 11 1. Disease Prevention and Control
- 12
- 13 2. Safety and First Aid
- 14
- 15 3. Mental Health
- 16
- 17 4. Nutrition
- 18
- 19 5. Substance Use/Abuse
- 20
- 21 6. Sexuality and Family Life
- 22
- 23 7. Personal Fitness and Related Skills

Legal References

- 1. TRR/MS 0520-1-3-.05(6)(e)(2) (i)
- 2. TRR/MS 0520-1-3-.05(6)(e)(2) (ii)

Cross References

- Student Drug and Alcohol Use 6.307
- Acquired Immune Deficiency Syndrome (AIDS) 6.404

Hickman County Board of Education

Monitoring: Review: Annually, in November	Descriptor Term: Family Life Education	Descriptor Code: 4.2013	Issued Date: 12/04/17
		Rescinds: 4.2013	Issued: 08/02/99

1 Boards of education in counties in which the pregnancy rates exceed 19.5 pregnancies per 1,000 females
2 ages fifteen (15) through seventeen (17) shall devise, adopt and implement a program of family life
3 education according to the guidelines established by the State Board of Education.¹

4 The Board shall annually evaluate the program and shall conduct public hearings and parental
5 conferences at least once (1) each September as part of the evaluation.

6 A parent who chooses not to have a student participate in the family life education program shall submit
7 such request in writing to the director of schools. A student who is excused from family life instruction
8 shall be assigned alternative activities and shall not be penalized academically.

9 Prior to implementing the family life education curriculum, the Board shall conduct at least one (1)
10 public hearing at which the plan will be explained and parents and community members shall be given
11 the opportunity to express their opinions.

12 The goals of instruction for the family life education program shall be to:²

- 13 1. Provide accurate information about human reproduction, including conception, birth, and
14 prenatal care, with specific emphasis on the family unit and the responsibilities and consequences
15 relating to sexual activity;
- 16 2. Adapt this information to the age and grade level of students;
- 17 3. Promote, encourage and increase communication between parents and students;
- 18 4. Increase decision-making skills;
- 19 5. Offer information that will help students act responsibly; and
- 20 6. Enhance and develop the student's self-esteem.

21 Within these goals and at appropriate age and grade levels, the information presented will include:

- 22 1. Anatomy, physiology, and psychology of adolescence and sexual growth;
- 23 2. Marriage and responsibilities of family life;
- 24 3. Responsibilities of parents and child care;
- 25 4. Legal aspects of sexual conduct;
- 26 5. Self-respect, self-control, and individual differences among people;
- 27 6. Community resources; and
- 28 7. Pregnancy and childbirth.

- 1 Instruction on family life education shall emphasize that abstinence from sexual relations is the only
- 2 method of protection that is 100% effective.

- 3 Personnel involved in instruction regarding human sexuality will conduct such instruction with maturity
- 4 and discretion. Personnel providing family life instruction shall receive in-service training prior to
- 5 presenting such instruction.

Legal References

1. TCA 49-6-1302
2. TCA 49-6-1301

Hickman County Board of Education

Monitoring: Review: Annually, in November	Descriptor Term: <h2 style="text-align: center;">Special Education</h2>	Descriptor Code: 4.202	Issued Date: 12/04/17
		Rescinds: 4.202	Issued: 08/02/99

1 The Board shall provide access to a free appropriate public education to all handicapped children ages
 2 3- 21, inclusive, residing within the jurisdiction of the school system. The plan for implementation of
 3 appropriate instruction and special education services shall be in accordance with the current Rules,
 4 Regulations, and Minimum Standards of the State Board of Education,¹ and state² and federal³ law.

5 The Board shall develop and periodically update a local plan for providing special education services
 6 for handicapped students. Specifically, the Board assures that:

- 7 1. All handicapped children living within the school system have available to them a free,
 8 appropriate public education which emphasizes special education and related services to meet
 9 their unique needs; and
- 10 2. The rights of handicapped children and their parents are protected.

12 The plan shall aim toward meeting the following objectives:

- 13 1. To carry out a comprehensive screening and assessment plan emphasizing the early
 14 identification and evaluation of handicapped students.
- 15 2. To use the Individual Educational Program (IEP-Team) for reviewing assessment, formulating
 16 programming, and determining placement for every handicapped student, including review of
 17 proposed suspensions when appropriate, in accordance with the State Board of Education
 18 Rules, Regulations, and Minimum Standards;
- 19 3. To ensure that placements are made which educate handicapped children with non-handicapped
 20 to the maximum extent appropriate in the schools these children would normally attend if not
 21 handicapped and with age-appropriate peers;
- 22 4. To provide each handicapped child with an individual educational program (IEP) specifically
 23 designed to meet his unique needs;
- 24 5. To provide continuing evaluation of each handicapped child's progress, including at least
 25 annual review of his IEP and complete re-evaluation at least every three (3) years;
- 26 6. To ensure that procedural safeguards required by state and federal laws are adhered to; and
- 27 7. To involve parents of handicapped children in a meaningful dialogue with school personnel
 28 which will begin with initial referral and continue throughout the student's educational career.

Legal References

1. TRR/MS 0520-01-09
2. TCA 49-10-101 et seq.
3. Education of Individuals with Disabilities, 20 U.S. C. Sections 1400-1485; Section 504 of the Rehabilitation Act of 1973 (Note: Section 504 of the Rehabilitation Act of 1973 has been interpreted by the courts to protect individuals with contagious diseases.)

Cross References

Compulsory Attendance Ages 6.201
Alternative School Program 6.319
Student Communicable Diseases 6.403
Acquired Immune Deficiency Syndrome 6.404
Special Education Students 6.500

Hickman County Board of Education

Monitoring: Review: Annually, in November	Descriptor Term: Advanced College Placement	Descriptor Code: 4.203	Issued Date: 12/04/17
		Rescinds: 4.203	Issued: 08/02/99

1 In keeping with the State Board of Education's endorsement of the Early Admission Program,¹ an
2 academically gifted high school student may complete the twelfth grade at a participating institution of
3 higher learning. The student will earn a year's credit in college at the same time that he earns credit for
4 his/her senior year in high school.

5 To be considered for this program, the student shall:

- 6 1. Earn a cumulative grade point average of at least 95.00 through three (3) years of high school;
7
- 8 2. Earn an ACT composite of at least 25;
9
- 10 3. Submit a written request to the high school principal at the end of the eleventh year of school,
11 signed by student and parents;
12
- 13 4. With parents, meet with principal and counselor for consultation;
14
- 15 5. Submit a letter stating educational and vocational goals, his/her plans for attaining them, and
16 ways in which early admission will assist in reaching these goals;
17
- 18 6. Secure the recommendation to the program by the principal, counselor and two classroom
19 teachers;
20
- 21 7. Be accepted into an early admission program by an accredited institution of higher learning;
22 and
23
- 24 8. Not be required to participate in the graduation program.

Legal References

1. TRR/MS 0520-01-03-.06(4)(a)

Cross References

- Enrollment in College Level Courses 4.205

Hickman County Board of Education

Monitoring: Review: Annually, in November	Descriptor Term: Summer School	Descriptor Code: 4.204	Issued Date: 01/08/18
		Rescinds: 4.204	Issued: 08/02/99

1 Summer schools organized and operated as a part of the public school program shall be under the
2 control and management of the Board having jurisdiction and shall comply with rules and regulations
3 prescribed by the state and local boards of education.¹ The qualifications of the teachers, the equipment
4 and the standards enforced shall be the same as in the regular school term. All summer school work
5 shall be organized by, and under the direction of, the principal or a qualified person designated by the
6 local board of education. All summer school classes shall meet in the school building.

7 No subject required for graduation by the State Board of Education shall be taken for new credit during
8 summer school unless approved by the principal of the school where the student expects to graduate.

9 In summer schools, not more than one unit for new credit to two units in review (make-up) work can
10 be earned by a student.

11 For grades 1 through 8 summer schools shall be established only for removing deficiencies of pupils
12 and for providing opportunities for enrichment.

13 For grades 9-12, in order to earn one unit of credit, a minimum of 140 contract hours shall be required
14 to achieve one full unit of credit in summer school. Not more than three (3)-sixty (60) minute periods
15 a day shall be spent in recitation for one subject. Teachers shall not be permitted to teach more than
16 one course during any given class period. None of the eleven (11) subjects required for graduation
17 shall be taken for the first time during a summer school session unless the student has maintained a
18 cumulative grade point average of at least 3.5 or its equivalent. The Commissioner of Education may
19 grant a waiver of this rule upon appeal of the local education agency authorities in cases of hardship in
20 order that students may take eleventh or twelfth grade English classes in summer school for the first
21 time.

22 The Board shall annually determine the tuition rates.²

23 Three (3) unexcused absences in any course offered during summer school renders a student ineligible
24 to receive credit in that course.

25 Absences shall be classified as either excused or unexcused as determined by the principal or his/her
26 designee. Excused absences shall include:

- 27 1. Personal illness;
- 28 2. Illness of an immediate family member;
- 29 3. Death in the family;

Hickman County Board of Education

	Descriptor Term: <h2 style="text-align: center;">Homebound Instruction</h2>	Descriptor Code: <h3 style="text-align: center;">4.206</h3>	Issued Date: <h3 style="text-align: center;">11/05/18</h3>
		Rescinds: <h3 style="text-align: center;">4.206</h3>	Issued: <h3 style="text-align: center;">04/02/18</h3>

1 The homebound instruction program is for students who because of a medical condition are unable to
 2 attend the regular instructional program.¹ The homebound instruction program shall consist of three (3)
 3 hours of instruction per week for a period of time determined, on a case-by-case basis, by the district.

4 To qualify for this program, a student shall have a medical condition that will require the student to be
 5 absent for a minimum of ten (10) consecutive instructional days, or for an aggregate of at least ten (10)
 6 instructional days for a student who has a chronic medical condition. The student shall be certified by a
 7 physician as having a medical condition that prevents him/her from attending the regular instructional
 8 program. The services provided to the homebound student shall reflect the student’s capabilities and be
 9 determined by the homebound instructor, after consultation with appropriate professional staff of the
 10 student’s assigned school.

11 Recertification shall be obtained after the expiration of each period of homebound instruction if the
 12 student’s physician certifies, in writing, that the student has a medical condition that prevents him/her
 13 from returning to the regular instructional program.

Legal References

1. TCA 49-10-1101; Public Acts of 2018, Chapter No. 625, TRR/MS 0520-01-02-.10

Cross References

- Student Communicable Diseases 6.403
 Acquired Immune Deficiency Syndrome 6.404

Hickman County Board of Education			
Monitoring: Review: Annually, in November	Descriptor Term: English Learners	Descriptor Code: 4.207	Issued Date: 12/04/17
		Rescinds: 4.207	Issued: 01/09/17

1 If the inability to speak and understand the English language excludes a student from effective
2 participation in the educational programs offered by the district, the district shall take reasonable actions
3 to provide the student equal access to its programs. Students who are English learners (“EL”) shall be
4 identified, assessed, and provided appropriate services. No child shall be admitted to or excluded from
5 any program or extra-curricular activity based on the student’s surname or EL status.¹

6 The director of schools shall evaluate the effectiveness of the district’s language assistance programs to
7 ensure EL students will acquire English proficiency and the ability to participate in the standard
8 instructional program within a reasonable period of time.

9 **ENGLISH LANGUAGE INSTRUCTION PROGRAM**

10 The board directs the administration to develop and implement language instruction programs that:²

- 11 1. Appropriately identify EL students in a timely, valid, and reliable manner.
- 12 2. Determine the appropriate instructional environment for EL students.
- 13 3. Provide EL students with a language assistance program that is educationally sound and proven
14 successful.
- 15 4. Annually assess the English proficiency of EL students and monitor the progress of students in
16 order to determine their readiness for standard instructional program.
- 17 5. Monitor the progress of students that have exited the EL program.

18 **PARENTAL NOTIFICATION³**

19 Parents of EL students shall be given notice of, and information regarding, the instructional program
20 within the first thirty (30) days of the school year, or within the first two weeks of a student being placed
21 in a language instruction educational program (LIEP). At a minimum, the notice will include the
22 following:³

- 23 1. The reason for identifying the child as an EL student;
- 24 2. The child’s level of English language proficiency, including how the level was assessed, and the
25 status of the child’s academic achievement;
- 26 3. Methods of instruction used in the program, methods of instruction in other available programs,
27 and how they differ;

- 1 4. How the program meets the educational strengths and needs of the student, and how the program
2 will help the student reach English language proficiency and meet academic standards;
- 3 5. Program exit requirements, rate of transition to a standard instructional program classroom, and
4 expected rate of high school graduation;
- 5 6. How the program meets the goals of an EL student with an IEP; and
- 6 7. Information on the parents' right to withdraw the student from the program or choose another
7 program or method of instruction if available.
- 8 Parental involvement will be encouraged and parents will be regularly apprised of their child's progress.⁴

Legal References

1. Elementary and Secondary Education Act, as amended by ESSA (Pub. L. 114-95), § 1112(e)(3)(D)
2. Elementary and Secondary Education Act, as amended by ESSA (Pub. L. 114-95), § 3113(b)(3)(B)
3. Elementary and Secondary Education Act, as amended by ESSA (Pub. L. 114-95), § 1112(e)(3)(A)
4. Elementary and Secondary Education Act, as amended by ESSA (Pub. L. 114-95), § 1112(e)(3)(C)

Hickman County Board of Education

Monitoring: Review: Annually, in November	Descriptor Term: Adult Education Program	Descriptor Code: 4.208	Issued Date: 01/08/18
		Rescinds: 4.208	Issued: 07/07/14

- 1 An Adult Education Program shall be provided to enable students and out-of-school youth who are
- 2 seventeen (17) years of age and over to meet high school graduation requirements and receive a high
- 3 school diploma.^{1,2}
- 4 The director of schools shall appoint a member of the staff to coordinate, plan and develop the
- 5 program.
- 6 Written parental permission and the approval of the coordinator is required for those students under 18
- 7 years of age.

Legal References

1. TCA 49-6-409; TRR/MS 0520-01-02-.05

Hickman County Board of Education

	Descriptor Term: Alternative Credit Options	Descriptor Code: 4.209	Issued Date: 08/05/19
		Rescinds: 4.209	Issued: 04/01/19

1 **ONLINE COURSES**

2 High school students may earn credit to be applied toward graduation requirements by completing online
3 courses offered through agencies or institutions approved by the Board. Credit from these online courses
4 may be earned only in the following circumstances:

- 5 1. The course is not offered at the high school, or although the course is offered at the high school,
6 the student has an unavoidable scheduling conflict;
- 7 2. The course will serve as a supplement to homebound instruction;
- 8 3. The student had been served by a recognized home school during the 2018 – 2019 school year
9 and has re-enrolled in the local education agency;
- 10 4. The student has been expelled from a regular school setting, but educational services are to be
11 continued; or
- 12 5. The principal, with agreement from the student's teachers and parent(s)/guardian(s), determines
13 the student requires a differentiated or accelerated learning environment.

14 The express approval of the principal/designee shall be obtained before a student enrolls in an online
15 course. Enrollment in approved online courses will be considered on a case by case basis by the principal
16 and teachers. The school shall receive an official record of the final grade before credit toward graduation
17 will be recognized.

18 Through a supervision plan, the school shall be responsible for providing appropriate supervision and
19 monitoring of students taking online courses.

20 **COURSE ACCESS PROGRAM**

21 Students in grades seven through twelve (7-12) may participate in the statewide course access
22 program. To become eligible to participate, students shall:

- 23 1. Meet all prerequisite requirements for the course access course; and
 - 24 2. Be unable to enroll in a comparable course at the student's school because:
 - 25 a. A comparable course is not offered; or
 - 26 b. A legitimate situation exists that prevents the student from enrolling in a comparable
27 course.¹
- 28

- 1 The Director of Schools shall develop administrative procedures to ensure that students and
- 2 parent(s)/guardian(s) are given written notice of their right to appeal any denial of a course access
- 3 course enrollment in a timely manner.² All appeals shall be submitted in writing to the Board within
- 4 ten (10) days of a denial.

- 5 After a timely appeal is made, the Board will provide written notification to the student and
- 6 parent(s)/guardian(s) of the time, place, and date of the hearing. The hearing shall be held no later than
- 7 ten (10) days after the appeal is submitted. At the hearing, the Board shall determine whether there was
- 8 an error in denying the student the ability to participate in the course access program.³

Legal References

1. TRR/MS 0520-01-14-.03(1)
2. TRR/M 0520-01-14-.03(7)
3. TRR/MS 0520-01-14-.03(6)

Cross References

Homebound Instruction 4.206
Grading System 4.600
Graduation Requirements 4.605

Hickman County Board of Education

Monitoring: Review: Annually, in November	Descriptor Term: Credit Recovery	Descriptor Code: 4.210	Issued Date: 01/08/18
		Rescinds: 4.210	Issued: 08/07/17

1 **GENERAL**¹

2 The director of schools shall ensure that credit recovery facilitators receive training regarding course
3 organization, online instruction management and related technology.

4 Credit recovery teachers shall comply with all State Board of Education certification requirements.¹

5 **ADMISSION AND REMOVAL**²

6 No student shall be admitted to or otherwise enrolled in credit recovery courses unless:

- 7 1. The student's parent/guardian gives written consent for the student to enroll in the proposed
8 credit recovery course. Parents/guardians should be informed that not all postsecondary
9 institutions will accept credit recovery courses for credit and that the NCAA Clearinghouse will
10 not accept credit recovery courses for credit; and
11
- 12 2. The student has previously taken an initial, non-credit recovery section of the proposed course
13 and received a grade of at least fifty percent (50%). Students who receive a grade of below fifty
14 percent (50%) in the non-credit recovery section of the course must re-take the course.

15 If a student is seeking to recover credit for the first semester of a two-semester course, the student may
16 not receive the full credit for the course until he/she has enrolled in and passed the second semester of
17 the course and taken any applicable End of Course examinations.

18 The board shall track students enrolled in credit recovery courses as directed by the Tennessee
19 Department of Education.

20 **INSTRUCTION AND CONTENT**¹

21 Credit recovery teachers shall work closely with credit recovery facilitators to correlate class content
22 and instruction.

23 The director of schools shall ensure that all credit recovery courses:

- 24 1. Align with Tennessee's current academic standards for the relevant course content area, as
25 approved by the State Board of Education; and
26
- 27 2. Differentiate instruction to address individual student growth needs based on diagnostic
28 assessment or End of Course data.

1 Students in credit recovery programs shall:

2 1. Complete a course skill-specific diagnostic to determine skill-specific goals;

3

4 2. Meet individual skill-specific goals in a flexible time frame as established by identified student
5 need; and

6

7 3. Master all individualized skill-specific goals as established by the diagnostic process in order to
8 earn credit.

9 **GRADES³**

10 Students passing credit recovery shall receive a grade of seventy percent (70%).

11 Grades awarded in credit recovery courses shall adhere to the State Board of Education's Uniform
12 Grading Policy.

Legal References

1. SBOE Policy 2.103(7)(b)
2. SBOE Policy 2.103(7)(a)
3. SBOE Policy 2.103(7)(c)

Cross References

Grading System 4.600
Promotion and Retention 4.603

Hickman County Board of Education

Monitoring: Review: Annually, in November	Descriptor Term: <h2 style="text-align: center;">Work Based Learning Program</h2>	Descriptor Code: 4.211	Issued Date: 12/04/17
		Rescinds: 4.211	Issued: 10/03/16

- 1 Students shall have access to a system of structured work-based learning (WBL) experiences that allow
- 2 them to apply classroom theories to practical problems as well as explore career options.

- 3 The director of schools shall develop administrative procedures to govern the efficient administration
- 4 of the WBL program. Such procedures shall include, among other things, a process for evaluation and
- 5 assessment of the program to ensure that it is of high quality and meets the needs of students.

Legal References

1. State Board of Education Policy 2.103

Exhibit 1

PROPOSED FUNDRAISING ACTIVITIES

Fund/account name EHS Fundraising

Proposed fundraising activities: Bunny Hop - April 9th
students will participate in a walk/run-athon. students
will get donations to earn prizes

Purposed Uses of funds raised
General Fund

Expected student involvement (school-wide or specific school organization) _____
School-wide

Method by which school will receive profit Cash or check

Requested by Angelo Campbell/Teacher Date 1-23-20
Name/Title

Approved by Leigha Cole Date 1-23-20
Principal

Approved by Michelle Sivert Date 1/24/20
Director of Schools*

* The Director of Schools must approve all fundraising activities that involve the participation of the general student population in the marketing process of the fundraising effort.

Exhibit 1

PROPOSED FUNDRAISING ACTIVITIES

Fund/account name EHES Fundraising

Proposed fundraising activities: Sweetheart Dance -
March 13th, 2020 this will be a Daddy/Daughter
Dance where each couple pays an entrance fee to come.

Purposed Uses of funds raised
we plan to use the funds
to help pay for new playground
equipment.

Expected student involvement (school-wide or specific school organization) _____
whole community

Method by which school will receive profit Cash or check

Requested by Angela Campbell / Teacher Date 1-23-20
Name/Title

Approved by Reigha Cole Date 1-23-20
Principal

Approved by Michelle Brewer Date 1/24/20
Director of Schools*

* The Director of Schools must approve all fundraising activities that involve the participation of the general student population in the marketing process of the fundraising effort.

Tennessee Internal School Uniform Accounting Policy Manual
Applicable Laws and Exhibits - Appendix A

Exhibit 1

PROPOSED FUNDRAISING ACTIVITIES

Fund/account name Yearbooks

Proposed fundraising activities: raise money for the general fund

Purposed Uses of funds raised teacher supplies

Expected student involvement (school-wide or specific school organization) _____

Students will preorder yearbooks

Method by which school will receive profit yearbook cost \$15 per copy - school will make \$5 per book

Requested by Penny Wilson Date 1-6-20
Name/Title

Approved by Reigha Coble Date 1-6-20
Principal

Approved by Michelle Hebert Date 1/8/20
Director of Schools*

* The Director of Schools must approve all fundraising activities that involve the participation of the general student population in the marketing process of the fundraising effort.

Tennessee Internal School Uniform Accounting Policy Manual
Applicable Laws and Exhibits-Appendix A

Exhibit 1

PROPOSED FUNDRAISING ACTIVITIES

Fund/account name Fundraising 4010

Proposed fundraising activities: Winter Wonderland

Purposed Uses of funds raised building general fund

Expected student involvement (school-wide or specific school organization) school-wide

Method by which school will receive profit entrance fee and collection over purchase price of concession items

Requested by EHS Leadership Team Date 1-9-20
Name/Title

Approved by Mary Tidwell Date 1-9-20
Principal

Approved by Michelle Hibert Date 1/9/20
Director of Schools*

* The Director of Schools must approve all fundraising activities that involve the participation of the general student population in the marketing process of the fundraising effort.

PROPOSED FUNDRAISING ACTIVITIES

Fund/account name EHMS Student Council

Proposed fundraising activities: Spring Dance/Social

Purposed Uses of funds raised General Funds to build an account for future activities related to school projects.

Expected student involvement (school-wide or specific school organization) _____

* ~~EHMS~~ EHMS students

Method by which school will receive profit cash / check

Requested by Yarissa Campbell Sr. Sponsor Date 1/22/2020
Name/Title

Approved by Byron Anfi Date 1/22/20
Principal

Approved by Michelle Gilbert Date 1/22/20
Director of Schools*

* The Director of Schools must approve all fundraising activities that involve the participation of the general student population in the marketing process of the fundraising effort.

PROPOSED FUNDRAISING ACTIVITIES

Fund/account name Boys Soccer

Proposed fundraising activities: Selling Krispy Kreme

Purposed Uses of funds raised Referee fees

Expected student involvement (school-wide or specific school organization) Team Only

Method by which school will receive profit Cash & Check

Requested by Wendell Gordon / Coach Date 1-10-20
Name/Title

Approved by Bryan Angh Date 1/10/20
Principal

Approved by Michelle Helbert Date 1/13/20
Director of Schools*

* The Director of Schools must approve all fundraising activities that involve the participation of the general student population in the marketing process of the fundraising effort.

PROPOSED FUNDRAISING ACTIVITIES

Fund/account name Shannon Nolen - Library

Proposed fundraising activities: _____
chocolate bars, fruit snacks, beef sticks

Purposed Uses of funds raised
Library receipt printer, portable scanner + large wall
school calendar

Expected student involvement (school-wide or specific school organization) -none-
staff only will sale

Method by which school will receive profit cash from profit of
sale item

Requested by Shannon Nolen
Name/Title

Date 12/20/19

Approved by Bryan Angli
Principal

Date 12/20/19

Approved by Michelle Helvert
Director of Schools*

Date 1/7/20

* The Director of Schools must approve all fundraising activities that involve the participation of the general student population in the marketing process of the fundraising effort.

Tennessee Internal School Uniform Accounting Policy Manual
Applicable Laws and Exhibits – Appendix A

Exhibit 1

PROPOSED FUNDRAISING ACTIVITIES

Fund/account name FBLA 846

Proposed fundraising activities: School Bookstore

Purposed Uses of funds raised
Conferences ; competitions
Travel

Expected student involvement (school-wide or specific school organization) _____
FBLA members

Method by which school will receive profit as items are sold

Requested by Cindi Morgan Date 1-10-20
Name/Title

Approved by [Signature] Date 1-10-20
Principal

Approved by Michelle Hebert Date 1/23/20
Director of Schools*

* The Director of Schools must approve all fundraising activities that involve the participation of the general student population in the marketing process of the fundraising effort.

PROPOSED FUNDRAISING ACTIVITIES



East Hickman High School
7700 Hwy 7, Lyles, TN 37098
Phone 931-670-1366 Fax 931-670-1039

Fund/Account Name Class of 2020

Account Number _____

Proposed fundraising activities: Students will vote on a candidit
to kiss a pig by donating various amounts of money

Purposed Uses of funds raised: graduation / sr trip

Expected Student involvement (school-wide or specific school organization): School wide
teachers by volunteer only

Method by which school will receive profit: cash

Requested by: Sheryl Robinson / sr Class Sponsor 1-8-20
Name/Title Date

Approved by: Michelle Been _____
Principal Date

Approved by: Michelle Hevert 1/16/20
Director of Schools* Date

* The Director of Schools must approve all fundraising activities that involve the participation of the general student population in the marketing process of the fundraising effort.

PROPOSED FUNDRAISING ACTIVITIES



East Hickman High School
7700 Hwy 7, Lyles, TN 37098
Phone 931-670-1366 Fax 931-670-1039

Fund/Account Name Boy Soccer

Account Number _____

Proposed fundraising activities: Host a playday on 2-29-20

Purposed Uses of funds raised: Referee Fee

Expected Student involvement (school-wide or specific school organization): Team Only

Method by which school will receive profit: Cash & Check

Requested by: Wendell Gordon - Coach
Name/Title

1-13-20
Date

Approved by: Wendell Boem
Principal

1-13-20
Date

Approved by: Michelle Gilbert
Director of Schools*

1/16/20
Date

* The Director of Schools must approve all fundraising activities that involve the participation of the general student population in the marketing process of the fundraising effort.

PROPOSED FUNDRAISING ACTIVITIES



East Hickman High School
7700 Hwy 7, Lyles, TN 37098
Phone 931-670-1366 Fax 931-670-1039

Fund/Account Name Boy Soccer

Account Number _____

Proposed fundraising activities: Krispy Kreme

Purposed Uses of funds raised: Referee Fee

Expected Student involvement (school-wide or specific school organization): Team Only

Method by which school will receive profit: Cash & Check

Requested by: Wendell Gordon - Coach
Name/Title

1-13-20
Date

Approved by: Wendell Gordon
Principal

1-19-20
Date

Approved by: Michelle Stewart
Director of Schools*

1/16/20
Date

* The Director of Schools must approve all fundraising activities that involve the participation of the general student population in the marketing process of the fundraising effort.

PROPOSED FUNDRAISING ACTIVITIES

Fund/account name Library

Proposed fundraising activities: Scholastic Book Fair
March 2-6, 2020

Purposed Uses of funds raised Library equip., supplies,
books

Expected student involvement (school-wide or specific school organization) School - wide

Method by which school will receive profit cash / check deposited
to library account

Requested by Kathy Brown
Name/Title

Date 1-16-2020

Approved by Jina S. Huguenot
Principal

Date 1-23-20

Approved by Michelle Hiebert
Director of Schools*

Date 1/24/20

* The Director of Schools must approve all fundraising activities that involve the participation of the general student population in the marketing process of the fundraising effort.

PROPOSED FUNDRAISING ACTIVITIES

Fund/account name School Wide Fundraiser

Proposed fundraising activities: Valentine's Day Social

Purposed Uses of funds raised rewards & instructional use

Expected student involvement (school-wide or specific school organization) School wide

Method by which school will receive profit cash

Requested by Christie Carter / teacher Date 1-10-20
Name/Title

Approved by [Signature] Date 1-10-20
Principal

Approved by [Signature] Date 1/13/20
Director of Schools*

* The Director of Schools must approve all fundraising activities that involve the participation of the general student population in the marketing process of the fundraising effort.

PROPOSED FUNDRAISING ACTIVITIES

Fund/account name Student Council

Proposed fundraising activities: Valentine Crush Fundraiser

Purposed Uses of funds raised To support STUCO activities, council t-shirts, and fall 2020 training

Expected student involvement (school-wide or specific school organization) _____

STUCO will sell, ~~and~~ will pass out during 7th on 2/14/20.

Method by which school will receive profit Collection of funds from Student Sales

Requested by Mary Scott Riley STUCO sponsor Name/Title Date 2/21/2020

Approved by Ken D. East Principal Date 2/21/2020

Approved by Michelle Hewitt Director of Schools* Date 1/24/20

* The Director of Schools must approve all fundraising activities that involve the participation of the general student population in the marketing process of the fundraising effort.

Exhibit 1

PROPOSED FUNDRAISING ACTIVITIES

Fund/account name Football

Proposed fundraising activities: Ball dog Discount Cards, Start
selling first of April

Purposed Uses of funds raised
for equipment, apparel, etc.

Expected student involvement (school-wide or specific school organization) Football Team
and Track Team

Method by which school will receive profit selling cards that they can use
year round (cards designed by coaches)

Requested by Brett Lovett / Football Coach Date 1/22/20
Name/Title

Approved by Ken D. [Signature] Date 1/22/2020
Principal

Approved by Michelle Gilbert Date 1/24/20
Director of Schools*

* The Director of Schools must approve all fundraising activities that involve the participation of the general student population in the marketing process of the fundraising effort.

Do track getting portion of money?

Exhibit 1

PROPOSED FUNDRAISING ACTIVITIES

Fund/account name ~~Boys & Girls Club~~ Track

Proposed fundraising activities: Lap-A-Thon, End of Feb.

Purposed Uses of funds raised
uniforms, apparel, equipment, etc.

Expected student involvement (school-wide or specific school organization) Track team

Method by which school will receive profit Donations / Pledges per lap

Requested by Brett Lovett Date 1/22/20
Name/Title

Approved by [Signature] Date 1/24/2020
Principal

Approved by Michelle Gilbert Date 1/23/20
Director of Schools*

* The Director of Schools must approve all fundraising activities that involve the participation of the general student population in the marketing process of the fundraising effort.

PROPOSED FUNDRAISING ACTIVITIES

Fund/account name Senior Class

Proposed fundraising activities: Balloons + stuffed animals
for Valentine's Day

Purposed Uses of funds raised Senior Class Graduation

Expected student involvement (school-wide or specific school organization) _____
Sell to entire school

Method by which school will receive profit Sales

Requested by K. Carter Date 1/10/20
Name/Title

Approved by Ken D. [Signature] Date 1/10/2020
Principal

Approved by Michelle Helvert Date 1/10/20
Director of Schools*

* The Director of Schools must approve all fundraising activities that involve the participation of the general student population in the marketing process of the fundraising effort.