

MINUTES OF BOARD OF EDUCATION
South Platte School District #95
Regular Board Meeting March 11, 2024 7:00 PM

President Darrel Armstrong called to order the Regular Board Meeting of the school board at 7:00 PM with board members: **Present:** Darrel Armstrong, Adam Hayward, Amy Stanley, Tim Van Zee, Patricia Welsh, **Absent:** Duane Duncan. **Present:** Duane Duncan. Also present were Superintendent David Spencer and Business Manager Lisa Wilson. Notice of the meeting was published in the Keith County News, online, and available at the office.

The Pledge of Allegiance was recited and President Armstrong made note of the Open Meetings Act poster that is on display in the meeting room.

Motion by Adam Hayward seconded by Tim Van Zee to approve the consent agenda as presented: A. Confirmation of the last regular meeting minutes B. Financial Reports C. Treasurer's Report D. Claims: General Fund E. Claims: Building/Bond/Depreciation Fund (if any). Motion carried.

Darrel Armstrong: yes, Patricia Welsh: yes, Tim Van Zee: yes, Adam Hayward: yes, Amy Stanley: yes, Duane Duncan: yes

CLAIMS: GENERAL FUND: Activity Account 20,000.00; All Star Auto Glass 39.95; Amazon Capital Services, Inc. 3,139.78; Big Springs Truck and Travel 3,605.62; Black Hills Energy 4,200.00; Cambria Hotel Omaha Downtown 272.45; Card Service Center 1,542.65; Cash-Wa Dist. 453.07; Century Link 671.90; Eakes 1,141.18; EduTrack, LLC 2,242.44; ESU 16 16,341.41; Family Market Food & Hardware 27.70; Follett School Solutions, LLC 847.89; Goddard, M 13.08; HealthEquity Inc. 146.00; Hometown Leasing 2,624.97; Hot Lunch Account 468.00; Hot Lunch 1,384.80; Ideal Linen Supply 348.28; Inland Truck Parts 3,536.25; Johnson, C 136.61; JWPepper 211.94; Keith Co. News; 88.68; Kelli Thompson LLC 999.00; Lane, M 62.00; Menards 906.82; Mid-American Research 286.50; NPPD (Nebraska Public Power District) 3,400.00; NPPD MLBRY Acct 68.19; NPPD Plum 2 Acct 47.37; Office Service, Inc. 2,982.00; Platform Athletics, LLC 2,700.00; R Lawn LLC 10,323.66; Ray's Cement Works 3,575.00; S & W Auto Supply 182.99; Sidney Heavy Truck & Auto, LLC 361.37; Snell Services, Inc. 1,074.62; Staples 26.59; Verizon Wireless 248.33; Village Of Big Springs 669.80; Walmart 327.89; Weber, T 20.41; WEX Bank 78.73; Wiest Hardware 52.45; Payroll: \$320,564.54

COMMITTEE REPORTS: EDUCATION: A financial education board seminar is scheduled later in the month. TRANSPORTATION: One suburban is getting a new starter and several were serviced over the spring break.

Mr. Nick Brost's Principal's Report: Congratulations to: February the Students of the Month: Brooke Moorhous, Brooke Fox, Ella Stanley, Kaitlynn Brown, Nathan Jacobs, and Jaquelyn Ornelas; MAC Speech Meet: Dashle Richards: 5th in Humorous, 1st in POI Quinten Koenen: 2nd in Extemp Josie Schneider: 7th in Serious Madison Johnson: 3rd in POI, 1st in Persuasive Zaerihya Doncheske: 2nd in Entertainment: Gering Twilight Speech Meet: Madison Johnson: POI 6th place. Special Thank You to Mrs. Spady for all of her work in organizing and running the MAC Speech Meet. Congratulations to the HS Basketball teams and wrestling teams for the successful completion of the season. GBB finished the season as District D1-2 Runner up. BBB finished with a winning record (12-11) for the first time since 2005-06. Wrestling finished with South Platte's first state wrestling qualifier. Bradyn Miller went 0-2 at state

wrestling. Congratulations MAC All-Conference Basketball Selections: GBB:1st Team: Maddi Cheleen; 2nd Team: Isabelle Reichman; Sportsmanship Award: Maddi Cheleen; BBB: 1st Team: Dash Richards; 2nd Team: Quinten Koenen; Honorable Mention: Conner Evans. GBB School record breakers: Maddi Cheleen: 3 pointers in a career (133), Career Assists (337) and season assists per game (4.61). Isabelle Reichman: 3 pointers in a season (63). Congratulations to Maddi Cheleen as she signed with Mid-Plains Community College to play basketball. Congratulations to HS Show Choir for the Gold Award at the NCDA Show Choir Festival, Feb. 12 at Chase County. Congratulations to the many District FFA Award Recipients; the Welding Team placed 5th and qualified to compete at the state competition. The Nebraska Department of Education has recognized Maddi Cheleen, Madison Johnson, Jaquelyn Ornelas, and Isabelle Reichman as World Language Distinguished Scholars. The Scholastic Book fair was February 26th -March 1st. South Platte will receive around \$1,400 in scholastic dollars from the book fair proceeds. FFA students (18) visited the sugar beet factory in Fort Morgan.

Mr. David Spencer's Superintendent's Report included highlights about the school safety E3 System update, the school improvement visitation April 9-10, the Show Choir Showcase, Missoula Children's Theatre, P/T Conferences, Spring Break, upgrades to be completed to the intercom system by Nebraska Fire and Safety, Mr. McConnell's report, District Speech March 13, Penny Carnival. Mr. Spencer attended a financial meeting with other administration members across the state and Bryce Johnson from the Dept. of Education via zoom. SPPS has received a Perkins Grant for \$7,500 to be used for technology and vocational instructional improvements. The public is invited on March 21 to the 6th Grade Wax Museum at 1:30.

There was discussion about summer projects. Motion by Amy Stanley seconded by Patricia Welsh to approve gym floor bid by Midwest Floor Specialists for the Big Springs only for \$2,740. Motion carried.

Darrel Armstrong: yes, Patricia Welsh: yes, Adam Hayward: yes, Tim Van Zee: yes, Duane Duncan: yes, Amy Stanley: yes

Motion by Tim Van Zee seconded by Duane Duncan to accept RLAWN bid for 2024 summer \$10,323.66 with aeration. Motion carried.

Amy Stanley: yes, Adam Hayward: yes, Darrel Armstrong: yes, Tim Van Zee: yes, Duane Duncan: yes, Patricia Welsh: yes

Motion by Adam Hayward seconded by Amy Stanley to approve track project bid by Ray's Cement Works for \$29,727.50. Motion carried.

Darrel Armstrong: Abstain (With Conflict), Duane Duncan: yes, Amy Stanley: yes, Tim Van Zee: yes, Patricia Welsh: yes, Adam Hayward: yes

There was a discussion about the proposed 2024-25 school calendar.

Review the minutes.

Motion by Adam Hayward seconded by Tim Van Zee to adjourn the meeting at 8:23 PM.

Motion carried.

Tim Van Zee: yes, Darrel Armstrong: yes, Patricia Welsh: yes, Adam Hayward: yes, Duane Duncan: yes, Amy Stanley: yes

The meeting was adjourned at 8:23 PM.

Tim Van Zee, Secretary

MINUTES OF BOARD OF EDUCATION
South Platte School District #95
Regular Board Meeting February 12, 2024 7:00 PM

President Darrel Armstrong called to order the Regular Board Meeting of the board at 7:00 PM with board members: **Present:** Darrel Armstrong, Duane Duncan, Adam Hayward, Amy Stanley, Tim Van Zee, Patricia Welsh. Also present were Superintendent David Spencer, Principal Nick Brost and Business Manager Lisa Wilson. Notice of the meeting was published in the Keith County News and available at the office.

The Pledge of Allegiance was recited and President Armstrong made note of the Open Meetings Act poster that is on display in the meeting room.

Motion by Tim Van Zee seconded by Amy Stanley to approve the consent agenda as presented: A. Confirmation of the last regular meeting minutes B. Financial Reports C. Treasurer's Report D. Claims: General Fund E. Claims: Building Funds. Motion carried.

Amy Stanley: yes, Adam Hayward: yes, Patricia Welsh: yes, Tim Van Zee: yes, Darrel Armstrong: yes, Duane Duncan: yes

CLAIMS: Amazon Capital Services, Inc. 2,129.68; Big Springs Tire & Auto Repair LLC 1,122.55; Black Hills Energy 4,181.77; Brule Activity Center 2,500.00; Card Service Center 2,610.54; Carlson Electric 278.42; Cash-Wa Dist. 392.25; Cdw Government, Inc 10,419.73; Century Link 668.67; Detmer, M 550.00; Eakes Office Solutions 3,070.21; ESU 16 16,341.41; Family Zone, Inc. 1,841.57; Flinn Scientific, Inc. 16.66; Frenchman Valley Coop 24.25; HealthEquity (FLEX-125 PLAN)146.00; Hometown Leasing 2,624.97; Hot Lunch Account 442.00; Hot Lunch 1,321.30; Huff, K 299.00; Ideal Linen Supply 546.73; Imagine Learning LLC 2,200.00; Inland Truck Parts 1,444.33; Jostens 1,088.95; JWPepper 103.92; Keith Co. News 100.10; Mid-American Research 223.47; NASB (Nebraska Association Of School Boards) 3,284.00; Nebraska Safety and Fire Equipment 410.00; NPPD (Nebraska Public Power District) 3,378.86; NPPD MLBRY Acct 68.19; NPPD Plum 2 Acct 47.37; Office Service, Inc. 590.98; Ray's Cement Works 1,000.00; Scherbarth, S 550.00; Scholastic, Inc. 128.69; Staples 34.16; Verizon Wireless 244.07; Village Of Big Springs 568.05; Walmart 298.86; Wiest Hardware 113.64; Wilson, L 29.55; Yanda's Music & Pro Audio 83.00; PAYROLL: \$314,620.83; BUILDING CLAIMS: A-L Tree Service 3,500.00; Office Products Professionals LLC 18,601.14; Reese Mechanical 1,483.00; Snell Services, Inc. 397.76

COMMITTEE REPORTS: BUILDING AND GROUNDS: A contractor has been hired to clean up the dead trees. Work continues on the outside lights. TRANSPORTATION: The suburban has new tires and the bus lights are repaired.

Mr. Nick Brost gave the principal's report. Congratulations to: SPEECH: Perkins County Speech Meet: Quinten Koenen, 3rd Place in Extemp and Dashle Richards, 9th Place in POI; HSBB MAC Tournament: Boys placed 2nd, Girls placed 3rd; Conference Wrestling Tournament: Bradyn Miller, 4th; Gabe Kendrick, 5th; Bradyn Miller qualified for the State Wrestling Tournament. The January Students of the Month are: Tyler Spiehs, Heidi Maupin, Jayla Paulsen, Emma Spiehs, Madison Johnson, Britany Lofton. Congratulations to the 2024 National Honor Society and Junior Honor Society Inductees: Zaerihya Doncheske, Joshua Estrada, Cordell Frerichs, Johanna Frerichs, Madison Johnson, Quinten Koenen, Chloe Ortega, Isabelle Reichman, Drake Arensdorf, Emalee Armstrong, Brayden Kendall, Heidi Maupin and

Audrey Moorhead. The FFA report was presented and the first semester Honor Roll dinner was held with 66 students, several staff and board members attending. Mr Brost attended the school improvement workday with Mr. Spencer, Mrs. Goddard and Alison Smith at ESU and the NSAA 2024-25 Football Schedule workday.

School Resource Officer Report: Mr. Spencer provided an update about the SRO program.

Mr. David Spencer's Superintendent's Report included an update on school safety and the implementation of a software / alert program. The lunch tables have been installed. The school improvement visitation will be the first part of April. He provided DJ services for the ESU 16 Social Skills Dance. The Show Choir competed this week and did well. The Missoula Children's Theater is the week of Feb 19; P/T Conferences & Teacher In-Service is Feb 28. Spring Break: March 4-8, 2024. March 13: NO SCHOOL: MAC Speech (Teacher In-Service); March 15: Penny Carnival. SPPS received a Perkins Grant for updates to the vocational program. Several staff will be attending an upcoming technical training. Mr. Mayer presented a proposed weight software program for the student population.

Discussion was held about the school calendar and upcoming dates.

Motion by Adam Hayward seconded by Patricia Welsh to approve 2024-25 Teacher Negotiated Agreement as presented. Motion carried.

Duane Duncan: yes, Patricia Welsh: yes, Tim Van Zee: yes, Adam Hayward: yes, Darrel Armstrong: yes, Amy Stanley: yes

Discussion was held about the ESU 16 Contracts. Motion by Amy Stanley seconded by Duane Duncan to approve 2024-25 ESU 16 Contracts. Motion carried.

Amy Stanley: yes, Patricia Welsh: yes, Adam Hayward: yes, Darrel Armstrong: yes, Tim Van Zee: yes, Duane Duncan: yes

A discussion was held about the McConnell Psychological Contract. Motion by Tim Van Zee seconded by Amy Stanley to approve Dr. McConnell's Contract 2024-25. Motion carried.

Adam Hayward: yes, Amy Stanley: yes, Darrel Armstrong: yes, Patricia Welsh: yes, Tim Van Zee: yes, Duane Duncan: yes

Review the minutes.

Motion by Duane Duncan seconded by Patricia Welsh to go into executive session to discuss personnel at 8:36 PM. Motion carried.

Tim Van Zee: yes, Darrel Armstrong: yes, Amy Stanley: yes, Patricia Welsh: yes, Adam Hayward: yes, Duane Duncan: yes

Motion by Adam Hayward seconded by Amy Stanley to return to regular session at 10:32 PM. Motion carried.

Amy Stanley: yes, Darrel Armstrong: yes, Duane Duncan: yes, Tim Van Zee: yes, Patricia Welsh: yes, Adam Hayward: yes

Motion by Duane Duncan seconded by Amy Stanley to approve superintendent two year contract. Motion carried.

Duane Duncan: yes, Adam Hayward: yes, Tim Van Zee: yes, Patricia Welsh: yes, Amy Stanley: yes, Darrel Armstrong: yes

Motion by Adam Hayward seconded by Amy Stanley to adjourn the meeting at 10:38 PM.
Motion carried.

Amy Stanley: yes, Adam Hayward: yes, Patricia Welsh: yes, Tim Van Zee: yes, Darrel
Armstrong: yes, Duane Duncan: yes

The meeting was adjourned at 10:38 PM.

Tim Van Zee, Secretary

Activity Fund Balance Report - Summary - Include Encumbrances
02/2024 - 02/2024
Regular; Beginning Month 02/2024; Accounts to Include Accounts with Activity; Active Chart
of Account Number True; Fund Number 05

South Platte Public Schools
03/05/2024 1:00 PM

Fund: 05	STUDENT ACTIVITY FUND	Chart of Account Number	Chart of Account Description	Beginning Balance	Expenses	Revenues	Outstanding AP	Outstanding PO	Balance Change	Balance
05 704 1000			ATHLETICS	4,553.97	4,466.82	1,653.29	0.00	0.00	0.00	1,750.44
05 704 1010			CHEERLEADERS	715.67	110.00	90.00	0.00	0.00	0.00	695.67
05 704 1030			JH ATHLETIC FUND - MEMORIAL MONEY	3,530.00	0.00	0.00	0.00	0.00	0.00	3,530.00
05 704 3010			ART CLUB	243.84	0.00	0.00	0.00	0.00	0.00	243.84
05 704 3020			CROSS COUNTRY	753.67	0.00	0.00	0.00	0.00	0.00	753.67
05 704 3025			GOLF TEAM	291.42	0.00	0.00	0.00	0.00	0.00	291.42
05 704 3030			JR. HIGH BASKETBALL	53.63	0.00	0.00	0.00	0.00	0.00	53.63
05 704 3035			BOYS BASKETBALL TEAM	1,516.69	61.73	490.00	0.00	0.00	0.00	1,944.96
05 704 3037			GIRLS BASKETBALL TEAM	315.79	45.73	32.00	0.00	0.00	0.00	302.06
05 704 3040			SPEECH	1,720.95	0.00	0.00	0.00	0.00	0.00	1,720.95
05 704 3042			WRESTLING	250.00	44.00	0.00	0.00	0.00	0.00	206.00
05 704 3045			FOOTBALL TEAM	6,048.67	0.00	0.00	0.00	0.00	0.00	6,048.67
05 704 3047			VOLLEYBALL TEAM	2,435.60	0.00	0.00	0.00	0.00	0.00	2,435.60
05 704 3050			FFA	22,312.04	17.00	0.00	0.00	0.00	0.00	22,295.04
05 704 3056			SPANISH CLUB	87.38	0.00	0.00	0.00	0.00	0.00	87.38
05 704 3060			TRACK	1,383.97	0.00	119.82	0.00	0.00	0.00	1,503.79
05 704 3065			UNIFIED BOWLING	1,061.38	0.00	0.00	0.00	0.00	0.00	1,061.38
05 704 3080			FBLA	1,155.00	0.00	0.00	0.00	0.00	0.00	1,155.00
05 704 3090			QUIZ BOWL	365.67	0.00	0.00	0.00	0.00	0.00	365.67
05 704 4030			CLASS OF 2029	292.87	0.00	0.00	0.00	0.00	0.00	292.87
05 704 4040			CLASS OF 2024	2,443.85	0.00	0.00	0.00	0.00	0.00	2,443.85
05 704 4070			CLASS OF 2027	1,122.35	0.00	0.00	0.00	0.00	0.00	1,122.35
05 704 4075			CLASS OF 2026	719.35	0.00	144.66	0.00	0.00	0.00	864.01
05 704 4080			CLASS OF 2028	525.45	0.00	0.00	0.00	0.00	0.00	525.45
05 704 4090			CLASS OF 2025	4,795.28	1,297.93	0.00	0.00	0.00	0.00	3,498.35
05 704 5010			MUSIC	1,595.66	0.00	0.00	0.00	0.00	0.00	1,595.66
05 704 5020			STUDENT ADVISORY COUNCIL FUND BALANCE	121.83	901.82	1,015.00	0.00	0.00	0.00	535.01
05 704 5030			STUCO	3,380.18	569.30	1,260.89	0.00	0.00	0.00	4,051.77
05 704 5035			AG STUDIES	781.07	0.00	0.00	0.00	0.00	0.00	781.07
05 704 5040			IND ART	6,362.38	0.00	96.93	0.00	0.00	0.00	6,459.31
05 704 5045			ONE ACT	5,424.22	96.85	0.00	0.00	0.00	0.00	5,325.37
05 704 5050			YEARBOOK	3,205.25	0.00	0.00	0.00	0.00	0.00	3,205.25
05 704 5080			LIFESKILLS	3,605.86	0.00	0.00	0.00	0.00	0.00	3,605.86
05 704 5090			FITNESS CENTER	5,134.74	0.00	150.00	0.00	0.00	0.00	5,284.74
05 704 6030			RECYCLE PROGRAM	5,454.88	0.00	0.00	0.00	0.00	0.00	5,454.88
05 704 6040			SPECIAL PROJECTS	11,570.73	1,484.71	0.00	0.00	0.00	0.00	10,086.02
05 704 8000			BANK CHARGES/INTEREST	907.68	0.00	43.82	0.00	0.00	0.00	951.50
05 704 8050			SCHOLARSHIPS	0.00	0.00	0.00	0.00	0.00	0.00	0.00
Fund Total: 05				106,240.97	8,817.89	5,108.41	0.00	0.00	0.00	102,529.49

Checking Account ID: 5

Check Type: Check

Check Number	Check Date	Cleared	Void	Void Date	Entity ID	Entity Name	Amount
9142	02/13/2024	X			SOUTHPLATT	SOUTH PLATTE SCHOOLS	320.00
9143	02/13/2024	X			MORRILPUBL	MORRIL PUBLIC SCHOOL	75.00
9144	02/13/2024	X			CAMERONM	CAMERON MILLER	504.82
9145	02/14/2024	X			CHRISGEARY	CHRIS GEARY	120.00
9146	02/14/2024	X			SCHOBRI	BRIAN SCHOENIG	120.00
9147	02/14/2024	X			CHUCKCHRIS	CHUCK CHRISTENSEN	120.00
9148	02/14/2024	X			BEHRROGER	ROGER BEHREND	753.00
9149	02/14/2024	X			MATHAMAN	Amanda Mathis	450.00
9150	02/14/2024				CHELEENR	RYAN CHELEEN	1,166.00
9151	02/14/2024	X			JENNYREICH	Jenny Reichman	82.29
9152	02/14/2024				GERINGHS	GERING HIGH SCHOOL	21.00
9153	02/14/2024	X			NPHS	NORTH PLATTE HIGH SCHOOL	21.00
9154	02/14/2024				SUTHERLAND	SUTHERLAND HIGH SCHOOL	28.00
9155	02/14/2024	X			PEPSI	PEPSI COLA OF WESTERN NEBRASKA	145.40
9156	02/15/2024	X			FOSTDEBR	Debra Foster	165.00
9157	02/21/2024				HYANNISHS	HYANNIS HIGH SCHOOL	100.00
9158	02/21/2024				KENEPUB	KENESAW PUBLIC SCHOOLS	50.00
9159	02/21/2024	X			OGALFLO	OGALLALA FLOWER SHOP	154.00
9160	02/21/2024	X			LOGOZ	LOGOZ LLC	448.00
9161	02/21/2024				SOUTHPLATT	SOUTH PLATTE SCHOOLS	153.82
9162	02/21/2024	X			JENNIFERBL	JENNIFER BLOCHOWITZ	17.00
9163	02/21/2024				SOUTHPLATT	SOUTH PLATTE SCHOOLS	98.85
9164	02/21/2024	X			KNIGHTWATC	KNIGHT WATCHERS BOOSTER CLUB	850.00
9165	02/21/2024				SOUTHPLATT	SOUTH PLATTE SCHOOLS	737.00
9166	02/21/2024				SOUTHPLATT	SOUTH PLATTE SCHOOLS	314.61
9167	02/21/2024				SOUTHPLATT	SOUTH PLATTE SCHOOLS	437.26
9168	02/29/2024				WEBETOM	Thomas Weber	107.46
9169	02/29/2024				SOUTHPLATT	SOUTH PLATTE SCHOOLS	495.31
9170	02/29/2024				SOUTHPLATT	SOUTH PLATTE SCHOOLS	112.84
9171	02/29/2024				ANDERSONS	ANDERSONS	720.33
9172	02/29/2024				PEPSI	PEPSI COLA OF WESTERN NEBRASKA	443.90
Check Type Total:			Check		Void Total:	0.00	Total without Voids: 9,331.89
Checking Account Total:		5			Void Total:	0.00	Total without Voids: 9,331.89
Grand Total:					Void Total:	0.00	Total without Voids: 9,331.89

Receipt Number	Received From ID/Name	Receipt Date	Description	Receipt Key	Amount
		02/02/2024	BB GATE PAXTON	1478	370.00
		02/02/2024	VENDING	1479	161.00
		02/15/2024	CONC/WT ROOM/GATE/CHEER	1480	1,339.14
		02/15/2024	VENDING	1481	133.00
		02/15/2024	KNIGHT VISION	1482	445.00
		02/15/2024	CANDY GRAM	1483	570.00
		02/15/2024	CHEER FLOWERS	1484	66.00
		02/24/2024	STS/BBB/GBB SUBS	1485	160.66
		02/20/2024	CONCESSIONS/WR/POST PROM	1488	1,143.13
		02/22/2024	GATE HITCHCOCK CO	1487	263.00
		02/22/2024	VENDING	1488	213.75
		02/28/2024	GBB PARENTS NIGHT FLOWERS	1489	32.00
		02/29/2024	GBB SUBSTATE-KENESAW	1490	65.91
		02/29/2024	FEB. INTEREST CFB	1491	43.82
		02/17/2024	FITNESS CENTER-SHOUP ONLINE	1492	50.00
		02/20/2024	FITNESS CENTER - SUTTER ONLINE	1493	50.00
Report Total:					5,106.41

South Platte Schools Treasurer's Report
FEB 2024 Expenses - Meeting March 2024

Name of Account	Feb-23	Feb-24	Jan-24		
General Fund(ABT)					
Beginning Balance		\$96,532.38	\$80,692.81		
Interest on Checking	\$512.77	\$1,071.23	\$759.05		
Garden Co. Taxes	\$3,042.14	\$492.13	\$3,531.60		
Perkins Co. Taxes	\$41,521.56	\$36,450.54	\$39,928.00		
Keith County Taxes	\$135,012.55	\$265,022.14	\$254,711.11		
Deuel County Taxes	\$85,162.30	\$106,030.27	\$136,324.76		
Co. Fines/Licenses					
REAP Funds					
Lunch Reimbursement	\$11,201.49				
Pro Rata Motor Vehicles					
Spec. Ed Payment	\$22,926.00	\$64,941.00	\$70,263.00		
Tuition Reimbursement					
Title 1 Reimbursement					
Title IV					
State Apportionment			\$29,392.55		
STATE AID	\$63,636.00	\$75,969.00	\$75,969.00		
ESSER/Cares Act			\$125,900.00		
Interfund Transfer(Activity/Blding/Depr)					
State of Ne-High Ability Learners					
Insurance Claim Receipts					
Medicaid Receipts					
Other State Receipts (Perkins Grant)		\$7,500.00			
Sale of Junk					
Private Grant/Donations		\$540.00			
Misc. Receipts	\$30.49	\$150.96	\$0.24		
Total Receipts	\$363,045.30	\$558,167.27	\$736,779.31		
Total Disbursements	\$342,855.44	\$344,428.48	\$720,939.74		
General Fund End. Balance (ABT)	\$391,097.20	\$310,271.17	\$96,532.38	Per Bank Bal-	Before Claims &
				Before O/S Checks	
Building Fund (ABT) 493	\$225,442.50	\$87,498.42	\$107,473.03		
Depreciation Fund (ABT) 458	\$281,165.01	\$15,648.76	\$15,622.12	Blding Fund: Paid Lunch Room	
Bond Account (ABT) 549	\$227,757.24	\$578,930.67	\$531,558.54	Tables , Tree Trim, Heater, Water	
Employee Flex Spending (ABT)	\$10,494.24	\$7,897.36	\$8,823.31	Fountain Repair(Feb 2024)	
Savings Account (CFB)	\$216,036.14	\$56,002.59	\$55,944.80		
CD # 2357	\$250,000.00	\$50,000.00	\$50,000.00		
Unemployment Svgs (CFB)	\$29,814.15	\$30,138.34	\$30,107.24		
Employee Benefit (CFB)	\$6,793.15	\$7,497.45	\$7,494.47		
Activity Fund (CFB)	\$132,900.69	\$102,529.49	\$106,240.97		
Lunch Fund (CFB)	\$33,231.76	\$25,246.78	\$21,744.46		
Total Funds All Accounts	\$1,444,684.70	\$1,271,661.03	\$1,031,541.32		
Fund Distribution - CFB	\$668,775.89	\$271,414.65	\$271,531.94		
AB&T		\$1,000,246.38	\$760,009.38		
General Fund Expenditures for March 2024					
General Fund Checks	\$91,878.37				
Gross Payroll (DD/Cks/Liab)	\$320,564.54				
Subtotal:	\$412,442.91				
Less: Hot Lunch Payroll	\$16,446.97				
Net General Fund Expenses	\$395,995.94				
***General Fund Bank Balance ABT** C	02/29/24				

Fund: 01 GENERAL FUND

<u>Chart of Account Number</u>	<u>Transaction Description</u>	<u>Debit</u>	<u>Credit</u>	<u>Net Change</u>	<u>Reimb Lunch to General Fund</u>	
01 2190 110 001	PR Salary Expense	5,725.56	0.00	5,725.56		06 3100 110 000
01 2190 110 002	PR Salary Expense	5,725.54	0.00	5,725.54	\$11,451.10	Reg Salaries
01 2190 130 001	PR Salary Expense	561.64	0.00	561.64		06 3100 130 000
01 2190 130 002	PR Salary Expense	561.61	0.00	561.61	\$1,123.25	OT Salaries
01 2190 210 001	PR Deduction Expense	814.99	0.00	814.99		
01 2190 210 001	PR Salary Expense	51.88	0.00	51.88		
01 2190 210 002	PR Deduction Expense	814.99	0.00	814.99		06 3100 210 000
01 2190 210 002	PR Salary Expense	51.90	0.00	51.90	\$1,733.76	Insurance Health
01 2190 220 001	PR Tax Expense	484.92	0.00	484.92		06 3100 220 000
01 2190 220 002	PR Tax Expense	484.95	0.00	484.95	\$969.87	FICA
01 2190 230 001	PR Deduction Expense	614.71	0.00	614.71		06 3100 230 000
01 2190 230 002	PR Deduction Expense	614.76	0.00	614.76	\$1,229.47	Retirement
01 2190 290 001	PR Deduction Expense	3.00	33.24	30.24	(\$60.48)	06 3100 290 000
01 2190 290 002	PR Deduction Expense	3.00	33.24	30.24		Other Benefits
Fund Total: 01		16,513.45	66.48	\$ 16,446.97	\$16,446.97	

\$ 16,446.97

March Nutrition Reimbursement

Checking Account ID: 1

Check Type: Automatic Payment

Check Number	Check Date	Cleared	Void	Void Date	Entity ID	Entity Name	Amount	
9137034	03/11/2024				AMAZCAPITA	Amazon Capital Services, Inc.	3,139.78	
9137035	03/11/2024				BHENERGY	Black Hills Energy	4,200.00	
9137036	03/11/2024				CARDSERV	Card Service Center	1,542.65	
9137037	03/11/2024				KELLITHOMP	Kelli Thompson LLC	999.00	
9137038	03/11/2024				NPPD	NPPD (Nebraska Public Power District)	3,400.00	
9137039	03/11/2024				NPPDMLBRY	NPPD MLBRY Acct	68.19	
9137040	03/11/2024				NPPDPLUM2	NPPD Plum 2 Acct	47.37	
9137041	03/11/2024				WALMART	Walmart Business: Capital ONE Online	327.89	
9137042	03/11/2024				WEXBANK	WEX Bank	78.73	
Check Type Total: Automatic Payment							Void Total: 0.00	Total without Voids: 13,803.61

Checking Account ID: 1

Check Type: Check

Check Number	Check Date	Cleared	Void	Void Date	Entity ID	Entity Name	Amount	
138149	03/11/2024				ACTIACCO	Activity Account	20,000.00	
138150	03/11/2024				ALLSTAR	All Star Auto Glass	39.95	
138151	03/11/2024				BSTT	Big Springs Truck and Travel	3,605.62	
138152	03/11/2024				CAMHOTEL	Cambria Hotel Omaha Downtown	272.45	
138153	03/11/2024				CASHWA	Cash-Wa Dist.	453.07	
138154	03/11/2024				CENTLINK	Century Link	671.90	
138155	03/11/2024				WORDWARE	EduTrack, LLC	2,242.44	
138156	03/11/2024				ESU16	ESU 16	16,341.41	
138157	03/11/2024				FAMMARKJUL	Family Market Food & Hardware	27.70	
138158	03/11/2024				FOLLSCHO	Follett School Solutions, LLC.	847.89	
138159	03/11/2024				HOTLUNCH	Hot Lunch	1,384.80	
138160	03/11/2024				HOTLUN	Hot Lunch Account	468.00	
138161	03/11/2024				IDEAL	Ideal Linen Supply	348.28	
138162	03/11/2024				INLAND	Inland Truck Parts	3,536.25	
138163	03/11/2024				KCN	Keith Co. News	88.68	
138164	03/11/2024				MENARDSNP	MENARDS	906.82	
138165	03/11/2024				MARC	Mid-American Research	286.50	
138166	03/11/2024				OFFICE	Office Service, Inc.	2,982.00	
138167	03/11/2024				PLATFORMAT	Platform Athletics, LLC	2,700.00	
138168	03/11/2024				RLAWN	R Lawn LLC	10,323.66	
138169	03/11/2024				RAYSCEMEN	Ray's Cement Works	3,575.00	
138170	03/11/2024				SW	S & W Auto Supply	182.99	
138171	03/11/2024				SIDNEYHEAV	Sidney Heavy Truck & Auto, LLC	361.37	
138172	03/11/2024				SNELL	Snell Services, Inc.	1,074.62	
138173	03/11/2024				STAPLES	Staples	26.59	
138174	03/11/2024				VERIZON	Verizon Wireless	248.33	
138175	03/11/2024				WIEST	Wiest Hardware	52.45	
Check Type Total: Check							Void Total: 0.00	Total without Voids: 73,048.77

Checking Account ID: 1

Check Type: Direct Deposit

Check Number	Check Date	Cleared	Void	Void Date	Entity ID	Entity Name	Amount	
2156	03/11/2024				JWPEPPER	JWPepper	211.94	
2157	03/11/2024				EAKESOFFIC	Eakes, Inc./dba Eakes Office Solutions	1,141.18	
2158	03/11/2024				GODDMELI	Melisa Goddard	13.08	
2159	03/11/2024				HEALTHQFL	HealthEquity - Wage Works, Inc. (FLEX-125 PLAN)	146.00	
2160	03/11/2024				HOMETOWN	Hometown Leasing	2,624.97	
2161	03/11/2024				JOHNCOUR	Courtney Johnson	136.61	
2162	03/11/2024				LANEMARK	Mark Lane	62.00	
2163	03/11/2024				VILLAGEBS	Village Of Big Springs	669.80	
2164	03/11/2024				WEBETOM	Thomas Weber	20.41	
Check Type Total: Direct Deposit							Void Total: 0.00	Total without Voids: 5,025.99

Checking Account Total: 1

Void Total: 0.00 Total without Voids: 91,878.37

Type: Payroll Total Cash

Total without Voids: 320,564.54

Total Claims March: \$412,442.91

Checking Account ID: 1

Check Type: Automatic Payment

Check Number	Check Date	Cleared	Void	Void Date	Entity ID	Entity Name	Amount	
9137034	03/11/2024				AMAZCAPITA	Amazon Capital Services, Inc.	3,139.78	
9137035	03/11/2024				BHENERGY	Black Hills Energy	4,200.00	
9137036	03/11/2024				CARDSERV	Card Service Center	1,542.65	
9137037	03/11/2024				KELLITHOMP	Kelli Thompson LLC	999.00	
9137038	03/11/2024				NPPD	NPPD (Nebraska Public Power District)	3,400.00	
9137039	03/11/2024				NPPDMLBRY	NPPD MLBRY Acct	68.19	
9137040	03/11/2024				NPPDPLUM2	NPPD Plum 2 Acct	47.37	
9137041	03/11/2024				WALMART	Walmart Business: Capital ONE Online	327.89	
9137042	03/11/2024				WEXBANK	WEX Bank	78.73	
Check Type Total: Automatic Payment							Void Total: 0.00	Total without Voids: 13,803.61

Checking Account ID: 1

Check Type: Check

Check Number	Check Date	Cleared	Void	Void Date	Entity ID	Entity Name	Amount	
138149	03/11/2024				ACTIACCO	Activity Account	20,000.00	
138150	03/11/2024				ALLSTAR	All Star Auto Glass	39.95	
138151	03/11/2024				BSTT	Big Springs Truck and Travel	3,605.62	
138152	03/11/2024				CAMHOTEL	Cambria Hotel Omaha Downtown	272.45	
138153	03/11/2024				CASHWA	Cash-Wa Dist.	453.07	
138154	03/11/2024				CENTLINK	Century Link	671.90	
138155	03/11/2024				WORDWARE	EduTrack, LLC	2,242.44	
138156	03/11/2024				ESU16	ESU 16	16,341.41	
138157	03/11/2024				FAMMARKJUL	Family Market Food & Hardware	27.70	
138158	03/11/2024				FOLLSCHO	Follett School Solutions, LLC.	847.89	
138159	03/11/2024				HOTLUNCH	Hot Lunch	1,384.80	
138160	03/11/2024				HOTLUN	Hot Lunch Account	468.00	
138161	03/11/2024				IDEAL	Ideal Linen Supply	348.28	
138162	03/11/2024				INLAND	Inland Truck Parts	3,536.25	
138163	03/11/2024				KCN	Keith Co. News	88.68	
138164	03/11/2024				MENARDSNP	MENARDS	906.82	
138165	03/11/2024				MARC	Mid-American Research	286.50	
138166	03/11/2024				OFFICE	Office Service, Inc.	2,982.00	
138167	03/11/2024				PLATFORMAT	Platform Athletics, LLC	2,700.00	
138168	03/11/2024				RLAWN	R Lawn LLC	10,323.66	
138169	03/11/2024				RAYSCEMEN	Ray's Cement Works	3,575.00	
138170	03/11/2024				SW	S & W Auto Supply	182.99	
138171	03/11/2024				SIDNEYHEAV	Sidney Heavy Truck & Auto, LLC	361.37	
138172	03/11/2024				SNELL	Snell Services, Inc.	1,074.62	
138173	03/11/2024				STAPLES	Staples	26.59	
138174	03/11/2024				VERIZON	Verizon Wireless	248.33	
138175	03/11/2024				WIEST	Wiest Hardware	52.45	
Check Type Total: Check							Void Total: 0.00	Total without Voids: 73,048.77

Checking Account ID: 1

Check Type: Direct Deposit

Check Number	Check Date	Cleared	Void	Void Date	Entity ID	Entity Name	Amount	
2156	03/11/2024				JWPEPPER	JWPepper	211.94	
2157	03/11/2024				EAKESOFFIC	Eakes, Inc./dba Eakes Office Solutions	1,141.18	
2158	03/11/2024				GODDMELI	Melisa Goddard	13.08	
2159	03/11/2024				HEALTHQFL	HealthEquity - Wage Works, Inc. (FLEX-125 PLAN)	146.00	
2160	03/11/2024				HOMETOWN	Hometown Leasing	2,624.97	
2161	03/11/2024				JOHNCOUR	Courtney Johnson	136.61	
2162	03/11/2024				LANEMARK	Mark Lane	62.00	
2163	03/11/2024				VILLAGEBS	Village Of Big Springs	669.80	
2164	03/11/2024				WEBETOM	Thomas Weber	20.41	
Check Type Total: Direct Deposit							Void Total: 0.00	Total without Voids: 5,025.99

Checking Account Total: 1 Void Total: 0.00 Total without Voids: 91,878.37

Type: Payroll Total Cash Total without Voids: 320,564.54

Total Claims March: \$412,442.91



David Spencer <dspencer@southplatteschools.com>

South Platte BOE

Luke McConnell <tmlmcconnell@icloud.com>

Mon, Mar 11, 2024 at 10:09 AM

To: David Spencer <dspencer@southplatteschools.com>

Mr. Spencer.

Here you go.

McConnell Psychological Solutions will provide 4, ½ day in-services to school counselors during the academic year and direct clinical consultation each month to address building capacity to assist students with mental health needs.

Staff Development:

- QPR - suicide trying.
- Self-Harm training.
- Nebraska Dyslexia requirements.
- Sped transition plan training.
- T.I.P development with special education.

Special education evaluations:

- 5 initial evaluations.
- 19 re-evaluations.

General education referrals:

- 9 Consultation consent referrals.
- Roughly 80 individual/family counseling sessions.

Let me know if additional information is needed.

Luke

[Quoted text hidden]

PRINCIPAL'S CONTRACT

FOR CLASS II, III, AND VI SCHOOLS AND CLASS I SCHOOLS WITH A SUPERINTENDENT

THIS CONTRACT made by and between the School District No. 95 in the County of Deuel in the State of Nebraska, hereinafter referred to as the District and Nicholas Brost, a legally qualified Teacher/Administrator, hereinafter referred to as "Principal".

WITNESSETH: That the Board of Education of the District hereby agrees to employ the Principal above named in the schools of the District, which shall begin on or about July 1, 2024 and end on or about June 30, 2025. The Principal hereby agrees to accept such employment at a salary of \$95,604.60 for this contract.

FIRST: The salary of the Principal shall be payable in twelve (12) equal installments each year. The first installment shall be payable on the 15th day of August and the remaining installments shall be payable on the 15th day of each month thereafter.

SECOND: The Principal hereby agrees to be governed by the policies of the Board of Education of the District and that the Principal duties to be performed by him/her under this contract shall be subject to assignment of the Superintendent of the District with the approval of the Board of Education of the District; and further agrees to devote full time, during days of school to his/her position in all respects, to diligently and faithfully perform the assigned duties as Principal to the best of his/her professional ability.

THIRD: In addition to the duties set forth herein, the Principal may be assigned such "extra duty" assignments as defined from time to time by the parties of this agreement which shall be upon such terms and conditions and at such additional stated rate of compensation as the Principal and the District may from time to time agree upon.

FOURTH: This contract may be canceled or amended by a majority of the members of the school board during the school year for any of the following reasons: (a) upon cancellation, termination, revocation or suspension of the teacher's certificate by the State Board of Education; (b) breach of any of the material provisions of this contract; (c) for any reason set forth in this contract; (d) incompetency; (e) neglect of duty; (f) unprofessional conduct; (g) insubordination; (h) immorality, or (i) physical or mental incapacity. Cancellation or amendment under this contract shall be governed by the provision of 79-12.110 R.R.S. (1982 Supp).

FIFTH: That upon termination of this contract for just cause, or upon the release of the Principal from this contract, the compensation paid or to be paid hereunder shall be an amount which bears the same ratio to the yearly salary herein specified as the number of months of service to the date of such termination bears to 12 months of service. Any unearned fractional proportion of an installment paid but not earned prior to termination of the contract shall be refunded by the Principal.

SIXTH: There shall be no penalty for release or resignation by the Principal from this contract; provided no resignation shall become effective until the close of the school year unless accepted by the Board of Education of the District and the Board shall fix the time at which the resignation is to take effect.

SEVENTH: This contract shall conform to the regulations governing deductions for the above stated compensation with reference to Withholding Tax, Social Security and Teacher Retirement. Other deductions may be withheld as agreed to by the parties to this contract.

EIGHTH: Annual Vacation Leave and Other Fringe Benefits: The Principal shall be responsible for ensuring that all responsibilities are complied with throughout the summer months, as needed, although his/her daily or weekly schedule may vary. The Principal shall receive the same sick leave, personal leave, or bereavement leave as other certificated employees of the District. Health insurance shall be the same as the teacher's family coverage policy paid by the District.

NINETH: The Principal hereby affirms that he/she is not under contract with another School Board or Board of Education within this State covering a part of all of the same time of performance as is contemplated by this agreement. The Principal further affirms that at the beginning of the term of this contract he/she holds or will hold a valid Nebraska Administrative Certificate. It is understood and agreed that this contract is not valid until the Teacher's Certificate, as herein listed, is registered in the office of the Superintendent of Schools in this County and that the Principal shall not be compensated for any services performed prior to the date of registration of this certificate.

TENTH: Hereinafter, this contract may be continued by a separated, annual written "Renewal Agreement" which shall incorporate all the provisions hereof by reference, except as stated on such Renewal Agreements. Renewal Agreements or renewal contracts must be executed by the Teacher and delivered to the Superintendent of Schools or the Secretary of the Board of Education of the District within fifteen (15) calendar days of receipt thereof from the district. Said Renewal Agreement or renewal contract shall not be subject to the requirements of Sections 79-12.111 through 79-12.114 R.R.S. (1982 Supp.) and any other applicable state statutes.

ELEVENTH: The failure to return a signed copy of the contract or renewal agreement to the Superintendent of Schools or Secretary of the Board of Education of the district on or before June 1, 2023 shall constitute rejection by the Principal of the offer of employment.

Executed by the principal this 11th day of March 2024 by

Nicholas Brost, Principal, South Platte High School

Executed by the Board this 11th day of March 2024 By

Darrel Armstrong, President, Board of Education

R Lawn LLC

17464 County Road 36 Julesburg, CO 80737

(970) 474-2766



Billing Address

**South Platte Schools
School
610 Plum St P O Box 457
Big Springs, NE 69122**

Service Address

South Platte Schools
School
610 Plum St P O Box 457
Big Springs, NE 69122

Customer Number: 35

2/9/2024

**VALUED
CUSTOMER
PREPAY
DISCOUNT**

SAVE!

5%

**On Your Service
for One Full Year**

Expires on 3/15/2024

We thank you so much for your continued business and support as we go into the 2024 season. It's been very rewarding teaming up with you to achieve beautiful lawns and landscapes that we are all proud of. Our team is dedicated to making this a reality and we never stop making improvements to that effort. Please make sure we always have your latest phone number for receiving text messages. To reach us we have one phone number for texting and calls >970-474-2766. Texting has proven to be the best way to get you the info you need quickly. As always, an invoice/receipt will be left at your door at the time of service. Account updates and payments can be made by phone, texting, and online at RLAWN.com. All services not paid within 30 days will acquire a monthly \$10 Statement Fee.

Our services include: "R" 4-Step Lawn Program (starting in April or May and treatments following every 6-8 weeks), Aeration, Total Vegetation Control (starts in March - rock beds, driveways, alleys, commercial properties, and parking lots), Weed Control (beyond the lawn, around farms, and lots), and "R" Tree Care Program.

Again thank you for your business. ~The R Lawn Family

Go to RLAWN.com then click on My Account. Offer Code: MIV-SO6Y-7QX

2024 Services you are already signed up for:

Scheduled Services

Lawn Step 1 - Spring App	\$1,891.13 *
Lawn Step 2 - Late Sp/Early Su	\$1,891.13 *
Lawn Step 3 - Summer App	\$1,891.13 *
Lawn Step 4 - Fall App	\$1,891.13 *
Broadleaf Control & Prevent 1	\$418.50

We are recommending you upgrade to:

Scheduled Services

Lawn Step 1 - Spring App	\$1,891.13 *
Lawn Step 2 - Late Sp/Early Su	\$1,891.13 *
Lawn Step 3 - Summer App	\$1,891.13 *
Lawn Step 4 - Fall App	\$1,891.13 *
Broadleaf Control & Prevent 1	\$418.50

Recommended Services

Aeration - Spring	\$2,884.00
-------------------	------------

* Large Property 25%

Total Service Amount	\$7,983.02
After 5% Prepay Discount	\$7,583.86
You Save	\$399.16
Total	\$7,583.86

Total Service Amount	\$10,867.02
After 5% Prepay Discount	\$10,323.66
You Save	\$543.36
Total	\$10,323.66

ESTIMATE

Ray's Cement Works
414 RD West M 5 South
Brule NE 69127
402-430-4580 or 308-289-6639

South Platte School
Attn: David Spencer
Big Springs NE 69122
Job: track improvements

Date: 3/1/2024

Sidewalk - 260' x 5' x 4"

High jump pad - 40' x 50' x 4"

Pole Vault pad - 22' x 20' x 4"

Tear out of old concrete

Reset pole vault trough

Supplies:

Tie Downs for high jump pad

** Does not include concrete mileage, fuel surcharge, taxes or pump truck if needed **

Total: \$29,727.50

Estimated Start Date: negotiable

Thank you for your business

This is an estimate only, any changes made will be discussed with owner and contractor.

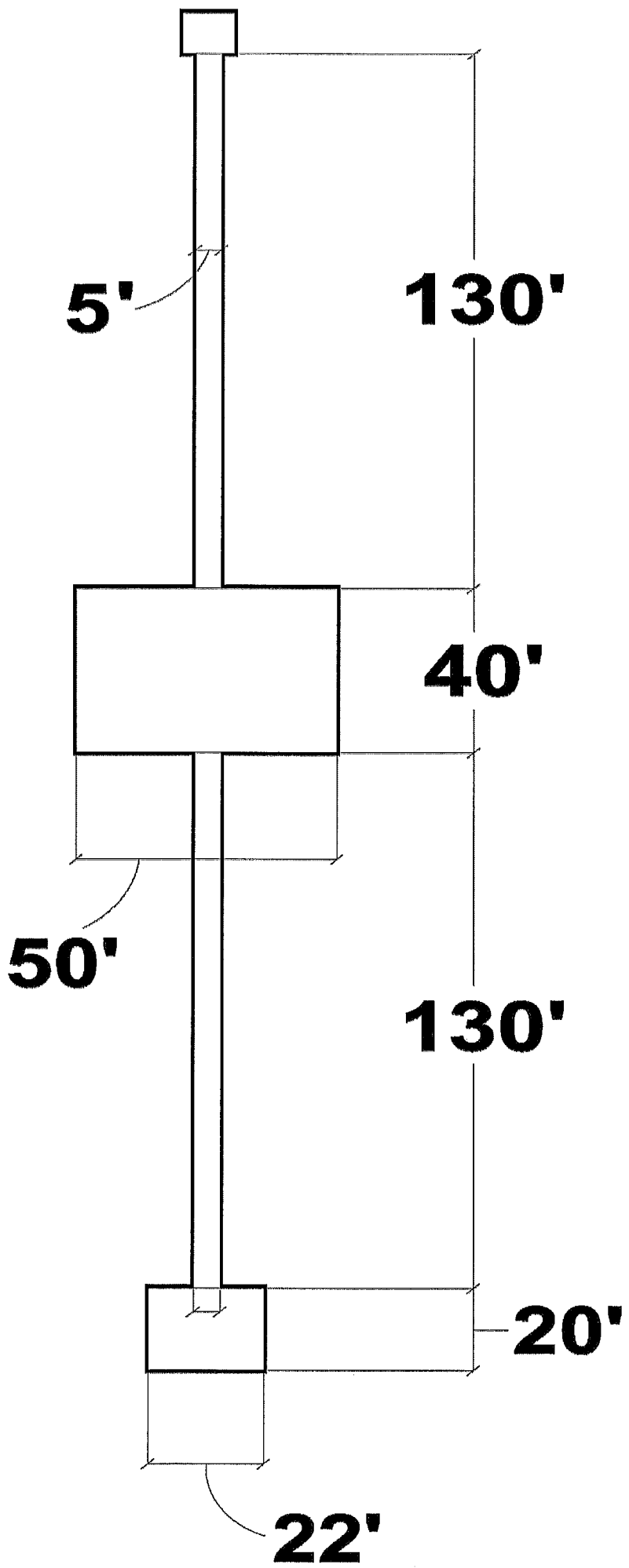



March 11, 2024

South Platte School
David Spencer
610 Plum St
PO Box 457
Big Springs, NE 69122

David Spencer

Thank you for reaching out with the opportunity to quote you for the screen and refinish for your gym floor. Below you will find pricing for screening and recoating of your gym floor with one coat of PoloPlaz oil-based finish. If you have any questions, please let us know.

South Platte	One Coat
Floor	2024 Pricing oil based finish
Main Gym	\$2,740

This price includes all labor and materials to complete this project. We look forward to the opportunity to work with you. As family-owned business, we are here for any questions you have. Please reach out at any time.

Regards,

Broc and Erin Howard
Midwest Floor Specialists
1006 9th Ave
Kearney, NE 68845
308.440.8048