

Board of Education Regular Meeting

Thursday, November 12, 2015 6:30 PM

East Butler School  
212 South Madison Street  
Brainard, NE 68626-0036

Jan Bostelman: Present

Stonie Cooper: Present

Mark Janak: Present

Megan Kozisek: Present

Nate Radenslaben: Present

Chris Rezac: Present

Kim TePoel: Present

Marlene Wade: Present

Dan Zysset: Present

1. Call Meeting To Order

2. Roll Call

3. Flag Salute

4. Approve Agenda

Motion to approve the agenda as presented Passed with a motion by Jan Bostelman and a

second by Stonie Cooper.

Jan Bostelman: Yea, Stonie Cooper: Yea, Mark Janak: Yea, Megan Kozisek: Yea, Nate Radenslaben: Yea, Chris Rezac: Yea, Kim TePoel: Yea, Marlene Wade: Yea, Dan Zysset: Yea

5. Patron's Comments- Limited to 5 minutes.

6. Informational Items

6.1. East Butler Foundation Update

6.2. Discussion on Long Term Facilities Needs Study

6.3. Dates for Elementary Restructuring Proposal Community Meetings November 16 in Dwight November 17 in Prague November 18 in Brainard

6.4. Discussion of Election Wards

6.5. First Reading of 6000s Policy

6.6. Negotiations Update

7. Consent Agenda

Motion to approve the consent agenda as presented Passed with a motion by Stonie Cooper and a second by Marlene Wade.

Jan Bostelman: Yea, Stonie Cooper: Yea, Mark Janak: Yea, Megan Kozisek: Yea, Nate Radenslaben: Yea, Chris Rezac: Yea, Kim TePoel: Yea, Marlene Wade: Yea, Dan Zysset: Yea

7.1. Approval of Minutes

7.2. Treasurer's Report

8. Regular Agenda

8.1. Second Reading of 5000s Policy

Second reading and Approval of 5000s Policies Passed with a motion by Stonie Cooper and a second by Kim TePoel.

Jan Bostelman: Yea, Stonie Cooper: Yea, Mark Janak: Yea, Megan Kozisek: Yea, Nate Radenslaben: Yea, Chris Rezac: Yea, Kim TePoel: Yea, Marlene Wade: Yea, Dan Zysset: Yea

8.2. Assistant Wrestling Coach Position for the 2015-2016 Season

Approve assistant wrestling coach position for the 2015-2016 season Passed with a motion by Kim TePoel and a second by Nate Radenslaben.

Marlene Wade: Abstain (With Conflict), Stonie Cooper: Nay, Mark Janak: Nay, Jan

Bostelman: Yea, Megan Kozisek: Yea, Nate Radenslaben: Yea, Chris Rezac: Yea, Kim TePoel: Yea, Dan Zysset: Yea

### 8.3. Shop Ventilation and Exhaust Hood Quote

Accepting the quote from Lee's Refrigeration to address the shop ventilation and exhaust hood needs. Passed with a motion by Stonie Cooper and a second by Marlene Wade.

Jan Bostelman: Yea, Stonie Cooper: Yea, Mark Janak: Yea, Megan Kozisek: Yea, Nate Radenslaben: Yea, Chris Rezac: Yea, Kim TePoel: Yea, Marlene Wade: Yea, Dan Zysset: Yea

### 9. Administrative Comments

### 10. Items for next Meeting

### 11. Adjournment

Motion to adjourn at 7:47 p.m. Passed with a motion by Stonie Cooper and a second by Mark Janak.

Jan Bostelman: Yea, Stonie Cooper: Yea, Mark Janak: Yea, Megan Kozisek: Yea, Nate Radenslaben: Yea, Chris Rezac: Yea, Kim TePoel: Yea, Marlene Wade: Yea, Dan Zysset: Yea

InstructionCurriculum Review Cycle

## TEXTBOOK ADOPTION SCHEDULE

EVALUATION	IMPLEMENTATION	SUBJECT
2015-2016	2016-2017	Social Studies
2016-2017	2017-2018	Art, Music, Health 7-12, and Journalism
2017-2018	2018-2019	Industrial Technology, FCS
2018-2019	2019-2020	Spanish
2019-2020	2020-2021	Language Arts
2020-2021	2021-2022	Science
2021-2022	2022-2023	Math and Accounting
2022-2023	2023-2024	Repeat the cycle

- Computer tests will be purchased as needed due to the constant changing of technology.

Date of Adoption: [Insert Date]

Board of Education Regular Meeting  
October 14, 2015 6:30 PM  
Dwight Elementary School

1. Call Meeting To Order at 6:30 P.M.

2. Roll Call: Present Board Members: Jan Bostelman, Megan Kozisek, Nate Radenslaben, Chris Rezac, Kim TePoel, and Dan Zysset. Absent Board Members: Stonie Cooper, Mark Janak, and Marlene Wade. Also present: Mr. Sam Stecher, Superintendent, Mr. Michael Eldridge, Secondary Principal, and Mr. Shawn Biltoft, Elementary Principal.

Motion Passed: Motion to excuse Stonie Cooper, Mark Janak, and Marlene Wade from the meeting passed with a motion by Dan Zysset and a second by Kim TePoel.

Jan Bostelman	Yes
Stonie Cooper	Absent
Mark Janak	Absent
Megan Kozisek	Yes
Nate Radenslaben	Yes
Chris Rezac	Yes
Kim TePoel	Yes
Marlene Wade	Absent
Dan Zysset	Yes

3. Flag Salute

4. Approve Agenda

Motion Passed: Motion to approve the agenda as presented passed with a motion by Jan Bostelman and a second by Nate Radenslaben.

Jan Bostelman	Yes
Stonie Cooper	Absent
Mark Janak	Absent
Megan Kozisek	Yes
Nate Radenslaben	Yes
Chris Rezac	Yes
Kim TePoel	Yes
Marlene Wade	Absent
Dan Zysset	Yes

5. Patron's Comments - None

6. Informational Items: HAL Composting Presentation by Mrs. Jodi Chapek and the HAL students; Update on Negotiations; Presentation of Annual Report; Discussion of Restructuring Elementary Services/Discussion of Expanding Pre School Services; First Read Through of 5000s Policies; Review of Wrestling Coach Positions; NASB Regional Meeting Report; East Butler Foundation Report; and Ward/Election Discussion.

7. Consent Agenda

7.a. Approval of Minutes

7.b. Treasurer's Report

Motion Passed: Motion to approve the consent agenda as presented passed with a motion by Jan Bostelman and a second by Dan Zysset.

Jan Bostelman	Yes
Stonie Cooper	Absent
Mark Janak	Absent
Megan Kozisek	Yes
Nate Radenslaben	Yes
Chris Rezac	Yes
Kim TePoel	Yes
Marlene Wade	Absent
Dan Zysset	Yes

8. Regular Agenda

8.a. Addition of Shelby Rising City to the East Butler/David City Softball Cooperative for the 2016 season.

Motion Passed: Addition of Shelby Rising City to the East Butler/David City Softball Cooperative for the 2016 season passed with a motion by Dan Zysset and a second by Chris Rezac.

Jan Bostelman	Yes
Stonie Cooper	Absent
Mark Janak	Absent
Megan Kozisek	Yes
Nate Radenslaben	Yes
Chris Rezac	Yes
Kim TePoel	No
Marlene Wade	Absent
Dan Zysset	Yes

## 8.b. Second Reading and Approval of 4000s Policies

Motion Passed: Second Reading and Approval of 4000s Policies passed with a motion by Jan Bostelman and a second by Kim TePoel.

Jan Bostelman	Yes
Stonie Cooper	Absent
Mark Janak	Absent
Megan Kozisek	Yes
Nate Radenslaben	Yes
Chris Rezac	Yes
Kim TePoel	Yes
Marlene Wade	Absent
Dan Zysset	Yes

## 8.c. Vote for NASB District 16 Representative

Motion Passed: Vote for Candace Becher as NASB District 16 Representative passed with a motion by Jan Bostelman and a second by Nate Radenslaben.

Jan Bostelman	Yes
Stonie Cooper	Absent
Mark Janak	Absent
Megan Kozisek	Yes
Nate Radenslaben	Yes
Chris Rezac	Yes
Kim TePoel	Yes
Marlene Wade	Absent
Dan Zysset	Yes

## 9. Administrative Comments

10. Items for next Meeting: Facilities Need Assessment; Negotiations Update; Wrestling Coaching Position; NASB Convention; Vehicle Assessment Report; June 4 Auction for Prague Contents; and Striv TV.

## 11. Adjournment

Motion Passed: Motion to adjourn at 8:08 P.M. passed with a motion by Dan Zysset and a second by Kim TePoel.

Jan Bostelman	Yes
Stonie Cooper	Absent
Mark Janak	Absent
Megan Kozisek	Yes
Nate Radenslaben	Yes

Chris Rezac	Yes
Kim TePoel	Yes
Marlene Wade	Absent
Dan Zysset	Yes

Kim Fuehrer  
Recording Secretary

BALANCES OCTOBER 1-30, 2015 FOR NOVEMBER BOARD MEETING				
	BEG. BALANCE	OCTOBER RECEIPTS	OCTOBER EXPENDITURES	MONTH END BALANCE
<b>HOT LUNCH</b>	\$11,517.64	\$18,434.30	\$25,314.27	\$4,637.67
<b>ACTIVITIES</b>				
Ag Projects	\$1,206.35			\$1,206.35
Annual	\$8,244.70	\$730.00		\$8,974.70
Athletic	\$5,945.53	\$50,401.30	\$19,485.35	\$36,861.48
Box Tops for Educ	\$3,255.79			\$3,255.79
Cheerleaders	\$2,955.68		\$2,156.50	\$799.18
Class 2015	\$210.07			\$210.07
Class 2016	\$1,562.29			\$1,562.29
Class 2017	\$2,113.70			\$2,113.70
Class 2018	\$2,056.04	\$39.00		\$2,095.04
Class 2019	\$0.00			\$0.00
Close Up	\$1,328.01	\$7,137.42	\$741.28	\$7,724.15
Concessions	\$1,781.28	\$1,770.13	\$2,750.23	\$801.18
Dance Team	\$1,261.15	\$42.25		\$1,303.40
Drama	\$746.76	\$105.00	\$314.75	\$537.01
Drug Free Program	\$395.49			\$395.49
FBLA	\$616.45	\$149.00		\$765.45
FCCLA	\$1,030.40	\$970.96	\$508.00	\$1,493.36
FFA	(\$1,172.39)	\$3,358.00	\$807.00	\$1,378.61
FFA GREENHOUSE	\$7,877.12		\$372.50	\$7,504.62
Laptop Initiative	\$8,474.73	\$982.98		\$9,457.71
Letterclub	\$1,940.60	\$66.00	\$43.00	\$1,963.60
Miscellaneous	\$0.00			\$0.00
Music	\$730.84	\$6.00		\$736.84
Nat'l Honor Society	\$945.31			\$945.31
Speech	\$236.92			\$236.92
Student Council	\$662.42			\$662.42
Tiger Stripes	\$0.00			\$0.00
WR Spirit Leaders	\$111.27	\$738.55	\$404.00	\$445.82
<b>TOTALS</b>	<b>\$54,516.51</b>	<b>\$66,496.59</b>	<b>\$27,582.61</b>	<b>\$93,430.49</b>
<b>ACTIVITY FUND CERTIFICATE OF DEPOSIT</b>				
<b>DATE PURCHASED/NUMBER</b>	<b>NAME/AMOUNT</b>	<b>RATE</b>	<b>BALANCE</b>	<b>MATURITY</b>
9-3-91 #1013527	FFA Gilt Chain \$800.00	0.15%	\$1,635.54	3/3/16

BILLS NOVEMBER 12, 2015		
Certified Staff	\$208,585.12	Gross Salary
Classified Staff	\$68,254.87	Gross Salary
First Nebraska Bank	\$20,582.88	FICA (District share)
Nebraska School Retirement	\$26,139.65	Retirement(Dist share)
Blue Cross Blue Shield	\$41,898.26	Insurance
SUB TOTAL OF PAYROLL	\$365,460.78	
American Band Accessories	\$109.75	Fingerless gloves
Baker & Rastovski Service	\$2,500.00	Budget assistance
Butler Co Arts Council	\$450.00	Member dues/residency
Butler Co Clinic	\$125.00	Bus physical (AB)
Butler Co Welding	\$220.00	Bus barn power station
Butler Public Power Dist	\$981.87	Dwight electricity
Canon Financial Services	\$849.00	Copiers/printers
Canon Solutions America	\$1,254.64	Supply program/copies
Central Community College	\$79.00	Sped tuition (BW)
Central Ne Rehab	\$5,183.50	SPED services
Chem Tech	\$59.67	Prague pest elimination
Crescent Electric Supply	\$634.03	Electrical supply
CTF Service, Inc	\$820.34	Fleet repair/maintenance
Dale's Food Pride	\$162.44	PS/FCS grocery
David City Ace Hardware	\$5.98	Mount tabs-Mr E pix

David City Public School	\$718.04	Our share insurance (SH)	
David City Public School	\$28,363.51	Contract SPED/transport	
Didier's Grocery	\$170.49	FCS/Bd of Ed grocery	
Doug McGee	\$53.68	Mileage	
Eakes Office Solutions	\$196.98	Purchase option/toner	
EB Hot Lunch	\$119.35	PT Conf cookies	
EB Foundation Scholarship	\$75.00	Memorials(Schulz/Maca/ Lemke)	
ESU # 7	\$19,830.40	Sped services	
First National Bank Omaha	\$6.83	Mr E lunch	
First National Bank Omaha	\$6.00	Sch Imp mtg parking	
Follett School Solutions	\$2,000.00	Library manager	
Frontier Coop Co	\$5,870.43	Gas/Diesel/propane/oil	
Heather Kavan	\$30.00	Workshop reimbursement	
Jenn Nantkes	\$2,412.76	SPED vision services	
Jodi Chapek	\$24.94	Touch sensor Legos	
Ken Ekeler	\$225.00	Backflow testing	
Kiddie Cab	\$11.37	Sped transport	
Kuhlman & Kratochvil	\$395.00	Monthly processing	
Lincoln Winnelson	\$282.22	Plumbing supply	
Mackin Educ Resources	\$828.63	HS library books	
Madison Nat'l Life Ins	\$638.22	Disability insurance	
Matheson Tri Gas Inc	\$304.36	Welding supply	

Menards 27th Street	\$79.70	Posts Bus parking
Michael Eldridge	\$383.70	Air ticket to Florida
N C S A	\$280.00	State Principals' Conf
Nebraska Air Filter	\$1,065.49	Air filter order
N A S B	\$792.00	Bd/Supt State Conf register/meals
N E T S	\$1,200.00	Negotiations software
N E C O	\$118.80	Monitor Dwight
Norfolk Hampton Inn	\$89.00	Tchr room-workshop
Northeast Ne Telephone	\$72.85	Prague phone
Oliva Audio Visual	\$608.18	Computer repair
PerryGutheryHaaseGessford	\$280.00	Attorney fees
Quill Corporation	\$22.66	Office supply
Rebecca Matthews	\$137.30	Mileage Para Conf
Rumery Lawn & Landscape	\$467.40	FB field service call
Rehmer Auto Parts	\$2.30	FB field PA system
Sack Lumber Co	\$36.99	Deck paint FB field
Sandy Bongers	\$293.03	Mileage/FCS grocery
School Specialty Supply	\$232.42	Markerboard Coop order
Select Plumbing Inc	\$495.00	Plumbing service call
Sophie Hermelbracht	\$14.35	Tactile letters
Taylor Pollock	\$9.14	Locks-Mr E desk
Tyco Integrated Security	\$562.77	Annual service charge
U S P S	\$1,482.50	Personalized envelopes

Verizon Wireless	\$15.42	Cell phone	
Village of Prague	\$343.92	Utilities	
VT Fabrication	\$700.00	Compost bin	
Wage Works	\$115.00	Monthly fee/Compliance	
Waste Connections	\$570.80	B/D garbage pick up	
Windstream Ne Inc	\$347.20	2081/2092/2445	
Wright Way Drain & Sewer	\$345.00	Cable in Dwight	
SUB TOTAL OF BILLS	\$87,161.35		
GRAND TOTAL P/R & BILLS	\$452,622.13		xx

GENERAL FUND COMPARISON AND UPDATE				
	14 RECEIPTS	15 RECEIPTS	14 EXPENDITURES	15 EXPENDITURES
SEPT .08	\$1,040,026.34	\$932,822.86	\$427,565.49	\$439,762.27
OCT .17	\$369,612.23	\$341,746.44	\$442,681.64	\$474,535.51
NOV .25	\$198,838.98		\$678,938.02	
DEC .33	\$84,935.69		\$433,418.11	
JAN .42	\$993,832.95		\$406,428.09	
FEB .50	\$358,055.18		\$424,106.25	
MAR .58	\$193,498.53		\$431,216.83	
APR .67	\$185,892.43		\$417,557.63	
MAY .75	\$1,308,781.12		\$530,187.29	
JUNE .83	\$471,214.36		\$411,650.31	
JULY .92	\$62,862.94		\$426,420.83	
AUG 1.00	\$71,791.97		\$352,003.75	
TOTAL	\$5,339,342.72	\$1,274,569.30	\$5,382,174.24	\$914,297.78
2014-15 Beginning Cash Balance \$2,029,970.40				
2015-16 Beginning Cash Balance \$1,982,494.97				
2014 denotes the 2014-15 school year				
2015 denotes the 2015-16 school year				

**EAST BUTLER PUBLIC SCHOOLS INVESTMENTS**  
**AS OF NOVEMBER 1, 2015 For Bd Mtg November 12, 2015**  
**GENERAL FUND**

<u>NUMBER</u>	<u>TERM</u>	<u>MATURITY</u>	<u>AMOUNT</u>	<u>RATE</u>	
1026029	12 month	4/5/16	\$508.70	0.25%	McAuliffePrize (At Prague)
3212	24 month	10/1/16	\$380,697.38	0.55%	
1024535	9 month	2/15/16	\$165,342.45	0.20%	
1024295	12 month FLEX	7/13/16	<u>\$463,665.94</u>	0.25%	
			\$1,010,214.47		
41-513	Checking		<u>\$2,348,305.52</u>	0.25%	
<b>TOTAL</b>			<b>\$3,358,519.99</b>		

**DEPRECIATION RESERVE/VEHICLE REPLACEMENT FUND**

602837			\$78,590.00	0.25%
--------	--	--	-------------	-------

**QUALIFIED CAPITAL IMPROVEMENT PURPOSE UNDERTAKING FUND (QC-PUF)**

1507069			\$480,922.72	0.05%
---------	--	--	--------------	-------

**BUILDING FUND**

1041-718	Checking		\$721,243.47	0.05%
1024870	12 mo FLEX	6/10/16	\$220,908.60	0.25%

**EMPLOYEE BENEFIT FUND**

1505565	Checking		\$3,485.98	0.05%
---------	----------	--	------------	-------

**STUDENT FEE FUND**

1502837	Checking		\$21,188.79	
---------	----------	--	-------------	--

**PLEDGED SECURITIES**

FIRST NEBRASKA BANK	5/30/17	\$500,000.00	Cusip 3136G0JD4
FIRST NEBRASKA BANK	3/8/19	\$150,000.00	Cusip 313378QK0
FIRST NEBRASKA BANK	2/27/17	\$100,000.00	Cusip 3133787M7
FIRST NEBRASKA BANK	5/30/19	\$500,000.00	Cusip 3137EADG1
FIRST NEBRASKA BANK	1/30/2017	\$500,000.00	Cusip 3135G0GY3
FIRST NEBRASKA BANK	12/16/2016	\$150,000.00	Cusip 3133XHZK1
FIRST NEBRASKA BANK	11/30/2019	\$200,000.00	Cusip 912828UB4
FIRST NEBRASKA BANK	12/16/2016	\$100,000.00	Cusip 3133XHZK1
FIRST NATIONAL BANK OMAHA	12/15/2015	\$135,000.00	Cusip 67102CAK5 (Prague)
FIRST NEBRASKA BANK	11/17/2017	\$150,000.00	Cusip 3133XMQ87
FIRST NEBRASKA BANK	5/18/2016	\$200,000.00	Cusip 3133XFJF4
FIRST NEBRASKA BANK	12/16/2016	\$150,000.00	Cusip 3133XHZK1
FIRST NEBRASKA BANK	3/8/19	\$500,000.00	Cusip 3133782M2
FIRST NEBRASKA BANK	9/14/18	\$500,000.00	Cusip 313375K48
FIRST NEBRASKA BANK	9/14/18	\$250,000.00	Cusip 313375K48
FIRST NEBRASKA BANK	9/14/18	\$500,000.00	Cusip 313375K48
FIRST NEBRASKA BANK	11/30/17	\$200,000.00	Cusip 3134G3VB3
FIRST NEBRASKA BANK	4/30/20	\$200,000.00	Cusip 912828VA5
<b>TOTAL PLEDGED</b>		<b>\$4,985,000.00</b>	

PAID IN OCTOBER 2015					
<b>PRE-APPROVED BILLS (GENERAL FUND)</b>					
First National Bank Omaha			Natl Geog Bee entry/	Check # 23774	2015-16/07
PO Box 2818			Principals' lunches		
Omaha, Ne 68103-2818		\$126.43			
First National Bank Omaha			Background	Check # 23775	2015-16/08
PO Box 2818			check (RM)		
Omaha, Ne 68103-2818		\$18.00			
Lakeshore Learning Materials			Preschool supply	Check # 23776	2015-16/09
2695 E. Dominguez St.			(Duplicate check)	(CK # 34924 dated	
Carson, CA 90895		\$171.35		9-9-15)	
Nebraska Department of Education			C4L registration for	Check # 23777	2015-16/10
301 Centennial Mall South			Doug Glasshoff		
Lincoln, Ne 68507		\$42.00			
NCSA Region I % Dottie Hensman			Biltoft dues	Check # 23778	2015-16/11
Eagle Elementary, Principal					
District 145 Waverly Public Schools					
600 S. 1st Street					
Eagle, NE 68347		\$25.00			
First National Bank			School Improvement		
PO Box 2818			Parking		
Omaha, Ne 68103-2818		\$13.00		Check # 23779	2015-16/12
First National Bank			Eldridge-NASSP		
PO Box 2818			Conf in Florida/Room		
Omaha, NE 68103-2818		\$748.12	one night	Check # 23780	2015-16/13
First National Bank			Spelling Bee		
PO Box 2818			enrollment		
Omaha, NE 68103-2818		\$118.00		Check # 23781	2015-16/14
Clay Ewell Educational Services			AET subscription		
PO Box 15924					
College Station, TX 77841		\$265.00		Check # 23782	2015-16/15
TOTAL		\$1,526.90			
<b>PRE-APPROVED BILLS (DEPRECIATION FUND)</b>					
84 Lumber			Doors for Ag		
4401 South 33rd Court			Hallway		
Lincoln, NE 68516		\$7,281.81		Check # 1056	
TOTAL		\$7,281.81			

REVENUE REPORT THROUGH 11-1-15			
% of year completed this month .17%			
Category	Amount	Received	
	Budgeted	To Date	
1110 Property Taxes	\$4,984,705.99	\$1,215,460.26	
1115 Carline	\$4,000.00	\$477.56	
1120 Public Power District-Sales Tax	\$7,000.00		
1125 Motor Vehicle Taxes	\$205,000.00	\$28,258.03	
1270 Pre-School Tuition	\$10,000.00	\$1,810.00	
1410 Interest	\$5,000.00	\$996.27	
1610 Local License Fees	\$2,500.00		
1910 Other Local Receipts	\$500.00		
1991 Receipts from Other Districts			
2110 County Fines/Licenses	\$22,000.00	\$4,072.15	
2210 ESU Receipts	\$5,000.00	\$9,516.90	
3110 State Aid	\$19,379.81	\$3,875.96	
3120 SPED Programs/School Age	\$250,000.00		
3125 SPED Transportation/School Age	\$0.00		
3130 Homestead Exemption	\$0.00		
3135 St of Ne High Ability Learner	\$2,000.00	\$3,710.00	
3165 SPED - Below Age Five	\$0.00		
3180 Pro Rate Motor Vehicle	\$11,000.00	\$853.19	
3200 State Apportionment	\$52,000.00		
3300 In-Lieu-of-School Land Tax	\$0.00		
3500 State Categorical Grants	\$0.00		
3512 Dist. Ed. Incentive	\$1,000.00	\$2,000.00	
4200 Title I	\$65,749.60		
4300 TITLE VI (REAP)	\$15,000.00		
4310 Title II-A	\$0.00		
4320 Title V Grants	\$0.00		
4400 Special Education (Birth to Age 5)	\$0.00		
4402 Pre-School Transportation	\$0.00		
4404 SPED IDEA	\$0.00		
4406 IDEA	\$0.00		
4410 SPED IDEA	\$0.00		
4411 CEIS	\$0.00		
4412 IDEA NONPUBLIC	\$0.00		
4450 Medicaid in Schools	\$0.00		
4455 Medicaid Administrative Outreach	\$0.00	\$2,067.07	
5400 Sale of Property	\$0.00		
5690 Other Non Revenue Receipts	\$0.00	\$1,471.91	
TOTAL	\$5,661,835.40	\$1,274,569.30	22.00%

November 12, 2015				
<b>SPECIAL BUILDING FUND BILLS</b>				
NONE				
TOTAL		\$0.00		
<b>QUALIFIED CAPITAL IMPROVEMENT PURPOSE UNDERTAKING FUND</b>				
BOK Financial			Principal/Interest/	
Corporate Trust Services			Agent fee/	
1248 'O' Street, Ste 732			Filing fee for	
Lincoln, NE 68508		\$111,579.42	BCSD0502BABS	
BOK Financial			Interest due on	
Corporate Trust Services			BUTLERCTYS15	
1248 'O' Street, Ste 732				
Lincoln, NE 68508		\$22,030.94		
TOTAL		\$133,610.36		
				XX

BUDGET CATEGORY SUMMARY					
October, 2015					
% OF YEAR COMPLETED THIS MONTH .17%					
CATEGORY	BUDGETED	OCTOBER	YEAR TO DATE	BALANCE	
		EXPENDITURES			
Instruction	\$2,834,740.79	\$225,068.65	\$481,320.59	\$2,353,420.20	
SPED (School Age)	\$650,656.38	\$66,802.38	\$102,566.32	\$548,090.06	
Distance Learning	\$3,000.00	\$0.00	\$0.00	\$3,000.00	
Guidance Services	\$102,352.87	\$8,042.85	\$16,880.37	\$85,472.50	
Safety/Security	\$125,283.57	\$0.00	\$0.00	\$125,283.57	
Other Pupil Support	\$22,930.70	\$1,334.86	\$2,080.35	\$20,850.35	
Library	\$93,342.20	\$7,476.61	\$14,486.12	\$78,856.08	
Board of Education	\$57,227.10	\$2,006.38	\$5,686.82	\$51,540.28	
Exec Admin Service	\$171,774.00	\$15,169.84	\$28,598.08	\$143,175.92	
Office of Principal	\$248,082.36	\$20,586.02	\$41,039.83	\$207,042.53	
Business Support	\$267,374.19	\$22,659.07	\$45,244.69	\$222,129.50	
Operation of Plant	\$501,042.71	\$27,568.94	\$49,942.19	\$451,100.52	
Maintenance of Plant	\$157,000.00	\$9,458.59	\$18,719.40	\$138,280.60	
Pupil Transportation	\$271,912.50	\$21,539.29	\$53,517.25	\$218,395.25	
SPED Transportation	\$30,366.43	\$0.00	\$0.00	\$30,366.43	
TITLE I Part A(4200)	\$64,749.61	\$6,162.03	\$12,326.20	\$52,423.41	
High Ability (4301)	\$0.00	\$660.00	\$660.00	(\$660.00)	
Title V Grant (4320)	\$0.00	\$0.00	\$0.00	\$0.00	
PreSch Transportation 4402	\$0.00	\$0.00	\$0.00	\$0.00	
PreSchool Handicap 4404	\$0.00	\$0.00	\$1,229.57	(\$1,229.57)	
IDEA 4406	\$0.00	\$0.00	\$0.00	\$0.00	
SPED Idea 4410	\$0.00	\$0.00	\$0.00	\$0.00	
IDEA CEIS 4411	\$0.00	\$0.00	\$0.00	\$0.00	
IDEA NONPUBLIC 4412	\$0.00	\$0.00	\$0.00	\$0.00	
Medicaid Admin Outreach	\$0.00	\$0.00	\$0.00	\$0.00	
Transfers	\$360,000.00	\$40,000.00	\$40,000.00	\$320,000.00	
<b>TOTALS</b>	\$5,961,835.41	\$474,535.51	\$914,297.78	\$5,047,537.63	

StudentsOption EnrollmentA. Process and Time Lines to Option In

For a student to attend East Butler Public Schools as an option enrollment student, the student's parent or legal guardian must submit an application to the Board of Education of the East Butler Public School District between September 1 and March 15 for enrollment during the following and subsequent school years (the "application period").

Upon receipt of an application, the Superintendent or the Superintendent's designee shall provide the resident school district with the name of the applicant on or before April 1 or, in the case of an application submitted after March 15, within sixty days after submission.

**Provisions for Waiver of Application Deadline (Choose one or modify as desired):**

The application deadline will **not** be waived by the School Board for applications to option into the East Butler Public School District, except in the following circumstances:

1. Siblings: The application deadline will be waived where the application is for a student who is the sibling of a student attending East Butler Public Schools as of the time the application is filed, provided the application is filed at least 30 days prior to the semester in which first enrollment is sought. A "sibling" for this purpose means a child who resides in the same household on a permanent basis with a student who is currently attending East Butler Public Schools and who has the same natural or adoptive parent or who is a stepbrother or stepsister.

2. Kindergarten: The application deadline will be waived where the application is for a student who is seeking to enroll and attend the Kindergarten grade level provided the application was filed on or before June 1 prior to the first semester of the next school year.
3. Release Approval: For the foregoing exceptions, the application must contain a release approval from the resident district.
4. Other Conditions: The waiver of the deadline in the above circumstances does not require acceptance of the application, as such applications may be rejected for reasons other than late filing.
5. Capacity: For the foregoing exceptions, the application deadline shall not be waived if the application is for enrollment in any program, class, grade level or school building or in any special education programs operated by this School District which have been determined by the School Board to be at capacity in accordance with the capacity standards (Appendix "1"), and no waiver of the deadline shall be made for such an application regardless of whether such capacity determinations are declared invalid for any reason.
6. Capacity for Late Filed Applications: Where an application is filed for enrollment in the same school year in which enrollment is sought, the "projected enrollment" determinations made pursuant to paragraph D shall be replaced with the "actual enrollment" as of the first day of school for the year of application, as determined by the Superintendent or the Superintendent's designee, but only in the event such actual enrollment is higher than the projected enrollment. Actual enrollment shall include all students in attendance and all students registered to attend (even if not in actual attendance on the first day).

B. Rejection of Applications; Reasons

1. Capacity: An option enrollment application shall be rejected in the event the capacity of a program, class, grade level, or school building or the availability of appropriate special education programs operated by the School District would be exceeded by acceptance of the application, and an option enrollment application shall be rejected in the event the application is for enrollment in a program, class, grade level, or school building which has been declared unavailable to option students due to lack of capacity.
2. Timeliness: An option enrollment application shall be rejected in the event the application is not filed on a timely basis and the filing deadline has not been waived.

3. Previous Option Enrollment: An option enrollment application shall be rejected in the event the student has previously filed an option enrollment application for enrollment in any School District and has had such application accepted, unless a statutory exception to the “one-time” rule is applicable to the student’s circumstance.

4. Other Reasons: An option enrollment application may be rejected in the event the Superintendent, the Superintendent’s designee, or the School Board determines: The application is not submitted on a form prescribed by the State Department of Education, is not completely and accurately filled in, is not received within the time required by law, or any additional information requested to be supplied is not supplied to the School District within the time lines indicated; or in the event acceptance of the application is not required by law. Matters which are legally prohibited from being considered as standards for acceptance or rejection of applications (including “previous academic achievement, athletic or extracurricular ability, disabilities, proficiency in the English language, or previous disciplinary proceedings” and further including, without limitation, race, national origin, and gender) shall not be considered as reasons for acceptance or rejection.

C. Priority of Acceptance

Priority shall be accorded in the following order: (1) first, to those applications required to be given priority by law, (2) second, to those with a sibling in attendance at East Butler Public Schools, with priority within this group being given to those who had earliest filed applications, and (3) third to those without an option student sibling in attendance at East Butler Public Schools, with priority within this group to those who had earliest filed applications.

Filing date determinations are made by the Superintendent, or the Superintendent’s designee. In the event applications within a group are received at the same or substantially the same time, priority as between such same-date applications shall be determined on the basis of random drawing.

D. Determination of Capacity

The School Board will determine and set, on an annual basis, the maximum number of option enrollment applications the School District will accept in any program, class, grade level or school building or in any special education programs operated by this School District, based upon available staff, facilities, projected enrollment of resident students, projected number of students with which this School District will contract based on existing contractual arrangements, and availability of appropriate special education programs, and may declare a program, class or school unavailable to option students due to lack of capacity. Such determinations may be made in the form of an Appendix “1” to this Policy. The determination and declaration made for any school year shall continue in effect for the next and subsequent school years unless otherwise determined and/or declared.

E. Releases for Options Out**Provisions for Release (Choose one or modify as desired):**

A request for release of a resident student of the East Butler Public School District who submits an enrollment option application after March 15 or any other statutory deadline will be granted only on the following conditions:

1. Kindergarten: A release will be granted where the application is for a student who is seeking to enroll and attend the Kindergarten grade level provided the application was filed on or before June 1 prior to the first semester of the next school year.
2. Siblings: A release will be granted where the application would allow the student to attend the same school as a sibling, provided the application is filed at least 30 days prior to the semester in which first enrollment is sought. A “sibling” for this purpose means a child who resides in the same household on a permanent basis with a student who is currently enrolled in the option district and who has the same natural or adoptive parent or who is a stepbrother or stepsister.
3. Educational Programming: A release will be granted where the needs of the student require the District to obtain additional staffing or equipment and it is in the best interests of the District and the student to enroll in the option district. The determination of whether this condition is met shall be made by the Superintendent or the Superintendent’s designee.
4. No Pending Expulsion: The deadline shall not be waived if the administration is considering or has recommended expulsion of the student at the time the application is filed, and the administration determines it is appropriate to complete the expulsion process.

The Superintendent or the Superintendent's designee is hereby authorized to execute such releases on behalf of the School Board and the School District, subject to subsequent ratification by the School Board.

F. Notification of Acceptance or Rejection

In the case of an application to option enroll into the East Butler Public School District, the Superintendent or the Superintendent's designee shall notify, in writing, the parent or legal guardian of the student and the resident school district whether the application is accepted or rejected on or before April 1 or, in the case of an application submitted after March 15, within sixty days after submission.

If an option enrollment application or a request for release is rejected by the East Butler Public School District, the Superintendent or the Superintendent's designee shall provide written notification to the parent or guardian stating the reasons for the rejection and the process for appealing such rejection to the State Board of Education. Such notification shall be sent by certified mail.

G. Applications Subsequent to Relocations or Mergers

An option enrollment application does not require a release and shall be accepted or rejected within forty-five days after filing in the following circumstances:

1. the student relocated to a different resident school district after February 1, or
2. the student's option school district merged with another district effective after February 1, and
3. the application is for attendance during the immediately following and subsequent school years.

H. Status of Option Student

A student who is admitted under the enrollment option program shall be treated as a resident student, and in such regard shall be required to provide such enrollment information and documentation as is required for enrollment of other students (e.g., certified birth certificate and evidence of physical examination, visual evaluation and immunization), shall be required to be enrolled on a full-time basis, and shall be required to adhere to student conduct rules. The building assignment for an option student, as well as classroom and grade level assignments, shall be determined by the administration.

An option student shall not be entitled to transportation except as required by law.

I. Information Regarding Schools, Programs, Policies and Procedures.

As part of the option enrollment program, the administration shall make information about the East Butler Public Schools and its school, programs, policies and procedures available to

all interested persons and shall have a copy of the option enrollment policy and regulations available at each school building.

Legal Reference: Neb. Rev. Stat. §§ 79-232 to 79-246

Date of Adoption: [Insert Date]



## **East Butler Public Schools**

In order to graduate in less than 4 years, a student must follow these guidelines:

- A. Must have completed all graduation requirements.
- B. Must submit a letter of request signed by both student and parent to the High School Principal by September 15<sup>th</sup>. The Principal will then arrange for a meeting with the guidance counselor for both the student and the parent to review the needs and responsibilities.
- C. Student and parent must appear at the October School Board Meeting to request early graduation.
- D. Must turn in all books and other equipment and pay all fines or fees.

There will be no mid-year graduation ceremony. Those students who elect to graduate early may receive their diplomas at the February School Board Meeting or the May ceremony. Following completion of graduation requirements, and cessation of attendance, the student will be considered a graduate, and no longer entitled to the right and privileges of students of East Butler High School, including but not limited to attendance at prom and student rates to attend school athletic events or activities.

# PROPOSAL

Proposal Number 7436

Page 1 of 1

Lee's Refrigeration  
734 Seward St.  
PO Box 425  
Seward, NE 68434-  
PHONE : (402)643-3644  
FAX : (402)643-6464

To: 53045 EAST BUTLER SCHOOL PO BOX 36 BRAINARD, NE 68626-	Date 10/22/2015	PO #
	Job Name / Location: EAST BUTLER SCHOOL 212 S MADISON ST PO BOX 36 BRAINARD, NE 68626-	
Phone (402)545-2081 Fax (402)545-2023	Phone (402)545-2081	Fax (402)545-2023

We are pleased to provide you with the following proposal:

## NEW EXHAUST SYSTEM FOR INDUSTRIAL ARTS PLAZMA TABLE

CAPTIVE AIRE 4830VHB-G 8'4" X 4' EXHAUST HOOD  
430 STAINLESS STEEL  
EXHAUST RISER  
DU50HFA DIRECT DRIVE CENTRIFUGAL UPBLAST EXHAUST FAN WITH SPEED CONTROL  
BACK DRAFT DAMPER  
BIRD SCREEN  
ECM WIRING PACKAGE  
EF-1 CURB WITH HINGED BASE

DUCT WORK AND MATERIALS  
LABOR TO INSTALL  
FACTORY FRIEGHT

PROJECT INVESTMENT \$8,240.00

ESTIMATED ROOF REPAIR \$500 - \$750, NOT INCLUDED IN ABOVE  
ELECTRICAL IS NOT INCLUDED

We propose to hereby furnish material and labor - complete in accordance with the above specifications.

Payment to be made as follows:

DUE UPON RECEIPT

This quotation may be withdrawn by us if not accepted within 60 days.

Authorized Signature



Submitted By: JOHN WERNER

Note: This proposal may be  
withdrawn by us if not accepted within 60 days

### Acceptance of proposal

The above prices and specifications of this quotation are satisfactory and are hereby accepted. All work to be performed under same terms and conditions, unless otherwise stipulated.

Signature \_\_\_\_\_

Date of Acceptance: \_\_\_\_\_

Signature \_\_\_\_\_

**HOOD INFORMATION - Job#2468731**

HOOD NO.	TAG	MODEL	LENGTH	MAX. COOKING TEMP.	EXHAUST PLENUM RISERS(S)		TOTAL EXH. CFM	WIDTH	LENG.	DIA.	CFM	S.P.	HOOD CONSTRUCTION		END TO END	RDV	
					4830	VHB-G							430	SS			100%
1		4830	8' 4.00"	700 Deg	1250	16"	1250	-0.0954"									

**HOOD INFORMATION**

HOOD NO.	TAG	FILTER(S)		EFFICIENCY @ 9 MICRONS	QTY.	TYPE	LIGHT(S)		WIRE GUARD	LOCATION	TYPE	FIRE SYSTEM		ELECTRICAL MODEL #	SWITCHES QUANTITY	FIRE HOOD SYSTEM/HANGING PIPING	WGT	
		TYPE	QTY.				SIZE	MODEL #				SC-1100ip02	L F90g					ND
1					0					Right								

**HOOD OPTIONS**

HOOD NO.	TAG	OPTION
1		FINISHED BACK - GROUND/POLISH 100.00' Long

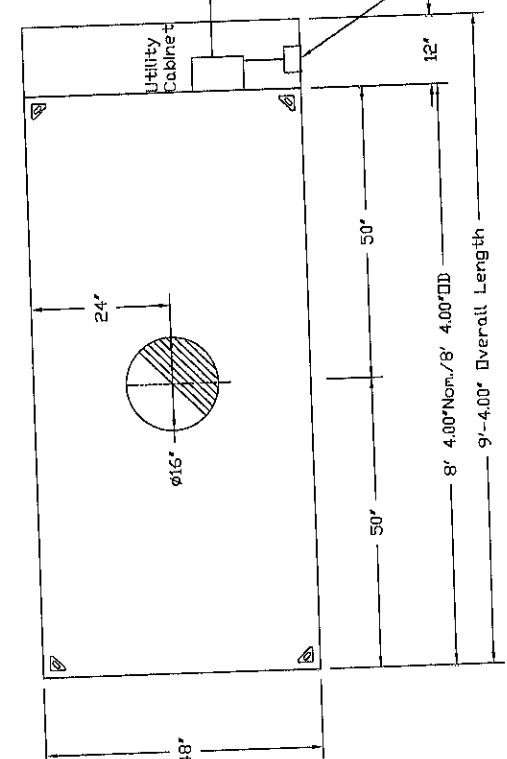

**PLAN VIEW - Hood #1**  
8' 4.00" LONG 4830VHB-G

IT IS THE RESPONSIBILITY OF THE ARCHITECT/OWNER TO ENSURE THAT THE HOOD CLEARANCE FROM LIMITED-COMBUSTIBLE AND COMBUSTIBLE MATERIALS IS IN COMPLIANCE WITH LOCAL CODE REQUIREMENTS.

EXHAUST RISER  
HANGING ANGLE

UTILITY CABINET(S)	ELECTRICAL	SWITCHES	FIRE HOOD SYSTEM/HANGING PIPING	WGT
SC-1100ip02		L F90g	ND	344

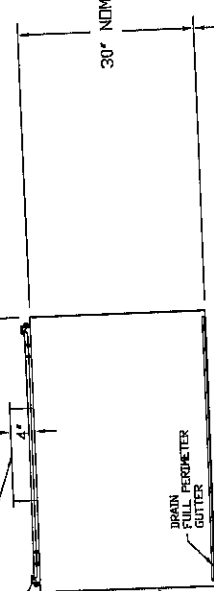

EQUIPMENT BY OTHERS

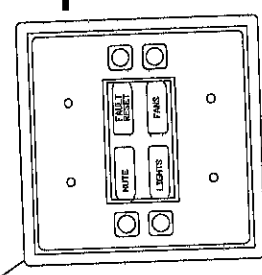

TOUCH-SCREEN USER INTERFACE

**SECTION VIEW - MODEL 4830VHB-G**  
HOOD - #1

JOB #	2468731
LOCATION	SEWARD, NE,
DATE	10/21/2015
DWG #	1
SCALE	3/8" = 1'-0"

JOB Plasma Table Hood

**CAPTIVE AIR**

**EXHAUST FAN INFORMATION - Job#2468731**

FAN UNIT TAG	FAN UNIT MODEL #	CFM	ESP.	RPM	HP.	B.H.P.	φ	VOLT.	FLA	WEIGHT (LBS.)	SDNES
1	DUS0HFA	1250	0.500	1408	0.500	0.3000	1	115	5.6	64	141

**FAN OPTIONS**

FAN UNIT TAG	OPTION (Qty. - Descr.)
1	1 - I 15-BDD Damper
1	1 - SCR-13 Bird Screen
1	1 - ECM Wiring Package for Exhaust Fans or Untempered Supply Fans - Manual Speed Control.

**FAN ACCESSORIES**

FAN UNIT TAG	EXHAUST	SUPPLY
1	GREASE CUP	GRAVITY DAMPER
1	WALL MOUNT	MOTORIZED DAMPER
1	YES	WALL MOUNT

**CURB ASSEMBLIES**

NO.	DN	FAN	WEIGHT	ITEM	SIZE
1	# 1	34	LBS	Curb	19,500"W x 19,500"L x 24,000"H - Hinged

FAN #1 DUS0HFA - EXHAUST FAN (EF-1)

**FEATURES:**

- ROOF MOUNTED FANS
- UL705
- VARIABLE SPEED CONTROL
- INTERNAL WIRING
- WEATHERPROOF DISCONNECT
- THERMAL OVERLOAD PROTECTION (SINGLE PHASE)

**OPTIONS**

- I 15-BDD DAMPER
- SCR-13 BIRD SCREEN
- ECM WIRING PACKAGE FOR EXHAUST FANS OR UNTEMPERED SUPPLY FANS - MANUAL SPEED CONTROL.

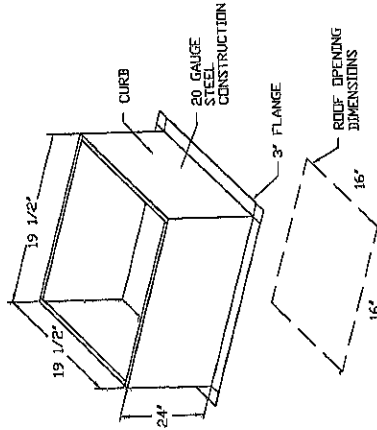
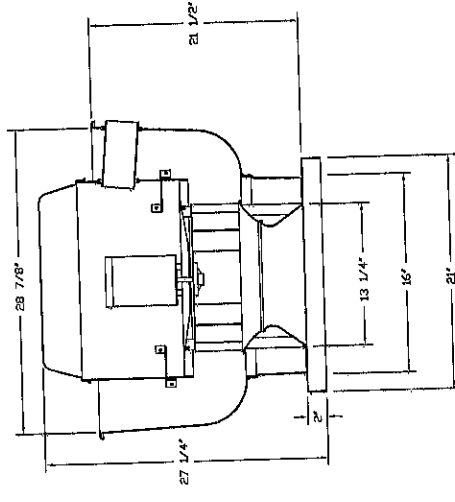

**BACKDRAFT DAMPER INSTALLATION**

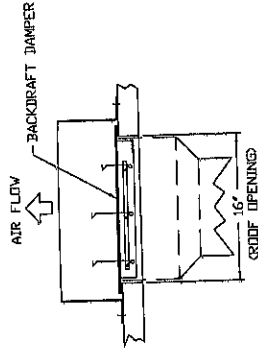

JOB Plasma Table Hood

LOCATION SEWARD, NE.

DATE 10/21/2015

DWG # 2

REV.

**CAPITV**



JOB # 2468731

DRAWN BY tjorgense

SCALE 3/8" = 1'-0"

**ELECTRICAL PACKAGES - Job #2468731**

NO.	TAG	PACKAGE #	LOCATION	SWITCHES		OPTION	FANS CONTROLLED					
				LOCATION	QUANTITY		FAN TAG	TYPE	HP	VOL. FLA		
1		SC-11001002	Utility Cabinet Right Hood # 1	Utility Cabinet Right Hood # 1	1 Fan	Smart Controls Basic	EF-1	Exhaust	1	0.500	115	5.6

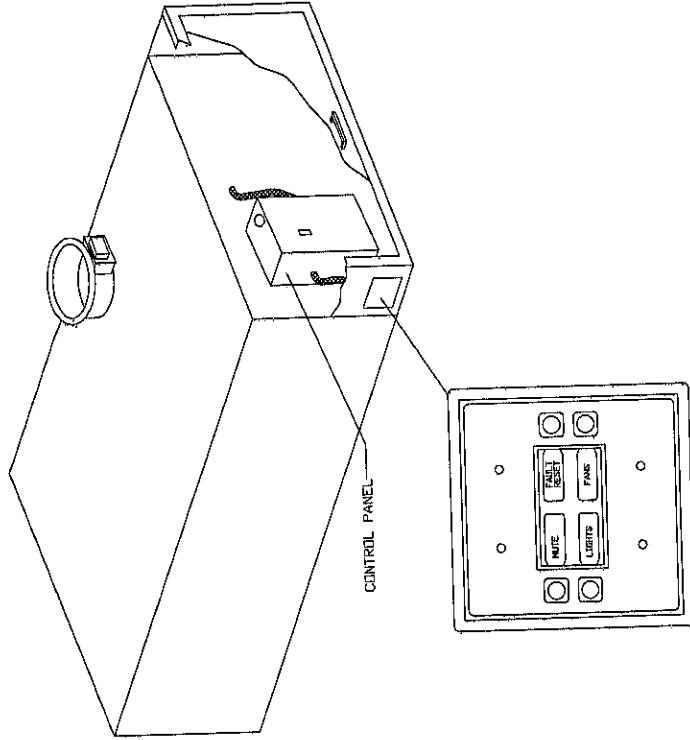

**TOUCH-SCREEN  
USER INTERFACE**

**TYPICAL CONTROL CENTER INSTALLATION**

JOB Plasma Table Hood	
LOCATION	SEWARD, NE,
DATE	10/21/2015
DWG #	4
REV.	
JOB #	2468731
DRAWN BY	t.jorgensen
SCALE	3/8" = 1'-0"

**CAPIVER**



## **Elementary Principal Report November Board Meeting**



### **I. Adequate Yearly Progress (AYP) Letter**

- A. East Butler Elementary in Brainard and Dwight are in year 2 of schools in need of improvement according to Adequate Yearly Progress (AYP) guidelines set by federal education legislation that requires 100% of the students to be proficient in reading and math by 2014.
- B. The school is required to send an approved letter explaining the status to parents, publish the letter on our website, and provide Public School Choice. East Butler does not qualify for Public School Choice because both schools are labeled as in need of improvement.
- C. The second year requirements also mean that we need to offer Supplemental Educational Services (SES). This could provide additional tutoring from a Nebraska Department of Education approved program that will also be listed on our website. A portion of our Title funds will also need to be designated to improvement.
- D. The letters sent to Dwight and Brainard elementary parents are attached. I will be working with Mr. Stecher on additional requirements.

### **II. Response to Intervention (RTI) Consortium Update**

- A. Members of our Response to Intervention (RTI) team attended training on November 4 in Columbus. The focus of the session was exploring intervention strategies for our math program. The group will be meeting in December to review DIBELS scores and discuss response rules.
- B. RTI has changed the name of the program to Multi-tiered Systems of Support (MTSS). This program has helped to focus our efforts and work to create a process to identify students that may need support earlier in school.

### **III. Veteran's Day Program**

- A. The Veteran's Day program will take place on Wednesday, Nov. 11 at 2:15 in the Brainard Gym. Elementary students sing patriotic songs and the Kindergarten students receive their flags.
- B. I appreciate the effort of Mrs. Hines, Mr. Fuehrer, Mr. Eldridge, and all who make this event such a positive and meaningful experience.

### **IV. Student Leadership Conference**

- A. East Butler sent 6 Fifth and Sixth grade students to the Student Leadership Conference held at Doane College in Crete on October 20.
- B. I attended the conference with the students and found it to be a positive experience for the students as a means to build leadership skills.

### **V. Additional Information**

- A. Parents Promoting Tigers will be sponsoring a free movie in the gym on November 13. Popcorn and juice boxes will be provided.

# East Butler Public Schools

"Where Futures Begin"

212 South Madison Street  
P.O. Box 36  
Brainard, NE 68626  
Phone: (402) 545-2081  
Fax: (402) 545-2023



Sam Stecher - Superintendent  
Michael Eldridge - Secondary Principal  
Shawn Biltoft - Elementary Principal

October 30, 2015

Dear East Butler Elementary Parents:

The federal education legislation, No Child Left Behind, requires that 100% of students must be proficient in reading and math academic standards by 2014. Schools are expected to make Adequate Yearly Process (AYP) toward that goal.

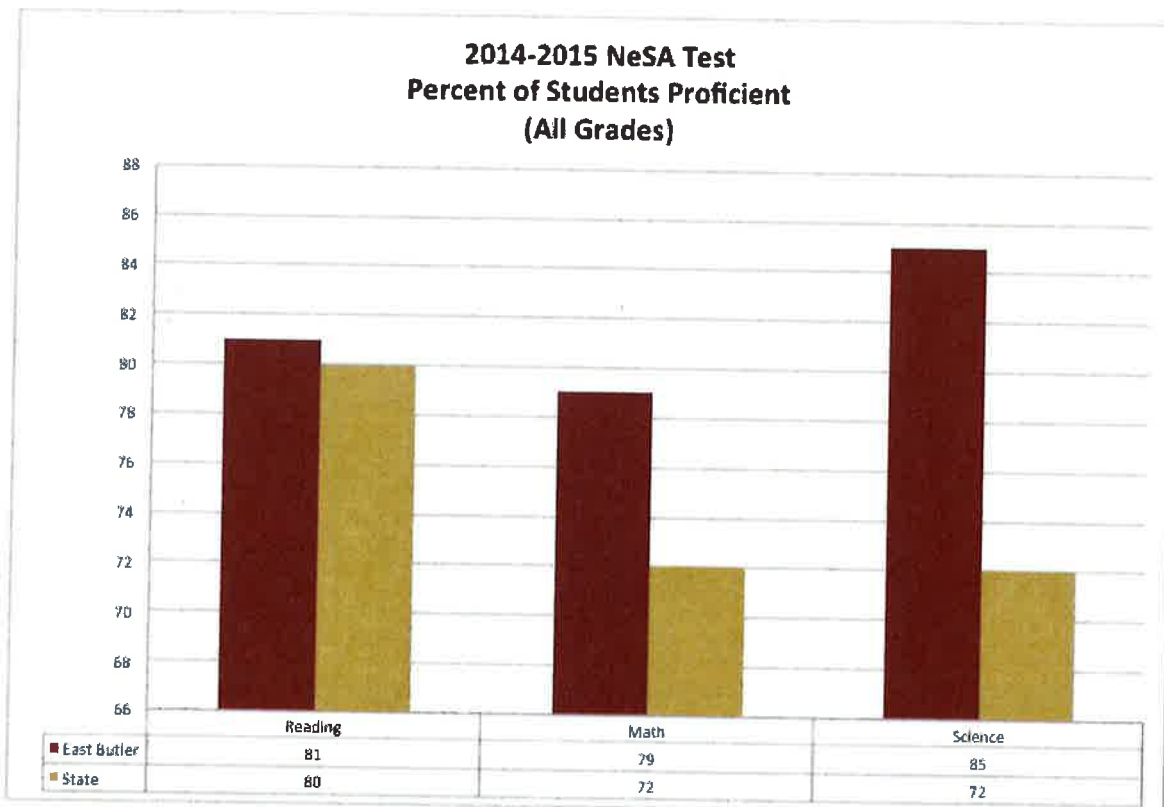

The chart above shows the percentage of all East Butler students that are proficient in reading, mathematics, and science on the Nebraska State Accountability (NeSA) assessments compared to the state average on the same test. As the chart reflects, East Butler is performing at or above the state level in each of the areas for 2014-2015.

The purpose of this letter is to inform you that, according to the 2014-2015 state student assessment results, East Butler Elementary School in Brainard is in Year 2 of Title I Schools identified as "in need of improvement" for the 2014-2015 school year under the federal No Child Left Behind law. The school is identified in this manner because the AYP goals for proficiency in math and reading for 2 consecutive years were not attained.

East Butler Elementary-Brainard

Student Groups	2012-2013		2013-2014	
	Performance	Participation	Performance	Participation
Reading: All Students	Not Met	Met	Not Met	Met
Math: All Students	Met	Met	Not Met	Met

	2014-2015	
	Performance	Participation
Reading: All Students	Not Met	Met
Math: All Students	Not Met	Met

Since East Butler Elementary Schools in Brainard and Dwight have been identified as schools in need of improvement, Public School Choice must be offered to all students who attend the identified schools. Our students do not have another choice of schools within our district and as a result do not qualify for Public School Choice. In 2015-2016, East Butler Public School-Brainard Elementary has a K-6 enrollment of 93 students with no public choice available. Additional information about how our school compared to other schools in the state is available on the State of the Schools Report on the Nebraska Department of Education website, <http://reportcard.education.ne.gov/>

This identification also requires East Butler to provide Supplemental Educational Services (SES) to eligible students (students who qualify for free and reduced lunch program). A list of SES providers that have been approved by the State Department of Education that could provide tutoring services for your child is available on the following website, <http://www.ebutlertigers.org>. Parents who choose to have their children participate in SES are asked to contact the East Butler School office at (402) 545-2081 by November 20 to enroll. A second enrollment window will be offered later in the school year. Once notice has been received, we will make enrollment arrangements as quickly as possible and will notify parents upon approval.

East Butler will continue to improve by providing ongoing training to maximize student progress by analyzing student scores. We are also encouraged by the implementation of our math series, Math Expressions. The East Butler support staff provides assistance to students receiving Special Education services and students in our Title I program. The entire staff at East Butler continues to work together to ensure a quality education for our students.

All children benefit greatly from parental involvement. Asking questions about school, having students read aloud, and setting aside a time and place for homework are only a few of the things you can do. Regular school attendance is also very important to student success. Student achievement is a partnership between school and home.

If you have questions about this information, please contact Mr. Biltoft. Thank you for working with us to ensure success for every student.

Sincerely,

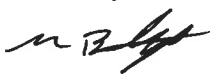

Shawn Biltoft  
East Butler Public Schools  
Elementary Principal

# East Butler Public Schools

"Where Futures Begin"



212 South Madison Street  
P.O. Box 36  
Brainard, NE 68626  
Phone: (402) 545-2081  
Fax: (402) 545-2023

Sam Stecher - Superintendent  
Michael Eldridge - Secondary Principal  
Shawn Biltoft - Elementary Principal

October 29, 2015

Dear East Butler Elementary Parents:

The federal education legislation, No Child Left Behind, requires that 100% of students must be proficient in reading and math academic standards by 2014. Schools are expected to make Adequate Yearly Process (AYP) toward that goal.

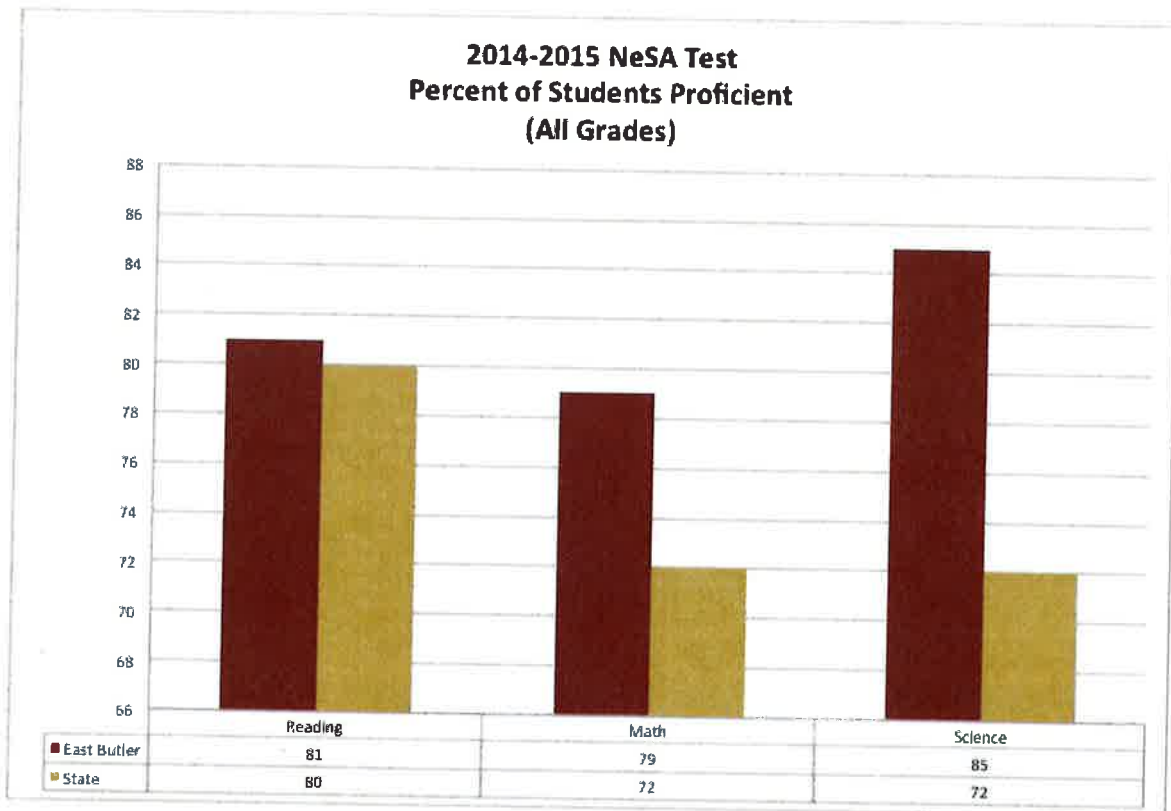

The chart above shows the percentage of all East Butler students that are proficient in reading, mathematics, and science on the Nebraska State Accountability (NeSA) assessments compared to the state average on the same test. As the chart reflects, East Butler is performing at or above the state level in each of the areas for 2014-2015.

The purpose of this letter is to inform you that, according to the 2014-2015 state student assessment results, East Butler Elementary School in Dwight is in Year 2 of Title I Schools identified as "in need of improvement" for the 2014-2015 school year under the federal No Child Left Behind law. The school is identified in this manner because the AYP goals for proficiency in math and reading for 2 consecutive years were not attained.

East Butler Elementary-Dwight			
Student Groups	2012-2013	2013-2014	2014-2015
	Performance	Performance	Performance
Reading: All Students	Not Met	Not Met	Not Met
Math: All Students	Met	Not Met	Not Met

Since East Butler Elementary Schools in Brainard and Dwight have been identified as schools in need of improvement, Public School Choice must be offered to all students who attend the identified schools. Our students do not have another choice of schools within our district and as a result do not qualify for Public School Choice. In 2015-2016, East Butler Public School-Dwight Elementary has a K-6 enrollment of 40 students with no public choice available. Additional information about how our school compared to other schools in the state is available on the State of the Schools Report on the Nebraska Department of Education website, <http://reportcard.education.ne.gov/>

This identification also requires East Butler to provide Supplemental Educational Services (SES) to eligible students (students who qualify for free and reduced lunch program). A list of SES providers that have been approved by the State Department of Education that could provide tutoring services for your child is available on the following website, <http://www.ebutlertigers.org>. Parents who choose to have their children participate in SES are asked to contact the East Butler School office at (402) 545-2081 by November 20 to enroll. A second enrollment window will be offered later in the school year. Once notice has been received, we will make enrollment arrangements as quickly as possible and will notify parents upon approval.

East Butler will continue to improve by providing ongoing training to maximize student progress by analyzing student scores. We are also encouraged by the implementation of our math series, Math Expressions. The East Butler support staff provides assistance to students receiving Special Education services and students in our Title I program. The entire staff at East Butler continues to work together to ensure a quality education for our students.

All children benefit greatly from parental involvement. Asking questions about school, having students read aloud, and setting aside a time and place for homework are only a few of the things you can do. Regular school attendance is also very important to student success. Student achievement is a partnership between school and home.

If you have questions about this information, please contact Mr. Bilstoft. Thank you for working with us to ensure success for every student.

Sincerely,



Shawn Bilstoft  
East Butler Public Schools  
Elementary Principal

To: East Butler Public Schools Board of Education  
From: Michael Eldridge, Secondary Principal  
Date: November 12, 2015  
Re: Secondary Principal's Report

**I. Professional Development for Staff**

- a. Our Professional Development on November 18th will be "Unwrapping" the Language Arts Standards.
- b. This will be the beginning of the process for designing and revising our Language Arts curriculum K-12.
- c. This was a request from our staff. We surveyed them towards the end of last year.
- d. Our plan will also be to go through each of the content areas with this process.
- e. We will also be beginning a partial book study of "Reaching Higher" by John Baylor.

**II. School Improvement Team Meeting**

- a. The School Improvement Team met on Thursday, October 22nd.
- b. The team discussed the creation of new school improvement goals. Since we met the last two goals that were established during the fall of 2013.
- c. It was decided that we would create two new goals that are attached to NeSA data, where we will increase the percentage of students meeting/exceeding the standard.
- d. It was also decided we will have a goal for MAP data, which simply will be MORE students meeting growth targets and MORE students at or above the National Average.

**III. Veterans Day Assembly**

- a. The assembly will take place on November 11th at 2:15pm.
- b. This year the American Legion is recognizing those people that have had 50 years of consecutive membership in the American Legion.

**IV. Adolescent Literacy Learning (ALL)**

- a. The ALL team has been conducting observations of one another and providing feedback regarding engagement.
- b. Recently they attended a workshop with Dr. Feldman that focused on vocabulary instruction. Which simply put, is teaching your students that necessary vocabulary that is used for your content area.
- c. Members of this team are: Ms. Widick, Mr. Behne, Mr. Christensen, Mrs. Svoboda, Mr. Wood, and Ms. Johnson.
- d. They will be conducting another observation this quarter, as well as completing a video recording of their own teaching.

**V. 7th Grade Laptops**

- a. Mr. McGee and I made the decision, based off of the responsible behavior that we were seeing from our 7th graders, to allow them to take their laptops home starting on October 20th.
- b. Families appeared to be appreciative of this, and of course the students were excited.