

Board of Education Regular Meeting

Monday, March 10, 2025 6:00 PM

1. OPEN THE MEETING

1.1. **Call to Order**

1.1.1. **Publication of Meeting**

1.1.2. **Nebraska Open Meetings Law**

1.1.3. **Pledge of Allegiance**

1.1.4. **District Mission Statement**

1.2. **Board Member Roll Call**

Motion was made to excuse absent board member Jacob Kringle. This motion, made by Lynette Mitchell and seconded by Ryan Martin, Passed.

Alicia Beavers: Yea, Cole Brodine: Yea, Hannah Hild: Yea, Ryan Martin: Yea, Lynette Mitchell: Yea

2. CELEBRATION OF EXCELLENCE (staff & student presentations, etc.)

3. PUBLIC COMMENT (agenda item specific)

4. INFORMATION ITEMS

4.1. **Administrator Reports**

4.1.1. **Superintendent Report - Mrs. Beran**

4.1.1.1. *Review Board Members Taking Insurance*

4.1.1.2. *CJUMP Natural Gas Purchasing Program*

4.1.1.3. *Review Drainage Solution from BD*

4.1.1.4. *Estimated Budget Documents for 2024-2025*

4.1.2. **Principal/AD Report - Mr. Marquez**

4.1.2.1. *Discuss JH/HS Math Instructional Materials*

4.1.3. **Principal Report - Mrs. Williams**

- 4.1.3.1. *Discuss PK Math Instructional Materials*
- 4.1.4. **Strategic Plan Update/District Goals Update**

4.2. **Board Committee Reports**

4.2.1. **Building, Grounds, and Transportation**

- 4.2.1.1. *Transportation Update - Cindy Stone*

4.2.2. **Finance and Personnel**

4.2.3. **Policy and Negotiations**

- 4.2.3.1. *Discussion on Policy 5032 Closed Campus*

4.2.4. **Americanism, Curriculum, and Technology**

5. **CONSENT AGENDA**

Motion was made to move on the consent agenda. This motion, made by Alicia Beavers and seconded by Cole Brodine, Passed.

Alicia Beavers: Yea, Cole Brodine: Yea, Hannah Hild: Yea, Ryan Martin: Yea, Lynette Mitchell: Yea

5.1. **Prior Meeting Minutes**

5.2. **Policy Final Reading and Adoption Including all New Policy Updates**

- 5.2.1. *Reviewed Policies 5035 through 5067 with no changes*

5.3. **Financial Reports and Claims according to Review of Bills policy 3007**

5.4.

Consider and Act Upon the Resignation of Jady Ehresman at the end of the 2024-2025 Contract Year

5.5. **Offer Employment Contract to Cadee Lagler to Serve as a 4th-6th Grade Teacher for the 2025-2026 School Year**

5.6. **Consider and Act Upon the Resignation of Royall Woodman at the end of the 2024-2025 Contract Year**

5.7. *Offer Employment Contract to Tyler Ehresman to Serve as a Math Teacher for the 2025-2026 School Year*

6. ACTION ITEMS

6.1. *Consider and Take any Necessary Action on Policy 5032 Closed Campus*

Motion was made to approve the action on Policy 5032 Closed Campus. This motion, made by Lynette Mitchell and seconded by Ryan Martin, Passed.

Cole Brodine: Yea, Alicia Beavers: Yea, Hannah Hild: Yea, Ryan Martin: Yea, Lynette Mitchell: Yea

6.2. *Consider and Take any Necessary Action on JH/HS Math Instruction Materials*

Motion was made to approve an additional \$3000.00 for JH/HS Math Instruction Materials. This motion, made by Alicia Beavers and seconded by Lynette Mitchell, Passed.

Alicia Beavers: Yea, Cole Brodine: Yea, Hannah Hild: Yea, Ryan Martin: Yea, Lynette Mitchell: Yea

6.3. *Consider and Take any Necessary Action on PK Math Instructional materials*

Motion was made to approve the additional \$2000 for the PK Math Instructional materials purchase. This motion, made by Alicia Beavers and seconded by Cole Brodine, Passed.

Alicia Beavers: Yea, Cole Brodine: Yea, Hannah Hild: Yea, Ryan Martin: Yea, Lynette Mitchell: Yea

6.4. *Consider & Take any Necessary Action to Participate in the CJUMP Natural Gas Purchasing Program*

Motion was made to take action in participating in the CJUMP Natural Gas Purchasing Program. This motion, made by Lynette Mitchell and seconded by Ryan Martin, Passed.

Alicia Beavers: Yea, Cole Brodine: Yea, Hannah Hild: Yea, Ryan Martin: Yea, Lynette Mitchell: Yea

7. SCHEDULE NEXT REGULAR BOARD MEETING

8. ADJOURN

Meeting adjourned at 6:50pm. This motion, made by Lynette Mitchell and seconded by Alicia Beavers, Passed.

Alicia Beavers: Yea, Cole Brodine: Yea, Hannah Hild: Yea, Ryan Martin: Yea, Lynette Mitchell: Yea

9. ****CLOSED SESSION: If, during the course of the meeting, discussion of any item on the agenda should be held in a closed meeting, the board will conduct a closed meeting in accordance with the Nebraska Open Meetings Act.**

10. ****SEQUENCE OF AGENDA: The sequence of agenda topics is subject to change at the discretion of the board.**

2009
Public Participation at Board Meetings

The board of education shall conduct its meetings in accordance with the Nebraska Open Meetings Act.

The board shall make reasonable efforts to accommodate the public's right to hear the discussions and testimony presented at its meetings. The board shall make available at the meeting, for examination and copying by members of the public, at least one copy of all reproducible written material to be discussed in open session of the meeting.

Except for closed sessions, the board will allow members of the public an opportunity to speak at each meeting. The board may make and enforce reasonable rules and regulations regarding the conduct of persons attending, speaking at, videotaping, photographing, or recording its meetings.

The board shall not require members of the public to identify themselves as a condition for admission to the meeting, nor shall such body require that the name of any member of the public be placed on the agenda prior to such meeting in order to speak about items on the agenda. However, the board shall require members of the public desiring to address the board to identify themselves, including an address and the name of any organization represented by such person unless the address requirement is waived to protect the security of the individual.

Adopted on: _____

Revised on: _____

Reviewed on: _____

PUBLIC PARTICIPATION

INSTRUCTIONS FOR MEMBERS OF THE PUBLIC WHO WISH TO SPEAK:
This is the portion of the meeting when members of the public may speak to the board about matters of public concern.

- **Getting Started:** When you have been recognized, please stand and state your name.
- **Time Limit:** The board will generally allow a total of 30 minutes for the presentation of all public comments. Individuals may speak only one time, and must limit comments to around 5 minutes. If there are more than 6 individuals who wish to address the board, the 30 minutes will be divided equally between the number of speakers. These time limits may be changed by a majority vote of the board members in attendance to extend the time for a specific item or speaker.
- **Personnel or Student Topic:** If you are planning to speak about a personnel or a student matter involving an individual, please understand that the district has a complaint policy and/or procedures to resolve such complaints and concerns. The Board requests that you follow the policy and procedures before addressing these matters with the Board. Board members will generally not respond to any questions you ask or comments about individual staff members or students.
- **General Rules:** This is a public meeting for the conduct of business. Comments from the audience while others are speaking will not be tolerated. Lewd, obscene, profane, slanderous, threatening and hostile conduct or statements and fighting words (words whose mere utterance entails a call to violence) will not be tolerated.
- **No Action by the Board:** The board will not act on any matter unless it is on the published agenda.

BOE Members Participating in Insurance			
Morgan Meier	Sept. 2024	Dec. 2024	March 2025
JC Ourada	Sept. 2024	Dec. 2024	March 2025

Choice Joint Utilities Management Program (CJUMP) Natural Gas Purchasing through NASB

What is it? Interlocal pool created to purchase natural gas & related services at competitive prices for Nebraska schools.

What are some of the area districts that currently utilize this program? Gibbon, Holdrege, Franklin, Axtell, Wood River, Arapahoe, Cozad, Ogallala, Blue Hill, Pleasanton, & Ravenna.

How much does it cost the district? No fees involved, we are NASB members. The CJUMP term is for 3 years (for us it will be 2 years to be on the cycle with the other school districts) with an automatic renewal unless the district gives notice. There is an annual meeting at the State Education Conference in Omaha each year.

When does the enrollment process begin? April 3 - 23.

What are the next steps?

1. Join the interlocal. Send the agreement & resolution to Jim after the March meeting.
2. Once Choice Gas selection forms arrive in April, contact Jim Luebbe. Jim takes it from there.

**INTERLOCAL AGREEMENT
FOR
THE PURCHASE OF NATURAL GAS AND RELATED SERVICES**

This Interlocal Agreement for Natural Gas and Related Services (Agreement) is made and entered into by and between separate political subdivisions of the State of Nebraska.

The Interlocal Agency created through this Agreement will be referred to as Nebraska Choice Joint Utilities Management Program (CJUMP).

The Nebraska Association of School Boards (NASB) is a corporation formed by Nebraska public school boards to stimulate and contribute to the continuing improvement of public elementary and secondary education including increased efficiency and economy for the ultimate benefit of Nebraska citizens. NASB will perform the functions related to the necessary administrative and management services required by this Agreement.

Nebraska law permits two or more public agencies to enter into arrangements defined under Nebraska statutes as Interlocal Cooperatives.

Participant shall mean (a) a public school as defined in §79-101, (b) an educational service unit established under the Educational Service Units Act, Neb. Rev. Stat. § 79-1201 through § 79-1249, and (c) a technical community college established under § 85-1501 through § 85-1542.

Authority:

Participant has the authority to procure and is responsible to ensure adequate natural gas service for its facilities.

Participant has the authority to enter into any contracts to effectuate its responsibilities relating to procurement of natural gas and energy related services.

Participant desires to enter into this agreement to provide reliable, cost effective natural gas and energy related services for its facilities.

Participant contemplates on taking necessary and appropriate actions to support the objective of providing cost effective natural gas and energy related services for its facilities.

Article XV, Section 18 of the Constitution of the State of Nebraska and the Interlocal Cooperation Act of the State of Nebraska, Neb. Rev. Stat. § 13-801 et seq., (the "Act"), authorize any two or more public agencies to enter into agreements for joint or cooperative exercise of power, privilege or authority exercised or capable of exercise individually by such public agencies. Participants are public agencies within the meaning of the Act.

Purpose:

It is the purpose of this Agreement for participants to make the most efficient use of their powers by cooperating with each other in good faith on the basis of mutual advantage and timely providing services and facilities as identified in this Agreement and in any addendum to this Agreement that will accord best with the geographic, economic, population and other factors influencing the needs and development of local political bodies.

In furtherance of such objectives and purposes, (i) the Participants hereby create a joint entity under the Interlocal Cooperation Act to be known as "Nebraska Choice Joint Utilities Management Program" ("CJUMP"), being a separate public body corporate and politic of the State of Nebraska (the "Agency"), which shall be constituted and administered by a board of Trustees (the "Board of Trustees"); and (ii) the Participants hereby delegate to the Agency those powers as are hereinafter provided by this Agreement.

Participation:

Participant hereby agrees to participate in CJUMP under the terms of this Agreement and the Bylaws of CJUMP. Only those Participants who are members of the Nebraska Association of School Boards shall be eligible to participate in CJUMP. Final determination of membership into CJUMP must be approved by the CJUMP Board or a committee thereof.

Each Participant hereby agrees to participate with all other Participants to this Agreement through the Agency jointly to conduct the activities of the Agency.

Administration:

In order to carry out the purposes of CJUMP, CJUMP may exercise and enjoy all powers, privileges, and authority exercised and capable of exercise by an Interlocal created pursuant to the Act, including, but not limited to the power to issue bonds or other obligations on behalf of Participants as a body as a whole.

CJUMP shall be administered by a Board of Trustees consisting of two voting ex-officio members and 6 persons, who are elected officials or appointed officials of the member Participants. The members of the Board of Trustees, other than the ex-officio members, shall be elected by a vote of the Board of Directors of NASB. A person elected to the Board of Trustees shall serve for a three year term. A vacancy on the Board shall be filled by the vote of the Board of Directors of NASB. The person appointed to fill a vacancy shall serve for the remainder of the term of the vacating Trustee. Each board member shall be entitled to one vote in all matters that come before the board. No action of the Board of Trustees shall be taken unless 50% or more of the board members are present at the meeting. Unless provided otherwise in the Bylaws, upon a majority affirmative vote of the board members present, such action shall be effective immediately. The two ex-officio members to the board shall be the current President of NASB and the Executive Director of NASB or designee.

Initial nominations for members of the CJUMP Board shall be made by the Executive Director of NASB, who shall nominate at least one person for each of the elected positions and designate

nominations by the three staggered terms in office so as to allow three of the CJUMP Board members to be up for reelection each year. For subsequent elections, a CJUMP nominating committee comprised of: (1) the Chair of CJUMP, (2) the Executive Director of NASB, and (3) a person selected by the Board of Trustees will request nominations from the member participants and give its recommendation for Board of Trustees member nomination to the NASB Board of Directors for its approval.

The Board of Trustees shall be responsible for administering the cooperative undertakings of CJUMP.

The CJUMP Board may assign responsibilities for functions and services to appropriate parties and may designate a representative who shall be the primary contact point for Participants and other parties involved.

The CJUMP Board may retain the services of such legal counsel, auditors, consultants, marketers, program administrators, and other advisors as it deems necessary to carry out the business and purpose of the Interlocal.

The CJUMP Board shall adopt an annual budget providing for financing the costs of any joint or cooperative undertaking pursuant to this Agreement.

CJUMP shall be financed by monies collected from appointed CJUMP Program Administrator(s).

Any real and personal property may be acquired, held and disposed as set forth in this Agreement or any amendment hereto. CJUMP may lease, purchase or acquire by any means, from Participant or from any other source, such real and personal property as is required and necessary for effectuating the purposes of this Agreement. The title to all such property, personal or real, shall be held in the name of CJUMP. If a Participant should be required to purchase real or personal property at its facilities to best achieve the purposes of this Agreement, such real or personal property shall remain property of the Participant.

Participants may meet from time to time to discuss any matters pertinent to this Agreement or the functions of CJUMP and its board.

Term of Agreement and Service:

This Agreement shall become effective and binding upon its ratification by the governing board of each Participant.

The term of this Agreement is for three years from the date of the execution of this Agreement, provided that this Agreement shall be considered automatically renewed for successive three year terms unless all Participants and/or Board of Trustees gives notice as required herein that the Agreement shall not automatically renew.

A Participant may withdraw from this Agreement by providing written notice to CJUMP and to all other Participants at least 365 days prior to the end of the third year of this Agreement's initial term or any renewal term of this Agreement. Any termination from this Agreement is to be effective 12:01A.M. of the first day of the immediately succeeding contract term.

An action to dissolve CJUMP must be communicated to all Participants and give Participants at least 30 days notice prior to its effective date. It is understood that specific individual Participants (as defined in this Agreement) may change during the duration of CJUMP's existence.

Participant hereby delegates to CJUMP the duty to buy natural gas for Participant's total requirements for the term of this Agreement. Participant acknowledges that it will be required to execute any required forms of the Local Distribution Company's Choice Program to select a supplier for each year of the term of this Agreement.

Participants may be responsible for reaffirming their natural gas purchase participation on an annual basis in order to accommodate administrators and others involved in the procurement of products and services on behalf of CJUMP. Such reaffirmation shall include but not be limited to Delegation Forms and any other documents determined to be necessary by the natural gas supplier to the CJUMP participants.

The effective date on which natural gas service is to be procured through CJUMP shall be no later than the immediate succeeding June 1 after execution of this Agreement and the point in time thereafter in which a natural gas distribution switch with the Local Distribution Company can be made.

Participants shall not resell any Natural Gas Service procured by CJUMP under this Agreement, but Participant can require any tenant or occupant of a Participant's facility to reimburse the Participant for the use of natural gas in connection with such tenancy or occupancy.

In the event a Participant fails to perform its obligations pursuant to this Agreement, CJUMP shall give written notice to the individual Participant specifying such failure to perform and establish a reasonable period in which the Participant shall have to fulfill its obligations pursuant to this agreement. If the Participant's failure to perform its obligation is continuing, CJUMP may immediately terminate this agreement.

Any distribution of CJUMP funds, either partial or complete, shall be approved by the CJUMP Board of Trustees. Any collective distribution return to the Participants shall be allocated among such Participants in proportion to the annual usage of each Participant as compared to the total usage of the Interlocal Agency during the immediately preceding twelve month agreement period.

Upon termination of CJUMP's existence, any personal and real property as well as surplus funds shall be distributed among the existing Participants (as determined and recognized by the CJUMP Board of Trustees). Such distribution shall be allocated among such Participants in proportion to the annual usage of each Participant as compared to the total usage of the Interlocal Agency during the immediately preceding twelve month agreement period.

Termination of participation in this Agreement or termination of this Agreement by the Board of Trustees shall not impair, amend or change any previous contracts or agreements. Such contracts and agreements shall continue in full force, including all rates, terms, obligations and conditions, until the expiration of such contracts and agreements in accordance with their respective terms, or unless sooner released by the Board of Trustees.

Indemnification:

Each Participant shall indemnify and hold harmless the other parties and the Public Alliance for Community Energy and the Nebraska Municipal Power Pool and their respective board, officers, trustees, employees and agents, from any claims, expenses, (including attorneys' fees and litigation expenses), for any damages or losses it may suffer as a result of any claims made regarding the validity of this Agreement or the effect of this Agreement on the expenditure or revenue authority of a Participant, including but not limited to taxpayer or regulatory claims.

Assignment:

This Agreement shall be binding upon and inure to the benefit of the Participants and their successors or assigns; provided however, that this Agreement shall not be assigned or otherwise transferred to a third party without the prior written consent of the other Participants to the Agreement.

Notices:

All notices or other communications which are required or permitted herein shall be in writing and sufficiently delivered to each Participant.

Fiscal Year:

The Fiscal year shall end on May 31 of each year.

Place of Business:

The principal place of business for CJUMP shall be at the offices of the Nebraska Association of School Boards. The CJUMP Board may employ necessary staff and may purchase, lease, or rent real and personal property in order to carry out the business of CJUMP.

Governing Law:

This Agreement shall be governed by an interpreted in accordance with the statutory and decisional law of the State of Nebraska.

Entire Agreement:

This Agreement, including any associated exhibits and any amendments, constitutes the entire Agreement of the Parties with respect to the subject matter hereof. All prior agreements, representations of CJUMP, statements, and negotiations, written or oral, are hereby superseded. This Agreement may be amended only by a writing executed by all Participants.

IN WITNESS WHEREOF, each of the Participants has caused this Interlocal Agreement for Natural Gas and Related Services to be executed by its duly authorized officer as of the day and year shown below.

PARTICIPANT: Elm Creek Public Schools

Date: March 10, 2025

By: Kim Beran

Title: Superintendent

Attest:

SEAL

**RESOLUTION FOR PARTICIPATION IN CJUMP
INTERLOCAL AGREEMENT**

WHEREAS, Participant has reviewed the attached Interlocal Agreement and desires to participate in the Nebraska Choice Joint Utilities Management Program (otherwise referred to as CJUMP) as authorized by the Interlocal Cooperation Act, Neb. Rev. Stat. §13-801 and

WHEREAS, Participant is allowed to participate in said cooperative undertakings; and

NOW THEREFORE, BE IT RESOLVED that the governing board hereby:

Declares the board will participate in CJUMP and hereby accepts the Participation Agreement which is attached to this Resolution.

After motion duly made by _____ and seconded by _____, the following members voted by roll call vote in favor of passage and adoption of the said Resolution:

The following members voted against the same:

The following members voted absent or not voting:

PASSED AND APPROVED this 10th day of March, 2025.

Participant Name (*School, ESU or Community College*) Elm Creek Public Schools

Signature from an Official of the Participant _____

Please print name and title: Lynette Mitchell, Elm Creek Schools board of education President



**ELM CREEK PUBLIC SCHOOLS
ADDITION & RENOVATION**
Elm Creek, Nebraska

Revision/Issue	Date

FLUME SITE PLAN

Project Number: 2101
Date: FEBRUARY 17, 2023

Copyright © 2021
WILKINS Architecture | Design | Planning LLC



- 6" CONCRETE PAVEMENT W/
PERIMETER TIED JOINTS
- 6" CONCRETE PAVEMENT
- 6" CONCRETE SIDEWALK
- 6" STAMPED CONCRETE
- SOD
- 8" CONCRETE PAVEMENT

GRADE NOTES:
T/S - TOP SLAB ELEVATION
T/C - TOP CURB/COVER
T/SC - TOP SURFACE COURSE
T/F - TOP FLOW LINE
G - PROPOSED GRADE ELEVATION

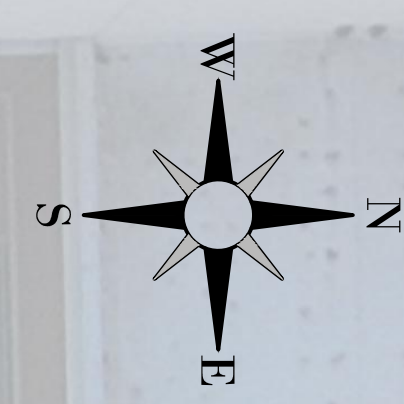

FLUME SITE PLAN
SCALE: 1" = 8'

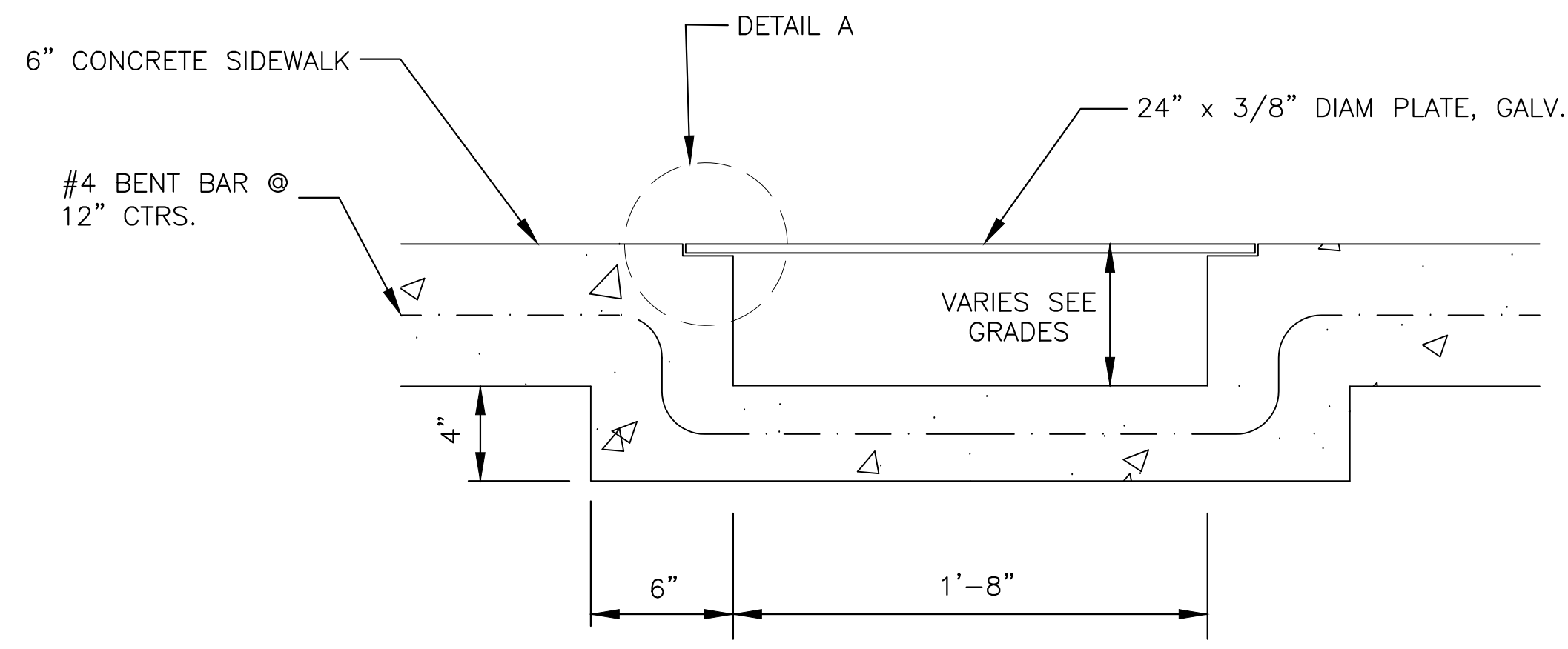

SIDEWALK TRENCH DRAIN
NO SCALE

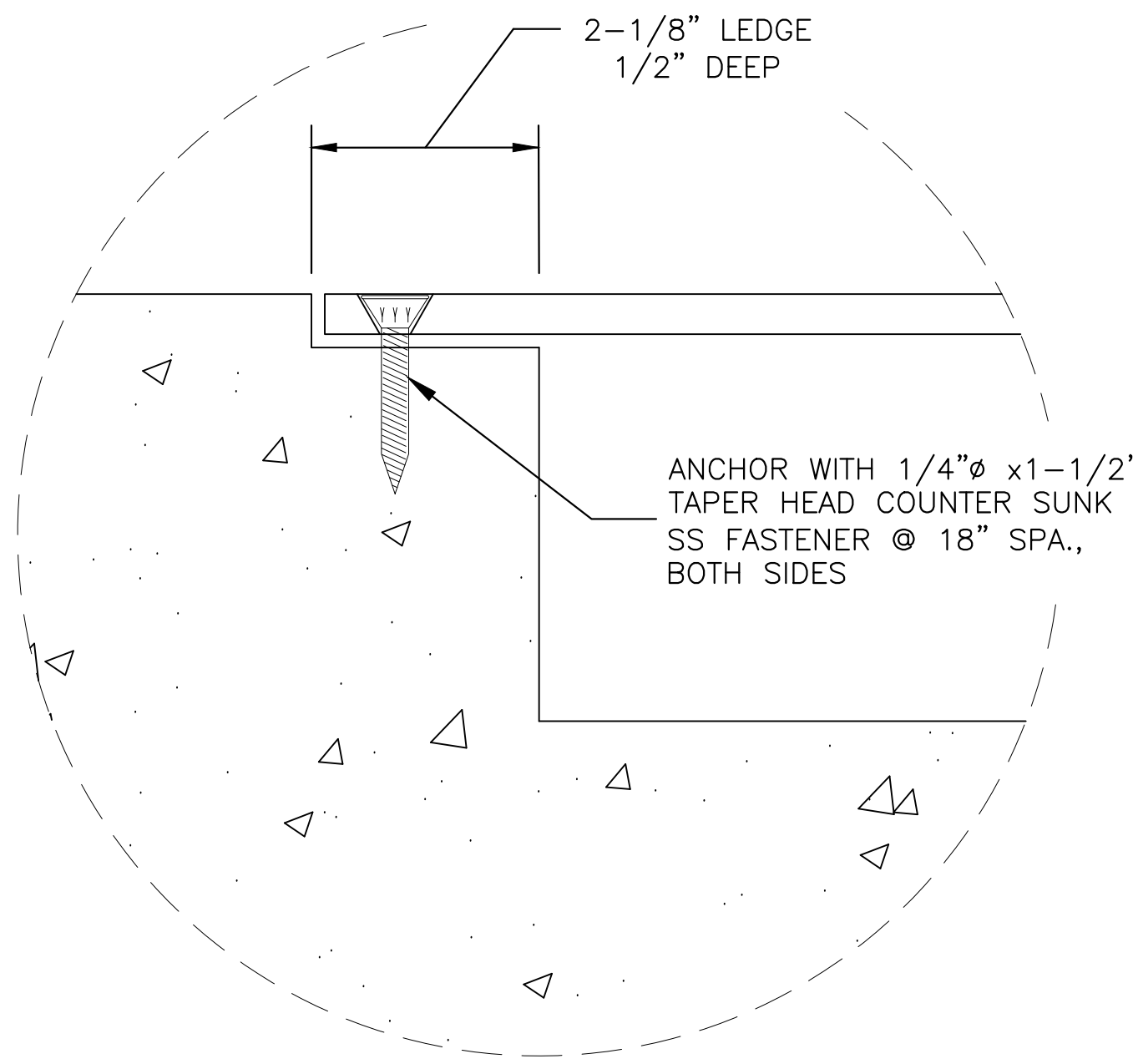
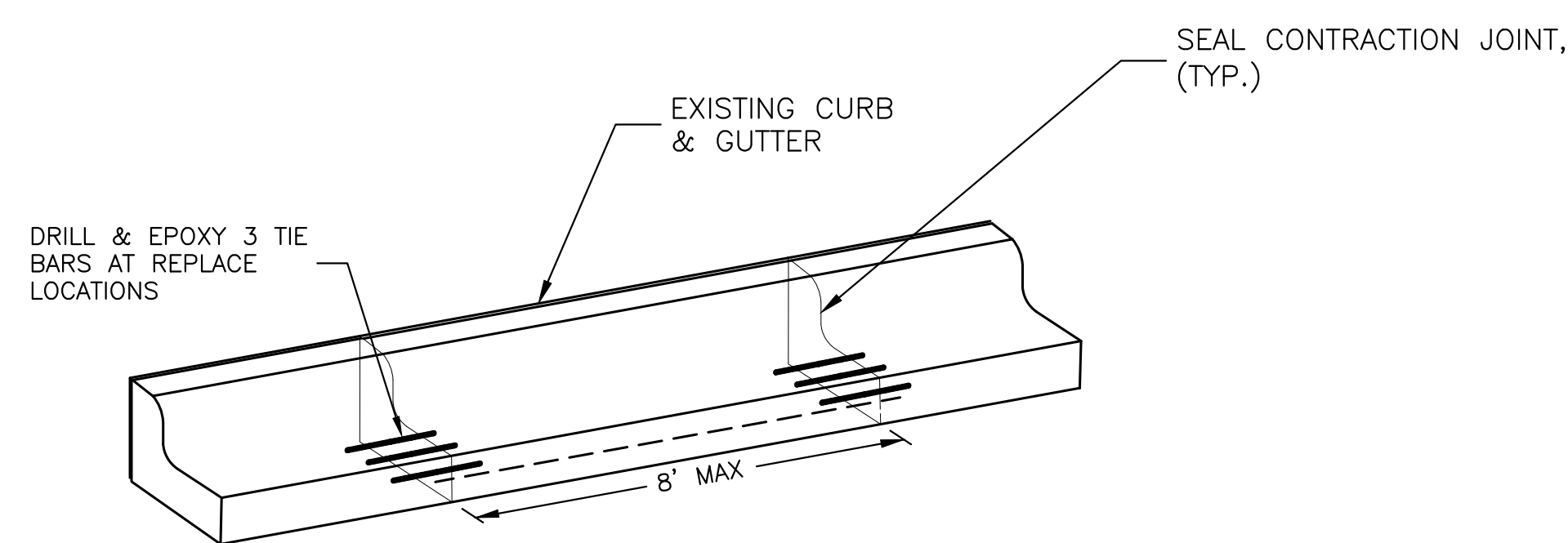

PLATE DETAIL
NO SCALE



PLATE

REBAR BENDS



CURB & GUTTER DETAIL
NO SCALE

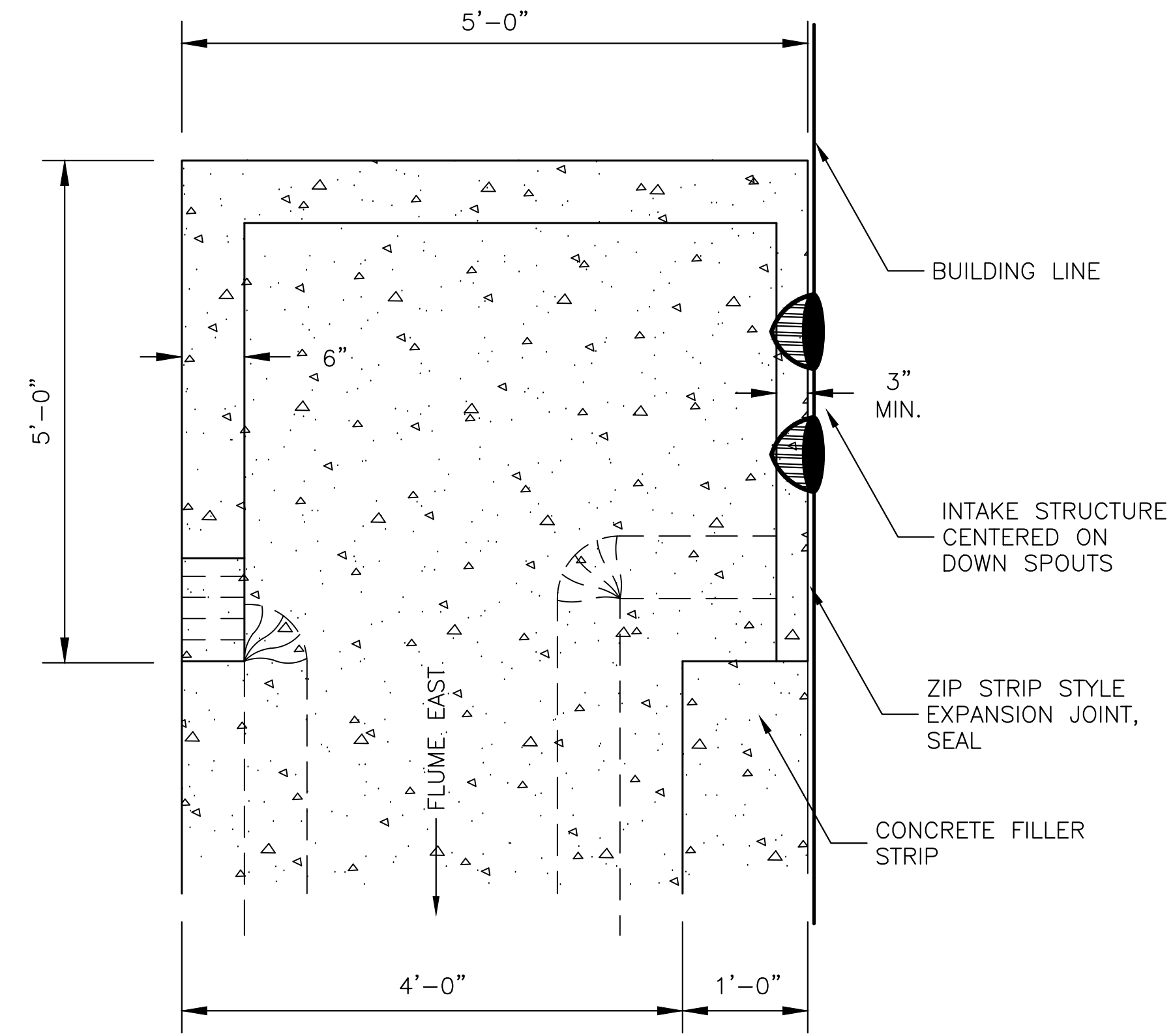

FLUME INTAKE - PLAN
NO SCALE

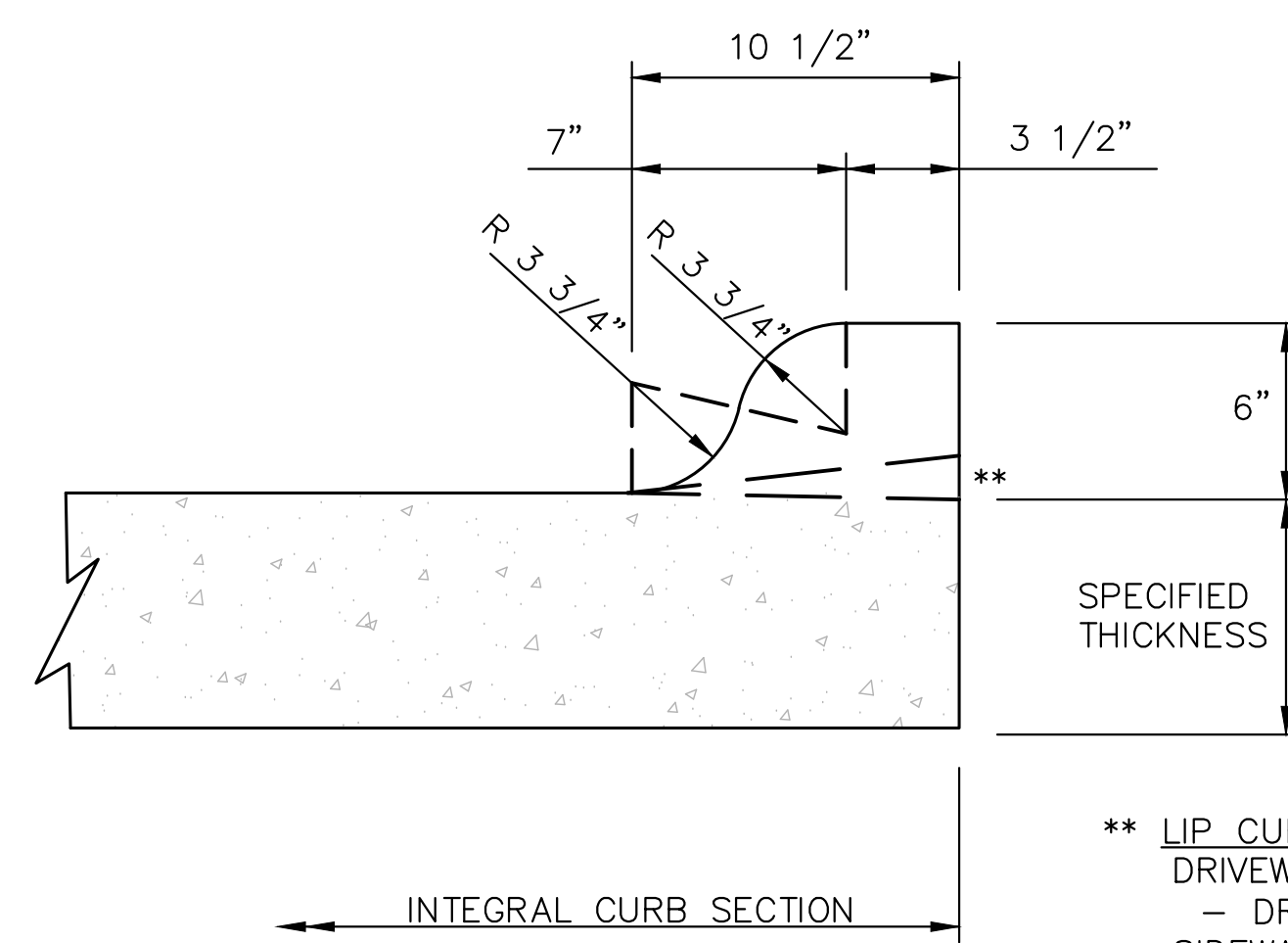

STANDARD CURB DETAIL

** LIP CURB DRIVEWAY & RETURNS:
- DROP CURB SHALL BE 1-1/2" AT BACK CURB.
SIDEWALK & RAMPS:
- DROP CURB SHALL BE 3/4" AT BACK CURB. SLOPE SHALL NOT EXCEED 8%.

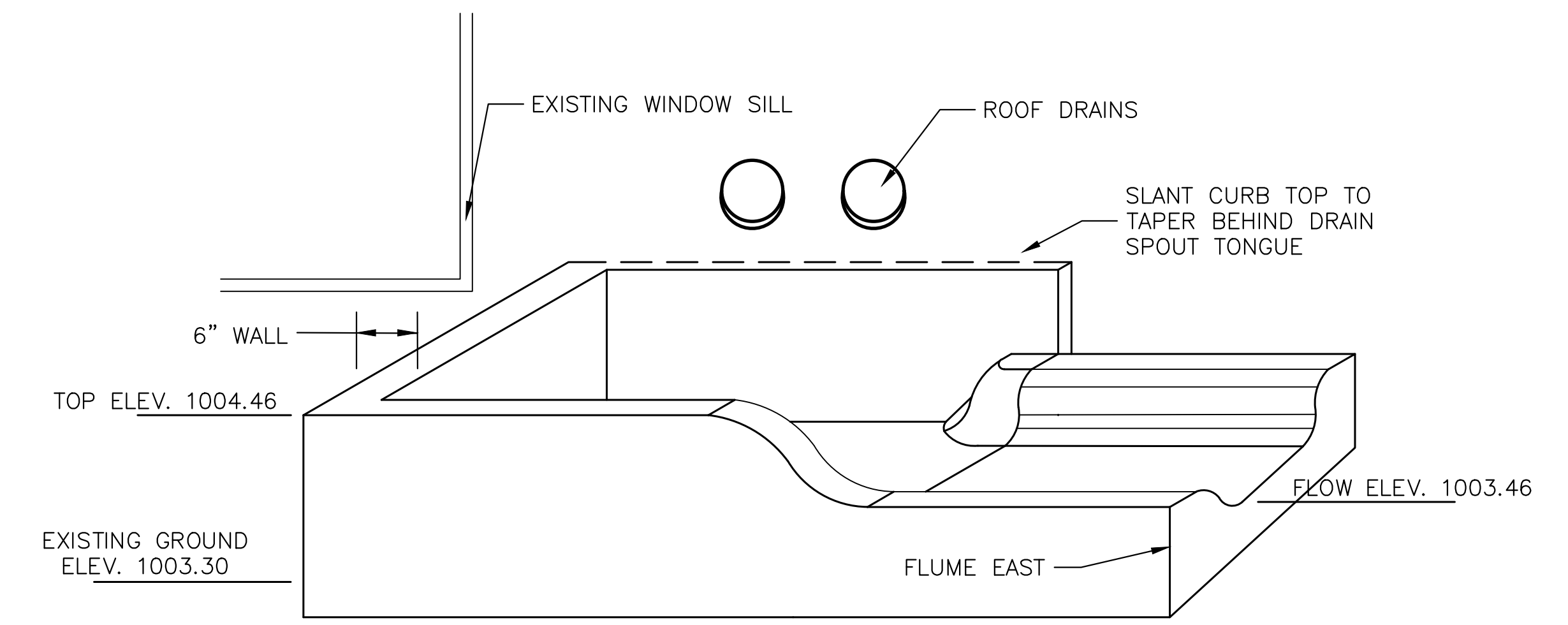

FLUME INTAKE - ISOMETRIC
NO SCALE

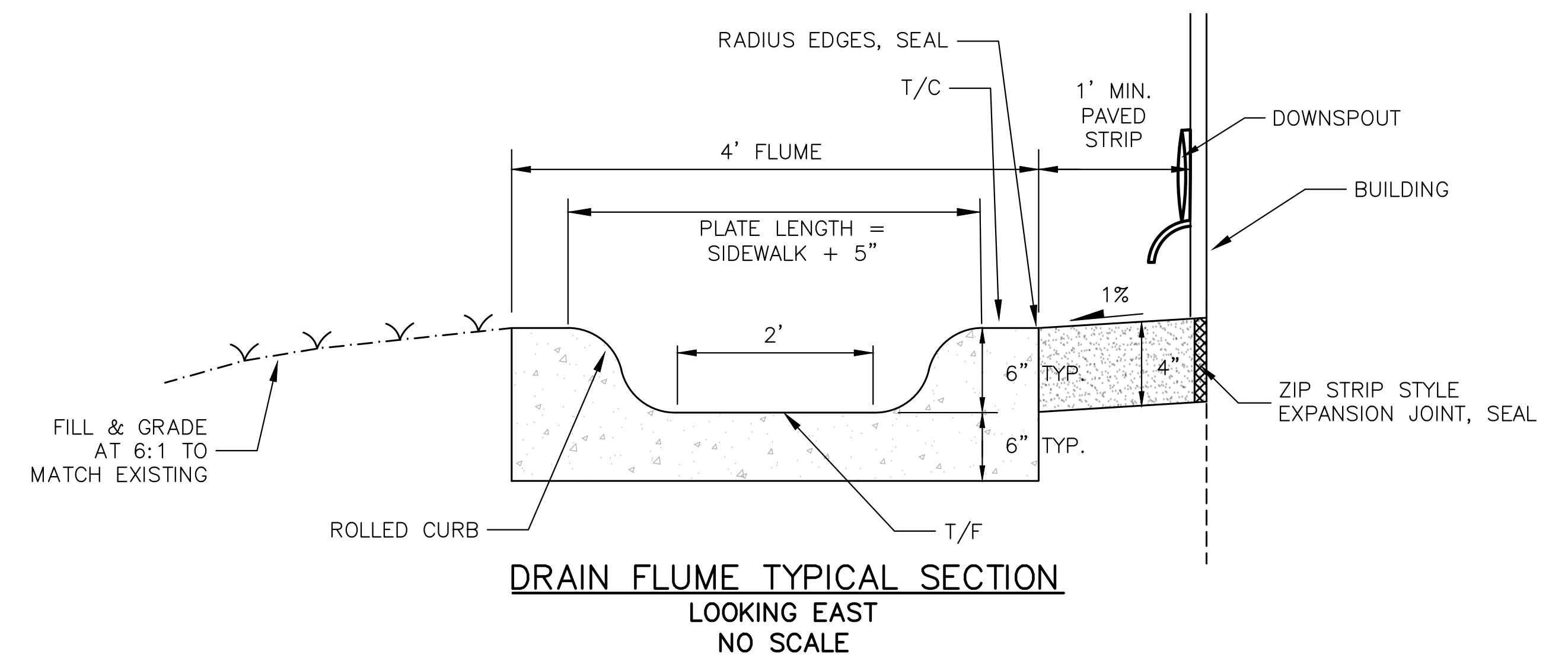

DRAIN FLUME TYPICAL SECTION
LOOKING EAST
NO SCALE

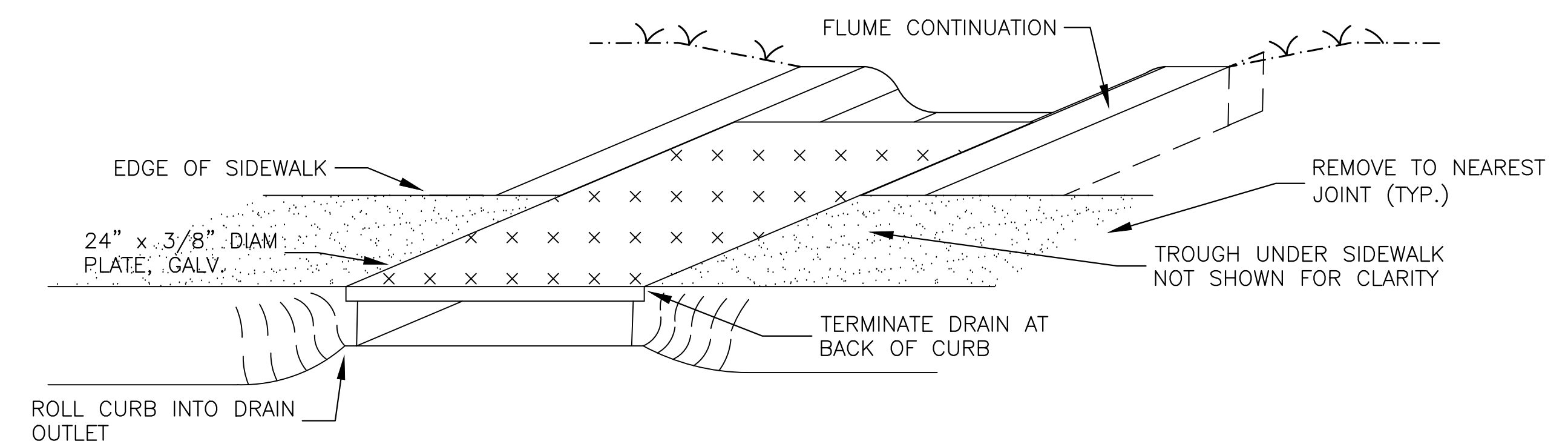

SIDEWALK TRENCH DRAIN - ISOMETRIC
NO SCALE

Revision/Issue	Date

		Elm Creek Schools Estimated Expenditures for 24-25					
Function 01 GENERAL FUND:							
<u>1100s</u>	<u>REGULAR INSTRUCTION</u>						
1100	REGULAR INSTRUCTIONAL PROGRAMS			\$2,991,990.20			
1160	PROVERTY PROGRAMS			\$91,256.87			
1190	EARLY CHILDHOOD ED PROGRAMS			\$127,746.59			
			TOTAL 1100	\$3,210,993.66			
<u>1200s</u>							
	<u>SPECIAL EDUCATION INSTRUCTION</u>						
1200	SPECIAL EDUCATION INSTRUCTIONAL PROGRAMS			\$576,879.38			
1291	SPED AGES 3-5			\$3,500.00			
1292	SPED AGES 0-2			\$3,500.00			
			TOTAL 1200	\$583,879.38			
<u>1300s</u>							
	<u>SUMMER SCHOOL INSTRUCTION</u>						
	Summer School			\$700.00			
			TOTAL 1300	\$700.00			
<u>2100s</u>							
	<u>NON-SPED PROGRAMS/SUPPORT SERVICES (students)</u>						
2110	ATTENDANCE & SOCIAL WORK			\$11,200.00			
2120	GUIDANCE SERVICES			\$20,622.53			
2130	HEALTH SERVICES			\$14,000.00			
			TOTAL 2100	\$45,822.53			
<u>2100s</u>							
	<u>SPED PROGRAMS/SUPPORT SERVICES (students)</u>						
2141	PSYCHOLOGICAL SERVICES SPED SCHOOL AGE			\$81,943.73			
2151	SPEECH & AUDIOLOGY SERV SPED SCHOOL AGE			\$155,478.10			
2152	SPEECH & AUDIOLOGY SERV SPED AGE 3-5			\$5,000.00			

Expenditure Report by Function 24-25.xlsx

2153	SPEECH & AUDIOLOGY SERV SPED AGE 0-2		\$1,000.00			
2161	OT SERVICES SPED SCHOOL AGE		\$30,000.00			
2162	OT SERVICES SPED AGE 3-5		\$4,000.00			
2163	OT SERVICES SPED AGE 0-2		\$4,000.00			
2171	PT SERVICES SPED SCHOOL AGE		\$14,000.00			
2172	PT SERVICES SPED AGE 3-5		\$2,000.00			
2173	PT SERVICES SPED AGE 0-2		\$2,000.00			
2181	VISUAL SPED SCHOOL AGE		\$34,000.00			
		TOTAL 2000	\$333,421.83			
<u>2200s</u>	<u>NON-SPED SUPPORT SERVICES (staff)</u>					
2213	INSTRUCTIONAL TRAINING		\$14,000.00			
2220	LIBRARY/MEDIA SERVICES		\$50,651.44			
2230	INSTRUCTION-RELATED TECHNOLOGY		\$57,297.90			
		TOTAL 2200	\$121,949.34			
<u>2300s/2400s</u>	<u>SUPPORT SERVICES</u>					
2310	BOARD OF EDUCATION		\$174,524.00			
2320	EXECUTIVE ADMINISTRATION (superintendent)		\$196,746.24			
2330	DISTRICT LEGAL SERVICES		\$22,000.00			
2410	OFFICE OF PRINCIPAL		\$388,210.46			
		TOTAL 2300 & 2400	\$781,480.70			
<u>2500s</u>	<u>CENTRAL SERVICES</u>					
2510	GENERAL ADMIN-BUSINESS SERVICE		\$274,373.00			
		TOTAL 2500	\$274,373.00			
<u>2600s</u>	<u>OPERATION & MAINTENANCE</u>					

Expenditure Report by Function 24-25.xlsx

2610	SUPPORT SERVICES OPERATION OF BUILDING		\$151,000.00			
2620	SUPPORT SERVICES-MAINT OF BUILDING		\$464,493.53			
2630	CARE AND UPKEEP OF GROUNDS		\$25,000.00			
2650	VEHICLE OPERATION (non-sped & non-student)		\$14,000.00			
		TOTAL 2600	\$654,493.53			
<u>2700s</u>	<u>NON-SPED STUDENT TRANSPORTATION</u>					
2710	VEHICLE OPP & PURCH REG ED		\$163,862.50			
		TOTAL 2700	\$163,862.50			
<u>2700s</u>	<u>SPED STUDENT TRANSPORTATION</u>					
2712	VEHICLE OPP & PURCH SCHOOL AGE SPED		\$89,933.00			
		TOTAL 2700	\$89,933.00			
<u>3500s</u>	<u>PRIVATE & STATE GRANTS</u>					
3512	DISTANCE EDUCATION INCENTIVE PAYMENTS		\$5,000.00			
3535	HIGH ABILITY LEARNERS		\$2,800.00			
		TOTAL 3500	\$7,800.00			
<u>6000s</u>	<u>FEDERAL PROGRAMS/GRANTS</u>					
6200	TITLE I, PART A ESSA IMP BASIC BY LOCAL		\$56,591.21			
6406	IDEA PRESCHOOL(619) BASE ALLOC		\$1,195.00			
6408	IDEA PART B (619) BASE ALLOC 0-21		\$82,107.69			
6992	REAP		\$40,252.00			
		TOTAL 6000	\$180,145.90			
<u>8000s</u>	<u>TRANSFERS (OUTGOING)</u>					
8000	TRANSFERS (OUTGOING)					

Expenditure Report by Function 24-25.xlsx

	Employee Benefit = \$0	\$0.00			
	Depreciation Fund = \$225,000	\$225,000.00			
	Nutrition Fund = \$95,000	\$95,000.00			
	Activities Fund = \$95,000	\$95,000.00			
	TOTAL 8000	\$415,000.00			
	GRAND TOTAL	\$6,863,855.37			
				OPERATING BUDGET =	\$6,886,291.00
					\$22,435.63

Elm Creek Public Schools Strategic Plan Needs Analysis Summary - Feb. 2025

<u>Guiding Principle I: Academic Learning & Success</u>				
1. Utilizing Instructional Framework/Model				
--Alignment of teaching practices with EC's framework by providing teachers professional development & collaborative opportunities				
<u>Guiding Principle II: Student-Centered Learning</u>				
1. Providing Inclusive Classrooms for all Learners				
--Increase teacher & para support by providing inclusion professional development & collaborative opportunities				
<u>Guiding Principle III: Cultural Inclusion & Engagement</u>				
1. Understanding Unique Needs of Students/Families of all Backgrounds				
--Increase teacher & para support by providing socio-economic & multicultural professional development				
<u>Guiding Principle IV: District/Building Culture & Climate</u>				
1. Improving Cohesion Across Buildings				
--Improve cohesion across the district by maintaining clear & consistent expectations for staff & students, with frequent feedback				
<u>Guiding Principle V: Personnel Effectiveness</u>				
1. Implementing the Continous School Improvement Goals				
--Create & share a process for implementing CSIP goals with all staff & students				
<u>Guiding Principle VI: Social-Emotional & Mental Health Well-Being</u>				
1. Improving Administrators' & Staffs' Overall Well-Being				
--Support administrators & staff by recognizing & celebrating achievements, both big & small				

<u>Guiding Principle VII: Access to Educational Opportunities</u>				
1. Adding a District Initiative or Program (e.g. after school program, mental health program, life skills program, PK transportation)				
--Discuss, analyze, & prioritize a district initiative or program with an anticipated timeline				
<u>Guiding Principle VIII: Family & Community Partnerships</u>				
1. Improving Family & Community Engagement				
--Seek & analyze feedback for engagement solutions for families & the community				
<u>Guiding Principle IX: District Resources</u>				
1. Improving Parking, Transportation, & Extracurricular Facilities				
--Create short & long term budgeting goals for transportation & facility needs				
<u>Guiding Principle X: Board Governance</u>				
1. Commit Resources to Support District Long-Term Goals				
--Plan & allocate district resources to meet & support identified goals				
Possibly meet with Ben again on 22nd of May. From there, NASB would update the Strategic Plan Framework and get that back to us tentatively sometime in June which would allow the district to famlize itself with the content ahead of the school year. I will send you more details as those dates get closer.				

DATE	VENDOR	COST	BUS/VAN #	REASON	NOTES
12/30/2024	Kelly's Sales and Ag Service	\$75.00	Van 25	Quarterly inspection	
12/30/2024	Kelly's Sales and Ag Service	\$75.00	Van 24	Quarterly inspection	
12/30/2024	Kelly's Sales and Ag Service	\$75.00	Van 23	Quarterly inspection	
12/30/2024	Kelly's Sales and Ag Service	\$84.26	Van 23	Oil change	
12/30/2024	Kelly's Sales and Ag Service	\$75.00	Van 22	Quarterly inspection	
12/30/2024	Kelly's Sales and Ag Service	\$84.26	Van 22	Oil change	
12/30/2024	Kelly's Sales and Ag Service	\$75.00	Van 14	Quarterly inspection	
12/30/2024	Kelly's Sales and Ag Service	\$69.03	Van 14	Oil change	
12/30/2024	Kelly's Sales and Ag Service	\$75.00	Van 12	Quarterly inspection	
1/28/2025	Kelly's Sales and Ag Service	\$21.77	Bus 18	Power steering fluid	
1/21/2025	Nebraska/Central Equipment	\$22.52	Bus 15	Defroster knob	
12/23/2024	Nebraska/Central Equipment Colorado/West Equip	\$906.25	Bus 13	Light bulb, hood cables, power outlet, shocks	
12/31/2024	Clevenger Petroleum - includes \$45.90 finance cha	\$3,105.90	All buses	#1 diesel for buses - 900 gallons	Kept in JC Ourada's fuel tank by his shop
1/10/2025	Truck Center - Freightliner	\$175.00	Bus 13	Quarterly inspection	
1/10/2025	Truck Center - Freightliner	\$2,376.27	Bus 13	Change transmission fluid, winter front fastener, ba	Bus 13 has approximately 110,000 miles
1/31/2025	Pump and Pantry Fuel	\$1,307.17	All vehicles	See separate sheet for cost per vehicle	
1/2/2025	Breinig Diesel	\$195.00	Bus 18	Quarterly inspection and tightening of power steeri	
12/31/2024	Breinig Diesel	\$130.00	Bus 21	Quarterly inspection	
12/30/2024	Breinig Diesel	\$130.00	Bus 15	Quarterly inspection	
2/28/2025	Pump and Pantry Fuel	\$976.93	All vehicles		
2/28/25	Total Expenses through 2/28/25	\$10,034.36			

**Elm Creek Public Schools
Policy & Negotiations Committee
Feb. 19, 2025**

The policy committee meeting was called to order by Kim Beran, Superintendent at **4:00** p.m. in the administration office conference room.

Committee Members Present: Cole Brodine, Lynette Mitchell, Ryan Martin

Committee Members Absent: None

Also Present: Kim Beran, Superintendent

The Committee Reviewed & Discussed:

- Double check wording of 5004 (4f)
 - Change 4f (ii) teachers' children have second priority
- Revisit 5032
 - <https://docs.google.com/spreadsheets/d/1MVfBxfHAPCu8wGj4fgoAUbSE0RzXutI5sRCLGEk3a0/edit?usp=sharing>
 - Closed campus is the recommendation of the committee
- Finish reviewing 5035-5067
- Decide on classified staff raises
 - 2.5% - 5%, superintendent with administration input
- Bus drivers
 - Increase \$1.00 hour across the board
- Substitutes
 - Find out what others are paying

Meeting ended at **5:50** p.m.

5032

Closed Campus

The school campus is a closed campus.

Adopted on: December 14, 2020

Revised on: March 10, 2025

Reviewed on: February 10, 2025

Board of Education Regular Meeting

Monday, February 10, 2025 6:00 PM

1. OPEN THE MEETING

1.1. Call to Order

Meeting was called to order by Board President Lynette Mitchell at 6pm.

1.1.1. Publication of Meeting

1.1.2. Nebraska Open Meetings Law

1.1.3. Pledge of Allegiance

1.1.4. District Mission Statement

1.2. Board Member Roll Call

All members present.

2. CELEBRATION OF EXCELLENCE

Elm Creek was featured as a Spotlight school in the January NRCSA flyer.

3. PUBLIC COMMENT (agenda item specific)

Five members of the public were in attendance. Marvin Reichert shared that his tax evaluations have increased and that they will continue to increase. Mrs. Kris Tool spoke on keeping class sizes small.

4. INFORMATION ITEMS

4.1. Administrator Reports

4.1.1. Superintendent Report - Mrs. Beran

4.1.1.1. *Review the 2023-2024 Audit Report*

4.1.1.2. *Board Training Opportunities*

4.1.1.3. *Discuss Needed Bleacher Repairs in the Main Gym*

4.1.1.4. *Reminder to Complete Second Superintendent Evaluation*

4.1.1.5. *Discuss the Lift, Old Elementary Doors, and Small Miscellaneous Items as Surplus Items*

4.1.2. Principal/AD Report - Mr. Marquez

Mr. Marquez updated the board with the preparations of spring and ACT testing coming up. As Athletic Director, he gave congratulations to the girls wrestling team.

4.1.3. Principal Report - Mrs. Williams

Mrs. Williams shared with the board the review of the teacher mentor program.

4.1.3.1. *Review Teacher Mentor Program*

4.1.4. Strategic Plan Update/District Goals Update

The administration team will meet with Ben from NASB on Feb. 26th to analyze the staff survey results to consider next steps.

4.2. Board Committee Reports

Mrs. Beran reported that there is a compressor going out on the HS side of the building and is awaiting an estimate from Andersons. Also, there is a glycol leak in the boiler in the new addition, Andersons and BD are aware of the issue.

4.2.1. Building, Grounds, and Transportation

4.2.1.1. *Discuss HVAC/Boiler Maintenance Contracts*

4.2.2. Finance and Personnel

4.2.2.1. *Discussion on Renewing Depreciation Fund CD*

4.2.2.2. *Discussion on Renewing Employee Benefit Fund CD*

4.2.2.3. *Discussion on Changing Construction Sweep Account to a CD*

4.2.3. Policy and Negotiations

4.2.3.1. *Review and Consider Possible Revisions to Board Policy 5004*

4.2.3.2. *Review and Consider Possible Revisions to Board Policy 5032*

4.2.4. Curriculum and Technology

5. CONSENT AGENDA

Motion was made that the board approves the consent agenda as presented. This motion, made by Lynette Mitchell and seconded by Ryan Martin, Passed.

Alicia Beavers: Yea, Cole Brodine: Yea, Hannah Hild: Yea, Jacob Kringle: Yea, Ryan Martin: Yea, Lynette Mitchell: Yea

5.1. Prior Meeting Minutes

5.2. Financial Reports and Claims according to Review of Bills policy 3007

5.3. Consider and Act Upon the Resignation of Carissa Jensen at the end of the 2025-2026 Contract Year

5.4. Offer Employment Contract to Cassi McNeil to Serve as 4th-6th Grade Teacher for the 2025-2026 School Year

5.5. Approve Principal Brandon Marquez's Salary of \$116,832 for the 25-26 School Year

5.6. Approve Principal Terah William's Salary of \$109,325 for the 25-26 School Year

5.7. Reaffirm BOE Policies 5001-5034, excluding policies 5004 & 5032

5.8. Consider and Approve the 2025-2026 School Year Calendar

6. ACTION ITEMS

6.1. Consider and Take any Necessary Action on the ESU 10 Special Education Contract for the 2025-2026 School Year

Motion was made to approve the ESU 10 special Education Contract as presented for the 2025-2026 School Year. This motion, made by Cole Brodine and seconded by Hannah Hild, Passed. Alicia Beavers: Yea, Cole Brodine: Yea, Hannah Hild: Yea, Jacob Kringle: Yea, Ryan Martin: Yea, Lynette Mitchell: Yea

6.2. Consider and Take any Necessary Action on HVAC/Boiler Maintenance Contract

Motion was made to approve Anderson Brothers, as presented, for HVAC/Boiler Maintenance Contract. This motion, made by Alicia Beavers and seconded by Cole Brodine, Passed. Alicia Beavers: Yea, Cole Brodine: Yea, Hannah Hild: Yea, Jacob Kringle: Yea, Ryan Martin: Yea, Lynette Mitchell: Yea

6.3. Consider and Take any Necessary Action for Bleacher Repairs and Servicing (main gym)

Motion was made to approve the repairs and servicing of the bleachers in the main gym as presented. This motion, made by Alicia Beavers and seconded by Hannah Hild, Passed. Alicia Beavers: Yea, Cole Brodine: Yea, Hannah Hild: Yea, Jacob Kringle: Yea, Ryan Martin: Yea, Lynette Mitchell: Yea

6.4. Consider and Take any Necessary Action on Renewing Depreciation Fund CD

Motion was made to approve renewing the employee benefit fund CD for 7 months. This motion, made by Lynette Mitchell and seconded by Jacob Kringle, Passed. Alicia Beavers: Yea, Cole Brodine: Yea, Hannah Hild: Yea, Jacob Kringle: Yea, Ryan Martin: Yea, Lynette Mitchell: Yea

6.5. Consider and Take any Necessary Action on Renewing the Employee Benefit Fund CD

Motion was made to approve renewing the employee benefit fund CD for 7 months. This motion, made by Lynette Mitchell and seconded by Ryan Martin, Passed. Alicia Beavers: Yea, Cole Brodine: Yea, Hannah Hild: Yea, Jacob Kringle: Yea, Ryan Martin: Yea, Lynette Mitchell: Yea

6.6. Consider and Take any Necessary Action on Elementary Construction Sweep Account

Motion was made to approve transferring \$100,000 of the Elementary Construction Sweep Account into a 7 month CD. This motion, made by Lynette Mitchell and seconded by Alicia Beavers, Passed. Alicia Beavers: Yea, Cole Brodine: Yea, Hannah Hild: Yea, Jacob Kringle: Yea, Ryan Martin: Yea, Lynette Mitchell: Yea

6.7. Consider and Take any Necessary Action to Revise/Reaffirm policy 5004

Motion was made for the board to revise policy 5004. District employees' children will receive second priority for option enrollment in the district. This motion, made by Ryan Martin and seconded by Alicia Beavers, Passed. Alicia Beavers: Yea, Cole Brodine: Yea, Hannah Hild: Yea, Jacob Kringle: Yea, Ryan Martin: Yea, Lynette Mitchell: Yea

6.8. Consider and Take any Necessary Action to Revise/Reaffirm policy 5032

No action taken.

7. SCHEDULE NEXT REGULAR BOARD MEETING

March 10, 2025 at 6:00 pm.

8. ADJOURN

Motion was made to adjourn the meeting at 6:42pm. This motion, made by Lynette Mitchell and

seconded by Alicia Beavers, Passed.

Alicia Beavers: Yea, Cole Brodine: Yea, Hannah Hild: Yea, Jacob Kringle: Yea, Ryan Martin:
Yea, Lynette Mitchell: Yea

9. ****CLOSED SESSION: If, during the course of the meeting, discussion of any item on the agenda should be held in a closed meeting, the board will conduct a closed meeting in accordance with the Nebraska Open Meetings Act.**

10. ****SEQUENCE OF AGENDA: The sequence of agenda topics is subject to change at the discretion of the board.**

Checking Account ID: BUILDING

Check Type: Check

<u>Check Number</u>	<u>Check Date</u>	<u>Cleared</u>	<u>Void</u>	<u>Void Date</u>	<u>Entity ID</u>	<u>Entity Name</u>	<u>Amount</u>
10059	03/10/2025				KIDWELL	KIDWELL INC.	2,395.50
Check Type Total:			Check			Void Total: 0.00	Total without Voids: 2,395.50
Checking Account Total:			BUILDING			Void Total: 0.00	Total without Voids: 2,395.50
Grand Total:						Void Total: 0.00	Total without Voids: 2,395.50

Checking Account ID: STACTIVITY

Check Type: Check

Check Number	Check Date	Cleared	Void	Void Date	Entity ID	Entity Name	Amount
17788	02/04/2025				FIRSTIER	FIRSTIER BANK	1,600.00
17789	02/04/2025				GILLMING	MARK GILLMING	35.00
17790	02/04/2025				HULSB	BEN HULS	153.00
17791	02/04/2025				JOHNSPAT	PATRICK JOHNS	50.00
17792	02/04/2025				THIELET	TIM THIELE	154.00
17793	02/04/2025				WISCHMEIER	TRAVIS WISCHMEIER	153.00
17794	02/05/2025				BERNALR	RAYMOND BERNAL	75.00
17795	02/05/2025				BUESCHER	DARIN BUESCHER	75.00
17796	02/07/2025				WALMART	CAPITAL ONE	300.19
17797	02/07/2025				CASHWAACT	CASH-WA DISTRIBUTING	6,940.45
17798	02/07/2025				USBANK	CORPORATE PAYMENT SYSTEMS	2,419.19
17799	02/07/2025				FIRSTIER	FIRSTIER BANK	174.00
17800	02/07/2025				FOSTFAM	FOSTER'S FAMILY FOODS	525.51
17801	02/07/2025				JOHNSONF	JOHNSON FITNESS & WELLNESS	525.75
17802	02/07/2025				PURDYAB	ABRIEANNA PURDY	75.00
17803	02/07/2025				PURDYA	ANJOLINA PURDY	75.00
17804	02/11/2025				AMHERSTPUB	AMHERST PUBLIC SCHOOLS	75.00
17805	02/11/2025				SORINEX	SORINEX EXERCISE EQUIPMENT, INC.	1,905.28
17806	02/13/2025				DUELANDJ	JAYCE DUELAND	146.00
17807	02/13/2025				FIRSTIER	FIRSTIER BANK	1,400.00
17808	02/13/2025				GILLMING	MARK GILLMING	35.00
17809	02/13/2025				HARBURD	DREW HARBUR	75.00
17810	02/13/2025				JOHNSPAT	PATRICK JOHNS	75.00
17811	02/13/2025				KLEINB	BEN KLEIN	75.00
17812	02/13/2025				RUPPC	CRAIG RUPP	147.00
17813	02/13/2025				SADDB	BRYCE SADD	75.00
17814	02/13/2025				VALLEAUT	TIM VALLEAU	147.00
17815	02/14/2025				ALBRECHTM	MARTY ALBRECHT	83.00
17816	02/14/2025		X	02/17/2025	BERNALR	RAYMOND BERNAL	75.00
17817	02/14/2025				BSNSPO	BSN SPORTS	875.60
17818	02/14/2025				CHESTERMAN	CHESTERMAN CO.	2,896.00
17819	02/14/2025				DIVAS	DIVAS at KEARNEY FLORAL CO.	27.00
17820	02/14/2025				EMALC	COLBY EMAL	83.00
17821	02/14/2025				FIRSTIER	FIRSTIER BANK	2,225.00
17822	02/14/2025				GILLMING	MARK GILLMING	35.00
17823	02/14/2025				JOHNSPAT	PATRICK JOHNS	25.00
17824	02/14/2025		X	02/17/2025	LAUBYT	THOMAS LAUBY	75.00
17825	02/14/2025				LONGA	AARON LONG	83.00
17826	02/14/2025				PROMNITE	PROM NITE	387.46
17827	02/14/2025				STEINERE	ERIC STEINER	25.00
17828	02/17/2025				ALBRECHTM	MARTY ALBRECHT	70.00
17829	02/17/2025				EMALC	COLBY EMAL	70.00
17830	02/17/2025				JOHNSPAT	PATRICK JOHNS	25.00
17831	02/17/2025				LONGA	AARON LONG	70.00
17832	02/17/2025				STEINERE	ERIC STEINER	25.00
17833	02/17/2025		X	02/21/2025	FIRSTIER	FIRSTIER BANK	1,850.00
17834	02/17/2025				GILLMING	MARK GILLMING	35.00
17835	02/17/2025				JOHNSPAT	PATRICK JOHNS	50.00
17836	02/17/2025				KOUPALK	KEITH KOUPAL	153.00
17837	02/17/2025				MILLERTH	THOMAS MILLER	153.00
17838	02/17/2025				SAMUELSONJ	JACOB SAMUELSON	153.00
17839	02/17/2025				STEINERE	ERIC STEINER	50.00
17840	02/20/2025				AWARDSUN	AWARDS UNLIMITED	294.16
17841	02/20/2025				BLUECROS	BLUE CROSS BLUE SHIELD OF NE	4,025.29
17842	02/20/2025				GILLMING	MARK GILLMING	35.00
17843	02/20/2025				HAMLINGT	TESSA HAMLING	136.20
17844	02/20/2025				JOHNSPAT	PATRICK JOHNS	25.00
17845	02/20/2025				JOHNSOND	DON JOHNSON	136.20

Checking Account ID: STACTIVITY

Check Type: Check

Check Number	Check Date	Cleared	Void	Void Date	Entity ID	Entity Name	Amount
17846	02/20/2025				KOUPALK	KEITH KOUPAL	82.00
17847	02/20/2025				KRACLM	MARTY KRACL	82.00
17848	02/20/2025				LANGEA	ABIGAIL LANGE	125.00
17849	02/20/2025				MISKO	MISKO SPORTS, LLC	498.50
17850	02/20/2025				NEFFAASSN	NEBRASKA FFA ASSN	36.00
17851	02/20/2025				NEMFCA	NEMFCA	125.00
17852	02/20/2025				NIEMEYER	DAREN NIEMEYER	174.00
17853	02/20/2025				PURDYAB	ABRIANNA PURDY	125.00
17854	02/20/2025				PURDYA	ANJOLINA PURDY	125.00
17855	02/20/2025				REINERPAUL	PAUL REINERTSON	82.00
17856	02/20/2025				SCHUSTERK	KIANNA SCHUSTER	161.20
17857	02/20/2025				SCREENM	SCREEN MACHINE LLC	225.45
17858	02/20/2025				STEINERE	ERIC STEINER	25.00
17859	02/20/2025				SULLIVANA	AYVA SULLIVAN	125.00
17860	02/20/2025				TEELM	MEGAN TEEL	125.00
17861	02/20/2025				VARSIYSPI	VARSIY SPIRIT FASHION	91.45
17862	02/20/2025				WRIGHTR	RAYGAN WRIGHT	150.00
17863	02/21/2025				FIRSTIER	FIRSTIER BANK	1,210.00
17864	02/24/2025				FIRSTIER	FIRSTIER BANK	2,225.00
17865	02/24/2025				FRIEST	TYLER FRIES	25.00
17866	02/24/2025				GILLMING	MARK GILLMING	35.00
17867	02/24/2025				GRUPEB	BRIAN GRUPE	92.00
17868	02/24/2025				JOHNSPAT	PATRICK JOHNS	25.00
17869	02/24/2025				MILLERSC	SCOTT MILLER	92.00
17870	02/24/2025				RUPPC	CRAIG RUPP	92.00
17871	02/25/2025				BELLN	NATE BELL	155.00
17872	02/25/2025				BURRELLT	TARYN BURRELL	155.00
17873	02/25/2025				FIRSTIER	FIRSTIER BANK	2,150.00
17874	02/25/2025				GILLMING	MARK GILLMING	35.00
17875	02/25/2025				JOHNSPAT	PATRICK JOHNS	50.00
17876	02/25/2025				MROCEKC	CHRIS MROCZEK	155.00
17877	02/25/2025				STEINERE	ERIC STEINER	50.00
17878	02/25/2025				EVERITTM	MARSHALL EVERITT	155.00
17879	02/26/2025				BERNALR	RAYMOND BERNAL	75.00
17880	02/26/2025				BUESCHER	DARIN BUESCHER	75.00
17881	02/26/2025				GUNDERSONF	FAITH GUNDERSON	211.20
17882	02/26/2025				JENSEND	DAN JENSEN	160.00
17883	02/26/2025				LOGUES	SARAH LOGUE	75.00
17884	02/26/2025				MINERT	TREY MINER	75.00
17885	02/26/2025				PURDYAB	ABRIANNA PURDY	75.00
17886	02/27/2025				ALMASCH	ALMA SCHOOLS	79.20
17887	02/27/2025				AMERICANH	AMERICAN HEART ASSOCIATION	180.00
17888	02/27/2025				AXTELLSCH	AXTELL SCHOOLS	54.00
17889	02/27/2025				BELLN	NATE BELL	85.00
17890	02/27/2025				EMALC	COLBY EMAL	85.00
17891	02/27/2025				FIRSTIER	FIRSTIER BANK	2,320.00
17892	02/27/2025				FRANKLINP	FRANKLIN PUBLIC SCHOOLS	58.50
17893	02/27/2025				GILLMING	MARK GILLMING	35.00
17894	02/27/2025				JOHNSPAT	PATRICK JOHNS	50.00
17895	02/27/2025				KENESAWSCH	KENESAW SCHOOLS	42.30
17896	02/27/2025				KLIMEKA	ABBIE KLIMEK	21.02
17897	02/27/2025				MARTINJ	JAZZMYN MARTIN	31.16
17898	02/27/2025				MROCEKC	CHRIS MROCZEK	85.00
17899	02/27/2025				NASSP	NASSP	385.00
17900	02/27/2025				NSAA	NEBRASKA SCHOOL ACTIVITIES ASSOCIATION	1,176.00
17901	02/27/2025				SCHOLBOOK8	SCHOLASTIC BOOK FAIRS-04	489.80
17902	02/27/2025				SPEECHWIRE	SPEECHWIRE TOURNAMENT SERVICES	225.00
17903	02/27/2025				STEINERE	ERIC STEINER	50.00

Checking Account ID: STACTIVITY **Check Type: Check**

<u>Check Number</u>	<u>Check Date</u>	<u>Cleared</u>	<u>Void</u>	<u>Void Date</u>	<u>Entity ID</u>	<u>Entity Name</u>	<u>Amount</u>
17904	02/28/2025				OGALLALAHS	OGALLALA SCHOOLS	50.00
Check Type Total:			Check			Void Total: 2,000.00	Total without Voids: 45,043.06
Checking Account Total:			STACTIVITY			Void Total: 2,000.00	Total without Voids: 45,043.06
Grand Total:						Void Total: 2,000.00	Total without Voids: 45,043.06

Checking Account ID: GENERAL

Check Type: Check

Check Number	Check Date	Cleared	Void	Void Date	Entity ID	Entity Name	Amount
20593	03/10/2025				AGDRYER	AG DRYER SERVICES	233.16
20594	03/10/2025				ANDERSONB	ANDERSON BROS.	1,189.24
20595	03/10/2025				BEACONO	BEACON OBSERVER	112.72
20596	03/10/2025				BERANK	KIMBERLY BERAN	368.90
20597	03/10/2025				BLACKHILLS	BLACK HILLS ENERGY	5,782.63
20598	03/10/2025				BREINIGD	BREINIG DIESEL, LLC	455.00
20599	03/10/2025				WALMART	CAPITAL ONE	96.21
20600	03/10/2025				USBANK	CORPORATE PAYMENT SYSTEMS	2,273.77
20601	03/10/2025				EAKESOFF	EAKES OFFICE PRODUCTS	3,268.89
20602	03/10/2025				ECOLAB	ECOLAB PEST ELIMINATION	82.06
20603	03/10/2025				ESU10	EDUCATIONAL SERVICE UNIT 10	7,691.84
20604	03/10/2025				ENGINEER	ENGINEERED CONTROLS	210.00
20605	03/10/2025				FOSTERC	CURT FOSTER	200.00
20606	03/10/2025				FOSTFAM	FOSTER'S FAMILY FOODS	448.61
20607	03/10/2025				PAYFLEX	INSPIRA FINANCIAL	150.00
20608	03/10/2025				INTEGRATED	INTEGRATED LIFE CHOICES	8,926.20
20609	03/10/2025				JOSTENS	JOSTENS	460.38
20610	03/10/2025				PEPPERJW	JW PEPPER	130.00
20611	03/10/2025				KEARNWINN	KEARNEY WINNELSON CO.	258.10
20612	03/10/2025				KELLYSA	KELLY'S SALES & AG SERVICE	71.66
20613	03/10/2025				KSBSCHOOL	KSB SCHOOL LAW, PC LLO	80.00
20614	03/10/2025				LOCKMOBILE	THE LOCKMOBILE	59.40
20615	03/10/2025				LINWELD	MATHESON TRI GAS	696.49
20616	03/10/2025				MENARD430	MENARDS - KEARNEY	35.26
20617	03/10/2025				MOSTEKE	MOSTEK ELECTRIC, INC.	1,021.98
20618	03/10/2025				NRCSA	NE RURAL COMMUNITY SCHOOLS ASSN	880.00
20619	03/10/2025				NEBOIL	NE STATE FIRE MARSHAL AGENCY	183.00
20620	03/10/2025				NPPD	NEBRASKA PUBLIC POWER DISTRICT	6,701.48
20621	03/10/2025				ONESOURCE	ONESOURCE	80.00
20622	03/10/2025				STATENE	STATE OF NEBRASKA	361.28
20623	03/10/2025				STONEC73	CINDY STONE	91.94
20624	03/10/2025				VILLAGEE	VILLAGE OF ELM CREEK	1,183.50
20625	03/10/2025				VILLAGEU	VILLAGE UNIFORM	469.35
20626	03/10/2025				WEXBANK	WEX BANK	976.93
20627	03/10/2025				WOODWARDS	WOODWARDS DISPOSAL SERVICE	32.50
Check Type Total:		Check			Void Total:	0.00	Total without Voids: 45,262.48
Checking Account Total:		GENERAL			Void Total:	0.00	Total without Voids: 45,262.48
Grand Total:					Void Total:	0.00	Total without Voids: 45,262.48

ELM CREEK SCHOOL BOARD TREASURER'S REPORTS
 FOR MARCH 10, 2025
 FEBRUARY 2025 FINANCIALS

GENERAL FUND - ACCT NO. 137766

BALANCE FEBRUARY 1, 2025		\$	1,206,971.50
RECEIPTS	ADAM MARSHALL LAND & AUCTION (DISPOSABLE PROP)	\$	8,370.00
	BUFFALO COUNTY	\$	73,255.16
	DAWSON COUNTY	\$	145.89
	ESU 10 - SUB PAY	\$	168.90
	FIRSTIER - INTEREST	\$	2,510.28
	PHELPS COUNTY	\$	33,487.00
	PRESCHOOL	\$	580.00
	SPED SCHOOL AGE FFR	\$	54,900.00
	STATE OF NEBRASKA - AID	\$	-
	SATTE OF NEBRASKA - APPORTIONMENT	\$	106,991.03
	TOTAL RECEIPTS	\$	280,408.26
AVAILABLE BALANCE		\$	1,487,379.76
DISBURSEMENTS:			
	BILLS PAID JANUARY 9, 2025	\$	63,171.97
	VOID SORINEX CHECK #20582	\$	(1,905.28)
	PAYROLL	\$	382,442.40
	TOTAL DISBURSEMENTS	\$	443,709.09
	BALANCE FEBRUARY 28, 2025	\$	1,043,670.67

DEPRECIATION FUND

ACCT 4152 (FROM 4832)	BALANCE FEBRUARY 1, 2025	\$	73,467.06
	EXPENSES	\$	-
	INTEREST	\$	84.59
	BALANCE FEBRUARY 28, 2025	\$	73,551.65
ACCOUNT 0119 (FROM 7651)	BALANCE FEBRUARY 1, 2025	\$	543,561.04
	EXPENSES	\$	-
	INTEREST	\$	2,237.21
	TRANSFER FROM GENERAL FUNDS	\$	-
	BALANCE FEBRUARY 28, 2025	\$	545,798.25
	DEPRECIATION BALANCE FEBRUARY 28, 2025	\$	619,349.90

ELM CREEK SCHOOL BOARD TREASURER'S REPORTS
FOR MARCH 10, 2025
FEBRUARY 2025 FINANCIALS

<u>BENEFIT FUND (UNEMPL CD)</u> ACCOUNT 0125	BALANCE FEBRUARY 1, 2025	\$ 12,325.49
	INTEREST	\$ 50.73
	BALANCE FEBRUARY 28, 2025	\$ 12,376.22
<u>BUILDING FUND</u>	BALANCE FEBRUARY 1, 2025	\$ 507,099.02
	BUFFALO COUNTY	\$ 2,232.55
	DAWSON COUNTY	\$ 1.63
	PHELPS COUNTY	\$ 1,170.48
	INTEREST	\$ 780.45
	BALANCE FEBRUARY 28, 2025	\$ 511,284.13
BOND FUND OPENED 01/01/2023	BALANCE FEBRUARY 1, 2025	\$ 207,107.23
	BUFFALO COUNTY	\$ 11,580.24
	DAWSON COUNTY	\$ 17.77
	PHELPS COUNTY	\$ 5,806.74
	BALANCE FEBRUARY 28, 2025	\$ 224,511.98
ELEM CONSTRUCTION (NLAF)	BALANCE FEBRUARY 1, 2025	\$ 1,255.41
	DIV REINVESTMENT	\$ 3.82
	BALANCE FEBRUARY 28, 2025	\$ 1,259.23
ELEM CONSTRUCTION (FIRSTIER) (ACCOUNT 7078)	BALANCE FEBRUARY 1, 2025	\$ 190,911.36
	INTEREST EARNED	\$ 958.21
	INTEREST TO SWEEP ACCOUNT	\$ (535.08)
	KIDWELL	\$ (820.00)
	BD CONSTRUCTION	\$ (19,573.66)
	BALANCE FEBRUARY 28, 2025	\$ 170,940.83
SWEEP SAVINGS ACCOUNT	BALANCE FEBRUARY 1, 2025	\$ 208,165.27
	MOVED TO CD 0109	\$ (100,000.00)
	INTEREST - SHOWED TWICE ON TREAS REPORT	\$ (25.93)
	INTEREST TRANSFER FROM CONSTRUCTION ACCT	\$ 535.08
	BALANCE FEBRUARY 28, 2025	\$ 108,674.42
CONSTRUCTION FUND CD	BALANCE FEBRUARY 1, 2025	\$ -
	TRANSFER FROM SWEEP SAVINGS	\$ 100,000.00
	BALANCE FEBRUARY 28, 2025	\$ 100,000.00

ELM CREEK SCHOOL BOARD TREASURER'S REPORTS
 FOR MARCH 10, 2025
 FEBRUARY 2025 FINANCIALS

LUNCH FUND

<u>BALANCE FEBRUARY 1, 2025</u>	\$	47,439.75
<u>RECEIPTS</u>		
LUNCH SALES	\$	5,542.50
EFUND PAYMENTS	\$	3,106.91
FEDERAL REIMBURSEMENT BREAKFAST	\$	6,974.64
FEDERAL REIMBURSEMENT LUNCH	\$	1,595.66
STATE REIMBURSEMENT LUNCH	\$	355.83
STATE REIMBURSEMENT BREAKFAST	\$	603.30
TOTAL RECEIPTS	\$	18,178.84
AVAILABLE BALANCE	\$	65,618.59
<u>DISBURSEMENTS</u>		
FOOD/GROCERIES/MILK ETC.	\$	20,458.33
SUPPLIES	\$	862.86
MISCELLANEOUS (REIMBURSEMENTS, BANK FEES)	\$	66.10
REPAIRS (WALK IN COOLER)	\$	2,944.86
PAYROLL	\$	7,384.93
TOTAL DISBURSEMENTS	\$	31,717.08
BALANCE FEBRUARY 28, 2025	\$	33,901.51

MARCH BILLS AS OF 3/3/25

BERNARD FOODS	\$	-
CASHWA	\$	10,494.98
DOLLAR GENERAL	\$	17.00
FOSTERS FAMILY FOODS	\$	344.68
HILAND (MILK)	\$	1,320.55
MARCH PAYROLL (ESTIMATE)	\$	7,500.00
US FOODS	\$	-
VILLAGE UNIFORM (TOWELS ETC)	\$	158.48
	\$	19,835.69

ELM CREEK SCHOOL BOARD TREASURER'S REPORTS
 FOR MARCH 10, 2025
 FEBRUARY 2025 FINANCIALS

ACTIVITY FUND (CURRENT CASH BALANCE SUMMARY)

	BALANCE FEBRUARY 1, 2025	\$	30,182.86
RECEIPTS	ATHLETICS & ACTIVITIES	\$	53,010.58
	CLUB & CLASS ACCOUNTS	\$	2,985.00
	DISTRICT ACTIVITIES	\$	4,564.05
	TRANSFER FROM GENERAL	\$	-
	TOTAL RECEIPTS	\$	60,559.63
EXPENSES	ATHLETICS & ACTIVITIES	\$	36,168.08
	CLUB & CLASS ACCOUNTS	\$	865.36
	DISTRICT ACTIVITIES	\$	8,035.45
	TOTAL EXPENSES	\$	45,068.89
	BALANCE FEBRUARY 28, 2025	\$	45,673.60

Cash Flow Report

School District #9
3/3/2025

Processing Month

02/2025

Page: 1
User ID: LKJ

FUND NI Account		BEGINNING CASH 09/01/2024	REVENUES	EXPENSES	ENDING CASH
01	GENERAL FUND	961,204.15	2,910,484.78	(2,828,018.26)	1,043,670.67
02	DEPRECIATION	379,511.89	146.55	(306,106.79)	73,551.65
02	DEPRECIATION CD	530,756.06	15,042.19	-	545,798.25
03	EMPLOYEE BENEFIT	12,035.14	341.08	-	12,376.22
05	ACTIVITY FUND	107,875.89	262,074.04	(324,276.33)	45,673.60
06	NUTRITION FUND	97,070.02	97,667.01	(160,835.52)	33,901.51
07	BOND FUND	565,867.11	452,427.20	(793,782.33)	224,511.98
08	BUILDING FUND	256,579.80	272,641.23	(17,936.90)	511,284.13
08	EL BLDG FUND-NLAF	1,231.97	27.26	-	1,259.23
08	EL BLDG FUND-FIRSTIER	1,000,021.32	8,095.46	(837,175.95)	170,940.83
08	EL SWEEP ACCT (INTEREST)	198,991.60	9,682.82	(100,000.00)	108,674.42
08	EL SWEEP ACCT CD	-	100,000.00	-	100,000.00
		4,111,144.95	4,128,629.62	(5,368,132.08)	2,871,642.49



Elm Creek Public Schools
230 East Calkins Avenue
Elm Creek, NE 68836

Invoice **800530**
 Draw 33
 Date 3/4/25
 Customer 5009
 Billing Thru: 2/28/2025

Contract: 21-02-025 School Addition and Renovation

Contract Recap:

Construction Budget	\$	11,426,358.29
Estimated Budget Change to Date	\$	105,110.81
Construction to Date	\$	11,531,469.10
Total Completed to Date	\$	11,274,730.27
Retainage	\$	(250,000.00)
Total Earned Less Retainage	\$	11,024,730.27
Less Previous Billings	\$	(11,011,299.34)
AMOUNT DUE THIS INVOICE	\$	13,430.93

Net 10 Days



CSI Division	Description	Quantity	Rate	Amount
-----------------	-------------	----------	------	--------

01 General Requirements

01-3100.40	Incidental Const Services			
	Superintendent	1.5	\$ 90.00	\$ 135.00
	Other Misc Costs			\$ 2,000.00
01-3100.50	Plan Documents			\$ -
01-3113.10	Sr. Accounting	3	\$ 75.00	\$ 225.00
01-3113.20	Accounting	3	\$ 70.00	\$ 210.00
01-3113.30	Construction Op Director		\$ 120.00	\$ -
01-3113.44	Field Operations Director	0	\$ 120.00	\$ -
01-3113.45	Project Engineer	0	\$ 150.00	\$ -
01-3113.50	Project Manager	6.5	\$ 85.00	\$ 552.50
		0	\$ 105.00	\$ -
01-3113.55	Assistant Project Manager	1	\$ 70.00	\$ 70.00
TOTAL GENERAL REQUIREMENTS				\$ 3,192.50

07 Thermal & Moisture Protection

07-9200.10	Building Sealants			
	Subcontractor			\$ 4,488.00
TOTAL THERMAL & MOISTURE PROTECTION				\$ 4,488.00

70 OTHER USER DEFINED

70-1100.99	Estimating Adjustment			\$ 5,500.00
TOTAL OTHER USER DEFINED				\$ 5,500.00



INVOICE SUB TOTAL	\$	13,180.50
CONTRACTOR FEE	\$	250.43
TOTAL COMPLETED TO DATE	\$	13,430.93
RETAINAGE	\$	-
TOTAL AMOUNT DUE	\$	13,430.93

Contract Summary:

Construction Budget	\$	11,426,358.29
Estimated Budget Change to Date	\$	105,110.81
Construction to Date	\$	11,531,469.10
Invoiced Amount	\$	11,274,730.27
Remaining Amount	\$	256,738.83
Billed Percent		98%
RETAINAGE Balance	\$	250,000.00

Approved By:

Name: *Kent Cordes*
 Kent Cordes, Project Manager

Date: 3/4/2025

Name: *Linette Butler*

Date: 3/4/2025

Name: 
 Wilkins ADP

Date: 3/6/2025

Thank you for choosing BD Construction, Inc./Kearney



Project:

Elm Creek Public Schools

Location:

Elm Creek, NE

Date:

February 28, 2025

Billed to Date

CSI	Description	Cont. / Supplier	Estimate	Billed to Date	Balance to Finish	Draw 33
01-0000-00	Pre-Construction General Conditions		\$ 28,700.00	\$ 28,555.00	\$ 145.00 99%	\$ -
01-3113-10	Sr. Accounting		\$ 150.00	\$ -	\$ 150.00	
01-3113-20	Accounting		\$ 280.00	\$ 385.00	\$ (105.00)	
01-3113-30	Sr. Estimating		\$ 14,400.00	\$ 26,700.00	\$ (12,300.00)	
01-3113-75	Contract Administration		\$ 1,470.00	\$ 1,470.00	\$ -	
01-3113-80	Project Executive		\$ 12,400.00	\$ -	\$ 12,400.00	
01-0000-00	General Conditions		\$ 518,823.78	\$ 549,096.13	\$ (30,272.35) 106%	\$ 1,057.50
01-3113-10	Sr. Accounting		\$ 11,700.00	\$ 9,412.50	\$ 2,287.50	\$ 225.00
01-3113-20	Accounting		\$ 10,920.00	\$ 15,365.00	\$ (4,445.00)	\$ 210.00
01-3113-30	Sr. Estimating		\$ -	\$ 840.00	\$ (840.00)	
01-3113-85	Field Operations Manager		\$ 37,440.00	\$ 17,700.00	\$ 19,740.00	
01-3113-50	Project Manager		\$ 127,880.00	\$ 97,600.00	\$ 30,280.00	\$ 552.50
01-3113-55	Assistant Project Manager		\$ -	\$ 20,685.00	\$ (20,685.00)	\$ 70.00
01-3113-60	Superintendent		\$ 287,950.00	\$ 364,645.00	\$ (76,695.00)	
	Mileage (Sup. And Admin.)		\$ 2,028.78	\$ 10,462.13	\$ (8,433.35)	
01-3113-65	Assistant Superintendent		\$ -	\$ 6,660.00	\$ (6,660.00)	
01-3113-70	Safety Consultant		\$ 2,925.00	\$ 1,528.00	\$ 1,397.00	
01-3113-75	Contract Administration		\$ 1,400.00	\$ 1,176.00	\$ 224.00	
01-3113-80	Project Executive		\$ 36,580.00	\$ 3,022.50	\$ 33,557.50	
01-0000-00	General Requirements		\$ 217,175.00	\$ 289,279.84	\$ (72,104.84) 133%	\$ 2,135.00
01-3100-40	Incidental Construction Services		\$ 27,000.00	\$ 101,825.88	\$ (74,825.88)	\$ 2,135.00
01-3100-50	Plan Documents		\$ 5,000.00	\$ (300.00)	\$ 5,300.00	
01-3300-10	Electronic Shop Drawing Reviewal Process	Submittal Exchange	\$ 12,500.00	\$ 18,218.61	\$ (5,718.61)	
01-4126-10	Permits		\$ 5,000.00	\$ 2,254.10	\$ 2,745.90	
01-4126-20	Fire Marshall Permit	Fire Marshall	\$ 500.00	\$ -	\$ 500.00	
01-4523-10	Soil Compaction	Allowance	\$ 15,000.00	\$ -	\$ 15,000.00	
01-4523-20	Geotech services / site investigation	Allowance	\$ 4,500.00	\$ -	\$ 4,500.00	
01-4523-30	Concrete Testing	Included in Soil testing above	\$ -	\$ -	\$ -	
01-4710-10	Builders Risk Insurance	OWNER	\$ -	\$ -	\$ -	
01-5113-10	Temporary Electrical	OWNER	\$ -	\$ -	\$ -	
01-5113-10	Power Office Trailer		\$ 1,500.00	\$ 446.94	\$ 1,053.06	
01-5123-10	Temporary Heat	NONE	\$ -	\$ 15,752.73	\$ (15,752.73)	
01-5133-10	Temporary Telephone (Cell Phone)		\$ 4,950.00	\$ 4,106.94	\$ 843.06	
01-5136-10	Temporary Water Drinking		\$ 630.00	\$ 271.66	\$ 358.34	
01-5136-20	Temporary Water Construction	OWNER	\$ -	\$ -	\$ -	
01-5213-10	Prjt Field Office Delivery (loaded mile)		\$ 330.00	\$ -	\$ 330.00	
01-5213-20	Project Field Office Rent		\$ 11,700.00	\$ 7,350.00	\$ 4,350.00	

77	01-5219-10	Sanitary Facilities		\$	2,565.00	\$	4,876.00	\$	(2,311.00)		
81	01-5626-10	Temp Chain Link Fence	Allowance	\$	15,000.00	\$	166.63	\$	14,833.37		
82	01-5813-10	Project Signage	None			\$	-	\$	-		
83	01-7113-10	Mobilization	Allowance	\$	4,000.00	\$	4,000.00	\$	-		
84	01-7113-20	Bugout	Included in Mobilization costs			\$	-	\$	-		
85	01-7419-10	Refuse Collection & Disposal		\$	9,000.00	\$	13,389.74	\$	(4,389.74)		
86	01-7423-10	Rough Cleaning	Allowance	\$	7,500.00	\$	-	\$	7,500.00		
87	01-7423-10	Final Cleaning	Allowance	\$	13,500.00	\$	8,312.56	\$	5,187.44		
	01-7700-99	Closeout Procedures				\$	14,670.00	\$	(14,670.00)		
89	60-1000-99	Survey (Site Plan) - including staking	Allowance	\$	8,000.00	\$	1,334.57	\$	6,665.43		
99	70-1000-20	Fuel	Allowance	\$	1,500.00	\$	2,332.56	\$	(832.56)		
100	70-7000-99	Equipment		\$	67,500.00	\$	90,270.92	\$	(22,770.92)		
101											
102	02000000	Existing Conditions		\$	65,169.00	\$	68,543.84	\$	(3,374.84)	105%	\$ -
103	02	Temporary Walls	Allowance	\$	20,000.00	\$	23,374.84	\$	(3,374.84)		
104	02-4100.99	Demolition	BD Construction	\$	45,169.00	\$	45,169.00	\$	-		
106		Site Demo	Included in Site Prep Below	\$	-	\$	-	\$	-		
107											
108	03000000	Concrete		\$	604,383.51	\$	569,392.54	\$	34,990.97	94%	\$ -
109	03-3000.00	Building Concrete (foundation, floors, stoops)	Bigzby's Concrete	\$	546,217.91	\$	534,927.54	\$	11,290.37		
		Add 1440 sf of hard surface court		\$	7,185.60	\$	-	\$	7,185.60		
111	03-3000.00	Concrete Topping	Included in Concrete			\$	-	\$	-		
112		Concrete Reinforcing Steel (including mesh)	Concrete Industries	\$	32,925.00	\$	32,925.00	\$	-		
114		Masonry Reinforcing Steel	Concrete Industries	\$	2,365.00	\$	1,540.00	\$	825.00		
116		Reinforcing steel (additional concrete)	Concrete Industries	\$	690.00	\$	-	\$	690.00		
117											
118	04000000	Masonry		\$	416,220.00	\$	416,220.00	\$	-	100%	\$ -
119	04-2000.99	Masonry	Masonry Unlimited	\$	416,220.00	\$	416,220.00	\$	-		
121											
122	05000000	Metals			\$1,184,433.00	\$	\$1,180,380.73	\$	\$4,052.27	100%	\$0.00
124		Structural Steel Fab	Apollo Steel	\$	832,200.00	\$	832,200.00	\$	-		
125		Structural Steel Stairs & Rails Fab	Apollo Steel	\$	74,500.00	\$	74,500.00	\$	-		
126		Structural Steel Erection	Schroeder Steel Erection	\$	277,733.00	\$	273,680.73	\$	4,052.27		
127											
128	06000000	Wood, Plastics & Composites		\$	304,951.00	\$	304,951.00	\$	-	100%	\$ -
129		Rough Carpentry	BD Construction	\$	161,130.00	\$	161,130.00	\$	-		
137		Casework	Designercraft	\$	143,821.00	\$	143,821.00	\$	-		
138	07 00 00	Thermal & Moisture Protection		\$	478,595.44	\$	485,154.24	\$	(6,558.80)	101%	\$ 4,488.00
139	07-2100.10	Batt Insulation Alternate in lieu of Sprayed	Midwest Partitions	\$	44,500.00	\$	44,500.00	\$	-		
140	07-2100.10	Foam Insulation	Estimated Cost	\$	15,000.00	\$	16,517.64	\$	(1,517.64)		
		Fluid Applied Membrane	Midwest Partitions	\$	48,750.00	\$	48,750.00	\$	-		
		Membrane at elevator pit	?	\$	2,000.00	\$	2,000.00	\$	-		
145		Building Expansion joint w/ covers	Allowance	\$	5,000.00	\$	818.43	\$	4,181.57		
		Roofing	Tri-Cities Group Roofing	\$	325,904.44	\$	335,009.59	\$	(9,105.15)		
152	07-7123.10	Gutter and Downspouts	Included in Roofing			\$	-	\$	-		
154	07-9200.10	Sealants	Global Caulking	\$	37,441.00	\$	37,558.58	\$	(117.58)		\$ 4,488.00
158		Insulation	Weatheright			\$	-	\$	-		

159	08 00 00	Openings		\$	414,082.00	\$	414,082.00	\$	-	100%	\$	-
		Doors and Hardware	Midwest Door & Hardware	\$	225,416.00	\$	225,416.00	\$	-			
169	08-3000.10	Overhead door	Bid #	\$	24,917.00	\$	24,917.00	\$	-			
172	08-5000.20	Exterior Windows	Included in Aluminum			\$	-	\$	-			
173	08-5000.20	Interior Windows	Included in Aluminum			\$	-	\$	-			
	08-5000.20	Aluminum Storefront & Glazing	Tri County Glass	\$	163,749.00	\$	163,749.00	\$	-			
183												
184	09 00 00	Finishes		\$	2,018,347.00	\$	2,016,937.00	\$	1,410.00	100%	\$	-
186	09-2116.10	Gypsum Drywall	Midwest Partitions	\$	1,427,583.00	\$	1,427,583.00	\$	-			
		Painting	Kucera Painting	\$	141,033.00	\$	141,033.00	\$	-			
		Acoustical Ceilings	TC Ceilings	\$	114,400.00	\$	112,990.00	\$	1,410.00			
	09-6000.99	Flooring	Floors Inc	\$	168,915.00	\$	168,915.00	\$	-			
	09-6000.99	Polished & Sealed Concrete	Kucera Painting	\$	37,200.00	\$	37,200.00	\$	-			
208	09-6000.99	Tile	Floors Inc	\$	129,216.00	\$	129,216.00	\$	-			
209												
210	10 00 00	Specialties		\$	155,518.00	\$	138,119.50	\$	17,398.50	89%	\$	-
212		Display Boards	EPCO	\$	35,728.00	\$	35,728.00	\$	-			
213		Wall Protection (corner guards; minor wp)	EPCO	\$	10,808.00	\$	10,808.00	\$	-			
214	10-4400.10	Fire Extinguishers	EPCO	\$	2,781.00	\$	2,781.00	\$	-			
215	10-2800.10	Toilet Accessories	EPCO	\$	5,872.00	\$	5,872.00	\$	-			
216	10-2800.10	Toilet Partitions	EPCO	\$	28,193.00	\$	28,193.00	\$	-			
217		Lockers (Material and installation)	Storage and Design	\$	47,500.00	\$	47,500.00	\$	-			
219	10-1400.10	AED - Difibulator (2 total???)	EPCO (Allowance)	\$	6,136.00	\$	6,136.00	\$	-			
220	10-1400.10	Interior Room Signage	Allowance	\$	3,500.00	\$	1,101.50	\$	2,398.50			
221	10-1400.10	Exterior Signage	Allowance	\$	15,000.00	\$	-	\$	15,000.00			
222												
230	12 00 00	Furnishings		\$	15,500.00	\$	16,971.00	\$	(1,471.00)	109%	\$	-
232		Roller window shades	Allowance	\$	15,500.00	\$	16,971.00	\$	(1,471.00)			
233												
237	14 00 00	Conveying Systems		\$	131,950.00	\$	131,950.00	\$	-	100%	\$	-
238		Elevator	Otis Elevator	\$	96,000.00	\$	96,000.00	\$	-			
239		Elevator - Lift	Access Elevator	\$	35,950.00	\$	35,950.00	\$	-			
240												
241	21 00 00	Fire Suppresion		\$	99,975.00	\$	100,095.00	\$	(120.00)	100%	\$	-
242	21-1300.99	Automatic Fire Sprinkler System	Bamford	\$	98,800.00	\$	98,920.00	\$	(120.00)			
243	21-1300.99	Auto. Fire Sprinkler System - Disconnect Existing	Bamford	\$	1,175.00	\$	1,175.00	\$	-			
244												
245	22 00 00	Plumbing		\$	2,232,598.00	\$	2,232,598.00	\$	-	100%	\$	-
246	22-1000.99	Plumbing	Anderson Bros	\$	2,223,728.00	\$	2,223,728.00	\$	-			
249	22-1000.99	Plumbing - Disconnect Existing Shop	Waggoner Plumbing	\$	8,870.00	\$	8,870.00	\$	-			
250												
257	26 00 00	Electrical		\$	1,284,743.66	\$	1,229,084.66	\$	55,659.00	96%	\$	-
258	26-0500.99	Electrical	Kidwell	\$	1,276,731.00	\$	1,221,072.00	\$	55,659.00			
264	26-0500.99	Electrical - Disconnect Existing Shop	Kidwell	\$	2,578.00	\$	2,578.00	\$	-			
	26-0500.99	Electrical - Disconnect Existing Shop (Additional)	Kidwell	\$	5,434.66	\$	5,434.66	\$	-			
266												
275	31 00 00	Earthwork		\$	374,858.00	\$	359,858.00	\$	15,000.00	96%	\$	-
276	31-1413.99	Site Prep	Morten Construction	\$	158,508.00	\$	158,508.00	\$	-			
277	31-1413.99	Elementary Building Demo	Morten Construction	\$	199,000.00	\$	199,000.00	\$	-			
278	31-1413.99	Erosion Control	Estimated Cost	\$	15,000.00	\$	-	\$	15,000.00			
279		Termite Control	Affordable Pest Control	\$	2,350.00	\$	2,350.00	\$	-			
281												

282	32 00 00	Exterior Improvements		\$	27,972.16	\$	20,472.16	\$	7,500.00	73%	\$	-
286	32-1723.99	Parking Lot Stripping	Estimated Cost	\$	7,500.00	\$	-	\$	7,500.00			
287		Fencing	Patriotic Builders	\$	20,472.16	\$	20,472.16	\$	-			
291												
292	33 00 00	Utilities		\$	10,000.00	\$	-	\$	10,000.00	0%	\$	-
293	33-0000.00	Site Utilities	included above in Plumbing	\$	-	\$	-	\$	-			
294	33-0000.00	Site Utilities - PIV and Misc	?	\$	10,000.00	\$	-	\$	10,000.00			
297	70 00 00	Misc		\$	-	\$	-	\$	-	#DIV/0!	\$	-
298												
299												
300			Net	\$	10,583,994.55	\$	10,551,740.64	\$	32,253.91		\$	7,680.50
			CO#1-overex,elevator,demo vestibule	\$	18,969.69	\$	18,969.69	\$	-			
			CO#2-fire marshal, fur out walls,band room carp	\$	43,566.97	\$	30,699.76	\$	12,867.21			
			CO#3-weight room demo	\$	42,574.15	\$	39,722.23	\$	2,851.92			
304			Estimating Adjustment	\$	525,217.22	\$	372,234.51	\$	152,982.71		\$	5,500.00
305			Credit cost of 2nd Flr Corridor window	\$	(14,878.50)	\$	-	\$	(14,878.50)			
306			Owner Contingency	\$	50,000.00	\$	-	\$	50,000.00			
307			Contractors Fee	\$	212,025.02	\$	192,981.43	\$	19,043.59		\$	250.43
308			Subtotal	\$	11,461,469.10	\$	11,206,348.26	\$	255,120.84		\$	13,430.93
309			CM Bond Cost	\$	70,000.00	\$	68,382.00	\$	1,618.00			
			Total	\$	11,531,469.10	\$	11,274,730.26	\$	256,738.84		\$	13,430.93

Invoices By Job per Cost Code

BD Construction, Inc. / Kearney

03-04-2025

Page 1

All Invoices

Invoice	Invoice Date	Description	Original Amount
21-02-025 Elm Creek Public Schools - CMR			
01-3100-40 Incidental Const Services			
11147 Kearney Builders, LLC			
13018 Heil Manor Drive			
Reisterstown MD 21136			
KB250130	01-30-2025	labor 11/18/24 to 2/2/25	2,000.00
			CSI Total 2,000.00*
07-9200-20 Joint Sealers			
7116 Global Caulking & Masonry			
714 Douglas St			
Sturgis SD 57785			
1027117	02-24-2025	Draw-ECS	4,488.00
			CSI Total 4,488.00*
70-1100-10 Estimating Adjustment			
11342 Kidwell			
3333 Folkways Circle			
Lincoln NE 68504			
262296	02-20-2025	Draw 25-ECS	5,500.00
			CSI Total 5,500.00*
Report Totals:			11,988.00*

5032

Closed Campus

The school campus is a closed campus.

Adopted on: December 14, 2020

Revised on: March 10, 2025

Reviewed on: February 10, 2025



Because learning changes everything.®

QUOTE PREPARED FOR:

Elm Creek Sch Dist 9
230 E CALKINS AVE
ELM CREEK, NE 68836
ACCOUNT NUMBER: 477076

SUBSCRIPTION/DIGITAL CONTACT:

Terah Williams
terah.williams@elmcreekschools.org
(308)856-4300

CONTACT:

Terah Williams
terah.williams@elmcreekschools.org
(308)856-4300

SALES REP INFORMATION:

Amanda Kelly
amanda.kelly@mheducation.com
(720) 601-3265

Section Summary	Value of All Materials	Free Materials	Product Subtotal
Reveal Math © 2025 - Course 1, Grade 6 (6 Year)	\$5,639.97	(\$476.07)	\$5,163.90
Reveal Math © 2025 - Course 2, Grade 7 (6 Year)	\$4,164.57	(\$476.07)	\$3,688.50
Reveal Math © 2025 - Course 3, Grade 8 (6 Year)	\$4,459.65	(\$476.07)	\$3,983.58
PRODUCT TOTAL*	\$14,264.19	(\$1,428.21)	\$12,835.98
ESTIMATED S&H**			\$1,026.88
ESTIMATED TAX**			\$0.00
GRAND TOTAL*			\$13,862.86

* Price firm for 120 days from quote date. Price quote must be attached to school purchase order to receive the quoted price and free materials.

**Shipping and handling charges shown are only estimates. Actual shipping and handling charges will be applied at time of order. Taxes shown are only estimates. If applicable, actual tax charges will be applied at time of order.

Comments:

PLEASE INCLUDE THIS PROPOSAL WITH YOUR PURCHASE ORDER

SEND ORDER TO:

McGraw Hill LLC | PO Box 182605 | Columbus, OH 43218-2605
Email: orders_mhe@mheducation.com | Phone: 1-800-338-3987 | Fax: 1-800-953-8691

QUOTE DATE: 02/26/2025

ACCOUNT NAME: Elm Creek Sch Dist 9

EXPIRATION DATE: 06/26/2025

QUOTE NUMBER: SSAMA99-02262025114418-001

ACCOUNT #: 477076

PAGE #: 1



Because learning changes everything.®

Product Description	ISBN	Qty	Unit Price	Free Materials	Line Subtotal
Reveal Math © 2025 - Course 1, Grade 6 (6 Year)					
REVEAL MATH COURSE 1 STUDENT BUNDLE 6 YEAR SUBSCRIPTION Includes: Interactive Student Edition (Ships Annually) + Student Digital License + MH Plus + 5 Month ALEKS Assessment	978-1-26-454398-4	35	\$147.54	\$0.00	\$5,163.90
Teacher Materials					
REVEAL MATH COURSE 1 TEACHER EDITION VOLUME 1	978-1-26-582930-8	1	\$113.46	\$113.46	*Free Materials
REVEAL MATH COURSE 1 TEACHER EDITION VOLUME 2	978-1-26-583011-3	1	\$113.46	\$113.46	*Free Materials
REVEAL MATH COURSE 1 ASSESSMENT RESOURCE BOOK	978-1-26-584044-0	1	\$70.62	\$70.62	*Free Materials
Digital Only - REVEAL MATH COURSE 1 TEACHER DIGITAL LICENSE 6 YEAR SUBSCRIPTION	978-1-26-581419-9	1	\$163.02	\$163.02	*Free Materials
Required - ALEKS 6-12 ADD-ON VIA MY.MHEDUCATION.COM 5 MONTH TEACHER SUBSCRIPTION	978-0-07-697171-8	1	\$15.51	\$15.51	*Free Materials

Teacher Materials Subtotal: \$476.07 \$0.00

Reveal Math © 2025 - Course 1, Grade 6 (6 Year) Subtotal: \$476.07 \$5,163.90

Reveal Math © 2025 - Course 2, Grade 7 (6 Year)					
REVEAL MATH COURSE 2 STUDENT BUNDLE 6 YEAR SUBSCRIPTION Includes: Interactive Student Edition (Ships Annually) + Student Digital License + MH Plus + 5 Month ALEKS Assessment	978-1-26-450438-1	25	\$147.54	\$0.00	\$3,688.50
Teacher Materials					
REVEAL MATH COURSE 2 TEACHER EDITION VOLUME 1	978-1-26-583228-5	1	\$113.46	\$113.46	*Free Materials
REVEAL MATH COURSE 2 TEACHER EDITION VOLUME 2	978-1-26-583281-0	1	\$113.46	\$113.46	*Free Materials
REVEAL MATH COURSE 2 ASSESSMENT RESOURCE BOOK	978-1-26-584120-1	1	\$70.62	\$70.62	*Free Materials
Digital Only - REVEAL MATH COURSE 2 TEACHER DIGITAL LICENSE 6 YEAR SUBSCRIPTION	978-1-26-581619-3	1	\$163.02	\$163.02	*Free Materials
Required - ALEKS 6-12 ADD-ON VIA MY.MHEDUCATION.COM 5 MONTH TEACHER SUBSCRIPTION	978-0-07-697171-8	1	\$15.51	\$15.51	*Free Materials

Teacher Materials Subtotal: \$476.07 \$0.00

Reveal Math © 2025 - Course 2, Grade 7 (6 Year) Subtotal: \$476.07 \$3,688.50

PLEASE INCLUDE THIS PROPOSAL WITH YOUR PURCHASE ORDER

SEND ORDER TO:

McGraw Hill LLC | PO Box 182605 | Columbus, OH 43218-2605
Email: orders_mhe@mheducation.com | Phone: 1-800-338-3987 | Fax: 1-800-953-8691

QUOTE DATE: 02/26/2025

ACCOUNT NAME: Elm Creek Sch Dist 9

EXPIRATION DATE: 06/26/2025

QUOTE NUMBER: SSAMA99-02262025114418-001

ACCOUNT #: 477076

PAGE #: 2



Because learning changes everything.®

Product Description	ISBN	Qty	Unit Price	Free Materials	Line Subtotal
Reveal Math © 2025 - Course 3, Grade 8 (6 Year)					
REVEAL MATH COURSE 3 STUDENT BUNDLE 6 YEAR SUBSCRIPTION Includes: Interactive Student Edition (Ships Annually) + Student Digital License + MH Plus + 5 Month ALEKS Assessment	978-1-26-454397-7	27	\$147.54	\$0.00	\$3,983.58
<u>Teacher Materials</u>					
REVEAL MATH COURSE 3 TEACHER EDITION VOLUME 1	978-1-26-583357-2	1	\$113.46	\$113.46	*Free Materials
REVEAL MATH COURSE 3 TEACHER EDITION VOLUME 2	978-1-26-583455-5	1	\$113.46	\$113.46	*Free Materials
REVEAL MATH COURSE 3 ASSESSMENT RESOURCE BOOK	978-1-26-584215-4	1	\$70.62	\$70.62	*Free Materials
Digital Only - REVEAL MATH COURSE 3 TEACHER DIGITAL LICENSE 6 YEAR SUBSCRIPTION	978-1-26-581693-3	1	\$163.02	\$163.02	*Free Materials
Required - ALEKS 6-12 ADD-ON VIA MY.MHEDUCATION.COM 5 MONTH TEACHER SUBSCRIPTION	978-0-07-697171-8	1	\$15.51	\$15.51	*Free Materials

Teacher Materials Subtotal: \$476.07 \$0.00
Reveal Math © 2025 - Course 3, Grade 8 (6 Year) Subtotal: \$476.07 \$3,983.58

PLEASE INCLUDE THIS PROPOSAL WITH YOUR PURCHASE ORDER

SEND ORDER TO:

McGraw Hill LLC | PO Box 182605 | Columbus, OH 43218-2605
 Email: orders_mhe@mheducation.com | Phone: 1-800-338-3987 | Fax: 1-800-953-8691

QUOTE DATE: 02/26/2025

ACCOUNT NAME: Elm Creek Sch Dist 9

EXPIRATION DATE: 06/26/2025

QUOTE NUMBER: SSAMA99-02262025114418-001

ACCOUNT #: 477076

PAGE #: 3



Because learning changes everything.®

QUOTE PREPARED FOR:

Elm Creek Sch Dist 9
230 E CALKINS AVE
ELM CREEK, NE 68836
ACCOUNT NUMBER: 477076

CONTACT:

Terah Williams
terah.williams@elmcreekschools.org
(308)856-4300

VALUE OF ALL MATERIALS	\$14,264.19
FREE MATERIALS	(\$1,428.21)
PRODUCT TOTAL*	\$12,835.98
ESTIMATED SHIPPING & HANDLING**	\$1,026.88
ESTIMATED TAX**	\$0.00
GRAND TOTAL	\$13,862.86

SUBSCRIPTION/DIGITAL CONTACT:

Terah Williams
terah.williams@elmcreekschools.org
(308)856-4300

Comments:

* Price firm for 120 days from quote date. Price quote must be attached to school purchase order to receive the quoted price and free materials.

**Shipping and handling charges shown are only estimates. Actual shipping and handling charges will be applied at time of order. Taxes shown are only estimates. If applicable, actual tax charges will be applied at time of order.

Terms of Service:

By placing an order for digital products (the 'Subscribed Materials'), the entity that this price quote has been prepared for ('Subscriber') agrees to be bound by the Terms of Service and any specific provisions required by Subscriber's state law, each located in the applicable links below. Subject to Subscriber's payment of the fees set out above, McGraw Hill LLC hereby grants to Subscriber a non-exclusive, non-transferable license to allow only the number of Authorized Users that corresponds to the quantity of Subscribed Materials set forth above to access and use the Subscribed Materials under the terms described in the Terms of Service and any specific provisions required by Subscriber's state law, each located in the applicable links below. The subscription term for the Subscribed Materials shall be as set forth in the Product Description above. If no subscription term is specified, the initial term shall be one (1) year from the date of this price quote (the 'Initial Subscription Term'), and thereafter the Subscriber shall renew for additional one (1) year terms (each a 'Subscription Renewal Term'), provided MHE has chosen to renew the subscription and has sent an invoice for such Subscription Renewal Term to Subscriber.

[Terms Of Service](#)

[Provisions required by Subscriber State law](#)

ATTENTION: In our effort to protect our customer's data, we will no longer store credit card data in any manner within in our system. Therefore, as of April 30, 2016 we will no longer accept credit card orders via email, fax, or mail/package delivery. Credit card orders may be placed over the phone by calling the number listed above or via our websites by visiting www.mheducation.com (or www.mhecoast2coast.com).

School Purchase Order Number: _____

Name of School Official (Please Print)

Signature of School Official

PLEASE INCLUDE THIS PROPOSAL WITH YOUR PURCHASE ORDER

SEND ORDER TO:

McGraw Hill LLC | PO Box 182605 | Columbus, OH 43218-2605
Email: orders_mhe@mheducation.com | Phone: 1-800-338-3987 | Fax: 1-800-953-8691

QUOTE DATE: 02/26/2025

ACCOUNT NAME: Elm Creek Sch Dist 9

EXPIRATION DATE: 06/26/2025

QUOTE NUMBER: SSAMA99-02262025114418-001

ACCOUNT #: 477076

PAGE #: 4



Because learning changes everything.®

QUOTE PREPARED FOR:

Elm Creek Sch Dist 9
230 E CALKINS AVE
ELM CREEK, NE 68836
ACCOUNT NUMBER: 477076

SUBSCRIPTION/DIGITAL CONTACT:

Brandon Marquez
brandon.marquez@elmcreekschools.org
(308) 856-4300

CONTACT:

Brandon Marquez
brandon.marquez@elmcreekschools.org
(308) 856-4300

SALES REP INFORMATION:

Amanda Kelly
amanda.kelly@mheducation.com
(720) 601-3265

Section Summary	Value of All Materials	Free Materials	Product Subtotal
REVEAL MATH 2020 (6-YEAR BDLS)	\$0.00	\$0.00	\$0.00
GRADE 6 - COURSE 1	\$4,973.31	(\$240.96)	\$4,732.35
GRADE 7 - COURSE 2	\$3,621.21	(\$240.96)	\$3,380.25
GRADE 8 - COURSE 3	\$3,891.63	(\$240.96)	\$3,650.67
ALGEBRA 1 (6-YEAR HC BDLS)	\$4,157.34	(\$247.59)	\$3,909.75
GEOMETRY	\$6,439.56	(\$245.16)	\$6,194.40
ALGEBRA 2	\$4,116.66	(\$245.16)	\$3,871.50
PRODUCT TOTAL*	\$27,199.71	(\$1,460.79)	\$25,738.92
ESTIMATED S&H**			\$2,059.11
ESTIMATED TAX**			\$0.00
GRAND TOTAL*			\$27,798.03

* Price firm for 120 days from quote date. Price quote must be attached to school purchase order to receive the quoted price and free materials.

**Shipping and handling charges shown are only estimates. Actual shipping and handling charges will be applied at time of order. Taxes shown are only estimates. If applicable, actual tax charges will be applied at time of order.

Comments:

PLEASE INCLUDE THIS PROPOSAL WITH YOUR PURCHASE ORDER

SEND ORDER TO:

McGraw Hill LLC | PO Box 182605 | Columbus, OH 43218-2605
Email: orders_mhe@mheducation.com | Phone: 1-800-338-3987 | Fax: 1-800-953-8691

QUOTE DATE: 11/11/2024

ACCOUNT NAME: Elm Creek Sch Dist 9

EXPIRATION DATE: 03/11/2025

QUOTE NUMBER: DCONO-11112024082533-001

ACCOUNT #: 477076

PAGE #: 1



Because learning changes everything.®

Product Description	ISBN	Qty	Unit Price	Free Materials	Line Subtotal
REVEAL MATH 2020 (6-YEAR BDLs)					
REVEAL MATH 2020 (6-YEAR BDLs) Subtotal:				\$0.00	\$0.00
GRADE 6 - COURSE 1					
REVEAL MATH COURSE 1 STUDENT BUNDLE WITH MH 6YR SUBSCRIPTION	978-1-26-537978-0	35	\$135.21	\$0.00	\$4,732.35
REVEAL MATH COURSE 1 TEACHER DIGITAL LICENSE 6 YEAR SUBSCRIPTION	978-0-07-696286-0	1	\$240.96	\$240.96	*Free Materials
GRADE 6 - COURSE 1 Subtotal:				\$240.96	\$4,732.35
GRADE 7 - COURSE 2					
REVEAL MATH COURSE 2 STUDENT BUNDLE WITH MH 6YR SUBSCRIPTION	978-1-26-538689-4	25	\$135.21	\$0.00	\$3,380.25
REVEAL MATH COURSE 2 TEACHER DIGITAL LICENSE 6 YEAR SUBSCRIPTION	978-0-07-696292-1	1	\$240.96	\$240.96	*Free Materials
GRADE 7 - COURSE 2 Subtotal:				\$240.96	\$3,380.25
GRADE 8 - COURSE 3					
REVEAL MATH COURSE 3 STUDENT BUNDLE WITH MH 6YR SUBSCRIPTION	978-1-26-539044-0	27	\$135.21	\$0.00	\$3,650.67
REVEAL MATH COURSE 3 TEACHER DIGITAL LICENSE 6 YEAR SUBSCRIPTION	978-0-07-696298-3	1	\$240.96	\$240.96	*Free Materials
GRADE 8 - COURSE 3 Subtotal:				\$240.96	\$3,650.67
ALGEBRA 1 (6-YEAR HC BDLs)					
REVEAL ALGEBRA 1 STUDENT HARDCOVER BUNDLE WITH MH 6YR SUBSCRIPTION	978-1-26-547299-3	25	\$156.39	\$0.00	\$3,909.75
REVEAL ALGEBRA 1 TEACHER DIGITAL LICENSE 6 YEAR SUBSCRIPTION	978-0-07-697205-0	1	\$247.59	\$247.59	*Free Materials
ALGEBRA 1 (6-YEAR HC BDLs) Subtotal:				\$247.59	\$3,909.75
GEOMETRY					
REVEAL GEOMETRY STUDENT HARDCOVER BUNDLE WITH MH 6YR SUBSCRIPTION	978-1-26-545726-6	40	\$154.86	\$0.00	\$6,194.40
REVEAL GEOMETRY TEACHER DIGITAL LICENSE 6 YEAR SUBSCRIPTION	978-0-07-697241-8	1	\$245.16	\$245.16	*Free Materials
GEOMETRY Subtotal:				\$245.16	\$6,194.40
ALGEBRA 2					
REVEAL ALGEBRA 2 STUDENT HARDCOVER BUNDLE WITH MH 6YR SUBSCRIPTION	978-1-26-547771-4	25	\$154.86	\$0.00	\$3,871.50
REVEAL ALGEBRA 2 TEACHER DIGITAL LICENSE 6 YEAR SUBSCRIPTION	978-0-07-697433-7	1	\$245.16	\$245.16	*Free Materials
ALGEBRA 2 Subtotal:				\$245.16	\$3,871.50

PLEASE INCLUDE THIS PROPOSAL WITH YOUR PURCHASE ORDER

SEND ORDER TO:

McGraw Hill LLC | PO Box 182605 | Columbus, OH 43218-2605
 Email: orders_mhe@mheducation.com | Phone: 1-800-338-3987 | Fax: 1-800-953-8691

QUOTE DATE: 11/11/2024

ACCOUNT NAME: Elm Creek Sch Dist 9

EXPIRATION DATE: 03/11/2025

QUOTE NUMBER: DCONO-11112024082533-001

ACCOUNT #: 477076

PAGE #: 2



Because learning changes everything.

QUOTE PREPARED FOR:

Elm Creek Sch Dist 9
230 E CALKINS AVE
ELM CREEK, NE 68836
ACCOUNT NUMBER: 477076

CONTACT:

Brandon Marquez
brandon.marquez@elmcreekschools.org
(308) 856-4300

SUBSCRIPTION/DIGITAL CONTACT:

Brandon Marquez
brandon.marquez@elmcreekschools.org
(308) 856-4300

VALUE OF ALL MATERIALS	\$27,199.71
FREE MATERIALS	(\$1,460.79)
PRODUCT TOTAL*	\$25,738.92
ESTIMATED SHIPPING & HANDLING**	\$2,059.11
ESTIMATED TAX**	\$0.00
GRAND TOTAL	\$27,798.03

Add PD \$1500

Comments:

[Empty comment box]

* Price firm for 120 days from quote date. Price quote must be attached to school purchase order to receive the quoted price and free materials.

**Shipping and handling charges shown are only estimates. Actual shipping and handling charges will be applied at time of order.

Terms of Service:

By placing an order for digital products (the 'Subscribed Materials'), the entity that this price quote has been... and any specific provisions required by Subscriber's state law, each located in the applicable links below. Su... LLC hereby grants to Subscriber a non-exclusive, non-transferable license to allow only the number of Autho... set forth above to access and use the Subscribed Materials under the terms described in the Terms of Servi... located in the applicable links below. The subscription term for the Subscribed Materials shall be as set forth... the initial term shall be one (1) year from the date of this price quote (the 'Initial Subscription Term'), and ther... (each a 'Subscription Renewal Term'), provided MHE has chosen to renew the subscription and has sent an...

Terms Of Service

Provisions required by Subscriber State law

ATTENTION: In our effort to protect our customer's data, we will no longer store credit card data in any man... longer accept credit card orders via email, fax, or mail/package delivery. Credit card orders may be placed c... visiting www.mheducation.com (or www.mhecoast2coast.com).

*Also need CCC
Trig. books \$1400.00*

Total \$30,698.03

School Purchase Order Number: _____

Name of School Official (Please Print)

Signature of School Official

PLEASE INCLUDE THIS PROPOSAL WITH YOUR PURCHASE ORDER

SEND ORDER TO:

McGraw Hill LLC | PO Box 182605 | Columbus, OH 43218-2605
Email: orders_mhe@mheducation.com | Phone: 1-800-338-3987 | Fax: 1-800-953-8691

QUOTE DATE: 11/11/2024

ACCOUNT NAME: Elm Creek Sch Dist 9

EXPIRATION DATE: 03/11/2025

QUOTE NUMBER: DCONO-11112024082533-001

ACCOUNT #: 477076

PAGE #: 3



every child
is capable of
greatness

Great Minds Quote

Date	February 28, 2025	Quote Number	00421122
Expiration Date	October 31, 2025	Contact Name	Terah Williams
Prepared By	Jeremy Newth	Phone	(308) 856-4300
Email	jeremy.newth@greatminds.org	Email	terah.williams@elmcreekschools.org
Bill to Name	Linda Johns	Ship to Name	Elm Creek Public Schools
Bill To	230 Calkins Street Elm Creek, NE 68836	Ship To	230 East Calkins Ave Elm Creek, NE 68836
		End User	Elm Creek Public Schools

Make Payment to:
Great Minds PBC Tax ID: 84-3785772
Mail payment to:
Great Minds PBC
P.O. Box 200283
Pittsburgh, PA 15251-0283

Phone: 202.223.1854
Email: ordertracking@greatminds.org

Wire/ACH details are available by visiting this link: <https://digitalsupport.greatminds.org/s/ach-instructions>

Eureka Math 2 - Kit	ISBN	Quantity	List Price	Discounts	Total Price
Grade PK					
Eureka Math Squared Grade PK Learn: How Many? Modules 1-6 (Incl. Teacher Digital Platform License)	979-8-89012-352-7	75.00	\$5.84	10.00%	\$394.20
Grade K					
Eureka Math Squared Grade K Learn & Digital Bundle: Part-Part-Total Modules 1-6	978-1-64929-023-6	105.00	\$35.02	10.00%	\$3,309.39
Grade 1					

Eureka Math Squared Grade 1 Learn & Digital Bundle: Units of Ten Modules 1-6	978-1-64929-024-3	105.00	\$35.02	10.00%	\$3,309.39
Grade 2					
Eureka Math Squared Grade 2 Learn & Digital Bundle: Ten Tens, Modules 1-6	978-1-64929-025-0	105.00	\$35.02	10.00%	\$3,309.39
Grade 3					
Eureka Math Squared Grade 3 Learn & Digital Bundle: Units of Any Number Modules 1-6	978-1-64929-026-7	105.00	\$35.02	10.00%	\$3,309.39
Grade 4					
Eureka Math Squared Grade 4 Learn & Digital Bundle: Fractional Units Modules 1-6	978-1-64929-027-4	105.00	\$35.02	10.00%	\$3,309.39
Grade 5					
Eureka Math Squared Grade 5 Learn & Digital Bundle: Fractions are Numbers Modules 1-6	978-1-64929-028-1	105.00	\$35.02	10.00%	\$3,309.39

2028-2029, 2029-2030, 2030-2031

Kit	\$22,500.60
Solution Subtotal	\$22,500.60
Discount	(\$2,250.06)
Shipping and Handling	\$2,025.05
*Pre-Tax Solution Total	\$22,275.59
Estimated Sales Tax	\$0.00
Estimated S&H Tax	\$0.00
Total Solution:	\$22,275.59

This Quote is governed by the Terms and Conditions at <https://greatminds.org/customer-quote-terms> which are hereby incorporated by reference as if fully set forth herein.

***Tax Exemption: If Customer is exempt from paying any or all taxes, customer shall provide written evidence of such tax exemption issued by the applicable taxing authority.**



every child
is capable of
greatness

Great Minds Quote

Date	February 28, 2025	Quote Number	00421118
Expiration Date	May 16, 2025	Contact Name	Terah Williams
Prepared By	Jeremy Newth	Phone	(308) 856-4300
Email	jeremy.newth@greatminds.org	Email	terah.williams@elmcreekschools.org
Bill to Name	Linda Johns	Ship to Name	Elm Creek Public Schools
Bill To	230 Calkins Street Elm Creek, NE 68836	Ship To	230 East Calkins Ave Elm Creek, NE 68836
		End User	Elm Creek Public Schools

Make Payment to:
Great Minds PBC Tax ID: 84-3785772
Mail payment to:
Great Minds PBC
P.O. Box 200283
Pittsburgh, PA 15251-0283

Phone: 202.223.1854
Email: ordertracking@greatminds.org

Wire/ACH details are available by visiting this link: <https://digitalsupport.greatminds.org/s/ach-instructions>

Eureka Math 2 - Kit	ISBN	Quantity	List Price	Discounts	Total Price
Grade PK					
Eureka Math Squared Grade PK Learn: How Many? Modules 1-6 (Incl. Teacher Digital Platform License)	979-8-89012-352-7	75.00	\$5.84	10.00%	\$394.20
Eureka Math Squared Grade PK Teacher Edition Set: Modules 1-6 (Incl. Digital Platform License)	979-8-89012-354-1	1.00	\$170.00	10.00%	\$153.00
Grade K					
Eureka Math Squared Grade K Learn & Digital	978-1-64929-023-6	105.00	\$35.02	10.00%	\$3,309.39

Bundle: Part-Part-Total Modules 1-6					
Eureka Math Squared Grade K Teacher Edition Set: Part-Part-Total Modules 1-6	978-1-64929-036-6	2.00	\$170.00	10.00%	\$306.00
Grade 1					
Eureka Math Squared Grade 1 Learn & Digital Bundle: Units of Ten Modules 1-6	978-1-64929-024-3	105.00	\$35.02	10.00%	\$3,309.39
Eureka Math Squared Grade 1 Teacher Edition Set: Units of Ten Modules 1-6	978-1-64929-037-3	2.00	\$170.00	10.00%	\$306.00
Grade 2					
Eureka Math Squared Grade 2 Learn & Digital Bundle: Ten Tens, Modules 1-6	978-1-64929-025-0	105.00	\$35.02	10.00%	\$3,309.39
Eureka Math Squared Grade 2 Teacher Edition Set: Ten Tens, Modules 1-6	978-1-64929-038-0	2.00	\$170.00	10.00%	\$306.00
Grade 3					
Eureka Math Squared Grade 3 Learn & Digital Bundle: Units of Any Number Modules 1-6	978-1-64929-026-7	105.00	\$35.02	10.00%	\$3,309.39
Eureka Math Squared Grade 3 Teacher Edition Set: Units of Any Number Modules 1-6	978-1-64929-039-7	2.00	\$170.00	10.00%	\$306.00
Grade 4					
Eureka Math Squared Grade 4 Learn & Digital Bundle: Fractional Units Modules 1-6	978-1-64929-027-4	105.00	\$35.02	10.00%	\$3,309.39
Eureka Math Squared Grade 4 Teacher Edition Set: Fractional Units Modules 1-6	978-1-64929-040-3	1.00	\$170.00	10.00%	\$153.00
Grade 5					
Eureka Math Squared Grade 5 Learn & Digital Bundle: Fractions are Numbers Modules 1-6	978-1-64929-028-1	105.00	\$35.02	10.00%	\$3,309.39
Eureka Math Squared Grade 5 Teacher Edition Set: Fractions are Numbers Modules 1-6	978-1-64929-041-0	1.00	\$170.00	10.00%	\$153.00

2025-2026; 2026-2027; 2027-2028

Eureka Math Kits - Manipulative	ISBN	Quantity	List Price	Discounts	Total Price
Grade PK					
Eureka Math Complete Manipulative Kit, Grade Pre-K	600709	1.00	\$450.00	5.00%	\$427.50
Grade K					
Eureka Math Squared - Complete Manipulative Kit, Grade K	GM-602210	2.00	\$710.00	5.00%	\$1,349.00
Grade 1					
Eureka Math Squared - Complete Manipulative Kit, Grade 1	GM-602211	2.00	\$680.00	5.00%	\$1,292.00
Grade 2					
Eureka Math Squared - Complete Manipulative Kit, Grade 2	GM-602212	2.00	\$530.00	5.00%	\$1,007.00
Grade 3					
Eureka Math Squared - Complete Manipulative Kit, Grade 3	GM-602213	2.00	\$675.00	5.00%	\$1,282.50
Grade 4					
Eureka Math Squared - Complete Manipulative Kit, Grade 4	GM-602214	1.00	\$320.00	5.00%	\$304.00
Grade 5					
Eureka Math Squared - Complete Manipulative Kit, Grade 5	GM-602215	1.00	\$315.00	5.00%	\$299.25

2025-2026; 2026-2027; 2027-2028

Kit	\$24,370.60
Manipulative	\$6,275.00
Solution Subtotal	\$30,645.60
Discount	(\$2,750.81)
Shipping and Handling	\$2,758.10
*Pre-Tax Solution Total	\$30,652.89
Estimated Sales Tax	\$0.00
Estimated S&H Tax	\$0.00
Total Solution:	\$30,652.89

This Quote is governed by the Terms and Conditions at <https://greatminds.org/customer-quote-terms> which are hereby incorporated by reference as if fully set forth herein.

**Tax Exemption: If Customer is exempt from paying any or all taxes, customer shall provide written evidence of such tax exemption issued by the applicable taxing authority.*



every child
is capable of
greatness

Great Minds Quote

Date	November 18, 2024	Quote Number	00416547
Expiration Date	February 15, 2025	Contact Name	Terah Williams
Prepared By	Jeremy Newth	Phone	(308) 856-4300
Email	jeremy.newth@greatminds.org	Email	terah.williams@elmcreekschools.org
Bill to Name	Terah Williams	Ship to Name	Terah Williams
Bill To	230 Calkins Street Elm Creek, NE 68836	Ship To	230 East Calkins Ave Elm Creek, NE 68836

End User

Make Payment to:
Great Minds PBC Tax ID: 84-3785772
Mail payment to:
Great Minds PBC
P.O. Box 200283
Pittsburgh, PA 15251-0283

Phone: 202.223.1854
Email: ordertracking@greatminds.org

Wire/ACH details are available by visiting this link: <https://digitalsupport.greatminds.org/s/ach-instructions>

PD - Services	ISBN	Quantity	List Price	Total Price
Grade Multiple				
Eureka Math Squared - Virtual PD Support Services - 6 Hours	GM-03332	1.00	\$2,500.00	\$2,500.00
Eureka Math Squared - Virtual PD Support Services - 6 Hours	GM-03332	1.00	\$2,500.00	\$2,500.00

Services	\$5,000.00
Solution Subtotal	\$5,000.00
Shipping and Handling	\$0.00
*Pre-Tax Solution Total	\$5,000.00
Estimated Sales Tax	\$0.00
Estimated S&H Tax	\$0.00
Total Solution:	\$5,000.00

This Quote is governed by the Terms and Conditions at <https://greatminds.org/customer-quote-terms> which are hereby incorporated by reference as if fully set forth herein.

****Tax Exemption: If Customer is exempt from paying any or all taxes, customer shall provide written evidence of such tax exemption issued by the applicable taxing authority.***



every child
is capable of
greatness

Great Minds Quote

Date	December 18, 2024	Quote Number	00421118
Expiration Date	March 16, 2025	Contact Name	Terah Williams
Prepared By	Jeremy Newth	Phone	(308) 856-4300
Email	jeremy.newth@greatminds.org	Email	terah.williams@elmcreekschools.org
Bill to Name	Linda Johns	Ship to Name	Elm Creek Public Schools
Bill To	230 Calkins Street Elm Creek, NE 68836	Ship To	230 East Calkins Ave Elm Creek, NE 68836
		End User	Elm Creek Public Schools

Make Payment to:
Great Minds PBC Tax ID: 84-3785772
Mail payment to:
Great Minds PBC
P.O. Box 200283
Pittsburgh, PA 15251-0283

Phone: 202.223.1854
Email: ordertracking@greatminds.org

Wire/ACH details are available by visiting this link: <https://digitalsupport.greatminds.org/s/ach-instructions>

Eureka Math 2 - Kit	ISBN	Quantity	List Price	Discounts	Total Price
Grade K					
Eureka Math Squared Grade K Learn & Digital Bundle: Part-Part-Total Modules 1-6	978-1-64929-023-6	105.00	\$35.02	10.00%	\$3,309.39
Eureka Math Squared Grade K Teacher Edition Set: Part-Part-Total Modules 1-6	978-1-64929-036-6	2.00	\$170.00	10.00%	\$306.00
Grade 1					
Eureka Math Squared Grade 1 Learn & Digital Bundle: Units of Ten Modules 1-6	978-1-64929-024-3	105.00	\$35.02	10.00%	\$3,309.39

Eureka Math Squared Grade 1 Teacher Edition Set: Units of Ten Modules 1-6	978-1-64929-037-3	2.00	\$170.00	10.00%	\$306.00
Grade 2					
Eureka Math Squared Grade 2 Learn & Digital Bundle: Ten Tens, Modules 1-6	978-1-64929-025-0	105.00	\$35.02	10.00%	\$3,309.39
Eureka Math Squared Grade 2 Teacher Edition Set: Ten Tens, Modules 1-6	978-1-64929-038-0	2.00	\$170.00	10.00%	\$306.00
Grade 3					
Eureka Math Squared Grade 3 Learn & Digital Bundle: Units of Any Number Modules 1-6	978-1-64929-026-7	105.00	\$35.02	10.00%	\$3,309.39
Eureka Math Squared Grade 3 Teacher Edition Set: Units of Any Number Modules 1-6	978-1-64929-039-7	2.00	\$170.00	10.00%	\$306.00
Grade 4					
Eureka Math Squared Grade 4 Learn & Digital Bundle: Fractional Units Modules 1-6	978-1-64929-027-4	105.00	\$35.02	10.00%	\$3,309.39
Eureka Math Squared Grade 4 Teacher Edition Set: Fractional Units Modules 1-6	978-1-64929-040-3	1.00	\$170.00	10.00%	\$153.00
Grade 5					
Eureka Math Squared Grade 5 Learn & Digital Bundle: Fractions are Numbers Modules 1-6	978-1-64929-028-1	105.00	\$35.02	10.00%	\$3,309.39
Eureka Math Squared Grade 5 Teacher Edition Set: Fractions are Numbers Modules 1-6	978-1-64929-041-0	1.00	\$170.00	10.00%	\$153.00

2025-2026; 2026-2027; 2027-2028

Eureka Math Kits - Manipulative	ISBN	Quantity	List Price	Discounts	Total Price
Grade K					
Eureka Math Squared - Complete Manipulative Kit, Grade K	GM-602210	2.00	\$710.00	5.00%	\$1,349.00
Grade 1					

Eureka Math Squared - Complete Manipulative Kit, Grade 1	GM-602211	2.00	\$680.00	5.00%	\$1,292.00
Grade 2					
Eureka Math Squared - Complete Manipulative Kit, Grade 2	GM-602212	2.00	\$530.00	5.00%	\$1,007.00
Grade 3					
Eureka Math Squared - Complete Manipulative Kit, Grade 3	GM-602213	2.00	\$675.00	5.00%	\$1,282.50
Grade 4					
Eureka Math Squared - Complete Manipulative Kit, Grade 4	GM-602214	1.00	\$320.00	5.00%	\$304.00
Grade 5					
Eureka Math Squared - Complete Manipulative Kit, Grade 5	GM-602215	1.00	\$315.00	5.00%	\$299.25

2025-2026; 2026-2027; 2027-2028

Kit	\$23,762.60
Manipulative	\$5,825.00
Solution Subtotal	\$29,587.60
Discount	(\$2,667.51)
Shipping and Handling	\$2,662.88
*Pre-Tax Solution Total	\$29,582.97
Estimated Sales Tax	\$0.00
Estimated S&H Tax	\$0.00
Total Solution:	\$29,582.97

This Quote is governed by the Terms and Conditions at <https://greatminds.org/customer-quote-terms> which are hereby incorporated by reference as if fully set forth herein.

***Tax Exemption: If Customer is exempt from paying any or all taxes, customer shall provide written evidence of such tax exemption issued by the applicable taxing authority.**



every child
is capable of
greatness

Great Minds Quote

Date	December 18, 2024	Quote Number	00421122
Expiration Date	March 16, 2025	Contact Name	Terah Williams
Prepared By	Jeremy Newth	Phone	(308) 856-4300
Email	jeremy.newth@greatminds.org	Email	terah.williams@elmcreekschools.org
Bill to Name	Linda Johns	Ship to Name	Elm Creek Public Schools
Bill To	230 Calkins Street Elm Creek, NE 68836	Ship To	230 East Calkins Ave Elm Creek, NE 68836
		End User	Elm Creek Public Schools

Make Payment to:
Great Minds PBC Tax ID: 84-3785772
Mail payment to:
Great Minds PBC
P.O. Box 200283
Pittsburgh, PA 15251-0283

Phone: 202.223.1854
Email: ordertracking@greatminds.org

Wire/ACH details are available by visiting this link: <https://digitalsupport.greatminds.org/s/ach-instructions>

Eureka Math 2 - Kit	ISBN	Quantity	List Price	Discounts	Total Price
Grade K					
Eureka Math Squared Grade K Learn & Digital Bundle: Part-Part-Total Modules 1-6	978-1-64929-023-6	105.00	\$35.02	10.00%	\$3,309.39
Grade 1					
Eureka Math Squared Grade 1 Learn & Digital Bundle: Units of Ten Modules 1-6	978-1-64929-024-3	105.00	\$35.02	10.00%	\$3,309.39
Grade 2					
Eureka Math Squared Grade 2 Learn & Digital	978-1-64929-025-0	105.00	\$35.02	10.00%	\$3,309.39

Bundle: Ten Tens, Modules 1-6					
Grade 3					
Eureka Math Squared Grade 3 Learn & Digital Bundle: Units of Any Number Modules 1-6	978-1-64929-026-7	105.00	\$35.02	10.00%	\$3,309.39
Grade 4					
Eureka Math Squared Grade 4 Learn & Digital Bundle: Fractional Units Modules 1-6	978-1-64929-027-4	105.00	\$35.02	10.00%	\$3,309.39
Grade 5					
Eureka Math Squared Grade 5 Learn & Digital Bundle: Fractions are Numbers Modules 1-6	978-1-64929-028-1	105.00	\$35.02	10.00%	\$3,309.39

2028-2029, 2029-2030, 2030-2031

Kit	\$22,062.60
Solution Subtotal	\$22,062.60
Discount	(\$2,206.26)
Shipping and Handling	\$1,985.63
*Pre-Tax Solution Total	\$21,841.97
Estimated Sales Tax	\$0.00
Estimated S&H Tax	\$0.00
Total Solution:	\$21,841.97

This Quote is governed by the Terms and Conditions at <https://greatminds.org/customer-quote-terms> which are hereby incorporated by reference as if fully set forth herein.

***Tax Exemption: If Customer is exempt from paying any or all taxes, customer shall provide written evidence of such tax exemption issued by the applicable taxing authority.**

**INTERLOCAL AGREEMENT
FOR
THE PURCHASE OF NATURAL GAS AND RELATED SERVICES**

This Interlocal Agreement for Natural Gas and Related Services (Agreement) is made and entered into by and between separate political subdivisions of the State of Nebraska.

The Interlocal Agency created through this Agreement will be referred to as Nebraska Choice Joint Utilities Management Program (CJUMP).

The Nebraska Association of School Boards (NASB) is a corporation formed by Nebraska public school boards to stimulate and contribute to the continuing improvement of public elementary and secondary education including increased efficiency and economy for the ultimate benefit of Nebraska citizens. NASB will perform the functions related to the necessary administrative and management services required by this Agreement.

Nebraska law permits two or more public agencies to enter into arrangements defined under Nebraska statutes as Interlocal Cooperatives.

Participant shall mean (a) a public school as defined in §79-101, (b) an educational service unit established under the Educational Service Units Act, Neb. Rev. Stat. § 79-1201 through § 79-1249, and (c) a technical community college established under § 85-1501 through § 85-1542.

Authority:

Participant has the authority to procure and is responsible to ensure adequate natural gas service for its facilities.

Participant has the authority to enter into any contracts to effectuate its responsibilities relating to procurement of natural gas and energy related services.

Participant desires to enter into this agreement to provide reliable, cost effective natural gas and energy related services for its facilities.

Participant contemplates on taking necessary and appropriate actions to support the objective of providing cost effective natural gas and energy related services for its facilities.

Article XV, Section 18 of the Constitution of the State of Nebraska and the Interlocal Cooperation Act of the State of Nebraska, Neb. Rev. Stat. § 13-801 et seq., (the "Act"), authorize any two or more public agencies to enter into agreements for joint or cooperative exercise of power, privilege or authority exercised or capable of exercise individually by such public agencies. Participants are public agencies within the meaning of the Act.

Purpose:

It is the purpose of this Agreement for participants to make the most efficient use of their powers by cooperating with each other in good faith on the basis of mutual advantage and timely providing services and facilities as identified in this Agreement and in any addendum to this Agreement that will accord best with the geographic, economic, population and other factors influencing the needs and development of local political bodies.

In furtherance of such objectives and purposes, (i) the Participants hereby create a joint entity under the Interlocal Cooperation Act to be known as "Nebraska Choice Joint Utilities Management Program" ("CJUMP"), being a separate public body corporate and politic of the State of Nebraska (the "Agency"), which shall be constituted and administered by a board of Trustees (the "Board of Trustees"); and (ii) the Participants hereby delegate to the Agency those powers as are hereinafter provided by this Agreement.

Participation:

Participant hereby agrees to participate in CJUMP under the terms of this Agreement and the Bylaws of CJUMP. Only those Participants who are members of the Nebraska Association of School Boards shall be eligible to participate in CJUMP. Final determination of membership into CJUMP must be approved by the CJUMP Board or a committee thereof.

Each Participant hereby agrees to participate with all other Participants to this Agreement through the Agency jointly to conduct the activities of the Agency.

Administration:

In order to carry out the purposes of CJUMP, CJUMP may exercise and enjoy all powers, privileges, and authority exercised and capable of exercise by an Interlocal created pursuant to the Act, including, but not limited to the power to issue bonds or other obligations on behalf of Participants as a body as a whole.

CJUMP shall be administered by a Board of Trustees consisting of two voting ex-officio members and 6 persons, who are elected officials or appointed officials of the member Participants. The members of the Board of Trustees, other than the ex-officio members, shall be elected by a vote of the Board of Directors of NASB. A person elected to the Board of Trustees shall serve for a three year term. A vacancy on the Board shall be filled by the vote of the Board of Directors of NASB. The person appointed to fill a vacancy shall serve for the remainder of the term of the vacating Trustee. Each board member shall be entitled to one vote in all matters that come before the board. No action of the Board of Trustees shall be taken unless 50% or more of the board members are present at the meeting. Unless provided otherwise in the Bylaws, upon a majority affirmative vote of the board members present, such action shall be effective immediately. The two ex-officio members to the board shall be the current President of NASB and the Executive Director of NASB or designee.

Initial nominations for members of the CJUMP Board shall be made by the Executive Director of NASB, who shall nominate at least one person for each of the elected positions and designate

nominations by the three staggered terms in office so as to allow three of the CJUMP Board members to be up for reelection each year. For subsequent elections, a CJUMP nominating committee comprised of: (1) the Chair of CJUMP, (2) the Executive Director of NASB, and (3) a person selected by the Board of Trustees will request nominations from the member participants and give its recommendation for Board of Trustees member nomination to the NASB Board of Directors for its approval.

The Board of Trustees shall be responsible for administering the cooperative undertakings of CJUMP.

The CJUMP Board may assign responsibilities for functions and services to appropriate parties and may designate a representative who shall be the primary contact point for Participants and other parties involved.

The CJUMP Board may retain the services of such legal counsel, auditors, consultants, marketers, program administrators, and other advisors as it deems necessary to carry out the business and purpose of the Interlocal.

The CJUMP Board shall adopt an annual budget providing for financing the costs of any joint or cooperative undertaking pursuant to this Agreement.

CJUMP shall be financed by monies collected from appointed CJUMP Program Administrator(s).

Any real and personal property may be acquired, held and disposed as set forth in this Agreement or any amendment hereto. CJUMP may lease, purchase or acquire by any means, from Participant or from any other source, such real and personal property as is required and necessary for effectuating the purposes of this Agreement. The title to all such property, personal or real, shall be held in the name of CJUMP. If a Participant should be required to purchase real or personal property at its facilities to best achieve the purposes of this Agreement, such real or personal property shall remain property of the Participant.

Participants may meet from time to time to discuss any matters pertinent to this Agreement or the functions of CJUMP and its board.

Term of Agreement and Service:

This Agreement shall become effective and binding upon its ratification by the governing board of each Participant.

The term of this Agreement is for three years from the date of the execution of this Agreement, provided that this Agreement shall be considered automatically renewed for successive three year terms unless all Participants and/or Board of Trustees gives notice as required herein that the Agreement shall not automatically renew.

A Participant may withdraw from this Agreement by providing written notice to CJUMP and to all other Participants at least 365 days prior to the end of the third year of this Agreement's initial term or any renewal term of this Agreement. Any termination from this Agreement is to be effective 12:01A.M. of the first day of the immediately succeeding contract term.

An action to dissolve CJUMP must be communicated to all Participants and give Participants at least 30 days notice prior to its effective date. It is understood that specific individual Participants (as defined in this Agreement) may change during the duration of CJUMP's existence.

Participant hereby delegates to CJUMP the duty to buy natural gas for Participant's total requirements for the term of this Agreement. Participant acknowledges that it will be required to execute any required forms of the Local Distribution Company's Choice Program to select a supplier for each year of the term of this Agreement.

Participants may be responsible for reaffirming their natural gas purchase participation on an annual basis in order to accommodate administrators and others involved in the procurement of products and services on behalf of CJUMP. Such reaffirmation shall include but not be limited to Delegation Forms and any other documents determined to be necessary by the natural gas supplier to the CJUMP participants.

The effective date on which natural gas service is to be procured through CJUMP shall be no later than the immediate succeeding June 1 after execution of this Agreement and the point in time thereafter in which a natural gas distribution switch with the Local Distribution Company can be made.

Participants shall not resell any Natural Gas Service procured by CJUMP under this Agreement, but Participant can require any tenant or occupant of a Participant's facility to reimburse the Participant for the use of natural gas in connection with such tenancy or occupancy.

In the event a Participant fails to perform its obligations pursuant to this Agreement, CJUMP shall give written notice to the individual Participant specifying such failure to perform and establish a reasonable period in which the Participant shall have to fulfill its obligations pursuant to this agreement. If the Participant's failure to perform its obligation is continuing, CJUMP may immediately terminate this agreement.

Any distribution of CJUMP funds, either partial or complete, shall be approved by the CJUMP Board of Trustees. Any collective distribution return to the Participants shall be allocated among such Participants in proportion to the annual usage of each Participant as compared to the total usage of the Interlocal Agency during the immediately preceding twelve month agreement period.

Upon termination of CJUMP's existence, any personal and real property as well as surplus funds shall be distributed among the existing Participants (as determined and recognized by the CJUMP Board of Trustees). Such distribution shall be allocated among such Participants in proportion to the annual usage of each Participant as compared to the total usage of the Interlocal Agency during the immediately preceding twelve month agreement period.

Termination of participation in this Agreement or termination of this Agreement by the Board of Trustees shall not impair, amend or change any previous contracts or agreements. Such contracts and agreements shall continue in full force, including all rates, terms, obligations and conditions, until the expiration of such contracts and agreements in accordance with their respective terms, or unless sooner released by the Board of Trustees.

Indemnification:

Each Participant shall indemnify and hold harmless the other parties and the Public Alliance for Community Energy and the Nebraska Municipal Power Pool and their respective board, officers, trustees, employees and agents, from any claims, expenses, (including attorneys' fees and litigation expenses), for any damages or losses it may suffer as a result of any claims made regarding the validity of this Agreement or the effect of this Agreement on the expenditure or revenue authority of a Participant, including but not limited to taxpayer or regulatory claims.

Assignment:

This Agreement shall be binding upon and inure to the benefit of the Participants and their successors or assigns; provided however, that this Agreement shall not be assigned or otherwise transferred to a third party without the prior written consent of the other Participants to the Agreement.

Notices:

All notices or other communications which are required or permitted herein shall be in writing and sufficiently delivered to each Participant.

Fiscal Year:

The Fiscal year shall end on May 31 of each year.

Place of Business:

The principal place of business for CJUMP shall be at the offices of the Nebraska Association of School Boards. The CJUMP Board may employ necessary staff and may purchase, lease, or rent real and personal property in order to carry out the business of CJUMP.

Governing Law:

This Agreement shall be governed by an interpreted in accordance with the statutory and decisional law of the State of Nebraska.

Entire Agreement:

This Agreement, including any associated exhibits and any amendments, constitutes the entire Agreement of the Parties with respect to the subject matter hereof. All prior agreements, representations of CJUMP, statements, and negotiations, written or oral, are hereby superseded. This Agreement may be amended only by a writing executed by all Participants.

IN WITNESS WHEREOF, each of the Participants has caused this Interlocal Agreement for Natural Gas and Related Services to be executed by its duly authorized officer as of the day and year shown below.

PARTICIPANT: Elm Creek Public Schools

Date: March 10, 2025

By: Kim Beran

Title: Superintendent

Attest:

SEAL

**RESOLUTION FOR PARTICIPATION IN CJUMP
INTERLOCAL AGREEMENT**

WHEREAS, Participant has reviewed the attached Interlocal Agreement and desires to participate in the Nebraska Choice Joint Utilities Management Program (otherwise referred to as CJUMP) as authorized by the Interlocal Cooperation Act, Neb. Rev. Stat. §13-801 and

WHEREAS, Participant is allowed to participate in said cooperative undertakings; and

NOW THEREFORE, BE IT RESOLVED that the governing board hereby:

Declares the board will participate in CJUMP and hereby accepts the Participation Agreement which is attached to this Resolution.

After motion duly made by _____ and seconded by _____, the following members voted by roll call vote in favor of passage and adoption of the said Resolution:

The following members voted against the same:

The following members voted absent or not voting:

PASSED AND APPROVED this 10th day of March, 2025.

Participant Name (*School, ESU or Community College*) Elm Creek Public Schools

Signature from an Official of the Participant _____

Please print name and title: Lynette Mitchell, Elm Creek Schools board of education President