

WAYZATA PUBLIC SCHOOLS

Independent School District 284
Wayzata, Minnesota

BOARD OF EDUCATION

Special Work Session Meeting - June 3, 2013 - 4:00 PM
District Administration Building, 210 County Rd. 101 N., Plymouth, MN

AGENDA

- | | |
|---|----|
| 1. Call to Order - Board Chair Droegemueller | 3 |
| 2. Implications of Statewide Funded All Day Kindergarten Starting in 2014-2015 - J. Westrum | 4 |
| 3. Review and Discussion of Phase III Projects - J. Westrum | 35 |
| 4. Adjourn - Board Chair Droegemueller | 57 |

WAYZATA PUBLIC SCHOOLS
Independent School District 284
Wayzata, Minnesota

MISSION

Our Core Purpose;

The Mission of Wayzata Public Schools is to ensure a world-class education that prepares each and every student to thrive today and excel tomorrow in an ever-changing global society.

VISION

What We Intend to Create and Experience;

The Vision of Wayzata Public Schools is to be a model of excellence where all students discover their unique talents, develop a love and tenacity for learning and demonstrate confidence and capacity for success through:

Exceptional Student Learning, Experiences and Relationships:

- High achievement by each and every student – no exceptions, no excuses;
- Content-rich, rigorous and personalized education;
- Meaningful relationships with teachers, staff, mentors and peers in a welcoming, nurturing and safe environment.

Community Trust, Confidence and Partnership:

- Comprehensive learning opportunities meeting diverse learner needs and community aspirations;
- Committed to being the first choice for students and families;
- Maintaining the highest levels of satisfaction and pride by staff, parents and community.

Operational Excellence:

- Attraction, development and retention of exemplary, creative and valued employees;
- Effective and efficient use of time and human, financial and physical resources;
- Culture of continuous improvement and responsive innovation;
- High performing district governance, management and partnerships.

WAYZATA PUBLIC SCHOOLS
Independent School District 284
Wayzata, Minnesota

BOARD OF EDUCATION

Special Work Session – June 3, 2013

AGENDA ITEM: 1. CALL TO ORDER/ROLL CALL

COMMENTS BY: Board Chair Droegemueller

	<u>PRESENT</u>	<u>ABSENT</u>
Ms. Linda A. Cohen	_____	_____
Ms. Susan J. Droegemueller	_____	_____
Ms. Susan Gaither	_____	_____
Mr. Jay A. Hesby	_____	_____
Mr. John A. Moroz	_____	_____
Ms. Carter G. Peterson	_____	_____
Ms. Cheryl Polzin	_____	_____
Dr. Chace B. Anderson, Ex Officio	_____	_____



Jim Westrum, Executive Director of Finance & Business Services
 210 County Road 101 North, P.O. Box 660 | Wayzata, MN 55391-0660
 763.745.5023 | Fax: 763.745.5091 | www.wayzata.k12.mn.us

To: Dr. Chace Anderson
From: Jim Westrum
Date: May 27, 2013
Re: Enrollment and Facilities Implications of Legislature Funding All Day Kindergarten in 2014-2015

The enrollment and facilities implications of the legislature funding all-day kindergarten programs beginning in fiscal year 2014-2015 are addressed in this memo. We have been in consultation with Hazel Reinhardt, the District’s Welcome Center, and Wold architects, and have quantified the impact on the District’s enrollment and elementary classroom facility needs as follows:

Current Assumption	Revised Assumption	Student Impact	Facility Impact
Families that seek private options for K, but join district in 1 st grade	Families that will no longer seek private options for K and instead join District in K	Additional 100 students in Kindergarten only	5 additional Kindergarten classrooms needed in Fall 2014
Families that seek public options for All Day K through open enrollment, and DO NOT join district in 1 st grade	Families will no longer need to open enroll outside the District, but instead will join district in Kindergarten and remain throughout academic career	Additional 20 students in Kindergarten with an additive affect as this population progresses through grades 1-12	1 additional K classroom in Fall 2014, 1 additional 1 st grade classroom in 2015, 1 additional 2 nd grade classroom 2016, 1 additional 3 rd grade classroom in 2017, etc...
Families seek non-public or private school Kindergarten	Families continue to seek non-public or private school for K	No impact	No impact
50% of families receive District’s fee-based All-Day K, remaining families receive ½ day K (demand exceeds ability to offer)	100% of current families receive District provided All Day K as fees are no longer charged to families	No increase in K students as students are already served by the District	10 additional classrooms (converts 20 ½ day to 20 full day)
Total additional classrooms needed in 2014-2015 - 16 additional classrooms, plus one additional classroom needed for each of the next 5 years – Grand total of 21 classrooms			

The chart below shows elementary enrollment as currently offered and also with offering all-day kindergarten:

Chart 1

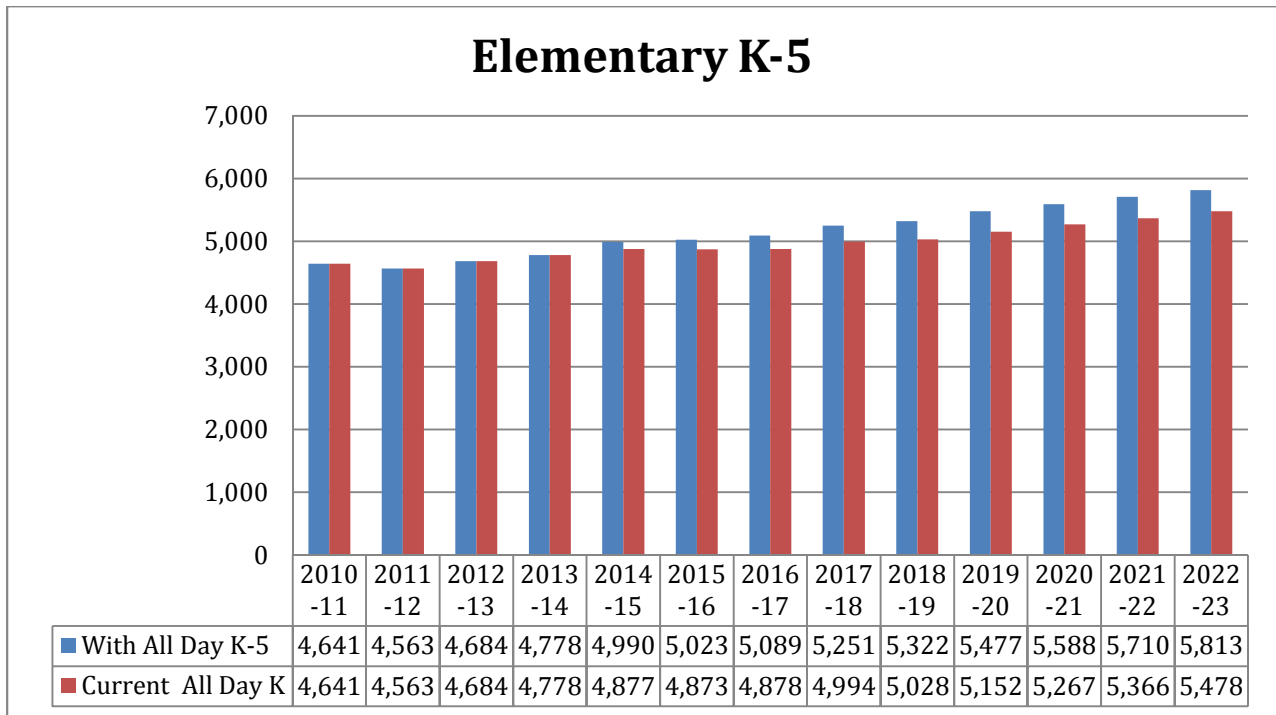

Elementary capacity after the classroom additions of 2013 is expected to be 4,978. The District anticipated that capacity in the elementary buildings would be adequate through 2017-18 when the projected enrollment reached 4,994. However, the impact of offering all-day kindergarten significantly accelerates the timeline to an immediate need in the fall of 2014-15, when projected enrollment reaches 4,990.

In summary, the impact of the legislature offering all-day kindergarten and providing state aid for the additional costs means that the Wayzata Public Schools may no longer be able to serve its student population in the existing seven elementary schools. While the recent classroom additions would have been able to relieve current and anticipated elementary resident student enrollment growth for the next several year, it would appear that the District will need to give careful consideration to the need to add an 8th elementary school.

Wayzata schools
33880917.xlsx Students Served 3-1-2013

Year	Actual 2010-11	Actual 2011-12	10/1/2012 2012-13	Projected 2013-14	Projected 2014-15	Projected 2015-16	Projected 2016-17	Projected 2017-18	Projected 2018-19	Projected 2019-20	Projected 2020-21	Projected 2021-22	Projected 2022-23
Kdgn	743	620	704	667	795	795	817	814	827	861	900	905	910
Grade 1	791	816	715	799	759	831	831	854	851	865	900	941	946
Grade 2	760	835	827	745	835	793	869	869	893	890	904	941	984
Grade 3	738	764	863	860	774	870	827	906	906	931	928	943	982
Grade 4	805	772	785	904	900	810	914	869	952	952	978	975	990
Grade 5	804	756	790	804	927	923	830	938	892	978	978	1,005	1,001
Grade 6	812	856	861	834	846	979	974	876	993	945	1,036	1,036	1,065
Grade 7	807	836	879	892	864	875	1,014	1,008	907	1,030	981	1,075	1,075
Grade 8	795	808	859	896	909	881	891	1,034	1,028	925	1,052	1,001	1,097
Grade 9	802	809	815	879	917	931	901	911	1,058	1,052	946	1,077	1,026
Grade 10	821	797	822	816	880	918	932	903	913	1,060	1,054	948	1,080
Grade 11	777	820	781	820	814	878	916	930	900	910	1,057	1,051	945
Grade 12	789	725	797	758	796	790	851	887	900	872	883	1,024	1,018
Total	10,244	10,214	10,498	10,673	11,016	11,274	11,568	11,800	12,022	12,271	12,597	12,922	13,119
<i>No All Day K</i>	<i>10,244</i>	<i>10,214</i>	<i>10,498</i>	<i>10,673</i>	<i>10,903</i>	<i>11,124</i>	<i>11,357</i>	<i>11,543</i>	<i>11,727</i>	<i>11,947</i>	<i>12,206</i>	<i>12,464</i>	<i>12,592</i>
Student Change		-30	284	175	343	258	294	232	222	250	326	325	197
Percent Change		-0.29%	2.78%	1.66%	3.21%	2.34%	2.61%	2.01%	1.88%	2.08%	2.65%	2.58%	1.53%
With All Day K-	4,641	4,563	4,684	4,778	4,990	5,023	5,089	5,251	5,322	5,477	5,588	5,710	5,813
<i>Current All Day K</i>	<i>4,641</i>	<i>4,563</i>	<i>4,684</i>	<i>4,778</i>	<i>4,877</i>	<i>4,873</i>	<i>4,878</i>	<i>4,994</i>	<i>5,028</i>	<i>5,152</i>	<i>5,267</i>	<i>5,366</i>	<i>5,478</i>
6-8	2,414	2,500	2,599	2,622	2,619	2,734	2,879	2,918	2,928	2,900	3,068	3,112	3,237
<i>No All Day K</i>	<i>2,414</i>	<i>2,500</i>	<i>2,599</i>	<i>2,622</i>	<i>2,619</i>	<i>2,734</i>	<i>2,879</i>	<i>2,918</i>	<i>2,928</i>	<i>2,900</i>	<i>2,999</i>	<i>2,998</i>	<i>3,045</i>
9-12	3,189	3,151	3,215	3,273	3,407	3,517	3,600	3,631	3,771	3,895	3,940	4,100	4,069
<i>No All Day K</i>	<i>3,189</i>	<i>3,151</i>	<i>3,215</i>	<i>3,273</i>	<i>3,407</i>	<i>3,517</i>	<i>3,600</i>	<i>3,631</i>	<i>3,771</i>	<i>3,895</i>	<i>3,940</i>	<i>4,100</i>	<i>4,069</i>

9

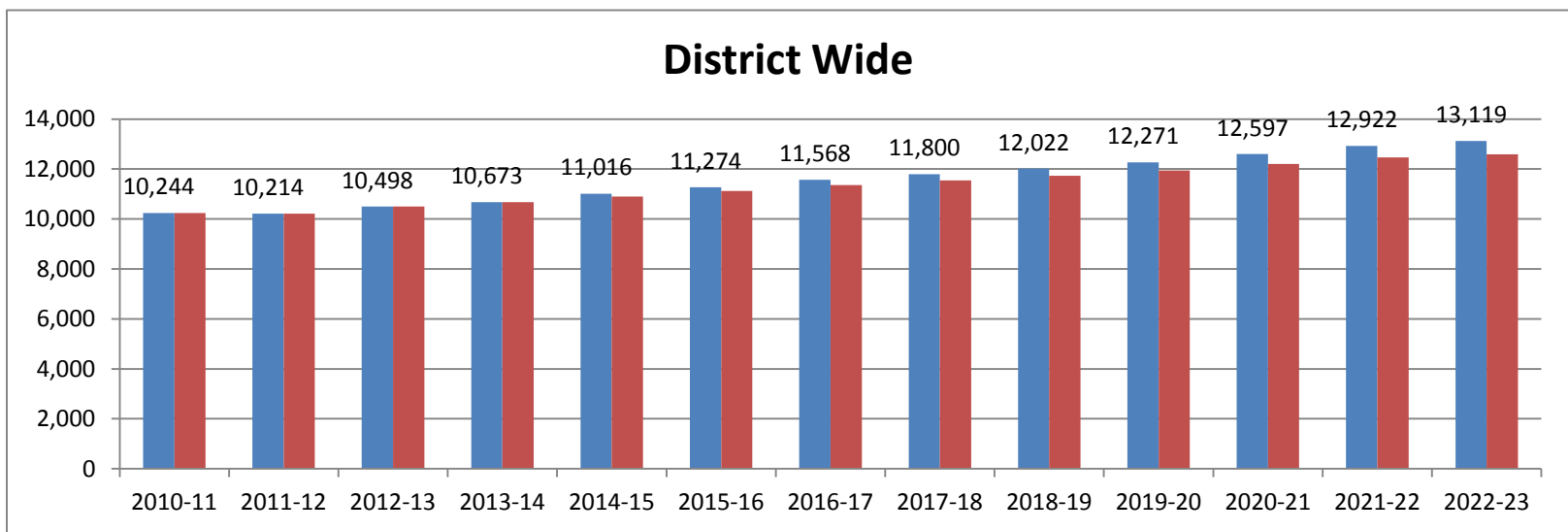

High School 9-12

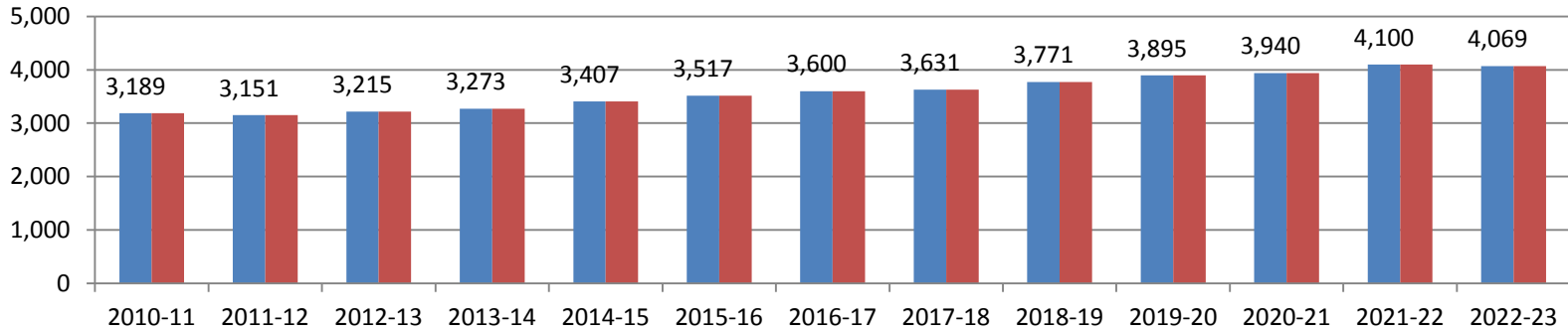

Middle Schools 6-8

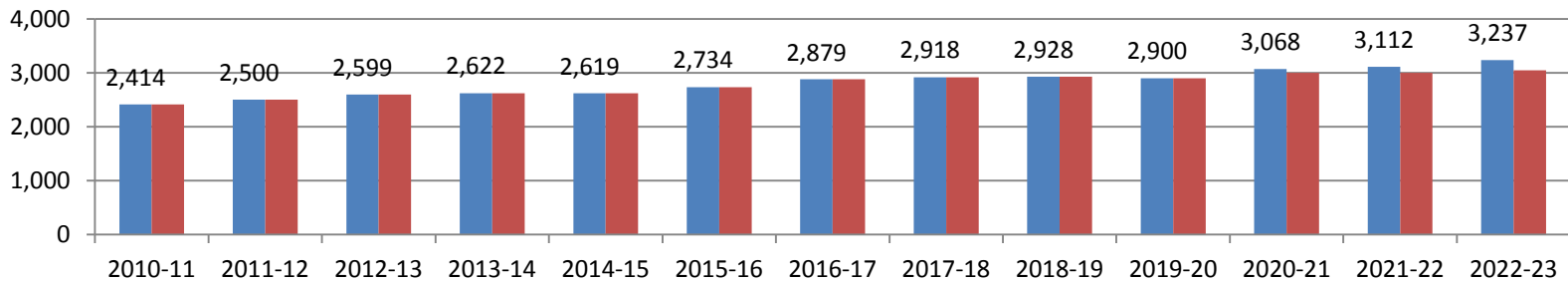

Elementary K-5

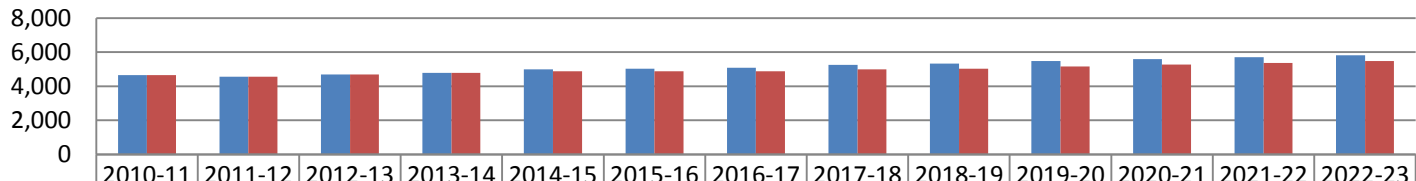

	2010-11	2011-12	2012-13	2013-14	2014-15	2015-16	2016-17	2017-18	2018-19	2019-20	2020-21	2021-22	2022-23
With All Day K-5	4,641	4,563	4,684	4,778	4,990	5,023	5,089	5,251	5,322	5,477	5,588	5,710	5,813
Current All Day K	4,641	4,563	4,684	4,778	4,877	4,873	4,878	4,994	5,028	5,152	5,267	5,366	5,478

Wayzata Resident Suburban K/High Mig
K (+Hdcp)

	1st	2nd	3rd	4th	5th	6th	7th	8th	9th	10th	11th	12th	K-5	6-8	9-12	K-12 total	
2010-11 Actual	743	791	760	738	805	804	812	807	795	802	821	777	789	4641	2414	3189	10244
10-11 Cohort	0	0	0	0	0	0	0	0	0	0	0	0	0	0	0	0	0
2011-12 Actual	620	816	835	764	772	756	856	836	808	809	797	820	725	4563	2500	3151	10214
	*	*	*	*	*	*	*	*	*	*	*	*	*				
11-12 Cohort	0	0	0	0	0	0	0	0	0	0	0	0	0	0	0	0	0
2012-13 10-1-12	704	715	827	863	785	790	861	879	859	815	822	781	797	4684	2599	3215	10498
12-13 Cohort	667	704	715	827	863	785	790	861	879	859	815	822	781	4561	2530	3277	10368
13-14 Proj	667	799	745	860	904	804	834	892	896	879	816	820	758	4778	2622	3273	10673
13-14 Cohort	758	667	799	745	860	904	804	834	892	896	879	816	820	4733	2529	3411	10673
14-15 Proj	795	759	835	774	900	927	846	864	909	917	880	814	796	4990	2619	3407	11016
14-15 Cohort	795	795	759	835	774	900	927	846	864	909	917	880	814	4858	2637	3520	11015
15-16 Proj	795	831	793	870	810	923	979	875	881	931	918	878	790	5023	2734	3517	11274
15-16 Cohort	817	795	831	793	870	810	923	979	875	881	931	918	878	4917	2776	3607	11301
16-17 Proj	817	831	869	827	914	830	974	1014	891	901	932	916	851	5089	2879	3600	11568
16-17 Cohort	814	817	831	869	827	914	830	974	1014	891	901	932	916	5072	2818	3641	11531
17-18 Proj	814	854	869	906	869	938	876	1008	1034	911	903	930	887	5251	2918	3631	11800
17-18 Cohort	827	814	854	869	906	869	938	876	1008	1034	911	903	930	5140	2823	3777	11740
18-19 Proj	827	851	893	906	952	892	993	907	1028	1058	913	900	900	5322	2928	3771	12022
18-19 Cohort	861	827	851	893	906	952	892	993	907	1028	1058	913	900	5291	2792	3899	11982
19-20 Proj	861	865	890	931	952	978	945	1030	925	1052	1060	910	872	5477	2900	3895	12271
19-20 Cohort	900	861	865	890	931	952	978	945	1030	925	1052	1060	910	5399	2953	3947	12300
20-21 Proj	900	900	904	928	978	978	1036	981	1052	946	1054	1057	883	5588	3068	3940	12597
20-21 Cohort	905	900	900	904	928	978	978	1036	981	1052	946	1054	1057	5516	2994	4109	12619
21-22 Proj	905	941	941	943	975	1005	1036	1075	1001	1077	948	1051	1024	5710	3112	4100	12922
20-21 Cohort	910	905	941	941	943	975	1005	1036	1075	1001	1077	948	1051	5615	3116	4078	12809
21-22 Proj	910	946	984	982	990	1001	1065	1075	1097	1026	1080	945	1018	5813	3237	4069	13119

10673	0
10673	0
11016	0
11015	0
11274	0
11301	0
11568	0
11531	0
11800	0
11740	0
12022	0
11982	0
12271	0
12300	0
12597	0
12619	0
12922	0
12809	0
13119	0

Wayzata Resident District K/High Mig K (+Hdcp)	1st	2nd	3rd	4th	5th	6th	7th	8th	9th	10th	11th	12th	K-5	6-8	9-12	K-12 total	
2010-11 Actual	663	723	648	668	736	723	726	705	701	709	730	708	719	4161	2132	2866	9159
11-12 ACTUAL	551	741	772	661	707	756	781	754	710	706	708	727	651	4188	2245	2792	9225
									*	*	*	*					
11-12 Cohort Historical																	
12-13 10-1-12	686	649	760	803	691	734	806	812	780	724	721	691	695	4323	2398	2831	9552
12-13 Cohort Historical	660	686	649	760	803	691	734	806	812	780	724	721	691	4249	2352	2916	9517
13-14 Proj	660	781	679	793	844	710	778	837	829	800	725	719	668	4466	2444	2912	9822
13-14 Cohort Historical	751	660	781	679	793	844	710	778	837	829	800	725	719	4508	2324	3073	9905
14-15 Proj	788	752	817	708	833	867	752	808	854	850	801	723	695	4765	2414	3069	10248
14-15 Cohort Historical	788	788	752	817	708	833	867	752	808	854	850	801	723	4686	2427	3228	10341
15-16 Proj	788	824	786	852	744	856	919	781	825	876	851	799	699	4851	2524	3225	10600
15-16 Cohort Historical	810	788	824	786	852	744	856	919	781	825	876	851	799	4805	2555	3350	10711
16-17 Proj	810	824	862	820	896	764	907	954	797	845	877	849	772	4977	2658	3343	10978
16-17 Cohort Historical	807	810	824	862	820	896	764	907	954	797	845	877	849	5019	2625	3369	11013
17-18 Proj	807	847	862	899	862	920	810	941	974	817	847	875	820	5198	2725	3359	11282
17-18 Cohort Historical	820	807	847	862	899	862	920	810	941	974	817	847	875	5098	2672	3512	11282
18-19 Proj	820	844	886	899	945	885	975	841	961	998	819	844	845	5280	2777	3506	11564
18-19 Cohort Historical	854	820	844	886	899	945	885	975	841	961	998	819	844	5249	2701	3622	11572
19-20 Proj	854	858	883	924	945	971	938	1012	859	985	1000	816	816	5435	2809	3618	11861
19-20 Cohort Historical	893	854	858	883	924	945	971	938	1012	859	985	1000	816	5357	2921	3660	11939
20-21 Proj	893	893	897	921	971	1029	974	1034	880	987	997	789	5546	3036	3653	12236	
20-21 Cohort Historical	898	893	893	897	921	971	971	1029	974	1034	987	997	5474	2973	3898	12345	
21-22 Proj	898	934	934	936	968	998	1029	1068	994	1059	882	984	964	5668	3091	3889	12648
21-22 Cohort Historical	903	898	934	934	936	968	998	1029	1068	994	1059	882	984	5573	3095	3920	12588
22-23	903	939	977	975	983	994	1058	1068	1090	1019	1062	879	951	5771	3216	3911	12898

12-13 Cohort	660	686	
Historical		1.139	
13-14 Proj	660	781.354	
13-14 Cohort	675	660	
Historical		1.139	
14-15 Proj	675	751.74	first graders back to k +20
14-15 Cohort	694	675	
Historical		1.139	
15-16 Proj	694	768.825	55
15-16 Cohort	691	694	
Historical		1.139	
16-17 Proj	691	790.466	34
16-17 Cohort	703	691	
Historical		1.139	
17-18 Proj	703	787.049	60
17-18 Cohort	733	703	
Historical		1.139	
18-19 Proj	733	800.717	43
18-19 Cohort	767	733	
Historical		1.139	
19-20 Proj	767	834.887	23
19-20 Cohort	771	767	
Historical		1.139	
20-21 Proj	771	873.613	20
20-21 Cohort	776	771	
Historical		1.139	
21-22 Proj	776	878.169	56
21-22 Cohort	780	776	
Historical		1.139	
22-23	780	883.864	55

Wayzata Resident Suburban K/High Mig
K (+Hdcp)

	1st	2nd	3rd	4th	5th	6th	7th	8th	9th	10th	11th	12th	K-5	6-8	9-12	K-12 total	
2010-11 Actual	80	68	112	70	69	81	86	102	94	93	91	69	70	480	282	323	1085

10-11 Cohort

Historical

11-12 ACTUAL	69	75	63	103	65	0	75	82	98	103	89	93	74	375	255	359	989
---------------------	----	----	----	-----	----	---	----	----	----	-----	----	----	----	-----	-----	-----	-----

Note: Actual open enrollment ADM's were updated from MDE MARSS ADM REPORT

11-12 Cohort

Historical

12-13 ACTUAL	18	66	67	60	94	56	55	67	79	91	101	90	102	361	201	384	946
---------------------	----	----	----	----	----	----	----	----	----	----	-----	----	-----	-----	-----	-----	-----

12-13 Cohort

Historical

	7	18	66	67	60	94	56	55	67	79	91	101	90	312	178	361	851
--	---	----	----	----	----	----	----	----	----	----	----	-----	----	-----	-----	-----	-----

13-14 Proj

	7	18	66	67	60	94	56	55	67	79	91	101	90	0	0	0	0
--	---	----	----	----	----	----	----	----	----	----	----	-----	----	---	---	---	---

13-14 Cohort

Historical

	7	7	18	66	67	60	94	56	55	67	79	91	101	225	205	338	768
--	---	---	----	----	----	----	----	----	----	----	----	----	-----	-----	-----	-----	-----

14-15 Proj

	7	7	18	66	67	60	94	56	55	67	79	91	101	0	0	0	0
--	---	---	----	----	----	----	----	----	----	----	----	----	-----	---	---	---	---

14-15 Cohort

Historical

	7	7	7	18	66	67	60	94	56	55	67	79	91	172	210	292	674
--	---	---	---	----	----	----	----	----	----	----	----	----	----	-----	-----	-----	-----

15-16 Proj

	7	7	7	18	66	67	60	94	56	55	67	79	91	0	0	0	0
--	---	---	---	----	----	----	----	----	----	----	----	----	----	---	---	---	---

15-16 Cohort

Historical

	7	7	7	7	18	66	67	60	94	56	55	67	79	112	221	257	590
--	---	---	---	---	----	----	----	----	----	----	----	----	----	-----	-----	-----	-----

16-17 Proj

	7	7	7	7	18	66	67	60	94	56	55	67	79	0	0	0	0
--	---	---	---	---	----	----	----	----	----	----	----	----	----	---	---	---	---

16-17 Cohort

Historical

	7	7	7	7	7	18	66	67	60	94	56	55	67	53	193	272	518
--	---	---	---	---	---	----	----	----	----	----	----	----	----	----	-----	-----	-----

17-18 Proj

	7	7	7	7	7	18	66	67	60	94	56	55	67	0	0	0	0
--	---	---	---	---	---	----	----	----	----	----	----	----	----	---	---	---	---

17-18 Cohort

Historical

	7	7	7	7	7	7	18	66	67	60	94	56	55	42	151	265	458
--	---	---	---	---	---	---	----	----	----	----	----	----	----	----	-----	-----	-----

18-19 Proj

	7	7	7	7	7	7	18	66	67	60	94	56	55	0	0	0	0
--	---	---	---	---	---	---	----	----	----	----	----	----	----	---	---	---	---

18-19 Cohort

Historical

	7	7	7	7	7	7	18	66	67	60	94	56	55	42	91	277	410
--	---	---	---	---	---	---	----	----	----	----	----	----	----	----	----	-----	-----

19-20 Proj

	7	7	7	7	7	7	18	66	67	60	94	56	55	0	0	0	0
--	---	---	---	---	---	---	----	----	----	----	----	----	----	---	---	---	---

19-20 Cohort

Historical

	7	7	7	7	7	7	7	18	66	67	60	94	94	42	32	287	361
--	---	---	---	---	---	---	---	----	----	----	----	----	----	----	----	-----	-----

20-21 Proj

	7	7	7	7	7	7	7	18	66	67	60	94	94	0	0	0	0
--	---	---	---	---	---	---	---	----	----	----	----	----	----	---	---	---	---

20-21 Cohort

Historical

	7	7	7	7	7	7	7	7	7	18	66	67	60	42	21	211	274
--	---	---	---	---	---	---	---	---	---	----	----	----	----	----	----	-----	-----

21-22 Proj

	7	7	7	7	7	7	7	7	7	18	66	67	60	0	0	0	0
--	---	---	---	---	---	---	---	---	---	----	----	----	----	---	---	---	---

21-22 Cohort

Historical

	7	7	7	7	7	7	7	7	7	18	66	67	67	42	21	158	221
--	---	---	---	---	---	---	---	---	---	----	----	----	----	----	----	-----	-----

22-23 Proj

	7	7	7	7	7	7	7	7	7	18	66	67	67	0	0	0	0
--	---	---	---	---	---	---	---	---	---	----	----	----	----	---	---	---	---

22-23 Cohort

Historical

	7	7	7	7	7	7	7	7	7	18	66	67	67	42	21	158	221
--	---	---	---	---	---	---	---	---	---	----	----	----	----	----	----	-----	-----

Wayzata schools
33880917.xlsx Students Served

Year	Actual 2010-11	Actual 2011-12	10/1/2012 2012-13	Projected 2013-14	Projected 2014-15	Projected 2015-16	Projected 2016-17	Projected 2017-18	Projected 2018-19	Projected 2019-20	Projected 2020-21
Kdgn	743	620	704	677	677	677	677	677	677	677	677
Grade 1	791	816	715	793	764	764	764	764	764	764	764
Grade 2	760	835	827	747	832	802	802	802	802	802	802
Grade 3	738	764	863	865	782	873	842	842	842	842	842
Grade 4	805	772	785	879	881	796	890	858	858	858	858
Grade 5	804	756	790	799	895	897	810	907	875	875	875
Grade 6	812	856	861	819	827	929	930	840	943	910	910
Grade 7	807	836	879	893	850	856	964	965	871	980	946
Grade 8	795	808	859	887	902	858	864	973	974	879	989
Grade 9	802	809	815	890	920	935	890	895	1,009	1,010	912
Grade 10	821	797	822	801	874	903	918	873	879	990	991
Grade 11	777	820	781	808	786	858	886	901	857	863	972
Grade 12	789	725	797	753	779	759	827	853	867	825	832
Total	10,244	10,214	10,498	10,612	10,769	10,907	11,064	11,150	11,218	11,276	11,371
<i>From 8-2011</i>	<i>10,304</i>	<i>10,422</i>	<i>10,496</i>	<i>10,561</i>	<i>10,669</i>	<i>10,777</i>	<i>10,881</i>	<i>10,939</i>	<i>10,967</i>	<i>10,997</i>	<i>11,060</i>
Student Change		-30	284	114	157	138	157	86	68	58	95
Percent Change		-0.29%	2.78%	1.08%	1.48%	1.28%	1.44%	0.78%	0.61%	0.52%	0.85%
K-5	4,641	4,563	4,684	4,761	4,831	4,809	4,785	4,850	4,819	4,819	4,819
<i>8-2011</i>	<i>4,641</i>	<i>4,647</i>	<i>4,653</i>	<i>4,702</i>	<i>4,746</i>	<i>4,682</i>	<i>4,593</i>	<i>4,625</i>	<i>4,625</i>	<i>4,625</i>	<i>4,625</i>
6-8	2,414	2,500	2,599	2,600	2,579	2,643	2,758	2,778	2,788	2,769	2,846
<i>8-2011</i>	<i>2,416</i>	<i>2,503</i>	<i>2,586</i>	<i>2,587</i>	<i>2,555</i>	<i>2,635</i>	<i>2,788</i>	<i>2,814</i>	<i>2,748</i>	<i>2,658</i>	<i>2,698</i>
9-12	3,189	3,151	3,215	3,252	3,360	3,455	3,521	3,522	3,612	3,688	3,707
<i>8-2011</i>	<i>3,247</i>	<i>3,272</i>	<i>3,258</i>	<i>3,271</i>	<i>3,369</i>	<i>3,459</i>	<i>3,500</i>	<i>3,500</i>	<i>3,594</i>	<i>3,715</i>	<i>3,736</i>

21

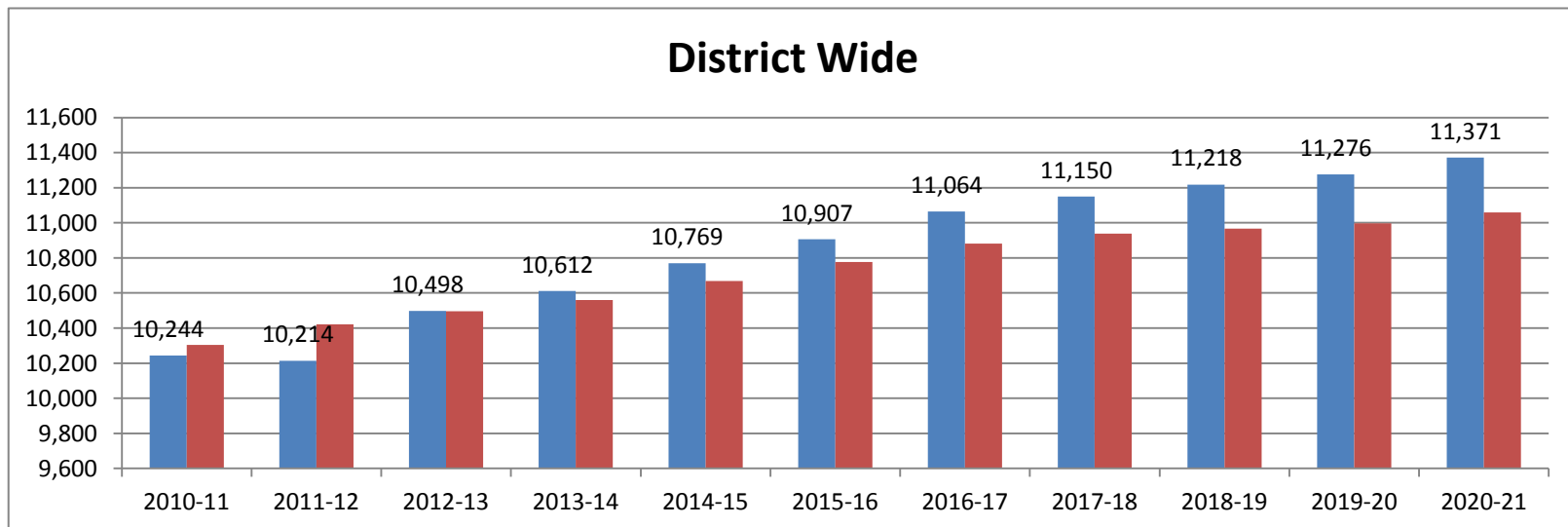

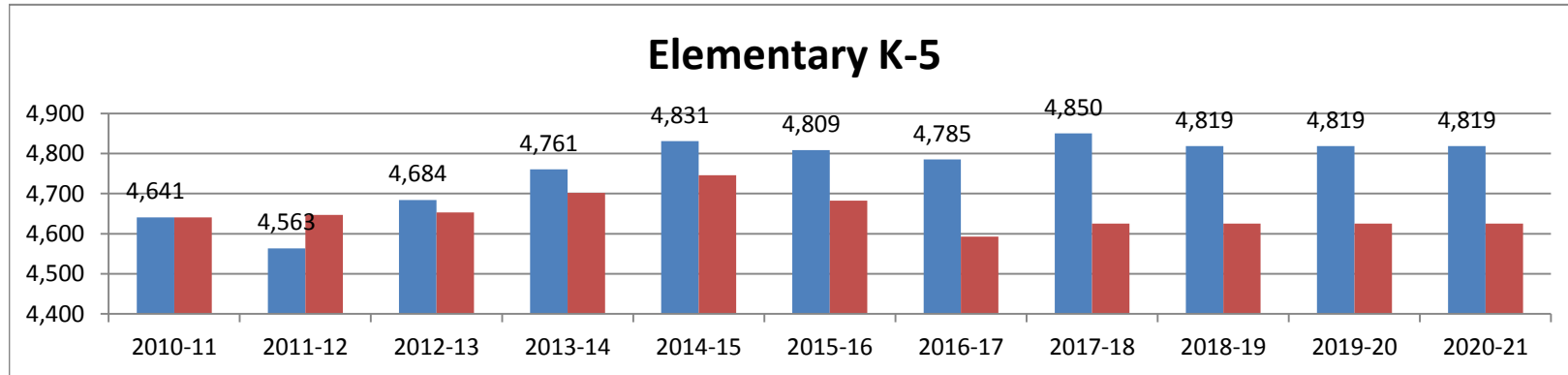
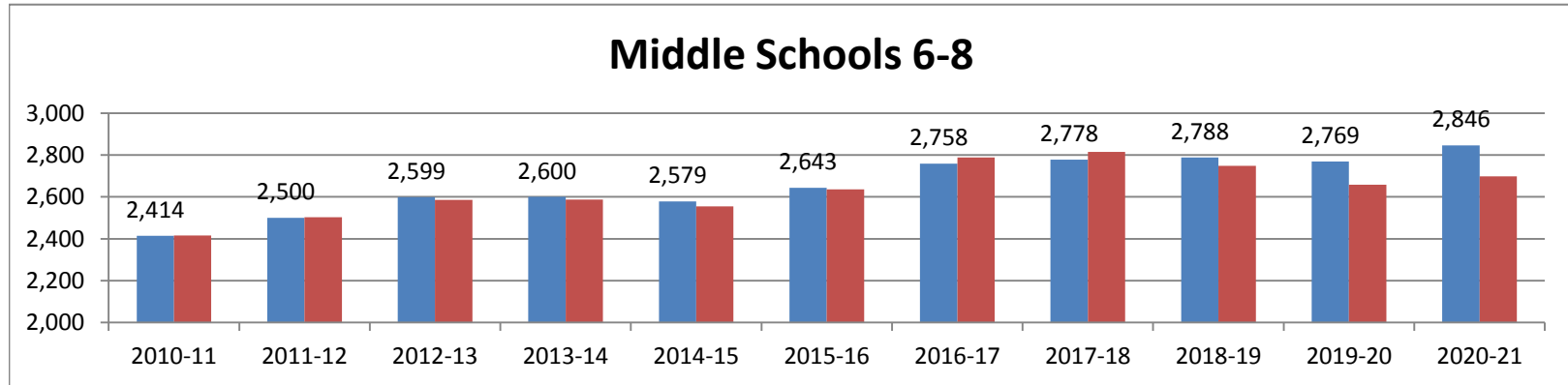
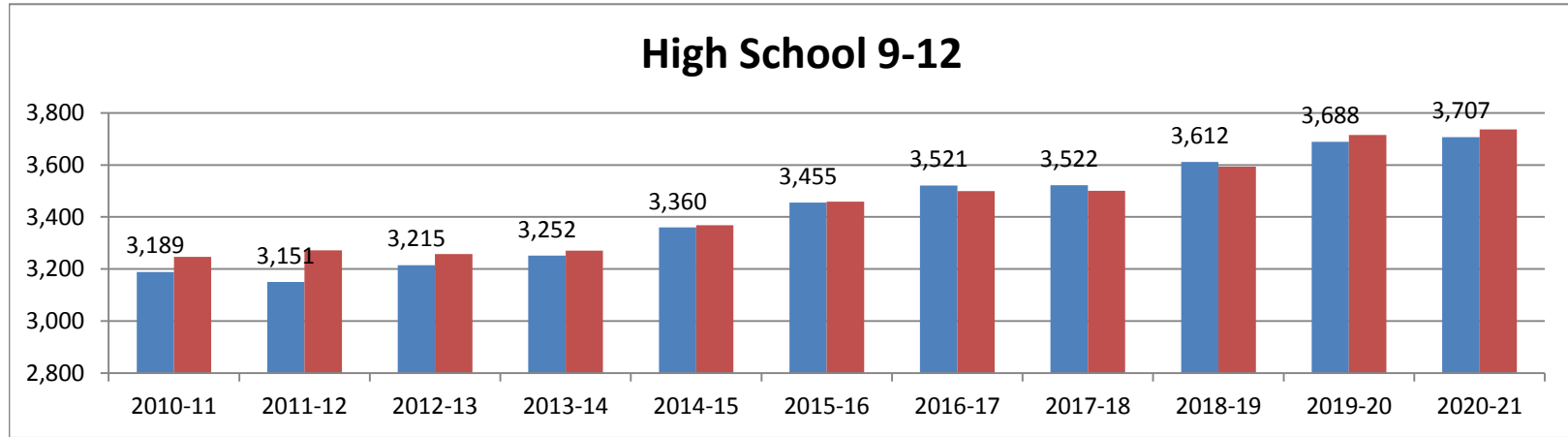

Wayzata Resident Suburban K/High Mig K (+Hdcp)	1st	2nd	3rd	4th	5th	6th	7th	8th	9th	10th	11th	12th	K-5	6-8	9-12	K-12 total	
2010-11 Actual	743	791	760	738	805	804	812	807	795	802	821	777	789	4641	2414	3189	10244
10-11 Cohort	0	0	0	0	0	0	0	0	0	0	0	0	0	0	0	0	0
2011-12 Actual	620	816	835	764	772	756	856	836	808	809	797	820	725	4563	2500	3151	10214
11-12 Cohort	0	0	0	0	0	0	0	0	0	0	0	0	0	0	0	0	0
2012-13 10-1-12	704	715	827	863	785	790	861	879	859	815	822	781	797	4684	2599	3215	10498
12-13 Cohort	677	704	715	827	863	785	790	861	879	859	815	822	781	4571	2530	3277	10378
13-14 Proj	677	793	747	865	879	799	819	893	887	890	801	808	753	4761	2600	3252	10612
13-14 Cohort	677	677	793	747	865	879	799	819	893	887	890	801	808	4639	2511	3385	10536
14-15 Proj	677	764	832	782	881	895	827	850	902	920	874	786	779	4831	2579	3360	10769
14-15 Cohort	677	677	764	832	782	881	895	827	850	902	874	786	786	4613	2572	3482	10667
15-16 Proj	677	764	802	873	796	897	929	856	858	935	903	858	759	4809	2643	3455	10907
15-16 Cohort	677	677	764	802	873	796	897	929	856	858	935	903	858	4589	2682	3554	10825
16-17 Proj	677	764	802	842	890	810	930	964	864	890	918	886	827	4785	2758	3521	11064
16-17 Cohort	677	677	764	802	842	890	810	930	964	864	890	918	886	4651	2704	3558	10914
17-18 Proj	677	764	802	842	858	907	840	965	973	895	873	901	853	4850	2778	3522	11150
17-18 Cohort	677	677	764	802	842	858	907	840	965	973	895	873	901	4620	2712	3641	10974
18-19 Proj	677	764	802	842	858	875	943	871	974	1009	879	857	867	4819	2788	3612	11218
18-19 Cohort	677	677	764	802	842	858	875	943	871	974	1009	879	857	4620	2689	3719	11028
19-20 Proj	677	764	802	842	858	875	910	980	879	1010	990	863	825	4819	2769	3688	11276
19-20 Cohort	677	677	764	802	842	858	875	910	980	879	1010	990	863	4620	2765	3743	11128
20-21 Proj	677	764	802	842	858	875	910	946	989	912	991	972	832	4819	2846	3707	11371

* These numbers were updated with actuals as of 12-1-2011

Wayzata Resident District K/High Mig K (+Hdcp)	1st	2nd	3rd	4th	5th	6th	7th	8th	9th	10th	11th	12th	K-5	6-8	9-12	K-12 total	
2010-11 Actual	663	723	648	668	736	723	726	705	701	709	730	708	719	4161	2132	2866	9159
11-12 ACTUAL	551	741	772	661	707	756	781	754	710	706	708	727	651	4188	2245	2792	9225
									*	*	*	*					
11-12 Cohort Historical																	
12-13 10-1-12	686	649	760	803	691	734	806	812	780	724	721	691	695	4323	2398	2831	9552
12-13 Cohort Historical	670	686	649	760	803	691	734	806	812	780	724	721	691	4259	2352	2916	9527
13-14 Proj	670	775	681	798	819	705	763	838	820	811	710	707	663	4449	2422	2891	9761
13-14 Cohort Historical	670	670	775	681	798	819	705	763	838	820	811	710	707	4414	2306	3047	9768
14-15 Proj	670	757	814	716	814	835	733	794	847	853	795	695	678	4606	2374	3022	10001
14-15 Cohort Historical	670	670	757	814	716	814	835	733	794	847	853	795	695	4441	2362	3190	9993
15-16 Proj	670	757	795	855	730	830	869	762	802	880	836	779	668	4637	2433	3163	10233
15-16 Cohort Historical	670	670	757	795	855	730	830	869	762	802	880	836	779	4477	2461	3297	10235
16-17 Proj	670	757	795	835	872	744	863	904	770	834	863	819	748	4673	2537	3264	10474
16-17 Cohort Historical	670	670	757	795	835	872	744	863	904	770	834	863	819	4598	2511	3286	10396
17-18 Proj	670	757	795	835	851	889	774	898	913	801	817	846	786	4797	2585	3250	10632
17-18 Cohort Historical	670	670	757	795	835	851	889	774	898	913	801	817	846	4578	2561	3376	10516
18-19 Proj	670	757	795	835	851	868	925	805	907	949	785	801	812	4777	2637	3347	10760
18-19 Cohort Historical	670	670	757	795	835	851	868	925	805	907	785	801	812	4578	2598	3442	10618
19-20 Proj	670	757	795	835	851	868	903	962	813	943	930	769	769	4777	2678	3411	10866
19-20 Cohort Historical	670	670	757	795	835	851	868	903	962	813	943	930	769	4578	2733	3456	10767
20-21 Proj	670	757	795	835	851	868	903	939	971	846	924	738	4777	2814	3420	11010	

* These numbers were updated with actuals as of 12-1-2011

Wayzata Resident High K/High Mig K (+Hdcp)	1st	2nd	3rd	4th	5th	6th	7th	8th	9th	10th	11th	12th	K-5	6-8	9-12	K-12 total	
2012-13 Actual	692	653	765	808	703	745	813	822	792	747	735	708	718	4366	2427	2908	9701
12-13 Cohort	660	692	653	765	808	703	745	813	822	792	747	735	708	4281	2380	2982	9643
Historical	1.139	1.046	1.043	1.051	1.027	1.06	1.038	1.021	1.025	1.002	0.997	0.964	0	0	0	0	
13-14 Proj	660	788	683	798	849	722	790	844	839	812	748	733	683	4500	2473	2976	9949
13-14 Cohort	675	660	788	683	798	849	722	790	844	839	812	748	733	4453	2356	3132	9941
Historical	1.139	1.046	1.043	1.051	1.027	1.06	1.038	1.021	1.025	1.002	0.997	0.964	0	0	0	0	
14-15 Proj	675	752	824	712	839	872	765	820	862	860	813	746	706	4674	2447	3126	10247
14-15 Cohort	694	675	752	824	712	839	872	765	820	862	860	813	746	4496	2457	3282	10235
Historical	1.139	1.046	1.043	1.051	1.027	1.06	1.038	1.021	1.025	1.002	0.997	0.964	0	0	0	0	
15-16 Proj	694	769	786	860	749	861	924	794	837	883	862	811	719	4719	2556	3275	10550
15-16 Cohort	691	694	769	786	860	749	861	924	794	837	883	862	811	4549	2580	3393	10522
Historical	1.139	1.046	1.043	1.051	1.027	1.06	1.038	1.021	1.025	1.002	0.997	0.964	0	0	0	0	
16-17 Proj	691	790	804	820	904	769	913	960	811	858	885	859	782	4778	2684	3384	10846
16-17 Cohort	703	691	790	804	820	904	769	913	960	811	858	885	859	4713	2641	3413	10767
Historical	1.139	1.046	1.043	1.051	1.027	1.06	1.038	1.021	1.025	1.002	0.997	0.964	0	0	0	0	
17-18 Proj	703	787	827	839	862	928	815	948	980	831	860	882	828	4946	2742	3402	11090
17-18 Cohort	733	703	787	827	839	862	928	815	948	980	831	860	882	4751	2691	3553	10994
Historical	1.139	1.046	1.043	1.051	1.027	1.06	1.038	1.021	1.025	1.002	0.997	0.964	0	0	0	0	
18-19 Proj	733	801	823	862	882	885	984	846	967	1004	833	857	851	4986	2797	3545	11328
18-19 Cohort	767	733	801	823	862	882	885	984	846	967	1004	833	857	4868	2715	3662	11245
Historical	1.139	1.046	1.043	1.051	1.027	1.06	1.038	1.021	1.025	1.002	0.997	0.964	0	0	0	0	
19-20 Proj	767	835	838	859	906	905	938	1021	864	992	1006	831	826	5110	2823	3655	11588
19-20 Cohort	771	767	835	838	859	906	905	938	1021	864	992	1006	831	4975	2865	3692	11533
Historical	1.139	1.046	1.043	1.051	1.027	1.06	1.038	1.021	1.025	1.002	0.997	0.964	0	0	0	0	
20-21 Proj	771	874	873	874	902	931	960	974	1043	885	994	1003	801	5225	2976	3683	11884
20-21 Cohort	776	771	874	873	874	902	931	960	974	1043	885	994	1003	5070	2865	3925	11859
Historical	1.139	1.046	1.043	1.051	1.027	1.06	1.038	1.021	1.025	1.002	0.997	0.964	0	0	0	0	
21-22 Proj	776	878	914	911	918	927	987	996	994	1069	887	991	967	5324	2977	3914	12215
21-22 Cohort	780	776	878	914	911	918	927	987	996	994	1069	887	991	5177	2910	3941	12028
Historical	1.139	1.046	1.043	1.051	1.027	1.06	1.038	1.021	1.025	1.002	0.997	0.964	0	0	0	0	
22-23 Proj	780	884	919	953	957	943	982	1024	1017	1019	1071	885	955	5436	3024	3930	12389

Wayzata Resident High K/High Mig K (+Hdcp)	1st	2nd	3rd	4th	5th	6th	7th	8th	9th	10th	11th	12th	K-5	6-8	9-12	K-12 total	
2012-13 Actual	6	4	5	5	12	11	7	10	12	23	14	17	23	43	29	77	149
13-14 Proj	-10	13	2	0	30	17	26	6	19	1	39	26	19	52	51	85	188
14-15 Proj	5	-5	11	-3	25	37	32	26	15	7	18	51	28	68	73	105	246
15-16 Proj	24	12	-9	5	19	31	56	32	35	3	26	32	52	82	123	113	318
16-17 Proj	21	33	9	-15	32	25	49	56	41	24	22	40	34	106	147	120	372
17-18 Proj	33	30	32	4	11	39	41	50	67	31	42	37	42	148	158	152	458
18-19 Proj	63	44	28	28	30	17	59	41	61	55	48	56	39	210	161	198	568
19-20 Proj	97	78	43	24	55	37	35	60	51	48	76	61	57	333	145	243	722
20-21 Proj	101	117	78	39	51	62	57	35	71	40	69	62	448	163	263	874	
21-22 Proj																	
22-23 Proj																	

39
58
71
55
85
111
154
152



PHASE III: SECONDARY CAPACITY / EDUCATIONAL ADEQUACY (BOND REFERENDUM FALL 2013)
BUDGET SCOPE WORKSHEET

Table with columns: 2012-2013 Scope Considerations, May 21, 2013 Recommended Scope. Rows include categories A through H, detailing various school capacity and infrastructure needs with associated costs.



ENHANCE INSTRUCTION: DISTRICTWIDE CLASSROOM RETROFIT

Draft Budget Assumptions for Districtwide Furniture Retrofits

Elementary Schools	Quantity of Existing Classrooms*
Birchview	26
Gleason Lake	29
Greenwood	26
Kimberly Lane	30
Oakwood	22
Plymouth Creek	29
Sunset Hill	24
Total Classrooms	186

* Includes general and kindergarten classrooms

Elementary School Subtotal:

186 Elementary School Classrooms x \$12,000 to \$15,000 of new furniture = \$2,232,000 to \$2,790,000

Middle School	Quantity of Existing Classrooms
Central	46
East	38
West	39
Total Classroom	123

Middle School Subtotal:

123 Middle School Classrooms x \$12,000 to \$15,000 of new furniture = \$1,476,000 to \$1,845,000

High School	Quantity of Existing Classrooms
High School	127
Total Classrooms	127

High School Subtotal:

127 High School Classrooms x \$12,000 to \$15,000 of new furniture = \$1,524,000 to \$1,905,000

TOTAL DRAFT FURNITURE RETROFIT BUDGET ASSUMPTION: \$5,232,000 to \$6,540,000



architects
engineers
www.woldae.com

305 Saint Peter Street
Saint Paul, MN 55102

tel 651 227 7773
fax 651 223 5646
mail@woldae.com

Elementary School Capacity Analysis:

Wayzata Public Schools

Phase III: Secondary Capacity and Educational Adequacy

Independent School District #284

210 County Road 101 North

P.O. Box 660

Wayzata, Minnesota 55391

Draft: September 25, 2012



DISTRICTWIDE ELEMENTARY CAPACITY

A.

Elementary School	2010 K-5 Capacity	2012 K-5 Capacity	New 2013 K-5 Capacity	New 2013 1-5 Capacity	2013 Capacity Assumption Notes
Birchview	642	649	646 (629)	528	Reclaims Computer Lab Reclaims Kindergarten extended day
Gleason Lake	698	739	718	600	Reclaims Home Base
Greenwood	629	742	790	672	Reclaims thinking skills, (1) computer lab
Kimberly Lane	745	762	718	600	Reclaims (1) Computer Lab Reclaims (1) Kindergarten
Oakwood	532	536	694	576	Adds (1) Kindergarten for total of (4)
Plymouth Creek	783	724 + CMS 63	718	600	Reclaims (2) Kindergarten extended day
Sunset Hill	601	601	694	576	Added (1) Kindergarten extended day
Total K-5 Capacity	4,630 Students	4,816 Students	4,978 Students (Depending on Extended Day K)	4,152 Students	Additional Net Capacity: 229-348 students - Assumes reclaiming (9) spaces (see above) - Assumes elimination of (3) spaces at CMS - Kindergarten ½ day vs extended day - TBD

B.

Room Use Summary	2012/13	2013/14	Notes
½ Day Kindergarten	14	14	
Extended Day Kindergarten	12	14	
Total K Rooms	26	28	

CAPACITY/USE ASSUMPTIONS

Each elementary shall reserve the following spaces:

- (2) Computer Labs
- (1) Art Classroom
- (1) Music Classroom
- (4) Kindergarten Rooms (1/2 day vs extended day TBD)
- (1) Home Base (minimum)



2012/2013 Elementary School Capacity



ISD # 284 - WAYZATA PUBLIC SCHOOLS

Wold Architects and Engineers

Phase III - Added Elem Capacity Analysis - Draft Sept. 24, 2012

2012-2013 Capacity

K	Half Day	2 (2 x 19)	=	76
K	Extended Day	1 x 21	=	21
●	Grades 1-5	22 x 24*	=	552

2012-2013 Capacity = 649

* 24 is average target class size.

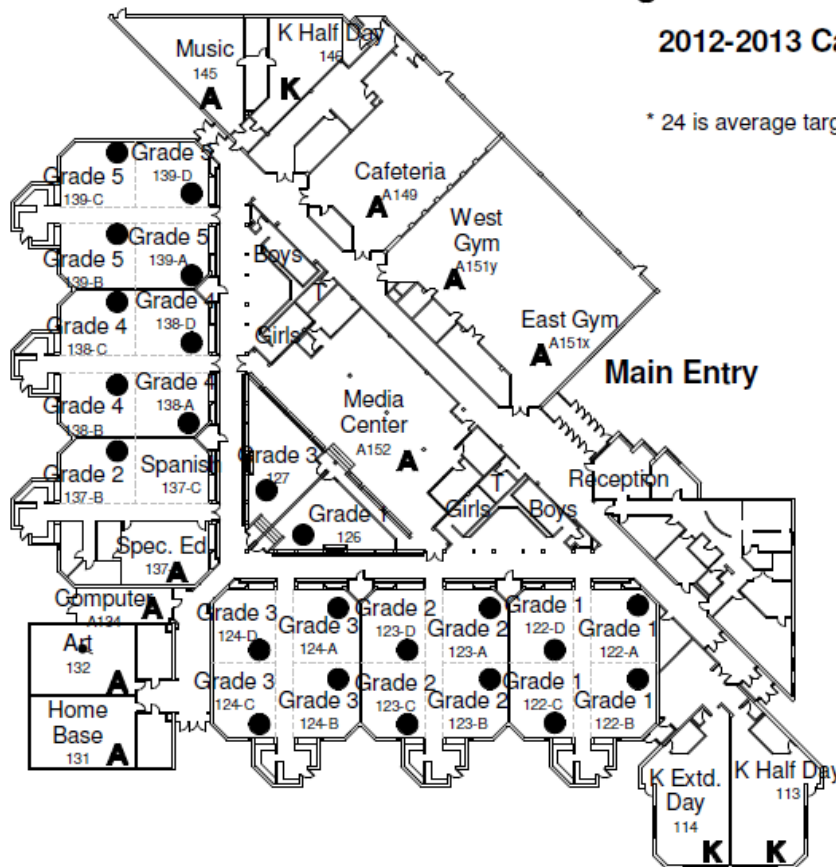

Birchview Elementary School 2012/2013 Capacity/Utilization

1/64" = 1'-0"



ISD # 284 - WAYZATA PUBLIC SCHOOLS

Wold Architects and Engineers

Phase III - Added Elem Capacity Analysis - Draft Sept. 24, 2012

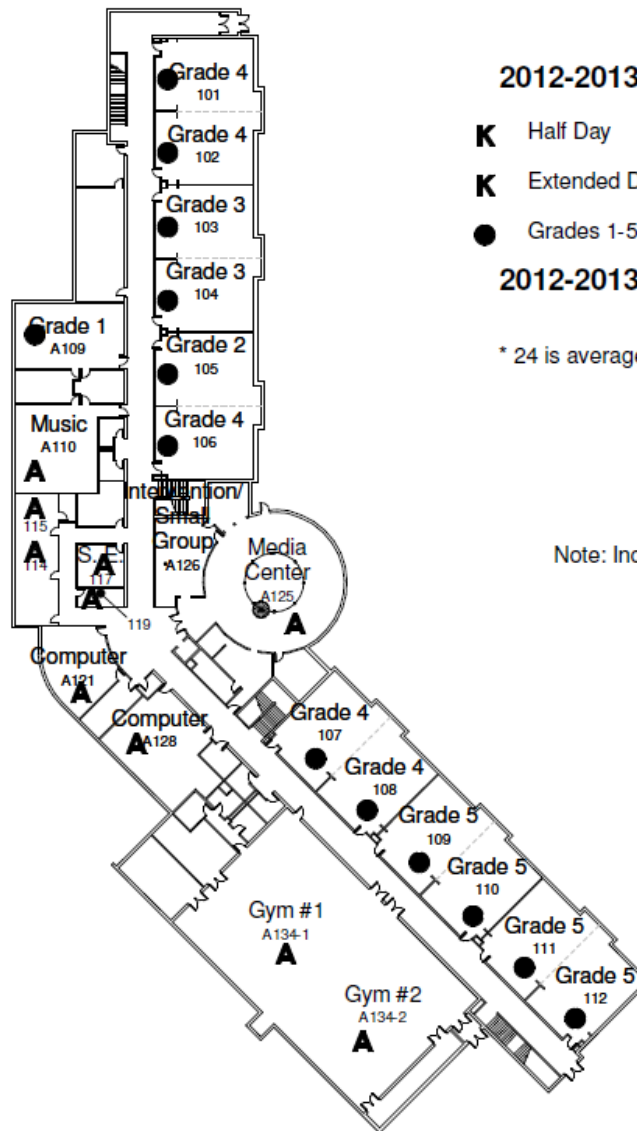

2012-2013 Capacity

K	Half Day	2 (2 x 19)	=	76
K	Extended Day	3 x 21	=	63
●	Grades 1-5	25 x 24*	=	600

2012-2013 Capacity = 739

* 24 is average target class size.

Note: Include 21 Kimberly Lane EDK Students



Gleason Lake Elementary School Lower Level 2012/2013 Capacity/Utilization

1/64" = 1'-0"



ISD # 284 - WAYZATA PUBLIC SCHOOLS

Wold Architects and Engineers

Phase III - Added Elem Capacity Analysis - Draft Sept. 24, 2012

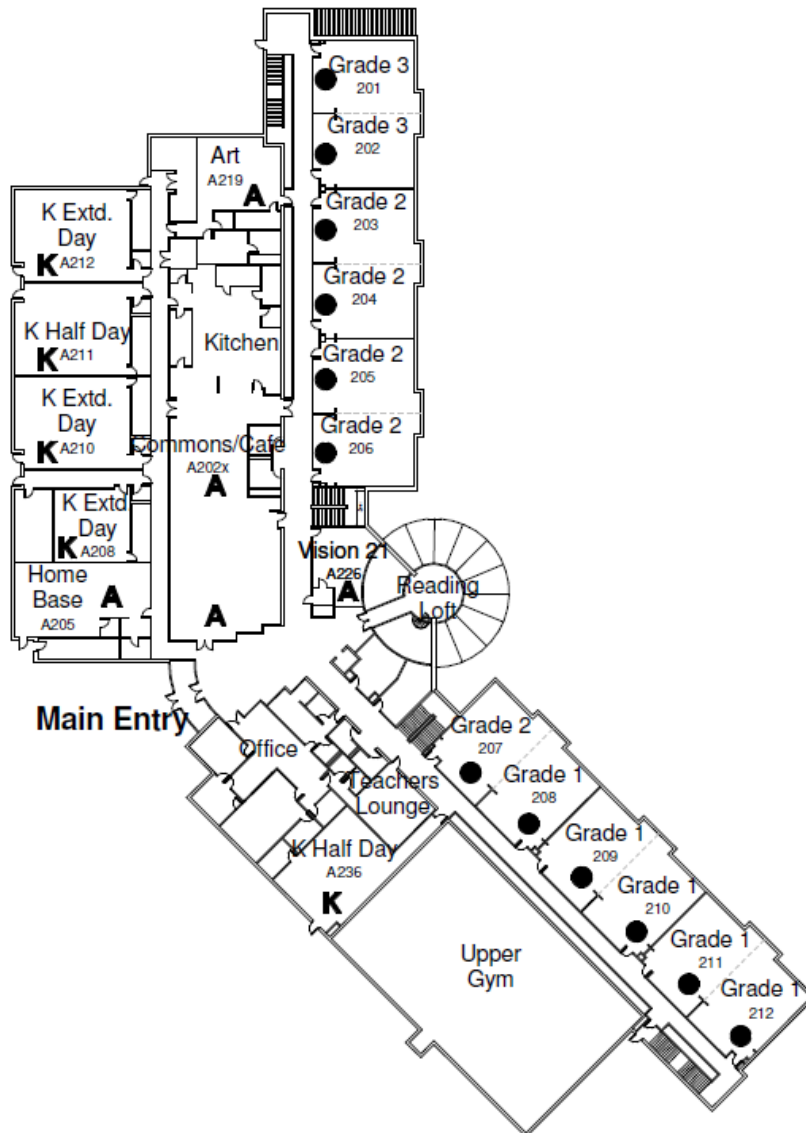

Gleason Lake Elementary School Upper Level 2012/2013 Capacity/Utilization

1/64" = 1'-0"



ISD # 284 - WAYZATA PUBLIC SCHOOLS

Wold Architects and Engineers

Phase III - Added Elem Capacity Analysis - Draft Sept. 24, 2012

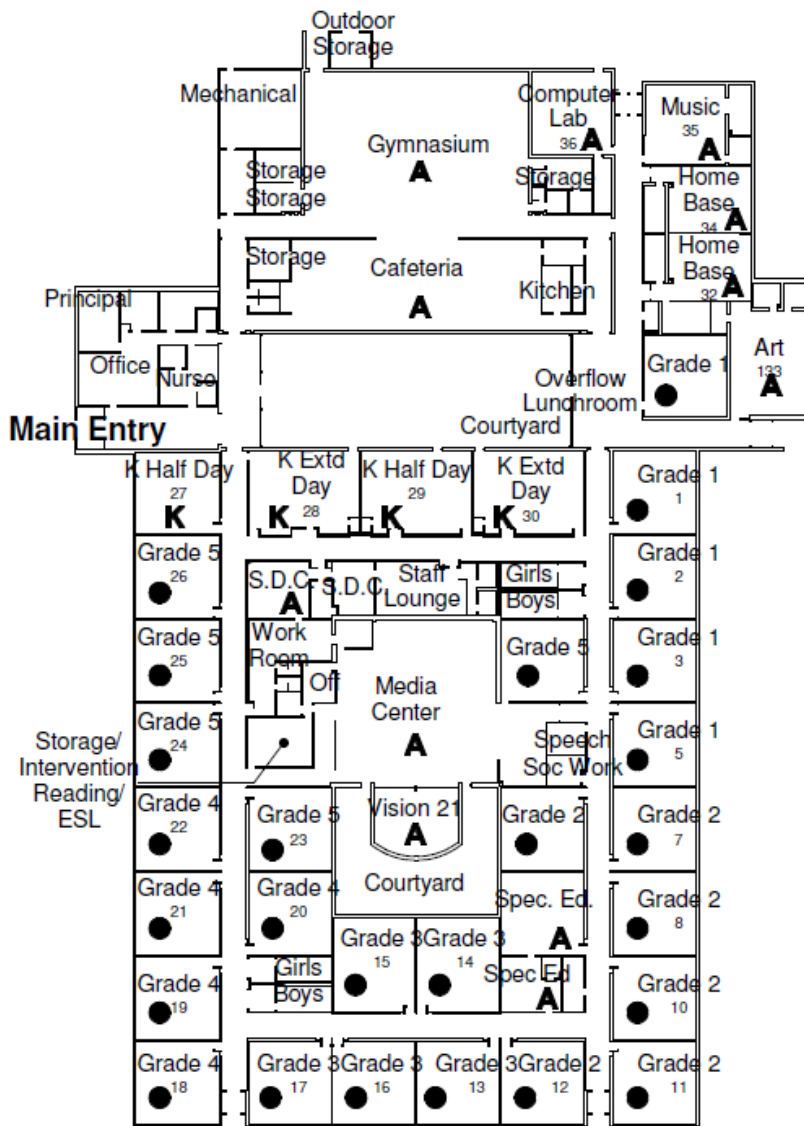

2012-2013 Capacity

K Half Day	2 (2 x 19)	=	76
K Extended Day	2 x 21	=	42
● Grades 1-5	26 x 24*	=	624
2012-2013 Capacity			= 742

* 24 is average target class size.

Greenwood Elementary School 2012/2013 Capacity/Utilization

1/64" = 1'-0"



ISD # 284 - WAYZATA PUBLIC SCHOOLS

Wold Architects and Engineers

Phase III - Added Elem Capacity Analysis - Draft Sept. 24, 2012

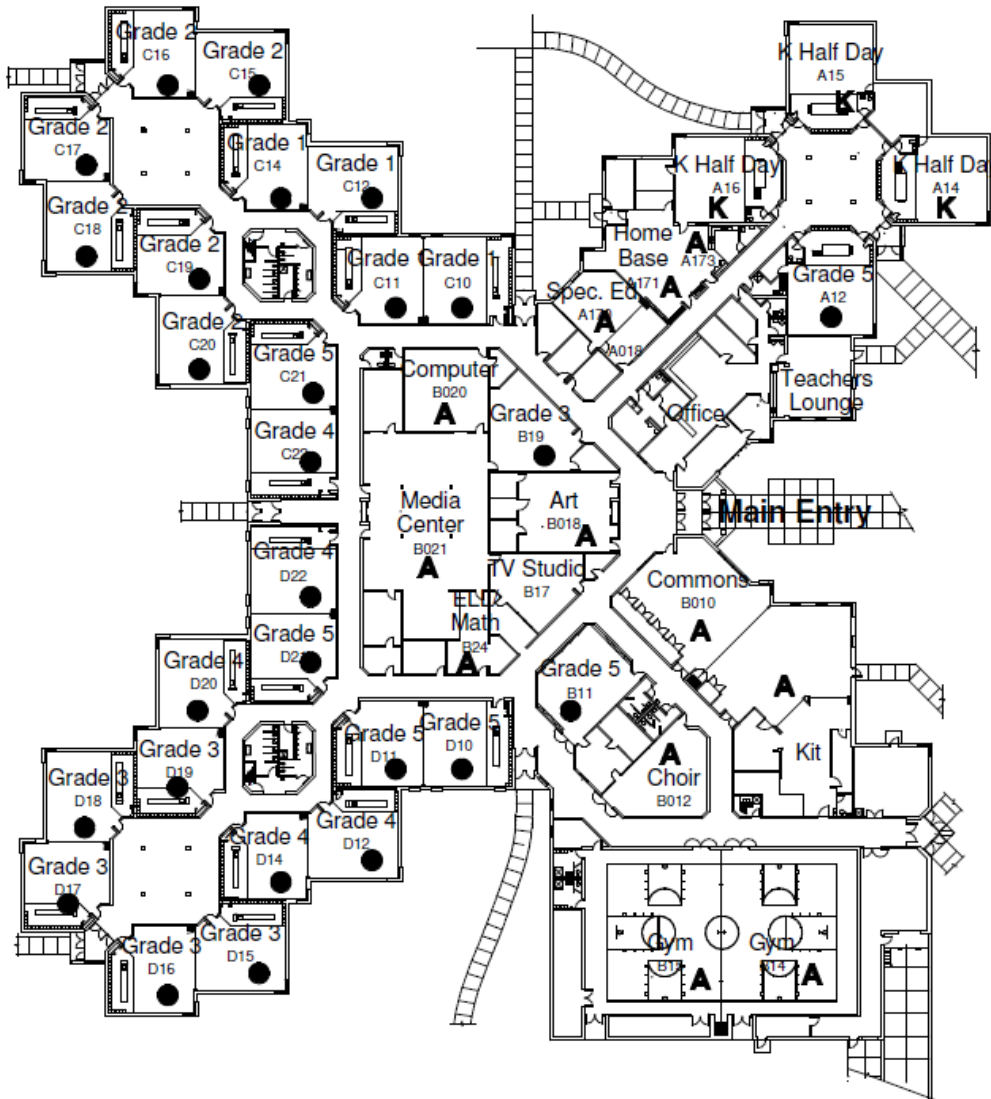

2012-2013 Capacity

K Half Day 3 (2 x 19) = 114

K Extended Day 0 x 21 = 0

● Grades 1-5 27 x 24* = 648

2012-2013 Capacity = 762

* 24 is average target class size.



Kimberly Lane Elementary School 2012/2013 Capacity/Utilization

1/64" = 1'-0"



ISD # 284 - WAYZATA PUBLIC SCHOOLS

Wold Architects and Engineers

Phase III - Added Elem Capacity Analysis - Draft Sept. 24, 2012

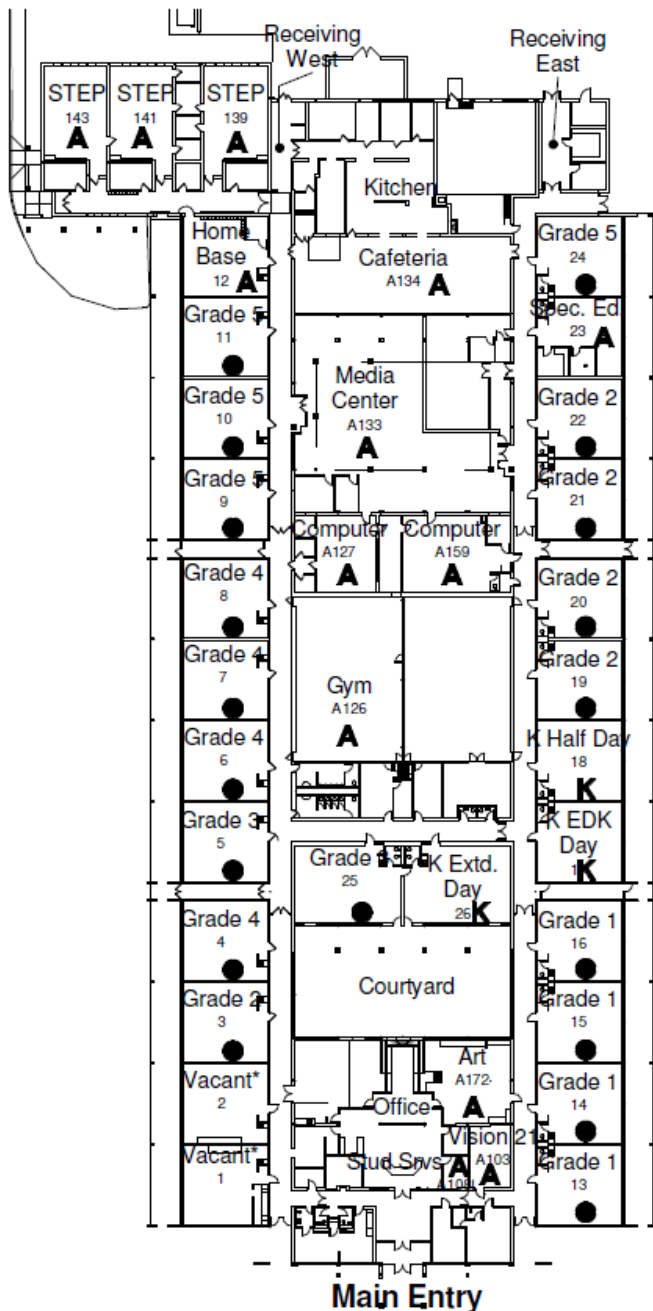

2012-2013 Capacity

K	Half Day	1 (2 x 19)	=	38
K	Extended Day	2 x 21	=	42
●	Grades 1-5	19 x 24*	=	456

2012-2013 Capacity = 536

* 24 is average target class size.

* Note: Rooms 1 and 2 are vacant in preparation for construction.



Oakwood Elementary School 2012/2013 Capacity/Utilization

1/64" = 1'-0"



ISD # 284 - WAYZATA PUBLIC SCHOOLS

Wold Architects and Engineers

Phase III - Added Elem Capacity Analysis - Draft Sept. 24, 2012

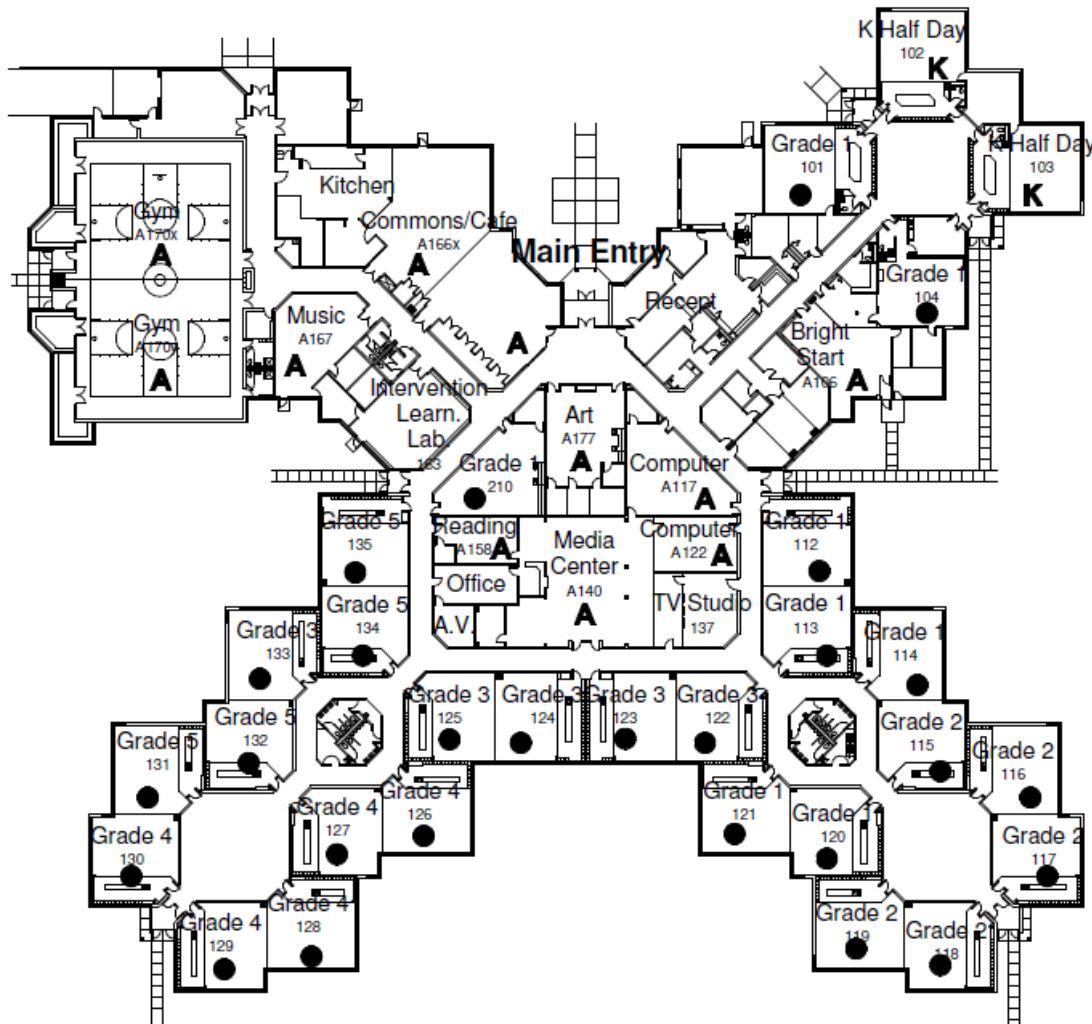

2012-2013 Capacity

K Half Day 2 (2 x 19) = 76

● Grades 1-5 27 x 24* = 648

2012-2013 Capacity = 724

K Extended Day (@ CMS) 3 x 21 = (63)

* 24 is average target class size.

787?



Plymouth Creek Elementary School 2012/2013 Capacity/Utilization

1/64" = 1'-0"



ISD # 284 - WAYZATA PUBLIC SCHOOLS

Wold Architects and Engineers

Phase III - Added Elem Capacity Analysis - Draft Sept. 24, 2012

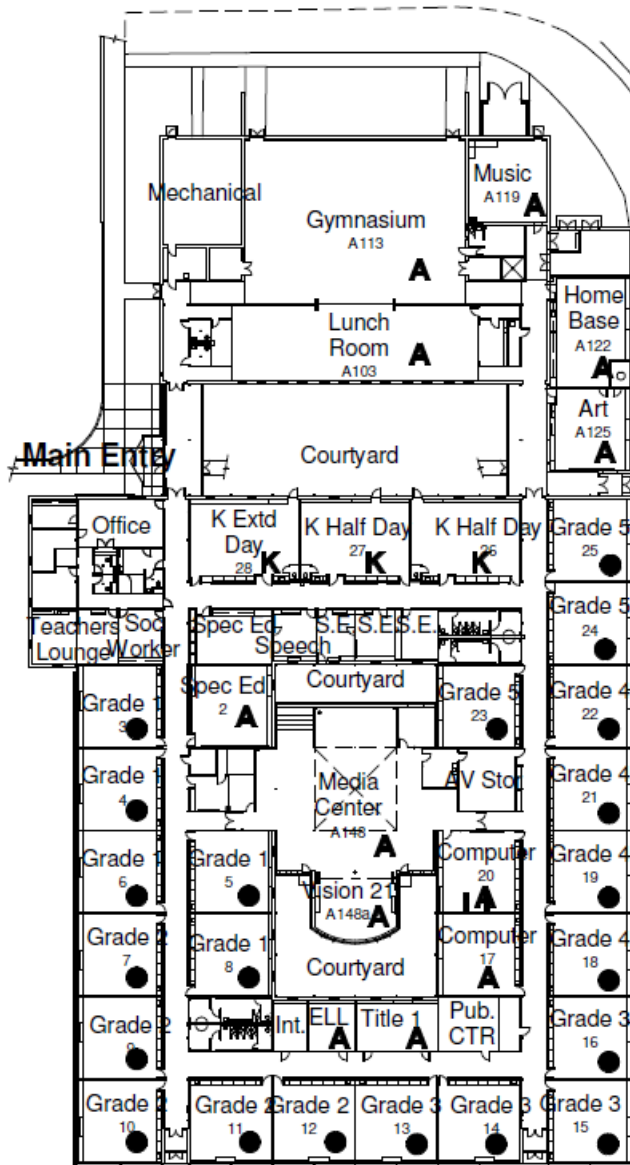

2012-2013 Capacity

K	Half Day	2 (2 x 19)	=	76
K	Extended Day	1 x 21	=	21
●	Grades 1-5	21 x 24*	=	504

2012-2013 Capacity

= 601

* 24 is average target class size.



Sunset Hill Elementary School 2012/2013 Capacity/Utilization

1/64" = 1'-0"



2013/2014 Elementary School Capacity



ISD # 284 - WAYZATA PUBLIC SCHOOLS

Wold Architects and Engineers

Phase III - Added Elem Capacity Analysis - Draft Sept. 24, 2012

2013-2014 Capacity

K	Half Day	2 (2 x 19)	=	76
K	Extended Day	2 x 21	=	42
●	Grades 1-5	22 x 24*	=	528
2013-2014 Capacity				= 646

* 24 is average target class size.

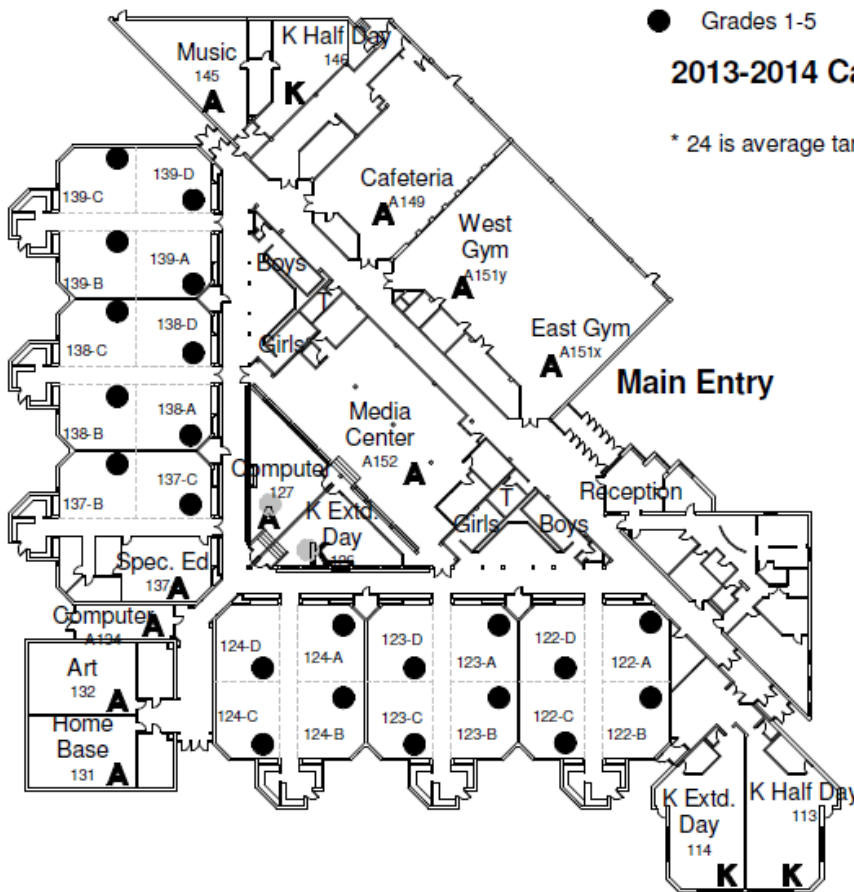

Birchview Elementary School 2013/2014 Capacity/Utilization

1/64" = 1'-0"



ISD # 284 - WAYZATA PUBLIC SCHOOLS

Wold Architects and Engineers

Phase III - Added Elem Capacity Analysis - Draft Sept. 24, 2012

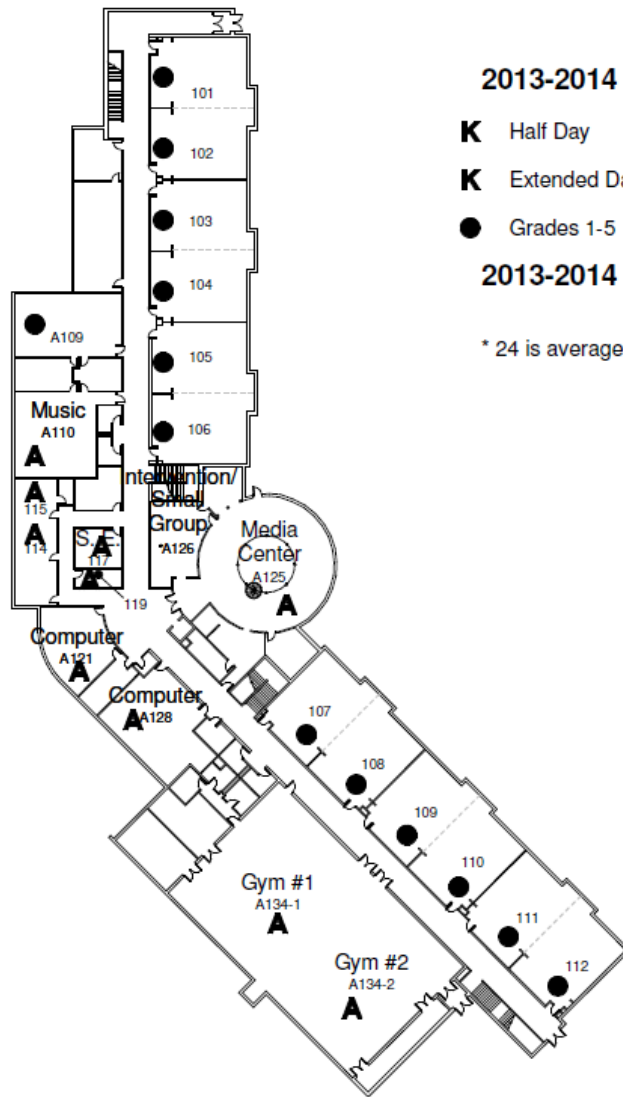

2013-2014 Capacity

K	Half Day	2 (2 x 19)	=	76
K	Extended Day	2 x 21	=	42
●	Grades 1-5	25 x 24*	=	600

2013-2014 Capacity = 718

* 24 is average target class size.



Gleason Lake Elementary School Lower Level 2013/2014 Capacity/Utilization

1/64" = 1'-0"



ISD # 284 - WAYZATA PUBLIC SCHOOLS

Wold Architects and Engineers

Phase III - Added Elem Capacity Analysis - Draft Sept. 24, 2012

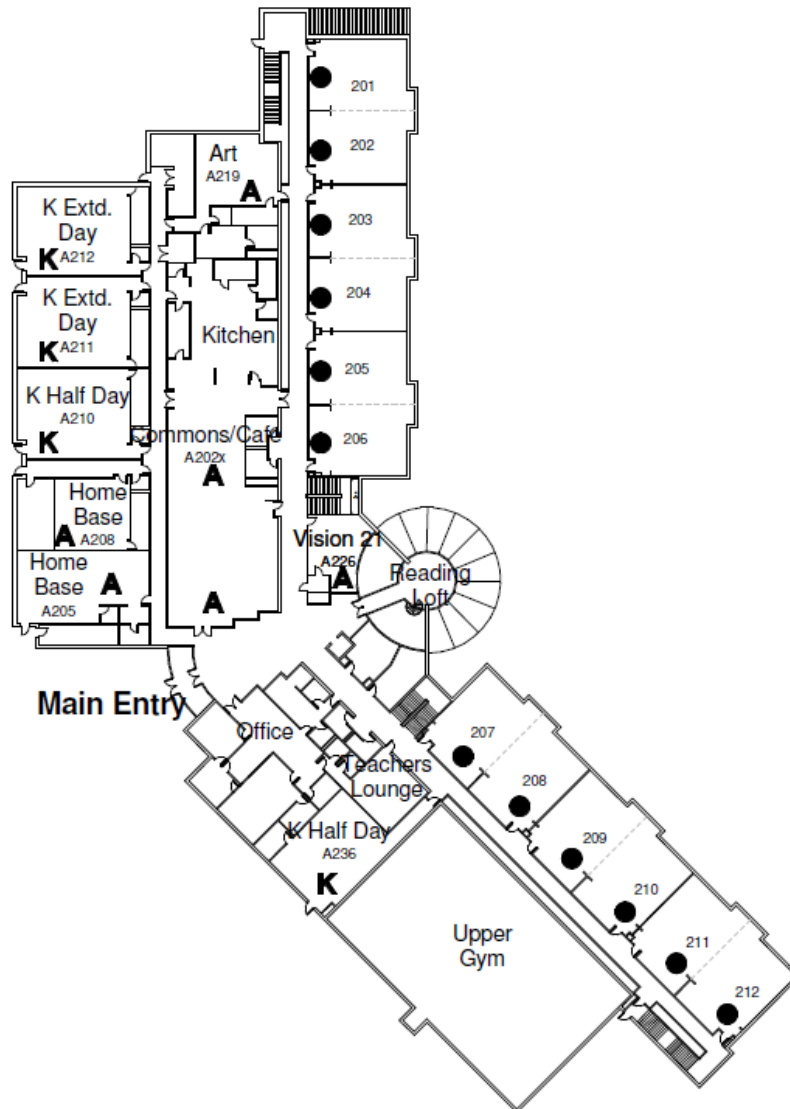

Gleason Lake Elementary School Upper Level 2013/2014 Capacity/Utilization

1/64" = 1'-0"



ISD # 284 - WAYZATA PUBLIC SCHOOLS

Wold Architects and Engineers

Phase III - Added Elem Capacity Analysis - Draft Sept. 24, 2012

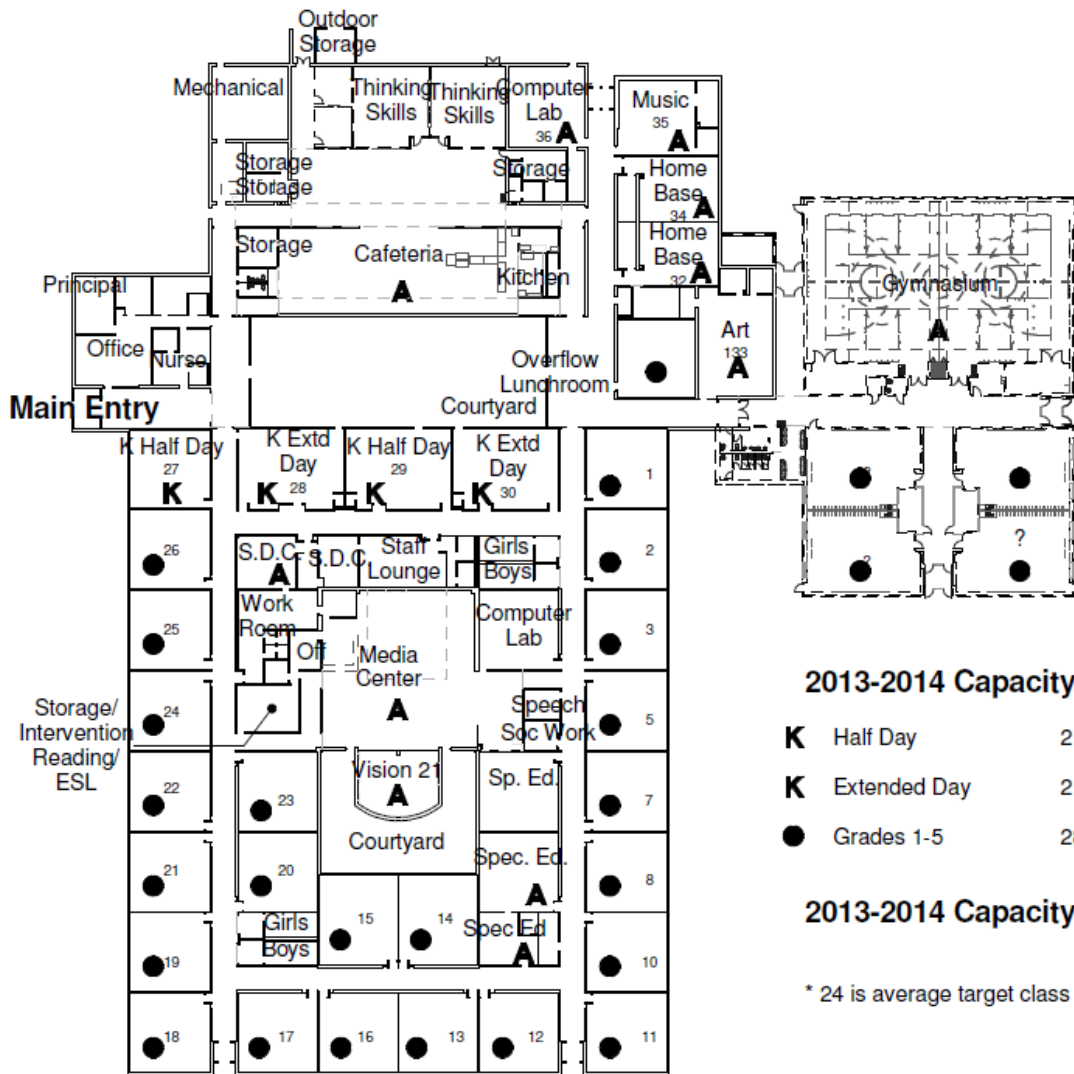

2013-2014 Capacity

K	Half Day	2 (2 x 19)	=	76
K	Extended Day	2 x 21	=	42
●	Grades 1-5	28 x 24*	=	672

2013-2014 Capacity = 790

* 24 is average target class size.



Greenwood Elementary School 2013/2014 Capacity/Utilization

1/64" = 1'-0"

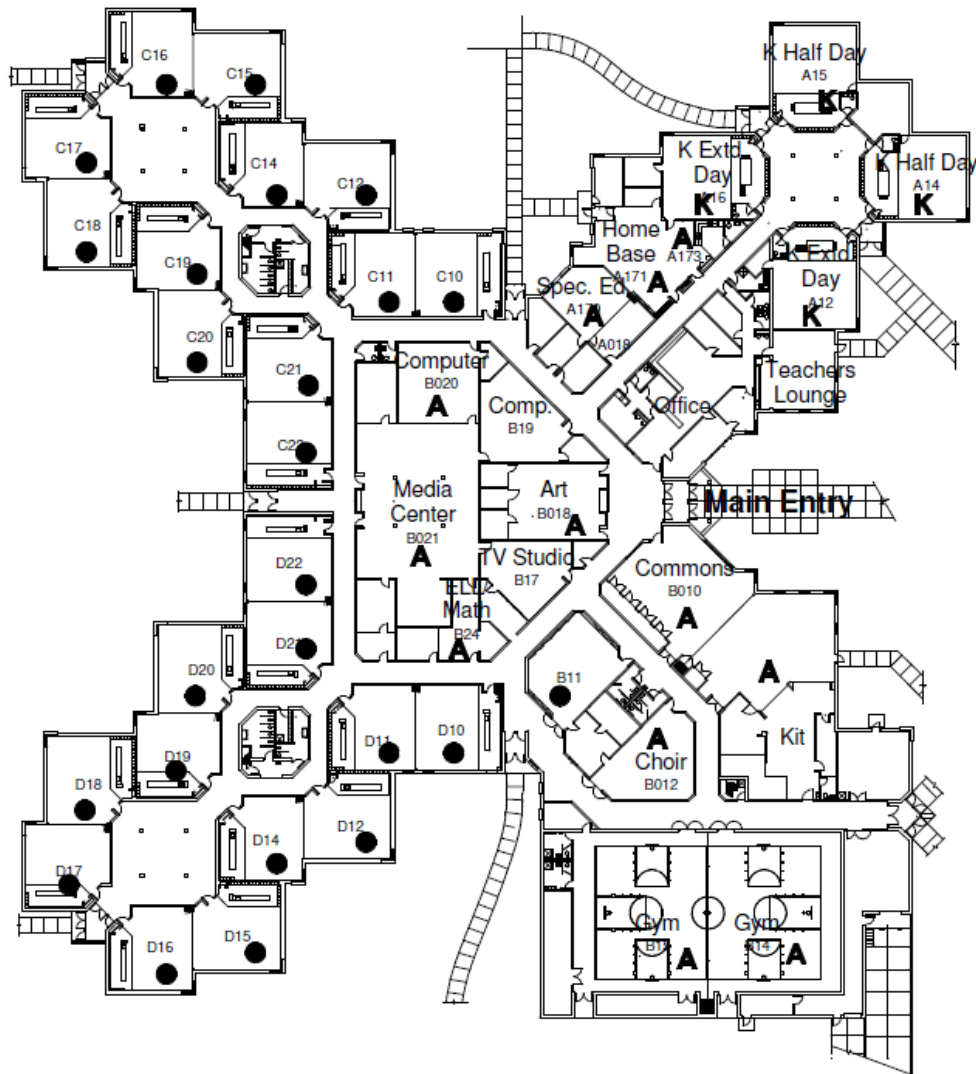

2013-2014 Capacity

K Half Day 2 (2 x 19) = 76

K Extended Day 2 x 21 = 42

● Grades 1-5 25 x 24* = 600

2013-2014 Capacity = 718

* 24 is average target class size.



Kimberly Lane Elementary School 2013/2014 Capacity/Utilization

1/64" = 1'-0"



ISD # 284 - WAYZATA PUBLIC SCHOOLS

Wold Architects and Engineers

Phase III - Added Elem Capacity Analysis - Draft Sept. 24, 2012

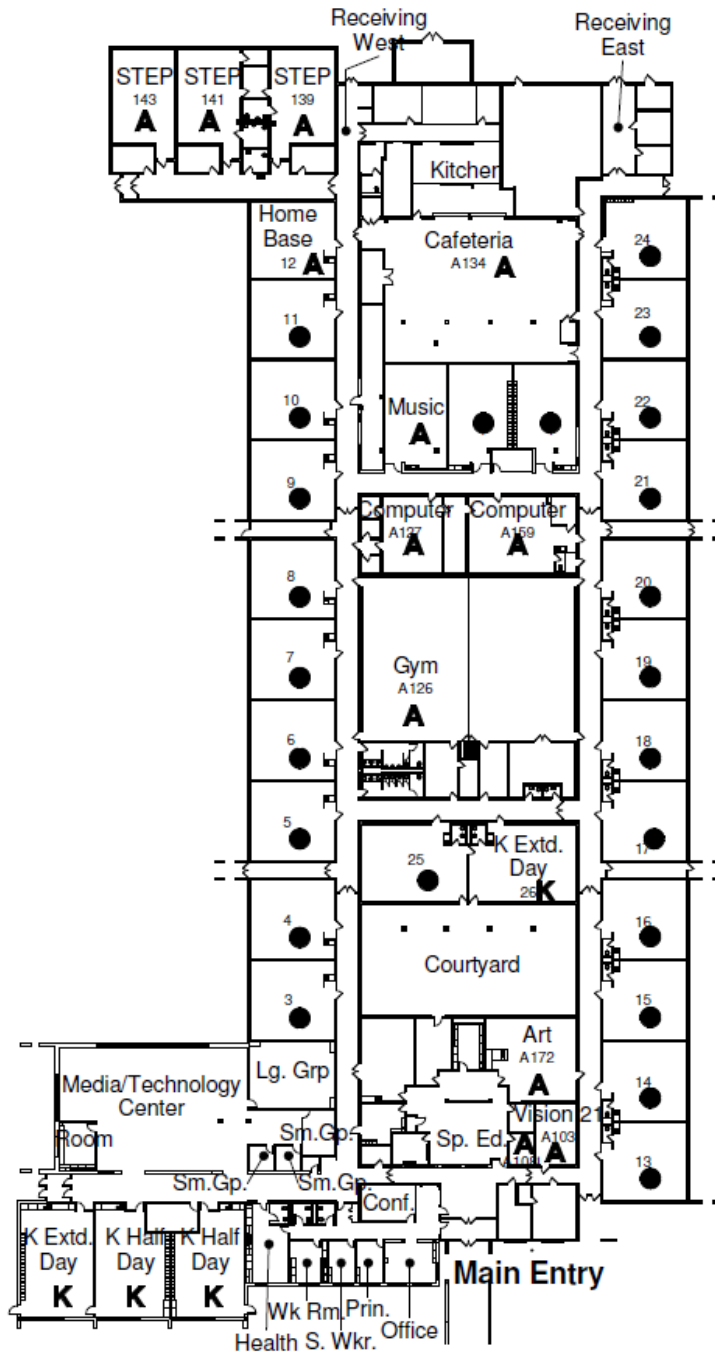

2013-2014 Capacity

K	Half Day	2 (2 x 19)	=	76
K	Extended Day	2 x 21	=	42
●	Grades 1-5	24 x 24*	=	576
				2013-2014 Capacity
				= 694

* 24 is average target class size.



Oakwood Elementary School 2013/2014 Capacity/Utilization

1/64" = 1'-0"



ISD # 284 - WAYZATA PUBLIC SCHOOLS

Wold Architects and Engineers

Phase III - Added Elem Capacity Analysis - Draft Sept. 24, 2012

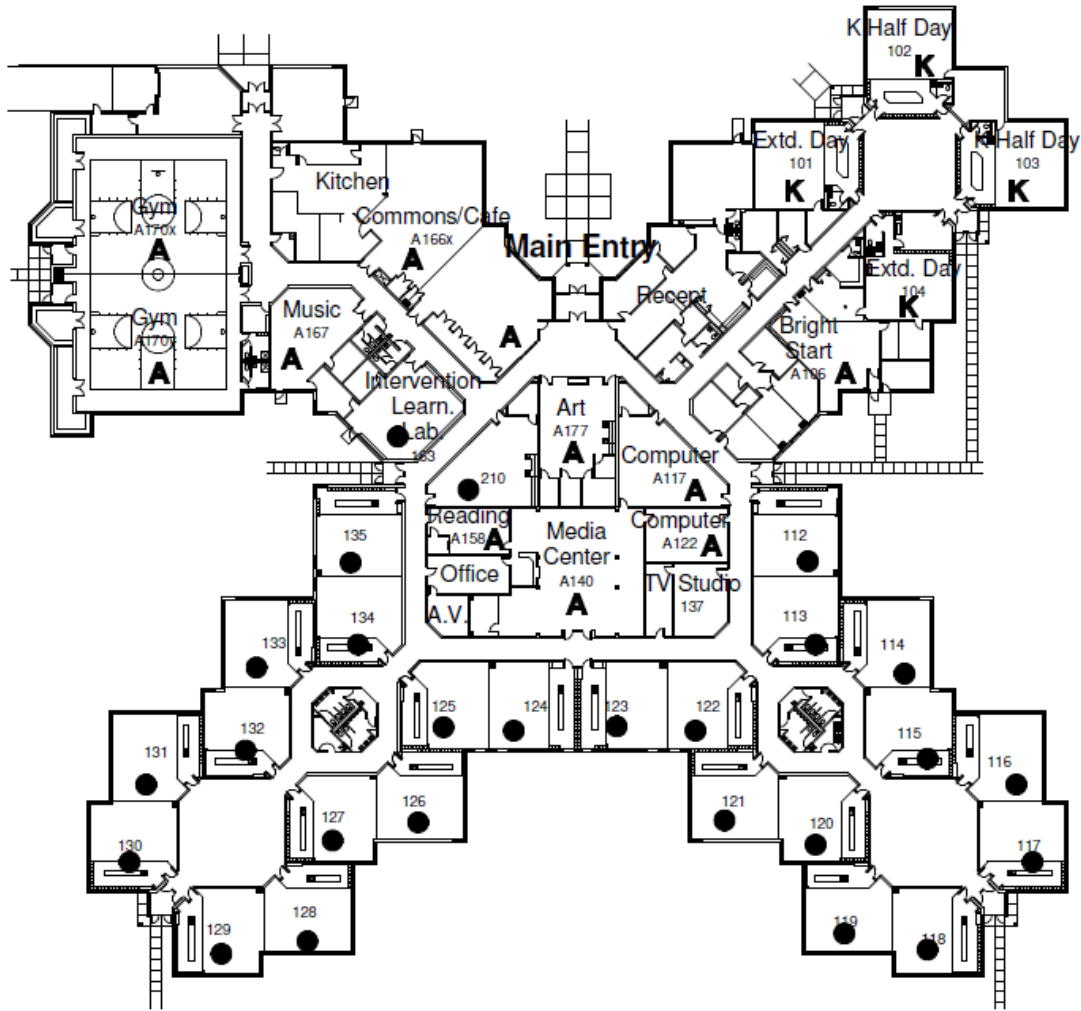

2013-2014 Capacity

K Half Day	2 (2 x 19) =	76
K Extended Day	2 x 21 =	42
● Grades 1-5	25 x 24* =	600

2014-2014 Capacity = 718

* 24 is average target class size.



Plymouth Creek Elementary School 2013/2014 Capacity/Utilization

1/64" = 1'-0"



ISD # 284 - WAYZATA PUBLIC SCHOOLS

Wold Architects and Engineers

Phase III - Added Elem Capacity Analysis - Draft Sept. 24, 2012

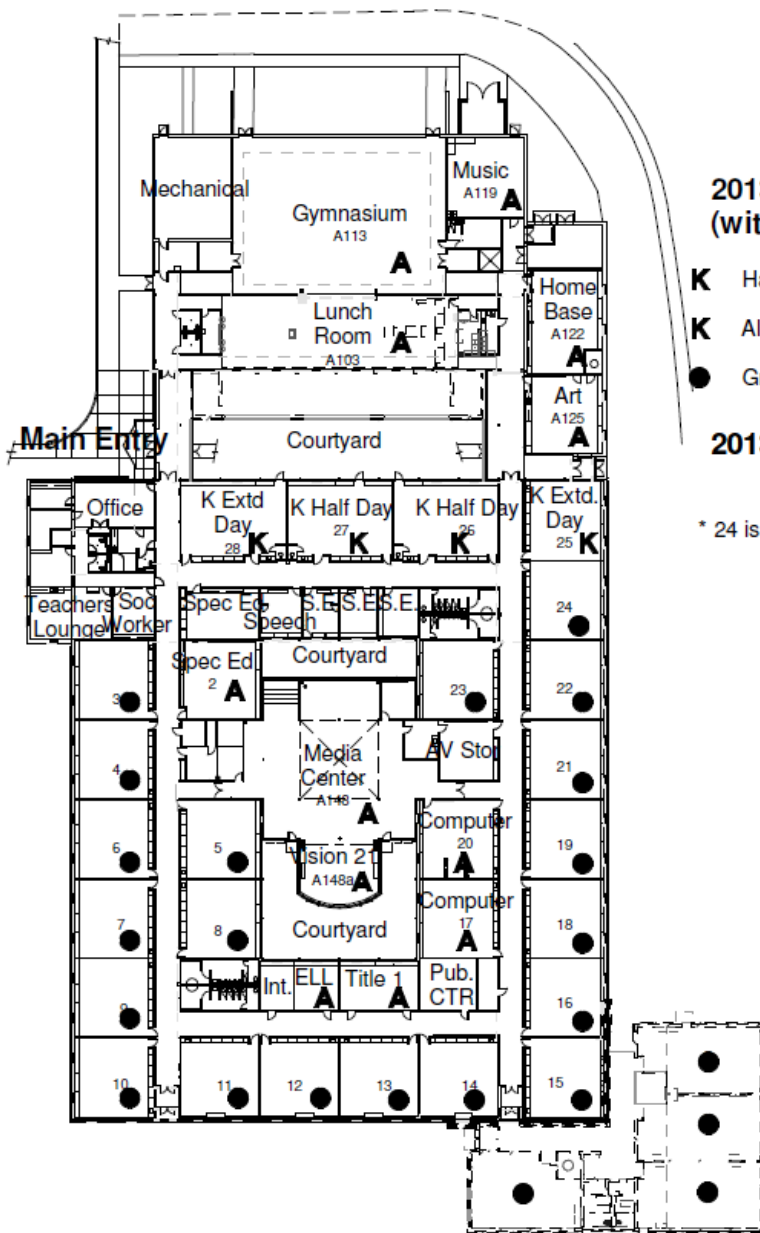

2013-2014 Anticipated Capacity (with Addition)

K Half Day	2 (2 x 19)	=	76
K All Day	2 x 21	=	42
● Grades 1-5	24 x 24*	=	576

2013-2014 Capacity = 694

* 24 is average target class size.



Sunset Hill Elementary School 2013/2014 Capacity/Utilization

1/64" = 1'-0"

WAYZATA PUBLIC SCHOOLS
Independent School District 284
Wayzata, Minnesota

BOARD OF EDUCATION

Special Work Session – June 3, 2013

AGENDA SECTION: _____

ITEM: _____

COMMENTS BY: Board Chair Droegemueller

4. Adjourn

If there is no additional business before the School Board, the Chair will adjourn the meeting.

Motion by: _____ Yes _____ Passed _____

Second by: _____ No _____ Failed _____

Abstentions _____