

GREENEVILLE CITY BOARD OF EDUCATION

AGENDA

Date of Meeting: September 26, 2023

Time: 5:00 PM

Location: Professional Development Center at the Kathryn W. Leonard
Administrative Office

{{Name: Agenda Item Name}} {{AnticipatedTime: Agenda Item Time}}

- I. **Call to Order**
- II. **Pledge to the Flag**
- III. **Recognition of Visitors**
- IV. **Public Hearing on Family Life Education** (5 Minutes)
- V. **Special Recognitions** (25 minutes)
 - Greenville High School Baseball (5 Minutes)
 - Greenville High School State Winner for Long Jump and Triple Jump Jayquan Price
 - Recognition of Schools with Level 5 TVASS (5 Minutes)
 - 2022-2023 TVAAS Report (10 Minutes)
- VI. **Public Comment Period** (20 Minutes)
- VII. **School Report** (10 minutes)
School Report Greenville Middle School
- VIII. **Reorganization of the Board** (5 Minutes)
Election of Chairman, Vice-Chairman, Treasurer, and TLN Representative
- IX. **Approval of Agenda**
- X. **Consent Agenda** (5 minutes)
 - A. Consideration of Approving Minutes of August 22, 2023, Board Meeting
 - B. Consideration of Accepting Personnel Report

- C. Consideration of Approving Board Policy Revisions - No Changes (1st Reading)
- D. Consideration of Approving Board Policy Revisions (2nd Reading)
- E. Consideration of Approving School Trip Requests
- F. Consideration of Approving Purchase of School Nutrition Equipment (Greeneville High School Dish Machine)
- G. Consideration of Approving Six-Month Update of Final ESSER 3 Public Spending Plan and Final Safe Return to In-Person Instruction and Continuity of Services Plan
- H. Consideration of Approving Fiscal Year 2024 Federal Projects Budget Amendment #1
- I. Consideration of Approving Disposal of Surplus
- J. Consideration of Accepting 2024 Employee Health Insurance Premium Rates
- K. Consideration of Approving 2023-2024 Greeneville City Schools Employee Handbook

XI. **Action Items**

- A. Consideration of Accepting August 2023 Financial Statements (5 minutes)
- B. Consideration of Approving Board Policy Revisions - 1st Reading (5 minutes)
- C. Consideration of Purchasing Furniture for Greenville Middle School Career Exploration and Career Lab Classrooms (5 Minutes)
- D. Consideration of Approving Greeneville High School Landscaping Project (5 Minutes)
- E. Consideration of Approving Participation in Public Entity Partners Grant Program: Property Conservation Grant (5 Minutes)
- F. Consideration of Approving Participation in Public Entity Partners Grant Program: Safety Partners (5 Minutes)

G. Consideration of Purchasing ColDesi Screen Printing Equipment and Supplies for Greeneville High School Student-Based Enterprise

H. Consideration of Approving Purchase of Communication Radios for Bus Fleet (5 Minutes)

XII. **Director's Report** (5 minutes)

XIII. **Adjournment**

OFFICIAL MINUTES OF THE GREENVILLE CITY BOARD OF EDUCATION

Tuesday, August 22, 2023

The Greeneville City Board of Education met in Regular session on Tuesday, August 22, 2023, at the Professional Development Center at the Kathryn W. Leonard Administrative Office, 129 W Depot St, Greeneville, TN 37743. Board Members Present: Pam Botta (Board Member), Cindy Luttrell (Chair), Josh Quillen (Treasurer), Dr. Craig Shepherd (Vice-Chair) and student representative Hank Hope. Board Members Absent: Crystal Hirschy (Board Member). Others in attendance included Steve Starnes, Director of Schools, several administrative personnel, school personnel, community members, and media representatives. The Chair called the meeting to order and welcomed all in attendance. Board student representative Hank Hope led in the pledge of allegiance to the American Flag.

BUSINESS TRANSACTED

I. Call to Order

II. Pledge to the Flag

III. Recognition of Visitors

IV. Special Recognition

- Recognition of New Student Board Representative - Hank Hope
- TSBA Board of Distinction
- GHS AP Scholars 2022-2023

Luttrell (Chair) recognized Hank Hope as the new Student Board Representative. Hank is currently a senior at Greenville High School.

Steve Willis, TSBA Northeast District Director, and Unicoi County Chair presented the TSBA Board of Distinction plaque to Greeneville City School Board Members.

The number of AP Scholars was twenty-nine (29). Fifteen (15) of those are AP Scholars,

nine (9) are AP Scholars with Honors and five (5) are AP Scholars with Distinction. The average AP Scholar score was 3.19. The average AP Scholar with Honor score was 3.79. The average AP Scholar with Distinction score was 4.27.

Student Name	Scholar Award	Grade Level
Armstrong; William J.	AP Scholar	12th Grade
Bakshi; Seleena P.	AP Scholar	11th Grade
Benson; Anna K.	AP Scholar	12th Grade
Gross; Marlee F.	AP Scholar	12th Grade
Hartman; Maggie F.	AP Scholar	12th Grade
Hayes; Zachary J.	AP Scholar	12th Grade
Helton; Noah A.	AP Scholar	12th Grade
Herrell; Luke U.	AP Scholar with Distinction	12th Grade
Howard; Aiden A.	AP Scholar	11th Grade
Hyde; Joshua A.	AP Scholar with Distinction	12th Grade
Lane; Abby D.	AP Scholar	12th Grade
Laughlin; Aidan J.	AP Scholar	12th Grade
Marion; Kaitlyn C.	AP Scholar	12th Grade
Morelock; London N.	AP Scholar with Honor	11th Grade
Neesen; Zachary M.	AP Scholar with Distinction	12th Grade
Rai; Allison G.	AP Scholar with Honor	12th Grade
Rogers; Asher E.	AP Scholar with Distinction	12th Grade
Sauceman; Caroline M.	AP Scholar with Distinction	12th Grade
Schubert; Faith M.	AP Scholar with Honor	12th Grade
Shelton; Allie F.	AP Scholar	12th Grade
Shelton; Drew G.	AP Scholar	12th Grade
Tipton; Levi G.	AP Scholar with Honor	12th Grade
Triebel; Kaden L.	AP Scholar with Honor	12th Grade
Waddell; Emma K.	AP Scholar with Honor	11th Grade
Wakefield; Alden C.	AP Scholar with Honor	12th Grade
Whitehouse; Libby P.	AP Scholar with Honor	12th Grade
Wilkerson; Madison F.	AP Scholar	12th Grade

Williams; Amelia J.	AP Scholar	12th Grade
Zou; Skyler L.	AP Scholar with Honor	11th Grade

V. Public Comment Period

Dr. Kathryn Sharp requested to speak on the Action Item “Consideration of Approving Purchase of Pre-K Curriculum.” Dr. Sharp stated that The Tennessee State Department of Education has required the purchase of a new Pre-K Curriculum this year. Dr. Sharp and Pre-K teachers have reviewed the curriculum and have been unanimous in their selection for The Creative Curriculum for Preschool presented for consideration on the agenda.

VI. School Report

School Report Tusculum View

Highlights of the report from Dr. Lana Luttrell, Tusculum View Principal.

- Level five school for growth. Level 5 Growth is significant evidence that the school’s students made more growth than expected.
- Four-time National Blue Ribbon School of Excellence.
- Zero retentions in third grade.
- Partners with the School Uplift Energy Conservation Program.
- Goal is to have 100% of all of TV students grow at least one year’s growth in math and ELA.

VII. Approval of Agenda

It was recommended to approve the Agenda as presented. Board approval was unanimous on a motion from Shepherd (Vice-Chair) and a second from Botta (Board Member).

VIII. Consent Agenda

It was recommended to approve the Consent Agenda as presented. Board approval was unanimous on a motion from Quillen (Treasurer) and a second from Shepherd (Vice-Chair).

A. Consideration of Approving Minutes of July 25, 2023, Board Meeting

Minutes of the July 25, 2023, Board meeting were unanimously approved as presented. A copy is on file in the Director of Schools' office.

B. Consideration of Accepting Personnel Report

Board approval was unanimous for acceptance of the changes in personnel since the

July report. A copy of the report is attached to the minutes.

C. Consideration of Approving Board Policy Revisions (2nd Reading)

Copies of these policies are attached to the minutes. Board approval was unanimous on second reading for the following policies:

- 1.102 Board Members Legal Status
- 1.106 Code of Ethics
- 1.400 School Board Meetings
- 2.100 Fiscal Management Goals and Objectives
- 2.200 Annual Operating Budget
- 2.201 Line-Item Transfer Authority
- 6.100 Student Goals
- 6.200 Attendance
 - 6.2001 Attendance During Postsecondary Visits
 - 6.201 Compulsory Attendance Ages
 - 6.202 Home Schools
 - 6.319 Alternative Education

D. Consideration of Approving Board Policy Revisions - No Changes (1st Reading)

Board approval was unanimous on first reading for the following policies:

- 1.100 School District - School Board Legal Status and Authority
 - 1.101 Role of the Board of Education
 - 1.1021 Student Member of the Board
 - 1.104 Memberships
 - 1.105 School Board Legislative Involvement
 - 1.108 Nepotism
- 2.300 Comparability of Services
- 2.400 Revenues August 2023
 - 2.401 Gifts and Bequests August 2023
- 3.208 Facilities Planning
 - 3.209 Estimating Facility Costs
 - 3.210 Naming Facilities

4.207 English Learners

4.301 Interscholastic Athletics

4.400 Textbooks and Instructional Materials

4.501 School Volunteers

5.101 Line and Staff Relations

5.102 Personnel Classification and Qualifications

5.103 Job Descriptions

5.104 Equal Opportunity Employment

5.105 Recruitment of Employees

6.203 School Admissions

6.205 Student Assignments

6.206 Transfer within the System

6.207 Withdrawals

6.208 Release During School Hours

6.209 Child Custody/Parental Access

E. Consideration of Approving School Trip Request

Board Policy 4.302 specifies that the Board must approve field trips that are both overnight and out-of-state. Additionally, approval is required when students must leave school early for participation in athletic events. The Board unanimously approved the following field trips:

- Greenville Middle School is requesting approval to travel to Washington D.C. for their end of the year trip from May 7, 2024 - May 11, 2024.
- Greenville Middle School is requesting approval to travel to Fort Mill, SC for the Carowinds Festival of Music from March 22, 2024 - March 23, 2024.

F. Consideration of Declaring Surplus and Approval of Disposal

GCS Board Policy 2.403 gives the Greenville Board of Education the authority to declare district property that is no longer useful nor necessary as surplus and to authorize the disposal of such equipment, books, or materials. The Board unanimously approved the declaring of surplus and disposal of several IT assets and items with a value of less than \$500.

IX. Action Items

A. Consideration of Accepting July 2023 Financial Statements

Chief Financial Officer Ellen Lipe presented the August financial statements to the Board for acceptance. Lipe stated that local revenue collected year-to-date through July is \$482,171, which is 5.3% of the total budgeted projection. The amount collected year-to-date is \$34,275 more than during the same time period last year. This reflects an actual percentage change of 7.65% compared to last year. The district has 593 tuition students as of August 15, 2023. The Federal General-Purpose Financial Report showed that encumbrances comprise \$1,720,609 year-to-date. Copies of the financial statements are on file in the Chief Financial Officer's office. It was recommended to approve the July 2023 financial statements. Board approval was unanimous on a motion from Shepherd (Vice-Chair) and a second from Quillen (Treasurer).

B. Consideration of Approving Purchase of New Hardware for Special Educators

GCS Special Educators are currently receiving training on the new student information and reporting system mandated by the Tennessee Department of Education. The new TN-Pulse system will be utilized to house data regarding students receiving special education services. While the data is critical to the overall effectiveness of the GCS Special Education Program, it is also important in the new TISA funding model now in place in Tennessee. Teachers and administrators will be required to maintain accurate and real-time data that will be used to determine district funding. The forms are built in such a way that utilizing a tablet to obtain signatures and process requests will make the process much more streamlined and easier for all those involved. After an evaluation of current market solutions available, a recommendation is made to purchase an Apple iPad Pro device along with an Apple Pencil, Magic Keyboard, and case for each. Beverly Miller notified the Board that the current purchase of the forty-one (41) Apple iPads listed on the agenda needed to be amended to forty-four (44) to include three additional Special Education team members in the district. Supporting documentation is attached with equipment specifications and line-item pricing. The cost to purchase the amended equipment and cases is \$60,520.56. Annual reoccurring costs associated with adding

the devices to the district mobile device management system (FileWave) is currently \$227.04 for the forty-four devices, making the total project price \$60,747.60.

ESSER 3.0 funds will be utilized for this purchase.

It was recommended to amend the purchase of forty-one (41) devices to forty-four (44) on a motion from Botta (Board Member) and a second from Shepherd (Vice-Chair). It was recommended to approve the purchase of forty-four (44) Apple iPads, with an Apple Pencil, Magic Keyboard, and case for each with a total price, as amended, of \$60,747.60. Board approval was unanimous on a motion from Shepherd (Vice-Chair) and a second from Botta (Board Member).

C. Consideration of Approving Purchase of a Vehicle for Family Resource Center Use to Support ARP 2.0 Homeless and Title V-Parent and Family Engagement

GCS receives ARP Homeless 2.0 funds. These funds help to support our homeless students through supplies and instructional materials, transportation, food/hygiene items, services outside of school, and emergency housing to help our homeless students remain engaged in school-related activities. A portion of these funds have been allocated to help purchase a vehicle to assist with these efforts. In addition, GCS receives Title V funding, part of which also has been allocated to help purchase a vehicle to assist with parent and family engagement, including transportation to school and district engagement events (school meetings, parent/teacher conferences, IEP meetings, Title I Parent night, and other school engagements). Using their own personal vehicle, the Director of the District's Family Resource Center (FRC) along with GCS Social Workers, and the Family Support Attendance Interventionist, made over two hundred home visits during the 2022-2023 school year. On regular and numerous occasions, the Director hauled loads of various types of items (food, supplies, etc.) which were a need for our students. In addition, the Director transports students and family members to places such as court dates, their homes, temporary housing, and healthcare facilities, among other locations. Purchasing a vehicle for these purposes will significantly help support this vital work. This vehicle will also provide an added measure of safety for our FRC director and other district employees who visit or transport families through an easily identified district

vehicle that will openly display the Greeneville City Schools logo.

For consideration is the purchase of a 2023 Ford Escape Base AWD Oxford White vehicle in the amount of \$28,981.00 through the Tennessee state procurement process. ARP Homeless 2.0 grant funds in the amount of \$11,689.00 and Title V grant funds in the amount of \$17,292.00 will be utilized to purchase the vehicle.

There will be no impact on local resources for the 23-24 school year.

It was recommended to approve the purchase of the vehicle at a total cost of \$28,981.00. Board approval was unanimous on a motion from Botta (Board Member) and a second from Quillen (Treasurer).

D. Consideration of Approving Purchase of Legacy Classic Acoustical Shells for NPAC Performances

The current acoustic shells are used to enhance the sound of band, choral, and other performances at the NPAC were purchased more than 15 years ago. The condition of the current shells has deteriorated to the point that they are falling apart and becoming dangerous to students and equipment. The acoustic shells need to be replaced. A quote was obtained through an Omnia purchasing cooperative contract (Contract #R191204). Impact on resources will be \$37,903.57.

It was recommended to approve the purchase of Legacy Classic Acoustical Shells at a total cost of \$37,903.57. Board approval was unanimous on a motion from Shepherd (Vice-Chair) and a second from Quillen (Treasurer).

E. Consideration of Approving Purchase of Pre-K Curriculum

The Tennessee State Department of Education has mandated the purchase of a new Pre-K curriculum selected from a state-approved list. The Pre-K teachers worked together with Dr. Kathryn Sharp, Pre-K Supervisor, to select a curriculum from the state approved list that will best meet the needs of our students. The Creative Curriculum for Preschool was selected. This will be the Pre-K curriculum for the next five years. Impact on resources will be \$31,868.00

It was recommended to approve the purchase of The Creative Curriculum for Preschool. Board approval was unanimous on a motion from Quillen (Treasurer) and a second from Shepherd (Vice-Chair).

F. Consideration of Approving Board Policy Revisions - 1st Reading

Revisions are recommended to the following policies on first reading:

4.606 Graduation Activities

6.204 Attendance of Non-Resident Students

It was recommended to approve the revisions to the policies as presented on the first reading. Board approval was unanimous on a motion from Quillen (Treasurer) and a second from Botta (Board Member).

G. Consideration of Approving Board Policy Revisions - (1st and Final Reading)

Revisions are recommended to the following policies on first and final reading:

6.3071 Student Alcohol and Drug Testing

It was recommended to approve the revisions to the policy as presented on first and final reading. Board approval was unanimous on a motion from Quillen (Treasurer) and a second from Shepherd (Vice-Chair).

H. Consideration of Approving New Position of School Nutrition Field Manager

The GCS School Nutrition Program has seen dramatic programmatic changes and turnaround since Mrs. Karen Wilhoit assumed the key leadership role of School Nutrition Supervisor approximately six years ago. During her six years of leading the program, Mrs. Wilhoit has been able to reinvest nearly \$500,000 into new equipment and has replaced many antiquated systems with state-of-the-art solutions. During her tenure, the fund balance for the program has also increased from \$369,063.44 in 2017 to \$1,519,066.12 in 2023 for an increase in fund balance of \$1,150,002.68. With the School Nutrition program in such excellent fiscal position, a recommendation is submitted for consideration to allow Mrs. Wilhoit to hire a new employee to serve in the role of Field Manager. A draft job description is attached to this item. A key focus for the new employee, if approved, will be to programmatically work to improve food quality, increase menu offerings, and continue to move the program forward by providing additional support to the excellent School Nutrition leaders in each school cafeteria. 2023-2024 School Nutrition funds will be utilized.

It was recommended to approve the new position of School Nutrition Field Manager.

Board approval was unanimous on a motion from Quillen (Treasurer) and a second from Shepherd (Vice-Chair).

X. Director's Report

Starnes congratulated and recognized:

1. Congratulations to all our AP Scholars who were recognized this evening. Starnes commended them for challenging themselves and excelling in their educational opportunities.
2. Congratulations to the Board on being recognized as a TSBA Board of Distinction. This award signifies the outstanding performance by a school board as a whole in four key areas, which are planning, policy, promotion, and board development. Thank you for your efforts and commitment to achieving excellence.
3. Congratulations and welcome to Hank Hope who will be serving as our Student Board Member for the 23-24 school year. We look forward to Hank's service this year and the insight and perspective he will provide.
4. The 23-24 Convocation was held on Friday, July 28th at the NPAC. It was a great kickoff to the new year! Jim Mahoney, our keynote speaker, did a fantastic job and was very well received. Jim also conducted training for our Aspiring Administrators during the afternoon. It was a great opportunity for the group to learn from a respected educator/administrator with over 50 years' experience in education.
5. Starnes announced that we will be hosting the Eastern States Consortium Fall Site Visit October 22-24. The ESC is a group of fifteen high-performing school systems representing nine states (AL, MS, LA, TN, VA, MO, IL, OH, and MI.) that was formed to benchmark, problem solve common issues, and learn from each other. The group is supported by the American Association of School Administrators (AASA). Please reserve the date of Sunday, October 22 from 6:00 to 8:30 pm for the Kickoff Dinner.
6. Starnes, along with several other Leadership Team members, attended the TDOE Town Hall Meeting on School Letter Grades held at the General Morgan Inn on Thursday, August 17, 2023. at 5:30 pm. Board member, Mrs. Pam Botta also attended. Dr. Bryant, Brandy Shelton, Dr. Luttrell, and Starnes spoke and advocated that the calculation method for School Letter Grades remain the same as has previously been communicated with

districts, which is the same as the Accountability Matrix which has been in place since the 2017-18 school year. Public comment can be submitted to schoollettergrades@tnedu.gov by September 15, 2023. <https://www.tn.gov/education/news/2023/8/9/tdoe-launches-public-engagementopportunities-on----school-letter-grades--.html>

7. The GCS Tech Blitz will take place on Friday, September 1, 2023, at the NPAC and GHS. Beverly Miller has planned and organized a great day of learning for our system, including nationally recognized speaker, Steve Dembo, who will be speaking on Artificial Intelligence. The Board is invited to join us.

8. Teachers, students, and school staff are off to a great start this year and lots of exciting things are taking place.

9. Reminder of our joint meeting with the City Council scheduled for August 29, 2023, here in the KLCO PDC beginning at 5 pm. The agenda and all supporting information will be sent on Wednesday.

XI. Adjournment

It was recommended to adjourn at approximately 6:57 p.m. Board approval was unanimous on a motion from Quillen (Treasurer) and a second from Botta (Board Member).

Respectfully submitted,

Cindy Luttrell, Chair

Steve Starnes, Director of Schools



. NYC

FIELD TRIP AND EXCURSION REQUEST FORM
Out-of-State *and* Overnight

Name of the school: Greenville High School

Person Requesting: Daniel Varnell

Purpose of the Field Trip: For chorus students to sight see and perform in New York City,

Destination of Field Trip: New York, New York

Grade(s) of students attending: 9-12

Dates requested: Mar 11-15, 2024 Departure Time: 5 AM Return Time: 11 PM

Approximate # of students to attend: 30

Number, names and affiliation of chaperones attending:

? female List names and affiliation: Beth Ann Noble - Teacher GHS

There will be several more

? male List names and affiliation: Daniel Varnell - Teacher GHS

There will be several more

("There must be at least one female and one male chaperone if the trip is for a mixed group. A chaperone of the same sex will accompany students on overnight trips")

All Greenville City Schools guidelines for out-of-state and overnight field trips shall be followed in planning and conducting this field trip per Board of Education policy 4.302, and approval of my principal, the Director of Schools, and Board of Education is required. For an Overnight and Out-of-State Field Trip Request to be considered for approval, it must be received in the director of school's office 10 days prior to the scheduled date of the Board meeting at which it will be considered for approval.

[Signature], Principal

date approved 8/28/23

_____, Director of Schools

date approved _____

_____, Chairman, BOE

date approved _____

Cultivate the Mind and Impact the Heart through Excellence and Equity



FIELD TRIP AND EXCURSION REQUEST FORM
Out-of-State *and* Overnight

Name of the school: GREENEVILLE High School

Person Requesting: ANDY COLLINS

Purpose of the Field Trip: BASEBALL

Destination of Field Trip: ATLANTA - PEACHTREE RIDGE & MT. PISGAH H.S.

Grade(s) of students attending: 9-12

Dates requested: 3/29 - 3/30/2024 Departure Time: 8AM Return Time: 7PM

Approximate # of students to attend: 26 MALES

Number, names and affiliation of chaperones attending:

female List names and affiliation: _____

5 male List names and affiliation: BRYAN EVERHART - GCS, ANDY BARNETT - GCS, ANDY COLLINS - GCS, RANDY RICHARDS - ASST., CODY HARTNESS - ASST.

("There must be at least one female and one male chaperone if the trip is for a mixed group. A chaperone of the same sex will accompany students on overnight trips")

All Greenville City Schools guidelines for out-of-state and overnight field trips shall be followed in planning and conducting this field trip per Board of Education policy 4.302, and approval of my principal, the Director of Schools, and Board of Education is required. For an Overnight and Out-of-State Field Trip Request to be considered for approval, it must be received in the director of school's office 10 days prior to the scheduled date of the Board meeting at which it will be considered for approval.

[Signature], Principal

date approved 8/28/23

_____, Director of Schools

date approved _____

_____, Chairman, BOE

date approved _____

Cultivate the Mind and Impact the Heart through Excellence and Equity



GREENEVILLE CITY SCHOOLS

FIELD TRIP & EXCURSION REQUEST FORM Out-of-State and/or Overnight

Name of the school: Hal Henard Elementary School

Person Requesting: Janet Ricker

Purpose of the Field Trip: Camp Explore

Destination of Field Trip: Clyde Austin 4-H Camp, Greeneville, TN 37743

Grade(s) of students attending: 5th grade

Dates requested: 9/14 - 9/15/23 Departure Time: 8:00am Return Time: 1:00pm

Approximate # of students to attend: 64

Number, names and affiliation of chaperones attending:

2 female List names and affiliation: Charity Wright, Kelly Lamons
(5th grade teachers)

2 male List names and affiliation: Daniel Myers, Ron Fields
(Hal Henard teachers)

("There must be at least one female and one male chaperone if the trip is for a mixed group. A chaperone of the same sex will accompany students on overnight trips")

All Greeneville City Schools guidelines for out-of-state and overnight field trips shall be followed in planning and conducting this field trip per BOE policy 4.302, and approval of my principal, the Director of Schools, and Board of Education is required. For an Overnight and Out-of-State Field Trip Request to be considered for approval, it must be received in the director of school's office 10 days prior to the scheduled date of the Board meeting at which it will be considered for approval.

Janet Ricker, Principal

date approved 8/30/23

_____, Director of Schools

date approved _____

_____, Chairman, BOE

date approved _____

Learning Without Limits

FW: Field Trip-HH

Steve Starnes <starness@gcschools.net>

Tue 9/5/2023 9:51 AM

To: Jamie Galyon <galyonj@gcschools.net>

Executive Committee Approval and Consent Agenda for Sept. meeting. Thanks!

Steve Starnes
Director of Schools
Greeneville City Schools
129 W. Depot St.
Greeneville, TN 37743
423-787-8014



From: Luttrell, Cindy <Cindy.Luttrell@balladhealth.org>

Sent: Tuesday, September 5, 2023 9:26 AM

To: Steve Starnes <starness@gcschools.net>

Subject: Re: Field Trip-HH

WARNING: This email originated from outside of the Greeneville City Schools network. Do not click links or open attachments unless you recognize the sender and know the content is safe.

That is fine with me. I enjoyed being off and hope you had a great holiday weekend as well. 😊

Cindy Luttrell, BS, CPXP
Director of Guest Relations
Greeneville Community Hospital
423-636-5480



From: Steve Starnes <starness@gcschools.net>
Sent: Tuesday, September 5, 2023 9:03 AM
To: Luttrell, Cindy <Cindy.Luttrell@balladhealth.org>
Subject: FW: Field Trip-HH

Caution: This email originated from outside Ballad Health. **DO NOT click links, open attachments, or reply to the email** unless you recognize and/or validate the sender, are expecting the email, and are confident the sender and content are safe.

Good morning Cindy,

I hope you had a good Labor Day weekend!

Please see the attached field trip request. Janet didn't find out the dates until the 3rd week of August for this trip and it was too late for inclusion on the August agenda and the field trip is set to occur before our Sept. meeting. HH participates each year. Are you okay to do Executive Committee approval? Thanks!

Have a great day!

Steve Starnes
Director of Schools
Greeneville City Schools
129 W. Depot St.
Greeneville, TN 37743
423-787-8014



From: Jamie Galyon <galyonj@gcschools.net>
Sent: Tuesday, September 5, 2023 8:55 AM
To: Steve Starnes <starness@gcschools.net>
Subject: Field Trip-HH

Here is the field trip form.

Jamie Galyon

Administrative Assistant to Director of Schools
Greenville City Schools
129 W. Depot St.
Greenville, TN 37743
423-787-8014

galyonj@gcschools.net



This message may contain confidential information. If you are not the intended recipient, please forward the message to mailadmin@gcschools.net. If you do not forward the message to us, we cannot determine the problem.

All email entering or leaving the Greenville City Schools mail server is archived and checked for content and security. All messages are checked for viruses before entering or leaving our server. Spam, viruses, dangerous

attachments, and offensive content are removed automatically.

The Greeneville City School System does not discriminate in employment, admission, or participation in educational programs on the basis of race, color, gender, age, national origin, religion, or disability.

Learning Without Limits www.gcschools.net

This message is from Ballad Health. The contents contained herein may contain confidential information. If you are not the intended recipient, you are hereby notified that any disclosure, copying, distribution, printing or action taken on the contents is strictly prohibited. If you have received this email in error, please notify the sender immediately and delete this message.



GREENEVILLE CITY SCHOOLS

FIELD TRIP & EXCURSION REQUEST FORM Out-of-State and/or Overnight

Name of the school: Greeneville Middle

Person Requesting: Robin Lafever

Purpose of the Field Trip: "All East" Honors Choir

Destination of Field Trip: Cleveland, TN

Grade(s) of students attending: 8th and 7th

Dates requested: Nov. 17-18, 2023 Departure Time: Fri 8:00am Return Time: Sat. 5:30-6:30pm

Approximate # of students to attend: 6-8

Number, names and affiliation of chaperones attending:

1 female List names and affiliation: Alyson Cutshall mother of one of my students going

1 male List names and affiliation: Stephen Cutshall father of one of my students going

("There must be at least one female and one male chaperone if the trip is for a mixed group. A chaperone of the same sex will accompany students on overnight trips")

All Greeneville City Schools guidelines for out-of-state and overnight field trips shall be followed in planning and conducting this field trip per BOE policy 4.302, and approval of my principal, the Director of Schools, and Board of Education is required. For an Overnight and Out-of-State Field Trip Request to be considered for approval, it must be received in the director of school's office 10 days prior to the scheduled date of the Board meeting at which it will be considered for approval.

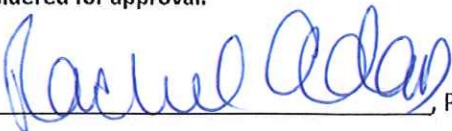
, Principal

date approved 8/31/23

_____, Director of Schools

date approved _____

_____, Chairman, BOE

date approved _____

Learning Without Limits



FIELD TRIP AND EXCURSION REQUEST FORM
Out-of-State *and* Overnight

Name of the school: Greeneville High School
Person Requesting: Maj. Tyler Stabiler
Purpose of the Field Trip: US Space & Rocket Center JROTC Stellar Explorers program
Destination of Field Trip: Huntsville AL
Grade(s) of students attending: 9-12
Dates requested: 3-6 Nov 2023 Departure Time: 08:00 Return Time: 4:00pm
Approximate # of students to attend: 20
Number, names and affiliation of chaperones attending:

2 female List names and affiliation: Noelle Smith, Debbie Talmage

2 male List names and affiliation: Maj. Tyler Stabiler, Msgr Jason Talmage

("There must be at least one female and one male chaperone if the trip is for a mixed group. A chaperone of the same sex will accompany students on overnight trips")

All Greeneville City Schools guidelines for out-of-state and overnight field trips shall be followed in planning and conducting this field trip per Board of Education policy 4.302, and approval of my principal, the Director of Schools, and Board of Education is required. For an Overnight and Out-of-State Field Trip Request to be considered for approval, it must be received in the director of school's office 10 days prior to the scheduled date of the Board meeting at which it will be considered for approval.

[Signature], Principal date approved 9-14-23
_____, Director of Schools date approved _____
_____, Chairman, BOE date approved _____

Cultivate the Mind and Impact the Heart through Excellence and Equity



FIELD TRIP AND EXCURSION REQUEST FORM
Out-of-State and Overnight

Name of the school: Greenville High School

Person Requesting: Randy Shelton, Atlas Fagundes

Purpose of the Field Trip: Wrestling tournament

Destination of Field Trip: Walsh - Jesuit Ironman, Cayahoga Falls, OH

Grade(s) of students attending: 11

Dates requested: Dec. 8-10 Departure Time: 8:00 am Return Time: 10:00 pm

Approximate # of students to attend: 1

Number, names and affiliation of chaperones attending:

0 female List names and affiliation: _____

1 male List names and affiliation: Carson Dupill - he will be staying in a room with his parents (Craig + Hilary Dupill)

("There must be at least one female and one male chaperone if the trip is for a mixed group. A chaperone of the same sex will accompany students on overnight trips")

All Greenville City Schools guidelines for out-of-state and overnight field trips shall be followed in planning and conducting this field trip per Board of Education policy 4.302, and approval of my principal, the Director of Schools, and Board of Education is required. For an Overnight and Out-of-State Field Trip Request to be considered for approval, it must be received in the director of school's office 10 days prior to the scheduled date of the Board meeting at which it will be considered for approval.

[Signature], Principal

date approved 9-14-23

_____, Director of Schools

date approved _____

_____, Chairman, BOE

date approved _____

Cultivate the Mind and Impact the Heart through Excellence and Equity



FIELD TRIP AND EXCURSION REQUEST FORM
Out-of-State *and* Overnight

Name of the school: Greeneville High School

Person Requesting: Randy Shelton

Purpose of the Field Trip: Wrestling tournament

Destination of Field Trip: Council Rock HS, PA (Escape the Rock)

Grade(s) of students attending: 11

Dates requested: Jan, 13-14 Departure Time: 8:00 am Return Time: Unknown

Approximate # of students to attend: 1

Number, names and affiliation of chaperones attending:

0 female List names and affiliation: _____

1 male List names and affiliation: Carson Dupill - he will be staying with his parents (Craig and Hilary Dupill)

("There must be at least one female and one male chaperone if the trip is for a mixed group. A chaperone of the same sex will accompany students on overnight trips")

All Greeneville City Schools guidelines for out-of-state and overnight field trips shall be followed in planning and conducting this field trip per Board of Education policy 4.302, and approval of my principal, the Director of Schools, and Board of Education is required. For an Overnight and Out-of-State Field Trip Request to be considered for approval, it must be received in the director of school's office 10 days prior to the scheduled date of the Board meeting at which it will be considered for approval.

DA Mon Principal date approved 9-14-23

_____, Director of Schools date approved _____

_____, Chairman, BOE date approved _____

Cultivate the Mind and Impact the Heart through Excellence and Equity



FIELD TRIP AND EXCURSION REQUEST FORM
Out-of-State and Overnight

Name of the school: Greeneville High School

Person Requesting: Randy Shelton, Atlas Fagundes

Purpose of the Field Trip: Wrestling Tournament

Destination of Field Trip: Bobby Bates Invitational @ UVA-Wise, Wise VA

Grade(s) of students attending: 9-12

Dates requested: Dec. 15-16 Departure Time: 8:00am Return Time: Unknown

Approximate # of students to attend: 14-20

Number, names and affiliation of chaperones attending:

female List names and affiliation: _____

14-20 male List names and affiliation: Varsity line-up and advanced JV wrestlers

("There must be at least one female and one male chaperone if the trip is for a mixed group. A chaperone of the same sex will accompany students on overnight trips")

All Greeneville City Schools guidelines for out-of-state and overnight field trips shall be followed in planning and conducting this field trip per Board of Education policy 4.302, and approval of my principal, the Director of Schools, and Board of Education is required. For an Overnight and Out-of-State Field Trip Request to be considered for approval, it must be received in the director of school's office 10 days prior to the scheduled date of the Board meeting at which it will be considered for approval.

DA Ma, Principal

date approved 9-14-23

_____, Director of Schools

date approved _____

_____, Chairman, BOE

date approved _____

Cultivate the Mind and Impact the Heart through Excellence and Equity



**FIELD TRIP AND EXCURSION REQUEST
FORM Out-of-State *or* Overnight**

Name of the school: Greenville Middle School

Person Requesting: Laura Lenker/Kelly Lamons

Purpose of the Field Trip: Cross Country State Championship Meet

Destination of Field Trip: Clarksville. TN

Grade(s) of students attending: 6th

Dates requested: 9/29/23 Departure Time: 10:30 am Return Time: 8 pm on 9/30

Approximate # of students to attend: 1

Number, names and affiliation of chaperones attending:

2 female List names and affiliation: Kelly Lamon and Laura Lenker

0 male List names and affiliation: _____

("There must be at least one female and one male chaperone if the trip is for a mixed group. A chaperone of the same sex will accompany students on overnight trips")

All Greenville City Schools guidelines for out-of-state and overnight field trips shall be followed in planning and conducting this field trip per Board of Education policy 4.302, and approval of my principal, the Director of Schools, and Board of Education is required. For an Overnight and Out-of-State Field Trip Request to be considered for approval, it must be received in the director of school's office 10 days prior to the scheduled date of the Board meeting at which it will be considered for approval.

Rachel Adams
Rachel Adams (Sep 25, 2023 14:01 EDT) _____, Principal date approved _____

_____, Director of Schools date approved _____

_____, Chairman, BOE date approved _____

Cultivate the Mind and Impact the Heart through Excellence and Equity





GCSOut-of-stateandOvernightFieldTripRequest

Final Audit Report

2023-09-25

Created:	2023-09-25
By:	Jamie Galyon (galyonj@gcschools.net)
Status:	Signed
Transaction ID:	CBJCHBCAABAAbCGYbp_HpbpzHX25qdBCKqEf82PYMd1o

"GCSOut-of-stateandOvernightFieldTripRequest" History

-  Document created by Jamie Galyon (galyonj@gcschools.net)
2023-09-25 - 12:45:51 PM GMT
-  Document emailed to Rachel Adams (adamsr2@gcschools.net) for signature
2023-09-25 - 12:46:32 PM GMT
-  Email viewed by Rachel Adams (adamsr2@gcschools.net)
2023-09-25 - 6:00:45 PM GMT
-  Document e-signed by Rachel Adams (adamsr2@gcschools.net)
Signature Date: 2023-09-25 - 6:01:00 PM GMT - Time Source: server
-  Agreement completed.
2023-09-25 - 6:01:00 PM GMT



From: Luttrell, Cindy <Cindy.Luttrell@balladhealth.org>
Sent: Tuesday, August 29, 2023 9:13 AM
To: Steve Starnes <starness@gcschools.net>
Subject: Re: Executive Committee Approval

WARNING: This email originated from outside of the Greenville City Schools network. Do not click links or open attachments unless you recognize the sender and know the content is safe.

I agree with that and appreciate you making me aware of it as well. Let's proceed in getting a replacement as quickly as possible.

*Cindy Luttrell, BS, CPXP
Director of Guest Relations
Greenville Community Hospital
423-636-5480*



From: Steve Starnes <starness@gcschools.net>
Sent: Tuesday, August 29, 2023 9:10 AM
To: Luttrell, Cindy <Cindy.Luttrell@balladhealth.org>
Cc: Jamie Galyon <galyonj@gcschools.net>
Subject: Executive Committee Approval

Caution: This email originated from outside Ballad Health. **DO NOT** [click links, open attachments, or reply to the email](#) unless you recognize and/or validate the sender, are expecting the email, and are confident the sender and content are safe.

Good morning,

Per our conversation yesterday, the dishwasher at GHS is 25+ years old and it is becoming extremely difficult to keep it operating. Currently, the dishwasher does not meet the temperature for sanitation purposes. It is the recommendation of Nutrition and Administration that we replace the dishwasher. The current lead time for a replacement is 6-8 weeks from ordering. Please reply to this email to confirm Executive Committee approval to purchase a dishwasher at a cost of \$64,665.61 for Greeneville High School and to purchase the installation from Hobart at a cost of \$14,745.30. The total cost of the project is \$79,410.91. This purchase will be from a Sourcewell contract (Purchasing Cooperative) which meets our purchasing requirements. If you have any questions, please let me know. Thanks!

Steve Starnes
Director of Schools
Greeneville City Schools
129 W. Depot St.
Greeneville, TN 37743
423-787-8014



This message may contain confidential information. If you are not the intended recipient, please forward the message to mailadmin@gcschools.net. If you do not forward the message to us, we cannot determine the problem.

All email entering or leaving the Greeneville City Schools mail server is archived and checked for content and security. All messages are checked for viruses before entering or leaving our server. Spam, viruses, dangerous attachments, and offensive content are removed automatically.

The Greeneville City School System does not discriminate in employment, admission, or participation in educational programs on the basis of race, color, gender, age, national origin, religion, or disability.

Learning Without Limits www.gcschools.net

This message is from Ballad Health. The contents contained herein may contain confidential information. If you are not the intended recipient, you are hereby notified that any disclosure, copying, distribution, printing or action taken on the contents is strictly prohibited. If you have received this email in error, please notify the sender immediately and delete this message.



Project _____
 AIA # _____ SIS # _____
 Item # _____ Quantity _____ C.S.I. Section 114000

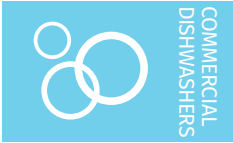

CLPS66eN-BAS ELECTRIC

High Temperature Rack Conveyor Dishwashing Machine

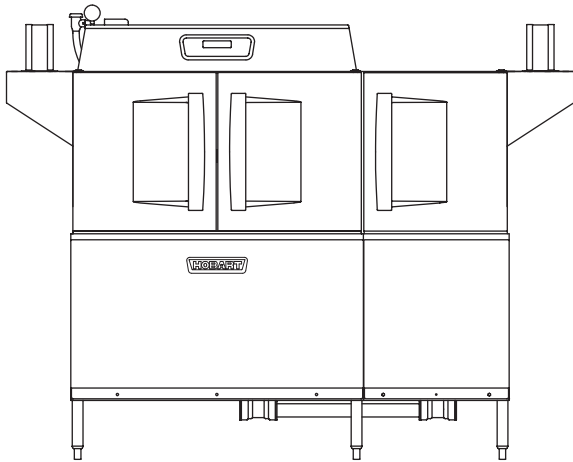

STANDARD FEATURES

- + 202 racks per hour
- + 22" power scrapper
- + Opti-Rinse™ system
- + Rapid return conveyor drive mechanism
- + Large double door opening for ease of cleaning
- + Doors are insulated & hinged with door interlock switches
- + 19.5" chamber height opening (accepts sheet pans)
- + Top mounted micro-processor control module
- + Energy saver mode (programmable auto-shut down)
- + Dirty water indicator
- + Manager activated low temperature alert
- + NSF rated configurable pot and pan dwell mode
- + Configurable "intelligent" delime notification
- + Service diagnostics
- + Self-aligning wash manifolds
- + Stainless steel anti-clogging wash arms
- + Stainless steel self-draining pump and impeller
- + Single, sloping scrap screen and deep scrap basket
- + Stainless panels enclose perimeter and bottom
- + Door actuated drain closure
- + Convertible hot water or low temp final rinse
- + Vent fan control
- + Booster heater control
- + Power scrapper vent cowl curtain kit
- + ENERGY STAR® Certified

CLEAN SERIES – CLPS66eN-BAS ELECTRIC



SPECIFIER STATEMENT

Specified dishwasher will be Hobart CLPS66eN Base electric tank heat model with Opti-Rinse™. Includes 22" power scrapper, insulated ergonomic cabinet style doors, dirty water indicator, configurable "intelligent" de-lime notification, top mounted computer controls, and NSF approved pot and pan cycle mode. The wash tank utilizes durable precision pressure sensor monitors in lieu of conventional mechanical floats. The 19.5" standard chamber height will accommodate up to (6) standard sheet pans at a time on an open-end sheet pan rack.

OPTIONS & ACCESSORIES (Available at extra cost)

- Standard, short, and extended stainless steel vent hoods
- Internal stainless steel pressure-less 30 kW booster heater field convertible to 15 kW (booster includes PRV)
 - + Dual point electrical connection standard on 208/60/3 and 240/60/3 voltage machines, when equipped with internal booster; single point kits available (see page 3)
 - + Single point connection standard on 480/60/3 and 600/60/3 voltage machines, when equipped with internal booster
- Direct drive unloader – adds 38" length. Reference spec F39520 for more details
- Side loader – SL23 adds 23" length, SL30 adds 30" length. Reference specs F40926 and F40927 for more details
- Blower-dryer – adds 33¼" to length. Reference spec F40252 for more details (ships separate from dishmachine, contact Hobart Service for installation)
- Drain water tempering kit (field installed)
- Flanged feet kit (requires two kits)
- Higher than standard chamber (24" opening)
- Table limit switch with 10' wire
- Correctional package (contact Hobart for details)
- Pressure regulator valve (PRV), for use with external booster
- Water shock absorber kit
- Factory-mounted circuit breakers (contact Hobart for details)
- Field installed single point kits available for 208/60/3 and 240/60/3 machines when equipped with internal booster

Approved by _____ Date _____ Approved by _____ Date _____



CLPS66eN-BAS ELECTRIC

High Temperature Rack Conveyor Dishwashing Machine

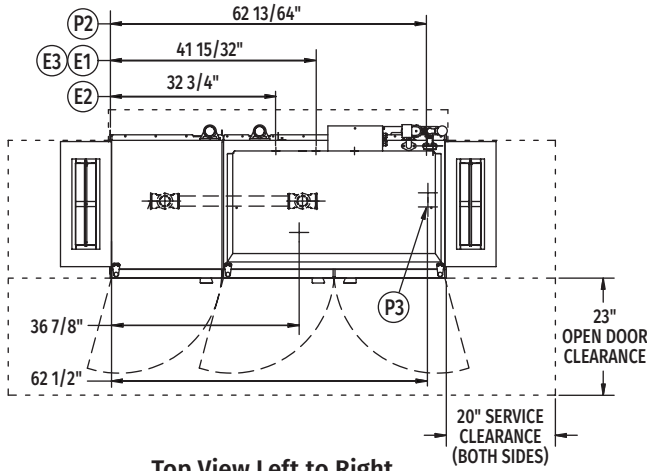

Top View Left to Right

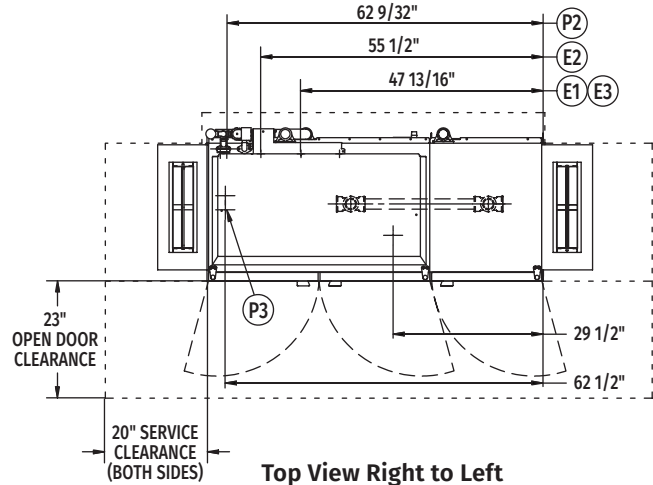

Top View Right to Left

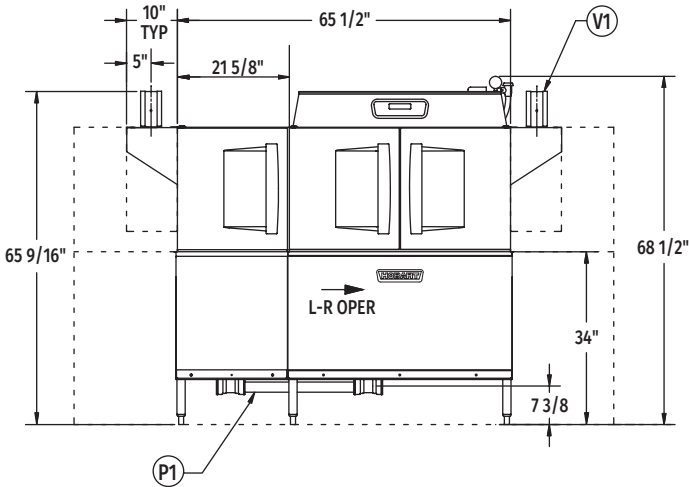

Front View Left to Right

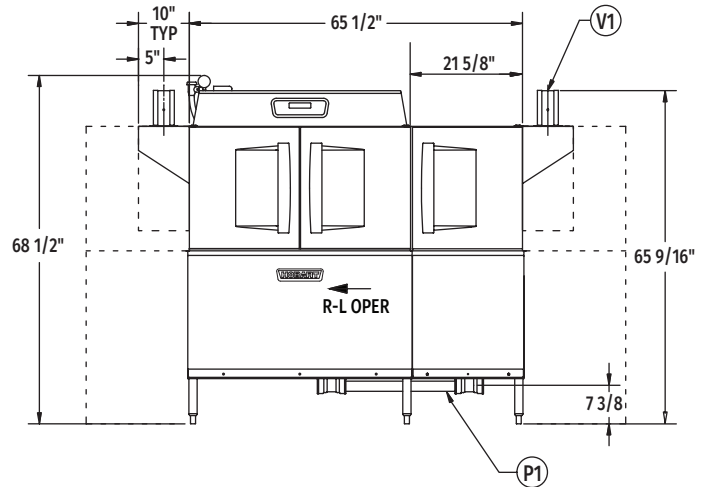

Front View Right to Left

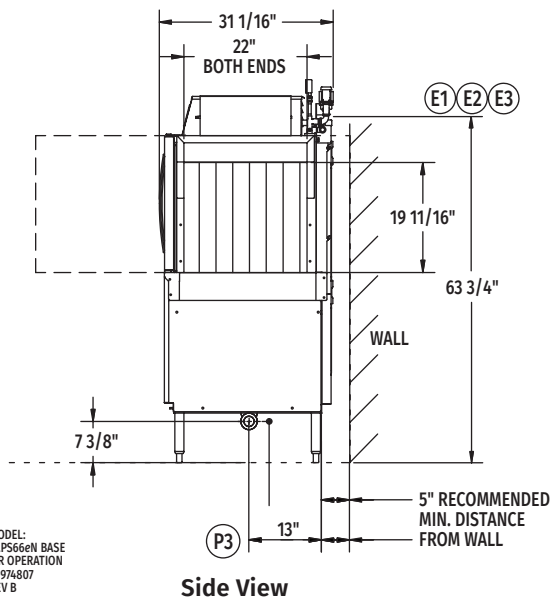

Side View

Tabling Connection: 66" inside tank (at table connection)

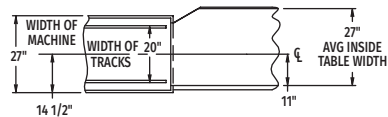

Suggested Track and Table Layout

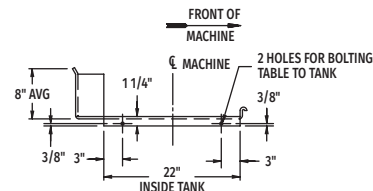

View Showing Hole Locations in Turned Down Portion of Table

MODEL: CLPS66eN BASE
L-R OPERATION
D-974807
REV B

MODEL: CLPS66eN BASE
R-L OPERATION
D-974806
REV B



CLPS66eN-BAS ELECTRIC

High Temperature Rack Conveyor Dishwashing Machine

LEGEND

Electrical Connections	
Required when machine equipped with SINGLE POINT ELECTRICAL CONNECTION	
E1	Tank heat, motors, controls AND 30kW booster heater – multiple knockouts provided, 63-3/4" AFF.
Required when machine equipped with DUAL POINT ELECTRICAL CONNECTION	
E2	Tank heat, motors and controls – multiple knockouts provided, 63-3/4" AFF.
E3	Internal 30kW booster heater – multiple knockouts provided, 63-3/4" AFF.
Multiple knockouts provided for 2", 1" and 1/2" trade size conduits.	
Plumbing Connections	
P1	Drain. May be drained to either side of valve, plug opposite side 2" FPT. Recommend a floor drain minimum of 12" from machine for access and maintenance. 7-3/8" AFF.
P2	Hot water. 1/2" FPT connection. 1/2", 11-3/16" AFF. See plumbing notes for required temperatures.
P3	Optional cold water connection for drain water tempering 1/2" FPT, cold water temperature 80°F, maximum 7-3/8" AFF.
Vent Connections	
V1	Optional vent hoods, 4" x 16" vent stack with damper.

SPECIFICATIONS

Capacities	
Racks per Hour (NSF rated)	202
Wash Tank (U.S. gallons)	23
Power Scrapper (U.S. gallons)	23
Conveyor Speed (feet per minute)	5.6
Motor Horsepower	
Drive	1/6
Wash	2
Power Scrapper	2
Water Consumption	
U.S. Gallons per Hour (maximum use at 20 PSI)	126
U.S. Gallons per Rack	0.62
Peak Drain Flow (U.S. gallons per minute)	38
Heating	
Tank Heat, Electric (kW)	15
Optional Electric Booster (built-in) (kW for 40°F rise)	15
Optional Electric Booster (built-in) (kW for 70°F rise)	30
Venting	
Load End (minimum CFM)	200
Unload End (minimum CFM)	400
Shipping Weight (approximate)	855 lbs.
Crated Dimensions	76"L x 38"W x 78"H

E1	Single Point Electrical Connection with internal 30 kW Booster Heater		
Voltage	(E1) Tank Heat, Motors, Controls 30kW Booster Heater		Single Point Service Connection
	Rated Amps	Minimum Supply Circuit Ampacity / Maximum Protective Device	
208/60/3	144.5	175	Field Installed SGLPT-KIT4-CLE required, order separately
240/60/3	138.2	150	Field Installed SGLPT-KIT2-CLE required, order separately
480/60/3	70.7	90	Ships Standard, Factory Installed
600/60/3	49.4	60	Ships Standard, Factory Installed

E2	Dual Point Electrical Connection with Internal 30 kW Booster Heater				
E3	(For machines without internal booster heater, refer to E2, Tank Heat, Motors & Controls connection only)				
Voltage	(E2) Tank Heat, Motors, Controls		(E3) 30kW Booster Heater		Dual Point Service Connection
	Rated Amps	Minimum Supply Circuit Ampacity / Maximum Protective Device	Rated Amps	Minimum Supply Circuit Ampacity / Maximum Protective Device	
208/60/3	60.6	80	83.9	90	Dual Point Ships Standard
240/60/3	58.0	80	80.2	90	Dual Point Ships Standard
480/60/3	30.6	40	40.1	50	Field Convertible
600/60/3	22.6	35	26.9	40	Field Convertible



CLPS66eN-BAS ELECTRIC

High Temperature Rack Conveyor Dishwashing Machine

WARNING: Plumbing and electrical connections should be made by qualified personnel who will observe all the applicable plumbing, sanitary, safety codes and National Electrical Code.

Plumbing Notes: Minimum incoming water temperatures: 110°F for 30kW internal booster, 140°F for 15kW field converted internal booster, 180°F without internal booster. Building flowing water pressure to dish machine is 20 PSI, (+/- 5 PSI). For non-booster machines, a PRV with internal expansion bypass is required. When ordered as an accessory, ½" brass regulator must be installed before the booster. Water temperature to the regulator must not exceed 140°F.

Recommended water hardness to be 3 grains or less for best results.

Electrical Note: Dishmachine not provided with internal GFCI protection.

CLPS66eN-BAS Electric Heat Dissipation		
Booster	BTU/HR.	
	Latent	Sensible
Without Booster	15,800	6,800
15kW Booster	29,300	12,600
30kW Booster	42,900	18,400

NOTE: 30kW Booster Heater field convertible to 15kW when 140°F incoming water provided. (Conversion instructions located in machine control box. Contact factory for 15kW booster amperage ratings.)

NOTE: Additional CLeN Voltages and Amperages are available, see document F40972.

VENT HOOD OPTIONS (Adjustable, vent stack can be adjusted 1" to either side)

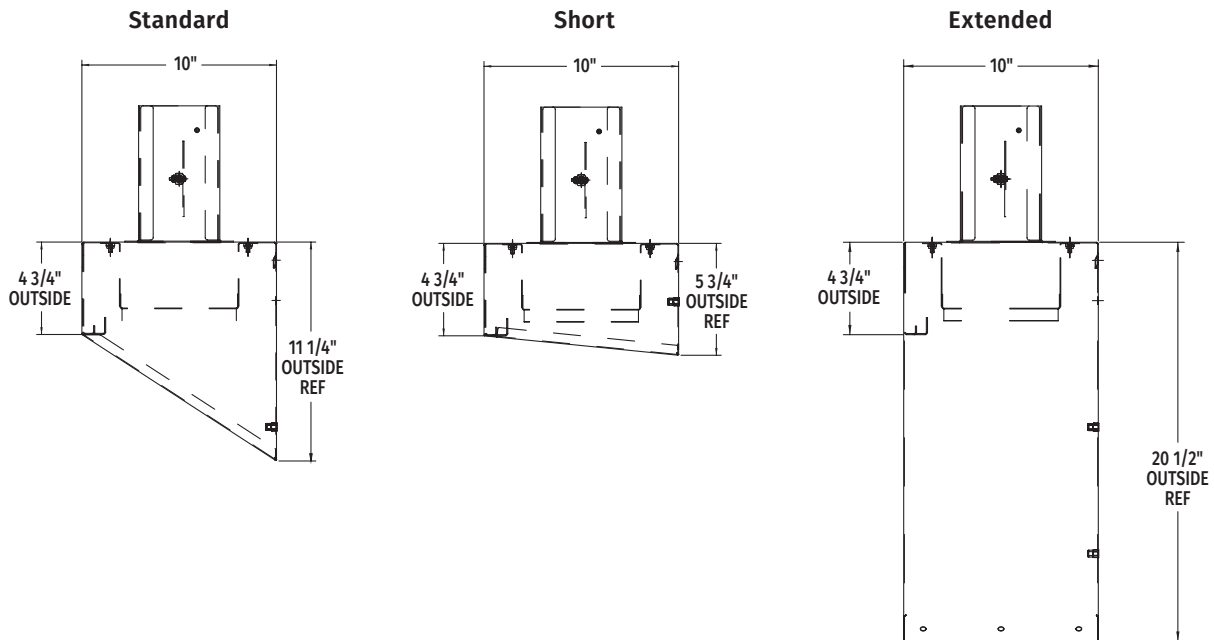

As continued product improvement is a policy of Hobart, specifications are subject to change without notice.



Oversized Equipment Quick Reference Guide

Oversized units with crated shipping dimensions greater or equal to 72" in length and/or 90" in height. If delivery is to a facility without a standard height dock, additional shipping charges will apply depending on the service requested.

HOBART

DOOR TYPES <ul style="list-style-type: none"> • AM15T • AM15VLT 	CONVEYOR TYPES (CL, FT) <ul style="list-style-type: none"> • CL44eN-ADV • CL44eNVL • All 54" Models or Greater • All FT Models 	PREP WASHERS <ul style="list-style-type: none"> • PW10eR • PW20eR • PWVeR 	TURBOWASHERS (TW), TOTEWASHERS (CL64T) WASTE PULPERS (WPS) <ul style="list-style-type: none"> • All Models 	WRAPPING SYSTEM (NGW) <ul style="list-style-type: none"> • All Models
--	---	---	--	---



Traulsen

centerline by Traulsen

G, R and A SERIES <ul style="list-style-type: none"> • All Roll-In & Roll-Thru Models • All Three Section Models 	UNDERCOUNTERS (UHT, UHD, ULT, TU) <ul style="list-style-type: none"> • All 72" Models or Greater 	PREP TABLES (UST, USD, UPT, UPD, TS, TB) <ul style="list-style-type: none"> • TB - 60" Models or Greater • TS - 66" Models or Greater • All 72" Models or Greater 	EQUIPMENT STANDS (TE) <ul style="list-style-type: none"> • All Models 48" or Greater 	UNDERCOUNTERS (CLUC) & PREP TABLES (CLPT) <ul style="list-style-type: none"> • All 72" Models or Greater
---	--	---	--	--



THE INFORMATION PROVIDED IS TO BE USED AS A QUICK REFERENCE GUIDE ONLY. PLEASE CONSULT ITW FEG CUSTOMER CARE FOR UNITS NOT LISTED OR ANY QUESTIONS SURROUNDING DELIVERY OPTIONS.

HOBART701 S Ridge Avenue, Troy, OH 45374
1-888-4HOBART • www.hobartservice.com**WATER SOFTENING SYSTEMS –
WS-40****HOBART****FEATURES:****Operating Profile**

Softener will remove hardness to less than 1/2 gpg when operated in accordance with the operating instructions. The system includes two tanks. This duplex configuration operates with one tank on-line during service. During regeneration cycles, one tank will provide water to service and to the regenerating tank. A water meter initiates system regeneration. The water meter measures the processed volume and is adjustable. Service flow is up-flow and regeneration flow is down-flow.

Regeneration Control Valve

The regeneration control valve is top mounted (top of media tank), and manufactured from non-corrosive materials. Control valve does not weigh more than four pounds. Control valve provides service and regeneration control for two media tanks. Inlet and outlet ports accept a quick connect, double o-ring sealed adapter. Interconnection between tanks are made through the regeneration valve with a quick connect adapter. Control valve operates using a minimum inlet pressure of 15 psi. Pressure is used to drive all valve functions. No electric hook-up is required. Control valve incorporates four operational cycles including; service, brine draw, slow rinse, and a combined fast rinse and brine refill. Service cycle operates in an up-flow direction. The brine cycle flows down-flow, opposite the service flow, providing a countercurrent regeneration. Control valve contains a fixed orifice eductor nozzle and self-adjusting backwash flow control. The control valve will prevent the bypass of hard water to service during the regeneration cycle.

Media Tanks

The tanks are designed for a maximum working pressure of 125 psi and hydrostatically tested at 300 psi. Tanks are made of engineered plastic with a 2.5 in. threaded top opening. Each tank is NSF approved. Upper distribution system is of a slot design. Lower distribution system is of a flat plate design. Distributors will provide even flow of regeneration water and the collection of processed water.

Conditioning Media

Each softener will include uniform bead cation resin having a minimum exchange capacity of 30,000 grains/ft³ when regenerated with 15.0 lbs/ft³. The media is solid, of a proper particle size and contains no plates, shells, agglomerates or other shapes, which might interfere with the normal function of the water softener.

Brine System

A combination salt storage and brine production tank is manufactured of corrosion resistant, plastic. The brine tank has a chamber to house the brine valve assembly. The brine float assembly allows for adjustable salt settings and provides for a shut-off to the brine refill. The brine tank includes a safety over-flow connection to be plumbed to a suitable drain.

Salt Alarm

Salt alarm consists of an alarm box and a brine sensor. Brine sensor is mounted internally on the grid plate and operates on the specific gravity of proper brine concentration. An alarm condition is triggered when the concentration falls below acceptable level for more than 15 minutes. The alarm is both an 80-db audible alarm every 3 seconds and a red LED flash every 7 seconds. The alarm box operates on three AA batteries and connects to the brine sensor with a standard 2-wire phone cord (7' phone cord supplied).

MODEL: **Model WS-40**

Specifications, Details and Dimensions on Back.

**Model WS-40****Salt Alarm****WATER SOFTENING SYSTEMS - WS-40**

WATER SOFTENING SYSTEMS – WS-40



701 S Ridge Avenue, Troy, OH 45374
1-888-4HOBART • www.hobartservice.com

System Components

Media Vessel (qty) Size(2) 6 x 13"
Media Vessel ConstructionFiberglass Wrapped Engineered Plastic
Empty Bed Volume0.16 ft³
Media TypeUniform Bead Cation Resin
Media Volume0.16 ft³
Bed DepthPacked
Free Board None
Riser Tube1" CPVC
Distributor
Upper0.012" Slots, Engineered Plastic Basket
Lower0.009" Slots, Stainless Steel Flat Plate
Under beddingNone
Regeneration ControlNon-electric Use Meter
Regeneration TypeCountercurrent
Meter Type0.30 - 25.00 gpm Polypropylene Turbine

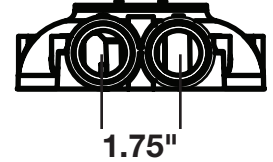

Inlet Water Quality

Pressure Range15 – 125 psi Dynamic Pressure
Temperature Range35 – 160° F
Temperature (Continuous)150° F
pH Range5 – 10 SU
Free Chlorine Cl₂ (Max.)2.0 mg/l
Hardness as CaCO₃ (Max.)30 gpg

Operating Specs

Flow Range (15 / 30 psig)9.1 – 15.2 gpm
Flow ConfigurationAlternating
Dimensions (width x depth x height)14 x 14 x 22"
Weight (Operating / Shipping)110 / 60 lbs.

Connections

Inlet / Outlet ConnectionsCustom Adapter and Bracket
Drain Connection0.375" Tube
Brine Line Connection0.375" Tube (internal)
Overflow Connection0.375" Tube
PowerNone
Salt Alarm.....3 AA Batteries

System Part Numbers

WS-40, Compact Cabinet Softener913091-123

Brine Tank Options

Tank Description206 Cabinet
Tank Height22"
Tank Footprint14 x 14"
MaterialHDPE
Salt Capacity40 lbs.

Regeneration Specifications

Regeneration Volume5 gallons
Regeneration Time11 minutes
Backwash Flow Control0.70 gpm
Brine Refill Flow Control0.20 gpm

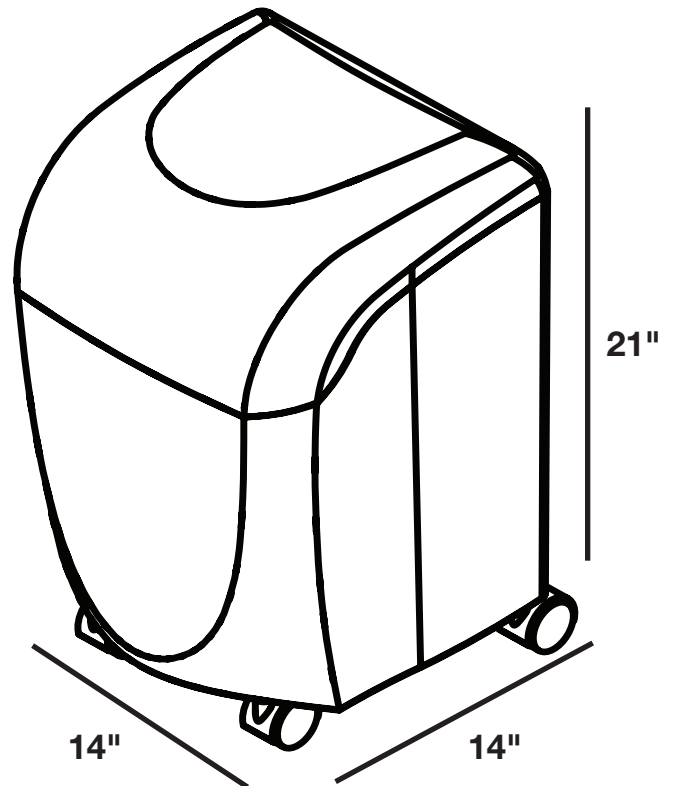

Disc Selection

(Compensated Hardness*)

Setting	Capacity	Efficiency	Dosing	Meter Disc	1	2	3	4	5	6	7	8
1.0 lbs.	2,527 grains	2,527 gr./lb.	5.5 lbs./ft ³		4	8	11	15	19	23	27	30
				Gallons/Regeneration:	583	282	194	146	117	97	83	73
				Flow during regeneration (@ 15 psig):	9.1	9.1	9.1	9.1	8.4	6.6	5.4	4.4

*Compensated hardness in gpg = Hardness + (3 x Fe in mg/l)

As continued product improvement is a policy of Hobart, specifications are subject to change without notice.

TriMark Sourcewell Contract #063022-SES

Foodservice Equipment, Supplies and Design

08/28/2023

Strategic Equipment, LLC
dba TriMark Strategic
dba TriMark Foodcraft
dba ISI Commercial Refrigeration

Project:
Greeneville City- SOURCEWELL
H.S.Dish machine

From:
Strategic Equipment, LLC
Heidi Keller
3011 Industrial Parkway East
Knoxville, TN 37921
(865)545-5222 (contact)
(865)522-4448 (Fax)

Job Reference Number: 82523

Thank you for allowing TriMark the opportunity to provide pricing. Please be aware in this very unstable market; manufacturers are experiencing delays, pricing increases and additional freight surcharges and storage fees. ***As such, quotes will remain in effect for 10 days.*** TriMark reserves the right to make any corrections or adjustments due to cost increases, market fluctuations, supply chain disruptions, tariffs, third party supplier changes in cost, general contractor delays, or any other factors outside of TriMark's control at any time prior to delivery. We apologize for the inconvenience.

For all custom fabricated equipment, exhaust hoods, walk-in coolers/freezers, and all items requiring owner selections of colors or laminate finishes, these prices are current estimates. We will re-quote those items based on the manufacturers' prices in effect at the time when field measurements can be taken and/or color/laminate selections are made by the owner. This policy also applies to all items of standard manufacture that cannot be shipped immediately upon fabrication to an owner's or general contractor's facility.

Item	Qty	Description	Sell	Sell Total
------	-----	-------------	------	------------

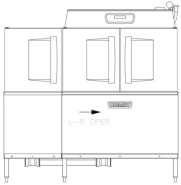
1	1 ea	DISHWASHER, CONVEYOR TYPE	\$64,665.61	\$64,665.61
		 <p>Model No. CLPS66EN-BAS+BUILDUP Conveyor Dishwasher, single tank with a Power Scrapper, (202) racks/hour, insulated hinged doors, .62 gallons/rack, stainless steel enclosure panels, microprocessor controls with low temperature & dirty water indicators, NSF Pot & Pan mode, programable de-lime notification, power scrapper vent cowl curtain kit, ENERGY STAR®, Free factory startup for installations within a 100 mile radius of a Hobart service office; installation beyond 100 miles will be charged at the quoted rate by the local Hobart service office</p>		
	1 ea	Oversized units with crated shipping dimensions greater or equal to 72" in length and/or 90" in height. If delivery is to a facility without a standard height dock, additional shipping charges will apply depending on the service requested. consult Factory.		
	1 ea	Standard warranty - 1-Year parts, labor & travel time during normal working hours within the USA		
	1 ea	CLPS66EN-BASHTE15K Electric tank heat 15kW		
	1 ea	CLPS66EN-BASERH30K 30kW electric booster		
	1 ea	CLPS66EN-BASELE0CD 480v/60/3-ph		
	1 ea	Single Point (1) service connection standard (Field convertible options available)		
	1 ea	CLPS66EN-BASHGTSTD Standard height		
	1 ea	CLPS66EN-BASDIROLR Left to right operation		
	1 ea	CLPS66EN-BASFETSTD Standard feet		
	1 ea	WS40-NOINSTALL Water Softening System, 2,527 grains/lb capacity, 5 gallons regeneration volume, & salt alarm, holds 1 bag of salt, pricing DOES NOT include standard installation. INSTALLATION BY AUTHORIZED HOBART SERVICE OFFICE IS RECOMMENDED (NET)		
	1 ea	DTV-CLEN Drain water tempering kit for CLEN models		
	1 ea	Installation of DWT kit only (NET)		
	2 ea	VNTHD/E-ADJ E-series vent hood domestic (adjustable)		
	3 ea	SHTPAN-RACK Rack, 6 sheet pan		
	1 ea	CLE/TBL-SWITCH Table limit switch CLE-Series		
			ITEM TOTAL:	\$64,665.61
2	1 ea	HOBART INSTALL	\$14,745.30	\$14,745.30
			ITEM TOTAL:	\$14,745.30
			Total	\$79,410.91

This Quote shall be subject to TriMark's Terms of Sale <https://www.trimarkusa.com/SiteMedia/SiteResources/Terms/TriMark-Terms-and-Conditions-of-Sale.pdf>, which are incorporated herein by reference and shall govern. The parties specifically agree that no signature shall be required in order for this Quote or its applicable terms and conditions to be deemed legally binding and enforceable on Customer where the intent to be so bound can be inferred (including by acceptance or retention of products or services), notwithstanding contrary requirements under any law.

Any tax or similar fees shown in this Quote are an estimate only.

Florida Refrigeration License # CAC1821900

Austin	Beaumont	Houston	Lewisville
TACLB52729R	TACLA35912C	TACLA108388C	TACLB16860C

Regulated by the Texas Department of Licensing and Regulation, P.O. BOX 12157, Austin, Texas, 1-800-803-9202. www.tdlr.texas.gov

I understand, agree to and accept the above terms and conditions.

ESSER 3.0 Public Plan for Remaining Funds

Addendum Guidance

2023

Local educational agencies (LEAs) are required to update the ESSER 3.0 Public Plan every six months through Sept. 30, 2023. Each time, LEAs must seek public input on the plan and any revisions and must take such input into account.

Each LEA must complete the addendum and upload it to ePlan in the LEA Document Library (**March 1 and Sept. 15**). The LEA must also post the addendum to the LEA's website. Like the development of the plan, all revisions must be informed by community input and reviewed and approved by the governing body prior to posting on the LEA's publicly available website. The plan intends to provide transparency to stakeholders.

Please consider the following when completing the addendum:

- On the summary page, the amounts should total the carryover amount for FY24 for each relief fund: ESSER 2.0 and ESSER 3.0.
- The LEA must respond to all questions in the document.
- The stakeholder engagement responses should closely align with the stakeholder engagement in the Health and Safety Plan.
- The LEA should ensure it uses multiple models of engagement offered to stakeholders. Examples may include surveys, in-person or virtual committee meetings, town hall meetings, or other inclusive engagement opportunities.
- LEAs should engage all applicable groups noted in meaningful consultation during the crafting of the plan and when making any significant revisions or updates to the plan.
- The number of stakeholders engaged should represent the composition of students. For example, if students with disabilities make up 15 percent of students, then 10-20 percent of respondents should represent this subgroup.
- Ensure the stakeholder engagement happened prior to the development/revision of the plan.
- Plans require local board approval and public posting.
- LEAs must update the ESSER Public Plan at least every six months through Sept. 30, 2023, seek public input on the plan and any revisions, and take such input into account.
- The American Rescue Plan (ARP) Act requires LEAs to post plans online in a language that parents/caregivers can understand, or it is not practicable to provide written translations to an individual with limited English proficiency, be orally translated. The plan also must be provided in an alternative format accessible, upon request, by a parent who is an individual with a disability as defined by the Americans with Disabilities Act.

ESSER 3.0 Public Plan for Remaining Funds

The Elementary and Secondary School Emergency Relief 3.0 (ESSER 3.0) Fund under the American Rescue Plan (ARP) Act of 2021, Public Law 117-2, was enacted on March 11, 2021. Funding provided to states and local educational agencies (LEAs) helps safely reopen and sustain the safe operation of schools and address the impact of the coronavirus pandemic on the nation’s students.

In the fall of 2021, LEAs developed and made publicly available a *Public Plan - Federal Relief Spending*. All plans were developed with meaningful public consultation with stakeholder groups. Like the development of the plan, all revisions must be informed by community input and reviewed and approved by the governing body prior to posting on the LEA’s publicly available website.

The following information is intended to update stakeholders and address the requirement.

General Information

LEA Name: Greeneville City Schools

Director of Schools (Name): Steve Starnes

ESSER Director (Name): Mike Fulkerson

Address: 129 W Depot Street, Greeneville, TN 37743

Phone #: 423-638-2540 District Website: <https://www2.gcschools.net/>

Addendum Date: September 15, 2023

Total Student Enrollment:	2,899
Grades Served:	Pre K-12
Number of Schools:	8

Funding

ESSER 2.0 Remaining Funds:	\$0
ESSER 3.0 Remaining Funds:	\$1,814,620.12
Total Remaining Funds:	\$1,814,620.12

Budget Summary

		ESSER 2.0 Remaining Funds	ESSER 3.0 Remaining Funds
Academics	Tutoring		
	Summer Programming		
	Early Reading		
	Interventionists		\$474,736.50
	Other		\$242,365.66
	Sub-Total		\$717,102.16
 			
Student Readiness	AP and Dual Credit/ Enrollment Courses		
	High School Innovation		\$22,000.00
	Academic Advising		
	Special Populations		\$32,747.00
	Mental Health		
	Other		
	Sub-Total		\$54,747.00
 			
Educators	Strategic Teacher Retention		\$16,800.00
	Grow Your Own		
	Class Size Reduction		
	Other		\$65,000.00
	Sub-Total		\$81,800.00
 			
Foundations	Technology		\$490,181.03
	High-Speed Internet		
	Academic Space (facilities)		\$35,882.97
	Auditing and Reporting		\$21,758.20
	Other		\$413,148.76
	Sub-Total		\$960,970.96
 			
Total			\$1,814,620.12

Academics

1. Describe strategic allocations to accelerate **Academic Achievement**, including how allocations support the investments identified in the district's needs assessment.

Interventionists

Learning Acceleration Specialists- This activity addresses learning loss by providing targeted, focused, standards-based acceleration by certified teachers or highly trained teacher assistants. Intervention takes place four to five days per week for at least thirty minutes per day at our elementary schools, our online school (TOPS), and our middle school.

2. Describe initiatives included in the "other" category.

Full-time ESL teacher –An additional full-time ESL teacher provides direct ELL services at the elementary and secondary levels and helps address the learning loss of our ELL students.

Comprehensive Educational Resources (CER) fee – CER provides high-quality materials for all core subjects. Teachers have access to all grade levels, with materials to fill in standard gaps or accelerate learning from other grade-level materials.

Online Professional Development - Teachers will have access to an online professional development platform that will provide them with additional learning to help our students close the learning loss gap in ELA and Mathematics.

Reading Plus - Used in Grades 3-5, Reading Plus is an adaptive literacy solution that improves fluency, comprehension, vocabulary, stamina, and motivation.

Sunday Reading RTI Materials - Sondag System Reading offers structured, systematic, multisensory reading intervention for readers at the beginning stages of reading through the end of the 2nd-grade reading level. Each lesson plan uses proven methods to provide effective intervention in small-group settings.

Teacher Position - A short-term teaching position will focus on working with elementary students in groups to improve learning outcomes from August through October 2023.

Student Readiness

1. Describe strategic allocations to support **Student Readiness** and the School-Related Supports necessary to access high-quality instruction, including how allocations support the investments identified in the district's needs assessment.

High School Innovation

Response to Intervention (RTI) Instructional Assistant –An RTI Instructional Assistant helps support learning loss at Greeneville High School by providing intervention services for math and reading, as well as individual instruction based on the needs of each student. RTI assistants monitor student progress.

Special Populations

CASE Assessments - CASE assessments assist in closing student learning gaps and mitigating student learning loss by providing data showing how students are progressing on specific grade-level standards. This allows teachers to differentiate instruction and create individual learning paths for students.

IXL Student Licenses - Funds will be utilized for individualized intervention with related IXL Math software resources.

2. Describe initiatives included in the “other” category.

Educators

1. Describe strategic allocations to **Recruit, Retain and Support Educators and School Personnel**, including how allocations support the investments identified in the district’s needs assessment.

Strategic Teacher Retention

Dedicated Substitutes – In years 1 and 2 of ESSER 3.0 funds, reliable, familiar substitutes who knew classroom protocol helped increase student achievement, increased student and teacher morale, and increased the likelihood of retaining high-quality teachers. Dedicated subs helped provide seamless classroom instruction for students during teacher absence. Year 3 is continued insurance benefits for those employed during the 2022-2023 school year.

2. Describe initiatives included in the “other” category.

NASSP – GCS leadership attended the NASSP Ignite23 leadership conference in July, designed to equip school and district leaders to better respond to student needs and learning gaps.

Aspiring Instructional Leadership Academy – Aspiring teacher leaders and aspiring administrators will participate in a two-year instructional program that will concentrate on basic knowledge of the core values of the school district, foundations of leadership standards, effective instructional practices, improving school-wide instruction, supervising and human capital management, cultivating leadership in

others, and other skills needed to make student-centered leadership decisions. This cohort model will provide aspiring leaders with the skills and competencies to enhance their leadership skills.

Foundations

1. Describe strategic allocations to **Strengthen Structural Expectations**, including how allocations support the investments identified in the district's needs assessment.

Technology

Devices - ESSER 3.0 funds continue to help pay for district-provided computers, ensuring that relevant and robust learning devices are in place at Greeneville City Schools.

iPads for SPED/ESL/Counselors - The district will purchase Pulse devices to help SPED/ESL/Counselors monitor and easily collect signatures from team members, improve GCS communication with parents, and assist with compliance, as the state moves to streamline paperwork using electronic signatures.

Academic Space (facilities)

Custodians – Additional custodial part-time positions provide additional cleaning throughout the school cafeterias and dining areas. This allows the daytime custodians to focus on cleaning touchpoints and commonly used areas such as libraries and gymnasiums.

Auditing and Reporting

Administrative Bonuses –One-time bonuses support personnel who have helped manage and report on ESSER funds in a compliant and effective manner.

2. Describe initiatives included in the “other” category.

Assistant Principals- The district will hire two additional assistant principals, one for Greeneville Middle School and one for Greeneville High School, to help assist our students who are most in need of social and emotional support.

Indirect Costs

Monitoring, Auditing, and Reporting

1. Outline how the LEA is continuing to actively monitor allocations; conducting interim audits to ensure an appropriate application of funds; collecting and managing data elements required to be reported; and reporting this information to the community.

Greeneville City Schools will be in compliance when monitoring, auditing, and reporting all ESSER allocations. Greeneville City Schools has protocols and procedures in place within the fiscal department to ensure an appropriate application and reporting of ESSER funds. Additional personnel support to collect and manage data elements, monitor revenue and expenditures of all ESSER grants on a monthly basis, as well as assists all stakeholders, grant coordinators and workers. Additionally, reimbursement requests and reports will be completed in ePlan in a timely manner to ensure that budgets and grant standards are met in accordance with school system initiatives, state, federal and local regulations and generally accepted accounting principles.

2. Describe how the LEA is meeting the requirements to spend 20 percent of **the total ESSER 3.0 allocation** on direct services to students to address learning loss, or indicate participation in TN ALL Corps.

Greeneville City measures learning loss and gain in several ways. We analyze NWEA universal screening data and CASE benchmark at the school level to provide RTI services to students who qualify and to target specific students and student groups to invite to participate in our 21st Century Tutoring Programs. This data is also used to differentiate instruction in tier 1.

The TVAAS data gives a good picture of individual student gain or loss. We look at individual student growth populated in the TVAAS site so that we can increase our data picture of each child and make adjustments to best serve their needs. We are proud of the overall student growth data in our schools and district but want to take a deeper dive in the individual student level data.

In addition to teacher use for classroom instruction, data teams at each school meet every 4.5 weeks to analyze RTI, universal screening data, and progress monitoring data to ensure that students are making adequate progress and the team makes data driven decisions to ensure that student needs are met. The district RTI team meets every 4.5 weeks to ensure fidelity to the RTI procedures and protocols, to analyze district and school level data trends, and make adjustments according to the data.

Outside of ESSER funding, we are providing before and after school tutoring through a 21st Century Grant and tutoring through the Niswonger Project on Track Program.

ESSER 3.0 funds support learning loss in several ways. We have analyzed TN Ready data at the 3-8 level and NWEA data at the K-2 level to identify students in the approaching category to target for specific intervention. Our students below the 25th percentile are currently receiving RTI services to meet their needs. We have looked at both all student data and subgroup level data and have targeted students in the approaching category to provide targeted, standards-based intervention programs.

ESSER 3.0 funds have helped and continue to help GCS support learning loss through resources and initiatives listed below.

- Evidence from previous programs in our district tells us that the most gain we see in student achievement is when certified teachers provide additional intervention services to our students. We have hired part-time, retired teachers or other certified teachers to provide these services as Learning Acceleration Interventionists. The teachers work with students for at least thirty minutes each day for at least four days per week. Specific grade level standards are the focus of these interventions using CASE formative assessments and CASE and NWEA benchmark assessment data. The teachers use state provided materials, along with other district curriculum for additional support.
- Through mandatory credit recovery provided by ESSER 3.0 funds in Spring 2022 helped support learning loss by providing additional time for high school students to recover credits. The additional period allowed students to accelerate learning by continuing to have the opportunity to attain four new credits each semester, while recovering a fifth credit.
- Response to Intervention (RTI) Instructional Assistant – The RTI Instructional Assistant helps support learning loss at Greeneville High School by providing intervention services for math and reading, as well as individual instruction based on the needs of each student. RTI assistants monitor student progress.
- Reading Plus - Used in Grades 3-5, Reading Plus is an adaptive literacy solution that improves fluency, comprehension, vocabulary, stamina, and motivation.
- Soliday System Reading – These reading RTI materials offer structured, systematic, multisensory reading intervention for readers at the beginning stages of reading through the end of the 2nd-grade reading level. Each lesson plan uses proven methods to provide effective intervention in small-group settings.
- Short-term Teacher Position – The instructor will focus on working with elementary students in groups to improve learning outcomes from August through October 2023.
- An additional ESL teacher provides direct ELL services at the elementary and secondary levels. Data highlights showed this need, as our ELL population experienced greater declines in learning than other student populations.
- Continued funding and use of CASE/Mastery Connect Item Banks and Benchmark assessments assist in closing student learning gaps and mitigating student learning loss by providing data showing how students are progressing on specific grade-level standards. This allows teachers to differentiate instruction and create individual learning paths for students.
- Aspiring Instructional Leadership Academy – Aspiring teacher leaders and aspiring administrators will participate in a two-year instructional program that will concentrate on basic knowledge of the core values of the school district, foundations of leadership standards, effective instructional practices, improving school-wide instruction, supervising and human capital management, cultivating leadership in others, and other skills needed to make student-centered leadership

decisions. This cohort model will provide aspiring leaders with the skills and competencies to enhance their leadership skills.

- NASSP – In July, GCS Leadership attended The National Association of Secondary School Principals Ignite 2023 conference. Grade levels Pre-K through 12 will be impacted by this work. The conference was designed to equip school and district leaders to better respond to student needs and learning gaps as a result of Covid-19 learning disruptions.

Family and Community Engagement

1. Describe how the LEA has continued to engage in meaningful consultation with stakeholders in the development of the revised plan.

Greeneville City Schools has continued to engage stakeholders through a final stakeholder update for planned use of remaining ESSER 3.0 funds. The update provided the opportunity for stakeholders to provide anonymous feedback, and was also discussed at the August 30, 2023, Greeneville City Schools Family Resource Center (FRC) Parent Advisory Board meeting, where ESSER 3.0 funds, as well as the district's Health and Safety plan, were discussed and input encouraged and welcomed.

2. Describe how the LEA engaged at minimum 10 percent of the total stakeholders engaged vs. responses received in the development of the revised plan.

The final GCS stakeholder input form outlined the final year of ESSER 3.0 spending and provided the opportunity for stakeholder feedback. It also pointed readers to our ESSER Web page so that previous Public Spending and Health and Safety plans could be reviewed. In addition, the form provided the opportunity for stakeholders to identify their role(s) such as parent, student, teacher, community member, etc.

Specifically, the form was sent to administration to be distributed by email to students, families, teachers, and other stakeholders. There were 204 responses received.

In addition, Greeneville City Schools Family Resource Center (FRC) Parent Advisory Board met August 30, 2023, to discuss the last year of ESSER 3 funds. The community board consists of: Parents, Board of Education president, PTO Presidents representing each school, Attendance director, Coordinated School Health Supervisor and Family Resource Director. Attendance was taken and minutes from the meeting forwarded to those in attendance.

3. Describe how the LEA engaged a representation of a diverse population of stakeholders.

The ESSER 3.0 final stakeholder form targeted all student populations, as well as families of students, through emails from administration. Other community members and stakeholders were included through our Family Resource Council Advisory Board meeting, which consists of parents, student

representatives, and community members. The form has been made available in Spanish to our ESL students and families.

4. Describe how the LEA used multiple modes of engagement (such as surveys, scheduled in-person or virtual meetings, and town halls) to gain input from stakeholders in the development of the revised plan.

Multiple modes of engagement included:

- Final ESSER 3.0 stakeholder form and input opportunity
- August 30, 2023, FRC Advisory Board Meeting
- Availability of previous plans posted on our district ESSER Web page; the link was provided to our stakeholders on the final form
- Email address is provided for ESSER inquiries at any time on our Web site

Safe Return to In-person Instruction and Continuity of Services Plan Addendum Guidance 2023

LEAs are required to update the Safe Return to In-Person Instruction and Continuity of Services Plan every six months through **Sept. 30, 2023**. Each time, local education agencies (LEAs) must seek public input on the plan and any revisions and must take such input into account. The purpose of the plan is to keep stakeholders informed.

Every LEA should complete the addendum and upload it to ePlan in the LEA document library and post it to the LEA's website (**March 1 and Sept. 15**). Like the development of the plan, all revisions must be informed by community input and reviewed and approved by the governing body prior to posting on the LEA's publicly available website.

Please consider the following when completing the addendum:

- Ensure the LEA used multiple models of engagement offered to stakeholders. Examples may include surveys, in-person or virtual committee meetings, town hall meetings, or other inclusive engagement opportunities.
- LEAs should engage all applicable groups noted in meaningful consultation during the crafting of the plan and when making any significant revisions or updates to the plan.
- The number of stakeholders engaged should represent the composition of students. For example, if students with disabilities make up 15 percent of students, then 10-20 percent of respondents should represent this subgroup.
- Ensure the stakeholder engagement happened prior to the development/revision of the plan.
- The LEA must engage the health department in the development and revision of the plan. This is different from providing the health department with COVID-19 numbers.
- Plans must explicitly address every bullet point in Question 3 regarding district policies and strategies.
- Plans require local board approval and public posting.
- LEAs must update the *Safe Return to In-Person Instruction and Continuity of Services Plan* at least every six months through Sept. 30, 2023, seek public input on the plan and any revisions, and take such input into account. All revisions must include an explanation and rationale of why the revisions were made.
- All revisions must include an explanation and rationale, with meaningful public consultation and in an understandable format. The American Rescue Plan (ARP) Act requires LEAs to post their Health and Safety Plans online in a language that parents/caregivers can understand, or, if it is not practicable to provide written translations to an individual with limited English proficiency, be orally translated. The plan also must be provided in an alternative format accessible, upon request, by a parent who is an individual with a disability as defined by the Americans with Disabilities Act.

Safe Return to In-Person Instruction and Continuity of Services Plan Addendum

The Elementary and Secondary School Emergency Relief 3.0 (ESSER 3.0) Fund under the American Rescue Plan (ARP) Act of 2021, Public Law 117-2, was enacted on March 11, 2021. Funding provided to states and local educational agencies (LEAs) helps safely reopen and sustain the safe operation of schools and address the impact of the coronavirus pandemic on the nation's students.

In the fall of 2021, LEAs developed and made publicly available a Safe Return to In-Person Instruction and Continuity of Services Plan. All plans were developed with meaningful public consultation with stakeholder groups. LEAs are required to update the plan every six months through Sept. 30, 2023, and must seek public input on the plan and any revisions and must take such input into account. LEAs also must review and update their plans and ensure they align with any significant changes to CDC recommendations for K-12 schools. Like the development of the plan, all revisions must be informed by community input and reviewed and approved by the governing body prior to posting on the LEA's publicly available website.

The following information is intended to update stakeholders and address the requirement.

LEA Name: Greeneville City Schools

Date: September 15, 2023

1. Describe how the LEA has continued to engage in meaningful consultation with stakeholders in the development of the revised plan.

Greeneville City Schools (GCS) has continued to engage stakeholders by providing information on the use of ESSER 3.0 Funds, as well as the opportunity for stakeholders to provide anonymous feedback, and through the Greeneville City Schools Family Resource Center (FRC) Parent Advisory Board, where ESSER funds, as well as the district's Health and Safety plan, are discussed and input is encouraged and welcomed.

GCS created an ESSER 3.0 final stakeholder form that was sent to stakeholders through emails from district administration. The form allowed stakeholders to identify their role such as parent, student, teacher, community member, etc. and provided the opportunity for anonymous feedback. A link in the form also pointed readers to our ESSER Web page, where all previous Public Spending and Health and Safety plans can be continually viewed.

Greeneville City Schools Family Resource Center (FRC) Parent Advisory Board met August 30, 2023, to discuss the impact of ESSER 3. The Health and Safety Plan was also discussed at this meeting. The community board consists of: Parents, Board of Education president, PTO Presidents representing each school, Attendance director, Coordinated School Health Supervisor and Family Resource Director. Attendance was taken and minutes from the meeting forwarded to those in attendance.

2. Describe how the LEA engaged the health department in the development of the revised plan.

Greenville City Schools has worked with state, regional, and local health agencies, including the Greene County Health Department, to draft and implement guidelines surrounding SARS-CoV-2. Though the district and its agents will work hard to implement and abide by these guidelines, neither the guidelines themselves nor even recommendations from the Center for Disease Control and Prevention (CDC) would ever allow the District to guarantee an environment that is entirely free of COVID-19 related risks.

Our school system works closely with the Northeast Regional Health Department to provide the most up-to-date management of the COVID-19 pandemic for our students and staff. Dr. Cynthia Thomas of the Northeast Regional Health Department provides constant updates to our district with the most recent recommendations from the Tennessee Department of Health and the CDC. Dr. Thomas or her designee are immediately available for consultation for the management of any infectious diseases including COVID that we see in our district. Greenville City Schools has designated the Coordinated School Health Supervisor as the direct liaison with the Greene County Health Department and the Northeast Regional Health Department.

In addition to partnering with local, regional, and state health and education officials, the resources below were reviewed for the development of COVID planning for the 2023-2024 school year and can continue to be accessed for updated information, which may be of interest to students and families in the GCS district.

[Tennessee Department of Health](#)

[Tennessee Department of Health Quarantine-Isolation Recommendations](#)

[Operational Guidance for K-12 Schools CDC](#)

[Summary of Guidance for Minimizing the Impact of COVID 19](#)

3. Provide the extent to which the LEA has updated adopted policies and a description of any such policies on each of the following health and safety strategies.

<p><i>Appropriate accommodations for children with disabilities with respect to health and safety policies</i></p> <p>Greeneville City Schools adhere to the infection control practices recommended by the Tennessee Department of Health. Students and staff are encouraged to stay home when they are sick. Staff receive continuing education regarding the techniques of appropriate handwashing. Custodial staff follow a regular cleaning schedule to decrease the likelihood of disease transmission.</p> <p>Parents or students who prefer to continue learning in a virtual mode have the option of applying to attend our K-12 online school, TOPS @Greeneville. Applications for TOPS @Greeneville must be completed prior to the beginning of each semester as enrollment is contingent on review of the application, as well as availability of classroom staffing. Information about enrollment in TOPS @Greeneville can be found here.</p>
<p><i>Physical distancing (e.g., use of cohorts/podding)</i></p> <p>According to experts in the field of public health, we are moving from considering COVID 19 as pandemic to considering COVID 19 as endemic. COVID 19 will be managed as other similar illnesses. No physical distancing will be implemented unless Tennessee Department of Health recommends change.</p>
<p><i>Hand washing and respiratory etiquette</i></p> <p>Students and staff will complete training in appropriate hand washing and respiratory etiquette procedures. Students will have scheduled times to wash their hands. Hand sanitizer will be available in all classrooms.</p> <p>Appropriate hand washing techniques and use of hand sanitizer will be emphasized. Principles of respiratory etiquette are provided to our school staff by our school nurses. School staff in turn provide age appropriate training for students.</p>
<p><i>Cleaning and maintaining healthy facilities including improving ventilation</i></p> <p>School campuses should undergo a level 4 (out of 5 levels) cleaning on a daily basis. Level 4 cleaning includes disinfecting all touch points daily, which includes desks, light switches, door handles, doors, chairs, benches, bathrooms, etc. all other flat surfaces (i.e., countertops) within the reach of the student and the floors. All disinfectants utilized for cleaning will be EPA-approved disinfectants chosen from List N: Disinfectants for Use Against SAR-CoV-2 (COVID-19). Areas that have had someone who tested positive for COVID-19 within the last 24 hours will undergo a Level 5 cleaning. Funds provided through the Elementary and Secondary Schools Emergency Relief Programs are being used to improve ventilation systems within our district.</p>
<p><i>Contact tracing in combination with isolation and quarantine</i></p> <p>Contact tracing is no longer a recommended practice per the Tennessee Department of Health.</p> <p>Quarantine is no longer recommended for contacts. CDC recommends that people who were exposed to COVID-19 (contacts) take precautions for 10 days after their exposure regardless of their vaccination status or if they have had a previous infection. Precautions include wearing a mask, watching for COVID-19 symptoms, and getting tested for COVID-19.</p>

Diagnostic and screening testing

COVID-19 Testing:

Niswonger Children’s Telemedicine Program

This program offers the ability to perform rapid COVID-19 screening, strep screens and influenza screening as a part of the telemedicine visit. Participation in this program requires parental/guardian consent and parents must enroll their students prior to the scheduling of an appointment. Please complete the forms that are provided in student packets and return them to your school nurse prior to your student’s first telemedicine visit.

Niswonger Children’s Hospital has partnered with Ballad Health Medical Associates Urgent Care to provide students and staff with a convenient option to access high-quality care using virtual health technology while at school.

With permission, a school nurse will use live video technology to connect the student or staff member with an off-site Ballad Health Medical Associates Urgent Care doctor, physician assistant or nurse practitioner. The urgent care provider will have the ability to diagnose, listen to the patient’s heart and lungs, order basic labs and send any needed prescriptions to the patient’s pharmacy – all without leaving the school nurse’s office.

This service will be available Monday through Friday during normal school hours.

Efforts to provide vaccinations to educators, other staff, and students, if eligible

Vaccination continues to be a significant public health prevention strategy against COVID-19. Initial vaccination and recommended boosters are encouraged but not required. Vaccinations are currently available free of charge at the Greene County Health Department. Information can be found [here](#).

Universal and correct wearing of masks

Masks help to slow the spread of the virus. Wearing of masks is encouraged but not required for Greeneville City School employees and students outlined in the Tennessee Department of Health Recommendations.

4. Provide a current description as to how the LEA is ensuring continuity of services including but not limited to services that address students’ academic needs and students’ and staff’s social, emotional, mental health, and other needs, whichd may include student health and food services.

Food Service and School Meals

- Given the very low risk of transmission from surfaces and shared objects, there is no need to limit food service approaches to single use items and packaged meals.

- Clean frequently touched surfaces. Surfaces that come in contact with food should be washed, rinsed, and sanitized before and after meals.

Mental Health

Mental health counselors will serve students in need of assistance. We have contracted the services of Frontier Mental Health to provide professional counseling for students who need this service and have parental consent.

Blue Cross/Blue Shield provides an EAP program for employees.

Guidance counselors will be meeting with students as needed to assist with needs.

Physical Health

Greeneville City Schools is partnering with the Ballard Health organization to provide a school based telemed program for students and staff. This program offers telehealth services to all students when parental consent is given for evaluation and treatment.

Visitors/Volunteers:

Visitors and volunteers will be encouraged to follow the current recommendations of the Tennessee Department of Health.

**Greenville City Schools
Federal Projects Budget Amendment #1
Fiscal Year 2023-2024
Presented September 2023**

Account Subfund #	Description	Federal Projects Budget 2023-2024	Amendment	Amended Federal Projects Budget 2023-2024
10	Consolidated Administration	\$ 108,227	\$ -	\$ 108,227
100	Title I	\$ 536,528	\$ -	\$ 536,528
150	Title I Neglected	\$ 70,934	\$ -	\$ 70,934
200	Title II Part A	\$ 91,911	\$ -	\$ 91,911
300	Title III	\$ 11,156	\$ -	\$ 11,156
400	Title IV	\$ 58,091	\$ -	\$ 58,091
430	21st Century Learning	\$ -	\$ -	\$ -
600	Title V	\$ 91,411	\$ -	\$ 91,411
900	IDEA	\$ 662,168	\$ -	\$ 662,168
910	IDEA, Preschool	\$ 13,343	\$ -	\$ 13,343
935	*ESSER 2.0	\$ -	\$ -	\$ -
936	*ESSER 3.0	\$ -	\$ -	\$ -
937	*Fiscal Premonitoring Supports Grant	\$ -	\$ -	\$ -
941	*Epidemiology & Laboratory Capacity Grant	\$ -	\$ -	\$ -
942	*Resilient School Communities Grant	\$ -	\$ -	\$ -
952	*Governors Civics Grant	\$ -	\$ -	\$ -
701	*ARP Homeless	\$ -	\$ 12,289	\$ 12,289
TBD	*Math Implementation Support Grant	\$ -	\$ -	\$ -
909	*ARP IDEA	\$ -	\$ 15,028	\$ 15,028
951	Literacy Stipend Grant	\$ -	\$ -	\$ -
	Total Revenue	\$ 1,643,769	\$ 27,316	\$ 1,671,085
10	Consolidated Administration	\$ 108,227	\$ -	\$ 108,227
100	Title I	\$ 536,528	\$ -	\$ 536,528
150	Title I Neglected	\$ 70,934	\$ -	\$ 70,934
200	Title II Part A	\$ 91,911	\$ -	\$ 91,911
300	Title III	\$ 11,156	\$ -	\$ 11,156
400	Title IV	\$ 58,091	\$ -	\$ 58,091
430	21st Century Learning	\$ -	\$ -	\$ -
600	Title V	\$ 91,411	\$ -	\$ 91,411
900	IDEA	\$ 662,168	\$ -	\$ 662,168
910	DEA, Preschool	\$ 13,343	\$ -	\$ 13,343
935	*ESSER 2.0	\$ -	\$ -	\$ -
936	*ESSER 3.0	\$ -	\$ -	\$ -
937	*Fiscal Premonitoring Supports Grant	\$ -	\$ -	\$ -
941	*Epidemiology & Laboratory Capacity Grant	\$ -	\$ -	\$ -
942	*Resilient School Communities Grant	\$ -	\$ -	\$ -
952	*Governors Civics Grant	\$ -	\$ -	\$ -
701	*ARP Homeless	\$ -	\$ 12,289	\$ 12,289
TBD	*Math Implementation Support Grant	\$ -	\$ -	\$ -
909	*ARP IDEA	\$ -	\$ 15,028	\$ 15,028
951	Literacy Stipend Grant	\$ -	\$ -	\$ -
	Total Expenses	\$ 1,643,769	\$ 27,316	\$ 1,671,085

To Budget ARP IDEA and ARP Homeless Carryover - Fiscal Year 2024
*Indicates CARES Act Funding

Number	Item
2	PORTER CABLE DRILL PRESSES
1	DELTA MILLING MACHINE
2	DELTA BAND SAWS
1	POWERMATIC BAND SAW
1	9 INCH UTILATHE
1	POWERMATIC SHAPER
1	DOERR AIR TANK
1	10 INCH RADIAL SAW
1	SMALL AIR COMPRESSOR
1	ROCKWELL MITER SAW
1	SMALL LINCOLN WELDER
1	METAL STORAGE CABINET
1	METAL TABLE WITH WOOD TOP
1	WOOD WORKING LATHE
1	POWERMATIC JOINTER
1	POWERMATIC 18 INCH PLAINER
1	POWERMATIC TABLE SAW
1	METAL BENDING TABLE
17	C-CLAMPS
20	BAR CLAMPS
35	HAND SAWS
	SEVERAL SAW BLADES
7	WOOD CLAMPS
1	WINCH CABLE PULLER
9	TABLE VICES
16	WOODEN HANDLE FILES
3	SANDPAPER
1	MILLER SPOT WELDER
6	WOOD PLANES
6	SMALL VICES
6	CUTTING DISKS
19	WOOD CHISELS
10	BOX OF WOODEN HANDLES
14	SANDING DISKS
1	DOWELING JIGS
2	HAND DRILLS
50	ELECTRODES
2	FRAMING SQUARES
6	BOX OF LEVELS
2	HAMMERS
21	BOX OF CHISELS
1	WHEEL GRINDER
	FIELD TURF
	METAL LOCKERS
	METAL VAULT DOOR
	MEAT SLICER

- 2 TRAY CAFÉ RACKS
- 2 WINDOW AIR CONDITIONERS
 - GHS SHOP CAR (GTC DOES NOT WANT)
- 2 Accutemps Steamers

Greeneville City Schools Surplus Disposal Approval Form

	Item Description
1	
2	(10) Acoustic shells Broken/ worn out
3	
4	
5	
6	
7	
8	
9	
10	
11	
12	
13	
14	
15	
16	
17	
18	
19	
20	
21	
22	
23	
24	
25	

*Items less than \$500.00 value can be disposed of without auction per BOE policy 2.403

The above listed individual items have a monetary value of less than \$500.00

Operations Supervisor Approval Phillip Gramam 9/12/2023

Director of Schools Approval Steve Starnes 9/12/2023

School Board Chair Approval Cindy Luttrell 9/13/2023

All items have been disposed of Yes No

Custodial Supervisor Roger Hensley 9/13/2023

Greenville City Schools 2024 State Health Plan Premiums- 10 Month Rates

Premier PPO	State Health Plan	District Portion	Employee Portion
Employee Only	\$ 855.60	\$ 855.60	\$ -
Employee +Child(ren)	\$ 1,410.00	\$ 993.60	\$ 416.40
Employee + Spouse	\$ 1,924.80	\$ 993.60	\$ 931.20
Family	\$ 2,222.40	\$ 1,001.00	\$ 1,221.40
Family- Both Spouses GCS	\$ 2,222.40	\$ 1,849.20	\$ 373.20

Standard PPO	State Health Plan	District Portion	Employee Portion
Employee Only	\$ 794.40	\$ 794.40	\$ -
Employee +Child(ren)	\$ 1,310.40	\$ 993.60	\$ 316.80
Employee + Spouse	\$ 1,788.00	\$ 993.60	\$ 794.40
Family	\$ 2,065.20	\$ 993.60	\$ 1,071.60
Family- Both Spouses GCS	\$ 2,065.20	\$ 1,849.20	\$ 216.00

Limited PPO	State Health Plan	District Portion	Employee Portion
Employee Only	\$ 750.00	\$ 750.00	\$ -
Employee +Child(ren)	\$ 1,237.20	\$ 993.60	\$ 243.60
Employee + Spouse	\$ 1,688.40	\$ 993.60	\$ 694.80
Family	\$ 1,950.00	\$ 993.60	\$ 956.40
Family- Both Spouses GCS	\$ 1,950.00	\$ 1,849.20	\$ 100.80

Healthsavings CDHP	State Health Plan	District Portion	Employee Portion
Employee Only	\$ 655.20	\$ 655.20	\$ -
Employee +Child(ren)	\$ 1,080.00	\$ 993.60	\$ 86.40
Employee + Spouse	\$ 1,473.60	\$ 993.60	\$ 480.00
Family	\$ 1,702.80	\$ 993.60	\$ 709.20
Family- Both Spouses GCS	\$ 1,702.80	\$ 1,702.80	\$ -

2024 Employee Rate Chart

Plan Tier	CDHP	Limited	Premier	Standard	*Cigna OAP/ BCBS P
Employee Only	\$ -	\$ -	\$ -	\$ -	Add \$90
Employee +Child(ren)	\$ 86.40	\$ 243.60	\$ 416.40	\$ 316.80	Add \$102
Employee + Spouse	\$ 480.00	\$ 694.80	\$ 931.20	\$ 794.40	Add \$180
Family	\$ 709.20	\$ 956.40	\$ 1,221.40	\$ 1,071.60	Add \$180
Family- Both Spouses GCS	\$ -	\$ 100.80	\$ 373.20	\$ 216.00	Add \$180

Carrier Options:

For each plan, employees must choose one of 3 carriers:

- Blue Cross Blue Shield of TN,
- Cigna Local Plus, or
- Cigna Open Access Plus (this carrier comes with an additional surcharge (see above)
- Blue Cross Blue Shield of TN Network P

*Cigna Open Access Plan/Blue Cross Blue Sheild Network P

Greenville City Schools 2024 State Health Plan Premiums

Premier PPO	State Health Plan	District Portion	Employee Portion	Employee Increase Over 2023	Employee % Increase Over 2023
Employee Only	\$ 713.00	\$ 713.00	\$ -	\$ -	0.00%
Employee +Child(ren)	\$ 1,175.00	\$ 828.00	\$ 347.00	\$ 19.00	5.79%
Employee + Spouse	\$ 1,604.00	\$ 828.00	\$ 776.00	\$ 105.00	15.65%
Family	\$ 1,852.00	\$ 834.00	\$ 1,018.00	\$ 41.00	4.20%
Family- Both Spouses GCS	\$ 1,852.00	\$ 1,541.00	\$ 311.00	\$ 17.00	5.78%

Standard PPO	State Health Plan	District Portion	Employee Portion	Employee Increase Over 2023	Employee % Increase Over 2023
Employee Only	\$ 662.00	\$ 662.00	\$ -	\$ -	0.00%
Employee +Child(ren)	\$ 1,092.00	\$ 828.00	\$ 264.00	\$ 16.00	6.45%
Employee + Spouse	\$ 1,490.00	\$ 828.00	\$ 662.00	\$ 96.00	16.96%
Family	\$ 1,721.00	\$ 828.00	\$ 893.00	\$ 42.00	4.94%
Family- Both Spouses GCS	\$ 1,721.00	\$ 1,541.00	\$ 180.00	\$ 12.00	7.14%

Limited PPO	State Health Plan	District Portion	Employee Portion	Employee Increase Over 2023	Employee % Increase Over 2023
Employee Only	\$ 625.00	\$ 625.00	\$ -	\$ -	0.00%
Employee +Child(ren)	\$ 1,031.00	\$ 828.00	\$ 203.00	\$ 11.00	5.73%
Employee + Spouse	\$ 1,407.00	\$ 828.00	\$ 579.00	\$ 86.00	17.44%
Family	\$ 1,625.00	\$ 828.00	\$ 797.00	\$ 34.00	4.46%
Family- Both Spouses GCS	\$ 1,625.00	\$ 1,541.00	\$ 84.00	\$ 4.00	5.00%

Healthsavings CDHP	State Health Plan	District Portion	Employee Portion	Employee Increase Over 2023	Employee % Increase Over 2023
Employee Only	\$ 546.00	\$ 546.00	\$ -	\$ -	0.00%
Employee +Child(ren)	\$ 900.00	\$ 828.00	\$ 72.00	\$ 7.00	10.77%
Employee + Spouse	\$ 1,228.00	\$ 828.00	\$ 400.00	\$ 73.00	22.32%
Family	\$ 1,419.00	\$ 828.00	\$ 591.00	\$ 29.00	5.16%
Family- Both Spouses GCS	\$ 1,419.00	\$ 1,419.00	\$ -	\$ -	0.00%

2024 Employee Rate Chart

Plan Tier	CDHP	Limited	Premier	Standard	*Cigna OAP/ BCBS P
Employee Only	\$ -	\$ -	\$ -	\$ -	Add \$75
Employee +Child(ren)	\$ 72.00	\$ 203.00	\$ 347.00	\$ 264.00	Add \$85
Employee + Spouse	\$ 400.00	\$ 579.00	\$ 776.00	\$ 662.00	Add \$150
Family	\$ 591.00	\$ 797.00	\$ 1,018.00	\$ 893.00	Add \$150
Family- Both Spouses GCS	\$ -	\$ 84.00	\$ 311.00	\$ 180.00	Add \$150

Carrier Options:

For each plan, employees must choose one of 3 carriers:

- Blue Cross Blue Shield of TN,
- Cigna Local Plus, or
- Cigna Open Access Plus (this carrier comes with an additional surcharge (see above)
- Blue Cross Blue Shield of TN Network P

*Cigna Open Access Plan/Blue Cross Blue Shield Network P

2023-2024 Employee Handbook Revisions

Page	Description
Page 13	Updated to add information on PC425, allowing more flexibility in hiring TCRS retirees
Page 14	Updated how new hire work experience is applied to pay level.
Page 17	take out the wording that mileage is determined by the Board of Education. We follow the State of TN, and they follow the IRS standard published mileage reimbursement rate.
Page 18	Changed approval from DOS to Immediate Supervisor for employee to work overtime
Page 20 & 21	Updated Works Compensation district contacts
Page 24	Added TN Paid Parental Leave information
Page 26	Added information regarding exterior doors

Employee Handbook

Effective September 2023



<http://www.gcschools.net>

TABLE OF CONTENTS

Table of Contents	2
Acknowledge Page	4
I ORGANIZATION	5
A Types of Employees	
B Board of Education	
C Board Beliefs, Mission, and Vision	
D Board Goals	
E Line and Staff Relations	
F Central Office Information	
G System Directory	
H Staff – Student Relations	
II EMPLOYMENT	7
A Equal Opportunity Employment	
B Americas with Disabilities Act	
C Recruitment	
D Application and Hiring	
E Contracts for Professional/Certified Staff	
F Assignment and Re-Assignment	
G Educator Licensure	
H Highly Qualified Status	
I Probation Period of Non-Certified Employees	
J Evaluation	
K Personnel Records	
L Employment or Supervision of Relatives	
M Tenure	
N Suspension	
O Dismissal or Non-Renewal	
P Resignation	
Q Retirement	
III COMPENSATION AND BENEFITS	13
A Salary Schedules and Scales	
B Payroll Procedures	
C Annuities	
D Section 125	
E Student Tuition	
F Travel and Expense Reimbursement	
G Special Expenditure Reimbursement	
H Overtime and Compensatory Time	
I Health Insurance	
J Life Insurance	
K Dental Insurance	
L Vision Insurance	
M Retirement Funding	
N Workers' Compensation	
IV LEAVE	21
A Request and Approval of Leave	
B Sick Leave	
C Bereavement Leave	
D Personal Leave	
E Professional Leave	
F Vacation	
G Family and Medical Leave Act	
H Other Available Leave	
V GENERAL EMPLOYEE RULES	24

A	Attendance Guidelines	
B	Blood-borne Pathogen Training	
C	Building Security: Keys/Security Cards/Doors	
D	Cash Collection Policy	
E	Cellular Phone Usage	
F	Confidentiality	
G	Copyright and Fair Use	
H	Classroom and Office Security	
I	Complaints and Grievances	
J	Criminal Activity	
K	Department of Transportation (DOT) Physicals	
L	Disciplinary Guidelines	
M	Discrimination/Harassment of Employees (Sexual, Racial, Ethnic, Religious)	
N	Drug-Free Workplace	
O	Elected Office	
P	E-Mail Use	
Q	Fundraising by Schools and Clubs	
R	Identification Badges	
S	Inclement Weather Attendance	
T	Internet Use	
U	Parking Tickets and Traffic Violations	
V	Trip Sheets	
W	Substitute Workers	
X	Tobacco- Free Schools	
Y	Vehicles – Private	
Z	Vehicles – School System	
AA	Vendor Relations	
BB	Video Surveillance	
CC	Visitors to the Schools	
DD	Work Breaks	
EE	Appendicies	34
	Appendix A – Extended Health Care Coverage (COBRA)	
	Appendix B – Health Insurance Portability and Accountability Act (HIPPA)	
	Appendix C – The Family and Medical Leave Act of 1996	
	Appendix D – Greeneville City Schools FMLA Policy	
	Appendix E – Equal Employment Opportunity	
	Appendix F – Employee Rights Under The Fair Labor Standards Act	
	Appendix G – Genetic Information Non-Discrimination Policy	
	Appendix H – Asbestos Management Plan Availability	
	Appendix I – Family Education Rights and Privacy Act (FERPA)	
	Appendix J – Personal Characteristics Expected of ALL Greeneville City School Personnel	
	Appendix K – Tennessee Teacher Code of Ethics	
	Appendix L – ACA Measurement Resolution	

**GREENEVILLE CITY SCHOOL EMPLOYEE HANDBOOK
ACKNOWLEDGEMENT PAGE
2023 - 2024 School Year**

This Handbook contains a general description of Greeneville City School's policies, benefits, and procedures. This Handbook applies to all employees who work for the Greeneville City School system. The purpose of this Handbook is to serve as a guide for employees regarding personnel policies and how they are implemented within the Greeneville City School system. Its primary focus is to communicate general information to the employees. The Handbook is in no way meant to serve as an employee contract or guarantee of employment. While this Handbook contains a general description of benefits, the terms and conditions of benefit plans are to be based solely on the plan documents.

The Board of Education and the Administration of Greeneville City Schools expressly reserve the right to unilaterally make additions, deletions, or substitutions to this Handbook at any time, with or without notice. In addition, nothing contained in this employment manual may be construed as altering the employee's status as an at-will employee.

Greeneville City Schools operates pursuant to the Greeneville City Schools Board of Education policies, and in the event of any inconsistency between this Handbook and Board policies, Board policy would prevail.

Review of the Handbook will be a requirement for all new hires, and for current employees on an annual basis at the beginning of each new school year. By completing this training, you are acknowledging that you have read a copy of the Handbook, and any appendices, and you understand that the policies in the Handbook apply to you. In addition, you are confirming that you understand it is your responsibility to read the Handbook, and any appendices, and that if you do not understand any section(s) of this Handbook, it is your responsibility to ask the Principal/Supervisor or the Human Resources department for clarification. You are also confirming that you understand the Greeneville City School Employee Handbook training should be completed within 14 days of hire (new hires), and annually at the beginning of each new school year (current GCS employee).

The most current version of the Employee Handbook is located on-line at <http://www.gcschools.net> under Employees/Human Resources. The current version of the handbook supersedes all other Employee Handbook versions.

I. ORGANIZATION

A. Types of Employees (Board Policy 5.102)

Within the Greeneville City School system there are two classifications of employees, certified and non-certified. Below is a description of the determining factors for each.

Certified Employees

In order to be considered a certified employee, an individual must possess a current valid Tennessee educator license.

Non-Certified Employees

Employees who do not possess an educator license are deemed non-certified employees, as their employment does not require certification in accordance with rules and regulations of the state Department of Education. Non-certified employees include, but may not be limited to, the following: Administrative Assistant, Athletic Trainer, Bookkeepers, Bus Driver, Custodian, Extended School Program Associate, Family Services Center (FSC), Instructional Assistant, Instructional Technology (IT), Maintenance, and School Nutrition.

An employee who has an educator license and has taught in the past is considered a certified employee for retirement funding purposes even if working presently in a non-certified position. If an employee has an educator license but has never worked as a certified Teacher and is presently working in a non-certified position, they will be deemed a non-certified employee for retirement funding purposes.

B. Board of Education

Cindy Luttrell	Member (Chairperson)
Dr. Craig Shepherd	Member (Vice Chairperson)
Joshua Quillen	Member (Treasurer)
Pamela Botta	Member (TLN Representative)
Crystal Hirschy	Member
Hank Hope	Student Member (Non-Voting)

School Board meetings are held the fourth Tuesday of each month at the Kathryn Leonard Central Office (KLCO) or at the Greene Technology Center (GTC). Joint School Board meetings are held on the fourth Thursday of October, January, April, and June. The meetings are open to the public unless otherwise stated and usually begin at 6:00pm. Occasionally, due to conflicts, the meetings may be held at a different date/time. The meeting schedule, agendas, and minutes of the meetings are available on the Board of Education section of the system website. All meetings will be properly reported using local media outlets.

C. Mission, and Vision

Vision

- Cultivate the Mind, Impact the Heart through Excellence and Equity.

Mission

- Graduates will be prepared and confident to own THEIR future!

Core Values

- ALL individuals can learn and grow. Rationale: A growth mindset and high expectations for ALL are essential for equitable learning. Educators and students are committed to continuous learning. Everyone involved with the learner's development has a unique role in this partnership.
- Trusting relationships are key to cultivating the mind and impacting the heart. Rationale: We are a family of learners committed to building relationships with students and colleagues to learn and grow together. We strive to develop the whole-child by nurturing purpose, passion, and strengths.

- ALL students deserve high-quality personalized instruction. Rationale: Learning is purposeful, engaging, rigorous, and relevant. It includes student voice and choice to equip students with the tools, resources, and support to be successful in life.
- We value a culture of high expectations and are committed to innovation and continuous improvement. Rationale: We are a learning organization that strives to move beyond what is and continually searches for what could be.
- The learning environment is safe and nurturing, empowering ALL to thrive. Rationale: The learning environment shall be clean, physically and emotionally safe, and foster a sense of well-being and belonging.
- Student success depends upon a strong partnership between the student, school, family, and community. Rationale: Everyone concerned with the child’s development has a unique role in this collaborative partnership.

D. Board Goals (Board Policy 1.700)

1. Provide excellence and equity in instruction and programs.
2. Provide a system of highly qualified world class faculty and staff.
3. Provide a state-of-the-art learning environment.
4. Focus expenditures on instruction and provide excellence in school district accounting.
5. Provide excellence and equity in family and community programs.

E. Line and Staff Relations (Board Policy 5.101)

The Director of Schools is responsible for establishing lines of authority which are approved by the Board and shown on the system organization chart (<http://www.gcschools.net/Human Resources/Job Descriptions/Greeneville City Schools Leadership Structure>).

All personnel are expected to keep their immediate supervisor informed of their activities and should refer matters to them. That administrator should refer such matters to the next higher administrative authority when necessary.

All personnel shall have the right to appeal any decision made by an administrative officer through grievance procedures established through Board policy.

F. Central Office Information

Kathryn W. Leonard Central Office (KLCO)
129 West Depot Street
Greeneville, TN 37743
(423) 787-8000

George Clem Operations Building (GCOB)
312 Floral Street
Greeneville, TN 37743
(423) 787-8003

Both Central Office locations are open to the public from 8:00am through 4:30pm, Monday through Friday.

G. System Directory

Central Office personnel are designated by location: Kathryn W. Leonard Central Office (KLCO) or George Clem Operations Building (GCOB).

Job Title/Location	Name	Phone Number
Director of Schools (KLCO)	Steven C. Starnes	(423) 787-8014
Assistant Director of Schools for Instruction (KLCO)	Dr. Suzanne C. Bryant	(423) 787-8005
Assistant Director of Schools for Administration (KLCO)	Beverly S. Miller	(423) 787-8019
Chief Human Resources Officer (KLCO)	Melissa A. Batson	(423) 787-0976
Chief Student Services Officer (KLCO)	Jeff A. Townsley	(423) 787-8009
Chief Financial Officer (KLCO)	Ellen M. Lipe	(423) 787-8002
Teaching & Learning Coordinator (KLCO)	Shelia A. Newland	(423) 787-8004

Job Title/Location	Name	Phone Number
EastView Elementary Principal	Kelly L. Ford	(423) 638-6351
Greene Technology Center Principal	Aaron T. Flanary	(423) 639-0171
Greeneville High School Principal	DeAnna Martin	(423) 787-8030
Greeneville Middle School Principal	Rachel L. Adams	(423) 639-7841
Hal Henard Elementary Principal	Janet L. Ricker	(423) 638-3511
Highland Elementary Principal	Noelle Smith	(423) 638-3341
Tusculum View Elementary Principal	Dr. Lana M. Luttrell	(423) 639-2751
TOPS at Greeneville Principal	Richard Tipton	(423) 278-9150
Director of Operations (GCOB)	Phillip J. Graham	(423) 787-8003
Assistant Director of Operations (GCOB)	Roger Hensley	(423) 787-8015
Director of Transportation	Kristen N. Rollins	(423) 787-8003
Coordinated School Health (GCOB)	Tracie Valentine	(423) 636-1696
School Psychologist (KLCO)	Amy M. Saunders	(423) 787-8011
School Psychologist (KLCO)	Sandra M. Kennedy	(423) 787-8010
Director of School Nutrition (KLCO)	Karen D. Wilhoit	(423) 787-8013
Alternative Learning Program (GCOB)	John R. Witt	(423) 787-8042
Federal Programs (KCLO)	J. Michael Fulkerson	(423) 823-5200
Pre-School (GCOB)	Dr. L. Kathryn Sharp	(423) 525-2694
Data & Assessment Specialist	Brandy R. Shelton	(423) 278-2423
Greeneville City Schools Education Foundation	Amanda Waddell, Executive Director	(423) 823-0001

H. Staff – Student Relations (Board Policy 5.610)

Staff members will maintain professional relationships with students at all times and develop wholesome and constructive relationships with them. Staff members are expected to regard each student as an individual and to accord each student the rights and respect that is due.

Staff members should use good judgment in their relationships with students beyond their work responsibilities and/or outside the school setting and shall avoid excessive informal and social involvement with individual students. Any appearance of impropriety must be avoided. Sexual relationships between employees and students are prohibited.

II. EMPLOYMENT

A. Equal Opportunity Employment (Board Policy 5.104)

Opportunity for employment, as well as continuation and advancement in employment, will be afforded equally to members of all races, creeds, colors, sexes, sexual orientations, gender identities, religions, ages, genetic information, national origins, and individuals with disabilities or veteran status with regard only for qualifications for the positions involved.

Please refer to the Appendix E for additional guidelines.

B. Americans with Disabilities Act

The Americans with Disabilities Act of 1990 (ADA), as amended, and Section 504 of the Rehabilitation Act of 1973 prohibits discrimination in employment activities against individuals on the basis of disability. The term “disability” means, with respect to an individual,

- A physical or mental impairment that substantially limits one or more of the major life activities of such an individual.
- A record of such an impairment.
- Being regarded as having such impairment. [42 U.S.C. Section 12102 (2)]

Any person having inquiries concerning Greeneville City Schools compliance with these regulations should contact the Chief Human Resources Officer.

C. Recruitment (Board Policy 5.105)

The authorization of all school system positions rests with the Board. Personnel employment is at the discretion of the Director of Schools.

Identification of personnel needs shall be the responsibility of the Director of Schools, Supervisors, and building Principals/Supervisors. Effort will be made to include representation of academic and professional experience, age, ethnic backgrounds, race, and sex.

Vacancies of positions are posted on the system website under Employees. Vacancies may be advertised locally and through placement offices. A deadline for receiving applications shall be established and disseminated with the vacancy notice.

D. Application and Hiring (Board Policy 5.106)

Application

All applications are taken on-line through the system website under Employees. Potential applicants who do not have access to apply on-line or need assistance in order to do so may contact the Human Resources department at (423) 787-8008.

Any current employee who desires to apply for a vacant position must apply on-line.

Background Checks (Board Policy 5.119)

In a continuing effort to further ensure the safety and welfare of students and staff, the system requires TBI criminal history records checks and fingerprinting of all employees who have proximity to children. All hiring decisions are contingent upon satisfactory background check results. Per T.C.A. 49-5-413, background checks are required to be run every five (5) years.

Knowingly falsifying information is sufficient grounds for termination of employment and also constitutes a Class A misdemeanor which must be reported to the District Attorney General for prosecution.

Any costs incurred by the Tennessee Bureau of Investigation in conducting such investigations of applicants are paid by the applicant.

The Greeneville City School system reserves the right to withdraw an offer of employment based in whole or in part based on information received as a result of a background check after the applicant has been afforded a reasonable amount of time to dispute and/or correct the results. Applicants will be given information on background check privacy rights prior to being fingerprinted. The results of all applicable background checks must be received and evaluated by the system before the individual becomes employed.

Hiring

Following the approval of a hire by the Director of Schools, Human Resources will offer the job to the applicant contingent on an acceptable physical and background check. An appointment for the employment physical will be scheduled for the new employee by the Human Resources department. The post-offer employment physical, including drug screen, is system paid. The physical must be completed prior to the new employee actually starting work.

Upon written receipt of employment notification, the person shall respond to the offer of employment within the timeline established by state law. From the date of the written acceptance, the person is considered to be under employment with the Board and is subject to all rights, privileges, and duties.

E. Contracts for Professional/Certified Staff (Board Policy 5.110)

The Director of Schools will establish the salary rating of each person employed and shall recommend such salary rating to the Board for approval.

As a general rule, all professional/certified personnel must make a written contract with the Board at a fixed salary per month before entering upon their duties. The purpose of the contract is to outline the compensation and benefits of the employee for the upcoming school year. The school calendar adopted by the Board each year shall become a part of each employee's contract. It is the employee's responsibility to review and sign the contract. If inaccuracies or questions pertain to the contract, all questions should be directed to the Finance department for clarification and revision if necessary.

Greeneville City Schools reserves the right to make corrections to contracts as information becomes available that necessitates a modification.

Non-certified staff positions are considered "at will" employees under Tennessee State Law. Non-certified staff will receive a letter of employment in lieu of a contract at the beginning of each school year. This letter will give the employee information such as hourly rate, work site, and general information about employment.

F. Assignment and Re-Assignment (Board Policy 5.115)

The Director of Schools is ultimately responsible for determining the assignment of school system personnel. The Director of Schools may transfer employees as necessary for efficient operation of the schools. Transfers shall be non-discriminatory and shall not be arbitrary or capricious. Immediate family members shall not be assigned to the instructional staff of the same school. Refer to policy 5.115 for definition of immediate family members.

Extra assignments for which supplements are provided, and upon which initial employment was based, may not be relinquished in part by the employee without the approval of the person making the assignment. Other assignments for which supplemental salary is provided shall be made on an annual contract basis.

G. Educator Licensure

All certified employees shall be responsible for obtaining an educator license, verifying its accuracy, maintaining its validity, registering it with the Greeneville City School Board of Education, and meeting the requirements of T.C.A. 49-5-101. In addition, it is the responsibility of all certified employees to report any name or address changes to the Office of Educator Licensing of the state Department of Education in Nashville, Tennessee, and the Human Resources department of Greeneville City Schools. Certified employees needing to renew their educator license, add a degree or endorsement must contact the Tennessee Office of Educator Licensing. The Tennessee Department of Educator Licensing may be contacted by the following means.

<https://www.tn.gov/education/educators/licensing.html>

Office of Educator Licensing
Tennessee Department of Education
4th Floor, Andrew Johnson Tower
710 James Robertson Parkway
Nashville, TN 37243-0377
Telephone (615) 741-5158
Fax (615) 532-1448

Licenses can now be renewed and personal information updated on line through TNCompass at <https://tdoe.tncompass.org>. Any time a new or revised license is obtained, the employee must notify the Human Resources department of Greeneville City Schools immediately.

H. Highly Qualified Status (New ESSA eliminated teacher requirement, Retained for IA's)

The NCLB Act of 2001 required that all public school teachers teaching in the core academic areas be highly qualified as outlined by the state of Tennessee. This requirement is now obsolete under ESSA. However, requirements for Instructional Assistants were retained. All Instructional Assistants must have either a minimum of two (2) years of college credit or have passed the ParaPro Exam.

I. Probation Period of Non-Certified Employees (Board Policy 5.107)

A probationary period is defined as the first ninety (90) days of employment for a new employee or for an employee who has been re-hired following a break in service. The probationary period will be used to allow the immediate Supervisor to closely observe and evaluate the employee and to encourage effective adjustment to the position.

Probationary employees will be allowed to accumulate sick leave and vacation days in accordance with the appropriate Board policies during the probationary period. Holidays for probationary employees will follow the same procedures as for regular employees.

J. Evaluation (Board Policy 5.109)

Administrative and Supervisory Personnel

Administrative and supervisory personnel will be evaluated by use of a state approved model for evaluating. The Director of Schools is responsible for ensuring that all administrative and supervisory personnel are evaluated annually.

Licensed Teaching Personnel

Licensed teaching personnel will be evaluated through use of a state approved model or one that has been submitted to the Commissioner of Education for approval. Greeneville City Schools has adopted the AIMS TIGER model.

Evaluations will be conducted by a school administrator and/or designee(s) who have been trained and certified through the state sanctioned training in evaluation procedures prior to conducting evaluations. The Principal shall be responsible for the final evaluation decision.

Evaluations shall use multiple data sources which include but are not limited to the following,

- Classroom or position observations including planning and reflecting information and/or review.
- Review of previous evaluations and an educator self-assessment.
- Conferences.
- Examination of professional growth.
- Review of indicators of student progress.
- Examination of assessment techniques, results, and applications.

As part of the evaluation, a growth plan for the Teacher will be developed collaboratively by the Teacher, Principal, and/or Supervisor.

Non-Certified Personnel

Non-certified personnel will be evaluated prior to their 90-day probationary period and once a year annually thereafter.

Evaluations will be used to help improve employee performance and as a basis for continuing employment. Evaluation reports will be discussed with the employee who will be given a copy of the evaluation and will sign the Supervisor's copy as evidence that it has been discussed.

K. Personnel Records (Board Policy 5.114)

Official personnel records will be maintained by the Human Resources department as authorized by the Director of Schools and according to state and federal law. Information contained in personnel records will

be limited to job related matters. An employee's personnel record may contain applications, contracts, professional certificates, evaluations, cumulative information files, and other documents required by state and federal laws and regulations.

Employee records are public records, except matters deemed confidential by law, and are open for inspection during regular business hours with a pre-scheduled appointment. Members of the public may not obtain the home telephone number, personal cell phone number, bank account information, social security number, residential street address, or driver license information (except where driving or operating a vehicle is considered to be a part of the employee's duties), of an employee or of the immediate family members or household members of an employee, unless release of this information is expressly authorized by the employee. A record of the person inspecting and the date of the inspection will be recorded.

An employee shall be granted the opportunity to respond in writing to material placed in his/her records.

L. Employment or Supervision of Relatives (Board Policies 1.108 and 5.115)

In order to avoid a conflict of interest in the supervision and evaluation of employees, the Director of Schools will not employ any teacher or other employee if such teacher or other employee is related to the Director of Schools or any member of the Board.

In addition, at no time may any administrator be the immediate supervisor of any employee who is their immediate family member nor is any employee to directly supervise or evaluate another employee who is an immediate family member. Immediate family shall be defined as spouse, child, parent, brother, sister, grandparent, grandchild, aunt, uncle, niece, and nephew. In addition, Greeneville City Schools recognizes any of the aforementioned relationships created by marriage.

This policy does not apply to any person within such relationship or relationships who has been regularly employed by the Board prior to the inception of the relationship, the adoption of this policy, or a Board member's election.

M. Tenure (Board Policies 5.116 and 5.117)

The Board of Education will grant tenure only to those teachers who can present documentation of a record of excellence as a teacher (i.e. Teacher Portfolio). The Director of Schools is responsible for documenting and presenting the recommendation for tenure to the Board of Education.

*See Tennessee Code Annotated 49-5-501 and 49-1-302 for more information on the changes in tenure, timelines, and Teacher evaluation requirements.

Documentation of a record of excellence in teaching must include the following:

1. A cover page including a photograph.
2. A letter of recommendation for tenure from his/her principal.
3. Two (2) letters of recommendation from parents of present or former students.
4. Record of attendance for the last five (5) years.
5. An educational philosophy which should include the educator's personal beliefs on teaching, what makes him/her an outstanding teacher, intrinsic rewards gained, and a description of their personal teaching style.
6. An autobiography which should include the factors which led him/her to become a teacher and how their background influenced them as a teacher.
7. Evaluation information including summative reports from the last five (5) years.
8. Specific evidence of effectiveness in teaching students (if appropriate):
 - Test scores, including the annual estimate of teacher effect on student progress

N. Suspension (Board Policies 5.200, 5.201, 5.202)

The Director of Schools may suspend an employee at any time when it is deemed necessary. Before an employee is suspended they will be, (1) provided with reasons for the suspension, and (2) given an opportunity to respond.

Under no circumstances are employees suspended with pay. If reinstated, the employee will be paid full salary for the period of suspension unless suspension without pay is deemed to be an appropriate penalty.

O. Dismissal or Non-Renewal

Certified Employees (Board Policies 5.200 and 5.201)

Dismissal or non-renewals of certified employees as defined by state law will be in accordance with procedures set forth in statute. Please refer to **Board Policies 5.200 and 5.201** for state defined procedures.

The Director of Schools is under no obligation to re-employ non-tenured Teachers at the end of their contract period. If the Director of Schools determines not to renew the contract of a non-tenured Teacher, the following action shall be taken,

- The Board will be notified at the next regular Board meeting.
- Written notice of non-renewal shall be sent to the teacher by certified mail or overnight carrier, or by email within five (5) business days following the last instructional day for the school year to be applicable to the next succeeding school year.

Non-Certified Employees (Board Policy 5.202)

Dismissal or non-renewals of non-certified employees as defined by state law will be in accordance with procedures set forth in statute.

P. Resignation

Certified Employees (Board Policies 5.200 and 5.201)

A Teacher is required to give the Director of Schools notice of resignation at least thirty (30) days prior to the effective date of the resignation. This notice should be in the form of a letter of resignation which is also copied to the Principal or Supervisor to which the Teacher reports. Failure to provide notice in the absence of justifiable extenuating circumstances may result in the forfeiture of all tenure status. The Board may waive the thirty days' notice requirement and allow the Teacher to resign in good standing.

Any Teacher on leave who does not notify the Director of Schools in writing at least thirty (30) days prior to the date of return, if the Teacher does not intend to return to the position from which they have taken leave, may be in breach of contract. Breach of contract may result in the Board's filing of a complaint with the State Board of Education to request suspension of the Teacher's educator license.

Non-Certified Employees (Board Policy 5.202)

A non-certified employee shall give their immediate Supervisor written notice of resignation at least two (2) weeks (ten working days) prior to the effective date of the resignation. The ten working days' notice may be waived by the Director of Schools for justifiable reasons. The employee's immediate Supervisor shall forward the notice of resignation to the Director of Schools on the day it is received. The employee will receive final payment on the next appropriate scheduled pay day.

Q. Retirement (Board Policies 5.200, 5.201, 5.202)

Full Retirement eligibility with TCRS is either 30 years credited service with TCRS or be age 60 and vested. Early retirement (25 years credited service with TCRS or age 55) is available at a reduced benefit. Central Office personnel shall assist employees in securing retirement benefits, but the retiring employee is responsible for providing written verification of eligibility from Tennessee Consolidated Retirement System (TCRS) to the Central Office and for filing for benefits.

Employees who retire under TCRS may be employed up to one hundred twenty (120) days per year without loss of retirement benefits. ~~Public Chapter 287 allows retired teachers to now teach beyond the 120 days provided the director of schools certifies, in writing, that no other qualified personnel are available.~~ Effective July 1, 2023, Public Chapter 425 allows more flexibility in hiring retirees. This change allows retirees to work as substitutes beyond the typical 120 day contract and permits retirees to serve as regular classroom teachers on an ongoing basis.

Retirement Incentive Program

All state certified teaching and non-certified leadership personnel who have completed fifteen (15) years of employment with Greeneville City Schools and who meet the eligibility retirement requirements for full benefits under TCRS are eligible to participate in the retirement incentive program offered by the Board and outlined in **Board Policy 5.200 and 5.202**. Participation in the program is voluntary and certain limitations apply. The deadline to apply to receive the incentive is May 15th each year. View board policy for more information.

Insurance for Retirees

To be eligible for a health insurance benefit, an employee must be eligible for full retirement benefits with TCRS.

Greeneville City Schools Health Insurance is provided through the State. State of Tennessee Benefits Administration eligibility guidelines are: (See *Policies 5.200, 5.201, and 5.202 for more details*)

If you have...

- Ten (10) years of creditable service with the state or a participating Local Education agency **and** at least three continuous years of insurance coverage in the plan immediately prior to final termination of employment. (Employees may cover family *at their cost* so long as the employee meets these requirements)
- At least Twenty (20) or more years of creditable service with the state or a participating Local Education agency **and** at least one (1) continuous year of insurance coverage in the plan immediately prior to final termination of employment. (Employees may cover family *at their cost* so long as the employee meets these requirements)

To be eligible for GCS paid individual health insurance coverage, an employee must have a total of at least ten (10) years of service with Greeneville City Schools. Eligible employees may receive individual health insurance coverage provided and paid by the school system for up to ten years or age 65. If an employee retires before age 55, they are responsible for a payment of insurance up to age 55 or after the system-paid 10 years.

At age 65, the employee will have the option of purchasing a Medicare supplement policy through the state insurance program. No supplement policy is offered by Greeneville City Schools. Life insurance will be system provided until age 65. After age 65, the retirees will have the right to convert this coverage to a private policy at his/her own expense.

Employees hired in Education after July, 2015: In 2015, the State Insurance plan made the decision to deny retiree eligibility to any employee hired into local education on or after 7/1/15.

III. COMPENSATION AND BENEFITS

Compensation for all employee types is established by the adoption of salary schedules and scales by action of the Board of Education.

A. Salary Schedules and Scales

Salary schedules and scales for various employment categories within Greeneville City Schools are available on the Greeneville City Schools website www.gcschools.net under Employees/Finance/Salary Scales.

Certified Employees

There is one salary schedule which pertains to all certified employees. In order to determine the appropriate salary, employees should refer to the salary schedule based on both their degree and years of experience.

Non-Certified Employees

Non-certified pay scales are provided for the various types of employment. Although years of service are tracked for retirement and longevity purposes, the non-certified scales are based on pay levels, and these levels are not strictly correlated to years of service.

New non-certified employees will begin at a pay level of zero (0) unless **relevant experience which correlates to the GCS position hired is submitted on a valid verification of employment form.** ~~one of the following applies:~~

- ~~• Experience in Education: Beginning pay level will be based on years of experience and will be accepted for pay so long as it is in the same position hired. A completed experience verification form from the previous system will be required.~~
- ~~• Experience outside of Education: (Effective 1/1/2020) Beginning pay level will be determined based on relevant years of experience correlating to the position hired and will be placed on the pay scale as indicated in the chart below. A completed experience verification form from the previous employer(s) will be required.~~

Experience	Pay Level
0 Years	Level 0
1-3 Years	Level 1
4-6 Years	Level 2
7-9 Years	Level 3
10-12 Years	Level 4
13-15 Years	Level 5
16-18 Years	Level 6
19-21 Years	Level 7
21+ Years	Level 8

Degree Changes

At the beginning of each year, certified personnel are required to document their intention to obtain an advanced degree for the upcoming school year by responding to the Employment Intention survey. This notification via the Employment Intention survey is necessary so that appropriate funding can be set aside to cover the increased cost of an advanced degree. The Employment Intention survey response does not replace the actual Contract Revision Form required for actual salary changes.

Salary changes based on a degree or additional hours earned can occur at two different points during the year and require submission of the Contract Revision Form (with appropriate supporting documentation) to the Human Resources department. Documentation must be received no later than September 1 for the beginning of the school year change and by January 1 for a change effective in the spring semester. Once the appropriate documentation has been received, the Teacher's monthly salary will be adjusted accordingly for the remainder of the school year. Official sealed transcripts are required.

Greeneville City Schools pays supplements for additional hours beyond a bachelor's or master's degree when the hours total 10 hours (\$100 supplement) or 20 hours (\$200 supplement). It is the responsibility of the educator to notify payroll and human resources if they have such hours beyond their degree. If 30

hours beyond a master's degree are completed, the Teacher is required to make application to the state for a new license and will be placed on the masters + 30 level on the salary schedule. All hours referred to above are semester hours.

Greeneville City School's forms, salary schedules, and scales are available on the system website www.gcschools.net under Employees. All licensure changes must be initiated through TNCompass at <http://tdoe.tncompass.org>

B. Payroll Procedures (Board Policy 2.802)

Pay Dates

Greeneville City School employees are paid either monthly or semi-monthly based on their position within the system.

Paid Semi-Monthly, 15th and last day of month	Paid Monthly, on the 20th
Custodian	Administrator (GCOB, KLCO, Principals)
Lawn Care	Administrative Assistant and/or Bookkeeper (School Locations)
Maintenance	Athletic Trainer
School Nutrition	Bus Driver and Substitute Bus Driver
Student Associate	Contracted Coach – Paid monthly during sport season.
Substitute (Custodian, School Nutrition, Teacher)	Coordinated School Health Supervisor
Support Staff (GCOB and KLCO)	Extended School Program Associate
	Family Services Center
	Instructional Assistant
	Instructional Technology (IT)
	JROTC Instructor
	Psychologist
	School Nurse
	School Nutrition Coordinator
	Teacher

Teachers and full time non-certified employees paid on a ten-month basis (August through May) have the option of requesting paychecks to be spread over a twelve-month period (which would be an August through July scenario).

If a designated pay date falls on a weekend or a holiday, the pay date will occur on the preceding business day.

Direct Deposit

Upon accepting employment with Greeneville City Schools, individuals are asked to provide the Finance department (Payroll) with a voided check for the account or accounts to which they would like their payroll deposited. Payroll checks can be deposited in up to five (5) different bank accounts if the employee chooses. When providing this information, if more than one account is being utilized, the employee must indicate the amounts to go into the various accounts.

Insurance Deductions

Deductions for elective insurances, medical reimbursement, and dependent care reimbursement occur during the months of August through May. Employees who receive their pay over twelve (12) months will not have these payments deducted from their paychecks during the months of June and July.

Insurances are paid in full through June 30th each year. In the event an employee resigns in July, they would be responsible for the employee portion of the premium.

C. Annuities

In addition to the retirement funding that Greeneville City Schools provides to full-time employees through the Tennessee Consolidated Retirement Service (TCRS), employees may elect to individually participate in annuity programs.

Currently, Greeneville City Schools offers the following annuity providers:

- American Fidelity
- Ameriprise
- Aspire
- Horace Mann
- Modern Woodman
- Primerica
- Tennessee Farmers Mutual
- Valic.

In order to establish an annuity account, an interested employee should contact one of the above listed providers (phone numbers are available from the Finance department). Once the annuity is set up, it is the employee's, or their selected annuity provider's, responsibility to communicate the deduction information to the Finance department (Payroll).

Some annuities are deducted on a ten (10) month basis while others are deducted on a twelve (12) month basis depending on the annuity provider selected. The annuity providers' documentation supplies details regarding the programs. Annuity documents contain terms of the plans that are subject to change and prevail over the Employee Handbook.

D. Section 125

Greeneville City Schools sponsors a Section 125 Cafeteria Plan which enables employees to purchase elective insurances and/or participate in medical and dependent care reimbursement plans and have those premiums deducted from their paycheck on either a taxable or pre-tax basis.

The plans, administered by American Fidelity, are based on group rates, and therefore afford employees the opportunity to purchase individual coverage at reduced rates.

Each year during the enrollment period in the fall, American Fidelity will hold open enrollment meetings in each school and at the Central Office during which employees will have the opportunity to add, delete, or change their elective insurances. At this time, employees also have the opportunity to begin participation, end participation, or change their level of participation in the medical reimbursement and/or dependent care reimbursement plans.

Any elections or changes will not take effect until January 1 of each year and will remain intact until December 31 of that same year. During the year, no changes may be made regarding pre-tax deductions unless a qualifying event occurs.

The plans' terms are subject to change and take precedence over any statement in this Handbook.

E. Student Tuition

Student tuition may be deducted from a Greeneville City School employees' payroll check if an employee chooses this method of payment. This option is only available to Greeneville City School employees and will be taken out of their paychecks during the months of August through May.

F. Travel and Expense Reimbursement (Board Policy 2.804)

Upon completion of travel for business purposes, the employee should complete the online Travel and Expense Reimbursement form located in the Finance section of the GCS website, Please submit reimbursements within 30 days of travel.

Mileage

Mileage is reimbursed at 62.5 cents per mile for required travel. This rate is determined by the Board of Education ~~State of Tennessee~~. Mileage incurred as a result of a specific trip should be reported on the Travel and Expense Reimbursement Form. The number of miles is then multiplied by 62.5 cents order to determine the reimbursement amount.

Employees who are required to drive their personal vehicles on a routine basis should complete a Mileage Reimbursement Form. This form requires that the employee list the date of the incurred miles, the origination and destination of the trip, and the purpose.

Meals

In order to be eligible for reimbursement for meals, an employee must be required to be away from home overnight for work related purposes. In order to receive reimbursement for breakfast, an employee must leave home prior to 6:30am. For lunch reimbursement, the employee must leave prior to 11:00am. The employee must return home after 7:00pm to be eligible for reimbursement for dinner.

Being required to attend a one-day seminar out of town, but not overnight, does not entitle the employee to be reimbursed for the cost of any meals they might purchase while attending the seminar.

Reimbursement rates for meals are on a per diem basis, and therefore, no receipts are required. The current per diem rates are as follows.

Breakfast	\$ 14.00
Lunch	\$ 16.00
Dinner	\$ 26.00

Reimbursement is not allowed for meals which were paid for by an outside party or for meals which were made available at no cost by the seminar or event the employee is attending. This rule will apply whether you choose to partake of the meal or not; if a meal is provided, reimbursement may not be requested.

Hotel/Motel

Receipts are required for motel/hotel reimbursement. These receipts should be attached to the Travel and Expense Reimbursement Form.

When an employee is required to stay in a hotel or motel for school related business, they should contact the Finance department (Accounts Payable) prior to departure to request a Sales Tax Exemption Form. The purpose of this form is to verify to the hotel or motel Greeneville City Schools tax exempt status. The completed form should be given to the desk clerk upon check in to avoid being billed sales tax as part of the expense of the stay. This form does not, however, waive the cost of occupancy municipal tax.

Miscellaneous Expenses

All requests for miscellaneous expenses incurred as a result of the trip for which the form is being completed should be documented with a receipt in order to receive reimbursement. These expenses might include, but are not limited to, such items as taxi receipts, parking receipts, and conference registration.

Method and Timing of Reimbursement

Reimbursement payments are typically processed each Friday. In order for a reimbursement to be issued on Friday, the request with immediate Supervisor approval must be received by the Finance department by Wednesday of that same week. Reimbursement payments to employees are direct deposited.

G. Special Expenditure Reimbursement

When an employee is required to spend their personal money for a school system related expense, a Special Expenditure Reimbursement Form must be completed and submitted to the Finance department (Accounts Payable) for reimbursement. The form is available on the system website. All receipts should be attached to the completed form. The form has space to list the expenditures, along with an explanation of the purpose of the expense(s) as well as the total cost. Sales tax is not reimbursable under most circumstances.

Reimbursement payments are typically processed each Friday. In order for a reimbursement to be issued on Friday, the request with immediate Supervisor approval must be received by the Finance department by Wednesday of that same week. Reimbursement payments to employees are direct deposited.

H. Overtime and Compensatory Time (Board Policy 5.604)

Greenville City Schools complies with the Fair Labor Standards Act (FLSA) to determine eligibility for overtime. The system classifies all employees as either exempt or non-exempt based upon their job duties and salary requirements (FLSA). Non-exempt employees must receive prior approval from ~~the Director of Schools, or designee,~~ **their immediate supervisor** to work additional hours beyond their regular work schedule. At that time, the Supervisor will determine whether the employee will receive compensation in the form of overtime pay or compensatory time off. Overtime pay for non-exempt employees will be paid at the rate of one and one-half times the employee's regular rate of pay for all hours worked over forty hours in a work week. Clocking in early or late without prior permission is strictly prohibited and will not result in automatic comp time or overtime. Any issues with clocking in/out shall be reported to the immediate supervisor.

Exempt employees are not eligible for overtime or compensatory time according to the FLSA.

I. Health Insurance

Greenville City Schools provides individual health insurance coverage for all full time employees. Because Greenville City Schools is a member of the state of Tennessee's health insurance plan, each year employees have the opportunity to choose between different state sponsored plans to meet the employee's medical insurance needs.

For the individual eligible employee, Greenville City Schools will pay 100% of the premium of the Premier Health Plan. Anyone who selects a more expensive plan will incur payroll deductions for the additional premium.

The state of Tennessee sets the required minimum percentage of a certified Teacher's family health insurance premium that must be paid by the school system by which the Teacher is employed.

The state of Tennessee Benefits Administration is responsible for Greenville City Schools employee health insurance, Employee Assistance Program, and Mental Health and Substance Abuse Program. The website is <https://www.tn.gov/partnersforhealth.html>. Dental and Vision are administered by private plans (not through the state plan).

Affordable Care Act

In accordance with the Affordable Care Act of 2010, GCS (for the purposes of health insurance) recognizes full time employees as those that work over 30 hours per week. Greenville City Schools adopted provisions of the lookback measurement method safe harbor in order to determine the full time status of variable hour employees. See Appendix L for more information.

If an employee is on a leave of absence covered by FMLA (Family Medical Leave Act), as required by law, the system will continue to pay the employer portion of the health insurance premium. If an employee has an accumulated paid leave balance (i.e. accumulated sick leave, personal leave, vacation, or sick leave

bank), the system will continue to pay the employer portion of the premium beyond FMLA coverage until the employee has exhausted all paid leave. At the point an employee exhausts all paid leave, but is still employed by the system, they may continue on insurance at the full cost of the premium paid by the employee. The employee does have the option to suspend their coverage while on leave if they chooses to do so.

Retiree Health Insurance

The Board of Education provides payment of individual health insurance premiums for ten (10) years or until the age of 65, whichever occurs first, for all certified and non-certified employees who retire with ten (10) years of service with the Greeneville City School system.

At age 65, the employee will have the option of purchasing a Medicare supplement policy through the state insurance plan. No supplement policy is offered by Greeneville City Schools.

Excluding employees whose first employment with local education commenced on or after July 1, 2015, eligible employees may receive individual health insurance coverage provided and paid by the school system for up to ten years or age 65. If an employee retires before age 55, they are responsible for a payment of insurance up to age 55 or after the system-paid 10 years. This benefit is separate from the Early Retirement Incentive Plan. The employee will receive this benefit provided the employee is eligible for full retirement under the eligibility standards as set by the Tennessee Consolidated Retirement System

If you have...

- Ten (10) years of creditable service with the state or a participating Local Education agency **and** at least three continuous years of insurance coverage in the plan immediately prior to final termination of employment. (Employees may cover family *at their cost* so long as the employee meets these requirements)
- At least Twenty (20) or more years of creditable service with the state or a participating Local Education agency **and** at least one (1) continuous year of insurance coverage in the plan immediately prior to final termination of employment. (Employees may cover family *at their cost* so long as the employee meets these requirements)

Employees hired in Education after July, 2015: In 2015, the State Insurance plan made the decision to deny retiree insurance eligibility to any employee hired into local education on or after 7/1/15.

J. Life Insurance

Greeneville City Schools provides board paid life insurance for all full time employees. The amount of coverage is dependent upon the employment position; however, in no event is the coverage less than \$20,000 unless over the age of 65. Life insurance benefits are reduced by 35% at age 65 and by 50% at age 70. Specific coverage amounts for each employee will be detailed in their annual employment contract distributed at the beginning of the school year or at the time of employment. Additionally, optional life insurance is available for the employee, spouse, and children. Employees are responsible for the cost of the optional insurance. The cost for this optional coverage will be payroll deducted over ten months.

Retiree Life Insurance

Life insurance will be system provided until age 65. After age 65, the retirees will have the right to convert this coverage to a private policy at their own expense.

The Board of Education provides payment of individual life insurance premiums until the age of 65 for all certified and non-certified employees who retire with fifteen (15) years of service with Greeneville City Schools. The employee will receive this benefit provided,

- The employee is eligible for full retirement under the eligibility standards as set by the Tennessee Consolidated Retirement System, and

- The employee was enrolled in the Board-sponsored insurance plan for one (1) full year prior to retirement.

K. Dental Insurance

Greeneville City Schools provides employees who meet eligibility requirements with the option to purchase dental insurance coverage for the employee and their dependents. The cost of this optional coverage will be payroll deducted over ten months. Employees may opt to enroll in this coverage when they are hired or during the annual enrollment period. Employees are responsible for 100% of the dental insurance premiums.

L. Vision Insurance

Greeneville City Schools provides employees who meet eligibility requirements with the option to purchase vision insurance coverage for the employee and dependents. The cost of this optional coverage will be payroll deducted over ten months. Employees may opt to enroll in this coverage when they are hired or during the annual enrollment period. Employees are responsible for 100% of the vision insurance premiums.

M. Retirement Funding

All full time Greeneville City Schools employees participate in the Tennessee Consolidated Retirement System (TCRS). Greeneville City Schools is required to contribute to retirement funding a certain percentage of each certified employee's wages each pay period. Funding for non-certified employees is provided solely by Greeneville City Schools. Employees can navigate to <https://mytcrs.tn.gov> to access TCRS information.

401K – Empower Retirement: Effective July 1, 2014, any new teacher (not previously a member of TCRS) is considered a “Hybrid” member. Hybrid members are automatic participants of TCRS and the State 401K program. GCS contributes to both plans. While the certified hybrid employee is required to contribute to the TCRS pension plan, employee contribution to the 401K is optional. Certified employees hired prior to July 2014 and non-certified employees are considered “Legacy” members and do have the option to contribute to the 401K, however, the system does not contribute for Legacy members.

N. Workers' Compensation (Board Policy 3.602)

Anytime an employee experiences a work-related injury, it should be reported to their Principal or direct Supervisor immediately. In addition, there is an accident report form to be completed and filed with the ~~Coordinated School Health department at the George Clem Operations Building~~ **Kathryn Leonard Central School Office**. This form may be obtained from the Greeneville City Schools website at www.gcschools.net under Employees/Human Resources/Employment Documents. All injuries shall be reported to ~~Coordinated School Health~~ **the Assistant Director of Schools for Administration or Human Resources** immediately.

Greeneville City Schools maintains workers' compensation insurance for each of its employees. The ~~Coordinated School Health department~~ **Assistant Director of Schools for Administration or Human Resources** should be contacted prior to visiting a physician for a workers' compensation claim as there is an approved panel of physicians who are used for treatment of those claims. In the case of an injury requiring emergency treatment, an employee may go or be taken to the emergency room or may be transported by ambulance. In those situations, the school Principal or immediate Supervisor should be contacted as soon as possible.

Workers' Compensation is designed to provide relief to employees injured during the performance of job duties. An employee who is injured or who becomes disabled while performing their job duties is entitled to medical care provided through the panel of physicians. It is important to note that sick leave benefits shall be paid to employees only when workers' compensation benefits are not involved.

Employee Pay While on Workers Compensation

Per Tennessee Workers Compensation Law. When a work-related injury occurs and if an employee is not able to work due to the injury, they may turn in system paid leave for the first seven (7) days. After the 7th day, if the employee is still out of work due to the work-related injury, Workers Compensation benefits pick up beginning on the eighth (8th) day. Workers Compensation does not allow for an employee to be paid from the employer while they are receiving workers compensation benefits. Therefore, an employee may not turn in any system paid leave during the time they are receiving WC benefits. If the employee is still out of work due to a work-related injury after fourteen (14) days, Workers Compensation will go back and pay the employee benefits back to the date of injury until the employee is back to work full time. Employees that are back to work but must leave for appointments related to their work-related injury are required to clock out for this time and report any time away from work to their workers compensation case manager.

TN Drug Free Workplace Program (Board Policy 5.403)

Greeneville City Schools participates in the Tennessee Drug Free Workplace Program. As a part of this program a drug screen test will be completed when an employee suffers a work-related injury requiring more than on-site first aid or an employee is involved in a job-related accident or incident which results in property damage estimated at ~~\$200~~1,000 or more, such testing will occur as soon as possible, but only after emergency or urgent medical care has been administered to the employee.

Procedure for Filing a Workers' Compensation Claim

- Notify the immediate Supervisor and the ~~Coordinated School Health department~~ Assistant Director of Schools or Human Resources of the injury and the employee's choice of physician from the panel. The names of the physicians and the emergency care facilities are posted in conspicuous places throughout the maintenance, transportation, administrative, and professional areas of schools and facilities.
- The ~~Coordinated School Health department~~ Assistant Director of Schools or Human Resources will schedule the appointment and notify the employee of the appointment time.
- Complete the Workers' Compensation Physician Choice form and the Workers' Compensation Pharmacy Program form to take to the appointment. These forms are available on the system website.
- Provide necessary information for completion of the "First Report of Injury" to the ~~Coordinated School Health department~~ Assistant Director of Schools or Human Resources.
- In the event of an emergency, treatment may be sought at either of the emergency care facilities listed with the panel of physicians.
- When seeking emergency treatment, inform the emergency care facility that this is a workers' compensation injury, and it should not be billed to the employee's health insurance provider. Inform them that it is a workers' compensation claim with Greeneville City Schools.
- In the event a specialist is required, the treating physician will provide the employee with a choice of physicians from the TML panel of specialists.

All accidents and injuries, regardless of their apparent significance, should be reported on the "Employee Accident Report" form, which is available on the system website. This requirement applies even if no medical treatment is received at the time of injury. The Principal/Supervisor reviewing the Employee Accident Report is responsible for filing this report with the ~~Coordinated School Health department~~ Assistant Director of Schools or Human Resources.

Employer Provided Clothing

In some cases, employees will be provided with and required to wear uniforms or safety accessories while performing job duties. These articles are to be worn only while on duty and are not to be worn outside of working hours. These articles must be turned in to the employee's supervisor upon exit from employment with Greeneville City Schools.

IV. LEAVE

A. Request and Approval of Leave

All requests, approval, and recording of leave (i.e. bereavement, jury duty, loss of pay, personal leave, professional leave, sick leave, and vacation) must be made through the system's designated leave management system which can be accessed via the Greeneville City Schools website <http://www.gcschools.net>. Part time employees should also request approval of absences in advance via the same designated leave system.

To request an extended leave of absence (FMLA or Non-FMLA) or sabbatical leave, the employee must notify the Human Resources department and request the appropriate paperwork.

B. Sick Leave (Board Policy 5.302)

Sick leave shall be defined as: illness of an employee from natural causes or accident, quarantine, or illness or death of a member of the immediate family of a teacher, including the teacher's wife or husband, parents, grandparents, children, grandchildren, brothers, sisters, mother-in-law, father-in-law, daughter-in-law, son-in-law, brother-in-law, and sister-in-law. In addition, Greeneville City Schools recognizes any of the aforementioned relationships created by marriage.

For detailed information on sick leave policy, please refer to **Board Policy 5.302**.

Employees wishing to request sick leave must do so through the system's designated leave management system. Leave may be requested in $\frac{1}{4}$, $\frac{1}{2}$, $\frac{3}{4}$ or whole days. To request an extended leave of absence (FMLA or Non-FMLA), sabbatical leave, etc., the employee must notify the Human Resources department and request the appropriate paperwork. The request should be made in advance of the leave unless an emergency prevents the request from being made until after the employee's return to work.

Employees wishing to transfer sick leave from a previous Tennessee state or governmental employer should contact the Human Resources department to discuss any necessary paperwork that must be filed. It is the employee's responsibility to have the previous employer send a notarized letter with the number of accumulated days to the Director of Schools or the Human Resources department.

Sick Leave Bank

The Greeneville City Schools Sick Leave Bank provides for the sharing of sick leave days among its participants according to regulations established by the board of trustees of the Sick Leave Bank.

All full-time employees, certified and non-certified, are eligible to join. A one-time donation of two (2) days are required to join the bank. Open enrollment for the bank begins in August and ends October 31st of each year. An annual email to employees will be sent as a reminder of the open enrollment period.

C. Bereavement Leave

For full time employees, three (3) days of bereavement leave will be granted due to the death of an employee's spouse, parent, child, grandchild, sibling, grandparents (including those of the employee's spouse), father-in-law or mother-in-law. One (1) day of bereavement will be granted due to the death of an employee's aunt or uncle (including those of the employee's spouse), son-in-law, daughter-in-law, brother-in-law, sister-in-law, or any other person living in the home of the employee as a member of the family.

D. Personal Leave (Board Policy 5.303)

All certified employees receive three (3) personal days per year to be used at their own discretion. These days are earned evenly throughout the year and are prorated for employees who do not work the entire school year. Any unused personal days remaining at the end of the fiscal year shall be credited to the employee's sick leave. Requests for personal day usage must be submitted through the system's designated leave management system prior to the date of the leave.

Subject to the following conditions, personal leave may be taken at the discretion of the employee.

- Except in emergency, each employee shall give the Principal at least one day's notice of intent to take leave.
- The approval of the Director of Schools or designee shall be required,
 - If more than ten percent (10%) of the Teachers in any given school request its use on the same day.
 - If requested during any prior established student examination period.
 - If requested on the day immediately preceding or following a holiday or vacation period.
 - If requested for a day scheduled for professional development or in-service training, according to the school calendar adopted by the Board.
 - If requested for a day scheduled for parent-teacher conferences, according to the school calendar adopted by the Board.

E. Professional Leave (Board Policy 5.303)

Professional leave is a short, temporary absence for the purpose of attending workshops and other meetings relating to school business or serving on Boards and commissions which meet during daytime hours when appointed by a mayor, city council, county executive, or county commission.

Requests for professional leave must be submitted through the system's designated leave management system five (5) days prior to the date of the leave.

F. Vacation (Board Policy 5.310)

Greeneville City Schools provides vacation at varying degrees for all **full time** employees with the exception of Teachers. The rate at which days are granted depends on the number of months the individual is employed, as well as the length of time the individual has been employed. For each full time employee to whom vacation is provided, the employee's vacation allocation is listed on their contract or letter of employment.

- 10 Month (Non-Certified): 3 days per year
- 11 Month (Non-Certified): 5 days per year
- 11 Month (System Wide & *Assistant Principals): 5 days per year
- 12 Month - 240 & 253.5 Day Contracts (Non-Certified): 10 days per year
- 12 Month (240 System Wide & *Principals): 10 days per year
- 12 Month – 260 Day Contracts (Non-Certified & CO Admins):
 - 1.00 day per month (1st – 4th year)
 - 1.25 days per month (at 5 years)
 - 1.5 days per month (at 10 years)

Any vacation time not used by the end of a fiscal year will be lost, with the exception of 260 day employees. 260 day employees may carry over twenty (20) days and can request for payment for up to five (5) days over the twenty (20) day limit. Beyond this, any days over twenty (20) are lost.

*Principals and Assistant Principals: Two (2) vacation days may be used during the school year and remaining days may only be used on days when school is not in session.

G. Family and Medical Leave Act (Board Policy 5.305)

Eligibility and Leave Entitlement

Eligible employees who have worked for the system for at least twelve (12) months (without a break in service of more than seven years, except for breaks caused by certain military service obligations) and at least 1,250 hours during the twelve month period immediately preceding the commencement of leave may take up to 12 weeks of leave under the Family and Medical Leave Act ("FMLA") on a 12 month rolling period, (1) for the birth of a son or daughter, and to care for the newborn child; (2) for placement with the employee of a son or daughter for adoption or foster care; (3) to care for the employee's spouse, son,

daughter, or parent with a serious health condition; (4) because of a serious health condition that makes the employee unable to perform the functions of the employee's job; (5) because of any qualifying exigency arising out of the fact that the employee's spouse, son, daughter, or parent is a covered military member on active duty (or has been notified of an impending call or order to active duty). Any employee requesting leave due to pregnancy, childbirth, or adoption shall be granted up to 16 weeks of leave.

The amount of FMLA leave available to the employee is determined by examining the amount of FMLA leave taken in the preceding twelve (12) month period, measured backward from the date an employee uses any FMLA leave. This is referred to as the "rolling period" method of calculation. In addition, eligible employees may take up to 26 weeks of leave to care for a covered military service member with a serious injury or illness, in a single 12 month period, if the employee is the spouse, son, daughter, parent, or next of kin of the service member.

Tennessee Paid Parental Leave

Six (6) work weeks of paid leave is available to eligible employees after a birth, stillbirth, or adoption of a newly placed minor child. An eligible employee taking leave under this provision shall not be required to utilize any other type of accrued leave during this period. All full-time employees who have been employed with a school district full time for at least twelve (12) consecutive months are eligible.

Employees shall provide notice to the school district thirty (30) days prior to the intended use of the leave. If the employee learns about the need for leave less than thirty (30) days in advance, the employee shall give notice as soon as reasonably possible in order to be eligible for the paid leave. This paid leave does not need to be taken consecutively; however, the paid leave shall be used within twelve (12) months of the qualifying event.

The entire Greeneville City Schools Family and Medical Leave Act Policy is located in Appendix D.

H. Other Available Leave

Please refer to the following Board policies for information on the following types of available leave.

Long Term Leave for Professional/Certified Personnel	Board Policy 5.304
Leave for Adoption, Pregnancy, Childbirth, and Nursing of a Child	Board Policy 5.3051
Military Leave	Board Policy 5.306
Physical Assault Leave	Board Policy 5.307
Sabbatical Leave	Board Policy 5.308
Legislative Leave	Board Policy 5.309

V. GENERAL EMPLOYEE RULES

A. Attendance Guidelines

Regular attendance and punctuality are expected and essential for the efficient operation of Greeneville City Schools. Our students, staff, parents, and community depend on us to provide services that ensure the best learning opportunities.

Greeneville City Schools understands that there may be legitimate reasons as to why an employee must miss work. These guidelines ensure a clear and consistent system to appropriately address absenteeism. It is the responsibility of Principals/Supervisors to evaluate each absenteeism situation using the guidelines and to ensure that absenteeism data is accurately maintained.

Definitions

Unscheduled Absence Any *unscheduled* time lost from work regardless of reason. The term "unscheduled" **excludes** pre-scheduled and approved vacations, leaves of absence, Family Medical Leave, jury duty, funeral, workers' compensation time, and loss of pay.

Tardiness The failure to report to the assigned work area at the appropriate time as defined by the Principal/Supervisor or leaves work prior to the end of the work schedule without prior approval.

No Call/No Show Employees must report an absence daily within two (2) hours of the scheduled start time unless the absence has been approved in advance and/or the Principal/Supervisor has excused the employee from calling in daily. Failure to call in daily within two (2) hours of the scheduled start time is considered a no call/no show.

Guidelines

- 1) Any unscheduled absences are to be reported by the employee on a daily basis to the Principal/Supervisor or designee at least two (2) hours prior to the scheduled start time. The Principal/Supervisor will communicate with you directly if the job you hold requires a modified absence reporting schedule. For example, Bus Drivers are required to report absences to work at least three (3) hours prior to the start of the scheduled start time.
- 2) The Principal/Supervisor may require a physician's clearance to return to work when the employee is absent for three (3) or more consecutive days.
- 3) An unscheduled absence for less than an hour is considered a tardy.
- 4) A No Call/No Show is immediate grounds for disciplinary action including written reprimand up to and including termination. Each day an employee does not call in and does not report for work as scheduled counts as an unscheduled absence. Any employee who fails to call in and/or report to work for three (3) consecutive days or four (4) non-consecutive days is voluntarily terminating employment.

The following schedule of recommended progressive discipline, which apply to the unscheduled absence and tardiness guidelines, are measurable within a six-month period. Based on the severity of the offense, Principals/Supervisors reserve the right to skip or repeat steps as deemed necessary.

- Level A Three (3) unscheduled absences or four (4) tardy occurrences
Documented Verbal Warning (Attendance Guidelines will be reviewed)
- Level B Four (4) unscheduled absences or six (6) tardy occurrences
Formal Written Warning (Attendance Guidelines will be reviewed)
- Level C Five (5) unscheduled absences or eight (8) tardy occurrences
Final Written Warning (Attendance Guidelines will be reviewed)

B. Blood-borne Pathogen Training

All Greeneville City School employees shall be advised of routine procedures to follow for handling body fluids. These procedures shall provide simple and effective precautions against transmission of diseases to persons potentially exposed to the blood or body fluids of another. Training and appropriate supplies shall be available to all employees.

Staff members who are at high risk for occupational exposure to blood or other potentially infectious materials will be provided with personal protective equipment, including Hepatitis B vaccinations. Employees considered to be at high risk shall include Custodians, Maintenance, Administrative Assistants (school locations), School Nurses, Special Education Teachers and Instructional Assistants, Coaches, and Physical Education Teachers.

A series of three Hepatitis B vaccinations will be provided free of charge to the high risk employee categories listed in the paragraph above. In most instances, these vaccinations can be obtained at the employee's doctor's office. If the employee's doctor does not provide this service, the employee should contact the Coordinated School Health department for assistance in finding a provider for these vaccinations. Any out of pocket costs incurred as a result of these vaccinations should be submitted to the Finance department for reimbursement.

C. Building Security - Keys/Security Cards/Doors

Building keys, door alarm codes, and/or security cards are issued to individual employees by the school Principal, Operations Manager, Human Resources or the employee's Supervisor. In order to protect Greeneville City Schools property, students, and employees and to ensure the building is adequately secured when no authorized personnel are present, employees are expected to follow these procedures.

- The duplication of keys is prohibited.
- Keys/security cards are not to be left on desks, tables, in mailboxes, or other unsecure areas.
- Keys/security cards may not be loaned to students or individuals not employed by Greeneville City Schools. Under no circumstances should employees provide keys/security cards to students to run errands, unlock/lock doors, or perform other actions.
- Building alarm codes are individual to the employee. Sharing of alarm codes is strictly prohibited.
- Lost or stolen keys/security cards must be reported to Human Resources and the school Principal or the employee's immediate Supervisor immediately at the discovery of the loss or theft so that measures may be taken to protect Greeneville City School's property. Three days will be allowed for the recovery of keys/security cards before any charges are assessed.
- Teachers and staff should keep their Greeneville City Schools key(s) on their person at all times in order to facilitate a lockdown if the need arises.
- Charges for lost or stolen keys/security cards may be made to the employee to whom the key(s) have been issued.
- This policy also applies to keys/security cards to all athletic facilities.
- By law, all exterior doors shall be locked at all times when students are present. No exterior door may be left propped open unsupervised.

D. Cash Collection Policy

Money collected by staff as a result of fundraisers or other school-related purposes shall be deposited in the office along with a collection log each day. At no time is money to be kept overnight in classrooms.

E. Cellular Phone Usage

Employee use of personal cellular phones during working hours and instructional time shall be limited to emergency situations only.

F. Confidentiality

Employees who have access to confidential information pertaining to students or other employees are expected to disclose such only to appropriate individuals within the system. Release of such information outside the system may result in violation of federal and state laws, rules, and regulations. Only those employees authorized to release such information may do so.

G. Copyright and Fair Use

A copyright is a form of protection provided by Title 17 of the United States Code to the authors of "original works of authorship" including literary, dramatic, musical, artistic, and certain other intellectual works. These laws apply to audio visual and electronic information as well as printed material. Copyrighted works are protected regardless of the medium in which they are created or reproduced; thus, copyright extends to digital works and works transformed into a digital format. All employees are required to abide by copyright regulations.

In addition, Teachers should follow "fair use" guidelines when utilizing copyrighted material in the classroom. The "fair use" doctrine allows limited reproduction of copyrighted works for educational and research purposes.

H. Classroom and Office Security

When leaving the classroom, locker room, or other work areas between classes or at the end of the day, employees are expected to turn off the lights and secure all doors and windows.

All staff are asked to refrain from keeping personal items of value in or about their desks. Purses should never be left unsecured. Greeneville City Schools will not be responsible for the loss of or damage to, personal property due to such causes as fire, theft, or accident.

Appropriate measures should be taken to protect school and system property from theft or vandalism.

I. Complaints and Grievances

Employment-Related Complaints and Grievances

In instances of questions by an individual staff member concerning the interpretation of policies and procedures to that staff member, administrative practices within their particular school, and relationships with other employees, the staff member concerned must consult the administrative or supervisory personnel to whom they are responsible. If a satisfactory resolution of the problem cannot be reached after ample opportunity for consideration of the matter, the staff member concerned may discuss the matter with the next level of supervision up to and including the Director of Schools.

In instances where an individual staff member feels for personal reasons that they cannot discuss a problem with their immediate superior, they may discuss the matter with the next level of supervision up to and including the Director of Schools. After review of the case, the Director of Schools shall take action as they deem appropriate and, within a prompt reasonable time, shall notify all parties concerned of their decision.

Harassment/Discrimination Grievances

Employees should notify any district Complaint Manager if they believe the Board, its employees or agents have violated their rights guaranteed by the state or federal constitution, state or federal statute or Board policy including the following,

- Title II of the Americans with Disabilities Act.
- Title IX of the Education Amendments of 1972.
- Section 504 of the Rehabilitation Act of 1973.
- Claims of sexual harassment under Title VII of the Civil Rights Act of 1964 and Title IX of the Education Amendments of 1972.

Grievance procedures are outlined in ***Board Policies 1.802 and 5.501***. Complaint Managers for the district are the Chief Student Services Officer and the Chief Human Resources Officer.

J. Criminal Activity

Any employee who is arrested and/or charged with criminal activity is responsible for notifying the Director of Schools within seventy-two (72) hours of the arrest or charge.

K. Department of Transportation (DOT) Physicals

All employees who drive school buses are required to have an annual DOT physical. The Coordinated School Health department will schedule the physical appointment and notify the employee of their appointment time.

Federal regulations require all school Bus Drivers to undergo random drug screening as well. The school system assumes all costs associated with the DOT physical and random drug testing.

L. Disciplinary Guidelines

Employees are to comply with policies, procedures, and laws to ensure a positive working and learning environment for staff and students. These guidelines were developed to protect the interests and safety of employees, Greeneville City Schools, students, parents, and the community at large.

Many situations can be resolved through verbal counseling or discussion between the employee and Principal/Supervisor; however, some one-time incidents may be severe enough to merit a formal written warning, final written warning (which may include suspension without pay), or termination. The seriousness of the offense and the employee's disciplinary and performance history will be considered when determining the level of discipline to be applied. All decisions to escalate progressive disciplinary action to a higher level of discipline should be made in consultation with the Chief Human Resources Officer.

- Step 1 Verbal Warning
- Step 2 Written Warning
- Step 3 Final Written Warning (may include a suspension without pay)
- Step 4 Termination of Employment

Examples of misconduct include, but are not limited to,

1. Violations of Greeneville City Schools policy and procedures, or violation of Tennessee Code Annotated Law including,
 - a. Anti-Harassment
 - b. Hours of Work (i.e., unauthorized sleeping while on scheduled work time)
 - c. Drug-Free Workplace
 - d. Electronic Communication Policy
 - e. Greeneville City Schools Personal Characteristics
 - f. Tennessee Teacher Code of Ethics.
2. Violence in the workplace.
 - a. Possessing an unauthorized weapon on Greeneville City Schools time or premises.
 - b. Threatening or assaulting another person on Greeneville City Schools time or premises.
3. Serious neglect of duty, insubordination, violation of safety rules, dishonesty, falsification of records, breach of confidentiality, unauthorized use of Greeneville City School resources for personal gain, unauthorized removal or destruction of property belonging to others.
4. Criminal activity and disclosures.
 - a. Failure to report a criminal arrest, charges, or conviction to the Principal/Supervisor within seventy-two (72) hours of the arrest or conviction.
 - b. Conviction of a crime involving dishonesty, violence, or other behavior that impacts suitability for employment.
 - c. Participating in activity that involves dishonesty, violence, or other behavior that impacts suitability for employment whether or not it results in criminal prosecution or conviction.

Tennessee is known as an "EMPLOYMENT-AT-WILL" state for non-certified staff. Generally, this means the employer may legally hire, fire, suspend, or discipline any employee at any time and for any reason. However, an employer may not discriminate against any employee on the basis of the employee's race, sex, age, religion, color, national origin, or disability.

M. Discrimination/Harassment of Employees (Sexual, Racial, Ethnic, Religious) (Board Policies 5.500 and 5.501)

Greeneville City Schools firmly believes that each employee should be treated with respect and should be able to work in an environment free of discrimination or harassment. That being the case, Greeneville City Schools prohibits any form of discrimination or harassment in the workplace by any individual.

Employee discrimination/harassment is defined as conduct, advances, gestures, or words either written or spoken of a sexual, racial, ethnic, or religious nature which,

1. Unreasonably interfere with the individual's work or performance.
2. Create an intimidating, hostile, or offensive work environment.
3. Imply that submission to such conduct is made an explicit or implicit term of employment.
4. Imply that submission to or rejection of such conduct will be used as a basis for an employment decision affecting the harassed employee.

Any employee who feels that they have been discriminated against/harassed should report the incident immediately to their immediate Supervisor, except when the immediate Supervisor is the offending party, at which time it should be reported to the one of the two following school system Complaint Managers, the Chief Human Resources Officer or the Chief Student Services Officer.

An oral complaint may be submitted; however, a formal written complaint must be provided in order to perform a more thorough investigation. The written complaint should include the following information,

- Identity of the alleged victim and person accused.
- Location, date, time, and circumstances surrounding the alleged incident.
- Description of what happened.
- Identity of witnesses.
- Any other evidence available.

The privacy and anonymity of all parties and witnesses to complaints will be respected. However, because an individual's need for confidentiality must be balanced with obligations to cooperate with police investigations or legal proceedings, to provide due process to the accused, to conduct a thorough investigation, or to take necessary action to resolve a complaint, the identity of parties and witnesses may be disclosed in appropriate circumstances to individuals with a need to know.

A substantiated charge against an employee will result in disciplinary action up to and including termination. There will be no retaliation against any person who reports discrimination/harassment or participates in an investigation. However, any employee who refuses to cooperate or gives false information during the course of any investigation may be subject to disciplinary action. The willful filing of a false report will itself be considered as harassment and will be treated as such.

N. Drug-Free Workplace (Board Policy 1.804)

Greeneville City Schools is committed to providing a safe work environment and fostering the well-being and health of our employees. That commitment is jeopardized when any Greeneville City Schools employee uses drugs on the workplace or off the job. "Workplace" shall include any school building or any school premise, any school owned, or any other school approved vehicle used to transport students to and from school or school activities and off school property during any school sponsored or school approved activity, event, or function. Pursuant to T.C.A. section 50-9-100 *et seq.*

- (1) It is a violation of Greeneville City School guidelines for any employee to use, possess, sell, trade, offer for sale, or offer to buy illegal drugs or otherwise engage in the illegal use of drugs on or off the job.
- (2) It is a violation of Greeneville City School guidelines for any employee to report to work under the influence of or while possessing in his or her body, blood or urine, illegal drugs in any detectable amount.
- (3) It is a violation of Greeneville City School guidelines for any employee to report to work under the influence of or impaired by alcohol.
- (4) It is a violation of Greeneville City School guidelines for any employee to use prescription drugs illegally, i.e., to use prescription drugs that have not been legally obtained or in a manner or purpose other than as prescribed. However, nothing in these guidelines precludes the appropriate use of legally prescribed medications.
- (5) Violations of these guidelines are subject to disciplinary action, up to and including, termination.
- (6) Employment candidates testing positive for drugs will have their conditional offer of hire withdrawn and will be ineligible to reapply for employment with Greeneville City Schools for a period of one year. Prior to reapplying for employment, the applicant must provide proof of having successfully completed an approved substance abuse program.

As a condition of employment, each employee shall notify their Principal/Supervisor of their conviction of any criminal drug violation no later than seventy two (72) hours after conviction. Within thirty (30) days after receiving such notice of conviction, the Director of Schools will take appropriate disciplinary action and/or refer the employee to an appropriate substance abuse rehabilitation program.

O. Elected Office

No employee of Greeneville City Schools shall retain his or her position in the school system and at the same time be a member of the Board of Mayor and Aldermen of the Town of Greeneville.

P. E-mail Use (Board Policy 1.805)

All Greeneville City Schools employees are assigned a Greeneville City Schools email account. Electronic mail capability among employees exists for the purpose of enhancing communication to better perform tasks associated with their positions and assignments. Employees are required to routinely check their Greeneville City Schools email account. All staff that have access to the system-wide network must adhere to the following guidelines when sending or receiving messages via system-wide electronic mail (e-mail),

- Messages shall pertain to legitimate Board/system business.
- Because all computer hardware and software belong to the Board, all data including e-mail communications stored or transmitted on school system computers will be monitored. Employees have no right to privacy with regard to such data. Confidentiality of e-mail communication cannot be assured. E-mail correspondence may be a public record under the public records law and may be subject to public inspection.
- Employees shall not reveal their passwords to others in the network or to anyone outside of it. If anyone has reason to believe that a password has been lost or stolen or that e-mail has been accessed by someone without authorization s/he shall contact the Assistant Director of Schools for Administration immediately.
- Senders are responsible for observing all copyright laws.
- Messages shall not be sent that contain material that may be defined by a reasonable person as obscene or that are racist, sexist, or promote illegal or unethical activity, or that violates any other policies in this Employee Handbook including but not limited to the policy prohibiting harassment or discrimination.
- Any usage contrary to the above shall be reported immediately to the Director of Schools and may result in the suspension and/or revocation of system access.

Q. Fundraising by Schools and Clubs (Board Policies 2.809 and 6.701)

In order to appropriately enter into a fundraising initiative, schools must first execute a written agreement with the vendor. The written agreement should include, but not be limited to the following information,

- The portion of the proceeds that will be retained by the school and the portion that will be paid to the vendor.
- The method by which sales tax will be paid.
- The date(s) of delivery.
- Package prices or other charges.
- Scheduled dates of service.

All fundraisers must be pre-approved in writing by the Director of Schools. No quotas will be imposed on students involved, and their efforts will be voluntary.

R. Identification Badges

Upon employment with Greeneville City Schools, each employee, whether full time or part time, will be photographed and provided with a Greeneville City School employee identification badge. This badge should be worn in a visible location at all times when providing services for Greeneville City Schools.

S. Inclement Weather Attendance

Schools Closed

On days that school is out due to inclement weather, non-exempt employees who work a student calendar are not expected to come to work. This list would include Instructional Assistants, School Nutrition

Associates, and Bus Drivers. Essential staff (Maintenance and Custodians) will report on all days if at all possible unless directed by their Supervisor. Exempt employees working a student calendar such as Teachers and School Nurses would not be expected to report to work either. All these employees would, however, be expected to work on any make-up days.

Non-exempt employees who work a twelve (12) month calendar such as Central Office support staff, Maintenance, and Custodians are expected to report to work or request an appropriate leave. When the Central Office is closed, the staff required to work will receive compensation time for reporting to work as required in order to clear sidewalks, parking lots, etc.

Delay in Starting Time and Early Dismissal

Each building level Supervisor or Principal will address the procedures for delays and early dismissals accordingly. For the safety of students, all instructional and office employees are expected to remain at their buildings to assist with dismissal. The Principal will determine when employees are dismissed during these times.

Principals and Custodians are expected to be at their buildings at regular time on delay days. Principals are expected to stay in their buildings on early dismissal days until they have received word that all buses have completed their runs and have ensured the safe departure of all employees.

Make Up Days

Eight (8) days may be missed for snow. On the ninth (9th) day, we must begin making up the days. Designated make up dates are listed on the calendar each year.

Employee Pay when out for snow

All full-time/benefits eligible employees are paid when the system is out for snow. If an employee had a planned paid leave day and a snow day occurs; that paid leave day will not be exhausted.

Part-Time employees are not paid for snow days, however, at the principal's discretion the hours lost due to snow days and early dismissal due to snow, may be made up during the immediate or next pay period only.

T. Internet Use (Board Policy 4.406)

Before any employee is allowed the use of the Greeneville City Schools internet or intranet access, the employee must electronically sign a Responsible Use Policy developed by the school system that sets out the terms and conditions of such use. Any employee who accesses the Greeneville City Schools computer system for any purpose agrees to be bound by the terms of that agreement, even if no signed written agreement is on file.

Prohibited and illegal activities, include, but are not limited to the following,

- Sending or displaying offensive messages or pictures.
- Using obscene language.
- Harassing, insulting, defaming, or attacking others.
- Damaging computers, computer systems, or networks.
- Hacking or attempting unauthorized access to any computer.
- Violation of copyright laws.
- Trespassing in another's folders, work, or files.
- Intentional misuse of resources.
- Buying or selling on the Internet during regular business hours.
- Using another's password or other identifier.
- Use of the network for commercial purposes.

U. Parking Tickets and Traffic Violations

Greeneville City Schools will not be responsible for paying fines or tickets incurred by Greeneville City School employees regardless if they are in the process of conducting Greeneville City School business when the ticket is incurred.

Parking on West Depot Street is limited to two (2) hours. In addition, a limited number of guest parking spots are located on the side of the Kathryn Leonard Central Office building. You may also park in the Town Square lot in spots that are located away from the sidewalks.

V. Trip Sheets

Anytime a bus is required to be utilized for an athletic trip or a field trip, a Trip Requisition Form must be completed and submitted online by using trip tracker. This should be submitted a minimum of two weeks before the trip date.

It is the responsibility of the Teacher or Coach sponsoring the trip to make sure the electronic form is completed in its entirety. This includes the time of departure, the time of return, the beginning odometer reading, the ending odometer reading, and whether or not the Bus Driver was required to stay with the group. The Bus Driver's copy of the trip sheet must be checked for accurate time and mileage before the trip leader signs it at the end of the trip.

W. Substitute Workers

Substitute hourly/certified/non-certified positions are employed by Greeneville City Schools, and applicants must apply on-line. Criminal history record checks, fingerprinting/background checks of applicants, and post offer employment physicals for substitutes are required.

Substitute Teachers (Board Policy 5.701)

Greeneville City Schools employs both Certified and Non-Certified substitute teachers. An online substitute software management system is utilized to assign substitute teachers to job assignments.

Substitute Teaching (20 or more days)

A Substitute Teacher must possess an educator license (with endorsement in the content area to be taught when applicable) when substituting for a Teacher who has been absent for twenty (20) or more consecutive days. When substituting for a Teacher without sick leave, the substitute must be certified. When this applies, the Substitute Teacher will be paid according to the Greeneville City Schools certified salary schedule.

Use of Other Staff Members as a Substitute Teacher

If needed, an Instructional Assistant may be used as a substitute for a Teacher, provided the Principal approves. Per TCA 49-5-111(b), **no educational assistant shall assume responsibility for the classroom for more than 3 consecutive days**. School Secretaries and clerks are also approved substitute teachers for use in emergency situations.

The Business and Finance department (Payroll) should be notified as soon as possible of such an arrangement in order to allow for modifications in the Instructional Assistant's paycheck.

X. Tobacco-Free Schools (Board Policy 1.803)

Employees are prohibited from all uses of tobacco and tobacco products, including smokeless tobacco, electronic cigarettes, vaporizers and associated paraphernalia in all of the school system's buildings and vehicles, owned, leased, or operated by the district. Use of these products is prohibited in any public seating area, including but not limited to, bleachers used for sporting events, or public restrooms. This also includes during any activity in which they represent the school district.

Y. Vehicles – Private (Board Policy 3.404)

From time to time, certain employees may need to use their private vehicles for school purposes. With the use of private vehicles for Greeneville City School business, the following policy must be observed.

To use a private vehicle for school purposes, the person must have permission of an appropriate school representative (Central Office or School Administrator, Athletic Director, or Head Coach) and provide proof of their valid driver's liability insurance coverage.

Although the Board carries liability insurance, the personal liability insurance of the driver of the private vehicle will be the primary protection in the event of an accident.

Z. Vehicles – School System (Board Policy 3.402)

The Director of Schools shall recommend for Board approval a list of Board owned vehicles to be assigned to positions requiring full time use. Such use will be restricted to commuting to and from job related sites, and must comply with IRS requirements, including implications for reporting taxable income. Employees' assigned full time use of Board owned vehicles shall be on call twenty-four (24) hours a day to perform services required by their job responsibilities. Other than commuting to and from work, use of these vehicles for personal use is prohibited.

AA. Vendor Relations (Board Policy 2.809)

Employees of Greeneville City Schools are prohibited from accepting anything of value from an individual or a vendor for the purpose of influencing their professional judgment.

In addition, the solicitation of employees by sales people, other staff, or agents during the regular workday is prohibited without prior approval from the school Principal or the immediate Supervisor. Any solicitation should be reported to the appropriate determining party.

BB. Video Surveillance

In the continuing effort to provide the safest possible environment for the students and employees of the Greeneville City Schools, video surveillance is conducted in all Greeneville City School locations and on the school buses.

In the event a video surveillance recording captures an employee, student, or other building user violating school policies, rules, or local, state, or federal laws, the video surveillance recording may be used in appropriate disciplinary proceedings and may also be provided to law enforcement agencies.

CC. Visitors to the Schools (Board Policy 1.501)

Except on occasions such as school programs, athletic events, open house, and similar public events, all visitors will report to the school office when entering the school and will be asked to submit proof of ID, sign a logbook, and submit to a background check through the Raptor system. Authorization to visit elsewhere in the building or on the school campus will be determined by the Principal or designee. Guest passes shall be issued for all persons other than students and employees of the school.

In order to maintain the conditions and atmosphere suitable for learning, no other person will be allowed to enter onto the grounds or into the school buildings during the hours of student instruction except students assigned to the school, the staff of the school, parents of students, and other persons with lawful and valid business on the school premises.

The Principal has the authority to exclude from the school premises any persons disrupting the educational programs in the classroom or in the school, disturbing the Teachers or students on the premises, or on the premises for the purpose of committing an illegal act. The Principal will engage law enforcement officials when they believe the situation warrants such measures.

DD. Work Breaks (Board Policy 5.602)

In order to ensure safety, efficiency, and to meet the requirements of the law, scheduled paid breaks are provided to all non-exempt employees. Non-exempt employees working four (4) hours are entitled to one fifteen-minute break during the four (4) hour period. Non-exempt employees working eight hours are entitled to two (2) fifteen (15) minute breaks, one for each four hours worked. Any non-exempt employee working over six (6) hours shall have at least a thirty (30) minute duty free lunch/dinner break. All teachers shall be provided with a duty-free lunch period as well.

Greeneville City Schools does not intend for, nor allow, non-exempt employees to perform job related functions during their lunch period or entitled break periods. Employees are expected to adhere to the break schedule established by the school Principal or immediate Supervisor. Deviation from the regularly scheduled break period requires prior Supervisor approval.

APPENDIX A – Extended Health Care Coverage (COBRA)

Under the Consolidated Omnibus Budget Reconciliation Act of 1986 (COBRA), employers must extend health coverage to you and your family for up to 18 months at your expense if you leave the system or your hours are reduced and result in loss of coverage, except if you are terminated for gross misconduct. The 18-month period may be extended to 29 months if you or your dependent becomes disabled for social security purposes during the first sixty days of continuation coverage.

Health care coverage may also be extended for up to 36 months to spouses and dependents of deceased employees, divorced or legally separated spouses and dependents of employees covered by Medicare, and dependent children who would no longer be covered under the Greeneville City Schools health plan. You will be given details of COBRA rights upon your enrollment in our health plan and upon termination of employment.

APPENDIX B – Health Insurance Portability and Accountability Act (HIPAA)

This policy is intended to promote awareness of the confidential nature of the medical information that is collected, maintained, and disseminated by the Greeneville City School System as a sponsor of group health plans (the "Plans"). The Plans are considered "group health plans" and "covered entities" under the Health Insurance Portability and Accountability Act of 1996 (HIPAA) and the regulations promulgated thereunder. This policy and these procedures reflect the commitment of the Greeneville City Schools to protect the confidentiality of its Plan participants' private health information.

This Policy shall be overseen by the Privacy Official, who shall report on privacy issues, as needed, to the Chief Human Resources Officer. The Privacy Official shall be the Human Resources Specialist, and shall have authority and responsibility for implementation and operation of the policy and will have the discretion to delegate any of his or her responsibilities or functions to another individual (the "Designee"). The Plan will use protected health information (PHI) to the extent of and in accordance with the uses and disclosures permitted by the Health Insurance Portability and Accountability Act of 1996 (HIPAA). Specifically, the Plan will use and disclose PHI for purposes related to health care treatment, payment for health care and health care operations, and otherwise to the extent permitted by and in accordance with the provisions of HIPAA.

Your Employee Rights Under the Family and Medical Leave Act

What is FMLA leave?

The Family and Medical Leave Act (FMLA) is a federal law that provides eligible employees with **job-protected leave** for qualifying family and medical reasons. The U.S. Department of Labor's Wage and Hour Division (WHD) enforces the FMLA for most employees.

Eligible employees can take **up to 12 workweeks** of FMLA leave in a 12-month period for:

- The birth, adoption or foster placement of a child with you,
- Your serious mental or physical health condition that makes you *unable* to work,
- To care for your spouse, child or parent with a serious mental or physical health condition, and
- Certain qualifying reasons related to the foreign deployment of your spouse, child or parent who is a military servicemember.

An eligible employee who is the spouse, child, parent or next of kin of a covered servicemember with a serious injury or illness **may take up to 26 workweeks** of FMLA leave in a single 12-month period to care for the servicemember.

You have the right to use FMLA leave in **one block of time**. When it is medically necessary or otherwise permitted, you may take FMLA leave **intermittently in separate blocks of time, or on a reduced schedule** by working less hours each day or week. Read Fact Sheet #26M(c) for more information.

FMLA leave is **not paid leave**, but you may choose, or be required by your employer, to use any employer-provided paid leave if your employer's paid leave policy covers the reason for which you need FMLA leave.

Am I eligible to take FMLA leave?

You are an **eligible employee** if **all** of the following apply:

- You work for a covered employer.
- You have worked for your employer at least 12 months,
- You have at least 1,250 hours of service for your employer during the 12 months before your leave, and
- Your employer has at least 50 employees within 75 miles of your work location.

Airline flight crew employees have different "hours of service" requirements.

You work for a **covered employer** if **one** of the following applies:

- You work for a private employer that had at least 50 employees during at least 20 workweeks in the current or previous calendar year,
- You work for an elementary or public or private secondary school, or
- You work for a public agency, such as a local, state or federal government agency. Most federal employees are covered by Title II of the FMLA, administered by the Office of Personnel Management.

How do I request FMLA leave?

Generally, to request FMLA leave you **must**:

- Follow your employer's normal policies for requesting leave,
- Give notice at least 30 days before your need for FMLA leave, or
- If advance notice is not possible, give notice as soon as possible.

You **do not have to share a medical diagnosis** but must provide enough information to your employer so they can determine whether the leave qualifies for FMLA protection. You **must also inform your employer if FMLA leave was previously taken** or approved for the same reason when requesting additional leave.

Your **employer may request certification** from a health care provider to verify medical leave and may request certification of a qualifying exigency.

The FMLA does not affect any federal or state law prohibiting discrimination or supersede any state or local law or collective bargaining agreement that provides greater family or medical leave rights.

State employees may be subject to certain limitations in pursuit of direct lawsuits regarding leave for their own serious health conditions. Most federal and certain congressional employees are also covered by the law but are subject to the jurisdiction of the U.S. Office of Personnel Management or Congress.

What does my employer need to do?

If you are eligible for FMLA leave, your **employer must**:

- Allow you to take job-protected time off work for a qualifying reason,
- Continue your group health plan coverage while you are on leave on the same basis as if you had not taken leave, and
- Allow you to return to the same job, or a virtually identical job with the same pay, benefits and other working conditions, including shift and location, at the end of your leave.

Your **employer cannot interfere with your FMLA rights** or threaten or punish you for exercising your rights under the law. For example, your employer cannot retaliate against you for requesting FMLA leave or cooperating with a WHD investigation.

After becoming aware that your need for leave is for a reason that may qualify under the FMLA, your **employer must confirm whether you are eligible** or not eligible for FMLA leave. If your employer determines that you are eligible, your **employer must notify you in writing**:

- About your FMLA rights and responsibilities, and
- How much of your requested leave, if any, will be FMLA-protected leave.

Where can I find more information?

Call 1-866-487-9243 or visit dol.gov/fmla to learn more.

If you believe your rights under the FMLA have been violated, you may file a complaint with WHD or file a private lawsuit against your employer in court. **Scan the QR code to learn about our WHD complaint process.**



WAGE AND HOUR DIVISION
UNITED STATES DEPARTMENT OF LABOR



APPENDIX D – Greeneville City Schools FMLA Policy 5.305

ELIGIBILITY

Anyone who has been employed for at least twelve (12) months by the school district and anyone who has at least 1,250 hours of service (hours used for leave, even FMLA leave, shall not be credited for service for purposes of FMLA eligibility¹) during the previous twelve (12) month period shall be eligible to use FMLA leave.² For the purposes of calculating FMLA leave, Greeneville City Schools uses a rolling 12-month period measured backward from the date an employee uses any FMLA leave.

GENERAL PRINCIPLES

An eligible employee shall be granted, upon request, up to twelve (12) weeks unpaid leave during a fixed calendar year for the following reasons:

1. The birth of a child;
2. The placement of a child with the employee for adoption or foster care;
3. A serious health condition of the employee that makes the employee unable to perform the essential functions of their job position;
4. The care of a spouse, child, or parent of the employee who has a serious health condition; and
5. Any qualifying circumstances arising out of the fact that a spouse, child, or parent of the employee is on covered active duty or has been notified of an impending call or order to covered active duty in the Armed Forces.

Granting of leave under this policy shall be subject to, and in accordance with, the provisions of applicable federal and state laws. An employee may substitute accrued paid leave for unpaid time. Use of accrued paid leave shall run concurrently with and be counted toward the employee's total period of FMLA leave.

MATERNITY/PATERNITY LEAVE

1. *Relationship between FMLA leave and Tennessee Maternity Leave Act*- FMLA leave shall run concurrently with leave provided under the Tennessee Maternity Act, which affords eligible employees leave for a period not to exceed four (4) months for the adoption, pregnancy, childbirth, and nursing of a newborn child.³
2. *Teachers' Leave*- In accordance with state law, any teacher who goes on maternity or paternity leave shall be allowed to use all or a portion of the teacher's accumulated sick or annual leave for maternity leave purposes. In order to be eligible to use sick leave, written request of the teacher accompanied by a statement from the teacher's physician verifying pregnancy shall be submitted. Upon verification by a written statement from an adoption agency or other entity handling an adoption, a teacher may also be allowed to use accumulated leave for adoption of a child. If both adoptive parents are teachers employed by the district, however, only one (1) parent is entitled to use such leave.⁴

Spouses who are both eligible employees of the school district are limited to a combined total of twelve (12) workweeks of FMLA leave in a single twelve (12) month period if the leave is taken for the birth and care of a newborn child, for the placement of a child for adoption or foster care, or to care for a parent who has a serious health condition. Under certain circumstances, spouses who share leave for the birth or adoption of a child may be eligible for limited amounts of additional leave for other qualifying FMLA reasons.⁵

3. *Paid Parental Leave* – Under state law, an additional six (6) work weeks of paid leave is available to eligible employees after a birth, stillbirth, or adoption of a newly placed minor child. An eligible employee taking leave under this provision shall not be required to utilize any other type of accrued leave during this period. All full-time employees who have been employed with a school district full time for at least twelve (12) consecutive months.

Employees shall provide notice to the school district thirty (30) days prior to the intended use of the leave. If the employee learns about the need for leave less than thirty (30) days in advance, the employee shall give notice as soon as reasonably possible in order to be eligible for the paid leave. This paid leave does not need to be taken consecutively; however, the paid leave shall be used within twelve (12) months of the qualifying event. The leave shall run concurrently with FMLA leave.⁶

LEAVE FOR A SERIOUS HEALTH CONDITION⁷

Eligible employees, upon request, shall be granted up to twelve (12) weeks of unpaid leave when they are unable to work because of a serious health condition or to care for an immediate family member with a serious health condition. Granting of such leave shall be subject to the provisions of applicable federal and state laws. Employees shall contact Human Resources to determine if the reason for leave qualifies as FMLA leave. If the leave is foreseeable, the employee shall give thirty (30) days' notice. If the leave is not foreseeable, the employee shall notify Human Resources as soon as practicable, generally, either the same or next business day.

LEAVE FOR MILITARY FAMILY MEMBERS

1. *Qualifying Exigency Leave⁸* - Eligible employees are entitled to up to twelve (12) workweeks of leave because of any “qualifying exigency” arising out of the fact that the spouse, son, daughter, or parent of the employee, as defined under the FMLA, is on active duty, or has been notified of an impending call to active duty, or has been notified of an impending call to active duty status in the Armed Forces. Qualifying exigencies may include:

- a. Issues arising from the service member’s short notice deployment;
- b. Military events and related activities (e.g. official ceremonies, support programs);
- c. Making or updating financial and legal arrangements;
- d. Attending counseling;
- e. Taking up to fifteen (15) days leave to spend time with a covered service member who is on short-term rest and recuperation leave during deployment; or
- f. Attending post-deployment activities.

2. *Military Caregiver Leave⁹* - An eligible employee who is the spouse, son, daughter, parent, or next of kin of a covered service member or covered veteran with a serious injury or illness is entitled to up to twenty-six (26) workweeks of leave in a “single twelve (12) month period.” A covered service member is a current member of the Armed Forces, including a member of the National Guard or Reserves, who is undergoing medical treatment, recuperation, or therapy, is otherwise in out-patient status, or is otherwise on the temporary disability retired list for a serious injury or illness.

A covered veteran is an individual who was a member of the Armed Forces at any time during the period of five (5) years preceding the date of the medical treatment, recuperation, or therapy that has a serious injury or illness who is currently receiving medical treatment, recuperation, or therapy. The calculation of this five (5) year period shall not include the interval of October 28, 2009 through March 8, 2013.

The “single twelve (12) month period” for military caregiver leave begins on the first day the employee takes leave for this reason and ends twelve (12) months later. An eligible employee is limited to a combined total of twenty-six (26) workweeks of leave to provide care for a covered service member. The maximum of twenty-six (26) workweeks may include no more than twelve (12) workweeks of leave that is taken for the birth and care of a newborn child, for the placement of a child for adoption or foster care, for care of a parent who has a serious health condition, or for the employee's own serious health condition.

INTERMITTENT LEAVE¹⁰

Eligible employees may take FMLA leave intermittently when medically necessary to care for a seriously ill family member, because of the employee's own serious health condition, or for the care for a newborn, a newly adopted child, or a newly placed foster care child. When an employee requests foreseeable leave for planned medical treatment and the employee would be on leave for greater than twenty percent (20%) of the total number of working days in the period during which the leave would extend, the school district may require that such employee elect either to take the leave for periods of a particular duration, not to exceed the duration of the planned medical treatment, or to transfer temporarily to an available alternative position offered by the school district for which the employee is qualified and that has equivalent pay and benefits and better accommodates recurring periods of leave.

RESTRICTIONS

1. Notice Requirements

- a. *Employee Notice¹¹*- For foreseeable leave, the employee shall provide the Director of Schools with at least thirty (30) days written notice before the beginning of the anticipated leave.
- b. *District Notice*- Once it has been established that the leave requested qualifies for FMLA, the Director of Schools/designee shall notify the employee within three (3) business days (absent extenuating circumstances) that any leave taken pursuant to state leave statutes (paid vacation leave, personal leave, sick leave, or workers’ compensation) shall run concurrently with FMLA leave.¹² The notice may be given orally or in writing. If the notice is oral, it shall be confirmed in writing, no later than the following pay day.¹³

2. Certification Requirement¹⁴

- a. The Director of Schools may require that a request for leave be supported by certification issued by a health care provider with the following information:
 - i. The date on which the serious health condition commenced;
 - ii. The probable duration of the condition;
 - iii. The appropriate medical facts within the knowledge of the health care provider regarding the condition; and

- iv. A statement that the eligible employee is needed to care for the son, daughter, spouse, or parent and an estimate of the amount of time that such employee is needed.
 - b. If there is any reason to doubt the validity of the certification provided, the Director of Schools may require, at the expense of the school district, an opinion of a second health care provider.
- 3. Period Near the End of an Academic Term (Professional Employees)¹⁵
 - a. If leave is taken more than five (5) weeks prior to the end of the term, the Director of Schools may require the employee to continue taking leave until the end of the term if the leave is at least three (3) weeks of duration and the return of employment would occur during the three (3) week period before the end of the term.
 - b. If the leave is taken five (5) weeks prior to the end of the term, the Director of Schools may require the employee to continue taking leave until the end of the term if the leave is greater than two (2) weeks duration and the return to employment would occur during the two (2) week period before the end of the term.

REQUIREMENTS OF THE BOARD¹⁶

- 1. The employee shall be restored to the same position of employment or an equivalent position with no loss of benefits, pay, or other terms of employment.
- 2. The employee shall be kept under any group health plan for the duration of the leave.
- 3. The Board may recover the premium paid under the following conditions:
 - a. The employee fails to return from leave after the period of leave has expired; and
 - b. The employee fails to return to work for a reason other than the continuation, recurrence, or onset of a serious health condition or other circumstances beyond the control of the employee.

APPENDIX E – *Equal Employee Opportunity is* **THE LAW**

Private Employers, State and Local Governments, Educational Institutions, Employment Agencies and Labor Organizations

Applicants to and employees of most private employers, state and local governments, educational institutions, employment agencies and labor organizations are protected under Federal law from discrimination on the following on the following bases:

RACE, COLOR, RELIGION, SEX, NATIONAL ORIGIN

Title VII of the Civil Rights Act of 1964, as amended, protects applicants and employees from discrimination in hiring, promotion, discharge, pay, fringe benefits, job training, classification, referral, and other aspects of employment, on the basis of race, color, religion, sex (including pregnancy), or national origin. Religious discrimination includes failing to reasonably accommodate an employee's religious practices where the accommodation does not impose undue hardship.

DISABILITY

Title I and Title V of the Americans with Disabilities Act of 1990, as amended, protect qualified individuals from discrimination on the basis of disability in hiring, promotion, discharge, pay, fringe benefits, job training, classification, referral, and other aspects of employment. Disability discrimination includes not making reasonable accommodation to the known physical or mental limitations of an otherwise qualified individual with a disability who is an applicant or employee, barring undue hardship.

AGE

The Age Discrimination in Employment Act of 1967, as amended, protects applicants and employees 40 years of age or older from discrimination based on age in hiring, promotion, discharge, pay, fringe benefits, job training, classification, referral, and other aspects of employment.

SEX (WAGES)

In addition to sex discrimination prohibited by Title VII of the Civil Rights Act, as amended, the Equal Pay Act of 1963, as amended, prohibits sex discrimination in the payment of wages to women and men performing substantially equal work, in jobs that require equal skill, effort, and responsibility, under similar working conditions, in the same establishment.

GENETICS

Title II of the Genetic Information Nondiscrimination Act of 2008 protects applicants and employees from discrimination based on genetic information in hiring, promotion, discharge, pay, fringe benefits, job training, classification, referral, and other aspects of employment. GINA also restricts employers' acquisition of genetic information and strictly limits disclosure of genetic information. Genetic information includes information about genetic tests of applicants, employees, or their family members; the manifestation of diseases or disorders in family members (family medical history); and requests for or receipt of genetic services by applicants, employees, or their family members.

RETALIATION

All of these Federal laws prohibit covered entities from retaliating against a person who files a charge of discrimination, participates in a discrimination proceeding, or otherwise opposes an unlawful employment practice.

WHAT TO DO IF YOU BELIEVE DISCRIMINATION HAS OCCURRED

There are strict time limits for filing charges of employment discrimination. To preserve the ability of EEOC to act on your behalf and to protect your right to file a private lawsuit, should you ultimately need to, you should contact EEOC promptly when discrimination is suspected:

The U.S. Equal Employment Opportunity Commission (EEOC), 1-800-669-4000 (toll-free) or 1-800-669-6820 (toll-free TTY number for individuals with hearing impairments). EEOC field office information is available at www.eeoc.gov or in most telephone directories in the U.S. Government or Federal Government section. Additional information about EEOC, including information about charge filing, is available at www.eeoc.gov.

Holding Federal Contracts or Subcontracts

Applicants to and employees of companies with a Federal government contract or subcontract are protected under Federal law from discrimination on the following bases:

RACE, COLOR, RELIGION, SEX, NATIONAL ORIGIN

Executive Order 11246, as amended, prohibits job discrimination on the basis of race, color, religion, sex or national origin, and requires affirmative action to ensure equality of opportunity in all aspects of employment.

INDIVIDUALS WITH DISABILITIES

Section 503 of the Rehabilitation Act of 1973, as amended, protects qualified individuals from discrimination on the basis of disability in hiring, promotion, discharge, pay, fringe benefits, job training, classification, referral, and other aspects of employment. Disability discrimination includes not making reasonable accommodation to the known physical or mental limitations of an otherwise qualified individual with a disability who is an applicant or employee, barring undue hardship. Section 503 also requires that Federal contractors take affirmative action to employ and advance in employment qualified individuals with disabilities at all levels of employment, including the executive level.

DISABLED, RECENTLY SEPARATED, OTHER PROTECTED AND ARMED FORCES SERVICE MEDAL VETERANS

The Vietnam Era Veterans' Readjustment Assistance Act of 1974, as amended, 38 U.S.C. 4212, prohibits job discrimination and requires affirmative action to employ and advance in employment disabled veterans, recently separated veterans (within

three years of discharge or release from active duty), other protected veterans (veterans who served during a war or in a campaign or expedition for which a campaign badge has been authorized), and Armed Forces service medal veterans (veterans who, while on active duty, participated in a U.S. military operation for which an Armed Forces service medal was awarded).

RETALIATION

Retaliation is prohibited against a person who files a complaint of discrimination, participates in an OFCCP proceeding, or otherwise opposes discrimination under these Federal laws.

Any person who believes a contractor has violated its nondiscrimination or affirmative action obligations under the authorities above should contact immediately:

The Office of Federal Contract Compliance Programs (OFCCP), U.S. Department of Labor, 200 Constitution Avenue, N.W., Washington, D.C. 20210, 1-800-397-6251 (toll-free) or (202) 693-1337 (TTY). OFCCP may also be contacted by e-mail at OFCCP-Public@dol.gov, or by calling an OFCCP regional or district office, listed in most telephone directories under U.S. Government, Department of Labor.

Programs or Activities Receiving Federal Financial Assistance

RACE, COLOR, RELIGION, SEX

In addition to the protections of Title VII of the Civil Rights Act of 1964, as amended, Title VI of the Civil Rights Act of 1964, as amended, prohibits discrimination on the basis of race, color or national origin in programs or activities receiving Federal financial assistance. Employment discrimination is covered by Title VI if the primary objective of the financial assistance is provision of employment, or where employment discrimination causes or may cause discrimination in providing services under such programs. Title IX of the Education Amendments of 1972 prohibits employment discrimination on the basis of sex in educational programs or activities which receive Federal financial assistance.

INDIVIDUALS WITH DISABILITIES

Section 504 of the Rehabilitation Act of 1973, as amended, prohibits employment discrimination on the basis of disability in any program or activity which receives Federal financial assistance. Discrimination is prohibited in all aspects of employment against persons with disabilities who, with or without reasonable accommodation, can perform the essential functions of the job.

If you believe you have been discriminated against in a program of any institution which received Federal financial assistance, you should immediately contact the Federal agency providing such assistance.

EMPLOYEE RIGHTS UNDER THE FAIR LABOR STANDARDS ACT

FEDERAL MINIMUM WAGE

\$7.25

 PER HOUR

BEGINNING JULY 24, 2009

The law requires employers to display this poster where employees can readily see it.

- OVERTIME PAY** At least 1½ times the regular rate of pay for all hours worked over 40 in a workweek.
- CHILD LABOR** An employee must be at least 16 years old to work in most non-farm jobs and at least 18 to work in non-farm jobs declared hazardous by the Secretary of Labor. Youths 14 and 15 years old may work outside school hours in various non-manufacturing, non-mining, non-hazardous jobs with certain work hours restrictions. Different rules apply in agricultural employment.
- TIP CREDIT** Employers of “tipped employees” who meet certain conditions may claim a partial wage credit based on tips received by their employees. Employers must pay tipped employees a cash wage of at least \$2.13 per hour if they claim a tip credit against their minimum wage obligation. If an employee’s tips combined with the employer’s cash wage of at least \$2.13 per hour do not equal the minimum hourly wage, the employer must make up the difference.
- NURSING MOTHERS** The FLSA requires employers to provide reasonable break time for a nursing mother employee who is subject to the FLSA’s overtime requirements in order for the employee to express breast milk for her nursing child for one year after the child’s birth each time such employee has a need to express breast milk. Employers are also required to provide a place, other than a bathroom, that is shielded from view and free from intrusion from coworkers and the public, which may be used by the employee to express breast milk.
- ENFORCEMENT** The Department has authority to recover back wages and an equal amount in liquidated damages in instances of minimum wage, overtime, and other violations. The Department may litigate and/or recommend criminal prosecution. Employers may be assessed civil money penalties for each willful or repeated violation of the minimum wage or overtime pay provisions of the law. Civil money penalties may also be assessed for violations of the FLSA’s child labor provisions. Heightened civil money penalties may be assessed for each child labor violation that results in the death or serious injury of any minor employee, and such assessments may be doubled when the violations are determined to be willful or repeated. The law also prohibits retaliating against or discharging workers who file a complaint or participate in any proceeding under the FLSA.
- ADDITIONAL INFORMATION**
- Certain occupations and establishments are exempt from the minimum wage, and/or overtime pay provisions.
 - Special provisions apply to workers in American Samoa, the Commonwealth of the Northern Mariana Islands, and the Commonwealth of Puerto Rico.
 - Some state laws provide greater employee protections; employers must comply with both.
 - Some employers incorrectly classify workers as “independent contractors” when they are actually employees under the FLSA. It is important to know the difference between the two because employees (unless exempt) are entitled to the FLSA’s minimum wage and overtime pay protections and correctly classified independent contractors are not.
 - Certain full-time students, student learners, apprentices, and workers with disabilities may be paid less than the minimum wage under special certificates issued by the Department of Labor.



WAGE AND HOUR DIVISION
UNITED STATES DEPARTMENT OF LABOR

1-866-487-9243
TTY: 1-877-889-5627
www.dol.gov/whd



WH1008 02/07/10

APPENDIX G – Genetic Information Non-Discrimination Policy

Greeneville City Schools respects all employees' privacy in their genetic information and enforces a strict policy of nondiscrimination on the basis of genetic information. The system will not discriminate, harass, or retaliate on the basis of genetic information when it comes to any aspect of employment. The system's policies regarding equal employment opportunity, harassment and retaliation are applicable to genetic information, as well as other categories protected by law.

Additionally, Greeneville City Schools will not use genetic information (as defined by applicable law and regulations) to make an employment decision. Genetic information includes information about an individual's genetic test and the genetic tests of an individual's family members, as well as information about any disease, disorder, or condition of an individual's family members (i.e., an individual's family medical history). In the event the system receives genetic information, it will treat such information confidential and will only use such information in accordance with applicable law.

APPENDIX H - ASBESTOS MANAGEMENT PLAN AVAILABILITY

Greeneville City Schools Phone (423) 787-8000
Director of Schools Phone (423) 787-8014
P. O. Box 1420 FAX (423) 638-2540
Greeneville, Tennessee 37744-1420

Memo

TO: Parents
FROM: Director of Schools
SUBJECT: ASBESTOSMANAGEMENTPLANAVAILABILITY

In November of 1988, the Greeneville City Board of Education submitted a Management Plan to the Tennessee Department of Finance and Administration. The Management Plan details all areas where asbestos-containing materials are present in the buildings of Greeneville City Schools and the manner in which the materials will be handled.

The Management Plan will be available to the public for review at the Greeneville City Schools' Operations office located at 312 Floral Street, Greeneville, Tennessee. Management Plans for the school buildings will be available in the office area of each school. Viewing time will be 9:00 a.m. to 4:00 p.m. (local time) Monday through Friday.

The Management Plan is updated every six months (beginning July 9, 1989) with progress reports being submitted to the state annually.

APPENDIX I - Family Educational Rights and Privacy Act (FERPA)

Greeneville City Schools Family Educational Rights and Privacy Act (FERPA) Annual Notification Rights

The Family Educational Rights and Privacy Act (FERPA) affords parents and students over 18 years of age (“eligible students”) certain rights with respect to the student’s education records. These rights are:

1. The right to inspect and review the student’s education records within 45 days of the day the school receives a request for access. Parents or eligible students should submit to the school Principal a written request that identifies the record(s) they wish to inspect. The Assistant Director will make arrangements for access and notify the parent or eligible student of the time and place where the records may be inspected.
2. The right to request the amendment of the student’s education records that the parent or eligible student believes are inaccurate or misleading. They should write the school Principal, clearly identify the part of the record they want changed, and specify why it is inaccurate or misleading. If the school decides not to amend the record as requested by the parent or eligible student, the school will notify the parent or eligible student of the decision and advise them of their right to a hearing regarding the request for amendment. Additional information regarding the hearing procedures will be provided to the parent or eligible student when notified of the right to a hearing.
3. The right to consent to disclosures of personally identifiable information contained in the students education records, except to the extent that FERPA authorizes disclosure without consent. Three exceptions which permit disclosure without consent are as follows,
 - a. Disclosure to school officials with legitimate educational interests. A school official is a person employed by the school as an Administrator, Supervisor, Instructor, or a Support Staff Member (including health or medical staff and law enforcement unit personnel); a person serving on the School Board; a person or company with whom the school has contracted to perform a special task (such as an attorney, auditor, medical consultant, or therapist); or a parent or student serving on an official committee, such as a disciplinary or grievance committee, or assisting another school official in performing his or her tasks. A school official has a legitimate educational interest if the official needs to review an education record in order to fulfill his or her professional responsibility.
 - b. Upon request, the school discloses education records without consent to officials of another school district in which a student seeks or intends to enroll.
 - c. In an emergency, FERPA permits school officials to disclose without consent education records, including personally identifiable information from those records, to protect the health or safety of parties such as law enforcement officials, public health officials, and trained medical personnel. This exception is limited to the period of the emergency and generally does not allow for a blanket release of personally identifiable information from a student’s education records.
4. The right to file a complaint with the U.S. Department of Education concerning alleged failures by the school district to comply with the requirements of FERPA. The name and address of the office that administers FERPA are as follows:

Family Policy Compliance Office
U.S. Department of Education
400 Maryland Avenue, SW
Washington, DC 20202-5920

**Greeneville City Schools
Family Rights and Privacy Act (FERPA)
Annual Release of Directory Information**

The Family Educational Rights and Privacy Act (FERPA) requires that Greeneville City Schools, with certain exceptions, obtain your written consent prior to the disclosure of personally identifiable information from your child's education records. However, the school district may disclose appropriately designated "directory information" without written consent, unless you have advised the district to the contrary in accordance with district procedures. The primary purpose of directory information is to allow the district to include this type of information from your child's education records in certain school publications. Examples of such publications include the following,

- A playbill, showing your student's role in a drama production.
- The annual yearbook.
- Honor roll or other recognition lists.
- Graduation programs.
- Sports activity sheets, such as for wrestling, showing weight and height of team members.

Directory information, which is information that is generally not considered harmful or an invasion of privacy if released, can also be disclosed to outside organizations without a parent's prior written consent. Outside organizations include, but are not limited to, companies that manufacture class rings or publish yearbooks.

In addition, two federal laws require local educational agencies (LEAs) receiving assistance under the Elementary and Secondary Education Act of 1965 (ESEA) to provide military recruiters, upon request, with three directory information categories—names, address and telephones listings—unless parents have advised the LEA that they do not want their student's information disclosed without their prior written consent.

If you do not want the school district to disclose directory information from your child's education records without prior written consent, you must notify the school Principal in writing within two weeks of your child's enrollment and clearly identify your child's name, grade, school and the information that you do not want released. Greeneville City Schools has designated the following information as directory information,

- Student's name, address and phone number.
- Participation in officially recognized activities and sports.
- Weight and height of members of athletic teams.
- Electronic mail address.
- Photograph.
- Degrees, honors and awards received.
- Date and place of birth.
- Major field of study.
- Dates of attendance grade level.
- The most recent educational agency or institution attended.

**Greeneville City Schools
Protection of Pupil Rights Amendment (PPRA)
Annual Notification of Rights**

PPRA affords parents certain rights regarding our conduct of surveys, collection and use of information for marketing purposes, and certain physical exams. These include the right to:

- *Consent* before students are required to submit to a survey that concerns one or more of the following protected areas (“protected information survey”) if the survey is funded in whole or in part by a program of the U.S. Department of Education (ED)—
 1. Political affiliations or beliefs of the student or student’s parent;
 2. Mental or psychological problems of the student or student’s family;
 3. Sex behavior or attitudes;
 4. Illegal, anti-social, self-incriminating, or demeaning behavior;
 5. Critical appraisals of others with whom respondents have close family relationships;
 6. Legally recognized privileged relationships, such as with lawyers, doctors, or ministers;
 7. Religious practices, affiliations, or beliefs of the student or parents; or
 8. Income, other than as required by law to determine program eligibility.
- *Receive notice and an opportunity to opt a student out of—*
 1. Any other protected information survey, regardless of funding;
 2. Any non-emergency, invasive physical exam or screening required as a condition of attendance, administered by the school or its agent, and not necessary to protect the immediate health and safety of a student, except for hearing, vision, or scoliosis screenings, or any physical exam or screening permitted or required under State law; and
 3. Activities involving collection, disclosure, or use of personal information obtained from students for marketing or to sell or otherwise distribute the information to others.
- *Inspect*, upon request and before administration or use—
 1. Protected information surveys of students’
 2. Instruments used to collect personal information from students for any of the above marketing, sales, or other distribution purposes; and
 3. Instructional material used as part of the educational curriculum.

These rights transfer to from the parents to a student who is 8 years old or an emancipated minor under State law.

Greeneville City Schools has developed and adopted policies, in consultation with parents, regarding these rights, as well as arrangements to protect student privacy in the administration of protected information surveys and the collection, disclosure, or use of personal information for marketing, sales, or other distribution purposes. The school district will directly notify parents of these policies at least annually at the start of each school year and after any substantive changes. The school district will also directly notify, such as through U.S. Mail or email, parents of students who are scheduled to participate in the specific activities or surveys noted below and will provide an opportunity for the parent to opt his or her child out of participation of the specific activity or survey. The school district will make this notification to parents at the beginning of the school year if the district has identified the specific or approximate dates of the activities or surveys at that time.

For surveys and activities scheduled after the school year starts, parents will be provided reasonable notification of the planned activities and surveys listed below and be provided an opportunity to opt their child out of such activities and surveys. Parents will also be provided an opportunity to review any pertinent surveys. Following is a list of the specific activities and surveys covered under this requirement,

- Collections, disclosure, or use of personal information for marketing, sales or other distribution.
- Administration of any protected information survey not funded in whole or in part by ED.

- Any non-emergency, invasive physical examination or screening as described above.

Parents who believe their rights have been violated may file a complaint with:

Family Policy Compliance Office
U.S. Department of Education
400 Maryland Avenue, SW
Washington, DC 20202-5920

Personal Characteristics Expected of ALL Greeneville City Schools Personnel

INTEGRITY	Soundness of moral character; adherence to generally accepted ethical principles
DEPENDABILITY	Worthy of trust; reliable
COOPERATIVENESS	Willingness to work with others to achieve organizational goals
ENTHUSIASM	Eager and excited interest in pursuing and achieving organization priorities
INITIATIVE	Readiness and ability to take first steps to solve a problem; to seek and pursue new solutions
COMMITMENT	Faithfulness to obligations and responsibilities; adherence to solutions, positions and decisions of the organization
JUDGMENT	The general ability to make sound decisions within the broad confines of policy and acceptable practices

APPENDIX K – Tennessee Teacher Code of Ethics



Tennessee Teacher Code of Ethics

49-5-1001. Short title.

This part shall be known and may be cited as the "Teacher Code of Ethics."

History

Acts 2010, ch. 916, § 1.

49-5-1002. Legislative findings.

The general assembly finds and declares that:

- (1) An educator, believing in the worth and dignity of each human being, recognizes the supreme importance of the pursuit of truth, devotion to excellence, and the nurture of democratic principles. Essential to these goals is the protection of freedom to learn and to teach and the guarantee of equal educational opportunity for all. An educator accepts the responsibility to adhere to the highest ethical standards; and
- (2) An educator recognizes the magnitude of the responsibility inherent in the teaching process. The desire for the respect and confidence of one's colleagues, of students, of parents and of the members of the community provides the incentive to attain and maintain the highest possible degree of ethical conduct.

History

Acts 2010, ch. 916, § 1.

49-5-1003. Educator's obligations to students.

(a) An educator shall strive to help each student realize the student's potential as a worthy and effective member of society. An educator therefore works to stimulate the spirit of inquiry, the acquisition of knowledge and understanding, and the thoughtful formulation of worthy goals.

(b) In fulfillment of this obligation to the student, an educator shall:

- (1) Abide by all applicable federal and state laws;
- (2) Not unreasonably restrain the student from independent action in the pursuit of learning;
- (3) Provide the student with professional education services in a nondiscriminatory manner and in consonance with accepted best practices known to the educator;
- (4) Respect the constitutional rights of the student;
- (5) Not unreasonably deny the student access to varying points of view;
- (6) Not deliberately suppress or distort subject matter relevant to the student's progress;
- (7) Make reasonable effort to protect the student from conditions harmful to learning or to health and safety;
- (8) Make reasonable effort to protect the emotional well-being of the student;
- (9) Not intentionally expose the student to embarrassment or disparagement;
- (10) Not on the basis of race; color; creed; disability; sex; national origin; marital status; political or religious beliefs; family, social, or cultural background; or sexual orientation, unfairly:
 - (A) Exclude the student from participation in any program;
 - (B) Deny benefits to the student; or
 - (C) Grant any advantage to the student;
- (11) Not use the educator's professional relationship with the student for private advantage;

- (12) Not disclose information about the student obtained in the course of the educator's professional service, unless disclosure of the information is permitted, serves a compelling professional purpose, or is required by law;
- (13) Not knowingly make false or malicious statements about students or colleagues;
- (14) Ensure interactions with the student take place in transparent and appropriate settings;
- (15) Not engage in any sexually related behavior with the student, whether verbal, written, physical, or electronic, with or without the student's consent. Sexually related behavior includes, but is not limited to, behaviors such as making sexual jokes or sexual remarks; engaging in sexual kidding, sexual teasing, or sexual innuendo; pressuring the student for dates or sexual favors; engaging in inappropriate physical touching, groping, or grabbing; kissing; rape; threatening physical harm; and committing sexual assault;
- (16) Not furnish alcohol or illegal or unauthorized drugs to the student;
- (17) Strive to prevent the use of alcohol or illegal or unauthorized drugs by the student when the student is under the educator's supervision on school or LEA premises, during school activities, or in any private setting;
- (18) Refrain from the use of alcohol while on school or LEA premises or during a school activity at which students are present; and
- (19) Maintain a professional approach with the student at all times.

History

Acts 2010, ch. 916, § 1; 2018, ch. 937, § 1.

49-5-1004. Educator's obligations to the education profession.

- (a) The education profession is vested by the public with a trust and responsibility requiring the highest ideals of professional service. In the belief that the quality of the services of the education profession directly influences the nation and its citizens, the educator shall exert every effort to raise professional standards, to promote a climate that encourages the exercise of professional judgment, to achieve conditions which attract persons worthy of the trust to careers in education, and to assist in preventing the practice of the profession by unqualified persons.
- (b) In fulfillment of this obligation to the profession, an educator shall not:
 - (1) Deliberately make a false statement or fail to disclose a material fact related to competency and qualifications in an application for a professional position;
 - (2) Misrepresent the educator's professional qualifications;
 - (3) Assist entry into the profession of a person known to be unqualified in respect to character, education, or other relevant attribute;
 - (4) Knowingly make a false statement concerning the qualifications of a candidate for a professional position;
 - (5) Assist a noneducator in the unauthorized practice of teaching;
 - (6) Disclose information about colleagues obtained in the course of professional service unless the disclosure serves a compelling professional purpose or is required by law;
 - (7) Knowingly make false or malicious statements about a colleague;
 - (8) Accept any gratuity, gift, or favor that might impair or appear to influence professional decisions or actions; and
 - (9) Use illegal or unauthorized drugs.
- (c) In fulfillment of this obligation to the profession, educators shall:
 - (1) Administer state-mandated assessments fairly and ethically; and
 - (2) Conduct themselves in a manner that preserves the dignity and integrity of the education profession.

History

Acts 2010, ch. 916, § 1; 2018, ch. 937, §§ 2, 3.

49-5-1005. Public access to teacher code of ethics.

The state board of education shall post the teacher code of ethics on its web site.

APPENDIX L – ACA Lookback Safe Harbor Resolution

RESOLUTION NO. _____

RESOLUTION OF GREENEVILLE CITY SCHOOLS ADOPTING THE LOOK BACK MEASUREMENT SAFE HARBOR UNDER THE PATIENT PROTECTION AND AFFORDABLE CARE ACT

WHEREAS, the Patient Protection and Affordable Care Act ("ACA") was enacted on March 23, 2010;

WHEREAS, ACA added Section 4980H Shared Responsibility for Employers Regarding Health Care Coverage to Title 26 of the United States Code, the Internal Revenue Code (Section 4980H);

WHEREAS, Section 4980H imposes an assessable payment on an applicable large employer when either it fails (1) to offer "substantially all" of its full-time employees (and their dependent children) the opportunity to enroll in minimum essential coverage or (2) offers full-time employees (and their dependents) coverage that is either not affordable or not minimum coverage and a full-time employee is certified to the employer as having received a subsidy for coverage through the exchange ("Assessable Payment");

WHEREAS, Greeneville City Schools is considered an applicable large employer because it employed an average of at least 50 full-time equivalent employees on business days during the preceding calendar year;

WHEREAS, the Department of Treasury issued final regulations regarding Section 4980H, that permit Greeneville City Schools to adopt a look-back measurement method safe harbor in order to determine the status of an employee as full-time for purposes of determining and calculating the Assessable Payment 26 CFR Parts 1, 54, and 301, 79 Fed. Reg. 8543 (Feb. 12, 2014);

WHEREAS, to determine look-back measurement period method for 2014, Greeneville City Schools will use any transitional rules contained in these final regulations; and

WHEREAS, Greeneville City Schools intends to adopt the provisions of the look-back measurement method safe harbor in order to determine the full-time status of variable hour employees for purposes of the Assessable Payment;

NOW THEREFORE, be it resolved by the Superintendent of Greeneville City Schools as follows:

- 1) That all of the recitals set forth above are true and correct, and the Superintendent so finds and determines.
- 2) Greeneville City Schools establishes the look-back measurement method with regard to all ongoing variable hour employees as follows:
 - a) Greeneville City Schools establishes a 6 month transitional standard measurement period for ongoing variable employees for 2014.

- b) Starting with April 5, 2014, a transitional standard measurement period will begin on April 5th and end on October 4th.
 - c) For any standard measurement period starting after 2014, it shall be a 12 month period for ongoing variable hour employees.
 - d) Starting with October 5, 2014 a standard measurement period will begin on October 5th and end on October 4th of the following year.
 - e) The standard measurement period will be the period during which an ongoing variable hour employees hours are measured.
 - f) Greeneville City Schools will establish an administrative period of 88 days.
 - g) For 2014, the administrative period associated with the transitional standard measurement period will begin on October 5th and end on December 31st.
 - h) For any administrative period starting after 2014, it shall begin each year on October 5th and end on December 31st.
 - i) Greeneville City Schools will establish a 12 month standard stability period for ongoing variable hour employees.
 - j) Starting in 2015, the 12 month standard stability period for ongoing variable hour employees will begin each year on January 1st and end on December 31st.
 - k) If an ongoing variable hour employee's employment status changes before the end of a stability period, the change in status will be effective the earlier of the end of the stability period or 4 months after the change in status.
- 3) On the start date of a new employee, Greeneville City Schools will make a determination as to whether that new employee is reasonably expected to be a full-time employee. If the new employee is reasonably expected to be a full-time employee and is not a variable hour employee, Greeneville City Schools will offer minimum essential coverage to that employment after the completion of a waiting period.
- 4) If, based on the facts and circumstances at the start date of a new employee, Greeneville City Schools is unable to determine that the employee is reasonably expected to be employed an average of at least thirty (30) hours per week over the initial measurement period, then the employee is considered a variable hour employee.
- 5) Greeneville City Schools establishes the look-back measurement method with regard to new variable hour employees as follows:
- a. Greeneville City Schools establishes a 12 month initial measurement period for each new employee.
 - b. The initial measurement period will start the 1st of the month following date of hire/start date after the new employee's hire date, unless the hire date is the first

of a calendar month in which case the initial measurement period will start on that date.

- c. The administrative period shall include all periods from hire date to the beginning of the initial measurement period and the day following the last day of the initial measurement period and shall end on the last day of the first calendar month beginning on or after the first anniversary of the employee's hire date.
 - d. Greeneville City Schools establishes a 12 month stability period associated with the initial measurement period.
 - e. If the new variable hour employee does not complete the hours to be considered as a full-time employee during the initial measurement period, the stability period associated with the initial measurement period shall not exceed the remainder of the standard measurement period and associated administrative period.
- 6) A new variable hour employee will be measured during the first complete standard measurement period for which he/she is employed. This means that a new variable employee may be tested under an initial measurement period and at the same time be measured under the overlapping standard measurement period.
- a) If a variable hour employee measures as full-time during the initial measurement period, he/she will retain full-time status for the entire associated stability period (even if the variable hour employee does not qualify as full-time during the standard measurement period).
 - b) If a variable hour employee does not complete the hours to be considered as a full-time employee during the initial measurement period, but qualifies as a full-time employee during the standard measurement period, the variable hour employee must be treated as full-time during the stability period associated with the standard measurement period (even if that means coverage must be offered before the end of the stability period associated with the initial measurement period).
- 7) When a variable hour employee is rehired after termination, upon return the employee will retain the status the employee had previously with respect to any stability period, except that an employee will be treated as a new employee:
- a) if the employee resumes employment after a period of at least 26 consecutive weeks with less than an hour of service; or
 - b) if the period (measured in weeks) during which no services are performed is at least four consecutive weeks long and exceeds the number of weeks of that employee's period of employment immediately preceding the period during which the employee was not credited with any hours of service.
- 8) When a variable hour employee takes special unpaid leave (i.e. unpaid leave under the Family and Medical Leave Act of 1993, unpaid leave under the Uniformed Services Employment and Reemployment Rights Act of 1994, or unpaid leave on account of jury duty), to determine hours of service Greeneville City Schools will exclude any periods of

special unpaid leave during the measurement period and apply that average for the entire measurement period.

- 9) If an ongoing or new variable hour employee is determined to be full-time during the measurement period, coverage will continue during the stability period no matter how many hours the employee competes during the stability period and the employee portion of the premium will be due monthly with a thirty (30) day grace period for payment.
- 10) If during any stability period, a variable hour employee fails to pay a premium during the 30 day period, any coverage will be terminated at the beginning of the month in which premiums were not received.

I, Lisa B. Shaw, Director of Schools of Greenville City Schools, State of Tennessee, hereby certify the above and foregoing to be a full, true and correct copy of a resolution adopted by said Superintendent on the 15th day of December, 2014.

DATED: This 15th day of December, 2014.

This sheet has been updated as of September 12 2023, with information through August 2023

GREENVILLE CITY SCHOOLS
2023 - 2024
ACTUAL LOCAL REVENUE COLLECTIONS

	Property Tax		Property Tax - Prior Year		Clerk & Master		Interest & Penalty		Pick-up Taxes		In Lieu of - Local Utility		In Lieu of - Other	
	2022-2023	2023-2024	2022-2023	2023-2024	2022-2023	2023-2024	2022-2023	2023-2024	2022-2023	2023-2024	2022-2023	2023-2024	2022-2023	2023-2024
July	\$ -	\$ -	\$ 9,188.59	\$ 10,188.94	\$ 2,701.20	\$ 2,979.58	\$ 2,087.99	\$ 2,414.16	\$ -	\$ -	\$ 12,443.75	\$ 11,499.77	\$ 259.49	\$ 203.70
August	\$ -	\$ -	\$ (8,670.69)	\$ 4,842.06	\$ 1,562.92	\$ 3,048.70	\$ 1,167.29	\$ 2,206.12	\$ -	\$ -	\$ 1,866.77	\$ 11,499.77	\$ -	\$ -
September														
October														
November														
December														
January														
February														
March														
April														
May														
ADA Adj.														
June														
Totals	\$ -	\$ -	\$ 517.90	\$ 15,031.00	\$ 4,264.12	\$ 6,028.28	\$ 3,255.28	\$ 4,620.28	\$ -	\$ -	\$ 14,310.52	\$ 22,999.54	\$ 259.49	\$ 203.70
Commission	\$ -	\$ -	\$ 10.36	\$ 300.62	\$ 42.64	\$ 60.28	\$ 65.11	\$ 92.41	\$ -	\$ -	\$ 143.11	\$ 230.00	\$ 2.59	\$ 2.04
Total Net	\$ -	\$ -	\$ 507.54	\$ 14,730.38	\$ 4,221.48	\$ 5,968.00	\$ 3,190.17	\$ 4,527.87	\$ -	\$ -	\$ 14,167.41	\$ 22,769.54	\$ 256.90	\$ 201.66
Difference		\$ -		\$ 14,513.10		\$ 1,764.16		\$ 1,365.00		\$ -		\$ 8,689.02		\$ (55.79)

	Sales Tax		Bank Excise Tax		Mixed Drink Tax		Statutory Local Tax		Marriage Licenses		Subtotal		2022-23% of Actual	2023-24 % of Budget
	2022-2023	2023-2024	2022-2023	2023-2024	2022-2023	2023-2024	2022-2023	2023-2024	2022-2023	2023-2024	2022-2023	2023-2024		
July	\$ 421,100.29	\$ 454,782.19	\$ -	\$ -	\$ -	\$ -	\$ -	\$ -	\$ 114.49	\$ 102.50	\$ 447,895.80	\$ 482,170.84	51.1%	5.3%
August	\$ 432,580.24	\$ 462,239.10	\$ -	\$ -	\$ -	\$ -	\$ -	\$ -	\$ 90.13	\$ 65.89	\$ 428,596.66	\$ 483,901.64	48.9%	5.3%
September											\$ -	\$ -	0.0%	0.0%
October											\$ -	\$ -	0.0%	0.0%
November											\$ -	\$ -	0.0%	0.0%
December											\$ -	\$ -	0.0%	0.0%
January											\$ -	\$ -	0.0%	0.0%
February											\$ -	\$ -	0.0%	0.0%
March											\$ -	\$ -	0.0%	0.0%
April											\$ -	\$ -	0.0%	0.0%
May											\$ -	\$ -	0.0%	0.0%
ADA Adj.											\$ -	\$ -	0.0%	0.0%
June											\$ -	\$ -	0.0%	0.0%
Totals	\$ 853,680.53	\$ 917,021.29	\$ -	\$ -	\$ -	\$ -	\$ -	\$ -	\$ 204.62	\$ 168.39	\$ 876,492.46	\$ 966,072.48		
Commission	\$ 8,536.81	\$ 9,170.21	\$ -	\$ -	\$ -	\$ -	\$ -	\$ -	\$ 2.05	\$ 1.68	\$ 8,802.66	\$ 9,857.24		
Total Net	\$ 845,143.72	\$ 907,851.08	\$ -	\$ -	\$ -	\$ -	\$ -	\$ -	\$ 202.57	\$ 166.71	\$ 867,689.80	\$ 956,215.24		
Difference		\$ 63,340.76		\$ -		\$ -		\$ -		\$ (36.23)		\$ 89,580.02		

Total budgeted projection for 2023 - 2024 is \$ 9,111,645 The year-to-date collection of \$ 966,072 is 10.6% of the total budgeted projection.
The amount collected year-to-date is \$ 89,580 more than this time last year. (This amount does not reflect commission fees.)

Greeneville City Schools Comparative Summary of Revenue Collections For the Month Ended August 31, 2023

<u>LOCAL REVENUE</u>	2022-2023		2023-2024		Variance	Actual % Change
Property Tax	\$ -	\$ -	\$ -	\$ -	\$ -	0.00%
Property Tax - Prior Year	517.90	15,031.00	14,513.10	2802.30%		
Clerk & Master	4,264.12	6,028.28	1,764.16	41.37%		
Interest & Penalty	3,255.28	4,620.28	1,365.00	41.93%		
Pick-Up Taxes	-	-	-	0.00%		
In Lieu Of - Local Utility	14,310.52	22,999.54	8,689.02	60.72%		
In Lieu Of - Other	259.49	203.70	(55.79)	-21.50%		
Sales Tax	853,680.53	917,021.29	63,340.76	7.42%		
Bank Excise Tax	-	-	-	0.00%		
Mixed Drink Tax	-	-	-	0.00%		
Statutory Local Taxes	-	-	-	0.00%		
Marriage Licenses	204.62	168.39	(36.23)	-17.71%		
Totals	\$ 876,492.46	\$ 966,072.48	\$ 89,580.02	10.22%		

Note: Amounts reflected do not take into consideration commission fees. Property tax, Interest & Penalty and Pick-Up Tax commission fees are calculated at 2% of total collections, while all other categories are calculated at 1% of total collections.

** Total budgeted amount of local revenue attributable to the GTC is \$684,206*

<u>BEP/TISA REVENUE</u>	2022-2023	2023-2024	Variance
July	\$ 400,115.00	\$ 416,759.00	\$ 16,644.00
August	1,694,900.00	1,995,544.00	300,644.00
September			\$ -
October			\$ -
November			\$ -
December			\$ -
January			\$ -
February			\$ -
March			\$ -
April			\$ -
May			\$ -
June			\$ -
Totals	\$ 2,095,015.00	\$ 2,412,303.00	\$ 317,288.00

Greenville City Schools General Purpose Financial Report For the Month of August 2023

Account #	Description	Month-to-Date	Year-to-Date	Total Budget	YTD % of Total Budget
<u>REVENUE</u>					
34765	Assigned for Support Services	\$ -	\$ -	6,519.00	0.0%
40000	Local Taxes	\$ 482,068.34	\$ 482,068.34	8,426,429.00	5.7%
41000	Marriage Licenses	\$ 102.50	\$ 102.50	1,010.00	10.1%
43511	Tuition	\$ 86,886.00	\$ 283,461.91	726,775.00	39.0% (1)
43570	Receipts from Individual Schools	\$ -	\$ -	157,369.00	0.0%
44000	Other Local Revenue	\$ 11,594.15	\$ 35,485.64	128,468.00	27.6%
46000	State Education Funds	\$ 1,995,544.43	\$ 1,996,707.83	19,720,336.00	10.1%
47100	Federal Through State Grants	\$ -	\$ -	50,000.00	0.0%
47600	Direct Federal Funds (ROTC)	\$ -	\$ -	54,185.00	0.0%
49000	Operating Transfers & Insurance Recovery	\$ -	\$ 2,006.80	6,280,447.00	0.0%
	Total Revenues	\$ 2,576,195.42	\$ 2,799,833.02	\$ 35,551,538.00	7.9%
<u>EXPENDITURES</u>					
		MTD	YTD		
71100	Regular Instruction	\$ 1,598,012.12	\$ 1,892,010.10	\$ 17,032,304.00	11.1%
71150	Alternative Instruction	11,922.26	13,720.35	135,284.00	10.1%
71200	Special Education	179,214.55	198,992.39	2,623,296.00	7.6%
71300	Vocational Education	39,523.61	134,388.82	189,959.00	70.7% (4)
71400	Student Body	120.00	120.00	1,500.00	8.0%
72110	Attendance	8,044.77	56,332.53	113,895.00	49.5% (4)
72120	Health Services	48,337.92	59,611.83	434,320.00	13.7%
72130	Other Student Support	113,403.57	169,072.47	1,428,963.00	11.8%
72210	Regular Instruction Support	121,875.78	197,009.70	1,479,439.00	13.3%
72220	Special Education Support	23,458.10	33,671.16	333,415.00	10.1%
72230	Vocational Education Support	-	-	2,400.00	0.0%
72250	Technology	72,721.29	154,122.11	1,112,903.00	13.8%
72310	Board of Education	47,731.93	409,888.41	898,667.00	45.6% (2)
72320	Office of Director	64,820.92	101,719.77	411,333.00	24.7%
72410	Office of Principal	185,827.36	324,371.43	2,024,573.00	16.0%
72510	Fiscal Services	34,210.67	61,136.83	361,526.00	16.9%
72520	Human Resources	29,938.43	71,182.92	353,622.00	20.1%
72610	Operation of Plant	166,340.98	447,891.49	2,342,010.00	19.1% (3)
72620	Maintenance of Plant	155,843.49	214,595.49	1,098,847.00	19.5% (3)
72710	Transportation	68,241.22	96,098.82	1,160,349.00	8.3%
73300	Community Services	3,983.62	4,068.74	20,000.00	20.3% (3)
73400	Early Childhood Education	76,725.90	83,772.02	595,255.00	14.1%
76100	Capital Outlay	50,556.55	97,776.45	600,000.00	16.3%
81300	Education Debt Service	-	-	326,200.00	0.0%
99100	Operating Transfers	-	-	471,478.00	0.0%
	Total Expenditures	\$ 3,100,855.04	\$ 4,821,553.83	\$ 35,551,538.00	13.6%
	Net Revenue (Expense)	\$ (524,659.62)	\$ (2,021,720.81)		

Explanation of Footnotes

(1) Tuition Count as of 09/12/2023 is 595 Students

(2) 2023-2024 Liability and Workers' Compensation Insurance Payments Reflected

(3) Reflects Open Purchase Orders for Routine Maintenance & Operations Expenditures and Open POs for Family Resource Center Purchases

(4) Reflects Expenditures for Innovative Schools Model Grant and Attendance Software. ISM Grant to be Added when FY24 Budget is Approved.

(5) Encumbrances Total \$1,793,821

Greeneville City Schools Federal Projects Financial Report For the Month of August 2023

<u>REVENUE</u>	<u>Month-to-Date</u>	<u>Year-to-Date</u>	<u>Total Budget</u>	<u>YTD % of Total Budget</u>
Consolidated Administration	\$ -	\$ -	\$ 108,227.00	0.0%
Title I-A	\$ -	\$ -	536,528.00	0.0%
Title I-A Neglected	\$ -	\$ -	70,934.00	0.0%
Title II-A	\$ -	\$ -	91,911.00	0.0%
Title III	\$ -	\$ -	11,156.00	0.0%
Title IV	\$ -	\$ -	58,091.00	0.0%
21st Century Learning	\$ -	\$ -	-	0.0%
Title V	\$ -	\$ -	91,411.00	0.0%
IDEA Part B	\$ -	\$ -	662,168.00	0.0%
IDEA Pre-School	\$ -	\$ -	13,343.00	0.0%
ESSER 3.0**	\$ -	\$ -	-	N/A
Fiscal Pre-Monitoring Supports Grant**	\$ -	\$ -	-	N/A
Resiliant School Communities Grant**	\$ -	\$ -	-	N/A
ARP IDEA**	\$ -	\$ -	-	N/A
Total Revenues	\$ -	\$ -	\$ 1,643,769.00	0.0%

<u>EXPENDITURES</u>	<u>MTD</u>	<u>YTD</u>	<u>Total Budget</u>	<u>YTD % of Total Budget</u>
Consolidated Administration	\$ 9,424.00	\$ 17,796.50	\$ 108,227.00	16.4%
Title I-A	23,639.33	27,277.71	536,528.00	5.1%
Title I-A Neglected	5,911.17	5,911.17	70,934.00	8.3%
Title II-A	6,603.36	12,209.95	91,911.00	13.3%
Title III	1,754.05	2,224.55	11,156.00	19.9%
Title IV	3,596.61	4,234.21	58,091.00	7.3%
21st Century Grant	2,221.84	2,603.24	-	N/A
Title V	17,787.73	17,787.73	91,411.00	19.5%
IDEA Part B	51,672.40	63,202.92	662,168.00	9.5%
IDEA Pre-School	-	-	13,343.00	0.0%
ESSER 3.0 **	71,898.76	106,002.23	-	N/A
Fiscal Pre-Monitoring Supports Grant**	-	-	-	N/A
Resiliant School Communities Grant**	9,607.75	11,093.95	-	N/A
ARP IDEA **	4,877.42	9,759.90	-	N/A
Total Expenditures	\$ 208,994.42	\$ 280,104.06	\$ 1,643,769.00	17.0%
Net Revenue (Expense)	\$ (208,994.42)	\$ (280,104.06)	\$ -	

*Encumbrances Total \$89,708

** Reflects CARES Act Funding Grants

Greeneville City Schools
Greene Technology Center Financial Report
For the Month of August 2023

Account #	Description	Month-to-Date	Year-to-Date	Total Budget	YTD % of Total Budget
<u>REVENUE</u>					
39000	Unassigned Fund Balance	\$ -	\$ -	\$ 46,912.00	0.0%
40000	Local Taxes			684,119.00	0.0% (1)
41000	Marriage Licenses			87.00	0.0% (1)
43542	Contracts with Other LEAs (Greene County)	141,024.75	141,024.75	564,099.00	25.0% (2)
44000	Other Local Revenue & Miscellaneous Refunds	8,159.34	9,384.34	39,519.00	23.7% (4)
46510	TISA			438,344.00	0.0% (1)
47100	Federal Through State- Carl Perkins			48,000.00	0.0%
49000	Operating Transfer (Grv City) & Insurance Recovery			242,112.00	0.0% (1)
	Total Revenues	\$ 149,184.09	\$ 150,409.09	\$ 2,063,192.00	7.3%
<u>EXPENDITURES</u>					
71300	Vocational Education	\$ 79,585.44	\$ 98,697.68	\$ 1,105,185.00	8.9%
72130	Other Student Support	7,733.67	13,812.87	83,664.00	16.5%
72230	Vocational Education Support	5,256.46	10,519.25	63,360.00	16.6%
72310	Board of Education	3,305.96	57,521.56	121,034.00	47.5% (3)
72410	Office of Principal	27,900.23	45,831.00	357,934.00	12.8%
72610	Operation of Plant (Custodial)	13,888.52	43,588.97	231,039.00	18.9%
72620	Maintenance of Plant	4,459.26	6,315.97	22,976.00	27.5%
76100	Capital Outlay	7,819.38	7,819.38	30,000.00	26.1%
	Carl Perkins Grant	3,720.04	4,022.67	48,000.00	8.4%
	Total Expenditures	\$ 153,668.96	\$ 288,129.35	\$ 2,063,192.00	14.0%
	Net Revenue (Expense)	\$ (4,484.87)	\$ (137,720.26)		

Explanation of Footnotes

(1) Revenues Allocated to GTC are Paid in Equal Installments from GCS Over 9 Months- Beginning in August; Then Adjusted Per Actual Revenue in July

(2) Represents Total Amount Received From Greene County Schools

(3) Reflects cost of 2023-2024 Liability and Workers' Compensation Insurance Payments

Encumbrances total \$58,840



Highway 65 South, Conway, AR 72032 - orders@virco.com
2027 Harpers Way, Torrance, CA 90501 - orders@virco.com

QUOTATION #8289795
r.1

Sold To:
GREENEVILLE CITY SCHOOLS
129 WEST DEPOT STREET
GREENEVILLE TN 37743

Ship To:
GREENEVILLE MIDDLE SCHOOL
433 E VANN ROAD
GREENEVILLE TN 37743
REFERENCE: LORI POWELL 423-639-7841 EXT
1239

Quotation Date: 8/14/2023

We appreciate the opportunity to quote the enclosed prices for our products. Unless otherwise indicated, prices are net and do not include sales tax. Please refer to the above referenced Quotation Number when corresponding with Virco regarding this quote. We offer our quotation priced from the US COMMUNITIES 2023 CONTRACT #R-TC-18004 CLASSROOM FURNITURE Contract. You will need to be registered for US Communities and provide your TIN number prior to acceptance of your purchase order. We offer our quotation subject to the following terms and conditions:

- 1) FOB Point: FOB Destination - Tailgate Delivery
- 2) Payment Terms: Net 30 days (subject to credit approval)
- 3) Prices Are Firm: For Orders Received By 12/31/2023
- 4) For Shipment By: Please note that prices are for orders placed prior to 12/31/2023 and shippable no later than 01/31/2024. Orders requiring delivery after this date will not be processed and will require a requote.
- 5) Shipment from Virco: Quick Ship: 10 business days or less
Campus Basics: 4 to 6 weeks
Made to Order: 8 weeks +

Models not included in Quick Ship or Campus Basics are Made to Order and typically ready in 8 weeks. Extended lead times may apply; contact your Virco Territory Sales Manager for more information. Variety of lead times on same sales order will carry longest lead time on entire order. Additional shipping and handling charges will apply to orders that are requested to partial ship before Virco's acknowledged due date. Orders requiring delivery date after expiration of quote will require revised quote and may include additional storage fees.

- 6) Color: Standard Virco colors only unless specified otherwise
- 7) Purchase Order: We require customer approval by purchase order or signed quote to be emailed to Orders@virco.com or faxed to (800) 258-7367 or (800) 396-8232
- 8) Acknowledgement: Final acceptance and acknowledgement of orders will be as stated on the standard Virco Purchase Order Acknowledgment



Highway 65 South, Conway, AR 72032 - orders@virco.com
2027 Harpers Way, Torrance, CA 90501 - orders@virco.com

QUOTATION #8289795
r.1

9) Quantity: Any change in quantities may result in a price change



QUOTATION #8289795
r.1

Shipping To: GREENEVILLE MIDDLE SCHOOL

Item #	Supplier/Model #	Description	Unit Price	Qty	Extension
1	Virco Inc #ANLAB	Stool, Analogy(tm) Series, Lab Stool, Ergonomically Contoured Polypropylene Shell, Adjustable Gas Cylinder For 19-1/2" To 27" Seat Height, Stool Swivels 360°, Five Dual-Wheeled Caster Base With 2" Hooded Swivel Casters. Footring Adjusts From 8" To 1 4 ea Soft Plastic->Eclipse (GRY11) Mobile Base->Char Black (BLK01)	\$288.84	4	\$1,155.36
2	Virco Inc #ANCANT18EL	Chair, Analogy(tm) Series, Cantilever Leg, 18-1/8" Seat Height, Ergonomically Contoured Extra Large Polypropylene Shell, Steel Frame, Nylon-Base Swivel Glides. Standard With Graphite Color Glide Sleeves On 44 ea Color Not Selected	\$135.72	44	\$5,971.68
3	Virco Inc #MC2432	Molecule Series Desk - 24" D x 32" W x 24-32" H with 1-1/8" thick high-pressure laminate particleboard-core work surface, T-mold edge banding, and height-adjustable legs. Unique shaped collaborative top allows for single-student use or grouping of multiple desks in various arrangements. 20 ea Laminate->Grey Nebula (GRY091) Edge Banding->Char Black (BLK01) Frame->Char Black (BLK01)	\$133.11	20	\$2,662.20
4	Virco Inc #4445A	Chair, Task Seating, Black Mesh Mid-Back, Molded Foam Black Fabric Seat, Height And Width Adjustable Arms, Seat Slider, Tilt Tension Control, 4 Paddle Task Mechanism, Dual Wheel Casters. Seat: 19"d X 21"w X 18 1/4"-22 1/8"h. Overall Dimensions: 35 5/8-42"h X 26 1/2"w X 23 1/2"d. 2 ea Accessory->BLACK (BLACK)	\$813.74	2	\$1,627.48
5	Virco Inc #PRFC643	Parameter File Credenza, Double, 64"w X 23"d X 29-1/2"h, 1-1/8" Particleboard Core With A High-Pressure Laminated Plastic Top, Unitized Steel Welded Cabinet. The File Credenza Has Full-Suspension Steel Ball-Bearing Slides On All File And Box Drawers And Full-Extension Heavy-Duty Steel Ball-Bearing Slides On All Lateral Drawers. A Master-Keyed, Core-Removable Lock Shall Secure Drawers With One Lock Assembly (Ilgang Locking); One Lock Per Unit. A Counter Weight Shall Be Installed In Each Unit To Help Prevent Tipping When Drawers Are Fully Extended. This Unit Has Three Lateral Drawers, One File Drawer And Two Box Drawers. (Color Not Selected)	\$2,944.37	2	\$5,888.74
6	Virco Inc #TR3660ADJ	Tetra Series Table, 60"l X 36"w X 26"-34"h, 1-1/8" Thick High-Pressure Laminate Top With T-Mold Edge Banding, Keel To Support Top, Tubular Steel 4-Leg Frame, Adjustable Nylon-Base Glides. Powder Coated Frame; Chromed Lower Legs. (Color Not Selected)	\$435.29	4	\$1,741.16



QUOTATION #8289795
r.1

Shipping To: GREENEVILLE MIDDLE SCHOOL

Item #	Supplier/Model #	Description	Unit Price	Qty	Extension
7	Virco Inc #VTT2460	60"W x 24"D x 30"H with casters. Tubular steel frame. The top has the ability to tilt from a horizontal to a vertical position by means of a lever. Models are available with an 1-1/8" thick particleboard-core high-pressure laminate work surface with 1-1/8" profile T-mold edge banding. Models come standard with two grommets and perforated steel modesty panel. Metal surfaces are available with a powder coat finish. Four 2-3/8" twin wheel locking soft casters. (Color Not Selected)	\$500.25	2	\$1,000.50
8	Virco Inc #2703MBTT	Mobile Cabinet, 2700 Series, Doors With Lock, 56"w X 48"h X 22 "d, With Casters, Unitized Steel Frame, Laminated Panel Surfaces; Marker Board On Back, Tote Tray Rails; Plastic Tote Trays Are Ordered Separately, Unit Holds Up To 40 - 3" Deep Tote Trays; Or 20 - 6" Deep Tote Trays; Or 8 - 12" Deep Tote Trays; Or A Combination Of The Various Sizes. Specify The Tote Tray Model Number And Quantity Desired When Ordering. (Color Not Selected)	\$1,547.44	1	\$1,547.44
9	Virco Inc #2513	Mobile Cabinet, 66" High Mobile Cabinet With Two Doors Has A Unitized Steel Frame, 2 Paper & 2 File Drawers, 2 Adjustable Shelves, A Coat Rod And Vanity Mirror. Shelves Adjust In 1/2" Increments. Panels Are 3/4" Particleboard Surfaced On Both Sides With Thermofused Melamine. T-Mold Edge Banding. Both Doors Have Keyed-Alike Locks And Hinges That Pivot 270° So That Each Door Can Be Opened Flat Against Its Side Of The Cabinet. Pull Handles Are 3/4" Chromed Tubular Steel And Are Recessed In Down Position And Pivot Upward And Lock In Operating Position. Two 5" Swivel Casters With A Tread Lock Brake And Two 5" Swivel Casters Without A Brake. 48"w X 28"d X 66"h. (Color Not Selected)	\$2,942.05	1	\$2,942.05
10	Virco Inc #T3060L	Desk, Textameter(tm) Series, 1 Left-Side Locking Box/Box/File Pedestal With Twin-Wheel Locking Nylon Casters Attached To Underside Of Top, 1 Right-Side T-Leg With Twin-Wheel Locking Nylon Casters, 30"w X 60"l X 28-3/4"h, 1-1/8" High-Pressure Laminate Particleboard Top With Two Round Hinged-Top Grommets And T-Mold Edge Banding, Non-Locking Steel Center Drawer, Steel Modesty Panel (Color Not Selected)	\$1,554.98	1	\$1,554.98
11	Virco Inc #53MP1520BBF	Mobile Pedestal, 15-1/8"w X 20-9/16"d X 26-7/8"h (Color Not Selected)	\$767.34	2	\$1,534.68



QUOTATION #8289795
r.1

Shipping To: **GREENEVILLE MIDDLE SCHOOL**

Item #	Supplier/Model #	Description	Unit Price	Qty	Extension
12	Virco Inc #53LF365D	Lateral File, 53 Series, 36"w X 18"d X 64"h, 5-Drawer, Steel Ball-Bearing Slides On All Drawers, Counter Weight, Steel, Standard With Lock. (Color Not Selected)	\$2,676.41	1	\$2,676.41
13	Virco Inc #53CAB361872	Storage Cabinet, 53 Series, 36 1/4"w X 18 1/4"d X 72 1/4"h, 6 Shelves, 5 Shelves Adjusts In 12" Increments, Steel, Standard With Lock. (Color Not Selected)	\$1,222.64	1	\$1,222.64
Total					\$31,525.32

The undersigned certifies understanding and agreement of this Quote Letter and has authority to sign for purchase.

GREENEVILLE CITY SCHOOLS
129 WEST DEPOT STREET
GREENEVILLE TN 37743

X _____
PO # (if available)

X _____
Name (Print)

X _____
Authorized Signature

If paying by credit card, please call 877-311-9157. The credit specialist will be pleased to assist with your payment.

How To Place Your Order With Virco

3 Ways To Order:

1. Email your PDF quote from Virco to orders@virco.com (please make sure the quote is signed before submitting)
2. Email your standard PO to orders@virco.com
3. Order online at Shop.Virco.com (must register with Inside Sales)

What to Expect Once Order Is Placed *(see below to complete the order process)*

- We will respond to let you know your order was received.
- Once we process your order, an electronic or paper acknowledgment will be sent

In Order to Complete the Order Process, Virco Must Receive The Following Information

Account Info

- "Sold To" Information
- "Ship To" Information
- Pricing source

Delivery Info

- Delivery contact information (name and phone number for a call before delivery)
- Special delivery requests such as specific delivery hours
- Requested delivery date if applicable (orders without requested delivery dates will be entered under ASAP priority and will be shipped as soon as product is ready)

****Please note - our system only allows 8 lines of 30 characters each so please make sure to prioritize any delivery info****

Product Info

- Model (Ex: 9018, ZBOOMMFG)

Color/Finish for the Following:

CHAIRS

- Bucket Color Frame Color Glide
- (Ex: Navy/Chrome/Nylon Glides)

TABLES/DESKS

- Top/Edge Banding Frame Color Glide
- (Ex: Dry Creek Plum/Adobe/Silver Mist/Felt Glides)





FILING CABINETS

- Frame Color
- (Ex: Moonstone)







QUOTE #8289795

r.1

Item #	Supplier/Model #	Description	
1	Virco Inc #ANLAB	<p>Stool, Analogy(tm) Series, Lab Stool, Ergonomically Contoured Polypropylene Shell, Adjustable Gas Cylinder For 19-1/2" To 27" Seat Height, Stool Swivels 360°, Five Dual-Wheeled Caster Base With 2" Hooded Swivel Casters. Footring Adjusts From 8" To 1</p> <p>4 ea Soft Plastic->Eclipse (GRY11) Mobile Base->Char Black (BLK01)</p>	
2	Virco Inc #ANCANT18EL	<p>Chair, Analogy(tm) Series, Cantilever Leg, 18-1/8" Seat Height, Ergonomically Contoured Extra Large Polypropylene Shell, Steel Frame, Nylon-Base Swivel Glides. Standard With Graphite Color Glide Sleeves On</p> <p>44 ea</p>	 <p align="right">Image Does Not Reflect Actual Color Priced</p>
3	Virco Inc #MC2432	<p>Molecule Series Desk - 24" D x 32" W x 24-32" H with 1-1/8" thick high-pressure laminate particleboard-core work surface, T-mold edge banding, and height-adjustable legs. Unique shaped collaborative top allows for single-student use or grouping of multiple desks in various arrangements.</p> <p>20 ea Laminate->Grey Nebula (GRY091) Edge Banding->Char Black (BLK01) Frame->Char Black (BLK01)</p>	
4	Virco Inc #4445A	<p>Chair, Task Seating, Black Mesh Mid-Back, Molded Foam Black Fabric Seat, Height And Width Adjustable Arms, Seat Slider, Tilt Tension Control, 4 Paddle Task Mechanism, Dual Wheel Casters. Seat: 19"d X 21"w X 18 1/4"-22 1/8"h. Overall Dimensions: 35 5/8-42"h X 26 1/2"w X 23 1/2"d.</p> <p>2 ea Accessory->BLACK (BLACK)</p>	

QUOTE #8289795

Item #	Supplier/Model #	Description	
5	Virco Inc #PRFC643	<p>Parameter File Credenza, Double, 64"w X 23" d X 29-1/2"h, 1-1/8" Particleboard Core With A High-Pressure Laminated Plastic Top, Unitized Steel Welded Cabinet. The File Credenza Has Full-Suspension Steel Ball-Bearing Slides On All File And Box Drawers And Full-Extension Heavy-Duty Steel Ball-Bearing S...</p> <p>2 ea (Color Not Selected)</p>	 <p align="center">Image Does Not Reflect Actual Color Priced</p>
6	Virco Inc #TR3660ADJ	<p>Tetra Series Table, 60"l X 36"w X 26"-34"h, 1-1/8" Thick High-Pressure Laminate Top With T-Mold Edge Banding, Keel To Support Top, Tubular Steel 4-Leg Frame, Adjustable Nylon-Base Glides. Powder Coated Frame; Chromed Lower Legs.</p> <p>4 ea (Color Not Selected)</p>	 <p align="center">Image Does Not Reflect Actual Color Priced</p>
7	Virco Inc #VTT2460	<p>60"W x 24"D x 30"H with casters. Tubular steel frame. The top has the ability to tilt from a horizontal to a vertical position by means of a lever. Models are available with an 1-1/8" thick particleboard-core high-pressure laminate work surface with 1-1/8" profile T-mold edge banding. Models come st...</p> <p>2 ea (Color Not Selected)</p>	 <p align="center">Image Does Not Reflect Actual Color Priced</p>
8	Virco Inc #2703MBTT	<p>Mobile Cabinet, 2700 Series, Doors With Lock, 56"w X 48"h X 22"d, With Casters, Unitized Steel Frame, Laminated Panel Surfaces; Marker Board On Back, Tote Tray Rails; Plastic Tote Trays Are Ordered Separately, Unit Holds Up To 40 - 3" Deep Tote Trays; Or 20 - 6" Deep Tote Trays; Or 8 - 12" Deep Tote...</p> <p>1 ea (Color Not Selected)</p>	 <p align="center">Image Does Not Reflect Actual Color Priced</p>

QUOTE #8289795

Item #	Supplier/Model #	Description	
9	Virco Inc #2513	<p>Mobile Cabinet, 66" High Mobile Cabinet With Two Doors Has A Unitized Steel Frame, 2 Paper & 2 File Drawers, 2 Adjustable Shelves, A Coat Rod And Vanity Mirror. Shelves Adjust In 1/2" Increments. Panels Are 3/4" Particleboard Surfaced On Both Sides With Thermofused Melamine. T-Mold Edge Banding. Bot...</p> <p>1 ea (Color Not Selected)</p>	 <p>Image Does Not Reflect Actual Color Priced</p>
10	Virco Inc #T3060L	<p>Desk, Textameter(tm) Series, 1 Left-Side Locking Box/Box/File Pedestal With Twin-Wheel Locking Nylon Casters Attached To Underside Of Top, 1 Right-Side T-Leg With Twin-Wheel Locking Nylon Casters, 30"w X 60" l X 28-3/4"h, 1-1/8" High-Pressure Laminate Particleboard Top With Two Round Hinged-Top Gromm...</p> <p>1 ea (Color Not Selected)</p>	 <p>Image Does Not Reflect Actual Color Priced</p>
11	Virco Inc #53MP1520BBF	<p>Mobile Pedestal, 15-1/8"w X 20-9/16"d X 26-7/8"h</p> <p>2 ea (Color Not Selected)</p>	 <p>Image Does Not Reflect Actual Color Priced</p>
12	Virco Inc #53LF365D	<p>Lateral File, 53 Series, 36"w X 18"d X 64"h, 5-Drawer, Steel Ball-Bearing Slides On All Drawers, Counter Weight, Steel, Standard With Lock.</p> <p>1 ea (Color Not Selected)</p>	 <p>Image Does Not Reflect Actual Color Priced</p>

QUOTE #8289795



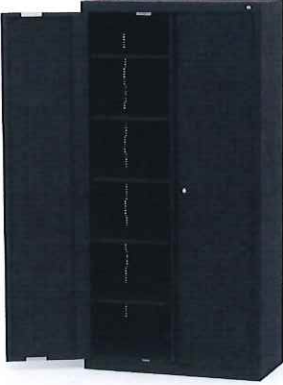

r.1

Item #	Supplier/Model #	Description	
13	Virco Inc #53CAB361872	Storage Cabinet, 53 Series, 36 1/4" w X 18 1/4" d X 72 1/4" h, 6 Shelves, 5 Shelves Adjusts In 12" Increments, Steel, Standard With Lock. 1 ea (Color Not Selected)	 <p data-bbox="1062 573 1549 600">Image Does Not Reflect Actual Color Priced</p>

Bowman

Quote #8289795

r.1

Supplier/Model #/Description/Color		Supplier/Model #/Description/Color
<p>Item #1 Qty: 4 ea</p> <p>Virco Inc #ANLAB - Stool, Analogy(tm) Series, Lab Stool, Ergonomically Contoured Polypropylene Shell, Adjustable Gas Cylinder For 19-1/2" To 27" Seat Height, Stool Swivels 360°, Five Dual-Wheeled Caster Base With 2" Hoo...</p> <p>Color: Soft Plastic->Eclipse (GRY11) Mobile Base->Char Black (BLK01)</p>		<p>Item #2 Qty: 24 ea</p> <p>Virco Inc #ANCANT18EL - Chair, Analogy(tm) Series, Cantilever Leg, 18-1/8" Seat Height Ergonomically Contoured Extra Large Polypropylene Shell, Steel Frame, Nylon-Base Swivel Glides Standard With Graphite Color Glide Sleeve...</p>
<p>Item #4 Qty: 2 ea</p> <p>Virco Inc #4445A - Chair, Task Seating, Black Mesh Mid-Back, Molded Foam Black Fabric Seat, Height And Width Adjustable Arms, Seat Slider, Tilt Tension Control, 4 Paddle Task Mechanism, Dual Wheel Casters. Seat: 19" X ...</p> <p>Color: Accessory->BLACK (BLACK)</p>		<p>Item #5 Qty: 2 ea</p> <p>Virco Inc #PRFC643 - Parameter File Credenza, Double, 64"w X 23"d X 29-1/2"h 1-1/8" Particleboard Core With A High Pressure Laminated Plastic Top, Unitized Steel Welded Cabinet. The File Credenza Has Full Suspension Steel...</p>
<p>Item #6 Qty: 4 ea</p> <p>Virco Inc #TR3660ADJ - Tetra Series Table, 60"l X 36"w X 26"-34"h, 1-1/8" Thick High-Pressure Laminate Top With T-Mold Edge Banding, Keel To Support Top, Tubular Steel 4-Leg Frame, Adjustable Nylon-Base Glides. Powder Coat...</p>	 <p style="text-align: center; font-size: small;">Image Does Not Reflect Actual Color Priced</p>	<p>Item #7 Qty: 2 ea</p> <p>Virco Inc #VTT2460 - 60"W x 24"D x 30"H with casters. Tubular steel frame. The top has the ability to tilt from a horizontal to a vertical position by means of a lever. Models are available with an 1-1/8" thick particlebo...</p>
<p>Item #8 Qty: 1 ea</p> <p>Virco Inc #2703MBTT - Mobile Cabinet, 2700 Series, Doors With Lock, 56"w X 48"h X 22"d, With Casters, Unitized Steel Frame, Laminated Panel Surfaces; Marker Board On Back, Tote Tray Rails; Plastic Tote Trays Are Ordered Se...</p>	 <p style="text-align: center; font-size: small;">Image Does Not Reflect Actual Color Priced</p>	<p>Item #9 Qty: 1 ea</p> <p>Virco Inc #2513 - Mobile Cabinet, 66" High Mobile Cabinet With Two Doors Has A Unitizer Steel Frame, 2 Paper & 2 File Drawers, ; Adjustable Shelves, A Coat Rod And Vanity Mirror. Shelves Adjust In 1/2" Increments Pane...</p>

<p>Item #10 Qty: 1 ea</p> <p>Virco Inc #T3060L - Desk, Textameter(tm) Series, 1 Left-Side Locking Box/Box/File Pedestal With Twin-Wheel Locking Nylon Casters Attached To Underside Of Top, 1 Right-Side T-Leg With Twin-Wheel Locking Nylon Casters, 30"...</p>	 <p>Image Does Not Reflect Actual Color Priced</p>	<p>Item #11 Qty: 2 ea</p> <p>Virco Inc #53MP1520BBF - Mobile Pedestal 15-1/8"w X 20-9/16"d X 26-7/8"h</p>
--	---	---

Guinn

Quote #8289795
r.1

Supplier/Model #/Description/Color		Supplier/Model #/Description/Color
<p>Item #2 Qty: 20 ea</p> <p>Virco Inc #ANCANT18EL - Chair, Analogy(tm) Series, Cantilever Leg, 18-1/8" Seat Height, Ergonomically Contoured Extra Large Polypropylene Shell, Steel Frame, Nylon-Base Swivel Glides. Standard With Graphite Color Glide Sleeve...</p>	 <p>Image Does Not Reflect Actual Color Priced</p>	<p>Item #3 Qty: 20 ea</p> <p>Virco Inc #MC2432 - Molecule Series Desk 24" D x 32" W x 24-32" H with 1-1/8" thick high pressure laminate particleboard-core work surface, T-mold edge banding, and height adjustable legs. Unique shaped collaborative t...</p> <p>Color: Laminate->Grey Nebula (GRY091) Edge Banding->Char Black (BLK01) Frame->Char Black (BLK01)</p>
<p>Item #12 Qty: 1 ea</p> <p>Virco Inc #53LF365D - Lateral File, 53 Series, 36"w X 18"d X 64"h, 5-Drawer, Steel Ball-Bearing Slides On All Drawers, Counter Weight, Steel, Standard With Lock.</p>	 <p>Image Does Not Reflect Actual Color Priced</p>	<p>Item #13 Qty: 1 ea</p> <p>Virco Inc #53CAB361872 - Storage Cabinet 53 Series, 36 1/4" w X 18 1/4" d X 72 1/4" h, 5 Shelves, 5 Shelves Adjusts In 12" Increments Steel, Standard With Lock.</p>

GREENEVILLE



GREENE DEVILS

Greeneville City Schools
Priority Landscape Projects

March 10, 2023



Landscape Recommendations

- ① Limb up Chinese Elm trees approximately 4' to provide views to the school.
- ② Remove all shrubs at corner of entrance drive and parking lot and plant lawn.
- ③ Remove overgrown Yews at sign and reduce plant bed.
-Suggest planting False Plum Yew or Pachysandra.
- ④ Remove mulch around tree and plant fescue lawn to match opposite side.
- ⑤ Selectively prune Chinese Elm trees to reduce conflicts with light poles at entrance.

Summary of Intent:

- Opening Views
- Removing excess mulch

Suggested Plant Images



Cephalotaxus harringtonia 'Prostrata'
Prostrate False Plum Yew
18"-30" T x 3-4' W
Evergreen foliage



Pachysandra terminalis
Japanese Pachysandra
6-10" T x 1-1.5' W
Evergreen foliage

Key Plan

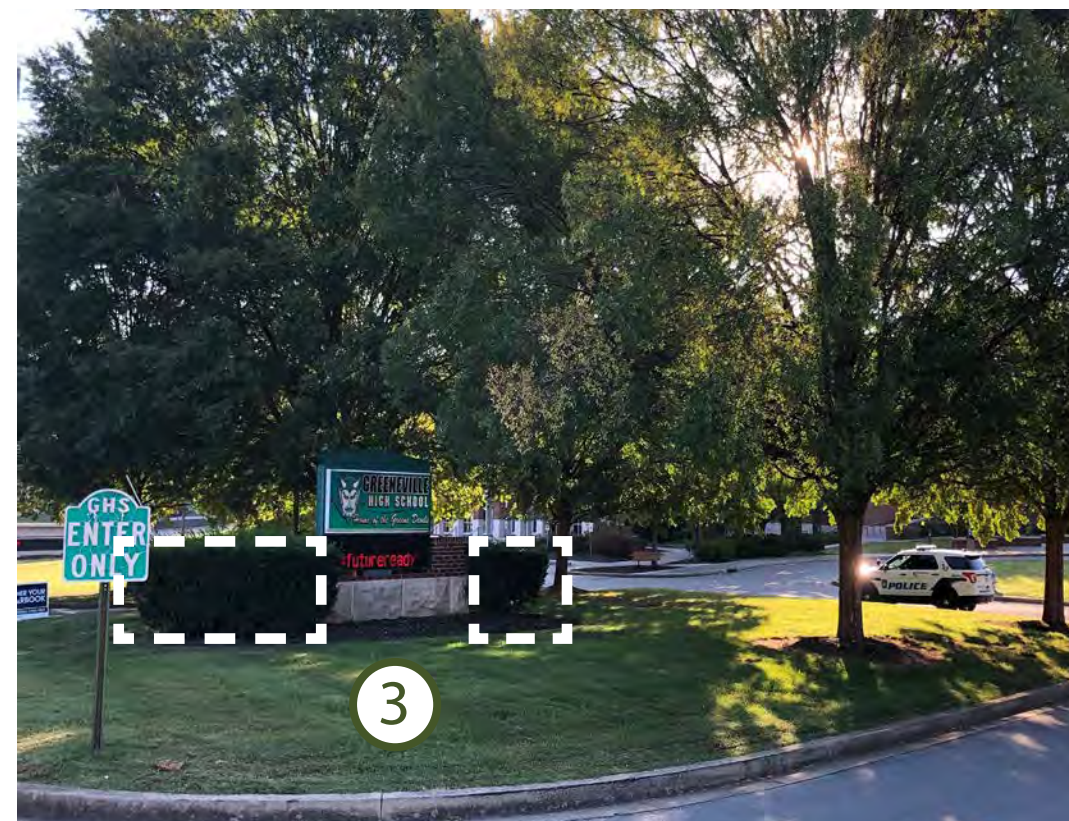
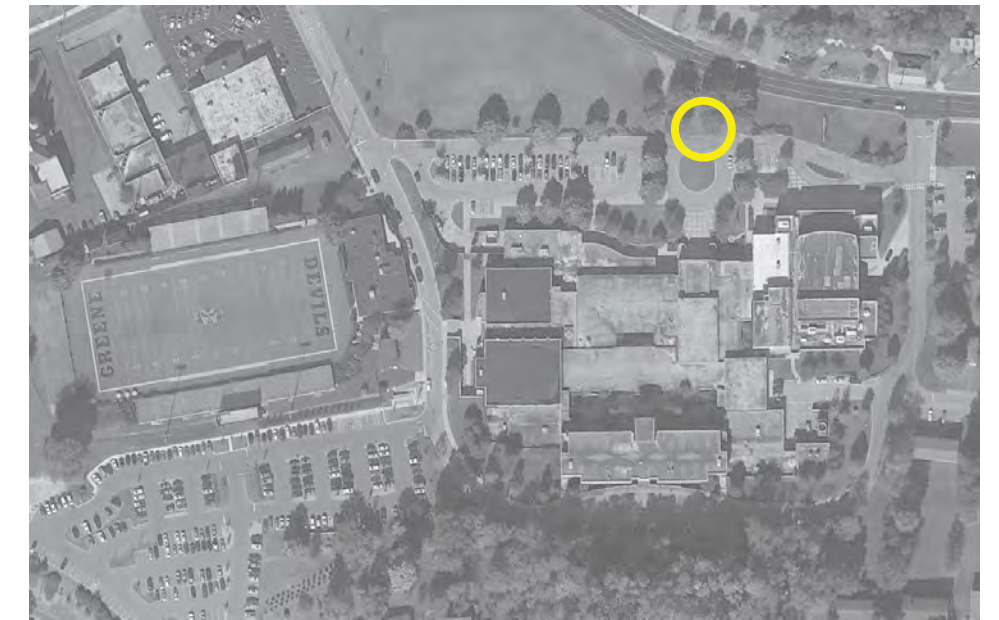

Priority Project #1: Main Entrance Drive

Greenville City Schools: Landscape Updates

MARCH 10, 2023

Landscape Recommendations:

- ① Establish a clean bed edge as shown and provide river rock around uplights to protect from mowing damage.
- ② Plant low shrubs in NPAC drop off island.
-Suggest planting Indian Hawthorn.

Summary of Intent:

-Planting infill

Suggested Plant Images



Rhaphiolepis x delacourii 'Georgia Petite'
Georgia Petite Indian Hawthorn
2-3' T x 3-4' W
Evergreen foliage, white Spring blooms

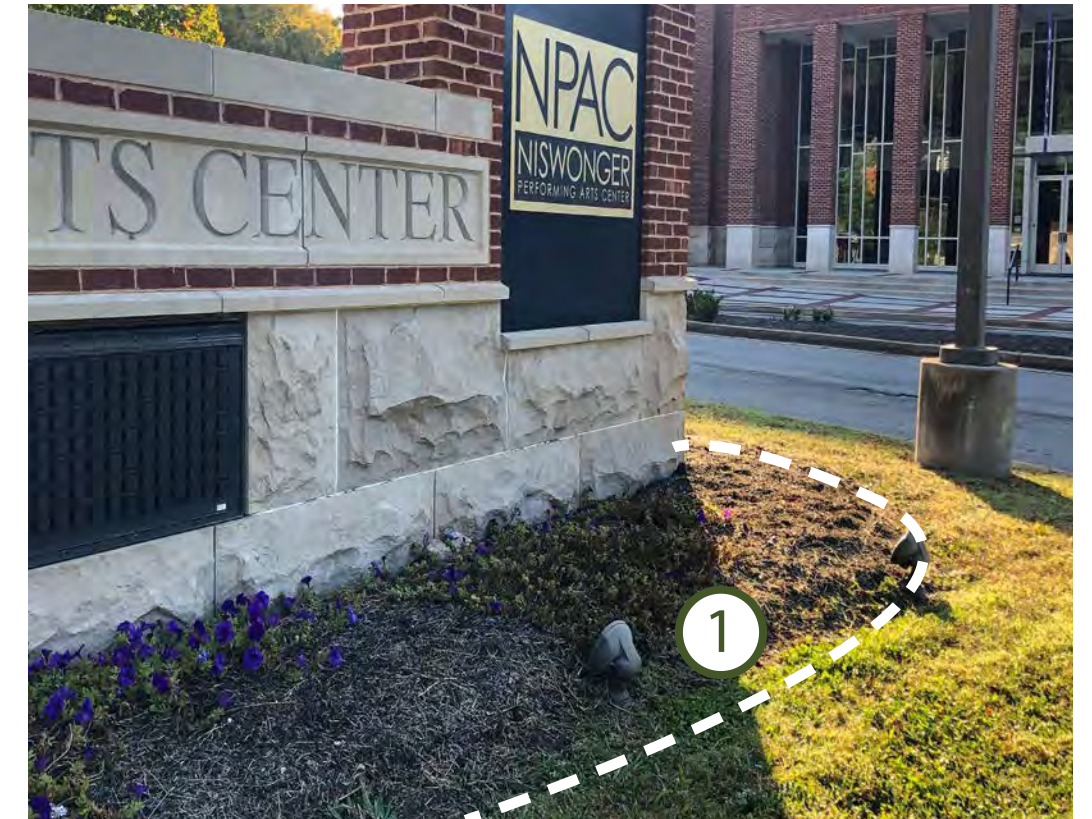
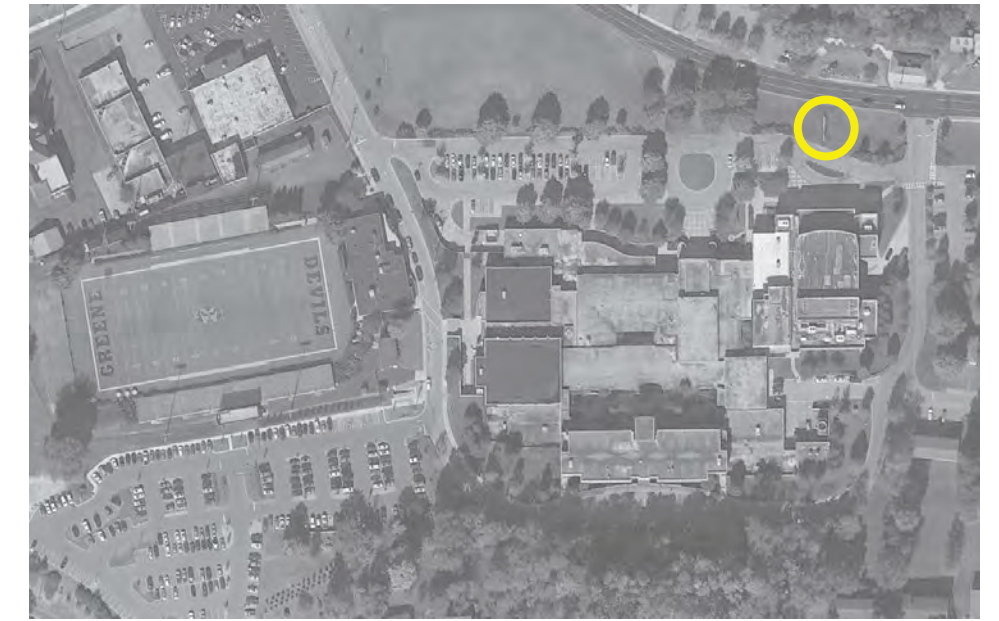

Landscape Recommendations:

- ① Remove Otto Luyken Laurels on either side of Winterberrys. Replace with an evergreen flowering shrub.
-Suggest planting Rose Creek Dwarf Abelia
- ② Remove and replace Inkberry on either side of entrance drive with a low spreading shrub.
-Suggest planting Gro-Low Sumac
- ③ Plant (3) multi-stem Autumn Brilliance Serviceberry trees within Gro-Low Sumac bed at corner as shown.

Summary of Intent:

-Planting rehabilitation & infill

Suggested Plant Images



Abelia 'Rose Creek'
Rose Creek Dwarf Abelia
2-3' T x 3-4' W
Evergreen foliage, pink Summer blooms



Amelanchier x grandiflora
'Autumn Brilliance'
Autumn Brilliance Serviceberry
15-25' T x 15-25' W
Red Fall foliage, white Spring blooms



Rhus aromatica 'Gro-Low'
Gro-Low Sumac
2-3' T x 6-8' W spreading
Red Fall foliage

Key Plan

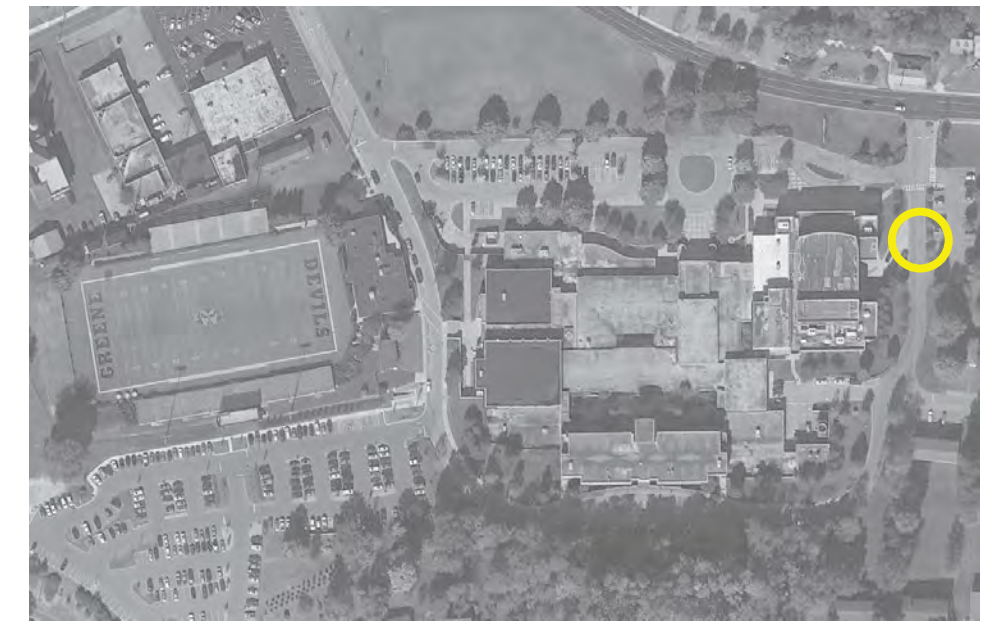

East Entrance at NPAC

Greenville City Schools: Landscape Updates

MARCH 10, 2023

Landscape Recommendations:

- ① Plant spreading groundcover on embankment between parking lot and road.
 - Suggest planting Lawn, Creeping Raspberry, Spreading Spicata Liriope, Gro-Low Sumac, or Blue Rug Juniper (lower variety than what was removed).

Summary of Intent:
-Planting infill



Key Plan

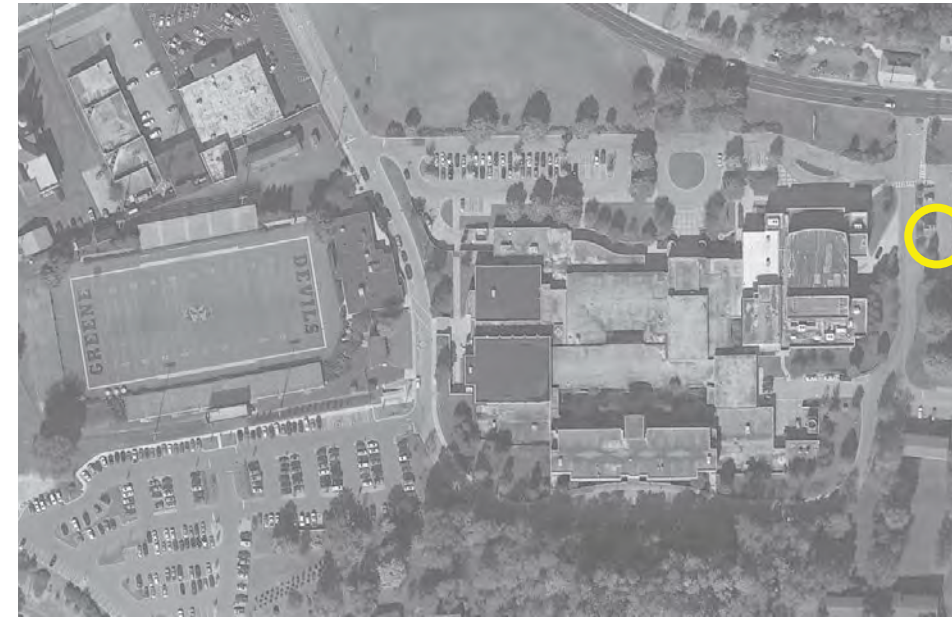

Suggested Plant Images



Rubus calycinoides
Creeping Raspberry
9"-1' T x spreading 3-4' W
Evergreen foliage



Liriope spicata
Spreading Liriope
9"-1.5' T x 2-3' W
Purple Summer blooms



Rhus aromatica 'Gro-Low'
Gro-Low Sumac
2-3' T x 6-8' W spreading
Red Fall foliage



Juniperus horizontalis 'Wiltonii'
Blue Rug Juniper
6" T x 6-8' W
Evergreen foliage

Landscape Recommendations:

- ① Grade out hump in lawn where tree was removed.
- ② Reduce landscape bed size as shown and plant with lawn.
- ③ Remove dead and declining Yew shrubs and Liriope.
- ④ Remove Yew to the right of bike rack as shown and plant lawn.
- ⑤ Remove dead Yew at railing and plant with low groundcover.
-Suggest planting Catlin's Giant Ajuga or Mondo Grass.

Summary of Intent:

-Planting rehabilitation & infill

Suggested Plant Images



Ajuga reptans 'Catlin's Giant'
Catlin's Giant Ajuga
3-9" T x 1-2' W
Blue Spring blooms



Ophiopogon japonicus
Mondo Grass
12" T x 12" W
Evergreen foliage

Key Plan

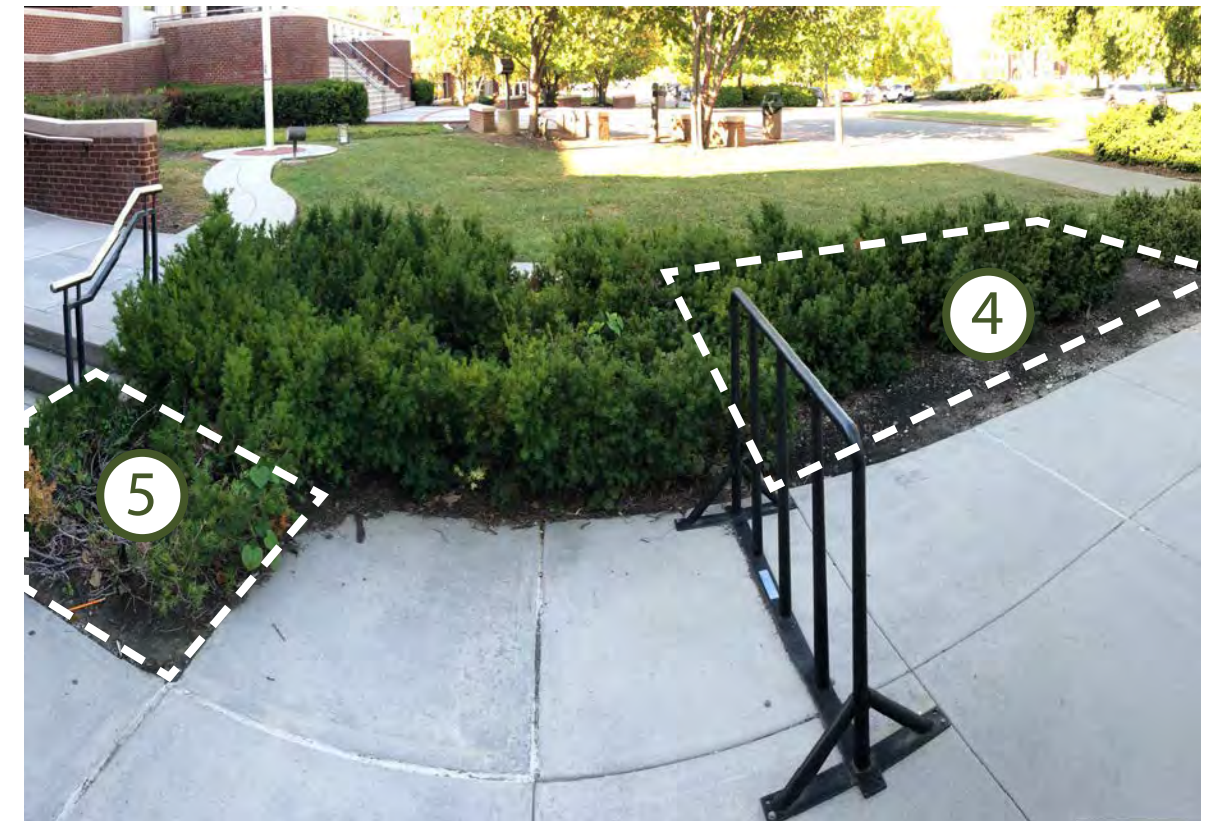
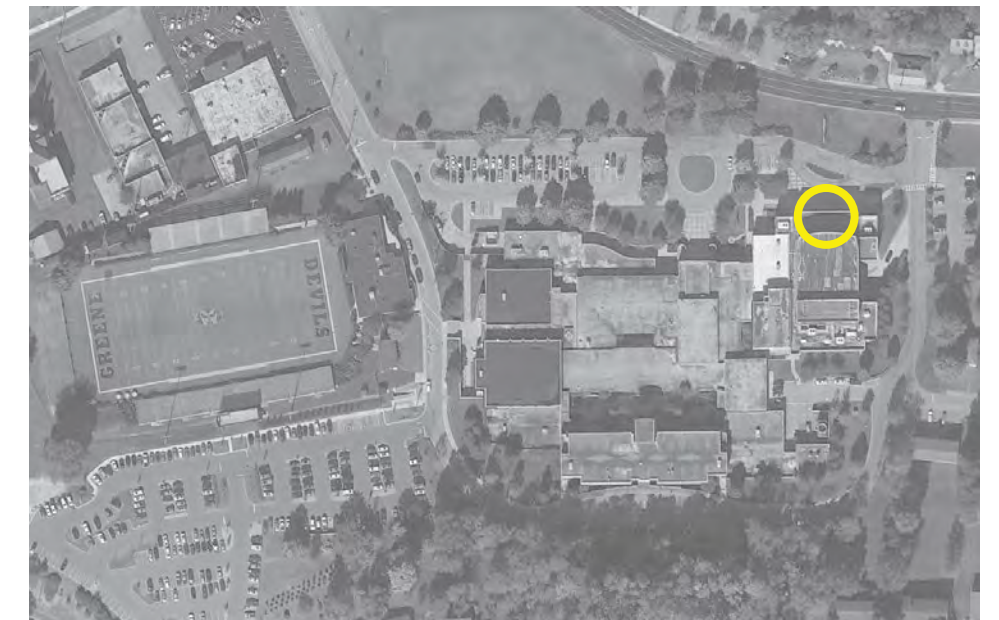

Landscape Recommendations:

- ① Remove all Otto Luyken Laurels from under Redbuds, remove all mulch and plant with shade tolerant groundcover.
-Suggest planting Pachysandra
- ② Remove Otto Luyken Laurel on either side of Winterberrys, reduce bed size as shown and plant lawn in place of removed shrubs.
- ③ Plant low evergreen groundcover to fill in space in front of Itea.
-Suggest planting Blue Rug Juniper, or Little Henry Dwarf Itea.
- ④ Plant low shrubs under Winterberry as shown.
-Suggest Rose Creek Dwarf Abelia

Summary of Intent:

-Planting rehabilitation & infill

Suggested Plant Images



Pachysandra terminalis
Japanese Pachysandra
6-10" T x 1-1.5' W
Evergreen foliage



Juniperus horizontalis
'Wiltonii'
Blue Rug Juniper
6" T x 6-8' W
Evergreen foliage



Itea virginiana 'Little Henry'
Little Henry Dwarf Itea
2-3' T x 2.5-3' W
White Summer blooms



Abelia 'Rose Creek'
Rose Creek Dwarf Abelia
2-3' T x 3-4' W
Evergreen foliage, pink
Summer blooms

Key Plan

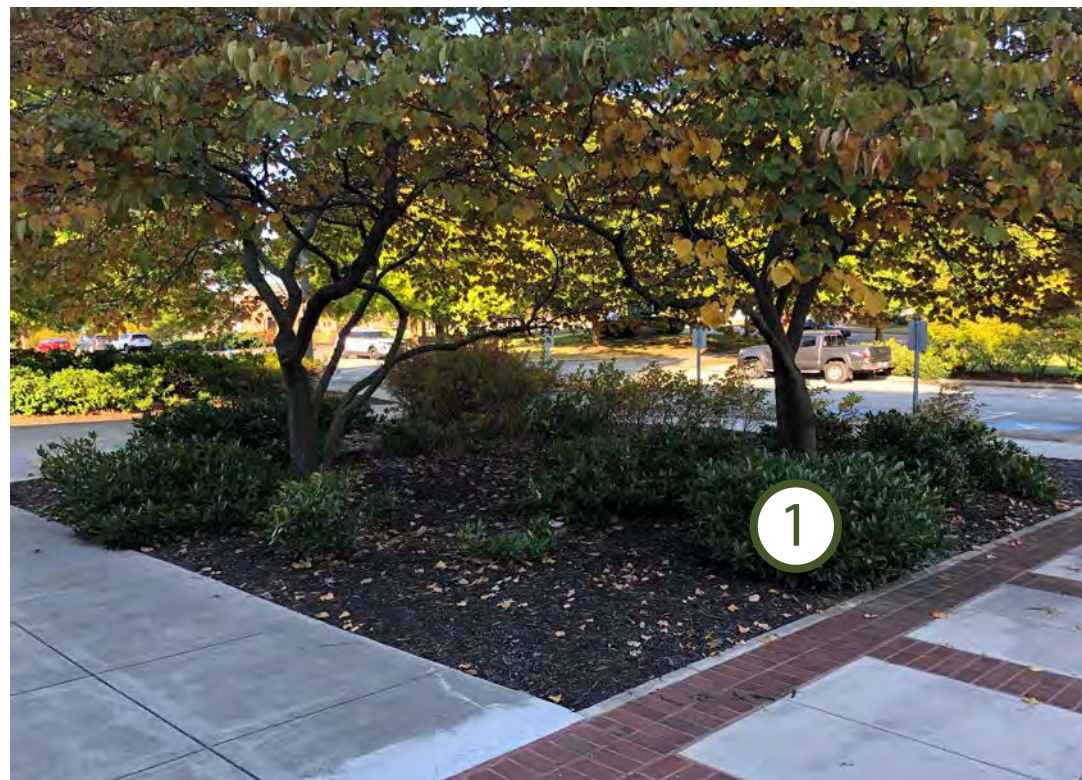
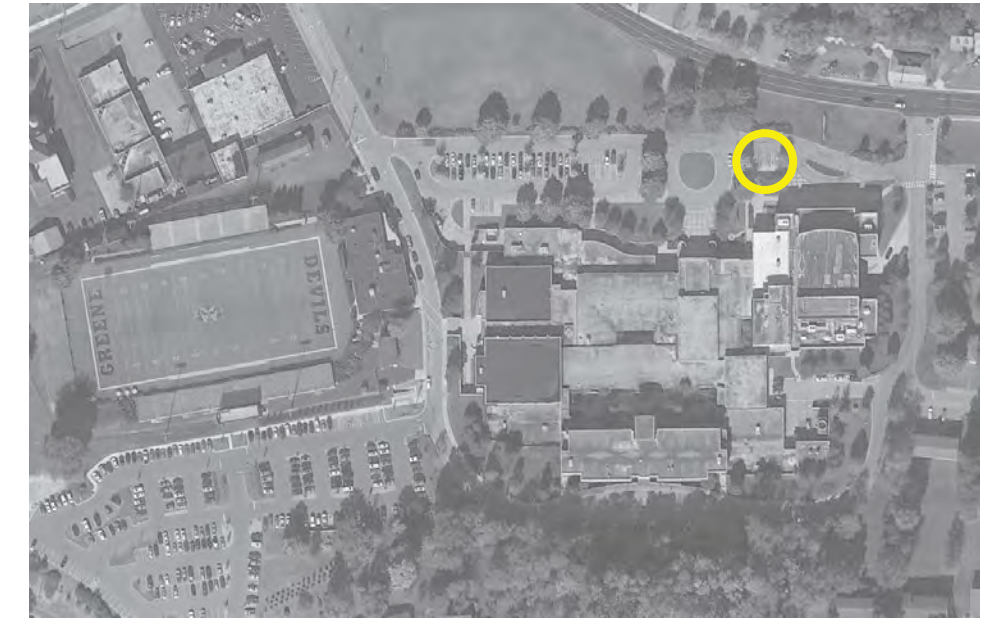

NPAC Accessible Parking Landscape Beds

Greenville City Schools: Landscape Updates

MARCH 10, 2023

Landscape Recommendations:

- ① Limb up Chinese Elm tree approximately 4' to match trees in alley.
- ② Remove mulch under tree and add flagstone to bench, and plant with low evergreen groundcover.
 - Suggest planting Blue Rug Juniper
- ③ Remove Chinese Elm tree from parking island and plant with a canopy tree.
 - Suggest Chinese Pistache and plant lawn.

Summary of Intent:

-Planting rehabilitation & infill

Suggested Plant Images



Juniperus horizontalis
'Wiltonii'
Blue Rug Juniper
6" T x 6-8' W
Evergreen foliage



Pistacia chinensis
Chinese Pistache Tree
30-35' T x 20-30' W
Red Fall foliage

Key Plan

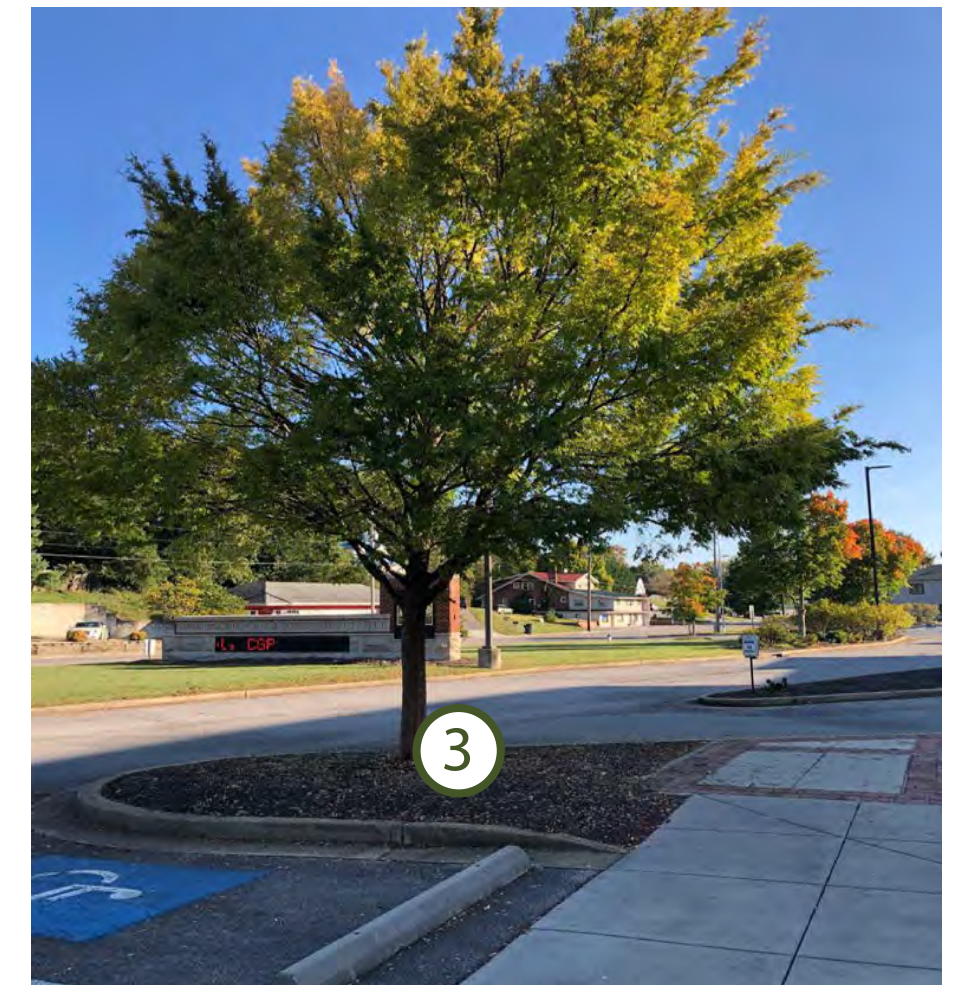
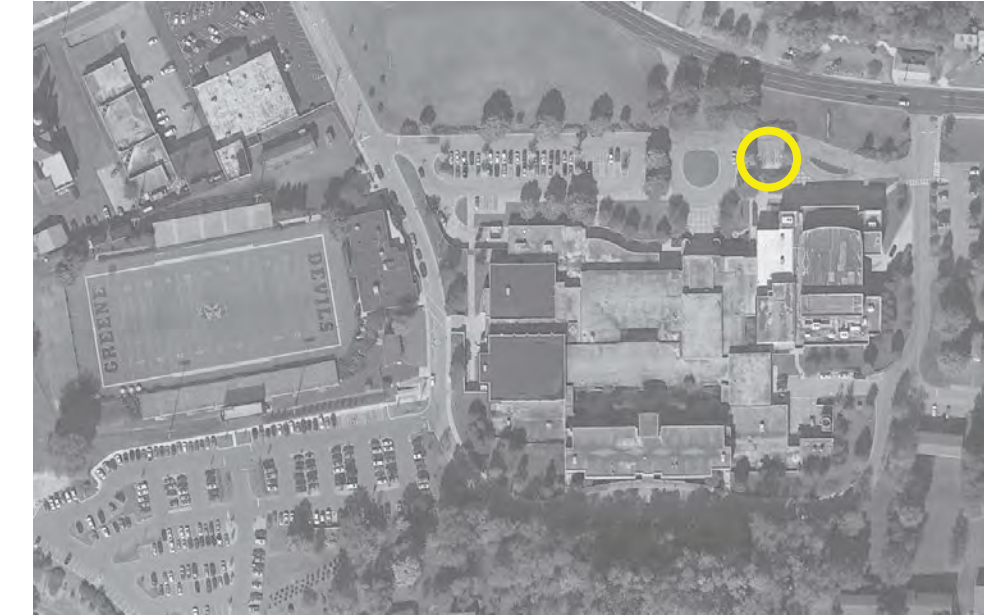

Islands at NPAC Accessible Parking

Greenville City Schools: Landscape Updates

MARCH 10, 2023

Landscape Recommendations:

- ① Prune Yew shrubs around Chinese Elms to a consistent height for clear sight line, or remove and plant low evergreen False Plum Yew.

Summary of Intent:

-Open views

Key Plan

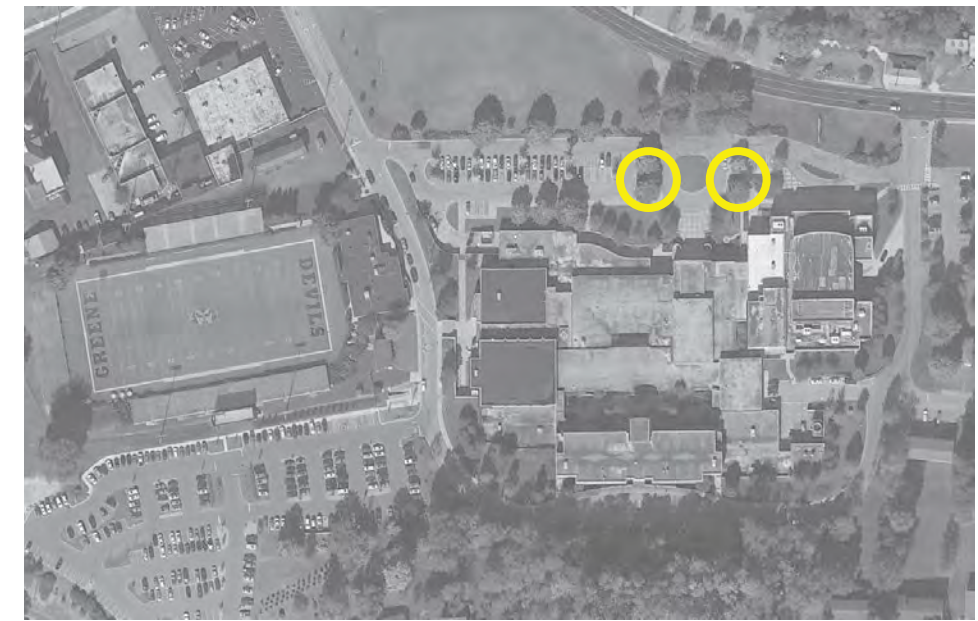

Landscape Recommendations:

- ① Consider moving existing flag pole to central grass island for increased visibility.
- ② Provide walkway connection to front of school in front of seat wall to match opposite side.
- ③ Remove all Yew along ramp wall and plant with flowering shrubs. -Suggest Edward Goucher Abelia.
- ④ Plant additional evergreen shrubs at sidewalk entrance.
- ⑤ Remove all spreading Liriope in front of Yew hedge and plant lawn.
- ⑥ Bring up grade behind seat wall at entrance walk to match main walkway.
- ⑦ Selectively prune limbs on Redbud tree to avoid conflict with lights.

Suggested Plant Images



Abelia 'Rose Creek'
Rose Creek Dwarf Abelia
2-3' T x 3-4' W
Evergreen foliage, pink
Summer blooms



Ilex crenata 'Soft Touch'
Soft Touch Holly
2-3' T x 2-3' W
Evergreen foliage



Abelia 'Edward Goucher'
Edward Goucher Abelia
3-5' T x 3-5' W
Evergreen foliage, pink
Summer blooms

Key Plan

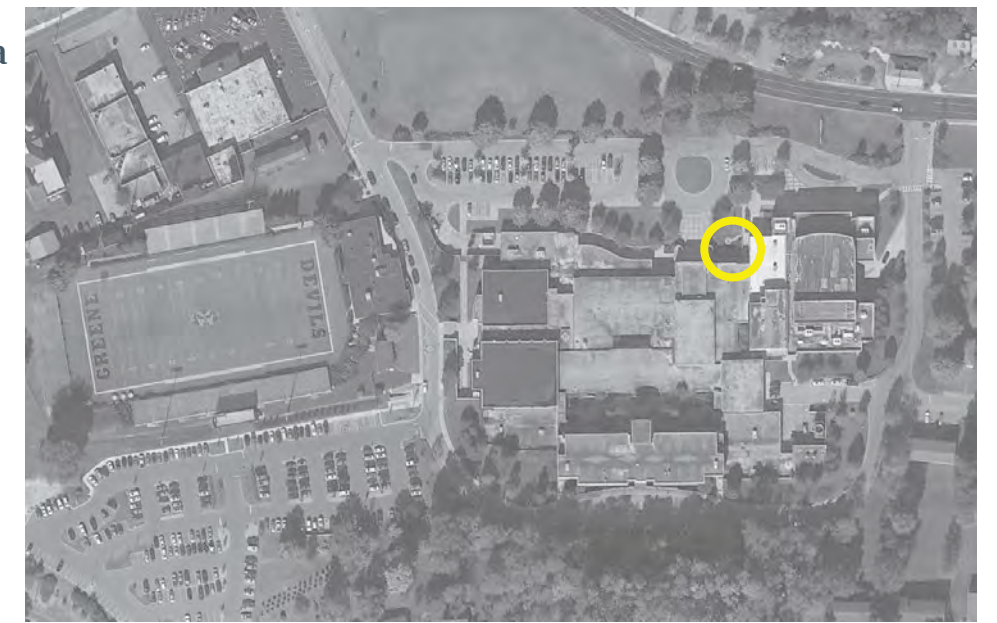

Summary of Intent:

-Redesign

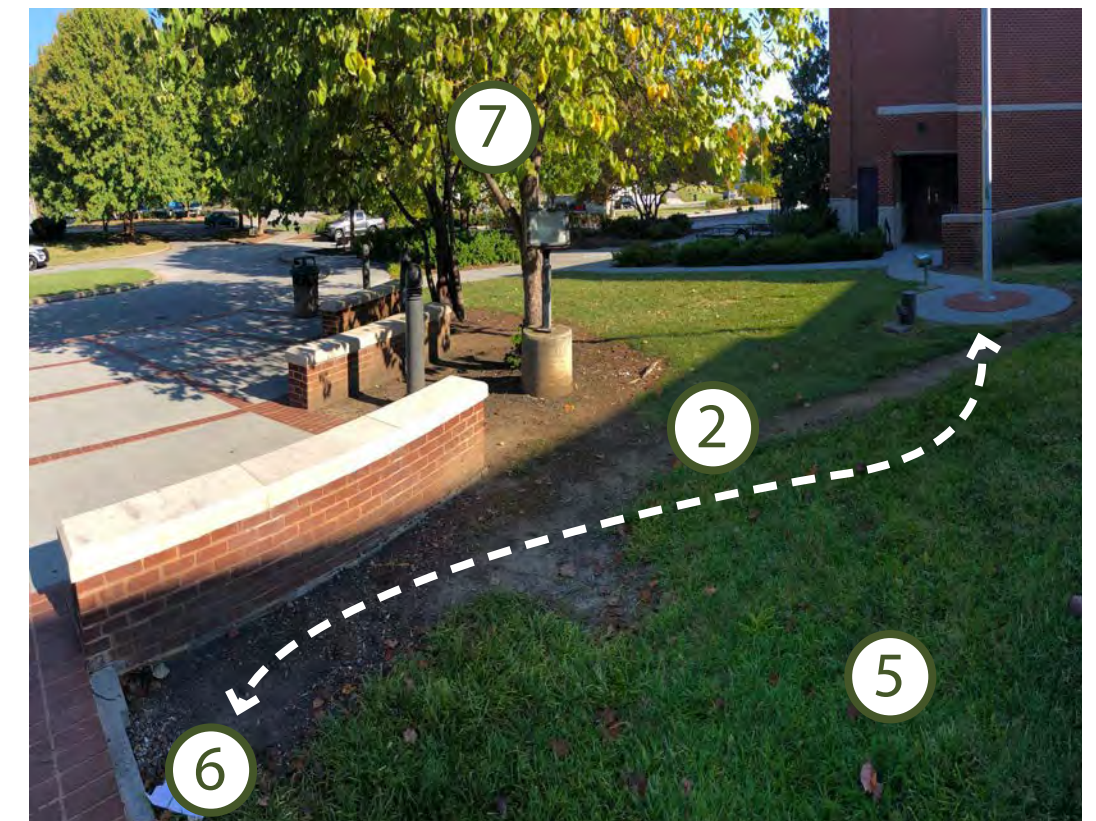
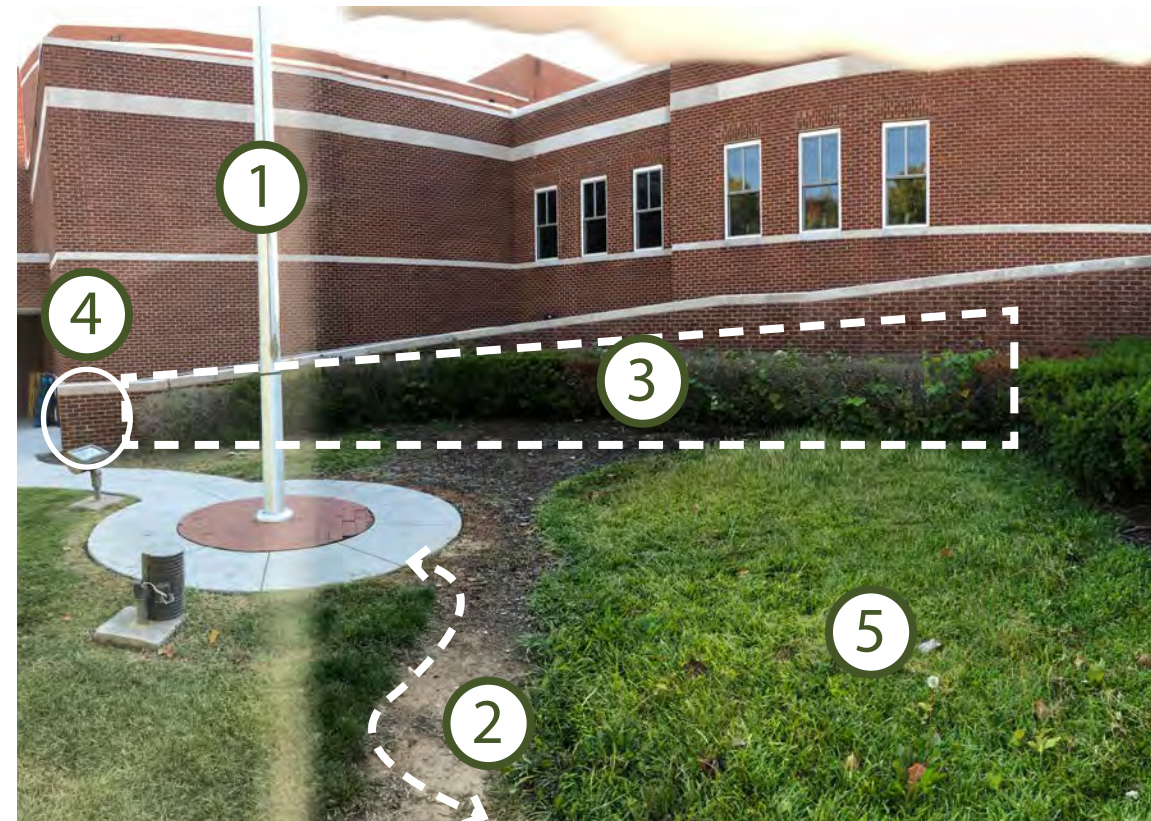
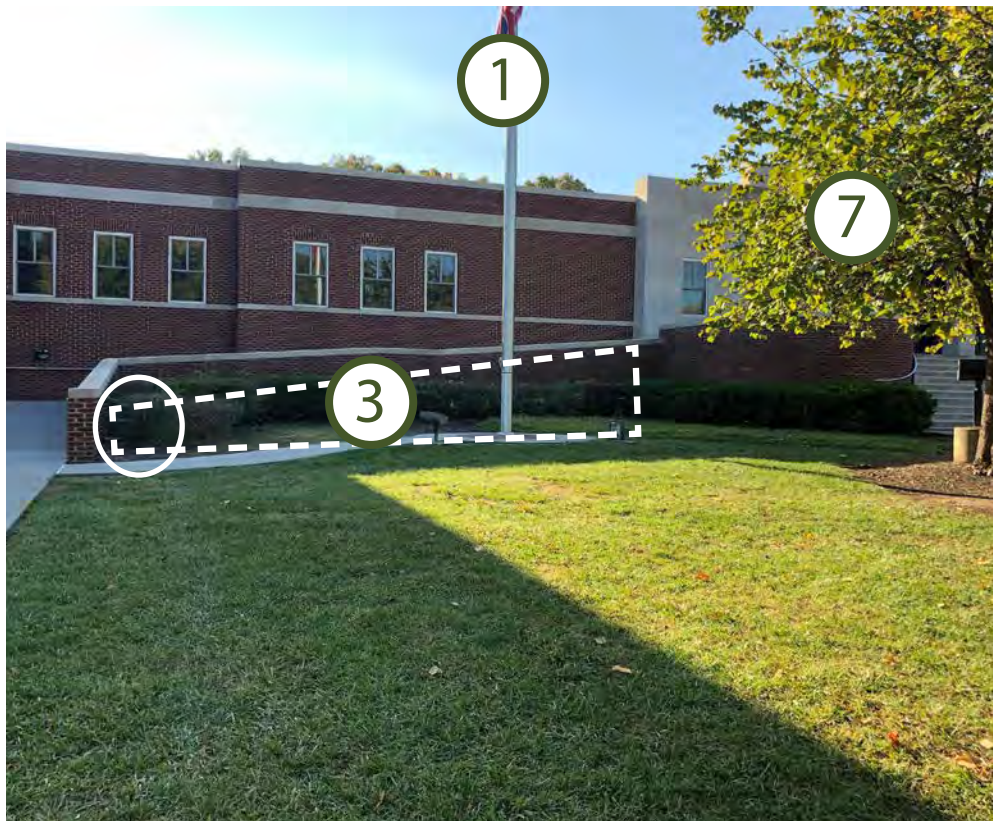

Priority Project #3: East Side School Entrance

Greeneville City Schools: Landscape Updates

MARCH 10, 2023

Landscape Recommendations:

- ① Remove Yew along top of wall, except at curved section and plant with flowering shrubs.
-Suggest planting Edward Goucher Abelia.
- ② Remove Spreading Liriope and plant with Lawn to establish a clean bedline as shown.
- ③ Remove all mulch along edge separating landscape beds and lawn.
- ④ Selectively prune limbs on Redbud tree to avoid conflicts with lights and pedestrians at benches.

Summary of Intent:
-Redesign

Suggested Plant Images



Abelia 'Edward Goucher'
Edward Goucher Abelia
3-5' T x 3-5' W
Evergreen foliage, pink
Summer blooms

Key Plan

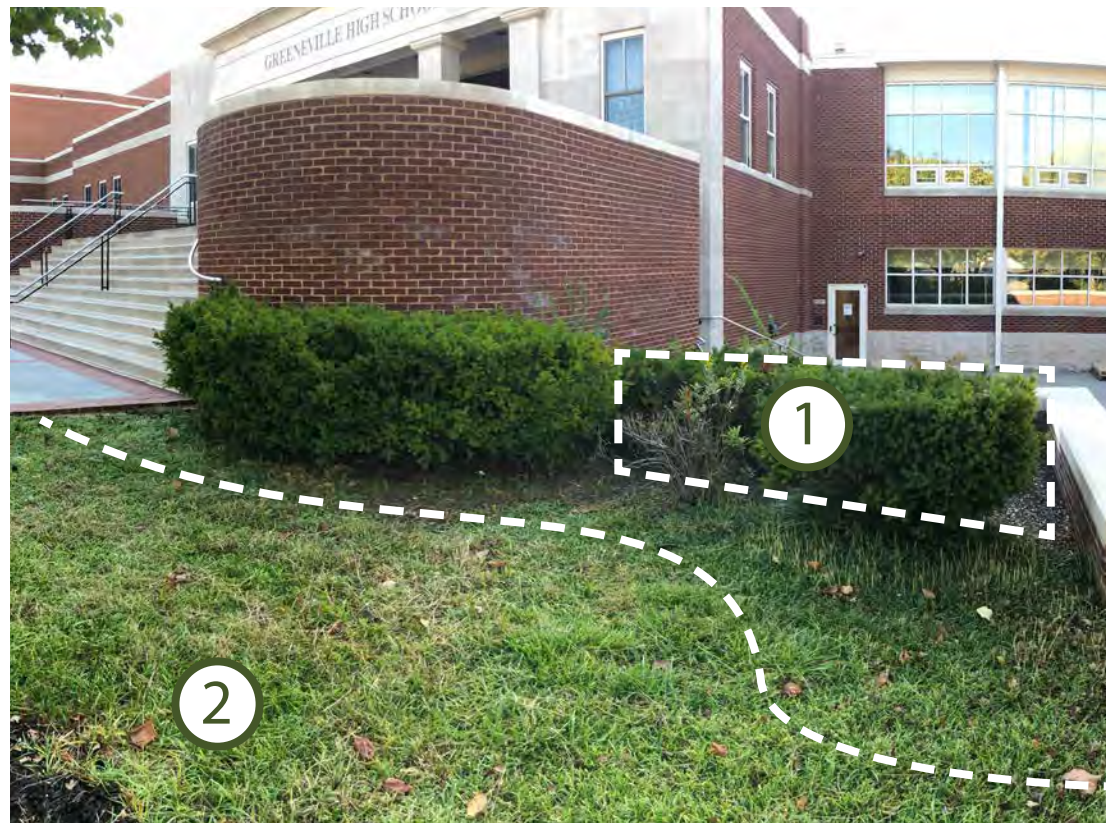
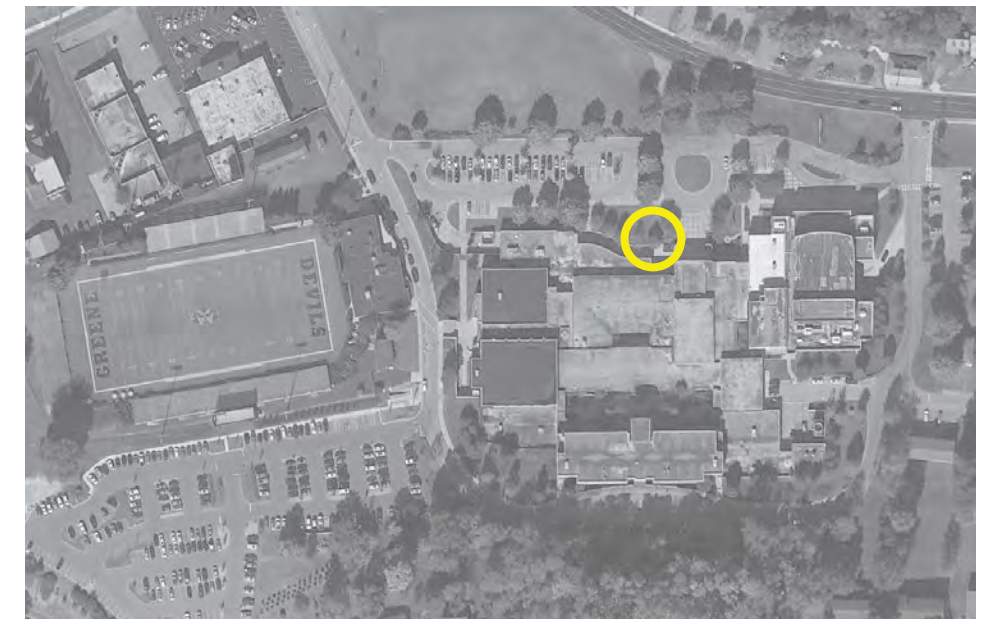

Priority Project #3: West Side School Entrance

Greenville City Schools: Landscape Updates

MARCH 10, 2023

Landscape Recommendations:

- ① Remove (1) declining Trident Maple along patio wall.
*Alternate Option: Remove all Trident Maples along patio wall and replace with multi-stem flowering trees, such as Sweetbay Magnolia.
- ② Remove all shrubs along top of wall and replace with evergreen flowering shrub.
-Suggest planting Rose Creek Dwarf Abelia.
- ③ Remove all mulch and reduce landscape bed as shown, and plant remainder with lawn.
- ④ Plant a single row of low evergreen shrubs along cafeteria window facade as shown.
-Suggest planting False Plum Yew.
- ⑤ Supplement Spreading Liriope on right side of sidewalk to match opposite side.
- ⑥ Prune Chinese Elm tree and Trident Maple where their branches are intertwined, or remove Elm tree to provide sun to help maintain lawn.

Summary of Intent:
-Redesign

Suggested Plant Images



Abelia 'Rose Creek'
Rose Creek Dwarf Abelia
2-3' T x 3-4' W
Evergreen foliage, pink Summer blooms



Magnolia virginiana
'Jim Wilson'
Moonglow Sweetbay Magnolia
15-35' T x 10-20' W
Semi-Evergreen Foliage
White Summer blooms



Cephalotaxus harringtonia
'Prostrata'
Prostrate False Plum Yew
18"-30" T x 3-4' W
Evergreen foliage

Key Plan

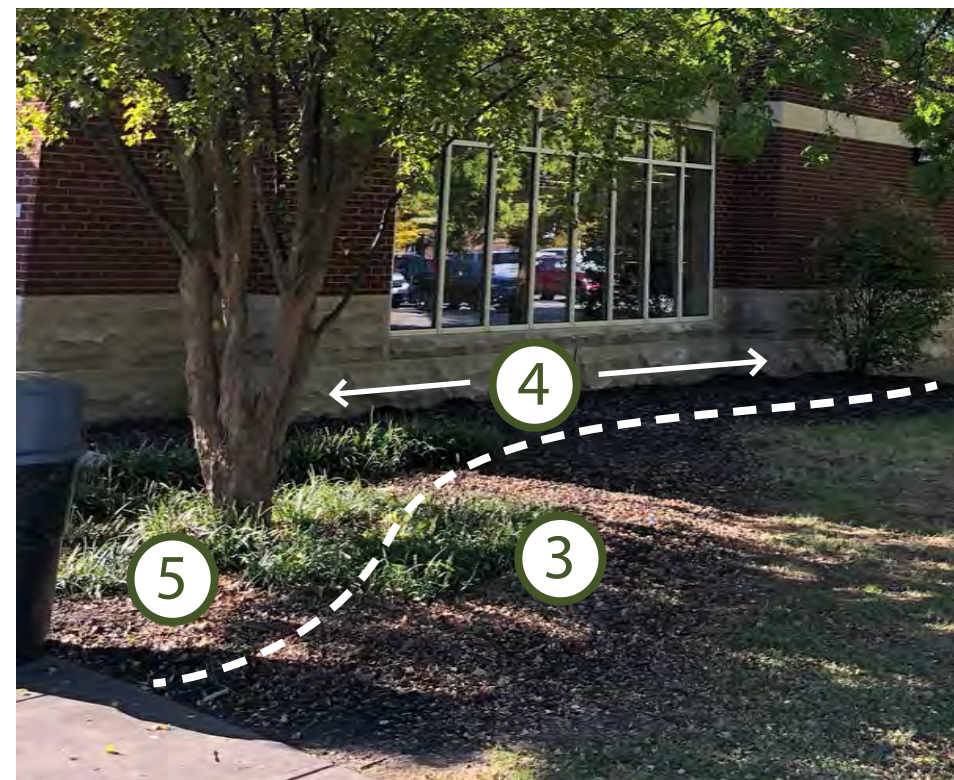
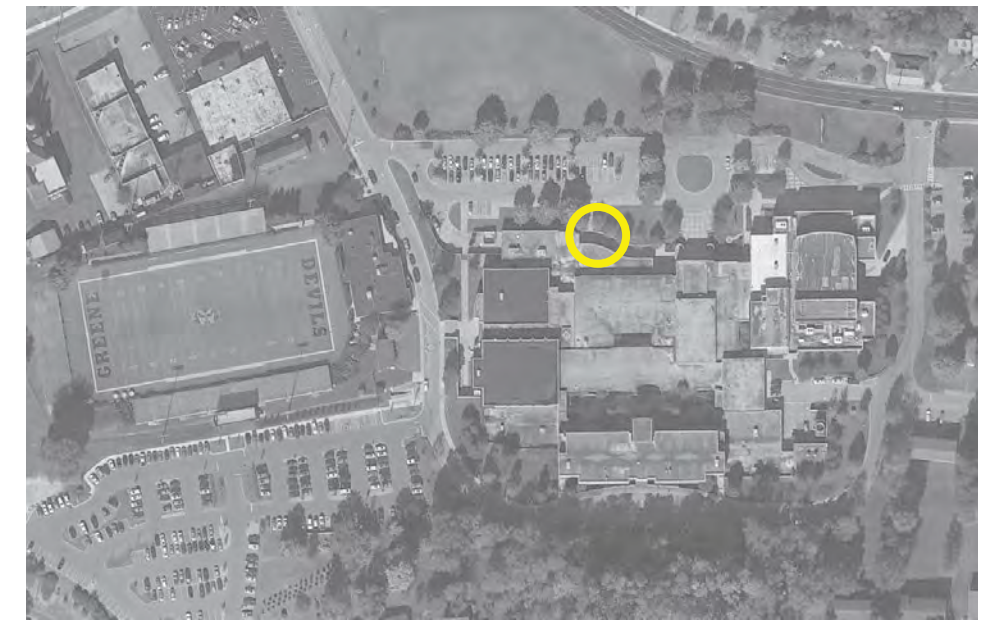

Priority Project #3B: Cafeteria Patio
Greenville City Schools: Landscape Updates

MARCH 10, 2023

Landscape Recommendations:

- ① Remove all shrubs between parking lot and practice field under trees except Blue Muffin Viburnum at intersection, and plant with lawn.
- ② Remove Chinese Elm tree with large split and replace with canopy tree.
-Suggest Sugar Maple.
- ③ Limb up all Chinese Elm trees along parking lot an additional 4'.

Summary of Intent:
-Planting rehabilitation

Suggested Plant Images



Acer saccharum 'Bailsta'
Fall Fiesta Sugar Maple
30-40' T x 25-35' W
Orange Fall foliage

Key Plan

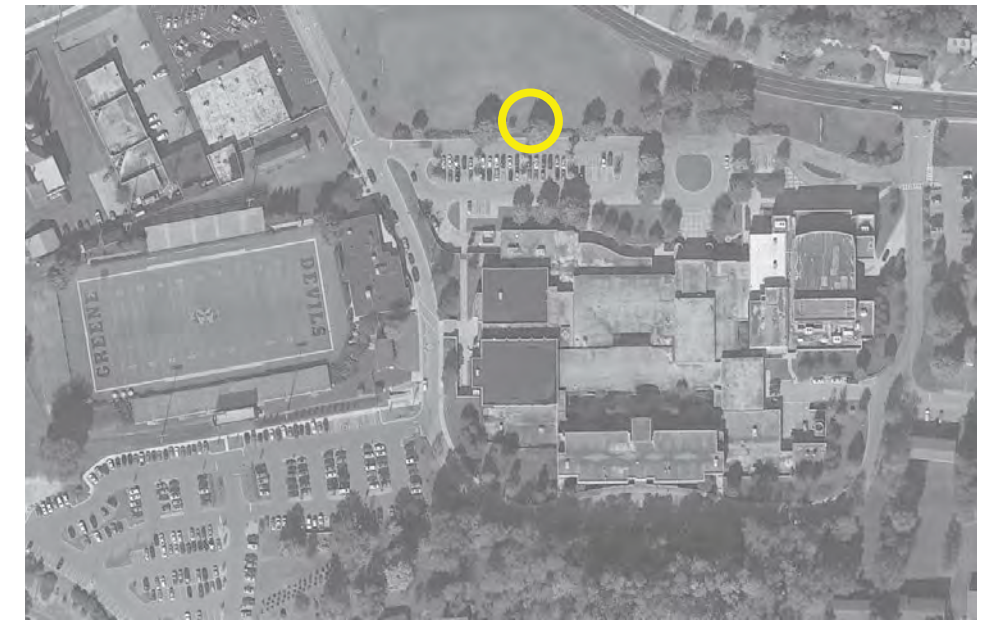

Priority Project #2: Practice Field Parking Lot
Greenville City Schools: Landscape Updates

MARCH 10, 2023

Landscape Recommendations:

- ① Maintain lawn along back of walls or plant with spreading groundcover.
-Suggest Sea Green Juniper or Gro-Low Sumac.
- ② Remove all Inkberry shrubs and plant with lawn or spreading groundcover.
-Suggest Gro-Low Sumac.
- ③ Remove scrubby Ash tree and plant slope and around drain with spreading groundcover to match opposite side.
-Suggest Gro-Low Sumac

Summary of Intent:
-Planting infill

Plant Suggestion Images



Juniperus x pfitzeriana
'Sea Green'
Sea Green Juniper
4-6' T x 6-8' W
Evergreen foliage



Rhus aromatica 'Gro-Low'
Gro-Low Sumac
2-3' T x 6-8' W spreading
Red Fall foliage

Key Plan

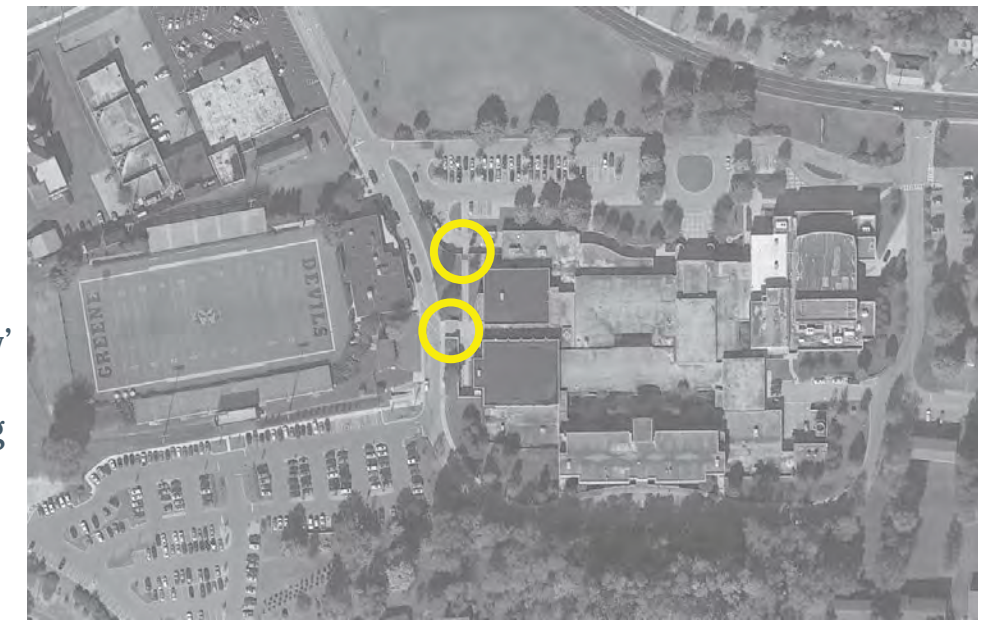

Landscape Recommendations:

- ① Remove all Boxwoods in raised seat wall planter and replace with shrubs and groundcover.
-Suggest planting Bowles Golden Sedge or False Plum Yew with Autumn Fern.
- ② Remove all Boxwoods in flush landscape bed and replace with groundcover.
- Suggest planting Bowles Golden Sedge or False Plum Yew and Autumn Fern.
- ③ Plant small flowering trees along wall in raised seat wall planter.
-Suggest American Fringe Tree, Dogwoods, or Sweetbay Magnolia.

Summary of Intent:

-Redesign

Key Plan

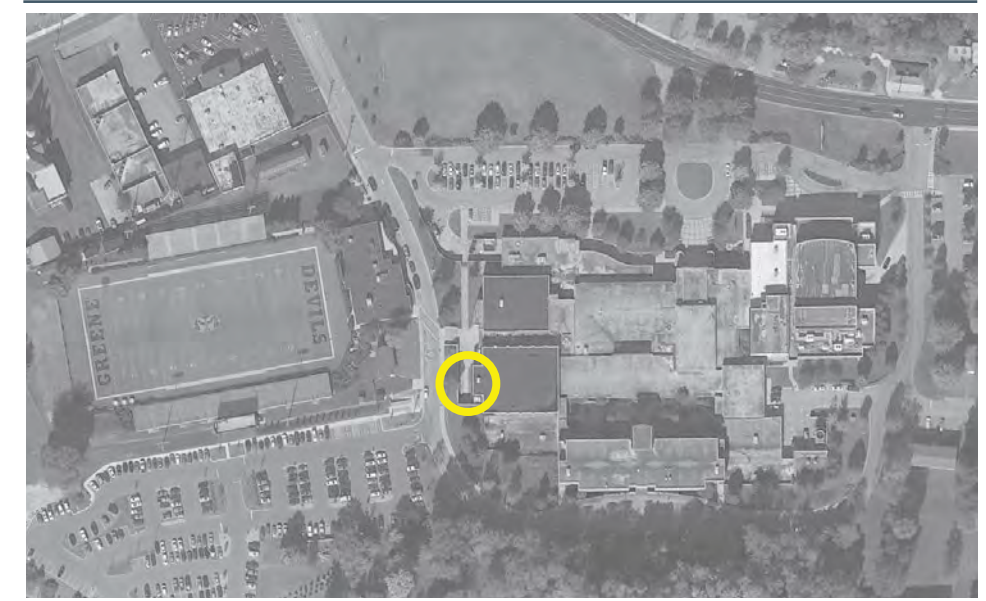

Suggested Plant Images



Carex elata 'Aurea'
Bowles Golden Sedge
2-3' T x 2-3' W
Golden foliage



Cephalotaxus harringtonia
'Prostrata'
Prostrate False Plum Yew
18"-30" T x 3-4' W
Evergreen foliage



Dryopteris erythrosora
'Brilliance'
Brilliance Autumn Fern
18"-2' T x 18"-2' W
Bronze foliage



Chionanthus virginicus
American Fringe Tree
12-20' T x 12-20' W
White Summer blooms

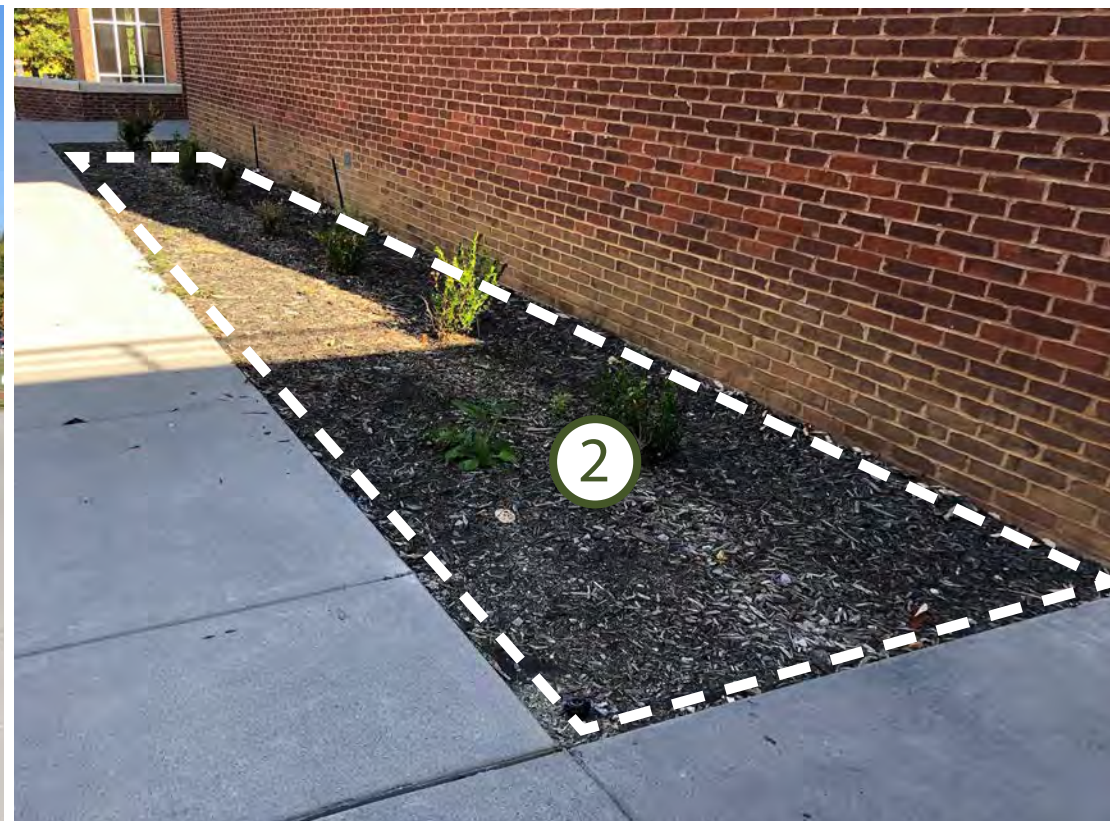
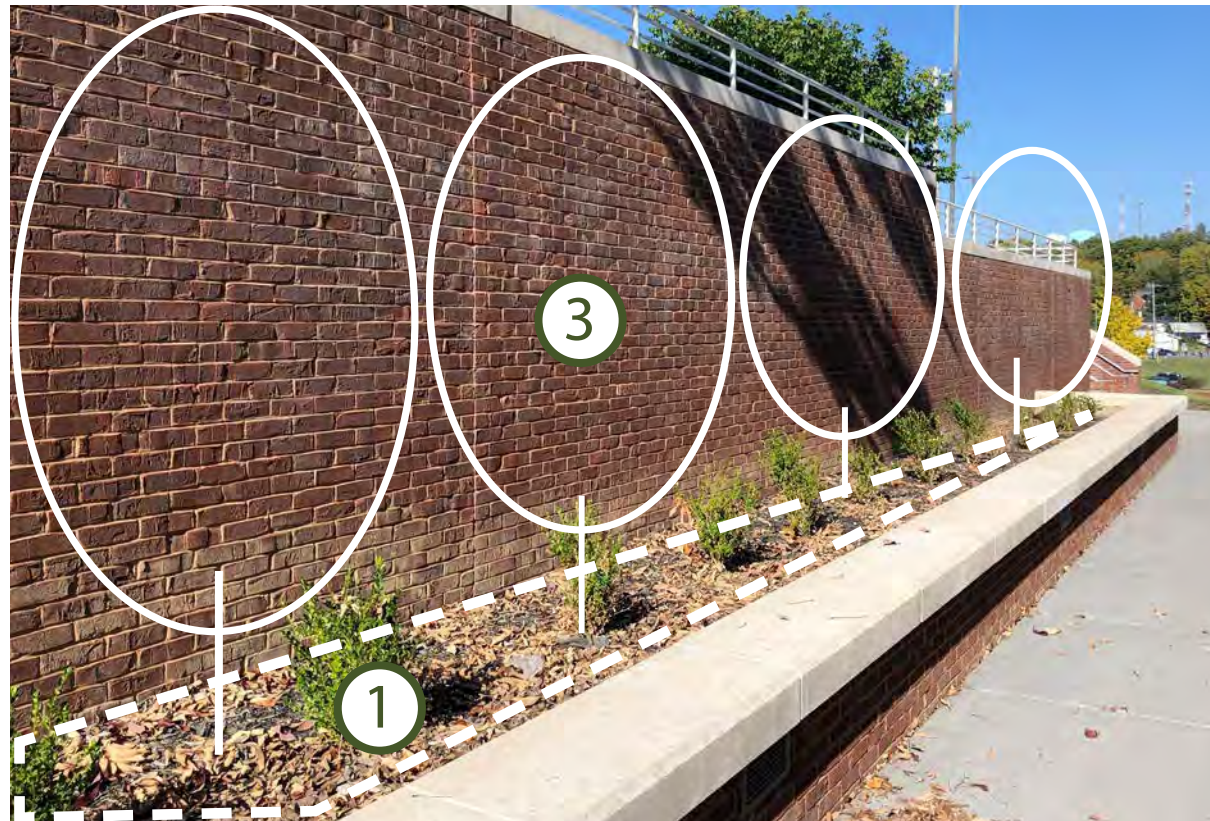

Cornus florida
Flowering Dogwood
15-30' T x 15-30' W
White Spring blooms



Magnolia virginiana
'Jim Wilson'
Moonglow Sweetbay Magnolia
15-35' T x 10-20' W
Semi-Evergreen Foliage
White Summer blooms

Landscape Recommendations:

- ① Remove all Forsythia shrubs and plant large standard form evergreen trees along building foundation.
-Suggest Green Giant Arborvitae or Radicans Cryptomeria.
- ② Remove all construction debris and plant with lawn on hillside.
- ③ Remove dead Hornbeam tree along sidewalk.

Summary of Intent:

-Planting rehabilitation & infill

Suggested Plant Images



Thuja 'Green Giant'
Green Giant Arborvitae
25-35' T x 8-10' W
Evergreen foliage
Standard form



Cryptomeria japonica
'Radicans'
Radicans Cryptomeria
30-40' T x 15-20' W
Evergreen foliage
Standard form

Key Plan

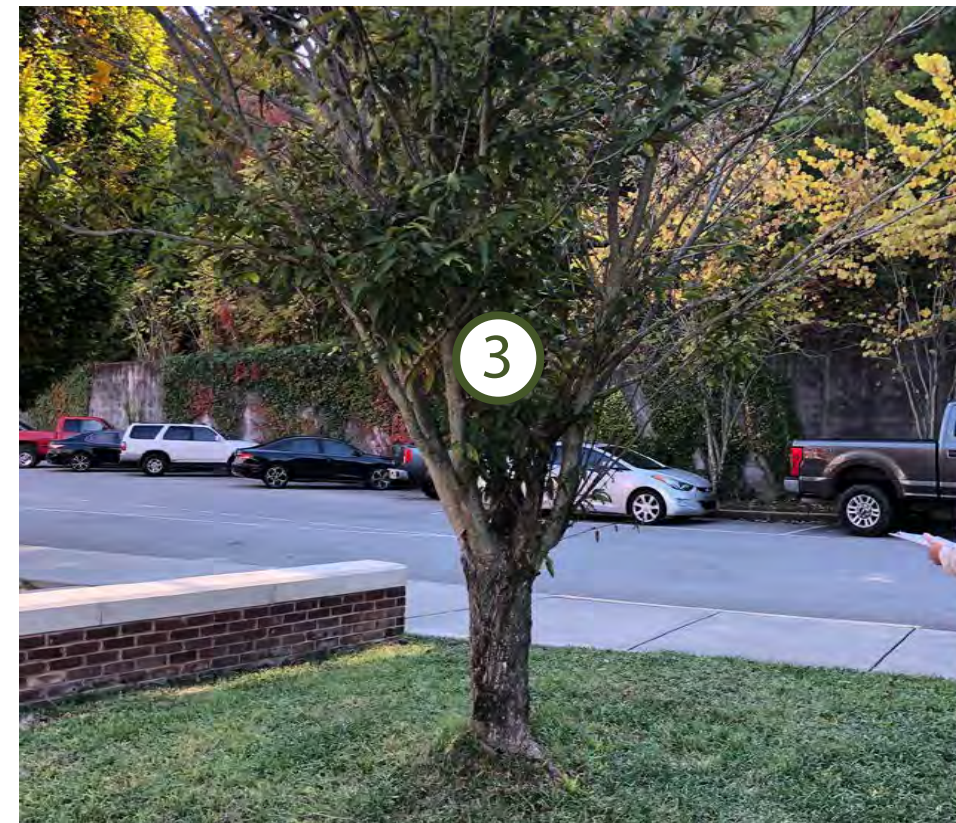
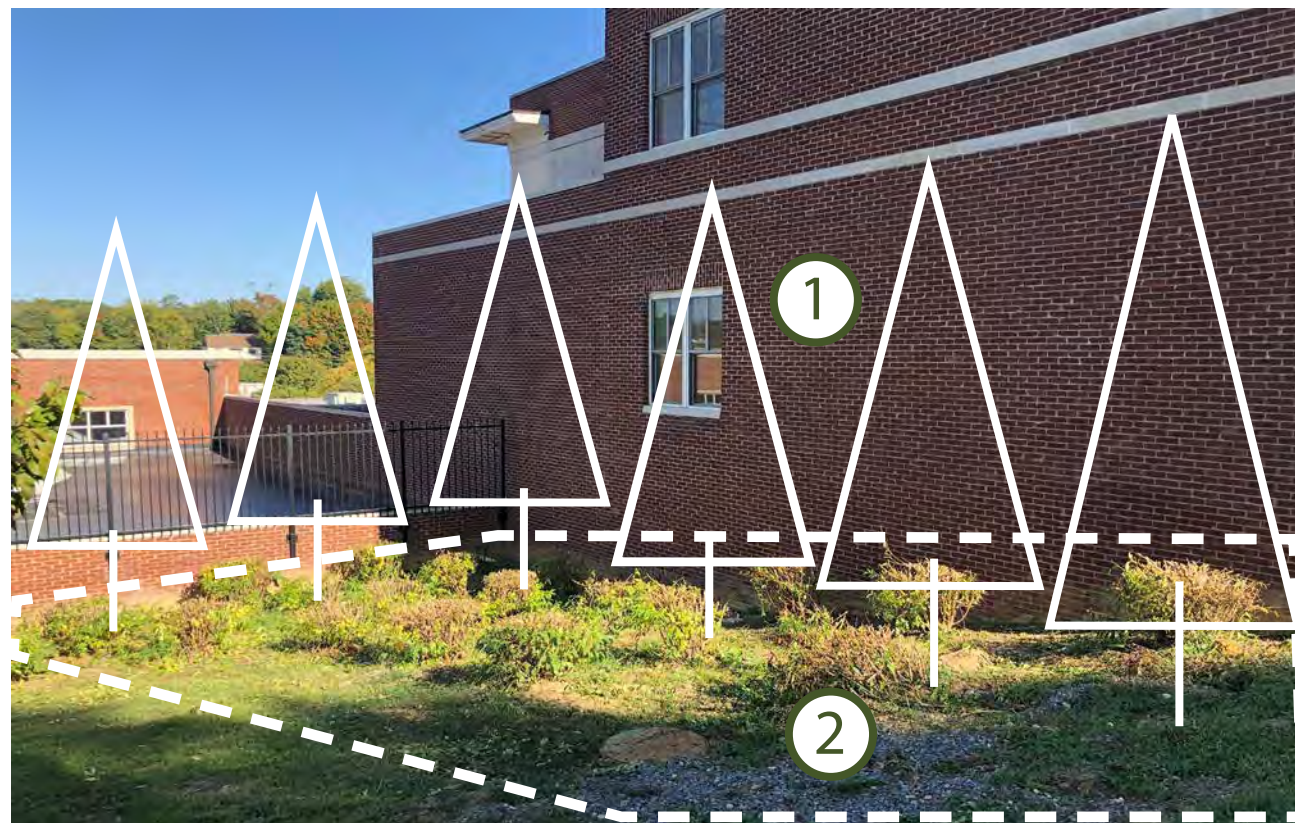
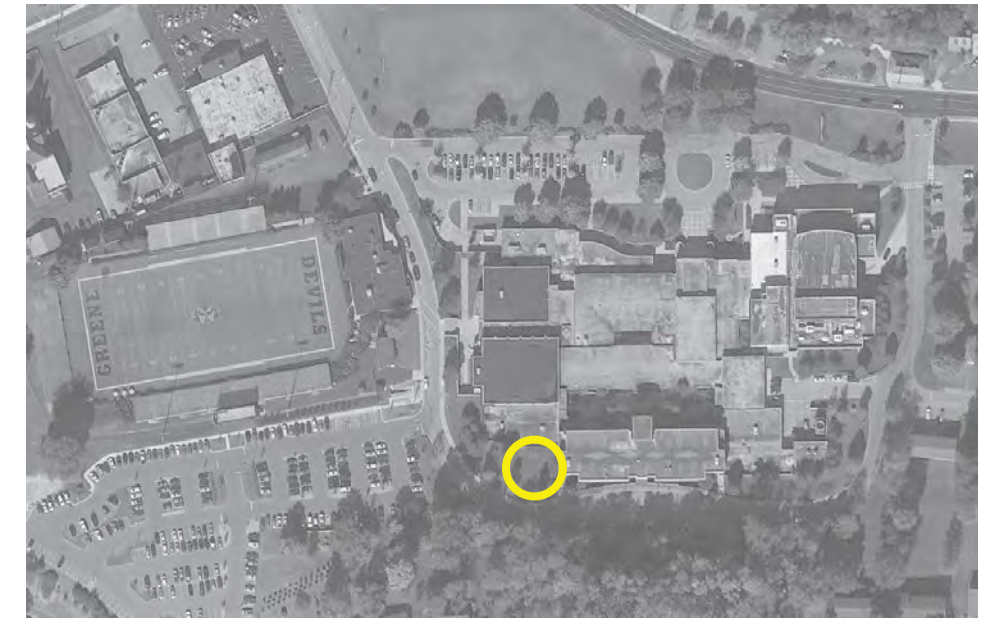

West Side Back Entrance
Greenville City Schools: Landscape Updates

MARCH 10, 2023

Landscape Recommendations:

- ① Remove damaged Dogwood tree with large scar on trunk.
- ② Remove all gravel, prepare soil, and plant (3) evergreen trees along foundation with spreading groundcover underneath.
-Suggest standard Foster Holly with Hypericum and lawn as shown.
- ③ Remove large Hornbeam tree between doorway and canopy.

Summary of Intent:

-Planting rehabilitation & infill

Suggested Plant Images



Ilex x attenuata 'Fosteri'
Foster Holly
20-30' T x 10-20' W
Evergreen foliage



Hypericum calycinum
Creeping St. John's Wort
1-1.5' T x 1-1.5' W
Yellow Summer blooms

Key Plan

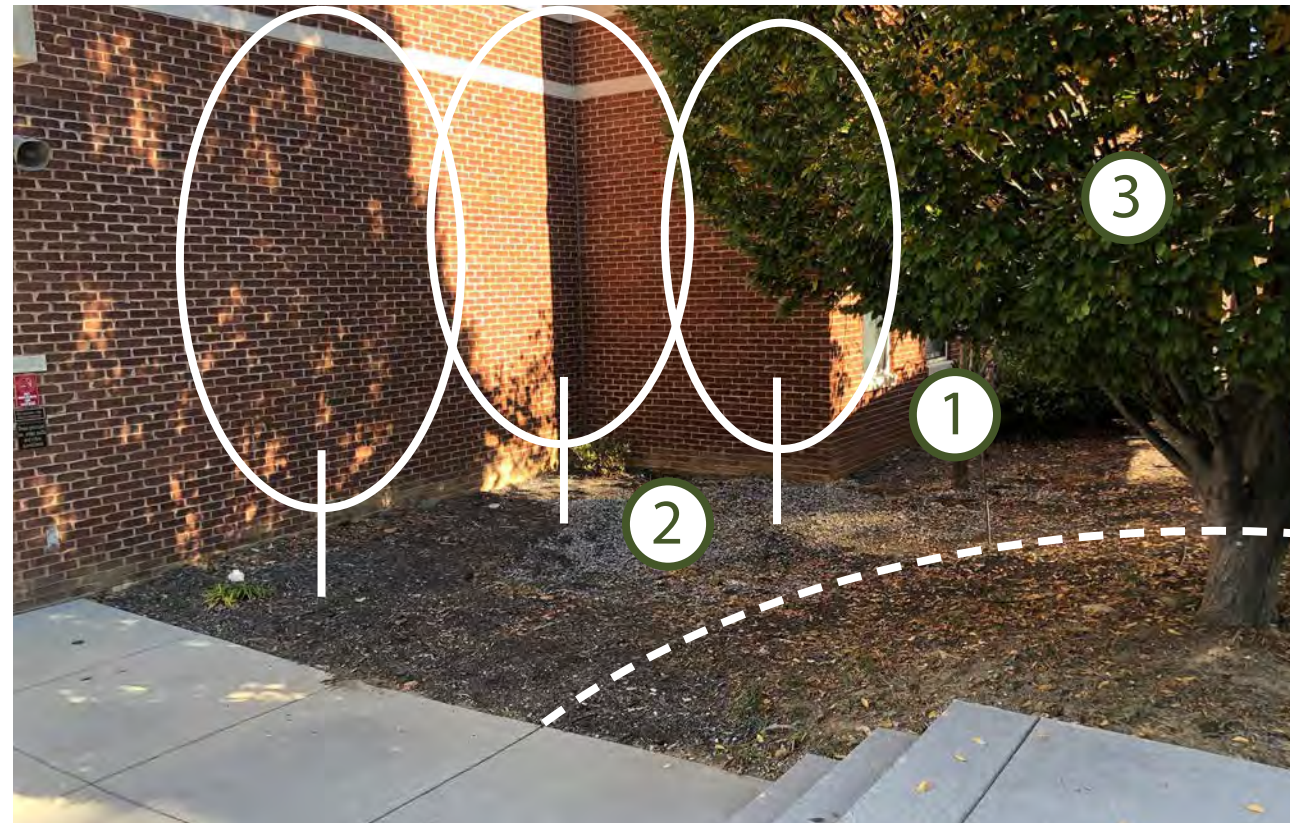
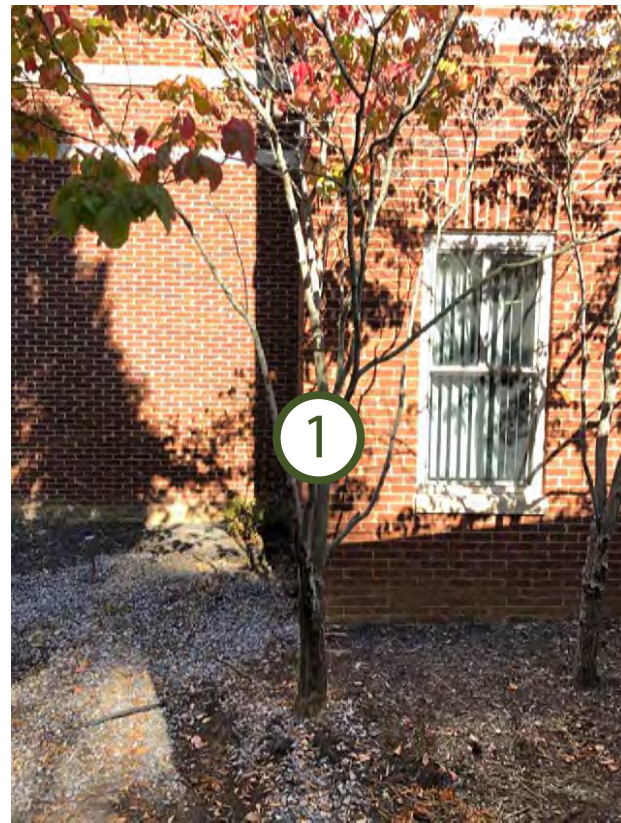
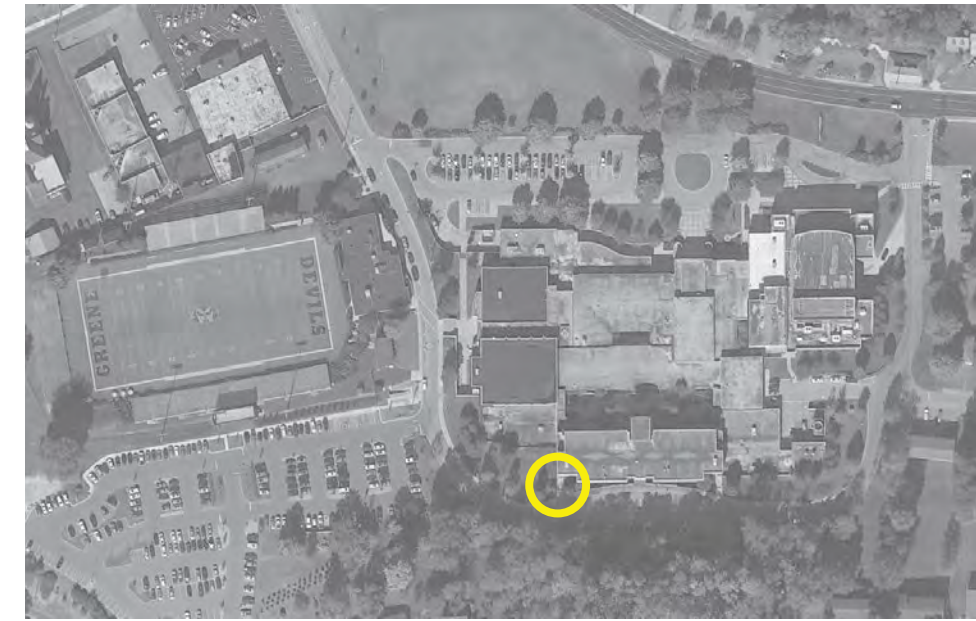

Landscape Recommendations:

- ① Supplement existing Otto Luyken Laurels at Southern Door drop off to create a full lush hedge.
- ② Install river rock in narrow parking lot island and along bottom of retaining wall.
- ③ Plant Big Blue Liriope in small landscape bed to match opposite doorway, or plant both with Bowles Golden Sedge.

Summary of Intent:

-Planting rehabilitation & infill

Suggested Plant Images



Liriope muscari 'Big Blue'
Big Blue Liriope
1-2' T x 1-2' W
Evergreen foliage
Purple Summer blooms



Carex elata 'Aurea'
Bowles Golden Sedge
2-3' T x 2-3' W
Golden foliage

Key Plan

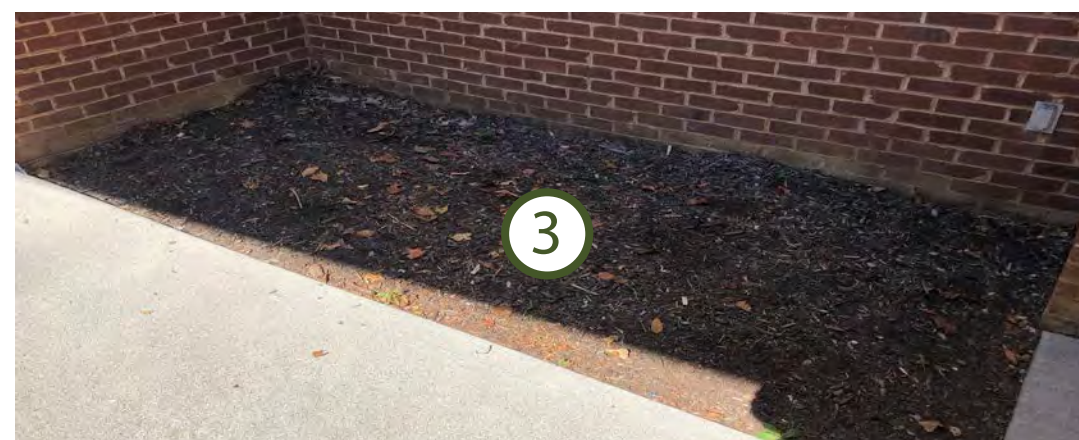
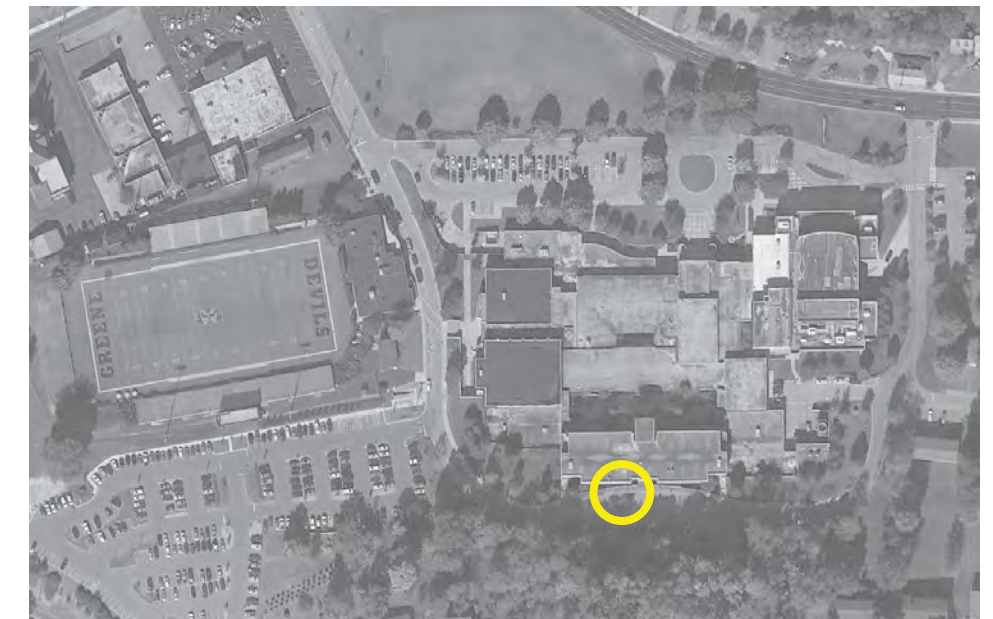

Southern Drop Off Doorway & Retaining Wall
Greenville City Schools: Landscape Updates

MARCH 10, 2023

Landscape Recommendations:

- ① Supplement existing Otto Luyken Laurels at Southern Door drop off to create a full lush hedge.
- ② Plant large flowering shrubs along foundation with spreading groundcover underneath as shown.
-Suggest Blue Muffin Viburnum with Hypericum.

Summary of Intent:

-Planting rehabilitation & infill

Suggested Plant Images



Viburnum dentatum 'Christom'
Blue Muffin Arrowwood
Viburnum
3-5' T x 3-4' W
White Summer blooms



Hypericum calycinum
Creeping St. John's Wort
1-1.5' T x 1-1.5' W
Yellow Summer blooms

Key Plan

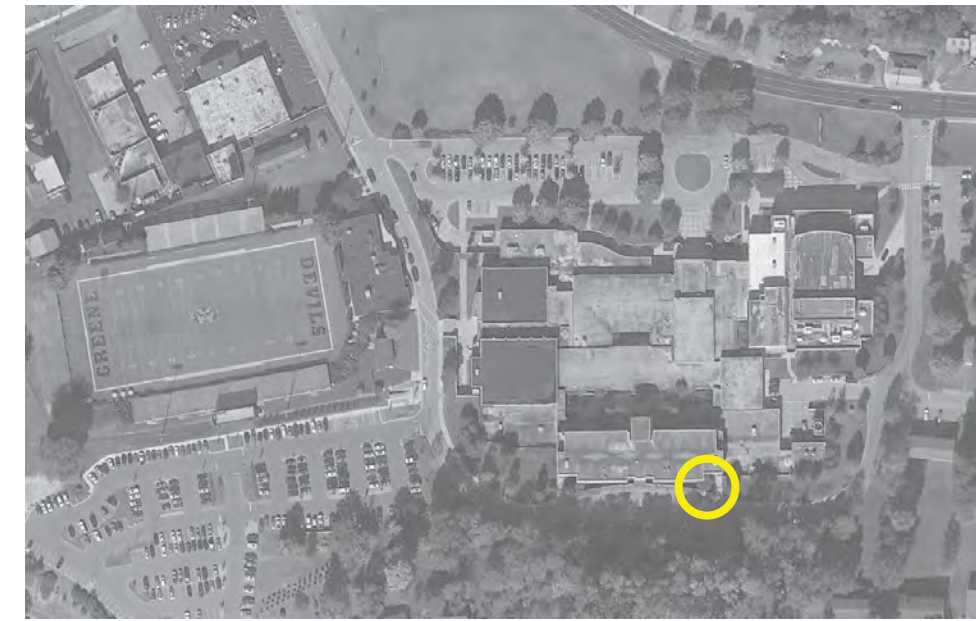

Landscape Recommendations:

- ① Remove declining Redbud trees along road and replace with canopy trees to provide shade.
-Suggest planting Chinese Pistache
- ② Hand prune dead branches from Laurel and Yew shrubs to keep from encroaching into courtyard space.
- ③ Remove excess decorative rock to be flush with courtyard sidewalk.

Summary of Intent:

-Planting rehabilitation & infill

Suggested Plant Images



Pistacia chinensis
Chinese Pistache Tree
30-35' T x 20-30' W
Red Fall foliage

Key Plan

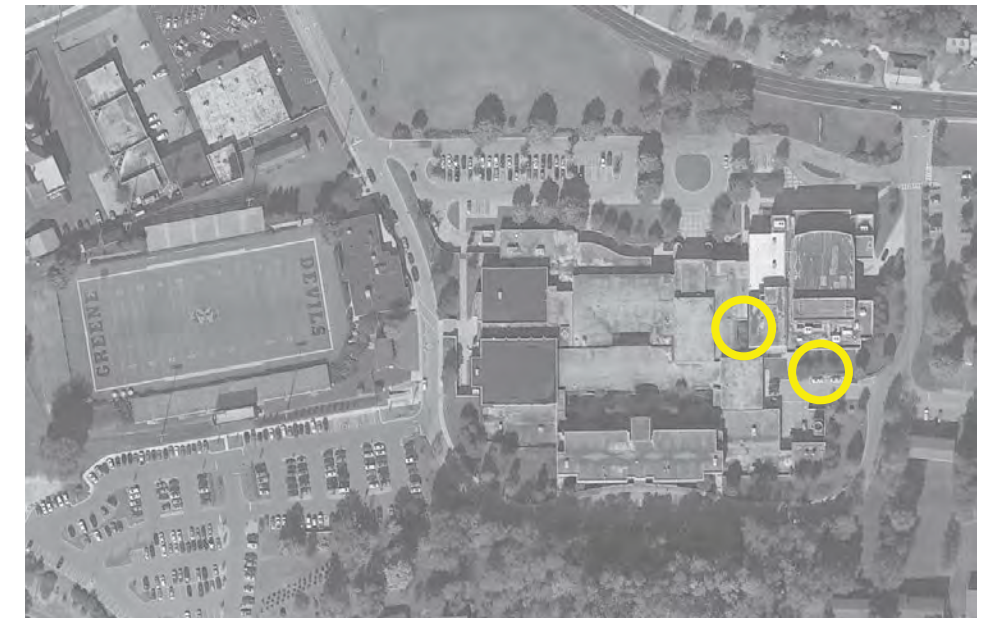

Dumpster Area & Small Courtyard

Greenville City Schools: Landscape Updates

MARCH 10, 2023

Landscape Recommendations:

- ① Remove gray rip rap stone and replace with river rock to match other areas at entrance.

*Alternate Option: Remove all riprap stone, provide planting soil, and plant with spreading groundcover. Suggest Blue Rug Juniper.

- ② Remove all mulch and plant lawn on upper side of retaining wall between fence and hedge.

- ③ Infill Nandina to complete hedge along facade.

Summary of Intent:

-Planting rehabilitation & infill

Suggested Plant Images



Juniperus horizontalis 'Wiltonii'
Blue Rug Juniper
6" T x 6-8' W
Evergreen foliage



Nandina domestica 'Firepower'
Firepower Heavenly Bamboo
2-2.5' T x 2-2.5' W
Red Fall foliage

Key Plan

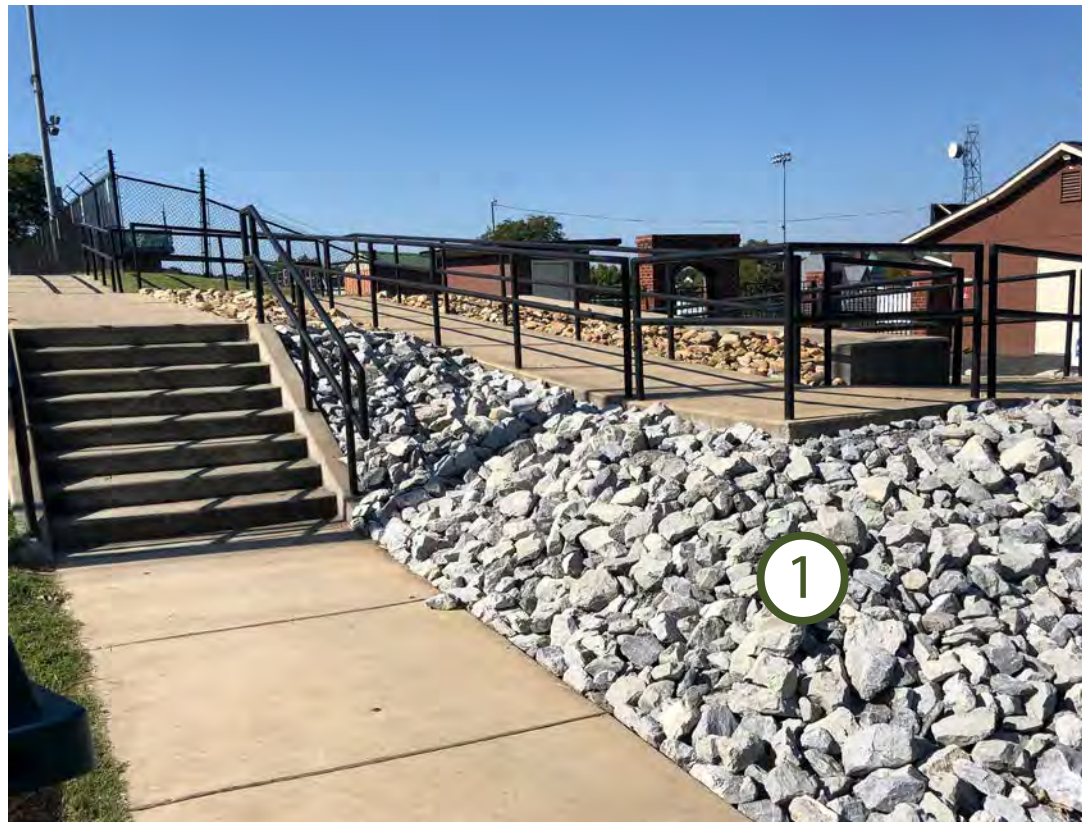
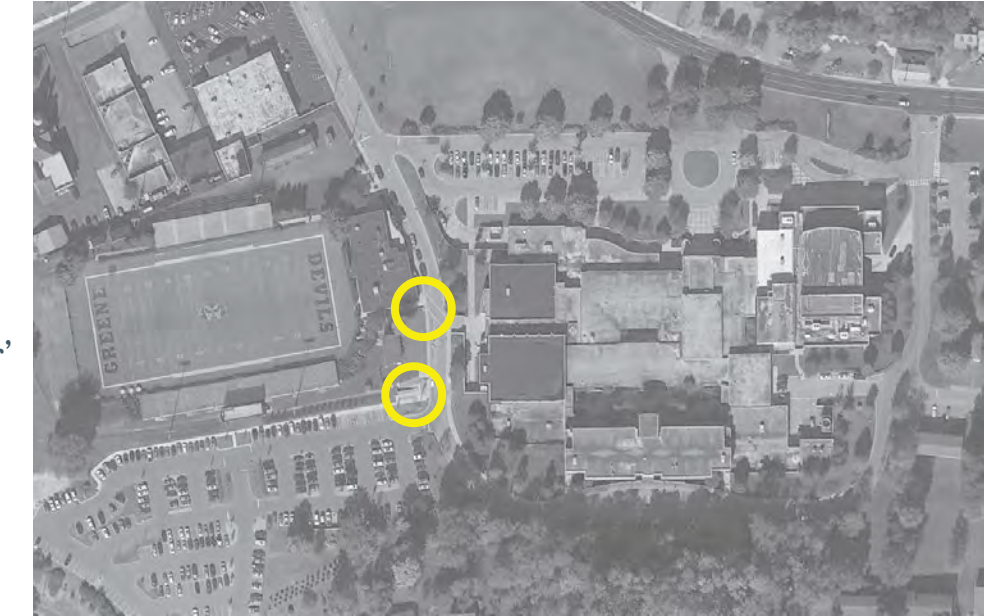

Football Stadium & Weight Room Entrance

Greenville City Schools: Landscape Updates

MARCH 10, 2023

Landscape Recommendations:

- ① Remove and replace railroad tie retaining wall with concrete block to match adjacent.
- ② Limb up existing Crape Myrtle tree at concession stand or replace with a canopy tree.

Summary of Intent:

-Planting rehabilitation & infill

Key Plan

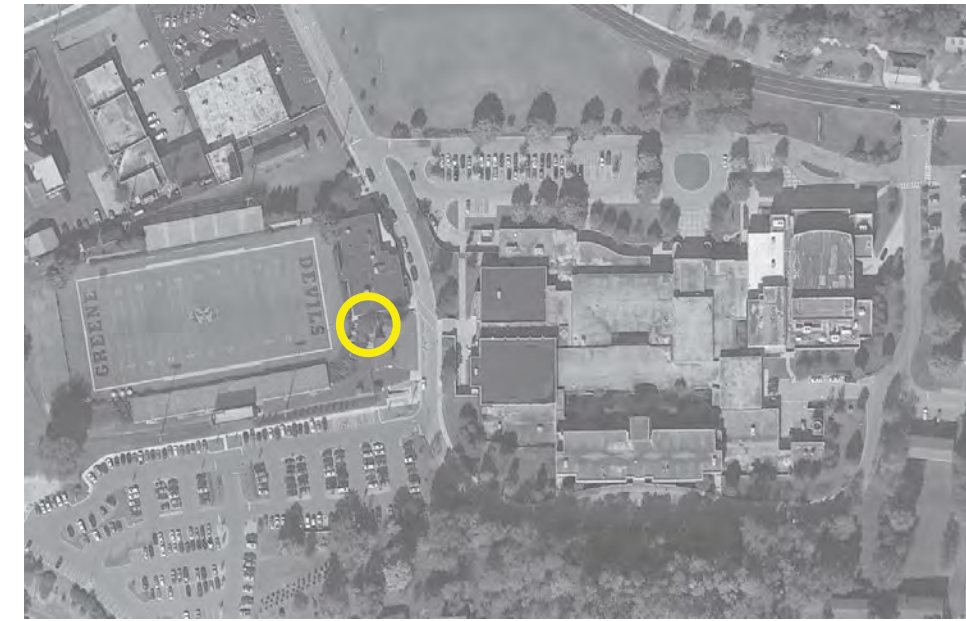

Landscape Recommendations:

- ① Along end zone hillside add a small wall 6-7' back from edge of turf to retain grade.
- ② Simplify hillside planting by removing existing shrubs and plant medium size evergreen shrubs.
-Suggest planting Parsons or Sea Green Juniper above wall and Spreading Liriope along edge of turf.
- ③ Consider replacing Schip Laurel hedge along shady side of bleachers with Densiformis Yew or Acuba.
- ④ Remove existing shrubs on western side of bleachers and plant medium size evergreen shrubs.
-Suggest Parsons or Sea Green Juniper.
- ⑤ Plant Spreading Liriope between fence and field to fill in landscape bed.

Summary of Intent:

-Planting rehabilitation & redesign

Suggested Plant Images



Juniperus x pfitzeriana
'Sea Green'
Sea Green Juniper
4-6' T x 6-8' W
Evergreen foliage



Juniperus chinensis 'Parsonii'
Parson's Juniper
1.5-2' T x 6-8' W
Evergreen foliage



Liriope spicata
Spreading Liriope
9"-1.5' T x 2-3' W
Purple Summer blooms



Taxus x media 'Densiformis'
Densiformis Yew
3-4' T x spreading 4-5' W
Evergreen foliage

Key Plan

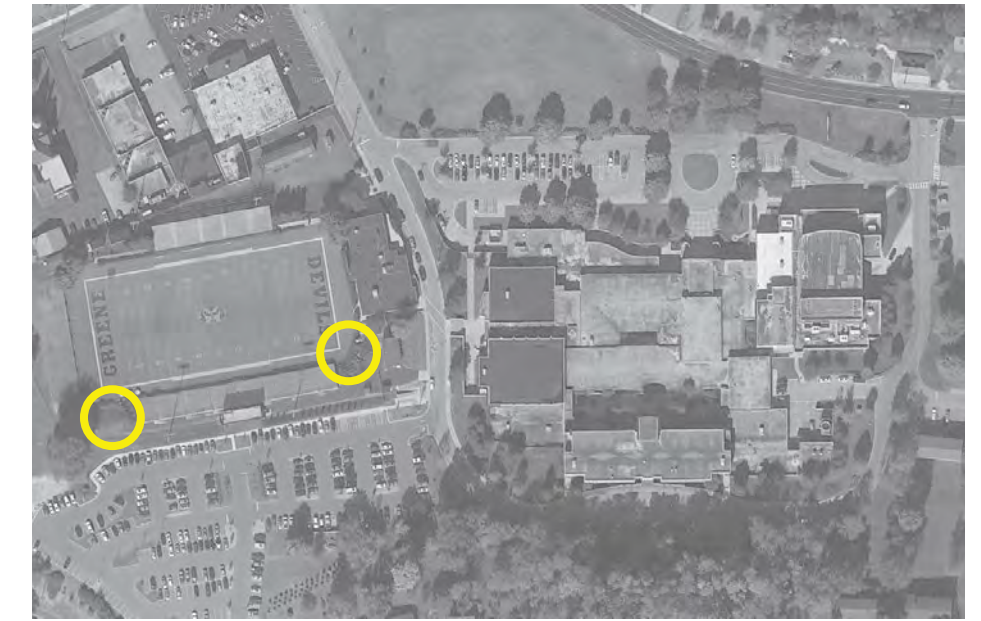

Acuba japonica
Spotted Laurel
6-10' T x spreading 5-9' W
Evergreen foliage

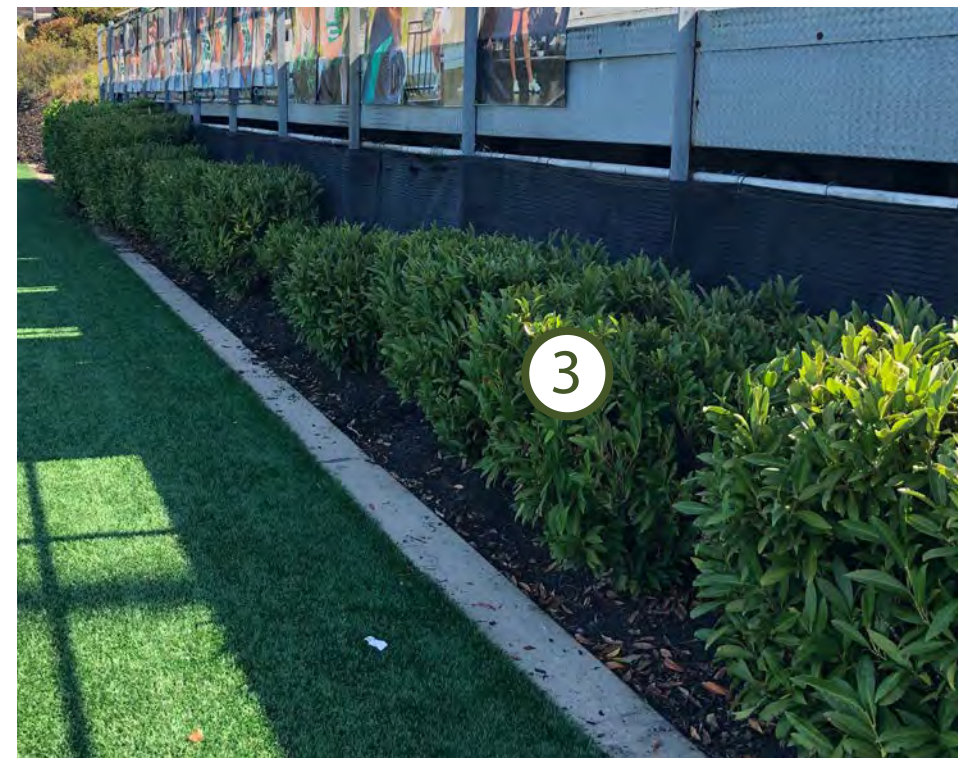

Landscape Recommendations:

- ① Monitor health of Chinese Elm tree by score board and prune out any dead branches.
- ② Plant an evergreen screen along side of concession stand to block neighboring views.
- ③ Remove concrete steppers and reduce landscape bed by planting lawn on slope as shown.

Summary of Intent:

-Planting rehabilitation & infill

Suggested Plant Images



Ilex x 'Conaf'
Oak Leaf Holly
14-16' T x 8-10' W
Evergreen foliage



Thuja 'Green Giant'
Green Giant Arborvitae
25-35' T x 8-10' W
Evergreen foliage



Cryptomeria japonica
'Radicans'
Radicans Cryptomeria
30-40' T x 15-20' W
Evergreen foliage

Key Plan

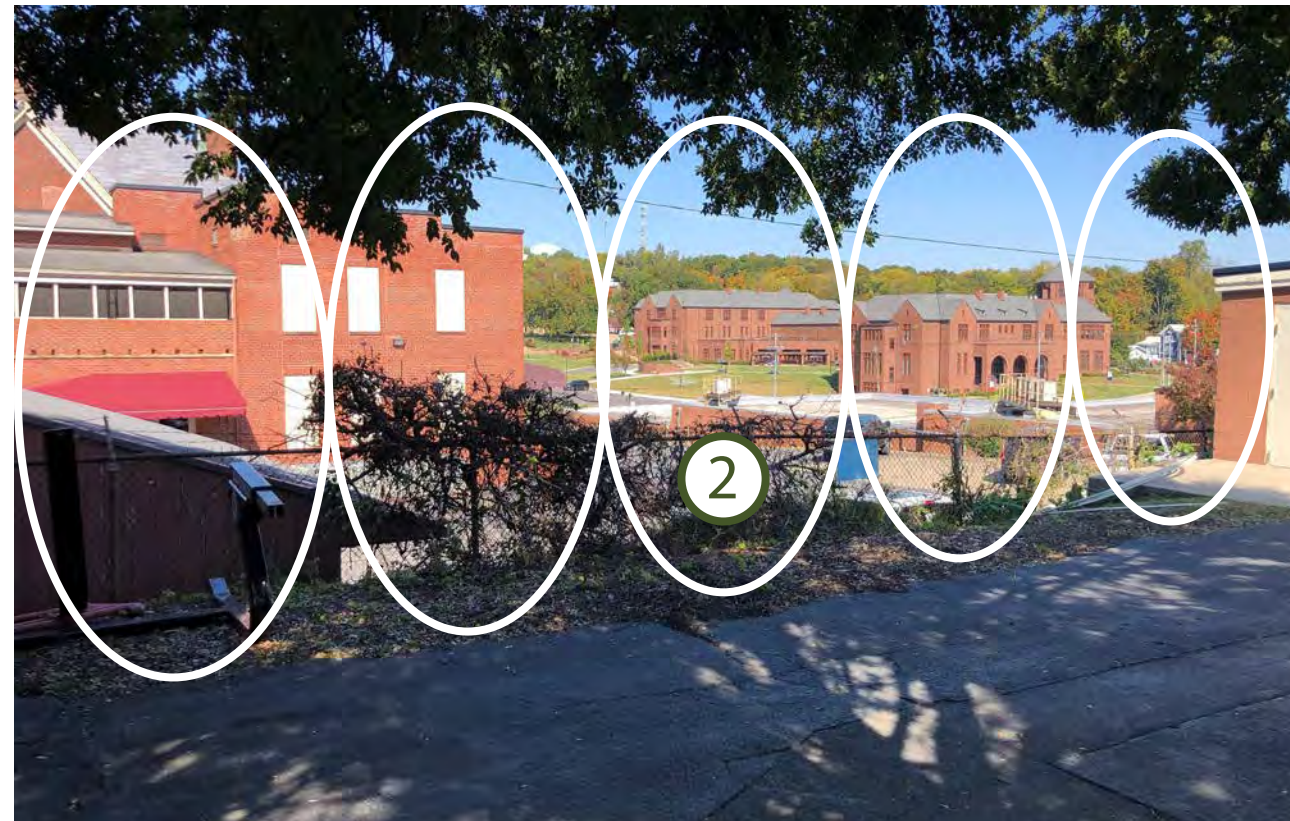
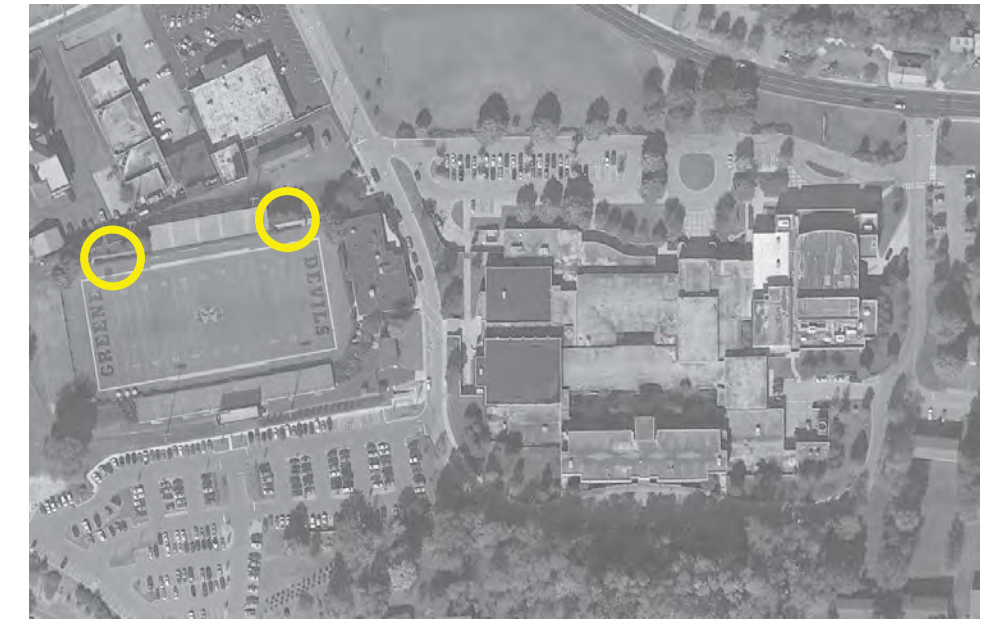

North Side Football Field
Greenville City Schools: Landscape Updates

MARCH 10, 2023

Landscape Recommendations:

- ① Remove all Inkberry at visitor entrance and plant with lawn. If hedge is desired, plant with evergreen shrubs and reduce bed width to size of hedge as shown.
-Suggest planting Schip Laurels.
- ② Remove all Otto Luyken Laurels along stairs, prepare soil, and plant with low spreading shrubs or groundcover.
-Suggest Davidi Viburnum, Pachysandra, or Spreading Liriope.

Summary of Intent:

-Planting rehabilitation & infill

Key Plan

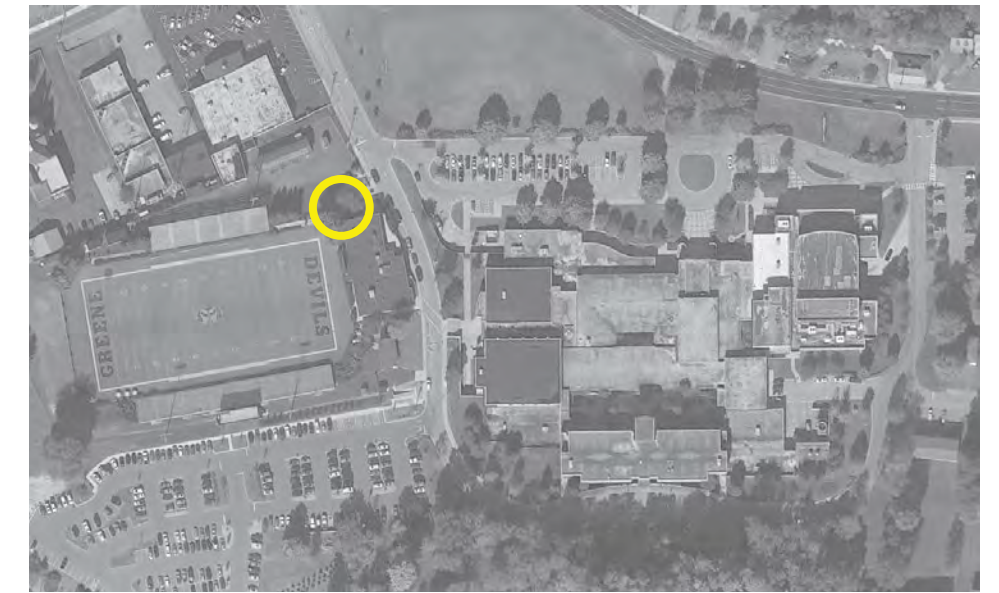

Suggested Plant Images



Prunus laurocerasus
'Schipkaensis'
Schip Laurel
6-10' T x 6-10' W
Evergreen foliage



Viburnum davidii
Davidi Viburnum
2-3' T x 3-4' W
Evergreen foliage
Blue Fall berries



Pachysandra terminalis
Japanese Pachysandra
6-10" T x 1-1.5' W
Evergreen foliage



Liriope spicata
Spreading Liriope
9"-1.5' T x 2-3' W
Purple Summer blooms



Visitor Stairs at Stadium
Greeneville City Schools: Landscape Updates

MARCH 10, 2023

Landscape Recommendations:

- 1 Remove mulch and plant with evergreen groundcover.
-Suggest Bowles Golden Sedge or Lawn.
- 2 Consider removing Schip Laurel hedge between fence and sidewalk to eliminate pruning and plant with narrow evergreen shrub.
-Suggest Emerald Green Arborvitae.

Summary of Intent:

-Planting rehabilitation & infill

Suggested Plant Images



Carex elata 'Aurea'
Bowles Golden Sedge
2-3' T x 2-3' W
Golden foliage



Thuja occidentalis 'Smaragd'
Emerald Green Arborvitae
15' T x 3-4' W
Evergreen foliage
Fastigiate form

Key Plan

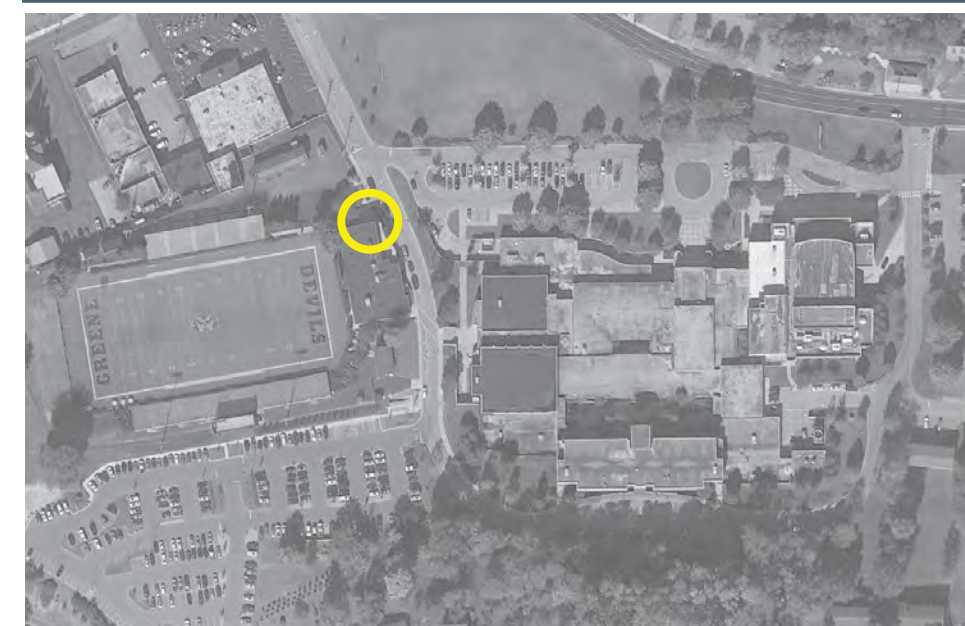

North Side Field

Greenville City Schools: Landscape Updates

MARCH 10, 2023

Landscape Recommendations:

- ① Remove most Otto Luyken Laurels , leaving single row along windows. Supplement gaps with new Otto Luyken Laurels to complete a uniform hedge.
- ② Remove all mulch and plant remainder of landscape bed with evergreen groundcover and ferns.
-Suggest Pachysandra, Catlin’s Giant Ajuga, and Autumn Ferns

Summary of Intent:

-Planting rehabilitation & redesign

Key Plan

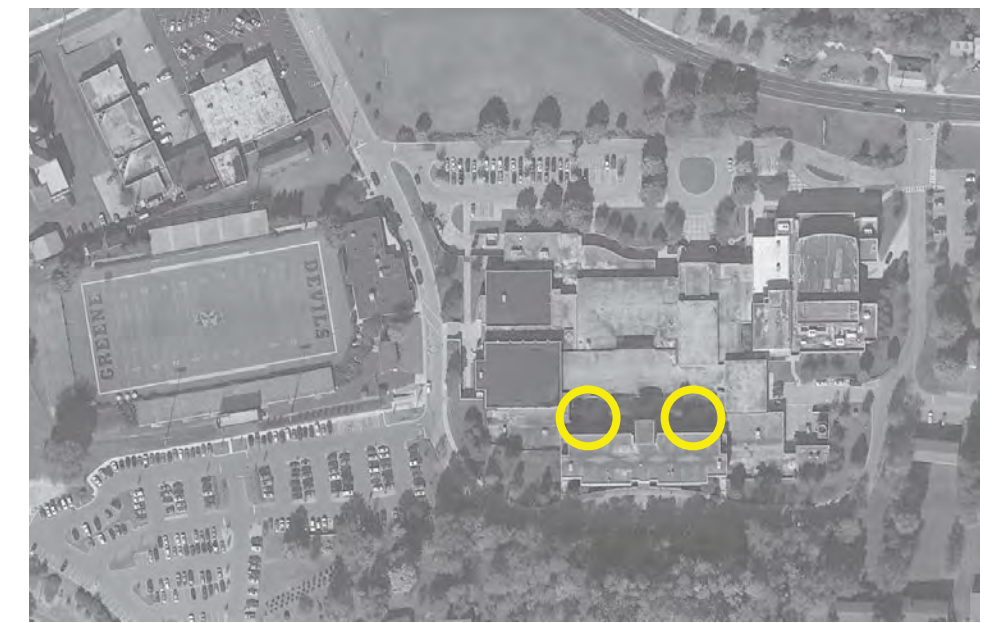

Suggested Plant Images



Pachysandra terminalis
Japanese Pachysandra
6-10” T x 1-1.5’ W
Evergreen foliage



Ajuga reptans ‘Catlin’s Giant’
Catlin’s Giant Ajuga
3-9” T x 1-2’ W
Blue Spring blooms



Dryopteris erythrosora
‘Brilliance’
Brilliance Autumn Fern
18”-2’ T x 18”-2’ W
Bronze foliage



Southern Side Interior Courtyard

Greenville City Schools: Landscape Updates

MARCH 10, 2023

Landscape Recommendations:

- ① Remove all shrubs along North and Western walls and plant with a uniform evergreen hedge.
-Suggest Snow Cap Indian Hawthorne
- ② Remove all shrubs below windows and plant with a uniform hedge.
-Suggest Rose Creek Dwarf Abelia
- ③ Remove Chinese Elm tree along windows.
- ④ Remove large Abelia along eastern courtyard ramp and guardrail and plant with uniform evergreen hedge to match opposite side.
-Suggest Snow Cap Indian Hawthorne
- ⑤ Plant Rose Creek Dwarf Abelia to fill patio landscape bed.
- ⑥ Plant (3) Sweetbay Magnolia trees along Northern building wall in large landscape pockets.

Summary of Intent:

-Planting rehabilitation & redesign

Suggested Plant Images



Rhapsiolepis x delacourii
'Georgia Petite'
Georgia Petite Indian Hawthorn
2-3' T x 3-4' W
Evergreen foliage, white Spring



Abelia 'Rose Creek'
Rose Creek Dwarf Abelia
2-3' T x 3-4' W
Evergreen foliage, pink
Summer blooms



Magnolia virginiana 'Jim Wilson'
Moonglow Sweetbay Magnolia
15-35' T x 10-20' W
Semi-Evergreen Foliage
White Summer blooms

Key Plan

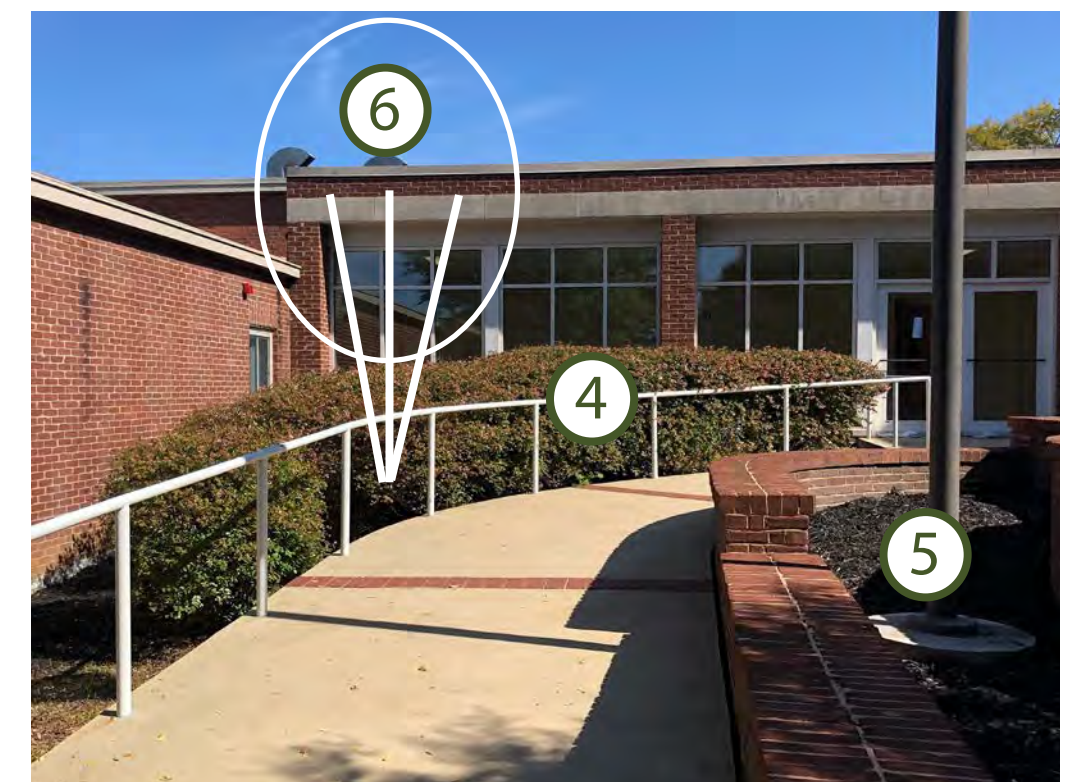
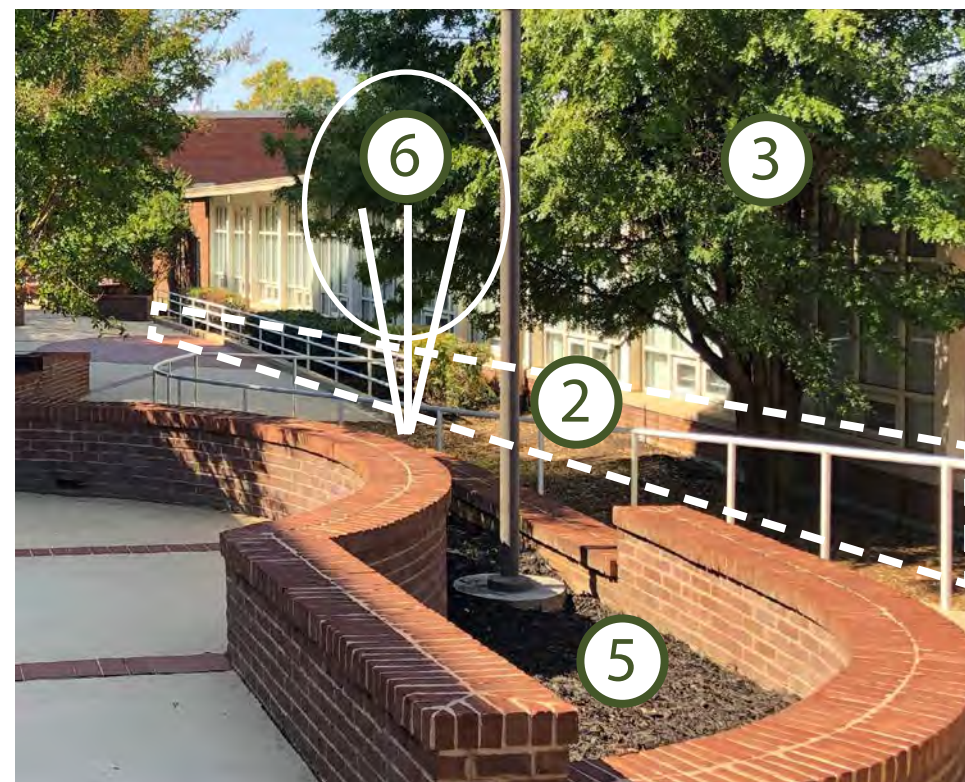
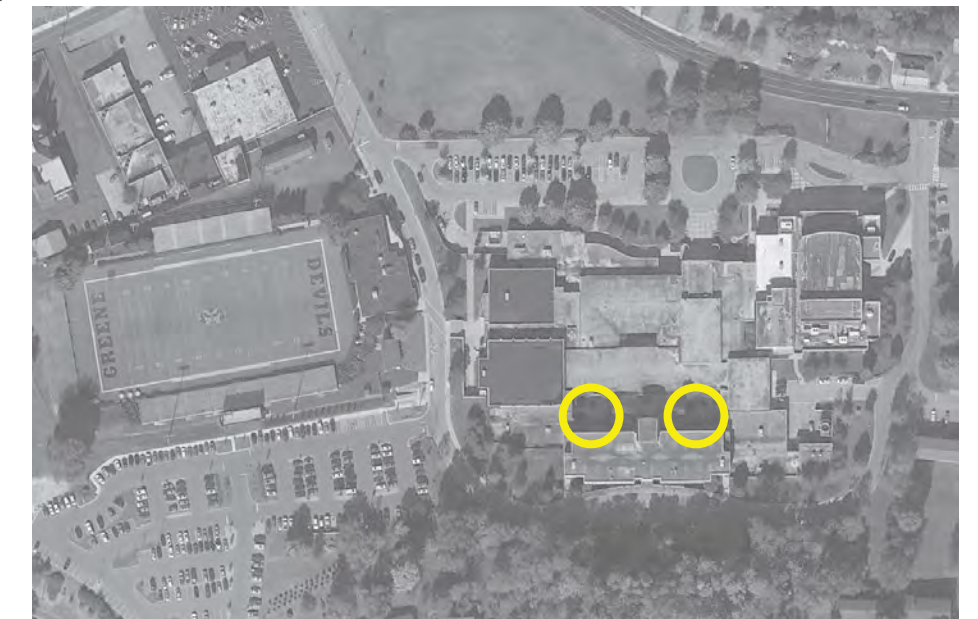

North, East & Western Side Interior Courtyard

Greenville City Schools: Landscape Updates

MARCH 10, 2023

New Planting Recommendations:

- ① Remove all shrubs along railing and patio space except Hollies under school sign.
- ② Remove all mulch and reduce bed to new planting limits and infill with lawn as shown.
- ③ Plant a single row of Sherwood Abelia, approximately 39 total, along brick patio wall and building on either side of entrance as shown.
- ④ Plant staggered double row of Variegated Liriope, approximately 76 total, along railing on either side of entrance as shown.
- ⑤ Plant pockets of Russian Sage, approximately 30 total, 24" o.c., at corners of stairs on either side of entrance as shown.

Summary of Intent:

-Redesign

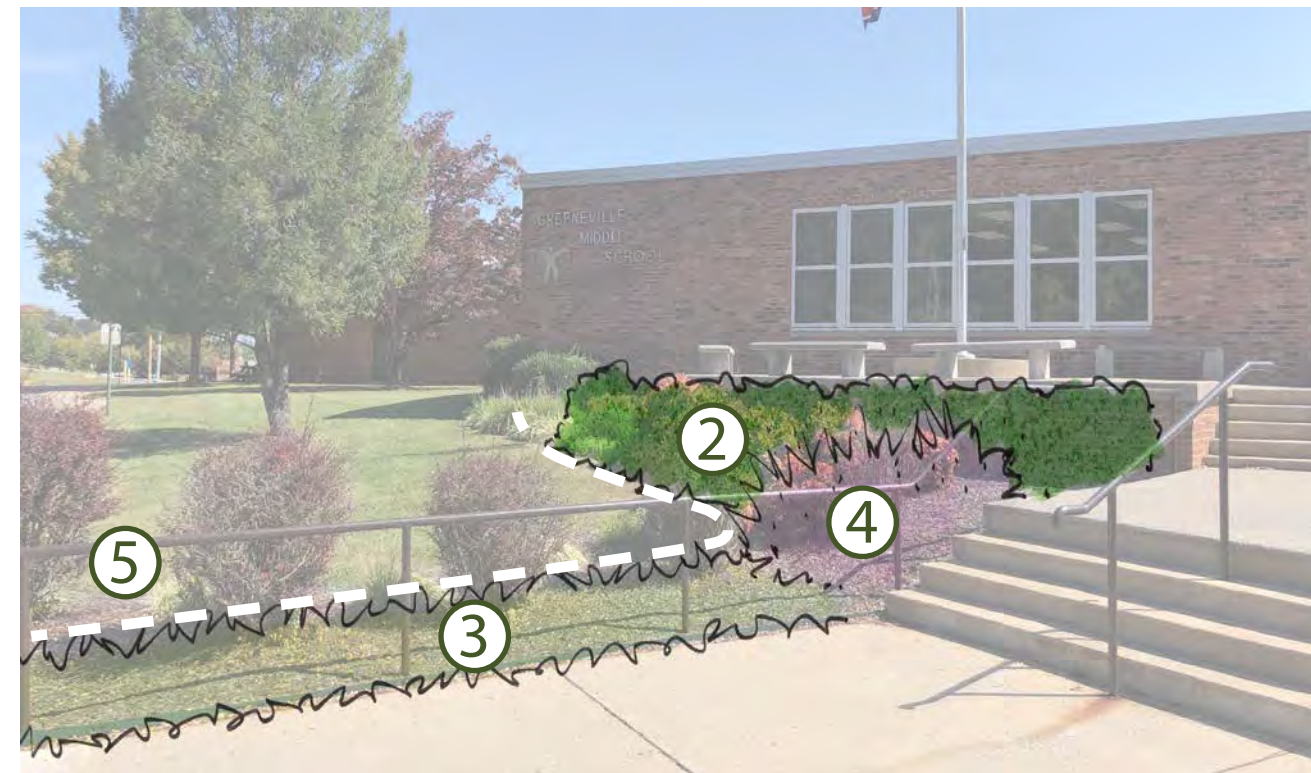

Suggested Plant Images



Abelia x grandiflora 'Sherwoodii'
 Sherwood Glossy Abelia
 3-4' T x 3-4' W
 Evergreen Foliage
 White/pink Summer blooms



Liriope muscari 'Variegata'
 Variegated Liriope
 1-1.5' T x 1-2' W
 Variegated foliage
 Purple Summer blooms



Perovskia atriplicifolia 'Blue Spire'
 Blue Spire Russian Sage
 3-4' T x 3-4' W
 Blue/Purple Summer blooms

Greeneville Middle School Entrance

Greeneville City Schools: Landscape Updates

MARCH 10, 2023

Greeneville City Schools



REQUEST FOR PROPOSALS

RFP 2022-23

PHASE 1 LANDSCAPING MAINTENANCE/REHABILITATION PROPOSAL

REQUEST FOR PROPOSALS SUBMITTAL DEADLINE

**May 5, 2023
2:00 PM**

**To be submitted to:
Greeneville City Schools
ATTN: Phillip Graham
312 Floral St
Greeneville, TN 37743**

GREENEVILLE CITY SCHOOLS

**REQUEST FOR QUALIFICATIONS
TABLE OF CONTENTS**

SOLICITATION ADVERTISEMENT 3

Section I - General Information 4

 1. Purpose..... 4

 2. Scope of Work..... 4

 3. Project Funding 4

 5. Proposal Format..... 4

 6. Contract Responsibility..... 4

 7. Required Insurance and Bonds 4

 8. Permits and Licensing 5

Section II – Statement of Qualifications Format and Preparation Instructions 6

 Table of Contents 6

 1. Executive Summary 6

 2. Background and Experience 6

 3. Technical Approach..... 7

EVALUATION CRITERIA 7

Appendix 1..... 8

Request for Proposals
SOLICITATION ADVERTISEMENT

GREENEVILLE CITY SCHOOLS (GCS) is accepting proposals for landscaping services. A copy of the request for proposals can be obtained by contacting Mr. Phillip Graham, Operations Supervisor at grahamp@gcschools.net or by calling 423-787-8003. GCS will be accepting proposals until 2:00pm on May 5th, 2023.

Please submit one (1) paper copy of responses completed according to the information prescribed by this RFP. After review of all accepted responses, firms selected based on their qualifications may be invited to participate in an on-site interview. Final selection will be made in accordance with the policies and administrative directive of the GCS and other applicable statutory provisions.

All questions concerning this request including general information, instructions, and selection criteria shall be submitted via email to:

Phillip Graham
Operations Supervisor
Greeneville City Schools
grahamp@gcschools.net

Project Selection Timeline

Advertisement Date: April 5, 2023
Site Meeting: Schedule with Mr. Phillip Graham
Request for Proposals (RFP Responses) Due: May 5th, 2023, at 2:00 PM



Section I - General Information

1. Purpose

Greeneville City Schools will receive proposals from contractors interested in performing a one-time landscape maintenance/rehab project. Each area included in the project is listed in Appendix One (1). The stated intent of GCS is to enter into a one-time landscape maintenance/rehab contract for Phase 1 at Greeneville High School as outlined in the project manual (see Appendix One (1)). GCS will make its final selection based upon the recommendation of a designated selection committee. GCS shall negotiate and execute an agreement with the selected company after approved by the Board of Education as required by purchasing guidelines.

2. Scope of Work

The landscaping of each area listed in Appendix one will need to be evaluated and a plan created based on the suggested plants and directions.

3. Project Funding

GCS intends to complete the entire landscaping rehab project in multiple phases. This RFP is for phase one as detailed in Appendix One (1) of this document.

4. Proposal Format

Proposals must be submitted in the format outlined in this document. Each proposal will be reviewed to determine if it is complete prior to actual evaluation. Proposals not containing the information requested will not be considered. Respondents shall use the prescribed format to indicate their experience and qualifications, describe their approach to the project and explain their proposed contract. In addition, the GCS reserves the right to waive any irregularities and formalities in the selection of the landscaping company for this project.

5. Contract Responsibility

The selected Landscaping contractor will be required to assume total responsibility of the project. The selected Landscaping contractor will be considered the prime contractor and the sole point of contact with regard to all contractual matters. The contractor will be responsible for protecting all concrete and asphalt surfaces from damage, including curbs. Any damage to these surfaces as a result of this project will be the sole responsibility of the Landscaping Contractor to repair to the same standard, quality, and appearance of surrounding surfaces that are undamaged. If GCS deems the landscaping contractor is unqualified to make the necessary repairs GCS reserves the right to hire a qualified contractor to make the needed repairs and deduct this cost from the overall project payment balance.

6. Required Insurance and Bonds

The successful respondent shall procure and maintain in effect during the project commercial general liability insurance in amount not less than \$1,000,000 for each occurrence, comprehensive automotive liability insurance in amount not less than \$1,000,000, and workers compensation insurance as required by State law. Evidence of required insurance shall be presented prior to contract execution. The contractor shall provide the GCS with evidence of the



ability to provide performance and payment bonds for the value of the contract for the installation period. All employees of the landscaping company that will be on school property shall meet the background requirements for schools as required by the State of Tennessee.

7. Permits and Licensing

The landscaping company shall maintain a permit or business license to work within the city limits of Greeneville. In locations where digging must occur the landscaping company will be required to make the necessary call(s) to 811 before digging.

8. Irrigation

The landscaping contractor shall be responsible for repairing any damage done to the irrigation system while completing the landscaping project. These repairs are limited to only damage done by the landscaping contractor.

Changes to the irrigation system to meet the needs of the new landscaping plan shall be included in the total cost of this project. This includes moving or changing the types of sprinkler heads and or completely removing heads if needed.

9. Plants

All plants as detailed in this document shall be planted according to the recommendations provided for the plant including, but not limited to planting season, depth, spacing, sunlight and irrigation requirements.

10. Warranty

All work and plants shall be guaranteed for a period of one year from project completion.

Section II – Statement of Qualifications Format and Preparation Instructions

RESPONSE FORMAT AND PREPARATION INSTRUCTIONS

Responses must be submitted in the format outlined in this section. Proposals should be limited to Ten (10) pages, not including a cover page, cover letter, table of contents or resumes. Greeneville City Schools reserves the right to eliminate from further consideration any response that is deemed to be substantially, or materially, unresponsive to the requests for information contained in this document. The intent of Greeneville City Schools is that all responses follow the same format and protocol, in order to evaluate each response fairly. Responses will be evaluated in light of the material and substantiating evidence presented therein, and not on the basis of what is inferred.

Table of Contents

Responses shall include a table of contents properly indicating the section and page numbers of the information included.

1. Executive Summary

Responses shall include a summary overview of the Respondent's qualifications, approach and other pertinent information. The Executive Summary should be no more than One (1) page in length.

2. Background and Experience

A. Company Profile

The firm shall provide the following information:

- Company name.
- Office address, number of employees and capabilities.
- Names and two (2) contact people within the company.
- Number of years the company has been performing landscaping services.
- Provide evidence of insurance coverage.
- Type of equipment the company has for use on this job.

B. Project Team and Support

Provide a list of the certificated personnel to be used on this project, with their specific roles and qualifications. Concise resumes including education, experience, landscape design and maintenance certificates.

C. References

Submission of a response constitutes permission to make inquiries concerning the respondent to any persons or firms deemed appropriate by the GCS. A minimum of 6 commercial jobs of similar size and scope shall be provided with contact names and numbers as well as a description of work performed and completion date.

3. Technical Approach

A. Approach to the Scope of Work

In two (2) pages or less, summarize how your company will perform the scope of work outlined in this RFP, including the total number of plants that will be provided in each prescribed location, and to what extent the owner will be involved in these activities.

B. Project Management

Indicate your firm's approach to managing the installation phase. Describe the various responsibilities of your team members during installation, and how they will keep the owner's personnel informed of the project's progress. What is the Respondent's approach to ensuring safety and minimizing interruption during the installation phase?

EVALUATION CRITERIA

The Greeneville City Schools evaluation team will consider the following criteria in evaluating responses; these categories will be weighted on importance and significance to this project. The Greeneville City Schools will select the responding firm that is deemed most qualified for the project and provides the greatest value to Greeneville City Schools for this project.

Evaluation Criteria: 100 Maximum Points

Capabilities of Company:	20
Company Experience:	30
References:	20
Technical Approach:	10
Pricing:	20

Total points to be earned are on a scale of 1 to 100, with 1 point being the lowest score and 100 points being the highest score. Points may be deducted if the company's response varies from requested format and number of pages.

Appendix 1

L100 attached.

L101 attached.



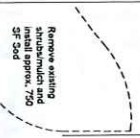

Provide 6 dia. tree ring to match other trees at entrance

Remove existing mulch and install approx. 300 SF 50d

Remove existing shrubs/mulch and install approx. 475 SF 50d

Remove existing shrubs, prepare soil and install 32 ARC

Remove existing shrubs/mulch and install approx. 305 SF 50d

Install approximately 115 LF metal edging

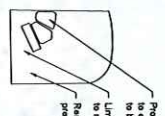
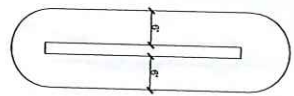

Remove mulch and prepare soil. Plant 80 HC

Remove mulch and prepare soil. Plant 80 HC

Remove mulch and prepare soil. Plant 80 HC

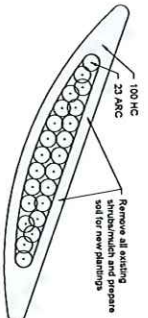

Remove existing shrubs, prepare soil and install 23 HC

Remove existing shrubs, prepare soil and install 20 CHP

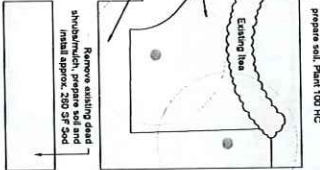

Remove existing dead shrubs/mulch and install approx. 200 SF 50d

Remove existing shrubs/mulch and install approx. 75 SF 50d

Remove existing mulch and install approx. 18 SF 50d

Plant Schedule

Qty	Quantity	Botanical Name	Common Name	Height	Notes
100	100	Hydrangea	Hydrangea	7'-8'	100 HC
23	23	Arctostaphylos	Arctostaphylos	3'-4'	23 ARC
750	750	Chamaecyparis	Chamaecyparis	1'-2'	750 SF 50d
300	300	Chamaecyparis	Chamaecyparis	1'-2'	300 SF 50d
475	475	Chamaecyparis	Chamaecyparis	1'-2'	475 SF 50d
305	305	Chamaecyparis	Chamaecyparis	1'-2'	305 SF 50d
200	200	Chamaecyparis	Chamaecyparis	1'-2'	200 SF 50d
75	75	Chamaecyparis	Chamaecyparis	1'-2'	75 SF 50d
18	18	Chamaecyparis	Chamaecyparis	1'-2'	18 SF 50d



Not for Construction

Project Name
Address
City, TN

hedstrom
LANDSCAPE ARCHITECTURE

Date: 03.03.20
Job Number: 20-000
Drawn By: INT
Ck'd By: SJP

Rev.	Description	Date

Sheet Name: **Planting Plan**
Sheet Number: **L100**

This drawing is the property of Hedstrom Landscape Architecture, Inc. and is not to be reproduced, copied, or used in any way without the written consent of Hedstrom Landscape Architecture, Inc. The client is responsible for providing accurate information and for obtaining all necessary permits. Hedstrom Landscape Architecture, Inc. is not responsible for any errors or omissions in this drawing. Hedstrom Landscape Architecture, Inc. is not responsible for any damage to property or injury to persons resulting from the use of this drawing. Hedstrom Landscape Architecture, Inc. is not responsible for any changes to this drawing after it has been issued. Hedstrom Landscape Architecture, Inc. is not responsible for any work not shown on this drawing. Hedstrom Landscape Architecture, Inc. is not responsible for any work not shown on this drawing.

ESTIMATE



Prepared For

Greeneville City Schools

FOC LANDSCAPES

790 Baileyton Road
Greeneville, TN 37745
Phone: (423) 329-0357
Email: miles@foclandscapes.com
Web: www.foclandscapes.com

Estimate # 333
Date 07/24/2023

Description	Total
Option L100	\$35,495.00
All work to be completed as specified in sheet L100 (attached). This will also include limbing trees (see attached photos). All Elm trees in the front circle included.	
Option L101	\$11,750.00
Assorted Beds. Work to be completed as specified in sheet L101. No additional work to be completed.	
Subtotal	\$47,245.00
Total	\$47,245.00

Notes:

GHS Landscape Rehab

Landscape Recommendations

- ① Limb up Chinese Elm trees approximately 4' to provide views to the school.
- ② Remove all shrubs at corner of entrance drive and parking lot and plant lawn.
- ③ Remove overgrown Yews at sign and reduce plant bed.
-Suggest planting False Plum Yew or Pachysandra.
- ④ Remove mulch around tree and plant fescue lawn to match opposite side.
- ⑤ Selectively prune Chinese Elm trees to reduce conflicts with light poles at entrance.

Summary of Intent:

- Opening Views
- Removing excess mulch

Suggested Plant Images



Cephalotaxus harringtonia 'Prostrata'
Prostrate False Plum Yew
18"-30" T x 3'-4' W
Evergreen foliage



Pachysandra terminalis
Japanese Pachysandra
6-10" T x 1-1.5' W
Evergreen foliage

Key Plan

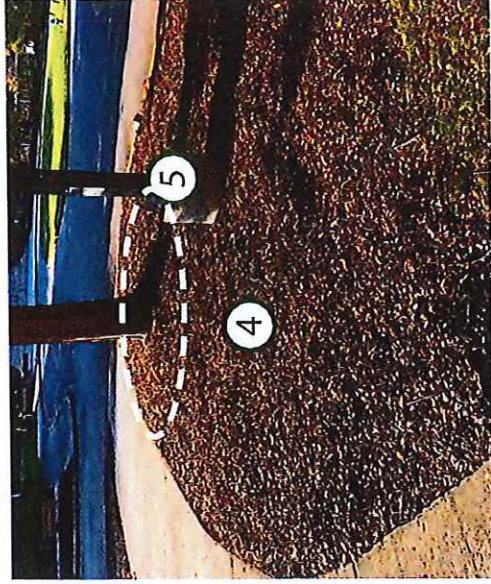
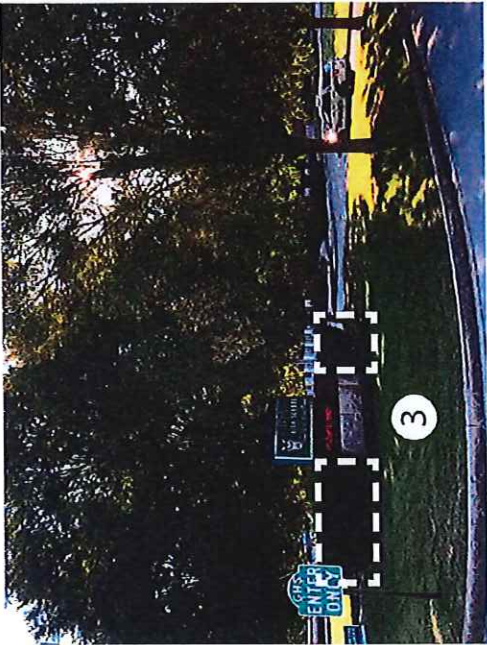
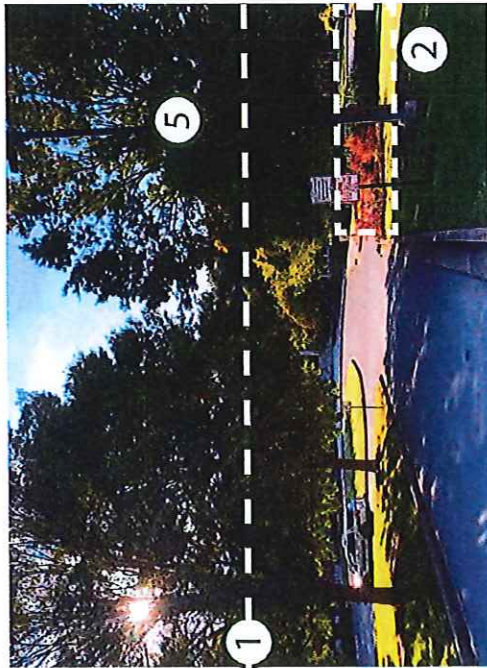
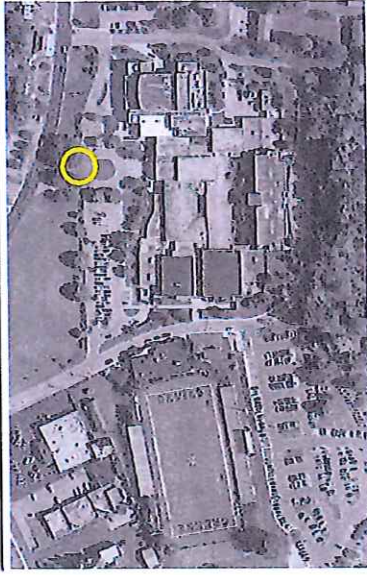

Priority Project #1: Main Entrance Drive

Greenville City Schools: Landscape Updates

MARCH 10, 2023



Landscaping Recommendations:

① Establish a clean bed edge as shown and provide river rock around uplights to protect from mowing damage.

② Plant low shrubs in NPAC drop off island.
-Suggest planting Indian Hawthorn.

Summary of Intent:

-Planting infill

Suggested Plant Images

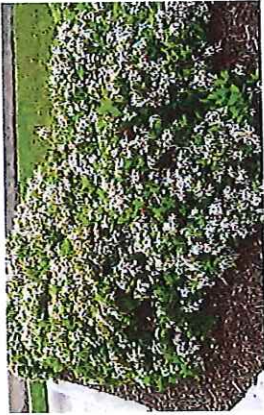

Rhapiolepis x delacourii 'Georgia Petite'
Georgia Petite Indian Hawthorn
2-3' T x 3-4' W
Evergreen foliage, white Spring blooms

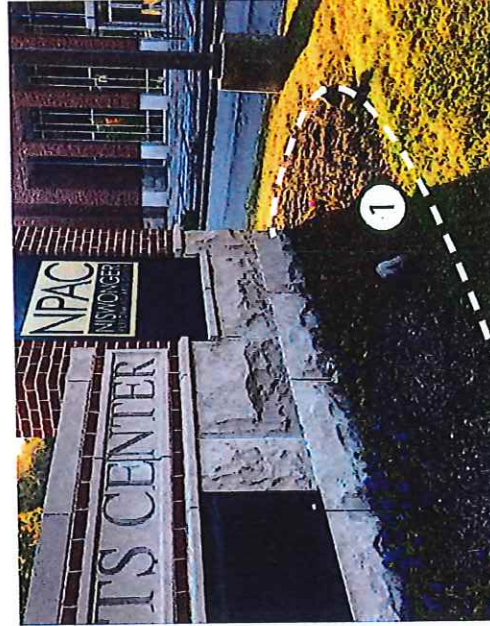
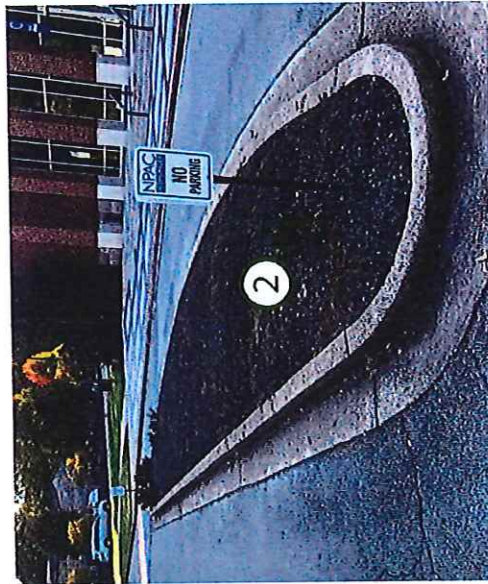
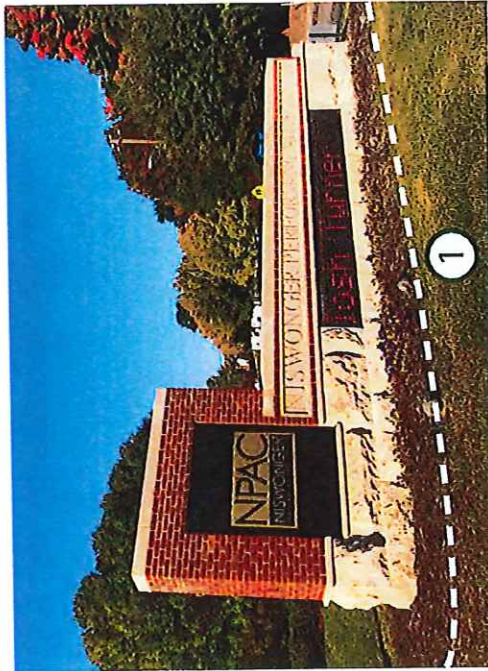
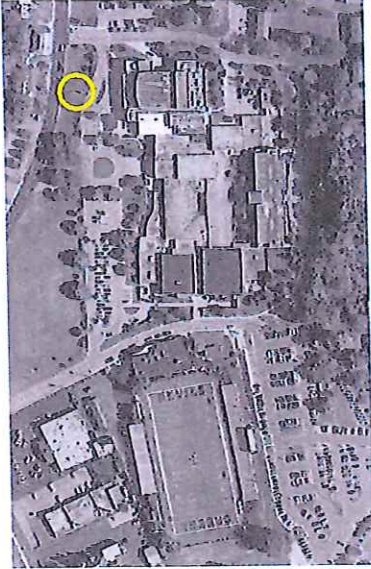

Landscaping Recommendations:

- ① Remove Otto Luyken Laurels on either side of Winterberrys. Replace with an evergreen flowering shrub.
-Suggest planting Rose Creek Dwarf Abelia
- ② Remove and replace Inkberry on either side of entrance drive with a low spreading shrub.
-Suggest planting Gro-Low Sumac
- ③ Plant (3) multi-stem Autumn Brilliance Serviceberry trees within Gro-Low Sumac bed at corner as shown.

Summary of Intent:

- Planting rehabilitation & infill

Suggested Plant Images



Abelia 'Rose Creek'
Rose Creek Dwarf Abelia
2-3' T x 3-4' W
Evergreen foliage, pink
Summer blooms



Rhus aromatica 'Gro-Low'
Gro-Low Sumac
2-3' T x 6-8' W spreading
Red Fall foliage



Amelanchier x grandiflora
'Autumn Brilliance'
Autumn Brilliance Serviceberry
15-25' T x 15-25' W
Red Fall foliage,
white Spring blooms

Key Plan

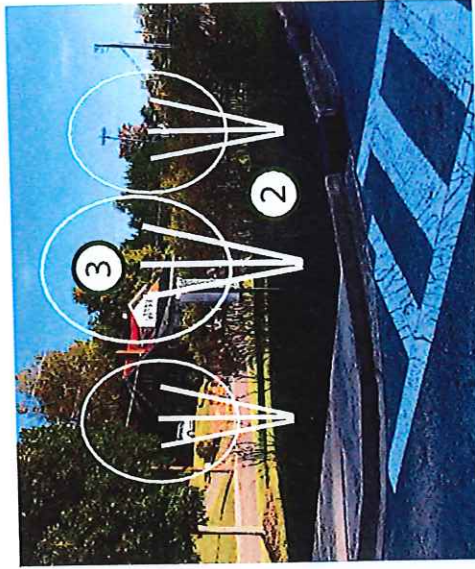
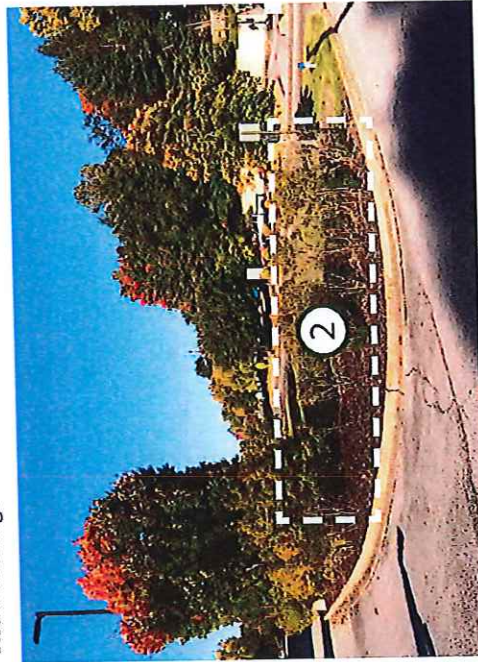
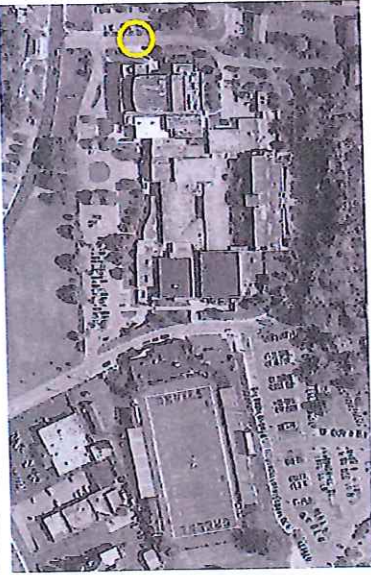

Landscape Recommendations:

- ① Plant spreading groundcover on embankment between parking lot and road.
 - Suggest planting Lawn, Creeping Raspberry, Spreading Spicata Liriope, Gro-Low Sumac, or Blue Rug Juniper (lower variety than what was removed).

Summary of Intent:
 -Planting infill



Key Plan



Suggested Plant Images



Rubus calycinoides
 Creeping Raspberry
 9"-1' T x spreading 3-4' W
 Evergreen foliage



Rhus aromatica 'Gro-Low'
 Gro-Low Sumac
 2-3' T x 6-8' W spreading
 Red Fall foliage



Liriope spicata
 Spreading Liriope
 9"-1.5' T x 2-3' W
 Purple Summer blooms



Juniperus horizontalis 'Wiltonii'
 Blue Rug Juniper
 6" T x 6-8' W
 Evergreen foliage

Landscape Recommendations:

- ① Grade out hump in lawn where tree was removed.
- ② Reduce landscape bed size as shown and plant with lawn.
- ③ Remove dead and declining Yew shrubs and Liriope.
- ④ Remove Yew to the right of bike rack as shown and plant lawn.
- ⑤ Remove dead Yew at railing and plant with low groundcover.
-Suggest planting Catlin's Giant Ajuga or Mondo Grass.

Summary of Intent:
-Planting rehabilitation & infill

Suggested Plant Images



Ajuga reptans 'Catlin's Giant'
Catlin's Giant Ajuga
3-9" T x 1-2' W
Blue Spring blooms



Ophiopogon japonicus
Mondo Grass
12" T x 12" W
Evergreen foliage

Key Plan

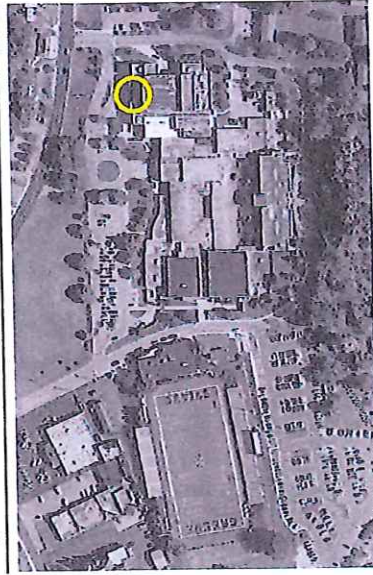

Landscape Recommendations:

- ① Remove all Otto Luyken Laurels from under Redbuds, remove all mulch and plant with shade tolerant groundcover.
-Suggest planting Pachysandra
- ② Remove Otto Luyken Laurel on either side of Winterberrys, reduce bed size as shown and plant lawn in place of removed shrubs.
- ③ Plant low evergreen groundcover to fill in space in front of Itea.
-Suggest planting Blue Rug Juniper, or Little Henry Dwarf Itea.
- ④ Plant low shrubs under Winterberry as shown.
-Suggest Rose Creek Dwarf Abelia

Summary of Intent:

- Planting rehabilitation & infill

Suggested Plant Images



Pachysandra terminalis
Japanese Pachysandra
6-10" T x 1-1.5' W
Evergreen foliage



Juniperus horizontalis
'Wiltonii'
Blue Rug Juniper
6" T x 6-8' W
Evergreen foliage



Itea virginiana 'Little Henry'
Little Henry Dwarf Itea
2-3' T x 2.5-3' W
White Summer blooms



Abelia 'Rose Creek'
Rose Creek Dwarf Abelia
2-3' T x 3-4' W
Evergreen foliage, pink
Summer blooms

Key Plan

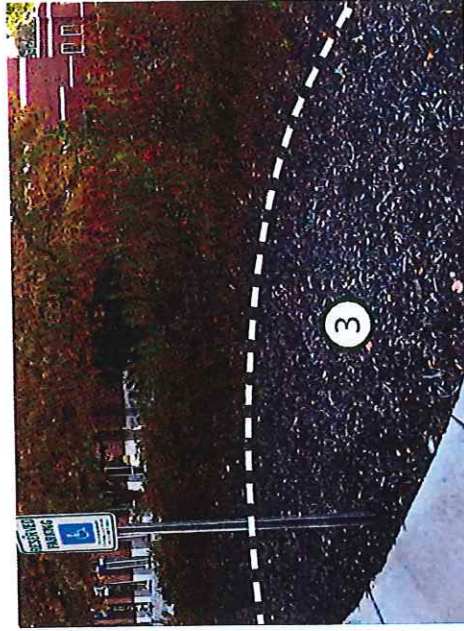
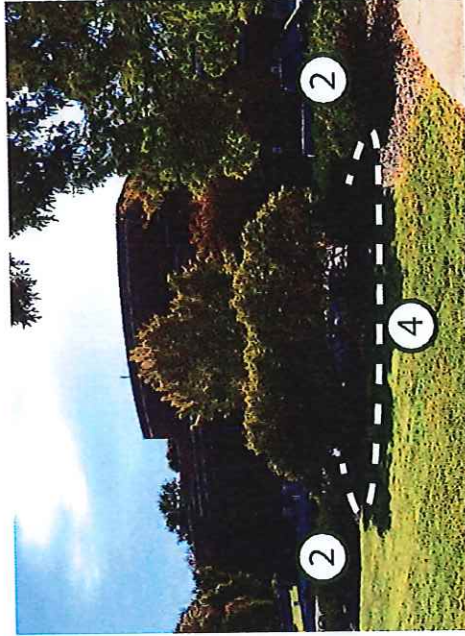
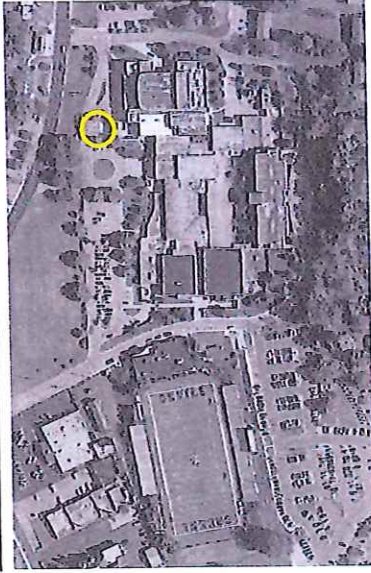

NPAC Accessible Parking Landscape Beds

Greenville City Schools: Landscape Updates

MARCH 10, 2023



Landscape Recommendations:

- ① Limb up Chinese Elm tree approximately 4' to match trees in allee.
- ② Remove mulch under tree and add flagstone to bench, and plant with low evergreen groundcover.
 - Suggest planting Blue Rug Juniper
- ③ Remove Chinese Elm tree from parking island and plant with a canopy tree.
 - Suggest Chinese Pistache and plant lawn.

Summary of Intent:

-Planting rehabilitation & infill

Suggested Plant Images



Juniperus horizontalis 'Wiltonii'
Blue Rug Juniper
6" T x 6-8' W
Evergreen foliage



Pistacia chinensis
Chinese Pistache Tree
30-35' T x 20-30' W
Red Fall foliage

Key Plan

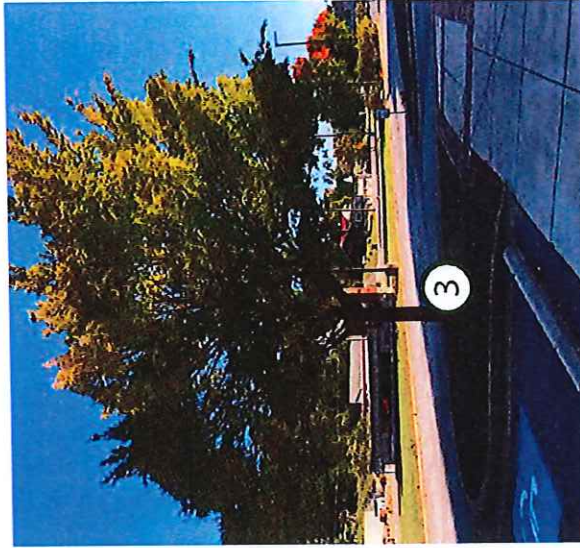
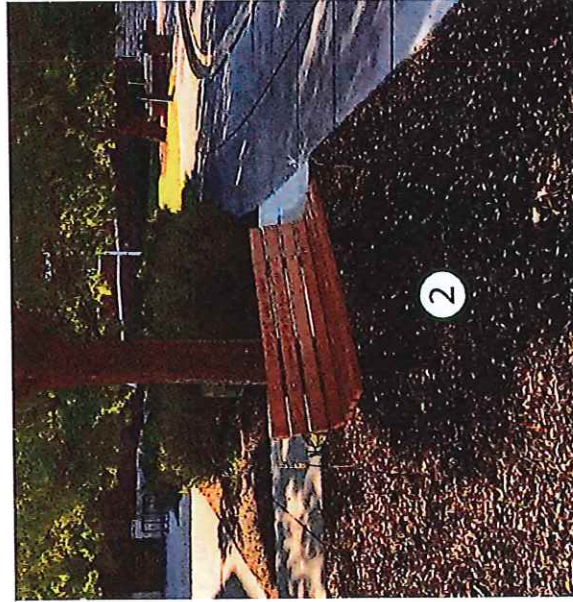
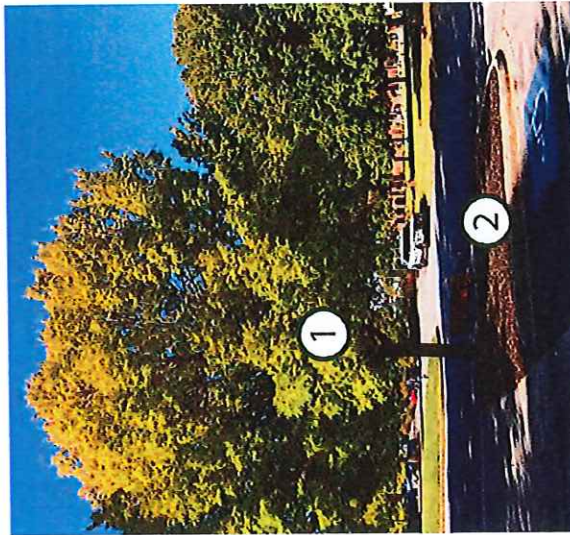

Islands at NPAC Accessible Parking

Greenville City Schools: Landscape Updates

MARCH 10, 2023



Landscape Recommendations:

- ① Prune Yew shrubs around Chinese Elms to a consistent height for clear sight line, or remove and plant low evergreen False Plum Yew.

Summary of Intent:
-Open views

Key Plan

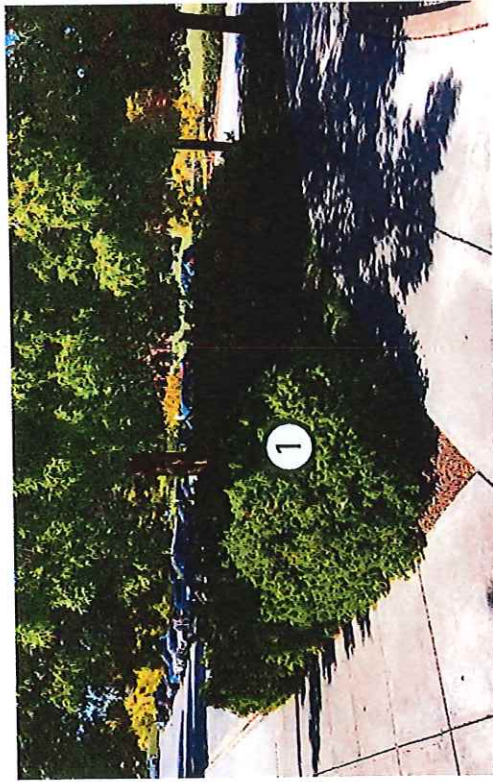
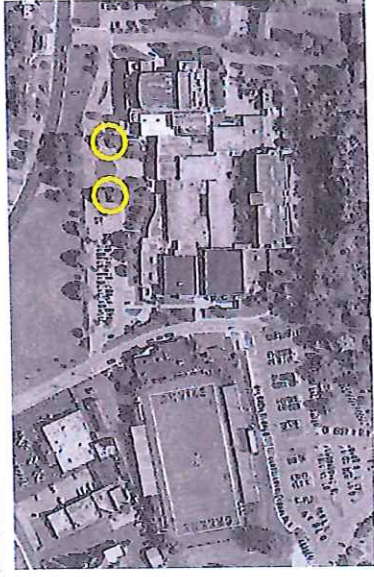

Addenda

Job: RFQ 2023 Comprehensive, one-time landscaping maintenance/rehabilitation proposal.

Addenda #1

Released April 14th, 2023.

The deadline for accepting proposals has been extended from May 5, 2023, until July 24, 2023, at 2:00 PM EST.

Proposals are to be turned in at the George Clem Operations Building located at 312 Floral Street 37743 as advertised in the Greeneville Sun.



Larry P. McCall – President/CEO
 Brad Hightower - Vice President
 Dennis Day- Vice President
 Eric McCall – Project Manager
 VA Contractors Lic. 2705-112238A



6248 Kingsport Hwy
 Gray, TN 37615
 Phone: (423)477-4882
 (423)477-3964
 Duns #:134220685



"The quality you expect....The service you deserve!"

proposal

TO: GREENEVILLE HIGH SCHOOL			DATE: 8/15/2023	OFFICE USE ONLY:
ADDRESS: 210 TUSCULUM BLVD			PROJECT NAME: BLACK VINYL CHAIN LINK FENCING & GATES	
CITY: GREENEVILLE	STATE: TN	ZIP CODE: 37745	PROJECT LOCATION: GREENEVILLE, TN	
PHONE:	FAX:		ARCHITECT/ENGINEER:	
ATTENTION: ESTIMATOR			DATE OF PLANS:	BY:

McCall Commercial Fencing is pleased to submit our PROPOSAL for furnishing the materials, labor and incidentals for the completion of:

MATERIALS AND LABOR TO INSTALL 284' OF 72" BLACK VINYL CHAIN LINK FENCING INCLUDING (1) 4' WALK GATE, (1) 8' DOUBLE DRIVE GATE WITH PANIC BAR DEVICES, AND (1) 22' DOUBLE DRIVE GATE. FENCING INCLUDES (3) STRANDS OF BARBED WIRE AT TOP OF FENCE AND BOTTOM TENSION WIRE. REMOVAL OF EXISTING FENCING INCLUDED.
TOTAL = \$23,768.00

NOTE: PROPOSED PRICING DOES NOT INCLUDE ANY OF THE ITEMS BELOW UNLESS SPECIFICALLY NOTED:
 DELEGATED DESIGN, ENGINEERING, STAKING, SURVEYING, EXCAVATION OF ROCK/PAVEMENT/CONCRETE,
 DEWATERING, GROUNDING OF FENCE, PREVAILING WAGE RATES, UNION FEES, PERMITS, OR BONDING.

ACCEPTED BY: _____ DATE: _____

All material is guaranteed to be as specified and the above work performed in accordance with the drawings and specifications submitted for the above work.

No allowance has been made for the establishment of the lines on which, or adjacent to which the fence is to be constructed. All surveying shall be the responsibility of the Prime Contractor or Owner

Unless otherwise noted no allowance has been made for bonding or a pro-rata share of the bonding. Upon request, McCall Commercial Fencing, Inc. shall present to the awarding contractor and owner, as needed, documentation demonstrating in force insurance meeting the requirements of this project, and shall keep such insurance in force for the duration of the work.

The awarding party assumes responsibility for the procurement of all needed permits. McCall Commercial Fencing shall, prior to beginning work obtain all applicable local licenses.

The work shall be completed in a workmanlike manner and in a timely fashion for the sum of **SEE ABOVE PRICING BREAKOUT**

(\$) with payments made as follows:

Payment in full within 30 calendar days of completion of the work.

Submitted by:

McCall Commercial Fencing

Dennis Day, Vice President

****This proposal may be withdrawn if not accepted in 30 days**

Accepted by:

Organization

Signature

Print Name/Position/Date

Attachment to this proposal are listed as follows:



McCALL COMMERCIAL FENCING
6248 KINGSPOUR HWY
GRAY, TN 37615
423-477-4882
www.mccallfencing.com
info@mccallfencing.com

CHAINLINK FENCE SPECIFICATION

FABRIC: 72" 9 GA FIN. EX BLACK (2" Mesh) KT VINYL CHAIN-LINK FABRIC.

TOP RAIL: 1 5/8" O.D. SWEDGE END BLACK PC LG-20 PIPE, 1.43 lbs. per foot. Top rail 21' in length.

LINE POST: 2 1/2" O.D. BLACK PC LG-20 PIPE CUT POST, 2.32 lbs. per foot. Line posts set 10' on center maximum spacing. Concrete footing: 12" diameter, 36" depth.

TERMINAL POST: 3" O.D. BLACK PC LG-20 PIPE CUT POST, 3.25 lbs. per foot. Concrete footing: 12" diameter, 36" depth.

BRACING: Terminal posts braced to the nearest line post with 1 5/8" O.D. SWEDGE END BLACK PC LG-20 PIPE.

GATES: SINGLE SWING GATE: Framework of 1 5/8" BLACK PC LG-20 PIPE, 1.43 lbs. per foot.
DOUBLE SWING GATE: Framework of 1 5/8" BLACK PC LG-20 PIPE, 1.43 lbs. per foot.
Gates braced and trussed as necessary. Same fabric as fence. Barbed wire included on all gates.

GATE POST: SINGLE SWING GATE: 3" O.D. BLACK PC LG-20 PIPE CUT POST, 3.25 lbs. per foot. Concrete footing: 18" diameter, 42" depth.
DOUBLE SWING GATE: 3" O.D. BLACK PC LG-20 PIPE CUT POST, 3.25 lbs. per foot. Concrete footing: 18" diameter, 42" depth.
DOUBLE SWING GATE: 4" O.D. BLACK PC LG-20 PIPE, 4.98 lbs. per foot. Concrete footing: 18" diameter, 42" depth.

TENSION WIRE: 6 GA. BLACK EX TENSION WIRE attached to bottom of fence fabric with 9 GA. BLACK HM VINYL PS 1 9/16" HOG RING spaced 24" on center.

BARBED WIRE: 3 strands of 12 1/2 GA. BLACK FB 4 PT (5" Sp.) BARBED WIRE on BLACK HM VINYL PS 45 Degree 6-WIRE ECONOMY BARB ARM.

FITTINGS: BLACK POWDER COATED PS PLAIN BRACE BAND & BLACK CARRIAGE BOLT W/NUT, BLACK POWDER COATED PS COMBO RAIL END, BLACK HM VINYL PS 45 Degree 6-WIRE ECONOMY BARB ARM, BLACK POWDER COATED ALUMINUM DOME CAP, BLACK HM VINYL 3/4" PS TENSION BAR, BLACK POWDER COATED PS PLAIN TENSION BAND & BLACK CARRIAGE BOLT W/NUT

TIE WIRE: 8 1/4" BLACK ALUMINUM CUT/HOOK 6 GA. TIE WIRE & 6 1/2" BLACK ALUMINUM CUT/HOOK 6 GA. TIE WIRE spaced 15" on center for line posts & 24" on center for rails.

POST FOOTING: HAND MIXED 80 LB BAGS CONCRETE.

120"

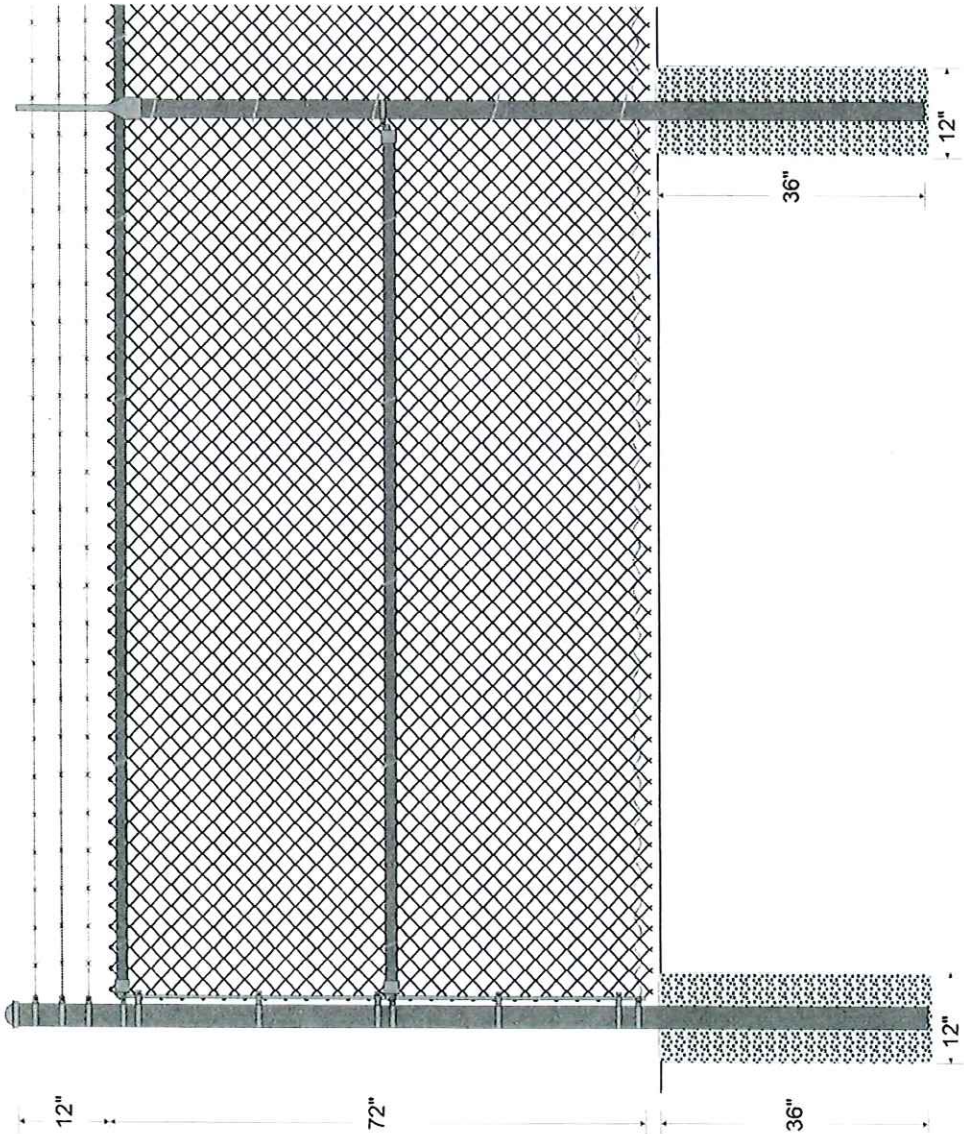

FABRIC: 72" 9 GA FIN. EX BLACK (2" Mesh) KT VINYL CHAIN-LINK FABRIC.

TOP RAIL: 1 5/8" O.D. SWEDGE END BLACK PC LG-20 PIPE, 1.43 lbs. per foot. Top rail 21" in length.

LINE POST: 2 1/2" O.D. BLACK PC LG-20 PIPE CUT POST, 2.32 lbs. per foot. Line posts set 10' on center maximum spacing. Concrete footing: 12" diameter, 36" depth.

TERMINAL POST: 3" O.D. BLACK PC LG-20 PIPE CUT POST, 3.25 lbs. per foot. Concrete footing: 12" diameter, 36" depth.

BRACING: Terminal posts braced to the nearest line post with 1 5/8" O.D. SWEDGE END BLACK PC LG-20 PIPE.

TENSION WIRE: 6 GA. BLACK EX TENSION WIRE attached to bottom of fence fabric with 9 GA. BLACK HM VINYL PS 1 9/16" HOG RING spaced 24" on center.

BARBED WIRE: 3 strands of 12 1/2 GA. BLACK FB 4 PT (5" Sp.) BARBED WIRE on BLACK HM VINYL PS 45 Degree 6-WIRE ECONOMY BARB ARM.

FITTINGS: BLACK POWDER COATED PS PLAIN BRACE BAND & BLACK CARRIAGE BOLT WINUT. BLACK POWDER COATED PS COMBO RAIL END, BLACK HM VINYL PS 45 Degree 6-WIRE ECONOMY BARB ARM. BLACK POWDER COATED ALUMINUM DOME CAP. BLACK HM VINYL 3/4" PS TENSION BAR. BLACK POWDER COATED PS PLAIN TENSION BAND & BLACK CARRIAGE BOLT WINUT.

TIE WIRE: 8 1/4" BLACK ALUMINUM CUT/HOOK 6 GA. TIE WIRE & 6 1/2" BLACK ALUMINUM CUT/HOOK 6 GA. TIE



McCALL COMMERCIAL FENCING
6248 KINGSPOUR HWY
GRAY, TN 37615
423-477-4882

GREENEVILLE HIGH SCHOOL
GRAY, TN

Drawn: 08/14/2023
File: GREENEVILLE HIGH SCHOOL F

LINE OF FENCE

RESOLUTION

A RESOLUTION AUTHORIZING GREENEVILLE CITY SCHOOLS TO PARTICIPATE IN PUBLIC ENTITY PARTNERS PROPERTY (PEP) CONSERVATION MATCHING GRANT PROGRAM.

* * * * *

WHEREAS, the citizens of Town of Greeneville, Tennessee have entrusted this administration with the care and custody of city-owned property; and

WHEREAS, all efforts shall be made to protect city-owned property from various perils that may arise for the Town of Greeneville; and

WHEREAS, PEP seeks to encourage members with property coverage to develop and implement a property conservation program by offering the **PROPERTY CONSERVATION MATCHING GRANT PROGRAM:** and

WHEREAS, Greeneville City Schools now seeks to participate in this important program.

NOW, THEREFORE BE IT RESOLVED BY THE BOARD OF EDUCATION OF GREENEVILLE CITY SCHOOLS OF GREENEVILLE, TENNESSEE the following:

SECTION 1. That Greeneville City Schools is hereby authorized to submit application for the *Property Conservation Matching Grant Program* through Public Entity Partners.

SECTION 2. Greeneville City Schools is further authorized to provide a matching sum to serve as a match for any monies provided by this grant.

Resolved this 26th day of September in the year of 2023.

Chairman Board of Education

ATTEST:

Director of Greeneville City Schools

CFO Greeneville City Schools

Beverly Miller

From: Tahtia Mitchell <TMitchell@PEpartners.org>
Sent: Tuesday, September 12, 2023 12:58 PM
To: Beverly Miller
Subject: SAFETY PARTNERS GRANT NOTIFICATION LETTER

WARNING: This email originated from outside of the Greeneville City Schools network. Do not click links or open attachments unless you recognize the sender and know the content is safe.



September 12, 2023

Greeneville City Schools
129 W. Depot Street
Greeneville, TN 37743

Subject: “SAFETY PARTNERS” MATCHING GRANT – APPROVED STATUS

Congratulations! This letter serves as official notification to the Greeneville City Schools that you have been **approved** for the 2023-2024 “Safety Partners” Matching Grant Program, for which you applied.

A Grant in the amount of \$2,000.00 was approved for your requested items. The PAID receipts for the approved items along with the invoices for the approved items must amount to at least \$4,000.00 to be eligible to receive the full reimbursement of \$2,000.00. Your 2023-2024 Priority Classification Rating is Class III.

Important! The deadline for all reimbursement receipts is April 1, 2024. If you have already sent us **proof of payment** for approved purchases, you will be receiving your Grant check shortly. If you have not sent this information, please do so by **April 1, 2024**, along with a copy of this notification. Please keep in mind that if we do not receive reimbursement items in a timely manner you may jeopardize your eligibility to receive funding the following fiscal year. If proof of payment is not received by this date, your reimbursement dollars may be reappropriated. Your check will not be processed until we have verification of payment. Please see list of mandatory items needed for reimbursement below.

GRANT REIMBURSEMENT CHECKLIST:

1. **“Notification of Approval” letter**
2. **Signed Resolution/Motion**
3. **Cover sheet listing description of items purchased, quantities, and grand total of all purchases. All receipts must follow in order of cover sheet.**
4. **Two proofs of payment which must include the following:**

- A. CANCELLED check/bank statement OR credit card receipt/credit card statement OR Automated Clearing House (ACH) OR Automated Funds Transfer (AFT)**
- B. Copy of invoice OR purchase order (serving as the backup to the cancelled check or credit card receipt). Submitting invoices alone will not be accepted.**

**Forward all receipts/documentation to:
Tahtia Mitchell
Grant & Scholarship Program
Email: Tmitchell@PEpartners.org or Fax: 615-371-9212**

Best Regards,

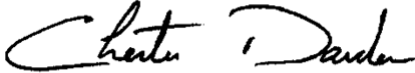

Chester Darden
Director of Loss Control

RESOLUTION

A RESOLUTION AUTHORIZING GREENEVILLE CITY SCHOOLS TO PARTICIPATE IN Public Entity Partners "Safety Partners" MATCHING GRANT PROGRAM.

* * * * *

WHEREAS, the safety and well-being of the employees of Greeneville City Schools is of the greatest importance; and

WHEREAS, all efforts shall be made to provide a safe and hazard-free workplace for Greeneville City School employees; and

WHEREAS PEP seeks to encourage the establishment of a safe workplace by offering a "Safety Partners" Matching Grant Program"; and

WHEREAS, Greeneville City Schools now seeks to participate in this important program.

NOW, THEREFORE BE IT RESOLVED BY THE BOARD OF EDUCATION OF GREENEVILLE CITY SCHOOLS OF GREENEVILLE, TENNESSEE the following:

SECTION 1. Greeneville City Schools is hereby authorized to submit application for a "Safety Partners" Matching Grant Program through PEP.

SECTION 2. Greeneville City Schools is further authorized to provide a matching sum to serve as a match for any monies provided by this grant.

Resolved this 26th day of September in the year of 2023.

Chairman Board of Education

ATTEST:

Director of Greeneville City Schools

CFO Greeneville City Schools



August 11, 2023

**Greeneville High School
210 Tusculum Blvd
Greeneville, TN 37743**

**Attn: Beverly Miller/Assistant Director of Schools for Administration/Chief
Technology Officer**

To whom it may concern

**Please accept this letter as notification that Coldesi, Inc. is the Sole and Exclusive
Distributor/Source for the Digital Heat FX DTF-24H2 Printer for North America.
Our Rip software is proprietary software for this piece of equipment that you will
be purchasing. The supplies that are included with our equipment are put together
by us. Our training and support are unlimited, and it is a service provided by no
other. If you have any questions or concerns, please contact mputnam@coldesi.com.**

Regards,

**Alex Duran
Sales Manager
Coldesi Inc,
877.793.3278 ext 1012
aduran@coldesi.com**

coldesi.com

HEADQUARTERS: 4537 South Dale Mabry Highway, Tampa, FL 33611 • 877-793-3278 [Toll-free] • 813-832-6830 [Local]
DISTRIBUTION CENTER: 3634 131st Avenue North, Clearwater, FL 33762 • 877-793-3278 [Toll-free] • 813-832-6830 [Local]



Headquarters: 4537 S. Dale Mabry Hwy., Tampa, FL 33611
 New Jersey: 1602 Lawrence Avenue, Ocean, NJ 07712
 Toll Free: 877-793-3278 Fax: 813-315-7007
 Email: sales@coldesi.com

Date	Sales Rep	Expires	Terms
8.11.23	Mike Putnam ext 1037	8.11.23	Due on Approval of Quote

Bill To					Ship To						
Company	Greeneville High School				Company	Greeneville High School					
Contact	Cody Baugh				Contact	Cody Baugh					
Address	210 Tusculum Blvd				Address	210 Tusculum Blvd					
City	Greeneville	State	TN	Zip	37743	City	Greeneville	State	TN	Zip	37743
Phone	(423) 552-0247	Email	baughc@gcschools.net			Phone	(423) 552-0247	Email	baughc@gcschools.net		

QTY	PART #	DESCRIPTION	RETAIL PRICE	SALE PRICE
1	DTF-24H2	Digital Heat FX-DTF-24H2-2 Head DTF Printer and Powder Applicator	\$25,995.00	\$23,995.00
1	DTF-PO-V2-Software	DTF Print Optimizer V2 Keyless Software	\$995.00	Included
1	DTF-Warranty	1-Year Warranty – Coldesi		Included
1	DTF-24H2-Start Up Kit	DTF-24H2-Start Up Kit: Online Training, Assembly, Support, Access to installation instructions and videos on Training website 2 - DTF White Ink 500ml each DTF CMYK Ink 500ml each 4 - DTF Adhesive White Powder 1 lb DTF Empty Tube, Flat Teflon 1721, DTF Head Cleaner, 150 Clean Wipes - 4x4, Clean Solution, 10-Foam Brush and DTF Film 60x100m	\$2,115.70	Included

CUSTOMIZED OPTIONS MENU				
1	DTF-Black-500	DTF Black Ink -500ml	\$45.00	\$45.00
1	DTF-Cyan-500	DTF Cyan Ink -500ml	\$45.00	\$45.00
1	DTF-Magenta-500	DTF Magenta Ink -500ml	\$45.00	\$45.00
1	DTF-Yellow-500	DTF Yellow Ink -500ml	\$45.00	\$45.00
6	DTF-White-500	DTF White Ink -500ml	\$56.00	\$336.00
2	DTF-Film-24	DTF Film 60 x 100M I Series	\$219.00	\$438.00
9	DTF-Pow-1lb	DTF Adhesive White Powder- 1Lb	\$18.99	\$170.91
1	DTF-400-Extractor	DTF SP400 Extractor	\$2,900.00	\$2,900.00
1	DTF-24H2-Extractor-Kit	DTF 24H2 Dryer Extractor Connection Kit: exhaust Tubing 2in Diameter by 4m, Stainless Steel Hose Clamp, 4in. X 2 in. Flexible PVC Coupling	\$99.95	Included
2	DK20A	16" x 20" Clam Shell Auto Release Heat Press	\$1,650.00	\$3,300.00
2	Store-Coupon-50	\$50 store Coupon for your supply needs	\$50.00	\$100.00 BONUS
3-4 weeks to process and ship				

ColDesi Secure-Ship Policy: ColDesi is committed to fighting fraud and keeping yours and your businesses finances safe! That's why we've implemented full payment security validation steps BEFORE any machine leaves our facility. These payment security steps are designs specifically to make sure that no one is using your information to buy equipment and that you are never charged for something you did not order. Secure-Ship validation will take between 3 and 5 businesses days on all forms of payment except for direct wire transfers. Transactions involving a credit card, cashier's check, bank check or personal check will all be subject to our full payment security validation . No equipment will be shipped before our Secure-Ship check is complete. Thank you for your patience and thank you for choosing ColDesi!	Total	\$31,319.91
	July Discount	(\$2,000.00)
	Sub Total	\$29,319.91
	FL Sales Tax	
	Freight & Ins	\$1750.00 FREE
Grand Total	\$29,319.91	

All orders are shipped Freight Collect, F.O.B Tampa, freight and insurance paid by buyer. I have read, understand and accept the terms of the Agreement and Limited Warranty, and agree that the terms and conditions of the Agreement and Limited Warranty, the terms and conditions of which are hereby incorporated by reference into this Quote/Sales Order. This Quote/Sales Order is not considered valid without the signature of Scott Colman, President, Linda Shahvaran, General Manager, or Alex Duran, Sale Manager.

Authorized Agent:		Dated:		Coldesi Management:	
--------------------------	--	---------------	--	----------------------------	--



Quote Number: QUOTE-2319807

Billing Address:
 Greenville City Schools
 129 W Depot Street, Ste 4
 Greenville TN, 37743

Quote Name: Qty 21 School Bus radios
Quote Date: 2023-09-07
Expiration Date: 2023-12-06
Contract Name: SWC 424

Quote Created By:
 Jimmy Hayes, Jr.

jimmy.hayes@metrocomm2way.com

Customer: Greenville City Schools
Contact Name: Phillip Graham
Contact Email: grahamp@gcschools.net

Currency: USD

Quote Summary: This quote is for 21 APX1500 mobile radios for buses. These are dash mount radios with low profile 2.6" antennas. No programming or installation has been included on this quote.

Terms and Conditions: none

Line #	Item Number	Description	Quantity	Unit List Price	Ext. List Price	Discount %	Discount \$	Unit Sale Price	Ext. Sale Price	APC	Parametric Data
	APX™ 1500 Enhanced										
1	M36URS9PW1BN	APX1500 ENHANCED 7/800 MHZ MOBILE.	21	\$1,932.32	\$40,578.72	28.00%	\$541.05	\$1,391.27	\$29,216.67	0466	
1a	GA00235AA	ADD: NO GPS ANTENNA NEEDED APX.	21	\$0.00	\$0.00	0.00%	\$0.00	\$0.00	\$0.00	0466	
1b	G66BF	ADD: DASH MOUNT O2 APXM.	21	\$138.00	\$2,898.00	28.00%	\$38.64	\$99.36	\$2,086.56	0466	
1c	GA00580AA	ADD: TDMA OPERATION.	21	\$495.00	\$10,395.00	28.00%	\$138.60	\$356.40	\$7,484.40	0466	
1d	G142AD	ADD: NO SPEAKER APX.	21	\$0.00	\$0.00	0.00%	\$0.00	\$0.00	\$0.00	0466	
1e	GA05100AA	ADD: STD WARRANTY - NO ESSENTIAL.	21	\$0.00	\$0.00	0.00%	\$0.00	\$0.00	\$0.00	0185	
1f	GA00804AA	ADD: APX O2 CH (GREY).	21	\$541.00	\$11,361.00	28.00%	\$151.48	\$389.52	\$8,179.92	0466	
1g	W969BQ	ADD: MULTIKEY OPERATION.	21	\$95.00	\$1,995.00	28.00%	\$26.60	\$68.40	\$1,436.40	0466	
1h	GA01339AA	ENH: SW P25 TRUNKING.	21	\$1,177.00	\$24,717.00	28.00%	\$329.56	\$847.44	\$17,796.24	0466	
1i	G444AH	ADD: APX CONTROL HEAD SOFTWARE.	21	\$0.00	\$0.00	0.00%	\$0.00	\$0.00	\$0.00	0466	
1j	W22BA	ADD: STD PALM MICROPHONE APX.	21	\$79.00	\$1,659.00	28.00%	\$22.12	\$56.88	\$1,194.48	0466	
1k	QA09113AB	ADD: BASELINE RELEASE SW.	21	\$0.00	\$0.00	0.00%	\$0.00	\$0.00	\$0.00	0466	
1l	G193AK	ADD: ADP ONLY (NON-P25 CAP COMPLIANT) (US ONLY).	21	\$0.00	\$0.00	0.00%	\$0.00	\$0.00	\$0.00	0466	
1m	G174AD	ADD: ANT 3DB LOW-PROFILE 762-870.	21	\$47.00	\$987.00	28.00%	\$13.16	\$33.84	\$710.64	0466	

Net Total \$68,105.31
Estimated Tax \$0.00
Estimated Freight \$0.00
Grand Total \$68,105.31

SWC# 424 – Motorola Radio Equipment and Services **Contract Information and Usage Instructions**

Summary/Background Information: The State has restructured its Supply Base in order to support the three most important Radio Equipment suppliers used by the State and Local Governments. Instead of the nine suppliers contracted under the old radio contract SWC 418 we have established two SWC's; SWC 423 to cover the products and services of JVCKenwood and BK Technologies. The JVCKenwood and BK Tech contracts are under the overall Naspo Participating Addendum to contract 06913 Public Safety Radio Equipment and SWC 424 which is a State of Tennessee contract dedicated to Motorola Solutions Products and Services. All radio contracts are catalog based.

Contractor/Edison Contract Number:

Motorola Solutions, Inc.

Edison Contract Number: 65725

Contract Period:

Term: 5-Years

Start: March 15, 2020

Expiration: March 14, 2025

Contacts:

State Contact Information

Contract Administrator:

Richard Kotler

Central Procurement

(615)-253-4723

Richard.Kotler@tn.gov

Contractor Contact

Account Executive

Mike Wagner

303-859-1332

mike.wagner@motorolasolutions.com

Access to Contract Documents Online:

1. Please check the following URL to ensure you are viewing the most recent version of the usage instructions:

<https://www.tn.gov/content/tn/generalservices/procurement/central-procurement-office-cpo-/state-agencies-/statewide-contract-instruction--swc-.html>

2. Click on the "Statewide Contract (SWC) Search" The link below will take you to the

Statewide Contract List.

- Scroll down the list of contracts and locate the contract number you need. Click on the picture of a folder under the “Details” column.
- You will get a rectangular box and one of the columns (to the right) will say “Contract Documents”, and below will be a picture of a file folder, click on it and you will get a new box with multiple contract documents shown. Click on the picture of the document to view the attachment.

https://hub.edison.tn.gov/psp/paprd/SUPPLIER/ERP/c/TN_PUBLIC_SUPPLIER.TN_ACTIVE_SWC_CM.P.GBL?Page=TN_ACTIVE_SWC&Action=U&ExactKeys=Y&TargetFrameName=None

Motorola Tennessee Dealer Network

- **Critical Tech Solutions (CTS)** 2948 Middlebrook Pike, Knoxville, TN : Contact: Mark Dorn, 865-202-6603, Email: mark@criticalts.com
- **Metro Communications, LLC**, 1210 Elm St Knoxville, TN: Contact: Jimmy Hayes, 865-546-0311, Email: jimmy.hayes@metrocomm2way.com
- **Integrated Communications, Inc.;** 6630 Reese RD Memphis, TN: Contact: Jim Marineau, 901-366-4412; Email: jim.marineau@iciwireless.com
- **Nashville Communications:** 330 Plus Park Blvd Nashville, TN: Contact: Lance Marrow, 615-255-5670; Email: lanec@nashvillecomm.com
- **Mobile Communications of America (MCA):** 1201 Crutchfield St Chattanooga, TN: Contact: Danny Moseley, 423-698-3306; Email: dannyloseley@callmc.com
- **Wireless Plus, Inc.:** 1136 Myatt BLVD, Madison, TN; 615-333-0108; Contact: Mark Walker, Email: mwalker@wirelessplusinc.com
- **Gemini Communications:** 318 Baker ST, Murfreesboro, TN: Contact: Jim Lowe; 615-895-5956; Email: Jim_Lowe@bellsouth.net
- **Integrated Communication, Inc.:** 335 Bellevue ST Jackson, TN; Contact: John Atkinson, 731-427-9851, Email: John.atkinson@iciwireless.com

Use of Third Party Resellers

State Agencies

1. The provisions of the contracts do not permit direct transactions or establishment of a legal obligation with the contracted parties resellers by State Agencies. Although the contracted party may have their reseller network perform work, such as, warranty, on-site installation, repair or other activities for the contracted party. This work must be the

result of a transaction initiated between the State and the Contracted Party (Contractor) where the Contracted Party incurs a legal obligation pursuant to the Terms and Conditions of the Contract. Examples of the transactions to the Contracted Party are, but not limited to: Issuance of a Purchase Order for Goods and or Services, Performance/Response to a Warranty Claim, Issuance and response to a Return Material Authorization, and Performance of Maintenance/Repair services that have been purchased and Premium Service Plans.

2. It is incumbent upon the Contracted Party to be the entity that receives requests for quotes, receives purchase orders from the State, be responsible for the shipment of purchased goods, be the party to submit invoices to the State and, in turn, be the recipient of payment for all goods and services provided. The State will not issue Purchase Orders to, nor pay for contracted goods and services to any third party that may perform any services, on behalf of the contracted party, that are covered by this Statewide Contract.

Authorized Users -- Statewide Contract. This Contract establishes a source or sources of supply for all Tennessee State Agencies. "Tennessee State Agency" refers to the various departments, institutions, boards, commissions, and agencies of the executive branch of government of the State of Tennessee with exceptions as addressed in Tenn. Comp. R. & Regs. 0690-03-01-.01. The Contractor shall provide all goods or services and deliverables as required by this Contract to all Tennessee State Agencies.

The Contractor shall make this Contract available to the following entities, who are authorized to and who may purchase off of this Statewide Contract ("Authorized Users"):

- a) all Tennessee State governmental entities (this includes the legislative branch; judicial branch; and, commissions and boards of the State outside of the executive branch of government);
- b) Tennessee local governmental agencies;
- c) the board of trustees of the University of Tennessee system, the Tennessee board of regents system, or the State university boards;
- d) any private nonprofit institution of higher education chartered in Tennessee; and,
- e) any corporation which is exempted from taxation under 26 U.S.C. Section 501(c)(3), as amended, and which contracts with the Department of Mental Health and Substance Abuse Services or the Department of Intellectual and Developmental Disabilities to provide services to the public (Tenn. Code Ann. § 33-2-1001).

These Authorized Users may utilize this Contract by purchasing directly from the Contractor according to their own procurement policies and procedures. The State is not responsible or liable for the transactions between the Contractor and Authorized Users.

Local Government Entity Instructions:

1. Local governments and other eligible entities are encouraged to use this contract.
2. Local entities should contact the vendor with respect to how they would like to conduct business transactions.
3. The State requires the Contractor to report all sales to Local Government entities making use of the State contract.

Directors Update to the Board

Tuesday, September 26, 2023

1. Congratulations to all our Level 5 Schools who were recognized tonight and to the district for its recognition for Level 5 Growth. Growth is about meeting students where they are, and the goal is to provide a year's growth which is measured as Level 3. Level 5 represents that there was substantial evidence that there was more than a year's worth of growth. So that is quite an accomplishment by students, teachers, and staff.
2. Congratulations to the Greene Devil Baseball team on their 2023 TSSAA State Championship. I had the honor of watching the game and it was very exciting. It was an extremely hard-fought contest and our guys showed grit and determination to bring home the trophy.
3. Congratulations to Jayquan Price on winning a TSSAA State Championship in the Long Jump and the Triple Jump. There is an old athletic adage that you always want to perform your best on the biggest stage and never has that been more true than with Jayquan as he had personal best performances in both events at the State Meet.
4. Congratulations to Greeneville High School student, teachers, and staff on being recognized as a US News and World Report Best High School! GHS was the eleventh ranked Traditional Public High School in TN (22nd including Magnet and Charter Schools) and rank in the Top 10% of High Schools in the Nation!

https://www.usnews.com/education/best-high-schools/tennessee/districts/greeneville/greeneville-high-school-17984#test_scores_section

5. On Friday, September 1, 2023, GHS served as the host for the GCS Tech Blitz. Beverly and her team did a phenomenal job planning, organizing, and providing a great day of learning for district staff. A total of over 500 pre-registered for the event. Steve Dembo, a nationally recognized speaker on technology topics, was the keynote speaker sharing about Artificial Intelligence and ChatGPT. There were over 100 additional sessions provided for participants as well. It was a great day of learning and professional development for all who attended.
6. I want to recognize and congratulate our School Nutrition Dept. Our fall cafeteria health inspections have been completed for all schools and I am excited to report that every school cafeteria received a score of 100! Congratulations to each Cafeteria Manager and their staff on this outstanding accomplishment. I also want to recognize Karen Wilhoit and her team for their leadership and support.

7. The Greeneville City Schools' community continues to mourn the loss of one of our beloved Greeneville Middle School students. Kaden Gunter, 7th grade student, was loved by his classmates, his teachers, his principals, and the entire GMS staff. Kaden was a member of the GMS Greene Devil Football Team. I want to thank our counselors and mental health staff for providing numerous supports this week for GMS students, faculty, and staff as they grieve this tremendous loss. Our thoughts and prayers are with Kaden's family, friends, classmates, and the entire GMS staff. We also want to thank our other schools, schools across East TN. and the community for their outpouring of support during this extremely difficult time. It has certainly been a blessing. Arrangements are being handled by Doughty-Stevens Funeral Home.

Respectfully submitted by Steve Starnes