

GREENEVILLE CITY BOARD OF EDUCATION

AGENDA

Date of Meeting: June 22, 2023

Time: Following the joint meeting

Location: Greene Technology Center

- I. **Call to Order**
- II. **Recognition of Visitors**
- III. **Special Recognition**
 - Chuck Broyles
 - Ellen Lipe
- IV. **Approval of Agenda**
- V. **Consent Agenda** (5 minutes)
 - A. Consideration of Approving Minutes of May 15, 2023, Board Meeting
 - B. Consideration of Accepting Personnel Report
 - C. Consideration of Approving Board Policy Revisions (2nd Reading)
 - D. Consideration of Approving Board Policy Revisions-No Changes (1st Reading)
 - E. Consideration of Approving 2023-24 Paper Contract for District
 - F. Consideration of Approving School Trip Request
 - G. Consideration of Approving Carmen Cox Scholarship Recipients
 - H. Consideration of Approving 2023-2024 Differentiated Pay Plan
 - I. Consideration of Approving 2023-24 School Nutrition Budget
 - J. Consideration of Approving 2023-24 Extended School Program Budget Amendment

- K. Consideration of Approving Final Fiscal Year 2023 Federal Projects Budget Amendment
 - L. Consideration of Approving 2023-2024 Federal Projects Budget
 - M. Consideration of Approving Purchase of Custodial Supplies and Equipment
- VI. **Action Item**
- A. Consideration of Accepting May 2023 Financial Statements (5 minutes)
 - B. Consideration of Approving Board Policy Revisions - (1st Reading) (5 minutes)
 - C. Consideration of Purchasing Vehicle for Family Resource Center Use to Support ARP 2.0 Homeless and Title V-Parent and Family Engagement (5 Minutes)
 - D. Consideration of Approving to Purchase GHS Video Production Computer Systems (5 Minutes)
 - E. Consideration for Approval to Purchase GHS Engineering Program Equipment (10 minutes)
 - F. Consideration of Approving Final 2022-2023 General Purpose Budget Amendment (5 minutes)
 - G. Consideration of Approval of Insurance Coverage for 2023-2024 (5 Minutes)
- VII. **Director's Report** (5 minutes)
- VIII. **Board Chair's Comments** (5 Minutes)
- IX. **Adjournment**

**OFFICIAL MINUTES OF THE
GREENEVILLE CITY BOARD OF EDUCATION
May 15, 2023**

The Greeneville City Board of Education met in Regular session on May 15, 2023, at the Professional Development Center at the Kathryn W. Leonard Administrative Office. Members in attendance were **Present:** Pam Botta (Board Member), Crystal Hirschy (Board Member), Cindy Luttrell (Chair), Josh Quillen (Treasurer), Dr. Craig Shepherd (Vice-Chair), and Asher Rogers (Student Board Representative). Others in attendance included Steve Starnes, Director of Schools; several administrative personnel; and media representatives. The Chair called the meeting to order and welcomed all in attendance. Student representative Rogers led in the pledge of allegiance to the flag.

BUSINESS TRANSACTED

I. Call to Order

II. Recognition of Visitors

III. Special Recognitions

- **Greeneville City Schools Education Foundation (GCSEF) Character Ed Students**

Amanda Waddell, GCSEF Executive Director, presented the awards. GCSEF donates to a selected charity on behalf of the student awarded the GCSEF Character Ed Award.

GHS			Parents				Charity	
Ty Thompson			Daniel and Jodie Thompson				Isaiah 117 House	
Faith Schubert			Mike and Amanda Schubert				Hope Center	
GMS								
Trey Bailey			Kenneth and Sandy Bailey				Isaiah 117 House	
Vivian Kammerdiener			Donny and Jennifer Kammerdiener				Isaiah 117 House	
Eastview								
Truett Shelton			Samantha Shelton and James Shelton				CASA of Northeast TN	
Melyna Doty			Lynn and Jama Doty				Greeneville Greene Co Humane Society	
Hal Henard								
Miles Reneau			Michael and Julie Reneau				Cystic Fibrosis Foundation, in honor of Jessica Streib	
Magdalyn "Maggie" Moore			Nicolle and Derrick Moore				Shriners Hospital, in honor of Trisha Wilhoit	
Highland								
Daunte Webb			Scenysa Dickenson				ALSAC/St. Jude Childrens Research	
Ja Farrah Freeman			Mr. Brennard and Mrs. Sharon Claridy				St. Jude Childrens Research Hospital	
Tusculum View								
Maps Gray			Jeremy and Crystal Gray				Greeneville Greene Co Humane Society	
Zaelyn Fillers			Sarah Fillers and Nick Fillers				Girl Scouts Troop 1090 Bronze Project	

- **Greeneville High School ACT 30+ students**

Dr. Suzanne Bryant, Assistant Director for Instruction, presented the GHS ACT 30+ recognition. The ACT 30+ students scored 30 or higher on ACT.

William Armstrong	Maggie Hartman	Carolyn Sauceman
Anna Benson	Zach Hayes	Faith Shubert
Madelyn Bowman	Luke Harrell	Drew Shelton
Madelyn Bowman	Joshua Hyde	Levi Tipton
Marly Burns	Kaitlyn Marion	Kaiden Trebal
Brenan K Spear	Delaina Martin	Alden Wakefield
Ainsley Ford	Zach Neeson	Madison Wilkerson
Cooper Graham	Alison Rai	Nicholas Wright
Marly Gross	Asher Rogers	

- **Tusculum College Math Winners**

Dr. Suzanne Bryant, Assistant Director for Instruction, presented the Tusculum College Math Winners. The following Greeneville High School students participated in the TMTA Math Contest at Tusculum University on April 4, 2023, and finished in the top three. These students' scores will advance on to the regional competition and then hopefully on to the state level.

Algebra 1: Gabriel Oakley (1st)
 Jayce Land (2nd) Tie
 Anthony Mascola (2nd)

Algebra 2: Annika Vines (1st)
 Eady Wright (2nd)
 Gwendolyn Marion (3rd)

Geometry: Jackson Lampe (1st)
 Zachary Howard (3rd)

Pre-Calculus: Riley Castro (2nd)
 Skyler Zou (3rd)

Statistics: Alex Vertiz-Ramos (3rd)

Calculus: Zachary Hayes (1st)
 Alden Wakefield (2nd)
 Luke Herrell (3rd)

- **Microsoft Academy Scholars**

Beverly Miller, Assistant Director for Administration, and Melissa Babb, GHS Business and Yearbook Instructor, presented this national recognition.

Microsoft Office Specialist-Associate (Certified in Word, Excel, and PowerPoint)

Paul Anderson	James Gudger	Om Patel
Devyn Berrier	Julissa Hernandez	Lily Propst
Kyndall Brewer	Mattison Hughes	Andrew Shelton
Madison Carpenter	Erica Jones	Emma Shelton
Riley Castro	Anne Marie Konieczny	Jordan Swatzell
Jayden Deeble	Jayce Land	Kaden Triebel
Hailee Dingus	Maggie Morelock	Solona Trohon
Sydney Doane	Kaylee Myers	Diana Vertiz-Ramos
McKinley Freeman	Sidney Najjar	Shilo Wang
Matea Gray	Gabriel Oakley	

Microsoft Office Specialist-Expert

(Microsoft Office Specialist - Associate plus two or more of the following: Word Expert, Excel Expert, and/or Access Expert)

- Jayden Deeble (Word Expert, Excel Expert)
- Caleb Ford (Word Expert, Excel Expert, Access Expert, plus Outlook)
- Mattison Hughes (Word Expert, Access Expert, Excel Expert)
- Abby Lane (Word Expert, Access Expert)
- Jeeya Patel (Word Expert, Excel Expert, Access Expert)
- Kaden Triebel (Excel Expert, Access Expert)
- Shilo Wang (Word Expert, Access Expert, Excel Expert)

IV. Approval of Agenda

It was recommended to approve the Agenda as presented. Board approval was unanimous on a motion from Botta (Board Member) and a second from Hirschy (Board Member).

V. Consent Agenda

It was recommended to approve the Consent Agenda as presented. Board approval was unanimous on a motion from Hirschy (Board Member) and a second from Botta (Board Member).

A. Consideration of Approving Minutes of April 27, 2023, Board Meeting

Minutes of the April 27, 2023, Board meeting were unanimously approved as presented. A copy is on file in the Director of Schools' office.

B. Consideration of Accepting Personnel Report

Board approval was unanimous for acceptance of the changes in personnel since the April report. A copy of the report is attached to the minutes.

C. Consideration of Approving Board Policy Revisions (2nd Reading)

Board approval was unanimous on 2nd reading for the following policies:

1.202 Duties of Board Members
1.203 New Member Orientation
1.204 Board Member Development Opportunities
1.205 Board-Director Relations
1.300 Board Committee
1.301 Executive Committee
1.302 School Attorney
1.303 Consultants
1.400 School Board Meetings
1.401 Public Hearings
1.402 Notification of Meetings
1.403 Agendas
2.404 School Support Organizations
2.808 Purchase Orders and Contracts
2.900 Student Activity Funds Management
4.400 Textbooks and Instructional Materials
4.501 School Volunteers
4.606 Graduation Activities
4.804 Religious Content of Courses
5.602 Time Schedules and Extra Duty
5.604 Overtime Pay
5.605 Staff Gifts and Solicitations
5.606 Political Activities
5.607 Non-School Employment
5.608 Tutoring for Pay
6.410 Emergency Contact Information
6.411 Student Wellness
6.412 Emergency Allergy Response Plan
6.413 Prevention and Treatment of Sports Related Concussions
6.414 Prevention and Treatment of Sudden Cardiac Arrest
6.415 Student Suicide Prevention

Copies of these policies are attached to the minutes.

D. Consideration of Approving Board Policy Revisions - No Changes (1st Reading)

Board approval was unanimous on 1st reading for the following policies:

4.207 English Learners
4.302 Field Trips and Excursions
4.502 Parent and Family Engagement
5.610 Staff-Student Relations
5.611 Ethics
5.700 Interim Employees

5.701 Substitute Teachers
5.702 Student Teachers
5.800 Director of Schools' Role, Recruitment and Selection
5.802 Director of Schools' Duties
5.803 Evaluation of the Director of Schools
6.600 Student Records
6.601 Student Records Annual Notification of Rights
6.602 Inspection and Correction of Student Records
6.604 Media Access to Students
6.704 Student Publications
6.709 Student Fees and Fines
6.710 Gifts

E. Consideration of Approving School Trip Request

Board Policy 4.302 specifies that the Board must approve field trips that are both overnight and out-of-state. Additionally, approval is required when students must leave school early for participation in athletic events.

- Greene Technology Center is requesting approval to travel to SkillsUSA National Competitions in Atlanta, GA from June 19, 23 through June 25, 2023.

Board approval was unanimous for the school trip request.

F. Consideration of Acceptance of the TVA EnergyRight Grant and the Learning Environment Grant for Highland Elementary School

Tight budgets and aging buildings leave community schools facing a difficult decision between funding learning programs and making needed facility upgrades that can lower energy costs and improve health and comfort. TVA's School Uplift program partnered with local power companies across seven states to help 64 public schools tackle energy waste this school year.

School Uplift is a year-long energy management training program developed with the State of Tennessee's Energy Efficient Schools Initiative that helps public schools make smart energy choices that improve the classroom learning environment and save money through decreased energy use.

Highland Elementary School has been awarded the School Uplift Building Energy Upgrade Grant in the amount of \$400,000. This grant will be used to replace and install new HVAC units. These upgrades will improve air quality and the overall learning environment. In addition, the school will receive a Learning Environment Grant of \$10,000. Highland's students voted to build an awning at the front of the school with the Learning Environment Grant funds.

Highland Elementary joins over 118 schools to have completed School Uplift over the past three years, competing to earn grants for building upgrades and other learning environment improvements. On average, participating schools save nearly 10% on their annual energy bills from behavior changes alone.

Board approval was unanimous for the acceptance of the TVA EnergyRight Grant and the Learning Environment Grant for Highland Elementary School.

VI. Action Items

A. Consideration of Accepting April 2023 Financial Statements

Chief Financial Officer Ellen Lipe presented the April financial statements to the Board for acceptance. Lipe stated that local revenue collected year-to-date through April is \$7,695,636, which is 92.8% of the total budgeted projection. The amount collected year-to-date is \$107,962 more than during the same time period last year. This reflects an actual percentage change of 1.42% compared to last year. The district has 590 tuition students as of May 10, 2023. The Federal General-Purpose Financial Report showed that encumbrances comprise \$419,215 year-to-date. Copies of the financial statements are on file in the Chief Financial Officer's office.

It was recommended to approve the April 2023 financial statements. Board approval was unanimous on a motion from Quillen (Treasurer) and a second from Hirschy (Board Member).

B. Consideration of Approving 2023-2024 General Purpose Budget

Greeneville City Board of Education approves a budget to be presented to the Mayor and Board of Aldermen each year. The 2023-2024 General Purpose Budget presented reflects the latest information available. The Budget is a culmination of a thorough and in-depth process. It reflects the Administration, Leadership Team, and the Board of Education's best efforts to address the needs of Greeneville City Schools and meet State and Federal requirements. The 2023 – 2024 General Purpose Budget presented reflected total revenues and equity of \$35,551,538, and total expenses of \$35,551,538. Copies of the budget are on file in the Chief Financial Officer's office.

It was recommended to approve the 2023-2024 General Purpose Budget. Board approval was unanimous on a motion from Shepherd (Vice-Chair) and a second from Quillen (Treasurer).

C. Consideration of Approving Board Policy Revisions - 1st Reading

Revisions are recommended to the following policy on 1st reading:

5.403 Drug and Alcohol Testing for Employees

It was recommended to approve the revisions to the policy as presented on 1st reading. Board approval was unanimous on a motion from Hirschy (Board Member) and a second from Shepherd (Vice-Chair).

D. Consideration of Approval to Amend the 2024 GHS Graduation Date on the 2023-24 Calendar

A concern was expressed that a conflict existed between the date of the 2023 GHS Graduation Ceremonies and the 2023 TSSAA Spring Fling State Championships (Baseball, Soccer, Softball, Tennis, and Track and Field) on May 26, 2023. Typically, the state championships have occurred on the 4th Friday in May dating back to at least 2015 with the tournaments beginning on Tuesday of that week. Previously, the Girls Softball team, the Baseball team, and the Soccer team State Championship games/matches have conflicted with the regularly scheduled graduation ceremonies and the students were not able to participate. In two instances, a special ceremony was held for the students who missed the regularly scheduled graduation ceremonies and in the other instance, the Soccer team won the State Championship and came into the regularly scheduled graduation ceremony late, still wearing their uniforms and carrying the State Championship trophy fresh from winning earlier that day and were able to participate.

A conflict exists between the 2024 Spring Fling and the 2024 GHS Graduation Ceremonies currently scheduled for May 24, 2024. To be proactive and alleviate the conflict, the Board directed that a recommendation be brought for their consideration to move the 2024 Graduation Date to a date that does not conflict. A team was formed at GHS that included teachers, coaches, extra-curricular sponsors, and administrators; and their recommendation is to move the 2024 Graduation Ceremony to May 25, 2024, at 10:00 am. The 2025 Graduation Date will be reviewed in May 2024.

It was recommended to approve the amendment of the 2024 Greeneville High School Graduation date on the 2023-24 calendar. Board approval was unanimous on a motion from Quillen (Treasurer) and a second from Botta (Board Member).

E. Consideration of Approving Purchase of Student Computing Devices for GMS Students in Grades 6-8

Computers are used daily by students in all schools and at all grade levels daily. In addition, many of our teachers and students are embracing the use of computing devices along with digital textbooks and resources to make teaching and learning more interactive and engaging.

The following devices were recommended for purchase for students at Greeneville Middle School.

- (750) Dell 3140 computers, \$330 each, for a total investment of \$247,500.00.

The recommended vendor for the purchase is Dell. The opportunity to purchase is due to the availability of a shared Wilson County Schools contract. IT funds and textbook funds will be utilized for the project.

It was recommended to approve the purchase. Board approval was unanimous on a motion from Hirschy (Board Member) and a second from Botta (Board Member).

F. Consideration of Approving Purchase of Maintenance Vehicle

GCS maintains a fleet of maintenance trucks for the purpose of providing services for all schools and offices in the district. The Greeneville City Schools Board of Education has established a cyclical replacement program to ensure dependable vehicles are always available. A recommendation is made to utilize the Tennessee state contract to purchase a 2022 Ford F-150 4WD truck. The total cost is \$43,205. 2022-2023 budgeted funds will be utilized.

It was recommended to approve the purchase. Board approval was unanimous on a motion from Shepherd (Vice-Chair) and a second from Quillen (Treasurer).

G. Consideration of Approving Purchase of ENA Replacement Phones

The district has utilized Education Networks of America (ENA) for VoIP services across the system including all schools and business offices. Most of the existing hardware is several years old and needs to be replaced.

Recent cost reductions in the pricing structure for voice services offered by ENA have afforded the district an opportunity to replace 80 desk phones identified by the district Tech Team for upgrade. The phone chosen is the Yealink SIP-T58W Pro. The cost to purchase 80 devices is \$335 per unit for a total cost of \$27,200 with details on the attached supporting documentation. This project will be paid for from 2022-2023 communication funds.

It was recommended to approve the purchase. Board approval was unanimous on a motion from Quillen (Treasurer) and a second from Hirschy (Board Member).

H. Consideration of Approving Work Based Learning Teacher Job Description

The current Work Based Learning Job description is included in the description of the counseling position at Greene Technology Center, but Greeneville City Schools does not currently have a Work Based Learning teacher at Greeneville

High School. With the Innovative Schools Model Grant, GCS was approved to hire a full time Work Based Learning Teacher at GHS. The purpose of Work Based Learning is to provide students the ability to develop knowledge, skills, and values from direct experiences outside a traditional academic setting and to provide students with sufficient education, training, and counseling to enable them to enter the job market or higher education with the necessary skills, interests, and understanding to continue their growth and maturity as workers and individuals. Some Essential Functions Include:

- Creates and maintains an online database of employers for student internships and pre-apprenticeships.
- Solicits, develops, manages, and creates partnerships with work sites and local organizations and acts as a liaison to participating companies.
- Works with instructors, administrators, and counselors to identify and place eligible students in WBL capstone placements aligned with their CTE pathway/elective focus.
- Processes student Personalized Learning Plans and maintains complete student records and documentation in compliance with standards.
- Meets with instructors to formulate course objectives and develop course content related to WBL experiences.
- Assists CTE teachers and host sites with following the Tennessee Department of Education WBL guidelines.

The impact on resources:

- No impact on resources for the 23-24 school year (100% covered by grant)
- \$18,000 for the 24-25 school year (75% covered by grant)
- \$37,531 for the 25-26 school year (50% covered by grant)
- \$75,062 for the 26-27 school year (grant funding ends)

It was recommended to approve the Work Based Learning Teacher Job Description. Board approval was unanimous on a motion from Botta (Board Member) and a second from Shepherd (Vice-Chair).

I. Consideration of Approval to Join the Frantz Law Group's Social Media Litigation to Pursue Damages on Behalf of Public Entities

There is a challenge being faced by school districts that needs to be addressed now: the mental health crisis of students that has been caused by social media companies. We see children constantly using these platforms, at home and at school, often to the point of developing a severe addiction. Inadequate age verification measures, insufficient parental controls, targeted algorithms, constant notifications, and endless scrolling have been designed to addict students.

The United States Surgeon General has declared a national advisory on the youth mental health crisis, blaming social media, in part, for the growing number of youths experiencing depression, anxiety, and other mental health challenges. The CDC National Youth Risk Behavior Survey found that the rate of teen depression rose by more than 60% between 2011 and 2018.

Frantz Law Group has commenced litigation on behalf of public entities, such as school districts, against Meta, TikTok, Snap, and YouTube as well as other social media companies. This lawsuit alleges that these companies have caused a mental health crisis among children and teenagers that is marked by higher proportions of anxiety, depression, and thoughts of self-harm, all of which severely affect their ability to succeed in school.

It was recommended to join the Frantz Law Group in its nationwide litigation efforts on behalf of school systems against social media companies such as Meta, Instagram, Tiktok, and others. This motion is the approval to enter into an Attorney Fee Agreement with the Frantz Law Group and to designate Steve Starnes, Director of Schools, as the authorized representative of the Greeneville City School System to direct Attorneys and to be the primary individual to communicate with Attorneys regarding the subject matter of Attorneys' representation of Client under this Agreement. Board approval was unanimous on a motion from Quillen (Treasurer) and a second from Shepherd (Vice-Chair).

VII. Director's Report

Starnes congratulated:

- All the students recognized for their scholarly achievements and the GCSEF Character Education students.
- Beverly Miller who was selected to participate in the AASA National Women's Leadership Consortium. This is a cohort of twenty-two professional women representing education and business from across the United States. The consortium will meet during the next year to share best-practices, collaborate, and further develop their leadership skills.
- Dr. Suzanne Bryant and Melissa Batson who represented Greeneville City Schools at the Diversity, Equity, and Inclusion (DEI) Alliance of Northeast TN and Southwest VA. Greeneville City Schools is one of four school systems, along with Kingsport City Schools, Johnson City Schools, and Bristol TN City Schools, from Northeast TN who participate in this alliance. Dr. Bryant serves on the DEI Alliance Board. The Alliance provides DEI-related technical assistance to "regional enterprises" that will ultimately attract and retain young professionals as well as present our region as welcoming and inclusive.
- GMS Girls Golf Team who won the Regional Championships.
- GMS Boys Track Team who won the TMSSA Sectional Championships.

Starnes thanked the George Clem Multi-Cultural Association and the Buel and Mildred Bequest Brooks Trust of Trinity United Methodist Church for their generous contributions to help with unpaid student lunch debt. This will allow our school nutrition program to finish the year with no unpaid debt as well as providing some resources to begin the 23-24 school year.

Saturday, May 20, 2023, is the first graduation ceremony for TOPS @Greeneville students. The TOPS graduates participated in the GHS Graduation Ceremony last year. This year's ceremony will take place in the Frank Winston Auditorium at Tennessee High School at 3 p.m.

GHS Graduation Ceremony which will take place on Saturday, May 27, 2023, at 10 a.m.

The Greeneville City Schools Personnel Banquet will be held on Wednesday, May 24, 2023, at the Fairgrounds beginning at 12:30 p.m.

VIII. Adjournment

It was recommended to adjourn at approximately 6:28 p.m. Board approval was unanimous on a motion from Botta (Board Member) and a second from Hirschy (Board Member).

Respectfully submitted,

Cindy Luttrell, Chair

Steve Starnes, Director of Schools

Greeneville City Board of Education

Monitoring: Review: Annually	Descriptor Term: English Learners	Descriptor Code: 4.207	Reviewed Date: 06/22/23
		Rescinds: 4.207	Adoption Date: 04/25/19

1 If the inability to speak and understand the English language excludes a student from effective
2 participation in the educational programs offered by the district, the district shall take reasonable actions
3 to provide the student equal access to its programs. Students who are English learners (“EL”) shall be
4 identified, assessed, and provided appropriate services. No ~~child-student~~ shall be admitted to or excluded
5 from any program or extracurricular activity based on the student’s surname or EL status.¹

6 The Director of Schools shall evaluate the effectiveness of the district’s language assistance programs
7 to ensure EL students will acquire English proficiency and the ability to participate in the standard
8 instructional program within a reasonable period of time.

9 ENGLISH LANGUAGE INSTRUCTION PROGRAM

10 The Board directs the administration to develop and implement language instruction programs that:²

- 11 1. Appropriately identify EL students in a timely, valid, and reliable manner-;
- 12 2. Determine the appropriate instructional environment for EL students-;
- 13 3. Provide EL students with a language assistance program that is educationally sound and proven
14 successful-;
- 15 4. Annually assess the English proficiency of EL students and monitor the progress of students in
16 order to determine their readiness for standard instructional program-; and
- 17 5. Monitor the progress of students that have exited the EL program-;

18 PARENTAL NOTIFICATION³

19 Parents of EL students shall be given notice of, and information regarding, the instructional program
20 within the first thirty (30) days of the school year, or within the first two (2) weeks of a student being
21 placed in a language instruction educational program (LIEP). At a minimum, the notice will include the
22 following:³

- 23 1. The reason for identifying the child as an EL student;
- 24 2. The student’s level of English language proficiency, including how the level was assessed, and
25 the status of the student’s academic achievement;
- 26 3. Methods of instruction used in the program, methods of instruction in other available programs,
27 and how they differ;

- 1 4. How the program meets the educational strengths and needs of the student, and how the program
2 will help the student reach English language proficiency and meet academic standards;
- 3 5. Program exit requirements, rate of transition to a standard instructional program classroom, and
4 expected rate of high school graduation;
- 5 6. How the program meets the goals of an EL student with an IEP; and
- 6 7. Information on the parents' right to withdraw the student from the program or choose another
7 program or method of instruction if available.
- 8 Parent and family engagement will be encouraged, and parents will be regularly apprised of their child's
9 progress.⁴

Legal References

1. Elementary and Secondary Education Act, as amended by ESSA (Pub. L. 114-95), § 1112(e)(3)(D); TRR/MS 0520-01-19
2. Elementary and Secondary Education Act, as amended by ESSA (Pub. L. 114-95), § 3113(b)(3)(B); TRR/MS 0520-01-19
3. Elementary and Secondary Education Act, as amended by ESSA (Pub. L. 114-95), § 1112(e)(3)(A); TRR/MS 0520-01-19
- ~~1. Elementary and Secondary Education Act, as amended by ESSA (Pub. L. 114-95), § 1112(e)(3)(C); TRR/MS 0520-01-19~~
~~Elementary and Secondary Education Act, as amended by ESSA (Pub. L. 114-95), § 1112(e)(3)(D); State Board of Education Policy 3.207~~
- ~~2. Elementary and Secondary Education Act, as amended by ESSA (Pub. L. 114-95), § 3113(b)(3)(B); State Board of Education Policy 3.207~~
- ~~3. Elementary and Secondary Education Act, as amended by ESSA (Pub. L. 114-95), § 1112(e)(3)(A); State Board of Education Policy 3.207~~
4. Elementary and Secondary Education Act, as amended by ESSA (Pub. L. 114-95), § 1112(e)(3)(C); State Board of Education Policy 3.207

Cross Reference

Parent and Family Engagement 4.502

Greeneville City Board of Education

Monitoring: Review: Annually	Descriptor Term: Field Trips/Excursions/Competitions	Descriptor Code: 4.302	Revised Date: 06/22/23
		Rescinds: 4.302	Adoption Date: 12/12/19

1 *General*

2 The Board encourages field trips, excursions, and competitions when the experiences are an integral part
3 of the school curriculum and contribute to the Board's desired educational goals.

4 The Director of Schools shall develop procedures for submitting, reviewing, and approving requests for
5 field trips, excursions, and competitions. Any request that requires students to travel out of state or stay
6 overnight requires prior Board approval.

7 **INDEPENDENTLY PLANNED TRIPS**

8 Trips privately planned by school district employees, acting outside the scope of their employment, are
9 not authorized by the school district.

10 These trips are not approved by the Board and are not considered a part of the curriculum. Total
11 responsibility for privately planned trips rests with the chaperone(s) as well as with the
12 parent(s)/guardian(s) of the students participating in the trip. The following restrictions shall apply:

- 13 1. Board funds or resources shall not be used;
- 14
- 15 2. School district materials shall not be used;
- 16
- 17 3. The Board shall not assume any liability;
- 18
- 19 4. Employees are not authorized to act on behalf of the school district;
- 20
- 21 5. Recruitment efforts made by an employee shall not occur during the instructional school
22 day; and
- 23
- 24 6. Absences caused by participation in privately planned trips shall be considered unexcused.

Cross References

Advertising and Distribution of Materials in the Schools 1.806
Special Use of School Vehicles 3.402
Extracurricular Activities 4.300
Attendance 6.200

Greeneville City Board of Education

Monitoring: Review: Annually	Descriptor Term: Parent and Family Engagement	Descriptor Code: 4.502	Reviewed Date: 06/22/23
		Rescinds: 4.502	Adoption Date: 04/25/19

1 GENERAL EXPECTATIONS FOR PARENT ENGAGEMENT

2 The Board is committed to increasing and ensuring the involvement of parents and other family
3 members in the education of students.

4 The Board shall implement the following as required by federal or state laws or regulations:¹

- 5 1. The school district shall annually work with parents in evaluating and potentially revising the
6 provisions of this policy in improving the quality of schools. Such an evaluation shall strive to
7 identify any barriers to greater participation by parents (with particular attention to parents who
8 are economically disadvantaged, are disabled, have limited English proficiency, have limited
9 literacy, or are of any racial or ethnic minority background).
- 10 2. The school district shall provide the coordination, technical assistance, and other necessary
11 support to assist individual schools with planning and implementing parental involvement
12 activities.
- 13 3. The school district shall involve parents with the development of required educational or
14 improvement plans.
- 15 4. The school district shall coordinate and integrate parental involvement strategies with those
16 associated with other federal or state programs.
- 17 5. The school district shall put into operation activities and procedures for the involvement of
18 parents in all of its schools.² Those programs, activities, and procedures will be planned and
19 operated with meaningful consultation with parents.
- 20 6. The school district shall ensure that activities and strategies are implemented to support this
21 policy and included in the district plan.
- 22 7. The district improvement plan shall include strategies for parental participation in the district's
23 schools which are designed to improve parent and teacher cooperation in such areas as
24 homework, attendance, discipline, and higher education opportunities for students.
- 25 8. The district plan shall include procedures to enable parents to learn about the course of study of
26 their children and have access to all learning materials.
- 27 9. The district plan shall identify opportunities for parents to participate in and support classroom
28 instruction in the school. Such opportunities include, but are not limited to, organizing

1 fundraising activities, volunteering as a field trip chaperone, assisting in the library, computer
2 lab, or on the playground, offering after-school clubs, and recycling clothes.

3 10. If the school district's plan is not satisfactory to parents, the school district shall submit parental
4 comments regarding the plan to the State Department of Education as required.

5 11. The school district shall ensure Title I schools are in compliance with the *Every Student*
6 *Succeeds Act*.

7 The Director of Schools shall develop and implement any procedures necessary to accomplish the
8 goals of this policy.

9 **SCHOOL LEVEL POLICY**

10 Each school shall submit to the Director of Schools and the Board, for review and comment, its Title I
11 school parent involvement policy which must meet state and federal requirements, including a school-
12 parent compact. This school level policy shall be developed jointly with and distributed to parents of
13 participating students. A copy of these documents shall be retained in the district office and made
14 available on the school's (if applicable) and school district's website.

15 **SUPPORT FOR PROGRAM**

16 If the Title I allocation is \$500,000 or more to the school district, then at least one percent (1%) of that
17 allocation shall be reserved for the purpose of promoting parent involvement. Parents of students
18 participating in the Title I programs shall be consulted on the use of these funds.

19 **FAMILY-SCHOOL PARTNERSHIPS¹**

20 Families and community members should be engaged in the education of students based on the
21 following standards:

- 22 1. Families are welcomed into the school community;
- 23 2. Families and school staff should engage in regular and meaningful communication about
24 student learning;
- 25 3. Families and school staff should work together to support student learning and development;
- 26 4. Families are informed and encouraged to be advocates for students;
- 27 5. Families are full partners in the decisions that affect children and families; and
- 28 6. Community, civic, and business resources are made available to strengthen school programs,
29 family practices, and student learning.

Legal References

1. Every Student Succeeds Act, Pub.L. 114-95, Dec. 10, 2015, 129 Stat. 1802; State Board of Education Policy 4.207; TCA 49-2-305; 20 USCA § 6318
2. TCA 49-6-7001

Cross References

English Learners 4.207
Homeless Students 6.503

Greeneville City Board of Education

/Monitoring: Review: Annually	Descriptor Term: Staff-Student Relations	Descriptor Code: 5.610	Revision Date: 06/22/23
		Rescinds: 5.610	Adoption Date: 09/27/01

1 Staff members shall maintain professional relationships with students at all times and develop
2 wholesome and constructive relationships with them. Staff members shall be expected to regard each
3 student as an individual and to accord each student the rights and respect that is due.

4 Staff members shall promote a learning environment that encourages fulfillment of each student's
5 potential in regard to ~~his/her~~ **their** program, consistent with district goals and with optimal opportunities
6 for students. This goal may be reached by adapting instruction to individual needs, by:

- 7 1. Insisting on reasonable standards of scholastic accomplishment for all students;
- 8 2. Creating a positive atmosphere in and out of the classroom;
- 9 3. Extending courtesy and respect to students; and
- 10 4. Treating all students with consistent fairness.¹

11 Staff members shall use good judgment in their relationships with students beyond their work
12 responsibilities and/or outside the school setting and shall avoid excessive informal and social
13 involvement with individual students. Any appearance of impropriety shall be avoided. Sexual
14 relationships between employees and students shall be prohibited.^{1,2}
15

16 **The Director of Schools/designee shall develop administrative procedures to implement this policy.**
17

Legal References

1. TCA 49-5-1003
2. TCA 39-13-506; TCA 39-13-527

Cross References

- Staff Rights & Responsibilities 5.600
Ethics 5.611
Student Discrimination, Harassment, Bullying, Cyber-
bullying, and Intimidation 6.304
Reporting Child Abuse and Neglect 6.409

Greeneville City Board of Education

Monitoring: Review: Annually	Descriptor Term: Ethics	Descriptor Code: 5.611	Revision Date: 06/22/23
		Rescinds: 5.611	Adoption Date: 09/23/99

1 An effective educational program requires the services of ~~men and women~~ individuals of integrity, high
2 ideals and human understanding. To maintain and promote these essentials, all employees are expected
3 to maintain high standards in their school relationships. These standards include the following:

- 4 1. The maintenance of just and courteous professional relationships with students,
5 parent(s)/guardian(s), staff members and others;
- 6 2. The maintenance of their own efficiency and knowledge of the developments in their fields of
7 work;
- 8 3. The transaction of all official business with the properly designated authorities of the school
9 system;
- 10 4. The establishment of friendly and intelligent cooperation between the community and the school
11 system;
- 12 5. The representation of the school system on all occasions that the contributions of the school
13 system to the community are recognized;
- 14 6. The welfare of children is the first concern of the school system when placing professional
15 personnel. The use of pressure on school officials for appointments or transfers is unethical;
- 16 7. Restraint from using school contacts and privileges to promote partisan politics, sectarian
17 religious views, or selfish propaganda of any kind;
- 18 8. The responsibility to make any criticism of other staff members or of the school system directly
19 to the particular school administrator who has the administrative responsibility for improving the
20 situation and then to the Director of Schools, if necessary; and
- 21 9. The proper use and protection of all school properties, equipment, and materials.
22

23 Beginning July 2018, it is required that all certified teachers be trained on the Teacher Code of Ethics
24 on an annual basis.¹ Training shall consist of a full understanding of the Teacher Code of Ethics;
25 including but not limited to, what constitutes unethical conduct and breach of the Teacher Code of
26 Ethics.²

Legal References

1. TCA 49-5-1007
2. TCA 49-5-1006

Cross References

- Code of Ethics 1.106
Staff Rights & Responsibilities 5.600
Staff-Student Relations 5.610

Greeneville City Board of Education

Monitoring: Review: Annually	Descriptor Term: Interim Employees	Descriptor Code: 5.700	Reviewed Date: 06/22/23
		Rescinds: 5.700	Adoption Date: 12/13/06

1 Employees shall be hired on an interim contract only when a vacancy is created by an employee taking
2 a leave of absence.¹ Such interim employees shall be considered as temporary replacements for the
3 remainder of the school year, and the contract term will not be considered as initial employment.

4 Said positions will be filled at the discretion of the Director of Schools in such a manner as to cause the
5 least disruption in the educational process for students and as quickly as possible to ensure a continuous
6 function of the position.

7 Persons filling any temporary positions shall have no expectancy of continued employment or any other,
8 but such person may be considered for employment in filling vacancies as specified in the section
9 dealing with initial employment. The offer letter of each interim employee shall indicate the interim
10 status of the position and require the signature of the interim employee as acknowledgment.

Legal References

1. TCA 49-2-203(a)(1)(A); TCA 49-5-702

Cross References

Application and Employment 5.106
Long-Term Leaves of Absence 5.304

Greeneville City Board of Education

Monitoring: Review: Annually	Descriptor Term: Substitute Teachers	Descriptor Code: 5.701	Reviewed Date: 06/22/23
		Rescinds: 5.701	Adoption Date: 03/23/06

1 Substitute teachers are those teachers used to replace teachers on leave or to fill temporary vacancies
2 until a licensed teacher is available.^{1,2} Substitute teachers may be employed and paid directly by a
3 local education agency or by a third party public or private employer through an agreement between
4 such third party employer and the board of education. Substitute teachers employed by third party
5 entities shall be subject to the same unemployment benefit eligibility conditions as substitute teachers
6 employed directly by the board of education.²

7 APPLICATION/QUALIFICATIONS

8 The contract with the service provider shall specify that criminal history record checks and
9 fingerprinting of applicants for substitute teaching are required.³

10 Applicants whose records with the State Department of Education indicate a license or certificate
11 currently in revoked status shall not be hired.⁴

12 Qualifications for substitute teachers shall be:

- 13 1. Must be at least 21 years of age;
- 14 2. Must have a high school or GED equivalency education; and
- 15 3. Must have a satisfactory background check.

16 The substitute teacher lists will be prepared by the Director of Schools, Human Resources, or service
17 provider, who will maintain a complete file on all substitute teachers. This file will include transcripts,
18 credentials, recommendations and other pertinent information. A list of all approved substitutes shall
19 be maintained by the service provider. **Only** those persons on the approved substitute list shall be
20 employed to substitute teach.

21 COMPENSATION

22 If employed directly by the school system, the compensation of substitute teachers shall be determined
23 annually by the Board.

24 Retired teachers serving as substitutes who do not have an active teaching license shall be paid the
25 same as a retired substitute teacher with an active teaching license. This only applies to teachers who
26 retired after July 1, 2011 through July 1, 2016.⁵

1 **CERTIFICATION**

2 When substituting for a regular teacher who has been absent for twenty (20) consecutive days, a
3 substitute teacher must possess a teaching certificate with endorsement in the discipline(s) to be taught
4 or shall be a retired teacher that held the appropriate endorsement.⁶ When substituting for a teacher
5 without sick leave, the substitute shall be certified and paid according to the state salary schedule.¹

6 **EMERGENCY NEEDS**

7 All teacher assistants, secretaries and clerks are approved substitute teachers for use in emergency
8 situations. Emergency use shall be defined as circumstances due to the regular or substitute teacher
9 being unable to arrive on time or remain for the full day.

10 Such substitutes shall receive a pay premium per day in addition to their regular daily rate of pay.
11 Currently employed certified teachers shall also be utilized on an as needed basis as substitutes during
12 their available planning periods and shall be compensated a rate of pay per hour for their time worked.

13 **TRAINING AND ORIENTATION**

14 The Director of Schools or service provider shall be responsible for providing appropriate training and
15 development programs for substitute teachers. Training procedures will be reviewed annually to
16 ensure compliance with system requirements.

17 All substitute teachers shall be required to attend an orientation session held at the beginning of each
18 school year to provide instructions regarding reporting, pay schedules, and other pertinent information
19 and to answer questions.

20 All substitute teachers will be given a copy of the local school's guidelines on the first day they
21 substitute in the school. These guidelines shall contain, but shall not be limited to:

- 22 a. Attendance procedures;
- 23 b. Lunchroom schedule and procedures;
- 24 c. Procedures for supervising student behavior;
- 25 d. Names and assignments of regular staff members;
- 26 e. Emergency evacuation procedures; and
- 27 f. Other helpful information particular to the local school.

28 Substitute teachers shall assume the same responsibilities and have the same authority as the regular
29 teacher, including bus duty and playground supervision.

1 **RE-EMPLOYMENT/TERMINATION**

2 On an annual basis, the Director of Schools, with input from the principals, shall determine which
3 substitute teachers performed at an acceptable level. Substitute teachers who performed below an
4 acceptable level shall not be re-employed.

5 All substitutes shall be responsible for providing correct addresses and phone numbers and for
6 notifying the principal if they wish to terminate their service as substitutes.

Legal References

1. TRR/MS 0520-01-02-.04(5)
2. TCA 49-5-709
3. TCA 49-5-413(a)(2)
4. TCA 49-2-203(a)(14)
5. TCA 49-3-312(b)
6. TCA 49-3-312(a); TRR/MS 0520-01-02-.04(5)(b)

Cross References

Background Investigations 5.118
Employment of Retirees 5.119

Greeneville City Board of Education

Monitoring: Review: Annually	Descriptor Term: Student Teachers	Descriptor Code: 5.702	Revision Date: 06/22/23
		Rescinds: 5.702	Adoption Date: 09/23/99

1 Student teachers shall be accepted or refused by the following people:

- 2 1. Director of Schools or Assistant Director
- 3 2. Principal
- 4 3. Cooperating and Supervising Teacher

5 System administrators reserve the right to interview student teachers before final placement decisions
6 are made.

7 A student teacher shall be accorded the same protection of the laws as all other teachers and shall comply
8 with all policies of the Board and observe all duties of teachers as set forth by state law.¹

9 In addition, student teachers shall be required to fulfill all normal local responsibilities, both school and
10 extracurricular, and shall familiarize themselves with the policies of the Board and procedures of the
11 Director of Schools.

12 The evaluation of a student teacher shall be based upon a joint agreement between the cooperating
13 teacher and the student's supervising teacher.

14 A student teacher may be asked to terminate ~~his or her~~ **their** service upon the mutual consent of the
15 principal, the cooperating teacher and the supervising teacher at any time during the term.

16 A student teacher should not be placed under the supervision of a family member. If there are extenuating
17 circumstances, the Director of Schools will make the final decision concerning placement.

Legal References

1. TCA 49-5-403(c); TCA 49-5-201

Greeneville City Board of Education

Monitoring: Review: Annually, in February	Descriptor Term: Director of Schools' Role, Recruitment, and Selection	Descriptor Code: 5.800	Revision Date: 06/22/23
		Rescinds: 5.800	Issued: 09/23/99

1 The Director of Schools shall be the chief executive officer of the school system and shall have, under
2 the direction of the Board, general supervision of all the public schools, personnel, and departments of
3 the school system. The Director of Schools is responsible for the management of the schools under the
4 Board's policies and is accountable to the Board.¹

5 The Director of Schools, at ~~his/her~~ their discretion, may delegate any of ~~his/her~~ their duties to other
6 school personnel.

7 **RECRUITMENT AND SELECTION**

8 When a vacancy occurs, the appointment of a Director of Schools is a function of the Board.² The Board
9 is responsible for finding the person it believes can most effectively translate into action the policies of
10 the Board and the goals of the community and the professional staff.

11 The Board may employ a consultant to advise and assist the Board in the search and selection process.
12 However, final selection shall rest with the Board after a thorough consideration of qualified
13 applicants. An interim Director of Schools appointed during the time of a search shall not become a
14 candidate unless the Board expressly permits such inclusion in the selection procedures. A board
15 member may not apply for or in any other way be considered for the position of Director of Schools.³

16 If the Board chooses to conduct a search to fill the position, the Board shall initially develop the
17 following:

- 18 1. A job description;
- 19
- 20 2. A timeline;
- 21
- 22 3. A process for accepting and reviewing applications; and
- 23
- 24 4. Selection procedures which shall include, but not be limited to, the following:⁴
 - 25
 - 26 a. The Board may invite the community, including board employees, to participate in the
27 process of selecting a Director of Schools.
 - 28
 - 29 b. The interview process for each finalist may include meetings with various staff,
30 community groups, individual board members, and/or an interview with the entire
31 Board.
 - 32

- 1 c. Candidates may be interviewed by individual board members. Candidates may also be
2 interviewed by the entire Board in an open session. Only board members will be
3 allowed to ask questions during the interview.
- 4 d. The Board shall attempt to select a Director by unanimous vote, but a simple majority
5 vote of the membership of the board shall be required for the appointment of a Director
6 of Schools.
7

Legal References

1. TCA 49-2-301(a)
2. TCA 49-2-203(a)(13)
3. TCA 49-2-203(a)(1)(D)
4. TCA 49-2-203(a)(13)(B)

Cross References

- Director of Schools' Duties 5.802
Evaluation of the Director of Schools 5.803

Greeneville City Board of Education

Monitoring: Review: Annually	Descriptor Term: Director of Schools' Duties	Descriptor Code: 5.802	Reviewed Date: 06/22/23
		Rescinds: 5.802	Adoption Date: 02/27/18

1 The Director of Schools' duties shall be as follows:¹

2 **QUALIFICATIONS**

- 3 1. A valid teacher's license is preferred.
- 4 2. Have educational administrative or supervisor experience.
- 5 3. Have an earned doctorate (preferred but not required) and other qualifications as set forth by
- 6 the Greeneville City Board of Education.

7 **JOB GOAL**

8 The Director of Schools serves as Chief Executive Officer of the Greeneville City Schools. The Director
9 of Schools provides leadership and administers the school system in accordance with all Greeneville
10 City School Board policies, state codes, and mandates set forth by the Tennessee State Board of
11 Education and the Tennessee State Department of Education. The Director maintains effective
12 relationships with staff, students, parents and community, area school systems and colleges, the
13 Tennessee State Department of Education, and other appropriate city, state, and federal agencies.

14 **ORGANIZATIONAL RELATIONSHIP**

15 The management responsibilities of the Director of Schools shall extend to all activities of the district,
16 to all phases of the educational program, to all aspects of the financial operation, to all parts of the
17 physical plant, and to the conduct of such other duties as may be assigned by the Board. The Director
18 of Schools may delegate these duties together with appropriate authority but may not delegate nor
19 relinquish ultimate responsibility for results or any portion of accountability.

20 **ESSENTIAL FUNCTIONS**

21 The Director of Schools is responsible for all duties of the Director of Schools as outlined by
22 Tennessee Statute 49-2-301 and any other duties as assigned by the Board of Education.¹

Legal References

1. TCA 49-2-301

Cross References

- Executive Committee 1.301
Evaluation of the Director of Schools 5.803
Director of Schools' Role, Recruitment, & Selection 5.800

Greeneville City Board of Education

Monitoring: Review: Annually	Descriptor Term: Evaluation of the Director of Schools	Descriptor Code: 5.803	Revision Date: 06/22/23
		Rescinds: 5.803	Adoption Date: 08/23/16

1 Through an annual evaluation of the Director of Schools¹, the Board will strive to accomplish the
2 following:

- 3 1. Clarify the role of the Director of Schools according to a job description as agreed upon by the
4 Board and the Director;
- 5
- 6 2. Develop harmonious working relationships between the Board and the Director of Schools; and
7
- 8 3. Develop improvements in the administrative leadership of the school system.

9 The Board will develop, with the Director of Schools, a set of performance objectives based on the needs
10 of the system. The performance of the Director of Schools will be reviewed in accordance with these
11 specified goals. The performance objectives will be memorialized in an evaluation plan that includes, at
12 a minimum, sections regarding job performance, student achievement, relationships with staff and
13 personnel, relationships with board members, and relationships with the community.¹ In addition, the
14 Director will also be evaluated on the progress of each board goal as it pertains to the evaluation of the
15 school district. As such, the Director will prepare a written assessment of the progress and prepare
16 revised board goals for the succeeding year.

17 In June, or as soon **as** thereafter as practical, the Board may meet as a body to evaluate the Director of
18 Schools' performance.

19 The following guidelines will be used in the evaluation process:

- 20 1. The Director of Schools will know the standards upon which **he/she they** will be evaluated and
21 will be involved in the development of those standards.
- 22
- 23 2. The evaluation will be a composite of the evaluation by individual board members. The Board
24 chair will meet with the Director to discuss the composite evaluation.
- 25
- 26 3. The evaluation shall include a discussion of strengths as well as weaknesses.
- 27
- 28 4. Both the Board and Director of Schools will prepare for the evaluation; the Director of Schools
29 will conduct a self-evaluation and the Board will examine information relating to the Director
30 of School's performance.
- 31
- 32 5. Each judgement will be supported by logical and objective evidences.

Legal References

1. TCA 49-2-203(a)(15)

Cross References

Board-Director Relations 1.205
Qualifications and Duties of the Director of Schools 5.802
Director of Schools' Role, Recruitment, & Selection 5.800

Greeneville City Board of Education

Monitoring: Review: Annually	Descriptor Term: Student Records	Descriptor Code: 6.600	Revision Date: 06/22/23
		Rescinds: 6.600	Issued: 07/24/14

1 *General*

2 A cumulative record shall be kept for each student enrolled in school. The folder shall contain a health
3 record, attendance record, and scholarship record; shall be kept current; and shall accompany the student
4 through ~~their~~ ~~his/her~~ school career.¹

5 The name used on the record of the student entering the school district shall be the same as that shown
6 on the birth certificate unless evidence is presented that such name has been legally changed. If the
7 parent/guardian does not have or cannot obtain a birth certificate, then the name used on the records of
8 such student shall be as shown on documents which are acceptable as proof of date of birth.

9 The name used on the records of a student entering the school district from another school shall be the
10 same as that shown on records from the school previously attended unless evidence is presented that
11 such name has been legally changed as prescribed by law.

12 When a student transfers to another school within the school district or to a school outside of the school
13 district, copies of the student's records, including the student's disciplinary records, shall be sent to the
14 transfer school.²

15 All records shall be remitted in accordance with the Family Education Rights and Privacy Act (FERPA).³

16 **ACCESS TO STUDENT RECORDS**

17 Student records shall be confidential. Authorized school officials shall have access to and permit access
18 to student education records for legitimate educational purposes.⁴ A legitimate educational interest is the
19 official's need to know information in order to:

- 20 1. Perform required administrative tasks;
- 21 2. Perform a supervisory or instructional task directly related to the student's education; and
- 22 3. Perform a service or benefit for the student or the student's family such as health care, counseling,
23 student job placement, or student financial aid.

24 Authorized school officials may release information from or permit access to a student's education record
25 without the parent(s)/guardian(s) or eligible student's* prior written consent in the following instances:

- 26 1. To comply with a judicial order or lawfully issued subpoena. The school district will make a
27 reasonable effort to notify the student's parent(s)/guardian(s) or the eligible student before
28 making a disclosure;⁵

- 1 2. If the disclosure is an item of directory information;⁶
- 2 3. To comply with the requirements of child abuse reports to the extent known by the school
3 officials including the name, address, and age of the student; the name and address of the person
4 responsible for the care of the student; and the facts requiring the report;⁷
- 5 4. When certain federal and state officials need information in order to audit or enforce legal
6 conditions related to federal- or state-supported education programs in the school district;⁸
- 7 5. When the school district has entered into a contract for an organization to conduct scientific
8 research on the school district's behalf to develop tests or improve instruction, provided that the
9 studies are conducted in a manner which will not permit the disclosure of personal identification
10 of students and their parent(s)/guardian(s) by individuals other than to representatives of the
11 organization, and that the information will be destroyed when no longer needed for the purpose
12 for which the study was conducted;⁹
- 13 6. To appropriate officials if the parent(s)/guardian(s) claim the student as a dependent as defined
14 by the Internal Revenue Code;¹⁰
- 15 7. To accrediting organizations to carry out their accrediting functions;¹¹
- 16 8. To officials of another school, school system, or postsecondary institution when a student seeks
17 or intends to enroll in another school district or a post-secondary institution.
18 Parent(s)/guardian(s) of the student shall be notified of the transfer and shall have the a right to
19 obtain copies of the record transferred as well as an opportunity to challenge the content of the
20 record;¹²
- 21 9. To financial institutions or government agencies that provide or may provide financial aid to a
22 student in order to establish eligibility, to determine the amount of financial aid, to establish
23 conditions for the receipt of financial aid, and to enforce financial aid agreements;¹³
- 24 10. To the appropriate officials in connection with a health or safety emergency if knowledge of the
25 information is necessary to protect the health or safety of the student or others;¹⁴
- 26 11. To the Attorney General/designee for official purposes related to the investigation or prosecution
27 of an act of domestic or international terrorism. An educational agency that, in good faith,
28 produces education records in accordance with an order shall not be liable to any person for that
29 production;¹⁵
- 30 12. To any agency caseworker or other representative of a state or local child welfare agency or tribal
31 organization authorized to access the student's educational records when such agencies or
32 organizations are legally responsible for the care and protection of the student;¹⁶
33
- 34 13. To the Secretary of Agriculture/designee for purposes of conducting program monitoring,
35 evaluations, and performance measurements, provided that the data collected will be protected
36 in a manner which will not permit the disclosure of personal identification of students and their
37 parent(s)/guardian(s) by individuals other than to representatives of the organization, and that
38 the information will be destroyed when no longer needed for the purpose for which it was

1 conducted;¹⁷ and

2

3 14. To state and local authorities to whom information is specifically allowed to be reported or
4 disclosed by state law that concerns the juvenile justice system and the system's ability to
5 effectively serve, prior to adjudication, the student whose records were released.¹⁸

6 *Consent to Disclose Records*¹⁹

7 Authorized school officials may release information from a student's education record if the student's
8 parent(s)/guardian(s) or the eligible student gives written consent for the disclosure. The written consent
9 shall include:

- 10 1. Specification of the records to be released;
- 11
- 12 2. Reasons for the disclosure;
- 13
- 14 3. Person, organization, or class of persons or organizations to whom the disclosure is to be made;
- 15
- 16 4. Signature of the parent(s)/guardian(s) or eligible student; and
- 17
- 18 5. Date of the consent, and if appropriate, a date when the consent is to be terminated.

19 The student's parent(s)/guardian(s) or the eligible student may obtain a copy of any records disclosed
20 under this provision.

21 **RECORDKEEPING**

22 The school district will maintain an accurate record of all requests to disclose information from or to
23 permit access to a student's education records. The school district will maintain an accurate record of
24 information it discloses and access it permits. The district will maintain this record as long as it maintains
25 the student's education record.²⁰

26 The record will include at least:²⁰

- 27 1. Name of the person or agency that makes the request;
- 28
- 29 2. Interest the person or agency has in the information;
- 30
- 31 3. Date the person or agency makes the request; and
- 32
- 33 4. Whether the request is granted, and if it is, the date access is permitted, or the disclosure is made.

34 * *The student becomes an "eligible student" when ~~they~~ ~~he/she~~ reaches age eighteen (18) or enrolls in a*
35 *postsecondary school, at which time all of the above rights become the student's right.*²¹

Legal References

1. 20 USCA § 1232g
2. TCA 49-6-3001(c)(1)
3. TCA 49-1-701 *et seq.*; 20 USCA § 1232g
4. TCA 10-7-504(a)(4); 20 USCA § 1232g
5. 20 USCA § 1232g(b)(2)(B); 20 USCA § 1232g(b)(1)(J)
6. 20 USCA § 1232g(b)(2); TCA 10-7-504(a)(4)(A)
7. TCA 37-1-403
8. 20 USCA § 1232g(b)(3), (5); 20 USCA § 1232g(b)(1)(C)
9. 20 USCA § 1232g(b)(1)(F)
10. 20 USCA § 1232g(b)(1)(H)
11. 20 USCA § 1232g(b)(1)(G)
12. 20 USCA § 1232g(b)(1)(B)
13. 20 USCA § 1232g(b)(1)(D)
14. 20 USCA § 1232g(b)(1)(I)
15. 20 USCA § 1232g(j); USA Patriot Act of 2001 § 507
16. 20 USCA § 1232g(b)(1)(L)
17. 20 USCA § 1232g(b)(1)(K)
18. 20 USCA § 1232g(b)(1)(E)
19. 34 CFR § 99.30; 20 USCA § 1232g(b)(2)(A)
20. 34 CFR § 99.32(a)
21. 34 CFR §§ 99.3, 99.5; TCA 49-1-704

Cross References

School District Records 1.407
Promotion and Retention 4.603
Testing Programs 4.700
Attendance 6.200
Withdrawals 6.207
Child Custody/Parental Access 6.209
Bus Safety and Conduct 6.308
Corporal Punishment 6.314
Disciplinary Hearing Authority 6.317
Admission of Suspended/Expelled Students 6.318
Acquired Immune Deficiency Syndrome 6.404
Reporting Child Abuse 6.409
Media Access to Students 6.604

Greeneville City Board of Education

Monitoring: Review: Annually	Descriptor Term: Student Records Annual Notification of Rights	Descriptor Code: 6.601	Reviewed Date: 06/22/23
		Rescinds: 6.601	Adoption Date: 12/05/02

1 Within the first three (3) weeks of each school year, the school district shall notify
2 parent(s)/guardian(s) of students and eligible students* of each student's privacy rights.¹ For students
3 enrolling after the above period, this information shall be given to the student's parent(s)/guardian(s)
4 or the eligible student at the time of enrollment.² The notice shall include the right of the student's
5 parent(s)/guardian(s) or the eligible student to:

- 6 1. Inspect and review the student's education records;
7
- 8 2. Seek correction of items in the record which are believed to be inaccurate, misleading, or in
9 violation of the student's rights, including the right to a hearing upon request;
10
- 11 3. File a complaint with the appropriate state or federal officials when the school district violates
12 laws and regulations relative to student records;
13
- 14 4. Obtain a copy of this policy and a copy of the student's educational records; and
15
- 16 5. Exercise control over other people's access to the records except when prior written consent is
17 given or under circumstances as provided by law or regulations or where the school district has
18 designated certain information as directory information. Parent(s)/guardian(s) of students or
19 eligible students have two (2) weeks after notification to advise the school district in writing of
20 items they designate not to be used as directory information. The records custodian shall mark
21 the appropriate student records for which directory information is to be limited, and this
22 designation shall remain in effect until it is modified by the written direction of the student's
23 parent(s)/guardian(s) or the eligible student.

24 **DIRECTORY INFORMATION**

25 "Directory information" is information contained in an education record of a student which would not
26 generally be considered harmful or an invasion of privacy if disclosed. It includes, but is not limited to,
27 the student's name, address, telephone number, e-mail address, date and place of birth, dates of
28 attendance, grade level, enrollment status, participation in officially recognized activities and sports,
29 weight and height of members of athletic teams, degrees, honors and awards received, and the most
30 recent educational agency or institution attended.³

31 Student directory information for 11th and 12th graders shall be made available upon request to
32 persons or groups which make students aware of occupational and educational options, including
33 official recruiting representatives of the military forces of Tennessee and the United States.⁴

- 1 *The student becomes an “eligible student” when *they he/she* reaches age eighteen (18) or enrolls in a
- 2 postsecondary school, at which time all of the above rights become the student’s rights.⁵

Legal References

1. 34 CFR §§ 99.4, 99.7
2. 34 CFR § 99.7
3. 34 CFR § 99.3
4. TCA 49-6-406; 10 USCA § 503(c)
5. 34 CFR §§ 99.3, 99.5; TCA 49-1-704

Cross References

Child Custody/Parental Access 6.209
Bus Safety and Conduct 6.308
Media Access to Students 6.604

Greeneville City Board of Education

Monitoring: Review: Annually	Descriptor Term: Inspection and Correction of Student Records	Descriptor Code: 6.602	Revision Date: 06/22/23
		Rescinds: 6.602	Adoption Date: 09/23/99

1 INSPECTION

2 Parent(s)/guardian(s) of students and eligible students* may inspect and review the student's education
3 records upon written request.¹

4 Parent(s)/guardian(s) or eligible students shall submit to the records custodian a request which identifies
5 as precisely as possible the record(s) to inspect, and this inspection shall be completed within forty-five
6 (45) days from the receipt of the request.

7 The right to inspect and review educational records includes the right to a response from school officials
8 concerning requests for explanation and interpretation of the data. School officials shall presume that
9 the parent/guardian has the authority to inspect and review records relating to **their his/her** child unless
10 the school district has been advised that the parent/guardian does not have the authority under applicable
11 state law governing guardianship, separation, and divorce.²

12 When a record contains information about a student other than the parent/guardian's child or the eligible
13 student, the parent(s)/guardian(s) or eligible student may not inspect and review that information.²

14 FEES FOR COPIES³

15 A reasonable fee for copies provided to parent(s)/guardian(s) or eligible students shall be determined by
16 the Director of Schools. If the fee represents an unusual hardship, it may be waived in part or entirely by
17 the records custodian.

18 CORRECTION

19 Parent(s)/guardian(s) of students or eligible students may seek to change any part of the student's record
20 they believe to be incorrect.⁴ The Director of Schools shall develop a procedure to establish an orderly
21 process to review and potentially correct an education record.

22 **The student becomes an "eligible student" when **they he/she** reaches age eighteen (18) or enrolls in a
23 postsecondary school, at which time all of the above rights become the student's rights.⁵*

Legal References

1. 34 CFR §§ 99.3, 99.10; TCA 49-1-704
2. 34 CFR § 99.4
3. 34 CFR § 99.11
4. 34 CFR §§ 99.20, 99.21, 99.22
5. 34 CFR §§ 99.3, 99.5; TCA 49-1-704

Cross References

Child Custody/Parental Access 6.209
Bus Safety and Conduct 6.308

Greeneville City Board of Education

Monitoring: Review: Annually	Descriptor Term: Media Access to Students	Descriptor Code: 6.604	Reviewed Date: 06/22/23
		Rescinds: 6.604	Adoption Date: 11/11/99

- 1 School administrators shall be authorized to grant permission and set parameters for media access to
- 2 students in their respective schools. Media representatives shall be required to report to the
- 3 administration for prior approval before accessing students involved in instructional programs and
- 4 activities not attended by the general public. The media may interview and photograph students involved
- 5 in instructional programs and school activities including athletic events, but such media access shall not
- 6 be unduly disruptive.

- 7 Each year, parent(s)/guardian(s) shall be given the option to withhold permission for public news media
- 8 interviews or photographs of their child at school.

- 9 Specific parent/guardian permission shall be obtained if the story or photograph covers topics of a
- 10 sensitive nature.

- 11 If any student is to be filmed or videotaped and will be identified or a primary subject of the filming or
- 12 videotaping, prior written consent/release/waiver shall be obtained from the student's parent/guardian.

- 13 District employees may release student information to the media only in accordance with applicable
- 14 provisions of the education records law and board policies governing directory information and
- 15 personally identifiable information.¹

- 16 Parent(s)/guardian(s) shall be advised of this policy at the time of the student's registration and each fall
- 17 in the student handbook.

Legal References

1. 20 USCA § 1232g

Cross References

- Student Records 6.600
 Student Records Annual Notification of Rights 6.601

Greeneville City Board of Education

Monitoring: Review: Annually	Descriptor Term: Student Publications	Descriptor Code: 6.704	Reviewed Date: 06/22/23
		Rescinds: 6.704	Adoption Date: 09/23/99

1 **STUDENT RIGHTS**

2 A student shall be allowed to responsibly express and disseminate **their his/her** views in writing.

3 Any student may submit articles and editorials for school-sponsored publications. The procedure for
4 submission of materials shall be published and distributed to all students.

5 **STANDARDS**

6 School-sponsored publications shall adhere to commonly accepted community standards, and no printed
7 material may be distributed which:

8 1. Is obscene;

9 2. Is libelous; or

10 3. May create a material and substantial disruption of the normal school activity or appropriate
11 discipline in the school.

12 **CONTROL AND SUPERVISION**

13 Student publications shall be under the control of the **P**incipal. Each school shall have a faculty sponsor
14 who reviews all publications proposed to be distributed in the school by a student or school group.

15 **DISTRIBUTION**

16 School authorities shall regulate the time, manner, place, and duration for the distribution of publications
17 on school grounds.

18 **APPEALS**

19 If a request for distributing any portion of a student publication is denied by the faculty sponsor, the
20 decision may be appealed to the **P**incipal, then to the Director of Schools, and ultimately to the Board.

Cross References

Advertising and Distribution of Materials in the Schools 1.806
Use of Copyrighted Materials 4.404
Use of the Internet 4.406
School and System Websites 4.407
Controversial Issues 4.800

Greeneville City Board of Education

Monitoring: Review: Annually	Descriptor Term: Student Fees and Fines	Descriptor Code: 6.709	Revision Date: 06/22/23
		Rescinds: 6.709	Adoption Date: 05/20/19

1 FEES

- 2 The Director of Schools shall develop procedures regarding fees for school activities and programs.
3 Such procedures shall comply with all state laws and regulations.¹

4 FINES

- 5 The Director of Schools shall develop procedures regarding the assessing and collections of fines for
6 the destruction or damage of school property. Such procedures shall comply with all state laws and
7 regulations.²

Legal References

1. TCA 49-2-114; TRR/MS 0520-01-02-.16
2. TCA 37-10-101, 102

Cross References

Revenues 2.400
Textbooks and Instructional Materials 4.400
Graduation Activities 4.606
Care of School Property 6.311

Greeneville City Board of Education

Monitoring: Review: Annually	Descriptor Term: Gifts	Descriptor Code: 6.710	Revision Date: 06/22/23
		Rescinds: 6.710	Adoption Date: 09/23/99

1 *General*

2 Students who wish to purchase gifts shall not use school funds but may collect funds from school
3 employees or the student body. No school funds may be used to purchase gifts, including but not limited
4 to presents, donations, memorials, and flowers.

5 **GIFTS TO EMPLOYEES**

6 The collection of funds from students for the purpose of providing gifts for school employees **may be**
7 **authorized by** ~~is permitted with approval of~~ the Principal. Extreme discretion will be exercised by
8 teachers in accepting student gifts.

9 **GIFTS TO STUDENTS**

10 Students shall be permitted, with the approval of the Principal, to exchange gifts on special occasions.

11 The Board strongly discourages delivery of student gifts such as flowers, balloons, candy, etc. to school
12 on birthdays and/or holidays. These gifts, when delivered at school, are disruptive and interfere with the
13 student's learning process. Parents are encouraged to celebrate these special occasions after school hours.

14 If student gifts (balloons, candy, flowers, etc.) are sent to school, the gifts will be kept in the school
15 office, or a place designated by the Principal and the gifts will be given to the student after school is
16 dismissed. Student gifts will not be delivered to students during the regular school day.

17 Because these items are often difficult to transport and are considered to be disruptive and interfere with
18 safety, students will not be permitted to take any gifts (balloons, flowers, candy, etc.) on the school bus.

Cross References

Gifts and Bequests 2.401
Fundraising Activities 2.601
Student Activity Funds Management 2.900
Staff Gifts & Solicitations 5.605

Greeneville City Board of Education

Monitoring: Review: Annually	Descriptor Term: Grading System	Descriptor Code: 4.600	Reviewed Date: 08/22/23
		Rescinds: 4.600	Adoption Date: 12/14/17

1 The Director of Schools shall develop an administrative procedure to establish a system of grading and
2 assessment for evaluating and recording student progress and to measure student performance in
3 conjunction with Board-adopted content standards for grades K-8.

4 The grading/assessment system shall follow all applicable statutes and rules and regulations of the State
5 Board of Education. The grading/assessment system shall be uniform, district-wide, at comparable
6 grade levels, except that the Director of Schools shall have the authority to establish and operate
7 ungraded and/or unstructured classes in grades K-3 according to state rules and regulations.¹

8 The Director of Schools shall submit a copy of the grading and assessment systems to the Board before
9 the system is implemented.² These guidelines shall be communicated annually to students and
10 parent(s)/guardian(s).¹

11 **GRADING SYSTEM¹**

12 Schools teaching grades nine (9) through twelve (12) shall use the uniform grading system established
13 by the State Board of Education. Using the uniform grading system, students' grades shall be reported
14 for the purposes of application for post-secondary financial assistance administered by the Tennessee
15 Student Assistance Corporation.

16 Subject-area grades for students in grades 3-12 shall be expressed by the following letters with their
17 corresponding percentage range:

- 18 • A (90-100)
- 19 • B (80-89)
- 20 • C (70-79)
- 21 • D (60-69)
- 22 • F (0-59)

23 Advanced coursework grades shall be weighted with additional percentage points to calculate the
24 semester average. Depending on the course taken, the following percentage points shall be assigned:

- 25
- 26 • Weighting for high school honors courses includes the addition of 3 percentage points to the
27 grades used to calculate the semester (9 weeks) average.
- 28 • Weighting for high school Advanced Placement Courses includes the addition of 5 percentage
29 points to the grades used to calculate the semester (9 weeks) average for students who sit for the

1 aligned culminating exam.

- 2 • Local and statewide dual credit courses, capstone industry certification-aligned courses, and
 3 dual enrollment courses will include the addition of 4 percentage points to grades used to
 4 calculate the semester average for students who sit for the aligned culminating exam or
 5 identified industry certification exam.
 6

7 If conduct grades are assigned, they shall be marked as follows:

8 EExcellent
 9 SSatisfactory
 10 U.....Unsatisfactory

11 Conduct grades are based on behavior and shall not be deducted from scholastic grades.

12 Attendance records **will not** be used in determining the awarding of grades or the passing of a course
 13 or promotion or retention. While grades earned by students cannot be withheld due to attendance, the
 14 awarding of credit is determined by the school system.

15 Plus and minus evaluations are not to be added to letter grades. Grades are not to be changed once
 16 recorded on a report card. If an erroneous grade has been recorded, correction must be made on a new
 17 card.

18 Grades represent a culmination of learning tasks for each reporting period. Learning tasks may include
 19 in-class work, projects, online assignments, written assignments, tests and/or homework. The teacher
 20 will weigh the value of grades given for various assignments and tests within the applicable period in
 21 computing the grade. This procedure will enable the teacher to allow for individual student differences
 22 in the grading process.

23 **LOTTERY SCHOLARSHIPS³**

24 Using the uniform grading system, students' grades shall be reported for the purposes of application
 25 for post-secondary financial assistance administered by the Tennessee Student Assistance Corporation.
 26 Each school counselor shall provide incoming freshmen with information on college core courses
 27 required for lottery scholarships as well as necessary criteria (grade point average, ACT and SAT score,
 28 etc.) that must be met in order to receive a scholarship.

29 Seniors may apply for the Tennessee HOPE Scholarship by completing the Free Application for Federal
 30 Student Aid (FAFSA). The FAFSA is available at the guidance office or online. Students shall be made
 31 aware of all applicable FAFSA deadlines and encouraged to submit applications in a timely manner.

32 Elementary and middle school counselors shall explain the HOPE Scholarship and its requirements to
 33 their students and impress upon them the benefits of making good grades.

1 LOTTERY SCHOLARSHIP DAY

- 2 Each school year, prior to scheduling courses for the following school year, schools teaching students in
3 grades 8-11 shall conduct a lottery scholarship day for students and their parents.⁴

Legal References

1. TRR/MS 0520-01-03-.02, State Board of Education Policy 3.301; TCA 49-6-407
2. TCA 49-2-203(b)(7); TCA 49-2-301(b)(1)(H)
3. TCA 49-4-904, 907
4. TCA 49-4-932(f)

Cross References

Alternative Credit Options 4.209
Credit Recovery 4.210
Reporting Student Progress 4.601
Honor Roll, Awards, & Class Ranking 4.602
Promotion and Retention 4.603
Transcript Alterations 4.608



For Greeneville City Schools:

Contract Pricing through June 30, 2024

Tennessee Office Supply agrees to provide the following pricing and services to all Greeneville, TN City Schools through June 30, 2024:

Services:

A. Online Ordering

1. All items will be available at contract pricing for ordering online for each of the city schools.
2. Items will be available on a list of contract items that can simple be checked and ordered.

B. Availability

1. Items on contract are normally stocked and available for next-day delivery.
2. In the rare occasion that a product is out of stock, we agree to communicate with the buyer for any items that will take longer than two days to deliver.

C. Order Requirements

1. A purchase order number must be placed on each order.
2. Prices include all shipping and handling fees.
3. Paper delivered as-needed.
4. Order placed through each school will be billed and delivered to said school.

D. Quality

1. All paper will be of commercial quality and anti-jam and low-lint.
2. White paper, and pastel colors will be 20lb. Dark and bright colors are 24lb.
3. White paper will be at least 92 bright.

E. Pricing

1. White Standard Copy Paper, 92 Bright, 8.5x11, 20lb - \$40.55 / cs
2. White 3-Hole paper, 92 Bright, 8.5x11, 20lb - \$56.22 / cs
3. Pastel Colors, 8.5x11, 20lb - \$7.81 / ream
4. Bright Colors, "Wausau Astrobrights," 8.5x11, 24lb - \$17.30 / ream

Tennessee Office Supply 3302 Wayfield Drive Johnson City, TN 37601

Signed  _____ Date June 1, 2023

James Jordan – owner



Quote: GV City Paper BID 2023-24

Dealer Address

Tennessee Office Supply
 3302 Wayfield Dr.
 Johnson City, Tennessee 37601
 Phone: 866-709-2666
 Fax: 866-929-0143

Bill-To Address

Greeneville City Schools
 Brenda Malone
 P.O. BOX 1420
 Greeneville, Tennessee 37744
 Phone: 423-787-8000

Ship-To Address

Greeneville City Schools-District Office
 KLCO - District Office
 129 West Depot Street
 Greeneville, Tennessee 37743
 Phone: 423-787-8000

Item #	Description	UOM	Qty	List Price	Customer Price	Line Total
SC851120	Copy paper, 20#, 8.5x11 Letter Size 92	CS OF 5000	850	\$89.00	40.55	\$34,467.50
BSN36592	Business Source Premium Multipurpose Copy Paper - White - 92 Brightness - Letter - 8 1/2" x 11" - 20 lb Basis Weight - 5000 / Carton - Acid-free	00010 RM/CT	20	\$300.84	56.22	\$1,124.40
SPR05121	Sparco Premium Copy Paper - Blue - Letter - 8 1/2" x 11" - 20 lb Basis Weight - 500 / Ream - Lint-free, Acid-free, Archival-safe	00500 SH/RM	7	\$27.08	7.81	\$54.67
SPR05122	Sparco Premium Copy Paper - Canary - Letter - 8 1/2" x 11" - 20 lb Basis Weight - 500 / Ream - Lint-free, Archival-safe, Acid-free	00500 SH/RM	7	\$27.08	7.81	\$54.67
SPR05123	Sparco Premium Copy Paper - Green - Letter - 8 1/2" x 11" - 20 lb Basis Weight - 500 / Ream - Lint-free, Acid-free, Archival-safe	00500 SH/RM	7	\$27.08	7.81	\$54.67
SPR05124	Sparco Premium Copy Paper - Pink - Letter - 8 1/2" x 11" - 20 lb Basis Weight - 500 / Ream - Lint-free, Archival-safe, Acid-free	00500 SH/RM	7	\$27.08	7.81	\$54.67
SPR05125	Sparco Premium Copy Paper - Goldenrod - Letter - 8 1/2" x 11" - 20 lb Basis Weight - 500 / Ream - Lint-free, Archival-safe, Acid-free	00500 SH/RM	7	\$27.08	7.81	\$54.67
SPR05126	Sparco Premium Copy Paper - Gray - Letter - 8 1/2" x 11" - 20 lb Basis Weight - 500 / Ream - Lint-free, Acid-free, Archival-safe	00500 SH/RM	7	\$27.08	7.81	\$54.67
SPR05127	Sparco Premium Copy Paper - Ivory - Letter - 8 1/2" x 11" - 20 lb Basis Weight - 500 / Ream - Lint-free, Acid-free, Archival-safe	00500 SH/RM	7	\$27.08	7.81	\$54.67
Subtotal:				\$82,993.72		\$35,974.59
Tax						\$0.00
Total						\$35,974.59

REQUEST FOR PROPOSAL
Paper Bid
Greeneville City Schools
May 30, 2023

The Greeneville City School District is accepting bids for approximately 850 cases of copy paper (of which approximately 20 cases are 3-hole punch, and approximately 50 cases are color paper).

Specifications are as follows:

1. Prices quoted should include all shipping and handling fees.
2. Paper should be delivered on an as-needed basis. Customer wishes to engage in VMI (vendor managed inventory) solution and/or on-demand with ordering facilitated and managed via online ordering system with min/max/re-order point inventory balancing and automated procurement based upon customer provided inventory information.
3. Paper should be 20 lb. and 92 bright or better.
4. Individual schools/locations will be billed directly.

Any variance from the specifications should be noted. Bid specifications should be considered minimum standards. Bids must be guaranteed for the entire 2023–2024 school year.

All bids must be submitted in a sealed envelope and clearly marked "Paper Bids 23-24". Bids may be mailed to Beverly W. Miller, Assistant Director of Schools for Administration, Greeneville City Schools, P.O. Box 1420, Greeneville, TN 37744-1420, or submitted in person at the Central Office, 129 West Depot Street, Greeneville, TN 37743.

The Greeneville City Board of Education reserves the right to reject any or all bids and to waive formalities.

Bids must be returned by June 8, 2023, at 3:00 p.m. EST., at which time they will be opened.

If you have any questions regarding the bid specifications, please call Beverly Miller at (423) 787-8019 or email her at millerb@gcschools.net.



Re: Greeneville City Schools RFP for Copy Paper, 2023

Ms. Miller,

Please find AP&T's copy paper pricing as requested:

Item# 1 – 780 cases of 8.5" x 11" white copy paper, 20 lb, 92 bright
\$41.50/case

Item# 2 – 20 cases of 8.5" x 11" white copy paper, 3 hole punch, 20 lb, 92 bright
\$46.90/case

Item# 3 – 50 cases of 8.5" x 11" color copy paper, 20 lb, 92 bright
\$5.90/ream for pastels, \$19.50/ream for brights

Thank you for the opportunity to earn your business.

Regards,



5/31/23

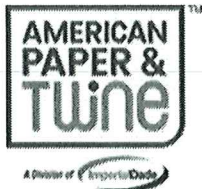

Brian Leitch
Vice President – Eastern Region
American Paper & Twine
D: 865.330.8812 | C: 908.296.3915 | F: 865.690.7008
2710 Redfern Lane | Knoxville, TN 37931
www.ShopAPT.com





FIELD TRIP AND EXCURSION REQUEST FORM
Out-of-State *and* Overnight

Name of the school: Greeneville High School

Person Requesting: Brad Woolsey

Purpose of the Field Trip: Basketball Camp

Destination of Field Trip: Spartanburg, SC - Wofford College

Grade(s) of students attending: 9-12

Dates requested: 6/8/23 - 6/10/23 Departure Time: TBD Return Time: TBD

Approximate # of students to attend: 25

Number, names and affiliation of chaperones attending:

female List names and affiliation: _____

3 male List names and affiliation: Brad Woolsey, Josh Bennett, Nathan

H-1c - GHS Basketball Coaches

("There must be at least one female and one male chaperone if the trip is for a mixed group. A chaperone of the same sex will accompany students on overnight trips")

All Greeneville City Schools guidelines for out-of-state and overnight field trips shall be followed in planning and conducting this field trip per Board of Education policy 4.302, and approval of my principal, the Director of Schools, and Board of Education is required. For an Overnight and Out-of-State Field Trip Request to be considered for approval, it must be received in the director of school's office 10 days prior to the scheduled date of the Board meeting at which it will be considered for approval.

[Signature], Principal

date approved 4/5/23

[Signature], Director of Schools

date approved 5-16-23

[Signature], Chairman, BOE

date approved 5/16/2023

Cultivate the Mind and Impact the Heart through Excellence and Equity

1
Execution Approval 5-16-23

Needs to go on consent
for June BOE mtg.

Steve Starnes

From: Luttrell, Cindy <Cindy.Luttrell@balladhealth.org>
Sent: Tuesday, May 16, 2023 12:16 PM
To: Steve Starnes
Subject: RE: GHS Basketball Camp - SC

WARNING: This email originated from outside of the Greeneville City Schools network. Do not click links or open attachments unless you recognize the sender and know the content is safe.

Not a problem. I will sign and scan and send back to you.

From: Steve Starnes <starnes@gcschools.net>
Sent: Tuesday, May 16, 2023 11:40 AM
To: Luttrell, Cindy <Cindy.Luttrell@balladhealth.org>
Subject: FW: GHS Basketball Camp - SC

Caution: This email originated from outside Ballad Health. **DO NOT click links, open attachments, or reply to the email unless you recognize and/or validate the sender, are expecting the email, and are confident the sender and content are safe.**

Good morning Cindy,

The attached trip request was sent in on time but was inadvertently left off last nights agenda. Are you okay to do Executive Committee approval so the team can go to the camp? If you are in agreement, please sign and return.

I will communicate in my weekly update and it will be placed on the consent agenda for our June meeting. My apologies for this oversight. Thanks!

Steve Starnes
Director of Schools
Greeneville City Schools
129 W. Depot St.
Greeneville, TN 37743
423-787-8014



From: Robin Knight Crabtree <crabtree@gcschools.net>

Sent: Tuesday, May 16, 2023 11:33 AM

To: Steve Starnes <starnes@gcschools.net>

Subject: GHS Basketball Camp - SC

Robin Crabtree
ESSER Data Specialist
Greenville City Schools
423-823-5219

Knightcrabtreei@gcschools.net



This message may contain confidential information. If you are not the intended recipient, please forward the message to mailadmin@gcschools.net. If you do not forward the message to us, we cannot determine the problem.

All email entering or leaving the Greenville City Schools mail server is archived and checked for content and security. All messages are checked for viruses before entering or leaving our server. Spam, viruses, dangerous attachments, and offensive content are removed automatically.

The Greenville City School System does not discriminate in employment, admission, or participation in educational programs on the basis of race, color, gender, age, national origin, religion, or disability.

Learning Without Limits www.gcschools.net

This message is from Ballad Health. The contents contained herein may contain confidential information. If you are not the intended recipient, you are hereby notified that any disclosure, copying, distribution, printing or action taken on the contents is strictly prohibited. If you have received this email in error, please notify the sender immediately and delete this message.

2023-24 Differentiated Pay Plan Submission

On May 24, 2017, the State Board of Education passed the new Strategic Compensation Policy which provides greater clarity on the qualifications for differentiated pay plans. Each LEA shall report annually on the implementation of its differentiated pay plan. Implementation of differentiated pay plans requires that districts compensate eligible educators as outlined by the approved district plan for the year in which they are reporting. Creating a plan in which there are no eligible educators to meet the criteria will not be considered for approval. When determining funding scenarios, districts should examine all applicable federal, state, and local funding received to determine what sources will fund the differentiated pay plan.

The department has released the 2023-24 differentiated pay submission process with some updates based on feedback from districts.

Districts will have 3 options for plan submission:

1. submit a new plan for the 2023-24,
2. submit minor changes to the 2022-23 plan,
3. continue to implement the approved 2022-23 plan.

Each differentiated pay plan submitted to the department shall include compensation for educators based on, at minimum, one of the following criteria:

- High-needs subject areas and schools, sometimes referred to as hard-to-staff subjects or schools
- Instructional roles and/or responsibilities
- Performance

Each district must submit this form by 5 p.m. CT, Friday, July 14. Submission includes:

- 2023-24 Differentiated Pay Plan (complete this form)
- Implementation Update on 2022-23 Differentiated Pay Plan (based on payouts to teachers during the 2022-23 school year)
- 2023-24 Salary Schedule (Excel format uploaded in this form)

The following items are optional, but do not meet the above-differentiated pay criteria.

- Responsibilities that support student organizations or extracurricular activities.
- Attendance bonuses
- National board certification
- School and district administrator compensation

Submission tips and guidelines:

- You may advance through the application without completing all required fields on a page.
- You may use the "Save and Resume Later" function to save your work and come back later. However, any file uploads will not be saved.
- All required fields must be completed in order to submit the application.

The deadline for submission is 5 p.m. CT, Friday, July 14.

District Name *

GREENEVILLE--301

Contact Information

Please provide your contact information in the event that we need to follow up with any questions.

Name *

Melissa Batson

Role in District Office *

Human Resources or Talent

Email Address *

batsonm@gcschools.net

Confirm Email Address *

batsonm@gcschools.net

Phone *

(423) 787-0976

CORE Region *

First

Update Options

Which update option is your district choosing?*

- My district is submitting a newly developed plan for implementation in 2023-24.
- My district is making minor changes to the 2022-23 plan for the 2023-24 implementation.
- My district is implementing as we did in 2022-23 and we do not need to make changes to the plan for the 2023-24 implementation.

Alternative Salary Schedule

An alternative salary schedule uses some other component, often performance criteria, in addition to or in lieu of education and experience to determine base pay.

Base pay increases determined by an educator's level of overall effectiveness (LOE) qualify as an alternative salary schedule and are subject to approval by the board.

Is your district implementing an alternative salary schedule?*

No ▾

An alternative salary schedule uses some other component, often performance criteria, in addition to or in lieu of education and experience to determine base pay.

2023-24 Salary Schedule

If you save and resume later, the attachment will not save and you will have to re-upload your salary schedule.

Describe how educators are compensated for earning advanced degrees in your district:*

Advanced degrees are awarded with a base pay increase.

List the advanced degrees your district compensates for (MA, MA+45, Ed.D, Ph.D).

2023-24 Salary Schedule (excel format only)

Choose File Remove File No File Chosen

Make sure your salary schedule is labeled 2023-24 salary schedule.

Data Used to Create Plan

Did you use data to support the development of your plan?*

- yes
- no

What type of data was used in developing your plan? (check all that apply)*

- Student achievement data
- Growth data
- Vacancy data
- Other:

The district utilizes the TIGER Evaluation model and the Stage 3 option which allows teachers the criteria to apply for leadership roles and additional d

Implementation Update on 2022-23 Differentiated Pay Plan

Per the Strategic Compensation policy (State Board of Education Policy 5.600), each LEA shall report annually on the implementation of its differentiated pay plan.

Total number of certified teachers in the district in 2022-23:*

236 ▾

Did your district pay out funds to educators for fulfilling a Hard-to-Staff component of your 2022-23 differentiated pay plan?*

No ▾

Implementation Update on 2022-23 Differentiated Pay Plan: Additional Roles/Responsibilities

Did your district pay out funds to educators for fulfilling additional roles and responsibilities as outlined in your 2022-23 differentiated pay plan?

Yes

How many teachers received the Additional Roles and Responsibilities award in 2022-23?*

25

What is the amount the individual educators received per additional role in 2022-23?*

Instructional Coaches (6) \$19,297
Team Leaders (19) \$26,287

Include amount per role, formatted as "Role (# of roles) x Compensation Amount". For example, "Teacher Coach (6) x \$1000".

Actual total cost of the Additional Roles and Responsibilities component:*

\$

45584.00

Total paid out to all teachers

When did you pay out for the Additional Roles and Responsibilities component?*

These are paid on a monthly basis

Implementation Update on 2022-23 Differentiated Pay Plan: Performance

Implementation updates for performance awards based on 2022-23 data are due **December 1, 2023**.

Did your district pay out funds (or plan to pay out funds) to educators based on performance criteria as outlined in your 2022-23 differentiated pay plan?*

No

If you are planning to make performance payouts using 2022-23 data but have not yet made payments, then you will submit this information by December 1, 2023.

[Save and Resume Later](#)

2023-2024 Budget Projections Worksheet

Revenue:

Lunch -Student	539,923
Lunch-Adult	29,946
Breakfast	54,807
A La Carte	215,618
Other charges for services	12,010
Commodity Rebate	23,546
State Matching Funds	16,107
Federal Fund Equipment Assistance Grant	80,000
USDA School Lunch Program	738,320
USDA Other (Commodities)	109,627
USDA Breakfast	256,787
After School Snack	19,927
Headstart/Pre-K	40,936
Sale Of Equipment	5,000
Total Revenue	2,142,554

Expenditures:

Director	81,644
Administrative Assistant/Bookkeeper	35,270
Cafeteria Personnel	643,719
Social Security	47,159
Retirement	71,522
Life Insurance	603
Health Insurance	146,960
Employer Medicare	7,202
Audit Services	3,500
Communication	384
Maintenance and Repair	8,000
Travel	4,000
Contracted Services	9,057
Food Prep Supplies	65,136
Food	688,648
Office Supplies	4,482
USDA Commodity Value	109,627
Software	1,177
Other Supplies and Materials	11,894
In Service/Staff Development	5,689
Other Charges	2,570
Food Service Equipment	200,000
Total Expenditures	2,142,554

Greenville City Schools
Extended School Placement (ESP) Program Final Budget Amendment
Fiscal Year 2022-2023
Presented June 2023

Account Subfund #	Description	ESP Budget 2022-2023	Amendment	Amended ESP Budget 2022-2023
43582	Community Service Fees- Children	\$ 70,000	\$ (59,800)	\$ 10,200
44990	Other Local Revenue	\$ 250		\$ 250
46990	Other State Revenue	\$ 69,000	\$ (69,000)	\$ -
	Total Revenue	\$ 139,250	\$ (128,800)	\$ 10,450
73300-105	Program Supervisor Wages	\$ 25,000	\$ (21,950)	\$ 3,050
73300-119	Bookkeeper	\$ -	\$ 5,000	\$ 5,000
73300-169	Part-Time Personnel	\$ 50,000	\$ (40,515)	\$ 9,485
73300-201	Social Security/FICA	\$ 5,000	\$ (3,912)	\$ 1,088
73300-204	Retirement	\$ -	\$ 720	\$ 720
73300-210	Unemployment Compensation	\$ 650	\$ (650)	\$ -
73300-212	Medicare	\$ 1,500	\$ (1,245)	\$ 255
73300-241	Bad Debt Expense	\$ -	\$ 1,561	\$ 1,561
73300-307	Communication	\$ 1,000	\$ (830)	\$ 170
73300-355	Travel	\$ 1,000	\$ (1,000)	\$ -
73300-422	Food	\$ 4,500	\$ (3,593)	\$ 907
73300-429	Instructional Supplies & Materials	\$ 4,500	\$ (4,500)	\$ -
73300-499	Other Supplies & Materials	\$ 4,500	\$ (4,167)	\$ 333
73300-509	Refunds	\$ -	\$ 38,930	\$ 38,930
73300-524	Inservice/Staff Development	\$ 4,500	\$ (4,500)	\$ -
73300-599	Other Charges	\$ 4,500	\$ 1,865	\$ 6,365
73300-790	Equipment	\$ 4,500	\$ (4,500)	\$ -
99100-590	Transfers Out	\$ -	\$ 75,296	\$ 75,296
	Total Expenses	\$ 111,150	\$ 32,010	\$ 143,160
	Surplus/Deficit	28,100		(132,710)

To Transfer Remaining Fund Balance from Extended School Placement Program Fund 146
To Update Budget to Reflect Revenues/Expenditures During Final Extended School Program Year 2023

Greeneville City Schools
Final Federal Projects Budget Amendment
Fiscal Year 2022-2023
Presented June 2023

Account Subfund #	Description	Federal Projects Budget 2022-2023	Amendment	Amended Federal Projects Budget 2022-2023
10	Consolidated Administration	\$ 109,580	\$ 3,454	\$ 113,034
100	Title I	\$ 658,832		\$ 658,832
150	Title I Neglected	\$ 80,444		\$ 80,444
200	Title II Part A	\$ 123,351		\$ 123,351
300	Title III**	\$ 53,166		\$ 53,166
400	Title IV	\$ 52,981		\$ 52,981
430	21st Century Learning	\$ 346,686		\$ 346,686
600	Title V	\$ 89,846	\$ (5,000)	\$ 84,846
900	IDEA	\$ 888,572		\$ 888,572
910	IDEA, Preschool	\$ 13,343		\$ 13,343
935	*ESSER 2.0	\$ 578,890		\$ 578,890
936	*ESSER 3.0	\$ 2,953,947		\$ 2,953,947
937	*Fiscal Premonitoring Supports Grant	\$ 37,467		\$ 37,467
941	*Epidemiology & Laboratory Capacity Grant	\$ 619,127		\$ 619,127
942	*Resilient School Communities Grant	\$ 163,062		\$ 163,062
952	*Governors Civics Grant	\$ 544		\$ 544
701	*ARP Homeless	\$ 20,965		\$ 20,965
938	*Math Implementation Support Grant	\$ 71,250		\$ 71,250
909	*ARP IDEA	\$ 119,890		\$ 119,890
951	Literacy Stipend Grant	\$ 33,000		\$ 33,000
	Total Revenue	\$ 7,014,943	\$ (1,545)	\$ 7,013,398
10	Consolidated Administration	\$ 109,580	\$ 3,454	\$ 113,034
100	Title I	\$ 658,832		\$ 658,832
150	Title I Neglected	\$ 80,444		\$ 80,444
200	Title II Part A	\$ 123,351		\$ 123,351
300	Title III**	\$ 53,166		\$ 53,166
400	Title IV	\$ 52,981		\$ 52,981
430	21st Century Learning	\$ 346,686		\$ 346,686
600	Title V	\$ 89,846	\$ (5,000)	\$ 84,846
900	IDEA	\$ 888,572		\$ 888,572
910	IDEA, Preschool	\$ 13,343		\$ 13,343
935	*ESSER 2.0	\$ 578,890		\$ 578,890
936	*ESSER 3.0	\$ 2,953,947		\$ 2,953,947
937	*Fiscal Premonitoring Supports Grant	\$ 37,467		\$ 37,467
941	*Epidemiology & Laboratory Capacity Grant	\$ 619,127		\$ 619,127
942	*Resilient School Communities Grant	\$ 163,062		\$ 163,062
952	*Governors Civics Grant	\$ 544		\$ 544
701	*ARP Homeless	\$ 20,965		\$ 20,965
938	*Math Implementation Support Grant	\$ 71,250		\$ 71,250
909	*ARP IDEA	\$ 119,890		\$ 119,890
951	Literacy Stipend Grant	\$ 33,000		\$ 33,000
	Total Expenses	\$ 7,014,943	\$ (1,545)	\$ 7,013,398

To budget Updated Federal Grant Allocations & Innovative Schools Grant - Fiscal Year 2023

*Indicates CARES Act Funding

**Includes Title III Consortium Member Allocations

Greeneville City Schools Federal Programs Budget 2023-2024

**Presented: June 2023
Preliminary Allocations**

Account #	Description	Federal Programs Budget 2023-2024
47141	Title I, A	536,528
47141	Title I, Neglected	70,934
47189	Title IIA	91,911
47146	Title III	11,156
47590	Title IV	58,091
47148	Title V	91,411
47143	IDEA, Part B	662,168
47145	IDEA, Preschool	13,343
49800	Consolidated Administration	108,227
Total Revenues and Equity		\$ 1,643,769
71100	Regular Instruction	520,109
71150	Alternative Instruction Program	70,934
71200	Special Education Program	595,955
72120	Health Services	53,686
72130	Other Student Support	83,224
72210	Regular Instruction - Support	225,447
72220	Special Education Program - Support	79,556
772710	Transportation	14,858
Total Expenses		\$ 1,643,769
Deficit		\$ -

ELC Grant Expenditures

Steve Starnes <starness@gcschools.net>

Thu 6/1/2023 4:56 PM

To: Kristen Rollins <rollinsk@gcschools.net>; Roger Hensley <hensleyr@gcschools.net>; Jeannie Woolsey <woolseyj@gcschools.net>; Tamara Clouse <clouset@gcschools.net>

Cc: Ellen Lipe <lipee@gcschools.net>; Beverly Miller <millerb@gcschools.net>; Jamie Galyon <galyonj@gcschools.net>

Good afternoon,

This is to follow up and confirm that I obtained Executive Committee approval to expend \$40,026.41 for custodial supplies and \$36,000 for 3 floor scrubbers from the ELC Grant funds. If anyone has questions, please let me know. Thanks!

Steve Starnes
Director of Schools
Greeneville City Schools
129 W. Depot St.
Greeneville, TN 37743
423-787-8014

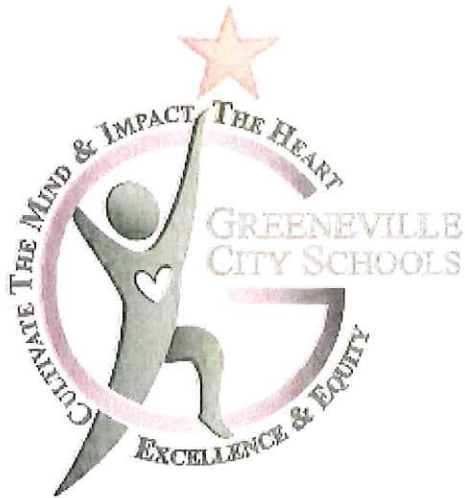

PO BOX 2317
 Jacksonville, FL 32203-2317

Ship To:
 GCS-GEORGE CLEM OPERATIONS
 312 FLORAL STREET
 GREENEVILLE TN 37743

Quote Date	06/05/23
Quote Number	44542879
Account Number	876499

Quoted To:
 GCS-GEORGE CLEM OPERATIONS
 312 FLORAL STREET
 GREENEVILLE TN 37743

Contact Info:
 ROGER HENSLEY
 (423) 787-8003

For Inquiries:
 (866) 412-6726 Fax (000) 000-0000
 www.HomeDepotPro.com/Institutional
 FED.ID 52-2418852

Management
 50982- GREENEVILLE CITY SCHOOLS

Quote Date	Customer PO#	Writer	Salesperson
06/05/23		Rachele	JOHN PAINTER

LN.	Item No.	Description	Qty	UOM	Price	Ext Amt	T
1	1.008-059.0	CHARIOT ISCRIB DELUXE 20 AGM iQuote#: 44542879 iExpected Delivery is PENDNG CONTRACT afte iSpecial Order Item Nonreturnable. iSpecial Orders may be Subject to iFreight Charges.	3	EA	11726.95	35180.85	Y
Quotation Sub-Total						\$35,180.85	
Tax						\$0.00	
Total						\$35,180.85	









Powered by HD Supply®

GC
16,224.86





- My Account Number 876499
- Currently Shopping As 876499 - GCS-GEORGE CLEM OPERATIONS
- Current Ship-To Address GCS-GEORGE CLEM OPERATIONS 312 FLORAL STREET GREENEVILLE, TN 37743

Supplies 1948
Scribbles 1949
40,026.41
+ 36,000.00 - HD
Fix GCS GMS - Flors
Supplier
76,026.41
Shipping

Shopping Cart

	Description	Availability	Price	Total
1	 <p>Renown Toilet Mop Brush (6-Pack) Item # 311535522 Manufacturer: Renown Category: CLEANING & JANITORIAL</p>	112 available - estimated arrival next day* *Delivery delays may occur during peak ordering periods. Exceptions apply. Estimated delivery is based on orders received by warehouse cut-off times and carrier schedule. Availability is based on your current ship-to address.	\$4.24 6 Pack	\$25.44
2	 <p>Renown 24 oz. 4-Ply Natural Cotton Metal Bolt-In Headband Cut End Mop Head (6/Case) Item # 311879353 Manufacturer: Renown Category: CLEANING & JANITORIAL</p>	28 available - estimated arrival next day* *Delivery delays may occur during peak ordering periods. Exceptions apply. Estimated delivery is based on orders received by warehouse cut-off times and carrier schedule. Availability is based on your current ship-to address.	\$27.61 1 Case	\$27.61
3	 <p>Blended Cotton Synthetic Replacement String Mop Medium Loop Wide Band Mop Head Item # 318353671 Manufacturer: ABCO PRODUCTS Category: CLEANING & JANITORIAL</p>	727 available - estimated arrival 2-3 days* *Delivery delays may occur during peak ordering periods. Exceptions apply. Estimated delivery is based on orders received by warehouse cut-off times and carrier schedule. Availability is based on your current ship-to address.	\$4.51 8 Each	\$36.08
4	 <p>HOSPECO 10 lbs. per Box White Terry Towel Rags Item # HOS537-10 Manufacturer: National Brand Alternative Category: CLEANING & JANITORIAL</p>	12 available - estimated arrival next day* *Delivery delays may occur during peak ordering periods. Exceptions apply. Estimated delivery is based on orders received by warehouse cut-off times and carrier schedule. Availability is based on your current ship-to address.	\$23.72 6 Box	\$142.32
5	 <p>Scott multi-fold Paper Towels with Fast-Drying Absorbency Pockets White (16-Packs/Case, 250 multi-fold Towels/Pack) Item # KCC01804 Manufacturer: Scott Category: CLEANING & JANITORIAL</p>	28 available - estimated arrival next day* *Delivery delays may occur during peak ordering periods. Exceptions apply. Estimated delivery is based on orders received by warehouse cut-off times and carrier schedule. Availability is based on your current ship-to address.	\$34.51 6 Case	\$207.06
6	 <p>WYPALL L30 DRC Towels Strong and Soft Wipes, White (12-Packs/Case, 90 Towels/Pack) Item # KCC05812 Manufacturer: WYPALL Category: CLEANING & JANITORIAL</p>	79 available - estimated arrival next day* *Delivery delays may occur during peak ordering periods. Exceptions apply. Estimated delivery is based on orders received by warehouse cut-off times and carrier schedule. Availability is based on your current ship-to address.	\$48.46 10 Case	\$484.60
7	 <p>Renown 36X5 2-PLY WHITE PREMIUM TWIST COTTON DUST MOP Item # REN02273-IB Manufacturer: Renown Category: CLEANING & JANITORIAL</p>	23 available - estimated arrival next day* *Delivery delays may occur during peak ordering periods. Exceptions apply. Estimated delivery is based on orders received by warehouse cut-off times and carrier schedule. Availability is based on your current ship-to address.	\$8.49 5 Each	\$42.45

	Description	Availability	Price	Total
8	 <p>Renown Natural 7.5 in. Controlled Hardwound Paper Towels (800 ft. per Roll, 6-Rolls per Case) Item # REN06132-WB Manufacturer: Renown Category: CLEANING & JANITORIAL</p>	34 available - estimated arrival next day* *Delivery delays may occur during peak ordering periods. Exceptions apply. Estimated delivery is based on orders received by warehouse cut-off times and carrier schedule. Availability is based on your current ship-to address.	\$46.11 25 Case	\$1,152.75
9	 <p>Renown 17 Gal. 24 in. x 32 in. Clear Low-Density Trash Bags (250 per Case) Item # REN20428-CA Manufacturer: Renown Category: CLEANING & JANITORIAL</p>	145 available - estimated arrival next day* *Delivery delays may occur during peak ordering periods. Exceptions apply. Estimated delivery is based on orders received by warehouse cut-off times and carrier schedule. Availability is based on your current ship-to address.	\$26.65 27 Case	\$719.55
10	 <p>Renown 60 Gal. 1.5 mil 38 in. x 58 in. Black Can Liner (10 per Roll, 10-Roll per Case) Item # REN66016-CA Manufacturer: Renown Category: CLEANING & JANITORIAL</p>	283 available - estimated arrival next day* *Delivery delays may occur during peak ordering periods. Exceptions apply. Estimated delivery is based on orders received by warehouse cut-off times and carrier schedule. Availability is based on your current ship-to address.	\$32.90 27 Case	\$888.30
11	 <p>SPARTAN CHEMICAL COMPANY Xcelente 1 Gal. Fresh Lavender Scent Multi-Purpose Cleaner Item # SPA0019-04 Manufacturer: SPARTAN CHEMICAL COMPANY Category: CLEANING & JANITORIAL</p>	234 available - estimated arrival next day* *Delivery delays may occur during peak ordering periods. Exceptions apply. Estimated delivery is based on orders received by warehouse cut-off times and carrier schedule. Availability is based on your current ship-to address.	\$38.84 2 Case	\$77.68
12	 <p>Spartan Lite'n Foamy Cranberry Ice 1 Gallon Hand Wash Item # SPA3152-04 Manufacturer: Spartan Category: CLEANING & JANITORIAL</p>	165 available - estimated arrival next day* *Delivery delays may occur during peak ordering periods. Exceptions apply. Estimated delivery is based on orders received by warehouse cut-off times and carrier schedule. Availability is based on your current ship-to address.	\$58.56 5 Case	\$292.80
13	 <p>Spartan Chemical BioTransport 1 Consume Eco-Lyzer 2 Liter Floral Scent Disinfectant/Deodorant Item # SPA4597 Manufacturer: Spartan Chemical Category: CLEANING & JANITORIAL</p>	57 available - estimated arrival next day* *Delivery delays may occur during peak ordering periods. Exceptions apply. Estimated delivery is based on orders received by warehouse cut-off times and carrier schedule. Availability is based on your current ship-to address.	\$69.48 2 Case	\$138.96
14	 <p>Spartan COPY 0 NABC Concentrate 2 I Floral Scent Restroom Disinfectant (4 per Pack) Item # SPA4716 Manufacturer: Spartan Category: CLEANING & JANITORIAL</p>	89 available - estimated arrival next day* *Delivery delays may occur during peak ordering periods. Exceptions apply. Estimated delivery is based on orders received by warehouse cut-off times and carrier schedule. Availability is based on your current ship-to address.	\$108.52 2 Case	\$217.04
15	 <p>Spartan Chemical Co. 2 Liter Fresh Scent Super Concentrated Glass & Hard Surface Cleaner Item # SPA4730 Manufacturer: Spartan Chemical Co. Category: CLEANING & JANITORIAL</p>	19 available - estimated arrival next day* *Delivery delays may occur during peak ordering periods. Exceptions apply. Estimated delivery is based on orders received by warehouse cut-off times and carrier schedule. Availability is based on your current ship-to address.	\$109.60 2 Case	\$219.20
16	 <p>SPARTAN CHEMICAL COMPANY Halt 2 Liter One Step Cleaner/Disinfectant Item # SPA4806 Manufacturer: SPARTAN CHEMICAL COMPANY Category: CLEANING & JANITORIAL</p>	18 available - estimated arrival next day* *Delivery delays may occur during peak ordering periods. Exceptions apply. Estimated delivery is based on orders received by warehouse cut-off times and carrier schedule. Availability is based on your current ship-to address.	\$47.52 3 Case	\$142.56

	Description	Availability	Price	Total
17	 <p>SPARTAN CHEMICAL COMPANY 2 Liter Clean by Peroxy Spring Rain Scent Multi-Purpose Cleaner Item # SPA4820 Manufacturer: SPARTAN CHEMICAL COMPANY Category: CLEANING & JANITORIAL</p>	<p>60 available - estimated arrival next day*</p> <p>*Delivery delays may occur during peak ordering periods. Exceptions apply. Estimated delivery is based on orders received by warehouse cut-off times and carrier schedule. Availability is based on your current ship-to address.</p>	<p>\$21.23</p> <p>4 Each</p>	\$84.92
18	 <p>SPARTAN CHEMICAL COMPANY BNC-15 2 Liter Floral Scent One Step Cleaner/Disinfectant (4 per Pack) Item # SPA4856-02 Manufacturer: SPARTAN CHEMICAL COMPANY Category: CLEANING & JANITORIAL</p>	<p>62 available - estimated arrival next day*</p> <p>*Delivery delays may occur during peak ordering periods. Exceptions apply. Estimated delivery is based on orders received by warehouse cut-off times and carrier schedule. Availability is based on your current ship-to address.</p>	<p>\$139.50</p> <p>2 Case</p>	\$279.00
19	 <p>Spartan SparCling 1 Qt. Mint Scent 1-Step Disinfectant Toilet Bowl Cleaner (12 per Pack) Item # SPA7118-12-C Manufacturer: Spartan Category: CLEANING & JANITORIAL</p>	<p>42 available - estimated arrival next day*</p> <p>*Delivery delays may occur during peak ordering periods. Exceptions apply. Estimated delivery is based on orders received by warehouse cut-off times and carrier schedule. Availability is based on your current ship-to address.</p>	<p>\$34.56</p> <p>3 Case</p>	\$103.68
20	 <p>Karcher Sensor and Versamatic Bags Parts in Black (10-Pack) Item # WIN5300CS Manufacturer: Karcher Category: CLEANING & JANITORIAL</p>	<p>2 available - estimated arrival next day* 1 may be backordered. Please allow for additional delivery time.</p> <p>*Delivery delays may occur during peak ordering periods. Exceptions apply. Estimated delivery is based on orders received by warehouse cut-off times and carrier schedule. Availability is based on your current ship-to address.</p>	<p>\$24.82</p> <p>3 Pack</p>	\$74.46
21	 <p>Karcher Windsor Sensor XP 12 Upright Vacuum with Tools Item # WINSRXP12 Manufacturer: Karcher Category: CLEANING & JANITORIAL</p>	<p>1 available - estimated arrival next day* 17 may be backordered. Please allow for additional delivery time.</p> <p>*Delivery delays may occur during peak ordering periods. Exceptions apply. Estimated delivery is based on orders received by warehouse cut-off times and carrier schedule. Availability is based on your current ship-to address.</p>	<p>\$603.80</p> <p>18 Each</p>	\$10,868.40

Order Summary

Total	\$16,224.86
Discount	\$0.00
Order Total	\$16,224.86









Powered by HD Supply*

17-L
2669.95

- My Account Number 876495
- Currently Shopping As 876495 - GCS-HIGHLAND ELEMENTARY
- Current Ship-To Address GCS-HIGHLAND ELEMENTARY 208 NORTH HIGHLAND AVE GREENEVILLE, TN 37745

-
-
-
-

Shopping Cart

	Description	Availability	Price	Total
1	 <p>BIOESQUE 1 Qt. Botanical Disinfectant Solution Item # 310650027 Manufacturer: BIOESQUE Category: CLEANING & JANITORIAL</p>	<p>112 available - estimated arrival next day*</p> <p>*Delivery delays may occur during peak ordering periods. Exceptions apply. Estimated delivery is based on orders received by warehouse cut-off times and carrier schedule. Availability is based on your current ship-to address.</p>	<p>\$7.93</p> <p>24 Each</p>	\$190.32
2	 <p>Renown 24 oz. 4-Ply Natural Cotton Metal Bolt-In Headband Cut End Mop Head (6/Case) Item # 311879353 Manufacturer: Renown Category: CLEANING & JANITORIAL</p>	<p>28 available - estimated arrival next day*</p> <p>*Delivery delays may occur during peak ordering periods. Exceptions apply. Estimated delivery is based on orders received by warehouse cut-off times and carrier schedule. Availability is based on your current ship-to address.</p>	<p>\$27.61</p> <p>1 Case</p>	\$27.61
3	 <p>Blended Cotton Synthetic Replacement String Mop Medium Loop Wide Band Mop Head Item # 318353671 Manufacturer: ABCO PRODUCTS Category: CLEANING & JANITORIAL</p>	<p>732 available - estimated arrival 2-3 days*</p> <p>*Delivery delays may occur during peak ordering periods. Exceptions apply. Estimated delivery is based on orders received by warehouse cut-off times and carrier schedule. Availability is based on your current ship-to address.</p>	<p>\$4.51</p> <p>2 Each</p>	\$9.02
4	 <p>HOSPECO 10 lbs. per Box White Terry Towel Rags Item # HOS537-10 Manufacturer: National Brand Alternative Category: CLEANING & JANITORIAL</p>	<p>12 available - estimated arrival next day*</p> <p>*Delivery delays may occur during peak ordering periods. Exceptions apply. Estimated delivery is based on orders received by warehouse cut-off times and carrier schedule. Availability is based on your current ship-to address.</p>	<p>\$23.72</p> <p>3 Box</p>	\$71.16
5	 <p>WYPALL L30 DRC Towels Strong and Soft Wipes, White (12-Packs/Case, 90 Towels/Pack) Item # KCC05812 Manufacturer: WYPALL Category: CLEANING & JANITORIAL</p>	<p>79 available - estimated arrival next day*</p> <p>*Delivery delays may occur during peak ordering periods. Exceptions apply. Estimated delivery is based on orders received by warehouse cut-off times and carrier schedule. Availability is based on your current ship-to address.</p>	<p>\$48.46</p> <p>3 Case</p>	\$145.38
6	 <p>Mr. Clean Professional Magic Eraser Extra Power Disposable Cleaning Pads Item # PGC16449 Manufacturer: Mr. Clean Category: CLEANING & JANITORIAL</p>	<p>13 available - estimated arrival next day*</p> <p>*Delivery delays may occur during peak ordering periods. Exceptions apply. Estimated delivery is based on orders received by warehouse cut-off times and carrier schedule. Availability is based on your current ship-to address.</p>	<p>\$50.40</p> <p>1 Case</p>	\$50.40
7	 <p>Renown Natural 7.5 in. Controlled Hardwound Paper Towels (800 ft. per Roll, 6-Rolls per Case) Item # REN06132-WB Manufacturer: Renown Category: CLEANING & JANITORIAL</p>	<p>34 available - estimated arrival next day*</p> <p>*Delivery delays may occur during peak ordering periods. Exceptions apply. Estimated delivery is based on orders received by warehouse cut-off times and carrier schedule. Availability is based on your current ship-to address.</p>	<p>\$46.11</p> <p>16 Case</p>	\$737.76

	Description	Availability	Price	Total
8	 <p>Renown 17 Gal. 24 in. x 32 in. Clear Low-Density Trash Bags (250 per Case) Item # REN20428-CA Manufacturer: Renown Category: CLEANING & JANITORIAL</p>	145 available - estimated arrival next day* *Delivery delays may occur during peak ordering periods. Exceptions apply. Estimated delivery is based on orders received by warehouse cut-off times and carrier schedule. Availability is based on your current ship-to address.	\$26.65 12 Case	\$319.80
9	 <p>Renown 60 Gal. 1.5 mil 38 in. x 58 in. Black Can Liner (10 per Roll, 10-Roll per Case) Item # REN66016-CA Manufacturer: Renown Category: CLEANING & JANITORIAL</p>	285 available - estimated arrival next day* *Delivery delays may occur during peak ordering periods. Exceptions apply. Estimated delivery is based on orders received by warehouse cut-off times and carrier schedule. Availability is based on your current ship-to address.	\$32.90 12 Case	\$394.80
10	 <p>SPARTAN CHEMICAL COMPANY Xcelente 1 Gal. Fresh Lavender Scent Multi-Purpose Cleaner Item # SPA0019-04 Manufacturer: SPARTAN CHEMICAL COMPANY Category: CLEANING & JANITORIAL</p>	234 available - estimated arrival next day* *Delivery delays may occur during peak ordering periods. Exceptions apply. Estimated delivery is based on orders received by warehouse cut-off times and carrier schedule. Availability is based on your current ship-to address.	\$38.84 1 Case	\$38.84
11	 <p>Spartan Lite'n Foamy Cranberry Ice 1 Gallon Hand Wash Item # SPA3152-04 Manufacturer: Spartan Category: CLEANING & JANITORIAL</p>	165 available - estimated arrival next day* *Delivery delays may occur during peak ordering periods. Exceptions apply. Estimated delivery is based on orders received by warehouse cut-off times and carrier schedule. Availability is based on your current ship-to address.	\$58.56 3 Case	\$175.68
12	 <p>Spartan Chemical BioTransport 1 Consume Eco-Lyzer 2 Liter Floral Scent Disinfectant/Deodorant Item # SPA4597 Manufacturer: Spartan Chemical Category: CLEANING & JANITORIAL</p>	57 available - estimated arrival next day* *Delivery delays may occur during peak ordering periods. Exceptions apply. Estimated delivery is based on orders received by warehouse cut-off times and carrier schedule. Availability is based on your current ship-to address.	\$69.48 1 Case	\$69.48
13	 <p>Spartan COPY 0 NABC Concentrate 2 l Floral Scent Restroom Disinfectant (4 per Pack) Item # SPA4716 Manufacturer: Spartan Category: CLEANING & JANITORIAL</p>	89 available - estimated arrival next day* *Delivery delays may occur during peak ordering periods. Exceptions apply. Estimated delivery is based on orders received by warehouse cut-off times and carrier schedule. Availability is based on your current ship-to address.	\$108.52 1 Case	\$108.52
14	 <p>Spartan Chemical Co. 2 Liter Fresh Scent Super Concentrated Glass & Hard Surface Cleaner Item # SPA4730 Manufacturer: Spartan Chemical Co. Category: CLEANING & JANITORIAL</p>	19 available - estimated arrival next day* *Delivery delays may occur during peak ordering periods. Exceptions apply. Estimated delivery is based on orders received by warehouse cut-off times and carrier schedule. Availability is based on your current ship-to address.	\$109.60 1 Case	\$109.60
15	 <p>SPARTAN CHEMICAL COMPANY Halt 2 Liter One Step Cleaner/Disinfectant Item # SPA4806 Manufacturer: SPARTAN CHEMICAL COMPANY Category: CLEANING & JANITORIAL</p>	18 available - estimated arrival next day* *Delivery delays may occur during peak ordering periods. Exceptions apply. Estimated delivery is based on orders received by warehouse cut-off times and carrier schedule. Availability is based on your current ship-to address.	\$47.52 1 Case	\$47.52
16	 <p>SPARTAN CHEMICAL COMPANY BNC-15 2 Liter Floral Scent One Step Cleaner/Disinfectant (4 per Pack) Item # SPA4856-02 Manufacturer: SPARTAN CHEMICAL COMPANY Category: CLEANING & JANITORIAL</p>	62 available - estimated arrival next day* *Delivery delays may occur during peak ordering periods. Exceptions apply. Estimated delivery is based on orders received by warehouse cut-off times and carrier schedule. Availability is based on your current ship-to address.	\$139.50 1 Case	\$139.50

Description

Availability

Price

Total

		Description	Availability	Price	Total
17		Spartan SparCling 1 Qt. Mint Scent 1-Step Disinfectant Toilet Bowl Cleaner (12 per Pack) Item # SPA7118-12-C Manufacturer: Spartan Category: CLEANING & JANITORIAL	42 available - estimated arrival next day* *Delivery delays may occur during peak ordering periods. Exceptions apply. Estimated delivery is based on orders received by warehouse cut-off times and carrier schedule. Availability is based on your current ship-to address.	\$34.56 1 Case	\$34.56

Order Summary







Total	\$2,669.95
Discount	\$0.00
Order Total	\$2,669.95





645
6,009.05

- My Account Number 876492
- Currently Shopping As 876492 - GCS-GREENEVILLE HIGH SCHOOL
- Current Ship-To Address GCS-GREENEVILLE HIGH SCHOOL TUSCULUM BLVD GREENEVILLE, TN 37745

Shopping Cart

	Description	Availability	Price	Total
1	 <p>BIOESQUE 1 Qt. Botanical Disinfectant Solution Item # 310650027 Manufacturer: BIOESQUE Category: CLEANING & JANITORIAL</p>	<p>112 available - estimated arrival next day*</p> <p>*Delivery delays may occur during peak ordering periods. Exceptions apply. Estimated delivery is based on orders received by warehouse cut-off times and carrier schedule. Availability is based on your current ship-to address.</p>	<p>\$7.93</p> <p>36 Each</p>	\$285.48
2	 <p>Renown 24 oz. 4-Ply Natural Cotton Metal Bolt-In Headband Cut End Mop Head (6/Case) Item # 311879353 Manufacturer: Renown Category: CLEANING & JANITORIAL</p>	<p>28 available - estimated arrival next day*</p> <p>*Delivery delays may occur during peak ordering periods. Exceptions apply. Estimated delivery is based on orders received by warehouse cut-off times and carrier schedule. Availability is based on your current ship-to address.</p>	<p>\$27.61</p> <p>3 Case</p>	\$82.83
3	 <p>Blended Cotton Synthetic Replacement String Mop Medium Loop Wide Band Mop Head Item # 318353671 Manufacturer: ABCO PRODUCTS Category: CLEANING & JANITORIAL</p>	<p>732 available - estimated arrival 2-3 days*</p> <p>*Delivery delays may occur during peak ordering periods. Exceptions apply. Estimated delivery is based on orders received by warehouse cut-off times and carrier schedule. Availability is based on your current ship-to address.</p>	<p>\$4.51</p> <p>12 Each</p>	\$54.12
4	 <p>HOSPECO 10 lbs. per Box White Terry Towel Rags Item # HOS537-10 Manufacturer: National Brand Alternative Category: CLEANING & JANITORIAL</p>	<p>12 available - estimated arrival next day*</p> <p>*Delivery delays may occur during peak ordering periods. Exceptions apply. Estimated delivery is based on orders received by warehouse cut-off times and carrier schedule. Availability is based on your current ship-to address.</p>	<p>\$23.72</p> <p>8 Box</p>	\$189.76
5	 <p>Scott multi-fold Paper Towels with Fast-Drying Absorbency Pockets White (16-Packs/Case, 250 multi-fold Towels/Pack) Item # KCC01804 Manufacturer: Scott Category: CLEANING & JANITORIAL</p>	<p>28 available - estimated arrival next day*</p> <p>*Delivery delays may occur during peak ordering periods. Exceptions apply. Estimated delivery is based on orders received by warehouse cut-off times and carrier schedule. Availability is based on your current ship-to address.</p>	<p>\$34.51</p> <p>8 Case</p>	\$276.08
6	 <p>WYPALL L30 DRC Towels Strong and Soft Wipes, White (12-Packs/Case, 90 Towels/Pack) Item # KCC05812 Manufacturer: WYPALL Category: CLEANING & JANITORIAL</p>	<p>79 available - estimated arrival next day*</p> <p>*Delivery delays may occur during peak ordering periods. Exceptions apply. Estimated delivery is based on orders received by warehouse cut-off times and carrier schedule. Availability is based on your current ship-to address.</p>	<p>\$48.46</p> <p>8 Case</p>	\$387.68
7	 <p>Mr. Clean Professional Magic Eraser Extra Power Disposable Cleaning Pads Item # PGC16449 Manufacturer: Mr. Clean Category: CLEANING & JANITORIAL</p>	<p>13 available - estimated arrival next day*</p> <p>*Delivery delays may occur during peak ordering periods. Exceptions apply. Estimated delivery is based on orders received by warehouse cut-off times and carrier schedule. Availability is based on your current ship-to address.</p>	<p>\$50.40</p> <p>1 Case</p>	\$50.40

	Description	Availability	Price	Total
8	 <p>Renown Natural 7.5 in. Controlled Hardwound Paper Towels (800 ft. per Roll, 6-Rolls per Case) Item # REN06132-WB Manufacturer: Renown Category: CLEANING & JANITORIAL</p>	34 available - estimated arrival next day* 1 may be backordered. Please allow for additional delivery time. *Delivery delays may occur during peak ordering periods. Exceptions apply. Estimated delivery is based on orders received by warehouse cut-off times and carrier schedule. Availability is based on your current ship-to address.	\$46.11 35 Case	\$1,613.85
9	 <p>Renown 17 Gal. 24 in. x 32 in. Clear Low-Density Trash Bags (250 per Case) Item # REN20428-CA Manufacturer: Renown Category: CLEANING & JANITORIAL</p>	145 available - estimated arrival next day* *Delivery delays may occur during peak ordering periods. Exceptions apply. Estimated delivery is based on orders received by warehouse cut-off times and carrier schedule. Availability is based on your current ship-to address.	\$26.65 25 Case	\$666.25
10	 <p>Renown 60 Gal. 1.5 mil 38 in. x 58 in. Black Can Liner (10 per Roll, 10-Roll per Case) Item # REN66016-CA Manufacturer: Renown Category: CLEANING & JANITORIAL</p>	285 available - estimated arrival next day* *Delivery delays may occur during peak ordering periods. Exceptions apply. Estimated delivery is based on orders received by warehouse cut-off times and carrier schedule. Availability is based on your current ship-to address.	\$32.90 30 Case	\$987.00
11	 <p>SPARTAN CHEMICAL COMPANY Xcelente 1 Gal. Fresh Lavender Scent Multi-Purpose Cleaner Item # SPA0019-04 Manufacturer: SPARTAN CHEMICAL COMPANY Category: CLEANING & JANITORIAL</p>	234 available - estimated arrival next day* *Delivery delays may occur during peak ordering periods. Exceptions apply. Estimated delivery is based on orders received by warehouse cut-off times and carrier schedule. Availability is based on your current ship-to address.	\$38.84 1 Case	\$38.84
12	 <p>Spartan Lite'n Foamy Cranberry Ice 1 Gallon Hand Wash Item # SPA3152-04 Manufacturer: Spartan Category: CLEANING & JANITORIAL</p>	165 available - estimated arrival next day* *Delivery delays may occur during peak ordering periods. Exceptions apply. Estimated delivery is based on orders received by warehouse cut-off times and carrier schedule. Availability is based on your current ship-to address.	\$58.56 6 Case	\$351.36
13	 <p>Spartan Chemical BioTransport 1 Consume Eco-Lyzer 2 Liter Floral Scent Disinfectant/Deodorant Item # SPA4597 Manufacturer: Spartan Chemical Category: CLEANING & JANITORIAL</p>	57 available - estimated arrival next day* *Delivery delays may occur during peak ordering periods. Exceptions apply. Estimated delivery is based on orders received by warehouse cut-off times and carrier schedule. Availability is based on your current ship-to address.	\$69.48 2 Case	\$138.96
14	 <p>Spartan COPY 0 NABC Concentrate 2 l Floral Scent Restroom Disinfectant (4 per Pack) Item # SPA4716 Manufacturer: Spartan Category: CLEANING & JANITORIAL</p>	89 available - estimated arrival next day* *Delivery delays may occur during peak ordering periods. Exceptions apply. Estimated delivery is based on orders received by warehouse cut-off times and carrier schedule. Availability is based on your current ship-to address.	\$108.52 2 Case	\$217.04
15	 <p>Spartan Chemical Co. 2 Liter Fresh Scent Super Concentrated Glass & Hard Surface Cleaner Item # SPA4730 Manufacturer: Spartan Chemical Co. Category: CLEANING & JANITORIAL</p>	19 available - estimated arrival next day* *Delivery delays may occur during peak ordering periods. Exceptions apply. Estimated delivery is based on orders received by warehouse cut-off times and carrier schedule. Availability is based on your current ship-to address.	\$109.60 1 Case	\$109.60
16	 <p>SPARTAN CHEMICAL COMPANY Halt 2 Liter One Step Cleaner/Disinfectant Item # SPA4806 Manufacturer: SPARTAN CHEMICAL COMPANY Category: CLEANING & JANITORIAL</p>	18 available - estimated arrival next day* *Delivery delays may occur during peak ordering periods. Exceptions apply. Estimated delivery is based on orders received by warehouse cut-off times and carrier schedule. Availability is based on your current ship-to address.	\$47.52 3 Case	\$142.56

	Description	Availability	Price	Total
17	 <p>SPARTAN CHEMICAL COMPANY BNC-15 2 Liter Floral Scent One Step Cleaner/Disinfectant (4 per Pack) Item # SPA4856-02 Manufacturer: SPARTAN CHEMICAL COMPANY Category: CLEANING & JANITORIAL</p>	<p>62 available - estimated arrival next day*</p> <p>*Delivery delays may occur during peak ordering periods. Exceptions apply. Estimated delivery is based on orders received by warehouse cut-off times and carrier schedule. Availability is based on your current ship-to address.</p>	<p>\$139.50</p> <p>2 Case</p>	\$279.00
18	 <p>Spartan SparCling 1 Qt. Mint Scent 1-Step Disinfectant Toilet Bowl Cleaner (12 per Pack) Item # SPA7118-12-C Manufacturer: Spartan Category: CLEANING & JANITORIAL</p>	<p>42 available - estimated arrival next day*</p> <p>*Delivery delays may occur during peak ordering periods. Exceptions apply. Estimated delivery is based on orders received by warehouse cut-off times and carrier schedule. Availability is based on your current ship-to address.</p>	<p>\$34.56</p> <p>4 Case</p>	\$138.24

Order Summary

Total	\$6,009.05
Discount	\$0.00
Order Total	\$6,009.05









Powered by HD Supply®







GTC
1907.23

- My Account Number 876498
- Currently Shopping As 876498 - GREENE TECHNOLOGY CENTER
- Current Ship-To Address GREENE TECHNOLOGY CENTER 1121 HAL HENARD RD GREENEVILLE, TN 37743

-
-
-
-

Shopping Cart

	Description	Availability	Price	Total
1	 <p>BIOESQUE 1 Qt. Botanical Disinfectant Solution Item # 310650027 Manufacturer: BIOESQUE Category: CLEANING & JANITORIAL</p>	<p>112 available - estimated arrival next day*</p> <p>*Delivery delays may occur during peak ordering periods. Exceptions apply. Estimated delivery is based on orders received by warehouse cut-off times and carrier schedule. Availability is based on your current ship-to address.</p>	<p>\$7.93</p> <p>24 Each</p>	\$190.32
2	 <p>Renown 24 oz. 4-Ply Natural Cotton Metal Bolt-In Headband Cut End Mop Head (6/Case) Item # 311879353 Manufacturer: Renown Category: CLEANING & JANITORIAL</p>	<p>28 available - estimated arrival next day*</p> <p>*Delivery delays may occur during peak ordering periods. Exceptions apply. Estimated delivery is based on orders received by warehouse cut-off times and carrier schedule. Availability is based on your current ship-to address.</p>	<p>\$27.61</p> <p>1 Case</p>	\$27.61
3	 <p>Blended Cotton Synthetic Replacement String Mop Medium Loop Wide Band Mop Head Item # 318353671 Manufacturer: ABCO PRODUCTS Category: CLEANING & JANITORIAL</p>	<p>732 available - estimated arrival 2-3 days*</p> <p>*Delivery delays may occur during peak ordering periods. Exceptions apply. Estimated delivery is based on orders received by warehouse cut-off times and carrier schedule. Availability is based on your current ship-to address.</p>	<p>\$4.51</p> <p>8 Each</p>	\$36.08
4	 <p>WYPALL L30 DRC Towels Strong and Soft Wipes, White (12-Packs/Case, 90 Towels/Pack) Item # KCC05812 Manufacturer: WYPALL Category: CLEANING & JANITORIAL</p>	<p>79 available - estimated arrival next day*</p> <p>*Delivery delays may occur during peak ordering periods. Exceptions apply. Estimated delivery is based on orders received by warehouse cut-off times and carrier schedule. Availability is based on your current ship-to address.</p>	<p>\$48.46</p> <p>4 Case</p>	\$193.84
5	 <p>Renown Natural 7.5 in. Controlled Hardwound Paper Towels (800 ft. per Roll, 6-Rolls per Case) Item # REN06132-WB Manufacturer: Renown Category: CLEANING & JANITORIAL</p>	<p>34 available - estimated arrival next day*</p> <p>*Delivery delays may occur during peak ordering periods. Exceptions apply. Estimated delivery is based on orders received by warehouse cut-off times and carrier schedule. Availability is based on your current ship-to address.</p>	<p>\$46.11</p> <p>8 Case</p>	\$368.88
6	 <p>Renown 17 Gal. 24 in. x 32 in. Clear Low-Density Trash Bags (250 per Case) Item # REN20428-CA Manufacturer: Renown Category: CLEANING & JANITORIAL</p>	<p>145 available - estimated arrival next day*</p> <p>*Delivery delays may occur during peak ordering periods. Exceptions apply. Estimated delivery is based on orders received by warehouse cut-off times and carrier schedule. Availability is based on your current ship-to address.</p>	<p>\$26.65</p> <p>8 Case</p>	\$213.20
7	 <p>Renown 60 Gal. 1.5 mil 38 in. x 58 in. Black Can Liner (10 per Roll, 10-Roll per Case) Item # REN66016-CA Manufacturer: Renown Category: CLEANING & JANITORIAL</p>	<p>285 available - estimated arrival next day*</p> <p>*Delivery delays may occur during peak ordering periods. Exceptions apply. Estimated delivery is based on orders received by warehouse cut-off times and carrier schedule. Availability is based on your current ship-to address.</p>	<p>\$32.90</p> <p>8 Case</p>	\$263.20

	Description	Availability	Price	Total
8	 <p>SPARTAN CHEMICAL COMPANY Xcelente 1 Gal. Fresh Lavender Scent Multi-Purpose Cleaner Item # SPA0019-04 Manufacturer: SPARTAN CHEMICAL COMPANY Category: CLEANING & JANITORIAL</p>	<p>234 available - estimated arrival next day*</p> <p>*Delivery delays may occur during peak ordering periods. Exceptions apply. Estimated delivery is based on orders received by warehouse cut-off times and carrier schedule. Availability is based on your current ship-to address.</p>	<p>\$38.84</p> <p>1 Case</p>	\$38.84
9	 <p>Spartan Lite'n Foamy Cranberry Ice 1 Gallon Hand Wash Item # SPA3152-04 Manufacturer: Spartan Category: CLEANING & JANITORIAL</p>	<p>165 available - estimated arrival next day*</p> <p>*Delivery delays may occur during peak ordering periods. Exceptions apply. Estimated delivery is based on orders received by warehouse cut-off times and carrier schedule. Availability is based on your current ship-to address.</p>	<p>\$58.56</p> <p>3 Case</p>	\$175.68
10	 <p>Spartan Chemical BioTransport 1 Consume Eco-Lyzer 2 Liter Floral Scent Disinfectant/Deodorant Item # SPA4597 Manufacturer: Spartan Chemical Category: CLEANING & JANITORIAL</p>	<p>57 available - estimated arrival next day*</p> <p>*Delivery delays may occur during peak ordering periods. Exceptions apply. Estimated delivery is based on orders received by warehouse cut-off times and carrier schedule. Availability is based on your current ship-to address.</p>	<p>\$69.48</p> <p>1 Case</p>	\$69.48
11	 <p>Spartan COPY 0 NABC Concentrate 2 l Floral Scent Restroom Disinfectant (4 per Pack) Item # SPA4716 Manufacturer: Spartan Category: CLEANING & JANITORIAL</p>	<p>89 available - estimated arrival next day*</p> <p>*Delivery delays may occur during peak ordering periods. Exceptions apply. Estimated delivery is based on orders received by warehouse cut-off times and carrier schedule. Availability is based on your current ship-to address.</p>	<p>\$108.52</p> <p>1 Case</p>	\$108.52
12	 <p>SPARTAN CHEMICAL COMPANY Halt 2 Liter One Step Cleaner/Disinfectant Item # SPA4806 Manufacturer: SPARTAN CHEMICAL COMPANY Category: CLEANING & JANITORIAL</p>	<p>18 available - estimated arrival next day*</p> <p>*Delivery delays may occur during peak ordering periods. Exceptions apply. Estimated delivery is based on orders received by warehouse cut-off times and carrier schedule. Availability is based on your current ship-to address.</p>	<p>\$47.52</p> <p>1 Case</p>	\$47.52
13	 <p>SPARTAN CHEMICAL COMPANY BNC-15 2 Liter Floral Scent One Step Cleaner/Disinfectant (4 per Pack) Item # SPA4856-02 Manufacturer: SPARTAN CHEMICAL COMPANY Category: CLEANING & JANITORIAL</p>	<p>62 available - estimated arrival next day*</p> <p>*Delivery delays may occur during peak ordering periods. Exceptions apply. Estimated delivery is based on orders received by warehouse cut-off times and carrier schedule. Availability is based on your current ship-to address.</p>	<p>\$139.50</p> <p>1 Case</p>	\$139.50
14	 <p>Spartan SparCling 1 Qt. Mint Scent 1-Step Disinfectant Toilet Bowl Cleaner (12 per Pack) Item # SPA7118-12-C Manufacturer: Spartan Category: CLEANING & JANITORIAL</p>	<p>42 available - estimated arrival next day*</p> <p>*Delivery delays may occur during peak ordering periods. Exceptions apply. Estimated delivery is based on orders received by warehouse cut-off times and carrier schedule. Availability is based on your current ship-to address.</p>	<p>\$34.56</p> <p>1 Case</p>	\$34.56

Order Summary

Total	\$1,907.23
Discount	\$0.00
Order Total	\$1,907.23







Powered by HD Supply®

H-H
3325.58

- My Account Number 876494
- Currently Shopping As 876494 - GCS-HAL HENARD ELEMENTARY
- Current Ship-To Address GCS-HAL HENARD ELEMENTARY 425 EAST VANN ROAD GREENEVILLE, TN 37743

-
-
-
-

Shopping Cart

	Description	Availability	Price	Total
1	 <p>BIOESQUE 1 Qt. Botanical Disinfectant Solution Item # 310650027 Manufacturer: BIOESQUE Category: CLEANING & JANITORIAL</p>	<p>112 available - estimated arrival next day*</p> <p>*Delivery delays may occur during peak ordering periods. Exceptions apply. Estimated delivery is based on orders received by warehouse cut-off times and carrier schedule. Availability is based on your current ship-to address.</p>	<p>\$7.93</p> <p>24 Each</p>	\$190.32
2	 <p>Renown 24 oz. 4-Ply Natural Cotton Metal Bolt-In Headband Cut End Mop Head (6/Case) Item # 311879353 Manufacturer: Renown Category: CLEANING & JANITORIAL</p>	<p>28 available - estimated arrival next day*</p> <p>*Delivery delays may occur during peak ordering periods. Exceptions apply. Estimated delivery is based on orders received by warehouse cut-off times and carrier schedule. Availability is based on your current ship-to address.</p>	<p>\$27.61</p> <p>1 Case</p>	\$27.61
3	 <p>HOSPECO 10 lbs. per Box White Terry Towel Rags Item # HOS537-10 Manufacturer: National Brand Alternative Category: CLEANING & JANITORIAL</p>	<p>12 available - estimated arrival next day*</p> <p>*Delivery delays may occur during peak ordering periods. Exceptions apply. Estimated delivery is based on orders received by warehouse cut-off times and carrier schedule. Availability is based on your current ship-to address.</p>	<p>\$23.72</p> <p>5 Box</p>	\$118.60
4	 <p>WYPALL L30 DRC Towels Strong and Soft Wipes, White (12-Packs/Case, 90 Towels/Pack) Item # KCC05812 Manufacturer: WYPALL Category: CLEANING & JANITORIAL</p>	<p>79 available - estimated arrival next day*</p> <p>*Delivery delays may occur during peak ordering periods. Exceptions apply. Estimated delivery is based on orders received by warehouse cut-off times and carrier schedule. Availability is based on your current ship-to address.</p>	<p>\$48.46</p> <p>2 Case</p>	\$96.92
5	 <p>Renown Natural 7.5 in. Controlled Hardwound Paper Towels (800 ft. per Roll, 6-Rolls per Case) Item # REN06132-WB Manufacturer: Renown Category: CLEANING & JANITORIAL</p>	<p>34 available - estimated arrival next day*</p> <p>*Delivery delays may occur during peak ordering periods. Exceptions apply. Estimated delivery is based on orders received by warehouse cut-off times and carrier schedule. Availability is based on your current ship-to address.</p>	<p>\$46.11</p> <p>15 Case</p>	\$691.65
6	 <p>Renown 17 Gal. 24 in. x 32 in. Clear Low-Density Trash Bags (250 per Case) Item # REN20428-CA Manufacturer: Renown Category: CLEANING & JANITORIAL</p>	<p>145 available - estimated arrival next day*</p> <p>*Delivery delays may occur during peak ordering periods. Exceptions apply. Estimated delivery is based on orders received by warehouse cut-off times and carrier schedule. Availability is based on your current ship-to address.</p>	<p>\$26.65</p> <p>15 Case</p>	\$399.75
7	 <p>Renown 60 Gal. 1.5 mil 38 in. x 58 in. Black Can Liner (10 per Roll, 10-Roll per Case) Item # REN66016-CA Manufacturer: Renown Category: CLEANING & JANITORIAL</p>	<p>285 available - estimated arrival next day*</p> <p>*Delivery delays may occur during peak ordering periods. Exceptions apply. Estimated delivery is based on orders received by warehouse cut-off times and carrier schedule. Availability is based on your current ship-to address.</p>	<p>\$32.90</p> <p>15 Case</p>	\$493.50

	Description	Availability	Price	Total
8	 <p>SPARTAN CHEMICAL COMPANY Xcelente 1 Gal. Fresh Lavender Scent Multi-Purpose Cleaner Item # SPA0019-04 Manufacturer: SPARTAN CHEMICAL COMPANY Category: CLEANING & JANITORIAL</p>	<p>234 available - estimated arrival next day*</p> <p>*Delivery delays may occur during peak ordering periods. Exceptions apply. Estimated delivery is based on orders received by warehouse cut-off times and carrier schedule. Availability is based on your current ship-to address.</p>	<p>\$38.84</p> <p>3 Case</p>	\$116.52
9	 <p>Spartan Lite'n Foamy Cranberry Ice 1 Gallon Hand Wash Item # SPA3152-04 Manufacturer: Spartan Category: CLEANING & JANITORIAL</p>	<p>165 available - estimated arrival next day*</p> <p>*Delivery delays may occur during peak ordering periods. Exceptions apply. Estimated delivery is based on orders received by warehouse cut-off times and carrier schedule. Availability is based on your current ship-to address.</p>	<p>\$58.56</p> <p>4 Case</p>	\$234.24
10	 <p>Spartan Chemical BioTransport 1 Consume Eco-Lyzer 2 Liter Floral Scent Disinfectant/Deodorant Item # SPA4597 Manufacturer: Spartan Chemical Category: CLEANING & JANITORIAL</p>	<p>57 available - estimated arrival next day*</p> <p>*Delivery delays may occur during peak ordering periods. Exceptions apply. Estimated delivery is based on orders received by warehouse cut-off times and carrier schedule. Availability is based on your current ship-to address.</p>	<p>\$69.48</p> <p>2 Case</p>	\$138.96
11	 <p>Spartan COPY 0 NABC Concentrate 2 l Floral Scent Restroom Disinfectant (4 per Pack) Item # SPA4716 Manufacturer: Spartan Category: CLEANING & JANITORIAL</p>	<p>89 available - estimated arrival next day*</p> <p>*Delivery delays may occur during peak ordering periods. Exceptions apply. Estimated delivery is based on orders received by warehouse cut-off times and carrier schedule. Availability is based on your current ship-to address.</p>	<p>\$108.52</p> <p>2 Case</p>	\$217.04
12	 <p>SPARTAN CHEMICAL COMPANY Halt 2 Liter One Step Cleaner/Disinfectant Item # SPA4806 Manufacturer: SPARTAN CHEMICAL COMPANY Category: CLEANING & JANITORIAL</p>	<p>18 available - estimated arrival next day*</p> <p>*Delivery delays may occur during peak ordering periods. Exceptions apply. Estimated delivery is based on orders received by warehouse cut-off times and carrier schedule. Availability is based on your current ship-to address.</p>	<p>\$47.52</p> <p>4 Case</p>	\$190.08
13	 <p>SPARTAN CHEMICAL COMPANY 2 Liter Clean by Peroxy Spring Rain Scent Multi-Purpose Cleaner Item # SPA4820 Manufacturer: SPARTAN CHEMICAL COMPANY Category: CLEANING & JANITORIAL</p>	<p>60 available - estimated arrival next day*</p> <p>*Delivery delays may occur during peak ordering periods. Exceptions apply. Estimated delivery is based on orders received by warehouse cut-off times and carrier schedule. Availability is based on your current ship-to address.</p>	<p>\$21.23</p> <p>1 Each</p>	\$21.23
14	 <p>SPARTAN CHEMICAL COMPANY BNC-15 2 Liter Floral Scent One Step Cleaner/Disinfectant (4 per Pack) Item # SPA4856-02 Manufacturer: SPARTAN CHEMICAL COMPANY Category: CLEANING & JANITORIAL</p>	<p>62 available - estimated arrival next day*</p> <p>*Delivery delays may occur during peak ordering periods. Exceptions apply. Estimated delivery is based on orders received by warehouse cut-off times and carrier schedule. Availability is based on your current ship-to address.</p>	<p>\$139.50</p> <p>2 Case</p>	\$279.00
15	 <p>Strategic Cleaner 1 Gallon Wood Floor Cleaner (4 per pack) Item # SPA5822-04 Manufacturer: Spartan Chemical Co., Inc. Category: CLEANING & JANITORIAL</p>	<p>2 available - estimated arrival next day*</p> <p>*Delivery delays may occur during peak ordering periods. Exceptions apply. Estimated delivery is based on orders received by warehouse cut-off times and carrier schedule. Availability is based on your current ship-to address.</p>	<p>\$41.04</p> <p>1 Case</p>	\$41.04
16	 <p>Spartan SparCling 1 Qt. Mint Scent 1-Step Disinfectant Toilet Bowl Cleaner (12 per Pack) Item # SPA7118-12-C Manufacturer: Spartan Category: CLEANING & JANITORIAL</p>	<p>42 available - estimated arrival next day*</p> <p>*Delivery delays may occur during peak ordering periods. Exceptions apply. Estimated delivery is based on orders received by warehouse cut-off times and carrier schedule. Availability is based on your current ship-to address.</p>	<p>\$34.56</p> <p>2 Case</p>	\$69.12

Order Summary

Total	\$3,325.58
Discount	\$0.00
Order Total	\$3,325.58







Powered by HD Supply®

TU
2632.57

- My Account Number 876496
- Currently Shopping As 876496 - GCS-TUSCULUM VIEW ELEMENTARY
- Current Ship-To Address GCS-TUSCULUM VIEW ELEMENTARY 1725 LAFAYETTE STREET GREENEVILLE, TN 37745

Shopping Cart

	Description	Availability	Price	Total
1	 <p>HOSPECO 10 lbs. per Box White Terry Towel Rags Item # HOS537-10 Manufacturer: National Brand Alternative Category: CLEANING & JANITORIAL</p>	<p>12 available - estimated arrival next day*</p> <p>*Delivery delays may occur during peak ordering periods. Exceptions apply. Estimated delivery is based on orders received by warehouse cut-off times and carrier schedule. Availability is based on your current ship-to address.</p>	<p>\$23.72</p> <p>5 Box</p>	\$118.60
2	 <p>Renown Natural 7.5 in. Controlled Hardwound Paper Towels (800 ft. per Roll, 6-Rolls per Case) Item # REN06132-WB Manufacturer: Renown Category: CLEANING & JANITORIAL</p>	<p>34 available - estimated arrival next day*</p> <p>*Delivery delays may occur during peak ordering periods. Exceptions apply. Estimated delivery is based on orders received by warehouse cut-off times and carrier schedule. Availability is based on your current ship-to address.</p>	<p>\$46.11</p> <p>15 Case</p>	\$691.65
3	 <p>Renown 17 Gal. 24 in. x 32 in. Clear Low-Density Trash Bags (250 per Case) Item # REN20428-CA Manufacturer: Renown Category: CLEANING & JANITORIAL</p>	<p>145 available - estimated arrival next day*</p> <p>*Delivery delays may occur during peak ordering periods. Exceptions apply. Estimated delivery is based on orders received by warehouse cut-off times and carrier schedule. Availability is based on your current ship-to address.</p>	<p>\$26.65</p> <p>15 Case</p>	\$399.75
4	 <p>Renown 60 Gal. 1.5 mil 38 in. x 58 in. Black Can Liner (10 per Roll, 10-Roll per Case) Item # REN66016-CA Manufacturer: Renown Category: CLEANING & JANITORIAL</p>	<p>285 available - estimated arrival next day*</p> <p>*Delivery delays may occur during peak ordering periods. Exceptions apply. Estimated delivery is based on orders received by warehouse cut-off times and carrier schedule. Availability is based on your current ship-to address.</p>	<p>\$32.90</p> <p>15 Case</p>	\$493.50
5	 <p>SPARTAN CHEMICAL COMPANY Xcelente 1 Gal. Fresh Lavender Scent Multi-Purpose Cleaner Item # SPA0019-04 Manufacturer: SPARTAN CHEMICAL COMPANY Category: CLEANING & JANITORIAL</p>	<p>234 available - estimated arrival next day*</p> <p>*Delivery delays may occur during peak ordering periods. Exceptions apply. Estimated delivery is based on orders received by warehouse cut-off times and carrier schedule. Availability is based on your current ship-to address.</p>	<p>\$38.84</p> <p>1 Case</p>	\$38.84
6	 <p>Spartan Lite'n Foamy Cranberry Ice 1 Gallon Hand Wash Item # SPA3152-04 Manufacturer: Spartan Category: CLEANING & JANITORIAL</p>	<p>165 available - estimated arrival next day*</p> <p>*Delivery delays may occur during peak ordering periods. Exceptions apply. Estimated delivery is based on orders received by warehouse cut-off times and carrier schedule. Availability is based on your current ship-to address.</p>	<p>\$58.56</p> <p>3 Case</p>	\$175.68
7	 <p>Spartan Chemical BioTransport 1 Consume Eco-Lyzer 2 Liter Floral Scent Disinfectant/Deodorant Item # SPA4597 Manufacturer: Spartan Chemical Category: CLEANING & JANITORIAL</p>	<p>57 available - estimated arrival next day*</p> <p>*Delivery delays may occur during peak ordering periods. Exceptions apply. Estimated delivery is based on orders received by warehouse cut-off times and carrier schedule. Availability is based on your current ship-to address.</p>	<p>\$69.48</p> <p>2 Case</p>	\$138.96

	Description	Availability	Price	Total
8	 <p>Spartan COPY 0 NABC Concentrate 2 l Floral Scent Restroom Disinfectant (4 per Pack) Item # SPA4716 Manufacturer: Spartan Category: CLEANING & JANITORIAL</p>	<p>89 available - estimated arrival next day*</p> <p>*Delivery delays may occur during peak ordering periods. Exceptions apply. Estimated delivery is based on orders received by warehouse cut-off times and carrier schedule. Availability is based on your current ship-to address.</p>	<p>\$108.52</p> <p>2 Case</p>	\$217.04
9	 <p>SPARTAN CHEMICAL COMPANY Halt 2 Liter One Step Cleaner/Disinfectant Item # SPA4806 Manufacturer: SPARTAN CHEMICAL COMPANY Category: CLEANING & JANITORIAL</p>	<p>73 available - estimated arrival next day*</p> <p>*Delivery delays may occur during peak ordering periods. Exceptions apply. Estimated delivery is based on orders received by warehouse cut-off times and carrier schedule. Availability is based on your current ship-to address.</p>	<p>\$11.88</p> <p>2 Each</p>	\$23.76
10	 <p>SPARTAN CHEMICAL COMPANY 2 Liter Clean by Peroxy Spring Rain Scent Multi-Purpose Cleaner Item # SPA4820 Manufacturer: SPARTAN CHEMICAL COMPANY Category: CLEANING & JANITORIAL</p>	<p>60 available - estimated arrival next day*</p> <p>*Delivery delays may occur during peak ordering periods. Exceptions apply. Estimated delivery is based on orders received by warehouse cut-off times and carrier schedule. Availability is based on your current ship-to address.</p>	<p>\$21.23</p> <p>1 Each</p>	\$21.23
11	 <p>SPARTAN CHEMICAL COMPANY BNC-15 2 Liter Floral Scent One Step Cleaner/Disinfectant (4 per Pack) Item # SPA4856-02 Manufacturer: SPARTAN CHEMICAL COMPANY Category: CLEANING & JANITORIAL</p>	<p>62 available - estimated arrival next day*</p> <p>*Delivery delays may occur during peak ordering periods. Exceptions apply. Estimated delivery is based on orders received by warehouse cut-off times and carrier schedule. Availability is based on your current ship-to address.</p>	<p>\$139.50</p> <p>2 Case</p>	\$279.00
12	 <p>Spartan SparCling 1 Qt. Mint Scent 1-Step Disinfectant Toilet Bowl Cleaner (12 per Pack) Item # SPA7118-12-C Manufacturer: Spartan Category: CLEANING & JANITORIAL</p>	<p>42 available - estimated arrival next day*</p> <p>*Delivery delays may occur during peak ordering periods. Exceptions apply. Estimated delivery is based on orders received by warehouse cut-off times and carrier schedule. Availability is based on your current ship-to address.</p>	<p>\$34.56</p> <p>1 Case</p>	\$34.56

Order Summary

Total	\$2,632.57
Discount	\$0.00
Order Total	\$2,632.57









Powered by HD Supply®

EV
3677.19

- My Account Number 876493
- Currently Shopping As 876493 - GCS-EAST VIEW ELEMENTARY
- Current Ship-To Address GCS-EAST VIEW ELEMENTARY 454 EAST BERNARD AVENUE GREENEVILLE, TN 37745

Shopping Cart

	Description	Availability	Price	Total
1	 <p>BIOESQUE 1 Qt. Botanical Disinfectant Solution Item # 310650027 Manufacturer: BIOESQUE Category: CLEANING & JANITORIAL</p>	<p>112 available - estimated arrival next day*</p> <p>*Delivery delays may occur during peak ordering periods. Exceptions apply. Estimated delivery is based on orders received by warehouse cut-off times and carrier schedule. Availability is based on your current ship-to address.</p>	<p>\$7.93</p> <p>36 Each</p>	\$285.48
2	 <p>Renown 24 oz. 4-Ply Natural Cotton Metal Bolt-In Headband Cut End Mop Head (6/Case) Item # 311879353 Manufacturer: Renown Category: CLEANING & JANITORIAL</p>	<p>28 available - estimated arrival next day*</p> <p>*Delivery delays may occur during peak ordering periods. Exceptions apply. Estimated delivery is based on orders received by warehouse cut-off times and carrier schedule. Availability is based on your current ship-to address.</p>	<p>\$27.61</p> <p>4 Case</p>	\$110.44
3	 <p>Blended Cotton Synthetic Replacement String Mop Medium Loop Wide Band Mop Head Item # 318353671 Manufacturer: ABCO PRODUCTS Category: CLEANING & JANITORIAL</p>	<p>732 available - estimated arrival 2-3 days*</p> <p>*Delivery delays may occur during peak ordering periods. Exceptions apply. Estimated delivery is based on orders received by warehouse cut-off times and carrier schedule. Availability is based on your current ship-to address.</p>	<p>\$4.51</p> <p>4 Each</p>	\$18.04
4	 <p>HOSPECO 10 lbs. per Box White Terry Towel Rags Item # HOS537-10 Manufacturer: National Brand Alternative Category: CLEANING & JANITORIAL</p>	<p>12 available - estimated arrival next day*</p> <p>*Delivery delays may occur during peak ordering periods. Exceptions apply. Estimated delivery is based on orders received by warehouse cut-off times and carrier schedule. Availability is based on your current ship-to address.</p>	<p>\$23.72</p> <p>5 Box</p>	\$118.60
5	 <p>Scott multi-fold Paper Towels with Fast-Drying Absorbency Pockets White (16-Packs/Case, 250 multi-fold Towels/Pack) Item # KCC01804 Manufacturer: Scott Category: CLEANING & JANITORIAL</p>	<p>28 available - estimated arrival next day*</p> <p>*Delivery delays may occur during peak ordering periods. Exceptions apply. Estimated delivery is based on orders received by warehouse cut-off times and carrier schedule. Availability is based on your current ship-to address.</p>	<p>\$34.51</p> <p>4 Case</p>	\$138.04
6	 <p>WYPALL L30 DRC Towels Strong and Soft Wipes, White (12-Packs/Case, 90 Towels/Pack) Item # KCC05812 Manufacturer: WYPALL Category: CLEANING & JANITORIAL</p>	<p>79 available - estimated arrival next day*</p> <p>*Delivery delays may occur during peak ordering periods. Exceptions apply. Estimated delivery is based on orders received by warehouse cut-off times and carrier schedule. Availability is based on your current ship-to address.</p>	<p>\$48.46</p> <p>6 Case</p>	\$290.76
7	 <p>Renown Natural 7.5 in. Controlled Hardwound Paper Towels (800 ft. per Roll, 6-Rolls per Case) Item # REN06132-WB Manufacturer: Renown Category: CLEANING & JANITORIAL</p>	<p>34 available - estimated arrival next day*</p> <p>*Delivery delays may occur during peak ordering periods. Exceptions apply. Estimated delivery is based on orders received by warehouse cut-off times and carrier schedule. Availability is based on your current ship-to address.</p>	<p>\$46.11</p> <p>15 Case</p>	\$691.65

	Description	Availability	Price	Total
8	 Renown 17 Gal. 24 in. x 32 in. Clear Low-Density Trash Bags (250 per Case) Item # REN20428-CA Manufacturer: Renown Category: CLEANING & JANITORIAL	145 available - estimated arrival next day* *Delivery delays may occur during peak ordering periods. Exceptions apply. Estimated delivery is based on orders received by warehouse cut-off times and carrier schedule. Availability is based on your current ship-to address.	\$26.65 12 Case	\$319.80
9	 Renown 60 Gal. 1.5 mil 38 in. x 58 in. Black Can Liner (10 per Roll, 10-Roll per Case) Item # REN66016-CA Manufacturer: Renown Category: CLEANING & JANITORIAL	285 available - estimated arrival next day* *Delivery delays may occur during peak ordering periods. Exceptions apply. Estimated delivery is based on orders received by warehouse cut-off times and carrier schedule. Availability is based on your current ship-to address.	\$32.90 12 Case	\$394.80
10	 SPARTAN CHEMICAL COMPANY Xcelente 1 Gal. Fresh Lavender Scent Multi-Purpose Cleaner Item # SPA0019-04 Manufacturer: SPARTAN CHEMICAL COMPANY Category: CLEANING & JANITORIAL	234 available - estimated arrival next day* *Delivery delays may occur during peak ordering periods. Exceptions apply. Estimated delivery is based on orders received by warehouse cut-off times and carrier schedule. Availability is based on your current ship-to address.	\$38.84 1 Case	\$38.84
11	 Spartan Lite'n Foamy Cranberry Ice 1 Gallon Hand Wash Item # SPA3152-04 Manufacturer: Spartan Category: CLEANING & JANITORIAL	165 available - estimated arrival next day* *Delivery delays may occur during peak ordering periods. Exceptions apply. Estimated delivery is based on orders received by warehouse cut-off times and carrier schedule. Availability is based on your current ship-to address.	\$58.56 3 Case	\$175.68
12	 Spartan Chemical BioTransport 1 Consume Eco-Lyzer 2 Liter Floral Scent Disinfectant/Deodorant Item # SPA4597 Manufacturer: Spartan Chemical Category: CLEANING & JANITORIAL	57 available - estimated arrival next day* *Delivery delays may occur during peak ordering periods. Exceptions apply. Estimated delivery is based on orders received by warehouse cut-off times and carrier schedule. Availability is based on your current ship-to address.	\$69.48 3 Case	\$208.44
13	 Spartan COPY 0 NABC Concentrate 2 l Floral Scent Restroom Disinfectant (4 per Pack) Item # SPA4716 Manufacturer: Spartan Category: CLEANING & JANITORIAL	89 available - estimated arrival next day* *Delivery delays may occur during peak ordering periods. Exceptions apply. Estimated delivery is based on orders received by warehouse cut-off times and carrier schedule. Availability is based on your current ship-to address.	\$108.52 3 Case	\$325.56
14	 SPARTAN CHEMICAL COMPANY Halt 2 Liter One Step Cleaner/Disinfectant Item # SPA4806 Manufacturer: SPARTAN CHEMICAL COMPANY Category: CLEANING & JANITORIAL	18 available - estimated arrival next day* *Delivery delays may occur during peak ordering periods. Exceptions apply. Estimated delivery is based on orders received by warehouse cut-off times and carrier schedule. Availability is based on your current ship-to address.	\$47.52 3 Case	\$142.56
15	 SPARTAN CHEMICAL COMPANY BNC-15 2 Liter Floral Scent One Step Cleaner/Disinfectant (4 per Pack) Item # SPA4856-02 Manufacturer: SPARTAN CHEMICAL COMPANY Category: CLEANING & JANITORIAL	62 available - estimated arrival next day* *Delivery delays may occur during peak ordering periods. Exceptions apply. Estimated delivery is based on orders received by warehouse cut-off times and carrier schedule. Availability is based on your current ship-to address.	\$139.50 3 Case	\$418.50

Order Summary

Total	\$3,677.19
Discount	\$0.00
Order Total	\$3,677.19



Powered by HD Supply®





GMS
3579.98

- My Account Number 876497
- Currently Shopping As 876497 - GCS-GREENEVILLE MIDDLE
- Current Ship-To Address GCS-GREENEVILLE MIDDLE 433 EAST VANN ROAD GREENEVILLE, TN 37743

-
-
-
-

Shopping Cart

	Description	Availability	Price	Total
1	 <p>BIOESQUE 1 Qt. Botanical Disinfectant Solution Item # 310650027 Manufacturer: BIOESQUE Category: CLEANING & JANITORIAL</p>	<p>112 available - estimated arrival next day*</p> <p>*Delivery delays may occur during peak ordering periods. Exceptions apply. Estimated delivery is based on orders received by warehouse cut-off times and carrier schedule. Availability is based on your current ship-to address.</p>	<p>\$7.93</p> <p>24 Each</p>	\$190.32
2	 <p>HOSPECO 10 lbs. per Box White Terry Towel Rags Item # HOS537-10 Manufacturer: National Brand Alternative Category: CLEANING & JANITORIAL</p>	<p>12 available - estimated arrival next day*</p> <p>*Delivery delays may occur during peak ordering periods. Exceptions apply. Estimated delivery is based on orders received by warehouse cut-off times and carrier schedule. Availability is based on your current ship-to address.</p>	<p>\$23.72</p> <p>3 Box</p>	\$71.16
3	 <p>Mr. Clean Professional Magic Eraser Extra Power Disposable Cleaning Pads Item # PGC16449 Manufacturer: Mr. Clean Category: CLEANING & JANITORIAL</p>	<p>13 available - estimated arrival next day*</p> <p>*Delivery delays may occur during peak ordering periods. Exceptions apply. Estimated delivery is based on orders received by warehouse cut-off times and carrier schedule. Availability is based on your current ship-to address.</p>	<p>\$50.40</p> <p>1 Case</p>	\$50.40
4	 <p>Renown Natural 7.5 in. Controlled Hardwound Paper Towels (800 ft. per Roll, 6-Rolls per Case) Item # REN06132-WB Manufacturer: Renown Category: CLEANING & JANITORIAL</p>	<p>34 available - estimated arrival next day*</p> <p>*Delivery delays may occur during peak ordering periods. Exceptions apply. Estimated delivery is based on orders received by warehouse cut-off times and carrier schedule. Availability is based on your current ship-to address.</p>	<p>\$46.11</p> <p>25 Case</p>	\$1,152.75
5	 <p>Renown 17 Gal. 24 in. x 32 in. Clear Low-Density Trash Bags (250 per Case) Item # REN20428-CA Manufacturer: Renown Category: CLEANING & JANITORIAL</p>	<p>145 available - estimated arrival next day*</p> <p>*Delivery delays may occur during peak ordering periods. Exceptions apply. Estimated delivery is based on orders received by warehouse cut-off times and carrier schedule. Availability is based on your current ship-to address.</p>	<p>\$26.65</p> <p>15 Case</p>	\$399.75
6	 <p>Renown 60 Gal. 1.5 mil 38 in. x 58 in. Black Can Liner (10 per Roll, 10-Roll per Case) Item # REN66016-CA Manufacturer: Renown Category: CLEANING & JANITORIAL</p>	<p>285 available - estimated arrival next day*</p> <p>*Delivery delays may occur during peak ordering periods. Exceptions apply. Estimated delivery is based on orders received by warehouse cut-off times and carrier schedule. Availability is based on your current ship-to address.</p>	<p>\$32.90</p> <p>15 Case</p>	\$493.50
7	 <p>Spartan Chemical BioTransport 1 Consume Eco-Lyzer 2 Liter Floral Scent Disinfectant/Deodorant Item # SPA4597 Manufacturer: Spartan Chemical Category: CLEANING & JANITORIAL</p>	<p>57 available - estimated arrival next day*</p> <p>*Delivery delays may occur during peak ordering periods. Exceptions apply. Estimated delivery is based on orders received by warehouse cut-off times and carrier schedule. Availability is based on your current ship-to address.</p>	<p>\$69.48</p> <p>3 Case</p>	\$208.44

	Description	Availability	Price	Total
8	 <p>Spartan COPY 0 NABC Concentrate 2 I Floral Scent Restroom Disinfectant (4 per Pack) Item # SPA4716 Manufacturer: Spartan Category: CLEANING & JANITORIAL</p>	<p>89 available - estimated arrival next day*</p> <p>*Delivery delays may occur during peak ordering periods. Exceptions apply. Estimated delivery is based on orders received by warehouse cut-off times and carrier schedule. Availability is based on your current ship-to address.</p>	<p>\$108.52</p> <p>3 Case</p>	\$325.56
9	 <p>SPARTAN CHEMICAL COMPANY Halt 2 Liter One Step Cleaner/Disinfectant Item # SPA4806 Manufacturer: SPARTAN CHEMICAL COMPANY Category: CLEANING & JANITORIAL</p>	<p>18 available - estimated arrival next day*</p> <p>*Delivery delays may occur during peak ordering periods. Exceptions apply. Estimated delivery is based on orders received by warehouse cut-off times and carrier schedule. Availability is based on your current ship-to address.</p>	<p>\$47.52</p> <p>2 Case</p>	\$95.04
10	 <p>SPARTAN CHEMICAL COMPANY 2 Liter Clean by Peroxy Spring Rain Scent Multi-Purpose Cleaner Item # SPA4820 Manufacturer: SPARTAN CHEMICAL COMPANY Category: CLEANING & JANITORIAL</p>	<p>60 available - estimated arrival next day*</p> <p>*Delivery delays may occur during peak ordering periods. Exceptions apply. Estimated delivery is based on orders received by warehouse cut-off times and carrier schedule. Availability is based on your current ship-to address.</p>	<p>\$21.23</p> <p>4 Each</p>	\$84.92
11	 <p>SPARTAN CHEMICAL COMPANY BNC-15 2 Liter Floral Scent One Step Cleaner/Disinfectant (4 per Pack) Item # SPA4856-02 Manufacturer: SPARTAN CHEMICAL COMPANY Category: CLEANING & JANITORIAL</p>	<p>62 available - estimated arrival next day*</p> <p>*Delivery delays may occur during peak ordering periods. Exceptions apply. Estimated delivery is based on orders received by warehouse cut-off times and carrier schedule. Availability is based on your current ship-to address.</p>	<p>\$139.50</p> <p>3 Case</p>	\$418.50
12	 <p>Strategic Cleaner 1 Gallon Wood Floor Cleaner (4 per pack) Item # SPA5822-04 Manufacturer: Spartan Chemical Co., Inc. Category: CLEANING & JANITORIAL</p>	<p>11 available - estimated arrival next day*</p> <p>*Delivery delays may occur during peak ordering periods. Exceptions apply. Estimated delivery is based on orders received by warehouse cut-off times and carrier schedule. Availability is based on your current ship-to address.</p>	<p>\$10.26</p> <p>2 Gallon</p>	\$20.52
13	 <p>Spartan SparCling 1 Qt. Mint Scent 1-Step Disinfectant Toilet Bowl Cleaner (12 per Pack) Item # SPA7118-12-C Manufacturer: Spartan Category: CLEANING & JANITORIAL</p>	<p>42 available - estimated arrival next day*</p> <p>*Delivery delays may occur during peak ordering periods. Exceptions apply. Estimated delivery is based on orders received by warehouse cut-off times and carrier schedule. Availability is based on your current ship-to address.</p>	<p>\$34.56</p> <p>2 Case</p>	\$69.12

Order Summary

Total	\$3,579.98
Discount	\$0.00
Order Total	\$3,579.98

This sheet has been updated as of June 14, 2023, with information through May 2023

**GREENVILLE CITY SCHOOLS
2022 - 2023
ACTUAL LOCAL REVENUE COLLECTIONS**

	Property Tax		Property Tax - Prior Year		Clerk & Master		Interest & Penalty		Pick-up Taxes		In Lieu of - Local Utility		In Lieu of - Other	
	2021-2022	2022-2023	2021-2022	2022-2023	2021-2022	2022-2023	2021-2022	2022-2023	2020-2021	2022-2023	2021-2022	2022-2023	2021-2022	2022-2023
July	\$ -	\$ -	\$ 7,233.62	\$ 9,188.59	\$ 2,460.24	\$ 2,701.20	\$ 1,752.78	\$ 2,087.99	\$ -	\$ -	\$ -	\$ 12,443.75	\$ 229.48	\$ 259.49
August	\$ -	\$ -	\$ 5,643.32	\$ (8,670.69)	\$ 3,236.72	\$ 1,562.92	\$ 2,656.12	\$ 1,167.29	\$ -	\$ -	\$ 20,193.41	\$ 1,866.77	\$ -	\$ -
September	\$ -	\$ -	\$ 12,511.86	\$ 8,843.53	\$ 2,755.65	\$ 2,448.00	\$ 3,390.50	\$ 2,314.04	\$ -	\$ -	\$ 12,112.55	\$ 12,443.75	\$ -	\$ -
October	\$ 317,860.47	\$ 310,678.20	\$ 14,045.37	\$ 24,699.44	\$ 5,106.88	\$ 4,361.74	\$ 5,028.67	\$ 5,053.22	\$ -	\$ -	\$ 12,112.55	\$ 23,922.74	\$ -	\$ -
November	\$ 294,348.41	\$ 254,859.08	\$ 7,196.09	\$ 5,023.07	\$ 5,595.97	\$ 2,940.19	\$ 5,240.67	\$ 2,216.44	\$ -	\$ -	\$ 12,112.55	\$ 11,478.99	\$ -	\$ -
December	\$ 788,057.72	\$ 727,728.65	\$ 7,144.70	\$ 4,516.08	\$ 12,647.24	\$ 1,537.24	\$ 10,670.87	\$ 1,719.37	\$ -	\$ -	\$ 10,295.46	\$ 11,478.99	\$ -	\$ 2,169.51
January	\$ 346,759.76	\$ 333,034.59	\$ 5,077.41	\$ 6,094.97	\$ 2,140.47	\$ 2,470.03	\$ 1,905.77	\$ 2,791.43	\$ -	\$ -	\$ 12,112.55	\$ 11,479.00	\$ 1,169.76	\$ -
February	\$ 1,399,144.29	\$ 1,269,694.23	\$ 14,336.52	\$ 14,448.44	\$ 2,020.50	\$ 3,042.81	\$ 3,664.48	\$ 4,442.79	\$ -	\$ -	\$ 12,112.55	\$ 11,478.99	\$ 1,528.12	\$ 1,010.65
March	\$ 202,317.96	\$ 125,938.84	\$ 17,959.00	\$ 18,463.97	\$ 3,628.64	\$ 3,190.94	\$ 7,001.09	\$ 6,261.48	\$ -	\$ -	\$ 12,112.55	\$ 11,478.99	\$ -	\$ 57.86
April	\$ 22,832.14	\$ 22,354.10	\$ -	\$ -	\$ 2,220.34	\$ 2,180.14	\$ 1,962.15	\$ 1,703.37	\$ -	\$ -	\$ 12,112.55	\$ 11,478.99	\$ 1,028.73	\$ -
May	\$ 13,710.72	\$ 12,785.63	\$ -	\$ -	\$ 6,701.07	\$ 3,509.15	\$ 2,803.28	\$ 1,758.02	\$ -	\$ -	\$ 12,112.55	\$ 11,472.27	\$ -	\$ 939.78
ADA Adj.	\$ 92,531.82	\$ 5,279.58	\$ 2,517.18	\$ 149.47	\$ 1,326.54	\$ 54.13	\$ 1,262.68	\$ 57.25	\$ -	\$ -	\$ 3,483.30	\$ 237.21	\$ 108.17	\$ 8.03
June														
Totals	\$ 3,477,563.29	\$ 3,062,352.90	\$ 93,665.07	\$ 82,756.87	\$ 49,840.26	\$ 29,998.49	\$ 47,339.06	\$ 31,572.69	\$ -	\$ -	\$ 130,872.57	\$ 131,260.44	\$ 4,064.26	\$ 4,445.32
Commission	\$ 69,551.27	\$ 61,247.06	\$ 1,873.30	\$ 1,655.14	\$ 498.40	\$ 299.98	\$ 946.78	\$ 631.45	\$ -	\$ -	\$ 1,308.73	\$ 1,312.60	\$ 40.64	\$ 44.45
Total Net	\$ 3,408,012.02	\$ 3,001,105.84	\$ 91,791.77	\$ 81,101.73	\$ 49,341.86	\$ 29,698.51	\$ 46,392.28	\$ 30,941.24	\$ -	\$ -	\$ 129,563.84	\$ 129,947.84	\$ 4,023.62	\$ 4,400.87
Difference		\$ (415,210.39)		\$ (10,908.20)		\$ (19,841.77)		\$ (15,766.37)		\$ -		\$ 387.87		\$ 381.06

	Sales Tax		Bank Excise Tax		Mixed Drink Tax		Statutory Local Tax		Marriage Licenses		Subtotal		2021-22% of Actual	2022-23 % of Budget
	2021-2022	2022-2023	2021-2022	2022-2023	2021-2022	2022-2023	2021-2022	2022-2023	2021-2022	2022-2023	2021-2022	2022-2023		
July	\$ 374,777.02	\$ 421,100.29	\$ -	\$ -	\$ -	\$ -	\$ -	\$ -	\$ 149.38	\$ 114.49	\$ 386,602.52	\$ 447,895.80	4.7%	5.4%
August	\$ 367,431.34	\$ 432,580.24	\$ -	\$ -	\$ -	\$ -	\$ -	\$ -	\$ 85.36	\$ 90.13	\$ 399,246.27	\$ 428,596.66	4.8%	5.2%
September	\$ 371,486.88	\$ 496,616.02	\$ -	\$ -	\$ -	\$ -	\$ -	\$ -	\$ 97.22	\$ 82.83	\$ 402,354.66	\$ 522,748.17	4.9%	6.3%
October	\$ 363,856.95	\$ 392,440.02	\$ -	\$ -	\$ 13,171.95	\$ 13,304.80	\$ -	\$ -	\$ 139.90	\$ 136.42	\$ 731,322.74	\$ 774,596.58	8.9%	9.3%
November	\$ 427,773.87	\$ 420,689.99	\$ -	\$ -	\$ -	\$ -	\$ -	\$ -	\$ 192.07	\$ 121.80	\$ 752,459.63	\$ 697,329.56	9.1%	8.4%
December	\$ 377,553.14	\$ 415,739.51	\$ -	\$ -	\$ -	\$ -	\$ 31.20	\$ 97.40	\$ 97.22	\$ 87.70	\$ 1,206,497.55	\$ 1,165,074.45	14.6%	14.1%
January	\$ 451,682.57	\$ 433,205.57	\$ -	\$ -	\$ 12,835.55	\$ 13,304.80	\$ 35.00	\$ -	\$ 73.51	\$ 56.03	\$ 833,792.35	\$ 802,436.42	10.1%	9.7%
February	\$ 444,723.39	\$ 499,814.62	\$ -	\$ -	\$ -	\$ -	\$ -	\$ 35.00	\$ 37.94	\$ 43.85	\$ 1,877,567.79	\$ 1,804,011.38	22.7%	21.8%
March	\$ 334,417.34	\$ 400,259.71	\$ 18,000.43	\$ 24,654.60	\$ -	\$ -	\$ -	\$ -	\$ 66.39	\$ 51.16	\$ 595,503.40	\$ 590,357.55	7.2%	7.1%
April	\$ 349,435.80	\$ 399,405.45	\$ -	\$ -	\$ 12,673.34	\$ 25,391.92	\$ -	\$ -	\$ 61.65	\$ 75.52	\$ 402,326.70	\$ 462,589.49	4.9%	5.6%
May	\$ 413,236.32	\$ 457,463.92	\$ -	\$ -	\$ -	\$ -	\$ -	\$ -	\$ 99.59	\$ 85.26	\$ 448,663.53	\$ 488,014.03	5.4%	5.9%
ADA Adj.	\$ 116,932.12	\$ 8,634.71	\$ 492.20	\$ 44.64	\$ -	\$ -	\$ -	\$ -	\$ 30.08	\$ 1.71	\$ 218,684.09	\$ 14,466.73	2.6%	0.2%
June											\$ -	\$ -	0.0%	0.0%
Totals	\$ 4,393,306.74	\$ 4,777,950.05	\$ 18,492.63	\$ 24,699.24	\$ 38,680.84	\$ 52,001.52	\$ 66.20	\$ 132.40	\$ 1,130.31	\$ 946.90	\$ 8,255,021.23	\$ 8,198,116.82		
Commission	\$ 43,933.07	\$ 47,779.50	\$ 184.93	\$ 246.99	\$ 386.81	\$ 520.02	\$ 0.66	\$ 1.32	\$ 11.30	\$ 9.47	\$ 118,735.89	\$ 113,747.99		
Total Net	\$ 4,349,373.67	\$ 4,730,170.55	\$ 18,307.70	\$ 24,452.25	\$ 38,294.03	\$ 51,481.50	\$ 65.54	\$ 131.08	\$ 1,119.01	\$ 937.43	\$ 8,136,285.34	\$ 8,084,368.83		
Difference		\$ 384,643.31		\$ 6,206.61		\$ 13,320.68		\$ 66.20		\$ (183.41)		\$ (56,904.41)		

Total budgeted projection for 2022 - 2023 is \$ 8,291,395 The year-to-date collection of \$ 8,198,117 is 98.9% of the total budgeted projection.
The amount collected year-to-date is \$ (56,904) more than this time last year. (This amount does not reflect commission fees.)

Greeneville City Schools Comparative Summary of Revenue Collections For the Month Ended May 31, 2023

<u>LOCAL REVENUE</u>	2021-2022	2022-2023	Variance	Actual % Change
Property Tax	\$ 3,477,563.29	\$ 3,062,352.90	\$ (415,210.39)	-11.94%
Property Tax - Prior Year	93,665.07	82,756.87	\$ (10,908.20)	-11.65%
Clerk & Master	49,840.26	29,998.49	\$ (19,841.77)	-39.81%
Interest & Penalty	47,339.06	31,572.69	\$ (15,766.37)	-33.31%
Pick-Up Taxes	-	-	\$ -	0.00%
In Lieu Of - Local Utility	130,872.57	131,260.44	\$ 387.87	0.30%
In Lieu Of - Other	4,064.26	4,445.32	\$ 381.06	9.38%
Sales Tax	4,393,306.74	4,777,950.05	\$ 384,643.31	8.76%
Bank Excise Tax	18,492.63	24,699.24	\$ 6,206.61	0.00%
Mixed Drink Tax	38,680.84	52,001.52	\$ 13,320.68	34.44%
Statutory Local Taxes	66.20	132.40	\$ 66.20	100.00%
Marriage Licenses	1,130.31	946.90	\$ (183.41)	-16.23%
Totals	\$ 8,255,021.23	\$ 8,198,116.82	\$ (56,904.41)	-0.69%

Note: Amounts reflected do not take into consideration commission fees. Property tax, Interest & Penalty and Pick-Up Tax commission fees are calculated at 2% of total collections, while all other categories are calculated at 1% of total collections.

** Total budgeted amount of local revenue attributable to the GTC is \$564,278*

<u>BEP REVENUE</u>	2021-2022	2022-2023	Variance
July	\$ -	\$ 400,115.00	\$ 400,115.00
August	1,607,700.00	1,694,900.00	\$ 87,200.00
September	1,607,700.00	1,694,900.00	\$ 87,200.00
October	1,607,700.00	1,694,900.00	\$ 87,200.00
November	1,607,700.00	1,694,900.00	\$ 87,200.00
December	1,607,700.00	1,694,900.00	\$ 87,200.00
January	1,620,900.00	1,723,100.00	\$ 102,200.00
February	1,609,900.00	1,699,600.00	\$ 89,700.00
March	1,609,900.00	1,699,600.00	\$ 89,700.00
April	1,609,900.00	1,808,100.00	\$ 198,200.00
May	-	-	-
June	-	-	-
Totals	\$ 14,489,100.00	\$ 15,805,015.00	\$ 1,315,915.00

Greenville City Schools General Purpose Financial Report For the Month of May 2023

Account #	Description	Month-to-Date	Year-to-Date	Total Budget	YTD % of Total Budget
<u>REVENUE</u>					
34565	Restricted for Support Services	\$ -	\$ -	3,143.00	
34590	Restricted for Other Purposes	\$ -	\$ -	17,650.00	
34760	Assigned for Instruction	\$ -	\$ -	182,225.00	0.0%
34765	Assigned for Support Services	\$ -	\$ -	2,292.00	0.0%
34785	Assigned for Capital Projects	\$ -	\$ -	242,353.00	0.0%
34790	Assigned for Other Purposes	\$ -	\$ -	111,875.00	0.0%
40000	Local Taxes	\$ 437,170.74	\$ 7,186,648.61	8,098,424.00	88.7%
41000	Marriage Licenses	\$ 75.52	\$ 787.93	1,090.00	72.3%
43511	Tuition	\$ 46,725.43	\$ 674,683.59	671,925.00	100.4% (1)
43570	Receipts from Individual Schools	\$ 26,007.79	\$ 140,354.16	115,100.00	121.9%
44000	Other Local Revenue	\$ 56,363.39	\$ 267,123.99	181,097.00	147.5%
46000	State Education Funds	\$ (29,358.69)	\$ 15,139,823.50	17,129,905.00	88.4%
47100	Federal Through State Grants	\$ -	\$ 43,785.00	50,000.00	87.6%
47600	Direct Federal Funds (ROTC)	\$ 5,692.96	\$ 49,799.98	53,565.00	93.0%
49000	Operating Transfers & Insurance Recovery	\$ 577,195.20	\$ 5,302,299.55	6,061,471.00	87.5%
	Total Revenues	\$ 1,119,872.34	\$ 28,805,306.31	\$ 32,922,115.00	87.5%
<u>EXPENDITURES</u>					
		MTD	YTD		
71100	Regular Instruction	\$ 1,252,234.01	\$ 13,049,459.27	\$ 15,909,390.00	82.0%
71150	Alternative Instruction	10,054.41	93,408.58	121,298.00	77.0%
71200	Special Education	166,051.07	1,626,421.01	2,061,366.00	78.9%
71300	Vocational Education	14,502.45	147,641.67	181,407.00	81.4%
71400	Student Body	-	120.00	1,900.00	6.3%
72110	Attendance	6,289.48	68,337.81	82,552.00	82.8%
72120	Health Services	38,537.29	225,377.63	407,376.00	55.3%
72130	Other Student Support	96,093.80	989,363.44	1,288,797.00	76.8%
72210	Regular Instruction Support	109,176.26	1,252,935.12	1,495,018.00	83.8%
72220	Special Education Support	30,770.03	302,442.46	314,495.00	96.2%
72230	Vocational Education Support	-	-	2,400.00	0.0%
72250	Technology	68,947.77	799,077.48	1,028,529.00	77.7%
72310	Board of Education	24,930.59	797,593.28	880,759.00	90.6% (2)
72320	Office of Director	25,115.19	346,795.22	391,935.00	88.5%
72410	Office of Principal	138,424.55	1,519,691.38	1,684,911.00	90.2%
72510	Fiscal Services	42,957.18	323,549.87	341,883.00	94.6%
72520	Human Resources	29,939.96	278,967.00	315,098.00	88.5%
72610	Operation of Plant	154,016.86	1,950,402.67	2,124,673.00	91.8% (3)
72620	Maintenance of Plant	85,552.97	943,128.39	994,203.00	94.9% (3)
72710	Transportation	82,839.73	957,588.63	1,177,015.00	81.4%
73100	School Nutrition	-	5,820.74	-	N/A
73300	Community Services	5,494.65	28,323.31	25,652.00	110.4% (4)
73400	Early Childhood Education	43,740.75	458,925.81	557,495.00	82.3%
76100	Capital Outlay	31,693.99	79,209.55	742,353.00	10.7%
81300	Education Debt Service	148,700.00	148,700.00	328,700.00	45.2%
99100	Operating Transfers	19,292.30	303,743.00	462,910.00	65.6%
	Total Expenditures	\$ 2,625,355.29	\$ 26,697,023.32	\$ 32,922,115.00	81.1%
	Net Revenue (Expense)	\$ (1,505,482.95)	\$ 2,108,282.99		

Explanation of Footnotes

(1) EOY Tuition Count is 582 Students

(2) 2022-2023 Liability and Workers' Compensation Insurance Payments Reflected

(3) Reflects Open Purchase Orders for Routine Maintenance & Operations Expenditures

(4) To Be Addressed in Final General Purpose Budget Amendment

(5) Encumbrances Total \$1,505,436

Greeneville City Schools

Federal Projects Financial Report

For the Month of May 2023

<u>REVENUE</u>	<u>Month-to-Date</u>	<u>Year-to-Date</u>	<u>Total Budget</u>	<u>YTD % of Total Budget</u>
Consolidated Administration	\$ -	\$ 52,015.55	\$ 109,580.00	47.5%
Title I-A	\$ 90,706.19	\$ 362,355.59	658,832.00	55.0%
Title I-A Neglected	\$ -	\$ 32,902.16	80,444.00	40.9%
Title II-A	\$ -	\$ 35,339.80	123,351.00	28.6%
Title III	\$ -	\$ 5,221.27	53,166.00	9.8%
Title IV	\$ -	\$ 17,523.25	52,981.00	33.1%
21st Century Learning	\$ -	\$ 129,529.88	346,686.00	37.4%
Title V	\$ -	\$ 44,690.38	89,846.00	49.7%
IDEA Part B	\$ -	\$ 294,947.03	888,572.00	33.2%
IDEA Pre-School	\$ -	\$ 4,376.95	13,343.00	32.8%
ESSER 2.0**	\$ -	\$ 321,471.63	578,890.00	55.5%
ESSER 3.0**	\$ 77,277.59	\$ 655,697.23	2,953,947.00	22.2%
Fiscal Pre-Monitoring Supports Grant**	\$ -	\$ -	37,467.00	0.0%
Epidemiology & Laboratory Capacity Grant**	\$ -	\$ 250,894.74	619,127.00	40.5%
Resilient School Communities Grant**	\$ -	\$ 31,122.65	163,062.00	19.1%
Governors Civics Grant**	\$ -	\$ -	544.00	0.0%
ARP Homeless**	\$ -	\$ 5,077.64	20,965.00	24.2%
Math Implementation Supports Grant**	\$ 69,250.00	\$ 69,250.00	71,250.00	97.2%
ARP Idea**	\$ -	\$ 35,707.71	119,890.00	29.8%
Literacy Training Stipend Grant	\$ -	\$ 33,000.00	33,000.00	100.0%
Total Revenues	\$ 237,233.78	\$ 2,381,123.46	\$ 7,014,943.00	33.9%

<u>EXPENDITURES</u>	<u>MTD</u>	<u>YTD</u>		
Consolidated Administration	\$ 8,946.71	\$ 95,473.93	\$ 109,580.00	87.1%
Title I-A	48,100.84	472,508.96	658,832.00	71.7%
Title I-A Neglected	6,697.13	67,411.66	80,444.00	83.8%
Title II-A	6,364.07	67,160.15	123,351.00	54.4%
Title III	8,516.14	19,421.34	53,166.00	36.5%
Title IV	17,941.03	48,525.57	52,981.00	91.6%
21st Century Grant	57,830.25	246,189.68	346,686.00	71.0%
Title V	5,466.87	71,070.73	89,846.00	79.1%
ARP Homeless**	250.65	8,676.57	20,965.00	41.4%
IDEA Part B	59,241.92	589,917.74	888,572.00	66.4%
IDEA Pre-School	2,893.56	13,859.42	13,343.00	103.9%
ESSER 2.0 **	56,263.42	458,240.45	578,890.00	79.2%
ESSER 3.0 **	235,118.21	947,032.73	2,953,947.00	32.1%
Fiscal Pre-Monitoring Supports Grant**	18,733.00	18,733.00	37,467.00	50.0%
Epidemiology & Laboratory Capacity **	7,956.55	499,361.82	619,127.00	80.7%
Resilient School Communities Grant**	24,826.79	68,565.37	163,062.00	42.0%
Governors Civics Grant**	-	431.70	544.00	79.4%
Math Implementation Supports Grant**	-	69,250.00	71,250.00	97.2%
ARP IDEA **	4,665.88	55,525.16	119,890.00	46.3%
Literacy Training Stipend Grant	-	38,202.90	33,000.00	115.8%
Total Expenditures	\$ 569,813.02	\$ 3,855,558.88	\$ 7,014,943.00	55.0%

Net Revenue (Expense) **\$ (332,579.24)** **\$ (1,474,435.42)** **\$ -**

*Encumbrances Total \$213,327.43

** Reflects CARES Act Funding Grants

Greeneville City Board of Education

Monitoring: Review: Annually	Descriptor Term: COVID-19 Leave	Descriptor Code: 5.3052	Revision Date: 08/22/23
		Rescinds: 5.3052	Adoption Date: 04/23/20

1 Employees are entitled to up to ~~10~~ **5** days of paid sick leave if they are unable to work or telework
2 because the employee:

- 3 1. is subject to a Federal, State, or local quarantine or isolation order related to COVID-19;
- 4
- 5 2. has been advised by a health care provider to self-quarantine related to COVID-19; or
- 6
- 7 3. is experiencing COVID-19 symptoms and is seeking a medical diagnosis.
- 8
- 9 4. is caring for a family member diagnosed with COVID-19; or must care for their school-age
10 child(ren) subject to quarantine order.

11 To demonstrate eligibility for the leave, the employee may be required to provide proof of COVID-19
12 testing or other suitable documentation for the circumstances. Employees should seek clarification
13 from Human Resources if they have questions regarding the total amount of leave available to them.

14 This paid leave may be taken if there is work available for the employee to complete and the employee
15 is unable to work or telework for one of the above reasons. Such leave is in addition to any paid leave
16 that an employee may already be entitled to (e.g., existing sick leave). Employees are not required to
17 exhaust any other paid leave benefit to utilize this new category of paid sick leave.

18 Employees will only be permitted up to ~~10~~ **5** days of their regular pay per school year for any leave
19 taken under this policy.

20 This policy will be in effect until June 30, ~~2023~~ **2024** unless the Board takes action to extend it. If the
21 state or federal government issues a mandate for COVID-19 related leave after adoption of this local
22 COVID-19 leave policy, such mandated leave will replace this policy entirely and this policy
23 simultaneously will expire.

Ford of Murfreesboro

John Hamby
1550 NW Broad St.
Murfreesboro, TN 37129

SALES QUOTATION

STATE CONTRACT- 000075348

TO:	(Pricing valid for 2023 models only.)
	MODEL U9F-100A
	GREENEVILLE SCHOOLS
	2023 FORD ESCAPE BASE AWD
	OXFORD WHITE

F.O.B.
TERMS
DELIVERY
NUMBER

Thank you for your inquiry dated: May 16, 2023

We are pleased to quote you the following:

ITEM	QUANTITY	DESCRIPTION	UNIT PRICE	DELIVERY DATE
1	1	2023 FORD ESCAPE BASE AWD	\$27,802.00	TBD
2		1.5 LITER ECO BOOST GAS ,8 SPEED TRANSMISSION		
3		EXTERIOR WHITE		
4		INTERIOR- EBONY CLOTH		
5		OPTIONS LISTED ON WINDOW STICKER	\$1,179.00	
6				
7				
8		CO-PILOT 360 W/ BLIND SPOT COLLISION AVOIDANCE		
9				
10				
11				
12		TOTAL X 1	\$28,981.00	

We will be happy to supply any further information you may need and trust that you call on us to fill your order, which will receive our prompt and careful attention.

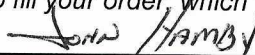

PER

May 16, 2023

DATE



Prepared by: JOHN HAMBY
05/15/2023

Ford of Murfreesboro | 1550 N.W. Broad St. Murfreesboro Tennessee | 371291709

2023 Escape 4dr AWD Base (U9F)

As Configured Vehicle

Code	Description	MSRP
Base Vehicle		
U9F	Base Vehicle Price (U9F)	\$29,500.00
Packages		
100A	Equipment Group 100A <i>Includes:</i> - Engine: 1.5L EcoBoost <i>Includes auto start-stop technology.</i> - Transmission: 8-Speed Automatic - 3.81 Axle Ratio - GVWR: TBD - Tires: 225/65R17 AS BSW - Wheels: 17" Steel w/Sparkle Silver-Painted Covers - Cloth Front Bucket Seats <i>Includes 6-way manual driver (fore/aft, up/down, recline) and 4-way manual front passenger (fore/aft with manual recline).</i> - Radio: AM/FM Stereo <i>Includes 6 speakers, speed compensated volume and steering wheel mounted controls.</i> - SYNC 4 <i>Includes 8" LCD capacitive touch-screen with swipe capability, wireless phone connection, cloud connected, AppLink with app catalog, 911 Assist, wireless Apple CarPlay and Android Auto, digital owners manual.</i> - FordPass Connect <i>Includes 4G LTE Wi-Fi hotspot that connects up to 10 devices (includes a wireless data trial that begins upon AT&T activation and expires at the end of 3 months or when 3GB of data is used, whichever comes first, but cannot extend beyond the trial subscription period for remote features. To activate, go to www.att.com/ford). Remote start with specific time scheduling, lock and unlock, locate parked vehicle and check vehicle status (the FordPass App and complimentary connected services are required for remote features (see FordPass terms for details). Connected services and features depend on compatible AT&T network availability. Evolving technology/cellular networks/vehicle capability may limit functionality and prevent operation of connected features. Connected services exclude Wi-Fi hotspot).</i>	N/C
Powertrain		
99N	Engine: 1.5L EcoBoost <i>Includes auto start-stop technology.</i>	Included
448	Transmission: 8-Speed Automatic	Included
STDAX	3.81 Axle Ratio	Included
STDGV	GVWR: TBD	Included
Wheels & Tires		
STDTR	Tires: 225/65R17 AS BSW	Included
STDWL	Wheels: 17" Steel w/Sparkle Silver-Painted Covers	Included
Seats & Seat Trim		

Prices and content availability as shown are subject to change and should be treated as estimates only. Actual base vehicle, package and option pricing may vary from this estimate because of special local pricing, availability or pricing adjustments not reflected in the dealer's computer system. See salesperson for the most current information.



Prepared by: JOHN HAMBY
05/15/2023

Ford of Murfreesboro | 1550 N.W. Broad St. Murfreesboro Tennessee | 371291709

2023 Escape 4dr AWD Base (U9F)

As Configured Vehicle (cont'd)

Code	Description	MSRP
V	Cloth Front Bucket Seats <i>Includes 6-way manual driver (fore/aft, up/down, recline) and 4-way manual front passenger (fore/aft with manual recline).</i>	Included

Other Options

PAINT	Monotone Paint Application	STD
106WB	106" Wheelbase	STD
STDRD	Radio: AM/FM Stereo <i>Includes 6 speakers, speed compensated volume and steering wheel mounted controls.</i> <i>Includes:</i> - SYNC 4 <i>Includes 8" LCD capacitive touch-screen with swipe capability, wireless phone connection, cloud connected, AppLink with app catalog, 911 Assist, wireless Apple CarPlay and Android Auto, digital owners manual.</i> - FordPass Connect <i>Includes 4G LTE Wi-Fi hotspot that connects up to 10 devices (includes a wireless data trial that begins upon AT&T activation and expires at the end of 3 months or when 3GB of data is used, whichever comes first, but cannot extend beyond the trial subscription period for remote features. To activate, go to www.att.com/ford). Remote start with specific time scheduling, lock and unlock, locate parked vehicle and check vehicle status (the FordPass App and complimentary connected services are required for remote features (see FordPass terms for details). Connected services and features depend on compatible AT&T network availability. Evolving technology/cellular networks/vehicle capability may limit functionality and prevent operation of connected features. Connected services exclude Wi-Fi hotspot).</i>	Included

Emissions

425	50-State Emissions System	STD
-----	---------------------------	-----

Exterior Color

YZ_01	Oxford White	N/C
-------	--------------	-----

Interior Color

VH_02	Ebony w/Cloth Front Bucket Seats	N/C
-------	----------------------------------	-----

Upfit Options

Ford accessory	Co-pilot 360 w/ blindspot avoidance	\$1,179.00
----------------	-------------------------------------	------------

SUBTOTAL		\$30,679.00
Destination Charge		\$1,495.00
TOTAL		\$32,174.00

Prices and content availability as shown are subject to change and should be treated as estimates only. Actual base vehicle, package and option pricing may vary from this estimate because of special local pricing, availability or pricing adjustments not reflected in the dealer's computer system. See salesperson for the most current information.



Proposal

Proposal Number

2111113796

Account Number/Name

591246

GREENEVILLE CITY SCHOOLS

Created On

05/31/2023

Created By

Larry Jones

Thank you for creating your proposal, details are provided below. You can access this proposal from your [Apple Store for Education Institution](#) by searching proposal number 2111113796.

Comments from Proposer:

Updated per Coach Hale - 31 May 2023

Item	Product / Description	Total Quantity	Unit Price	Total Price
1	Z13K 24-inch iMac with Retina 4.5K display: Apple M1 chip with 8-core CPU and 7-core GPU - Silver Specifications <ul style="list-style-type: none"> Processor: Apple M1 chip with 8-core CPU with 4 performance cores and 4 efficiency cores, 7-core GPU, and 16-core Neural Engine Memory: 16GB unified memory Storage: 512GB SSD storage Two Thunderbolt / USB 4 ports: Two Thunderbolt / USB 4 ports Ethernet: Gigabit Ethernet Mouse or Trackpad: Magic Mouse Pro Apps: Pro Apps Bundle for Education Logic Pro: None Keyboard Languages: Magic Keyboard - US English COUNTRY KIT: Accessory Kit 	15	1,835.99	27,539.85 USD

Subtotal 27,539.85 USD

Estimated Tax 0.00 USD

Total 27,539.85 USD

Please note that your order subtotal does not include sales tax or rebates. Sales tax and rebates, if applicable, will be added when your order is processed. Your order total may include estimated sales tax that is subject to change at the time your order is processed.

How to Order

If you would like to convert this Proposal to an order, log into your [Apple Store for Education Institution](#) and select 'Proposal' from the pull-down menu. Search for this Proposal by entering the Proposal Number referenced above.

Note: A Purchaser login is required to order. Visit your [Apple Store for Education Institution](#) to login or create your Purchaser Apple ID.

The prices and specifications above correspond to those valid at the time the Proposal was created and are subject to change. Purchases are subject to the terms and conditions of your agreement with Apple and the Apple Store for Education Institution.

Copyright © 2023 Apple Inc. All rights reserved.

Quantity	Item	JD2 Cost Per Item	JD2 Total	Phillips Cost Per Item	Phillips Total	Rev Robotics Cost Per Item	Rev Robotics Total	Thunder Laser Cost Per Item	Thunder Laser Total	Grainger Cost Per Item	Grainger Total	Dynamism Cost Per Item	Dynamism Total
1	Sharp SW-100T Miter Cutting Band Saw		\$0.00	\$ 13,799.10	\$13,799.10								
	With options: 3 ft. roller table												
1	HAAS Mini Mill		\$0.00	\$ 44,815.46	\$44,815.46								
	With Options: 20-Piece, CT40 Toolholder Kit												
1	HAAS TL-1 Lathe		\$0.00	\$ 41,831.46	\$41,831.46								
1	Sharp SWV Vertical Bandsaw		\$0.00	\$ 11,616.80	\$11,616.80								
	JET Floor Drill Press: Belt, Variable, 245 RPM – 2,000 RPM, 460V AC /Three-Phase, 20 in Swing, 2 hp		\$0.00		\$0.00					\$ 7,774.23	\$ 7,774.23		
1	LMV-49 Vertical Mill with DVS head with 3 axis DRO		\$0.00	\$ 21,576.30	\$21,576.30								
1	MAD Plasma Table MPR2 5'x5' with Extended Gantry	\$ 31,450.00	\$31,450.00		\$0.00								
	With options:												
1	CNC Cutting Table Platform - Air - 5' x 5'	\$ 1,050.00	\$1,050.00		\$0.00								
1	CNC Cutting Table - Air Deflector Set 5' x 5'	\$ 800.00	\$800.00		\$0.00								
1	Rolling Slap Disposal Tray	\$ 450.00	\$450.00		\$0.00								
1	CNC Router Attachment - Large	\$ 150.00	\$150.00		\$0.00								
1	XL Marking System	\$ 1,200.00	\$1,200.00		\$0.00								
1	Rotary Tube Attachment for Cutting Table	\$ 10,900.00	\$10,900.00		\$0.00								
1	Rotary Attachment Water Injection System	\$ 1,000.00	\$1,000.00		\$0.00								
1	Hypertherm Powermax 45 XP Plasma Unit with Serial Port	\$ 3,300.00	\$3,300.00		\$0.00								
2	HAAS Desktop Mill	\$0.00	\$ 13,289.95	\$26,579.90									
1	Thunder Laser Nova 63 (130 Watt)		\$0.00		\$0.00			\$ 17,700.00	\$ 17,700.00				
	With options: Rotoboss												
1	Markforged Mark Two 3D Printer (Gen 2)		\$0.00	\$ 20,919.00	\$20,919.00								
5	Form 3+ Printer with Complete Package		\$0.00		\$0.00						\$ 3,700.00	\$ 18,500.00	
5	Ultimaker Printer S3		\$0.00		\$0.00						\$ 5,367.00	\$ 26,835.00	
10	First Tech Challenge EDU Kit V2		\$0.00		\$0.00	\$ 990.00	\$ 9,900.00						
10	First Tech Challenge Kit V2 to Starter Kit V3 Upgrade		\$0.00		\$0.00	\$ 402.50	\$ 4,025.00						
10	First Tech Challenge Sensor Bundle		\$0.00		\$0.00	\$ 172.50	\$ 1,725.00						
			\$50,300.00		\$181,138.02		\$ 15,650.00		\$ 17,700.00		\$ 7,774.23		\$ 45,335.00

\$317,897.25

Formlabs Form 3+ Complete Package

Product# PKG-F3-P-WS-SVC-COMPLETE

The Form 3+ uses Low Force Stereolithography (LFS) to turn liquid resin into flawless parts. This advanced print process offers incredible print quality, surface detail, and a platform for more advanced materials and applications.

Key Features:

- Low-Force Stereolithography (LFS) 3D Printer
- 145 × 145 × 185 mm
- Resin / SLA
- Low-force stereolithography technology produces smooth parts with fine details and sharp points

Bundle Includes:

- Form 3+ Printer
- Form Wash
- Form Cure
- Form 3 Resin Tank
- Form 3 Build Platform
- Form 3 Finish Kit
- Cleaning Tools

Dynamism has been named a Formlabs Platinum Partner, their highest form of partnership, for consistently providing our customer base with Formlabs products and services.



Talk to an Expert

Ask one of our 3D Printing Specialists
sales@dynamism.com | [1-800-711-6277](tel:1-800-711-6277)

Low Price Guarantee - Price Match

In Stock

- ✓ Brand New
- ✓ Includes Warranty
- ✓ Unlimited Toll-Free Support

Service Plan / Extended Warranty

-- Please Select --

4.8 ★★★★★
Google
Customer Reviews

otions



-- Please Select --

Formlabs Form 3+ Complete Package ...

\$3,700.00

\$3,700.00

1

 ADD

[GET QUOTE](#)
[EDU/GOV PRICING](#)



formlabs  Promotion

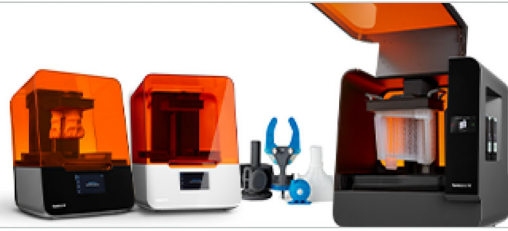

Who We Are

Founded in 1997. Offices in Chicago and Denver. Four showrooms across the U.S.



Our Company

The leading national supplier of Desktop 3D printers. Expertise in both Industrial and Desktop 3D printing. Supplier of next-generation Metal, SLS, ultrafast Industrial printers.



Customer Benefits

Unlimited toll-free support

Curated selection

Fast shipping



Product Overview

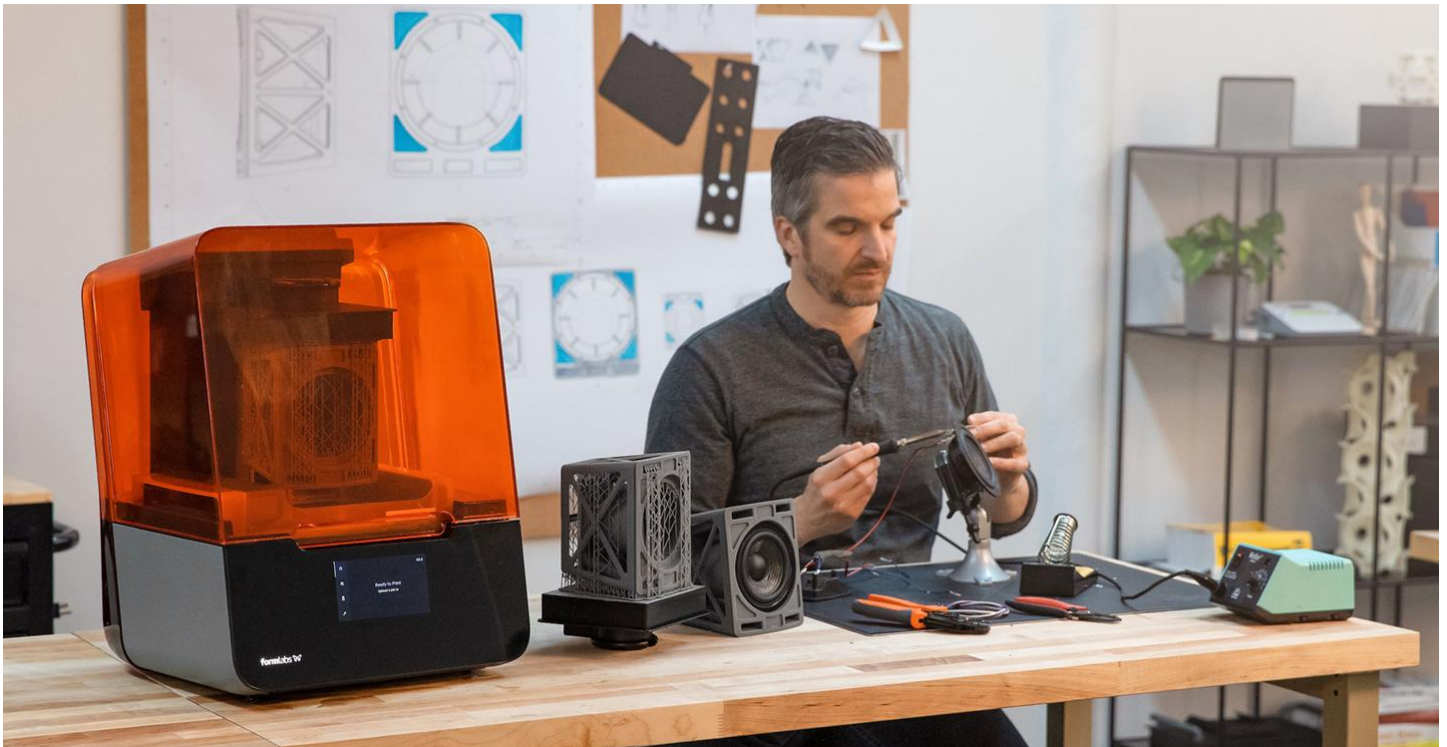

Formlabs Form 3+ Basic Package

Now includes a one-year warranty and the essential tools required to start printing.



Produce functional, high-quality prototypes and end-use parts in record time with the Form 3+, an affordable, industrial-quality 3D printer that consistently delivers. The Form 3+ offers rapid print speeds, industry-leading accuracy and reliability, and a wide range of materials.

The Form 3+ is powered by Low Force Stereolithography which consistently delivers presentation ready parts with unbelievable surface finish. After printing, detach supports in seconds with our enhanced Light Touch Support structures that save post-processing time.

The Form 3+ is simple to set up and maintain. Use the Form 3+ for both prototyping and production and easily add more capacity as demand grows.

What's Included

This package includes the basics required to start printing with the Form 3+ 3D Printer.



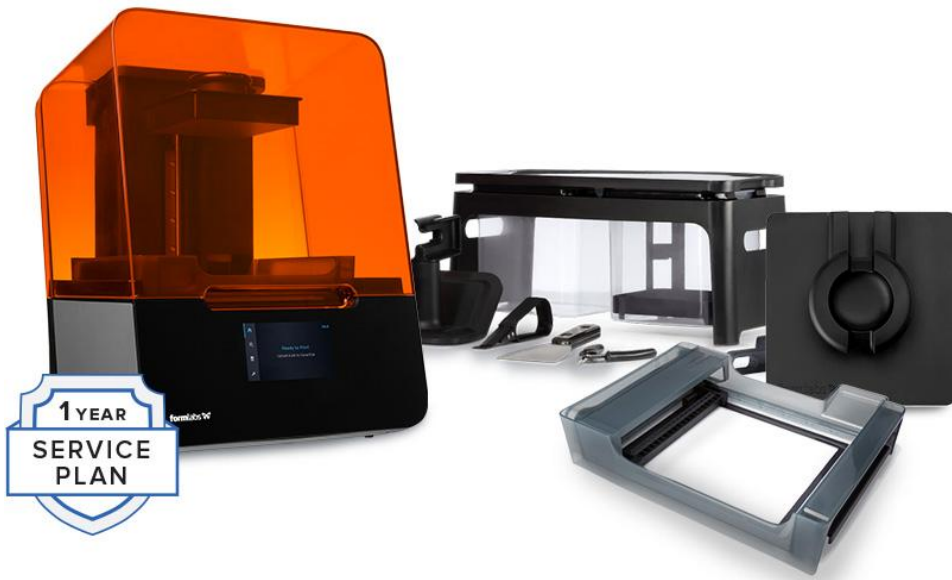

- Form 3+ 3D Printer
- Form 3 Finish Kit
- Cleaning tools
- Form 3 Build Platform
- Form 3 Resin Tank
- 1 Year Included Warranty (Extended Options Available)

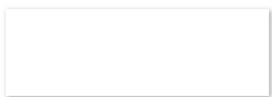
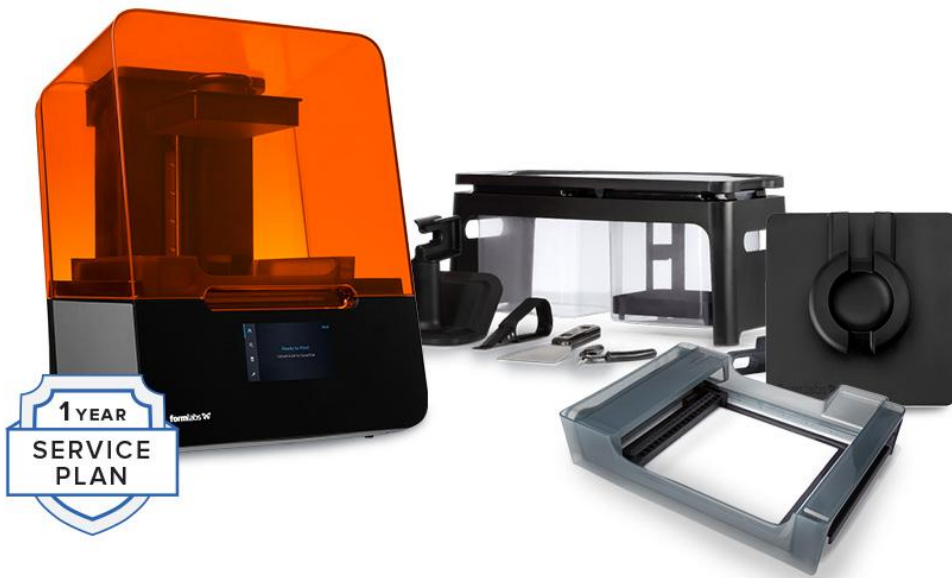

About the Basic Package

The Form 3+ uses Low Force Stereolithography (LFS)[™] to turn liquid resin into flawless parts. This advanced print process offers incredible print quality, surface detail, and a platform for more advanced materials and applications.

A key component of the LFS process is the flexible Resin Tank which significantly reduces peel forces during printing to make removing supports as easy as possible.

The included Build Platform provides a base for your part to adhere to during printing, while the cleaning tools assist with finishing and post-processing your prints.



New Resin Highlight

The latest resins for advanced applications



Formlabs ESD Resin

Use ESD Resin to prototype and validate electronics production workflows, print static-dissipative parts that repel dust and powder, and create enclosures to protect sensitive electronics from static discharge.

[Shop Now](#)



Formlabs Build Platform 2

Build Platform 2 with patented Quick Release Technology allows you to quickly and easily release parts from the build platform without tools in seconds, saving you valuable post-processing time.



[Shop Now](#)



Choose a Service Plan

Maximize your return, protect your investment, and eliminate unexpected costs with our service plans.

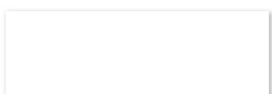



Pro Service Plans Set You Up for Success and Support You Along the Way

Priority access to Pro Service Experts

A direct line to a Pro Service Expert and prioritized email support from our dedicated staff.



Customized training

A 60-minute training session over video with a Pro Service Expert, customized to you.

Hot swaps for hardware replacements

Ensure constant uptime: Formlabs will ship you a replacement printer to keep you printing if your printer needs to be repaired or replaced.

Warranty for the duration of the plan

The Pro Service Plan extends the one-year warranty included with your printer to the full duration of the chosen plan.

Tech Specs

Printing

Build Volume: 14.5 x 14.5 x 18.5 cm [5.7 x 5.7 x 7.3 in]
Materials Supported: Formlabs resins (excluding Biocompatible resins)
Print Technology: Low Force Stereolithography (LFS)
Resin Fill System: Automated
Supports: Auto-generated
Laser Specifications:
1 Light Processing Unit
EN 60825-1:2007 certified Class 1 Laser Product
405 nm wavelength
250 mW power
85 micron (0.0033 in) laser spot
Layer Thickness: 25-300 microns
Minimum layer thickness dependent on resin type

Physical

Product Weight: 17.5 kg [38.5 lbs]
Dimensions: 40.5 x 37.5 x 53 cm [15.9 x 14.8 x 20.9 in]
Minimum Access: 40.5 x 53 x 78 cm [15.9 x 20.9 x 30.7 in]
Assembled: Yes

Connectivity

Connectivity: WiFi, Ethernet, USB 2.0
Printer Control: 5.5" 1280 x 720 touchscreen
Dashboard Printer Management Features:
Manage prints and printers via the cloud
Track resin and tank usage over time
SMS and email alerts
Create enterprise group accounts with admins to more easily share printers and control access

Software

Supported File Types: .STL & .OBJ
Software Bundle: PreForm Software
PreForm requires 4GB RAM and OpenGL 2.1
PreForm features:
One-Click Print
Adaptive layer thickness for faster printing with fine details • Remote Print (not available on Form 2)
Auto-orient for optimal print position
Auto-mesh repair
Auto-generation of supports
Rotate, scale, duplicate, and mirror
Layer slicer for path inspection
Available in multiple languages
Supported Operating Systems:
Windows 7 (64-bit)+
Mac OS X 10.10+

Support / Warranty

Warranty: One-year manufacturer's warranty

Electrical

Power Requirements:
100-240 VAC
2.5 A 50/60 Hz
220 W

Temperature

Operating Temperature: Auto-heats to 35 C [95 F]

Recommended Accessories

NEW!



NEW!

**Formlabs Form 2 / 3(+) /
3B(+) Build Platform 2**

\$229.00

1

ADD

[learn more](#)

**Formlabs Form 2 / 3 / 3B
Build Platform**

\$99.00

1

ADD

[learn more](#)

**Formlabs Form 3 Resin Tank
V2.1**

\$149.00

1

ADD

[learn more](#)

Formlabs Form Was

\$4,

ADD

Recommended Materials



**Formlabs Grey Resin
Cartridge v4 1L**

\$149.00

1

ADD

[learn more](#)

**Formlabs Clear Resin
Cartridge v4 1L**

\$149.00

1

ADD

[learn more](#)

**Formlabs Draft v2 Resin
Cartridge 1L**

\$149.00

1

ADD

[learn more](#)

**Formlabs Black Res
Cartridge v4 1L**

\$

1 A



WHY DYNAMISM?

We're dedicated to earning each customer's loyalty through exceptional service.

Who We Are

We were founded in 1997. We have offices in Chicago and Denver with four showrooms across the U.S.

Our Company

The leading national supplier of Desktop 3D printers. Expertise in both Industrial and Desktop 3D printing. Supplier of next-generation Metal, SLS, ultrafast Industrial printers.

Customer Benefits

Unlimited toll-free support

Curated selection

Fast shipping

2023 Edition **Professional 3D Printer Buyers Guide**

Choosing the right 3D printer doesn't have to be difficult. Find the perfect printer for your application. This in-depth guide covers pricing, materials, dimensional accuracy, and more.

[DOWNLOAD NOW](#)

How can we help?

[FAQ](#)

[Shipping & Returns](#)

[Promotions](#)

[Warranty](#)

[Privacy](#)

[Terms of Sale](#)

[Terms of Use](#)

Copyright © 2023 Dynamism All Rights Reserved.

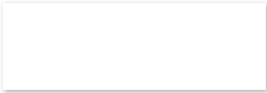



JD Squared
 915 Riverview Drive
 Johnson City TN 37601
 United States
 423-979-0309

Quote Number: 15798

QUOTE

Page: 1 of 2

<p>Quote To:</p> <p>The Greeneville City School District Greeneville High School 129 West Depot Street Greeneville TN 37743 United States Phone: 423-552-5954</p>	<p>Date: 6/2/2023</p> <p>Expires: 7/2/2023</p> <p>Sales Person: Brad McCoy</p>
---	---

US Dollar

Line	Part	Description	Unit Price	Ext. Price
1	109102-55	MPR2 CNC Cutting Table - Extended Gantry - 5' x	1.00 31,450.00	31,450.00
2	109250-5X5	MP CNC Cutting Table Platform - Air - 5' x 5'	1.00 1,050.00	1,050.00
3	109500-5X5	MP CNC Cutting Table - Air Deflector Set - 5' x 5'	1.00 800.00	800.00
4	109600-5	MP Rolling Slag Disposal Tray - 5'	1.00 450.00	450.00
5	109011- MPR2	MPR2 / XR6 - CNC Router Attachment - Large	1.00 150.00	150.00
6	109017-M	MADMP XL Marking System	1.00 1,200.00	1,200.00
7	107060-5	Rotary Tube Attachment for MP Cutting Table - 5'	1.00 10,900.00	10,900.00
8	107065	Rotary Attachment Water Injection System for MP	1.00 1,000.00	1,000.00



JD Squared
 915 Riverview Drive
 Johnson City TN 37601
 United States
 423-979-0309

Quote Number: 15798

QUOTE

Page: 2 of 2

9 103181-K Hypertherm Powermax 45 XP Plasma Unit, Serial 1.00 3,300.00 3,300.00

----- Kit Components -----

Kit Seq.	Part	Description	Qty Per	EA	Comp.
9.001	103181	Hypertherm Powermax 45 XP Plasma Unit with Serial Port	1.00	EA	3,300.0
9.002	103270-45	Accessories for HyperTherm PMX 45	1.00	EA	0.00

----- Kit Components -----

Kit Seq.	Part	Description	Qty Per	EA	Comp.
9.001	103181	Hypertherm Powermax 45 XP Plasma Unit with Serial Port	1.00	EA	3,300.0
9.002	103270-45	Accessories for HyperTherm PMX 45	1.00	EA	0.00

Lines Total	50,300.00
Total Taxes	3,889.25
Line Miscellaneous Charges	0.00
Quote Miscellaneous Charges	0.00
Quote Total	54,189.25

Debbie Collins

From: Brad McCoy <BradMcCoy@jd2.com>
Sent: Thursday, June 15, 2023 11:45 AM
To: Beverly Miller
Cc: Debbie Collins
Subject: RE: RFP INCLUDED: Do not open until June 15, 2023, 11 A.M., EDT - 301-2023-2024-01-Equipment

WARNING: This email originated from outside of the Greenville City Schools network. Do not click links or open attachments unless you recognize the sender and know the content is safe.

Beverly,

Please find two references below for JD Squared, Inc.:

Daniel Odom
Instructor, Agriculture Science
Newton Independent School District
2812 Highway 190 East
Newton, TX 75966
Phone: 409-291-1226
e-mail: daniel.odom@newtonisd.net

Joe Carr
Instructor
Elizabethton City Schools
307 West E Street
Elizabethton, TN 37643
Phone: 423-571-0915
e-mail: carrjoe@hotmail.com

Both customers have our CNC tables.

Thank you and have a great day!



Brad McCoy

Sales Representative

JD Squared, Inc. | www.jd2.com

(423) 979-0309 ext. 8003

BradMcCoy@jd2.com

915 Riverview Drive

Johnson City, TN 37601



From: Beverly Miller <millerb@gcschools.net>

Sent: Wednesday, June 14, 2023 8:50 AM

To: Brad McCoy <BradMcCoy@jd2.com>

Cc: Debbie Collins <collinsd@gcschools.net>

Subject: RE: RFP INCLUDED: Do not open until June 15, 2023, 11 A.M., EDT - 301-2023-2024-01-Equipment

I am in receipt of your proposal. My assistant, Debbie Collins, will open the document tomorrow morning at 10:45 am, print the documents, and bring to me at 11 am in the public bid opening. Thank you!
Beverly Miller

From: Brad McCoy <BradMcCoy@jd2.com>

Sent: Tuesday, June 13, 2023 5:13 PM

To: Beverly Miller <millerb@gcschools.net>

Subject: RFP INCLUDED: Do not open until June 15, 2023, 11 A.M., EDT - 301-2023-2024-01-Equipment

WARNING: This email originated from outside of the Greenville City Schools network. Do not click links or open attachments unless you recognize the sender and know the content is safe.

Beverly,

Debbie Collins

From: Beverly Miller
Sent: Wednesday, June 14, 2023 8:50 AM
To: Debbie Collins
Subject: FW: RFP INCLUDED: Do not open until June 15, 2023, 11 A.M., EDT - 301-2023-2024-01-Equipment
Attachments: Quote 15798 - The Greenville City School District.pdf

Follow Up Flag: Follow up
Flag Status: Completed

From: Brad McCoy <BradMcCoy@jd2.com>
Sent: Tuesday, June 13, 2023 5:13 PM
To: Beverly Miller <millerb@gcschools.net>
Subject: RFP INCLUDED: Do not open until June 15, 2023, 11 A.M., EDT - 301-2023-2024-01-Equipment

WARNING: This email originated from outside of the Greenville City Schools network. Do not click links or open attachments unless you recognize the sender and know the content is safe.

Beverly,

Please find the attached quote in response to proposal number 301-2023-2024-01-Equipment. The quote lists sales tax, but this can be removed after we have a copy of your tax exemption certificate.

All of JD Squared products included a full **one-year manufacturer warranty** against any defects. We machine and manufacture the tables at our factory in Johnson City, Tennessee. In person or remote training is included at no charge. Technical support and software updates are also provided at no charge for the life of the table.

We appreciate your interest in our CNC tables!

Here is some information on our MPR2 CNC Tables:

All of JD Squared products included a full **one-year manufacturer warranty** against any defects. We machine and manufacture the tables at our factory in Johnson City, Tennessee. In person or remote training is included at no charge. Technical support and software updates are also provided at no charge for the life of the table.

We appreciate your interest in our CNC tables!

Here is some information on our MPR2 CNC Tables:



Available Table Sizes:
5' x 5' / 4' x 8' / 5' x 10'

Maximum Plate Thickness:
2"

Rapid Speeds:
MAD MP: 1150+ IPM

Wood Router Compatibility:
The MP Series requires a standard hand router. If the optional automatic router control is being used, the maximum allowable amperage for the router is 15A.

Table Options:

The MP Series can be supplied as an Air Table or Wood Router Table at no additional cost. A Water Table is available for an additional cost

A Solid Foundation

Big machine features, small machine price.

The MP Series CNC Tables are configurable to use either an air table, water table, or wood routing table.

Precision Machined Frame.

All steel construction has been precision machined to guarantee parallelism of the V-Groove supporting the alloy steel rail, and the 3/4" ground facing gear rack.

The frame sides are keyed to make assembly a breeze.



Optional Extended Gantry

The extended gantry option allows the head to extend past the edge of the standard table to cut or route material that would not normally fit on the table. For example, cutting into square tubing using a sawhorse as support.

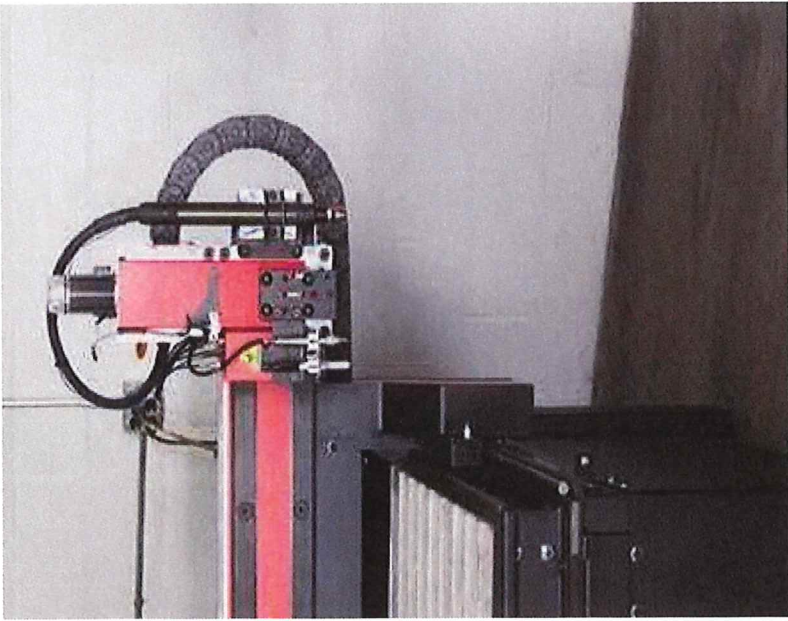

The X and Z Axes

Universal - Ready for plasma

The face plate of the X-Axis Carriage is universal to accept many types of tools. By default, it is configured with two magnetic docking stations, and a Z-Axis unit plasma ready.



Z Axis - Protection built in.

The Z-Axis rides on a 25mm linear guide behind protective covers. It includes magnetic torch break-away with automated sensing, and dual probing methods: ohmic contact, and floating head for when electrical contact cannot be sensed.

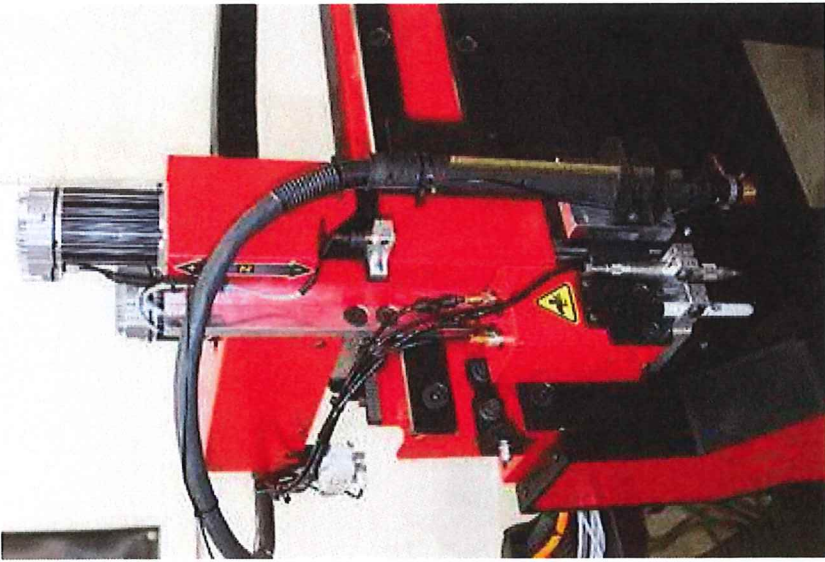

Brushless servo motors. Everywhere.

All axes are driven using high quality brushless servo motors to get the speed we desire. Application specific motor power supplies keep the machine running all day.



Hardened machine control.

Custom robust control electronics are reinforced, and isolated to protect sensitive circuits from damaging currents. Since we build it, obsolescence isn't a problem.



Automatic Torch Height Control.

Yes, it's included. The custom ATHC is capable of measuring a divided feedback voltage provided by the most popular plasma power units.

User Interface Computer Pedestal.

The MP Series CNC tables includes the matching computer pedestal, but the **computer is not included.**

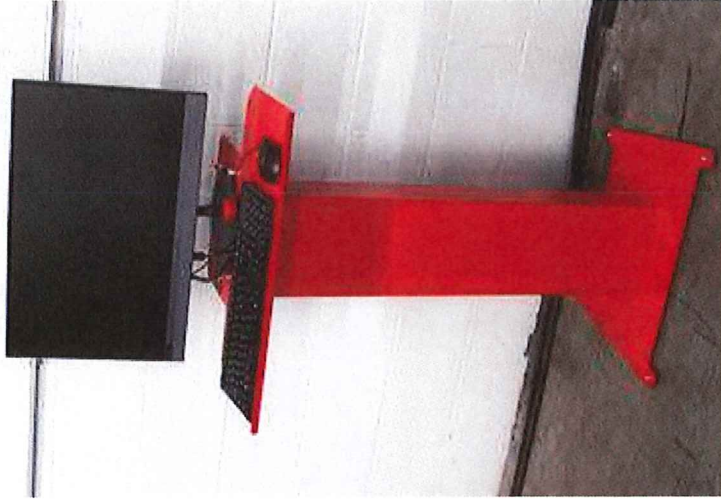

Constantly improving Machine Control Interface.

The latest version of our control software keeps improving. Easy to operate, easy to select cut settings, and easy to restart. The software automatically updates itself for bug fixes and select feature sets if connected to the internet. No subscription required, included for free.

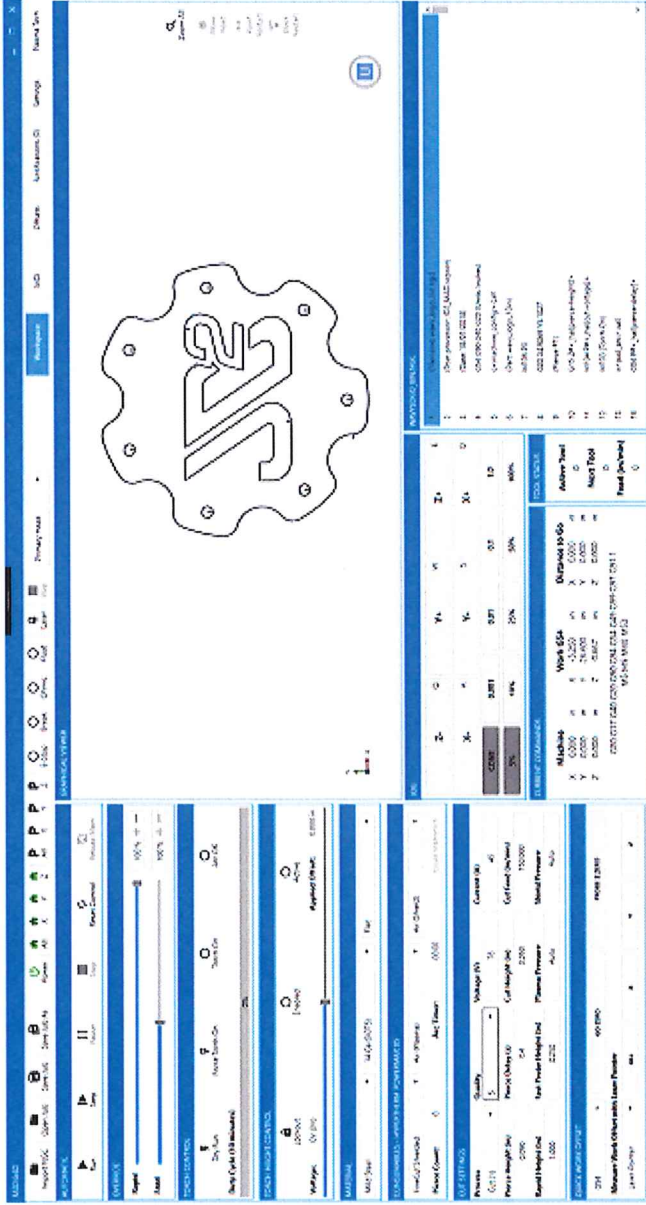

The MP Series is designed for configuration. Available Options include:

- Standard or Extended Gantry
- Starting Table Type - Choose between Air and Wood Routing or Select Water for an additional cost.
- The Air configuration is upgradable with tray and deflector Options.
- Purchase one of two router attachment sizes to complete the Wood Router configuration.
- The Water Table comes in powder coated steel or stainless steel.
- An available water sump system allows you to raise and lower the water level for cutting, part retrieval and cleaning.
- Compatible with the XL Marking System for drawing or engraving.

We recommend filling the water table with a plasma specific cutting fluid, such as Quench Guard G by PICO. These additives help protect the mild steel support slats, prolong the life of the water bath, and provide an antibacterial chemistry. Plain water is also an acceptable fluid, but it will require much more frequent maintenance and cleaning due to the increased corrosion of the slats. This would be diluted 5-7%.

Videos:

INTRO TO MULTI PLATFORM: https://www.youtube.com/watch?time_continue=6&v=ij5jrVhwROM

MULTI PLATFORM: <https://www.youtube.com/watch?v=dDyCBP5M1cJ0>

STANDARD GANTRY TUBE CUTTER/ROUTER ATTACHMENT: https://www.youtube.com/watch?v=3X_GGkPbOg



HAAS FACTORY OUTLET
A DIVISION OF PHILLIPS

TL-1 WITH SIMULATOR PROPOSAL

PROPOSAL: HFO-PC1633431

DATE: JUNE 15, 2023

PREPARED FOR:
BEVERLY MILLER
GREENVILLE HIGH SCHOOL
210 TUSCULUM BLVD
GREENEVILLE TN 37745-3999

PREPARED BY:
BILL WALSH
HAAS FACTORY OUTLET | A DIVISION OF PHILLIPS CORPORATION
865-599-3372
bwalsh@phillipscorp.com



QUOTATION

TL-1

\$31,695.00

Travels

X Axis	203 mm / 8.0 in
Z Axis	762 mm / 30.0 in

Options

1800-rpm Spindle, A2-5	Included
Standard Program Memory, 1 GB	Included
Coolant Pump Kit	Included
Chip Enclosure	Included
Early Power-Failure Detection Module	Included
Ethernet Interface	Included
HaasConnect: Remote monitoring	Included
HaasDrop	Included
User-Definable Macros	Included
Control Touch Screen	Included
Visual Part Programming System	Included
WiFi Connection for the Haas Control	Included
Work Light	Included
Inch Measurement Units	Included
4-Station Tool Turret	\$ 8,495.00
Manual Tailstock, MT4	\$ 3,095.00
LOW-VOLT	Included
8" Manual 3-Jaw Chuck, A2-5	\$ 1,795.00
1-Year Extended Warranty	\$ 2,195.00

Haas Tooling

SCLCR12-3C, 3/4" Square Steel Shank Turning Toolholder, Screw-Lock	\$ 69.95
SDJCR12-3B, 3/4" Square Steel Shank Turning Toolholder, Screw-Lock	\$ 65.95
SVJBR12-3B, 3/4" Square Steel Shank Turning Toolholder, Screw-Lock	\$ 65.95
HGER12-3, 3/4" Square Steel Shank External Grooving Toolholder	\$ 74.95
CCMT3251-HFP / CCMT09T304-HFP, Carbide Turning Insert, 80° Rhombic, Grade HTP15 - Pack of 5	\$ 15.95
DCMT3251-HFP / DCMT11T304-HFP, Carbide Turning Insert, 55° Rhombic, Grade HTP15 - Pack of 5	\$ 15.95
DCMT3252-HFP / DCMT11T308-HFP, Carbide Turning Insert, 55° Rhombic, Grade HTP25 - Pack of 5	\$ 15.95
CCGT3251-HAL / CCGT09T304-HAL, Carbide Turning Insert, 80° Rhombic, Grade HTSU10 - Pack of 5	\$ 21.95
DCGT3251-HAL / DCGT11T304-HAL, Carbide Turning Insert, 55° Rhombic, Grade HTSU10 - Pack of 5	\$ 23.95
VBGT331-HAL / VBGT160404-HAL, Carbide Turning Insert, 35° Rhombic, Grade HTSU10 - Pack of 5	\$ 26.95
VBMT331-HFP / VBMT160404-HFP, Carbide Turning Insert, 35° Rhombic, Grade HTM15 - Pack of 5	\$ 19.95
HGMN300-G, 3mm Carbide Grooving Insert, Grade HU30 - Pack of 10	\$ 99.95
4MT #4 Morse Taper Live Center, High Precision	\$ 379.95
2mm Insert Width Complete Cut-Off Kit, 3/4" Shank, Grade HU30 :	\$ 253.95
- 01-0150 HTB-075, 3/4" Steel Shank Tool Block	
- 01-0153 HCB-2, Cut-Off Blade (2mm Insert)	
- 02-0492 HCI-2R, 2mm Carbide Cut-Off Insert, Grade HU30 - Pack of 10	
- 06-0084 SW15S Cut-Off Wrench	

Machine & Options Total	\$ 47,275.00
Haas Toolings Total	\$ 1,151.30
MACHINE TOTAL	\$ 48,426.30

SIMULATOR

\$1,995.00

Options

SIMULATOR TOTAL	\$ 1,995.00
------------------------------	--------------------

ADDITIONAL ITEMS

SUB TOTAL	\$ 50,421.30
Haas School Discount: Includes FREE 2nd-Year Warranty and Simulator	\$ -11,239.84

SUB TOTAL **\$ 39,181.46**

TL Freight: from Oxnard CA to Customer \$ 1,800.00

Simulator Freight \$ 330.00

Rigging: Gillespie, Inc \$ 520.00

** Not available for field installation*

TOTAL INVESTMENT

\$41,831.46

Shipping Point FOB Oxnard, CA

Delivery 5-7 weeks

Payment Terms 25% due at time of order, Net due 15 days from shipment

Customs/Duty/Taxes Final invoice will include any applicable sales tax, Please be aware: If we have not received a current sales tax resale/exempt certificate from your organization by April 7th, 2023 you will be charged and expected to pay for any applicable sales tax on your order. Certificates may be emailed to Phillipscorp@certcapture.com to avoid taxation on your order. If there are any question related to this matter, please contact Pcexemptions@phillipscorp.com

Validity Pricing can change without notice

Warranty One-Year Standard (Parts & Labor)

Title Transfer The day your machine leaves the Haas Automation Facility, the ownership/title of the machine automatically transfers to your company.

Machine Storage Please note that machines held in storage may be subject to a storage charge.

Voltage 208-230 VAC, 3 Phase, 60 Hz (unless High-Voltage Transformer is added)

Purchase Orders PO for above should be made out to Phillips Corporation



TERMS AND CONDITIONS

1. STANDARD TERMS: This document contains the standard terms and conditions (the "Terms") applicable to dealings between Phillips Corporation (Haas Factory Outlet Phillips Corporation) ("SELLER") and its customers, including the customer signing this document below ("BUYER"). The Terms are incorporated into, and a material part of: (a) each proposal to sell goods ("Goods") and, if applicable, ancillary services ("Services") made by SELLER to BUYER (a "Proposal"), (b) each order to purchase Goods and/or Services submitted by BUYER to Seller (an "Order"), (c) each acceptance of an Order by SELLER (an "Acceptance"), (d) each invoice issued by SELLER (an "Invoice"), and (e) all other documents exchanged between SELLER and BUYER pertaining to any ORDER (each Proposal, Order, Acceptance, Invoice or other relevant document is a "Document"); in each case regardless of whether the Terms are referred to in the Document and regardless of whether the Document is submitted or provided electronically, on paper or otherwise. The Terms shall control over any contrary terms or conditions set forth in any Document, regardless of when the Document may be provided by BUYER to SELLER or SELLER to BUYER, except as expressly agreed by SELLER and BUYER in a writing specifically described as an amendment of the Terms, and SELLER and BUYER expressly object to any contrary terms or conditions.

2. PROPOSALS AND ORDERS:

- a) A Proposal is valid for 30 days from the date shown on it unless otherwise specified in it.
- b) A Proposal does not constitute a firm offer, but is rather an invitation to BUYER to place an Order.
- c) All Orders shall be in writing. All Orders shall be subject to written Acceptance by SELLER.
- d) SELLER is not the manufacturer of any of the Goods. All weights, measurements and other specifications of Goods set forth in Proposals, Orders and Acceptances are estimates based on information provided by the manufacturer, and SELLER shall not be responsible for any deviations therefrom. Brochures, photographs and other illustrations depicting or describing Goods are non-binding in detail, and BUYER acknowledges that such brochures, photographs and other illustrations may have been superseded since being provided by the manufacturer. BUYER acknowledges further that manufacturers reserve the right to discontinue or to make changes to their products at any time, and that Goods are subject to specification and/or design changes without prior notice. Nothing contained in any descriptions of the Goods set forth in any Proposal, Order, Acceptance or other Document shall expand or otherwise affect SELLER's warranty obligations as set forth in Section 7.
- e) Any production estimates provided by SELLER are not guarantees of actual production unless specifically so stated in writing and signed by a duly authorized officer of SELLER. All time study figures relating to Goods are only estimates based on information provided to SELLER pertaining to finish required, machine-ability of the Goods, amount of material to be removed, BUYER's operating conditions and similar factors.
- f) SELLER retains the right to correct in its Acceptance any clerical error contained in a Proposal or an Order. BUYER agrees to promptly notify SELLER of any suspected clerical error in a Proposal.

3. PRICES:

- a) All prices listed in a Proposal are F.O.B. Ship Point (i.e., manufacturer's factory, port of entry or stocking warehouse) unless otherwise specified. Prices are subject to change without notice until confirmed by SELLER in its Acceptance.
- b) Prices quoted in a Proposal do not include sales, use, excise, property or similar taxes arising out of or relating to the sale, purchase, ownership or use of Goods or Services, and all sales are made subject to applicable taxes, the entire amount of which BUYER agrees to pay. BUYER shall provide SELLER with any applicable tax exemption certificates acceptable to appropriate taxing authorities together with an Order. BUYER shall indemnify and hold SELLER harmless from and against the imposition and payment of such taxes. SELLER may in any Invoice or separately bill BUYER at any time for any such taxes, in which case BUYER shall pay the same to SELLER, but SELLER shall not be obligated to do so.
- c) All freight and rigging quoted in a Proposal is subject to change until confirmed by SELLER in its corresponding Invoice.
- d) SELLER will be compensated for all service work performed by SELLER on Goods not covered by manufacturer's warranty or after the manufacturer's warranty period has expired at SELLER's then prevailing rate, plus all expenses, transportation, material and parts.

4. PAYMENT TERMS: Subject to SELLER's credit approval of BUYER:

- a) The terms of payment with respect to any Order shall be as specified in the Proposal or the Acceptance applicable to the Order (with the Acceptance controlling if differing terms are specified). If terms of payment are not specified in a Proposal or Acceptance, then BUYER shall pay 25% of purchase price as a non-refundable deposit at time of transmitting an Order (the "Deposit") and 75% of purchase price net 15 days from SELLER'S shipment of Goods (the "Final Payment"). In the case of leased and financed Orders, the Final Payment is due upon the sooner of BUYER's signing the delivery slip or acceptance or installation of Goods, but in no event later than 15 days from SELLER's shipment of Goods. Any unpaid amount shall bear interest from the due date until payment at a rate equal to the lesser of 2% per month or the maximum percentage permitted by law. Delays in installation and/or delays in operation of Goods caused by damage, warranty service or warranty replacement of parts or otherwise shall not extend or alter time for payment.
- b) BUYER shall pay all of SELLER's costs (including without limitation court costs and reasonable attorney fees) incurred in collecting past due amounts (whether purchase price or other amounts owing pursuant to the Terms) regardless of whether litigation is commenced.
- c) To secure the Obligations, BUYER hereby grants SELLER a first priority security interest in all Goods sold by SELLER to BUYER, any accessions thereto and any insurance, sale or other proceeds of the foregoing (the "Collateral"). For these purposes, the "Obligations" means all amounts due to SELLER in connection with Goods and/or Services sold to BUYER, including without limitation purchase price, taxes and all fees, expenses and reasonable attorneys' fees incurred by SELLER pursuant to or in connection with the Terms, the Obligations or the Collateral. BUYER agrees to insure the Collateral against loss or damage by fire or other risks and hazards in an amount no less than the replacement value of the Collateral, and upon request to provide SELLER with evidence of such insurance identifying SELLER as loss payee as its interests may appear. BUYER authorizes SELLER to file with applicable governmental authorities financing statements and similar instruments describing the Collateral without the signature of BUYER. Upon BUYER's default in any payment or other performance under the Terms, SELLER may, in its sole and absolute discretion, declare all Obligations immediately due and payable without demand, protest or other notice of any kind, and

SELLER shall have the right to repossess the Collateral (BUYER hereby granting SELLER a right of access to BUYER's premises for such purposes) and all other remedies of a secured party under the Uniform Commercial Code as in from time to time in effect in the state origin of purchase.

5. SHIPPING:

- a) Goods subject to an accepted Order shall be sent to the address listed in the applicable Proposal.
- b) Shipping schedules identified in a Proposal are approximate and subject to confirmation by SELLER with the manufacturer following SELLER's issuance of its Acceptance, despite anything set forth in an Order or other Document.
- c) SELLER shall endeavor to accommodate BUYER's requested delivery schedule, but shall have no liability for loss to BUYER, whether direct, incidental and/or consequential, as a result of delays.

6. RISK OF LOSS: The risk of loss or damage to Goods shall pass to BUYER when Goods are placed with a carrier for delivery to BUYER. The carrier shall be deemed to be acting for and on behalf of BUYER, and the terms of payment for Goods shall not be affected by damage to or destruction of Goods.

7. WARRANTIES; REMEDIES:

a) Goods -- SELLER is NOT a manufacturer, and all Goods are manufactured by others. Accordingly, SELLER is not making and shall not make any warranties with respect to Goods other than that SELLER shall convey to BUYER good and marketable title to Goods. Other warranties available to BUYER are those, if any, extended by the manufacturer, to the extent they are in force and effect and may be assigned to BUYER. SELLER shall, upon written request, assign to BUYER any assignable rights SELLER has under the manufacturer's warranties. THE MANUFACTURER'S WARRANTY, IF ANY, AND SELLER'S WARRANTY OF TITLE, SHALL BE EXCLUSIVE AND IN LIEU OF ALL OTHER WARRANTIES WHETHER WRITTEN, ORAL OR IMPLIED BY LAW OR OTHERWISE, INCLUDING ANY WARRANTY OF MERCHANTABILITY OR WARRANTY OF FITNESS FOR ANY PARTICULAR PURPOSE, ALL OF WHICH ARE DISCLAIMED BY SELLER.

b) Services -- SELLER warrants that Services will be performed in a workmanlike manner. THIS WARRANTY IS EXCLUSIVE AND IS IN LIEU OF ALL OTHER WARRANTIES WHETHER WRITTEN, ORAL OR IMPLIED BY LAW OR OTHERWISE, ALL OF WHICH ARE DISCLAIMED BY SELLER.

c) Remedies -- If SELLER breaches any warranty granted by SELLER with respect to the Goods, SELLER'S sole responsibility shall be to repair, replace or refund the purchase price for the applicable Goods, as determined in SELLER'S sole and absolute discretion. If SELLER breaches any warranty granted by SELLER with respect to Services, Seller shall either refund the portion of the purchase price relating to the defective Services or correct the defective Services, as determined in SELLER'S sole and absolute discretion.

d) Limitation of Damages -- If SELLER breaches any of the Terms (including by breach of its warranties), BUYER'S remedies shall be limited as set forth in Section 7c) and this Section 7d). SELLER shall not be liable for any of BUYER'S indirect, incidental, special or consequential damages relating to or arising from the breach, or punitive damages of any nature, and BUYER'S recovery in connection with any Order shall in no event exceed the purchase price actually paid to SELLER with respect to that Order. Without limiting the generality of the foregoing sentence, in no event shall SELLER be liable to BUYER for BUYER'S loss of profits, loss of use, or damages of any nature based upon a claim for breach of warranty or for faulty workmanship or materials or otherwise, whether or not SELLER has been advised of the potential for any such damages. BUYER acknowledges that the purchase price at which SELLER has agreed to provide Goods and/or Services reflects the SELLER'S disclaimer of warranties and limitation of remedies set forth in this Section 7 and further acknowledges that the purchase price would be substantially higher without such disclaimer and limitation.

8. CANCELLATION: All Orders are non-cancelable by BUYER except as approved in writing by SELLER in its discretion. It is agreed that any cancellation, whether or not approved by SELLER, shall damage SELLER. Accordingly, SELLER shall be entitled to retain the Deposit, and BUYER shall pay to SELLER the following (against which the Deposit shall be credited):

- a) SELLER'S purchase price for the Goods delivered to BUYER prior to cancellation;
- b) SELLER'S costs incurred in connection with Services provided prior to cancellation (including compensation costs and overhead);
- c) All other out of pocket costs incurred by SELLER in connection with the Order, including without limitation cancellation or restocking charges that SELLER has or will incur; and
- d) In the case the cancellation is not approved by SELLER, any other amounts to which SELLER may be entitled at law for BUYER'S breach, it being understood that unapproved cancellation shall be a breach by BUYER of the contractual relationship existing between SELLER and BUYER.

9. BUYER'S USE: BUYER agrees that its employees, contractors and invitees when operating Goods will comply with all operating procedures set forth in the manufacturer's operators manuals and instruction sheets relating to such Goods, and BUYER further agrees not to remove or modify any safety device, warning sign, operators manual or work handling tools. BUYER shall immediately notify SELLER of any accident or injury connected with use of the Goods and agrees, upon SELLER'S request, to cooperate with SELLER in investigating and determining the cause of the same. BUYER agrees to indemnify and hold harmless SELLER from and against any and all claims, suits, damages of any nature, losses, costs or expenses, including without limitation all fees and expenses of counsel and other professional advisors arising from use of any Goods or BUYER'S failure to comply with the Terms.

10. PERFORMANCE IN THE EVENT OF DEFAULT; NON-WAIVER OF DEFAULT: In addition to the rights and remedies conferred on SELLER by law and the Terms, SELLER will not be required to respond to or perform an Order (even if previously accepted) if BUYER is in default with respect to any other Order. If SELLER at anytime, in SELLER'S sole and absolute discretion, doubts BUYER'S ability to pay for Goods consistent with the Terms, SELLER may ship the Goods C.O.D. In the event of any default by BUYER under the Terms, SELLER may decline, in its sole and absolute discretion, to make further shipments of Goods to BUYER without in any way affecting its rights under the Terms. If, despite any default by BUYER, SELLER elects to continue to make shipments, SELLER'S actions shall not constitute a waiver of any default by BUYER or in any way affect SELLER'S remedies for such default under the Terms or otherwise.

11. CONFIDENTIALITY: All drawings, designs, specifications, manuals, programs and prices furnished to BUYER by SELLER shall remain the confidential and proprietary property of SELLER. All such information, except as may be found in the public domain, shall be held in strict confidence by BUYER and shall not be disclosed by BUYER to any third parties. As between BUYER and SELLER, all copyright interests in all

material made available by SELLER shall remain in SELLER at all times, and BUYER waives any property or privacy rights BUYER may have with respect to all such information.

12. EMPLOYEES: BUYER agrees that neither it nor any of its affiliates will solicit for hire, hire or recommend for hire any employee of SELLER or any affiliate of SELLER during the period from SELLER's issuance of a Proposal until the first anniversary of the date on which Goods purchased pursuant to an Order are finally installed or Services obtained pursuant to an Order are fully provided. This Section 12 is a material inducement to SELLER to transact business with BUYER. This Section 12 shall cease to apply to any former employee of SELLER or an affiliate of SELLER on the date such employee has ceased to be employed by SELLER or an affiliate for six (6) months, and it shall not apply to the hiring of any employee of SELLER or an affiliate of SELLER whose initial contact with BUYER is such employee's response to a general public solicitation of employment applications by BUYER.

13. FORCE MAJEURE: SELLER shall not be responsible for nonperformance or late performance due to orders, regulations and/or ordinances by any government or governmental agency, act of God, war, terrorism, blockade, insurrection, mobilization, riots, fire, work stoppage, civil insurrection, flood, earthquake or any other circumstance beyond SELLER's reasonable control. Without limiting the preceding sentence, BUYER acknowledges that Goods originating from foreign countries are subject to export permit by the governmental authorities of the country from which such Goods originate.

14. REVISIONS: SELLER, in its sole and absolute discretion, may modify the Terms at any time and from time to time. The Terms as in effect at the time of SELLER's Acceptance shall govern the terms of sale of the Goods and Services contemplated by the Order so accepted, provided SELLER has provided BUYER with a copy of such Terms prior to or contemporaneously with the Acceptance.

15. SEVERABILITY: If any provision(s) of the Terms are held by any court of competent jurisdiction to be unenforceable or invalid, the remaining provisions of the Terms shall not be rendered invalid or unenforceable as a result thereof.

16. APPLICABLE LAW; VENUE: The Terms are governed by, and shall be construed in accordance with, the law of the State of Maryland without reference to the conflict of laws principles thereof. BUYER and SELLER agree that the State and Federal courts sitting in the City of Hanover, Maryland shall be the exclusive forums for resolving any dispute pertaining in any way to their dealings, the Terms, any Goods or any Services. BUYER consents to the jurisdiction of such courts and agrees that any such court is a convenient forum for the resolution of any such dispute, and agrees that it may be served with process for any suit in any such court by first class registered mail, return receipt requested and postage pre-paid, sent to BUYER at its address identified in an Order or by any other lawful means. BUYER acknowledges that Maryland is the headquarters state of SELLER's parent entity, and that this Section 16 is a material inducement to SELLER to transact business with BUYER.

17. NO DELEGATION OR ASSIGNMENT: BUYER may not assign or delegate any of its rights or obligations under or in connection with the Terms or the Order without the prior written consent of SELLER, and any purported assignment or delegation in violation of this sentence shall be void ab initio, without force or effect, and a material violation of the Terms by BUYER.

Phillips Corporation requires receipt of the 25% down payment before any Haas machine is ordered.
25% payments can be made via bank wire or ACH.

Bank Wires

Account Name: Phillips Corporation

Acct#: 1233252889

ACH ABA Number: 121000358

Wire ABA Number: 026009593

Routing Number: 122000030

Swift Code: BOFAUS3N

Bank of America

6000 Feldwood Rd

College Park, Ga 30349

*REQUIRED: All ACH Wire Remittance notifications should be sent to: pcar@phillipscorp.com.

Please address all Purchase Orders to the following:

Phillips Corporation

8500 Triad Drive

Colfax, NC 27235

Acknowledged and agreed as of the date indicated below:

PROPOSAL NUMBER: _____

BUYER SIGNATURE: _____

PRINTED NAME: _____ DATE: _____

TITLE: _____

Please email signed accepted proposal to pcmachineorders@phillipscorp.com or fax 336-665-1980.

Phillips[®]

**SERVICES EXCLUSIVELY
FOR OUR HAAS CUSTOMERS**

GET AHEAD OF THE CURVE - GET OPTO



OPTO
BY PHILLIPS CORPORATION

Applications support for process improvement, specialized programming, and on-site training provided by our Haas-Certified Applications Engineers.

CERTIFIED HAAS ANNUAL MAINTENANCE PROGRAM

CHAMP

Identify potential problems with your machine before they develop with this preventative maintenance program.

**MAINTENANCE & REPAIR
TRAINING**

Week-long class in Knoxville, TN designed for customers who want an employee trained for machine maintenance

Unlimited operator training at your local HFO

**LIFETIME OPERATOR
TRAINING**

336.665.1080

pcsales@phillipscorp.com



**Haas
F1 Team**
OFFICIAL MACHINE TOOL



Phillips®

HAAS SERVICE TRAINING

JOIN US FOR A HAAS TRAINING EXPERIENCE LIKE NO OTHER IN THE INDUSTRY

Haas Service Training will teach you how to **TROUBLESHOOT, REPAIR** and **MAINTAIN** your Haas *in hours, not days.*



LOCATIONS Knoxville, TN - Bensalem, PA - Rock Hill, SC **CONTACT** hfooster@phillipscorp.com - (800) 989-9181



"I wouldn't keep sending so many of our Techs (nearly 30 so far) if I didn't think the course was a great investment."

~ **Michael Goode**,
General Electric



"This is the best machine learning environment I've ever seen. You should take this class, it's a no brainer. You're going to benefit"

~ **Dale Miller**,
Southern Cast Products

Bottom-Line Benefits

This class more than pays for itself with fewer service calls, reduced downtime, and real gains in part quality.

For more information, email hfooster@phillipscorp.com or call (800) 989-9181.

****Interested in Mill and Lathe Crash Recovery Training?** Let us know and we can send information on those classes as well.



CLASSES RUN MONTHLY, YEAR-ROUND.
CALL (800) 989-9181 TO RESERVE YOUR SPOT TODAY! OR VISIT US AT:
PHILLIPSCORP.COM/SERVICE-TRAINING

SKILLS COVERED



In just five days, participants will take their service game to the next level by learning to perform the following skills

- Lathe Alignment
- Turret Repair (ST, SL & BMT)
- Tool Changer Repairs
- Ball Screw Replacement
- Spindle Replacement
- I/O Board & Vector Drive Troubleshooting
- Best Practices & MUCH MORE!!!

HANDS-ON LEARNING



This is a roll-up-your-sleeves, get inside-the-machine learning experience.

WORLD-CLASS FACILITIES



Training takes place in state-of-the-art facilities with more than a million dollars worth of Haas equipment - just like the ones on your floor.

EXPERIENCED INSTRUCTORS



Our teachers have spent years in the field. No question too basic. No problem too complex. Small class sizes mean you have plenty of one-on-one time for all your questions.

Plus every participant receives a free Haas Service Key, which unlocks the service parameters on any Next-Gen Control so you can take ownership of your Haas service and maintenance!



HUNDREDS HAVE ATTENDED, RATING THE COURSE 9.9/10

**Disclaimer - In order to attend any Advanced Courses, students must have already completed the basic Phillips Haas Service Training course. Please call/email for more information.



ADVANCED LATHE SERVICE TRAINING

Phillips
HAAS SERVICE TRAINING

LOCATION Knoxville, TN **CONTACT** hfoster@phillipscorp.com - (800) 989-9181

JOIN US FOR A HAAS TRAINING EXPERIENCE LIKE NO OTHER IN THE INDUSTRY

From **correcting lathe geometry** to **crash recovery**, this class will help you tackle some of the industry's most expensive and disruptive breakdowns.

■ SKILLS COVERED



In just five days, participants will take their lathe service skills to the next level by learning to perform the following skills:

- Haas Lathe geometry inspection using test bar
- Geometry correction (lathe alignment)
- Spindle replacement
- C-axis alignment & brake engagement
- Hydraulic union alignment
- Spindle lube verification
- Guide rail alignment and replacement
- Tool presetter alignment and calibration

Contact us about training grants that could cover your tuition!



"Repairing lathe geometry is often called an art. I disagree. All you need are the right skills and practice - exactly what you'll get in this class."

~ Todd Price, Head Service Instructor

■ HANDS-ON LEARNING

This is a roll-up-your-sleeves, get inside-the-machine learning experience.

■ WORLD-CLASS FACILITIES

Training takes place in state-of-the-art facilities with more than a million dollars worth of Haas equipment - just like the ones on your floor.

■ EXPERIENCED INSTRUCTORS

Our teachers have spent years in the field (If it's happened, they've seen it!). No question too basic. No problem too complex. Small class sizes mean you have plenty of one-on-one time for all your questions.

**CLASSES RUN MONTHLY, YEAR-ROUND.
CALL (800) 989-9181 TO RESERVE YOUR SPOT
TODAY! OR VISIT US AT:
PHILLIPSCORP.COM/ADVANCEDLATHE**

Bottom-Line Benefits

This class more than pays for itself with fewer service calls, reduced downtime, and real gains in part quality.

For more information,
email hfoster@phillipscorp.com or call
(800) 989-9181.

****Not quite ready for an advanced class?** Contact us to find out more about Phillips Haas Service Training - our introductory Haas Service Training class.

****Disclaimer - In order to attend any Advanced Courses, students must have already completed the basic Phillips Haas Service Training course. Please call/email for more information.**

Installed Dimensions

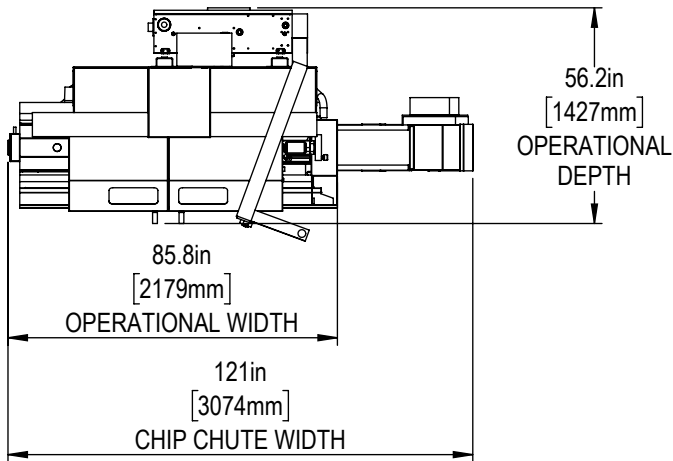
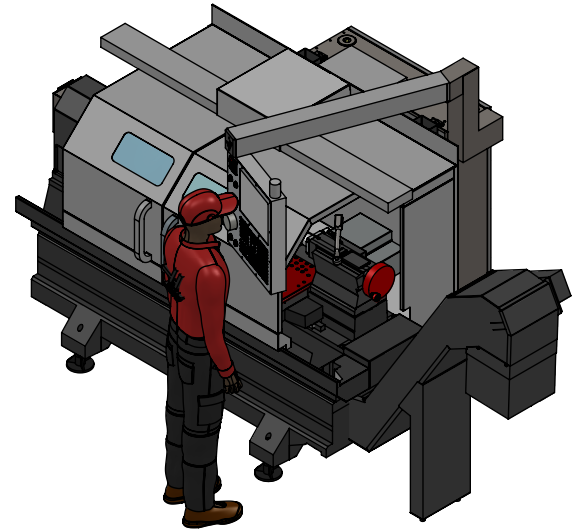
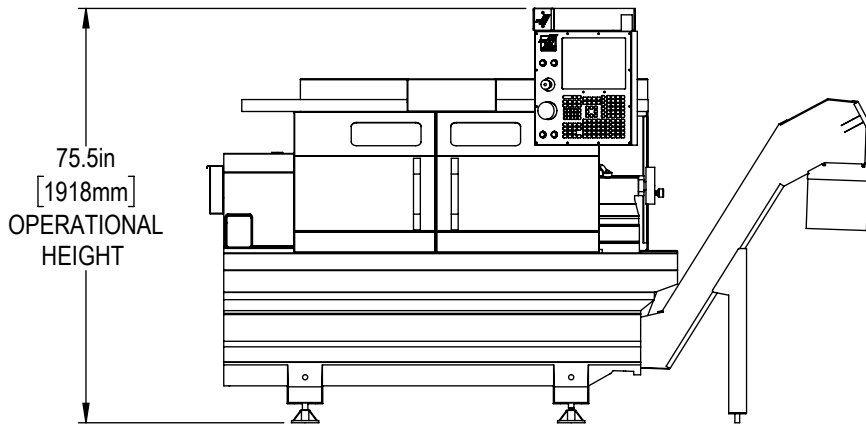

Leveling Pad Height

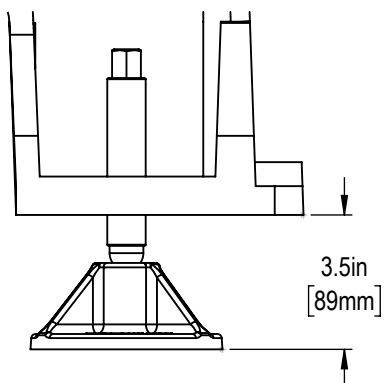

Shipping Dimensions

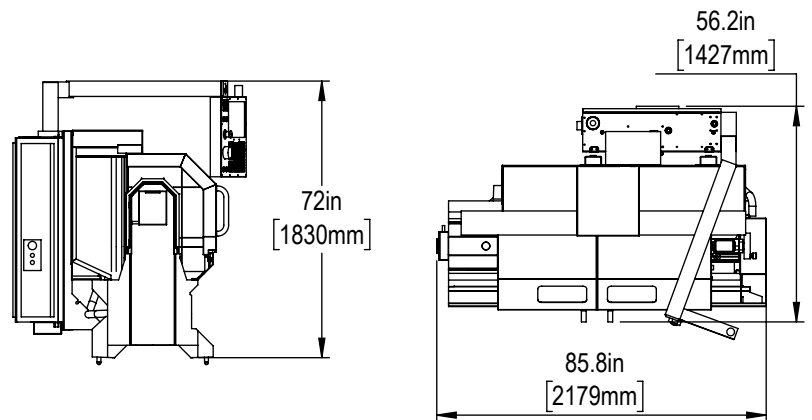

*All Height Dimensions Based on Suggested Leveling Pad Height

Air & Power

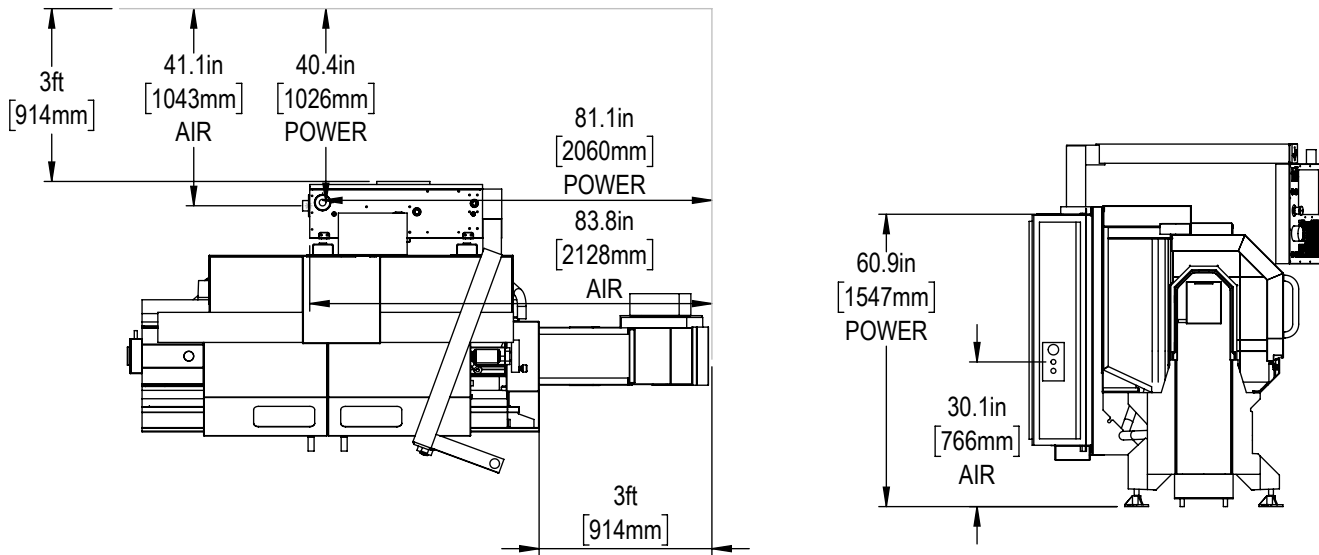

Anchor Pattern

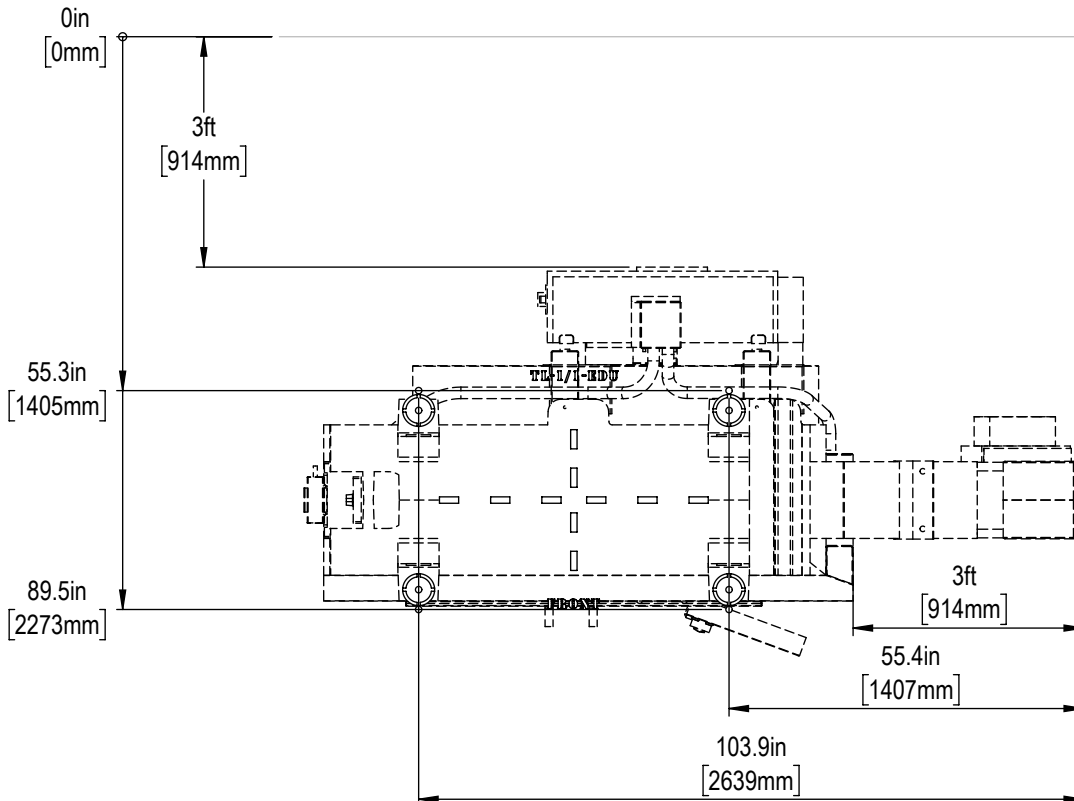



Height Breakdown

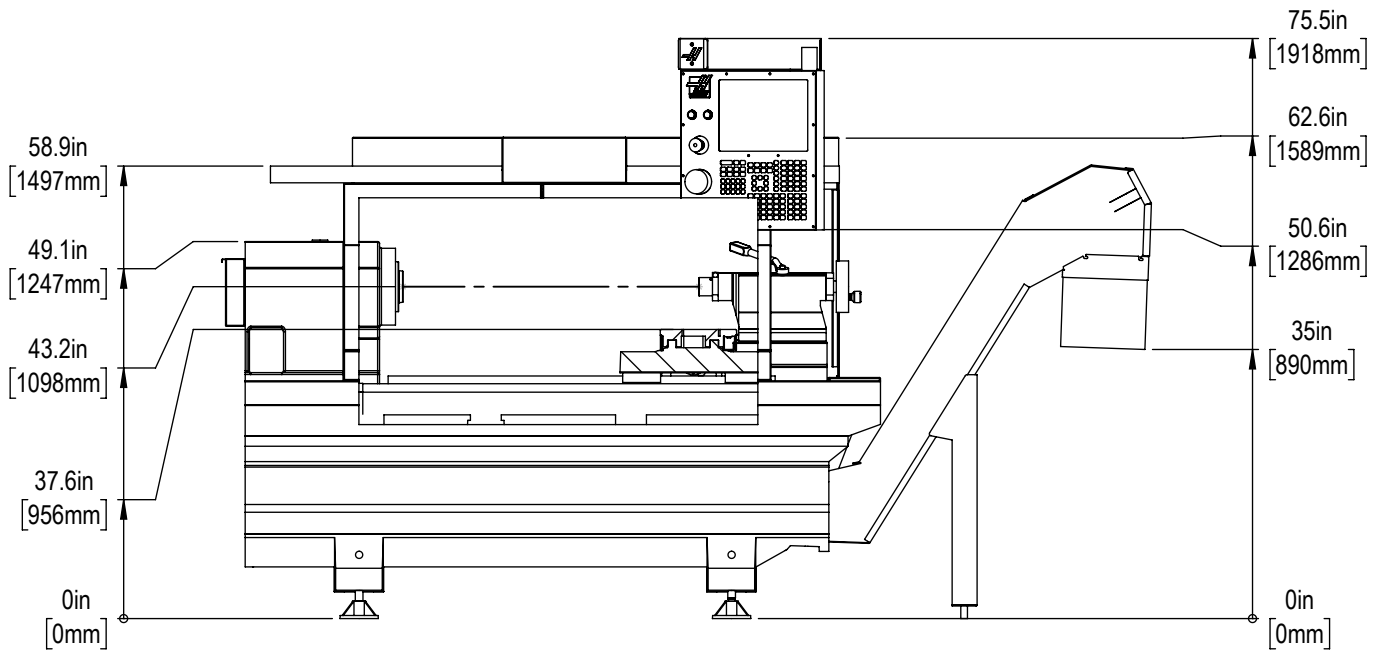

Width Breakdown

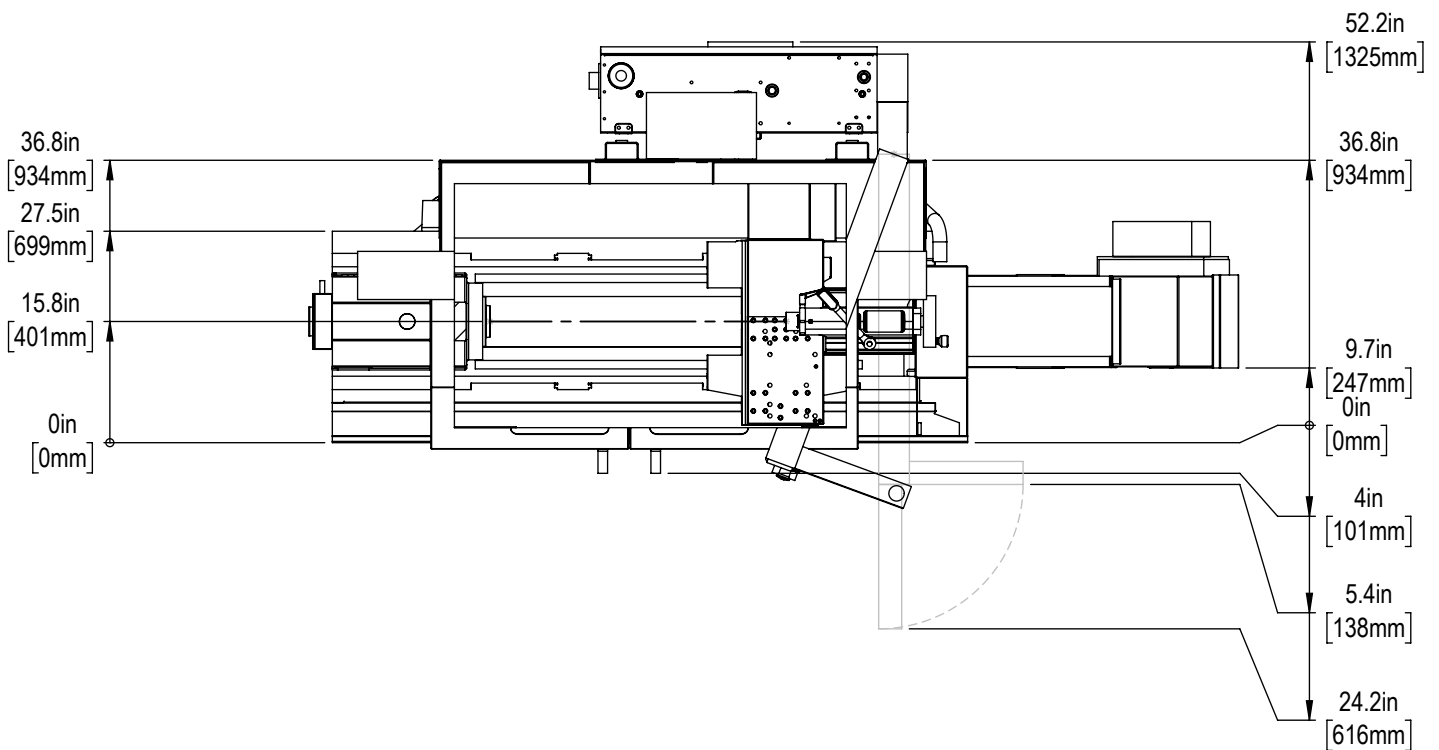

Maintain 3 feet [915mm] clearance to the nearest obstruction around all sides of machine perimeter for maintenance access

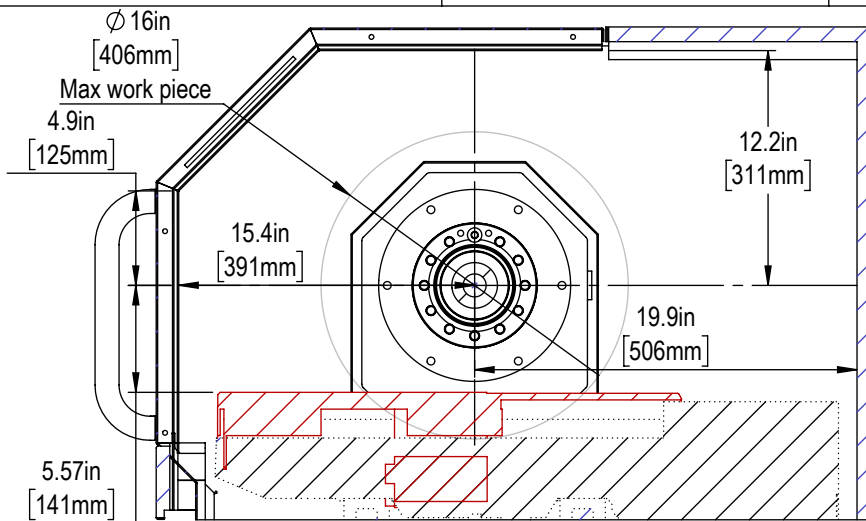

SECTION A-A

SCALE 1 : 10

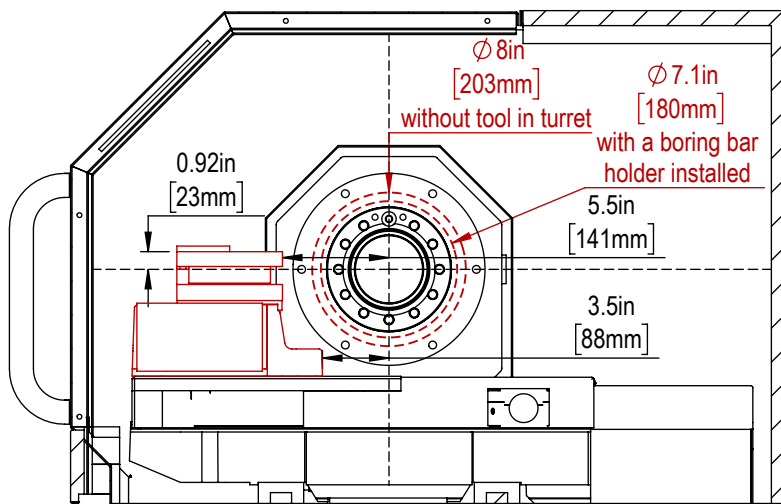
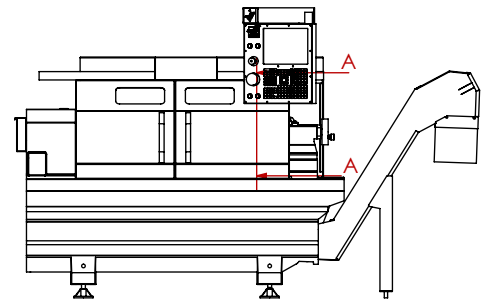

SECTION C-C

SCALE 1 : 10

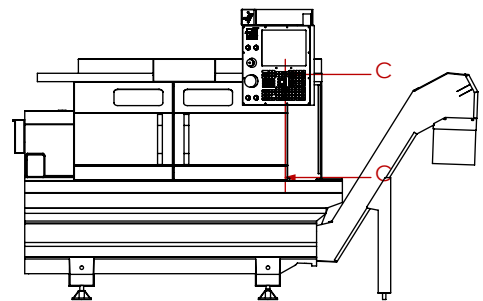

4-Station Tool Turret

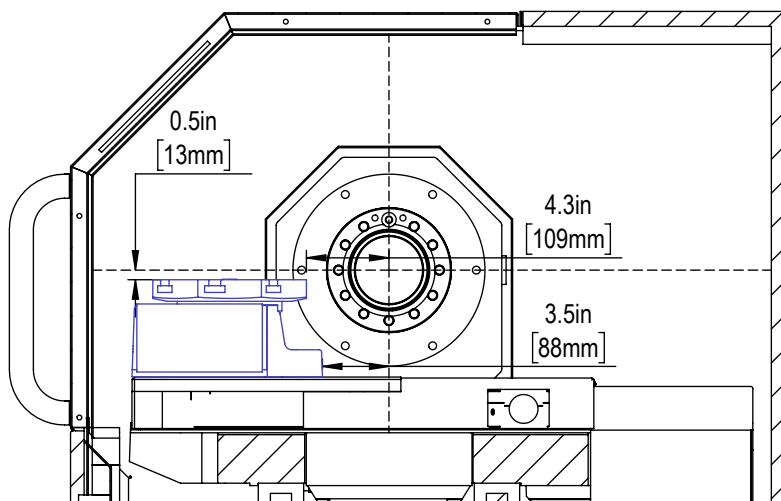

SECTION B-B

SCALE 1 : 10

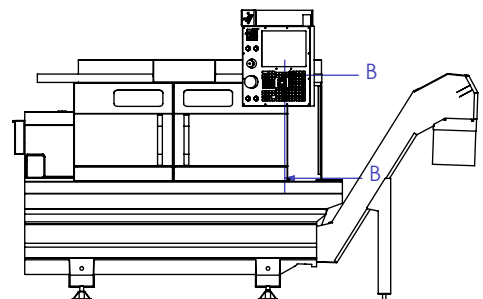

8-Station Tool Turret

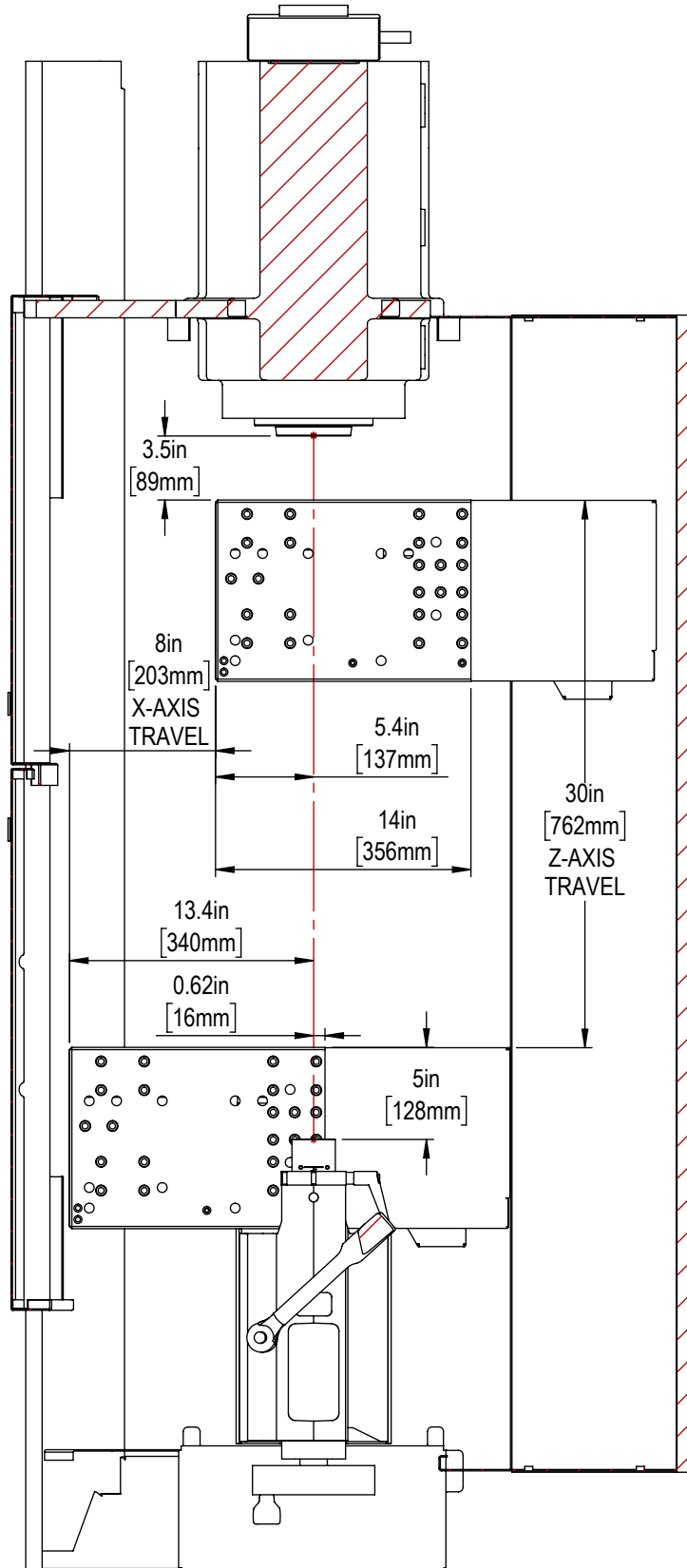

SECTION F-F

SCALE 1 : 10

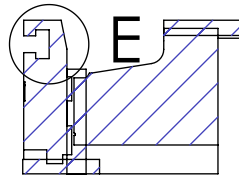
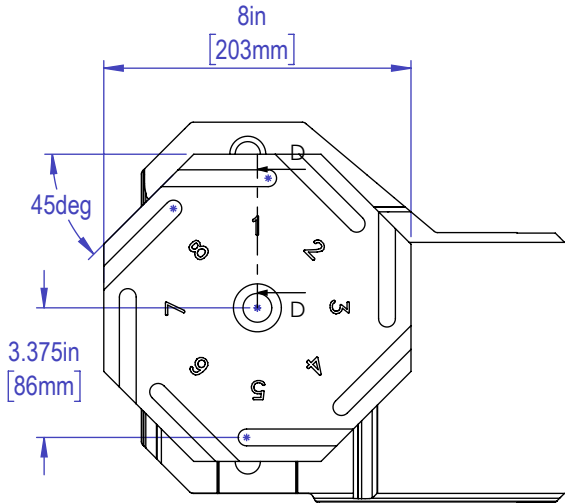

SECTION D-D
SCALE 1 : 5

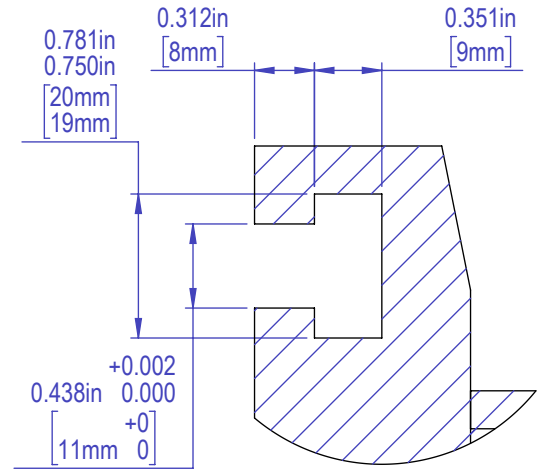

DETAIL E
SCALE 1 : 1

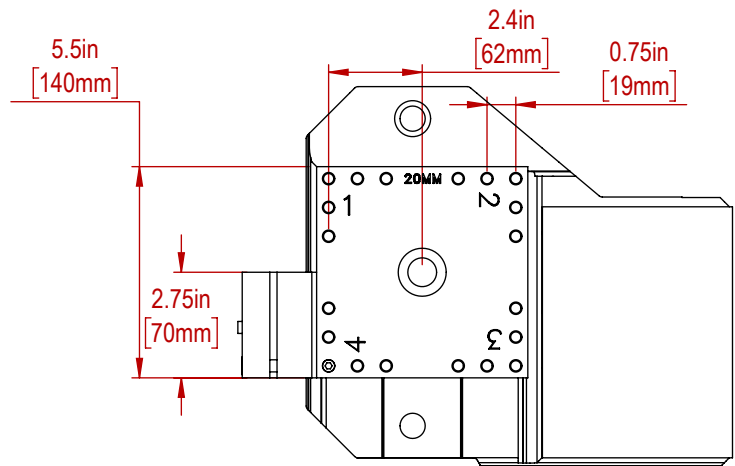
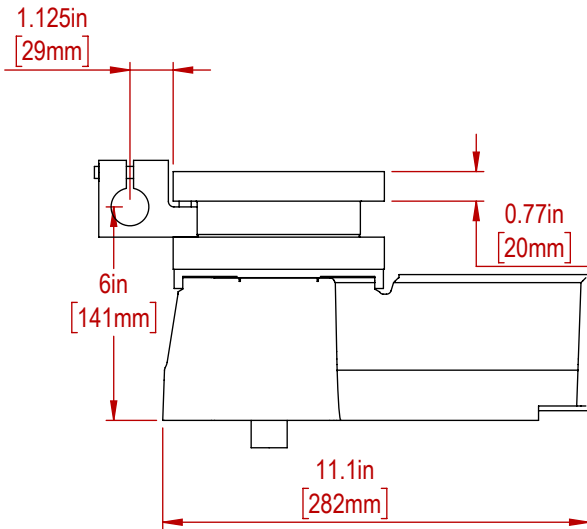

$\varnothing 0.268\text{in} [7\text{mm}] \nabla 0.8\text{in} [20\text{mm}]$
M8x1.25 - 6H $\nabla 0.8\text{in} [19\text{mm}]$

$\varnothing 0.257\text{in} [7\text{mm}] \nabla 0.8\text{in} [20\text{mm}]$
5/16-18 UNC $\nabla 0.8\text{in} [19\text{mm}]$

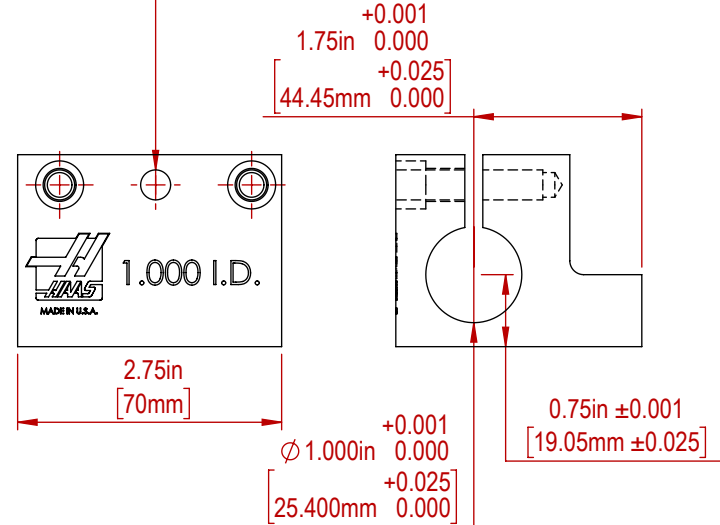
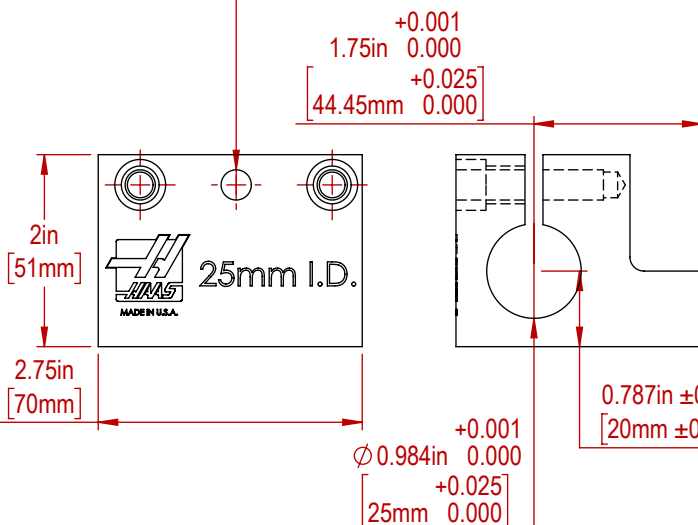

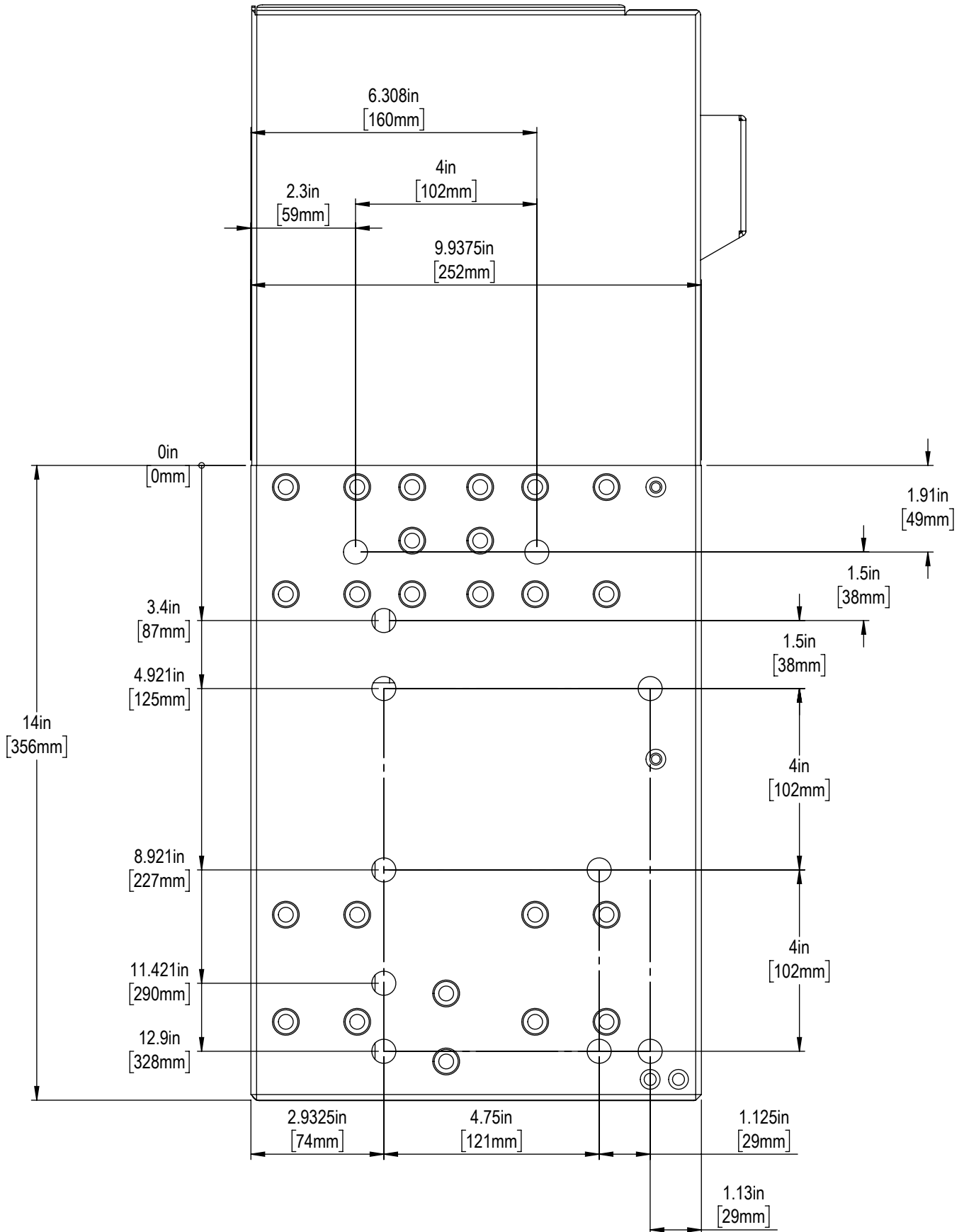

REQUEST FOR PROPOSAL
June 2023

NUMBER 301-2023-2024-01
Various Equipment for GHS Engineering Program Start-up

THE GREENEVILLE CITY SCHOOL DISTRICT
(K-12 PUBLIC SCHOOL DISTRICT)



CONTRACT(S) FOR
GHS Engineering Program Equipment

Beverly W. Miller
Assistant Director of Schools for Administration
Chief Technology Officer

Request for Proposal Specifications

Purpose and Scope

ALTERNATIVE PROPOSALS: Greeneville City Schools will not accept alternate proposals (those not equal to specifications) unless authorized by the Request for Proposal.

AWARD: Award will be made to the most responsive, responsible proposer(s) meeting all specifications and which present the product that is in the best interest of Greeneville City Schools. The evaluation criteria is listed herein.

COOPERATIVE PURCHASING: Proposers must indicate whether it is permissible for other School Districts in Tennessee to purchase these items or services at the same price. Freight charges can be adjusted to reflect differences in delivery cost. Indicate any additional delivery charges or minimum orders for purchases by other entities.

DECLARATIVE STATEMENT: Any statement or words (i.e.: must, shall, will, etc) are declarative statements and the vendor must comply with the condition. Failure to comply with any such condition may result in the proposal being non-responsive and disqualified.

NEW MATERIAL: Unless specified otherwise in the proposal package, the vendor *must* provide new supplies. New, as used in this clause, means previously unused materials. Material includes but is not limited to, raw material, parts, items, components, and end products. Vendor submission of other than new materials may be cause for the rejection of their proposal. ***Delivery of refurbished equipment after this proposal is awarded will be considered a breach of contract.***

REMANUFACTURED EQUIPMENT: Vendors are advised that remanufactured or refurbished equipment will *not* be accepted for this proposal. ***Delivery of refurbished equipment after this proposal is awarded will be considered a breach of contract.***

INTENT: The intent of this Request for Proposal is to obtain a vendor(s) to provide various equipment (per specifications) for the Greeneville City Schools. The manufacturer(s) proposed must have designed and manufactured the quoted equipment for a minimum of five years. No 3rd party or rebranded products will be accepted. All products must be OEM (original equipment manufacturer).

Award will be based on best value. Best value means more than low cost. It includes the initial cost, product quality, vendor support, consideration of installed base, warranty, and other factors detailed herein. Total cost of ownership will be carefully considered.

ADDITION OR DELETION OF GOODS OR SERVICES: Greeneville City Schools reserves the right to add or delete goods or services as the need arises. If services are to be added, Greeneville City Schools and the vendor will arrive at mutually agreed pricing.

PROPOSALS REQUESTED ON BRANDS OR EQUAL: Unit price proposals are requested on products that equal or exceed the quality and performance of the brand listed. References to brand names, trade names, model numbers or other descriptions peculiar to specific brand products are made to establish a required level of quality and functional capabilities and are not intended to exclude other products of that level.

It shall be the responsibility of the proposers to furnish descriptive literature with their proposal such that specifications, catalog pages, brochures or other data as will provide an adequate basis for verifying the quality and functional capabilities of the product offered. Failure to provide this data will be considered valid justification for rejection of the proposal.

COMPLIANCE WITH RFP: All proposals must be in strict compliance with this Request for Proposal. Failure to comply with **all** provisions of the RFP may result in disqualification.

EVALUATION CRITERIA: Proposals will be evaluated on the following criteria:

Itemized Product Pricing	60 Points
Warranty/Service Post Sale	20 Points
References (Please include two.)	20 Points

Greeneville City Schools will also consider whether the proposal demonstrates that the proposer can effectively meet the following criteria:

- Does the proposer have the ability, capacity, skill, and financial resources to provide the specified services?
- Does the proposer have the ability to take upon itself the responsibilities set forth in the RFP (and the resultant contract) and produce the required outcomes in a timely manner?
- Does the proposer have the character, integrity, reputation, judgment, expertise, and efficiency required by the contract?

Instructions for Proposal

A) Compliance with the RFP

Proposals must be in strict compliance with this Request for Proposals. Failure to comply with all provisions of the RFP may result in disqualification.

Delivery of Proposals

All proposals are to be delivered before Thursday, June 15, 2023, 11:00 A.M., EDT,

to:

Greeneville City School District
Attention: Beverly Miller
129 W. Depot Street
Greeneville, TN 37743

Responses may also be submitted via email to millerb@gcschools.net. Email submissions must contain the words 'RFP INCLUDED: Do not open until June 15, 2023, 11 A.M., EDT.

B) Proposals will be opened publicly; however, only names of proposers will be read aloud.

List the Proposal Number (301-2023-2024-01-Equipment) on the outside of the box or envelope and note "Request for Proposal enclosed."

C) Evaluation of Proposals (Procedure)

The District will first examine proposals to eliminate those that are clearly non-responsive to the stated requirements.

The District reserves the right to withdraw this RFP at any time and for any reason, and to issue such clarifications, modifications, and/or amendments as it may deem appropriate.

Receipt of a proposal by the District or a submission of a proposal to the District offers no rights upon the Vendor nor obligates the District in any manner.

The District reserves the right to waive minor irregularities in proposals, provided that such action is in the best interest of the District. Any such waiver shall not modify any remaining RFP requirements or excuse the Vendor from full compliance with the RFP specifications and other contract requirements if the Vendor is awarded the Contract.

D) Ambiguity, Conflict, or Other Errors in the RFP

If a Proposer discovers any ambiguity, conflict, discrepancy, omission, or other error in the Request for Proposal, it shall immediately notify the District of such error in writing and request modification or clarification of the document.

The Proposer is responsible for clarifying any ambiguity, conflict, discrepancy, omission, or other error in the Request for Proposals prior to submitting the proposal or it shall be waived.

E) Proposals and Presentation Costs

The District will not be liable in any way for any costs incurred by any Vendor in the preparation of its proposal in response to this RFP, nor for the presentation of its proposal and/or participation in any discussions or negotiations.

F) Rejection of Proposals

The District reserves the right to accept or reject in whole or in part any or all proposals submitted. The District shall reject the proposal of any Vendor that is determined to be non-responsive. The unreasonable failure of a Vendor to promptly supply information in connection with respect to responsibility may be grounds for a determination of non-responsibility.

The District reserves the right to reject all proposals and to waive all formalities.

G) Acceptance of Proposals

The District shall accept all proposals that are submitted properly. However, the District reserves the right to request clarifications or corrections to proposals.

H) Requests for Clarification of Proposals

Requests by the District for clarification of proposals shall be in writing. Said requests shall not alter the vendor's pricing information contained in its cost proposal.

I) Validity of Proposals

All proposals shall be valid for a period of 90 days from the submission date.

Items and specifications are as follows. Responding vendors may quote any/all components. Please email millerb@gcschools.net to receive the electronic Excel file required for inclusion with submission packet or add pricing to column provided below and return with packet.

Quantity	Item	Cost Per Item
1	Sharp SW-100T Miter Cutting Band Saw	13,799.10
	With options: 3 ft. roller table	
1	HAAS Mini Mill	44,815.46
	With Options: 20-Piece, CT40 Toolholder Kit	
1	HAAS TL-1 Lathe	37,003.42
	With Options: Electronic Handwheels	
1	Sharp SWV Vertical Bandsaw	11,616.80
	JET Floor Drill Press: Belt, Variable, 245 RPM – 2,000 RPM, 460V AC	
1	/Three-Phase, 20 in Swing, 2 hp	
1	LMV-49 Vertical Mill with DVS head with 3 axis DRO	21,576.30
1	MAD Plasma Table MPR2 5'x5' with Extended Gantry	
	With options:	
	CNC Cutting Table Platform - Air - 5' x 5'	
	CNC Cutting Table - Air Deflector Set 5' x 5'	
	Rolling Slap Disposal Tray	
	CNC Router Attachment - Large	
	XL Marking System	
	Rotary Tube Attachment for Cutting Table	
	Rotary Attachment Water Injection System	
	Hypertherm Powermax 45 XP Plasma Unit with Serial Port	
2	HAAS Desktop Mill	26,579.90
1	Thunder Laser Nova 63 (130 Watt)	
	With options: Rotoboss	
1	Markforged Mark Two 3D Printer (Gen 2)	20,919.00
5	Form 3+ Printer with Complete Package	
5	Ultimaker Printer S3	
	With options:	
	Magigoo #D Printing Adhesive	
	Ultimaker Print Core CC	
	Magnetic Flexible PEI Build Plate	
10	Adjustable Height Workbenches (52in W x 24in D Adjustable height (black))	
3	Grizzly ShopFox Downdraft Table	
10	First Tech Challenge EDU Kit V2	
10	First Tech Challenge Kit V2 to Starter Kit V3 Upgrade	
10	First Tech Challenge Sensor Bundle	

Phillips Corporation
8500 Triad Drive
Colfax, NC 27235
Federal ID# 52-0736062

President: Alan Phillips
Payment Remit to Address: P.O. Box 405649 Atlanta, GA 30384
Phone 336-665-1080
Fax 336-665-1980

Credit Manager – Dana Smagala 215-245-5500
Accounts Payable – Joanne McCann 215-245-5500

Bank Information
Account Name: Phillips Corporation
Routing # 026009593
Acct. # 1233252889
Bank of America
6000 Feldwood Road
College Park, GA 30349
William Kart
Telephone 888-715-1000 / FAX 904-312-6371

TRADE REFERENCES

Haas Automation
2900 Challenger Place
Oxnard, VA 93030
805-278-1800
Sara Bell – sbell@haascnc.com

Midaco Corporation
2000 East Touhy Avenue
Elk Grove, IL 60007
847-593-8420
847-593-8451 (Fax)

Bennett Motor Express
P.O. Box 100004
McDonough, GA 30253
678-835-7938



Phillips Commercial

8500 Triad Drive, Colfax, NC 27235
3599 Marshall Lane, Bensalem, PA19020

Ph. (336)665-1080
Ph. (215)245-5500

www.hfophilips.com

Parts Email: pcparts@phillipscorp.com
Service Email: pcservice@phillipscorp.com

Machine Quote

Date: 6/13/2023

Contact: Beverly Miller	Account: Greenville City Schools
Phone #: 4237878019	Address:
Email: millerb@gcschools.net	

Salesperson:	Terms:	FOB:	Delivery:
Bill Walsh	School Terms, Net 30	Gardena, CA	In stock, subject to prior sale; please allow 2-3 weeks for installed accessories

Sharp Precision Machine Tools Proposal

Sharp Model SW-100T Semi-Automatic Miter Cutting Bandsaw

This Sharp SW-100 T is a semi-automatic 10" cutting capacity (round) swivel head miter cutting saw features several great design characteristics for medium to high production with economical manufacturing criteria. The built-in power assist-unit incorporates a quiet running pump system to allow raising/lowering of the saw head and cutting pressure adjustment in one control station.

Phillips®

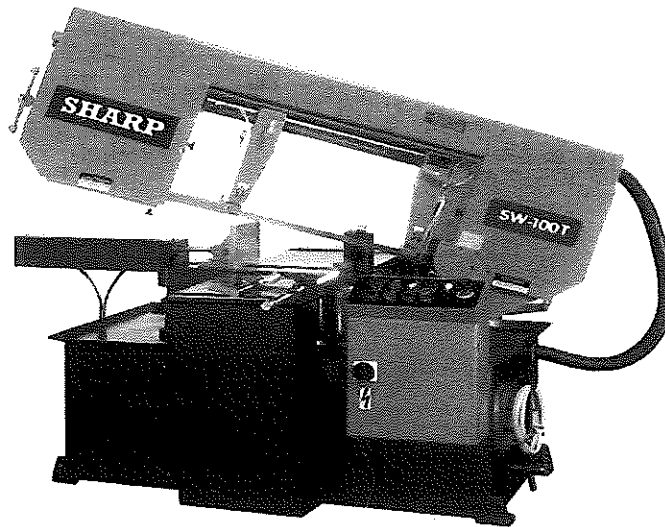

Model SW-100 T

MACHINE FEATURES

Machine Structure & Design:

- *Oversized power assist cylinder* plus precision ground hinge support guides the rugged saw frame up and down through the entire cutting cycle. Special wear resistant DU bushing is used to ensure durability and long use life.
- *Specially designed heavy-duty cast iron swivel center* features straight and miter cuts from 90 to 45 deg (backwards) with quick setting and precise positioning. It enables smooth turning of the saw frame for each angle viable via the large easy-to-read mitering scale. Turn Table for material support swivels automatically at miter adjustment.
- *Large rugged base* with built-in coolant systems offers both sound stability & all-in-one convenience.

Blade Drive:

- *A 2 hp motor, heavy-duty reducer, and variable step drive assembly* with excellent mechanical design feature the essentials for production cutting.
- *The 4-speed transmission* is equipped with the best worm gear speed reducer. The worm shaft is hardened and ground. Together, they provide quiet, powerful, and trouble-free drive.

Blade Guidance & Lubrication System:

- *Carbide blade guides with roller bearings* pre-align the blade before entering carbide blade guides. This feature reduces wear on blade guides and blade, thus enhancing blade life.
- The *rigid guide arms* are mounted on an extra wide *precision ground dovetail slide* for more solid and supportive surface. This rigid design owes to use of superior cast-iron which greatly reduces vibration and achieves better cutting result.



- Two *guides* located on a central axis support the blade from the top, giving it extra penetrating force. The carbide guides are relieved to allow coolant flow to lubricate and cool the blade as well as work piece.
- *Integral coolant system.*
- Blade brush to remove chips from blade gullet.

Control & Automation:

- *Down feed rate & cutting pressure control.* The feed rate may be adjusted by setting the dial between 0 and 10 via the power assisted down feed valve. The vast range of adjustment allows proper setting which results in longer blade life, shorter cutting times, and better finishes.
- A *work height selector* is used to adjust the blade to minimum clearance height over the work.
- The control panel is clearly arranged and conveniently located on front of the machine, eliminating the need for the operator to reach over a moving blade.

Material Clamping & Feeding:

- *Cast iron vises* with replaceable extension plate
- *Secure clamping* via a dependable manual lead screw system with anti-slip hand wheel.

Safety:

- *Conduits* protect all exposed electric wiring and hydraulic circuits.
- *Alert orange* for blade guards and access doors

Standard Accessories:

- Easy blade change with front access at waist level
- Adjustable material stop
- Bi-metal saw blade
- Tools, leveling pads, and an additional wire brush
- Operation & parts manual



MACHINE SPECIFICATIONS

MAXIMUM CUTTING CAPACITY	Round	90°: 250 mm (10") 45°: 190 mm (7.5")
	Square	90°: 250 x 250 mm (10" x 10") 45°: 175 x 175 mm (6.9" x 6.9")
	Rectangle	90°: 230 H x 400 W mm (9" x 15.7") 45°: 155 x 205 mm (6" x 8")
SAW BLADE	Speed	60Hz: 29, 46, 65, 98 m/min (95, 150, 213, 321 fpm)
	Size	25 x 0.9 x 3353 mm (1" x 0.035" x 132")
	Tension	Manual
	Cleaning	Wire Brush
MOTOR OUTPUT	Saw blade	2 HP (1.5 KW)
	Hydraulic	1/4 HP (0.2 KW)
	Coolant	1/8 HP (0.1 KW)
TABLE HEIGHT	630 mm (25")	
WISE CONTROL	Manual	
NET WEIGHT	540 kg (1188 lbs)	
GROSS WEIGHT	640 kg (1408 lbs)	
FLOOR SPACE	1700 x 1100 x 1400 mm (67" x 43.5" x 55.5")	

**** power consumption: 2.36 KVA, 6 AMP for 220 V**

List price : \$ 11,350.00 FOB, Gardena, CA 90248

All Payment made via wire transfer or other methods of digital payment delivery, you must call Sharp industries accounting department personnel at 310-370-5990 for the specific payment instruction details and verification

OPTIONAL FEATURES

- Infinitely variable blade speed—The variable stepless pulley drive assembly allows the operator to select the optimum speed for best performance in all cutting applications.

VS-SW100T	\$ 835.00
-----------	-----------
- 1 M roller table

RT-1 M	\$ 595.00
--------	-----------

Sharp SW-100T	SW-100T	\$11,350.00
1 M Roller Table	RT-1M	\$ 595.00
Discount		- 465.90
Freight		\$1,800.00
Rigging		\$ 520.00
TOTAL INVESTMENT		\$ 13,799.10



Final invoice will include any applicable sales tax.
Quotation valid thirty (30) days from date of issue.

Terms & Conditions: Phillips Corporation requires receipt of 25% down payment before any machine is ordered. 25% payments can be made via bank wire or ACH. Please see the following for sending your payment.

Bank Wires:	
Account Name: Phillips Corporation	Bank of America 6000 Feldwood Rd College Park, GA 30349
Account Number: 1233252889	
ACH ABA Number: 121000358	*All ACH Wire Remittance notifications should be sent to: pcar@phillipscorp.com *REQUIRED
Wire ABA Number: 026009593	
Routing Number: 122000030	
Swift Code: BOFAUS3N	



Customer Signature

Order Approval:

Authorized Signature

Print Name

Date

Purchase Order Number

An order resulting from this proposal should be addressed as follows:

Phillips Corporation

8500 Triad Drive

Colfax, NC 27235

FAX: 336-665-1980

Email: PCMachineorders@phillipscorp.com

Thank you for your consideration!



HAAS FACTORY OUTLET
A DIVISION OF PHILLIPS

MINIMILL WITH SIMULATOR PROPOSAL

PROPOSAL: HFO-PC1633418

DATE: JUNE 13, 2023

PREPARED FOR:

BEVERLY MILLER

GREENVILLE HIGH SCHOOL

210 TUSCULUM BLVD

GREENEVILLE TN 37745-3999

PREPARED BY:

BILL WALSH

HAAS FACTORY OUTLET | A DIVISION OF PHILLIPS CORPORATION

865-599-3372

bwalsh@phillipscorp.com



QUOTATION

MINIMILL

\$38,995.00

Travels

X Axis	406 mm / 16.0 in
Y Axis	305 mm / 12.0 in
Z Axis	254 mm / 10.0 in
Spindle Nose to Table (~ max)	356 mm / 14.0 in
Spindle Nose to Table (~ min)	102 mm / 4.0 in

Options

Standard Program Memory, 1 GB	Included
6000-rpm Spindle	Included
Coolant Pump Kit	Included
Early Power-Failure Detection Module	Included
Ethernet Interface	Included
HaasConnect: Remote monitoring	Included
HaasDrop	Included
Lifting Provision	Included
Media Display M-Code; M130	Included
Safe Run	Included
10-Pocket Carousel Tool Changer	Included
Control Touch Screen	Included
WiFi Connection for the Haas Control	Included
Window Air Blast	Included
Work Light	Included
CT-Style Tool Changer Grippers	Included
Chip Auger	\$ 3,695.00
Rigid Tapping	\$ 1,895.00
LOW-VOLT	Included
Convenience Package	\$ 1,095.00
1-Year Extended Warranty	\$ 2,195.00

Haas Tooling

Mini Mill Tooling Starter Kit, CT40 :	\$ 4,449.95
- 01-0001 HOP, 2" Diameter Shell Mill, 3/4" Pilot Bore x 45° Lead Angle, 5 Inserts (Octagon), Positive Geometry	
- 01-0009 HRNP, 2" Diameter Shell Mill, 3/4" Pilot Bore x 90° Lead Angle, 4 Inserts (Rectangle), Negative/Positive Geometry, TSC	
- 01-0128 45° Indexable Chamfer Mill, 0.281" - 0.850" Diameter x 3/4" Shank x 4.724" Overall Length, 1 Insert	
- 01-0161 HIEX, 1" Diameter Indexable End Mill, 1" Shank x 90° Lead Angle x 5" Overall Length, 2 Inserts, TSC	
- 01-0162 HIEX, 1-1/4" Diameter Indexable End Mill, 1-1/4" Shank x 90° Lead Angle x 5" Overall Length, 3 Inserts, TSC	
- 02-0001 HOP, Carbide Shell Mill Insert, Octagon Positive, Grade HP30 - Pack of 10	
- 02-0003 HOP, Carbide Shell Mill Insert, Octagon Positive, Grade HN25 - Pack of 10 x 4	
- 02-0010 HRNP, Carbide Shell Mill Insert, Rectangle Negative Positive, Grade HK25 - Pack of 10	
- 02-0013 HRNP, Carbide Shell Mill Insert, Rectangle Negative Positive, Grade HN25 - Pack of 10 x 4	
- 02-0502 HIEX/HPSM, Carbide Indexable End Mill Insert, Rectangle, MHS Chip Breaker, Grade MKP30 - Pack of 10	
- 02-0519 HPAL, Carbide Indexable End Mill Insert, Polygon, Grade HN25A - Pack of 10	
- 03-0081 HSAM1, 1/8" Ø Carbide End Mill, 1/8" Shank x 7/16" LOC, Square Profile, 3 Flute, Uncoated x 5	
- 03-0083 HSAM1, 1/4" Ø Carbide End Mill, 1/4" Shank x 3/4" LOC, Square Profile, 3 Flute, Uncoated x 5	
- 03-0085 HSAM1, 3/8" Ø Carbide End Mill, 3/8" Shank x 7/8" LOC, Square Profile, 3 Flute, Uncoated x 10	
- 03-0086 HSAM1, 1/2" Ø Carbide End Mill, 1/2" Shank x 1" LOC, Square Profile, 3 Flute, Uncoated x 10	
- 03-0185 1/4"-20 UNC HSS-E Spiral Flute Tap, 0.255" Shank x 0.433" Thread Length, 2.5XD, Mod. Bottoming, 2 Flute, GH3, Uncoated x 3	
- 03-0186 5/16"-18 UNC HSS-E Spiral Flute Tap, 0.318" Shank x 0.472" Thread Length, 2.5XD, Mod. Bottoming, 2 Flute, GH3, Uncoated x 3	
- 03-0187 3/8"-16 UNC HSS-E Spiral Flute Tap, 0.381" Shank x 0.551" Thread Length, 2.5XD, Mod. Bottoming, 2 Flute, GH3, Uncoated x 3	
- 03-0188 1/2"-13 UNC HSS-E Spiral Flute Tap, 0.367" Shank x 0.63" Thread Length, 2.5XD, Mod. Bottoming, 2 Flute, GH5, Uncoated x 3	
- 03-0255 29-Piece, HSSCO8 1/16" - 1/2" Fractional Jobber Drill Set	
- 03-0256 26-Piece, HSSCO8 A - Z Letter Jobber Drill Set	
- 03-0257 56-Piece, HSSCO8 #1 - #56 Number Jobber Drill Set	
- 03-0422 #3 HSS Center Drill, 1/4" Shank x 2" Overall Length x 60° Point Angle, Double End x 3	

- 03-0612 HSAM1, 1/4" Ø 45° Carbide Chamfer Mill, 1/8" LOC x 2-1/2" Overall Length, 2 Flute, TiCN Coated x 2
- 03-0614 HSAM1, 1/2" Ø 45° Carbide Chamfer Mill, 1/4" LOC x 3" Overall Length, 2 Flute, TiCN Coated x 2
- 04-0003 CT40 1" End Mill Holder x 1-3/4" Gage Length, TSC
- 04-0004 CT40 3/4" End Mill Holder x 1-3/4" Gage Length, TSC x 2
- 04-0007 CT40 ER16 Collet Chuck x 4" Gage Length, TSC
- 04-0009 CT40 ER25 Collet Chuck x 4" Gage Length, TSC
- 04-0010 CT40 ER32 Collet Chuck x 2-1/2" Gage Length, TSC x 2
- 04-0011 CT40 ER32 Collet Chuck x 4" Gage Length, TSC
- 04-0013 CT40 Shell Mill Holder, 1" Pilot Diameter x 2" Gage Length, TSC
- 04-0015 CT40 Shell Mill Holder, 3/4" Pilot Diameter x 2" Gage Length, TSC x 3
- 04-0201 Haas CT40 Pull Stud/Retention Knob, TSC - Pack of 10
- 04-0258 58-Piece, Inch Toe Clamp Kit for 5/8" (16mm) T-Slot Table, 1/2"-13 Thread
- 04-0292 Haas CT40 Pull Stud/Retention Knob, Standard - 1 Each
- 04-0293 Haas CT40 Pull Stud/Retention Knob, TSC - 1 Each
- 04-0718 10-Piece, ER16 Straight Bore Collet Set, 1/16" - 3/8"
- 04-0719 15-Piece, ER25 Straight Bore Collet Set, 1/8" - 5/8"
- 04-0720 18-Piece, ER32 Straight Bore Collet Set, 1/8" - 25/32"
- 05-0002 6" (150mm) Single-Station Fixed-Jaw Vise, 8" (200mm) Opening, Flange Style
- 06-0016 ER16A Hex Spanner Wrench
- 06-0017 ER25UM/RD Spanner Wrench
- 06-0018 ER32UM/RD Spanner Wrench
- 06-0310 3/4" Arbor 3/8"-24 UNF Thread, Shell Mill Coolant Slot Arbor Screw

Machine & Options Total \$ 47,875.00
 Haas Toolings Total \$ 4,449.95
MACHINE TOTAL \$ 52,324.95

SIMULATOR

\$1,995.00

Options

SIMULATOR TOTAL \$ 1,995.00

ADDITIONAL ITEMS

SUB TOTAL \$ 54,319.95

Haas School Discount: Includes FREE 2nd-Year Warranty and Simulator \$ -12,154.49

SUB TOTAL \$ 42,165.46

MM Freight: from Oxnard CA to Customer \$ 1,800.00

Simulator Freight \$ 330.00

Rigging: Gillespie, Inc \$ 520.00

** Not available for field installation*

TOTAL INVESTMENT

\$44,815.46

Shipping FOB Oxnard, CA

Point

Delivery 3-5 weeks

Payment Terms School terms, net 30 days

Customs/Duty/Taxes Final invoice will include any applicable sales tax, Please be aware: If we have not received a current sales tax resale/exempt certificate from your organization by April 7th, 2023 you will be charged and expected to pay for any applicable sales tax on your order. Certificates may be emailed to Phillipscorp@certcapture.com to avoid taxation on your order. If there are any question related to this matter, please contact Pcexemptions@phillipscorp.com

Validity Pricing can change without notice

Warranty One-Year Standard (Parts & Labor)

Title Transfer The day your machine leaves the Haas Automation Facility, the ownership/title of the machine automatically transfers to your company.

Machine Storage Please note that machines held in storage may be subject to a storage

Voltage 208-230 VAC, 3 Phase, 60 Hz (unless High-Voltage Transformer is added) charge.
Purchase Orders PO for above should be made out to Phillips Corporation



TERMS AND CONDITIONS

1. **STANDARD TERMS:** This document contains the standard terms and conditions (the "Terms") applicable to dealings between Phillips Corporation (Haas Factory Outlet Phillips Corporation) ("SELLER") and its customers, including the customer signing this document below ("BUYER"). The Terms are incorporated into, and a material part of: (a) each proposal to sell goods ("Goods") and, if applicable, ancillary services ("Services") made by SELLER to BUYER (a "Proposal"), (b) each order to purchase Goods and/or Services submitted by BUYER to Seller (an "Order"), (c) each acceptance of an Order by SELLER (an "Acceptance"), (d) each invoice issued by SELLER (an "Invoice"), and (e) all other documents exchanged between SELLER and BUYER pertaining to any ORDER (each Proposal, Order, Acceptance, Invoice or other relevant document is a "Document"); in each case regardless of whether the Terms are referred to in the Document and regardless of whether the Document is submitted or provided electronically, on paper or otherwise. The Terms shall control over any contrary terms or conditions set forth in any Document, regardless of when the Document may be provided by BUYER to SELLER or SELLER to BUYER, except as expressly agreed by SELLER and BUYER in a writing specifically described as an amendment of the Terms, and SELLER and BUYER expressly object to any contrary terms or conditions.

2. PROPOSALS AND ORDERS:

- a) A Proposal is valid for 30 days from the date shown on it unless otherwise specified in it.
- b) A Proposal does not constitute a firm offer, but is rather an invitation to BUYER to place an Order.
- c) All Orders shall be in writing. All Orders shall be subject to written Acceptance by SELLER.
- d) SELLER is not the manufacturer of any of the Goods. All weights, measurements and other specifications of Goods set forth in Proposals, Orders and Acceptances are estimates based on information provided by the manufacturer, and SELLER shall not be responsible for any deviations therefrom. Brochures, photographs and other illustrations depicting or describing Goods are non-binding in detail, and BUYER acknowledges that such brochures, photographs and other illustrations may have been superseded since being provided by the manufacturer. BUYER acknowledges further that manufacturers reserve the right to discontinue or to make changes to their products at any time, and that Goods are subject to specification and/or design changes without prior notice. Nothing contained in any descriptions of the Goods set forth in any Proposal, Order, Acceptance or other Document shall expand or otherwise affect SELLER's warranty obligations as set forth in Section 7.
- e) Any production estimates provided by SELLER are not guarantees of actual production unless specifically so stated in writing and signed by a duly authorized officer of SELLER. All time study figures relating to Goods are only estimates based on information provided to SELLER pertaining to finish required, machine-ability of the Goods, amount of material to be removed, BUYER's operating conditions and similar factors.
- f) SELLER retains the right to correct in its Acceptance any clerical error contained in a Proposal or an Order. BUYER agrees to promptly notify SELLER of any suspected clerical error in a Proposal.

3. PRICES:

- a) All prices listed in a Proposal are F.O.B. Ship Point (i.e., manufacturer's factory, port of entry or stocking warehouse) unless otherwise specified. Prices are subject to change without notice until confirmed by SELLER in its Acceptance.
- b) Prices quoted in a Proposal do not include sales, use, excise, property or similar taxes arising out of or relating to the sale, purchase, ownership or use of Goods or Services, and all sales are made subject to applicable taxes, the entire amount of which BUYER agrees to pay. BUYER shall provide SELLER with any applicable tax exemption certificates acceptable to appropriate taxing authorities together with an Order. BUYER shall indemnify and hold SELLER harmless from and against the imposition and payment of such taxes. SELLER may in any Invoice or separately bill BUYER at any time for any such taxes, in which case BUYER shall pay the same to SELLER, but SELLER shall not be obligated to do so.
- c) All freight and rigging quoted in a Proposal is subject to change until confirmed by SELLER in its corresponding Invoice.
- d) SELLER will be compensated for all service work performed by SELLER on Goods not covered by manufacturer's warranty or after the manufacturer's warranty period has expired at SELLER's then prevailing rate, plus all expenses, transportation, material and parts.

4. PAYMENT TERMS: Subject to SELLER's credit approval of BUYER:

- a) The terms of payment with respect to any Order shall be as specified in the Proposal or the Acceptance applicable to the Order (with the Acceptance controlling if differing terms are specified). If terms of payment are not specified in a Proposal or Acceptance, then BUYER shall pay 25% of purchase price as a non-refundable deposit at time of transmitting an Order (the "Deposit") and 75% of purchase price net 15 days from SELLER'S shipment of Goods (the "Final Payment"). In the case of leased and financed Orders, the Final Payment is due upon the sooner of BUYER's signing the delivery slip or acceptance or installation of Goods, but in no event later than 15 days from SELLER's shipment of Goods. Any unpaid amount shall bear interest from the due date until payment at a rate equal to the lesser of 2% per month or the maximum percentage permitted by law. Delays in installation and/or delays in operation of Goods caused by damage, warranty service or warranty replacement of parts or otherwise shall not extend or alter time for payment.
- b) BUYER shall pay all of SELLER's costs (including without limitation court costs and reasonable attorney fees) incurred in collecting past due amounts (whether purchase price or other amounts owing pursuant to the Terms) regardless of whether litigation is commenced.
- c) To secure the Obligations, BUYER hereby grants SELLER a first priority security interest in all Goods sold by SELLER to BUYER, any accessions thereto and any insurance, sale or other proceeds of the foregoing (the "Collateral"). For these purposes, the "Obligations" means all amounts due to SELLER in connection with Goods and/or Services sold to BUYER, including without limitation purchase price, taxes and all fees, expenses and reasonable attorneys' fees incurred by SELLER pursuant to or in connection with the Terms, the Obligations or the Collateral. BUYER agrees to insure the Collateral against loss or damage by fire or other risks and hazards in an amount no less than the replacement value of the Collateral, and upon request to provide SELLER with evidence of such insurance identifying SELLER as loss payee as its interests may appear. BUYER authorizes SELLER to file with applicable governmental authorities financing statements and similar instruments describing the Collateral without the signature of BUYER. Upon BUYER's default in any payment or other performance under the Terms, SELLER may, in its sole and absolute discretion, declare all Obligations immediately due and payable without demand, protest or other notice of any kind, and

SELLER shall have the right to repossess the Collateral (BUYER hereby granting SELLER a right of access to BUYER's premises for such purposes) and all other remedies of a secured party under the Uniform Commercial Code as in from time to time in effect in the state origin of purchase.

5. SHIPPING:

- a) Goods subject to an accepted Order shall be sent to the address listed in the applicable Proposal.
- b) Shipping schedules identified in a Proposal are approximate and subject to confirmation by SELLER with the manufacturer following SELLER's issuance of its Acceptance, despite anything set forth in an Order or other Document.
- c) SELLER shall endeavor to accommodate BUYER's requested delivery schedule, but shall have no liability for loss to BUYER, whether direct, incidental and/or consequential, as a result of delays.

6. RISK OF LOSS: The risk of loss or damage to Goods shall pass to BUYER when Goods are placed with a carrier for delivery to BUYER. The carrier shall be deemed to be acting for and on behalf of BUYER, and the terms of payment for Goods shall not be affected by damage to or destruction of Goods.

7. WARRANTIES; REMEDIES:

a) Goods -- SELLER is NOT a manufacturer, and all Goods are manufactured by others. Accordingly, SELLER is not making and shall not make any warranties with respect to Goods other than that SELLER shall convey to BUYER good and marketable title to Goods. Other warranties available to BUYER are those, if any, extended by the manufacturer, to the extent they are in force and effect and may be assigned to BUYER. SELLER shall, upon written request, assign to BUYER any assignable rights SELLER has under the manufacturer's warranties. THE MANUFACTURER'S WARRANTY, IF ANY, AND SELLER'S WARRANTY OF TITLE, SHALL BE EXCLUSIVE AND IN LIEU OF ALL OTHER WARRANTIES WHETHER WRITTEN, ORAL OR IMPLIED BY LAW OR OTHERWISE, INCLUDING ANY WARRANTY OF MERCHANTABILITY OR WARRANTY OF FITNESS FOR ANY PARTICULAR PURPOSE, ALL OF WHICH ARE DISCLAIMED BY SELLER.

b) Services -- SELLER warrants that Services will be performed in a workmanlike manner. THIS WARRANTY IS EXCLUSIVE AND IS IN LIEU OF ALL OTHER WARRANTIES WHETHER WRITTEN, ORAL OR IMPLIED BY LAW OR OTHERWISE, ALL OF WHICH ARE DISCLAIMED BY SELLER.

c) Remedies -- If SELLER breaches any warranty granted by SELLER with respect to the Goods, SELLER'S sole responsibility shall be to repair, replace or refund the purchase price for the applicable Goods, as determined in SELLER'S sole and absolute discretion. If SELLER breaches any warranty granted by SELLER with respect to Services, Seller shall either refund the portion of the purchase price relating to the defective Services or correct the defective Services, as determined in SELLER'S sole and absolute discretion.

d) Limitation of Damages -- If SELLER breaches any of the Terms (including by breach of its warranties), BUYER'S remedies shall be limited as set forth in Section 7c) and this Section 7d). SELLER shall not be liable for any of BUYER'S indirect, incidental, special or consequential damages relating to or arising from the breach, or punitive damages of any nature, and BUYER'S recovery in connection with any Order shall in no event exceed the purchase price actually paid to SELLER with respect to that Order. Without limiting the generality of the foregoing sentence, in no event shall SELLER be liable to BUYER for BUYER'S loss of profits, loss of use, or damages of any nature based upon a claim for breach of warranty or for faulty workmanship or materials or otherwise, whether or not SELLER has been advised of the potential for any such damages. BUYER acknowledges that the purchase price at which SELLER has agreed to provide Goods and/or Services reflects the SELLER'S disclaimer of warranties and limitation of remedies set forth in this Section 7 and further acknowledges that the purchase price would be substantially higher without such disclaimer and limitation.

8. CANCELLATION: All Orders are non-cancelable by BUYER except as approved in writing by SELLER in its discretion. It is agreed that any cancellation, whether or not approved by SELLER, shall damage SELLER. Accordingly, SELLER shall be entitled to retain the Deposit, and BUYER shall pay to SELLER the following (against which the Deposit shall be credited):

- a) SELLER'S purchase price for the Goods delivered to BUYER prior to cancellation;
- b) SELLER'S costs incurred in connection with Services provided prior to cancellation (including compensation costs and overhead);
- c) All other out of pocket costs incurred by SELLER in connection with the Order, including without limitation cancellation or restocking charges that SELLER has or will incur; and
- d) In the case the cancellation is not approved by SELLER, any other amounts to which SELLER may be entitled at law for BUYER'S breach, it being understood that unapproved cancellation shall be a breach by BUYER of the contractual relationship existing between SELLER and BUYER.

9. BUYER'S USE: BUYER agrees that its employees, contractors and invitees when operating Goods will comply with all operating procedures set forth in the manufacturer's operators manuals and instruction sheets relating to such Goods, and BUYER further agrees not to remove or modify any safety device, warning sign, operators manual or work handling tools. BUYER shall immediately notify SELLER of any accident or injury connected with use of the Goods and agrees, upon SELLER'S request, to cooperate with SELLER in investigating and determining the cause of the same. BUYER agrees to indemnify and hold harmless SELLER from and against any and all claims, suits, damages of any nature, losses, costs or expenses, including without limitation all fees and expenses of counsel and other professional advisors arising from use of any Goods or BUYER'S failure to comply with the Terms.

10. PERFORMANCE IN THE EVENT OF DEFAULT; NON-WAIVER OF DEFAULT: In addition to the rights and remedies conferred on SELLER by law and the Terms, SELLER will not be required to respond to or perform an Order (even if previously accepted) if BUYER is in default with respect to any other Order. If SELLER at anytime, in SELLER'S sole and absolute discretion, doubts BUYER'S ability to pay for Goods consistent with the Terms, SELLER may ship the Goods C.O.D. In the event of any default by BUYER under the Terms, SELLER may decline, in its sole and absolute discretion, to make further shipments of Goods to BUYER without in any way affecting its rights under the Terms. If, despite any default by BUYER, SELLER elects to continue to make shipments, SELLER'S actions shall not constitute a waiver of any default by BUYER or in any way affect SELLER'S remedies for such default under the Terms or otherwise.

11. CONFIDENTIALITY: All drawings, designs, specifications, manuals, programs and prices furnished to BUYER by SELLER shall remain the confidential and proprietary property of SELLER. All such information, except as may be found in the public domain, shall be held in strict confidence by BUYER and shall not be disclosed by BUYER to any third parties. As between BUYER and SELLER, all copyright interests in all

material made available by SELLER shall remain in SELLER at all times, and BUYER waives any property or privacy rights BUYER may have with respect to all such information.

12. EMPLOYEES: BUYER agrees that neither it nor any of its affiliates will solicit for hire, hire or recommend for hire any employee of SELLER or any affiliate of SELLER during the period from SELLER's issuance of a Proposal until the first anniversary of the date on which Goods purchased pursuant to an Order are finally installed or Services obtained pursuant to an Order are fully provided. This Section 12 is a material inducement to SELLER to transact business with BUYER. This Section 12 shall cease to apply to any former employee of SELLER or an affiliate of SELLER on the date such employee has ceased to be employed by SELLER or an affiliate for six (6) months, and it shall not apply to the hiring of any employee of SELLER or an affiliate of SELLER whose initial contact with BUYER is such employee's response to a general public solicitation of employment applications by BUYER.

13. FORCE MAJEURE: SELLER shall not be responsible for nonperformance or late performance due to orders, regulations and/or ordinances by any government or governmental agency, act of God, war, terrorism, blockade, insurrection, mobilization, riots, fire, work stoppage, civil insurrection, flood, earthquake or any other circumstance beyond SELLER's reasonable control. Without limiting the preceding sentence, BUYER acknowledges that Goods originating from foreign countries are subject to export permit by the governmental authorities of the country from which such Goods originate.

14. REVISIONS: SELLER, in its sole and absolute discretion, may modify the Terms at any time and from time to time. The Terms as in effect at the time of SELLER's Acceptance shall govern the terms of sale of the Goods and Services contemplated by the Order so accepted, provided SELLER has provided BUYER with a copy of such Terms prior to or contemporaneously with the Acceptance.

15. SEVERABILITY: If any provision(s) of the Terms are held by any court of competent jurisdiction to be unenforceable or invalid, the remaining provisions of the Terms shall not be rendered invalid or unenforceable as a result thereof.

16. APPLICABLE LAW; VENUE: The Terms are governed by, and shall be construed in accordance with, the law of the State of Maryland without reference to the conflict of laws principles thereof. BUYER and SELLER agree that the State and Federal courts sitting in the City of Hanover, Maryland shall be the exclusive forums for resolving any dispute pertaining in any way to their dealings, the Terms, any Goods or any Services. BUYER consents to the jurisdiction of such courts and agrees that any such court is a convenient forum for the resolution of any such dispute, and agrees that it may be served with process for any suit in any such court by first class registered mail, return receipt requested and postage pre-paid, sent to BUYER at its address identified in an Order or by any other lawful means. BUYER acknowledges that Maryland is the headquarters state of SELLER's parent entity, and that this Section 16 is a material inducement to SELLER to transact business with BUYER.

17. NO DELEGATION OR ASSIGNMENT: BUYER may not assign or delegate any of its rights or obligations under or in connection with the Terms or the Order without the prior written consent of SELLER, and any purported assignment or delegation in violation of this sentence shall be void ab initio, without force or effect, and a material violation of the Terms by BUYER.

Phillips Corporation requires receipt of the 25% down payment before any Haas machine is ordered.
25% payments can be made via bank wire or ACH.

Bank Wires

Account Name: Phillips Corporation

Acct#: 1233252889

ACH ABA Number: 121000358

Wire ABA Number: 026009593

Routing Number: 122000030

Swift Code: BOFAUS3N

Bank of America

6000 Feldwood Rd

College Park, Ga 30349

*REQUIRED: All ACH Wire Remittance notifications should be sent to: pcar@phillipscorp.com.

Please address all Purchase Orders to the following:

Phillips Corporation

8500 Triad Drive

Colfax, NC 27235

Acknowledged and agreed as of the date indicated below:

PROPOSAL NUMBER: _____

BUYER SIGNATURE: _____

PRINTED NAME: _____ DATE: _____

TITLE: _____

Please email signed accepted proposal to pcmachineorders@phillipscorp.com or fax 336-665-1980.

Phillips[®]

**SERVICES EXCLUSIVELY
FOR OUR HAAS CUSTOMERS**

GET AHEAD OF THE CURVE - GET OPTO

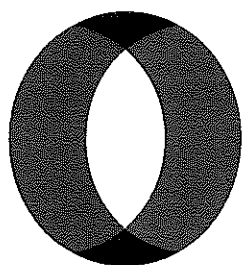

OPTO

BY PHILLIPS CORPORATION

Applications support for process improvement, specialized programming, and on-site training provided by our Haas-Certified Applications Engineers.

CERTIFIED HAAS ANNUAL MAINTENANCE PROGRAM

CHAMP

Identify potential problems with your machine before they develop with this preventative maintenance program.

**MAINTENANCE & REPAIR
TRAINING**

Week-long class in Knoxville, TN designed for customers who want an employee trained for machine maintenance

Unlimited operator training at your local HFO

**LIFETIME OPERATOR
TRAINING**

336.665.1080

pcsales@phillipscorp.com



**Haas
F1 Team**
OFFICIAL MACHINE TOOL

Phillips®

HAAS SERVICE TRAINING

JOIN US FOR A HAAS TRAINING EXPERIENCE LIKE NO OTHER IN THE INDUSTRY

Haas Service Training will teach you how to **TROUBLESHOOT, REPAIR** and **MAINTAIN** your Haas *in hours, not days.*

LOCATIONS *Knoxville, TN - Bensalem, PA - Rock Hill, SC* CONTACT hfooster@phillipscorp.com - (800) 989-9181



"I wouldn't keep sending so many of our Techs (nearly 30 so far) if I didn't think the course was a great investment."

~ **Michael Goode,**
General Electric

"This is the best machine learning environment I've ever seen. You should take this class, it's a no brainer. You're going to benefit"

~ **Dale Miller,**
Southern Cast Products



Bottom-Line Benefits

This class more than pays for itself with fewer service calls, reduced downtime, and real gains in part quality.

For more information, email hfooster@phillipscorp.com or call (800) 989-9181.

****Interested in Mill and Lathe Crash Recovery Training?** Let us know and we can send information on those classes as well.

SKILLS COVERED



In just five days, participants will take their service game to the next level by learning to perform the following skills

- Lathe Alignment
- Turret Repair (ST, SL & BMT)
- Tool Changer Repairs
- Ball Screw Replacement
- Spindle Replacement
- I/O Board & Vector Drive Troubleshooting
- Best Practices & MUCH MORE!!!

HANDS-ON LEARNING



This is a roll-up-your-sleeves, get inside-the-machine learning experience.

WORLD-CLASS FACILITIES



Training takes place in state-of-the-art facilities with more than a million dollars worth of Haas equipment - just like the ones on your floor.

EXPERIENCED INSTRUCTORS



Our teachers have spent years in the field. No question too basic. No problem too complex. Small class sizes mean you have plenty of one-on-one time for all your questions.

Plus every participant receives a free Haas Service Key, which unlocks the service parameters on any Next-Gen Control so you can take ownership of your Haas service and maintenance!



**HUNDREDS HAVE ATTENDED,
RATING THE COURSE 9.9/10**

CLASSES RUN MONTHLY, YEAR-ROUND.
CALL (800) 989-9181 TO RESERVE YOUR SPOT
TODAY! OR VISIT US AT:
PHILLIPSCORP.COM/SERVICE-TRAINING

****Disclaimer - In order to attend any Advanced Courses, students must have already completed the basic Phillips Haas Service Training course. Please call/email for more information.**



ADVANCED MILL SERVICE TRAINING

Phillips
HAAS SERVICE TRAINING

LOCATION *Knoxville, TN* CONTACT hfooster@phillipscorp.com - (800) 989-9181

JOIN US FOR A HAAS TRAINING EXPERIENCE LIKE NO OTHER IN THE INDUSTRY

From replacing guide rails to inspecting geometry, Advanced Mill Service Training will help you **repair your Haas mill if it crashes** and **uncover hidden problems before they affect quality** or slow production.

■ SKILLS COVERED



In just five days, participants will take their mill service skills to the next level by learning how to:

- Conduct a detailed geometry inspection
- Read ball bar information
- Use a granite square
- Correct machine geometry
- Replace machine guide rails
- Change out drawbars
- Replace different styled encoders

Contact us about training grants that could cover your tuition!

■ HANDS-ON LEARNING

This is a roll-up-your-sleeves, get inside-the-machine learning experience.

■ WORLD-CLASS FACILITIES

Training takes place in state-of-the-art facilities with more than a million dollars worth of Haas equipment - just like the ones on your floor.

■ EXPERIENCED INSTRUCTORS

Our teachers have spent years in the field (if it's happened, they've seen it!). No question too basic. No problem too complex. Small class sizes mean you have plenty of one-on-one time for all your questions.

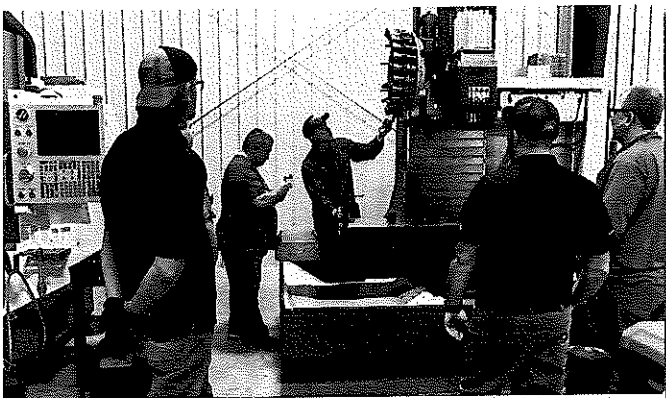

"This class takes the mystery out of these bigger mill repairs, which can be daunting. I think it's going to be a game changer for companies and on-site service techs."

~ Todd Price, Head Service Instructor

**CLASSES RUN MONTHLY, YEAR-ROUND.
CALL (800) 989-9181 TO RESERVE YOUR SPOT
TODAY! OR VISIT US AT:
PHILLIPSCORP.COM/ADVANCEDMILL**

Bottom-Line Benefits

This class more than pays for itself with fewer service calls, reduced downtime, and real gains in part quality.

For more information,
email hfooster@phillipscorp.com or call
(800) 989-9181.

****Not quite ready for an advanced class?** Contact us to find out more about Phillips Haas Service Training - our introductory Haas Service Training class.

****Disclaimer - In order to attend any Advanced Courses, students must have already completed the basic Phillips Haas Service Training course. Please call/email for more information.**



Installed Dimensions

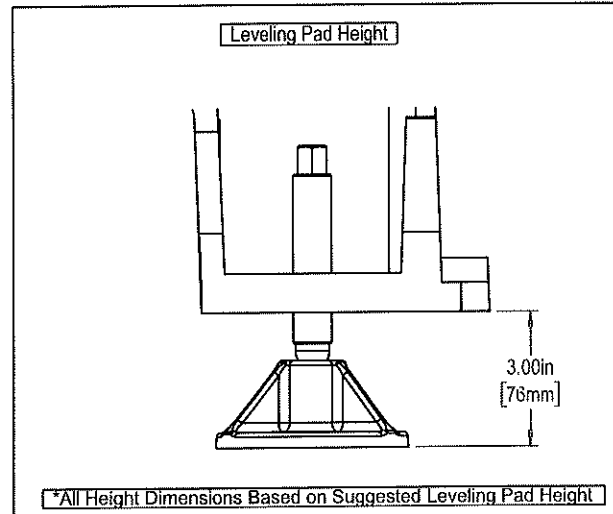
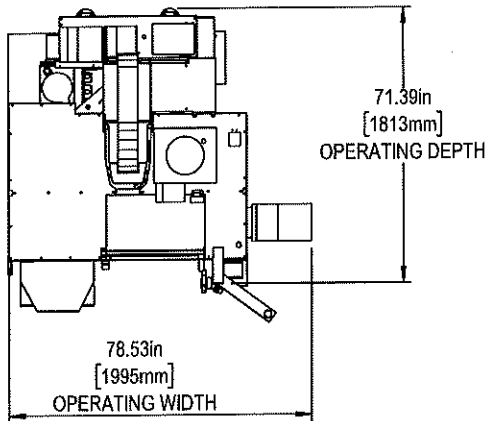
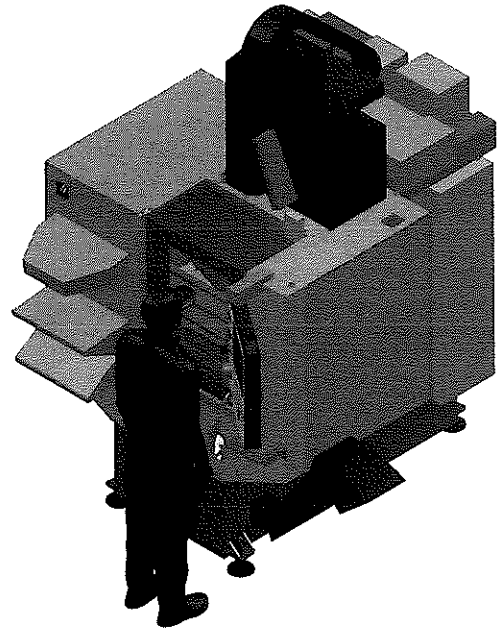
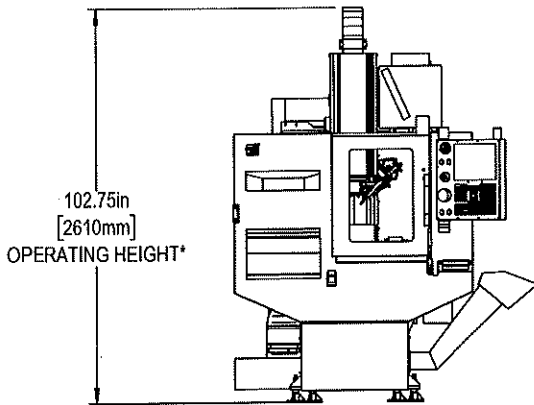

*ADD 4in for Extended Z-Clearance

Shipping Dimensions

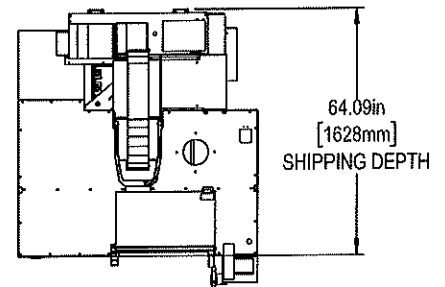
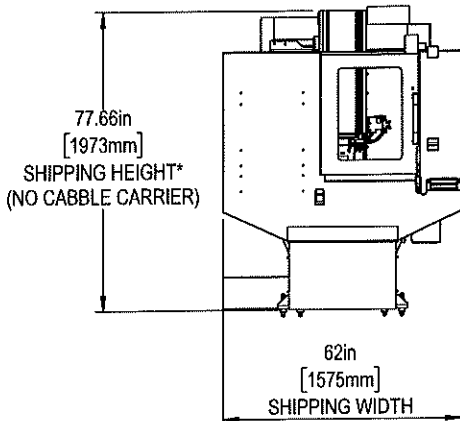

Air & Power

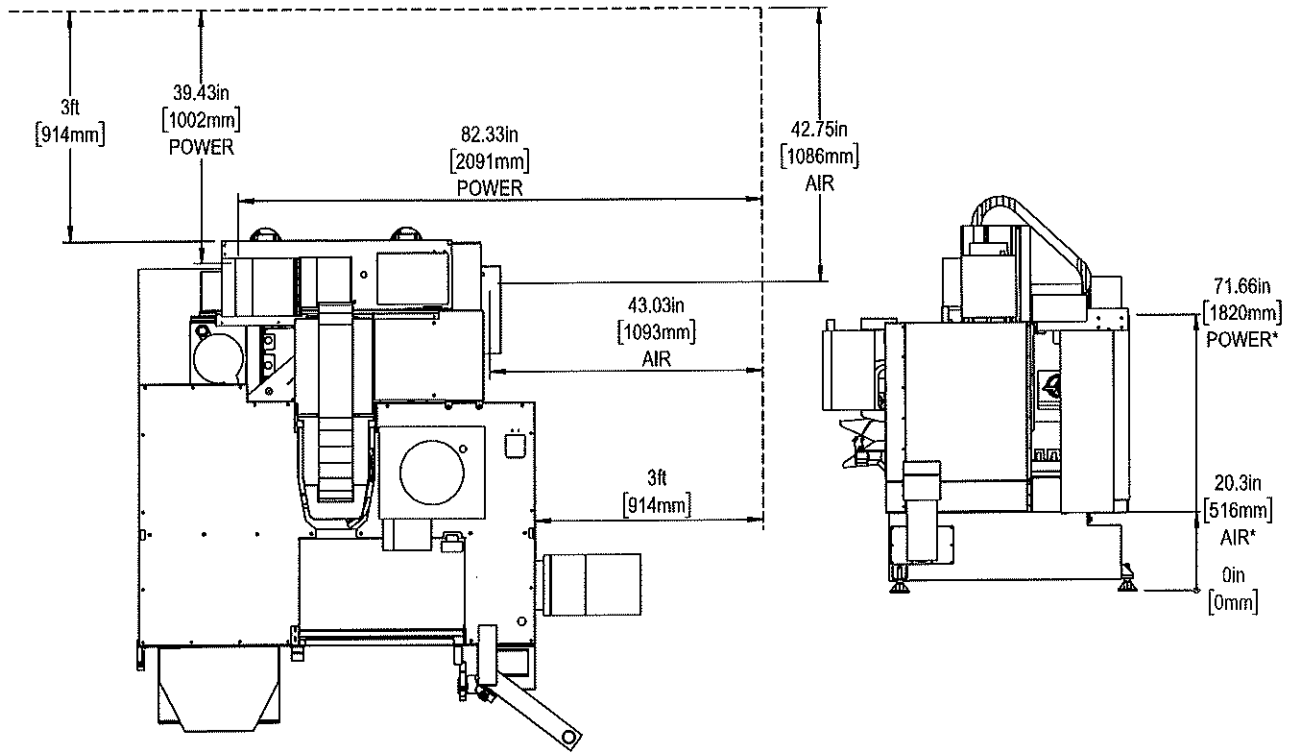

Maintain 3 feet [915mm] clearance to the nearest obstruction around all sides of machine perimeter for maintenance access

Note:
Machine must be placed on one continuous concrete slab. Slab should extend 12in [305mm] beyond anchor holes in all directions

Anchor Pattern

Anchor Hole Detail
Ø 5/8in [15.9mm]
▽ 2.0in [50mm]-
▽ 2.5in [66mm]

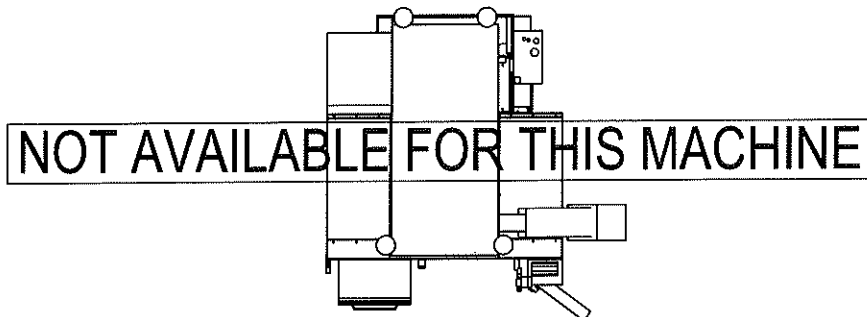



Height Breakdown

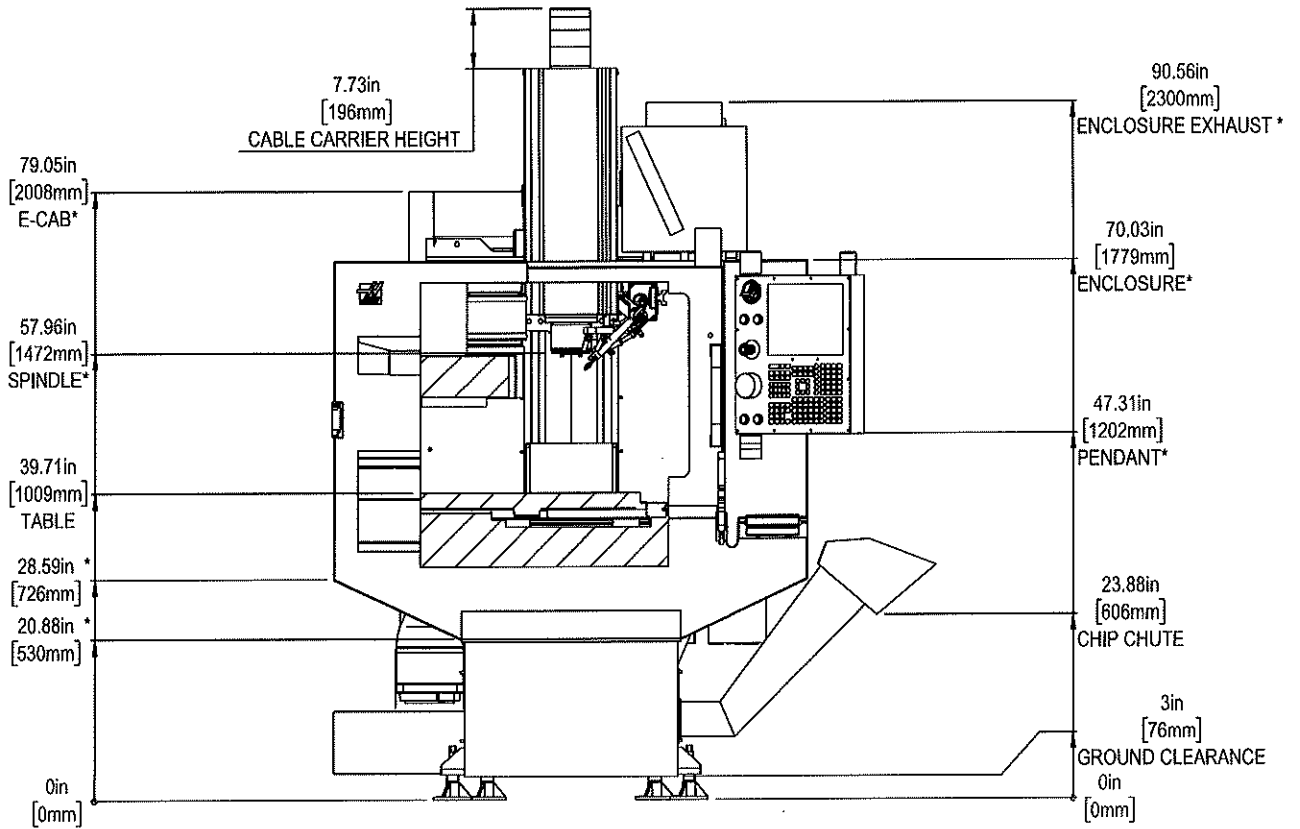

Width Breakdown

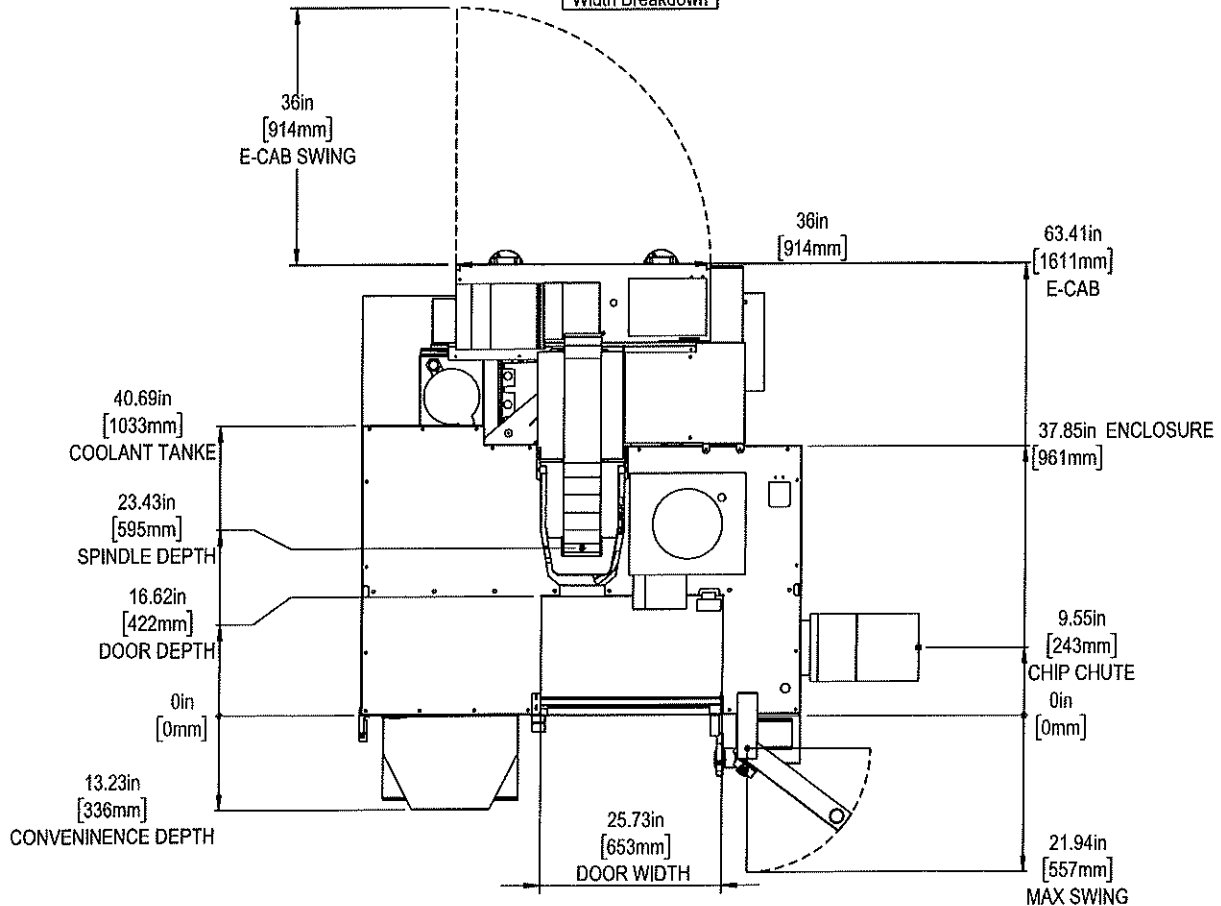

X&Y-Axis Travel and Clearance

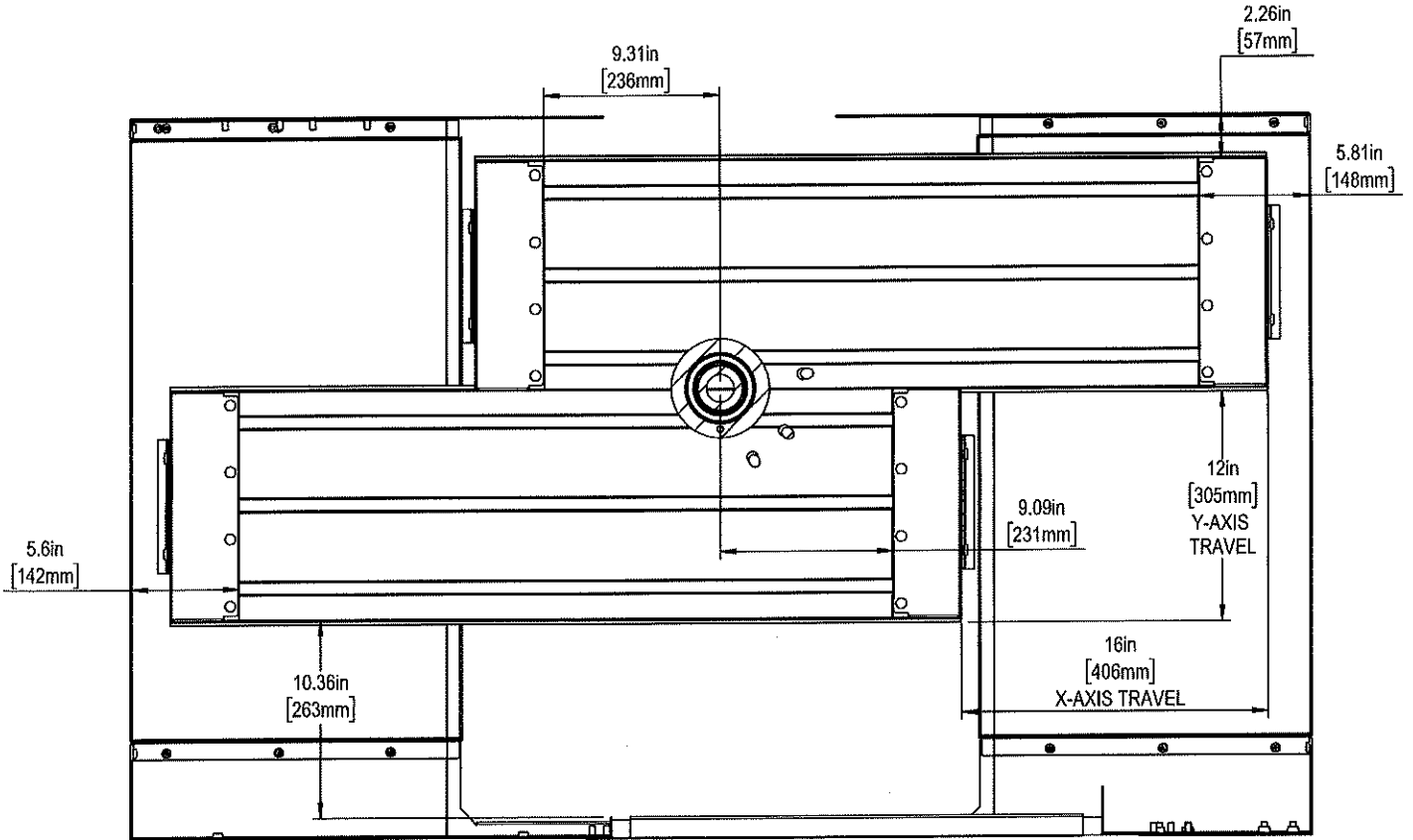

Z-AXIS TRAVEL & CLEARANCE

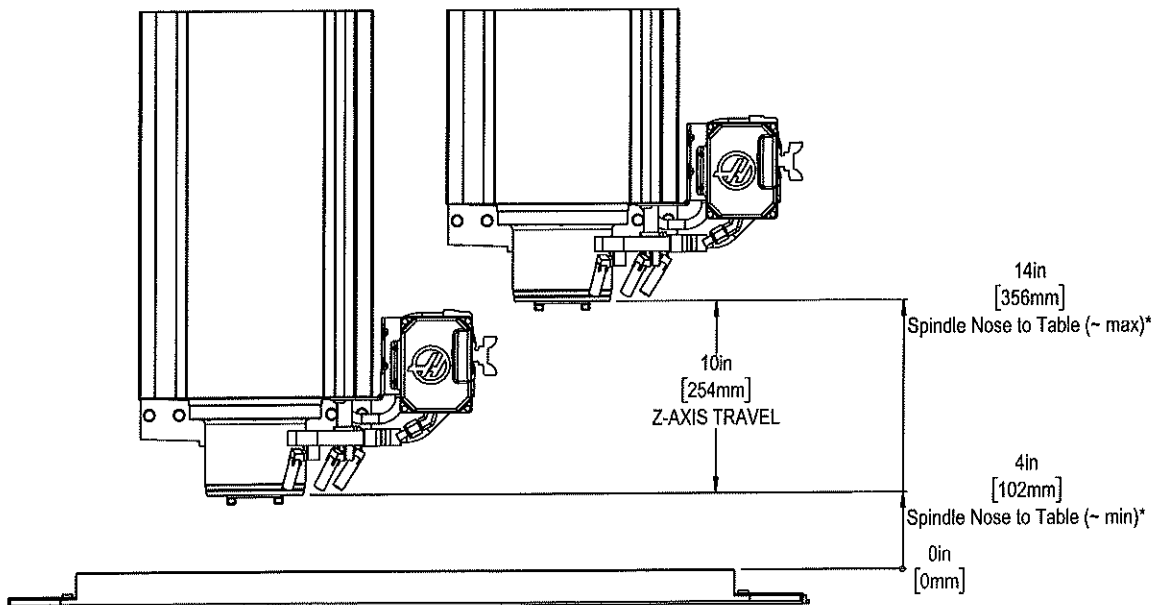
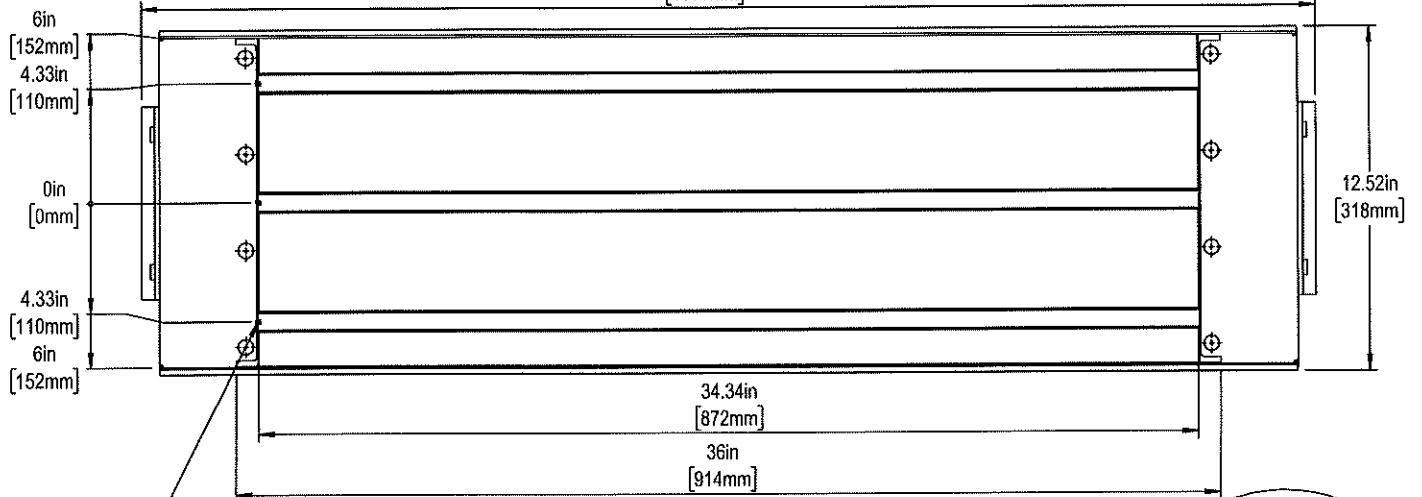
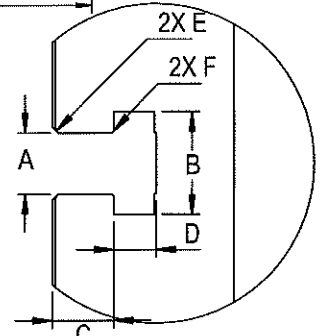

Table
42.91in
[1090mm]



16mm T-SLOTS



T-Slot Dimensions in inches

Slot Size	A	B	C	D	E	F
12mm	$0.438 \begin{smallmatrix} +.002 \\ -.000 \end{smallmatrix}$	0.76 ± 0.02	0.310 ± 0.010	0.318 ± 0.010	$0.03 \times 45^\circ$	$0.020 \times 45^\circ$
16mm	0.628 ± 0.002	1.06 ± 0.02	0.640 ± 0.010	0.420 ± 0.010	$0.06 \times 45^\circ$	$0.020 \times 45^\circ$

Tool Changer

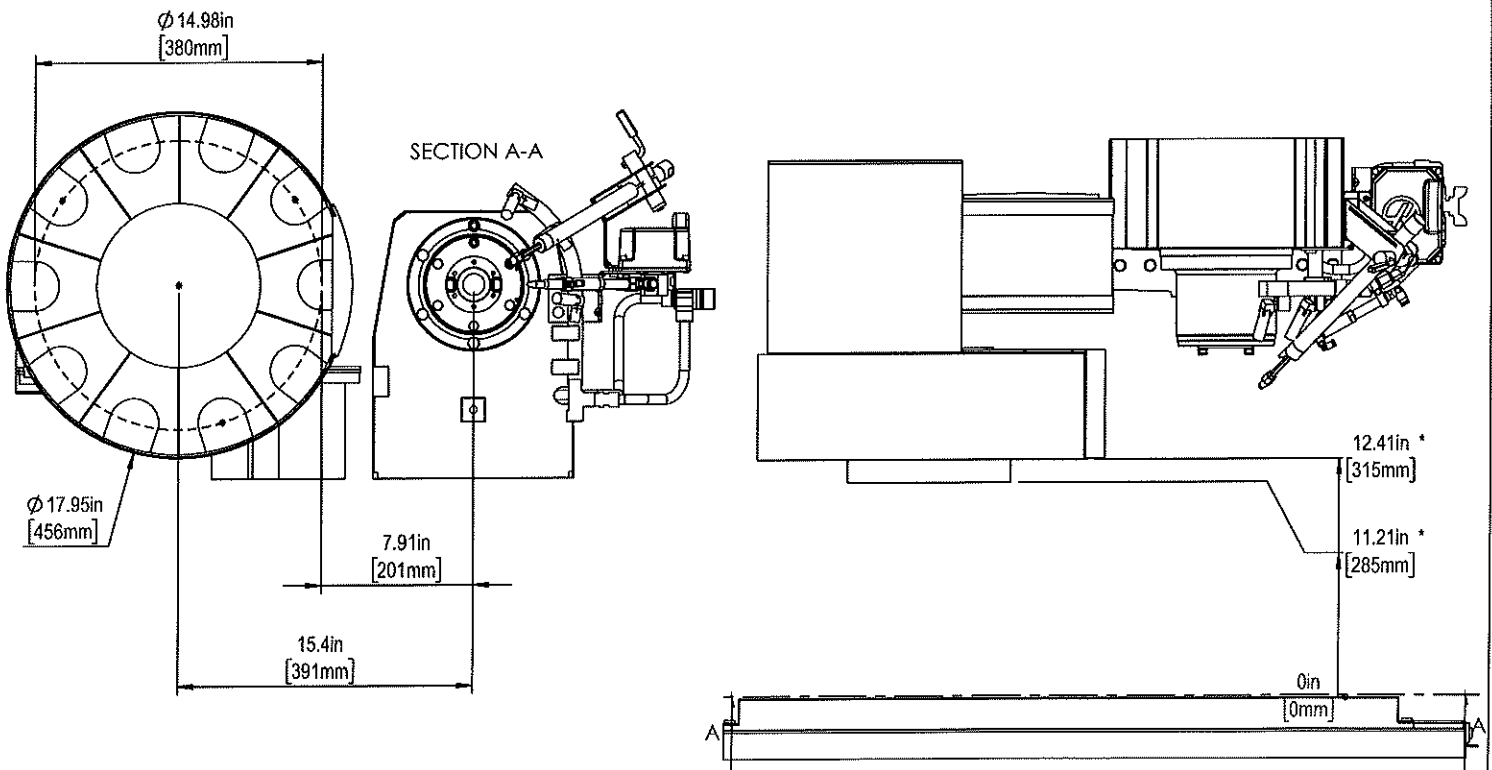



HAAS FACTORY OUTLET
A DIVISION OF PHILLIPS

TL-1 WITH SIMULATOR PROPOSAL

PROPOSAL: **HFO-PC1633431**

DATE: **JUNE 13, 2023**

PREPARED FOR:
BEVERLY MILLER
GREENVILLE HIGH SCHOOL
210 TUSCULUM BLVD
GREENEVILLE TN 37745-3999

PREPARED BY:
BILL WALSH
HAAS FACTORY OUTLET | A DIVISION OF PHILLIPS CORPORATION
865-599-3372
bwalsh@phillipscorp.com



QUOTATION

TL-1

\$31,695.00

Travels

X Axis	203 mm / 8.0 in
Z Axis	762 mm / 30.0 in

Options

1800-rpm Spindle, A2-5	Included
Standard Program Memory, 1 GB	Included
Coolant Pump Kit	Included
Chip Enclosure	Included
Early Power-Failure Detection Module	Included
Ethernet Interface	Included
HaasConnect: Remote monitoring	Included
HaasDrop	Included
User-Definable Macros	Included
Control Touch Screen	Included
Visual Part Programming System	Included
WiFi Connection for the Haas Control	Included
Work Light	Included
Cross-Slide, Tooling Ready	Included
Inch Measurement Units	Included
Electronic Handwheels	\$ 1,495.00
Manual Tailstock, MT4	\$ 3,095.00
LOW-VOLT	Included
8" Manual 3-Jaw Chuck, A2-5	\$ 1,795.00
1-Year Extended Warranty	\$ 2,195.00

Haas Tooling

SCLCR12-3C, 3/4" Square Steel Shank Turning Toolholder, Screw-Lock	\$ 69.95
SDJCR12-3B, 3/4" Square Steel Shank Turning Toolholder, Screw-Lock	\$ 65.95
SVJBR12-3B, 3/4" Square Steel Shank Turning Toolholder, Screw-Lock	\$ 65.95
HGER12-3, 3/4" Square Steel Shank External Grooving Toolholder	\$ 74.95
CCMT3251-HFP / CCMT09T304-HFP, Carbide Turning Insert, 80° Rhombic, Grade HTP15 - Pack of 5	\$ 15.95
DCMT3251-HFP / DCMT11T304-HFP, Carbide Turning Insert, 55° Rhombic, Grade HTP15 - Pack of 5	\$ 15.95
DCMT3252-HFP / DCMT11T308-HFP, Carbide Turning Insert, 55° Rhombic, Grade HTP25 - Pack of 5	\$ 15.95
CCGT3251-HAL / CCGT09T304-HAL, Carbide Turning Insert, 80° Rhombic, Grade HTSU10 - Pack of 5	\$ 21.95
DCGT3251-HAL / DCGT11T304-HAL, Carbide Turning Insert, 55° Rhombic, Grade HTSU10 - Pack of 5	\$ 23.95
VBGT331-HAL / VBGT160404-HAL, Carbide Turning Insert, 35° Rhombic, Grade HTSU10 - Pack of 5	\$ 26.95
VBMT331-HFP / VBMT160404-HFP, Carbide Turning Insert, 35° Rhombic, Grade HTM15 - Pack of 5	\$ 19.95
HGMN300-G, 3mm Carbide Grooving Insert, Grade HU30 - Pack of 10	\$ 99.95
4MT #4 Morse Taper Live Center, High Precision	\$ 379.95
6-Piece, Inch Quick-Change Tool Post Kit	\$ 1,495.95
2mm Insert Width Complete Cut-Off Kit, 3/4" Shank, Grade HU30 :	\$ 253.95
- 01-0150 HTB-075, 3/4" Steel Shank Tool Block	
- 01-0153 HCB-2, Cut-Off Blade (2mm Insert)	
- 02-0492 HCI-2R, 2mm Carbide Cut-Off Insert, Grade HU30 - Pack of 10	
- 06-0084 SW15S Cut-Off Wrench	

Machine & Options Total	\$ 40,275.00
Haas Toolings Total	\$ 2,647.25

MACHINE TOTAL \$ 42,922.25

SIMULATOR

\$1,995.00

Options

SIMULATOR TOTAL \$ 1,995.00

ADDITIONAL ITEMS

SUB TOTAL	\$ 44,917.25
Haas School Discount: Includes FREE 2nd-Year Warranty and Simulator	\$ -10,563.83
SUB TOTAL	\$ 34,353.42
TL Freight: from Oxnard CA to Customer	\$ 1,800.00
Simulator Freight	\$ 330.00
Rigging: Gillespie, Inc	\$ 520.00

* Not available for field installation

TOTAL INVESTMENT \$37,003.42

Shipping Point Delivery FOB Oxnard, CA
5-7 weeks

Payment Terms 25% due at time of order, Net due 15 days from shipment

Customs/Duty/Taxes Final invoice will include any applicable sales tax, Please be aware: If we have not received a current sales tax resale/exempt certificate from your organization by April 7th, 2023 you will be charged and expected to pay for any applicable sales tax on your order. Certificates may be emailed to Phillipscorp@certcapture.com to avoid taxation on your order. If there are any question related to this matter, please contact Pcexemptions@phillipscorp.com

Validity Pricing can change without notice

Warranty One-Year Standard (Parts & Labor)

Title Transfer The day your machine leaves the Haas Automation Facility, the ownership/title of the machine automatically transfers to your company.

Machine Storage Please note that machines held in storage may be subject to a storage charge.

Voltage 208-230 VAC, 3 Phase, 60 Hz (unless High-Voltage Transformer is added)

Purchase Orders PO for above should be made out to Phillips Corporation



TERMS AND CONDITIONS

1. **STANDARD TERMS:** This document contains the standard terms and conditions (the "Terms") applicable to dealings between Phillips Corporation (Haas Factory Outlet Phillips Corporation) ("SELLER") and its customers, including the customer signing this document below ("BUYER"). The Terms are incorporated into, and a material part of: (a) each proposal to sell goods ("Goods") and, if applicable, ancillary services ("Services") made by SELLER to BUYER (a "Proposal"), (b) each order to purchase Goods and/or Services submitted by BUYER to Seller (an "Order"), (c) each acceptance of an Order by SELLER (an "Acceptance"), (d) each invoice issued by SELLER (an "Invoice"), and (e) all other documents exchanged between SELLER and BUYER pertaining to any ORDER (each Proposal, Order, Acceptance, Invoice or other relevant document is a "Document"); in each case regardless of whether the Terms are referred to in the Document and regardless of whether the Document is submitted or provided electronically, on paper or otherwise. The Terms shall control over any contrary terms or conditions set forth in any Document, regardless of when the Document may be provided by BUYER to SELLER or SELLER to BUYER, except as expressly agreed by SELLER and BUYER in a writing specifically described as an amendment of the Terms, and SELLER and BUYER expressly object to any contrary terms or conditions.

2. **PROPOSALS AND ORDERS:**

- a) A Proposal is valid for 30 days from the date shown on it unless otherwise specified in it.
- b) A Proposal does not constitute a firm offer, but is rather an invitation to BUYER to place an Order.
- c) All Orders shall be in writing. All Orders shall be subject to written Acceptance by SELLER.
- d) SELLER is not the manufacturer of any of the Goods. All weights, measurements and other specifications of Goods set forth in Proposals, Orders and Acceptances are estimates based on information provided by the manufacturer, and SELLER shall not be responsible for any deviations therefrom. Brochures, photographs and other illustrations depicting or describing Goods are non-binding in detail, and BUYER acknowledges that such brochures, photographs and other illustrations may have been superseded since being provided by the manufacturer. BUYER acknowledges further that manufacturers reserve the right to discontinue or to make changes to their products at any time, and that Goods are subject to specification and/or design changes without prior notice. Nothing contained in any descriptions of the Goods set forth in any Proposal, Order, Acceptance or other Document shall expand or otherwise affect SELLER's warranty obligations as set forth in Section 7.
- e) Any production estimates provided by SELLER are not guarantees of actual production unless specifically so stated in writing and signed by a duly authorized officer of SELLER. All time study figures relating to Goods are only estimates based on information provided to SELLER pertaining to finish required, machine-ability of the Goods, amount of material to be removed, BUYER's operating conditions and similar factors.
- f) SELLER retains the right to correct in its Acceptance any clerical error contained in a Proposal or an Order. BUYER agrees to promptly notify SELLER of any suspected clerical error in a Proposal.

3. **PRICES:**

- a) All prices listed in a Proposal are F.O.B. Ship Point (i.e., manufacturer's factory, port of entry or stocking warehouse) unless otherwise specified. Prices are subject to change without notice until confirmed by SELLER in its Acceptance.
- b) Prices quoted in a Proposal do not include sales, use, excise, property or similar taxes arising out of or relating to the sale, purchase, ownership or use of Goods or Services, and all sales are made subject to applicable taxes, the entire amount of which BUYER agrees to pay. BUYER shall provide SELLER with any applicable tax exemption certificates acceptable to appropriate taxing authorities together with an Order. BUYER shall indemnify and hold SELLER harmless from and against the imposition and payment of such taxes. SELLER may in any Invoice or separately bill BUYER at any time for any such taxes, in which case BUYER shall pay the same to SELLER, but SELLER shall not be obligated to do so.
- c) All freight and rigging quoted in a Proposal is subject to change until confirmed by SELLER in its corresponding Invoice.
- d) SELLER will be compensated for all service work performed by SELLER on Goods not covered by manufacturer's warranty or after the manufacturer's warranty period has expired at SELLER's then prevailing rate, plus all expenses, transportation, material and parts.

4. **PAYMENT TERMS:** Subject to SELLER's credit approval of BUYER:

- a) The terms of payment with respect to any Order shall be as specified in the Proposal or the Acceptance applicable to the Order (with the Acceptance controlling if differing terms are specified). If terms of payment are not specified in a Proposal or Acceptance, then BUYER shall pay 25% of purchase price as a non-refundable deposit at time of transmitting an Order (the "Deposit") and 75% of purchase price net 15 days from SELLER'S shipment of Goods (the "Final Payment"). In the case of leased and financed Orders, the Final Payment is due upon the sooner of BUYER's signing the delivery slip or acceptance or installation of Goods, but in no event later than 15 days from SELLER's shipment of Goods. Any unpaid amount shall bear interest from the due date until payment at a rate equal to the lesser of 2% per month or the maximum percentage permitted by law. Delays in installation and/or delays in operation of Goods caused by damage, warranty service or warranty replacement of parts or otherwise shall not extend or alter time for payment.
- b) BUYER shall pay all of SELLER's costs (including without limitation court costs and reasonable attorney fees) incurred in collecting past due amounts (whether purchase price or other amounts owing pursuant to the Terms) regardless of whether litigation is commenced.
- c) To secure the Obligations, BUYER hereby grants SELLER a first priority security interest in all Goods sold by SELLER to BUYER, any accessions thereto and any insurance, sale or other proceeds of the foregoing (the "Collateral"). For these purposes, the "Obligations" means all amounts due to SELLER in connection with Goods and/or Services sold to BUYER, including without limitation purchase price, taxes and all fees, expenses and reasonable attorneys' fees incurred by SELLER pursuant to or in connection with the Terms, the Obligations or the Collateral. BUYER agrees to insure the Collateral against loss or damage by fire or other risks and hazards in an amount no less than the replacement value of the Collateral, and upon request to provide SELLER with evidence of such insurance identifying SELLER as loss payee as its interests may appear. BUYER authorizes SELLER to file with applicable governmental authorities financing statements and similar instruments describing the Collateral without the signature of BUYER. Upon BUYER's default in any payment or other performance under the Terms, SELLER may, in its sole and absolute discretion, declare all Obligations immediately due and payable without demand, protest or other notice of any kind, and

SELLER shall have the right to repossess the Collateral (BUYER hereby granting SELLER a right of access to BUYER's premises for such purposes) and all other remedies of a secured party under the Uniform Commercial Code as in from time to time in effect in the state origin of purchase.

5. SHIPPING:

- a) Goods subject to an accepted Order shall be sent to the address listed in the applicable Proposal.
- b) Shipping schedules identified in a Proposal are approximate and subject to confirmation by SELLER with the manufacturer following SELLER's issuance of its Acceptance, despite anything set forth in an Order or other Document.
- c) SELLER shall endeavor to accommodate BUYER's requested delivery schedule, but shall have no liability for loss to BUYER, whether direct, incidental and/or consequential, as a result of delays.

6. RISK OF LOSS: The risk of loss or damage to Goods shall pass to BUYER when Goods are placed with a carrier for delivery to BUYER. The carrier shall be deemed to be acting for and on behalf of BUYER, and the terms of payment for Goods shall not be affected by damage to or destruction of Goods.

7. WARRANTIES; REMEDIES:

- a) Goods -- SELLER is NOT a manufacturer, and all Goods are manufactured by others. Accordingly, SELLER is not making and shall not make any warranties with respect to Goods other than that SELLER shall convey to BUYER good and marketable title to Goods. Other warranties available to BUYER are those, if any, extended by the manufacturer, to the extent they are in force and effect and may be assigned to BUYER. SELLER shall, upon written request, assign to BUYER any assignable rights SELLER has under the manufacturer's warranties. THE MANUFACTURER'S WARRANTY, IF ANY, AND SELLER'S WARRANTY OF TITLE, SHALL BE EXCLUSIVE AND IN LIEU OF ALL OTHER WARRANTIES WHETHER WRITTEN, ORAL OR IMPLIED BY LAW OR OTHERWISE, INCLUDING ANY WARRANTY OF MERCHANTABILITY OR WARRANTY OF FITNESS FOR ANY PARTICULAR PURPOSE, ALL OF WHICH ARE DISCLAIMED BY SELLER.
- b) Services -- SELLER warrants that Services will be performed in a workmanlike manner. THIS WARRANTY IS EXCLUSIVE AND IS IN LIEU OF ALL OTHER WARRANTIES WHETHER WRITTEN, ORAL OR IMPLIED BY LAW OR OTHERWISE, ALL OF WHICH ARE DISCLAIMED BY SELLER.
- c) Remedies -- If SELLER breaches any warranty granted by SELLER with respect to the Goods, SELLER'S sole responsibility shall be to repair, replace or refund the purchase price for the applicable Goods, as determined in SELLER'S sole and absolute discretion. If SELLER breaches any warranty granted by SELLER with respect to Services, Seller shall either refund the portion of the purchase price relating to the defective Services or correct the defective Services, as determined in SELLER'S sole and absolute discretion.
- d) Limitation of Damages -- If SELLER breaches any of the Terms (including by breach of its warranties), BUYER'S remedies shall be limited as set forth in Section 7c) and this Section 7d). SELLER shall not be liable for any of BUYER'S indirect, incidental, special or consequential damages relating to or arising from the breach, or punitive damages of any nature, and BUYER'S recovery in connection with any Order shall in no event exceed the purchase price actually paid to SELLER with respect to that Order. Without limiting the generality of the foregoing sentence, in no event shall SELLER be liable to BUYER for BUYER'S loss of profits, loss of use, or damages of any nature based upon a claim for breach of warranty or for faulty workmanship or materials or otherwise, whether or not SELLER has been advised of the potential for any such damages. BUYER acknowledges that the purchase price at which SELLER has agreed to provide Goods and/or Services reflects the SELLER'S disclaimer of warranties and limitation of remedies set forth in this Section 7 and further acknowledges that the purchase price would be substantially higher without such disclaimer and limitation.

8. CANCELLATION: All Orders are non-cancelable by BUYER except as approved in writing by SELLER in its discretion. It is agreed that any cancellation, whether or not approved by SELLER, shall damage SELLER. Accordingly, SELLER shall be entitled to retain the Deposit, and BUYER shall pay to SELLER the following (against which the Deposit shall be credited):

- a) SELLER'S purchase price for the Goods delivered to BUYER prior to cancellation;
- b) SELLER'S costs incurred in connection with Services provided prior to cancellation (including compensation costs and overhead);
- c) All other out of pocket costs incurred by SELLER in connection with the Order, including without limitation cancellation or restocking charges that SELLER has or will incur; and
- d) In the case the cancellation is not approved by SELLER, any other amounts to which SELLER may be entitled at law for BUYER'S breach, it being understood that unapproved cancellation shall be a breach by BUYER of the contractual relationship existing between SELLER and BUYER.

9. BUYER'S USE: BUYER agrees that its employees, contractors and invitees when operating Goods will comply with all operating procedures set forth in the manufacturer's operators manuals and instruction sheets relating to such Goods, and BUYER further agrees not to remove or modify any safety device, warning sign, operators manual or work handling tools. BUYER shall immediately notify SELLER of any accident or injury connected with use of the Goods and agrees, upon SELLER'S request, to cooperate with SELLER in investigating and determining the cause of the same. BUYER agrees to indemnify and hold harmless SELLER from and against any and all claims, suits, damages of any nature, losses, costs or expenses, including without limitation all fees and expenses of counsel and other professional advisors arising from use of any Goods or BUYER'S failure to comply with the Terms.

10. PERFORMANCE IN THE EVENT OF DEFAULT; NON-WAIVER OF DEFAULT: In addition to the rights and remedies conferred on SELLER by law and the Terms, SELLER will not be required to respond to or perform an Order (even if previously accepted) if BUYER is in default with respect to any other Order. If SELLER at anytime, in SELLER'S sole and absolute discretion, doubts BUYER'S ability to pay for Goods consistent with the Terms, SELLER may ship the Goods C.O.D. In the event of any default by BUYER under the Terms, SELLER may decline, in its sole and absolute discretion, to make further shipments of Goods to BUYER without in any way affecting its rights under the Terms. If, despite any default by BUYER, SELLER elects to continue to make shipments, SELLER'S actions shall not constitute a waiver of any default by BUYER or in any way affect SELLER'S remedies for such default under the Terms or otherwise.

11. CONFIDENTIALITY: All drawings, designs, specifications, manuals, programs and prices furnished to BUYER by SELLER shall remain the confidential and proprietary property of SELLER. All such information, except as may be found in the public domain, shall be held in strict confidence by BUYER and shall not be disclosed by BUYER to any third parties. As between BUYER and SELLER, all copyright interests in all

material made available by SELLER shall remain in SELLER at all times, and BUYER waives any property or privacy rights BUYER may have with respect to all such information.

12. EMPLOYEES: BUYER agrees that neither it nor any of its affiliates will solicit for hire, hire or recommend for hire any employee of SELLER or any affiliate of SELLER during the period from SELLER's issuance of a Proposal until the first anniversary of the date on which Goods purchased pursuant to an Order are finally installed or Services obtained pursuant to an Order are fully provided. This Section 12 is a material inducement to SELLER to transact business with BUYER. This Section 12 shall cease to apply to any former employee of SELLER or an affiliate of SELLER on the date such employee has ceased to be employed by SELLER or an affiliate for six (6) months, and it shall not apply to the hiring of any employee of SELLER or an affiliate of SELLER whose initial contact with BUYER is such employee's response to a general public solicitation of employment applications by BUYER.

13. FORCE MAJEURE: SELLER shall not be responsible for nonperformance or late performance due to orders, regulations and/or ordinances by any government or governmental agency, act of God, war, terrorism, blockade, insurrection, mobilization, riots, fire, work stoppage, civil insurrection, flood, earthquake or any other circumstance beyond SELLER's reasonable control. Without limiting the preceding sentence, BUYER acknowledges that Goods originating from foreign countries are subject to export permit by the governmental authorities of the country from which such Goods originate.

14. REVISIONS: SELLER, in its sole and absolute discretion, may modify the Terms at any time and from time to time. The Terms as in effect at the time of SELLER's Acceptance shall govern the terms of sale of the Goods and Services contemplated by the Order so accepted, provided SELLER has provided BUYER with a copy of such Terms prior to or contemporaneously with the Acceptance.

15. SEVERABILITY: If any provision(s) of the Terms are held by any court of competent jurisdiction to be unenforceable or invalid, the remaining provisions of the Terms shall not be rendered invalid or unenforceable as a result thereof.

16. APPLICABLE LAW; VENUE: The Terms are governed by, and shall be construed in accordance with, the law of the State of Maryland without reference to the conflict of laws principles thereof. BUYER and SELLER agree that the State and Federal courts sitting in the City of Hanover, Maryland shall be the exclusive forums for resolving any dispute pertaining in any way to their dealings, the Terms, any Goods or any Services. BUYER consents to the jurisdiction of such courts and agrees that any such court is a convenient forum for the resolution of any such dispute, and agrees that it may be served with process for any suit in any such court by first class registered mail, return receipt requested and postage pre-paid, sent to BUYER at its address identified in an Order or by any other lawful means. BUYER acknowledges that Maryland is the headquarters state of SELLER's parent entity, and that this Section 16 is a material inducement to SELLER to transact business with BUYER.

17. NO DELEGATION OR ASSIGNMENT: BUYER may not assign or delegate any of its rights or obligations under or in connection with the Terms or the Order without the prior written consent of SELLER, and any purported assignment or delegation in violation of this sentence shall be void ab initio, without force or effect, and a material violation of the Terms by BUYER.

Phillips Corporation requires receipt of the 25% down payment before any Haas machine is ordered.
25% payments can be made via bank wire or ACH.

Bank Wires

Account Name: Phillips Corporation

Acct#: 1233252889

ACH ABA Number: 121000358

Wire ABA Number: 026009593

Routing Number: 122000030

Swift Code: BOFAUS3N

Bank of America

6000 Feldwood Rd

College Park, Ga 30349

*REQUIRED: All ACH Wire Remittance notifications should be sent to: pcar@phillipscorp.com.

Please address all Purchase Orders to the following:

Phillips Corporation

8500 Triad Drive

Colfax, NC 27235

Acknowledged and agreed as of the date indicated below:

PROPOSAL NUMBER: _____

BUYER SIGNATURE: _____

PRINTED NAME: _____ DATE: _____

TITLE: _____

Please email signed accepted proposal to pcmachineorders@phillipscorp.com or fax 336-665-1980.

Phillips[®]

SERVICES EXCLUSIVELY
FOR OUR HAAS CUSTOMERS

GET AHEAD OF THE CURVE - GET OPTO

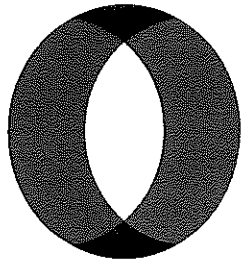

OPTO
BY PHILLIPS CORPORATION

Applications support for process improvement, specialized programming, and on-site training provided by our Haas-Certified Applications Engineers.

CERTIFIED HAAS ANNUAL MAINTENANCE PROGRAM

CHAMP

Identify potential problems with your machine before they develop with this preventative maintenance program.

**MAINTENANCE & REPAIR
TRAINING**

Week-long class in Knoxville, TN designed for customers who want an employee trained for machine maintenance

Unlimited operator training at your local HFO

**LIFETIME OPERATOR
TRAINING**

336.665.1080

pcsales@phillipscorp.com



Haas
F1 Team
OFFICIAL MACHINE TOOL

Phillips®

HAAS SERVICE TRAINING

JOIN US FOR A HAAS TRAINING EXPERIENCE LIKE NO OTHER IN THE INDUSTRY

Haas Service Training will teach you how to **TROUBLESHOOT, REPAIR and MAINTAIN** your Haas *in hours, not days.*



LOCATIONS *Knoxville, TN - Bensalem, PA - Rock Hill, SC* CONTACT hfooster@phillipscorp.com - (800) 989-9181



"I wouldn't keep sending so many of our Techs (nearly 30 so far) if I didn't think the course was a great investment."

~ **Michael Goode,**
General Electric



"This is the best machine learning environment I've ever seen. You should take this class, it's a no brainer. You're going to benefit!"

~ **Dale Miller,**
Southern Cast Products

Bottom-Line Benefits

This class more than pays for itself with fewer service calls, reduced downtime, and real gains in part quality.

For more information, email hfooster@phillipscorp.com or call (800) 989-9181.

****Interested in Mill and Lathe Crash Recovery Training?** Let us know and we can send information on those classes as well.

SKILLS COVERED



In just five days, participants will take their service game to the next level by learning to perform the following skills

- *Lathe Alignment*
- *Turret Repair (ST, SL & BMT)*
- *Tool Changer Repairs*
- *Ball Screw Replacement*
- *Spindle Replacement*
- *I/O Board & Vector Drive Troubleshooting*
- *Best Practices & MUCH MORE!!!*

HANDS-ON LEARNING



This is a roll-up-your-sleeves, get inside-the-machine learning experience.

WORLD-CLASS FACILITIES



Training takes place in state-of-the-art facilities with more than a million dollars worth of Haas equipment - just like the ones on your floor.

EXPERIENCED INSTRUCTORS



Our teachers have spent years in the field. No question too basic. No problem too complex. Small class sizes mean you have plenty of one-on-one time for all your questions.

Plus every participant receives a free Haas Service Key, which unlocks the service parameters on any Next-Gen Control so you can take ownership of your Haas service and maintenance!



HUNDREDS HAVE ATTENDED, RATING THE COURSE 9.9/10



CLASSES RUN MONTHLY, YEAR-ROUND.
CALL (800) 989-9181 TO RESERVE YOUR SPOT TODAY! OR VISIT US AT:
PHILLIPSCORP.COM/SERVICE-TRAINING

****Disclaimer - In order to attend any Advanced Courses, students must have already completed the basic Phillips Haas Service Training course. Please call/email for more information.**

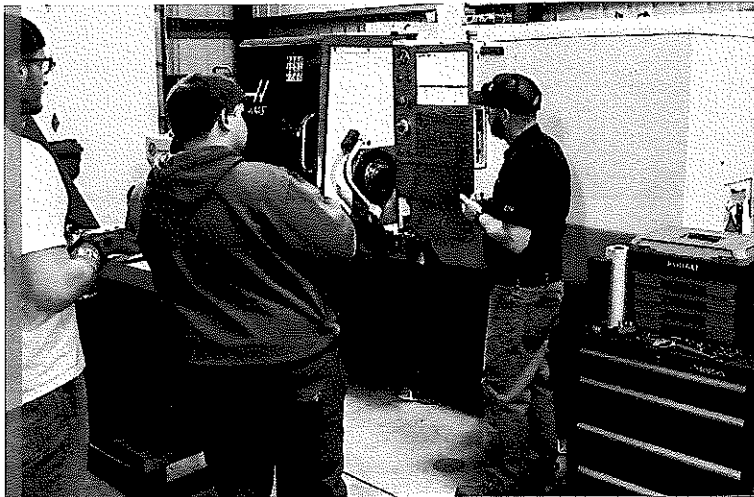

ADVANCED LATHE SERVICE TRAINING

Phillips
HAAS SERVICE TRAINING

LOCATION **Knoxville, TN** CONTACT hfooster@phillipscorp.com - (800) 989-9181

JOIN US FOR A HAAS TRAINING EXPERIENCE LIKE NO OTHER IN THE INDUSTRY

From **correcting lathe geometry** to **crash recovery**, this class will help you tackle some of the industry's most expensive and disruptive breakdowns.

■ SKILLS COVERED



In just five days, participants will take their lathe service skills to the next level by learning to perform the following skills:

- Haas Lathe geometry inspection using test bar
- Geometry correction (lathe alignment)
- Spindle replacement
- C-axis alignment & brake engagement
- Hydraulic union alignment
- Spindle lube verification
- Guide rail alignment and replacement
- Tool presetter alignment and calibration

Contact us about training grants that could cover your tuition!

■ HANDS-ON LEARNING

This is a roll-up-your-sleeves, get inside-the-machine learning experience.

■ WORLD-CLASS FACILITIES

Training takes place in state-of-the-art facilities with more than a million dollars worth of Haas equipment - just like the ones on your floor.

■ EXPERIENCED INSTRUCTORS

Our teachers have spent years in the field (If it's happened, they've seen it!). No question too basic. No problem too complex. Small class sizes mean you have plenty of one-on-one time for all your questions.



"Repairing lathe geometry is often called an art. I disagree. All you need are the right skills and practice - exactly what you'll get in this class."

~ Todd Price, Head Service Instructor

**CLASSES RUN MONTHLY, YEAR-ROUND.
CALL (800) 989-9181 TO RESERVE YOUR SPOT
TODAY! OR VISIT US AT:
PHILLIPSCORP.COM/ADVANCEDLATHE**

Bottom-Line Benefits

This class more than pays for itself with fewer service calls, reduced downtime, and real gains in part quality.

For more information,
email hfooster@phillipscorp.com or call
(800) 989-9181.

****Not quite ready for an advanced class?** Contact us to find out more about Phillips Haas Service Training - our introductory Haas Service Training class.

****Disclaimer - In order to attend any Advanced Courses, students must have already completed the basic Phillips Haas Service Training course. Please call/email for more information.**



Installed Dimensions

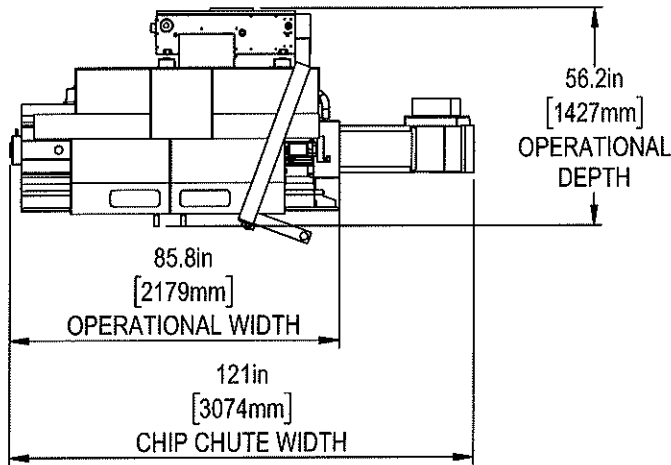
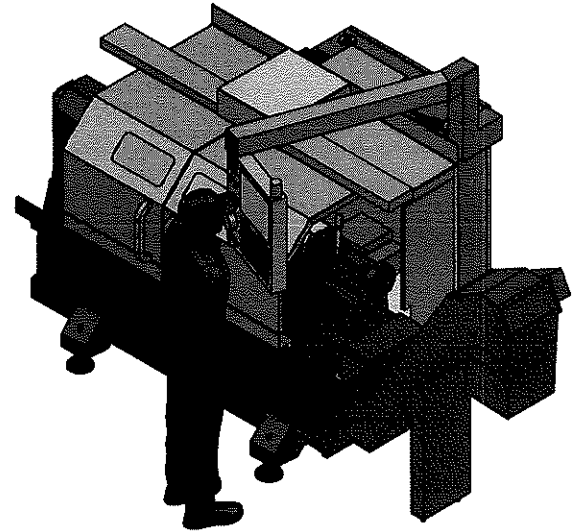
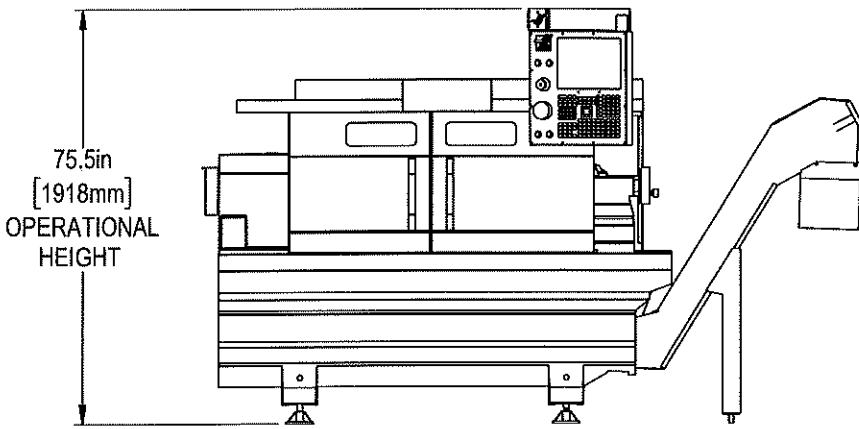

Leveling Pad Height

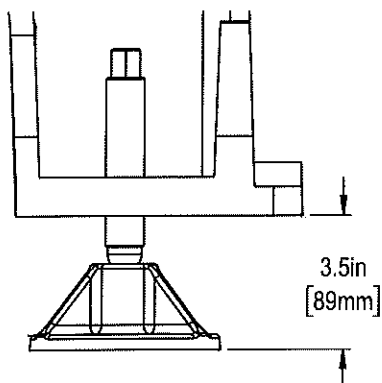

Shipping Dimensions

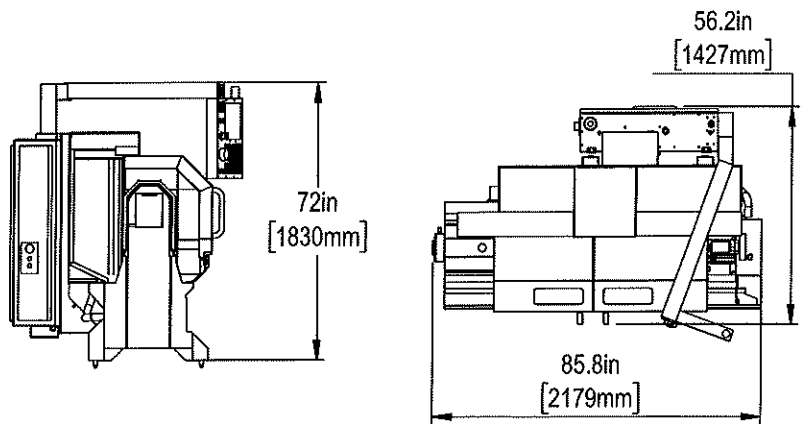

*All Height Dimensions Based on Suggested Leveling Pad Height

Air & Power

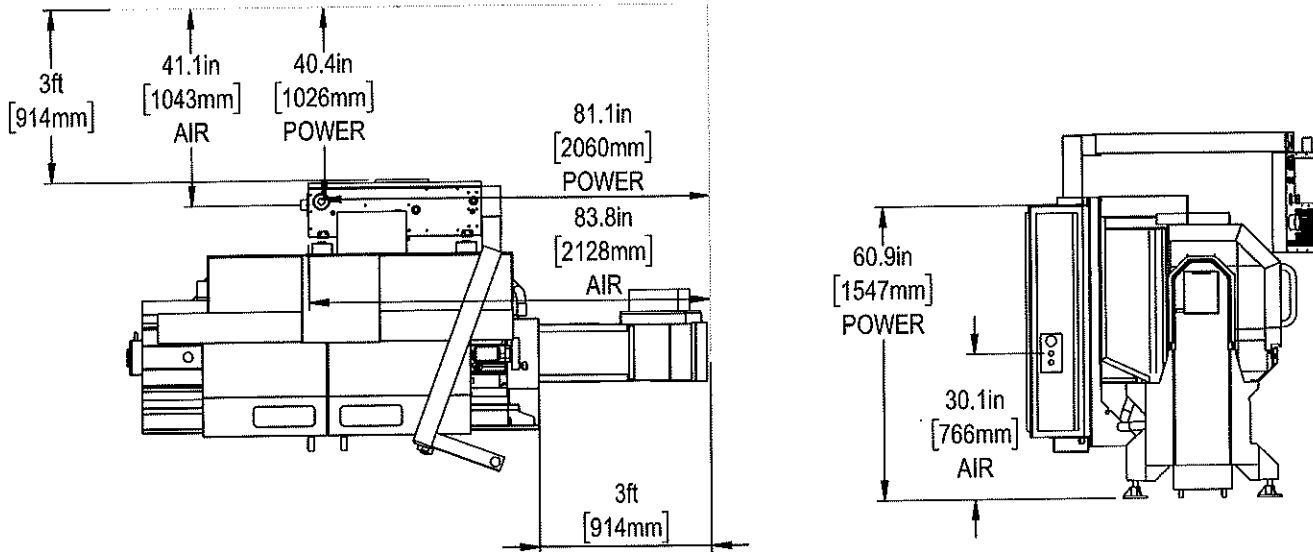

Anchor Pattern

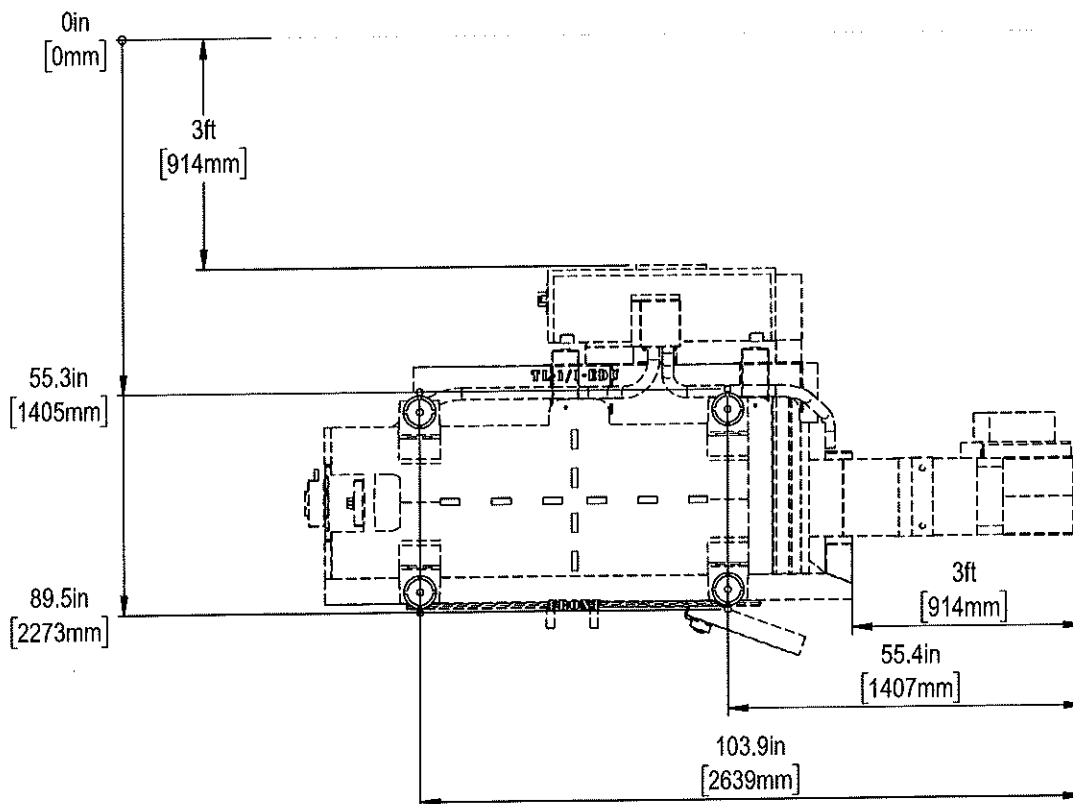



Height Breakdown

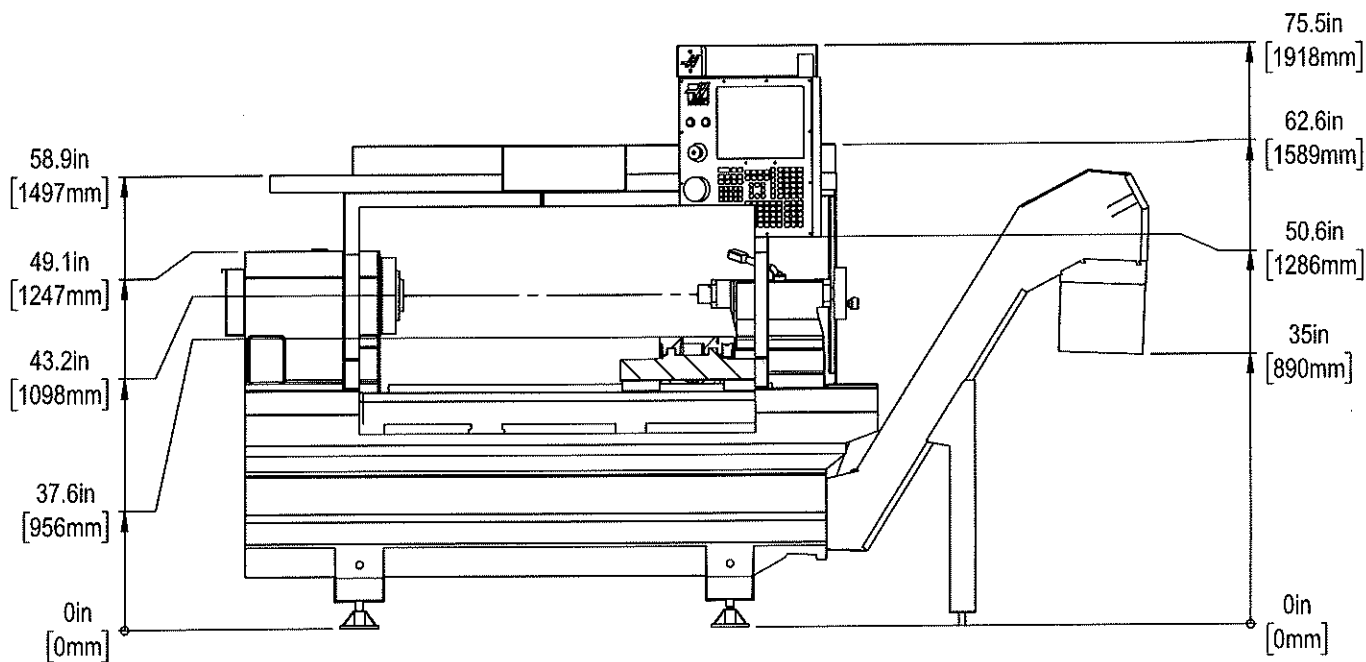

Width Breakdown

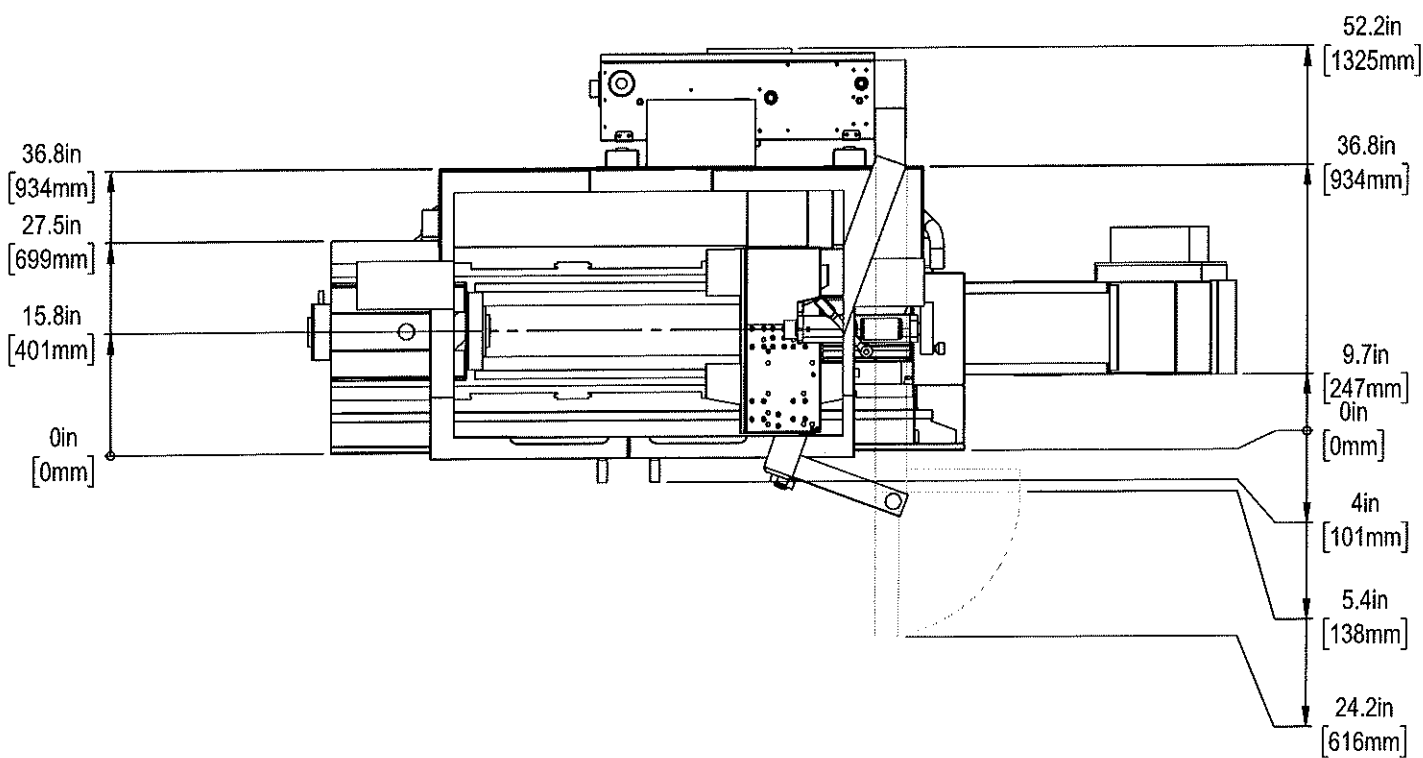

Maintain 3 feet [915mm] clearance to the nearest obstruction around all sides of machine perimeter for maintenance access.

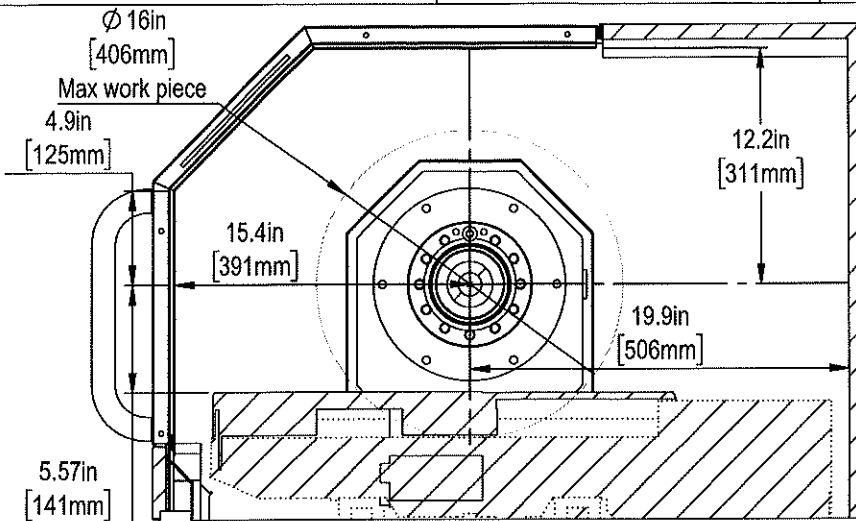

SECTION A-A

SCALE 1 : 10

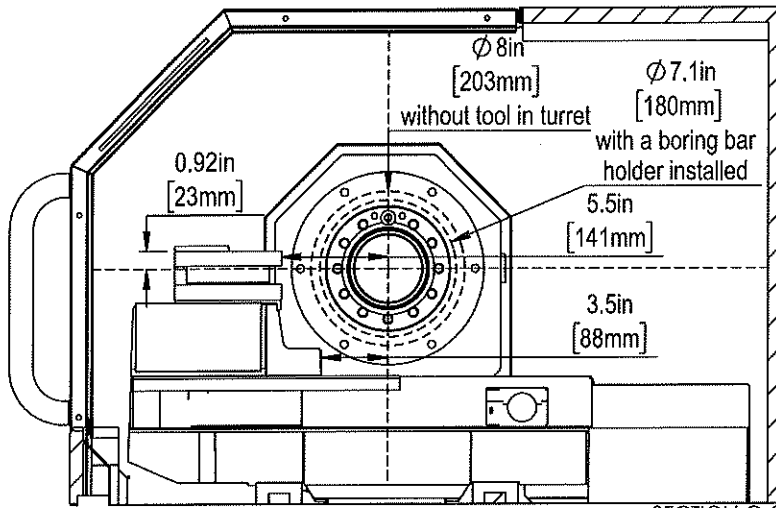
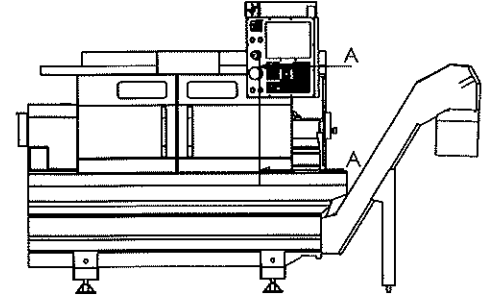

4-Station Tool Turret

SECTION C-C

SCALE 1 : 10

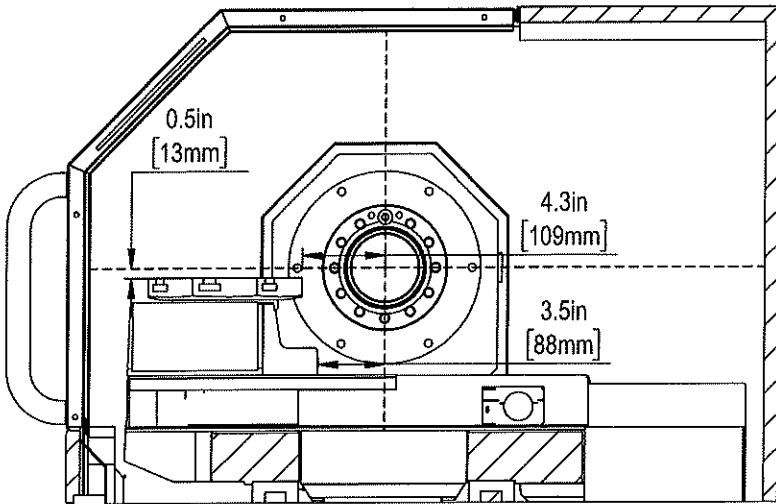
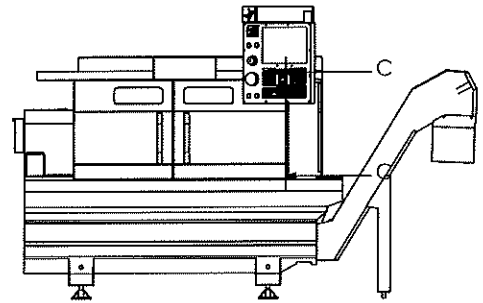

8-Station Tool Turret

SECTION B-B

SCALE 1 : 10

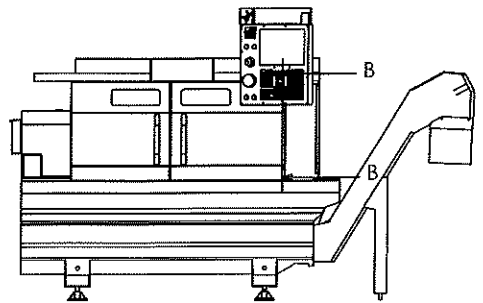

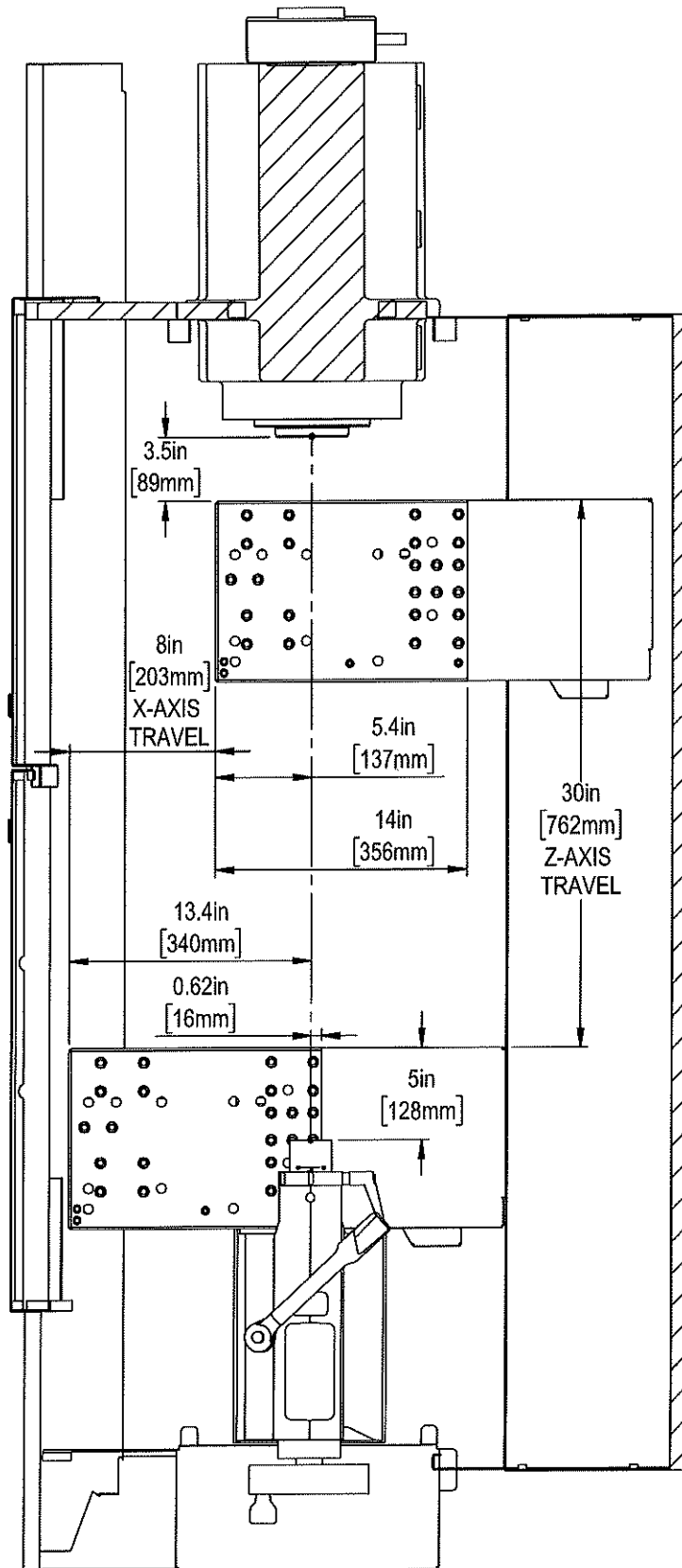

SECTION F-F

SCALE 1 : 10

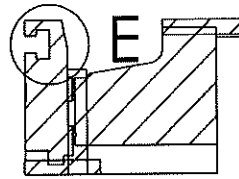
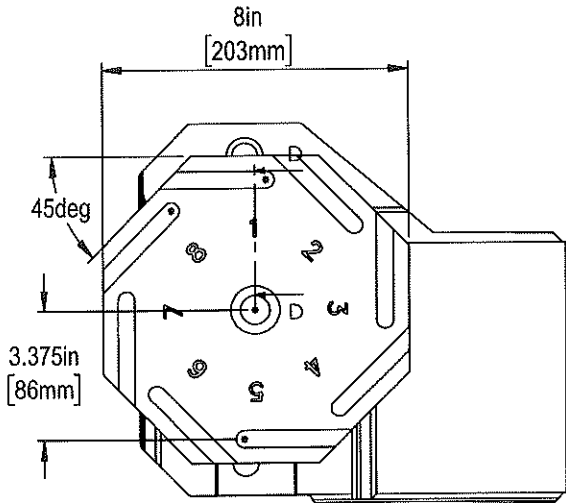

SECTION D-D
SCALE 1 : 5

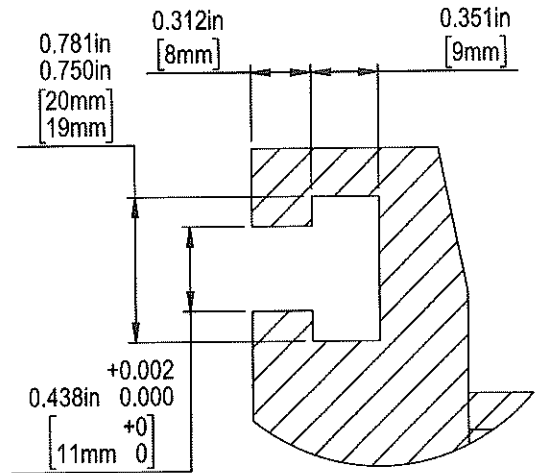

DETAIL E
SCALE 1 : 1

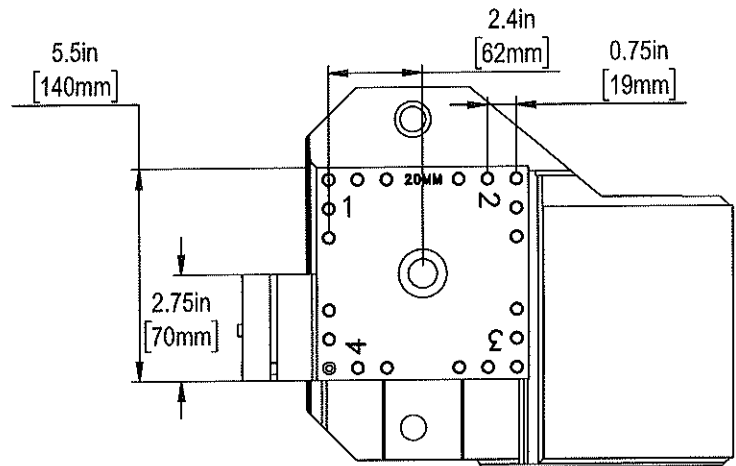
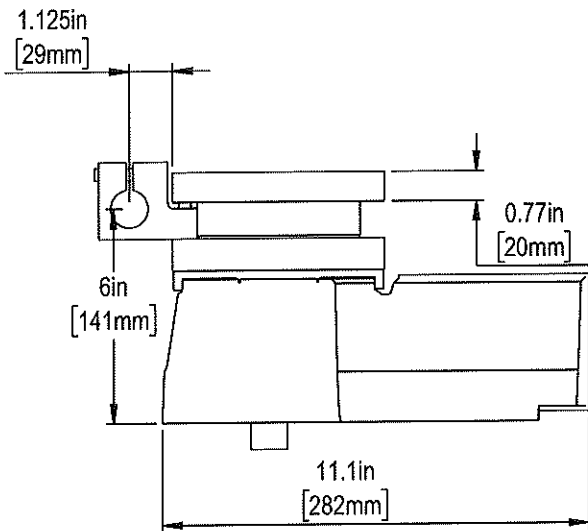

ϕ 0.268in [7mm] ∇ 0.8in [20mm]
M8x1.25 - 6H ∇ 0.8in [19mm]

ϕ 0.257in [7mm] ∇ 0.8in [20mm]
5/16-18 UNC ∇ 0.8in [19mm]

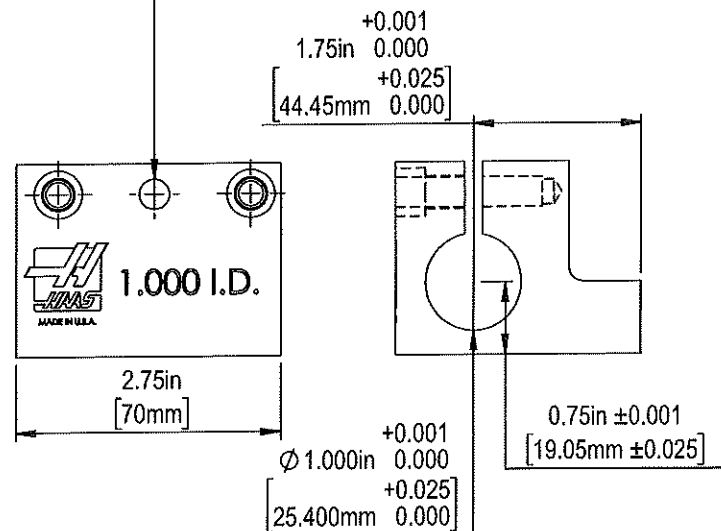
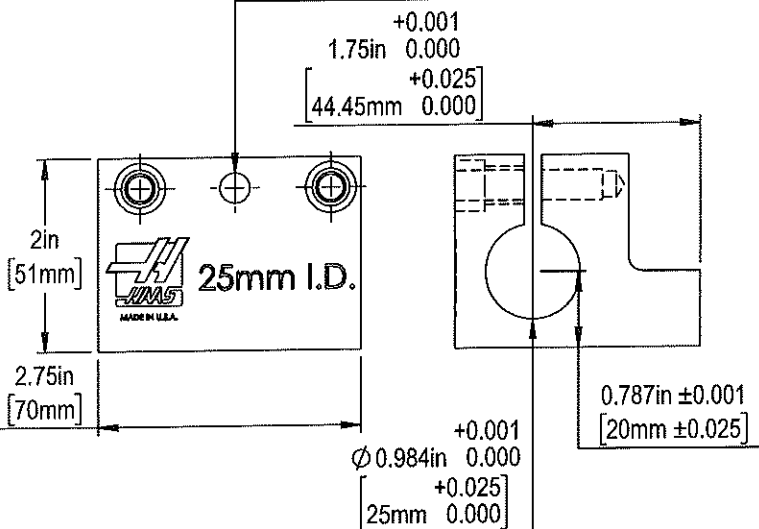

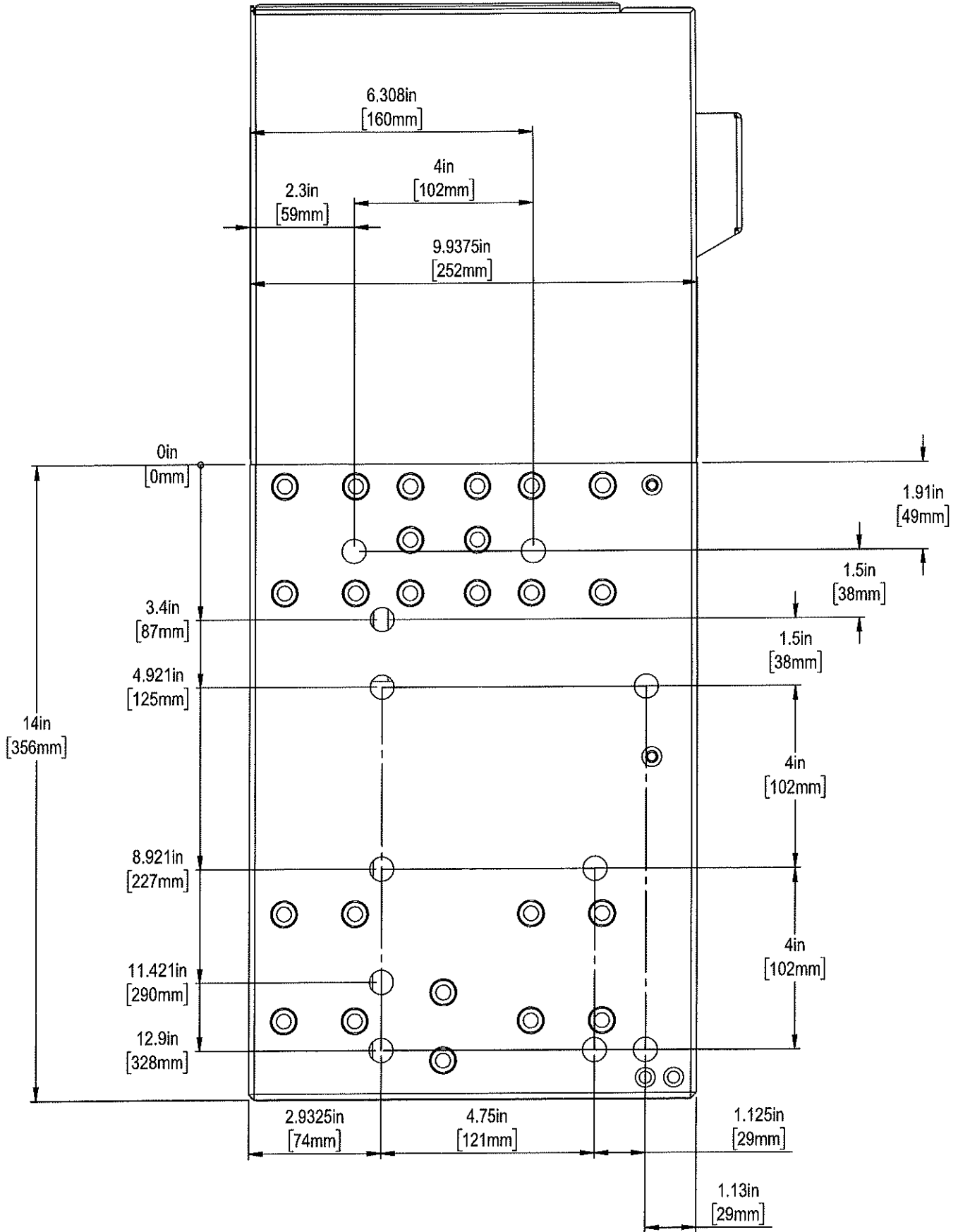

Phillips Commercial
8500 Triad Drive, Colfax, NC 27235
3599 Marshall Lane, Bensalem, PA19020

Ph. (336)665-1080
Ph. (215)245-5500

www.hfophillips.com

Parts Email: pcparts@phillipscorp.com
Service Email: pcservice@phillipscorp.com

Machine Quote

Date: 6/13/2023

Contact: Beverly Miller	Account: Greeneville City Schools
Phone #: 4237878019	Address:
Email: millerb@gcschools.net	

Salesperson:	Terms:	FOB:	Delivery:
Bill Walsh	Standard Terms: 25% down, net 15 days from shipment at factory	Gardena, CA	In stock, subject to prior sale; please allow 2-3 weeks for installed accessories

Sharp Precision Machine Tools Proposal

Sharp Vertical Contour Saw: SWV 1614

Sharp's multi-function design along with easy operating system makes our vertical band saw suitable for cutting a wide range of materials. The superior flexibility allows users to accurately cut contour shapes, straight cuts and even make internal cuts on one self-contained machine.

SWV 1614

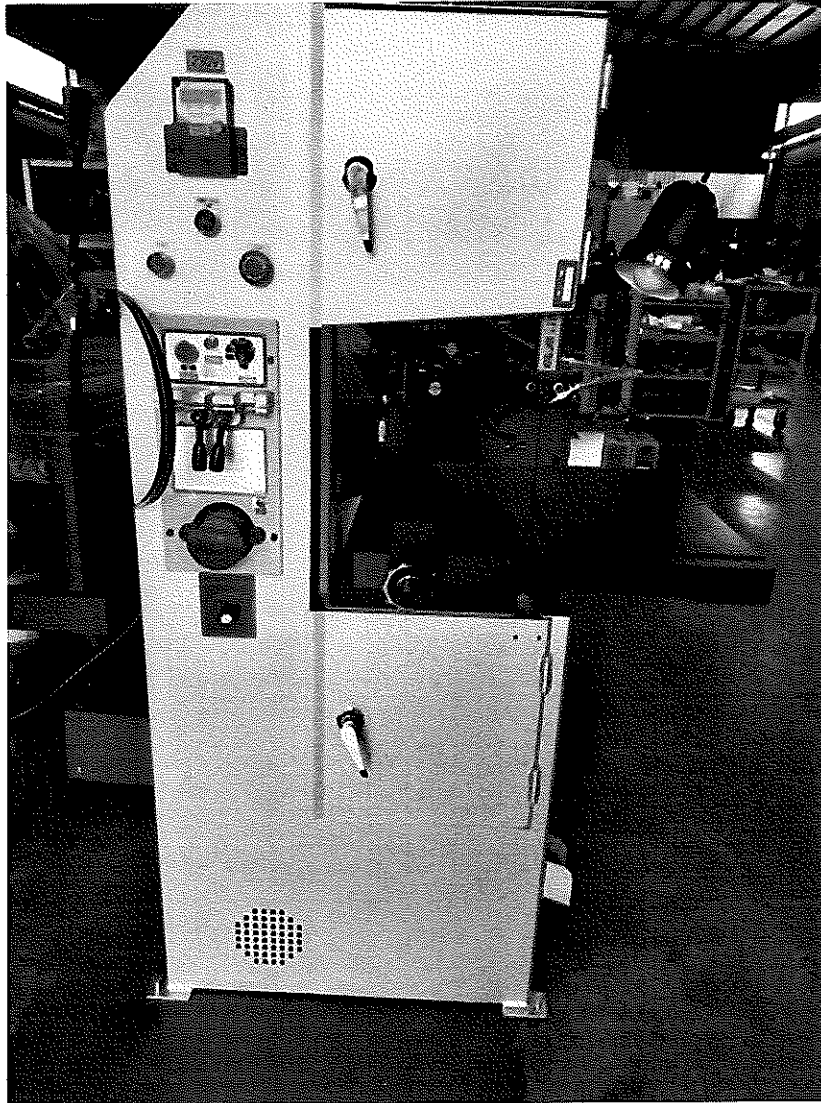



SWV 1614 Vertical Contour Band Saw

\$ 9,830.00.

Main Features

The Sharp Vertical Band saw is one of the most versatile machines on the market today. It's multi-purpose design, inverter drive, and heavily constructed base allows the machine to cut smoothly even while operating at a high-speed range: 36m~400m/min or 118 ft. to 1312 ft./min.

With just the turn of a knob the band speed is digitally displayed and is easily adjusted for the material being cut from 36m~400m/min. This allows the machine to cut effectively, and accurately, on a very broad range of materials.

Wood: 300m~400m/min	984 ft. /min-1,312 ft. /min.
Plastic: 200m~350m/min	650ft/min-1150 ft. /min.
Copper & Aluminum: 100m~250m/min	330ft/min-820ft./min
Steel : 36m~80m/min	118ft/min-350ft./min

One of the biggest advantages this versatile machine provides is allowing the operator to make straight, contour, or internal cuts on metal, wood, plastic, etc.

Structure Features:

1. Infinite Variable Blade Speed
The inverter drive with the digitally displayed band speed range makes the machine ideal for cutting a wide variety of materials.
2. LED Industrial Work light
The work light allows the operator to easily see exactly where the band saw blade is cutting.
3. The One-Piece Construction
Increases the rigidity of the machine reducing vibration in the sawing process for increased productivity and long blade life.
4. Manual Band Tension & Indicator
This allows for the proper tension of the band saw blade based on the width of the blade being used.
5. Post Elevation Retention Knob
This allows for proper positioning of the upper saw guide for more accurate cutting and longer blade life.
6. Cast Iron Table



Provides for a very rigid working surface for the parts being cut.

7. Rip Fence

Make cutting of straight cuts of any length very simple for operator.

Shuts machine off if the blade breaks.

8. Chip Blower

Make it easy to see scribed line during cutting process.

Component Features

1. Blade Shear

Allows the operator to cut the blade to the appropriate length at the machine before welding, greatly enhancing convenience.

2. Blade Welder:

Compared with the general design of copper material, Sharp uses the gold-plated welding port that are less likely to oxidize and affect the welding process. This standard feature allows the operator to thread the saw blade through a hole in the part, re-weld the sawblade at the machine, and perform internal cutting. This process increases productivity and saves money.

3. Built in Blade Grinder

Allows the operator to grind off the slag created in the blade welding process at the saw.

4. Power Button

Conveniently located on the front of the machine for easy operation.

5. Blade Guides & Back up Bearing

Tungsten carbide tipped for extended life and accuracy of cut.

6. Brush For Cleaning Drive Wheel

Eliminates chip interference in the cutting process

SPECIFICATIONS:

SWV -1614 Vertical Band Saw

SPECIFICATIONS	Imperial Unit	Metric Unit
Max Cutting Capacity, Throat	15.7"	400 mm
Max Cutting Capacity , Height	13.8"	350 mm
Wheel Diameter	13.8"	400 mm
Inclination , Front/Back	10 degrees	10 degrees
Inclination , Left/Right	15 degrees	15 degrees
Table size	23.6 x 19.7"	600x 500 mm
Table Working Stroke		
Blade Length	0.75x 136.2"	19 x 3460 mm



Motor	1 HP	0.75 KW
Blade Speed	1181 - 18110 ipm	30-460 M/min
Machine Dimensions	43.3x 34.6x74.4"	1100 x 880x 1890 mm
Weight	550Lbs	410
List price	\$9,830	

SWV 1614 Vertical Contour Band Saw	\$ 9,830.00
Education Discount	- 393.20
Freight	\$ 1,660.00
Rigging	\$ 520.00
TOTAL INVESTMENT	\$ 11,616.80

**Final invoice will include any applicable sales tax.
Quotation valid thirty (30) days from date of issue.**

Terms & Conditions: Phillips Corporation requires receipt of 25% down payment before any machine is ordered. 25% payments can be made via bank wire or ACH. Please see the following for sending your payment.

Bank Wires:	
Account Name: Phillips Corporation	Bank of America 6000 Feldwood Rd College Park, GA 30349
Account Number: 1233252889	
ACH ABA Number: 121000358	
Wire ABA Number: 026009593	*All ACH Wire Remittance notifications should be sent to: pcar@phillipscorp.com *REQUIRED
Routing Number: 122000030	
Swift Code: BOFAUS3N	





Customer Signature

Order Approval:

Authorized Signature

Print Name

Date

Purchase Order Number

An order resulting from this proposal should be addressed as follows:

Phillips Corporation

8500 Triad Drive

Colfax, NC 27235

FAX: 336-665-1980

Email: PCMachineorders@phillipscorp.com

Thank you for your consideration!

Phillips Commercial
8500 Triad Drive, Colfax, NC 27235
3599 Marshall Lane, Bensalem, PA19020

Ph. (336)665-1080
Ph. (215)245-5500

www.hfophillips.com

Parts Email: pcparts@phillipscorp.com
Service Email: pcservice@phillipscorp.com

Machine Quote

Date: 6/13/2023

Contact: Beverly Miller	Account: Greeneville City Schools
Phone #: 4237878019	Address:
Email: millerb@gcschools.net	

Salesperson:	Terms:	FOB:	Delivery:
Bill Walsh	School Terms, Net 30	Gardena, CA	July 2023; please allow 2-3 weeks for installed accessories

Sharp Precision Machine Tools Proposal

LMV49 with Standard DVS Head

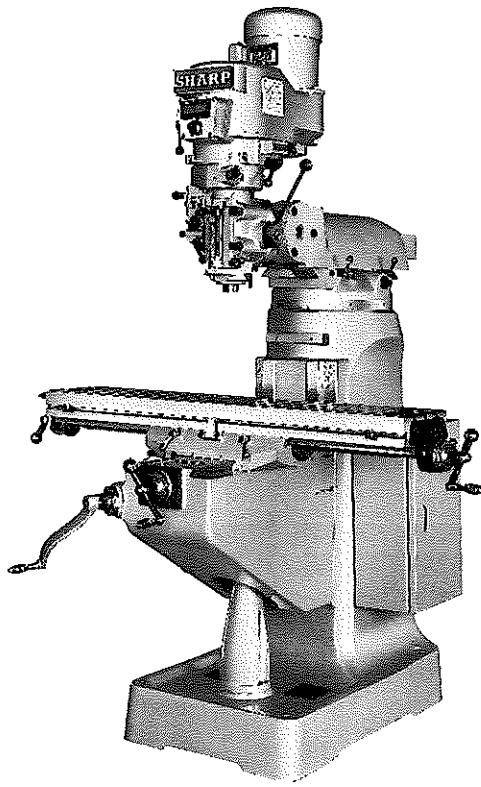



LMV-49 VERTICAL MILL with DVS head:

\$ 14,600.00

All Payment made via wire transfer or other methods of digital payment delivery, you must call Sharp industries accounting department personnel at 310-370-5990 for the specific payment instruction details and verification

STANDARD EQUIPMENT:

- ◆ Hard-Chrome Ways And Gibbs
- ◆ Precision Ground And Flaked Table
- ◆ Unique Double Nut Backlash System
- ◆ Cutler Hammer On/Off Switch
- ◆ Front And Rear Way Covers
- ◆ One Shot Lube System (X , Y , Z Axes)
- ◆ Tool Kit Includes:
Machine Manual, Half Nut Wrench, Wrench 17m, 19m, Set Of 6 Allen Wrenches, Philip Screw Driver, Flat Head Screw Driver, Oil Can, Grease Gun, Rear Way Cover Bracket, Pin For Indicator, Can Of Paint
- ◆ Wired 220V or 440V. Please Specify. (Note: 440V requires additional transformer, 220 V single phase is available)

FEATURES:

- ◆ 3HP Motor
- ◆ Digital Variable Speed Drive
- ◆ R-8 Spindle
- ◆ Meehanite Casting
- ◆ Chromed Ways
- ◆ Self-Lubricating Motor Shaft Extends Pulley Life
- ◆ Abec-7 Super Precision Spindle Bearings

SPECIFICATIONS:

- ✓ Table



◆ Working Surface	9" x 49"
◆ T-Slots Number and Size	3 Slots, 5/8"
✓ Capacity	
◆ Travels (X, Y, And Z)	36.6" x 12" x 5"
◆ Ram Travel	12"
◆ Knee Travel	16"
◆ Spindle To Column (Min-Max)	6-3/4"-18 1/2"
◆ Spindle Nose To Table (Min-Max)	2-1/8"-18"
✓ Spindle	
◆ Spindle Motor	3 HP
◆ Spindle Nose Taper	R8
◆ Digital Variable Speed Drive (DVS)	65- 4500 RPM
◆ Quill Feed 3 Speed (IPR)	0.0015,0.003, 0.006"
◆ Head Swivels	360°
◆ Head Tilt (Lt. To Rt)	45°
◆ Head Tilt (Up And Down)	45°
✓ Dimensions and Weight	
◆ Floor Area (W x D x H)	7'x 6.5'x 6.75'
◆ Weight	2,100 Lbs.
✓ Total Power Consumptions	
◆ 220V	3KVA/8 amps
◆ 440V	3KVA/4 amps

OPTIONAL ACCESSORIES:

6" "Kurt" Vise with Swivel Base (DX6 vise & D50-4-SA swivel base)

•	5000-2126 A	\$ 1,470.00
• Auto lube pump		\$ 970.00
• Right Angle Milling Attachment with Arbor	ACC-10-NT30	\$ 2,270.00



• Right Angle Milling Attachment with Arbor	ACC-10LMV-R8	\$ 2,270.00
• “Sharp” Power Table Feed with Safety Handle (X-Axis)	* SP-250A (see notes)	\$ 925.00
• “Sharp” Power Cross Feed with Safety Handle (Y-Axis)	SP-250B	\$ 925.00
• “Sharp” Power Knee Feed with Safety Handle (Z-Axis)	SP-250D	\$ 925.00
X Axis Installation		\$ 185.00 NET
Y Axis Installation		\$ 300.00 NET
Z Axis Installation		\$ 300.00 NET
* NOTES: SP-250A installation may reduce the X-axis travel.		
•		
• Drill Chuck & Drill Arbor	LMV-D/A	\$ 560.00
• 6” Riser Block	ACC-26	\$ 1,250.00
Riser Block Installation		\$ 210.00 NET
• Coolant System with Chip Pan at Base (pump included)	C311-LMV	\$ 970.00
• “Maxi Torque Rite” Power Draw Bar	TR-100	\$ 1,040.00
Factory Installation		\$ 215.00 NET
• R-8 Collet (Set of 11) - 1/8”-3/4” BY 1/16”	ACC-R8	\$ 280.00
• Clamping Kit (52 pcs/Steel Rack)	CK-104	\$ 270.00
• Halogen Work light	WL-110V55W	\$ 280.00
• NT 30 spindle in lieu of R 8	R8-NT30	\$ 3000.00
• CE mark	net	\$ 1,735.00
• 380V and 575 V transformer	440T4	\$ 910.00 Net
• UL(to meet state of Californi)a components upgrade with electrical box (factory order)	LMV-UL	\$ 4,040.00
• UL compliance certificate under State of California		net \$ 4,725.00
• Upgrade X/Y axis with ball screw (factory order)		\$ 4,500.00

DIGITAL READOUT SYSTEMS:

• Fagor Digital Readout		
• 2-Axis X&Y (Fagor 20i)	FG-LMV50	\$ 2,075.00
• 3-Axis X&Y on Quill (Z) (Fagor 30i)	FG-LMV50-3A	\$ 2,795.00
• 3-Axis X&Y on Knee (Z) (Fagor 30i)	FG-LMV50-3AK	\$ 2,920.00
• 2 Axis D.R.O. Installation		\$ 510.00 NET
• 3 Axis D.R.O. Installation		\$ 845.00 NET
•		
• Acu-Rite 203S Digital Readout		



2-Axis X&Y	AR-LMV50	\$ 2,480.00
3-Axis X&Y on Quill (Z)	AR-LMV50-3A	\$ 3025.00
3Axis X&Y on Knee (Z)	AR-LMV50-3AK	\$ 3,250.00
4 – Axis X/Y/Quill/Knee (Z) 300 S	AR-LMV50-4AK	\$ 4,500.00
2 Axis D.R.O. Installation		\$ Net 510.00
3 Axis D.R.O. Installation		\$ Net 845.00
4 Axis DRO installation		\$ Net 1,095.00
• Newall DP700 Digital Readout		
2-Axis X&Y	NWDP-LMV50	\$ 2935.00
3-Axis X&Y on Quill (Z)	NWDP-LMV50-3A	\$ 3935.00
3-Axis X&Y on Knee (Z)	NWDP-LMV50-3AK	\$ 3935.00
• Newall NMS 800 DRO (N/A until March 23)		
2-Axis X&Y	NWN-LMV50	\$ 2170.00
3-Axis X&Y on Quill (Z)	NWN-LMV50-3A	\$ 2955.00
3-Axis X&Y on Knee (Z)	NWN-LMV50-3AK	\$ 2955.00
2 Axis D.R.O. Installation		\$ 510.00 NET
3 Axis D.R.O. Installation		\$ 845.00 NET



LMV-49 VERTICAL MILL with DVS head: \$ 14,600.00

• R-8 Collet (Set of 11) - 1/8"-3/4" BY 1/16"	ACC-R8	\$ 280.00
• Clamping Kit (52 pcs/Steel Rack)	CK-104	\$ 270.00
• Newall DP700 Digital Readout		
o 3-Axis X&Y on Knee (Z)	NWDP-LMV50-3AK	\$ 3,935.00
• 3 Axis D.R.O. Installation		\$ 845.00 NET
Discount		- 673.70
Freight		\$ 1,800.00
Rigging		\$ 520.00
TOTAL INVESTMENT		\$21,576.30

Final invoice will include any applicable sales tax.
Quotation valid thirty (30) days from date of issue.

Bank Wires:	
Account Name: Phillips Corporation	Bank of America 6000 Feldwood Rd College Park, GA 30349 *All ACH Wire Remittance notifications should be sent to: pcar@phillipscorp.com *REQUIRED
Account Number: 1233252889	
ACH ABA Number: 121000358	
Wire ABA Number: 026009593	
Routing Number: 122000030	
Swift Code: BOFAUS3N	



Customer Signature

Order Approval:

Authorized Signature

Print Name

Date

Purchase Order Number

An order resulting from this proposal should be addressed as follows:

Phillips Corporation

8500 Triad Drive

Colfax, NC 27235

FAX: 336-665-1980

Email: PCMachineorders@phillipscorp.com

Thank you for your consideration!



HAAS FACTORY OUTLET
A DIVISION OF PHILLIPS

DESKTOP MILL PROPOSAL

PROPOSAL: HFO-PC1633713

DATE: JUNE 12, 2023

**PREPARED FOR:
BEVERLY MILLER
GREENVILLE HIGH SCHOOL
210 TUSCULUM BLVD
GREENEVILLE TN 37745-3999**

**PREPARED BY:
BILL WALSH
HAAS FACTORY OUTLET | A DIVISION OF PHILLIPS CORPORATION
865-599-3372
bwalsh@phillipscorp.com**



QUOTATION

DESKTOP MILL × 2

\$19,990.00

Travels

X Axis	152 mm / 6.0 in
Y Axis	254 mm / 10.0 in
Z Axis	76 mm / 3.0 in
Spindle Nose to Table (~ max)	80 mm / 3.2 in

Options

Visual Part Programming System × 2	Included
15,000-rpm ER11 Spindle × 2	Included
Ethernet Interface × 2	Included
Standard Program Memory, 1 GB × 2	Included
User-Definable Macros × 2	Included
7" Desktop Mill Vise × 2	Included
Coordinate Rotation and Scaling × 2	Included
HaasConnect: Remote monitoring × 2	Included
HaasDrop × 2	Included
Media Display M-Code; M130 × 2	Included
6-Month Standard Warranty × 2	Included
Control Touch Screen × 2	Included
WiFi Connection for the Haas Control × 2	Included
High-Speed Machining × 2	Included
Desktop Software Package × 2	\$ 4,390.00
LOW-VOLT × 2	Included

Haas Tooling

Desktop Mill Tooling Starter Kit × 2 :	\$ 999.90
- 03-0080 HSAM1, 1/16" Ø Carbide End Mill, 1/8" Shank x 3/16" LOC, Square Profile, 3 Flute, Uncoated	
- 03-0685 1/16" Ø Carbide Drill, 3mm Shank x 140° Point Angle x 17° Helix, 3XD, 2 Flute, TiAIN Coated	
- 03-0686 5/64" Ø Carbide Drill, 3mm Shank x 140° Point Angle x 17° Helix, 3XD, 2 Flute, TiAIN Coated	
- 03-0688 3/32" Ø Carbide Drill, 4mm Shank x 140° Point Angle x 18° Helix, 3XD, 2 Flute, TiAIN Coated	
- 03-0693 7/64" Ø Carbide Drill, 4mm Shank x 140° Point Angle x 19° Helix, 3XD, 2 Flute, TiAIN Coated	
- 03-0697 1/8" Ø Carbide Drill, 6mm Shank x 140° Point Angle x 30° Helix, 3XD, 2 Flute, TiAIN Coated	
- 03-0701 9/64" Ø Carbide Drill, 6mm Shank x 140° Point Angle x 30° Helix, 3XD, 2 Flute, TiAIN Coated	
- 03-0705 5/32" Ø Carbide Drill, 6mm Shank x 140° Point Angle x 30° Helix, 3XD, 2 Flute, TiAIN Coated	
- 03-0711 11/64" Ø Carbide Drill, 6mm Shank x 140° Point Angle x 30° Helix, 3XD, 2 Flute, TiAIN Coated	
- 03-0713 3/16" Ø Carbide Drill, 6mm Shank x 140° Point Angle x 30° Helix, 3XD, 2 Flute, TiAIN Coated	
- 03-0717 7/32" Ø Carbide Drill, 6mm Shank x 140° Point Angle x 30° Helix, 3XD, 2 Flute, TiAIN Coated	
- 03-0718 15/64" Ø Carbide Drill, 6mm Shank x 140° Point Angle x 30° Helix, 3XD, 2 Flute, TiAIN Coated	
- 03-0720 1/4" Ø Carbide Drill, 8mm Shank x 140° Point Angle x 30° Helix, 3XD, 2 Flute, TiAIN Coated	
- 03-1921 HSAM2, 1/8" Ø Carbide End Mill, 1/8" Shank x 3/8" LOC, 0.01" Radius, 3 Flute, DLC Coated	
- 03-1922 HSAM2, 3/16" Ø Carbide End Mill, 3/16" Shank x 9/16" LOC, 0.01" Radius, 3 Flute, DLC Coated	
- 03-2088 Carbide Engraving Tapered Ball End Mill, 1/8" Shank x 5/16" LOC, 0.0313" Radius, 2 Flute, Uncoated	
- 03-2089 Carbide Engraving Tapered Ball End Mill, 1/8" Shank x 5/16" LOC, 0.0313" Radius, 2 Flute, TiAIN Coated	
- 03-2103 Carbide Engraving Cutter, 1/8" Shank x 1/8" LOC, 0.021" Radius, 1 Flute, Double End, Uncoated	
- 03-2104 Carbide Engraving Cutter, 1/8" Shank x 1/8" LOC, 0.021" Radius, 1 Flute, Double End, TiAIN Coated	
- 04-0291 15-Piece, ER11 Straight Bore Collet Set, 1mm - 8mm	

Machine & Options Total	\$ 24,380.00
Haas Toolings Total	\$ 999.90

MACHINE TOTAL **\$ 25,379.90**

ADDITIONAL ITEMS

Desktop Mill Freight: from Oxnard CA to Customer × 2	\$ 1,200.00
--	-------------

* Not available for field installation

TOTAL INVESTMENT

\$26,579.90

Shipping
Point
Delivery

FOB Oxnard, CA

6-7
weeks

Payment Terms School terms, net 30 days

Customs/Duty/Taxes Final invoice will include any applicable sales tax, Please be aware: If we have not received a current sales tax resale/exempt certificate from your organization by April 7th, 2023 you will be charged and expected to pay for any applicable sales tax on your order. Certificates may be emailed to Phillipscorp@certcapture.com to avoid taxation on your order. If there are any question related to this matter, please contact Pcexemptions@phillipscorp.com

Validity Pricing can change without notice

Warranty 6 month warranty

Title Transfer The day your machine leaves the Haas Automation Facility, the ownership/title of the machine automatically transfers to your company.

Machine Storage Please note that machines held in storage may be subject to a storage charge.

Voltage Single Phase 120 V

Purchase Orders PO for above should be made out to Phillips Corporation



TERMS AND CONDITIONS

1. **STANDARD TERMS:** This document contains the standard terms and conditions (the "Terms") applicable to dealings between Phillips Corporation (Haas Factory Outlet Phillips Corporation) ("SELLER") and its customers, including the customer signing this document below ("BUYER"). The Terms are incorporated into, and a material part of: (a) each proposal to sell goods ("Goods") and, if applicable, ancillary services ("Services") made by SELLER to BUYER (a "Proposal"), (b) each order to purchase Goods and/or Services submitted by BUYER to Seller (an "Order"), (c) each acceptance of an Order by SELLER (an "Acceptance"), (d) each invoice issued by SELLER (an "Invoice"), and (e) all other documents exchanged between SELLER and BUYER pertaining to any ORDER (each Proposal, Order, Acceptance, Invoice or other relevant document is a "Document"); in each case regardless of whether the Terms are referred to in the Document and regardless of whether the Document is submitted or provided electronically, on paper or otherwise. The Terms shall control over any contrary terms or conditions set forth in any Document, regardless of when the Document may be provided by BUYER to SELLER or SELLER to BUYER, except as expressly agreed by SELLER and BUYER in a writing specifically described as an amendment of the Terms, and SELLER and BUYER expressly object to any contrary terms or conditions.

2. **PROPOSALS AND ORDERS:**

- a) A Proposal is valid for 30 days from the date shown on it unless otherwise specified in it.
- b) A Proposal does not constitute a firm offer, but is rather an invitation to BUYER to place an Order.
- c) All Orders shall be in writing. All Orders shall be subject to written Acceptance by SELLER.
- d) SELLER is not the manufacturer of any of the Goods. All weights, measurements and other specifications of Goods set forth in Proposals, Orders and Acceptances are estimates based on information provided by the manufacturer, and SELLER shall not be responsible for any deviations therefrom. Brochures, photographs and other illustrations depicting or describing Goods are non-binding in detail, and BUYER acknowledges that such brochures, photographs and other illustrations may have been superseded since being provided by the manufacturer. BUYER acknowledges further that manufacturers reserve the right to discontinue or to make changes to their products at any time, and that Goods are subject to specification and/or design changes without prior notice. Nothing contained in any descriptions of the Goods set forth in any Proposal, Order, Acceptance or other Document shall expand or otherwise affect SELLER's warranty obligations as set forth in Section 7.
- e) Any production estimates provided by SELLER are not guarantees of actual production unless specifically so stated in writing and signed by a duly authorized officer of SELLER. All time study figures relating to Goods are only estimates based on information provided to SELLER pertaining to finish required, machine-ability of the Goods, amount of material to be removed, BUYER's operating conditions and similar factors.
- f) SELLER retains the right to correct in its Acceptance any clerical error contained in a Proposal or an Order. BUYER agrees to promptly notify SELLER of any suspected clerical error in a Proposal.

3. **PRICES:**

- a) All prices listed in a Proposal are F.O.B. Ship Point (i.e., manufacturer's factory, port of entry or stocking warehouse) unless otherwise specified. Prices are subject to change without notice until confirmed by SELLER in its Acceptance.
- b) Prices quoted in a Proposal do not include sales, use, excise, property or similar taxes arising out of or relating to the sale, purchase, ownership or use of Goods or Services, and all sales are made subject to applicable taxes, the entire amount of which BUYER agrees to pay. BUYER shall provide SELLER with any applicable tax exemption certificates acceptable to appropriate taxing authorities together with an Order. BUYER shall indemnify and hold SELLER harmless from and against the imposition and payment of such taxes. SELLER may in any Invoice or separately bill BUYER at any time for any such taxes, in which case BUYER shall pay the same to SELLER, but SELLER shall not be obligated to do so.
- c) All freight and rigging quoted in a Proposal is subject to change until confirmed by SELLER in its corresponding Invoice.
- d) SELLER will be compensated for all service work performed by SELLER on Goods not covered by manufacturer's warranty or after the manufacturer's warranty period has expired at SELLER's then prevailing rate, plus all expenses, transportation, material and parts.

4. **PAYMENT TERMS:** Subject to SELLER's credit approval of BUYER:

- a) The terms of payment with respect to any Order shall be as specified in the Proposal or the Acceptance applicable to the Order (with the Acceptance controlling if differing terms are specified). If terms of payment are not specified in a Proposal or Acceptance, then BUYER shall pay 25% of purchase price as a non-refundable deposit at time of transmitting an Order (the "Deposit") and 75% of purchase price net 15 days from SELLER'S shipment of Goods (the "Final Payment"). In the case of leased and financed Orders, the Final Payment is due upon the sooner of BUYER's signing the delivery slip or acceptance or installation of Goods, but in no event later than 15 days from SELLER's shipment of Goods. Any unpaid amount shall bear interest from the due date until payment at a rate equal to the lesser of 2% per month or the maximum percentage permitted by law. Delays in installation and/or delays in operation of Goods caused by damage, warranty service or warranty replacement of parts or otherwise shall not extend or alter time for payment.
- b) BUYER shall pay all of SELLER's costs (including without limitation court costs and reasonable attorney fees) incurred in collecting past due amounts (whether purchase price or other amounts owing pursuant to the Terms) regardless of whether litigation is commenced.
- c) To secure the Obligations, BUYER hereby grants SELLER a first priority security interest in all Goods sold by SELLER to BUYER, any accessions thereto and any insurance, sale or other proceeds of the foregoing (the "Collateral"). For these purposes, the "Obligations" means all amounts due to SELLER in connection with Goods and/or Services sold to BUYER, including without limitation purchase price, taxes and all fees, expenses and reasonable attorneys' fees incurred by SELLER pursuant to or in connection with the Terms, the Obligations or the Collateral. BUYER agrees to insure the Collateral against loss or damage by fire or other risks and hazards in an amount no less than the replacement value of the Collateral, and upon request to provide SELLER with evidence of such insurance identifying SELLER as loss payee as its interests may appear. BUYER authorizes SELLER to file with applicable governmental authorities financing statements and similar instruments describing the Collateral without the signature of BUYER. Upon BUYER's default in any payment or other performance under the Terms, SELLER may, in its sole and absolute discretion, declare all Obligations immediately due and payable without demand, protest or other notice of any kind, and

SELLER shall have the right to repossess the Collateral (BUYER hereby granting SELLER a right of access to BUYER's premises for such purposes) and all other remedies of a secured party under the Uniform Commercial Code as in from time to time in effect in the state origin of purchase.

5. SHIPPING:

- a) Goods subject to an accepted Order shall be sent to the address listed in the applicable Proposal.
- b) Shipping schedules identified in a Proposal are approximate and subject to confirmation by SELLER with the manufacturer following SELLER's issuance of its Acceptance, despite anything set forth in an Order or other Document.
- c) SELLER shall endeavor to accommodate BUYER's requested delivery schedule, but shall have no liability for loss to BUYER, whether direct, incidental and/or consequential, as a result of delays.

6. RISK OF LOSS: The risk of loss or damage to Goods shall pass to BUYER when Goods are placed with a carrier for delivery to BUYER. The carrier shall be deemed to be acting for and on behalf of BUYER, and the terms of payment for Goods shall not be affected by damage to or destruction of Goods.

7. WARRANTIES; REMEDIES:

a) Goods -- SELLER is NOT a manufacturer, and all Goods are manufactured by others. Accordingly, SELLER is not making and shall not make any warranties with respect to Goods other than that SELLER shall convey to BUYER good and marketable title to Goods. Other warranties available to BUYER are those, if any, extended by the manufacturer, to the extent they are in force and effect and may be assigned to BUYER. SELLER shall, upon written request, assign to BUYER any assignable rights SELLER has under the manufacturer's warranties. THE MANUFACTURER'S WARRANTY, IF ANY, AND SELLER'S WARRANTY OF TITLE, SHALL BE EXCLUSIVE AND IN LIEU OF ALL OTHER WARRANTIES WHETHER WRITTEN, ORAL OR IMPLIED BY LAW OR OTHERWISE, INCLUDING ANY WARRANTY OF MERCHANTABILITY OR WARRANTY OF FITNESS FOR ANY PARTICULAR PURPOSE, ALL OF WHICH ARE DISCLAIMED BY SELLER.

b) Services -- SELLER warrants that Services will be performed in a workmanlike manner. THIS WARRANTY IS EXCLUSIVE AND IS IN LIEU OF ALL OTHER WARRANTIES WHETHER WRITTEN, ORAL OR IMPLIED BY LAW OR OTHERWISE, ALL OF WHICH ARE DISCLAIMED BY SELLER.

c) Remedies -- If SELLER breaches any warranty granted by SELLER with respect to the Goods, SELLER'S sole responsibility shall be to repair, replace or refund the purchase price for the applicable Goods, as determined in SELLER'S sole and absolute discretion. If SELLER breaches any warranty granted by SELLER with respect to Services, Seller shall either refund the portion of the purchase price relating to the defective Services or correct the defective Services, as determined in SELLER'S sole and absolute discretion.

d) Limitation of Damages -- If SELLER breaches any of the Terms (including by breach of its warranties), BUYER'S remedies shall be limited as set forth in Section 7c) and this Section 7d). SELLER shall not be liable for any of BUYER'S indirect, incidental, special or consequential damages relating to or arising from the breach, or punitive damages of any nature, and BUYER'S recovery in connection with any Order shall in no event exceed the purchase price actually paid to SELLER with respect to that Order. Without limiting the generality of the foregoing sentence, in no event shall SELLER be liable to BUYER for BUYER'S loss of profits, loss of use, or damages of any nature based upon a claim for breach of warranty or for faulty workmanship or materials or otherwise, whether or not SELLER has been advised of the potential for any such damages. BUYER acknowledges that the purchase price at which SELLER has agreed to provide Goods and/or Services reflects the SELLER'S disclaimer of warranties and limitation of remedies set forth in this Section 7 and further acknowledges that the purchase price would be substantially higher without such disclaimer and limitation.

8. CANCELLATION: All Orders are non-cancelable by BUYER except as approved in writing by SELLER in its discretion. It is agreed that any cancellation, whether or not approved by SELLER, shall damage SELLER. Accordingly, SELLER shall be entitled to retain the Deposit, and BUYER shall pay to SELLER the following (against which the Deposit shall be credited):

- a) SELLER'S purchase price for the Goods delivered to BUYER prior to cancellation;
- b) SELLER'S costs incurred in connection with Services provided prior to cancellation (including compensation costs and overhead);
- c) All other out of pocket costs incurred by SELLER in connection with the Order, including without limitation cancellation or restocking charges that SELLER has or will incur; and

d) In the case the cancellation is not approved by SELLER, any other amounts to which SELLER may be entitled at law for BUYER'S breach, it being understood that unapproved cancellation shall be a breach by BUYER of the contractual relationship existing between SELLER and BUYER.

9. BUYER'S USE: BUYER agrees that its employees, contractors and invitees when operating Goods will comply with all operating procedures set forth in the manufacturer's operators manuals and instruction sheets relating to such Goods, and BUYER further agrees not to remove or modify any safety device, warning sign, operators manual or work handling tools. BUYER shall immediately notify SELLER of any accident or injury connected with use of the Goods and agrees, upon SELLER'S request, to cooperate with SELLER in investigating and determining the cause of the same. BUYER agrees to indemnify and hold harmless SELLER from and against any and all claims, suits, damages of any nature, losses, costs or expenses, including without limitation all fees and expenses of counsel and other professional advisors arising from use of any Goods or BUYER'S failure to comply with the Terms.

10. PERFORMANCE IN THE EVENT OF DEFAULT; NON-WAIVER OF DEFAULT: In addition to the rights and remedies conferred on SELLER by law and the Terms, SELLER will not be required to respond to or perform an Order (even if previously accepted) if BUYER is in default with respect to any other Order. If SELLER at anytime, in SELLER'S sole and absolute discretion, doubts BUYER'S ability to pay for Goods consistent with the Terms, SELLER may ship the Goods C.O.D. In the event of any default by BUYER under the Terms, SELLER may decline, in its sole and absolute discretion, to make further shipments of Goods to BUYER without in any way affecting its rights under the Terms. If, despite any default by BUYER, SELLER elects to continue to make shipments, SELLER'S actions shall not constitute a waiver of any default by BUYER or in any way affect SELLER'S remedies for such default under the Terms or otherwise.

11. CONFIDENTIALITY: All drawings, designs, specifications, manuals, programs and prices furnished to BUYER by SELLER shall remain the confidential and proprietary property of SELLER. All such information, except as may be found in the public domain, shall be held in strict confidence by BUYER and shall not be disclosed by BUYER to any third parties. As between BUYER and SELLER, all copyright interests in all

material made available by SELLER shall remain in SELLER at all times, and BUYER waives any property or privacy rights BUYER may have with respect to all such information.

12. EMPLOYEES: BUYER agrees that neither it nor any of its affiliates will solicit for hire, hire or recommend for hire any employee of SELLER or any affiliate of SELLER during the period from SELLER's issuance of a Proposal until the first anniversary of the date on which Goods purchased pursuant to an Order are finally installed or Services obtained pursuant to an Order are fully provided. This Section 12 is a material inducement to SELLER to transact business with BUYER. This Section 12 shall cease to apply to any former employee of SELLER or an affiliate of SELLER on the date such employee has ceased to be employed by SELLER or an affiliate for six (6) months, and it shall not apply to the hiring of any employee of SELLER or an affiliate of SELLER whose initial contact with BUYER is such employee's response to a general public solicitation of employment applications by BUYER.

13. FORCE MAJEURE: SELLER shall not be responsible for nonperformance or late performance due to orders, regulations and/or ordinances by any government or governmental agency, act of God, war, terrorism, blockade, insurrection, mobilization, riots, fire, work stoppage, civil insurrection, flood, earthquake or any other circumstance beyond SELLER's reasonable control. Without limiting the preceding sentence, BUYER acknowledges that Goods originating from foreign countries are subject to export permit by the governmental authorities of the country from which such Goods originate.

14. REVISIONS: SELLER, in its sole and absolute discretion, may modify the Terms at any time and from time to time. The Terms as in effect at the time of SELLER's Acceptance shall govern the terms of sale of the Goods and Services contemplated by the Order so accepted, provided SELLER has provided BUYER with a copy of such Terms prior to or contemporaneously with the Acceptance.

15. SEVERABILITY: If any provision(s) of the Terms are held by any court of competent jurisdiction to be unenforceable or invalid, the remaining provisions of the Terms shall not be rendered invalid or unenforceable as a result thereof.

16. APPLICABLE LAW; VENUE: The Terms are governed by, and shall be construed in accordance with, the law of the State of Maryland without reference to the conflict of laws principles thereof. BUYER and SELLER agree that the State and Federal courts sitting in the City of Hanover, Maryland shall be the exclusive forums for resolving any dispute pertaining in any way to their dealings, the Terms, any Goods or any Services. BUYER consents to the jurisdiction of such courts and agrees that any such court is a convenient forum for the resolution of any such dispute, and agrees that it may be served with process for any suit in any such court by first class registered mail, return receipt requested and postage pre-paid, sent to BUYER at its address identified in an Order or by any other lawful means. BUYER acknowledges that Maryland is the headquarters state of SELLER's parent entity, and that this Section 16 is a material inducement to SELLER to transact business with BUYER.

17. NO DELEGATION OR ASSIGNMENT: BUYER may not assign or delegate any of its rights or obligations under or in connection with the Terms or the Order without the prior written consent of SELLER, and any purported assignment or delegation in violation of this sentence shall be void ab initio, without force or effect, and a material violation of the Terms by BUYER.

Phillips Corporation requires receipt of the 25% down payment before any Haas machine is ordered.
25% payments can be made via bank wire or ACH.

Bank Wires

Account Name: Phillips Corporation

Acct#: 1233252889

ACH ABA Number: 121000358

Wire ABA Number: 026009593

Routing Number: 122000030

Swift Code: BOFAUS3N

Bank of America

6000 Feldwood Rd

College Park, Ga 30349

*REQUIRED: All ACH Wire Remittance notifications should be sent to: pcar@phillipscorp.com.

Please address all Purchase Orders to the following:

Phillips Corporation

8500 Triad Drive

Coffax, NC 27235

Acknowledged and agreed as of the date indicated below:

PROPOSAL NUMBER: _____

BUYER SIGNATURE: _____

PRINTED NAME: _____ DATE: _____

TITLE: _____

Please email signed accepted proposal to pcmachineorders@phillipscorp.com or fax 336-665-1980.

Phillips[®]

**SERVICES EXCLUSIVELY
FOR OUR HAAS CUSTOMERS**

GET AHEAD OF THE CURVE - GET OPTO

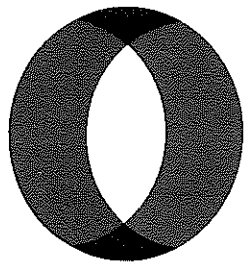

OPTO
BY PHILLIPS CORPORATION

Applications support for process improvement, specialized programming, and on-site training provided by our Haas-Certified Applications Engineers.

CERTIFIED HAAS ANNUAL MAINTENANCE PROGRAM

CHAMP

Identify potential problems with your machine before they develop with this preventative maintenance program.

**MAINTENANCE & REPAIR
TRAINING**

Week-long class in Knoxville, TN designed for customers who want an employee trained for machine maintenance

Unlimited operator training at your local HFO

**LIFETIME OPERATOR
TRAINING**

336.665.1080

pcsales@phillipscorp.com



**Haas
F1 Team**
OFFICIAL MACHINE TOOL

Phillips®

HAAS SERVICE TRAINING

JOIN US FOR A HAAS TRAINING EXPERIENCE LIKE NO OTHER IN THE INDUSTRY

Haas Service Training will teach you how to **TROUBLESHOOT, REPAIR** and **MAINTAIN** your Haas *in hours, not days.*

LOCATIONS *Knoxville, TN - Bensalem, PA - Rock Hill, SC* CONTACT hfooster@phillipscorp.com - (800) 989-9181



"I wouldn't keep sending so many of our Techs (nearly 30 so far) if I didn't think the course was a great investment."

~ Michael Goode,
General Electric

"This is the best machine learning environment I've ever seen. You should take this class, it's a no brainer. You're going to benefit"

~ Dale Miller,
Southern Cast Products



Bottom-Line Benefits

This class more than pays for itself with fewer service calls, reduced downtime, and real gains in part quality.

For more information, email hfooster@phillipscorp.com or call (800) 989-9181.

****Interested in Mill and Lathe Crash Recovery Training?** Let us know and we can send information on those classes as well.

SKILLS COVERED



In just five days, participants will take their service game to the next level by learning to perform the following skills

- Lathe Alignment
- Turret Repair (ST, SL & BMT)
- Tool Changer Repairs
- Ball Screw Replacement
- Spindle Replacement
- I/O Board & Vector Drive Troubleshooting
- Best Practices & MUCH MORE!!!

HANDS-ON LEARNING



This is a roll-up-your-sleeves, get inside-the-machine learning experience.

WORLD-CLASS FACILITIES



Training takes place in state-of-the-art facilities with more than a million dollars worth of Haas equipment - just like the ones on your floor.

EXPERIENCED INSTRUCTORS



Our teachers have spent years in the field. No question too basic. No problem too complex. Small class sizes mean you have plenty of one-on-one time for all your questions.

Plus every participant receives a free Haas Service Key, which unlocks the service parameters on any Next-Gen Control so you can take ownership of your Haas service and maintenance!



HUNDREDS HAVE ATTENDED, RATING THE COURSE 9.9/10

CLASSES RUN MONTHLY, YEAR-ROUND.
CALL (800) 989-9181 TO RESERVE YOUR SPOT TODAY! OR VISIT US AT:
PHILLIPSCORP.COM/SERVICE-TRAINING

****Disclaimer - In order to attend any Advanced Courses, students must have already completed the basic Phillips Haas Service Training course. Please call/email for more information.**



ADVANCED MILL SERVICE TRAINING

Phillips
HAAS SERVICE TRAINING

LOCATION *Knoxville, TN* CONTACT hfooster@phillipscorp.com - (800) 989-9181

JOIN US FOR A HAAS TRAINING EXPERIENCE LIKE NO OTHER IN THE INDUSTRY

From replacing guide rails to inspecting geometry, Advanced Mill Service Training will help you **repair your Haas mill if it crashes** and **uncover hidden problems before they affect quality** or slow production.

■ SKILLS COVERED



In just five days, participants will take their mill service skills to the next level by learning how to:

- Conduct a detailed geometry inspection
- Read ball bar information
- Use a granite square
- Correct machine geometry
- Replace machine guide rails
- Change out drawbars
- Replace different styled encoders

■ HANDS-ON LEARNING

This is a roll-up-your-sleeves, get inside-the-machine learning experience.

■ WORLD-CLASS FACILITIES

Training takes place in state-of-the-art facilities with more than a million dollars worth of Haas equipment - just like the ones on your floor.

■ EXPERIENCED INSTRUCTORS

Our teachers have spent years in the field (If it's happened, they've seen it!). No question too basic. No problem too complex. Small class sizes mean you have plenty of one-on-one time for all your questions.

Contact us about training grants that could cover your tuition!

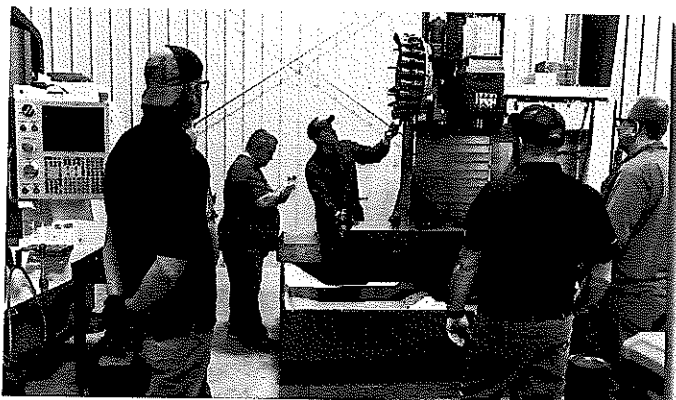

"This class takes the mystery out of these bigger mill repairs, which can be daunting. I think it's going to be a game changer for companies and on-site service techs."

~ Todd Price, Head Service Instructor

**CLASSES RUN MONTHLY, YEAR-ROUND.
CALL (800) 989-9181 TO RESERVE YOUR SPOT
TODAY! OR VISIT US AT:
PHILLIPSCORP.COM/ADVANCEDMILL**

Bottom-Line Benefits

This class more than pays for itself with fewer service calls, reduced downtime, and real gains in part quality.

For more information,
email hfooster@phillipscorp.com or call
(800) 989-9181.

****Not quite ready for an advanced class?** Contact us to find out more about Phillips Haas Service Training - our introductory Haas Service Training class.

****Disclaimer - In order to attend any Advanced Courses, students must have already completed the basic Phillips Haas Service Training course. Please call/email for more information.**



Phillips Commercial

8500 Triad Drive, Colfax, NC 27235

Phone: (336) 665-1080

www.phillipscorp.com

Fax: (336) 665-6041

Markforged Sales Quote

Table with 2 columns: Customer, Salesperson. Rows include Beverly Miller, Greenville City Schools, millerb@gcschools.net, Hunter Kubitz, Phillips Corporation, hkubitz@phillipscorp.com

Quote #: QUO-05783-L9S8W0 - Revision #: 0

Table with 5 columns: Product Name, Product ID, Qty, Price, Ext. Price. Rows include Mark Two (Gen 2), Digital Forge Essential Subscription - Mark Two (Gen 2), 800cc Onyx Spool, 150cc Carbon Fiber Spool, Shipping and Handling, Installation

Summary table with 2 columns: Discount, Total. Values: \$1,000.00, \$20,919.00 Before tax

Quotation valid until 7/31/2023 only.

Table with 2 rows: Payment Terms: Net 30, Freight Terms: FOB - Shipping Point

Sales Comments: This printer will be covered under the Essentials Tier of the Digital Forge Subscription. This tier includes free consumables, virtual support, and unlimited seats of Markforged University. No Installation charge for school accounts.

Payments can be made via bank wire or ACH. All ACH Wire Remittance notifications should be sent to pcar@phillipscorp.com.

Account Name: Phillips Corporation
ACH ABA Number: 121000358
Routing Number: 122000030

Account Number: 1233252889
Wire ABA Number: 026009593
Swift Code: BOFAUS3N

Bank of America
6000 Feldwood Rd
College Park, GA 30349

An order resulting from this proposal should be addressed as follows:

Phillips Corporation
8500 Triad Drive
Colfax, NC 27235
Fax: 336.665.1980
Email: Markforged@phillipscorp.com

Quote #: QUO-05783-L9S8W0

Revision #: 0



Phillips Commercial

8500 Triad Drive, Colfax, NC 27235

Phone: (336) 665-1080

www.phillipscorp.com

Fax: (336) 665-6041

TERMS AND CONDITIONS

1. STANDARD TERMS: This document contains the standard terms and conditions (the "Terms") applicable to dealings between Phillips Corporation ("SELLER") and its customers, including the customer signing this document below ("BUYER"). The Terms are incorporated into, and a material part of: (a) each proposal to sell goods ("Goods") and, if applicable, ancillary services ("Services") made by SELLER to BUYER (a "Proposal"), (b) each order to purchase Goods and/or Services submitted by BUYER to Seller (an "Order"), (c) each acceptance of an Order by SELLER (an "Acceptance"), (d) each invoice issued by SELLER (an "Invoice"), and (e) all other documents exchanged between SELLER and BUYER pertaining to any ORDER (each Proposal, Order, Acceptance, Invoice or other relevant document is a "Document"); in each case regardless of whether the Terms are referred to in the Document and regardless of whether the Document is submitted or provided electronically, on paper or otherwise. The Terms shall control over any contrary terms or conditions set forth in any Document, regardless of when the Document may be provided by BUYER to SELLER or SELLER to BUYER, except as expressly agreed by SELLER and BUYER in a writing specifically described as an amendment of the Terms, and SELLER and BUYER expressly object to any contrary terms or conditions.

2. PROPOSALS AND ORDERS:

- a) A Proposal is valid for 30 days from the date shown on it unless otherwise specified in it.
- b) A Proposal does not constitute a firm offer, but is rather an invitation to BUYER to place an Order.
- c) All Orders shall be in writing. All Orders shall be subject to written Acceptance by SELLER.
- d) SELLER is not the manufacturer of any of the Goods. All weights, measurements and other specifications of Goods set forth in Proposals, Orders and Acceptances are estimates based on information provided by the manufacturer, and SELLER shall not be responsible for any deviations therefrom. Brochures, photographs and other illustrations depicting or describing Goods are non-binding in detail, and BUYER acknowledges that such brochures, photographs and other illustrations may have been superseded since being provided by the manufacturer. BUYER acknowledges further that manufacturers reserve the right to discontinue or to make changes to their products at any time, and that Goods are subject to specification and/or design changes without prior notice. Nothing contained in any descriptions of the Goods set forth in any Proposal, Order, Acceptance or other Document shall expand or otherwise affect SELLER's warranty obligations as set forth in Section 7.
- e) Any production estimates provided by SELLER are not guarantees of actual production unless specifically so stated in writing and signed by a duly authorized officer of SELLER. All time study figures relating to Goods are only estimates based on information provided to SELLER pertaining to finish required, machine-ability of the Goods, amount of material to be removed, BUYER's operating conditions and similar factors.
- f) SELLER retains the right to correct in its Acceptance any clerical error contained in a Proposal or an Order. BUYER agrees to promptly notify SELLER of any suspected clerical error in a Proposal.

3. PRICES:

- a) All prices listed in a Proposal are F.O.B. Ship Point (i.e., manufacturer's factory, port of entry or stocking warehouse) unless otherwise specified. Prices are subject to change without notice until confirmed by SELLER in its Acceptance.
- b) Prices quoted in a Proposal do not include sales, use, excise, property or similar taxes arising out of or relating to the sale, purchase, ownership or use of Goods or Services, and all sales are made subject to applicable taxes, the entire amount of which BUYER agrees to pay. BUYER shall provide SELLER with any applicable tax exemption certificates acceptable to appropriate taxing authorities together with an Order. BUYER shall indemnify and hold SELLER harmless from and against the imposition and payment of such taxes. SELLER may in any Invoice or separately bill BUYER at any time for any such taxes, in which case BUYER shall pay the same to SELLER, but SELLER shall not be obligated to do so.
- c) All freight and rigging quoted in a Proposal is subject to change until confirmed by SELLER in its corresponding Invoice.
- d) SELLER will be compensated for all service work performed by SELLER on Goods not covered by manufacturer's warranty or after the manufacturer's warranty period has expired at SELLER's then prevailing rate, plus all expenses, transportation, material and parts.

4. PAYMENT TERMS: Subject to SELLER's credit approval of BUYER:

- a) The terms of payment with respect to any Order shall be as specified in the Proposal or the Acceptance applicable to the Order (with the Acceptance controlling if differing terms are specified). If terms of payment are not specified in a Proposal or Acceptance, then BUYER shall pay 25% of purchase price as a non-refundable deposit at time of transmitting an Order (the "Deposit") and 75% of purchase price net 15 days from SELLER'S shipment of Goods (the "Final Payment"). In the case of leased and financed Orders, the Final Payment is due upon the sooner of BUYER's signing the delivery slip or acceptance or installation of Goods, but in no event later than 15 days from SELLER's shipment of Goods. Any unpaid amount shall bear interest from the due date until payment at a rate equal to the lesser of 2% per month or the maximum percentage permitted by law. Delays in installation and/or delays in operation of Goods caused by damage, warranty service or warranty replacement of parts or otherwise shall not extend or alter time for payment.
- b) BUYER shall pay all of SELLER's costs (including without limitation court costs and reasonable attorney fees) incurred in collecting past due amounts (whether purchase price or other amounts owing pursuant to the Terms) regardless of whether litigation is commenced.

Quote #: QUO-05783-L9S8W0

Revision #: 0



Phillips Commercial

8500 Triad Drive, Colfax, NC 27235

Phone: (336) 665-1080

www.phillipscorp.com

Fax: (336) 665-6041

c) To secure the Obligations, BUYER hereby grants SELLER a first priority security interest in all Goods sold by SELLER to BUYER, any accessions thereto and any insurance, sale or other proceeds of the foregoing (the "Collateral"). For these purposes, the "Obligations" means all amounts due to SELLER in connection with Goods and/or Services sold to BUYER, including without limitation purchase price, taxes and all fees, expenses and reasonable attorneys' fees incurred by SELLER pursuant to or in connection with the Terms, the Obligations or the Collateral. BUYER agrees to insure the Collateral against loss or damage by fire or other risks and hazards in an amount no less than the replacement value of the Collateral, and upon request to provide SELLER with evidence of such insurance identifying SELLER as loss payee as its interests may appear. BUYER authorizes SELLER to file with applicable governmental authorities financing statements and similar instruments describing the Collateral without the signature of BUYER. Upon BUYER's default in any payment or other performance under the Terms, SELLER may, in its sole and absolute discretion, declare all Obligations immediately due and payable without demand, protest or other notice of any kind, and SELLER shall have the right to repossess the Collateral (BUYER hereby granting SELLER a right of access to BUYER's premises for such purposes) and all other remedies of a secured party under the Uniform Commercial Code as in from time to time in effect in the state origin of purchase.

5. SHIPPING:

a) Goods subject to an accepted Order shall be sent to the address listed in the applicable Proposal.

b) Shipping schedules identified in a Proposal are approximate and subject to confirmation by SELLER with the manufacturer following SELLER's issuance of its Acceptance, despite anything set forth in an Order or other Document.

c) SELLER shall endeavor to accommodate BUYER's requested delivery schedule, but shall have no liability for loss to BUYER, whether direct, incidental and/or consequential, as a result of delays.

6. RISK OF LOSS: The risk of loss or damage to Goods shall pass to BUYER when Goods are placed with a carrier for delivery to BUYER. The carrier shall be deemed to be acting for and on behalf of BUYER, and the terms of payment for Goods shall not be affected by damage to or destruction of Goods.

7. WARRANTIES; REMEDIES:

a) Goods -- SELLER is NOT a manufacturer, and all Goods are manufactured by others. Accordingly, SELLER is not making and shall not make any warranties with respect to Goods other than that SELLER shall convey to BUYER good and marketable title to Goods. Other warranties available to BUYER are those, if any, extended by the manufacturer, to the extent they are in force and effect and may be assigned to BUYER. SELLER shall, upon written request, assign to BUYER any assignable rights SELLER has under the manufacturer's warranties, THE MANUFACTURER'S WARRANTY, IF ANY, AND SELLER'S WARRANTY OF TITLE, SHALL BE EXCLUSIVE AND IN LIEU OF ALL OTHER WARRANTIES WHETHER WRITTEN, ORAL OR IMPLIED BY LAW OR OTHERWISE, INCLUDING ANY WARRANTY OF MERCHANTABILITY OR WARRANTY OF FITNESS FOR ANY PARTICULAR PURPOSE, ALL OF WHICH ARE DISCLAIMED BY SELLER.

b) Services -- SELLER warrants that Services will be performed in a workmanlike manner. THIS WARRANTY IS EXCLUSIVE AND IS IN LIEU OF ALL OTHER WARRANTIES WHETHER WRITTEN, ORAL OR IMPLIED BY LAW OR OTHERWISE, ALL OF WHICH ARE DISCLAIMED BY SELLER.

c) Remedies -- If SELLER breaches any warranty granted by SELLER with respect to the Goods, SELLER'S sole responsibility shall be to repair, replace or refund the purchase price for the applicable Goods, as determined in SELLER'S sole and absolute discretion. If SELLER breaches any warranty granted by SELLER with respect to Services, Seller shall either refund the portion of the purchase price relating to the defective Services or correct the defective Services, as determined in SELLER'S sole and absolute discretion.

d) Limitation of Damages -- If SELLER breaches any of the Terms (including by breach of its warranties), BUYER'S remedies shall be limited as set forth in Section 7c) and this Section 7d). SELLER shall not be liable for any of BUYER'S indirect, incidental, special or consequential damages relating to or arising from the breach, or punitive damages of any nature, and BUYER'S recovery in connection with any Order shall in no event exceed the purchase price actually paid to SELLER with respect to that Order. Without limiting the generality of the foregoing sentence, in no event shall SELLER be liable to BUYER for BUYER'S loss of profits, loss of use, or damages of any nature based upon a claim for breach of warranty or for faulty workmanship or materials or otherwise, whether or not SELLER has been advised of the potential for any such damages. BUYER acknowledges that the purchase price at which SELLER has agreed to provide Goods and/or Services reflects the SELLER'S disclaimer of warranties and limitation of remedies set forth in this Section 7 and further acknowledges that the purchase price would be substantially higher without such disclaimer and limitation.

8. CANCELLATION: All Orders are non-cancelable by BUYER except as approved in writing by SELLER in its discretion. It is agreed that any cancellation, whether or not approved by SELLER, shall damage SELLER. Accordingly, SELLER shall be entitled to retain the Deposit, and BUYER shall pay to SELLER the following (against which the Deposit shall be credited):

a) SELLER'S purchase price for the Goods delivered to BUYER prior to cancellation;

b) SELLER'S costs incurred in connection with Services provided prior to cancellation (including compensation costs and overhead);

c) All other out of pocket costs incurred by SELLER in connection with the Order, including without limitation cancellation or restocking charges that SELLER has or will incur; and

d) In the case the cancellation is not approved by SELLER, any other amounts to which SELLER may be entitled at law for BUYER'S breach, it being understood that unapproved cancellation shall be a breach by BUYER of the contractual relationship existing between SELLER and BUYER.

9. BUYER'S USE: To the extent allowable by law, BUYER agrees to indemnify and hold harmless SELLER from and against any and all claims, suits, damages of any nature, losses, costs or expenses, including without limitation all fees and expenses of counsel and other professional

Quote #: QUO-05783-L9S8W0

Revision #: 0



Phillips Commercial

8500 Triad Drive, Colfax, NC 27235

Phone: (336) 665-1080

www.phillipscorp.com

Fax: (336) 665-6041

advisors arising from use of any Goods or BUYER's failure to comply with the Terms. BUYER agrees that its employees, contractors and invitees when operating Goods will comply with all operating procedures set forth in the manufacturer's operators manuals and instruction sheets relating to such Goods, and BUYER further agrees not to remove or modify any safety device, warning sign, operators manual or work handling tools. BUYER shall immediately notify SELLER of any accident or injury connected with use of the Goods and agrees, upon SELLER's request, to cooperate with SELLER in investigating and determining the cause of the same. BUYER agrees to indemnify and hold harmless SELLER from and against any and all claims, suits, damages of any nature, losses, costs or expenses, including without limitation all fees and expenses of counsel and other professional advisors arising from use of any Goods or BUYER's failure to comply with the Terms.

10. **PERFORMANCE IN THE EVENT OF DEFAULT; NON-WAIVER OF DEFAULT:** In addition to the rights and remedies conferred on SELLER by law and the Terms, SELLER will not be required to respond to or perform an Order (even if previously accepted) if BUYER is in default with respect to any other Order. If SELLER at anytime, in SELLER's sole and absolute discretion, doubts BUYER's ability to pay for Goods consistent with the Terms, SELLER may ship the Goods C.O.D. In the event of any default by BUYER under the Terms, SELLER may decline, in its sole and absolute discretion, to make further shipments of Goods to BUYER without in any way affecting its rights under the Terms. If, despite any default by BUYER, SELLER elects to continue to make shipments, SELLER's actions shall not constitute a waiver of any default by BUYER or in any way affect SELLER'S remedies for such default under the Terms or otherwise.

11. **CONFIDENTIALITY:** To the extent allowable by law, all such information, except as maybe found in the public domain, shall be held in strict confidence by BUYER. All drawings, designs, specifications, manuals, programs and prices furnished to BUYER by SELLER shall remain the confidential and proprietary property of SELLER. All such information, except as may be found in the public domain, shall be held in strict confidence by BUYER and shall not be disclosed by BUYER to any third parties. As between BUYER and SELLER, all copyright interests in all material made available by SELLER shall remain in SELLER at all times, and BUYER waives any property or privacy rights BUYER may have with respect to all such information.

12. **EMPLOYEES:** BUYER agrees that neither it nor any of its affiliates will solicit for hire, hire or recommend for hire any employee of SELLER or any affiliate of SELLER during the period from SELLER's issuance of a Proposal until the first anniversary of the date on which Goods purchased pursuant to an Order are finally installed or Services obtained pursuant to an Order are fully provided. This Section 12 is a material inducement to SELLER to transact business with BUYER. This Section 12 shall cease to apply to any former employee of SELLER or an affiliate of SELLER on the date such employee has ceased to be employed by SELLER or an affiliate for six (6) months, and it shall not apply to the hiring of any employee of SELLER or an affiliate of SELLER whose initial contact with BUYER is such employee's response to a general public solicitation of employment applications by BUYER.

13. **FORCE MAJEURE:** SELLER shall not be responsible for nonperformance or late performance due to orders, regulations and/or ordinances by any government or governmental agency, act of God, war, terrorism, blockade, insurrection, mobilization, riots, fire, work stoppage, civil insurrection, flood, earthquake or any other circumstance beyond SELLER's reasonable control. Without limiting the preceding sentence, BUYER acknowledges that Goods originating from foreign countries are subject to export permit by the governmental authorities of the country from which such Goods originate.

14. **REVISIONS:** SELLER, in its sole and absolute discretion, may modify the Terms at any time and from time to time. The Terms as in effect at the time of SELLER's Acceptance shall govern the terms of sale of the Goods and Services contemplated by the Order so accepted, provided SELLER has provided BUYER with a copy of such Terms prior to or contemporaneously with the Acceptance.

15. **SEVERABILITY:** If any provision(s) of the Terms are held by any court of competent jurisdiction to be unenforceable or invalid, the remaining provisions of the Terms shall not be rendered invalid or unenforceable as a result thereof.

16. **APPLICABLE LAW; VENUE:** The Terms are governed by, and shall be construed in accordance with, the law of the State of Maryland without reference to the conflict of laws principles thereof. BUYER and SELLER agree that the State and Federal courts sitting in the City of Hanover, Maryland shall be the exclusive forums for resolving any dispute pertaining in any way to their dealings, the Terms, any Goods or any Services. BUYER consents to the jurisdiction of such courts and agrees that any such court is a convenient forum for the resolution of any such dispute, and agrees that it may be served with process for any suit in any such court by first class registered mail, return receipt requested and postage pre-paid, sent to BUYER at its address identified in an Order or by any other lawful means. BUYER acknowledges that Maryland is the headquarters state of SELLER's parent entity, and that this Section 16 is a material inducement to SELLER to transact business with BUYER.

17. **NO DELEGATION OR ASSIGNMENT:** BUYER may not assign or delegate any of its rights or obligations under or in connection with the Terms or the Order without the prior written consent of SELLER, and any purported assignment or delegation in violation of this sentence shall be void ab initio, without force or effect, and a material violation of the Terms by BUYER.

Quote #: QUO-05783-L9S8W0

Revision #: 0



Phillips Commercial

8500 Triad Drive, Colfax, NC 27235

Phone: (336) 665-1080

www.phillipscorp.com

Fax: (336) 665-6041

Customer Signature

Account Name: Greeneville City Schools

Address:

Acknowledged and agreed upon as of the date indicated below:

Buyer Signature _____ Printed Name _____

Title _____ Date _____

Beverly Miller

From: Robin McConahey <robinm@phillipscorp.com>
Sent: Thursday, June 15, 2023 2:45 PM
To: Beverly Miller
Cc: Bill Walsh; Elliott Gefellers; David Pauley
Subject: RE: 301-2023-2024-01 RFP INCLUDED: Do not open until June 15, 2023, 11 A.M., EDT.

WARNING: This email originated from outside of the Greenville City Schools network. Do not click links or open attachments unless you recognize the sender and know the content is safe.

I apologize for that mistake! It should be \$26,579.90 for both Desktop Mills. Each one would be \$13,289.95.

Sincerely,

Robin McConahey
Sales Support

Phillips Commercial
8500 Triad Drive
Colfax, NC 27235

T 336-355-5095
F 336-665-1980
www.phillipscorp.com



///Phillips®

If we have not received a current sales tax resale/exempt certificate from your organization by April 7th, 2023 you will be charged and expected to pay for any applicable sales tax on your order. Certificates may be emailed to Pcexemptions@phillipscorp.com to avoid taxation on your order. If there are any questions related to this matter, please contact Pcexemptions@phillipscorp.com.

From: Beverly Miller <millerb@gcschools.net>
Sent: Thursday, June 15, 2023 2:38 PM
To: Robin McConahey <robinm@phillipscorp.com>
Cc: Bill Walsh <bwalsh@phillipscorp.com>; Elliott Gefellers <gefellerse@gcschools.net>; David Pauley <Pauleyd@gcschools.net>
Subject: RE: 301-2023-2024-01 RFP INCLUDED: Do not open until June 15, 2023, 11 A.M., EDT.

Robin – Please look at the RFP and the page where you wrote in the COST PER ITEM column. We specified a quantity of (2) HAAS Desktop Mill units. You wrote in \$26,579.90. I assumed that 2 units (per our request) would then be a TOTAL COST of \$53, 159.80. Please clarify – what is the total cost for TWO HAAS Desktop Mill units?
Beverly Miller

From: Robin McConahey <robinm@phillipscorp.com>

Sent: Thursday, June 15, 2023 2:21 PM

To: Beverly Miller <millerb@gcschools.net>

Cc: Bill Walsh <bwalsh@phillipscorp.com>; Elliott Gefellers <gefellerse@gcschools.net>; David Pauley <Pauleyd@gcschools.net>

Subject: RE: 301-2023-2024-01 RFP INCLUDED: Do not open until June 15, 2023, 11 A.M., EDT.

WARNING: This email originated from outside of the Greenville City Schools network. Do not click links or open attachments unless you recognize the sender and know the content is safe.

Please see attached and let me know if any more changes are needed.

Thanks,

Robin McConahey
Sales Support

Phillips Commercial
8500 Triad Drive
Colfax, NC 27235

T 336-355-5095

F 336-665-1980

www.phillipscorp.com



From: Beverly Miller <millerb@gcschools.net>

Sent: Thursday, June 15, 2023 2:05 PM

To: Robin McConahey <robinm@phillipscorp.com>

Cc: Bill Walsh <bwalsh@phillipscorp.com>; Elliott Gefellers <gefellerse@gcschools.net>; David Pauley <Pauleyd@gcschools.net>

Subject: RE: 301-2023-2024-01 RFP INCLUDED: Do not open until June 15, 2023, 11 A.M., EDT.

Robin – Can you give me pricing to eliminate the electronic hand wheels from the TL1 and ADD the 4 Station Tool Turret?

Can you REMOVE the quick change tool post kit from the tooling options, too?

I need this quickly! Thanks.

Bev

From: Robin McConahey <robinm@phillipscorp.com>

Sent: Wednesday, June 14, 2023 8:20 AM

To: Beverly Miller <millerb@gcschools.net>

Subject: 301-2023-2024-01 RFP INCLUDED: Do not open until June 15, 2023, 11 A.M., EDT.

WARNING: This email originated from outside of the Greenville City Schools network. Do not click links or open attachments unless you recognize the sender and know the content is safe.

Good morning,

Please find the attached bid submission for bid number 301-2023-2024-01 from Phillips Corporation to be opened on June 15, 2023, at 11AM.

Thank you,

Robin McConahey
Sales Support

Phillips Commercial
8500 Triad Drive
Colfax, NC 27235

T 336-355-5095
F 336-665-1980
www.phillipscorp.com



If we have not received a current sales tax resale/exempt certificate from your organization by April 7th, 2023 you will be charged and expected to pay for any applicable sales tax on your order. Certificates may be emailed to Pcexemptions@phillipscorp.com to avoid taxation on your order. If there are any questions related to this matter, please contact Pcexemptions@phillipscorp.com.

This message may contain confidential information. If you are not the intended recipient, please forward the message to mailadmin@gcschools.net. If you do not forward the message to us, we cannot determine the problem.

All email entering or leaving the Greenville City Schools mail server is archived and checked for content and security. All messages are checked for viruses before entering or leaving our server. Spam, viruses, dangerous attachments, and offensive content are removed automatically.

The Greenville City School System does not discriminate in employment, admission, or participation in educational programs on the basis of race, color, gender, age, national origin, religion, or disability.

Learning Without Limits www.gcschools.net

This message may contain confidential information. If you are not the intended recipient, please forward the message to mailadmin@gcschools.net. If you do not forward the message to us, we cannot determine the problem.

All email entering or leaving the Greenville City Schools mail server is archived and checked for content and security. All messages are checked for viruses before entering or leaving our server. Spam, viruses, dangerous attachments, and offensive content are removed automatically.

The Greeneville City School System does not discriminate in employment, admission, or participation in educational programs on the basis of race, color, gender, age, national origin, religion, or disability.

Learning Without Limits www.gcschools.net



Search by keyword, brand or SKU

126 results for



SKU: REV-45-2041
EDU Kit V2

\$990.00



SKU: REV-45-2042

EDU Kit V2 to Starter Kit
V3 Upgrade

\$402.50



SKU: REV-45-1885

FTC Sensor Bundle

\$172.50

Out of stock

Excellent  903 reviews on 

Nova 63

100w

130w



STARTING AT:
\$15,100 as low as \$297.02/mo >>

The Nova 63 is our flagship model and is available in 100 watt and 130 watt configurations.

What's Included?

- ✓ 2 Year Warranty
- ✓ Free LightBurn Software
- ✓ Free Shipping to Lower 48
- ✓ USA-Based Customer Service



GET A FREE QUOTE TODAY

Search results for: 'Ultimaker Printer S3'

Relevance

[Products](#) | [Other Content](#)

Sale
Includes Free Items



UltiMaker S3

Product# 216932

Professional and reliable composite-ready 3D printing from Ultimaker, in an efficient and accessible desktop format.

Key Features:

- Fused Filament Fabrication (FFF) 3D Printer
- 230 × 190 × 200 mm
- Material Extrusion
- A smaller, but every bit as powerful, version of the award-winning Ultimaker S5
- Includes Ultimaker Essentials / Personal software

 **UltiMaker** Promotion

FREE with S3

Enhanced Service Plan & CC Print Core

When you buy an Ultimaker S3 by June 30th and you will receive a 2nd year Enhanced Service Plan and CC Print Core FREE.

Please make selection when you add it cart

4.8 ★★★★★
Google
Customer Reviews



Buy 5 and SAVE 5 % OFF on UltiMaker S3 Printers

When you buy (5) Ultimaker S3 printers by June 30th and you will save 5% off the printers and receive (5) 2nd year Enhanced Service Plans **FREE**.

Contact us for details.

FREE Enhanced Service Plans Included!

[LEARN MORE](#)

- ✓ Brand New
- ✓ In stock
- ✓ Includes Warranty
- ✓ Unlimited Toll-Free Support
- ✓ **Free Shipping** & In-stock verified orders before 3pm EST ship the same day

\$4,450.00

1

 ADD

[GET QUOTE](#)



UltiMaker S3 Refurbished

Product# Ultimaker-S3-Refurb

UltiMaker S3 Demonstration Model (Refurbished). Six month manufacturer's warranty, may have minor cosmetic imperfections.

Professional and reliable composite-ready 3D printing from UltiMaker, in an efficient and accessible desktop format.

Key Features:

- Fused Filament Fabrication (FFF) 3D Printer
- 230 × 190 × 200 mm
- Material Extrusion
- A smaller, but every bit as powerful, version of the award-winning UltiMaker S5

Please Note: Refurbished printers do not include UltiMaker Essentials / Personal software

[LEARN MORE](#)

- ✓ In stock
- ✓ Includes Warranty
- ✓ Unlimited Toll-Free Support
- ✓ **Free Shipping** & In-stock verified orders before 3pm EST ship the same day

\$3,699.00

1

 ADD

GET QUOTE



UltiMaker S3 Engineering Bundle

Product# UltimakerS3-Eng

Professional and reliable composite-ready 3D printing from UltiMaker, in an efficient and accessible desktop format.

Key Features:

- Fused Filament Fabrication (FFF) 3D Printer
- 230 × 190 × 200 mm
- Material Extrusion
- A smaller, but every bit as powerful, version of the award-winning UltiMaker S5

Bundle Includes:

- UltiMaker S3
- UltiMaker Essentials / Personal software
- 2 Rolls PLA-NFC 750g: Black
- 2 Rolls PLA-NFC 750g: White
- 2 Rolls Nylon-NFC 750g: Black
- 2 Rolls Nylon-NFC 750g: Transparent
- 2 Rolls ABS-NFC 750g: Black
- 2 Rolls ABS-NFC 750g: White
- 2 Rolls PVA-NFC 750g
- 2 Rolls Breakaway-NFC 750g

LEARN MORE

- ✓ Brand New
- ✓ Available
- ✓ Includes Warranty
- ✓ Unlimited Toll-Free Support
- ✓ **Free Shipping**

\$5,367.00

1

 ADD

GET QUOTE



UltiMaker S3 Starter Bundle

Product# UltimakerS3-Starter

Professional and reliable composite-ready 3D printing from UltiMaker, in an efficient and accessible desktop format.

Key Features:

- Fused Filament Fabrication (FFF) 3D Printer
- 230 × 190 × 200 mm
- Material Extrusion
- A smaller, but every bit as powerful, version of the award-winning UltiMaker S5

Bundle Includes:

- UltiMaker S3
- UltiMaker Essentials / Personal software
- 2 Rolls PLA-NFC 750g: Black
- 2 Rolls PLA-NFC 750g: White
- 2 Rolls PLA-NFC 750g: Red
- 2 Rolls PLA-NFC 750g: Blue
- 2 Rolls PVA-NFC 750g

[LEARN MORE](#)

- ✓ Brand New
- ✓ Available
- ✓ Includes Warranty
- ✓ Unlimited Toll-Free Support
- ✓ **Free Shipping**

\$5,019.00

1

 ADD

GET QUOTE



UltiMaker Print Table Glass S3 / UM3 / 2+ Connect

Product# 227639

Print Table Glass for UltiMaker.

Compatible with UltiMaker 2 / 2+ / 2+ Connect / 3 series and S3 printers.

[LEARN MORE](#)

- ✓ Brand New
- ✓ In stock
- ✓ Unlimited Toll-Free Support
- ✓ In-stock verified orders before 3pm EST ship the same day

\$54.00

1

 ADD

GET QUOTE



UltiMaker S3 Enhanced Service Plan 2 Year

Product# 226060

Protect your investment and extend your standard warranty with UltiMaker's Enhanced Service Plan for UltiMaker S3 printers.

Please Note: must be purchased within 90 days of printer purchase.

[LEARN MORE](#)

- ✓ Brand New
- ✓ Available
- ✓ Includes Warranty
- ✓ Unlimited Toll-Free Support
- ✓ Free Shipping

\$1,240.00

1

 ADD

GET QUOTE



UltiMaker S3 Enhanced Service Plan 1 Year

Product# 220859

Protect your investment and extend your standard warranty with UltiMaker's Enhanced Service Plan for UltiMaker S3 printers.

Please Note: must be purchased within 90 days of printer purchase.

[LEARN MORE](#)

- ✓ Brand New
- ✓ Available
- ✓ Includes Warranty
- ✓ Unlimited Toll-Free Support
- ✓ **Free Shipping**

\$645.00

1

 ADD

GET QUOTE

NEW! _ Expert's Pick _ Sale
Includes Free Items



UltiMaker S7 Pro Bundle

Product# ultimaker-s7-pro-bundle

Expand your 3D printing capabilities with the UltiMaker S7 Pro Bundle. The built in material station makes production seamless and easy so you can hit the ground running.

Key Features :

- Fused filament fabrication (FFF)
- Print head Dual extrusion print head with auto-nozzle lifting system and swappable print cores
- Build volume: 330 x 240 x 300 mm
- Includes Material Station

Choose Your
UltiMaker Promotion

FREE
10 Spools + AA
.80mm Print Core
When you buy two
UltiMaker S5 or S7s

SAVE 25%
on the PVA
Removal Station
When you buy an
UltiMaker S5 or S7

Promotion below

Please note: This item ships freight and is ineligible for most expedited shipping methods. Customers can upgrade to FedEx Priority Freight for an additional cost. Please contact us for more information.

[LEARN MORE](#)

- ✓ Brand New
- ✓ In Stock
- ✓ Includes Warranty
- ✓ Unlimited Toll-Free Support
- ✓ **Free Shipping**

\$11,500.00

1

 **ADD**

[GET QUOTE](#)



UltiMaker Print Core AA 0.40mm

Product# 9529

UltiMaker Print Core AA 0.4mm for use with build materials and Breakaway support material.

Print Cores are the entire hot-end for use with the UltiMaker 3 and S-series, with a chip built-in to communicate and sync with the printer. This chip contains information about the print core type and its runtime statistics. Print Cores are designed as a single assembly, making them easy to change and increases uptime.

[LEARN MORE](#)

- ✓ Brand New
- ✓ Extended backorder, current estimate is mid June
- ✓ Unlimited Toll-Free Support

✓ Free Shipping

\$114.95

1

ADD

GET QUOTE

NEW! _ Expert's Pick _ Sale
Includes Free Items



UltiMaker S7

Product# ultimaker-s7

Take your material extrusion 3D printing to the next level with the UltiMaker S7. This latest generation from UltiMaker continues to be the easy-to-use solution its customers have come to expect, all with increased productivity and performance with the built in air manager.

Key Features :

- Fused filament fabrication (FFF)
- Print head Dual extrusion print head with auto-nozzle lifting system and swappable print cores
- Build volume: 330 x 240 x 300 mm



Choose Your
UltiMaker Promotion

FREE

**10 Spools + AA
.80mm Print Core**
When you buy two
UltiMaker S5 or S7s

SAVE 25%

**on the PVA
Removal Station**
When you buy an
UltiMaker S5 or S7

Promotion below

Please note: This item ships freight and is ineligible for most expedited shipping methods. Customers can upgrade to FedEx Priority Freight for an additional cost. Please contact us for more information.

[LEARN MORE](#)

✓ Brand New

- ✓ Usually ships in 2-3 days
- ✓ Includes Warranty
- ✓ Unlimited Toll-Free Support
- ✓ Free Shipping

\$8,299.00

1

 ADD

GET QUOTE



UltiMaker Axial Fan 35x35x10

Product# 227102

Axial (Hot End) Cooling Fan for UltiMaker Please note: compatible with UltiMaker 3/3E/S3/S5 models

[LEARN MORE](#)

- ✓ Brand New
- ✓ In stock
- ✓ Unlimited Toll-Free Support
- ✓ In-stock verified orders before 3pm EST ship the same day

\$19.20

1

 ADD

GET QUOTE



UltiMaker Print Core BB 0.40mm

Product# 9530

UltiMaker Print Core BB 0.4mm for use with PVA support material.

Print Cores are the entire hot-end for use with the UltiMaker 3 and S-series, with a chip built-in to communicate and sync with the printer. This chip contains information about the print core type and its runtime statistics. Print Cores are designed as a single assembly, making them easy to change and increases uptime.

[LEARN MORE](#)

- ✓ Brand New
- ✓ Extended backorder, current estimate is mid June
- ✓ Unlimited Toll-Free Support
- ✓ **Free Shipping**

\$114.95

1

 ADD

GET QUOTE



UltiMaker Print Core AA 0.25mm

Product# 200454

UltiMaker Print Core AA 0.25mm for use with build materials and Breakaway support material.

Print Cores are the entire hot-end for use with the UltiMaker 3 and S-series, with a chip built-in to communicate and sync with the printer. This chip contains information about the print core type and its runtime statistics. Print Cores are designed as a single assembly, making them easy to change and increases uptime.

[LEARN MORE](#)

- ✓ Brand New
- ✓ In stock
- ✓ Unlimited Toll-Free Support
- ✓ **Free Shipping** & In-stock verified orders before 3pm EST ship the same day

\$114.95

1

 ADD

GET QUOTE



UltiMaker Print Core AA 0.80mm

Product# 9531

UltiMaker Print Core AA 0.8mm for use with build materials and Breakaway support material.

Print Cores are the entire hot-end for use with the UltiMaker 3 and S-series, with a chip built-in to communicate and sync with the printer. This chip contains information about the print core type and its runtime statistics. Print Cores are designed as a single assembly, making them easy to change and increases uptime.

[LEARN MORE](#)

- ✓ Brand New
- ✓ In stock
- ✓ Unlimited Toll-Free Support
- ✓ **Free Shipping** & In-stock verified orders before 3pm EST ship the same day

\$114.95

1

 ADD

GET QUOTE



UltiMaker Metal Expansion Pack

Product# ultimaker-metal-expansion-pack

The UltiMaker Metal Expansion Kit is an upgrade for the UltiMaker S5 to unlock new metal FFF printing capabilities and allows you to explore a new range of metal 3D printing applications. Its easy workflow makes creating stainless steel parts easier, more efficient, and affordable.

The Metal Expansion Kit is a complete solution that combines materials, accessories, software, and services.

Bundle Includes:

- BASF Forward AM Ultrafuse® 17-4 PH (1 kg)
- Packaging for green parts and a voucher toward post-processing
- UltiMaker Print Core CC 0.4
- Magigoo Pro Metal (50 ml) adhesive
- Free UltiMaker Cura software with optimized metal part slicing features
- Access to exclusive metal FFF e-learning content on UltiMaker Academy

LEARN MORE

- ✓ Brand New
- ✓ Usually ships in 1-2 weeks
- ✓ Includes Warranty
- ✓ Unlimited Toll-Free Support
- ✓ **Free Shipping**

\$699.00

1

 ADD

GET QUOTE



UltiMaker Clamp Clip

Product# 2137

Clamp Clip for UltiMaker Please note: compatible with UltiMaker 2+/E+/Go/3/3E/S3/S5 models

[LEARN MORE](#)

- ✓ Brand New
- ✓ In stock
- ✓ Unlimited Toll-Free Support
- ✓ In-stock verified orders before 3pm EST ship the same day

\$1.20

1

 ADD

GET QUOTE

NEW!



UltiMaker Print Core CC 0.6mm

Product# 226560

UltiMaker Print Core CC 0.6mm, for use with abrasive materials.

Please Note: Abrasive material printing compatible with UltiMaker S-line only.

The print core CC 0.6 is ideal for printing composite applications that don't require a high level of detail. As this print core can print at thicker line widths, you will benefit from a shorter print time, allowing you to have the end result faster.

[LEARN MORE](#)

- ✓ Brand New
- ✓ In stock
- ✓ Unlimited Toll-Free Support
- ✓ **Free Shipping** & In-stock verified orders before 3pm EST ship the same day

\$299.00

1

 ADD

GET QUOTE



UltiMaker Bowden Pack

Product# 226572

Bowden Pack for UltiMaker.

Includes Bowden Tube, 2x Clamp Clips, and 2x Coupling Collets.

Compatible with UltiMaker 2/2+/3 series and S3 printers.

[LEARN MORE](#)

- ✓ Brand New
- ✓ In stock
- ✓ Unlimited Toll-Free Support
- ✓ In-stock verified orders before 3pm EST ship the same day

\$24.00

1

 ADD

GET QUOTE



UltiMaker Tube Coupling Collet

Product# 1069

Tube Coupling Collet for UltiMaker Please note: compatible with UltiMaker 2+/E+/3/3E/S3/S5 models

[LEARN MORE](#)

- ✓ Brand New
- ✓ Usually ships in 1-2 weeks

✓ Unlimited Toll-Free Support

\$1.50

1

🛒 ADD

GET QUOTE



UltiMaker Print Core BB 0.80mm

Product# 9532

UltiMaker Print Core BB 0.8mm for use with PVA support material.

Print Cores are the entire hot-end for use with the UltiMaker 3 and S-series, with a chip built-in to communicate and sync with the printer. This chip contains information about the print core type and its runtime statistics. Print Cores are designed as a single assembly, making them easy to change and increases uptime.

[LEARN MORE](#)

- ✓ Brand New
- ✓ Extended backorder, current estimate is mid June
- ✓ Unlimited Toll-Free Support
- ✓ **Free Shipping**

\$114.95

1

🛒 ADD

GET QUOTE



We can't find products matching the selection.

How can we help?

[FAQ](#)

[Shipping & Returns](#)

[Promotions](#)

[Warranty](#)

[Privacy](#)

[Terms of Sale](#)

[Terms of Use](#)

ISA

Copyright © 2023 Dynamism All Rights Reserved.

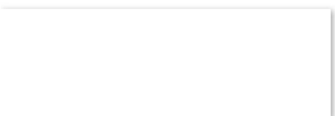



Compare

JET Floor Drill Press: Belt, Variable, 245 RPM – 2,000 RPM, 460V AC /Three-Phase, 20 in Swing, 2 hp

Item 52XJ01

Mfr. Model JDP-20EVST-460

Save money on this similar product!



DAYTON Floor Drill Press: Belt, Variable, 40 RPM – 5,000 RPM, 230V AC /Single-Phase, 22 in Swing

[Compare Products](#)

Web Price ⁱ
\$7,774.23 / each

Qty
1

Add to Cart

Web Price ⁱ
\$7,132.43 / each

This item requires special shipping, additional charges may apply.

Qty
1

Add to Cart

Ship

Pickup

! Ships from supplier. Expected to arrive by end of Sep, 2023.

Ship to 37201 | [Change](#)

Shipping Weight 792 lbs

[Ship Availability Terms](#)

[Add to List](#)

G Alternate Products ⁱ



DAYTON Floor Drill Press: Belt, Variable, 40 RPM – 5,000 RPM, 230V AC /Single-Phase, 22 in Swing

Item 53UH06

Compare

Web Price ⁱ
\$7,774.23 / each

Qty
1

Add to Cart

Product Details Catalog Page [2345](#)

Drive Type Belt

Speed Control Variable

Motor Voltage 460V AC ; Three-Phase

Voltage 460V AC

Phase Three-Phase

Swing 20 in

Spindle-to-Column Distance 10-7/16 in

Horsepower 2 hp

Spindle Speed Range 245 RPM – 2,000 RPM

Spindle Speed 65 to 2,000 RPM

Minimum Spindle Speed 245 RPM

Chat with an Agent

Maximum Spindle Speed **2,000 RPM**

Current **9.2 A**

Drilling Capacity in Steel **1-3/8 in**

Spindle Travel **6 in**

Drill Press Application **Drilling; Tapping**

Power Down Feed Included **No**

Brand **JET**

Number of Spindle Speeds **Variable**

Application **Drilling; Tapping**

Base Length **27 in**

Base Width **19 in**

Chuck Size **5/8 in**

Chuck Style **Keyed**

Column Diameter **4-1/2 in**

Coolant System **Yes**

Drilling Capacity in Cast Iron **1-1/2 in**

Drilling Capacity in Stainless Steel **1 in**

Drilling Capacity in Wood **1-1/2 in**

Drill Press Type **Floor Stand**

Guard Included **Yes**

Includes **Chuck Guard**

Maximum Overall Height **79-1/2 in**

Maximum Spindle-to-Base Height **44-1/2 in**

Maximum Spindle-to-Table Height **30-1/4 in**

Number of Speeds **Variable**

Number of T-Slots **2**

Overall Length **38-1/8 in**

Power Source **Corded**

Primary Material Application **Metal**

Quill Diameter **2-61/64 in**

Radial Arm **No**

Speed Control Type **Mechanical Variable Speed Drive System**

Spindle Taper **3MT**

Standards **CSA Certified; CUS Certified**

Table Length **22 in**

Table Load Capacity **154 lb**

Table Shape **Rectangular**

Table Slot **Yes**

Table Slot Width **5/8 in**

Table Width **18-3/4 in**

Tapping Capacity in Stainless Steel **5/8 in**

Tapping Capacity in Steel **3/4 in**

Tapping Compatible **Yes**

Tool Weight **792 lb**

UNSPSC **27112703**

Country of Origin **Taiwan (subject to change)**

Product Description

The manual downfeed of these benchtop drill presses requires hand-cranking to lower the bit so it can drill holes in metal workpieces.

Greeneville City Schools
Final General Purpose Budget Amendment
For the 2022 - 2023 Fiscal Year
Presented: June 2023

Account #	Description	General Purpose Budget 2022 - 2023	Amendment	Amended General Purpose Budget 2022 - 2023	
34555	Restricted for Education	-	3,963	3,963	(3)
34565	Restricted for Support Services	3,143		3,143	
34590	Restricted for Other Purposes	17,650		17,650	
34760	Assigned for Instruction	182,225		182,225	
34765	Assigned for Support Services	2,292		2,292	
34785	Assigned for Capital Projects	242,353		242,353	
34790	Assigned for Other Purposes	111,875		111,875	
40000	Local Taxes	8,098,424		8,098,424	
41000	Licenses & Permits	1,090		1,090	
43000	Charges for Current Services (Education)	787,025		787,025	
44000	Other Local Revenue	181,097	3,335,903	3,517,000	(5),(10),(11)
46000	State Education Funds & Other State Revenues	17,129,905	1,846,085	18,975,990	(1),(2),(8)
47100	Federal Through State	50,000		50,000	
47600	Direct Federal Revenue (ROTC)	53,565		53,565	
49000	City Appropriation, Indirect Cost & Insurance Recovery	6,061,471	126,882	6,188,353	(6),(7)
	Total Revenue & Equity	\$ 32,922,115	\$ 5,312,833	\$ 38,234,948	
71100	Regular Instruction	15,909,390	206,638	16,116,028	(1),(3),(9),(10)
71150	Alternative Instruction Program	121,298		121,298	
71200	Special Education Program	2,061,366		2,061,366	
71300	Vocational Education Program	181,407	1,392,501	1,573,908	(8)
71400	Student Body Education Program	1,900		1,900	
72110	Attendance	82,552	1,831	84,383	(1)
72120	Health Services	407,376	4,882	412,258	(1)
72130	Other Student Support	1,288,797		1,288,797	
72210	Regular Instruction - Support	1,495,018	6,970	1,501,988	(1)
72220	Special Education Program - Support	314,495		314,495	
72230	Vocational Education Program - Support	2,400	25,699	28,099	(8)
72250	Technology	1,028,529	(20,000)	1,008,529	(9)
72310	Board of Education	880,759		880,759	
72320	Office of the Superintendent	391,935	10,000	401,935	(9)
72410	Office of Principal	1,684,911	10,000	1,694,911	(9)
72510	Fiscal Services	341,883	20,000	361,883	(6)
72520	Human Resources	315,098	14,500	329,598	(6)
72610	Operation of Plant	2,124,673	205,379	2,330,052	(1),(5),(7),(9)
72620	Maintenance of Plant	994,203	97,086	1,091,289	(6),(9)
72710	Transportation	1,177,015	23,133	1,200,148	(2),(4),(8)
73100	School Nutrition	-	35,224	35,224	(1),(9)
73300	Community Services	25,652	7,500	33,152	(9)
73400	Early Childhood Education	557,495		557,495	
76100	Capital Outlay	742,353	3,311,490	4,053,843	(8),(11)
81300	Education Debt Service	328,700	(80,000)	248,700	(9)
99100	Operating Transfers	462,910	40,000	502,910	(4)
	Total Expenses	\$ 32,922,115	\$ 5,312,833	\$ 38,234,948	

This Amendment Accomplishes the Following Objectives:

- (1) To Budget for Summer Learning Camps: \$292,952
- (2) To Budget Summer Learning Camps Transportation: \$53,133
- (3) TOPS Reserve Owed to Bristol City Schools: \$3,963
- (4) Moves \$40k in BEP Transportation Funds to Correct Transfers Out Account to Send to GTC
- (5) Budgets \$35,829 in TVA EnergyRight Light & Power Rebates
- (6) Budgets ESSER 2.0 Indirect Cost: \$51,586
- (7) ESP Fund Balance Transfer to General Purpose: \$75,296
- (8) To Budget Innovative Schools Models Grant: \$1,500,000
- (9) Moves Funding to State Mandated Account Codes for Expenditure Type
- (10) To Budget Project on Track: \$60,384
- (11) To Budget Total for Potential FY23 EESI HVAC/Lighting Project Payments Paid on Behalf of GCS by the Town of Greeneville: \$3,239,690

Note: Budgets Remaining Total of Loan Proceeds Remainng After FY22

Re: GCS Cyber Policy Quote 2023-2024 Explanation

Jamie Galyon <galyonj@gcschools.net>

Thu 6/15/2023 1:28 PM

To: Beverly Miller <millerb@gcschools.net>; Steve Starnes <starness@gcschools.net>

Will do, thank you.

Jamie Galyon
Administrative Assistant to Director of Schools
Greeneville City Schools
129 W. Depot St.
Greeneville, TN 37743
423-787-8014

From: Beverly Miller <millerb@gcschools.net>
Sent: Thursday, June 15, 2023 1:27 PM
To: Jamie Galyon <galyonj@gcschools.net>; Steve Starnes <starness@gcschools.net>
Subject: GCS Cyber Policy Quote 2023-2024 Explanation

Please use this email as an additional piece of supporting documentation for the BOE June 2023 Insurance Item as it will help to explain the difference between the quote and the summary amount. Thanks.
Bev

From: Amanda Gibson <agibson@mmbinsurance.com>
Sent: Thursday, June 15, 2023 1:18 PM
To: Beverly Miller <millerb@gcschools.net>
Cc: John McInturff, III <jmcinturff@tsclaims.com>
Subject: GCS Cyber Policy Quote 2023-2024 Explanation

WARNING: This email originated from outside of the Greeneville City Schools network. Do not click links or open attachments unless you recognize the sender and know the content is safe.

Bev,

See below for a list of the fees. I believe the \$800 policy fee is what you are needing to see. Unfortunately, the quotes do not list the policy fee on the quotes. They only show them on the email with the quote.

Attached you will find a premium quotation for Data Breach coverage for this risk. This proposed coverage is provided by: Lloyds.

Premium:	\$27,225.00
Carrier Policy Fee	\$500.00
Policy Fee	\$800.00
Taxes:	\$0.00

Best Regards,

Amanda Gibson, CISR ELITE

Customer Service Representative | McInturff, Milligan & Brooks, Inc.
237 W. Summer Street, Greeneville, TN 37743 | P. O. Box 1600 | Greeneville, TN 37744
Phone: 423-639-5171 Ext. 1 | Fax: 423-639-7129 | Email: agibson@mmbinsurance.com

For a full description of the extent of your insurance coverage and exclusions please read your insurance policy. **Correll Insurance Group, LLC including all DBAs does not warrant or guarantee insurance coverage for claim activity and encourages you to be familiar with your insurance program as it relates to your own operations and lifestyles. NO POLICY INSURES ALL RISKS. HIGHER LIABILITY LIMITS AND PROPERTY VALUES MAY BE AVAILABLE FOR YOUR POLICIES – Please discuss with your agent or customer service rep.**

Confidentiality Notice: This electronic mail transmission is intended for the use of the individual or entity to which it is addressed and may contain confidential information belonging to the sender which is legally privileged. If you are not the intended recipient, you are hereby notified that any disclosure, copying, distribution, or the taking of any action in reliance on the contents of this information is strictly prohibited. If you have received this transmission in error, please notify the sender immediately by email and delete the original message. **Insurance cannot be bound or altered by email unless the request is approved and confirmed by an agent of Correll Insurance Group, LLC including all DBAs.**

Directors Update to the Board

Thursday, June 22, 2023

1. Congratulations to Chuck Broyles on his completion of the Consortium for School Networking K-12 Early Career Academy. Chuck is an integral part of our amazing IT Team, and we are very appreciative of his leadership and dedication to the students and staff of GCS.
2. Congratulations to Ellen Lipe on her recognition as the 2023 Woman to Watch by the Tennessee Society of Certified Public Accountants. Ellen is a phenomenal CFO who serves with passion and purpose. GCS is blessed to have someone with not only her knowledge and expertise, but someone with her strong character and servant's heart overseeing our finances for the benefit of students and staff.
3. Congratulations to the Greeneville High School Baseball Team on winning the TSSAA 2023 Class 3A State Baseball championship. The championship game was a thrilling affair as the Greene Devils won 1-0 over Upperman.
4. Congratulations to Jayquan Price who won two gold medals in the TSSAA Class 2A State Championships. He set personal records of 22'-3" in the long jump and 44'-4.25" in the triple jump as he won the state championship in each event. Also, congratulations to Zayden Anderson who finished 2nd in the long jump, J.J. Durbin who finished third in the discus, and Adjantay Dabbs who finished fourth in the 400 meters and seventh in the 200 meters at the state meet.
5. Congratulations to the Greeneville High School Soccer Team on their TSSAA Class 2A State Runner-up finish. The soccer team lost a heartbreaker to Valor prep on penalty kicks after playing to a scoreless tie through regulation and two overtime periods.
6. Today marked the last day of our GCS Summer Camps. Students served for rising K through rising 9th grades equaled 263 students. There were 3 site directors (Nancy Philbeck at HH, Cathy Duncan at TV and Haley Barkley for GMS), 36 teachers and 25 Assistants supporting RTI, plus Project on Track Site Director- Lauren Johnson (We utilized Zearn and Amplify for summer camp tutoring.). Additional staff who supported summer camps included office support, custodians, cafeteria staff, bus drivers, school nurses, and SROs for each site. I also want to recognize Shelia Newland, who coordinated Summer Camps from the Central Office. I want to say a big thank you to all staff involved in delivering this outstanding summer learning opportunity for students.
7. GHS provided two summer programs for rising 9th grade students: the Bridge program and the Promise program. The Bridge program is designed to help rising 9th graders transition to high school. Components of the program are to provide innovative opportunities to support students in math, language arts, and reading enhancement. Additionally, students are provided with an hour of enrichment time for college and career that includes activities and support to help students be successful at the high

school level and beyond. Students who have satisfactory attendance and participation in the program earn elective credit. The Promise program is designed to help rising 9th graders transition to high school. Components of the program are to provide social/emotional support and reading enhancement to students. Program goals are to help students gain self-awareness, manage emotions, handle difficult conversations, and solve problems. Students who have satisfactory attendance and participation in the Promise program earn elective credit as well.

8. I want to recognize Angie Wells, Sandy Fox, Phillip Graham, Roger Hensley, and the entire GHS Graduation planning team and everyone that worked and supported the 2023 GHS Graduation. It was a spectacular event, and everything went very smoothly.
9. The principals, assistant principals, Dr. Bryant, Mrs. Newland, and I will be attending the 2023 Ignite Conference for school principals July 12 – 15. This is a premiere event for school leaders to expand and grow their leadership skills.
10. Our Leadership Retreat will be held on July 17-19 as we kick off the 2023-24 School Year. These three days are focused on team building, professional development, and preparing for the upcoming school year.
11. Also, I want to remind the Board of our TSBA Summer Law Conference which will occur July 20-23. Jamie has prepared packets for each of you.
12. The Opening In-Service has been scheduled for Friday, July 28 beginning at 8 am. Jim Mahoney, author of the book “To Lead is to Teach” will be the keynote speaker. Jim’s extensive experience as a teacher, principal, superintendent, college professor, and launching and leading a large national not for profit organization have added considerable value to his skills and expertise in strengths-based leadership, motivation, culture, engagement, and change management. He is currently an assistant professor and Executive in Residence with the George Voinovich School of Leadership and Public Service at Ohio University in Athens, Ohio.

Respectfully submitted by Steve Starnes