



City of Franklin Regular Meeting October 14, 2025 6:00 PM City Hall

1. Call Meeting to Order Roll Call

2. Verification of Open Meetings Notice

I encourage residents to participate in our council meetings. Public comment is an essential part of our democratic process. To ensure everyone has a fair opportunity to speak, we are implementing a three-minute time limit for each speaker per topic during the public comments section. This will allow us to hear from as many community members as possible. We appreciate your understanding and cooperation as we work to create a space that is respectful and open to all. Thank you

3. Mayor Communications

Thank you, from the Franklin Public School Yearbook students for the ad we put in their annual each year.

4. Consent Agenda

4.a. Minutes of the previous meetings

4.b. Treasurer's Report

4.c. Budget Report

4.d. Payroll

4.e. **CLAIMS - no invoice this month from Duncan Welding**

4.f. Permits: Verlyn Obering, Demo Permit; Chase Bislow, Fence permit; James Barber, new structure; Franklin Rural Fire Department, new structure; Jr Stover, new structure.

4.g. Franklin County Sheriff's report

5. Discussion and Action Items

5.a. Consider a motion to ratify all actions of Raquel Felzien, your LARM representative, identified in the minutes of the Annual Members Meeting of the League Association of Risk Management on September 24, 2025, including the election of nominees to the LARM Board of Directors.

5.b. Discussion and action on quarterly report from Franklin Little Flyer Academy

5.c. Discussion and action on approving payment #4 to RMV Construction LLC of \$111,568.50 for construction work

5.d. Discussion and action on the change order from RMV Construction for basement tuck pointing was \$26,210; Extended Electrical Service \$4,086.05; Floor Decking replacement \$4,252; Fire Extinguishers deducted \$665 total in a change order of \$33883.05.

The City of Franklin follows the Nebraska Open Meetings Act. A copy is displayed in this room as required by state law. The Mayor and City Council may enter an Executive Session anytime during the meeting, even if not listed on the agenda. The Mayor and City Council intend to follow the agenda order but may rearrange items to suit schedules. Individuals who wish to address the council may be allotted a speaking time of three minutes per person, per topic. Speakers are kindly requested to approach the podium and articulate their topic with clarity and professionalism.



- 5.e. Discussion, update and action on the RCRP grant, park equipment, and Library patio.
- 5.f. Discussion and action on possibly installing connecting sidewalks from the musical playground and fitness station to the parameter sidewalk at the city park or maybe a couple benches and trash cans.
- 5.g. Discussion and action on approving Erickson Sullivan Architects invoice 8-35024 for NAHTF grant (Marcellus Building) \$1,856.25
- 5.h. Discussion and action on approving Erickson Sullivan Architects invoice 5-15025 for RCRP grant (Library project) \$1,150.00
- 5.i. Discussion and action on Franklin Flyer Beef Boosters request for donations
- 6. **Resolution**
 - 6.a. Resolution 2025-10 - Salaries for fiscal year 2025-2026
 - 6.b. **Resolution 2025-11** Rightway Grocery 601 15th Ave, Franklin NE
SDL (Special Designated Liquor License) for November 21, 2025, from 4:30 PM to 8:30 PM
- 7. Discussion and review of the salary range ordinance
- 8. **Public Comments**
- 9. **Adjourn**

The City of Franklin follows the Nebraska Open Meetings Act. A copy is displayed in this room as required by state law. The Mayor and City Council may enter an Executive Session anytime during the meeting, even if not listed on the agenda. The Mayor and City Council intend to follow the agenda order but may rearrange items to suit schedules. Individuals who wish to address the council may be allotted a speaking time of three minutes per person, per topic. Speakers are kindly requested to approach the podium and articulate their topic with clarity and professionalism.



The City of Franklin follows the Nebraska Open Meetings Act. A copy is displayed in this room as required by state law. The Mayor and City Council may enter an Executive Session anytime during the meeting, even if not listed on the agenda. The Mayor and City Council intend to follow the agenda order but may rearrange items to suit schedules. Individuals who wish to address the council may be allotted a speaking time of three minutes per person, per topic. Speakers are kindly requested to approach the podium and articulate their topic with clarity and professionalism.

Tritny Kappes

Rosey
Johnson♡

Musegal

Lynn Sidman
adviser

Jan
Jaite

Audra Hoopie

ity of Franklin,

Thank you so much for your purchases
an advertisement in the 2025-26 Franklin
book. Without the support of small businesses
yours, we definitely could not make a book.
ur contribution gives students the opportunity to
valuable skills like photography, interviewing +
ng. Thank you again!

Sincerely,

The Flyer Staff

Franklin, Nebraska
September 9, 2025

A meeting of the Mayor and Council of the City of Franklin, Nebraska was held at City Hall in said City on September 9, 2025, at 6:00 PM

Upon roll call, the following board members were in attendance: Margaret Siel, Dave Duncan, Dave Platt, Mike Stephens, Absent: Sandy Urbina.

Mayor Siel gave notice that a copy of the Open Meetings Act was properly posted in the Council Chambers.

Notice of this meeting was simultaneously given to all members and a copy of their acknowledgement of receipt of the notice and agenda was communicated in the advance notice as in the notice to the board members of this meeting. All proceedings hereafter shown were taken while the convened meeting was held open to the attendance of the public.

Mayor Communications: Thank you from Nebraska Rural Water Association for the donation for the work they did for us, and Franklin Public Schools Teachers Association for sponsoring a table at their back-to-school luncheon.

Motion made by Dave Platt, seconded by Mike Stephens to approve and/or receive the items on the Consent Agenda and to waive the oral reading of the minutes. Motion Passed.

Duncan: Yea, Platt: Yea, Stephens: Yea, Urbina: Absent

Yea: 3, Nay: 0, Absent: 1

AFLAC	INS.	\$1,041.69
AMANDA SHELTON	REIMB.	\$267.40
AMY LYNN STEPHENS	REIMB. C4K	\$75.00
BELLAMY LAW	FEE	\$2,550.00
BCBS	INS.	\$11,070.65
BLACK HILLS	GAS	\$1,384.87
CASPIAN CREATES	FEE	\$540.00
CENTER STONEWORKS LLC	MAINT.	\$5,000.00
CHRISTIE MALL	SERV.	\$80.00
CITY OF HOLDREGE	DISP.FEE	\$3,220.28
CORE & MAIN LP	SUPPLIES	\$1,182.82
CPI	FUEL	\$3,078.92
DELTA DENTAL	INS.	\$631.18
DUNCAN LAW	FEE	\$5,242.00
DUNCAN WELDING	CDA GRANT	\$590.98

DUNCAN WELDING	MAINT.	\$397.60
DUTTON LAINSON	DIST.SUPPLY	\$24,974.25
EAKES	FEE	\$79.74
EFTPS	PAYROLL	\$10,312.67
ELECTRIC FUND	ELECTRIC	\$4,497.78
EMILY CLEVELAND	REIMB.TRAINING	\$750.00
ERICKSON SULLIVAN ARCHITECT	GRANT/RCRP/NAHTF	\$3,712.50
FAST	FEE	\$100.00
FELZIEN RAQUEL	REIMB.	\$134.66
FRANKLIN AUTO PARTS	MAINT.	\$778.20
FRANKLIN PUBLIC SCHOOL	FEE	\$160.00
FRANKLIN CO. SHERIFF	FEE	\$6,032.00
FREEDOM CLAIMS	FEE	\$3,000.00
GERDES FEE & SUPPLY	SUPPLY	\$18.99
GLENWOOD TELE.	PHONE	\$587.79
HOMETOWN LEASING	FEE	\$423.78
JEO CONSUTLING GROUP	FEE	\$3,085.00
JOHNSON SERVICE	MAINT.	\$15,000.00
JR'S WESTERN INC	UNIFORMS	\$1,201.49
MADISON LIFE	INS	\$56.30
MICHELLE KAHRS	REIMB. FEE	\$114.10
MG TRUST	FEE	\$4,360.33
MUNICIPAL SUPPLY	SUPPLY	\$534.38
NE DEPT OF REV	SALES TAX	\$8,221.46
NE MUNICIPAL CLERKS	FEE	\$100.00
NE PUBLIC HEALTH	FEE	\$61.00
NE RURAL WATER ASSOC	FEE	\$500.00
NUESYNERGY INC	PAYROLL	\$1,134.99
PAYROLL	PAYROLL	\$48,322.49
PITSTOP	FUEL	\$498.70
PLANK'S HWDE	SUPPLY	\$224.30
QUADIENT/FINANCE	POSTAGE	\$350.00
QUADIENT/LEASING	FEE	\$719.88

RIGHTWAY GROCERY	SUPP.	\$12.68
RMV CONSTRUCTION LLC	FEE/NAHTF	\$168,976.80
S.E. SMITH & SONS	SUPPLIES	\$20.74
SARGENT DRILLING	MAINT.	\$4,235.00
SMILEY SWEET CAKES	FEE/C4K	\$78.00
SOUTHERN POWER	FEE	\$76,043.84
STEINBRINK LANDSCAPE	MAINT.	\$1,972.94
U.S. BANK	SUPPLY	\$3,209.82
VERIZON	PHONE	\$79.94
VSP	INS	\$185.87
WAPA	FEE	\$6,838.35
	TOTAL	\$438,054.15

Motion made by Dave Platt, seconded by Mike Stephens to approval of a claim for \$397.60 from Duncan Welding for services to the City of Franklin. Motion Passed.

Duncan: Abstain (With Conflict), Platt: Yea, Siel: Yea, Stephens: Yea, Urbina: Absent
Yea: 3, Nay: 0, Absent: 1, Abstain (With Conflict): 1

Motion made by Dave Duncan, seconded by Dave Platt to approval of a claim from Amy Stephens for \$75.00 for C4K food for June 9, 2025, Orientation meeting. Motion Passed.

Duncan: Yea, Platt: Yea, Siel: Yea, Stephens: Abstain (With Conflict), Urbina: Absent
Yea: 3, Nay: 0, Absent: 1, Abstain (With Conflict): 1

Motion made by Dave Duncan, seconded by Mike Stephens to approve payment #3 to RMV Construction LLC of \$168,976.80 for construction work. Motion Passed.

Duncan: Yea, Platt: Yea, Stephens: Yea, Urbina: Absent
Yea: 3, Nay: 0, Absent: 1

Motion made by Dave Platt, seconded by Mike Stephens to approve moving forward with recommendation of Miller & Associates and Sargent Drilling Company. Motion Passed.

Duncan: Yea, Platt: Yea, Stephens: Yea, Urbina: Absent
Yea: 3, Nay: 0, Absent: 1

Motion made by Mike Stephens, seconded by Dave Duncan to table fence ordinance changes for temporary swimming pools until next meeting. Motion Tabled.

Duncan: Yea, Platt: Yea, Stephens: Yea, Urbina: Absent
Yea: 3, Nay: 0, Absent: 1

Discussion and update on the NAHTF grant – Marcellus building.

Discussion and update on the RCRP grant – Park grant.

Discussion on tree removal at 1203 J Street.

Discussion on employee reviews.

Motion made by Mike Stephens, seconded by Dave Duncan to approve moving Tuesday November 11, 2025, council meeting to Wednesday November 12, 2025, at 6 PM due to Veteran's Day holiday. Motion Passed.

Duncan: Yea, Platt: Yea, Stephens: Yea, Urbina: Absent
Yea: 3, Nay: 0, Absent: 1

Motion made by Mike Stephens, seconded by Dave Platt to approve Resolution 2025-09 Parade of Lights - November 2, 2025. Motion Passed.

Duncan: Yea, Platt: Yea, Stephens: Yea, Urbina: Absent
Yea: 3, Nay: 0, Absent: 1

Public comments: Connie Schmidt, 617 12th Ave, inquired about the final amount of the demo grant and the progress on radon testing vapor barrier for the Marcellus building. Helen Sweet, 922 J Street, inquired about the dumpster on K Street for Golden Age Village and raised concerns regarding shingles falling off the roof of the house north of Patty Johnson's property.

ATTEST:

APPROVED:

Raquel Felzien, City Clerk

Margaret Siel, Mayor

Franklin, Nebraska
September 9, 2025

A meeting of the Mayor and Council of the City of Franklin, Nebraska was held at City Hall in said City on September 9, 2025, at 5:45 PM

Upon roll call, the following board members were in attendance: Margaret Siel, Dave Duncan, Dave Platt, Mike Stephens, Absent: Sandy Urbina.

Mayor Siel gave notice that a copy of the Open Meetings Act was properly posted in the Council Chambers.

Notice of this meeting was simultaneously given to all members and a copy of their acknowledgement of receipt of the notice and agenda was communicated in the advance notice as in the notice to the board members of this meeting. All proceedings hereafter shown were taken while the convened meeting was held open to the attendance of the public.

Open the public hearing at 5:46 PM to discuss the one- & six-year plan for the streets.

Close the public hearing at 5:50 PM

Motion made by Dave Platt, seconded by Dave Duncan to Approve Resolution 2025-09 Municipal Annual Certification of Program Compliance 2025. Motion Passed.

Duncan: Yea, Platt: Yea, Stephens: Yea, Urbina: Absent

Yea: 3, Nay: 0, Absent: 1

Motion made by Mike Stephens, seconded by Dave Duncan to Approve Annual Certification of Program Compliance to Nebraska Board of Public Roads Classifications and Standards 2025. Motion Passed.

Duncan: Yea, Platt: Yea, Stephens: Yea, Urbina: Absent

Yea: 3, Nay: 0, Absent: 1

No public comments

Adjourn meeting at 5:51 PM

ATTEST:

APPROVED:

Raquel Felzien, City Clerk

Margaret Siel, Mayor

Franklin, Nebraska
September 9, 2025

City of Franklin Community Development Authority of the City of Franklin, Nebraska was held at City Hall in said City on September 9, 2025, at 5:40 PM

Upon roll call, the following board members were in attendance: Margaret Siel, Dave Duncan, Dave Platt, Mike Stephens, and Sandy Urbina: Absent.

Mayor Siel gave notice that a copy of the Open Meetings Act was properly posted in the Council Chambers.

Notice of this meeting was simultaneously given to all board members and a copy of their acknowledgement of receipt of the notice and agenda was communicated in advance notice as in the notice to the board of this meeting. All proceedings hereafter shown were taken while the convened meeting was held open to the attendance of the public.

Motion made by Mike Stephens, seconded by Dave Duncan to approve resolution 2025-01 CDA to pause the CDA forgivable loan grants for fiscal year 2026, with fulfilling the applications that are in the process of finishing. Motion Passed.

Dave Duncan: Yea, Dave Platt: Yea, Mike Stephens: Yea, Sandy Urbina: Absent
Yea: 3, Nay: 0, Absent: 1

No public comments

Adjourn meeting at 5:43 PM

Submitted by:
Raquel Felzien

Franklin, Nebraska
September 22, 2025

A meeting of the Mayor and Council of the City of Franklin, Nebraska was held at City Hall in said City on September 22, 2025, at 6:00 PM

Upon roll call, the following board members were in attendance: Margaret Siel, Dave Duncan, Dave Platt, Mike Stephens, Absent: Sandy Urbina.

Mayor Siel gave notice that a copy of the Open Meetings Act was properly posted in the Council Chambers.

Notice of this meeting was simultaneously given to all members and a copy of their acknowledgement of receipt of the notice and agenda was communicated in the advance notice as in the notice to the board members of this meeting. All proceedings hereafter shown were taken while the convened meeting was held open to the attendance of the public.

Mayor Siel opens the public hearing at 6:00 PM for the budget for fiscal year 2026 to discuss support, opposition, and suggestions regarding the outline and key provisions of the proposed budget statement.

Mayor Siel closes the public hearing for budget fiscal year 2026 at 6:17 PM

Adjourn meeting at 6:17 PM

ATTEST:

APPROVED:

Raquel Felzien, City Clerk

Margaret Siel, Mayor

Franklin, Nebraska
September 22, 2025

A meeting of the Mayor and Council of the City of Franklin, Nebraska was held at City Hall in said City on September 22, 2025, at 6:10 PM

Upon roll call, the following board members were in attendance: Margaret Siel, Dave Duncan, Dave Platt, Mike Stephens, Absent: Sandy Urbina.

Mayor Siel gave notice that a copy of the Open Meetings Act was properly posted in the Council Chambers.

Notice of this meeting was simultaneously given to all members and a copy of their acknowledgement of receipt of the notice and agenda was communicated in the advance notice as in the notice to the board members of this meeting. All proceedings hereafter shown were taken while the convened meeting was held open to the attendance of the public.

Motion made by Dave Duncan, seconded by Mike Stephens to approve 1% increase in restricted funds for fiscal year 2026. Motion Passed.

Duncan: Yea, Platt: Yea, Stephens: Yea, Urbina: Absent
Yea: 3, Nay: 0, Absent: 1

Motion made by Dave Platt, seconded by Mike Stephens to approve Resolution 2025-10 Fiscal Year budget 2025-2026. Motion Passed.

Duncan: Yea, Platt: Yea, Stephens: Yea, Urbina: Absent
Yea: 3, Nay: 0, Absent: 1

Motion made by Dave Platt, seconded by Dave Duncan to approval of 2025-2026 Fiscal Year Budget. Motion Passed.

Duncan: Yea, Platt: Yea, Stephens: Yea, Urbina: Absent
Yea: 3, Nay: 0, Absent: 1

Adjourn the meeting at 6:21 PM

ATTEST:

APPROVED:

Raquel Felzien, City Clerk

Margaret Siel, Mayor

Franklin, Nebraska
September 30, 2025

A meeting of the Mayor and Council of the City of Franklin, Nebraska was held at City Hall in said City on September 30, 2025, at 9:45 AM

Upon roll call, the following board members were in attendance: Margaret Siel, Dave Duncan, Dave Platt, Mike Stephens, Sandy Urbina.

Mayor Siel gave notice that a copy of the Open Meetings Act was properly posted in the Council Chambers.

Notice of this meeting was simultaneously given to all members and a copy of their acknowledgement of receipt of the notice and agenda was communicated in the advance notice as in the notice to the board members of this meeting. All proceedings hereafter shown were taken while the convened meeting was held open to the attendance of the public.

Discussion regarding the RCRP grant for the musical playground equipment and fitness station area. The council has expressed concerns about the installation of these areas and has requested that we contact the contractor to address the identified issues.

The council discussed the NAHTF grant awarded for the Marcellus building project, which involves collaboration with Erickson Sullivan Architects and RMV Construction. An structural engineer was on site today to address any concerns and determine appropriate steps to resolve them.

No public comments

Adjourn the meeting at 10:53 AM

ATTEST:

APPROVED:

Raquel Felzien, City Clerk

Margaret Siel, Mayor

Cornerstone Bank & SCSB		for October 14, 2025 meeting				
Beginging Balance	\$815,302.60					
Credit Transactions	\$397,873.20					
Debit Transactions	\$416,798.99					
ending bank balance	\$796,376.81					
C & D Enterprise Fund	\$80,359.38					
Farmers State Bank Trust/ Health Acct	\$56,597.83					
TOTAL OF ALL CHECKING ACCOUNTS	\$933,334.02					
CD BALANCES CORNERSTONE BANK (CBS)	CERTIFICATE VALUE	INTEREST EARNED	RATE	MATURITY DATE	ACCOUNT TERM	
CSB CD#114064	\$54,888.02	\$565.49	4.13%	01/05/2026	7 MONTHS	
CSB CD# 115430	\$277,112.61	\$0.00	4.13%	2/20/2026	7 MONTHS	
CSB CD#127417	\$56,931.80	\$378.49	1.60%	8/9/2026	11 MONTHS	
CSB CD#127418	\$56,398.60	\$374.94	1.60%	8/9/2026	11 MONTHS	
CSB CD#127419	\$153,237.97	\$0.00	4.04%	12/9/2025	7 MONTHS	
CSB CD#128049	\$302,682.74	\$0.00	4.13%	01/06/2026	7 MONTHS	
CSB CD#128711	\$178,003.71	\$0.00	4.13%	01/26/2026	7 MONTHS	
CSB CD#135024	\$76,783.51	\$0.00	4.13%	1/26/2026	7 MONTHS	
Total CBS:	\$1,156,038.96	\$1,318.92				
SOUTH CENTRAL STATE BANK (SCSB)	CERTIFICATE VALUE	INTEREST EARNED	RATE	MATURITY DATE	ACCOUNT TERM	
SCSB CD#405884	\$54,494.67	\$0.00	4.08%	01/07/2026	5 MONTHS	
SCSB CD#405922	\$444,659.13	\$0.00	4.08%	10/21/2025	5 MONTHS	
SCSB CD#405923	\$328,345.69	\$0.00	4.08%	10/21/2025	5 MONTHS	
SCSB CD#405929	\$118,516.69	\$1,206.40	4.08%	11/06/2025	6 MONTHS	
SCSB CD#405930	\$142,892.81	\$1,454.53	4.08%	11/06/2025	6 MONTHS	
Total SCSB:	\$1,088,908.99	\$2,660.93				
Total CD's Investments:	\$2,244,947.95	\$3,979.85				
GRAND TOTAL CHECKING & CD'S:	\$3,178,281.97					

BUDGET REPORT
CALENDAR 9/2025, FISCAL 12/2025

ACCOUNT NUMBER	ACCOUNT TITLE	MONTH BALANCE	YTD BALANCE	PERCENT OF BUDGET	REMAINING BUDGET	TOTAL BUDGET
ADMIN DEPARTMENT						
05-00-4100	PROPERTY TAX	47,877.37	227,660.34	100.65	1,461.25-	226,199.09
05-00-4103	CITY SALES TAX	8,149.77	114,106.17	95.09	5,893.83	120,000.00
05-00-4211	STATE EQUALIZATION PYMT	24,938.92	152,621.10	102.10	3,144.52-	149,476.58
05-00-4301	INSURANCE REVENUE		10.00		10.00-	
05-00-4305	MISC REVENUES	12,281.40	24,544.27	196.35	12,044.27-	12,500.00
05-00-4310	DOG LICENSE/IMPOUND FEES	480.00	660.00	66.00	340.00	1,000.00
05-00-4320	LIQUOR/TOBACCO LICENSE		2,875.00	82.14	625.00	3,500.00
05-00-4340	FINES & FEES	128.00	9,719.50	129.59	2,219.50-	7,500.00
05-00-4348	MOSQUITO SPRAYING/BLOOMINGTON	647.50	1,683.75	336.75	1,183.75-	500.00
05-00-4380	FRANCHISE FEES		3,325.44	66.51	1,674.56	5,000.00
05-00-4400	INSURANCE PROCEES		70,431.50	140.86	20,431.50-	50,000.00
05-00-4611	HSA REIMBURSEMENT	786.78	3,312.40		3,312.40-	
05-00-4910	TRANSFER REVENUE		140,582.92	43.26	184,417.08	325,000.00
	ADMIN TOTAL	95,289.74	751,532.39	83.44	149,143.28	900,675.67
SUMMER RECREATION DEPARTMENT						
05-01-4010	BALL PARK REGISTRATIONS		2,020.00	80.80	480.00	2,500.00
05-01-4014	BALL PARK ADMISSIONS		5,022.00	154.52	1,772.00-	3,250.00
05-01-4016	BALL PARK CONCESSIONS				5,000.00	5,000.00
05-01-4640	SUMMER REC DONATIONS		3,915.00	195.75	1,915.00-	2,000.00
	SUMMER RECREATION TOTAL	.00	10,957.00	85.94	1,793.00	12,750.00
POOL DEPARTMENT						
05-03-4014	POOL ADMISSIONS		6,521.33	130.43	1,521.33-	5,000.00
05-03-4016	POOL CANDY		1,743.19	116.21	243.19-	1,500.00
05-03-4017	SWIMMING LESSONS				1,500.00	1,500.00
05-03-4108	SWIM TEAM REVENUE				300.00	300.00
05-03-4305	MISC REVENUE - POOL				200.00	200.00
05-03-4610	MISC POOL REV		236.50		236.50-	
	POOL TOTAL	.00	8,501.02	100.01	1.02-	8,500.00
PARK DEPARTMENT						
05-04-4015	RV PARK INCOME	443.19	5,064.96	253.25	3,064.96-	2,000.00
05-04-4343	GRANT MONEY		203,431.24	42.83	271,568.76	475,000.00
	PARK TOTAL	443.19	208,496.20	43.71	268,503.80	477,000.00
LIBRARY DEPARTMENT						
05-08-4018	LIBRARY INCOME	101.20	1,117.75	74.52	382.25	1,500.00
05-08-4305	MISC REVENUE - LIBRARY		200.00	40.00	300.00	500.00
	LIBRARY TOTAL	101.20	1,317.75	65.89	682.25	2,000.00

BUDGET REPORT
CALENDAR 9/2025, FISCAL 12/2025

ACCOUNT NUMBER	ACCOUNT TITLE	MONTH BALANCE	YTD BALANCE	PERCENT OF BUDGET	REMAINING BUDGET	TOTAL BUDGET
CEMETERY DEPARTMENT						
05-11-4020	CEMETERY INCOME	50.00	5,550.00	55.50	4,450.00	10,000.00
	CEMETERY TOTAL	50.00	5,550.00	55.50	4,450.00	10,000.00
	GENERAL TOTAL	95,884.13	986,354.36	69.91	424,571.31	1,410,925.67
ADMIN DEPARTMENT						
12-00-4125	LOAN PROCEEDS-STREET				125,000.00	125,000.00
12-00-4230	HIGHWAY ALLOCATIONS - STR	13,994.19	180,616.47	103.23	5,646.47-	174,970.00
12-00-4231	MOTOR VEHICLE FEES - STR	1,507.92	20,888.17	104.44	888.17-	20,000.00
12-00-4305	SALE OF EQUIPMENT-STR		1,291.90		1,291.90-	
12-00-4321	ROAD TAX - STR	965.84	4,763.76	119.09	763.76-	4,000.00
12-00-4331	MOTOR VEHICLE SALESTAX RECEIPT	1,402.90	27,002.04	108.01	2,002.04-	25,000.00
12-00-4910	TRANSFER REVENUE - STR				110,000.00	110,000.00
	ADMIN TOTAL	17,870.85	234,562.34	51.11	224,407.66	458,970.00
	STREET TOTAL	17,870.85	234,562.34	51.11	224,407.66	458,970.00
15-00-4020	KENO LOTTO REVENUE				150.00	150.00
15-00-4610	MISC KENO REV		80.00		80.00-	
	ADMIN TOTAL	.00	80.00	53.33	70.00	150.00
	COMMUNITY BETTERMENT TOTAL	.00	80.00	53.33	70.00	150.00
16-00-4103	CDA CITY SALES TAX REVENUE	2,716.59	38,035.36	108.67	3,035.36-	35,000.00
16-00-4125	LOAN PROCEEDS/CDA GRANT	43,081.17	132,218.39	9.30	1289,781.61	1,422,000.00
16-00-4910	TRANSFER FROM OTHER FUNDS				500,000.00	500,000.00
	ADMIN TOTAL	45,797.76	170,253.75	8.70	1786,746.25	1,957,000.00
	CDA TOTAL	45,797.76	170,253.75	8.70	1786,746.25	1,957,000.00
	TOTAL REVENUE	159,552.74	1,391,250.45	36.35	2435,795.22	3,827,045.67

BUDGET REPORT
CALENDAR 9/2025, FISCAL 12/2025

ACCOUNT NUMBER	ACCOUNT TITLE	MONTH BALANCE	YTD BALANCE	PERCENT OF BUDGET	REMAINING BUDGET	TOTAL BUDGET
SUMMER RECREATION DEPARTMENT						
05-01-5010	FUEL	19.70	268.16	13.41	1,731.84	2,000.00
05-01-5040	ELECTRICITY BALL PARK	78.19	98.09	49.05	101.91	200.00
05-01-5070	PENSION BENEFIT				200.00	200.00
05-01-5110	SALARIES- SUMMER REC		2,500.00	100.00		2,500.00
05-01-5111	UMPIRE FEES		1,650.00	82.50	350.00	2,000.00
05-01-5120	FICA		191.25	95.63	8.75	200.00
05-01-5150	PLAYER INSURANCE		14.83		14.83-	
05-01-5280	UNIFORMS		518.00	51.80	482.00	1,000.00
05-01-5310	CHEMICALS				250.00	250.00
05-01-5320	MATERIALS/SUPPLIES		1,269.70	126.97	269.70-	1,000.00
05-01-5321	EQUIPMENT		1,002.87	50.14	997.13	2,000.00
05-01-5350	PRINTING		48.76	48.76	51.24	100.00
05-01-5420	MAINT/REPAIRS		1,931.14	128.74	431.14-	1,500.00
05-01-5450	FEES/DUES		1,258.80	104.90	58.80-	1,200.00
05-01-5610	SUMMER RECREATION MISC EXPENSE		120.00	24.00	380.00	500.00
05-01-5800	CAPITAL OUTLAY- SUM REC		9,900.00	198.00	4,900.00-	5,000.00
	SUMMER RECREATION TOTAL	97.89	20,771.60	105.71	1,121.60-	19,650.00
POOL DEPARTMENT						
05-03-5020	PHONE - POOL	53.14	395.12	79.02	104.88	500.00
05-03-5030	NATURAL GAS - POOL	40.32	945.64	378.26	695.64-	250.00
05-03-5040	ELECTRICITY - POOL	1,421.70	3,057.76	203.85	1,557.76-	1,500.00
05-03-5110	SALARIES - POOL		31,354.03	78.39	8,645.97	40,000.00
05-03-5120	FICA EXPENSE - POOL		2,382.55	63.53	1,367.45	3,750.00
05-03-5140	PROFESSIONAL - POOL	19.95	1,344.42	89.63	155.58	1,500.00
05-03-5150	INSURANCE - POOL		3,764.16	75.28	1,235.84	5,000.00
05-03-5310	CHEMICALS - POOL		7,702.86	77.03	2,297.14	10,000.00
05-03-5320	MATERIAL/SUPPLIES - POOL		3,031.46	101.05	31.46-	3,000.00
05-03-5420	MAINTENANCE & REPAIRS - POOL	23.25	1,452.01	14.52	8,547.99	10,000.00
05-03-5440	SCHOOLING - POOL		640.00	64.00	360.00	1,000.00
05-03-5450	FEES & DUES - POOL		884.95	110.62	84.95-	800.00
05-03-5610	MISC EXPENSE - POOL		200.00	66.67	100.00	300.00
05-03-5611	SWIM TEAM EXPENSES				500.00	500.00
05-03-5630	CONTRACTS & AGREEMENTS - POOL		266.51	106.60	16.51-	250.00
05-03-5800	CAPITAL OUTLAY - POOL		2,184.44	54.61	1,815.56	4,000.00
	POOL TOTAL	1,558.36	59,605.91	72.38	22,744.09	82,350.00
PARK DEPARTMENT						
05-04-5010	FUEL - PARK	334.37	2,275.89	113.79	275.89-	2,000.00
05-04-5020	PHONE - PARK	34.95	419.40	83.88	80.60	500.00
05-04-5040	ELECTRICITY - PARK	354.38	2,495.80	83.19	504.20	3,000.00
05-04-5070	PENSION PLAN - PARK	89.23	1,043.09	104.31	43.09-	1,000.00
05-04-5110	SALARIES - PARK	1,807.75	27,478.03	124.90	5,478.03-	22,000.00
05-04-5120	SOCIAL SECURITY - PARK	103.82	1,838.50	73.54	661.50	2,500.00
05-04-5140	PROFESSIONAL - PARK		1,330.83	88.72	169.17	1,500.00

BUDGET REPORT
CALENDAR 9/2025, FISCAL 12/2025

ACCOUNT NUMBER	ACCOUNT TITLE	MONTH BALANCE	YTD BALANCE	PERCENT OF BUDGET	REMAINING BUDGET	TOTAL BUDGET
05-04-5150	INSURANCE - PARK		2,860.28	71.51	1,139.72	4,000.00
05-04-5151	LIFE INSURANCE - PARK	3.20	41.66	20.83	158.34	200.00
05-04-5152	FSA NUESYENERGY	896.70	2,294.53		2,294.53-	
05-04-5160	UNEMPLOYMENT - PARK		25.09	25.09	74.91	100.00
05-04-5190	HEALTH INSURANCE - PARK	1,161.70	13,712.10	204.66	7,012.10-	6,700.00
05-04-5192	DENTAL/VISION INS	86.34	1,099.60		1,099.60-	
05-04-5280	UNIFORMS - PARK		192.78	96.39	7.22	200.00
05-04-5310	CHEMICALS - PARK		1,525.45	87.17	224.55	1,750.00
05-04-5320	MATERIALS/SUPPLIES - PARK		4,011.68	72.94	1,488.32	5,500.00
05-04-5340	OFFICE EXPENSES - PARK		22.56	4.51	477.44	500.00
05-04-5420	MAINTENANCE/REPAIRS - PARK	156.04	5,055.29	81.54	1,144.71	6,200.00
05-04-5450	FEES & DUES - PARK		840.00		840.00-	
05-04-5610	MISCELLANEOUS - PARK				900.00	900.00
05-04-5630	CONTRACTS & AGREEMENTS -PARK		784.51	156.90	284.51-	500.00
05-04-5800	CAPITAL OUTLAY - PARK		211,373.19	37.41	353,626.81	565,000.00
05-04-5801	GRANT EXPENDITURES-PARK		24,139.64		24,139.64-	
	PARK TOTAL	5,028.48	304,859.90	48.85	319,190.10	624,050.00
GENERAL DEPARTMENT						
05-05-5010	FUEL - GEN	107.21	688.26	229.42	388.26-	300.00
05-05-5020	PHONE - GEN	216.80	2,614.20	113.66	314.20-	2,300.00
05-05-5030	NATURAL GAS - GEN		945.85		945.85-	
05-05-5040	ELECTRICITY - GEN	197.17	3,930.83	157.23	1,430.83-	2,500.00
05-05-5070	PENSION PLAN - GEN	283.29	4,169.74	119.14	669.74-	3,500.00
05-05-5110	SALARIES - GEN	5,427.93	89,390.40	111.74	9,390.40-	80,000.00
05-05-5120	SOCIAL SECURITY - GEN	401.29	6,755.34	109.84	605.34-	6,150.00
05-05-5140	PROFESSIONAL - GEN	8,062.00	47,632.47	198.47	23,632.47-	24,000.00
05-05-5150	INSURANCE - GEN		37,019.45	185.10	17,019.45-	20,000.00
05-05-5151	LIFE INSURANCE - GEN	6.39	76.80	51.20	73.20	150.00
05-05-5152	FSA NUESYENERGY		100.00		100.00-	
05-05-5160	UNEMPLOYMENT - GEN		25.09	33.45	49.91	75.00
05-05-5190	HEALTH INSURANCE - GEN	2,406.67	29,060.52	72.65	10,939.48	40,000.00
05-05-5192	VISION/DENTAL INS	218.81	2,669.00	133.45	669.00-	2,000.00
05-05-5280	UNIFORM - GEN				250.00	250.00
05-05-5310	CHEMICALS - GEN		551.25		551.25-	
05-05-5320	MATERIALS/SUPPLIES - GEN		6,963.75	92.85	536.25	7,500.00
05-05-5340	OFFICE EXPENSES - GEN		1,822.26	91.11	177.74	2,000.00
05-05-5360	POSTAGE - GENERAL	48.12	225.34	75.11	74.66	300.00
05-05-5420	MAINTENANCE/REPAIRS - GEN	52.74	25,985.43	117.05	3,785.43-	22,200.00
05-05-5440	SCHOOLING - GEN	354.45	5,812.31	12.92	39,187.69	45,000.00
05-05-5450	FEES & DUES - GEN	399.78	66,339.33	132.68	16,339.33-	50,000.00
05-05-5459	ELECTION EXPENSES - GEN		335.21	67.04	164.79	500.00
05-05-5610	MISC - GENERAL	786.44	27,157.84	67.89	12,842.16	40,000.00
05-05-5630	CONTRACTS & AGREEMENTS- GEN	484.70	26,437.45	75.54	8,562.55	35,000.00
05-05-5795	LOAN TO CDA				250,000.00	250,000.00
05-05-5800	CAPITAL OUTLAY - GEN		3,700.00	12.33	26,300.00	30,000.00
	GENERAL TOTAL	19,453.79	390,408.12	58.82	273,316.88	663,725.00

BUDGET REPORT
CALENDAR 9/2025, FISCAL 12/2025

ACCOUNT NUMBER	ACCOUNT TITLE	MONTH BALANCE	YTD BALANCE	PERCENT OF BUDGET	REMAINING BUDGET	TOTAL BUDGET
POLICE DEPARTMENT						
05-06-5110	SALARIES - POL	576.93	7,133.05	28.53	17,866.95	25,000.00
05-06-5120	SOCIAL SECURITY - POL	44.14	540.32		540.32-	
05-06-5140	PROFESSIONAL - POL		1,324.47		1,324.47-	
05-06-5150	INSURANCE - POL		9,410.41		9,410.41-	
05-06-5160	UNEMPLOYMENT - POL		25.09		25.09-	
05-06-5280	POLICE UNIFORMS		293.00-		293.00	
05-06-5320	MATERIALS/SUPPLIES - POL		51.20		51.20-	
05-06-5630	CONTRACTS & AGREEMENTS - POL	6,032.00	82,705.00	82.71	17,295.00	100,000.00
	POLICE TOTAL	6,653.07	100,896.54	80.72	24,103.46	125,000.00
LIBRARY DEPARTMENT						
05-08-5020	PHONE - LIB	109.23	1,312.75	100.98	12.75-	1,300.00
05-08-5040	ELECTRICITY - LIB	198.06	3,009.65	66.88	1,490.35	4,500.00
05-08-5070	PENSION PLAN - LIB	182.63	2,239.01	124.39	439.01-	1,800.00
05-08-5110	SALARIES - LIB	4,287.01	51,122.72	107.63	3,622.72-	47,500.00
05-08-5111	SALARIES- CLEANING	50.00	600.00	100.00		600.00
05-08-5120	SOCIAL SECURITY - LIB	320.20	3,818.61	127.29	818.61-	3,000.00
05-08-5140	PROFESSIONAL - LIB		1,324.47	88.30	175.53	1,500.00
05-08-5150	INSURANCE - LIB		1,919.24	95.96	80.76	2,000.00
05-08-5151	LIFE INSURANCE - LIB	6.39	261.25	43.54	338.75	600.00
05-08-5152	FSA NUESYENERGY	23.36	92.55		92.55-	
05-08-5160	UNEMPLOYMENT - LIB		25.09	25.09	74.91	100.00
05-08-5190	HEALTH INSURANCE - LIB	641.78	7,595.68	94.95	404.32	8,000.00
05-08-5192	DENTAL/VISION INS	62.69	765.46	127.58	165.46-	600.00
05-08-5280	UNIFORMS - LIB		168.83	84.42	31.17	200.00
05-08-5310	CHEMICALS - LIB				50.00	50.00
05-08-5320	MATERIALS/SUPPLIES - LIB	95.55	1,533.26	95.83	66.74	1,600.00
05-08-5340	OFFICE EXPENSES - LIB	207.42	1,119.24	74.62	380.76	1,500.00
05-08-5420	MAINTENANCE/REPAIRS - LIB		257.88	4.30	5,742.12	6,000.00
05-08-5440	SCHOOLING - LIB	271.78	1,132.36	94.36	67.64	1,200.00
05-08-5450	FEES & DUES - LIB	37.96	2,087.77	119.30	337.77-	1,750.00
05-08-5610	MISCELLANEOUS - LIB				100.00	100.00
05-08-5630	CONTRACTS & AGREEMENTS - LIB	205.00	1,929.50	77.18	570.50	2,500.00
05-08-5662	SUMMER READING PROGRAM - LIB		1,002.62	100.26	2.62-	1,000.00
05-08-5800	CAPITAL OUTLAY - LIB				2,000.00	2,000.00
05-08-5801	BOOKS/VIDEOS/MAG.LIB	527.60	6,003.28	96.05	246.72	6,250.00
	LIBRARY TOTAL	7,226.66	89,321.22	93.38	6,328.78	95,650.00
CEMETERY DEPARTMENT						
05-11-5010	FUEL - CEM	165.07	962.08	80.17	237.92	1,200.00
05-11-5070	PENSION PLAN - CEM	89.21	854.75	85.48	145.25	1,000.00
05-11-5110	SALARIES - CEM	1,807.75	27,442.73	137.21	7,442.73-	20,000.00
05-11-5120	SOCIAL SECURITY - CEM	103.82	1,839.99	122.67	339.99-	1,500.00
05-11-5140	PROFESSIONAL - CEM		1,324.47	88.30	175.53	1,500.00
05-11-5150	INSURANCE - CEM		941.04	67.22	458.96	1,400.00

BUDGET REPORT
CALENDAR 9/2025, FISCAL 12/2025

ACCOUNT NUMBER	ACCOUNT TITLE	MONTH BALANCE	YTD BALANCE	PERCENT OF BUDGET	REMAINING BUDGET	TOTAL BUDGET
05-11-5151	LIFE INSURANCE - CEM	3.19	41.57	8.31	458.43	500.00
05-11-5160	UNEMPLOYMENT - CEM		25.09	33.45	49.91	75.00
05-11-5190	HEALTH INSURANCE - CEM	1,161.67	13,534.29	205.07	6,934.29-	6,600.00
05-11-5192	DENTAL/VISION INS	86.38	1,049.30	209.86	549.30-	500.00
05-11-5310	CHEMICALS - CEM				1,000.00	1,000.00
05-11-5320	MATERIALS/SUPPLIES - CEM		1,569.34	52.31	1,430.66	3,000.00
05-11-5420	MAINTENANCE/REPAIRS - CEM	5,000.00	6,329.68	90.42	670.32	7,000.00
05-11-5450	FEES & DUES - CEM				300.00	300.00
05-11-5610	MISCELLANEOUS - CEM				300.00	300.00
05-11-5630	CONTRACTS & AGREEMENTS - CEM		560.84	560.84	460.84-	100.00
05-11-5800	CAPITAL OUTLAY - CEM		8,945.16	99.39	54.84	9,000.00
	CEMETERY TOTAL	8,417.09	65,420.33	119.00	10,445.33-	54,975.00
	GENERAL TOTAL	48,435.34	1,031,283.62	61.92	634,116.38	1,665,400.00

ADMIN DEPARTMENT

12-00-5010	FUEL - STR	727.33	8,751.92	70.02	3,748.08	12,500.00
12-00-5020	PHONE - STR	74.88	928.62	92.86	71.38	1,000.00
12-00-5040	ELECTRICITY - STR	1,585.68	23,286.21	84.68	4,213.79	27,500.00
12-00-5070	PENSION PLAN - STR	268.80	3,612.91	111.17	362.91-	3,250.00
12-00-5110	SALARIES - STR	4,480.00	62,455.39	104.09	2,455.39-	60,000.00
12-00-5120	SOCIAL SECURITY - STR	334.96	4,713.82	94.28	286.18	5,000.00
12-00-5140	PROFESSIONAL - STR		5,104.17	78.53	1,395.83	6,500.00
12-00-5150	INSURANCE - STR		14,239.18	79.11	3,760.82	18,000.00
12-00-5151	LIFE INSURANCE - STR	5.18	63.49	63.49	36.51	100.00
12-00-5160	UNEMPLOYMENT - STR		25.09	25.09	74.91	100.00
12-00-5190	HEALTH INSURANCE - STR	2,599.20	30,762.56	87.89	4,237.44	35,000.00
12-00-5192	DENTAL/VISION INS	170.75	2,089.58	139.31	589.58-	1,500.00
12-00-5280	UNIFORMS - STR				200.00	200.00
12-00-5310	CHEMICALS - STR		521.25	74.46	178.75	700.00
12-00-5320	MATERIALS/SUPPLIES - STR	103.57	3,242.33	101.32	42.33-	3,200.00
12-00-5340	OFFICE EXPENSES - STR		236.56	47.31	263.44	500.00
12-00-5380	SAND AND GRAVEL - STR		3,480.90	58.02	2,519.10	6,000.00
12-00-5390	CEMENT - STR		670.00	6.70	9,330.00	10,000.00
12-00-5400	SIGNS - STR		1,826.20	24.35	5,673.80	7,500.00
12-00-5420	MAINTENANCE/REPAIRS - STR	411.74	32,861.66	82.15	7,138.34	40,000.00
12-00-5421	ARMOR COATING - STR				40,000.00	40,000.00
12-00-5422	TAC COTE AND COLD MIX - STR		963.27	96.33	36.73	1,000.00
12-00-5423	ICE MELT - STR		2,334.85	93.39	165.15	2,500.00
12-00-5450	FEES & DUES - STR		145.00		145.00-	
12-00-5630	CONTRACTS & AGREEMENTS - STREET		227.20	45.44	272.80	500.00
12-00-5800	CAPITAL OUTLAY - STR		14,200.00	7.10	185,800.00	200,000.00
	ADMIN TOTAL	10,762.09	216,742.16	44.92	265,807.84	482,550.00

BUDGET REPORT
CALENDAR 9/2025, FISCAL 12/2025

ACCOUNT NUMBER	ACCOUNT TITLE	MONTH BALANCE	YTD BALANCE	PERCENT OF BUDGET	REMAINING BUDGET	TOTAL BUDGET
	STREET TOTAL	10,762.09	216,742.16	44.92	265,807.84	482,550.00
14-00-5640	C4K EXPENSE	217.66	217.66		217.66-	
	ADMIN TOTAL	217.66	217.66	.00	217.66-	.00
	C4K GRANT TOTAL	217.66	217.66	.00	217.66-	.00
15-00-5640	DONATIONS- COMMUNTIY BETTERMNT		689.69	81.14	160.31	850.00
	ADMIN TOTAL	.00	689.69	81.14	160.31	850.00
	COMMUNITY BETTERMENT TOTAL	.00	689.69	81.14	160.31	850.00
16-00-5640	CDA EXPENDITURE		318,472.08	318.47	218,472.08-	100,000.00
16-00-5700	REVOLVING LOAN		37,863.61	75.73	12,136.39	50,000.00
16-00-5705	PROFESSIONAL FEES				1,000.00	1,000.00
16-00-5800	CDA CAPITAL OUTLAY	172,689.30	568,961.90	29.60	1353,038.10	1,922,000.00
	ADMIN TOTAL	172,689.30	925,297.59	44.64	1147,702.41	2,073,000.00
	CDA TOTAL	172,689.30	925,297.59	44.64	1147,702.41	2,073,000.00
	TOTAL EXPENSES	232,104.39	2,174,230.72	51.50	2047,569.28	4,221,800.00
	NET PROFIT/LOSS:	72,551.65-	782,980.27-	198.35	388,225.94	394,754.33-

BUDGET REPORT
CALENDAR 9/2025, FISCAL 12/2025

ACCOUNT NUMBER	ACCOUNT TITLE	MONTH BALANCE	YTD BALANCE	PERCENT OF BUDGET	REMAINING BUDGET	TOTAL BUDGET
	ADMIN TOTAL	95,289.74	751,532.39	83.44	149,143.28	900,675.67
	SUMMER RECREATION TOTAL	.00	10,957.00	85.94	1,793.00	12,750.00
	POOL TOTAL	.00	8,501.02	100.01	1.02-	8,500.00
	PARK TOTAL	443.19	208,496.20	43.71	268,503.80	477,000.00
	LIBRARY TOTAL	101.20	1,317.75	65.89	682.25	2,000.00
	CEMETERY TOTAL	50.00	5,550.00	55.50	4,450.00	10,000.00
	GENERAL TOTAL	95,884.13	986,354.36	69.91	424,571.31	1,410,925.67
	ADMIN TOTAL	17,870.85	234,562.34	51.11	224,407.66	458,970.00
	STREET TOTAL	17,870.85	234,562.34	51.11	224,407.66	458,970.00
	TOTAL REVENUE	113,754.98	1,220,916.70	65.29	648,978.97	1,869,895.67
	SUMMER RECREATION TOTAL	97.89	20,771.60	105.71	1,121.60-	19,650.00
	POOL TOTAL	1,558.36	59,605.91	72.38	22,744.09	82,350.00
	PARK TOTAL	5,028.48	304,859.90	48.85	319,190.10	624,050.00
	GENERAL TOTAL	19,453.79	390,408.12	58.82	273,316.88	663,725.00
	POLICE TOTAL	6,653.07	100,896.54	80.72	24,103.46	125,000.00

BUDGET REPORT
CALENDAR 9/2025, FISCAL 12/2025

ACCOUNT NUMBER	ACCOUNT TITLE	MONTH BALANCE	YTD BALANCE	PERCENT OF BUDGET	REMAINING BUDGET	TOTAL BUDGET
	LIBRARY TOTAL	7,226.66	89,321.22	93.38	6,328.78	95,650.00
	CEMETERY TOTAL	8,417.09	65,420.33	119.00	10,445.33-	54,975.00
	GENERAL TOTAL	48,435.34	1,031,283.62	61.92	634,116.38	1,665,400.00
	ADMIN TOTAL	10,762.09	216,742.16	44.92	265,807.84	482,550.00
	STREET TOTAL	10,762.09	216,742.16	44.92	265,807.84	482,550.00
	TOTAL EXPENSES	59,197.43	1,248,025.78	58.10	899,924.22	2,147,950.00
	NET PROFIT/LOSS:	54,557.55	27,109.08-	9.75	250,945.25-	278,054.33-

BUDGET REPORT
CALENDAR 9/2025, FISCAL 12/2025

ACCOUNT NUMBER	ACCOUNT TITLE	MONTH BALANCE	YTD BALANCE	PERCENT OF BUDGET	REMAINING BUDGET	TOTAL BUDGET
ADMIN DEPARTMENT						
01-00-4010	CONSUMERS REVENUE - ELEC	131,183.34	1,320,336.59	101.56	20,336.59-	1,300,000.00
01-00-4050	PENALTY REVENUE - ELEC	1,810.84	8,746.55	116.62	1,246.55-	7,500.00
01-00-4300	INTEREST - ELEC	160.95	1,781.24	59.37	1,218.76	3,000.00
01-00-4340	FINES & FEES - ELEC		25.00		25.00-	
01-00-4500	METER DEPOSITS		2,220.00	63.43	1,280.00	3,500.00
01-00-4610	MISC REVENUES - ELEC	2,260.38	107,089.61	2,677.24	103,089.61-	4,000.00
01-00-4611	HSA REIMBURSEMENT	275.54	975.03		975.03-	
01-00-4950	LOAN PROCEEDS - ELEC				150,000.00	150,000.00
	ADMIN TOTAL	135,691.05	1,441,174.02	98.17	26,825.98	1,468,000.00
POWER PLANT DEPARTMENT						
01-10-4360	NPPD AGREEMENT REV - PP	13,687.50	168,082.50	101.87	3,082.50-	165,000.00
01-10-4362	NPPD REIMB NATURAL GAS - PP	52.49	9,277.09	309.24	6,277.09-	3,000.00
01-10-4363	NPPD REIMB CELL PHONE - PP	20.00	240.00	100.00		240.00
01-10-4611	HSA REIMBURSEMENT	1.11	21.78		21.78-	
	POWER PLANT TOTAL	13,761.10	177,621.37	105.58	9,381.37-	168,240.00
	ELECTRIC TOTAL	149,452.15	1,618,795.39	98.93	17,444.61	1,636,240.00
ADMIN DEPARTMENT						
02-00-4010	CONSUMERS REVENUE - WTR	23,972.20	216,033.70	93.93	13,966.30	230,000.00
02-00-4011	LRNRD WATER INCOME - WTR	8,580.17	74,724.49	114.96	9,724.49-	65,000.00
02-00-4020	MISC WATER INCOME	10.00	15,548.97	518.30	12,548.97-	3,000.00
02-00-4050	PENALTY REVENUE - WTR	411.15	1,920.38	12.80	13,079.62	15,000.00
02-00-4125	LOAN PROCEEDS - WATER				150,000.00	150,000.00
02-00-4300	INTEREST - WATER	160.95	1,781.24	64.77	968.76	2,750.00
02-00-4611	HSA REIMBURSEMENT	85.04	337.49		337.49-	
	ADMIN TOTAL	33,219.51	310,346.27	66.63	155,403.73	465,750.00
	WATER TOTAL	33,219.51	310,346.27	66.63	155,403.73	465,750.00
03-00-4010	CONSUMERS REVENUE - SWR	9,546.75	115,457.64	100.40	457.64-	115,000.00
03-00-4050	PENALTY REVENUE - SWR	123.00	1,019.69	101.97	19.69-	1,000.00
03-00-4125	LOAN PROCEEDS - SEWER				150,000.00	150,000.00
03-00-4300	INTEREST -SEWER	160.95	1,781.24	59.37	1,218.76	3,000.00
03-00-4305	GRANT REVEUNE		10.00		10.00-	
03-00-4611	HSA REIMBURSEMENT	68.75	276.83		276.83-	

BUDGET REPORT
CALENDAR 9/2025, FISCAL 12/2025

ACCOUNT NUMBER	ACCOUNT TITLE	MONTH BALANCE	YTD BALANCE	PERCENT OF BUDGET	REMAINING BUDGET	TOTAL BUDGET	
	ADMIN TOTAL	9,899.45	118,545.40	44.07	150,454.60	269,000.00	
		=====	=====	=====	=====	=====	
	SEWER TOTAL	9,899.45	118,545.40	44.07	150,454.60	269,000.00	
		=====	=====	=====	=====	=====	
04-00-4611	HSA REIMBURSEMENT	197.78	736.47		736.47-		
		-----	-----	-----	-----	-----	
	ADMIN TOTAL	197.78	736.47	.00	736.47-	.00	
		-----	-----	-----	-----	-----	
	SANITATION DEPARTMENT						
04-07-4010	CONSUMERS REVENUE - SAN	16,836.78	193,031.45	110.30	18,031.45-	175,000.00	
04-07-4050	PENALTY REVENUE - SAN	233.60	1,515.75	101.05	15.75-	1,500.00	
04-07-4200	C & D REVENUE - SAN	567.20	9,243.90	92.44	756.10	10,000.00	
04-07-4300	INTEREST - SAN	160.96	1,781.08	55.66	1,418.92	3,200.00	
		-----	-----	-----	-----	-----	
	SANITATION TOTAL	17,798.54	205,572.18	108.37	15,872.18-	189,700.00	
		-----	-----	-----	-----	-----	
	WASTE REDUCTION DEPARTMENT						
04-14-4012	RECYCLING REVENUE - WR	65.00	2,276.22	45.52	2,723.78	5,000.00	
04-14-4304	COUNTY REIMBURSEMENT/WAGES - W		11,063.43	73.76	3,936.57	15,000.00	
		-----	-----	-----	-----	-----	
	WASTE REDUCTION TOTAL	65.00	13,339.65	66.70	6,660.35	20,000.00	
		-----	-----	-----	-----	-----	
	SANITATION/WASTE REDUCT TOTAL	18,061.32	219,648.30	104.74	9,948.30-	209,700.00	
		=====	=====	=====	=====	=====	
		=====	=====	=====	=====	=====	
	TOTAL REVENUE	210,632.43	2,267,335.36	87.86	313,354.64	2,580,690.00	
		=====	=====	=====	=====	=====	
		=====	=====	=====	=====	=====	
	ADMIN DEPARTMENT						
01-00-5010	FUEL - ELEC	145.38	1,693.07	56.44	1,306.93	3,000.00	
01-00-5020	PHONE - ELEC	37.45	449.40	89.88	50.60	500.00	
01-00-5030	NATURAL GAS - ELEC	52.49	1,422.88	94.86	77.12	1,500.00	
01-00-5041	POWER PURCHASED - ELEC	81,405.19	747,315.06	96.43	27,684.94	775,000.00	
01-00-5070	PENSION PLAN - ELEC	624.62	7,224.71	111.15	724.71-	6,500.00	
01-00-5110	SALARIES - ELEC	10,424.38	116,844.70	106.22	6,844.70-	110,000.00	
01-00-5120	SOCIAL SECURITY - ELEC	738.22	8,346.49	109.10	696.49-	7,650.00	
01-00-5140	PROFESSIONAL - ELEC	270.00	4,564.47	152.15	1,564.47-	3,000.00	
01-00-5150	INSURANCE - ELEC		10,193.17	84.94	1,806.83	12,000.00	
01-00-5151	LIFE INSURANCE - ELEC	19.17	217.39	86.96	32.61	250.00	
01-00-5152	FSA NUESYENERGY	210.00	3,537.35		3,537.35-		
01-00-5160	UNEMPLOYMENT - ELEC		25.09	25.09	74.91	100.00	
01-00-5190	HEALTH INSURANCE - ELEC	5,743.60	68,260.06	117.69	10,260.06-	58,000.00	

BUDGET REPORT
CALENDAR 9/2025, FISCAL 12/2025

ACCOUNT NUMBER	ACCOUNT TITLE	MONTH BALANCE	YTD BALANCE	PERCENT OF BUDGET	REMAINING BUDGET	TOTAL BUDGET
01-00-5192	DENTAL/VISION INS	406.51	4,659.40	133.13	1,159.40-	3,500.00
01-00-5240	DISTRIBUTION SUPPLIES - ELEC	25,054.07	49,742.51	198.97	24,742.51-	25,000.00
01-00-5280	UNIFORM - ELEC	1,425.09	1,538.18	96.14	61.82	1,600.00
01-00-5310	CHEMICALS - ELEC		193.95		193.95-	
01-00-5320	MATERIALS/SUPPLIES - ELEC	31.93	1,640.10	109.34	140.10-	1,500.00
01-00-5340	OFFICE EXPENSES - ELEC	73.69	1,102.34	73.49	397.66	1,500.00
01-00-5360	POSTAGE - ELEC	87.50	875.00	87.50	125.00	1,000.00
01-00-5420	MAINTENANCE/REPAIRS - ELEC	115.25	2,531.22	50.62	2,468.78	5,000.00
01-00-5440	SCHOOLING - ELEC	310.35	2,013.16	100.66	13.16-	2,000.00
01-00-5450	FEES & DUES - ELEC		2,481.67	124.08	481.67-	2,000.00
01-00-5620	MISC REBATE REFUND		854.03	42.70	1,145.97	2,000.00
01-00-5630	CONTRACTS & AGREEMENTS - ELEC	249.73	13,449.40	179.33	5,949.40-	7,500.00
01-00-5710	FRONTDESK SERVICE CHARGES	5.00	125.60	25.12	374.40	500.00
01-00-5800	CAPITAL OUTLAY - ELEC		4,187.62	1.99	205,812.38	210,000.00
01-00-5910	TRANSFER EXPENSE - ELEC				685,000.00	685,000.00
	ADMIN TOTAL	127,429.62	1,055,488.02	54.81	870,111.98	1,925,600.00

POWER PLANT DEPARTMENT

01-10-5030	NATURAL GAS - PP	52.49	10,005.52	333.52	7,005.52-	3,000.00
01-10-5110	SALARIES - PP	48.00	4,238.25	94.18	261.75	4,500.00
01-10-5120	FICA EXPENSE - PP	3.81	330.83	66.17	169.17	500.00
01-10-5150	INSURANCE - PP		20,702.89	82.81	4,297.11	25,000.00
01-10-5300	OIL - PP	1,632.13	1,632.13		1,632.13-	
01-10-5310	CHEMICALS - PP				1,000.00	1,000.00
01-10-5320	MATERIALS/SUPPLIES - PP	13.67	1,338.92	3.77	34,161.08	35,500.00
01-10-5420	MAINTENANCE/REPAIRS - PP	397.60	361,452.22	186.32	167,452.22-	194,000.00
01-10-5630	CONTRACTS & AGREEMENTS - PP		4,619.69		4,619.69-	
	POWER PLANT TOTAL	2,147.70	404,320.45	153.44	140,820.45-	263,500.00
	ELECTRIC TOTAL	129,577.32	1,459,808.47	66.69	729,291.53	2,189,100.00

ADMIN DEPARTMENT

02-00-5010	FUEL - WTR	227.30	1,546.61	55.24	1,253.39	2,800.00
02-00-5020	PHONE - WTR	71.38	854.93	65.76	445.07	1,300.00
02-00-5040	ELECTRICITY - WTR	1,886.58	25,624.09	91.51	2,375.91	28,000.00
02-00-5070	PENSION PLAN - WTR	188.20	2,620.88	104.84	120.88-	2,500.00
02-00-5110	SALARIES - WTR	3,175.78	44,046.36	104.87	2,046.36-	42,000.00
02-00-5120	SOCIAL SECURITY - WTR	190.92	2,811.79	102.25	61.79-	2,750.00
02-00-5140	PROFESSIONAL - WTR		1,324.47	52.98	1,175.53	2,500.00
02-00-5150	INSURANCE - WTR		5,895.03	78.60	1,604.97	7,500.00
02-00-5151	LIFE INSURANCE - WTR	3.20	51.30	17.10	248.70	300.00
02-00-5160	UNEMPLOYMENT - WTR		25.09	25.09	74.91	100.00
02-00-5190	HEALTH INSURANCE - WTR	1,918.35	22,693.11	126.07	4,693.11-	18,000.00
02-00-5192	DENTAL/VISION INS	131.24	1,627.12	135.59	427.12-	1,200.00

BUDGET REPORT
CALENDAR 9/2025, FISCAL 12/2025

ACCOUNT NUMBER	ACCOUNT TITLE	MONTH BALANCE	YTD BALANCE	PERCENT OF BUDGET	REMAINING BUDGET	TOTAL BUDGET
02-00-5240	DISTRIBUTION SUPPLIES - WTR	534.38	12,363.20	72.72	4,636.80	17,000.00
02-00-5280	UNIFORMS - WTR		196.32	98.16	3.68	200.00
02-00-5320	MATERIALS/SUPPLIES - WTR	694.21	2,429.96	97.20	70.04	2,500.00
02-00-5340	OFFICE EXPENSES - WTR		707.10	235.70	407.10-	300.00
02-00-5360	POSTAGE - WTR	193.55	1,452.70	96.85	47.30	1,500.00
02-00-5420	MAINTENANCE/REPAIRS - WTR	4,235.00	28,556.03	95.19	1,443.97	30,000.00
02-00-5440	SCHOOLING - WTR		3,565.13	118.84	565.13-	3,000.00
02-00-5450	FEES & DUES - WTR		1,802.05	225.26	1,002.05-	800.00
02-00-5520	LABORATORY TESTING/MONITORING	61.00	2,252.25	75.08	747.75	3,000.00
02-00-5610	MISCELLANEOUS - WTR		1,000.00		1,000.00-	
02-00-5630	CONTRACTS & AGREEMENTS - WATER	64.75	3,159.21	31.59	6,840.79	10,000.00
02-00-5800	CAPITAL OUTLAY - WTR		31,176.12	16.67	155,823.88	187,000.00
02-00-5910	TRANSFER OUT				250,000.00	250,000.00
	ADMIN TOTAL	13,575.84	197,780.85	32.20	416,469.15	614,250.00
	WATER TOTAL	13,575.84	197,780.85	32.20	416,469.15	614,250.00
03-00-5010	FUEL - SWR		1,564.95	104.33	64.95-	1,500.00
03-00-5040	ELECTRICITY - SWR	169.52	3,810.40	89.66	439.60	4,250.00
03-00-5070	PENSION PLAN - SWR	180.18	2,247.43	112.37	247.43-	2,000.00
03-00-5110	SALARIES - SWR	3,020.53	37,661.87	107.61	2,661.87-	35,000.00
03-00-5120	SOCIAL SECURITY - SWR	181.34	2,325.80	84.57	424.20	2,750.00
03-00-5140	PROFESSIONAL - SWR		1,324.47	88.30	175.53	1,500.00
03-00-5150	INSURANCE - SWR		1,189.83	84.99	210.17	1,400.00
03-00-5151	LIFE INSURANCE	3.19	51.20	51.20	48.80	100.00
03-00-5160	UNEMPLOYMENT		25.09	25.09	74.91	100.00
03-00-5190	HEALTH INSURANCE - SWR	1,873.61	22,259.64	111.30	2,259.64-	20,000.00
03-00-5192	DENTAL/VISION INS	128.40	1,536.10	153.61	536.10-	1,000.00
03-00-5310	CHEMICALS - SWR		20,646.01	103.23	646.01-	20,000.00
03-00-5320	MATERIALS/SUPPLIES - SWR	591.41	4,083.59	816.72	3,583.59-	500.00
03-00-5340	OFFICE EXPENSES - SWR		700.31	70.03	299.69	1,000.00
03-00-5360	POSTAGE - SWR	87.50	875.00	125.00	175.00-	700.00
03-00-5420	MAINTENANCE/REPAIRS - SEWER	15,000.00	18,090.32	60.30	11,909.68	30,000.00
03-00-5630	CONTRACTS & AGREEMENTS -SEWER	64.76	2,812.71	18.75	12,187.29	15,000.00
03-00-5800	CAPITAL OUTLAY - SWR		31,176.13	18.34	138,823.87	170,000.00
	ADMIN TOTAL	21,300.44	152,380.85	49.67	154,419.15	306,800.00
	SEWER TOTAL	21,300.44	152,380.85	49.67	154,419.15	306,800.00
SANITATION DEPARTMENT						
04-07-5010	FUEL - SAN	1,085.88	11,990.02	66.61	6,009.98	18,000.00
04-07-5020	PHONE - SANITATION	69.90	838.80	98.68	11.20	850.00

BUDGET REPORT
CALENDAR 9/2025, FISCAL 12/2025

ACCOUNT NUMBER	ACCOUNT TITLE	MONTH BALANCE	YTD BALANCE	PERCENT OF BUDGET	REMAINING BUDGET	TOTAL BUDGET
04-07-5070	PENSION PLAN - SAN	331.41	4,161.98	138.73	1,161.98-	3,000.00
04-07-5110	SALARIES - SAN	6,007.50	72,057.19	102.94	2,057.19-	70,000.00
04-07-5120	SOCIAL SECURITY - SAN	403.97	5,073.09	78.05	1,426.91	6,500.00
04-07-5140	PROFESSIONAL - SAN	3,085.00	5,974.47	119.49	974.47-	5,000.00
04-07-5150	INSURANCE - SAN		11,292.49	98.20	207.51	11,500.00
04-07-5151	LIFE INSURANCE	6.39	74.56		74.56-	
04-07-5152	FSA NUESYENERGY		17.64		17.64-	
04-07-5160	UNEMPLOYMENT		25.09	12.55	174.91	200.00
04-07-5190	HEALTH INSURANCE - SAN	1,265.43	12,764.03	159.55	4,764.03-	8,000.00
04-07-5192	DENTAL/VISION INS	208.99	2,384.11	183.39	1,084.11-	1,300.00
04-07-5280	UNIFORMS		195.32	97.66	4.68	200.00
04-07-5320	MATERIALS/SUPPLIES - SAN		910.21	18.20	4,089.79	5,000.00
04-07-5340	OFFICE EXPENSES - SAN	23.96	800.67	160.13	300.67-	500.00
04-07-5360	POSTAGE - SAN	87.50	875.00	87.50	125.00	1,000.00
04-07-5420	MAINTENANCE/REPAIRS - SAN	29.80	22,284.86	74.28	7,715.14	30,000.00
04-07-5450	FEES & DUES - SAN	775.00	6,746.10	96.37	253.90	7,000.00
04-07-5451	DISPOSAL FEES - SAN	3,220.28	33,288.30	83.22	6,711.70	40,000.00
04-07-5475	C & D TICKET FEE	70.00	1,130.00	94.17	70.00	1,200.00
04-07-5630	CONTRACTS & AGREEMENTS -SAN	64.76	2,791.67	31.02	6,208.33	9,000.00
04-07-5800	CAPITAL OUTLAY - SAN		4,157.63	16.63	20,842.37	25,000.00
04-07-5850	C&D CLOSURE/POST-CLOSURE EXP		16,070.00	100.44	70.00-	16,000.00
	SANITATION TOTAL	16,735.77	215,903.23	83.28	43,346.77	259,250.00
WASTE REDUCTION DEPARTMENT						
04-14-5010	FUEL - WR	26.40	672.76	269.10	422.76-	250.00
04-14-5040	ELECTRICITY - WR	83.50	1,459.07	72.95	540.93	2,000.00
04-14-5140	PROFESSIONAL - WR		1,324.47	75.68	425.53	1,750.00
04-14-5150	INSURANCE - WR				1,400.00	1,400.00
04-14-5160	UNEMPLOYMENT		25.17	25.17	74.83	100.00
04-14-5310	CHEMICALS - WR				250.00	250.00
04-14-5320	MATERIALS/SUPPLIES - WR		35.69		35.69-	
04-14-5420	MAINTENANCE/REPAIRS - WR		2,615.83	87.19	384.17	3,000.00
04-14-5800	CAPITAL OUTLAY - WR				15,000.00	15,000.00
	WASTE REDUCTION TOTAL	109.90	6,132.99	25.82	17,617.01	23,750.00
	SANITATION/WASTE REDUCT TOTAL	16,845.67	222,036.22	78.46	60,963.78	283,000.00
	TOTAL EXPENSES	181,299.27	2,032,006.39	59.89	1361,143.61	3,393,150.00
	NET PROFIT/LOSS:	29,333.16	235,328.97	28.96-	1047,788.97-	812,460.00-

BUDGET REPORT
CALENDAR 9/2025, FISCAL 12/2025

ACCOUNT NUMBER	ACCOUNT TITLE	MONTH BALANCE	YTD BALANCE	PERCENT OF BUDGET	REMAINING BUDGET	TOTAL BUDGET
	ADMIN TOTAL	135,691.05	1,441,174.02	98.17	26,825.98	1,468,000.00
	POWER PLANT TOTAL	13,761.10	177,621.37	105.58	9,381.37-	168,240.00
	ELECTRIC TOTAL	149,452.15	1,618,795.39	98.93	17,444.61	1,636,240.00
	ADMIN TOTAL	33,219.51	310,346.27	66.63	155,403.73	465,750.00
	WATER TOTAL	33,219.51	310,346.27	66.63	155,403.73	465,750.00
	ADMIN TOTAL	9,899.45	118,545.40	44.07	150,454.60	269,000.00
	SEWER TOTAL	9,899.45	118,545.40	44.07	150,454.60	269,000.00
	ADMIN TOTAL	197.78	736.47	.00	736.47-	.00
	SANITATION TOTAL	17,798.54	205,572.18	108.37	15,872.18-	189,700.00
	WASTE REDUCTION TOTAL	65.00	13,339.65	66.70	6,660.35	20,000.00
	SANITATION/WASTE REDUCT TOTAL	18,061.32	219,648.30	104.74	9,948.30-	209,700.00
	TOTAL REVENUE	210,632.43	2,267,335.36	87.86	313,354.64	2,580,690.00
	ADMIN TOTAL	127,429.62	1,055,488.02	54.81	870,111.98	1,925,600.00
	POWER PLANT TOTAL	2,147.70	404,320.45	153.44	140,820.45-	263,500.00

BUDGET REPORT
CALENDAR 9/2025, FISCAL 12/2025

ACCOUNT NUMBER	ACCOUNT TITLE	MONTH BALANCE	YTD BALANCE	PERCENT OF BUDGET	REMAINING BUDGET	TOTAL BUDGET
	ELECTRIC TOTAL	129,577.32	1,459,808.47	66.69	729,291.53	2,189,100.00
		=====	=====	=====	=====	=====
	ADMIN TOTAL	13,575.84	197,780.85	32.20	416,469.15	614,250.00
		=====	=====	=====	=====	=====
	WATER TOTAL	13,575.84	197,780.85	32.20	416,469.15	614,250.00
		=====	=====	=====	=====	=====
	ADMIN TOTAL	21,300.44	152,380.85	49.67	154,419.15	306,800.00
		=====	=====	=====	=====	=====
	SEWER TOTAL	21,300.44	152,380.85	49.67	154,419.15	306,800.00
		=====	=====	=====	=====	=====
	SANITATION TOTAL	16,735.77	215,903.23	83.28	43,346.77	259,250.00
		=====	=====	=====	=====	=====
	WASTE REDUCTION TOTAL	109.90	6,132.99	25.82	17,617.01	23,750.00
		=====	=====	=====	=====	=====
	SANITATION/WASTE REDUCT TOTAL	16,845.67	222,036.22	78.46	60,963.78	283,000.00
		=====	=====	=====	=====	=====
	TOTAL EXPENSES	181,299.27	2,032,006.39	59.89	1361,143.61	3,393,150.00
		=====	=====	=====	=====	=====
	NET PROFIT/LOSS:	29,333.16	235,328.97	28.96-	1047,788.97-	812,460.00-

C CTR DESCRIPTION	REG HRS	OT HRS	VAC HRS	SCK HRS	TOT HRS	REG AMT	OT AMT	VAC AMT	SCK AMT	TOT AMT	DEDUCTIONS
10010 ELECTRIC	161.00	3.75	.00	.00	164.75	4685.75	139.13	.00	.00	4824.88	812.22
11010 POWER PLANT	.00	1.00	.00	.00	1.00	.00	48.00	.00	.00	48.00	.00
12010 STREET	56.00	.25	22.00	.00	80.25	1568.00	.00	616.00	.00	2240.00	319.50
20010 WATER	60.00	5.88	.00	.00	65.88	1406.25	87.28	.00	.00	1493.53	.00
30010 SEWER	60.00	2.87	.00	.00	62.87	1406.25	87.28	.00	.00	1493.53	.00
40710 SANITATION	92.50	4.50	.00	3.00	123.50	2222.25	.00	.00	69.00	2831.75	256.38
50410 PARK	40.00	4.25	.00	.00	44.25	857.50	.00	.00	.00	857.50	.00
50510 GENERAL	72.00	3.50	8.00	.00	83.50	2627.93	147.00	224.00	.00	2998.93	358.53
50810 LIBRARY	123.50	2.00	.00	.00	125.50	2033.13	.00	.00	.00	2033.13	163.88
50811 LIB- CLEANING	.00	.00	.00	.00	.00	50.00	.00	.00	.00	50.00	.00
51110 CEMETERY	40.00	4.25	.00	.00	44.25	857.50	.00	.00	.00	857.50	.00
99999 SPLIT PAY	.00	.00	.00	.00	.00	.00	.00	.00	.00	.00	1884.08
TOTAL	705.00	32.25	30.00	3.00	795.75	17714.56	508.69	840.00	69.00	19728.75	3794.59

C CTR DESCRIPTION	REG HRS	OT HRS	VAC HRS	SCK HRS	TOT HRS	REG AMT	OT AMT	VAC AMT	SCK AMT	TOT AMT	DEDUCTIONS
10010 ELECTRIC	171.31	9.25	.00	6.44	191.75	4868.75	444.00	.00	163.75	5599.50	858.46
12010 STREET	74.25	.00	.00	3.00	80.00	2079.00	.00	.00	84.00	2240.00	319.50
20010 WATER	60.06	7.00	.00	1.44	69.25	1397.00	241.50	.00	28.75	1682.25	.00
30010 SEWER	57.81	4.00	.00	1.44	64.00	1336.25	147.00	.00	28.75	1527.00	.00
40710 SANITATION	96.57	14.25	.00	11.43	130.50	2201.50	528.00	.00	258.75	3175.75	256.38
50410 PARK	40.00	3.50	.00	.00	43.50	840.00	110.25	.00	.00	950.25	.00
50510 GENERAL	87.00	2.25	.00	.00	89.25	2334.50	94.50	.00	.00	2429.00	355.38
50610 POLICE	.00	.00	.00	.00	.00	576.93	.00	.00	.00	576.93	.00
50810 LIBRARY	121.75	.00	18.00	.00	139.75	2006.38	.00	247.50	.00	2253.88	171.31
51110 CEMETERY	40.00	3.50	.00	.00	43.50	840.00	110.25	.00	.00	950.25	.00
99999 SPLIT PAY	.00	.00	.00	.00	.00	.00	.00	.00	.00	.00	1911.41
TOTAL	748.75	43.75	18.00	23.75	851.50	18480.31	1675.50	247.50	564.00	21384.81	3872.44

CLAIMS BY VENDOR

10/14/2025 THRU 10/14/2025

INVOICE NUMBER	VENDOR NAME REFERENCE	GL ACCOUNT #	AMOUNT	PAYMENT AMOUNT	CHECK #	CHECK DATE
10142025	AMGL CPAS ADVISORS BUDGET PREP WORK	01-00-5140	458.15			
	BUDGET PREP WORK	02-00-5140	458.15			
	BUDGET PREP WORK	03-00-5140	458.15			
	BUDGET PREP WORK	04-07-5140	458.15			
	BUDGET PREP WORK	04-14-5140	458.15			
	BUDGET PREP WORK	05-05-5140	458.15			
	BUDGET PREP WORK	05-06-5140	458.15			
	BUDGET PREP WORK	05-08-5140	458.15			
	BUDGET PREP WORK	05-11-5140	458.15			
	BUDGET PREP WORK	12-00-5140	458.15			
	BUDGET PREP WORK	05-03-5140	458.15			
	BUDGET PREP WORK	05-04-5140	460.35			
				5,500.00		
10142025	BARCO MUNICIPAL PRODUCTS SUPPLIES/WATER	02-00-5320	83.37			
				83.37		
10142025	BELLAMY LAW PROFESSIONAL FEE	05-05-5140	2,602.40			
				2,602.40		
101402025	BUSINESS WORLD PRODUCTS CALENDARS	01-00-5340	84.20			
	CALENDARS	02-00-5340	6.79			
	CALENDARS	05-04-5340	23.54			
	CALENDARS	04-07-5340	23.54			
				138.07		
10142025	CENTRAL PLAINS LIBRARY PROGRAM FEE	05-08-5450	50.00			
				50.00		
10142025	CHEMQUEST, INC TESTING	01-10-5630	595.00			
				595.00		
10142025	CHRISTIE MALL CLEANING FEE	05-05-5450	80.00			
				80.00		
10142025	CITY OF FRANKLIN FILING FEES/GEN	05-05-5450	17.50			
	DOG DROP OFF FEE/GENERAL	05-05-5450	35.00			
	HEARTLAND CLERK MEMBERSHIP	05-05-5450	20.00			
	MEAL/STREET	12-00-5450	11.97			
	POOL RE CERTIFY LICENSE/REIMB	05-03-5450	67.50			
	SUPPLIES/POOL	05-03-5320	3.49			
				155.46		
10142025	CITY OF HOLDREGE DISPOSAL FEES	04-07-5451	3,032.12			
				3,032.12		
10142025	COMMUNITY ACTION ANNUAL MEMBERSHIP DONATION	05-05-5450	5,000.00			
				5,000.00		
10142025	CONSUMER REPORTS MAGAZINE SUBSCRIPTION	05-08-5801	37.28			
				37.28		
	DITCH WITCH OF NEBRASKA					

CLAIMS BY VENDOR

10/14/2025 THRU 10/14/2025

INVOICE NUMBER	VENDOR NAME REFERENCE	GL ACCOUNT #	AMOUNT	PAYMENT AMOUNT	CHECK #	CHECK DATE
10142025	DITCH WITCH OF NEBRASKA SUPPLIES/WATER/DITCH WITCH	02-00-5320	127.66	127.66		
10142025	DUTTON-LAINSON COMPANY DIST. SUPPLIES/ELECT MAINT/STREET LIGHTS	01-00-5240 12-00-5420	733.46 400.32	1,133.78		
10142025	EAKES OFFICE SOLUTIONS EGOLD FAX EGOLD FAX	05-08-5450 05-05-5450	25.74 19.25	44.99		
10142025	ELECTRIC FUND ELECTRICITY ELECTRICITY ELECTRICITY ELECTRICITY ELECTRICITY ELECTRICITY ELECTRICITY	02-00-5040 03-00-5040 05-04-5040 05-05-5040 05-08-5040 12-00-5040 04-14-5040	372.86 162.45 202.73 170.81 156.22 1,814.78 76.53	2,956.38		
10142025	FELZIEN RAQUEL SCHOOLING/RF	05-05-5440	298.73	298.73		
10142025	FRANKLIN AUTO PARTS SUPPLIES/POWER PLANT SUPPLIES/WATER MAINT/SAN. TRUCK SUPPLIES/PARK MAINT/PARK MAINT/CEMETERY MAINT/STREET	01-10-5320 02-00-5320 04-07-5420 05-04-5320 05-04-5420 05-11-5420 12-00-5320	52.13 9.99 172.98 9.99 24.01 24.01 133.10	426.21		
10142025	FRANKLIN COUNTY CHRONICLE ADS/GENERAL/AUGUST 2025 ADS/POOL/AUGUEST 2025 ADS/GENERAL/SEPT 2025 ADS/LIBRARY/SEPT 2025	05-05-5630 05-03-5630 05-05-5630 05-08-5630	261.33 38.70 474.39 27.62	802.04		
10142025	FRANKLIN COUNTY SHERIFF ENFORCEMENT CONTRACT ANNUAL EQUIP.CONTRACT	05-06-5630 05-06-5630	6,032.00 10,000.00	16,032.00		
10142025	GERDES FEED & SUPPLY LLC MAINT/PARK MAINT/CEMETERY	05-04-5420 05-11-5420	24.53 24.52	49.05		
10142025	GOLDSTAR PRODUCTS INC CHEMICALS/SEWER	03-00-5310	5,247.51	5,247.51		
10142025	JEO CONSULTING GROUP INC C&D LANDFILL	04-07-5630	1,816.25	1,816.25		
	JIM'S OK TIRE-FRANKLIN					

10/14/2025 THRU 10/14/2025

INVOICE NUMBER	VENDOR NAME REFERENCE	GL ACCOUNT #	AMOUNT	PAYMENT AMOUNT	CHECK #	CHECK DATE
10142025	JIM'S OK TIRE-FRANKLIN MAINT/SANITATION TRUCK	12-00-5420	50.00	50.00		
10142025	LARM INSURANCE	05-05-5150	17,046.30			
	INSURANCE	05-08-5150	2,272.84			
	INSURANCE	05-04-5150	3,327.36			
	INSURANCE	05-11-5150	1,136.42			
	INSURANCE	05-03-5150	4,545.68			
	INSURANCE	05-06-5150	11,364.20			
	INSURANCE	12-00-5150	17,046.30			
	INSURANCE	01-00-5150	10,227.78			
	INSURANCE	01-10-5150	25,001.24			
	INSURANCE	02-00-5150	6,818.52			
	INSURANCE	03-00-5150	1,136.42			
	INSURANCE	04-07-5150	13,637.04			
				113,560.10		
10142025	MID-AMERICAN RESEARCH CHEMICALS/SEWER	03-00-5310	271.10	271.10		
10142025	MID-WEST ROOFING FINAL PAYMENT/MARCELLUS BLDG	05-05-5610	9,931.63	9,931.63		
10142025	MIDWEST CONNECT LLC INK CARTRIDGE FOR POSTAL MACH.	01-00-5320	56.80			
	INK CARTRIDGE FOR POSTAL MACH.	02-00-5320	56.80			
	INK CARTRIDGE FOR POSTAL MACH.	04-07-5320	56.80			
	INK CARTRIDGE FOR POSTAL MACH.	05-05-5320	113.60			
				284.00		
10142025	MUNICIPAL SUPPLY, INC DIST SUPPLIES/WATER	02-00-5240	1,118.76	1,118.76		
10142025	NE PUBLIC HEALTH ENVIRONM WATER TESTING	02-00-5520	396.00	396.00		
10142025	NEBRASKA LIBRARY COMM OVERDRIVE ANNUAL FEE	05-08-5450	500.00	500.00		
10142025	PEOPLE MAGAZINE SUBSCRIPTION	05-08-5801	260.16	260.16		
10142025	PITSTOP & SHOP FUEL/SANITATION	04-07-5010	104.01			
	FUEL/PARK	05-04-5010	57.70			
	FUEL/BALL PARK	05-01-5010	57.69			
	FUEL/CEMETERY	05-11-5010	171.59			
				390.99		
10142025	PLANKS LUMBER & HARDWARE SUPPLIES/POWER PLANT	01-10-5320	7.44			
	SUPPLIES/ELECTRIC	01-00-5320	10.63			
	MAINT/WATER	02-00-5420	45.86			
	SUPPLIES/SAN	04-07-5320	1.69			
	MAINT/PARK	05-04-5420	2.38			

CLAIMS BY VENDOR

10/14/2025 THRU 10/14/2025

INVOICE NUMBER	VENDOR NAME REFERENCE	GL ACCOUNT #	AMOUNT	PAYMENT AMOUNT	CHECK #	CHECK DATE
	PLANKS LUMBER & HARDWARE SUPPLIES/DAYCARE	05-05-5320	12.30			
	SUPPLIES/STREET	12-00-5320	12.17			
				92.47		
10142025	R&R SALES & SERVICES INC MAINT/#10/STREET	12-00-5420	68.16			
	MAINT/WATER	02-00-5420	8.38			
				76.54		
10142025	RIGHTWAY GROCERY ACCT#245 SUPPLIES/LIBRARY	05-08-5320	78.44			
	ACCT#212 SUPPLIES/WATER	02-00-5320	85.72			
	ACCT#212 SUPPLIES/GENERAL	05-05-5320	10.96			
	ACCT#134 SUPPLIES/GENERAL	05-05-5320	37.72			
	ACCT#134 SUPPLIES/C4K EXP	14-00-5640	37.76			
				250.60		
10142025	S.E. SMITH & SONS MAINT/POWER PLANT	01-10-5420	30.36			
	SUPPLIES/POST HOLE DIGGER/WA	02-00-5320	69.99			
	MAINT/DAYCARE/CEILING TILE	05-05-5420	7.95			
	MAINT/STREET	12-00-5420	64.36			
				172.66		
10142025	SOUTHERN POWER DISTRICT POWER	01-00-5041	71,467.39			
				71,467.39		
10142025	USA BLUE BOOK STERNER PUMP/WATER WELLS	02-00-5420	665.50			
				665.50		
10142025	WERNER CONSTRUCTION INC COST SHARE OF G ROAD & 9TH AVE	12-00-5800	18,965.00			
				18,965.00		
10142025	WOODWARD'S DISPOSAL SERVI DROP OFF FEE/FALL CLEANUP	04-07-5450	430.00			
				430.00		
				=====		
	REPORT TOTAL			265,091.20		

Paid Claims, reviewed and approved at October 14, 2025		by Council members Platt, Stephens, Urbina, Duncan	
Date	Vendor	Amount	Item
9/26/25	Aflac	\$694.46	Insurance
9/2/25	BCBS	\$11,070.65	Insurance
9/17/25	Black Hills Energy	\$145.30	gas bill
9/17/25	Caspian Creates	\$540.00	Website/Calendar fee/Accessibility
10/15/25	CPI	\$1,378.31	Fuel/C&D tickets
09/08/25	Delta Dental	\$631.18	Insurance
9/12/25	EFTPS	\$3,943.49	Payroll taxes
9/26/25	EFTPS	\$4,522.43	Payroll taxes
10/15/25	Erickson Sullivan Architects	\$1,856.25	NAHTF/Marcellus bldg
10/15/25	Erickson Sullivan Architects	\$1,150.00	Library/Park grant
9/29/25	Franklin County Clerk	\$178.00	Foreclosure fee/T.Martin/C.Vigil
9/30/25	Franklin County Treasurer	\$786.44	Taxes T.Davis property
10/6/25	Freedom Claims	\$6,000.00	Insurance/SEPT & OCT 2025
10/03/2025	Glenwood	\$603.52	phone/internet
9/25/25	Hometown Leasing	\$423.78	lease agreement
10/15/2025	Madison National Life Ins	\$56.30	insurance
10/14/25	Menards	\$974.96	Dist.supplies/Electric
9/8/25	MG Trust	\$2,294.04	Payroll retirement
09/30/25	MG Trust	\$2,435.58	Payroll retirement
9/18/25	NE Dept of Rev	\$9,456.15	Sales Tax
9/22/2025	Ne Dept of Rev	\$25.00	Waste/Recycling Fee
9/22/2025	NE Dept of Water, Engery & Envir.	\$750.00	Annual Fee for C&D site
9/1/25-9/30/25	Nuesynergy inc	\$1,130.06	payroll/fsa/dca employee accounts
10/15/2025	One Call Concepts inc	\$57.86	locate fees
09/12/2025	Payroll	\$12,754.29	Payroll
9/26/25	Payroll	\$13,829.42	Payroll
9/8/25	Quadient Finance/NEO Post	\$350.00	Postage
10/15/2025	RMV Construction LLC	\$111,568.50	Pynt#3 construction NAHTF Marcellus bld
10/15/2025	Southern Public Power Dist	\$1,347.00	power/water wells
10/15/2025	US Bank	\$3,332.87	supplies/maint/fuel/
10/17/25	Verizon	\$79.95	phone
09/02/25	VSP	\$185.87	Insurance
10/15/2025	WAPA	\$5,417.59	Power
	TOTAL CLAIMS REPORT:	\$199,969.25	



CITY OF FRANKLIN

Application for Zoning Permit

Date of Application: 09/19/2025 Phone Number: _____

Homeowner Name: Verlyn O Bering Email: _____

Legal Description of Property and residence address: E 34 1/2' W 52.5' Lot 24 BLK 7; Original Town Franklin FR Bloomington
W 18' Lot 24; BLK. 7; Original Town; FR. Bloomington

1411 L Street Franklin Ne 68939 0-0-20 Parcel # 0500039600

Name of Contractor (business or individual): SCED - DEMO PERMIT

PERMIT TYPE & FEE CALCULATION Permit# 2025-33

NOTE: The cost (fee) for each permit is listed next to the permit type. Check one

- | New Structure Permit (\$25.00)
- | Addition to Existing Structure Permit (\$25.00)
- | Remodeling of Existing Structure Permit (\$25.00)
- | Demolition of a Structure Permit (\$25.00)
- | Moving a Structure Permit (\$25.00)
- | Fence Building Permit (\$25.00)
- | Water System Connection Permit (\$10.00)

Total project valuation: \$ _____

Describe Work to be Completed:

Wood/Metal/Other structure type and purpose of permit: Concrete & Brick

Continued on Next Page →



Application for Zoning Permit

Draw an outline of the structure here (required):

***Show all dimensions of the lot, building, front yard, side yards, rear yard, garages and other buildings. The proposed structure in residential must be at least five (5) feet on the sides and (7) feet inside the rear yard (10) feet from front property lines unless you are a corner lot.

Commercial storage units ask for regulations.

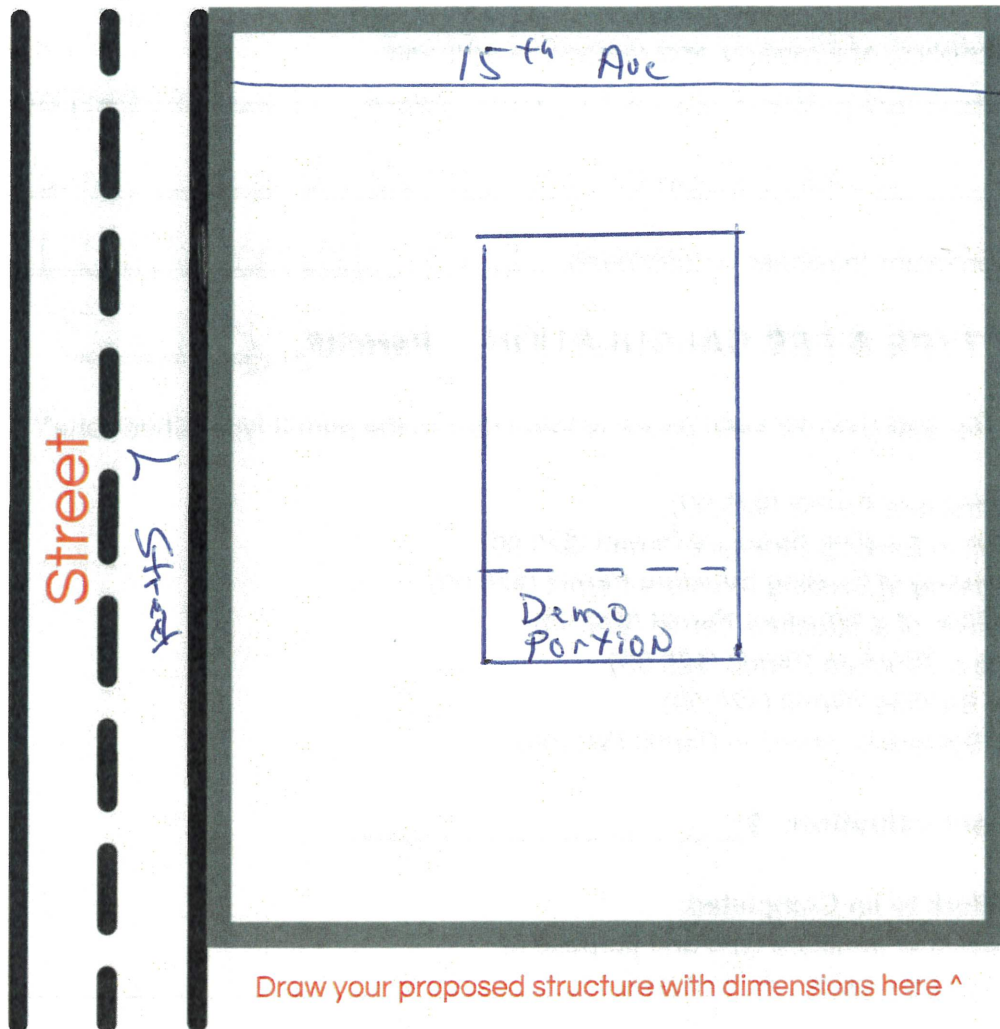

Continued on Next Page →



+1 (308) 425-6295



info@cityoffranklin.net



www.franklinnebraska.com



619 15th Ave., Franklin, NE 68939





CITY OF FRANKLIN

Application for Zoning Permit

I, the undersigned, hereby certify that the above statements are true and correct to the best of my knowledge. I also certify that, if a permit is issued, all work will be completed in accordance with the ordinances of the City of Franklin, Nebraska. **By signing this zoning permit, you authorize access to the ongoing and completed project site as necessary by the Franklin County Assessor's Office or its designee, to allow measurement of the completed work for the purpose of determining value as required by Nebraska law.**

Applicant Signature: Verly R. Chasing Date: 9/19/25

OFFICE USE ONLY

| APPROVED

PAYMENT DATE AND TYPE: 9/19/25 OKP 10/2

| DECLINED

Date Approved/Declined: 9/22/2025

Date of Permit Expiry: 9/22/2026

If declined, reason for declination: _____

[Signature]
Zoning Enforcement Officer Signature

Council Approval Signature





CITY OF FRANKLIN

Application for Zoning Permit

Date of Application: 9/16/25 Phone Number: 308-470-0272

Homeowner Name: Chase Bislow Email: chasebislow@gmail.com

Legal Description of Property and residence address:

36 2 15 lots 37-38; N 12' Lot 36; 20' strip N lot 38 B1K4; Addition
301 16th Ave - Residence corner lot
*Franklin
Bloomington*

Name of Contractor (business or individual): Chase Bislow

PERMIT TYPE & FEE CALCULATION Permit# 2025-34

NOTE: The cost (fee) for each permit is listed next to the permit type. Check one

- | New Structure Permit (\$25.00)
- | Addition to Existing Structure Permit (\$25.00)
- | Remodeling of Existing Structure Permit (\$25.00)
- | Demolition of a Structure Permit (\$25.00)
- | Moving a Structure Permit (\$25.00)
- | Fence Building Permit (\$25.00)
- | Water System Connection Permit (\$10.00)

Total project valuation: \$ 1,200.00

Describe Work to be Completed:

Wood/Metal/Other structure type and purpose of permit: wood 6' Cedar fence

Continued on Next Page →





Application for Zoning Permit

Draw an outline of the structure here (required):

***Show all dimensions of the lot, building, front yard, side yards, rear yard, garages and other buildings. The proposed structure in residential must be at least five (5) feet on the sides and (7) feet inside the rear yard (10) feet from front property lines unless you are a corner lot.

Commercial storage units ask for regulations.



Street

P Street

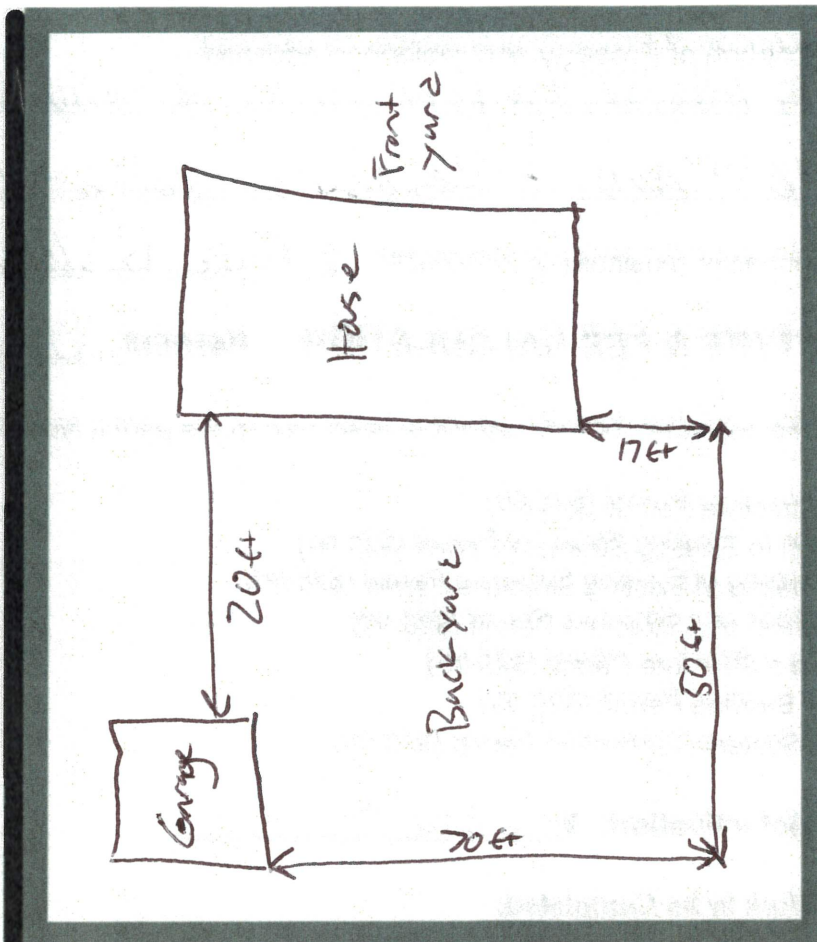

Draw your proposed structure with dimensions here ^

Continued on Next Page →



+1 (308) 425-6295



info@cityoffranklin.net



www.franklinnebraska.com



619 15th Ave., Franklin, NE 68939





CITY OF FRANKLIN

Application for Zoning Permit

I, the undersigned, hereby certify that the above statements are true and correct to the best of my knowledge. I also certify that, if a permit is issued, all work will be completed in accordance with the ordinances of the City of Franklin, Nebraska. **By signing this zoning permit, you authorize access to the ongoing and completed project site as necessary by the Franklin County Assessor's Office or its designee, to allow measurement of the completed work for the purpose of determining value as required by Nebraska law.**

Applicant Signature: [Signature] Date: 9/18/25

OFFICE USE ONLY

APPROVED

PAYMENT DATE AND TYPE: 9/18/25

DECLINED

Date Approved/Declined: 9/22/2025

Date of Permit Expiry: 9/22/2026

If declined, reason for declination: _____

[Signature]
Zoning Enforcement Officer Signature

Council Approval Signature





CITY OF FRANKLIN

Application for Zoning Permit

Date of Application: 7 Oct 2025 Phone Number: 402-762-5654

Homeowner Name: James Barber Email: jimbarber67@gmail

Legal Description of Property and residence address:

PT. Lots 11-12: BLK 3 Country Club View
Franklin - Bloomington

Name of Contractor (business or individual): Gingerich Structures/Jeff Higel
712-600-2410

PERMIT TYPE & FEE CALCULATION Permit# 2025-35

NOTE: The cost (fee) for each permit is listed next to the permit type. Check one

- | New Structure Permit (\$25.00)
- | Addition to Existing Structure Permit (\$25.00)
- | Remodeling of Existing Structure Permit (\$25.00)
- | Demolition of a Structure Permit (\$25.00)
- | Moving a Structure Permit (\$25.00)
- | Fence Building Permit (\$25.00)
- | Water System Connection Permit (\$10.00)

Total project valuation: \$ 71,000

Describe Work to be Completed:

Wood/Metal/Other structure type and purpose of permit: Metal Garage/Shop

Continued on Next Page →

P





Application for Zoning Permit

Draw an outline of the structure here (required):

***Show all dimensions of the lot, building, front yard, side yards, rear yard, garages and other buildings. The proposed structure in residential must be at least five (5) feet on the sides and (7) feet inside the rear yard (10) feet from front property lines unless you are a corner lot.

Commercial storage units ask for regulations.

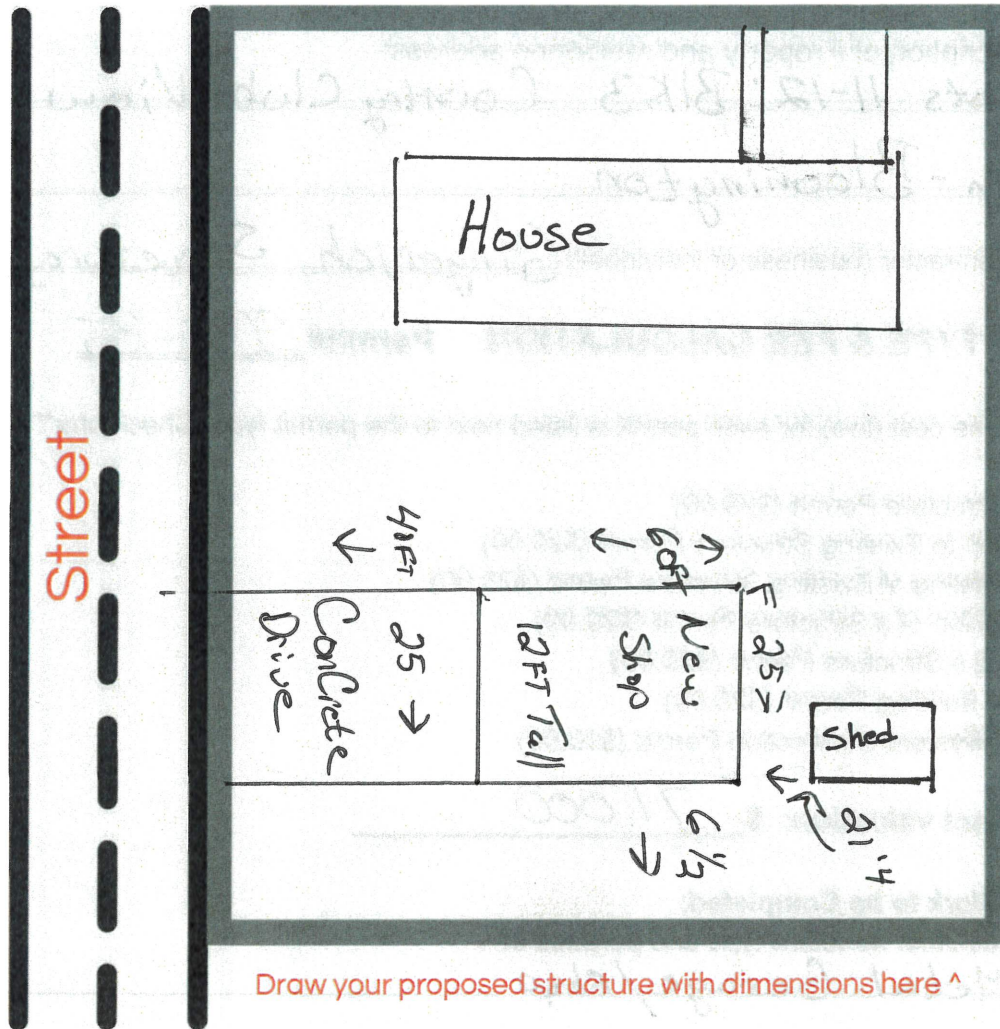

Draw your proposed structure with dimensions here ^

Continued on Next Page →



+1 (308) 425-6295



info@cityoffranklin.net



www.franklinnebraska.com



619 15th Ave., Franklin, NE 68939





CITY OF FRANKLIN

Application for Zoning Permit

I, the undersigned, hereby certify that the above statements are true and correct to the best of my knowledge. I also certify that, if a permit is issued, all work will be completed in accordance with the ordinances of the City of Franklin, Nebraska. **By signing this zoning permit, you authorize access to the ongoing and completed project site as necessary by the Franklin County Assessor's Office or its designee, to allow measurement of the completed work for the purpose of determining value as required by Nebraska law.**

Applicant Signature: [Signature] Date: 7 Oct 2025

OFFICE USE ONLY

APPROVED
 DECLINED

PAYMENT DATE AND TYPE: CASH 10/7/25

Date Approved/Declined: 10/7/25

Date of Permit Expiry: 10/7/26

If declined, reason for declination: _____

[Signature]
Zoning Enforcement Officer Signature

Council Approval Signature





Salesman:
Jeff Higel
jeffhigel@gingerichstructures.com
(402) 469-2971

CLIENT
Jim Barber

DRAWN BY
MW

ISSUE
10.07.25

DESCRIPTION
Cover Sheet

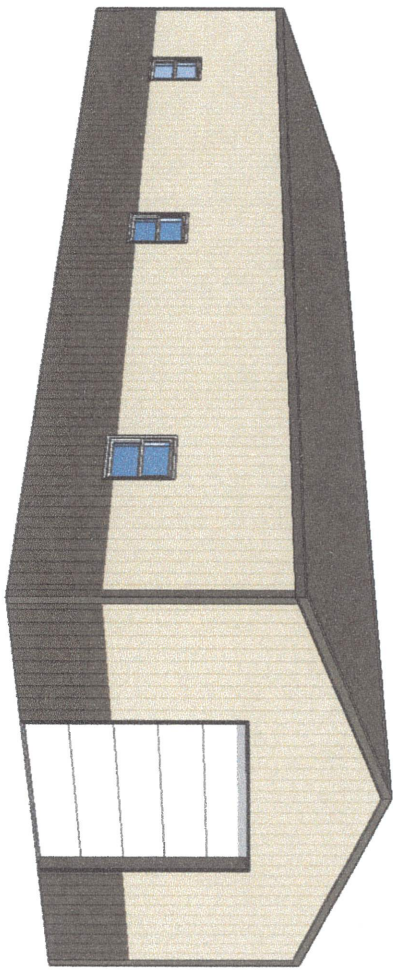



CITY OF FRANKLIN

Application for Zoning Permit

Date of Application: 10-3-25 Phone Number: 308-234-1836

Homeowner Name: Franklin Fire Hall Email: Jmosbarger@bdconstruction.com

Legal Description of Property and residence address:

625 20th Ave Franklin, NE 68939

Lot 1 Block 1 of Smith's Addition Report to the City of Franklin

Name of Contractor (business or individual): BD Construction Inc. / Kearney

PERMIT TYPE & FEE CALCULATION Permit# 2025-36

NOTE: The cost (fee) for each permit is listed next to the permit type. Check one

- New Structure Permit (\$25.00)
- Addition to Existing Structure Permit (\$25.00)
- Remodeling of Existing Structure Permit (\$25.00)
- Demolition of a Structure Permit (\$25.00)
- Moving a Structure Permit (\$25.00)
- Fence Building Permit (\$25.00)
- Water System Connection Permit (\$10.00)

excepting however the south 113.00 feet thereof.

Total project valuation: \$ 3.5M

Describe Work to be Completed:

Wood/Metal/Other structure type and purpose of permit: Metal Building facility / Fire Hall

Continued on Next Page →



+1 (308) 425-6295



info@cityoffranklin.net



www.franklinnebraska.com



619 15th Ave., Franklin, NE 68939





Application for Zoning Permit

Draw an outline of the structure here (required):

***Show all dimensions of the lot, building, front yard, side yards, rear yard, garages and other buildings. The proposed structure in residential must be at least five (5) feet on the sides and (7) feet inside the rear yard (10) feet from front property lines unless you are a corner lot. Commercial storage units ask for regulations.

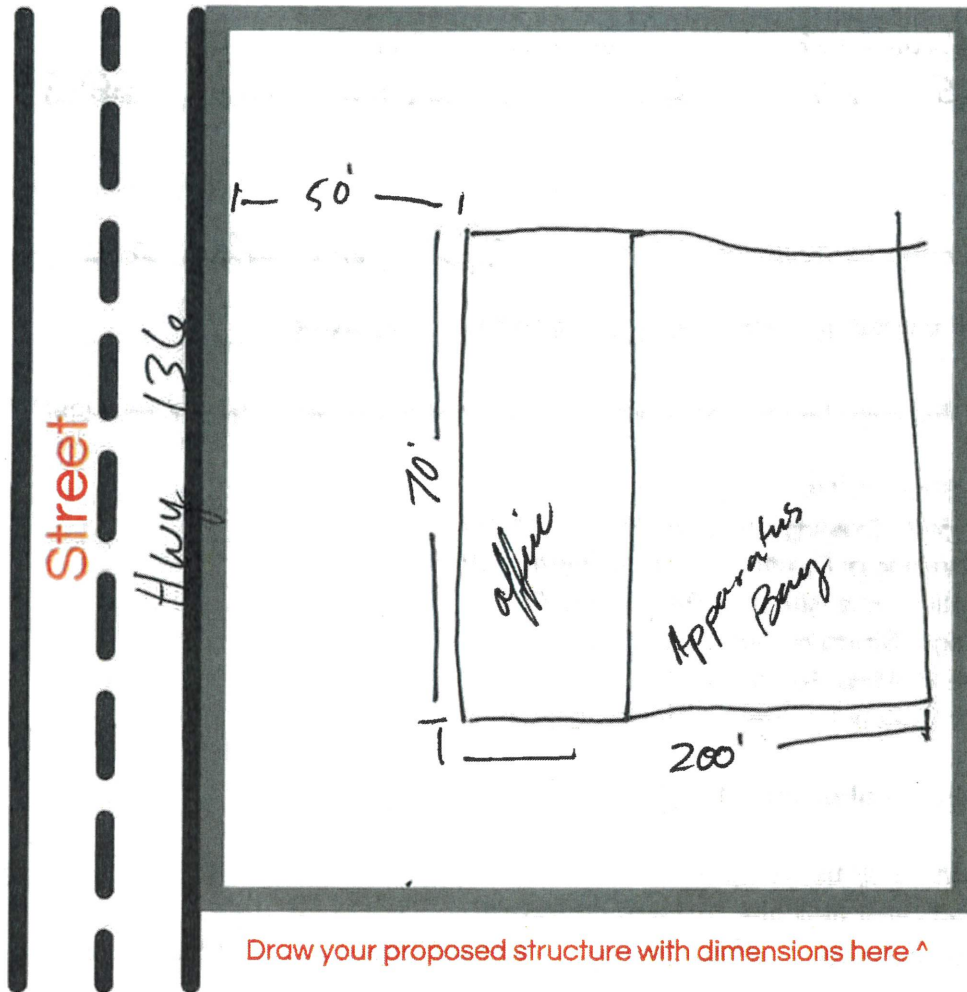

Draw your proposed structure with dimensions here ^

Continued on Next Page →



+1 (308) 425-6295



info@cityoffranklin.net



www.franklinnebraska.com



619 15th Ave., Franklin, NE 68939





CITY OF FRANKLIN

Application for Zoning Permit

I, the undersigned, hereby certify that the above statements are true and correct to the best of my knowledge. I also certify that, if a permit is issued, all work will be completed in accordance with the ordinances of the City of Franklin, Nebraska. **By signing this zoning permit, you authorize access to the ongoing and completed project site as necessary by the Franklin County Assessor's Office or its designee, to allow measurement of the completed work for the purpose of determining value as required by Nebraska law.**

Applicant Signature:  Date: 10-6-25

OFFICE USE ONLY

APPROVED

PAYMENT DATE AND TYPE: _____

DECLINED

Date Approved/Declined: 10/9/25

Date of Permit Expiry: 10/9/26

If declined, reason for declination: _____

Zoning Enforcement Officer Signature

Council Approval Signature



+1 (308) 425-6295



info@cityoffranklin.net



www.franklinnebraska.com



619 15th Ave., Franklin, NE 68939





CITY OF FRANKLIN

Application for Zoning Permit

Date of Application: 10-10-25 Phone Number: 308-470-0559

Homeowner Name: Stove's Storage LLC Email: _____

Legal Description of Property and residence address:
1711 Q Street P 51/2 NW 1/4 31-2-14 NON-descript; Franklin

Name of Contractor (business or individual): Self

PERMIT TYPE & FEE CALCULATION Permit# 2025-37

NOTE: The cost (fee) for each permit is listed next to the permit type. Check one

- | New Structure Permit (\$25.00)
- | Addition to Existing Structure Permit (\$25.00)
- | Remodeling of Existing Structure Permit (\$25.00)
- | Demolition of a Structure Permit (\$25.00)
- | Moving a Structure Permit (\$25.00)
- | Fence Building Permit (\$25.00)
- | Water System Connection Permit (\$10.00)

Total project valuation: \$ 3,000

Describe Work to be Completed:

Wood/Metal/Other structure type and purpose of permit: wood frame new metal roof & siding

Continued on Next Page →



Application for Zoning Permit

Draw an outline of the structure here (required):

***Show all dimensions of the lot, building, front yard, side yards, rear yard, garages and other buildings. The proposed structure in residential must be at least five (5) feet on the sides and (7) feet inside the rear yard (10) feet from front property lines unless you are a corner lot.

Commercial storage units ask for regulations.

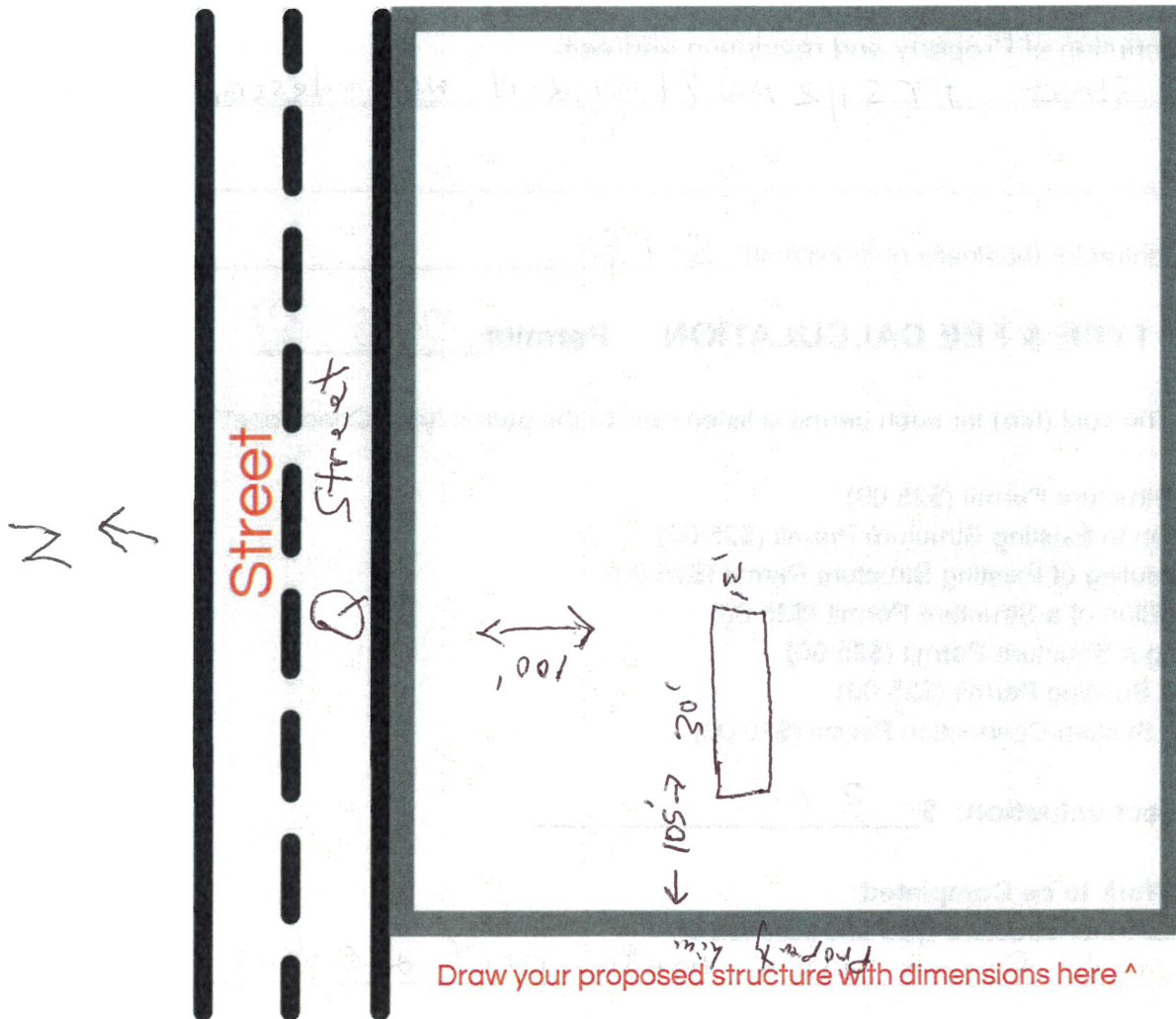

Continued on Next Page →



CITY OF FRANKLIN

Application for Zoning Permit

I, the undersigned, hereby certify that the above statements are true and correct to the best of my knowledge. I also certify that, if a permit is issued, all work will be completed in accordance with the ordinances of the City of Franklin, Nebraska. **By signing this zoning permit, you authorize access to the ongoing and completed project site as necessary by the Franklin County Assessor's Office or its designee, to allow measurement of the completed work for the purpose of determining value as required by Nebraska law.**

Applicant Signature: *Loren Stouff* Date: 10-10-25

OFFICE USE ONLY

| APPROVED

PAYMENT DATE AND TYPE: 10-10-25

| DECLINED

Date Approved/Declined: _____

Date of Permit Expiry: _____

If declined, reason for declination: _____

Zoning Enforcement Officer Signature

Council Approval Signature





FRANKLIN COUNTY SHERIFFS OFFICE



Bryon Detlefsen, Sheriff

405 15th Avenue
P.O. Box 292
Franklin, NE. 68939

Office: (308) 425-6231
Fax: (308) 425-3261
sheriff@franklincountyne.gov

Monthly Report for the City of Franklin

The following report is activity for the month of September 2025

Dispatch received 115 calls that generated a number in our CAD system regarding activities within the City Limits,

Deputies patrolled 132 hours.

In addition to patrol hours Deputies had 81 hours spent on calls, which consisted of two fresh arrests and one warrant arrest. Deputies have attended school activities and have been running school traffic which have resulted in several traffic stops. We have handled two sexual assaults and three domestic complaints.

Sheriff Bryon Detlefsen

FRANKLIN Little Flyer ACADEMY

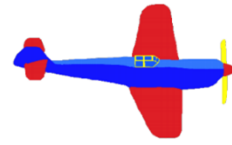

Monthly Report October 2025

Classification	Part-Time	Full-Time	Drop-In
Infant	1		1
Toddler	2	3	
Preschool	1		
Infant Holds		1	
Current Total	3	4	1
Expected Enrollments			
Infant	1 (June 2026)	1(January 2026)	
Toddler	1 (October 2025)		
Preschool	1 (October 2025)		

Currently Providing Service for:

Infants	2
Toddlers	5
Preschool	1
Total	8

Other Information:

We have three enrollment packets for drop-ins and part-time care disbursed out but have not received them back yet.

Parent Concerns:

We had one parent bring forward an issue regarding the automatic billing through Brightwheel. We contacted Brightwheel and they have assisted in correcting this issue. It created a double billing on a child, but once they paid one of the bills it zero out the other bill. We have the double billing of statement corrected. No other issues have been brought to our attention.

FRANKLIN Little Flyer ACADEMY

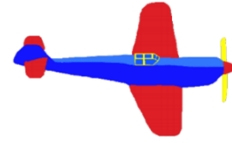

Possible Maintenance Concerns:

We have been having problems with the lights in the big room, not all coming on. They will turn on randomly, but after 30 minutes they are all on. Not sure if they need new bulbs.
As fall is approaching, we are seeing an increase in live bugs in the building. Do we need to take care of this?

Other Comments:

We would like to thank the city employees for all the hard work they do at the daycare. We are truly grateful and appreciate everything that they do!

We are currently working on a grant through the Hirschfeld Foundation. According to Shonna Werth, they are very supportive of childcare and usually provide around \$25,000 to all the daycares that have applied. It is a two-step grant including preliminary application and if approved then we provide more information.

We are in the process of getting our food reimbursement program going. There were issues with us being in a commercial building, but there are two consultants in the State of Nebraska that work with Home II licensure in a commercial building to allow the reimbursement program. Other consultants refuse to oversee Home II in commercial buildings.

Andrea Schurman

Lead Teacher

(308) 470-6543

"Play is the work of the child" – Maria Montessori

AIA Document G702® – 1992

Application and Certificate for Payment

TO OWNER: City of Franklin
619 15th Avenue
Franklin, NE 68939

PROJECT: City of Franklin Downtown Apartments & Commercial Project a/k/a The Marcellus Building Project
615 15th Ave
Franklin, NE 68939

APPLICATION NO: 004

Distribution to:
OWNER: [X]
ARCHITECT: [X]
CONTRACTOR: []
FIELD: []
OTHER: []

PERIOD TO: September 26, 2025

CONTRACT FOR: General Construction

CONTRACT DATE: 04-08-2025

PROJECT NOS: 35024 / 2510 /

FROM RMV Construction LLC

VIA Erickson Sullivan Architects & Associates, LLC

ARCHITECT: 110 S. 14th Street, Suite 200
Lincoln, NE 68508

CONTRACTOR: 1515 E 11th Street
Kearney, NE 68847

CONTRACTOR'S APPLICATION FOR PAYMENT

Application is made for payment, as shown below, in connection with the Contract. AIA Document G703®, Continuation Sheet, is attached.

The undersigned Contractor certifies that to the best of the Contractor's knowledge, information and belief the Work covered by this Application for Payment has been completed in accordance with the Contract Documents, that all amounts have been paid by the Contractor for Work for which previous Certificates for Payment were issued and payments received from the Owner, and that current payment shown herein is now due.

1. ORIGINAL CONTRACT SUM..... 1,922,800.00

2. NET CHANGE BY CHANGE ORDERS..... 25,495.00

3. CONTRACT SUM TO DATE (Line 1 ± 2)..... 1,948,295.00

4. TOTAL COMPLETED & STORED TO DATE (Column G on G703)..... \$525,126.00

5. RETAINAGE:

a. 10% of Completed Work
(Column D + E on G703: \$525,126.00)= 52,512.60

b. 10.00% of Stored Material
(Column F on G703: \$0.00)= \$0.00

Total Retainage (Lines 5a + 5b or Total in Column I of G703)..... 52,512.60

6. TOTAL EARNED LESS RETAINAGE..... 472,613.40
(Line 4 Less Line 5 Total)

7. LESS PREVIOUS CERTIFICATES FOR PAYMENT..... 361,044.90
(Line 6 from prior Certificate)

8. CURRENT PAYMENT DUE..... 111,568.50

9. BALANCE TO FINISH, INCLUDING RETAINAGE..... 1,475,681.60
(Line 3 less Line 6)

CONTRACTOR: RMV CONSTRUCTION LLC

By: [Signature] Date: 9/29/2025

State of: Nebraska

County of: Buffalo

Subscribed and sworn to before me this 29th day of September 2025

Notary Public: Kristie R France

My Commission expires: 11-16-2027

State of Nebraska – General Notary
KRISTIE R FRANCE
My Commission Expires
November 16, 2027

ARCHITECT'S CERTIFICATE FOR PAYMENT

In accordance with the Contract Documents, based on on-site observations and the data comprising this application, the Architect certifies to the Owner that to the best of the Architect's knowledge, information and belief the Work has progressed as indicated, the quality of the Work is in accordance with the Contract Documents, and the Contractor is entitled to payment of the AMOUNT CERTIFIED.

AMOUNT CERTIFIED..... 111,568.50

(Attach explanation if amount certified differs from the amount applied. Initial all figures on this Application and on the Continuation Sheet that are changed to conform with the amount certified.)

ARCHITECT:

By: [Signature] Date: 10/1/25

This Certificate is not negotiable. The AMOUNT CERTIFIED is payable only to the Contractor named herein. Issuance, payment and acceptance of payment are without prejudice to any rights of the

CHANGE ORDER SUMMARY	ADDITIONS	DEDUCTIONS
Total changes approved in previous months by Owner	0.00	0.00
Total approved this Month	26,210.00	715.00
TOTALS	26,210.00	715.00



AIA Document G703[®] – 1992

Continuation Sheet

AIA Document G702*, Application and Certification for Payment, or G732™, Application and Certificate for Payment, Construction Manager as Adviser Edition, containing Contractor's signed certification is attached.
Use Column I on Contracts where variable retainage for line items may apply.

City of Franklin Downtown
Apartments & Commercial
Project a/k/a The Marcellus
Building Project
615 15th Ave
Franklin, NE 68939

APPLICATION NO:

004

APPLICATION DATE:

09-29-2025

PERIOD TO:

September 26, 2025

ARCHITECT'S PROJECT NO:

35024

A ITEM NO.	B DESCRIPTION OF WORK	C SCHEDULED VALUE	D WORK COMPLETED		F MATERIALS PRESENTLY STORED (NOT IN D OR E)	G		H BALANCE TO FINISH (C - G)	I RETAINAGE (IF VARIABLE RATE)
			FROM PREVIOUS APPLICATION (D + E)	THIS PERIOD		TOTAL COMPLETED AND STORED TO DATE (D + E + F)	% (G+C)		
001	General Conditions	338,406.00	83,299.00	20,825.00	0.00	104,124.00	30.77%	234,282.00	0.00
002	Demolition	110,400.00	89,424.00	12,144.00	0.00	101,568.00	92.00%	8,832.00	0.00
003	Cast-In-Place Concrete - Reinforcing	3,100.00	0.00	3,100.00	0.00	3,100.00	100.00%	0.00	0.00
004	Cast-In-Place Concrete	22,360.00	2,683.00	0.00	0.00	2,683.00	12.00%	19,677.00	0.00
005	Structural Steel	54,732.00	3,500.00	5,000.00	0.00	8,500.00	15.53%	46,232.00	0.00
006	Rough Carpentry	139,240.00	92,954.00	4,500.00	0.00	97,454.00	69.99%	41,786.00	0.00
007	Finish Carpentry / Casework	83,114.00	0.00	0.00	0.00	0.00	0.00%	83,114.00	0.00
008	Insulation	11,683.00	0.00	0.00	0.00	0.00	0.00%	11,683.00	0.00
009	Liner	9,776.00	0.00	0.00	0.00	0.00	0.00%	9,776.00	0.00
010	Joint Sealants	2,500.00	0.00	0.00	0.00	0.00	0.00%	2,500.00	0.00
011	Doors, Frames, and Hardware	92,047.00	6,586.00	0.00	0.00	6,586.00	7.16%	85,461.00	0.00
012	Gypsum Board Assemblies	149,126.00	0.00	0.00	0.00	0.00	0.00%	149,126.00	0.00
013	Flooring	40,155.00	0.00	17,978.00	0.00	17,978.00	44.77%	22,177.00	0.00
014	Painting	48,193.00	0.00	0.00	0.00	0.00	0.00%	48,193.00	0.00
015	Specialties / Accessories	8,572.00	0.00	0.00	0.00	0.00	0.00%	8,572.00	0.00
016	Fire Suppression	39,950.00	0.00	0.00	0.00	0.00	0.00%	39,950.00	0.00
017	Plumbing	178,750.00	50,950.00	0.00	0.00	50,950.00	28.50%	127,800.00	0.00
018	HVAC	182,950.00	0.00	0.00	0.00	0.00	0.00%	182,950.00	0.00
019	Electrical	184,990.00	22,141.00	21,762.00	0.00	43,903.00	23.73%	141,087.00	0.00
020	Earthwork	23,000.00	1,500.00	0.00	0.00	1,500.00	6.52%	21,500.00	0.00
021	Bond	16,961.00	16,961.00	0.00	0.00	16,961.00	100.00%	0.00	0.00
022	Contractor's Fee	191,295.00	36,346.00	11,478.00	0.00	47,824.00	25.00%	143,471.00	0.00
023	Alternate #003 - Disposal Fees	(8,500.00)	(2,500.00)	(1,000.00)	0.00	(3,500.00)	41.18%	(5,000.00)	0.00
		0.00	0.00	0.00	0.00	0.00	0.00%	0.00	0.00
CO #001	Change Order #001	0.00	0.00	0.00	0.00	0.00	0.00%	0.00	0.00

A ITEM NO.	B DESCRIPTION OF WORK	C SCHEDULED VALUE	D E WORK COMPLETED		F MATERIALS PRESENTLY STORED (NOT IN D OR E)	G TOTAL COMPLETED AND STORED TO DATE (D + E + F)		H BALANCE TO FINISH (C - G)	I RETAINAGE (IF VARIABLE RATE)
			FROM PREVIOUS APPLICATION (D + E)	THIS PERIOD		% (G+C)			
024	RFP #002 - Fire Extinguisher	(715.00)	0.00	(715.00)	0.00	(715.00)	100.00%	0.00	0.00
025	COR #001 - Basement - Stone Tuckpointing	26,210.00	0.00	26,210.00	0.00	26,210.00	100.00%	0.00	0.00
	GRAND TOTAL	1,948,295.00	403,844.00	121,282.00	0.00	525,126.00	26.95%	1,423,169.00	0.00

NET CHANGES by Change Order		25,495.00

Owner or Contractor under this Contract.

Change Order

PROJECT: <i>(Name and address)</i> City of Franklin Downtown Apartments & Commercial Project Franklin, NE	CONTRACT INFORMATION: Contract For: General Construction Date: 04/03/2025	CHANGE ORDER INFORMATION: Change Order Number: 001 Date: 10/07/2025
OWNER: <i>(Name and address)</i> Margaret Siel Mayor City of Franklin, Nebraska 619 15th Avenue Franklin, NE 68939	ARCHITECT: <i>(Name and address)</i> Trevor Hull Principal Erickson Sullivan Architects & Associates, LLC 110 S. 14th Street, Suite 200 Lincoln, NE 68508	CONTRACTOR: <i>(Name and address)</i> Steven Buckley Project Manager RMV Construction LLC 1515 E. 11th Street Kearney, NE 68847

THE CONTRACT IS CHANGED AS FOLLOWS:

(Insert a detailed description of the change and, if applicable, attach or reference specific exhibits. Also include agreed upon adjustments attributable to executed Construction Change Directives.)

- COR-001 - Basement Tuckpointing - Add \$26,210
- COR-003 - Extend Electrical Service - Add \$4,086.05
- RFP-001 - Floor Decking Replacement - Add \$4,252
- RFF-002 - Fire Extinguishers - Deduct \$665.00

The original Contract Sum was	\$ 1,922,800.00
The net change by previously authorized Change Orders	\$ 0.00
The Contract Sum prior to this Change Order was	\$ 1,922,800.00
The Contract Sum will be increased by this Change Order in the amount of	\$ 33,883.05
The new Contract Sum including this Change Order will be	\$ 1,956,683.05

The Contract Time will be increased by Zero (0) days.
The new date of Substantial Completion will be

NOTE: This Change Order does not include adjustments to the Contract Sum or Guaranteed Maximum Price, or the Contract Time, that have been authorized by Construction Change Directive until the cost and time have been agreed upon by both the Owner and Contractor, in which case a Change Order is executed to supersede the Construction Change Directive.

NOT VALID UNTIL SIGNED BY THE ARCHITECT, CONTRACTOR AND OWNER.

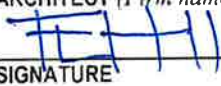
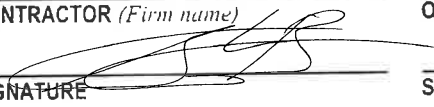
Erickson Sullivan Architects ARCHITECT <i>(Firm name)</i>  SIGNATURE Trevor Hull, Principal PRINTED NAME AND TITLE 10/18/25 DATE	RMV Construction CONTRACTOR <i>(Firm name)</i>  SIGNATURE Steven Buckley, Project Manager PRINTED NAME AND TITLE 10/14/2025 DATE	City of Franklin, Nebraska OWNER <i>(Firm name)</i> SIGNATURE PRINTED NAME AND TITLE DATE
---	--	--



RMV Construction LLC

1515 E 11th Street
Kearney, NE 68847
Phone: 308-893-2010 Fax: 308-238-0910

CHANGE ORDER REQUEST

No. 001

TITLE: Basement Tuckpointing

DATE: July 7, 2025

PROJECT: City of Franklin - The Marcellus Building Renovation

JOB #: 2510

TO: Erickson Sullivan Architects
110 S. 14th Street, Suite 200
Lincoln, NE 68508

**PR/COR void if not accepted
within 15 days.**

ATTN: Trevor Hull

DESCRIPTION OF CHANGE

Stone repair of alley side (south wall)and back foundation wall (west wall).

Item	Description	Net Amount
00001	Materials -	\$ -
00002	Labor -	\$ -
00003	Small Tools -	\$ -
00004	Equipment -	\$ -
00005	Site Supervision - 10 Hrs at \$ 75 Per Hr	\$ 750
00006	Project Management - 5 Hrs at \$ 85 Per Hr	\$ 425
00007	General Conditions - 3 Days at \$ 595 Per Day	\$ 1,785
00008	Done Right Masonry - Stone Repair	\$ 23,250
00009	-	\$ -
00010	-	\$ -
00011	-	\$ -
00012	-	\$ -
00013	-	\$ -
00014	Profit / Fee - RMV Construction LLC	\$ -
00015	Profit / Fee - Subcontractors / Suppliers	\$ -
00016	Bond / Insurance	\$ -
Total:		\$ 26,210

APPROVAL: By approval of authorized parties below, RMV Construction LLC is authorized to proceed with this work and the cost listed above will be incorporated into a Change Order.

By:
Steven Buckley

By: _____
Trevor Hull

By: _____
Margaret Seil

RMV Construction LLC

Erickson Sullivan Architects

City of Franklin

Date: July 7, 2025

Date: _____

Date: _____



RMV Construction LLC

CHANGE ORDER REQUEST BREAKDOWN

1515 E 11th Street

No. 001

Kearney, NE 68847

Phone: 308-893-2010 Fax: 308-238-0910

PROJECT: City of Franklin - The Marcellus Building Renovation

JOB #: 2510

TITLE Basement Tuckpointing

DESCRIPTION OF CHANGE

Stone repair of alley side (south wall)and back foundation wall (west wall).

RMV Construction LLC Labor / Material / Equipment

Item	Description					Value
Materials						\$ -
Labor						\$ -
Small Tools						\$ -
Equipment						\$ -
Site Supervision	10	Hrs	x	\$ 75	Per Hr	\$ 750
Project Management	5	Hrs	x	\$ 85	Per Hr	\$ 425
General Conditions	3	Days	x	\$ 595	Per Day	\$ 1,785
Subtotal RMV Construction LLC						\$ 2,960.00

Subcontractors / Suppliers

Company	Scope / Description	Value
Done Right Masonry	Stone Repair	\$ 23,250.00
		\$ -
		\$ -
		\$ -
		\$ -
Subtotal Subcontractors / Supplier		\$ 23,250.00

Subtotal - RMV / Subcontractors / Suppliers		\$ 26,210.00
Profit / Fee - RMV Construction LLC	0%	\$ -
Profit / Fee - Subcontractors / Suppliers	0%	\$ -
Bond / Insurance	0%	\$ -
Total Change Order Request		\$ 26,210.00

Additional Days Requested to Contract 0 days

ESTIMATE

Done Right Masonry
4620 68th Ave
Kearney, NE 68845

donerightmasonryrf@yahoo.com

Bill to

RMV Construction Company
1515 E 11th st
Kearney, Ne 68847

Ship to

RMV Construction Company
1515 E 11th st
Kearney, Ne 68847

Estimate details

Estimate no.: 1011
Estimate date: 06/19/2025

#	Date	Product or service	Description	Qty	Rate	Amount
1.		Stone Labor	Labor on stone repair of alley side and back foundation wall will be grouted with Type S mortar cleaned and fill voids in the foundation stone. must have stairwell access to basement, water and power is assumed onsite and lights in basement	1	\$23,250.00	\$23,250.00
					Total	\$23,250.00

Accepted date

Accepted by



RMV Construction LLC

1515 E 11th Street
Kearney, NE 68847
Phone: 308-893-2010 Fax: 308-238-0910

CHANGE ORDER REQUEST

No. 003

TITLE: Extend Electrical Service

DATE: August 19, 2025

PROJECT: City of Franklin - The Marcellus Building Renovation

JOB #: 2510

TO: Erickson Sullivan Architects
110 S. 14th Street, Suite 200
Lincoln, NE 68508

**PR/COR void if not accepted
within 15 days.**

ATTN: Trevor Hull

DESCRIPTION OF CHANGE

Electrical Site Plan depicts the pad-mounted transformer located at the Patio. Utility Plan depicts it at a location further to the west.

Item	Description	Net Amount
00001	Materials -	\$ -
00002	Labor -	\$ -
00003	Small Tools -	\$ -
00004	Equipment -	\$ -
00005	Site Supervision - 2 Hrs at \$ 75 Per Hr	\$ 150
00006	Project Management - 1 Hrs at \$ 85 Per Hr	\$ 85
00007	General Conditions - 0 Days at \$ 595 Per Day	\$ -
00008	Cornerstone Electric - Extend Electrical Service	\$ 3,595
00009	-	\$ -
00010	-	\$ -
00011	-	\$ -
00012	-	\$ -
00013	-	\$ -
00014	Profit / Fee - RMV Construction LLC	\$ 35
00015	Profit / Fee - Subcontractors / Suppliers	\$ 180
00016	Bond / Insurance	\$ 41
Total:		\$ 4,086

APPROVAL: By approval of authorized parties below, RMV Construction LLC is authorized to proceed with this work and the cost listed above will be incorporated into a Change Order.

By:
Steven Buckley

By: _____
Trevor Hull

By: _____
Margaret Seil

RMV Construction LLC

Erickson Sullivan Architects

City of Franklin

Date: 8/19/2025

Date: _____

Date: _____



RMV Construction LLC

CHANGE ORDER REQUEST BREAKDOWN

1515 E 11th Street

No. 003

Kearney, NE 68847

Phone: 308-893-2010 Fax: 308-238-0910

PROJECT: City of Franklin - The Marcellus Building Renovation

JOB #: 2510

TITLE Extend Electrical Service

DESCRIPTION OF CHANGE

Electrical Site Plan depicts the pad-mounted transformer located at the Patio. Utility Plan depicts it at a location further to the west.

RMV Construction LLC Labor / Material / Equipment

Item	Description					Value
Materials						\$ -
Labor						\$ -
Small Tools						\$ -
Equipment						\$ -
Site Supervision	2	Hrs	x	\$ 75	Per Hr	\$ 150
Project Management	1	Hrs	x	\$ 85	Per Hr	\$ 85
General Conditions	0	Days	x	\$ 595	Per Day	\$ -
Subtotal RMV Construction LLC						\$ 235.00

Subcontractors / Suppliers

Company	Scope / Description	Value
Cornerstone Electric	Extend Electrical Service	\$ 3,595.00
		\$ -
		\$ -
		\$ -
		\$ -
Subtotal Subcontractors / Supplier		\$ 3,595.00

Subtotal - RMV / Subcontractors / Suppliers		\$ 3,830.00
Profit / Fee - RMV Construction LLC	15%	\$ 35.30
Profit / Fee - Subcontractors / Suppliers	5%	\$ 179.75
Bond / Insurance	1%	\$ 41.00
Total Change Order Request		\$ 4,086.05

Additional Days Requested to Contract 0 days

Extend Electrical Service

Quantity	Description	Unit		Labor	
		Price	Total	Unit	Total
60	Ft 3" PVC	1.92	115.09	0.158	9.480
240	Ft 500 MCM Aluminun Wire	3.10	744.01	0.044	10.440
30	Ft Excavation & Backfill	0.00	0.00	0.067	2.001
	Total Material & Labor Add		859.11		21.92

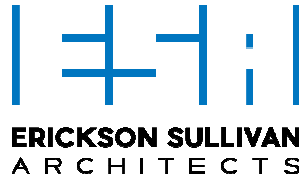

June 10, 2025

Mr. Steven Buckley
RMV Construction
steven@rmvconst.com

RE: City of Franklin Downtown Apartments and Commercial – **Request For Proposal #1 – Flooring Replacement**

Mr. Buckley,

Please provide a proposal outlining the revisions to the construction documents as detailed herein to complete all necessary labor and material to meet the intent of this request for proposal, including cost breakdown, and total costs for changes to the General Construction Contract Documents as detailed herein.

Please provide pricing for replacing flooring decking in areas indicated in RFI-002 (attached). Decking should be leveled to match existing flooring.

Thank you,

Ben Brewer



1515 East 11th Street
Kearney, NE 68847
Phone: (308) 893-2010
Fax: (308) 238-0910

REQUEST FOR INFORMATION

Date: 5/20/2025

RFI #: 002

From: Steven Buckley

To: Trevor Hull

Information Requested: Flooring Demolition

Description

Midwest Plaster & Construction has proceeded with removing some of the existing floors in the north portion of the 1st floor. It is approximately 4' wide and to the extent depicted in the drawing and pictures.

Is Midwest Plaster & Construction replacing what they removed or how are we to proceed?

Please advise.

Location & Limits:

References: Drawing and Pictures

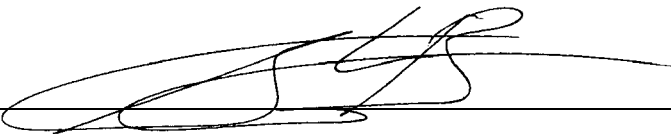
Signature  Date 5/20/2025

Description

Empty box for description



1515 East 11th Street
Kearney, NE 68847
Phone: (308) 893-2010
Fax: (308) 238-0910

REQUEST FOR INFORMATION

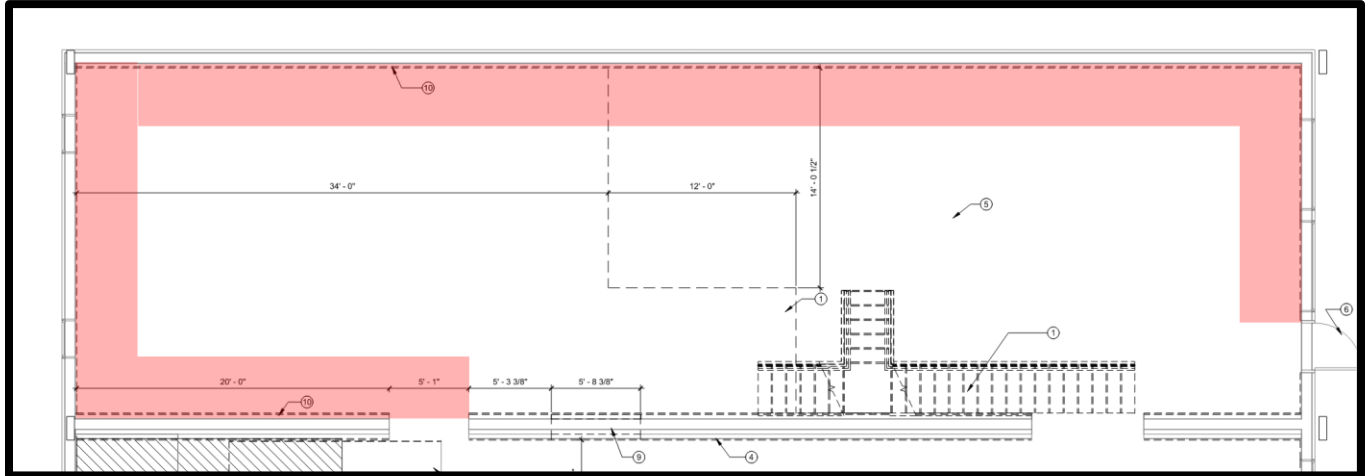



1515 East 11th Street
Kearney, NE 68847
Phone: (308) 893-2010
Fax: (308) 238-0910

REQUEST FOR INFORMATION





RMV Construction LLC

1515 E 11th Street
Kearney, NE 68847
Phone: 308-893-2010 Fax: 308-238-0910

PROPOSAL REQUEST

No. 001R

August 8, 2025

TITLE: PR #001 - Floor Decking Replacement
PROJECT: City of Franklin - The Marcellus Building Renovation
TO: Erickson Sullivan Architects
110 S. 14th Street, Suite 200
Lincoln, NE 68508

DATE: ~~July 7, 2025~~
JOB #: 2510

ATTN: Trevor Hull

PR void if not accepted within 10 days.

DESCRIPTION OF PROPOSAL

Erickson Sullivan Architects - Request For Proposal #001 - Floor Decking Replacement
Date of Issuance - June 10, 2025

Please provide pricing for replacing flooring decking in areas indicated in RFI-002 (attached). Decking should be leveled to match existing flooring.

Unit Price - Cost per SF of damaged floor and roof decking replacment, thickness to match existing

Total - 670 SF x \$4.65/SF = \$3,316.50

This will still require additional saw cutting and demo beyond what was included in the Unit Price.

Item	Description	Net Amount
00001	Materials - Additional Blocking	\$ 50
00002	Labor - Sawcutting / Additional Demo	\$ 520
00003	Small Tools -	\$ -
00004	Equipment -	\$ -
00005	Site Supervision - 2 Hrs x \$75 Per Hr	\$ 150
00006	Project Management - 1 Hrs x \$85 Per Hr	\$ 85
00007	General Conditions - 0 Days x \$595 Per Day	\$ -
00008	UNIT PRICE = 670 SF x \$4.65/SF	\$ 3,317
00009	-	\$ -
00010	-	\$ -
00011	-	\$ -
00012	-	\$ -
00013	-	\$ -
00013	-	\$ -
00013	-	\$ -
00014	Profit / Fee - RMV Construction LLC	\$ 121
00015	Profit / Fee - Subcontractors / Suppliers	\$ -
00016	Bond / Insurance	\$ 9
Total:		\$ 4,252

APPROVAL: By approval of authorized parties below, RMV Construction LLC is authorized to proceed with this work and the cost listed above will be incorporated into a Change Order.

By:
Steven Buckley
RMV Construction LLC

By: _____
Trevor Hull
Erickson Sullivan Architects

By: _____
Margaret Seil
City of Franklin

Date: ~~July 7, 2025~~

Date: _____

Date: _____

August 8, 2025



RMV Construction LLC

PROPOSAL REQUEST BREAKDOWN

1515 E 11th Street

No. 001

Kearney, NE 68847

Phone: 308-893-2010 Fax: 308-238-0910

PROJECT: City of Franklin - The Marcellus Building Renovation
JOB #: 2510

CCD # _____
PR # 001
RFI # _____
Other _____

TITLE: PR #001 - Floor Decking Replacement

DESCRIPTION OF PROPOSAL

Erickson Sullivan Architects - Request For Proposal #001 - Floor Decking Replacement
Date of Issuance - June 10, 2025

Please provide pricing for replacing flooring decking in areas indicated in RFI-002 (attached). Decking should be leveled to match existing flooring.

Unit Price - Cost per SF of damaged floor and roof decking replacment, thickness to match existing

Total - 670 SF x \$4.65/SF = \$3,316.50

RMV Construction LLC Labor / Material / Equipment

Item	Description	Value
Materials	Additional Blocking	\$ 50
Labor	Sawcutting / Additional Demo	\$ 520
Small Tools		\$ -
Equipment		\$ -
Site Supervision	2 Hrs x \$ 75 Per Hr	\$ 150
Project Management	1 Hrs x \$ 85 Per Hr	\$ 85
General Conditions	0 Days x \$ 595 Per Day	\$ -
Subtotal RMV Construction LLC		\$ 805

Subcontractors / Suppliers

Company	Scope / Description	Value
UNIT PRICE	670 SF x \$4.65/SF	\$ 3,317
		\$ -
		\$ -
		\$ -
		\$ -
		\$ -
		\$ -
		\$ -
Subtotal Subcontractors / Supplier		\$ 3,317

Subtotal - RMV / Subcontractors / Suppliers	\$	805
Profit / Fee - RMV Construction LLC	15%	\$ 121
Profit / Fee - Subcontractors / Suppliers	5%	\$ -
Bond / Insurance	1%	\$ 9
Total Change Order Request	\$	4,252

Additional Days Requested to Contract 0 days



June 12, 2025

Mr. Steven Buckley
RMV Construction
steven@rmvconst.com

RE: City of Franklin Downtown Apartments and Commercial – **Request For Proposal #2 – Fire Extinguisher Revision**

Mr. Buckley,

Please provide a proposal outlining the revisions to the construction documents as detailed herein to complete all necessary labor and material to meet the intent of this request for proposal, including cost breakdown, and total costs for changes to the General Construction Contract Documents as detailed herein.

Please provide credit for reducing the number and size of fire extinguishers. The original drawings called for four 20lb multi-purpose fire extinguishers. The new requirement will be two 10lb multipurpose fire extinguishers, located at the location shown in the attached drawing. The owner will provide and install other code required Fire Extinguishers.

Thank you,

Ben Brewer

A handwritten signature in black ink, appearing to read "Ben Brewer", is written in a cursive style.

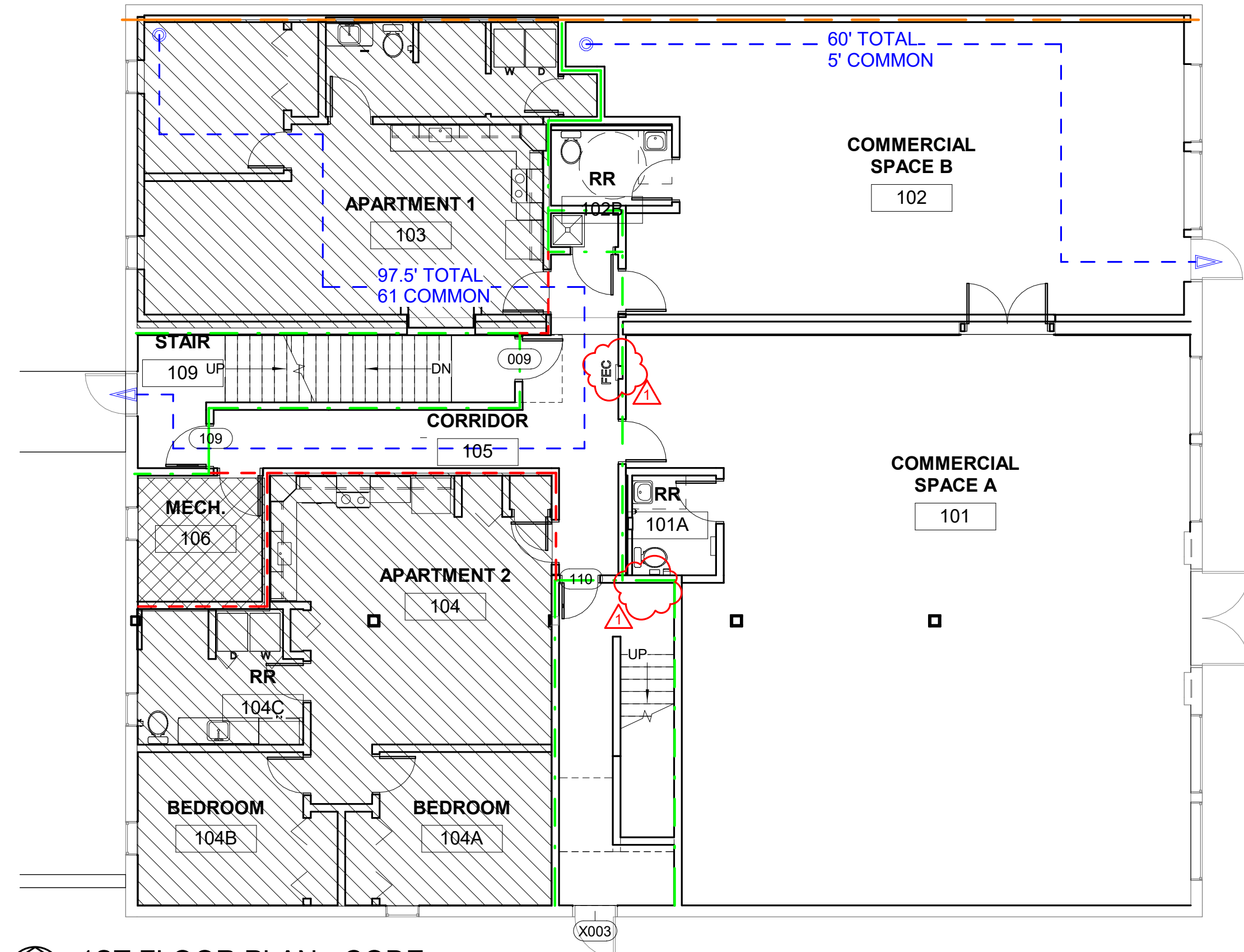

1ST FLOOR PLAN - CODE
SCALE: 1/8" = 1'-0"

FIRE RATED ASSEMBLY WALL TYPES

- - - 5 HR FIRE
- · - · 1 HR FIRE
- - - 3 HR FIRE

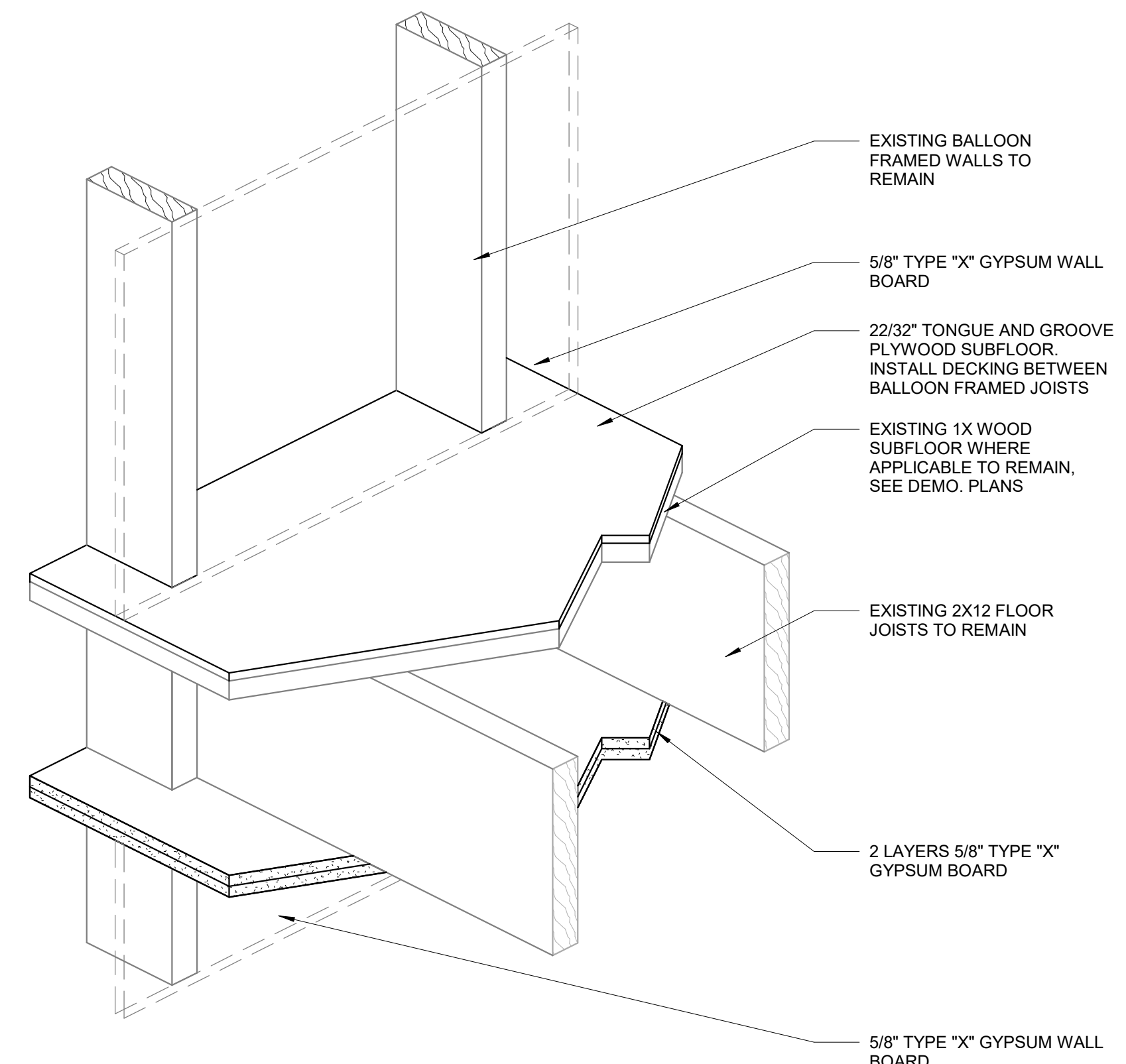

RC-2601 AND GA-FC-5406

3 FIRE RATED BALLOON FRAMED FLOOR
SCALE: 1 1/2" = 1'-0"

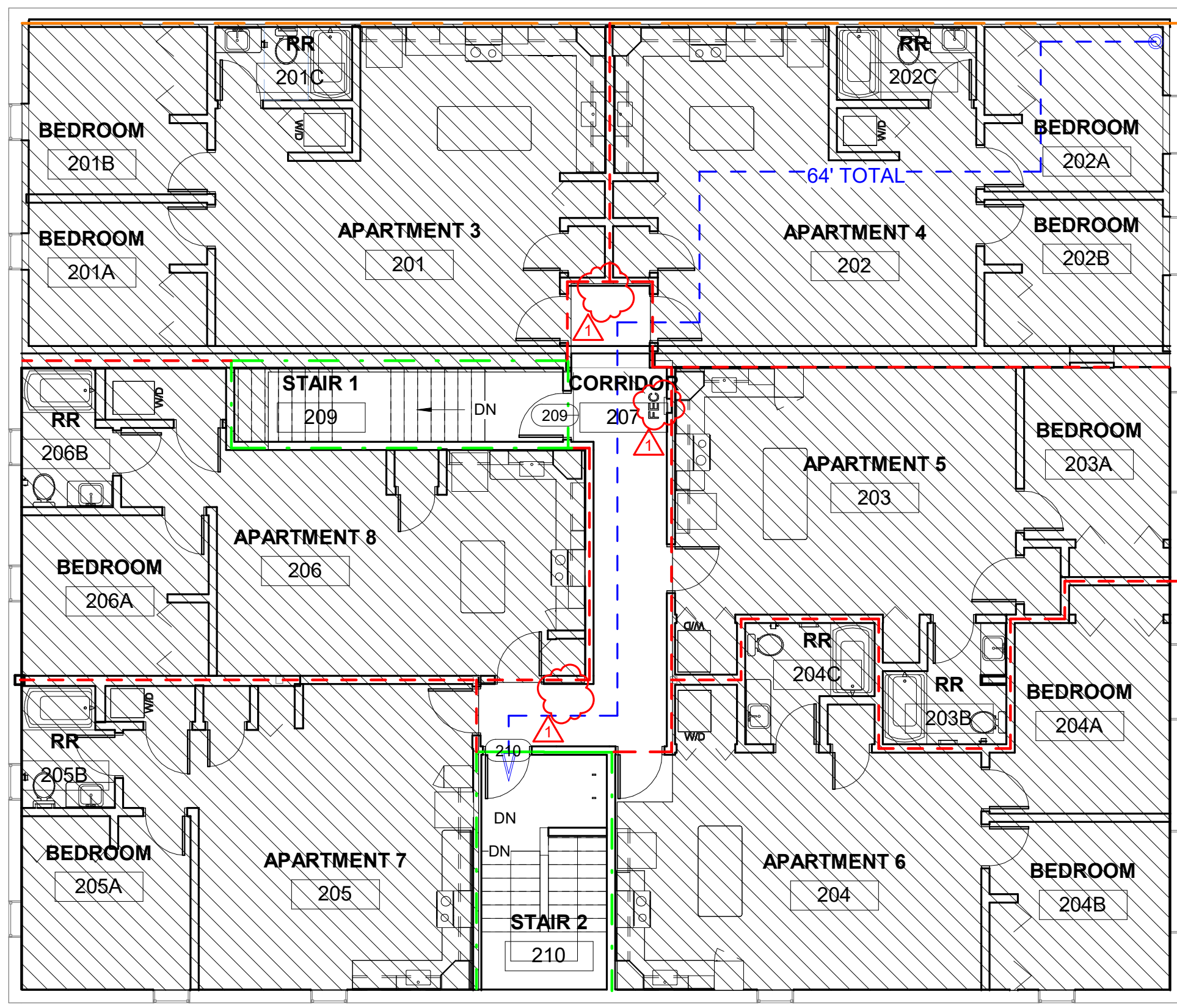

2ND FLOOR PLAN - CODE
SCALE: 1/8" = 1'-0"

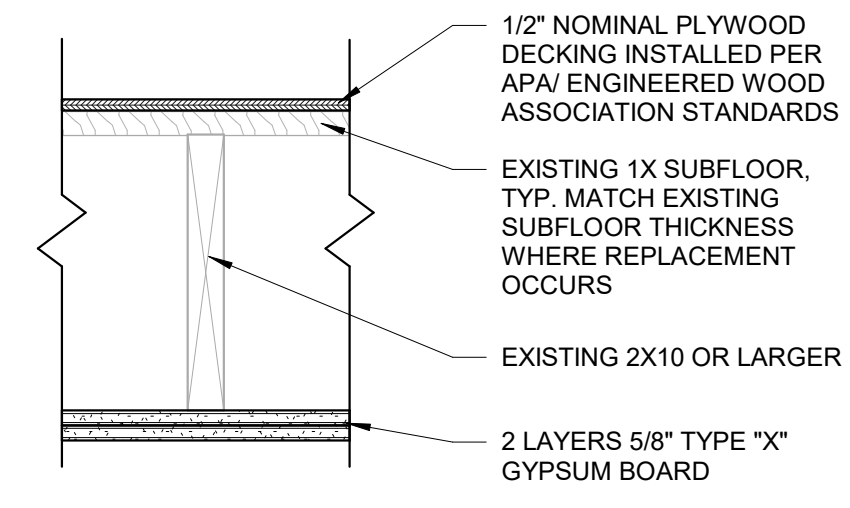

RC-2601 AND GA-FC-5406

4 RATED FLOOR ASSEMBLY TYPICAL
SCALE: 1 1/2" = 1'-0"

2018 IBC CODE REVIEW

ADOPTED CODES

- 2018 IECC & LOCAL AMENDMENTS
- 2018 IFC & LOCAL AMENDMENTS
- 2018 UNIFORM PLUMBING CODE & LOCAL AMENDMENTS
- 2012 LIFE SAFETY CODE 101
- 2010 ADA STANDARDS FOR ACCESSIBLE DESIGN
- 2018 INTERNATIONAL BUILDING CODE
- 2018 INTERNATIONAL MECHANICAL CODE
- 2017 NATIONAL ELECTRIC CODE

GENERAL REQUIREMENTS

OCCUPANCY CLASSIFICATION: MIXED, SEPARATED
 -R-2 - RESIDENTIAL GROUP 2
 -M - MERCANTILE

CONSTRUCTION TYPE: VB
 AUTOMATIC SPRINKLER SYSTEM: YES

BUILDING HEIGHT & AREA:

HEIGHT (TABLE 504.3)
 ALLOWED: 60 FEET
 ACTUAL: 35 FEET

STORIES (TABLE 504.4)
 ALLOWED: 3
 ACTUAL: 2

AREA (SECTION 506.2)
 ALLOWED: 13,704 SF PER STORY
 5,500 SF PER STORY
 ACTUAL: 11,000 SF TOTAL (2 STORIES)

TYPES OF CONSTRUCTION:

FIRE-RESISTANCE REQUIREMENTS FOR BUILDING ELEMENTS (TABLE 601)
 CONSTRUCTION TYPE: VB
 EXTERIOR BEARING WALLS: 0HR/3hr
 INTERIOR BEARING WALLS: 0HR
 NONBEARING EXTERIOR: 0HR (TABLE 602)
 NON BEARING INTERIOR: 0HR
 FLOOR CONSTRUCTION: 0HR
 ROOF CONSTRUCTION: 0HR

FIRE WALLS (TABLE 706.4)
 MERCANTILE/RESIDENTIAL: 3HR

FIRE BARRIERS (TABLE 707.3.10)
 BETWEEN OCCUPANCY GROUP: R-2 & M1HR

FIRE PROTECTION SYSTEMS

AUTOMATIC SPRINKLER SYSTEMS (SECTION 903)

MEANS OF EGRESS

MAX. FLOOR AREA PER OCCUPANT (TABLE 1004.5)
 RESIDENTIAL: 200 SF / OCCUPANT
 MERCANTILE: 60 SF / OCCUPANT

EGRESS WIDTH (SECTION 1005.3)
 THE TOTAL WIDTH OF MEANS OF EGRESS SHALL NOT BE LESS THAN THE TOTAL OCCUPANT LOAD SERVED BY THE MEANS OF EGRESS MULTIPLIED BY .3 INCHES PER OCCUPANT FOR STAIRWAYS AND BY .2 INCHES PER OCCUPANT FOR OTHER EGRESS COMPONENTS.

PATH OF EGRESS TRAVEL DISTANCE (TABLE 1006.2)
 REQUIRED RESIDENTIAL R-2: 125'
 ACTUAL RESIDENTIAL R-2: 93'
 REQUIRED RESIDENTIAL M: 75'
 ACTUAL RESIDENTIAL M: 60'

	MIN. WIDTH	MIN. WIDTH BY OCCUPANT LOAD
STAIRS	(IBC 1011.2) 44"	(IBC 1005.3.1) .3" / OCCUPANT # OCCUPANTS x .3" = 7.2" MIN.
DOORS	(IBC 1010.1.1) 32" CLEAR WIDTH	(IBC 1005.3.2 "OTHER COMPONENTS") .2" / OCCUPANT # OCCUPANTS x .2" = 4.8" MIN.
CORRIDORS	(IBC 1020.1.2) 44" CLEAR WIDTH	(IBC 1005.3.2 "OTHER COMPONENTS") .2" / OCCUPANT # OCCUPANTS x .2" = 4.8" MIN.

OF EXITS CALCULATION: 2
 MAX. COMMON PATH OF EGRESS: 75
 (IBC TABLE 1006.2.1)
 EXIT ACCESS TRAVEL DISTANCE: 250
 (IBC TABLE 1017.2)

CODE - PLUMBING FIXTURES

OCC. TYPE	OCC. LOAD	WATER CLOSETS		LAVATORIES	
		MEN	WOMEN	MEN	WOMEN
M	48 people 24 / sex	1 per 100	1 per 100	1 per 100	1 per 100
REQUIRED:		WATER CLOSETS: 2		LAVATORIES: 2	
PROVIDED:		WATER CLOSETS: 2		LAVATORIES: 2	

COPYRIGHT © 2025
 All rights reserved. All information contained herein is property of Erickson Sullivan Architects. No part of these drawings may be reproduced in any form or by any means without prior written permission of Erickson Sullivan Architects.
 Note: Original drawing format is 22" x 34". Any other sheet size will affect drawing scale.
 Erickson Sullivan Architects
 Certificate of Authorization No: CA-4491

CONSULTANTS:

STRUCTURAL ENGINEER:
RO YOUKER
 STRUCTURAL ENGINEERING
 811 S. 13th Street, Lincoln, NE 68508
 p:402.477.7640 www.royouker.com
 Certificate of Authorization No: CA-0025

MEP ENGINEERS:
GEARY
 ENGINEERING, INC.
 7800 Q STREET SUITE 100 Lincoln, Nebraska 68512
 Tel: (402) 489-7627
 Certificate of Authorization No: CA-0405

CIVIL ENGINEER:
REGA
 ENGINEERING
 601 OLD CHENEY RD, SUITE A LINCOLN, NEBRASKA 68513
 (402) 484-7342
 Certificate of Authorization No: CA-1678

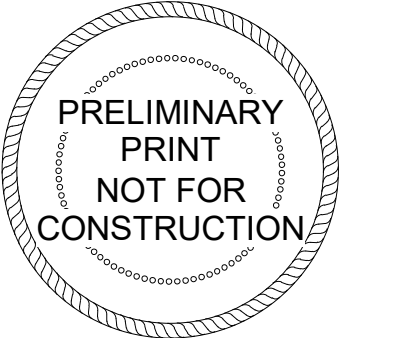

CITY OF FRANKLIN DOWNTOWN APARTMENTS AND COMMERCIAL

615 15TH AVE
 FRANKLIN, NE 68939
 PROJECT NO. 35024

CONSTRUCTION DOCUMENTS

DATE: FEBRUARY 10TH, 2025

REV.	DATE	REF.
1	06/12/2025	



ERICKSON SULLIVAN ARCHITECTS

110 S. 14TH STREET, SUITE 200
 LINCOLN, NE 68508 TEL. 402.475.1787

G001
 CODE ANALYSIS



RMV Construction LLC

1515 E 11th Street
Kearney, NE 68847
Phone: 308-893-2010 Fax: 308-238-0910

PROPOSAL REQUEST

No. 002

TITLE: PR #002 - Fire Extinguishers **DATE:** June 19, 2025
PROJECT: City of Franklin - The Marcellus Building Renovation **JOB #:** 2510
TO: Erickson Sullivan Architects
110 S. 14th Street, Suite 200
Lincoln, NE 68508

ATTN: Trevor Hull

**PR void if not accepted within
10 days.**

DESCRIPTION OF PROPOSAL

Erickson Sullivan Architects - Request For Proposal #002 - Fire Extinguisher Revision
Date of Issuance - June 13, 2025

Please provide credit for reducing the number and size of fire extinguishers. The original drawings called for four 20lb multi-purpose fire extinguishers. The new requirement will be two 10lb multipurpose fire extinguishers, located at the location shown in the attached drawing.

The owner will provide and install other code required Fire Extinguishers.

Item	Description	Net Amount
00001	Materials -	\$ -
00002	Labor -	\$ (50)
00003	Small Tools -	\$ -
00004	Equipment -	\$ -
00005	Site Supervision - 0 Hrs x \$75 Per Hr	\$ -
00006	Project Management - 0 Hrs x \$85 Per Hr	\$ -
00007	General Conditions - 0 Days x \$595 Per Day	\$ -
00008	EPCO - Fire Extinguishers	\$ (665)
00009	-	\$ -
00010	-	\$ -
00011	-	\$ -
00012	-	\$ -
00013	-	\$ -
00013	-	\$ -
00013	-	\$ -
00014	Profit / Fee - RMV Construction LLC	\$ -
00015	Profit / Fee - Subcontractors / Suppliers	\$ -
00016	Bond / Insurance	\$ -
Total:		\$ (715)

APPROVAL: By approval of authorized parties below, RMV Construction LLC is authorized to proceed with this work and the cost listed above will be incorporated into a Change Order.

By: By: Trevor Hull By: Margaret Seil
Steven Buckley Erickson Sullivan Architects City of Franklin
RMV Construction LLC
Date: 6/19/2025 Date: _____ Date: _____



RMV Construction LLC

PROPOSAL REQUEST BREAKDOWN

1515 E 11th Street

No. 002

Kearney, NE 68847

Phone: 308-893-2010 Fax: 308-238-0910

PROJECT: City of Franklin - The Marcellus Building Renovation
JOB #: 2510

CCD # _____
PR # 002
RFI # _____
Other _____

TITLE: PR #002 - Fire Extinguishers

DESCRIPTION OF PROPOSAL

Erickson Sullivan Architects - Request For Proposal #002 - Fire Extinguisher Revision
Date of Issuance - June 13, 2025

Please provide credit for reducing the number and size of fire extinguishers. The original drawings called for four 20lb multi-purpose fire extinguishers. The new requirement will be two 10lb multipurpose fire extinguishers, located at the location shown in the attached drawing.

The owner will provide and install other code required Fire Extinguishers.

RMV Construction LLC Labor / Material / Equipment

Item	Description	Value
Materials		\$ -
Labor		\$ (50)
Small Tools		\$ -
Equipment		\$ -
Site Supervision	0 Hrs x \$ 75 Per Hr	\$ -
Project Management	0 Hrs x \$ 85 Per Hr	\$ -
General Conditions	0 Days x \$ 595 Per Day	\$ -
Subtotal RMV Construction LLC		\$ (50)

Subcontractors / Suppliers

Company	Scope / Description	Value
EPCO	Fire Extinguishers	\$ (665)
		\$ -
		\$ -
		\$ -
		\$ -
		\$ -
		\$ -
		\$ -
Subtotal Subcontractors / Supplier		\$ (665)

Subtotal - RMV / Subcontractors / Suppliers	\$ (715)
Profit / Fee - RMV Construction LLC	0% \$ -
Profit / Fee - Subcontractors / Suppliers	0% \$ -
Bond / Insurance	0% \$ -
Total Change Order Request	\$ (715)

Additional Days Requested to Contract 0 days



E P C O

To: RMV Construction
Steven Buckley
steven@rmvconst.com

Quote 250349A

Tuesday, June 17, 2025

Project	Downtown Apts & Commercial Marcellus Bldg
Location	Franklin, NE
Quoted By	Brian@epcoltdinc.com
Addenda	1 & 2
Expires	September 15, 2025

ITEM	PRICE
<p>Fire Extinguisher Change - RFP#2 To Change The 4 - 20lb Extinguishers To 2 - 10lb Extinguishers Results In A Credit Of</p>	<p>\$665.00</p>
<p>TERMS AND CONDITIONS</p> <ol style="list-style-type: none"> 1. Prices DO NOT include sales tax 2. Prices are quoted delivered to job site 3. Pricing includes one shipment per specification section. No separate phased shipments are included. 4. Fasteners provided for toilet partitions only. We exclude all other fasteners. 5. Lift gate deliveries and reconsignments will result in extra freight charges. 6. Prices are for material only unless otherwise noted 7. Net 30 days, we are a supplier not a contractor, and as such cannot allow retention to be held 8. Prices do not include costs of electronic billing (i.e. Textura or similar) <div style="text-align: right; border: 1px solid black; padding: 2px; display: inline-block;">EPCO Job# 25309</div>	

To accept this quotation sign here and return: _____ Date: _____

EPCO Ltd., Inc. · 1159 E Pierce ST · Council Bluffs, IA 51503 · epcoltdinc.com



October 1, 2025

Margaret Siel, Mayor
City of Franklin, Nebraska
619 15th Avenue
Franklin, NE 68939

Project: City of Franklin Marcellus Building

Progress Report for Invoice No. 8-35024

Ms. Siel:

Please find attached our current invoice for services. Our work on this invoice includes:

- Site visits for Owner/Architect/Contractor (OAC) Meeting
- Responses to Contractor's questions, including unforeseen structural concerns
- Design work for the Radon Mitigation System
- Review of Contractor work and approval of Contractor pay application

Thank you,

A handwritten signature in blue ink, appearing to read "T. Hull", with a stylized flourish above the letters.

Trevor L. Hull, AIA

Bill to:
 Margaret Siel, Mayor
 City of Franklin, Nebraska
 619 15th Avenue
 Franklin, NE 68939
 ap@cityoffranklin.net



Date: 10/1/2025
Invoice: 8-35024
Due date: 10/15/2025

Project: City of Franklin Downtown Apartments and Commercial
Project #: 35024

Amount due for Architectural Services for the period ending September 30, 2025:

Description: Lump Sum Fee of \$148,500 + Reimbursable Expenses						Amount
Service Type:	Contract Fee:	Percentage Complete:	Billed to Date:	Previous Fee Billing:	Current Fee Billing:	
Construction Documents Phase:	\$44,550.00	100%	\$44,550.00	\$44,550.00	\$0.00	
Procurement Phase:	\$7,425.00	100%	\$7,425.00	\$7,425.00	\$0.00	
Construction Phase:	\$37,125.00	35%	\$12,993.75	\$11,137.50	\$1,856.25	
Basic Compensation Due this Invoice:					\$1,856.25	
Reimbursable Expenses:					\$0.00	
Total Due This Period:					\$1,856.25	
Finance Charge:					\$0.00	
Total Due This Invoice:					\$1,856.25	

Thank you,



Trevor L. Hull, AIA

Unpaid balances overdue 30 days from this Statement Date are subject to a finance charge of 1% per month.



October 1, 2025

Margaret Siel, Mayor
City of Franklin, Nebraska
619 15th Avenue
Franklin, NE 68939

Project: City of Franklin Library

Progress Report for Invoice No. 5-15025

Ms. Siel:

Please find attached our current invoice for services. Our work on this invoice includes:

- Site visits for Owner/Architect/Contractor (OAC) Meeting
- Responses to Contractor's questions and RFIs
- Review of Shop Submittals

Thank you,

Trevor L. Hull, AIA

Bill to:
Margaret Siel, Mayor
City of Franklin, Nebraska
619 15th Avenue
Franklin, NE 68939



Date: 10/1/2025
Invoice: 5-15025
Due date: 10/15/2025

Project: City of Franklin Park
Project #: 15025

Amount due for Architectural Services for the period ending September 30, 2025:

Description: Lump Sum Fee of \$57,500	Amount
Basic Compensation Earned to Date: (87% Completed)	\$50,025.00
Amount Previously Billed:	\$48,875.00
Basic Compensation Due this Invoice:	\$1,150.00
Reimbursable Expenses:	\$0.00
Total Due This Period:	\$1,150.00
Past Due Balance:	\$0.00
Finance Charge:	\$0.00
Total Due This Invoice:	\$1,150.00

Thank you,

A handwritten signature in blue ink, appearing to read "T. Hull", with a stylized flourish.

Trevor L. Hull, AIA

Unpaid balances overdue 30 days from this Statement Date are subject to a finance charge of 1% per month.



Dear Parents, Grandparents, Community Members, and Local Businesses,

We are excited to announce the relaunch of the Franklin Beef Boosters Program for the 2025-2026 school year! This initiative continues to connect our students to the "farm to table" experience by incorporating locally raised beef into our school meals.

Through this program, our goal is for students to enjoy local beef twice a week in the form of ground beef, roasts, and stew meat. More importantly, they will gain hands-on educational opportunities to better understand where their food comes from, and the vital role local agriculture plays in our community and state. After all Nebraska is known as the Beef State!

To make this program possible, we are seeking donations from families, businesses, and community members. Your contribution will directly support processing, storage, purchase of local beef (if beef donations are not reached), and program expenses. All contributions are tax deductible.

WAYS TO DONATE



MONETARY DONATION

Checks payable to:
Franklin Public Schools
Memo: Franklin Beef Boosters



DONATE A FINISHED BEEF

Beef must be processed
through a USDA
inspected facility



SPONSOR PROCESSING FEES

Let us know you are interested in
sponsoring and once we have a
beef we will reach out with a total

ANNUAL DONATION LEVELS

- PRODUCER**
\$2,000 and up
- PRIME**
\$1,000 - \$1,999
- CHOICE**
\$500 - \$999
- SELECT**
\$100 - \$499
- STANDARD**
\$50 - \$99

Together, we can provide healthy, locally sourced meals for our students and highlight the importance of agriculture in our daily lives.

Thank you for considering a donation to support this program. Your partnership makes a difference for our students, our school, and our community. To stay in touch of upcoming fundraisers and happenings with the program. Check out the Franklin Public Schools Facebook page or the Franklin Public Schools website at fpsflyers.org.

With gratitude,
Franklin Beef Boosters

Erica Bonham
(308) 470-1619

Steph Rupprecht
(402) 746-4379

Erica Schluntz
(308) 920-3191

RESOLUTION 2025-10

WHEREAS, the Mayor and Council of the City of Franklin, Nebraska intend to provide adequate salaries for its appointed officials and employees within the salary range provided by Sec. 1-218 of the Municipal Code;;

NOW THEREFORE BE IT RESOLVED by the Mayor and Council of the City of Franklin, Nebraska that the following salaries are hereby filed for the following named appointed officials and employees:

Drew Boston, Water/Sewer Operator	\$ 25.16 per hour
Mike Bower, Electric Supt/Plant Supt.	\$ 32.86 per hour
Shannon Carraher, Utility Worker	\$ 27.73 per hour
Cory Davis, Sanitation/Recycling	\$ 23.62 per hour
Raquel Felzien, City Clerk/Treasurer	\$ 28.76 per hour
Michelle Kahrs, Deputy City Clerk	\$ 20.54 per hour
Sam McKinney, Park/Cemetery	\$ 21.57 per hour
Barry Rubendall, Street Commissioner	\$ 28.76 per hour
Cindy Seifert, Assistant Librarian	\$ 15.25 per hour
Amanda Shelton, Head Librarian	\$ 17.97 per hour
Lawrence Stover, Jr, Ordinance Officer, Zoning Admin.	\$1,283.75 per month
Temporary Outside employee	\$ 23.62 per hour
Temporary Clerical work	\$15.25 per hour
City Lawyer	\$2550.00 per month for 15 hours per month and \$180.00 per hour for additional hours

FURTHER RESOLVED, that said salaries shall be effective as of **OCTOBER 8, 2025 the first day of the **October 8, 2025** payroll of fiscal year 2025-2026. Passed and approved this 14, day of October, 2025.**

Raquel Felzien, City Clerk

Margaret M. Siel, Mayor

SDL – LOCAL RECOMMENDATION

NEBRASKA LIQUOR CONTROL COMMISSION
301 CENTENNIAL MALL SOUTH
PO BOX 95046
LINCOLN, NE 68509-5046
PHONE: (402) 471-2571
FAX: (402) 471-2814
EMAIL: lcc.sdl.licensing@nebraska.gov
WEBSITE: www.lcc.nebraska.gov

154240 License # SK Inc dba Rightway grocery Licensee Name/Non-Profit Organization

Event location name: Rightway grocery

Event address/location: 6001 15th Avenue

Event Type: tasting

Event date(s): 11/21/25

Event start time(s): 4:30pm

Event end time(s): 8:30 pm

Indoor area to be licensed in length & width: 97' x 120'

Outdoor area to be licensed in length & width: _____ X _____ (Must submit a diagram)

Estimated number of attendees: 200

Alternate dates/times: none

Alternate location name/location: none

Type of alcohol to be served: Beer Wine Distilled Spirits

Event contact name: Alyssa Nielsen Event contact phone number: 308-425-3233

Event contact Email: franklinrightway@gmail.com

*Signature Authorized Representative: Alyssa Nielsen

Local Governing Body completes below:

The local governing body for the City of _____ **OR** _____
County of _____ approves the issuance of a Special Designated License as
requested above.

Local Governing Body Authorized Signature

Date

**RESOLUTION #2025-11
CITY OF FRANKLIN, NEBRASKA**

WHEREAS, that the Mayor and City Council of the City of Franklin, Nebraska grant their approval for the issuance by the Nebraska Liquor Control Commission of a Special Designated License to **SK Incorporated dba Rightway Grocery** to serve alcoholic liquors at the **601 15th Ave**, Franklin Nebraska on **November 21, 2025, between the hours of 4:30 o'clock p.m. and 8:30 o'clock p.m.** We will have the business follow the current direct health measure from Two River Public Health Department.

I, Raquel Felzien, do hereby certify that I am the duly appointed City Clerk of the City of Franklin, Nebraska and am keeper of the minutes and records of the Mayor and City Council of said City. I further certify that the attached document is a true and accurate copy of a resolution adopted by said board at a meeting held on the 14th day of October, 2025 as the same appears in the minutes of said meeting.

Adopted this 14th day of October 2025, at Franklin, Nebraska.

ATTEST:

City Council,
Franklin, Nebraska

Raquel Felzien, City Clerk

Margaret M. Siel, Mayor

Council member:

Moved _____ seconded the adoption of said
Resolution; 2025-11

Roll Call: _____ YES _____ NO

Resolution adopted, signed and billed as adopted.

ORDINANCE NO. 944

Working Copy

BOLD numbers in the middle of the page are the new wages as of October 14th

The rates that need possibly changed

The rates for the swimming pool if you give them 2.7% COL raise next year

AN ORDINANCE OF THE CITY OF FRANKLIN, NEBRASKA PERTAINING TO COMPENSATION TO BE PAID TO APPOINTED OFFICIALS; TO SET MINIMUM AND MAXIMUM SALARIES FOR SUCH OFFICIALS; TO PROVIDE FOR PUBLICATION IN PAMPHLET FORM; AND TO DECLARE AN EFFECTIVE DATE.

BE IT ORDAINED BY THE MAYOR AND COUNCIL OF THE CITY OF FRANKLIN, NEBRASKA:

Section 1. That the Municipal Code of the City of Franklin, Nebraska is hereby amended to add the following code section:

§1-218 SALARIES OF APPOINTED OFFICIALS. The salary ranges for the Appointed Officials of the City of Franklin, Nebraska is hereby fixed as follows:

BALL PARK MANAGER		\$2,500.00 PER YEAR
CITY CLERK/TREASURER	\$28.76	\$15.00 to \$30.00 PER HOUR
CITY CLERK/DEPUTY	\$20.54	\$15.00 to \$25.00 PER HOUR
CLERICAL/CITY HALL - PART-TIME	\$15.25	\$12.00 to \$15.00 PER HOUR
CITY ATTORNEY	\$2550.00	\$1,725.00 PER MONTH for 15 hours or \$180.00 per hour for additional hours.
ELECTRIC/POWER PLANT SUPERINTENDENT	\$32.86	\$15.000 to \$35.00 PER HOUR
ELECTRIC/POWER PLANT ASSISTANT	\$27.73	\$15.00 to \$30.00 PER HOUR
LIBRARY DIRECTOR	\$17.97	\$15.00 to \$20.00 PER HOUR
LIBRARY ASSISTANT (REGULAR PART TIME)	\$15.25	\$10.00 to \$15.00 PER HOUR
LIBRARY PART TIME	???	\$10.00 to \$15.00 PER HOUR
ORDINANCE OFFICER	\$1283.75	\$1,200.00 PER MONTH

OUTSIDE PART TIME EMPLOYEE	\$23.62	\$8.00 TO \$25.00 PER HOUR
PARK/CEMETERY CARETAKER	\$21.57	\$15.00 to \$25.00 PER HOUR
SANITATION/RECYCLING	\$23.62	\$15.00 to \$30.00 PER HOUR
RECYCLING/PART-TIME	???	\$12.50 to \$15.00 PER HOUR
STREET SUPERINTENDENT	\$28.76	\$15.00 to \$30.00 PER HOUR
SWIMMING POOL MANAGER	\$17.00	\$12.00 to \$20.00 PER HOUR \$17.46
SWIMMING POOL ASST.MANAGER	\$14.00- \$15.50	\$12.00 to \$18.00 PER HOUR \$14.38- \$15.92
SWIMMING POOL LIFEGUARDS	\$11.00-\$13.50	\$10.00 to \$12.50 PER HOUR \$11.30-\$13.87
SWIMMING POOL JR LIFEGUARDS	???	\$8.50 to \$10.50 PER HOUR
WATER/SEWER SUPERINTENDENT	\$25.16	\$15.00 to \$30.00 PER HOUR

The exact salary of the above-named Appointed Officials within the salary ranges set forth above shall be established from time to time by resolution of the City Council, and this ordinance and the resolutions adopted pursuant hereto shall be available for public inspection in the office of the City Clerk. All salaries of elected and appointed officials of the City of Franklin shall be published as provided by law.

Section 2. That this ordinance shall be published in pamphlet form as part of the Municipal Code of the City of Franklin, Nebraska.

Section 3. That this ordinance shall be in full force and effect from and after its passage, approval, and publication according to law.

PASSED AND APPROVED this 12th day of December, 2023.

Margaret Siel, Mayor

ATTEST:

Raquel Felzien, City Clerk