

City of Beatrice, Nebraska
Beatrice Regular City Council Meeting
Monday, January 19, 2026 at 6:00 PM
BPS Administration Building Board Room
320 N 5th Street
Beatrice, NE 68310



Pledge of Allegiance

1. **PLEDGE OF ALLEGIANCE**
2. **ROLL CALL**
3. **CONSENT AGENDA**
 - 3.a. Approve agenda as submitted.
 - 3.b. Receive and place on file all notices pertaining to this meeting.
 - 3.c. Receive and place on file all materials having any bearing on this meeting.
 - 3.d. Approval of minutes of regular meeting on January 5, 2026, as on file in the City Clerk's Office.
 - 3.e. Approval of Treasurer's Report of Claims in the amount of \$1,102,110.64.
 - 3.f. Approval of BASWA Report of Claims in the amount of \$251,755.90.
 - 3.g. Approval of BPW Report of Claims in the amount of \$799,841.91.
 - 3.h. Approval of certificate of substantial completion for the Corral Crossing Addition project, as recommended by the Board of Public Works.
 - 3.i. Approval of Pay Request #12 in the amount of \$67,950.00, to Genesis Contracting Group for the BASWA South MSW Landfill Site Entrance Facility project.
 - 3.j. Approval of Change Order #1 increase in the amount of \$4,917.22 to Genesis Contracting Group for the BASWA South MSW Landfill Site Entrance Facility project.
 - 3.k. Approval of Pay Request #6 in the amount of \$57,861.20 to Van Kirk Brothers Contracting for the 2025 Corral Crossing Addition project.
 - 3.l. Approval of Change Order #3 regarding the time extension for the Substantial and Final Completion Time Extension with a \$11,000 contract reduction and Pay Request #5 in the amount of \$171,721.11 to Van Kirk Brothers Contracting for the 2025 Heritage Heights Addition project.
 - 3.m. Approval of special designated license for Beatrice Mary Family YMCA for a fundraiser on February 28, 2026, from 5:30 p.m. to 11:00 p.m., at 1801 Scott Street, Beatrice, Nebraska.
 - 3.n. Resolution Number 7705 executing the ACCO Chemical System Usage Agreement #01152026 for the purchase of ACCO Liquid Chlorinating Concentrate Solution-L, as recommended by the Board of Public Works.
 - 3.o. Resolution Number 7706 appointing Thomas Bradney, David Painter, and Vaughn Wright to the Beatrice Planning and Zoning Commission.
 - 3.p. Resolution Number 7707 executing the Renewal of Excess Stop Loss Agreement with QBE Insurance Corporation for the City's self-funded employee health plan.

- 3.q. Resolution Number 7708 entering into a farm lease with Taiten Harms for farming purposes.
- 3.r. Resolution Number 7709 entering into a farm lease with Adam Kimmerling for farming purposes.
- 3.s. Resolution Number 7710 entering into a farm lease with Devon Tate for farming purposes.
- 3.t. Resolution Number 7711 executing the Grant Agreement with Nebraska Department of Water, Energy, and Environment (DWEE) for the purpose of funding the City's Tire Amnesty Program through DWEE's Waste Reduction & Recycling Incentive Grant Program.
- 3.u. Resolution Number 7712 entering into a Smart Print Agreement between the City and Eakes Office Solutions, for the leasing and servicing of printers and other office equipment.
- 4. **PUBLIC HEARINGS/BIDS**
 - 4.a. Public Hearing for the purpose of considering the application of Beatrice Petroleum, LLC, dba, NP Mart 36, 200 North 6th Street, Beatrice, Nebraska, for a Class D liquor license.
- 5. **RESOLUTIONS**
 - 5.a. Resolution Number 7713 entering into an Agreement with Gage County regarding the disbursement of GCED funds.
 - 5.b. Resolution Number 7714 executing the General Release, Request for Reconveyance, and the Deed of Reconveyance, along with all other necessary documents to release and discharge MEI Homes, LLC, regarding their Contract for Sale of Real Estate.
- 6. **ORDINANCES**
 - 6.a. Ordinance vacating a portion of 25th Street adjacent to Lots 1, 2, and 3, and Outlot A, Crest 1st Addition to the City of Beatrice, Gage County, Nebraska.
 - 6.b. Ordinance conveying real estate owned by the City to RWR, LLC.
 - 6.c. Ordinance conveying real estate owned by the City to Landmark Snacks, LLC.
- 7. **RESOLUTIONS**
 - 7.a. Resolution Number 7715 entering into a Contract for Sale of Real Estate with RWR, LLC.
 - 7.b. Resolution Number 7716 entering into a Contract for Sale of Real Estate with Landmark Snacks, LLC.
- 8. **PUBLIC FORUM**
- 9. **DISCUSSIONS/REPORTS**
 - 9.a. 2025 Year End Review.
 - 9.b. City Administrator's Monthly Report.
- 10. **MISCELLANEOUS**
 - 10.a. The next regular City Council meeting is February 2, 2026 at 6:00 p.m. in the BPS Administration Building Board Room.

**NOTICE OF MEETING
CITY OF BEATRICE, NEBRASKA**

Notice is hereby given that a meeting of the Mayor and Council of the City of Beatrice, Nebraska will be held at 6:00 P.M. on January 19, 2026, in the BPS Administration Building Board Room, 320 North 5th Street, Beatrice, Nebraska, and will be open to the public. An agenda for such meeting is available for public inspection at the office of the City Clerk, 400 Ella Street, Beatrice, Nebraska, and on the City website, www.beatrice.ne.gov.

Erin Saathoff, MMC, City Clerk

January 14, 2025

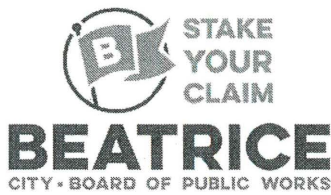

CITY OF BEATRICE, NEBRASKA
MINUTES OF THE REGULAR CITY COUNCIL MEETING

JANUARY 5, 2026

6:00 P.M.

The Mayor and City Council of the City of Beatrice, Nebraska met in regular session in the in the BPS Administration Building Board Room, 320 North 5th Street, Beatrice, Nebraska on the 5th day of January, 2026, beginning at 6:00 p.m.

Notice of this meeting was given in advance thereof by publication in the Beatrice Daily Sun on December 31, 2025, a copy of the proof of publication being on file in the City Clerk's office. Notice of this meeting was simultaneously given to the Mayor and all members of the City Council and a copy of their acknowledgement of receipt of the advance notice and agenda is filed in this office. Availability of the agenda was communicated in the advance notice and in the notice to the Mayor and City Council of this meeting. All proceedings hereafter shown were taken while the convened meeting was open to the attendance of the public.

Mayor Morgan led those in attendance in the Pledge of Allegiance.

ROLL CALL

Attending: Mayor Morgan, Councilmembers: Barnard, Doyle, Eckhoff, Eskra, Fairbanks, Hydo, McLain
Absent: Ruh

Mayor Morgan announced that a copy of the Open Meetings Act is posted in the meeting room and is accessible to members of the public.

Meritorious Service Award

Jason Moore, Street/Sanitation/Landfill Superintendent, presented Meritorious Service Awards to Charles Elliott and Jeff Creek for their actions on December 19, 2025. Moore stated while Elliott and Creek were collecting solid waste near rural Firth, they came across an elderly woman who was lost. They all agreed she would follow them to Highway 41, however, while following them, she took another wrong turn. When they went back and found her, they decided to have Creek drive her vehicle to her friend's house near Rockford. Elliott and Creek went above and beyond to ensure the woman arrived safely at her destination.

Mayor Morgan noted this is another example of the outstanding employees the City has and thanked them for their actions.

CONSENT AGENDA

- a. Approve agenda as submitted.
- b. Receive and place on file all notices pertaining to this meeting.
- c. Receive and place on file all materials having any bearing on this meeting.
- d. Approval of minutes of regular meeting on December 15, 2025, as on file in the City Clerk's Office.
- e. Approval of Treasurer's Report of Claims in the amount of \$2,558,562.49.
- f. Approval of BASWA Report of Claims in the amount of \$105,255.92.

- g. Approval of BPW Report of Claims in the amount of \$1,599,022.39.
- h. Approval of Pay Request #5 in the amount of \$109,864.70 to Van Kirk Brothers Contracting for the 2025 Corral Crossing Addition project.
- i. Approval of Pay Request #4 in the amount of \$46,525.65 to Van Kirk Brothers Contracting for the 2025 Heritage Heights Addition project.
- j. Approval of a new keno sales satellite application for The Manes Way, LLC, 2223 Court Street, Beatrice, Nebraska.
- k. Approval of public funding request from Rotary Club of Beatrice in the amount of \$6,000.00 for the Patriotic Beatrice 4th of July Fireworks event.
- l. Resolution Number 7692 appointing Craig Zarybnicky to the Beatrice Housing Authority Board.
- m. Resolution Number 7693 appointing Julie Feist to the Citizens Advisory Review Committee.
- n. Resolution Number 7694 executing the Donation Agreement between the City and the Beatrice Pickleball Association (Association), regarding the donation from the Association to be used for the construction of a shade structure over the seating area of the pickleball courts located at Chautauqua Park.
- o. Resolution Number 7695 executing the Donation Agreement between the City and the Beatrice Public Library Foundation, Inc. (Foundation), regarding the donation from the Foundation to be used to reimburse the City for the City's eighty percent (80%) of tuition and book costs for classes and training for Morgan Fox at Emporia State University.
- p. Resolution Number 7696 executing the Donation Agreement between the City and the Beatrice Girls Softball Association for the expansion of the concession stand at Hannibal Park.
- q. Resolution Number 7697 executing the Agreement for Professional Services retaining JEO to perform MS4 Compliance Assistance Services during FY26.

Moved by McLain, seconded by Fairbanks, that the items listed under the consent agenda, be approved, accepted, and/or ratified as presented.

Roll Call: Yea: Barnard, Doyle, Eckhoff, Eskra, Fairbanks, Hydo, McLain
 Nay: None

MOTION CARRIED.

PUBLIC HEARINGS/BIDS

Public Hearing for the purpose of considering adoption of a Workforce Housing Tax Increment Financing Incentive Plan pursuant to Neb. Rev. Stat. § 18-2142.05

Mayor Morgan announced that the public hearing will now be held for the purpose of considering adoption of a Workforce Housing Tax Increment Financing Incentive Plan pursuant to Neb. Rev. Stat. § 18-2142.05.

Tobias J. Tempelmeyer, City Administrator/General Manager, reported to the Council State statute requires a city to have a Tax Increment Financing (TIF) incentive plan in place prior to approving a redevelopment project for workforce housing. The project has to be located in a blight and substandard area, and the developer cannot be unjustly enriched, which is not defined in state statute. Councilmember Doyle inquired if there is anything required that the City does not already do for TIF projects and Tempelmeyer stated there is not. Councilmember Doyle inquired about the requirement of a housing study done every five (5) years. Tempelmeyer stated that is a requirement of state statute. Tempelmeyer noted the current housing study was done in 2020 and the City is working with the University of Nebraska to get a new one done.

Mayor Morgan inquired if anyone from the public wished to comment, and no one came forward.

Moved by McLain, seconded by Fairbanks, that the public hearing be closed at 6:10 p.m.

Roll Call: Yea: Barnard, Doyle, Eckhoff, Eskra, Fairbanks, Hydo, McLain
Nay: None

MOTION CARRIED.

Public Hearing for the purpose of discussing the draft EPA Brownfields grant application for the clean-up and remediation of the Dempsters Site

Mayor Morgan announced that the public hearing will now be held for the purpose of discussing the draft EPA Brownfields grant application for the clean-up and remediation of the Dempsters Site.

Tobias J. Tempelmeyer, City Administrator/General Manager, reported to the Council the same hearing was conducted a couple of months ago, however, due to the federal government being shut down at that time, Merchant McIntyre asked that a hearing be held again. Tempelmeyer explained the City is applying for an EPA Brownfields grant for just under \$4 million to clean up the Dempsters site, including the demolition and removal of buildings on the eastern side of the parcel. Councilmember Fairbanks reviewed the history of Dempsters, including ownership transfers over the years. Councilmember Fairbanks noted the City did not own all of the parcels until approximately three (3) months ago. Councilmember Fairbanks stated the EPA began their cleanup process in 2024. In December 2025, the Street Department began cleaning up, as well as five (5) part-time employees who cleaned out the buildings to prepare for demolition. Twelve (12) rollofs and one hundred forty-six (146) dump truck loads were removed from the buildings.

Councilmember Eskra inquired when the grant will be awarded and Councilmember Fairbanks stated it will be approximately May 1st. Councilmember Eskra inquired if Merchant McIntyre is involved with this grant and Councilmember Fairbanks stated they are, noting they submitted the grant last time and have revised the grant application with additional information.

Councilmember Barnard inquired about the stability of the front of the structure where the fire was and Tempelmeyer stated the City has not had a structural engineer look at it at this time. Tempelmeyer noted the City continues to monitor it and take care of any issues that arise.

Councilmember Eckhoff inquired what the cost would be to clean up the entire site and Tempelmeyer stated it would be approximately \$10-\$11 million.

Councilmember Fairbanks commended the Street Department and part-time employees for the work they have done on the cleanup of the site. Councilmember Fairbanks noted in addition to applying for this grant, the City has \$100,000 budgeted for site cleanup.

Mayor Morgan inquired if anyone from the public wished to comment, and no one came forward.

Moved by McLain, seconded by Eckhoff, that the public hearing be closed at 6:25 p.m.

Roll Call: Yea: Barnard, Doyle, Eckhoff, Eskra, Fairbanks, Hydo, McLain
Nay: None

MOTION CARRIED.

RESOLUTIONS

Resolution Number 7698 adopting the Workforce Housing Tax Increment Financing Incentive Plan for the City of Beatrice

Mayor Morgan introduced Resolution Number 7698 adopting the Workforce Housing Tax Increment Financing Incentive Plan for the City of Beatrice.

Moved by McLain, seconded by Eckhoff, that Resolution Number 7698 be passed and adopted.

Tobias J. Tempelmeyer, City Administrator/General Manager, explained to the Council this resolution will adopt the Workforce Housing Tax Increment Financing Incentive Plan that was just discussed. Tempelmeyer noted the Plan does not obligate the City to do anything.

There was no further discussion by the Council or public.

Roll Call: Yea: Barnard, Doyle, Eckhoff, Eskra, Fairbanks, Hydo, McLain
Nay: None

MOTION CARRIED.

RESOLUTION NUMBER 7698 – Passed and Adopted – adopting the Workforce Housing Tax Increment Financing Incentive Plan for the City of Beatrice
Incorporated into the Minute Record by Reference

Resolution Number 7699 executing any and all documents necessary to apply for the 2026 United States Environmental Protection Agency (EPA) Brownfield Grant Program for site cleanup at the Dempster’s Site

Mayor Morgan introduced Resolution Number 7699 executing any and all documents necessary to apply for the 2026 United States Environmental Protection Agency (EPA) Brownfield Grant Program for site cleanup at the Dempster’s Site.

Moved by McLain, seconded by Fairbanks, that Resolution Number 7699 be passed and adopted.

Tobias J. Tempelmeyer, City Administrator/General Manager, explained to the Council this resolution authorizes the signing of all documents regarding the EPA Brownfield Grant. Tempelmeyer noted a similar resolution was passed previously, however, the City is passing another one now that the federal government is back in session.

There was no further discussion by the Council or public.

Roll Call: Yea: Barnard, Doyle, Eckhoff, Eskra, Fairbanks, Hydo, McLain
Nay: None

MOTION CARRIED.

RESOLUTION NUMBER 7699 – Passed and Adopted – executing any and all documents necessary to apply for the 2026 United States Environmental Protection Agency (EPA) Brownfield Grant Program for site cleanup at the Dempster’s Site
Incorporated into the Minute Record by Reference

Resolution Number 7700 executing Supplement #1 of the Agreement for Professional Services dated March 3, 2025 to retain JEO to inventory additional trees for the City's tree inventory

Mayor Morgan introduced Resolution Number 7700 executing Supplement #1 of the Agreement for Professional Services dated March 3, 2025 to retain JEO to inventory additional trees for the City's tree inventory.

Moved by McLain, seconded by Eckhoff, that Resolution Number 7700 be passed and adopted.

Tobias J. Tempelmeyer, City Administrator/General Manager, explained to the Council the City was able to acquire additional grant funding to extend the current tree inventory project. JEO completed a portion of the inventory last year and will document every tree within the City right-of-way east of Highway 77. Total cost for this agreement is \$28,250. Tempelmeyer noted JEO may begin the project this week.

There was no further discussion by the Council or public.

Roll Call: Yea: Barnard, Doyle, Eckhoff, Eskra, Fairbanks, Hydo, McLain

Nay: None

MOTION CARRIED.

RESOLUTION NUMBER 7700 – Passed and Adopted – executing Supplement #1 of the Agreement for Professional Services dated March 3, 2025 to retain JEO to inventory additional trees for the City's tree inventory

Incorporated into the Minute Record by Reference

Resolution Number 7701 executing the Letter Agreement for Professional Services with Olsson, Inc., to retain Olsson, Inc., for Wellhead Protection Area Amendment support services

Mayor Morgan introduced Resolution Number 7701 executing the Letter Agreement for Professional Services with Olsson, Inc., to retain Olsson, Inc., for Wellhead Protection Area Amendment support services.

Moved by McLain, seconded by Eckhoff, that Resolution Number 7701 be passed and adopted.

Tobias J. Tempelmeyer, City Administrator/General Manager, explained to the Council the City has two (2) wellfields located northwest of town. In the past, both wellfields were used to bring water into the City, however, in recent years the wellfield furthest west is no longer used for drinking water. Tempelmeyer stated the City expanded the Wellhead Protection Area to include the Schwaninger property to the east. The City is proposing to eliminate the Wellfield Protection Area west of the Big Blue River. This agreement will hire Olsson, Inc., to conduct a study to ensure this will not have any affect to our drinking water. Assuming that is what the study finds, the City will look to reduce the Wellhead Protection Area.

There was no further discussion by the Council or public.

Roll Call: Yea: Barnard, Doyle, Eckhoff, Eskra, Fairbanks, Hydo, McLain

Nay: None

MOTION CARRIED.

RESOLUTION NUMBER 7701 – Passed and Adopted – executing the Letter Agreement for Professional Services with Olsson, Inc., to retain Olsson, Inc., for Wellhead Protection Area Amendment support services

Incorporated into the Minute Record by Reference

Resolution Number 7702 entering into a State Grant Agreement with the Nebraska Department of Transportation, Aeronautics Division for Project No. 3-31-0009-024-2025 for the purpose of obtaining state financial aid in the development of the Beatrice Municipal Airport

Mayor Morgan introduced Resolution Number 7702 entering into a State Grant Agreement with the Nebraska Department of Transportation, Aeronautics Division for Project No. 3-31-0009-024-2025 for the purpose of obtaining state financial aid in the development of the Beatrice Municipal Airport.

Moved by McLain, seconded by Fairbanks, that Resolution Number 7702 be passed and adopted.

Tobias J. Tempelmeyer, City Administrator/General Manager, explained to the Council the City was awarded \$2.8 million from Senator Fischer, which is a 90/10 split similar to other FAA grants. Tempelmeyer stated the funds will be used to build a new hangar and install PAPI lighting. The City's share will be approximately \$300,000.

There was no further discussion by the Council or public.

Roll Call: Yea: Barnard, Doyle, Eckhoff, Eskra, Fairbanks, Hydo, McLain
Nay: None

MOTION CARRIED.

RESOLUTION NUMBER 7702 – Passed and Adopted – entering into a State Grant Agreement with the Nebraska Department of Transportation, Aeronautics Division for Project No. 3-31-0009-024-2025 for the purpose of obtaining state financial aid in the development of the Beatrice Municipal Airport

Incorporated into the Minute Record by Reference

Resolution Number 7703 dedicating All of Lots Twenty-Three (23) and Twenty-Four (24), South Beatrice, an Addition to the City of Beatrice, Gage County, Nebraska as a public park to be known as A.J. Stoddard Park

Mayor Morgan introduced Resolution Number 7703 dedicating All of Lots Twenty-Three (23) and Twenty-Four (24), South Beatrice, an Addition to the City of Beatrice, Gage County, Nebraska as a public park to be known as A.J. Stoddard Park.

Moved by McLain, seconded by Fairbanks, that Resolution Number 7703 be passed and adopted.

Tobias J. Tempelmeyer, City Administrator/General Manager, explained to the Council part of Hoppe Development's grant agreement for the Stoddard School Redevelopment requires them to have a playground located on the parcel. This resolution will dedicate two (2) lots along 8th Street as a City park, known as A.J. Stoddard. Stoddard was born in Auburn, Nebraska, and was the superintendent for Beatrice Public School from 1917-1922.

There was no further discussion by the Council or public.

Roll Call: Yea: Barnard, Doyle, Eckhoff, Eskra, Fairbanks, Hydo, McLain
Nay: None

MOTION CARRIED.

RESOLUTION NUMBER 7703 – Passed and Adopted – dedicating All of Lots Twenty-Three (23) and Twenty-Four (24), South Beatrice, an Addition to the City of Beatrice, Gage County, Nebraska as a public park to be known as A.J. Stoddard Park

Incorporated into the Minute Record by Reference

Resolution Number 7704 approving the Declarations of Restrictive Covenants for Corral Crossing Addition and Heritage Heights Addition, both Additions to the City of Beatrice, Gage County, Nebraska

Mayor Morgan introduced Resolution Number 7704 approving the Declarations of Restrictive Covenants for Corral Crossing Addition and Heritage Heights Addition, both Additions to the City of Beatrice, Gage County, Nebraska.

Moved by McLain, seconded by Eckhoff, that Resolution Number 7704 be passed and adopted.

Tobias J. Tempelmeyer, City Administrator/General Manager, presented the proposed restrictive covenants for Corral Crossing and Heritage Heights to the Council. The single-family dwelling units must be a minimum of 1,250 square feet with a basement that has at least one (1) egress window. The exterior finish must be muted earthtone colors, with a minimum of twenty-five percent (25%) of the front being brick, stone, or stucco, and have at least a two-stall attached garage. Tempelmeyer noted construction must begin within ninety (90) days of acquiring the lot and must be substantially completed within eighteen (18) months. Tempelmeyer stated a five-hundred-dollar (\$500.00) down payment, and lots will be distributed on a first come, first served basis. Tempelmeyer noted the application will be available on the City's website tomorrow morning under the "Development" tab. Once the application and down payment have been made, the City will contact the applicant to obtain the proper legal documents to transfer ownership of the lot.

Councilmember Barnard noted the committee spent a considerable amount of time on these covenants and tried to come up with a plan to please the majority of people. Councilmember Doyle inquired if the City will work with homeowners if circumstances arise causing the construction to not be completed within the allotted timeframe. Councilmember Barnard noted the City has the authority to waive some of the required timelines, upon showing a valid reason for delay, noting we should be flexible for items such as weather.

Councilmember McLain inquired if the pictures distributed will be available to the public and Tempelmeyer noted they will be available on the website, and a sign has been ordered which will be installed onsite at Corral Crossing.

There was no further discussion by the Council or public.

Roll Call: Yea: Barnard, Doyle, Eckhoff, Eskra, Fairbanks, Hydo, McLain
Nay: None

MOTION CARRIED.

RESOLUTION NUMBER 7704 – Passed and Adopted – approving the Declarations of Restrictive Covenants for Corral Crossing Addition and Heritage Heights Addition, both Additions to the City of Beatrice, Gage County, Nebraska

Incorporated into the Minute Record by Reference

ORDINANCES

There were no ordinances.

PUBLIC FORUM

No one appeared during public forum.

DISCUSSIONS/REPORTS

There were no discussions/reports.

ADJOURNMENT

The next regular City Council meeting is January 19, 2026 at 6:00 p.m. in the BPS Administration Building Board Room.

Moved by McLain, seconded by Fairbanks, that the meeting be adjourned at 6:39 p.m.

Roll Call: Yea: Barnard, Doyle, Eckhoff, Eskra, Fairbanks, Hydo, McLain
Nay: None

MOTION CARRIED.

Erin Saathoff, MMC, City Clerk

Robert Morgan, Mayor

City Claims approved as follows: (*Abbreviations are: Ex, Expenses; Fe, Fees; Re, Reimbursement; Se, Services; Su, Supplies*): A T And T Mobility, Se, \$52.07; Alfred Benesch And Company, Ex, \$79,542.68; All Copy Products, Se, \$1,823.30; Axon Enterprise, Inc, Su, \$7,419.50; Beatrice Community Hospital, Se, \$873.00; Beatrice Fire Protection Llc, Se, Su, \$1,434.37; Beatrice Iron And Metal Co, Su, \$357.56; Beatrice Ready Mixed, Su, \$1,477.38; Black Hills Energy, Se, \$2,873.71; Blue Cross Blue Shield, Re, \$770.55; Blue Valley Door Co. Inc, Su, \$3,068.00; Board Of Public Works, Re, \$9,143.59; Bomgaars Supply Inc, Su, \$112.18; Bond Owner, Ex, \$1,071,958.75; Bound Tree Medical Llc, Su, \$5,915.17; Bragg, Robert, Se, \$6,000.00; Breland, Emma, Re, \$297.24; Burns And Mcdonnell, Inc, Ex, \$49,629.20; Busboom Truck Repair And Sales Llc, Su, \$1,387.41; Carahsoft Technology Corporation, Ex, Fe, \$19,785.13; Cary's Cleaning, Se, \$5,412.00; Caselle, Inc, Se, \$4,840.00; Centurylink Communications Llc, Se, \$3,379.40; Charter Communications, Se, \$408.51; City Motor Supply, Su, \$632.77; City Treasurer, Re, \$208,565.74; Cody Creek, Se, \$328.00; Colleen's Catering Llc, Se, \$500.00; Column Software Pbc, Fe, \$206.98; Creative Sites Llc, Ex, \$68,262.48; Das State Acctg-Central Finance Ocio, Se, \$45.00; Datashield Corporation, Se, \$109.06; Dawgs Sports Specialties, Su, \$200.00; Diamond T Truck And Trailer, Su, \$658.95; Eakes, Inc, Su, \$173.04; Earl's Window Service, Se, \$94.00; Echo Group, Inc, Su, \$579.85; Extreme Motorsports, Su, \$670.00; Fastenal Company, Su, \$82.62; Fcw, Llc, Su, \$4,140.00; First Wireless Inc, Se, \$4,517.43; Firstar Fiber Inc, Su, \$2,715.22; Gage County Register Of Deeds, Fe, \$64.00; Gage County Sheriff, Fe, \$6.73; Galls Llc, Su, \$1,256.74; Gb Auto Service Inc, Se, Su, \$1,305.07; George Ulrick Iii Forklift Service, Se, \$447.16; Global
January 5, 2026 Regular Meeting Page 8 of 9

Payments, Fe, \$48.80; Hamm Glass, Inc, Se, Su, \$780.40; Heartland Business Systems Llc, Se, Su, \$3,297.00; Hometown Leasing, Se, \$344.91; Interstate Power Systems, Inc, Se, Su, \$7,812.43; Jeo Consulting Group Inc, Ex, \$3,487.50; Jeremy Seggerman, Re, \$908.51; Johnny's Welding Inc, Se, Su, \$1,105.32; Johnstone Supply, Su, \$264.04; Jon's Outdoor Service, Se, \$67.00; Justin Wollenburg, Se, Su, \$651.35; Klecans Diverse Service Llc, Se, \$3,637.50; Lammel Plumbing Inc, Se, Su, \$1,703.00; Lampton Welding Supply Co., Inc, Su, \$457.84; Landmark Implement Inc, Su, \$489.96; Language Line Services, Se, \$2.36; Larry's Tire And Service Inc, Se, Su, \$172.00; Leseberg Properties, Ex, \$17,907.25; Lighthouse Uniform Co, Su, \$194.85; Macqueen Equipment Llc, Su, \$818.59; Mead Lumber And Rental-Beatrice, Su, \$13.42; Merchant McIntyre & Assoc Llc, Se, \$8,000.00; Mes I Acquisition Inc, Su, \$181.00; Midwest Turf And Irrigation, Su, \$495.32; Molina Healthcare Of Nebraska, Re, \$628.54; Nebraska Assoc. Of Airport Officials, Fe, \$250.00; Nebraska Title Company, Su, \$366.50; Neemann, Joanne, Re, \$166.59; Nmc, Inc, Se, Su, \$3,134.99; Oakview Veterinary Clinic, Se, Su, \$150.74; Olsson Inc, Ex, \$4,264.00; O'reilly Auto Parts, Su, \$1,440.01; Paymentech, Fe, \$939.74; Pitney Bowes, Su, \$182.58; Podany, Nicholas, Re, \$661.35; Police Chiefs Association, Fe, \$200.00; Precision Auto Tune Inc, Se, Su, \$2,702.12; Reef Tectonics, Inc, Se, Su, \$86.49; Refuse Inc, Su, \$4,640.00; Rewound Power Motors Sls And Svc Inc, Su, \$13.07; Ricoh Usa Inc, Se, \$239.66; Roehr's Machinery Inc, Su, \$4.69; Rollins Inc, Se, \$75.00; Rose Equipment Inc, Su, \$237.23; Rusk, Geanie, Re, \$22.00; Saathoff, Erin, Re, \$128.80; Sack Lumber Company, Su, \$92.99; Sand, Tyler, Re, \$1,744.90; Sandra Schatz, Phd, Llc, Se, \$465.00; Sapp Brothers, Su, \$9,087.97; Schuster's Outdoor And Rv Inc, Su, \$500.16; Sesac, Fe, \$641.00; Seth Ray, Se, \$80.00; Sherwin-Williams Co, Su, \$110.83; Sparq Data, Fe, \$2,125.00; State Of Nebraska, Se, \$818.33; Summit Fire Protection Co, Se, Su, \$687.00; Sunny Smith, Se, \$1,260.00; The Emblem Authority, Su, \$416.00; The Overhead Door Co Of Lincoln Inc, Se, \$215.00; Tmk Enterprises, Su, \$350.00; Transunion Risk And Alternative, Fe, \$100.00; Travelers, Fe, \$824,168.00; Trizetto Provider Solutions, Fe, \$103.82; Truck Center Companies, Su, \$411.92; Tsys Merchant Solutions, Fe, \$1,717.36; Twin Rivers Ford Inc, Se, Su, \$1,597.50; U.S. Cellular, Se, \$1,219.07; Unifirst Corporation, Se, \$81.83; Urgent Care Clinic Of Lincoln, Se, \$410.00; Van Kirk Sand & Gravel Inc, Ex, \$156,390.35; Verizon Wireless, Se, \$1,325.35; Walker Uniform Rental, Se, \$111.14; Waters Edge Aquatic Design Llc, Ex, \$6,900.00; Westlake Ace Hardware, Su, \$446.90; Windstream, Se, \$709.56; Witmer Public Safety Group, Inc, Su, \$2,122.68; Xpress Bill Pay, Fe, \$512.76

BPW Claims approved as follows: (Abbreviations are: Ex, Expenses; Fe, Fees; Re, Reimbursement; Se, Services; Su, Supplies): American Electric Power, Se, \$723,074.51; Beatrice Ready Mixed, Su, \$677.26; Black Hills Energy, Se, \$1,491.15; Blue Valley Door Co., Inc., Se, Su, \$569.70; Bomgaars Supply Inc, Su, \$519.72; Border States Industries, Inc, Su, \$38,257.45; Cary D Udell, Se, \$1,465.88; Chaffin, Charles, Re, \$45.00; Chubb, Fe, \$2,118.00; Cintas Loc 749, Se, \$74.20; City Motor Supply, Su, \$15.02; City Treasurer, Re, \$25.00; Collection Associates Llc, Se, \$631.28; Column Software Pbc, Se, \$13.02; Datashield Corporation, Se, \$54.53; Eakes Office Solutions, Su, \$144.90; Extreme Motorsports, Su, \$279.50; Fastenal Company, Su, \$52.40; Gordon, Yvonne, Re, \$93.77; Jk Energy Consulting Llc, Se, \$600.00; Johnstone Supply, Su, \$1,300.77; Ken's Pest Control, Se, \$80.63; Lampton Welding Supply, Su, \$1,277.43; Layne Christensen Company, Se, \$36,310.00; Lincoln Winwater Works, Su, \$8,277.81; Macqueen Equipment Llc, Se, Su, \$370.00; Mead Lumber Company, Su, \$3,444.23; Metering And Technology Solutions, Su, \$9,132.11; Ne Department Of Revenue, Fe, \$88,720.55; Nebraska Health And Human Services, Re, \$1,889.00; Nebraska Public Health Environmental Lab, Se, \$248.00; Nextera Energy Resources, Se, \$186,196.63; Olsson, Inc., Se, \$29,031.50; O'reilly Automotive, Inc., Su, \$74.78; Philippi Electric Inc, Se, \$982.27; Powertech Llc, Se, \$778.62; Quadiant Leasing Usa Inc, Se, \$4,037.91; Roehr's Machinery, Inc., Su, \$209.56; Sapp Bros. Petroleum, Inc., Su, \$4,358.69; Slim's Body Shop, Se, Su, \$6,895.36; The Cincinnati Insurance Company, Fe, \$25.00; Tractor Supply Company, Su, \$152.52; Travelers, Fe, \$381,642.00; Trojan Technologies Corp, Su, \$8,768.00; Tyndale Company, Inc., Su, \$969.39; Wesco Distributing, Inc., Su, \$14,881.70; Western Area Power Administration, Se, \$37,858.68; Westlake Hardware, Inc., Su, \$906.96

Vendor	Vendor Name	Invoice Number	Description	Invoice Date	Net Invoice Amount
GENERAL FUND					
12696	CALVIN WEARLEY	OVERPAYMENT	Reimburse overpayment f/1123 S 6th St	01/09/2026	85.50
Total :					85.50
ADMINISTRATION					
580	ASCAP	500580033-FY26	License Fee	12/20/2025	458.54
840	BEATRICE AREA SOLID WASTE AGNC	236-DEC25	Annual Interlocal BASWA Fee	12/31/2025	55,174.50
960	BEATRICE HUMANE SOCIETY	JANUARY 2026	Monthly Contractual Service Fee	01/01/2026	5,000.00
960	BEATRICE HUMANE SOCIETY	REIMB. UT. NOV25	Reimb BPW Utilities- Nov25	12/08/2025	1,000.00
1350	BOARD OF PUBLIC WORKS	86-11770	Ambulance postage - Dec25	12/31/2025	180.84
1350	BOARD OF PUBLIC WORKS	86-11770	City Admin postage - Dec25	12/31/2025	395.18
9650	CARDMEMBER SERVICE	0889	Registration f/ICMA Membership - Templemeyer	12/26/2025	1,200.00
9650	CARDMEMBER SERVICE	1457	Beatrice Daily Sun monthly subscription	12/30/2025	38.99
9650	CARDMEMBER SERVICE	2925-FY26	Omaha Bar Assn Membership f/Templemeyer	12/26/2025	200.00
9650	CARDMEMBER SERVICE	4270	Renewal f/Bar License - Templemeyer	12/12/2025	98.00
9650	CARDMEMBER SERVICE	5688	Beatrice Daily Sun monthly subscription	12/02/2025	38.99
9650	CARDMEMBER SERVICE	6046	Postage	12/30/2025	33.40
2060	CITY SELF INSURED HEALTH PLAN	JANUARY 2026	Admin Health Insurance Funding	01/01/2026	25,200.00
2080	CITY TREASURER	JAN26-IT GENERAL	IT Services	01/01/2026	10,810.00
2080	CITY TREASURER	PLUS-ASTRO PLAYGROU	Plus Funds - Sertoma Astro Park Playground	10/08/2024	10,000.00
12490	COLUMN SOFTWARE PBC	7FF24556-0601	Notice of Public Hearing - NP Mart Liquor License	12/16/2025	14.16
12490	COLUMN SOFTWARE PBC	7FF24556-0607	Notice of Mtg - 1/19/26	12/22/2025	9.63
12490	COLUMN SOFTWARE PBC	7FF24556-0608	Notice of P&Z Mtg - 1/19/26	12/22/2025	9.06
12490	COLUMN SOFTWARE PBC	7FF24556-0609	Notice of Mtg - 1/5/26	12/22/2025	9.63
12490	COLUMN SOFTWARE PBC	7FF24556-0610	Notice of P&Z Mtg - 1/5/26	12/22/2025	9.06
12490	COLUMN SOFTWARE PBC	7FF24556-0612	Notice of P&Z Public Hearing f/Stoddard Place II - LI	12/29/2025	59.43
12490	COLUMN SOFTWARE PBC	7FF24556-0613	Notice of P&Z Public Hearing f/Stoddard Place II - Wo	12/29/2025	61.56
12490	COLUMN SOFTWARE PBC	7FF24556-0616	Notice of CRA Mtg - 1/16/2026	12/30/2025	8.49
12490	COLUMN SOFTWARE PBC	7FF24556-0617	CC Minutes - 12/15/25	01/05/2026	167.62
12490	COLUMN SOFTWARE PBC	7FF24556-0618	CC Minutes - 12/1/25	01/06/2026	176.69
12398	Dvorak Law Group, LLC	116420	Dempsters Litigation - File #1008040-0003	01/07/2026	350.00
2940	Eakes, Inc.	9240243-1	2-bx) letter folder	11/20/2025	85.98
12450	FORVIS MAZARS	2751149	2nd Billing 2025 Financial Statement Audit	12/22/2025	24,580.00
3680	GAGE COUNTY REGISTER OF DEEDS	01062026	Subper Beatrice Mennonite Church	01/06/2026	34.00
3680	GAGE COUNTY REGISTER OF DEEDS	01062026	Rel Pethoud	01/06/2026	10.00
3680	GAGE COUNTY REGISTER OF DEEDS	01062026	Restcv Corral Crossing Addition	01/06/2026	28.00
3680	GAGE COUNTY REGISTER OF DEEDS	01062026	Restcv Heritage Heights Addition	01/06/2026	28.00
3920	Government Finance Officers Assoc	23622001-2026	Membership Renewal f/ 2-1-26 thru 1-31-27	01/07/2026	500.00
12676	JEFFERSON COUNTY EMA	M90252 - EVERBRIDGE I	City - Everbridge Notification System - 10/1/2025 - 9/	10/01/2025	714.68
8690	SOUTHEAST AREA CLERKS' ASSOC	2026	2026 Annual Dues - Clerk	01/01/2026	10.00
11528	Tri-County Credit Bulletin	DEC25	Credit Bulletin - February 2026-July 2026	12/25/2025	172.75
12005	TriZetto Provider Solutions	4G14012600	Electronic Claims - 200 - December 2025	01/01/2026	123.60
Total ADMINISTRATION:					136,990.78
COMMUNITY DEVELOPMENT					
840	BEATRICE AREA SOLID WASTE AGNC	236-DEC25	Property Cleanup by Christ Community Church - 121	12/31/2025	630.00
1350	BOARD OF PUBLIC WORKS	1417.40-CD-DEC25	53.43 gal Unleaded @ 2.309	12/31/2025	123.37
1350	BOARD OF PUBLIC WORKS	86-11770	Community Development postage - Dec25	12/31/2025	159.32
1360	BOCKMANN INC	20250519-1	Asbestos Survey - Schwartzkopf Barn - Land Parcel	01/06/2026	200.00
1360	BOCKMANN INC	20250519-1	Asbestos Samples - Schwartzkopf Barn - Land Parcel	01/06/2026	30.00
9650	CARDMEMBER SERVICE	1257	12) lined notepad	12/18/2025	17.12
9650	CARDMEMBER SERVICE	2651-FY26	1-rm parchment paper	12/31/2025	38.79
9650	CARDMEMBER SERVICE	4505	Membership f/ICC - Guiffre	12/27/2025	170.00
2060	CITY SELF INSURED HEALTH PLAN	JANUARY 2026	Insp. Health Insurance Funding	01/01/2026	8,400.00

Vendor	Vendor Name	Invoice Number	Description	Invoice Date	Net Invoice Amount
2080	CITY TREASURER	JAN26-IT GENERAL	IT Services	01/01/2026	258.00
Total COMMUNITY DEVELOPMENT:					10,026.60
POLICE ADMINISTRATION					
9650	CARDMEMBER SERVICE	6117-FY26	2) keyboard cover	12/06/2025	22.53
9650	CARDMEMBER SERVICE	8022-FY26	candy, hat f/holiday lighted parade	12/06/2025	84.21
2060	CITY SELF INSURED HEALTH PLAN	JANUARY 2026	PD Health Insurance Funding	01/01/2026	6,300.00
2080	CITY TREASURER	JAN26-IT GENERAL	IT Services	01/01/2026	168.00
12124	Mid-States Organized Crime Information	2600909-IN	MOCIC Annual Membership	01/06/2026	150.00
Total POLICE ADMINISTRATION:					6,724.74
POLICE VAC					
2060	CITY SELF INSURED HEALTH PLAN	JANUARY 2026	VAC Health Insurance Funding	01/01/2026	2,800.00
Total POLICE VAC:					2,800.00
POLICE COMMUNICATIONS					
9650	CARDMEMBER SERVICE	3252	4) replacement batteries f/PD radio	12/15/2025	356.68
9650	CARDMEMBER SERVICE	5073-FY26	APCO Recertification f/Eldridge	12/15/2025	35.00
9650	CARDMEMBER SERVICE	8306-FY26	humidifier	12/14/2025	30.09
12445	Centurylink Communications LLC	764619045	911 phones - Dec 16-Jan 15 2026	12/16/2025	1,126.34
12445	Centurylink Communications LLC	764619045	Mech Vesta Bundle Nov 16-Dec 15 2025 - Auburn	12/16/2025	2,253.06
2060	CITY SELF INSURED HEALTH PLAN	JANUARY 2026	Comm. Health Insurance Funding	01/01/2026	28,000.00
2080	CITY TREASURER	JAN26-IT GENERAL	IT Services	01/01/2026	267.00
11267	DAS STATE ACCTG-CENTRAL FINANC	1507321	TELETYPE- December 2025	12/23/2025	614.40
11267	DAS STATE ACCTG-CENTRAL FINANC	1508887	TELETYPE- December 2025	01/13/2026	45.00
3025	Language Line Services	11798307	Interpretation access line - December 2025	12/31/2025	24.90
Total POLICE COMMUNICATIONS:					32,752.47
POLICE PATROL					
1350	BOARD OF PUBLIC WORKS	1417.20-PD-DEC25	776.41 gal Unleaded @ 2.236	12/31/2025	1,736.05
1350	BOARD OF PUBLIC WORKS	1417.20-PD-DEC25	233.06 gal Unleaded @ 2.066	12/31/2025	481.51
1350	BOARD OF PUBLIC WORKS	86-11770	Police Dept postage - Dec25	12/31/2025	44.50
9650	CARDMEMBER SERVICE	0120-FY26	1-cs thermal paper f/citations	12/22/2025	230.00
9650	CARDMEMBER SERVICE	1507	Halo Care Collar monthly subscription	12/11/2025	9.99
9650	CARDMEMBER SERVICE	1783	2) windshield scraper	12/02/2025	17.94
9650	CARDMEMBER SERVICE	2893-FY26	vehicle code reader w/fix assist	12/29/2025	102.09
9650	CARDMEMBER SERVICE	5017-FY26	undercover wire minutes	12/09/2025	30.27
9650	CARDMEMBER SERVICE	8638	postage	12/04/2025	6.08
2060	CITY SELF INSURED HEALTH PLAN	JANUARY 2026	PD Health Insurance Funding	01/01/2026	63,700.00
2080	CITY TREASURER	JAN26-IT GENERAL	IT Services	01/01/2026	992.00
12566	DATASHIELD CORPORATION	0181536	Shredding Service - PD - January 2026	12/29/2025	54.53
12616	DAVID HAUPTMAN	000297	Tow - Case #25-12110	12/23/2025	200.00
3720	GALLS LLC	033621723	1) belt	12/30/2025	108.00
3720	GALLS LLC	033621723	Shipping	12/30/2025	9.24
12221	GB Auto Service Inc	511713928	Supplies - 1) tpms sensor	12/30/2025	49.99
1008	TRANSUNION RISK AND ALTERNATIV	41141-DEC25	Records Search - December	01/01/2026	100.00
Total POLICE PATROL:					67,872.19
FIRE ADMINISTRATION					
9650	CARDMEMBER SERVICE	2665-FY26	usb charging port, 10-pk flash drives	12/08/2025	81.98
9650	CARDMEMBER SERVICE	3360	The Witmer Group; 2) uniform boot - shipping	12/20/2025	18.28
9650	CARDMEMBER SERVICE	4434-FY26	20-pk laminating pouch	12/07/2025	9.96

Vendor	Vendor Name	Invoice Number	Description	Invoice Date	Net Invoice Amount
9650	CARDMEMBER SERVICE	4607-FY26	shipping	12/10/2025	20.93
9650	CARDMEMBER SERVICE	8599	Amazon Prime Membership yearly subscription	12/23/2025	139.00
2060	CITY SELF INSURED HEALTH PLAN	JANUARY 2026	FD Ad Health Insurance Funding	01/01/2026	5,600.00
2080	CITY TREASURER	JAN26-IT GENERAL	IT Services	01/01/2026	1,383.00
12566	DATASHIELD CORPORATION	0181535	Shredding Service - Fire - January 2026	12/29/2025	54.53
11867	MacQueen Equipment LLC	P59953	shipping	12/23/2025	15.00
12465	WITMER PUBLIC SAFETY GROUP, INC	INV815199	Shipping	01/08/2026	79.15
Total FIRE ADMINISTRATION:					7,401.83
FIRE SUPPRESSION					
980	BEATRICE IRON AND METAL CO	111188	50) 50-lb oil dry	12/30/2025	749.50
1350	BOARD OF PUBLIC WORKS	1417.30-FIRE-DEC25	69.826 gal Diesel @ 2.94	12/31/2025	205.27
1350	BOARD OF PUBLIC WORKS	1417.30-FIRE-DEC25	73.782 gal Unleaded @ 2.309	12/31/2025	170.38
1420	BOUND TREE MEDICAL LLC	86046911	Labor - 10) PM f/defibrillators	01/02/2026	4,000.00
9650	CARDMEMBER SERVICE	0407 1699	3) pledge, 3) bleach	12/26/2025	40.01
9650	CARDMEMBER SERVICE	3360	The Witmer Group; 2) uniform boot	12/20/2025	340.00
9650	CARDMEMBER SERVICE	4481	6) blue shop towel	12/03/2025	19.22
9650	CARDMEMBER SERVICE	5609 7027	2) lysol, 2) clorox wipes, 2) windex, 12) paper towel, d	12/09/2025	115.15
9650	CARDMEMBER SERVICE	6877	toilet paper holder, extension cord, replacement parts	12/21/2025	105.06
9650	CARDMEMBER SERVICE	7312-FY26	12) kleenex	12/02/2025	27.70
2010	CITY MOTOR SUPPLY	914260	threadlocker, screw f/E1	12/29/2025	8.07
2010	CITY MOTOR SUPPLY	914433	1/4" socket	01/07/2026	11.00
2010	CITY MOTOR SUPPLY	914524	2) utility knife	01/12/2026	32.19
2060	CITY SELF INSURED HEALTH PLAN	JANUARY 2026	FD Health Insurance Funding	01/01/2026	47,040.00
2080	CITY TREASURER	JAN26-IT GENERAL	IT Services	01/01/2026	200.00
11506	DesignWear, Inc	210606	6) jacket	12/30/2025	960.00
11506	DesignWear, Inc	210606	18) jacket, tall	12/30/2025	3,072.00
11506	DesignWear, Inc	211869	22) crewneck	01/08/2026	330.00
11506	DesignWear, Inc	211869	20) crewneck fleece	01/08/2026	940.00
11506	DesignWear, Inc	211869	18) pullover sweatshirt	01/08/2026	818.00
11506	DesignWear, Inc	211873	10) stocking cap	01/05/2026	130.00
3960	GRAINGER	9750078033	gas detector sensor	12/19/2025	306.98
3960	GRAINGER	9757412243	calibration gas, air/disposable	01/02/2026	134.40
3960	GRAINGER	9757412243	calibration gas, nitrogen/disposable	01/02/2026	198.57
3960	GRAINGER	9757412243	Shipping	01/02/2026	50.00
11867	MacQueen Equipment LLC	P59953	3) leatherette front	12/23/2025	231.00
5690	MEAD LUMBER AND RENTAL-BEATRI	12882604	10) plywood f/training	11/25/2025	127.30
6430	NMC, INC	INV753982	Labor - transfer switch inspection f/generator	12/22/2025	694.00
12657	SUMMIT FIRE PROTECTION CO	3762840	Labor - 17) Fire Extinguisher Inspection	01/05/2026	119.00
12657	SUMMIT FIRE PROTECTION CO	3762840	15) SCBA o-ring	01/05/2026	150.00
12657	SUMMIT FIRE PROTECTION CO	3762840	2) DOT compliance	01/05/2026	8.00
12657	SUMMIT FIRE PROTECTION CO	3762840	Labor - 17) SCBA Cylinder hydrotested	01/05/2026	612.00
9730	WALKER UNIFORM RENTAL	1447148	Shop Towel Service	12/25/2025	26.70
9730	WALKER UNIFORM RENTAL	1449654	Shop Towel Service	01/08/2026	26.70
12465	WITMER PUBLIC SAFETY GROUP, INC	INV812325	2) uniform pant	01/05/2026	200.00
12465	WITMER PUBLIC SAFETY GROUP, INC	INV815199	4) badge shirt, ss	01/08/2026	178.08
12465	WITMER PUBLIC SAFETY GROUP, INC	INV817467	1) radio earpiece	01/12/2026	43.39
Total FIRE SUPPRESSION:					62,419.67
FIRE AMBULANCE					
890	BEATRICE COMMUNITY HOSPITAL	689	Laundry Service - December 2025	01/07/2026	627.00
1350	BOARD OF PUBLIC WORKS	1417.30-FIRE-DEC25	138.31 gal Diesel @ 3.06	12/31/2025	423.23
1350	BOARD OF PUBLIC WORKS	1417.30-FIRE-DEC25	128.708 gal Diesel @ 2.94	12/31/2025	378.41
1350	BOARD OF PUBLIC WORKS	1417.30-FIRE-DEC25	30.59 gal Unleaded @ 2.236	12/31/2025	68.40
1350	BOARD OF PUBLIC WORKS	1417.30-FIRE-DEC25	465.714 gal Unleaded @ 2.309	12/31/2025	1,075.32

Vendor	Vendor Name	Invoice Number	Description	Invoice Date	Net Invoice Amount
1420	BOUND TREE MEDICAL LLC	86041434	1) snap-lok w/tamper evident seal, blue	12/29/2025	54.99
1420	BOUND TREE MEDICAL LLC	86041434	1) snap-lok w/tamper evident seal, yellow	12/29/2025	55.99
1420	BOUND TREE MEDICAL LLC	86052564	6) PPE kit	01/07/2026	69.54
1420	BOUND TREE MEDICAL LLC	86052564	1) lucas suction cup	01/07/2026	749.99
1420	BOUND TREE MEDICAL LLC	86052564	1) iGel, size 2	01/07/2026	209.90
1420	BOUND TREE MEDICAL LLC	86052564	2-cs) ambu bluesensor	01/07/2026	984.00
1420	BOUND TREE MEDICAL LLC	86052564	1) spO2 ear sensor	01/07/2026	352.90
1420	BOUND TREE MEDICAL LLC	86052564	1) spO2 neonate, adult	01/07/2026	445.80
9650	CARDMEMBER SERVICE	2256 2399	1) firstaid training pack	12/05/2025	7.50
9650	CARDMEMBER SERVICE	2256 2399	1) BLS instructor manual	12/05/2025	51.50
9650	CARDMEMBER SERVICE	2256 2399	1) BLS course video	12/05/2025	111.95
9650	CARDMEMBER SERVICE	2256 2399	4) BLS provider manual	12/05/2025	78.60
9650	CARDMEMBER SERVICE	2256 2399	1) firstaid CPR AED video	12/05/2025	215.00
9650	CARDMEMBER SERVICE	2256 2399	5) firstaid student workbook	12/05/2025	22.50
9650	CARDMEMBER SERVICE	2256 2399	Shipping	12/05/2025	34.36
9650	CARDMEMBER SERVICE	4360 2513	5) dashboard phone mount	12/21/2025	250.98
9650	CARDMEMBER SERVICE	4607-FY26	6) LED marker light	12/10/2025	83.70
9650	CARDMEMBER SERVICE	4607-FY26	1) eject cover, red	12/10/2025	58.25
9650	CARDMEMBER SERVICE	4607-FY26	2) eject cover, white	12/10/2025	116.50
9650	CARDMEMBER SERVICE	5998-FY26	Paramedic Recertification App fee f/Beavers	12/30/2025	32.00
9650	CARDMEMBER SERVICE	6129	Paramedic Recertification App fee f/Lieneman	12/28/2025	32.00
9650	CARDMEMBER SERVICE	9015	Heartsaver Instructor Manual	12/15/2025	98.29
2010	CITY MOTOR SUPPLY	914331	4) 2.5 gal DEF	12/31/2025	51.96
2010	CITY MOTOR SUPPLY	914331	1) 1-qt 4-cycle, 2) 1-qt 50:1 pre-mix	12/31/2025	32.32
2010	CITY MOTOR SUPPLY	914331	3) 15W40	12/31/2025	51.87
2010	CITY MOTOR SUPPLY	914418	winsield washer hose f/M2	01/07/2026	2.82
2060	CITY SELF INSURED HEALTH PLAN	JANUARY 2026	EMS Health Insurance Funding	01/01/2026	20,160.00
2040	CITY TREAS. PETTY CASH	P-CASH 1-19-2026	22) Meal - OTT	01/15/2026	162.06
2080	CITY TREASURER	JAN26-IT GENERAL	IT Services	01/01/2026	250.00
2080	CITY TREASURER	W-O AMBUL-JAN26	W-O Ambulance bad debt - send to CA	01/13/2026	17,859.62
3210	FARMERS COOPERATIVE	200370-DEC25	Supplies - 6) tire f/M3	12/31/2025	1,177.50
3210	FARMERS COOPERATIVE	200370-DEC25	Labor - LOF f/M3	12/31/2025	25.00
3210	FARMERS COOPERATIVE	200370-DEC25	Supplies - 9) oil f/M3	12/31/2025	64.80
3210	FARMERS COOPERATIVE	200370-DEC25	Supplies - air filter, oil filter f/M3	12/31/2025	50.51
5110	LAMPTON WELDING SUPPLY Co., INC	0001149868	Cylinder rent - Fire	12/31/2025	585.17
5110	LAMPTON WELDING SUPPLY Co., INC	0020313210	Medical Oxygen	01/07/2026	260.82
7060	O'REILLY AUTO PARTS	0749-122817	air brake fitting f/M5	12/29/2025	8.33
7060	O'REILLY AUTO PARTS	0749-122834	air brake fitting f/M5	12/29/2025	18.72
7060	O'REILLY AUTO PARTS	0749-123574	1) 40-oz degreaser	01/02/2026	6.49
7060	O'REILLY AUTO PARTS	0749-123574	1) 15-oz engine cleaner	01/02/2026	5.99
12412	Twin Rivers Ford Inc	13446	Labor - R&R brake, rotor, rear axles f/M2	01/02/2026	1,335.10
12412	Twin Rivers Ford Inc	13446	Supplies - brakes, rotors, rear axles f/M2	01/02/2026	2,085.76
12412	Twin Rivers Ford Inc	13446	Shop Supplies	01/02/2026	27.00
11989	Zoellner Ford-Lincoln of Beatrice	356716	cold air intake tube f/M2	01/07/2026	245.00
Total FIRE AMBULANCE:					51,155.44
PUBLIC PROPERTIES					
1010	BEATRICE MECHANICAL SERV INC	218504	Labor - install zone control panel f/PD Investigator Off	01/12/2026	225.00
12095	Bomgaars Supply Inc	538980	filter f/shop vac	12/30/2025	24.99
12095	Bomgaars Supply Inc	538980	bulk fasteners	12/30/2025	11.80
12095	Bomgaars Supply Inc	540937	chain f/saw	01/06/2026	36.99
12095	Bomgaars Supply Inc	541737	bulk bolts f/trail bollard	01/09/2026	3.83
2010	CITY MOTOR SUPPLY	914338	10) wheel bearing grease	01/02/2026	32.40
2010	CITY MOTOR SUPPLY	914349	battery f/West Scott gator	01/02/2026	53.56
2010	CITY MOTOR SUPPLY	914482	1) 1-qt oil	01/09/2026	6.49
2060	CITY SELF INSURED HEALTH PLAN	JANUARY 2026	Pub Prop Health Insurance Fund	01/01/2026	11,200.00

Vendor	Vendor Name	Invoice Number	Description	Invoice Date	Net Invoice Amount
2080	CITY TREASURER	JAN26-IT GENERAL	IT Services	01/01/2026	425.00
4700	ECHO GROUP, INC	S011551338.001	fixture f/Library	12/18/2025	75.36
4700	ECHO GROUP, INC	S011575541.001	16) bulb f/Veteran's Park	01/07/2026	43.04
4700	ECHO GROUP, INC	S011575579.001	4) bulb f/Aud	01/07/2026	154.68
4700	ECHO GROUP, INC	S011578297.001	supplies f/Aud fixture	01/08/2026	10.55
4700	ECHO GROUP, INC	S011578503.001	5) bulb, supplies f/Aud fixture	01/08/2026	101.41
4700	ECHO GROUP, INC	S011582052.001	10) bulb f/Aud front hallway	01/12/2026	128.40
4700	ECHO GROUP, INC	S011582069.001	10) bulb f/Aud front hallway	01/12/2026	78.72
4700	ECHO GROUP, INC	S011582069.001	credit - return - 10) bulb f/Aud front hallway	01/12/2026	128.40-
3210	FARMERS COOPERATIVE	3010-DEC25	15.827 gal Super No Lead @ 2.47615	12/31/2025	39.19
3210	FARMERS COOPERATIVE	3010-DEC25	9.653 gal Premium @ 3.209	12/31/2025	30.98
3210	FARMERS COOPERATIVE	3010-DEC25	8.644 gal Premium @ 3.209	12/31/2025	27.74
3210	FARMERS COOPERATIVE	3010-DEC25	10.856 gal Super No Lead @ 2.47881	12/31/2025	26.91
3210	FARMERS COOPERATIVE	3010-DEC25	16.285 gal Super E89 @ 2.899	12/31/2025	47.21
3210	FARMERS COOPERATIVE	3010-DEC25	30.64 gal Super No Lead @ 2.46606	12/31/2025	75.56
3210	FARMERS COOPERATIVE	3010-DEC25	Supplies - 2) tire f/99 flatbed	12/31/2025	232.50
3210	FARMERS COOPERATIVE	3010-DEC25	27.122 gal Super No Lead @ 2.41907	12/31/2025	65.61
3210	FARMERS COOPERATIVE	3010-DEC25	21.227 gal Super No Lead @ 2.41909	12/31/2025	51.35
3210	FARMERS COOPERATIVE	3010-DEC25	Supplies - 1) tire f/Exmark	12/31/2025	140.25
3210	FARMERS COOPERATIVE	3010-DEC25	30.143 gal Super No Lead @ 2.31895	12/31/2025	69.90
3210	FARMERS COOPERATIVE	3010-DEC25	17.169 gal Super No Lead @ 2.3158	12/31/2025	39.76
3210	FARMERS COOPERATIVE	3010-DEC25	Supplies - 1) tire f/3-wheel drag @ HP	12/31/2025	81.25
3210	FARMERS COOPERATIVE	3010-DEC25	22.991 gal Super No Lead @ 2.29916	12/31/2025	52.86
3210	FARMERS COOPERATIVE	3010-DEC25	19.992 gal Super No Lead @ 2.29892	12/31/2025	45.96
2960	J AND B WINDOW AND GRAPHICS INC	12052025	Clean windows f/BPW building	12/05/2025	54.00
2960	J AND B WINDOW AND GRAPHICS INC	12052025	Clean windows f/PD	12/05/2025	50.00
11503	Johnstone Supply	1668329	motor f/BPW office heat pump	12/11/2025	252.56
5100	LAMMEL PLUMBING INC	86010	plumbing supplies - 1" screwdriver stop	12/23/2025	77.57
5100	LAMMEL PLUMBING INC	86174	Sump pump lid, ejector pit w/lid f/buildings	01/06/2026	152.06
5110	LAMPTON WELDING SUPPLY Co., INC	0001149868	Cylinder rent - Pub. Prop.	12/31/2025	35.16
5160	LARRY'S TIRE AND SERVICE INC.	017733	Labor - 3) tire repair	12/30/2025	90.00
5160	LARRY'S TIRE AND SERVICE INC.	017737	Labor - 1) tire repair	01/06/2026	20.00
5690	MEAD LUMBER AND RENTAL-BEATRI	13000940	Labor - 3) sharpen chainsaw chain	01/02/2026	28.50
5690	MEAD LUMBER AND RENTAL-BEATRI	13018558	Labor - 4) sharpen chainsaw chain	01/07/2026	38.00
5690	MEAD LUMBER AND RENTAL-BEATRI	13042133	10) ceiling tile f/PD	01/14/2026	159.68
5690	MEAD LUMBER AND RENTAL-BEATRI	65241220	3) chain, chain oil f/saws	01/02/2025	112.74
6500	NEBRASKA DEPT. OF REVENUE	34-4153596-DEC25	Chautauqua Park Camping Lodging Tax-December 2	12/31/2025	27.16
6500	NEBRASKA DEPT. OF REVENUE	34-4153618-2025	Riverside Camp Lodging Tax 2025	12/31/2025	808.16
6290	NEBRASKA STATE FIRE MARSHALL	137039	Annual Boiler Certificate f/Library	01/14/2026	36.00
6290	NEBRASKA STATE FIRE MARSHALL	137039	Annual Boiler Certificate f/PD	01/14/2026	36.00
12218	Premier GMC Beatrice LLC	6031414-1	Labor - LOF f/22 Silverado	01/05/2026	28.95
12218	Premier GMC Beatrice LLC	6031414-1	Supplies - 6) oil f/22 Silverado	01/05/2026	33.00
12218	Premier GMC Beatrice LLC	6031414-1	Supplies - oil filter f/22 Silverado	01/05/2026	8.00
12218	Premier GMC Beatrice LLC	6031414-1	Shop Supplies	01/05/2026	5.79
8150	SACK LUMBER COMPANY	2601-142128	300) cable tie f/Pickleball screens	01/12/2026	48.47
8370	SCHUSTER'S OUTDOOR AND RV INC.	32255	1) 1-gal hydraulic oil	01/05/2026	56.99
8370	SCHUSTER'S OUTDOOR AND RV INC.	32255	1) 1-gal transmission fluid	01/05/2026	51.99
8370	SCHUSTER'S OUTDOOR AND RV INC.	32255	2) hydro filter	01/05/2026	115.98
8370	SCHUSTER'S OUTDOOR AND RV INC.	32265	6) blade f/Exmark mowers	01/14/2026	209.79
8370	SCHUSTER'S OUTDOOR AND RV INC.	32267	bulk supplies f/mowers; cutter housing asy, double sh	01/14/2026	3,173.76
8370	SCHUSTER'S OUTDOOR AND RV INC.	32268	bulk supplies f/mowers; blade, mud flap, tire guard	01/15/2026	1,758.26
8370	SCHUSTER'S OUTDOOR AND RV INC.	32268	bulk supplies f/mowers; transmission fluid	01/15/2026	717.46
1050	SHERIDAN INDUSTRIES	15571	Clean @ Indoor Hitting Facility - December 2025	01/02/2026	62.00
8510	SHERWIN-WILLIAMS CO.	4167-1	Paint f/Caregie	01/08/2026	145.85
12521	SUNNY SMITH	DEC29 2025 - JAN9 2026	Office cleaning f/Aud offices	01/09/2026	405.00
12521	SUNNY SMITH	DEC29 2025 - JAN9 2026	Office cleaning f/BPW offices	01/09/2026	405.00
12092	TK Elevator Corp.	3008975801	Elevator inspections - Library, Police Dept, Carnegie	11/01/2025	528.79

Vendor	Vendor Name	Invoice Number	Description	Invoice Date	Net Invoice Amount
3062	TrafficGuard, Inc.	11739	2) fixed surface mount posts, safety yellow	01/06/2026	916.00
9760	Westlake Ace Hardware	10358441	2) rodent repellent	11/30/2025	15.00
9760	Westlake Ace Hardware	10358650	supplies f/PD exhaust vent	12/15/2025	45.28
9760	Westlake Ace Hardware	10358696	supplies f/PD exhaust vent	12/18/2025	31.51
9760	Westlake Ace Hardware	10358755	supplies f/PD boiler water piping	12/23/2025	28.91
9760	Westlake Ace Hardware	10358818	spray paint, caulk gun f/Riverside playground	12/30/2025	23.38
9760	Westlake Ace Hardware	10358844	supplies f/Library fan repair	01/05/2026	62.16
9760	Westlake Ace Hardware	10358854	2) glass cleaner, power wash spray, swiffer duster, 2)	01/05/2026	46.26
9760	Westlake Ace Hardware	10358902	fuses f/Aud	01/08/2026	35.07
9760	Westlake Ace Hardware	10358906	shower curtain, 4) hand soap	01/08/2026	30.55
9760	Westlake Ace Hardware	10358955	paper towels, broom, dustpan	01/13/2026	42.30
9760	Westlake Ace Hardware	10358979	supplies f/PD ceiling heater	01/14/2026	61.08
Total PUBLIC PROPERTIES:					24,581.02

LIBRARY

9660	CARDMEMBER SERVICE	DECEMBER 2025	Archive of Romance Deluxe	01/02/2026	10.99
9660	CARDMEMBER SERVICE	DECEMBER 2025	30-pc scarves	01/02/2026	14.99
9660	CARDMEMBER SERVICE	DECEMBER 2025	Code Blue	01/02/2026	18.95
9660	CARDMEMBER SERVICE	DECEMBER 2025	Shoot of Cut Bait	01/02/2026	28.95
9660	CARDMEMBER SERVICE	DECEMBER 2025	Last Days of Marilyn Monroe	01/02/2026	17.88
9660	CARDMEMBER SERVICE	DECEMBER 2025	Credit - return The Cartel Deluxe	01/02/2026	14.66-
9660	CARDMEMBER SERVICE	DECEMBER 2025	mat, black	01/02/2026	487.00
9660	CARDMEMBER SERVICE	DECEMBER 2025	self-adhesive hose reinforcement stickers	01/02/2026	2.97
9660	CARDMEMBER SERVICE	DECEMBER 2025	3) two-sided laminate refill	01/02/2026	93.60
9660	CARDMEMBER SERVICE	DECEMBER 2025	Blood Meridian	01/02/2026	9.07
9660	CARDMEMBER SERVICE	DECEMBER 2025	If Only I Had Told Her	01/02/2026	6.34
9660	CARDMEMBER SERVICE	DECEMBER 2025	What Was the Industrial Revolution?	01/02/2026	7.99
9660	CARDMEMBER SERVICE	DECEMBER 2025	Red Riding Hood	01/02/2026	14.10
9660	CARDMEMBER SERVICE	DECEMBER 2025	I Survived the Dust Bowl 1935	01/02/2026	5.56
9660	CARDMEMBER SERVICE	DECEMBER 2025	Better in Black	01/02/2026	14.93
9660	CARDMEMBER SERVICE	DECEMBER 2025	Eternal Ruin	01/02/2026	13.12
9660	CARDMEMBER SERVICE	DECEMBER 2025	You've Found Oliver	01/02/2026	11.93
9660	CARDMEMBER SERVICE	DECEMBER 2025	Way Things Work	01/02/2026	16.76
9660	CARDMEMBER SERVICE	DECEMBER 2025	Stickler Valentine	01/02/2026	18.99
9660	CARDMEMBER SERVICE	DECEMBER 2025	Quiet Weight of Wings	01/02/2026	16.98
9660	CARDMEMBER SERVICE	DECEMBER 2025	Dragon Tales	01/02/2026	13.97
9660	CARDMEMBER SERVICE	DECEMBER 2025	Fly Away Home, DVD	01/02/2026	9.24
9660	CARDMEMBER SERVICE	DECEMBER 2025	Host, DVD	01/02/2026	8.11
9660	CARDMEMBER SERVICE	DECEMBER 2025	Family of Spies	01/02/2026	20.99
9660	CARDMEMBER SERVICE	DECEMBER 2025	At Morning's Light	01/02/2026	13.04
9660	CARDMEMBER SERVICE	DECEMBER 2025	Lighthouse at the Cove	01/02/2026	12.52
9660	CARDMEMBER SERVICE	DECEMBER 2025	Spasm	01/02/2026	25.18
9660	CARDMEMBER SERVICE	DECEMBER 2025	2) Witch's Guide to Magical Innkeeping	01/02/2026	24.20
9660	CARDMEMBER SERVICE	DECEMBER 2025	Life and Death and Giants	01/02/2026	23.44
9660	CARDMEMBER SERVICE	DECEMBER 2025	White Wolf	01/02/2026	29.99
9660	CARDMEMBER SERVICE	DECEMBER 2025	Blown Away	01/02/2026	20.58
9660	CARDMEMBER SERVICE	DECEMBER 2025	Mona's Eyes	01/02/2026	26.92
9660	CARDMEMBER SERVICE	DECEMBER 2025	How to Catch a Reindeer	01/02/2026	6.96
9660	CARDMEMBER SERVICE	DECEMBER 2025	Bluey's Night Before Christmas	01/02/2026	15.18
9660	CARDMEMBER SERVICE	DECEMBER 2025	Press Here	01/02/2026	9.65
9660	CARDMEMBER SERVICE	DECEMBER 2025	Jane Austen's Bookshelf	01/02/2026	25.21
9660	CARDMEMBER SERVICE	DECEMBER 2025	Angels of Death	01/02/2026	11.45
9660	CARDMEMBER SERVICE	DECEMBER 2025	24) AA batteries	01/02/2026	18.65
9660	CARDMEMBER SERVICE	DECEMBER 2025	Credit - return Magic Paper Coloring book	01/02/2026	8.99-
9660	CARDMEMBER SERVICE	DECEMBER 2025	Credit - return A Witch's Guid to Magical	01/02/2026	9.65-
9660	CARDMEMBER SERVICE	DECEMBER 2025	A Parent's Guide to Gifted Children	01/02/2026	24.42

Vendor	Vendor Name	Invoice Number	Description	Invoice Date	Net Invoice Amount
9660	CARDMEMBER SERVICE	DECEMBER 2025	Pitney Bowes - ink cartridge, red	01/02/2026	182.58
9660	CARDMEMBER SERVICE	DECEMBER 2025	The Real Yellow Pages - formerly Vivial monthly fee	01/02/2026	60.70
9660	CARDMEMBER SERVICE	DECEMBER 2025	Magic Paper Coloring book	01/02/2026	8.99
9660	CARDMEMBER SERVICE	DECEMBER 2025	The Girl in Question	01/02/2026	9.74
9660	CARDMEMBER SERVICE	DECEMBER 2025	Pitney Bowes - Quarterly charge f/postage	01/02/2026	192.99
9660	CARDMEMBER SERVICE	DECEMBER 2025	Credit - shipping	01/02/2026	4.91-
2060	CITY SELF INSURED HEALTH PLAN	JANUARY 2026	Lib Health Insurance Funding	01/01/2026	8,400.00
2080	CITY TREASURER	JAN26-IT GENERAL	IT Services	01/01/2026	579.00
12490	COLUMN SOFTWARE PBC	7FF24556-0604	Notice of Library Advisory Board Mtg - 1/15/26	12/22/2025	9.06
6400	NEBRASKA LIBRARY COMMISSION	33362	New York Times - all access 12/19/25 - 12/18/26	12/29/2025	333.07
6400	NEBRASKA LIBRARY COMMISSION	33383	RENEW SUBSCRIPTION to ProQuest Ancestry Libra	01/02/2026	1,610.27
12137	Unite Private Networks LLC	SCM-25-000534	Education Wide Area Network Monthly fee w/ E-Rate	10/01/2025	365.00
12137	Unite Private Networks LLC	SCM-25-000534	Federal Regulatory Recovery	10/01/2025	1.52
12137	Unite Private Networks LLC	SCM-25-000534	NE Universal Service	10/01/2025	25.48
12137	Unite Private Networks LLC	SCM-25-000534	E-Rate FRN 2599014260 (monthly rate) - July	10/01/2025	313.60-
12137	Unite Private Networks LLC	SCM-25-000534	E-Rate FRN 2599014260 (monthly rate) - August	10/01/2025	313.60-
12137	Unite Private Networks LLC	SCM-25-000534	E-Rate FRN 2599014260 (monthly rate) - September	10/01/2025	313.60-
12137	Unite Private Networks LLC	SI-25-000439	Education Wide Area Network Monthly fee w/ E-Rate	01/01/2026	365.00
12137	Unite Private Networks LLC	SI-25-000439	Federal Regulatory Recovery	01/01/2026	1.52
12137	Unite Private Networks LLC	SI-25-000439	NE Universal Service	01/01/2026	25.48
12137	Unite Private Networks LLC	SI-25-000439	E-Rate FRN 2599014260 (monthly rate) - January	01/01/2026	313.60-
12137	Unite Private Networks LLC	SI-25-026065-2	Education Wide Area Network Monthly fee w/ E-Rate	10/01/2025	365.00
12137	Unite Private Networks LLC	SI-25-026065-2	Federal Regulatory Recovery	10/01/2025	1.42
12137	Unite Private Networks LLC	SI-25-026065-2	NE Universal Service	10/01/2025	25.47
12137	Unite Private Networks LLC	SI-25-041903	Education Wide Area Network Monthly fee w/ E-Rate	10/01/2025	365.00
12137	Unite Private Networks LLC	SI-25-041903	Federal Regulatory Recovery	10/01/2025	1.52
12137	Unite Private Networks LLC	SI-25-041903	NE Universal Service	10/01/2025	25.48
12137	Unite Private Networks LLC	SI-25-041903	E-Rate FRN 2599014260 (monthly rate) - October	10/01/2025	313.60-
12137	Unite Private Networks LLC	SI-25-046306	Education Wide Area Network Monthly fee w/ E-Rate	11/01/2025	365.00
12137	Unite Private Networks LLC	SI-25-046306	Federal Regulatory Recovery	11/01/2025	1.52
12137	Unite Private Networks LLC	SI-25-046306	NE Universal Service	11/01/2025	25.48
12137	Unite Private Networks LLC	SI-25-046306	E-Rate FRN 2599014260 (monthly rate) - November	11/01/2025	313.60-
12137	Unite Private Networks LLC	SI-25-050662	Education Wide Area Network Monthly fee w/ E-Rate	12/01/2025	365.00
12137	Unite Private Networks LLC	SI-25-050662	Federal Regulatory Recovery	12/01/2025	1.52
12137	Unite Private Networks LLC	SI-25-050662	NE Universal Service	12/01/2025	25.48
12137	Unite Private Networks LLC	SI-25-050662	E-Rate FRN 2599014260 (monthly rate) - December	12/01/2025	313.60-
Total LIBRARY:					12,655.68
Total GENERAL FUND:					415,465.92
STREET FUND					
3051	Auto Shop Inc.	9769	Insurance payment	12/03/2025	8,280.42-
Total :					8,280.42-
STREET FUND					
11744	Armstrong Rentals LLC	14628	2)Lowboy Landfill 963 track loader to Hannibal park	01/07/2026	350.00
3051	Auto Shop Inc.	9769	Labor- Truck Repair-deductible	12/03/2025	2,500.00
3051	Auto Shop Inc.	9769	Repair Parts-deductible	12/03/2025	2,500.00
3051	Auto Shop Inc.	9769	Insurance cover expense	12/03/2025	8,280.42
840	BEATRICE AREA SOLID WASTE AGNC	225-DEC25	#16077-Vac Truck -1ydx12	12/31/2025	12.00
12695	Blackburn, Joseph D.	SETTLEMENT	Settlement to repair damaged vehicle from snow plow	01/08/2026	1,908.95
1350	BOARD OF PUBLIC WORKS	1131.01-JAN26	share building Repair Fund	01/01/2026	250.00
1350	BOARD OF PUBLIC WORKS	1146.40-STFUEL-DEC25	401.47 gal Diesel @ 2.94	12/31/2025	1,180.32
1350	BOARD OF PUBLIC WORKS	1146.40-STFUEL-DEC25	747.8 gal Diesel @ 2.62	12/31/2025	1,959.24

Vendor	Vendor Name	Invoice Number	Description	Invoice Date	Net Invoice Amount
1350	BOARD OF PUBLIC WORKS	1146.40-STFUEL-DEC25	116.07 gal Unleaded @ 2.066	12/31/2025	239.78
1350	BOARD OF PUBLIC WORKS	1456.00-JAN26	Engineering Services-Street	01/01/2026	5,612.00
11435	Carroll Distributing and Const Supply In	LI171646	14)9" x 25' Straw Log@29.00	12/25/2025	406.00
2060	CITY SELF INSURED HEALTH PLAN	JAN26-STREET	Street Dept Health Insurance Funding	01/01/2026	25,200.00
2080	CITY TREASURER	ATTY-JAN26	Attorney Services-Street	01/01/2026	827.00
2080	CITY TREASURER	GM-JAN26	general Manager Stry-Street	01/01/2026	1,776.00
2080	CITY TREASURER	ST IT-JAN26	IT Fund Monthly Obligation-Street	01/01/2026	7,192.00
2460	CORNHUSKER STATE INDUSTRIES	1507933	5)No Truck Traffice Over 8000lbs 18x24@21.75(Virgi	01/05/2026	108.75
3210	FARMERS COOPERATIVE	2265-DEC25	Tire Repair	12/31/2025	65.00
3210	FARMERS COOPERATIVE	2265-DEC25	27.3240 Gals Dyed Diesel	12/31/2025	79.13
3210	FARMERS COOPERATIVE	2265-DEC25	21.2720 gal Super E89	12/31/2025	54.56
3210	FARMERS COOPERATIVE	2265-DEC25	17.2810 Gals Dyed Diesel	12/31/2025	52.29
3210	FARMERS COOPERATIVE	2265-DEC25	15.4650 gal Dyed Diesel	12/31/2025	46.80
3210	FARMERS COOPERATIVE	2265-DEC25	2)11R22.5 Samson Tires @298.50	12/31/2025	597.00
3210	FARMERS COOPERATIVE	2265-DEC25	Tire Disposal	12/31/2025	14.00
3210	FARMERS COOPERATIVE	2265-DEC25	Tire Tax	12/31/2025	2.00
3210	FARMERS COOPERATIVE	2265-DEC25	3)Valve Stem@8.00	12/31/2025	24.00
3210	FARMERS COOPERATIVE	2265-DEC25	19.7890 gal Dyed Diesel	12/31/2025	59.88
3240	FASTENAL COMPANY	180114	1)T190-AG Jobber 5/16@8.65	01/14/2026	8.65
3960	GRAINGER	9713742857	120) 60lb bags Pavement Patch @22.14/ea	11/17/2025	2,656.80
3960	GRAINGER	9713742857	Shipping	11/17/2025	159.00
12591	Interstate Power Systems, Inc	R023065537 01	Labor- service on EngineWiring faults for failed LED	01/05/2026	450.00
12591	Interstate Power Systems, Inc	R023065537 01	Service DTS	01/05/2026	31.50
12591	Interstate Power Systems, Inc	R023065538 01	Labor - Active Emission Codes	01/05/2026	450.00
12591	Interstate Power Systems, Inc	R023065538 01	Service DTS	01/05/2026	31.50
11646	J and A Traffic Products	41296	25)1 3/4" x 1 3/4" x10'@37.50	01/14/2026	937.50
11646	J and A Traffic Products	41296	25)2" X 2" X 10' 12 GA TELES PAR POST@59.50	01/14/2026	1,487.50
11646	J and A Traffic Products	41296	25)2"X2"X36" 12GA OMNI ANCHOR @42.00	01/14/2026	1,050.00
11646	J and A Traffic Products	41296	25) 1 1/2" x 1 1/2" x 12' 14ga Telespar Post @48.00	01/14/2026	1,200.00
4670	JEO CONSULTING GROUP INC	170565	33rd & Lincoln Construction Engineering & Inspection	12/29/2025	28.75
4670	JEO CONSULTING GROUP INC	170565	33rd & Lincoln Construction Engineering & Inspection	12/29/2025	3,620.00
4670	JEO CONSULTING GROUP INC	170565	33rd & Lincoln Construction Engineering & Inspection	12/29/2025	1,681.25
4670	JEO CONSULTING GROUP INC	170566	Construction Administration f/25th - 27th Lincoln Stre	12/29/2025	293.75
4670	JEO CONSULTING GROUP INC	170566	Resident Project Representation f/25th - 27th Lincoln	12/29/2025	915.00
4670	JEO CONSULTING GROUP INC	170570	Construction Administration & Staking f/Heritage Heig	12/29/2025	5,908.75
4670	JEO CONSULTING GROUP INC	170570	Construction Observation & Material Testing f/Heritag	12/29/2025	7,731.45
4670	JEO CONSULTING GROUP INC	170571	Construction Administration & Staking f/Corral Crossi	12/29/2025	2,701.25
4670	JEO CONSULTING GROUP INC	170571	Construction Observation & Material Testing f/Corral	12/29/2025	6,679.00
4770	JOHNNY'S WELDING INC.	198408	1)6MP-6FPX90 Hose Adapter@3.67	12/15/2025	3.67
4770	JOHNNY'S WELDING INC.	198408	80) Inches of 3/8" Hose 4800 PSI @.57	12/15/2025	45.60
4770	JOHNNY'S WELDING INC.	198408	1)6G-8MPX Hose Fitting @15.32	12/15/2025	15.32
4770	JOHNNY'S WELDING INC.	198408	1)6G-6FP Hose Fitting@9.26	12/15/2025	9.26
4770	JOHNNY'S WELDING INC.	198408	Labor to make hose	12/15/2025	8.00
5110	LAMPTON WELDING SUPPLY Co., INC	0001149868	Cylinder rent - Street	12/31/2025	23.43
3052	Landmark Implement Inc	12032707	1)18" Wiper Blade @16.73	12/30/2025	16.73
3052	Landmark Implement Inc	12032707	1)Wiper Arm @43.44	12/30/2025	43.44
6430	NMC, INC	CUI1563648	1)Reservoir@91.78	12/24/2025	91.78
6430	NMC, INC	CUI1563648	freight	12/24/2025	25.00
6430	NMC, INC	CUI1567400	2)Key@6.903	01/08/2026	13.81
7060	O'REILLY AUTO PARTS	0749-122874	1)LED POD @42.96	12/30/2025	42.96
7060	O'REILLY AUTO PARTS	0749-122874	1) Quick splice @4.46	12/30/2025	4.46
7060	O'REILLY AUTO PARTS	0749-122874	1)Mini Bulb @7.40	12/30/2025	7.40
7060	O'REILLY AUTO PARTS	0749-122874	1)Mini Bulb @7.48	12/30/2025	7.48
7060	O'REILLY AUTO PARTS	0749-122922	1)Rubber Plugs @8.17	12/30/2025	8.17
11544	PowerPlan	2593744	1)Center Edge Wheel Loader 2.5yd@702.25	01/08/2026	702.25
11544	PowerPlan	2593744	Freight	01/08/2026	84.00
11544	PowerPlan	2597155	Labor- Look over tooth holders-mill head	01/14/2026	648.45

Vendor	Vendor Name	Invoice Number	Description	Invoice Date	Net Invoice Amount
11544	PowerPlan	2597155	2)Pick w1 10ng20x2@713.77	01/14/2026	1,427.54
11544	PowerPlan	2597155	1)Drum @6737.32	01/14/2026	6,737.32
11544	PowerPlan	2597155	1)Gasket @17.25	01/14/2026	17.25
11544	PowerPlan	2597155	Service Accessories	01/14/2026	45.39
12694	Reimers Kaufman Concrete Co	RI 563567	6)Barrier Curb 10'@240.00	01/09/2026	1,440.00
12393	Rollins Inc	287447595	Pest Control Standard f/Street -Nov25	11/24/2025	65.00
12393	Rollins Inc	289084967	Pest Control Standard f/Street -Dec25	12/29/2025	65.00
8370	SCHUSTER'S OUTDOOR AND RV INC.	31952	2)SPK Blade Notched 24.5@39.94	08/27/2025	79.88
9260	TRACTOR SUPPLY	470527	1)TSC Receiver Tube@19.99	01/07/2026	19.99
9260	TRACTOR SUPPLY	471078	1)Cnl Top Link Pin Cat 3 1-1/4x4-3/8@15.99	01/14/2026	15.99
9260	TRACTOR SUPPLY	471078	2)Cnl Lynch Pin 7/16@3.19	01/14/2026	6.38
12636	VAN KIRK SAND & GRAVEL INC	PMT 5 - HH	2025 Heritage Heights Development - Grading, Road	01/14/2026	171,721.11
12636	VAN KIRK SAND & GRAVEL INC	PMT 6 - CC	2025 Corral Crossing Development - Grading, Roadw	01/14/2026	57,861.20
11418	VISA	20081-S-DEC25	7) command hooks, 2) cable tie	01/02/2026	63.62
11418	VISA	20081-S-DEC25	ladder	01/02/2026	69.74
11418	VISA	20081-S-DEC25	42" holiday lighted star	01/02/2026	107.23
Total STREET FUND:					340,862.62
Total STREET FUND:					332,582.20
AIRPORT FUND					
AIRPORT-GENERAL					
9650	CARDMEMBER SERVICE	1801	8-tn hydraulic bottle jack	12/02/2025	37.99
9650	CARDMEMBER SERVICE	2317	door stop	12/21/2025	36.28
9650	CARDMEMBER SERVICE	3675	4-amp battery charger	12/17/2025	50.98
9650	CARDMEMBER SERVICE	4202	Registration f/NE Aviation Symposium - Schmitt	12/17/2025	180.00
9650	CARDMEMBER SERVICE	4963-FY26	1-cs foam cup	12/10/2025	52.39
9650	CARDMEMBER SERVICE	5451	direcTV monthly subscription	12/10/2025	49.99
9650	CARDMEMBER SERVICE	6762	2-rm paper, thin tape f/dry erase board	12/12/2025	48.27
9650	CARDMEMBER SERVICE	9540	2) halogen flood light f/MALSR	12/31/2025	99.16
2060	CITY SELF INSURED HEALTH PLAN	AIRPORT-JAN26	Airport Health Insurance Funding	01/01/2026	8,400.00
2080	CITY TREASURER	JAN26-IT AIRPORT	IT Services	01/01/2026	242.00
12490	COLUMN SOFTWARE PBC	7FF24556-0605	Notice of Airport Advisory Board Mtg - 1/13/26	12/22/2025	8.49
12217	Hughey and Phillips	82628	5) light engine, 861 colors, white	01/06/2026	1,166.60
12217	Hughey and Phillips	82628	Freight	01/06/2026	20.73
7060	O'REILLY AUTO PARTS	0749-122875	heater core, 2) 1-gal antifreeze f/Ford	12/30/2025	63.14
7060	O'REILLY AUTO PARTS	0749-123103	thermostat, gasket f/Ford	12/31/2025	5.89
7470	PLYMOUTH ELECTRIC INC	124963	Labor - R&R Trickle charger f/generator	12/23/2025	400.00
7470	PLYMOUTH ELECTRIC INC	124963	Supplies - trickle charger f/generator	12/23/2025	1,590.00
9850	UNIFIRST CORPORATION	1910106680	Laundry mats, shop towel	01/12/2026	81.83
Total AIRPORT-GENERAL:					12,533.74
AIRPORT-CAPITAL IMPROVEMENTS					
1080	ALFRED BENESCH AND COMPANY	3E-NAVAID	Design f/Grant No: 3-31-0009-025, Navaid Upgrades	01/14/2026	10,824.52
12519	VOGTS PARGA CONSTRUCTION LLC	PMT 9	Reconstruct Taxiway "C" & Apron (AIP 3-31-0009-021	01/03/2026	35,797.16
12519	VOGTS PARGA CONSTRUCTION LLC	PMT 9 IJA	Reconstruct Taxiway "C" & Apron (AIP 3-31-0009-021	01/03/2026	31,638.32
Total AIRPORT-CAPITAL IMPROVEMENTS:					78,260.00
Total AIRPORT FUND:					90,793.74
BEATRICE AREA SOLID WASTE AGNC					
BASWA					
980	BEATRICE IRON AND METAL CO	111146	credit - return brake rotor f/Ford	12/30/2025	137.28-
980	BEATRICE IRON AND METAL CO	111146	brake rotor, f/Ford	12/30/2025	140.38

Vendor	Vendor Name	Invoice Number	Description	Invoice Date	Net Invoice Amount
980	BEATRICE IRON AND METAL CO	111146	12) starter fluid	12/30/2025	73.20
980	BEATRICE IRON AND METAL CO	111146	oil filter, air filter f/Ford	12/30/2025	41.19
980	BEATRICE IRON AND METAL CO	111300	Silicone gasket maker, ultra gray	01/08/2026	6.51
1350	BOARD OF PUBLIC WORKS	40154911-JAN26	Security Lights f/Compost	01/07/2026	13.89
1350	BOARD OF PUBLIC WORKS	JANUARY 2026	Engineering Services	01/01/2026	1,104.00
12095	Bomgaars Supply Inc	539031	Milwaukee HEX impact driver kit	12/30/2025	249.99
12095	Bomgaars Supply Inc	539031	2) chain	12/30/2025	39.98
12095	Bomgaars Supply Inc	539031	saw chain file, round	12/30/2025	7.99
12095	Bomgaars Supply Inc	540652	hydraulic cylinder f/DEF tank	01/05/2026	94.99
12095	Bomgaars Supply Inc	540652	15-gal spot sprayer	01/05/2026	119.99
12095	Bomgaars Supply Inc	540898	2) coupling f/tracker	01/06/2026	134.98
12095	Bomgaars Supply Inc	541530	192-pc Dewalt mechanics tool set	01/08/2026	188.99
12095	Bomgaars Supply Inc	541530	100' hose	01/08/2026	84.99
12095	Bomgaars Supply Inc	541530	4-port hose end	01/08/2026	27.99
3119	Burns and McDonnell, Inc.	191457-1	Task #4 - South MSW LF Groundwater Well & Gas Pr	12/29/2025	110,311.09
2010	CITY MOTOR SUPPLY	914285	battery	12/29/2025	199.00
2010	CITY MOTOR SUPPLY	914285	Milwaukee Impact Wrench	12/29/2025	232.50
2010	CITY MOTOR SUPPLY	914285	credit - instant rebate f/impact wrench	12/29/2025	232.50
2010	CITY MOTOR SUPPLY	914298	2) oil filter	12/30/2025	65.98
2010	CITY MOTOR SUPPLY	914332	battery f/spray truck	12/31/2025	91.16
2060	CITY SELF INSURED HEALTH PLAN	BASWA-JAN26	BASWA Health Insurance Funding	01/01/2026	14,000.00
2080	CITY TREASURER	JAN26-IT BASWA	IT Services	01/01/2026	1,913.00
2080	CITY TREASURER	JANUARY 2026	Legal Services	01/01/2026	460.00
2080	CITY TREASURER	JANUARY 2026	Accounting Services	01/01/2026	3,201.00
2080	CITY TREASURER	JANUARY 2026	Landfill Manager Salary	01/01/2026	1,594.00
2080	CITY TREASURER	JANUARY 2026	Lease Payment	01/01/2026	4,000.00
2080	CITY TREASURER	JANUARY 2026	Management Contract	01/01/2026	2,577.00
2460	CORNHUSKER STATE INDUSTRIES	1507930	1) desk	01/05/2026	1,737.00
2460	CORNHUSKER STATE INDUSTRIES	1507934	2) BRUSH LINE STOP HERE sign	01/05/2026	27.90
12656	ENDICOTT CLAY PRODUCTS COMPA	388370	12.0 yd) crushed brick	01/08/2026	195.00
3210	FARMERS COOPERATIVE	3010-DEC25	29.388 gal Super E89 @ 2.909	12/31/2025	85.49
3210	FARMERS COOPERATIVE	3010-DEC25	89.498 gal Super E89 @ 2.909	12/31/2025	260.35
3210	FARMERS COOPERATIVE	3010-DEC25	15.869 gal Premium @ 3.149	12/31/2025	49.97
3210	FARMERS COOPERATIVE	3010-DEC25	Labor - 3) tire repair f/dump truck	12/31/2025	195.00
3210	FARMERS COOPERATIVE	3010-DEC25	50.814 gal Super E89 @ 2.729	12/31/2025	138.67
3210	FARMERS COOPERATIVE	3010-DEC25	Labor - 2) tire repair f/dump truck	12/31/2025	130.00
12592	GENESIS CONTRACTING GROUP LLC	PMT 12	Site Entrance Facility	01/14/2026	67,950.00
12591	Interstate Power Systems, Inc	R023065539.01	Labor - code diagnosis f/924	01/05/2026	450.00
12591	Interstate Power Systems, Inc	R023065539.01	Misc Charges	01/05/2026	31.50
12591	Interstate Power Systems, Inc	R023065539.01	Shop Supplies	01/05/2026	64.66
12591	Interstate Power Systems, Inc	R023065539.01	Service DTS	01/05/2026	31.50
12591	Interstate Power Systems, Inc	R023065540.01	Labor - cleaned parking brake solenoid area f/963	01/07/2026	2,025.00
12591	Interstate Power Systems, Inc	R023065540.01	Misc Charges	01/07/2026	30.00
12591	Interstate Power Systems, Inc	R023065662.01	Labor - R&R horn button, switch asy f/924	01/14/2026	618.75
12591	Interstate Power Systems, Inc	R023065662.01	Misc Charges	01/14/2026	20.00
5160	LARRY'S TIRE AND SERVICE INC.	017736	Labor - 1) tire repair	01/05/2026	30.00
5810	MIDWEST LABORATORIES INC	1268352	Shipping f/test kits	01/05/2025	18.00
6640	Nebraska Dept. Environment and Energy	57411	4th qtr Tipping Fee @ LF - 8,605.44 tons	12/15/2025	20,136.73
6430	NMC, INC	CUI1565633	Solenoid valve f/963	01/02/2026	296.29
6430	NMC, INC	CUI1565634	rocker switch asy f/963	01/02/2026	39.21
6430	NMC, INC	CUI1566856	horn button asy f/963	01/07/2026	126.40
6430	NMC, INC	CUI1567468	primary element, lube filter, fuel filter asy, filter asy f/D	01/08/2026	339.02
6430	NMC, INC	CUI1567526	2) solenoid valve f/963	01/08/2026	534.58
6430	NMC, INC	CUI1567528	2) horn asy f/963	01/08/2026	167.98
6430	NMC, INC	INV757108	Labor - Preventative maintenance f/963	01/12/2026	429.75
6430	NMC, INC	INV757108	Labor - travel time f/963 PM	01/12/2026	382.00
6430	NMC, INC	INV757108	Supplies - lube filter, element asy f/963	01/12/2026	297.68

Vendor	Vendor Name	Invoice Number	Description	Invoice Date	Net Invoice Amount
6430	NMC, INC	INV757108	Supplies - oil f/963	01/12/2026	93.00
6820	NORRIS PUBLIC POWER DISTRICT	304097500-DEC25	Energy Charge f/LF	01/05/2026	4,243.52
6820	NORRIS PUBLIC POWER DISTRICT	304098500-DEC25	Electric charge f/Compost Site	01/05/2026	588.64
6820	NORRIS PUBLIC POWER DISTRICT	312515400-DEC25	Electric charge f/W Locust Rd Lift Station	01/05/2026	105.00
6820	NORRIS PUBLIC POWER DISTRICT	312515800-DEC25	Electric charge f/W Locust Rd Leachate Pond	01/05/2026	35.00
6820	NORRIS PUBLIC POWER DISTRICT	312516000-DEC25	Electric charge f/W Locust Admin/Equipment Building	01/05/2026	1,847.84
7060	O'REILLY AUTO PARTS	0749-121898	fuel water separator f/dump truck	12/23/2025	17.12
7060	O'REILLY AUTO PARTS	0749-121898	oil filter, coolant filter f/dump truck	12/23/2025	71.02
7060	O'REILLY AUTO PARTS	0749-122214	coolant hose	12/26/2025	20.64
7060	O'REILLY AUTO PARTS	0749-122214	utility knife, knife blade	12/26/2025	19.18
7060	O'REILLY AUTO PARTS	0749-122214	6) 1-gal antifreeze	12/26/2025	65.94
7060	O'REILLY AUTO PARTS	0749-122691	12) 32-oz diesel treatment	12/29/2025	107.88
7060	O'REILLY AUTO PARTS	0749-122691	6) 1-gal Antifreeze	12/29/2025	65.94
7060	O'REILLY AUTO PARTS	0749-122691	1) mystery oil	12/29/2025	29.99
7060	O'REILLY AUTO PARTS	0749-122802	lug nut f/Ford	12/29/2025	5.99
7060	O'REILLY AUTO PARTS	0749-123446	fuel filter, air filter, 2) oil filter f/dump truck	01/02/2026	201.59
7060	O'REILLY AUTO PARTS	0749-123446	1-bx) rubber glove	01/02/2026	21.84
7060	O'REILLY AUTO PARTS	0749-123997	DEF pump	01/05/2026	759.99
12393	Rollins Inc	289084969	Pest Control Standard - December 2025	12/29/2025	75.00
8260	SAPP BROTHERS	IN4911926	750.0 gal ULSD #2 Dyed Winter Diesel @ 2.279988	12/24/2025	1,710.00
8260	SAPP BROTHERS	IN4912954	191.37 gal ULSD #1 Dyed Winter Diesel @ 2.640067	12/26/2025	505.22
8260	SAPP BROTHERS	IN4912954	446.53 gal ULSD #2 Dyed Winter Diesel @ 2.239982	12/26/2025	1,000.23
8260	SAPP BROTHERS	IN4912957	10.71 gal ULSD #2 Dyed Winter Diesel @ 2.64044	12/26/2025	28.27
8260	SAPP BROTHERS	IN4912957	24.99 gal ULSD #2 Dyed Winter Diesel @ 2.24068	12/26/2025	55.98
8260	SAPP BROTHERS	IN4915080	55.6 gal DEF @ 2.104446	12/26/2025	117.01
8260	SAPP BROTHERS	IN4918754	DEF pump	01/05/2026	780.00
8260	SAPP BROTHERS	IN4919260	30.0 bulk 15W-40 @ 12.50	01/05/2026	380.00
8260	SAPP BROTHERS	IN4919260	80.0 bulk tractor fluid @ 10.50	01/05/2026	845.00
11418	VISA	20081-B-DEC25	3) 8' table	01/02/2026	389.97
9730	WALKER UNIFORM RENTAL	1447151	Uniform Service	12/25/2025	42.22
9730	WALKER UNIFORM RENTAL	1448392	Uniform Service	01/01/2026	42.22
9730	WALKER UNIFORM RENTAL	1449657	Uniform Service	01/08/2026	42.22
Total BASWA:					251,755.90
Total BEATRICE AREA SOLID WASTE AGNC:					251,755.90
CAPITAL IMP FUND					
CAPITAL IMPROVEMENTS-GENERAL					
840	BEATRICE AREA SOLID WASTE AGNC	236-DEC25	Dempsters Clean-up	12/31/2025	2,978.22
11503	Johnstone Supply	2364272	credit - return 5-year warranty	12/29/2025	1,412.88-
11503	Johnstone Supply	2364273	5-year warranty	12/29/2025	1,412.88
Total CAPITAL IMPROVEMENTS-GENERAL:					2,978.22
CAPITAL IMPROVEMENTS-PSDS					
11867	MacQueen Equipment LLC	P60516	1) 1.5" pressure gauge	01/08/2026	411.00
11867	MacQueen Equipment LLC	P60516	1) 2.5" pressure gauge	01/08/2026	405.00
11867	MacQueen Equipment LLC	P60516	Shipping	01/08/2026	36.53
Total CAPITAL IMPROVEMENTS-PSDS:					852.53
Total CAPITAL IMP FUND:					3,830.75
ECONOMIC DEVELOPMENT FUND					
3580	Gage Area Growth-NGage	JANUARY 2026	Qtrly Economic Development Support	01/01/2026	34,930.55

Vendor	Vendor Name	Invoice Number	Description	Invoice Date	Net Invoice Amount
5470	MAIN STREET BEATRICE INC	ED SUPP - QUAR 4 - FY2	Economic Development Support - Quarter 4	12/01/2025	10,000.00
Total :					44,930.55
Total ECONOMIC DEVELOPMENT FUND:					44,930.55
INFO TECH SERV FUND					
11930	A T and T Mobility	287301368820X01112026	Cell service f/ Chief's Phone - Fire	01/03/2026	52.06
12056	ALL COPY PRODUCTS	41009250	Copier Rental	01/12/2025	389.54
12056	ALL COPY PRODUCTS	41009250	Copy usage - 12/5 - 1/4	01/12/2025	113.01
12056	ALL COPY PRODUCTS	41034538	Copier Rental - Billing	01/14/2026	438.76
12667	CARASOFT TECHNOLOGY CORPOR	52363562INV	2) OpenFlows Hydraulic Toolset yearly subscription	01/12/2026	1,030.00
9650	CARDMEMBER SERVICE	0549-FY26	1) Cove Data Protection - Dec25	12/16/2025	11.00
9650	CARDMEMBER SERVICE	0759	100) UniFi Hosting	12/16/2025	29.00
9650	CARDMEMBER SERVICE	1078	1) Microsoft 365 - Dec25	12/18/2025	38.70
9650	CARDMEMBER SERVICE	3909-FY26	100) label (my asset tag)	12/11/2025	66.73
9650	CARDMEMBER SERVICE	4265	2) high-capacity toner, black	12/11/2025	311.98
9650	CARDMEMBER SERVICE	4265	1) xerox phaser, black	12/11/2025	18.99
9650	CARDMEMBER SERVICE	6800	Linode - Dec25	01/01/2025	60.00
9650	CARDMEMBER SERVICE	6828-FY26	3) Microsoft 365 - Nov25	12/03/2025	26.61
9650	CARDMEMBER SERVICE	7609	AI voice generator - Dec25	12/13/2025	50.00
9650	CARDMEMBER SERVICE	9079-FY26	wifi projector	12/03/2025	127.93
11714	Caselle, Inc.	INV-15186	Maintenance & Support - Feb 2026	01/05/2026	3,937.00
11714	Caselle, Inc.	INV-15186	Cloud Hosting - Feb 2026	01/05/2026	903.00
1034	CHARTER COMMUNICATIONS	156544301010726	Cable charges/500 N Commerce - Jan26	01/07/2026	56.87
1034	CHARTER COMMUNICATIONS	176176901010726	Internet f/AMI & Sub 8 - Jan26	01/07/2026	139.98
1034	CHARTER COMMUNICATIONS	176178901122125	Cable services/Police - Dec25	12/21/2025	33.48
1034	CHARTER COMMUNICATIONS	176179201010726	Internet f/AMI & Sub 5 - Dec25	01/07/2026	129.98
12067	Diode Communications	(SEC)000-0123-JAN26	OpenPath f/Library	01/01/2026	33.20
12067	Diode Communications	(SEC)000-0123-JAN26	OpenPath f/Fire	01/01/2026	83.67
12067	Diode Communications	(SEC)000-0123-JAN26	OpenPath f/Fire	01/01/2026	35.86
12067	Diode Communications	(SEC)000-0123-JAN26	OpenPath f/Police	01/01/2026	46.48
12067	Diode Communications	(SEC)000-0123-JAN26	OpenPath f/Hannibal Park	01/01/2026	6.64
12067	Diode Communications	(SEC)000-0123-JAN26	OpenPath f/Auditorium	01/01/2026	59.77
12067	Diode Communications	(SEC)000-0123-JAN26	OpenPath f/City Hall	01/01/2026	26.56
12067	Diode Communications	(SEC)000-0123-JAN26	Rhombus f/Police	01/01/2026	49.74
12067	Diode Communications	(SEC)000-0123-JAN26	Rhombus f/Hannibal	01/01/2026	49.74
12067	Diode Communications	(SEC)000-0123-JAN26	OpenPath f/Senior Center	01/01/2026	13.28
12067	Diode Communications	(SEC)000-0123-JAN26	OpenPath f/Service Center	01/01/2026	66.41
12067	Diode Communications	(SEC)000-0123-JAN26	OpenPath f/Electric	01/01/2026	46.49
12067	Diode Communications	(SEC)000-0123-JAN26	OpenPath f/Aud IT	01/01/2026	6.64
10370	DIODE TECHNOLOGIES LLC	15431	Landfill Camera License	12/31/2025	895.00
12419	HEARTLAND BUSINESS SYSTEMS LL	853952-H	Labor - Windows Activation	12/31/2025	120.00
4300	HOMETOWN LEASING	0051798789-JAN26	Staff Copier - pymt #40	01/01/2026	328.49
4300	HOMETOWN LEASING	0051799160-JAN26	Admin. Copier - PMT #35	01/01/2026	166.35
4300	HOMETOWN LEASING	0051799496-JAN26	Copier Lease - Pymt #29	01/01/2026	44.18
4300	HOMETOWN LEASING	0051799496-JAN26	Copier Lease - Pymt #29	01/01/2026	44.18
4300	HOMETOWN LEASING	0051799496-JAN26	Copier Lease - Pymt #29	01/01/2026	44.18
4300	HOMETOWN LEASING	51797138-JAN26	Library Public Copier - PMT #52	01/01/2026	164.42
12675	INTERMEDIA.NET INC	2601049580	Phone Service	01/01/2026	175.17
12675	INTERMEDIA.NET INC	2601049580	Phone Service	01/01/2026	105.10
12675	INTERMEDIA.NET INC	2601049580	Phone Service	01/01/2026	70.06
4420	RICOH USA INC	BUY-OUT 20066926	Buy-Out Account # 431107-1028573USC2	12/12/2025	239.66
2091	Ricoh USA Inc	BUY-OUT 6086114	Buy-Out to Keep Contract # 603-0135413-000	01/06/2026	358.84
2096	Ricoh USA, Inc	5072541380	Additional Copies - December 25	01/01/2026	2.80
2096	Ricoh USA, Inc	5072541380	Additional Copies - December 25	01/01/2026	117.36

Vendor	Vendor Name	Invoice Number	Description	Invoice Date	Net Invoice Amount
2076	U.S. Cellular	0773952224 CXXN	Water - Cell Phone Charges - cxxn from Dec	12/06/2025	72.00
2076	U.S. Cellular	0780634551	Electric - Cell Phone Charges	01/06/2026	255.98
2076	U.S. Cellular	0780634551	Electric - Tablet Data Charges	01/06/2026	143.60
2076	U.S. Cellular	0780634551	Water - Cell Phone Charges	01/06/2026	215.51
2076	U.S. Cellular	0780634551	Water - Tablet Data Charges	01/06/2026	286.30
2076	U.S. Cellular	0780634551	WPC - Cell Phone Charges	01/06/2026	52.82
2076	U.S. Cellular	0780634551	Street - Cell Phone Charges	01/06/2026	36.71
2076	U.S. Cellular	0780634551	MARS - Cell Phone Charges	01/06/2026	136.52
2076	U.S. Cellular	0780634551	MARS - Tablet Data Charges	01/06/2026	163.60
9610	VERIZON WIRELESS	6131491490	Cell phone service - Fire	12/20/2025	117.49
9610	VERIZON WIRELESS	6131491490	Cell phone service - Fire	12/20/2025	40.01
9610	VERIZON WIRELESS	6131491490	Cell phone service - Fire	12/20/2025	40.01
9920	WINDSTREAM	092151344-DEC25	Library Phone Service	12/24/2025	98.86
9920	WINDSTREAM	092226581-DEC25	Airport Phone Service	12/24/2025	86.56
9920	WINDSTREAM	092256506-JAN26	Utility Billing fax service	12/31/2025	70.79
9920	WINDSTREAM	092256507-JAN26	WPC phone service	12/31/2025	65.12
9920	WINDSTREAM	092256543-JAN26	4) lines	01/05/2026	307.35
Total :					13,554.12
Total INFO TECH SERV FUND:					13,554.12

SANITATION FUND

840	BEATRICE AREA SOLID WASTE AGNC	480-DEC25	Tonnage Fees - December 2025	12/31/2025	79,601.30
980	BEATRICE IRON AND METAL CO	111118	butt connector	12/29/2025	3.80
980	BEATRICE IRON AND METAL CO	111118	electronic cleaner	12/29/2025	8.70
980	BEATRICE IRON AND METAL CO	111118	brake cleaner	12/29/2025	7.66
1350	BOARD OF PUBLIC WORKS	86-11770	MARS postage - Dec25	12/31/2025	763.97
2060	CITY SELF INSURED HEALTH PLAN	JANUARY 2026	Sanitation Health Insurance	01/01/2026	39,200.00
2080	CITY TREASURER	JAN26-IT SANITATION	IT Services	01/01/2026	2,071.00
2080	CITY TREASURER	SANITATION-JAN26	Accounting Services	01/01/2026	7,417.00
3210	FARMERS COOPERATIVE	44575-DEC25	Supplies - 1) tire f/trailer	12/31/2025	71.25
3210	FARMERS COOPERATIVE	44577-DEC25	0.012 gal Super E89 @ 2.909	12/31/2025	.03
3210	FARMERS COOPERATIVE	44577-DEC25	28.108 gal Super No Lead @ 2.659	12/31/2025	74.74
3210	FARMERS COOPERATIVE	44577-DEC25	7.9 lb Propane @ 3.00	12/31/2025	23.70
3210	FARMERS COOPERATIVE	44577-DEC25	Supplies - 8) tire	12/31/2025	2,603.00
3210	FARMERS COOPERATIVE	44577-DEC25	30.88 gal Super No Lead @ 2.499	12/31/2025	77.17
3210	FARMERS COOPERATIVE	44577-DEC25	Supplies - 4) tire	12/31/2025	1,104.00
3210	FARMERS COOPERATIVE	44577-DEC25	27.725 gal Super No Lead @ 2.499	12/31/2025	69.28
3210	FARMERS COOPERATIVE	44577-DEC25	250.05 bulk DEF @ 1.99	12/31/2025	497.60
3210	FARMERS COOPERATIVE	44577-DEC25	1) RPV valve buttress f/DEF tank	12/31/2025	16.68
3210	FARMERS COOPERATIVE	44577-DEC25	35.02 bulk 15W40 oil @ 14.71	12/31/2025	515.14
3210	FARMERS COOPERATIVE	44577-DEC25	40.01 bulk transdraulic fluid @ 14.10	12/31/2025	564.14
3210	FARMERS COOPERATIVE	44577-DEC25	Supplies - 1) tire	12/31/2025	248.00
3210	FARMERS COOPERATIVE	44577-DEC25	Supplies - 1) tire	12/31/2025	248.00
3210	FARMERS COOPERATIVE	44577-DEC25	Supplies - 4) tire	12/31/2025	1,239.48
10570	HOTSY EQUIPMENT CO.	359992	1) 5-gal breakthrough soap	12/16/2025	121.55
12300	Klecans Diverse Service LLC	770	Labor - unloader sticking	01/02/2026	337.50
12300	Klecans Diverse Service LLC	771	Labor - hydraulic leak at hydraulic pump	01/02/2026	187.50
12114	MHC	T01125600111981	suspension shock absorber	01/14/2026	183.02
12123	Mid-Iowa Solid Waste Equipment Co., In	0065216-IN	Labor - 928.0 miles f/baler repair	12/30/2025	1,206.40
12123	Mid-Iowa Solid Waste Equipment Co., In	0065216-IN	Labor - 14.0 hours travel f/baler repair	12/30/2025	1,050.00
12123	Mid-Iowa Solid Waste Equipment Co., In	0065216-IN	Labor - R&R hydraulic cylinder f/baler	12/30/2025	1,870.00
12123	Mid-Iowa Solid Waste Equipment Co., In	0065216-IN	Supplies - hydraulic cylinder, 2) cylinder pin f/baler	12/30/2025	7,427.43
12123	Mid-Iowa Solid Waste Equipment Co., In	0065216-IN	Freight f/baler supplies	12/30/2025	489.37
7060	O'REILLY AUTO PARTS	0749-117867	2) 1-qt antifreeze	12/04/2025	16.98

Vendor	Vendor Name	Invoice Number	Description	Invoice Date	Net Invoice Amount
7060	O'REILLY AUTO PARTS	0749-119061	camshaft	12/09/2025	27.82
7060	O'REILLY AUTO PARTS	0749-124188	24) 64-oz diesel treatment	01/06/2026	323.76
7060	O'REILLY AUTO PARTS	0749-124545	2) shop towel	01/07/2026	37.98
7060	O'REILLY AUTO PARTS	0749-124880	2) tape, 1) wire tie	01/09/2026	24.37
8260	SAPP BROTHERS	FC 1231	late fee f/Invoice IN4873783	12/31/2025	13.88
8260	SAPP BROTHERS	IN4914188	845.0 gal ULSD #2 Clear Winter Diesel @ 2.485987	12/29/2025	2,100.67
8260	SAPP BROTHERS	IN4919412	900.0 gal ULSD #2 Clear Winter Diesel @ 2.495997	01/05/2026	2,246.40
8260	SAPP BROTHERS	IN4926003	850.0 gal ULSD #2 Clear Winter Diesel @ 2.712004	01/12/2026	2,305.20
12081	Sierra Container Group	11773	702) 95-gal carts @ 56.55	01/07/2026	41,869.10
11678	Truck Center Companies	XA108204832.01	particulate sensor	01/09/2026	604.44
11678	Truck Center Companies	XA108204832.01	core deposit f/particulate sensor	01/09/2026	156.25
11678	Truck Center Companies	XA108205087.01	fuel water separator, fuel filter, oil filter	01/13/2026	213.34
11418	VISA	20081-M-DEC25	20) glove	01/02/2026	115.48
11418	VISA	20081-M-DEC25	Adams Repair f/Sheppler damage	01/02/2026	1,209.48
11418	VISA	20081-M-DEC25	10) glove	01/02/2026	185.90
11418	VISA	20081-M-DEC25	2) face mask	01/02/2026	19.98
11418	VISA	20081-M-DEC25	12) hand sanitizer	01/02/2026	46.95
11418	VISA	20081-M-DEC25	1-cs blue towel	01/02/2026	65.70
11418	VISA	20081-M-DEC25	2) all purpose cleaner	01/02/2026	11.88
11418	VISA	20081-M-DEC25	1) hi-vis safety jacket, 3xl	01/02/2026	59.39

Total : 200,953.36

Total SANITATION FUND: 200,953.36

Grand Totals: 1,353,866.54

Dated: 1-19-26

Mayor: _____

City Council: _____

Invoice Number	Invoice Date	Description	Segment Fund	Net Invoice Amount
BASWA				
222-DEC25	12/31/2025	#21026-YARD BOX-2.49TX2.34	ELECTRIC FUND	5.83
226-DEC25	12/31/2025	#16088-Vac Truck -1ydx12	WPC	12.00
226-DEC25	12/31/2025	#20612-Grit/Rags-1.14x2.34	WPC	2.67
226-DEC25	12/31/2025	#21100-.71bx2.34	WPC	1.66
SLUDGE-DEC25	01/01/2026	SLUDGE-DEC25	WPC	13,408.79
Total BASWA:				13,430.95
Beatrice Ready Mixed				
1B 52776	01/08/2026	13.81tn Fill Sand @17.00	WATER FUND	234.77
1B 52776	01/08/2026	Sales Tax	WATER FUND	17.61
Total Beatrice Ready Mixed:				252.38
Black Hills Energy				
0660445975-JAN26	01/14/2026	Gas Bill/ 820 Herbert LS #5/JAN26	WPC	65.59
2096271272-JAN26	01/14/2026	Gas Bill/ 300 Irving LS #6/Jan26	WPC	59.16
4320807688-JAN26	01/14/2026	Gas Bill/321 Grant Street -JAN26	WATER FUND	115.73
7743125526-JAN26	01/14/2026	Gas Bill/1300 Beaver -JAN26	WPC	1,271.82
7743125526-JAN26	01/14/2026	Gas Bill/1300 Beaver/Dewatering Bldg-JAN26	WPC	405.30
7743125526-JAN26	01/14/2026	Gas Bill/1831 1/2 Carlyle Street/LS#4/JAN26	WPC	51.51
9197736828-JAN26	01/14/2026	Gas Bill/312 Grant Street -JAN26	WATER FUND	72.40
Total Black Hills Energy:				2,041.51
Bomgaars Supply Inc				
541278	01/07/2026	1)Sta-bil@5.99	WATER FUND	5.99
541278	01/07/2026	2)Starting Fluid@2.99	WATER FUND	5.98
541278	01/07/2026	Sales Tax	WATER FUND	.90
541655	01/09/2026	2)Clevis Slip Hook @7.99	WATER FUND	15.98
541655	01/09/2026	6)Spring Snap@4.49	WATER FUND	26.94
541655	01/09/2026	Sales Tax	WATER FUND	3.22
541661	01/09/2026	2)Hydraulic Hose@32.99	ELECTRIC FUND	65.98
541661	01/09/2026	Sales Tax	ELECTRIC FUND	4.95
542627	01/12/2026	1)Pipe Coupling @7.99	WATER FUND	7.99
542627	01/12/2026	Sales Tax	WATER FUND	.60
Total Bomgaars Supply Inc:				138.53
Border States Industries, Inc				
931772031	01/09/2026	200)SQUEEZON 1/0ACSR 4SOL WR189	ELECTRIC FUND	161.25
931772031	01/09/2026	200)SQUEEZON 2 SOL 2 SOL WR159	ELECTRIC FUND	156.95
931772031	01/09/2026	100)SQUEEZON 4/0 STR 2/0 STR WR399	ELECTRIC FUND	147.28
931772031	01/09/2026	100)TAPE ELECTRIC SCOTCH #33+ 3M	ELECTRIC FUND	635.33
Total Border States Industries, Inc:				1,100.81
BPW - Bldg Repair				
1131.01-JAN26	01/01/2026	Electric Building Repair Fund	ELECTRIC FUND	1,250.00
1131.01-JAN26	01/01/2026	Water Building Repair Fund	WATER FUND	850.00
Total BPW - Bldg Repair:				2,100.00
BPW - Bond Reserve				
JAN2026	01/01/2026	Water D311674 - SFR Land	WATER FUND	3,611.00
JAN2026	01/01/2026	Water D311685 - SRF Projects	WATER FUND	20,770.00

Invoice Number	Invoice Date	Description	Segment Fund	Net Invoice Amount
JAN2026-SERIES	01/01/2026	Electric Series 2025 Bonds	ELECTRIC FUND	16,476.00
JAN2026-SERIES	01/01/2026	Water Series 2025 Bonds	WATER FUND	8,007.00
JAN2026-SERIES	01/01/2026	WPC Series 2025 Bonds	WPC	1,000.00
Total BPW - Bond Reserve:				49,864.00
BPW - Engineering Charges				
1456.00-JAN26	01/01/2026	Water Engineering Charges	WATER FUND	3,903.00
1456.00-JAN26	01/01/2026	WPC Engineering Charges	WPC	3,903.00
Total BPW - Engineering Charges:				7,806.00
BPW - Petty Cash				
PETTY CASH 1-19-26	01/19/2026	USPS-Office Postage for shipping	ELECTRIC FUND	1.70
PETTY CASH 1-19-26	01/19/2026	Gage Co Sheriff-Inspection new #81	WATER FUND	10.00
PETTY CASH 1-19-26	01/19/2026	Walmart-Halloween Candy water dept	WATER FUND	29.82
PETTY CASH 1-19-26	01/19/2026	USPS- Postage Due Water Dept	WATER FUND	.29
PETTY CASH 1-19-26	01/19/2026	Sunrise-Bata Retirement cake	WPC	40.00
PETTY CASH 1-19-26	01/19/2026	Walmart-Supplies Barta Retirement	WPC	27.55
Total BPW - Petty Cash:				109.36
BPW - Utilities				
12058900-DEC25	01/07/2026	Utilities/Electric/Sub 1	ELECTRIC FUND	566.82
15051800-DEC25	01/07/2026	Utilities/WPC/Lift Station 424 Irving	WPC	243.19
21104000-DEC25	01/07/2026	Utilities/Water/19th & Hoyt	WATER FUND	76.02
21104500-DEC25	01/07/2026	Utilities/electric/Sub 3	ELECTRIC FUND	92.46
21176000-DEC25	01/07/2026	Utilities/WPC/Lift Station 1831 1/2 carlyle	WPC	83.71
23001000-DEC25	01/07/2026	Utilities/WPC/Lift Station 204 s 1st	WPC	729.78
24107600-DEC25	01/07/2026	Utilities/WPC/Lift Station 2118 market	WPC	40.36
31004001-DEC25	01/07/2026	Utilities/electric/Sub 5	ELECTRIC FUND	203.35
31013810-DEC25	01/07/2026	Utilities/electric/Switch Station #1	ELECTRIC FUND	11.51
32011800-DEC25	01/07/2026	Utilities/WPC/Lift Station 910 w Court	WPC	39.32
35041000-DEC25	01/07/2026	Utilities/WPC/Lift Station 624 Pleasant	WPC	44.61
37009500-DEC25	01/07/2026	Utilities/WPC/Lift Station 800 herbert	WPC	324.61
37039110-DEC25	01/07/2026	Utilities/electric/Sub 2	ELECTRIC FUND	29.87
38146000-DEC25	01/07/2026	Utilities/Water/Mulberry & West	WATER FUND	43.63
39079000-DEC25	01/07/2026	Utilities/WPC/Disposal Plant	WPC	13,242.71
39079100-DEC25	01/07/2026	Utilities/WPC/Disposal Plant	WPC	704.79
39093000-DEC25	01/07/2026	Utilities/WPC/Lift Station 1618 Country Club In	WPC	73.48
40013000-DEC25	01/07/2026	Utilities/Water Reed & W Scott	WATER FUND	323.64
40013500-DEC25	01/07/2026	Utilities/Electric/Sub 6	ELECTRIC FUND	218.21
4002110-DEC25	01/07/2026	Utilities/Electric/1st & Ella Security Light	ELECTRIC FUND	11.51
40031000-DEC25	01/07/2026	Utilities/Water/Hoyt Rd & Blueridge	WATER FUND	21.10
40033500-DEC25	01/07/2026	Utilities/Electric/Sub 9	ELECTRIC FUND	240.29
40057600-DEC25	01/07/2026	Utilities/Water/500 N commerce	WATER FUND	2,272.11
40057700-DEC25	01/07/2026	Utilities/Electric/500 N Commerce	ELECTRIC FUND	2,785.79
40086010-DEC25	01/07/2026	Utilities/Electric/Sub 7	ELECTRIC FUND	14.65
40116000-DEC25	01/07/2026	Utilities/Electric/Sub 4	ELECTRIC FUND	145.13
40137200-DEC25	01/07/2026	Utilities/electric/Sub 10	ELECTRIC FUND	159.96
40260000-DEC25	01/07/2026	Utilities/Water/North Reservoir	WATER FUND	2,939.22
40260500-DEC25	01/07/2026	Utilities/Water/South Reservoir	WATER FUND	2,465.08
40261000-DEC25	01/07/2026	Utilities/Water/Wells Hoag	WATER FUND	4,607.69
45016000-DEC25	01/07/2026	Utilities/Water RR3	WATER FUND	21.59
5013000-DEC25	01/07/2026	Utilities/Electric/400 Ella	ELECTRIC FUND	953.65

Invoice Number	Invoice Date	Description	Segment Fund	Net Invoice Amount
Total BPW - Utilities:				33,729.84
Building Crafts Inc				
021-01277-PMT4	01/14/2026	WPC Grit Improvements Project No. 021-01277	WPC	147,785.83
Total Building Crafts Inc:				147,785.83
Burroughs, Debbie				
MILEAGE JUL-DEC25	12/31/2025	Mileage Reimbursement	ELECTRIC FUND	23.10
Total Burroughs, Debbie:				23.10
Call Management Resources				
25121623184274	12/16/2025	After Hours Call Service St	ELECTRIC FUND	149.92
25121623184274	12/16/2025	After Hours Call Service Elec	ELECTRIC FUND	149.93
25121623184274	12/16/2025	After Hours Call Service Water	WATER FUND	149.93
25121623184274	12/16/2025	After Hours Call Service Sewer	WPC	149.93
26011323185573	01/13/2026	After Hours Call Service St	ELECTRIC FUND	46.00
26011323185573	01/13/2026	After Hours Call Service Elec	ELECTRIC FUND	46.00
26011323185573	01/13/2026	After Hours Call Service Water	WATER FUND	46.00
26011323185573	01/13/2026	After Hours Call Service Sewer	WPC	46.00
Total Call Management Resources:				783.71
CINTAS LOC 749				
4254710334	12/30/2025	Uniform Cleaning/Rental WPC	WPC	37.10
4255390275	01/06/2026	Uniform Cleaning/Rental WPC	WPC	37.10
4256147057	01/13/2026	Uniform Cleaning/Rental WPC	WPC	37.10
Total CINTAS LOC 749:				111.30
City Economic Development Fund				
ED-JAN26	01/01/2026	Economic Development Support-JAN25	ELECTRIC FUND	25,000.00
Total City Economic Development Fund:				25,000.00
City Motor Supply				
914444	01/08/2026	1)Oil filter@6.82	WPC	6.82
914444	01/08/2026	1)Oil Filter @6.82	WPC	6.82
914444	01/08/2026	1)Oil Filter @6.82	WPC	6.82
914444	01/08/2026	12)5W30 Oil @7.99/split	WPC	47.94
914444	01/08/2026	12)5W30 Oil @7.99/split	WPC	47.94
914444	01/08/2026	5)15W50 Oil@7.99	WPC	39.95
Total City Motor Supply:				156.29
City Treasurer				
ATTY-JAN26	01/01/2026	Attorney Salary -JAN25	ELECTRIC FUND	4,257.00
ATTY-JAN26	01/01/2026	Attorney Salary -JAN25	WATER FUND	2,554.00
ATTY-JAN26	01/01/2026	Attorney Salary -JAN25	WPC	1,703.00
CR-JAN26	01/01/2026	Community Relations Coord(50% of Amanda)-JAN25	ELECTRIC FUND	2,747.00
CR-JAN26	01/01/2026	Community Relations Coord(50% of Amanda)-JAN25	WATER FUND	1,648.20
CR-JAN26	01/01/2026	Community Relations Coord(50% of Amanda)-JAN25	WPC	1,098.80
FINANCE-HR-JAN26	01/01/2026	Finance/HR Salary-JAN25	ELECTRIC FUND	8,424.00
FINANCE-HR-JAN26	01/01/2026	Finance/HR Salary-JAN25	WATER FUND	5,054.40
FINANCE-HR-JAN26	01/01/2026	Finance/HR Salary-JAN25	WPC	3,369.60

Invoice Number	Invoice Date	Description	Segment Fund	Net Invoice Amount
GARBAGE-DEC25	01/07/2026	Garbage-DEC25	ELECTRIC FUND	127,302.31
GM-JAN26	01/01/2026	General Manager Salary -JAN25	ELECTRIC FUND	10,933.00
GM-JAN26	01/01/2026	General Manager Salary -JAN25	WATER FUND	6,559.80
GM-JAN26	01/01/2026	General Manager Salary -JAN25	WPC	4,373.20
IT-JAN26	01/01/2026	IT Monthly Contribution -JAN25	ELECTRIC FUND	40,030.00
IT-JAN26	01/01/2026	IT Monthly Contribution -JAN25	WATER FUND	13,614.00
IT-JAN26	01/01/2026	IT Monthly Contribution -JAN25	WPC	9,432.00
PLUS-DEC25	01/07/2026	Beatrice Plus-DEC25	ELECTRIC FUND	2,438.65
Total City Treasurer:				245,538.96
Collection Associates LLC				
186-DEC25	12/31/2025	Collections/Dec 2025	ELECTRIC FUND	777.31
Total Collection Associates LLC:				777.31
Column Software PBC				
7FF24556-0606	12/22/2025	Notice of Meeting 1/14/26	WPC	13.59
Total Column Software PBC:				13.59
DataShield Corporation				
0181534	12/29/2025	Onsite Certified Destruction Weight Per Order	ELECTRIC FUND	49.50
0181534	12/29/2025	Fuel Surcharge	ELECTRIC FUND	5.03
Total DataShield Corporation:				54.53
Diversified Safety and Compliance LLC				
25111447	11/21/2025	Annual Membership/split	ELECTRIC FUND	25.80
25111447	11/21/2025	Annual Membership/split	ELECTRIC FUND	25.80
25111447	11/21/2025	Annual Membership/split	ELECTRIC FUND	25.80
25111447	11/21/2025	Annual Membership/split	WATER FUND	25.80
25111447	11/21/2025	Annual Membership/split	WPC	25.80
25632	01/08/2026	Random Drug Test@95.00/baswa	ELECTRIC FUND	95.00
25632	01/08/2026	Random Drug Test@95.00/street	ELECTRIC FUND	95.00
25632	01/08/2026	Random Drug Test@95.00/mars	ELECTRIC FUND	95.00
25632	01/08/2026	Random Drug Test@55.00/elec	ELECTRIC FUND	110.00
25632	01/08/2026	Random Drug Test@95.00/elec	ELECTRIC FUND	285.00
25632	01/08/2026	Trip Charge	ELECTRIC FUND	10.00
Total Diversified Safety and Compliance LLC:				819.00
Eakes Office Solutions				
9256002-0	12/22/2025	State Sales/Use	ELECTRIC FUND	14.35-
9256002-0	12/22/2025	City Sales/Use	ELECTRIC FUND	5.22-
9256002-0	12/22/2025	3)Paper Bright white 36x300@86.99	ELECTRIC FUND	260.97
9256002-0	12/22/2025	Sales Tax	ELECTRIC FUND	19.57
Total Eakes Office Solutions:				260.97
Employee Benefit Account				
HEALTH INS-JAN26	01/01/2026	Engineering Health Ins	ELECTRIC FUND	8,400.00
HEALTH INS-JAN26	01/01/2026	Electric Health Ins	ELECTRIC FUND	36,400.00
HEALTH INS-JAN26	01/01/2026	Billing & Service-elec	ELECTRIC FUND	5,600.00
HEALTH INS-JAN26	01/01/2026	Jean & Zab-elec	ELECTRIC FUND	2,800.00
HEALTH INS-JAN26	01/01/2026	Water Health Ins	WATER FUND	28,000.00
HEALTH INS-JAN26	01/01/2026	Billing & Service-wtr	WATER FUND	3,360.00

Invoice Number	Invoice Date	Description	Segment Fund	Net Invoice Amount
HEALTH INS-JAN26	01/01/2026	Jean & Zab-wtr	WATER FUND	1,680.00
HEALTH INS-JAN26	01/01/2026	WPC Health Ins	WPC	16,800.00
HEALTH INS-JAN26	01/01/2026	Billing & Service-wpc	WPC	2,240.00
HEALTH INS-JAN26	01/01/2026	Jean & Zab - wpc	WPC	1,120.00
Total Employee Benefit Account:				106,400.00
Farmers Cooperative				
2266-DEC25	12/31/2025	Tire Repair	WATER FUND	25.00
2267-DEC25	12/31/2025	3.160 Super no lead	WPC	7.83
2267-DEC25	12/31/2025	21.4380 Super no lead	WPC	53.14
2267-DEC25	12/31/2025	12.3610 Super No lead	WPC	30.64
2267-DEC25	12/31/2025	19.1370 super No lead	WPC	47.25
2267-DEC25	12/31/2025	7.2670 Super no lead	WPC	17.94
2267-DEC25	12/31/2025	20.8080 Super no lead	WPC	48.25
2267-DEC25	12/31/2025	14.2510 Super no lead	WPC	33.05
2267-DEC25	12/31/2025	14.3820 Super no lead	WPC	33.21
2267-DEC25	12/31/2025	27.1330 Super no lead	WPC	62.65
2267-DEC25	12/31/2025	9.1190 Super no lead	WPC	21.06
2267-DEC25	12/31/2025	13.100 Super no lead	WPC	30.12
2267-DEC25	12/31/2025	5.3150 Premium	WPC	17.00
2267-DEC25	12/31/2025	20.6580 Super no lead gas can	WPC	47.70
Total Farmers Cooperative:				474.84
FORVIS LLP				
0095629	12/22/2025	Second progress filling for fiscal year 2025	ELECTRIC FUND	7,650.00
0095629	12/22/2025	Second progress filling for fiscal year 2025	WATER FUND	4,590.00
0095629	12/22/2025	Second progress filling for fiscal year 2025	WPC	3,060.00
Total FORVIS LLP:				15,300.00
Fossler Excavating LLC				
1015	11/20/2025	Haul off trees from 11th st	WATER FUND	1,200.00
Total Fossler Excavating LLC:				1,200.00
GE Software Inc				
225748	12/31/2025	Fuel Site Modeul Monthly Service-Dec25	ELECTRIC FUND	86.00
225748	12/31/2025	State Sales/Use	ELECTRIC FUND	4.40-
225748	12/31/2025	City Sales/Use	ELECTRIC FUND	1.60-
Total GE Software Inc:				80.00
Grainger				
9765475216	01/09/2026	1)Intake Louver 12x12@196.10	WATER FUND	196.10
9765475216	01/09/2026	Sales Tax	WATER FUND	14.71
Total Grainger:				210.81
HDR Engineering Inc				
1200790519	01/08/2026	11/30-12/27/25)Evaluate generation equip/develop comprehensive strategy	ELECTRIC FUND	20,371.81
Total HDR Engineering Inc:				20,371.81
HULS BODY SHOP INC.				
26889	12/31/2025	State Sales/Use	ELECTRIC FUND	4.67-

Invoice Number	Invoice Date	Description	Segment Fund	Net Invoice Amount
26889	12/31/2025	City Sales/Use	ELECTRIC FUND	1.70-
26889	12/31/2025	Tow 2020 Chivy Silverado to BPW office 4/Ella to Permier	ELECTRIC FUND	85.00
26889	12/31/2025	Use Tax	ELECTRIC FUND	6.37
Total HULS BODY SHOP INC.:				85.00
Husker Electric Supply				
77718	01/06/2026	12)MILBANK UC7445-XL METER SOCKET	ELECTRIC FUND	3,457.20
Total Husker Electric Supply:				3,457.20
JEO Consulting Group, Inc.				
170322	12/18/2025	Engineering design for Chemical Feed Improvement Project #251912	WATER FUND	6,362.50
Total JEO Consulting Group, Inc.:				6,362.50
Johnstone Supply				
2364622	01/06/2026	ND-12X12@241.87	WATER FUND	241.87
2364622	01/06/2026	1)Fan Control Center @42.50	WATER FUND	42.50
2364622	01/06/2026	Freight	WATER FUND	23.00
2364622	01/06/2026	Sales Tax	WATER FUND	23.05
Total Johnstone Supply:				330.42
Ken's Pest Control				
1737	01/15/2026	Pest Control Service Center/ Jan26	ELECTRIC FUND	80.63
Total Ken's Pest Control:				80.63
Lammel Plumbing, Inc.				
86051	01/02/2026	Replaced 12' Section of Main Pipe Union bet Monroe & Irving	WPC	4,461.75
86124	01/02/2026	1)2" PVC x 1 1/2 MIP Adapter @3.22	WPC	3.22
86124	01/02/2026	1)1" PVCx3/4"MIP@2.29	WPC	2.29
86124	01/02/2026	1)3/4"x Close Sch 80 pvc NIP@.36	WPC	.36
Total Lammel Plumbing, Inc.:				4,467.62
Landis and Gyr Technology, Inc.				
90423541	01/05/2026	SaaS Monthly flat Fee/Dec2025	ELECTRIC FUND	3,645.00
Total Landis and Gyr Technology, Inc.:				3,645.00
Leech, Greg				
MEAL FUND	12/31/2025	Meal Fund Balance	ELECTRIC FUND	10.50
Total Leech, Greg:				10.50
Lincoln Winwater Works				
116216 04	12/29/2025	8)2" METER FLANGES 73197 KIT	WATER FUND	696.60
116765 02	12/29/2025	2)2956-20 JOBSITE RADIO + CHARGE	WATER FUND	612.75
116999 02	01/02/2026	1)8" 826 FLG LW CHECK VALVE 14-204-0800 MFP# 826-080	WATER FUND	3,870.00
117322 01	01/02/2026	4)100lb Drum Chlorine-5gal bucket @550.00	WATER FUND	2,200.00
117322 01	01/02/2026	Sales Tax	WATER FUND	165.00
117412 01	01/08/2026	20ft) PVC 9800B 8x20 S40 BE Pipe @7.77	WATER FUND	155.40
117412 01	01/08/2026	1)1056-88 8" CI/PL-CI/PL@29.37	WATER FUND	29.37
117412 01	01/08/2026	1)PVCDWV Coupling @45.89	WATER FUND	45.89
117412 01	01/08/2026	1) 8 PVCDWV HxH 90 Bell @101.29	WATER FUND	101.29

Invoice Number	Invoice Date	Description	Segment Fund	Net Invoice Amount
117412 01	01/08/2026	Sales Tax	WATER FUND	24.90
117435 01	01/09/2026	4)100lb Drum Chlorine-5gal bucket @550.00	WATER FUND	2,200.00
117435 01	01/09/2026	Sales Tax	WATER FUND	165.00
117436 01	01/09/2026	1)6 FE Blind CL Imp @141.88	WATER FUND	141.88
117436 01	01/09/2026	1)6 STD 1/8 Red Rubber FF GSK@6.79	WATER FUND	6.79
117436 01	01/09/2026	1)8 FE Blind CL Imp @236.22	WATER FUND	236.22
117436 01	01/09/2026	1)8 STD 1/8 Red Rubber FF Gsk@10.22	WATER FUND	10.22
117436 01	01/09/2026	Sales Tax	WATER FUND	29.63
117503 01	01/13/2026	1)8" 50lb Black UV Cable Ties 1000ct@20.00	WATER FUND	20.00
117503 01	01/13/2026	Sales Tax	WATER FUND	1.50
Total Lincoln Winwater Works:				10,712.44
Maguire, Patrick				
842102	01/02/2026	Reinstall fence at 1507 Court - from sewer repair	WPC	563.50
Total Maguire, Patrick:				563.50
Mead Lumber Company				
12995349	12/30/2025	1)4'x1'6" fixed pickture window @227.00	WATER FUND	227.00
12995349	12/30/2025	15)Mal Vista AR Storm Grey @49.24	WATER FUND	738.60
12995349	12/30/2025	4)5" Style SR Roof Edge @8.99	WATER FUND	35.96
12995349	12/30/2025	6)5x10' Gut Apron @8.99	WATER FUND	53.94
12995349	12/30/2025	1)Tamko 10" Starter 100lf@58.79	WATER FUND	58.79
12995349	12/30/2025	6)DAP Caulk@14.60	WATER FUND	87.60
12995349	12/30/2025	20)5x4x4-16" Quarry Gray EF Cedar Tex Trim @30.20	WATER FUND	604.00
12995349	12/30/2025	66)8"x6" Quarry Gray EF Smartside lap@25.64	WATER FUND	1,692.24
12995349	12/30/2025	1)LP Quarry Gray EF Touch up kit@56.30	WATER FUND	56.30
12995349	12/30/2025	5)16"x12' C-Vent Soffit Snowmist @36.17	WATER FUND	180.85
12995349	12/30/2025	8)6" Steel W/G Fascia @23.40	WATER FUND	187.20
12995349	12/30/2025	1)3/8" Mitre Divider@23.28	WATER FUND	23.28
12995349	12/30/2025	8)3/8 J Channel @6.74	WATER FUND	53.92
12995349	12/30/2025	1)24"x50' PVC Trim Coil @155.51	WATER FUND	155.51
12995349	12/30/2025	1)Omni Ridge Roll Low-Profile 30'@95.99	WATER FUND	95.99
12995349	12/30/2025	1)Nail 1-1/4" Rnd Head Galv @38.35	WATER FUND	38.35
12995349	12/30/2025	Delivery	WATER FUND	10.00
12995349	12/30/2025	Sales Tax	WATER FUND	322.46
12998566	12/31/2025	2)2x8-10 spf#2@10.50	WATER FUND	21.00
12998566	12/31/2025	1)1lb PP Exterior 8x2@10.07	WATER FUND	10.07
12998566	12/31/2025	1)Wthrstrp 2"x25@5.56	WATER FUND	5.56
12998566	12/31/2025	1)12" Beddar Wood Shims @7.67	WATER FUND	7.67
12998566	12/31/2025	Sales Tax	WATER FUND	3.33
12998641	12/31/2025	2)2x10-10 Struct #1@14.61	WATER FUND	29.22
12998641	12/31/2025	Sales Tax	WATER FUND	2.19
12998947	12/31/2025	1)2"x55 yd Tyvek tape@18.61	WATER FUND	18.61
12998947	12/31/2025	Sales Tax	WATER FUND	1.39
13001702	01/02/2026	1)MAL H&R Ridgeflex 12" Natural wood @78.39	WATER FUND	78.39
13001702	01/02/2026	Sales Tax	WATER FUND	5.88
13003591	01/02/2026	1)16"x12' C-vent Soffit Snowmist @36.25	WATER FUND	36.25
13003591	01/02/2026	1)6" Steel W/G Fascia @24.49	WATER FUND	24.49
13003591	01/02/2026	Sales Tax	WATER FUND	4.55
13008586	01/05/2026	1)2x10-8 HF Select Struct #1@10.84	WATER FUND	10.84
13008586	01/05/2026	20)23x46 Durovent Baffle@2.93	WATER FUND	58.60
13008586	01/05/2026	Sales Tax	WATER FUND	5.21
13008653	01/05/2026	1)5/16" Staple @5.75	WATER FUND	5.75
13008653	01/05/2026	1)Staple Gun @24.99	WATER FUND	24.99
13008653	01/05/2026	Sales Tax	WATER FUND	2.30

Invoice Number	Invoice Date	Description	Segment Fund	Net Invoice Amount
13009560	01/05/2026	1)MAL H&R Ridgeflex 12" Storm Grey @78.39	WATER FUND	78.39
13009560	01/05/2026	Sales Tax	WATER FUND	5.88
13027035	01/09/2026	36)8"x16" Quarry Gray Smartside Lap@25.64	WATER FUND	923.04
13027035	01/09/2026	Delivery	WATER FUND	10.00
13027035	01/09/2026	Sales Tax	WATER FUND	69.98
13037999	01/13/2026	22)15x39'2 KF-R19@34.67	WATER FUND	762.74
13037999	01/13/2026	1)Great Stuff big cap filler @7.29	WATER FUND	7.29
13037999	01/13/2026	4)Great Stuff Window/Door@8.49	WATER FUND	33.96
13037999	01/13/2026	Delivery	WATER FUND	10.00
13037999	01/13/2026	Sales Tax	WATER FUND	61.05
13040655	01/14/2026	5)DAP Caulk@14.60	WATER FUND	73.00
13040655	01/14/2026	Sales Tax	WATER FUND	5.48
915412	12/31/2025	2)2x8-10 spf#2@10.50--returned-invoice 12998566	WATER FUND	21.00-
915412	12/31/2025	Sales Tax	WATER FUND	1.58-
917255	01/09/2026	2) Mal Vista AR Storm Grey @49.24--returned	WATER FUND	98.48-
917255	01/09/2026	Sales Tax	WATER FUND	7.39-
Total Mead Lumber Company:				6,890.64
Midlands Contracting Inc				
18063	01/13/2026	Install 12" Point Repair Liner, Repair Lift Station Floor Spalling(LS #6)	WPC	10,600.00
Total Midlands Contracting Inc:				10,600.00
Midwest Laboratories, Inc.				
1268351	01/05/2026	Weekly Wastewater Samples/DEC25	WPC	1,174.45
1268353	01/05/2026	Water Samples/shipping	WATER FUND	25.75
Total Midwest Laboratories, Inc.:				1,200.20
Midwest Petroleum Equipment LLC				
40949	01/13/2026	Service Labor--diesel has black sludge	ELECTRIC FUND	218.00
40949	01/13/2026	Mobilization	ELECTRIC FUND	96.00
Total Midwest Petroleum Equipment LLC:				314.00
Nebraska Public Power District				
9000061516	12/31/2025	2) MTR Translation & Rpt Mtr Srv--Comb Rpt	ELECTRIC FUND	184.00
Total Nebraska Public Power District:				184.00
Norris Public Power District				
311885100-DEC25	01/05/2026	Power Bill/City Wells/Dec 2025	WATER FUND	3,263.12
Total Norris Public Power District:				3,263.12
Olsson, Inc.				
564957	01/13/2026	WPC Grit Improvement Project	WPC	13,077.65
Total Olsson, Inc.:				13,077.65
One Call Concepts, Inc.				
5120132	12/31/2025	Street-locate fees	ELECTRIC FUND	24.95
5120132	12/31/2025	Elec-locate fees	ELECTRIC FUND	24.95
5120132	12/31/2025	Water-locate fees	WATER FUND	24.95
5120132	12/31/2025	WPC-locate fees	WPC	24.95

Invoice Number	Invoice Date	Description	Segment Fund	Net Invoice Amount
Total One Call Concepts, Inc.:				99.80
O'Reilly Automotive, Inc.				
0749-119656	12/12/2025	4)Hyd Hose @8.03	WATER FUND	32.12
0749-119656	12/12/2025	1)MegaCrimp @12.25	WATER FUND	12.25
0749-119656	12/12/2025	1)1)MegaCrimp@29.79	WATER FUND	29.79
0749-119656	12/12/2025	Sales Tax	WATER FUND	5.56
0749-122911	12/30/2025	1)Battery @150.81 LS #6	WPC	150.81
0749-122911	12/30/2025	Core charge	WPC	22.00
0749-122911	12/30/2025	Core Exchange	WPC	22.00-
0749-123230	12/31/2025	2)Antifreeze@22.99	ELECTRIC FUND	45.98
0749-123230	12/31/2025	Sales Tax	ELECTRIC FUND	3.45
0749-124026	01/05/2026	1)Battery @150.81 LS #5	WPC	150.81
0749-124026	01/05/2026	Core charge	WPC	22.00
0749-124026	01/05/2026	Core Exchange	WPC	22.00-
Total O'Reilly Automotive, Inc.:				430.77
Pollman LLC				
301215	12/26/2025	100)Bored 4" line S 8th 7 Doane@16.64/ft	ELECTRIC FUND	1,664.00
Total Pollman LLC:				1,664.00
Polydyne, Inc.				
1989343	12/29/2025	4)Clarifloc 450lb Drum @ 1.73/lb	WPC	3,114.00
Total Polydyne, Inc.:				3,114.00
PowerTech LLC				
90815093	12/31/2025	1)Cummins Fuel Shut off solenoid@177.92	WATER FUND	177.92
90815093	12/31/2025	Generator Tech Labor	WATER FUND	140.00
Total PowerTech LLC:				317.92
Premier GMC Beatrice LLC				
6031236	12/24/2025	Sales Tax	ELECTRIC FUND	5.99
6031236	12/24/2025	1)SL-N-Filter @8.00	ELECTRIC FUND	8.00
6031236	12/24/2025	8)Oil @5.50	ELECTRIC FUND	44.00
6031236	12/24/2025	Shop Supplies	ELECTRIC FUND	5.59
6031236	12/24/2025	Labor-Lube oil filter	ELECTRIC FUND	27.95
Total Premier GMC Beatrice LLC:				91.53
Production Creek, LLC				
66296	12/29/2025	TEE-SHIRTS ,Caps	WPC	282.00
Total Production Creek, LLC:				282.00
Quadient Leasing USA Inc				
31270251-DEC25	01/04/2026	Postage /split	ELECTRIC FUND	505.00
31270251-DEC25	01/04/2026	Postage /split	WATER FUND	303.00
31270251-DEC25	01/04/2026	Postage /split	WPC	202.00
Total Quadient Leasing USA Inc:				1,010.00

Invoice Number	Invoice Date	Description	Segment Fund	Net Invoice Amount
Quill Corporation				
47305328	01/09/2026	Street Office Supplies	ELECTRIC FUND	32.38
47305328	01/09/2026	Electric Office Supplies	ELECTRIC FUND	32.40
47305328	01/09/2026	Water Office Supplies	WATER FUND	32.40
47329633	01/12/2026	Electric Office Supplies-Zab	ELECTRIC FUND	4.74
47329633	01/12/2026	Sales Tax	ELECTRIC FUND	.36
Total Quill Corporation:				102.28
Railroad Management Co. III, LLC				
537547	10/27/2025	License Fee 300881 2/9/26-2/8/27	WPC	458.76
539205	11/25/2025	License Fee/301514/Power Line Crossing 3/11/26-3/10/27	ELECTRIC FUND	458.76
540618	12/23/2025	License Fee/Hoag/License 301890 4/8/26-4/7/27	WATER FUND	678.69
540705	12/23/2025	License Fee/Power Line Encroachment/License 301891 4/8/26-4/7/27	ELECTRIC FUND	830.10
Total Railroad Management Co. III, LLC:				2,426.31
RDJ Construction LLC				
01	01/13/2026	Roof and side new chlorine building, Grant st	WATER FUND	4,150.00
Total RDJ Construction LLC:				4,150.00
Rural Electric Supply Cooperative				
3099053	01/07/2026	1)25 KVA OVERHEAD DIST. TRANSFORMER. M7112C25ZZT30V1. AS P	ELECTRIC FUND	1,630.78
Total Rural Electric Supply Cooperative:				1,630.78
Sack Lumber Company				
2510-121010	10/16/2025	1)Blockade firerated slnt @19.49-returned	WATER FUND	20.95-
2512-137256	12/17/2025	State Sales/Use	ELECTRIC FUND	.33-
2512-137256	12/17/2025	city sales/use	ELECTRIC FUND	.12-
2512-137256	12/17/2025	2)1"x200'Pnk Flagging Tape@2.99	ELECTRIC FUND	5.98
2512-137256	12/17/2025	Use Tax	ELECTRIC FUND	.45
2601-140130	01/02/2026	1)7" Magnum Fafter Sq@12.99	WATER FUND	12.99
2601-140130	01/02/2026	1)12"HI-Vis Rafter Sq@26.99	WATER FUND	26.99
2601-140130	01/02/2026	4)1pk Black Fine Marker@1.29	WATER FUND	5.16
2601-140130	01/02/2026	Sales Tax	WATER FUND	3.39
2601-141796	01/09/2026	2)10oz Wet/Dry Roof Cement @4.99 (Well F5)	WATER FUND	9.98
2601-141796	01/09/2026	1)10.5oz Clr Roof Sealant@12.99	WATER FUND	12.99
2601-141796	01/09/2026	Sales Tax	WATER FUND	1.72
Total Sack Lumber Company:				58.25
Sapp Bros. Petroleum, Inc.				
IN4918058	01/02/2026	800)DIESEL 50/50 blend@2.41	ELECTRIC FUND	1,928.00
IN4918058	01/02/2026	1210)UNLEADED GASOLINE@2.116	ELECTRIC FUND	2,560.36
IN4926008	01/12/2026	364)#1 Dyed Winter Diesel@3.000017	WPC	1,092.00
IN4926008	01/12/2026	364)#2 Dyed Winter Diesel@2.230017	WPC	811.72
IN4929153	01/14/2026	1113.8)UNLEADED GASOLINE@2.266	ELECTRIC FUND	2,523.87
IN4929153	01/14/2026	1000)DIESEL 50/50 blend@2.66	ELECTRIC FUND	2,660.00
Total Sapp Bros. Petroleum, Inc.:				11,575.95
Total Tool Supply, Inc.				
07559716	01/08/2026	1)1-1/4in x 2in HSS Annular @99.42	ELECTRIC FUND	99.42
07559716	01/08/2026	1)1in x 2in HSS Annular Cutter@69.70	ELECTRIC FUND	69.70
07559716	01/08/2026	Sales Tax	ELECTRIC FUND	12.26

Invoice Number	Invoice Date	Description	Segment Fund	Net Invoice Amount
Total Tool Supply, Inc.:				181.38
Tractor Supply Company				
470607	01/09/2026	1)Skid Steer 1/2 Pipe femal @79.99	ELECTRIC FUND	79.99
470607	01/09/2026	1)Skid Steet 1/2 SAE Male @59.99	ELECTRIC FUND	59.99
470607	01/09/2026	Sales Tax	ELECTRIC FUND	10.50
470619	01/09/2026	2)2X25 YW STAND DOUBLE J HOOK 1PK @19.99	ELECTRIC FUND	39.98
470619	01/09/2026	Sales Tax	ELECTRIC FUND	3.00
470648	01/09/2026	2)FG FRG EYE GRAB HK @21.99	ELECTRIC FUND	43.98
470648	01/09/2026	Sales Tax	ELECTRIC FUND	3.30
471073	01/14/2026	1)4G Ultra Gel Super Glue @5.99	WATER FUND	5.99
471073	01/14/2026	Sales Tax	WATER FUND	.45
471091	01/14/2026	4)Trv DEF 5gal @16.99	ELECTRIC FUND	67.96
471091	01/14/2026	Sales Tax	ELECTRIC FUND	5.10
754521	12/19/2025	2)Clevis Pin Adjustable @5.79	WATER FUND	11.58
754521	12/19/2025	Sales Tax	WATER FUND	.88
755563	12/30/2025	1)GW Sq point shovel w long hard wood @22.99	WPC	22.99
755563	12/30/2025	1)Rinco MNPigskin Work Glove @21.24	WPC	21.24
755810	01/02/2026	1)Trv ISO 46 Hyd Fluid 5 gal @44.99	ELECTRIC FUND	44.99
755810	01/02/2026	Sales Tax	ELECTRIC FUND	3.37
Total Tractor Supply Company:				425.29
Truck Center Companies				
XA108204287 01	01/05/2026	1)Switch-Pressure Normannly open @7.82	ELECTRIC FUND	7.82
XA108204287 01	01/05/2026	6)Coolant Rotella @7.99	ELECTRIC FUND	47.94
XA108204287 01	01/05/2026	Sales Tax	ELECTRIC FUND	4.05
Total Truck Center Companies:				59.81
US Postmaster				
01072026	01/07/2026	cycle billing postage	ELECTRIC FUND	1,565.89
01072026	01/07/2026	cycle billing postage	WATER FUND	939.53
01072026	01/07/2026	cycle billing postage	WPC	626.35
Total US Postmaster:				3,131.77
Vermeer High Plains				
P3966701	01/08/2026	1)Seal Kit@157.28	ELECTRIC FUND	157.28
P3966701	01/08/2026	Sales Tax	ELECTRIC FUND	11.40
P3966801	01/08/2026	1)1/4-1/2 Pull Grip @31.29	ELECTRIC FUND	31.29
P3966801	01/08/2026	1)1/2-3/4 Pull Grip @42.89	ELECTRIC FUND	42.89
P3966801	01/08/2026	Sales Tax	ELECTRIC FUND	5.38
Total Vermeer High Plains:				248.24
Viking Painting LLC				
PS-INV106381	12/31/2025	South Tank Year 1 -1st qtr	WATER FUND	5,500.00
PS-INV106382	12/31/2025	North Tank Year 1 -1st qtr	WATER FUND	7,500.00
Total Viking Painting LLC:				13,000.00
Visa				
20081-DEC25	01/02/2026	Amazon-Amanda reimbursement	ELECTRIC FUND	103.37
20081-DEC25	01/02/2026	Tractor Supply-Chain Saw Kit	ELECTRIC FUND	623.49
20081-DEC25	01/02/2026	Walmart-Cell phone cover	ELECTRIC FUND	22.36

Invoice Number	Invoice Date	Description	Segment Fund	Net Invoice Amount
20081-DEC25	01/02/2026	NEbraska floodplan-Membership renewal/burroughs	ELECTRIC FUND	35.00
20081-DEC25	01/02/2026	Remarkable-Monthly Subscription digital notepad	ELECTRIC FUND	3.21
20081-DEC25	01/02/2026	Valentino's - Board meeting	ELECTRIC FUND	75.80
20081-DEC25	01/02/2026	Home Depot-vents	WATER FUND	258.00
20081-DEC25	01/02/2026	Ameritrol inc-Electronic flow switch	WATER FUND	397.87
20081-DEC25	01/02/2026	USE Tax	WATER FUND	29.84
20081-DEC25	01/02/2026	State Sales/Use	WATER FUND	21.88-
20081-DEC25	01/02/2026	City Sales/Use	WATER FUND	7.96-
20081-DEC25	01/02/2026	Lesoing Truck -Flush/Repair Radiator	WATER FUND	275.00
20081-DEC25	01/02/2026	Harbor Freight--Tools	WATER FUND	53.73
20081-DEC25	01/02/2026	Amazon-space heater	WATER FUND	53.72
20081-DEC25	01/02/2026	White Cap-Reservoir	WATER FUND	453.60
20081-DEC25	01/02/2026	Zorro-Unit heater	WATER FUND	2,650.95
20081-DEC25	01/02/2026	E 470 Express Tolls	WATER FUND	9.20
20081-DEC25	01/02/2026	Taco Johns-safety meeting	WATER FUND	79.70
20081-DEC25	01/02/2026	Harbor Freight-supplies	WATER FUND	29.00
20081-DEC25	01/02/2026	Zoro-Business Radio bundle	WATER FUND	429.99
20081-DEC25	01/02/2026	Zoro-Way Lock Lubricate	WATER FUND	20.55
20081-DEC25	01/02/2026	Amazon-squeegees	WATER FUND	271.01
20081-DEC25	01/02/2026	Home Depot-Scaffolding	WATER FUND	864.41
20081-DEC25	01/02/2026	Amazon-Kneeling Mat	WATER FUND	75.26
20081-DEC25	01/02/2026	Tractor Supply-kneeling pad	WATER FUND	85.91
20081-DEC25	01/02/2026	Tractor Supply-Fodable EVA Utility pad	WATER FUND	32.24
20081-DEC25	01/02/2026	Amazon-Dock Edge+Postlight	WATER FUND	94.02
20081-DEC25	01/02/2026	Industrialsafety-Confined space detector kit	WATER FUND	3,223.07
20081-DEC25	01/02/2026	RS Group-generator bulb	WPC	26.26
20081-DEC25	01/02/2026	HM Cragg-new key LS#6 generator	WPC	36.95
20081-DEC25	01/02/2026	Home Depot-Tools	WPC	238.94
20081-DEC25	01/02/2026	Harbor Freight--Tools	WPC	86.93
20081-DEC25	01/02/2026	Grainger-supplies	WPC	87.30
20081-DEC25	01/02/2026	Uline-safety	WPC	1,410.81
20081-DEC25	01/02/2026	Harbor Freight-saftey	WPC	8.99
Total Visa:				12,116.64
Wesco Distributing, Inc.				
829076	01/08/2026	100)SQEEZON 1/0 STR 1/0 STR T&B WR259	ELECTRIC FUND	204.25
829076	01/08/2026	100)CLAMP SERVICE WEDGE 1/0 T&B W20-1	ELECTRIC FUND	440.75
Total Wesco Distributing, Inc.:				645.00
Westlake Hardware, Inc.				
10358797	12/29/2025	1)Key ID Tags@2.42	WPC	2.42
10358797	12/29/2025	1)CD Nckl Belt Snap @5.03	WPC	5.03
10358797	12/29/2025	1)Scissors@4.49	WPC	4.49
10358797	12/29/2025	3)KeyKrafter #78 @4.49	WPC	13.47
10358807	12/30/2025	1)Cord Extn 16/3@8.09	WATER FUND	8.09
10358807	12/30/2025	1)Term SP16-14g8@3.59	WATER FUND	3.59
10358807	12/30/2025	2)Term SPD Xtreme@6.29	WATER FUND	12.58
10358807	12/30/2025	Sales Tax	WATER FUND	1.82
10358842	01/05/2026	6)Clorox@7.19	WATER FUND	43.14
10358842	01/05/2026	Sales Tax	WATER FUND	3.24
10358851	01/05/2026	1)Closed RL Lng Tape @24.29	WPC	24.29
10358874	01/06/2026	2)Surg Protctr@17.99	WATER FUND	35.98
10358874	01/06/2026	Sales Tax	WATER FUND	2.70
10358880	01/06/2026	1)Tank Sprayer Ortho 2@35.09	WPC	35.09
10358891	01/07/2026	1)Adaptr Terminal	WPC	1.43

Invoice Number	Invoice Date	Description	Segment Fund	Net Invoice Amount
10358891	01/07/2026	2)Coupling PVC @1.43	WPC	2.86
10358891	01/07/2026	1)3/4 PL Ins Bush 2[k @1.25	WPC	1.25
10358891	01/07/2026	1)3/4 Locknut 2pk@1.43	WPC	1.43
10358891	01/07/2026	Bulk Fastenres	WPC	1.09
10358895	01/07/2026	1)Sheet Alum 6x18@10.79	WPC	10.79
10358914	01/09/2026	1)CM W/D Vacuum 6G@76.49	WPC	76.49
10358921	01/09/2026	4)Paintbrs Chip 1.5wt@1.61	WATER FUND	6.44
10358921	01/09/2026	Sales Tax	WATER FUND	.48
10358941	01/12/2026	2)Comptr Surge Protct7@28.79	ELECTRIC FUND	57.58
10358941	01/12/2026	Sales Tax	ELECTRIC FUND	4.32
10358957	01/13/2026	1)One-Wrap Tie Roll 12 @13.49	ELECTRIC FUND	13.49
10358957	01/13/2026	1)One Wrap Tie Roll 4'@7.19	ELECTRIC FUND	7.19
10358957	01/13/2026	Sales Tax	ELECTRIC FUND	1.55
10358961	01/13/2026	1)Hose Adprt 3/4@8.99	WATER FUND	8.99
10358961	01/13/2026	Sales Tax	WATER FUND	.67
10358983	01/14/2026	1)Alum Tube 3/4 x4'sq@16.19	WATER FUND	16.19
10358983	01/14/2026	1)Channel Trim 1/2-4'@10.79	WATER FUND	10.79
10358983	01/14/2026	1)Angle Alum 1/16x1x48@10.79	WATER FUND	10.79
10358983	01/14/2026	1)XL-SP Sheeters 10x2@10.79	WATER FUND	10.79
10358983	01/14/2026	Sales Tax	WATER FUND	3.64
10358988	01/14/2026	4)Dur Batt Med 76A@3.60	ELECTRIC FUND	14.40
10358988	01/14/2026	1)Dur Batt Alkn@8.10	ELECTRIC FUND	8.10
10358988	01/14/2026	Sales Tax	ELECTRIC FUND	1.69
Total Westlake Hardware, Inc.:				468.37
Wrightsmen Plbg, Heat and Cool, Inc.				
107758	12/29/2025	supplies for Washer/dryer hookups in shop	WATER FUND	208.18
Total Wrightsmen Plbg, Heat and Cool, Inc.:				208.18
Zoellner Ford-Lincoln of Beatrice				
250846	01/13/2026	1)Antifreeze	WPC	35.00
250846	01/13/2026	1)Hose Asy	WPC	177.50
250846	01/13/2026	1)Element Asy-Air Cleaner	WPC	35.00
250846	01/13/2026	1)Filter -Pollen	WPC	35.00
250846	01/13/2026	1)Fuel System Kit	WPC	119.95
250846	01/13/2026	1)Trans Flush	WPC	67.95
250846	01/13/2026	16)Oil-Automatic Transmission	WPC	112.00
250846	01/13/2026	Misc Charge	WPC	10.39
250846	01/13/2026	Labor-Antifreeze Overflow drain line leak	WPC	243.00
250846	01/13/2026	Labor-Multipoint instection service	WPC	388.00
Total Zoellner Ford-Lincoln of Beatrice:				1,223.79
Grand Totals:				799,841.91

Invoice Number	Invoice Date	Description	Segment Fund	Net Invoice Amount
	1-19-26			
Dated: _____				
Mayor: _____				
City Council: _____				



AGENDA ITEM

Subject: Approval of certificate of substantial completion of the Corral Crossing Addition project, as recommended by the Board of Public Works

For Agenda of: January 19, 2026

Exhibit(s):

Date Submitted: January 14, 2026

CONSENT AGENDA

- a. Approve agenda as submitted.
- b. Receive and place on file all notices pertaining to this meeting.
- c. Receive and place on file all materials having any bearing on this meeting.
- d. Approval of minutes of regular meeting on December 10, 2025, as on file in the City Clerk's Office.
- e. Recommend approval of certificate of substantial completion for the Corral Crossing Addition project, to the Mayor and City Council.

Moved by Zarybnicky, seconded by Baehr, that the items listed under the consent agenda, be approved, accepted, and/or ratified as presented.

Roll Call: Yea: Baehr, Hartley, Jones, Moran, Zarybnicky
Nay: None

MOTION CARRIED.

CERTIFICATE OF SUBSTANTIAL COMPLETION

Owner:	City of Beatrice, Nebraska	Owner's Project No.:
Engineer:	JEO Consulting Group, Inc.	Engineer's Project No.: 240608.02
Contractor:	Van Kirk Bros	Contractor's Project No.:
Project:	Corral Crossing Addition	
Contract Name:	Corral Crossing Addition	

This Preliminary Final Certificate of Substantial Completion applies to:

All Work The following specified portions of the Work:

All work except seeding and establishment vegetation.

Date of Substantial Completion: **November 30, 2025**

The Work to which this Certificate applies has been inspected by authorized representatives of Owner, Contractor, and Engineer, and found to be substantially complete. The Date of Substantial Completion of the Work or portion thereof designated above is hereby established, subject to the provisions of the Contract pertaining to Substantial Completion. The date of Substantial Completion in the final Certificate of Substantial Completion marks the commencement of the contractual correction period and applicable warranties required by the Contract.

A punch list of items to be completed or corrected is attached to this Certificate. This list may not be all-inclusive, and the failure to include any items on such list does not alter the responsibility of the Contractor to complete all Work in accordance with the Contract Documents.

Amendments of contractual responsibilities recorded in this Certificate should be the product of mutual agreement of Owner and Contractor; see Paragraph 15.03.D of the General Conditions.

The responsibilities between Owner and Contractor for security, operation, safety, maintenance, heat, utilities, insurance, and warranties upon Owner's use or occupancy of the Work must be as provided in the Contract, except as amended as follows:

Amendments to Owner's Responsibilities: None As follows:

N/A



Amendments to Contractor's Responsibilities: None As follows:

N/A

The following documents are attached to and made a part of this Certificate:

Punch List included.

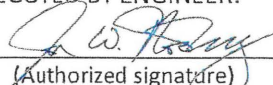
This Certificate does not constitute an acceptance of Work not in accordance with the Contract Documents, nor is it a release of Contractor's obligation to complete the Work in accordance with the Contract Documents.

EXECUTED BY ENGINEER: By: <u></u> (Authorized signature) Title: <u>Project Manager</u> Date: <u>1/5/2026</u>	RECEIVED: By: _____ Owner (Authorized Signature) Title: _____ Date: _____	RECEIVED: By: <u></u> Contractor (Authorized Signature) Title: <u>President</u> Date: <u>1-5-2025</u>
---	---	--



Pre-Punch List Document

DATE | December 17th, 2025
PROJECT | Corral Crossing Addition
PROJECT NO. | 240608.01
LOCATION | Beatrice Nebraska
OWNER | City of Beatrice
CONTRACTOR | Van Kirk

General Items:

- ~~1. A final sweep of the street, detectable warning panels, and sidewalk once all final grading and seeding is completed.~~
- Clean out and seal all joints on mainline along with all expansion joints on the sidewalk.
- ~~3. Remove all debris from all manholes and curb inlets. (this included any concrete or debris on the lid).~~
- ~~4. Install remaining curb inlet protection on all curb inlets.~~
- ~~5. Complete final grading and install seeding and matting for the project. (Ensure that chunks of concrete, rock, and debris larger than 1" are removed).~~
6. Ensure City can access all water main valves.

Mainline

- ~~1. Install all permanent signage for the project.~~
- ~~2. Remove and replace panels on Park at N 15th Street. (STA 27+59 marked out.)~~
- ~~3. Remove and replace four panels with cracks between STA 40+75 to 40+00 on Lariat Circle.~~
4. Route and seal curb and gutter section on Lariat Circle south side. **(Monitor under warranty)**
- ~~5. Remove and replace 14th Street curb and gutter as marked in the field.~~
6. Expansion joint material needs to be installed on the ends of each curb inlet top.
- ~~7. Complete sidewalk on N 15th Street north south runs between Irving and Monroe Street.~~
- ~~8. Complete sidewalk on Irving Street east west run between N 15th and N 16th Street by detention pond.~~
- ~~9. Complete sidewalk on N 16th Street north south run connecting to Irving Street by detention pond.~~
10. Remove and replace cracked ADA ramps at Irving & N 15th, N 15th & Monroe, and Irving & N 16th Street.

Note, items on the punch list will be crossed off as completed. The punch list will not be signed until all items are completed or approved otherwise by Engineer/Owner. The punch list items contained here-in are not all inclusive for final acceptance of the project, nor does completion of punch list items relieve the Contractor of addressing other deficient items identified during warranty periods and fulfilling contract obligations.

Punch List Items Completed:

Project Manager Date

APPLICATION AND CERTIFICATION FOR PAYMENT

AIA DOCUMENT G702

TO OWNER: PROJECT: APPLICATION NO: 12
 Beatrice Area Solid Waste Agency BASWA South MSW Landfill
 400 Ella Street Site Entrance Facility
 Beatrice, NE 68310
 FROM CONTRACTOR: VIA ENGINEER:
 Genesis Contracting Group Burns & McDonnell
 404 Hill Street 6909 South Lyncrest Place - Suite 120
 Lincoln NE. 68502 Sioux Falls, SD 57108
 CONTRACT FOR: New Construction

Distribution to:
 OWNER
 CONSTRUCTION MANAGER
 ARCHITECT/ENGINEER
 CONTRACTOR
 PERIOD TO: 12/31/2025
 APPLICATION DATE: 12/30/2025
 PROJECT NOS: 25-002
 CONTRACT DATE: January 6, 2025

CONTRACTOR'S APPLICATION FOR PAYMENT

Application is made for payment, as shown below, in connection with the Contract. Continuation Sheet, AIA Document G703, is attached.

The undersigned Contractor certifies that to the best of the Contractor's knowledge, information and belief the Work covered by this Application for Payment has been completed in accordance with the Contract Documents, that all amounts have been paid by the Contractor for Work for which previous Certificates for Payment were issued and payments received from the Owner, and that current payment shown herein is now due.
 CONTRACTOR: Genesis Contracting Group LLC.

1. ORIGINAL CONTRACT SUM	\$	4,052,000.00
2. Net change by Change Orders	\$	0.00
3. CONTRACT SUM TO DATE (Line 1 ± 2)	\$	4,052,000.00
4. TOTAL COMPLETED & STORED TO DATE (Column G on G703)	\$	4,052,000.00
5. RETAINAGE:		
a. 10 % of Completed Work (Column D + E on G703)	\$	405,200.00
b. 10 % of Stored Material (Column F on G703)	\$	
Total Retainage (Lines 5a + 5b or Total in Column I of G703)	\$	405,200.00
6. TOTAL EARNED LESS RETAINAGE (Line 4 Less Line 5 Total)	\$	3,646,800.00
7. LESS PREVIOUS CERTIFICATES FOR PAYMENT (Line 6 from prior Certificate)	\$	3,578,850.00
8. CURRENT PAYMENT DUE	\$	67,950.00
9. BALANCE TO FINISH, INCLUDING RETAINAGE (Line 3 less Line 6)	\$	405,200.00

By: Cary Zipp Date: 12/30/2025
 State of: Nebraska County of: _____
 Subscribed and sworn to before me this 30 day of December 2025
 Notary Public: Rebecca Petrzilka
 My Commission expires: 09-30-29

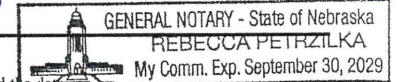

CERTIFICATE FOR PAYMENT

In accordance with the Contract Documents, based on on-site observations and the best of their knowledge, information and belief the Work has progressed as indicated, the quality of the Work is in accordance with the Contract Documents, and the Contractor is entitled to payment of the AMOUNT CERTIFIED.

AMOUNT CERTIFIED \$ 67,950.00

(Attach explanation if amount certified differs from the amount applied for. Initial all figures on this Application and on the Continuation Sheet that changed to conform to the amount certified.)

CHANGE ORDER SUMMARY	ADDITIONS	DEDUCTIONS
Total changes approved in previous months by Owner	\$0.00	\$0.00
Total approved this Month	\$0.00	\$0.00
TOTALS	\$0.00	\$0.00
NET CHANGES by Change Order		\$0.00

ARCHITECT: Rebecca Petrzilka Date: 1/14/2026

This Certificate is not negotiable. The AMOUNT CERTIFIED is payable only to the Contractor named herein. Issuance, payment and acceptance of payment are without prejudice to any rights of the Owner or Contractor under this Contract.

G703 Document

APPLICATION NO: 12

APPLICATION DATE: 12/30/2025

PERIOD TO: 12/31/2025

DESCRIPTION OF WORK	Current SCHEDULED VALUE	WORK COMPLETED THIS APPLICATION		WIP THIS PERIOD PLUS STORED	TOTAL COMPLETED AND STORED TO DATE	RETAINAGE THIS PERIOD	NET AMOUNT DUE THIS PERIOD	%	BALANCE TO FINISH	RETAINAGE	
		PREVIOUS APPLICATIONS	THIS APPLICATION								
			Work In Place								STORED MATERIAL
General Conditions	205,000.00	191,000.00	14,000.00	0.00	14,000.00	205,000.00	1,400.00	12,600.00	100.00%	0.00	20,500.00
Bond and Insurance	85,000.00	85,000.00	0.00	0.00	0.00	85,000.00	0.00	0.00	100.00%	0.00	8,500.00
Site Excavation and Grading	520,000.00	520,000.00	0.00	0.00	0.00	520,000.00	0.00	0.00	100.00%	0.00	52,000.00
Site Fencing	25,000.00	25,000.00	0.00	0.00	0.00	25,000.00	0.00	0.00	100.00%	0.00	2,500.00
Landscaping/Seeding	45,000.00	3,500.00	41,500.00	0.00	41,500.00	45,000.00	4,150.00	37,350.00	100.00%	0.00	4,500.00
Reinforcement	60,000.00	60,000.00	0.00	0.00	0.00	60,000.00	0.00	0.00	100.00%	0.00	6,000.00
Foundation	175,000.00	175,000.00	0.00	0.00	0.00	175,000.00	0.00	0.00	100.00%	0.00	17,500.00
Slab on Grade	180,000.00	180,000.00	0.00	0.00	0.00	180,000.00	0.00	0.00	100.00%	0.00	18,000.00
Site Paving	350,000.00	350,000.00	0.00	0.00	0.00	350,000.00	0.00	0.00	100.00%	0.00	35,000.00
Miscellaneous Steel	50,000.00	50,000.00	0.00	0.00	0.00	50,000.00	0.00	0.00	100.00%	0.00	5,000.00
Steel Erection	9,000.00	9,000.00	0.00	0.00	0.00	9,000.00	0.00	0.00	100.00%	0.00	900.00
Rough Carpentry	10,000.00	10,000.00	0.00	0.00	0.00	10,000.00	0.00	0.00	100.00%	0.00	1,000.00
Finish Carpentry	8,500.00	8,500.00	0.00	0.00	0.00	8,500.00	0.00	0.00	100.00%	0.00	850.00
Casework	9,000.00	9,000.00	0.00	0.00	0.00	9,000.00	0.00	0.00	100.00%	0.00	900.00
Countertops	15,000.00	15,000.00	0.00	0.00	0.00	15,000.00	0.00	0.00	100.00%	0.00	1,500.00
Metal Stud Framing and GWB	110,000.00	90,000.00	20,000.00	0.00	20,000.00	110,000.00	2,000.00	18,000.00	100.00%	0.00	11,000.00
Frames Doors and Hardware	41,000.00	41,000.00	0.00	0.00	0.00	41,000.00	0.00	0.00	100.00%	0.00	4,100.00
Aluminum Frames and Glazing	65,000.00	65,000.00	0.00	0.00	0.00	65,000.00	0.00	0.00	100.00%	0.00	6,500.00
Overhead Door	47,000.00	47,000.00	0.00	0.00	0.00	47,000.00	0.00	0.00	100.00%	0.00	4,700.00
Acoustical Ceilings	6,500.00	6,500.00	0.00	0.00	0.00	6,500.00	0.00	0.00	100.00%	0.00	650.00
Tiling	10,000.00	10,000.00	0.00	0.00	0.00	10,000.00	0.00	0.00	100.00%	0.00	1,000.00
Flooring	5,000.00	5,000.00	0.00	0.00	0.00	5,000.00	0.00	0.00	100.00%	0.00	500.00
Painting	26,000.00	26,000.00	0.00	0.00	0.00	26,000.00	0.00	0.00	100.00%	0.00	2,600.00
Concrete Floor Finishes	25,000.00	25,000.00	0.00	0.00	0.00	25,000.00	0.00	0.00	100.00%	0.00	2,500.00
Specialties	8,000.00	8,000.00	0.00	0.00	0.00	8,000.00	0.00	0.00	100.00%	0.00	800.00
Fuel Tank	25,000.00	25,000.00	0.00	0.00	0.00	25,000.00	0.00	0.00	100.00%	0.00	2,500.00
Storm Shelter	12,000.00	12,000.00	0.00	0.00	0.00	12,000.00	0.00	0.00	100.00%	0.00	1,200.00
Scale	490,000.00	490,000.00	0.00	0.00	0.00	490,000.00	0.00	0.00	100.00%	0.00	49,000.00
Roof Accessories	6,000.00	6,000.00	0.00	0.00	0.00	6,000.00	0.00	0.00	100.00%	0.00	600.00
Insulated Metal Panels	300,000.00	300,000.00	0.00	0.00	0.00	300,000.00	0.00	0.00	100.00%	0.00	30,000.00
PEMB Materials	220,000.00	220,000.00	0.00	0.00	0.00	220,000.00	0.00	0.00	100.00%	0.00	22,000.00
PEMB Erection	189,000.00	189,000.00	0.00	0.00	0.00	189,000.00	0.00	0.00	100.00%	0.00	18,900.00
Site Utilities	70,000.00	70,000.00	0.00	0.00	0.00	70,000.00	0.00	0.00	100.00%	0.00	7,000.00
Plumbing	235,000.00	235,000.00	0.00	0.00	0.00	235,000.00	0.00	0.00	100.00%	0.00	23,500.00
HVAC	150,000.00	150,000.00	0.00	0.00	0.00	150,000.00	0.00	0.00	100.00%	0.00	15,000.00
Electrical	265,000.00	265,000.00	0.00	0.00	0.00	265,000.00	0.00	0.00	100.00%	0.00	26,500.00
											0.00
GRANDTOTAL:	4,052,000.00	3,976,500.00	75,500.00	0.00	75,500.00	4,052,000.00	7,550.00	67,950.00	100.00%	0.00	405,200.00

-43-

CHANGE ORDER NO. 01
For Contract between BASWA and Genesis

Project Name: BASWA South MSW Landfill Site Entrance Facility
 Owner: Beatrice Areac Solid Waste Agency Owner Project No. 172420
 Contractor: Genesis Contracting Group, LLC

The below noted modification(s) to subject Contract have been directed by Owner and accepted by Contractor.

SCOPE OF WORK

This change order summarises the total change order cost adjustments for the Project and approved contract time extension due to weather-related delays. Change Order Log and Contract Time Request is attached.

COST

As a result of the modification(s) described above:

The revised **Contract Price** is adjusted as follows:

Original Contract Price	\$ <u>4,052,000.00</u>
Total net amount of all previous Change Orders (+ or -).	\$ <u>0</u>
Current Contract Price prior to this Change Order.....	\$ <u>4,052,000.00</u>
Total Net Increase (Decrease) for this Change Order (+ or -).	\$ <u>4,917.22</u>
<hr/>	
Revised Contract Price, including all approved change orders	\$ <u>4,056,917.22</u>

SCHEDULE

As a result of the modification(s) described above:

The revised **adjusted Schedule (Time)** is adjusted as follows:

	<u>Substantial Completion</u>	<u>Ready for Final Payment</u>
Original Completion Date(s)	<u>10/17/2025</u>	<u>10/31/2025</u>
Total net time adjustment* of all previous Change Orders(+ or -)	<u>25</u>	<u>0</u>
Total net time adjustment* of this Change Order (+ or -)	<u>11/24/2025</u>	<u>12/09/2025</u>
* Time adjustment is specified in: <input checked="" type="checkbox"/> Working Days <input type="checkbox"/> Calendar Days <input type="checkbox"/> Other _____		
<hr/>		
Actual Completion Date(s)	... <u>11/19/2025</u>	<u>12/04/2025</u>

ACCEPTANCE

This Change Order, when executed, constitutes a modification to the Contract and all provisions of the Contract, except as modified above and by any previous Change Orders, shall apply hereto.

CONTRACTOR:

OWNER:

GENESIS CONTRACTING GROUP, LLC

BEATRICE AREA SOLID WASTE AGENCY

By: 

By: _____

Title: Project Manager

Title: _____

Date: 01/16/2026

Date: _____

ATTACHMENT 1 – CONTRACT TIME REQUEST

January 2nd, 2026

BASWA Site Entrance Facility

400 Ella Street

Beatrice, NE 68310

RE: Contract Extension Request

Attention: Pedro Ruiz Fabian, PE

As requested, this letter provides a summary of weather-related delays that impacted the critical path and overall completion of the project. In addition to these weather delays, changes in project scope also contributed to the final completion date.

The weather delay information is substantiated by documentation from the National Weather Service as well as our Superintendent's daily reports. This request is **solely for an extension of contract time** and does **not** include any request for additional compensation related to lost productivity or costs incurred.

It should also be noted that, beyond the documented rain days, additional consideration should be given to the days immediately following rain events, during which work was impacted due to site conditions. National Weather Service data does not provide a means to quantify these secondary delay days; however, they are reflected in our daily reports. Please see the attached documentation and the monthly summary below.

Monthly Weather Delay Summary

- **April**
5-year average: 5 days
2025 actual: 7 days
Total delay claimed: 2 days
- **May**
5-year average: 10 days
2025 actual: 13 days
Total delay claimed: 3 days
- **June**
5-year average: 8 days
2025 actual: 14 days
Total delay claimed: 6 days
- **July**
5-year average: 10 days

- 2025 actual: 16 days
Total delay claimed: 6 days
- **August**
5-year average: 7 days
2025 actual: 7 days
Total delay claimed: 0 days
 - **September**
5-year average: 6 days
2025 actual: 7 days
Total delay claimed: 1 day
 - **October**
5-year average: 4 days
2025 actual: 6 days
Total delay claimed: 2 days

The project experienced a total of **20 working days of weather-related precipitation delays**. In addition, **changes in scope**—specifically the implementation of NO₂/CO monitoring and GFCI receptacle requirements—resulted in **5 additional lost days**.

Based on the above, we are requesting a **25-calendar-day extension** to the contract time. Other items contributed smaller project delays, but with the intent of justifying the decision to not assess any Liquidate Damages, I am hopeful that this explanation will be sufficient.

Please let me know if you have any questions or need additional supporting documentation.

Sincerely,



Casey Leif
Senior Project Manager
Genesis Contracting Group

Monthly Number of Days Precipitation \geq .01 for BEATRICE 1N, NE

Year	Jan	Feb	Mar	Apr	May	Jun	Jul	Aug	Sep	Oct	Nov	Dec	Annual
2020	7	1	7	5	9	7	10	4	5	4	5	2	66
2021	7	8	7	6	10	8	6	8	6	7	4	2	79
2022	3	0	5	4	13	9	12	4	8	3	3	5	69
2023	3	5	5	3	6	7	12	13	6	3	3	6	72
2024	4	2	5	9	12	10	8	8	3	2	10	3	76
Mean	5	3	6	5	10	8	10	7	6	4	5	4	72
Max	7 2021	8 2021	7 2021	9 2024	13 2022	10 2024	12 2023	13 2023	8 2022	7 2021	10 2024	6 2023	79 2021
Min	3 2023	0 2022	5 2024	3 2023	6 2023	7 2023	6 2021	4 2022	3 2024	2 2024	3 2023	2 2021	66 2020

Monthly Number of Days Precipitation \geq .01 for BEATRICE 1N, NE

Year	Jan	Feb	Mar	Apr	May	Jun	Jul	Aug	Sep	Oct	Nov	Dec	Annual
2025	3	4	3	7	13	14	16	M	7	6	5	M	M
Mean	3	4	3	7	13	14	16	M	7	6	5	M	M
Max	3 2025	4 2025	3 2025	7 2025	13 2025	14 2025	16 2025	M -	7 2025	6 2025	5 2025	M -	M M
Min	3 2025	4 2025	3 2025	7 2025	13 2025	14 2025	16 2025	M -	7 2025	6 2025	5 2025	M -	M M

ATTACHMENT 2 – CHANGE ORDER LOG

Change Order Log



COR No.	COR Title	Description	Additional Cost / Deduct	Approval	Notes
100	Overhead Door Glazing	Cost to add glazing to the overhead sectional doors in the Equipment/Maintenance Building.	\$ -	Not Approved	
101	Additional Fire Extinguisher	Cost to add a dry fire extinguisher in Electrical Room 106.	\$ -	Not Approved	BASWA to provide additional fire extinguisher.
102	Temp. Electrical Panel Relocation	Cost to relocate temporary electrical panel.	\$ -	Not Approved	
103	OWS & Septic Tank High Level Alarm	Cost to provide power to the oil water system and septic tank alarm panels.	\$ -	Not Approved	Solar panel options provided.
104	Shop Bay GFI	Cost to provide GFI protection to the shop bay outlets in the Equipment/Maintenance Building per RFI #19.	\$ 1,353.13	Verbally Approved	
105	CO & NO2 Monitoring System Power	Cost to install breakers and provide power for the control panel and exhaust fans for the CO/NO2 monitoring system.	\$ 667.59	Verbally Approved	
106	Fire Marshal Exit Lights	Cost to install additional emergency lights per the State Fire Marshal's request.	\$ 295.37	Verbally Approved	
107	Diesel Tank High-Level Alarm	Cost to install a high-level alarm on the fuel tank per the State Fire Marshal's comments.	\$ 2,601.13	Verbally Approved	
		COR Subtotal	\$ 4,917.22		
		CO #1 Total	\$ 4,917.22		

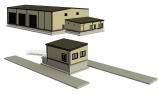

Project: 25-002 - BASWA Landfill Site Entrance Facility
31229 SW 32 Road
Beatrice , Nebraska 68310

Prime Contract Potential Change Order #104: COR #104 - RFI #19 - Shop Bay GFI

TO:	City of Beatrice 400 Ella Street Beatrice, Nebraska 68310	FROM:	Genesis Contracting 404 Hill St Lincoln, Nebraska 68502
PCO NUMBER/REVISION:	104 / 0	CONTRACT:	1 - BASWA Contract
REQUEST RECEIVED FROM:	Britton Scheele (PLYMOUTH ELECTRIC)	CREATED BY:	Bryce McGill (Genesis Contracting)
STATUS:	Pending - In Review	CREATED DATE:	10/6/2025
REFERENCE:	RFI #19	PRIME CONTRACT CHANGE ORDER:	None
FIELD CHANGE:	No		
LOCATION:		ACCOUNTING METHOD:	Amount Based
SCHEDULE IMPACT:		PAID IN FULL:	No
EXECUTED:	No	SIGNED CHANGE ORDER RECEIVED DATE:	
		TOTAL AMOUNT:	\$1,353.13

POTENTIAL CHANGE ORDER TITLE: COR #104 - RFI #19 - Shop Bay GFI

CHANGE REASON: Design Development

POTENTIAL CHANGE ORDER DESCRIPTION: *(The Contract Is Changed As Follows)*
CE #1007 - RFI #19 - Shop Bay GFI
Additional costs to add GFI protection to the shop bay outlets per RFI #19.

ATTACHMENTS:

[20251003153644142.pdf](#)

#	Budget Code	Description	Amount
1	16-176.SUB Plymouth	GFI Protection	\$1,206.00
Subtotal:			\$1,206.00
Bond & Insurance (2.00%):			\$24.12
OH&P (10.00%):			\$123.01
Grand Total:			\$1,353.13

Luke Rodig (Burns & McDonnell)

City of Beatrice
400 Ella Street
Beatrice, Nebraska 68310

Genesis Contracting
404 Hill St
Lincoln, Nebraska 68502

SIGNATURE DATE

SIGNATURE DATE



SIGNATURE DATE 10/06/2025

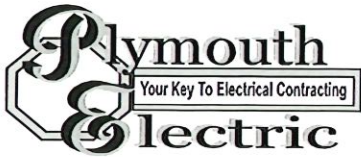

Since 1979

RFI QUOTE

Plymouth Electric, Inc
P.O. Box 96 211 East Main
Plymouth NE 68424
Phone 402-656-4505 FAX: 402-656-3182

Genesis Contracting
ATTN Bryce

RFI
Project: BASWA Entrance
Location: Beatrice Ne
Date 10-3-2025

Plymouth Electric offers the following for changes per RFI for adding GFI protection to the shop bay welders and 110 volt receptacles and includes the following:

Material
labor

TOTAL ADD FOR GFI RFI \$ 1,206.00

If the above price in acceptable, please sign proposal and return so the work can be scheduled

We propose hereby to furnish material and labor-complete in accordance with these specifications, for the sum of

Amount: One thousand two hundred six and no/100----- Dollars

Britton Scheele

Britton Scheele

PRICE GOOD FOR 30 DAYS

Acceptance of Proposal: The prices, specifications and conditions are satisfactory and are hereby accepted. You are authorized To do the work as specified. Payment will be made as outlined above. Plymouth Electric Terms are Net 30.

Signature _____ Date _____

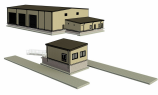

PCO #105R

Project: 25-002 - BASWA Landfill Site Entrance Facility
31229 SW 32 Road
Beatrice, Nebraska 68310

Prime Contract Potential Change Order #105R: COR #105R - CO and NO2 Monitoring System Power

TO:	City of Beatrice 400 Ella Street Beatrice, Nebraska 68310	FROM:	Genesis Contracting 404 Hill St Lincoln, Nebraska 68502
PCO NUMBER/REVISION:	105R / 1	CONTRACT:	1 - BASWA Contract
REQUEST RECEIVED FROM:		CREATED BY:	Bryce McGill (Genesis Contracting)
STATUS:	Pending - In Review	CREATED DATE:	10/20/2025
REFERENCE:		PRIME CONTRACT CHANGE ORDER:	None
FIELD CHANGE:	Yes		
LOCATION:		ACCOUNTING METHOD:	Amount Based
SCHEDULE IMPACT:		PAID IN FULL:	No
EXECUTED:	No	SIGNED CHANGE ORDER RECEIVED DATE:	
		TOTAL AMOUNT:	\$667.59

POTENTIAL CHANGE ORDER TITLE: COR #105R - CO and NO2 Monitoring System Power

CHANGE REASON: Scope Addition

POTENTIAL CHANGE ORDER DESCRIPTION: *(The Contract Is Changed As Follows)*

CE #106 - CO and NO2 Monitoring System Power

Additional costs to install breakers and power for the control panel and exhaust fans for the CO/NO2 Monitoring system, not shown on the electrical drawings or schedules.

ATTACHMENTS:

[20251007085751977.pdf](#)

#	Budget Code	Description	Amount
1	16-176.SUB Plymouth	Exhaust Fan Wiring for Co2 System	\$595.00
Subtotal:			\$595.00
Bond & Insurance (2.00%):			\$11.90
OH&P (10.00%):			\$60.69
Grand Total:			\$667.59

Luke Rodig (Burns & McDonnell)

City of Beatrice
400 Ella Street
Beatrice, Nebraska 68310

Genesis Contracting
404 Hill St
Lincoln, Nebraska 68502

SIGNATURE DATE

SIGNATURE DATE



SIGNATURE DATE 10/20/2025



Since 1979

Plymouth Electric, Inc
P.O. Box 96 211 East Main
Plymouth NE 68424
Phone 402-656-4505 FAX: 402-656-3182

Genesis Construction
ATTN Casey

CHANGE ORDER
Project: BASWA BUILDING
Location: Beatrice Ne
Date 10-15-2025

Plymouth Electric offers the following labor and material to supply 120 volt circuit to CO2 cabinet and supply low voltage chases for CO2 cabinet and t stats in shop bay area and includes the following:

Material
Labor

TOTAL \$595.00

If the above price is acceptable, please sign proposal and return so the work can be scheduled

We propose hereby to furnish material and labor-complete in accordance with these specifications, for the sum of

Amount: Five hundred ninety five and no/100----- Dollars

Britton Scheele
Britton Scheele

PRICE GOOD FOR 30 DAYS

Acceptance of Proposal: The prices, specifications and conditions are satisfactory and are hereby accepted. You are authorized To do the work as specified. Payment will be made as outlined above. Plymouth Electric Terms are Net 30.

Signature _____ Date _____

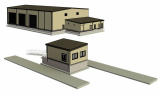

Project: 25-002 - BASWA Landfill Site Entrance Facility
31229 SW 32 Road
Beatrice , Nebraska 68310

Prime Contract Potential Change Order #106: COR #106 - Fire Marshall Exit Lights

TO:	City of Beatrice 400 Ella Street Beatrice, Nebraska 68310	FROM:	Genesis Contracting 404 Hill St Lincoln, Nebraska 68502
PCO NUMBER/REVISION:	106 / 0	CONTRACT:	1 - BASWA Contract
REQUEST RECEIVED FROM:		CREATED BY:	Bryce McGill (Genesis Contracting)
STATUS:	Pending - In Review	CREATED DATE:	12/29/2025
REFERENCE:	Fire Marshall Walkthrough	PRIME CONTRACT CHANGE ORDER:	None
FIELD CHANGE:	No		
LOCATION:		ACCOUNTING METHOD:	Amount Based
SCHEDULE IMPACT:		PAID IN FULL:	No
EXECUTED:	No	SIGNED CHANGE ORDER RECEIVED DATE:	
		TOTAL AMOUNT:	\$295.37

POTENTIAL CHANGE ORDER TITLE: COR #106 - Fire Marshall Exit Lights

CHANGE REASON: Design Development

POTENTIAL CHANGE ORDER DESCRIPTION: *(The Contract Is Changed As Follows)*

CE #113 - Fire Marshall Exit Lights

Cost to add emergency exit lights per the Fire Marshall's request.

ATTACHMENTS:

[0704_001.pdf](#)

#	Budget Code	Description	Amount
1	16-176.SUB Plymouth	Exit Lights	\$263.25
Subtotal:			\$263.25
Bond & Insurance (2.00%):			\$5.27
OH&P (10.00%):			\$26.85
Grand Total:			\$295.37

Luke Rodig (Burns & McDonnell)

City of Beatrice
400 Ella Street
Beatrice, Nebraska 68310

Genesis Contracting
404 Hill St
Lincoln, Nebraska 68502

SIGNATURE DATE

SIGNATURE DATE



SIGNATURE DATE 12/29/2025

INVOICE

Page 1

Plymouth Electric, Inc.

PO Box 96
Plymouth, NE 68424
Phone: (402) 656-4505
Fax: (402) 656-3182

Invoice Number 124954

Invoice Date 12/19/2025

SOLD TO GENESIS CONTRACTING
9833 CYRUS CIR.
FIRTH, NE 68358

When paying with a credit card, a 3% bank transaction fee will be added to your total.

P.O. Number		Terms: Net 30
Customer Code GENESIS		Due Date: 1/18/2026
Email caseyL@genesiscontractinggroup.com		
1.5% After 30 Days		Min Fin Chg \$3.50

ITEM	ORDERED	DESCRIPTION	PRICE	UOM	AMOUNT
FIXTURE WHIP	1.00	18/3 FIXTURE WHIP EPW1863SA	16.97	EA	16.97
9361-ESK BOX	1.00	CUT IN SWITCH BOX 9361-ESK	6.29	EA	6.29
820-D HANGAR ST	1.00	820-D HANGAR STRP DSI2A	3.74	EA	3.74
APC7R LED EX/EM	1.00	APC7RG LED EXIT/EMERG. SIGN	66.25	EA	66.25
LABOR SERVICE	1.00	INSTALLED EXIT LIGHT AS PER FIRE MARSHALL AT BASWA.	170.00		170.00

Net Due: 263.25

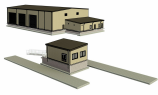

Project: 25-002 - BASWA Landfill Site Entrance Facility
31229 SW 32 Road
Beatrice , Nebraska 68310

Prime Contract Potential Change Order #107: COR #107 - Diesel Tank High Level Alarm

TO:	City of Beatrice 400 Ella Street Beatrice, Nebraska 68310	FROM:	Genesis Contracting 404 Hill St Lincoln, Nebraska 68502
PCO NUMBER/REVISION:	107 / 0	CONTRACT:	1 - BASWA Contract
REQUEST RECEIVED FROM:		CREATED BY:	Bryce McGill (Genesis Contracting)
STATUS:	Pending - In Review	CREATED DATE:	1/7/2026
REFERENCE:	Fire Marshall Review	PRIME CONTRACT CHANGE ORDER:	None
FIELD CHANGE:	No		
LOCATION:		ACCOUNTING METHOD:	Amount Based
SCHEDULE IMPACT:		PAID IN FULL:	No
EXECUTED:	No	SIGNED CHANGE ORDER RECEIVED DATE:	
		TOTAL AMOUNT:	\$2,601.13

POTENTIAL CHANGE ORDER TITLE: COR #107 - Diesel Tank High Level Alarm

CHANGE REASON: Design Development

POTENTIAL CHANGE ORDER DESCRIPTION: *(The Contract Is Changed As Follows)*
CE #115 - Diesel Tank High Level Alarm
Cost to install a high-level alarm on the fuel tank per the Fire Marshall Review Comments

ATTACHMENTS:

[11465.pdf](#)

#	Budget Code	Description	Amount
1	11-125.O Envirosafe	High Level Alarm	\$1,638.29
2	200-201.O General Labor	Install Labor	\$680.00
Subtotal:			\$2,318.29
Bond & Insurance (2.00%):			\$46.37
OH&P (10.00%):			\$236.47
Grand Total:			\$2,601.13

Luke Rodig (Burns & McDonnell)

City of Beatrice
400 Ella Street
Beatrice, Nebraska 68310

Genesis Contracting
404 Hill St
Lincoln, Nebraska 68502

SIGNATURE DATE

SIGNATURE DATE

 01/07/2026

SIGNATURE DATE

Sales Order



Memco Inc.

1789 E C 48
 Bushnell, FL
 USA, 33513
 Phone : 800-555-4754

Sales Order No.	00011465
Date :	01/05/2026
Contact :	Bryce McGill Phone : (402) 791-0151

Ship To	GENISCON
Genesis Contracting	
404 Hill Street,	
Lincoln, NE	
USA, 68502	

Bill To	GENISCON
Genesis Contracting	
404 Hill Street,	
Lincoln, NE	
USA, 68502	

PO No.	Quotes No.	Terms	Carrier	FOB
		DUE NOW	Not Applicable	
Sales Rep		Currency	Ship Method	Delivery Date
Randy Headley (RH)		USD	Non applicable	01/05/2026

No.	Qty	UN	Item	Description	Delivery Date	Retail Price	Disc. %	Net Price	Amount
1	1.000	EA	P-918-0100AG	Gauge Clock 2" Alarm w/Standard Float	01/05/2026	\$1,588.29	0%	\$1,588.29	\$1,588.29
2	1.000	EA	SHIPPING	Shipping	01/05/2026	\$50.00	0%	\$50.00	\$50.00

Total : \$1,638.29
 USD



JEO Consulting Group Inc.

Detailed Payment

240608.02 - Corral Crossing Housing Development

Description Construct Corral Crossing Housing Development in Beatrice Nebraska.

Payment Number 6

Pay Period 12/16/2025 to 01/10/2026

Approval Date 02/02/2026

Prime Contractor Van Kirk Brothers Contracting
1200 W Ash Street
Sutton, NE 68979

Payment Status Pending

Awarded Project Amount \$979,364.75

Authorized Amount \$987,430.07

-44-

Line Number	Item ID	Unit	Unit Price	Authorized Quantity	Current Paid Quantity	Previous Paid Quantity	Total Quantity Paid To Date	Total Quantity Placed To Date	Current Payment Amount	Total Amount Paid To Date
Section: 1 - GROUP A - GRADING AND EROSION CONTROL										
0020	1	LS	\$13,000.000	1.000	0.000	1.000	1.000	1.000	\$0.00	\$13,000.00
Mobilization										

Line Number	Item ID	Unit	Unit Price	Authorized Quantity	Current Paid Quantity	Previous Paid Quantity	Total Quantity Paid To Date	Total Quantity Placed To Date	Current Payment Amount	Total Amount Paid To Date
0030	2	LS	\$1,540.000	1.000	0.000	1.000	1.000	1.000	\$0.00	\$1,540.00
Bonding and Insurance										
0040	3	EA	\$5,800.000	1.000	0.000	1.000	1.000	1.000	\$0.00	\$5,800.00
Construction Entrance										
0050	4	CY	\$4.300	6,473.000	0.000	6,473.000	6,473.000	6,473.000	\$0.00	\$27,833.90
Site Grading										
0060	5	CY	\$6.250	0.000	0.000	0.000	0.000	0.000	\$0.00	\$0.00
Excavation, Established Quantity										
0070	6	CY	\$4.200	6,600.000	3,300.000	3,300.000	6,600.000	6,600.000	\$13,860.00	\$27,720.00
Stripping and Topsoiling										
0080	7	LF	\$5.500	31.000	31.000	0.000	31.000	31.000	\$170.50	\$170.50
Silt Fence, High Porosity										
0090	8	LF	\$3.500	1,506.000	0.000	1,429.000	1,429.000	1,429.000	\$0.00	\$5,001.50
Silt Fence, Low Porosity										
0100	9	EA	\$220.000	10.000	8.000	2.000	10.000	10.000	\$1,760.00	\$2,200.00
Curb Inlet Protection										
0110	10	ACRE	\$2,200.000	8.000	9.000	0.000	9.000	9.000	\$19,800.00	\$19,800.00
Seeding, Fertilizer and Mulch										
0120	11	SY	\$1.450	1,130.000	1,200.000	0.000	1,200.000	1,200.000	\$1,740.00	\$1,740.00
Erosion Control Mat										
0130	12	TONS	\$138.000	8.000	0.000	8.000	8.000	8.000	\$0.00	\$1,104.00
Rock Riprap, NDOR Type B										

Detailed Payment:

240608.02 - Corral Crossing Housing Development

01/14/2026

Page 2 of 12

Line Number	Item ID	Unit	Unit Price	Authorized Quantity	Current Paid Quantity	Previous Paid Quantity	Total Quantity Paid To Date	Total Quantity Placed To Date	Current Payment Amount	Total Amount Paid To Date
0140	13	EA	\$100.000	2.000	0.000	0.000	0.000	0.000	\$0.00	\$0.00
Remove and Relocate Sign										
0150	14	EA	\$532.000	0.000	0.000	1.000	1.000	1.000	\$0.00	\$532.00
Remove Tree										
0860	9000-40	CY	\$12.850	738.000	0.000	738.000	738.000	738.000	\$0.00	\$9,483.30
Earthwork Measured in Embankment - Contractor Borrow										
0870	9000-41	CY	\$11.090	2,898.000	0.000	2,898.000	2,898.000	2,898.000	\$0.00	\$32,138.82
Earthwork Measured in Embankment - Beatrice Borrow										
Section Totals:									\$37,330.50	\$148,064.02
Section: 2 - GROUP B - ROADWAY										
0160	15	LS	\$8,300.000	1.000	0.000	1.000	1.000	1.000	\$0.00	\$8,300.00
Mobilization										
0170	16	LS	\$3,450.000	1.000	0.000	1.000	1.000	1.000	\$0.00	\$3,450.00
Bonding and Insurance										
0180	17	LS	\$1,800.000	1.000	0.000	1.000	1.000	1.000	\$0.00	\$1,800.00
Temporary Traffic Control Measures										
0190	18	SF	\$1.400	35.000	35.000	0.000	35.000	35.000	\$49.00	\$49.00
Remove Sidewalk										
0200	19	SY	\$14.000	367.000	57.220	72.200	129.420	129.420	\$801.08	\$1,811.88
Remove Pavement										
0210	20	SY	\$2.800	3,128.000	0.000	3,128.000	3,128.000	3,128.000	\$0.00	\$8,758.40
Subgrade Preparation										

Detailed Payment:

240608.02 - Corral Crossing Housing Development

01/14/2026

Page 3 of 12

Line Number	Item ID	Unit	Unit Price	Authorized Quantity	Current Paid Quantity	Previous Paid Quantity	Total Quantity Paid To Date	Total Quantity Placed To Date	Current Payment Amount	Total Amount Paid To Date
0220	21	SY	\$62.600	3,128.000	0.000	3,128.000	3,128.000	3,128.000	\$0.00	\$195,812.80
7" Concrete Pavement										
0230	22	SF	\$6.100	9,395.000	1,255.000	7,858.000	9,113.000	9,113.000	\$7,655.50	\$55,589.30
4" Concrete Sidewalk										
0240	23	SF	\$88.000	112.000	48.000	64.000	112.000	112.000	\$4,224.00	\$9,856.00
Detectable Warning Panels										
0250	24	LF	\$31.050	139.000	146.000	54.900	200.900	200.900	\$4,533.30	\$6,237.95
Concrete Curb and Gutter (24"-36" wide)										
0260	25	EA	\$450.000	3.000	3.000	0.000	3.000	3.000	\$1,350.00	\$1,350.00
Install Stop Sign with Street Sign and Post										
0270	26	EA	\$311.000	1.000	1.000	0.000	1.000	1.000	\$311.00	\$311.00
Adjust Valve Box to Grade										
0280	27	EA	\$400.000	6.000	1.875	0.000	1.875	1.875	\$750.00	\$750.00
Install End of Road Marker										
0290	28	LF	\$26.000	64.000	0.000	0.000	0.000	0.000	\$0.00	\$0.00
Concrete Header										
Section Totals:									\$19,673.88	\$294,076.33
Section: 3 - GROUP C - STORM SEWER										
0300	29	LS	\$19,000.000	1.000	0.000	1.000	1.000	1.000	\$0.00	\$19,000.00
Mobilization										
0310	30	LS	\$1,955.000	1.000	0.000	1.000	1.000	1.000	\$0.00	\$1,955.00
Bonding and Insurance										

-47-

Line Number	Item ID	Unit	Unit Price	Authorized Quantity	Current Paid Quantity	Previous Paid Quantity	Total Quantity Paid To Date	Total Quantity Placed To Date	Current Payment Amount	Total Amount Paid To Date
0320	31	LF	\$55.250	359.000	0.000	359.000	359.000	359.000	\$0.00	\$19,834.75
18" RCP, Class III										
0330	32	LF	\$75.750	85.000	0.000	85.000	85.000	85.000	\$0.00	\$6,438.75
24" RCP, Class III										
0340	33	LF	\$88.000	82.000	0.000	82.000	82.000	82.000	\$0.00	\$7,216.00
24" Round Equivalent (RE) RCP, Class III										
0350	34	LF	\$93.500	77.000	0.000	77.000	77.000	77.000	\$0.00	\$7,199.50
30" RCP, Class III										
0360	35	EA	\$994.000	1.000	0.000	1.000	1.000	1.000	\$0.00	\$994.00
18" RCP Flared End Section										
0370	36	EA	\$1,228.000	1.000	0.000	1.000	1.000	1.000	\$0.00	\$1,228.00
24" RCP Flared End Section										
0380	37	EA	\$1,285.000	1.000	0.000	1.000	1.000	1.000	\$0.00	\$1,285.00
30" RCP Flared End Section										
0390	38	EA	\$6,075.000	9.000	0.000	9.000	9.000	9.000	\$0.00	\$54,675.00
Curb Inlet (y=10')										
0400	39	EA	\$5,198.000	1.000	0.000	1.000	1.000	1.000	\$0.00	\$5,198.00
48" Dia. Storm Sewer Manhole										
0410	40	EA	\$375.000	2.000	0.000	1.000	1.000	1.000	\$0.00	\$375.00
Remove Storm Sewer Structure (< 6' deep)										
0420	41	EA	\$735.000	1.000	0.000	1.000	1.000	1.000	\$0.00	\$735.00
Connect to Existing Storm Sewer Structure										

-48-

Line Number	Item ID	Unit	Unit Price	Authorized Quantity	Current Paid Quantity	Previous Paid Quantity	Total Quantity Paid To Date	Total Quantity Placed To Date	Current Payment Amount	Total Amount Paid To Date
0430	42	EA	\$29,934.000	1.000	0.000	1.000	1.000	1.000	\$0.00	\$29,934.00
Hydrodynamic Separator										
0440	43	EA	\$6,025.000	1.000	0.000	1.000	1.000	1.000	\$0.00	\$6,025.00
72" Dia. Storm Sewer Manhole										
Section Totals:									\$0.00	\$162,093.00
Section: 4 - GROUP D – SANITARY SEWER										
0450	44	LS	\$4,950.000	1.000	0.000	1.000	1.000	1.000	\$0.00	\$4,950.00
Mobilization										
0460	45	LS	\$540.000	1.000	0.000	1.000	1.000	1.000	\$0.00	\$540.00
Bonding and Insurance										
0470	46	LF	\$49.500	321.000	0.000	321.000	321.000	321.000	\$0.00	\$15,889.50
8" PVC Sanitary Sewer Main, SDR 35										
0480	47	LF	\$40.000	264.000	0.000	264.000	264.000	264.000	\$0.00	\$10,560.00
4" PVC Sanitary Sewer Service, SDR 26										
0490	48	VF	\$882.000	5.000	0.000	5.000	5.000	5.000	\$0.00	\$4,410.00
48" Dia. Concrete Manhole										
0500	49	EA	\$430.000	12.000	0.000	12.000	12.000	12.000	\$0.00	\$5,160.00
10" x 4" Wye, PVC										
0510	50	LF	\$16.500	40.000	0.000	0.000	0.000	0.000	\$0.00	\$0.00
Remove 10" Sanitary Sewer Main										
0520	51	EA	\$723.000	1.000	0.000	1.000	1.000	1.000	\$0.00	\$723.00
Connect to Existing Sanitary Sewer Main										

Detailed Payment:

240608.02 - Corral Crossing Housing Development

01/14/2026

Page 6 of 12

Line Number	Item ID	Unit	Unit Price	Authorized Quantity	Current Paid Quantity	Previous Paid Quantity	Total Quantity Paid To Date	Total Quantity Placed To Date	Current Payment Amount	Total Amount Paid To Date
Section Totals:									\$0.00	\$42,232.50
Section: 5 - GROUP E - ROADWAY										
0530	52	LS	\$2,475.000	1.000	0.000	1.000	1.000	1.000	\$0.00	\$2,475.00
Mobilization										
0540	53	LS	\$900.000	1.000	0.000	1.000	1.000	1.000	\$0.00	\$900.00
Bonding and Insurance										
0550	54	LS	\$1,800.000	1.000	0.000	1.000	1.000	1.000	\$0.00	\$1,800.00
Temporary Traffic Control Measures										
0560	55	SY	\$2.800	1,002.000	0.000	1,002.000	1,002.000	1,002.000	\$0.00	\$2,805.60
Subgrade Preparation										
0570	56	SY	\$62.600	1,002.000	0.000	1,002.000	1,002.000	1,002.000	\$0.00	\$62,725.20
7" Concrete Pavement										
0580	57	EA	\$100.000	3.000	0.000	0.000	0.000	0.000	\$0.00	\$0.00
Salvage End of Road Marker										
0590	58	EA	\$450.000	1.000	1.000	0.000	1.000	1.000	\$450.00	\$450.00
Install Stop Sign with Street Sign and Post										
Section Totals:									\$450.00	\$71,155.80
Section: 6 - GROUP F - SANITARY SEWER										
0600	59	LS	\$4,950.000	1.000	0.000	1.000	1.000	1.000	\$0.00	\$4,950.00
Mobilization										
0610	60	LS	\$580.000	1.000	0.000	1.000	1.000	1.000	\$0.00	\$580.00
Bonding and Insurance										

-05-

Line Number	Item ID	Unit	Unit Price	Authorized Quantity	Current Paid Quantity	Previous Paid Quantity	Total Quantity Paid To Date	Total Quantity Placed To Date	Current Payment Amount	Total Amount Paid To Date
0620	61	LF	\$49.500	124.000	0.000	124.000	124.000	124.000	\$0.00	\$6,138.00
8" PVC Sanitary Sewer Main, SDR 35										
0630	62	LF	\$40.000	309.000	0.000	309.000	309.000	309.000	\$0.00	\$12,360.00
4" PVC Sanitary Sewer Service, SDR 26										
0640	63	VF	\$887.000	21.000	0.000	21.000	21.000	21.000	\$0.00	\$18,627.00
48" Dia. Concrete Manhole										
0650	64	EA	\$430.000	4.000	0.000	0.000	0.000	0.000	\$0.00	\$0.00
10" x 4" Wye, PVC										
0660	65	EA	\$282.000	4.000	0.000	8.000	8.000	8.000	\$0.00	\$2,256.00
8" x 4" Wye, PVC										
0670	66	EA	\$723.000	1.000	0.000	1.000	1.000	1.000	\$0.00	\$723.00
Connect to Existing Sanitary Sewer Main										
Section Totals:									\$0.00	\$45,634.00
Section: 7 - GROUP G – ROADWAY										
0680	67	LS	\$2,475.000	1.000	0.000	1.000	1.000	1.000	\$0.00	\$2,475.00
Mobilization										
0690	68	LS	\$2,100.000	1.000	0.000	1.000	1.000	1.000	\$0.00	\$2,100.00
Bonding and Insurance										
0700	69	LS	\$1,800.000	1.000	0.000	1.000	1.000	1.000	\$0.00	\$1,800.00
Temporary Traffic Control Measures										
0710	70	SY	\$2.800	2,195.000	19.880	2,049.600	2,069.480	2,069.480	\$55.66	\$5,794.54
Subgrade Preparation										

Detailed Payment:

240608.02 - Corral Crossing Housing Development

01/14/2026

Page 8 of 12

-15-

Line Number	Item ID	Unit	Unit Price	Authorized Quantity	Current Paid Quantity	Previous Paid Quantity	Total Quantity Paid To Date	Total Quantity Placed To Date	Current Payment Amount	Total Amount Paid To Date
0720	71	SY	\$62.600	2,195.000	19.880	2,049.600	2,069.480	2,069.480	\$1,244.49	\$129,549.45
7" Concrete Pavement										
0730	72	SF	\$6.100	1,456.000	0.000	1,428.000	1,428.000	1,428.000	\$0.00	\$8,710.80
4" Concrete Sidewalk										
0740	73	LF	\$31.000	22.000	22.000	0.000	22.000	22.000	\$682.00	\$682.00
Concrete Curb and Gutter (24"-36" wide)										
0750	74	SF	\$88.000	48.000	0.000	48.000	48.000	48.000	\$0.00	\$4,224.00
Detectable Warning Panels										
0760	75	EA	\$580.000	2.000	2.000	0.000	2.000	2.000	\$1,160.00	\$1,160.00
Install Stop Sign with Street Sign and Post										
0770	76	EA	\$310.000	1.000	1.000	0.000	1.000	1.000	\$310.00	\$310.00
Adjust Valve Box to Grade										
0780	77	EA	\$100.000	3.000	0.000	0.000	0.000	0.000	\$0.00	\$0.00
Salvage End of Road Marker										
Section Totals:									\$3,452.15	\$156,805.79
Section: 8 - GROUP H – SANITARY SEWER										
0790	78	LS	\$5,775.000	1.000	0.000	1.000	1.000	1.000	\$0.00	\$5,775.00
Mobilization										
0800	79	LS	\$660.000	1.000	0.000	1.000	1.000	1.000	\$0.00	\$660.00
Bonding and Insurance										
0810	80	LF	\$49.500	285.000	0.000	285.000	285.000	285.000	\$0.00	\$14,107.50
8" PVC Sanitary Sewer Main, SDR 35										

Detailed Payment:

240608.02 - Corral Crossing Housing Development

01/14/2026

Page 9 of 12

Line Number	Item ID	Unit	Unit Price	Authorized Quantity	Current Paid Quantity	Previous Paid Quantity	Total Quantity Paid To Date	Total Quantity Placed To Date	Current Payment Amount	Total Amount Paid To Date
0820	81	LF	\$40.000	330.000	0.000	330.000	330.000	330.000	\$0.00	\$13,200.00
4" PVC Sanitary Sewer Service, SDR 26										
0830	82	VF	\$887.000	18.000	0.000	18.000	18.000	18.000	\$0.00	\$15,966.00
48" Dia. Concrete Manhole										
0840	83	EA	\$282.000	8.000	0.000	8.000	8.000	8.000	\$0.00	\$2,256.00
8" x 4" Wye, PVC										
0850	84	EA	\$723.000	1.000	0.000	1.000	1.000	1.000	\$0.00	\$723.00
Connect to Existing Sanitary Sewer Main										
Section Totals:									\$0.00	\$52,687.50
Section: Section ID - Section Description										
0010	Item No.	Unit	\$0.000	0.000	0.000	0.000	0.000	0.000	\$0.00	\$0.00
Item										
Section Totals:									\$0.00	\$0.00
Total Payments:									\$60,906.53	\$972,748.94

Time Charges

Time Limit	Original Deadline	Authorized Deadline	Charges This Period	Damages This Period	Days Completed To Date	Days Remaining To Date	Damages To Date
Final Completion	11/30/2025	12/31/2025	N/A	\$0.00	N/A	0.0 Days	\$0.00
Substantial Completion	10/31/2025	11/30/2025	N/A	\$0.00	N/A	0.0 Days	\$0.00
Total Damages:							\$0.00

Summary

Current Approved Work:	\$60,906.53	Approved Work To Date:	\$972,748.94
Current Stockpile Advancement:	\$0.00	Stockpile Advancement To Date:	\$0.00
Current Stockpile Recovery:	\$0.00	Stockpile Recovery To Date:	\$0.00
Current Retainage:	\$3,045.33	Retainage To Date:	\$48,637.45
Current Retainage Released:	\$0.00	Retainage Released To Date:	\$0.00
Current Liquidated Damages:	\$0.00	Liquidated Damages To Date:	\$0.00
Current Adjustment:	\$0.00	Adjustments To Date:	\$0.00
Current Payment:	\$57,861.20	Payments To Date:	\$924,111.49
Previous Payment:	\$109,864.70	Previous Payments To Date:	\$866,250.29

-54-

Contractor's Certification

The undersigned Contractor certifies, to the best of its knowledge, the following:

- (1) All previous progress payments received from Owner on account of Work done under the Contract have been applied on account to discharge Contractor's legitimate obligations incurred in connection with the work covered by prior Applications for Payment;
- (2) Title to all work, materials and equipment incorporated in said work, or otherwise listed in or covered by this application for payment, will pass to Owner at time of payment free and clear of all liens, security interests and encumbrances (except such as are covered by a bond acceptable to Owner indemnifying Owner against any such liens, security interest or encumbrances); and
- (3) All work covered by this Application for Payment is in accordance with the Contract Documents and is not defective.

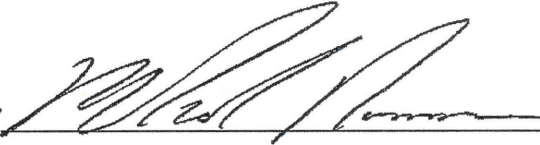
Contractor  Date 1-14-2026

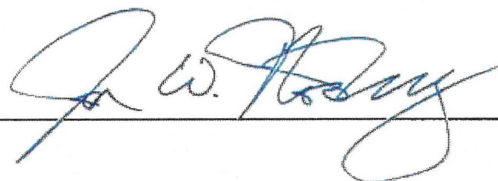
Engineer  Date 1/14/2026

Owner _____ Date _____

-55-



JEO Consulting Group Inc.

Change Order Details

240608.01 - Heritage Heights Housing Development

Description	Construct Heritage Heights Housing Development in Beatrice Nebraska.
Prime Contractor	Van Kirk Brothers Contracting 1200 W Ash Street Sutton, NE 68979
Change Order	3
Status	Pending
Date Created	01/12/2026
Type	Changed Conditions
Summary	Time Extension
Change Order Description	Substantial and Final Completion Time Extension with a \$11,000 contract reduction.
Awarded Project Amount	\$1,324,909.05
Authorized Project Amount	\$1,323,518.44
Change Order Amount	-\$11,000.00
Revised Project Amount	\$1,312,518.44

New Items

Line Number	Item ID	Unit	Quantity	Unit Price	Extension
Section: 2 - GROUP B - ROADWAY					

0730	9000-47	LS	1.000	-\$11,000.000	-\$11,000.00
------	---------	----	-------	---------------	--------------

Contract Reduction

Reason: Contractor and Owner agreed to contract reduction with approval of Spring time extension.

1 item	Total: -\$11,000.00
--------	---------------------

Time Limit Changes

-57-

Type	Original Deadline	Current Deadline	Pending Extension	Pending Deadline
------	-------------------	------------------	-------------------	------------------

Completion Date	11/30/2025	11/30/2025	151.0 Days	04/30/2026
-----------------	------------	------------	------------	------------

Final Completion

Reason: Project delays

Completion Date	10/31/2025	10/31/2025	152.0 Days	04/01/2026
-----------------	------------	------------	------------	------------

Substantial Completion

Reason: Project delays

2 time limits

When authorized, the contractor agrees to perform the work outlined above in accordance with provisions of the contract documents

Contractor  Date 1-14-2026

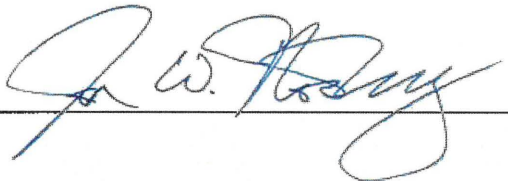
Engineer  Date 1/14/2026

Owner _____ Date _____

-58-



JEO Consulting Group Inc.

Detailed Payment

240608.01 - Heritage Heights Housing Development

Description Construct Heritage Heights Housing Development in Beatrice Nebraska.

Payment Number 5

Pay Period 12/16/2025 to 01/10/2026

Approval Date 02/02/2026

Prime Contractor Van Kirk Brothers Contracting
1200 W Ash Street
Sutton, NE 68979

Payment Status Pending

Awarded Project Amount \$1,324,909.05

Authorized Amount \$1,323,518.44

-59-

Line Number	Item ID	Unit	Unit Price	Authorized Quantity	Current Paid Quantity	Previous Paid Quantity	Total Quantity Paid To Date	Total Quantity Placed To Date	Current Payment Amount	Total Amount Paid To Date
Section: 1 - GROUP A - GRADING AND EROSION CONTROL										
0020	1	LS	\$39,750.000	1.000	0.500	0.500	1.000	1.000	\$19,875.00	\$39,750.00
Mobilization										

Line Number	Item ID	Unit	Unit Price	Authorized Quantity	Current Paid Quantity	Previous Paid Quantity	Total Quantity Paid To Date	Total Quantity Placed To Date	Current Payment Amount	Total Amount Paid To Date
0030	2	LS	\$6,725.000	1.000	0.000	1.000	1.000	1.000	\$0.00	\$6,725.00
Bonding and Insurance										
0040	3	EA	\$5,800.000	1.000	0.000	1.000	1.000	1.000	\$0.00	\$5,800.00
Construction Entrance										
0050	4	CY	\$4.750	1,740.000	0.000	1,740.000	1,740.000	1,740.000	\$0.00	\$8,265.00
Site Grading										
0060	5	CY	\$12.850	3,729.000	0.000	3,729.000	3,729.000	3,729.000	\$0.00	\$47,917.65
Earthwork Measured in Embankment (Established Quantity)										
0070	6	CY	\$2.300	12,995.000	0.000	5,000.000	5,000.000	5,000.000	\$0.00	\$11,500.00
Stripping and Topsoiling										
0080	7	LF	\$3.500	1,786.000	0.000	1,219.000	1,219.000	1,219.000	\$0.00	\$4,266.50
Silt Fence, Low Porosity										
0090	8	LF	\$5.500	30.000	0.000	30.000	30.000	30.000	\$0.00	\$165.00
Silt Fence, High Porosity										
0100	9	EA	\$220.000	8.000	0.000	2.000	2.000	2.000	\$0.00	\$440.00
Curb Inlet Protection										
0110	10	SY	\$1.450	2,011.000	0.000	0.000	0.000	0.000	\$0.00	\$0.00
Erosion Control Mat										
0120	11	ACRE	\$2,200.000	7.000	0.000	0.000	0.000	0.000	\$0.00	\$0.00
Seeding, Fertilizer and Mulch										
0130	12	TONS	\$138.000	8.000	0.000	8.000	8.000	8.000	\$0.00	\$1,104.00
Rock Riprap, NDOR Type B										

Detailed Payment:

240608.01 - Heritage Heights Housing Development

01/14/2026

Page 2 of 11

Line Number	Item ID	Unit	Unit Price	Authorized Quantity	Current Paid Quantity	Previous Paid Quantity	Total Quantity Paid To Date	Total Quantity Placed To Date	Current Payment Amount	Total Amount Paid To Date
0140	13	LF	\$8.000	500.000	0.000	0.000	0.000	0.000	\$0.00	\$0.00
Remove Existing Gas Line										
0150	14	LF	\$3.750	19.000	0.000	0.000	0.000	0.000	\$0.00	\$0.00
Remove Fence										
0160	15	EA	\$605.000	0.000	0.000	0.000	0.000	0.000	\$0.00	\$0.00
Remove Tree										
0720	9000-41	CY	\$11.090	33,386.000	0.000	33,386.000	33,386.000	33,386.000	\$0.00	\$370,250.74
Earthwork Measured in Embankment - Beatrice Borrow										
Section Totals:									\$19,875.00	\$496,183.89
Section: 2 - GROUP B - ROADWAY										
0170	16	LS	\$15,150.000	1.000	0.000	0.500	0.500	0.500	\$0.00	\$7,575.00
Mobilization										
0180	17	LS	\$4,275.000	1.000	0.000	1.000	1.000	1.000	\$0.00	\$4,275.00
Bonding and Insurance										
0190	18	LS	\$1,800.000	1.000	0.000	0.250	0.250	0.250	\$0.00	\$450.00
Temporary Traffic Control Measures										
0200	19	SF	\$1.400	150.000	0.000	0.000	0.000	0.000	\$0.00	\$0.00
Remove Sidewalk										
0210	20	SY	\$14.000	277.000	0.000	54.000	54.000	54.000	\$0.00	\$756.00
Remove Pavement										
0220	21	SY	\$16.000	0.000	0.000	0.000	0.000	0.000	\$0.00	\$0.00
Remove driveway										

-61-

Line Number	Item ID	Unit	Unit Price	Authorized Quantity	Current Paid Quantity	Previous Paid Quantity	Total Quantity Paid To Date	Total Quantity Placed To Date	Current Payment Amount	Total Amount Paid To Date
0230	22	LF	\$14.500	131.000	0.000	0.000	0.000	0.000	\$0.00	\$0.00
Remove Curb and Gutter										
0240	23	EA	\$54.000	3.000	0.000	0.000	0.000	0.000	\$0.00	\$0.00
Remove Detectable Warning Panels										
0250	24	SY	\$2.800	3,620.000	2,133.330	243.330	2,376.660	2,376.660	\$5,973.33	\$6,654.65
Subgrade Preparation										
0260	25	SY	\$65.500	3,507.000	2,133.330	243.330	2,376.660	2,376.660	\$139,733.11	\$155,671.23
7" Concrete Pavement										
0270	26	SY	\$58.500	113.000	0.000	0.000	0.000	0.000	\$0.00	\$0.00
6" Concrete Driveway										
0280	27	SF	\$6.100	6,980.000	0.000	0.000	0.000	0.000	\$0.00	\$0.00
4" Concrete Sidewalk										
0290	28	LF	\$18.650	131.000	0.000	0.000	0.000	0.000	\$0.00	\$0.00
Concrete Curb and Gutter (24"-36" wide)										
0300	29	SF	\$88.000	104.000	0.000	0.000	0.000	0.000	\$0.00	\$0.00
Detectable Warning Panels										
0310	30	EA	\$580.000	3.000	0.000	0.000	0.000	0.000	\$0.00	\$0.00
Install Stop Sign with Street Sign and Post										
0320	31	EA	\$435.000	3.000	0.000	0.000	0.000	0.000	\$0.00	\$0.00
Install End of Road Marker										
0330	32	LF	\$26.000	32.000	0.000	0.000	0.000	0.000	\$0.00	\$0.00
Concrete Header										

-62-

Line Number	Item ID	Unit	Unit Price	Authorized Quantity	Current Paid Quantity	Previous Paid Quantity	Total Quantity Paid To Date	Total Quantity Placed To Date	Current Payment Amount	Total Amount Paid To Date	
0730	9000-47	LS	\$0.000	0.000	0.000	0.000	0.000	0.000	\$0.00	\$0.00	
Contract Reduction											
									Section Totals:	\$145,706.44	\$175,381.88
Section: 3 - GROUP C - STORM SEWER											
0340	33	LS	\$19,450.000	1.000	0.000	1.000	1.000	1.000	\$0.00	\$19,450.00	
Mobilization											
0350	34	LS	\$1,750.000	1.000	0.000	1.000	1.000	1.000	\$0.00	\$1,750.00	
Bonding and Insurance											
0360	35	LF	\$54.000	209.000	0.000	209.000	209.000	209.000	\$0.00	\$11,286.00	
18" RCP, Class III											
0370	36	LF	\$70.000	345.000	0.000	345.000	345.000	345.000	\$0.00	\$24,150.00	
24" RCP, Class III											
0380	37	EA	\$994.000	1.000	0.000	1.000	1.000	1.000	\$0.00	\$994.00	
18" RCP Flared End Section											
0390	38	EA	\$1,228.000	1.000	0.000	1.000	1.000	1.000	\$0.00	\$1,228.00	
24" RCP Flared End Section											
0400	39	EA	\$6,115.000	8.000	0.000	4.500	4.500	4.500	\$0.00	\$27,517.50	
Curb Inlet (y=10')											
0410	40	EA	\$4,693.000	1.000	0.000	1.000	1.000	1.000	\$0.00	\$4,693.00	
48" Dia. Storm Sewer Manhole											
0420	41	EA	\$735.000	2.000	0.000	1.000	1.000	1.000	\$0.00	\$735.00	
Connect to Existing Storm Sewer Pipe											

Line Number	Item ID	Unit	Unit Price	Authorized Quantity	Current Paid Quantity	Previous Paid Quantity	Total Quantity Paid To Date	Total Quantity Placed To Date	Current Payment Amount	Total Amount Paid To Date
0430	42	LF	\$14.000	12.000	0.000	0.000	0.000	0.000	\$0.00	\$0.00
Remove CMP Storm Sewer Pipe										
0440	43	EA	\$115.000	2.000	0.000	0.000	0.000	0.000	\$0.00	\$0.00
Remove CMP Storm Sewer FES										
0450	44	EA	\$275.000	2.000	0.000	0.000	0.000	0.000	\$0.00	\$0.00
Remove Storm Sewer Structure (< 6' deep)										
0460	45	EA	\$27,250.000	1.000	0.000	1.000	1.000	1.000	\$0.00	\$27,250.00
Hydrodynamic Separator										
0470	46	EA	\$0.000	0.000	0.000	0.000	0.000	0.000	\$0.00	\$0.00
72" Dia. Storm Sewer Manhole										
0710	6.5.010	EA	\$5,785.000	1.000	0.000	1.000	1.000	1.000	\$0.00	\$5,785.00
60" Dia. Storm Sewer Manhole										
Section Totals:									\$0.00	\$124,838.50
Section: 4 - GROUP D - SANITARY SEWER										
0480	47	LS	\$8,900.000	1.000	0.000	1.000	1.000	1.000	\$0.00	\$8,900.00
Mobilization										
0490	48	LS	\$1,275.000	1.000	0.000	1.000	1.000	1.000	\$0.00	\$1,275.00
Bonding and Insurance										
0500	49	LF	\$48.000	729.000	0.000	729.000	729.000	729.000	\$0.00	\$34,992.00
8" PVC Sanitary Sewer Main, SDR 35										
0510	50	LF	\$40.000	587.000	0.000	587.000	587.000	587.000	\$0.00	\$23,480.00
4" PVC Sanitary Sewer Service, SDR 26										

-64-

Line Number	Item ID	Unit	Unit Price	Authorized Quantity	Current Paid Quantity	Previous Paid Quantity	Total Quantity Paid To Date	Total Quantity Placed To Date	Current Payment Amount	Total Amount Paid To Date
0520	51	VF	\$724.000	40.000	0.000	29.760	29.760	29.760	\$0.00	\$21,546.24
48" Dia. Concrete Manhole										
0530	52	EA	\$282.000	12.000	0.000	12.000	12.000	12.000	\$0.00	\$3,384.00
8" x 4" Wye, PVC										
0540	53	EA	\$90.000	1.000	0.000	0.000	0.000	0.000	\$0.00	\$0.00
8" Cap, PVC										
0550	54	EA	\$695.000	1.000	0.000	1.000	1.000	1.000	\$0.00	\$695.00
Connect to Existing Sanitary Sewer Main										
0560	55	LF	\$12.000	30.000	0.000	0.000	0.000	0.000	\$0.00	\$0.00
Remove Sanitary Sewer Pipe										
Section Totals:									\$0.00	\$94,272.24
Section: 5 - GROUP E - ROADWAY										
0570	56	LS	\$5,580.000	1.000	0.000	0.500	0.500	0.500	\$0.00	\$2,790.00
Mobilization										
0580	57	LS	\$2,110.000	1.000	0.000	1.000	1.000	1.000	\$0.00	\$2,110.00
Bonding and Insurance										
0590	58	LS	\$1,800.000	1.000	0.000	0.250	0.250	0.250	\$0.00	\$450.00
Temporary Traffic Control Measures										
0600	59	SY	\$2.800	2,169.000	222.220	122.220	344.440	344.440	\$622.21	\$964.43
Subgrade Preparation										
0610	60	SY	\$65.500	2,169.000	222.220	122.220	344.440	344.440	\$14,555.41	\$22,560.82
7" Concrete Pavement										

-65-

Line Number	Item ID	Unit	Unit Price	Authorized Quantity	Current Paid Quantity	Previous Paid Quantity	Total Quantity Paid To Date	Total Quantity Placed To Date	Current Payment Amount	Total Amount Paid To Date
0620	61	SF	\$88.000	16.000	0.000	0.000	0.000	0.000	\$0.00	\$0.00
Detectable Warning Panels										
0630	62	EA	\$580.000	1.000	0.000	0.000	0.000	0.000	\$0.00	\$0.00
Install Stop Sign with Street Sign and Post										
0640	63	EA	\$435.000	3.000	0.000	0.000	0.000	0.000	\$0.00	\$0.00
Salvage End of Road Marker										
Section Totals:									\$15,177.62	\$28,875.25
Section: 6 - GROUP F – SANITARY SEWER										
0650	64	LS	\$5,320.000	1.000	0.000	1.000	1.000	1.000	\$0.00	\$5,320.00
Mobilization										
0660	65	LS	\$505.000	1.000	0.000	1.000	1.000	1.000	\$0.00	\$505.00
Bonding and Insurance										
0670	66	LF	\$48.000	304.000	0.000	304.000	304.000	304.000	\$0.00	\$14,592.00
8" PVC Sanitary Sewer Main, SDR 35										
0680	67	LF	\$40.000	280.000	0.000	280.000	280.000	280.000	\$0.00	\$11,200.00
4" PVC Sanitary Sewer Service, SDR 26										
0690	68	VF	\$724.000	9.000	0.000	8.970	8.970	8.970	\$0.00	\$6,494.28
48" Dia. Concrete Manhole										
0700	69	EA	\$282.000	8.000	0.000	8.000	8.000	8.000	\$0.00	\$2,256.00
8" x 4" Wye, PVC										
Section Totals:									\$0.00	\$40,367.28
Section: Section ID - Section Description										

Line Number	Item ID	Unit	Unit Price	Authorized Quantity	Current Paid Quantity	Previous Paid Quantity	Total Quantity Paid To Date	Total Quantity Placed To Date	Current Payment Amount	Total Amount Paid To Date
0010	Item No.	Unit	\$0.000	0.000	0.000	0.000	0.000	0.000	\$0.00	\$0.00
Item										
Section Totals:									\$0.00	\$0.00
Total Payments:									\$180,759.06	\$959,919.04

Time Charges

Time Limit	Original Deadline	Authorized Deadline	Charges This Period	Damages This Period	Days Completed To Date	Days Remaining To Date	Damages To Date
Final Completion	11/30/2025	11/30/2025	N/A	\$0.00	N/A	-41.0 Days	\$0.00
Substantial Completion	10/31/2025	10/31/2025	N/A	\$0.00	N/A	-71.0 Days	\$0.00
Total Damages:							\$0.00

-67-

Summary

Current Approved Work:	\$180,759.06	Approved Work To Date:	\$959,919.04
Current Stockpile Advancement:	\$0.00	Stockpile Advancement To Date:	\$0.00
Current Stockpile Recovery:	\$0.00	Stockpile Recovery To Date:	\$0.00
Current Retainage:	\$9,037.95	Retainage To Date:	\$47,995.95
Current Retainage Released:	\$0.00	Retainage Released To Date:	\$0.00
Current Liquidated Damages:	\$0.00	Liquidated Damages To Date:	\$0.00
Current Adjustment:	\$0.00	Adjustments To Date:	\$0.00
Current Payment:	\$171,721.11	Payments To Date:	\$911,923.09
Previous Payment:	\$46,525.65	Previous Payments To Date:	\$740,201.98

-68-

Contractor's Certification

The undersigned Contractor certifies, to the best of its knowledge, the following:

- (1) All previous progress payments received from Owner on account of Work done under the Contract have been applied on account to discharge Contractor's legitimate obligations incurred in connection with the work covered by prior Applications for Payment;
- (2) Title to all work, materials and equipment incorporated in said work, or otherwise listed in or covered by this application for payment, will pass to Owner at time of payment free and clear of all liens, security interests and encumbrances (except such as are covered by a bond acceptable to Owner indemnifying Owner against any such liens, security interest or encumbrances); and
- (3) All work covered by this Application for Payment is in accordance with the Contract Documents and is not defective.

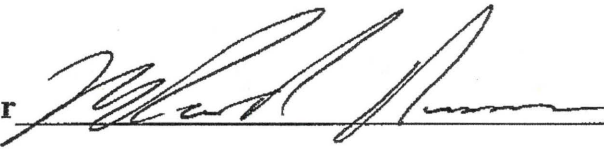
Contractor  **Date** 1-14-2026

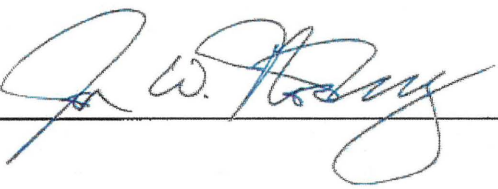
Engineer  **Date** 1/14/2026

Owner _____ **Date** _____

-69-

SDL – LOCAL RECOMMENDATION

NEBRASKA LIQUOR CONTROL COMMISSION
301 CENTENNIAL MALL SOUTH
PO BOX 95046
LINCOLN, NE 68509-5046
PHONE: (402) 471-2571
FAX: (402) 471-2814
EMAIL: lcc.sdl.licensing@nebraska.gov
WEBSITE: www.lcc.nebraska.gov

159493

Mary Young Mens Christian Association

License # _____ Licensee Name/Non-Profit Organization _____

Event location name: Beatrice Mary Family YMCA

Event address/location: 1801 Scott St

Event Type: Fundraiser

Event date(s): 2-28-26

Event start time(s): 5:30 pm

Event end time(s): 11:00pm

Indoor area to be licensed in length & width: 114 X 70

Outdoor area to be licensed in length & width: _____ X _____ (Must submit a diagram)

Estimated number of attendees: 250

Alternate dates/times: no

Alternate location name/location: no

Type of alcohol to be served: Beer Wine Distilled Spirits

Event contact name: alison leonard Event contact phone number: 4022394850

Event contact Email: aleonard@beatriceymca.org

*Signature Authorized Representative: *Alison Leonard*

Local Governing Body completes below:

The local governing body for the City of _____ OR
County of _____ approves the issuance of a Special Designated License as
requested above.

Local Governing Body Authorized Signature

Date

Non-Profit Organization Affidavit for Special Designated License

NEBRASKA LIQUOR CONTROL COMMISSION
301 CENTENNIAL MALL SOUTH
PO BOX 95046
LINCOLN, NE 68509-5046
PHONE: (402) 471-2571
FAX: (402) 471-2814
EMAIL: lcc.frontdesk@nebraska.gov
WEBSITE: www.lcc.nebraska.gov

Affidavit of Non-Profit Status

I HEREBY DECLARE THAT THE CORPORATION MAKING APPLICATION FOR A SPECIAL DESIGNATED LICENSE UNDER THE NEBRASKA LIQUOR CONTROL ACT IS EITHER A MUNICIPAL CORPORATION, A FINE ARTS MUSEUM INCORPORATED AS A NONPROFIT CORPORATION, A RELIGIOUS NONPROFIT CORPORATION WHICH HAS BEEN EXEMPTED FROM THE PAYMENT OF FEDERAL INCOME TAXES, A POLITICAL ORGANIZATION WHICH HAS BEEN EXEMPTED FROM THE PAYMENT OF FEDERAL INCOME TAXES, OR ANY OTHER NONPROFIT CORPORATION, THE PURPOSE OF WHICH IS FRATERNAL, CHARITABLE, OR PUBLIC SERVICE AND WHICH HAS BEEN EXEMPTED FROM THE PAYMENT OF FEDERAL INCOME TAXES AS PER §53-124.11(1).

AS SIGNATORY I CONSENT TO THE RELEASE OF ANY DOCUMENTS SUPPORTING THIS DECLARATION AND ANY DOCUMENTS SUPPORTING THIS DECLARATION WILL BE PROVIDED TO THE NEBRASKA LIQUOR CONTROL COMMISSION, THE NEBRASKA STATE PATROL OR ANY AGENT OF THE LIQUOR CONTROL COMMISSION IMMEDIATELY UPON DEMAND. I ALSO CONSENT TO THE INVESTIGATION OF THIS CORPORATE ENTITY TO DETERMINE IT'S NONPROFIT STATUS.

I AGREE TO WAIVE ANY RIGHTS OR CAUSES OF ACTION AGAINST THE NEBRASKA LIQUOR CONTROL COMMISSION, THE NEBRASKA STATE PATROL OR ANY PARTY RELEASING INFORMATION TO THE AFOREMENTIONED PARTIES.

Mary Young Men's Christian Association
NAME OF CORPORATION

47-0415814
FEDERAL ID NUMBER

Adam Leanders, CEO
SIGNATURE OF TITLE OF CORPORATE OFFICERS

THE ABOVE INDIVIDUAL STATES THAT THE STATEMENT ABOVE IS TRUE AND CORRECT: IF ANY FALSE STATEMENT IS MADE ON THIS APPLICATION, THE APPLICANT SHALL BE DEEMED GUILTY OF PERJURY AND SUBJECT TO PENALTIES PROVIDED BY LAW. (SEC. §53-131.01) NEBRASKA LIQUOR CONTROL ACT

SUBSCRIBED IN MY PRESENCE AND SWORN TO BEFORE ME THIS 12th DAY OF December, 2025.

Hannah Hennerberg
NOTARY PUBLIC SIGNATURE & SEAL

HANNAH HENNERBERG
General Notary - State of Nebraska
My Commission Expires Jan 7, 2028



AGENDA ITEM

Subject: Resolution executing the ACCO Chemical System Usage Agreement, as recommended by the Board of Public Works

For Agenda of: January 19, 2026

Exhibit(s):

Date Submitted: January 14, 2026

Recommend a resolution executing the ACCO Chemical System Usage Agreement #01152026 for the purchase of ACCO Liquid Chlorinating Concentrate Solution-L, to the Mayor and City Council

Rob Mierau, Water Superintendent, explained to the Board the City's chlorine generator has been out of commission for some time and the Department is looking to simplify the treatment process. ACCO will install four (4) tanks that the liquid solution will be kept in, in the Chem Feed building being built to the west of the north reservoir. Mierau noted the Department is also changing the monitoring system by integrating into the SCADA system, which will sound alarms if the levels go above or below the required limits. Currently, employees monitor the system two (2) times a day, seven (7) days a week. Mierau noted the City will likely enter into a maintenance agreement with ACCO to have the system checked quarterly to ensure it is working properly. Mierau stated the total cost to replace the chlorine generator is approximately \$300,000. Mierau estimates the breakeven point for the cost of the new process, including employee on call time, is approximately \$500,000, which will be met in an estimated ten (10) years.

Moved by Baehr, seconded by Hartley, that the Mayor and City Council execute the ACCO Chemical System Usage Agreement #01152026 for the purchase of ACCO Liquid Chlorinating Concentrate Solution-L.

Roll Call: Yea: Baehr, Hartley, Jones, Moran, Zarybnicky
Nay: None

MOTION CARRIED.

RESOLUTION NUMBER _____

A resolution authorizing the Mayor and City Clerk to enter into an ACCO Chemical System Usage Agreement with ACCO Unlimited Corporation for the provision of ACCO Liquid Chlorinating Concentrate Solution-L for the City of Beatrice Water Department.

NOW, THEREFORE, BE IT RESOLVED BY THE MAYOR AND CITY COUNCIL OF THE CITY OF BEATRICE, NEBRASKA:

SECTION 1. That the Mayor and City Clerk are hereby authorized to execute the ACCO Chemical System Usage Agreement with ACCO Unlimited Corporation for the provision of ACCO Liquid Chlorinating Concentrate Solution-L for the City of Beatrice Water Department. A copy of said Agreement is attached hereto as Exhibit "A" and is incorporated herein by reference.

SECTION 2. That all resolutions or parts of resolutions in conflict herewith are hereby repealed.

RESOLUTION PASSED AND ADOPTED this 19th day of January, 2026.

Attest:

Erin Saathoff, MMC, City Clerk

Robert Morgan, Mayor

ACCO CHEMICAL SYSTEM USAGE AGREEMENT # 01152026

ACCO Unlimited Corporation ("ACCO") and the City of Beatrice, NE ("Customer") agree to as follows:

ACCO shall sell to Customer and Customer shall purchase from ACCO, Customer's total requirements of ACCO Liquid Chlorinating Concentrate Solution-L at \$ 2.88 per/gallon for a period of 36 Months commencing on 01/31/2026 . Thereafter, this agreement shall automatically continue for successive one-year terms unless it is terminated by either party, in writing, with a 60-day notice after Customer provides ACCO the opportunity to negotiate and discuss reasons for termination.

Chemical pricing listed above shall remain unchanged for one year following the effective date of this agreement. ACCO reserves the right to adjust (increase/decrease) pricing on an annual basis due to changes in the chemical industry supply, transportation, taxes, insurance, and government regulations.

The system/equipment will be located at North Reservoir 312 Grant Street Beatrice, NE 68310 and consists of the following:

Chemical resistant tank(s) with berm and cam-lock fill connections per customer needs and space requirements.

Add-On: Chemical Resistant Day Tank Option

The system/equipment shall remain, at all times, the sole and exclusive property of ACCO Unlimited Corporation.

The ACCO Advantage – ACCO provides the following courtesy services as applicable: Routine visits to check equipment and chemical inventory as necessary, water testing/analysis and recommendations for changes in water chemistry parameters and/or operations, in-person and phone availability for troubleshooting and assistance. Products will be delivered to Customer by ACCO in accordance with ACCO's regular truck route schedule.

Installation, maintenance, and service to be provided to Customer for all elected system/equipment listed above at no charge for the first year. Routine maintenance parts (if any) are chargeable to Customer following the first year of usage. System related labor is at no charge. Equipment to be maintained and serviced by ACCO as needed and regularly scheduled. Customer responsible for daily maintenance of equipment provided. Labor rates apply for: Moving elected system/equipment to a different location from where originally installed and any tank cleaning by Customer request.

The system shall be operated only by Customer and its employees who are authorized to operate the system/equipment elected. Customer shall take the proper cautions that are necessary to protect the equipment from vandalism and other damages, and shall maintain liability insurance and insurance against loss, theft, damage, or destruction of the equipment. In no event shall ACCO be liable for loss of profits, loss of use, direct or indirect damages of any kind in connection with or arising out of the Customer's personnel, performance, maintenance, or use of the equipment or product.

Customer may not contract with, assign, or transfer this agreement or its rights hereunder. In the event that a notice of termination is not honored, Customer agrees to pay a penalty of \$500 in addition to any labor/trip costs for equipment removal and chemical disposal fees.

This agreement shall be governed by and construed in accordance with the laws of the State of Iowa. This agreement supersedes any and all prior agreements.

The undersigned has full authority to sign this agreement:

ACCO Unlimited Corporation
5105 NW Johnston Dr.
Johnston, IA 50131
515-278-0487

Customer Information:
Board of Public Works
500 North Commerce Street
Beatrice, NE 68310

Additional Billing Information:
402-228-5217
ap@beatrice.ne.gov

Sierra Woods
Sierra Woods General Manager
12/23/2025



Everything for Water



Beatrice Water

ACCO Bulk System Usage Agreement



Stan Weihs

Sales Representative

ACCO Unlimited Corporation
5105 NW Johnston Drive
Johnston, Iowa 50131

Toll: 800-548-2226
Office: 515-278-0487
Fax: 515-278-2183
Cell: 712-250-4665
Email: sweihs@accounlimited.com



Bulk System Usage Agreement

ACCO Liquid Chlorinating Solution-L.....\$2.88/gallon

\$80/Freight Charge Per Delivery

HOW IT WORKS

THE COMPONENTS OF AN ACCO BULK SYSTEM



CHEMICAL TANKS

Our spec'd chemical tanks are engineered for improved strength and resistance to environmental stress and cracking. Convenient manifold system for multiple tanks allows you to draw from tanks simultaneously or individually.



CHEMICAL DELIVERY

Chemical is only handled by certified ACCO drivers and technicians. Fill lines with dedicated Quick-Connects ensure that chemicals are always pumped into the correct tank.



DEPENDABLE SERVICE

We pride ourselves on our dependable deliveries and service. Deliveries are available once a month according to the ACCO delivery schedule. We are quick to service and repair components of the ACCO bulk system when needed.

PROPRIETARY DATA

PROPERTY OF ACE ROTO-MOLD MFG, INC. INFORMATION FURNISHED HEREIN IS THE PROPERTY OF ACE ROTO-MOLD MFG, INC. AND SHALL NOT BE USED, DISCLOSED TO OTHERS, OR COPIED WITHOUT THE EXPRESSED WRITTEN CONSENT OF ACE ROTO-MOLD MFG, INC. ALL RIGHTS RESERVED.

VT0265-31

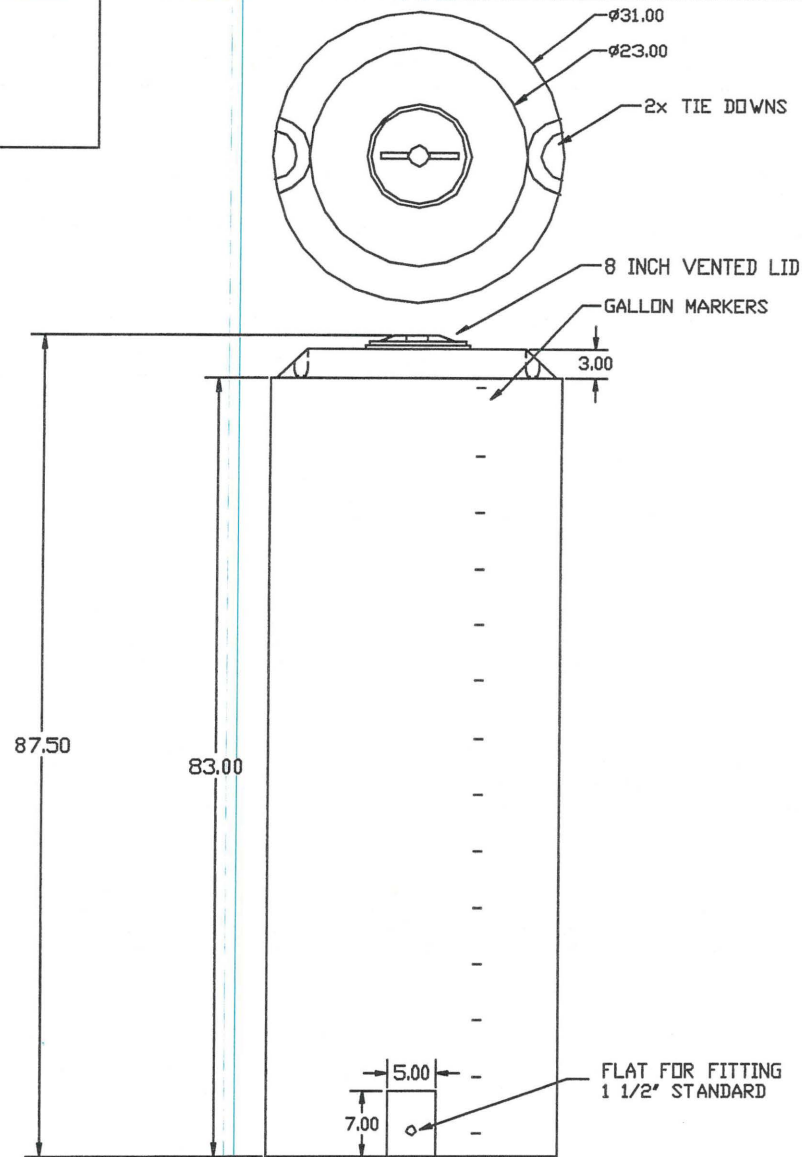

-77-

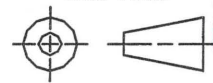
		DRAWN / DATE DHJ 5/3/04		MATERIAL / SHOT WEIGHT POLYETHYLENE 74 LBS.		 Ace Roto-Mold A DIVISION OF DEN HARTOG INDUSTRIES, INC.	
		APPRD. / DATE				CLIENT / DESCRIPTION 265 GALLON VERTICAL TANK	
REV	DESCRIPTION	DATE	APPRD.	THIRD ANGLE PROJECTION ANSI 14.5M		SCALE NONE	PART NO. VT0265-31
ALL DIMENSIONS ARE IN DECIMAL INCHES TOLERANCES UNLESS OTHERWISE SPECIFIED ±1% @ 88° F						NOTES: 1. NOM. WALL .250 2. YELLOW, BLUE, BLACK OR WHITE COLOR 3. OPTIONAL 16 INCH LID	

PROPRIETARY DATA

PROPERTY OF ACE ROTO-MOLD MFG, INC. INFORMATION FURNISHED HEREIN IS THE PROPERTY OF ACE ROTO-MOLD MFG, INC AND SHALL NOT BE USED, DISCLOSED TO OTHERS, OR COPIED WITHOUT THE EXPRESSED WRITTEN CONSENT OF ACE ROTO-MOLD MFG, INC. ALL RIGHTS RESERVED.

VT0110-32

A

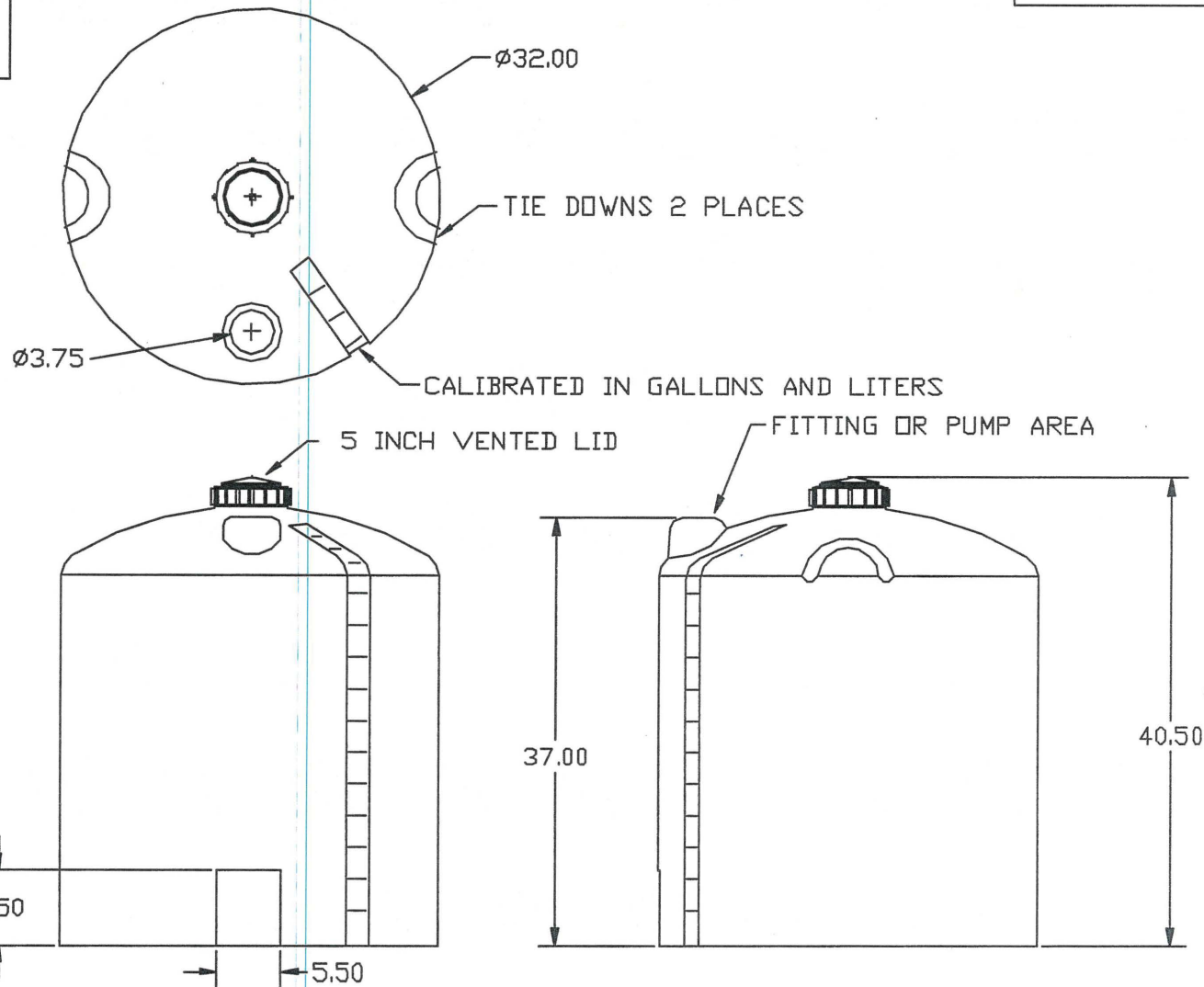

-78-

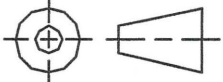
				DRAWN / DATE DHJ 12/17/02		MATERIAL		 ACE ROTO-MOLD A DIVISION OF DEN HARTOG INDUSTRIES, INC. 4018 HWY. 60 BLVD., BOX 421, HOSPERS, IOWA 51238	
				APPRD. / DATE REH 4/11/07		HOPE OR EQUIVALENT REFERENCE MATERIAL DATA SHEET FOR SPECIFIC PROPERTIES.			
REV	DESCRIPTION	DATE	APPRD	THIRD ANGLE PROJECTION ANSI 15.1		NOTES:		CLIENT / DESCRIPTION	
A	WAS 39.50 CCN 1290	4/9/07	DHJ			1. GREEN, WHITE, OR YELLOW COLOR 2. SHOT WEIGHT 41 LBS. 3. NOM. WALL .221 4. 2 INCH STANDARD FITTING		110 GALLON VERTICAL TANK	
ALL DIMENSIONS ARE IN DECIMAL INCHES TOLERANCES UNLESS OTHERWISE SPECIFIED $\pm 1\% @ 68^\circ F$								SCALE	
								N.S.	



Direct Purchase Option

	List Price	Price Each
Stenner S Series 4-20ma Pump	\$2,279.07	\$1,937.00
Corporation Stop Assembly		\$481.95

Price includes installation at time of bulk installation; miscellaneous fittings, piping and tubing are not included in the price.

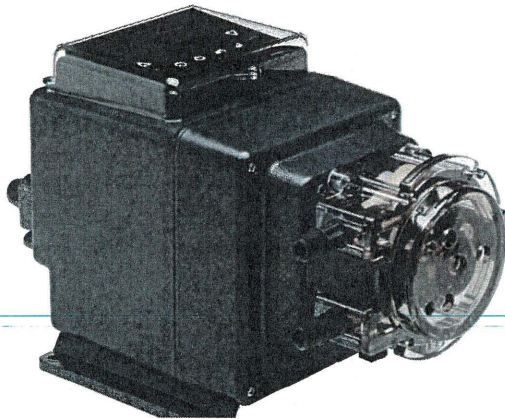

Stenner S44 Model S407X

THE S SERIES INTERFACES WITH PROCESS CONTROL SYSTEMS UTILIZING A 4-20mA OUTPUT SIGNAL, THREE OUTPUT RELAYS AND IS MODBUS CAPABLE. Select from multiple status indicators and operational modes with OLED operating display. Fine-tune the pump to fit the application and monitor for peace of mind. Prevent unauthorized access to programmed settings with password protection. Built to NEMA 4X for demanding applications.

- Max. Flow rate: 60 gpd
- Rated up to 100 psi
- Turndown 100:1

Quarterly Service Option

	Per Service
ACCO Quarterly Service	\$675.00 + Parts

ACCO service quarterly visits to check over system including: Replacing tubing, cleaning POI's, Servicing Feed Pump(s), Reaming Corp Stop, and Making Repairs as Needed.

STENNER PUMPS

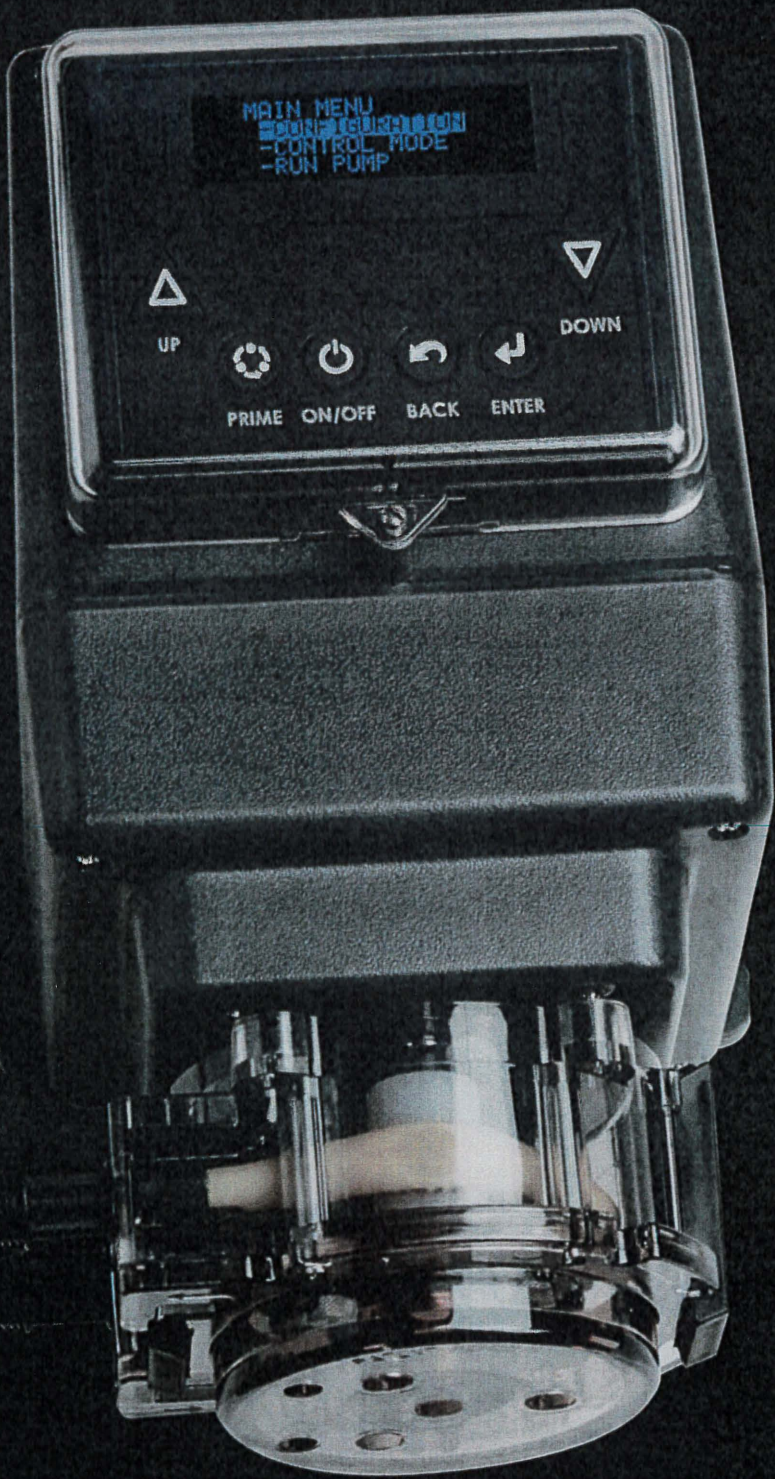

S SERIES

PERISTALTIC PUMP

SMART TECHNOLOGY

SIMPLE PROGRAMMING

SOLID CONSTRUCTION

For Demanding Applications

S SERIES

PERISTALTIC PUMP

For Demanding Applications

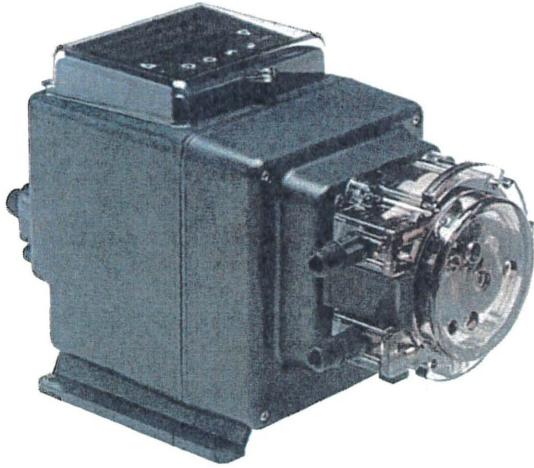

THE S SERIES INTERFACES WITH PROCESS CONTROL SYSTEMS UTILIZING A 4-20mA OUTPUT SIGNAL AND THREE RELAY OUTPUTS

Built to NEMA 4X for demanding applications. Select from multiple performance indicators and operational modes with intuitive programming and easy navigation. Fine-tune the pump to fit the application; monitor the pump for peace of mind. Prevent unauthorized access to programmed settings with the password protection.

SMART TECHNOLOGY

PERFORMANCE INDICATORS

Program the pump to respond based on a selected condition:

- Tube Leak
- Tube Change
- Standby
- Repeat Pulse
- Run
- Mode Change
- Low Signal
- High Signal
- Low Flow
- High Flow
- Drive Fault
- Signal Overrun
- Transfer
- Off



TUBE LEAK DETECTOR

- Can detect solution in the pump head, vertically or horizontally
- Program alarm indicator with option to stop pump upon alarm
- Calibrate the sensitivity to avoid false detection



TUBE TIMER

Set the tube's life expectancy in hours. When the set time is reached, the display shows the tube change alarm indicator.



STANDBY

Program the transfer function to activate a relay to start a second S Series in Standby, as a back up to the primary pump.



SIMPLE PROGRAMMING

PUMP SIGNAL INPUTS

ANALOG 4-20mA

- Proportional response to a 4-20mA signal; scalable, invertible.
- Speed varies to the signal level.

0-10VDC

- Proportional response to a 0-10VDC signal; scalable, invertible.
- Speed varies to the signal level.

DIGITAL Pulse

- Accepts a dry contact or open collector type input signal from a controller or water meter.
- Activates at the number of pulses received, to run for a set amount of time.

Hall Effect

- Speed varies according to Hall Effect input from a controller or flow meter.
- Program is based on meter's K factor, process flow range and desired pump output.

PPM Feed Constant Flow

- Accepts a dry contact or open collector type input signal from a flow switch.
- Program is based on the process flow rate, chemical concentration, chemical specific gravity and the desired ppm feed rate.

PPM Feed Variable Flow

- Accepts a Hall Effect input from a flow meter.
- Speed varies to maintain the desired ppm feed rate.
- Program is based on meter's K factor, process flow range, chemical concentration, chemical specific gravity and desired ppm feed rate.

MANUAL Manual

- Speed controlled manually.
- Adjustable from 0% to 100% in 1% increments.

7 Day / 24 Hour Timer

- Program with a clock in real time.
- Run for a specific day, at a specific time, at speeds from 1% to 100%.
- 24 independent events, any combination of days.

Cycle Timer

- Run on a repeatable ON/OFF sequence.

PUMP SIGNAL OUTPUTS

ANALOG 4-20mA

- Produces a non-adjustable, proportional signal corresponding to the speed percentage the pump is running. 4mA=0% & 20mA=100%

DIGITAL Relays

- Dry contact signal; program normally open or normally closed.
- Indicate an alarm.
- Repeat an incoming signal.
- Transfer operation to another S Series pump in Standby.

SOLID CONSTRUCTION

- Brushless DC motor is equipped with ball bearing support
- Switch mode power supply is energy efficient
- Totally enclosed pump is outdoor rated
- OLED operating display is easy to navigate with intuitive programming
- QuickPro® pump head offers tube replacement without tools
- Splined shaft designed pump head & roller assembly allow smooth installation & replacement
- NEMA 4X, NSF 61 & 372, cULus indoor/outdoor, CE IP65

MAXIMUM FLOW RATES

40 gpd, up to 100 psi / 151.4 lpd, up to 6.9 bar

85 gpd, up to 25 psi / 321.8 lpd, up to 1.7 bar

VOLTAGE

120 VAC, 60Hz

230 VAC, 50Hz

STENNER PUMPS BUILT WITH A STRONG WORK ETHIC

1. Self-priming against maximum working pressure
2. Can inject off-gassing solutions
3. No vapor lock or loss of prime
4. Easy tube replacement without tools
5. Uniquely manufactured solid one piece tube construction
6. Tube lubrication not required
7. Three point roller design assists with anti-siphoning
8. Output reproducibility
9. Output volume not affected by back pressure
10. Foot, prime or de-gassing valve not required

S SERIES SPECIFICATIONS

STENNER PUMPS®

S30 Models

Shipping Weight
9 lbs (3.7 kg)

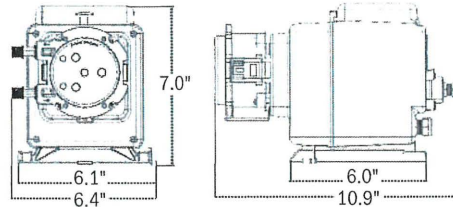
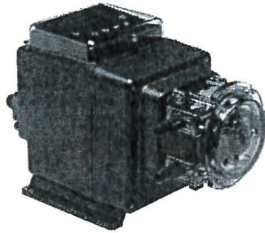

AGENCY LISTINGS



Intertek
94247

CONFORMS TO
ANSI/NSF STD. 50
Equipment for swimming pools,
spas, hot tubs and other
recreational water facilities.

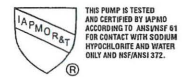

Listings vary by model

S40 Models

Shipping Weight
9 lbs (3.7 kg)

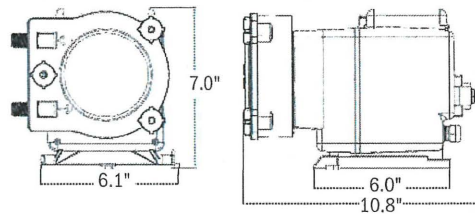
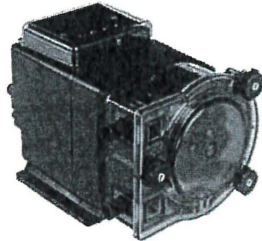

S50 Models

Shipping Weight
14 lbs (6.3 kg)

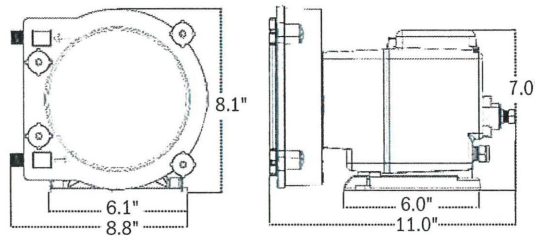
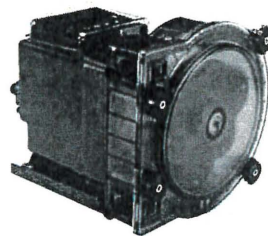

FEATURES

- Operational mode options: 4-20mA, 0-10VDC, dry contact, hall effect signals, cycle timer, 7 day/24 hour timer and manual
- Backup pump capability
- Standby input option to stop or start pump remotely
- Leak detection with dedicated output relay
- Modbus RTU over RS-485 capable (accessory required)
- Performance indicators with optional dry contact output relays
- Password protection
- Totally enclosed housing, NEMA 4X
- 2 year warranty
- Self-priming, does not lose prime or vapor lock
- Pumps off-gassing solutions and can run dry
- 3-point roller design assists with anti-siphon
- Simple tube replacement
- Output reproducibility

SPECIFICATIONS

Flow Rate Output Control Varies per control mode; digital keypad
Reproducibility ±2%
Maximum Working Pressure 25 psi (1.7 bar), 100 psi (6.9 bar)
Maximum Operating Temperature 104°F (40°C)
Maximum Suction Lift 25 ft (7.6 m) vertical lift, based on water
Motor Type Brushless DC motor
Shaft rpm (average maximum) 45
Duty Cycle Continuous
Maximum Viscosity 1500 Centipoise
Motor Voltage (Amp Draw)
 120V 60Hz 1PH (0.6), 230V 50Hz 1PH (0.3)
Hall Effect Max. Input Frequency 100 KHz
Pulse Duration Required 10 milliseconds
 Minimum duration required for pump to read signal.
Power Cord Type 120V 60Hz SJTOWA, 230V 50Hz H05RN-F
Power Cord Plug End 120V 60Hz 5-15P, 230V 50Hz CEE7/7
Power Cord Length 6 ft (1.8 m)
Classification Indoor/Outdoor

S SERIES SPECIFICATIONS



MATERIALS OF CONSTRUCTION

All Housings Polycarbonate

Pump Tube (S30) Santoprene® (FDA approved), or Versilon®
(S40, S50) Santoprene® (FDA approved)

Check Valve Duckbill (S30) Santoprene® (FDA approved), or Pellethane®

Ball Check Valve Components (S40, S50)

- Ceramic ball (FDA approved); Tantalum spring; FKM seat & O-ring OR
- Ceramic ball (FDA approved); Stainless steel spring; EPDM seat; Santoprene® O-ring

Pump Head Rollers (S30, S40) Polyethylene **(S50)** Polycarbonate

Guide Rollers (S40, S50) Polyethylene

Suction/Discharge Tubing, Ferrules Polyethylene (FDA approved)

Tube Fittings, Injection Fittings PVC or Polypropylene (both NSF listed)

Connecting Nuts PVC or Polypropylene (both NSF listed)

3/8" Adapter (S30) PVC or Polypropylene (both NSF listed)

Suction Line Strainer and Cap PVC or Polypropylene (both NSF listed); ceramic weight

All Fasteners Stainless steel

Pump Head Latches (S30) Polypropylene

Pump Head Thumb Screws (S40, S50) Stainless steel; PVC

Pump Head Support and Transition Sleeve (S40, S50) Santoprene®

Tube Pull (S40, S50) PVC

Leak Detect Components (S30) Hastelloy® **(S40, S50)** Hastelloy®; stainless steel

NOTE: Refer to the chemical guide for material compatibility.

Santoprene® is a registered trademark of Celanese International Corporation. Versilon® is a registered trademark of Saint-Gobain Performance Plastics. Pellethane® is a registered trademark of Lubrizol Advanced Materials, Inc. Hastelloy® is a registered trademark of Haynes International, Inc.

ACCESSORIES

S30 Models

- 3 Connecting Nuts 1/4" & 3 Ferrules 1/4" or 6 mm *Europe* or 3 Connecting Nuts & 2 Adapters 3/8"
- 1 Injection Fitting 25 psi (1.7 bar) max. or 1 Duckbill Check Valve 100 psi (6.9 bar) max.
- 1 Weighted Suction Line Strainer 1/4", 3/8" or 6 mm *Europe*
- 20' Suction/Discharge Tubing 1/4" or 3/8", white or UV black or 20' Suction/Discharge Tubing 6 mm white *Europe*
- 1 Additional Pump Tube
- 2 Additional Latches
- 1 Mounting Bracket
- 1 Quick Start Guide

S40, S50 Models

- 3 Connecting Nuts 3/8"
- 1 Ball Check Valve 3/8"
- 1 Weighted Suction Line Strainer 3/8"
- 20' Suction/Discharge Tubing 3/8", white or UV black
- 1 Additional Pump Tube
- 1 Mounting Bracket
- 1 Quick Start Guide

Download S Series Manual www.stenner.com

FLOW RATE OUTPUTS

25 psi (1.7 bar) maximum

Pump Prefix	Pump Tube	Turndown Ratio	Gallons per Day	Gallons per Hour	Ounces per Hour	Ounces per Minute	Liters per Day	Liters per Hour	Milliliters per Hour	Milliliters per Minute
S3003	3	100:1	0.40-40.0	0.017-1.67	2.13-213.0	0.036-3.56	1.51-151.0	0.063-6.31	63.09-6309.0	1.05-105.0
S3004	4	100:1	0.60-60.0	0.025-2.50	3.20-320.0	0.053-5.33	2.27-227.0	0.095-9.46	94.64-9464.0	1.58-158.0
S3005	5	100:1	0.85-85.0	0.035-3.54	4.53-453.0	0.076-7.56	3.22-322.0	0.134-13.41	134.07-13,407.0	2.23-223.0
S405X	5X	100:1	1.5-150.0	0.06-6.25	8.0-800.0	0.13-13.33	5.7-567.0	0.24-23.66	236.59-23,659.0	3.94-394.0
S505G	5G	100:1	3.2-315.0	0.133-13.13	17.07-1680.0	0.284-28.00	12.11-1192.0	0.505-49.68	504.72-49,684.0	8.41-828.0

Approximate outputs @ 50/60Hz

100 psi (6.9 bar) maximum

Pump Prefix	Pump Tube	Turndown Ratio	Gallons per Day	Gallons per Hour	Ounces per Hour	Ounces per Minute	Liters per Day	Liters per Hour	Milliliters per Hour	Milliliters per Minute
S3001	1	100:1	0.05-5.0	0.002-0.21	0.27-27.0	0.004-0.44	0.19-19.0	0.008-0.79	7.89-789.0	0.13-13.0
S3002	2	100:1	0.17-17.0	0.007-0.71	0.91-91.0	0.015-1.51	0.64-64.0	0.027-2.68	26.81-2681.0	0.45-45.0
S3007	7	100:1	0.40-40.0	0.017-1.67	2.13-213.0	0.036-3.56	1.51-151.0	0.063-6.31	63.09-6309.0	1.05-105.0
S407X	7X	100:1	0.60-60.0	0.03-2.50	3.2-320.0	0.053-5.34	2.3-227.0	0.09-9.46	94.64-9464.0	1.58-158.0
S507G	7G	100:1	1.3-125.0	0.054-5.21	6.93-667.0	0.116-11.11	4.92-473.0	0.205-19.72	205.04-19,716.0	3.42-329.0

Approximate outputs @ 50/60Hz



NOTICE: The information within this chart is solely intended for use as a guide. The output data is an approximation based on pumping water under a controlled testing environment. Many variables can affect the output of the pump. Stenner Pump Company recommends that all metering pumps undergo field calibration by means of analytical testing to confirm their outputs. The information contained in this flyer is not intended for specific application purposes. Stenner Pump Company reserves the right to make changes to prices, products, and specifications at any time without prior notice.

A large, artistic splash of water in shades of blue and white, with many droplets and bubbles, positioned on the left side of the page.

References

Harrison County PWD#2

Randy Garrett
660-373-1000

Ashland Water

Greg Leuck
420-618-3660

Red Oak Water

Shane Harrison
712-789-0806

Testimonials

"We are very satisfied with the new system you installed in our pool for the chlorine. Stan Weihs was very professional and very informative about the system. He did a good job of showing us how we would save money and he was correct. We would like to thank him for the job he did. We look forward to working more with Stan."

—Chris Baird, Red Oak Pool

"Our pool was built to use chlorine tablets to disinfect the pool. We quickly found out that we wanted to change to liquid chlorine. The ease of use and the elimination of clogged feeders made it a great switch for our facility. The cost savings in man hours for maintenance and the actual cost of the product was certainly a plus as well. The other factor is that my staff no longer handles buckets. The liquid chlorine is safely pumped into the tanks by certified professionals and my staff doesn't have to touch anything. We have been completely satisfied with the switch over to liquid chlorine."

—Dan Haynes, Nishna Valley Family YMCA

"Everything happened like ACCO promised, no smoke or mirrors! We saved what they said we would and it was easier. The decision to stay with them was a no brainer!"

—Chris Clarcken, Humboldt Family Aquatic Center



Advantages of the ACCO Bulk System

1. No Capital Investment

All you pay for is the chemicals.

2. Cost Savings in Labor and Chemicals

With the ACCO bulk system there is no need to refill tablet feeders or unclog feed lines. This translates into valuable time savings.

3. Increased Safety

Eliminate the need for respirator masks. Chemical tanks remain closed at all times and are opened only by ACCO professionals.

4. Bermed Chlorine Tanks

Bermed tanks greatly reduce the risk of leaks while keeping your facility in compliance with state regulations.

5. No Splashing, Spilling, Lifting and Mixing

No heavy buckets to dump into feeders or carboys to risk spilling.

6. Dependable Deliveries

Dependable, timely deliveries according to the ACCO delivery schedule.

The Bottom Line

The ACCO Bulk System will increase safety at your site, decrease chemical costs, and decrease labor costs. Don't spend another minute unclogging feed lines, hauling buckets, or splashing tablets into a sludge pot.

Call today to get started with the ACCO Bulk System.

Stan Weihs

Sales Representative

ACCO Unlimited Corporation
5105 NW Johnston Drive
Johnston, Iowa 50131

Toll: 800-548-2226
Office: 515-278-0487
Fax: 515-278-2183
Cell: 712-250-4665
Email: sweihs@accounlimited.com

RESOLUTION NUMBER ____

WHEREAS, Thomas Bradney, Jim Franz, and Vaughn Wright's terms on the Beatrice Planning and Zoning Commission will expire on January 21, 2026; and

WHEREAS, the Mayor and City Council desire to reappoint Thomas Bradney and Vaughn Wright to the Beatrice Planning and Zoning Commission; and

WHEREAS, the Mayor and City Council desire to appoint David Painter to the Beatrice Planning and Zoning Commission.

NOW, THEREFORE, BE IT RESOLVED BY THE MAYOR AND CITY COUNCIL OF THE CITY OF BEATRICE, NEBRASKA:

SECTION 1. That Thomas Bradney and Vaughn Wright be and hereby are reappointed to the Beatrice Planning and Zoning Commission, for a term expiring January 21, 2029.

SECTION 2. That David Painter be and hereby is appointed to the Beatrice Planning and Zoning Commission, for a term expiring January 21, 2029.

SECTION 3. That all resolutions or parts of resolutions in conflict herewith are hereby repealed.

RESOLUTION PASSED AND ADOPTED this 19th day of January, 2026.

Attest:

Erin Saathoff, MMC, City Clerk

Robert Morgan, Mayor

RESOLUTION NUMBER _____

WHEREAS, the City of Beatrice, Nebraska (“City”) has a self-funded employee health plan for which it maintains excess stop loss insurance; and

WHEREAS, on December 16, 2024, the City entered into an excess stop loss agreement with QBE Insurance Corporation for the City’s self-funded employee health plan; and

WHEREAS, the City desires to renew its excess stop loss plan with QBE Insurance Corporation for the City’s self-funded employee health plan.

NOW, THEREFORE, BE IT RESOLVED BY THE MAYOR AND CITY COUNCIL OF THE CITY OF BEATRICE, NEBRASKA:

SECTION 1. That the Mayor, City Administrator, and City Clerk are hereby authorized to execute the Renewal of Excess Stop Loss Agreement with QBE Insurance Corporation and any and all other contracts, documents, exhibits, and memoranda necessary, to renew the Excess Stop Loss Agreement, effective January 1, 2026 to December 31, 2026, for the City’s self-funded employee health plan. A copy of said Agreement marked as “Exhibit A”, is attached hereto and incorporated herein by reference.

SECTION 2. That all resolutions or parts of resolutions in conflict herewith are hereby repealed.

RESOLUTION PASSED AND ADOPTED this 19th day of January, 2026.

Attest:

Erin Saathoff, MMC, City Clerk

Robert Morgan, Mayor

Exhibit "A"

QBE A&H
123 Pleasant Street, 3rd Floor
Marblehead, MA 01945
Toll Free: 800.742.9279
qbeah.com



October 14, 2025

Patrick Chakales
Lockton Dunning Series - Dallas
2100 Ross Avenue, Suite 1200
Dallas, TX 75201

Dear Patrick,

Re: Policy Issuance
Policyholder: City of Beatrice, January 01, 2026
Policy Number: LGS02656-26

Thank you for renewing coverage with QBE Insurance Corporation. We are pleased to have the opportunity to continue to service your client during the upcoming plan year.

Enclosed please find the appropriate renewal documents for completion. In order to bind coverage, the following requirements are needed.

- Signed and completed Application for Excess Loss Policy
- First month's renewal premium: (Specific)\$64,391.19 + (Aggregate)\$4,564.00 = \$68,955.19
- If you have had banking changes within the past 12 months, please make us aware to update your ACH Claim Reimbursement information on file.
- State Required Licensing: The signing agent must be licensed in the state where the prospective client is located, in the producer's resident state, and will need to be appointed with QBE where required. Last year's signing agent: **Stephen J. Idoux**
- Signed Master Plan Document: If a new Plan Document is being drafted ensure it states all the provisions of the plan and delineates the various responsibilities for financing the plan, the eligibility, and all the other aspects of the plan (summary descriptions and certificates alone are not acceptable). If there have been no changes to the document on file with QBE, please provide written confirmation and ensure we have any Amendments not previously sent submitted.

The following Endorsement(s) modify the Excess Loss Policy and will be provided upon Policy Issuance.

- Advance Reimbursement Endorsement
- Amendatory Endorsement
- Plan Mirror Endorsement
- Rate Stabilization Endorsement (**50%**)
- Nebraska Endorsement

Please review the application and advise your underwriter of any requested changes prior to the client's signature. We will promptly re-issue the paperwork with any necessary changes.

Also enclosed is the Premium & Enrollment statement. Premium is due on the first of every month. Please note that premium must be remitted directly to the PO BOX address listed on the Premium & Enrollment statement. A completed copy of this statement should be remitted with each payment.

QBE and the links logo are registered service marks of QBE Insurance Group Limited.

We appreciate your business partnership and the opportunity to service the needs of our mutual client. Please do not hesitate in contacting us with any questions or concerns.

Regards,



Mark Suchy
Account Manager
QBE A&H
Cc: Jennifer DiCanio



QBE INSURANCE CORPORATION
STATE OF DOMICILE: PENNSYLVANIA

APPLICATION FOR EXCESS LOSS INSURANCE POLICY

Policy Number: **LGS02656-26**

1. Full legal name of Policyholder: **City of Beatrice** Tax ID Number: **47-6006092**
(as it will appear in the Policy)

2. Principal Office Address:
400 Ella Street, Beatrice, NE 68310

3. Contact Person: **Erin Saathoff** Email: **esaathoff@beatrice.ne.gov**

4. Nature of Business: **9199: General Government, NEC**

5. If Employee Benefit Plans of subsidiary or affiliated companies (companies under common control through stock ownership, contract, or otherwise) are to be included, list legal names and addresses of such companies and the nature of their business:

6. Full name of Your Employee Benefit Plan:

A copy of Your Employee Benefit Plan Document, and those of any subsidiary or affiliated companies that are to be included, must be attached to, and shall form a part of, this Application.

7. Effective Date: **January 01, 2026**

8. Endorsements:

Advance Reimbursement Endorsement	AH-MSL-5013
Amendatory Endorsement	AH-MSL-5002
Plan Mirroring Endorsement	AH-MSL-5003
Rate Stabilization Endorsement	AH-MSL-5005
Nebraska Endorsement	AH-MSL-5010-NB

9. N/A

10. Your Designated Third Party Administrator (for purpose of claims administration under Your Employee Benefit Plan):

Name: **Allegiance Benefit Plan Management**
Address: **2806 S. Garfield Street**
City, State, Zip: **Missoula, MT 59801-7733**
Telephone: **(406) 721-2222**

11. Your broker/agent of record:

Name: **Lockton Dunning Series - Dallas**
Address: **2100 Ross Avenue, Suite 1200, Dept 3042**
City, State, Zip: **Dallas, TX 75201**

12. Your PPO Network is: Cigna OAP
13. Your Utilization Review Provider is: Allegiance Benefit Plan Management
14. Eligible for coverage:
 Retirees: Yes No Late Entrants: Yes No

15. Estimated Covered Units:

Covered Unit Description	Units
<u>Single</u>	<u>29</u>
<u>Composite</u>	<u>111</u>

16. Initial premium deposit accompanying this Application:
(Specific)\$64,391.19 + (Aggregate)\$4,564.00 = \$68,955.19

17. **COVERAGES**

The Coverage shown applies only during the Policy Period from January 01, 2026 (Effective Date) through December 31, 2026 (Expiration Date) and is further subject to all the provisions of the Policy.

- A. SPECIFIC EXCESS LOSS COVERAGE Yes, included No, not included
- 1) Coverage to be included (not included unless checked):
 Medical Prescription Drugs
 - 2) Specific Attachment Point: **\$100,000.00.**
 Per Covered Person.
 - 3) Aggregating Specific Deductible: **\$0**
N/A
 - 4) Specific Policy Period Maximum Reimbursement **Unlimited upon satisfaction of Specific Attachment Point** per Covered Person.
 - 5) Basis of Specific Excess Loss coverage benefit payment (Benefit Period):

Plan Benefits Incurred from January 01, 2021 through December 31, 2026 and paid from January 01, 2026 through December 31, 2026.

Plan Benefits Incurred prior to the Effective Date (Run-In-Period) will be limited to:
N/A per Covered Person
N/A for all Covered Persons combined

6) Premium Rates (per month):

Covered Unit Description	Amount
<u>Single:</u>	<u>29</u> <u>\$181.89</u>
<u>Composite:</u>	<u>111</u> <u>\$532.58</u>

7) Estimated Annual Specific Premium: **\$772,694.00.**

- B. AGGREGATE EXCESS LOSS INSURANCE Yes, Included No, not included

1) Coverage to be included (not included unless checked):
 Medical Prescription Drugs

2) Monthly Aggregate Factor:

Covered Unit Description	Total	Medical	Prescription Drugs
Employee:	\$1,323.99	X	X

Family:	\$3,833.31	X	X
---------	------------	---	---

- 3) Estimated Annual Aggregate Attachment Point: **\$5,566,717.44**
- 4) Minimum Annual Aggregate Attachment Point Percentage: **100%**
- 5) Estimated Minimum Annual Aggregate Attachment Point: **\$5,566,717.44 (Estimated)**
- 6) Individual Claim Limit **\$100,000.00**
Per Covered Person.
- 7) Aggregate Policy Period Maximum Reimbursement (per Policy Period): **\$1,000,000.00**
- 8) Basis of Aggregate Excess Loss coverage benefit payment (Benefit Period):

Plan Benefits Incurred from **January 01, 2021** through **December 31, 2026**
and paid from **January 01, 2026** through **December 31, 2026**.

Plan Benefits Incurred prior to the Effective Date (Run-In-Period) will be limited to:
N/A per Covered Person
N/A for all Covered Persons combined

- 9) Premium Rates (per month):

Covered Unit Description	Amount
<u>Aggregate Composite</u>	<u>\$32.60</u>
<u>Total</u>	<u>\$</u>

- 10) Estimated Annual Aggregate Premium: **\$54,768.00**.

18. Special Limitations and Additional Information: **N/A**

You have read the foregoing and understand and agree with the terms and conditions of the coverage as set forth by Us and as reflected in the Application. You represent that You have formed Your Employee Benefit Plan in compliance with all applicable state and federal laws. It is agreed that the statements in the Application or in any materials submitted with this Application or attached to it, including all disclosure information, are Your representations and shall be deemed material to acceptance of the risk by Us and that the Policy is issued by Us in reliance on the truth and accuracy of such representations. Should subsequent information become known which, if known prior to issuance of the Policy, would affect the premium rates, factors, terms or conditions for coverage thereunder, We will have the right to revise the premium rates, factors, terms or conditions as of the Effective Date, by providing written notice to You. Any fraudulent statement will render the Policy null and void and claims, if any, will be forfeited.

THIS APPLICATION DOES NOT BIND COVERAGE. Upon approval of the Application, the Policy evidencing that the coverage is in force will be issued by Us. Coverage will commence on the Effective Date set forth in the Policy. This Application will attach to and form part of the Policy.

FRAUD WARNING: Any person who knowingly, and with intent to injure, defraud or deceive any insurer, submits an application for insurance or makes any claim for the proceeds of an insurance policy containing any false, incomplete or misleading information may be guilty of insurance fraud. (Policyholders located in AL, AR, CA, CO, DC, FL, KS, KY, LA, ME, MD, NJ, NM, NY, OH, OK, PA, RI, TN, VA, WA and WV must read the Fraud Warning applicable to their state.)

ACCEPTED BY THE POLICYHOLDER:

Signed at _____

Policyholder (correct legal name)

Date _____

By (Officer's signature and title)

(Print Name)

Signature Broker/Agent of Record

(Print Name)

ACCEPTED BY THE COMPANY:

Signed at Marblehead, Massachusetts

On behalf of the Company

Date _____

Tara Krauss, President of A&H
By (Officer's name and title)

NOTICE TO ALABAMA APPLICANTS: Any person who knowingly presents a false or fraudulent claim for payment of a loss or benefit or who knowingly presents false information in an application for insurance is guilty of a crime and may be subject to restitution, fines, or confinement in prison, or any combination thereof.

NOTICE TO ARKANSAS APPLICANTS: Any person who knowingly presents a false or fraudulent claim for payment of a loss or benefit, or knowingly presents false information in an application for insurance is guilty of a crime and may be subject to fines and confinement in prison.

NOTICE TO CALIFORNIA APPLICANTS: The falsity of any statement in the application for any policy shall not bar the right to recovery under the policy unless such false statement was made with actual intent to deceive or unless it materially affects either the acceptance of the risk or the hazard assumed by the insurer.

NOTICE TO COLORADO APPLICANTS: It is unlawful to knowingly provide false, incomplete, or misleading facts or information to an insurance company for the purpose of defrauding or attempting to defraud the company. Penalties may include imprisonment, fines, denial of insurance and civil damages. Any insurance company or agent of an insurance company who knowingly provides false, incomplete, or misleading facts or information to a policyholder or claimant for the purpose of defrauding or attempting to defraud the policyholder or claimant with regard to a settlement or award payable from insurance proceeds shall be reported to the Colorado Division of Insurance within the Department of Regulatory Agencies.

NOTICE TO DISTRICT OF COLUMBIA APPLICANTS: WARNING: It is a crime to provide false or misleading information to an insurer for the purpose of defrauding the insurer or any other person. Penalties include imprisonment and/or fines. In addition, an insurer may deny insurance benefits if false information materially related to a claim was provided by the applicant.

NOTICE TO FLORIDA APPLICANTS: Any person who knowingly and with intent to injure, defraud, or deceive any insurer files a statement of claim or an application containing any false, incomplete or misleading information is guilty of a felony in the third degree.

NOTICE TO KANSAS APPLICANTS: Any person who commits a fraudulent insurance act is guilty of a crime and may be subject to restitution, fines and confinement in prison. A fraudulent insurance act means an act committed by any person who, knowingly and with intent to defraud, presents, causes to be presented or prepares with knowledge or belief that it will be presented to or by an insurer, purported insurer or insurance agent or broker, any written, electronic, electronic impulse, facsimile, magnetic, oral or telephonic communication or statement as part of, or in support of, an application for insurance, or the rating of an insurance policy, or a claim for payment or other benefit under an insurance policy, which such person knows to contain materially false information concerning any material fact thereto; or conceals, for the purpose of misleading, information concerning any fact material thereto.

NOTICE TO KENTUCKY APPLICANTS: Any person who knowingly and with the intent to defraud any insurance company or other person files an application for insurance containing any materially false information, or conceals for the purpose of misleading, information concerning any fact material thereto, commits a fraudulent insurance act, which is a crime.

NOTICE TO LOUISIANA & WEST VIRGINIA APPLICANTS: Any person who knowingly presents a false or fraudulent claim for payment of a loss or benefit or knowingly presents false information in an application for insurance is guilty of a crime and may be subject to fines and confinement in prison.

NOTICE TO MAINE, TENNESSEE, VIRGINIA & WASHINGTON APPLICANTS: It is a crime to knowingly provide false, incomplete or misleading information to an insurance company for the purpose of defrauding the company. Penalties may include imprisonment, fines or a denial of insurance benefits.

NOTICE TO MARYLAND APPLICANTS: Any person who knowingly or willfully presents a false or fraudulent claim for payment of a loss or benefit or who knowingly or willfully presents false information in an application for insurance is guilty of a crime and may be subject to fines and confinement in prison.

NOTICE TO NEW JERSEY APPLICANTS: Any person who includes any false or misleading information on an application for an insurance policy is subject to criminal and civil penalties.

NOTICE TO NEW MEXICO APPLICANTS: ANY PERSON WHO KNOWINGLY PRESENTS A FALSE OR FRAUDULENT CLAIM FOR PAYMENT OF A LOSS OR BENEFIT OR KNOWINGLY PRESENTS FALSE INFORMATION IN AN APPLICATION FOR INSURANCE IS GUILTY OF A CRIME AND MAY BE SUBJECT TO CIVIL FINES AND CRIMINAL PENALTIES.

NOTICE TO NEW YORK APPLICANTS: Any person who knowingly and with intent to defraud any insurance company or other person files an application for insurance or statement of claim containing any materially false information, or conceals for the purpose of misleading, information concerning any fact material thereto, commits a fraudulent insurance act, which is a crime, and shall also be subject to a civil penalty not to exceed five thousand dollars and the stated value of the claim for each such violation.

NOTICE TO OHIO APPLICANTS: Any person who, with intent to defraud or knowing that he is facilitating a fraud against an insurer, submits an application or files a claim containing a false or deceptive statement is guilty of insurance fraud.

NOTICE TO OKLAHOMA APPLICANTS: WARNING: Any person, who knowingly and with intent to injure, defraud or deceive any insurer, makes any claim for the proceeds of an insurance policy containing any false, incomplete or misleading information is guilty of a felony.

NOTICE TO PENNSYLVANIA APPLICANTS: Any person who knowingly and with the intent to defraud any insurance company or other person files an application for insurance or statement of claim containing any fact materially false information, or conceals for the purpose of misleading, information concerning any fact material thereto, commits a fraudulent insurance act, which is a crime and subjects such person to criminal and civil penalties.

NOTICE TO RHODE ISLAND APPLICANTS: Any person who knowingly presents a false or fraudulent claim for payment of a loss or benefit or knowingly presents false information in an application for insurance is guilty of a crime and may be subject to fines and confinement in prison.

RESOLUTION NUMBER _____

A resolution authorizing the Mayor and City Clerk to enter into a Farm Lease with Taiten Harms, for farming purposes, on real property situated in the County of Gage, State of Nebraska, currently owned by the City of Beatrice, a Nebraska Municipal Corporation.

NOW, THEREFORE, BE IT RESOLVED BY THE MAYOR AND CITY COUNCIL OF THE CITY OF BEATRICE, NEBRASKA:

SECTION 1. That the Mayor and City Clerk be and hereby are authorized to enter into a Farm Lease between the City of Beatrice, Nebraska and Taiten Harms, for farming purposes, on real property described in said Farm Lease. A copy of said Farm Lease, marked as Exhibit "A", is attached hereto and incorporated by reference.

SECTION 2. That all resolutions or parts of resolutions in conflict are hereby repealed.

RESOLUTION PASSED AND APPROVED this 19th day of January, 2026.

Attest:

Erin Saathoff, MMC, City Clerk

Robert Morgan, Mayor

Exhibit "A"

FARM LEASE

THIS AGREEMENT made this _____ day of _____, 2026, by and between the City of Beatrice, Nebraska, a municipal corporation, hereinafter called the "Lessor" and Taiten Harms, hereinafter collectively called the "Lessee".

WITNESSETH:

1. PREMISES. Lessor agrees to lease unto Lessee and Lessee agrees to rent, hire and take from Lessor for farming purposes, the real property situated in the County of Gage, State of Nebraska, described as follows:

All of Parcel H, as shown in Exhibit "A", attached hereto and incorporated herein.

All of Parcel I, as shown in Exhibit "B", attached hereto and incorporated herein.

Measurements on all attached maps are not exact measurements of farm acres bid.

2. TERM. The original term of this Lease shall commence on the 1st day of March, 2026, for a term of three (3) years, ending on the 28th day of February, 2029, at which time the Lease automatically terminates without further notice to Lessee.

3. CONSIDERATION. The rental of the crop land is based upon estimated acreage which the parties agree shall be 39.3 acres of crop land for "Parcel H" and 54.5 acres of crop land for "Parcel I". The first half payment is due May 1st of each year and the balance is due November 1st of each year. Said rent shall be payable as follows:

PARCEL H (39.3 acres)

<u>Lease Year</u>	<u>\$/Acre</u>	<u>May 1st Payment</u>	<u>November 1st Payment</u>	<u>Total Rent</u>
2026	\$215.00	\$4,224.75	\$4,224.75	\$8,449.50
2027	\$215.00	\$4,224.75	\$4,224.75	\$8,449.50
2028	\$215.00	\$4,224.75	\$4,224.75	\$8,449.50

PARCEL I (54.5 acres)

<u>Lease Year</u>	<u>\$/Acre</u>	<u>May 1st Payment</u>	<u>November 1st Payment</u>	<u>Total Rent</u>
2026	\$215.00	\$5,858.75	\$5,858.75	\$11,717.50
2027	\$215.00	\$5,858.75	\$5,858.75	\$11,717.50
2028	\$215.00	\$5,858.75	\$5,858.75	\$11,717.50

4. **POSSESSION.** Lessor warrants that Lessor is the owner of the premises and has the full right to lease the same and that Lessee shall have full right of possession for the term herein stated.

5. **GOVERNMENT PAYMENTS.** Lessee shall be entitled to 100% of all Government payments by the Farm Service Agency (FSA), for the crop year 2026 and all years in which this Lease is in full force and effect.

6. **FSA REQUIREMENTS.** If the Farm Service Agency requires set-aside acres, cover crops, tillage requirements, or similar mandated agricultural practices to comply with and be eligible for such government payments, then Lessee shall comply with the same. Thus, Lessee agrees to comply with all the rules and regulations of the FSA, to and including all conservation practices.

7. **GOVERNMENT COMPLIANCE.** Lessee agrees to join and comply with any crop production control program offered by the United States Government if so requested by Lessor; and any payment by the United States Government to Lessor or Lessee, shall in no manner affect the terms of this lease; and even though the Lessee is not required to join any such program, Lessee shall control production of any and all crops, and comply with any rules or regulations set forth by the United States Government which affect these premises on account of Lessor joining any such program on any other land owned or controlled by Lessor.

8. **AGRICULTURAL PRACTICES.** Lessee agrees to use good agricultural practices, destroy noxious weeds to prevent the same from ripening and going to seed. Lessee is expressly prohibited from "double-cropping" without the consent of Lessor, it being the intent of the parties hereto that only one crop should be raised upon the premises in any one calendar year. Lessee shall keep the waterways mowed or hayed, and plow up the terraces and blade the dirt away from the tile outlets (if any) as needed. Lessee agrees to return the premises in as good a condition as they were at the time this Lease was entered into, ordinary deterioration by the elements excepted.

Lessee shall farm said land in a good, careful and proper manner as directed by Lessor and will carefully protect all fences of every kind that are now on said premises or that may be erected thereon during the continuance of the Lease. Lessee shall destroy all weeds along fences and appurtenances, including the roads adjoining the land and along the borders of the leased premises and shall destroy and remove all trees growing in cultivated fields at least once during the growing season. Lessee will also farm within the field areas, and no land shall be fallowed in the fall of the year, except upon written consent of Lessor.

9. **ENTRY OF PREMISES.** Lessor shall have the privilege of entering and occupying any portion of the demised premises which is desired by Lessor for economic development or any other purposes at any time, whereupon Lessee shall cease to have a leasehold interest in such portion of the demised premises. Lessor shall give Lessee seven (7) calendar days' written notice of such intention. The amount of the rent to be paid to Lessor as provided in

Paragraph 3 shall be reduced in the amount of the rental price per acre for each acre in which the Lessee shall cease to have a leasehold interest if Lessor occupies such acres prior to harvest of Lessee's crop planted thereon. If prior to the date that Lessee receives such written notification of Lessor's intention to occupy a portion of the leased premises Lessee has sowed or planted any crop but has not harvested such crop, then Lessor shall further pay to Lessee the amount of the Lessee's crop production expense, so long as customary and reasonable, for each acre which the Lessee shall cease to have a leasehold interest as provided in this paragraph.

10. EXISTING CROPS BEYOND LEASE EXPIRATION. Lessee agrees not to plow, or prepare the ground for planting, or sow or plant any crop, on any portion of said land, which crop would not mature until after the expiration of this Lease, except upon written consent of Lessor, and, if consent is so given, and if said land is not rented to Lessee for the next succeeding year, Lessee is to be paid by the January 1st following the year in which this lease is terminated, the amount of Lessee's crop production expense, so long as customary and reasonable, for each acre which Lessee shall cease to have a leasehold interest as provided in this paragraph, and upon such payment, this lease shall become null and void, and Lessee shall forthwith, upon demand, surrender said premises peaceably to Lessor.

11. EARLY POSSESSION. Lessee shall surrender possession of the premises of Lessor, a subsequent owner or subsequent tenant, after the harvesting and removal of any portion of the crop on said land. Lessor, subsequent owner or subsequent tenant shall have the right to enter upon said premises after said harvesting to prepare, work or plant said land. Lessee agrees not to plant wheat on the premises during the last year of this Lease, or any renewals thereof, which would be harvested after March 1 of any year subject to the renewal of this Lease. If the Lease is not renewed, Lessee shall not plow down or till the ground after September 1 of the year in which the Lease is terminated.

12. POSSESSION AT END OF LEASE. At the expiration of this lease, Lessee agrees to yield possession of the premises, and all improvements thereon, peaceably, without notice, the improvements to be in as good repair as they may be at anytime during the term of this lease.

13. INSPECTION OF PREMISES. Lessor, or Lessor's legal representatives, shall have the right to enter on said premises and into any buildings thereon to inspect same or make improvements; and the Lessor also expressly reserves the right for the Lessor to plow for future crops and to sow grass and grain in stubble ground in the fall before the expiration of this lease. In the event of sale or rental for the succeeding year, Lessee agrees that his successor may go upon these premises to plow and to seed grass and grain in stubble ground, and to make repairs and improvements in the fall before the expiration of this Lease.

14. SUB-LEASE AND ASSIGNMENTS. Lessee agrees not to release, sub-lease, or assign this lease, on all or any part of said premises, except upon written consent of Lessor. Lessee agrees not to apply for the transfer of the premises from one school district to another, without the written consent of the Lessor.

15. PERFORMANCE. It is expressly understood and agreed that no oral agreements or modifications of this lease shall be valid, and the provisions hereof may be waived only by written consent of Lessor; that unless the rent is paid in advance, Lessee expressly contracts and agrees to secure the performance of the terms and conditions of this lease by giving Lessor, upon demand, a first chattel mortgage or lien upon all or any part of the crops growing or gathered on said premises during said term, and, if Lessee, upon demand, neglects or refuses to give such chattel mortgage or lien, or shall at any time give, or attempt to give, to any person or persons, a first lien upon all or any part of said crops, or if the rent, or any portion thereof, is not paid when due, or if Lessee defaults and fails to comply with any of the covenants of, or violates any conditions or agreements of this lease, Lessor at Lessor's option may declare the lease terminated, and may cancel and annul the same, and take immediate possession of the premises, and all crops thereon, and in order to enforce the forfeiture for non-payment of rent, it shall not be necessary to make a demand on the same day the rent becomes due, and Lessee shall be held and considered to have planted and cultivated such crops for the benefit of Lessor, and shall be paid for such services as follows: Lessor may sell said crop and the unexpired term of this lease for cash at a private sale; or Lessor may, at Lessor's option, procure said crops to be further cultivated or gathered and sold in such market as Lessor may see fit, and in either event, the proceeds thereof shall be applied: First, to the payment of expenses incurred by Lessor in the premises, including the time spent by Lessor in connection therewith; Second, in payment of said rent; Third, the remainder, if any, shall be paid to Lessee for services in planting and tending said crops, and seed furnished by Lessee.

16. TAXES. Lessee shall pay all real estate taxes levied and assessed against leased premises.

17. PERSONAL PROPERTY TAXES. Lessee shall pay any grain tax assessed by virtue of the grain being raised upon the premises, and any personal property owned by Lessee on the premises.

18. REPRESENTATIONS AND WARRANTIES. Lessee further UNDERTAKES, REPRESENTS AND WARRANTS to Lessor that Lessee: (1) has sufficient working knowledge of the federal state and local environmental laws, rules and regulations relevant to farming and ranching operations on the land described herein, and will conduct all such operations thereon in strict conformity with such law, rules and regulations; and (2) will handle, transport, store, use, apply and dispose of all agricultural chemicals, hazardous and toxic materials, and containers therefor, as required by such laws, rules and regulations; and (3) will notify Lessor immediately of any conditions on the property that may not be in compliance with such laws, rules and regulations. Lessee further UNDERTAKES, REPRESENTS AND WARRANTS that Lessee has not installed, nor will install, any underground storage tank for petroleum products on the leased premises. Lessee covenants to INDEMNIFY AND SAVE HARMLESS Lessor from all loss, costs, expenses or damage to Lessor or Lessor's property arising from Lessee's failure to strictly comply with the undertakings, representations or warranties herein.

19. ENTIRE AGREEMENT. It is expressly understood and agreed that no oral agreement or modifications of this lease shall be valid, and the provisions hereof may be waived only by written consent of Lessor.

20. CONSTRUCTION. This Lease shall be binding upon and shall inure to the benefit of the executors, administrators, heirs, personal representatives, assigns and successors of the parties hereto and shall be construed in accordance with the laws of the State of Nebraska.

21. INDEMNIFICATION. Lessee further agrees, that if Lessee causes any damage to any of Lessor's property, whether real or personal, Lessee shall at Lessee's costs promptly replace or repair said property as directed by Lessor. Lessor agrees that if it causes any damages to the Lessee's crops, the cost of said damages shall be deducted from the next rental payment due and owing.

22. NOTICES. Notice to Lessor shall be given to Lessor at:

400 Ella Street, Beatrice, NE 68310

Notices to Lessee shall be given to Lessee at:

Taiten Harms, 603 Madison Street, Pickrell, NE 68422

Notice shall be deemed given when notice has been given in writing, by regular U.S. mail, postage pre-paid.

23. DEFAULT. If Lessee shall fail to make the payments above set forth when the same become due, time being of the essence, or keep any of the covenants set forth herein, or seek protection in bankruptcy, Lessor may declare default, and at the option of Lessor, all sums due herein to be immediately due and payable. Upon such default, Lessee agrees to surrender immediate possession of the premises to Lessor, and upon failure to do so, shall be liable to Lessor for any loss sustained by Lessor.

24. BINDING. It is further agreed that the covenants herein shall extend and be binding upon the heirs, executors, administrators, successors or assigns of the parties hereto.

25. HEADINGS/CAPTIONS. The headings and captions contained in this Agreement are for convenience purposes only and are not determinative nor are they to be considered in construction of the terms or provisions herein.

IN WITNESS WHEREOF, we have hereunto set our hands and seals the day, month and year first above written.

CITY OF BEATRICE, NEBRASKA,
A Municipal Corporation,
"Lessor"

Attest:

Erin Saathoff, City Clerk

Robert Morgan, Mayor

Taiten

Taiten Harms, "Lessee"

STATE OF NEBRASKA)
) ss.
COUNTY OF GAGE)

The foregoing instrument was acknowledged before me this 14 day of,
January, 2026, by Taiten Harms, to be his voluntary act and deed.

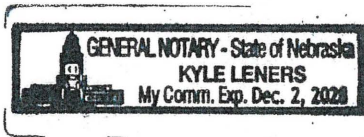

Kyle Leners

Notary Public

Exhibit "A"



North

Ridgeview Drive

012390800

015292200

011643300 Sec 21
Town 14
Range 6E

011643523

Parcel H

39.33 acres

Beatrice Muni
Airport

011643521

011643518

011643525

01164353

West Sargent Street

Exhibit "B"

North

Beatrice Municipal
Airport

Sec 21
Twp 4
Rng 18

Parcel I
54.5 acres

RESOLUTION NUMBER _____

A resolution authorizing the Mayor and City Clerk to enter into a Farm Lease with Adam Kimmerling, for farming purposes, on real property situated in the County of Gage, State of Nebraska, currently owned by the City of Beatrice, a Nebraska Municipal Corporation.

NOW, THEREFORE, BE IT RESOLVED BY THE MAYOR AND CITY COUNCIL OF THE CITY OF BEATRICE, NEBRASKA:

SECTION 1. That the Mayor and City Clerk be and hereby are authorized to enter into a Farm Lease between the City of Beatrice, Nebraska and Adam Kimmerling, for farming purposes, on real property described in said Farm Lease. A copy of said Farm Lease, marked as Exhibit "A", is attached hereto and incorporated by reference.

SECTION 2. That all resolutions or parts of resolutions in conflict are hereby repealed.

RESOLUTION PASSED AND APPROVED this 19th day of January, 2026.

Attest:

Erin Saathoff, MMC, City Clerk

Robert Morgan, Mayor

Exhibit "A"

FARM LEASE

THIS AGREEMENT made this _____ day of _____, 2026, by and between the City of Beatrice, Nebraska, a municipal corporation, hereinafter called the "Lessor" and Adam Kimmerling, hereinafter called the "Lessee".

WITNESSETH:

1. PREMISES. Lessor agrees to lease unto Lessee and Lessee agrees to rent, hire and take from Lessor for farming purposes, the real property situated in the County of Gage, State of Nebraska, described as follows:

One parcel located where the old fairgrounds were located between the Big Blue River and Farmers Co-op Elevator, comprising of approximately 13.9 acres. Gage County FSA Farm #8394. See map attached hereto titled "Parcel B"; and

Measurements on all attached maps are not exact measurements of farm acres bid.

2. TERM. The original term of this Lease shall commence on the 1st day of March, 2026, for a term of three (3) years, ending on the 28th day of February, 2029, at which time the Lease automatically terminates without further notice to Lessee.

3. CONSIDERATION. The rental of the crop land is based upon estimated acreage which the parties agree shall be 13.9 acres of crop land for "Parcel B". The first half payment is due May 1st of each year and the balance is due November 1st of each year. Said rent shall be payable as follows:

PARCEL B (13.9 acres)

<u>Lease Year</u>	<u>\$/Acre</u>	<u>May 1st Payment</u>	<u>November 1st Payment</u>	<u>Total Rent</u>
2026	\$185.00	\$1,285.75	\$1,285.75	\$2,571.50
2027	\$185.00	\$1,285.75	\$1,285.75	\$2,571.50
2028	\$185.00	\$1,285.75	\$1,285.75	\$2,571.50

4. POSSESSION. Lessor warrants that Lessor is the owner of the premises and has the full right to lease the same and that Lessee shall have full right of possession for the term herein stated.

5. GOVERNMENT PAYMENTS. Lessee shall be entitled to 100% of all Government payments by the Farm Service Agency (FSA), for the crop year 2026 and all years in which this Lease is in full force and effect.

6. FSA REQUIREMENTS. If the Farm Service Agency requires set-aside acres, cover crops, tillage requirements, or similar mandated agricultural practices to comply with and be eligible for such government payments, then Lessee shall comply with the same. Thus, Lessee agrees to comply with all the rules and regulations of the FSA, to and including all conservation practices.

7. GOVERNMENT COMPLIANCE. Lessee agrees to join and comply with any crop production control program offered by the United States Government if so requested by Lessor; and any payment by the United States Government to Lessor or Lessee, shall in no manner affect the terms of this lease; and even though the Lessee is not required to join any such program, Lessee shall control production of any and all crops, and comply with any rules or regulations set forth by the United States Government which affect these premises on account of Lessor joining any such program on any other land owned or controlled by Lessor.

8. AGRICULTURAL PRACTICES. Lessee agrees to use good agricultural practices, destroy noxious weeds to prevent the same from ripening and going to seed. Lessee is expressly prohibited from "double-cropping" without the consent of Lessor, it being the intent of the parties hereto that only one crop should be raised upon the premises in any one calendar year. Lessee shall keep the waterways mowed or hayed, and plow up the terraces and blade the dirt away from the tile outlets (if any) as needed. Lessee agrees to return the premises in as good a condition as they were at the time this Lease was entered into, ordinary deterioration by the elements excepted.

Lessee shall farm said land in a good, careful and proper manner as directed by Lessor and will carefully protect all fences of every kind that are now on said premises or that may be erected thereon during the continuance of the Lease. Lessee shall destroy all weeds along fences and appurtenances, including the roads adjoining the land and along the borders of the leased premises and shall destroy and remove all trees growing in cultivated fields at least once during the growing season. Lessee will also farm within the field areas, and no land shall be fallowed in the fall of the year, except upon written consent of Lessor.

9. ENTRY OF PREMISES. Lessor shall have the privilege of entering and occupying any portion of the demised premises which is desired by Lessor for economic development or any other purposes at any time, whereupon Lessee shall cease to have a leasehold interest in such portion of the demised premises. Lessor shall give Lessee seven (7) calendar days' written notice of such intention. The amount of the rent to be paid to Lessor as provided in Paragraph 3 shall be reduced in the amount of the rental price per acre for each acre in which the Lessee shall cease to have a leasehold interest if Lessor occupies such acres prior to harvest of Lessee's crop planted thereon. If prior to the date that Lessee receives such written notification of Lessor's intention to occupy a portion of the leased premises Lessee has sowed or planted any crop but has not harvested such crop, then Lessor shall further pay to Lessee the amount of the Lessee's crop production expense, so

long as customary and reasonable, for each acre which the Lessee shall cease to have a leasehold interest as provided in this paragraph.

10. EXISTING CROPS BEYOND LEASE EXPIRATION. Lessee agrees not to plow, or prepare the ground for planting, or sow or plant any crop, on any portion of said land, which crop would not mature until after the expiration of this Lease, except upon written consent of Lessor, and, if consent is so given, and if said land is not rented to Lessee for the next succeeding year, Lessee is to be paid by the January 1st following the year in which this lease is terminated, the amount of Lessee's crop production expense, so long as customary and reasonable, for each acre which Lessee shall cease to have a leasehold interest as provided in this paragraph, and upon such payment, this lease shall become null and void, and Lessee shall forthwith, upon demand, surrender said premises peaceably to Lessor.

11. EARLY POSSESSION. Lessee shall surrender possession of the premises of Lessor, a subsequent owner or subsequent tenant, after the harvesting and removal of any portion of the crop on said land. Lessor, subsequent owner or subsequent tenant shall have the right to enter upon said premises after said harvesting to prepare, work or plant said land. Lessee agrees not to plant wheat on the premises during the last year of this Lease, or any renewals thereof, which would be harvested after March 1 of any year subject to the renewal of this Lease. If the Lease is not renewed, Lessee shall not plow down or till the ground after September 1 of the year in which the Lease is terminated.

12. POSSESSION AT END OF LEASE. At the expiration of this lease, Lessee agrees to yield possession of the premises, and all improvements thereon, peaceably, without notice, the improvements to be in as good repair as they may be at anytime during the term of this lease.

13. INSPECTION OF PREMISES. Lessor, or Lessor's legal representatives, shall have the right to enter on said premises and into any buildings thereon to inspect same or make improvements; and the Lessor also expressly reserves the right for the Lessor to plow for future crops and to sow grass and grain in stubble ground in the fall before the expiration of this lease. In the event of sale or rental for the succeeding year, Lessee agrees that his successor may go upon these premises to plow and to seed grass and grain in stubble ground, and to make repairs and improvements in the fall before the expiration of this Lease.

14. SUB-LEASE AND ASSIGNMENTS. Lessee agrees not to release, sub-lease, or assign this lease, on all or any part of said premises, except upon written consent of Lessor. Lessee agrees not to apply for the transfer of the premises from one school district to another, without the written consent of the Lessor.

15. PERFORMANCE. It is expressly understood and agreed that no oral agreements or modifications of this lease shall be valid, and the provisions hereof may be waived only by written consent of Lessor; that unless the rent is paid in advance, Lessee expressly contracts and agrees to secure the performance of the terms and conditions of this lease by

giving Lessor, upon demand, a first chattel mortgage or lien upon all or any part of the crops growing or gathered on said premises during said term, and, if Lessee, upon demand, neglects or refuses to give such chattel mortgage or lien, or shall at any time give, or attempt to give, to any person or persons, a first lien upon all or any part of said crops, or if the rent, or any portion thereof, is not paid when due, or if Lessee defaults and fails to comply with any of the covenants of, or violates any conditions or agreements of this lease, Lessor at Lessor's option may declare the lease terminated, and may cancel and annul the same, and take immediate possession of the premises, and all crops thereon, and in order to enforce the forfeiture for non-payment of rent, it shall not be necessary to make a demand on the same day the rent becomes due, and Lessee shall be held and considered to have planted and cultivated such crops for the benefit of Lessor, and shall be paid for such services as follows: Lessor may sell said crop and the unexpired term of this lease for cash at a private sale; or Lessor may, at Lessor's option, procure said crops to be further cultivated or gathered and sold in such market as Lessor may see fit, and in either event, the proceeds thereof shall be applied: First, to the payment of expenses incurred by Lessor in the premises, including the time spent by Lessor in connection therewith; Second, in payment of said rent; Third, the remainder, if any, shall be paid to Lessee for services in planting and tending said crops, and seed furnished by Lessee.

16. TAXES. Lessee shall pay all real estate taxes levied and assessed against leased premises.

17. PERSONAL PROPERTY TAXES. Lessee shall pay any grain tax assessed by virtue of the grain being raised upon the premises, and any personal property owned by Lessee on the premises.

18. REPRESENTATIONS AND WARRANTIES. Lessee further UNDERTAKES, REPRESENTS AND WARRANTS to Lessor that Lessee: (1) has sufficient working knowledge of the federal state and local environmental laws, rules and regulations relevant to farming and ranching operations on the land described herein, and will conduct all such operations thereon in strict conformity with such law, rules and regulations; and (2) will handle, transport, store, use, apply and dispose of all agricultural chemicals, hazardous and toxic materials, and containers therefor, as required by such laws, rules and regulations; and (3) will notify Lessor immediately of any conditions on the property that may not be in compliance with such laws, rules and regulations. Lessee further UNDERTAKES, REPRESENTS AND WARRANTS that Lessee has not installed, nor will install, any underground storage tank for petroleum products on the leased premises. Lessee covenants to INDEMNIFY AND SAVE HARMLESS Lessor from all loss, costs, expenses or damage to Lessor or Lessor's property arising from Lessee's failure to strictly comply with the undertakings, representations or warranties herein.

19. ENTIRE AGREEMENT. It is expressly understood and agreed that no oral agreement or modifications of this lease shall be valid, and the provisions hereof may be waived only by written consent of Lessor.

20. CONSTRUCTION. This Lease shall be binding upon and shall inure to the benefit of the executors, administrators, heirs, personal representatives, assigns and successors of the parties hereto and shall be construed in accordance with the laws of the State of Nebraska.

21. INDEMNIFICATION. Lessee further agrees, that if Lessee causes any damage to any of Lessor's property, whether real or personal, Lessee shall at Lessee's costs promptly replace or repair said property as directed by Lessor. Lessor agrees that if it causes any damages to the Lessee's crops, the cost of said damages shall be deducted from the next rental payment due and owing.

22. NOTICES. Notice to Lessor shall be given to Lessor at:

400 Ella Street, Beatrice, NE 68310

Notices to Lessee shall be given to Lessee at:

Adam Kimmerling, 20664 US Hwy 77, Beatrice, NE 68310

Notice shall be deemed given when notice has been given in writing, by regular U.S. mail, postage pre-paid.

23. DEFAULT. If Lessee shall fail to make the payments above set forth when the same become due, time being of the essence, or keep any of the covenants set forth herein, or seek protection in bankruptcy, Lessor may declare default, and at the option of Lessor, all sums due herein to be immediately due and payable. Upon such default, Lessee agrees to surrender immediate possession of the premises to Lessor, and upon failure to do so, shall be liable to Lessor for any loss sustained by Lessor.

24. BINDING. It is further agreed that the covenants herein shall extend and be binding upon the heirs, executors, administrators, successors or assigns of the parties hereto.

25. HEADINGS/CAPTIONS. The headings and captions contained in this Agreement are for convenience purposes only and are not determinative nor are they to be considered in construction of the terms or provisions herein.

IN WITNESS WHEREOF, we have hereunto set our hands and seals the day, month and year first above written.

(Signatures on the following page.)

CITY OF BEATRICE, NEBRASKA,
A Municipal Corporation,
"Lessor"

Attest:

Erin Saathoff, City Clerk

Robert Morgan, Mayor

Adam Kimmerling
Adam Kimmerling, "Lessee"

STATE OF NEBRASKA)
) ss.
COUNTY OF GAGE)

The foregoing instrument was acknowledged before me this 13TH day of, JANUARY, 2026, by Adam Kimmerling, to be his voluntary act and deed.

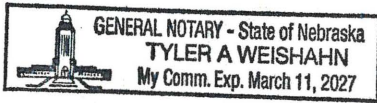

[Signature]
Notary Public



RESOLUTION NUMBER _____

A resolution authorizing the Mayor and City Clerk to enter into a Farm Lease with Devon Tate, for farming purposes, on real property situated in the County of Gage, State of Nebraska, currently owned by the City of Beatrice, a Nebraska Municipal Corporation.

NOW, THEREFORE, BE IT RESOLVED BY THE MAYOR AND CITY COUNCIL OF THE CITY OF BEATRICE, NEBRASKA:

SECTION 1. That the Mayor and City Clerk be and hereby are authorized to enter into a Farm Lease between the City of Beatrice, Nebraska and Devon Tate, for farming purposes, on real property described in said Farm Lease. A copy of said Farm Lease, marked as Exhibit "A", is attached hereto and incorporated by reference.

SECTION 2. That all resolutions or parts of resolutions in conflict are hereby repealed.

RESOLUTION PASSED AND APPROVED this 19th day of January, 2026.

Attest:

Erin Saathoff, MMC, City Clerk

Robert Morgan, Mayor

Exhibit "A"

FARM LEASE

THIS AGREEMENT made this _____ day of _____ 2026, by and between the City of Beatrice, Nebraska, a municipal corporation, hereinafter called the "Lessor" and Devon Tate, hereinafter called the "Lessee".

WITNESSETH:

1. PREMISES. Lessor agrees to lease unto Lessee and Lessee agrees to rent, hire and take from Lessor for farming purposes, the real property situated in the County of Gage, State of Nebraska, described as follows:

All of Parcel D, shown in yellow as shown in Exhibit "A", attached hereto and incorporated herein.

2. TERM. The original term of this Lease shall commence on the 1st day of March, 2026, for a term of three (3) year, ending on the 28th day of February, 2029, at which time the Lease automatically terminates without further notice to Lessee.

3. CONSIDERATION. The rental of the crop land is based upon estimated acreage which the parties agree shall be approximately 332 acres of crop land for "Parcel D". The first half payment is due May 1st of each year and the balance is due November 1st of each year. Said rent shall be payable as follows:

PARCEL D (332 acres)

<u>Lease Year</u>	<u>\$/Acre</u>	<u>May 1st Payment</u>	<u>November 1st Payment</u>	<u>Total Rent</u>
2026	\$210.00	\$34,860.00	\$34,860.00	\$69,720.00
2027	\$210.00	\$34,860.00	\$34,860.00	\$69,720.00
2028	\$210.00	\$34,860.00	\$34,860.00	\$69,720.00

4. NON-CROP LAND. Lessee agrees that no crops shall be grown within 400 feet of the North/South Runway #17-35 centerline or within 250 feet of the Northwest/Southeast Runway #13-31 centerline, nor in such a way as to obstruct the line of sight from any point on a runway to a point on any other runway. Crops grown in the approach areas at the ends of each runway shall be restricted to low-growing varieties and shall not be grown within 300 feet of the runway ends, except not within 1,000 feet of the ends of the North/South Runway #17-35. Lessor shall not grow any crops within 65 feet of any taxiway centerline or within 40 feet of any apron edges.

5. INTERFERENCE WITH AIRPORT OPERATIONS. Lessee understands and agrees that the rights granted hereunder shall not be exercised in such a way as to interfere with or adversely affect the use, operation, maintenance, or development of the Beatrice Municipal Airport.

6. POSSESSION. Lessor warrants that Lessor is the owner of the premises and has the full right to lease the same and that Lessee shall have full right of possession for the term herein stated.

7. GOVERNMENT PAYMENTS. Lessee shall be entitled to 100% of all Government payments by the Farm Service Agency (FSA), for the crop year 2026 and all years in which this Lease is in full force and effect.

8. FSA REQUIREMENTS. If the Farm Service Agency requires set-aside acres, cover crops, tillage requirements, or similar mandated agricultural practices to comply with and be eligible for such government payments, then Lessee shall comply with the same. Thus, Lessee agrees to comply with all the rules and regulations of the FSA, to and including all conservation practices.

9. GOVERNMENT COMPLIANCE. Lessee agrees to join and comply with any crop production control program offered by the United States Government if so requested by Lessor; and any payment by the United States Government to Lessor or Lessee, shall in no manner affect the terms of this lease; and even though the Lessee is not required to join any such program, Lessee shall control production of any and all crops, and comply with any rules or regulations set forth by the United States Government which affect these premises on account of Lessor joining any such program on any other land owned or controlled by Lessor. Lessee shall participate in federal government agricultural programs as directed by Lessor.

10. AGRICULTURAL PRACTICES. Lessee agrees to use good agricultural practices, destroy noxious weeds to prevent the same from ripening and going to seed. Lessee is expressly prohibited from "double-cropping" without the consent of Lessor, it being the intent of the parties hereto that only one crop should be raised upon the premises in any one calendar year. Lessee shall keep the waterways mowed or hayed, and plow up the terraces and blade the dirt away from the tile outlets (if any) as needed. Lessee agrees to return the premises in as good a condition as they were at the time this Lease was entered into, ordinary deterioration by the elements excepted.

Lessee shall farm said land in a good, careful and proper manner as directed by Lessor and will carefully protect all fences of every kind that are now on said premises or that may be erected thereon during the continuance of the Lease. Lessee shall destroy all weeds along fences and appurtenances, including the roads adjoining the land and along the borders of the leased premises and shall destroy and remove all trees growing in cultivated fields at least once during the growing season. Lessee will also farm within the field areas, and no land shall be fallowed in the fall of the year, except upon written consent of Lessor.

11. PERMISSIBLE USES. Grazing of animals is not permitted. Lessee shall not drive or operate any equipment on the paved runways. Lessee will not farm over any drains and also will maintain a fifty (50) foot radius around any drains. Lessee also agrees to move all machinery and crops in and out of the north and south gates when possible. Lessee further

agrees and understands that no equipment is to be left or parked overnight within the marked areas on the attached map. It is further agreed that no hay bales will be stored or piled on the runway safety areas as marked on the attached farming map, marked as Exhibit "A". Lessee will also keep the weeds cut down on idle acres, and no corn is allowed to be planted on any of the acreage. Lessee shall also farm within the field areas and no land shall be fallowed in the fall of the year. Lessee agrees to cultivate all tillable land in a good husbandlike manner and to plow or break land, plant and rotate crops as Lessor may direct. Lessee agrees to destroy all cockle-burrs, sunflowers and weeds of similar nature in the early fall before they ripen their seeds, and to keep all weeds cut from around the buildings, the lots, and along the fences and roads, and to mow all stubble and pasture ground in the fall. Lessee agrees not to plow land seeded to any kind of grass or hay. Lessee agrees to use no rent crops, or sell the same, without written permission from the Lessor. Lessee agrees to cut no trees, shrubs, etc., without written consent of Lessor. Lessee agrees to plant or sow the particular kind of crop or crops, which the Lessor or the Lessor's legal representatives may specify, and in the particular field or fields, which the Lessor or the Lessor's legal representatives may designate.

12. CROP PRODUCTION CONTROL PROGRAMS. Lessee agrees to join and comply with any crop production control program offered by the United States Government if so requested by the Lessor; and any payment by the United States Government to the Lessor or the Lessee, shall in no manner affect the terms of this lease; and even though the Lessee is not requested to join any such program, Lessee shall control production of any and all crops, and comply with any rules or regulations set forth by the United States Government which affect these premises on account of the Lessor joining any such program on any other land owned or controlled by the Lessor.

13. ENTRY OF PREMISES. Lessor shall have the privilege of entering and occupying any portion of the demised premises which is desired by Lessor for the operation or development of the Beatrice Municipal Airport or any other purposes at any time, whereupon Lessee shall cease to have a leasehold interest in such portion of the demised premises. Lessor shall give Lessee seven (7) calendar days' written notice of such intention. The amount of the rent to be paid to Lessor as provided in Paragraph 3 shall be reduced in the amount of the rental price per acre for each acre in which the Lessee shall cease to have a leasehold interest if Lessor occupies such acres prior to harvest of Lessee's crop planted thereon. If prior to the date that Lessee receives such written notification of Lessor's intention to occupy a portion of the leased premises Lessee has sowed or planted any crop but has not harvested such crop, then Lessor shall further pay to Lessee the amount of the Lessee's crop production expense, so long as customary and reasonable, for each acre which the Lessee shall cease to have a leasehold interest as provided in this paragraph.

14. EXISTING CROPS BEYOND LEASE EXPIRATION. Lessee agrees not to plow, or prepare the ground for planting, or sow or plant any crop, on any portion of said land, which crop would not mature until after the expiration of this Lease, except upon written consent of Lessor, and, if consent is so given, and if said land is not rented to Lessee for the next succeeding year, Lessee is to be paid by the January 1st following the year in which this lease

is terminated, the amount of Lessee's crop production expense, so long as customary and reasonable, for each acre which Lessee shall cease to have a leasehold interest as provided in this paragraph, and upon such payment, this lease shall become null and void, and Lessee shall forthwith, upon demand, surrender said premises peaceably to Lessor.

15. EARLY POSSESSION. Lessee shall surrender possession of the premises of Lessor, a subsequent owner or subsequent tenant, after the harvesting and removal of any portion of the crop on said land. Lessor, subsequent owner or subsequent tenant shall have the right to enter upon said premises after said harvesting to prepare, work or plant said land. Lessee agrees not to plant wheat on the premises during the last year of this Lease, or any renewals thereof, which would be harvested after March 1 of any year subject to the renewal of this Lease. If the Lease is not renewed, Lessee shall not plow down or till the ground after September 1 of the year in which the Lease is terminated.

16. POSSESSION AT END OF LEASE. At the expiration of this lease, Lessee agrees to yield possession of the premises, and all improvements thereon, peaceably, without notice, the improvements to be in as good repair as they may be at any time during the term of this lease.

17. INSPECTION OF PREMISES. Lessor, or Lessor's legal representatives, shall have the right to enter on said premises and into any buildings thereon to inspect same or make improvements; and the Lessor also expressly reserves the right for the Lessor to plow for future crops and to sow grass and grain in stubble ground in the fall before the expiration of this lease. In the event of sale or rental for the succeeding year, Lessee agrees that his successor may go upon these premises to plow and to seed grass and grain in stubble ground, and to make repairs and improvements in the fall before the expiration of this Lease.

18. SUB-LEASE AND ASSIGNMENTS. Lessee agrees not to release, sub-lease, or assign this lease, on all or any part of said premises, except upon written consent of Lessor. Lessee agrees not to apply for the transfer of the premises from one school district to another, without the written consent of the Lessor.

19. PERFORMANCE. It is expressly understood and agreed that no oral agreements or modifications of this lease shall be valid, and the provisions hereof may be waived only by written consent of Lessor; that unless the rent is paid in advance, Lessee expressly contracts and agrees to secure the performance of the terms and conditions of this lease by giving Lessor, upon demand, a first chattel mortgage or lien upon all or any part of the crops growing or gathered on said premises during said term, and, if Lessee, upon demand, neglects or refuses to give such chattel mortgage or lien, or shall at any time give, or attempt to give, to any person or persons, a first lien upon all or any part of said crops, or if the rent, or any portion thereof, is not paid when due, or if Lessee defaults and fails to comply with any of the covenants of, or violates any conditions or agreements of this lease, Lessor at Lessor's option may declare the lease terminated, and may cancel and annul the same, and take immediate possession of the premises, and all crops thereon, and in order to enforce the forfeiture for non-payment of rent, it shall not be necessary to make a demand on the same day the rent

becomes due, and Lessee shall be held and considered to have planted and cultivated such crops for the benefit of Lessor, and shall be paid for such services as follows: Lessor may sell said crop and the unexpired term of this lease for cash at a private sale; or Lessor may, at Lessor's option, procure said crops to be further cultivated or gathered and sold in such market as Lessor may see fit, and in either event, the proceeds thereof shall be applied: First, to the payment of expenses incurred by Lessor in the premises, including the time spent by Lessor in connection therewith; Second, in payment of said rent; Third, the remainder, if any, shall be paid to Lessee for services in planting and tending said crops, and seed furnished by Lessee.

20. TAXES. Lessee shall pay all real estate taxes levied and assessed against leased premises.

21. PERSONAL PROPERTY TAXES. Lessee shall pay any grain tax assessed by virtue of the grain being raised upon the premises, and any personal property owned by Lessee on the premises.

22. REPRESENTATIONS AND WARRANTIES. Lessee further UNDERTAKES, REPRESENTS AND WARRANTS to Lessor that Lessee: (1) has sufficient working knowledge of the federal state and local environmental laws, rules and regulations relevant to farming and ranching operations on the land described herein, and will conduct all such operations thereon in strict conformity with such law, rules and regulations; and (2) will handle, transport, store, use, apply and dispose of all agricultural chemicals, hazardous and toxic materials, and containers therefor, as required by such laws, rules and regulations; and (3) will notify Lessor immediately of any conditions on the property that may not be in compliance with such laws, rules and regulations. Lessee further UNDERTAKES, REPRESENTS AND WARRANTS that Lessee has not installed, nor will install, any underground storage tank for petroleum products on the leased premises. Lessee covenants to INDEMNIFY AND SAVE HARMLESS Lessor from all loss, costs, expenses or damage to Lessor or Lessor's property arising from Lessee's failure to strictly comply with the undertakings, representations or warranties herein.

23. ENTIRE AGREEMENT. It is expressly understood and agreed that no oral agreement or modifications of this lease shall be valid, and the provisions hereof may be waived only by written consent of Lessor.

24. CONSTRUCTION. This Lease shall be binding upon and shall inure to the benefit of the executors, administrators, heirs, personal representatives, assigns and successors of the parties hereto and shall be construed in accordance with the laws of the State of Nebraska.

25. INDEMNIFICATION. Lessee further agrees, that if Lessee causes any damage to any of Lessor's property, whether real or personal, Lessee shall at Lessee's costs promptly replace or repair said property as directed by Lessor. Lessor agrees that if it causes any

damages to the Lessee's crops, the cost of said damages shall be deducted from the next rental payment due and owing.

26. NOTICES. Notice to Lessor shall be given to Lessor at:

Taylor Rivera, 400 Ella Street, Beatrice, NE 68310

Notices to Lessee shall be given to Lessee at:

Devon Tate, 3223 W Pickrell Road, Pickrell, NE 68422

Notice shall be deemed given when notice has been given in writing, by regular U.S. mail, postage pre-paid.

27. BREACH & CURE. Failure of either party to this Lease to abide by any provision set forth herein shall constitute a breach of this Lease. In such event, the non-breaching party may provide written notice to the breaching party describing the breach. The breaching party shall rectify, cure, or refute within thirty (30) calendar days. If the breaching party fails to rectify, cure, or refute within thirty (30) calendar days, the non-breaching party may terminate this agreement without notice.

28. TERMINATION. This Lease may be terminated by either Lessor or Lessee by giving the other party written notice thereof at least ninety (90) calendar days before the end of term of this Lease. Upon damage to the leased premises herein to such an extent that the premises is no longer usable for the purposes intended, this Lease may be immediately terminated by either party.

In the event that Lessor determines that all or any part of said leased premises is needed for use as a part of the operation of the Beatrice Municipal Airport or for any other purpose, Lessor shall so notify Lessee in writing, and Lessee shall immediately surrender possession of the portion of the leased premises described in said notification. In such an event, this Lease shall be null and void, and shall terminate upon such surrender, for whatever portion of the demised premises is surrendered. If said notification is received after spring chemicals have been applied and before the crop is harvested, Lessor shall pay to Lessee the actual monetary damages sustained by the Lessee for each row crop acre described in said notification, and in such case Lessee shall not be reimbursed by Lessor for any payments made pursuant to Paragraph Number 3. If the surrender occurs prior to spring chemical application, Lessee shall not receive any damages and shall not pay any rent pursuant to Paragraph 3 for such surrendered acres.

Upon termination of this Lease, Lessee shall, at Lessee's sole expense, remove all of its personal property and shall return the leased premises to Lessor in as good a condition as at the inception of this Lease, reasonable wear and tear accepted.

29. DEFAULT. If Lessee shall fail to make the payments above set forth when the same become due, time being of the essence, or keep any of the covenants set forth herein, or seek protection in bankruptcy, Lessor may declare default, and at the option of Lessor, all sums due herein to be immediately due and payable. Upon such default, Lessee agrees to surrender immediate possession of the premises to Lessor, and upon failure to do so, shall be liable to Lessor for any loss sustained by Lessor.

30. BINDING. It is further agreed that the covenants herein shall extend and be binding upon the heirs, executors, administrators, successors or assigns of the parties hereto.

31. HEADINGS/CAPTIONS. The headings and captions contained in this Agreement are for convenience purposes only and are not determinative nor are they to be considered in construction of the terms or provisions herein.

32. COUNTERPARTS. This Lease may be executed in two (2) or more counterparts, each of which shall be deemed an original but all of which together shall be and constitute one and the same instrument.

IN WITNESS WHEREOF, we have hereunto set our hands and seals the day, month and year first above written.

Attest:

CITY OF BEATRICE, NEBRASKA,
A Municipal Corporation,
"Lessor"

Erin Saathoff, City Clerk

Robert Morgan, Mayor

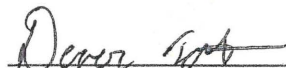

Devon Tate, "Lessee"

STATE OF NEBRASKA)
) ss.
COUNTY OF GAGE)

The foregoing instrument was acknowledged before me this 14th day of, January 2026, by Devon Tate, to be his voluntary act and deed.

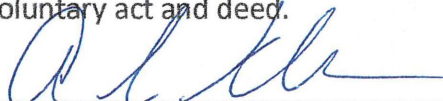

Notary Public

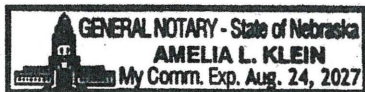



Alternate year NAIP imagery may be displayed for tracts physically located in other states, along state borders, or years of partial imagery acquisition.

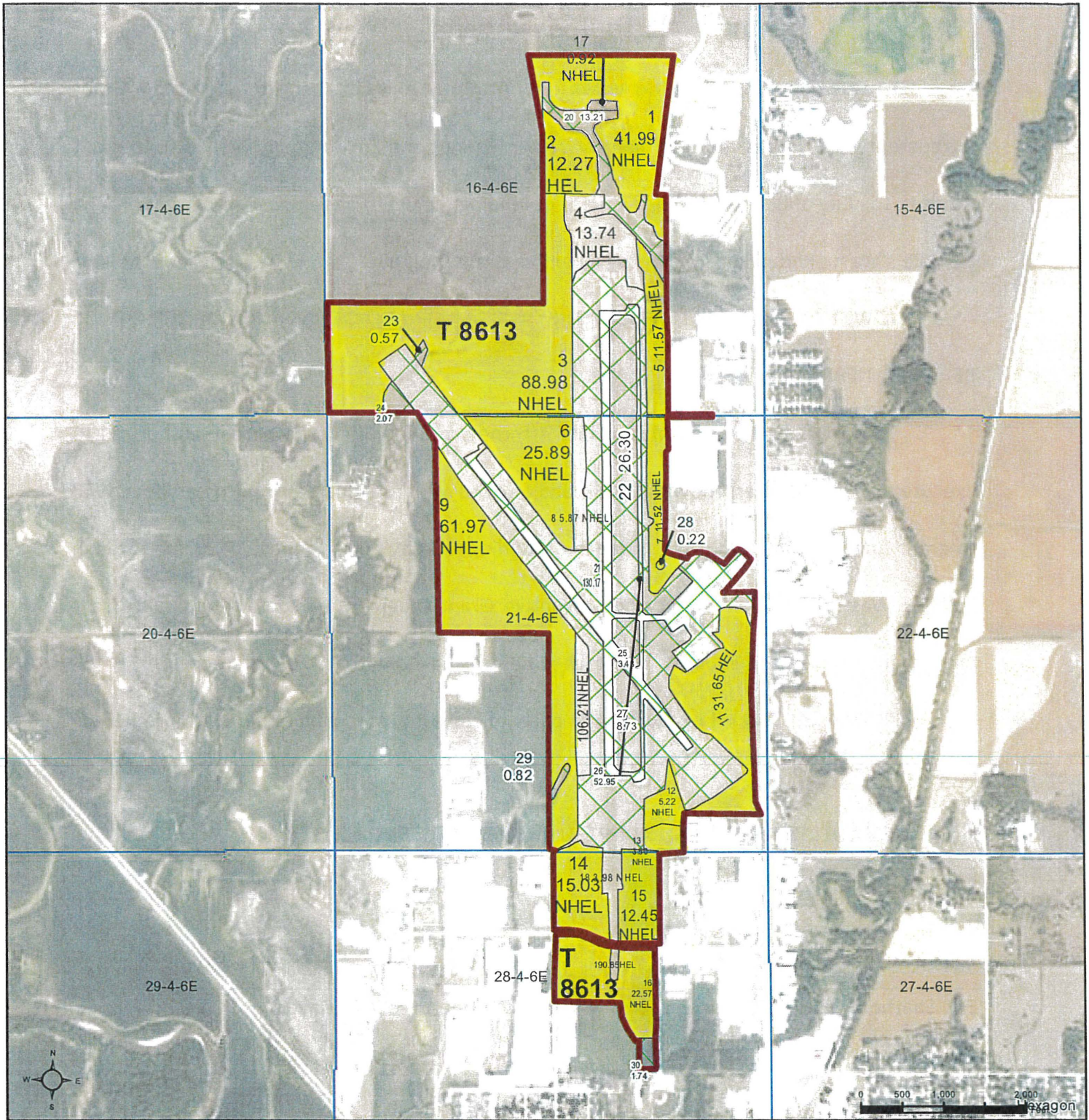

Common Land Unit
 Tract Boundary
 PLSS
 Non-Cropland
 Cropland

Wetland Determination Identifiers
● Restricted Use
▼ Limited Restrictions
■ Exempt from Wetland Provisions

Parcel D

2024 EAWS Production Ortho Imagery

2025 Program Year

Map Created February 20, 2025

2025 All fields NI and all crops as listed below unless otherwise noted
 Wheat, HRW, Gr, I _____
 Corn, Yel, Gr, I _____
 Soybean, Com, Gr, I _____
 Shares: _____

Farm 9600
 Tract 8613

United States Department of Agriculture (USDA) Farm Service Agency (FSA) maps are for FSA Program administration only. This map does not represent a legal survey or reflect actual ownership; rather it depicts the information provided directly from the producer and/or National Agricultural Imagery Program (NAIP) imagery. The producer accepts the data 'as is' and assumes all risks associated with its use. USDA-FSA assumes no responsibility for actual or consequential damage incurred as a result of any user's reliance on this data outside FSA Programs. Wetland identifiers do not represent the size, shape, or specific determination of the area. Refer to your original determination (CPA-026 and attached maps) for exact boundaries and determinations or contact USDA Natural Resources Conservation Service (NRCS).

RESOLUTION NUMBER _____

A resolution authorizing the Mayor, City Attorney, and City Clerk to enter into a Grant Agreement with Nebraska Department of Water, Energy, and Environment (“DWEE”), to grant funds to the City of Beatrice for the purpose of funding the City’s Tire Amnesty Program through NDWEE’s Waste Reduction & Recycling Incentive Grant Program.

NOW, THEREFORE, BE IT RESOLVED BY THE MAYOR AND CITY COUNCIL OF THE CITY OF BEATRICE, NEBRASKA:

SECTION 1. That the Mayor, City Attorney, and City Clerk are hereby authorized to execute the Grant Agreement with DWEE, and any and all other documents necessary for DWEE to grant funds to the City for the purpose of funding the City’s Tire Amnesty Program through DWEE’s Waste Reduction & Recycling Incentive Grant Program. A copy of the said Grant Agreement, marked as Exhibit “A”, is attached hereto and incorporated by reference.

SECTION 2. That all resolutions or parts of resolutions in conflict herewith are hereby repealed.

RESOLUTION PASSED AND ADOPTED this 19th day of January, 2026.

Attest:

Erin Saathoff, MMC, City Clerk

Robert Morgan Mayor

Exhibit "A"

GRANT AGREEMENT
Between the
Nebraska Department of Water, Energy, and Environment
And
City of Beatrice
Regarding the Implementation of the
Waste Reduction & Recycling Incentive Grant Application Project,
Reference Number: 2025-152706443

THIS GRANT AGREEMENT (Agreement) is made and entered into by and between the Nebraska Department of Water, Energy, and Environment (Department) and City of Beatrice (Grantee)

WHEREAS, the Grantee agrees to utilize funds which have been made available to Department pursuant to the Nebraska Waste Reduction & Recycling Incentive Act; and

WHEREAS, grant funds in an amount up to \$58,264.00 and a match of at least \$0.00 are to be used to implement the workplan as outlined in Attachment A.

NOW, THEREFORE, the parties do hereby agree to the terms and conditions of this Agreement as follows:

1) TERM OF AGREEMENT

- a) This Agreement will go into effect when both parties sign, but no earlier than January 1, 2026 and will remain in effect until all identified tasks are completed for the workplan as outlined in Attachment A unless terminated under Section 4)h)v) of this Agreement, but will not remain in effect past December 31, 2026 unless extended by an amendment.

2) PROJECT DESCRIPTION

- a) This Agreement encompasses the project described in Attachment A. Attachment A is hereby incorporated into this document in its entirety.

3) DEFINITIONS

- a) **Equipment** means tangible property that is used for a particular purpose, not consumable in nature, with an expected useful life of more than one year, purchased by Grantee and reimbursed wholly or in part by the Department with grant funds.
- b) **Indirect Cost** means costs for expenses that are not directly attributable to a specific project or activity but are necessary for the overall operation (including but not limited to rent, utilities, phone, internet, printing). allocated to the individual employee as a percentage of gross wages, rather than considering these costs as a separate expense.
- c) **Matching Funds (Match)** means cash, or the economic value of non-cash contributions provided by the applicant or outside parties including but not limited to labor, equipment usage, real property, supplies and other expendable property, and the value of goods and services directly benefiting and specifically identifiable to the grant project.
- d) **Related party** means a person or a member of that person's family (including in-laws) that is related to someone who has control, joint control, or significant influence over the Grantee or is a member of its key management personnel, or an entity if, among other circumstances, it is a parent, subsidiary, fellow subsidiary, associate, or joint venture of the Grantee, or it is controlled, jointly controlled, or

significantly influenced or managed by a person who is a related party.

- e) **Responsible bidder** means a bidder who has the capability in all respects to perform fully and lawfully all requirements with integrity and reliability to assure good faith performance.
- f) **Similar supply items** mean items of a similar purpose or use purchased to perform a related task.

4) CONDITIONS OF AGREEMENT

a) General Conditions

- i) Statutes and Regulations. The Grantee will comply with all local, state, and federal statutes, rules, regulations, ordinances, and orders applicable to Grantee. Applicants must be authorized to conduct business in Nebraska (corporations registered with the Nebraska Secretary of State and remain active. Violation of this condition will be considered a breach of this Agreement and will be subject to penalties or termination as set forth in this Agreement.

- (1) For Waste Reduction & Recycling Incentive Grants: The requirements of Title 199 –Waste Reduction and Recycling Incentive Grants Program, and the Waste Reduction and Recycling Incentive Act, Neb. Rev. Stat. §§ 81-15,158.01 through 81-15,165, are hereby incorporated in this Agreement.

For Litter Reduction & Recycling Grants: The requirements of Title 133 – Litter Reduction and Recycling Grant Program, and the Nebraska Litter Reduction and Recycling Act, Neb. Rev. Stat. §§ 81-1534 through 81-1566, are hereby incorporated in this Agreement.

- ii) False or Misleading Information. If Grantee provides false or misleading information or withholds material facts during the application or quarterly reporting process in any way, it will be considered a breach of this Agreement and be subject to penalties or termination as set forth in this Agreement.

- iii) Independent Contractor. The Grantee is and will perform this Agreement as an independent contractor and as such will have and maintain exclusive control over all its employees, agents, and operations. Neither the Grantee nor any person employed by the Grantee shall act, propose to act, or be deemed the Department's agent, representative, or employee.

- (1) The Grantee assumes full and exclusive responsibility for the payment of all premiums, payroll taxes, and other taxes now or hereafter required by any law or regulation.
- (2) The Grantee and any contractor or subcontractor will comply with all applicable laws, regulations, and orders, including but not limited to, those relating to social security, unemployment compensation, OSHA, affirmative action, equal employment opportunity, and the Americans with Disabilities Act.
- (3) The Grantee and any contractor or subcontractor of the Grantee is required to use the E-Verify Program authorized by the Illegal Immigration Reform and Immigrant Responsibility Act of 1996, 8 U.S.C. 1324a to determine the work eligibility status of newly hired employees physically performing services within the State of Nebraska.
- (4) The Grantee, by executing this Agreement, certifies and assures that Grantee and any contractor or subcontractor operates a drug free workplace as addressed in the State of Nebraska Drug Free Workplace Policy of February 5, 2024.
- (5) The Grantee and any contractor or subcontractor will comply with the Nebraska Fair

Employment Practice Act.

- iv) Conflict of Interest. The Grantee certifies that it will not employ any individual known by the Grantee to have a conflict of interest. The Grantee certifies that there does not now exist any relationship between the Grantee and any person or entity which gives the appearance of a conflict of interest. Any new, undiscovered, or undisclosed conflicts of interest arising during the duration of this Agreement may be considered a breach of this Agreement and will be subject to penalties or termination as set forth in this Agreement.
- v) Related Parties. Transactions between the Grantee and related parties must be disclosed to the Department if grant funds will be used for reimbursement of the transaction, or the transaction will be counted towards the Grantee's match. Department may deny reimbursement or reject as match if Grantee:
 - (1) Fails to receive Department approval prior to incurring expense, or
 - (2) Does not include a bid from the related party as part of the grant application.
- vi) Schedule. Grantee agrees to complete the objectives and work items as described in Attachment A.
- vii) Expenditures. To be eligible for reimbursement by grant funds, any contract, interagency agreement, and/or sub-agreement, except as identified in Attachment A, under this grant for a value of \$5,000 or more, must receive Department approval prior to expenditure of funds associated with those transactions.
- viii) Environmental Data. To be eligible for reimbursement by grant funds, a Quality Assurance/Quality Control plan must be approved by the Department prior to expending any funds for environmental data collection. Any environmental data collected must be provided to Department.
- ix) Recognition. Grantee agrees to recognize funding from the Department on all published materials and news releases related to the grantees funded project or activities. The Department may also require that equipment partially or wholly funded with grant dollars be identified by a decal or other means provided by the Department acknowledging the source of funding.
- x) Publication. All parties shall have publication and reproduction rights for all reports and materials which are produced as a result of this Agreement.
- xi) Insurance. The Grantee must provide Department proof of coverage under an insurance policy which covers the Department's investment in personal property with a purchase value greater than \$5,000 or real property as it pertains to the Litter and/or Waste Reduction & Recycling Grants funds.
- xii) Site Visits. Department staff may schedule visits during the grant period, and if applicable, throughout the estimated service life of equipment purchased with grant funds.
 - (1) Grantee will comply with requests for information and grant access for inspection of all grants funded equipment and facilities.
- xiii) Department grant funds cannot be used to offset costs when bidding for services for any other grant-funded activities.
- xiv) Department grant funds cannot be used as matching funds for another Department grant.

b) Reporting and Reimbursement

i) Quarterly Performance Report. The Grantee agrees to submit to the Department quarterly performance reports using the online quarterly reporting process even when project funds have not been expended during the quarter. Reports for quarters 1, 2, and 3 must be submitted within 30 days after the end of each respective calendar quarter. The report for the 4th quarter must be submitted within 45 days after the end of the 4th quarter.

(1) These reports must address project activity for the previous calendar quarter, and contain the following components:

- (a) Detailed descriptions of grant project activities and accomplishments for the quarter.
- (b) Financial report of money spent for each approved activity element by grant and match with required documentation attached.
 - (i) Goods or services documentation must include itemized invoices and cancelled checks (electronic bank copies are sufficient).
- (c) Detailed report of equipment purchased and certification that any equipment and supplies purchased with grant funds or match were used for grant purposes only.
- (d) Corrective actions taken to resolve any significant or material problems that are encountered; and
- (e) Any additional information required by the Department.

(2) For studies funded by grant money, the Grantee must include a report detailing the findings of the study with the fourth quarter report.

ii) Reimbursement. Grants will be funded on a reimbursement basis subject to availability of funds and will be in accordance with the conditions of this Agreement.

(1) Reimbursement will be made only if required reports have been provided to the Department.

(2) Reimbursements will be made only for documented expenditures.

(3) Reimbursement requests can only be made in conjunction with quarterly reports.

(4) To be eligible for reimbursement, the Grantee must submit appropriate supporting documentation to the Department with the required quarterly report, including a line-by-line document listing all reimbursable expenses.

(a) Required Documentation:

(i) Personnel Expenses: submit copies of paycheck stubs or payroll records showing employee name, dates worked, hourly rate, and hours worked. If unable to provide paystubs showing all required documentation, Grantee must submit a copy of the front and back of cancelled paychecks and a payroll report. If claiming FICA, a 941 report and proof of 941 payments must be included.

(ii) Supply and Operating Expenses: submit copies of detailed invoices.

(iii) Travel Expense: submit copies of the detailed receipts for all expense reimbursements being requested. Submit a log for mileage showing the date, start and stop point of destination, odometer reading, number of miles, and purpose of the trip. If requesting conference travel expenses, a copy of the agenda must be submitted.

(iv) Contractual Expenses: submit copies of detailed invoices and images of

- the front and back of cancelled checks.
- (v) Equipment Expenses: submit copies of the detailed invoices (listing make, model, and serial number of item) and images of the front and back of cancelled checks.
 - (vi) Matching Cash/Non-Cash Expenses: submit a detailed list of matching expenses and the calculations used to determine matching expenses. Documentation must be provided for all cash and non-cash match reported.
- (5) Travel Expenses. In-state travel expenses must comply with policies and regulations of the Nebraska Department of Administrative Services policies and regulations to be eligible for reimbursement. (<https://das.nebraska.gov/accounting/erd.html>). Out-of-state meal expenses will be eligible for reimbursement according to U.S. General Services Administration per diem rates (<https://www.gsa.gov/travel/plan-book/per-diem-rates>). Reimbursement of in-state and out-of-state travel expenses will be at the rates posted on the date the travel occurred. See the Litter Reduction & Recycling and Waste Reduction & Recycling Incentive Grant Application Guidance for limits.
- (6) Clothing and Personal Accessory items may be used for cash match only.
- (7) Telephone. Landline telephone and cell phone services are reimbursable if the service contract is billed to the Grantee.
- (8) Personnel Costs.
- (a) The Department will reimburse for the following:
 - (i) Personnel wages up to a maximum of \$30.00 per hour worked, per employee, limited to a 40-hour work week.
 - (ii) The employer's share of social security taxes and Medicare taxes on wages up to \$30.00 per hour (7.65% of gross wages), workers' compensation, and unemployment insurance will be reimbursed in addition to the \$30.00 per hour maximum reimbursement.
 - (iii) The employer's share of employer-provided health, dental, or vision insurance premiums, not to exceed actual cost up to \$5.00 per hour in total.
 - (b) The following personnel expenses are not reimbursable with grant funds, but can be used as matching funds:
 - (i) Actual wages more than \$30.00 per hour and more than a 40-hour work week
 - (ii) Employer-paid social security and Medicare (FICA) taxes paid on wages in excess of \$30.00 per hour, limited to a 40-hour work week.
 - (iii) Health, dental, and vision insurance costs over \$5.00 per hour and more than a 40-hour work week
 - (iv) Employer stipends to cover health insurance premiums or health savings account contributions.
 - (v) Life insurance costs
 - (vi) Retirement account contributions or software pertaining to retirement
 - (vii) Tuition or higher education paid as an employee benefit
 - (viii) A payout for unused sick or vacation leave
 - (ix) Overtime payments
 - (x) Indirect costs as a percentage of gross wages
 - 1. If a Grantee uses indirect costs as a cash match to the grant, the Department will not reimburse costs for office rent, utilities, phone, internet, printing, etc.

- (c) In accordance with Section 4)b)10, bonuses will not be reimbursed with grant funds and cannot be used as matching funds.

(9) Timing.

- (a) Grant funds will not be reimbursed for expenses or goods incurred outside the grant term. Liabilities incurred or money expended before or after the grant term are not eligible to be used as matching funds. This does not apply to completed projects under the scrap tire program.
- (b) Liabilities incurred during the grant term are eligible for reimbursement or consideration for match if satisfied by payment within 45 days after the end of the grant term. This does not apply to completed projects under the scrap tire program.
- (c) Expenses incurred prior to both parties signing the agreement will not be reimbursed. This does not apply to completed projects under the scrap tire program.

(10) Unauthorized Expenses.

- (a) The department reserves the right to deny reimbursement for any ineligible items requested on quarterly reports/reimbursement requests.
- (b) Grantee will not be reimbursed, or allowed to claim match, for unauthorized expenditures, including, but not limited to:
 - i. Beautification expenses, such as painting or other building enhancements, seeds, trees, flowers, planters, and other landscaping items
 - ii. Recognition expenses such as prizes, plaques, awards, certificates, or trophies
 - iii. Foods, snacks, or beverages unrelated to travel
 - iv. Landfill closure assessment, closure, monitoring, and remediation
 - v. Late fees or interest charged on invoices
 - vi. Property tax and real estate tax
 - vii. Standalone Trash bins
 - viii. Prizes, gift cards, or donations of any kind
 - ix. Guest/non-staff travel expenses
 - x. Grant writer costs
 - xi. Supplies for pet waste clean-up or any project that is pet related
 - xii. Employee bonus/recognition expense
 - xiii. Clothing and Personal Accessory Items (Allowed to be used as match funds)
 - xiv. Decorating services

(11) Payment Timeline.

- (a) The Department will make payments in accordance with the Prompt Payment Act, Neb. Rev. Stat. §§81-2401 to 81-2408.
- iii) Records. Grantee must keep separate financial records for grant funds for a period of three years following the completion of the grant period. Including:
- (1) Cancelled checks
 - (2) Invoices/receipts for all grant expenditures and matching cash expenditures

- (3) Documentation for all matching funds (matching cash and matching in-kind/non-cash expenditures)
- iv) Inspection of Records. Throughout the duration of the grant period and three years following the completion of the grant period, the Department will have the right to request, inspect, and make copies of any books, records, or reports of the Grantee pertaining to this Agreement or related matters during regular office hours. The Grantee shall maintain and make available for such inspection accurate records of all costs, disbursements, and receipts with respect to its activities under this Agreement.
- c) Matching Funds. Only funds used to advance the project set forth in Attachment A will be eligible to be applied as match to the grant.
 - i) If the Department determines that any cash or non-cash contribution does not advance the project set forth in Attachment A, the Department will deny all or a portion of the contribution from being applied to the grant as match. Funds awarded as part of a different grant provided by the Department cannot be used as match for the purposes of this grant.
- d) Equipment
 - i) Equipment Purchase. If specific equipment was part of the approved application and the grantee purchases the equipment from the lowest responsible bidder, the grantee is approved to purchase the equipment.
 - (1) Only an amount equal to the lowest bid by a responsible bidder will be considered eligible for reimbursement.
 - (a) If Grantee provides adequate justification, as determined by the Department, why the lowest bid is unacceptable, the Department may approve the selection of a higher bid.
 - (b) If Grantee selects a higher bid without the approval of the Department, the additional amount paid by Grantee can serve as match to the grant.
 - ii) Expected Service Life (ESL). The Department will assign an ESL to all equipment that has a value of \$5,000 or more. Equipment worth less than \$5,000 may be assigned an ESL on a case-by-case basis. The ESL may exceed the designated grant period.
 - iii) Equipment Titles. Grantee will put the grantee's name on the title of all equipment that is assigned an ESL.
 - iv) Equipment Usage. Equipment will be used only for the purposes identified in the grant application and approved by the Department by the award of grant funds throughout the ESL. Grantee will make effective and efficient use of the equipment during its ESL, as determined by the Department.
 - (1) If equipment is used for a purpose that is not approved, or the Grantee fails to make effective and efficient use of the equipment throughout the ESL, the Department may:
 - (a) Require the Grantee repay all or a portion of the grant used to reimburse for the purchase of the equipment as determined by the Department,
 - (b) Decline reimbursement for other, unrelated approved expenses in an amount up to the grant funds used for equipment purchase, or
 - (c) Require the Grantee to surrender the equipment to the Department.
 - (i) Grantee must store surrendered equipment safely until the Department can arrange for the equipment to be redistributed.
 - (ii) Grantee must complete all paperwork required for transfer of surrendered

equipment.

- v) Equipment Maintenance. The Grantee is responsible for keeping all equipment purchased with grant funds in good working order and operational throughout the Expected Service Life (ESL). This responsibility includes all necessary and reasonable maintenance, as well as any expenses required to repair or service the equipment. The Department will not provide additional funding for maintenance or repairs, and the absence of an extended warranty does not relieve the Grantee of this responsibility. While some equipment may only carry a limited manufacturer's warranty (e.g., one year), the Grantee remains fully responsible for ensuring that the equipment continues to function effectively for the duration of the ESL. The Grantee may be held liable by the Department for any loss, damage, neglect, or unreasonable deterioration of the equipment.
 - vi) Equipment Liens. The Department will maintain first lien status on all redistributed equipment and equipment purchased, in whole or in part, with grant funds, unless otherwise approved by the Director.
 - (1) Length of lien on redistributed equipment and equipment purchased with grant funds shall correspond to the ESL of the equipment.
 - vii) Ownership Interest. The Department maintains an ownership interest in all equipment during the ESL. The grant recipient will gain unrestricted ownership after the ESL period expires unless Grantee was required to surrender the equipment.
 - viii) Equipment Disposition. The Department shall approve or deny the disposition of equipment throughout the ESL.
 - (1) Funds realized from the sale of equipment will revert to the Department in an amount congruent with the percentage of funding provided by the Department for purchase of the equipment.
 - ix) Equipment Identification. Any piece of equipment that is assigned an ESL is required to be permanently identified. The Department will provide a tag for the grantee to place on the equipment.
 - x) Equipment Inventory. After the end of the designated grant term, the grant recipient must continue to maintain a listing of all equipment that is assigned an ESL and respond to Department requests for updates on the status of such equipment and be subject to inspection throughout its ESL.
- e) Scrap Tire Cleanup Events. The conditions set forth in this section apply to funded scrap tire cleanup events.
- i) Scrap tire cleanup events will be open to the public and businesses that do not collect a tire disposal fee. Tire retailers or businesses that have charged or collected fees to accept scrap tires are not eligible to bring in scrap tires for disposal at the grant-funded scrap tire cleanup
 - ii) The collection of tires is not allowed outside of the designated collection event days and will not be reimbursable.
 - iii) Tires accepted at scrap tire cleanup events must be off the rims.
 - iv) Bids for the services of a scrap tire hauler must stipulate the hauler will load all scrap tires.

- v) Expenses for the use or purchase of equipment will not be eligible for reimbursement unless prior approval from the Department is obtained in writing.
- vi) The grantee must submit a completed Grant Conditions Acceptance Form (provided by the Department) at least thirty (30) days prior to the collection event and may not begin the event until the Department approves the form.
- vii) The duration of scrap tire events will be no longer than three days, unless approved by the Department. If approved, reimbursement for labor will be limited to three, eight-hour days for a total of twenty-four hours per person. A cleanup log is required for all days of the event.
- viii) Labor is approved for up to two people to monitor the required scrap tire cleanup log sign-in sheet during the hours the event is open.
- ix) Advertising expenses, up to \$1,000 or a maximum of 5% of the grant award, whichever is less, are eligible for reimbursement.
- x) Grantee is responsible for locating and utilizing a commercial scale to weigh empty trailers and full loads of scrap tires collected by the scrap tire hauler.
 - (1) The scale must be long enough to weigh an entire tractor-trailer at one time. Weights derived from split-weighing will not be accepted by the Department.
 - (2) A scale operator must be available any time the scrap tire hauler needs to weigh empty or full loads of scrap tires.
 - (3) Only machine printed scale tickets will be accepted for reimbursement. Manually entered gross or tare weights will not be accepted for reimbursement.
- xi) To be eligible for reimbursement, the Grantee must submit appropriate supporting documentation to the Department, including:
 - (1) Copies of scale tickets and invoices from your hauler for all scrap tires cleaned up,
 - (2) Scrap tire cleanup log (will be provided to grantee),
 - (3) If applicable, copies of timesheets for laborers, listing date worked, name of worker(s), hours worked per day, and
 - (4) If applicable, copies of invoices for advertising, along with a sample copy of the ad.
- f) Partial Reimbursement for Tire-derived Products and/or Crumb Rubber. The conditions set forth in this section apply to proposed applications for Partial Reimbursement. Only projects using tire-derived products containing a minimum of 25% recycled tire content are eligible for funding. A priority is given to those projects certifying that the tire derived products and/or crumb rubber are made from scrap tires originating from Nebraska.
 - i) Three bids are required for reimbursement of the cost of tire-derived products and/or crumb rubber if the project is proposed at the time of grant application submittal, and the project cost is \$25,000 or more.
 - ii) The grant amount will be based on the lowest reasonable bid as determined by the Department.

- iii) To be eligible for partial reimbursement, the Grantee must provide a paid invoice, front, and back images of cancelled checks, and documentation certifying the origin of scrap tires used in the project.
- g) Deconstruction Grants. The conditions set forth in this section apply to funded deconstruction grants. Prior to any deconstruction or demolition activity, Grantee must:
 - i) Hold title to all property and have the necessary easements and right-of-way for the project described in Attachment A;
 - ii) Submit to the department proof of a completed asbestos survey on any structures to be deconstructed or demolished.
- h) Terms of Agreement
 - i) Amendments. This agreement may be amended in writing at any time by mutual agreement of the parties, except insofar as any proposed amendments are in any way contrary to applicable law or requirements of the Department.
 - (1) Budget modifications and grant period extension requests must be submitted as a written change request during the grant period. The request must:
 - (a) Stay within the scope of the original proposal,
 - (b) Include justification for changes,
 - (c) Include a revised work plan, and
 - (d) Include a revised comprehensive line-item budget.
 - (2) The Department will notify the grant recipient regarding approval or denial of project modifications.
 - ii) Indemnification. The Grantee agrees to indemnify and hold the Department harmless for loss or damage sustained by any person as a direct result of the negligent or willful acts by the Grantee, its employees, subcontractors, or agents in the performance of this Agreement, including all associated costs of any defending action.
 - iii) Assignment. No assignment or transfer of this agreement or any part hereof, rights hereunder, or interest herein by the Grantee shall be valid unless and until it is approved by the Department and made subject to such reasonable terms and conditions as the Department may impose.
 - iv) Waiver of Rights. The Grantee or Department may, from time to time, waive any of their rights under this agreement. However, any waiver of rights with respect to a default of any condition of this agreement shall not be deemed to be a waiver of such condition or any other right or power granted by this agreement.
 - v) Termination. The following remedies are exclusive and any terminations of this Contract shall be limited to the following:
 - (1) Terminated with cause in the event either party defaults on any of its material obligations or representations under this Agreement. The non-defaulting party shall notify the other party in writing, specifying in detail the nature and extent of such breach. If within thirty (30) calendar days after written notice of such default, the defaulting party fails to remedy the default, this agreement will terminate.
 - (2) Terminated by the Department, in whole or in part, in the event funding is no longer available. If funds are revoked by the Legislature, the Department may terminate any

portions of the Agreement for which funds have become unavailable. The Department will give the Sponsor notice of such revocation as soon as possible. The Sponsor shall be entitled to receive just and equitable reimbursement for any authorized work that has been satisfactorily completed as of the termination date.

- vi) Relinquishment. Grantee shall provide notice to the Department within ten (10) days of decision to relinquish grant if Grantee no longer intends to carry out the project as described in Attachment A. Upon notification, the Department may make the funds and any equipment that was allotted for the project covered by this agreement available to another party and release the Grantee from any further reporting duties.
- vii) Violations and Nonperformance. If the Grantee violates any condition of this agreement or fails to complete and maintain the project in a manner described in Attachment A, the Department retains the right to hold and delay any and all funds if a potential violation or noncompliance has occurred or is being investigated. Funds can be withheld until the potential violation or noncompliance has been resolved. The Department may also:
 - 1) Require the Grantee to repay any or all funds previously disbursed according to this Agreement,
 - 2) Require the Grantee to surrender any equipment, and
 - 3) Pursue any other remedy available under the law.
- viii) Remedies Not Exclusive. Except where specifically stated otherwise, the use by the Department of any remedy specified herein for the enforcement of this Agreement is not exclusive and shall not deprive the Department from using such remedy or limit the application of any other remedy provided by law.
- ix) Severability. If any provision of this Agreement is found to be illegal, void, or unenforceable, the other provisions of this Agreement will remain in full force and effect.
- x) Integration. The parties intend this Agreement to constitute the complete, exclusive, and fully integrated statement of their agreement. As such, it is the sole repository of their agreement and they are not bound by any other agreements, promises, representations, or writings of whatsoever kind or nature. The parties also intend that this, complete, exclusive, and fully integrated statement of their agreement may not be supplemented or explained by any evidence of trade usage or course of dealing.
- xi) Nondiscrimination. The Nebraska Fair Employment Practice Act prohibits contractors to the State of Nebraska and their subcontractors from discriminating against any employee, or applicant for employment in the performance of such contracts, with respect to hire, tenure, terms, conditions, or privileges of employment because of race, color, religion, sex, disability, or national origin. The Contractor's signature is a guarantee of compliance with the Nebraska Fair Employment Practice Act, and breach of this provision shall be regarded as a material breach of this Contract. The Contractor shall insert a similar provision in all subcontracts for Services to be covered by any contract resulting from this Contract.
- xii) Suspension and Debarment
 - (a) The suspension and debarment process protects the Department from fraud, waste, and abuse by using tools to avoid doing business with non-responsible grant applicants. Any Grantee that is directly or indirectly involved in alleged wrongdoing is subject to suspension or debarment. By signing this agreement, Grantee certifies that it is not presently nor has ever been

debarred, suspended, or proposed for debarment by any federal, state, or local agency. Grantee must notify the Department within 30 days if debarred, suspended, or proposed for debarment from participation in any contract by any federal, state, or local agency during this agreement.

(b) Below are the causes for suspension or debarment:

- Commission of fraud, embezzlement, theft, forgery, bribery, falsification or destruction of records, making false statements, tax evasion, violating state or federal criminal laws, receiving stolen property, and unfair trade practice
- Violation of antitrust laws
- Willful failure to perform
- Knowing failure to disclose violation of criminal law
- Any other cause that affects present responsibility under the current Agreement

Suspension is a temporary measure with a 12-month limit based on adequate evidence, such as an indictment or investigation by law enforcement. Debarment is up to 3 years in length, determined by the Department, based on a criminal conviction or civil judgment for any of the causes listed above.

The Department will initiate suspension or debarment by letter to the Grantee explaining the reason for the action. A Grantee receiving a Suspension or Debarment letter has 30 days from the date of the letter to respond before the Department Director makes a final decision. A Grantee can also request to meet with Department staff to discuss the letter in person.

A grantee who is suspended or debarred by the Department or a federal agency agrees to make full restitution of misappropriated Department grant funds to the Department.

- xiii) Force Majeure. Neither Party shall be liable for losses, delays, failure, errors, interruption or loss of data occurring directly or indirectly by reason of circumstances beyond its reasonable control, including, without limitation, Acts of Nature (including fire, flood, earthquake, storm, hurricane or other natural disaster); action or inaction of civil or military authority; acts of foreign enemies; war; terrorism; riot; insurrection; sabotage; epidemics; labor disputes; civil commotion; or interruption, loss or malfunction of utilities, transportation, computer or communications capabilities, government action which makes it impossible for a party to perform its contractual duties, and the other Party shall have no right to terminate this Agreement in such circumstances.

RESOLUTION NUMBER _____

A resolution authorizing the City of Beatrice, Nebraska to enter into a Smart Print Agreement with Eakes Office Solutions, for the leasing and servicing of printers and other office equipment.

NOW, THEREFORE, BE IT RESOLVED BY THE MAYOR AND CITY COUNCIL OF THE CITY OF BEATRICE, NEBRASKA:

SECTION 1. That the Mayor, City Clerk, and City Administrator be and hereby are authorized to enter into a Smart Print Agreement and any and all other documents necessary between the City of Beatrice, Nebraska and Eakes Office Solutions, for the leasing and servicing of printers and other office equipment. A copy of said Lease Agreement, marked as Exhibit "A", is attached hereto and incorporated by reference.

SECTION 2. That all resolutions or parts of resolutions in conflict are hereby repealed.

RESOLUTION PASSED AND ADOPTED this 19th day of January, 2026.

Attest:

Erin Saathoff, MMC, City Clerk

Robert Morgan, Mayor

PERFORMANCE GUARANTEE

Eakes Smart Print Management Program Guarantee of Customer Satisfaction

Fleet Performance Guarantee

Eakes Office Solutions guarantees that all Copier, MFP, and Printer equipment covered under the Smart Print Agreement dated _____ will maintain a minimum of **96% monthly uptime** cumulatively throughout the term of the Agreement for all covered equipment.

If the covered equipment fails to meet the 96% monthly uptime requirement, the City of Beatrice may issue a written notice of default, triggering a **90-day cure period**. During the final **30 days** of the cure period, the total of all equipment must achieve at least **96% monthly uptime**. If Eakes fails to meet this requirement, the City may terminate the Agreement without penalty.

Unit Performance Guarantee

Eakes Office Solutions guarantees that each Copier, MFP, and Printer unit covered under the Agreement will maintain a minimum of **96% monthly uptime** throughout the term of the Agreement (96% monthly uptime for each unit). If an individual unit fails to meet the 96% monthly uptime requirement, the City of Beatrice may require Eakes to replace any specific non-performing equipment with a unit of comparable functionality and specifications to achieve 96% monthly uptime.

No Modification of Existing Obligations

This Guarantee shall not alter, amend, or modify any obligations, rights, or responsibilities of either party under the original Smart Print Agreement, except as expressly stated herein. All terms and conditions of the Smart Print Agreement remain in full force and effect.

City of Beatrice

Eakes Office Solutions

Customer (Signature and Title) City Administrator

Managing Partner

Date

Date



Scott Lilleskov
Managing Partner

402-898-8017 | slillekov@eakes.com



110 North 35th Street
Lincoln, NE 68503
402-438-6700

Smart Print Agreement

(SPA - Includes Service & Supplies)

Contract Date: _____

LESSEE INFORMATION

Full Legal Name: City of Beatrice
Billing Address: 400 Ella Street Phone: 402.228.5200
City: Beatrice County: State: NE Zip: 68310

EQUIPMENT LOCATION Note: Equipment shall not be removed from this location without written consent of Lessor.

Street Address: 400 Ella Street
City: Beatrice County: State: NE Zip: 68310

EQUIPMENT INFORMATION

Make/Model/Description	Serial Number	Location
See Exhibit A		

CONNECTED CARE

You have declined Connected Care coverage. _____ x \$3.00 = _____
of devices per device monthly total

Connected Care coverage includes: loading drivers, diagnostics of printing problems and scanning issues, hard drive security, and general printing support limited to machines under this agreement. If accepted, Connected Care charges are included in the "Total Monthly Payment" below.

TERM & PAYMENT INFORMATION

	MFP Mono	MFP Color		Monthly Payment +	Sales Tax =	Total Monthly Payment
Monthly Output Included	20,439	8,012				
Additional Cost Per Copy	\$0.00280	\$0.02700		\$1,802.66		\$1,802.66
Term in Months	Down Payment +		Security Deposit +		Sales Tax =	Total Payment Enclosed
60						

CUSTOMER SIGNATURE

I have read and agree to all of the terms and conditions contained on this Agreement, the attached Terms, Letter of Instruction, and any other attachments to same (all of which are included by reference) and become part of this Agreement. I understand and agree that Lessee is solely responsible for the security of the property and all data and information stored within it. I acknowledge to have read and agree to all the terms and conditions and understand that this is a non-cancelable Agreement for the full term shown above. I take responsibility for equipment selection and that equipment is completely acceptable. I hereby acknowledge and represent that I have lawful authority to execute this Agreement and to bind the Lessee to its terms and conditions.

Signature _____ Title: City Administrator Date: _____
(Authorized Signature)

Print Name Tobias Templemeyer For: City of Beatrice

EAKES ACCEPTANCE

Signature _____ Date: _____
(Authorized Signature)

Title: _____ For: Eakes

Salesperson: 5174 Lindsey Kirkendall

SPA TERMS AND CONDITIONS

The words YOU and YOUR mean the user of Equipment. The words WE, US, and OUR refer to Eakes, Inc., the owner of the equipment. The words COPY or COPIES refer to all output produced including copies, prints, faxes received and other output.

1. **SPA PLAN ("AGREEMENT"):** WE agree to rent to YOU and YOU agree to rent from US the Equipment listed in the "Equipment Information" section of this Agreement and/or in any attached schedule ("Equipment"). YOU promise to pay US as follows: (a) A MONTHLY MINIMUM PAYMENT SET FORTH ON THE FACE OF THIS AGREEMENT ("Total Monthly Payment") (b) The Cost Per Copy of additional copies in excess of the Monthly Output Included, at current average fee rate. Additional Copies will be the excess of the actual copies made less three times the Monthly Output Included. Additional Copies will be invoiced at the end of each 3-month period. If you have not used the Monthly Output Included for the 3-month period you will not be allowed to apply that unused number of copies to the next 3-month period. YOU authorize US to insert in this Agreement the serial numbers of the Equipment when WE so determine them.
2. **TERM AND RENT:** This Agreement goes into effect and the term of this Agreement begins when it is signed and accepted by US (the "Commencement Date"). WE will provide without charge equipment, parts, labor, and all supply cartridges, if included. In the event YOU have machines not included in this agreement that use the same or similar consumable supplies as machines originally on or added to this agreement, WE reserve the right to add any and all of those machines to this agreement, with or without notification to YOU, at per click rates that are in effect at the time of the addition. You are responsible for paper and staples, if applicable. This agreement includes Eakes general printing and scanning support which covers: loading drivers, diagnostics of printing problems and scanning issues, hard drive security, and general printing support limited to machines under this agreement unless YOU have opted out of Connected Care. Extent and limitations of support determined exclusively by US. You are responsible for repairs made necessary by accident, misuse, abuse, neglect, theft, vandalism, electrical power failure, water, fire, or other casualty. Equipment operated in excess of 130% of the Monthly Output Included on the face of this Agreement may be subject to overhauling or rebuilding at YOUR expense. Emergency service calls will be made during regular business hours Monday through Friday. YOU agree to provide accurate and timely meter readings at the end of each applicable billing period on the forms or other alternative means specified by US. If meter readings are not received in a timely manner, charges may be estimated by US. Your obligation to pay the Total Monthly Payments and other obligations hereunder shall be absolute and unconditional. This agreement is non-cancelable. At the end of the first year of this Agreement, and with each successive twelve-month period for the duration of the Agreement term, WE may increase the Additional Cost Per Copy charge and service and supply component of YOUR Total Monthly Payment by a maximum of 15% over the existing charge. Machine portion of YOUR payment will stay fixed for the duration of this Agreement. All supplies provided under this agreement remain the property of Eakes, Inc. until consumed. During the contract period if supply yield falls below the manufacturer's stated yield, Eakes has the right to charge for excess toner/ developer consumption. Eakes reserves the right to charge for excessive service on a time and materials basis or increase the per copy rate if it is determined that any conditions listed exist: a.) Use of substandard media and supplies or use of items not designated for use with products being serviced; or b.) site conditions that do not conform to Eakes' site specifications; or c.) fire or water damage, neglect, improper use, electrical disturbances, transportation by Customer, work or modification by people other than Eakes employees or subagreements, or other causes beyond Eakes' control; or d.) failure to follow manufacturer's operating instructions or recommended volume.
3. **USE, MAINTENANCE, REPAIR, SUPPLIES AND WARRANTIES:** YOU agree to provide suitable space and electrical services for the operation of the Equipment as recommended by the manufacturer. We are not the manufacturer of the Equipment and we are renting the Equipment to YOU "AS-IS". YOU have selected the Equipment and WE MAKE NO WARRANTIES, EXPRESS OR IMPLIED, INCLUDING WARRANTIES OF MERCHANTABILITY OR FITNESS FOR A PARTICULAR PURPOSE IN CONNECTION WITH THIS AGREEMENT. WE transfer to YOU for the term of this Agreement all warranties, if any, made by the manufacturer. YOU ALSO ACKNOWLEDGE THAT NO ONE IS AUTHORIZED TO WAIVE OR CHANGE ANY TERM, PROVISION OR CONDITION OF THIS AGREEMENT OR MAKE ANY REPRESENTATION OR WARRANTY ABOUT THIS AGREEMENT OR THE EQUIPMENT. WE SHALL NOT BE LIABLE FOR ANY DELAYS IN MAKING DELIVERIES OR REPAIRS NOR IN ANY EVENT FOR SPECIAL, RESULTING OR CONSEQUENTIAL DAMAGES OR LOSS OF PROFIT OCCASIONED BY ANY BREACH OF WARRANTY OR REPRESENTATION OR RESULTING FROM THE USE OR PERFORMANCE OF ANY UNIT. YOUR OBLIGATION TO PAY IN FULL ANY AMOUNT DUE UNDER THIS AGREEMENT SHALL NOT BE AFFECTED BY ANY DISPUTE, CLAIM, COUNTERCLAIM, DEFENSE OR OTHER RIGHT WHICH YOU MAY HAVE OR ASSERT AGAINST US OR THE EQUIPMENT MANUFACTURER.
4. **METER COLLECTION:** In order to ensure accurate and timely billings, you agree to comply with any billing procedures designated by Eakes, including providing meter readings upon the request of Eakes and/or supporting Eakes efforts to install/maintain technology to gather meter readings on automated basis. If you do not provide Eakes with meter readings and/or support Eakes efforts to install/maintain technology to gather meter readings on an automated basis, as required, Eakes may estimate readings and bill you accordingly. If we are unable to gather meter readings from you after 3 consecutive billing cycles, you may be assessed a \$25 per machine fee for our personnel to collect those readings.
5. **TITLE, PERSONAL PROPERTY, LOCATION AND INSPECTION:** WE own the Equipment and YOU have the right to use the Equipment for the full term provided YOU comply with the terms and conditions of the Agreement. The Equipment is personal property even though the Equipment may become attached to any real estate. YOU agree not to permit a lien to be placed upon the Equipment or to remove the Equipment from the "Equipment Location". If WE feel it is necessary, YOU agree to provide US with waivers of interest or liens, from anyone claiming any interest in the real estate on which any item of Equipment is located. WE also have the right, at reasonable times, to inspect the Equipment.
6. **ASSIGNMENT:** YOU AGREE NOT TO TRANSFER, SELL, SUBRENT, ASSIGN, PLEDGE OR ENCUMBER EITHER THE EQUIPMENT OR ANY RIGHTS UNDER THIS AGREEMENT WITHOUT OUR PRIOR WRITTEN CONSENT. WE may sell, assign or transfer this Agreement. YOU agree that if WE sell, assign or transfer this Agreement, the new owner will have the same rights and benefits that WE have now and will not have to perform any of OUR obligations. YOU agree that the right of the new owner will not be subject to any claims, defenses, or set-offs that YOU may have against US.
7. **LOSS OR DAMAGE:** YOU are responsible for the risk of loss or destruction of, or damage to the Equipment. No such loss or damage relieves YOU from any obligation under this Agreement. In the event of damage to, or loss or destruction of the Equipment, YOU agree to promptly notify US in writing of such fact and shall, at OUR option, (a) repair the Equipment to good condition and working order, (b) replace the Equipment with like equipment in good repair, condition and working order, acceptable to US and transfer clear title to such replacement equipment to US, such equipment shall be subject to this Agreement and be deemed the Equipment, or (c) pay to US the present value of the total of all unpaid SPA Payments for the full rental term plus the estimated fair market value of the Equipment at the end of the originally scheduled term, all discounted at six percent (6%) per year whereupon this Agreement shall terminate. All proceeds of insurance received by US as a result of such loss or damage will be applied, where applicable, toward the replacement or repair of the Equipment or the payment of your obligations.
8. **TAXES:** YOU agree to pay all license and registration fees, sales and use taxes, personal property taxes and all other taxes and charges, relating to the ownership, leasing, rental, sale, purchase, possession or use of the Equipment as part of the Total Monthly Payment or as billed by US or as billed by a County Assessor's Office. YOU agree that if WE pay any taxes or charges on YOUR behalf, YOU shall reimburse US for all such payments and shall pay US interest and a late charge (as calculated in Section 12) on such payments with the next Total Monthly Payments, plus reasonable costs incurred in collecting and administering any taxes, assessments or fees and remitting them to the proper authorities.
9. **INDEMNITY:** WE are not responsible for any losses or injuries caused by the installation or use of the Equipment. YOU agree to reimburse US for and to defend US against any claim for losses or injuries caused by the Equipment.
10. **INSURANCE:** During the term of this Agreement, YOU will keep the Equipment insured against all risks of loss or damage in an amount not less than the replacement cost of the Equipment, with comprehensive public liability insurance covering both personal injury and property damage of at least \$100,000 per person and \$300,000 per occurrence for bodily injury and \$50,000 for property damage. WE shall be the sole named loss payee on the property insurance and shall be named as an additional insured on the public liability insurance. YOU will pay all premiums for such insurance and shall deliver proof of insurance coverage satisfactory to US. If YOU do not provide such insurance, YOU agree that WE have the right, but not the obligations, to obtain such insurance, in which event YOU agree to pay US for all costs thereof.
11. **DEFAULT:** YOU are in default of this Agreement if any of the following occurs; (a) YOU fail to pay any Total Monthly Payment or other sum when due; (b) YOU breach any warranty or other obligation under this Agreement, or any other agreement with US. (c) YOU, any partner or guarantor dies, YOU become insolvent or unable to pay YOUR debts when due; YOU stop doing business as a going concern; YOU merge, consolidate, transfer all or substantially all of YOUR assets; YOU make an assignment for the benefit of creditors or YOU undergo a substantial deterioration in YOUR financial condition, or (d) YOU, any guarantor or any partner, shall voluntarily file or have filed against it involuntarily, a petition for liquidation, reorganization, adjustment of debt or similar relief under the Federal Bankruptcy Code or any present or future federal or state bankruptcy or insolvency law, or a trustee, receiver or liquidator shall be appointed of it or substantial part of its assets.
12. **REMEDIES:** WE have the following remedies if a default should occur:
 - a. Upon written notice, declare the entire balance of the unpaid Total Monthly Payment for the future term immediately due and payable, sue for and receive all Total Monthly Payments and any other payment then accrued or accelerated under this
 - b. Charge YOU interest on all monies due US at the rate of eighteen percent (18%) per year from the date of default until paid, but in no event more than the maximum rate permitted by law and
 - c. Require that YOU return the Equipment to US and in the event YOU fail to return the Equipment, enter upon the premises peaceably with or without legal process where the Equipment is located and repossess the Equipment. Such return or repossession of the Equipment shall not constitute a termination of this Agreement unless WE expressly notify YOU in writing.
 You are also required to pay (i) all expenses incurred by US in connection with the enforcement of any remedies, including all expenses of repossessing, storing, shipping, repairing and selling the Equipment and (ii) reasonable attorneys' fees. ALL OUR remedies are cumulative, are in addition to any other remedies provided for by law, and may, to the extent permitted by law, be exercised either concurrently or separately. The exercise of any one remedy shall not be deemed an election of such remedy, or preclude the exercise of any other remedy. No failure on OUR part to exercise any right or remedy and no delay in exercising any right or remedy shall operate as a waiver of any right or remedy or modify the terms of this Agreement. A waiver of default shall not be construed as a waiver of any other subsequent default.
13. **LEASE OPTIONS:** The following options are available for this agreement:
 - a. **PURCHASE OPTION.** If not in default you may purchase the Equipment, "AS IS, WHERE IS" and WITHOUT ANY WARRANTY AS TO CONDITION OR VALUE at the end of the lease term for the Purchase Option indicated in the Letter of Instruction attached to this Agreement (i.e. either a set dollar amount or the Fair Market Value of the Equipment at the lease term's conclusion) plus all applicable taxes.
 - b. **RENEWAL.** Unless either party provides notice at least thirty (30) days before the end of the lease term of its intention not to renew this Agreement, it will be renewed automatically on a month-to-month basis at the same price, terms and conditions and billing frequency as the original Agreement. During this renewal period, either party may terminate this Agreement upon at least thirty (30) days notice. Service will continue at current rates and terms.
 - c. **TERMINATION.** Upon termination pursuant to b, above, and if you have not purchased the Equipment, you shall immediately deliver all equipment to us at 110 N 35th Street, Lincoln, NE 68503. At the time of removal, the Equipment shall be in the same condition as when delivered, reasonable wear and tear excepted, together with any software. If you wish to cancel this agreement, e-mail contracts@eakes.com 90 days prior to the anniversary date of the contract.
 - d. **SUBSCRIPTION SOFTWARE.** Upon termination of this Agreement, the subscription software, if any, identified on the face of this Agreement will be billed to YOU at then current rates on a month-to-month basis by Eakes Office Solutions. If YOU wish to terminate subscriptions software services in conjunction with or after termination of this Agreement, cancellation of subscription software will occur only upon at least 30 days written notice from YOU to Eakes Office Solutions.
14. **SECURITY DEPOSIT:** WE will retain any required security deposit as security for YOUR performance of YOUR obligations. Any security deposit is non-interest bearing. WE may apply any security deposit to cure any default by YOU, in which event YOU will promptly restore any amount so applied. If YOU are not in default, any security deposit will be applied to the last month's billing or returned to YOU at the termination of the Agreement.
15. **UCC FILINGS AND FINANCIAL STATEMENTS:** YOU authorize US to file a financing statement with respect to the Equipment signed by US where permitted by the Uniform Commercial Code and to be construed as evidence that any security interest was intended to be created, but only to give public notice of OUR ownership of the Equipment. If this Agreement is deemed at any time to be one intended as security then YOU grant US a security interest in the Equipment and the proceeds from the sale, rent or other disposition of the Equipment.
16. **NOTICE:** Written notices will be deemed to have been given when delivered personally or deposited in the United States mail, postage prepaid, addressed to such party at its address set forth above or at such other address as such party may have subsequently provided in writing.
17. **CHOICE OF LAW:** The parties hereto expressly agree that this Agreement will be governed by, interpreted under, and construed and enforced exclusively in accordance with the laws of the State of Nebraska and that venue for disputes shall be in the courts of Hall County, Nebraska.
18. **ENTIRE AGREEMENT; SEVERABILITY; WAIVERS:** This Agreement contains the entire agreement and understanding. No agreements or understandings are binding on the parties unless set forth in writing and signed by the parties. Any provision of this Agreement which for any reason may be held unenforceable in any jurisdiction shall, as to such jurisdiction, be effective without invalidating the remaining provisions of this Agreement. It is further agreed that the rights and remedies of the parties are governed by this Agreement and YOU waive any and all rights and remedies granted by Sections 2A-508 through 2A-522 of the Uniform Commercial Code.
19. **AMENDMENT BY FORCE MAJEURE:** The services in this Agreement are based on current governmental laws and regulations. In the event of any changes in laws, regulations, tariffs, taxes, or other governmental mandates that increase the cost of goods, materials, or services, the seller reserves the right to adjust pricing accordingly. Any such price adjustments will be communicated in writing and supported by relevant documentation.
20. **LATE CHARGE:** If a payment is 10 days or more late, YOU will be charged 5.000% of the regularly scheduled payment or \$5.00, whichever is greater.
21. **DISHONORED ITEM FEE.** YOU will pay a fee to US or assignee of \$25.00 if YOU make a payment and the check or preauthorized charge with which YOU pay is later dishonored.

Additional Terms for Municipal Entities:

Lessee and Lessor contemplate that interest payable under this Lease will be excluded from gross income for federal income tax purposes under section 103 of the Internal Revenue Code of 1986 (the "Code").

Lessee represents that it is a duly constituted political subdivision possessing the power to tax, the power of eminent domain or police power. Lessee will comply with all applicable provisions of the Code, including sections 102 and 148 thereof, and the regulations of the Treasury Department thereunder, from time to time proposed or in effect, in order to maintain the excludability from gross income for federal income tax purposes of the interest component of the monthly payments under the Lease and will not use or permit the use of the equipment financed under the Lease in such a manner as to cause the Lease to be a "private activity bond" under Section 141(a) of the Code. Lessee has not and will not create or establish any sinking fund, reserve fund, or other similar fund to pay monthly payments under the lease. Lessee agrees to maintain a system with respect to the Lease, which tracks the name, and ownership interest of each assignee who has both the responsibility for administration of, and ownership interest in the Lease.

The aggregate amount of the principal component of the monthly payments is \$ 74491.62 and the principal component of the monthly payments accrue interest at a per annum rate not to exceed 6.00%.

Lessee shall have the right to terminate its obligation to make monthly payments under this Lease with respect to all, but not less than all, of the equipment financed thereunder effective on the last day of any fiscal year of Lessee during the term of the Lease if Lessee's governing body does not appropriate money sufficient to pay the monthly payments coming due for the next fiscal year. Lessee may effect such termination by giving Lessor written notice and by paying to Lessor any monthly payment and other amounts which are due and have not been paid at or before the end of its then current fiscal year. Lessee shall endeavor to give notice of such termination not less than 120 days prior to the end of the fiscal year for which appropriations were made and shall notify Lessor of any anticipated termination.

Version 251103 11/03/2025

Lincoln



110 North 35th Street
Lincoln, NE 68503
402-438-6700

Letter of Instruction

(Quarterly Meter Billing)

For: City of Beatrice
400 Ella Street
Beatrice, NE 68310

We are pleased to provide this letter of instruction for the Smart Print Agreement dated January 15, 2026. Eakes Office Solutions will provide you with service and supplies for the equipment covered by this agreement according to the terms stated on the agreement and in this letter.

1. Your administrative fees payment is due to Eakes Office Solutions upon signing this agreement.
2. Subsequent monthly payments on this agreement will be made to Hometown Leasing. The next payment is due on February 15, 2026 and will be due on the same day of each following. The security deposit will be applied to the last month's payment if you are not in default at that time.
3. You will receive monthly invoices directly from Hometown Leasing. If you are interested in other electronic payment options you may contact Hometown Leasing.
4. Eakes Office Solutions will send you an e-mail to record the current meter reading for any equipment not reporting meters electronically. Please return this information to Eakes Office Solutions according to the instructions provided within three (3) days of receipt.
5. Eakes Office Solutions will bill you quarterly for any output above the output included.
6. This agreement includes all service parts, developer, and toner. All black toner is included at no additional charge. For color machines, color toner is included up to the manufacturer's stated yield, additional color toner used is billed quarterly. Black and color toner for all machines must be ordered as needed.
7. When you need to order toner, please contact us in Grand Island at (308) 398-6882 or at (800) 658-4072, ext. 6882. We will ship toner upon your request.
8. If, at any time, you need to request service, please contact Service Dispatch at (308) 382-9580, ext. 1 or at (800)658-4072, ext. 1 or go to our website at www.eakes.com.
9. At the end of the lease you may return the equipment to Eakes Office Solutions, relieving you of any further commitment.
10. Or, if you have fulfilled all of the obligations under this lease and are not in default thereunder, at the end of the term of the lease the equipment may be purchased at \$1.00. If lessee fails to remit to lessor the purchase price within thirty (30) days after the end of the term of the lease, or within thirty (30) days after lessor notifies lessee in writing of the availability of the option to purchase, whichever is later, this option to purchase shall expire.
11. As stated in the agreement, personal property taxes and insurance coverage on the rented equipment are the responsibility of the lessee.

Your business is greatly appreciated, and we look forward to being of service.

EXHIBIT "A"

Eakes, Inc.
 110 North 35th Street
 Lincoln, NE 68503

Dated: January 15, 2026

Exhibit forming part of the Agreement between Eakes Inc., Lincoln, Nebraska (Lessor)
 and City of Beatrice, Beatrice, NE (Lessee)

Salesperson: 5174 Lindsey Kirkendall

Make & Model	Description	Serial	Initial Meter Reading	Location
Sharp BP-70C31	31 PPM Digital Color MFP-Copy, Print & Scan	53012732		Airport
Sharp BP-FN11	50-sheet Staple Inner Finisher	5Q402869		
Sharp BP-DE14	Stand/3 x 550-sheet Paper Drawers	5L000918		
Sharp MX-PN14B	3-Hole Punch Unit (requires BP-FN11)	53008067		
Sharp BP-70C31	31 PPM Digital Color MFP-Copy, Print & Scan	53019605		Community Development
Sharp MX-PN14B	3-Hole Punch Unit (requires BP-FN11)	5L000908		
Sharp BP-FN11	50-sheet Staple Inner Finisher	5Q402849		
Sharp BP-DE14	Stand/3 x 550-sheet Paper Drawers	53008057		
Sharp BP-70C31	31 PPM Digital Color MFP-Copy, Print & Scan	53019585		Police Dept
Sharp BP-DE14	Stand/3 x 550-sheet Paper Drawers	53017406		
Sharp BP-TU10	Center Exit Tray (required if no finisher installed)	55051105		
Sharp BP-70C31 Eco-Smart	Please enter details	25048026		Beatrice Public Library
Sharp BP-70C31 Eco-Smart	Please enter details	3561324		BPW- Jean
Sharp BP-70C55 Eco-Smart	Please enter details.	25184976		City Hall
Ricoh IM C320F	32 PPM Digital Color MFP-Copy, Print, Scan & Fax	A0B5R900084		Information Technology
Ricoh IM C320F	32 PPM Digital Color MFP-Copy, Print, Scan & Fax	A0B5R900149		Landfill Scalehouse
Ricoh IM C320F	32 PPM Digital Color MFP-Copy, Print, Scan & Fax	A0B5R900181		Landfill Supervisor
Ricoh IM C320F	32 PPM Digital Color MFP-Copy, Print, Scan & Fax	A0B5R900182		Dispatch
Ricoh IM C320F	32 PPM Digital Color MFP-Copy, Print, Scan & Fax	A0B5R900183		Police Experience Room
Ricoh IM C320F	32 PPM Digital Color MFP-Copy, Print, Scan & Fax	A0B5R900184		Electric
Ricoh IM C320F	32 PPM Digital Color MFP-Copy, Print, Scan & Fax	A0B5R900185		Street
Ricoh IM C320F	32 PPM Digital Color MFP-Copy, Print, Scan & Fax	A0B5R900510		Water
Ricoh IM C320F	32 PPM Digital Color MFP-Copy, Print, Scan & Fax	A0B5R900511		WPC
Sharp MX3071 Eco-Smart	Please Enter Details	0300542X		Beatrice Public Library
Sharp MX4071 Eco-Smart	Please Enter Details	85131720		Beatrice Public Library
*Ricoh P 311	34 PPM B&W printer	5875Z810281		Administration- Erin S
*Ricoh P 311	34 PPM B&W printer	5875Z810282		BPW Drive Thru
*Ricoh P 311	34 PPM B&W printer	5875Z810284		BPW Front Counter
*Ricoh P 311	34 PPM B&W printer	5875Z810790		Finance Kris Anello
*Ricoh P 311	34 PPM B&W printer	5875Z810795		Finance Hannah Bell
*Ricoh P 311	34 PPM B&W printer	5874Z910380		Administration Tobisas T
*Ricoh P 311	34 PPM B&W printer	5874Z910373		Fire Department App Bay
*Ricoh P 311	34 PPM B&W printer	5874Z910379		Fire Department Emily F
*Ricoh P 311	34 PPM B&W printer	5874Z910384		MARS
*Ricoh P 311	34 PPM B&W printer	5874Z910382		Police Bat Cave
*Ricoh P 311	34 PPM B&W printer	5874Z910378		Public Properties
*Ricoh P 311	34 PPM B&W printer	5874Z910375		Electric Locates
*Ricoh P 311	34 PPM B&W printer	5874Z910383		Electric Jean V

* Existing customer equipment for Service Agreement only.

NOTICE OF HEARING

Notice is hereby given that Beatrice Petroleum, LLC, dba, NP Mart 36, 200 North 6th Street, Beatrice, Nebraska, has submitted a new application for a Class D liquor license.

Public Hearing on said application will be held in the in the BPS Administration Building Board Room, 320 North 5th Street, Beatrice, Nebraska on Monday, January 19, 2026, at 6:00 p.m. Any person or persons desiring to submit evidence, under oath, either orally or by affidavit, bearing upon the propriety of the issuance of such a license to the above applicant may appear at the hearing on the time and place above specified.

Erin Saathoff, MMC, City Clerk

January 9, 2026



Nebraska Liquor Control

301 Centennial Mall
South - 1st Floor PO
Box 95046 Lincoln
NE 68508

Application Copy

File Number: 141655

LICENSE TYPE Class D Beer, Wine, Spirits Off Sale Only	APPLICATION DATE RECEIVED 2025-12-15
SECONDARY LICENSE(S) None selected	
LICENSEE LEGAL NAME Beatrice Petroleum LLC	LICENSEE TYPE Corporation
DOING BUSINESS AS NP Mart 36	CORPORATE NUMBER
INCORPORATION DATE 2025-11-07	
CORRESPONDENCE ADDRESS 3024 Ames Avenue Omaha, NE 68111	
MAILING ADDRESS 3024 Ames Avenue Omaha, NE 68111	
PHYSICAL ADDRESS 3024 Ames Avenue Omaha, NE 68111	
CONTACT NAME Arshad Nazir	PREFERRED CONTACT METHOD Email
CONTACT PHONE (414) 916-9300	ALTERNATE PHONE

FAX

EMAIL

ranaarshadwi@yahoo.com

CORPORATE STRUCTURE

NAME	POSITION/TITLE	PARENT COMPANY	% INTEREST
Arshad Nazir	President		100

ADDITIONAL INFORMATION

MARITAL STATUS

Single

MANAGED BY AGENT

Yes

AGENT

Kerry Harrahill

AGENT TYPE

Individual

PREMISES TYPE

Convenience with Gas

PREMISES NAME

NP Mart 36

OPERATOR

CORPORATE LIMIT DESIGNATION

Inside

LEASE OR OWN

Own

PHYSICAL ADDRESS

200 N 6th Street
Beatrice, NE 68310

MAILING ADDRESS

CONTACT NAME

Arshad Nazir

PREFERRED CONTACT METHOD

Email

CONTACT PHONE
(414) 916-9300

ALTERNATE PHONE

FAX

EMAIL
RANAARSHADWI@YAHOO.COM

PREMISES MANAGER

Anne Gordon

PREMISES MANAGER EMAIL

petro.mart@yahoo.com

QUESTIONS

Class D Beer, Wine, Spirits Off S

1. READ CAREFULLY. ANSWER COMPLETELY AND ACCURATELY

Has any officer, member, owner, or manager named in this application; or their spouse, EVER been convicted of or plead guilty to any charge?

*The Commission must be notified of any arrests and/or convictions that may occur after the date of this application.

No

2. What are the building dimensions: Enter length and width in feet separated by a comma (i.e. L20, W15) *Not square feet*

A simple sketch of the area to be licensed will be required to be uploaded in the Documents Section.. Include the length x width, direction of NORTH and number of floors of the building. (NO BLUEPRINTS)

L55, W46

3. Will a basement be used for alcoholic storage or sale?

No

4. How many floors of the building? (excluding basement) Please indicate which floors will be included in the liquor license.

one

5. Is premises to be licensed within 150 feet of a church, school, hospital, home for indigent persons or for veterans, their wives, and children?

Yes

(document uploaded)

6. Is premises to be licensed within 300 feet of a college campus or university?

No

7. Are you acquiring any alcohol prior to obtaining this liquor license? If you are purchasing a business with a current license; this includes alcohol purchased as part of a business purchase agreement.

No

8. What date do you intend to open for business?

As soon as construction is completed

9. What are the anticipated hours of operation?

5:00am - 12:00am

10 Are you borrowing any money from any source, including family or friends, to establish and/or operate the business?

No

11 Will any person or entity, other than the applicant, be entitled to a share of the profits of this business?

No

12 Is anyone listed on this application a law enforcement officer?

No

13 What is the primary bank and/or financial institution to be utilized by the business AND list the individual(s) who are authorized to write checks and/or withdrawals on accounts at this institution.

Five Points Bank Arshad Nazir

14 Do you have prior experience or training in selling, serving or managing alcohol sales?

Yes

Arshad owns several NP Marts across Nebraska

15 Are all individuals named in this application as a part of the ownership and/or manager over 21 years of age?

Yes

16 Do you intend to allow drive through services (curb side pick up) allowed under Neb Rev. Statute 53-178.01(2)

No

17 List all past and present liquor licenses held in Nebraska or any other state by any person named in this application. List the license holder name, location of license, and license number (if available). Also list reason for termination of license(s) previously held.

121104
106718
122216
122146
123735
123827
123317
122944
123318
124426
124721
125011
125012
125013
125098
125126
125438
125363
125436
125437
126180
126331
126346
126411
153094
153007
125012
124333
114506
122113

18 Has the premises location been previously licensed within the last 2 years?

No

19 Are you applying for a Temporary Operating Permit?

No

20 Is the lease or deed for the premises listed under the applicant's name (LLC, Corporation, or Individual)? If the property is owned personally but the application is under an LLC or Corporation, a lease agreement must be made between the owner and the entity applying for the license.

Yes

21 If applying as a LLC or Corporation; is your LLC or Corporation active with the Nebraska Secretary of State? (Please mark yes if applying as an individual or partnership)

Yes

22 Per Nebraska Revised Statute 53-103.18 - Manager, defined: Manager means a person appointed by a corporation or limited liability company to oversee the daily operation of the business licensed in Nebraska. A manager shall meet all the requirements of the Nebraska Liquor Control Act as though he or she were the applicant, including residency.

What is the premises manager's name?

Anne Gordon

23 What is the manager's address?

3907 N 67th Avenue
Omaha, NE 68104

24 What is the manager's phone number?

402-210-8949

25 What county is the manager registered to vote in?

The manager must be a resident of the state of Nebraska. If the manager is not registered to vote they can complete their voter registration here - <https://www.nebraska.gov/apps-sos-voter-registration/>

Douglas

26 What is the manager's email address? An email will be sent to them to obtain their personal information.

petro.mart@yahoo.com

27 Is the manager married?

Yes

William Gordon

chevynogo@hotmail.com

DOCUMENTS

TYPE	FILE NAME	DESCRIPTION
Lease / Deed / Purchase Agreement	200 N 6th St executed PSA (dated).pdf	Purchase Agreement
Premises Description & Diagram	Diagram - NP Mart 36.docx	Diagram
Business Plan	NP_MART_36_Project_Overview_Updated.docx	Business Plan
Privacy Act Statement	Privacy Act Statement - Anne Gordon.pdf	PAS - Anne Gordon
Privacy Act Statement	Privacy Act Statement - Arshad Nazir.pdf	PAS - Arshad Nazir
Privacy Act Statement	Privacy Act Statement - Nabila.pdf	PAS - Nabila Arshad
Additional Document	SPK Letter - Church info.pdf	SPK Letter
Affidavit of non-participation	Spousal Affidavit - Anne.pdf	Spousal Affidavit - Anne Gordon
Church within 150' waiver	First Christian - Waiver Form.pdf	Waiver Form

APPLICANT

Kerry Harrahill

DECLARATION

I (We) the applicant(s) agree and consent

By checking the box next to "I (We) the applicant(s) agree and consent", the applicant(s) hereby consent(s) to an investigation of background and release present and future records of every kind and description including, but not limited to, police records, tax records, bank or lending institution records, and corporate records. I consent to the release of any documents supporting any declarations made in this application and agree to provide any documents supporting these declarations to the Nebraska Liquor Control Commission (NLCC) or the Nebraska State Patrol (NSP) immediately upon demand. I agree to provide any record needed in furtherance of any investigation related to this application immediately upon demand to the NLCC or the NSP. I waive any right or cause of action that I may have against the NLCC, the NSP, or any other individual or entity disclosing or releasing any investigatory or supporting records related to this application or the review of this application.

I acknowledge that false information submitted in this application is grounds for denial of a license. Any license issued based on the information submitted in this application is subject to additional conditions, cancellation, revocation, or suspension if the information contained herein is incomplete, inaccurate, or fraudulent. I acknowledge that any changes to the information contained in this application must be reported to the NLCC. I acknowledge the review of this application will involve a criminal record check of all owners, partners, managers, officers and stockholders or members owning 25% interest in the applying entity and their spouses. Any license granted by the NLCC is subject to the provisions of the Nebraska Liquor Control Act and the Rules & Regulations of the NLCC, and that failure to comply with these provisions and rules may subject the license to suspension, cancellations, or revocation. I acknowledge that a licensee must keep complete, accurate, and separate records and that a licensee's records and books are subject to inspection by the NLCC. NLCC auditors and law enforcement officers are authorized to enter and inspect the licensed premises at any time to determine whether any provision of the Act, rule or regulation, or ordinance has been or is being violated. I acknowledge that it is the licensee's responsibility to comply with the provisions of the Nebraska Liquor Control Act and the Commission's rules and regulations.

If I am an individual applicant, I will supervise in person the management and operation of the business and operate the business authorized by the license for myself and not as an agency for any other person or entity. If I am a corporate applicant, I will ensure that an approved manager will supervise in person the management and operation of the business. If I am a partnership applicant, I will ensure one partner supervises the management and operation of the business.

I will operate the licensed business in compliance with all applicable laws, rules and regulations, and ordinances and to cooperate fully with any authorized agent of the NLCC.

I declare under penalty of perjury that I have read the contents of this application and, to the best of my knowledge, believe all statements made in this application are true, correct, and complete.

Applicant Notification and Record Challenge: An applicant's fingerprints will be used to check the criminal history records of the FBI. The applicant may complete or challenge the accuracy of the information contained in the FBI Identification Record. The procedures for obtaining a change, correction, or updating an FBI identification record are set forth in 28 CFR 16.34.

WAIVER FORM FOR APPLICATION WITHIN 150' OF CHURCH

NEBRASKA LIQUOR CONTROL COMMISSION
301 CENTENNIAL MALL SOUTH
PO BOX 95046
LINCOLN, NE 68509-5046
PHONE: (402) 471-2571
FAX: (402) 471-2814
EMAIL: lcc.frontdesk@nebraska.gov
WEBSITE: www.lcc.nebraska.gov

§53-177(2) If a proposed location for the sale at retail of any alcoholic liquor is within 150' of any church, a license may be issued if the commission gives notice to the affected church and holds a hearing as prescribed in §53-133

The plain, ordinary, and popular meaning of the word "church" includes a building in which people assemble for the worship of God and for the administration of such offices and services as pertain to that worship, a building used predominantly for the honor of God and religion, and a place where persons regularly assemble for worship. A building which is used predominantly for the honor of a religion would likewise include buildings in which people assemble for non-Christian worship, such as a mosque, a synagogue, or a temple. *City of Omaha v. Kum & Go*, 263 Neb. 724, 642 N.W.2d 154 (2002). Distance between church and place where intoxicating liquor is sold is measured in a straight line between the nearest walls of the two buildings. *Calvary Baptist Church v. Coonrad*, 163 Neb. 25, 77 N.W.2d 821 (1956).

PREMISES INFORMATION

Trade Name (doing business as) NP Mart 36
Street Address 200 N. 6th Street
City Beatrice County Gage Zip Code 68310

CHURCH INFORMATION

Provide letter of support if there is no opposition to the license being issued

Name of Church: First Christian Church
Address of Church: 205 N. 7th Street
Contact Person _____
Phone Number (402) 223-3842

DISTANCE FROM AFOREMENTIONED CHURCH

72 FEET

AMOUNT AND FREQUENCY OF SERVICES HELD AT CHURCH (if known)

NP MART 36

Project Overview

200 North 6th Street

Beatrice Nebraska

NP MART 36 is a full redevelopment of the former US Bank building into a newly built NP Mart gas station and convenience store.

The project includes construction of a new 3 pump fuel station allowing 6 vehicles to fuel simultaneously.

Fuel offerings will include Regular Gasoline Diesel and E 15 to support local farmers and commercial traffic.

The store will offer grocery items fresh food Hunt Brothers Pizza beer liquor beverages coffee and grab and go meals.

This is a full service gas station and convenience store.

Liquor and beer sales are essential to the financial strength of the project.

NP Mart will invest approximately \$1500000.00 to \$1600000.00 one million five hundred thousand dollars to one million six hundred thousand dollars into this redevelopment.

This includes building upgrades new fuel system tanks equipment canopy branding security lighting paving and traffic improvements.

This investment represents a long term community commitment not a short term project.

The project will create 6 to 7 permanent jobs and increase local sales tax fuel tax and long term property value.

Construction will also generate temporary local employment and local contractor income.

NP Mart operates over 30 locations across Nebraska and is known for clean safe stores fair fuel pricing and long term community investment.

NP Mart specializes in redeveloping older properties and bringing new life into local neighborhoods.

We respectfully request the City of Beatrice City Council and Liquor Commission to approve this redevelopment project and liquor license.

Approval is essential to move forward with construction project financing and full community redevelopment.

Upon approval construction will begin immediately without delay.

Respectfully submitted

ANN F GORDON

General Manager

NP Marts Group

Phone 402-210-8949

Email Petro mart@yahoo.com

On behalf of the NP Marts Management and Operations Teams



CITY HALL

400 Ella Street | Beatrice, NE 68310
Phone: 402.228.5200 Fax: 402.228.2312

ENGINEERING & COMMUNITY DEVELOPMENT

205 North 4th Street | Beatrice, NE 68310
Phone: 402.228.5250 Fax: 402.228.5252

Planning and Zoning Report for Liquor License Application

December 17, 2025

Within the Corporate Limits of the Municipality: Yes (X) No ()

Establishment: NP Mart 36

Applicant: Beatrice Petroleum, LLC

Address: 200 North 6th Street

Legal Description: Lots 7-10, Block 35, Beatrice Original

Requested License or Action: Class D; Beer, Wine, Distilled spirits, off sale only

Annexation Date: N/A

Ordinance Number: N/A

Existing Zoning: Central Business District (CBD)

Existing Land Use: Business (CBD)

Adjacent Zoning and Land Use:

North: CBD; General Office, Residential, Mortuary (Assembly A3)

East: CBD: Church (Assembly A3)

West: CBD: Downtown Residential, Public Park

South: CBD: Bank (Business), Commercial, General Office and Downtown Residential

General Neighborhood/Area Land Uses: Church, Mortuary, Residential, Commercial, Business and Office use.

Analysis of Neighborhood Effects: No foreseeable negative effects.

Additional Comments: This is a change of use from a bank (business) to convenience store (mercantile). This establishment is within 100 feet of a church. There has been an establishment in the vicinity that has served alcohol in the past.

Prepared by:

Chet McGrury

Community Development Director



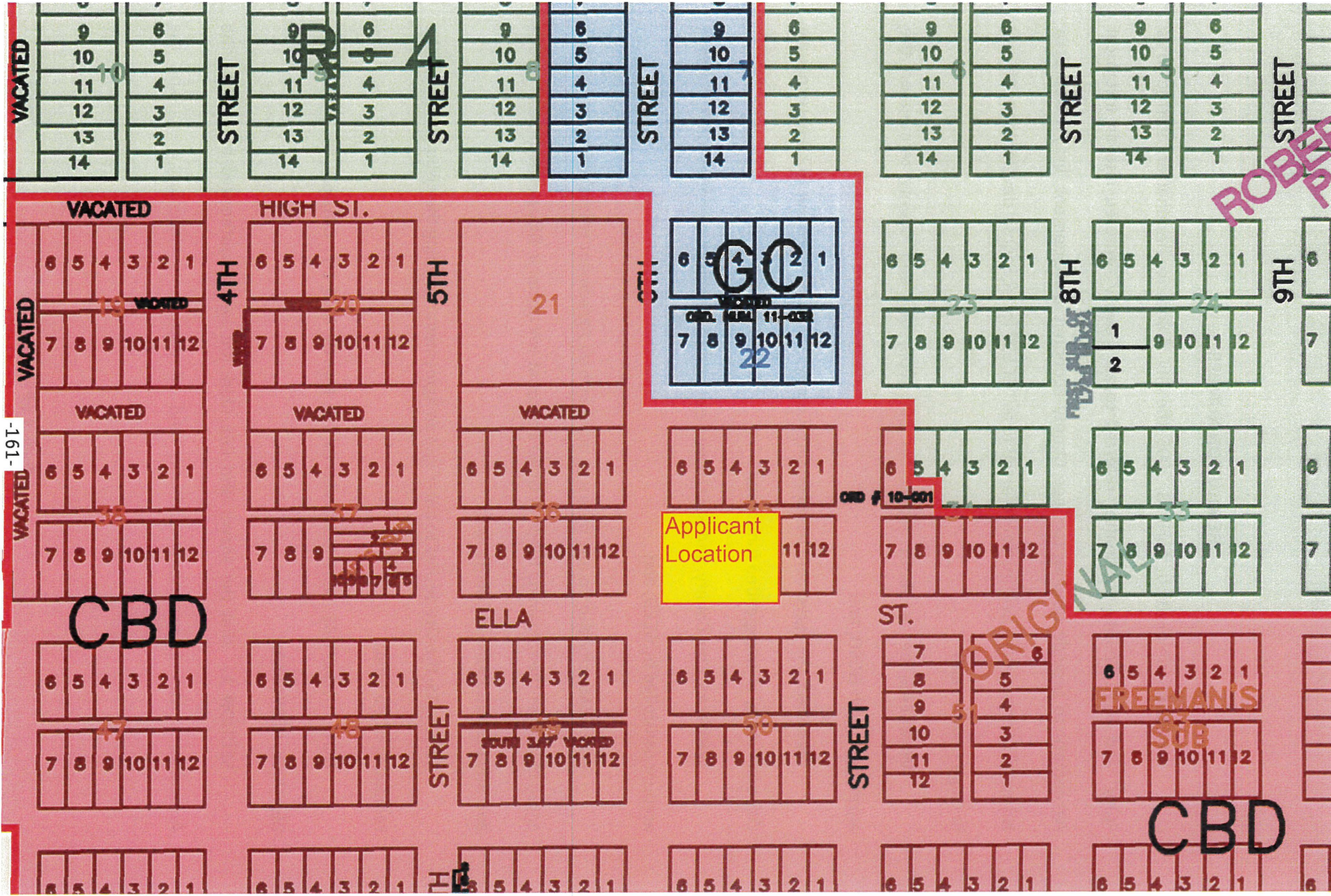

-161-

VACATED

VACATED

VACATED

VACATED

VACATED

CBD

STREET

4TH

HIGH ST.

VACATED

STREET

STREET

5TH

ELLA

STREET

VACATED

VACATED

VACATED

SOUTH 347 VACATED

STREET

6TH

Applicant Location

VACATED

VACATED

VACATED

VACATED

VACATED

ORD # 10-001

STREET

VACATED

VACATED

VACATED

ST.

VACATED

STREET

8TH

FIRST SUB OF 8TH

VACATED

VACATED

VACATED

VACATED

FREEMAN'S SUB

VACATED

CBD

STREET

9TH

VACATED

VACATED

ROBERT P...

ORIGINAL



**STAKE
YOUR
CLAIM**

BEATRICE
CITY • BOARD OF PUBLIC WORKS

CITY HALL

400 Ella Street | Beatrice, NE 68310
Phone: 402.228.5200 Fax: 402.228.2312

BEATRICE POLICE DEPARTMENT

201 North 5th Street | Beatrice, NE 68310
Phone: 402.223.4080 Fax: 402.228.3765

December 18th, 2025

Mayor Robert Morgan
Beatrice City Council
400 Ella Street
Beatrice, NE 68310

Dear Mayor and City Council:

In reference to the Liquor License Application submitted by Beatrice Petroleum LLC dba NP Mart #36 at 200 North 6th Street in Beatrice, NE, the background investigations into the owner and manager have been completed. Please be advised that the background investigation into owner Arshan Nazir revealed nothing which would prohibit the issuance of the license. The background of the manager, Anne Gordon, did show a 2010 conviction in Douglas County, NE for selling tobacco to a minor. It is of particular note that this conviction was not listed on the liquor license application where it asks for previous arrests/convictions.

Another issue of consideration is the fact that the NP Mart #36 will be statutorily too close to a church, the First Christian Church at 205 North 7th, and will require a waiver. State statute requires that the premises selling liquor be at least 150 feet away from a church, unless a waiver is granted. A waiver application is noted to be filled out and included with the liquor license application paperwork. There are no other known issues which would prevent the issuance of the proposed liquor license.

Sincerely,

Sgt. Erin Byrne #322
Beatrice Police Department

RESOLUTION NUMBER ____

WHEREAS, on or about April 18, 2005, the City of Beatrice hereinafter referred to as "City" and Gage County hereinafter referred to as "County" entered into an Interlocal Agreement to provide funding to Gage County Economic Development, Inc., a Nebraska Nonprofit Corporation, hereinafter referred to as "GCED" for economic development efforts in Gage County; and

WHEREAS, on or about September 30, 2008, City and County terminated the agreement with GCED; and

WHEREAS, the agreement between City, County, and GCED called for GCED to reimburse City and County all unexpended funds; and

WHEREAS, City, County, and GCED have been made aware of unexpended funds in a bank account controlled by GCED; and

WHEREAS, City and County desire to enter into an Agreement whereby City and County agree that all of the remaining funds in GCED's account will disburse fifty percent (50%) to City and fifty percent (50%) to County; and

WHEREAS, the City desires to enter into an Agreement regarding the disbursement of the remaining GCED funds.

NOW, THEREFORE, BE IT RESOLVED BY THE MAYOR AND CITY COUNCIL OF THE CITY OF BEATRICE, NEBRASKA:

SECTION 1. That the Mayor and City Clerk are hereby authorized to execute the Amendment with Gage County and any and all documents necessary, regarding the

disbursement of the remaining GCED funds. A copy of said Agreement is attached hereto as Exhibit "A" and incorporated by this reference.

SECTION 2. That Resolution Number 7652 and all resolutions or parts of resolutions in conflict herewith are hereby repealed.

RESOLUTION PASSED AND ADOPTED this 19th day of January, 2026.

Attest:

Erin Saathoff, MMC, City Clerk

Robert Morgan, Mayor

Exhibit "A"

AGREEMENT

THIS AGREEMENT is made and entered into on this ___ day of _____, 2026, by and between the CITY OF BEATRICE, NEBRASKA, a Municipal Corporation, hereinafter referred to as "City", and the COUNTY OF GAGE, NEBRASKA, a body politic and corporate, hereinafter referred to as "County".

WITNESSETH:

WHEREAS, on or about April 18, 2005, the City and County entered into an Interlocal Agreement to provide funding to Gage County Economic Development, Inc., a Nebraska Nonprofit Corporation, hereinafter referred to as "GCED" for economic development efforts in Gage County;

WHEREAS, on or about September 30, 2008, City and County terminated the agreement with GCED;

WHEREAS, the agreement between City, County, and GCED called for GCED to reimburse City and County all unexpended funds;

WHEREAS, City, County, and GCED have been made aware of unexpended funds in a bank account controlled by GCED;

WHEREAS, City and County desire to enter into an Agreement whereby City and County agree that all of the remaining funds in GCED's account will disburse fifty percent (50%) to City and fifty percent (50%) to County; and

NOW, THEREFORE, in consideration of the premises and the mutual representations, covenants and agreement set forth herein, the City and County agree as follows:

1. Disbursement of Funds: The City and County agree that each party shall be entitled to and receive fifty percent (50%) of the GCED unexpended funds. City's and County's intent is to reallocate the disbursed funds to be used for economic development purposes.

2. Interlocal Agreement and Governing Law: No joint entity is created to administer this Agreement. The effect and meaning of the Agreement and all rights between the parties shall be governed by and construed according to the laws of the State of Nebraska.

3. Severability: If any one or more of the covenants or agreements provided in this Agreement shall be declared by any court or competent jurisdiction to be contract to law, then such covenant or covenants agreement or agreements, shall be null and void and

shall be deemed separable from the remaining covenants and agreements, and shall in no way affect the validity of any other provisions of this agreement.

4. Assignability and Successors and Assigns: This agreement shall not be assignable by any party without express written consent from all other parties. All the covenants and representations contained in this agreement, by or on behalf of the City or County shall bind and inure to the benefit of its successors and assigns whether so expressed or not.

5. Entire Agreement: This Agreement contains the entire Agreement between the parties hereto with respect to the subject matter thereof, and supersedes any prior understanding or written or oral agreements between the parties with respect to the subject matter of this Agreement. No amendments, modification, or alteration to the terms of this Agreement shall be binding on any party unless the same is in writing, date subsequent to the date thereof, and duly executed by the party against enforcement is sought.

6. Article and Section Headings: The heading or titles of several paragraphs hereof shall be solely for the convenience or reference and shall not affect the meaning or construction, interpretation or effect of this Agreement.

IN WITNESS WHEREOF, the City and County, have caused this Agreement to be executed on their behalf by their respective officers there to duly authorized.

ATTEST:

THE CITY OF BEATRICE, NEBRASKA
A Municipal Corporation

Erin Saathoff, MMC, City Clerk

Robert Morgan, Mayor

ATTEST:

THE COUNTY OF GAGE, NEBRASKA
A body politic and corporate

Dawn Hill, County Clerk

Erich Tiemann, Chairperson

Red line

AGREEMENT

THIS AGREEMENT is made and entered into on this ___ day of _____, 20252026, by and between the CITY OF BEATRICE, NEBRASKA, a Municipal Corporation, hereinafter referred to as "City", and the COUNTY OF GAGE, NEBRASKA, a body politic and corporate, hereinafter referred to as "County".

WITNESSETH:

WHEREAS, on or about April 18, 2005, the City and County entered into an Interlocal Agreement to provide funding to Gage County Economic Development, Inc., a Nebraska Nonprofit Corporation, hereinafter referred to as "GCED" for economic development efforts in Gage County;

WHEREAS, on or about September 30, 2008, City and County terminated the agreement with GCED;

WHEREAS, the agreement between City, County, and GCED called for GCED to reimburse City and County all unexpended funds;

WHEREAS, City, County, and GCED have been made aware of unexpended funds in a bank account controlled by GCED;

WHEREAS, City and County desire to enter into an Agreement whereby City and County agree that all of the remaining funds in GCED's account will disburse fifty percent (50%) to City and fifty percent (50%) to County; and

NOW, THEREFORE, in consideration of the premises and the mutual representations, covenants and agreement set forth herein, the City and County agree as follows:

1. Disbursement of Funds: The City and County agree that each party shall be entitled to and receive fifty percent (50%) of the GCED unexpended funds. City's and County's intent is to reallocate the disbursed funds ~~to the NGage, Beatrice Area Chamber of Commerce, and Main Street Beatrice merged organization~~ to be used for economic development purposes.

2. Interlocal Agreement and Governing Law: No joint entity is created to administer this Agreement. The effect and meaning of the Agreement and all rights between the parties shall be governed by and construed according to the laws of the State of Nebraska.

3. Severability: If any one or more of the covenants or agreements provided in this Agreement shall be declared by any court or competent jurisdiction to be contract to

law, then such covenant or covenants agreement or agreements, shall be null and void and shall be deemed separable from the remaining covenants and agreements, and shall in no way affect the validity of any other provisions of this agreement.

4. Assignability and Successors and Assigns: This agreement shall not be assignable by any party without express written consent from all other parties. All the covenants and representations contained in this agreement, by or on behalf of the City or County shall bind and inure to the benefit of its successors and assigns whether so expressed or not.

5. Entire Agreement: This Agreement contains the entire Agreement between the parties hereto with respect to the subject matter thereof, and supersedes any prior understanding or written or oral agreements between the parties with respect to the subject matter of this Agreement. No amendments, modification, or alteration to the terms of this Agreement shall be binding on any party unless the same is in writing, date subsequent to the date thereof, and duly executed by the party against enforcement is sought.

6. Article and Section Headings: The heading or titles of several paragraphs hereof shall be solely for the convenience or reference and shall not affect the meaning or construction, interpretation or effect of this Agreement.

IN WITNESS WHEREOF, the City and County, have caused this Agreement to be executed on their behalf by their respective officers there to duly authorized.

ATTEST:

THE CITY OF BEATRICE, NEBRASKA
A Municipal Corporation

Erin Saathoff, MMC, City Clerk

Robert Morgan, Mayor

ATTEST:

THE COUNTY OF GAGE, NEBRASKA
A body politic and corporate

Dawn Hill, County Clerk

Erich Tiemann, Chairperson

RESOLUTION NUMBER _____

WHEREAS, on or about August 19, 2024, the City of Beatrice, Nebraska (“City”) executed a Contract for Sale of Real Estate, Promissory Note, and Deed of Trust between the City and MEI Homes, LLC, a Nebraska limited liability company for the following parcel of real estate

The South 50 feet of the West 10 feet of Lot Eight (8), and the South 50 feet of Lots Nine (9) through Twelve (12), inclusive, Block Twenty-Eight (28), A.J. Cropsey’s Addition, Beatrice, Gage County, Nebraska, commonly known as 430 North 5th Street (the “Property”); and

WHEREAS, on or about August 18, 2025, the City executed the First Amendment to the Contract for Sale of Real Estate Agreement in order to extend the date by which MEI Homes, LLC must acquire a Certificate of Occupancy for the Property from August 1, 2025 to January 1, 2026; and

WHEREAS, MEI Homes, LLC has acquired the Certificate of Occupancy for the Property; and

WHEREAS, the Mayor and City Council for the City of Beatrice desire to authorize the Mayor, City Attorney, and City Clerk to execute any and all releases, any and all requests for reconveyances, deeds of reconveyance, and any and all other documents necessary to release and discharge MEI Homes, LLC, along with its heirs, executors, administrators, successors and assigns from any and all actions, debts, claims and demands whatsoever the City every had or may have regarding said Contract for Sale of Real Estate with MEI Homes, LLC.

NOW, THEREFORE, BE IT RESOLVED BY THE MAYOR AND CITY COUNCIL OF THE CITY OF BEATRICE, NEBRASKA:

SECTION 1. That the Contract for Sale of Real Estate dated August 19, 2024, and amended on August 18, 2025, is designated as terminated and satisfied.

SECTION 2. That the corresponding Promissory Note dated August 19, 2024, is hereby terminated and satisfied.

SECTION 3. That the Deed of Trust for said Contract for Sale of Real Estate, dated August 19, 2024, and recorded in the Gage County Register of Deeds Office on September 26, 2024, and recorded as Instrument No. 2024-2477, is hereby terminated and satisfied.

SECTION 4. That all securities, guarantees, or obligations of MEI Homes, LLC regarding the Contract for Sale of Real Estate dated August 19, 2024, as amended on August 18, 2025, are hereby terminated and satisfied.

SECTION 5. That the Mayor, City Attorney, and City Clerk are hereby authorized to sign and execute any and all other documents necessary to release and discharge MEI Homes, LLC, along with their heirs, executors, administrators, successors and assigns from any and all actions, debts, claims and demands whatsoever, the City ever had or may have regarding said Contract for Sale of Real Estate.

SECTION 6. That all resolutions or parts of resolutions in conflict herewith are hereby repealed.

RESOLUTION PASSED AND ADOPTED this 19th day of January, 2026.

Attest:

Erin Saathoff, MMC, City Clerk

Robert Morgan, Mayor

GENERAL RELEASE

City of Beatrice, Nebraska, a Municipal corporation, 400 Ella Street, Beatrice, Nebraska, 68310, as RELEASOR, in consideration of the satisfactory completion and compliance with the conditions and covenants of the Contract for Sale of Real Estate, dated August 19, 2024, as amended on August 18, 2025, entered into by the RELEASOR and MEI Homes, LLC, a Nebraska limited liability company, RELEASEE, the completion of which is hereby acknowledged, agrees to release and discharge the RELEASEE, RELEASEE's heirs, executors, administrators, successors and assigns from any and all actions, causes of action, suits, charges and obligations, debts, dues, sums of money, accounts, reckonings, bonds, bills, specialties, covenants, contracts, controversies, agreements, promises, variances, trespasses, damages, judgments, extents, executions, claims and demands whatsoever, in law, admiralty or equity, which against the RELEASEE, the RELEASOR, RELEASOR's heirs, executors, administrators, successors and assigns ever had, now have or hereafter can, shall or may have for, upon or by reason of any matter, cause or thing whatsoever from the beginning of time to the date of this RELEASE, and regarding:

Contract for Sale of Real Estate dated August 19, 2024, as amended on August 18, 2025;
Promissory Note dated August 19, 2024;
Deed of Trust dated August 19, 2024, recorded on September 26, 2024 as Instrument No. 2024-2477

Wherever the sense of this RELEASE requires, a singular number shall be construed to be plural and vice versa, and words of the masculine gender shall be construed to be feminine and vice versa.

This RELEASE may only be changed in writing signed by both RELEASOR and RELEASEE.

IN WITNESS WHEREOF, the RELEASOR has executed this RELEASE on the ____ day of _____, 2026.

Attest:

City of Beatrice, RELEASOR

Erin Saathoff, MMC, City Clerk

Robert Morgan, Mayor

STATE OF NEBRASKA)
) ss.
COUNTY OF GAGE)

The foregoing instrument was acknowledged before me this ____ day of _____, 2026 by Robert Morgan, Mayor of the City of Beatrice, Nebraska, a Municipal Corporation, on behalf of the corporation.

Notary Public

Space Above Reserved for Recording Information

Return to:
Taylor Rivera
City of Beatrice
400 Ella Street
Beatrice, NE 68310

REQUEST FOR RECONVEYANCE

The undersigned Beneficiaries request the Trustee to reconvey the real estate described as follows:

The South 50 feet of the West 10 feet of Lot Eight (8) and the South 50 feet of Lots Nine (9) through Twelve (12) inclusive, Block Twenty-Eight (28), A.J. Cropsey's Addition, Beatrice, Gage County, Nebraska,

to the person or persons entitled thereto.

Robert Morgan, Mayor
City of Beatrice, Nebraska, Beneficiary

STATE OF NEBRASKA)
) ss.
COUNTY OF GAGE)

The foregoing instrument was acknowledged before me this _____ day of _____, 2026 by Robert Morgan, Mayor of the City of Beatrice, Nebraska, a Municipal Corporation, on behalf of the corporation.

Notary Public

DEED OF RECONVEYANCE

The Trustor of the indebtedness secured by the Deed of Trust executed by, MEIHomes, LLC, a Nebraska limited liability company, as Trustor, to Taylor Rivera, an Attorney and Member in good standing with the Nebraska State Bar Association, as Trustee, for the benefit of City of Beatrice, Nebraska, a Municipal corporation, as Beneficiary, dated August 19, 2024, recorded in the office of the Gage County Register of Deeds on September 26, 2024, recorded as Instrument No. 2024-2477, has been satisfied in full, and the Beneficiary has requested in writing that this Deed of Reconveyance be executed and delivered as confirmed by its endorsement above.

In accordance with the request of the Beneficiary, the Trustee reconveys to the person or persons entitled thereto all the right, title, interest and claim acquired by the Trustee pursuant to the Deeds of Trust in the following:

The South 50 feet of the West 10 feet of Lot Eight (8) and the South 50 feet of Lots Nine (9) through Twelve (12) inclusive, Block Twenty-Eight (28), A.J. Cropsey's Addition, Beatrice, Gage County, Nebraska,

DATED: _____, 2026.

Taylor Rivera, Trustee

STATE OF NEBRASKA)
) ss.
COUNTY OF GAGE)

The foregoing instrument was acknowledged before me on the _____ day of _____,
2026, by Taylor Rivera, Trustee.

Notary Public

MEMORANDUM

TO: Mayor & City Council

DATE SUBMITTED: January 14, 2026

FROM: Taylor Rivera
City Attorney

FOR AGENDA OF: January 19, 2026

SUBJECT: Sale of Real Estate – RWR, LLC

EXHIBIT(S): Contract

RWR, LLC has requested that a portion of South 25th Street be vacated and sold to RWR, LLC. The total purchase price will be Nine Thousand Dollars (\$9,000.00).



ORDINANCE NUMBER 26-_____

An ordinance to vacate the following described real property:

All of that portion of South 25th Street commencing at a point on the Northwest corner of Lot Three (3), Crest 1st Addition to the City of Beatrice, Gage County, Nebraska, thence running South a distance of 383.51 feet to the Southwest corner of Outlot A, Crest 1st Addition to the City of Beatrice, Gage County, Nebraska, thence running West a distance of 66 feet to the Southeast corner of Lot Twelve (12), Block Forty-Four (44), Wittenberg's Addition to the City of Beatrice, Gage County, Nebraska, thence running North a distance of 383.51 feet to the Northeast corner of Lot Six (6), First Subdivision of Block Forty-One (41), Wittenberg Addition to the City of Beatrice, Gage County, Nebraska, thence running East a distance of 66 feet to the point of beginning,

and to provide for publication in electronic form and an effective date of this ordinance.

BE IT ORDAINED BY THE MAYOR AND CITY COUNCIL OF THE CITY OF BEATRICE, NEBRASKA:

SECTION 1. That the following described property, to wit:

All of that portion of South 25th Street commencing at a point on the Northwest corner of Lot Three (3), Crest 1st Addition to the City of Beatrice, Gage County, Nebraska, thence running South a distance of 383.51 feet to the Southwest corner of Outlot A, Crest 1st Addition to the City of Beatrice, Gage County, Nebraska, thence running West a distance of 66 feet to the Southeast corner of Lot Twelve (12), Block Forty-Four (44), Wittenberg's Addition to the City of Beatrice, Gage County, Nebraska, thence running North a distance of 383.51 feet to the Northeast corner of Lot Six (6), First Subdivision of Block Forty-One (41), Wittenberg Addition to the City of Beatrice, Gage County, Nebraska, thence running East a distance of 66 feet to the point of beginning,

be and hereby is vacated.

SECTION 2. That the cost of the vacation of the above-described property, including the recording and publication of this ordinance provided therefore, shall be the cost of the applicants for said vacation.

SECTION 3. That all ordinances or parts of ordinances in conflict herewith are hereby repealed.

SECTION 4. That all ordinances or parts of ordinances in conflict herewith are hereby repealed.

SECTION 5. That this ordinance shall be in full force and effect from and after its passage, approval, and publication in electronic form as provided by law.

PASSED AND APPROVED this 19th day of January, 2026.

Attest:

Erin Saathoff, MMC, City Clerk

Robert Morgan, Mayor

MEMORANDUM

TO: Mayor & City Council

DATE SUBMITTED: January 14, 2026

FROM: Taylor Rivera
City Attorney

FOR AGENDA OF: January 19, 2026

SUBJECT: Sale of Real Estate – RWR, LLC

EXHIBIT(S): Contract

RWR, LLC has requested that a portion of South 25th Street be vacated and sold to RWR, LLC. The total purchase price will be Nine Thousand Dollars (\$9,000.00).



ORDINANCE NUMBER 26-____

An ordinance to convey real estate owned by the City of Beatrice, Nebraska; to provide for the terms of the sale thereof; to repeal conflicting ordinances; and to provide for publication in electronic form and for an effective date of this ordinance.

BE IT ORDAINED BY THE MAYOR AND CITY COUNCIL OF THE CITY OF BEATRICE, NEBRASKA:

SECTION 1. That the real estate, more completely described as follows:

All of that portion of vacated South 25th Street commencing at a point on the Northwest corner of Lot Three (3), Crest 1st Addition to the City of Beatrice, Gage County, Nebraska, thence running South a distance of 278.17 feet to the Southwest corner of Lot One (1), Crest 1st Addition to the City of Beatrice, Gage County, Nebraska, thence running West a distance of 66 feet to a point lying on the east line of Lot Twelve (12), Block Forty-Four (44), Wittenberg's Addition to the City of Beatrice, Gage County, Nebraska, thence running North a distance of 278.17 feet to the Northeast corner of Lot Six (6), First Subdivision of Block Forty-One (41), Wittenberg Addition to the City of Beatrice, Gage County, Nebraska, thence running East a distance of 66 feet to the point of beginning,

is hereby ordered conveyed to RWR, LLC, a Nebraska limited liability company, herein "Purchaser," and the Mayor and City Clerk are hereby authorized and directed to execute a Deed to said Purchaser after passage, approval, and publication of this ordinance for three (3) consecutive weeks in a legal newspaper published in or of general circulation in such city immediately after the passage and publication of such ordinance, and deliver said deed to the Purchaser upon the passage of thirty-one (31) calendar days from the date of the passage and approval of this ordinance.

SECTION 2. That said property is hereby sold to said Purchaser in consideration of Nine Thousand Dollars (\$9,000.00) and the City will receive cash or cashier's check for said real estate prior to the delivery of the Deed to Purchaser. The cost of title insurance shall be evenly split between the City and RWR, LLC.

SECTION 3. That all ordinances or parts of ordinance in conflict herewith are hereby repealed.

SECTION 4. That this ordinance shall be in full force and effect from and after its passage, approval, and publication as provided by law.

PASSED AND APPROVED this 19th day of January, 2026.

Attest:

Erin Saathoff, MMC, City Clerk

Robert Morgan, Mayor

ORDINANCE NUMBER 26-_____

An ordinance to convey real estate owned by the City of Beatrice, Nebraska; to provide for the terms of the sale thereof; to repeal conflicting ordinances; and to provide for publication in electronic form and for an effective date of this ordinance.

BE IT ORDAINED BY THE MAYOR AND CITY COUNCIL OF THE CITY OF BEATRICE, NEBRASKA:

SECTION 1. That the real estate, more completely described as follows:

All of Lot One (1), Landmark Addition to the City of Beatrice, Gage County, Nebraska,

is hereby ordered conveyed to Landmark Snacks, LLC, a Nebraska limited liability company, herein "Purchaser," and the Mayor and City Clerk are hereby authorized and directed to execute a Deed to said Purchaser after passage, approval, and publication of this ordinance for three (3) consecutive weeks in a legal newspaper published in or of general circulation in such city immediately after the passage and publication of such ordinance, and deliver said deed to the Purchaser upon the passage of thirty-one (31) calendar days from the date of the passage and approval of this ordinance.

SECTION 2. That said property is hereby sold to said Purchaser in consideration of Three Hundred Thirty-Six Thousand One Hundred Forty Dollars (\$336,140.00) and the City will receive cash or cashier's check for said real estate prior to the delivery of the Deed to Purchaser. The cost of title insurance shall be evenly split between the City and Landmark Snacks, LLC.

SECTION 3. That all ordinances or parts of ordinance in conflict herewith are hereby repealed.

SECTION 4. That this ordinance shall be in full force and effect from and after its passage, approval, and publication as provided by law.

PASSED AND APPROVED this 19th day of January, 2026.

Attest:

Erin Saathoff, MMC, City Clerk

Robert Morgan, Mayor

MEMORANDUM

TO: Mayor & City Council

DATE SUBMITTED: January 14, 2026

FROM: Taylor Rivera
City Attorney

FOR AGENDA OF: January 19, 2026

SUBJECT: Sale of Real Estate – RWR, LLC

EXHIBIT(S): Contract

RWR, LLC has requested that a portion of South 25th Street be vacated and sold to RWR, LLC. The total purchase price will be Nine Thousand Dollars (\$9,000.00).



RESOLUTION NUMBER _____

WHEREAS, the City of Beatrice has received an offer to buy certain real estate in said City from RWR, LLC, a Nebraska limited liability company (“Purchaser”); and

WHEREAS, as consideration for the sale of said real estate, Purchaser has agreed to pay the City of Beatrice the amount of Nine Thousand Dollars (\$9,000.00); and

WHEREAS, the Mayor and City Council of the City of Beatrice desire to enter into a Contract for Sale of Real Estate with Purchaser.

NOW, THEREFORE, BE IT RESOLVED BY THE MAYOR AND CITY COUNCIL OF THE CITY OF BEATRICE, NEBRASKA:

SECTION 1. That the Mayor, City Clerk, and City Attorney be and are hereby authorized to sign a Contract for Sale of Real Estate and all necessary documents to transfer the following described real estate, pursuant to the terms, conditions, and contingencies contained in the Contract for Sale of Real Estate, to RWR, LLC:

All of that portion of vacated South 25th Street commencing at a point on the Northwest corner of Lot Three (3), Crest 1st Addition to the City of Beatrice, Gage County, Nebraska, thence running South a distance of 278.17 feet to the Southwest corner of Lot One (1), Crest 1st Addition to the City of Beatrice, Gage County, Nebraska, thence running West a distance of 66 feet to a point lying on the east line of Lot Twelve (12), Block Forty-Four (44), Wittenberg’s Addition to the City of Beatrice, Gage County, Nebraska, thence running North a distance of 278.17 feet to the Northeast corner of Lot Six (6), First Subdivision of Block Forty-One (41), Wittenberg Addition to the City of Beatrice, Gage County, Nebraska, thence running East a distance of 66 feet to the point of beginning.

A copy of said Contract for Sale of Real Estate, marked as Exhibit “A”, is attached hereto and incorporated herein by this reference.

SECTION 2. That all resolutions or parts of resolutions in conflict here with are hereby repealed.

RESOLUTION PASSED AND ADOPTED this 19th day of January, 2026.

Attest:

Erin Saathoff, MMC, City Clerk

Robert Morgan, Mayor

CONTRACT FOR SALE OF REAL ESTATE

THIS CONTRACT AND AGREEMENT, made and entered into this ____ day of _____, 2026, by and between City of Beatrice, Nebraska, a Nebraska Municipal Corporation, hereinafter referred to as "Seller", and RWR, LLC, a Nebraska limited liability company, hereinafter referred to as "Buyer";

WITNESSETH:

WHEREAS, Seller is the owner of the real estate hereinafter described, which real estate Buyer desires to purchase, and the parties have reached an agreement with respect to the terms and conditions of the sale of said real estate and desire to reduce the same to writing,

NOW, THEREFORE, IN CONSIDERATION OF THE MUTUAL COVENANTS CONTAINED HEREIN, IT IS AGREED BY AND BETWEEN THE PARTIES HERETO AS FOLLOWS:

1. LEGAL DESCRIPTION: Seller agrees to sell to Buyer, and Buyer agrees to purchase from Seller, all under the terms and conditions hereinafter set forth, all right, title and interest in and to the real estate described as follows, to-wit:

All of that portion of vacated South 25th Street commencing at a point on the Northwest corner of Lot Three (3), Crest 1st Addition to the City of Beatrice, Gage County, Nebraska, thence running South a distance of 278.17 feet to the Southwest corner of Lot One (1), Crest 1st Addition to the City of Beatrice, Gage County, Nebraska, thence running West a distance of 66 feet to a point lying on the east line of Lot Twelve (12), Block Forty-Four (44), Wittenberg's Addition to the City of Beatrice, Gage County, Nebraska, thence running North a distance of 278.17 feet to the Northeast corner of Lot Six (6), First Subdivision of Block Forty-One (41), Wittenberg Addition to the City of Beatrice, Gage County, Nebraska, thence running East a distance of 66 feet to the point of beginning,

subject to easements and restrictions of record, herein "the Premises".

2. PURCHASE PRICE: The purchase price shall be Nine Thousand Dollars (\$9,000.00) payable as follows:

\$9,000.00 shall be due unto the Seller on the date of closing, in the form of a Cashier's Check or Cash.

3. IMPROVEMENTS: This is an unimproved tract, with no improvements.

4. RISK OF LOSS: Seller shall bear all risks including but not limited to liability on said property until the time of closing.

5. TAXES AND ASSESSMENTS: Real estate taxes for 2025 (due in 2026) and all prior years

shall be paid by Seller. All future years shall be paid by Buyer.

6. **POSSESSION:** Buyer shall be entitled to full possession at the time of Closing.
7. **MARKETABLE TITLE:** Seller shall provide Buyer with a Warranty Deed subject only to easements and restrictions of record. Seller shall furnish unto Buyer a commitment for Title Insurance, with a Title Insurance Company authorized to do business in the State of Nebraska. This Title Insurance commitment shall reflect insurable title in Seller, subject only to easements and restrictions of record. Any defects found in said commitment shall be removed by the Seller at or prior to closing. Seller and Buyer shall evenly split the cost of title insurance.
8. **EXCISE TAX/FILING FEES:** No documentary stamp tax shall be levied upon the filing of said Deed. Buyer shall pay all filing fees associated with the filing of the Warranty Deed.
9. **ESCROW:** The Seller will, on the execution of this agreement, execute a Warranty Deed, conveying said real estate to Buyer.
10. **ESCROW AGENT:** Seller and Buyer hereby appoint Taylor Rivera as Escrow Agent pursuant to the terms of this agreement, to do the following:
 - (a) to receive and execute a copy of this agreement, the deed from the Seller to the Buyer, and evidence of title (title insurance commitment), all releases of liens or other instruments to be filed.
 - (b) to prepare closing statements which the parties hereto agree to sign as part of their obligation herein.
 - (c) to deliver the deed to the Buyer at time of closing, and if so instructed, file all documents with the Office of the Register of Deeds.
 - (d) to receive all payments from Buyer to Seller under this agreement, and receive any funds required with the obligation of Seller herein.
 - (e) to pay all costs associated with this transaction, including abstracting, title insurance premiums, transfer tax on the deed, filing fees, legal fees, escrow fee, and real estate taxes, existing encumbrances, and all liens and mortgages, if any.
 - (f) to collect a closing fee of \$0.00, which shall be paid by Buyer.
 - (g) to remit unto Seller all sums to Seller, after deducting any sums required to be paid as set forth herein.
11. **CLOSING:** The parties shall close this transaction at such time and date as they shall mutually agree, and in the absence of prior mutual agreement, this transaction shall close at the City Offices, 400 Ella Street, Beatrice, Nebraska 68310 at 10:00 o'clock a.m., on or before February 27, 2026. At the time of closing, Seller shall deliver to Buyer the Warranty Deed and Real Estate Transfer Statement in exchange for the payment of the balance of the purchase price due from Buyer to Seller in the form of a Cashier's Check or Cash.
12. **WAIVER:** A waiver by the Seller of any default or breach hereunder shall not be construed as a continuing waiver of such default or breach, nor as a waiver of remission, express or implied, or of any other subsequent default or breach.

13. DEFAULT: Time is of the essence in performance of this agreement. It is understood and agreed by the parties hereto that in the event Buyer shall fail to complete the payment of the purchase price as hereinabove set forth or fail to keep any of the other requirements to be kept by Buyer, then Seller may declare default.

14. NOTICES: Notices to Seller shall be given to Seller, c/o Taylor Rivera, 400 Ella Street, Beatrice, NE, 68310.

Notice to Buyer shall be sent to RWR, LLC, 3301 South 6th Street, Lincoln, NE 68502.

15. REAL ESTATE SETTLEMENT PROCEDURES ACT (RESPA): Seller and Buyer hereby agree to make all disclosures and to sign all documents necessary to allow full compliance with the provisions of the Real Estate Settlement Procedures Act of 1974, as amended, to furnish Federal Identification Numbers and/or Social Security Numbers as required, for the proper reporting to the Internal Revenue Service, if required.

16. BINDING EFFECT: This contract shall be binding upon the heirs, executors, administrators and assigns of the parties hereto.

17. MISCELLANEOUS: The headings of the paragraphs of this agreement are inserted for convenience only and shall not constitute a part hereof. Wherever applicable the singular shall include the plural and the masculine the feminine. This agreement shall be executed in triplicate and each shall be considered an original.

18. INTEREST: It is agreed that from the date of this Agreement until date of closing that no interest shall be due from Buyer to Seller.

19. WARRANTIES AND REPRESENTATIONS: Buyer purchases the premises "as is", based upon the Buyer's own inspection of the premises, and no warranties, express or implied have been given by Seller as to the condition of the same, the same being expressly denied.

20. SURVIVAL OF CONTRACT: Upon the delivery of the deed all warranties and representations, if any, shall merge and the acceptance thereof shall be full and complete satisfaction of all obligations of the Seller.

21. COUNTERPARTS: This Agreement may be executed in any number of counterparts, each of which will be deemed an original, but all of which together will constitute one and the same instrument.

22. ENTIRE AGREEMENT: It is agreed between the parties hereto that there are no other agreements or understandings between them relating to the subject matter of this Agreement. This Agreement supersedes all prior agreements, oral or written between the parties and is intended as a complete and exclusive statement of the Agreement between the parties. Neither this Agreement, nor its execution, have been induced by any reliance, representation, stipulation, warranty, agreement or understanding of any kind other than those herein expressed. No

RESOLUTION NUMBER _____

WHEREAS, the City of Beatrice has received an offer to buy certain real estate in said City from Landmark Snacks, LLC, a Nebraska limited liability company (“Purchaser”); and

WHEREAS, as consideration for the sale of said real estate, Purchaser has agreed to pay the City of Beatrice the amount of Three Hundred Thirty-Six Thousand One Hundred Forty Dollars (\$336,140.00); and

WHEREAS, the Mayor and City Council of the City of Beatrice desire to enter into a Contract for Sale of Real Estate with Purchaser.

NOW, THEREFORE, BE IT RESOLVED BY THE MAYOR AND CITY COUNCIL OF THE CITY OF BEATRICE, NEBRASKA:

SECTION 1. That the Mayor, City Clerk, and City Attorney be and are hereby authorized to sign a Contract for Sale of Real Estate and all necessary documents to transfer the following described real estate, pursuant to the terms, conditions, and contingencies contained in the Contract for Sale of Real Estate, to Landmark Snacks, LLC:

All of Lot One (1), Landmark Addition to the City of Beatrice, Gage County, Nebraska.

A copy of said Contract for Sale of Real Estate, marked as Exhibit “A”, is attached hereto and incorporated herein by this reference.

SECTION 2. That all resolutions or parts of resolutions in conflict here with are hereby repealed.

RESOLUTION PASSED AND ADOPTED this 19th day of January, 2026.

Attest:

Erin Saathoff, MMC, City Clerk

Robert Morgan, Mayor

CONTRACT FOR SALE OF REAL ESTATE

THIS CONTRACT AND AGREEMENT, made and entered into this ____ day of _____, 2026, by and between City of Beatrice, Nebraska, a Nebraska Municipal Corporation, hereinafter referred to as "Seller", and Landmark Snacks, LLC, a Nebraska limited liability company, hereinafter referred to as "Buyer";

WITNESSETH:

WHEREAS, Seller is the owner of the real estate hereinafter described, which real estate Buyer desires to purchase, and the parties have reached an agreement with respect to the terms and conditions of the sale of said real estate and desire to reduce the same to writing,

NOW, THEREFORE, IN CONSIDERATION OF THE MUTUAL COVENANTS CONTAINED HEREIN, IT IS AGREED BY AND BETWEEN THE PARTIES HERETO AS FOLLOWS:

1. LEGAL DESCRIPTION: Seller agrees to sell to Buyer, and Buyer agrees to purchase from Seller, all under the terms and conditions hereinafter set forth, all right, title and interest in and to the real estate described as follows, to-wit:

All of Lot One (1), Landmark Addition to the City of Beatrice, Gage County, Nebraska,

subject to easements and restrictions of record, herein "the Premises".

2. PURCHASE PRICE: The purchase price shall be Three Hundred Thirty-Six Thousand One Hundred Forty Dollars (\$336,140.00) payable as follows:

\$336,140.00 shall be due unto the Seller on the date of closing, in the form of a Cashier's Check or Cash.

3. CONTINGENCIES: The sale is contingent upon Buyer receiving approval for financing to purchase the Premises and construct a 156,000 square foot building on the Premises. Said financing shall be subject to terms and conditions that are agreeable to Buyer. Buyer shall have until February 27, 2026 to secure financing suitability for the intended use of the Premises.

4. IMPROVEMENTS: This contains a barn that shall be considered part of the real estate and shall be sold to the Buyer.

5. RISK OF LOSS: Seller shall bear all risks including but not limited to liability on said property until the time of closing.

6. TAXES AND ASSESSMENTS: Real estate taxes for 2025 (due in 2026) and all prior years shall be paid by Seller. All future years shall be paid by Buyer.

7. **POSSESSION:** Buyer shall be entitled to full possession at the time of Closing.
8. **MARKETABLE TITLE:** Seller shall provide Buyer with a Warranty Deed subject only to easements and restrictions of record. Seller shall furnish unto Buyer a commitment for Title Insurance, with a Title Insurance Company authorized to do business in the State of Nebraska. This Title Insurance commitment shall reflect insurable title in Seller, subject only to easements and restrictions of record. Any defects found in said commitment shall be removed by the Seller at or prior to closing. Seller and Buyer shall evenly split the cost of title insurance.
9. **EXCISE TAX/FILING FEES:** No documentary stamp tax shall be levied upon the filing of said Deed. Buyer shall pay all filing fees associated with the filing of the Warranty Deed.
10. **ESCROW:** The Seller will, on the execution of this agreement, execute a Warranty Deed, conveying said real estate to Buyer.
11. **ESCROW AGENT:** Seller and Buyer hereby appoint Taylor Rivera as Escrow Agent pursuant to the terms of this agreement, to do the following:
 - (a) to receive and execute a copy of this agreement, the deed from the Seller to the Buyer, and evidence of title (title insurance commitment), all releases of liens or other instruments to be filed.
 - (b) to prepare closing statements which the parties hereto agree to sign as part of their obligation herein.
 - (c) to deliver the deed to the Buyer at time of closing, and if so instructed, file all documents with the Office of the Register of Deeds.
 - (d) to receive all payments from Buyer to Seller under this agreement, and receive any funds required with the obligation of Seller herein.
 - (e) to pay all costs associated with this transaction, including abstracting, title insurance premiums, transfer tax on the deed, filing fees, legal fees, escrow fee, and real estate taxes, existing encumbrances, and all liens and mortgages, if any.
 - (f) to collect a closing fee of \$0.00, which shall be paid by Buyer.
 - (g) to remit unto Seller all sums to Seller, after deducting any sums required to be paid as set forth herein.
12. **CLOSING:** The parties shall close this transaction at such time and date as they shall mutually agree, and in the absence of prior mutual agreement, this transaction shall close at the City Offices, 400 Ella Street, Beatrice, Nebraska 68310 at 10:00 o'clock a.m., on or before February 27, 2026. At the time of closing, Seller shall deliver to Buyer the Warranty Deed and Real Estate Transfer Statement in exchange for the payment of the balance of the purchase price due from Buyer to Seller in the form of a Cashier's Check or Cash.
13. **WAIVER:** A waiver by the Seller of any default or breach hereunder shall not be construed as a continuing waiver of such default or breach, nor as a waiver of remission, express or implied, or of any other subsequent default or breach.
14. **DEFAULT:** Time is of the essence in performance of this agreement. It is understood and

agreed by the parties hereto that in the event Buyer shall fail to complete the payment of the purchase price as hereinabove set forth or fail to keep any of the other requirements to be kept by Buyer, then Seller may declare default.

15. NOTICES: Notices to Seller shall be given to Seller, c/o Taylor Rivera, 400 Ella Street, Beatrice, NE, 68310.

Notice to Buyer shall be sent to PO Box 187, Beatrice, NE 68310.

16. REAL ESTATE SETTLEMENT PROCEDURES ACT (RESPA): Seller and Buyer hereby agree to make all disclosures and to sign all documents necessary to allow full compliance with the provisions of the Real Estate Settlement Procedures Act of 1974, as amended, to furnish Federal Identification Numbers and/or Social Security Numbers as required, for the proper reporting to the Internal Revenue Service, if required.

17. BINDING EFFECT: This contract shall be binding upon the heirs, executors, administrators and assigns of the parties hereto.

18. MISCELLANEOUS: The headings of the paragraphs of this agreement are inserted for convenience only and shall not constitute a part hereof. Wherever applicable the singular shall include the plural and the masculine the feminine. This agreement shall be executed in triplicate and each shall be considered an original.

19. INTEREST: It is agreed that from the date of this Agreement until date of closing that no interest shall be due from Buyer to Seller.

20. WARRANTIES AND REPRESENTATIONS: Buyer purchases the premises "as is", based upon the Buyer's own inspection of the premises, and no warranties, express or implied have been given by Seller as to the condition of the same, the same being expressly denied.

21. SURVIVAL OF CONTRACT: Upon the delivery of the deed all warranties and representations, if any, shall merge and the acceptance thereof shall be full and complete satisfaction of all obligations of the Seller.

22. COUNTERPARTS: This Agreement may be executed in any number of counterparts, each of which will be deemed an original, but all of which together will constitute one and the same instrument.

23. ENTIRE AGREEMENT: It is agreed between the parties hereto that there are no other agreements or understandings between them relating to the subject matter of this Agreement. This Agreement supersedes all prior agreements, oral or written between the parties and is intended as a complete and exclusive statement of the Agreement between the parties. Neither this Agreement, nor its execution, have been induced by any reliance, representation, stipulation, warranty, agreement or understanding of any kind other than those herein expressed. No

change or modification of this Agreement shall be valid unless the same be in writing and signed by the parties.

IN WITNESS WHEREOF, the parties hereto have set their hands and seals the day and year first above written, on this Contract For Sale of Real Estate.

Chad Lottman, on behalf of
Landmark Snacks, LLC, a Nebraska
limited liability company, Buyer

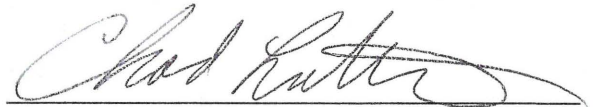

Chad Lottman, Member

Attest:

CITY OF BEATRICE, NEBRASKA
A Nebraska Municipal Corporation, Seller

Erin Saathoff, City Clerk

Robert Morgan, Mayor

STATE OF NEBRASKA)
) ss.
COUNTY OF GAGE)

The foregoing Contract for Sale of Real Estate was acknowledged before me this 15 day of January, 2026, by Chad Lottman, Member of Landmark Snacks, LLC, as his voluntary act and deed on behalf of Landmark Snacks, LLC.

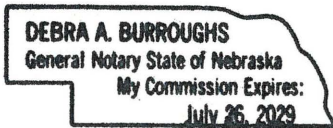

Debra A Burroughs
Notary Public

STATE OF NEBRASKA)
) ss:
COUNTY OF GAGE)

The foregoing Contract for Sale of Real Estate was acknowledged before me this _____ day of _____, 2026, by Robert Morgan, Mayor, and authorized signatory of the City of Beatrice, Nebraska, to be his voluntary act and deed on behalf of the City of Beatrice, Nebraska.

Notary Public

CITY OF BEATRICE

2025 Year in Review



LINCOLN STREET - 25TH TO 27TH



Before



During



After

RESIDENTIAL LOTS



Corral Crossing



RESIDENTIAL LOTS



Heritage Heights



BASWA SOUTH MSW LANDFILL



BASWA SOUTH MSW LANDFILL



AQUATIC PARK STUDY

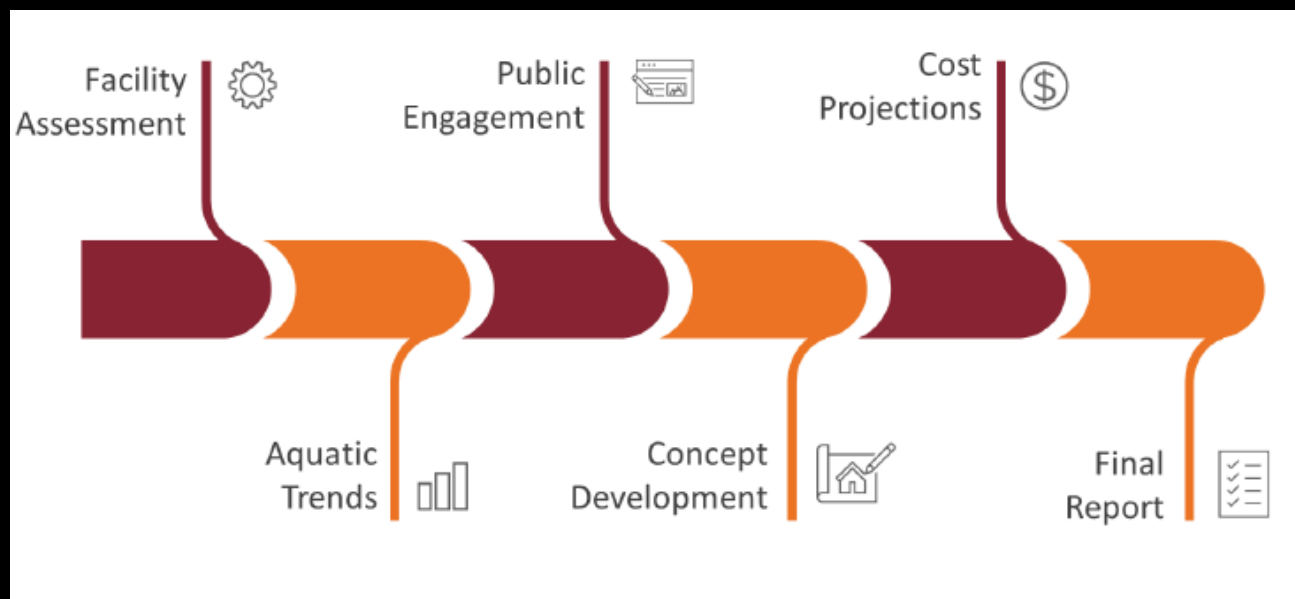

Big Blue Water Park Outdoor Aquatic Master Plan



Scenario Summary

Tier 1 – Repair



Summary

All deficient items identified during the inventory and assessment would be addressed. No additional amenities or upgrades would be incorporated.

Opinion of Cost

\$1.5 to \$2.0 Million

Tier 2 – Upgrade

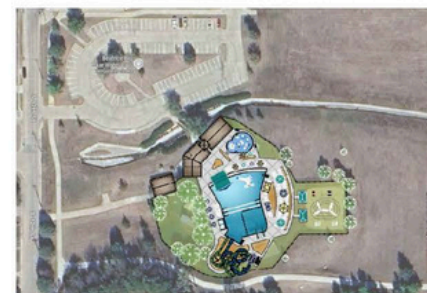

Summary

This would be a repair and upgrade of the swimming pool, plus a renovation of the pool house. The conceptual layout below was based on modern aquatic center amenities, public feedback and feedback from staff.

Opinion of Cost

\$6.0 to \$8.0 Million

Tier 3 – Replacement



Summary

This would be a replacement for the swimming pool, plus a renovation of the pool house. This scenario is focused on creating a shallow water leisure pool for novice swimmers, a new lazy river and a new deep basin at an elevation more favorable for existing groundwater.

Opinion of Cost

\$9.0 to \$11.0 Million

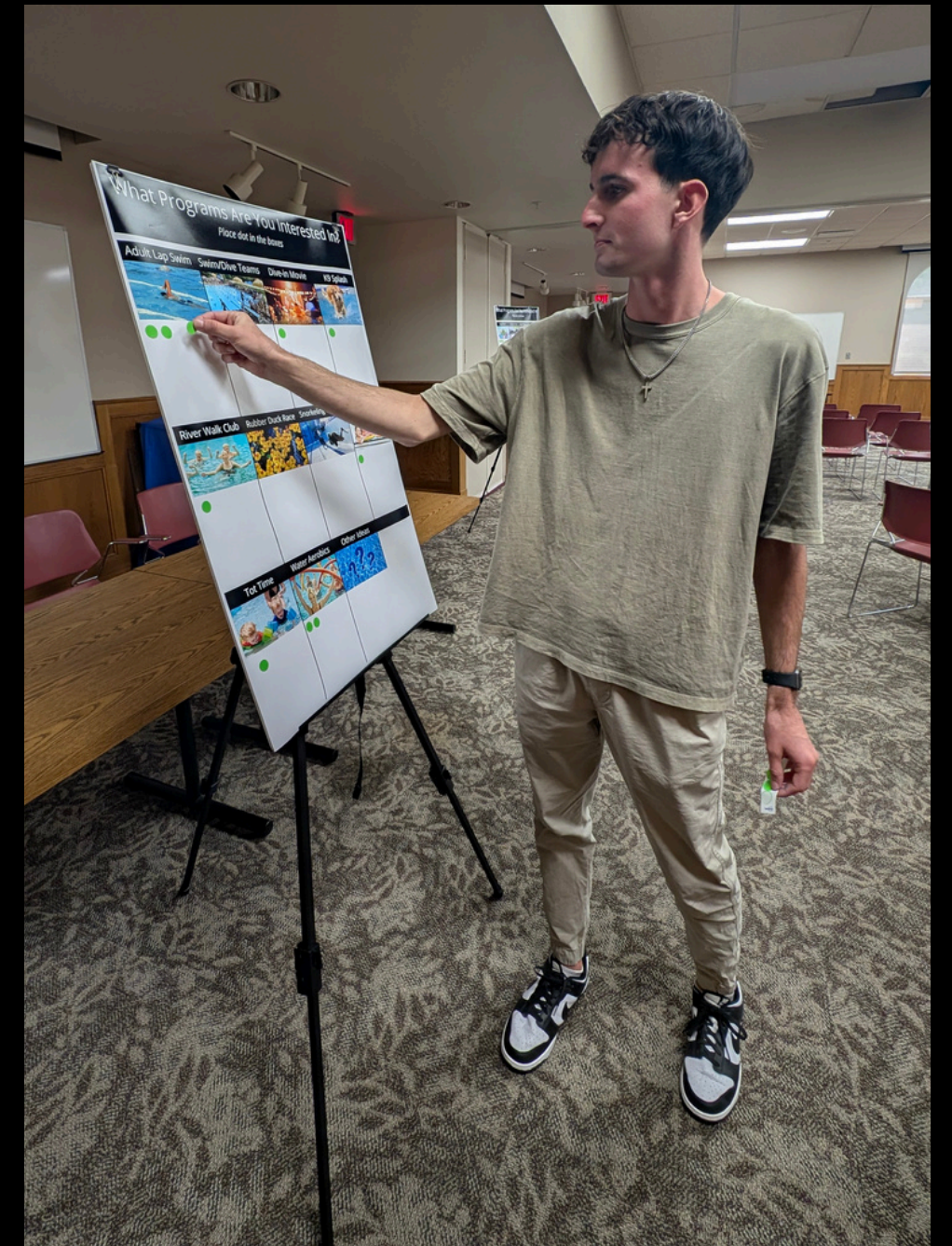

NEW FIRE HOSES



TAXIWAY C



Beatrice Municipal Airport

WEST COURT WATER MAIN CROSSING



CHAUTAUQUA PARK PLAYGROUND



SERTOMA-ASTRO PARK PLAYGROUND



After



FROBERRY PARK PLAYGROUND



Before

PICKLEBALL SEATING AREA



LIFT STATION #6



4TH STREET IMPROVEMENTS



Before



After

5TH STREET IMPROVEMENTS



CITY OF BEATRICE

2025 Year in Review





BEATRICE

CITY • BOARD OF PUBLIC WORKS

CITY ADMINISTRATOR'S MONTHLY REPORT JANUARY 2026

CAPITAL PROJECTS	1
PLANNING & ZONING	5
ECONOMIC DEVELOPMENT	5
EMPLOYEE	5
FINANCIALS	6
CODE VIOLATIONS / BUILDING PERMITS / DEMOLITIONS	6
PUBLIC PROPERTIES	6
STORM SEWER/DRAINAGE	6
STREETS	6
UTILITIES	7
SPECIAL DESIGNATED LICENSES	9
COMPLETED CAPITAL PROJECTS	10

CAPITAL PROJECTS

DEVELOPMENT OF CORRAL CROSSING AND HERITAGE HEIGHTS:

A master plan has been approved. Bid was awarded to Van Kirk Brothers Contracting on May 5th for the installation of storm sewer, sanitary sewer, street paving, and grading for Corral Crossing Addition and Heritage Heights Addition. Pre-construction meeting was held June 9, 2025. *Utility work, final grading, and seeding at Corral Crossing have been completed. Electrical will be installed as schedule and weather permits. Utility work at Heritage Heights is nearly complete. RL Tieman has moved onto the site and is beginning the concrete pavement construction operation.*

Funding: LB840 **Est. Cost:** TBD **Amt Spent as of 11/30/25:** \$2,420,878 **Est. Completion:** 2026

CAST INITIATIVE:

The City was awarded a \$21.3 million RAISE Grant. A Program Agreement has been signed with NDOT. JEO was selected as the engineer for the project. Waiting on a Grant Agreement from the Federal Highway.

Funding: Grant **Est. Cost:** TBD **Amt Spent as of 11/30/25:** \$0 **Est. Completion:** 2033

COMPREHENSIVE PLAN:

Updated Comprehensive Plan for the City. *Entered into the CDBG grant agreement with SENDD December 15th.*

Funding: General/Grant **Est. Cost:** \$75,000 **Amt Spent as of 11/30/25:** \$0 **Est. Completion:** 2026

DEMPSTERS:

The City has budgeted \$200,000 annually. The City has acquired the main buildings and should acquire the last parcel this fall. Asbestos removal is complete. *The Street Department, with the help of six (6) part-time employees, worked on cleaning up the Dempster's property. The Street Department hauled a total of 146 total dump truck loads of brush, construction rubble, and garbage from the site. MARS also hauled approximately twelve (12) rolloffs during the cleanup.*

Funding: General **Est. Cost:** TBD **Amt Spent as of 11/30/25:** \$161,644 **Est. Completion:** Years

TAXIWAY C and APRON RECONSTRUCTION:

Bid was awarded on June 3, 2024 to Vogts Parga Construction in the amount of \$5,660,502.12. Airport was awarded FAA Airport Improvement Program (AIP) grant of \$4,810,000.00. The project duration is anticipated to be one hundred eighty-two (182) days and will be broken into four (4) phases, allowing the Airport to stay open during construction. Construction began May 5th, with a tentative completion date of November 2, 2025. Phase 1 began on May 5th and was completed on July 3, 2025, twenty-one (21) days behind schedule due to the Contactor not securing the required base aggregate for the Phase 1 paving and a few days for rain. Phase 2 started on July 4th and was completed on October 4th. Phase 2 ended up being twenty-two (22) days behind schedule, putting the whole project forty-three (43) days behind schedule at this point. *The current completion date is projected to be January 16, 2026.*

Funding: Airport **Est. Cost:** \$6,245,177 **Amt Spent as of 11/30/25:** \$4,720,485 **Est. Completion:** Fall 2025

T-HANGAR and TAXILNE CONSTRUCTION:

Plans are being made to construct a 10-unit T-Hangar along with reconstruct/rehabilitate surrounding hangar approaches/taxilanes. Senator Fischer secured \$2,850,000 for a new hangar. Benesch recommended the contract be awarded to Vogts Parga and the City Council approved that recommendation on April 7, 2025. The Federal grant will cover 95%, the State grant will cover 2% and the remaining 3% is our local share, estimated to be \$82,554.86. Federal funds were finally released, and the Hangar Grant Agreement was signed and returned on August 25th. The contract was awarded to Vogts Parga on April 7, 2025 however the bid hold period was exceeded due to the delayed release of federal funds. Vogts Parga declined to honor the original bid and

increased the projected cost by \$277,000.00. It was determined that it was in our best interest to reject the increased cost and rebid the project. On the rebid, we received four (4) bids with AHRS Construction being the low bidder at \$2,260,852. *Bid was awarded to AHRS Construction on December 15th.*

Funding: Grant/Airport **Est. Cost:** \$3,310,000 **Amt Spent as of 11/30/25:** \$193,182 **Est. Completion:** Fall 2025

RUNWAY 14 & RUNWAY 32 PAPI-2L:

Both Runway 14 and Runway 32 do not currently have PAPIs. New L-881 LED PAPIs will enhance safety for the airport's crosswind runway 14/32. 95/5 Grant. Pre-design conference was held on November 10, 2025.

Funding: Grant/Bonds **Est. Cost:** \$382,000 **Amt Spent as of 11/30/25:** \$0 **Est. Completion:** Fall 2026

RUNWAY 18 & RUNWAY 36 PAPI-2L:

The existing PAPIs for Runway 36 are old and are reaching the end of their useful life. Runway 18 does not currently have PAPIs. New L-881 LED PAPIs will enhance safety and reduce maintenance costs. 95/5 Grant. Pre-design conference was held on November 10, 2025.

Funding: Grant/Bonds **Est. Cost:** \$384,000 **Amt Spent as of 11/30/25:** \$0 **Est. Completion:** Fall 2026

DESIGN and CONSTRUCTION OF NEW LANDFILL:

Cell Construction:

Awarded bid for the cell construction to Pruss Excavation Co., in the amount of \$6.2 million. Final walk through has been completed. Waiting for permit approval by the State.

South MSW Landfill Site Entrance Facility:

Bid was awarded to Genesis Contracting Group on January 6, 2025 in the amount of \$4,052,00. Final walk through has been completed.

Funding: BASWA **Est. Cost:** \$10.3 mill **Amt Spent as of 11/30/25:** \$11,007,624 **Est. Completion:** Fall 2025

EMS AMBULANCE:

The ambulance is on order and is anticipated to be delivered in Spring 2026.

Funding: CARES **Est. Cost:** \$450,000 **Amt Spent as of 11/30/25:** \$0 **Est. Completion:** Spring 2026

FIRE HOSE REPLACEMENT:

Final hose training was held on January 7, 2026.

Funding: Grants **Est. Cost:** \$14,000 **Amt Spent as of 11/30/25:** \$139,020 **Est. Completion:** Fall 2025

COMMUNICATION EQUIPMENT:

Replacement of Base Radio, Communications Work Station, Enterprise Records, and Radio Consoles.

Funding: Fischer Grant **Est. Cost:** \$584,000 **Amt Spent as of 11/30/25:** \$0 **Est. Completion:** Fall 2025

DRONE:

Drone w/night vision capabilities and equipment. A total of \$4,000 in donations have been received.

Funding: Private/General **Est. Cost:** \$25,000 **Amt Spent as of 11/30/25:** \$0 **Est. Completion:** 2026

WATER PARK DESIGN STUDY:

RFQ was issued in February 2025. Four (4) responses were received. An Agreement for Professional Services between the City and Waters Edge Aquatic Design to develop an Aquatic Park Master Plan was awarded May 19, 2025. Meeting with Water Edge Aquatic the week of July 14th to do an assessment of the Big Blue Waterpark. It will serve as the first phase of the physical condition assessment of the Waterpark. The assessment will evaluate the condition of equipment and components of the park. The first public meeting on this project was held on September 10, 2025. The second public meeting was held on October 22, 2025.

Funding: Lodging **Est. Cost:** \$250,000 **Amt Spent as of 11/30/25:** \$8,250 **Est. Completion:** Fall 2025

HANNIBAL PARK IMPROVEMENTS – 2026:

Design of Field 8 is underway. *Public Properties staff is working on cleaning up around the area where the new field will be installed. The trees and asphalt parking lot was removed by the Street Department the week of January 5th.*

Funding: Lodging/PR/Grant **Est. Cost:** \$287,000 **Amt Spent as of 11/30/25:** \$2,835 **Est. Completion:** Fall 2026

FOREST MANAGEMENT PLAN:

IRA Community Forestry Grant for Forest Mgt Plan and tree planting/removal. Additional tree removal and tree planting will occur as part of this grant.

Funding: Grant **Est. Cost:** \$140,000 **Amt Spent as of 11/30/25:** \$39,499 **Est. Completion:** Ongoing

RCRP GRANT:

The City received \$955,000 in grant funding for various park improvements:

Chautauqua Park: New Playground. One (1) bid was received on May 22, 2025. Bid was awarded to Play-Pro Recreation, LLC, in the amount of \$200,586.00 on June 2, 2025. *The playground installation is complete and open to the public.*

Heritage Heights: New Playground. Two (2) bids were received on November 13, 2025. Bid was awarded to Play-Pro Recreation, LLC, in the amount of \$250,000 on November 17, 2025.

Stoddard: New Playground. *One (1) bid was received from Play-Pro Recreation, LLC, in the amount of \$198,808, which was awarded on December 15, 2025.*

HOMESTEAD TRAIL:

Grant 80/20 split with State + \$550,000 for National Park Service. Design is underway. Bid is anticipated in January 2027 with construction in 2027. Approved Plan-In-Hand on October 7, 2024. Environmental review is in progress.

Funding: Lodging **Est. Cost:** \$2.5m **Amt Spent as of 11/30/25:** \$0 **Est. Completion:** Summer 2027

DUCK POND IMPROVEMENTS:

Remove silt or change channel and clean up. Met with local tree contractors for removal of trees around the Duck Pond.

Funding: Keno **Est. Cost:** \$50,000 **Amt Spent as of 11/30/25:** \$0 **Est. Completion:** Summer 2027

INDUSTRIAL PARK DISTRIBUTION LINE IMPROVEMENTS:

This project will include both, rebuilding existing lines to allow for increased loading in the Industrial Park, and the addition of new lines to better serve the existing loads and for new customer loads in the future.

Funding: Bond/Utility **Est. Cost:** \$551,000 **Amt Spent as of 11/30/25:** \$0 **Est. Completion:** Fall 2026

POWER GENERATION FACILITY:

HDR is investigating different technologies, lead times, and permitting.

Funding: Bonds **Est. Cost:** \$1m **Amt Spent as of 11/30/25:** \$0 **Est. Completion:** Fall 2026

SUBSTATION #2 IMPROVEMENTS:

Replace the substation transformer with a larger size, increase the footprint of the substation to accommodate the new control building, and install a new breaker and control lineup in the building. Bond funding has been secured. This work is being done to allow a larger substation transformer to be installed along with a switchgear lineup that will be able to support the larger loads we are forecasting due to additions to existing companies

and new customers. The initial layout and groundwork are being done to allow for drainage improvements and the new equipment.

Funding: Bonds/Utility **Est. Cost:** \$1.01m **Amt Spent as of 11/30/25:** \$0 **Est. Completion:** Fall 2026

SUBSTATION #7 IMPROVEMENTS:

Substation #7 was originally built to provide 4.16Kv voltage on the distribution feeders. The area that this substation provided service to has all been converted to 12.5Kv. This project will include the installation of a new transformer and breaker lineup that will serve the area at the 12.5Kv voltage level.

Funding: Bonds **Est. Cost:** \$1.28m **Amt Spent as of 11/30/25:** \$0 **Est. Completion:** Fall 2026

SUBSTATION #9 IMPROVEMENTS:

This will include upsizing the existing bus bar to allow for the installation of an additional feeder to increase the total load capacity that we are able to export from this substation.

Funding: Bonds/Utility **Est. Cost:** \$414,000 **Amt Spent as of 11/30/25:** \$0 **Est. Completion:** Fall 2026

24" VALVE AT FARM WELLS:

Purchase and install a 24" butterfly valve between farm wells, to allow for more redundancy and the ability to use wells and transmission lines as intended.

Funding: Infra Funds **Est. Cost:** \$60,000 **Amt Spent as of 11/30/25:** \$75 **Est. Completion:** Fall 2026

CHLORINE BUILDING:

Construct a new building to house our chlorine disinfectant operations. This cost would be for the complete construction of the building. Located west of the north reservoir. We have met with JEO on two (2) occasions to prepare plans for the chem feed system. JEO will then approach the State for the required permit. *We completed the footings and floor in November. In December we completed most of the framing, installed doors and windows, and have the building dried in.*

Funding: Utility **Est. Cost:** \$40,000 **Amt Spent as of 11/30/25:** \$24,788 **Est. Completion:** Summer 2026

WATER MAIN PROJECT – HAYES TO HIGH:

Replace 6" water main. The Engineering Department has performed a topographical survey of the area. Line work based on the survey has been created.

Funding: Infra Funds **Est. Cost:** \$60,000 **Amt Spent as of 11/30/25:** \$0 **Est. Completion:** Summer 2026

WATER MAIN PROJECT – NORTH 7TH, LINCOLN TO GARFIELD STREET:

Replace 8" water main. The Engineering Department has performed a topographical survey of the area. Line work based on the survey has been created.

Funding: Infra Funds **Est. Cost:** \$180,000 **Amt Spent as of 11/30/25:** \$0 **Est. Completion:** Summer 2026

GRIT CONSTRUCTION:

Design and Installation of the new Grit process equipment and building. Received grant with help of Congressman Smith in the amount of \$2 million. Letter Agreement with Olsson, Inc., entered into on November 21, 2022 for the design process. Bids were received on April 10, 2025 for the construction of the project. The EPA has authorized the City to award this project. The contract was awarded to Building Crafts, Inc., on June 2nd. A pre-construction meeting was held on June 25th to kick off the project. Building Crafts has mobilized to the WWTF site. Reconstruction of the effluent water reuse line from the flow metering structure to the Bio-solids building has been completed. BCI Construction is continuing to work and make upgrades. *Currently pouring the concrete footings for the building that will support the pre-cast wall panels. A fiber network backbone is being installed to select buildings. HOA has been onsite beginning the installation of the new SCADA*

equipment. BCI has continued to pour the concrete foundation walls which will support the new pre-cast wall panels.

Funding: Grant/Util **Est. Cost:** \$3.9m **Amt Spent as of 11/30/25:** \$840,710 **Est. Completion:** 2026

SCADA DESIGN:

Contract for engineering services has been created and approved by the City Council. A letter Agreement with Olsson, Inc., was entered into on November 21, 2022. A project kickoff meeting was conducted on January 23, 2023. Final Specifications and drawings have been submitted and approved by the City of Beatrice. Drawings and specifications will be sent to NDEE for review and approval. The project will coincide with the Grit Improvement project. *A fiber backbone is being installed to select buildings for connection to the new SCADA system and HOA has begun the installation of the SCADA system.*

Funding: Utility **Est. Cost:** \$35,000 **Amt Spent as of 11/30/25:** \$0 **Est. Completion:** Fall 2025

ELLA STREET, 2nd to 3rd:

Seven (7) bids were received on October 30, 2025. R.L. Tiemann was the low bidder with a total of \$426,609.15 and was awarded the contract, with a completion date of June 1, 2026.

Funding: Street **Est. Cost:** \$486,667 **Amt Spent as of 11/30/25:** \$37,001 **Est. Completion:** Spring 2026

7TH STREET CONCRETE RECONSTRUCTION, ARTHUR TO MONROE:

A topographical survey of the area has been conducted by the Engineering Department. The design phase of the project has been initiated by the Engineering Department. *Anticipate completing the project this month and placing it out for bids during the month of February 2026.*

Funding: Street **Est. Cost:** \$375,000 **Amt Spent as of 11/30/25:** \$0 **Est. Completion:** Fall 2026

ARMOR COATING VARIOUS LOCATIONS

Plans and Specifications were created by the Engineering Dept. The project was sent out for bids during the month of November 2025. Two (2) bids were received on December 4, 2025. Sta-Bilt was the low bidder with a total of \$33,317.20 and was awarded the contract with a completion date of August 1, 2026.

Funding: Street **Est. Cost:** \$33,317 **Amt Spent as of 11/30/25:** \$0 **Est. Completion:** Fall 2026

ASPHALT SEALING VARIOUS LOCATIONS

Plans and Specifications were created by the Engineering Dept. The project was sent out for bids during the month of November 2025. One (1) bid was received on December 4, 2025. Hall Brothers was the low bidder with a total of \$29,007.24 and was awarded the contract with a completion date of August 1, 2026.

Funding: Street **Est. Cost:** \$29,007 **Amt Spent as of 11/30/25:** \$0 **Est. Completion:** Fall 2026

PLANNING & ZONING

There were no Planning and Zoning Commission meetings held in December.

ECONOMIC DEVELOPMENT

Recent TIF Activity:

A TIF application for Landmark Snacks is working its way through the TIF process.

LB840 Loans:

All existing LB840 loans are current. The program income for FY25 as of November 30, 2025 is \$83,237. The current unexpended funds as of November 30, 2025 total \$172,070, and those funds are deposited in Pinnacle Bank.

EMPLOYEE

Safety:

During the month of December, there were two (2) workers comp claims filed. We currently have two (2) employees on modified duty.

FINANCIALS

Financial statements for the General and Street Fund for the month ending November 30, 2025, are attached, marked as **Exhibit "A"**. Financial statements for the Electric, Water, and WPC Departments for the month ending November 30, 2025, are attached, marked as **Exhibit "B"**.

CODE VIOLATIONS / BUILDING PERMITS / DEMOLITIONS

Code Violations:

Code Compliance Officer responded to and worked on fifty-six (56) various code violations in December, bringing the year-to-date total to one thousand one hundred ten (1,110). See attached list, marked as **"Exhibit C"**.

Building Permits:

Processed eighteen (18) permits/applications/inquiries, bringing the year-to-date total to five hundred sixty (560). See attached list, marked as **"Exhibit D"**.

Demolitions:

A list of demolition projects is attached, marked as **"Exhibit E"**.

PUBLIC PROPERTIES

- Staff are currently servicing equipment getting it ready for the Spring 2026 season.
- Staff prepared the Beatrice City Auditorium for the MUDECAS Basketball Tournament, which was held the week of January 12th.
- Staff spent three (3) days trimming trees along Chief Standing Bear Trail.

STORM SEWER/DRAINAGE

1. MS4: JEO was hired to update the City of Beatrice MCM#5 – Post Construction Stormwater section of the Stormwater Management Plan. *City code was amended December 15, 2025, to match the Drainage Criteria Plan. JEO is under contract to provide support services for the 2026 year to create the Annual Stormwater Report.*

STREETS

Dempsters:

The Street Department, with the help of six (6) part-time employees, worked on cleaning up the Dempster's property. The Street Department hauled a total of 146 total dump truck loads of brush, construction rubble, and garbage from the site. MARS also hauled approximately twelve (12) rollofs during the cleanup.

Blading Gravel Streets/Alleys:

We were able to blade all the gravel streets in five (5) days. We hauled gravel and rock to areas around town needing it.

Sweeping:

We swept a total of fourteen (14) days with both sweepers.

Stormwater:

We noticed a hole along the north side of Highway 136 near 25th Street. This hole was caused by a section of concrete storm culvert that had separated. This area was deep to get to and had multiple utility lines above it, which caused us to have to vac the area for excavation. Hole walls were shored for safety and repairs were made.

Winter Precipitation Event:

We had four (4) days of precipitation, using a total of 129.5 tons of rock salt.

Dirt Work:

We worked to fill drop-offs along the edge of Hickory Road.

UTILITIES

UTILITY DELINQUENT NOTICES and DISCONNECTIONS:

There were 1,083 disconnect notices mailed out in December. There was a total of 68 disconnections for non-payment on January 5th.

Overhead Distribution:

We have begun rebuilding a new section of overhead line between 7th and 8th Streets, Lincoln to Park Streets. This line is being rebuilt for conversion of the voltage from 4.16Kv to 12.5Kv. All the new poles from Arthur Street north to Park Street have been framed and set and the old lines spread out on extension arms in preparation to pull in new wires. All the new poles have been set and hardware installed except for one concrete pole that delivery was delayed on. As soon as we receive it we will get it set and pull in the new conductors. The concrete pole was received and has been set. The new conductors are being installed and tied into the new poles. The crew is currently working on connecting the new transformers and services to the new lines and removing the old transformers. *Work is ongoing for this project.*

A new overhead rebuild project has been started at 7th and Perkins. This will include new poles and overhead lines to extend services back to the building located between 7th and 8th, south of Perkins Street. The new poles have been set and the crew is getting ready to install the new conductors. This project will provide electric service to the east portion of the building. *The new overhead conductors have been installed and tied in. The underground portion of this project has been bored under South 8th Street to the new transformer location. The*

transformer has been set, primary and secondary connections made, and the transformer has been energized. This project is complete.

A new project has been started on North 7th Street and Stockman Road to rebuild the overhead line. This line is the main source on the east side of Hwy 77. The poles and hardware are all being replaced and the conductor is being upsized to manage the loads we have there. All the poles have been set, and the crew is preparing to pull in the new conductors. The new primary conductors and all the pole mount transformers have been installed and the customers switched over to the new lines. We are now beginning to work on the underground sections. Boring and installing conduits has been completed on three (3) sections of the underground lines. Provisions are being made for the changeover of the two (2) hotels to the new line. All the high voltage underground circuits have been replaced and the new lines energized. All the businesses and one hotel have been moved to the new lines.

Exmark Upgrades

The Exmark Corporation asked for two (2) of its incoming services at the south end of their buildings to be upgraded to accommodate additional load and machines that they are moving in. We upgraded our underground circuit that provides service to these two (2) locations. We worked with Exmark to combine these two (2) services into one (1) and only had to upgrade one (1) transformer and we were able to remove the second transformer. This change was beneficial for both the customer and the Electric Department. This project is complete and Exmark has installed their additional equipment.

Underground Services

Two (2) new underground services were installed. Both services were for upgrades to existing homes.

Substation Maintenance

Winter preparation maintenance has been performed at the substations. Several of the substation transformers voltage regulators were low on oil. Oil was added to the proper level so the operation of the unit would not be compromised. We have also started going through the substations with our infrared camera searching for hotspots that might cause issues. *We are continuing the infrared testing in the substations.*

Substation Control And Data Acquisition Projects:

There were two (2) projects started under our SCADA system. The first one (1) was to upgrade our main data collection equipment at the Service Center that communicates with all the substations and collects our load data and alarms. The installation of this equipment is complete and now we are looking at converting the communications over to the fiber lines installed by Pinpoint. We are currently working on extending pinpoint fiber into our substations for secure communications and future upgrades. Conduits have been extended from pinpoint junction boxes into our substation control buildings. Pinpoint has begun to terminate the fiber lines in the substation buildings.

The second project is a distribution automation project that combines functions of our AMI system and the SCADA system. Utilizing the AMI communication network, we are able to install remotely operated controls on our capacitor banks to allow our SCADA system to turn them on and off when needed according to the substation loads. This is an expandable project where we will be able to install and monitor controls and equipment on the distribution lines utilizing our existing systems. Work continues on installing the remote equipment at the capacitor bank sights and rewiring the controls for remote operation.

Water Service Leaks and Service Calls:

- 1509 North 19th Street - lower valve box
- 1603 Northridge - Service leak
- 903 Pleasant Street- Install service tap
- 2322 High Street- Service leak
- 2201 Elk Street - Repair angle valve
- Blue Ridge Road - Repair leak on transmission line

Water Main Replacement/Construction:

We were able to get into the Heritage Heights Development on Friday October 17, 2025, to prep for main installation. We began main installation on October 20, 2025, and had all the pipe in the ground by October 31, 2025. All material has been installed. We located our pressure loss/leak on the east side of the system, identified, and repaired the issue the week of Christmas. Samples will be taken in early January.

Also in December, we started and completed a new water main installation on South 11th Street, just north of Oak Street.

Water Main Breaks:

We did not have any true main breaks this month. We had a few leaks reported as main breaks, however, upon excavation they were determined to be a service leak.

Maintenance and Miscellaneous Work:

We began annual flushing of mains and hydrants in September. We are approximately 50-60% complete with these at this time.

We are continuing to exercise main valves as often as possible.

We are in the midst of testing backflows as well. The City has approximately 450 backflow devices, which the Department tests and repairs annually. We are currently on schedule with our backflow tests.

The Water Department used manhours to construct the chem feed building and construct as much as we could with our in-house knowledge, expertise, and tools.

Conducted preparation for the cleaning of our two (2) underground water reservoirs, which will occur in January and February 2026.

Sewer Line Maintenance/Blockages:

We had eight (8) sewer calls this month.

- 2021 Jefferson Street - Blockage in the line (Roots)
- 339 North 25th Street - Blockage in the line (Rags, Roots, & Grease)
- 1506 Lincoln Street - No Blockage
- 2123 High Street - No Blockage
- 1312 Market Street - No Blockage
- 904 North 19th Street - No Blockage
- 101 South 13th Street - No Blockage
- 629 Bismark Street - No Blockage

Jet Truck Footage:

Daily maintenance for the entire month was 5,658 ft. Monthly maintenance for the month was 3,860 ft.

TV/Camera Trailer Inspections:

A total of 4,859 linear feet was videoed and auto coded with the new SewerAI software.

Plant Maintenance:

- Plant maintenance is up to date at the WPC Plant.
- Sewer Main Break (N Union Ave) - Lammel Plumbing was contacted. All repairs were made and the line was placed back into service.
- Lift Station #6 – The Department worked with Johnson Services to install two (2) separate point repair liners at the lift station. The bad sections of pipe were allowing sand to enter our sewer and cause pump issues at the lift station.
- Lift Station #3, #4, #6, #8 & #9 - Were vac'd and cleaned.

SPECIAL DESIGNATED LICENCES (SDL)

A list of special designated licenses (SDL) requested for 2025 is attached, marked as “Exhibit F”.

COMPLETED CAPITAL PROJECTS

33RD AND LINCOLN STREET - COMPLETED

FY24: \$3m ; FY25: \$1m

Contract for design services was awarded to JEO on May 15, 2023. Seven (7) bids were received on April 23, 2024. The apparent low bidder was Constructors of Lincoln, NE with an estimated bid of \$2.3 million. Contract was awarded May 6, 2024. 33rd Street is open to traffic. The project was extended west approximately fifty feet (50'). A final walk thru of the project was conducted on November 12, 2024. Final payment scheduled for January 20, 2025.

Funding: Street **Est. Cost:** \$4.3m **Amt Spent as of 9/30/25:** \$2,851,718 **Est. Completion:** Fall 2024

LINCOLN STREET, 25th to 27th - COMPLETED

Contract for design services was awarded to JEO on August 5, 2024. Ten (10) bids were received on February 20, 2025. Project was awarded to M.E. Collins Contracting Co., Inc., in the amount of \$554,222.30. A pre-construction meeting was held on May 13, 2025. Lincoln Street was closed, and construction began on May 27, 2025. The project is complete, and a final walk thru was conducted on September 10, 2025.

Funding: Street **Est. Cost:** \$107,000 **Amt Spent as of 11/30/25:** \$708,106 **Est. Completion:** Fall 2025

WATERMAIN – OVERHEAD CROSSING – COURT STREET BRIDGE – COMPLETED

Replace overhead crossing on Court Street bridge and bore under the river. Entered into a Master Agreement Work Order #2 with Olsson on October 21, 2024. Bid was awarded to Judds Brothers Construction in the amount of \$415,000.00 on June 2, 2025. Judds Brothers has completed the majority of this project, the only remaining items to be completed is final grading and seeding, which will take place in early October; and the Water Department will remove a hydrant from the old main on the east side of the River. Otherwise, the pipe was filled, samples taken and passed, and the main has been put into operation.

Funding: Bonds **Est. Cost:** \$500,000 **Amt Spent as of 11/30/25:** \$77,153 **Est. Completion:** Fall 2025

20 YARD REAR LOAD GARBAGE TRUCK - COMPLETED

Replace 20 yard rear load garbage truck. Truck was delivered the week of September 2nd.

Funding: Utility **Est. Cost:** \$275,000 **Amt Spent as of 11/30/25:** \$218,000 **Est. Completion:** Fall 2025

LIFT STATION #6 + BACKUP GENERATOR:

Back-up generator will be installed. Design will be completed in FY24, with construction following shortly thereafter. A project kickoff meeting was conducted October 25, 2023. The Engineering Department has completed the topographical survey and submitted the information to the design engineer. Olsson, Inc., designer engineer, has submitted 90% drawings and specifications for review. Project drawings and specifications were approved by the City and NDEE. Project was sent out for bids and a bid opening was conducted on May 15, 2024. The apparent low bidder was Philip Carkoski Construction of Loup City, Nebraska with a bid of \$547,785.00. The project began on April 29, 2025. Pumps and piping are installed and in operation. Final items to be completed include training and start up services. It is estimated the project will be completed within the next two (2) weeks. Contractor has achieved substantial completion, and the lift station is now back in control by the WPC. Olsson has created a punch list of items that need to be completed or rectified in order for the contractor to achieve final completion. Contractor achieved final completion after addressing all of the punch list items as of October 2, 2025.

Funding: Utility **Est. Cost:** \$700,000 **Amt Spent as of 11/30/25:** \$484,965 **Est. Completion:**

RCRP GRANT:

Pickleball: Contract was awarded July 7, 2025 to Lottman Excavating in the amount of \$82,160. Construction is underway. Public Properties staff finished with the pickleball seating area. The handrails were installed and new four-foot (4') fencing was installed for better viewing of the courts. The area was also fine graded and seeded.

Froberry Park: Bid was awarded April 21, 2025 to Play-Pro Recreation, LLC, in the amount of \$167,162. The new playground has been installed and is open to the public.

4TH and 5TH STREET, MARKET TO ELLA - COMPLETED

The bid opening was held on June 26, 2025. R.L. Tiemann was the low bidder with a total of \$98,921.68 for both bid sections. The contract was awarded at the July 7th Council Meeting. The project has reached final completion status. Sealing of the concrete pavement joints in the parking areas and curbing was completed on November 8th. Cleaning and sealing the colored concrete sidewalk areas will be done at a later date by the Public Properties Department.

Funding: Grants **Est. Cost:** \$550,000 **Amt Spent as of 11/30/25:** \$120,375 **Est. Completion:** Fall 2025

SERTOMA ASTRO PARK ADA PLAYGROUND:

Install ADA compliant playground. The contractor finished the poured in play matting at Sertoma-Astro Park. Then staff completed final grading and seeding of the park.

Funding: Grant **Est. Cost:** \$160,000 **Amt Spent as of 11/30/25:** \$159,488 **Est. Completion:** Fall 2025

FUND	FUND BALANCE 10/1/2025	REVENUE	TRNSFR IN	TOTAL AVAILABLE	EXPEND.	TRNSFR OUT	FUND BALANCE 11/30/2025
GENERAL ALL-PURPOSE FUNDS							
GENERAL	\$ 4,914,104	\$ 1,728,528	\$ -	\$ (5) 6,642,632	\$ 2,191,360	\$ -	\$ (3) 4,438,475
<i>moves to (from)restricted</i>	\$ -		\$ -	\$ (2)		\$ 12,797	\$ (1)
<i>Restricted Gas Plant</i>	\$ 700,000		\$ -	\$ (1) 700,000			XX \$ 700,000
<i>Designated CARES ffuture eq</i>	\$ 290,300		\$ -	\$ (1) 290,300		\$ -	\$ (2) 290,300
<i>Designated EMS Equip</i>	\$ 348,323		\$ -	\$ (1) 348,323		\$ -	\$ (2) 348,323
<i>Designated Lodging Tax Proj</i>	\$ 443,762		\$ 12,797	\$ (1) 456,559		\$ -	\$ (2) 456,559
SPECIAL REVENUE:							
Street	\$ 4,918,061	\$ 723,234		\$ 5,641,295	\$ 935,408	\$ 20,752	\$ 4,685,135
<i>Restricted Debt Serv</i>	\$ 31,128		\$ 20,752	\$ 51,880			\$ 51,880
Keno	\$ 519,743	\$ 13,379		\$ 533,122	\$ -	\$ -	\$ (4) 533,122
DEBT SERVICE							
GO Debt	\$ 2,987,560	\$ 249,042		\$ 3,236,602	\$ -		\$ 3,236,602
Special Assess.-Unbonded	\$ 20,620	\$ 466		\$ 21,086	\$ -		\$ 21,086
CAPITAL PROJECTS							
Capital Improvement	\$ 145,505	\$ 492,603	\$ -	\$ (3) 638,108	\$ 402,264		\$ 235,844
Capital Imp.-Keno	\$ (0)	\$ -	\$ -	\$ (4) (0)	\$ -		\$ (0)
Capital Imp.-Public Safety	\$ 309,073	\$ 56,116	\$ -	\$ (3) 365,189	\$ 217,874		\$ 147,314
General All-Purpose Fund	<u>\$ 15,628,177</u>	<u>\$ 3,263,369</u>	<u>\$ 33,549</u>	<u>\$ 18,925,094</u>	<u>\$ 3,746,906</u>	<u>\$ 33,549</u>	<u>\$ 15,144,640</u>
RESTRICTED FUNDS							
SPECIAL REVENUE:							
Airport*	\$ 1,075,801	\$ 1,958,883	\$ -	\$ 3,034,684	\$ 2,129,382		\$ 905,302 manual entry
CDBG*	\$ (447,770)	\$ 447,770		\$ 0	\$ -		\$ 0
Economic Development*	\$ 149,955	\$ 83,237	\$ -	\$ 233,192	\$ 36,640	\$ 24,482	\$ 172,070
<i>Restricted Debt Serv</i>	\$ 168,758		\$ 24,482	\$ 193,240			\$ 193,240
911 Service Surcharge	\$ 140,471	\$ 19,371		\$ 159,842	\$ -	\$ -	\$ (5) 159,842
CRA	\$ -	\$ 1,994		\$ 1,994	\$ -		\$ 1,994
Sanitation*	\$ 305,825	\$ 569,347		\$ 875,172	\$ 499,226	\$ 48,317	\$ 327,629 manual entry
<i>Restricted Debt Serv</i>	\$ 155,916		\$ 48,317	\$ 204,233			\$ 204,233
INTERNAL SERVICE							
Employee Benefit Acct	\$ 620,845	\$ 945,531		\$ 1,566,376	\$ 562,410		\$ 1,003,966
Info Tech Services	\$ -	\$ 179,652		\$ 179,652	\$ 162,970		\$ 16,682
ENTERPRISE							
Board of Public Works*	\$ 20,934,668	\$ 4,379,282		\$ 25,313,949	\$ 4,717,986		\$ 20,595,963 manual entry
Norcross/Horner	\$ 6,978	\$ -		\$ 6,978	\$ -		\$ 6,978
TOTAL RESTRICTED	<u>\$ 23,111,447</u>	<u>\$ 8,585,067</u>	<u>\$ 72,799</u>	<u>\$ 31,769,313</u>	<u>\$ 8,108,615</u>	<u>\$ 72,799</u>	<u>\$ 23,587,900</u>
TOTAL	<u>\$ 38,739,624</u>	<u>\$ 11,848,436</u>	<u>\$ 106,348</u>	<u>\$ 50,694,407</u>	<u>\$ 11,855,520</u>	<u>\$ 106,347</u>	<u>\$ 38,732,539</u>

*cash basis

Exhibit "A"
CITY OF BEATRICE, NEBRASKA
GENERAL FUND BUDGETARY STATEMENTS
FOR THE CURRENT YEAR TO DATE

AS COMPARED TO THE PRIOR TWO FISCAL YEARS

DESCRIPTION	PRIOR YEAR 2 ACTUAL FY2024	PRIOR YEAR 1 ACTUAL FY2025	Current as of 9/30/2026	CURRENT YEAR BUDGET FY2026	% YTD
GENERAL REVENUES					
TAXES	7,200,663.51	7,417,491.31	663,601.17	7,746,500.00	8.57%
LICENSES & PERMITS	156,065.63	180,450.32	14,371.65	201,300.00	7.14%
INTERGOVERNMENTAL REVENUE	2,422,881.54	2,389,145.82	280,466.55	1,803,516.00	15.55%
CHARGES FOR SERVICES	2,782,998.98	2,761,871.03	651,637.13	3,046,944.00	21.39%
MISCELLANEOUS REVENUES	1,062,907.38	652,891.35	118,451.26	565,100.00	20.96%
OTHER FINANCING SOURCES	63,100.44	65,801.12	0.00	86,155.00	0.00%
TOTAL REVENUES	13,688,617.48	13,467,650.95	1,728,527.76	13,449,515.00	12.85%
GENERAL EXPENDITURES BY TYPE					
PERSONAL SERVICES	9,285,811.04	10,062,465.28	1,708,890.18	11,110,071.00	15.38%
OTHER SERVICES & CHARGES	1,419,868.56	1,448,138.48	341,563.45	1,629,949.00	20.96%
SUPPLIES	456,530.46	513,537.17	42,584.04	523,385.00	8.14%
CAPITAL OUTLAYS	687,521.74	243,284.03	60,195.70	253,221.00	23.77%
CONTINGENCY	7,334.50	122,704.77	0.00	122,000.00	0.00%
CONTRACTUAL SERVICES	463,255.03	#REF!	38,126.25	284,066.00	13.42%
INTERFUND TRANSFERS	933,600.98	1,569,128.48	0.00	1,252,200.00	0.00%
TOTAL EXPENDITURES	13,253,922.31	#REF!	2,191,359.62	15,174,892.00	14.44%
OVERALL NET CHANGE	434,695.17	#REF!	(462,831.86)	(1,725,377.00)	26.82%
GENERAL ADMINISTRATION					
PERSONAL SERVICES	1,141,786.73	1,211,474.95	218,168.64	1,263,478.00	17.27%
OTHER SERVICES & CHARGES	331,027.63	334,507.13	118,600.49	452,310.00	26.22%
SUPPLIES	15,530.51	16,976.64	2,169.02	18,020.00	12.04%
CAPITAL OUTLAYS	443,913.29	36,696.53	15,231.72	30,000.00	50.77%
CONTINGENCY	7,334.50	122,704.77	0.00	122,000.00	0.00%
CONTRACTUAL SERVICES	333,540.28	530,758.30	12,212.25	139,066.00	8.78%
INTERFUND TRANSFER	933,600.98	1,569,128.48	0.00	1,252,200.00	0.00%
GENERAL ADMINISTRATION	3,206,733.92	3,822,246.80	366,382.12	3,277,074.00	11.18%
COMMUNITY DEVELOPMENT					
PERSONAL SERVICES	225,433.82	257,644.86	45,908.95	280,609.00	16.36%
OTHER SERVICES & CHARGES	94,167.87	59,771.45	507.99	81,630.00	0.62%
SUPPLIES	2,533.78	4,235.80	229.88	5,300.00	4.34%
CAPITAL OUTLAYS	0.00	0.00	0.00	0.00	
COMMUNITY DEVELOPMENT	322,135.47	#REF!	46,646.82	367,539.00	12.69%
OTHER SERVICES & CHARGES					
PERSONAL SERVICES	4,269,331.20	4,610,688.14	798,079.70	5,029,664.00	15.87%
OTHER SERVICES & CHARGES	369,478.24	395,557.49	140,033.79	390,380.00	35.87%
SUPPLIES	87,895.61	128,788.88	6,088.73	130,815.00	4.65%
CAPITAL OUTLAYS	40,975.52	32,176.67	0.00	32,500.00	0.00%
CONTRACTUAL SERVICES	60,000.00	60,000.00	12,000.00	60,000.00	20.00%

Exhibit "A"
CITY OF BEATRICE, NEBRASKA
GENERAL FUND BUDGETARY STATEMENTS
FOR THE CURRENT YEAR TO DATE

AS COMPARED TO THE PRIOR TWO FISCAL YEARS

DESCRIPTION	PRIOR YEAR 2	PRIOR YEAR 1	Current as of	CURRENT YEAR	%
	ACTUAL FY2024	ACTUAL FY2025	9/30/2026	BUDGET FY2026	YTD
POLICE	4,827,680.57	5,227,211.18	956,202.22	5,643,359.00	16.94%
PERSONAL SERVICES	2,797,074.28	3,078,807.52	511,795.09	3,464,710.00	14.77%
OTHER SERVICES & CHARGES	376,880.97	391,032.87	45,291.71	405,860.00	11.16%
SUPPLIES	161,729.02	159,109.18	14,455.30	181,300.00	7.97%
CAPITAL OUTLAYS	717.99	1,390.92	1,607.78	6,500.00	24.74%
FIRE	3,336,402.26	3,630,340.49	573,149.88	4,058,370.00	14.12%
PERSONAL SERVICES	515,567.01	550,335.90	69,567.19	663,404.00	10.49%
OTHER SERVICES & CHARGES	192,935.42	196,015.42	13,246.73	227,465.00	5.82%
SUPPLIES	174,442.40	193,801.85	19,212.01	173,950.00	11.04%
CAPITAL OUTLAYS	83,011.55	29,151.24	9,563.78	62,400.00	15.33%
CONTRACTUAL SERVICES	69,714.75	85,203.43	13,914.00	85,000.00	16.37%
PUBLIC PROPERTIES	1,035,671.13	1,054,507.84	125,503.71	1,212,219.00	10.35%
PERSONAL SERVICES	336,618.00	353,513.91	65,370.61	408,206.00	16.01%
OTHER SERVICES & CHARGES	55,378.43	71,254.12	23,882.74	72,304.00	33.03%
SUPPLIES	14,399.14	10,624.82	429.10	14,000.00	3.07%
CAPITAL OUTLAYS	118,903.39	143,868.67	33,792.42	121,821.00	27.74%
LIBRARY	525,298.96	#REF!	123,474.87	616,331.00	20.03%
GENERAL FUND EXPENDITURES	13,253,922.31	#REF!	2,191,359.62	15,174,892.00	14.44%

Exhibit "B"

Budgetary comments at 11/30/2025 (17%):

Electric Fund

- 1) Operating revenues increased 16.5% as compared to November 2024, operating expenses decreased 1.1% than the prior year, therefore the net operating income as of 11/30/2025 is \$70,797, as compared to a loss of \$368,300 in 2024. The margin over purchased power for November 2025 is 63%, for November 2024 the margin was 47%. Purchased power costs are 3.9% higher than 2024, while revenue on those costs increased 14.8%.
- 2) Cottonwood Wind sales less power costs have resulted in a loss in revenue of \$81,093 fiscal year to date. November 2024, Cottonwood wind sale power cost exceeded revenue by \$192,265.
- 3) The fund recognized an overall net income of \$134,850 at 11/30/2025 with revenues at 15% of budget and expenses at 15.9% of budget; as compared to the prior year revenues were at 14.5% and expenses at 17.4%.
- 4) Net change in total cash at 11/30/2025 as compared to the beginning of the year is an increase of \$508,251, which includes capital costs to date of \$188,244.

Water Fund

- 1) Operating revenues decreased 6.3% as compared to November 2024, operating expenses are 5% higher than the prior year, therefore the net operating income as of 11/30/2025 is a loss of \$76,871 as compared to a loss of \$20,609 in 2024.
- 2) The fund recognized an overall net income of \$19,956 at 11/30/2025, with revenues at 15.6% of budget and expenses at 15.8% of budget; as compared to the prior year revenues were at 17.9% and expenses at 19.6%.
- 3) Net change in total cash at 11/30/2025 as compared to the beginning of the year is a decrease of \$533,891 which includes capital costs to date of \$379,620.

WPC Fund

- 1) Operating revenues increased 4.3% as compared to November 2024, operating expenses are 27.7% higher than the prior year, therefore the net operating income as of 11/30/2025 is a loss of \$21,666 as compared to \$56,534 in 2024.
- 2) The fund recognized an overall net income of \$12,483 at 11/30/2025 with revenues at 16.4% of budget and expenses at 18.8% of budget; as compared to the prior year revenues were at 17.1% and expenses at 17.3%.
- 3) Net change in total cash at 11/30/2025 as compared to the beginning of the year is a decrease of \$313,064, which includes capital costs to date of \$143,161.

Street Fund

- 1) Projected revenues are at 19.4% of budget and expenditures, not including capital, are at 16.3% of budget. Revenues are under expenditures by \$212,174 as of 11/30/2025.
- 2) Capital outlay costs include \$20,650 for miscellaneous concrete, \$1,039 for Lincoln Street – 25th to 27th, and \$577,785 for Heritage Heights and Corral Crossing development.
- 3) The Street fund operating cash at 11/30/2025 is \$3,664,534.

Exhibit "B"
 BEATRICE BOARD OF PUBLIC WORKS
 COMBINED CASH INVESTMENT
 NOVEMBER 30, 2025

COMBINED CASH ACCOUNTS

9-127-21	SFB - DEBT SERVICE RESERVE	524,854.95
9-127-22	SERIES 2011/2013 BONDS - REST	(317,648.46)
9-127-23	SRF RESV - REST	(207,206.49)
9-127-80	SFB - BOND REVENUE RESV	3,968,508.02
9-127-81	REST - BOND REV	(3,968,508.02)
9-131-00	SECURITY 1ST BANK - CHECKING	99,222.97
9-132-00	PINNACLE BANK - PAYROLL	1,783.55
9-132-01	PAYROLL - PINNACLE RESTRICTED	(1,000.00)
9-133-00	CASH-BUSINESS DEBIT ACCOUNT	650.00
9-135-00	SFB - REVOLVING LOAN FUND	367,953.79
9-135-10	REST - REVOLVING LOAN FUND	(367,953.79)
9-137-00	SECURITY FIRST BANK MM	7,199,465.37
		<hr/>
	TOTAL COMBINED CASH	7,300,121.89
9-100-00	CASH ALLOCATED TO OTHER FUNDS	(7,300,121.89)
		<hr/>

TOTAL UNALLOCATED CASH .00

CASH ALLOCATION RECONCILIATION

1	ALLOCATION TO ELECTRIC FUND	6,024,293.06
2	ALLOCATION TO WATER FUND	603,561.55
3	ALLOCATION TO WPC	672,267.28
		<hr/>
	TOTAL ALLOCATIONS TO OTHER FUNDS	7,300,121.89
	ALLOCATION FROM COMBINED CASH FUND - 1-10000	(7,300,121.89)
		<hr/>

ZERO PROOF IF ALLOCATIONS BALANCE .00

Exhibit "B"
 BEATRICE BOARD OF PUBLIC WORKS
 BALANCE SHEET
 NOVEMBER 30, 2025

ELECTRIC FUND

	CURRENT YEAR	PREVIOUS YEAR
<u>ASSETS</u>		
PLANT	42,933,881.40	40,866,930.05
ACCUMULATED DEPRECIATION	(25,936,451.33)	(24,497,891.84)
BOOK VALUE OF PLANT	16,997,430.07	16,369,038.21
CONSTRUCTION WORK IN PROGRESS	194,299.50	262,127.40
<u>CASH ACCOUNTS</u>		
CASH & CASH EQUIVALENTS	6,024,293.06	5,017,414.52
CUSTOMER DEPOSITS MM	237,329.56	460,283.13
CUSTOMER DEPOSITS INVESTMENTS	726,944.16	318,903.62
PAYROLL ACCOUNT	500.00	500.00
PETTY CASH	1,375.00	1,375.00
RATE STABILIZATION FUND	1,076,670.01	1,047,299.57
ELECTRIC INFRASTRUCTURE FUND	45,559.60	.00
XPRESS BILL PAY FUND	15,231.16	.00
TEMPORARY CASH INVESTMENTS	1,909,360.86	1,831,974.84
BOND DEBT & RESERVE ACCOUNT	4,060,968.51	33,519.23
REVOLVING LOAN FUND RESERVE	367,953.79	366,473.38
TOTAL CASH ACCOUNTS	14,466,185.71	9,077,743.29
CUSTOMER ACCOUNTS RECEIVABLE	47,374.91	(17,024.60)
GARBAGE ACCOUNTS RECEIVABLE	18,086.73	15,465.63
COTTONWOOD SALES RECEIVABLE	45,670.77	18,573.21
DEVELOPER CONTRIBUTION RECEIVABLE	98,117.74	161,299.24
ALLOWANCE FOR BAD DEBTS	(22,056.81)	(22,167.89)
BALANCE OF ACCOUNTS RECEIVABLE	187,193.34	156,145.59
BUILDING MAINTENANCE FUND	(8,264.85)	(12,592.84)
INTERDEPARTMENTAL ACCOUNTS RECEIVABLE	4,063.95	5,339.54
OPERATION AND MAINTENANCE INVENTORY	1,042,073.55	1,086,586.76
PREPAID EXPENSES	2,517.00	112,282.00
INTEREST RECEIVABLE	14,535.16	19,331.27
ACCRUED UTILITY REVENUES	1,385,897.28	1,222,365.60
TOTAL ASSETS	34,285,930.71	28,298,366.82

Exhibit "B"
 BEATRICE BOARD OF PUBLIC WORKS
 BALANCE SHEET
 NOVEMBER 30, 2025

ELECTRIC FUND

	CURRENT YEAR	PREVIOUS YEAR
<u>LIABILITIES AND EQUITY</u>		
<u>LIABILITIES</u>		
2025 BONDS PAYABLE	3,896,390.70	.00
2025 BOND PREMIUM	54,777.03	.00
ACCOUNTS PAYABLE	1,302,325.76	1,178,992.74
UNCLAIMED PROPERTY PAYABLE	(3,035.25)	.00
EMPLOYEE INSUR. PAYABLE	472.38	345.00
ACCOUNTS PAYABLE-GARBAGE	23,762.98	20,640.70
CUSTOMER DEPOSITS PAYABLE	876,527.57	736,060.00
SALES TAX PAYABLE-STATE	(.01)	.00
SALES TAX PAYABLE-LOCAL	(.05)	.00
SALES TAX PAYABLE-COUNTY	.51 (.02)
ACCRUED INTEREST PAYABLE	(221.01)	.00
ACCRUED FICA TAX PAYABLE	9,422.79	10,837.66
ACCRUED FWH TAX PAYABLE	6,595.59	7,429.71
ACCRUED SWH TAX PAYABLE	2,484.61	3,106.77
OTHER MISC PAYROLL PAYABLE	12,747.78	13,420.72
ACCRUED VACATION TIME	161,267.73	145,612.36
ACCRUED COMP TIME PAYABLE	23,048.22	19,657.75
ACCRUED PAYROLL	42,687.29	49,507.90
ACCRUED SICK TIME PAYABLE	314,710.12	307,304.38
	6,723,964.74	2,492,915.67
<u>FUND EQUITY</u>		
NET INVEST IN CAPITAL ASSETS	13,345,660.00	16,620,637.00
RESTRICTED FOR DEBT SERVICE	59,376.00	.00
RESTRICTED FOR REVLOVING LOAN	367,707.52	366,228.52
UNRESTRICTED NET POSITION	13,654,372.17	9,231,886.78
REVENUE OVER EXPENDITURES - YTD	134,850.28	(413,301.15)
BALANCE - CURRENT DATE	27,561,965.97	25,805,451.15
TOTAL FUND EQUITY	27,561,965.97	25,805,451.15
TOTAL LIABILITIES AND EQUITY	34,285,930.71	28,298,366.82

Exhibit "B"
BEATRICE BOARD OF PUBLIC WORKS
OPERATING STATEMENT
FOR THE 2 MONTHS ENDING NOVEMBER 30, 2025

ELECTRIC FUND

	PERIOD ACTUAL	YTD ACTUAL	BUDGET	UNEARNED	PCNT	PREV YTD AMT
OPERATING REVENUE						
RESIDENTIAL SALES	263,629.36	529,310.38	(3,868,500.00)	(4,397,810.38)	13.7	493,272.73
RESIDENTIAL HEATING SALES	245,195.75	446,430.85	(3,072,000.00)	(3,518,430.85)	14.5	400,891.40
GENERAL SERVICE SALES	120,834.54	246,805.10	(1,600,000.00)	(1,846,805.10)	15.4	225,158.82
GENERAL SERVICE HEATING SALES	70,519.43	127,493.78	(910,500.00)	(1,037,993.78)	14.0	110,439.17
GENERAL SERVICE DEMAND SALES	469,293.13	982,596.22	(5,900,000.00)	(6,882,596.22)	16.7	975,393.36
LARGE POWER CONTRACT	160,236.19	342,461.35	(1,750,000.00)	(2,092,461.35)	19.6	160,496.10
PUBLIC STREET & HIGHWAY LIGHTING	7,398.83	15,210.30	(88,000.00)	(103,210.30)	17.3	14,535.84
INFRASTRUCTURE FEE	18,426.60	45,559.60	(840,000.00)	(885,559.60)	5.4	.00
INTERDEPARTMENTAL SALES	3,856.03	7,951.59	(50,000.00)	(57,951.59)	15.9	7,855.05
SECURITY LIGHTING SALES	8,590.85	17,124.59	(102,000.00)	(119,124.59)	16.8	17,514.79
ENGINEERING DEPARTMENT INCOME	14,522.00	29,104.00	(174,000.00)	(203,104.00)	16.7	26,616.00
MARKET SALES	52,396.05	78,291.14	(650,000.00)	(728,291.14)	12.0	29,162.78
RENEWABLE ENERGY CREDITS	.00	.00	(100,000.00)	(100,000.00)	.0	.00
TOTAL OPERATING REVENUE	1,434,898.76	2,868,338.90	(19,105,000.00)	(21,973,338.90)	15.0	2,461,336.04
OPERATING EXPENSE						
PURCHASED POWER	(872,652.99)	(1,616,766.05)	(10,200,000.00)	(8,583,233.95)	(15.9)	(1,560,440.31)
PURCHASED POWER - WAPA	(37,858.68)	(79,869.94)	(525,000.00)	(445,130.06)	(15.2)	(72,878.60)
PURCHASED POWER - COTTONWOOD	(65,910.02)	(159,384.44)	(1,300,000.00)	(1,140,615.56)	(12.3)	(221,427.65)
OPERATION & MAINTENANCE	(84,339.44)	(173,887.78)	(1,506,638.00)	(1,332,750.22)	(11.5)	(235,155.41)
ACCOUNTING & COLLECTING	(14,196.54)	(36,172.14)	(164,121.00)	(127,948.86)	(22.0)	(63,435.23)
METER READING	(2,731.32)	(5,566.15)	(35,378.00)	(29,811.85)	(15.7)	(6,248.08)
ENGINEERING DEPARTMENT	(35,727.51)	(79,768.35)	(455,420.00)	(375,651.65)	(17.5)	(78,635.19)
INFOMATIONAL TECH - COMPUTERS	(1,653.03)	(8,597.85)	.00	8,597.85	.0	(64,007.93)
ADMINISTRATIVE	(66,941.27)	(133,804.87)	(807,385.00)	(673,580.13)	(16.6)	(34,117.33)
GENERAL	(128,689.29)	(214,146.37)	(988,076.00)	(773,929.63)	(21.7)	(221,474.94)
VEHICLE & EQUIPMENT EXPENSES	(10,136.48)	(37,156.68)	(171,500.00)	(134,343.32)	(21.7)	(26,595.23)
DEPRECIATION	(126,185.89)	(252,421.17)	(1,465,000.00)	(1,212,578.83)	(17.2)	(245,220.16)
TOTAL OPERATING EXPENSES	(1,447,022.46)	(2,797,541.79)	(17,618,518.00)	(14,820,976.21)	(15.9)	(2,829,636.06)
NET OPERATING REVENUE	(12,123.70)	70,797.11	(36,723,518.00)	(36,794,315.11)	.2	(368,300.02)
OTHER INCOME (EXPENSES)						
MISCELLANEOUS INCOME	64,057.38	112,183.02	(1,058,000.00)	(1,170,183.02)	10.6	61,796.27
INTEREST INCOME	24,047.36	46,101.65	(101,000.00)	(147,101.65)	45.7	54,373.08
RESTRICTED INTEREST INCOME	11,104.30	22,702.64	.00	22,702.64	.0	341.22
INTEREST EXPENSES	.00	.00	(197,930.00)	(197,930.00)	.0	.00
MUNICIPAL EXPENSE	(62,682.49)	(116,934.14)	(742,185.00)	(625,250.86)	(15.8)	(161,511.70)
NET NONOPERATING INCOME (EXPENSE)	25,559.44	41,461.34	(2,099,115.00)	(2,140,576.34)	2.0	(45,245.99)
TOTAL NET INCOME OR (LOSS)	24,402.85	134,850.28	(38,822,633.00)	(38,957,483.28)	.4	(413,301.15)

Exhibit "B"
 BEATRICE BOARD OF PUBLIC WORKS
 BALANCE SHEET
 NOVEMBER 30, 2025

WATER FUND

	CURRENT YEAR	PREVIOUS YEAR
<u>ASSETS</u>		
PLANT	33,823,394.17	33,274,257.86
ACCUMULATED DEPRECIATION	(16,959,380.76)	(16,032,113.69)
	16,864,013.41	17,242,144.17
BOOK VALUE OF PLANT		
CONSTRUCTION WORK IN PROGRESS	808,921.66	99,456.51
 <u>CASH ACCOUNTS</u>		
CASH & CASH EQUIVALENTS	603,561.55	1,108,722.85
PAYROLL ACCOUNT	300.00	300.00
PETTY CASH	300.00	300.00
WATER INFRASTRUCTURE FEE	1,164,245.63	935,125.70
TEMPORARY CASH INVESTMENTS CD'S	580,493.35	557,723.98
BOND DEBT & RESERVE ACCOUNT	94,410.83	70,037.66
SRF RESERVE ACCOUNT	182,825.49	182,860.31
	2,626,136.85	2,855,070.50
TOTAL CASH ACCOUNTS		
CUSTOMER ACCOUNTS RECEIVABLE	21,395.81	21,281.35
ALLOWANCE FOR BAD DEBTS	(13,099.41)	(13,402.72)
	8,296.40	7,878.63
BALANCE OF ACCOUNTS RECEIVABLE		
OPERATION AND MAINTENANCE INVENTORY	710,160.15	792,403.54
PREPAID EXPENSES	(14,965.01)	89,910.99
INTEREST RECEIVABLE	6,158.85	6,880.66
ACCRUED UTILITY REVENUES	215,677.20	205,669.75
	21,224,399.51	21,299,414.75
TOTAL ASSETS	21,224,399.51	21,299,414.75

Exhibit "B"
 BEATRICE BOARD OF PUBLIC WORKS
 BALANCE SHEET
 NOVEMBER 30, 2025

WATER FUND

	CURRENT YEAR	PREVIOUS YEAR
<u>LIABILITIES AND EQUITY</u>		
<u>LIABILITIES</u>		
SRF BONDS PAYABLE	8,245,630.79	8,528,191.73
2025 BONDS PAYABLE	629,437.99	.00
2025 BOND PREMIUM	8,449.56	.00
ACCOUNTS PAYABLE	92,054.93	619,224.54
EMPLOYEE INSUR. PAYABLE	214.12	209.00
SALES TAX PAYABLE-STATE	86.18	.00
SALES TAX PAYABLE-LOCAL	(86.18)	.00
ACCRUED INTEREST PAYABLE	1,265.06	1,484.00
ACCRUED FICA TAXES PAYABLE	4,465.45	3,710.98
ACCRUED FWH TAXES PAYABLE	1,970.77	1,516.75
ACCRUED SWH TAX PAYABLE	981.82	831.14
OTHER MISC PAYROLL PAYABLE	5,439.84	3,799.30
ACCRUED VACATION TIME	47,122.13	36,986.21
ACCRUED COMP TIME PAYABLE	18,891.56	13,464.44
ACCURED PAYROLL	21,009.85	17,837.46
ACCRUED SICK TIME	32,789.43	33,208.56
	9,109,723.30	9,260,464.11
<u>FUND EQUITY</u>		
NET INVEST IN CAPITAL ASSETS	8,155,441.00	8,202,869.00
RESTRICTED FOR DEBT SERVICE	73,176.00	.00
UNRESTRICTED NET POSITION	3,866,103.41	3,827,847.20
REVENUE OVER EXPENDITURES - YTD	19,955.80	8,234.44
	12,114,676.21	12,038,950.64
TOTAL FUND EQUITY	12,114,676.21	12,038,950.64
TOTAL LIABILITIES AND EQUITY	21,224,399.51	21,299,414.75

Exhibit "B"
BEATRICE BOARD OF PUBLIC WORKS
OPERATING STATEMENT
FOR THE 2 MONTHS ENDING NOVEMBER 30, 2025

WATER FUND

	PERIOD ACTUAL	YTD ACTUAL	BUDGET	UNEARNED	PCNT	PREV YTD AMT
OPERATING REVENUE						
RESIDENTIAL SALES	117,683.06	254,602.22	(1,658,500.00)	(1,913,102.22)	15.4	286,524.82
COMMERCIAL SALES	20,503.20	101,418.58	(680,000.00)	(781,418.58)	14.9	121,474.39
CONTRACT SALES	32,205.78	67,639.96	(400,000.00)	(467,639.96)	16.9	67,617.82
INFRASTRUCTURE FEE	22,903.00	45,904.00	(276,000.00)	(321,904.00)	16.6	23,593.00
TOTAL OPERATING REVENUE	193,295.04	469,564.76	(3,014,500.00)	(3,484,064.76)	15.6	499,210.03
OPERATING EXPENSE						
OPERATION & MAINTENANCE	(71,356.84)	(184,206.38)	(1,261,512.00)	(1,077,305.62)	(14.6)	(197,961.24)
ACCOUNTING & COLLECTING	(9,454.96)	(21,318.34)	(112,152.00)	(90,833.66)	(19.0)	(26,121.57)
METER READING	(1,638.79)	(3,339.68)	(21,726.00)	(18,386.32)	(15.4)	(3,706.02)
ENGINEERING DEPARTMENT	(3,903.00)	(7,806.00)	(46,837.00)	(39,031.00)	(16.7)	(6,706.00)
ADMINISTRATIVE	(29,815.40)	(59,903.80)	(353,670.00)	(293,766.20)	(16.9)	(20,572.60)
GENERAL	(49,959.50)	(90,561.66)	(592,960.00)	(502,398.34)	(15.3)	(90,608.48)
VEHICLE & EQUIPMENT EXPENSES	(532.56)	(8,507.20)	(91,000.00)	(82,492.80)	(9.4)	(14,989.65)
DEPRECIATION	(86,194.46)	(170,792.93)	(990,000.00)	(819,207.07)	(17.3)	(159,153.58)
TOTAL OPERATING EXPENSES	(252,855.51)	(546,435.99)	(3,469,857.00)	(2,923,421.01)	(15.8)	(519,819.14)
NET OPERATING INCOME (LOSS)	(59,560.47)	(76,871.23)	(6,484,357.00)	(6,407,485.77)	(1.2)	(20,609.11)
OTHER INCOME (EXPENSES)						
MISCELLANEOUS INCOME	46,526.77	84,586.99	(287,500.00)	(372,086.99)	29.4	26,930.19
INTEREST INCOME	8,133.61	16,889.56	(100,000.00)	(116,889.56)	16.9	21,144.49
RESTRICTED INTEREST INCOME	623.12	1,294.94	(3,000.00)	(4,294.94)	43.2	1,133.18
OTHER INCOME	156.20	4,617.69	(2,000.00)	(6,617.69)	230.9	280.02
INTEREST EXPENSES	.00	.00	(441,424.00)	(441,424.00)	.0	.00
MUNICIPAL EXPENSE	(4,124.98)	(10,562.15)	(70,500.00)	(59,937.85)	(15.0)	(20,644.33)
NET NONOPERATING INCOME (EXPENSE)	51,314.72	96,827.03	(904,424.00)	(1,001,251.03)	10.7	28,843.55
TOTAL NET INCOME (LOSS)	(8,245.75)	19,955.80	(7,388,781.00)	(7,408,736.80)	.3	8,234.44

Exhibit "B"
 BEATRICE BOARD OF PUBLIC WORKS
 BALANCE SHEET
 NOVEMBER 30, 2025

WPC

	CURRENT YEAR	PREVIOUS YEAR
<u>ASSETS</u>		
PLANT	28,971,195.57	27,433,635.51
ACCUMULATED DEPRECIATION	(18,471,576.33)	(18,167,329.35)
BOOK VALUE OF PLANT	10,499,619.24	9,266,306.16
CONSTRUCTION WORK IN PROGRESS	143,161.05	6,479.50
<u>CASH ACCOUNTS</u>		
CASH & CASH EQUIVALENTS	672,267.28	1,230,040.05
PAYROLL ACCOUNT	200.00	200.00
PETTY CASH	175.00	175.00
SEWER INFRASTRUCTURE FEE	2,725,704.40	2,261,410.09
BOND DEBT & RESERVE ACCOUNT	105,294.11	118,592.95
TOTAL CASH ACCOUNTS	3,503,640.79	3,610,418.09
CUSTOMER ACCOUNTS RECEIVABLE	409,399.14	18,462.20
ALLOWANCE FOR BAD DEBTS	(6,964.58)	(6,963.73)
BALANCE OF ACCOUNTS RECEIVABLE	402,434.56	11,498.47
INTERDEPARTMENTAL ACCOUNTS RECEIVABLE	925.37	964.67
PREPAID EXPENSES	(10,724.00)	62,186.00
ACCRUED UTILITY REVENUES	203,282.96	191,040.98
TOTAL ASSETS	14,742,339.97	13,148,893.87

Exhibit "B"
 BEATRICE BOARD OF PUBLIC WORKS
 BALANCE SHEET
 NOVEMBER 30, 2025

WPC

	CURRENT YEAR	PREVIOUS YEAR
<u>LIABILITIES AND EQUITY</u>		
<u>LIABILITIES</u>		
2025 BONDS PAYABLE	469,171.31	.00
2025 BOND PREMIUM	6,298.11	.00
ACCOUNTS PAYABLE	230,676.56	27,828.92
EMPLOYEE INSUR. PAYABLE	25.00	105.00
ACCRUED INTEREST PAYABLE	(129.57)	.00
ACCRUED FICA TAX PAYABLE	3,079.68	2,667.08
ACCRUED FWH TAX PAYABLE	1,141.19	1,048.63
ACCRUED SWH TAX PAYABLE	603.09	547.62
OTHER MISC PAYROLL PAYABLE	3,018.24	2,432.59
ACCRUED VACATION TIME	31,071.54	35,427.39
ACCRUED COMP TIME PAYABLE	9,626.36	5,489.20
ACCURED PAYROLL	12,627.22	11,008.59
ACCRUED SICK TIME	38,030.00	41,733.69
	805,238.73	128,288.71
<u>FUND EQUITY</u>		
NET INVEST IN CAPITAL ASSETS	9,649,202.00	9,343,905.00
RESTRICTED FOR DEBT SERVICE	102,753.00	.00
UNRESTRICTED NET POSITION	4,172,663.06	3,585,330.82
REVENUE OVER EXPENDITURES - YTD	12,483.18	91,369.34
	13,937,101.24	13,020,605.16
TOTAL FUND EQUITY	13,937,101.24	13,020,605.16
TOTAL LIABILITIES AND EQUITY	14,742,339.97	13,148,893.87

Exhibit "B"
BEATRICE BOARD OF PUBLIC WORKS
OPERATING STATEMENT
FOR THE 2 MONTHS ENDING NOVEMBER 30, 2025

WPC

	PERIOD ACTUAL	YTD ACTUAL	BUDGET	UNEARNED	PCNT	PREV YEAR YTD
OPERATING REVENUE						
RESIDENTIAL SALES	118,180.15	236,433.75	(1,396,000.00)	(1,632,433.75)	16.9	232,652.97
COMMERCIAL SALES	13,376.75	102,870.75	(680,000.00)	(782,870.75)	15.1	111,636.20
INFRASTRUCTURE FEE	39,565.00	79,105.00	(470,000.00)	(549,105.00)	16.8	56,761.00
TOTAL OPERATING REVENUE	171,121.90	418,409.50	(2,546,000.00)	(2,964,409.50)	16.4	401,050.17
OPERATING EXPENSE						
OPERATION & MAINTENANCE	(73,198.77)	(180,091.94)	(875,812.00)	(695,720.06)	(20.6)	(154,175.78)
ACCOUNTING & COLLECTING	(6,400.10)	(22,904.16)	(93,519.00)	(70,614.84)	(24.5)	(17,242.67)
METER READING	(1,092.51)	(2,226.42)	(13,151.00)	(10,924.58)	(16.9)	(2,569.60)
ENGINEERING DEPARTMENT	(3,903.00)	(7,806.00)	(46,837.00)	(39,031.00)	(16.7)	(6,706.00)
ADMINISTRATIVE	(19,976.60)	(40,057.69)	(240,211.00)	(200,153.31)	(16.7)	(13,714.40)
GENERAL	(28,097.94)	(56,569.66)	(366,575.00)	(310,005.34)	(15.4)	(44,600.54)
VEHICLE & EQUIPMENT EXPENSES	(3,604.50)	(11,493.67)	(65,000.00)	(53,506.33)	(17.7)	(4,917.21)
DEPRECIATION	(59,397.17)	(118,926.17)	(640,000.00)	(521,073.83)	(18.6)	(100,590.38)
TOTAL OPERATING EXPENSES	(195,670.59)	(440,075.71)	(2,341,105.00)	(1,901,029.29)	(18.8)	(344,516.58)
NET OPERATING REVENUE	(24,548.69)	(21,666.21)	(4,887,105.00)	(4,865,438.79)	(.4)	56,533.59
OTHER INCOME (EXPENSES)						
MISCELLANEOUS INCOME	9,426.20	15,843.61	(68,000.00)	(83,843.61)	23.3	19,952.07
INTEREST INCOME	10,061.03	21,561.98	(100,000.00)	(121,561.98)	21.6	24,460.30
RESTRICTED INTEREST INCOME	323.51	672.16	(4,000.00)	(4,672.16)	16.8	969.59
GRANT INCOME	.00	.00	(2,000,000.00)	(2,000,000.00)	.0	.00
OTHER INCOME	490.00	840.00	(1,000.00)	(1,840.00)	84.0	980.00
INTEREST EXPENSES	.00	.00	(111,055.00)	(111,055.00)	.0	.00
MUNICIPAL EXPENSE	(2,513.36)	(4,768.36)	(30,500.00)	(25,731.64)	(15.6)	(11,526.21)
NET NONOPERATING INCOME (EXPENSE)	17,787.38	34,149.39	(2,314,555.00)	(2,348,704.39)	1.5	34,835.75
TOTAL NET INCOME (LOSS)	(6,761.31)	12,483.18	(7,201,660.00)	(7,214,143.18)	.2	91,369.34

Exhibit "B"
 CITY OF BEATRICE
 BALANCE SHEET
 NOVEMBER 30, 2025

STREET FUND

ASSETS

03-00-100-00	CASH - COMBINED CASH FUND	3,664,533.81	
03-00-101-03	CASH-HIGHWAY ALLOC DEBT RESV	51,880.00	
03-00-103-01	CASH-BOND FUNDS	1,061,486.25	
03-00-120-00	ACCOUNTS RECEIVABLE	76,310.31	
03-00-128-00	DUE FROM OTHER FUND	447,769.65	
03-00-129-00	DUE FROM OTHER GOVERNMENTS	304,926.44	
03-00-130-00	DUE FROM SPEC ASSESS FUND	49,626.00	
	TOTAL ASSETS		5,656,532.46

LIABILITIES AND EQUITY

LIABILITIES

03-00-201-00	ACCOUNTS PAYABLE	99,137.60	
03-00-202-01	SALARIES & WAGES PAYABLE	15,208.97	
03-00-202-02	TAXES PAYABLE	5,561.06	
03-00-202-03	MISC PAYROLL PAYABLE	3,629.09	
03-00-215-00	ACCRUED INTEREST PAYABLE	34,585.00	
03-00-231-00	BONDS PAYABLE-L.T.	2,600,000.00	
	TOTAL LIABILITIES		2,758,121.72

FUND EQUITY

03-00-250-01	DESIGNATED FOR STREETS	2,312,581.07	
	UNAPPROPRIATED FUND BALANCE:		
	REVENUE OVER (UNDER) EXPENDITURES - YTD	(212,173.84)	
	BALANCE - CURRENT DATE	(212,173.84)	
	TOTAL FUND EQUITY		2,100,407.23
	TOTAL LIABILITIES AND EQUITY		4,858,528.95

Exhibit "B"
CITY OF BEATRICE
REVENUES WITH COMPARISON TO BUDGET
FOR THE 2 MONTHS ENDING NOVEMBER 30, 2025

STREET FUND

	PERIOD ACTUAL	YTD ACTUAL	BUDGET	UNEARNED	PCNT
<u>SALES TAX</u>					
03-20-313-01 SALES TAX (30%OF1%)LESS MV	20,000.00	34,334.33	250,000.00	215,665.67	13.7
03-20-313-02 SALES TAX ON MOTOR VEHICLES	60,000.00	113,670.92	630,000.00	516,329.08	18.0
TOTAL SALES TAX	80,000.00	148,005.25	880,000.00	731,994.75	16.8
<u>STATE AGENCY AID</u>					
03-20-332-01 HIGHWAY ALLOCATION,INCEN PMT	156,921.19	310,962.00	1,845,514.00	1,534,552.00	16.9
03-20-332-02 STATE MAINTENANCE CONTRACT	.00	.00	65,898.00	65,898.00	.0
03-20-332-05 STATE PROJECT FUNDING	.00	.00	280,000.00	280,000.00	.0
03-20-332-06 MOTOR VEHICLE FEE PMT	.00	.00	125,000.00	125,000.00	.0
TOTAL STATE AGENCY AIDL	156,921.19	310,962.00	2,316,412.00	2,005,450.00	13.4
<u>FEDERAL AGENCY AID</u>					
03-20-334-01 FEDERAL GRANTS	.00	170,644.67	500,000.00	329,355.33	34.1
TOTAL FEDERAL AGENCY AID	.00	170,644.67	500,000.00	329,355.33	34.1
<u>STREET FEES</u>					
03-20-349-00 STREET CHARGES FOR SERVICES	(2,300.81)	2,300.81	8,000.00	5,699.19	28.8
03-20-349-02 STREET SALES	.00	150.00	500.00	350.00	30.0
03-20-349-03 STREET REIMBURSEMENTS	1,608.00	3,491.80	24,000.00	20,508.20	14.6
TOTAL STREET FEES	(692.81)	5,942.61	32,500.00	26,557.39	18.3
<u>INTEREST EARNINGS</u>					
03-20-361-01 INTEREST EARNING - HWY ALL BND	4,881.44	13,670.14	.00	(13,670.14)	.0
TOTAL INTEREST EARNINGS	4,881.44	13,670.14	.00	(13,670.14)	.0
<u>DONATIONS</u>					
03-20-367-01 PRIVATE FUNDING	.00	74,009.50	.00	(74,009.50)	.0
TOTAL DONATIONS	.00	74,009.50	.00	(74,009.50)	.0
TOTAL FUND REVENUE	241,109.82	723,234.17	3,728,912.00	3,005,677.83	19.4

Exhibit "B"
CITY OF BEATRICE
EXPENDITURES WITH COMPARISON TO BUDGET
FOR THE 2 MONTHS ENDING NOVEMBER 30, 2025

STREET FUND

	PERIOD ACTUAL	YTD ACTUAL	BUDGET	UNEXPENDED	PCNT
<u>STREET FUND</u>					
03-20-411-01 SALARIES (MAINT)	43,226.65	93,319.10	549,237.00	455,917.90	17.0
03-20-411-02 SALARIES (OVERTIME)	.00	281.33	12,765.00	12,483.67	2.2
03-20-411-03 SALARIES (PART-TIME)	.00	.00	17,500.00	17,500.00	.0
03-20-411-06 SALARIES(BPW SNOW/OTHER MAINT)	.00	.00	2,000.00	2,000.00	.0
03-20-411-07 SALARIES (LEGAL/CITY)	827.00	1,654.00	11,677.00	10,023.00	14.2
03-20-411-10 SALARIES (BPW ENGINEERING)	5,612.00	11,224.00	67,349.00	56,125.00	16.7
03-20-411-20 SALARIES (CITY-MGR SERVICES)	1,776.00	3,552.00	21,306.00	17,754.00	16.7
03-20-412-01 SOCIAL SECURITY	3,168.61	6,823.31	45,507.00	38,683.69	15.0
03-20-413-01 RETIREMENT	2,360.44	5,013.66	32,817.00	27,803.34	15.3
03-20-414-01 HEALTH & LIFE INSURANCE	25,225.00	50,425.00	293,664.00	243,239.00	17.2
03-20-415-01 WORKERS' COMPENSATION	.00	.00	54,218.00	54,218.00	.0
03-20-421-01 INSURANCE	.00	138.00	34,287.00	34,149.00	.4
03-20-422-60 INFO. TECH. SERVICES	7,192.00	14,384.00	86,303.00	71,919.00	16.7
03-20-424-01 BUILDING MAINT./REPAIRS	.00	65.00	2,500.00	2,435.00	2.6
03-20-424-02 EQUIP OTHER & RADIO REPAIR	.00	.00	1,000.00	1,000.00	.0
03-20-424-03 ROAD EQUIP REP/MAINT (LABOR)	11,964.53	15,970.78	45,000.00	29,029.22	35.5
03-20-425-01 BUILDING RENTALS (SHOP-BPW)	250.00	500.00	3,000.00	2,500.00	16.7
03-20-425-04 EQUIPMENT RENTALS	.00	.00	8,000.00	8,000.00	.0
03-20-425-05 SOFTWARE MAINTENANCE	.00	.00	5,800.00	5,800.00	.0
03-20-425-06 WEED SPRAYING/TREE TRIMMING	465.00	465.00	4,750.00	4,285.00	9.8
03-20-426-01 TRAINING/TRAVEL EXPENSES	50.00	50.00	4,000.00	3,950.00	1.3
03-20-427-01 TELEPHONE	50.00	125.00	.00	(125.00)	.0
03-20-429-04 BAD DEBT EXPENSE	.00	.00	200.00	200.00	.0
03-20-429-05 OTHER SERV & CHGS (MS4)	8,677.50	8,677.50	35,000.00	26,322.50	24.8
03-20-429-06 OTHER SERV & CHGS (SPC FEES)	20,085.13	20,184.08	45,000.00	24,815.92	44.9
03-20-432-01 GAS & OIL	2,575.99	2,600.98	58,000.00	55,399.02	4.5
03-20-432-02 UNIFORMS	387.07	412.06	3,000.00	2,587.94	13.7
03-20-432-04 CHEMICALS	49.98	49.98	10,000.00	9,950.02	.5
03-20-432-09 TRAFFIC CONTROL	.00	.00	25,000.00	25,000.00	.0
03-20-432-13 SHOP/JANITORIAL/OSHA SUPPLIES	405.56	1,174.17	8,500.00	7,325.83	13.8
03-20-433-02 ROAD EQ MNT TIRES/BROOMS/BLADE	10,086.00	10,086.00	30,000.00	19,914.00	33.6
03-20-433-03 ROAD EQUIP REPAIRS (PARTS)	12,212.39	17,445.00	55,000.00	37,555.00	31.7
03-20-433-05 ROAD IMP MATERIALS (IN-HOUSE)	.00	8,785.72	125,000.00	116,214.28	7.0
03-20-433-06 ROAD MATERIALS ICE CONTROL	13,177.92	13,899.80	75,000.00	61,100.20	18.5
03-20-434-01 SMALL TOOLS & MINOR EQ	1,630.95	2,448.66	3,500.00	1,051.34	70.0
03-20-443-01 STREET IMP/ARMORCOAT/REJUVINAT	.00	.00	65,000.00	65,000.00	.0
03-20-443-06 STREET IMP/MISC CONC REPAIR	6,716.23	20,649.52	150,000.00	129,350.48	13.8
03-20-443-12 STREET IMP/HIGHWAY PROJECTS	.00	.00	500,000.00	500,000.00	.0
03-20-443-15 STREET IMP - DT BEAUTIFICATION	.00	(5,696.70)	.00	5,696.70	.0
03-20-443-20 STREET IMP/RECONSTRUCTION	1,038.75	1,038.75	375,000.00	373,961.25	.3
03-20-443-21 STREET IMP/NEW STREETS	471,964.17	577,785.29	1,496,631.00	918,845.71	38.6
03-20-443-24 STREET IMP/STORM SEWER RECONC	.00	.00	50,000.00	50,000.00	.0
03-20-444-01 MACHINERY & EQUIPMENT	.00	.00	514,000.00	514,000.00	.0
03-20-451-01 CONTINGENCY	.00	.00	100,000.00	100,000.00	.0
03-20-471-01 PRINCIPAL-HWY ALLOC SERIES 25	.00	.00	109,165.00	109,165.00	.0
03-20-472-01 INTEREST-HWY ALLOC SERIES 25	51,877.02	51,877.02	.00	(51,877.02)	.0
TOTAL STREET FUND	703,051.89	935,408.01	5,135,676.00	4,200,267.99	18.2

Exhibit "B"
 CITY OF BEATRICE
 EXPENDITURES WITH COMPARISON TO BUDGET
 FOR THE 2 MONTHS ENDING NOVEMBER 30, 2025

STREET FUND

	<u>PERIOD ACTUAL</u>	<u>YTD ACTUAL</u>	<u>BUDGET</u>	<u>UNEXPENDED</u>	<u>PCNT</u>
TOTAL FUND EXPENDITURES	703,051.89	935,408.01	5,135,676.00	4,200,267.99	18.2
NET REVENUE OVER(UNDER)EXPENDITURE	(461,942.07)	(212,173.84)	(1,406,764.00)	(1,194,590.16)	(15.1)

Exhibit "C"
CODE VIOLATIONS SUMMARY

	Year-to-Date
No Violation Found	8
Referred to BPD	2
Referred to Other City Department	2
Closed Cases	1,001

Current Open Cases	72
Current Pending Cases	17

PENDING CASES

Case #	Date Opened	Violation	Location
20250074	2/26/2025	Code	903 Pleasant Street
20250181	4/17/2025	Zoning	421 N 13th Street
20250231	4/28/2025	Code	2403 Scott Street
20250456	6/2/2025	JMV	1011 W Court Street
20250497	6/5/2025	JMV	1526 Market Street
20250484	6/5/2025	Code	1701 Lincoln Street
20250505	6/9/2025	Zoning	1708 N 11th Street
20250768	8/13/2025	Zoning	709 S 25th Street
20250802	8/21/2025	Code	1226 S 7th Street
20250848	9/3/2025	JMV	1723 High Street
20250904	9/18/2025	JMV	1014 Scott Street
20250907	9/19/2025	JMV	601 N 9th Street
20250915	9/22/2025		813 N 13th Street
20250953	10/10/2025	JMV	410 Grant Street
20250959	10/13/2025	Code	1800 Grant Street
20251014	11/4/2025	JMV	1008 Elk Street
20251054	12/4/2025	Zoning	102 W Park Street

Exhibit "C"
OPEN CASES

Case #	Date Opened	Violation	Location
20250170	4/9/2025	JMV	411 N 9th Street
20250211	4/23/2025	Code	910 Garden Street
20250210	4/23/2025	JMV	910 Garden Street
20250207	4/23/2025	JMV	910 Garden Street
20250206	4/23/2025	JMV	910 Garden Street
20250205	4/23/2025	JMV	910 Garden Street
20250204	4/23/2025	Code	900 Garden Street
20250203	4/23/2025	JMV	900 Garden Street
20250347	5/12/2025	JMV	1022 Scott Street
20250346	5/12/2025	Code	1022 Scott Street
20250390	5/19/2025	Zoning	1215 N 13th Street
20250408	5/21/2025	JMV	418 S 11th Street
20250517	6/10/2025	JMV	817 Elk Street
20250516	6/10/2025	JMV	817 Elk Street
20250535	6/13/2025	Code	3345 W US Highway 136
20250562	6/17/2025	JMV	322 Eastridge Street
20250640	7/10/2025	Dilapidated	403 Thayer Street
20250654	7/14/2025	JMV	1613 E Court Street
20250735	7/31/2025	JMV	721 S 9th Street
20250780	8/15/2025	Code	420 W Irving Street
20250779	8/15/2025	JMV	420 W Irving Street
20250843	9/2/2025	Dilapidated	1115 S 3rd Avenue
20250858	9/4/2025	JMV	823 Ella Street
20250873	9/8/2025	Code	323 PENNER
20250911	9/22/2025	JMV	1705 Woodland Avenue
20250919	9/23/2025	Code	922 Bell Street
20250921	9/24/2025	Dilapidated	922 Bell Street
20250923	9/25/2025	JMV	1301 Court Street
20250949	10/9/2025	Code	
20250957	10/13/2025	JMV	1222 S 6th Street
20250967	10/15/2025	JMV	1720 Garfield Street
20250975	10/16/2025	JMV	1323 May Street
20250974	10/16/2025	JMV	814 Bell Street
20250987	10/22/2025	JMV	916 Ella Street
20250984	10/22/2025	Code	1006 Ella Street
20250991	10/23/2025	Code	1320 N 7th Street

OPEN CASES

Case #	Date Opened	Violation	Location
20250988	10/23/2025	JMV	916 Ella Street
20251003	10/31/2025	Code	1923 S 4th Avenue
20251009	11/4/2025	Code	216 Cedar Street
20251019	11/10/2025	Code	1123 Ella Street
20251020	11/12/2025	Zoning	1723 High Street
20251045	11/26/2025	JMV	917 N 5th Street
20251044	11/26/2025	JMV	609 N 5th Street
20251043	11/26/2025	JMV	1212 Elk Street
20251042	11/26/2025	Code	1300 High Street
20251049	12/2/2025	JMV	905 S 7th Street
20251048	12/2/2025	Code	425 S 7th Street
20251046	12/2/2025	Code	2111 Arapahoe Trail
20251051	12/3/2025	Code	1511 Grant Street
20251056	12/4/2025	JMV	207 Lasalle Street
20251055	12/4/2025	JMV	207 Lasalle Street
20251064	12/8/2025	Code	684 W Court Street
20251063	12/8/2025	Code	688 W Court Street
20251066	12/9/2025	JMV	636 W Court Street
20251079	12/10/2025	Code	1217 S 8th Street
20251078	12/10/2025	JMV	00600 S 8TH
20251077	12/10/2025	Code	1301 Court Street
20251074	12/10/2025	Code	817 Elk Street
20251073	12/10/2025	Code	1344 MARKET
20251072	12/10/2025	Code	1008 Elk Street
20251071	12/10/2025	JMV	1008 Elk Street
20251070	12/10/2025	JMV	1008 Elk Street
20251069	12/10/2025	JMV	1008 Elk Street
20251068	12/10/2025	JMV	1008 Elk Street
20251087	12/15/2025	Code	1722 Lincoln Boulevard
20251090	12/16/2025	JMV	1409 N 10th Street
20251089	12/16/2025	JMV	722 Millikin Avenue
20251088	12/16/2025	Code	722 Millikin Avenue
20251096	12/17/2025	JMV	916 Ella Street
20251097	12/19/2025	Code	911 N 6th Street
20251101	12/22/2025	Code	1220 S 7th Street
20251091	12/23/2025	Code	823 N 5th Street

MONTHLY CASE REPORT
TOTAL CASES WORKED IN DECEMBER 2025: 56

CLOSED: 17

Case #	Date Opened	Violation	Location
20251047	12/2/2025	Code	914 S 8th Street
20251050	12/3/2025	Code	600 Nicholls Avenue
20251052	12/3/2025	Code	305 N 7th Street
20251053	12/4/2025	Code	
20251058	12/4/2025	Code	319 S 10th Street
20251059	12/5/2025	Code	
20251060	12/8/2025	Code	610 N 9th Street
20251061	12/8/2025	Code	1410 Scott Street
20251062	12/8/2025	Code	1211 N 10th Street
20251065	12/9/2025	Code	820 N 5th Street
20251067	12/9/2025	Code	310 Thayer Street
20251075	12/10/2025	Temp Sign	19th & Dorsey
20251081	12/10/2025	Code	729 - 745 W Mary Street
20251082	12/11/2025	Code	1313 Jefferson Street
20251084	12/15/2025	JMV	426 N 13th Street
20251093	12/16/2025	Code	818 N 4th Street
20251094	12/16/2025	Code	615-617 N 17th Street

OPEN: 38

Case #	Date Opened	Violation	Location
20251046	12/2/2025	Code	2111 Arapahoe Trail
20251048	12/2/2025	Code	425 S 7th Street
20251049	12/2/2025	JMV	905 S 7th Street
20251051	12/3/2025	Code	1511 Grant Street
20251055	12/4/2025	JMV	207 Lasalle Street
20251056	12/4/2025	JMV	207 Lasalle Street
20251057	12/4/2025	JMV	121 N Lasalle Street
20251063	12/8/2025	Code	688 W Court Street
20251064	12/8/2025	Code	684 W Court Street
20251066	12/9/2025	JMV	636 W Court Street
20251068	12/10/2025	JMV	1008 Elk Street
20251069	12/10/2025	JMV	1008 Elk Street
20251070	12/10/2025	JMV	1008 Elk Street

Exhibit "C"

20251071	12/10/2025	JMV	1008 Elk Street
20251072	12/10/2025	Code	1008 Elk Street
20251073	12/10/2025	Code	1344 MARKET
20251074	12/10/2025	Code	817 Elk Street
20251076	12/17/2025	Code	210 N 9th Street
20251077	12/10/2025	Code	1301 Court Street
20251078	12/10/2025	JMV	00600 S 8TH
20251079	12/10/2025	Code	1217 S 8th Street
20251080	12/10/2025	Code	1212 S 7th Street
20251083	12/11/2025	JMV	418 N 13th Street
20251085	12/15/2025	Code	418 N 13th Street
20251086	12/15/2025	Code	823 Ella Street
20251087	12/15/2025	JMV	1722 Lincoln Boulevard
20251088	12/16/2025	Code	722 Millikin Avenue
20251089	12/16/2025	JMV	722 Millikin Avenue
20251090	12/16/2025	JMV	1409 N 10th Street
20251091	12/23/2025	Code	823 N 5th Street
20251092	12/16/2025	Code	1611 N 19th Street
20251095	12/16/2025	Illegal Dump/Debris	1112 Pelham Avenue
20251096	12/17/2025	JMV	916 Ella Street
20251097	12/19/2025	Code	911 N 6th Street
20251098	12/19/2025	Code	738 W Mary Street
20251099	12/19/2025	Code	120 Logan Street
20251100	12/19/2025	Code	811 Elk Street
20251101	12/22/2025	Code	1220 S 7th Street

PENDING: 1

Case #	Date Opened	Violation	Location
20251054	12/4/2025	Zoning	102 W Park Street

PERMIT SUMMARY REPORT

	December 2025	December 2024	Current Year-to-Date 2025	Last Year-to-Date 2024
Administrative Setback Adjustment (Zoning)				
Count	0	1	3	2
Fees Paid	\$ -	\$ 50.00	\$ 100.00	\$ 100.00
Administrative Subdivision Application (Zoning)				
Count	1	0	6	5
Fees Paid	\$ 124.00	\$ -	\$ 742.00	\$ 500.00
Appeals Application				
Count	0	0	0	0
Fees Paid	\$ -	\$ -	\$ -	\$ -
Building Permit Application				
Count	10	17	309	365
Fees Paid	\$ 4,278.77	\$ 3,753.03	\$ 152,744.59	\$ 140,104.13
Change of Occupancy				
Count	1	0	1	0
Fees Paid	\$ 100.00	\$ -	\$ 100.00	\$ -
Demolition Permit Application				
Count	0	1	21	12
Fees Paid	\$ -	\$ 5.00	\$ 90.00	\$ 35.00
Encroachment Permit Application				
Count	0	1	44	68
Fees Paid	\$ -	\$ -	\$ 1,155.00	\$ 2,010.00
Final Plat Application (Zoning)				
Count	0	0	6	3
Fees Paid	\$ -	\$ -	\$ 524.00	\$ 530.00
Flood District Development Permit				
Count	0	0	3	0
Fees Paid	\$ -	\$ -	\$ -	\$ -
Hobbyist Vehicle Permit				
Count	0	0	0	0
Fees Paid	\$ -	\$ -	\$ -	\$ -
Inquiry				
Count	2	1	13	2
Fees Paid	\$ -	\$ -	\$ -	\$ -
Mechanical Permit Application				
Count	0	0	20	14
Fees Paid	\$ -	\$ -	\$ 2,370.00	\$ 540.00
Moving Permit Application				
Count	0	0	3	3
Fees Paid	\$ -	\$ -	\$ 300.00	\$ 300.00
Mow-to-Own				
Count	0	0	0	0
Fees Paid	\$ -	\$ -	\$ -	\$ -
Plumber Registration				
Count	0	5	54	10
Fees Paid	\$ -	\$ 225.00	\$ 1,157.00	\$ 410.00
Plumbing Permit Application				
Count	3	5	35	28
Fees Paid	\$ 80.00	\$ 1,842.00	\$ 3,898.00	\$ 4,200.00
Preliminary Plat Application				
Count	0	0	0	0
Fees Paid	\$ -	\$ -	\$ -	\$ -
Racecar Permit				
Count	0	0	0	0
Fees Paid	\$ -	\$ -	\$ -	\$ -
Re-Zoning Application				
Count	0	0	4	3
Fees Paid	\$ -	\$ -	\$ 400.00	\$ 300.00
Sign Permit Application				
Count	1	3	21	13
Fees Paid	\$ 75.00	\$ 225.00	\$ 1,575.00	\$ 975.00

PERMIT SUMMARY REPORT

	December 2025	December 2024	Current Year-to-Date 2025	Last Year-to-Date 2024
Special Use Permit (Zoning)				
Count	0	1	8	7
Fees Paid	\$ -	\$ 122.00	\$ 880.00	\$ 644.00
Vacate Public Ways				
Count	0	0	0	0
Fees Paid	\$ -	\$ -	\$ -	\$ -
Water Tap				
Count	0	0	0	0
Fees Paid	\$ -	\$ -	\$ -	\$ -
Zoning Verification				
Count	0	0	1	0
Fees Paid	\$ -	\$ -	\$ 100.00	\$ -
Voided Permits	0	2	8	16
TOTAL COUNT	17	37	560	551
TOTAL FEES PAID	\$ 4,657.77	\$ 6,222.03	\$ 166,135.59	\$ 150,648.13

MONTHLY BUILDING PERMIT APPLICATIONS
12/1/25 to 12/31/25

Permit #	Permit Date	Description	Owner Name	Parcel Address	Parcel #	Total Fees	Total Valuation	Primary Contractor
20250554	12/23/2025	New foundation	David & Sandra Sherwood	1705 Market	013627000	\$421.55	28,000.00	Brown's Masonry, LLC
20250553	12/23/2025	Replace south wall	Rodney & Elizabeth Hartig Nespor-	212 N 12th Street	009489000	\$237.25	14,000.00	Brown's Masonry, LLC
20250549	12/18/2025	Wall Support	Sandra Nickel	325 South 23rd Street	012635000	\$123.30	5,861.02	Thrasher Group
20250545	12/12/2025	Garage	Jolen Kay Rusell, Trustee	1209 Jane Way	011139000	\$335.25	21,000.00	Brett Wells Construction
20250544	12/11/2025	Fence 6' Cedarwood	Trevor Dean & Erin Leigh Chadwick	1923 Ella Street	015132000		4,000.00	
20250542	12/8/2025	Convert bank to convenience store.	Batis Dev-Beatrice, LLC	200 S 6th Street	009571000	\$1,833.75	250,000.00	Mercury Builders
20250540	12/8/2025	Roofing	Anita Meyers	1010 North14Tth	010731000	\$75.00	7,100.00	
20250538	12/4/2025	Ramp Enclosure	Hybrid Turkeys LLC	520 Tegtmeier Lane	012360800	\$685.42	55,953.00	We Design
20250537	12/2/2025	Antenna Modifications	Co Of Amer %~Gordon Lapp701 E 22Ne Natural Gas Pipeline		013459100	\$492.25	35,000.00	TBD

DEMOLITION PROJECTS

The dilapidated structures process starts with compiling evidence and continues until the structure is demolished. This process is essentially a 16-step process with various timelines/deadlines that have to be adhered too. The following information will provide will give you a better understanding of where we are with removing dilapidated structures:

	Address	Status	Notes
1	820 Market Street	City to demo/held up	Condemned by City. Ready for demo.
2	1617 Court Street	Owner to Demo	Dilapidated garage
3	517 S 10th Street	Owner to Demo	Demo garage
4	321 N 20th Street	Owner to Demo	Demo garage
5	424 N 17th	Owner to Demo	Demo Garage
6	1013 Court Street	Owner to Demo	Demo house
7	1115 S 3rd	Pending	City condemned property. Unfit and unsafe for human habitation
8	903 Grant Street	Owner to Demo	Small garage

DEMO PROCESS:

Receive complaint

Compile evidence

- 1 Send owner intent letter and inspection request
- 2 Owner responds and will comply – Monitor progress
- 3 Obtain Inspection Warrant
- 4 Serve Inspection Warrant
- 5 Order title search
- 6 Condemn property
- 7 Notice and Order all with legal interest
- 8 Disconnect BPW utilities
- 9 Prepare Affidavit of Service
- 10 File Certificate of Substandard Building
- 11 Schedule appeals hearings (if necessary)
- 12 Obtain demolition quotes
- 13 Have local utilities shut off
- 14 Demolition

SPECIAL DESIGNATED LICENSES (SDLs) REQUESTED IN 2025

Name	Date of Event	Location of Event	Date Approved	By
Tall Tree Tastings	2/14/2025	Kala's Savory Bites & Sifted Sweets	1/9/2025	ES
Community Players, Inc.	2/14, 2/21, 4/4, 4/11	Community Players Theatre	1/6/2025	ES
Stone Hollow Brewing Co, LLC	2/14, 2/15 & 2/16	Envision Landscapes Garden Center	1/24/2025	ES
Knights of Columbus, Council #1723	3/7/2025	St Joseph Parish Center	2/5/2025	ES
Knights of Columbus, Council #1723	3/14/2025	St Joseph Parish Center	2/5/2025	ES
Knights of Columbus, Council #1723	3/21/2025	St Joseph Parish Center	2/5/2025	ES
Knights of Columbus, Council #1723	3/28/2025	St Joseph Parish Center	2/5/2025	ES
Knights of Columbus, Council #1723	4/4/2025	St Joseph Parish Center	2/5/2025	ES
Knights of Columbus, Council #1723	4/11/2025	St Joseph Parish Center	2/5/2025	ES
American Legion Biting-Norman Post #27	6/13/2025	Charles Park	3/26/2025	ES
Tall Tree Tastings	4/30/2025	Beatrice Public Library	4/8/2025	ES
Main Street Beatrice	5/3/2025	Envision Landscapes Garden Center	4/15/2025	ES
Code Beer Company	5/3/2025	Envision Landscapes Garden Center	4/15/2025	ES
Corn Coast Brewing	5/3/2025	Envision Landscapes Garden Center	4/15/2025	ES
Deer Springs Winery	5/3/2025	Envision Landscapes Garden Center	4/15/2025	ES
Rich Harvest Vinyard & Winery	5/3/2025	Envision Landscapes Garden Center	4/15/2025	ES
Salt Mine City	5/3/2025	Envision Landscapes Garden Center	4/15/2025	ES
Sideshow Spirits	5/3/2025	Envision Landscapes Garden Center	4/15/2025	ES
Thunderhead Brewing Company	5/3/2025	Envision Landscapes Garden Center	4/15/2025	ES
Whiskey Run Creek Vineyard & Winery	5/3/2025	Envision Landscapes Garden Center	4/15/2025	ES
Stone Hollow Brewing Co, LLC	5/1 - 5/4/2025	Envision Landscapes Garden Center	5/1/2025	ES
Community Players, Inc.	6/5, 6/6, 6/13, 9/5 & 9/12	Community Players Theatre	4/18/2025	ES
Stone Hollow Brewing Co, LLC	5/25/2025	Merchantile Building	5/12/2025	ES
Good Liv'in LLC	6/11/2025	Sip N Spa - 205 North 19th Street	6/2/2025	CC
The Mechanical Room	6/21/2025	Merchantile Building	6/5/2025	ES
Colleen's Catering	6/21/2025	West Scott Ballfield	6/9/2025	ES
Good Liv'in LLC	7/19/2025	Sip N Spa - 205 North 19th Street	7/2/2025	ES
Tall Tree Tastings	8/13/2025	Gorgeous Hanger	7/17/2025	ES
Community Players, Inc.	10/24 & 10/25; 10/31 & 11/1	Community Players Theatre	8/6/2025	ES
American Legion Biting-Norman Post #27	10/18/2025	American Legion	8/6/2025	ES
Stone Hollow Brewing Co, LLC	9/27/2025	Merchantile Building	8/13/2025	ES
Micheal J's	9/27/2025	Micheal J's	9/2/2025	CC
Eagles Club	9/27 & 9/28	Eagles Club	9/10/2025	ES
Stone Hollow Brewing Co, LLC	10/18/2025	Merchantile Building	9/24/2025	ES
Tall Tree Tastings	11/10/2025	Starlight Candles & Gifts	10/13/2025	ES
Tall Tree Tastings	12/9/2025	Starlight Candles & Gifts	10/13/2025	ES
Stone Hollow Brewing Co, LLC	11/15/2025	Kala's Savory Bites & Sifted Sweets	10/28/2025	ES
Stone Hollow Brewing Co, LLC	12/4/2025	Swing 365 Golf	11/17/2025	CC