

Business Committee - Regular School Board Meeting

Duluth Public Schools, ISD 709

Agenda

Tuesday, September 19, 2017

District Services Center

709 Portia Johnson Dr.

Duluth, MN 55811

6:30 PM

1. Financial Report

- | | |
|---|-----------|
| A. <u>Financial Report</u> - Financial statements only (Cash Flow report will resume later this year) | <u>4</u> |
| B. <u>Approval of Payment of Claims</u> - Attached as an "extra" | |
| C. <u>Budget Revisions</u> | <u>17</u> |
| D. <u>Wire Transfers</u> | <u>19</u> |
| E. <u>Investment Transactions</u> | <u>20</u> |
| F. <u>APU Projections</u> - None (resumes in October) | |
| G. <u>Fundraisers</u> | <u>21</u> |

2. Bids, R.F.P.s and Quotes Reports

- | | |
|---|-----------|
| A. <u>Bids</u> - None | |
| B. <u>RFPs</u> - None | |
| C. <u>Quotes</u> | |
| 1) <u>Quote #4275 Annual District-Wide Painting Labor</u> | <u>22</u> |
| Quote #4275 was advertised according to statute and School Board Policy for services to be performed July 1, 2017 through June 30, 2018, with the option to renew for two (2) additional one-year periods if acceptable to both parties. Two (2) responses were received. | |

Recommendation: It is recommended that the Duluth School Board approve entering into a contract with Swanson & Youngdale, Inc. based on their low quote for services to be performed July 1, 2017 through June 30, 2018, with the option to renew for two (2) additional one-year periods if acceptable to both parties.

3. Policies and Regulations - None

4. Contracts, Change Orders, and Leases

- | | |
|--|-----------|
| A. <u>Contracts</u> | |
| 1) <u>Duluth Energy Systems (Duluth Steam - City of Duluth)</u> | <u>28</u> |
| This agreement was brought before the Duluth School Board in September, 2016. However, the agreement was in its draft form. This is the final agreement. | |

Recommendation: It is recommended that the Duluth School Board approve

entering into an agreement with Duluth Energy Systems to procure steam service for the Historic Old Central High School.

B. Change Orders

1) Change Order #2 for RFP #306 - Removal of Rubber Mulch from Playgrounds for SAS+ Associates Phase II - **POSTPONED DEFINITELY UNTIL OCTOBER BOARD MEETING** 67

RFP #306 – Phase II Removal of Rubber Mulch from Playgrounds was approved February 28, 2017, for a not to exceed fee of \$46,500.00. CO #1 was approved June 20, 2017, for a new contract total amount of \$55,950.00 as related to the re-bid process. However, once work began, it was quickly realized that there were many unknown conditions at all sites. Sites were not constructed as plans showed, and resulted in much more construction observation and design effort to “individualize” the specification and the plan to each site. This condition as well as the fact that this type of work has not been done before with no baseline for the consultant to base fee’s upon has led to the need for CO #2. Further details are attached as related to this change order from our consultant. Change order #2 to the RFP results in an increase of \$12,475.00, to the previously awarded base bid and CO #1 for a new not to exceed contract total of \$68,425.00.

Recommendation: It is recommended that the Duluth Public Schools approve the change order as listed pertaining RFP #306 - Removal of Rubber Mulch from Playgrounds. This change order adds \$12,475.00 to the previously awarded base bid plus CO#1 for a new contract sum of \$68,425.00.

2) **PLACEHOLDER - Other Change Orders**

C. Leases

1) **PLACEHOLDER - The Hills (formerly Woodland Hills) Lease**
 2) Great Lakes Office Solutions for a five (5) year lease for one (1) new color copier for the Print Shop 72

Quotes for a sixty month lease for one new Konica Minolta color copier were obtained from five vendors. The Print Shop and Purchasing departments analyzed the responses. The lease being recommended will include all lease costs, toner, on-site maintenance, parts, initial set-up, training and 25,000 prints per month for a total lease cost of \$72,068.40.

Recommendation: It is recommended that the Duluth School Board approve a lease agreement between ISD 709 and Great Lakes Office Solutions with terms as described and authorize the School Board Chair to sign the agreement.

5. Resolutions

A. B-9-17-3481 - Acceptance of Donations to Duluth Public Schools 78

Recommendation: It is recommended that the Duluth School Board approve Resolution B-9-17-3481.

B. B-9-17-3482 - Authorized Bank Account Signer 79

Recommendation: It is recommended that the Duluth School Board approve Resolution B-9-17-3482.

C. B-9-17-3483 - Maximum Levy Certification 80

Recommendation: It is recommended that the Duluth School Board approve Resolution B-9-17-3483.

D. B-9-17-3484 - Kraus-Anderson Construction and Rockridge School 81

Recommendation: It is recommended that the Duluth School Board approve Resolution B-9-17-3484.

E. PLACEHOLDER - Sale of Property

6. Informational - These items are provided for informational purposes only and no action is required.

A. Expenditure Contracts 82

Superintendent Gronseth or the CFO/Executive Director of Business has signed the following contracts during the month of August 2017.

B. Revenue Contracts 124

Superintendent Gronseth or the CFO/Executive Director of Business has signed the following contracts during the month of August 2017.

C. No Cost Contracts 143

Superintendent Gronseth or the CFO/Executive Director of Business has signed the following contracts during the month of August 2017.

D. Change Orders Signed - None

E. Facilities Management & Capital Project Status Report 160

F. Energy Consumption Update (in color on BoardBook) 162

G. Transition to Paperless Process using BoardBook 177

7. Future Items

A. Final Levy Approval (December)

B. FY 2016-17 Audit Results (December)

C. Policy Updates

STATEMENT OF REVENUES AND EXPENDITURES
 (IN THOUSANDS)

Revenues	CURRENT MONTH		YEAR-TO-DATE		ANNUAL BUDGET	
	FY2018	FY2017	FY2018	FY2017	Adopted	Revised
	\$	\$	\$	\$		
		Variance		Variance		
		%		%		
Levy	\$0	\$0	\$0	\$0	\$32,268	\$32,268
Interest	12	(3)	12	15	1,064	1,064
Tuition, Fees, Admissions	132	(1,358)	132	1,490	4,460	4,460
Other Local Revenues	200	147	200	52	1,672	1,673
State Sources	1,783	(255)	1,783	2,038	86,204	86,323
Federal Aids from MDE	60	(1,310)	60	1,370	8,120	8,120
Federal Direct Aids	-	0	-	-	2,954	2,954
Local Sales	1	1	1	0	2,001	2,001
Sale of Bonds or Loans	-	0	-	1	4,200	4,200
Total Revenues	2,188	(2,778)	2,188	4,966	142,942	143,062
Expenditures						
Salaries	1,019	(345)	1,019	674	61,501	61,565
Benefits	1,242	54	1,242	1,296	28,696	28,716
Purchased Services	298	(189)	298	109	15,191	15,123
Supplies & Materials	546	(513)	546	33	6,070	6,373
Chargebacks	-	0	-	-	179	179
Capital Expenditures	249	(239)	249	10	8,610	8,414
Debt Service	3,969	443	3,969	4,412	30,809	30,809
Other	36	4	36	39	897	893
Total Expenditures	7,359	(786)	7,359	6,573	151,953	152,073
Transfers In (Out)	0	0	0	0	0	0
Operating Excess (Deficit)	(5,171)	(\$1,608)	(5,171)	(\$1,608)	(\$9,011)	(\$9,011)

STATEMENT OF REVENUES AND EXPENDITURES
 (IN THOUSANDS)

Revenues	CURRENT MONTH		YEAR - TO - DATE		ANNUAL BUDGET	
	FY2018	FY2017	FY2018	FY2017	Adopted	Revised
	\$	\$	\$	\$		
		Variance	Variance	Variance		
		%	%	%		
Levy	\$0	\$0	N/A	\$0	\$9,906	\$9,906
Interest	12	15	(20.4)	15	50	50
Tuition, Fees, Admissions	13	1,386	(99.0)	1,386	2,294	2,294
Other Local Revenues	29	4	615.9	4	235	235
State Sources	1,399	1,771	(21.0)	1,771	74,260	74,378
Federal Aids from MDE	0	843	(100.0)	843	5,732	5,732
Federal Direct Aids	0	0	N/A	0	135	135
Local Sales	0	0	N/A	0	0	0
Sale of Bonds or Loans	0	0	N/A	0	0	0
Total Revenues	1,453	4,019	(63.8)	4,019	92,611	92,731
		(2,566)		(2,566)		
<u>Expenditures</u>						
Salaries	878	520	(68.9)	520	54,570	54,633
Benefits	1,103	1,087	(1.5)	1,087	24,327	24,348
Purchased Services	365	165	(121.0)	165	7,281	7,309
Supplies & Materials	248	26	(854.1)	26	2,158	2,304
Chargebacks	0	0	N/A	0	(296)	(296)
Capital Expenditures	0	0	N/A	0	345	210
Debt Service	0	0	N/A	0	0	0
Other	29	36	18.9	36	674	670
Total Expenditures	2,623	1,834	(43.0)	1,834	89,058	89,178
		(789)		(789)		
Transfers In (Out)	0	0	N/A	0	(3,371)	(3,371)
Operating Excess (Deficit)	(\$1,170)	\$2,185	(153.5)	\$2,185	\$182	\$182
		(3,355)		(\$3,355)		

STATEMENT OF REVENUES AND EXPENDITURES
 (IN THOUSANDS)

Revenues	CURRENT MONTH		YEAR-TO-DATE		ANNUAL BUDGET	
	FY2018	FY2017	FY2018	FY2017	Adopted	Revised
	\$	\$	\$	\$		
		Variance	Variance	Variance		
		%	%	%		
Levy	\$0	\$0	\$0	\$0	\$9,402	\$9,402
Interest	12	15	12	15	50	50
Tuition, Fees, Admissions	4	1,386	4	1,386	1,787	1,787
Other Local Revenues	5	4	5	4	235	235
State Sources	1,398	1,750	1,398	1,750	64,386	64,504
Federal Aids from MDE	0	0	0	0	0	0
Federal Direct Aids	0	0	0	0	0	0
Local Sales	0	0	0	0	0	0
Sale of Bonds or Loans	0	0	0	0	0	0
Total Revenues	1,418	3,155	1,418	3,155	75,859	75,978
Expenditures						
Salaries	812	391	812	391	44,932	44,996
Benefits	940	910	940	910	19,320	19,340
Purchased Services	363	143	363	143	6,560	6,588
Supplies & Materials	212	24	212	24	1,476	1,623
Chargebacks	0	0	0	0	(299)	(299)
Capital Expenditures	0	0	0	0	265	129
Debt Service	0	0	0	0	0	-
Other	28	36	28	36	52	47
Total Expenditures	2,356	1,504	2,356	1,504	72,306	72,425
Transfers In (Out)	0	0	0	0	(3,371)	(3,371)
Operating Excess (Deficit)	(\$937)	\$1,651	(\$937)	\$1,651	\$182	\$182

STATEMENT OF REVENUES AND EXPENDITURES
 (IN THOUSANDS)

Revenues	CURRENT MONTH			YEAR-TO-DATE			ANNUAL BUDGET	
	FY2018	FY2017	Variance	FY2018	FY2017	Variance	Adopted	Revised
	\$	\$	%	\$	\$	%		
Levy	\$0	\$0	N/A	\$0	\$0	N/A	\$504	\$504
Interest	0	0	N/A	0	0	N/A	0	0
Tuition, Fees, Admissions	10	0	N/A	10	0	N/A	507	507
Other Local Revenues	24	0	N/A	24	0	N/A	0	1
State Sources	2	21	(92.5)	2	21	(19)	9,874	9,874
Federal Aids from MDE	0	843	(100.0)	0	843	(843)	5,732	5,732
Federal Direct Aids	0	0	N/A	0	0	N/A	135	135
Local Sales	0	0	N/A	0	0	N/A	0	0
Sale of Bonds or Loans	0	0	N/A	0	0	N/A	0	0
Total Revenues	35	864	(95.9)	35	864	(829)	16,752	16,753
Expenditures								
Salaries	66	129	48.8	66	129	63	9,637	9,637
Benefits	163	177	8.0	163	177	14	5,007	5,007
Purchased Services	1	22	94.0	1	22	21	721	722
Supplies & Materials	36	2	(1,717.1)	36	2	(34)	682	681
Chargebacks	0	0	N/A	0	0	0	3	3
Capital Expenditures	0	0	N/A	0	0	0	80	80
Debt Service	0	0	N/A	0	0	0	0	0
Other	1	0	(1)	1	0	(1)	621	622
Total Expenditures	268	330	18.9	268	330	62	16,752	16,753
Transfers In (Out)	0	0	N/A	0	0	0	0	0
Operating Excess (Deficit)	(\$233)	534	(143.5)	(\$233)	\$534	(\$767)	\$0	\$0

STATEMENT OF REVENUES AND EXPENDITURES
 (IN THOUSANDS)

Revenues	CURRENT MONTH			YEAR - TO - DATE			ANNUAL BUDGET	
	\$		%	\$		%	Adopted	Revised
	FY2018	FY2017	Variance	FY2018	FY2017	Variance		
Levy	\$0	\$0	N/A	\$0	\$0	N/A	\$0	\$0
Interest	0	0	N/A	0	0	N/A	0	0
Tuition, Fees, Admissions	0	0	N/A	0	0	N/A	0	0
Other Local Revenues	1	0	83.5	1	0	83.5	6	6
State Sources	1	0	N/A	1	0	N/A	190	190
Federal Aids from MDE	60	61	(1.9)	60	61	(1.9)	2,371	2,371
Federal Direct Aids	0	0	N/A	0	0	N/A	0	0
Local Sales	1	0	4,433.3	1	0	4,433.3	1,204	1,204
Sale of Bonds or Loans	0	0	N/A	0	0	N/A	0	0
Total Revenues	62	61	1.6	62	61	1.6	3,771	3,771
Expenditures								
Salaries	27	27	1.4	27	27	1.4	1,205	1,205
Benefits	14	14	0.2	14	14	0.2	544	544
Purchased Services	0	0	N/A	0	0	N/A	86	86
Supplies & Materials	(0)	0	N/A	(0)	0	N/A	2,125	2,125
Chargebacks	0	0	N/A	0	0	N/A	168	168
Capital Expenditures	0	0	N/A	0	0	N/A	14	14
Debt Service	0	0	N/A	0	0	N/A	0	0
Other	0	0	N/A	0	0	N/A	15	15
Total Expenditures	41	41	1.2	41	41	1.2	4,156	4,156
Transfers In (Out)	0	0	N/A	0	0	N/A	0	0
Operating Excess (Deficit)	\$22	\$20	7.2	\$22	\$20	\$1	(\$385)	(\$385)

STATEMENT OF REVENUES AND EXPENDITURES
 (IN THOUSANDS)

Revenues	CURRENT MONTH			YEAR-TO-DATE			ANNUAL BUDGET	
	\$		%	\$		%	Adopted	Revised
	FY2018	FY2017	Variance	FY2018	FY2017	Variance		
Levy	\$0	\$0	N/A	\$0	\$0	N/A	\$0	\$0
Interest	0	0	N/A	0	0	N/A	0	0
Tuition, Fees, Admissions	0	0	N/A	0	0	N/A	0	0
Other Local Revenues	0	0	N/A	0	0	N/A	0	0
State Sources	88	104	(15.1)	88	104	(15.1)	6,018	6,018
Federal Aids from MDE	0	0	N/A	0	0	N/A	0	0
Federal Direct Aids	0	0	N/A	0	0	N/A	0	0
Local Sales	0	0	N/A	0	0	N/A	0	0
Sale of Bonds or Loans	0	0	N/A	0	0	N/A	0	0
Total Revenues	88	104	(15.1)	88	104	(15.1)	6,023	6,023
<u>Expenditures</u>								
Salaries	25	26	4.8	25	26	4.8	1,241	1,241
Benefits	22	22	(1.8)	22	22	(1.8)	900	900
Purchased Services	(110)	(80)	38.0	(110)	(80)	38.0	3,744	3,744
Supplies & Materials	6	0	N/A	6	0	N/A	348	348
Chargebacks	0	0	N/A	0	0	N/A	1	1
Capital Expenditures	183	0	N/A	183	0	N/A	231	231
Debt Service	0	0	N/A	0	0	N/A	0	0
Other	0	0	N/A	0	0	N/A	1	1
Total Expenditures	126	(32)	(493.0)	126	(32)	(493.0)	6,466	6,466
Transfers In (Out)	0	0	N/A	0	0	N/A	0	0
Operating Excess (Deficit)	(\$38)	\$136	(127.6)	(\$38)	\$136	(127.6)	(\$443)	(\$443)

STATEMENT OF REVENUES AND EXPENDITURES
 (IN THOUSANDS)

Revenues	CURRENT MONTH		YEAR-TO-DATE		ANNUAL BUDGET	
	FY2018	FY2017	FY2018	FY2017	Adopted	Revised
	\$	\$	\$	\$		
		Variance		Variance		
		%		%		
Levy	\$0	\$0	\$0	\$0	\$954	\$954
Interest	0	0	0	0	0	0
Tuition, Fees, Admissions	119	104	119	104	1,624	1,624
Other Local Revenues	1	1	1	1	146	146
State Sources	54	75	54	75	2,414	2,414
Federal Aids from MDE	0	0	0	0	17	17
Federal Direct Aids	0	0	0	0	1,934	1,934
Local Sales	0	0	0	0	0	0
Sale of Bonds or Loans	0	0	0	0	0	0
Total Revenues	174	180	174	180	7,089	7,089
		(6)		(6)		(3.4)
		%		%		
		(3.4)		(3.4)		
Expenditures						
Salaries	37	45	37	45	3,740	3,740
Benefits	74	69	74	69	1,645	1,645
Purchased Services	16	3	16	3	1,171	1,171
Supplies & Materials	9	7	9	7	291	291
Chargebacks	0	0	0	0	307	307
Capital Expenditures	0	10	0	10	5	5
Debt Service	0	0	0	0	0	0
Other	6	0	6	0	172	172
Total Expenditures	142	134	142	134	7,331	7,331
		(7)		(7)		(5.6)
		%		%		
		(5.6)		(5.6)		
Transfers In (Out)	0	0	0	0	0	N/A
		N/A				
Operating Excess (Deficit)	\$32	\$46	\$32	\$46	(\$242)	(\$242)
		(\$14)		(\$14)		(29.9)
		(29.9)		(29.9)		

STATEMENT OF REVENUES AND EXPENDITURES
 (IN THOUSANDS)

Revenues	CURRENT MONTH			YEAR-TO-DATE			ANNUAL BUDGET	
	FY2018	FY2017	Variance	FY2018	FY2017	Variance	Adopted	Revised
	\$	\$	%	\$	\$	%		
Levy	\$0	\$0	N/A	\$0	\$0	N/A	\$2,849	\$2,849
Interest	0	0	N/A	0	0	N/A	0	0
Tuition, Fees, Admissions	0	0	N/A	0	0	N/A	0	0
Other Local Revenues	6	1	539.0	6	1	539.0	17	17
State Sources	28	32	(13.4)	28	32	(13.4)	1,079	1,079
Federal Aids from MDE	0	0	N/A	0	0	N/A	0	0
Federal Direct Aids	0	0	N/A	0	0	N/A	0	0
Local Sales	0	0	N/A	0	0	N/A	0	0
Sale of Bonds or Loans	0	0	N/A	0	0	N/A	600	600
Total Revenues	34	33	3.3	34	33	3.3	4,545	4,545
Expenditures								
Salaries	52	51	(2.5)	52	51	(1)	745	745
Benefits	41	35	(16.3)	41	35	(6)	310	310
Purchased Services	23	16	(45.3)	23	16	(7)	1,832	1,736
Supplies & Materials	283	0	N/A	283	0	(283)	441	598
Chargebacks	0	0	N/A	0	0	0	0	0
Capital Expenditures	66	0	N/A	66	0	(66)	4,580	4,520
Debt Service	0	0	N/A	0	0	0	0	0
Other	1	3	79.2	1	3	2	8	8
Total Expenditures	466	105	(343.9)	466	105	(361)	7,916	7,916
Transfers In (Out)	0	0	N/A	0	0	0	3,371	3,371
Operating Excess (Deficit)	(\$432)	(\$72)	(500.0)	(\$432)	(\$72)	(\$360)	\$0	(\$0)

STATEMENT OF REVENUES AND EXPENDITURES
 (IN THOUSANDS)

Revenues	CURRENT MONTH			YEAR-TO-DATE			ANNUAL BUDGET	
	FY2018	FY2017	Variance	FY2018	FY2017	Variance	Adopted	Revised
	\$	\$	%	\$	\$	%		
Levy	\$0	\$0	N/A	\$0	\$0	N/A	\$18,559	\$18,559
Interest	0	0	N/A	0	0	N/A	1,000	1,000
Tuition, Fees, Admissions	0	0	N/A	0	0	N/A	0	0
Other Local Revenues	0	0	N/A	0	0	N/A	0	0
State Sources	213	56	281.0	213	56	281.0	2,242	2,242
Federal Aids from MDE	0	466	(100.0)	0	466	(100.0)	0	0
Federal Direct Aids	0	0	N/A	0	0	N/A	885	885
Local Sales	0	0	N/A	0	0	N/A	0	0
Sale of Bonds or Loans	0	0	N/A	0	0	N/A	0	0
Total Revenues	213	522	(59.1)	213	522	(59.1)	22,687	22,687
Expenditures								
Salaries	0	0	N/A	0	0	N/A	0	0
Benefits	0	0	N/A	0	0	N/A	0	0
Purchased Services	0	0	N/A	0	0	N/A	0	0
Supplies & Materials	0	0	N/A	0	0	N/A	0	0
Chargebacks	0	0	N/A	0	0	N/A	0	0
Capital Expenditures	0	0	N/A	0	0	N/A	0	0
Debt Service	3,969	4,412	10.0	3,969	4,412	10.0	30,809	30,809
Other	0	0	N/A	0	0	N/A	0	0
Total Expenditures	3,969	4,412	10.0	3,969	4,412	10.0	30,809	30,809
Transfers in (Out)	0	0	N/A	0	0	N/A	0	0
Operating Excess (Deficit)	(\$3,756)	(\$3,890)	3.5	(\$3,756)	(\$3,890)	3.5	(\$8,122)	(\$8,122)

STATEMENT OF REVENUES AND EXPENDITURES
 (IN THOUSANDS)

Revenues	CURRENT MONTH				YEAR - TO - DATE				ANNUAL BUDGET	
	\$		%		\$		%		Adopted	Revised
	FY2018	FY2017	Variance	Variance	FY2018	FY2017	Variance	Variance		
Levy	\$0	\$0	\$0	N/A	\$0	\$0	\$0	N/A	\$0	\$0
Interest	0	0	0	N/A	0	0	0	N/A	13	13
Tuition, Fees, Admissions	0	0	0	N/A	0	0	0	N/A	0	0
Other Local Revenues	0	0	0	N/A	0	0	0	N/A	200	200
State Sources	0	0	0	N/A	0	0	0	N/A	0	0
Federal Aids from MDE	0	0	0	N/A	0	0	0	N/A	0	0
Federal Direct Aids	0	0	0	N/A	0	0	0	N/A	0	0
Local Sales	0	0	0	N/A	0	0	0	N/A	0	0
Sale of Bonds or Loans	0	0	0	N/A	0	0	0	N/A	0	0
Total Revenues	0	0	0	N/A	0	0	0	N/A	213	213
<u>Expenditures</u>										
Salaries	0	0	0	N/A	0	0	0	N/A	0	0
Benefits	0	0	0	N/A	0	0	0	N/A	250	250
Purchased Services	0	0	0	N/A	0	0	0	N/A	0	0
Supplies & Materials	0	0	0	N/A	0	0	0	N/A	0	0
Chargebacks	0	0	0	N/A	0	0	0	N/A	0	0
Capital Expenditures	0	0	0	N/A	0	0	0	N/A	0	0
Debt Service	0	0	0	N/A	0	0	0	N/A	0	0
Other	0	0	0	N/A	0	0	0	N/A	0	0
Total Expenditures	0	0	0	N/A	0	0	0	N/A	250	250
Transfers In (Out)	0	0	0	N/A	0	0	0	N/A	0	0
Operating Excess (Deficit)	\$0	\$0	\$0	N/A	\$0	\$0	\$0	N/A	(\$37)	(\$37)

STATEMENT OF REVENUES AND EXPENDITURES
 (IN THOUSANDS)

Revenues	CURRENT MONTH			YEAR - TO - DATE			ANNUAL BUDGET			
	FY2018	FY2017	Variance	%	FY2018	FY2017	Variance	%	Adopted	Revised
	\$	\$	\$		\$	\$	\$			
Levy	\$0	\$0	\$0	N/A	\$0	\$0	\$0	N/A	\$0	\$0
Interest	0	0	0	N/A	0	0	0	N/A	0	0
Tuition, Fees, Admissions	0	0	0	N/A	0	0	0	N/A	0	0
Other Local Revenues	163	46	117	253.9	163	46	117	253.9	815	815
State Sources	0	0	0	N/A	0	0	0	N/A	0	0
Federal Aids from MDE	0	0	0	N/A	0	0	0	N/A	0	0
Federal Direct Aids	0	0	0	N/A	0	0	0	N/A	0	0
Local Sales	0	0	0	N/A	0	0	0	N/A	0	0
Sale of Bonds or Loans	0	0	0	N/A	0	0	0	N/A	0	0
Total Revenues	163	46	117	253.9	163	46	117	253.9	815	815
<u>Expenditures</u>										
Salaries	0	0	0	N/A	0	0	0	N/A	0	0
Benefits	(12)	66	78	117.9	(12)	66	78	117.9	720	720
Purchased Services	5	5	0	3.8	5	5	0	3.8	58	58
Supplies & Materials	0	0	0	N/A	0	0	0	N/A	0	0
Chargebacks	0	0	0	N/A	0	0	0	N/A	0	0
Capital Expenditures	0	0	0	N/A	0	0	0	N/A	0	0
Debt Service	0	0	0	N/A	0	0	0	N/A	0	0
Other	0	0	0	N/A	0	0	0	N/A	0	0
Total Expenditures	(7)	71	78	109.9	(7)	71	78	109.9	778	778
Transfers In (Out)	0	0	0	N/A	0	0	0	N/A	0	0
Operating Excess (Deficit)	\$170	(\$25)	\$195	779.2	\$170	(\$25)	\$195	779.2	\$37	\$37

STATEMENT OF REVENUES AND EXPENDITURES
 (IN THOUSANDS)

	CURRENT MONTH		YEAR-TO-DATE		ANNUAL BUDGET	
	FY2018	FY2017	FY2018	FY2017	Adopted	Revised
Revenues	\$	\$	\$	\$	\$	\$
		Variance		Variance		
		%		%		
Lewy	0	0	0	0	0	0
Interest	0	0	0	0	2	2
Tuition, Fees, Admissions	0	0	0	0	542	542
Other Local Revenues	0	0	0	0	249	249
State Sources	0	0	0	0	0	0
Federal Aids from MDE	0	0	0	0	0	0
Federal Direct Aids	0	0	0	0	0	0
Local Sales	0	0	0	0	797	797
Sale of Bonds or Loans	0	0	0	0	0	0
Total Revenues	0	0	0	0	1,589	1,589
<u>Expenditures</u>						
Salaries	0	0	0	0	0	0
Benefits	0	0	0	0	0	0
Purchased Services	0	0	0	0	855	855
Supplies & Materials	0	0	0	0	706	706
Chargebacks	0	0	0	0	0	0
Capital Expenditures	0	0	0	0	0	0
Debt Service	0	0	0	0	0	0
Other	0	0	0	0	28	28
Total Expenditures	0	0	0	0	1,589	1,589
Transfers In (Out)	0	0	0	0	0	0
Operating Excess (Deficit)	\$0	\$0	\$0	\$0	\$0	\$0

ISD #709 - Duluth Public Schools
ACH & Wire Transfer Summary
Period Ending 07/31/2017

<u>CHECK DATE</u>	<u>VENDOR ID</u>	<u>DESCRIPTION</u>	<u>MSDLFA</u>
07/12/2017	V106466	CITISTREET FOR MSRS	357,160.20
07/12/2017	V106637	EBC - FLEX EFT	11,448.58
07/12/2017	V106636	EBC - TSA EFT	66,430.66
07/12/2017	V102915	FEDERAL 941 PR TAXES	532,792.08
07/12/2017	V107231	HARBOR POINTE CREDIT UNION	7,771.00
07/12/2017	V108066	MG TRUST	93,916.38
07/12/2017	V05173	MN CHILD SUPPORT EFT	1,508.97
07/12/2017	V108320	MN DEPT OF REVENUE EFT	315.63
07/12/2017	V102916	MN STATE PR TAXES	87,380.75
07/12/2017	V79708	PUBLIC EMPLOYEES RETIREMENT	49,761.78
07/12/2017	V108783	TEACHERS RETIREMENT ASSOC EFT	270,632.86
07/12/2017	V79704	U S BANK - PY DIRECT DEPOSIT	1,385,608.01
07/25/2017	V106737	ASSOCIATED BANK (EFT)	1,356,778.75
07/25/2017	V06645	MEDICA HEALTH PLAN (EFT)	181,170.60
07/25/2017	V106638	PEIP - HLTH EFT	2,615,923.22
07/25/2017	V05012	U S BANK TRUST N A CORP EFT	2,612,262.25
07/25/2017	V80030	DELTA DENTAL PLAN OF MN(EFT)	73,654.36
07/25/2017	V104923	HARRIS BANK	30,207.65
07/25/2017	V100499	MN DEPT OF REVENUE EFT	143.00
07/28/2017	V106466	CITISTREET FOR MSRS	119,760.30
07/28/2017	V106637	EBC - FLEX EFT	11,737.36
07/28/2017	V106636	EBC - TSA EFT	66,333.94
07/28/2017	V102915	FEDERAL 941 PR TAXES	516,039.15
07/28/2017	V107231	HARBOR POINTE CREDIT UNION	7,746.00
07/28/2017	V108066	MG TRUST	93,916.39
07/28/2017	V05173	MN CHILD SUPPORT EFT	1,508.97
07/28/2017	V108320	MN DEPT OF REVENUE EFT	315.62
07/28/2017	V102916	MN STATE PR TAXES	85,021.68
07/28/2017	V79708	PUBLIC EMPLOYEES RETIREMENT	45,390.06
07/28/2017	V108783	TEACHERS RETIREMENT ASSOC EFT	264,574.40
07/28/2017	V79704	U S BANK - PY DIRECT DEPOSIT	1,338,912.43
			<u>12,286,123.03</u>

ISD 709 - Duluth Public Schools
GF Investment Activity for FY 2017
As of July 31, 2017

Beginning Investment Balance (June 30, 2017) \$ 9,790,350.05

Add Purchases:

<u>Date</u>	<u>Issuer</u>	<u>Broker</u>	<u>Matures</u>	<u>Yield (YTM)</u>	
7/3/2017	Sterling Bk Poplar Bluff MO	MBS	4/3/2018	1.10%	146,000.00
7/5/2017	Beal Bk USA Las Vegas NV	MBS	1/3/2018	1.10%	245,000.00
7/6/2017	Cathay Bk Los Angeles CA	MBS	9/29/2017	1.05%	245,000.00
7/19/2017	ZBNA Instl CTF Dep Prog	MBS	1/16/2018	1.25%	245,000.00
7/28/2017	MN Trust Term Series	MNT	1/26/2018	1.134%	248,500.00
7/28/2017	MN Trust Term Series	MNT	1/26/2018	1.142%	248,500.00

Total Purchases \$ 1,378,000.00

Deduct Maturities/Calls/Sales:

<u>Date</u>	<u>Issuer</u>	<u>Broker</u>	<u>Matures</u>	<u>Yield (YTM)</u>	
7/27/2017	MN Trust Term Series	MNT	7/27/2017	1.00%	\$ 5,000,000.00

Total Maturities \$ 5,000,000.00

Other items:

Add:	Money Market Funds Interest (June)	\$	46.99
	Beginning Value Adjustment		
	Other Interest/Cash Balance on Account (Reverse)		

Deduct:	Transaction Fees/Other		
	Market Value Adjustment-Adjust for Cost Basis		

Total Other \$ 46.99

Ending Investment Balance (July 31, 2017) \$ 6,168,397.04

Note: Ending Investment Balance as of July 31, 2016 was \$10,423,378.76

Memorandum

To: Doug Hasler, CFO/Executive Director of Business Services
School Board Members

From: Dave Spooner 
Manager of Facilities

Date: September 13, 2017

Re: Quote #4275 Annual District-Wide Painting Labor

Quote #4257 Annual Painting Labor was advertised according to statute and School Board Policy for services to be performed from July 1, 2017 through June 30, 2018, with the option to renew for two (2) additional one-year periods if acceptable to both parties. Two (2) responses were received.

Recommendation

I recommend the Duluth School Board approve entering into a contract with Swanson & Youngdale, Inc. based on their low quote for services to be performed from July 1, 2017 through June 30, 2018, with the option to renew for two (2) additional one-year periods if acceptable to both parties. Quote tabulation is attached for your reference. If you concur, please sign all copies of the attached agreements.

Attachments

AGREEMENT

THIS AGREEMENT, made and entered into this 19th day of September 2017, by and between Independent School District #709, a public corporation, hereinafter called District, and Swanson & Youngdale, Inc., an independent contractor, hereinafter called Contractor.

THE PURPOSE OF THE AGREEMENT is to set out the terms and conditions whereby Contractor will provide programs or services for the District at the times and locations set forth in this Agreement.

The terms and conditions of this Agreement are as follows:

1. **Dates of Service.** This Agreement shall be deemed to be effective as of July 1, 2017, and shall remain in effect until June 30, 2018 unless terminated earlier as provided for herein, or unless and until all obligations set forth in this Agreement have been satisfactorily fulfilled, whichever occurs first.
2. **Performance.** Perform all work as specified in Quote #4275, District-Wide Painting Labor for the period of July 1, 2017 through June 30, 2018, with the option to renew for two (2) additional one-year periods. This hourly rate contract award amount is approximately \$14,900.00 based on 100 estimated hours at each of the following hourly rates; painter foreman \$74.50, drywall taper journeyman \$74.50. Total Contract award amount to be determined through execution of this contract based upon rates as defined in the contractor's quote proposal.
3. **Contract Documents.** It is understood that this Contract consists of the following:
 1. Printed Memoranda of Agreement and Title Sheet;
 2. Contractor's response;
 3. Contractors Insurance Policy;
 4. Asbestos Containing Materials Acknowledgment Form; and
 5. Any other documents identified by ISD 709.
4. **Reimbursement.** In consideration of the performance of Contractor of its obligations pursuant to this Agreement, District hereby agrees to reimburse Contractor for its services and expenses in performing said obligations at a rate of approximately \$14,900.00. Contractors are required by Minnesota Statutes, Section 270.66, subd. 3, to provide their Taxpayer Identification Number (TIN) used in the enforcement of Federal and State tax laws. The TIN will be available to Federal and State tax authorities and State personnel involved in the payment of State obligations. This Agreement will not be approved unless the TIN is provided.
5. **Requests for Reimbursement.** The terms of payment under this Agreement are as follows:
 - a. Payment shall be made by the District within 30 days of submission of a proper invoice by the Contractor;
 - b. Any other terms of payment in the performance of services are incorporated by reference in this Agreement.
6. **Propriety of Expenses.** The fact that the District has reimbursed Contractor for any expense claimed by Contractor shall not preclude District from questioning the propriety of any such item. District reserves the right to offset any overpayment or disallowance of any item or items at any time under this Agreement by reducing future payments to Contractor. This clause

shall not be construed to bar any other legal remedies District may have to recover funds expended by Contractor for disallowed costs, or to seek other damages.

7. **Ownership of Materials.** The District reserves the rights to reproduce the documents that are the subject of the Contract, in any form, in any fashion, or appropriate the contents of the documents, or any portion thereof, to its own use for any and all programs, forms and other materials that Contractor has provided, prepared, or utilized in performance of the terms of this Agreement.

8. **Independent Contractor.** Both the District and Contractor agree that the Contractor will act as an independent contractor in the performance of its duties under this Agreement and is not an employee of the District. Nothing contained in this Agreement shall be construed as in any manner creating a relationship of joint venture between the parties, which shall remain independent contractors with respect to all actions performed pursuant to this Agreement.

Accordingly, Contractor shall be responsible for payment of all taxes, including Federal, State, and local taxes, arising out of Contractor's activities in accordance with this Agreement, including by way of illustration, but not limited to, Federal and State income tax, Social Security tax, Unemployment Insurance taxes, workers compensations, and any other taxes or business license fees as required.

9. **Indemnity and defense of the District.** Contractor hereby agrees to defend, indemnify and hold the District harmless from all claims relating to its work pursuant to this Agreement.

In the event that Contractor breaches its obligation to defend, indemnify and hold the District harmless, then in addition to its other damages the District shall be entitled to recover its attorney's fees and costs and disbursements incurred in enforcing this Agreement.

10. **Notices.** All notices to be given by Contractor to District shall be deemed to have been given by depositing the same in writing in the United States Mail care of David J. Spooner, ISD 709, Duluth Public Schools, 215 North 1st Avenue East, Duluth, MN 55802. All notices to be given by District to Contractor shall be deemed to have been given by depositing the same in writing in the United States Mail care of Swanson & Youndale, Inc., 3805 Prosperity Rd, Duluth, MN 55811.

11. **Assignment.** Contractor shall not in any way assign or transfer any of its rights, interests or obligations under this Agreement in any way whatsoever without the prior written approval of the District.

12. **Modification or Amendment.** No amendment, change or modification of this Agreement shall be valid unless in writing signed by the parties' hereto.

13. **Governing Laws.** This Agreement, together with all its paragraphs, terms and provisions is made in the State of Minnesota and shall be construed and interpreted in accordance with the laws of the State of Minnesota without regard to conflict of laws considerations.

14. **Compliance with Laws.** The Contractor shall comply with all governing laws, rules and regulations, whether federal, state, local or those of the District. Those governing laws include but are not limited to Minnesota Statute 16C.05 (5) (formerly 1998 Minnesota Laws Ch. 386, Art. 1 Section 6) which Statute presently provides that the books, records, documents and accounting procedures and practices of the vendor or other party, that are relevant to the Contractor transaction, are subject to examination by the contracting agency and either the

legislative auditor or the state auditor, as appropriate, for a minimum of six years. The other provisions of the Statute also apply.

The Contractor recognizes that, to the extent that competitive bidding requirements apply to this Contract, those requirements apply to the award and performance of this Contract.

The Regulations of the District are incorporated into this Contract by reference and must be complied with whether or not specifically identified in this Contract.

15. **Entire Agreement.** This Agreement contains the entire understanding of the parties hereto with respect to the subject matter hereof and shall not be changed or otherwise altered except by written agreement of the parties.

16. **Cancellation.** Either party shall have the right to terminate this Agreement, without cause, upon (30) days written notice to the other party as provided for in this Agreement.

17. **Data Practices.** Contractor further understands and agrees that it shall be bound by the Minnesota Government Data Practices Act (Minnesota Statutes 13.03-13.04) with respect to “data on individuals”; as defined in 13.02, subd. 5 of that Statute) which it collects, receives, stores, uses, creates or disseminates pursuant to this Agreement.

18. **Insurance.** Contractor shall not commence work under the contract until they have obtained all the insurance described below and Duluth Public Schools has approved such insurance. Contractor shall maintain such insurance in force and effect throughout the term of the contract.

Contractor is required to maintain and furnish satisfactory evidence of the following insurance policies:

19. **Workers’ Compensation Insurance:** Contractor must provide Worker’s Compensation insurance for all its employees and, in case any work is subcontracted, Contractor will require the subcontractor to provide Workers’ Compensation insurance in accordance with the statutory requirements of the State of Minnesota including Coverage B, Employer’s Liability.

20. **Commercial General Liability:** Contractor is required to maintain insurance protecting it from claims for damages for bodily injury, including sickness or disease, death, and for care and loss of services as well as claims for property damage, including loss of use which may arise from operations under the Contract whether the operations are by the contractor or subcontractor or by anyone directly or indirectly employed under the contract. The District shall be listed as the certificate holder and shall be named an additional insured under said policy and proof of this insurance shall be provided to the District. This insurance shall be in at least the amount of \$1,500,000.

21. **Bonding.** Contractor shall provide such Payment and Performance Bonds as may be required, if any.

22. **Representatives of the District.** The Contractor shall perform work pursuant to this Agreement pursuant to the request and authority of the following persons:

District Employee
Doug Hasler

Position
CFO/Executive Director of Business Services

The Consultant shall report to the following persons regarding its work pursuant to this Agreement, or the designees:

<u>District Employee</u>	<u>Position</u>
David Spooner	Manager of Facilities

23. **Protection of the District.** To the extent that work by the Contractor or others on behalf of the District is to be planned, conducted, supervised or reviewed by the Contractor, the Contractor shall advise the District if such work:

- a. is not being performed pursuant to the plans and specifications, according to the best practice or in accordance with industry standards;
- b. should be rejected or modified;
- c. should be performed in a different manner and whether other work should be performed;
- d. requires ISD 709 to be advised of any other facts or opinions regarding that work.

In all respects, the Contractor shall represent the interests of the District and act to protect those interests and endeavor to guard the District against defects, deficiencies and omissions in the performance of the work.

24. **Negotiation, Mediation and Arbitration.** Any disputes between the parties shall first be negotiated. If the parties are not successful in negotiation, they then shall subject the dispute to mediation. If mediation is not successful, then any disputes between the district and the Consultant shall be resolved through binding arbitration. The arbitration shall be conducted in the State of Minnesota, and Minnesota law shall apply. Unless otherwise agreed by the parties, the arbitration shall be conducted pursuant to the rules of the American Arbitration Association.

At the option of the District, the arbitration shall include in one consolidated arbitration proceeding, all claims and disputes regarding the Contractor and any architects, contractors, subcontractors, material men and other consultants as may be involved in the dispute. Contractor shall include this paragraph in all its subcontracts dealing with the work of the District.

Following the issuance of a demand for arbitration, any party to the arbitration shall be entitled to use all discovery methods permitted in the Minnesota Rules of Civil Procedures for the District courts. Once selected, the arbitrator shall hear any discovery disputes regarding discovery unless otherwise agreed by the parties.

AS EVIDENCE OF THEIR ASSENT TO THE TERMS AND CONDITIONS OF THIS AGREEMENT, set forth above, the parties hereto have caused this Agreement to be executed by their duly authorized officers as of the day and year first above written.

INDEPENDENT SCHOOL DISTRICT NO. 709

SWANSON & YOUNGDALE, INC.

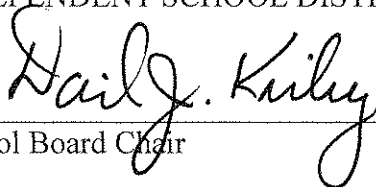

School Board Chair

By _____

Title

QUOTE TABULATION
PAINTING LABOR
July 1, 2017 through June 30, 2018
QUOTE #4275
Tuesday, September 12, 2017 - 2:00 p.m.

Vendor	Painter Foreman	Painter Apprentice	Drywall Taper Journeyman	Drywall Taper Apprentice	Plasterers Journeyman	Total Annual Amount (500 hrs)
Calco Painting of Duluth 5904 MacQuade Road Duluth, Minnesota 55804 phone: 218-525-2137	regular hourly rate \$92.50	regular hourly rate \$87.50	regular hourly rate \$92.50	regular hourly rate \$87.50	regular hourly rate \$92.50	\$45,250.00
	overtime hourly rate \$110.00	overtime hourly rate \$105.00	overtime hourly rate \$110.00	overtime hourly rate \$105.00	overtime hourly rate \$110.00	
Ed Lundberg Painting 2530 East 5th Street Duluth, Minnesota 55812-1442 phone: 218-728-1062	regular hourly rate	regular hourly rate	regular hourly rate	regular hourly rate	regular hourly rate	
	overtime hourly rate	overtime hourly rate	overtime hourly rate	overtime hourly rate	overtime hourly rate	
Lakehead Painting Company, Inc. 910 Hammond Avenue Superior, Wisconsin 54880 phone: 715-394-5799	regular hourly rate	regular hourly rate	regular hourly rate	regular hourly rate	regular hourly rate	
	overtime hourly rate	overtime hourly rate	overtime hourly rate	overtime hourly rate	overtime hourly rate	
Northland Painting Contractors 5506 Thompson Hill Road Duluth, Minnesota 55810 phone: 218-348-1327	regular hourly rate	regular hourly rate	regular hourly rate	regular hourly rate	regular hourly rate	
	overtime hourly rate	overtime hourly rate	overtime hourly rate	overtime hourly rate	overtime hourly rate	
Northstar Painting, LLC 1313 Anderson Road Duluth, Minnesota 55811 phone: 218-260-9447	regular hourly rate	regular hourly rate	regular hourly rate	regular hourly rate	regular hourly rate	
	overtime hourly rate	overtime hourly rate	overtime hourly rate	overtime hourly rate	overtime hourly rate	
Steinbrecher Painting, Inc. 1408 7th Street North Princeton, Minnesota 55371 phone: 763-389-3887	regular hourly rate	regular hourly rate	regular hourly rate	regular hourly rate	regular hourly rate	
	overtime hourly rate	overtime hourly rate	overtime hourly rate	overtime hourly rate	overtime hourly rate	
Swanson & Youngdale, Inc. 3805 Prosperity Road Duluth, Minnesota 55811 phone: 218-727-6682	regular hourly rate \$74.50	regular hourly rate	regular hourly rate \$74.50	regular hourly rate	regular hourly rate	\$14,900.00
	overtime hourly rate \$111.75	overtime hourly rate	overtime hourly rate \$111.75	overtime hourly rate	overtime hourly rate	
Zywicki Painting & Decorating 5499 Canosia Road Saginaw, Minnesota 55779 phone: 218-729-8066	regular hourly rate	regular hourly rate	regular hourly rate	regular hourly rate	regular hourly rate	
	overtime hourly rate	overtime hourly rate	overtime hourly rate	overtime hourly rate	overtime hourly rate	

Memorandum

To: Doug Hasler
School Board

From: David Spooner 

Date: August 10, 2017

Re: Approval of Agreement with Duluth Energy Systems (Duluth Steam – City of Duluth)

Since 1995, the District has been connected to City Steam serving the Historic Old Central High School Building. There was an agreement made at that time which continued to auto renew. With the change in operation status from the Duluth Steam Cooperative to Duluth Energy Systems, the new operator has requested updated agreements for continued service.

City Steam has been a reliable and efficient source of heat for this building, and the attached agreement has been reviewed by District Administration, Mark Knutson, the District's legal counsel, and edits to the Agreement document have been negotiated.

This agreement may look familiar, as it was inadvertently brought forth and approved last September. However that specific agreement was in draft format and not finalized.

Recommendation:

I recommend the Duluth School Board approve entering into an agreement with Duluth Energy Systems to procure steam service for the Historic Old Central High School.

Attachment



STEAM SERVICE AGREEMENT

THIS DULUTH ENERGY SYSTEMS STEAM SERVICE AGREEMENT

("Agreement") is entered into as of _____, 2017 ("Effective Date"), by and between Ever-Green Energy, Inc., as manager for the City of Duluth, and on behalf of its agents, successors and assigns (collectively, the "Supplier"), and the following:

CUSTOMER:

Independent School District #709 - City of Duluth Public Schools

ADDRESS WHERE STEAM SERVICE IS TO BE PROVIDED:

Historic Old Central High School
215 N. First Ave East Duluth, MN 55802

BILLING ADDRESS:

Historic Old Central High School
c/o ISD #709
Attn: Accounts Payable
215 North 1st Ave East
Duluth, MN 55802

CUSTOMER CONTACT INFORMATION:

Name: David Spooner
Title: Manager of Facilities - Duluth Public Schools
Telephone: 218-336-8700
eMail: David.Spooner@isd709.org

EXHIBITS:

- A. Easement
- B. Equipment Ownership and Maintenance Responsibility Schematics
- C. Connection Standards
- D. Rate Calculation Methodology & 2016 Capacity Charge Rates
- E. Definitions

ARTICLE I
CUSTOMER PURCHASE

1.1 The undersigned, whether one or more persons or entities or any combination thereof, all of which shall collectively be referred to herein as the “Customer”, is the owner of certain real properties legally described as: Duluth Proper 1st Division East 3rd Street Lots 2 thru 22 Even Numbered Lots hereafter referred to as the “Premises”. Supplier and Customer are parties “Parties” to this agreement “Agreement”. Supplier has installed or is in the process of installing the necessary District Energy System components required “District Energy System” to provide the Premises with High Pressure Steam ”HP Steam” for heating and other proposed purposes in the Premises “Steam Service”. Customer hereby agrees to be connected to the District Energy System and to pay for all HP Steam delivered to the Premises.

- (a) Payment obligations for any HP Steam provided may be assigned by Customer from time to time to its tenant or tenants of the Premises, but Customer agrees that it is and shall remain responsible for all Customer obligations as set forth herein and for all undisputed amounts due and owing hereunder.

1.2 Customer, in consideration of Supplier making HP Steam available to the Premises grant to Supplier, a permanent easement, Exhibit A, for the purposes of installing, operating, and maintaining the District Energy System in the Premises, and the right to extend and maintain the District Energy System through said Premises to serve other buildings.

1.3 Customer hereby grants Supplier reasonable free and unobstructed entry into the Premises for the purposes of reading Supplier’s Meters, and for maintaining the District Energy System and those components of the Premises Heating System for which Supplier has maintenance responsibility. The party to which maintenance responsibility falls for various components of the District Energy System and the Premises Heating Systems is indicated on Exhibit B. The delineation point between the Supplier-owned District Energy System and the Customer-owned Premises Heating System is located at the outlet of the Supplier’s HP Steam First Shut-off Valve in each Premise. The Meters installed in Customer’s Premises are also owned by Supplier and are components of the District Energy System. For the purposes of clarity, Supplier and Customer acknowledge and agree that the District Energy System is separate from and does not include Premises Heating System equipment.

1.4 Supplier and Customer agree that Steam Service provided under this agreement shall commence on December 1, 2017 (“Commencement Date”). The term of this Agreement shall, unless terminated as provided herein, continue until December 31, 2027 (“Initial Term”).

- (a) Upon completion of the Initial Term, this Agreement shall continue for successive three (3) year terms (the Initial Term and any subsequent terms occurring hereunder shall collectively be referred to as the “Term, unless

Customer gives written notice to Supplier at least 180 days before the start of the upcoming successive term, that Customer does not elect to continue this Agreement for that upcoming successive term.”

- (b) At the end of the Term (Initial Term or any number of renewal terms), Supplier agrees to repair any damage to Premises caused by Supplier’s exercise of its rights hereunder, to the extent practical, with reasonable wear and tear excepted.

1.5 Supplier hereby agrees as follows:

- (a) To limit Customer’s share of Connection Charges, as defined in Article V, to zero dollars (\$0.00).
- (b) To provide, at no cost to Customer, maintenance and repairs to the First Shut-Off Valves and any high pressure steam traps, valves or other District Energy System equipment installed in the Premises before (upstream of) the First Shut-Off Valves.

1.6 Customer hereby agrees as follows:

- (a) To accept HP Steam at the Premises and pay for such Steam Service in accordance with the terms detailed herein;
- (b) That unless otherwise negotiated at a later date, Customer shall, for the Initial Term and all applicable renewal term(s), use Supplier exclusively as its provider for Premises heat and domestic water heating. However, if Supplier defaults in providing steam at times that are critical to Customer in order to protect Customer’s property and in order to assure that there are not substantial interruptions to Customer’s operations, then Customer can use other sources of steam or other heat and domestic hot water heating for the period of the interruption and until service is restored.
- (c) That the amount paid for Steam Service is based on a rate structure established by the Supplier and approved by the City Council, the two major components of which are a Capacity Charge and a Consumption Charge, as specified in Article V. The approved Rate Calculation Methodology and associated Capacity Charge Rates as of the Effective Date of this Agreement are provided as Exhibit D.
- (d) That Supplier’s District Energy System Connection Standards (Exhibit C) have been provided to Customer. Connection Standards represent Supplier’s recommendations and best practices. Connection Standards and, or, revisions to Connection Standards shall not apply to Customer retroactively.
- (g) That Customer shall retain ownership of the Premises Heating System and agrees that Supplier shall not be liable to Customer for damage caused by, or

resulting from the malfunction or failure of any Premises Heating System component within the Customer's Premises except to the extent arising from Supplier's (or Supplier's agents, employees, contractors or other persons for whom Supplier is responsible), negligent acts, omissions or misconduct or breach of the contract by Supplier;

- (h) That should Supplier modify the District Energy System to provide thermal energy in the form of hot water rather than HP Steam in and around the area of Customer's Premises:
 - (i) Supplier agrees to provide Customer one-hundred and eighty (180) days' notice of such change and, at that time, to provide Customer with an offer to enter into an amendment (Hot Water Amendment) to this Agreement accepting such hot water in place of HP Steam.
 - (ii) During the Term of this Agreement, Supplier agrees to continue to provide Customer HP Steam in accordance with this Agreement in the event Customer elects not to connect to Supplier's hot water distribution system.

1.7 Should Customer terminate Steam Service in Premises prior to the end of the Initial Term, except due to default of Supplier or pursuant to paragraph 1.8, Customer shall immediately be responsible for:

- (a) The Capacity Charge described in Article V through the end of the Initial Term, based on the then current means of calculating the Capacity Charge for the system.
- (b) All other undisputed amounts due and owing hereunder from Customer to Supplier.

1.8 The Customer may terminate this Agreement in the event it sells or otherwise transfers its interest in the Premises to an unrelated third party as long as the Customer meets the following conditions:

- (a) Provides written notice to Supplier within seven (7) days of entering into an agreement for the sale of the Premises;
- (b) Provides relevant information in the notice referenced above including but not limited to the prospective buyer's name and contact information;
- (c) Uses reasonable effort to facilitate introduction of the Supplier to the prospective buyer and assists Supplier in the transfer of service to buyer.
- (d) In the event the prospective buyer does not assume this Agreement or enter into a new Steam Service Agreement with Supplier prior to Customer's transfer of the Premises to a third party, Customer will be responsible for paying applicable

disconnection charges and Capacity Charge for the remainder of the then current calendar year.

1.9 Upon termination of Steam Service to Customer's Premises, the easement described in Section 1.2 of this Agreement and the reasonable right of access to the Premises discussed in Section 1.3 of this agreement shall continue for the purposes of maintenance, repair, operation or extension of District Energy System equipment if such equipment remains in Premises.

1.10 The parties hereto agree that this Article I and Exhibit A represent unique Customer characteristics and shall be controlling as they relate to Articles II-XII and to Exhibits B through E.

DULUTH ENERGY SYSTEMS STEAM SERVICE AGREEMENT

ARTICLE II TERM

2.1 The Initial Term of this Agreement commences on the Commencement Date, and continues for the period specified in Section 1.4 unless otherwise terminated according to the terms detailed herein below.

- (a) The Commencement Date shall be the date on which Customer first begins to consume District Energy System-provided HP Steam. If the Commencement Date occurs after the date specified in Section 1.4 due exclusively to Supplier delays. Customer shall not be billed for, and Supplier shall credit Customer the total of Capacity Charges which would have been due between the date specified in Section 1.4 and the date District Energy System-provided HP Steam was first available for consumption by Customer. In this circumstance, the Initial Term end date shall not change from that specified in Section 1.4.

ARTICLE III CONNECTION TO SYSTEM

3.1 The District Energy System shall remain the personal property of Supplier and shall not be deemed a fixture of the Premises, and the Premises Heating System shall remain the personal property of Customer and shall not be deemed a part of the District Energy System.

3.2 Customer shall provide a safe and secure space within the Premises that is reasonable and appropriate for the installation, inspection, testing, repair maintenance, operation, replacement and removal of the District Energy System.

3.3 Except as otherwise specified in Article I of this Agreement, Customer shall be responsible for maintaining the Premises Heating System during the term of this Agreement, at Customer's sole cost and expense, provided, however, that if the Premises Heating System is damaged or destroyed as a result of negligent acts or omissions or willful misconduct or breach of contract of Supplier or its agents, employees, contractors or other persons for whom Supplier is responsible, then Supplier shall be liable for the cost of the required repairs or replacements. If such Supplier-responsible damage or destruction of Premises Heating System prevents customer from consuming Supplier-provided HP Steam, Customer shall not be billed for total of Capacity Charges and Consumption Charges which would have been due Supplier between the date the Premises Heating System was disabled and the date it was restored and made capable of consuming Supplier-provided HP Steam.

3.4 Unless otherwise stipulated in Article I, Customer will furnish the following at the Customer's sole expense:

- (a) One or more main hand control valves by which HP Steam may be shut off from all parts of the Customer's Premises Heating System internal to the Premises. Such valve(s) shall be installed after (downstream of) the Supplier's First Shut-off Valve.
- (b) Proper piping to permit the installation of Supplier-owned and installed Meter.
- (c) Any necessary pressure reducing valve(s) and accessories required to reduce the pressure carried in Supplier's District Energy System to that pressure required by Customer's Premises Heating System or other steam energized equipment.

Note: Any such Premises Heating System valves, piping, or other steam components installed upstream (on the high pressure side) of the reducing valve(s) shall be designed and rated for (saturated) steam at an operating pressure of at least 250 pounds per square inch (psi).

- (d) Properly sized and configured safety valve(s) and safety valve vent piping.
- (e) A sewer connection or other means of disposing of condensate, appropriately designed to provide Supplier's Condensate Meter a free flowing discharge.

3.5 Unless otherwise specified in Article I and Exhibit B, all piping and other equipment between Supplier's First Shut-off Valve and the condensate drain into the sewer connection, with the exception of Supplier's Meter, shall be installed, owned and maintained by the Customer. Supplier shall not be liable for any damages resulting from any failure of such equipment, or of any other part of the Customer's Premises Heating System installation, except if such damage is a result of Supplier's negligent acts or omissions or willful misconduct of Supplier, its agents, employees, contractors or other persons for whom Supplier is responsible. All equipment between and including the

Supplier's plant(s) and the First Shut-off Valve; and all Meters located in, on or around the Premises, shall be the installed, maintained and owned by Supplier as depicted in Exhibit B.

3.6 The Customer shall promptly notify Supplier of any leaks known to Customer within Customer's Premises. Customer agrees that it remains responsible for payment of applicable Consumption Charges for all HP Steam consumed on the Premises, unless there is a leak or loss of steam or condensate that is not attributable to the actions of Customer or does not emanate from Customer's Premises Heating System. Customer shall not be responsible for such leak or loss of condensate from Premises Heating System attributable to negligent acts or omissions or willful misconduct or breach of contract of Supplier or its agents, employees, contractors, or other persons for whom Supplier is responsible, or for leaks or losses from Supplier's District Energy System.

3.7 Supplier may, at reasonable times, inspect the Customer's Premises Heating System installation, and shall provide Customer with notice of any repairs or modifications noted by Supplier for which Customer is responsible which are necessary to conform to applicable federal, state or local codes, rules or regulations ("Code") or the requirements of Supplier's Connections Standards. Supplier shall not be held responsible or liable for issues caused by such deficiencies in Customer's Premises Heating System which Supplier does not detect or report to Customer. Undisputed repairs or modifications necessary to prevent imminent harm to persons or property shall be completed in an expedient manner by Supplier to correct District Energy System or Premises Heating System issues for which Supplier is responsible, or by Customer to correct Premises Heating System issues for which Customer is responsible.

ARTICLE IV

DISTRICT ENERGY SYSTEM

4.1 "District Energy System" shall mean all production and distribution equipment, facilities, materials, and any other type of property now or hereafter owned, operated, or controlled by Supplier for the purpose of or incidental or useful to producing, distributing, receiving, collecting, monitoring and metering steam, excluding any part of any Customer's Premises Heating System.

4.2 All property constituting a part of the District Energy System in, on or around the Premises, shall at all times be the property of Supplier, and upon the earlier of termination or expiration of this Agreement and any extension or amendments hereto, Supplier shall have the right at its option to remove such property from the Premises as provided in 1.4(b);

- (a) Supplier shall inform Customer of its intention to remove the property from the Premises within thirty (30) days after the earlier of the termination or expiration of this Agreement, or such property shall become the property of Customer. If Supplier shall elect to cause the removal of its property (and thus, also restoration of Customer's Premises), it shall do so within sixty

(60) days following the date of notice of its intention to remove such property unless any delay in such removal is caused by or is the result of any obstruction or interference caused by Customer.

- (b) Customer shall have the right to demand that Supplier remove its property from the Premises at the end of this Agreement if Supplier does not elect to do so on its own. Customer can make such a demand to remove Supplier's property at any time and Supplier shall remove its property from the Premises within 180 days of the date of Customer's demand, or within 180 days after the end of this Agreement, whichever is later. However, if Supplier has extended its system to serve other buildings, Supplier shall be entitled to keep such property in the Premises as is necessary to serve those other buildings.
- (c) Any removal by Supplier of any System equipment following the termination or expiration of this Agreement shall not affect or otherwise modify Supplier's right to keep and maintain its rights of access created hereunder in, on or around premises for any remaining equipment. Customer agrees Supplier shall have the right to extend and maintain its system through Premises to serve other buildings. Supplier agrees that it will take the necessary steps to ensure that any such activity will not negatively impact Premises or Customer's intended use of Premises.

4.4 Commencing on the Effective Date of this Agreement, Supplier and its employees, agents, contractors and representatives shall have a non-exclusive right of reasonable access to and through the Premises, to the extent reasonably necessary for the convenient and efficient exercise and performance of Supplier's rights, duties and obligations under this Agreement, including the installation, testing, maintenance, operation, repair, replacement and removal of the District Energy System.

- (a) Neither Customer nor its agents, employees, tenants, customers, contractors or other persons under its control shall knowingly authorize or permit any person (other than a duly authorized employee or agent of Supplier) to operate, maintain, alter or otherwise have access to any component of the District Energy System or other property of Supplier located on, in or around the Premises without the consent of the Supplier, or to break or replace any seal or lock of Supplier, or to alter or interfere with the operation of the Meter or Supplier's connection, or any other equipment installed by Supplier in, on or around the Premises; **provided, however**, that if Customer reasonably believes that access to the aforementioned equipment or property is necessary to prevent imminent harm to persons or property, then such access shall be permissible if and only if Customer takes only those actions with respect to such equipment or property, as it believes are reasonably necessary to prevent said imminent harm and Supplier is promptly notified of such access and other action taken by Customer.

4.5 Supplier shall, at its own expense, replace the wear parts in all Meters with

calibrated parts as often as is necessary to ensure accurate HP Steam consumption measurement. Additional Meter calibration tests will be conducted by Supplier upon reasonable request by a Customer. Such additional tests shall be paid for by the Customer unless the Meter is found to register more than two and one-half percent (2.5%) high. Metering Equipment will be considered accurate if within two and one-half percent (2.5%) of actual measured flow. Supplier shall credit or charge the Customer's account for any amounts overbilled or under-billed as a result of Meter calibration issues or malfunctions, starting on the date the Meter began to malfunction (when it can be determined) or to the first billing cycle of the current calendar year, whichever is later. The parties hereto agree that all such Meters shall remain the property of the Supplier, and that the Supplier assumes all responsibility for the maintenance and operation of all such Meters.

4.6 If it is reasonably determined that a Meter has been knowingly or deliberately tampered with by Customer, its agents, employees, representatives or contractors, so as to avoid proper measurement, Supplier shall immediately notify Customer and provide Customer the opportunity to investigate the situation and take corrective actions which shall provide Supplier with reasonable assurance that further tampering will not occur. If such assurance is not provided within ten (10) business days after Customer has been notified of the issue, Supplier may discontinue service. In this case, Steam Service will not be restored until the metering deficiency has been corrected and Customer has paid, in full, the Supplier's reasonably estimated Consumption Charge for the amount of HP Steam consumed but not metered, plus any and all reasonable costs incurred by Supplier which are directly attributable to the tampering, and any and all reasonable costs expended by Supplier in such effort to determine the cause of and amount of any such deficiency. If Supplier discovers that the Meter was deliberately and/or willfully tampered with, and Customer had knowledge of such tampering and did not immediately report it to Supplier, Supplier may, at its discretion, elect not to restore the affected service.

4.7 Supplier may, whenever it determines it necessary to make repairs or extensions to the District Energy System, temporarily shut off the supply of HP Steam to any Customer provided a reasonable notice of such intention is given to the Customer, and that such repairs or extension are made with due diligence, and Supplier makes all commercially reasonable efforts to avoid any interruption, reduction or complete shut off of the supply of HP Steam during the normal business hours of the Premises. In such event, Supplier shall not be liable for any damage caused by, or resulting from, such suspension of Steam Service. Notice of shut off shall not be required, however, if the repairs are necessitated by unavoidable accident or risk of damage or harm to others in proximity to District Energy System happening beyond the control of Supplier. Notice to any party identified by Customer as being in charge of said Premises shall be deemed notice to the Customer for the purpose of this Article IV.

ARTICLE V
CHARGES AND ADJUSTMENTS

5.1 Customer shall pay the “Capacity Charge” for the HP Steam supplied to Premises. Unless otherwise specified in Article I, the monthly Capacity Charge shall be determined annually by Supplier according to policy approved by the Duluth City Council. The City Council approved policy in effect as of the Effective Date of this Agreement is provided as Exhibit D. The Capacity Charge reflects the anticipated fixed costs of Supplier incurred in supplying HP Steam to Customer on a monthly basis during the ensuing twelve month period.

- (a) Fixed costs used to determine the Capacity Charge include, but are not limited to, the amortized costs of acquiring, installing and constructing the District Energy System and financing costs related thereto, and projected maintenance and operational costs. The Capacity Charge is an annual charge, which shall be billed to Customer in twelve (12) equal consecutive monthly installments spread over the course of the ensuing calendar year, **provided, however**, that Customer may, at its sole discretion, elect to pay the Capacity Charge as determined hereunder in one lump sum on or before January 31 of any given year. The Capacity Charge shall be established by Supplier pursuant to this Agreement in each calendar year, with the first monthly payment of the Capacity Charge appearing on the January Invoice.
- (b) The Capacity Charge payable by Customer shall be based on Customer's projected HP Steam consumption in relation to the projected aggregate HP Steam consumption by all District Energy System customers. In the event Supplier connects new customers to the District Energy System which results in more than a five percent (5%) reduction in Customer's Capacity Charge, the Supplier, shall re-determine the Capacity Charge payable by Customer as of the commencement of Steam Service to such other customers. The Capacity Charge, if adjusted as aforesaid, shall remain unchanged until it is adjusted again pursuant to the terms of this Article V. The Capacity Charge Rate Cap described in Article I of this Agreement shall remain in effect throughout the Term, even if the aggregate District Energy System consumption decreases sufficiently to have otherwise increased the Customer's Capacity Charge beyond the Capacity Charge Rate Cap.
- (c) Unless otherwise stipulated in Article I, the Capacity Charge payable by Customer shall be recalculated annually each December for the ensuing twelve (12) month period based on the methodology approved by the Duluth City Council and as adjusted in this Agreement. The approved methodology as of the Effective Date of this Agreement is provided as Exhibit D.

5.2 Customer shall also pay to Supplier the monthly “Consumption Charge” for HP Steam actually provided to Customer during each month. The Consumption Charge rate shall be based on the variable costs incurred by Supplier in providing HP Steam,

including, but not limited to, the cost of fuel, water, electricity, and additives.

- (a) Customer's Consumption Charge shall be calculated by measuring the volume of HP Steam consumed in Customer's Premises using Supplier's Meter and multiplying the measured consumption by the Consumption Charge rate as per the method set forth in Exhibit D.
- (b) In the case of failure of Supplier's Meter to accurately measure the amount of HP Steam consumed by Customer, an estimate of the HP Steam actually consumed shall be made by Supplier based upon the average consumption of the Customer or of customers similarly situated to Customer during prior periods with similar outside temperatures; **provided however**, that such estimated adjustment period shall not exceed the beginning of the current calendar year.
- (c) In the event Customer believes the Premises Heating System is causing an inaccurate measure of HP Steam consumption, it is the Customer's responsibility to provide evidence of the issue to Supplier. Adjustments to charges for HP Steam consumption due to the malfunction of the Premises Heating System shall be made by Supplier for a maximum of ninety (90) days, if warranted, or for such longer period as determined at the sole and complete discretion of Supplier, **provided, however**, that such adjustment period shall not exceed the beginning of the current calendar year unless mutually agreed upon by the parties.
- (d) In the event Supplier reasonably determines the Premises Heating System is deficient or being operated by Customer in a manner which results in less than complete metering of all consumed HP Steam, Supplier shall:
 - (i) Immediately provide Customer with written notice of the discovered deficiency or inappropriate operation;
 - (ii) Estimate, based on the best data and information available, the consumption charge for HP Steam consumed but not metered. In no single incident shall Supplier bill customer for more than 90 days of inadvertently un-metered HP Steam consumption.
 - (iii) Provide Customer with a written explanation of how the estimate was arrived at. Customer shall be obligated to pay all undisputed charges over a period of time not to exceed ninety (90) days. Disputed charges shall be resolved pursuant any dispute resolution provisions of this Agreement and pursuant to the rights of the parties under the law if not addressed in any dispute resolution provisions of this Agreement.

5.3 Customer shall pay to Supplier, any applicable taxes pertaining to or resulting from the supply of HP steam to the Customer and /or the use of such HP Steam by Customer.

5.4 Customer shall pay to Supplier the sanitary sewer fee at the then applicable rate as established by the City of Duluth or such other governmental authority responsible for such sanitary sewer system **when** use of the HP Steam provided by Supplier results in discharge into the **sanitary** sewer system. However, if Customer pays any sanitary sewer fee directly to the City of Duluth or other governmental authority responsible for the sanitary sewer system, then Customer will not pay this fee to Supplier.

ARTICLE VI PAYMENT TERMS

6.1 Supplier shall deliver to Customer monthly statements reflecting all amounts then owing by Customer ("Invoice") by the tenth (10th) day of each month, including the Capacity Charge, the Consumption Charge and any additional amounts incurred by or otherwise accruing to Customer. Payment shall be due in full on or before the last day of the month in which that Invoice was timely delivered to Customer by Supplier.

6.2 Any undisputed amounts owing by Customer to Supplier pursuant to the terms of this Agreement and not paid when due shall accrue interest at the rate of 1.5% per month or the highest rate permitted by Minnesota Statute, whichever is less, until all amounts due hereunder are paid in full ("Service Charge").

ARTICLE VII EVENTS OF DEFAULT

7.1 The occurrence at any time of any of the following events shall constitute a "Supplier Default" unless such event occurs by reason of a Force Majeure Event as defined in Article X Section 10.3:

- (a) The failure of Supplier to provide Customer with HP Steam as required by this Agreement if and only if:
 - (i) Supplier has not provided Customer with substitute heat reasonably capable of meeting the Premises Heating System requirements of Customer; and
 - (ii) Such failure is not due to an interruption of service that is permitted pursuant to Article X below, and such failure continues for 10 consecutive days; and
 - (iii) Customer is ready, willing and able to receive such HP Steam and Supplier's failure is not otherwise the result of Customer's acts or omissions, or those of its agents, employees, tenants, customers or

contractors, or of any other persons for whom Customer is responsible or over which Customer has control; or

(iv) For a continuous period of forty-five (45) days Supplier is unable to provide HP Steam to the Customer in substantial compliance with this Agreement. Substantial compliance with this Agreement shall mean HP Steam is supplied to Customer by way of the Supplier's permanently installed District Energy System at a sufficient pressure and rate to maintain Premises Heating System steam operating pressures at or above the operating pressures experienced during all Premises operating conditions prior to Supplier's initial failure to provide HP Steam.

(b) If Supplier fails to perform or cause to be performed any obligation other than the requirement to provide HP Steam or substitute heat required to be performed by Supplier under this Agreement, **provided, however**, that if such failure by its nature can be cured, then Supplier shall have a period of forty-five (45) days after receipt of written notice from Customer of such failure to cure the same, and a Supplier Default shall not be deemed to exist during such period, and **provided further**, that if Supplier commences to cure such failure during such period and is diligently and in good faith attempting to effect such cure, said period shall be extended for an additional period of up to sixty (60) days to effect such cure.

7.2 At the discretion of Supplier, the occurrence at any time of any of the following events may constitute a "Customer Default" unless such event occurs by reason of a Force Majeure Event as defined in Article X:

(a) The failure of Customer to pay on or before the 15th day following the date when due and payable any undisputed amounts owing to Supplier under this Agreement;

(b) If Customer fails to perform or cause to be performed any other obligations required to be performed by Customer under this Agreement, **provided, however**, Customer shall have a period of forty-five (45) days after receipt of written notice from Supplier of such failure to cure the same, and a Customer Default shall not be deemed to exist during such period, and **provided further**, that if Customer commences to cure such failure during such period and is diligently and in good faith attempting to effect such cure, said period shall be extended for additional sixty (60) days.

(c) If the Customer Default is of such nature that immediate action on the part of Supplier is required, Supplier may terminate HP Steam supply to the Customer and to any and all Premises subject to the terms and conditions of this Agreement. Immediate actions are those instances that pose direct, immediate harm to the occupants of the Premises, such as uncontrolled leak. In such event, Supplier shall provide Customer reasonable time and

opportunity to cure the default by removing the risk of imminent harm to life or property. Provided Customer is diligently and in good faith attempting to affect such cure, Supplier shall not terminate this Agreement.

ARTICLE VIII REMEDIES

8.1 Customer's remedies upon the occurrence of a Supplier Default are as follows:

- (a) If a Supplier Default described in Section 7.1 above has occurred and Supplier has failed to cure such default within the time allowed thereunder, then this Agreement may be terminated by Customer upon five (5) days written notice and this Agreement shall be of no further force or effect.
- (b) Customer shall be entitled to an abatement of the Capacity Charge from the date on which such Supplier Default commenced through the date on which such Supplier Default is waived or cured or on which this Agreement is terminated.
- (c) In addition to the rights and remedies of Customer set forth above, Customer may pursue any and all other rights or remedies available to it at law or in equity upon the occurrence of a Supplier Default, including but not limited to any claims which Customer may have for property damage, (note, these provisions should not prevent claims for property damage, etc. from escape of steam, etc.)

8.2 Supplier's remedies upon Customer Default are as follows:

- (a) If any Customer Default described in Section 7.2 has occurred and Customer has failed to cure such default within the time allowed thereunder, then this Agreement may be terminated by Supplier upon five (5) days written notice and this Agreement shall be of no further force or effect except for the provisions of Section 1.7. Upon such termination, Supplier shall have the right to immediately discontinue the supply of HP Steam to Customer, and also shall have the right to disconnect all related piping and connections.
- (b) In addition to the rights and remedies of Supplier set forth above, Supplier may pursue any and all other rights or remedies available to it at law or in equity upon the occurrence of a Customer Default, including but not limited to any claims which Supplier may have for property damage.

8.3 Nothing in this Agreement is intended to cause either party to be, and neither party shall be, liable to the other party for any lost business, lost profits or revenues (other than profits and revenues lost by Supplier directly from Customer on account of a Customer Default), all claims for which are hereby irrevocably waived by Customer and Supplier.

ARTICLE IX **TERMINATION**

9.1 Notwithstanding anything to the contrary herein, if one or more of the following events or conditions shall exist or occur Supplier may elect at its option to terminate this Agreement by giving notice to Customer not less than sixty (60) days prior to the date of such termination:

- (a) Customer's Building is abandoned, destroyed, demolished, substantially destroyed or demolished and Customer does not commence restoration of the building within ninety (90) days after the date the damage occurs; becomes permanently inoperable or is taken by right of eminent domain for a period of 20 days or more; or,
- (b) It becomes unlawful under any valid federal or state law, regulation or rule for either Supplier to deliver to the Customer or the Customer to receive and pay for Thermal Energy.

9.2 If one or more of the following events or conditions shall exist or occur, Customer may elect at its option to terminate this Agreement by giving notice to Supplier of such fact no less than) sixty (60) days prior to the date of such termination:

- (a) It becomes unlawful under any valid federal or state law, regulation or rule for either Supplier to deliver to Customer or Customer to receive and pay for Thermal Energy;
- (b) For a continuous default lasting more than twenty (20) days, Supplier is unable to deliver HP Steam to the Customer in substantial compliance with this Agreement or if there is substantial damage to Customer's property or substantial interference with Customer's operations.

9.3 Upon the termination or expiration of this Agreement, any undisputed amounts then owing by a party to this Agreement to other party to this Agreement (including the amounts set forth in any riders attached hereto, if applicable), shall become immediately due and payable according to the terms herein, and the then future obligations of Customer or Supplier under this Agreement shall be terminated, including the requirements of Article 5 through the end of the Initial Term or any renewal terms if the Customer is in a renewal term, and all Capacity

Charges and Consumption Charges, excepting the indemnity obligations set forth in Article XI below.

ARTICLE X
SERVICE INTERRUPTIONS

10.1 Supplier shall have the right to interrupt or reduce Customer's HP Steam supply for a reasonable duration, upon prior notice to Customer, for the purpose of performing ordinary maintenance, repairs, replacements, connections or changes (on or off the Premises) of or to the District Energy System, or any other equipment or apparatus which is required by good engineering and operating practices or by manufacturers' specifications. Supplier shall diligently attempt to restore service as soon as is reasonably possible and, in order to minimize interference with the normal operation of the Premises, Supplier shall schedule such interruptions and reductions during summer months and during non-business hours to the extent reasonably practicable. Supplier shall not allow damage to Customer's property or substantial interference with Customer's operations.

10.2 Supplier shall have the right to interrupt or reduce Customer's HP Steam supply for a duration determined necessary by Supplier, in its good faith judgment, without prior notice to Customer, if: a Force Majeure Event has occurred that causes or requires such interruption or reduction of such service; or the Premises Heating System, the District Energy System, or the Premises has become dangerous or defective in Supplier's good faith judgment and, as a result thereof, Supplier believes that such interruption or reduction is necessary to prevent injury to other persons or damage to or destruction of any component of the District Energy System or the Premises Heating System, or to prevent the interruption or reduction of Supplier's steam service to its other customers. Supplier shall not allow damage to Customer's property or substantial interference with Customer's operations unless this is unavoidable.

10.3 **Force Majeure Events.** If either party to this Agreement is prevented from or delayed in performing any of its obligations under this Agreement by reason of a Force Majeure Event, including but not limited to strikes, labor unrest, war, acts of nature, acts of God, or acts of terrorism, such party shall notify the other party in writing as soon as practicable after the onset of such Force Majeure Event, and shall be excused from the performance of its obligations under this Agreement to the extent such Force Majeure Event has interfered with such performance. The party whose performance under this Agreement is prevented or delayed as the result of a Force Majeure Event shall use reasonable efforts to remedy its inability to perform. If a party's failure to perform its obligations under this Agreement is due to a Force Majeure Event, then such failure shall not be deemed a Supplier Default or a Customer Default. Notwithstanding anything in this Section to the contrary, the rights of access of the Supplier and the payment obligation of Customer under this Agreement shall not be interfered with, excused or delayed as the result of a Force Majeure Event.

ARTICLE XI
INDEMNIFICATION

11.1 TO THE EXTENT PERMITTED BY LAW SUPPLIER SHALL FULLY INDEMNIFY, SAVE HARMLESS AND DEFEND CUSTOMER FROM AND AGAINST ANY AND ALL EXPENSES INCURRED BY CUSTOMER IN CONNECTION WITH OR ARISING FROM ANY CLAIM BY A THIRD PARTY FOR PHYSICAL DAMAGE TO OR PHYSICAL DESTRUCTION OF PROPERTY, OR DEATH OF OR BODILY INJURY TO ANY PERSON, CAUSED BY (i) THE GROSS-NEGLIGENCE OR MISCONDUCT OR BREACH OF CONTRACT OF SUPPLIER, ITS AGENTS OR EMPLOYEES, OR OTHERS UNDER SUPPLIER'S CONTROL, AND (ii) A SUPPLIER DEFAULT.

11.2 TO THE EXTENT PERMITTED BY LAW CUSTOMER SHALL FULLY INDEMNIFY, SAVE HARMLESS AND DEFEND SUPPLIER FROM AND AGAINST ANY AND ALL EXPENSES INCURRED BY SUPPLIER IN CONNECTION WITH OR ARISING FROM ANY CLAIM BY A THIRD PARTY FOR PHYSICAL DAMAGE TO OR PHYSICAL DESTRUCTION OF PROPERTY, OR DEATH OF OR BODILY INJURY TO ANY PERSON, CAUSED BY (i) THE GROSS-NEGLIGENCE OR MISCONDUCT OR BREACH OF CONTRACT OF CUSTOMER, ITS AGENTS OR EMPLOYEES, OR OTHERS UNDER CUSTOMER'S CONTROL, AND (ii) A CUSTOMER DEFAULT.

11.3 Any party seeking indemnification under this Article XI ("Indemnified Party") shall deliver to the party against whom they are seeking indemnity ("Indemnitor") a notice describing the facts underlying its indemnification claim and the amount of such claim ("Claim Notice"). A Claim Notice describing any action at law or in equity involving an Indemnified Party shall be delivered promptly to the Indemnitor after the such Indemnified Party receives notice that such action or suit has commenced; **provided, however**, that failure to deliver such Claim Notice as aforesaid shall not relieve the Indemnitor of its obligations under this Article XI, except to the extent that such Indemnitor has been prejudiced by such failure.

11.4 The amount to which an Indemnified Party is entitled under this Article XI shall be determined by (i) a mutually satisfactory written agreement between such Indemnified Party and the Indemnitor, (ii) a final judgment or decree of any court of competent jurisdiction, or (iii) any other means agreed upon by such Indemnified Party and the Indemnitor.

11.5 If requested by an Indemnified Party, the Indemnitor shall assume on behalf of the Indemnified Party, and conduct with due diligence and in good faith, the defense of such Indemnified Party with counsel reasonably satisfactory to the Indemnified Party; **provided, however**, that if the Indemnitor is a defendant in any such action and the Indemnified Party believes that there may be legal defenses available to it which are inconsistent with those available to the Indemnitor, the Indemnified Party shall have the right to select separate counsel to participate in the defense of such action at the Indemnitor's expense. If any claim, action, proceeding or investigation arises as to which

the indemnity provided for in this Article XI applies, and the Indemnitor fails to assume the defense of such claim, action, proceeding or investigation after having been requested to do so by the Indemnified Party, then the Indemnified Party may, at the Indemnitor's expense, contest or, with the prior written consent of the Indemnitor, which consent shall not be unreasonably withheld, contest or settle such claim, action, proceeding or investigation. All reasonable costs and expenses incurred by the Indemnified Party in connection with any such contest or settlement shall be paid by and shall be an obligation hereunder of the Indemnitor.

11.6 The provisions of this Article XI shall survive the expiration or termination of this Agreement.

ARTICLE XII **MISCELLANEOUS**

12.1 Customer shall be able to assign its obligations under this Agreement if and only if Customer is concurrently assigning or otherwise conveying its entire interest in the Premises, provided that such assignee must acknowledge and accept such assignment and assume all of Customer's obligations in writing, and provided further than such assignment shall not relieve Customer from liability for any of the payment obligations of Customer then existing, unless otherwise specifically agreed to in writing by such assignee and by Supplier.

12.2 Supplier shall have the right to assign its interests hereunder at its sole discretion and the Customer hereby agrees that all of the rights, powers and remedies of Supplier shall inure to the benefit of Supplier's successors and assigns. Supplier's assignment shall not relieve Supplier of any obligations or liabilities under this Agreement, Customer provides written consent thereto; which consent shall not be unreasonably withheld, conditioned or delayed.

12.3 This Agreement (including any Exhibits attached hereto) represents the entire agreement between the parties with respect to the subject matter of this Agreement, and supersedes all prior and contemporaneous oral or written agreements.

12.4 This Agreement shall not be amended, modified or supplemented without the written agreement of Supplier and Customer at the time of such amendment, modification or supplementation.

12.5 No waiver of any provision of this Agreement shall be effective unless set forth in writing signed by the party making such waiver, and any such waiver shall be effective only to the extent it is set forth in such writing. Failure by a party to this Agreement to insist upon full and prompt performance of any provision of this Agreement, or to take action in the event of any breach of any such provision or upon the occurrence of any Supplier Default or Customer Default, as applicable, shall not constitute a waiver of any rights of such party, and, subject to the notice requirements of this Agreement, such party may at any time after such failure exercise all rights and remedies available under this Agreement with respect to such Supplier Default or

Customer Default. Receipt by a party to this Agreement of any instrument or document shall not constitute or be deemed to be an approval of such instrument or document. Any approvals required under this Agreement must be in writing, and signed by the party whose approval is being sought.

12.6 In the event that any provision of this Agreement is deemed to be invalid by reason of the operation of law, or by reason of the interpretation of such provision by any administrative agency or any court of competent jurisdiction, Supplier and Customer shall negotiate an equitable adjustment in the provisions of the same in order to effect, to the maximum extent permitted by law, the purpose of this Agreement, and the validity and enforceability of the remaining provisions, or portions or applications thereof, shall not be affected by such adjustment and shall remain in full force and effect. If any provisions of this Agreement are determined to be invalid, the remaining provisions shall be given full force and effect to the extent possible.

12.7 This Agreement may be executed in counterparts, and all said counterparts when taken together shall constitute one and the same Agreement. The parties hereto agree that scanned or electronic signatures shall be considered as originals.

12.8 This Agreement shall be governed by and construed in accordance with the laws of Minnesota. The appropriate venue and jurisdiction for any litigation hereunder shall be in a court located in the City of Duluth, Saint Louis County, Minnesota. This paragraph does not limit the parties' power to arbitrate any disputes by mutual consent.

12.9 This Agreement is only for the benefit of the parties to this Agreement, their successors and permitted assigns and persons expressly benefited by the indemnity provisions of this Agreement. Unless otherwise identified herein, no other person (including, without limitation, tenants of the Premises) shall be entitled to rely on any matter set forth in, or shall have any rights on account of the performance or non-performance by any party of its obligations under, this Agreement.

12.10 Except as provided in Article IX of this Agreement, including Section 11.5, in the event the Parties are required to employ legal counsel or incur other expenses to enforce any obligation of the other Party hereunder, each party shall be responsible for its own incurred legal expenses and shall not be entitled to recover such expenses from the other Party.

12.11 Supplier reserves the right from time to time to assign its rights under this Agreement (including its rights to payments hereunder) to one or more creditors (each, a "Secured Party") as collateral security for one or more financings, and Customer hereby agrees to any and all such assignments. As a result of such assignment, Customer may receive notice from such Secured Party with an assertion that an event of default has occurred under the financing, and that payments under this Agreement are to be made to such Secured Party. Customer also hereby agrees to make such payments to such Secured Party, and Supplier agrees to hold Customer harmless for making such payments to such Secured Party after Customer has received such notice of default. Customer further agrees that all such Secured Parties shall be deemed third- party beneficiaries of this

Agreement, until such time as Customer receives written notice to the contrary from Supplier and each such Secured Party.

12.12 All notices, communications and waivers under this Agreement shall be in writing and shall be hand delivered or mailed, postage prepaid, to the addresses as set forth herein, or to any other address as the parties to this Agreement shall designate in writing.

12.13 This Agreement shall not be binding upon Customer until such time as it is signed by a duly authorized representative of Customer. The person(s) executing this Agreement on behalf of Customer represent(s) and warrant(s) that, if Customer is a corporation or a partnership or other legal entity, the undersigned is/are duly authorized and empowered to execute and enter into this Agreement, and obligate and bind Customer to this Agreement and to the covenants, obligations, and requirements hereof.

12.14 This Agreement shall not be binding upon Supplier until such time as it is signed by a duly authorized representative of Supplier. Supplier's representative executing this Agreement also represents and warrants that he or she is duly authorized and empowered to enter into this Agreement on behalf of Supplier and obligate and bind Supplier to this Agreement and to the covenants, obligations, and requirements hereof..

12.15 In the event that a dispute arises between the Supplier and the Customer, they shall first attempt to resolve such issues between themselves. If they are not successful in doing so, then the parties shall participate in nonbinding mediation with a mutually agreed mediator and shall do so within 90 days of the request for mediation by either party. If the parties do not resolve their dispute through mediation, then they may exercise all rights which they have to resolve such dispute. If any applicable statute of limitation might run during the time for mediation, the parties may commence an action as permitted by law without waiting for the completion of the mediation, but shall still participate in the mediation nonetheless if that is possible.

(Remainder of page intentionally blank)

IN WITNESS WHEREOF, the parties hereto have executed this Agreement as of the Effective Date first written above.

CUSTOMER:

By: _____ Date: _____
(Signature)

Print Name: _____

Its: _____

SUPPLIER: (by and through its manager, Ever-Green Energy, Inc.):

By: _____ Date: _____
(Signature)

Terry W. Nanti

Its: General Manager

EXHIBIT A – Easement

Remainder of page intentionally blank

EASEMENT AGREEMENT

THIS EASEMENT AGREEMENT (this “**Easement Agreement**”) is made and entered into as of this _____ day of _____, 2017, by and between Independent School District 709, a public school district existing under the laws of the State of Minnesota (hereinafter referred to as “**Grantor**”) and the City of Duluth, Minnesota, a body politic and corporate under the laws of Minnesota (hereinafter referred to as “**Grantee**”).

WHEREAS, Grantor is the owner of the real property (the “**Premises**”) located in the City of Duluth, St. Louis County, Minnesota, commonly known as Historic Old Central High School, which Premises is legally described on Easement Exhibit A attached hereto and incorporated herein; and

WHEREAS, Grantor desires to receive high pressure steam service (the “**Steam Service**”) from the district heating system (hereinafter referred to as the **District Energy System**) owned by Grantee for heating and other purposes at the building located on the Premises; and

WHEREAS, in order for Grantee to provide the Steam Service to the Premises, certain piping, equipment and other appurtenances owned by Grantee thereto (collectively, the “**District Energy System Equipment**”) must be installed and/or constructed by Grantee or its agents at the Premises to enable the building’s heating system (the **Premises Heating System**) owned by Grantor and located at the Premises to be connected to the District Energy System; and

WHEREAS, in order to facilitate the installation and construction of the District Energy System Equipment required to provide the Steam Service, Grantor and Grantee are entering into a certain Steam Service Agreement (the “**Service Agreement**”), pursuant to which Grantee shall agree to provide the Steam Service to the Premises in consideration of Grantor agreeing to certain obligations which shall include, among other things, granting an easement to Grantee for the District Energy System Equipment; and

WHEREAS, the parties recognize that an easement through a portion of the Premises for the construction, installation, inspection, maintenance, repair, replacement, reconstruction, and improvement of the District Energy System Equipment is necessary for Grantee to deliver the Steam Service in accordance with the Service Agreement.

NOW, THEREFORE, in consideration of the foregoing and the representations, covenants, and agreements of the parties set forth herein and other good and valuable consideration, the receipt and sufficiency of which each party acknowledges, Grantor and Grantee hereby represent, covenant, and agree as follows:

1. Grant of Easement. Grantor does hereby grant and convey to Grantee, its successors and assigns, the following easement (the “**Easement**”):

A permanent nonexclusive easement in, under and through the portion of the Premises depicted/legally described in Easement Exhibit B attached hereto and incorporated herein (the “**Easement Property**”) for the construction, installation, inspection (including reading

of meters), maintenance, repair, replacement, reconstruction, or improvement of the District Energy System Equipment to be located subsurface and/or within the basement of the building or buildings located at the Premises, including the right to enter onto the Easement Property for the foregoing purposes and further including the right of access to the Easement Property through the structures or improvements now or hereafter located on all or a part of the Premises. The Easement expressly includes the right of Grantee to extend its pipes through and outside of the Premises in order to connect to and serve other buildings on the District Energy System.

2. Maintenance. Grantor is responsible at its sole expense for maintaining of all Premises Heating System equipment unless otherwise assigned to Grantee in the Service Agreement. Grantee is responsible at its sole expense for maintaining any District Energy System Equipment located within the Easement Property depicted in Easement Exhibit B.

3. Repair and Restoration; Compliance with Laws. Grantee shall repair or restore that part of the Easement Property disturbed by Grantee in the course of its permitted activities under this Easement Agreement to its existing condition prior to Grantee's disturbance, reasonable and normal wear and tear excepted. Grantee agrees that all activities performed on its behalf in the Easement Area shall be performed in compliance with all laws, rules, regulations, orders and ordinances of the governmental authorities having jurisdiction.

4. Indemnification. Grantee agrees to indemnify, defend and hold harmless Grantor from and against any and all costs, liabilities, claims, liens, encumbrances or causes of action (including reasonable attorneys' fees) arising out of the use of the Easement Area by Grantee or its tenants, employees, invitees, contractors, or agents. Grantor agrees to indemnify, defend and hold harmless Grantee from and against all costs, liabilities, claims, liens, encumbrances of causes of action (including reasonable attorneys' fees) arising out of: (a) any failure by Grantor to provide access to the Premises to Grantee as required under this Easement Agreement, or (b) negligence or misconduct by Grantor in its maintenance of the Premises.

Notwithstanding anything contained herein, should this Easement be assigned by the Grantee to a non-public entity, it is agreed that:

- (i) The Minnesota Municipal Liability Tort Act shall no longer be applicable.
- (ii) Grantee shall insure its obligations hereunder through an insurance policy from a reputable carrier acceptable to Grantor, with liability limits of no less than \$5,000,000 per incident and \$10,000,000 in aggregate. Grantor shall be entitled to Acord certificates regarding the coverages to be furnished annually by Grantee. Such certificates and underlying policy shall provide that no termination or non-renewal of the insurance shall be effective without ten (10) days' notice to Grantor.

5. Governing Law. This Agreement is made under and shall be interpreted, governed by, and enforced pursuant to the laws of the State of Minnesota.

6. Inurement. This Agreement and each and every covenant, agreement, and other provision hereof shall inure to the benefit of and be binding upon the each of parties hereto and their respective successors and assigns.

7. Title to Easement Area. Grantor warrants that it is the owner in fee simple of the Premises and has good right to convey the interest in the Easement Property conveyed to Grantee.

8. Counterparts. This Agreement may be executed in two or more counterparts, each of which shall be deemed to be an original, but all of which together shall constitute one and the same instrument.

9. Notices. All notices, demands and requests (collectively “**Notice**”) required or permitted to be given under this Easement Agreement must be in writing and delivered to the below address via U.S. certified mail, postage prepaid, return receipt requested, or by nationally-recognized overnight delivery service, delivery charges prepaid, and Notice will be deemed to have been given on the date shown on the return receipt if delivered via certified mail, or on the date shown on the confirmation form if delivered by nationally-recognized overnight delivery service.

If Notice to Grantor: Independent School District No. 709
 Historic Old Central High School
 215 N. First Ave East
 Duluth, MN 55802

Attn: _____

If Notice to Grantee: City of Duluth
 411 W. First St.
 Duluth, MN 55802
 Attn: City Attorney

With a Copy to: Duluth Energy Systems
 c/o Ever-Green Energy, Inc.
 305 St. Peter Street
 St. Paul, MN 55102
 Attn: General Counsel

Rejection or refusal to accept or the inability to deliver because of a changed address of which no Notice was given will be deemed to be receipt of Notice as of the date of rejection, refusal or inability to deliver. Either party may change its Notice address by giving Notice to the other party to any other address by giving Notice of address change in the manner for giving Notice set forth in this Section. If applicable, Notice will be given to successors and assigns of the parties to the current record owner at the address stated for receipt of tax records as maintained by the St. Louis County Assessor’s Office.

**EASEMENT EXHIBIT A
LEGAL DESCRIPTION OF PROPERTY**

DULUTH PROPER 1ST DIVISION EAST 2ND STREET
LOTS 2 THRU 22 EVEN NUMBERED LOTS

EASEMENT EXHIBIT B LEGAL DESCRIPTION OF EASEMENT

LEGAL DESCRIPTION FOR STEAM LINE EASEMENT

An easement for steam line purposes lying over, under and across that part of Lots 2, 4 and 6, DULUTH PROPER FIRST DIVISION EAST THIRD STREET, according to the recorded plat thereof, St. Louis County, Minnesota and over that part of the platted alley lying adjacent to said Lot 2, described as follows:

Commencing at the intersection of the Northwestern line of East Second Street and the Northeasterly line of Lake Avenue as dedicated on said DULUTH PROPER FIRST DIVISION; thence on an assumed bearing of North 48 degrees 25 minutes 43 seconds West, along said Northeasterly line of Lake Avenue, a distance of 146.90 feet to the point of beginning of the easement herein described; thence North 38 degrees 26 minutes 27 seconds East 11.14 feet; thence North 24 degrees 16 minutes 19 seconds East 14.58 feet; thence North 02 degrees 35 minutes 08 seconds West 49.32 feet; thence North 41 degrees 16 minutes 21 seconds East 52.42 feet; thence North 46 degrees 40 minutes 59 seconds West 8.92 feet; thence North 43 degrees 19 minutes 01 seconds East 3.39 feet; thence North 46 degrees 40 minutes 59 seconds West 9.50 feet; thence South 43 degrees 19 minutes 01 seconds West 9.50 feet; thence South 46 degrees 40 minutes 59 seconds East 9.50 feet; thence North 43 degrees 19 minutes 01 seconds East 3.11 feet; thence South 46 degrees 40 minutes 59 seconds East 6.03 feet; thence South 41 degrees 16 minutes 21 seconds West 50.73 feet; thence South 02 degrees 35 minutes 08 seconds East 49.81 feet; thence South 24 degrees 16 minutes 19 seconds West 13.49 feet; thence South 38 degrees 26 minutes 27 seconds West 10.60 feet to said Northeasterly line of Lake Avenue; thence South 48 degrees 25 minutes 43 seconds East, along said Northeasterly line a distance of 3.00 feet to the point of beginning.

Said easement contains 491 sq. ft.

THIS IS NOT A BOUNDARY SURVEY.

BEARINGS ARE BASED ON THE ST. LOUIS COUNTY TRANSVERSE MERCATOR COORDINATE SYSTEM OF 1996.

BUILDING DIMENSIONS SHOWN ARE FOR HORIZONTAL & VERTICAL PLACEMENT OF STRUCTURE ONLY.

THIS SURVEY HAS BEEN PREPARED WITHOUT BENEFIT OF A TITLE COMMITMENT OR TITLE OPINION. A TITLE SEARCH FOR RECORDED OR UNRECORDED EASEMENTS WHICH MAY BENEFIT OR ENCUMBER THIS PROPERTY HAS NOT BEEN COMPLETED BY ALTA LAND SURVEY COMPANY.

I hereby certify that this survey, plan, or report was prepared by me or under my direct supervision and that I am a duly Licensed Land Surveyor under the laws of the State of Minnesota.

David R. Evanson
David R. Evanson

Date: 10-26-2016 MN Lic. No. 49505

STEAM LINE EASEMENT EXHIBIT	
CLIENT: DULUTH ENERGY SYSTEMS	REVISIONS: XXX
DATE: 10-26-2016	
ADDRESS: 15 EAST SECOND STREET DULUTH, MN	
JOB NUMBER: 16-313	SHEET 1 OF 2 SHEETS



ALTA
LAND SURVEY COMPANY

* LAND SURVEYING PHONE: 218-727-5211
* LAND DEVELOPMENT LICENSED IN MN & WI
* PLATTING CERTIFIED FEDERAL SURVEYOR
* LEGAL DESCRIPTIONS WWW.ALTLANDSURVEYDULUTH.COM
* CONSTRUCTION STAKING

EASEMENT EXHIBIT B (continued)

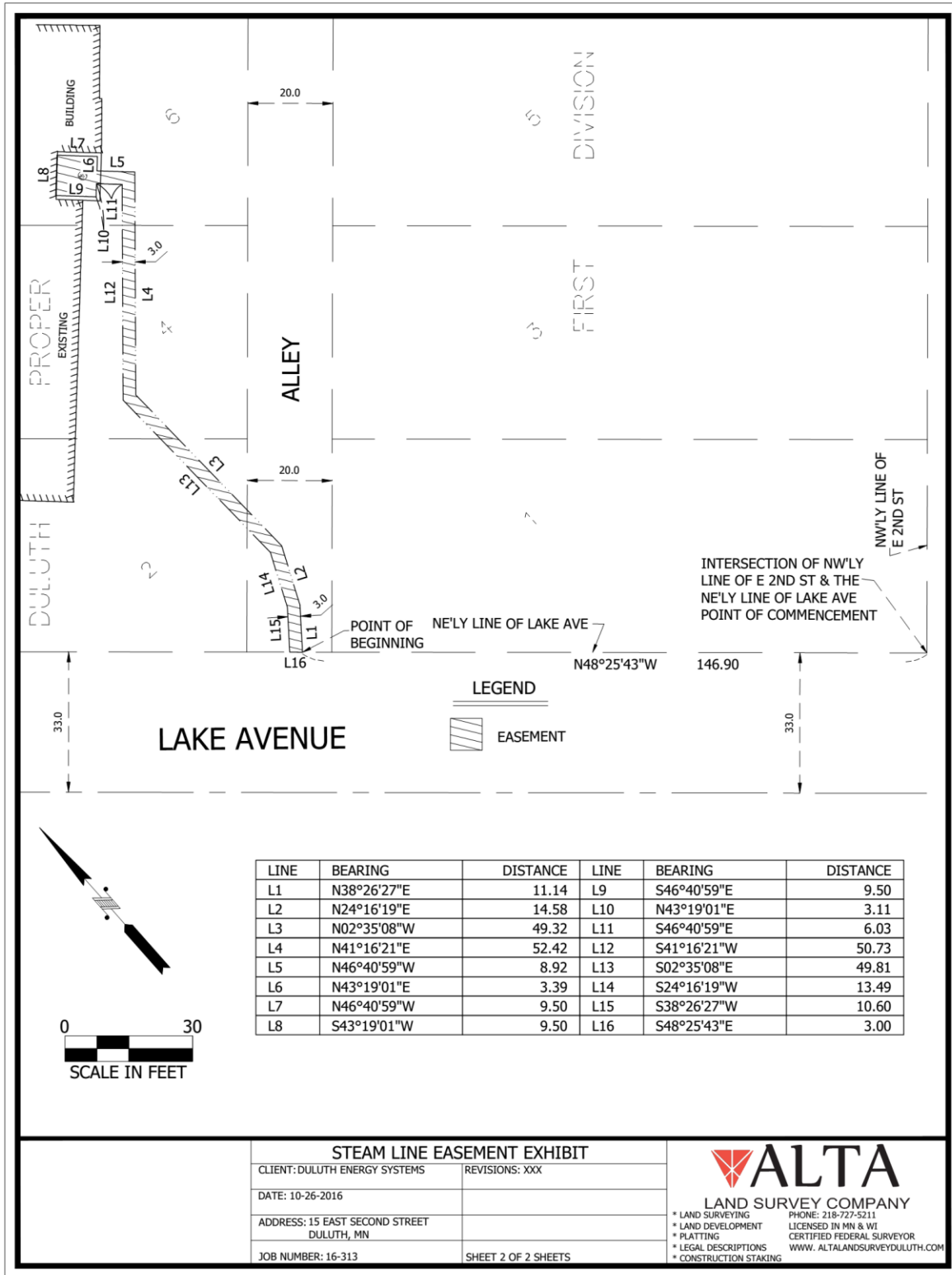

EXHIBIT B: Equipment Ownership and Maintenance Responsibility Schematic

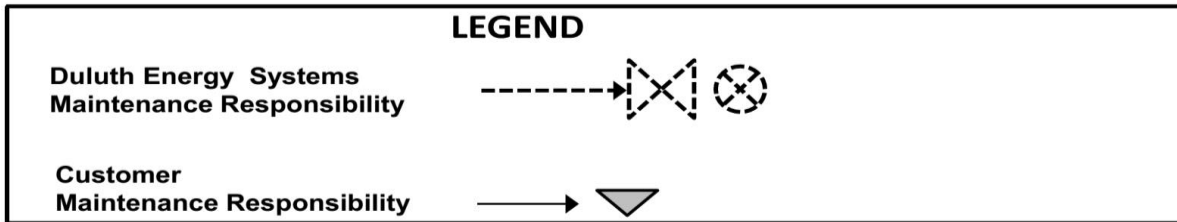
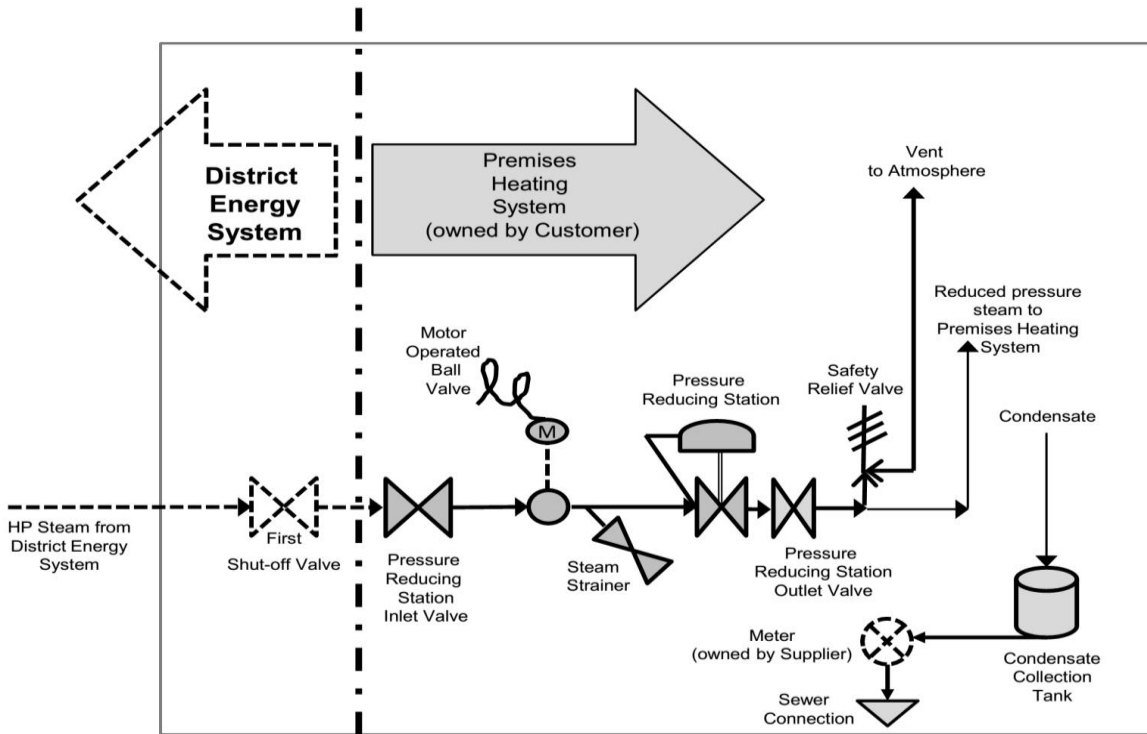
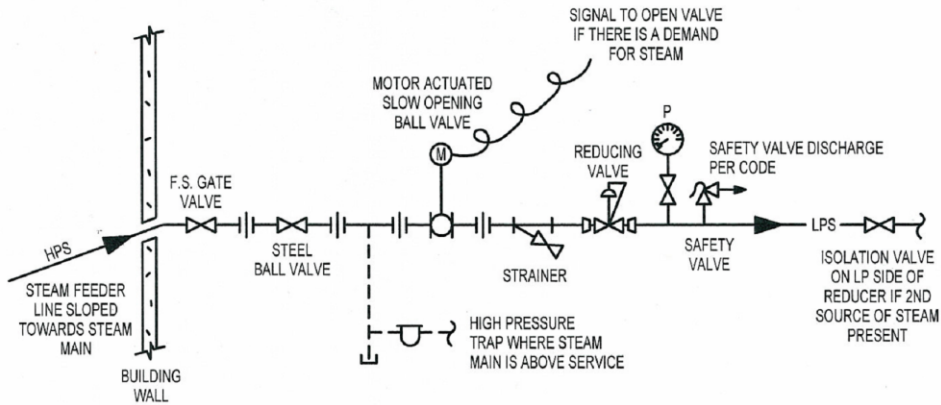
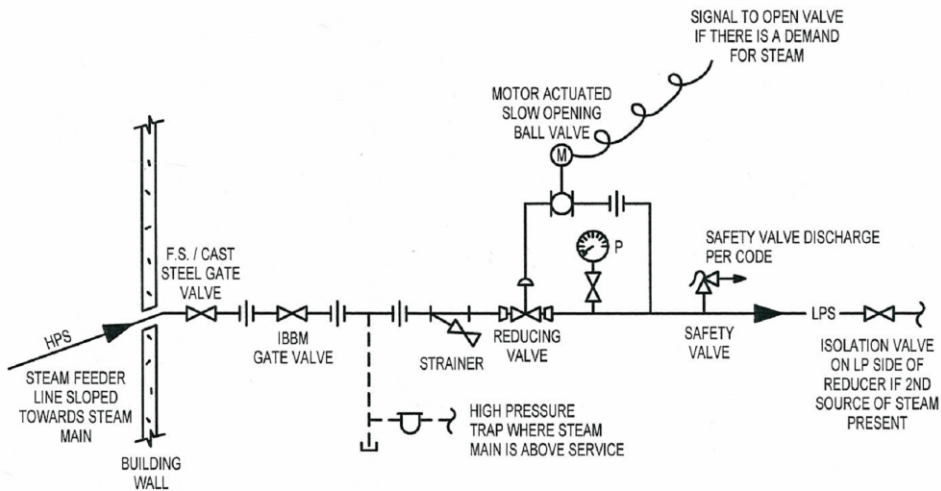



EXHIBIT C – Connection Standards



1 LESS THAN 1" SERVICE
NO SCALE



2 GREATER THAN 1" SERVICE
NO SCALE

 <p>PERFORMANCE DRIVEN DESIGN. LH@corp.com 21 W. Superior St., Ste 500 Duluth, MN 55802 218.727.8448</p>	<p>CLIENT NAME: DULUTH STEAM</p> <p>One Lake Place Drive Duluth, MN 55802 218.723.3601</p>	<p>I HEREBY CERTIFY THAT THIS PLAN, SPECIFICATION OR REPORT WAS PREPARED BY ME OR UNDER MY DIRECT SUPERVISION AND THAT I AM A DULY LICENSED PROFESSIONAL ENGINEER UNDER THE LAWS OF THE STATE OF MINNESOTA.</p> <p>Signature: <i>David Williams</i></p> <p>Typed or Printed Name: <u>DAVID WILLIAMS</u></p> <p>Date: <u>05/05/14</u> Reg. No.: <u>18929</u></p>	<p>DWG. TITLE: STEAM SERVICE DETAILS</p> <hr/> <p>PROJ. NO: 140155 DRAWN BY: MPT CHECKED BY: DTW DRAWING NO: M1.01</p>
	<p>COPYRIGHT 2014 BY LHB, INC. ALL RIGHTS RESERVED.</p>		

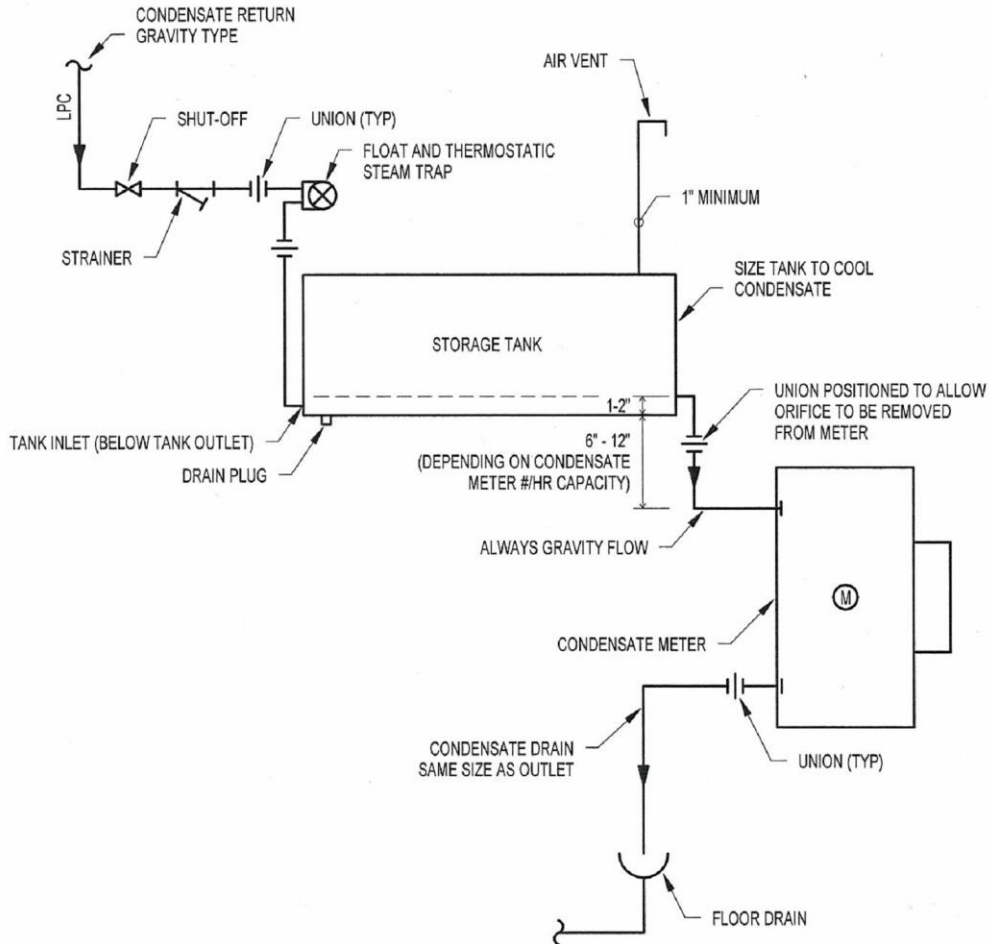

1 TYPICAL CONDENSATE METER INSTALLATION
NO SCALE

 <p>PERFORMANCE DRIVEN DESIGN. LHBcorp.com</p> <p>21 W. Superior St., Ste 500 Duluth, MN 55802 218.727.9446</p>	<p>CLIENT NAME: DULUTH STEAM</p> <p>One Lake Place Drive Duluth, MN 55802 218.723.3601</p>	<p>I HEREBY CERTIFY THAT THIS PLAN, SPECIFICATION OR REPORT WAS PREPARED BY ME OR UNDER MY DIRECT SUPERVISION AND THAT I AM A DULY LICENSED PROFESSIONAL ENGINEER UNDER THE LAWS OF THE STATE OF MINNESOTA.</p> <p>Signature: <i>David Williams</i></p> <p>Typed or Printed Name: DAVID WILLIAMS</p> <p>Date: 05/05/14 Reg. No.: 18929</p>	<p>DWG. TITLE: CONDENSATE METER DETAIL</p> <p>PROJ. NO: 140155 DRAWN BY: MPT CHECKED BY: DTW DRAWING NO: M1.00</p>
---	---	--	---

COPYRIGHT 2014 BY LHB, INC. ALL RIGHTS RESERVED.

EXHIBIT D – 2016 Rate Calculation

Customer s' Total Monthly Cost of Steam Service

$$\text{Cost} = \text{Consumption Charge} + \text{Capacity Charge} + \text{Condensate Sewer Charge} + \text{State and City Sales Tax}$$

$$\text{Consumption Charge} = \text{Consumption Rate} \times \text{Customer's Metered Consumption}$$

For the purposes of the rate calculation, the months of January, February, March, April, May, October, November and December comprise the "Heating Season"; the remaining months of June, July, August and September comprise the "Off-Season".

At the beginning of the fiscal year, the Heating Season Consumption Rate (**R_{HS}**) is set at 95% of the projected annual Consumption Rate. As the year progresses from January, actual variable costs and consumption will replace projected costs and consumption resulting in monthly changes to the **R_{HS}** calculated as follows:

$$\text{R}_{\text{HS}} = \left(\frac{(\text{Actual Variable Costs incurred} + \text{Remaining Projected Variable Costs})}{\text{Actual Steam Consumed to date} + \text{Projected Additional Steam Consumption for the year}} \right) \times 95\%$$

The Off Season Consumption Charge Rate (**R_{OS}**) is calculated each month; June through September with actual variable costs and consumption replacing projected costs and consumption as follows:

$$\text{R}_{\text{OS}} = \frac{(\text{Actual Variable Costs Incurred} + \text{Projected Additional Annual Costs} - \text{Actual Heating Season Consumption Charges Billed} - \text{Remaining Projected Heating Season Variable Costs})}{(\text{Actual Off-Season Consumption to date} + \text{Remaining Projected Off-Season Consumption})}$$

Each customer's monthly Consumption Charge is equal to the customer's metered consumption multiplied by the appropriate Consumption Rate (**R_{HS}** or **R_{OS}**).

$$\text{Monthly Capacity Charge} = \frac{\text{Normalized Steam Consumption} \times \text{Group Capacity Charge Rate}}{12}$$

Capacity Year Consumption = a building's average steam consumption for a given 12 month period starting on July 1st and ending on June 30th for each of the three previous years (n, n-1, n-2)

$$\text{Weather Normalization Factor} = \frac{\text{(the normal total number of Heating Degree days for a given 12 month July 1 to June 30 period)}}{\text{(the actual total number of Heating Degree Days for a given 12 month July 1 to June 30 period)}}$$

Note: Heating Degree Days (HDD) as reported by NOAA at the Duluth International Airport using a 65⁰ F base temperature

$$\text{Normalized Steam Consumption} = \frac{\text{(Capacity Year Consumption}_n \times \text{Weather Normalization Factor}_n + \text{Capacity Year Consumption}_{n-1} \times \text{Weather Normalization Factor}_{n-1} + \text{Capacity Year Consumption}_{n-2} \times \text{Weather Normalization Factor}_{n-2})}{3}$$

Consumption Group = Customer grouping categories based on a customer's Normalized Steam Consumption

Normalized Group Consumption = Total Normalized Steam Consumption for all Customers in a Consumption Group

$$\text{Group Consumption Percentage} = \frac{\text{Normalized Group Consumption}}{\text{(Total Normalized Group Consumption for all Consumption Groups)}}$$

Group Factor = Factor for each Consumption Group

Group Factor Percentage = Group Factor x Group Consumption Percentage

$$\text{Adjusted Group Factor Percentage} = \frac{\text{Group Factor Percentage}}{\text{Sum of all Group Factor Percentages}}$$

Group Fixed Capacity Charge Allocation = Adjusted Group Factor Percentage x Total System Projected Fixed Costs

$$\text{Group Capacity Charge Rate} = \frac{\text{Group Fixed Capacity Charge Budget Allocation}}{\text{Normalized Group Consumption}}$$

2016 Capacity Charge Rates

Consumption Group	Group Consumption Ranges (klbs/yr)	Normalized Group Consumption (klbs/yr)	Group Consumption Percentage	Projected Group Capacity Charge Annual Revenue	2016 Capacity Charge Rate (\$/klb)
1	Less than 1,000	34,488	10.14%	\$429,159	\$12.44
2	1,000 - 4,999	119,782	35.23%	\$1,416,005	\$11.82
3	5,000 - 9,999	23,359	6.87%	\$261,599	\$11.20
4	10,000 - 14,999	59,981	17.64%	\$634,428	\$10.58
5	15,000 - 24,999	35,652	10.49%	\$354,918	\$9.95
6	25,000 - 39,999	0	0.00%	\$0	\$0.00
7	40,000 - 54,999	0	0.00%	\$0	\$0.00
8	55,000 - 69,999	66,749	19.63%	\$539,891	\$8.09
9	70,000 - 84,999	0	0.00%	\$0	\$0.00
10	85,000 - 104,999	0	0.00%	\$0	\$0.00
11	105,000 - 144,999	0	0.00%	\$0	\$0.00
12	Over 125,000	0	0.00%	\$0	\$0.00

A **Condensate Sanitary Sewer Charge** is applied in those cases where buildings' steam condensate discharges to the sanitary sewer system.

EXHIBIT E – Definitions

Capacity Charge: The annual charge for fixed costs incurred by Supplier to supply HP Steam to Customer. Fixed costs include, but are not limited to: the amortized costs of acquiring, installing and constructing the District Energy System and financing costs related thereto; projected maintenance costs; and projected fixed operational costs (payroll, insurance, etc.). The Capacity Charge is calculated annually and is normally billed to Customer in twelve (12) equal consecutive monthly installments. See Article V - Section 5.1.

Commencement Date: The date Customer commences consuming District Energy System-provided HP Steam.

Condensate: Condensate is simply steam in its liquid form, i.e. water. As heat is transferred or removed from steam, either intentionally to do useful work such as heating a building or unintentionally due to missing steam pipe insulation, steam vapor changes phase to liquid condensate. Because water flow is more accurately measured than steam flow, Duluth Energy Systems meters condensate flow in customers' buildings rather than measuring HP Steam flow.

Connection Charge: All reasonable expenses and charges related to connecting Customer's Premises to the District Energy System.

Consumption Charge: The monthly charge for variable costs incurred by Supplier to produce the HP Steam consumed by Customer. Variable costs include, but are not limited to the cost of fuel, water, electricity, and chemical additives. Customers' Consumption Charges are calculated each month based on that Customer's metered HP Steam consumption. See Article V - Section 5.2.

District Energy System: The Supplier's production facilities, distribution system and metering equipment.

Effective Date: The later of date the Customer or Supplier signs this Agreement.

First Shut-off Valve: The first steam valve installed in the Premises on the pipe which runs between the District Energy System and the Premises Heating System. See Exhibit B.

High Pressure Steam (HP Steam): Steam at a pressure greater than or equal to 15 pounds per square inch (psi). The District Energy System provides High Pressure Steam to its customers.

Meter: Steam consumed in Customer's Premises is measured in pounds (lbs) using a condensate meter. As heat is removed from steam, it cools and changes phase from a vapor (steam) to a liquid (condensate). One (1) lb of steam changes phase to one (1) lb of condensate when cooled.

Metered Steam: The abbreviation for one-thousand (1,000) pounds is klb. One thousand pounds of steam (1 klb) has an energy content of one million, one hundred, ninety six thousand (1,196,000) British Thermal Units (Btu). The abbreviation for one million BTU is mmBtu. Therefore, 1,000 lbs steam = 1klb steam = 1.196 mmBtu

Premises Heating System: All steam and condensate piping, valves other and components or equipment installed in the Premises after (downstream of) the First Shut-off Valve, with the exception of the Supplier-owned condensate Meter. The Premises Heating System is owned and operated by the Customer. See Exhibit B.

Steam Service: The Supplier-produced and distributed HP Steam and associated Supplier-performed activities (metering, invoicing, account management, maintenance, etc.) received and purchased by Customer.

Memorandum

To: Doug Hasler
Director of Business Services

From: Dave Spooner 
Manager of Facilities

Date: September 5, 2017

Re: SAS+ Associates Phase II – Removal of Rubber Mulch from Playgrounds – RFP #306 – Change Order #2

RFP #306 – Phase II Removal of Rubber Mulch from Playgrounds was approved February 28, 2017, for a not to exceed fee of \$46,500.00. CO #1 was approved June 20, 2017, for a new contract total amount of \$55,950.00 as related to the re-bid process.

However, once work began, it was quickly realized that there were many unknown conditions at all sites. Sites were not constructed as plans showed, and resulted in much more construction observation and design effort to “individualize” the specification and the plan to each site. This condition as well as the fact that this type of work has not been done before with no baseline for the consultant to base fee’s upon has led to the need for CO #2. Further details are attached as related to this change order from our consultant.

Change order #2 to the RFP results in an increase of \$12,475.00, to the previously awarded base bid and CO #1 for a new not to exceed contract total of \$68,425.00.

Recommendation:

I am recommending that the Director of Business Services approve the change order as listed above pertaining to RFP #306 – Removal of Rubber Mulch from Playgrounds. This change order adds \$12,475.00 to the previously awarded base bid plus CO #1 for a new contract sum of \$68,425.00.

Attachments

DATE: 1 September 2017

TO: Doug Hasler, CFO/Director of Business Services
Independent School District #709
730 East Central Entrance
Duluth, MN 55811

FROM: Luke Sydow
SAS+Associates

RE: Request for Amendment #1 to ISD 709 Rubber Mulch Replacement
Additional Professional Services

Mr. Hasler,

Per my conversations with Mr. Spooner on August 31st concerning the status of this project, the need for additional professional design and construction administrative services has become apparent.

The removal and replacement of the rubber mulch within an existing playground is a project filled with unknowns and uncertainties for design and construction administration, as well as the on-site construction of the project. This being a rather unusual project does not have a precedent to calculate the amount hours and anticipated changes needed to provide adequate clarification, document changes, and oversight of the contractor's construction work, all of which has become extensive.

The redesign and rebidding of the project to leave the playground equipment in place rather than removing and reinstalling it, while overall, a less expensive approach for the district, has complicated and slowed construction, and is requiring more on-site meetings and clarification of, and adjustments to, the construction documents beyond what was anticipated.

SAS+Associates' original contract hours were based on a quick design and construction timeline and on anticipated typical construction means and methods. As construction progresses at each individual school site and existing conditions at each school site becomes exposed, changes in design and construction are necessary. The additional on-going, and anticipated need, for more site visits for meetings, site investigations necessary for design clarification, additional clarifications and changes to the design and contractor construction oversight throughout the remainder of the project, exceeds our original proposal.

See below for our proposal for these additional services. Please feel free to call me with any questions regarding the following proposal.

Our proposal is as follows:

Additional work is required due to:

- Additional site investigations, meetings, and contractor oversight.
- Unforeseen/unknown previous construction methods and existing conditions such as:
 - ❑ Drainage material used
 - ❑ Varying sidewalk thickness
 - ❑ Footing depth and required excavation
- Development of additional designs and details identifying RFI options for discussion by Contractor and Owner to identify construction costs, methods, and alternatives based on exposed conditions.
 - ❑ Results will create opportunities to save the district funds, identify construction methods, identify maintenance requirements, etc.

We propose to provide the additional services for this work for the amount of \$12,475.

Upon completion of the additional meetings, details and coordination, the project's regular schedule will be on track for completion in early October.

SAS+Associates does not anticipate any additional services beyond the proposed work outlined above. The services of any supplementary professionals will be considered an additional service and billed accordingly as per our Rate and Expense Sheet.

Deliverables:

- Additional meetings, construction observation, meeting minutes, RFI Plans

We have attempted to describe all tasks and products in this scope of work so there is a clear expectation of SAS+Associates' products and responsibilities. We are ready to proceed with work as soon as authorized.

SAS+ASSOCIATES

Luke W. Sydow, PLA
Owner



SAS+Associate - Hours Estimate

Proposal #	17-035	Project Name	ISD 709 - Additional Services - Proposal
Date	8/30/2017	Client	

TASK DESCRIPTION	Hours Breakdown						SUBTOTAL
	Principle	LA II	LA I	CAD/TECH	ADMIN	CLARICAL	
BASE BID - LANDSCAPE ARCHITECTURE ELEMENTS							
Schematic Design Phase (Completed)							\$ -
Design Development Phase							\$ -
- Permitting (3 meetings, County, DNR, Owner)							\$ -
Plan Preparation							\$ -
- Septic Coordination							\$ -
- Site Plan							\$ -
- Layout Plan							\$ -
- Landscape Plan							\$ -
- Details							\$ -
- Utility Layout Plans - For use by Design Build contractor							\$ -
- Cost Estimates							\$ -
Construction Document Phase							\$ -
Bidding /Negotiation Phase							\$ -
Costruction Phase - Administration of Contract							\$ -
Plan Preparation							\$ -
- Additional Details-		8	8	30	8		\$ 3,670.00
- Contractor Coordination			30	15			\$ 3,225.00
Project Meetings / Partial Day Site Visits		54			18		\$ 5,580.00
							\$ -
							\$ -
* Assumes an Engineer signature will not be required for plan preparation, utilities plans will be signed by contractor (or contractors engineer) at time of permitting.							\$ -
							\$ -
Task Total	0	62	38	45	26	0	\$ 12,475.00

TASK DESCRIPTION	Hours Breakdown - ADDITIONAL SERVICES						SUBTOTAL
	Principle	LA II	LA I	CAD/TECH	ADMIN	CLARICAL	
SITE - LANDSCAPE ARCHITECTURE ELEMENTS							
							\$ -
							\$ -
							\$ -
On Site Visit Per Day If Requested		8					\$ 680.00
							\$ -
							\$ -
							\$ -
							\$ -
Task Total	0	8	0	0	0	0	\$ 680.00

HOURLY RATES	
Principle	\$ 90.00
LA II	\$ 85.00
LA I	\$ 75.00
CAD / TECH	\$ 65.00
Clerical	\$ 55.00
Administrative	\$ 40.00

REIMBURSABLES	Qty	Cost
Copies B/W	\$ 1.00	0 \$ -
Plots B/W	\$ 5.00	0 \$ -
Plots Color	\$ 10.00	0 \$ -
Boards	\$ 15.00	0 \$ -
Mileage	\$ 0.55	0 \$ -
Total Reimursables		\$ -

SUMMARY	
Hours Total	
Contingency - 0%	\$ -
Reimbursables	\$ -
Project Total	\$ -

- SAS+Associates may shift tasks within the hours breakdown but will remain within estimate.



AIA®

Document G701™ – 2001

Change Order

PROJECT: <i>(Name and address)</i> 1258- Rubber Mulch Replacement 215 N. 1st Ave East, Duluth MN	CHANGE ORDER NUMBER: 002 DATE: September 5, 2017 ARCHITECT'S PROJECT NUMBER: 16140	OWNER <input type="checkbox"/> ARCHITECT <input type="checkbox"/> CONTRACTOR <input type="checkbox"/> FIELD <input type="checkbox"/> OTHER <input type="checkbox"/>
TO CONTRACTOR: <i>(Name and address)</i> SAS+Associates 219 West First Street, Ste 350 Duluth, MN 55802	CONTRACT DATE: January 24, 2017 CONTRACT FOR: Landscape Arch. Services	

The Contract is changed as follows:

(Include, where applicable, any undisputed amount attributable to previously executed Construction Change Directives.)

Additional site visits for meetings, site investigations necessary for design clarification, clarifications and changes to the design and contractor construction oversight.

The original (Contract Sum) (Guaranteed M) was	\$	<u>46,450</u>
The net change by previously authorized Change Orders	\$	<u>9,500</u>
The (Contract Sum) (Guaranteed N) prior to this Change Order was	\$	<u>55,950</u>
The (Contract Sum) (Guaranteed M) will be (increased) (by this Change Order in the amount of	\$	<u>12,475</u>
The new (Contract Sum) (Guaranteed N), including this Change Order, will be	\$	<u>68,425</u>
The Contract Time will be (increased) (by	(0)	days.

The date of Substantial Completion as of the date of this Change Order, therefore, is October 15, 2017

(NOTE: This Change Order does not include changes in the Contract Sum, Contract Time or Guaranteed Maximum Price that have been authorized by Construction Change Directive until the cost and time have been agreed upon by both the Owner and Contractor, in which case a Change Order is executed to supersede the Construction Change Directive.)

NOT VALID UNTIL SIGNED BY THE ARCHITECT, CONTRACTOR AND OWNER.

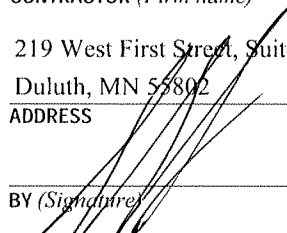
_____ ARCHITECT <i>(Firm name)</i>	SAS+Associates _____ CONTRACTOR <i>(Firm name)</i>	Independent School District #709 _____ OWNER <i>(Firm name)</i>
_____ ADDRESS	219 West First Street, Suite 350 Duluth, MN 55802 _____ ADDRESS	730 East Central Entrance Duluth, MN 55811 _____ ADDRESS
_____ BY <i>(Signature)</i>	 _____ BY <i>(Signature)</i>	_____ BY <i>(Signature)</i>
_____ <i>(Typed name)</i>	Luke Syrow _____ <i>(Typed name)</i>	Doug Hasler, CFO/ Dir. of Bus. Serv. _____ <i>(Typed name)</i>
_____ DATE	September 5, 2017 _____ DATE	_____ DATE

INDEPENDENT SCHOOL DISTRICT NO. 709
Duluth Public Schools
Historic Old Central High School - 215 N. 1st Avenue E.
Tel. (218) 336-8738 Duluth, Minnesota 55802-2069 Fax (218) 336-8777

72

MEMORANDUM

To: Doug Hasler, CFO/Executive Director of Business Services
From: ^{TK} Tony Kelekovich, Supervisor of Purchasing
Subject: Quote-4273 Print Shop Color Copier Lease
Date: August 30, 2017

Quotes for a sixty (60) month lease of one (1) new color copier for the Print Shop were sent to five (5) vendors with the following results:

<u>VENDOR</u>	<u>TOTAL</u>	<u>MANUFACTURER</u>
GREAT LAKES OFFICE SOLUTIONS	\$ 72,068.40	KONICA MINOLTA
METRO SALES	\$ 79,774.80	RICOH
MARCO	\$ 82,479.00	KONICA MINOLTA
OFFICE ENTERPRISES INC (OEI)	\$ 90,116.40	XEROX
SHELDON	\$ 93,445.90	CANON

The Print Shop (Terry McEwen) and the Purchasing Department (Tony Kelekovich) analyzed the results.

The lease includes all lease costs, toner, on-site maintenance, parts, initial set-up, training, and up to a total of 25,000 prints per month. This is a true lease with the equipment being returned at the end of the lease.

The low quote meeting specifications for a sixty (60) month lease as submitted by Great Lakes Office Solutions in the amount of \$72,068.40 is recommended.

Fund: 1-110-012-000-130-1370.00

Program: Print Shop

Fund Custodian: Terry McEwen/Manager

VENDOR LIST/TABULATIONQUOTE-4273PRINT SHOP COPIER LEASE

GREAT LAKES OFFICE SOLUTIONS SUPERIOR WI	\$ 72,068.40
MARCO DULUTH MN	\$ 82,479.00
METRO SALES DULUTH MN	\$ 79,774.80
OFFICE ENTERPRISES INC (OEI) SUPERIOR WI	\$ 90,116.40
SHELDON DULUTH MN	\$ 93,445.90



LEASE AGREEMENT

1720A Crete Street, Moberly, MO 65470
Phone: 800-662-3759, Fax: 800-426-2626

LESSEE LEGAL NAME: Independent School District 709
Tax ID#: 416003776
Telephone No. 2183368700
Billing Address: 215 N 1st Ave E, Duluth, MN 55802-2069
Equipment Location (if other than Billing Address): 215 N 1st Ave E, Duluth, MN 55802-2069
EQUIPMENT DESCRIPTION: (indicate quantity, new or used and include make, model, serial # and all attachments - see below and/or attached Schedule A)
Unit Quantity: 1
Description of Equipment Leased: Konica Minolta bizhub Press C2060 Copier System
Make and Type:
Model Number:
Serial Number:
BASE TERM IN MONTHS: 60
TOTAL NUMBER OF LEASE PAYMENTS: 60 @ \$1,201.14 (plus taxes)
END OF LEASE PURCHASE OPTION:
[X] Fair market value, plus taxes
10% of Equipment cost, plus taxes
\$1 00, plus taxes
(a) Advance Payment: \$0.00
(b) Security Deposit: \$0.00
(c) Documentation Fee: \$95.00
Total due a + b + c =: \$95.00
**If more than one lease payment is required as an Advance Payment, the balance will be applied to lease payments in inverse order, starting with the last lease payment.
Your obligation to pay all amounts and perform all other obligations is non-cancellable, absolute, unconditional and not subject to abatement, set-off or defense.

TERMS AND CONDITIONS

In this agreement ("Lease"), "we," "our," and "us" refers to LEAF Capital Funding, LLC as Lessor and "you" and "your" refer to the Lessee. You agree to lease the Equipment upon the following terms and conditions:

- 1. LEASE PAYMENTS AND TERM: The Lease is enforceable on you upon your execution. The term of the Lease shall commence on the date the Equipment is delivered to you ("Lease Commencement Date"). The first Lease Payment shall be due on the date we specify in the month following the Lease Commencement Date as set forth in our invoice, and the remaining Lease Payments will be due on the same day of each subsequent month (each, a "Payment Date") until paid in full. The Base Term shall commence on the date one month prior to the first Payment Date. We may charge you a portion of one Lease Payment for the period from the Lease Commencement Date until the first day of the Base Term ("Interim Rent"). The Interim Rent shall be due as invoiced. We may adjust the Lease Payments up to 15% if the actual costs are different than the estimate used to calculate the Lease Payments.
2. DELIVERY, ACCEPTANCE, USE AND REPAIR: You are responsible for Equipment delivery and installation. You unconditionally accept the Equipment upon the earlier of (a) your oral or written acceptance of the Equipment, or (b) 10 days after delivery of the Equipment. You authorize us to fill in the Lease Commencement Date, serial numbers and other information. You will not move the Equipment from the above location without our written consent and are responsible for maintaining the Equipment in good repair. We are not responsible for Equipment or vendor failures.
3. INDEMNIFICATION: You agree to indemnify, defend and hold us harmless from and against any losses, damages, penalties, claims and suits, including attorneys' fees and expenses related to the ordering, manufacture, installation, ownership, condition, use, lease, possession, delivery or return of Equipment.
4. LEASE EXPIRATION, RENEWAL: Unless you notify us at least 90 days prior to the expiration of the Lease of your election to return or purchase the Equipment, this Lease will renew on a month-to-month basis at the same monthly Lease Payment until you either exercise the purchase option or provide us with at least 90 days notice and return the Equipment. If you return the Equipment, (i) it must be to the location we designate and you are responsible for all return costs and we may charge a Restocking Fee equal to one Lease Payment, and (ii) you must securely remove all data from any and all disk drives or magnetic media prior to returning the Equipment (and you are solely responsible for selecting an appropriate removal standard that meets your business needs and complies with applicable laws). You will pay us for any loss in value resulting from failure to maintain the Equipment in accordance with this Lease or for damages incurred in shipping and handling. If you exercise a purchase option we will convey all of our interest in such Equipment to you on an AS-IS WHERE IS basis without representation or warranty.
5. LATE FEES AND CHARGES: If any amount is not paid within three (3) days of when due, you agree to pay us a late charge equal to the lesser of 10% of the amount past due or the maximum legal amount. Amounts which are not paid within 30 days of when due shall accrue interest at 1.5% per month (or if less, the maximum legal rate) until paid. You agree to pay \$25 for each pay by phone and \$35 for each returned payment.
6. NO WARRANTY: We do not manufacture the Equipment and you have selected the Equipment and the supplier. WE MAKE NO EXPRESS OR IMPLIED WARRANTIES, INCLUDING THOSE OF MERCHANTABILITY OR FITNESS FOR A PURPOSE AND ARE NOT RESPONSIBLE FOR CONSEQUENTIAL OR INCIDENTAL DAMAGES.
7. INSURANCE, RISK OF LOSS: You bear all risk of loss or damage to the Equipment from its order until it is returned in the required condition or purchased by you ("Risk Period"). During the Risk Period you will maintain property and liability insurance on the Equipment acceptable to us, naming us loss payee and additional insured. If you do not

provide us with proof of such insurance, we may secure insurance on the Equipment to cover our interests (and only our interests). If we obtain such insurance, you will pay us an additional amount for the cost of such insurance and an administrative fee, the cost of which may be more than the cost to obtain your own insurance and on which we may make a profit.

8. OWNERSHIP AND TAXES: We own the Equipment (excluding licensed software). If you are deemed to own it, you grant us a security interest in the Equipment. You authorize us to file UCC financing statements to confirm our interest. You will pay, when due, all taxes, fines and penalties relating to the purchase, use, leasing and/or ownership of the Equipment. If we pay any taxes, (including property tax), fees or penalties on your behalf, you will pay us the amount we paid plus an administrative fee. You agree to pay us the documentation fee specified above or if not so specified, the greater of either \$125 or 0.5% of the Equipment cost. If we require an Equipment site inspection, or you request administrative services, you agree to reimburse our costs.

9. DEFAULT: If you or any guarantor do not pay us any amount within ten (10) days of its due date, or breach any terms of this Lease, any guaranty or any license relating to the Equipment, you will be in default. If you default, we may require you to do any combination of the following: (a) immediately pay all amounts then due, plus the present value of the remaining Lease Payments, Interim Rent and residual value of the Equipment, as determined by us, discounted at an annual rate of 3%; (b) return all of the Equipment; (c) allow us to repossess the Equipment; or (d) use any and all remedies available to us under applicable law. If you default, you agree to pay the cost of repossession and our attorney's fees and costs. In addition to all other charges and as reimbursement for expenses incurred and not as a penalty, we may require you to reimburse us for the phone calls, letters, and any additional expense incurred in the collection or servicing of this Lease for you. If we take possession of the Equipment, we may sell or otherwise dispose of it with or without notice, at a public or private sale, and apply the net proceeds (after we have deducted all costs related to the sale or disposition of the Equipment) to the amounts that you owe us. You agree that if notice of sale is required by law, 10 days' notice shall constitute reasonable notice. You remain responsible for any amounts that are due after we have applied such net proceeds. We may apply any security deposits to your obligations and if you do not default, the balance will be refunded without interest.

10. ASSIGNMENT: You have no right to sell or assign the Equipment or Lease. We may sell or assign our rights in the Lease and/or Equipment and the new owner will have all our rights but will not be subject to any claim or defense you have against us.

11. ARTICLE 2A: You agree this Lease is a "finance lease" as defined in Article 2A of the Uniform Commercial Code. You waive all rights and remedies conferred upon a lessee by Article 2A (508-522) of the UCC. You have received a copy of the Supply Contract or been informed of the identity of the Supplier and you may have rights under the Supply Contract and may contact the Supplier for a description of those rights.

12. CREDIT INFORMATION: You authorize us or any of our affiliates to obtain credit bureau reports, and make other credit inquiries that we deem necessary.

13. CHOICE OF LAW: THIS LEASE WILL BE GOVERNED BY PENNSYLVANIA LAW. YOU CONSENT TO JURISDICTION IN THE STATE OR FEDERAL COURTS IN PENNSYLVANIA AND WAIVE ANY RIGHT TO A TRIAL BY JURY.

14. MISCELLANEOUS: This Lease is the parties' entire agreement and can be amended only in writing signed by both parties. This Lease may be executed in counterparts (manually or by electronic means) and, when transmitted to us shall be binding upon you for all purposes. This Lease is not binding on us until we sign it. You agree not to raise as a defense to the enforcement of this Lease that it was executed or transmitted to us by electronic means. You will use the Equipment only for business purposes and not for personal, family or household use.

ACCEPTED BY LESSEE: Independent School District 709
Print Name:
Title:
X Lessee Authorized Signature
E-Mail Address:
Date:

PERSONAL GUARANTY: Undersigned guarantees that Lessee will make all payments and perform all other obligations under the Lease when due. Undersigned agrees that this is a guaranty of payment and not of collection, and that we can proceed directly against undersigned without first proceeding against Lessee or the Equipment. Undersigned also waives all suretyship defenses and notification if the Lessee is in default and consents to any extensions or modifications granted to Lessee. Undersigned will pay us all expenses (including attorneys' fees) we incur in enforcing our rights against undersigned or Lessee. If more than one person signs this guaranty, each agrees that his/her liability is joint and several. Undersigned authorizes us and our affiliates to obtain credit bureau reports and make inquiries regarding undersigned's personal credit. You consent to jurisdiction in the State or Federal courts in Pennsylvania and expressly waive any right to a trial by jury.

SIGNED X
Print Name:
E-Mail Address:
Accepted by:
LEAF Capital Funding, LLC By:
Title:
Date:



SCHEDULE A TO LEASE AGREEMENT
(EQUIPMENT DESCRIPTION)

Lease Application No.: **418880**

QNT	Equipment Description	New/Used	Make	Model	Serial Number
-----	-----------------------	----------	------	-------	---------------

Location: 215 N 1st Ave E, Duluth, MN 55802-2069

1	Konica Minolta bizhub Press C2060 Copier System	New
---	---	-----

LESSEE: Independent School District 709

LEAF CAPITAL FUNDING, LLC

BY: _____

BY: _____

PRINT NAME: _____

PRINT NAME: _____

TITLE: _____

TITLE: _____

DATE: _____

DATE: _____



State and Local Government Addendum

Reference: Application No. 418880

This State and Local Government Addendum (this "Addendum") is made part of the Agreement related to the above referenced application number ("Agreement") between **LEAF Capital Funding, LLC** ("we" "us" and "ours") and **Independent School District 709** ("you" and "your"). Capitalized terms used but not defined will have the meaning given to them in the Agreement. If there is any conflict between the terms of this Addendum and the terms of the Agreement, the terms of this Addendum will control and prevail. The parties hereby agree as follows:

1. Funding Intent. You reasonably believe that funds can be obtained sufficient to make all Payments set forth in the Agreement and any other amounts owed during the term of the Agreement. You agree that your chief executive or administrative officer (or your administrative office that has the responsibility of preparing the budget submitted to your governing body, as applicable) will provide for funding for such payments in your annual budget request submitted to your governing body. You covenant that you will do all things lawfully within your power to obtain, maintain and properly request and pursue funds from which the Payments may be made, including making provisions for such payments to the extent necessary in each budget submitted for the purpose of obtaining funding, using your best efforts to have such portion of the budget approved and exhausting all available administrative reviews and appeals in the event such portion of the budget is not approved. If your governing body chooses not to appropriate funds for such payments, you agree that your governing body will evidence such nonappropriation by omitting funds for such payments due during the applicable fiscal period from the budget that it adopts. You and we agree that your obligation to make payments under the Agreement will be your current expense and will not be interpreted to be a debt in violation of applicable law or constitutional limitations or requirements. Nothing contained in the Agreement will be interpreted as a pledge of your general tax revenues, funds or moneys.

2. Nonappropriation of Funds. If (a) sufficient funds are not appropriated and budgeted by your governing body in any fiscal period for Payments set forth in the Agreement or any other amounts owed to us and (b) you have exhausted all funds legally available for such payments due under the Agreement (together, a "Non-Appropriation Event"), then you will give us not less than ninety (90) days written notice (a "Termination Notice") and the Agreement will terminate as of the last day of your fiscal period for which funds for such payments are available ("Termination Date"). Such termination is without any expense or penalty, except for the portions of such payments and those expenses associated with your return of the Equipment in accordance with the Agreement for which funds have been budgeted or appropriated or are otherwise legally available. You agree that, to the extent permitted by law, you will not terminate the Agreement if any funds are appropriated by you or to you for the acquisition or use of equipment or services performing functions similar to the Equipment during your fiscal period in which such termination would occur. You shall (i) on or before the Termination Date, return the Equipment in accordance with the return requirements set forth in the Agreement, (ii) provide in the Termination Notice a certification of a responsible official that a Non-Appropriation Event has occurred, (iii) deliver to us, upon our request, an opinion of your counsel (addressed to us) verifying that the Non-Appropriation Event as set forth in the Termination Notice has occurred, and (iv) pay us all sums payable to us under the Agreement up to and including the Termination Date. You acknowledge and agree that, in the event of the termination of the Agreement and the return of the Equipment as provided for herein, you shall have no interest whatsoever in the Equipment or proceeds thereof and we shall be entitled to retain for our own account the proceeds resulting from any disposition or re-leasing of the Equipment along with any advance rentals, security deposits or other sums previously paid by you pursuant to the terms of the Agreement.

3. Authority and Authorization. You represent and agree that: (a) you are a state or a political subdivision or agency of a state; (b) the entering into and performance of the Agreement is authorized under your state laws and Constitution and does not violate or contradict any judgment, law, order, or regulation, or cause any default under any agreement to which you are party; (c) you have complied with all bidding requirements and, where necessary, have properly presented the Agreement for approval and adoption as a valid obligation on your part; and (d) you have sufficient appropriated funds or other moneys available to pay all amounts due under the Agreement for your current fiscal period. Upon our request, you agree to provide us with an opinion of counsel as to clauses (a) through (d) above, an incumbency certificate, and other documents that we request, with all such documents being in a form satisfactory to us.

4. **Government Use.** You agree that (a) you will comply with all information reporting requirements of the Internal Revenue Code of 1986, as amended, including but not limited to the execution and delivery to us of information statements requested by us, and (b) the use of the Equipment is essential for your proper, efficient and economic operation, you will be the only entity to use the Equipment during the term of the Agreement and you will use the Equipment only for your governmental purposes. Upon our request you will provide us with an essential use letter in a form satisfactory to us as to clause (b) above.

5. **Insurance.** You agree to provide and maintain at your own expense (a) property insurance against the loss, theft, destruction of, or damage to, the Equipment for its full replacement value, naming us as loss payee, and (b) public liability and third party property insurance, naming us as an additional insured. You will give us certificates or other evidence of such insurance on the Equipment at such times as we request. All insurance obtained from a third party insurer will be in a form, amount and with companies acceptable to us, and will provide that we will be given 30 days' advance notice of any cancellation or material change of such insurance. If you do not provide us with proof of such insurance, we may secure insurance on the Equipment to cover our interests (and only our interests). If we obtain such insurance, you will pay us an additional amount for the cost of such insurance and an administrative fee, the cost of which may be more than the cost to obtain your own insurance and on which we may make a profit.

6. **Indemnification.** With respect to any claims, actions, or suits that are made against us as a result of your actions, omissions, negligence or willful misconduct ("Claims"), to the extent permitted by law, you agree to reimburse us for, and if we request, defend us against, any such Claims.

7. **Choice of Law.** Regardless of any conflicting provision in the Agreement, **THE AGREEMENT WILL BE GOVERNED BY THE LAWS OF THE STATE IN WHICH YOU ARE LOCATED.**

8. This Addendum supplements and amends the Agreement only to the extent and in the manner set forth, and in all other respects, the Agreement will remain in full force and effect.

IN WITNESS WHEREOF the parties hereto, by their authorized signatories, have executed this Addendum at the date set forth below their respective signatures.

CUSTOMER: Independent School District 709	LEAF CAPITAL FUNDING, LLC
By: _____	By: _____
Print	Print
Name: _____	Name: _____
Title: _____	Title: _____
Date: _____	Date: _____

RESOLUTION
Maximum Levy Certification

WHEREAS, the School Board of Independent School District No. 709, St. Louis County, Minnesota, will hold a regular school board meeting on December 19, 2017 at 6:30 PM in the Board Room of the Historic Old Central High School, and will receive input from the public on the proposed certified levy for 2017 payable in 2018.

THEREFORE BE IT RESOLVED, that the School Board propose the ceiling for the tax levy for Independent School District No. 709 for 2017 payable 2018 at the maximum amount.

RESOLUTION
Rockridge School Renovation

WHEREAS, Independent School District 709 currently has a lease for a building located at 110 West Redwing Street that houses the Woodland Hills Academy, State location number 580; and

WHEREAS, ISD No. 709's current lease is expiring on 12/31/2017 for the building located at 110 West Redwing Street that houses the Woodland Hills Academy; and

WHEREAS, staff evaluation of available spaces has led to a location for the Woodland Hills Academy at the District Owned building located at 4849 Ivanhoe Street formerly known as Rockridge Elementary School; and

WHEREAS, there is deferred maintenance and remodeling that needs to take place at this site to effectively run the operation for the Woodland Hills Academy currently known as "The Hills"; and

WHEREAS, the current schedule needed in order to complete this project by the lease expiration date is critical;

NOW, THEREFORE, BE IT RESOLVED that the School Board of ISD No. 709, St. Louis County, State of Minnesota, directs the District's Administration to finalize the project construction scope to maximize the efficiency of the dollars spent and work accomplished, and upon finalization of such project scope, does grant the authority for the School Board Chair to enter into agreement and execute an AIA agreement with Kraus-Anderson Construction Company, through the National Joint Powers Alliance (NJPA) procurement contract MN02IR-042517-KRU. This contract is in a **not to exceed amount of \$2,700,000.00** for the construction work on the project.

**Expenditure Contracts Signed
August 2017**

For your information, the Superintendent or the Executive Director of Business Services has signed the following expenditure contracts during the month of August 2017:

Name	Amount	Source	Description
Schick Corporate Learning	\$1,000.00	Child Nutrition	Presentation
Tara Frisbie, RD	\$5,000.00	Child Nutrition	Menu analysis, menu compliance and special diet menus (contract renewal)
Kathy Hermes	\$1,700.00	Curriculum	Professional development training
Lake Superior College	\$14,000.00	Curriculum	Amendment to contract signed in July; increase from \$12,000.00 to \$14,000.00
Amy Anderson	\$1,000.00	Denfeld	Professional development training
John Hoban	\$10,000.00	Facilities	HVAC temporary winter position (contract renewal)
Jessica Vargason	\$12,000.00	Head Start	Nutritionist
Emily Engel	\$6,000.00	Special Services	Deaf /Hard of Hearing Interpreter
Amanda Gilderman	\$6,000.00	Special Services	Deaf /Hard of Hearing Interpreter
KY Interpreter Services	\$6,000.00	Special Services	Deaf /Hard of Hearing Interpreter
TIES Consulting Services	\$1,700.00	Technology	Training on cyber security
The Westlund Group	\$5,000.00	Technology	Telecommunications standards
Aardvark	\$840.00	Technology	Ransomware containment and mitigation protection

AGREEMENT

THIS AGREEMENT, made and entered into this 3rd day of August, 2017, by and between Independent School District #709, a public corporation, hereinafter called District, and Ted Schick, Schick Corporate Learning, an independent contractor, hereinafter called Contractor.

THE PURPOSE OF THE AGREEMENT is to set out the terms and conditions whereby Contractor will provide programs or services for the District at the times and locations set forth in this Agreement.

The terms and conditions of this Agreement are as follows:

1. **Dates of Service.** This Agreement shall be deemed to be effective as of August 29, 2017, and shall remain in effect until August 30, 2017, unless terminated earlier as provided for herein, or unless and until all obligations set forth in this Agreement have been satisfactorily fulfilled, whichever occurs first.
2. **Performance.** (Speaker for the Back to ^{School} Session for Child Nutrition)
3. **Contract Documents.** It is understood that this Contract consists of the following:
 1. Printed Memoranda of Agreement and Title Sheet;
 2. Advertisement for Quotes, Contractor's Quote, and Quote Tabulation;
 3. Contractors Insurance Policy;
 4. Supplementary Conditions and Insurance Requirements; and
 5. Any other documents identified by the District.
4. **Background Check .** (Applies to contractors working independent with students)

Contractor must provide an executed criminal history consent form and a money order or check payable to the District in an amount equal to the actual cost of conducting a criminal history background check on all of its employees assigned to the program. Contractor is precluded from performance of contract until the results of the criminal background check(s) are on file.

5. **Reimbursement.** In consideration of the performance of Contractor of its obligations pursuant to this Agreement, District hereby agrees to reimburse Contractor for its services and expenses in performing said obligations up to a sum not to exceed \$1,000.00. Contractors are required by Minnesota Statutes, Section 270.66, subd. 3, to provide their Taxpayer Identification Number (TIN) used in the enforcement of Federal and State tax laws. The TIN will be available to Federal and State tax authorities and State personnel involved in the payment of State obligations. This Agreement will not be approved unless the TIN is provided.

6. **Requests for Reimbursement.** The terms of payment under this Agreement are as follows:

- a. Payment shall be made by the District within 30 days of submission of a proper invoice by the Contractor;

- b. Any other terms of payment in the performance of services are incorporated by reference in this Agreement.

7. **Propriety of Expenses.** The fact that the District has reimbursed Contractor for any expense claimed by Contractor shall not preclude District from questioning the propriety of any such item. District reserves the right to offset any overpayment or disallowance of any item or items at any time under this Agreement by reducing future payments to Contractor. This clause shall not be construed to bar any other legal remedies District may have to recover funds expended by Contractor for disallowed costs, or to seek other damages.

8. **Ownership of Materials.** The District reserves the rights to reproduce the documents that are the subject of the Contract, in any form, in any fashion, or appropriate the contents of the documents, or any portion thereof, to its own use for any and all programs, forms and other materials that Contractor has provided, prepared, or utilized in performance of the terms of this Agreement.

9. **Independent Contractor.** Both the District and Contractor agree that the Contractor will act as an independent contractor in the performance of its duties under this Agreement and is not an employee of the District. Nothing contained in this Agreement shall be construed as in any manner creating a relationship of joint venture between the parties, which shall remain independent contractors with respect to all actions performed pursuant to this Agreement.

Accordingly, Contractor shall be responsible for payment of all taxes, including Federal, State, and local taxes, arising out of Contractor's activities in accordance with this Agreement, including by way of illustration, but not limited to, Federal and State income tax, Social Security tax, Unemployment Insurance taxes, workers compensations, and any other taxes or business license fees as required.

10. **Indemnity and defense of the District.** Contractor hereby agrees to defend, indemnify and hold the District harmless from all claims relating to its work pursuant to this Agreement.

In the event that Contractor breaches its obligation to defend, indemnify and hold the District harmless, then in addition to its other damages the District shall be entitled to recover its attorney's fees and costs and disbursements incurred in enforcing this Agreement.

11. **Notices.** All notices to be given by Contractor to District shall be deemed to have been given by depositing the same in writing in the United States Mail care of _____, ISD 709, Duluth Public Schools, 215 North 1st Avenue East, Duluth, MN 55802. All notices to be given by District to Contractor shall be deemed to have been given by depositing the same in writing in the United States Mail _____ (mailing address including Zip Code).

12. **Assignment.** Contractor shall not in any way assign or transfer any of its rights, interests or obligations under this Agreement in any way whatsoever without the prior written approval of the District.

13. **Modification or Amendment.** No amendment, change or modification of this Agreement shall be valid unless in writing signed by the parties' hereto.

14. **Governing Laws.** This Agreement, together with all its paragraphs, terms and provisions is made in the State of Minnesota and shall be construed and interpreted in accordance with the laws of the State of Minnesota without regard to conflict of laws considerations.

15. **Compliance with Laws.** The Contractor shall comply with all governing laws, rules and regulations, whether federal, state, local or those of the District. Those governing laws include but are not limited to Minnesota Statute 16C.05 (5) (formerly 1998 Minnesota Laws Ch. 386, Art. 1 Section 6) which Statute presently provides that the books, records, documents and accounting procedures and practices of the vendor or other party, that are relevant to the Contractor transaction, are subject to examination by the contracting agency and either the legislative auditor or the state auditor, as appropriate, for a minimum of six years. The other provisions of the Statute also apply.

The Contractor recognizes that, to the extent that competitive bidding requirements apply to this Contract, that those requirements apply to the award and performance of this Contract.

The Regulations of the District are incorporated into this Contract by reference and must be complied with whether or not specifically identified in this Contract.

16. **Entire Agreement.** This Agreement contains the entire understanding of the parties hereto with respect to the subject matter hereof and shall not be changed or otherwise altered except by written agreement of the parties.

17. **Cancellation.** Either party shall have the right to terminate this Agreement, without cause, upon (30) days written notice to the other party as provided for in this Agreement.

18. **Data Practices.** Contractor further understands and agrees that it shall be bound by the Minnesota Government Data Practices Act (Minnesota Statutes 13.03-13.04) with respect to "data on individuals"; as defined in 13.02, subd. 5 of that Statute) which it collects, receives, stores, uses, creates or disseminates pursuant to this Agreement.

19. **Insurance.** (If applicable) Contractor shall not commence work under the contract until they have obtained all the insurance described below and Duluth Public Schools has approved such insurance. Contractor shall maintain such insurance in force and effect throughout the term of the contract.

Contractor is required to maintain and furnish satisfactory evidence of the following insurance policies:

20. **Workers' Compensation Insurance:** Contractor must provide Worker's Compensation insurance for all its employees and, in case any work is subcontracted, Contractor will require the subcontractor to provide Workers' Compensation insurance in accordance with the statutory requirements of the State of Minnesota including Coverage B, Employer's Liability.

21. **Commercial General Liability:** Contractor is required to maintain insurance protecting it from claims for damages for bodily injury, including sickness or disease, death, and for care and loss of services as well as claims for property damage, including loss of use which may arise from operations under the Contract whether the operations are by the contractor or subcontractor or by anyone directly or indirectly employed under the contract.

The District shall be named an additional insured under said policy and proof of this insurance shall be provided to the District. This insurance shall be in at least the amount of \$2,000,000.

22. **Bonding.** Contractor shall provide such Payment and Performance Bonds as may be required, if any.

23. **Representatives of the District.** The Contractor shall perform work pursuant to this Agreement pursuant to the request and authority of the following persons:

<u>District Employee</u>	<u>Position</u>
Douglas Hasler	Director of Business Services

The Consultant shall report to the following persons regarding its work pursuant to this Agreement, or the designees:

<u>District Employee</u>	<u>Position</u>
Pamela Bowe, R.D.L.D.	Food Service Director

24. **Protection of the District.** To the extent that work by the Contractor or others on behalf of the District is to be planned, conducted, supervised or reviewed by the Contractor, the Contractor shall advise the District if such work:

- a. is not being performed pursuant to the plans and specifications, according to the best practice or in accordance with industry standards;
- b. should be rejected or modified;
- c. if the work should be performed in a different manner and whether other work should be performed;
- d. if the District should be advised of any other facts or opinions regarding that work.

In all respects, the Contractor shall represent the interests of the District and act to protect those interests and endeavor to guard the District against defects, deficiencies and omissions in the performance of the work.

25. **Negotiation, Mediation and Arbitration.** Any disputes between the parties shall first be negotiated. If the parties are not successful in negotiation, they then shall subject the dispute to mediation. If mediation is not successful, then any disputes between the district and the Consultant shall be resolved through binding arbitration. The arbitration shall be conducted in the State of Minnesota, and Minnesota law shall apply. Unless otherwise agreed by the parties, the arbitration shall be conducted pursuant to the rules of the American Arbitration Association.

Following the issuance of a demand for arbitration, any party to the arbitration shall be entitled to use all discovery methods permitted in the Minnesota Rules of Civil Procedures for the District courts. Once selected, the arbitrator shall hear any discovery disputes regarding discovery unless otherwise agreed by the parties.

AS EVIDENCE OF THEIR ASSENT TO THE TERMS AND CONDITIONS OF THIS AGREEMENT, set forth above, the parties hereto have caused this Agreement to be executed by their duly authorized officers as of the day and year first above written.

AGREEMENT

THIS AGREEMENT, made and entered into this 7th day of September, 2017, by and between Independent School District #709, a public corporation, hereinafter called District, and Tara Frisbie, R.D., an independent contractor, hereinafter called Contractor.

THE PURPOSE OF THE AGREEMENT is to set out the terms and conditions whereby Contractor will provide programs or services for the District at the times and locations set forth in this Agreement.

The terms and conditions of this Agreement are as follows:

1. **Dates of Service.** This Agreement shall be deemed to be effective as of September 7, 2017, and shall remain in effect until June 30, 2018, unless terminated earlier as provided for herein, or unless and until all obligations set forth in this Agreement have been satisfactorily fulfilled, whichever occurs first.
2. **Performance.** Work with Child Nutrition on nutritional menu analysis, menu compliance and special diet menus as scheduled by the Food Service Supervisor.
3. **Contract Documents.** It is understood that this Contract consists of the following:
 1. Printed Memoranda of Agreement and Title Sheet;
 2. Advertisement for Quotes, Contractor's Quote, and Quote Tabulation;
 3. Contractors Insurance Policy;
 4. Supplementary Conditions and Insurance Requirements; and
 5. Any other documents identified by the District.
4. **Background Check .** (Applies to contractors working independent with students)

Contractor must provide an executed criminal history consent form and a money order or check payable to the District in an amount equal to the actual cost of conducting a criminal history background check on all of its employees assigned to the program. Contractor is precluded from performance of contract until the results of the criminal background check(s) are on file.

5. **Reimbursement.** In consideration of the performance of Contractor of its obligations pursuant to this Agreement, District hereby agrees to reimburse Contractor for its services and expenses in performing said obligations up to a rate of \$22.00 per hour not to exceed \$5, 000. Contractors are required by Minnesota Statutes, Section 270.66, subd. 3, to provide their Taxpayer Identification Number (TIN) used in the enforcement of Federal and State tax laws. The TIN will be available to Federal and State tax authorities and State personnel involved in the payment of State obligations. This Agreement will not be approved unless the TIN is provided.

6. **Requests for Reimbursement.** The terms of payment under this Agreement are as follows:

- a. Payment shall be made by the District within 30 days of submission of a proper invoice by the Contractor;

- b. Any other terms of payment in the performance of services are incorporated by reference in this Agreement.

7. **Propriety of Expenses.** The fact that the District has reimbursed Contractor for any expense claimed by Contractor shall not preclude District from questioning the propriety of any such item. District reserves the right to offset any overpayment or disallowance of any item or items at any time under this Agreement by reducing future payments to Contractor. This clause shall not be construed to bar any other legal remedies District may have to recover funds expended by Contractor for disallowed costs, or to seek other damages.

8. **Ownership of Materials.** The District reserves the rights to reproduce the documents that are the subject of the Contract, in any form, in any fashion, or appropriate the contents of the documents, or any portion thereof, to its own use for any and all programs, forms and other materials that Contractor has provided, prepared, or utilized in performance of the terms of this Agreement.

9. **Independent Contractor.** Both the District and Contractor agree that the Contractor will act as an independent contractor in the performance of its duties under this Agreement and is not an employee of the District. Nothing contained in this Agreement shall be construed as in any manner creating a relationship of joint venture between the parties, which shall remain independent contractors with respect to all actions performed pursuant to this Agreement.

Accordingly, Contractor shall be responsible for payment of all taxes, including Federal, State, and local taxes, arising out of Contractor's activities in accordance with this Agreement, including by way of illustration, but not limited to, Federal and State income tax, Social Security tax, Unemployment Insurance taxes, workers compensations, and any other taxes or business license fees as required.

10. **Indemnity and defense of the District.** Contractor hereby agrees to defend, indemnify and hold the District harmless from all claims relating to its work pursuant to this Agreement.

In the event that Contractor breaches its obligation to defend, indemnify and hold the District harmless, then in addition to its other damages the District shall be entitled to recover its attorney's fees and costs and disbursements incurred in enforcing this Agreement.

11. **Notices.** All notices to be given by Contractor to District shall be deemed to have been given by depositing the same in writing in the United States Mail care of _____, ISD 709, Duluth Public Schools, 215 North 1st Avenue East, Duluth, MN 55802. All notices to be given by District to Contractor shall be deemed to have been given by depositing the same in writing in the United States Mail _____ (mailing address including Zip Code) _____.

12. **Assignment.** Contractor shall not in any way assign or transfer any of its rights, interests or obligations under this Agreement in any way whatsoever without the prior written approval of the District.

13. **Modification or Amendment.** No amendment, change or modification of this Agreement shall be valid unless in writing signed by the parties' hereto.

14. **Governing Laws.** This Agreement, together with all its paragraphs, terms and provisions is made in the State of Minnesota and shall be construed and interpreted in accordance with the laws of the State of Minnesota without regard to conflict of laws considerations.

15. **Compliance with Laws.** The Contractor shall comply with all governing laws, rules and regulations, whether federal, state, local or those of the District. Those governing laws include but are not limited to Minnesota Statute 16C.05 (5) (formerly 1998 Minnesota Laws Ch. 386, Art. 1 Section 6) which Statute presently provides that the books, records, documents and accounting procedures and practices of the vendor or other party, that are relevant to the Contractor transaction, are subject to examination by the contracting agency and either the legislative auditor or the state auditor, as appropriate, for a minimum of six years. The other provisions of the Statute also apply.

The Contractor recognizes that, to the extent that competitive bidding requirements apply to this Contract, that those requirements apply to the award and performance of this Contract.

The Regulations of the District are incorporated into this Contract by reference and must be complied with whether or not specifically identified in this Contract.

16. **Entire Agreement.** This Agreement contains the entire understanding of the parties hereto with respect to the subject matter hereof and shall not be changed or otherwise altered except by written agreement of the parties.

17. **Cancellation.** Either party shall have the right to terminate this Agreement, without cause, upon (30) days written notice to the other party as provided for in this Agreement.

18. **Data Practices.** Contractor further understands and agrees that it shall be bound by the Minnesota Government Data Practices Act (Minnesota Statutes 13.03-13.04) with respect to "data on individuals"; as defined in 13.02, subd. 5 of that Statute) which it collects, receives, stores, uses, creates or disseminates pursuant to this Agreement.

19. **Insurance.** (If applicable) Contractor shall not commence work under the contract until they have obtained all the insurance described below and Duluth Public Schools has approved such insurance. Contractor shall maintain such insurance in force and effect throughout the term of the contract.

Contractor is required to maintain and furnish satisfactory evidence of the following insurance policies:

20. **Workers' Compensation Insurance:** Contractor must provide Worker's Compensation insurance for all its employees and, in case any work is subcontracted, Contractor will require the subcontractor to provide Workers' Compensation insurance in accordance with the statutory requirements of the State of Minnesota including Coverage B, Employer's Liability.

21. **Commercial General Liability:** Contractor is required to maintain insurance protecting it from claims for damages for bodily injury, including sickness or disease, death, and for care and loss of services as well as claims for property damage, including loss of use which may arise from operations under the Contract whether the operations are by the contractor or subcontractor or by anyone directly or indirectly employed under the contract.

AS EVIDENCE OF THEIR ASSENT TO THE TERMS AND CONDITIONS OF THIS AGREEMENT, set forth above, the parties hereto have caused this Agreement to be executed by their duly authorized officers as of the day and year first above written.

INDEPENDENT SCHOOL DISTRICT NO. 709

CONTRACTOR

Samuel K. Lowe R.A.D.
Program Director

David Zucchi R.P. I.D.
Name

Douglas A. Hark
Director of Business Service

On file with the district
Taxpayer Identification Number

AGREEMENT

THIS AGREEMENT, made and entered into this 24th day of August, 2017, by and between Independent School District #709, a public corporation, hereinafter called District, and Kathy Hermes; Together for Youth / Lutheran Social Services, an independent contractor, hereinafter called Contractor.

THE PURPOSE OF THE AGREEMENT is to set out the terms and conditions whereby Contractor will provide programs or services for the District at the times and locations set forth in this Agreement.

The terms and conditions of this Agreement are as follows:

1. **Dates of Service.**

This Agreement shall be deemed to be effective as of 8/24/17, and shall remain in effect until 6/15/18, unless terminated earlier as provided for herein, or unless and until all obligations set forth in this Agreement have been satisfactorily fulfilled, whichever occurs first.

2. **Performance.**

Provide professional development to District Employees for up to 20 hours of training at \$85 per hour, not to exceed 20 hrs or \$1700. 2 trainings currently scheduled on 8/29/17 10:45am-Noon with Paraprofessional employees at East and 1-3:30pm with Early Childhood employees at Denfeld. Other dates to be determined as needed.

3. **Background Check .** (Applies to contractors working independent with students)

N/A for this contract. Contractor must provide an executed criminal history consent form and a money order or check payable to the District in an amount equal to the actual cost of conducting a criminal history background check on all of its employees assigned to the program. Contractor is precluded from performance of contract until the results of the criminal background check(s) are on file.

4. **Reimbursement.**

In consideration of the performance of Contractor of its obligations pursuant to this Agreement, District hereby agrees to reimburse Contractor for its services and expenses in performing said obligations up to a sum not to exceed \$85 per hour, not to exceed \$1700 for 20 hrs of training. Contractor is required by Minnesota Statutes, Section 270.66, subd. 3, to provide their Taxpayer Identification Number (TIN) used in the enforcement of Federal and State tax laws. The TIN will be available to Federal and State tax authorities and State personnel involved in the payment of State obligations. This Agreement will not be approved unless TIN is provided.

5. **Requests for Reimbursement.**

The terms of payment under this Agreement are as follows:

- a. Payment shall be made by the District within 30 days of submission of a proper invoice by the Contractor;
- b. Any other terms of payment in the performance of services are incorporated by reference in this Agreement.

6. **Propriety of Expenses.**

The fact that the District has reimbursed Contractor for any expense claimed by Contractor shall not preclude District from questioning the propriety of any such item. District reserves the right to offset any overpayment or disallowance of any item or items at any time under this Agreement by reducing future payments to Contractor. This clause shall not be construed to bar any other legal remedies District may have to recover funds expended by Contractor for disallowed costs.

7. **Ownership of Materials.**

The District reserves the rights to reproduce the programming in any fashion, or appropriate the contents of the programming, or any portion thereof, to its own use for any and all programs, forms and other materials that Contractor has provided, prepared, or utilized in performance of the terms of this Agreement.

8. **Independent Contractor.**

Both the District and Contractor agree that they will act as an independent contractor in the performance of its duties under this Agreement. Nothing contained in this Agreement shall be construed as in any manner creating a relationship of joint venture between the parties, which shall remain independent contractors with respect to all actions performed pursuant to this Agreement.

Accordingly, Contractor shall be responsible for payment of all taxes, including Federal, State, and local taxes, arising out of Contractor's activities in accordance with this Agreement, including by way of illustration, but not limited to, Federal and State income tax, Social Security tax, Unemployment Insurance taxes, workers compensations, and any other taxes or business license fees as required.

9. **Indemnity and defense of the District.**

Contractor hereby agrees to defend, indemnify and hold the District harmless from all claims relating to its work pursuant to this Agreement.

In the event that Contractor breaches its obligation to defend, indemnify and hold the District harmless, then in addition to its other damages the District shall be entitled to recover its attorney's fees and costs and disbursements incurred in enforcing this Agreement.

10. **Notices.**

All notices to be given by Contractor to District shall be deemed to have been given by depositing the same in writing in the United States Mail care of Ron Lake, ISD 709, Duluth Public Schools, 215 North 1st Avenue East, Duluth, MN 55802. All notices to be given by District to Contractor shall be deemed to have been given by depositing the same in writing in the United States mail Kathy Hermes; Lutheran Social Services, 424 West Superior Street, Suite 204, Duluth MN, 55802.

11. **Assignment.**

Contractor shall not in any way assign or transfer any of its rights, interests or obligations under this Agreement in any way whatsoever without the prior written approval of the District.

12. **Modification or Amendment.**

No amendment, change or modification of this Agreement shall be valid unless in writing signed by the parties' hereto.

13. **Governing Laws.**

This Agreement, together with all its paragraphs, terms and provisions is made in the State of Minnesota and shall be construed and interpreted in accordance with the laws of the State of Minnesota.

14. **Entire Agreement.**

This Agreement contains the entire understanding of the parties hereto with respect to the subject matter hereof and shall not be changed or otherwise altered except by written agreement of the parties.

15. **Cancellation.**

Either party shall have the right to terminate this Agreement, without cause, upon (30) days written notice to the other party as provided for in this Agreement.

16. **Data Practices.**

Contractor further understands and agrees that it shall be bound by the Minnesota Government Data Practices Act (Minnesota Statutes 13.03-13.04) with respect to "data on individuals"; as defined in 13.02, subd. 5 of that Statute) which it collects, receives, stores, uses, creates or disseminates pursuant to this Agreement.

17. **Insurance.**

(If applicable) Contractor shall not commence work under the contract until they have obtained all the insurance described below and Duluth Public Schools has approved such insurance. Contractor shall maintain such insurance in force and effect throughout the term of the contract.

Contractor is required to maintain and furnish satisfactory evidence of the following insurance policies:



Workers' Compensation Insurance:

Contractor must provide Worker's Compensation insurance for all its employees and, in case any work is subcontracted, Contractor will require the subcontractor to provide Workers' Compensation insurance in accordance with the statutory requirements of the State of Minnesota including Coverage B, Employer's Liability.

Commercial General Liability:

Contractor is required to maintain insurance protecting it from claims for damages for bodily injury, including sickness or disease, death, and for care and loss of services as well as claims for property damage, including loss of use which may arise from operations under the Contract whether the operations are by the contractor or subcontractor or by anyone directly or indirectly employed under the contract.

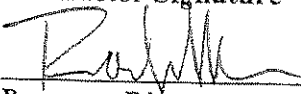
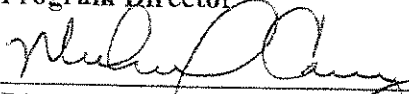
AS EVIDENCE OF THEIR ASSENT TO THE TERMS AND CONDITIONS OF THIS AGREEMENT, set forth above, the parties hereto have caused this Agreement to be executed by their duly authorized officers as of the day and year first above written.

Contractor Signature	SSN/Tax ID Number	Date
 RON LAKE		8/24/17
Program Director		Date
		8/24/17
Director of Curriculum and Instruction		Date
		8/28/17
CFO/Director of Business Services/Superintendent of Schools		Date

AS EVIDENCE OF THEIR ASSENT TO THE TERMS AND CONDITIONS OF THIS AGREEMENT, set forth above, the parties hereto have caused this Agreement to be executed by their duly authorized officers as of the day and year first above written.

Kathleen A. Hermes _____ 8-29-17
Contractor Signature SSN/Tax ID Number Date

James M. Bean _____ 8-29-17
Program Director Date

Director of Curriculum and Instruction Date

CFO/Director of Business Services/Superintendent of Schools Date

Amendment to LSC Contract Agreement for 2017-2018 School Year

Submitted prior to August 1, 2016 (No changes shall be revised after this date)

Change Requested: Add BIOL 1005 and 1140 taught by Alison Wood

Reason for Change: Addition of credentialed teacher

Payment change: \$14,000 (7 courses at \$2,000 per course)

REVISED COURSE LIST

The following courses will be covered under this Concurrent Enrollment agreement:

Course	Title	Credits	HS Instructor	LSC Faculty	Indicate Offerings (x)		
					Fall (Sept- Jan.)	Spring (Jan-June)	All Year (Sept-June)
*ALTH 1400	Intro to Allied Health (D&E)	2	Kimberly Olson	TBD	X		
*ALTH 1410	Medical Terminology (D&E)	1	Kimberly Olson	TBD	X		
*BIOL 1005	Intro to Cell Biology (E)	1	James Kyes	TBD			X
*BIOL 1140	Human Anat & Phys (E)	4	James Kyes	TBD			X
** *BIOL 1005	Intro to Cell Biology (D)	1	Alison Wood	TBD			X
** *BIOL 1140	Human Anat & Phys (D)	4	Alison Wood	TBD			X
MATH 1150	Pre-Calc (E)	5	Peter Graves	TBD			X
MATH 1150	Pre-Calc (D)	5	Ed Lewis	TBD			X
MATH 1150	Pre-Calc (E)	5	Bill Garnett	TBD			X
NUNA 1420	Nursing Asst/HHA (D&E)	4	Kimberly Olson	TBD		X	

*Courses are considered one course for one fee.

**Contingent upon submission and approval of Educational Plan

Duluth Public Schools



 Superintendent or Assistant Superintendent

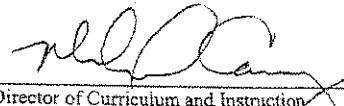

 Director of Curriculum and Instruction

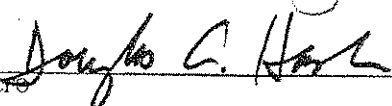

 CFO

8/16/17

 Date

Lake Superior College

 Jenna Trenberth, College in the Schools Coordinator

 Melissa Lenc, Director of Admissions

 Michael Seymour, VP Academic & Student Affairs

 Date

*Note: Contract not valid until all signatures are obtained Cc: LSC Business Office



**2017- 2018 Concurrent Enrollment
Between
Lake Superior College
And
Duluth Public Schools ISD #709**



PURPOSE

The Concurrent Enrollment or College in the Schools (CITS) program is available as part of the Post-Secondary Enrollment Option program. CITS allows high school students to earn both high school and college credit for classes offered through a high school and taught by a high school teacher.

This agreement between Duluth Public Schools (ISD #709) and Lake Superior College, Duluth, Minnesota is effective for the 2017-2018 academic year. The intent of this agreement is to provide Duluth Public Schools students an opportunity to enroll in Lake Superior College courses through Concurrent Enrollment to create a seamless educational path for area high school students. Lake Superior College will work cooperatively and in partnership with high school personnel and students to process registrations, validate course competencies, and transcribe grades.

COST

The cost to the high school is **\$2,000 per course per teacher**. If one teacher teaches multiple sections, it is one fee; if more than one teacher is assigned to separate sections of the same course, there is an additional fee of \$2,000.00 per teacher. The billing date for courses is November 1, 2017 with payment expected 30 days later. The total cost is **\$12,000 for the courses listed (\$2,000 x 6 courses = \$12,000)**.

TRANSCRIPTS

LSC College in the Schools staff works with high school staff to verify class rosters and final grades each term for the enrolled students, and LSC will record final course grades on an official LSC transcript. Students may request an official transcript by following the steps found here: <http://www.lsc.edu/current-students/records-registration/transcripts/>.

STUDENT QUALIFICATIONS

Students must meet minimum requirements for PSEO enrollment. For more information, please see <https://mnscu.edu/admissions/pseo/index.html>.

Eligibility:

- Seniors must rank in the top half of their class or have a 2.5 cumulative G.P.A.
- Juniors must rank in the top third of their high school class or have a 3.0 cumulative G.P.A.;
- Sophomores may enroll in specific Career and Technical Education (CTE) courses if they achieved the composite proficiency level of “meets or exceeds” on the 8th grade MCA reading test.
- Students must also meet the pre-requisites of individual courses, which may include Accuplacer scores, ACT scores, or prior college coursework.

INSTRUCTOR QUALIFICATIONS

High School instructors of CITS courses must meet the minimum qualifications set by the Minnesota State College Faculty Association and Minnesota State Colleges and Universities. Please refer to the following link: <http://www.cfc.mnscu.edu/fields/Code/credentials.php>

COLLABORATION REQUIREMENTS

Lake Superior College College in the Schools Staff

- Complete registration for each CITS class.
- Maintain registration, waiver, and grade records for all completed CITS classes.
- Adjust records for student in accordance with add/drop and withdrawal policies.

- Provide high schools with course outlines for each CITS class.
- Inform CITS students about academic and student support services available to all college students.
- Provide necessary registration, withdrawal, and add/drop policy tools and information.
- Provide transcript request information to all students.
- Send class lists to high school as soon as the registrations are complete.
- Work with each high school to ensure that CITS class lists are correct.
- Work with each high school to ensure all grades are submitted and transcribed.

Lake Superior College Faculty Mentors:

- Arrange to guest lecture if requested by the high school instructor.
- Collaborate with the high school CITS instructor to clarify approved college course outline and outcomes, to create a syllabus with the CITS instructor, and to verify the syllabus meets college criteria.
- Extend invitations to appropriate campus-based faculty development activities to CITS teachers.
- Meet regularly (face-to-face, email, telephone) with high school CITS instructor and monitor assignments, exams, projects, and instructional effectiveness to ensure course meets the learning outcomes in the LSC course outline.
- Make at least one visit to the high school per course.
- Upon request, provide current college text information, course outlines, sample syllabi, sample exams, assignments, and exercises for the high school CITS teacher's use.
- Provide instructors who have taught the course previously with copies of new course outlines, new calendars, schedules, or other information as courses change.
- Create records of site visits and course evaluations per NACEP accreditation requirements.
- Support CITS instructors, giving additional time and attention to instructors new to the program.

High School Instructors, Administrators, and Staff:

- Notify parents/students of CITS course offerings and student eligibility.
- To the extent possible, provide counseling services to students and their parents or guardian before students enroll in CITS courses to ensure students and their parents/guardians are fully aware of the risks and possible consequences of enrolling in CITS courses.
- Agree to terms of the LSC policy for add/drop processes and withdrawals and contact the LSC CITS staff for withdrawals in accordance with LSC policy.
- Collaborate with LSC staff to administer Accuplacer test to potential CITS students and/or provide ACT scores to assure compliance with PSEO eligibility requirements.
- Ensure completion of LSC registration forms and verify class rosters.
- Assign final, whole letter grades to each student on the class rosters provided by LSC's CITS staff and share grades with LSC CITS staff for recording.
- Meet regularly (face-to-face, email, telephone) with LSC faculty mentor.
- Provide LSC with a course syllabus and sample assignments, exams, projects for each CITS course to ensure the course meets the learning outcomes in the LSC course outline.
- Ensure teachers of CITS courses comply with the Minnesota State credentialing policy.
- Assist LSC staff in administering course evaluations for each CITS course in keeping with NACEP accreditation requirements.
- Participate in professional development opportunities offered by LSC in keeping with NACEP accreditation requirements.
- Sign CITS contract and return to LSC by April 28, 2017. Submit amendments by August 1, 2017 for the 2017-18 academic year. Submit new course proposals by April 28, 2017.

Cost: \$12,000

COURSES

The following courses will be covered under this Concurrent Enrollment agreement:

Course	Title	Credits	HS Instructor	LSC Faculty	Indicate Offerings (x)		
					Fall (Sept-Jan.)	Spring (Jan-June)	All Year (Sept-June)
*ALTH 1400	Intro to Allied Health (D&E)	2	Kimberly Olson	TBD	X		
*ALTH 1410	Medical Terminology (D&E)	1	Kimberly Olson	TBD	X		
*BIOL 1005	Intro to Cell Biology (E)	1	James Kyes	TBD			X
*BIOL 1140	Human Anat & Phys (E)	4	James Kyes	TBD			X
MATH 1150	Pre-Calc (E)	5	Peter Graves	TBD			X
MATH 1150	Pre-Calc (D)	5	Ed Lewis	TBD			X
MATH 1150	Pre-Calc (E)	5	Bill Garnett	TBD			X
NUNA 1420	Nursing Assit/HHA (D&E)	4	Kimberly Olson	TBD		X	

For multiple terms for a course, please indicate both terms with (x).
 *Courses are considered one course for one fee.

**SIGN
HERE**



Duluth Public Schools

[Signature]
 Superintendent or Assistant Superintendent

[Signature]
 Director of Curriculum and Instruction

Lake Superior College

Jenna Trenberth, College in the Schools Coordinator

 Melissa Leno, Director of Admissions

 Michael Seymour, VP Academic & Student Affairs

6/14/17

Date

*Note: Contract not valid until all signatures are obtained.
 Please pay close attention to designated terms of course offerings as LSC faculty mentor assignments must be made prior to start of terms.
 Changes/amendments to this contract must be made by August 1, 2017 for fall semester terms.
 Additions to the contract for spring term only courses may be considered if requested and approved by December 1, 2017.

[Signature]
 CFO

Contract Agreement

101

This Agreement, made and entered into this 1st day of August, 2017 by and between Independent School District #709, a public corporation, hereinafter called District, and Amy Anderson, and independent contractor, hereinafter called Contractor.

The purpose of the agreement is to set out the terms and conditions whereby Contractor will provide programs or services for the District at the times and locations set forth in this Agreement.

The terms and conditions of this Agreement are as follows:

1. **Dates of Service.** This Agreement shall be deemed to be effective as of August 1, 2017, and shall remain in effect until June 7, 2018 terminated earlier as provided for herein, or unless and until all obligations set forth in this Agreement have been satisfactorily fulfilled, whichever occurs first.
2. **Performance.** (Provide a separate page detailing a description of the programs or services to be performed by contractor, as well as the funding source for payment.)
3. **Reimbursement.** In consideration of the performance of Contractor of its obligations pursuant to this Agreement, District hereby agrees to reimburse Contractor for its services and expenses in performing said obligations up to a sum not to exceed \$1,000. Contractor is required by Minnesota Statutes, Section 270.66, subd. 3, to provide their Taxpayer Identification Number (TIN) used in the enforcement of Federal and State tax laws. The TIN will be available to Federal and State tax authorities and State personnel involved in the payment of State obligations. This Agreement will not be approved unless TIN is provided.
4. **Requests for Reimbursement.** Contractor shall request reimbursement on a monthly basis, using either the District Invoice OR the contractor's official invoice. This invoice must be submitted within 10 days of the end of the period being billed for.
5. **Propriety of Expenses.** The fact that the District has reimbursed Contractor for any expense claimed by Contractor shall not preclude District from questioning the propriety of any such item. District reserves the right to offset any overpayment or disallowance of any item or items at any time under this Agreement by reducing future payments to Contractor. This clause shall not be construed to bar any other legal remedies District may have to recover funds expended by Contractor for disallowed costs.
6. **Relationship.** It is agreed that nothing contained herein is intended to or shall be construed in any manner as creating or establishing a relationship between the parties for any purpose whatsoever. Contractor and its officers, agents, servants and employees shall not be construed as employees of the District and any and all claims which may or might arise under the Worker's Compensation Act on behalf of the Contractor's officers, agents, servants, or employees shall in no way be the responsibility of the District.
7. **Notices.** All notices to be given by Contractor to District shall be deemed to have been given by depositing the same in writing in the United States Mail care of Doug Hasler, Director of Budget & Finance, ISD709, Duluth Public Schools, 215 N. 1st Ave. E. Duluth, MN 55802. All notices to be given by District to Contractor shall be deemed to have been given by depositing the same in writing in the United States Mail to 1705 University Ave NE, Minneapolis MN 55413. (Mailing address, including zip code.

Finance ISD709, Duluth Public Schools, 215 N. 1st Ave. E. Duluth, MN 55802. All notices to be given by District to Contractor shall be deemed to have been given by depositing the same in writing in the United States Mail to 1705 University Ave NE, Minneapolis MN 55413. (Mailing address, including zip code.

- 9. **Assignment.** Contractor shall not in any way assign or transfer any of its rights, interests or obligations under this Agreement in any way whatsoever without the prior written approval of the District.
- 10. **Governing Laws.** This Agreement, together with all its paragraphs, terms and provisions is made in the State of Minnesota and shall be construed and interpreted in accordance with the laws of the State of Minnesota.
- 11. **Entire Agreement.** This Agreement contains the entire understanding of the parties hereto with respect to the subject matter hereof and shall not be changed or otherwise altered except by written agreement of the parties.
- 12. **Cancellation.** Either party shall have the right to terminate this Agreement, without cause, upon (30) days written notice to the other party as provided for in this Agreement.
- 13. **Data Practices.** Contractor further understands and agrees that it shall be bound by the Minnesota Government Data Practices Act (Minnesota Statutes 13.03-13.04) with respect to "data on individuals", as defined in 13.02, subd. 5 of that Statute) which it collects, receives, stores, uses, creates or disseminates pursuant to this Agreement.
- 14. **Insurance.** (If applicable)

As evidence of their assent to the terms and conditions of this agreement, set forth above, the parties hereto have caused this Agreement to be executed by their duly authorized officers as of the day and year first above written.

Independent School District #709

Contractor

Chair

Amy Anderson
Name

Clerk

Independent Contractor 8/1/17
Title Date

Program Director

Taxpayer Identification Number

Director of Budget and Finance

Date

Sent from my iPhone

On Aug 25, 2017, at 10:01 AM, Tonya Sconiers <tonya.sconiers@me.com> wrote:

Memorandum

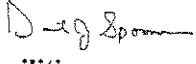
To: Doug Hasler
From: Dave Spooner 
Manager of Facilities
Date: August 29, 2017
Re: HVAC Temporary Winter Position

The District HVAC shop employs two personnel that maintain heating and ventilation systems district-wide. These positions are housed and work out of Facilities Management.

Currently we have 3 vacant buildings, which need inspection 3 times per week to ensure heating systems are operating correctly, and that there are no hazards that could impact building integrity. This weekly effort consumes 3 hours of time each day, with 9 hours total over the three days each week.

To properly focus our in-house staff on current regular work, I am recommending we temporarily hire John Hoban, in a similar manner as years past, to perform this vacant building inspection task, for a time period not to exceed 26 weeks, and a cost not to exceed \$10,000.

Recommendation:

I am recommending that we enter into agreement with John Hoban, in a temporary manner not to exceed 26 week, and not to exceed \$10,000, as per attached contract.

Enclosure(s)

AGREEMENT

THIS AGREEMENT, made and entered into this 19th day of September, 2017, by and between Independent School District No. 709, a public corporation, hereinafter called ISD 709, and Mr. John K. Hoban, an independent contractor, hereinafter called Contractor.

THE PURPOSE OF THE AGREEMENT is to set out the terms and conditions whereby Contractor will provide programs or services for ISD 709 at the times and locations set forth in this Agreement.

The terms and conditions of this Agreement are as follows:

1. **Dates of Service.** This Agreement shall be deemed to be effective as of Monday, October 30, 2017, and shall remain in effect until Friday, April 27, 2018, unless terminated earlier as provided for herein, or unless and until all obligations set forth in this Agreement have been satisfactorily fulfilled, whichever occurs first.
2. **Performance.** To work in the capacity as a School Equipment Maintenance Mechanic, performing work as assigned or directed, between the hours of 6:00 AM to 2:30 PM, Monday through Friday, for up to 26 weeks. Tasks assigned will be directly related to the attached position description. (Addendum A)
3. **Contract Documents.** It is understood that this Contract consists of the following:
 1. Printed Memoranda of Agreement;
 2. Any other documents identified by ISD 709.
4. **Reimbursement.** In consideration of the performance of Contractor of its obligations pursuant to this Agreement, ISD 709 hereby agrees to reimburse Contractor for its services and expenses in performing said obligations at a rate of \$32.68 per hour, up to a sum not to exceed \$10,000.00.
5. **Requests for Reimbursement.** The terms of payment under this Agreement are as follows:
 - a. Payment shall be made by ISD 709 within 30 days of submission of a proper invoice by the Contractor;
 - b. Any other terms of payment in the performance of services are incorporated by reference in this Agreement.
6. **Propriety of Expenses.** The fact that ISD 709 has reimbursed Contractor for any expense claimed by Contractor shall not preclude ISD 709 from questioning the propriety of any such item. ISD 709 reserves the right to offset any overpayment or disallowance of any item or items at any time under this Agreement by reducing future payments to Contractor. This clause shall not be construed to bar any other legal remedies ISD 709 may have to recover funds expended by Contractor for disallowed costs, or to seek other damages.
7. **Independent Contractor.** Both ISD 709 and Contractor agree that the Contractor will act as an independent contractor in the performance of its duties under this Agreement and is not an employee of ISD 709. Nothing contained in this Agreement shall be construed as in

any manner creating a relationship of joint venture between the parties, which shall remain independent contractors with respect to all actions performed pursuant to this Agreement.

8. **Indemnity and defense of ISD 709.** Contractor shall indemnify, hold harmless and defend ISD709, its employees, agents, successors and assigns, and their respective shareholders, directors, officers, employees and agents against and in respect to any and all claims, suits, actions, proceedings, investigations, judgments, deficiencies, damages, settlements, liabilities, general losses, costs and reasonable attorneys' fees, court costs and litigation expenses (collectively "Liabilities") which may arise out of, relate to or result from any act or omission of the Contractor.

In the event that Contractor breaches its obligation to defend, indemnify and hold ISD 709 harmless, then in addition to its other damages ISD 709 shall be entitled to recover its attorney's fees and costs and disbursements incurred in enforcing this Agreement.

9. **Notices.** All notices to be given by Contractor to ISD 709 shall be deemed to have been given by depositing the same in writing in the United States Mail care of Dave Spooner, ISD 709, Duluth Public Schools, 215 North 1st Avenue East, Duluth, MN 55802. All notices to be given by ISD 709 to Contractor shall be deemed to have been given by depositing the same in writing in the United States Mail to: John K. Hoban, 3352 Lindahl Road, Duluth MN 55810

10. **Assignment.** Contractor shall not in any way assign or transfer any of its rights, interests or obligations under this Agreement in any way whatsoever without the prior written approval of ISD 709.

11. **Modification or Amendment.** No amendment, change or modification of this Agreement shall be valid unless in writing signed by the parties' hereto.

12. **Entire Agreement.** This Agreement contains the entire understanding of the parties hereto with respect to the subject matter hereof and shall not be changed or otherwise altered except by written agreement of the parties.

13. **Cancellation.** Either party shall have the right to terminate this Agreement, without cause, upon 7 days written notice to the other party as provided for in this Agreement.

14. **Representatives of ISD 709.** The Contractor shall perform work pursuant to this Agreement pursuant to the request and authority of the following persons:

<u>ISD 709 Employee</u>	<u>Position</u>
Douglas Hasler	CFO

The Consultant shall report to the following persons regarding its work pursuant to this Agreement, or the designees:

<u>ISD 709 Employee</u>	<u>Position</u>
David Spooner	Manager of Facilities

AS EVIDENCE OF THEIR ASSENT TO THE TERMS AND CONDITIONS OF THIS AGREEMENT, set forth above, the parties hereto have caused this Agreement to be executed by their duly authorized officers as of the day and year first above written.

Contractor Signature

Joseph A. Horler

CFO/Executive Director of Business Services

Date

8/30/17

Date

AGREEMENT

THIS AGREEMENT, made and entered into this **23rd day of August, 2017**, by and between Independent School District #709, a public corporation, hereinafter called District, and **Jessica Vargason**, an independent contractor, hereinafter called Contractor.

THE PURPOSE OF THE AGREEMENT is to set out the terms and conditions whereby Contractor will provide programs or services for the District at the times and locations set forth in this Agreement.

The terms and conditions of this Agreement are as follows: (insert as appropriate)

1. **Dates of Service.** This Agreement shall be deemed to be effective as of **August 21, 2017**, and shall remain in effect until **June 30, 2018**, unless terminated earlier as provided for herein, or unless and until all obligations set forth in this Agreement have been satisfactorily fulfilled, whichever occurs first.

2. **Performance.** Please see attached job description.

3. **Background Check .** (Applies to contractors working independent with students)

Contractor must provide an executed criminal history consent form and a money order or check payable to the District in an amount equal to the actual cost of conducting a criminal history background check on all of its employees assigned to the program. Contractor is precluded from performance of contract until the results of the criminal background check(s) are on file.

4. **Reimbursement.** In consideration of the performance of Contractor of its obligations pursuant to this Agreement, District hereby agrees to reimburse Contractor for its services and expenses in performing said obligations at the rate of **\$27.00 per hour up to a sum not to exceed \$12,000**. Contractor is required by Minnesota Statutes, Section 270.66, subd. 3, to provide their Taxpayer Identification Number (TIN) used in the enforcement of Federal and State tax laws. The TIN will be available to Federal and State tax authorities and State personnel involved in the payment of State obligations. This Agreement will not be approved unless TIN is provided.

5. **Requests for Reimbursement.** The terms of payment under this Agreement are as follows:

- a. Payment shall be made by the District within 30 days of submission of a proper invoice by the Contractor;
- b. Any other terms of payment in the performance of services are incorporated by reference in this Agreement.

6. **Propriety of Expenses.** The fact that the District has reimbursed Contractor for any expense claimed by Contractor shall not preclude District from questioning the propriety of any such item. District reserves the right to offset any overpayment or disallowance of any item or items at any time under this Agreement by reducing future payments to Contractor.

This clause shall not be construed to bar any other legal remedies District may have to recover funds expended by Contractor for disallowed costs.

7. **Ownership of Materials.** The District reserves the rights to reproduce the programming in any fashion, or appropriate the contents of the programming, or any portion thereof, to its own use for any and all programs, forms and other materials that Contractor has provided, prepared, or utilized in performance of the terms of this Agreement.

8. **Independent Contractor.** Both the District and Contractor agree that they will act as an independent contractor in the performance of its duties under this Agreement. Nothing contained in this Agreement shall be construed as in any manner creating a relationship of joint venture between the parties, which shall remain independent contractors with respect to all actions performed pursuant to this Agreement.

Accordingly, Contractor shall be responsible for payment of all taxes, including Federal, State, and local taxes, arising out of Contractor's activities in accordance with this Agreement, including by way of illustration, but not limited to, Federal and State income tax, Social Security tax, Unemployment Insurance taxes, workers compensations, and any other taxes or business license fees as required.

9. **Indemnity and defense of the District.** Contractor hereby agrees to defend, indemnify and hold the District harmless from all claims relating to its work pursuant to this Agreement.

In the event that Contractor breaches its obligation to defend, indemnify and hold the District harmless, then in addition to its other damages the District shall be entitled to recover its attorney's fees and costs and disbursements incurred in enforcing this Agreement.

10. **Notices.** All notices to be given by Contractor to District shall be deemed to have been given by depositing the same in writing in the United States Mail care of Pam Rees, ISD 709, Duluth Public Schools, 215 North 1st Avenue East, Duluth, MN 55802. All notices to be given by District to Contractor shall be deemed to have been given by depositing the same in writing in the United States Mail

11. **Assignment.** Contractor shall not in any way assign or transfer any of its rights, interests or obligations under this Agreement in any way whatsoever without the prior written approval of the District.

12. **Modification or Amendment.** No amendment, change or modification of this Agreement shall be valid unless in writing signed by the parties' hereto.

13. **Governing Laws.** This Agreement, together with all its paragraphs, terms and provisions is made in the State of Minnesota and shall be construed and interpreted in accordance with the laws of the State of Minnesota.

14. **Entire Agreement.** This Agreement contains the entire understanding of the parties hereto with respect to the subject matter hereof and shall not be changed or otherwise altered except by written agreement of the parties.

15. **Cancellation.** Either party shall have the right to terminate this Agreement, without cause, upon (30) days written notice to the other party as provided for in this Agreement.

16. **Data Practices.** Contractor further understands and agrees that it shall be bound by the Minnesota Government Data Practices Act (Minnesota Statutes 13.03-13.04) with respect to "data on individuals"; as defined in 13.02, subd. 5 of that Statute) which it collects, receives, stores, uses, creates or disseminates pursuant to this Agreement.

17. **Insurance.** (If applicable) Contractor shall not commence work under the contract until they have obtained all the insurance described below and Duluth Public Schools has approved such insurance. Contractor shall maintain such insurance in force and effect throughout the term of the contract.

Contractor is required to maintain and furnish satisfactory evidence of the following insurance policies:

Workers' Compensation Insurance: Contractor must provide Worker's Compensation insurance for all its employees and, in case any work is subcontracted, Contractor will require the subcontractor to provide Workers' Compensation insurance in accordance with the statutory requirements of the State of Minnesota including Coverage B, Employer's Liability.

Commercial General Liability: Contractor is required to maintain insurance protecting it from claims for damages for bodily injury, including sickness or disease, death, and for care and loss of services as well as claims for property damage, including loss of use which may arise from operations under the Contract whether the operations are by the contractor or subcontractor or by anyone directly or indirectly employed under the contract.

AS EVIDENCE OF THEIR ASSENT TO THE TERMS AND CONDITIONS OF THIS AGREEMENT, set forth above, the parties hereto have caused this Agreement to be executed by their duly authorized officers as of the day and year first above written.

INDEPENDENT SCHOOL DISTRICT NO. 709
DULUTH HEAD START

CONTRACTOR- Nutrition Services Coordinator
Jessica Vargas 08/23/17

Chair

Title

Clerk

Title

[Signature]
Program Director

Taxpayer Identification Number

[Signature]
Director of Business Service

**DULUTH HEAD START
JOB DESCRIPTION**

JOB TITLE: Head Start Nutritionist/Dietitian

IMMEDIATE SUPERVISOR: Head Start Director

DEPARTMENT: ISD 709 E-12 Operations

PAY GRADE ASSIGNMENT: \$27.00 per hour

MINIMUM QUALIFICATIONS: Minimum Bachelor's degree in health, nutrition or related field and possesses a current registration with the Commission on Dietetic Registration of the American Dietetic Association or be eligible, registered and ready to take the examination. Have a current valid driver's license and access to reliable transportation.

DESIRED QUALIFICATIONS: Coursework and/or experience with families from a variety of social and cultural backgrounds and families living in economic poverty. Ability to demonstrate effective verbal and written communication skills and to work independently.

DUTIES AND RESPONSIBILITIES:

Overseeing program operations and compliance with Head Start Performance Standards and regulations in the area of food and nutrition;

Consult with the Health & Nutrition Services Coordinator

Review all child files for dietary and nutritional needs;

Develop monthly menus for breakfast, lunch and snack that meet nutritional guidelines and work with school district food service department to coordinate meal service;

Reflect cultural and ethnic preferences, and include a wide variety of foods;

Work with food service, nurse and families on special diets for identified food allergies

Monitor food safety practices;

Train staff on food safety and proper serving procedures in accordance with Head Start performance standards;

Monitor hemoglobin levels, height and weight on all children in order to identify potential problems and provide follow-up

Monitor and coordinate oral health activities in the program

Provide nutrition counseling and education to individual parents regarding the nutritional needs of their children;

Provide information and materials for nutrition education activities in the classroom;

Coordinate and provide nutrition education at parent meetings;

Consult with teachers regarding concerns about children's eating;

Update and revise nutrition area of the program plan;

Serve as liaison to nutrition and food resources in the community;

Member of Head Start Health Advisory Committee;

Other duties as assigned by supervisor.

Contract between Duluth Public Schools
And
Emily Engel

THIS CONTRACT, entered into this August 24th, 2017 by and between Duluth Public Schools (hereinafter referred to as DISTRICT), and Emily Engel (hereinafter referred to as CONSULTANT).

NOW THEREFORE, the parties hereto agree as follows:

1. Consultant shall perform the following tasks: Deaf Hard of Hearing Interpreter for Special Education as needed.

2. Consideration and Conditions of Payment

a. In consideration for services provided under the terms of this contract, DISTRICT shall pay CONSULTANT per unit rate at the rate of \$40 per hour. This contract for consultant services shall observe a 48 business hour cancellation policy whereas services that are canceled 48 hours or more before the service date will not be billed. The CONSULTANT requires a two hour minimum (appearance fee). Also there will be a 10% differential for nights and weekends. Payments shall be made upon presentation of an invoice within 30 days of date of invoice. Total value of this contract shall not exceed \$6,000.



3. Term

This contract shall become effective on August 24th 2017 and shall remain in effect until June 9 2018. This contract may be cancelled prior to said termination date by either of the parties hereto upon thirty (30) days written notice and without showing cause.

4. Under this Contract the CONSULTANT is an independent contractor and is not an agent or an employee of the DISTRICT. CONSULTANT shall have no claim against the DISTRICT for vacation pay, sick leave, retirement benefits, social security, worker's compensation benefits, health or disability benefits, unemployment insurance, or employee benefits of any kind, the CONSULTANT shall be responsible for paying all taxes.

5. No changes may be made in the terms or conditions of this contract except by the mutual written consent of the parties hereto.

6. All services provided under this contract shall be performed to the DISTRICT. In the event that this contract is canceled prior to the termination date specified in clause 3, CONSULTANT shall be entitled to payment, determined on a pro rata basis, for work or services satisfactorily performed.

<u>Emily J Engel</u>	<u></u>	<u>8/24/17</u>
Consultant's Name	Consultant's Signature	Date
<u>Jessiah Beck</u>	<u></u>	<u>8/28/17</u>
District's Representative	Representative's Signature	Date

INDIVIDUAL OR AGENCY – INTERPRETER AGREEMENT

This Consultant Agreement is by and between KY Interpreting Services and ISD 709. Services to be provided and other details have been listed below.

Name/Agency: Amanda Gilderman

Address: 5278 S County Road P, Poplar, WI 54864-9114

Telephone #(s): 218-393-1882 cell 715-364-2922 home

Social Security or
Federal ID Number: _____

Description of Service

to be Provided: Interpreting Services as needed by the school district

Population to be

Served: students and staff requiring ASL-English interpreting Services

Location and times of Services: Any ISD 709 location

Required Qualifications: Nationally Certified Interpreter

File Folder # If Needed: _____

Date(s) of Service: 8/9/2017-7/31/2018

Rate of Pay: \$ 42 per hour with a two hour minimum

Invoicing Procedure: Payment due upon receipt of invoice

Cancellation Requirements: Organization reserves the right to cancel this agreement due to severe weather or low enrollment. In either case, organization assumes no financial obligation for this agreement

Relationship: The parties hereto are independent contractors. Nothing in this Agreement shall be understood or construed to create or imply any relationship between the parties in the nature of any joint venture, employer/employee, principal/agent or partnership. The provider shall not become an employee of the Agency by acting under this Agreement and the provider shall be responsible for the payment of any taxes, fees or costs resulting from the above compensation. If the compensation reaches \$600 or more, a 1099 will be issued to this provider at the end of the calendar year.

Miscellaneous: This Agreement shall be governed by and construed exclusively in accordance with the laws of the State of MN. This Agreement may not be assigned without the written consent of the other party. Any copy of this document shall be considered to have the binding and legal effect of an original document. Contract not to exceed \$6,000.00

SIGNATURES

ISD 709 Representative _____ Date

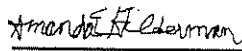
 8/9/2017
Interpreter _____ Date

RECEIVED

AUG 21 2017

HUMAN RESOURCES

INDIVIDUAL OR AGENCY - INTERPRETER AGREEMENT

This Consultant Agreement is by and between KY Interpreting Services and ISD 709. Services to be provided and other details have been listed below.

Name/Agency: KY Interpreter Referral Services
Address: 3251 Dahl Rd Duluth, MN 55804
Telephone #(s): 218-393-3504

Social Security or Federal ID Number: [REDACTED]

Description of Service to be Provided: Interpreting Services as needed by the school district
Population to be Served: students and staff requiring ASL-English interpreting Services

Location and times of Services: Any ISD 709 location

Required Qualifications: Nationally Certified Interpreter File Folder # If Needed:

Date(s) of Service: 7/1/17 - 6/30/18

Rate of Pay: \$ 65/hour - 2 hr Base rate

Invoicing Procedure: Invoices will be submitted monthly

Cancellation Requirements: Organization reserves the right to cancel this agreement due to severe weather or low enrollment. In either case, organization assumes no financial obligation for this agreement

Relationship: The parties hereto are independent contractors. Nothing in this Agreement shall be understood or construed to create or imply any relationship between the parties in the nature of any joint venture, employer/employee, principal/agent or partnership. The provider shall not become an employee of the Agency by acting under this Agreement and the provider shall be responsible for the payment of any taxes, fees or costs resulting from the above compensation. If the compensation reaches \$600 or more, a 1099 will be issued to this provider at the end of the calendar year. Not to exceed \$6,000.

Miscellaneous: This Agreement shall be governed by and construed exclusively in accordance with the laws of the State of MN. This Agreement may not be assigned without the written consent of the other party. Any copy of this document shall be considered to have the binding and legal effect of an original document.

SIGNATURES

[Signature]
ISD 709 Representative Date

[Signature] 8/3/17
Interpreter Date



TIES Consulting Services
STATEMENT OF WORK
Fixed Charge Project

Independent School District #709
215 North 1st Avenue East
Duluth, MN 55802

Primary Contact: Bart Smith Phone 218-236-8700ext1136 email bart.smith@isd709.org

This Statement of Work describes a **Fixed Charge Project**. This is for a specific project or task with a specified completion. It defines the scope, estimates labor costs and specifies other purchases and expenses needed to complete the work as defined. Work will be billed at a specified amount regardless of hours used. Subcontractor costs may be variable.

Project Name

Independent School District #709

Project Summary Description

Professional development training on cybersecurity

Project Timeline

Completion: August 29th, 2017

Project Scope and Deliverables

1. Presentation
2. Q&A Sessions

Items Out of Scope

All requests or previously unidentified tasks outside the scope of this project or task as described in this Statement of Work will be considered as additional work and will be added as a separate project or task. A Change Order addendum will be added or an additional Statement of Work will be created and work will be billed as an additional or separate cost.

Out of Scope Items:

Projected TIES Staff:

Ryan Cloutier Principal Security Architect

Recommended Products

Microphone, Projector, Internet connection

Prerequisites, Assumptions and Customer ResponsibilitiesPrerequisites and Assumptions:

1. TIES consultants will have access to the work areas in all appropriate locations during normal business hours.
2. Customer will be responsible to test functionality during the time period when TIES personnel are on-site.
3. Any changes to the project scope or deliverables as described here will require a written change order and will be charged and billed supplemental to this.

Customer to provide:

1. Supporting resources, facilities, equipment and local staff assistance as needed and applicable to the task
2. If requested, on-site technical contact while TIES personnel is on-site.

Cost Estimate and Payment Summary

Half day session of consulting including Travel time (millage list separately below)

\$1,500.00 USD for the training session

\$35.00 for Meals

\$165 for Mileage

Lodging included

\$1,700.00 total Engagement Price

Travel, Lodging and Related Expenses: Unless excluded or specified otherwise, all travel, lodging and related expenses will be expensed to the customer. Expenses will be at actual cost. Automobile expenses will be charged at the prevailing IRS mileage rate. Consultant travel time will be billed at half the current hourly rate for that consultant.

Materials and Supplies: While we attempt to estimate all costs involved in a project, additional materials and supplies that may be needed will be billed to the client at reasonable retail cost.

Work Outside Business Hours: Hourly rates are normally quoted based on standard Monday-Friday business hours. Work scheduled outside business hours (before 6AM or after 6PM weekdays, any time on weekends or holidays) will be billed at a 50% premium.

Customer Acceptance

Customer acknowledges that this Statement of Work correctly describes the scope of work desired, that the projected timelines are acceptable, that all prerequisites and assumptions are accurate, that all customer responsibilities will be met in a timely manner, and that all invoices will be paid when due.

Customer also acknowledges receipt of the accompanying TIES Technical Services Master Services Agreement that is hereby incorporated by reference.

The individual named below is executing this Contract on behalf of the Customer and is duly authorized to make the representations contained herein.

1 *Douglas A. Hasler*
Signed
Douglas A. Hasler
Printed name

8/24/17
Date

Completion Acknowledgement

Customer acknowledges that all work described in this statement of work and any addenda is complete and satisfactory.

Douglas A. Hasler
Signed
Douglas A. Hasler
Printed name

8/24/17
Date

August 16, 2017



Duluth Public Schools
Mr. Bart Smith
215 North First Avenue East
Duluth, Minnesota 55802

The Westlund Group, Inc.
12527 Central Ave NE
Suite 310
Blaine, MN 55434

Dear Mr. Smith:

Thank you for the opportunity to propose Technology Consulting services to assist Duluth Public Schools in the review and updating the District's Telecommunications Standards.

1. Scope of Basic Services included:

A. Coordination and Meetings:

- Meeting with Duluth Public Schools Staff.
- Review existing systems effectiveness.
- Research and review available documents.
- Research available product for review and recommendations.

B. Provide, in PDF format, proposed District Standards for:
Telecommunications Cabling System.
Classroom Presentation System.

2. Professional Services Fee:

We propose a fee of \$3,150.00 that will be invoiced monthly on an estimated percentage completed basis, plus reimbursable expenses.

3. Reimbursable Expenses:

Reimbursable expenses will be invoiced at actual cost. These expenses include, but may not be limited to, mileage at federal rate, lodging, per diem for meals, postage and delivery charges, specification and drawing reproduction.

4. Additional Services:

Additional services are work that is not defined and included above. This work will be completed after written authorization is received to proceed from a Duluth Public Schools authorized representative.

If the matters addressed above correctly set forth your understanding of our agreement, please indicate your acceptance and approval below and return one signed copy to The Westlund Group as our authorization to proceed.

We will be happy to meet with you and your staff to discuss any of these items as described above, at your convenience.

We look forward to working with you on this project. If you have any questions on the above information or would like to discuss any portion of this proposal in greater detail, please feel free to contact me at 763-767-2534 or email me at jwestlund@thewginc.com.

Sincerely,

The Westlund Group, Inc.

Jeff Westlund, RCDD, CTS
President

Accepted and agreed to on this date 8/21/17, 2017, by Duluth Public Schools

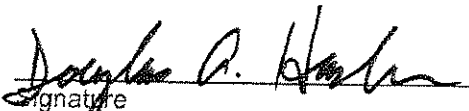
Signature

Douglas A. Hasler
Printed

CFO
Title

5. Other Terms:

This agreement shall be interpreted and enforced in accordance with the laws of the state of Minnesota.

Payments for professional services rendered and for reimbursable charges will be made within thirty days of receipt of invoice. Payments due under this Agreement will include a service charge of one percent (1.0%) per month on any amount not paid within thirty (30) days of receipt of invoice.

The Westlund Group, hereafter referred to as "TWG", agrees to use our best efforts in the performance of our Services. The Basic Services covered by this Agreement are estimated to be completed within three(9) months of the date hereof. If, at no fault of TWG, the Basic Services have not been completed, an extension of TWG's services beyond that time shall be compensated.

It is recognized that TWG has no control over the cost of materials or labor, competitive bidding, market or negotiating construction costs. Consequently, TWG cannot and does not warrant that bids or negotiated prices will not vary from any estimate or evaluation prepared.

Duluth Public Schools, hereafter referred to as "the Client", shall appoint a sole Representative with full authority to provide or obtain any necessary information and approvals that may be required by TWG. The Client shall provide accurate and complete information and materials to TWG and shall be responsible for the accuracy and completeness of all information and materials provided. The Client guarantees that all materials supplied to TWG are owned by the Client or that the Client has all necessary rights in such materials to permit TWG to use them for the Project.

This Agreement may be terminated by either party hereto upon ten (10) days written notice in the event the other party breaches any significant terms or conditions hereof through no fault of the party initiating the termination. In the event that TWG was not at fault, then TWG shall be paid for all services rendered and reimbursable expenses incurred up to the date of termination and all termination charges.

Claims, disputes and other matters in question between the Client and TWG relating to this Agreement shall be decided by arbitration in accordance with the Construction Industry Arbitration Rules of the American Arbitration Association. The award rendered by the arbitrator shall be final, and judgment may be entered upon it in accordance with applicable law in any court having jurisdiction thereof.

This letter contains the entire agreement of the parties with respect to the subject matter hereof and supersedes any previous proposals, understandings, commitments or representations whatsoever, oral or written. This Agreement shall not be varied except by written agreement of the same or subsequent date signed on behalf the Client and TWG by their respective duly authorized representatives.

This agreement may be executed by separate instrument in any number of counterparts whether in form of purchase order, acknowledgment, acceptance or other documents. However, acceptance of this Agreement by separate instrument is limited to the terms hereof. Further, any use of documents or information prepared by TWG utilized by the client shall constitute acceptance in whole of this agreement.

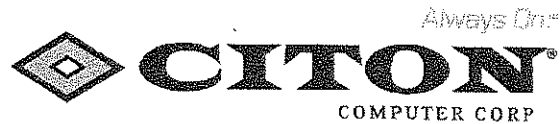
Aardvark Software as a Service Agreement

This Aardvark Software as a Service ("Agreement") is made by and between The Citon Computer Corporation, a Minnesota corporation ("Citon") and ISD 709 Duluth Schools ("Customer") as of the 1st day of July, 2017. For purposes of this Agreement, the "Effective Date" is defined as the date upon which "Citon" begins delivering the Service.

NOW, THEREFORE, in consideration of the mutual covenants contained herein, the parties agree as follows:

Customer requests that the Services be provided to cover the equipment listed on Citon proposal # CCCQ47389.

BACKGROUND RECITALS

- A. Customer has asked Citon to provide and Citon has agreed to provide the following computer related "Services":
- Premium ransomware containment and mitigation protection
 - Automatic Version Upgrades - no software or labor costs to upgrade to new version
 - Access to Citon's Aardvark Ransomware Defense Console.
 - Malware Notification - notification to your IT staff or designated staff when ransomware is detected
 - Automatic continuous protection

(the "Services").

1. **Incorporation of Background Recitals.** The Background Recitals set forth for each service listed below are true and correct statements of fact and are hereby incorporated into this Agreement by reference.
2. **Authority and Capacity.** The parties signing this Agreement warrant and represent that they have full legal authority to enter into this Agreement and any documents attached hereto or incorporated herein by reference.
3. **Price and Payment Arrangements for Services.** The price for the Services shall be \$70.00 per month paid in advance prior to the first day of the month via ACH from Customer's checking or savings account beginning 7/1/2017. Customer authorizes Citon Computer Corp to deduct monthly payment amount in accord with automatic payment authorization form. If payment is not received by the 10th day of any month, Citon reserves the right to suspend services to Customer until payment in full has been made. Citon reserves the right to decline sale or service should Customer's account balance with Citon become past due. Partial months will be pro-rated. Work performed will be tracked on a monthly basis and Citon will provide written notice to Customer indicating if an adjustment to the monthly price (increase or decrease) will be applied. Any services performed outside the scope of this agreement will be quoted individually and will be subject to Citon's standard terms and conditions, with payment due 10 days after invoice date.

The monthly price for Services is broken down as follows as outlined in Citon Proposal # CCCQ47389
One-time initial program launch of WAIVED to cover service setup, administrative costs and integration in to the Customer's network.

4. **Additional Equipment.** If Customer has or purchases additional equipment, the monthly fee for Services will automatically be increased at the beginning of the following month to cover the additional equipment based on the schedule above. Additional equipment must be inspected and certified as "fit for purpose" by Citon before it is covered under this service agreement.
5. **Equipment Retirement.** If Customer retires equipment that is not replaced in kind, the monthly fee for Services will automatically be decreased based on the schedule above at the beginning of the next month to account for the decrease in the need for support. Customer must notify Citon of the equipment retirement date via e-mail. Retroactive adjustments will not be made.
6. **Third Party Vendors Authorization.** Upon execution of this Agreement, Customer will provide Citon with letters of authorization to any computer or telephony related vendors authorizing Citon to request third party vendors' services

on Customers behalf and granting Citon access to all information necessary to perform said Services. Citon is not responsible for delays caused by third party vendors or costs incurred by Customer from third party vendors.

7. **Scheduled Maintenance Windows.** Citon will regularly install patches and critical updates to covered equipment to help ensure that Customer is protected against the latest vulnerability threats. For many of these updates to be installed properly, your server must be restarted. Citon will restart Customer's servers and/or workstations, as necessary, at an agreed upon time between Customer and Citon. If the expected downtime is greater than 15 minutes, Citon staff will contact Customer to inform of the outage. Customer reserves the right to request that Citon reschedule the outage to align with Customer's business needs.
8. **Rates.** Services and Products not covered under this Agreement shall be quoted separately and will be subject to Citon's Standard Terms and Conditions. Travel time for services covered under this agreement will not be billed. Travel time will be tracked on a monthly basis and Citon will provide written notice to Customer indicating if an adjustment to the monthly price (increase or decrease) will be applied. If additional trips on-site are required, travel time will be billed. Projects will be billed on a per project basis. Citon reserves the right to periodically increase its Base Rates, and will provide Customer with a minimum of 30 days written notice thereof.
9. **Term.** The Agreement Term shall commence upon the Effective Date and shall continue for a term of thirty-six (36) months. Once the Effective Date has passed, Customer must pay for the Services through the end of the Agreement Term regardless of whether Customer is actually using the Service throughout the duration of such Term. Following the expiration of the Agreement term and failure of the parties to enter into any agreement for extension thereof, this Agreement and Customer's right to use services shall continue in effect on a month-to month basis upon the same terms and conditions specified herein, unless terminated by either Customer or Citon upon thirty (30) days' prior written notice to the other party.
10. **Alterations to Services or Equipment.** If Customer alters any Services or Equipment covered under this Agreement without the express written consent of Citon, Customer does so at its own risk and expense. Citon shall not be liable or responsible for problems created as a result of Customer's alteration of Services, Equipment and/or Customer's network or system. If Customer wishes Citon to correct or fix its alterations or problems relating thereto, such Services by Citon will be considered a new project and Customer agrees that the same terms and conditions set out in this Agreement shall apply.
11. **Obligation to Back-up Software and Data.** Customer shall be responsible for maintaining backups of all critical software, documents, and applications on all of Customer's servers, workstations, personal computers, smart phones, etc as well as backups of all data on Customer's network. Customer is responsible for scheduling of backup jobs, changing of media and storage. In no event shall Citon be liable to Customer or any other person for any loss, cost or damage related to data. Citon recommends creation of a disaster recovery plan, with monthly test restores of backups and annual full tests of the plan, available from Citon as a special project outside the scope of this Agreement.
12. **Additional Terms and Conditions.** The parties agree that Citon's standard terms and conditions shall be incorporated into this Agreement. Customer acknowledges and agrees that it has read and understands Citon's standard terms and conditions. Anywhere a direct conflict exists between the Standard terms and Condition and this Agreement, the term in the Agreement shall prevail.
13. **Counterparts and Facsimile Signatures.** This Agreement may be executed in one or more counterparts and facsimile signatures shall be deemed as good as an original signature.
14. **Modification.** This Agreement may be amended or modified only in writing, signed by the parties.
15. **Binding Effect.** This Agreement shall be binding on all heirs, successors, and assigns of the parties.
16. **Entire Agreement.** This is the entire agreement between the parties regarding the services described. There are no other agreements or understandings, express or implied, except as set forth above.
17. **Other Client Responsibilities.** The following items will be the sole responsibility of Customer:
 - a. Customer will provide full and complete access, including admin usernames and password, to all equipment covered under agreement.

- 18. **Citon Service Stipulations.** The following stipulations are in place for the Services provided by Citon:
 - a. Citon may, at its discretion, place any product, hardware or software, on a DNR (Do Not Resuscitate) list, if continued problems are encountered. Once an item is placed on a DNR list it is no longer covered under the terms of this agreement and any further support will be billed on a time and materials basis.
 - b. In the course of providing service to Customer end users, Citon will deploy agent based software on each covered device. Unless otherwise specified in writing by Customer, Customer acknowledges and grants Citon remote unassisted access to covered devices. Citon warrants that per its confidentiality agreement no confidential information will be accessed, stored, saved, copied or removed from Customer systems.
 - c. Citon adheres to I.T. industry standard best practices for all support and recommendations. If best practices warrant an upgrade to any equipment or software such upgrade will be considered a special project and will be quoted and billed individually.
 - d. In addition to the stipulations in Section 3, Citon shall implement an automatic yearly percentage increase for Services based on the current Consumer Price Index.
- 19. **Notifications and Response.** Ransomware notifications will be sent to contact designated by Customer, as well as Citon's Network Operations Center (NOC). Response to a ransomware attack will be acted upon by Citon's NOC during regular business hours as defined in Citon's Standard Terms and Conditions and will be billable as outside the scope of this Agreement.
- 20. **Remediation Services.** Remediation of a ransomware attack on a covered device will be billable as outside the scope of this Agreement. Citon recommends that Customer have a Citon approved backup solution in place and regularly tested to assist with remediation of a ransomware attack.
- 21. **Equipment Coverage.** All domain connected windows devices should have Citon Aardvark installed; if Aardvark is not deployed on a domain connected windows device the efficacy of the solution will be diminished.
- 22. **Policy.** Aardvark will be deployed in accordance with the ransomware defense policy created in conjunction with the Customer.
- 23. **EULA.** Customer understands and accepts the Aardvark End User License Agreement.
- 24. **Exclusions.** The Services to be provided pursuant to this Agreement shall not include work on or related to the following:
 - a. Response to a ransomware attack outside of regular business hours is available via Citon's on-call engineer, and will be billable as out of scope.
 - b. Citon does not backup workstations under this Agreement. Attempted restoration of files or other data residing on the workstation is a special project not covered under the scope of this Agreement.
 - c. Remediation of any ransomware attack originating from a device WITHOUT Aardvark will be considered out of the scope of this Agreement, and billed as a special project.
 - d. If ransomware is detected on Customer's network and Customer decides to pay the ransom, the costs associated with that ransom will be paid 100% by Customer; in no circumstance will Citon directly pay or reimburse Customer for a ransom.

THE CITON COMPUTER CORPORATION

CUSTOMER:

By _____
 Title _____
 Date _____

By Joseph A. Hardin
 Title CEO
 Date 8/8/17

F.Y.	Cost Center	Obj. Code	Amount	Vendor #	P.O. #

STATE OF MINNESOTA

MINNESOTA STATE COLLEGES AND UNIVERSITIES

Lake Superior College

INTER-AGENCY AGREEMENT

WHEREAS, the Board of Trustees of the Minnesota State Colleges and Universities acting on behalf of *Lake Superior College* (hereinafter "MnSCU") is empowered to enter into interagency agreements pursuant to Minnesota Statutes, Chapter 471.59, Subd. 10; and

WHEREAS, the Independent School District # 709, Adult Basic Education (hereinafter " STATE AGENCY") is empowered to enter into interagency agreements pursuant to Minnesota Statutes, Chapter 471.59, Subd. 10; and

NOW, THEREFORE, it is agreed:

1. DUTIES

- a. STATE AGENCY'S DUTIES. The STATE AGENCY shall:
Provide adult basic education services to Lake Superior College Integrated Manufacturing students on an hourly basis 10 weeks in the Fall '17 semester and Spring '18 semester at the Downtown site. Structured as 'Drop-In" time for Math, and Reading remediation done within the context of Manufacturing
- b. MnSCU'S DUTIES. MnSCU shall: provide the space and necessary classroom equipment to allow the contractor to do the work as well as the necessary coordination with instructors, support staff and administration.

2. CONSIDERATION AND TERMS OF PAYMENT.

- a. Consideration for all services performed by Adult Basic Education, I.S.D. 709 pursuant to this Agreement shall be paid by the Minnesota Advanced Manufacturing Partnership grant and Lake Superior College as follows:

Fifty five and 00/100 Dollars (\$55.00) an hour for four (4) hours per week for ten (10) weeks per each semester (Fall 2017, Spring 2018) for a total not to exceed eight thousand (\$8,000.) dollars. Upon the successful completion and acceptance of instructional duties, with invoices sent at the end of each semester for hours documented and completed

The final invoice to be presented to Lake Superior College no later than June 15, 2018.

- b. Terms of Payment. Payment shall be made by Lake Superior College 30 days after Adult Basic Education, I.S.D. # 709 has presented invoices for services performed to Lake Superior College.
3. CONDITIONS OF PAYMENT. All services provided by ISD # 709, Adult Basic Education pursuant to this Agreement shall be performed to the satisfaction of Lake Superior College, as determined at the sole discretion of its Authorized Representative.
4. TERMS OF AGREEMENT. This agreement shall be effective August 21, 2017, or upon the date that the final required signature is obtained by the ISD #709, Adult Basic Education, whichever occurs later, and shall remain in effect until June 30, 2018, or until all obligations set forth in this Agreement have been satisfactorily fulfilled, whichever occurs first.
5. CANCELLATION. This Agreement may be cancelled by either party at any time, with or without cause, upon thirty (30) days written notice to the other party. In the event of such a cancellation, the party providing work or services to the other party shall be entitled to payment, determined on a pro rata basis, for work or services satisfactorily performed.
6. AUTHORIZED REPRESENTATIVES.
- a. The STATE AGENCY'S Authorized Representative for the purposes of administration of this Agreement is:
- Name and Title: Doug Hasler, CFO/Executive Director Business Services, I.S.D. 709
 Address: 215 North First Avenue East
 Telephone: 218.336.8704
 E-Mail: douglas.hasler@isd709.org
 Fax: 218.336.8773
- b. MnSCU'S Authorized Representative for the purpose of administration of the Agreement is:
- Name and Title: Michael Seymour, Vice President of Student and Academic Affairs
 Address: 2101 Trinity Road
 Telephone: 218.733.7628
 E-Mail: Michael.seymour@lsc.edu
 Fax:

Each Authorized Representative shall have final authority for acceptance of services of the other party and shall have responsibility to insure that all payments due to the other party are made pursuant to the terms of this Agreement.

7. ASSIGNMENT. Neither party shall assign nor transfer any rights or obligations under this Agreement without the prior written consent of the other party.
8. AMENDMENTS. Any amendments to this Agreement shall be in writing, and shall be executed by the same parties who executed the original agreement, or their successors in office.

9. LIABILITY. Each party will be responsible for its own acts and the results thereof to the extent authorized by law and shall not be responsible for the acts of any others and the results thereof. The parties' liabilities shall be governed by the provisions of the Minnesota Tort Claims Act, Minnesota Statutes, Chapter 3.736, and other applicable law.

10. OWNERSHIP OF MATERIALS AND INTELLECTUAL PROPERTY RIGHTS.

a. Lake Superior College shall own all rights, title and interest in all of the materials conceived or created by Adult Basic Education, Independent School District #709, or its employees or subcontractors, either individually or jointly with others and which arise out of the performance of this Agreement, including any inventions, reports, studies, designs, drawings, specifications, notes, documents, software and documentation, computer based training modules, electronically, magnetically or digitally recorded material, and other work in whatever form ("MATERIALS").

I.S.D. #709, Adult Basic Education assigns to Lake Superior College all rights, title and interest to the MATERIALS. Adult Basic Education, Independent School District #709 shall, upon request of Lake Superior College, execute all papers and perform all other acts necessary to assist Lake Superior College to obtain and register copyrights, patents or other forms of protection provided by law for the MATERIALS. The MATERIALS created under this Agreement by Adult Basic Education, ISD # 709, its employees or subcontractors, individually or jointly with others, shall be considered "works made for hire" as defined by the United States Copyright Act. All of the MATERIALS, whether in paper, electronic, or other form, shall be remitted to Lake Superior College by Adult Basic Education, Independent School District #709, its employees and any subcontractors and Adult Basic Education, Independent School District #709, shall not copy, reproduce, allow or cause to have the MATERIALS copied, reproduced or used for any purpose other than performance of Lake Superior College obligations under this Agreement without the prior written consent of the REQUESTING AGENCY'S Authorized Representative.

b. ISD # 709, Adult Basic Education represents that MATERIALS produced or used under this Agreement do not and will not infringe upon any intellectual property rights of another, including but not limited to patents, copyrights, trade secrets, trade names, and service marks and names.

11. PUBLICITY. Any publicity given the program, publications, or services provided resulting from this Agreement, including, but not limited to, notices, informational pamphlets, press releases, research, reports, signs, and similar public notices prepared by or for either party, or its employees individually or jointly with others, or any subcontractors shall not be released prior to approval by the other party's authorized representative.

12. FERPA. The parties additionally acknowledge that the Family Educational Rights and Privacy Act, 20 U.S.C. 1232g and 34 C.F.R. 99, apply to the use and disclosure of education records that are created or maintained under this agreement.

13. OTHER PROVISIONS. none

The rest of this page intentionally left blank. Signature page to follow.

IN WITNESS WHEREOF, the parties have caused this agreement to be duly executed intending to be bound thereby.

APPROVED:

1. STATE AGENCY

ISD #709, Adult Basic Education

By (authorized signature)
<i>Douglas A. Hase</i>
Title <i>CFD</i>
Date <i>8/24/17</i>

2. VERIFIED AS TO ENCUMBRANCE

By (authorized signature)
Title
Date

3. MINNESOTA STATE COLLEGES AND UNIVERSITIES

Lake Superior College

By (authorized signature)
Title
Date

4. AS TO FORM AND EXECUTION

By (authorized college/university/system office initiating agreement)
Title
Date

Child and Adult Care Food Program Contract for Vended Meals

A Center that participates in the U.S. Department of Agriculture (USDA) Child and Adult Care Food Program (CACFP) must meet CACFP requirements for meals that will be claimed for CACFP reimbursements, as specified in this contract.

I. Purpose and Authority

This contract, between Center: St. Michael's Lakeside Early Learning

Center's Cyber-Linked Interactive Child Nutrition System (CLiCS) Sponsor ID Number:

and Vendor: ISD 709

authorizes that Vendor will provide meals to Center in accordance with this contract and federal CACFP regulations at 7 Code of Federal Regulations (CFR) 226, for the period of _____ through _____.

Vendor will provide the meals to the Center's site(s) listed below, or on an attached list.

Site Name	Address	CLiCS Site Number (if known)
<u>SMLSEL</u>	<u>4628 Pitt St Duluth</u>	<u>53804</u>
_____	_____	_____
_____	_____	_____

Center will notify Vendor with 5 days' notice of changes to sites.

II. Meals

A. Vendor will provide the following meal types:

- Breakfast
- Lunch
- Snack
- Supper
- Extra Milk
- At-Risk Afterschool Snack
- At-Risk Afterschool Supper

If more than one site, indicate any differences between sites in the meal types provided:

- B. Vendor will provide meals that meet CACFP meal pattern requirements in accordance with 7 CFR 226. Vendor has attached to this contract the menus that were used in solicitation of this contract. Effective October 1, 2017, Vendor will provide meals that meet the revisions to the USDA meal pattern requirements that are effective beginning October 2017. Menus may be adjusted as needed by mutual agreement of the parties. Vendor may not subcontract for the total meal, with or without milk, or for the assembly of the meal.

Meals provided will meet these menu planning requirements (check all applicable):

- C. CACFP Meal Pattern(s)

Breakfast Lunch/Supper Snack

- D. School Nutrition Programs Meal Pattern(s)*

Breakfast Lunch

*If Vendor is a school that participates in School Nutrition Programs, Vendor may provide meals meeting the age-appropriate standards in 7 CFR 210 (school lunch) and/or 220 (school breakfast). The School Nutrition Programs "Offer vs. Serve" provision may not be used when serving meals to preschool age children but may be used for school-age children when serving meals that meet School Nutrition Programs standards.

- C. Vendor will provide meal substitutions for disabled participants who provide a statement from a licensed physician, physician assistant or advanced practice registered nurse such as a certified nurse practitioner, that they are unable to consume the regular Program meals due to their disability. The statement must identify how the disability affects the participant's diet, the food or foods to be omitted from the participant's diet, and the food or choice of foods that must be substituted.

Center will pay the regular meal charges for meals with substitutions or modifications unless other charges or adjustments are specified in Section IV(A). Participants with disabilities may not be charged any fees for modifications or substitutions.

- D. Vendor will also provide:
(Indicate items such as condiments, eating utensils, paper items, extra milk, and transportation containers, if applicable. If more than one site, indicate any differences between sites.)

- E. Vendor will provide:

Unitized meals.

Bulk quantities, accompanied by written instructions on planned portion size of each food component to meet meal pattern requirements.

If checked here, Vendor will serve meals. Vendor will **not** count the number of meals to be claimed for reimbursement.

Other:

III. Ordering and Delivering

- A. Center or Center's sites will notify Vendor in advance of the number of meals needed. Vendor will use an organized system for receiving orders for delivery adjustments; documenting orders for delivery adjustments; adjusting production levels, if necessary; ensuring that delivery receipts are changed to reflect adjusted meal orders; and ensuring that adjusted meal orders for each site are correctly packaged and loaded for delivery.

Indicate deadline(s) for Center or sites to send meal orders (such as by a set time on the previous day or the same day of the meal service) and how notice will be provided, by e-mail, telephone or in person. Indicate timeline(s) for increasing and decreasing an order that has been made. If more than one site, indicate any differences between sites. Describe here, or reference here to attached information.

- B. Vendor will deliver meals as described. Include time(s) for each site. (For each meal service, indicate time that meal will be delivered, or picked up by Center. If more than one site, indicate for each site.) Describe here, or reference here to attached information.

- C. Responsibility for transport containers:
Indicate whether Vendor or Center will be responsible for cleaning transport containers and, if applicable, schedule for Vendor to pick up or Center/Site to return transport containers. If more than one site, indicate any differences between sites. Describe here, or reference here to attached information.

IV. Meal Charges and Billing

- A. Center will pay the following charges for meals.

Breakfast \$ N/A
 Snack \$ N/A
 Lunch \$ 3.00/child
 Supper \$ N/A

Meals (check one) include milk do not include milk

If applicable, indicate charges for extra milk, adult meals, adjustments to meals to accommodate special dietary needs, or other. Describe here, or reference here to attached information.

Center will pay Vendor for ordered meals that meet CACFP meal requirements including health and sanitation standards in Section VI, and are delivered in accordance with the contract.

- B. Describe when Vendor will bill Center (for example weekly or monthly) and when payment is due:

NOTE: Neither the Minnesota Department of Education (MDE) nor the U.S. Department of Agriculture assumes any liability for payment of meal charges.

V. Recordkeeping and Availability of Records

- A. Vendor agrees to maintain full and accurate records, which Center requires to meet its responsibility for claiming reimbursements through the Child and Adult Care Food Program. Required records include: 1) daily menu records; 2) daily quantities of food prepared, by type of meal; 3) daily number of meals furnished, by type of meal.
- B. At the end of each month, Vendor will submit copies of the records of menus and numbers of meals furnished to Center. Vendor will submit copies of food production records to Center upon request.
- C. Vendor agrees that books and records pertaining to Vendor's food service fund will be made available to Center upon request and agrees to retain all records for inspection and audit by representatives of Center, Minnesota Department of Education, USDA, and U.S. General Accounting Office, at any reasonable time and place for a period of three (3) years after the final payment for the contract, except that in circumstances where audit findings have not been resolved the records must be retained beyond the three-year period until resolution of the audit.
- D. Vendor will cooperate in studies and evaluations conducted by or on behalf of USDA related to programs authorized under the Richard B. Russell National School Lunch Act and the Child Nutrition Act of 1966.

VI. Health and Sanitation

- A. Vendor and Center agree that state and local health and sanitation requirements will be met at all times. Vendor will meet all state and local health regulations that apply to Vendor facilities and any other facilities in which meals are prepared. Vendor will maintain applicable health certifications for facilities outside Center in which meals are prepared.
- B. All food will be properly stored, prepared, packaged and transported free of contamination and at appropriate temperatures.
- C. Center will not pay for meals or snacks that are unwholesome or spoiled at time of delivery.

VII. Center Control of Food Service

Center will maintain overall responsibility for administration of the food service, in accordance with CACFP regulations and policies. Center will:

- A. Retain control of the quality, extent and general nature of the food service, including counting the numbers of reimbursable meals and claiming CACFP reimbursement from the Minnesota Department of Education.
- B. Ensure that the food service operation is in conformance with Center's agreement with the Minnesota Department of Education to participate in CACFP.
- C. Retain control of the nonprofit food service account, overall financial responsibility for the nonprofit food service operation, and meal prices.
- D. Maintain all applicable health certifications for Center and ensure that state and local health regulations are being met by Vendor, if Vendor prepares or serves meals at a Center facility.
- E. Monitor meals to ensure the food service is in conformance with program regulations.
- F. Retain signature authority on the agreement with the Minnesota Department of Education. Retain signature authority for the annual application and monthly claims by electronically submitting required information to the Minnesota Department of Education.
- G. Prepare contract for vended meals documents.
- H. Review, approve or deny, and if applicable verify CACFP Household Income Statements.

VIII. Additional Vendor Responsibilities

Vendor agrees to comply with the following. As applicable, incorporated into this contract by reference.

- A. If contract exceeds \$100,000: Sections 3702 and 3704 of the Contract Work Hours and Safety Standards Act (40 United States Code (USC) 3701 – 3708) as supplemented by the U.S. Department of Labor regulations (29 CFR Part 5).
- B. If contract exceeds \$150,000: All applicable standards, orders and requirements issued pursuant to the Clean Air Act (42 USC 7401 – 7671q) and the Federal Water Pollution Control Act as amended (33 USC 1251 – 1387). Violations must be reported to the federal awarding agency and the regional office of the Environmental Protection Agency (EPA).

IX. Nonperformance or Noncompliance

In cases of nonperformance or noncompliance on the part of Vendor, Vendor will pay Center for any excess costs which Center may incur by obtaining meals from another source. Center will notify Vendor (and surety company if performance bond is in effect) of specific instances of unsatisfactory performance. If Vendor does not immediately take corrective action, Center may negotiate another contract (or request surety company to provide another Vendor). The defaulting Vendor is liable for any difference in price between the original price and the new contract price.

Indicate here any additional requirements regarding nonperformance or noncompliance, or any bonding requirements:

X. Termination

Either party may terminate this contract for cause by notice in writing as described: (The number of days required for notice of termination, which may not exceed 60 days, must be stated.) The contract may be terminated for convenience (no cause) if the parties mutually agree to terminate for convenience.

XI. Contract Renewals

This contract may be renewed up to four times, not to exceed a total of five years, by mutual agreement of Center and Vendor. The contract may not automatically renew. Renewal of the contract is contingent upon the fulfillment of all contract provisions. The CACFP Renewal of Contract for Vended Meals form, available from MDE, will be used to renew the contract. Prices will be adjusted from the previous year's prices by a percentage not to exceed the percentage change in the Consumer Price Index for All Urban Consumers (CPI-U), Food Away From Home in the Midwest Region. The change in the index will be measured by the calendar year preceding the contract effective date, unless a different time period is specific here:

XII. Summer Food Service Program (Optional)

Vendor agrees to provide meals for the Summer Food Service Program (SFSP), in accordance with federal regulations at 7 CFR 225 and other SFSP requirements, if Center participates in the SFSP during the original contract term or during any contract renewal, unless otherwise stated below. If non-unitized meals (bulk foods) will be provided, MDE waives the SFSP requirement to provide unitized meals. Center will pay for SFSP meals provided by Vendor using the same payment structure used for CACFP meals.

XIII. Vendor Certification Statements

Check one:

- The contract amount is expected to be less than \$100,000. The following certifications are attached to this contract: (1) Independent Price Determination Certificate (signed by Vendor and SFA) and (2) Certification Regarding Debarment, Suspension, Ineligibility and Voluntary Exclusion—Lower-Tier Covered Transactions (signed by Vendor).
- The contract amount is expected to be \$100,000 or more. In addition to the two certifications listed above, a Certification Regarding Lobbying (signed by Vendor) and, if applicable, a Disclosure of Lobbying Activities (signed by Vendor) are attached to this contract.

XIV. Additional Provisions at Option of Center and Vendor

Describe any additional provisions here, or reference here to additional attached provisions. Additional provisions may not conflict with other contract provisions or materially change the required provisions of the contract, and are subject to review by MDE.

Signatures

Center Name: St Michael's Lakeside Early Learning

Authorized Representative:  Christopher McElahan

Title: St. Michael's Catholic Church Parish Administrator

Signature of Authorized Representative: 

Date: 8/18/17

Vendor Name: ISO 709

Authorized Representative: Douglas A. Hasler

Title: CEO / Executive Director of Business Services

Signature of Authorized Representative: 

Date: 8/18/17

Education

Child Meal Patterns for the Child and Adult Care Food Program

Breakfast	1 and 2	3 – 5	6 – 12
Fluid Milk¹	½ cup	¾ cup	1 cup
Vegetable or Fruit or Juice²	¼ cup	½ cup	½ cup
Grains/Breads³ Whole Grain, Bran, Germ or Enriched	½ serving	½ serving	1 serving
Cold Dry Cereal Whole Grain, Bran, Germ Enriched or Fortified	¼ cup (or 1/3 oz)	1/3 cup (or ½ oz)	¾ cup (or 1 oz)
Cooked: Cereal, Rice, Pasta or Noodles	¼ cup	¼ cup	½ cup

Snack Select two of the four components⁴	1 and 2	3 – 5	6 – 12
Fluid Milk¹	½ cup	½ cup	1 cup
Vegetable or Fruit or Juice²	½ cup	½ cup	¾ cup
Meat or Meat Alternate	½ ounce	½ ounce	1 ounce
Grains/Breads³	½ serving	½ serving	1 serving

Lunch/Supper	1 and 2	3 – 5	6 – 12
Fluid Milk¹	½ cup	¾ cup	1 cup
Meat or Poultry or Fish or Alternate Protein Products ⁵	1 ounce	1 ½ ounces	2 ounces
or Cheese	1 ounce	1 ½ ounces	2 ounces
or Cottage Cheese, Cheese Food/Spread	2 ounces	3 ounces	4 ounces
or Egg	½ egg	¾ egg	1 egg
or Cooked Dry Beans or Peas	¼ cup	3/8 cup	½ cup
or Peanut or Soybean or Sunflower Seed Butter	2 tablespoons	3 tablespoons	4 tablespoons
or Peanuts, Soybeans, Tree Nuts or Seeds⁶	½ ounce	¾ ounce	1 ounce
or Yogurt⁷	4 ounces or ½ cup	6 ounces or ¾ cup	8 ounces or 1 cup
Vegetables and/or Fruits/Juice² (Two or more servings of different vegetables and/or fruits)	¼ cup total	½ cup total	¾ cup total
Grains/Breads³	½ serving	½ serving	1 serving

¹Milk served must be low-fat (one percent) or non-fat (skim) for children two years and older.

²Fruit or vegetable juice must be full-strength (100 percent).

³Breads and grains must be made from whole-grain or enriched meal or flour.

⁴For snack, juice may not be served when milk is served as the only other component. Also two food items from the same component cannot be served at snack.

⁵Alternate protein products must meet requirements in Appendix A of 7 CFR Part 226.

⁶Nuts and seeds may meet only one-half of the total meat/meat alternate serving and must be combined with another meat/meat alternate to fulfill the lunch or supper requirement.

⁷Yogurt may be plain or flavored, unsweetened, or sweetened – commercially prepared.

<http://education.state.mn.us> Food and Nutrition Services 651-582-8526 800-366-8922

This institution is an equal opportunity provider and employer

Afterschool Snack Meal Pattern

Select two of the four components for a reimbursable snack.

Food Components and Food Items ¹	Children Ages 1 and 2	Children Ages 3-5	Children Ages 6-12 ¹
Milk Fluid milk	4 fl. oz. (1/2 cup)	4 fl. oz. (1/2 cup)	8 fl. oz. (1 cup)
Vegetable or Fruit ^{2, 9} Juice ^{2, 9} , fruit, and/or vegetable	1/2 cup	1/2 cup	3/4 cup
Grains/Breads ^{3, 4} Bread or Cornbread or biscuit or roll or muffin or Cold dry cereal ⁴ or Cooked cereal grains or Cooked pasta or noodles	1/2 slice 1/2 serving 1/4 cup or 1/3oz. ⁴ 1/4 cup 1/4 cup	1/2 slice 1/2 serving 1/3 cup or 1/2oz. ⁴ 1/4 cup 1/4 cup	1 slice 1 serving 3/4 cup or 1oz. ⁴ 1/2 cup 1/2 cup
Meat/Meat Alternate ^{5, 6, 7} Lean meat or poultry or fish ⁵ or Alternate protein products ⁶ or Cheese or Egg (large) or Cooked dry beans or peas or Peanut or other nut or seed butters or Nuts and/or seeds ⁷ or Yogurt ⁸	1/2 oz. 1/2 oz. 1/2 oz. 1/2 large egg 1/8 cup 1 Tbsp 1/2 oz. ⁷ 2 oz. or 1/4 cup	1/2 oz. 1/2 oz. 1/2 oz. 1/2 large egg 1/8 cup 1 Tbsp 1/2 oz. ⁷ 2 oz. or 1/4 cup	1 oz. 1 oz. 1 oz. 1/2 large egg 1/4 cup 2 Tbsp 1 oz. 4 oz. or 1/2 cup

¹ Children age 12 and older may be served larger portions based on their greater food needs. They may not be served less than the minimum quantities listed in this column.

² Full strength vegetable and/or fruit juice or an equivalent quantity of any combination of vegetable(s), fruit(s), and juice.

³ Grains/Breads must be whole-grain or enriched, or made from whole-grain or enriched flour or meal that may include bran and/or germ. Cereal must be whole-grain, enriched, or fortified.

⁴ Either volume (cup) or weight (oz.), whichever is less.

⁵ A serving consists of the edible portion of cooked lean meat or poultry or fish.

⁶ Alternate protein products must meet requirements in Appendix A of 7 CFR Part 210.

⁷ Nuts and seeds are not recommended for children under three years of age because choking may occur.

⁸Yogurt may be plain or flavored, unsweetened, or sweetened – commercially prepared.

⁹Juice may not be served when milk is the only other component at snack.

Independent Price Determination Certificate

Both the Food Service Management Company (Offerer) and the Sponsoring Organization shall execute this Independent Price Determination Certificate.

ISD 709
Name of Food Service Management Company

St Michael's Catholic Church
Name of Sponsoring Organization

By submission of this offer, the Offerer certifies, and in the case of a joint offer, each party thereto certifies as to its own organization, that in connection with this procurement:

1. The prices in this offer have been arrived at independently, without consultation, communication, or agreement for the purpose of restricting competition, as to any matter relating to such prices with any other Offerer or with any competitor.
2. Unless otherwise required by law, the prices which have been quoted in this offer have not been knowingly disclosed to the Offerer and will not knowingly be disclosed by the Offerer prior to opening in the case of an advertised procurement or prior to award in the case of a negotiated procurement, directly or indirectly to any other Offerer for the purpose of restricting competition.
3. No attempt has been made or will be made by the Offerer to induce any person or firm to submit or not submit an offer for the purpose of restricting competition.

Each person signing this offer on behalf of the Offerer certifies that:

1. He or she is the person in Offerer's organization responsible within the organization for the decision as to the prices being offered herein and has not participated, and will not participate, in any action contrary to A.1 through A.3 above; or
2. He or she is not the person in Offerer's organization responsible within the organization for the decision as to the prices being offered herein, but that he or she has been authorized in writing to act as agent for the persons responsible for such decision in certifying that such persons have not participated and will not participate in any action contrary to A.1 through A.3 above, and as their agent does hereby certify; and he or she has not participated, and will not participate, in any action contrary to A.1 through A.3 above.

To the best of my knowledge, this Offerer, its affiliates, subsidiaries, officers, directors and employees are not currently under investigation by any government agency and have not in the last three years been convicted of or found liable for any act prohibited by state or federal law in any jurisdiction, involving conspiracy or collusion with respect to bidding on any public contract, except as follows:

Signature of Food Service Management Company's
Authorized Representative

CFO
Title

8/18/17
Date

In accepting this offer, the Sponsoring Organization certifies that no representative of the Sponsoring Organization has taken any action that may have jeopardized the independence of the offer referred above.

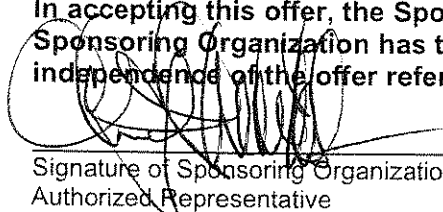
Signature of Sponsoring Organization's
Authorized Representative

Sara B. Adams
Title

5/23/17
Date

Instructions for Certification Regarding Debarment Form

1. By signing and submitting this form, the prospective lower-tier participant is providing the certification set out on the certification form in accordance with these instructions.
2. The certification in this clause is a material representation of fact upon which reliance was placed when this transaction was entered into. If it is later determined that the prospective lower-tier participant knowingly rendered an erroneous certification, in addition to other remedies available to the federal government, the department or agency with which this transaction originated may pursue available remedies, including suspension and/or debarment.
3. The prospective lower-tier participant shall provide immediate written notice to the person to which this proposal is submitted if at any time the prospective lower-tier participant learns that its certification was erroneous when submitted or has become erroneous by reason of changed circumstances.
4. The terms "covered transaction," "debarred," "suspended," "ineligible," "lower-tier covered transaction," "participant," "person," "primary-covered transaction," "principal," "proposal" and "voluntarily excluded," as used in this clause, have the meanings set out in the Definitions and Coverage sections of rules implementing Executive Order 12549. You may contact the person to which this proposal is submitted for assistance in obtaining a copy of those regulations.
5. The prospective lower-tier participant agrees by submitting this form that, should the proposed covered transaction be entered into, it shall not knowingly enter into any lower-tier covered transaction with a person who is debarred, suspended, declared ineligible or voluntarily excluded from participation in this covered transaction, unless authorized by the department or agency with which this transaction originated.
6. The prospective lower-tier participant further agrees by submitting this form that it will include this clause titled "Certification Regarding Debarment, Suspension, Ineligibility and Voluntary Exclusion - Lower-tier Covered Transactions," without modification, in all lower-tier covered transactions and in all solicitations for lower-tier covered transactions.
7. A participant in a covered transaction may rely upon a certification of a prospective participant in a lower-tier covered transaction that it is not debarred, suspended, ineligible or voluntarily excluded from the covered transaction, unless it knows that the certification is erroneous. A participant may decide the method and frequency by which it determines the eligibility of its principals. Each participant may, but is not required to, check the Excluded Parties List System (EPLS) at <http://epls.arnet.gov/>.
8. Nothing contained in the foregoing shall be construed to require establishment of a system of records in order to render in good faith the certification required by this clause. The knowledge and information of a participant is not required to exceed that which is normally possessed by a prudent person in the ordinary course of business dealings.
9. Except for transactions authorized under paragraph 5 of these instructions, if a participant in a covered transaction knowingly enters into a lower-tier covered transaction with a person who is suspended, debarred, ineligible or voluntarily excluded from participation in this transaction, in addition to other remedies available to the federal government, the department or agency with which this transaction originated may pursue available remedies as appropriate, including suspension and/or debarment.

**Certification Regarding Debarment, Suspension, Ineligibility
And Voluntary Exclusion—Lower-Tier Covered Transactions**

This certification is required by the regulations implementing Executive Order 12549, Executive Order 12689, and 31 U.S.C. 6101; Debarment and Suspension, 2 CFR Part 417, Subpart C, Responsibilities of Participants Regarding Transactions.

(Read instructions on previous page before completing Certification.)

- (1) The prospective lower-tier participant certifies, by submission of this proposal, that neither it nor its principals is presently debarred, suspended, proposed for debarment, declared ineligible or voluntarily excluded from participation in this transaction by any federal department or agency.
- (2) Where the prospective lower-tier participant is unable to certify to any of the statements in this certification, such prospective participant shall attach an explanation to this proposal.

Vendor Name: ISD 709

Award Number or Project Name: Child and Adult Care Food Program

Name and Title of Authorized Representative:

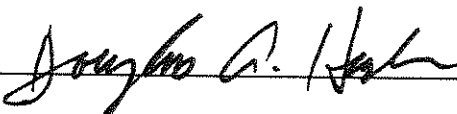
Signature:  Date: 8/18/17

Certification Regarding Lobbying

The undersigned certifies, to the best of his or her knowledge and belief, that:

- (1) No federal appropriated funds have been paid or will be paid, by or on behalf of the undersigned, to any person for influencing or attempting to influence an officer or employee of any agency, a Member of Congress, an officer or employee of Congress, or an employee of a Member of Congress in connection with the awarding of a federal contract, the making of any federal grant, the making of a federal loan, the entering into a cooperative agreement, and the extension, continuation, renewal, amendment or modification of a federal contract, grant, loan or cooperative agreement;
- (2) If any funds other than federal appropriated funds have been paid or will be paid to any person for influencing or attempting to influence an officer or employee of any agency, a Member of Congress, an officer or employee of Congress, or an employee of a Member of Congress in connection with this federal contract, grant, loan or cooperative agreement, the undersigned shall complete and submit Standard Form-LLL, Disclosure Form to Report Lobbying, in accordance with its instructions;
- (3) The undersigned shall require that the language of this certification be included in the award documents for all subawards at all tiers (including subcontracts, subgrants and contracts under grants, loans and cooperative agreements) and that all subrecipients shall certify and disclose accordingly.

This certification is a material representation of fact upon which reliance was placed when this transaction was made or entered into. Submission of this certification is a prerequisite for making or entering into this transaction imposed by section 1352, title 31, U.S. Code. Any person who fails to file the required certification shall be subject to a civil penalty of not less than \$10,000 and not more than \$100,000 for each such failure.

Vendor Name: ISD 709

Award Number or Project Name: Child and Adult Care Food Program

Name and Title of Authorized Representative:

Signature: Joseph A. Ham Date: 8/18/17



License Number L
Standard Short Term

UNIVERSITY OF MINNESOTA USE AGREEMENT

THIS USE AGREEMENT (the "Agreement") is entered into effective as of 8/14/2017 by and between the Regents of the University of Minnesota (the "University"), a Minnesota constitutional corporation, and Independent School District #709 (the "Landlord"), an unincorporated entity. This Agreement is entered into by the University through its Department of Intercollegiate Athletics.

1. Leased Premises. Landlord, in consideration of the rents and covenants contained in this Agreement, does lease to University, and University does rent from Landlord premises situated in the County of St Louis, and State of Minnesota, described as follows:

Central High School Track facility (the "Premises").

2. Use. University will use and occupy the Premises, just as they are, during the hours of 8 am to 8 pm on the following date(s): August 28, 2017 to September 30, 2018, for the following purpose(s):

Use of Central High School track facility, shot put, discus

3. Rent. University agrees to pay to the Landlord as gross rent for the Premises the sum of zero and no/100 dollars (\$0, reciprocal use in lieu of fee), to be paid within thirty (30) days of its receipt of a fully executed copy of this Agreement, unless other payment terms are specified in paragraph 14 this Agreement.

4. Quiet Possession. Landlord promises that upon paying rent and performing the promises contained herein, the University will peacefully and quietly have, hold, and enjoy the Premises for the entire term specified above.

5. Assignment or Sublease. University will not assign this Agreement or sublet the Premises without the consent of the Landlord.

6. Surrender of Premises. University will, at the expiration of this Agreement, remove all of its personal property and equipment from the Premises and will quietly yield and surrender the Premises to the Landlord in the same good condition that existed when it took them, normal wear and tear and damage from fire, casualty and the elements excepted.

7. Indemnification. University agrees to hold the Landlord harmless and indemnify it from liability for claims for bodily injury and property damage, including personal injury liability, occurring on the Premises, except to the extent such injury or damage is caused by the negligent or wrongful acts or omissions of the Landlord, its agents, employees or representatives.

7.1 Landlord agrees to hold the University harmless and indemnify it from liability for claims for bodily injury or property damage, including personal injury liability, occurring on or about the Premises or building of which Premises is a part, except to the extent such injury or damage is caused by the negligent or wrongful acts or omissions of the University, its agents, employees, representatives and/or volunteers who are under the direction and the control of the University.

8. **Notices.** All notices, requests and other communications that a party is required or elects to deliver shall be in writing and shall be delivered personally, or by facsimile or electronic mail (provided such delivery is confirmed), or by a recognized overnight courier service or by United States mail, first-class, certified or registered, postage prepaid, return receipt requested, to the other party at its address set forth below or to such other address as such party may designate by notice given pursuant to this section:

If to the University:

University of Minnesota
Attn.:
c/o Real Estate Office
424 Donhowe Building
319-15th Avenue SE
Minneapolis, MN 55455-0199
Facsimile No: (612) 624-6345
E-mail: reo@umn.edu

With a copy of
default notices to:

University of Minnesota
Office of the General Counsel
Attn.: Transactional Law Services Group
360 McNamara Alumni Center
200 Oak Street SE
Minneapolis, MN 55455-2006
Facsimile No.: (612) 626-9624
E-mail: contracts@mail.ogc.umn.edu

If to the Landlord:

ISD #709
Attn: Douglas A. Hasler
215 N 1st Ave E
Duluth, MN 55802
Facsimile No.: 218-336-8909
E-mail: douglas.hasler@isd709.org

9. **Amendments.** This Agreement shall be amended only in a writing duly executed by both parties. This Agreement (including all addenda, exhibits and schedules) is intended by the parties as the final and binding expression of their agreement and all prior negotiations and agreements related to the subject matter of this Agreement are superceded by this Agreement.

10. **Use of University Name or Logo.** Landlord agrees not to use the name, logo, or any other marks (including, but not limited to, colors and music) owned by or associated with the University or the name of any representative of the University in any sales promotion work or advertising, or any form of publicity, without the written permission of the University in each instance.

11. **Non-Waiver.** No waiver by any party of a default or non-performance by the other party shall be deemed a waiver of any subsequent default or non-performance.

12. **Governing Law; Forum.** The laws of the state of Minnesota shall govern the validity, construction and enforceability of this Agreement. All suits, actions, claims and causes of action relating to the construction, validity, performance and enforcement of this Agreement shall be brought in the state courts of Minnesota.

13. **Special Conditions.** none

IN WITNESS WHEREOF, University and Landlord have executed this Agreement on the day and year first above written.

Regents of the University of Minnesota ISD 709

By: 
Name: Josh Beilo
Title: Athletic Director
Date: 8-21-17

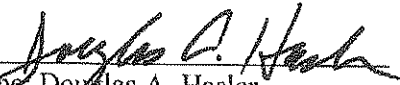
By: 
Name: Douglas A. Hasler
Title: CFO
Date: 8/17/17

**AFFILIATION AGREEMENT FOR PLACEMENT
OF UNIVERSITY OF WISCONSIN STUDENTS**

This Agreement is between the Board of Regents of the University of Wisconsin System on behalf of the University of Wisconsin-Superior (hereinafter referred to as "University") and Duluth Public Schools (hereinafter referred to as "Facility").

In consideration of the mutual benefits to the respective parties, the University and the Facility agree to the terms set forth below.

THE UNIVERSITY AGREES:

That each school or college of the University wishing to participate in a clinical education placement program with the Facility will annually provide the Facility with a Program Memorandum, detailing the academic content of the proposed program. Upon acceptance of this Program Memorandum as provided hereafter, it shall become a part of this agreement and shall be incorporated by reference. The Program Memorandum will include discussion of program concepts; the controls which the University and the Facility may exercise or are required to exercise; the rights of the Facility to review the University's program; the number of students to be assigned, the academic qualifications and the schedule of those students; and any other matters pertaining to the specific program content proposed by the department; and

To provide the Facility with a listing of students who will be participating in the program and to update that listing periodically.

- An appropriate background check for pre-service students requesting placement will be in place prior to their arrival for their experience. The background check will have been completed within a year of the desired start date of the placement experience. A pre-service student who is a Wisconsin resident will have completed a state (CCAP) or national background check. Pre-service students who are not residents of WI will have completed a national background check.
- Notice of completion of background checks will be communicated by UW-Superior directly to the Office of Academic Programs (OAP) via the school district's "Background Check Acknowledgement" form. Notification will occur no less than two-weeks prior to the beginning of the desired placement experience. Pre-service students will be unable to initiate their field experience until after (1) the OAP has received and reviewed the completed "Background Check Acknowledgement" form, and (2) notice to proceed with the placement has been thereafter communicated to the building principal and UW-Superior by the OAP. UW-Superior accepts responsibility to identify alternate placement for a pre-service candidate in the event the candidate's application is rejected by the Facility.

UW-Superior agrees to run the required CBC and to pay any fees associated with the CBC.

THE FACILITY AGREES:

To review any Program Memorandum concerning a clinical education program submitted by a

school or college of the University. Upon review, the Facility will notify the school or college of its acceptance or rejection of the academic program proposal; and

Not to accept students as participants in the program unless the student is certified as a program participant in writing by the appropriate coordinator of a particular University school or college.

THE UNIVERSITY AND THE FACILITY JOINTLY AGREE:

The parties shall not discriminate in their training or education of any person or in the conditions of training or education or in other actions taken as a result of this Agreement by reason of age, race, religion, color, handicap, sex, physical condition, developmental disability, sexual orientation, or national origin. Each party will make reasonable accommodations to assure accessibility to training programs for persons with disabilities;

That during the term of this Agreement, the State will indemnify University employees, officers, and agents (students in required training, a credit program, or for graduation) against liability for damages arising out of their activities while acting within the scope of their respective employment or agency, pursuant to §895.46(1) and §893.82, Stats.;

That the Facility will indemnify its employees, officers and agents against liability for damages arising out of their activities while acting within the scope of their respective employment or agency;

By executing this agreement, neither the University nor the Facility waives any constitutional, statutory or common law defenses, nor shall the provisions of agreement create any rights in any third party; and

This agreement shall be construed and governed by the laws of the State of Wisconsin.

TERM OF AGREEMENT:

This agreement shall be for a term of 5 years, commencing August 1, 2017. It may be terminated solely by written notice, one year in advance, by either party to the designated agent of the other as shown below.

FOR THE UNIVERSITY:

UW - Superior

Attn: Georgette Koenig

P.O. Box 2000

Superior, WI 54880

FOR THE FACILITY:

Attn: Doug Hasler

215 N. 1st Ave. E.

Duluth, MN 55802

Name of Department Requesting the Agreement:

Department of Educational Leadership

Program Memoranda presented by the University and accepted by the Facility shall be for a term of no longer than one year. They may be renewed upon mutual agreement. Such Program Memoranda do not require the specific approval of either party provided they contain provisions relating solely to program arrangements and content.

Any fully executed Program Memoranda shall be incorporated by reference and become a part of this agreement if not inconsistent in any manner with this agreement.

FOR THE UNIVERSITY:

FOR THE FACILITY:

Georgette Koenig 8/4/17

Douglas A. Hasler 8/16/17

Signature of Authorized Official Date

Signature of Authorized Official Date

Georgette Koenig, VC-Administration & Finance

Douglas A. Hasler, CFO

Printed Name and Position of Authorized Official

Region 7AA Facilities Use Agreement – 2017-2018

This Agreement is entered into on _____ (Date) by and between Minnesota State High School League and Region 7AA (Region), and Denfeld High School (Host School).

The term of this agreement is August 1, 2017 through July 31, 2018.

WHEREAS, Region conducts playoff contests in various interscholastic athletic and arts activities and Host wishes to conduct and administer such contests.

NOW, THEREFORE, in consideration for the promises contained herein and other good and valuable consideration, the sufficiency of which is hereby acknowledged, the parties agree as follows:

1. When applicable, Host agrees to provide reasonable and necessary facilities (the "Facilities") to conduct Region contests at a date, time, and location to be determined once sub-section/section contest sites are determined. A specific contest facilities agreement shall be executed as soon as reasonably possible after sub-section/section contests sites are determined based on the usual and customary practice regarding fees, including but not limited to information from the Region "____" Tournament Report Form. Host is responsible to comply with all federal, state, and local laws and regulations, including those relating to public health, safety, and welfare.
2. Host understands and acknowledges that during Region contests the Facilities are to be used exclusively for Region contests and are not to be shared with other events. Host agrees to comply with all MSHSL and Region bylaws, policies, and guidelines, including but not limited to those relating to media credentials, ticket pricing, passes, program/merchandise sales, televising, videotaping, audiotaping, web streaming, and any other electronic recording. MSHSL and Region reserves and retains the exclusive rights to any and all advertising, copyright, broadcast and other similar or related rights to the contests.
3. When applicable, Region shall be responsible for obtaining and compensating game officials and the tournament director/manager for the contest.
4. Subject to Paragraph 3, Host shall provide, manage, pay, and supervise all other personnel reasonably necessary to safely and properly conduct the contest, including for illustrative purposes only, ticket sellers/takers, announcers, concession workers, statisticians, time-clock/scoreboard operators, security personnel, custodial workers, and others deemed necessary to safely and properly conduct the contest. Host shall be solely responsible for compliance with all laws and regulations regarding payment for the labor and/or services of individuals hired by Host as part of its management responsibilities, including without limitation, compliance with IRS and Minnesota Department of Revenue regulations regarding income tax, FICA and other withholdings, the issuance of tax reports, and any and all other applicable federal, state, and local laws and regulations.
5. This Agreement cannot be transferred or assigned by Host to any other party without the express written consent of the Region.
6. Host agrees to indemnify, defend and hold harmless Region and its officers, agents, employees, board members, contractors, and volunteers from and against any and all claims, damages or allegations arising from or relating to this Facilities Use Agreement except for claims that arise from the gross negligence or intentional misconduct of Region or its agents. Region agrees to indemnify, defend and hold harmless Host and its officers, agents, employees, board members, contractors, and volunteers from and against any and all claims, damages or

allegations arising from or relating to this Facilities Use Agreement except for claims that arise from the gross¹⁵¹ negligence or intentional misconduct of Host or its agents.

7. Region may terminate this agreement immediately at any time it reasonably determines the Facilities are not adequate, safe, or otherwise suitable for the contests. Region may terminate this agreement by written notice if Host materially breaches this Agreement and such breach has not been cured within five (5) days of written notification.

8. This Agreement constitutes the entire agreement between the parties and supersedes any and all prior agreements or discussions. No changes to this Agreement will be valid or enforceable unless in writing and signed by all parties. The undersigned warrants and represents that he/she is authorized to enter into this agreement for and on behalf of Host.

9. The parties understand and agree that the invalidity or partial invalidity of any portion of this Agreement shall not invalidate the remainder of it, and the remainder shall remain in full force and effect. This Agreement is to be interpreted and enforced in accordance with the laws of the State of Minnesota.

10. This agreement will terminate on July 31, 2018.

This agreement is signed by the member school designee acting on the authority of the local school board.

School Name Denfeld High School
Authorized Signer Name Douglas A. Hahn
Title CFO
Date 8/16/17

MSHSL Region 7AA
Authorized Signer Name Douglas L. MacIver
Title Executive Secretary/Treasurer
Date 8/14/17

Region 7AA Facilities Use Agreement – 2017-2018

This Agreement is entered into on _____ (Date) by and between Minnesota State High School League and Region 7AA (Region), and Duluth East High School (Host School).
The term of this agreement is August 1, 2017 through July 31, 2018.

WHEREAS, Region conducts playoff contests in various interscholastic athletic and arts activities and Host wishes to conduct and administer such contests.

NOW, THEREFORE, in consideration for the promises contained herein and other good and valuable consideration, the sufficiency of which is hereby acknowledged, the parties agree as follows:

1. When applicable, Host agrees to provide reasonable and necessary facilities (the "Facilities") to conduct Region contests at a date, time, and location to be determined once sub-section/section contest sites are determined. A specific contest facilities agreement shall be executed as soon as reasonably possible after sub-section/section contests sites are determined based on the usual and customary practice regarding fees, including but not limited to information from the Region "____" Tournament Report Form. Host is responsible to comply with all federal, state, and local laws and regulations, including those relating to public health, safety, and welfare.
2. Host understands and acknowledges that during Region contests the Facilities are to be used exclusively for Region contests and are not to be shared with other events. Host agrees to comply with all MSHSL and Region bylaws, policies, and guidelines, including but not limited to those relating to media credentials, ticket pricing, passes, program/merchandise sales, televising, videotaping, audiotaping, web streaming, and any other electronic recording. MSHSL and Region reserves and retains the exclusive rights to any and all advertising, copyright, broadcast and other similar or related rights to the contests.
3. When applicable, Region shall be responsible for obtaining and compensating game officials and the tournament director/manager for the contest.
4. Subject to Paragraph 3, Host shall provide, manage, pay, and supervise all other personnel reasonably necessary to safely and properly conduct the contest, including for illustrative purposes only, ticket sellers/takers, announcers, concession workers, statisticians, time-clock/scoreboard operators, security personnel, custodial workers, and others deemed necessary to safely and properly conduct the contest. Host shall be solely responsible for compliance with all laws and regulations regarding payment for the labor and/or services of individuals hired by Host as part of its management responsibilities, including without limitation, compliance with IRS and Minnesota Department of Revenue regulations regarding income tax, FICA and other withholdings, the issuance of tax reports, and any and all other applicable federal, state, and local laws and regulations.
5. This Agreement cannot be transferred or assigned by Host to any other party without the express written consent of the Region.
6. Host agrees to indemnify, defend and hold harmless Region and its officers, agents, employees, board members, contractors, and volunteers from and against any and all claims, damages or allegations arising from or relating to this Facilities Use Agreement except for claims that arise from the gross negligence or intentional misconduct of Region or its agents. Region agrees to indemnify, defend and hold harmless Host and its officers, agents, employees, board members, contractors, and volunteers from and against any and all claims, damages or

allegations arising from or relating to this Facilities Use Agreement except for claims that arise from the gross¹⁵³ negligence or intentional misconduct of Host or its agents.

7. Region may terminate this agreement immediately at any time it reasonably determines the Facilities are not adequate, safe, or otherwise suitable for the contests. Region may terminate this agreement by written notice if Host materially breaches this Agreement and such breach has not been cured within five (5) days of written notification.

8. This Agreement constitutes the entire agreement between the parties and supersedes any and all prior agreements or discussions. No changes to this Agreement will be valid or enforceable unless in writing and signed by all parties. The undersigned warrants and represents that he/she is authorized to enter into this agreement for and on behalf of Host.

9. The parties understand and agree that the invalidity or partial invalidity of any portion of this Agreement shall not invalidate the remainder of it, and the remainder shall remain in full force and effect. This Agreement is to be interpreted and enforced in accordance with the laws of the State of Minnesota.

10. This agreement will terminate on July 31, 2018.

This agreement is signed by the member school designee acting on the authority of the local school board.

School Name Duluth East High School
Authorized Signer Name Douglas A. Maclver
Title CFO
Date 8/16/17

MSHSL Region 7AA
Authorized Signer Name Douglas L. Maclver
Title Executive Secretary/Treasurer
Date 8/14/17



Memorandum of Understanding

I. PURPOSE AND SCOPE:

- A. Positive Energy Outdoors (PEO) of Duluth, Minnesota, and Lowell Elementary School of Duluth, Minnesota, enter into this Memorandum of Understanding (MOU) to establish the framework under which PEO programming will be provided.
- B. This MOU outlines the agreed upon arrangements for implementing Adventure Club programming between PEO and Lowell Elementary School for the 2017 - 2018 academic year.

II. PRIMARY POINT OF CONTACT (POC)

Positive Energy Outdoors
Stephanie Love
Director
4757 Datka Road
Duluth, MN 55803
steph@outdooredventures.org
218-391-0147

Adventure Club On-Site Contact
Megan Lidd
Adventure Club Coordinator
4757 Datka Road]
Duluth, MN 55803
megan@outdooredventures.org
218-461-7171 (answered 1:00-6:00 p.m. M-F)

School Contact
Jennifer Larva
Lowell Elementary School Principal
2000 Rice Lake Road
Duluth, MN 55811
jennifer.larva@isd709.org
218-336-8895 x 1007

III. PROGRAM OFFERINGS AND SCHEDULE

- A. PEO agrees to provide programming during the following timeframes:
 - i. Fall Semester: September 5, 2017 – December 21, 2017
 - ii. Spring Semester: January 3, 2018 – June 7, 2018
 - iii. Summer Program Option: June 18, 2018 – August 24, 2018
- B. Specific site schedule, including orientation week for staff/volunteers, start/end dates for participants, and any scheduled non-meeting days will be confirmed no later than 4-weeks prior to the start of each semester with the Lowell Elementary School Principal.

PEO programs will meet at the following times:

- i. Adventure Club Full Time Program: Monday-Friday, 2:15 p.m. - 5:30 p.m.
- ii. Adventure Club Part Time Program: M, W, F, 2:15 p.m. - 5:30 p.m.
- iii. Adventure Club Part Time Program: T, Th, 2:15 p.m. - 5:30 p.m.
- iv. Adventure Club Flexible Part Time Program: Combination of 1-4 days, M, T, W, Th, F, 2:15 p.m. - 5:30 p.m.

PEO program staff and volunteers require access to the site 1 hour and 15 minutes before and 30 minutes after above stated meeting times for planning, setup, debrief, and cleanup.

IV. FACILITY

- A. Lowell Elementary School agrees to provide an indoor meeting space (small gym) for severe weather options and access to outdoor classroom/nature playscape for program offerings listed in Section III.B of this MOU. Access to these spaces a minimum of 10 minutes before and after program time is required for setup and cleanup.
- B. PEO staff and volunteers will have access to outdoor classroom spaces/nature playscape, teacher lounge, support services classroom, school lobby or similarly sized/configured space 1 hour and 15 minutes before and 30 minutes after clubs for the purpose of pre-meeting and post-debrief with staff and volunteers.
- C. Lowell Elementary School will provide storage in the support services classroom (1) locked storage container (size TBD) for the storage of materials and supplies to be used during the Adventure Club program. Space shall be secured by the same means Lowell Elementary School secures its own property from loss, theft, or damage.

V. MATERIALS

- A. PEO will be responsible for procuring all required programming materials.
- B. PEO will arrange for providing program participants with snack prior to club meetings.
- C. PEO will be responsible for making sure participants are dressed appropriately for outdoor play in a variety of year round weather conditions

VI. PARTICIPANTS

PEO Adventure Club programming is offered on a sliding fee scale for participants, and targeted to children whose families need full or part time after school care, and/or have an interest in nature play, social-emotional learning and outdoor skill development for their children. Consistent attendance by participants (minimum of 70%, per individual) is expected.

- A. PEO Adventure Club programming is open to all children in grades K-5, as designated in section III.B of this MOU.
- B. All interested participants must pre-register through PEO's online application process.
- C. PEO will be responsible for the recruitment, placement, and program release of all children for PEO Adventure Club programming, and will provide Lowell Elementary School with the following participant information:
 - i. At the time of signing MOU:
 - 1. Copy of PEO Statement of Non-Affiliation (one per family), which clearly states that Adventure Club is an independent program of Positive Energy Outdoors and there is no affiliation with ISD 709 or Lowell Elementary School.
 - 2. Copy of PEO Assumption of Risk Form (parent permission form), which clearly states that permission has been given for participants to participate in Adventure Club, and includes an image/media release.
 - 3. Copy of PEO Behavior Policy.
 - ii. No later than 1-week prior to start of clubs:
 - 1. Complete daily roster of children attending Adventure Club.
 - 2. List of individual participants who do not have signed image releases.
 - iii. Information for new children joining the program will be provided to the PEO POC weekly.

Space permitting, new participants are allowed to join Adventure Club at any time during the school year.

iv. At the end of daily program sessions, PEO participants will be released back to the care of their parent/guardian for dismissal. PEO program staff will follow PEO sign out procedures, including checking IDs, and signing out (day and time) each child. Copies of participant sign in/sign out rosters will be kept on file by PEO for six (6) years as required by the St. Louis County Child Care Assistance Program (CCAP).

D. If the number of participants is fewer than 20 (full and part time), PEO reserves the right to cancel Adventure Club

VII. PROGRAM STAFF AND VOLUNTEERS

A. All PEO programming will be managed, on-site, by PEO professional staff members.

B. A PEO Director will remotely manage PEO programming, and perform a minimum of 2 on-site program quality assessment visits per year as well as provide weekly on-sight oversight for the programming.

C. PEO Adventure Club is run by professional PEO staff, with a minimum staff to student ratio of 1:10. All PEO professional staff are over the age of 18. Volunteers and interns may also be recruited by PEO.

D. PEO is responsible for the recruitment, placement, and supervision of all adult volunteers and interns. PEO will share its volunteer and intern recruitment materials with Lowell School to help to identify potential volunteers.

E. PEO is responsible for training all staff, volunteers and interns.

F. PEO is responsible for completing background checks for all adult professional staff, volunteers and interns.

VIII. COSTS

PEO programming is provided on a sliding scale for all participants. To help ensure that our programs remain affordable for low-moderate income families, Lowell Elementary School agrees to provide the following in-kind support.

A. In-kind support:

i. Use of program facility as outlined in this MOU.

IX. MISCELLANEOUS

A. PROTECTION OF REPUTATION

Through the execution of this MOU, both organizations acknowledge the other's community reputation for high-quality education and program offerings. Both parties agree to uphold these standards and do nothing that will compromise the other's reputation and community standing with their staff, constituents, and stakeholders.

B. COMPLEMENTARY PROGRAMMING

Adventure Club was created to fill a gap in outdoor education/nature play programming available after school for students and families at their request. Both parties agree that future program development or expansion of PEO Adventure Club programming will further enhance opportunities for students and families, while avoiding competition with or duplication of services already provided by either party.

C. INSURANCE

Positive Energy Outdoors will maintain a Commercial General Liability coverage limit of \$1,000,000 per occurrence, and a \$1,000,000 umbrella coverage policy to indemnify the school district and hold it harmless from any liability arising from PEO's use of school district property. ISD #709, 215 North 1st Avenue East, Duluth, MN 55802, is listed as the Certificate Holder and as an Additional Insured on the policy.

D. LOGOS

Use of any organizational logos may be done so only with written permission and approval from the appropriate POC. All organizational logos are to be used in accordance with each organization's graphic guidelines.

E. USE OF IMAGES

Contingent on individual participant releases, organizations grant the other usage of any images and/or voice of participants in this program on websites, social media, promotional and program materials, in perpetuity, as it relates to promoting Adventure Club and PEO programming.

F. MEDIA

Organizations agree to mutually support each other's media activities and share copies of any articles, stories or other coverage related to Adventure Club. Organizations involved in this MOU must approve all media releases and opportunities related to Adventure Club.

G. FUNDING

Organizations may jointly or independently pursue funding to support and enhance Adventure Club, provided both organizations are informed prior to submittal of applications or requests.

H. SETTLEMENT OF DISAGREEMENTS

Organizations will endeavor to resolve any issues that arise in the management and quality of PEO programming. If a dispute arises out of or relates to this contract, and if the dispute cannot be settled through negotiation, either party may choose to terminate this contract after making a good faith effort to resolve the matter. At that time, neither party shall use the name of the other in grant applications or publicity materials not already produced/submitted.

X. TERM AND EXECUTION OF MOU

- A. This MOU shall be effective from August 28, 2017 through June 24 2018. The terms of the agreement may be amended by mutual written agreement of both parties, and may be terminated by either party with 60 days written notice.
- B. Signing this document acknowledges each party's understanding of, and agreement with, the terms outlined herein.

THE REST OF THIS PAGE WAS LEFT INTENTIONALLY BLANK

Please return a signed copy of this MOU to the listed PEO POC for our records.

Signature: _____ Date: _____

Lowell Elementary School
By: Jennifer Larva, Principal
Jennifer.larva@isd709.org
218-336-8895 x 1007

Signature: _____ Date: _____

Duluth Public Schools
By: Douglas A. Hasler, CFO
Douglas.hasler@isd709.org
218-336-8704

Signature: _____ Date: _____

Positive Energy Outdoors (PEO)
By: Stephanie Love, Director
Steph@outdooredventures.org
218-391-0147

REVIEW AND CONTINUATION OF THE
CLINICAL LEARNING EXPERIENCE AGREEMENT
BETWEEN

The College of St. Scholastica
School of Nursing
1200 Kenwood Avenue
Duluth, Minnesota 55811-4199
(Hereinafter referred to as the **COLLEGE**)

ORIG

AND

Duluth Public School System - ISD #709
215 N 1st Ave E
Duluth, MN 55802
(Hereinafter referred to as the **FACILITY**)

We have reviewed the Clinical Learning Experience Agreement between the **COLLEGE** and the **FACILITY**. The **COLLEGE** and the **FACILITY** agree to continue all terms and conditions previously agreed upon in the Clinical Learning Experience Agreement entered into on 7/30/2013.

This Agreement will be reviewed and evaluated at the close of each academic year by both parties and revisions or alterations made as are deemed advisable. Agreed upon revisions and alterations must be made in writing approved with signatures of those positions required on the primary Agreement.

This Agreement shall continue in effect unless written notice of desire to change or terminate the Agreement is given by either party to the other by June 1 of the year preceding the one in which termination is to become effective with provisions for safeguarding the program of students currently enrolled in the nursing program.

Upon signature of all parties listed below, this extension becomes effective.

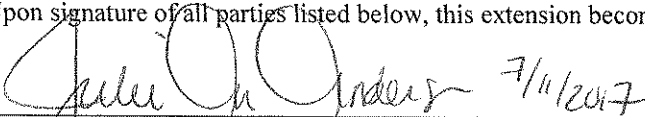

Signature Date
Julie Anderson, PhD, RN
Dean and Professor, School of Nursing
The College of St. Scholastica

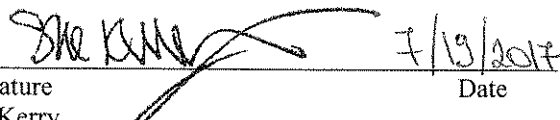

Signature Date
Sue Kerry
Vice President, Finance
Chief Financial Officer
The College of St. Scholastica

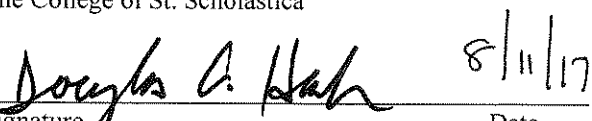

Signature Date
Douglas A. Hasler

Printed Name
CFO

Title
Duluth Public School System - ISD #709

FACILITIES MANAGEMENT & CAPITAL PROJECT STATUS REPORT AUGUST 2017

Facilities Management – Maintenance and Operations - General

- In the past month, Facilities maintenance crews have completed 86 work orders, and are currently working on 761 open work orders.
- Facilities maintenance trade crews are currently scheduled at District Wide.
- Efforts will be taken to start updating Facilities Management trades and operations position descriptions. Most current position descriptions that we are using are from 1990.

Capital Construction:

- Refinement of the project scope at Rockridge is occurring in conjunction with ARI and Kraus-Anderson, the GC for the project. The required amendment or modification of the Regulating Plan as related to current Rockridge site zoning classification will be heard at the Planning Commission August 8th, and City Counsel August 28th and September 11th. Once that process is complete and if successful, we will have all documents needed to proceed.
- A “Regulating Plan” is being developed for Rockridge with the City of Duluth, to allow us to perform needed construction compliant with the Zoned R-P Concept Plan.
- HOCHS parking lot is complete.
- The Playground Rubber Mulch Replacement project is underway, with a completion date of October 15th.
- The Stowe playground reconstruction project will be completed the second week of September.

Building Operations

- Operations staff has been on track deep cleaning our schools in preparation for the start of the school year. Our gym floor refinishing crew has remained on schedule throughout the district.
- Fireperson II position at Denfeld High School has been filled by an internal candidate. This has opened up a maintenance custodian position at Piedmont Elementary. Due to a resignation, a maintenance custodian position has opened up at Stowe Elementary as well. Also, a custodial position has opened up at Lincoln Park Middle School. An

anticipated retirement in September will open up another custodial position. Operations will have their hands full filling these positions during the start of the school year.

- Local police departments and sheriff's office continue to utilize some of our vacant sites for live trainings and demos.

Health, Safety & Environmental Management

Environmental/Health/Safety

- The safety department presented to facilities, transportation, and food services for the professional development day. Employees were trained in workers compensation and the importance of reporting injuries, risks and how to recognize them, hazardous communications and training locations, and lifting techniques.
- Confined space areas were catalogued and will be reviewed for proper designation per OSHA requirements.
- Basketball hoop inspections resulted in a few repairs needed. Repairs have been scheduled for the beginning of September.
- Kitchen hood inspections were completed. The fire marshal was out to review some of the corrective measures. She noticed that the inspectors did not apply the regulations appropriately resulting in some of the corrections not needing to be made at Lowell.
- Sprinkler inspections were completed. Once the reports are reviewed the recommended corrections will be completed.
- The door used as a second exit between the science classrooms at East was completed per fire marshal orders.

Emergency Response

- ERCM classroom guides were distributed prior to school starting.
- Site plans were moved to Google and are now available to be updated online by the principal and their admins.

Workers' Compensation Activities

- OSHA recordable injuries for the month: 1 – Teacher fell off of countertop reaching for a book and fractured their heel.
- First report of injuries: 4

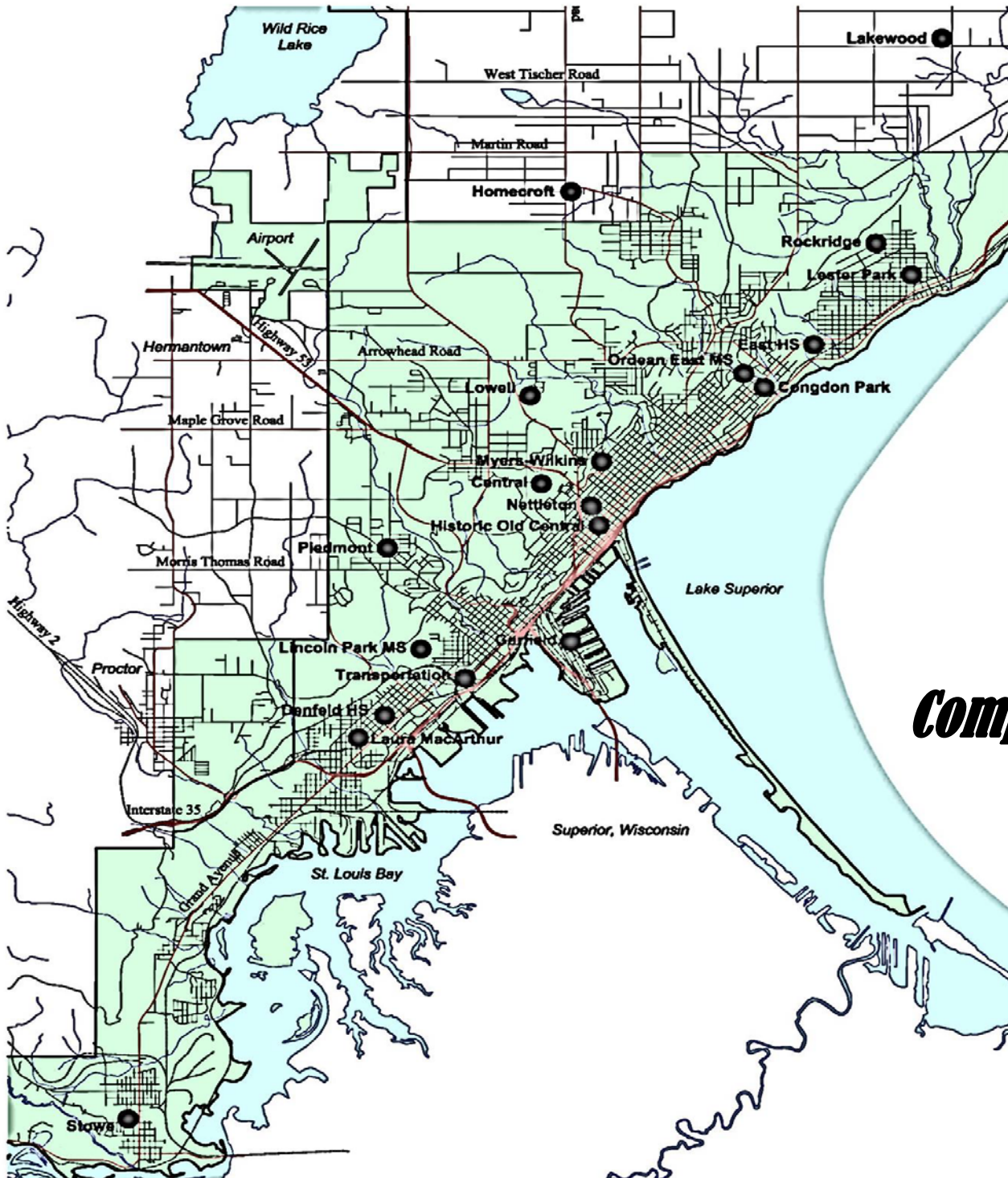

FY 2017

***ENERGY
REPORT***

***Comparison Of Usage & Cost
FY07 - FY17***

TOTAL ENERGY COSTS COMPARISON - FY07 & FY17

SITE	SQUARE FOOTAGE * EXTERNAL GROSS	ENERGY COSTS FY 07		SITE	SQUARE FOOTAGE * EXTERNAL GROSS	ENERGY COSTS FY 17		CHANGE TO TOTAL UTILITY COST	CHANGE TO COST PER SQUARE FOOT
		TOTAL UTILITY COST	COST PER SQUARE FOOT			TOTAL UTILITY COST	COST PER SQUARE FOOT		
Central Administration Building	196,120	\$111,855.23	\$0.57	HOCHS (Admin/ALC)	196,120	\$189,923.19	\$0.97	\$78,067.96	0.40
Central High School	249,768	\$219,892.00	\$0.88	CHS/STC (Closed June 2011)-Facilities Occupies STC	249,768	\$94,411.72	\$0.38	-\$125,480.28	-0.50
Congdon Park Elementary	66,520	\$59,528.00	\$0.89	Congdon Park ES	80,961	\$67,521.00	\$0.83	\$7,993.00	-0.06
Denfeld High School	258,798	\$228,608.00	\$0.88	Denfeld HS	395,703	\$278,424.15	\$0.70	\$49,816.15	-0.18
East High School	200,340	\$140,630.00	\$0.70	Ordean East MS	230,205	\$212,283.97	\$0.92	\$71,653.97	0.22
Grant Elementary/MWES	60,074	\$68,364.00	\$1.14	Myers-Wilkins ES	102,340	\$77,219.93	\$0.75	\$8,855.93	-0.38
Homecroft Elementary	46,921	\$46,007.00	\$0.98	Homecroft ES	58,140	\$61,872.37	\$1.06	\$15,865.37	0.08
Lakewood Elementary	50,607	\$43,814.00	\$0.87	Lakewood ES	50,607	\$45,841.03	\$0.91	\$2,027.03	0.04
Lester Park Elementary	48,430	\$44,672.00	\$0.92	Lester Park ES	84,252	\$79,404.66	\$0.94	\$34,732.66	0.02
Lincoln Park Elementary/Middle	170,596	\$138,832.00	\$0.81	Lincoln Park MS	204,600	\$221,393.64	\$1.08	\$82,561.64	0.27
Lowell Elementary	98,873	\$113,629.00	\$1.15	Lowell Elementary	98,226	\$101,710.89	\$1.04	-\$11,918.11	-0.11
MacArthur Elementary	155,406	\$124,866.00	\$0.80	Laura MacArthur ES	96,617	\$90,321.97	\$0.93	-\$34,544.03	0.13
Morgan Park Middle	128,628	\$122,180.00	\$0.95	Morgan Park (Sold 2015)				-\$122,180.00	-0.95
Nettleton Elementary	99,330	\$83,681.00	\$0.84	Nettleton (Closed June 2013)	99,330	\$30,137.24	\$0.30	-\$53,543.76	-0.54
Ordean Middle	128,105	\$133,027.00	\$1.04	East HS	316,069	\$197,441.96	\$0.62	\$64,414.96	-0.41
Piedmont Elementary	47,910	\$39,561.00	\$0.83	Piedmont ES	91,968	\$87,035.22	\$0.95	\$47,474.22	0.12
Rockridge Elementary	31,038	\$32,694.00	\$1.05	Rockridge (Closed June 2011)	31,038	\$13,093.45	\$0.42	-\$19,600.55	-0.63
Secondary Technical Center Main	52,863	\$66,777.00	\$1.26	Secondary Tech Center Main (Closed June 2011)	52,863	\$21,474.34	\$0.41	-\$45,302.66	-0.86
Stowe Elementary	80,203	\$75,204.00	\$0.94	Stowe ES	80,203	\$84,598.47	\$1.05	\$9,394.47	0.12
Woodland Middle	119,920	\$152,225.00	\$1.27	Woodland Sold 2012 (property) 2013 (building)				-\$152,225.00	-1.27
SUB TOTAL	2,290,450	\$2,046,046.23	\$0.89	SUB TOTAL	2,519,010	\$1,954,109.20	\$0.78	-\$91,937.03	-0.12
OTHER SITES									
Garfield	37,356	\$21,381.00	\$0.57	Garfield	37,395	\$20,789.69	\$0.56	-\$591.31	-0.02
Maintenance (Facilities Mgmt)	21,190	\$23,442.09	\$1.11	CHS/STC - See Above				-\$23,442.09	-1.11
Ordean Stadium	9,963	\$8,749.00	\$0.88	Included in EHS - See Above				-\$8,749.00	-0.88
Public School Stadium (PSS)	7,562	\$20,345.50	\$2.69	Public School Stadium (PSS)	7,076	\$21,572.65	\$3.05	\$1,227.15	0.36
Transportation Center	13,675	\$17,965.00	\$1.31	Transportation/Trans Shed	13,675	\$17,708.95	\$1.29	-\$256.05	-0.02
Warming House-Congdon Park	2,581	\$2,210.00	\$0.86	Warming House Congdon (Removed 2013)				-\$2,210.00	-0.86
SUB TOTAL	92,327	\$94,092.59	\$1.02	SUB TOTAL	58,146	\$60,071.29	\$1.03	-\$34,021.30	0.01
TOTAL	2,382,777	\$2,140,138.82	\$0.90	TOTAL	2,577,156	\$2,014,180.49	\$0.78	-\$125,958.33	-0.12

CHANGE TO SQUARE FOOTAGE TIMELINE

TOTAL ENERGY COST SAVINGS

-\$125,958.33

TOTAL INCREASE TO SQUARE FOOTAGE FROM FY7 TO FY17: 194,379 SQUARE FEET

SQUARE FOOTAGE IS REPORTED AS EXTERNAL GROSS SQUARE FOOTAGE

ADDITIONS/NEW CONSTRUCTION - INCREASE TO SQUARE FOOTAGE

- 2009 - HOMECROFT ELEMENTARY SCHOOL - ADDITION
- 2010 - DENFELD HIGH SCHOOL - ADDITION
- 2010 - EAST HS (CONVERSION FROM ORDEAN EAST MIDDLE SCHOOL)
- 2010 - ORDEAN EAST MS (CONVERSION FROM EAST HIGH SCHOOL)
- 2010 - LAURA MACARTHUR ES - DEMOLISHED & NEW CONSTRUCTION

- 2010 - LESTER PARK ES - DEMOLISHED & NEW CONSTRUCTION
- 2010 - PIEDMONT ES - DEMOLISHED & NEW CONSTRUCTION
- 2010 - LINCOLN PARK ES - SOLD & NEW CONSTRUCTION ON NEW LOCATION
- 2011 - MYERS WILKINS ELEMENTARY SCHOOL - ADDITION
- 2012 - CONGDON PARK ELEMENTARY SCHOOL - ADDITION

ENERGY COSTS COMPARISON - COST BY SQUARE FOOT - FY07 & FY17

FY07 FY17

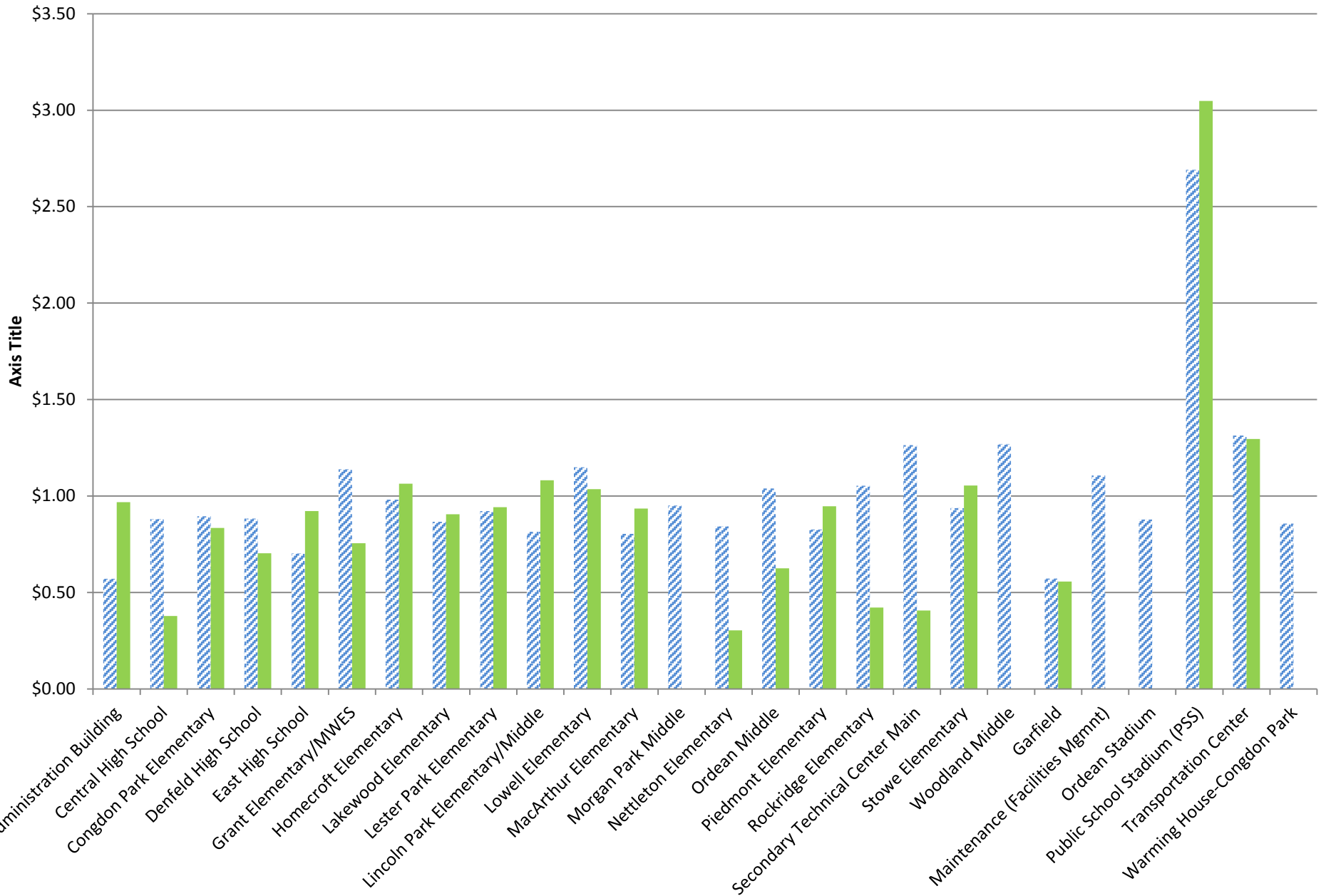

COMPARISON OF ELECTRICITY USAGE - FY07 & FY17

SITE	FY07			SITE	FY17			CHANGE TO ELECTRICITY COST	CHANGE TO COST PER SQUARE FOOT
	ELECTRICITY/ kWh	TOTAL COST	COST PER SQUARE FOOT		ELECTRICITY/ kWh	TOTAL COST	COST PER SQUARE FOOT		
Central Administration Building	1,153,144	\$76,690	\$0.39	HOCHS (Admin/ALC)	650,645.51	\$73,689.04	\$0.38	-\$3,001.19	-\$0.02
Central High School	1,682,496	\$108,856	\$0.44	CHS/STC (Closed June 2011)-Facilities Occupies STC	339,696.00	\$33,358.66	\$0.13	-\$75,497.34	-\$0.30
Congdon Park Elementary	311,520	\$22,945	\$0.34	Congdon Park ES	445,527.37	\$49,055.22	\$0.61	\$26,110.22	0.26
Denfeld High School	1,384,600	\$85,005	\$0.33	Denfeld HS	1,875,168.00	\$188,309.72	\$0.48	\$103,304.72	0.15
East High School	958,020	\$68,766	\$0.34	Ordean East MS	1,269,651.29	\$129,944.85	\$0.56	\$61,178.85	0.22
Grant Elementary/MWES	337,064	\$24,014	\$0.40	Myers-Wilkins ES	495,485.37	\$54,731.08	\$0.53	\$30,717.08	0.14
Homecroft Elementary	225,840	\$16,410	\$0.35	Homecroft ES	339,997.16	\$37,966.53	\$0.65	\$21,556.53	0.30
Lakewood Elementary	432,888	\$29,537	\$0.58	Lakewood ES	248,239.51	\$30,380.30	\$0.60	\$843.30	0.02
Lester Park Elementary	147,396	\$11,670	\$0.24	Lester Park ES	522,956.32	\$57,849.56	\$0.69	\$46,179.56	0.45
Lincoln Park Elementary/Middle	762,560	\$56,706	\$0.33	Lincoln Park MS	1,427,161.63	\$150,286.55	\$0.73	\$93,580.55	0.40
Lowell Elementary	752,640	\$49,878	\$0.50	Lowell Elementary	541,747.20	\$64,659.68	\$0.66	\$14,781.68	0.15
MacArthur Elementary	616,634	\$42,873	\$0.28	Laura MacArthur ES	639,549.74	\$69,914.80	\$0.72	\$27,041.80	0.45
Morgan Park Middle	386,538	\$27,037	\$0.21	Morgan Park (Sold 2015)				-\$27,037.00	-\$0.21
Nettleton Elementary	716,737	\$52,724	\$0.53	Nettleton (Closed June 2013)	48,926.00	\$5,680.12	\$0.06	-\$47,043.88	-\$0.47
Ordean Middle	712,160	\$50,122	\$0.39	East HS	1,261,247.94	\$141,926.60	\$0.45	\$91,804.60	0.06
Piedmont Elementary	194,179	\$14,969	\$0.31	Piedmont ES	559,246.73	\$61,932.05	\$0.67	\$46,963.05	0.36
Rockridge Elementary	183,424	\$13,689	\$0.44	Rockridge (Closed June 2011)	28,503.00	\$3,363.20	\$0.11	-\$10,325.80	-\$0.33
Secondary Technical Center Main	492,480	\$34,244	\$0.65	Secondary Tech Center Main (Closed June 2011)	80,640.00	\$9,875.99	\$0.19	-\$24,368.01	-\$0.46
Stowe Elementary	417,300	\$30,370	\$0.38	Stowe ES	446,241.80	\$52,194.69	\$0.65	\$21,824.69	0.27
Woodland Middle	688,080	\$48,837	\$0.41	Woodland Sold 2012 (property) 2013 (building)				-\$48,837.00	-\$0.41
SUB TOTAL	12,555,700	\$865,342.23	\$0.38	SUB TOTAL	11,220,630.55	\$1,215,118.63	\$0.48	\$349,776.40	0.10
OTHER SITES									
Garfield	31,800	\$2,444	\$0.07	Garfield	36,290.50	\$4,249.98	\$0.11	\$1,805.98	0.05
Maintenance (Facilities Mgmt)	75,402	\$5,899	\$0.28	CHS/STC - See Above				-\$5,899.00	-\$0.28
Ordean Stadium	17,464	\$1,483	\$0.15	Included in EHS - See Above				-\$1,483.00	-\$0.15
Public School Stadium (PSS)	121,920	\$9,218	\$1.22	Public School Stadium (PSS)	112,268.74	\$13,713.30	\$1.94	\$4,495.30	0.72
Transportation Center	99,369	\$8,071	\$0.59	Transportation/Trans Shed	72,638.93	\$9,347.00	\$0.68	\$1,276.00	0.09
Warming House-Congdon Park	22,601	\$2,210	\$0.86	Removed 2013				-\$2,210.00	-\$0.86
SUB TOTAL	368,556	\$29,325.00	\$0.32	SUB TOTAL	221,198.17	\$27,310.28	\$0.47	-\$2,014.72	0.15
TOTAL	12,924,256	\$894,667.23	\$0.38	TOTAL	11,441,828.72	\$1,242,428.91	\$0.48	\$347,761.68	0.11

AVG COST PER UNIT (kWh) 2007 - \$0.7 2017 - \$0.11 57.142% INCREASE				TOTAL ELECTRICITY (kWh) USAGE REDUCTION -1,482,427.28					
TOTAL ENERGY COST SAVINGS \$347,761.68		ELECTRICITY \$347,761.68		GAS/OIL/STEAM -\$445,385.46		WATER/SEWER/STORM -\$28,334.54		-\$125,958.33	

ELECTRICITY COMPARISON - COST PER SQ FOOT - FY07 & FY17

FY07 FY17

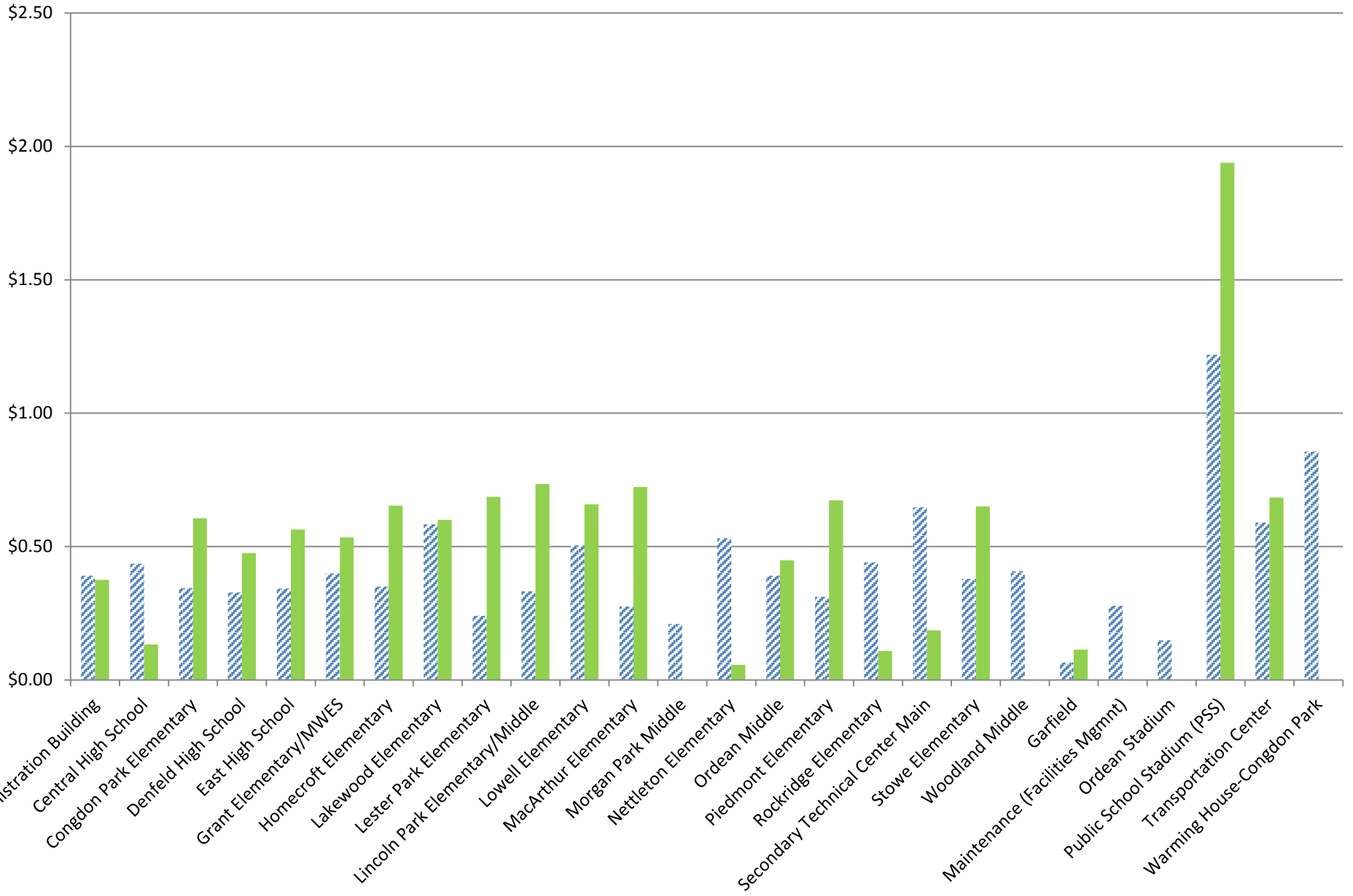

COMPARISON OF NATURAL GAS/HEATING OIL/STEAM - FY07 & FY17

SITE	FY07			SITE	FY17			CHANGE TO GAS/OIL/STEAM COST	CHANGE TO COST PER SQUARE FOOT
	GAS/CCF OIL/GALS STEAM/LBS	TOTAL COST	COST PER SQUARE FOOT		GAS/CCF OIL/GALS STEAM/LBS	TOTAL COST	COST PER SQUARE FOOT		
Central Administration Building	2,895,234	\$24,811	\$0.13	HOCHS (Admin/ALC)	5,097,422.05	\$101,259.45	\$0.52	\$76,448.45	0.39
Central High School	102,444	\$81,000	\$0.32	CHS/STC (Closed June 2011)-Facilities Occupies STC	62,008.00	\$36,613.41	\$0.15	-\$44,386.59	-\$0.18
Congdon Park Elementary	35,053	\$28,838	\$0.43	Congdon Park ES	17,009.81	\$10,179.46	\$0.13	-\$18,658.55	-\$0.31
Denfeld High School	151,410	\$115,309	\$0.45	Denfeld HS	112,579.27	\$64,259.27	\$0.16	-\$51,049.73	-\$0.28
East High School	73,265	\$56,400	\$0.28	Ordean East MS	93,843.81	\$53,779.47	\$0.23	-\$2,620.53	-\$0.05
Grant Elementary/MWES	41,467	\$33,225	\$0.55	Myers-Wilkins ES	21,570.69	\$12,767.30	\$0.12	-\$20,457.70	-\$0.43
Homecroft Elementary	25,280	\$23,653	\$0.50	Homecroft ES	25,310.88	\$14,863.77	\$0.26	-\$8,789.23	-\$0.25
Lakewood Elementary*	7,000	\$14,277	\$0.28	Lakewood ES	9,955.85	\$15,460.73	\$0.31	\$1,183.73	0.02
Lester Park Elementary	34,039	\$27,459	\$0.57	Lester Park ES	23,272.24	\$13,820.79	\$0.16	-\$13,638.21	-\$0.40
Lincoln Park Elementary/Middle	83,862	\$65,627	\$0.38	Lincoln Park MS	88,447.78	\$50,462.95	\$0.25	-\$15,164.05	-\$0.14
Lowell Elementary	55,390	\$48,362	\$0.49	Lowell Elementary	38,039.75	\$22,102.02	\$0.23	-\$26,259.98	-\$0.26
MacArthur Elementary	82,551	\$63,746	\$0.41	Laura MacArthur ES	21,864.40	\$12,841.12	\$0.13	-\$50,904.88	-\$0.28
Morgan Park Middle	95,504	\$76,153	\$0.59	Morgan Park (Sold 2015)				-\$76,153.00	-\$0.59
Nettleton Elementary	27,600	\$22,728	\$0.23	Nettleton (Closed June 2013)	33,997.00	\$19,885.90	\$0.20	-\$2,842.10	-\$0.03
Ordean Middle	85,680	\$66,351	\$0.52	East HS	62,065.35	\$35,990.18	\$0.11	-\$30,360.82	-\$0.40
Piedmont Elementary	23,818	\$20,013	\$0.42	Piedmont ES	25,404.86	\$14,835.90	\$0.16	-\$5,177.10	-\$0.26
Rockridge Elementary	14,420	\$12,885	\$0.42	Rockridge (Closed June 2011)	9,071.00	\$5,709.53	\$0.18	-\$7,175.47	-\$0.23
Secondary Technical Center Main	27,320	\$24,183	\$0.46	Secondary Tech Center Main (Closed June 2011)	11,330.00	\$6,950.27	\$0.13	-\$17,232.73	-\$0.33
Stowe Elementary	39,170	\$34,481	\$0.43	Stowe ES	32,045.74	\$18,688.12	\$0.23	-\$15,792.88	-\$0.20
Woodland Middle	111,911	\$87,073	\$0.73	Woodland Sold 2012 (property) 2013 (building)				-\$87,073.00	-\$0.73
SUB TOTAL GAS	1,110,184	\$887,486.00	\$0.43	SUB TOTAL GAS	677,860.58	\$393,749.45	\$0.17	-\$493,736.55	-\$0.26
OTHER SITES									
Garfield	16,340	\$13,825	\$0.37	Garfield	18,099.00	\$10,785.00	\$0.29	-\$3,040.01	-\$0.25
Maintenance (Facilities Mgmt)	19,052	\$16,315	\$0.77	CHS/STC - See Above				-\$16,315.00	-\$0.86
Ordean Stadium	4,352	\$4,617	\$0.46	Ordean Stadium (Included in EHS - See Above)				-\$4,617.00	-\$1.06
Public School Stadium (PSS)	9,200	\$8,509	\$1.13	Public School Stadium (PSS)	9,055.03	\$5,658.39	\$0.80	-\$2,850.61	-\$0.30
Transportation Center	7,900	\$7,267	\$0.53	Transportation/Trans Shed	7,608.31	\$4,808.53	\$0.35	-\$2,458.47	-\$0.29
Warming House-Congdon Park	0	\$0	\$0.00	Removed 2013				\$0.00	0.00
SUB TOTAL GAS	56,844	\$50,533.00	\$0.55	SUB TOTAL GAS	34,762.33	\$21,251.91	\$0.37	-\$29,281.09	-\$0.18
TOTAL GAS	1,167,028	\$938,019.00	\$0.44	TOTAL GAS	712,622.92	\$415,001.36	\$0.18	-\$523,017.64	-\$0.26
TOTAL STEAM	2,895,234	\$24,811.00	\$0.13	TOTAL STEAM	5,097,422.05	\$101,259.45	\$0.52	\$76,448.45	0.39
TOTAL HEATING OIL	7,000	\$14,277.00	\$0.28	TOTAL HEATING OIL	9,955.85	\$15,460.73	\$0.31	\$1,183.73	0.02
AVG COST PER SQ FOOT				TOTAL GAS/HEATING OIL/STEAM COST REDUCTION				-\$445,385.46	
2007 - \$0.46 2017 - \$0.24 47.826% DECREASE									
TOTAL ENERGY COST SAVINGS			ELECTRICITY	GAS/OIL/STEAM		WATER/SEWER/STORM		-\$125,958.33	
			\$347,761.68	-\$445,385.46		-\$28,334.54			
STEAM/LBS			HEATING OIL/GALLONS			*Includes \$130/propane			

NATURAL GAS/OIL/STEAM COMPARISON - COST PER SQ FT - FY07 & FY17

FY07 FY17

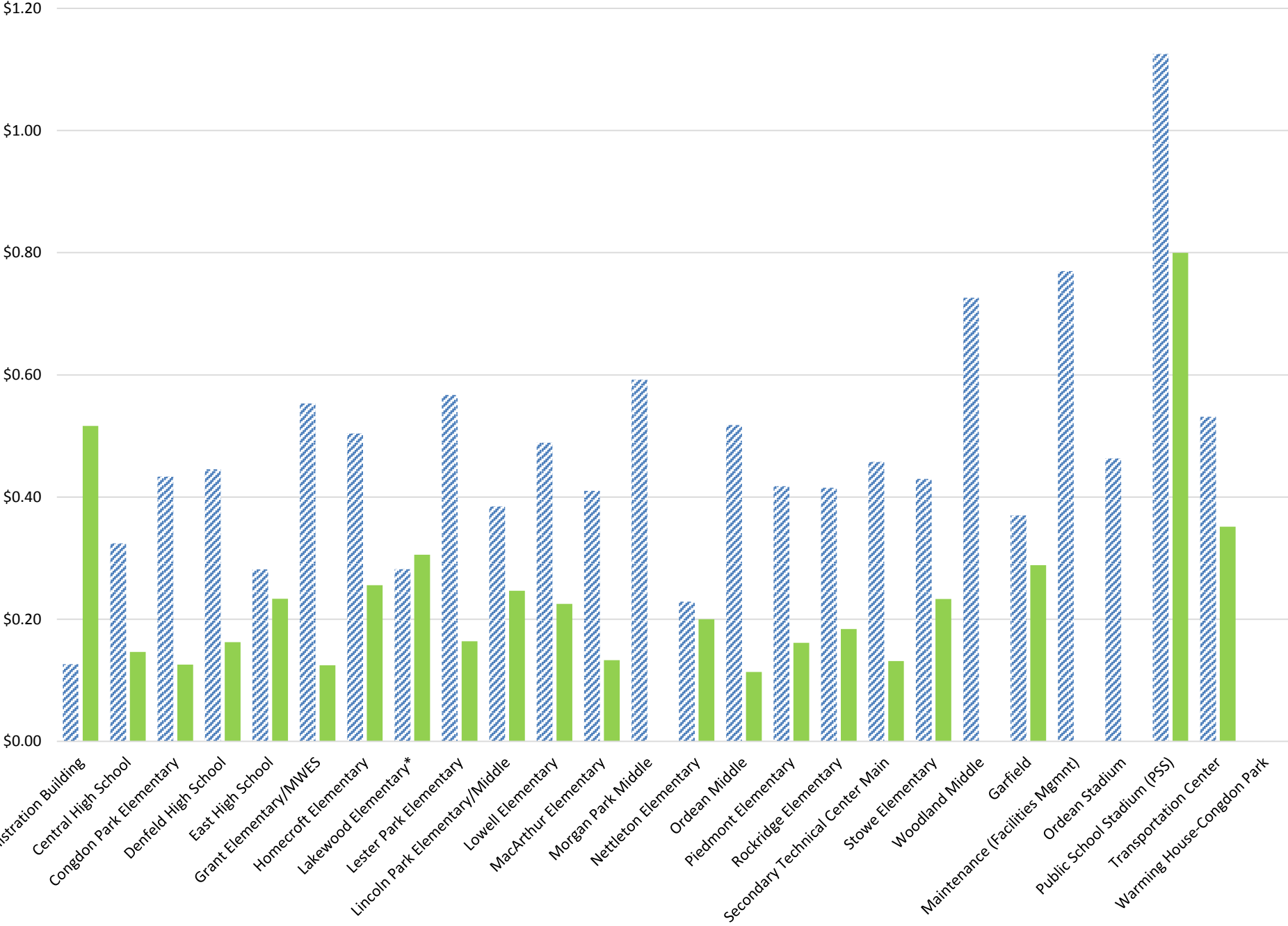

COMPARISON OF WATER/SEWER/STORM USAGE - FY07 & FY17

SITE	FY07			SITE	FY17			CHANGE TO WATER SEWER STORM COST	CHANGE TO COST PER SQUARE FOOT
	WATER SEWER STORM kGAL	TOTAL COST	COST PER SQ FT		WATER SEWER STORM kGAL	TOTAL COST	COST PER SQ FT		
Central Administration Building	732	\$10,354	\$0.05	HOCHS (Admin/ALC)	494.01	\$14,974.70	\$0.08	\$4,620.70	\$0.02
Central High School	2,425	\$30,036	\$0.12	CHS/STC (Closed June 2011)-Facilities Occupies STC	85.27	\$24,439.65	\$0.10	-\$5,596.35	-\$0.02
Congdon Park Elementary	795	\$7,745	\$0.12	Congdon Park ES	600.36	\$8,286.33	\$0.10	\$541.33	-\$0.01
Denfeld High School	3,132	\$28,294	\$0.11	Denfeld HS	1,039.86	\$25,855.16	\$0.07	-\$2,438.84	-\$0.04
East High School	1,295	\$15,464	\$0.08	Ordean East MS	1,384.64	\$28,559.66	\$0.12	\$13,095.66	\$0.05
Grant Elementary/MWES	1,472	\$11,125	\$0.19	Myers-Wilkins ES	496.10	\$9,721.56	\$0.09	-\$1,403.44	-\$0.09
Homecroft Elementary	384	\$5,944	\$0.13	Homecroft ES	322.35	\$9,042.07	\$0.16	\$3,098.07	\$0.03
Lakewood Elementary	0	\$0	\$0.00	Lakewood ES	262.02	\$0.00	\$0.00	\$0.00	\$0.00
Lester Park Elementary	881	\$5,543	\$0.11	Lester Park ES	554.75	\$7,734.31	\$0.09	\$2,191.31	-\$0.02
Lincoln Park Elementary/Middle	2,092	\$16,499	\$0.10	Lincoln Park MS	1,805.79	\$20,644.14	\$0.10	\$4,145.14	\$0.00
Lowell Elementary	1,545	\$15,389	\$0.16	Lowell Elementary	522.70	\$14,949.19	\$0.15	-\$439.81	\$0.00
MacArthur Elementary	2,403	\$18,247	\$0.12	Laura MacArthur ES	544.05	\$7,566.05	\$0.08	-\$10,680.95	-\$0.04
Morgan Park Middle	2,478	\$18,990	\$0.15	Morgan Park (Sold 2015)				-\$18,990.00	-\$0.15
Nettleton Elementary	910	\$8,229	\$0.08	Nettleton (Closed June 2013)	49.37	\$4,571.22	\$0.05	-\$3,657.78	-\$0.04
Ordean Middle	1,863	\$16,554	\$0.13	East HS	1,872.15	\$19,525.18	\$0.06	\$2,971.18	-\$0.07
Piedmont Elementary	411	\$4,579	\$0.10	Piedmont ES	554.42	\$10,267.27	\$0.11	\$5,688.27	\$0.02
Rockridge Elementary	576	\$6,120	\$0.20	Rockridge (Closed June 2011)	1.50	\$4,020.72	\$0.13	-\$2,099.28	-\$0.07
Secondary Technical Center Main	864	\$8,350	\$0.16	Secondary Tech Center Main (Closed June 2011)	0.00	\$4,648.08	\$0.09	-\$3,701.92	-\$0.07
Stowe Elementary	692	\$10,353	\$0.13	Stowe ES	377.49	\$13,715.66	\$0.17	\$3,362.66	\$0.04
Woodland Middle	1,896	\$16,315	\$0.14	Woodland Sold 2012 (property) 2013 (building)				-\$16,315.00	-\$0.14
SUB TOTAL	26,846	\$254,130.00	\$0.11	SUB TOTAL	10,966.83	\$228,520.95	\$0.09	-\$25,609.05	-\$0.02
OTHER SITES									
Garfield	446	\$5,112	\$0.14	Garfield	185.61	\$5,754.72	\$0.15	\$642.72	\$0.02
Maintenance (Facilities Mgmt)	104	\$1,228	\$0.06	CHS/STC - See Above				-\$1,228.09	-\$0.06
Ordean Stadium	410	\$2,649	\$0.27	Included in EHS - See Above				-\$2,649.00	-\$0.27
Public School Stadium (PSS)	407	\$2,619	\$0.35	Public School Stadium (PSS)	150.12	\$2,200.96	\$0.31	-\$417.54	-\$0.04
Transportation Center	122	\$2,627	\$0.19	Transportation/Trans Shed	66.88	\$3,553.42	\$0.26	\$926.42	\$0.07
Warming House-Congdon Park	0	\$0	\$0.00	Removed 2013				\$0.00	\$0.00
SUB TOTAL	1,489	\$14,234.59	\$0.15	SUB TOTAL	402.61	\$11,509.10	\$0.20	-\$2,725.49	\$0.04
TOTAL	28,335	\$268,364.59	\$0.11	TOTAL	11,369.44	\$240,030.05	\$0.09	-\$28,334.54	-\$0.02

AVG COST PER SQ FOOT				TOTAL WATER/SEWER/STORM COST REDUCTION			-\$28,334.54
2007 - \$0.13	2017 - \$0.12	7.692%	DECREASE				
TOTAL ENERGY COST SAVINGS		ELECTRICITY	GAS/OIL/STEAM	WATER/SEWER/STORM		-\$125,958.33	
		\$347,761.68	-\$445,385.46	-\$28,334.54			

WATER/SEWER/STORM COMPARISON - COST PER SQ FT - FY07 & FY17

 FY07
 FY17

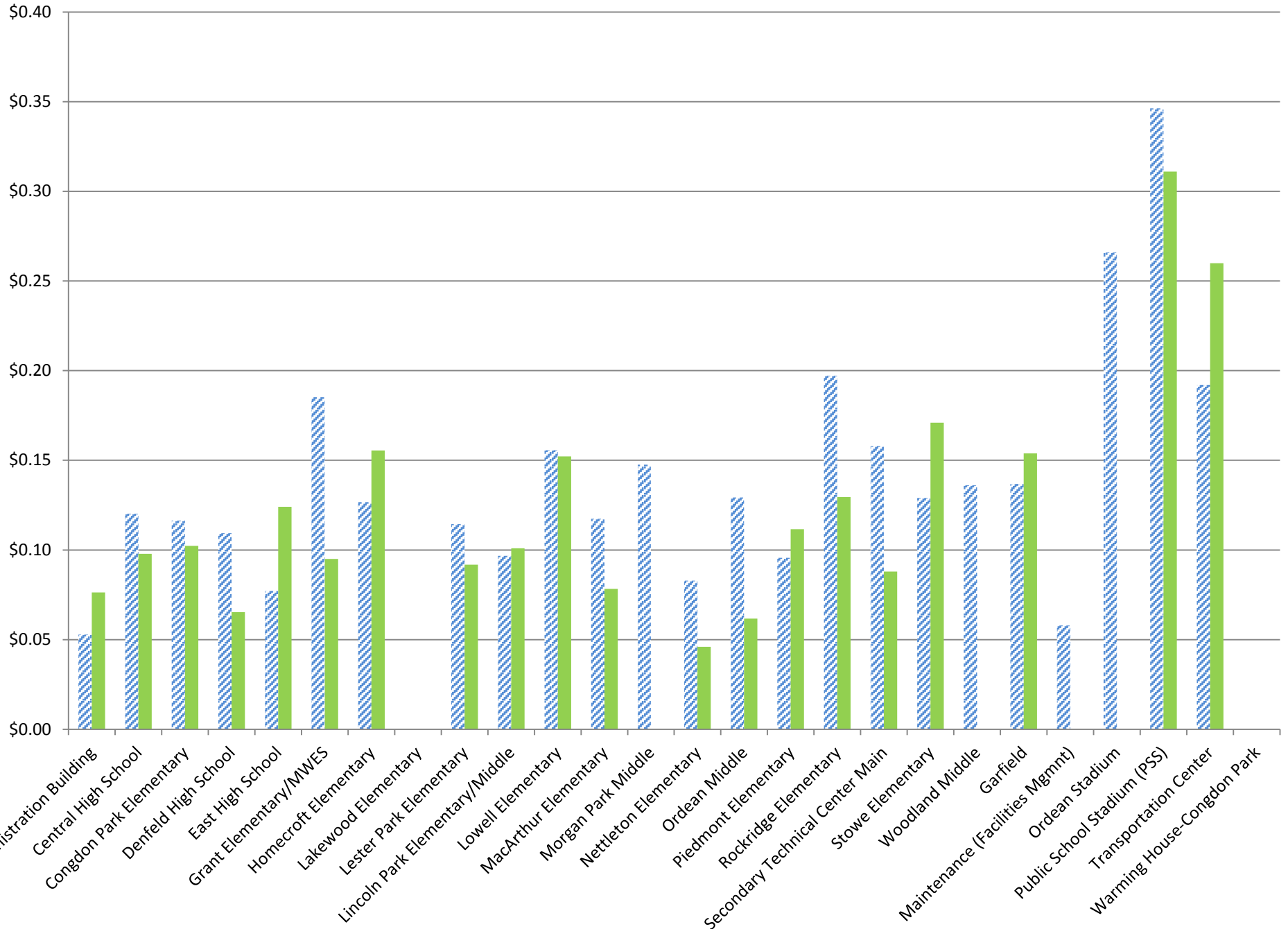

BENCHMARK REPORT

*SF NORMALIZED

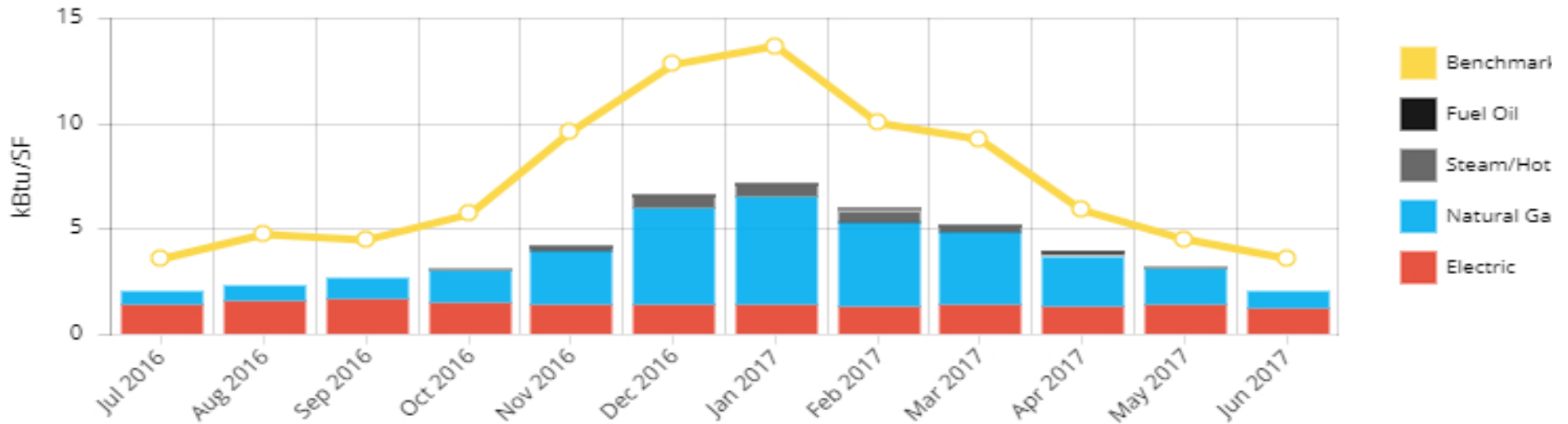

Displays benchmarking consumption (electricity, natural gas, heating oil, steam) as a line to represent the expected consumption were the site built to current energy code.

*SF Normalized - "Normalize" consumption by square footage. This changes the units on the vertical y-axis.

CURRENT ENERGY STAR RATING

172

ENERGY STAR® is a national program designed to promote energy efficiency. B3 Benchmarking automatically creates an ENERGY STAR Portfolio Manager property for each site and transfers building and meter information for the purpose

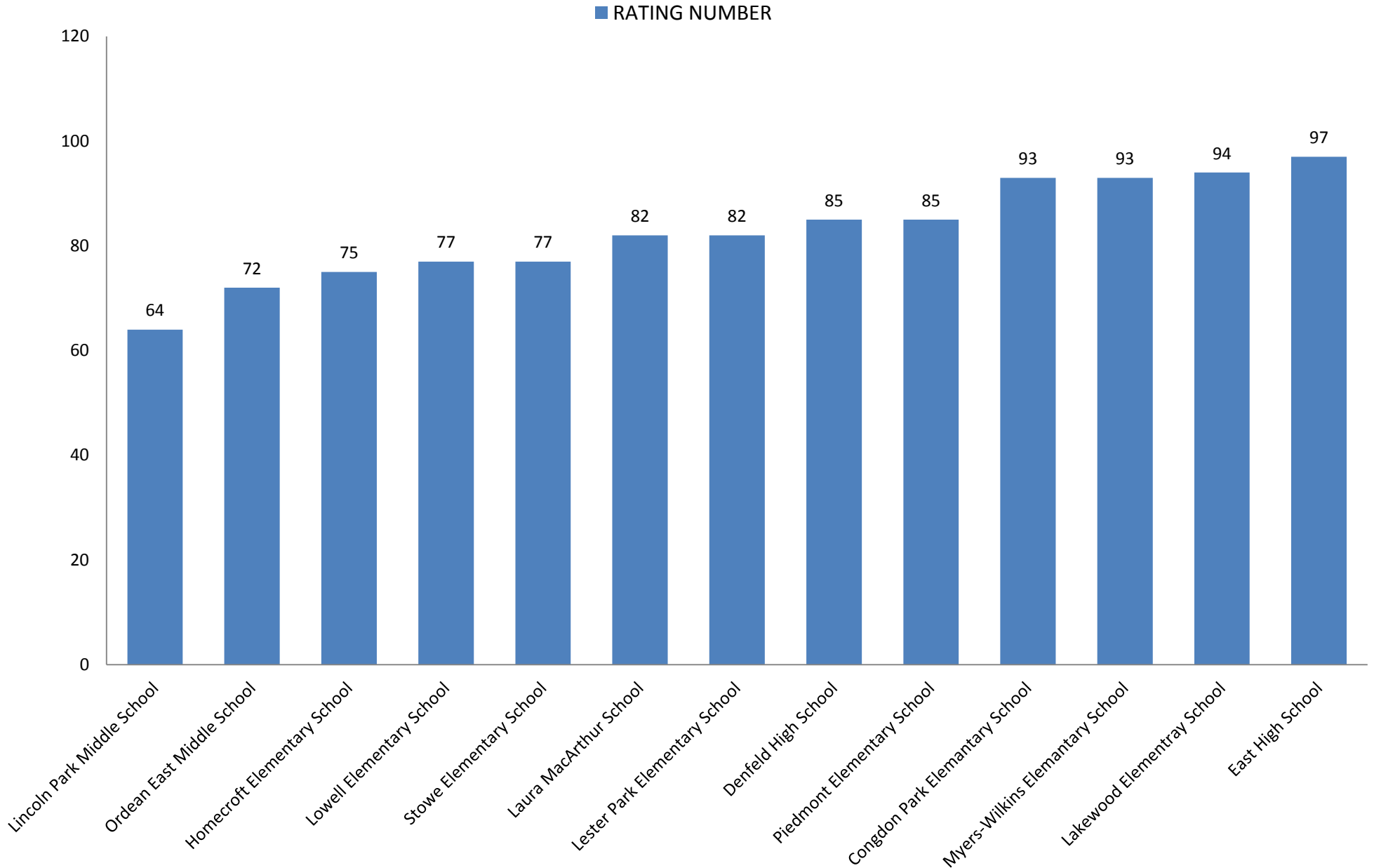



UNITED STATES ENVIRONMENTAL PROTECTION AGENCY
WASHINGTON, D.C. 20460

Climate Protection Partnership Division
U.S. EPA 6202A
Washington, DC 20460

OFFICE OF AIR AND RADIATION

July 03, 2017

Dave Spooner
730 East Central Entrance
Duluth, MN 55811

Dear Dave Spooner:

Congratulations! You have earned EPA's ENERGY STAR for Minnesota Public, K12, Duluth Public Schools, Denfeld High School [MN008282], located at 401 North 44th Avenue West, Duluth, MN 55807. This letter outlines all the ways you can promote your achievement:

Decal and certificate: To help you identify your building as one of America's energy all-stars, enclosed is a certificate of achievement and an ENERGY STAR certification decal that bears the well-recognized ENERGY STAR certification mark. If applicable, we've also enclosed an anniversary decal that you can affix below the main decal. We encourage you to affix the decal prominently near the exterior entrance of your building. Find instructions at www.energystar.gov/Promote.

Promotional toolkit: We have more than a dozen ready-to-use promotional materials for you, such as social media graphics, sample text, posters, a 30-second audio clip, and more. Find them at www.energystar.gov/Promote.

Online store: You can also purchase metal or glass plaques, flags, banners, and static cling decals from the ENERGY STAR online store at www.energystar.gov/OnlineStore.

Registry listing: Your building is now listed in our registry at www.energystar.gov/buildinglist. If you have not already done so, please submit a photo of your building. Simply log in to Portfolio Manager, click on the building name, and follow the instructions.

ENERGY STAR logo: We hope you will proudly use the ENERGY STAR certification logo, which was attached to your "Congratulations" email, in any materials about your building or this achievement. Before doing so, please refer to the US EPA's logo guidelines at www.energystar.gov/LogoUse.

Again, congratulations on your commitment to energy efficiency. We look forward to receiving your application for the ENERGY STAR again next year!

Sincerely,

A handwritten signature in black ink that reads "Jean Lupinacci".

Jean Lupinacci

Director, Commercial & Industrial Branch
ENERGY STAR

Enclosures:
(1) ENERGY STAR Labeled Building Award Decal



2017

In recognition of superior energy performance,
the U.S. Environmental Protection Agency awards
the ENERGY STAR® to

**Minnesota Public, K12,
Duluth Public Schools,
Denfeld High School
[MN008282]**

Buildings that earn EPA's ENERGY STAR use 35 percent less energy and generate 35 percent fewer greenhouse gas emissions than similar buildings across the nation.



Jean Lupinacci
Director, ENERGY STAR Commercial & Industrial Branch

July 03, 2017

Date

UNITED STATES ENVIRONMENTAL PROTECTION AGENCY
WASHINGTON, D.C. 20460



Climate Protection Partnership Division
U.S. EPA 6202A
Washington, DC 20460

OFFICE OF AIR AND RADIATION

March 06, 2017

David Spooner
215 North 1st Avenue East
Duluth, MN 55802

Dear David Spooner:

Congratulations! You have earned EPA's ENERGY STAR for Minnesota Public, K12, Duluth Public Schools, East High School [MN008283], located at 301 North 40th Avenue East, Duluth, MN 55804 (Registry name: Duluth East High School). This letter outlines all the ways you can promote your achievement:

Decal and certificate: To help you identify your building as one of America's energy all-stars, enclosed is a certificate of achievement and an ENERGY STAR certification decal that bears the well-recognized ENERGY STAR certification mark. If applicable, we've also enclosed an anniversary decal that you can affix below the main decal. We encourage you to affix the decal prominently near the exterior entrance of your building. Find instructions at www.energystar.gov/Promote.

Promotional toolkit: We have more than a dozen ready-to-use promotional materials for you, such as social media graphics, sample text, posters, a 30-second audio clip, and more. Find them at www.energystar.gov/Promote.

Online store: You can also purchase metal or glass plaques, flags, banners, and static cling decals from the ENERGY STAR online store at www.energystar.gov/OnlineStore.

Registry listing: Your building is now listed in our registry at www.energystar.gov/buildinglist. If you have not already done so, please submit a photo of your building. Simply log in to Portfolio Manager, click on the building name, and follow the instructions.

ENERGY STAR logo: We hope you will proudly use the ENERGY STAR certification logo, which was attached to your "Congratulations" email, in any materials about your building or this achievement. Before doing so, please refer to the US EPA's logo guidelines at www.energystar.gov/LogoUse.

Again, congratulations on your commitment to energy efficiency. We look forward to receiving your application for the ENERGY STAR again next year!

Sincerely,

Jean Lupinacci

Director, Commercial & Industrial Branch
ENERGY STAR

Enclosures:
(1) ENERGY STAR Labeled Building Award Decal



2017

In recognition of superior energy performance,
the U.S. Environmental Protection Agency awards
the ENERGY STAR® to

Duluth East High School

Buildings that earn EPA's ENERGY STAR use 35 percent less energy and generate 35 percent fewer greenhouse gas emissions than similar buildings across the nation.



A handwritten signature in black ink that reads "Jean Lupinacci".

Jean Lupinacci
Director, ENERGY STAR Commercial & Industrial Branch

March 06, 2017

Date

September 6, 2017

TO: School Board
William Gronseth

FROM: Douglas A. Hasler

SUBJECT: Paperless Board Meetings

“Paperless” Board meetings have become increasingly common among school districts in Minnesota, and in states around the country. Hardware and software technology have improved to facilitate the distribution of meeting documents electronically. In addition, costs for such technology have fallen.

I am providing an attachment that summarizes cost estimates for our current process to gather, organize, copy, print, and distribute documents that are part of the Board (or committee) meeting packet. Based on those estimates, the annual cost for our current process to provide paper copies of meeting materials is approximately \$10,280.

We have also generated a cost estimate for using an alternative process to distribute materials for Board and committee meetings. The alternative process would be to post meeting materials exclusively through the BoardBook software that we currently use, and provide Board members (and the student representatives) with a Chromebook that they can use to access meeting materials. One concern that Board members have raised in the past is that they want to be able to make notes on meeting documents. There is now an application (KAMI Google app) that allows a user to mark up an electronic document and save the modified document. The total cost of acquisition for the Chromebooks (and a mouse) would be approximately \$4,725.

I believe it is reasonable to assume that Chromebooks issued to Board members and student representatives could last for a period of up to 4 years. Organizing and distributing Board meeting materials exclusively through BoardBook represents a potential cost savings of approximately \$35,000 over a 4-year period.

Another advantage associated with electronic distribution of meeting materials is that Board members would no longer have to wait to receive paper documents mailed to them. Meeting documents can be available to Board members immediately upon being posted onto BoardBook.

To facilitate a smooth transition to “paperless” Board meetings, Board members would receive training on the use of their Chromebook to access materials posted on BoardBook. I believe it is realistic for us to target the implementation of “paperless” Board meetings for January 2018.

I am recommending that the Board authorize the transition to “paperless” Board meetings. I believe such a process would generate cost savings, and would represent a more efficient use of staffing resources. Further, I believe that distribution of electronic documents would be more timely than the mailing of paper documents have been in the past. I welcome input and comment that Board members might have on this matter.

Document Handling Cost Estimates

Committee Meetings:

Paper/Printing Costs	\$75
Print Shop Staff Time	25
Melinda Staff Time	50
Staff Time to Prepare 3 Committee Reports	75
Postage Processing	<u>80</u>
	\$305

Regular School Board Meetings:

Paper/Printing Costs	\$257
Print Shop Staff Time	90
Melinda Staff Time	50
Staff Time to Prepare 3 Committee Reports	75
Postage Processing	<u>80</u>
	\$552

Total Monthly Costs	\$857
x	12
Total Annual Costs	\$10,284

Cost to Go "Paperless":

Chromebook Plus w/touchscreen	\$500
Mouse	25
KAMI Google App	<u>0</u>
	\$525
x	<u>9</u>
	\$4,725