

Board of Education Regular Meeting

July 25, 2023 6:00 PM

City Hall Council Chambers

I. CALL TO ORDER Procedural Item	Chair Butch Campbell
A. Pledge of Allegiance Procedural Item The Pledge of Allegiance will be led by new John Pittard Principal Dr. Christy Robinson, new School Safety Supervisor Andy Taylor, and new City Schools Attorney Lauren Bush	
B. Moment of Silence Procedural Item	
C. Public Comment Procedural Item	
II. APPROVAL OF AGENDA Action Item	Chair Butch Campbell
III. COMMUNICATIONS Information Item Congratulations to MCS Communications Department on receiving the NSPRA Award.	Dr. Trey Duke
A. Introduction of New Staff Dr. Christy Robinson-Principal at John Pittard Ms. Lauren Bush-Assistant City Attorney Mr. Andy Taylor-New Security Supervisor Procedural Item	Dr. Trey Duke
B. The Best of MCS-Patti McCloy Procedural Item	Dr. Trey Duke
C. Spotlight on Education-New Teacher Orientation Procedural Item	Ms. Sheri Arnette
IV. CONSENT ITEMS Consent Agenda	Chair Butch Campbell
A. Approval of 6-13-23 Board Minutes Consent Item	
V. ACTION ITEMS Action Item	Chair Butch Campbell
A. Waive Board Policy 1.600 Policy Development and Adoption Action Item	Ms. Lauren Bush
B. Approval of Board Policy 1.102 Board Members Legal Status on First and Final Reading Action Item	Ms. Lauren Bush
C. Approval of Board Policy 1.106 Code of Ethics on First and Final Reading Action Item	Ms. Lauren Bush
D. Approval of Board Policy 1.400 School Board Meetings on First and Final Reading Action Item	Ms. Lauren Bush
E. Approval of Board Policy 1.401 Public Participation in Board Meetings on First and Final Reading Action Item	Ms. Lauren Bush

F. Approval of Board Policy 1.402 Notification of Meetings on First and Final Reading Action Item	Ms. Lauren Bush
G. Approval of Board Policy 3.202 Emergency Preparedness Drills on First and Final Reading Action Item	Ms. Lauren Bush
H. Approval of Board Policy 3.204 Threat Assessment Team on First and Final Reading Action Item	Ms. Lauren Bush
I. Approval of Board Policy 3.205 Security on First and Final Reading Action Item	Ms. Lauren Bush
J. Approval of Board Policy 4.300 Extracurricular Activities on First and Final Reading Action Item	Ms. Lauren Bush
K. Approval of Board Policy 5.106 Application and Employment on First and Final Reading Action Item	Ms. Lauren Bush
L. Approval of Board Policy 5.1061 Employment of Retirees on First and Final Reading Action Item	Ms. Lauren Bush
M. Approval of Board Policy 5.305 Family and Medical Leave on First and Final Reading Action Item	Ms. Lauren Bush
N. Approval of Board Policy 5.307 Physical Assault Leave on First and Final Reading Action Item	Ms. Lauren Bush
O. Approval of Board Policy 6.202 Home Schools on First and Final Reading Action Item	Ms. Lauren Bush
P. Approval of Board Policy 6.309 Zero Tolerance Offenses on First and Final Reading Action Item	Ms. Lauren Bush
Q. Approval of Board Policy 6.4001 Student Surveys, Analyses, and Evaluations on First and Final Reading Action Item	Ms. Lauren Bush
R. Approval of Board Policy 6.402 Physical Examinations and Immunizations on First and Final Reading Action Item	Ms. Lauren Bush
S. Approval of School Resource Officer Memorandums of Understanding Action Item	Dr. Trey Duke
T. Approval of the Architect Agreement for the new MNE Playground Action Item	Dr. Trey Duke
U. Approval of 2023-2024 Student Field Trips \$20 or less Action Item	Dr. Trey Duke
V. Approval of the FY24 Federal Stronger Connections Grant-Budget Amendment Action Item	Dr. Trey Duke
W. Approval of the FY24 GPS United Way Grant/Budget Amendment Action Item	Dr. Trey Duke
X. Approval of the FY24 Nutrition LFS Grant Action Item	Dr. Trey Duke

Y. Approval of FY24 Federal AALN Grant Action Item	Dr. Trey Duke
Z. Approval of FY24 TISA Budget Amendment Action Item	Dr. Trey Duke
AA. Approval of Revenue and Expenditure Report Action Item	Ms. Kim Williams
VI. REPORTS AND INFORMATION Information Item	Chair Butch Campbell
A. Update on Capital Improvement Projects Information Item	Mr. Don Bartch
B. Director's Update Information Item	Dr. Trey Duke
VII. OTHER BUSINESS Information Item	Chair Butch Campbell
VIII. ADJOURNMENT Action Item	Chair Butch Campbell



Public Comment Registration Form

Public Comment Period Information

Pursuant to Board Policy 1.401, any public meeting of the Murfreeboro City Schools Board of Education with actionable items on the agenda will have 15 minutes set aside at the beginning of the meeting for public comment. Individuals wishing to make a public comment will be allowed 3 minutes to speak with respect to an action item on the agenda for the meeting subject to the following:

- All comments are restricted to comments on action items on the agenda for the meeting.
- The Chair shall have the authority to declare an individual out of order, if after an initial warning, an individual continues to speak on a topic that is unrelated to an action item on the agenda.
- The Chair shall have the authority to terminate the remarks of any individual who violates state law or does not adhere to board rules.

If you wish to address the Board during the public comment period, you must sign up **at least 6 hours** prior to the meeting’s scheduled start time by:

- Sending an e-mail to lisa.vancleave@cityschools.net with this completed form or an e-mail with your name/phone number/address and the action on which you are wishing to speak and whether you are speaking in support or against the action; OR
- Calling Lisa Van Cleave at 615-893-2313, Ext. 10010, before the meeting with the request to speak and your name/phone number/address and the action on which you are wishing to speak and whether you are speaking in support or against the action.

Speakers will be recognized in the order their request was received.

Speaker Information

Name _____

Phone _____

Email _____

Address _____

Action Item you are addressing: _____

Are you in support of or opposed to action item? _____

Murfreeboro City Schools

2552 South Church Street, Murfreeboro, TN 37127

Phone: (615) 893-2313

Fax: (615) 893-2352

MINUTES

Board of Education Regular Meeting

June 13, 2023 6:00 PM

City Hall Council Chambers

<p>I. CALL TO ORDER Procedural Item Present: Mr. Butch Campbell, Ms. Karen Dodd, Ms. Barbara Long, Ms. Amanda Moore, Mr. Jimmy Richardson III, Mr. David Settles, Absent: Mr. Wesley Ballard.</p> <p>In attendance: Dr. Trey Duke, Ralph Ringstaff, Sheri Arnette, Angela Fairchild, Joe Marlin, Kim Williams, Chris George, Maria Johnson, Lisa Trail, Cindy Cliche, Amanda Adams, Ms. Florence Smith, Stephanie Turner</p> <p>City Liaison Bill Shacklett</p>	Chair Butch Campbell
<p>A. Pledge of Allegiance Procedural Item</p> <p>The Pledge of Allegiance was led by Mr. Ralph Ringstaff, retiring Assistant Superintendent of Human Resources and School Operations and Mr. Joe Marlin, retiring Assistant Superintendent of Student Services.</p>	Ralph Ringstaff/Joe Marlin
<p>B. Moment of Silence Procedural Item</p>	
<p>II. APPROVAL OF AGENDA Action Item</p> <p>Motion to approve the agenda. This motion, made by Mr. Jimmy Richardson III and seconded by Ms. Barbara Long, passed. Yea: 6, Nay: 0, Absent: 1</p>	Chair Butch Campbell
<p>III. COMMUNICATIONS Information Item</p>	Mrs. Lisa Trail
<p>A. The Best of MCS-Cindy Cliche and Stephanie Turner Procedural Item</p>	Dr. Trey Duke
<p>B. Spotlight on Education-Summer School Update and Update on 3rd Grade Data Procedural Item</p> <p>Sheri Arnette did a PowerPoint presentation for the Board with an update on Summer School and Dr. Chris George also did a presentation with information on 3rd grade testing. (Attached)</p> <p>Mr. David Settles publicly commended Mrs. Arnette and Dr. George for this Herculean task. He appreciates their responsiveness and speed at which they got things done. He thanked them both for their hard work.</p> <p>Mr. Jimmy Richardson asked if we had received feedback from the State on appeals. Dr. George said that he should be receiving a master list from the State each week on how the appeals are going.</p>	Ms. Sheri Arnette

<p>Ms. Karen Dodd said that she visited Bradley's summer school today, and it was amazing. She was very impressed with the low student-teacher ratio and how smoothly it was all running.</p> <p>Dr. Duke told the Board that Ms. Arnette and Dr. George will be working on a significant schedule to make sure that the tutoring program is structured. Tutoring will be provided during the school day when school starts with a 1 to 3 ratio and a certain number of minutes per day.</p>	
<p>C. Presentation of Director's Evaluation Results Information Item</p> <p>Mr. Adam Tucker presented the results of the qualitative section of Dr. Duke's evaluation.</p> <p>He explained that this section was broken into the survey to administrators and school board members He informed the board that 20 administrators responded, and Dr. Duke received an average score of 4.85. This was based on survey questions where administrators ranked Dr. Duke on a scale from 1 to 5.</p> <p>The score from the board totaled 4.71</p> <p>The last section of the evaluation is the quantitative section and will be done when TCAP scores come back.</p> <p>Chair Campbell thanked Mr. Tucker for attending the meeting and presented those results to the Board.</p> <p>Chair Campbell's words to Dr. Duke was "Job well done for sure."</p>	Mr. Adam Tucker
<p>IV. CONSENT ITEMS Consent Agenda</p> <p>Motion to approve consent agenda.. This motion, made by Ms. Amanda Moore and seconded by Ms. Karen Dodd, passed. Yea: 6, Nay: 0, Absent: 1</p>	Chair Butch Campbell
<p>A. Approval of 5-23-23 Board Minutes Consent Item</p>	
<p>V. ACTION ITEMS Action Item</p>	Chair Butch Campbell
<p>A. Approval of MOU for City Schools Legal Counsel Action Item</p> <p>Motion to approve MOU for City Schools Legal Counsel. This motion, made by Mr. David Settles and seconded by Ms. Karen Dodd, passed. Yea: 6, Nay: 0, Absent: 1</p> <p>Dr. Duke informed the Board that we have hired a new in-house Assistant City Attorney. He explained that she would be a joint employee of MCS and the City of Murfreesboro. He said that unlike previous MCS attorneys, she will be placed on the MCS payroll, but her evaluation will remain with the city attorney.</p> <p>Amanda Moore had questions about the relationship between the attorney and the board. She</p>	Dr. Trey Duke

<p>stated that since Ms. Bush is part of the city legal team, she wanted to clarify who the client is.</p> <p>Mr. Tucker said that it is unlikely for conflict between a school district and its funding body, but according to the city charter, it has two provisions. One provision is that the city attorney is responsible for all legal matters relating to the city and the city council creates a school district as part of the city so from Mr. Tucker's standpoint is that the client is, in fact, City Schools.</p>	
<p>B. Approval of Surety Bond for Finance Director Action Item</p> <p>Motion to approve the Surety Bond for Finance Director. This motion, made by Mr. David Settles and seconded by Ms. Amanda Moore, passed. Yea: 6, Nay: 0, Absent: 1</p>	Dr. Trey Duke
<p>C. Approval of Agreement with Mid-Cumberland Head Start Action Item</p> <p>Motion to approve the Agreement with Mid-Cumberland Head Start. This motion, made by Mr. David Settles and seconded by Mr. Jimmy Richardson III, passed. Yea: 6, Nay: 0, Absent: 1</p>	Dr. Trey Duke
<p>D. Approval of 2023-2024 Board Annual Agenda Action Item</p> <p>Motion to approve the 2023-2024 Board Annual Agenda. This motion, made by Mr. David Settles and seconded by Ms. Barbara Long, passed. Yea: 6, Nay: 0, Absent: 1</p>	Dr. Trey Duke
<p>E. Approval of Board Attendance at Conventions and Other Educational Meetings as per Board Policy 2.804 Action Item</p> <p>Motion to approve Board Attendance at Conventions and Other Educational Meetings as per Board Policy 2.804. This motion, made by Ms. Karen Dodd and seconded by Mr. David Settles, passed. Yea: 6, Nay: 0, Absent: 1</p> <p>Dr. Duke explained that other than TSBA-sponsored events will have to be approved by the Board. He said that the new National School Board Organization COSSBA will also require approval by the Board.</p>	Dr. Trey Duke
<p>F. Approval of the Revenue and Expenditure Report Action Item</p> <p>Motion to approve the Revenue and Expenditure Report. This motion, made by Mr. David Settles and seconded by Mr. Jimmy Richardson III, passed. Yea: 6, Nay: 0, Absent: 1</p> <p>Mr. Settles asked when TISA funding starts. Ms. Williams said that TISA funding begins in July and will be 10-month installments, just like BEP funding.</p>	Dr. Trey Duke
<p>VI. REPORTS AND INFORMATION Information Item</p>	Chair Butch Campbell
<p>A. Tentative Assignment Lists Information Item</p>	Ms. Maria Johnson

<p>B. Bullying Report Information Item</p> <p>Amanda Adams presented the yearly bullying report. She stated that there has been a decrease in bullying reports in every category, and she feels that it is because school counselors have been complained in bullying curriculum, along with admin being trained as well. She said that the curriculum is a research-based curriculum and was a great tool.</p> <p>Dr. Duke commended Ms. Adams on an amazing first year. He appreciated having Ms. Adams in the system, especially with Mr. Marlin retiring.</p>	<p>Ms. Amanda Adams</p>
<p>C. Enrollment (PTR) Report Information Item</p> <p>After presenting the Enrollment Report, Dr. Duke told the Board that Mr. Marlin does a great job of pinpointing numbers and trends and sparks administrators to come up with ideas. Dr. Duke said that our major absenteeism trends seem to be in kindergarten and 1st grade, and we will begin planning to target these grades.</p>	<p>Mr. Joe Marlin</p>
<p>D. Personnel Report Information Item</p>	<p>Dr. Trey Duke</p>
<p>E. Director's Update Information Item</p> <p>Dr. Duke told the Board that with Summer School, we have had a very busy first 13 days of June.</p> <p>Dr. Duke gave the Board an update on major construction projects that are going on over the summer months.</p> <p>He said that they are still working on the roof at Mitchell Neilson and should be done by early July. He said that Mitchell Neilson Elementary also has a new ceiling throughout the building.</p> <p>Because of a Coordinated School Health grant, the tennis courts are being replaced and refinished as multi-surface courts at Erma Siegel and Cason Lane and will done by June 30.</p> <p>He told the Board that there is alot of work going on at the new Prek building. They have removed the old playground equipment and are moving in new equipment.</p> <p>Gym floors and bleachers have been replaced at Black Fox and Erma Siegel, and every classroom and the gym has been painted at Reeves Rogers.</p> <p>He gave the Board an ABM custodial update. He said that they cleaning and waxing floors in all schools that do not have summer school and will be finished with all schools over the next few months.</p> <p>Dr. Duke thanked Ralph Ringstaff and Joe Marlin for their support and hard work as he transitioned into the position of Director of Schools. He said that they were beyond gracious with him and would be missed.</p> <p>Chair Campbell agreed that they have both done an amazing job during their time at MCS and he also appreciated their hard work.</p>	<p>Dr. Trey Duke</p>

VII. OTHER BUSINESS Information Item	Chair Butch Campbell
VIII. ADJOURNMENT Action Item The meeting adjourned at 7:15 p.m.	Chair Butch Campbell

Director of Schools

Agenda Item Title: Waiver of Second Reading Limitation of Board Policy 1.600

Board Meeting Date: July 25, 2023

Department: Legal

Presented by: Lauren Bush

Board Agenda Category:

- Consent Agenda
 - Action Item
 - Reports and Information
-

Summary

Board Policy 1.600 requires two readings of a policy prior to the adoption of the policy. However, on matters of unusual urgency, and by an affirmative vote by a majority of the members of the Board, the Board may waive the second reading requirement and take immediate action to adopt new or revised policies.

Policy changes recommended for first and final reading at the July 25, 2023, meeting are made to comply with changes made to State law during the 2023 legislative session and will require action by the Board prior to the start of the school year.

Staff Recommendation

Recommendation to waive the second reading limitation of Policy 1.600 to approve policies presented at the July 25, 2023 Board meeting on first and final reading to ensure MCS is in compliance with all new state laws.

Fiscal Impact

Not applicable

Connection to MCS's Five-Year Strategic Plan

- Known:** Every student will be *known* through whole-child programs and support.
- Safe:** Every student will be *safe* through equitable access to buildings, facilities, and infrastructure that meets their needs.
- Challenged:** Every student will be *challenged* by learning from highly effective educators and employees.
- Empowered:** Every student will be *empowered* through academic success

Murfreesboro City School Board

Monitoring: Review: Annually, in September	Descriptor Term: <h2 style="text-align: center;">Policy Development and Adoption</h2>	Descriptor Code: 1.600	Issued Date: 01/24/17
		Rescinds: BO 10, BO 11, BO 42	Issued:

1 The Board shall reserve for itself the function of providing guides for the discretionary action of those
 2 to whom it delegates authority. These guides for discretionary action shall constitute the policies
 3 governing the operations of the school system. They shall be recorded in writing.

4 The formulation and adoption of these written policies shall constitute the basic method by which the
 5 Board shall exercise its leadership in the operation of the school system. The study and evaluation of
 6 reports concerning the execution of its written policies shall constitute the basic method by which the
 7 Board shall exercise its control over the operation of the school system.

8 The formal adoption of policies shall be recorded in the minutes of the Board and shall be placed in the
 9 policy manual. Policies and amendments shall be effective immediately upon adoption unless a
 10 specific effective date is provided, and shall supersede any previous Board action on the subject. Only
 11 those written statements so adopted and recorded shall be regarded as official Board policy.

12 Adoption of new policies, or changing existing policies, is solely the responsibility of the Board.

13 Proposals for new policies, or changes to existing policies, any be initiated in writing by any Board
 14 member or by any employee of the Board. The policy proposals shall be referred to the Director of
 15 Schools for consultation with the attorney, staff, principals, teachers, community, or others as may be
 16 deemed appropriate. The consultation, if indicated, should be accomplished prior to presentation to the
 17 Board.

18 A proposed policy or policy change shall be submitted to the Board as part of the agenda. The Board's
 19 approval of the proposal or return for study and/or further revision shall constitute the first reading.

20 Adoption of policy proposals requires two readings at regular or special called meetings of the Board,
 21 except as provided below. Thus, time shall be given to permit further study and also to give
 22 opportunity for interested parties to react.

23 Adoption shall require an affirmative vote by a majority of the members of the Board.

24 Upon the advice and consent of the Chair and Director, the Board may designate minor changes to
 25 policies as editorial in nature or as necessary to conform to a change of policy. Accordingly, the Board
 26 may accept such changes without promulgating those changes through the normal two vote process.
 27 Formal notice of changes to Board policies made through this provision shall appear on the next
 28 Board's agenda under Consent Items. For example, if the Board changes a policy and other policies are

1 affected by that change, then changes made to other policies may be regarded as necessary to conform,
2 and thus not require two votes.

3 **POLICY MAINTENANCE**

4 The Director of Schools shall be responsible for drafting policy proposals and maintaining the Board
5 Policy Manual. At least biennially, the Board shall review its policy manual for the purpose of passing,
6 revising or deleting policies mandated by changing conditions.

7 Policies shall be accessible to all employees of the school system, members of the Board, and citizens
8 of the community¹ on the school system's website, www.cityschools.net, and will be updated
9 accordingly. All policy manuals shall remain the property of the Board and are subject to recall any
10 time deemed necessary by the Director of Schools.

11 **PROCEDURE FOR EXPEDITED ACTION**

12 On matters of unusual urgency, by an affirmative vote by a majority of the members of the Board, the
13 Board may waive the second reading limitation and take immediate action to adopt new or revised
14 policies. The Board may also vote to waive the second reading if a proposed amendment to a policy is
15 considered housekeeping or clerical in nature.

16 **SUSPENSION OF POLICIES**

17 Any board policy or part thereof may be suspended by an affirmative vote by a majority of the
18 members of the Board.

19 **ADMINISTRATION IN POLICY ABSENCE**

20 In cases where the Board has provided no guidelines for administrative action, the Director of Schools
21 shall have the power to act, but report to the Board at its next meeting.

Legal References

1. TCA 49-2-207(a)

Cross References

Role of the Board of Education 1.101
Agendas 1.403

Agenda Item Title: Approval of Board Policy 1.102, Board Members, on First and Final Reading

Board Meeting Date: July 25, 2023

Department: Legal

Presented by: Lauren Bush

Board Agenda Category:

- Consent Agenda
 - Action Item
 - Reports and Information
-

Summary

Public Chapter 114 requires that high school equivalency credentials approved by the State Board of Education be accepted as proof of high school completion for Board members. The recommended changes to Board Policy 1.102 amend the “Qualifications” section to comply with the changes made by Public Chapter 114. The footnotes to statutes have also been updated.

Staff Recommendation

Recommend approval of changes to Board Policy 1.102 on first and final reading

Fiscal Impact

Not applicable

Connection to MCS’s Five-Year Strategic Plan

- Known:** Every student will be *known* through whole-child programs and support.
- Safe:** Every student will be *safe* through equitable access to buildings, facilities, and infrastructure that meets their needs.
- Challenged:** Every student will be *challenged* by learning from highly effective educators and employees.
- Empowered:** Every student will be *empowered* through academic success

Murfreesboro City School Board

Monitoring: Review: Annually, in September	Descriptor Term: Board Members Legal Status	Descriptor Code: 1.102	Issued: 09/13/22
		Rescinds: 1.102	Issued: 09/24/19

1 The legal status of board members shall be as follows:

2 **NUMBER OF MEMBERS**¹

3 The Board is composed of seven (7) members.

4 **QUALIFICATIONS**

5 Members of the Board shall have been residents in the City for at least one year prior to election and
6 shall be at least 25 years of age at the time of such election.² Members shall be elected on a non-
7 partisan basis, and shall be citizens of recognized integrity, intelligence, and ability to administer the
8 duties of the office.³ To qualify as a candidate, an individual must show proof of graduation from high
9 school or receipt of a G.E.D® or HiSET® or other high school equivalency credential approved by the
10 State Board of Education.⁴

11 **TERMS OF OFFICE**

12 Members of the Board shall serve four (4)-year terms.¹

13 **VACANCIES**

14 Vacancies shall be declared to exist on account of death, resignation, removal from the city or school
15 district, or through due process proceedings based on allegations of misconduct.⁵

16 When a vacancy occurs the unexpired term shall be filled at the next regular or special meeting of the
17 local legislative body.⁶ This appointment shall be an interim appointment, valid only until the next
18 primary or general election or referendum that is held after the vacancy occurs.

Legal References

1. TCA 49-2-201(a)(1)
2. Murfreesboro City Code § 25-2; ~~Public Acts of 2022, Chapter No. 809~~ TCA 49-2-202(a)
3. TCA 49-2-202(a)(1)
4. TCA 49-2-202(a)(4); Public Acts of 2023, Chapter No. 114
5. TCA 8-47-101; TCA 49-1-611; TCA 49-2-202(e)(2); Tenn. Att’y Gen. Op. No. 21-14 (September 1, 2021)
6. TCA 49-2-202(e)(1)

Agenda Item Title: Approval of Board Policy 1.106, Code of Ethics, on First and Final Reading

Board Meeting Date: July 25, 2023

Department: Legal

Presented by: Lauren Bush

Board Agenda Category:

- Consent Agenda
 - Action Item
 - Reports and Information
-

Summary

Public Chapter 37 requires local Boards of Education to notify the Tennessee Ethics Commission of the primary person responsible for enforcing ethical standards. A section has been added to Board Policy 1.106 to establish the Board Chair as the point of contact for the Tennessee Ethics Commission. The update to this policy requires the Director of Schools to report the contact information to the Tennessee Ethics Commission by January 1, 2024, and within 30 days of any change of Board Chair.

Staff Recommendation

Recommend approval of changes to Board Policy 1.106 on first and final reading

Fiscal Impact

Not applicable

Connection to MCS's Five-Year Strategic Plan

- Known:** Every student will be *known* through whole-child programs and support.
- Safe:** Every student will be *safe* through equitable access to buildings, facilities, and infrastructure that meets their needs.
- Challenged:** Every student will be *challenged* by learning from highly effective educators and employees.
- Empowered:** Every student will be *empowered* through academic success.

Murfreesboro City School Board

Monitoring: Review: Annually, in September	Descriptor Term: Code of Ethics	Descriptor Code: 1.106	Issued Date: 12/08/20
		Rescinds: BO40	Issued: 03/01/11

1 Section 1. Definitions

2 (1) "School district" means Murfreesboro City School District, which includes all boards, committees,
3 commissions, authorities, corporations or other instrumentalities appointed or created by the school
4 district or an official of the school district.

5 (2) "Officials and employees" means and includes any official, whether elected or appointed, officer,
6 employee or servant, or any member of any board, agency, commission, authority or corporation
7 (whether compensated or not), or any officer, employee or servant thereof, of the school district.

8 (3) "Personal interest" means, for the purpose of disclosure of personal interests in accordance with
9 this Code of Ethics, a financial interest of the official or employee, or a financial interest of the
10 official's or employee's spouse or child living in the same household, in the matter to be voted upon,
11 regulated, supervised, or otherwise acted upon in an official capacity. A financial interest which
12 benefits or which may benefit the official or employee or their family members, by one thousand
13 dollars (\$1,000.00) or more a year is a "personal interest" requiring disclosure under these standards.

14 Section 2. Disclosure of personal interest in voting matters

15 An official or employee with the responsibility to vote on a measure shall disclose during the meeting
16 at which the vote takes place, before the vote and to be included in the minutes, any personal interest
17 that affects, or that would lead a reasonable person to infer that it affects, the official's or employee's
18 vote on the measure. In addition, the official or employee may, to the extent allowed by law, recuse
19 himself or herself from voting on the measure.

20 Section 3. Disclosure of personal interest in non-voting matters

21 An official or employee who must exercise discretion relative to any matter other than casting a vote
22 and who has a personal interest in the matter that affects or that would lead a reasonable person to infer
23 that it affects the exercise of the discretion shall disclose, before the exercise of the discretion when
24 possible, the interest on the attached disclosure form and file the disclosure form with the
25 Murfreesboro City School District's Human Resources Director. In addition, the official or employee
26 may, to the extent allowed by law, recuse himself or herself from the exercise of discretion in the
27 matter.

1 **Section 4. Acceptance of gifts and other things of value**

2 An official or employee, or an official's or employee's spouse or child living in the same household,
3 may not accept, directly or indirectly, any gift, money, gratuity, or other consideration or favor of any
4 kind from anyone other than the school district, that a reasonable person would understand was

5 intended to influence the vote, official action or judgment of the official or employee in executing
6 decision-making authority affecting the school district.

7 It shall not be considered a violation of this policy for an official or employee to receive entertainment,
8 food, refreshments, meals, health screenings, amenities, foodstuffs, or beverages that are provided in
9 connection with a conference sponsored by an established or recognized statewide association of
10 school board officials or by an umbrella or affiliate organization of such statewide association of
11 school board officials.

12 **Section 5. Ethics Complaints**

13 Questions and complaints regarding violations of this Code of Ethics or of any violation of state law
14 governing ethical conduct should be directed to the chair of the Murfreesboro City School Board.

15 Complaints shall be in writing and signed by the person making the complaint, and shall set forth in
16 reasonable detail the facts upon which the complaint is based. If the chair of the School Board is the
17 subject of the complaint, the complaint should be made to the Board Attorney.

18 The Murfreesboro City School Board may investigate any credible complaint against an official or
19 employee charging any violation of this Code of Ethics, or may undertake an investigation on its own
20 initiative when it acquires information indicating a possible violation, and make recommendations for
21 action to end or seek retribution for any activity that, in the Board's judgment, constitutes a violation
22 of this Code of Ethics. If a member of the Board is the subject of a complaint, such member shall
23 recuse himself or herself from all proceedings involving such complaint.

24 The Board may:

25 (1) refer the matter to the Board Attorney for a legal opinion and/or recommendations for action;

26 (2) in the case of an official, the Board may consider possible public censure if the Board body
27 finds such action warranted;

28 (3) in the case of an employee, refer the matter to the official responsible for supervision of the
29 employee for possible disciplinary action if the official finds discipline warranted;

30 (4) in a case involving possible violation of state statutes, refer the matter to the district attorney
31 for possible ouster or criminal prosecution;

32 The interpretation that a reasonable person in the circumstances would apply shall be used in
33 interpreting and enforcing this Code of Ethics. When a violation of this Code of Ethics also constitutes
34 a violation of a personnel policy, the violation shall be dealt with as a violation of the personnel
35 provisions rather than as a violation of this Code of Ethics.

1 **POINT OF CONTACT²**

2 The Board Chair shall serve as the point of contact for the Tennessee Ethics Commission. The Director
3 of Schools shall provide the contact information to the Commission by January 1, 2024, and ensure
4 that any changes are submitted within thirty (30) calendar days of any change in responsibility.

Legal References

1. TCA 8-17-103

~~2.~~ Public Acts of 2023, Chapter No. 37

**MURFREESBORO CITY SCHOOL DISTRICT CODE OF ETHICS
CONFLICT OF INTEREST DISCLOSURE STATEMENT**

Instructions: This form is for reporting personal interests required to be disclosed under Section of the Code of Ethics of this school district. Officials and employees are required to disclose personal interests in matters that affect or would lead a reasonable person to infer that it would affect the exercise of discretion of an official or employee.

1. Date of disclosure: _____

2. Name of official or employee: _____

3. Office and position: _____

4. Description of personal interest (describe below in detail):

Signature of official or employee

Witness Signature

Agenda Item Title: Approval of Board Policy 1.400, School Board Meetings, on First and Final Reading

Board Meeting Date: July 25, 2023

Department: Legal

Presented by: Lauren Bush

Board Agenda Category:

- Consent Agenda
 - Action Item
 - Reports and Information
-

Summary

Public Chapter 350 creates additional opportunities for board members to attend board meetings electronically. Now, board members will be able to use this method of attendance for two additional reasons: (1) if they are sick or in a period of convalescence on the advice of a healthcare professional; and (2) due to inclement weather. The recommended changes to Board Policy 1.400 incorporate these additional opportunities for board participation.

Staff Recommendation

Recommend approval of changes to Board Policy 1.400 on first and final reading

Fiscal Impact

Not applicable

Connection to MCS's Five-Year Strategic Plan

- Known:** Every student will be *known* through whole-child programs and support.
- Safe:** Every student will be *safe* through equitable access to buildings, facilities, and infrastructure that meets their needs.
- Challenged:** Every student will be *challenged* by learning from highly effective educators and employees.
- Empowered:** Every student will be *empowered* through academic success.

Murfreesboro City School Board

Monitoring: Review: Annually, in September	Descriptor Term: School Board Meetings	Descriptor Code: 1.400	Issued Date: 09/24/19
		Rescinds: BO 5	Issued: 04/79; 07/98; 02/01; 07/08; 02/11; 01/13; 05/16

1 The Board will transact all business at official meetings which may be either regular or special.

2 Every meeting of the Board shall be open to the public, except for those meetings in which the law allows
3 closed sessions.¹ Open meetings will be physically accessible to all students, employees, and interested
4 citizens.²

5 The Board may restrict the recording of Board meetings via camera, camcorder or other photographic
6 equipment when such recording creates a threat to public safety and welfare or impedes the conducting
7 of efficient and orderly public meetings.³

8 **REGULAR MEETINGS**

9 Regular meetings of the Board shall be held on the second and fourth Tuesdays of each month at 6:00
10 p.m.

11 In instances when any regular meeting date falls on a legal holiday, the meeting shall be rescheduled by
12 the Chair.

13 **SPECIAL MEETING**

14 The Board shall hold such special meetings as necessary to transact the business of the Board. Such
15 meetings shall be called by the Chair whenever, in the Chair's judgment, the interests of the schools
16 require it, or when requested to do so by a majority of the Board.⁴

17 Only business related to the call of the meeting, and details related to agenda items shall be discussed or
18 transacted by the Board at a special meeting.

19 **ELECTRONIC ATTENDANCE⁵**

20 Absent Board members may attend a regular or special meeting by electronic means if the member is
21 absent because of work, a family emergency, or the member's military service. If a board member is
22 absent due to military service, the board member may participate electronically as often as board member
23 is able to do so. However, a board member may not participate electronically more than two (2) times
24 per year for absences due to work and/or family emergencies.

1 *General Requirements*

2 The following requirements apply to all electronic attendance, regardless of the reason for the
3 member's absence:

- 4 1. A quorum of the Board must be physically present at the meeting in order for any member to
5 attend electronically.
- 6 2. Any member wishing to participate electronically must do so using technology which allows
7 the Chair to visually identify the member.
- 8 3. The responsibility for the connection lies with the member wishing to participate electronically.
9 No more than three (3) attempts to connect shall be made, unless the Board chooses to make
10 additional attempts.
- 11 4. If a member is participating via electronic means, there must be a roll call vote.

12 *Work-Related Absence*

13 The following requirements apply to electronic attendance due to a ~~work-related~~work-related absence:

- 14 1. The Board member must be absent from the county due to work.
- 15 2. The member wishing to participate must give the Chair and Director at least five (5) days' notice
16 prior to the meeting of the member's desire to participate electronically.

17 *Sickness or Period of Convalescence*

18 A board member may attend a meeting by electronic means if sick or in a period of convalescence on
19 the advice of a healthcare professional; however, he/she may only participate electronically three (3)
20 times per year for this reason.

21 *Inclement Weather or Natural Disaster*

22 ~~2.~~ A board member may attend a meeting by electronic means due to inclement weather or natural
23 disaster if the schools in the school district are closed; however, he/she may only participate
24 electronically three (3) times per year for this reason.

25 *Family Emergency*

26 The following requirement applies to electronic attendance due to a family emergency:

27 The member must be absent due to the hospitalization of the member or the death or hospitalization of
28 the member's spouse, father, mother, son, daughter, brother, sister, son-in-law, daughter-in-law, step-
29 son, step-daughter, father-in-law, mother-in-law, brother-in-law, sister-in-law, or grandparents.

Formatted: Font: (Default) Times New Roman, 12 pt, Italic, Font color: Black

Formatted: Normal, No bullets or numbering

Formatted: Font: (Default) Times New Roman, 12 pt, Font color: Black

Formatted: Font: (Default) Times New Roman, 12 pt, Italic, Font color: Black

Legal References

1. TCA 8-44-102(a); TCA 49-6-804(b); *Smith County Education Association v. Anderson*, 676 SW 29 328, 332-33 (Tenn. 1984)
2. 28 CFR § 36.201(a); 36.202
3. OP Tenn. Atty. Gen. 95-126
4. TCA 49-2-202(c)(1)
5. TCA 49-2-203(c); TCA 8-44-108

Cross References

School Board Legal Status and Authority 1.100
Section 504 & ADA Grievance Procedures 1.802

Agenda Item Title: Approval of Board Policy 1.401, Public Participation in Board Meetings, on First and Final Reading

Board Meeting Date: July 25, 2023

Department: Legal

Presented by: Lauren Bush

Board Agenda Category:

- | | |
|-------------------------|-------------------------------------|
| Consent Agenda | <input type="checkbox"/> |
| Action Item | <input checked="" type="checkbox"/> |
| Reports and Information | <input type="checkbox"/> |
-

Summary

Public Chapter 300 requires that each board meeting with actionable items on the agenda is required to have a time dedicated to public comment. The law allows Boards to establish reasonable restrictions on the length of the comment period and length of time per speaker. Additionally, Murfreesboro City Council adopted Resolution 23-R-23 on June 15, 2023, and set public comment requirements for the public meetings of the City’s commissions, boards, and committees that are comprised of elected and/or appointed officials and subject to the Tennessee Open Meetings Act. Teacher disciplinary hearings are exempted from these requirements.

The proposed amendments to Board Policy 1.401 establishes the following guidelines regarding public participation during the public comment period:

- Individuals will be allowed three minutes to speak with respect to an action item on the agenda;
- The total public comment period shall be for no more than fifteen minutes;
- Individuals wishing to address the Board must sign up at least six hours prior to the meeting through e-mail or phone call; and
- Individuals should state the action item about which they wish to speak and whether they will be speaking in support or opposition to the item.

These recommended changes to Board Policy 1.401 comply with the requirements of Public Chapter 300 and Resolution 23-R-23.

Staff Recommendation

Recommend approval of changes to Board Policy 1.401 on first and final reading

Fiscal Impact

Not applicable

Connection to MCS's Five-Year Strategic Plan

- Known:** Every student will be *known* through whole-child programs and support.
- Safe:** Every student will be *safe* through equitable access to buildings, facilities, and infrastructure that meets their needs.
- Challenged:** Every student will be *challenged* by learning from highly effective educators and employees.
- Empowered:** Every student will be *empowered* through academic success.

Murfreesboro City School Board

Monitoring: Review: Annually, in September	Descriptor Term: Public Participation in Board Meetings	Descriptor Code: 1.401	Issued Date: 05/24/16 Revised 09/28/21
		Rescinds:	Issued: 01/00; 02/11

INTENT OF POLICY

~~All meetings of the Board of Education are intended to allow Board members to address topics on the prepared and disseminated agenda. Public participation in Board of Education meetings may occur under four different circumstances.~~

~~The Board of Education recognizes the value of stakeholder engagement through public comment on educational issues and the importance of allowing community members to express themselves on school-related business. The Board offers public participation to members of the public in four circumstances:~~

~~1. First, 1. The Director of Schools may ask a citizen with business before the Board to make a presentation as part of the regular agenda.~~

~~Second, 2. The Board may, when topics of general interest occur, schedule public hearings on specific topics as part of its regular agenda.~~

~~Third, 3. In accordance with other Board policies or state or federal law, the Board may schedule a hearing in which members of the public may be witnesses as part of its predetermined preset agenda.~~

~~4. During a public comment period in compliance with this policy.~~

~~Fourth, the Director and the Board Chair may grant a request from an individual or a group to address the Board to express a concern or complaint. Any such matter shall be scheduled by the Director and Board Chair for presentation at a Board meeting only after the concern or complaint has been processed in accordance with established complaint procedures. A concern or complaint must first be addressed with the employee most directly involved. If the result is unsatisfactory to those raising the concern or complaint, they shall seek additional review by a supervisor of that employee or program and shall proceed through successive supervisors to the Director of Schools. If they are not satisfied with the response of the Director, they may ask to bring the matter to the Board. Any request to address the Board must be submitted to the Director after completion of the complaint procedure. The Director and Board Chair shall then make their determination about whether to grant the request and, if granted, shall schedule a date. The request shall include the names of all persons who wish to speak and the nature of their business. The Director and Board Chair may limit the number of persons given prior approval to speak.~~

Formatted: Numbered + Level: 1 + Numbering Style: 1, 2, 3, ... + Start at: 1 + Alignment: Left + Aligned at: 0.25" + Indent at: 0.5"

PUBLIC COMMENT PERIOD¹

Any public meeting of the Board with actionable items on the agenda shall have a period of public comment on those actionable items at the beginning of the meeting, with the exception of teacher disciplinary hearings. The total public comment period shall be for no more than fifteen minutes.

Individuals will be allowed three minutes to speak with respect to an action item on the agenda. All comments are restricted to comments on action items on the agenda for the meeting. The Chair shall have the authority to declare an individual out of order, if after an initial warning, an individual continues to speak on a topic that is unrelated to an action item on the agenda. The Chair shall have the authority to terminate the remarks of any individual who violates state law or does not adhere to board rules.²

The Board shall not take up any action item on the agenda before the end of the public comment period; provided, however, the Chair may close the public comment period prior to the end of the fifteen-minute period if all individuals who signed up to speak at the meeting have been afforded an opportunity to speak. The Chair shall have the discretion to extend the public comment period for no more than an additional fifteen minutes if additional time is reasonably necessary to ensure that opposing viewpoints are fairly represented during the public comment period. The Chair need not extend the public period beyond fifteen minutes merely because the fifteen-minute period expired before all of the individuals who registered to speak were able to speak.

ADDRESSING THE BOARD DURING PUBLIC COMMENT

Individuals wishing to address the Board during the public comment period must sign up at least six hours prior to the meeting start time by either sending an e-mail or calling the phone number set forth in the public notice of the meeting. Individuals registering to speak at a meeting should state the action item about which they wish to speak and whether they will be speaking in support or in opposition to the item.

At the Board meeting, persons speaking shall address their remarks to the Chair and shall state their name, address, and the subject of their presentation. Remarks will generally be limited to three minutes but may be extended by the Chair or majority vote of the Board. Questions may be addressed to individual Board members or staff members only with the approval of the Chair. The Chair has the authority to terminate the remarks of any individual or group if necessary to insure compliance with Board policies or to prevent abusive or inappropriate remarks.

It is the intent of this policy to:

1. Allow the Director of Schools to take direct action when policies have already been
2. established by the Board on the subject of a request;
3. Provide adequate time for the Director of Schools or the Board to obtain necessary information and give thorough thought in situations where a policy does exist, a change of policy is proposed, or an exception to policy is specifically requested; and
4. See that the time so devoted does not interfere with fulfillment of the regular agenda of the Board.

¹ [Public Acts of 2023, Chapter No. 300: City of Murfreesboro, Resolution 23-R-23](#)

² [TCA 39-17-306](#)

Formatted: Font: (Default) Calibri

Formatted: Font: (Default) Calibri

Formatted: Font: (Default) Calibri

Agenda Item Title: Approval of Board Policy 1.402, Notification of Meetings, on First and Final Reading

Board Meeting Date: July 25, 2023

Department: Legal

Presented by: Lauren Bush

Board Agenda Category:

- Consent Agenda
 - Action Item
 - Reports and Information
-

Summary

Public Chapter 300 requires that notice of board meetings include information on how individuals may provide public comment on agenda action items. Additionally, Murfreesboro City Council adopted Resolution 23-R-23 on June 15, 2023, and set requirements for the public meetings of the City's commissions, boards, and committees that are comprised of elected and/or appointed officials and subject to the Tennessee Open Meetings Act. The recommended changes to Board Policy 1.402 comply with the requirements of Public Chapter 300 and Resolution 23-R-23.

Staff Recommendation

Recommend approval of changes to Board Policy 1.402 on first and final reading

Fiscal Impact

Not applicable

Connection to MCS's Five-Year Strategic Plan

- Known:** Every student will be *known* through whole-child programs and support.
- Safe:** Every student will be *safe* through equitable access to buildings, facilities, and infrastructure that meets their needs.
- Challenged:** Every student will be *challenged* by learning from highly effective educators and employees.
- Empowered:** Every student will be *empowered* through academic success.

Murfreesboro City School Board

Monitoring: Review: Annually, in September	Descriptor Term: Notification of Meetings	Descriptor Code: 1.402	Issued Date: 05/24/16
		Rescinds: BO 6	Issued: 04/79; 09/93; 02/01 02/01/11

1 Adequate public notice of all regular and special meetings of the Board shall be disseminated through a
2 local newspaper and shall be placed on the school system’s website: <http://www.cityschools.net/>.¹

3 Except in the case of a special meeting, this policy shall be interpreted to mean that notifications for all
4 special and/or rescheduled meetings shall be sent to the media in time for the public to be notified at
5 least forty-eight (48) hours in advance. All notices of special board meetings shall state the time, place
6 and purpose of the meeting.

7 The only exception permitted is in case of emergency, defined for this policy as “a sudden, generally
8 unexpected occurrence or set of circumstances demanding immediate action.” In such exceptions,
9 notice shall be given to all appropriate parties as is practical.

10 Dates of regular meetings of the Board shall be provided in annual announcements made available in
11 printed form to the news media, the public, all Board members, and the president of the local education
12 association.²

13 Notice of all meetings with actionable items on the agenda, with the exception of teacher disciplinary
14 hearings, shall include information on how community members can participate in the public comment
15 portion of the board meeting, including an e-mail address and phone number that individuals wishing
16 to speak at the meeting can use to communicate their desire to speak at the meeting.³

Legal References

1. TCA 8-44-103
2. TCA 49-2-202(c)(1)
3. Public Acts of 2023, Chapter No. 300; City of Murfreesboro, Resolution 23-R-23

Agenda Item Title: Approval of Board Policy 3.202, Emergency Preparedness Drills, on First and Final Reading

Board Meeting Date: July 25, 2023

Department: Legal

Presented by: Lauren Bush

Board Agenda Category:

- Consent Agenda
 - Action Item
 - Reports and Information
-

Summary

Public Chapter 367 requires that schools conduct an incident command drill and an emergency safety bus drill in addition to the currently required armed intruder drill. The changes to Board Policy 3.202 comply with the requirements of Public Chapter 367.

Staff Recommendation

Recommend approval of changes to Board Policy 3.202 on first and final reading

Fiscal Impact

Not applicable

Connection to MCS's Five-Year Strategic Plan

- Known:** Every student will be *known* through whole-child programs and support.
- Safe:** Every student will be *safe* through equitable access to buildings, facilities, and infrastructure that meets their needs.
- Challenged:** Every student will be *challenged* by learning from highly effective educators and employees.
- Empowered:** Every student will be *empowered* through academic success.

Murfreesboro City School District

Monitoring: Review: Annually, in October	Descriptor Term: Emergency Preparedness Plan	Descriptor Code: 3.202	Issued Date: 10/11/22
		Rescinds: 3.202	Issued: 09/13/22

1 The Director of Schools shall be responsible for developing, maintaining, and acquiring Board
2 approval of the district Multi-Hazard Operations Plan,¹ which shall include, but not be limited to,
3 procedures for nuclear or bomb threats, civil disturbances, armed intruders, earthquakes, fires,
4 tornadoes or other severe weather, and medical emergencies.

5 The principal of each school shall develop and implement emergency preparedness drills which shall
6 be approved by the Director of Schools. When appropriate, such drills shall be held in conjunction with
7 emergency response agencies. These procedures shall be in written form and distributed to all staff,
8 students, and parents.

9 FIRE AND SAFETY DRILLS

10 The principal shall ensure that one fire drill requiring full evacuation is given every thirty (30) school
11 days, with two (2) fire drills occurring during the first thirty (30) full days of the school year.
12 Additionally, he/she shall ensure that four (4) fire safety educational announcements are conducted
13 throughout the year.²

14 The principal shall ensure that three (3) additional safety drills are given during the school year. These
15 drills may cover inclement weather, earthquakes, armed intruders, or other emergency drills that do not
16 require full evacuation. A record of all fire or safety drills, including the time and date, shall be kept in
17 each school's office.³

18 The principal shall regularly check the quantity, locations, and conditions of fire extinguishers and
19 shall give all school personnel instructions on how to properly use fire extinguishers.

20 ~~ARMED INTRUDER DRILLS~~ ANNUAL DRILLS⁴

21 The Director of Schools or designee shall ensure that each school safety team conducts each of the
22 following type of drills annually:

- 23 1. ~~At~~ least one (1) armed intruder drill annually in coordination with local law enforcement.
- 24 2. An incident command drill; and,
- 25 3. An emergency safety bus drill.⁴

Formatted: Superscript

Formatted: Font: (Default) Times New Roman, 12 pt

Formatted: Superscript

Formatted: Indent: Left: 0.79", No bullets or numbering

Formatted: Superscript

Formatted: Normal, No bullets or numbering

Formatted: List Paragraph, Numbered + Level: 1 +
Numbering Style: 1, 2, 3, ... + Start at: 1 + Alignment: Left +
Aligned at: 0.54" + Indent at: 0.79"

29 **AED DRILLS⁵**

30 ~~Any school with an AED~~All schools shall conduct a CPR and AED drill for school personnel to
 31 practice the use of these life saving devices and to evaluate the school's preparedness in the event of a
 32 medical emergency. The principal shall be responsible for ensuring the drill occurs.

33
 34 ~~Any school with an AED shall schedule annual AED training for all school personnel. The AED~~
 35 ~~training shall:~~

- 36 ~~• Teach the use of AEDs;~~
- 37 ~~• Inform school personnel of the location of AEDs;~~
- 38 ~~• Inform school personnel of the school's response plan; and~~
- 39 ~~• Inform school personnel of the members of the school response team.~~

40 All schools shall establish a program for the use of an AED in compliance with TCA 68-140-404 and
 41 conduct an annual AED training with expected users. The Director of Schools shall develop the
 42 necessary administrative procedures on AED and CPR training, planning, notification, and
 43 maintenance to comply with state law.

44 ~~•~~

45 **MEDICAL EMERGENCIES/PANDEMIC FLU⁶**

46 In the event of medical emergencies, such as a pandemic flu outbreak, school officials shall cooperate
 47 and consult with the local and state health departments and other local emergency or healthcare
 48 providers in protecting students and the community from further infection. The Director of Schools
 49 shall develop procedures for health emergencies in accordance with state law and regulations.⁵

50 **REMOTE LEARNING DRILLS⁷**

51 At least once each school year, a remote learning drill shall be conducted. The drill shall accurately
 52 reflect how students will transition to remote learning in the event of a disruption to school operations.
 53 Students shall not be asked or required to transition to remote learning at any time during the drill

Formatted: Don't suppress line numbers

Formatted: Font: (Default) Times New Roman, 12 pt

Formatted: Normal, Indent: Left: 0.25", No bullets or numbering

1. TRR/MS 0520-01-02-.30(2); TCA 49-6-804; TCA 49-6-805(8)
2. TCA 68-102-137(b)
3. TCA 68-102-137(f)
4. TCA 49-6-807; [Public Acts of 2023; Chapter No. 367](#)
5. TCA 49-2-122; TCA 49-6-1208
6. TCA 49-6-3004(a), (e); TCA 49-5-404
7. TCA 49-2-139

Emergency Closings 1.8011
Safety 3.201
Community Use of School Facilities 3.206

Agenda Item Title: Approval of Board Policy 3.204, Threat Assessment Team, on First and Final Reading

Board Meeting Date: July 25, 2023

Department: Legal

Presented by: Lauren Bush

Board Agenda Category:

- Consent Agenda
 - Action Item
 - Reports and Information
-

Summary

Public Chapter 367 requires that school districts have a policy on threat assessment administration. Board Policy 3.204 is a new policy recommendation that complies with the requirements of Public Chapter 367.

Staff Recommendation

Recommend approval of changes to Board Policy 3.204 on first and final reading

Fiscal Impact

Not applicable

Connection to MCS's Five-Year Strategic Plan

- Known:** Every student will be *known* through whole-child programs and support.
- Safe:** Every student will be *safe* through equitable access to buildings, facilities, and infrastructure that meets their needs.
- Challenged:** Every student will be *challenged* by learning from highly effective educators and employees.
- Empowered:** Every student will be *empowered* through academic success.

Murfreesboro City Schools

Monitoring: Review: Annually, in September	Descriptor Term: Threat Assessment Team	Descriptor Code: 3.204	Issued Date:
		Rescinds:	Issued:

1 *General¹*

2 A threat assessment team shall be created within the school district to develop intervention-based
 3 approaches to prevent violence, manage reports of potential threats, and create a system that fosters a
 4 safe, supportive, and effective school environment. The Director of Schools shall appoint the members
 5 of the threat assessment team.

6 The Director of Schools shall develop administrative procedures regarding the training and operations
 7 of the team to comply with state law and State Board of Education rules and regulations.

8 **TEAM MEETINGS**

9 All threat assessment team meetings shall be closed to the public.²

10 **RECORDKEEPING³**

11 The team shall document all behaviors and incidents deemed to pose a risk to school safety or that
 12 resulted in intervention and shall provide the information to the Director of Schools.

13 A report of the activities of the threat assessment team will be compiled and shared with the Board
 14 before each regular meeting.

15 Documents produced or obtained regarding these assessment activities will not be open for public
 16 inspection.

Legal References

1. TCA 49-6-2701 *et seq.*; Public Chapter 2023, Chapter No. 367
2. TCA 49-6-2701(f)
3. TCA 49-6-2702

Cross References

- School District Records 1.407
- Safety 3.201
- Security 3.205
- Student Records 6.600

Agenda Item Title: Approval of Board Policy 3.205, Security, on First and Final Reading

Board Meeting Date: July 25, 2023

Department: Legal

Presented by: Lauren Bush

Board Agenda Category:

- Consent Agenda
 - Action Item
 - Reports and Information
-

Summary

Public Chapter 367 requires that all schools lock all exterior doors during school hours as well as when students are present outside of regular school hours for school-related purposes or activities. Board Policy 3.205 is amended to require that all exterior doors leading into a school building be locked at all times during the school day and during afterschool activities when students may be present. The updated policy requires that a school district employee be stationed by an unlocked door during a school activity occurring after school hours to ensure access to the school is limited to authorized persons.

Staff Recommendation

Recommend approval of changes to Board Policy 3.205 on first and final reading

Fiscal Impact

Not applicable

Connection to MCS's Five-Year Strategic Plan

- Known:** Every student will be *known* through whole-child programs and support.
- Safe:** Every student will be *safe* through equitable access to buildings, facilities, and infrastructure that meets their needs.
- Challenged:** Every student will be *challenged* by learning from highly effective educators and employees.
- Empowered:** Every student will be *empowered* through academic success.

Murfreesboro City School Board

Monitoring: Review: Annually, in October	Descriptor Term: Security	Descriptor Code: 3.205	Issued Date: 10/11/22
		Rescinds: 3.205	Issued: 08/24/21

1 The Director of Schools shall establish procedures to protect school property which shall include, but
2 not be limited to:

- 3 1. Closing and securing teacher work areas when left unattended or at the end of the day;
- 4 2. Denying students permission to use the classrooms, laboratories, gymnasiums or other school
5 facilities or equipment without appropriate supervision;
- 6 3. Controlling the issuance of keys; and
- 7 4. Developing programs that contribute to the proper care and use of school facilities and
8 equipment.

9
10 4. All exterior doors leading into a school building shall be locked at all times and access to
11 school buildings is limited to the school's primary entrance during the school day as well as
12 when students are present outside of regular school hours. If, outside of regular school hours,
13 there is a need to unlock the doors during a school activity, a school district employee shall be
14 stationed by the door to ensure access is limited to authorized persons.¹

15 Equipment purchased with federal funds shall be managed as directed by federal and state law.¹

16 The principal shall call law enforcement officials in cases involving illegal entry, theft or vandalism.

17
18 The principal shall notify the Director of Schools as soon as practical but no longer than 24 hours after
19 discovering a case of vandalism, theft, building damage and/or illegal entry.

20 The Director of Schools, or designee, is authorized to sign a criminal complaint and to press charges
21 against perpetrators for vandalism of school property. The Director of Schools shall report all signing
22 of such complaints to the Board.

23 SCHOOL POLICING-LAW ENFORCEMENT SERVICES

24 The Board may enter into a memorandum of understandings with the chief of a law enforcement
25 agency to provide school policing appropriate law enforcement agencies for education and recreational
26 programs, delinquency prevention, mentoring initiatives, and school policing. Any memorandum of
27 understanding to provide school policing shall address, at a minimum, the following issues:²

Formatted: Font: (Default) Times New Roman, 12 pt

Formatted: Indent: Left: 0.5", Space After: 10 pt, Line spacing: Multiple 1.15 li, No bullets or numbering, Adjust space between Latin and Asian text, Adjust space between Asian text and numbers

Commented [LB1]: For consideration- we can create alternate local procedures for door locking outside of school hours.

Formatted: Superscript

Formatted: Don't suppress line numbers

- 28 1. Any School Resource Officer (~~SRO~~(SRO) assigned under a memorandum must be in
29 compliance with all laws, regulations and rules of the Peace Officer Standards and Training
30 Commission at the time of assignment and remain compliant throughout the tenure of their
31 assignment;
- 32 2. As a condition of assignment, any SRO must participate in forty (40) hours of basic training in
33 school policing within twelve (12) months of assignment. Every year thereafter, the SRO shall
34 participate in a minimum of sixteen (16) hours of training specific to school policing. All
35 training programs shall be approved by the Peace Officers Standards and Training
36 Commission.
- 37 3. Any SRO assigned under the memorandum remains an employee of the law enforcement
38 agency, subject to that agency's direction, control, supervision and discipline, though the Board
39 may agree to indemnify and reimburse the law enforcement agency for any part or all of the
40 increased costs incurred by the law enforcement agency as a result of the assignment of the
41 SROs.
- 42 4. No officer shall be assigned to a school, or continue in such an assignment, without the consent
43 of the Director.
- 44 5. In the event that more than one SRO is assigned to a school system, the law enforcement
45 agency shall designate one of the SROs as the senior SRO, or such other, appropriate title. The
46 duties of the senior SRO, however designated, shall include, but not be limited to, the
47 following:
 - 48 a. To represent and carry out the policies of the law enforcement agency assigning the
49 SROs.
 - 50 b. To supervise the SROs in the performance of their duties;
 - 51 c. To consult with the Director regarding the best use of the available resources for school
52 policing; and
 - 53 d. To resolve disputes between the SROs and students or faculty members.
- 54 6. The memorandum may be effective for any length of time, including continuing until
55 terminated by the parties, and may contain any reasonable notice requirement for the
56 termination of the memorandum. However, the memorandum shall contain a provision
57 allowing the Director to suspend the active participation of the SROs in the event that the
58 Director believes that such suspension is best for the health, safety and/or well-being of the
59 students and/or school staff.

60 CYBERSECURITY³

- 61 The Director of Schools/designee shall develop an administrative procedure regarding the district's
62 cybersecurity plan to identify cybersecurity risks, implement mitigation planning, and protect
63 cyberinfrastructure against cyberattacks and other cybersecurity threats and incidents.

Legal References

- [1. Public Acts of 2023, Chapter No. 367](#)
- [4.2. -2 CFR 200.313](#)
- [2.3. TCA 49-6-4217](#)
- [3.4. TCA 49-6-805\(9\)](#)

Cross References

- Visitors to the Schools 1.501
- Care of School Property 6.311

Agenda Item Title: Approval of Board Policy 4.300, Extracurricular Activities, on First and Final Reading

Board Meeting Date: July 25, 2023

Department: Legal

Presented by: Lauren Bush

Board Agenda Category:

- Consent Agenda
 - Action Item
 - Reports and Information
-

Summary

Public Chapter 353 requires parents or guardians to opt-in to allow their child to participate in a club or extracurricular activity. An opt-out model is not allowable under the law. The recommended changes to Board Policy 4.300 comply with Public Chapter 353.

Staff Recommendation

Recommend approval of changes to Board Policy 4.300 on first and final reading

Fiscal Impact

Not applicable

Connection to MCS's Five-Year Strategic Plan

- Known:** Every student will be *known* through whole-child programs and support.
- Safe:** Every student will be *safe* through equitable access to buildings, facilities, and infrastructure that meets their needs.
- Challenged:** Every student will be *challenged* by learning from highly effective educators and employees.
- Empowered:** Every student will be *empowered* through academic success.

Murfreesboro City School Board

Monitoring: Review: Annually, in November	Descriptor Term: Extracurricular Activities	Descriptor Code: 4.300	Issued Date: 06/26/18
		Rescinds:	Issued:

1 The following guidelines shall be followed in administering school-sponsored extracurricular
2 activities:

- 3 1. All extracurricular activities and clubs must have the approval of the principal.
- 4 2. Student activities occurring before or after regularly scheduled school hours must be under the
5 supervision of the principal or designee.
- 6 3. Secret organizations shall not be operated in any school.
- 7 4. Activities which restrict participation because of race, color, religion, sex, disabilities, or
8 national origin are strictly forbidden.¹

9 5. A student shall not be required to attend an extracurricular activity that is scheduled at a time
10 which conflicts with his/her religious practices.²

11 6. Activities sponsored by outside groups or agents will be approved only if they are co-sponsored
12 by the school and meet the guidelines of Board policies and Administrative Directives.
13
14

15 **STUDENT CLUBS & ORGANIZATIONS**³

16 5. All students under the age of eighteen (18) shall present a signed and dated statement from their
17 parent/guardian before joining any club or organization or participating in activities of a club or
18 organization. The Director of Schools shall develop administrative procedures outlining this
19 recordkeeping process.

Legal References

1. 20 USCA § 1703
2. TCA 49-6-1002(c)
3. Public Acts of 2023, Chapter No. 353

Formatted: Superscript

Formatted: Font: 11 pt, Font color: Black

Formatted: Font: (Default) Times New Roman, 12 pt

Formatted: Indent: Left: 0.5", Space Before: 0 pt, After: 10 pt, Line spacing: Multiple 1.15 li, No bullets or numbering

Formatted: Font: 11 pt, Font color: Black

Formatted: Font: (Default) Times New Roman, Font color: Black

Formatted: Indent: Left: 0.5", Space Before: 0 pt, After: 10 pt, Line spacing: Multiple 1.15 li, No bullets or numbering

Formatted: Normal, No bullets or numbering

Formatted: Font: (Default) Times-Roman

Agenda Item Title: Approval of Board Policy 5.106, Application and Employment, on First and Final Reading

Board Meeting Date: July 25, 2023

Department: Legal

Presented by: Lauren Bush

Board Agenda Category:

- Consent Agenda
 - Action Item
 - Reports and Information
-

Summary

Public Chapter 222 clarifies that school districts may not hire individuals who appear on abuse of vulnerable persons lists maintained by other states that are similar to Tennessee's Department of Children's Services list of perpetrators of child abuse and the Department of Health's registry of abuse of vulnerable persons. The recommended changes to Board Policy 5.106 comply with the requirements of Public Chapter 222.

Staff Recommendation

Recommend approval of changes to Board Policy 5.106 on first and final reading

Fiscal Impact

Not applicable

Connection to MCS's Five-Year Strategic Plan

- Known:** Every student will be *known* through whole-child programs and support.
- Safe:** Every student will be *safe* through equitable access to buildings, facilities, and infrastructure that meets their needs.
- Challenged:** Every student will be *challenged* by learning from highly effective educators and employees.
- Empowered:** Every student will be *empowered* through academic success.

Murfreesboro City School Board

Monitoring: Review: Annually, in January	Descriptor Term: Application and Employment	Descriptor Code: 5.106	Reviewed Date: 02/28/23
		Rescinds: 5.106	Issued: 05/24/22

1 APPLICATION

2 An individual desiring a position shall make application to the Director of Schools on forms developed
3 by his/her office. To ensure the safety and welfare of students and staff, the district shall require
4 criminal history background checks and fingerprinting of applicants for teaching positions and any
5 other positions that require proximity to children.^{1, 10} If applying for a teaching position, the Director of
6 Schools shall also check the applicant's license status in the Tennessee Department of Education's
7 database to determine if there is a hold on that applicant's license, and if so, the reasoning behind the
8 hold.²

9 Knowingly falsifying information shall be sufficient grounds for termination of employment and shall
10 also constitute a Class A misdemeanor which must be reported to the District Attorney General for
11 prosecution.³ The Board shall pay any costs incurred to perform these background checks and
12 fingerprinting.⁴

13 *Professional Employees*

14 The application shall include the colleges or universities attended along with references from persons
15 such as previous employers, college professors, and supervisors of student teachers. Other information
16 shall include whether such applicant has been dismissed for cause from a school system.⁵ If previously
17 employed by a local board of education, the applicant shall provide evidence of acceptable resignation.

18 No person shall be employed:

- 19 1. Who does not hold a valid license to teach or a temporary permit to teach from the Tennessee
20 Board of Education;⁶
- 21 2. Who has been identified by the Department of Children's Services, or on a similar registry in
22 another jurisdiction, as a perpetrator of child abuse, severe child abuse, child sexual abuse, or
23 child neglect, or who poses an immediate threat to the health, safety, or welfare of children;⁷
- 24 3. Who is listed on the state's abuse of vulnerable persons registry maintained by the Department
25 of Health;⁷
- 26 4. Who does not present a physician's certificate showing a satisfactory health record or has any
27 contagious or communicable disease in such form that might endanger the health of school
28 children;⁸
- 29 5. Who refuses to take and subscribe to an oath to support the Constitution of the State of
30 Tennessee and of the United States of America;⁹
- 31 6. Who fails to make a full disclosure of any prior criminal record and any prior dismissals from
32 employment for cause; or
- 33 7. Who does not receive a satisfactory background check.¹⁰

34 *Support Employees*

35 No person shall be employed:

- 36 1. Without the appropriate qualifications listed in the job description and/or stated in law;
37 ~~2.~~ Who does not present a physician's certificate showing a satisfactory health record or has any
38 contagious or communicable disease in such form that might endanger the health of school
39 children;⁸
40 ~~2.~~⁸
- 41 3. Who has been identified by the Department of Children's Services as a perpetrator of child
42 abuse, severe child abuse, child sexual abuse, or child neglect, or who poses an immediate
43 threat to the health, safety, or welfare of children;⁷
44 4. Who is listed on the state's abuse of vulnerable persons registry maintained by the Department
45 of Health;⁷
46 5. Who has not complied with the Immigration Reform and Control Act of 1986;¹¹
47 6. Who fails to make a full disclosure of any prior criminal record and any prior dismissals from
48 employment for cause; or
49 7. Who does not receive a satisfactory background check.¹⁰

50 **EMPLOYMENT**51 *Professional Employees*52 After checking references and receiving written recommendations, the Director of Schools shall hire
53 and assign qualified applicants.54 Upon initial employment, the Director of Schools shall notify such person, in writing, of the offer and
55 conditions of employment. Upon receipt of employment notification, such person shall respond within
56 the timeline established by state law.¹² From the date of the written acceptance, such person is
57 considered to be under employment with the system and is subject to all rights, privileges, and duties.58 *Support Employees*59 After checking references and receiving written recommendations from principals and/or supervisors,
60 the Director of Schools shall hire and assign qualified applicants. The Employment at Will Agreement
61 of each support employee shall contain a statement regarding the required ninety (90) day probationary
62 period.63 *Anticipation of Advanced Degree or Academic Credentials*64 The teacher shall be responsible for securing a license or certificate, verifying its accuracy, maintaining
65 its validity, registering it with the Murfreesboro City Schools Human Resources Department, and
66 meeting the requirements of T.C.A. 49-5-101. Initial salary shall reflect the established degree shown
67 on the Tennessee Department of Education certificate presented at the time of employment.**Formatted:** Font: (Default) Times New Roman, 12 pt**Formatted:** Space Before: 0 pt, After: 10 pt, Line spacing:
Multiple 1.15 li, Numbered + Level: 1 + Numbering Style: 1,
2, 3, ... + Start at: 1 + Alignment: Left + Aligned at: 0.25" +
Indent at: 0.5"

68 For budgetary purposes, all licensed employees who anticipate receiving an advanced degree or
 69 additional graduate hours to meet the MA+30 requirement shall report this to the Director of Schools
 70 no later than March 1.

71 The licensed employee shall be responsible for filing an official copy of the transcripts with the
 72 Murfreesboro City Schools' Human Resources Department once the required coursework has been
 73 completed or the degrees have been awarded. The employee may but is not required to complete the
 74 necessary process to have their school/university send official transcripts directly to the state
 75 certification office in order to add the degree to their license in TNCompass.

76 The employee has 60 calendar days to submit the required documentation to Human Resources in
 77 order for the new level of pay to backdate to the degree conferral date. If documentation is received
 78 after 60 calendar days, the new level of pay will begin the date that the documentation is received by
 79 Human Resources.

80 For courses to count towards a MA+30 status on the pay lane, they must be graduate level education
 81 courses taken after completion of a Master's degree. These courses must be traditional, credited
 82 courses and not continuing education credits or courses needed for initial licensure.

 Legal References

1. TCA 49-5-406; [TCA 49-5-413](#)
2. State Board of Education Policy 5.501
3. TCA 49-5-406(a)(2)(A)
4. TCA 49-5-413(c)
5. TCA 49-2-131
6. TCA 49-5-403; TCA 49-5-101; TCA 49-5-106
7. TCA 49-5-413(e); [Public Acts of 2023, Chapter No. 222](#)
8. TCA 49-5-404
9. TCA 49-5-405
10. TCA 49-5-413(a), (f)
11. Immigration Reform and Control Act of 1986; Pub. L. No. 99-603, 100 Stat. 3359, 8 USCA § 1101 *et seq.*
12. TCA 49-5-406(b)

 Cross References

- Orientation and Probation 5.107
- Compensation Guides & Contracts 5.110
- Background Investigations 5.118
- Recommendations and File Transfers 5.203
- Interim Employees 5.700
- Qualifications and Duties of the Director of Schools 5.802

Formatted: English (United States)

Agenda Item Title: Approval of Board Policy 5.1061, Employment of Retirees, on First and Final Reading

Board Meeting Date: July 25, 2023

Department: Legal

Presented by: Lauren Bush

Board Agenda Category:

- Consent Agenda
 - Action Item
 - Reports and Information
-

Summary

Public Chapter 425 offers additional flexibility in hiring retirees. The recommended changes to Board Policy 5.1061 allows retirees to work as substitutes beyond the typical 120 day contract and permits retirees to serve as regular classroom teachers on an ongoing basis in compliance with the language included in Public Chapter 425. Under this option, the retirement benefit payable to the retired member is reduced to seventy percent (70%) of the retirement allowance.

Staff Recommendation

Recommend approval of changes to Board Policy 5.1061 on first and final reading

Fiscal Impact

Not applicable

Connection to MCS's Five-Year Strategic Plan

- Known:** Every student will be *known* through whole-child programs and support.
- Safe:** Every student will be *safe* through equitable access to buildings, facilities, and infrastructure that meets their needs.
- Challenged:** Every student will be *challenged* by learning from highly effective educators and employees.
- Empowered:** Every student will be *empowered* through academic success.

Murfreesboro City School Board

Monitoring: Review: Annually, in January	Descriptor Term: Employment of Retirees	Descriptor Code: 5.1061	Issued Date: 09/13/22
		Rescinds: 5.1061	Issued: 02/00/20

1 *General*

2 The Director of Schools may hire a retired individual if certain conditions are met as provided for in
3 state law.

4 **EMPLOYMENT CONTRACTS FOR UP TO 120 DAYS**

5 ~~Teachers who retire~~Retired members under the Tennessee Consolidated Retirement System (TCRS) may
6 be employed for up to one hundred twenty (120) days per year without loss of retirement benefits. Retired
7 ~~teachers~~members may substitute teach for additional days ~~if the Director of Schools certifies in writing~~
8 ~~to the Division of Retirement that no other qualified personnel are available to substitute teach.~~¹

9 **GENERAL EMPLOYMENT CONTRACTS**

10 The Director of Schools may employ retired teachers. Retirement benefits will not be lost or suspended
11 under certain conditions which include, but are not limited to, the following:²
12

- 13 1. The retired teacher shall hold a valid license and shall not be entitled to tenure status;
- 14
- 15 2. The retired teacher shall not be eligible to accrue additional retirement benefits, accrue leave, or
16 receive medical insurance coverage; and
- 17
- 18 3. The salary paid to the retired teacher shall not be less than the rate of compensation set by the
19 Board for teachers with no experience filling similar positions or more than eighty-five percent
20 (85%) of the rate of compensation set by the Board for teachers with comparable training and
21 years of experience filling similar positions.

22 **EMPLOYMENT CONTRACTS FOR ONE YEAR**

23 The Director of Schools may employ teachers retired for at least one (1) year for full-time employment
24 as a kindergarten through twelfth (K-12) grade teacher on a year-to-year basis. Retirement benefits will
25 not be lost or suspended under certain conditions which include, but are not limited to, the following:²

- 26 1. The Director of Schools of the employing district shall certify in writing that no other qualified
27 individuals are available to fill the position;
28

- ~~2. The Commissioner of Education shall certify that the employing school district serves an area that lacks qualified teachers to serve in the position to be filled;~~
- ~~— The retired teacher shall hold a valid license and shall not be entitled to tenure status;~~
- ~~3. The retired teacher shall not be eligible to accrue additional retirement benefits, accrue leave, or receive medical insurance coverage; and~~
- ~~3. The salary paid to the retired teacher shall not be less than the rate of compensation set by the Board for teachers with no experience filling similar positions or more than eighty five percent (85%) of the rate of compensation set by the Board for teachers with comparable training and years of experience filling similar positions.~~

Formatted: Font: (Default) Times New Roman, 12 pt, Font color: Black

Formatted: List Paragraph, Numbered + Level: 1 + Numbering Style: 1, 2, 3, ... + Start at: 1 + Alignment: Left + Aligned at: 0.25" + Indent at: 0.5"

Formatted: List Paragraph

13 **ADDITIONAL EMPLOYMENT OPTION FOR RETIREES³**

14 Retired members of TCRS or a similar system may be offered reemployment for up to one (1) year as
15 a kindergarten through twelfth (K-12) grade teacher, substitute teacher, or bus driver under the
16 following conditions:

- 17 1. The retired member has been retired for at least sixty (60) calendar days;
- 18 2. The retirement benefit payable to the retired member is reduced to seventy percent (70%) of the
19 retirement allowance;
- 20 ~~3. The retired member's employment can't be longer than a one (1) year period; however, the~~
21 ~~retired member can be reemployed for additional one (1) year periods;~~
- 22 ~~4.3.~~ The retired member is not drawing disability retirement benefits; and
- 23 ~~5.4.~~ The retired member can't accrue additional retirement benefits.

28 The Director of Schools shall notify TCRS of the member's reemployment and certify in writing that
29 the retired member has the required experience and training for the position and that no other qualified
30 persons are available to fill the position.

31 Once the retired member is hired by the district, the district shall pay TCRS as prescribed by state law.
32 The school district shall pay to TCRS during the period of reemployment the greater of (1) a payment
33 equal to the amount the school district would have contributed to TCRS; or (2) an amount equal to five
34 percent (5%) of the retired member's pay rate.

35 **~~CAREER LADDER PAY~~**

36 ~~A retiree whose license has remained continually active and who has a Career Ladder endorsement is~~
37 ~~eligible to receive Career Ladder pay. The retiree must work at least 100 days to be eligible, and the~~

- 1 pay is pro-rated according to the number of days worked. If the retiree had a break in service of more
- 2 than 1 year, they would no longer be eligible for Career Ladder pay.

Legal References

- 1. TCA 8-36-805; Public Acts of 2023, Chapter No. 425
- 2. TCA 8-36-821; Public Acts of 2023, Chapter No. 425
- 3. TCA 8-36-822; Public Acts of 2023, Chapter No. 425

Cross References

- Application and Employment 5.106
- Substitute Teachers 5.701

Agenda Item Title: Approval of Board Policy 5.305, Family and Medical Leave, on First and Final Reading

Board Meeting Date: July 25, 2023

Department: Legal

Presented by: Lauren Bush

Board Agenda Category:

- Consent Agenda
 - Action Item
 - Reports and Information
-

Summary

Public Chapter 399 gives employees who are required by law to hold a valid license of qualification for employment and who have been employed with the school district for at least twelve consecutive months six weeks of paid leave that can be used after the birth, stillbirth, or adoption of a newly placed minor child. This leave must be used within twelve months of the qualifying event and does not have to be used consecutively. Additionally, this leave counts towards federally granted leave under the Family Medical Leave Act. The recommended changes to Board Policy 5.305 comply with the requirements of Public Chapter 399.

Staff Recommendation

Recommend approval of changes to Board Policy 5.305 on first and final reading

Fiscal Impact

Not applicable

Connection to MCS's Five-Year Strategic Plan

- Known:** Every student will be *known* through whole-child programs and support.
- Safe:** Every student will be *safe* through equitable access to buildings, facilities, and infrastructure that meets their needs.
- Challenged:** Every student will be *challenged* by learning from highly effective educators and employees.
- Empowered:** Every student will be *empowered* through academic success.

Murfreesboro City School Board

Monitoring: Review: Annually, in January	Descriptor Term: Family and Medical Leave	Descriptor Code: 5.305	Issued Date: 08/28/18; 01/28/20
		Rescinds:	Issued:

1 ELIGIBILITY

2 Anyone who has been employed for at least twelve (12) months by the school district and who has at
3 least 1,250 hours of service (hours used for leave, even FMLA leave, shall not be credited for service
4 for purposes of FMLA eligibility¹) during the previous twelve-month period shall be eligible to use
5 FMLA leave.^{4,2}

6 GENERAL PRINCIPLES

7 An eligible employee shall be granted, upon request, up to twelve (12) weeks unpaid leave during a
8 fixed calendar year for the following reasons:

- 9 1. The birth of a child;
- 10 2. The placement of a child with the employee for adoption or foster care;
- 11 3. A serious health condition of the employee that makes the employee unable to perform the
12 essential functions of his or her job position;
- 13 4. The care of a spouse, child, or parent – (but not a parent “in-law”) with a serious health
14 condition; and
- 15 5. Any qualifying circumstances arising out of the fact that a spouse, child, or parent of the
16 employee is on covered active duty or has been notified of an impending call or order to
17 covered active duty in the Armed Forces.

22 Granting of leave under this policy shall be subject to, and in accordance with, the provisions of
23 applicable federal and state laws. An employee may substitute accrued paid leave for unpaid time. Use
24 of accrued paid leave shall run concurrently with and be counted toward the employee’s total period of
25 FMLA leave.

26 MATERNITY/PATERNITY LEAVE

- 27 1. *Relationship between FMLA leave and Tennessee Maternity Leave Act*- FMLA leave shall run
28 concurrently with leave provided under the Tennessee Maternity Act, which affords eligible
29 employees leave for a period not to exceed four (4) months for the adoption, pregnancy,
30 childbirth, and nursing of a newborn child.^{2,3}

1 2. *Employee's Leave*- Any employee who goes on maternity/paternity leave shall be allowed to
 2 use all or a portion of the employee's accumulated sick or annual leave for maternity/paternity
 3 leave purposes. In order to be eligible to use sick leave, written request of the employee
 4 accompanied by a statement from the employee's physician verifying pregnancy shall be
 5 submitted. Upon verification by a written statement from an adoption agency or other entity
 6 handling an adoption, an employee may also be allowed to use accumulated leave for adoption
 7 of a child. If both adoptive parents are employees employed by the district, however, only one
 8 (1) parent is entitled to use such leave.³

9 Spouses who are both eligible employees of the school district are limited to a combined total
 10 of twelve (12) workweeks of FMLA leave in a single twelve (12) month period if the leave is
 11 taken for the birth and care of a newborn child, for the placement of a child for adoption or
 12 foster care, or to care for a parent who has a serious health condition. Under certain
 13 circumstances, spouses who share leave for the birth or adoption of a child may be eligible for
 14 limited amount of additional leave for other qualifying FMLA reasons.⁴

15
 16
 17 3. *Paid Parental Leave – Under state law, an additional six (6) work weeks of paid leave is available*
 18 *to eligible employees after a birth, stillbirth, or adoption of a newly placed minor child. An*
 19 *eligible employee taking leave under this provision shall not be required to utilize any other type*
 20 *of accrued leave during this period. Eligible employees include teachers, principals, supervisors,*
 21 *or other individuals required by law to hold a valid license of qualification for employment who*
 22 *have been employed with a school district full time for at least twelve (12) consecutive months.*

23
 24 *Employees shall provide notice to the school district thirty (30) days prior to the intended use of*
 25 *the leave. If the employee learns about the need for leave less than thirty (30) days in advance,*
 26 *the employee shall give notice as soon as reasonably possible in order to be eligible for the paid*
 27 *leave. This paid leave does not need to be taken consecutively; however, the paid leave shall be*
 28 *used within twelve (12) months of the qualifying event. The leave shall run concurrently with*
 29 *FMLA leave.*⁶

30 **LEAVE FOR A SERIOUS HEALTH ~~CONDITION~~⁵ CONDITION⁷**

31 Eligible employees, upon request, shall be granted up to twelve (12) weeks of unpaid leave when
 32 he/she is unable to work because of a serious health condition or to care for an immediate family
 33 member with a serious health condition. Granting of such leave shall be subject to the provisions of
 34 applicable federal and state laws. Employees shall contact Human Resources to determine if the reason
 35 for leave qualifies as FMLA leave. If the leave is foreseeable, the employee shall give thirty (30) days'
 36 notice. If the leave is not foreseeable, the employee shall notify Human Resources as soon as
 37 practicable—generally, either the same or next business day.

38 **LEAVE FOR MILITARY FAMILY MEMBERS**

39 1. *Qualifying Exigency Leave*⁸⁶ - Eligible employees are entitled to up to twelve (12) workweeks
 40 of leave because of any "qualifying exigency" arising out of the fact that the spouse, son,
 41 daughter, or parent of the employee, as defined under the FMLA, is on active duty, or has been

Formatted: List Paragraph, Space Before: 12 pt, After: 0 pt, Don't suppress line numbers, Adjust space between Latin and Asian text, Adjust space between Asian text and numbers

Formatted: Font: (Default) Times New Roman, 12 pt

Formatted: Numbered + Level: 1 + Numbering Style: 1, 2, 3, ... + Start at: 1 + Alignment: Left + Aligned at: 0.25" + Indent at: 0.5"

Formatted: Font: (Default) Times New Roman, 12 pt, Bold

Formatted: List Paragraph

1 notified of an impending call to active duty, or has been notified of an impending call to active
2 duty status in the Armed Forces. Qualifying exigencies may include:

- 3 a. Issues arising from the service member's short notice deployment;
- 4 b. Military events and related activities (~~e.g.~~e.g. official ceremonies, support programs);
- 5 c. Making or updating financial and legal arrangements;
- 6 d. Attending counseling;
- 7 e. Taking up to fifteen (15) days leave to spend time with a covered service member who
8 is on short-term rest and recuperation leave during deployment; or
- 9 f. Attending post-deployment activities.

10 2. *Military Caregiver Leave*⁹⁷ - An eligible employee who is the spouse, son, daughter, parent, or
11 next of kin of a covered service member or covered veteran with a serious injury or illness is
12 entitled to up to twenty-six (26) workweeks of leave in a "single twelve (12) month period." A
13 covered service member is a current member of the Armed Forces, including a member of the
14 National Guard or Reserves, who is undergoing medical treatment, recuperation, or therapy, is
15 otherwise in out-patient status, or is otherwise on the temporary disability retired list for a
16 serious injury or illness.

17 A covered veteran is an individual who was a member of the Armed Forces at any time during
18 the period of five (5) years preceding the date of the medical treatment, recuperation, or therapy
19 that has a serious injury or illness who is currently receiving medical treatment, recuperation, or
20 therapy.

21 The "single twelve (12) month period" for military caregiver leave begins on the first day the
22 employee takes leave for this reason and ends twelve (12) months later. An eligible employee is
23 limited to a combined total of twenty-six (26) workweeks of leave to provide care for a covered
24 service member. The maximum of twenty-six (26) workweeks may include no more than
25 twelve (12) workweeks of leave that is taken for the birth and care of a newborn child, for the
26 placement of a child for adoption or foster care, for care of a parent who has a serious health
27 condition, or for the employee's own serious health condition.

28 **INTERMITTENT ~~LEAVE~~⁸LEAVE¹⁰**

29 Eligible employees may take FMLA leave intermittently when medically necessary to care for a
30 seriously ill family member, because of the employee's own serious health condition, or for the care for
31 a newborn, a newly adopted child, or a newly placed foster care child. When a licensed employee
32 requests foreseeable leave for planned medical treatment and the employee would be on leave for
33 greater than 20% of the total number of working days in the period during which the leave would
34 extend, the school district may require that such employee elect either to take the leave for periods of a
35 particular duration, not to exceed the duration of the planned medical treatment, or to transfer
36 temporarily to an available alternative position offered by the school district for which the employee is
37 qualified and that has equivalent pay and benefits and better accommodates recurring periods of leave.

38 **RESTRICTIONS**

1 1. Notice Requirements

2 a. *Employee Notice⁹-Notice¹¹* - For foreseeable leave, the employee shall provide the
3 Director of Schools with at least thirty (30) days written notice before the beginning of
4 the anticipated leave.

5 *b. District Notice*- Once it has been established that the leave requested qualifies for
6 FMLA, the Director of Schools/designee shall notify the employee within three (3)
7 business days (absent extenuating circumstances) that any leave taken pursuant to state
8 leave statutes (paid vacation leave, personal leave, sick leave, or workers'
9 compensation) shall run concurrently with FMLA leave.^{10,12} The notice may be given
10 orally or in writing. If the notice is oral, it shall be confirmed in writing, no later than
11 the following pay day.^{13,2}
12

13 2. Certification *Requirement¹²Requirement¹⁴*

14 a. The Director of Schools may require that a request for leave be supported by
15 certification issued by a health care provider with the following information:

- 16 i. The date on which the serious health condition commenced;
17 ii. The probable duration of the condition;
18 iii. The appropriate medical facts within the knowledge of the health care provider
19 regarding the condition; and
20 iv. A statement that the eligible employee is needed to care for the son, daughter,
21 spouse, or parent and an estimate of the amount of time that such employee is
22 needed.
23
24
25

26 b. If there is any reason to doubt the validity of the certification provided, the Director of
27 Schools may require, at the expense of the school district, an opinion of a second health
28 care provider.

29 3. Period Near the End of an Academic Term (Professional Employees)^{15,3}

30 a. If leave is taken more than five (5) weeks prior to the end of the term, the Director of
31 Schools may require the employee to continue taking leave until the end of the term if
32 the leave is at least three (3) weeks of duration and the return of employment would
33 occur during the three (3) week period before the end of the term.

34 b. If the leave is taken five (5) weeks prior to the end of the term, the Director of Schools
35 may require the employee to continue taking leave until the end of the term if the leave
36 is greater than two (2) weeks duration and the return to employment would occur during
37 the two (2) week period before the end of the term.

38 **REQUIREMENTS OF THE BOARD^{16,4}**

Formatted: Indent: Left: 1", No bullets or numbering

Formatted: Font: (Default) Times New Roman, Font color: Black

Formatted: Indent: Left: 1", Don't adjust space between Latin and Asian text, Don't adjust space between Asian text and numbers

Formatted: List Paragraph, Indent: Left: 1", Space Before: 0 pt, Don't suppress line numbers, Don't adjust space between Latin and Asian text, Don't adjust space between Asian text and numbers

- 1 1. The employee shall be restored to the same position of employment or an equivalent position
2 with no loss of benefits, pay, or other terms of employment.
- 3 2. The employee shall be kept under any group health plan for the duration of the leave. The
4 Board may recover the premium paid under the following conditions:
- 5 a. The employee fails to return from leave after the period of leave has expired; and
6 b. The employee fails to return to work for a reason other than the continuation,
7 recurrence, or onset of a serious health condition or other circumstances beyond the
8 control of the employee.

Legal References

- ~~1.~~ [*Hinson v. Tecumseh Products Co.*, 2000 U.S. App. LEXIS 26778, at *1—10 \(6th Cir. Oct. 17, 2000\)](#)
- ~~2.~~ Federal Family and Medical Leave Act of 1993, 29 USCA § 2601, 2611 – 2619
- ~~3.~~ TCA 49-5-702; TCA 4-21-408
- ~~3-4.~~ TCA 49-5-710(a)(2); [TCA 8-50-802\(a\)\(4\)](#)
- ~~5.~~ 29 CFR § 825.120(a)(3)
- ~~4-6.~~ [Public Acts of 2023, Chapter No. 399](#)
- ~~5-7.~~ 29 CFR § 825.113
- ~~6-8.~~ 29 CFR § 825.126
- ~~7-9.~~ 29 CFR § 825.124; 29 CFR § 825.127
- ~~8-10.~~ 29 CFR § 825.202
- ~~9-11.~~ 29 CFR § 825.302-825.304
- ~~10-12.~~ 29 CFR § 825.207
- ~~11-13.~~ OP Tenn. Atty Gen 94-004 (Jan 13, 1994); *Plant v. Morton International, Inc.*, 212 F.3d 929, 932 (6th Cir. 2000)
- ~~12-14.~~ 29 CFR § 825.305-825.313
- ~~13-15.~~ 29 CFR § 825.602
- ~~14-16.~~ 29 USCA § 2614

Cross References

- Sick Leave 5.302
Long-Term Leaves of Absence 5.304

Formatted: Font: (Default) Times New Roman, 9 pt, Font color: Black

Agenda Item Title: Approval of Board Policy 5.307, Physical Assault Leave, on First and Final Reading

Board Meeting Date: July 25, 2023

Department: Legal

Presented by: Lauren Bush

Board Agenda Category:

Consent Agenda

Action Item

Reports and Information

Summary

Public Chapter 343 clarifies that teachers will receive their full salary while on leave due to a physical assault that sustained during their course of their employment duties. The recommended changes to Board Policy 5.307 comply with the requirements of Public Chapter 343. This is a practice we have already been implementing as a district.

Staff Recommendation

Recommend approval of changes to Board Policy 5.307 on first and final reading

Fiscal Impact

Not applicable

Connection to MCS's Five-Year Strategic Plan

- Known:** Every student will be *known* through whole-child programs and support.
- Safe:** Every student will be *safe* through equitable access to buildings, facilities, and infrastructure that meets their needs.
- Challenged:** Every student will be *challenged* by learning from highly effective educators and employees.
- Empowered:** Every student will be *empowered* through academic success.

Murfreesboro City School Board

Monitoring: Review: Annually, in February	Descriptor Term: Physical Assault Leave	Descriptor Code: 5.307	Issued Date: Revised 03/22/22
		Rescinds:	Issued:

- 1 ~~A teacher who is absent from assigned duties as a result of personal injury caused by physical assault or~~
2 ~~other violent criminal acts committed in the course of the teacher's employment duties shall receive~~
3 ~~his/her full salary and full benefits until the teacher is released by his/her physician to return to work or~~
4 ~~his/her physician determines the teacher is permanently unable to return to work. If the teacher receives~~
5 ~~workers' compensation or other similar benefits, the Board shall pay the difference between that amount~~
6 ~~and the teacher's full salary.¹~~
- 7 ~~An employee who is absent from assigned duties as a result of personal injury caused by physical~~
8 ~~assault or other violent criminal acts committed in the course of the employee's employment duties~~
9 ~~shall receive workers' compensation or comparable benefits without loss of accumulated or granted~~
10 ~~sick, personal or professional leave.⁴~~
- 11 ~~The school system shall continue to pay the employee's full benefits including, but not limited to~~
12 ~~health insurance benefits, until the earlier of the date on which the employee is released by the~~
13 ~~employee's physician to return to work or the date on which the employee is determined by the~~
14 ~~employee's physician to be permanently disabled from returning to work.²~~
- 15 A signed statement listing the cause of the absence shall be provided by the employee on forms
16 furnished by the Director of Schools and shall promptly be given to the immediate supervisor in
17 support of all claims. A certificate from the physician on forms furnished by the Director of Schools
18 may also be required to verify the extent of the injury.^{3,2}

Legal References

Cross References

1. TCA 49-5-714(a); [Public Acts of 2023, Chapter No. 343](#) Worker's Compensation 3.602
- ~~2. TCA 49-5-714(b)~~
- ~~3. TRR/MS 0520-01-02-.04(4)(b)~~

Formatted: Font: (Default) Times-Roman, 9 pt, Font color: Black

Agenda Item Title: Approval of Board Policy 6.202, Home Schools, on First and Final Reading

Board Meeting Date: July 25, 2023

Department: Legal

Presented by: Lauren Bush

Board Agenda Category:

- Consent Agenda
 - Action Item
 - Reports and Information
-

Summary

Public Chapter 114 requires the acceptance of GED, HiSET, and other high school equivalency credentials approved by the State Board of Education in allowing a parent to conduct a home school. Public Chapter 296 removes the requirement that parents of home school students provide proof of immunization. The recommended changes to Board Policy 6.202 comply with the requirements of Public Chapter 114 and Public Chapter 296.

Staff Recommendation

Recommend approval of changes to Board Policy 6.202 on first and final reading

Fiscal Impact

Not applicable

Connection to MCS's Five-Year Strategic Plan

- Known:** Every student will be *known* through whole-child programs and support.
- Safe:** Every student will be *safe* through equitable access to buildings, facilities, and infrastructure that meets their needs.
- Challenged:** Every student will be *challenged* by learning from highly effective educators and employees.
- Empowered:** Every student will be *empowered* through academic success.

Murfreesboro City School Board

Monitoring: Review: Annually, in April	Descriptor Term: Home Schools	Descriptor Code: 6.202	Issued Date: 04/28/20 01/23/18; Reviewed 08/24/21 05/10/22
		Rescinds: BO 52	Issued: 04/01/14

1 A "home school" is a school conducted or directed by a parent or parents or legal guardian or
2 guardians for their own children. Home schools which teach grades K-12 where the
3 parents- are ~~associated with~~associated with an organization that conducts church-related schools¹ (~~as~~
4 ~~defined by T.C.A. §49-50-801~~) are exempt from the following provisions, but must follow procedures
5 issued by the State Department of Education.

6 A parent wishing to conduct a home school shall meet the following requirements:²

- 7 1. Provide annual notice to the Director of Schools before the commencement of each school year
8 of the intent to conduct a home school;
- 9 2. Submit to the Director of Schools the name, number, age, grade level of children involved,
10 location of the school, curriculum to be offered, proposed hours of instruction qualification of
11 the parent/teacher;
- 12 3. Maintain attendance records, subject to inspection of the local Director of Schools;
- 13 4. Submit attendance records to the Director of Schools at the end of each school year;
- 14 5. Provide instruction for at least four (4) hours per day for the same number of instructional days
15 as are required by state law for public schools;³
- 16 6. Possess a high school diploma, ~~GED, or HiSET~~ or a high school equivalency credential
17 approved by the State Board of Education;⁴
- 18 7. Cooperate in the administration to home school students of appropriate tests by the
19 Commissioner of Education, his/her designee or by a professional testing service in grades five
20 (5), seven (7), and nine (9);
- 21 8. Take actions according to state law if home school student falls behind appropriate grade level;
- 22 9. ~~Submit proof to the Director of Schools that the home school student has been vaccinated as~~
23 ~~required by law;~~⁵

1 ~~10.9.~~ Submit proof to the Director of Schools that other health services and examinations as
2 required by law have been received by the home school student; and

3
4 ~~11.10.~~ In the event of illness or inadequacy of the home school parent-teacher to teach a
5 specific subject, employ a tutor having the same qualifications as required of parent/teacher.

6 If one or more of these requirements are not met, the Board authorizes the Director of Schools to take
7 formal action to bring the child into compliance with the compulsory attendance law (until the child
8 has reached age 17), either in the home school or in a public, private, or church-related school.

9 FACILITIES USE

10
11 It shall be the policy of this Board that public school facilities ~~shall be~~ ~~shall be~~ ~~available~~ ~~be~~ ~~for~~ ~~available~~
12 ~~for~~ home-school instruction only when all of the following conditions exist:

- 13 1. Special needs courses are being taught which require services unavailable to the home school
14 student;
- 15 2. These services cannot be provided through any means other than the public schools;
- 16 3. Requests for services are made known by the home school parent when notice is given to the
17 Director of Schools of the intent to conduct a home school;
- 18 4. The Director of Schools investigates request and make recommendations to the Board;
- 19 5. No ~~overcrowding, additional overcrowding, expenses~~ ~~additional~~
20 ~~expenses, - including - providing~~ ~~including providing~~ -transportation, -or- other special situations
21 which interfere with the normal operation of the school system shall be incurred; and
22
- 23 6. Approval by the Board on a case-by-case basis.

28 RECORD ACCESS

29 The Director of Schools, through the ~~A~~attendance ~~S~~supervisor, shall have the attendance records of the
30 home school ~~submitted annually~~ ~~inspected at least two (2) times~~ each school year in order to provide
31 assistance in implementing the ~~Compulsory Attendance Law. However, the LEA may request to~~
32 ~~inspect attendance records at the end of each semester~~ ~~compulsory attendance law.~~

33 STUDENT ~~PERFORMANCE~~⁶PERFORMANCE⁵

34 If a home school student falls more than one (1) year behind his/her appropriate grade level in his/her
35 comprehensive test score for two (2) consecutive tests, and if a certified teacher who would
36 have taught the child at his/her grade level determines through appropriate means that the student is
37 not learning disabled, the Director of Schools shall require the parents to enroll the child in a public,
38 private or church-related school.

Legal References

1. TCA 49-50-801(a)
2. TCA 49-6-3050(b)
3. TCA 49-6-3004(a); TCA 49-6-3050(b)(3)
- ~~4.~~ TCA 49-6-3050(b)(4); [Public Acts of 2023, Chapter No. 114](#)
- ~~5.~~ ~~4.~~ [TCA 49-6-5001](#)
- ~~6.~~ ~~5.~~ TCA 49-6-3050(b)(6)

Cross References

Compulsory Attendance Ages 6.201

Formatted: Font: (Default) Times New Roman, 9 pt, Font color: Black

Agenda Item Title: Approval of Board Policy 6.309, Zero Tolerance Offenses, on First and Final Reading

Board Meeting Date: July 25, 2023

Department: Legal

Presented by: Lauren Bush

Board Agenda Category:

- Consent Agenda
 - Action Item
 - Reports and Information
-

Summary

Public Chapter 299 adds an additional zero tolerance offense to state law. “Threats of mass violence on school property or at a school-related activity” as defined by TCA 39-16-517 has been added to the list of offenses punishable by a one-year expulsion. The recommended changes to Board Policy 6.309 are in compliance with Public Chapter 299. Updates will be made to the Parent Handbook to reflect changes in law and policy.

Staff Recommendation

Recommend approval of changes to Board Policy 6.309 on first and final reading

Fiscal Impact

Not applicable

Connection to MCS’s Five-Year Strategic Plan

- Known:** Every student will be *known* through whole-child programs and support.
- Safe:** Every student will be *safe* through equitable access to buildings, facilities, and infrastructure that meets their needs.
- Challenged:** Every student will be *challenged* by learning from highly effective educators and employees.
- Empowered:** Every student will be *empowered* through academic success.

Murfreesboro City School Board

Monitoring: Review: Annually, in March	Descriptor Term: Zero Tolerance Offenses	Descriptor Code: 6.309	Issued Date: 04/28/20 04/26/22
		Rescinds: STU 38	Issued: 05/08/11

1 In order to ensure a safe and secure learning environment, the following offenses shall not be
2 tolerated:¹

- 3 1. Unauthorized possession of a firearm on school property;²
- 4
- 5 2. Unlawful possession of any drug, including any controlled substance, controlled substance
6 analogue, or legend drug on school grounds or at a school-sponsored event;³ and
7
- 8 3. Aggravated assault⁴ or assault that results in bodily injury⁵ upon any teacher, principal,
9 administrator, any other employee of the school or school resource officer.
- 10
- 11 4. ~~Threats of mass violence on school property or at a school-related activity. Transmittal by an~~
12 ~~electronic device any communication containing a credible threat to cause bodily injury or~~
13 ~~death to another student or school employee and the transmission of such threat creates actual~~
14 ~~disruptive activity at the school that requires administrative intervention.~~⁶

15 Committing any of these offenses shall result in a student being expelled from regular attendance at
16 school for at least one (1) calendar year, unless modified by the Director of Schools. Modification to
17 the length of time shall be granted on a case-by-case basis.

18 DETERMINATION AND NOTIFICATION

19 The principal or the principal's designee shall be responsible for investigating alleged violations of this
20 policy. If the investigation reveals that a violation of this policy has occurred, the principal shall expel
21 the student for not less than (1) calendar year, subject only to the due process procedures set forth in
22 Board Policy 6.316 and this policy and the authority of the Director of Schools to modify the expulsion
23 requirement on a case-by-case basis.⁷

24 When it is determined that a student has violated this policy, the principal of the school shall notify the
25 student's parent(s)/guardian(s) and the criminal justice or juvenile delinquency system as required by
26 law.⁸

27 APPEAL

28 An appeal of a principal's determination that a student has committed a zero-tolerance offense must
29 be filed in accordance with the procedures set forth in Board Policy 6.316. The review on appeal, by
30 either the Disciplinary Hearing Authority or the School Board, of a principal's determination that a

1 student committed a zero-tolerance offense shall be limited in scope to the question of whether the
 2 evidence supports the principal's determination that the student committed the offense.

3 **PUBLICATION OF POLICY**

4 This policy shall be published in the Code of Conduct as set forth in the *Parent Handbook*, and
 5 provided annually to all teachers, administrative staff, and parents.

Legal References

1. TCA 49-6-3401(g)
2. 18 USCA § 921(a)(3); 20 USCA § 7961
3. TCA 39-17-454; TCA 53-10-101
4. TCA 39-13-102
5. TCA 39-13-101(a)(1)
6. ~~TCA 49-6-4002(d)(5)~~ [TCA 39-16-517; Public Acts of 2023, Chapter No. 299](#)
7. TCA 49-6-3401(g)(2); TCA 49-6-3402
8. TCA 49-6-4209; TCA 39-17-1312; 20 USCA § 7961(h)(1)

Cross References

Code of Conduct 6.300
 Drug-Free Schools 6.307
 Suspension 6.316
 Student Disciplinary Hearing Authority 6.317
 Alternative Education 6.319
 Safe Relocation of Students 6.4081

Agenda Item Title: Approval of Board Policy 6.4001, Student Surveys, Analyses and Evaluations, on First and Final Reading

Board Meeting Date: July 25, 2023

Department: Legal

Presented by: Lauren Bush

Board Agenda Category:

- Consent Agenda
 - Action Item
 - Reports and Information
-

Summary

Public Chapter 353 requires parents and guardians to opt-in before a minor child participates in a non-instructional survey, analysis, or evaluation. Previously, Board policy and law only required parent notification with the option to opt-out. The recommended changes to Board Policy 6.4001 comply with the requirements of Public Chapter 353.

Staff Recommendation

Recommend approval of changes to Board Policy 6.4001 on first and final reading

Fiscal Impact

Not applicable

Connection to MCS's Five-Year Strategic Plan

- Known:** Every student will be *known* through whole-child programs and support.
- Safe:** Every student will be *safe* through equitable access to buildings, facilities, and infrastructure that meets their needs.
- Challenged:** Every student will be *challenged* by learning from highly effective educators and employees.
- Empowered:** Every student will be *empowered* through academic success.

Murfreesboro City School Board

Monitoring: Review: Annually, in May	Descriptor Term: Student Surveys, Analyses, and Evaluations	Descriptor Code: 6.4001	Issued Date: Reviewed 05/26/20 10/09/18
		Rescinds: STU 49, STU 56	Issued: 10/01/02; 6/10

1 Surveys, analyses, and evaluations for research purposes shall be allowed by the Board when the project
2 is viewed as contributory to a greater understanding of the teaching-learning process, the project does
3 not violate the goals of the Board, and the disruption of the regular school program is minimal. The
4 Director of Schools shall develop administrative procedures for approving requests for conducting
5 surveys, analyses, or evaluations by agencies, organizations or individuals. The requests shall outline
6 what is to be done, who is to be involved and how the results will be used and distributed.¹

Formatted: Don't suppress line numbers

~~8 Prior to the dissemination of a survey, analysis, or evaluation to students, parent(s)/guardian(s) shall be
9 notified of the opportunity to review the materials.¹ Such notification shall include information indicating
10 the purpose of the survey, analysis, or evaluation as well as who will have access to the results. The
11 survey, analysis, or evaluation shall only be administered to students under the age of eighteen (18)
12 whose parent(s)/guardian(s) provide written, informed, and voluntarily signed consent. A student who
13 is eighteen (18) years of age or older may participate after he/she provides written, informed, and
14 voluntarily signed consent. The Director of Schools shall develop procedures for granting such parental
15 requests.¹~~

~~16 Prior to the dissemination of a survey, analysis, or evaluation to students, parents/guardians shall be
17 notified of their ability to review the materials. Such notification shall include information indicating the
18 purpose of the survey, analysis, or evaluation as well as who will have access to the results. Following
19 such notification and prior to the administration of the survey, analysis, or evaluation, parents/guardians
20 may opt their child out of participation.~~

~~21 The Director of Schools shall develop procedures for granting such parental requests and to implement
22 the other provisions of this policy.⁵~~

23 No student shall be required, as part of any program, to submit to a survey, analysis or evaluation that
24 reveals information concerning any of the following subject matter without the prior consent of the
25 student (if the student is an adult or emancipated minor), or in the case of an unemancipated minor,
26 without the prior written consent of the paren:^{2,53}

- 27 1. Mental or psychological problems of the student or the student's family;
- 28 2. Sexual behavior or attitudes;
- 29 3. Illegal, anti-social, self-incriminating, or demeaning behavior;
- 30 4. Critical appraisals of other individuals with whom respondents have close family relationships;
- 31 5. Legally privileged relationships;

6. ~~I~~ncome; or

~~6. T~~he collection of student biometric data involving the analysis of facial expressions, EEG brain wave patterns, skin conductance, galvanic skin response, heart-rate variability, pulse, blood volume, posture, and eye-~~tracking~~⁶~~tracking~~³.

~~7. without the prior consent of the student (if the student is an adult or emancipated minor), or in the case of an unemancipated minor, without the prior written consent of the parent.~~⁵

The collection of the following student data is strictly prohibited:⁷⁴

1. ~~P~~olitical affiliation or voting history;
2. ~~R~~eligious practices; and
3. ~~F~~irearm ownership.

COLLECTING, DISCLOSING OR USING INFORMATION FOR ~~MARKETING~~³

In general, the district will not collect, disclose or use personal student information for the purpose of marketing or selling that information or otherwise providing that information to others for that purpose.

If any collected information is to be marketed or sold, parents will be directly notified at least annually at the beginning of the school year of the specific or approximate dates when such information will be collected. Parents, upon request, may inspect any instrument used to collect personal information for the purpose of marketing or selling that information before the instrument is administered or distributed to the student. All parents and students of appropriate age may decline to provide the information requested.

This portion of the policy does not apply to the collection, disclosure or use of personal information collected from students for the exclusive purpose of developing, evaluating or providing educational products or services for or to students or educational institutions to the extent allowed by law, such as the following:⁴

1. College or other postsecondary education recruitment or military recruitment;~~;~~
2. Book clubs, magazines and programs providing access to low-cost literary products;~~;~~
3. Tests and assessments used by elementary schools and secondary schools to provide cognitive, evaluative, diagnostic, clinical, aptitude or achievement information about students (or to generate other statistically useful data for the purpose of securing such tests and assessments) and the subsequent analysis and public release of the aggregate data from such tests and assessments;~~;~~
4. The sale by students of products or services to raise funds for school-related or education related activities; ~~or;~~
5. Student recognition programs.

Formatted: Font: (Default) Times New Roman, 12 pt

Formatted: List Paragraph, Justified, Numbered + Level: 1 + Numbering Style: 1, 2, 3, ... + Start at: 1 + Alignment: Left + Aligned at: 0.25" + Indent at: 0.5"

Formatted: List Paragraph, Numbered + Level: 1 + Numbering Style: 1, 2, 3, ... + Start at: 1 + Alignment: Left + Aligned at: 0.25" + Indent at: 0.5"

Legal References

Cross References

1. TCA 49-2-211; [Public Acts of 2023; Chapter No. 353](#)
2. 20 USCA § 1232h
3. ~~20USCA § 1232h(e)(4); No Child Left Behind, Part F § 1061(1)(E)-(F)-(2)~~
4. ~~3. 20 USCA § 1232h(e)(4); No Child Left Behind, Part F § 1061(4)(A);TCA 49-1-706~~
5. ~~4. TCA 49-2-211;TCA 49-1-705~~
6. ~~5. TCA 49-1-706;20 USCA § 1232h(c)(1); 20 USCA § 1232h(c)(4)~~
7. TCA 49-1-705

Testing Programs 4.700

- Formatted: Portuguese (Brazil)
- Formatted: Portuguese (Brazil)
- Formatted: Indent: Left: 0.25", No bullets or numbering

Agenda Item Title: Approval of Board Policy 6.402 Student Surveys, Analyses and Evaluations, on First and Final Reading

Board Meeting Date: July 25, 2023

Department: Legal

Presented by: Lauren Bush

Board Agenda Category:

- Consent Agenda
 - Action Item
 - Reports and Information
-

Summary

Public Chapter 353 gives parents and guardians the ability to opt-out of health screenings conducted as part of the coordinated school health program. The recommended changes to Board Policy 6.402 comply with the requirements of Public Chapter 353.

Staff Recommendation

Recommend approval of changes to Board Policy 6.402 on first and final reading

Fiscal Impact

Not applicable

Connection to MCS's Five-Year Strategic Plan

- Known:** Every student will be *known* through whole-child programs and support.
- Safe:** Every student will be *safe* through equitable access to buildings, facilities, and infrastructure that meets their needs.
- Challenged:** Every student will be *challenged* by learning from highly effective educators and employees.
- Empowered:** Every student will be *empowered* through academic success.

Murfreesboro City School Board

Monitoring: Review: Annually, in April	Descriptor Term: Physical Examinations and Immunizations	Descriptor Code: 6.402	Issued Date: 05/09/23
		Rescinds: 6.402	Issued: 04/13/21 04/28/20 05/28/19; Reviewed 08/24/21

1 **PHYSICAL EXAMINATIONS**¹

Formatted: Superscript

2 The principal shall ensure that there is a complete physical examination of each student prior to:²

Formatted: Superscript

- 3 1. Entering school for the first time;⁺ and
- 4
- 5 2. Participation as a member of any athletic team or in any other strenuous physical activity
- 6 program.

7 Cost of the examination shall be borne by the parent or guardian of the student. These records shall be
8 on file in the principal's office.

9
10
11 ~~Screening tests as recommended by the Tennessee Department of Education and the Department of~~
12 ~~Health will be conducted. Parent(s)/guardian(s) will receive written notice of any screening result that~~
13 ~~indicates a condition that might interfere with the student's progress. Parent(s)/guardian(s) may excuse~~
14 ~~their student from participating in health screenings that are part of a coordinated school health~~
15 ~~program by submitting a request in writing to the school nurse, instructor, school counselor, or~~
16 ~~principal.²Screening tests for vision, hearing, height, weight, blood pressure, scoliosis, and lice will be~~
17 ~~conducted. Parents/Guardians will receive written notice of any screening result that indicates a~~
18 ~~condition that might interfere or tend to interfere with a student's progress.~~

Formatted: Superscript

19
20
21 In general, the school district will not conduct physical examinations of a student without parental
22 consent to do so or a court order, unless the health or safety of the student or others is in question.²³

Formatted: Don't suppress line numbers

23 **IMMUNIZATIONS**

24 No students entering school, including those entering kindergarten or first grade, those from out-of-
25 state and those from nonpublic schools, will be permitted to enroll (or attend) without proof of
26 immunization, as determined by the Commissioner of Public Health. It is the responsibility of the
27 parents or guardians to have their children immunized and to provide such proof to the principal of the
28 school that the student is to attend.²⁴

- 1 Exceptions will be granted to any student whose parent/guardian files with school authorities a signed,
2 written statement that such measures conflict with the one of the following:
- 3 1. His/her religious tenets and practices if in the absence of an epidemic or immediate threat of an
4 epidemic, ~~except in the event of a COVID-19 or any variant outbreak;~~^{4,5} or
5
 - 6 2. Due to medical reasons if the student has a written statement from his/her doctor excusing
7 him/her from the immunization.⁵
- 8 The Director of Schools shall ensure that appropriate immunization records are maintained for each
9 student.

Legal References

1. [20 USCA § 1232h\(c\)](#)
- ~~1,2.~~ [TRR/MS 0520-01-13-.01\(1\)\(a\)](#)
- ~~2,3.~~ [Public Acts of 2023, Chapter No. 353](#); Tennessee School Health
Screening Guidelines.; 20 USCA § 1232h(c)(2)(C)
- ~~3,4.~~ [TCA 49-6-5001\(a\),\(c\)](#)
- ~~4,5.~~ [TCA 49-6-5001\(b\)\(2\)-\(3\)](#); [Public Acts of 2021, Chapter No. 513](#)
- ~~5,6.~~ [TCA 49-6-5001\(c\)\(2\)](#)

Cross References

Promoting Student Welfare 6.400

Agenda Item Title: Approval of School Resource Officer Memorandums of Understanding

Board Meeting Date: July 25, 2023

Department: School Operations

Presented by: Dr. Trey Duke, Director of Schools

Board Agenda Category:

- Consent Agenda
 - Action Item
 - Reports and Information
-

Summary

Public Chapter 367 was passed during the 2023 TN General Assembly’s legislative session. Part of this law established The Statewide School Resource Officer (SRO) Program Grant to provide funding to local law enforcement to place one full-time SRO in each K-12 public school. A requirement of obtaining the grant funding is to enter into a program-specific MOU as outlined by the Department Safety.

Additionally, MCS has recommended a second MOU which contains information specific to the partnership between MCS and MPD. This second MOU is similar to previous MOUs between MPD and MCS.

Staff Recommendation

Approval of both MOUs between Murfreesboro City Schools and Murfreesboro Police Department.

Fiscal Impact

There is no direct fiscal impact for MCS. However, with this agreement in place, MPD is eligible to apply for funding not to exceed \$75,000 per year, per SRO, per school for which they are providing services.

Connection to MCS’s Five-Year Strategic Plan

- Known:** Every student will be *known* through whole-child programs and support.
- Safe:** Every student will be *safe* through equitable access to buildings, facilities, and infrastructure that meets their needs.
- Challenged:** Every student will be *challenged* by learning from highly effective educators and employees.
- Empowered:** Every student will be *empowered* through academic success

Agenda Item Title: Approval of Architect Agreement for the new Mitchell-Neilson Playground

Board Meeting Date: July 25, 2023

Department: School Operations

Presented by: Dr. Trey Duke, Director of Schools

Board Agenda Category:

Consent Agenda

Action Item

Reports and Information

Summary

The School Operations department is presenting the attached agreement with Johnson + Bailey Architects to provide full architectural services for the new Mitchell-Neilson playground project. This project was previously approved by the Board as part of the district's five-year capital improvement plan.

City of Murfreesboro guidelines require that anything that is structural, changes the grading/drainage, or includes land disturbances must be designed by an architect or engineer.

Staff Recommendation

Approval agreement with Johnson + Bailey Architects to provide full architectural services for the Mitchell-Nielson playground project.

Fiscal Impact

The proposed fixed fee for these services is \$31,448.00. The total construction budget for this project is estimated at \$400,000. This project will be funded through ESP.

Connection to MCS's Five-Year Strategic Plan

- Known:** Every student will be *known* through whole-child programs and support.
- Safe:** Every student will be *safe* through equitable access to buildings, facilities, and infrastructure that meets their needs.
- Challenged:** Every student will be *challenged* by learning from highly effective educators and employees.
- Empowered:** Every student will be *empowered* through academic success



Johnson + Bailey Architects P.C.

April 12, 2023

Mr. Scott Elliott
Manager of Project Development
City of Murfreesboro
111 West Vine Street
Murfreesboro, TN 37130

Re: Playground at
Mitchell-Neilson Elementary School
Murfreesboro City Schools
J+B No. 2222

Dear Mr. Elliott:

In response to your request, Johnson + Bailey Architects is pleased to submit the following proposal for architectural services for the referenced project. It is our understanding that the City of Murfreesboro intends to construct a new playground at Mitchell-Neilson Elementary School, to be located to the east of the existing sixth grade wing. The current planned scope of work is as follows:

- 1) Construction of six play areas similar to what is currently located at Salem Elementary School. This consists of three swing set areas and three play structures.
- 2) Construct a four foot high vinyl coated chain link fence enclosure with 4 four foot wide gates (with panic bar exiting) and a double eight foot wide gate for lawn equipment. Locate fence to leave approximately 15 feet of grass space between playgrounds and fence. Provide a shade space with park benches and trash receptacles for adults.
- 3) Construction of safety mulch with perimeter containment compliant with Consumer Product Safety Commission requirements at the six play area noted above. Provide skid pads at swings and exit ends of slides.
- 4) Site grading and underground storm water drainage system to provide positive site drainage.
- 5) Construction of concrete sidewalks to provide paved access from the building.
- 6) Construction of site lighting for security.
- 7) Construction contract is to include a playground safety audit.

It is our understanding that the proposed construction area is near a TVA power line easement. Therefore, we should have this area surveyed by a Land Surveyor registered in the State of Tennessee, and obtain written approval of the final construction plans from TVA prior to bidding. Site plan approval from the City of Murfreesboro Planning & Engineering Department will also be required.

We propose the following Project Schedule.

Procure Site Survey of the Construction Area	Completed
Complete Project Design	On or Before 7-10-23
Execute Agreement for Architectural Services	7-11-23
Prepare Bidding Documents	7-12-23 thru 8-2-23 (21 calendar days)
Procure Required Plans Approvals	8-3-23 thru 8-17-23 (14 calendar days)
Bidding	8-18-23 thru 9-7-23 (20 calendar days)
School Board Approval of Low Bid and Execution of Contract	9-8-23 thru 9-29-23 (21 calendar days)
Procure Playground Equipment	10-2-23 thru 1-2-24 (92 Calendar Days)***
Construction of New Playground	1-3-24 thru 3-3-24 (60 calendar days)
Demolition of Existing Playgrounds	3-4-24 thru 3-5-24 (21 calendar days)

*** Procurement time for playground equipment materials will be discussed with the low bidder after bid opening. The time allocated for playground equipment procurement may be reduced based on materials availability at that time.



Mr. Scott Elliott
Playground at
Mitchell-Neilson Elementary School
Murfreesboro City Schools
April 12, 2023
Page 2

Based upon similar playground construction costs provided by Murfreesboro City Schools Maintenance Department by e-mail dated December 16, 2022, we recommend a construction budget of \$400,000.00.

Johnson + Bailey Architects proposes to provide full architectural services for this project for the State of Tennessee Architectural Fee Schedule, which is calculated by the formula $35/[(\text{Log } P) - 1.15]$ where P is the construction cost. For the construction cost stated above, the rate is 7.862% of the construction cost. The estimated construction of \$400,000.00 times 7.862% equals \$31,448.00. Therefore, we propose a fixed fee of \$31,448.00.

This fee includes architectural and civil design disciplines. The scope of services includes Schematic Design, Design Development, Construction Documents, Obtaining all required Plans Approval, Bidding, and Construction Phase services as described in AIA Document B101 - 2007, Standard Form of Agreement Between Owner and Architect.

If you find the above acceptable, please review and execute the attached AIA Document B101 - 2017, Standard Form of Agreement Between Owner and Architect, dated April 12, 2023.

If you should have any questions concerning the above proposal, please do not hesitate to call.

Sincerely,

JOHNSON + BAILEY ARCHITECTS, P.C.

A handwritten signature in black ink, appearing to read 'R. Lyle Lynch'.

R. Lyle Lynch, Architect

Encl: AIA Document B101 - 2017, Standard Form of Agreement Between Owner and Architect, dated 4-12-23

cc: James Hill
Trey Duke
Ralph Ringstaff
Larry Willeford
Brandon Richardson

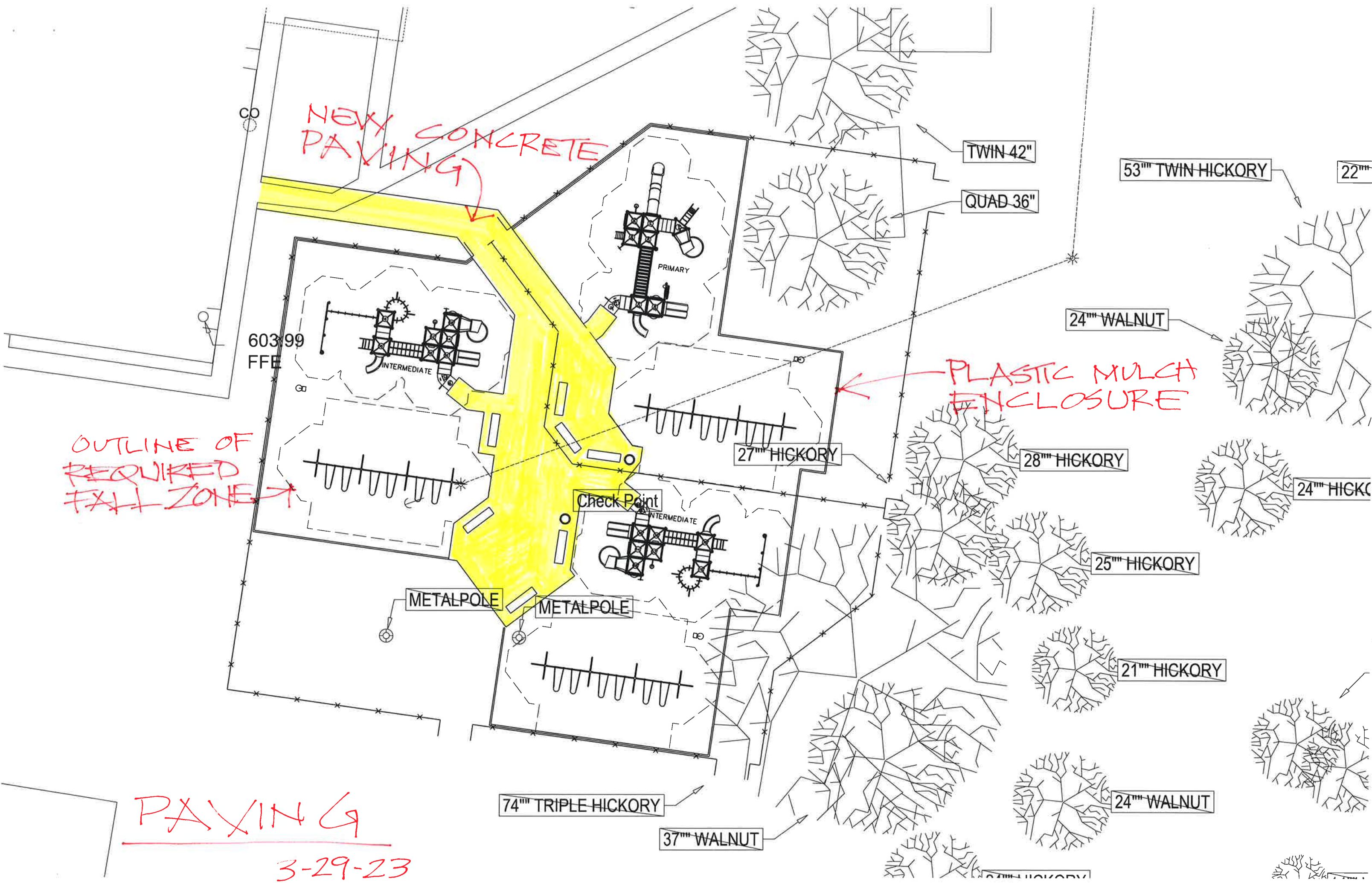

NEW CONCRETE PAVING

OUTLINE OF REQUIRED FALL ZONE

PLASTIC MULCH ENCLOSURE

PAVING

3-29-23

603 99
FFE

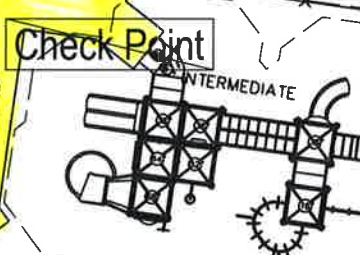
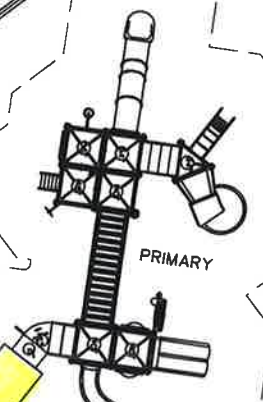

METALPOLE

METALPOLE

TWIN 42"

QUAD 36"

53" TWIN HICKORY

22"

24" WALNUT

27" HICKORY

28" HICKORY

24" HICKO

25" HICKORY

21" HICKORY

74" TRIPLE HICKORY

37" WALNUT

24" WALNUT

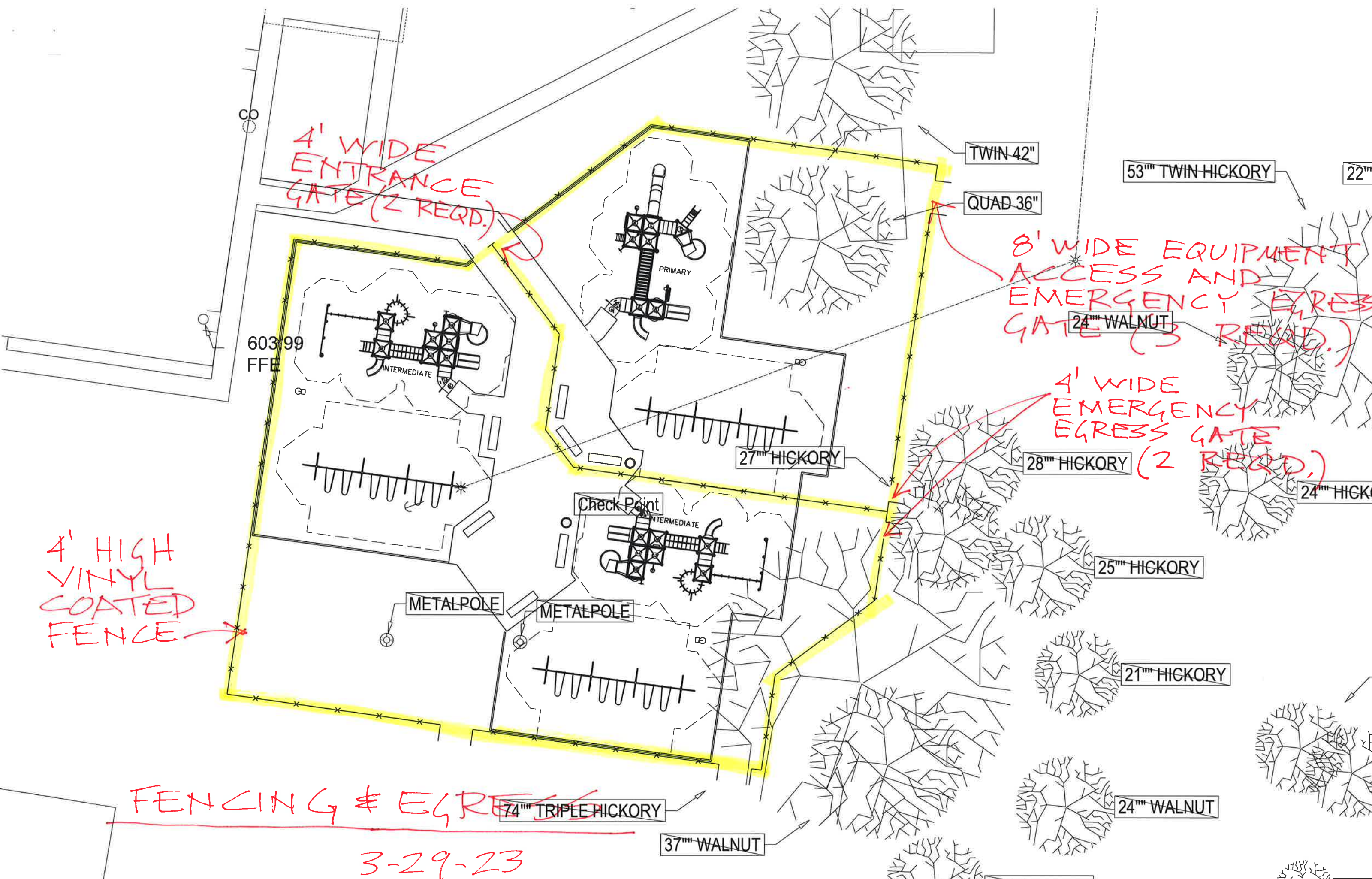

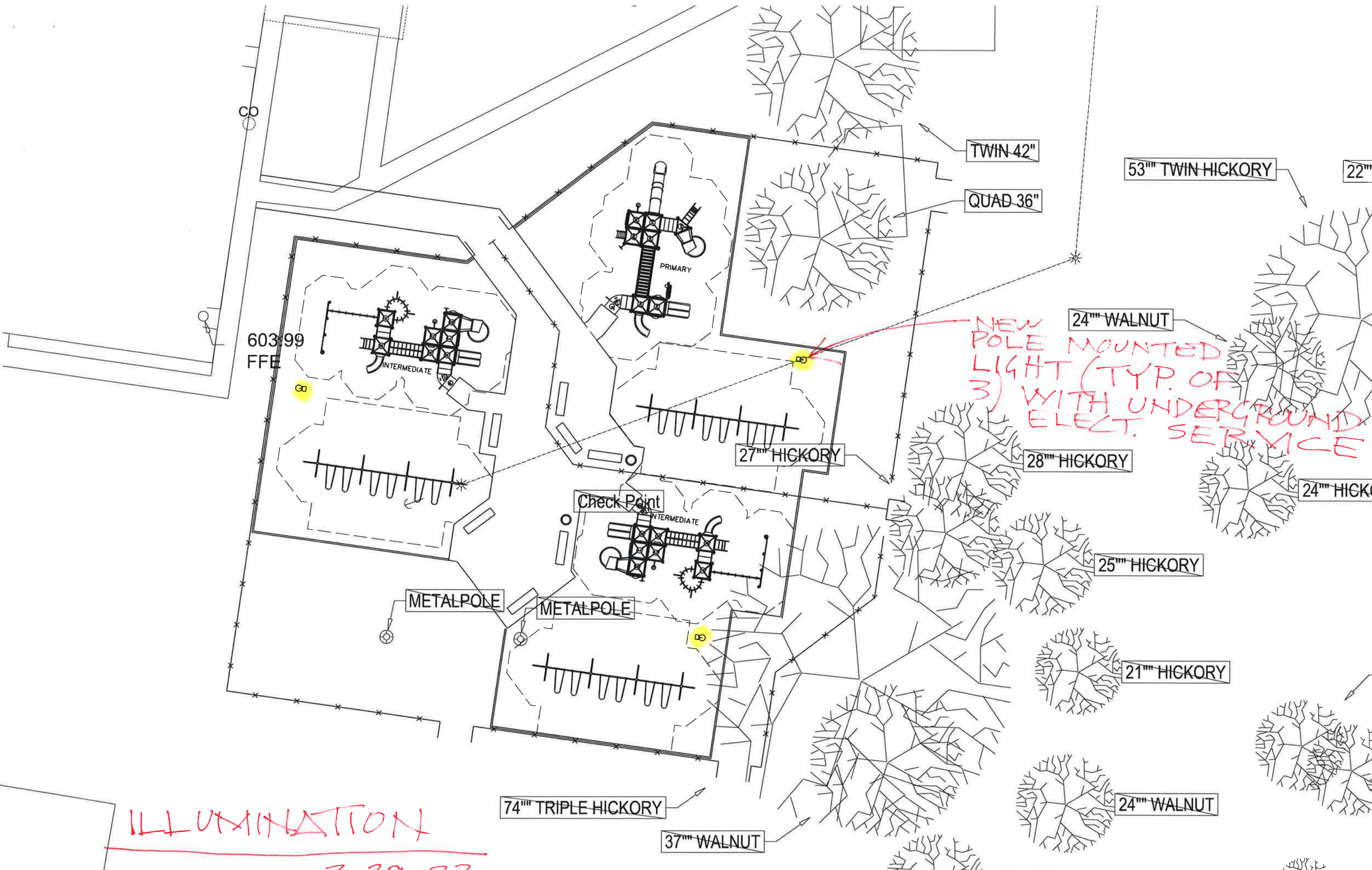

ILLUMINATION

3-29-23

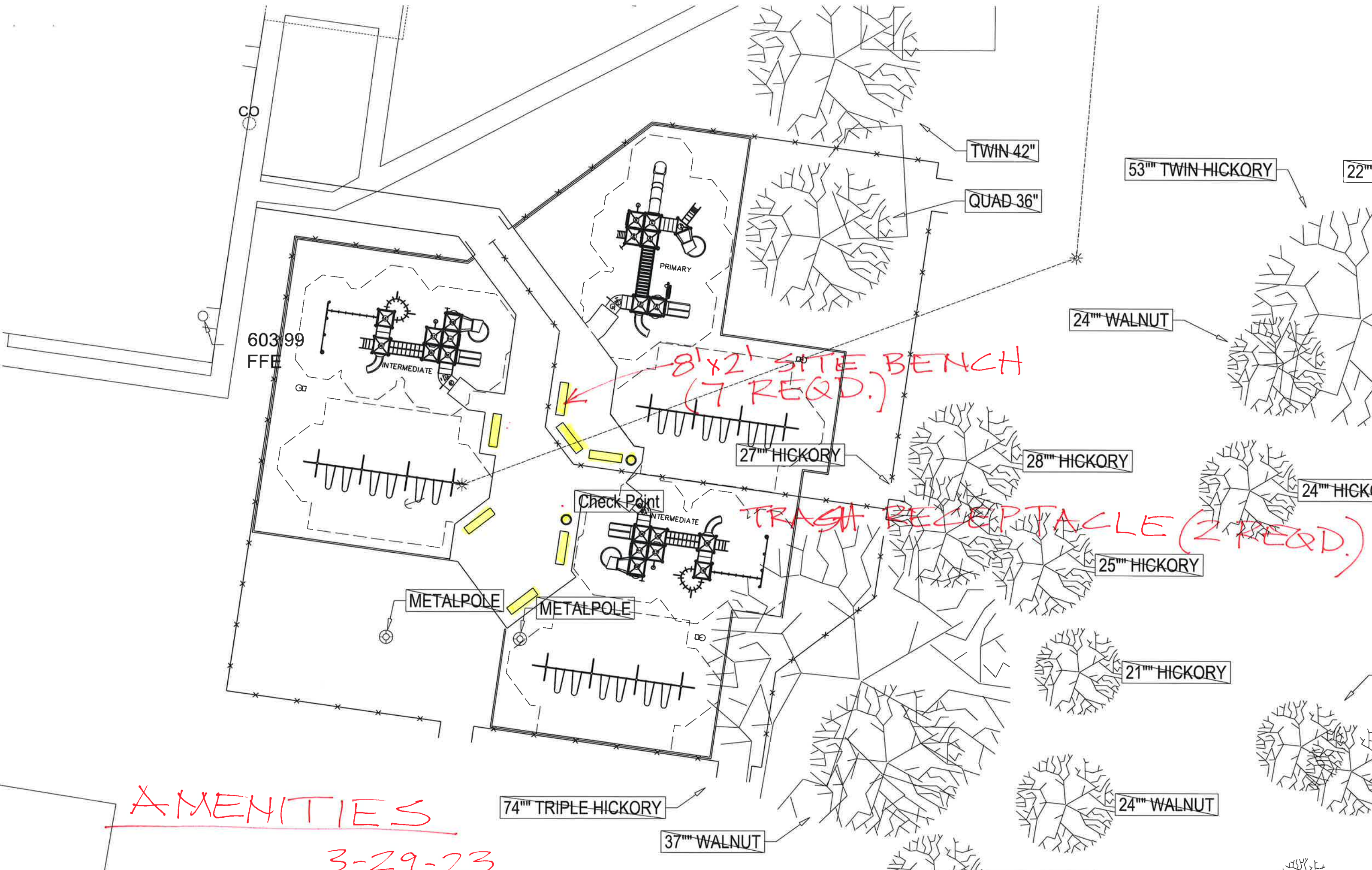

60399
FFE

8'x2' SITE BENCH
(7 REQD.)

TRASH RECEPTACLE (2 REQD.)

AMENITIES
3-29-23

TWIN 42"

QUAD 36"

53" TWIN HICKORY

22"

24" WALNUT

27" HICKORY

28" HICKORY

24" HICKO

25" HICKORY

21" HICKORY

74" TRIPLE HICKORY

37" WALNUT

24" WALNUT

24" HICKORY

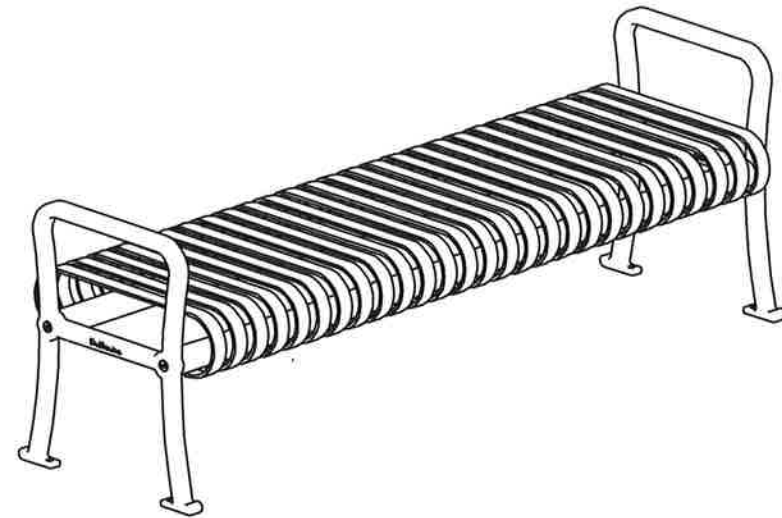
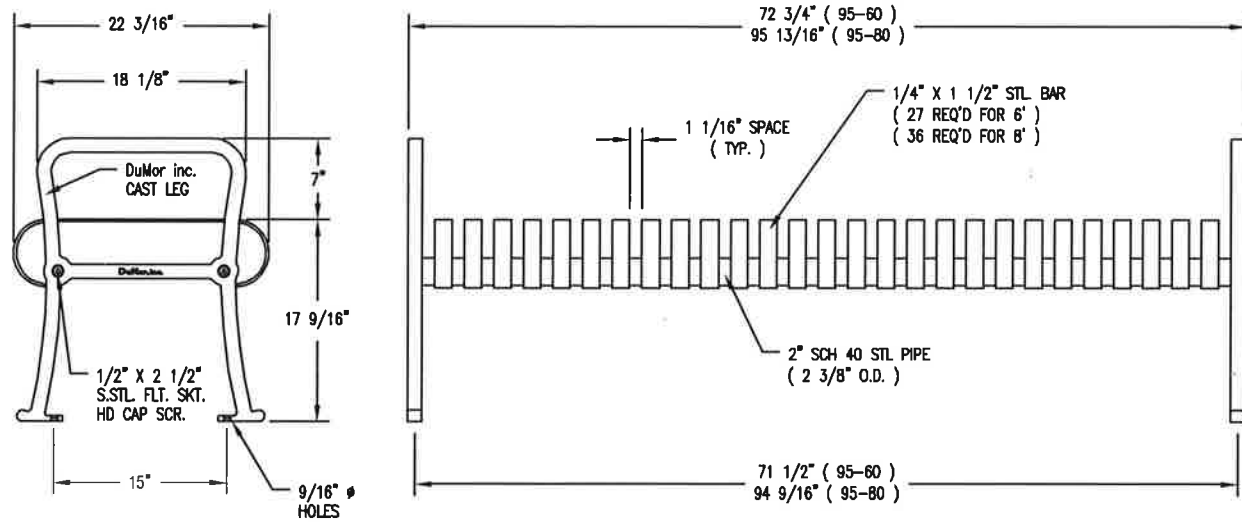

LENGTH OPTIONS

- 6' BENCH
- 8' BENCH

NOTES:

- 1.) ALL STL. MEMBERS COATED W/ ZINC RICH EPOXY THEN FINISHED W/ POLYESTER POWDER COATING.
- 2.) 1/2" X 3 3/4" EXPANSION ANCHOR BOLTS PROVIDED.
- 3.) BENCH IS SHIPPED UNASSEMBLED.

DuMor, inc.
P.O. Box 142 Mifflintown, PA 17059-0142

SCALE : NONE	TITLE : BENCH		
DATE DRAWN : 12/12/00			
DRAWN BY : JSB	REV. C	DRAWING NUMBER 95 SERIES	SHEET 1 OF 2
DATE REV. : 1/13/04			
REV. BY : JSB			

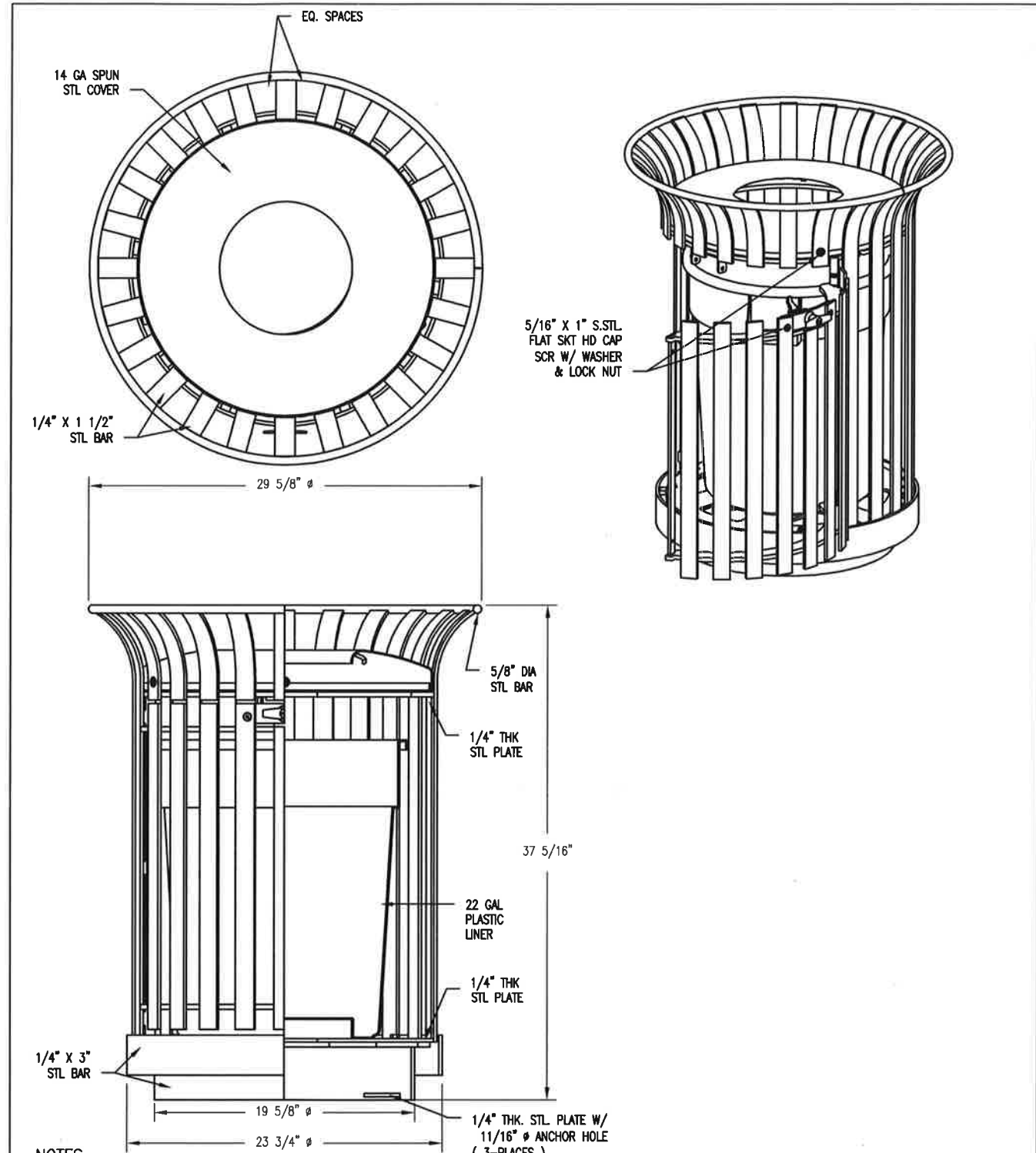

NOTES:

- 1.) ALL STL. MEMBERS COATED W/ ZINC RICH EPOXY THEN FINISHED W/ POLYESTER POWDER COATING.
- 2.) 1/2" X 3 3/4" EXPANSION ANCHOR BOLTS PROVIDED.
- 3.) LATCH PROVIDED W/ KEY, USE OF KEY OPTIONAL.

DuMor, inc.
P.O. Box 142 Mifflintown, PA 17059-0142

SCALE : NONE	TITLE : RECEPTACLE		
DATE DRAWN : 1/11/13			
DRAWN BY : JSB	REV. A	DRAWING NUMBER 157-22-FT0	SHEET 1 OF 2
DATE REV. :			
REV. BY :			

AIA® Document B101® – 2017

Standard Form of Agreement Between Owner and Architect

AGREEMENT made as of the Twelfth (12th) day of July in the year Two Thousand Twenty Three (2023)

(In words, indicate day, month and year.)

BETWEEN the Architect's client identified as the Owner:
(Name, legal status, address and other information)

Murfreesboro City Schools
2552 South Church Street
Murfreesboro, Tennessee 37127

and the Architect:
(Name, legal status, address and other information)

Johnson + Bailey Architects P.C.
100 Est Vine Street
City Center, Suite 700
Murfreesboro, Tennessee 37130

for the following Project:
(Name, location and detailed description)

Playground Replacement at
Mitchell Neilson Elementary School
Murfreesboro, Tennessee
J+B No. 2222

The Owner and Architect agree as follows.

ADDITIONS AND DELETIONS:

The author of this document has added information needed for its completion. The author may also have revised the text of the original AIA standard form. An *Additions and Deletions Report* that notes added information as well as revisions to the standard form text is available from the author and should be reviewed. A vertical line in the left margin of this document indicates where the author has added necessary information and where the author has added to or deleted from the original AIA text.

This document has important legal consequences. Consultation with an attorney is encouraged with respect to its completion or modification.

Init.

AIA Document B101 – 2017. Copyright © 1974, 1978, 1987, 1997, 2007 and 2017. All rights reserved. "The American Institute of Architects," "American Institute of Architects," "AIA," the AIA Logo, and "AIA Contract Documents" are registered trademarks of The American Institute of Architects. This document was produced at 17:27:46 ET on 04/24/2023 under Order No.2114381871 which expires on 11/09/2023, is not for resale, is licensed for one-time use only, and may only be used in accordance with the AIA Contract Documents® Terms of Service. To report copyright violations, e-mail docinfo@aiacontracts.com.

User Notes:

(1632130644)

TABLE OF ARTICLES

1	INITIAL INFORMATION
2	ARCHITECT'S RESPONSIBILITIES
3	SCOPE OF ARCHITECT'S BASIC SERVICES
4	SUPPLEMENTAL AND ADDITIONAL SERVICES
5	OWNER'S RESPONSIBILITIES
6	COST OF THE WORK
7	COPYRIGHTS AND LICENSES
8	CLAIMS AND DISPUTES
9	TERMINATION OR SUSPENSION
10	MISCELLANEOUS PROVISIONS
11	COMPENSATION
12	SPECIAL TERMS AND CONDITIONS
13	SCOPE OF THE AGREEMENT

ARTICLE 1 INITIAL INFORMATION

§ 1.1 This Agreement is based on the Initial Information set forth in this Section 1.1.

(For each item in this section, insert the information or a statement such as "not applicable" or "unknown at time of execution.")

§ 1.1.1 The Owner's program for the Project:

(Insert the Owner's program, identify documentation that establishes the Owner's program, or state the manner in which the program will be developed.)

See attached Johnson + Bailey Architects P.C. letter dated April 12, 2023.

§ 1.1.2 The Project's physical characteristics:

(Identify or describe pertinent information about the Project's physical characteristics, such as size; location; dimensions; geotechnical reports; site boundaries; topographic surveys; traffic and utility studies; availability of public and private utilities and services; legal description of the site, etc.)

§ 1.1.3 The Owner's budget for the Cost of the Work, as defined in Section 6.1:

(Provide total and, if known, a line item breakdown.)

Four Hundred Thousand Dollars (\$400,000.00).

§ 1.1.4 The Owner's anticipated design and construction milestone dates:

.1 Design phase milestone dates, if any:

To be determined

.2 Construction commencement date:

To be determined

.3 Substantial Completion date or dates:

To be determined

(Paragraph deleted)

(Paragraphs deleted)

§ 1.1.11 The Architect shall retain the consultants identified in Sections 1.1.11.1 and 1.1.11.2:
(List name, legal status, address, and other contact information.)

§ 1.1.11.1 Consultants retained under Basic Services:

(Paragraphs deleted)

§ 1.1.11.2 Consultants retained under Supplemental Services:

Site Survey prepared by Energy Land & Infrastructure dated February 23, 2023

§ 1.1.12 Other Initial Information on which the Agreement is based:

None

§ 1.2 The Owner and Architect may rely on the Initial Information. Both parties, however, recognize that the Initial Information may materially change and, in that event, the Owner and the Architect shall appropriately adjust the Architect's services, schedule for the Architect's services, and the Architect's compensation. The Owner shall adjust the Owner's budget for the Cost of the Work and the Owner's anticipated design and construction milestones, as necessary, to accommodate material changes in the Initial Information.

§ 1.3 The parties shall agree upon protocols governing the transmission and use of Instruments of Service or any other information or documentation in digital form. The parties will use AIA Document E203™-2013, Building Information Modeling and Digital Data Exhibit, to establish the protocols for the development, use, transmission, and exchange of digital data.

(Paragraph deleted)

ARTICLE 2 ARCHITECT'S RESPONSIBILITIES

§ 2.1 The Architect shall provide professional services as set forth in this Agreement. The Architect represents that it is properly licensed in the jurisdiction where the Project is located to provide the services required by this Agreement, or shall cause such services to be performed by appropriately licensed design professionals.

§ 2.2 The Architect shall perform its services consistent with the professional skill and care ordinarily provided by architects practicing in the same or similar locality under the same or similar circumstances. The Architect shall perform its services as expeditiously as is consistent with such professional skill and care and the orderly progress of the Project.

§ 2.3 The Architect shall identify a representative authorized to act on behalf of the Architect with respect to the Project.

§ 2.4 Except with the Owner's knowledge and consent, the Architect shall not engage in any activity, or accept any employment, interest or contribution that would reasonably appear to compromise the Architect's professional judgment with respect to this Project.

§ 2.5 The Architect shall maintain the following insurance until termination of this Agreement. If any of the requirements set forth below are in addition to the types and limits the Architect normally maintains, the Owner shall pay the Architect as set forth in Section 11.9. Architect shall not cancel or modify any insurance coverage required by this Agreement without at least 30-days' prior written notice to Owner.

§ 2.5.1 Commercial General Liability with policy limits of not less than One Million Dollars (\$ 1,000,000.00) for each occurrence and One Million Dollars (\$ 1,000,000.00) in the aggregate for bodily injury and property damage.

§ 2.5.2 Automobile Liability covering vehicles owned, and non-owned vehicles used, by the Architect with policy limits of not less than One Million Dollars (\$ 1,000,000.00) per accident for bodily injury, death of any person, and property damage arising out of the ownership, maintenance and use of those motor vehicles, along with any other statutorily required automobile coverage.

§ 2.5.3 The Architect may achieve the required limits and coverage for Commercial General Liability and Automobile Liability through a combination of primary and excess or umbrella liability insurance, provided such primary and excess or umbrella liability insurance policies result in the same or greater coverage as the coverages required under Sections 2.5.1 and 2.5.2, and in no event shall any excess or umbrella liability insurance provide narrower coverage than the primary policy. The excess policy shall not require the exhaustion of the underlying limits only through the actual payment by the underlying insurers.

§ 2.5.4 Workers' Compensation at statutory limits.

§ 2.5.5 Employers' Liability with policy limits not less than One Hundred Thousand Dollars (\$ 100,000.00) each accident, One Hundred Thousand Dollars (\$ 100,000.00) each employee, and One Hundred Thousand Dollars (\$ 100,000.00) policy limit.

§ 2.5.6 Professional Liability covering negligent acts, errors and omissions in the performance of professional services with policy limits of not less than One Million Dollars (\$ 1,000,000.00) per claim and One Million Dollars (\$ 1,000,000.00) in the aggregate.

§ 2.5.7 **Additional Insured Obligations.** To the fullest extent permitted by law, the Architect shall cause the primary and excess or umbrella policies for Commercial General Liability and Automobile Liability to include the Owner as an additional insured for claims caused in whole or in part by the Architect's negligent acts or omissions. The additional insured coverage shall be primary and non-contributory to any of the Owner's insurance policies and shall apply to both ongoing and completed operations

§ 2.5.8 The Architect shall provide certificates of insurance to the Owner that evidence compliance with the requirements in this Section 2.5.

2.5.9 Indemnification Architect agrees to indemnify, save and hold harmless the Owner, its officials, officers, and employees, from claims including all costs, expenses and reasonable attorney's fees, to the extent losses and damages are caused by Architect's negligent acts, errors or omissions in performing professional services under this Agreement, except for claims arising out of the negligence of the Owner.

2.6 The Architect shall review laws, codes and regulations applicable to the Architect's services. The Architect shall exercise due professional care in endeavoring to comply with requirements imposed by governmental authorities having jurisdiction over the Project including, but not limited to, applicable ADA standards. Architect shall use the standard care utilized by other architects in designing projects under the applicable standards, in identifying requirements imposed by governmental authorities, and shall identify to the Owner requirements that may be interpreted in different ways of which conflict with other requirements.

2.7 Pursuant to T.C.A. & 49-5-413, Architect and any subcontractors must agree to a background check, which requires a criminal history records check conducted by the TBI and FBI, for each employee prior to permitting the employee to enter school grounds when students are present.

2.8 Pursuant to Murfreesboro City Schools Board Policy 1.803 and State law, the use of tobacco and tobacco products, including smokeless tobacco, is prohibited on all of Murfreesboro City Schools' property. The Architect and all employees and/or subcontractors of Architect must abide by this policy.

ARTICLE 3 SCOPE OF ARCHITECT'S BASIC SERVICES

§ 3.1 The Architect's Basic Services consist of those described in this Article 3 and include usual and customary structural, mechanical, and electrical engineering services. Services not set forth in this Article 3 are Supplemental or Additional Services.

§ 3.1.1 The Architect shall manage the Architect's services, research applicable design criteria, attend Project meetings, communicate with members of the Project team, and report progress to the Owner.

§ 3.1.2 The Architect shall coordinate its services with those services provided by the Owner and the Owner's consultants. The Architect shall be entitled to rely on, and shall not be responsible for, the accuracy, completeness, and timeliness of, services and information furnished by the Owner and the Owner's consultants. The Architect shall review the services and information for completeness and sufficiency and provide timely written notice to the Owner if the Architect becomes aware of any error, omission, or inconsistency in such services or information.

§ 3.1.3 As soon as practicable after the date of this Agreement, the Architect shall submit for the Owner's approval a schedule for the performance of the Architect's services. The schedule initially shall include anticipated dates for the commencement of construction and for Substantial Completion of the Work as set forth in the Initial Information. The schedule shall include allowances for periods of time required for the Owner's review, for the performance of the Owner's consultants, and for approval of submissions by authorities having jurisdiction over the Project. Once approved by the Owner, time limits established by the schedule shall not, except for reasonable cause, be exceeded by the Architect or Owner. With the Owner's approval, the Architect shall adjust the schedule, if necessary, as the Project proceeds until the commencement of construction.

§ 3.1.4 The Architect shall not be responsible for an Owner's directive or substitution, or for the Owner's acceptance of non-conforming Work, made or given without the Architect's written approval.

§ 3.1.5 The Architect shall contact governmental authorities required to approve the Construction Documents and entities providing utility services to the Project. The Architect shall respond to applicable design requirements imposed by those authorities and entities.

§ 3.1.6 The Architect shall assist the Owner in connection with the Owner's responsibility for filing documents required for the approval of governmental authorities having jurisdiction over the Project.

3.1.7 The Architect shall assist the Owner in determining allowable construction time and amount of liquidated damages.

3.1.8 In accordance with the standard of care, the Architect is responsible for the coordination of all drawings and design documents relating to Architect's design used on the Project, regardless of whether such drawings and documents are prepared or provided by Architect, by Architect's consultants. Architect is responsible for coordination and internal checking of all drawings and for the accuracy of all dimensional and layout information contained therein, as fully as if each drawing were prepared by Architect. Architect is responsible for the completeness and accuracy of all drawings and specifications submitted by or through Architect and for their compliance with all applicable codes, ordinances, regulations, laws and statutes.

§ 3.2 Schematic Design Phase Services

§ 3.2.1 The Architect shall review the program and other information furnished by the Owner, and shall review laws, codes, and regulations applicable to the Architect's services.

§ 3.2.2 The Architect shall prepare a preliminary evaluation of the Owner's program, schedule, budget for the Cost of the Work, Project site, the proposed procurement and delivery method, and other Initial Information, each in terms of the other, to ascertain the requirements of the Project. The Architect shall review such information to ascertain that it is

consistent with the requirements of the Project and shall notify the Owner of (1) any inconsistencies discovered in the information, and (2) other information or consulting services that may be reasonably needed for the Project.

§ 3.2.3 The Architect shall present its preliminary evaluation to the Owner and shall discuss with the Owner alternative approaches to design and construction of the Project. The Architect shall reach an understanding with the Owner regarding the requirements of the Project.

§ 3.2.4 Based on the Project requirements agreed upon with the Owner, the Architect shall prepare and present, for the Owner's approval, a preliminary design illustrating the scale and relationship of the Project components.

§ 3.2.5 Based on the Owner's approval of the preliminary design, the Architect shall prepare Schematic Design Documents for the Owner's approval. The Schematic Design Documents shall consist of drawings and other documents including a site plan, if appropriate, and preliminary building plans, sections and elevations; and may include some combination of study models, perspective sketches, or digital representations. Preliminary selections of major building systems and construction materials shall be noted on the drawings or described in writing.

§ 3.2.5.1 The Architect shall consider sustainable design alternatives, such as material choices and building orientation, together with other considerations based on program and aesthetics, in developing a design that is consistent with the Owner's program, schedule and budget for the Cost of the Work. The Owner may obtain more advanced sustainable design services as a Supplemental Service under Section 4.1.1.

§ 3.2.5.2 The Architect shall consider the value of alternative materials, building systems and equipment, together with other considerations based on program and aesthetics, in developing a design for the Project that is consistent with the Owner's program, schedule, and budget for the Cost of the Work.

§ 3.2.6 The Architect shall submit to the Owner an estimate of the Cost of the Work prepared in accordance with Section 6.3.

§ 3.2.7 The Architect shall submit the Schematic Design Documents to the Owner, and request the Owner's approval thereof. Owner's approval of the documents must be in writing to be binding against either party.

§ 3.3 Design Development Phase Services

§ 3.3.1 Based on the Owner's approval of the Schematic Design Documents, and on the Owner's authorization of any adjustments in the Project requirements and the budget for the Cost of the Work, the Architect shall prepare Design Development Documents for the Owner's approval. The Design Development Documents shall illustrate and describe the development of the approved Schematic Design Documents and shall consist of drawings and other documents including plans, sections, elevations, typical construction details, and diagrammatic layouts of building systems to fix and describe the size and character of the Project as to architectural, structural, mechanical and electrical systems, and other appropriate elements. The Design Development Documents shall also include outline specifications that identify major materials and systems and establish, in general, their quality levels.

§ 3.3.2 The Architect shall update the estimate of the Cost of the Work prepared in accordance with Section 6.3.

§ 3.3.3 The Architect shall submit the Design Development Documents to the Owner, advise the Owner of any adjustments to the estimate of the Cost of the Work, and request the Owner's approval of the documents and any adjustments must be in writing to be binding against either party.

§ 3.4 Construction Documents Phase Services

§ 3.4.1 Based on the Owner's approval of the Design Development Documents, and on the Owner's authorization of any adjustments in the Project requirements and the budget for the Cost of the Work, the Architect shall prepare Construction Documents for the Owner's approval. The Construction Documents shall illustrate and describe the further development of the approved Design Development Documents and shall consist of Drawings and Specifications setting forth in detail the quality levels and performance criteria of materials and systems and other requirements for the construction of the Work. The Owner and Architect acknowledge that, in order to perform the Work, the Contractor will provide additional information, including Shop Drawings, Product Data, Samples and other similar submittals, which the Architect shall review in accordance with Section 3.6.4.

§ 3.4.2 The Architect shall incorporate the design requirements of governmental authorities having jurisdiction over the Project into the Construction Documents.

§ 3.4.3 During the development of the Construction Documents, the Architect shall assist the Owner in the development and preparation of (1) procurement information that describes the time, place, and conditions of bidding, including bidding or proposal forms; (2) the form of agreement between the Owner and Contractor; and (3) the Conditions of the Contract for Construction (General, Supplementary and other Conditions). The Architect shall also compile a project manual that includes the Conditions of the Contract for Construction and Specifications, and may include bidding requirements and sample forms.

§ 3.4.4 The Architect shall update the estimate for the Cost of the Work prepared in accordance with Section 6.3.

§ 3.4.5 The Architect shall submit the Construction Documents to the Owner, advise the Owner of any adjustments to the estimate of the Cost of the Work, inform the Owner of any tests, studies, analyses, or reports that are necessary or advisable to be performed by or for the Owner at that point of time, and take any action required under Section 6.5, and request the Owner's written approval. Owner's approval of the documents and any adjustments or actions suggested by the Architect must be in writing to be binding against either party. The Architect will also ascertain that all elements of the construction documents specific to the Owner's requirements, including modifications to the General Conditions, are correctly contained within the construction documents prior to bidding.

§ 3.5 Procurement Phase Services

§ 3.5.1 General

The Architect shall assist the Owner in establishing a list of prospective contractors. Following the Owner's approval of the Construction Documents, the Architect shall assist the Owner in (1) obtaining either competitive bids or negotiated proposals; (2) confirming responsiveness of bids or proposals; (3) determining the successful bid or proposal, if any; and, (4) awarding and preparing contracts for construction.

§ 3.5.2 Competitive Bidding

§ 3.5.2.1 Bidding Documents shall consist of bidding requirements and proposed Contract Documents.

§ 3.5.2.2 The Architect shall assist the Owner in bidding the Project by:

- .1 facilitating the distribution of Bidding Documents to prospective bidders;
- .2 organizing and conducting a pre-bid conference for prospective bidders;
- .3 preparing responses to questions from prospective bidders and providing clarifications and interpretations of the Bidding Documents to the prospective bidders in the form of addenda; and,
- .4 organizing and conducting the opening of the bids, and subsequently documenting and distributing the bidding results, as directed by the Owner.

§ 3.5.2.3 If the Bidding Documents permit substitutions, upon the Owner's written authorization, the Architect shall, as an Additional Service, consider requests for substitutions and prepare and distribute addenda identifying approved substitutions to all prospective bidders.

§ 3.5.3 Negotiated Proposals

§ 3.5.3.1 Proposal Documents shall consist of proposal requirements and proposed Contract Documents.

§ 3.5.3.2 The Architect shall assist the Owner in obtaining proposals by:

- .1 facilitating the distribution of Proposal Documents for distribution to prospective contractors and requesting their return upon completion of the negotiation process;
- .2 organizing and participating in selection interviews with prospective contractors;
- .3 preparing responses to questions from prospective contractors and providing clarifications and interpretations of the Proposal Documents to the prospective contractors in the form of addenda; and,
- .4 participating in negotiations with prospective contractors, and subsequently preparing a summary report of the negotiation results, as directed by the Owner.

§ 3.5.3.3 If the Proposal Documents permit substitutions, upon the Owner's written authorization, the Architect shall, as an Additional Service, consider requests for substitutions and prepare and distribute addenda identifying approved substitutions to all prospective contractors.

§ 3.6 Construction Phase Services

§ 3.6.1 General

§ 3.6.1.1 The Architect shall provide administration of the Contract between the Owner and the Contractor as set forth below and in AIA Document A201™-2017, General Conditions of the Contract for Construction. If the Owner and Contractor modify AIA Document A201-2017, those modifications shall not affect the Architect's services under this Agreement unless the Owner and the Architect amend this Agreement.

§ 3.6.1.2 The Architect shall advise and consult with the Owner during the Construction Phase Services. The Architect shall have authority to act on behalf of the Owner only to the extent provided in this Agreement. The Architect shall not have control over, charge of, or responsibility for the construction means, methods, techniques, sequences or procedures, or for safety precautions and programs in connection with the Work, nor shall the Architect be responsible for the Contractor's failure to perform the Work in accordance with the requirements of the Contract Documents. The Architect shall be responsible for the Architect's negligent acts or omissions, but shall not have control over or charge of, and shall not be responsible for, acts or omissions of the Contractor or of any other persons or entities performing portions of the Work.

§ 3.6.1.3 Subject to Section 4.2 and except as provided in Section 3.6.6.5, the Architect's responsibility to provide Construction Phase Services commences with the award of the Contract for Construction and terminates on the date the Architect issues the final Certificate for Payment.

3.6.1.4 The Architect shall be responsible for conducting progress meetings not less than monthly or as needed and for the preparation, distribution, and accuracy of minutes pertaining thereto to all parties as directed by the Owner.

§ 3.6.2 Evaluations of the Work

§ 3.6.2.1 The Architect shall visit the site at intervals appropriate to the stage of construction, or as otherwise required in Section 4.3.3, to become generally familiar with the progress and quality of the portion of the Work completed, and to determine, in general, if the Work observed is being performed in a manner indicating that the Work, when fully completed, will be in accordance with the Contract Documents. However, the Architect shall not be required to make exhaustive or continuous on-site inspections to check the quality or quantity of the Work. On the basis of the site visits, the Architect shall keep the Owner reasonably informed about the progress and quality of the portion of the Work completed, and promptly report to the Owner (1) known deviations from the Contract Documents, (2) known deviations from the most recent construction schedule submitted by the Contractor, and (3) defects and deficiencies observed in the Work.

§ 3.6.2.2 The Architect and Owner shall have the authority to reject Work that does not conform to the Contract Documents. Whenever the Architect considers it necessary or advisable, the Architect shall have the authority to require inspection or testing of the Work in accordance with the provisions of the Contract Documents, whether or not the Work is fabricated, installed or completed. However, neither this authority of the Architect nor a decision made in good faith either to exercise or not to exercise such authority shall give rise to a duty or responsibility of the Architect to the Contractor, Subcontractors, suppliers, their agents or employees, or other persons or entities performing portions of the Work.

§ 3.6.2.3 The Architect shall interpret and decide matters concerning performance under, and requirements of, the Contract Documents on written request of either the Owner or Contractor. The Architect's response to such requests shall be made in writing within any time limits agreed upon timely so as not to affect the Contract Time or the Contract Sum.

§ 3.6.2.4 Interpretations and decisions of the Architect shall be consistent with the intent of, and reasonably inferable from, the Contract Documents. The Architect shall render initial decisions on claims, disputes or other matters in question between the Owner and Contractor as provided in the Contract Documents; provided however, the Owner, with advise and assistance from the Architect, shall make final decisions on matters relating to aesthetic effect, Contract Sum and Contract Time..

AIA Document B101 – 2017. Copyright © 1974, 1978, 1987, 1997, 2007 and 2017. All rights reserved. "The American Institute of Architects," "American Institute of Architects," "AIA," the AIA Logo, and "AIA Contract Documents" are registered trademarks of The American Institute of Architects. This document was produced at 17:27:46 ET on 04/24/2023 under Order No.2114381871 which expires on 11/09/2023, is not for resale, is licensed for one-time use only, and may only be used in accordance with the AIA Contract Documents® Terms of Service. To report copyright violations, e-mail docinfo@aiacontracts.com.

User Notes:

(1632130644)

§ 3.6.2.5 Unless the Owner and Contractor designate another person to serve as an Initial Decision Maker, as that term is defined in AIA Document A201–2017, the Architect shall render initial decisions on Claims between the Owner and Contractor as provided in the Contract Documents.

§ 3.6.3 Certificates for Payment to Contractor

§ 3.6.3.1 The Architect shall review and certify the amounts due the Contractor and shall issue certificates in such amounts. The Architect's certification for payment shall constitute a representation to the Owner, based on the Architect's evaluation of the Work as provided in Section 3.6.2 and on the data comprising the Contractor's Application for Payment, that, to the best of the Architect's knowledge, information and belief, the Work has progressed to the point indicated, the quality of the Work is in accordance with the Contract Documents, and that the Contractor is entitled to payment in the amount certified. The foregoing representations are subject to (1) an evaluation of the Work for conformance with the Contract Documents upon Substantial Completion, (2) results of subsequent tests and inspections, (3) correction of minor deviations from the Contract Documents prior to completion, and (4) specific qualifications expressed by the Architect.

§ 3.6.3.2 The issuance of a Certificate for Payment shall not be a representation that the Architect has (1) made exhaustive or continuous on-site inspections to check the quality or quantity of the Work, (2) reviewed construction means, methods, techniques, sequences or procedures, (3) reviewed copies of requisitions received from Subcontractors and suppliers and other data requested by the Owner to substantiate the Contractor's right to payment, or (4) ascertained how or for what purpose the Contractor has used money previously paid on account of the Contract Sum.

§ 3.6.3.3 The Architect shall maintain a record of the Applications and Certificates for Payment.

§ 3.6.4 Submittals

§ 3.6.4.1 The Architect shall review the Contractor's submittal schedule and shall not unreasonably delay or withhold approval. The Architect's action in reviewing submittals shall be taken in accordance with the approved submittal schedule or, in the absence of an approved submittal schedule, timely so as not to affect the Contract Time or Contract Sum..

§ 3.6.4.2 The Architect shall review and approve, or take other appropriate action upon, the Contractor's submittals such as Shop Drawings, Product Data and Samples, but only for the limited purpose of checking for conformance with information given and the design concept expressed in the Contract Documents. Review of such submittals is not for the purpose of determining the accuracy and completeness of other information such as dimensions, quantities, and installation or performance of equipment or systems, which are the Contractor's responsibility. The Architect's review shall not constitute approval of safety precautions or construction means, methods, techniques, sequences or procedures. The Architect's approval of a specific item shall not indicate approval of an assembly of which the item is a component.

§ 3.6.4.3 If the Contract Documents specifically require the Contractor to provide professional design services or certifications by a design professional related to systems, materials, or equipment, the Architect shall specify the appropriate performance and design criteria that such services must satisfy. The Architect shall review and take appropriate action on Shop Drawings and other submittals related to the Work designed or certified by the Contractor's design professional, provided the submittals bear such professional's seal and signature when submitted to the Architect. The Architect's review shall be for the limited purpose of checking for conformance with information given and the design concept expressed in the Contract Documents. The Architect shall be entitled to rely upon, and shall not be responsible for, the adequacy and accuracy of the services, certifications, and approvals performed or provided by such design professionals.

§ 3.6.4.4 Subject to Section 4.2, the Architect shall review and respond to requests for information about the Contract Documents. The Architect shall set forth, in the Contract Documents, the requirements for requests for information. Requests for information shall include, at a minimum, a detailed written statement that indicates the specific Drawings or Specifications in need of clarification and the nature of the clarification requested. The Architect's response to such requests shall be made in writing within any time limits agreed upon, or otherwise with reasonable promptness. If

Init.

appropriate, the Architect shall prepare and issue supplemental Drawings and Specifications in response to the requests for information.

§ 3.6.4.5 The Architect shall maintain a record of submittals and copies of submittals supplied by the Contractor in accordance with the requirements of the Contract Documents.

§ 3.6.5 Changes in the Work

§ 3.6.5.1 The Architect may authorize minor changes in the Work that are consistent with the intent of the Contract Documents and do not involve an adjustment in the Contract Sum or an extension of the Contract Time. Subject to the provisions of Section 4.3, the Architect shall prepare Change Orders and Construction Change Directives for the Owner's approval and execution in accordance with the Contract Documents. The Architect shall timely report to Owner, in writing, those minor changes in the Work authorized by Architect pursuant to this section. If the Architect and the Owner determine that the implementation of the requested change would result in a material change to the Contract that may cause an adjustment in the Contract Time or Contract Sum, the Architect shall make a recommendation to the Owner who may authorize further investigation of such change.

§ 3.6.5.2 The Architect shall maintain records relative to changes in the Work. Additionally, the Architect shall review and, upon request by Owner, provide written documentation of the same of all change order requests and proposals with respect to the following criteria:

1. confirm proposed change is a material change to the Contract;
2. confirm appropriate credits are included for Work not completed;
3. verify that the proposed additional cost or credit is reasonable with respect to industry standards. Cost verifications may, as authorized by Owner, include independent estimates and/or consultations with contractors and vendors; and
4. confirm that the appropriate back up documentation is included and mathematically correct including markups and taxes pursuant to the requirements of the Contract Documents.

§ 3.6.6 Project Completion

§ 3.6.6.1 The Architect shall:

- .1 conduct inspections to determine the date or dates of Substantial Completion and the date of final completion;
- .2 issue Certificates of Substantial Completion;
- .3 forward to the Owner, for the Owner's review and records, written warranties and related documents required by the Contract Documents and received from the Contractor; and,
- .4 issue a final Certificate for Payment based upon a final inspection indicating that, to the best of the Architect's knowledge, information, and belief, the Work complies with the requirements of the Contract Documents.

§ 3.6.6.2 The Architect's inspections shall be conducted with the Owner to check conformance of the Work with the requirements of the Contract Documents and to verify the accuracy and completeness of the list submitted by the Contractor of Work to be completed or corrected.

§ 3.6.6.3 When Substantial Completion has been achieved, the Architect shall inform the Owner about the balance of the Contract Sum remaining to be paid the Contractor, including the amount to be retained from the Contract Sum, if any, for final completion or correction of the Work.

§ 3.6.6.4 The Architect shall review, approve and forward to the Owner the following information received from the Contractor: (1) consent of surety or sureties, if any, to reduction in or partial release of retainage or the making of final payment; (2) affidavits, receipts, releases and waivers of liens, or bonds indemnifying the Owner against liens; and (3) any other documentation required of the Contractor under the Contract Documents.

§ 3.6.6.5 Upon request of the Owner, and prior to the expiration of one year from the date of Substantial Completion, the Architect shall, without additional compensation, conduct a meeting with the Owner and the Contractor, to review the facility operations and performance.

Init.

ARTICLE 4 SUPPLEMENTAL AND ADDITIONAL SERVICES

§ 4.1 Supplemental Services

§ 4.1.1 The services listed below are not included in Basic Services but may be required for the Project. The Architect shall provide the listed Supplemental Services only if specifically designated in the table below as the Architect’s responsibility, and the Owner shall compensate the Architect as provided in Section 11.2. Unless otherwise specifically addressed in this Agreement, if neither the Owner nor the Architect is designated, the parties agree that the listed Supplemental Service is not being provided for the Project.

(Designate the Architect’s Supplemental Services and the Owner’s Supplemental Services required for the Project by indicating whether the Architect or Owner shall be responsible for providing the identified Supplemental Service. Insert a description of the Supplemental Services in Section 4.1.2 below or attach the description of services as an exhibit to this Agreement.)

Supplemental Services	Responsibility <i>(Architect, Owner, or not provided)</i>
§ 4.1.1.1 Programming	Architect & Owner
§ 4.1.1.2 Multiple preliminary designs	Architect’s Basic Services
§ 4.1.1.3 Measured drawings	Not Provided
§ 4.1.1.4 Existing facilities surveys	Not Provided
§ 4.1.1.5 Site evaluation and planning	Not Provided
§ 4.1.1.6 Building Information Model management responsibilities	Not Provided
§ 4.1.1.7 Development of Building Information Models for post construction use	Not Provided
§ 4.1.1.8 Civil engineering	Not Provided
§ 4.1.1.9 Landscape design	Not Provided
§ 4.1.1.10 Architectural interior design	Not Provided
§ 4.1.1.11 Value analysis	Not Provided
§ 4.1.1.12 Detailed cost estimating beyond that required in Section 6.3	Not Provided
§ 4.1.1.13 On-site project representation	Not Provided
§ 4.1.1.14 Conformed documents for construction	Not Provided
§ 4.1.1.15 As-designed record drawings	Not Provided
§ 4.1.1.16 As-constructed record drawings	Not Provided
§ 4.1.1.17 Post-occupancy evaluation	Not Provided
§ 4.1.1.18 Facility support services	Not Provided
§ 4.1.1.19 Tenant-related services	Not Provided
§ 4.1.1.20 Architect’s coordination of the Owner’s consultants	Not Provided
§ 4.1.1.21 Telecommunications/data design	Not Provided
§ 4.1.1.22 Security evaluation and planning	Not Provided
§ 4.1.1.23 Commissioning	Not Provided
§ 4.1.1.24 Sustainable Project Services pursuant to Section 4.1.3	Not Provided
§ 4.1.1.25 Fast-track design services	Not Provided
§ 4.1.1.26 Multiple bid packages	Not Provided
§ 4.1.1.27 Historic preservation	Not Provided
§ 4.1.1.28 Furniture, furnishings, and equipment design	Not Provided
§ 4.1.1.29 Other services provided by specialty Consultants	Not Provided

Init.

AIA Document B101 – 2017. Copyright © 1974, 1978, 1987, 1997, 2007 and 2017. All rights reserved. "The American Institute of Architects," "American Institute of Architects," "AIA," the AIA Logo, and "AIA Contract Documents" are registered trademarks of The American Institute of Architects. This document was produced at 17:27:46 ET on 04/24/2023 under Order No.2114381871 which expires on 11/09/2023, is not for resale, is licensed for one-time use only, and may only be used in accordance with the AIA Contract Documents® Terms of Service. To report copyright violations, e-mail docinfo@aiacontracts.com.

User Notes:

(1632130644)

Supplemental Services	Responsibility <i>(Architect, Owner, or not provided)</i>
§ 4.1.1.30 Other Supplemental Services	Not Provided

§ 4.1.2 Description of Supplemental Services

§ 4.1.2.1 A description of each Supplemental Service identified in Section 4.1.1 as the Architect’s responsibility is provided below.

(Describe in detail the Architect’s Supplemental Services identified in Section 4.1.1 or, if set forth in an exhibit, identify the exhibit. The AIA publishes a number of Standard Form of Architect’s Services documents that can be included as an exhibit to describe the Architect’s Supplemental Services.)

The Architect is to perform all required Programming and Design Services, and to coordinate all work with the Owner’s Consultants.

§ 4.1.2.2 A description of each Supplemental Service identified in Section 4.1.1 as the Owner’s responsibility is provided below.

(Describe in detail the Owner’s Supplemental Services identified in Section 4.1.1 or, if set forth in an exhibit, identify the exhibit.)

§ 4.1.3 If the Owner identified a Sustainable Objective in Article 1, the Architect shall provide, as a Supplemental Service, the Sustainability Services required in AIA Document E204™–2017, Sustainable Projects Exhibit, attached to this Agreement. The Owner shall compensate the Architect as provided in Section 11.2.

§ 4.2 Architect’s Additional Services

The Architect may provide Additional Services after execution of this Agreement without invalidating the Agreement. Except for services required due to the fault of the Architect, any Additional Services provided in accordance with this Section 4.2 shall entitle the Architect to compensation pursuant to Section 11.3 and an appropriate adjustment in the Architect’s schedule.

§ 4.2.1 Upon recognizing the need to perform the following Additional Services, the Architect shall notify the Owner with reasonable promptness and explain the facts and circumstances giving rise to the need. The Architect shall not proceed to provide the following Additional Services until the Architect receives the Owner’s written authorization:

- .1 Services necessitated by a change in the Initial Information, previous instructions or approvals given by the Owner, or a material change in the Project including size, quality, complexity, the Owner’s schedule or budget for Cost of the Work, or procurement or delivery method;
- .2 Services necessitated by the enactment or revision of codes, laws, or regulations, including changing or editing previously prepared Instruments of Service;
- .3 Changing or editing previously prepared Instruments of Service necessitated by official interpretations of applicable codes, laws or regulations that are either (a) contrary to specific interpretations by the applicable authorities having jurisdiction made prior to the issuance of the building permit, or (b) contrary to requirements of the Instruments of Service when those Instruments of Service were prepared in accordance with the applicable standard of care;
- .4 Services necessitated by decisions of the Owner not rendered in a timely manner or any other failure of performance on the part of the Owner or the Owner’s consultants or contractors;
- .5 Preparing digital models or other design documentation for transmission to the Owner’s consultants and contractors, or to other Owner-authorized recipients;

(Paragraphs deleted)

- .8 Preparation for, and attendance at, a dispute resolution proceeding or legal proceeding, except where the Architect is party thereto;
- .10 Consultation concerning replacement of Work resulting from fire or other cause during construction; or,

.11 Assistance to the Initial Decision Maker, if other than the Architect.

§ 4.2.2 To avoid delay in the Construction Phase, the Architect shall provide the following Additional Services, notify the Owner with reasonable promptness, and explain the facts and circumstances giving rise to the need. If, upon receipt of the Architect's notice, the Owner determines that all or parts of the services are not required, the Owner shall give timely written notice to the Architect of the Owner's determination. The Owner shall compensate the Architect for the services provided prior to the Architect's receipt of the Owner's notice.

(Paragraphs deleted)

.5 Evaluating substitutions proposed by the Owner or Contractor and making subsequent revisions to Instruments of Service resulting therefrom.

§ 4.2.3 The Architect shall provide Construction Phase Services exceeding the limits set forth below as Additional Services. When the limits below are reached, the Architect shall notify the Owner:

- .1 One (1) review of each Shop Drawing, Product Data item, sample and similar submittals of the Contractor
- .2 Weekly visits to the site by the Architect during construction
- .3 One (1) inspection for any portion of the Work to determine whether such portion of the Work is substantially complete in accordance with the requirements of the Contract Documents
- .4 One (1) inspection for any portion of the Work to determine final completion.

§ 4.2.4 Except for services required under Section 3.6.6.5 and those services that do not exceed the limits set forth in Section 4.2.3, Construction Phase Services provided more than 60 days after (1) the date of Substantial Completion of the Work or (2) the initial date of Substantial Completion identified in the agreement between the Owner and Contractor, whichever is earlier, shall be compensated as Additional Services to the extent the Architect incurs additional cost in providing those Construction Phase Services.

§ 4.2.5 If the services covered by this Agreement have not been completed within Twelve (12) months of the date of this Agreement, through no fault of the Architect, extension of the Architect's services beyond that time shall be compensated as Additional Services.

ARTICLE 5 OWNER'S RESPONSIBILITIES

§ 5.1 Unless otherwise provided for under this Agreement, the Owner shall provide information in a timely manner regarding requirements for and limitations on the Project, including a written program, which shall set forth the Owner's objectives; schedule; constraints and criteria, including space requirements and relationships; flexibility; expandability; special equipment; systems; and site requirements.

§ 5.2 The Owner, with Architect's assistance, shall establish the Owner's budget for the Project, including (1) the budget for the Cost of the Work as defined in Section 6.1; (2) the Owner's other costs; and, (3) reasonable contingencies related to all of these costs. The Owner shall update the Owner's budget for the Project as necessary throughout the duration of the Project until final completion. If the Owner significantly increases or decreases the Owner's budget for the Cost of the Work, the Owner shall notify the Architect. The Owner and the Architect shall thereafter agree to a corresponding change in the Project's scope and quality.

§ 5.3 The Owner shall identify a representative authorized to act on the Owner's behalf with respect to the Project. The Owner shall render decisions and approve the Architect's submittals in a timely manner in order to avoid unreasonable delay in the orderly and sequential progress of the Architect's services.

5.3.1 The Owner has the right to reject any portion of the Architect's services on the Project, including but not limited to Schematic Design Documents, Design Development Documents, Construction Documents, or the Architect's provision of services during the construction of the Project, or any other design services or documents on any reasonable basis, including, but not limited to aesthetics or because in the Owner's opinion, the construction cost of such design is likely to exceed the budget for Cost of the Services. If at any time, the Architect's services is rejected by the Owner, the Architect must proceed when requested by the Owner, to revise the design services or documents prepared for that phase to the Owner's satisfaction. These revisions shall be made without adjustment to the compensation provided hereunder, unless revisions are made to services previously approved by the Owner under previous phases, in which case such revision services will be paid as a Change in Services. Should there be substantial

revisions to the original program after the approval of the Schematic Design Documents, which changes substantially increase the scope of design services to be furnished hereunder, such revision services will be paid as a Change in Services. The Architect must so notify the Owner of all Changes in Services in writing and receive approval from Owner before proceeding with revisions necessitated by such changes. No payment, of any nature whatsoever, will be made to the Architect for additional services or Changes in Services without such written approval by Owner.

§ 5.4 The Owner shall furnish surveys to describe physical characteristics, legal limitations and utility locations for the site of the Project, and a written legal description of the site. The surveys and legal information shall include, as applicable, grades and lines of streets, alleys, pavements and adjoining property and structures; designated wetlands; adjacent drainage; rights-of-way, restrictions, easements, encroachments, zoning, deed restrictions, boundaries and contours of the site; locations, dimensions, and other necessary data with respect to existing buildings, other improvements and trees; and information concerning available utility services and lines, both public and private, above and below grade, including inverts and depths. All the information on the survey shall be referenced to a Project benchmark.

§ 5.5 To the extent reasonably required for the timely and safe design and construction of the Project, the Owner shall furnish services of geotechnical engineers, which may include test borings, test pits, determinations of soil bearing values, percolation tests, evaluations of hazardous materials, seismic evaluation, ground corrosion tests and resistivity tests, including necessary operations for anticipating subsoil conditions, with written reports and appropriate recommendations. Architect shall assist Owner in obtaining these services.

§ 5.6 The Owner shall provide the Supplemental Services designated as the Owner's responsibility in Section 4.1.1.

§ 5.7 If the Owner identified a Sustainable Objective in Article 1, the Owner shall fulfill its responsibilities as required in AIA Document E204™-2017, Sustainable Projects Exhibit, attached to this Agreement.

§ 5.8 The Owner shall coordinate the services of its own consultants with those services provided by the Architect. Upon the Architect's request, the Owner shall furnish copies of the scope of services in the contracts between the Owner and the Owner's consultants. The Owner shall furnish the services of consultants other than those designated as the responsibility of the Architect in this Agreement, or authorize the Architect to furnish them as an Additional Service, when the Architect requests such services and demonstrates that they are reasonably required by the scope of the Project. The Owner shall require that its consultants and contractors maintain insurance, including professional liability insurance, as appropriate to the services or work provided.

§ 5.9 The Owner shall furnish tests, inspections and reports required by law or the Contract Documents, such as structural, mechanical, and chemical tests, tests for air and water pollution, and tests for hazardous materials.

§ 5.10 The Owner shall furnish all legal, insurance and accounting services, including auditing services, that may be reasonably necessary at any time for the Project to meet the Owner's needs and interests.

§ 5.11 In accordance with the standard of care, the Owner shall be entitled to rely on the accuracy and completeness of services and information provided by the Architect. The Owner shall provide timely written notice to the Architect if the Owner becomes aware of any fault or defect in the Project, including errors, omissions or inconsistencies in the Architect's Instruments of Service.

§ 5.12 The Owner shall include the Architect in all communications with the Contractor that relate to or affect the Architect's services or professional responsibilities. The Owner shall timely notify the Architect of the substance of any direct communications between the Owner and the Contractor otherwise relating to the Project. Communications by and with the Architect's consultants shall be through the Architect.

§ 5.13 Before executing the Contract for Construction, the Owner shall coordinate the Architect's duties and responsibilities set forth in the Contract for Construction with the Architect's services set forth in this Agreement. The Owner shall provide the Architect a copy of the executed agreement between the Owner and Contractor, including the General Conditions of the Contract for Construction.

§ 5.14 The Owner shall provide the Architect access to the Project site prior to commencement of the Work and shall obligate the Contractor to provide the Architect access to the Work wherever it is in preparation or progress.

(Paragraph deleted)

ARTICLE 6 COST OF THE WORK

§ 6.1 For purposes of this Agreement, the Cost of the Work shall be the total cost to the Owner to construct all elements of the Project designed or specified by the Architect and shall include contractors' general conditions costs, overhead and profit. The Cost of the Work also includes the reasonable value of labor, materials, and equipment, donated to, or otherwise furnished by, the Owner. The Cost of the Work does not include the compensation of the Architect; the costs of the land, rights-of-way, financing, or contingencies for changes in the Work; or other costs that are the responsibility of the Owner.

§ 6.2 The Owner's budget for the Cost of the Work is provided in Initial Information, and shall be adjusted throughout the Project as required under Sections 5.2, 6.4 and 6.5. Evaluations of the Owner's budget for the Cost of the Work, and the preliminary estimate of the Cost of the Work and updated estimates of the Cost of the Work, prepared by the Architect, represent the Architect's judgment as a design professional. It is recognized, however, that neither the Architect nor the Owner has control over the cost of labor, materials, or equipment; the Contractor's methods of determining bid prices; or competitive bidding, market, or negotiating conditions. Accordingly, the Architect cannot and does not warrant or represent that bids or negotiated prices will not vary from the Owner's budget for the Cost of the Work, or from any estimate of the Cost of the Work, or evaluation, prepared or agreed to by the Architect.

§ 6.3 In preparing estimates of the Cost of Work, the Architect, in consultation with the Owner, shall be permitted to include contingencies for design, bidding, and price escalation; to determine what materials, equipment, component systems, and types of construction are to be included in the Contract Documents; to recommend reasonable adjustments in the program and scope of the Project; and to include design alternates as may be necessary to adjust the estimated Cost of the Work to meet the Owner's budget. The Architect's estimate of the Cost of the Work shall be based on current area, volume or similar conceptual estimating techniques. If the Owner requires a detailed estimate of the Cost of the Work, the Architect shall provide such an estimate, if identified as the Architect's responsibility in Section 4.1.1, as a Supplemental Service.

§ 6.4 If, through no fault of the Architect, the Procurement Phase has not commenced within 90 days after the Architect submits the Construction Documents to the Owner, the Owner's budget for the Cost of the Work shall be adjusted to reflect changes in the general level of prices in the applicable construction market.

§ 6.5 If at any time the Architect's estimate of the Cost of the Work exceeds the Owner's budget for the Cost of the Work, the Architect shall make appropriate recommendations to the Owner to adjust the Project's size, quality, or budget for the Cost of the Work, and the Owner shall cooperate with the Architect in making such adjustments.

§ 6.6 If the Owner's budget for the Cost of the Work at the conclusion of the Construction Documents Phase Services is exceeded by the lowest bona fide bid or negotiated proposal, the Owner shall

- .1 undertake a good faith effort to obtain necessary and timely approval of Council for an increase in the budget for the cost of the Work, as may be necessary, and then if approval is timely obtained, give written approval of an increase in the budget for the Cost of the Work;
- .2 authorize rebidding or renegotiating of the Project within a reasonable time;
- .3 terminate in accordance with Section 9.5;
- .4 in consultation with the Architect, revise the Project program, scope, or quality as required to reduce the Cost of the Work; or,
- .5 implement any other mutually acceptable alternative.

§ 6.7 If the Owner chooses to proceed under Section 6.6.2, the Architect, without additional compensation, shall assist the Owner in rebidding, or renegotiating the Project within a reasonable time. If the Owner chooses to proceed under Section 6.6.4, the Architect, without additional compensation, shall modify the documents which the Architect is responsible for preparing under this Agreement as necessary to comply with the Owner's budget for the Cost of the Work, and shall assist the Owner in rebidding or renegotiating the Project within a reasonable time. The modification

Init.

of such documents and the rebidding or renegotiating of the Project shall be the limit of the Architect's responsibility under Section 6.6.

ARTICLE 7 COPYRIGHTS AND LICENSES

§ 7.1 The Architect and the Owner warrant that in transmitting Instruments of Service, or any other information, the transmitting party is the copyright owner of such information or has permission from the copyright owner to transmit such information for its use on the Project.

§ 7.2 The Architect and the Architect's consultants shall be deemed the authors and owners of their respective Instruments of Service, including the Drawings and Specifications, and shall retain all common law, statutory and other reserved rights, including copyrights. Submission or distribution of Instruments of Service to meet official regulatory requirements or for similar purposes in connection with the Project is not to be construed as publication in derogation of the reserved rights of the Architect and the Architect's consultants.

§ 7.3 Upon execution of this Agreement, the Architect grants to the Owner a nonexclusive irrevocable, royalty-free, right and license to use the Architect's Instruments of Service for purposes of constructing, using, maintaining, altering and adding to the Project, provided that the Owner substantially performs its obligations, including timely payment of all sums when due, under this Agreement. The Architect shall obtain similar nonexclusive licenses from the Architect's consultants consistent with this Agreement. The license granted under this section permits the Owner to authorize the Contractor, Subcontractors, Sub-subcontractors, and material or equipment suppliers, as well as the Owner's consultants and separate contractors, to reproduce applicable portions of the Instruments of Service solely and exclusively for use in performing services or construction for the Project. Upon completion of the Project, or upon termination of this Agreement for any reason prior to the completion of the Project, Owner shall be entitled to retain copies of all Instruments of Service and shall have an irrevocable, royalty-free, right and license to use all of the Instruments of Service for any and all purposes related to the Project in any manner the Owner deems fit, including Electronics Filing and Archiving for the purpose of record keeping at Owner designated areas; any future renovations, addition, or alteration to the Project; and any future maintenance or operations issue as it pertains to the Project. Architect or Architect's Consultants shall not be responsible for any modifications to the Work made by the Owner or Owner's representatives using the Architect's Instruments of Service.

§ 7.3.1 In the event the Owner uses the Instruments of Service without retaining the author of the Instruments of Service, the Owner releases the Architect from liability for claims and causes of action arising from such use.

§ 7.4 Except for the licenses granted in this Article 7, no other license or right shall be deemed granted or implied under this Agreement. The Owner shall not assign, delegate, sublicense, pledge or otherwise transfer any license granted herein to another party without the prior written agreement of the Architect. Any unauthorized use of the Instruments of Service shall be at the Owner's sole risk and without liability to the Architect and the Architect's consultants.

§ 7.5 Except as otherwise stated in Section 7.3, the provisions of this Article 7 shall survive the termination of this Agreement.

ARTICLE 8 CLAIMS AND DISPUTES

§ 8.1 General

§ 8.1.1 The Owner and Architect shall commence all claims and causes of action against the other and arising out of or related to this Agreement, whether in contract, tort, or otherwise, within the period specified by applicable Tennessee law.

§ 8.1.2 To the extent damages are covered by property insurance, the Owner and Architect waive all rights against each other and against the contractors, consultants, agents, and employees of the other for damages, except such rights as they may have to the proceeds of such insurance as set forth in AIA Document A201-2017, General Conditions of the Contract for Construction. The Owner or the Architect, as appropriate, shall require of the contractors, consultants, agents, and employees of any of them, similar waivers in favor of the other parties enumerated herein.

(Paragraph deleted)

§ 8.2 Mediation

§ 8.2.1 Any claim, dispute or other matter in question arising out of or related to this Agreement shall be subject to mediation as a condition precedent to binding dispute resolution. If such matter relates to or is the subject of a lien arising out of the Architect's services, the Architect may proceed in accordance with applicable law to comply with the lien notice or filing deadlines prior to resolution of the matter by mediation or by binding dispute resolution.

§ 8.2.2 The Owner and Architect shall endeavor to resolve claims, disputes and other matters in question between them by mediation, which, unless the parties mutually agree otherwise, shall be administered by the American Arbitration Association in accordance with its Construction Industry Mediation Procedures in effect on the date of this Agreement. A request for mediation shall be made in writing, delivered to the other party to this Agreement, and filed with the person or entity administering the mediation. The request may be made concurrently with the filing of a complaint or other appropriate demand for binding dispute resolution but, in such event, mediation shall proceed in advance of binding dispute resolution proceedings, which shall be stayed pending mediation for a period of 60 days from the date of filing, unless stayed for a longer period by agreement of the parties or court order. If an arbitration proceeding is stayed pursuant to this section, the parties may nonetheless proceed to the selection of the arbitrator(s) and agree upon a schedule for later proceedings.

§ 8.2.3 The parties shall share the mediator's fee and any filing fees equally. The mediation shall be held in the place where the Project is located, unless another location is mutually agreed upon. Agreements reached in mediation shall be enforceable as settlement agreements in any court having jurisdiction thereof.

§ 8.2.4 If the parties do not resolve a dispute through mediation pursuant to this Section 8.2, the method of binding dispute resolution shall be the following:

(Check the appropriate box.)

- Arbitration pursuant to Section 8.3 of this Agreement
- Litigation in a court of competent jurisdiction
- Other: *(Specify)*

(Paragraphs deleted)

ARTICLE 9 TERMINATION OR SUSPENSION

§ 9.1 If the Owner fails to make payments to the Architect in accordance with this Agreement, such failure shall be considered substantial nonperformance and cause for termination or, at the Architect's option, cause for suspension of performance of services under this Agreement. If the Architect elects to suspend services, the Architect shall give seven days' written notice to the Owner before suspending services. In the event of a suspension of services, in accordance herewith, the Architect shall have no liability to the Owner for delay or damage caused the Owner because of such suspension of services. Before resuming services, the Architect shall be paid all sums due prior to suspension and shall negotiate with the Owner any expenses incurred in the interruption of the Architect's services. The Architect's fees for the remaining services and the time schedules shall be equitably adjusted.

§ 9.2 If the Owner suspends the Project for more than 30 consecutive days, the Architect shall be compensated for services performed prior to notice of such suspension. When the Project is resumed, the Owner and the Architect shall negotiate the amount of any compensation the Owner will pay the Architect for expenses incurred in the interruption and resumption of the Architect's services. The Owner and the Architect shall negotiate any adjustments to the Architect's fees for the remaining services and the time schedules for completion.

§ 9.3 If the Owner suspends the Project for more than 90 cumulative days for reasons other than the fault of the Architect, the Architect may terminate this Agreement by giving not less than seven days' written notice.

§ 9.4 Either party may terminate this Agreement upon not less than seven days' written notice should the other party fail substantially to perform in accordance with the terms of this Agreement through no fault of the party initiating the termination.

Init.

§ 9.5 The Owner may terminate this Agreement upon not less than seven days' written notice to the Architect for the Owner's convenience and without cause.

§ 9.6 If the Owner terminates this Agreement for its convenience pursuant to Section 9.5, or the Architect terminates this Agreement pursuant to Section 9.3, the Owner shall compensate the Architect for services performed prior to termination, Reimbursable Expenses incurred, and costs attributable to termination, including the costs attributable to the Architect's termination of consultant agreements.

(Paragraphs deleted)

§ 9.8 Except as otherwise expressly provided herein, this Agreement shall terminate one year from the date of Substantial Completion.

§ 9.9 The Owner's rights to use the Architect's Instruments of Service in the event of a termination of this Agreement are set forth in Article 7 and Section 9.7.

9.10 In the event of any termination under this Article, the Architect consents to the owner's selection of another architect of the Owner's choice to assist the Owner in any way in completing the Project. Architect further agrees to cooperate and provide any information requested by Owner in connection with the completion of the Project and consents to and authorizes the making of any reasonable changes to the design of the Project by Owner and such other architect as Owner may desire. Any services provided by Architect that are requested by Owner after termination will be fairly compensated by Owner in accordance with Article 11.

ARTICLE 10 MISCELLANEOUS PROVISIONS

§ 10.1 This Agreement shall be governed by the law of the place where the Project is located, excluding that jurisdiction's choice of law rules. If the parties have selected arbitration as the method of binding dispute resolution, the Federal Arbitration Act shall govern Section 8.3.

§ 10.2 Terms in this Agreement shall have the same meaning as those in AIA Document A201-2017, General Conditions of the Contract for Construction.

§ 10.3 The Owner and Architect, respectively, bind themselves, their agents, successors, assigns, and legal representatives to this Agreement. Neither the Owner nor the Architect shall assign this Agreement without the written consent of the other, except that the Owner may assign this Agreement to a lender providing financing for the Project if the lender agrees to assume the Owner's rights and obligations under this Agreement, including any payments due to the Architect by the Owner prior to the assignment.

§ 10.4 If the Owner requests the Architect to execute certificates, the proposed language of such certificates shall be submitted to the Architect for review at least 14 days prior to the requested dates of execution. If the Owner requests the Architect to execute consents reasonably required to facilitate assignment to a lender, the Architect shall execute all such consents that are consistent with this Agreement, provided the proposed consent is submitted to the Architect for review at least 14 days prior to execution. The Architect shall not be required to execute certificates or consents that would require knowledge, services, or responsibilities beyond the scope of this Agreement.

§ 10.5 Nothing contained in this Agreement shall create a contractual relationship with, or a cause of action in favor of, a third party against either the Owner or Architect.

§ 10.6 Unless otherwise required in this Agreement, the Architect shall have no responsibility for the discovery, presence, handling, removal or disposal of, or exposure of persons to, hazardous materials or toxic substances in any form at the Project site. The Architect shall immediately report to the Owner's project manager the presence, handling, removal or disposal of, or exposure of persons to and location of any hazardous material which it discovers.

§ 10.7 The Architect shall have the right to include photographic or artistic representations of the design of the Project among the Architect's promotional and professional materials. The Architect shall be given reasonable access to the completed Project to make such representations. However, the Architect's materials shall not include the Owner's confidential or proprietary information if the Owner has previously advised the Architect in writing of the specific

information considered by the Owner to be confidential or proprietary. The Owner shall provide professional credit for the Architect in the Owner's promotional materials for the Project. This Section 10.7 shall survive the termination of this Agreement unless the Owner terminates this Agreement for cause pursuant to Section 9.4.

§ 10.8 If the Architect or Owner receives information specifically designated as "confidential" or "business proprietary," the receiving party shall keep such information strictly confidential and shall not disclose it to any other person except as set forth in Section 10.8.1. This Section 10.8 shall survive the termination of this Agreement. Notwithstanding the foregoing, the Owner may disclose any information specifically required by law.

§ 10.8.1 The receiving party may disclose "confidential" or "business proprietary" information after 7 days' notice to the other party, when required by law, arbitrator's order, or court order, including a subpoena or other form of compulsory legal process issued by a court or governmental entity, or to the extent such information is reasonably necessary for the receiving party to defend itself in any dispute. The receiving party may also disclose such information to its employees, consultants, or contractors in order to perform services or work solely and exclusively for the Project, provided those employees, consultants and contractors are subject to the restrictions on the disclosure and use of such information as set forth in this Section 10.8.

§ 10.9 The invalidity of any provision of the Agreement shall not invalidate the Agreement or its remaining provisions. If it is determined that any provision of the Agreement violates any law, or is otherwise invalid or unenforceable, then that provision shall be revised to the extent necessary to make that provision legal and enforceable. In such case the Agreement shall be construed, to the fullest extent permitted by law, to give effect to the parties' intentions and purposes in executing the Agreement.

ARTICLE 11 COMPENSATION

§ 11.1 For the Architect's Basic Services described under Article 3, the Owner shall compensate the Architect as follows:

(Paragraphs deleted)

A fixed fee of \$31,448.00.

.3 Other

(Describe the method of compensation)

§ 11.2 For the Architect's Supplemental Services designated in Section 4.1.1 and for any Sustainability Services required pursuant to Section 4.1.3, the Owner shall compensate the Architect as follows:

(Insert amount of, or basis for, compensation. If necessary, list specific services to which particular methods of compensation apply.)

Hourly Rates for services indicated in this Agreement.

§ 11.3 For Additional Services that may arise during the course of the Project, including those under Section 4.2, the Owner shall compensate the Architect as follows:

(Insert amount of, or basis for, compensation.)

Hourly Rates for services indicated in this Agreement.

§ 11.4 Compensation for Supplemental and Additional Services of the Architect's consultants when not included in Section 11.2 or 11.3, shall be the amount invoiced to the Architect plus Zero percent (0 %), or as follows:

(Insert amount of, or basis for computing, Architect's consultants' compensation for Supplemental or Additional Services.)

Hourly Rates for services indicated in this Agreement.

§ 11.5 When compensation for Basic Services is based on a stipulated sum or a percentage basis, the proportion of compensation for each phase of services shall be as follows:

Schematic & Design Development Phase	Thirty Five Percent	(35%)
Construction Documents Phase	Forty Two Percent	(42%)
Bidding or Negotiation Phase	Three Percent	(03%)
Construction Phase	Twenty Percent	(20%)
 Total Basic Compensation	 One Hundred Percent ((100%)

§ 11.6 When compensation identified in Section 11.1 is on a percentage basis, progress payments for each phase of Basic Services shall be calculated by multiplying the percentages identified in this Article by the Owner's most recent budget for the Cost of the Work. Compensation paid in previous progress payments shall not be adjusted based on subsequent updates to the Owner's budget for the Cost of the Work.

§ 11.6.1 When compensation is on a percentage basis and any portions of the Project are deleted or otherwise not constructed, compensation for those portions of the Project shall be payable to the extent services are performed on those portions. The Architect shall be entitled to compensation in accordance with this Agreement for all services performed whether or not the Construction Phase is commenced.

§ 11.7 The hourly billing rates for services of the Architect and the Architect's consultants are set forth below. The rates shall be adjusted in accordance with the Architect's and Architect's consultants' normal review practices. *(If applicable, attach an exhibit of hourly billing rates or insert them below.)*

Employee or Category	Rate (\$0.00)
Architectural Services	
Principal Architect	\$200.00 Per Hour
Staff Architect	\$150.00 Per Hour
Intern Architect	\$ 125.00 Per Hour
 Field Representative	 \$ 100.00 Per Hour
Draftsman	\$ 100.00 Per Hour
Administrative Personnel	\$ 65.00 Per Hour

The Architect's rates and multiples for service as set forth in this Agreement shall remain in effect for the life of this Agreement unless unforeseen events which are not the fault of the Architect delay the Project completion. In such event, an equitable adjustment in the Architect's rates may be negotiated with the Owner.

§ 11.8 Compensation for Reimbursable Expenses

§ 11.8.1 Reimbursable Expenses are in addition to compensation for Basic, Supplemental, and Additional Services and include expenses incurred by the Architect and the Architect's consultants directly related to the Project, as follows:

(Paragraphs deleted)

.3 Fees paid for securing approval of permitting and other fees required by authorities having jurisdiction over the Project;

.4 Printing, reproductions, plots, and standard form documents;

(Paragraphs deleted)

.7 Renderings, physical models, mock-ups, professional photography, and presentation materials requested by the Owner or required for the Project;

.8 If required by the Owner, and with the Owner's prior written approval, the Architect's consultants' expenses of professional liability insurance dedicated exclusively to this Project, or the expense of additional insurance coverage or limits in excess of that normally maintained by the Architect's consultants;

(Paragraphs deleted)

.13 **Third party exploration test for investigations of existing roof substrates.**

§ 11.8.2 For Reimbursable Expenses the compensation shall be the expenses incurred by the Architect and the Architect's consultants plus Ten percent (10 %) of the expenses incurred.

(Paragraphs deleted)

§ 11.10 Payments to the Architect

§ 11.10.1 Initial Payments

§ 11.10.1.1 An initial payment of Zero (\$ 0) shall be made upon execution of this Agreement and is the minimum payment under this Agreement. It shall be credited to the Owner's account in the final invoice.

(Paragraph deleted)

§ 11.10.2 Progress Payments

§ 11.10.2.1 Unless otherwise agreed, payments for services shall be made monthly in proportion to services performed. Payments are due and payable upon presentation of the Architect's invoice. Amounts unpaid Thirty (30) days after the invoice date shall bear interest at the rate entered below, or in the absence thereof at the legal rate prevailing from time to time at the principal place of business of the Architect.

(Insert rate of monthly or annual interest agreed upon.)

Three Percent per annum

§ 11.10.2.2 The Owner shall not withhold amounts from the Architect's compensation to impose a penalty or liquidated damages on the Architect, or to offset sums requested by or paid to contractors for the cost of changes in the Work, unless the Architect agrees or has been found liable for the amounts in a binding dispute resolution proceeding.

§ 11.10.2.3 Records of Reimbursable Expenses, expenses pertaining to Supplemental and Additional Services, and services performed on the basis of hourly rates shall be available to the Owner at mutually convenient times.

ARTICLE 12 SPECIAL TERMS AND CONDITIONS

Special terms and conditions that modify this Agreement are as follows:

(Include other terms and conditions applicable to this Agreement.)

ARTICLE 13 SCOPE OF THE AGREEMENT

§ 13.1 This Agreement represents the entire and integrated agreement between the Owner and the Architect and supersedes all prior negotiations, representations or agreements, either written or oral. This Agreement may be amended only by written instrument signed by both the Owner and Architect.

§ 13.2 This Agreement is comprised of the following documents identified below:

.1 AIA Document B101™–2017, Standard Form Agreement Between Owner and Architect

(Paragraphs deleted)

- 4 Other documents:
(List other documents, if any, forming part of the Agreement.)

Johnson + Bailey Architects P.C. letter dated April 12, 2023.

This Agreement entered into as of the day and year first written above.

Murfreesboro City Schools

Johnson + Bailey Architects P.C.

OWNER (Signature)

Dr. Trey Duke
Director of Schools
Date:

(Printed name and title)

ARCHITECT (Signature)

Keaton S. Pettit, Vice President

Date: 4/25/23

(Printed name, title, and license number, if required)

Owner

APPROVED AS TO FORM:

(Signature)

Elizabeth Taylor
Assistant City Attorney

Date:

(Printed name, title, and license number, if required)

Init.

Additions and Deletions Report for AIA® Document B101® – 2017

This Additions and Deletions Report, as defined on page 1 of the associated document, reproduces below all text the author has added to the standard form AIA document in order to complete it, as well as any text the author may have added to or deleted from the original AIA text. Added text is shown underlined. Deleted text is indicated with a horizontal line through the original AIA text.

Note: This Additions and Deletions Report is provided for information purposes only and is not incorporated into or constitute any part of the associated AIA document. This Additions and Deletions Report and its associated document were generated simultaneously by AIA software at 17:27:46 ET on 04/24/2023.

PAGE 1

AGREEMENT made as of the Twelfth (12th) day of July in the year Two Thousand Twenty Three (2023)

...

Murfreesboro City Schools
2552 South Church Street
Murfreesboro, Tennessee 37127

...

Johnson + Bailey Architects P.C.
100 Est Vine Street
City Center, Suite 700
Murfreesboro, Tennessee 37130

...

(Name, location and detailed description)

Playground Replacement at
Mitchell Neilson Elementary School
Murfreesboro, Tennessee
J+B No. 2222

PAGE 2

See attached Johnson + Bailey Architects P.C. letter dated April 12, 2023.

...

Four Hundred Thousand Dollars (\$400,000.00).

PAGE 3

To be determined

...

To be determined

...

To be determined

.4 — Other milestone dates:

:

~~§ 1.1.5~~ The Owner intends the following procurement and delivery method for the Project:
(Identify method such as competitive bid or negotiated contract, as well as any requirements for accelerated or fast-track design and construction, multiple bid packages, or phased construction.)

~~§ 1.1.6~~ The Owner's anticipated Sustainable Objective for the Project:
(Identify and describe the Owner's Sustainable Objective for the Project, if any.)

~~§ 1.1.6.1~~ If the Owner identifies a Sustainable Objective, the Owner and Architect shall complete and incorporate AIA Document E204™ 2017, Sustainable Projects Exhibit, into this Agreement to define the terms, conditions and services related to the Owner's Sustainable Objective. If E204 2017 is incorporated into this agreement, the Owner and Architect shall incorporate the completed E204 2017 into the agreements with the consultants and contractors performing services or Work in any way associated with the Sustainable Objective.

~~§ 1.1.7~~ The Owner identifies the following representative in accordance with Section 5.3:
(List name, address, and other contact information.)

~~§ 1.1.8~~ The persons or entities, in addition to the Owner's representative, who are required to review the Architect's submittals to the Owner are as follows:
(List name, address, and other contact information.)

~~§ 1.1.9~~ The Owner shall retain the following consultants and contractors:
(List name, legal status, address, and other contact information.)

.1 — Geotechnical Engineer:

.2 — Civil Engineer:

~~3~~ — Other, if any:
~~———— (List any other consultants and contractors retained by the Owner.)~~

~~§ 1.1.10~~ The Architect identifies the following representative in accordance with Section 2.3:
~~(List name, address, and other contact information.)~~

...

~~.1~~ — Structural Engineer:

~~.2~~ — Mechanical Engineer:

~~.3~~ — Electrical Engineer:

...

Site Survey prepared by Energy Land & Infrastructure dated February 23, 2023

...

None

...

~~§ 1.3.1~~ Any use of, or reliance on, all or a portion of a building information model without agreement to protocols governing the use of, and reliance on, the information contained in the model and without having those protocols set forth in AIA Document E203™-2013, Building Information Modeling and Digital Data Exhibit, and the requisite

~~AIA Document G202™ 2013, Project Building Information Modeling Protocol Form, shall be at the using or relying party's sole risk and without liability to the other party and its contractors or consultants, the authors of, or contributors to, the building information model, and each of their agents and employees.~~

PAGE 4

§ 2.5 The Architect shall maintain the following insurance until termination of this Agreement. If any of the requirements set forth below are in addition to the types and limits the Architect normally maintains, the Owner shall pay the Architect as set forth in Section 11.9. Architect shall not cancel or modify any insurance coverage required by this Agreement without at least 30-days' prior written notice to Owner.

§ 2.5.1 Commercial General Liability with policy limits of not less than One Million Dollars (\$ 1,000,000.00) for each occurrence and One Million Dollars (\$ 1,000,000.00) in the aggregate for bodily injury and property damage.

§ 2.5.2 Automobile Liability covering vehicles owned, and non-owned vehicles used, by the Architect with policy limits of not less than One Million Dollars (\$ 1,000,000.00) per accident for bodily injury, death of any person, and property damage arising out of the ownership, maintenance and use of those motor vehicles, along with any other statutorily required automobile coverage.

...

§ 2.5.5 Employers' Liability with policy limits not less than One Hundred Thousand Dollars (\$ 100,000.00) each accident, One Hundred Thousand Dollars (\$ 100,000.00) each employee, and One Hundred Thousand Dollars (\$ 100,000.00) policy limit.

§ 2.5.6 Professional Liability covering negligent acts, errors and omissions in the performance of professional services with policy limits of not less than One Million Dollars (\$ 1,000,000.00) per claim and One Million Dollars (\$ 1,000,000.00) in the aggregate.

§ 2.5.7 **Additional Insured Obligations.** To the fullest extent permitted by law, the Architect shall cause the primary and excess or umbrella policies for Commercial General Liability and Automobile Liability to include the Owner as an additional insured for claims caused in whole or in part by the Architect's negligent acts or omissions. The additional insured coverage shall be primary and non-contributory to any of the Owner's insurance policies and shall apply to both ongoing and completed ~~operations.~~
operations

...

2.5.9 Indemnification Architect agrees to indemnify, save and hold harmless the Owner, its officials, officers, and employees, from claims including all costs, expenses and reasonable attorney's fees, to the extent losses and damages are caused by Architect's negligent acts, errors or omissions in performing professional services under this Agreement, except for claims arising out of the negligence of the Owner.

2.6 The Architect shall review laws, codes and regulations applicable to the Architect's services. The Architect shall exercise due professional care in endeavoring to comply with requirements imposed by governmental authorities having jurisdiction over the Project including, but not limited to, applicable ADA standards. Architect shall use the standard care utilized by other architects in designing projects under the applicable standards, in identifying requirements imposed by governmental authorities, and shall identify to the Owner requirements that may be interpreted in different ways of which conflict with other requirements.

2.7 Pursuant to T.C.A. & 49-5-413, Architect and any subcontractors must agree to a background check, which requires a criminal history records check conducted by the TBI and FBI, for each employee prior to permitting the employee to enter school grounds when students are present.

2.8 Pursuant to Murfreesboro City Schools Board Policy 1.803 and State law, the use of tobacco and tobacco products, including smokeless tobacco, is prohibited on all of Murfreesboro City Schools' property. The Architect and all employees and/or subcontractors of Architect must abide by this policy.

PAGE 5

§ 3.1.2 The Architect shall coordinate its services with those services provided by the Owner and the Owner's consultants. The Architect shall be entitled to rely on, and shall not be responsible for, the accuracy, completeness, and timeliness of, services and information furnished by the Owner and the Owner's consultants. The Architect shall provide prompt review the services and information for completeness and sufficiency and provide timely written notice to the Owner if the Architect becomes aware of any error, omission, or inconsistency in such services or information.

...

3.1.7 The Architect shall assist the Owner in determining allowable construction time and amount of liquidated damages.

3.1.8 In accordance with the standard of care, the Architect is responsible for the coordination of all drawings and design documents relating to Architect's design used on the Project, regardless of whether such drawings and documents are prepared or provided by Architect, by Architect's consultants. Architect is responsible for coordination and internal checking of all drawings and for the accuracy of all dimensional and layout information contained therein, as fully as if each drawing were prepared by Architect. Architect is responsible for the completeness and accuracy of all drawings and specifications submitted by or through Architect and for their compliance with all applicable codes, ordinances, regulations, laws and statutes.

...

§ 3.2.2 The Architect shall prepare a preliminary evaluation of the Owner's program, schedule, budget for the Cost of the Work, Project site, the proposed procurement and delivery method, and other Initial Information, each in terms of the other, to ascertain the requirements of the Project. The Architect shall review such information to ascertain that it is consistent with the requirements of the Project and shall notify the Owner of (1) any inconsistencies discovered in the information, and (2) other information or consulting services that may be reasonably needed for the Project.

PAGE 6

§ 3.2.7 The Architect shall submit the Schematic Design Documents to the Owner, and request the Owner's approval-approval thereof. Owner's approval of the documents must be in writing to be binding against either party.

...

§ 3.3.3 The Architect shall submit the Design Development Documents to the Owner, advise the Owner of any adjustments to the estimate of the Cost of the Work, and request the Owner's approval-approval of the documents and any adjustments must be in writing to be binding against either party.

PAGE 7

§ 3.4.5 The Architect shall submit the Construction Documents to the Owner, advise the Owner of any adjustments to the estimate of the Cost of the Work, inform the Owner of any tests, studies, analyses, or reports that are necessary or advisable to be performed by or for the Owner at that point of time, and take any action required under Section 6.5, and request the Owner's written approval. Owner's approval of the documents and any adjustments or actions suggested by the Architect must be in writing to be binding against either party. The Architect will also ascertain that all elements of the construction documents specific to the Owner's requirements, including modifications to the General Conditions, are correctly contained within the construction documents prior to bidding.

PAGE 8

3.6.1.4 The Architect shall be responsible for conducting progress meetings not less than monthly or as needed and for the preparation, distribution, and accuracy of minutes pertaining thereto to all parties as directed by the Owner.

§ 3.6.2.1 The Architect shall visit the site at intervals appropriate to the stage of construction, or as otherwise required in Section ~~4.2.3, 4.3.3~~ to become generally familiar with the progress and quality of the portion of the Work completed, and to determine, in general, if the Work observed is being performed in a manner indicating that the Work, when fully completed, will be in accordance with the Contract Documents. However, the Architect shall not be required to make exhaustive or continuous on-site inspections to check the quality or quantity of the Work. On the basis of the site visits, the Architect shall keep the Owner reasonably informed about the progress and quality of the portion of the Work completed, and promptly report to the Owner (1) known deviations from the Contract Documents, (2) known deviations from the most recent construction schedule submitted by the Contractor, and (3) defects and deficiencies observed in the Work.

§ 3.6.2.2 The Architect ~~has and Owner shall have~~ the authority to reject Work that does not conform to the Contract Documents. Whenever the Architect considers it necessary or advisable, the Architect shall have the authority to require inspection or testing of the Work in accordance with the provisions of the Contract Documents, whether or not the Work is fabricated, installed or completed. However, neither this authority of the Architect nor a decision made in good faith either to exercise or not to exercise such authority shall give rise to a duty or responsibility of the Architect to the Contractor, Subcontractors, suppliers, their agents or employees, or other persons or entities performing portions of the Work.

§ 3.6.2.3 The Architect shall interpret and decide matters concerning performance under, and requirements of, the Contract Documents on written request of either the Owner or Contractor. The Architect's response to such requests shall be made in writing within any time limits agreed upon ~~or otherwise with reasonable promptness, timely so as not to affect the Contract Time or the Contract Sum.~~

§ 3.6.2.4 Interpretations and decisions of the Architect shall be consistent with the intent of, and reasonably inferable from, the Contract Documents ~~and shall be in writing or in the form of drawings. When making such interpretations and decisions, the Architect shall endeavor to secure faithful performance by both Owner and Contractor, shall not show partiality to either, and shall not be liable for results of interpretations or decisions rendered in good faith. The Architect's Documents. The Architect shall render initial decisions on claims, disputes or other matters in question between the Owner and Contractor as provided in the Contract Documents; provided however, the Owner, with advise and assistance from the Architect, shall make final decisions on matters relating to aesthetic effect shall be final if consistent with the intent expressed in the Contract Documents effect, Contract Sum and Contract Time.~~

PAGE 9

§ 3.6.4.1 The Architect shall review the Contractor's submittal schedule and shall not unreasonably delay or withhold ~~approval of the schedule approval.~~ The Architect's action in reviewing submittals shall be taken in accordance with the approved submittal schedule or, in the absence of an approved submittal schedule, ~~with reasonable promptness while allowing sufficient time, in the Architect's professional judgment, to permit adequate review, timely so as not to affect the Contract Time or Contract Sum.~~

PAGE 10

§ 3.6.5.1 The Architect may ~~order authorize~~ minor changes in the Work that are consistent with the intent of the Contract Documents and do not involve an adjustment in the Contract Sum or an extension of the Contract Time. Subject to ~~Section 4.2, the provisions of Section 4.3,~~ the Architect shall prepare Change Orders and Construction Change Directives for the Owner's approval and execution in accordance with the Contract Documents. The Architect shall timely report to Owner, in writing, those minor changes in the Work authorized by Architect pursuant to this section. If the Architect and the Owner determine that the implementation of the requested change would result in a material change to the Contract that may cause an adjustment in the Contract Time or Contract Sum, the Architect shall make a recommendation to the Owner who may authorize further investigation of such change.

§ 3.6.5.2 The Architect shall maintain records relative to changes in the Work. Additionally, the Architect shall review and, upon request by Owner, provide written documentation of the same of all change order requests and proposals with respect to the following criteria:

1. confirm proposed change is a material change to the Contract;
2. confirm appropriate credits are included for Work not completed;

3. verify that the proposed additional cost or credit is reasonable with respect to industry standards. Cost verifications may, as authorized by Owner, include independent estimates and/or consultations with contractors and vendors; and
4. confirm that the appropriate back up documentation is included and mathematically correct including markups and taxes pursuant to the requirements of the Contract Documents.

...

§ 3.6.6.4 The Architect shall review, approve and forward to the Owner the following information received from the Contractor: (1) consent of surety or sureties, if any, to reduction in or partial release of retainage or the making of final payment; (2) affidavits, receipts, releases and waivers of liens, or bonds indemnifying the Owner against liens; and (3) any other documentation required of the Contractor under the Contract Documents.

§ 3.6.6.5 Upon request of the Owner, and prior to the expiration of one year from the date of Substantial Completion, the Architect shall, without additional compensation, conduct a meeting with the Owner and the Contractor, to review the facility operations and performance.

PAGE 11

§ 4.1.1.1	Programming	<u>Architect & Owner</u>
§ 4.1.1.2	Multiple preliminary designs	<u>Architect's Basic Services</u>
§ 4.1.1.3	Measured drawings	<u>Not Provided</u>
§ 4.1.1.4	Existing facilities surveys	<u>Not Provided</u>
§ 4.1.1.5	Site evaluation and planning	<u>Not Provided</u>
§ 4.1.1.6	Building Information Model management responsibilities	<u>Not Provided</u>
§ 4.1.1.7	Development of Building Information Models for post construction use	<u>Not Provided</u>
§ 4.1.1.8	Civil engineering	<u>Not Provided</u>
§ 4.1.1.9	Landscape design	<u>Not Provided</u>
§ 4.1.1.10	Architectural interior design	<u>Not Provided</u>
§ 4.1.1.11	Value analysis	<u>Not Provided</u>
§ 4.1.1.12	Detailed cost estimating beyond that required in Section 6.3	<u>Not Provided</u>
§ 4.1.1.13	On-site project representation	<u>Not Provided</u>
§ 4.1.1.14	Conformed documents for construction	<u>Not Provided</u>
§ 4.1.1.15	As-designed record drawings	<u>Not Provided</u>
§ 4.1.1.16	As-constructed record drawings	<u>Not Provided</u>
§ 4.1.1.17	Post-occupancy evaluation	<u>Not Provided</u>
§ 4.1.1.18	Facility support services	<u>Not Provided</u>
§ 4.1.1.19	Tenant-related services	<u>Not Provided</u>
§ 4.1.1.20	Architect's coordination of the Owner's consultants	<u>Not Provided</u>
§ 4.1.1.21	Telecommunications/data design	<u>Not Provided</u>
§ 4.1.1.22	Security evaluation and planning	<u>Not Provided</u>
§ 4.1.1.23	Commissioning	<u>Not Provided</u>
§ 4.1.1.24	Sustainable Project Services pursuant to Section 4.1.3	<u>Not Provided</u>
§ 4.1.1.25	Fast-track design services	<u>Not Provided</u>
§ 4.1.1.26	Multiple bid packages	<u>Not Provided</u>
§ 4.1.1.27	Historic preservation	<u>Not Provided</u>

§ 4.1.1.28 Furniture, furnishings, and equipment design	<u>Not Provided</u>
§ 4.1.1.29 Other services provided by specialty Consultants	<u>Not Provided</u>
§ 4.1.1.30 Other Supplemental Services	<u>Not Provided</u>

PAGE 12

The Architect is to perform all required Programming and Design Services, and to coordinate all work with the Owner's Consultants.

...

- ~~.6 — Preparation of design and documentation for alternate bid or proposal requests proposed by the Owner;~~
- ~~.7 — Preparation for, and attendance at, a public presentation, meeting or hearing;~~

- ~~.9 — Evaluation of the qualifications of entities providing bids or proposals;~~

PAGE 13

§ 4.2.2 To avoid delay in the Construction Phase, the Architect shall provide the following Additional Services, notify the Owner with reasonable promptness, and explain the facts and circumstances giving rise to the need. If, upon receipt of the Architect's notice, the Owner determines that all or parts of the services are not required, the Owner shall give ~~prompt~~timely written notice to the Architect of the Owner's determination. The Owner shall compensate the Architect for the services provided prior to the Architect's receipt of the Owner's notice.

- ~~.1 — Reviewing a Contractor's submittal out of sequence from the submittal schedule approved by the Architect;~~
- ~~.2 — Responding to the Contractor's requests for information that are not prepared in accordance with the Contract Documents or where such information is available to the Contractor from a careful study and comparison of the Contract Documents, field conditions, other Owner provided information, Contractor prepared coordination drawings, or prior Project correspondence or documentation;~~
- ~~.3 — Preparing Change Orders and Construction Change Directives that require evaluation of Contractor's proposals and supporting data, or the preparation or revision of Instruments of Service;~~
- ~~.4 — Evaluating an extensive number of Claims as the Initial Decision Maker; or,~~

...

- ~~.1 (—) reviews One (1) review~~ of each Shop Drawing, Product Data item, sample and similar submittals of the Contractor
- ~~.2 (—) Weekly~~ visits to the site by the Architect during construction
- ~~.3 (—) inspections One (1) inspection~~ for any portion of the Work to determine whether such portion of the Work is substantially complete in accordance with the requirements of the Contract Documents
- ~~.4 (—) inspections One (1) inspection~~ for any portion of the Work to determine final completion.

...

§ 4.2.5 If the services covered by this Agreement have not been completed within Twelve (12) months of the date of this Agreement, through no fault of the Architect, extension of the Architect's services beyond that time shall be compensated as Additional Services.

...

§ 5.2 ~~The Owner~~Owner, with Architect's assistance, shall establish the Owner's budget for the Project, including (1) the budget for the Cost of the Work as defined in Section 6.1; (2) the Owner's other costs; and, (3) reasonable contingencies related to all of these costs. The Owner shall update the Owner's budget for the Project as necessary throughout the duration of the Project until final completion. If the Owner significantly increases or decreases the Owner's budget for the Cost of the Work, the Owner shall notify the Architect. The Owner and the Architect shall thereafter agree to a corresponding change in the Project's scope and quality.

...

5.3.1 The Owner has the right to reject any portion of the Architect's services on the Project, including but not limited to Schematic Design Documents, Design Development Documents, Construction Documents, or the Architect's provision of services during the construction of the Project, or any other design services or documents on any reasonable basis, including, but not limited to aesthetics or because in the Owner's opinion, the construction cost of such design is likely to exceed the budget for Cost of the Services. If at any time, the Architect's services is rejected by the Owner, the Architect must proceed when requested by the Owner, to revise the design services or documents prepared for that phase to the Owner's satisfaction. These revisions shall be made without adjustment to the compensation provided hereunder, unless revisions are made to services previously approved by the Owner under previous phases, in which case such revision services will be paid as a Change in Services. Should there be substantial revisions to the original program after the approval of the Schematic Design Documents, which changes substantially increase the scope of design services to be furnished hereunder, such revision services will be paid as a Change in Services. The Architect must so notify the Owner of all Changes in Services in writing and receive approval from Owner before proceeding with revisions necessitated by such changes. No payment, of any nature whatsoever, will be made to the Architect for additional services or Changes in Services without such written approval by Owner.

~~§ 5.5 The~~ To the extent reasonably required for the timely and safe design and construction of the Project, the Owner shall furnish services of geotechnical engineers, engineers, which may include test borings, test pits, determinations of soil bearing values, percolation tests, evaluations of hazardous materials, seismic evaluation, ground corrosion tests and resistivity tests, including necessary operations for anticipating subsoil conditions, with written reports and appropriate recommendations. Architect shall assist Owner in obtaining these services.

PAGE 14

~~§ 5.11 The Owner shall provide prompt~~ In accordance with the standard of care, the Owner shall be entitled to rely on the accuracy and completeness of services and information provided by the Architect. The Owner shall provide timely written notice to the Architect if the Owner becomes aware of any fault or defect in the Project, including errors, omissions or inconsistencies in the Architect's Instruments of Service.

~~§ 5.12~~ The Owner shall include the Architect in all communications with the Contractor that relate to or affect the Architect's services or professional responsibilities. The Owner shall promptly-timely notify the Architect of the substance of any direct communications between the Owner and the Contractor otherwise relating to the Project. Communications by and with the Architect's consultants shall be through the Architect.

PAGE 15

~~§ 5.15 Within 15 days after receipt of a written request from the Architect, the Owner shall furnish the requested information as necessary and relevant for the Architect to evaluate, give notice of, or enforce lien rights.~~

...

~~§ 6.3~~ In preparing estimates of the Cost of Work, the Architect-Architect, in consultation with the Owner, shall be permitted to include contingencies for design, bidding, and price escalation; to determine what materials, equipment, component systems, and types of construction are to be included in the Contract Documents; to recommend reasonable adjustments in the program and scope of the Project; and to include design alternates as may be necessary to adjust the estimated Cost of the Work to meet the Owner's budget. The Architect's estimate of the Cost of the Work shall be based on current area, volume or similar conceptual estimating techniques. If the Owner requires a detailed estimate of the Cost of the Work, the Architect shall provide such an estimate, if identified as the Architect's responsibility in Section 4.1.1, as a Supplemental Service.

...

- .1 undertake a good faith effort to obtain necessary and timely approval of Council for an increase in the budget for the cost of the Work, as may be necessary, and then if approval is timely obtained, give written approval of an increase in the budget for the Cost of the Work;

...

§ 6.7 If the Owner chooses to proceed under Section 6.6.4, the Architect shall modify the Construction Documents 6.6.2, the Architect, without additional compensation, shall assist the Owner in rebidding, or renegotiating the Project within a reasonable time. If the Owner chooses to proceed under Section 6.6.4, the Architect, without additional compensation, shall modify the documents which the Architect is responsible for preparing under this Agreement as necessary to comply with the Owner's budget for the Cost of the Work at the conclusion of the Construction Documents Phase Services, or the budget as adjusted under Section 6.6.1. If the Owner requires the Architect to modify the Construction Documents because the lowest bona fide bid or negotiated proposal exceeds the Owner's budget for the Cost of the Work due to market conditions the Architect could not reasonably anticipate, the Owner shall compensate the Architect for the modifications as an Additional Service pursuant to Section 11.3; otherwise the Architect's services for modifying the Construction Documents shall be without additional compensation. In any event, the Architect's modification of the Construction Documents Work, and shall assist the Owner in rebidding or renegotiating the Project within a reasonable time. The modification of such documents and the rebidding or renegotiating of the Project shall be the limit of the Architect's responsibility under this Article 6. Section 6.6.

PAGE 16

§ 7.3 The Upon execution of this Agreement, the Architect grants to the Owner a nonexclusive irrevocable, royalty-free, right and license to use the Architect's Instruments of Service solely and exclusively for purposes of constructing, using, maintaining, altering and adding to the Project, provided that the Owner substantially performs its obligations under this Agreement, including prompt payment of all sums due pursuant to Article 9 and Article 11. obligations, including timely payment of all sums when due, under this Agreement. The Architect shall obtain similar nonexclusive licenses from the Architect's consultants consistent with this Agreement. The license granted under this section permits the Owner to authorize the Contractor, Subcontractors, Sub-subcontractors, and material or equipment suppliers, as well as the Owner's consultants and separate contractors, to reproduce applicable portions of the Instruments of Service, subject to any protocols established pursuant to Section 1.3, Service solely and exclusively for use in performing services or construction for the Project. If the Architect rightfully terminates this Agreement for cause as provided in Section 9.4, the license granted in this Section 7.3 shall terminate. Upon completion of the Project, or upon termination of this Agreement for any reason prior to the completion of the Project, Owner shall be entitled to retain copies of all Instruments of Service and shall have an irrevocable, royalty-free, right and license to use all of the Instruments of Service for any and all purposes related to the Project in any manner the Owner deems fit, including Electronics Filing and Archiving for the purpose of record keeping at Owner designated areas; any future renovations, addition, or alteration to the Project; and any future maintenance or operations issue as it pertains to the Project. Architect or Architect's Consultants shall not be responsible for any modifications to the Work made by the Owner or Owner's representatives using the Architect's Instruments of Service.

§ 7.3.1 In the event the Owner uses the Instruments of Service without retaining the authors-author of the Instruments of Service, the Owner releases the Architect and Architect's consultant(s) from all from liability for claims and causes of action arising from such uses. The Owner, to the extent permitted by law, further agrees to indemnify and hold harmless the Architect and its consultants from all costs and expenses, including the cost of defense, related to claims and causes of action asserted by any third person or entity to the extent such costs and expenses arise from the Owner's use of the Instruments of Service under this Section 7.3.1. The terms of this Section 7.3.1 shall not apply if the Owner rightfully terminates this Agreement for cause under Section 9.4.usc.

...

§ 8.1.1 The Owner and Architect shall commence all claims and causes of action against the other and arising out of or related to this Agreement, whether in contract, tort, or otherwise, in accordance with the requirements of the binding dispute resolution method selected in this Agreement and within the period specified by applicable law, but in any case not more than 10 years after the date of Substantial Completion of the Work. The Owner and Architect waive all claims and causes of action not commenced in accordance with this Section 8.1.1-Tennessee law.

...

~~§ 8.1.3~~ The Architect and Owner waive consequential damages for claims, disputes, or other matters in question, arising out of or relating to this Agreement. This mutual waiver is applicable, without limitation, to all consequential damages due to either party's termination of this Agreement, except as specifically provided in Section 9.7.

PAGE 17

Litigation in a court of competent jurisdiction

...

If the Owner and Architect do not select a method of binding dispute resolution, or do not subsequently agree in writing to a binding dispute resolution method other than litigation, the dispute will be resolved in a court of competent jurisdiction.

~~§ 8.3 Arbitration~~

~~§ 8.3.1~~ If the parties have selected arbitration as the method for binding dispute resolution in this Agreement, any claim, dispute or other matter in question arising out of or related to this Agreement subject to, but not resolved by, mediation shall be subject to arbitration, which, unless the parties mutually agree otherwise, shall be administered by the American Arbitration Association in accordance with its Construction Industry Arbitration Rules in effect on the date of this Agreement. A demand for arbitration shall be made in writing, delivered to the other party to this Agreement, and filed with the person or entity administering the arbitration.

~~§ 8.3.1.1~~ A demand for arbitration shall be made no earlier than concurrently with the filing of a request for mediation, but in no event shall it be made after the date when the institution of legal or equitable proceedings based on the claim, dispute or other matter in question would be barred by the applicable statute of limitations. For statute of limitations purposes, receipt of a written demand for arbitration by the person or entity administering the arbitration shall constitute the institution of legal or equitable proceedings based on the claim, dispute or other matter in question.

~~§ 8.3.2~~ The foregoing agreement to arbitrate, and other agreements to arbitrate with an additional person or entity duly consented to by parties to this Agreement, shall be specifically enforceable in accordance with applicable law in any court having jurisdiction thereof.

~~§ 8.3.3~~ The award rendered by the arbitrator(s) shall be final, and judgment may be entered upon it in accordance with applicable law in any court having jurisdiction thereof.

~~§ 8.3.4 Consolidation or Joinder~~

~~§ 8.3.4.1~~ Either party, at its sole discretion, may consolidate an arbitration conducted under this Agreement with any other arbitration to which it is a party provided that (1) the arbitration agreement governing the other arbitration permits consolidation; (2) the arbitrations to be consolidated substantially involve common questions of law or fact; and (3) the arbitrations employ materially similar procedural rules and methods for selecting arbitrator(s).

~~§ 8.3.4.2~~ Either party, at its sole discretion, may include by joinder persons or entities substantially involved in a common question of law or fact whose presence is required if complete relief is to be accorded in arbitration, provided that the party sought to be joined consents in writing to such joinder. Consent to arbitration involving an additional person or entity shall not constitute consent to arbitration of any claim, dispute or other matter in question not described in the written consent.

~~§ 8.3.4.3~~ The Owner and Architect grant to any person or entity made a party to an arbitration conducted under this Section 8.3, whether by joinder or consolidation, the same rights of joinder and consolidation as the Owner and Architect under this Agreement.

~~§ 8.4~~ The provisions of this Article 8 shall survive the termination of this Agreement.

§ 9.1 If the Owner fails to make payments to the Architect in accordance with this Agreement, such failure shall be considered substantial nonperformance and cause for termination or, at the Architect's option, cause for suspension of performance of services under this Agreement. If the Architect elects to suspend services, the Architect shall give seven days' written notice to the Owner before suspending services. In the event of a suspension of services, in accordance herewith, the Architect shall have no liability to the Owner for delay or damage caused the Owner because of such suspension of services. Before resuming services, the ~~Owner shall pay the Architect~~ Architect shall be paid all sums due prior to suspension and shall negotiate with the Owner any expenses incurred in the interruption ~~and~~ resumption of the Architect's services. The Architect's fees for the remaining services and the time schedules shall be equitably adjusted.

§ 9.2 If the Owner suspends the ~~Project~~, Project for more than 30 consecutive days, the Architect shall be compensated for services performed prior to notice of such suspension. When the Project is resumed, ~~the Architect shall be compensated~~ the Owner and the Architect shall negotiate the amount of any compensation the Owner will pay the Architect for expenses incurred in the interruption and resumption of the Architect's services. The Owner and the Architect shall negotiate any adjustments to the Architect's fees for the remaining services and the time schedules shall be equitably adjusted for completion.

PAGE 18

§ 9.7 In addition to any amounts paid under Section 9.6, if the Owner terminates this Agreement for its convenience pursuant to Section 9.5, or the Architect terminates this Agreement pursuant to Section 9.3, the Owner shall pay to the Architect the following fees:
(Set forth below the amount of any termination or licensing fee, or the method for determining any termination or licensing fee.)

.1 — Termination Fee:

.2 — Licensing Fee if the Owner intends to continue using the Architect's Instruments of Service:

...

9.10 In the event of any termination under this Article, the Architect consents to the owner's selection of another architect of the Owner's choice to assist the Owner in any way in completing the Project. Architect further agrees to cooperate and provide any information requested by Owner in connection with the completion of the Project and consents to and authorizes the making of any reasonable changes to the design of the Project by Owner and such other architect as Owner may desire. Any services provided by Architect that are requested by Owner after termination will be fairly compensated by Owner in accordance with Article 11.

...

§ 10.6 Unless otherwise required in this Agreement, the Architect shall have no responsibility for the discovery, presence, handling, removal or disposal of, or exposure of persons to, hazardous materials or toxic substances in any form at the Project site. The Architect shall immediately report to the Owner's project manager the presence, handling, removal or disposal of, or exposure of persons to and location of any hazardous material which it discovers.

PAGE 19

Notwithstanding the foregoing, the Owner may disclose any information specifically required by law.

...

§ 11.1 For the Architect's Basic Services described under Article 3, the Owner shall compensate the Architect as follows:

1 — Stipulated Sum
 — (Insert amount)

2 — Percentage Basis
 — (Insert percentage value) A fixed fee of \$31,448.00.

() % of the Owner's budget for the Cost of the Work, as calculated in accordance with Section 11.6.

...

.

...

Hourly Rates for services indicated in this Agreement.

...

Hourly Rates for services indicated in this Agreement.

§ 11.4 Compensation for Supplemental and Additional Services of the Architect's consultants when not included in Section 11.2 or 11.3, shall be the amount invoiced to the Architect plus Zero percent (0 %), or as follows:

...

Hourly Rates for services indicated in this Agreement.

PAGE 20

<u>Schematic & Design Development Phase</u>	<u>Thirty Five Percent</u>	<u>(35%)</u>
<u>Construction Documents Phase</u>	<u>Forty Two Percent</u>	<u>(42%)</u>
<u>Bidding or Negotiation Phase</u>	<u>Three Percent</u>	<u>(03%)</u>
<u>Construction Phase</u>	<u>Twenty Percent</u>	<u>(20%)</u>

Total Basic Compensation One Hundred Percent (100%)

<u>Schematic Design Phase</u>	<u>percent</u> (<u>%)</u>
<u>Design Development Phase</u>	<u>percent</u> (<u>%)</u>
<u>Construction Documents Phase</u>	<u>percent</u> (<u>%)</u>
<u>Procurement Phase</u>	<u>percent</u> (<u>%)</u>
<u>Construction Phase</u>	<u>percent</u> (<u>%)</u>

Total Basic Compensation one hundred percent (100 %)

...

<u>Architectural Services</u>	
<u>Principal Architect</u>	<u>\$200.00 Per Hour</u>
<u>Staff Architect</u>	<u>\$150.00 Per Hour</u>
<u>Intern Architect</u>	<u>\$ 125.00 Per Hour</u>

<u>Field Representative</u>	<u>\$ 100.00 Per Hour</u>
<u>Draftsman</u>	<u>\$ 100.00 Per Hour</u>
<u>Administrative Personnel</u>	<u>\$ 65.00 Per Hour</u>

The Architect's rates and multiples for service as set forth in this Agreement shall remain in effect for the life of this Agreement unless unforeseen events which are not the fault of the Architect delay the Project completion. In such event, an equitable adjustment in the Architect's rates may be negotiated with the Owner.

...

- ~~.1~~ — Transportation and authorized out-of-town travel and subsistence;
- ~~.2~~ — Long distance services, dedicated data and communication services, teleconferences, Project web sites, and extranets;
- ~~.3~~ — ~~Permitting.~~ .3 Fees paid for securing approval of permitting and other fees required by authorities having jurisdiction over the Project;
- ~~.4~~ — Printing, reproductions, plots, and standard form documents;
- ~~.5~~ — Postage, handling, and delivery;
- ~~.6~~ — Expense of overtime work requiring higher than regular rates, if authorized in advance by the Owner;

PAGE 21

- ~~.9~~ — All taxes levied on professional services and on reimbursable expenses;
- ~~.10~~ — Site office expenses;
- ~~.11~~ — Registration fees and any other fees charged by the Certifying Authority or by other entities as necessary to achieve the Sustainable Objective; and,
- ~~.12~~ — Other similar Project-related expenditures. .13 Third party exploration test for investigations of existing roof substrates.

§ 11.8.2 For Reimbursable Expenses the compensation shall be the expenses incurred by the Architect and the Architect's consultants plus Ten percent (10 %) of the expenses incurred.

~~§ 11.9 Architect's Insurance. If the types and limits of coverage required in Section 2.5 are in addition to the types and limits the Architect normally maintains, the Owner shall pay the Architect for the additional costs incurred by the Architect for the additional coverages as set forth below:~~

~~(Insert the additional coverages the Architect is required to obtain in order to satisfy the requirements set forth in Section 2.5, and for which the Owner shall reimburse the Architect.)~~

...

§ 11.10.1.1 An initial payment of Zero (\$ 0) shall be made upon execution of this Agreement and is the minimum payment under this Agreement. It shall be credited to the Owner's account in the final invoice.

~~§ 11.10.1.2 If a Sustainability Certification is part of the Sustainable Objective, an initial payment to the Architect of (\$ —) shall be made upon execution of this Agreement for registration fees and other fees payable to the Certifying Authority and necessary to achieve the Sustainability Certification. The Architect's payments to the Certifying Authority shall be credited to the Owner's account at the time the expense is incurred.~~

§ 11.10.2.1 Unless otherwise agreed, payments for services shall be made monthly in proportion to services performed. Payments are due and payable upon presentation of the Architect's invoice. Amounts unpaid Thirty (30)

days after the invoice date shall bear interest at the rate entered below, or in the absence thereof at the legal rate prevailing from time to time at the principal place of business of the Architect.

...

~~% Three Percent per annum~~

...

~~2~~ — AIA Document E203™ 2013, Building Information Modeling and Digital Data Exhibit, dated as indicated below:

— *(Insert the date of the E203-2013 incorporated into this agreement.)*

~~3~~ — Exhibits:

(Check the appropriate box for any exhibits incorporated into this Agreement.)

— AIA Document E204™ 2017, Sustainable Projects Exhibit, dated as indicated below:

(Insert the date of the E204-2017 incorporated into this agreement.)

— Other Exhibits incorporated into this Agreement:

(Clearly identify any other exhibits incorporated into this Agreement, including any exhibits and scopes of services identified as exhibits in Section 4.1.2.)

(List other documents, if any, forming part of the Agreement.)

Johnson + Bailey Architects P.C. letter dated April 12, 2023.

This Agreement entered into as of the day and year first written above.

Murfreesboro City Schools

Johnson + Bailey Architects P.C.

PAGE 22

Dr. Trey Duke

Director of Schools

Date:

Keaton S. Pettit, Vice President

Date:

...

Owner

APPROVED AS TO FORM:

(Signature)

Elizabeth Taylor

Assistant City Attorney

Date:

(Printed name, title, and license number, if required)

Certification of Document's Authenticity

AIA® Document D401™ – 2003

I, James Richard Pettit, hereby certify, to the best of my knowledge, information and belief, that I created the attached final document simultaneously with its associated Additions and Deletions Report and this certification at 17:27:46 ET on 04/24/2023 under Order No. 2114381871 from AIA Contract Documents software and that in preparing the attached final document I made no changes to the original text of AIA® Document B101™ – 2017, Standard Form of Agreement Between Owner and Architect, other than those additions and deletions shown in the associated Additions and Deletions Report.



(Signed)

VICE-PRESIDENT

(Title)

4/25/23

(Dated)

Agenda Item Title: Student Field Trip Fees for the 2023-2024 School Year

Board Meeting Date: July 25, 2023

Department: Finance

Presented by: Dr. Trey Duke, Director of Schools

Board Agenda Category:

- Consent Agenda
 - Action Item
 - Reports and Information
-

Summary

Board Policy 6.709 states that prior to the start of each school year, the Board, upon the recommendation of the principals and Director of Schools, shall approve all known student fees for the upcoming school year. Additional fees may be approved during the year as needed.

The Director of Schools is recommending the Board pre-approve student field trip fees up to \$20.00 per student for the upcoming school year. This pre-approval will decrease turnaround time and allow schools to begin collecting funds immediately after Central Office approval of a standard field trip. Field trips beyond the \$20.00 per student limit will still be approved individually at the next Board meeting.

The Board began this procedure of pre-approving field trips under \$20.00 at the beginning of the 2022-2023 school year.

Staff Recommendation

Recommending approval of student field trip fees up to \$20.00 per student, per trip for the 2023-2024 school year.

Fiscal Impact

No fiscal impact.

Connection to MCS's Five-Year Strategic Plan

- Known:** Every student will be *known* through whole-child programs and support.
- Safe:** Every student will be *safe* through equitable access to buildings, facilities, and infrastructure that meets their needs.
- Challenged:** Every student will be *challenged* by learning from highly effective educators and employees.
- Empowered:** Every student will be *empowered* through academic success

Agenda Item Title: Stronger Connections Grant/Budget Amendment

Board Meeting Date: July 25, 2023

Department: Student Support Services

Presented by: Trey Duke

Board Agenda Category:

Consent Agenda

Action Item

Reports and Information

Summary

The Department of Education has designated a component of the Bipartisan Safer Communities Act (BSCA) for the Stronger Connections Grant. On June 27, 2023, Murfreesboro City Schools was awarded \$1,105,338.94 over three years to focus on the areas of Mental Health/Social Emotional learning for students, families, and educators. We will increase support for mental wellness by hiring seven (7) Calm Coaches to assist with meeting the behavioral needs of students and provide professional development through BEST, LLC, and STARS, Nashville.

Staff Recommendation

Recommend approval of the Stronger Connections Grant/Budget Amendment.

Fiscal Impact

The award amount is \$1,105,338.94 over three years which includes \$144,748.80 for Equitable Services.

Connection to MCS's Five-Year Strategic Plan

- Known:** Every student will be *known* through whole-child programs and support.
- Safe:** Every student will be *safe* through equitable access to buildings, facilities, and infrastructure that meets their needs.
- Challenged:** Every student will be *challenged* by learning from highly effective educators and employees.
- Empowered:** Every student will be *empowered* through academic success

Schools Federal Projects Fund 142
Fiscal Year 2023-2024

Stronger Connections Grant

Account Number	Account Description	BUDGET AS PASSED OR		AMENDED BUDGET	AMENDMENT INCREASE (DECREASE)
		PREV AMENDED			
<u>Revenues</u>					
142 R 47590	Stronger Connections Grant	-		1,105,339	1,105,339
Total Increase in Revenues		\$ -		\$ 1,105,339	\$ 1,105,339

<u>Expenditures</u>					
71100 163	Regular Instruction - Educ Assistants	-		582,471	582,471
71100 201	Regular Instruction - Social Security	-		36,421	36,421
71100 204	Regular Instruction - State Retirement	-		68,817	68,817
71100 206	Regular Instruction - Life Insurance	-		1,428	1,428
71100 207	Regular Instruction - Medical Insurance	-		220,500	220,500
71100 208	Regular Instruction - Dental Insurance	-		6,450	6,450
71100 212	Regular Instruction - Medicare	-		8,211	8,211
71100 299	Regular Instruction - Fringe Benefits	-		1,867	1,867
72130 399	Other Student Support - Contract Services	-		179,174	179,174
Total Increase in Expenditures		\$ -		\$ 1,105,339	\$ 1,105,339

CHANGE IN FUND BALANCE (CASH) -

To budget a new three-year Stronger Connections federal grant totaling \$1,105,339 for mental and emotional support in the classroom. MCS will hire seven Calm Coaches to teach students emotional regulation skills while collaborating with the school behavior support teach and teachers.

Kim Pisciotta 7-18-2023
Reviewed by Finance Director/Finance Manager Date

Approved	<input checked="" type="checkbox"/>	<u>Bobby W. Duckitt</u>	
Declined	<input type="checkbox"/>	Director of Schools	Date

Agenda Item Title: United Way Grant and Budget Amendment

Board Meeting Date: July 25, 2023

Department: Student Support Services

Presented by: Trey Duke

Board Agenda Category:

Consent Agenda

Action Item

Reports and Information

Summary

Murfreesboro City Schools was awarded a grant by United Way of Rutherford and Cannon Counties in the amount of \$51,500. Funds from the Expanding Supports4Success grant will be used to support expansion programs providing therapeutic materials for twelve (12) additional Calm Centers at schools.

Staff Recommendation

Recommend approval of the budget amendment of \$51,500 for the General Purpose fund.

Fiscal Impact

\$51,500 will be amended in the general purpose fund.

Connection to MCS's Five-Year Strategic Plan

- Known:** Every student will be *known* through whole-child programs and support.
- Safe:** Every student will be *safe* through equitable access to buildings, facilities, and infrastructure that meets their needs.
- Challenged:** Every student will be *challenged* by learning from highly effective educators and employees.
- Empowered:** Every student will be *empowered* through academic success

General Purpose Schools Fund 141
Fiscal Year 2023-24

Account Number	Account Description	BUDGET AS PASSED OR PREV AMENDED	AMENDED BUDGET	AMENDMENT INCREASE (DECREASE)
<u>Revenues</u>				
141 R 44570	Donations (United Way)	383,426	434,926	51,500
Total Increase in Revenues		\$ 383,426	\$ 434,926	\$ 51,500
<u>Expenditures</u>				
141 E 72130 499	Other Student Support - Materials & Supplies	\$ 40,935	\$ 92,435	\$ 51,500
Total Increase in Expenditures		\$ 40,935	\$ 92,435	\$ 51,500

CHANGE IN FUND BALANCE (CASH) -

MCS was awarded a grant by the United Way of Rutherford & Cannon Counties in the amount of \$51,500. Funds from the Expanding Supports4Success grant will be used to support expansion programs providing therapeutic materials for 12 additional Calm Centers.

Jim Pucian 7-18-23

Reviewed by Finance Director/Finance Manager

Date

Approved	<input checked="" type="checkbox"/>	<u><i>Bobby J. Dinkels</i></u>	
Declined	<input type="checkbox"/>	Director of Schools	Date

Agenda Item Title: FY24 Nutrition Fund USDA Local Food for Schools Grant and Budget Amendment

Board Meeting Date: July 25, 2023

Department: Finance

Presented by: Dr. Trey Duke, Director of Schools

Board Agenda Category:

- Consent Agenda
 - Action Item
 - Reports and Information
-

Summary

The Finance Department is seeking Board approval to appropriate \$100,000 of new revenue in the FY24 School Nutrition fund for the USDA Local Food for Schools Cooperative grant. These grant funds will be budgeted in the Food Supplies category to purchase domestic, locally grown foods, from local producers, small businesses, and socially disadvantaged farmers. The grant period is July 2023 – August 2024.

Staff Recommendation

Recommend approval of the FY24 Nutrition budget amendment of \$100,000.

Fiscal Impact

This budget amendment increases total FY24 Revenues to \$5,094,943 and total Expenditures to \$8,536,989 with no change to budgeted fund balance of \$3,442,046.

Connection to MCS's Five-Year Strategic Plan

- Known:** Every student will be *known* through whole-child programs and support.
- Safe:** Every student will be *safe* through equitable access to buildings, facilities, and infrastructure that meets their needs.
- Challenged:** Every student will be *challenged* by learning from highly effective educators and employees.
- Empowered:** Every student will be *empowered* through academic success

School Nutrition Fund 143
Fiscal Year 2023-24

Local Food for Schools Cooperative Grant

Account Number	ACCOUNT DESCRIPTION	BUDGET PASSED	AMENDED BUDGET	AMENDMENT INCREASE (DECREASE)
<u>Revenues</u>				
143 R 47114	USDA - Other	78,645	178,645	100,000
Total Increase in Revenues		\$ 78,645	\$ 178,645	\$ 100,000
<u>Expenditures</u>				
143 E 73100 422	Nutrition - Food Supplies	3,300,950	3,400,950	100,000
Total Increase in Expenditures		\$ 3,300,950	\$ 3,400,950	\$ 100,000

CHANGE IN FUND BALANCE (CASH) \$ - \$ - -

MCS Nutrition Department was awarded \$100,000 to operate the USDA Local Food for Schools (LFS) Cooperative Grant. These grant funds will allow the District to purchase domestic, locally grown foods, from local producers, small businesses, and socially disadvantaged farmers/producers. The grant period is July 2023 - August 2024.

Kim Williams 7.17.23
 Reviewed by Finance Director/Finance Manager Date

Approved	<input checked="" type="checkbox"/> <i>Bobby S. Park</i> Director of Schools	7-11-23
Declined	<input type="checkbox"/>	Date

Agenda Item Title: FY24 Access for All Learning Network (AALN) Grant /Budget Amendment

Board Meeting Date: 7/25/2023

Department: Special Education

Presented by: Dr. Trey Duke, Director

Board Agenda Category:

- Consent Agenda
 - Action Item
 - Reports and Information
-

Summary

The AALN focuses on empowering districts to ensure access to high-quality literacy and mathematics instruction for students with disabilities. This grant will allow the district to provide opportunities for general and special education teachers to collaborate around unit and lesson preparation. This assists in units and lessons being adapted for individual student needs.

Staff Recommendation

Approve the budget amendment recognizing new revenue from the Access for All Learning Network Grant.

Fiscal Impact

MCS will be awarded funds in the amount of \$50,000 for the first year of implementation. These funds will be used for stipends paid to participants.

Connection to MCS's Five-Year Strategic Plan

- Known:** Every student will be *known* through whole-child programs and support.
- Safe:** Every student will be *safe* through equitable access to buildings, facilities, and infrastructure that meets their needs.
- Challenged:** Every student will be *challenged* by learning from highly effective educators and employees.
- Empowered:** Every student will be *empowered* through academic success

Schools Federal Projects Fund 142
Fiscal Year 2023-2024

Access for All Learning Networks

Account Number	Account Description	BUDGET AS PASSED OR		AMENDED BUDGET	AMENDMENT INCREASE (DECREASE)
		PREV AMENDED			
<u>Revenues</u>					
142 R 47590	Access for All Learning Grant	-		50,000	50,000
Total Increase in Revenues		\$ -		\$ 50,000	\$ 50,000
<u>Expenditures</u>					
71200 189	Special Educ - Other Salaries (Stipends)	-		43,500	43,500
71200 201	Special Educ - Social Security	-		2,700	2,700
71200 204	Special Educ - State Retirement	-		3,100	3,100
71200 212	Special Educ - Medicare	-		700	700
Total Increase in Expenditures		\$ -		\$ 50,000	\$ 50,000

CHANGE IN FUND BALANCE (CASH)

-

To budget the new FY24 Access for All Learning Networks federal grant. The allocation of \$50,000 will fund a \$1,500 stipend for 29 participating teachers. MCS will provide opportunities for general and special education teachers to collaborate around unit and lesson preparation.

Kim Williams
Reviewed by Finance Director/Finance Manager

7.18.23
Date

Approved	<input checked="" type="checkbox"/>	<i>Bobby J. Duke III</i>	Date
Declined	<input type="checkbox"/>	Director of Schools	

Agenda Item Title: FY24 General Purpose Fund TISA Budget Amendment

Board Meeting Date: July 25, 2023

Department: Finance

Presented by: Dr. Trey Duke, Director of Schools

Board Agenda Category:

- Consent Agenda
 - Action Item
 - Reports and Information
-

Summary

The Finance Department is seeking Board approval to appropriate \$300,000 of new revenue in the FY24 General Purpose Schools fund based on the State’s final TISA allocation. The amendment budgets additional funds for an additional full-time behavioral Calm Coach, transfers funds from the previously approved legal services line item to salary and benefits for the staff attorney, and increases funds in the Worker’s Compensation line item. The amendment also includes a new bi-weekly payroll assistant, one part-time Warehouse assistant, and the movement of a portion of two Coordinated School Health positions from the Nutrition fund to the General Purpose Schools fund. Additional equipment for the new Pre-K building is also included.

Staff Recommendation

Recommend approval of the FY24 GPS TISA budget amendment in the amount of \$300,000.

Fiscal Impact

This budget amendment increases total FY24 Revenues to \$101,185,186 and total Expenditures to \$105,061,633 with no change to budgeted fund balance of \$3,876,447.

Connection to MCS’s Five-Year Strategic Plan

- Known:** Every student will be *known* through whole-child programs and support.
- Safe:** Every student will be *safe* through equitable access to buildings, facilities, and infrastructure that meets their needs.
- Challenged:** Every student will be *challenged* by learning from highly effective educators and employees.
- Empowered:** Every student will be *empowered* through academic success

General Purpose Schools Fund 141
Fiscal Year 2023-24

Account Number	Account Description	BUDGET AS PASSED OR PREV AMENDED	AMENDED BUDGET	AMENDMENT INCREASE (DECREASE)
Revenues				
141 R 46510	State of TN - TISA	58,849,465	59,149,465	300,000
Total Increase in State Revenues		\$ 58,849,465	\$ 59,149,465	\$ 300,000
Grand Total FY24 Revenues		\$ 100,885,186	\$ 101,185,186	\$ 300,000
Expenditures				
141 E 71100 163	Instruction - Educ Assistants (1 Calm Coach)	\$ 3,610,000	\$ 3,636,921	\$ 26,921
141 E 71100 201	Instruction - Social Security	\$ 2,597,955	2,599,625	1,670
141 E 71100 204	Instruction - State Retirement	\$ 2,683,580	2,686,857	3,277
141 E 71100 207	Instruction - Medical Insurance	\$ 5,800,000	5,810,500	10,500
141 E 71100 208	Instruction - Dental Insurance	\$ 176,000	176,305	305
141 E 71100 212	Instruction - Medicare	\$ 607,590	607,981	391
Total Instruction (Calm Coach)		\$ 15,475,125	\$ 15,518,189	\$ 43,064
141 E 72310 189	Board of Educ - Other Salaries (Attorney)	\$ 5,430	\$ 127,430	\$ 122,000
141 E 72310 201	Board of Educ - Social Security	1,940	9,505	7,565
141 E 72310 204	Board of Educ - State Retirement	665	15,512	14,847
141 E 72310 206	Board of Educ - Life Insurance	-	187	187
141 E 72310 207	Board of Educ - Health Insurance	-	11,355	11,355
141 E 72310 208	Board of Educ - Dental Insurance	-	300	300
141 E 72310 212	Board of Educ - Medicare	455	2,225	1,770
141 E 72310 331	Board of Educ - Legal Services	178,000	35,000	(143,000)
141 E 72310 513	Board of Educ - Workers Comp Insurance	350,000	460,007	110,007
Total Board of Education		\$ 536,490	\$ 661,521	\$ 125,031
141 E 72510 119	Finance - Accountant/Bookkeeper	\$ 235,580	\$ 286,580	\$ 51,000
141 E 72510 201	Finance - Social Security	32,985	36,150	3,165
141 E 72510 204	Finance - State Retirement	64,745	67,485	2,740
141 E 72510 207	Finance - Medical Insurance	76,000	83,500	7,500
141 E 72510 208	Finance - Dental Insurance	2,550	2,850	300
141 E 72510 212	Finance - Medicare	7,715	8,455	740
Total Finance		\$ 419,575	\$ 485,020	\$ 65,445
141 E 72610 189	Operation of Plant - Other Salaries (Warehouse)	\$ 143,000	\$ 161,000	\$ 18,000
141 E 72610 212	Operation of Plant - Medicare	2,760	3,020	260
Total Operation of Plant		\$ 145,760	\$ 164,020	\$ 18,260
141 E 72120 105	Health Services - CSH Supervisor 50%	\$ -	\$ 27,535	\$ 27,535
141 E 72120 189	Health Services - CSH Assistant 20%	20,000	27,140	7,140
141 E 72120 201	Health Services - Social Security	41,795	43,945	2,150
141 E 72120 204	Health Services - State Retirement	59,500	63,720	4,220
141 E 72120 212	Health Services - Medicare	9,500	10,005	505
141 E 72120 299	Health Services - Fringe Benefits	9,000	10,050	1,050
141 E 72120 355	Health Services - Mileage	1,000	1,500	500
141 E 72120 499	Health Services - Materials/Supplies	5,000	5,400	400
141 E 72120 524	Health Services - Staff Development	4,500	5,500	1,000
Total Health Services		\$ 150,295	\$ 194,795	\$ 44,500
141 E 73400 790	Early Childhood Education - Equipment	\$ 2,500	\$ 6,200	\$ 3,700
Total Early Childhood Education		\$ 2,500	\$ 6,200	\$ 3,700
Total Increase in Expenditures		\$ 16,729,745	\$ 17,029,745	\$ 300,000
Grand Total FY24 Expenditures		\$ 104,761,633	\$ 105,061,633	\$ 300,000
FY24 Budgeted Fund Balance			3,876,447	

CHANGE IN FUND BALANCE (CASH)

To budget an additional revenue of \$300,000 in TISA funds based on the final State allocation. Funds will be used to add one-full-time Instructional Calm Coach, add attorney's salary and benefits & increase Worker's Comp from savings in Legal Services and \$125,030 TISA funds, new bi-weekly payroll accountant and summer payroll assistance, one part-time Warehouse assistant, move a portion of two Coordinated School Health positions from Nutrition fund to General Purpose fund, and add equipment for the new Cason Lane Pre-K building.

Kim Williams *7-18-23*

Reviewed by Finance Director/Finance Manager

Date

Approved	<input checked="" type="checkbox"/>	<u><i>Robert D. Pettit III</i></u>	<u><i>7/19/23</i></u>
Declined	<input type="checkbox"/>	Director of Schools	Date

COMPARISON OF BUDGET TOTALS
July 1, 2022 Through June 30, 2023

TOTAL ESTIMATED INCOME	7/1/22 - 6/30/23	\$	98,403,526
TOTAL ESTIMATED EXPENSES	7/1/22 - 6/30/23		<u>94,296,930</u>
ESTIMATED NET INCOME	6/30/23	\$	<u><u>4,106,596</u></u>

YEAR-TO-DATE REVENUE COMPARISON

JUNE 2023 ESTIMATED

PAGE 1

	BUDGET CLASS.	2021-22 BUDGET	2021-22 YTD REV.	2021-22 OVR/(UNDR) BUDGET	2021-22 %	2022-23 BUDGET	2022-23 YTD REV.	2022-23 OVR/(UNDR) BUDGET	2022-23 %
1	40110-Current Prop. Tax	15,700,000	16,240,640	540,640	103.4%	15,000,000	14,952,361	(47,639)	99.7%
2	40210-Local Option Sales Tax	13,021,844	16,693,348	3,671,504	128.2%	14,300,000	17,001,688	2,701,688	118.9%
3	40000-41110-Other County Rev	1,705,000	2,035,725	330,725	119.4%	1,761,800	2,170,655	408,855	123.2%
4	43300-44000-Other Local Revenue	1,792,500	541,214	(1,251,286)	30.2%	950,926	858,150	(92,776)	90.2%
5	46310-Health Department Programs	-	-	-	N/A	142,600	142,591	(9)	100.0%
6	46511-Basic Educ. Program	48,115,000	48,527,405	412,405	100.9%	52,851,000	52,987,982	136,982	100.3%
7	46515-Early Childhood Ed.	1,063,812	1,064,465	653	100.1%	1,063,812	1,063,812	-	100.0%
8	46530-Energy Efficient Sch	-	-	-	N/A	-	-	-	N/A
9	46590-Other State Education	1,689,401	1,012,016	(677,385)	59.9%	1,521,737	-	(1,521,737)	N/A
10	46610-Career Ladder Program	82,000	87,082	5,082	106.2%	82,000	70,728	(11,272)	86.3%
11	46615-Ext. Contract-ARRA	-	-	-	N/A	-	-	-	N/A
12	46591-Coordinated School Health	100,000	100,000	-	100.0%	100,000	100,000	-	100.0%
13	46595-Family Resource	29,600	29,612	12	100.0%	29,600	29,612	12	100.0%
14	46800-46990-Other State Revenue	227,419	118,196	(109,223)	52.0%	302,513	302,513	-	100.0%
15	47000- Federal Funds	1,007,488	1,538,458	530,970	152.7%	507,508	510,257	2,749	100.5%
16	49100-49800 Bond & City Transfers	477,720	635,976	158,256	133.1%	464,413	21,729	(442,684)	4.7%
17	49810-Approp./City Gen. Fund	7,885,103	7,885,103	-	100.0%	7,885,103	7,885,103	-	100.0%
18	49820-Operating Transfers	863,138	863,138	-	100.0%	500,000	306,344	(193,656)	61.3%
	TOTALS	\$ 93,760,025	\$97,372,380	\$ 3,612,355	103.9%	\$97,463,012.00	\$ 98,403,526	\$ 940,514	101.0%

YEAR-TO-DATE EXPENDITURE COMPARISON

JUNE 2023 ESTIMATED

PAGE 1

	BUDGET CLASS.	2021-22 BUDGET	2021-22 YTD EXP.	2021-22 OVR/(UNDR) BUDGET	2021-22 %	2022-23 BUDGET	2022-23 YTD EXP.	2022-23 OVR/(UNDR) BUDGET	2022-23 %
1	71100-Reg. Instruction	53,405,843	50,207,030	(3,198,813)	94.0%	54,131,308	\$ 52,069,195	(2,062,113)	96.2%
2	71200-Sp. Ed. Instruction	10,493,199	10,041,403	(451,796)	95.7%	11,069,380	10,720,565	(348,815)	96.8%
3	71400-Student Body Ed.	-	-	-	N/A	-	-	-	N/A
4	72110-Attendance	101,955	97,394	(4,561)	95.5%	182,175	156,196	(25,979)	85.7%
5	72120-Health Services	350,470	198,383	(152,087)	56.6%	618,920	318,792	(300,128)	51.5%
6	72130-Guidance	2,664,745	2,236,399	(428,346)	83.9%	3,310,196	2,990,519	(319,677)	90.3%
7	72210-Reg. Instr. Support	2,337,484	2,082,052	(255,432)	89.1%	2,391,127	2,006,020	(385,107)	83.9%
8	72220-Sp. Ed. Support	1,763,075	1,654,398	(108,677)	93.8%	1,826,392	1,698,350	(128,042)	93.0%
9	72250-Technology	2,092,276	1,913,076	(179,200)	91.4%	2,464,180	2,279,000	(185,180)	92.5%
10	72310-Bd. Of Education	1,739,801	1,554,425	(185,376)	89.3%	1,751,350	1,620,848	(130,502)	92.5%
11	72320-Office of Supt.	433,002	371,831	(61,171)	85.9%	423,750	374,356	(49,394)	88.3%
12	72410-Office of Principal	4,987,241	4,883,964	(103,277)	97.9%	5,217,780	5,006,171	(211,609)	95.9%
13	72510-Fiscal Services	556,510	533,720	(22,790)	95.9%	754,345	720,899	(33,446)	95.6%
14	72520-Personnel Services	497,494	457,166	(40,328)	91.9%	505,320	451,214	(54,106)	89.3%
15	72610-Oper. Of Plant	6,534,981	6,264,006	(270,975)	95.9%	6,691,130	6,056,090	(635,040)	90.5%
16	72620-Maint. Of Plant	2,938,194	2,167,893	(770,301)	73.8%	3,092,033	2,549,397	(542,636)	82.5%
17	72710-Pupil Transp.	4,087,128	3,346,182	(740,946)	81.9%	4,092,271	3,529,958	(562,313)	86.3%
18	73300-Community Service	587,955	456,089	(131,866)	77.6%	444,655	402,113	(42,542)	90.4%
19	73400-Early Childhood Educ.	1,240,007	1,133,896	(106,111)	91.4%	1,166,640	1,003,643	(162,997)	86.0%
20	76100-Reg. Cap. Outlay	130,000	88,199	(41,801)	67.8%	130,000	74,898	(55,102)	57.6%
21	82130-Education Debt Serv.	-	-	-	N/A	-	-	-	N/A
22	99100-Operating Transfers	350,900	350,898	(2)	100.0%	776,800	268,705	(508,095)	34.6%
	TOTALS	97,292,260	90,038,404	\$ (7,253,856)	92.5%	101,039,752	94,296,930	\$ (6,742,822)	93.3%