

SHERRI BAKER
9037 E 40 Rd., Bon Aqua, TN 37025

RONALD GAMMONS
6419 Rick Ln., Lyles, TN 37098

TIM HOBBS
9220 Old Bon Aqua Rd., Bon Aqua, TN 37025

JIM HUDGINS
1297 E. Grinders Switch Rd., Centerville, TN 37033



John Mullins
Director of Schools
115 MURPHREE AVENUE
CENTERVILLE, TN 37033

JAMES LANE
2059 Lake Dr., Centerville, TN 37033

CHRISTY MAYS
450 Hwy 50, Centerville, TN 37033

VANCE WILLIS
2868 Hwy. 48 N., Nunnely, TN 37137

REGULAR BOARD MEETING
Monday, October 3, 2022 7:00 PM
Room 203 Central Office

- I. Call To Order
- II. Moment of Silence
- III. Pledge of Allegiance
- IV. Approval of August 1, 2022 Regular Board Meeting Minutes
- V. September 7, 2022 Special Called Board Meeting Minutes
- VI. Approval of Agenda
- VII. Special Recognition
 - A. Employee of the Month
 - B. Recognition of Retiring Employees
- VIII. Communications to the Board
 - A. Director's Report
 - B. Financial Report
 - C. ESSER Updates
 - D. Safe TN app
 - E. 2022 Accountability
- IX. Items Requiring Board Action
 - A. 2022-2023 Board Officer Elections
 - B. Trip Request
 - 1. HCHS Senior Class
 - 2. HCMS 8th Grade Boys Basketball
 - C. Budget Amendments
 - D. Textbook Certification
 - E. 2023-2024 School Calendar Proposal
 - F. 2022-2023 Substitute Teacher Pay Scale
 - G. Declaration of Surplus Property
 - H. School Intercom System Bid
 - I. HCHS Auditorium Sound and Video Bid
 - J. Revised Board Policies 4.201, 4.402, 4.403, 4.603, 4.605, 6.200 (1st Reading)
 - K. Revised Board Policies 4.400, 4.601, 6.310 (2nd Reading)

- L. Board Policy Review 5.100-5.110
- X. Announcements
- XI. Adjourn

Monday, August 1, 2022
REGULAR BOARD MEETING MINUTES

The Hickman County Board of Education met in regular session on Monday, August 1, 2022, at 7:00 p.m. in Room 203 of the Central Office building. School board members in attendance at the meeting were Chair Amy Bryant, Ron Gammons, Steve Gianakos, Jane Herron, Tim Hobbs, Jim Hudgins, and Vance Willis.

Chair Amy Bryant asked the group to observe a moment of silence.

Amy Bryant led the group in the Pledge of Allegiance.

Jane Herron made a motion to approve the minutes from the meeting held on July 11, 2022. Steve Gianakos seconded the motion.

Monday, July 11, 2022
REGULAR BOARD MEETING MINUTES

The Hickman County Board of Education met in regular session on Monday, July 11, 2022, at 7:00 p.m. in Room 203 of the Central Office building. School board members in attendance at the meeting were Chair Amy Bryant, Ron Gammons, Steve Gianakos, Jane Herron, Tim Hobbs, Jim Hudgins, and Vance Willis.

Chair Amy Bryant asked the group to observe a moment of silence.

Amy Bryant led the group in the Pledge of Allegiance.

Steve Gianakos made a motion to approve the minutes from the meeting held on June 6, 2022. Jim Hudgins seconded the motion.

Monday, July 11, 2022
REGULAR BOARD MEETING MINUTES

The Hickman County Board of Education met in regular session on Monday, July 11, 2022, at 7:00 p.m. in Room 203 of the Central Office building. School board members in attendance at the meeting were Chair Amy Bryant, Ron Gammons, Steve Gianakos, Jane Herron, Tim Hobbs, Jim Hudgins, and Vance Willis.

Chair Amy Bryant asked the group to observe a moment of silence.

Amy Bryant led the group in the Pledge of Allegiance.

Steve Gianakos made a motion to approve the minutes from the meeting held on June 6, 2022. Jim Hudgins seconded the motion.

Monday, June 6, 2022
REGULAR BOARD MEETING MINUTES

The Hickman County Board of Education met in regular session on Monday, June 6, 2022, at 7:00 p.m. in Room 203 of the Central Office building. School board members in attendance at the meeting were Chair Amy Bryant, Ron Gammons, Steve Gianakos, Tim Hobbs, and Jim Hudgins. Jane Herron attended the meeting remotely. Vance Willis was absent from the meeting.

Chair Amy Bryant asked the group to observe a moment of silence.

Ron Gammons led the group in the Pledge of Allegiance.

Steve Gianakos made a motion to approve the minutes from the meeting held on May 2, 2022. Tim Hobbs seconded the motion.

On a voice vote, the motion was approved 6-0.

Tim Hobbs made a motion to approve the minutes from the special called meeting held on May 16, 2022. Steve Gianakos seconded the motion.

On a voice vote, the motion was approved 6-0.

Tim Hobbs made a motion to approve the minutes from the special called meeting held on May 18, 2022. Jim Hudgins seconded the motion.

On a voice vote, the motion was approved 6-0.

Steve Gianakos made a motion to amend the agenda to EHHS Girls and Boys Basketball Trip Requests to #2 under trip requests. Ron Gammons seconded the motion. On a voice vote, the motion was approved 6-0.

Steve Gianakos made a motion to approve the amended meeting agenda for June 6, 2022.

Ron Gammons seconded the motion.

The Hickman County Board of Education will meet in regular session on Monday, June 6, 2022, at 7:00 p.m. in Room 203 of the Hickman County Board of Education Central Office. A work session will be held in Room 203 at 6:00 p.m.

- I. Call to Order
- II. Moment of Silence
- III. Pledge of Allegiance
- IV. Approval of May 2, 2022 Regular Board Meeting Minutes
- V. Approval of May 16, 2022 Special Called Board Meeting Minutes
- VI. Approval of May 18, 2022 Special Called Board Meeting Minutes

- VII. Approval of Agenda
- VIII. Special Recognition
 - A. Employee of the Month--Jim Hudgins
 - B. Principal of the Year--Ron Gammons
 - C. Supervisor of the Year--Steve Gianakos
 - D. Employee of the Year--Tim Hobbs
 - E. Friend of Education--Amy Bryant
 - F. Lifetime Transportation Award--Jim Hudgins
 - G. District Championship Recognition--Tim Hobbs
 - H. State Level Competitor Recognition--Steve Gianakos
- IX. Communications to the Board
 - A. Director's Report--Director of Schools
 - B. Financial Report--Business Officer
 - C. ESSER Updates--ESSER Manager
 - D. Family Resource Centers-- Family Resource Centers Directors
 - E. Transportation Bus Routes
- X. Items Requiring Board Action
 - A. Trip Request
 - 1. EHHS HOSA National Competition--Sponsor and Students
 - 2. EHHS Girls/Boys Basketball Teams--Coaches and Students
 - B. Board Meeting Schedule for 2022-2023--Director of Schools
 - C. Annual Agenda for 2022-2023--Director of Schools
 - D. ESSER Plan Revisions--Director of Schools
 - E. Recommendations for Tenure--Director of Accountability
 - F. Budget Amendments--Business Officer
 - G. Resolution to Grant Authority to Designate Reserves--Director of Schools
 - H. Grant Executive Committee Authority to Close Out Fiscal Year--Director of Schools
 - I. Authorize Director of Schools to Submit Grants, Applications, Reports, Amendments, and Addenda--Director of Schools
 - J. 2022-2023 142 Federal Budget--Business Officer and Federal Programs Director
 - K. 2022-2023 Differentiated Pay Plan--Director of Schools
 - L. 2022-2023 Pay Scales--Director of Schools
 - M. Personnel Decisions--Director of Schools
 - N. TSSE Membership Dues--Director of Schools
 - O. Capital Outlay Projects 2021-2022--Director of Schools
 - P. Point of Sale Bid Approval for School Nutrition--Food Service Director
 - Q. Revised Board Policy 6.204 - (2nd Reading)--Director of Schools
 - R. Revised Board Policy 1.108 - (2nd Reading)--Director of Schools
 - S. Revised Board Policy 3.3001 - (2nd Reading)--Director of Accountability
 - T. Board Policy Review 4.300--4.408 --Director of Accountability
- XI. Announcements
- XII. Adjourn

On a voice vote, the motion was approved 6-0.

Alayna Duffel, EHES teacher, was recognized as Employee of the Month.

Jennifer Hudgins was recognized as the Principal of the Year. Julia Thomasson was recognized as Supervisor of the Year.

Floy Ann McCutchen and Becky Malugin were recognized as the Employees of the Year.

Juanest and Eartha Cathey were recognized as the Friends of Education.

Debbie Buchanan was recognized for the Lifetime Transportation Award.

The EHHS Girls Basketball team and HCHS Volleyball teams were recognized for achieving district championships during the school year.

Steve Gianakos made a motion to accept the Director's Report. Jim Hudgins seconded the motion.

Memorandum

To: Board Members
From: Michelle Gilbert
Date: May 28, 2022
RE: June Director's Report

Leave of Absence

Professional
Kendra Mayberry 2022-2023 school year

Support Staff

Hiring

Professional
David Carroll HCHS Math
Support Staff
Glenn Devore Maintenance Technician
Tina Tidwell EHHS Guidance Secretary
Heather Jefferson Food Service
Tiffany Underwood Food Service
Anissa Western Food Service

Resignation

Professional
Anndrea Eubanks EHIS Teacher
Cayla Moulton EHMS Teacher/Athletic Director
Gabrielle Horner EHMS Teacher
Paul Ewing EHHS Teacher
Jason Terlecki EHHS Teacher
Support Staff
Kayla Pardue EHHS Guidance Secretary
Jennifer Chilton HCMS Softball Coach

Retirement

Professional
Jennifer Lynn HCMS/HCHS Choir
Judi Culver EHIS Special Education
Support Staff

Transfers

Professional

Support Staff

Appointment

Professional

Support Staff

Open Positions

- 2 Secondary Math Positions
- 2 Secondary English Positions
- 2 Secondary Science Positions
- 1 Spanish Position
- 2 Special Education Positions
- 1 Speech Language Position
- 1 Behavior Support Position
- Bus Drivers

* Denotes a relationship under board policy 1.108. Applicants are qualified for the positions.

On a voice vote, the motion was approved 6-0.

Jim Hudgins made a motion to accept the financial report as presented. Tim Hobbs seconded the motion. On a voice vote, the motion was approved 6-0.

Steve Gianakos made a motion to accept the ESSER updates as presented. Jim Hudgins seconded the motion. On a voice vote, the motion was approved 6-0.

Ron Gammons made a motion to accept the Family Resource Center End of Year Report. Steve Gianakos seconded the motion. On a voice vote, the motion was approved 6-0.

Ron Gammons made a motion to approve the EHHS HOSA overnight trip request to attend the national competition in Nashville, TN on June 22-24, 2022. Steve Gianakos seconded the motion. On a voice vote, the motion was approved 6-0.

Tim Hobbs made a motion to approve the EHHS Girls Basketball overnight trip request to attend basketball camp at the University of North Alabama in Florence, AL on June 8, 2022. Ron Gammons seconded the motion. On a voice vote, the motion was approved 6-0.

Ron Gammons made a motion to approve the EHHS Boys Basketball overnight trip request to attend basketball camp at Wayne County High School on June 19-June 22, 2022. Tim Hobbs seconded the motion. On a voice vote, the motion was approved 6-0.

Steve Gianakos made a motion to approve the board meeting schedule for the 2022-2023 school year. Ron Gammons seconded the motion.

2022-2023
Hickman County Board of Education Meeting Dates
July 11, 2022
August 1, 2022
September 12, 2022 Work Session
October 3, 2022
November 7, 2022
December 5, 2022
January 9, 2023
February 6, 2023
March 6, 2023
April 3, 2023
May 1, 2023
June 5, 2023

On a voice vote, the motion was approved 6-0.

Tim Hobbs made a motion to approve the annual agenda with the addition of the review of the safety plan. Steve Gianakos seconded the motion.

Ron Gammons made a motion to amend the motion to add the safety plan discussion at the July work session. Jim Hudgins seconded the motion. On a voice vote, the motion was approved 6-0.

Hickman County Board of Education
Annual Agenda 2022-2023
July 2022

Work Session	Board Meeting
Evaluation tool selected for the Director of Schools for the 2022-2023 school year	Student Discipline Hearing Authority Designation
	Approval of School Fees
Board Policy Review	Board Policy Review
Safety Plan Review	

August 2022

Work Session	Board Meeting
Board Policy Review	Board Policy Review

September 2022

Work Session	Board Meeting
Strategic Plan and Goals	

October 2022

Work Session	Board Meeting
Board Policy Review	Board Policy Review
	Election of Officers of the Board
	Compliance Report
	Textbook Certification
	Approval of School Calendar
	Honor Retirees

November 2022

Work Session	Board Meeting
Board Policy Review	Board Policy Review
	Approval of Supplement Splitting

December 2022

Work Session	Board Meeting
--------------	---------------

January 2023

Work Session	Board Meeting
Set Date(s) for Board Retreat	
Board Policy Review	Board Policy Review

February 2023

Work Session	Board Meeting
Board Policy Review	Board Policy Review
2022-2023 Budget Discussion	2022-2023 Budget Calendar

March 2023

Work Session	Board Meeting
Board Policy Review	Board Policy Review
2022-2023 Budget Discussion	Set Attendance Zones
Evaluation Distribution	

April 2023

Work Session	Board Meeting
Board Policy Review	Board Policy Review
2022-2023 Budget Discussion	Textbook Adoption Approval

May 2023

Work Session	Board Meeting
Board Policy Review	Board Policy Review
	Tuition Rate Approval for Out of County Students
	Teacher Tenure
2022-2023 Budget	2022-2023 Budget (141, 142, 143)
	Authorize Superintendent to Submit Grants, Applications, Reports, Amendments, and Addenda
	Recognize Teachers of the Year

June 2023

Work Session	Board Meeting
Board Policy Review	Board Policy Review
	Personnel Decisions and Placement
Annual Agenda	Annual Agenda
Meeting Schedule 2022-2023	Adopt Board Meeting Schedule 2022-2023
	Annual Budget 2022-2023 (if needed)
	Grant Executive Committee authority to close

	out fiscal year
Director of Schools Evaluation	Director of Schools Evaluation
	Recognize Employee of the Year and Friend of Education

On a voice vote, the motion was approved 6-0.

Steve Gianakos made a motion to approve the ESSER revision of adding an LPN to the plan as presented. Tim Hobbs seconded the motion.

Aye _____ Nay _____ Pass _____ Absent _____

Amy Bryant

Ron Gammons

Steve Gianakos

Jane Herron

Tim Hobbs

Jim Hudgins

Vance Willis

On a roll call vote, the motion was approved 6-0-1.

Amy Bryant made a motion to approve the recommendations for tenure as presented and read aloud to the Board of Education. Steve Gianakos seconded the motion.

Recommendations for Tenure

June 2022

Charlotte Boehms

Patricia Qualls

Cheri Cutelle

Kendra Mayberry

Leah Isenberg

Tracy Rivers

Rebecca Powers

Allison Gilbert

Amber Warren

On a voice vote, the motion was approved 6-0.

Steve Gianakos made a motion to approve budget amendments 35-36. Jim Hudgins seconded the motion.

Aye _____ Nay _____ Pass _____ Absent _____

Amy Bryant
Ron Gammons
Steve Gianakos
Jane Herron
Tim Hobbs
Jim Hudgins

Vance Willis

On a roll call vote, the motion was approved 6-0-1.

Jim Hudgins made a motion to approve Resolution 22-01. Steve Gianakos seconded the motion.

Aye _____ Nay _____ Pass _____ Absent _____

Amy Bryant
Ron Gammons
Steve Gianakos
Jane Herron
Tim Hobbs
Jim Hudgins

Vance Willis

On a roll call vote, the motion was approved 6-0-1.

Steve Gianakos made a motion to allow the the Executive Committee, with guidance from our State Financial Consultant, Business Officer, and Finance Office Director and Assistant Director close out the financial books, including budget amendments. Jim Hudgins seconded the motion.

Aye _____ Nay _____ Pass _____ Absent _____

Amy Bryant
Ron Gammons
Steve Gianakos
Jane Herron
Tim Hobbs
Jim Hudgins

Vance Willis

On a roll call vote, the motion was approved 6-0-1.

Ron Gammons made a motion to allow authorize the Director of Schools to submit Reports, Applications, Amendments, and Addenda including Federal applications and Budgets, and any other grants or awards in closing the 2021-2022 school year and for the rising 2022-2023 school year on behalf of the Hickman County School System. Jim Hudgins seconded the motion.

Aye _____ Nay _____ Pass _____ Absent _____

Amy Bryant
Ron Gammons
Steve Gianakos
Jane Herron
Tim Hobbs
Jim Hudgins

Vance Willis

On a roll call vote, the motion was approved 6-0-1.

Amy Bryant made a motion to approve the 142 federal budgets as presented. Steve Gianakos seconded the motion.

Aye _____ Nay _____ Pass _____ Absent _____

Amy Bryant
Ron Gammons
Steve Gianakos
Jane Herron
Tim Hobbs
Jim Hudgins

Vance Willis

On a roll call vote, the motion was approved 6-0-1.

Steve Gianakos made a motion to approve the differentiated pay plan for 2022-2023. Tim Hobbs seconded the motion.

Aye _____ Nay _____ Pass _____ Absent _____

Amy Bryant
Ron Gammons
Steve Gianakos
Jane Herron
Tim Hobbs
Jim Hudgins

Vance Willis

On a roll call vote, the motion was approved 6-0-1.

Amy Bryant made a motion to approve the 2022-2023 pay scales as presented. Steve Gianakos seconded the motion.

<u>Aye</u>	<u>Nay</u>	<u>Pass</u>	<u>Absent</u>
------------	------------	-------------	---------------

Amy Bryant
Ron Gammons
Steve Gianakos
Jane Herron
Tim Hobbs
Jim Hudgins

Vance Willis

On a roll call vote, the motion was approved 6-0-1.

Steve Gianakos made a motion to approve the personnel decisions as presented. Tim Hobbs seconded the motion. On a voice vote, the motion was approved 6-0.

Amy Bryant made a motion to approve the TSSE dues for the 2022-2023 school year for \$3,435.00. Jim Hudgins seconded the motion.

<u>Aye</u>	<u>Nay</u>	<u>Pass</u>	<u>Absent</u>
------------	------------	-------------	---------------

Amy Bryant

Ron Gammons

Steve Gianakos
Jane Herron

Tim Hobbs

Jim Hudgins

Vance Willis

On a roll call vote, the motion was approved 4-2-1.

Jim Hudgins made a motion to approve the expenditures towards tennis court repairs (quotes presented at \$23,000 and \$19,000) at both high schools, sealing and striping the HCMS/HCHS parking lots(bid presented at \$107,625.80) , and the grate drain at EHHS (bid presented at \$39,750.00) in an amount not to exceed a total of \$200,000.00 from the 2021-2022 budget. Tim Hobbs seconded the motion.

<u>Aye</u>	<u>Nay</u>	<u>Pass</u>	<u>Absent</u>
------------	------------	-------------	---------------

Amy Bryant
Ron Gammons
Steve Gianakos
Jane Herron
Tim Hobbs
Jim Hudgins

Vance Willis

On a roll call vote, the motion was approved 6-0-1.

Steve Gianakos made a motion to approve the point of sale bid for school nutrition not to exceed \$35,000.00. Ron Gammons seconded the motion.

Aye _____ Nay _____ Pass _____ Absent _____

Amy Bryant
Ron Gammons
Steve Gianakos
Jane Herron
Tim Hobbs
Jim Hudgins

Vance Willis

On a roll call vote, the motion was approved 6-0-1.

Steve Gianakos made a motion to approve revised board policy 6.204 on second reading. Jim Hudgins seconded the motion. On a voice vote, the motion was approved 6-0.

Tim Hobbs made a motion to approve revised board policy 1.108 on second reading. Steve Gianakos seconded the motion. Ron Gammons requested a roll call vote.

Aye _____ Nay _____ Pass _____ Absent _____

Amy Bryant

Ron Gammons

Steve Gianakos
Jane Herron
Tim Hobbs
Jim Hudgins

Vance Willis

On a roll call vote, the motion was approved 5-1-1.

Amy Bryant made a motion to approve board policy 3.301 on second reading. Tim Hobbs seconded the motion. On a voice vote, the motion was approved 6-0.

Amy Bryant made a motion to approve the review and update of board policies 4.300-4.408. Jim Hudgins seconded the motion. On a voice vote, the motion was approved 6-0.

Michelle Gilbert announced that summer camp would be held from June 6-30 at six locations.

Amy Bryant announced the changes in TSBA training.

The meeting was adjourned at 8:12 p.m.

On a voice vote, the motion was approved 6-0-1. Vance Willis passed on the motion.

Vance Willis made a motion to amend the agenda to add Item VIII. N. Employee Health Insurance under Items Requiring Board Action. Steve Gianakos seconded the motion. On a voice vote, the motion was approved 7-0.

Ron Gammons made a motion to approve the amended agenda. Tim Hobbs seconded the motion.

The Hickman County Board of Education will meet in regular session on Monday, July 11, 2022, at 7:00 p.m. in Room 203 of the Hickman County Board of Education Central Office. A work session will be held in Room 203 at 6:00 p.m.

- I. Call to Order
- II. Moment of Silence
- III. Pledge of Allegiance
- IV. June 6, 2022 Regular Board Meeting Minutes
- V. Approval of Agenda
- VI. Special Recognition
 - A. Employee of the Month--Jim Hudgins
- VII. Communications to the Board
 - A. Director's Report--Director of Schools
 - B. Financial Report--Business Officer
 - C. ESSER Updates--ESSER Manager
 - D. School Safety Measures--School Safety Team
 - E. Transportation Bus Routes
 - F. 2021-2022 State Assessment Results--Academic Supervisors
- VIII. Items Requiring Board Action
 - A. Budget Amendments--Business Officer
 - B. Close Out Budget Amendments--Business Officer
 - C. 2022-2023 Consolidated Application--Federal Programs Director
 - D. Recommendation for Tenure--Secondary Supervisor
 - E. 2022-2023 Student Discipline Hearing Authority--Director of Schools
 - F. 2022-2023 School Fees--Director of Schools
 - G. 2022-2023 Nutrition Program Prices--Nutrition Coordinator and Business Officer
 - H. Federal Programs Cashflow Request--Business Officer
 - I. 2022-2023 BEP Teacher Scale--Director of Schools
 - J. Revised Board Policies - 1.102, 3.202, 4.101, 4.212, 4.402, 4.403, 4.406, 4.600, 5.119, 5.200, 5.201, 5.701, 5.201, 6.200, 6.318, 6.409, 1.104, 1.105, 1.204 (1st Reading)--Director of Accountability
 - K. Board Policy Review - 4.500--4.608--Director of Accountability
 - L. Declaration of Surplus--HCHS Basketball Program
 - M. ESSER Grant Contracts--Director of Schools
 - N. Employee Health Insurance
- IX. Announcements
- X. Adjourn

On a roll call vote, the motion was approved 7-0.

Vance Willis made a motion to approve the Director's Report. Steve Gianakos seconded the motion.

Memorandum

To: Board Members
From: Michelle Gilbert
Date: June 28, 2022
RE: July Director's Report

Leave of Absence

Professional
Support Staff

Hiring

<u>Professional</u>	
Cullen Homolka	EHHS Physical Education/Assistant Football Coach
Nick Bentley*	CES Physical Education
Kelly Medford	HCMS/HCHS Music
Robert Brewer*	HCHS/EHHS Career Technical Education Teacher
Tonda Gainey	EHIS ELA Teacher
Jennifer Presson	EHHS ELA Teacher
Samantha Avery	EHHS/HCHS Art Teacher
Jenny Sensing	EHIS ELA Teacher
<u>Support Staff</u>	
Pamela Hunnicutt	EHES Sp. Ed. Assistant

Resignation

<u>Professional</u>	
Bethany Ring	EHMS Teacher
Joseph Slaughter	EHES/EHIS Physical Education
Heather Turner	EHES Teacher
Abigail Loveless	HCMS ELA Teacher
Mason Rochelle	EHIS Physical Education Teacher
<u>Support Staff</u>	
Preston Hall	EHMS Baseball Coach
Ray Ragan	EHHS Baseball Coach
Clay Chessor	HCHS Baseball Coach

Retirement

Professional
Support Staff

Transfers

<u>Professional</u>	
Brandy Warren	EHMS Math to HCMS ELA
Stacia Anglin	Alternative School to CES School Counselor
Gavin Gordon	EHHS to HCHS Physical Education/Girls Basketball
Shelby Owens	HCMS ELA Teacher to Math Teacher
Chastity Lampley	HCMS ELA Teacher to Special Education
Robin DeVault	HCMS ELA Teacher to Library Steam Specialist
<u>Support Staff</u>	
Chelsea Anglin	CES/CIS to CES Pre-K Assistant

Appointment

Professional

Joey Chilton
Kimberly Clark
Gabby Poston
Ben Bentley

CTE Director
HCMS Boys & Girls Cross-Country Coach
HCMS Girls Soccer Coach
HCHS Girls Cross-Country Coach

Support Staff

Christie Carter
Madelyn True*
Heather Nihoff
Allie Burgess
Adam Huffines
Caleb Garrett
Ben Green

HCMS Volleyball Coach
HCMS Assistant Volleyball Coach
EHMS Volleyball Coach
EHMS Girls Basketball Coach
EHMS Asst. Football Coach
EHMS Asst. Football Coach
HCMS Head Football Coach

Open Positions

2 Secondary Math Positions
2 Secondary English Positions
2 Secondary Science Positions
1 Spanish Position
2 Special Education Positions
1 Speech Language Position
1 Behavior Support Position
Bus Drivers

* Denotes a relationship under board policy 1.108. Applicants are qualified for the positions.

On a roll call vote, the motion was approved 7-0.

Vance Willis made a motion to approve the financial report. Steve Gianakos seconded the motion. On a voice vote, the motion was approved 7-0.

Steve Gianakos made a motion to approve the ESSER update. Jim Hudgins seconded the motion. On a voice vote, the motion was approved 7-0.

The school safety team presented preventative measures that are in place for the safety of students and staff members at each building location to the board members and public present at the meeting.

The transportation director presented information regarding the support provided from TDOE for scheduling bus routes.

Steve Gianakos made a motion to approve budget amendment 1. Jane Herron seconded the motion.

<u>Aye</u>	<u>Nay</u>	<u>Pass</u>	<u>Absent</u>
------------	------------	-------------	---------------

Amy Bryant
Ron Gammons
Steve Gianakos
Jane Herron
Tim Hobbs
Jim Hudgins
Vance Willis

On a roll call vote, the motion was approved 7-0.

Steve Gianakos made a motion to approve close out budget amendments 35-41 for fiscal year 2022. Tim Hobbs seconded the motion.

<u>Aye</u>	<u>Nay</u>	<u>Pass</u>	<u>Absent</u>
------------	------------	-------------	---------------

Amy Bryant
Ron Gammons
Steve Gianakos
Jane Herron
Tim Hobbs
Jim Hudgins
Vance Willis

On a roll call vote, the motion was approved 7-0.

Tim Hobbs made a motion to approve tenure for Jennifer Cooper. Amy Bryant seconded the motion. On a voice vote, the motion was approved 7-0.

Steve Gianakos made a motion to approve the appointment of the Student Discipline Hearing Authority for 2022-2023. Vance Willis seconded the motion. On a voice vote, the motion was approved 7-0.

Vance Willis made a motion to approve the 2022-2023 school fees submitted from the schools. Steve Gianakos seconded the motion. On a voice vote, the motion was approved 7-0.

Steve Gianakos made a motion to approve the school nutrition program prices for 2022-2023. Jim Hudgins seconded the motion.

<u>Aye</u>	<u>Nay</u>	<u>Pass</u>	<u>Absent</u>
------------	------------	-------------	---------------

Amy Bryant
Ron Gammons
Steve Gianakos
Jane Herron
Tim Hobbs
Jim Hudgins
Vance Willis

On a roll call vote, the motion was approved 7-0.

Vance Willis made a motion to approve a federal cash flow request to increase the reserve from \$500,000.00 to \$750,000.00. Ron Gammons seconded the motion.

<u>Aye</u>	<u>Nay</u>	<u>Pass</u>	<u>Absent</u>
------------	------------	-------------	---------------

Amy Bryant
Ron Gammons
Steve Gianakos
Jane Herron
Tim Hobbs
Jim Hudgins
Vance Willis

On a roll call vote, the motion was approved 7-0.

Steve Gianakos made a motion to approve the revised BEP Teacher Scale for 2022-2023. Jane Herron seconded the motion.

<u>Aye</u>	<u>Nay</u>	<u>Pass</u>	<u>Absent</u>
------------	------------	-------------	---------------

Amy Bryant
Ron Gammons
Steve Gianakos
Jane Herron
Tim Hobbs
Jim Hudgins
Vance Willis

On a roll call vote, the motion was approved 7-0.

Vance Willis made a motion to suspend the rules and approve revised board policy 4.600 without second reading. Steve Gianakos seconded the motion. On a voice vote, the motion was approved 7-0.

Vance Willis made a motion to approve board policy 4.402 on first reading and add the lines regarding BEP funding to board policy 4.400. Tim Hobbs seconded the motion. On a voice vote, the motion was approved 7-0.

Amy Bryant made a motion to approve board policies 1.102, 3.202, 4.101, 4.212, 4.403, 4.406, 5.119, 5.200, 5.201, 5.701, 5.201, 6.200, 6.318, 6.409, 1.104, 1.105, and 1.204 on first reading. Steve Gianakos seconded the motion. On a voice vote, the motion was approved 7-0.

Amy Bryant made a motion to approve the review of board policies 4.500-4.608 and to ask TSBA for guidance on board policy 4.601, lines 11-17 regarding driver license requirements and if needed to bring back policy 4.601 in August. Tim Hobbs seconded the motion. On a voice vote, the motion was approved 7-0.

Amy Bryant made a motion to approve the HCHS Basketball program request to declare a Dr. Dish piece of equipment as surplus to be sold through online auction with a reserve. Jim Hudgins seconded the motion.

<u>Aye</u>	<u>Nay</u>	<u>Pass</u>	<u>Absent</u>
------------	------------	-------------	---------------

Amy Bryant
Ron Gammons
Steve Gianakos
Jane Herron
Tim Hobbs
Jim Hudgins
Vance Willis

On a roll call vote, the motion was approved 7-0.

Vance Willis made a motion to approve the construction management contract for the ESSER funded projects. Steve Gianakos seconded the motion.

<u>Aye</u>	<u>Nay</u>	<u>Pass</u>	<u>Absent</u>
------------	------------	-------------	---------------

Amy Bryant
Ron Gammons
Steve Gianakos
Jane Herron
Tim Hobbs
Jim Hudgins
Vance Willis

On a roll call vote, the motion was approved 7-0.

Amy Bryant made a motion to approve employee health insurance at 70/30 unless it hurts the employee and grandfather those employees at the current rate of insurance level of up to \$7,900.00. Jim Hudgins seconded the motion.

<u>Aye</u>	<u>Nay</u>	<u>Pass</u>	<u>Absent</u>
------------	------------	-------------	---------------

Amy Bryant
Ron Gammons
Steve Gianakos
Jane Herron
Tim Hobbs
Jim Hudgins
Vance Willis

On a roll call vote, the motion was approved 7-0.

The meeting was adjourned at 8:16 p.m.

On a voice vote, the motion was approved 7-0.

Steve Gianakos made a motion to approve the minutes from the special called meeting held on July 21, 2022. Jim Hudgins seconded the motion.

On a voice vote, the motion was approved 5-0-2. Tim Hobbs and Vance Willis passed on the motion because they were absent from the meeting.

Ron Gammons made a motion to approve the agenda. Jim Hudgins seconded the motion.

Amy Bryant made a motion to amend the agenda to add under Items Requiring Board Action, items H. Substitute Teacher and Bus Driver Pay, I. Golf Course MOU, J. Letter to Board of Education, and K. Flat Screen Purchase. Steve Gianakos seconded the motion. On a voice vote, the amendment was approved 7-0.

The Hickman County Board of Education will meet in regular session on Monday, August 1, 2022, at 7:00 p.m. in Room 203 of the Hickman County Board of Education Central Office. A work session will be held in Room 203 at 6:00 p.m.

- I. Call to Order
- II. Moment of Silence
- III. Pledge of Allegiance
- IV. July 11, 2022 Regular Board Meeting Minutes
- V. July 21, 2022 Special Called Board Meeting Minutes
- VI. Approval of Agenda
- VII. Special Recognition
 - A. Employee of the Month--Jim Hudgins
 - B. Board Member Recognition--Director of Schools
- VII. Communications to the Board
 - A. Director's Report--Director of Schools
 - B. Financial Report--Business Officer
 - C. ESSER Updates--Director of Schools
 - D. 2021-2022 Academic Report--Academic Supervisors
 - E. OPEB Quarterly Report--Director of Schools
- VIII. Items Requiring Board Action
 - A. Event Request
 1. HCHS JROTC--Sponsor and Students
 - B. Budget Amendments--Business Officer
 - C. 2022-2023 Health and Safety Plan--Director of Schools
 - D. Revised Board Policies - 4.400, 4.601, 6.310 (1st Reading)--Director of Accountability
 - E. Revised Board Policies - 1.102, 3.202, 4.101, 4.212, 4.402, 4.403, 4.406, 4.600, 5.119, 5.200, 5.201, 5.701, 6.200, 6.318, 6.409, 1.104, 1.105, 1.204 (2nd Reading)--Director of Accountability
 - F. Board Policy Review - 4.700 – 4.804--Director of Accountability
 - G. ESSER Grant Contracts--Director of Schools
 - H. Substitute Teacher and Bus Driver Pay--Director of Schools
 - I. Golf Course MOU--Director of Schools
 - J. Letter to Board of Education--Director of Schools
 - K. Flat Screen Purchase--Director of Schools
- IX. Announcements
- X. Adjourn

On a voice vote, the motion was approved 7-0.

Julie Rice was recognized by Jim Hudgins as Employee of the Month.

Amy Bryant, Steve Gianakos, and Jane Herron were recognized by the Hickman County Board of Education for their years of service as board members.

Michelle Gilbert reported the addition of Misty Shelton under appointments as the Deputy Superintendent. Ron Gammons made a motion to approve the amended Director's Report. Vance Willis seconded the motion.

Memorandum

To: Board Members
From: Michelle Gilbert
Date: July 26, 2022
RE: August Director's Report

Leave of Absence

Professional

Cary Wright

FMLA July 25-August 9, 2022

Support Staff

Hiring

Professional

Jeffery Kapke

HCHS Math/Head Baseball Coach

Caleb Brewer*

EHHS Physical Education/Head Baseball Coach

Brittany Gilbert

EHHS School Counselor

Hannah Redden

EHES/EHIS Physical Education

Gabriel Ruiz-Ballard

HCHS Spanish

Shannon Profitt

EHHS Math

Shannon Kwidkawski

HCHS English

Spencer Harris

EHMS English

Mark Gobble

EHMS Social Studies

Thomas Burkett

EHMS Science

Jayden Malugin*

EHHS Math

Madelyn Owens

CIS ELA

Emma Orton

EHES Teacher

Support Staff

Gia Lawrence

Special Education Assistant

Cassidy LaCasse

Special Education Assistant

Resignation

Professional

Teresa Tharpe

EHHS Math

Bert Buchler

EHMS Special Education

Lauren Sauls

EHMS ELA

Support Staff

Retirement

Professional

Support Staff

Transfers

Professional

Support Staff

Appointment

Professional

Joey Chilton
Misty Shelton

CTE Director
Deputy Director of Schools

Support Staff

Christie Carter
Madelyn True*
Heather Nihoff
Allie Burgess
Adam Huffines
Caleb Garrett
Ben Green
Kimberly Clark
Gabby Poston
Ben Bentley

HCMS Volleyball Coach
HCMS Assistant Volleyball Coach
EHMS Volleyball Coach
EHMS Girls Basketball Coach
EHMS Asst. Football Coach
EHMS Asst. Football Coach
HCMS Head Football Coach
HCMS Boys & Girls Cross-Country Coach
HCMS Girls Soccer Coach
HCHS Girls Cross-Country Coach

Open Positions

1 Secondary Math Position
1 Secondary Science Position
1 K-5 position
1 Intervention Position
1 Spanish Position
2 Special Education Positions
1 Speech Language Position
1 Behavior Support Position
Bus Drivers

* Denotes a relationship under board policy 1.108. Applicants are qualified for the positions.

On a voice vote, the motion was approved 7-0.

Steve Gianakos made a motion to approve the financial reports from June and July 2022. Ron Gammons seconded the motion. On a voice vote, the motion was approved 7-0.

Vance Willis made a motion to accept the ESSER report. Jane Herron seconded the motion. On a voice vote, the motion was approved 7-0.

The academic supervisors presented academic information regarding achievement on TCAP testing for 2021-2022. Amy Bryant made a motion to accept the report. Ron Gammons seconded the motion. On a voice vote, the motion was approved 7-0.

Ron Gammons made a motion to accept the OPEB Trust quarterly report. Steve Gianakos seconded the motion. On a voice vote, the motion was approved 7-0.

Ron Gammons made a motion to approve the HCHS JROTC Raider Meet to be held on the campus of HCHS on September 3, 2022. Tim Hobbs seconded the motion. On a voice vote, the motion was approved 7-0.

Steve Gianakos made a motion to approve budget amendments 2-4. Vance Willis seconded the motion.

<u>Aye</u>	<u>Nay</u>	<u>Pass</u>	<u>Absent</u>
------------	------------	-------------	---------------

Amy Bryant

Ron Gammons

Steve Gianakos

Jane Herron

Tim Hobbs

Jim Hudgins

Vance Willis

On a roll call vote, the motion was approved 7-0.

Vance Willis made a motion to approve the 2022-2023 health and safety plan for COVID-19. Tim Hobbs seconded the motion. On a voice vote, the motion was approved 7-0.

Amy Bryant made a motion to approve revised board policies 4.400, 4.601, and 6.310 with the added footnote on first reading. Ron Gammons seconded the motion. On a voice vote, the motion was approved 7-0.

Vance Willis made a motion to approve revised board policies 1.102, 3.202, 4.101, 4.212, 4.402, 4.403, 4.406, 4.600, 5.119, 5.200, 5.201, 5.701, 6.200, 6.318, 6.409, 1.104, 1.105, and 1.204 on second reading. Steve Gianakos seconded the motion. On a voice vote, the motion was approved 7-0.

Vance Willis made a motion to approve the review of board policies 4.700-4.804. Amy Bryant seconded the motion. On a voice vote, the motion was approved 7-0.

Amy Bryant made a motion to approve the substitute teacher daily rate as \$75/day for a base rate and to approve substitute bus driver pay at the level of 0 years daily rate. Ron Gammons seconded the motion. On a voice vote, the motion was approved 7-0.

Steve Gianakos made a motion to approve the 2022-2023 MOU with the Town of Centerville and the Centerville Municipal Golf Course. Jane Herron seconded the motion.

Amy Bryant made a motion to amend the MOU to correct the payment day to June 30, 2023 instead of June 30, 2023. Vance Willis seconded the motion. On a voice vote the motion to amend the motion was approved 7-0.

Amy Bryant declared a potential conflict of interest because her son plays on the golf team and stated she would abstain from voting.

<u>Aye</u>	<u>Nay</u>	<u>Pass</u>	<u>Absent</u>
		Amy Bryant	

Ron Gammons
Steve Gianakos
Jane Herron
Tim Hobbs
Jim Hudgins
Vance Willis

On a roll call vote, the motion was approved 6-0-1.

Amy Bryant made a motion to accept the letter received from Michelle Gilbert regarding not requesting another contract at the end of the current contract and to place acknowledgement in the minutes. Jim Hudgins seconded the motion. On a voice vote, the motion was approved 6-0.

Ron Gammons made a motion to approve the purchase of interactive panels in the Best for All grant not to exceed \$122,000.00. Tim Hobbs seconded the motion.

<u>Aye</u>	<u>Nay</u>	<u>Pass</u>	<u>Absent</u>
------------	------------	-------------	---------------

Amy Bryant
Ron Gammons
Steve Gianakos
Jane Herron
Tim Hobbs
Jim Hudgins
Vance Willis

On a roll call vote, the motion was approved 7-0.

Vance Willis made a motion to revise the scheduled September work session from September 12 to September 7, 2022, at 6:00 p.m. Tim Hobbs seconded the motion. On a voice vote, the motion was approved 7-0.

The meeting was adjourned at 8:38 p.m.

Tuesday, September 7, 2022
SPECIAL CALLED BOARD MEETING MINUTES

The Hickman County Board of Education met in special session on Tuesday, September 7, 2022, at 6:00 p.m. in Room 203 of the Central Office building. School board members in attendance at the meeting were Chair Tim Hobbs, Sherri Baker, Ron Gammons, Jim Hudgins, Doug Lane, Christy Mays, and Vance Willis.

Tim Hobbs called the meeting to order and asked the group to observe a moment of silence.

Ron Gammons led the group in the Pledge of Allegiance.

Jim Hudgins made a motion to approve the agenda. Vance Willis seconded the motion.

The Hickman County Board of Education will meet in a special called session on Wednesday, September 7, 2022, at 6:00 p.m. in Room 203 of the Hickman County Board of Education Central Office. A work session will be held in Room 203 following the special called board meeting.

- I. Call to Order
- II. Moment of Silence
- III. Pledge of Allegiance
- IV. Approval of Agenda
- V. Communications to the Board
 - A. Board Policy 1.2021--Board of Education Vice-Chair
- VI. Items Requiring Board Action
 - A. 2022-2023 Return to In-Person Learning and Continuity of Services--Director of Schools
 - B. 2022-2023 Federal Grants Approval--Director of Schools
 - 1. ESSER Public Plan for Remaining Funds--Director of Schools
 - 2. Consolidated Application--Federal Programs Director
 - C. Edmentum contract--Business Officer
 - D. Employee Insurance--Director of Schools
 - E. Budget Amendments--Business Officer
- IX. Announcements
- X. Adjourn

On a voice vote, the motion was approved 7-0.

Tim Hobbs asked the group to review board policy 1.2021 to make sure everyone is aware of the policy.

Vance Willis made a motion to approve the Health and Safety Plan that will be submitted. Tim Hobbs seconded the motion. On a voice vote, the motion was approved 6-0.

Christy Mays entered the meeting.

Vance Willis made a motion to approve the ESSER public plan for use of the remaining ESSER funds. Tim Hobbs seconded the motion.

Aye _____ Nay _____ Pass _____ Absent _____

Sherri Baker
Ron Gammons
Tim Hobbs
Jim Hudgins
Doug Lane
Christy Mays
Vance Willis

On a roll call vote, the motion was approved 7-0.

Vance Willis made a motion to approve the approval of entering the Edmentum contract for a three year period. Jim Hudgins seconded the motion.

Aye _____ Nay _____ Pass _____ Absent _____

Sherri Baker
Ron Gammons
Tim Hobbs
Jim Hudgins
Doug Lane
Christy Mays
Vance Willis

On a roll call vote, the motion was approved 7-0.

Ron Gammons made a motion to approve budget amendments 5 and 6. Jim Hudgins seconded the motion.

Aye _____ Nay _____ Pass _____ Absent _____

Sherri Baker
Ron Gammons
Tim Hobbs
Jim Hudgins
Doug Lane
Christy Mays
Vance Willis

On a roll call vote, the motion was approved 7-0.

Vance Willis made a motion to not modify the budget for the 2022-2023 school year for employee medical insurance but to consider it in the 2023-2024 budget. Ron Gammons seconded the motion.

On a voice vote, the motion was approved 7-0.

The meeting was adjourned at 6:57 p.m.

DOUG LANE
2059 Lake Drive, Centerville, TN 37033

RONALD GAMMONS
6419 Rice Ln., Lyles, TN 37098

TIM HOBBS
9220 Old Bon Aqua Rd., Bon Aqua, TN 37025

JIM HUDGINS
1297 E. Grinders Switch Rd., Centerville, TN 37033



Michelle Gilbert
Director of Schools
115 MURPHREE AVENUE
CENTERVILLE, TN 37033

CHRISTY MAYS
450 Hwy. 50, Centerville, TN 37033

SHERRI BAKER
9037 E 40 Rd., Bon Aqua, TN 37025

VANCE WILLIS
2868 Hwy 48 N., Nunnally, TN 37137

The Hickman County Board of Education will meet in regular session on Monday, October 3, 2022, at 7:00 p.m. in the library of Hickman County High School. A work session will be held from 6:00 p.m. until 6:30 p.m. in the Hickman County High School Library. A reception honoring employees that retired will be held from 6:30 p.m. until 7:00 p.m. in the Hickman County High School cafeteria.

- I. Call to Order
- II. Moment of Silence
- III. Pledge of Allegiance
- IV. August 1, 2022 Regular Board Meeting Minutes
- V. September 7, 2022 Special Called Board Meeting Minutes
- VI. Approval of Agenda
- VII. Special Recognition
 - A. Employee of the Month--Jim Hudgins
 - B. Recognition of Retiring Employees
- VIII. Communications to the Board
 - A. Director's Report--Director of Schools
 - B. Financial Report--Business Officer
 - C. ESSER Updates--Director of Schools
 - D. Safe TN app--Director of Schools
 - E. 2022 Accountability--Director of Schools
- IX. Items Requiring Board Action
 - A. 2022-2023 Board Officer Elections--Current Board Chair
 - B. Trip Request
 1. HCHS Senior Class--Sponsor and Students
 2. HCMS 8th Grade Boys Basketball--Coach and Players
 - C. Budget Amendments--Business Officer
 - D. Textbook Certification--Director of Schools
 - E. 2023-2024 School Calendar Proposal--Calendar Committee
 - F. 2022-2023 Substitute Teacher Pay Scale--Director of Schools
 - G. Declaration of Surplus Property--Transportation Director
 - H. School Intercom System Bid--Maintenance Director
 - I. HCHS Auditorium Sound and Video Bid--Technology Director
 - J. Revised Board Policies 4.210, 4.402, 4.403, 4.603, 4.605, 6.200 (1st Reading)--Director of Accountability
 - K. Revised Board Policies 4.400, 4.601, 6.310 (2nd Reading)--Director of Accountability
 - L. Board Policy Review 5.100--5.110--Director of Accountability
- X. Announcements
- XI.. Adjourn

DOUG LANE
2059 Lake Drive, Centerville, TN 37033

RONALD GAMMONS
6419 Rice Ln., Lyles, TN 37098

TIM HOBBS
9220 Old Bon Aqua Rd., Bon Aqua, TN 37025

JIM HUDGINS
1297 E. Grinders Switch Rd., Centerville, TN 37033



Michelle Gilbert
Director of Schools
115 MURPHREE AVENUE
CENTERVILLE, TN 37033

CHRISTY MAYS
450 Hwy. 50, Centerville, TN 37033

SHERRI BAKER
9037 E 40 Rd., Bon Aqua, TN 37025

VANCE WILLIS
2888 Hwy 48 N., Nunnally, TN 37137

Memorandum

To: Board Members
From: Michelle Gilbert
Date: September 26, 2022
RE: October Director's Report

Leave of Absence

Professional

Cary Wright

FMLA September 6, 2022 – December 2, 2022

Support Staff

Hiring

Professional

Mark Bentley
Chauca Moore
Cole Keller
Derek Newsom
Demetria Worley
Scott Tays
Abigail Beard
Nicolette Booth
Sam McGreevy
David Carroll
Kristin Kelly
Rachel Howsden
Katie Edwards
Nick Bentley
Shawnee Stewart

CIS Social Studies/Science
HCHS Biology
EHMS Math/STEM
Central Office ESSER Grants Manager
EHHS P/T Math
HCMS Science
EHIS Physical Education
EHHS Science/Biology
EHMS ELA
HCHS Math
EHMS ELA
EHMS Math
CES 1st Grade
CES Physical Education
CES 1st Grade

Support Staff

Maryanne Opperman
Caitlyn Bowdoin
Amanda Redden
Isabella Armstrong
Kimberly Rocker
Tammy Anderson
Ruth Gardner
Jackie Bishop
Christy Fisher
Anna Spears

EHES Educational Assistant
EHIS Sp Ed. Assistant
EHES Sp Ed Pre-K Assistant
EHES P/T ESSER Sp Ed Assistant
EHES Sp Ed Assistant
EHES Sp Ed Assistant
CIS P/T ESSER Assistant
CIS P/T ESSER Sp Ed Assistant
EHES Sp Ed Pre-K Assistant
CES P/T ESSER Assistant

Rhonda Dobbins	School Nutrition
Emily Donaldson	School Nutrition
Skylar Baxter	School Nutrition
Paige Capley	School Nutrition
Donald Vise	School Nutrition
Amanda Scott	School Nutrition
Raygan Adkins	Substitute Teacher
Keiera Gill-Bolden	Substitute Teacher
Lacey Carter	Substitute Teacher
Connie Chumley	Substitute Teacher
Mollie Clark	Substitute Teacher
Cathy Duncan	Substitute Teacher
Charlee Fowlkes	Substitute Teacher
Mandy Harper	Substitute Teacher
Teresa Harrington	Substitute Teacher
Sidney Hudgins	Substitute Teacher
Jenna Hudson	Substitute Teacher
Carole Loveless	Substitute Teacher
Elizabeth Hope Myers	Substitute Teacher
Mary Phillips	Substitute Teacher
Patricia Primm	Substitute Teacher
Roger Puckett	Substitute Teacher
Preston Reyome	Substitute Teacher
Stephen Sain	Substitute Teacher
Phyllis England	Substitute Teacher
Brandt Gibson	Substitute Teacher
Teresa Gregory	Substitute Teacher
Kaylynn King	Substitute Teacher
Ernesto Rosas	Substitute Teacher
Suzan Rosas-Adair	Substitute Teacher
Alison Stanley	Substitute Teacher
Kearstin Tuten	Substitute Teacher
Harper Shelton	Substitute Teacher
Hannah N. Simmons	Substitute Teacher
Helen St. Germain	Substitute Teacher
Tanya Sims	Substitute Teacher
Ronnie Sullivan	Substitute Teacher
Stacey Talton	Substitute Teacher
Linda Tidwell	Substitute Teacher
Madelyn True	Substitute Teacher
Ann Webster	Substitute Teacher
Savannah Westbrooks	Substitute Teacher
Chiquita Wright	Substitute Teacher
Gary Wright	Substitute Teacher
Dana Davis	Substitute Teacher
Joy Duncan	Substitute Teacher
Chauca Moore	Substitute Teacher
Jane Morgan	Substitute Teacher
Brianna Moss	Substitute Teacher
Laura Sanders	Substitute Teacher

Burt Wilkerson
Colene Beasley
Mary Bennett
Brooke Eisenhuen

Substitute Teacher
Substitute Teacher
Substitute Teacher
Substitute Teacher

Resignation

Professional

Houston Hamblin
Thomas Burkett
Cheri Cutulle
Gabby Poston
Christy Uhl
Tammy Anderson

HCMS ELA
EHMS Science
EHHS Theater Arts
EHES/EHIS Behavior Position
Student Support Specialist
ESSER Assistant (Part-Time Position)

Support Staff

Jolean McNatt
Leah Owens
Alison Stantley
Michelle Weatherspoon

EHES Sp Ed Assistant
HCMS DBA
East Family Resource Center
EHMS ISS

Retirement

Professional

Don Qualls
Melinda Stone
Pam Mitchell-Clark
Jennifer Lynn
Judi Culver
Tony Choate
Kathy Brown

CTE/Deputy Superintendent
EHMS
EHHS/HCHS
HCHS/HCMS
EHIS
HCHS
HCMS

Support Staff

Don Vise
Angela Thornton
Patti Edwards
Colene Beasley
Wanda Lemaster

Bus Driver
School Nutrition
School Nutrition
School Nutrition
EHIS

Transfers

Professional

Support Staff

McKensy Patrick

EHES Assistant to
EHES P/T ESSER Assistant

Appointment

Professional

Support Staff

Tony Roder
Shawn Lawson
Ray Hunter
David Kwiatkowski
Nick Simmons
Tucker Hobbs
Dalton Thomas
John D. Fisher
Lafayette Spears
Paula Broyles

HCMS Assistant Football Coach
HCMS Assistant Football Coach
HCMS Volunteer Football Coach
HCHS Volunteer Math Tutor
EHHS Assistant Girls Basketball Coach
EHHS Volunteer Girls Basketball Coach
EHHS Volunteer Football Coach
EHMS Volunteer Football Coach
HCHS Assistant Football Coach
EHMS Cheer Coach

Open Positions

1 Secondary Math Position
1 Secondary Science Position
1 K-5 position
1 Intervention Position
1 Spanish Position
2 Special Education Positions
1 Speech Language Position
1 Behavior Support Position
Bus Drivers

* Denotes a relationship under board policy 1.108. Applicants are qualified for the positions.

141	General Purpose School	Account	Description	Year-To-Date			Month-To-Date		
				Budget Estimate	Actual	% of Budget	Estimate Avg/Mth	Actual	% of Avg
Revenues									
40110		Current Property Tax	2,953,480.00	(255.60)	0.01 %	246,123.33	0.00	0.00 %	
40120		Trustee's Collections - Prior Year	80,000.00	(12,489.61)	15.61 %	6,666.67	(6,250.37)	93.76 %	
40125		Trustee's Collections - Bankruptcy	0.00	(29.70)	0.00 %	0.00	(10.50)	0.00 %	
40130		Cir Clk/Clk & Master Collections-Pr Yr	45,000.00	(1,470.64)	3.27 %	3,750.00	(1,470.64)	39.22 %	
40140		Interest And Penalty	21,000.00	(1,003.08)	4.78 %	1,750.00	(552.38)	31.56 %	
40161		Payments In Lieu Of Taxes - T. V. A.	4,000.00	(817.12)	20.43 %	333.33	(268.36)	80.51 %	
40162		Payments In Lieu Of Taxes-Local	6,000.00	0.00	0.00 %	500.00	0.00	0.00 %	
40210		Local Option Sales Tax	2,350,000.00	(488,764.83)	20.80 %	195,833.33	(238,755.38)	121.92 %	
40270		Business Tax	30,000.00	(1,151.29)	3.84 %	2,500.00	(1,151.29)	46.05 %	
41110		Marriage Licenses	1,300.00	(133.00)	10.23 %	108.33	(133.00)	122.77 %	
43517		Tuition - Other	2,000.00	(500.00)	25.00 %	166.67	(500.00)	300.00 %	
43570		Receipts From Individual Schools	30,000.00	0.00	0.00 %	2,500.00	0.00	0.00 %	
43582		Community Service Fees - Adults	200.00	(31.20)	15.60 %	16.67	(31.20)	187.20 %	
44120		Lease/Rentals	10,000.00	(6,513.17)	65.13 %	833.33	(6,513.17)	781.58 %	
44170		Miscellaneous Refunds	30,000.00	(1,383.89)	4.61 %	2,500.00	(369.89)	14.80 %	
44530		Sale Of Equipment	15,000.00	0.00	0.00 %	1,250.00	0.00	0.00 %	
44560		Damages Recovered From Individuals	3,000.00	0.00	0.00 %	250.00	0.00	0.00 %	
44570		Contributions & Gifts	15,000.00	(508.00)	3.39 %	1,250.00	(185.00)	14.80 %	
46175		On-Behalf Contributions For OPEB	35,000.00	0.00	0.00 %	2,916.67	0.00	0.00 %	
46511		Basic Education Program	23,031,000.00	(2,326,187.84)	10.10 %	1,919,250.00	(2,326,187.84)	121.20 %	
46515		Early Childhood Education	417,796.00	0.00	0.00 %	34,816.33	0.00	0.00 %	
46520		School Food Service	22,000.00	0.00	0.00 %	1,833.33	0.00	0.00 %	
46550		Driver Education	5,000.00	0.00	0.00 %	416.67	0.00	0.00 %	
46590		Other State Education Funds	240,000.00	0.00	0.00 %	20,000.00	0.00	0.00 %	
46591		Coordinated School Health	90,000.00	(13,325.77)	14.81 %	7,500.00	(13,325.77)	177.68 %	
46594		Family Resource Centers	59,223.00	0.00	0.00 %	4,935.25	0.00	0.00 %	
46610		Career Ladder Program	45,000.00	0.00	0.00 %	3,750.00	0.00	0.00 %	
46851		State Revenue Sharing -T.V.A.	240,000.00	0.00	0.00 %	20,000.00	0.00	0.00 %	
46981		Safe Schools	86,560.00	0.00	0.00 %	7,213.33	0.00	0.00 %	
46990		Other State Revenues	15,000.00	0.00	0.00 %	1,250.00	0.00	0.00 %	
47640		Rotc Reimbursement	70,000.00	0.00	0.00 %	5,833.33	0.00	0.00 %	
48990		Other	292,123.52	(10,000.00)	3.42 %	24,343.63	0.00	0.00 %	
49700		Insurance Recovery	10,000.00	0.00	0.00 %	833.33	0.00	0.00 %	
49800		Transfers In	25,000.00	0.00	0.00 %	2,083.33	0.00	0.00 %	
Total Revenues			30,279,682.52	(2,864,564.74)	9.46 %	2,523,306.88	(2,595,704.79)	102.87 %	
Expenditures									
71100		Regular Instruction Program	(15,319,463.00)	994,392.86	6.49 %	(1,276,621.92)	968,952.03	75.90 %	

141	General Purpose School	Account	Description	Year-To-Date		Month-To-Date		% of Avg
				Budget Estimate	Actual	Estimate	Actual	
71150		Alternative Instruction Program	(238,087.00)	13,067.23	5.49 %	(19,840.58)	13,067.23	65.86 %
71200		Special Education Program	(3,329,017.00)	206,688.93	6.21 %	(277,418.08)	206,258.33	74.35 %
71300		Career and Technical Education	(1,315,400.00)	99,359.11	7.55 %	(109,616.67)	82,716.42	75.46 %
72110		Attendance	(180,519.00)	20,800.22	11.52 %	(15,043.25)	10,630.32	70.67 %
72120		Health Services	(390,722.00)	45,490.00	11.64 %	(32,560.17)	39,042.14	119.91 %
72130		Other Student Support	(1,065,415.00)	81,963.42	7.69 %	(88,784.58)	62,486.24	70.38 %
72210		Regular Instruction Program	(1,421,957.00)	112,108.50	7.88 %	(118,496.42)	83,512.28	70.48 %
72220		Special Education Program	(125,050.00)	16,753.93	13.40 %	(10,420.83)	9,632.15	92.43 %
72230		Career and Technical Education	(211,246.52)	30,205.42	14.30 %	(17,603.88)	15,599.05	88.61 %
72250		Technology	(511,826.00)	80,232.86	15.68 %	(42,652.17)	14,858.23	34.84 %
72290		Other Programs	(35,000.00)	0.00	0.00 %	(2,916.67)	0.00	0.00 %
72310		Board Of Education	(684,913.00)	238,818.09	34.87 %	(57,076.08)	8,702.43	15.25 %
72320		Director Of Schools	(303,453.00)	56,234.96	18.53 %	(25,287.75)	20,325.26	80.38 %
72410		Office Of The Principal	(1,923,819.00)	228,100.13	11.86 %	(160,318.25)	132,876.84	82.88 %
72510		Fiscal Services	(50,000.00)	0.00	0.00 %	(4,166.67)	0.00	0.00 %
72610		Operation Of Plant	(2,433,500.00)	520,038.25	21.37 %	(202,791.67)	179,079.41	88.31 %
72620		Maintenance Of Plant	(1,424,070.00)	317,167.32	22.27 %	(118,672.50)	151,756.54	127.88 %
72710		Transportation	(2,405,422.00)	217,897.61	9.06 %	(200,451.83)	111,987.56	55.87 %
72810		Central And Other	(257,883.00)	8,876.65	3.44 %	(21,490.25)	8,688.90	40.43 %
73100		Food Service	(38,571.00)	0.00	0.00 %	(3,214.25)	0.00	0.00 %
73300		Community Services	(143,813.00)	12,276.44	8.54 %	(11,984.42)	9,215.00	76.89 %
73400		Early Childhood Education	(494,196.00)	42,483.23	8.60 %	(41,183.00)	32,520.74	78.97 %
76100		Regular Capital Outlay	(690,000.00)	0.00	0.00 %	(57,500.00)	0.00	0.00 %
Total		Expenditures	(34,993,342.52)	3,342,955.16	9.55 %	(2,916,111.88)	2,161,907.10	74.14 %
Total	141	General Purpose School	(4,713,660.00)	478,390.42	10.15 %	(392,805.00)	(433,797.69)	-110.44

142	School Federal Projects	Account	Description	Year-To-Date		Month-To-Date		% of Avg
				Budget Estimate	Actual	Estimate Avg/Mth	Actual	
Revenues								
44170		Miscellaneous Refunds	0.00	0.00	0.00 %	0.00	0.00	0.00 %
47131		Vocational Educ - Basic Grants To	65,196.32	0.00	0.00 %	5,433.03	0.00	0.00 %
47141		Title 1 Grants To Local Educ Agencies	1,110,404.96	(113,376.29)	10.21 %	92,533.75	(95,509.46)	103.22 %
47143		Special Education - Grants To States	1,121,031.36	(128,478.92)	11.46 %	93,419.28	(124,466.53)	133.23 %
47145		Special Education Preschool Grants	47,431.09	(6,750.95)	14.23 %	3,952.59	(6,750.95)	170.80 %
47146		English Language Acquisition Grants	11,375.64	(580.06)	5.10 %	947.97	(580.06)	61.19 %
47148		Rural Education	183,248.52	(23,822.75)	13.00 %	15,270.71	(18,282.25)	119.72 %
47189		Eisenhower Prof Development State	154,711.92	(12,922.69)	8.35 %	12,892.66	(12,922.69)	100.23 %
47301		COVID-19 Grant #1	0.00	0.00	0.00 %	0.00	0.00	0.00 %
47307		COVID-19 Grant B	2,713,579.90	0.00	0.00 %	226,131.66	0.00	0.00 %
47309		COVID-19 Grant D	195,510.00	0.00	0.00 %	16,292.50	0.00	0.00 %
47401		American Rescue Plan Act Grant #1	6,615,811.52	(124,159.53)	1.88 %	551,317.63	(124,159.53)	22.52 %
47402		American Rescue Plan Act Grant #2	144,953.85	0.00	0.00 %	12,079.49	0.00	0.00 %
47403		American Rescue Plan Act Grant #3	11,038.16	0.00	0.00 %	919.85	0.00	0.00 %
47404		American Rescue Plan Act Grant #4	26,009.13	0.00	0.00 %	2,167.43	0.00	0.00 %
47590		Other Federal Through State	415,000.00	0.00	0.00 %	34,583.33	0.00	0.00 %
Total Revenues			12,815,302.37	(410,091.19)	3.20 %	1,067,941.86	(382,671.47)	35.83 %
Expenditures								
71100		Regular Instruction Program	(3,843,394.36)	205,142.33	5.34 %	(320,282.86)	197,348.29	61.62 %
71150		Alternative Instruction Program	(52,214.09)	5,323.08	10.19 %	(4,351.17)	5,323.08	122.34 %
71200		Special Education Program	(989,729.54)	39,755.38	4.02 %	(82,477.46)	39,755.38	48.20 %
71300		Career and Technical Education	(44,146.32)	1,874.54	4.25 %	(3,678.86)	1,874.54	50.95 %
72110		Attendance	(68,356.35)	2,530.05	3.70 %	(5,696.36)	2,530.05	44.42 %
72120		Health Services	(47,752.80)	0.00	0.00 %	(3,979.40)	0.00	0.00 %
72130		Other Student Support	(589,127.82)	66,688.96	11.32 %	(49,093.99)	53,090.65	108.14 %
72210		Regular Instruction Program	(1,223,346.29)	70,925.31	5.80 %	(101,945.52)	38,273.15	37.54 %
72220		Special Education Program	(529,118.04)	38,030.98	7.19 %	(44,093.17)	33,039.67	74.93 %
72230		Career and Technical Education	(2,550.00)	0.00	0.00 %	(212.50)	0.00	0.00 %
72250		Technology	(179,476.10)	4,673.81	2.60 %	(14,956.34)	4,673.81	31.25 %
72610		Operation Of Plant	(2,026,828.17)	0.00	0.00 %	(168,902.35)	0.00	0.00 %
72710		Transportation	(3,000.00)	0.00	0.00 %	(250.00)	0.00	0.00 %
73100		Food Service	(200,000.00)	0.00	0.00 %	(16,666.67)	0.00	0.00 %
76100		Regular Capital Outlay	(3,008,003.58)	0.00	0.00 %	(250,666.97)	0.00	0.00 %
99100		Transfers Out	(8,258.91)	0.00	0.00 %	(688.24)	0.00	0.00 %
Total Expenditures			(12,815,302.37)	434,944.44	3.39 %	(1,067,941.86)	375,908.62	35.20 %
Total	142	School Federal Projects	0.00	24,853.25	100.00 %	0.00	(6,762.85)	0.00 %

Account	Description	Year-To-Date		Month-To-Date		% of Avg
		Budget Estimate	Actual	% of Budget	Estimate Avg/Mth	
143	Central Cafeteria					
Revenues						
43521	Lunch Payments - Children	603,000.00	(43,360.02)	7.19 %	50,250.00	(43,360.02) 86.29 %
43522	Lunch Payments - Adults	75,000.00	(2,943.26)	3.92 %	6,250.00	(2,943.26) 47.09 %
43523	Income From Breakfast	55,000.00	(12,823.32)	23.32 %	4,583.33	(12,823.32) 279.78 %
43525	A La Carte Sales	175,000.00	(17,647.12)	10.08 %	14,583.33	(22,475.42) 154.12 %
43570	Receipts From Individual Schools	0.00	0.00	0.00 %	0.00	0.00 %
44110	Investment Income	0.00	(34.31)	0.00 %	0.00	(17.05) 0.00 %
44170	Miscellaneous Refunds	0.00	0.00	0.00 %	0.00	0.00 %
47111	USDA School Lunch Program	873,000.00	(118,837.22)	13.61 %	72,750.00	(118,837.22) 163.35 %
47113	Breakfast	540,000.00	(41,536.72)	7.69 %	45,000.00	(41,536.72) 92.30 %
47114	USDA - Other	15,000.00	(70,181.39)	467.88 %	1,250.00	(70,181.39) 5,614.51 %
	Total Revenues	2,336,000.00	(307,363.36)	13.16 %	194,666.67	(312,174.40) 160.36 %
Expenditures						
73100	Food Service	(2,336,000.00)	775,579.14	33.20 %	(194,666.67)	480,568.13 246.87 %
	Total Expenditures	(2,336,000.00)	775,579.14	33.20 %	(194,666.67)	480,568.13 246.87 %
Total 143	Central Cafeteria	0.00	468,215.78	100.00 %	0.00	168,393.73 0.00 %

141	General Purpose School	Account	Description	Year-To-Date		Month-To-Date		% of Budget	% of Avg
				Budget Estimate	Actual	Estimate Avg/Mth	Actual		
Revenues									
40110		Current Property Tax	2,953,480.00	(255.60)	246,123.33	0.01 %	0.00	0.00 %	
40120		Trustee's Collections - Prior Year	80,000.00	(17,448.08)	6,666.67	21.81 %	(4,958.47)	74.38 %	
40125		Trustee's Collections - Bankruptcy	0.00	(103.34)	0.00	0.00 %	(73.64)	0.00 %	
40130		Cir Clk/Clk & Master Collections-Pr Yr	45,000.00	(3,766.41)	3,750.00	8.37 %	(2,295.77)	61.22 %	
40140		Interest And Penalty	21,000.00	(1,723.82)	1,750.00	8.21 %	(720.74)	41.19 %	
40161		Payments In Lieu Of Taxes - T. V. A.	4,000.00	(1,079.47)	333.33	26.99 %	(262.35)	78.71 %	
40162		Payments In Lieu Of Taxes-Local	6,000.00	0.00	500.00	0.00 %	0.00	0.00 %	
40210		Local Option Sales Tax	2,350,000.00	(472,179.03)	195,833.33	20.09 %	16,585.80	-8.47 %	
40270		Business Tax	30,000.00	(3,609.52)	2,500.00	12.03 %	(2,458.23)	98.33 %	
41110		Marriage Licenses	1,300.00	(285.00)	108.33	21.92 %	(152.00)	140.31 %	
43517		Tuition - Other	2,000.00	(500.00)	166.67	25.00 %	0.00	0.00 %	
43570		Receipts From Individual Schools	30,000.00	(4,200.00)	2,500.00	14.00 %	(4,200.00)	168.00 %	
43582		Community Service Fees - Adults	200.00	(36.20)	16.67	18.10 %	(5.00)	30.00 %	
44120		Lease/Rentals	10,000.00	(6,513.17)	833.33	65.13 %	0.00	0.00 %	
44170		Miscellaneous Refunds	30,000.00	(1,839.70)	2,500.00	6.13 %	(455.81)	18.23 %	
44530		Sale Of Equipment	15,000.00	0.00	1,250.00	0.00 %	0.00	0.00 %	
44560		Damages Recovered From Individuals	3,000.00	(83.48)	250.00	2.78 %	(83.48)	33.39 %	
44570		Contributions & Gifts	15,000.00	(3,511.00)	1,250.00	23.41 %	(3,003.00)	240.24 %	
46175		On-Behalf Contributions For OPEB	35,000.00	0.00	2,916.67	0.00 %	0.00	0.00 %	
46511		Basic Education Program	23,031,000.00	(4,652,375.68)	1,919,250.00	20.20 %	(2,326,187.84)	121.20 %	
46515		Early Childhood Education	417,796.00	0.00	34,816.33	0.00 %	0.00	0.00 %	
46520		School Food Service	22,000.00	0.00	1,833.33	0.00 %	0.00	0.00 %	
46550		Driver Education	5,000.00	0.00	416.67	0.00 %	0.00	0.00 %	
46590		Other State Education Funds	240,000.00	0.00	20,000.00	0.00 %	0.00	0.00 %	
46591		Coordinated School Health	90,000.00	0.00	7,500.00	0.00 %	0.00	0.00 %	
46594		Family Resource Centers	59,223.00	(14,805.83)	4,935.25	25.00 %	(13,325.77)	-177.68 %	
46610		Career Ladder Program	45,000.00	0.00	3,750.00	0.00 %	0.00	0.00 %	
46851		State Revenue Sharing -T.V.A.	240,000.00	0.00	20,000.00	0.00 %	0.00	0.00 %	
46981		Safe Schools	86,560.00	0.00	7,213.33	0.00 %	0.00	0.00 %	
46990		Other State Revenues	15,000.00	0.00	1,250.00	0.00 %	0.00	0.00 %	
47640		Rotc Reimbursement	70,000.00	(2,397.35)	5,833.33	3.42 %	(2,397.35)	41.10 %	
48990		Other	292,123.52	(39,064.88)	24,343.63	13.37 %	(29,064.88)	119.39 %	
49700		Insurance Recovery	10,000.00	0.00	833.33	0.00 %	0.00	0.00 %	
49800		Transfers In	25,000.00	0.00	2,083.33	0.00 %	0.00	0.00 %	
Total Revenues			30,279,682.52	(5,225,777.56)	2,523,306.88	17.26 %	(2,361,212.82)	93.58 %	
Expenditures									
71100		Regular Instruction Program	(15,319,463.00)	2,296,897.30	(1,276,621.92)	14.99 %	1,302,504.44	102.03 %	

141	General Purpose School	Account	Description	Year-To-Date			Month-To-Date		
				Budget Estimate	Actual	% of Budget	Estimate Avg/Mth	Actual	% of Avg
71150		Alternative Instruction Program	(238,087.00)	26,934.45	11.31 %	(19,840.58)	13,867.22	69.89 %	
71200		Special Education Program	(3,329,017.00)	434,380.65	13.05 %	(277,418.08)	227,691.72	82.08 %	
71300		Career and Technical Education	(1,315,400.00)	180,427.83	13.72 %	(109,616.67)	81,068.72	73.96 %	
72110		Attendance	(180,519.00)	31,309.48	17.34 %	(15,043.25)	10,509.26	69.86 %	
72120		Health Services	(390,722.00)	74,025.84	18.95 %	(32,560.17)	28,535.84	87.64 %	
72130		Other Student Support	(1,065,415.00)	139,753.64	13.12 %	(88,784.58)	57,790.22	65.09 %	
72210		Regular Instruction Program	(1,421,957.00)	201,531.28	14.17 %	(118,496.42)	89,422.78	75.46 %	
72220		Special Education Program	(125,050.00)	24,849.85	19.87 %	(10,420.83)	8,095.92	77.69 %	
72230		Career and Technical Education	(211,246.52)	37,407.06	17.71 %	(17,603.88)	7,201.64	40.91 %	
72250		Technology	(511,826.00)	183,738.78	35.90 %	(42,652.17)	103,505.92	242.67 %	
72290		Other Programs	(35,000.00)	0.00	0.00 %	(2,916.67)	0.00	0.00 %	
72310		Board Of Education	(684,913.00)	255,354.06	37.28 %	(57,076.08)	16,535.97	28.97 %	
72320		Director Of Schools	(303,453.00)	76,197.98	25.11 %	(25,287.75)	19,963.02	78.94 %	
72410		Office Of The Principal	(1,923,819.00)	351,472.94	18.27 %	(160,318.25)	123,372.81	76.95 %	
72510		Fiscal Services	(50,000.00)	0.00	0.00 %	(4,166.67)	0.00	0.00 %	
72610		Operation Of Plant	(2,433,500.00)	660,073.61	27.12 %	(202,791.67)	140,035.36	69.05 %	
72620		Maintenance Of Plant	(1,424,070.00)	463,767.23	32.57 %	(118,672.50)	146,599.91	123.53 %	
72710		Transportation	(2,405,422.00)	309,958.82	12.89 %	(200,451.83)	92,061.21	45.93 %	
72810		Central And Other	(257,883.00)	9,072.40	3.52 %	(21,490.25)	195.75	0.91 %	
73100		Food Service	(38,571.00)	0.00	0.00 %	(3,214.25)	0.00	0.00 %	
73300		Community Services	(143,813.00)	20,980.01	14.59 %	(11,984.42)	8,703.57	72.62 %	
73400		Early Childhood Education	(494,196.00)	73,951.50	14.96 %	(41,183.00)	31,468.27	76.41 %	
76100		Regular Capital Outlay	(690,000.00)	0.00	0.00 %	(57,500.00)	0.00	0.00 %	
Total		Expenditures	(34,993,342.52)	5,852,084.71	16.72 %	(2,916,111.88)	2,509,129.55	86.04 %	
Total	141	General Purpose School	(4,713,660.00)	626,307.15	13.29 %	(392,805.00)	147,916.73	37.66 %	

Account	Description	Year-To-Date		Month-To-Date		% of Avg
		Budget Estimate	Actual	Estimate Avg/Mth	Actual	
142	School Federal Projects					
Revenues						
44170	Miscellaneous Refunds	0.00	0.00	0.00 %	0.00	0.00 %
47131	Vocational Educ - Basic Grants To	65,196.32	0.00	0.00 %	5,433.03	0.00 %
47141	Title 1 Grants To Local Educ Agencies	1,140,404.96	(160,713.34)	14.09 %	95,033.75	(47,337.05)
47143	Special Education - Grants To States	1,121,124.51	(109,585.63)	9.77 %	93,427.04	18,893.29
47145	Special Education Preschool Grants	47,431.09	(2,786.86)	5.88 %	3,952.59	3,964.09
47146	English Language Acquisition Grants	32,149.35	(2,149.00)	6.68 %	2,679.11	(1,568.94)
47148	Rural Education	183,248.52	(5,540.50)	3.02 %	15,270.71	18,282.25
47189	Eisenhower Prof Development State	168,769.29	(23,493.52)	13.92 %	14,064.11	(10,570.83)
47301	COVID-19 Grant #1	0.00	0.00	0.00 %	0.00	0.00 %
47307	COVID-19 Grant B	2,713,579.90	0.00	0.00 %	226,131.66	0.00
47309	COVID-19 Grant D	195,510.00	0.00	0.00 %	16,292.50	0.00
47401	American Rescue Plan Act Grant #1	6,615,811.52	0.00	0.00 %	551,317.63	124,159.53
47402	American Rescue Plan Act Grant #2	144,953.85	0.00	0.00 %	12,079.49	0.00
47403	American Rescue Plan Act Grant #3	11,038.16	0.00	0.00 %	919.85	0.00
47404	American Rescue Plan Act Grant #4	26,009.13	0.00	0.00 %	2,167.43	0.00
47590	Other Federal Through State	442,977.75	(53,732.26)	12.13 %	36,914.81	(53,732.26)
	Total Revenues	12,908,204.35	(358,001.11)	2.77 %	1,075,683.70	52,090.08
Expenditures						
71100	Regular Instruction Program	(3,869,888.31)	318,033.52	8.22 %	(322,490.69)	112,891.19
71150	Alternative Instruction Program	(52,214.09)	5,323.08	10.19 %	(4,351.17)	0.00
71200	Special Education Program	(976,341.58)	93,480.01	9.57 %	(81,361.80)	53,724.63
71300	Career and Technical Education	(44,146.32)	3,749.08	8.49 %	(3,678.86)	1,874.54
72110	Attendance	(68,356.35)	5,060.10	7.40 %	(5,696.36)	2,530.05
72120	Health Services	(47,752.80)	0.00	0.00 %	(3,979.40)	0.00
72130	Other Student Support	(622,611.62)	103,488.66	16.62 %	(51,884.30)	36,799.70
72210	Regular Instruction Program	(1,256,177.37)	125,790.54	10.01 %	(104,681.45)	54,865.23
72220	Special Education Program	(542,599.15)	62,439.95	11.51 %	(45,216.60)	24,408.97
72230	Career and Technical Education	(2,550.00)	0.00	0.00 %	(212.50)	0.00
72250	Technology	(179,476.10)	9,347.62	5.21 %	(14,956.34)	4,673.81
72610	Operation Of Plant	(2,026,828.17)	0.00	0.00 %	(168,902.35)	0.00
72710	Transportation	(3,000.00)	0.00	0.00 %	(250.00)	0.00
73100	Food Service	(200,000.00)	0.00	0.00 %	(16,666.67)	0.00
76100	Regular Capital Outlay	(3,008,003.58)	0.00	0.00 %	(250,666.97)	0.00
99100	Transfers Out	(8,258.91)	0.00	0.00 %	(688.24)	0.00
	Total Expenditures	(12,908,204.35)	726,712.56	5.63 %	(1,075,683.70)	291,768.12
Total	142	0.00	368,711.45	100.00 %	0.00	343,858.20
	School Federal Projects					27.12 %

143	Central Cafeteria	Account	Description	Year-To-Date		Month-To-Date		
				Budget Estimate	Actual	% of Budget	Estimate Avg/Mth	Actual
Revenues								
43521		Lunch Payments - Children		(43,360.02)	7.19 %	50,250.00	0.00	0.00 %
43522		Lunch Payments - Adults		(2,943.26)	3.92 %	6,250.00	0.00	0.00 %
43523		Income From Breakfast		(12,823.32)	23.32 %	4,583.33	0.00	0.00 %
43525		A La Carte Sales		(17,602.72)	10.06 %	14,583.33	44.40	-0.30 %
43570		Receipts From Individual Schools		(78,000.00)	0.00 %	0.00	(78,000.00)	0.00 %
44110		Investment Income		(54.29)	0.00 %	0.00	(19.98)	0.00 %
44170		Miscellaneous Refunds		0.00	0.00 %	0.00	0.00	0.00 %
47111		USDA School Lunch Program		(118,837.22)	13.61 %	72,750.00	0.00	0.00 %
47113		Breakfast		(41,536.72)	7.69 %	45,000.00	0.00	0.00 %
47114		USDA - Other		(70,181.39)	467.88 %	1,250.00	0.00	0.00 %
		Total Revenues		(385,338.94)	16.50 %	194,666.67	(77,975.58)	40.06 %
Expenditures								
73100		Food Service		1,014,433.89	43.43 %	(194,666.67)	238,854.75	122.70 %
		Total Expenditures		1,014,433.89	43.43 %	(194,666.67)	238,854.75	122.70 %
Total	143	Central Cafeteria		629,094.95	100.00 %	0.00	160,879.17	0.00 %



Hickman County Schools Board Agenda Item Request

Date: September 9, 2022

Name of School: HCHS

Item Request: Overnight Sr. Trip

Explanation:

The Class of 2023 is requesting
an Overnight Sr. Trip this year.
The proposed trip would be to
Cathkinburg, TN.

Attachments (if necessary and appropriate):

Signature of Person requesting to be placed on the agenda:

 (Matthew Dotson)

Signature of Building Principal or Director of Schools:





Hickman County Schools Board Agenda Item Request

Date: 9-13-22

Name of School: HCMS

Item Request: Overnight Trip to Cedar Crest Camp

Explanation:
8th Grade Boys Basketball Overnight
trip to Cedar Crest camp for team
building & leadership development.

Attachments (if necessary and appropriate):

Signature of Person requesting to be placed on the agenda:
Joel Sato

Signature of Building Principal:
Jenia S. Shupp

Hickman County Board of Education

Budget Amendment No. 7

Federal Programs - Fund 142

October 3, 2022

Account	Description	Debit	Credit	Justification	
47141 - - - 101	Revenue	\$941.00		To bring Title I into agreement with ePlan	
71100 - 116 - - 101	Teacher	3,200.00			
71100 - 189 - - 101	Other Salaries & Wages		\$3,200.00		
72130 - 499 - - 101	Other Supplies and Materials	1,500.00			
72210 - 524 - - 101			2,441.00		
47189 - - - 201	Revenue	1.63		To bring Title II into agreement with ePlan	
72210 - 212 - - 201	Employer Medicare		1.63		
47590 - - - 401	Revenue	32,249.35		To bring Title IV into agreement with ePlan	
47146 - - - 401	Revenue		32,149.35		
72210 - 201 - - 401	Social Security		1.00		
72210 - 212 - - 401	Medicare Expenditures		99.00		
72210 - 499 - - 401	Other Salaries & Wages	22,000.00			
72210 - 790 - - 401	Other Equipment		22,000.00		
47131 - - - 801	Revenue	10,829.18		To book additional funds in CTE Perkins Basic	
71300 - 730 - - 801	Vocational Instruction Equip		10,829.18		
47402 - - - 909	Revenue		11,212.80	American Rescue Plan IDEA Part B	
71200 - 204 - - 909	State Retirement		65.70		
71200 - 429 - - 909	Instructional Supplies	16,695.73			
71200 - 725 - - 909	Special Education Equip	13,439.24			
72220 - 189 - - 909	Other Salaries & Wages		24,500.00		
72220 - 201 - - 909	Social Security		1,519.00		
72220 - 204 - - 909	State Retirement		2,072.70		
72220 - 212 - - 909	Medicare Exp		355.25		
72220 - 312 - - 909	Contracts with Private Agcy	40,804.92			
72220 - 399 - - 909	Other Contracted Services		33,711.94		
72220 - 499 - - 909	Other Supplies & Materials		14,735.82		
72220 - 790 - - 909	Other Equipment	17,233.32			
47401 - - - 937	TN ALL Corps - Revenue	115,134.28			TN ALL Corps
72210 - 189 - - 937	Other Salaries & Wages		12,303.58		
72210 - 201 - - 937	Social Security	727.08			
72210 - 204 - - 937	State Retirement		9,350.00		
72210 - 212 - - 937	Medicare	167.10			
72210 - 429 - - 937	Instructional Supplies		33,744.88		
72210 - 499 - - 937	Other Supplies		27,000.00		
72210 - 599 - - 937	Other Charges		33,630.00		
47401 - - - 939	Revenue	1,458.78		ESSER Planning Grant	
72210 - 189 - - 939	Other Salaries & Wages	11,100.00			
72210 - 201 - - 939	Social Security	688.20			
72210 - 204 - - 939	State Retirement	1,892.10			
72210 - 212 - - 939	Medicare	160.95			
72210 - 355 - - 939	Travel		1,750.00		
72210 - 524 - - 939	Professional Development		13,550.03		
	Totals	\$ 290,222.86	\$ 290,222.86		

Approved:

Attest:

Board Chair

Michelle Gilbert

Hickman County Board of Education
 Budget Amendment No. 8
 Federal Programs - Fund 142
 October 3, 2022

Account	Description	Debit	Credit	Justification
71200 - 429 - - 901	Instructional Supplies		\$ 20,063.15	IDEA Part B
72220 - 399 - - 901	Other Contracted Svc	\$ 20,063.15		
71200 - 429 - - 919	Instructional Materials		22.35	ARP - IDEA PreSchool
71200 - 725 - - 919	Special Education Equip	22.35		
72130 - 399 - - 964	Other Contracted Svc	13,000.00		Adjustments to Project AWARE
72130 - 435 - - 964	Office Supplies		5,000.00	
72130 - 499 - - 964	Other Supplies		5,000.00	
72130 - 599 - - 964	Other Charges		3,000.00	
Totals		\$ 33,085.50	\$ 33,085.50	

Approved:

Attest:

Board Chair

Michelle Gilbert

Hickman County Board of Education
Budget Amendment No. 9
General Purpose - Fund 141
October 4, 2021

Account	Description	Debit	Credit	Justification
48900 - -	Revenue	\$ 20,000.00		Give - 2 - Grant
71300 - 499 - GG	Other Supplies		\$ 20,000.00	
	TOTALS	\$ 20,000.00	\$ 20,000.00	

Approved:

Attest:

Board Chair

Michelle Gilbert



2022-2023
Substitute Teacher Pay Scale Discussion

Level of Training	Compensation
High School Diploma or Equivalent	\$75/day
Teacher License	\$100/day



Steven George
Director of Transportation
115 Murphree Avenue
Centerville, TN. 37033

The Transportation Department would like to declare the following items surplus;

Buses		VIN	Description
13	05 Frt	1T88R4C2X61168372	Grant Replacement
14	05 Frt	1T88R4C2161168373	Grant Replacement
22	05 Frt	1T88R4C2361168374	Age of Service 18+Years
30	05 Frt	1T88R4C2561168375	Grant Replacement
41	08 IH	1FD4E45P88DB17714	Age of Service 18+Years
42	08 IH	1FD4E45PX8DB17715	Age of Service 18+Years
43	04 IH	4DRBRAAN04B961735	Grant Replacement



Steven George
Director of Transportation
115 Murphree Avenue
Centerville, TN. 37033

The Transportation Department would like to declare the following items surplus;

Buses		VIN	Description
13	05 Frt	1T88R4C2X61168372	Grant Replacement
14	05 Frt	1T88R4C2161168373	Grant Replacement
22	05 Frt	1T88R4C2361168374	Age of Service 18+Years
30	05 Frt	1T88R4C2561168375	Grant Replacement
41	08 IH	1FD4E45P88DB17714	Age of Service 18+Years
42	08 IH	1FD4E45PX8DB17715	Age of Service 18+Years
43	04 IH	4DRBRAAN04B961735	Grant Replacement



Hickman County Schools Board Agenda Item Request

Date: 9-2-00

Name of School: EHES / EHIS

Item Request: Intercom "bid" funding Approval

Explanation:

Bids higher than funding - request fund
Balance supplement County fund to replace

Attachments (if necessary and appropriate):

Bid copy by Debbie Breece

Signature of Person requesting to be placed on the agenda:

[Handwritten Signature]

Signature of Building Principal:

Michelle Sliver

Invitation To Bid

The Hickman County Finance Office is accepting sealed bids for "School Intercom Systems".

Bid specifications may be found at www.hickmank12.org/request-for-proposal, or by contacting the Building Maintenance Office at 931-729-3391 ext. 3.

All bidders will be required to submit a conflict of interest disclosure form that can be obtained at www.hickmank12.org/request-for-proposal. This bid requires a performance bond upon bid awarding.

All bidders must have TN business license, 1 million dollar liability insurance, workers compensation insurance, and comply with all local, state and federal requirements for working on school properties per TCA 49-5-406.

Sealed bids must be hand mailed or hand delivered to the Hickman County Finance Office, 114 North Central Ave. Suite 203, Centerville TN 37033 and clearly marked on the outside of the envelope "School Intercom Systems". Bids will be opened at the Finance office on Monday, August 29, 2022 at 10:00 a.m.

Hickman County Board of Education reserves the right to accept, or reject any and all bids or parts of bids and to waive any informalities that may prevent the acceptance of a better bid.

Present Penny Mayberry
Misty Weems

	<u>East Elementary</u>	<u>West Int.</u>	<u>Both</u>
Progressive technologies			105,245.42 + 110,402.56
Galaxy Next Generation Inc.	77,759.46	55,198.20	
SWC	116,364.21	109,281.01	
Central Technologies, Inc			81,726.87



REQUEST FOR PROPOSAL

Hickman County Schools

School Intercom Systems

Bid Due Date: August 29, 2022 @ 10am

Central Technologies, Inc.

PO Box 30867
Knoxville, TN 37930

OR

6101 Industrial Heights Drive NW
Knoxville, TN 37909

Account Executive
Jordan Walker
jwalker@centralinc.com
Direct: 843.425.2265
Toll-Free: 800.315.4132
Fax: 865.312.8190

SPIN #: 143035655
General Contractors License #: 00067550
TN Alarm Contractors License: 2138

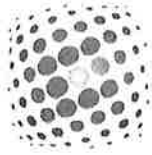

CENTRAL
Technologies, Inc.

Hickman County Schools Evaluation Committee:

It is with great pleasure that Central Technologies, Inc submits this bid for "School Intercom Systems" for Hickman County Schools. We are excited to have the opportunity to continue a relationship with Hickman County Schools and would be honored to be selected as your preferred partner for intercom needs.

- Central Technologies is bidding Galaxy Three Sixty and complies with part B Scope of Work
- Central Technologies complies with the "No Nonsense Warranty" with labor for 1yr
- Central Technologies has 5yrs + experience with installation of intercom equipment
- Central Technologies will provide a bid bond if Central is the successful bidder
- Central Technologies is a drug free workplace
- Central Technologies has local representation

Our staff has spent the past 17+ years helping districts successfully implement technology throughout the state of Tennessee and our certified technical personnel have completed hundreds of successful installations, all with a high degree of customer satisfaction. Our #1 goal is customer satisfaction 100% of the time with our better service and smarter solutions.

We look forward to the opportunity to partner with you on this project!

Thank you,

Jordan Walker

Senior Account Executive: Jordan Walker

Email: jwalker@centralinc.com

Direct: 843.425.2265

Toll-Free: 800.315.4132

Fax: 865.312.8190

Hickman County Government

Conflict of Interest Disclosure Form

The County Financial Management System of 1981 contains the most stringent conflict of interest provisions. TCA §5-21-121 provides:

- (a) The director, purchasing agent, members of the committee, members of the county legislative body or other officials, employees, or members of the board of education or highway commission shall not be financially interested or have any personal beneficial interest, either directly or indirectly, in the purchase of any supplies, materials, equipment or contractual services for the county.
- (b) No firm, corporation, partnership, association or individual furnishing any such supplies, materials, equipment or contractual services, shall give or offer, nor shall the director or purchasing agent or any assistant or employee accept or receive directly or indirectly from any person, firm, corporation, partnership or association to whom any contract may be awarded, by rebate, gift or otherwise, any money or other things of value whatsoever, or any promise, obligation or contract for future reward or compensation.

Date: August 25, 2022 Name: Jordan Walker

Please describe below any relationships, transactions, positions you hold (volunteer or otherwise), or circumstances that you believe could contribute to a conflict of interest:

I have no conflict of interest to report.

I have the following conflict of interest to report (please specify any boards or committees you (and/or your spouse) sit on, the name of your employer and any businesses you or your spouse may own.

I hereby certify that the information set forth above is true and complete to the best of my knowledge.

Date: August 25, 2022 Signature: Jordan Walker



References

Clinton City Schools

212 North Hicks St.

Clinton, TN 37716

Scott Johnson - (865) 274-8375

johnsons@clintonschools.org

- Avigilon System
- Intercom System
- Network Infrastructure

Maury County Schools

501 W. 8th St.

Columbia, TN 38401

Glenn Hannah - (931) 388-8403

ighannah@mauryk12.org

- Network Infrastructure
- Intercom System
- Classroom Technology
- Managed Services

Hawkins County Schools

200 North Depot Street

Rogersville, TN 37857

Wayne Absher - (423) 272-7679

wayne.absher@hck12.net Avigilon

- Network Infrastructure
- Classroom Technology



CENTRAL
Technologies, Inc.

We have prepared a quote for you

Intercom Bid

Quote # 012829
Version 1

Prepared for:

Hickman County Schools

Brad Gilbert
brad.gilbert@hickmank12.org



Products

Description	Price	Qty	Ext. Price
IPCMD IP Command System - Software Pkg. & Raid 1 Computer	\$11,952.57	1	\$11,952.57
SIP-T33G Yealink IP Phone - Corded/Cordless - Corded - Wal	\$81.00	3	\$243.00
ENGINEER - LEVEL 2 Installation and Configuration of IP Intercom Server	\$85.00	20	\$1,700.00
TQIP-40TB 2-Way IP Lay In Speaker w/ Talk Back Incl. Amp Interface w/Mic - PER UNIT	\$545.90	45	\$24,565.50
TQS2001 Call-In Rocker Switch w/ Wires	\$17.43	43	\$749.49
TSRFW-JB2 Junction Box Single Gang - 2" Deep, Office White	\$8.42	43	\$362.06
TSR2FW-8A Hellermann Surface Raceway 1 1/4"	\$2.18	344	\$749.92
TQS6IP Paging Horn w/ Square Backbox and Grille, External IP-AMP1 M	\$528.57	2	\$1,057.14
TQIP-40 1-Way IP Lay In Speaker Amp/Interface w/Connector - PER UNIT	\$498.70	16	\$7,979.20
TQS6IP Paging Horn w/ Square Backbox and Grille, External IP-AMP1 M	\$528.57	7	\$3,699.99
WHITECAT6RISER CAT6 RISER WHITE	\$0.21	14000	\$2,940.00
4S255-S24 Leviton QuickPort Shielded 24-Port Blank Patch Pa	\$48.00	4	\$192.00
61110-RT6 Light Almond Quickport Keystone Jack Office White	\$6.50	70	\$455.00
WHITECAT6-1 1' White Cat6 Patch Cable	\$1.50	70	\$105.00
LABORCB Central Tech labor	\$55.00	420	\$23,100.00
Misc Misc Cable, Raceway Etc..	\$400.00	1	\$400.00
TL-SG3428MP TP-Link - JetStream™ 28-Port Gigabit L2+ Managed Switch with 24-Port PoE+ - Limited Lifetime Warranty - 24 PoE+ Port @384W - 4 x SFP Slots - PoE Auto Recovery - Omada SDN Integrated - IPv6 - Static Routing	\$369.00	4	\$1,476.00



Subtotal: **\$81,726.87**

Intercom Bid

Prepared by:

Central Technologies Inc

Jordan Walker

843-425-2265

Fax 865-312-8190

jwalker@centralinc.com

Prepared for:

Hickman County Schools

115 Murphree Avenue

Centerville, TN 37033

Brad Gilbert

(931) 729-3391

brad.gilbert@hickmank12.org

Quote Information:

Quote #: 012829

Version: 1

Delivery Date: 08/24/2022

Expiration Date: 11/19/2022

Quote Summary

Description	Amount
Products	\$81,726.87

Total: **\$81,726.87**

Taxes, shipping, handling and other fees may apply. We reserve the right to cancel orders arising from pricing or other errors.

Central Technologies Inc

Hickman County Schools

Signature: _____



Name: Jordan Walker

Title: Senior Account Manager

Date: 08/24/2022

Signature: _____

Name: Brad Gilbert

Date: _____

Part B

Bid Specs: School Intercom Systems

Scope of Work:

The existing Intercom will remain in place operational, until the new intercom is up and working, then upon completion the older hardware will be removed, boxed and turned over to the Maintenance Dept. Prior to the final bid award of the prospective company, there shall be a "pre-installation meeting" and prior to purchase of any equipment. Meeting will occur at the school to review the proposed purchasing equipment and ensure that all features and needs of the system, as well as the installation schedules, agree with both the School Principal and Maintenance Director of schools.

Installation Schedules:

Classroom hardware, speakers, and cabling will be installed during the first week during school shutdown week as Phase 1, then upon return weeks 2/3 as needed, the halls and offices will be phase 2. This is to minimize techs having to be in classrooms during instruction.

Damages:

Any and all damages not limited to ceiling tile, grid are to be replaced as new, and any drilled fire walls are to be fire caulked as installed and is the responsibility of the installer. Where there are tile or grid materials available maintenance will provide materials, but this does not exempt the installer from having to provide such.

Equipment:

This is the total replacement with new separate cabling of the existing intercom with a IP based Communications system in an existing building, requiring new call buttons, with emergency call feature, new cables, new two way talk lay in 2 x 2 speakers, minimum of 3 new speakers in the kitchen, the call in buttons will place normal call, and will serve as check in button in event of emergency or lock down, 3 new consoles to include the main front office, principal office, and assistant principals office. Main console is to receive calls from classrooms when call button is pushed, all consoles are to allow for "ALL CALL", zone page, bell control, and emergency initiation. Head in components shall be installed in the existing rack location.

Services:

All **to include balancing & Dolby Quality Clarity and site employee training as needed to insure a smooth transition of the new operational system. Training shall include: School Administrative Staff Teachers, SRO personnel.**

System shall include a "No Nonsense Warranty" complete with "Labor" for a period of not less than 1 year from the date the system is "Operational and 100% completed". In addition, to the 1 year minimum workmanship warranty, the system shall have an "Additional 10 year Parts & Servicing Contract Warranty", by the installing company/ or manufacturer.

Other Specifications:

EAST HICKMAN INTERMEDIATE BUILDING:

This building will consist of a **5 zone system**:

(Interior speaker and button stations consist of approximately 40 rooms speakers and call buttons, 3 offices head units, 2 gymnasium large speakers, 1 gym office speaker w/call button, café dining room 2 speakers/ 1 call button, kitchen 3 speakers and 1 call button

ZONES:

3rd Grade Hall/rooms

4th Grade Hall/rooms

5th Grade Hall/rooms

TWA 3rd, 4th, 5th grade halls, main hall conference locations, copying room

Cafeteria Kitchen

Gym/ front hall

Playground, outside building inset corners, speakers at all corridor exits outside.

Special Requirements Notes:

For site visit prior to the bid, please contact Mike Plunkett/ Tanya Williams to set up the time to visit the school. No admittance will be granted without prior approved appointment with the Maintenance office. **(931)-729-3391 ext. 3**

All bidding companies, and the installing techs shall have **at least 5 years minimum experience of large jobsite installation of Intercom equipment in Schools, Hospitals, or larger venues.**

This bid requires at least 3 prior references of recent large location jobs completed with a contact for inquiries to past performances to be provided with the sealed bid.

This bid requires a performance bond, as well as bid bond, and minimum 1 million dollar business liability insurance, workers compensation insurance, and TN business license, all attached inside the sealed bid document.

ALL AWARDED BIDDERS ARE REQUIRED TO COMPLETE THE BIDDED WORK AND NO SUBS WILL BE PERMITTED WITHOUT THE EXPRESSED APPROVAL OF THE BOARD OF EDUCATION OR DIRECTOR OF SCHOOLS, AND OR MAINTENANCE DIRECTOR.



THE HARTFORD
BUSINESS SERVICE CENTER
3600 WISEMAN BLVD
SAN ANTONIO TX 78251

August 25, 2022

Sevier County Schools
126 CEDAR ST
SEVIERVILLE TN 37862

Account Information:

Policy Holder Details :	CENTRAL KNOX INC DBA CENTRAL TECHNOLOGIES INC
--------------------------------	--



Contact Us

Need Help?

Start a live chat online or call us at
(866) 467-8730.

We're here weekdays from 8:00 AM to
8:00 PM ET.

Enclosed please find a Certificate Of Insurance for the above referenced Policyholder. Please contact us if you have any questions or concerns.

Sincerely,
Your Hartford Service Team



CERTIFICATE OF LIABILITY INSURANCE

DATE (MM/DD/YYYY)

08/25/2022

THIS CERTIFICATE IS ISSUED AS A MATTER OF INFORMATION ONLY AND CONFERS NO RIGHTS UPON THE CERTIFICATE HOLDER. THIS CERTIFICATE DOES NOT AFFIRMATIVELY OR NEGATIVELY AMEND, EXTEND OR ALTER THE COVERAGE AFFORDED BY THE POLICIES BELOW. THIS CERTIFICATE OF INSURANCE DOES NOT CONSTITUTE A CONTRACT BETWEEN THE ISSUING INSURER(S), AUTHORIZED REPRESENTATIVE OR PRODUCER, AND THE CERTIFICATE HOLDER.

IMPORTANT: If the certificate holder is an ADDITIONAL INSURED, the policy(ies) must be endorsed. If SUBROGATION IS WAIVED, subject to the terms and conditions of the policy, certain policies may require an endorsement. A statement on this certificate does not confer rights to the certificate holder in lieu of such endorsement(s).

PRODUCER NORTHEAST AGENCIES INC/PHS 01214608 The Hartford Business Service Center 3600 Wiseman Blvd San Antonio, TX 78251	CONTACT NAME: PHONE (866) 467-8730 (A/C, No, Ext):		FAX (A/C, No):
	E-MAIL ADDRESS:		
INSURER(S) AFFORDING COVERAGE		NAIC#	
INSURED CENTRAL KNOX INC DBA CENTRAL TECHNOLOGIES INC 6101 INDUSTRIAL HEIGHTS DR KNOXVILLE TN 37909-1228	INSURER A : Sentinel Insurance Company Ltd.		11000
	INSURER B : Hartford Fire Insurance Company		19682
	INSURER C :		
	INSURER D :		
	INSURER E :		
	INSURER F :		

COVERAGES**CERTIFICATE NUMBER:****REVISION NUMBER:**

THIS IS TO CERTIFY THAT THE POLICIES OF INSURANCE LISTED BELOW HAVE BEEN ISSUED TO THE INSURED NAMED ABOVE FOR THE POLICY PERIOD INDICATED. NOTWITHSTANDING ANY REQUIREMENT, TERM OR CONDITION OF ANY CONTRACT OR OTHER DOCUMENT WITH RESPECT TO WHICH THIS CERTIFICATE MAY BE ISSUED OR MAY PERTAIN, THE INSURANCE AFFORDED BY THE POLICIES DESCRIBED HEREIN IS SUBJECT TO ALL THE TERMS, EXCLUSIONS AND CONDITIONS OF SUCH POLICIES. LIMITS SHOWN MAY HAVE BEEN REDUCED BY PAID CLAIMS.

INSR LTR	TYPE OF INSURANCE	ADDL INSR	SUBR WVD	POLICY NUMBER	POLICY EFF (MM/DD/YYYY)	POLICY EXP (MM/DD/Y YYY)	LIMITS					
A	COMMERCIAL GENERAL LIABILITY <input type="checkbox"/> CLAIMS-MADE <input checked="" type="checkbox"/> OCCUR <input checked="" type="checkbox"/> General Liability			01 SBA AW7587	01/29/2022	01/29/2023	EACH OCCURRENCE	\$1,000,000				
	GEN'L AGGREGATE LIMIT APPLIES PER:											
	<input type="checkbox"/> POLICY	<input type="checkbox"/> PRO-JECT	<input checked="" type="checkbox"/> LOC									
	OTHER:											
A	AUTOMOBILE LIABILITY <input type="checkbox"/> ANY AUTO <input checked="" type="checkbox"/> ALL OWNED AUTOS <input checked="" type="checkbox"/> HIRED AUTOS <input type="checkbox"/> SCHEDULED AUTOS <input checked="" type="checkbox"/> NON-OWNED AUTOS <input type="checkbox"/> AUTOS			01 SBA AW7587	01/29/2022	01/29/2023	COMBINED SINGLE LIMIT (Ea accident)	\$1,000,000				
A	<input checked="" type="checkbox"/> UMBRELLA LIAB <input checked="" type="checkbox"/> EXCESS LIAB <input checked="" type="checkbox"/> OCCUR <input type="checkbox"/> CLAIMS-MADE			01 SBA AW7587	01/29/2022	01/29/2023	EACH OCCURRENCE	\$5,000,000				
	<input type="checkbox"/> DED <input checked="" type="checkbox"/> RETENTION \$ 10,000									AGGREGATE	\$5,000,000	
B	WORKERS COMPENSATION AND EMPLOYERS' LIABILITY ANY PROPRIETOR/PARTNER/EXECUTIVE OFFICER/MEMBER EXCLUDED? (Mandatory in NH) If yes, describe under DESCRIPTION OF OPERATIONS below	Y/N	N/A	01 WEC AR0CEE	01/29/2022	01/29/2023	<input checked="" type="checkbox"/> PER STATUTE	<input type="checkbox"/> OTHER				
										E.L. EACH ACCIDENT	\$1,000,000	
											E.L. DISEASE -EA EMPLOYEE	\$1,000,000
											E.L. DISEASE - POLICY LIMIT	\$1,000,000
A	EMPLOYMENT PRACTICES LIABILITY			01 SBA AW7587	01/29/2022	01/29/2023	Each Claim Limit	\$10,000				
							Aggregate Limit	\$10,000				

DESCRIPTION OF OPERATIONS / LOCATIONS / VEHICLES (ACORD 101, Additional Remarks Schedule, may be attached if more space is required)

Those usual to the Insured's Operations. Ref: Northview Academy Job# 21C1224E

CERTIFICATE HOLDER

Sevier County Schools
 126 CEDAR ST
 SEVIERVILLE TN 37862

CANCELLATION

SHOULD ANY OF THE ABOVE DESCRIBED POLICIES BE CANCELLED BEFORE THE EXPIRATION DATE THEREOF, NOTICE WILL BE DELIVERED IN ACCORDANCE WITH THE POLICY PROVISIONS.

AUTHORIZED REPRESENTATIVE

Susan L. Castaneda

© 1988-2015 ACORD CORPORATION. All rights reserved.

Document A310™ – 2010

Conforms with The American Institute of Architects AIA Document 310

Bid Bond

CONTRACTOR:

(Name, legal status and address)

South Western Communications, Inc.
4871 Rosebud Lane
Newburgh, IN 47630

SURETY:

(Name, legal status and principal place of business)

Travelers Casualty and Surety Company of America

One Tower Square
Hartford, CT 06183
Mailing Address for Notices

This document has important legal consequences. Consultation with an attorney is encouraged with respect to its completion or modification.

OWNER:

(Name, legal status and address)

Hickman County Schools
115 Murphree Ave.
Centerville, TN 37033

Any singular reference to Contractor, Surety, Owner or other party shall be considered plural where applicable.

BOND AMOUNT: 5% Five Percent of Amount Bid

PROJECT:

(Name, location or address, and Project number, if any)

School Intercom Systems

The Contractor and Surety are bound to the Owner in the amount set forth above, for the payment of which the Contractor and Surety bind themselves, their heirs, executors, administrators, successors and assigns, jointly and severally, as provided herein. The conditions of this Bond are such that if the Owner accepts the bid of the Contractor within the time specified in the bid documents, or within such time period as may be agreed to by the Owner and Contractor, and the Contractor either (1) enters into a contract with the Owner in accordance with the terms of such bid, and gives such bond or bonds as may be specified in the bidding or Contract Documents, with a surety admitted in the jurisdiction of the Project and otherwise acceptable to the Owner, for the faithful performance of such Contract and for the prompt payment of labor and material furnished in the prosecution thereof; or (2) pays to the Owner the difference, not to exceed the amount of this Bond, between the amount specified in said bid and such larger amount for which the Owner may in good faith contract with another party to perform the work covered by said bid, then this obligation shall be null and void, otherwise to remain in full force and effect. The Surety hereby waives any notice of an agreement between the Owner and Contractor to extend the time in which the Owner may accept the bid. Waiver of notice by the Surety shall not apply to any extension exceeding sixty (60) days in the aggregate beyond the time for acceptance of bids specified in the bid documents, and the Owner and Contractor shall obtain the Surety's consent for an extension beyond sixty (60) days.

If this Bond is issued in connection with a subcontractor's bid to a Contractor, the term Contractor in this Bond shall be deemed to be Subcontractor and the term Owner shall be deemed to be Contractor.

When this Bond has been furnished to comply with a statutory or other legal requirement in the location of the Project, any provision in this Bond conflicting with said statutory or legal requirement shall be deemed deleted herefrom and provisions conforming to such statutory or other legal requirement shall be deemed incorporated herein. When so furnished, the intent is that this Bond shall be construed as a statutory bond and not as a common law bond.

Signed and sealed this 29th day of August, 2022.



(Witness)

South Western Communications, Inc.
(Principal) (Seal)

By: 
(Title) Elizabeth Wallace CFO

(Witness) Sharon Griffith

Travelers Casualty and Surety Company of America
(Surety) (Seal)

By: 
(Title) Gregg A. Tatum, Attorney-in-Fact



**Travelers Casualty and Surety Company of America
Travelers Casualty and Surety Company
St. Paul Fire and Marine Insurance Company**

POWER OF ATTORNEY

KNOW ALL MEN BY THESE PRESENTS: That Travelers Casualty and Surety Company of America, Travelers Casualty and Surety Company, and St. Paul Fire and Marine Insurance Company are corporations duly organized under the laws of the State of Connecticut (herein collectively called the "Companies"), and that the Companies do hereby make, constitute and appoint **GREGG A TATUM** of **BIRMINGHAM**, **Alabama**, their true and lawful Attorney(s)-in-Fact to sign, execute, seal and acknowledge any and all bonds, recognizances, conditional undertakings and other writings obligatory in the nature thereof on behalf of the Companies in their business of guaranteeing the fidelity of persons, guaranteeing the performance of contracts and executing or guaranteeing bonds and undertakings required or permitted in any actions or proceedings allowed by law.

IN WITNESS WHEREOF, the Companies have caused this instrument to be signed, and their corporate seals to be hereto affixed, this **21st** day of **April**, 2021.



State of Connecticut

City of Hartford ss.

By: 
Robert L. Raney, Senior Vice President

On this the **21st** day of **April**, 2021, before me personally appeared **Robert L. Raney**, who acknowledged himself to be the Senior Vice President of each of the Companies, and that he, as such, being authorized so to do, executed the foregoing instrument for the purposes therein contained by signing on behalf of said Companies by himself as a duly authorized officer.

IN WITNESS WHEREOF, I hereunto set my hand and official seal.

My Commission expires the **30th** day of **June**, 2026



Anna P. Nowik, Notary Public

This Power of Attorney is granted under and by the authority of the following resolutions adopted by the Boards of Directors of each of the Companies, which resolutions are now in full force and effect, reading as follows:

RESOLVED, that the Chairman, the President, any Vice Chairman, any Executive Vice President, any Senior Vice President, any Vice President, any Second Vice President, the Treasurer, any Assistant Treasurer, the Corporate Secretary or any Assistant Secretary may appoint Attorneys-in-Fact and Agents to act for and on behalf of the Company and may give such appointee such authority as his or her certificate of authority may prescribe to sign with the Company's name and seal with the Company's seal bonds, recognizances, contracts of indemnity, and other writings obligatory in the nature of a bond, recognizance, or conditional undertaking, and any of said officers or the Board of Directors at any time may remove any such appointee and revoke the power given him or her; and it is

FURTHER RESOLVED, that the Chairman, the President, any Vice Chairman, any Executive Vice President, any Senior Vice President or any Vice President may delegate all or any part of the foregoing authority to one or more officers or employees of this Company, provided that each such delegation is in writing and a copy thereof is filed in the office of the Secretary; and it is

FURTHER RESOLVED, that any bond, recognizance, contract of indemnity, or writing obligatory in the nature of a bond, recognizance, or conditional undertaking shall be valid and binding upon the Company when (a) signed by the President, any Vice Chairman, any Executive Vice President, any Senior Vice President or any Vice President, any Second Vice President, the Treasurer, any Assistant Treasurer, the Corporate Secretary or any Assistant Secretary and duly attested and sealed with the Company's seal by a Secretary or Assistant Secretary; or (b) duly executed (under seal, if required) by one or more Attorneys-in-Fact and Agents pursuant to the power prescribed in his or her certificate or their certificates of authority or by one or more Company officers pursuant to a written delegation of authority; and it is

FURTHER RESOLVED, that the signature of each of the following officers: President, any Executive Vice President, any Senior Vice President, any Vice President, any Assistant Vice President, any Secretary, any Assistant Secretary, and the seal of the Company may be affixed by facsimile to any Power of Attorney or to any certificate relating thereto appointing Resident Vice Presidents, Resident Assistant Secretaries or Attorneys-in-Fact for purposes only of executing and attesting bonds and undertakings and other writings obligatory in the nature thereof, and any such Power of Attorney or certificate bearing such facsimile signature or facsimile seal shall be valid and binding upon the Company and any such power so executed and certified by such facsimile signature and facsimile seal shall be valid and binding on the Company in the future with respect to any bond or understanding to which it is attached.

I, **Kevin E. Hughes**, the undersigned, Assistant Secretary of each of the Companies, do hereby certify that the above and foregoing is a true and correct copy of the Power of Attorney executed by said Companies, which remains in full force and effect.

Dated this **29th** day of **August**, 2022



Kevin E. Hughes, Assistant Secretary

**To verify the authenticity of this Power of Attorney, please call us at 1-800-421-3880.
Please refer to the above-named Attorney(s)-in-Fact and the details of the bond to which this Power of Attorney is attached.**

Hickman County Government

Conflict of Interest Disclosure Form

The County Financial Management System of 1981 contains the most stringent conflict of interest provisions. TCA §5-21-121 provides:

- (a) The director, purchasing agent, members of the committee, members of the county legislative body or other officials, employees, or members of the board of education or highway commission shall not be financially interested or have any personal beneficial interest, either directly or indirectly, in the purchase of any supplies, materials, equipment or contractual services for the county.
- (b) No firm, corporation, partnership, association or individual furnishing any such supplies, materials, equipment or contractual services, shall give or offer, nor shall the director or purchasing agent or any assistant or employee accept or receive directly or indirectly from any person, firm, corporation, partnership or association to whom any contract may be awarded, by rebate, gift or otherwise, any money or other things of value whatsoever, or any promise, obligation or contract for future reward or compensation.

Date: 8/26/2022 Name: BT Rook

Please describe below any relationships, transactions, positions you hold (volunteer or otherwise), or circumstances that you believe could contribute to a conflict of interest:

I have no conflict of interest to report.

I have the following conflict of interest to report (please specify any boards or committees you (and/or your spouse) sit on, the name of your employer and any businesses you or your spouse may own.

I hereby certify that the information set forth above is true and complete to the best of my knowledge.

Date: 8/26/2022 Signature: [Signature]



CERTIFICATE OF LIABILITY INSURANCE

DATE (MM/DD/YYYY)

8/25/2022

THIS CERTIFICATE IS ISSUED AS A MATTER OF INFORMATION ONLY AND CONFERS NO RIGHTS UPON THE CERTIFICATE HOLDER. THIS CERTIFICATE DOES NOT AFFIRMATIVELY OR NEGATIVELY AMEND, EXTEND OR ALTER THE COVERAGE AFFORDED BY THE POLICIES BELOW. THIS CERTIFICATE OF INSURANCE DOES NOT CONSTITUTE A CONTRACT BETWEEN THE ISSUING INSURER(S), AUTHORIZED REPRESENTATIVE OR PRODUCER, AND THE CERTIFICATE HOLDER.

IMPORTANT: If the certificate holder is an ADDITIONAL INSURED, the policy(ies) must have ADDITIONAL INSURED provisions or be endorsed. If SUBROGATION IS WAIVED, subject to the terms and conditions of the policy, certain policies may require an endorsement. A statement on this certificate does not confer rights to the certificate holder in lieu of such endorsement(s).

PRODUCER Arthur J. Gallagher Risk Management Services, Inc. 1601 Alliant Avenue Louisville KY 40299	CONTACT NAME: Terri Cook PHONE (A/C, No, Ext): 502-716-7856 E-MAIL ADDRESS: terri_cook@ajg.com	FAX (A/C, No): 502-716-7909													
	<table border="1"> <thead> <tr> <th>INSURER(S) AFFORDING COVERAGE</th> <th>NAIC #</th> </tr> </thead> <tbody> <tr> <td>INSURER A : Zurich American Insurance Company</td> <td>16535</td> </tr> <tr> <td>INSURER B : AXIS Surplus Insurance Company</td> <td>26620</td> </tr> <tr> <td>INSURER C :</td> <td></td> </tr> <tr> <td>INSURER D :</td> <td></td> </tr> <tr> <td>INSURER E :</td> <td></td> </tr> <tr> <td>INSURER F :</td> <td></td> </tr> </tbody> </table>		INSURER(S) AFFORDING COVERAGE	NAIC #	INSURER A : Zurich American Insurance Company	16535	INSURER B : AXIS Surplus Insurance Company	26620	INSURER C :		INSURER D :		INSURER E :		INSURER F :
INSURER(S) AFFORDING COVERAGE	NAIC #														
INSURER A : Zurich American Insurance Company	16535														
INSURER B : AXIS Surplus Insurance Company	26620														
INSURER C :															
INSURER D :															
INSURER E :															
INSURER F :															
INSURED South Western Communications, Inc. 4871 Rosebud Lane Newburg IN 47630	KOCHENT-01														

COVERAGES**CERTIFICATE NUMBER:** 1989799708**REVISION NUMBER:**

THIS IS TO CERTIFY THAT THE POLICIES OF INSURANCE LISTED BELOW HAVE BEEN ISSUED TO THE INSURED NAMED ABOVE FOR THE POLICY PERIOD INDICATED. NOTWITHSTANDING ANY REQUIREMENT, TERM OR CONDITION OF ANY CONTRACT OR OTHER DOCUMENT WITH RESPECT TO WHICH THIS CERTIFICATE MAY BE ISSUED OR MAY PERTAIN, THE INSURANCE AFFORDED BY THE POLICIES DESCRIBED HEREIN IS SUBJECT TO ALL THE TERMS, EXCLUSIONS AND CONDITIONS OF SUCH POLICIES. LIMITS SHOWN MAY HAVE BEEN REDUCED BY PAID CLAIMS.

INSR LTR	TYPE OF INSURANCE	ADDL INSD	SUBR WVD	POLICY NUMBER	POLICY EFF (MM/DD/YYYY)	POLICY EXP (MM/DD/YYYY)	LIMITS
A	<input checked="" type="checkbox"/> COMMERCIAL GENERAL LIABILITY <input type="checkbox"/> CLAIMS-MADE <input checked="" type="checkbox"/> OCCUR GEN'L AGGREGATE LIMIT APPLIES PER: <input checked="" type="checkbox"/> POLICY <input checked="" type="checkbox"/> PRO-JECT <input checked="" type="checkbox"/> LOC OTHER:			GLO 0244268-03	3/1/2022	3/1/2023	EACH OCCURRENCE \$ 2,000,000 DAMAGE TO RENTED PREMISES (Ea occurrence) \$ 1,000,000 MED EXP (Any one person) \$ 10,000 PERSONAL & ADV INJURY \$ 1,000,000 GENERAL AGGREGATE \$ 4,000,000 PRODUCTS - COMP/OP AGG \$ 4,000,000 \$
A	<input checked="" type="checkbox"/> AUTOMOBILE LIABILITY <input checked="" type="checkbox"/> ANY AUTO <input type="checkbox"/> OWNED AUTOS ONLY <input type="checkbox"/> SCHEDULED AUTOS NON-OWNED AUTOS ONLY <input type="checkbox"/> HIRED AUTOS ONLY			BAP 0244269-03	3/1/2022	3/1/2023	COMBINED SINGLE LIMIT (Ea accident) \$ 2,000,000 BODILY INJURY (Per person) \$ BODILY INJURY (Per accident) \$ PROPERTY DAMAGE (Per accident) \$ \$
B	<input type="checkbox"/> UMBRELLA LIAB <input checked="" type="checkbox"/> OCCUR <input checked="" type="checkbox"/> EXCESS LIAB <input type="checkbox"/> CLAIMS-MADE <input type="checkbox"/> DED <input checked="" type="checkbox"/> RETENTION \$ 0			P-001-000288768	3/1/2022	3/1/2023	EACH OCCURRENCE \$ 3,000,000 AGGREGATE \$ 3,000,000 \$
A	<input checked="" type="checkbox"/> WORKERS COMPENSATION AND EMPLOYERS' LIABILITY ANY PROPRIETOR/PARTNER/EXECUTIVE OFFICER/MEMBER EXCLUDED? (Mandatory in NH) If yes, describe under DESCRIPTION OF OPERATIONS below		N/A	WC 0244267-03	3/1/2022	3/1/2023	<input checked="" type="checkbox"/> PER STATUTE <input type="checkbox"/> OTHER E.L. EACH ACCIDENT \$ 1,000,000 E.L. DISEASE - EA EMPLOYEE \$ 1,000,000 E.L. DISEASE - POLICY LIMIT \$ 1,000,000

DESCRIPTION OF OPERATIONS / LOCATIONS / VEHICLES (ACORD 101, Additional Remarks Schedule, may be attached if more space is required)
 OTHER EXCESS LIABILITY

Excess Liability-Westfield Specialty Insurance Company
 Policy # XSL-00004XW
 3/1/22-3/1/23
 Limits Shown Are Excess of the Axis \$3,000,000 Umbrella
 \$5,000,000 Each Occurrence Limit
 \$5,000,000 General Aggregate Limit
 See Attached...

CERTIFICATE HOLDER**CANCELLATION**

Hickman County School System
 115 Murphree Avenue
 Centerville TN 37033

SHOULD ANY OF THE ABOVE DESCRIBED POLICIES BE CANCELLED BEFORE THE EXPIRATION DATE THEREOF, NOTICE WILL BE DELIVERED IN ACCORDANCE WITH THE POLICY PROVISIONS.

AUTHORIZED REPRESENTATIVE

© 1988-2015 ACORD CORPORATION. All rights reserved.



ADDITIONAL REMARKS SCHEDULE

AGENCY Arthur J. Gallagher Risk Management Services, Inc.		NAMED INSURED South Western Communications, Inc. 4871 Rosebud Lane Newburg IN 47630	
POLICY NUMBER		EFFECTIVE DATE:	
CARRIER	NAIC CODE		

ADDITIONAL REMARKS

THIS ADDITIONAL REMARKS FORM IS A SCHEDULE TO ACORD FORM,
FORM NUMBER: 25 FORM TITLE: CERTIFICATE OF LIABILITY INSURANCE

\$5,000,000 Products & Completed Operations Aggregate Limit

Excess Liability-Everest Indemnity Insurance Company
 Policy # XC1EX00464-221
 3/1/22-3/1/23
 Limits Shown Are Excess of the Axis and Westfield \$8,000,000 Umbrella's
 \$7,000,000 Each Occurrence Limit
 \$7,000,000 General Aggregate Limit
 \$7,000,000 Products & Completed Operations Aggregate Limit

STATE OF TENNESSEE
DEPARTMENT OF
COMMERCE AND INSURANCE



SOUTH WESTERN COMMUNICATIONS, INC.

382071

ID NUMBER: 29581
LIC STATUS: ACTIVE
EXPIRATION DATE: September 30, 2023

BOARD FOR LICENSING CONTRACTORS
CONTRACTOR

THIS IS TO CERTIFY THAT ALL REQUIREMENTS
OF THE STATE OF TENNESSEE HAVE BEEN MET

SOUTH WESTERN COMMUNICATIONS, INC.
4871 ROSEBUD LANE
NEWBURGH, IN 47630

State of Tennessee ³⁸²⁰⁷¹ 12717913

BOARD FOR LICENSING CONTRACTORS
CONTRACTOR

SOUTH WESTERN COMMUNICATIONS, INC.

This is to certify that all requirements of the State of Tennessee have been met.

ID NUMBER: 29581
LIC STATUS: ACTIVE
EXPIRATION DATE: September 30, 2023
UNLIMITED; CE



IN-1313
DEPARTMENT OF
COMMERCE AND INSURANCE

BOARD FOR LICENSING CONTRACTORS

AREAS OF CERTIFICATION/MONEY LIMITS

UNLIMITED; CE

Davidson County Clerk's Office
700 Second Avenue South, Suite 101
P.O. Box 196333
Nashville, Tennessee 37219-6333
615-862-6254

NASHVILLE AND DAVIDSON COUNTY BUSINESS
TAX LICENSE

BUSINESS NUMBER	56122
RECEIPT NUMBER	0959608
THIS LICENSE EXPIRES	05/15/2023

OWNER(S)/OFFICER(S)
JAMES R. MILLER

BUSINESS LOCATION ADDRESS
SOUTH WESTERN COMM. INC.
4871 ROSEBUD LN
NEWBURGH, IN 47630

SOUTH WESTERN COMM. INC.
4871 ROSEBUD LANE
NEWBURGH, IN 47630

MUST DISPLAY IN A CONSPICUOUS PLACE

Contact Metro Codes to verify this location is properly zoned.

BUSINESS NUMBER	56122
RECEIPT NUMBER	0959608
CLASSIFICATION	4

TAX PERIOD

FROM	01/01/2021
TO	12/31/2021

THIS LICENSE EXPIRES 05/15/2023
ISSUE DATE 04/15/2022

Brenda Wynn

BRENDA WYNN, COUNTY CLERK

A ROBERSON
DEPUTY CLERK

South Western Communications

Rauland Installation References

Cleveland City Schools

4300 Mouse Creek Rd NW

Cleveland, TN 37312

423-472-9571

Dr Cody Raper

St Thomas Mid Town, West, and Rutherford Hospitals

1700 Medical Center Parkway

Murfreesboro, TN 37129

423-791-4037

John Rutherford

Chickamauga City Schools

402 Cove Road

Chickamauga, GA 30707

706-382-3100

Wes Brown



Critical Communications

One Solution, Multiple Pathways





Proposal Submission

Hickman County Intercom Bid

51618 8

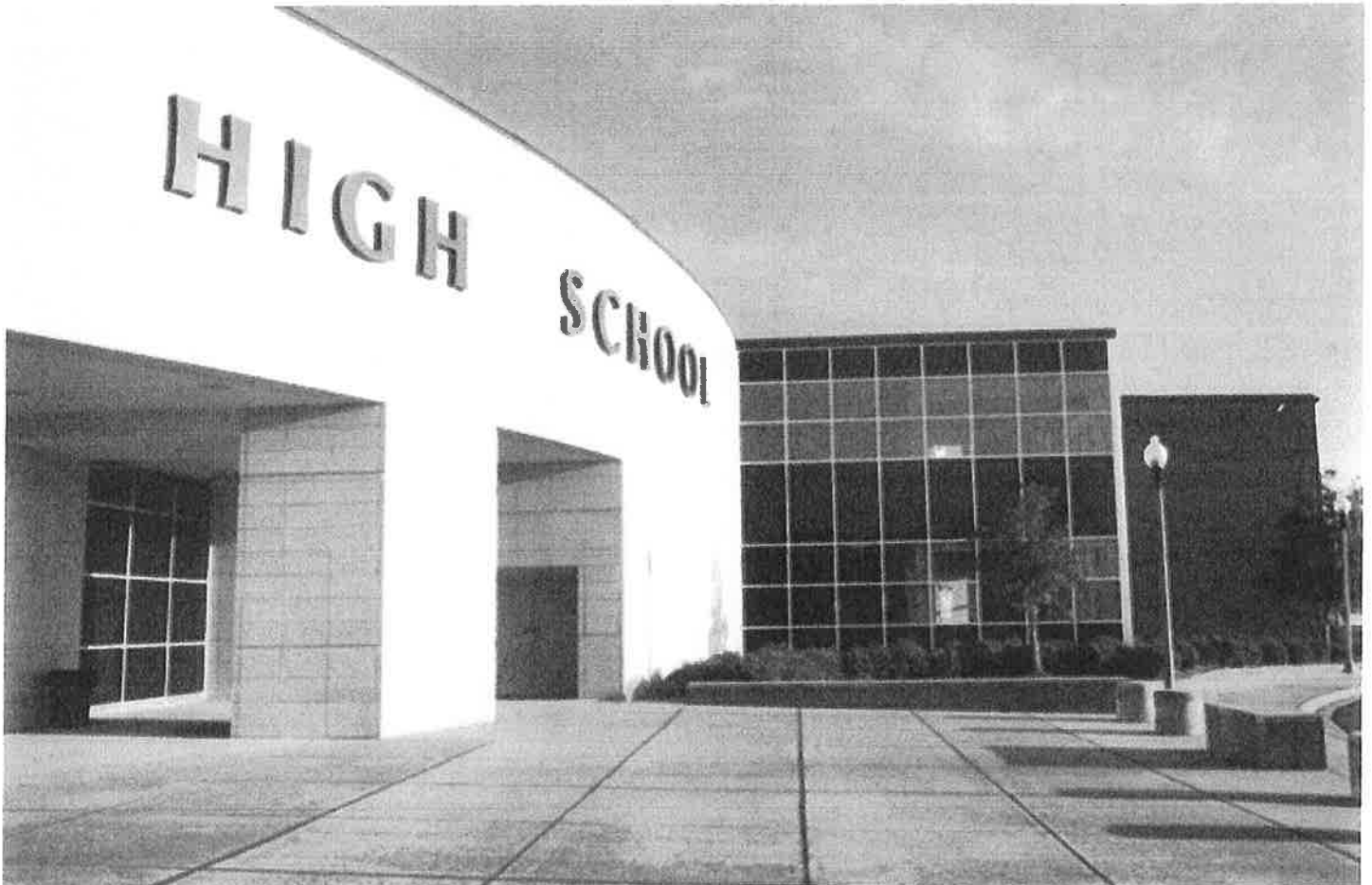

Company Address

SWC of Nashville
2513 Perimeter Place Dr
Nashville, TN 37214

Phone & Fax

Phone: 615-330-7370
Fax:

Email

bj.rook@swc.net



Central Education
(615) 330-7370

Company & Team

OUR PEOPLE MAKE THE DIFFERENCE.

At SWC our people make the difference. We are admired for our top talent within the industry and take pride in our team making your experience with our services exceptional. The relationship we build with our clients extends beyond the current needs of the project and instead partners with you to meet both current goals and continuously engage for interminable improvement.



BJ leads SWC's middle Tennessee market in Education Solutions, helping school systems design and install life safety, integrated security and communication solutions. BJ has been involved in providing cutting edge technology solutions in the education market for more than two decades. His knowledge of structured cabling and security solutions for school systems is an asset in determining the best solution for current and future customers.



Central Education
(615) 330-7370



SWC ENRICHES LIVES BY PROVIDING INTEGRATED ELECTRONIC SOLUTIONS AND SERVICES WITH PROGRESSIVE TECHNOLOGIES. THAT ENABLE OUR CUSTOMERS TO OPTIMIZE THEIR MISSION-CRITICAL PROCESSES.

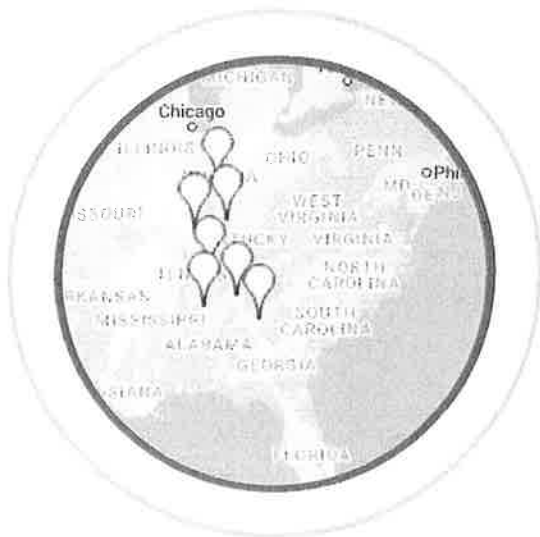

OUR LOCATIONS

SWC Corporate Headquarters

- Evansville, IN -
- Atlanta, GA -
- Chattanooga, TN -
- Decatur, AL -
- Indianapolis, IN -
- Louisville, KY -
- Nashville, TN -

SWC is your trusted source for communication, physical security and life safety solutions to meet the needs of **Healthcare, Education, Detention and Commercial** customers. We utilize a consultative approach to conduct an in-depth needs analysis, enabling our customers to fulfill their mission-critical processes. We continuously research and select only the **best-in-class product collection**. We utilize these products to create an integrated solution with your goals and needs in mind, ensuring satisfaction and flawless integration. **At SWC, we strive to exceed your expectations** and invest the time and resources into every job because we care about our customers.



Central Education
(615) 330-7370

Pricing Summary

ACCOUNT
HICKMAN CO SCHOOL DISTRICT
115 MURPHREE AVE
CENTERVILLE, TN 37033

FACILITY LOCATION
HICKMAN CO SCHOOL DISTRICT
115 MURPHREE AVE
CENTERVILLE, TN 37033

OFFER: In accordance with the Scope of Work, Bill of Materials, and Terms and Conditions attached hereto, SWC is pleased to offer this pricing for the following project:

TITLE:

REF #: 51618_8

ESTIMATE GROUP	TOTAL PRICE
Hickman Intermediate	\$104281.01
Hickman E.S.	\$116364.21
Extend Warranty to 10 years	\$10096.25

ACCOUNT EXECUTIVE:	SUB-TOTAL	\$230,741.47
	TAX (EXEMPT):	\$.00

TERMS:

TOTAL \$230,741.5

Per my authority as an executing agent, please accept this as an intent to award and enter into a contractual agreement with SWC.

_____ NAME

_____ CLIENT'S SIGNATURE



Scope & Bill of Materials

SWC IS PLEASED TO PRESENT A QUOTE FOR THE Hickman County Intercom Bid PROJECT.

Scope of Work:

The existing Intercom will remain in place operational, until the new intercom is up and working, then upon completion the older hardware will be removed, boxed and turned over to the Maintenance Dept. Prior to the final bid award of the prospective company, there shall be a "pre-installation meeting" and prior to purchase of any equipment. Meeting will occur at the school to review the proposed purchasing equipment and ensure that all features and needs of the system, as well as the installation schedules, agree with both the School Principal and Maintenance Director of schools.

Installation Schedules:

Classroom hardware, speakers, and cabling will be installed during the first week during school shutdown week as Phase 1, then upon return weeks 2/3 as needed, the halls and offices will be phase 2. This is to minimize techs having to be in classrooms during instruction.

Damages:

Any and all damages not limited to ceiling tile, grid are to be replaced as new, and any drilled fire walls are to be fire caulked as installed and is the responsibility of the installer. Where there are tile or grid materials available maintenance will provide materials, but this does not exempt the installer from having to provide such.

Equipment:

This is the total replacement with new separate cabling of the existing intercom with a IP based Communications system in an existing building, requiring new call buttons, with emergency call feature, new cables, new two way talk lay in 2 x 2 speakers, minimum of 3 new speakers in the kitchen, the call in buttons will place normal call, and will serve as check in button in event of emergency or lock down, 3 new consoles to include the main front office, principal office, and assistant principals office. Main console is to receive calls from classrooms when call button is pushed, all consoles are to allow for "ALL CALL", zone page, bell control, and emergency initiation. Head in components shall be installed in the existing rack location.

Services:

All to include balancing & Dolby Quality Clarity and site employee training as needed to insure a smooth transition of the new operational system. Training shall include: School Administrative Staff Teachers, SRO personnel.

System shall include a "No Nonsense Warranty" complete with "Labor" for a period of not less than 1 year from the date the system is "Operational and 100% completed". In addition, to the 1 year minimum workmanship warranty, the system shall have an "Additional 10 year Parts & Servicing Contract Warranty", by the installing company/ or manufacturer.

Other Specifications:

EAST HICKMAN INTERMEDIATE BUILDING:

This building will consist of a 5 zone system:

(Interior speaker and button stations consist of approximately 40 rooms speakers and call buttons, 3 offices head units, 2 gymnasium large speakers, 1 gym office speaker w/call button, café dining room 2 speakers/ 1 call button, kitchen 3 speakers and 1 call button

ZONES:

3rd Grade Hall/rooms

4th Grade Hall/rooms

5th Grade Hall/rooms

TWA 3rd, 4th, 5th grade halls, main hall conference locations, copying room

Cafeteria Kitchen

Gym/ front hall



Central Education
(615) 330-7370

Playground, outside building inset corners, speakers at all corridor exits outside.

EAST HICKMAN ELEMENTARY SCHOOL:

ZONES:

Kindergarten hall
Title wing
First grade wing
Second grade wing
Enrichment wing
Gym/café

Installing techs shall have at least 5 years minimum experience of large jobsite installation of Intercom equipment in Schools, Hospitals, or larger venues.

3 prior references enclosed

Bid bond enclosed

Business liability insurance, workers compensation insurance enclosed

Business license enclosed

Tennessee State Contractor license enclosed

Performance bond provided on contract award



EST. GROUP - Hickman E.S.

Mfg	Part Num	Description	Quantity	Sales Price	Ext. Price
Rauland	TCC2000	CAMPUS CONTROLLER	1.00	\$4762.85	\$4762.85
Rauland	TCU3000SW	TCU License - Controller	1.00	\$790.00	\$790.00
Rauland	BAFKIT2X2L8R J	8 ohm 2X2 Lay-in Speaker Assembly with RJ45	48.00	\$110.71	\$5314.08
Rauland	BAFKIT2X2L25 70	2x2 Lay-in Combo Bafkit 25/70v	51.00	\$120.00	\$6120.00
Proco	TYPE A	TYPE A Input Jack Plate	1.00	\$16.35	\$16.35
Rauland	TCC2045	Telecenter Campus IP Console V2	4.00	\$1414.28	\$5657.12
Rauland	3603	Wide angle paging horn	3.00	\$154.28	\$462.84
Rauland	A30G	Weather Tight Strain Relief Adapter	3.00	\$22.14	\$66.42
Rauland	TCC2055	PROGRAM LINE INPUT MODULE	1.00	\$557.14	\$557.14
Rauland	TCC2033	AUXILIARY I/O MODULE	1.00	\$557.14	\$557.14
Rauland	TCC2211PB	Call Switch RJ45 Emer Check-in	51.00	\$47.42	\$2418.42
Rauland	TCC2011A	IP Classroom Module V2	53.00	\$417.14	\$22108.42
Rauland	TCC3022	Zone Page Amplifier Module	7.00	\$768.57	\$5379.99
Rauland	TCC3022PS	24VDC power supply (UL Listed) for TCC3022	7.00	\$87.00	\$609.00
Cables 2 Go	CG37093	One Port Keystone Single Gang Wall Plate - Stainl	4.00	\$4.68	\$18.72
Quam	CIS2/8	HIGH SECURITY INTERCOM	2.00	\$84.21	\$168.42
Rauland	ACC1119	V-proof Surf Bbox HSS1, 2, 14, CIS2/25	2.00	\$53.71	\$107.42
Wiremold	V500	WIRE MOLD 10FT	10.00	\$14.45	\$144.50
Wiremold	V504	STL STRAP 500 IVORY	30.00	\$0.42	\$12.60
Wiremold	V5744	Single Gang Deep Surface Mounted Box	10.00	\$23.68	\$236.80
Rauland	TCC2099	UNIVERSAL RACK MOUNT	1.00	\$64.85	\$64.85
Lowell	LWR-1623	Rack-Sectional Wall Mount-16U, 23in Deep, 1pr A	1.00	\$639.10	\$639.10
Panduit	NKFP24Y	24 port MFP Patch Panel	1.00	\$35.02	\$35.02
Tripp lite	SMART1500LC D	1500VA RACKMT./TOWER DIG.UPS	1.00	\$721.42	\$721.42
Panduit	NKBMBL-X	Black Blank Insert - 10 PACK	2.00	\$2.71	\$5.42
Panduit	NK688MGR	CAT6 KEYSTONE JACK Green	100.00	\$6.35	\$635.00
Mohawk	M58286B	Cat6 Plenum, Green, 6P4P24-GN-P-MOH-APCE	11.00	\$382.17	\$4203.87
West Penn	25292BGN1000	1P 20G STRD SHLD PLENUM, Green	4.00	\$190.24	\$760.96
Panduit	NK2BXWH-A	Panduit Netkey 2 Port Surface Mount Box	53.00	\$2.04	\$108.12
Lynn Elec	CAT6PL-10-GR	Patch Cable CAT6 Plenum 10ft Green	53.00	\$10.44	\$553.32
Lynn Elec	CAT6PL-50-GR	Patch Cable CAT6 Plenum 50ft Green	53.00	\$34.82	\$1845.46
Hewlett Packard	JL322A	Hewlett Packard Enterprise -HPE Aruba 2930M 48	1.00	\$8696.65	\$8696.65
Cables 2 Go	33047	3M LC-LC 10G OM3 DPX MM FIBER-AQUA	1.00	\$24.28	\$24.28
Hewlett Packard	J9150D	Aruba 10G SFP+ LC SR 300m MMF Transceiver	1.00	\$392.58	\$392.58
Hewlett	JL086A	Aruba X372 54VDC 680W 100-240VAC Power Su	2.00	\$658.25	\$1316.50



Central Education
(615) 330-7370

EST. GROUP - Hickman E.S.

Mfg	Part Num	Description	Quantity	Sales Price	Ext. Price
Packard					
Siemon	M1-50	Siemon 66 Block	1.00	\$11.98	\$11.98
SWC	Misc-Cable	Misc. Cable, Connectors and Consumables	5.00	\$142.85	\$714.25
HUTCH & SON	TPE-115GI	PoE+ Gigabit Injector	2.00	\$47.14	\$94.28
Trendnet	TPE-115GI	PoE+ Gigabit Injector	2.00	\$47.14	\$94.28
Rauland	ACCWB8RJ	Surf. Mt. Spkr Assy 8 Ohm RJ45	3.00	\$64.85	\$194.55
Hewlett Packard	JL320A	Aruba 2930M 24G POE+ 1-Slot Switch - L3 - ma	1.00	\$5067.14	\$5067.14
Lynn Elec	CAT6PL-07-GR	Patch Cable CAT6 Plenum 7ft Green	65.00	\$8.61	\$559.65
ACCU-TECH CORPORATION	WMP1E	HORZ MGR FRT&RR 2RU	1.00	\$75.64	\$75.64
Middle Atlantic	PHCM-1-2	PHCM-1-2 HORIZONTAL CABLE MNGMT	2.00	\$21.08	\$42.16
Panduit	NKPP48HDY	Keystone 48-port modular high density patch pane	1.00	\$101.78	\$101.78
Graybar	J-Hook	J-Hooks & Hardware	500.00	\$2.57	\$1285.00

Group Materials Price	\$83,657.21
Group Labor Price	\$31,866.45
Freight Price	\$840.55
Total Sales Tax	\$.00



Central Education
(615) 330-7370

EST. GROUP - Hickman Intermediats

Mfg	Part Num	Description	Quantity	Sales Price	Ext. Price
Graybar	J-Hook	J-Hooks & Hardware	500.00	\$2.57	\$1285.00
Panduit	NKPP48HDY	Keystone 48-port modular high density patch pane	1.00	\$101.78	\$101.78
ACCU-TECH CORPORATI ON	WMP1E	HORZ MGR FRT&RR 2RU	1.00	\$75.64	\$75.64
Hewlett Packard	JL320A	Aruba 2930M 24G POE+ 1-Slot Switch - L3 - ma	2.00	\$5067.14	\$10134.28
Middle Atlantic	PHCM-1-2	PHCM-1-2 HORIZONTAL CABLE MNGMT	2.00	\$21.08	\$42.16
SWC	Misc-Cable	Misc. Cable, Connectors and Consumables	4.00	\$142.85	\$571.40
Siemon	M1-50	Siemon 66 Block	1.00	\$11.98	\$11.98
Quam	CIS2/8	HIGH SECURITY INTERCOM	1.00	\$84.21	\$84.21
Rauland	ACC1119	V-proof Surf Bbox HSS1, 2, 14, CIS2/25	1.00	\$53.71	\$53.71
Wiremold	V500	WIRE MOLD 10FT	5.00	\$14.45	\$72.25
Wiremold	V504	STL STRAP 500 IVORY	15.00	\$0.42	\$6.30
Wiremold	V5744	Single Gang Deep Surface Mounted Box	5.00	\$23.68	\$118.40
Cables 2 Go	33047	3M LC-LC 10G OM3 DPX MM FIBER-AQUA	1.00	\$24.28	\$24.28
Panduit	NK2BXWH-A	Panduit Netkey 2 Port Surface Mount Box	40.00	\$2.04	\$81.60
Rauland	TCU3000SW	TCU License - Controller	1.00	\$790.00	\$790.00
Rauland	TCC2000	CAMPUS CONTROLLER	1.00	\$4762.85	\$4762.85
Rauland	TCC2045	Telecenter Campus IP Console V2	3.00	\$1414.28	\$4242.84
Cables 2 Go	CG37093	One Port Keystone Single Gang Wall Plate - Stainl	3.00	\$4.68	\$14.04
Rauland	TCC2055	PROGRAM LINE INPUT MODULE	1.00	\$557.14	\$557.14
Rauland	TCC2033	AUXILIARY I/O MODULE	1.00	\$557.14	\$557.14
Rauland	TCC2099	UNIVERSAL RACK MOUNT	1.00	\$64.85	\$64.85
Rauland	BAFKIT2X2L8R J	8 ohm 2X2 Lay-in Speaker Assembly with RJ45	40.00	\$110.71	\$4428.40
Rauland	TCC2211PB	Call Switch RJ45 Emer Check-in	40.00	\$47.42	\$1896.80
Rauland	BAFKIT2X2L25 70	2x2 Lay-in Combo Bafkit 25/70v	23.00	\$120.00	\$2760.00
Rauland	3603	Wide angle paging horn	6.00	\$154.28	\$925.68
Rauland	A30G	Weather Tight Strain Relief Adapter	6.00	\$22.14	\$132.84
Rauland	TCC2011A	IP Classroom Module V2	41.00	\$417.14	\$17102.74
Rauland	TCC3022	Zone Page Amplifier Module	7.00	\$768.57	\$5379.99
Rauland	TCC3022PS	24VDC power supply (UL Listed) for TCC3022	7.00	\$87.00	\$609.00
Mohawk	M58286B	Cat6 Plenum, Green, 6P4P24-GN-P-MOH-APCE	11.00	\$382.17	\$4203.87
Proco	TYPE A	TYPE A Input Jack Plate	1.00	\$16.35	\$16.35
Lynn Elec	CAT6PL-50-GR	Patch Cable CAT6 Plenum 50ft Green	41.00	\$34.82	\$1427.62
Lynn Elec	CAT6PL-10-GR	Patch Cable CAT6 Plenum 10ft Green	41.00	\$10.44	\$428.04
Panduit	NKFP24Y	24 port MFP Patch Panel	1.00	\$35.02	\$35.02
Panduit	NK688MGR	CAT6 KEYSTONE JACK Green	90.00	\$6.35	\$571.50



Central Education
 (615) 330-7370

EST. GROUP - Hickman Intermediate

Mfg	Part Num	Description	Quantity	Sales Price	Ext. Price
Hewlett Packard	JL322A	Hewlett Packard Enterprise -HPE Aruba 2930M 48	1.00	\$8696.65	\$8696.65
Hewlett Packard	J9150D	Aruba 10G SFP+ LC SR 300m MMF Transceiver	1.00	\$392.58	\$392.58
Hewlett Packard	JL086A	Aruba X372 54VDC 680W 100-240VAC Power Su	2.00	\$658.25	\$1316.50
West Penn	25292BGN1000	1P 20G STRD SHLD PLENUM, Green	4.00	\$190.24	\$760.96
Middle Atlantic	PD-915R	PD-915R 9Outlet 51A Surge Prot. Rack Mount Po	1.00	\$118.61	\$118.61
Panduit	NKBMBL-X	Black Blank Insert - 10 PACK	2.00	\$2.71	\$5.42
Lynn Elec	CAT6PL-07-GR	Patch Cable CAT6 Plenum 7ft Green	54.00	\$8.61	\$464.94

Group Materials Price \$75,325.36
Group Labor Price \$28,199.10
Freight Price \$756.55
Total Sales Tax \$.00



Central Education
(615) 330-7370

Terms & Conditions

Scope Includes:

All terms and conditions will apply to School District Standardization Agreement on file at the Purchasing Department if applicable. Furnishing and installing wire and cable for systems listed. Installation and termination of field devices. Installation and termination of head-end equipment in Equipment Rooms and MDF and IDF areas. Factory and field testing of equipment and systems. Project management in coordination with SWC scope of work. Applicable Permit Fees.

Project Management services in coordination with SWC scope of work. Site Supervision during the installation of SWC scope of work ONLY. As required; site conditions verification for SWC Scope of work ONLY.

The Project Schedule will be a mutually agreed upon document between the parties, including all revisions. Scope and price are based on regular working hours Monday through Friday; any deviation, unless requested by SWC, may be cause for additional compensation.

Final payment including will is remitted within 30 days of substantial completion of our scope of work regardless of the status and nature of other trades and the overall project status. No Retainage to be withheld.

Scope Excludes:

Service and circuit power requirements including final connections to all our electronic equipment. Server(s) and workstation(s) hardware and Microsoft operating system. All demolition work, trenching, concrete work and finish painting. Patching of concrete, tile, drywall or masonry, core drilling, sleeves and caulking with sealants.

Quote is based on SWCs scope of work being performed during normal business hours Mon-Fri. Performance and Payment Bond is available if required at 1% of total contract value to SWC. It is not included in our price. No Retainage to be withheld.



**HICKMAN
COUNTY SCHOOLS**

East Hickman Intermediate
East Hickman Elementary

"School Intercom Systems"

August 29, 2022

10:00 AM



Galaxy Next Generation, Inc.



Galaxy Next Generation, Inc
285 Big A Rd
Toccoa, GA 30577

Hickman County School System
114 North Central Ave, Suite 203
Centerville, TN 37033

To Whom It May Concern:

I am writing to ask your 'consideration of acceptance' of this response to your IFB for *School Intercom Systems*. 'G2' or 'Galaxy' is a leading manufacturer of Interactive Touch Panels, Intercom, Paging, and Bell systems as well as our *G2 LINK Classroom Audio solution*. G2/Galaxy has successfully installed over 8,000 SLIM interactive flat panels in the US over the course of the past couple of years. With our national expansion, Galaxy has acquired successful manufacture and implementation of Bells, Paging & Intercom solutions as well as Galaxy's G2 LINK Classroom Audio solution that is developed, manufactured and distributed in the U.S.

At G2, we understand the importance of effective communication and a successful implementation. We want nothing more than your district to be fully satisfied with our systems as we provide multiple levels of Customer Service through Professional Development Training as well as experienced technicians who are *local* and dedicated to this endeavor.

Our proposal is enclosed for your consideration. Please feel free to reach out to me directly with any questions, concerns, or additional information as needed.

Sincerely,

A handwritten signature in black ink that reads 'Magen McGahee'. The signature is written in a cursive, slightly slanted style.

Magen McGahee
CFO
Galaxy Next Generation, Inc
magen@galaxynext.us

Invitation to Bid

- Conflict of Interest Form
- Certificate of Insurance
- TN Sales Tax Certificate



Invitation To Bid

The Hickman County Finance Office is accepting sealed bids for "School Intercom Systems".

Bid specifications may be found at www.hickmank12.org/request-for-proposal, or by contacting the Building Maintenance Office at 931-729-3391 ext. 3.

All bidders will be required to submit a conflict of interest disclosure form that can be obtained at www.hickmank12.org/request-for-proposal. This bid requires a performance bond upon bid awarding.

All bidders must have TN business license, 1 million dollar liability insurance, workers compensation insurance, and comply with all local, state and federal requirements for working on school properties per TCA 49-5-406.

Sealed bids must be hand mailed or hand delivered to the Hickman County Finance Office, 114 North Central Ave. Suite 203, Centerville TN 37033 and clearly marked on the outside of the envelope "School Intercom Systems". Bids will be opened at the Finance office on Monday, August 29, 2022 at 10:00 a.m.

Hickman County Board of Education reserves the right to accept, or reject any and all bids or parts of bids and to waive any informalities that may prevent the acceptance of a better bid.

Part B

Bid specs:

School Intercom Systems

Scope of Work:

The existing Intercom will remain in place operational, until the new intercom is up and working, then upon completion the older hardware will be removed, boxed and turned over to the Maintenance Dept. Prior to the final bid award of the prospective company, there shall be a "pre-installation meeting" and prior to purchase of any equipment. Meeting will occur at the school to review the proposed purchasing equipment and ensure that all features and needs of the system, as well as the installation schedules, agree with both the School Principal and Maintenance Director of schools.

Installation Schedules:

Classroom hardware, speakers, and cabling will be installed during the first week during school shutdown week as Phase 1, then upon return weeks 2/3 as needed, the halls and offices will be phase 2. This is to minimize techs having to be in classrooms during instruction.

Damages:

Any and all damages not limited to ceiling tile, grid are to be replaced as new, and any drilled fire walls are to be fire caulked as installed and is the responsibility of the installer. Where there are tile or grid materials available maintenance will provide materials, but this does not exempt the installer from having to provide such.

Equipment:

This is the total replacement with new separate cabling of the existing intercom with a IP based Communications system in an existing building, requiring new call buttons, with emergency call feature, new cables, new two way talk lay in 2 x 2 speakers, minimum of 3 new speakers in the kitchen, the call in buttons will place normal call, and will serve as check in button in event of emergency or lock down, 3 new consoles to include the main front office, principal office, and assistant principals office. Main console is to receive calls from classrooms when call button is pushed, all consoles are to allow for "ALL CALL", zone page, bell control, and emergency initiation. Head in components shall be installed in the existing rack location.

Services:

All to include balancing & Dolby Quality Clarity and site employee training as needed to insure a smooth transition of the new operational system. Training shall include: School Administrative Staff Teachers, SRO personnel.

System shall include a "No Nonsense Warranty" complete with "Labor" for a period of not less than 1 year from the date the system is "Operational and 100% completed". In addition, to the 1 year minimum workmanship warranty, the system shall have an "Additional 10 year Parts & Servicing Contract Warranty", by the installing company/ or manufacturer.

Other Specifications:

EAST HICKMAN INTERMEDIATE BUILDING:

This building will consist of **a 5 zone system:**

(Interior speaker and button stations consist of approximately 40 rooms speakers and call buttons, 3 offices head units, 2 gymnasium large speakers, 1 gym office speaker w/call button, café dining room 2 speakers/ 1 call button, kitchen 3 speakers and 1 call button

ZONES:

3rd Grade Hall/rooms

4th Grade Hall/rooms

5th Grade Hall/rooms

TWA 3rd, 4th, 5th grade halls, main hall conference locations, copying room

Cafeteria Kitchen

Gym/ front hall

Playground, outside building inset corners, speakers at all corridor exits outside.

EAST HICKMAN ELEMENTARY SCHOOL:

ZONES:

Kindergarten hall

Title wing

First grade wing

Second grade wing

Enrichment wing

Gym/café

Special Requirements Notes:

For site visit prior to the bid, please contact Mike Plunkett/ Tanya Williams to set up the time to visit the school. No admittance will be granted without prior approved appointment with the Maintenance office. (931)-729-3391 ext. 3

All bidding companies, and the installing techs shall have at least 5 years minimum experience of large jobsite installation of Intercom equipment in Schools, Hospitals, or larger venues.

This bid requires at least 3 prior references of recent large location jobs completed with a contact for inquiries to past performances to be provided with the sealed bid.

This bid requires a performance bond, as well as bid bond, and minimum 1 million dollar business liability insurance, workers compensation insurance, and TN business license, all attached inside the sealed bid document.

ALL AWARDED BIDDERS ARE REQUIRED TO COMPLETE THE BIDDED WORK AND NO SUBS WILL BE PERMITTED WITHOUT THE EXPRESSED APPROVAL OF THE BOARD OF EDUCATION OR DIRECTOR OF SCHOOLS, AND OR MAINTENANCE DIRECTOR.

NOTE: G2/ Galaxy Next Generation will be performing installation and does not use any sub-contractors.

Hickman County Government

Conflict of Interest Disclosure Form

The County Financial Management System of 1981 contains the most stringent conflict of interest provisions. TCA §5-21-121 provides:

- (a) The director, purchasing agent, members of the committee, members of the county legislative body or other officials, employees, or members of the board of education or highway commission shall not be financially interested or have any personal beneficial interest, either directly or indirectly, in the purchase of any supplies, materials, equipment or contractual services for the county.
- (b) No firm, corporation, partnership, association or individual furnishing any such supplies, materials, equipment or contractual services, shall give or offer, nor shall the director or purchasing agent or any assistant or employee accept or receive directly or indirectly from any person, firm, corporation, partnership or association to whom any contract may be awarded, by rebate, gift or other otherwise, any money or other things of value whatsoever, or any promise, obligation or contract for future reward or compensation.

Date: 8-22-2022 Name: Magen McGahee, CFO Galaxy Next Generation, Inc.

Please describe below any relationships, transactions, positions you hold (volunteer or otherwise), or circumstances that you believe could contribute to a conflict of interest:

I have no conflict of interest to report.

I have the following conflict of interest to report (please specify any boards or committees you (and/or your spouse) sit on, the name of your employer and any businesses you or your spouse may own.

I hereby certify that the information set forth above is true and complete to the best of my knowledge.

Date: 8-22-2022 Signature: Magen McGahee



STATE OF TENNESSEE
DEPARTMENT OF REVENUE

Certificate of Registration

July 25, 2022



MAGEN MCGAHEE
GALAXY NEXT GENERATION, INC.
285 BIG A RD
TOCCOA GA 30577-6019

Letter ID: L0085189504
Account ID: 1002146695-SLC
Account Type: Sales and Use Tax

The above named taxpayer has filed an application for sales and use tax registration for the place of business at the below referenced location address. The Tennessee Department of Revenue issued this Certificate of Registration in accordance with Tenn. Code Ann. §§ 67-6-601 and 67-6-602. The Certificate of Registration must be publicly displayed at the location address for which it is issued. The tax account number and location number on this certificate are used by the Department to identify your account and must be shown on all correspondence and reports. The certificate is not assignable and is valid only for the above referenced taxpayer and for transactions of business for this registration. **In accordance with Tenn Code Ann. § 67-6-607, it is a Class C misdemeanor for any person to misuse a Certificate of Registration for the purpose of obtaining taxable property without the payment of sales or use tax when it is due. Such wrongful use is grounds for the Commissioner to revoke the taxpayer's Certificate of Registration.**

Tax Returns

All sales and use tax returns must be filed and associated tax payments made electronically to the Department. Taxpayers may do this at <https://tntap.tn.gov/eservices/>. Taxpayers should file the sales and use tax return according to their filing frequency on the 20th day of the month following the reporting period. If your business opens after the 20th of the month, you may report sales made during the remaining days of the month with the next reporting period. In order to avoid penalty and interest charges, all returns must be filed and all associated tax payments must be made on or before the due date for the reporting period. Taxpayers should always file a return for their business, even if they do not make any sales during a reporting period.

Detach here and display in public area



Tennessee Department of Revenue
Certificate of Registration
Sales and Use Tax

MAGEN MCGAHEE
GALAXY NEXT GENERATION, INC.
285 BIG A RD
TOCCOA GA 30577-6019

Effective Date: August 1, 2022
Account No.: 1002146695-SLC
Location No.: 1001545750
Filing Status: Annually

David Gerregano
Commissioner of Revenue

2022

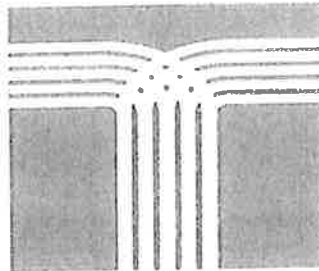

City of Toccoa

OCCUPATIONAL TAX

GALAXY NEXT GENERATION INC.

P.O. BOX 818
TOCCOA, GA 30577

LICENSE NO: 7937

ISSUED: 02/25/2022

EXPIRATION: 12/31/2022

LOCATION: 285 BIG A ROAD

CLASS 1 / CLASS 1

50 / WHOLESALE TRADE--DURABLE GOOD
GARY LECROY

"This License is a mere privilege subject to be revoked and annulled, and is subject to any further ordinances which may be enacted."

A handwritten signature in cursive script that reads "Yvonna J. Wheeler".

AUTHORIZED SIGNATURE

GALAXY NEXT GENERATION INC.
P.O. BOX 818
TOCCOA, GA 30577

IMPORTANT INFORMATION AND INSTRUCTIONS

Attached is your Georgia Department of Revenue Sales Tax Certificate of Registration. **This is an important document.** This Certificate of Registration should be prominently displayed in your place of business, as provided by law.

The Georgia Department of Revenue must be contacted for correction, cancellation, or re-issuance of certificate as necessary if there are any changes relating to this business that include the following: (1) Business closed; (2) Change in ownership; (3) Change in physical location of business; (4) Change of mailing address; (5) Change of trade name and; (6) Change in business type or business function.

If any dealer liable for any tax, interest, or penalty, levied hereunder shall sell his business or stock of goods or shall quit the business, he shall make a final return and payment within fifteen (15) days after the date of selling or quitting business.

SUPPLEMENTAL INSTRUCTIONS TO FORM ST-3 FOR FILING SALES AND USE TAX RETURN

A report must be filed for the month you begin selling or purchasing items subject to sales and use tax. For your convenience we offer electronic tax management through the Georgia Tax Center (GTC) which is located at <https://gtc.dor.ga.gov>. Please visit this website for more details and instructions.

You must file a report monthly for the first six months of filing with the exception of identified Dealers and Contractors. Your return and payment must be submitted by the 20th of the month following the period for which the tax is due.

If you have received a new certificate for your business due to changes such as a change of address or request for a duplicate license, your filing status will not change.

State law requires that dealers and contractors must file timely returns, even if no tax is due.

If there are errors on your certificate or if there are any changes to your business, please contact Taxpayer Services at (877) 423-6711 or via e-mail at st-license@dor.ga.gov.

Effective Thursday, March 8th, 2018, the Georgia Department of Revenue will no longer print sales tax certificates on color bonded certificate paper with a watermark. It will be printed on plain white stock paper. Access to sales tax certificates will be available to view and print through the Georgia Tax Center (GTC), after logging into your account.

ST-2

THIS CERTIFICATE MUST BE PUBLICLY DISPLAYED AS PROVIDED BY LAW



SALES TAX CERTIFICATE OF REGISTRATION

STATE OF GEORGIA
DEPARTMENT OF REVENUE
Taxpayer Services Division

Issued Pursuant to the Retailers' and Consumers' Sales and Use Tax Act of 1951, as Amended
Said Person Named Hereon is Authorized and Empowered to Collect Georgia Sales and Use Tax,
Local Option, Special County, Motor Fuel, Homestead, Education, and MARTA.

STATE TAXPAYER IDENTIFIER: 20016274509	EFFECTIVE DATE: 01-Oct-2004	SALES TAX NUMBER: 302328896	COUNTY NAME: STEPHENS
NAICS:333318 - Other Commercial and Service Industry Machinery Manufacturing		Secondary NAICS: None	

GALAXY NEXT GENERATION, INC.
GALAXY NEXT GENERATION, INC.
285 BIG A RD
TOCCOA, GA 30577-6019

IMPORTANT - This Certificate is
NON TRANSFERABLE

COMMISSIONER OF REVENUE

EACH PLACE OF BUSINESS MUST BE REGISTERED SEPARATELY.

Cost Proposal

- East Hickman Intermediate
- East Hickman Elementary





East Hickman Intermediate

G2 Communicator Bell, Paging, and Intercom System (Cloud Based)
includes ceiling speakers in hallways approx 26 ft apart,
assumes network drops from poe switches provided where needed.

G2 Communicator Bell, Paging, and Intercom (Cloud Based)	
Material	Qty.
Phoenix Bell & Intercom Server (Cloud Based) includes setup	1
4 channel 120-watt 70-volt amplifier	1
IP audio endpoint device (used in conjunction with common areas)	4
Phoenix Bell & Intercom Console phone (Bat Phones)	4
IP Speakers and Microphone Wall mounted	41
IP Speakers with Volume control Wall mounted	9
Call Button Emg and Intercom	41
Call Button conduit	4
70 Volt Wall Speaker	4
70 Volt Ceiling Speaker Hallways Drop ceiling	40
External Horn and Enclosure	5
22 guage 4 pair cable	600 ft
18 guage 2 conductor cable	2600 ft
	Total
	\$55,198.20

Optional Addition

Gym and Cafeteria Audio G2 Links/2 Pendant Mics and 2 handheld Mics, and 8 speakers per location, with accessories,	\$4,743.00
---	------------

Year 2+ G2 Cloud Annual License	
Annual License 1-year Cloud-Based License	\$ 1,440.00
3-year upfront Cloud-Based License	\$ 6,720.00
5-year upfront Cloud-Based License	\$ 9,600.00





East Hickman Elementary

G2 Communicator Bell, Paging, and Intercom System (Cloud Based)
 includes ceiling speakers in hallways approx 26 ft apart,
 assumes network drops from poe switches provided where needed.

G2 Communicator Bell, Paging, and Intercom (Cloud Based)	
Material	Qty.
Phoenix Bell & Intercom Server (Cloud Based) includes setup	1
4 channel 120-watt 70-volt amplifier	1
IP audio endpoint device (used in conjunction with common areas)	4
Phoenix Bell & Intercom Console phone (Bat Phones)	4
IP Speakers and Microphone Wall mounted	68
IP Speakers with Volume control Wall mounted	9
Call Button Emg and Intercom	68
Call Button conduit	4
70 Volt Wall Speaker	4
70 Volt Ceiling Speaker Hallways Drop ceiling	68
External Horn and Enclosure	8
22 guage 4 pair cable	800 ft
18 guage 2 conductor cable	4000 ft
Total	\$77,759.46

Optional Addition

Gym and Cafeteria Audio G2 Links/2 Pendant Mics and 2 handheld Mics, and 8 speakers per location, with accessories,	\$4,743.00
---	------------

Year 2+ G2 Cloud Annual License	
Annual License 1-year Cloud-Based License	\$ 1,440.00
3-year upfront Cloud-Based License	\$ 6,720.00
5-year upfront Cloud-Based License	\$ 9,600.00



G2 Communicator

- Technical Specifications
- Professional Development
- Warranty



Executive Summary

G2/Galaxy Next Generation, offers our G2 Communicator System that encompasses our Bells, Paging & Intercom Solution to provide Hickman County Schools a paramount experience in classroom enhancement through effective sound technology and efficient school safety integrations:

The G2 Communicator system, designed and developed by Galaxy Next Generation's Internal Engineering team, provides an IP based, "open architecture" system which allows the school / district to use a number of IP based audio systems designed by other vendors. The G2 Communicator solution provides options for today and the future.

At its core, G2 Communicator is a SIP based Bell, Intercom and Paging solution. Under the hood of our Linux based server is an enterprise level PBX which allows our system to provide a multitude of implementation options. G2 Communicator is designed to easily connect with the school's current SIP or Analog phone system. In addition, G2 Communicator works seamlessly with other SIP products. Examples include IP Speakers and horns for locations where a single speaker needs to be added, IP Strobes for classroom which are inherently noisy, i.e., Shop, Art, PE, Band, Music, IP Video Doorbells with an integrated relay to activate the door lock actuator.

The IP Video doorbell interfaces with our custom Video Intercom Console. The doorbell will dial the Intercom Console. Once the call is received, a live video image is displayed on the screen. Pressing the passcode into the keypad will allow the doorbell to release the doors lock actuator allowing the patron entry into the school. These doorbells may be placed throughout the school. The Intercom Console is also synchronized to the bell system. For instance, when a new paging zone, intercom device, pre-recorded announcement or alert is added to the system, the Intercom Console is automatically updated.

The G2 Communicator may interface with the school's lockout/lockdown systems allowing a single button press that *simultaneously* engages the current door locking systems, and ignites the G2 Communicator to play audio file(s) throughout the schools intercom system.



Even more, G2 Communicator offers *Visual Alerts*. When G2 Visual Alerts are activated, the system will send visual notifications to any or all devices registered to the G2 Communicator system based on the zone where the device is located. For example, if the school were to go into Lock Down, the alert would be activated and a window will appear on all registered devices. Visual Alerts may be used in conjunction with the audio alerts. G2 Visual Alerts are available for PC, MAC, Chrome OS, Android 5.0 Interactive Flat Panels, IOS and Android phones. Our solution is device agnostic. Working in concert with G2 Visual Alerts, G2 Activator for IOS and Android phones allow pre-recorded announcements, audio, and visual alerts to be activated from the user's phone.

G2 Communicator offers larger school systems the ability for direct paging and intercom calls from the central office to one or all schools. Imagine... the Superintendent welcoming all staff and students back to a new school year over each school's intercom system. For more serious announcements, school officials will have the ability to send an immediate alert about a dangerous weather situation to a single school, a group of schools or all schools from the central office.

G2 LINK by Galaxy Next Generation is an all-inclusive 60-watt audio amplifier/receiver with the ability to interface 6 wireless (DECT RF) microphones as well as 3-3.5 line inputs and 3-RJ45 audio inputs. G2 LINK allows for multiple audio sources to be integrated such as- classroom displays, projectors, smart phone, iPad, Android tablet, Chromebook , Mac, PC, etc. It allows for BlueTooth audio to broadcast through G2 LINK and offers an input for any hearing-impaired student to connect via 3.5 audio connection. G2 LINK not only meets, but it also exceeds the specifications of the AE MS 500. It is easily installed to a wall, ceiling or behind an interactive panel.

At G2, we understand the importance of effective communication and a successful implementation. We want nothing more than your district to be fully satisfied with our systems as we provide multiple levels of Customer Service through Professional Development Training as well as experienced technicians who are local and dedicated to this endeavor.

The G2 opportunity allows for effective sound amplification within the school and classroom, reaches across multiple devices and equips leadership with immediate campus communications.



The Future of School Communication



G2 Communicator

Initiate Communication to your entire ecosystem with one user interface

G2 Secure

Visual and Audible Lockdown notification and instant communication with first responders

G2 Link

Classroom amplified audio with built in connectivity to G2 Communicator for quick and easy communication throughout the ecosystem

G2 Interactive

In-Classroom or Hybrid Learning for easy instruction

G2 Products create equity in education through instant communication in all learning environments

G2 GALAXY NEXT GENERATION, INC.

www.galaxynext.us | 285 N. Big A Road, Toccoa, GA 30577 | 888.859.1274

Product Overview

G2 Products create equity in education through instant communication in all learning environments.



COMMUNICATOR

Initiate communication to the entire ecosystem with one user interface.

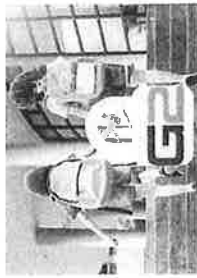

Visual and audible lockdown notification and instant communication with first responders.



Classroom amplified audio with built in connectivity to G2 Communicator for quick and easy communication throughout the ecosystem.



In-classroom or hybrid learning for easy instruction.



G2 COMMUNICATOR

Controls Communication Throughout Schools and Monitors Every Product

Emergency Communication

- Instant audio communication to any enrolled audio end-point
- Immediate Visual Alert sent to any end user device (panel, tablet, computer, etc.)
- Instant communication with first responders through G2 aChat
- Constant updating of audible, visual and chat messaging during any emergency situation

Bell, Paging & Intercom

- Browser-based appliance
- No dedicated console required
- Three defined user groups (standard, admin, master admin)
- On-prem or Cloud based options
- Multiple school support from single interface
- 3rd party trigger and alert activations
- Easy integration with most phone systems
- Custom mapping that is end user changeable
- Custom audio files
- Device status notifications

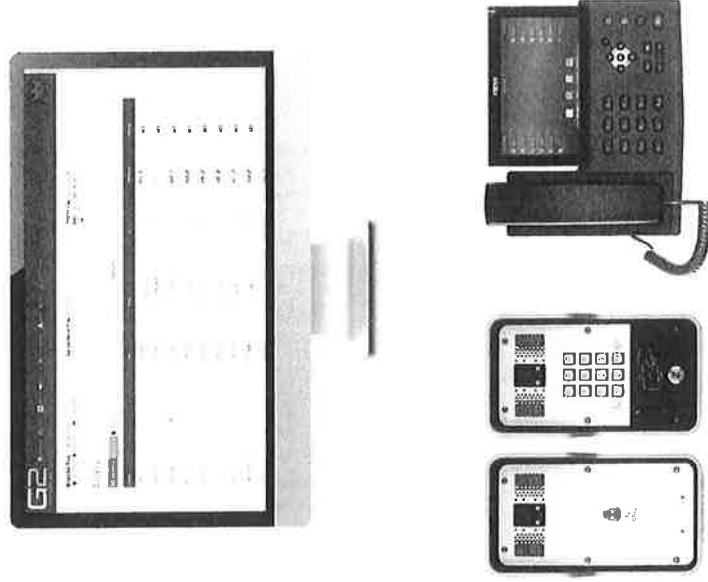

<https://sales5.g2com.online/#/>





G2 Communicator

At its core, communication leads to knowledge. G2 Communicator provides key information to your school campus and district wide.

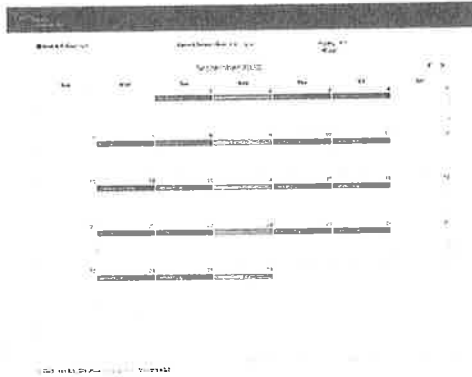

Bells

Schools depend on their bell schedules to communicate with the students when it is time to head toward their class, get to the next class, or even clean up the lab for their current class.

G2 Communicator allows for virtually unlimited schedules playing throughout the entire school, specific zones, or classrooms.

The school staff may choose from over 60 included audio files or upload their own custom files to the system. The staff may even create a playlist for special vents. Setting unique colors for each schedule allows easy identification on the G2 Communicator bell schedule calendar, as well as setting exceptions for special events and holidays.

Paging

A time-honored tradition of paging an individual to contact the office seems almost forgotten in our modern school communication models. The necessity for impromptu audio paging to the full campus or zones on the campus will always be part of the school's needs. The G2 Communicator Intercom Console is ready with a push of a button.



Intercom

Email, SMS, Chat Application etc. make communicating easy. However, when you need the attention of the classroom, nothing is quicker and more efficient than the intercom call. With G2

Communicator, the office staff can quickly call the room and have a hands-free conversation with the instructor who can return to teaching with little instructional time lost. When a more private conversation is required, G2 Communicator does offer a classroom telephone option.

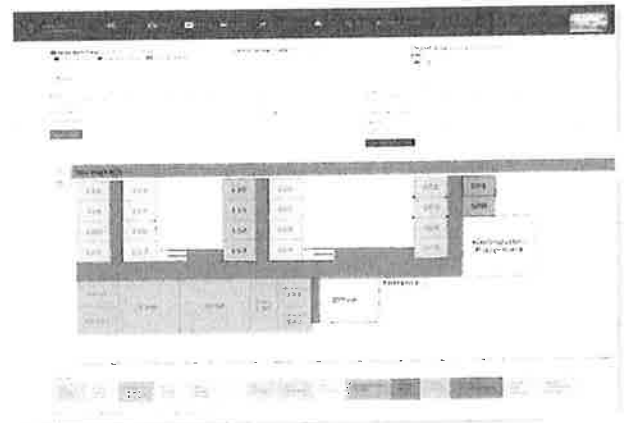

Devices

G2 Communicator's ability to connect with its devices is *paramount* to the system's operation. G2 Communicator provides both passive and active information related to each device being online. While we would love to provide your school with all your required devices, we are aware of the investment in other equipment. For this reason, G2 Communicator works with a large array of SIP and Multicast devices.



G2 Bell ▪ Paging ▪ Intercom & Alerts

Browser Based Intercom, Paging and Alert Management

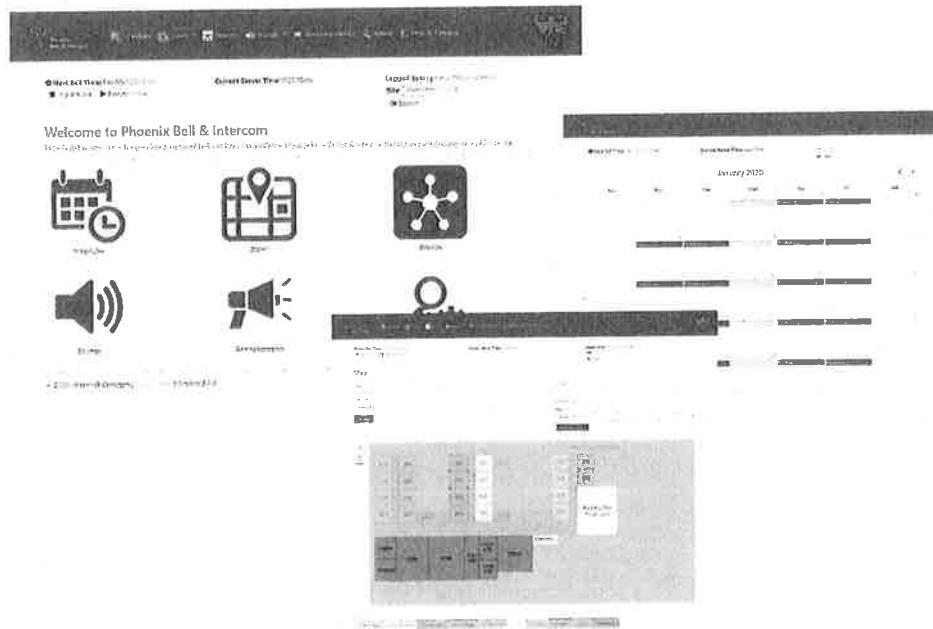

Key Features

- Open Architecture Design using industry standard protocols
- Cloud or Locally Based
- Managed via Web Interface
- End User Friendly
- 70 Custom Audio Files
- User uploaded MP3 and WAV files
- Prerecorded Announcements
- Audible and Visual Alerts
- Integrates with third party security applications
- Virtually Unlimited Schedules
- Schedules include description(s)
- Schedule two schedules per day
- Fully Integrated Intercom Console
- Integrates with most school phone systems
- Device Status (Passive and Active Notifications)
- Custom Maps showing Zones & Device Status
- Defined User Groups
- Backup to local network or cloud controlled
- Integrated with G2 Activator & G2 Communicator Mobile and Desktop Applications

Contact us for more information and pricing:
888-859-1274 ♦ sales@galaxynext.us



G2 Secure
allows school
administrators the ability
to secure their campuses
and send alerts when
seconds count...
All with One Touch



Controlled Communication for School Safety



G2 Secure initiates a controlled emergency notification protocol with one software platform.

Each safety and security component provides a comprehensive approach to seamlessly initiate the process of immediate response to any on-campus threat.

G2 Secure allows for controlled yet expedited communication, empowering school administrators and district leaders to make better decisions to prevent further risk, while simultaneously strengthening first responder's tactical approach during an active threat.



ALERT

Immediate notification to teachers for lockdown of internal doors and instant pop-up alerts on any enrolled device in the school.



NOTIFY

Instantaneous notification of law enforcement and first responders.



MONITOR

Monitor communication within your entire ecosystem with one software platform.

Let us help you put a crisis management plan in place with G2 Secure





Controlled Communication for School Safety

- G2 Secure initiates a controlled emergency notification protocol with one software platform
- Each safety and security component provides a comprehensive approach to seamlessly initiate the process of immediate response to any on-campus threat
- Allows for controlled yet expedited communication, empowering school administrators and district leaders to make better decisions to prevent further risk, while simultaneously strengthening first responder's tactical approach during an active threat



ALERT

Immediate notification to teachers for lockdown of internal doors and instant pop-up alerts on any enrolled device in the school.



NOTIFY

Instantaneous notification of law enforcement and first responders.



MONITOR

Monitor communication within the entire ecosystem with one software platform.

G2 Secure allows school and district leaders to secure campuses and send alerts when seconds count





Classroom Audio System that enhances the teacher communication and their student engagement in the classroom and throughout the school community.



- Teachers speak into G2 LINK's microphone and increase student's achievement
- G2 Link is a connection to communicating in and outside the walls of a classroom
- Access the front office, enable daily communications campus wide or initiate an emergency alert... all with the touch of a button on a teacher microphone



- 60 Watts (30 Watts per channel)
- Controllable Network or USB
- Supports 2,4, 8 speaker config
- Integrated microphone receiver
- Up to 6 Mics to 1 Amp
- 3 Audio Line Inputs (3.5)
- 2 Audio Line Inputs (RJ 45)
 - With power and RS 232
- 1 Audio Line Output (RJ 45)
 - With power and RS 23
- 1 Audio Line Output (3.5)
- Bluetooth Audio Input
- Page Mute function
- Intercom Ready
- Supports wired and wireless networking

Input 1 - 3.5 mm
Input 2 - 3.5 mm
Input 3 - 3.5 mm
Input 4 - RJ45
Input 5 - RJ45
Input 6 - T/S Microphone
Output 1 - Speaker
Output 2 - Speaker
Output 3 - 3.5 mm
Output 4 - ALD
Output 5 - RJ45

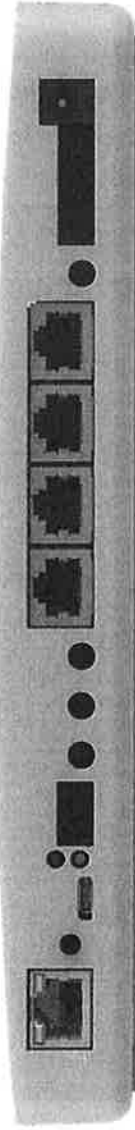

Power Input
Page Mute
Output 1 Speaker
Output 2 Speaker
Output 3
MIC GPIO's
Output 5
Input 5
Input 4
Input 3
Input 2
Input 1
RS 232
Status
USB C
Reset
POE



- Neck or Body worn
 - Body worn will require an external microphone
- Back Lit Buttons
- One Button Pairing
- Volume Up and Down Buttons
- Mute Button
- Programmable Left and Right Buttons (Think Power Point Slide advance! or... You pick)
- *Call the office from the MIC
- *One-button emergency call from the MIC
- All day (10 hour) battery and USB C charging!

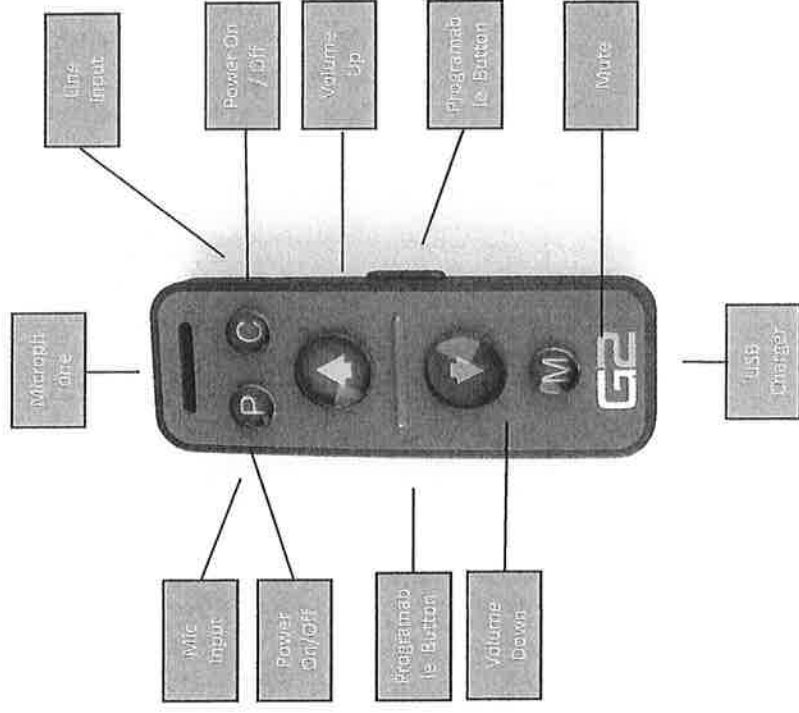



- Slender Design, great for little and larger hands
- Back Lit Buttons
- One Button Pairing
- Push to Talk Button
- Toggle Constant Talk Switch
- Line In Audio Input
- All day battery (10 hour) and USB C charging!

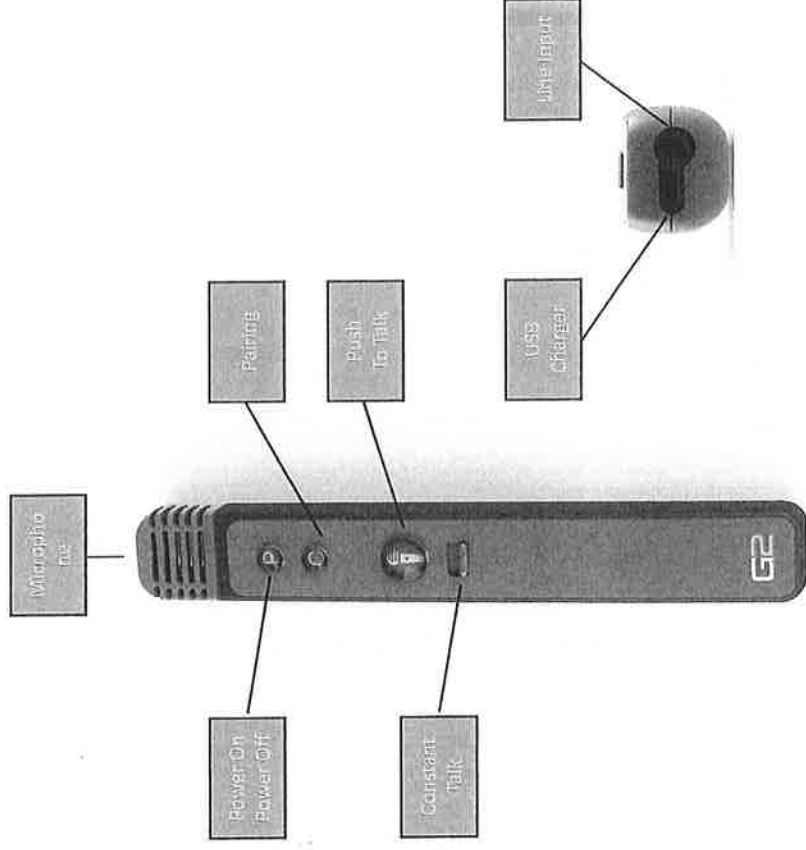

G2LINK

Simply Speak.

Introducing G2 LINK, the Classroom Audio System that enhances teacher communication and student engagement in the classroom and throughout the school community.



Simply speak into G2 LINK's teacher microphone and increase your student's achievement.

G2 LINK is your connection to communicating in and outside the walls of your classroom.

Access the front office, enable your daily communications campus wide or initiate an emergency alert... all with the touch of a button on your teacher microphone.

G2 LINK Classroom Audio System includes:

- Multi-Input Amplifier
- Teacher Microphone with programmable buttons
- Supports 2, 4, or 8 speaker arrays
- USB-C cable and charger
- Supports up to 6 concurrent microphones



G2LINK
Simply Speak.



GALAXY NEXT GENERATION

www.galaxynext.us | 285 N. Big A Road, Toccoa, GA 30577 | 888.859.1274



G2 LINK Amplifier	G2 LINK Teacher Microphone	G2 LINK Student Microphone
The G2 LINK amplifier is both a network and standalone classroom audio amplifier. The integrated receiver allows G2 LINK to pair with up to six G2 Teacher and/or Student microphones.	The G2 LINK teacher microphone provides additional features beyond enhancing the student's experience with clarifying audio.	The G2 LINK student microphone will help students feel empowered as everyone in the classroom will clearly hear their voice
Allow access to G2 LINK over the Network, WiFi or USB.	Additional programmable features included with the press of a button on teacher microphone:	Pairing: Press Button/High Frequency
60-watt amplifier- 2 channel 30 watts	<ul style="list-style-type: none"> Contact the office via SIP 	Microphone works while being charged
Integrated audio receiver <ul style="list-style-type: none"> DECT RF 	<ul style="list-style-type: none"> Initiate an alert via SIP 	Push to talk button
Pairing: Press Button/High Frequency	<ul style="list-style-type: none"> 3.5 Audio In 3.5 Mic In 	Toggle to talk slide-lock
External and POE powered	Interact with computer <ul style="list-style-type: none"> Page up/slide forward Page down/slide back 	Works with up to 5 additional G2vLINK Microphones
Web user interfaced (hardwired, WiFi, USB) <ul style="list-style-type: none"> No additional software required 	Power On/Off Button - Auto power off	3.5mm audio input for streaming audio from external devices
Bluetooth Receiver <ul style="list-style-type: none"> Requires G2 LINK Bluetooth Dongle 	Mute button	<p style="text-align: center;">G2 LINK <i>What's in the Box</i></p> <ul style="list-style-type: none"> G2 LINK Amplifier G2 LINK Teacher Microphone External Power Supply USB-A Wall Charger USB-A to UBC-C Charging Cable 
WiFi <ul style="list-style-type: none"> Requires G2 LINK WiFi Dongle 	Volume Up and Down buttons	
Integrated SIP interface <ul style="list-style-type: none"> Inbound and Outbound Calls Alert Calling 	Pairing: Press Button/High Frequency	
Integrates with G2 Communicator (Bell, Paging and Intercom) and other systems.	Microphone works while being charged	
Integrates with G2 Secure	Works with up to 5 additional G2 LINK Microphones	
	Integrates with G2 Secure	

G2 LINK Amplifier Technical Specifications



Amplifier Type	Class D
Continuous Power	60 Watts (30 Watts (rms) per channel x 2 channels @ 4 ohms) Secondary amp powered by POE (10 Watts)
Network	10/100 Mbps Wi-Fi Dongle
Power	External 24 VDC (120/240 VAC converter) Power Over Ethernet (POE)
PA Connector (Page Mute)	Connect amplifier to building paging system, mutes all amplifier inputs in the event of a building page.
USB Interface A x 2	Front side – Wi-Fi and/or Bluetooth Dongle
USB Interface C	Back side – Interface with G2 LINK amplifier
Control	Quantity 1 - 3 Pin Phoenix Connector, RS 232
Audio Line In with Control	Quantity 2 - RJ 45 Line Level Audio Input, RS 232, Power 5/24 DC output option
Audio Line Out with Control	Quantity 1 – RJ 45 Line Level Audio Output, RS 232, Power 5/24 DC output option
Audio Line In	Quantity 3 - 3.5 mm Line level
General Purpose Input / Output (GIO) w/Microphone Input	Quantity 1 – RJ 45 GPIO 1, GPIO 2, GPIO 3, Power (5 vdc) Microphone Input
Speaker Output	Phoenix Connector Speaker A, B
Integrated Audio Receiver	Connect any combination of 6 G2 LINK Teacher or Student Microphones
Frequency	DECT RF (Does not interfere with Bluetooth or Wi-Fi)
Enclosure	PC/ABS Plastic UL Compliant
Dimensions	9 ¼ x 3 ¾ x 1 ¼ (235 mm x 95.25mm x 31.75 mm)
Weight	11.9 ounces (336 grams)

G2 LINK Amplifier Technical Specifications

User/Admin Controls	
User Control	Volume Control (Inputs and Output Levels) Plus Mute Preset Equalizer Settings Multiband Equalizer Network Settings Streaming Audio Control Bluetooth Pairing Firmware Updateable Programmable Left Button Programmable Right Button
User Level Access	Multiple User Level <ul style="list-style-type: none"> • General User • IT User
Integration	G2 Communicator G2 Secure Carehawk Ch2000

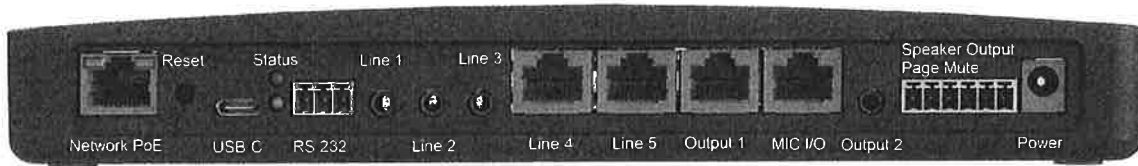

Front

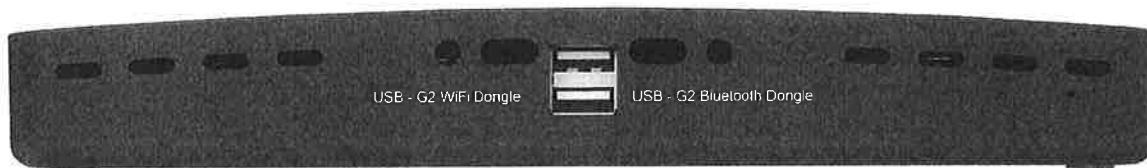

Back

What is in the box:

- G2 LINK Amplifier
- External Power Supply
- G2 LINK Teacher Microphone
- USB A Wall Charger
- USB-A to USB-C Charging Cable



Top

Documentation

- Via QR Code
- Warranty Card/Quick Start Guide



G2 LINK Teacher Microphone Technical Specifications



Teacher Microphone	
Frequency	DECT RF (1.9 GHz.)
Microphone Type	Omni Directional
Control	On / Off Button Mute Button Volume Up Button Volume Down Button Pairing Button Programmable Left Button Programmable Right Button
Auxiliary Mic Input	1 – 3.5 mm mic level input
Auxiliary Line Input	1 – 3.5 mm line level input
Battery	Lithium-ion (rechargeable)
Talk Time	10-hours
Charge Time	2-hours
Charging Method	USB-C (supplied)
Dimensions	3.5 x 1.75 x .75 in. (89 mm x 45 mm x 19 mm)
Weight	2.2 oz. (61 g)

Sold with G2 LINK Classroom Kit or separately.

What is in the box (when sold separately):

- G2 LINK Teacher Microphone
- USB A Wall Charger
- USB-A to USB-C Charging Cable

Documentation

- Via QR Code
- Warranty Card/Quick Start Guide



Top



Side – Mic Input



Side – Line Input



Connector



G2 LINK Student Microphone Technical Specifications



Student Microphone	
Frequency	DECT RF (1.9 GHz.)
Microphone Type	Omni Directional
Control	On / Off Button Pair Button Push to Talk Button Toggle to Talk Slide-lock
Auxiliary Line Input	1 – 3.5 mm line line input
Battery	Lithium-ion (rechargeable)
Talk Time	10-hours
Charge Time	2-hours
Charging Method	USB-C (supplied)
Dimensions	8.5 in. x 1.25 in. x 1.25 in. (216 mm x 32 mm x 32 mm)
Weight	3.9 oz. (111 g)

Sold separately.

What is in the box:

- G2 LINK Student Microphone
- USB A Wall Charger
- USB-A to USB-C Charging Cable

Documentation

- Via QR Code
- Warranty Card/Quick Start Guide

Specifications are subject to change without notice.



Top



Connector





Exceeding Expectations

Compare G2 LINK Amplifier to AE- MS 500 Model

Comparison Points - Amplifier

Device Type	G2 LINK	MS 500
Total Watts	60	30
Number of Channels	2	2
RS 232 CTRL	Yes	Yes
3.5 Audio Line Inputs	3	3
GPIO	3	2
External Mic Input	Yes	Yes
RI 45 Audio Input w/ PWR & RS 232	2	0
RI 45 Audio Output w/ PWR & RS 232	1	0
3 Pin Phx RS 232 Connectors	1	2
Wired Network	Yes	Yes
Wireless Network	Yes	No
Bluetooth	Yes	No
Compatible w Microphones	Yes	No
Compatible w/ AE Receivers and Microphones	Yes	Yes
Network firmware update	Yes	No
Fully Network Controlled	Yes	No
Fully USB Controlled	Yes	No
Integrated with Studio	Yes	No
Total Number of Microphones	4	2



Exceeding Expectations

Compare G2 LINK Teacher and Student Mics to AE Models

Comparison Points Teacher and Student Microphone

Microphone Type	One Button Pairing	Backlit Buttons	Volume Up	Volume Down	Mute	External Mic In	Line In	USB C Connector	Use While Charging	User Programmable Button Left	User Programmable Button Right	Alert Button Capable	Push to Talk	Toggle to Talk
Clarity Teacher	Yes	Yes	Yes	Yes	Yes	Yes	Yes	Yes	Yes	Yes	Yes	Yes	-	-
XD Teacher	No	No	Yes	Yes	Yes	Yes	Yes	No	No	No	No	Yes	-	-
IR Teacher	No	No	Yes	Yes	Yes	Yes	Yes	No	No	No	No	Yes	-	-
Clarity Student	Yes	Yes	-	-	-	-	Yes	Yes	Yes	-	-	-	Yes	Yes
XD Teacher	No	No	-	-	-	-	Yes	No	No	-	-	-	Yes	Yes
XD Students	No	No	-	-	-	-	Yes	No	No	-	-	-	Yes	Yes

Typical Full Classroom Wiring Schematic

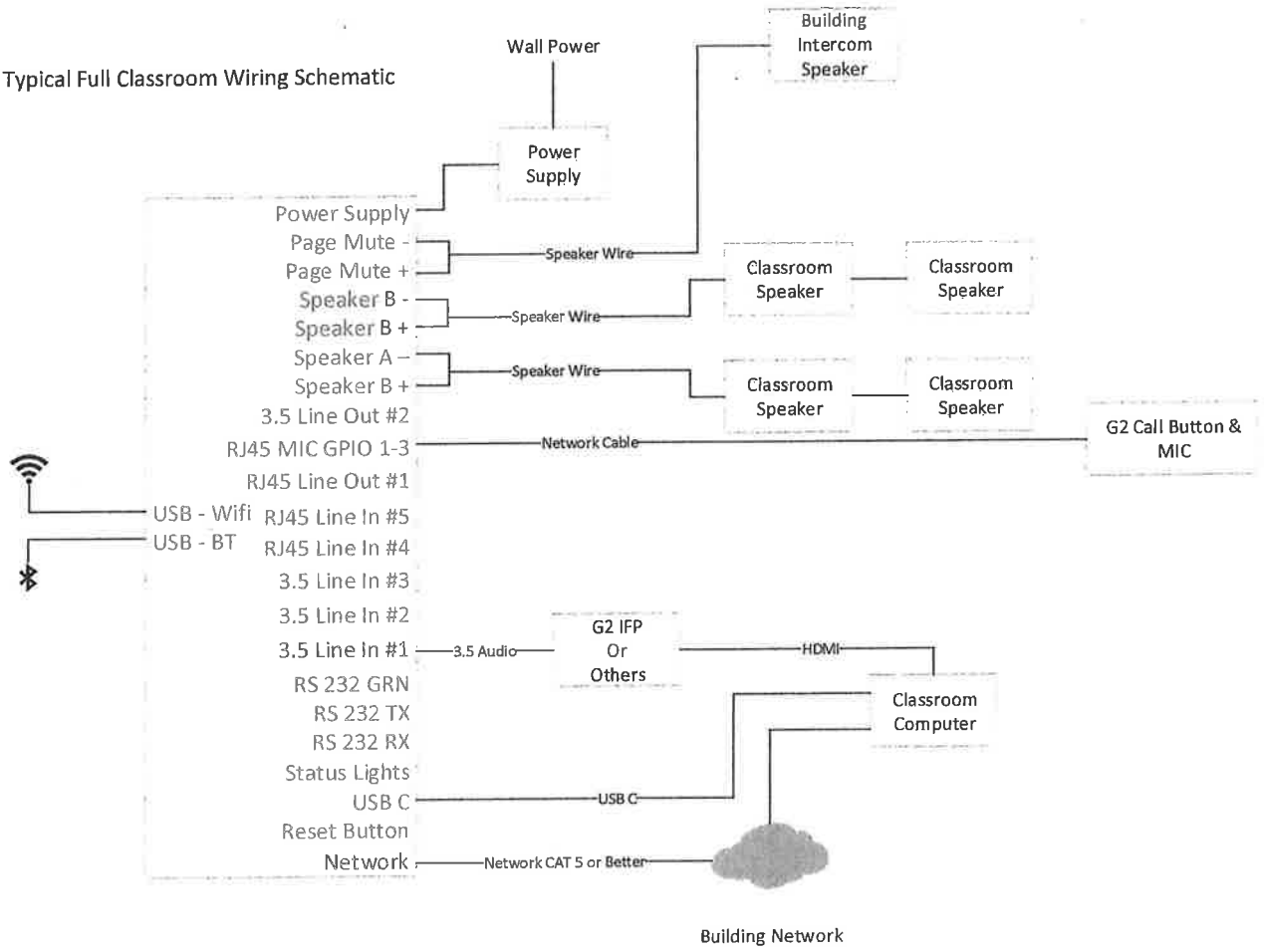

G2 LINK Two Speaker System with Page Mute (Parallel) 8-Ohm

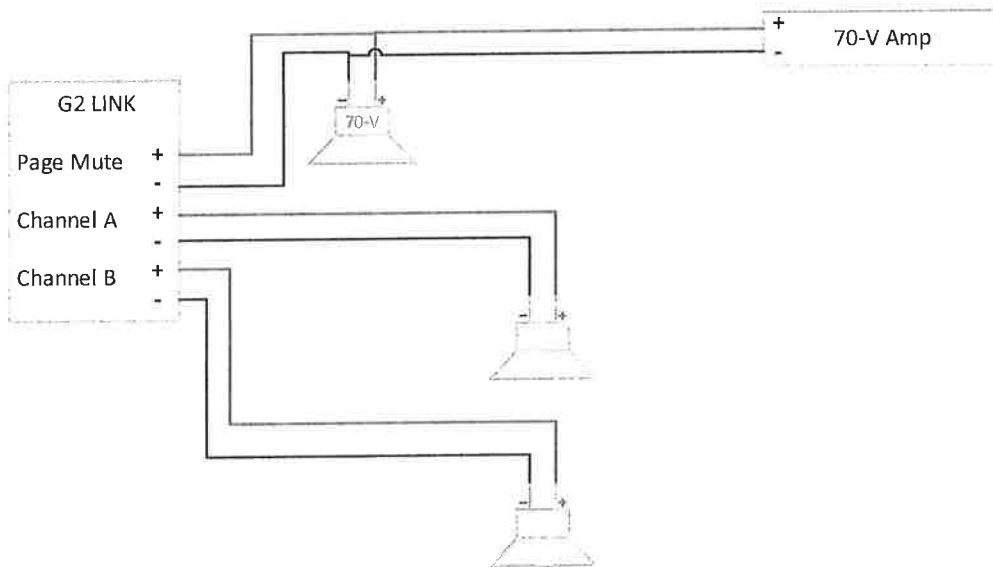

G2 LINK Four Speaker System with Page Mute (Parallel) 4-Ohm

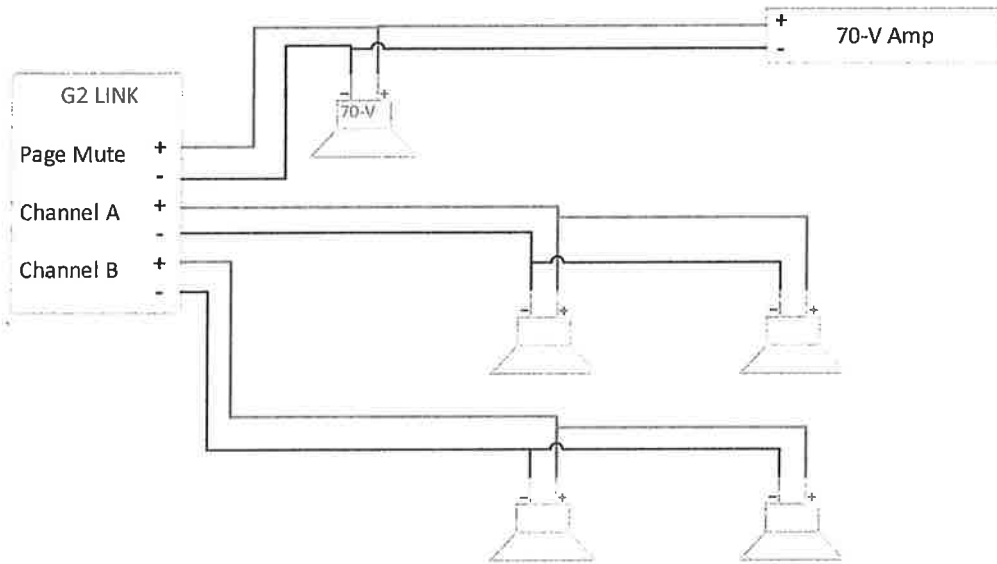

G2 LINK Eight Speaker System with Page Mute (Series – Parallel) 8-Ohm

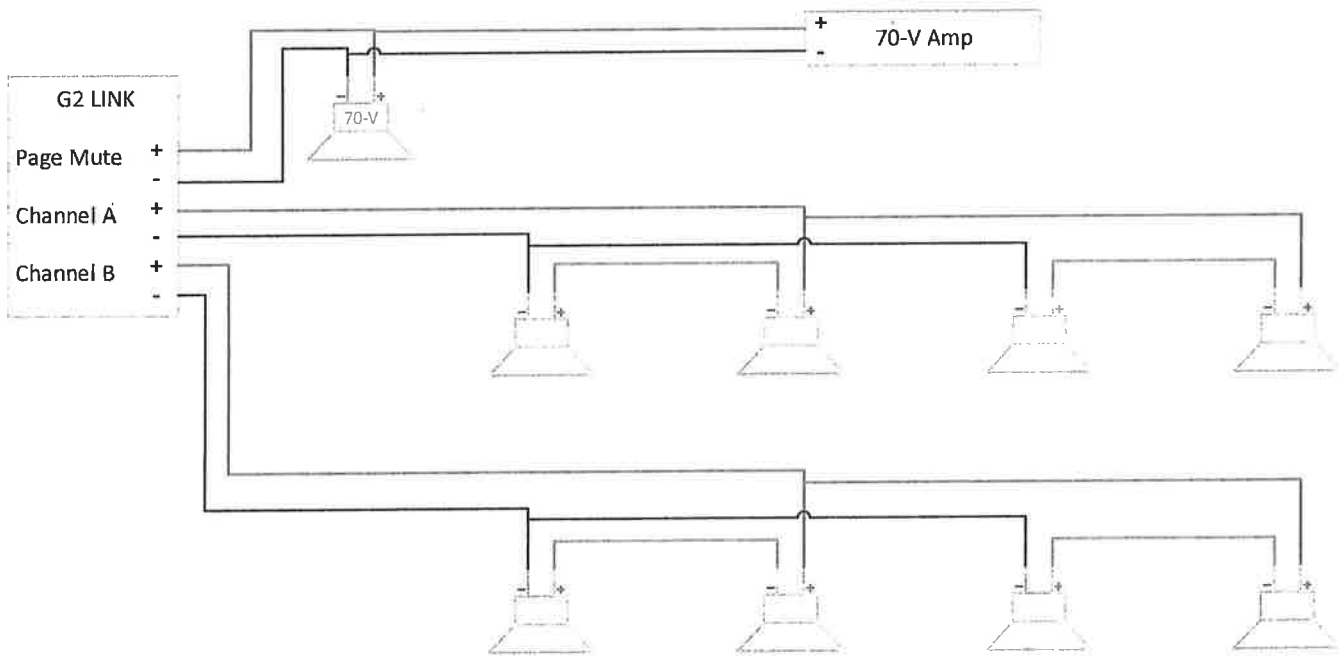

Certifications and Quality Control





- ✓ G2 LINK is designed, manufactured, programmed, and assembled in the US.
- ✓ Our Peoria, Arizona facility is **Nemko certified**.





G2 LINK
Classroom Amplifier
Model: GIMXL-X-X (X=A-Z)
TMIC-X-X (X=A-Z)
SMIC-X-X (X=A-Z)

CE FC  
62368

Galaxy Next Generation, Inc.
285 Big A Road Toccoa, GA 30577



- ✓ Prior to shipping, each component is inspected and tested for material defect, workmanship and finally functionality before it leaves the facility.
- ✓ Should any unforeseen issues arise, Galaxy Next Generation is the manufacturer. We have the knowledge and skills to solve any issues.

Installation Methodology



The following will outline the installation methodology portion of this RFP.

I. Certified Technicians

Galaxy Next Generation is committed to providing quality installations of our G2 LINK voice lift/classroom audio system. This will be accomplished by placing certified technicians on-site to be managed by a qualified G2 project manager.

II. Campus Maps / PO Scheduling

We ask the school district to provide PDF maps of the individual buildings and campus room numbers of where equipment will be installed. Before commencement of work at any location G2 will require a purchase order to be issued for that location. Upon receipt of the purchase orders G2 and School District will set an installation schedule for each location.

III. Turnkey Installations

Galaxy will need access to the buildings and individual rooms based on the individual needs of each school. Each room will contain an amplifier, the appropriate number speakers based on room size and shape, and a teacher microphone. The number of speakers installed in each room will be determined before installation. The method of installation for each room will be decided before the installation process commences. The G2 installation team will provide cable management and connect existing classroom technologies which consist of the teacher's computer, projector, television, and interactive panels. The classroom technologies that will be connected by G2's install team to the G2 LINK System will be determined before installation begins. All trash and debris will be hauled off-site and disposed of by G2. Each room will be completely installed, and the work areas will be cleaned before leaving said room as to have a completely functioning system in the classroom for the next school day.

IV. Dedicated Team Support

G2 will be working on an eight-hour workday schedule Monday-Friday. Galaxy will be available under special circumstances to work weekends and or holidays as decided on a per school basis. Galaxy Next Generation will have a crew of six installers including the project manager working onsite each workday. The crew of six will complete a minimum of 42 rooms per eight-hour workday.

V. Weekly Asset Management

Galaxy will provide a weekly asset management worksheet to the Asset Management Department at your district. This worksheet will contain an asset tag, serial number, equipment model, location installed, purchase order number, and dollar amount. Installed equipment will be labeled with an asset tag which will be provided by the school district. A separate invoice will be issued to the school district upon completing each location.

Professional Development Hickman County Schools



Training

Training is imperative to any technology implementation. In order to be successful, Galaxy Next Generation fully understands that post initial training is *just as important*. In doing so, our G2 support efforts are outlined below, *at no additional cost to the district*.

Galaxy Next Generation offers the following options:

- **In Person or Virtual Trainingg**
G2 will provide in-person or Zoom training, as determined by individual school needs
- **End User Training**
G2 will provide train-the-trainer workshop(s) to each school's staff. G2 recommends a minimum of three persons to receive this training.
- **Online Video Tutorials & Written Training Materials**
- **Technical User Trainingg**
G2 will provide technical training for up to 5- Hickman County School Staff members. At the end of this workshop, these individuals will be G2 LINK certified.

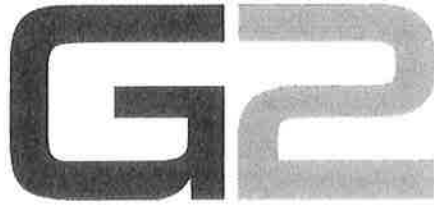

5- YEAR WARRANTY

No Additional Cost

Warranty Summary Sheet Attached

Warranty Services Guarantee

G2 commits to respond within a couple hours request or no later than 24- 48 hours, to address the needs of the district.

- G2 supports a 5 year warranty, including parts, service and labor.
- G2 covers any repairs/ replacements during that 5 year warranty period, including all shipping costs both ways, whenever necessary , at no additional cost to the district.
- G2 provides *On-Site Support* whenever necessary during the warranty period.
- If requested, Galaxy will offer extended 2 -year warranty pricing at the end of the 5 year term, to make 7 years of coverage.



FIVE-Year Limited Warranty Summary Sheet

Warranty Matrix by Country/State			
All Galaxy Next Generation Inc. Products			
Galaxy Next Generation Inc. Warranty Types Available			
Country	RFRR	AR	OSS
United States of America¹	X	X	X
All other U.S. States and Territories and Other Countries	X	X	N/A
Notes:	¹ Contiguous 48 US states only, excludes Hawaii, Alaska and any other U.S. territory		
(RFRR) – What does “Return for Repair or Replacement Mean?”			
Return for Repair or Replacement is automatically provided at no charge for all Galaxy Next Generation Inc. products as a part of the Galaxy Standard Warranty. Once a product has been diagnosed as defective by Galaxy Next Generation Customer Support, the faulty product must be returned (at the customer’s expense) to Galaxy Next Generation Inc. Following receipt, inspection and approval by Galaxy Next Generation Inc., the product will either be repaired or replaced at the discretion of Galaxy Next Generation Inc. and the repaired or replaced product will be sent to the customer at Galaxy Next Generation Inc.’s expense.			
(AR) – What does “Advanced Replacement” Mean?			
Advanced Replacement is a service included in the Galaxy Plus Warranty, a warranty enhancement to the Galaxy Standard Warranty that may be purchased from Galaxy Next Generation Inc. or an authorized Galaxy Next Generation Inc partner or reseller. Advanced Replacement reduces waiting time to receive replacement products, which ship at no charge to you and before the faulty products are returned to Galaxy Next Generation Inc. However, if a customer fails to return the faulty product within 30 days of the replacement product being received by the customer, Galaxy Next Generation Inc. reserves the right to invoice the customer for the replacement part. Advanced Replacement is only available in the contiguous 48 U.S. States as shown in the Warranty Matrix.			
(OSS) – What does “On-Site Support” Mean?			
On-Site Support is a service included in the Galaxy Premium Warranty, a warranty enhancement to the Galaxy Standard Warranty that may be purchased from Galaxy Next Generation Inc. or an authorized Galaxy Next Generation Inc. partner or reseller. Once Galaxy Next Generation Inc. Customer Support diagnoses a product as defective via telephone or e-chat, they will arrange for a Galaxy Next Generation Inc. Service Provider (GSP) to visit you on-site, at Galaxy Next Generation Inc.’s cost, to repair or replace faulty parts. On-Site Support is only available for customers residing in the contiguous 48 U.S. states, as shown in the Warranty Matrix.			
Every customer will read, select, register, and activate their warranty prior to purchase. All Galaxy Next Generation Inc. product warranties last 5 years from the date of purchase, unless otherwise voided.			

Qualifications & Experience

- Company Profile
- References
- G2 Support
- Project Team



COMPANY PROFILE



Business Description

Galaxy is a manufacturer and U.S. distributor of interactive learning technology hardware and software that allows the presenter and participant to engage in a fully collaborative instructional environment. Galaxy's product offerings include Galaxy's own private-label , SLIM interactive touch screen panel, its own Intercom, Bell, and Paging solution, as well as an audio amplification line of products that is currently supported by both our OEM relationships and our direct brand. Galaxy's distribution channel consists of a direct sales model, as well as approximately 37 resellers across the U.S. who primarily sell the products offered by Galaxy within the commercial and educational market. Galaxy does not control where the resellers focus their reselling efforts; however, the K-12 education market is the largest customer base for Galaxy products comprising nearly 90% of Galaxy's sales. In addition, Galaxy's OEM division also manufactures products for other vendors in its industry and white labels the products under other brands.

G2/Galaxy Next Generation Inc. is a public corporation. We are headquartered in Toccoa, GA with satellite offices in AZ, CO, FL, PA and TX.

Location and Contact

Corporate: 285 Big A Road Toccoa, Georgia 30577

Office: 706-898-6201

Sales: 706-391-5030

Fax: 706-886-8400

Email: sales@galaxynext.us

State of Incorporation: Georgia , 2004

Years in Business: 17 years

Website:

<https://galaxynext.us/>

Financials:

<https://irdirect.net/gaxy>

Warranty Service Response

Our Senior Lead Technician and Galaxy Sales Manager will respond within **a couple hours request or no later than 24 hours**, to address the needs of the district.

Industry Classifications

Sector: Technology

Industry: Communications Equipment

NAICS: Educational Support Services (611710)

SIC: Schools and Educational Services, not elsewhere classified

(8229)

© 2019

Expanding Footprint, Sales Team & Distribution Channels

Corporate Headquarters
Toccoa, GA

Physical Satellite Locations
Peoria, AZ (Manufacturing Facility)
Broomfield, CO (Warehousing)
Jacksonville, FL (Sales and Marketing)

Remote Employees
Salt Lake City, UT (2) (Engineers)
Dallas, TX (2) (Sales and COO)
Macon, GA (Sales)
Tifton, GA (Sales)
Valdosta, GA (CFO)
Pittsburg, PA (Sales)
Silver Springs, MD (Software Developer)

Manufacturer's Rep Firm:
Lake, NJ (Sales)
Covering NY, NJ, PA, MD, and DE

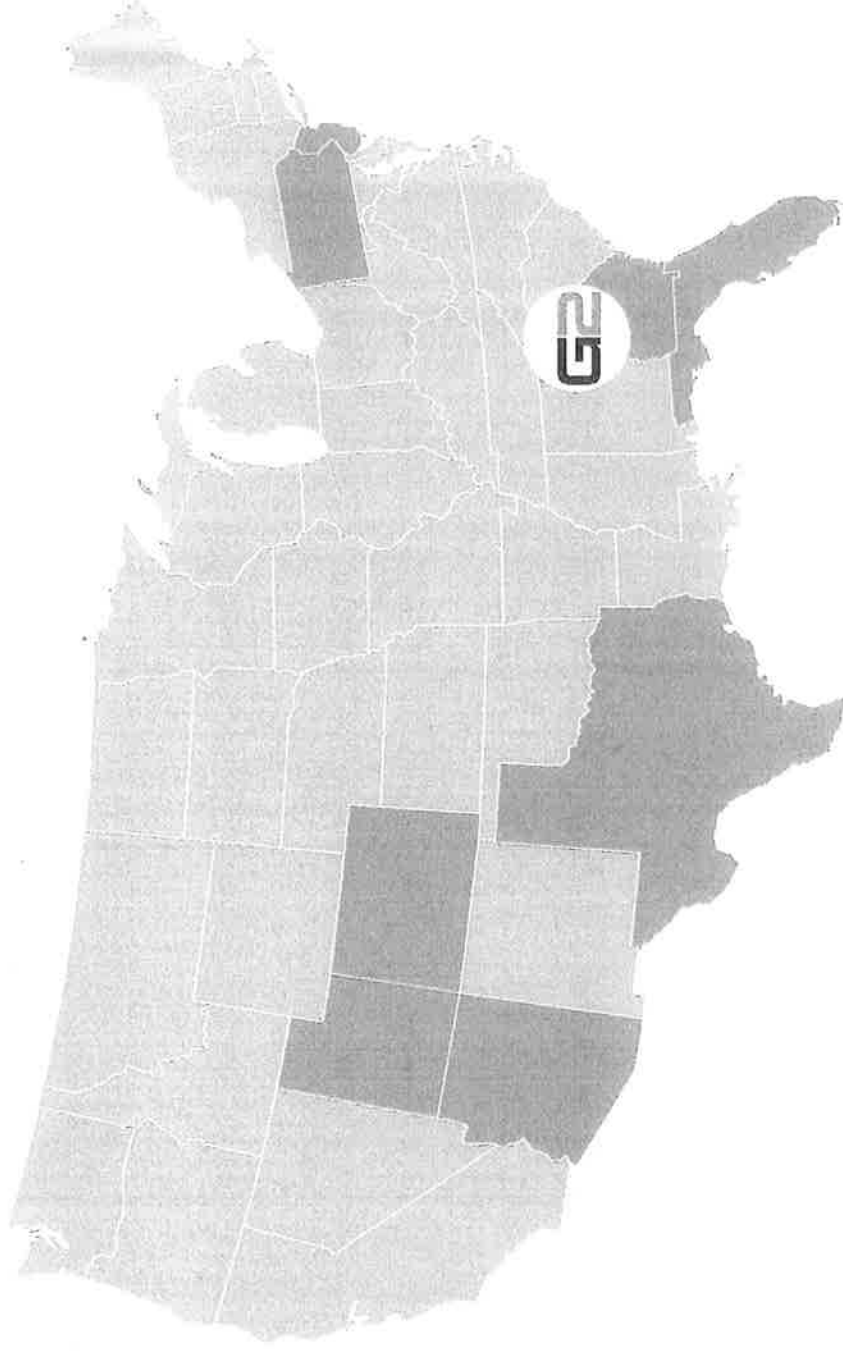



History and Financials

*Galaxy Next Generation, Inc is a publicly held corporation and is a fully reporting financial institution. Our financial statements for the past several years can be found via the EDGAR system or at the direct link below:
<https://irdirect.net/GAXY>*

Galaxy was founded in 2014 and ran privately, until going public in 2018. We have moved from a start-up into an emerging growth company and have recently hit the major milestone of being cash flow positive as well as reporting a net positive adjusted EBITDA. We report our financials under the SEC requirements of GAAP accounting and therefore often use EBITDA to reflect the true financial stability of the company, as GAAP accounting also accounts for non-cash transactions such as stock issuances and the interest related to such.

Galaxy has access to raising capital through several measures in the open market to support our growth as well as traditional banking means. We have established a relationship with a financial institute for traditional PO and AR financing which helps us tackle larger jobs with limited cash outlay to our operational needs.

Our structure and public status gives us the financial flexibility needed to support our customers.

References



Boulder Valley School District

6500 Arapahoe Rd Boulder, CO 80303

Brad Gefke, *IT Bond Manager*

720-207-1474

brad.gefke@bvsd.org

- Completed 43 total Schools/ 4 Ground-Up/ 7 Retro-Fits -- all with our G2 Bell Intercom Solution System

Thompson School District R2-J

800 South Taft Ave Loveland, CO 80537

Bryan Lilly, *A/V/I Systems Technician III*

970-613-5000

bryan.lilly@thompsonschoools.org

- Completed 41 Total Schools/ 13 Current/ 1 Ground-Up/ 3 Retro-Fits underway, will open in August 2021 (District Standard as other schools are converted.)

Park County Schools District 6 / Cody Public Schools

919 Cody Avenue Cody, WY 82414

Tim Foley, *Assistant Superintendent*

307-250-3753

timfoley@park6.org

- 6 Schools Completed
- Summer of 2018, Began working with an un-budgeted retro fitting of the high schools aging bell and paging system. G2 worked with the school district to quickly restore bell and paging to the school as well as identifying and replacing any failed components of the 30 plus year old system
- Over the next two years, G2 worked with Park six to convert the remaining five schools to our G2 Communicator product line

G2 Support

Full technical assistance from first purchase order through our 5 year Product warranty!



Our Guarantee:

- **Prompt & Friendly Customer Service** from initial purchase order to any technical service need to product training all the way through completion of project invoicing.
- **Quick Response**--Our Tech Support team will respond locally on-site, or via phone call within minutes, or within 2-3 hours and no later than 24 hours to resolve ANY technical issues and determine warranty support. Support is provided throughout the 5 year warranty. G2 covers repairs/ replacements during that 5 year period, including all shipping costs both ways, whenever necessary.
- **Turn-key Installations** --Full-Service installations are available that include all materials, testing and clean-up with complete professionalism and quality assurance, before leaving the school site. Our Experienced Lead Techs come highly recommended and are available to answer any questions that may arise to operate our Intercom System to meet the needs of your district. Tech certifications/ resumes are enclosed.
- **5 Year Warranty** --G2 supports a 5 year warranty. G2 covers *any repairs/ replacements* during that 5 year period, including *all* shipping costs both ways, whenever necessary. See WARRANTY information provided in Technical Specifications. If requested, Galaxy will offer extended warranty & pricing at the end of the 5 year term.
- **Manufacturing Certifications**-- G2 LINK is designed, manufactured, programmed and assembled all within the U.S. Our Peoria, AZ facility is NEMKO Certified. Prior to shipping, each component is inspected and tested for material defect, workmanship and finally functionality -- before leaving our facilities. G2/Galaxy is the U.S. manufacturer! Our knowledgeable teams have the skills to solve any issues.

Our People:

Project Manager:

Coby Hughes, *Lead On-Site Manager SE*
706-716-9505 coby@galaxynext.us

Director of Sales:

Mark Swift mark@galaxynext.us
229-560-6423 mark@g2systemsinc.com

Management:

Bill Brinkman, COO bill@galaxynext.us
Magen McGahee, CFO magen@galaxynext.us
Gary LeCroy, CEO gary@galaxynext.us

Controller/ Purchasing:

Juliana Butts, AP/ AR juliana@galaxynext.us



G2 SUPPORT

TECHNICAL SUPPORT & CUSTOMER PRIORITY

SERVICE AFTER-THE-SALE

G2 pricing includes a five (5) year on-site warranty for all components including parts and labor. The complete cost of repair, parts and labor, shall be covered by our service agreement. The warranty service agreement period shall begin from the installation date and CCSD sign-off of the system.

With our 5 Year warranty , G2 will make every effort to remedy any situation, no questions asked, during the 5 year warranty support period.

RESPONSE TIME

- ✓ G2 Support will respond within 1 hour of service call or within 24 hours , and will schedule a service visit as deemed necessary to repair/ replace issue.

TECHNICAL ASSESSMENTS UNDER WARRANTY

RFRR- Return For Repair/Replacement

Return for Repair or Replacement is automatically provided at no charge for all Galaxy Next Generation Inc. products as a part of the Galaxy Standard Warranty. Once a product has been diagnosed as defective, by Galaxy Next Generation Customer Support, the faulty product must be returned *at no cost to the district.*

ARR- "Advance Return Replacement"

Advanced Replacement reduces waiting time to receive new replacement products, which ship at no charge to the district.

OSS- "On-Site Support"

G2 Customer Support diagnoses a product as defective via telephone or email, then they will arrange for a Galaxy Technician to visit you on-site, at no cost, to repair or replace faulty parts.

- ✓ When necessary, G2 service technicians will bring new inventory on hand for quick resolution. *Again, G2 will make every effort to remedy any situation, no questions asked, and at no cost to the district, coming or going, during the 5 year warranty support period.*
- ✓ G2 Service Technicians provide "turnkey installations" and *always check* operation of installed equipment *before leaving site.*



TECHNICAL Installation *Support Services & Performance*

❖ **Prompt Purchase Order Processing**

Galaxy acknowledges all purchase orders received, verifying delivery schedules with the school, within 60 days of receipt.

❖ **Technician Certifications**

Galaxy provides top-notch, experienced technicians specially certified to properly install and service a variety of audio/visual technology for our company. *Our technical staff comes highly recommended!* Certifications are enclosed.

❖ **Installation Performance & Professionalism**

G2 delivers and performs all installations and *does not use* any subcontractors. Professionalism by our techs is guaranteed. They are recognizable in G2 team shirts and pants during installation while on campus.

❖ **Turnkey Installations**

Turnkey installations offered to cover all cabling to be connected, including HDMI and USB cable inputs, raceways, wall mounts whether installing panels on mobile stand or a concrete wall/ sheet rock/ stud wall to the final check of working equipment before leaving each location.

❖ **Serials and Google Sheets Organization**

Delivery and installation will be performed by G2 technicians who record all serial numbers, asset tags, locations and dates when completed, and before leaving jobsite. After installation is complete, Google Sheets are utilized to record all information and can be shared with the school district for open communication.

❖ **Quality Assurance & *Clean-Up* Guarantee!**

Quality assurance of working equipment is *guaranteed* before leaving as well as clean-up of materials used and location restored as-it-was, upon completion of installation.

❖ **Drug-Free Environment**

Our technicians are dedicated to a drug-free environment.

G2 Project Team

The G2 Project Team is an educated and experienced staff who utilize their skills to complete their tasks from sales to installation to support and invoicing.

Mark Swift

Director of Sales / Project Lead- Primary Contact

229-560-6423

mark@galaxynext.us

** Resume Enclosed.*

Shawn Wheeler

Chief Technology Officer / Project Manager

602-466-8855

shawn@galaxynext.us

** Resume Enclosed.*

Coby Hughes

Project Lead On-Site/ Installations SouthEast

706-716-9505

coby@galaxynext.us

** Resume Enclosed.*

Chris Jones

National Sales Implementation / Project Lead On-Site

208-241-7721

chris@galaxynext.us

** Resume Enclosed.*

Bill Brinkman, COO

214-215-4491

bill@galaxynext.us

Magen McGahee, CFO

706-391-5030

magen@galaxynext.us

Gary LeCroy , CEO

706-898-6201

gary@galaxynext.us

Company Contact Information



Enclosed Company Profile

Corporate Office: 285 Big A Road Toccoa, Georgia 30577
Satellite Locations: AZ, CO, FL, PA and TX

Hickman County Schools

G2 Project Manager: Mark Swift, *Director of Sales*
229-560-6423 mark@galaxynext.us

Purchase Orders:

PO Emails:
PO Fax #:
PO Mail :

*G2 accepts email, faxed and mailed POs.
mark@galaxynext.us / sales@galaxynext.us
706-886-8400
285 Big A Road Toccoa, GA 30577

Invoices Remit To:

Corporate Office address above *or* as
otherwise designated on the invoice.

VITA

MARK SWIFT

(229) 560-6423 mark@g2systemsinc.com

EDUCATIONAL EXPERIENCE

Doctoral Level work in Curriculum and Instruction, Valdosta State University
M.Ed. Instructional Technology, Valdosta State University
B.F.A Telecommunications, Valdosta State University
The Georgia Professional Standards Commission Certification Level 6

WORK EXPERIENCE

Director of Sales

Galaxy Next Generation, Inc

June 2018-Present

- Ensure the optimum growth of strategic reseller programs to support the company's expansion objectives in education, medical and corporate markets
- Supervise and grow Sales Department Team
- Proactively and responsively develop strong partnerships with prospective partners to maximize client growth opportunities
- Aggressively network and prospect to develop opportunities and partnerships across the nation and abroad
- Develop and lead both proactive proposals and responses to RFPs
- Build and leverage relationships with peers and management in operations and account management to optimize company growth
- Seek opportunities to advocate for the company at tradeshow and conferences
- Collect and analyze CRM data to develop solutions to meet customer needs

Chief Technology Officer/Director of

Instructional Technology

Valdosta/GA

Valdosta City Schools

March 2007-June 2018

- Implemented technology for new state of the art high school to include interactive flat panels, informational kiosks, digital media, 1:1 Chromebooks initiative, NEC 9100 series VOIP, and STEM ready technology
- Facilitated, based on data driven goals, plans, and initiatives, the implementation of 21st century classrooms throughout the school system. In 2012 researched, coordinated, and implemented one of the most technologically advanced elementary schools in the country consisting of touch-panel TVs, Apple TVs, Ipads, and Win 8 devices, as well as inclusion with the system-wide NEC 2000 and 8300 series VOIP.
- Presented with the district's Extreme Exemplary School National Award for creativity and technological innovation in the classroom for the system-wide Wi-Fi, and BYOD initiative with faculty and students.
- Administrator for setup and implementation for initiatives OAS, SLDS, TKES, FitnessGram, 21st Century Skills Assessment, as well as system SIS Infinite

Campus, Destiny, Crosspointe, Successmaker, Waterford, Taskstream, PD360, AR, Myon, Dreambox, GMAS, and many other required systems.

- Responsible for state reporting of technology, writing and presenting to the Board of Education all technology related policies for review and adoption, the system's Technology Plan, grants, and implementation plans.
- Supervising Technology Department employees and Media Specialists, updating, submitting, and maintaining budget requirements based on approved technology goals.
- Restructured the Technology Department to better coordinate all technology initiatives based on curricular needs and act as a liaison between all departments.
- Perform needs analysis, needs assessment, project management, evaluation of instructional products, CBI, public speaking
- Standard 5 Chair for AdvancED Quality Assurance Review SACS 2009.
- Standard 4 Chair for AdvancED Quality Assurance Review SACS 2016.
- Served on SACS Quality Assurance Review teams to other districts.
- Responsible for monitoring technology content filtering, acceptable use, and needs as are appropriate for curriculum requirements performance standards.
- Certified Internet Webmaster - Designed, created and maintained National School Public Relations Association awarded the former VCS website including extensive use of ASP coding and database design. Designed and developed websites for delivering and collecting data. Implemented district-wide asset management system.

Instructor /Project Coordinator/Instructional Technology Professional
1995-2007

Valdosta State University College of Education, Valdosta, GA

- Taught graduate level classes: Integrating Technology for Special Education Teachers. Visited surrounding area school systems to instruct teacher technology classes.
- Using Macintosh, Windows, and Linux platforms, served as the COE Webmaster since 1995. Extensive use of HTML, BBEdit, forms, Access, and ASP for web delivered data and data collection by administrating Win-NT, Internet Information Server. Performed Needs Analysis, Needs Assessment, Project Management, Evaluation of Instructional Products, Projects and Programs, CBI, Public Speaking.
- Project Manager for the Development, Field Testing, and Evaluation of a CD-R Prototype for Teacher Use Tools for Non-Aversive Behavior Intervention for Young Children. Developed the software using tools such as Authorware, Photoshop, Inspiration, Toast, Adobe Premiere, and Avid Cinema. Taught HTML, Javascript, Multimedia, and Computer use classes for Special Educators.
- Designed, developed and implemented web-enhanced instruction, including enhancing web-based instruction with PowerPoint, video-streaming and the construction of electronic portfolios.
- Instructed faculty, staff, and students in the proper use of distance learning and instructional media equipment.
- Provided technical assistance and support for the Transdisciplinary Inclusive Practices and Strategies (TIPS) program funded by the Office of Special Education. Developed the TIPS webpage, electronic reflective logs, and quest lecturer chat room.
- Conducted HTML programming, design and navigation of the College of Education Folio for Programs in Special Education for the Council for Exceptional Children. (Recognized nationally as model site for universities, 2000)

SHAWN WHEELER

8558 W Pershing ♦ Peoria, AZ 85381 ♦ (602) 466-8855 ♦ swheeler@3wheeler.com

CHIEF TECHNOLOGY OFFICER AREAS OF EMPHASIS – EDUCATIONAL TECHNOLOGY

Executive Director of Technology with more than 25 years of experience in the Education Industry seeking a new opportunity. Extensive experience analyzing business and educational processes and overseeing the design, installation, and implementation of new technologies and systems. Well-developed skills managing department budgets, purchasing new equipment, negotiating pricing, managing vendor relationships, and supervising and training staff. Dedicated leader with outstanding communication skills and a proven track record of success providing information technology leadership for a school district with more than 40 sites, 30,000 students, and 3,000 employees.

Areas of Expertise

Design, Installation & Implementation of New Technologies | IP Audio | IP Video | Learning Management Systems |
Purchasing | Vendor Management | Budget Management | Technology System Upgrades | Contract Negotiations

EXPERIENCE

Galaxy Next Generation “G2”, Toccoa GA

November 2019 – Present

Technology Education Company with offices in Arizona, Colorado, Georgia, and Florida offering K-12 Education technologies related to Classroom Multimedia, Bell, Paging & Intercom and OEM related equipment.

Chief Technology Officer

- Provide vision and leadership for all company technology needs.
- Provide vision and leadership for product and software development.
- Manage G2’s Arizona office.

Ehlert Solutions Group & Interlock Concepts, Sandy UT

April 2014 – 2019

Start-up Companies – Ehlert Solutions Group an educational design and consulting company with an installation arm. Interlock Concepts a manufacture and sales organization building cutting edge products for the K-12 educational market with a focus on audio, video, bells, public address, and surveillance.

Director of Integrated Learning

- Manage the business development and business Phoenix Bell and Paging.
- Develop technical and training documentation for all developed and OEM products.
- QA, test and trouble-shoot OEM software applications.
- Design, install, deploy, train and maintain IP Intercom Systems.
- Integrate IP Intercom systems to cloud hosted VOIP providers.
- Design, install, deploy, train and maintain IP Video delivery systems.
- Provide direct and video-based training for Interlock Concepts dealers.
- Provide direct and video-based training for end user customers of Ehlert Solutions Group.
- Manage manufacturing and delivery of products.
- Generate responses to RFP’s, RFI’s, Submittals, Owners Manuals etc...
- Work directly with customers both dealer and end-user ensuring a positive experience with both Ehlert Solutions Group and Interlock Concepts.
- Test, trouble-shoot and demonstrate software application hosted virtual servers’ cloud-based servers (Azure).
- Manage cloud-based company SharePoint system.
- Manage company Office 365 accounts.

Audio Enhancement, Bluffdale, UT

January 2012 – March 2014

A manufacturer of classroom amplification systems with offices throughout the United States and annual sales revenue of \$20 Million.

Director of Innovative Technologies

- Manage the business development and business strategy for the SAFARI Montage/VIEWpath educational software product.
- Establish pricing, sell directly to customers, and train sales staff on how to position product and establish value with customers; provide pre-sale design support for sales team.
- Provided post-sale implementation and training support to customers.

Tolleson Elementary School District, Tolleson, AZ

2009 – 2011

A school district with 6 sites, 4 schools, 3000 students, and 250 staff members.

Executive Director of Technology

- Provided strategic leadership and direction for all technology used in the district for classroom and business operations.
- Created, tracked, and monitored a \$750,000 technology budget.
- Specified technology needs and worked with vendors to obtain the best pricing while keeping the district within legal purchasing requirements.
- Managed and oversaw the implementation and installation of new and upgraded software systems and technologies.
- Managed and supervised 3 employees and 3 consultants; hired and trained staff on new technologies.

Key Accomplishments

- Managed the installation of new technologies, including New Active Directory Domain, Exchange 2010, SharePoint 2010, Lync 2010, Data Protection Manager, SQL 2008, System Center and Configuration Manager, Hyper V deployment, Windows 7 and Office 2010 upgrades.
- Trained staff on SharePoint 2010, Lync 2010, SMART Board Notebook Software, and Office 2010.
- Facilitated the purchase and implementation of a new Student Information System.
- Purchased and deployed the SAFARI Montage Video System and Moodle Learning Management System.

SAFARI Montage, Phoenix, AZ

2009 – 2009

SAFARI Montage provides K-12 school districts with a comprehensive solution for their digital media distribution and visual instruction needs.

Director of Systems Solutions – Western Region

- Provided technical pre-sales system design and configuration consulting.
- Managed and oversaw installation, implementation, and training.
- Facilitated administrative and end-user training.
- Collaborated with software development team and provided customer feedback on what features to add to future versions of the software.

Peoria Unified School District, Peoria, AZ

1993 – 2009

A school district with more than 40 sites, 30,000 students, and more than 3,000 employees.

Director of Information Technology – Technology and Training (2004 – 2009)

- Managed and oversaw technology training for the district; supervised and led a team of trainers and 2 Media Specialists.
- Provided leadership to the district in new technology for classroom education and business operations.
- Specified new software and equipment, managed all site design and hardware, and performed maintenance of all public-facing websites.
- Tested, vetted, and recommended all education technology tools.

Key Accomplishments

- Designed and implemented a plan to move the district web site to a Microsoft SharePoint Portal Server.
- Designed, planned, and implemented a training program to teach employees and students how to use Microsoft SharePoint Portal Server Services.
- Planned and managed the deployment of specialized technology projects including mobile wireless laptop centers and mobile projector carts.
- Co-authored the district's Technology Policy.
- Installed and deployed the first Learning Management System; located, purchased, and implemented the replacement of the Blackboard LMS to the Moodle LMS.
- Brought podcasting and videocasting to the district; facilitated move to become one of the first school districts in the nation to broadcast and record all school board meetings live.
- Received Technology Coordinator of the Year Award by the Arizona Technology in Education Alliance.

Technology Training Specialist
Technology Life Careers Teacher

1997 – 2004
1993 – 1997

Northern Arizona University, Flagstaff, AZ
Adjunct Faculty

2001 – 2009

Ottawa University, Phoenix, AZ
Adjunct Faculty

2001 – 2003

EDUCATION & CERTIFICATIONS

Northern Arizona University, Flagstaff, AZ, Master's Degree in Vocational Education
 Northern Arizona University, Flagstaff, AZ, Bachelor of Science Degree in Technology Education
 Arizona Teaching Certificate
 SAFARI Montage Certified Designer, Installer and Trainer

Christopher W. Jones
6250 Promenade Dr. North
Westminster, Colorado 80020
(208) 241-7721
Chris@galaxynext.us

Objective:

Committed to providing my customers with a quality product as well a positive project experience in a cost effective and efficient manner.

Experience:

**National Implementation Specialist / Regional Sales Director, West - Galaxy Next Generation, Broomfield, Colorado
(3/20-Current Position)**

- Maintain/grow current and new customer accounts by keeping open lines of communication with current customers and searching out new bidding opportunities
- Oversee construction on any Western Operations projects from bidding to project completion
- Lead and support any G2 Communicator projects (bell, paging, and intercom) that Galaxy Next Generation is bidding on or awarded throughout the Nation
- Administer any day to day operations in the Broomfield, Colorado office

**Supervisor - Ehlert Solutions Group, Broomfield, Colorado
(10/18-3/20)**

- Manage crew through daily tasks by setting a worker specific schedule that ensures efficiency
- Organized multiple projects occurring simultaneously including G2 Communicator systems, Pro Audio systems, and audio/visual installations
- Responsible for inventory, tools, and vehicles
- Communicate with security and the IT department in Boulder Valley School District and any other district with open contracts on a regular basis as to guarantee that contract is in good standing and moving forward

**Audio Visual Installer - Ehlert Solutions Group, Broomfield, Colorado
(3/18-10/18)**

- Learned how to install complete bell, paging, and intercom systems; and audio visual systems utilizing televisions and projectors
- Became proficient in basic low voltage wiring, and terminating Cat 5 and Cat 6 cables.

- Trained in basic programming for network endpoints

**Crew Lead - Mauriello's Landscaping, Jacksonville, Florida
(1/17-2/18)**

- Led crew through daily jobs.
- Operated the dump truck and kept track of tools
- Ensured customer satisfaction by completing yard renovations in a clean and timely fashion

**Foreman - Ocean Fencing, Florida Keys, Florida
(5/16-12/16)**

- Responsible for customer relations including: taking measurements of properties, drawing site plans, estimating cost of jobs, and talking customer through estimates
- Oversaw construction of fences by following appropriate permitting, and inspection guidelines, ascertaining the proper materials were delivered to the site on time, working with sub-contractors to ensure proper work was done, and managing crews through the construction process
- Responsible for obtaining steady flow of new projects by handing out business cards, speaking with contractors, building strong customer relationships for referrals, and developing company website

Internships:

**Field Safety and Labor Internship - P&H MinePro Services, Western and Southern Operations
(5/09-5/10)**

- Participated in all assembly aspects of new P&H Boss 4100 Series Shovel.
- Project Safety and Quality Manager on site for dragline outage repair project at Colowyo Mine in Colorado
 - Organized and conducted daily toolbox talks on various safety topics.
 - Completed reports and documentation regarding safety
 - Drafted and organized comprehensive project pictorial report for billing and project history purposes
 - Maintained good customer communication on safety and quality related matters
- Participated in multiple outage and equipment repair projects in Texas, North Carolina, and Florida

**Field Safety and Labor Internship - P&H MinePro Services, Texas Operations
(5/08-7/08)**

- Dragline base repair project.
 - Field Safety Assistant duties

- Provided assistance in various labor aspects including weld, paint, and prep work.

**Safety Internship - P&H MinePro Services, Western Operations Office
(5/07-7/07)**

- Updated chemical database utilizing excel spreadsheet with MSDS sheets detailing applicable chemicals for viewing by Wyoming rebuild and rewind shops and field operations
- Updated near miss, minor injury, and lost time injury database for 5 prior years for entire Western Operations and Southeastern Operations.
- Oversaw and coordinated certification of all shop-made tools and apparatuses with an outside engineering firm

Education and Certifications:

University of North Florida - Jacksonville

- Bachelor of Arts Degree in Construction Management in progress.

Florida State College - Jacksonville

- Associates of Arts Degree with an emphasis in Construction Management - May 4, 2012

State of Idaho

- Certified Nursing Assistant - 2005

Affiliations:

Boy Scouts of America

- Eagle Scout

Joshua Coby Hughes

285 Big A Road Toccoa, GA 30577 • joshuacobyhughes@gmail.com • (706) 716-9505

PROFESSIONAL EXPERIENCE

Project Manager/ Installation Manager

**2003-Present
Toccoa, GA**

Project Manager

- Worked with many school districts in the southeast to purchase and implement a wide variety of classroom technology
- Managed many large Interactive Flat Panel installations and roll-outs to coordinate deliveries, installation times, and after-sales training support. Some of the projects that were included in his management are listed below;
 - Bibb County Schools, GA- 1500 Unit Project
 - Anderson 5 SC- 700 Unit Project
 - Valdosta City Schools, GA- 200 Unit Project
- Produced and developed individualized scheduling and inventory procedures
 - Developed an asset tagging system that can be done at time of install and be immediately available to school district with serial numbers, school locations, and room numbers.
- Prepared and provided purchasing quotes and purchasing schedules for large technology implementations
 - Arranged for on time deliveries of product, timely disposal of discarded trash upon completion, and training scheduling for follow-up support
- Worked with decision makers, professional development coordinators, and other project managers to devise plans for implementing technology that best suites all individuals involved.

Installation Manager

- Managed installation teams of 2-8 members to coordinate installs of many large district implementations
- Managed multiple site installations, installing at same time to ensure all groups were on time, and upholding the standards of the company
- Experienced and/or certified in the installation of the following products
 - Interactive Flat Panels
 - Interactive Boards
 - Interactive and non-interactive projectors
 - Projector Screens
 - Audio and classroom audio systems
 - Large auditorium display and audio systems
 - Standard TV
 - Multi-format displays
- Experienced and/or certified in running AV cabling, installing raceway and face plates, and insuring connectivity throughout the space
- Experienced and or/certified in imaging PCs, downloading software, trouble shooting minor software issues
- Certified in tech support repair of G2 SAM series of panels and all of their ancillary equipment (see attached certification)

Certified Technician

Galaxy Next Generation certifies that

Coby Hughes, Senior Lead Installer

has completed G2 training in quality assurance as a Certified Technician in the installation and service of all Galaxy Next Generation products including SAM Panels, Integrated PCs and Stands.

August 31, 2016

Ellen Spencer, Operations Manager

G2

Awards



2022 Platinum Awards

- **Safety & Security- Emergency Communication**
G2 Secure aChat
- **Classroom Audio Enhancement**
G2 LINK Classroom Audio System



G2 Visual Alerts



CAMPUS
TECHNOLOGY

G2 Secure



G2 Secure



THE
JOURNAL

G2 Secure

G2

G2/ Galaxy Next Generation used the following recyclable materials in production of this bid submission.

Follows:
Binding Combs

Plastic comb
Koroplast
Ablus plastic
Plastic binding
Duralplast
Plastic binding
Plastic binding
Duralplast
Ablus plastic

14	100	A4/21	Black, Red, Silver
✓	✓	✓	✓
✓	✓	✓	✓
✓	✓	✓	✓
✓	✓	✓	✓

www.fsc.org



MIX
Paper from
responsible sources
FSC® C014786



PROGRESSIVE TECHNOLOGIES

August 26th, 2022

Mike Plunkett
Hickman Count Board of Education

Project: Intercom Upgrade for Elementary School and Intermediate School.

Progressive Technologies is pleased to present this proposal and we look forward to working with you. Below is a brief description of the work to be performed. Feel free to call should you have any questions.

Intermediate School :

- Provide and Install (103) Ceiling Speakers for hallways, and classrooms.
- Provide ad Install (39) Call Buttons for Classrooms.
- Provide and Install (1) NETDEV Zone Controller to connect gym speakers to the new intercom system.
- Provide and Install (3) Outdoor Speakers.
- Provide and Install (103) Cat 6 Cables, (1) to each speaker.
- Provide and Install (204) Cat 6 Jacks.
- Provide and Install (103) Surface mount Boxes, (1) for each speaker.
- Provide and Install (206) Cat 6 Patch Cables.
- Provide and Install (3) 48- Port Patch Panels.
- Provide and Install J-Hooks where needed.
- Demo Existing Intercom system.

Price: \$105,245.42

- Only work listed in the above scope of work summary is included in this proposal.
- All new cabling will be labeled with a Brother P-Touch labeler, per customer's existing labeling scheme.
- All new cabling will be tested with Fluke Cable Analyzer, test results to be provided upon completion.
- Progressive Technologies will provide a (1) year warranty upon completion of the project, PTI will also coordinate with the manufacturer for warranty requests in the RFP.

MEMPHIS, TN
3750 Old Getwell
Memphis, TN 38118
(901) 591-1900 P
(901) 591-1901 F

www.ThinkProgressive.com

MEMPHIS, TN (CORPORATE OFFICE) | JACKSON, TN | DALLAS, TX | LITTLE ROCK, AR | ROGERS, AR

TN LIC. # 364/ TX LIC. # B20906/ AR LIC. # CMPY.0002187/ MS LIC. # 15024678/ OK LIC. # AC440538

- All cabling will be supported every 4 to 5 feet with appropriate devices.
- Any add-ons, moves or changes that affect the final cost of the job beyond the accepted quote, will be considered a "Change Order". All change orders must be documented and approved. The documentation must include the person requesting the change, date change was requested, date change was made, and a line item cost of the changes. All change orders will be combined and paid with one P.O. number that is separate than the main job P.O. number.
- PAYMENT TERMS: NET 30 days from the date of invoice.

Exclusions:

All work to be performed during normal business hours 8:00am to 5:00pm. Any overtime, if required will be handled on a change order basis.

Please allow (2) weeks for delivery of material and scheduling upon receipt of P.O.
The above pricing is based on Progressive Technologies, Inc. being awarded both the labor and material portions of the project. Any deviation from this concept may result in rate changes. Pricing is valid for (15) days.

Thank you for this opportunity and we look forward to working with you.

Sincerely,

Foster Hedden
Account Representative
Progressive Technologies, Inc.
3750 Old Getwell Rd.
Memphis, TN 38118
901-591-1928 Office
901-574-2952 Cell
fhedden@thinkprogressive.com





**PROGRESSIVE
TECHNOLOGIES**

August 26th, 2022

Mike Plunkett
Hickman Count Board of Education

Project: Intercom Upgrade for Elementary School and Intermediate School.

Progressive Technologies is pleased to present this proposal and we look forward to working with you. Below is a brief description of the work to be performed. Feel free to call should you have any questions.

Elementary School:

- Provide and Install (103) Ceiling Speakers for hallways, and classrooms.
- Provide and Install (49) Call Buttons for Classrooms.
- Provide and Install (1) NETDEV Zone Controller to connect gym speakers to the new intercom system.
- Provide and Install (3) Outdoor Speakers.
- Provide and Install (103) Cat 6 Cables, (1) to each speaker.
- Provide and Install (204) Cat 6 Jacks.
- Provide and Install (103) Surface mount Boxes, (1) for each speaker.
- Provide and Install (206) Cat 6 Patch Cables.
- Provide and Install (3) 48- Port Patch Panels.
- Provide and Install J-Hooks where needed.

Price: \$110,402.56

- Only work listed in the above scope of work summary is included in this proposal.
- All new cabling will be labeled with a Brother P-Touch labeler, per customer's existing labeling scheme.
- All new cabling will be tested with Fluke Cable Analyzer, test results to be provided upon completion.
- Progressive Technologies will provide a (1) year warranty upon completion of the project, PTI will also coordinate with the manufacturer for warranty requests in the RFP.
- All cabling will be supported every 4 to 5 feet with appropriate devices.

MEMPHIS, TN
3750 Old Getwell
Memphis, TN 38118
(901) 591-1900 P
(901) 591-1901 F

www.ThinkProgressive.com

MEMPHIS, TN (CORPORATE OFFICE) | JACKSON, TN | DALLAS, TX | LITTLE ROCK, AR | ROGERS, AR

TN LIC. # 364/ TX LIC. # B20906/ AR LIC. # CMPY.0002187/ MS LIC. # 15024678/ OK LIC. # AC440538

- Any add-ons, moves or changes that affect the final cost of the job beyond the accepted quote, will be considered a "Change Order". All change orders must be documented and approved. The documentation must include the person requesting the change, date change was requested, date change was made, and a line item cost of the changes. All change orders will be combined and paid with one P.O. number that is separate than the main job P.O. number.
- PAYMENT TERMS: NET 30 days from the date of invoice.

Exclusions:

All work to be performed during normal business hours 8:00am to 5:00pm. Any overtime, if required will be handled on a change order basis.

Please allow (2) weeks for delivery of material and scheduling upon receipt of P.O.
The above pricing is based on Progressive Technologies, Inc. being awarded both the labor and material portions of the project. Any deviation from this concept may result in rate changes. Pricing is valid for (15) days.

Thank you for this opportunity and we look forward to working with you.

Sincerely,

Foster Hedden
Account Representative
Progressive Technologies, Inc.
3750 Old Getwell Rd.
Memphis, TN 38118
901-591-1928 Office
901-574-2952 Cell
fhedden@thinkprogressive.com





STATE OF TENNESSEE
DEPARTMENT OF
COMMERCE AND INSURANCE



PROGRESSIVE TECHNOLOGIES, INC.

378276

ID NUMBER: 43609
LIC STATUS: ACTIVE
EXPIRATION DATE: April 30, 2023

BOARD FOR LICENSING CONTRACTORS
CONTRACTOR

THIS IS TO CERTIFY THAT ALL REQUIREMENTS
OF THE STATE OF TENNESSEE HAVE BEEN MET

PROGRESSIVE TECHNOLOGIES, INC.
3750 OLD GETWELL RD
MEMPHIS, TN 38118-6032

State of Tennessee

378276

12575337

BOARD FOR LICENSING CONTRACTORS
CONTRACTOR
PROGRESSIVE TECHNOLOGIES, INC.

This is to certify that all requirements of the State of Tennessee have been met.

ID NUMBER: 43609
LIC STATUS: ACTIVE
EXPIRATION DATE: April 30, 2023
UNLIMITED; CE-D; CE-F; CE-G



IN-1313
DEPARTMENT OF
COMMERCE AND INSURANCE



CERTIFICATE OF LIABILITY INSURANCE

DATE (MM/DD/YYYY)
1/25/2022

THIS CERTIFICATE IS ISSUED AS A MATTER OF INFORMATION ONLY AND CONFERS NO RIGHTS UPON THE CERTIFICATE HOLDER. THIS CERTIFICATE DOES NOT AFFIRMATIVELY OR NEGATIVELY AMEND, EXTEND OR ALTER THE COVERAGE AFFORDED BY THE POLICIES BELOW. THIS CERTIFICATE OF INSURANCE DOES NOT CONSTITUTE A CONTRACT BETWEEN THE ISSUING INSURER(S), AUTHORIZED REPRESENTATIVE OR PRODUCER, AND THE CERTIFICATE HOLDER.

IMPORTANT: If the certificate holder is an ADDITIONAL INSURED, the policy(ies) must be endorsed. If SUBROGATION IS WAIVED, subject to the terms and conditions of the policy, certain policies may require an endorsement. A statement on this certificate does not confer rights to the certificate holder in lieu of such endorsement(s).

PRODUCER Collier Insurance 606 South Mendenhall Rd Memphis TN 38117		CONTACT NAME: Melissa Person PHONE (A/C, No, Ext): (901) 529-2900 FAX (A/C, No): (901) 529-2916 E-MAIL ADDRESS: mperson@collier.com	
INSURED Progressive Technologies Inc 3750 Old Getwell Road Memphis TN 38118		INSURER(S) AFFORDING COVERAGE INSURER A: National Fire Ins. of Hartford INSURER B: Valley Forge Ins Co INSURER C: The Continental Insurance Company INSURER D: Accident Fund General Insurance Company INSURER E: INSURER F:	
		NAIC # 12304	

COVERAGES CERTIFICATE NUMBER: CI2212524922 REVISION NUMBER:

THIS IS TO CERTIFY THAT THE POLICIES OF INSURANCE LISTED BELOW HAVE BEEN ISSUED TO THE INSURED NAMED ABOVE FOR THE POLICY PERIOD INDICATED. NOTWITHSTANDING ANY REQUIREMENT, TERM OR CONDITION OF ANY CONTRACT OR OTHER DOCUMENT WITH RESPECT TO WHICH THIS CERTIFICATE MAY BE ISSUED OR MAY PERTAIN, THE INSURANCE AFFORDED BY THE POLICIES DESCRIBED HEREIN IS SUBJECT TO ALL THE TERMS, EXCLUSIONS AND CONDITIONS OF SUCH POLICIES. LIMITS SHOWN MAY HAVE BEEN REDUCED BY PAID CLAIMS.

INSTR	TYPE OF INSURANCE	ADDL INSD	SUBR WVD	POLICY NUMBER	POLICY EFF (MM/DD/YYYY)	POLICY EXP (MM/DD/YYYY)	LIMITS
A	<input checked="" type="checkbox"/> COMMERCIAL GENERAL LIABILITY <input type="checkbox"/> CLAIMS-MADE <input checked="" type="checkbox"/> OCCUR GEN'L AGGREGATE LIMIT APPLIES PER: <input checked="" type="checkbox"/> POLICY <input type="checkbox"/> PRO-JECT <input type="checkbox"/> LOC OTHER:			6080129655	2/6/2022	2/6/2023	EACH OCCURRENCE \$ 1,000,000 DAMAGE TO RENTED PREMISES (Ea occurrence) \$ 100,000 MED EXP (Any one person) \$ 15,000 PERSONAL & ADV INJURY \$ 1,000,000 GENERAL AGGREGATE \$ 2,000,000 PRODUCTS - COMP/OP AGG \$ 2,000,000 Employee Benefits \$ 1,000,000
B	<input checked="" type="checkbox"/> AUTOMOBILE LIABILITY <input checked="" type="checkbox"/> ANY AUTO <input type="checkbox"/> ALL OWNED AUTOS <input type="checkbox"/> SCHEDULED AUTOS <input type="checkbox"/> HIRED AUTOS <input type="checkbox"/> NON-OWNED AUTOS			6080129669	2/6/2022	2/6/2023	COMBINED SINGLE LIMIT (Ea accident) \$ 1,000,000 BODILY INJURY (Per person) \$ BODILY INJURY (Per accident) \$ PROPERTY DAMAGE (Per accident) \$ Uninsured motorist combined single \$ 1,000,000
C	<input checked="" type="checkbox"/> UMBRELLA LIAB <input type="checkbox"/> OCCUR <input type="checkbox"/> EXCESS LIAB <input type="checkbox"/> CLAIMS-MADE DED <input checked="" type="checkbox"/> RETENTION \$ 10,000			6080129686	2/6/2022	2/6/2023	EACH OCCURRENCE \$ 5,000,000 AGGREGATE \$ 5,000,000
D	WORKERS COMPENSATION AND EMPLOYERS' LIABILITY ANY PROPRIETOR/PARTNER/EXECUTIVE OFFICER/MEMBER EXCLUDED? (Mandatory in NH) If yes, describe under DESCRIPTION OF OPERATIONS below		N/A	AFWCF100001456	2/6/2022	2/6/2023	PER STATUTE OTH-ER E.L. EACH ACCIDENT \$ 1,000,000 E.L. DISEASE - EA EMPLOYEE \$ 1,000,000 E.L. DISEASE - POLICY LIMIT \$ 1,000,000
A	Rented/Leased Equipment			6080129655	2/6/2022	2/6/2023	\$50,000 Limit
A	Crime			6080129655	2/6/2022	2/6/2023	\$200,000 Limit

DESCRIPTION OF OPERATIONS / LOCATIONS / VEHICLES (ACORD 101, Additional Remarks Schedule, may be attached if more space is required)

CERTIFICATE HOLDER For Informational Purposes	CANCELLATION SHOULD ANY OF THE ABOVE DESCRIBED POLICIES BE CANCELLED BEFORE THE EXPIRATION DATE THEREOF, NOTICE WILL BE DELIVERED IN ACCORDANCE WITH THE POLICY PROVISIONS. AUTHORIZED REPRESENTATIVE J Dabney Collier III/
---	---

Invitation To Bid

The Hickman County Finance Office is accepting sealed bids for Hickman County High School Auditorium Audio and Video System

Additional specifications can be found at: www.hickmank12.org/request-for-proposal.

All bidders will be required to submit a conflict of interest disclosure form that can also be found at: www.hickmank12.org/request-for-proposal.

Sealed bids must be mailed or delivered to the Hickman County Finance Office, 114 North Central Avenue, Suite 203, Centerville, TN 37033 and clearly marked on the outside of the bid envelope "HCHS Auditorium Audio and Video System".

Bids will be opened on September 19th, 2022 at 10:00 A.M. in the Finance Office. The Hickman County School District reserves the right to accept or reject any and all bids or parts of bids and to waive any informalities, which in the opinion of the school system, would prevent the acceptance of a better bid.

Present Penny Mayhew
Mindy Williams

Roman A/V LLC 98,600.00

SWC 90,520.10

ROMAN AV, LLC

Hickman County High School AV System Quote

Intellectual Property of ROMAN AV, LLC. Quote Valid For 30 Days

CC: Brad Gilbert

REV 1: 9-19-22



Part 1. Audio

Goal of project: To achieve maximum sound quality throughout the auditorium allowing speakers and performers to be heard clearly in all areas.

- New Digital Soundboard with iPad compatibility
Behringer X32 + S32 Combo + 8 Antenna Router for maximum reception.
- One touch reset for system to return to working specifications
Instant Scene Recall and Power Sequencer makes all audio turn on in order without causing damaging pops.
- Additional subwoofers placed above newly installed speakers at front of auditorium
JBL PRX418S securely mounted above new main speakers. Both enclosures are the exact same width for aesthetics.
- Removing four speakers on sidewalls and replacing them with new speakers
Removing all distorted Peavey speakers and replacing with 2 JBL PRX412
- New cabling and installation of backup cabling
Minimal copper installation with 1 CAT5 E Shielded cable with no coupling attachments.
- New wireless mics with at least 12 theater mics. Mics should be able to be used throughout the auditorium with clarity and clear reception. Lapel and handheld mics should be included.
A Shure BLX system with 14 receivers. Either 14 body-packs at once, or up to 2 hand-held mics with 12 body-pack mics. 2 amplified diversity paddle antennas fed from cascaded antenna combiners will ensure the best reception available at this price point (mid-level). The new rf bands are in the legal spectrum as of 9-16-22.
- Possible relocation of amps and redesign of control booth
Amps will live in the AV Rack side stage left. Booth will have a redesigned rack to house new equipment. Locking mechanisms will be installed in both the stage and booth racks.
- Any additional sound treatment needed for the auditorium to improve sound quality
Two Options are available to deal with the acoustical issues in the auditorium. Note internal treatment is not soundproofing. The internal acoustics issues, in order of importance, are firstly, slapback echo from the rear wall which smears the transients and decreases intelligibility; secondly, the lack of linear absorption of low range frequencies, which causes a lingering muddiness; thirdly, a redesign of the current side wall panels. Package 1 (more expensive) includes addressing all 3 issues, and package 2 includes addressing the first 2 issues. Package 1 is priced in the initial quote below.

- Expectation of service for an extended time after installation in case of problems.
While item repair/replacement is expected over several years, with proper care, the system is expected to operate up to 15 years.

Part 2. Video

Goal of project: To provide quality video experience throughout the auditorium that can be seen clearly and integrate seamlessly with the new audio equipment being installed.

The following are areas that the school district would like to see addressed.

- New digital projector
Recommending the newest digital technology laser projector at 9,800 lumens to be mounted on the ceiling under the catwalk, to save at least \$10k on the added lumens and long throw lens equipment, as a comparable projector mounted in the booth.
- Additional inputs at one or both sides of stage including one in the booth
1 HDMI stage left, 2 HDMI ports stage right (where presenters are more likely to be with a backup), and 1 HDMI port in the booth.
- Retractable projector screen
275" diagonal, tensioned, 4k compatible projector screen hung from pre-existing unistrut on stage.
- Seamless integration with sound equipment
Sound will be synced with all video sources, and any sound routed to the projector will be returned on a stereo line input on the console.
- Any additional items needed for the auditorium to provide quality video performance
A single video system startup button will power on/off the projector and lower/raise the screen at once. An additional screen up/down button will make manual changes possible.
- Expectation of service for an extended time after installation in case of problems.
The new laser projector technology does not wear out after 2,000-3,000 hours like bulb projectors. Laser projector light source will last 30,000 hours.

Audio Materials: \$42,000

Video Materials: \$24,600

Acoustical Materials: \$8,000

Combined Labor: \$24,000

JOB TOTAL: \$98,600

About our plan:

We would love to be involved in making the HCHS auditorium into an extremely high quality, user friendly, highly capable event space. We have really enjoyed working with you all in the past, and I've appreciated gaining the insight on the school system workflow as well. Here is a highlight overview of our tech vision for the auditorium. We hope it will open up Hickman County to exciting possibilities not previously possible in the auditorium.

I have designed a system for the room that would meet all of the tech needs you may encounter. The heart of the system is a digital sound board and digital snake. A major upgrade feature is a one-button scene-recall feature, so all of the volumes, settings, and routing can be instantly optimized for each type of event. Another incredibly helpful feature is iPad connectivity. One could operate the entire system from any seat in the auditorium if necessary.

This past school year we installed new main speakers and a new main power amp in the auditorium. Those should be great for an expected 10 to 15 years. I would recommend mounting an additional subwoofer directly above the new main speakers on both house left and house right. I recommend decommissioning the four delay speakers on the sidewalls since they are either distorting or not producing any sound. I recommend replacing those four with two speakers halfway back on the side walls. The power amps for those speakers would live racked in the booth as well. Having 2 powered wedge monitors is also very helpful in events.

To accomplish this installation, new and updated cabling would be required. Running back-up cabling on the initial installation of the digital gear is also strongly recommended. It doesn't add much labor on the front end, but it could save thousands on the backend if a cable were to get damaged.

I would recommend starting over on wireless audio gear. Having 2 dependable handheld mics will add flexibility, clarity, and reliability to the events. And because of the FCC mandate, as of July 13, 2020, all 600 MHz band equipment will need to be replaced, and I believe that includes all of the theater mics. And with so many budget ranges available for wireless gear, the BLX series may be the best fit. I would recommend 14 body-pack theater mics. I can also make any of the handheld mics compatible with a body pack counterpart without having to purchase additional receivers. That means you can purchase a few extra theater mics without having to purchase additional receivers. Also as a sidenote, having some extra empty rack spaces for additional wireless mics in the future is a smart plan.

I would recommend purchasing a new digital projector and relocating it to the ceiling directly under the catwalk. Instead of fighting the inverse-square law, having a projector mounted near the stage will add clarity, color, brightness, and save probably \$10-15k from a comparable long-throw option. To access inputs to the video system, I would recommend having a video input stage left, stage right, and in the booth, with a backup. That way there are several options for conveniently queuing video. If a presenter on stage is queuing slides, the stage right wall will be closest, if backstage left techs need to fire a sound or video cue where the rack currently is, that will be convenient, and there needs to be an additional third input from the balcony booth to access the projector. Audio from video will be integrated into the new system

as well and controlled with the same iPad/ console as everything else perfectly in sync. We can also install retractable projector screens. The large electronic ones can get pretty expensive pretty quickly, so I'm happy to find exactly the right fit, one that doesn't need to showcase unparalleled viewing, but one that is tension controlled, electronic, and 20' horizontal.

The acoustical situation in the room could also be a major upgrade for clarity. While the mics and speakers can only be optimized so much, all sound is colored by the room it is in. The acoustical issues I noted included slap-back and non-linear decay. The slap-back echo is caused by parallel walls, but it can be fixable with treatment. The other acoustical issue is an imbalance between the low and high frequency absorption that acoustical issue manifests as boomy lingering that decreases clarity in speech especially. It can also be improved with acoustical treatment. And just in case it helps, the sanctuary at Centerville Church of Christ had several very similar issues, and they were all clarified to satisfaction if you would like to check it out as a gauge. And also as a note, sound treatment does not mean soundproofing. Very different techniques for each of those. I haven't heard about any complaints about sound spilling into classrooms, but let me know if that is actually a need as well.

I believe the new gear and new workflow should be supported with a new booth layout as well. Changing the way a few pieces of gear are set up could increase productivity and capabilities for the gear operators. It won't require a complete overhaul by any means, but modernizing the layout could be helpful.

Recommending new upgraded technology comes with some responsibility as well. Even though we would set up the gear to be as user-friendly as possible, all the gear is still pretty advanced and can be complicated. It is absolutely critical for the operators of the gear to be hands on and also understand the basics about adjusting the sound. Please understand that I am not recommending a system that should never be touched or adjusted, I'm recommending one that is flexible and will accommodate every need. I would consider it a requirement to have firstly, an in-person training session for anybody likely to use the gear (staff and students), and secondly having a set of YouTube links from professional audio teachers that go into detail about the features. Plus for any students wanting to learn, there are professional employment opportunities guaranteed for those who can use digital consoles. I am happy to be as helpful as I can getting you all started and answering questions, but the only good long-term solution is continuing to learn about the new technology. I'm always eager to set you up to win, and don't want any confusion on this point. :)

When we design a system to install, we come from a very gear-operator perspective. That means we use our experience actually operating the gear as a guide for installing it. Many other companies have professional bid writers, who don't install the gear, nor know how to operate the gear. And our last 10 years of event production has helped us gain an understanding for how to create a workflow optimized for the gear we will have. We offer a best bid guarantee, if you would like to work with us but another bid offers a feature not specifically mentioned in our overview, we would like the opportunity to either clarify or add that feature if it's possible. We will always be honest and clear.

We expect it to take 3 weeks to complete. We are willing to work around the school's theater schedule. We are licensed and insured. We are expecting the purchase to be tax exempt, and the pricing reflects that. Additional lift rental may be required to install the screen.

Thanks,

Tanner Roman

Owner ROMAN AV, LLC

615-812-5517

A handwritten signature in black ink, appearing to read "Tanner Roman". The signature is written in a cursive, flowing style with a large initial "T" and "R".

Hickman County Government

Conflict of Interest Disclosure Form

The County Financial Management System of 1981 contains the most stringent conflict of interest provisions. TCA §5-21-121 provides:

- (a) The director, purchasing agent, members of the committee, members of the county legislative body or other officials, employees, or members of the board of education or highway commission shall not be financially interested or have any personal beneficial interest, either directly or indirectly, in the purchase of any supplies, materials, equipment or contractual services for the county.
- (b) No firm, corporation, partnership, association or individual furnishing any such supplies, materials, equipment or contractual services, shall give or offer, nor shall the director or purchasing agent or any assistant or employee accept or receive directly or indirectly from any person, firm, corporation, partnership or association to whom any contract may be awarded, by rebate, gift or otherwise, any money or other things of value whatsoever, or any promise, obligation or contract for future reward or compensation.

Date: 9-11-22 Name: Tanner Roman ROMAN A/V, LLC

Please describe below any relationships, transactions, positions you hold (volunteer or otherwise), or circumstances that you believe could contribute to a conflict of interest:

I have no conflict of interest to report.

I have the following conflict of interest to report (please specify any boards or committees you (and/or your spouse) sit on, the name of your employer and any businesses you or your spouse may own.

I do not believe my company, ROMAN A/V, LLC has any conflicts of interest with the Hickman County School Systems. We have been contracted by HCSS from time to time for audio and video starting in 2020, mostly consisting of graduation live streams and student assemblies.

I hereby certify that the information set forth above is true and complete to the best of my knowledge.

Date: 9-11-22 Signature: 



Pricing Summary

ACCOUNT:
HICKMAN CO HIGH SCHOOL
1645 BULLDOG BLVD
CENTERVILLE, TN 37033

FACILITY LOCATION:
HICKMAN CO HIGH SCHOOL
1645 BULLDOG BLVD
CENTERVILLE, TN 37033

OFFER: In accordance with the Scope of Work, Bill of Materials, and Terms and Conditions attached hereto, SWC is pleased to offer this pricing for the following project:

TITLE:

REF #: 51856_1

ESTIMATE GROUP	TOTAL PRICE
Base Budget Sound System	\$55198.56
Base Budget Video System	\$35321.54
ACCOUNT EXECUTIVE:	SUB-TOTAL \$90,520.10
	TAX (EXEMPT): \$.00
TERMS:	
	TOTAL \$90,520.1

Per my authority as an executing agent, please accept this as an intent to award and enter into a contractual agreement with SWC.

NAME

CLIENT'S SIGNATURE



Scope & Bill of Materials

SWC IS PLEASED TO PRESENT A QUOTE FOR THE Hickman HS Auditorium AV Bid PROJECT.

Part 1. Audio

Speakers

Sound system to consist of all JBL speakers. SWC will keep the two SRX800 speakers that are left and right of stage in place. Two new SRX 18 inch subwoofers will be added to the left and right of stage adjacent to the existing SRX800 main speakers. The 4 side wall Peavey speakers will be removed and changed out to JBL Architectural series dual 8 inch full range speakers (4) with wall brackets.

Amplifiers & Signal Processing

SWC to install 2 new Lab Gruppen 1200w 2 channel amplifiers (Mains and subs) and two 800w Lab Gruppen amps for the delay side speakers. The existing Crown DCI amp can be utilized to run any stage monitors if needed. Amplifiers will be moved to the room behind the mix area into a new Middle Atlantic equipment rack with sequencing and power conditioning. Customer will be responsible for provide 3 dedicated 15 amp circuits to power the new equipment. A new Symetrix 8x8 Digital audio processor will be installed to provide signal processing such as equalization, crossover, delay, etc.

Digital Mixer

A new 24 channel Allen & Heath QU 24C mixer will be installed at the mix position. Mixer has ability to connect to customer provided IPAD. for remote control of mixer. Main features include:

- Inputs: 24 Mono / 3 Stereo
- Mixes: 4 Mono / 5 Stereo / LR
- Matrix: 2 Stereo
- 32x30 USB Audio Interface
- Comprehensive Channel Processing and FX
- Intuitive Interface with Full Color Touchscreen

A new digital snake is included in the price and will replace the Horizon wall mounted snake box on the side stage. The snake is a 16 x8 channel box to give you inputs for any stage hardwire mics or other inputs or monitor aux outputs. The existing rack sitting by the mixer will be removed to free up tabletop space. A dedicated 110VAC outlet will be required to power the mic snake and wireless mic receivers. Preferred the outlet to be on the same breaker box and phase as the audio amplifiers at rear of room.

Wireless Mics

12 new Audix wireless mic receivers with 12 beltacks and flesh colored headset mics (Provder Series equivalents to the Countryman E6 elements) to be installed in new wall mounted equipment rack on side stage. 2 additional beltacks with lapel mics and 2 handheld transmitters to be provided for connection to the 12 receivers. An antenna distribution system will be added with directional paddles for optimal signal reception.

SWC to provide a line diagram of the system as installed and system training at completion.

Part 2. Video

Video system to consist of a Vivitek Large Venue 8000 Lumen DLP laser projector WUXGA resolution 10,000:1 contrast ratio. Laser light source up to 20,000 hours. Projector will be mounted in ceiling opening in



front of the stage by the catwalk. A CAT transmitter receiver will be provided to feed the video over IP to the projector from the booth. The two old electric screens will be removed from back stage wall and a new Da-Lite electric tensioned screen will be mounted in the old screen(s) location. On the stage (podium side) will have a HDMI connection for laptop or other video player connection back to the booth. The booth will have a 2nd HDMI connection that will be connected to a six input scaler video switcher to select between the stage or rear of room devices. For system control a 3.5" FSR touch panel will be installed to turn projector on/off and raise and lower electric screen. An audio output will be sent from the video switcher into an open channel on the audio mixer. Customer to provide power for projector in the ceiling and wire the power into the new screen. A training session will be conducted after completion of installation, date and time TBD.

Projector Info

Native Resolution WUXGA (1920 x 1200)
Brightness 8000 ANSI Lumens
Contrast Ratio 10,000:1
Max. Supported Resolution WUXGA (1920 x 1200) @60Hz
Native Aspect Ratio 16:10
Lamp Life and Type Lamp free design. Laser light source last up to 20,000 hours
Display Type Single chip DLP® Technology by Texas Instruments
Chip Size 0.67" DMD

Scaler/Switcher Info

- Supports HDMI 2.0 and video resolution up to 4K@60Hz
- 4:4:4 8bit, 1080P, and 3D •
- 18Gbps high bandwidth and supports HDR 10 • HDCP 2.3 compliant
- Supports automatic switching •
- CEC control for display volume and ON/OFF •
- Controllable via RS232 and IR •
- VGA resolution is selectable on the front panel •
- Optical and balanced analog audio for audio de-embedding
- Smart EDID management for various application and customized setting

Video System Controller

NEW FLEX CONTROL BUILDER FEATURES

- Built in Flex Panel Remote Viewer
- View and Press on the Actual Panel Graphic for Remote Testing and Support
- Device Command Checking and Direct Control
- Test any Library Command; IR, Serial or IP
- View Device Responses and Response Timing
- Direct Input Commands to Test Device or Command Syntax
- Display Clocks and Timers:
 - Can be the full size on the splash, or smaller in a window or on other screens.
 - Various formats with or without seconds and military time.
 - Actions can associate at the terminus of the timer.
 - Time can be offset to show multiple time zones.



EST. GROUP - Base Budget Sound System

Mfg	Part Num	Description	Quantity	Sales Price	Ext. Price
West Penn	25227BGY1000	1P 12G STRD UNSHLD PLENUM, Gray	3.00	\$659.82	\$1979.46
JBL	AC28/95-WH	AC28/95-WH AC28/95 - Dual 8" 2way	4.00	\$1125.00	\$4500.00
Audix	ADS48	ANTENNA DISTRIBUTION SYSTEM	2.00	\$616.61	\$1233.22
Allen and Heath	AH-AB-168	16X8 Portable Stage Box	1.00	\$1431.63	\$1431.63
Allen and Heath	AH-AB-168-RK19	Rack Mount for AB168	1.00	\$108.38	\$108.38
Allen and Heath	AH-QU-24C	24 channel digital, 24 Mic/Line + 3 stereo, 100mm	1.00	\$3183.73	\$3183.73
Audix	ANTDA4161	ANT, PAIR, WIDE BAND PADDLE 500-700MHZ	2.00	\$616.61	\$1233.22
Audix	AP62 BP	R62 Receiver with two B60 bodypack transmitters	6.00	\$1543.08	\$9258.48
Audix	B60	Audix beltpack transmitter no mic	2.00	\$269.41	\$538.82
Lab.gruppen	E12:2	1,200 Watt Amplifier with 2 Flexible Output Chann	2.00	\$1432.86	\$2865.72
Lab.gruppen	E82US	E 8:2 US, 800 Watt Amplifier w	2.00	\$1241.69	\$2483.38
Middle Atlantic	EWR-12-17SD	EWR-12-17SD SEC CAB 21PS 12RU 14D ADJ R	1.00	\$618.89	\$618.89
Audix	H60 OM2	Audix handheld mic transmitter	2.00	\$316.17	\$632.34
Graybar	J-Hook	J-Hooks & Hardware	40.00	\$2.64	\$105.60
Mohawk	M57546B	Cat5e Plenum, Blue, 5EP4P24-BL-P-MOH-AP	1.00	\$270.92	\$270.92
SWC	Misc-Blanks	Misc 19in blanks for equipment racks 1 per rack.	2.00	\$294.11	\$588.22
SWC	Misc-Cable	Misc. Cable, Connectors and Consumables	14.00	\$147.05	\$2058.70
JBL	MTU-18	JBL Yoke bracket for AC18 series speakers	4.00	\$115.42	\$461.68
Middle Atlantic	PD-815R-PL	PD-815R-PL POWER STRIP	2.00	\$112.50	\$225.00
Middle Atlantic	PDS-615R	PDS-615R Sequencer	1.00	\$551.83	\$551.83
Symetrix	Prism 8X8	Symetrix DPS, Dante, 8x8	1.00	\$3191.17	\$3191.17
NEW	PSE9	Provider Series headset mic flesh tone or black	12.00	\$145.58	\$1746.96
NEW	PSL6	Provider Series lavalier mic element	2.00	\$101.47	\$202.94
Sun belt	Scaffold Rental	Scaffold Rental (day) 3 sections	2.00	\$220.58	\$441.16
JBL	SRX818S	JBL SRX passive 18" subwoofer	2.00	\$1682.01	\$3364.02

Group Materials Price	\$43,275.47
Group Labor Price	\$11,489.60
Freight Price	\$433.49
Total Sales Tax	\$.00



EST. GROUP Base Budget Video System

Mfg	Part Num	Description	Quantity	Sales Price	Ext. Price
ACCU-TECH CORPORATION	12' HDMI	12' HDMI EXTENTION CABLE	2.00	\$66.17	\$132.34
MCM	24-14757	HDMI CABLE, 6'	2.00	\$6.16	\$12.32
NEW	3797745400SVK	Vivitek long throw lens 3.58-5.38	1.00	\$3842.64	\$3842.64
DA-LITE SCREEN CO	70272L	Da-Lite Cosmopolitan tensioned electrol scren wit	1.00	\$6115.58	\$6115.58
NEW	ALF-EXT60IR18G	Alfatron Video over IP transmitter/ receiver kit	2.00	\$225.00	\$450.00
NEW	ALF-SCU61E	Alfatron two input video switcher HDMI	1.00	\$582.35	\$582.35
MILESTONE AV TECHNOLOGIES INC	CMA360	BEAM CLAMP	1.00	\$277.94	\$277.94
Chief	CMA370	Unistrut adapter	1.00	\$17.64	\$17.64
Chief	CMS0305	Adjustable Pipe 36" to 60"	1.00	\$138.23	\$138.23
NEW	DU8090Z	Vivitek 8000 Lumen video projector WUXGA	1.00	\$11764.70	\$11764.70
Middle Atlantic	ERK-2725LRD	27SP/25D STANDALONE W/ST LRD	1.00	\$716.69	\$716.69
FSR INC	FLEX-LT200	Flex LT200 TOUCH SCREEN CONTROL SCREE	1.00	\$928.16	\$928.16
Graybar	J-Hook	J-Hooks & Hardware	40.00	\$2.64	\$105.60
Mohawk	M57550B	Cat5e Plenum, Yellow, 5EP24P24-YL-P-MOH-AP	1.00	\$270.92	\$270.92
SWC	Misc-Cable	Misc. Cable, Connectors and Consumables	15.00	\$147.05	\$2205.75
Sun belt	Scaffold Rental	Scaffold Rental	1.00	\$220.58	\$220.58
Chief	VCMUW	HEAVY DUTY PROJECTOR MOUNT (White)	1.00	\$400.00	\$400.00

Group Materials Price	\$28,181.44
Group Labor Price	\$6,613.18
Freight Price	\$526.92
Total Sales Tax	\$0.00



Terms & Conditions

Scope Includes:

All terms and conditions will apply to School District Standardization Agreement on file at the Purchasing Department if applicable. Furnishing and installing wire and cable for systems listed. Installation and termination of field devices. Installation and termination of head-end equipment in Equipment Rooms and MDF and IDF areas. Factory and field testing of equipment and systems. Project management in coordination with SWC scope of work. Applicable Permit Fees.

Project Management services in coordination with SWC scope of work. Site Supervision during the installation of SWC scope of work ONLY. As required; site conditions verification for SWC Scope of work ONLY.

The Project Schedule will be a mutually agreed upon document between the parties, including all revisions. Scope and price are based on regular working hours Monday through Friday; any deviation, unless requested by SWC, may be cause for additional compensation.

Final payment including will is remitted within 30 days of substantial completion of our scope of work regardless of the status and nature of other trades and the overall project status. No Retainage to be withheld.

Scope Excludes:

Service and circuit power requirements including final connections to all our electronic equipment. Server(s) and workstation(s) hardware and Microsoft operating system. All demolition work, trenching, concrete work and finish painting. Patching of concrete, tile, drywall or masonry, core drilling, sleeves and caulking with sealants.

Quote is based on SWCs scope of work being performed during normal business hours Mon-Fri. Performance and Payment Bond is available if required at 1% of total contract value to SWC. It is not included in our price. No Retainage to be withheld.

Hickman County Government

Conflict of Interest Disclosure Form

The County Financial Management System of 1981 contains the most stringent conflict of interest provisions. TCA §5-21-121 provides:

- (a) The director, purchasing agent, members of the committee, members of the county legislative body or other officials, employees, or members of the board of education or highway commission shall not be financially interested or have any personal beneficial interest, either directly or indirectly, in the purchase of any supplies, materials, equipment or contractual services for the county.
- (b) No firm, corporation, partnership, association or individual furnishing any such supplies, materials, equipment or contractual services, shall give or offer, nor shall the director or purchasing agent or any assistant or employee accept or receive directly or indirectly from any person, firm, corporation, partnership or association to whom any contract may be awarded, by rebate, gift or other otherwise, any money or other things of value whatsoever, or any promise, obligation or contract for future reward or compensation.

Date: 9/16/22 Name: BT Rook

Please describe below any relationships, transactions, positions you hold (volunteer or otherwise), or circumstances that you believe could contribute to a conflict of interest:

I have no conflict of interest to report.

I have the following conflict of interest to report (please specify any boards or committees you (and/or your spouse) sit on, the name of your employer and any businesses you or your spouse may own.

I hereby certify that the information set forth above is true and complete to the best of my knowledge.

Date: [Signature] Signature: 9/16/22



CERTIFICATE OF LIABILITY INSURANCE

DATE (MM/DD/YYYY)

8/25/2022

THIS CERTIFICATE IS ISSUED AS A MATTER OF INFORMATION ONLY AND CONFERS NO RIGHTS UPON THE CERTIFICATE HOLDER. THIS CERTIFICATE DOES NOT AFFIRMATIVELY OR NEGATIVELY AMEND, EXTEND OR ALTER THE COVERAGE AFFORDED BY THE POLICIES BELOW. THIS CERTIFICATE OF INSURANCE DOES NOT CONSTITUTE A CONTRACT BETWEEN THE ISSUING INSURER(S), AUTHORIZED REPRESENTATIVE OR PRODUCER, AND THE CERTIFICATE HOLDER.

IMPORTANT: If the certificate holder is an ADDITIONAL INSURED, the policy(ies) must have ADDITIONAL INSURED provisions or be endorsed. If SUBROGATION IS WAIVED, subject to the terms and conditions of the policy, certain policies may require an endorsement. A statement on this certificate does not confer rights to the certificate holder in lieu of such endorsement(s).

PRODUCER Arthur J. Gallagher Risk Management Services, Inc. 1601 Alliant Avenue Louisville KY 40299	CONTACT NAME: Terri Cook	
	PHONE (A/C, No, Ext): 502-716-7856	FAX (A/C, No): 502-716-7909
E-MAIL ADDRESS: terri_cook@ajg.com		
INSURER(S) AFFORDING COVERAGE		NAIC #
INSURER A : Zurich American Insurance Company		16535
INSURER B : AXIS Surplus Insurance Company		26620
INSURER C :		
INSURER D :		
INSURER E :		
INSURER F :		

INSURED KOCHENT-01
 South Western Communications, Inc.
 4871 Rosebud Lane
 Newburg IN 47630

COVERAGES

CERTIFICATE NUMBER: 1989799708

REVISION NUMBER:

THIS IS TO CERTIFY THAT THE POLICIES OF INSURANCE LISTED BELOW HAVE BEEN ISSUED TO THE INSURED NAMED ABOVE FOR THE POLICY PERIOD INDICATED. NOTWITHSTANDING ANY REQUIREMENT, TERM OR CONDITION OF ANY CONTRACT OR OTHER DOCUMENT WITH RESPECT TO WHICH THIS CERTIFICATE MAY BE ISSUED OR MAY PERTAIN, THE INSURANCE AFFORDED BY THE POLICIES DESCRIBED HEREIN IS SUBJECT TO ALL THE TERMS, EXCLUSIONS AND CONDITIONS OF SUCH POLICIES. LIMITS SHOWN MAY HAVE BEEN REDUCED BY PAID CLAIMS.

INSR LTR	TYPE OF INSURANCE	ADDL INSD	SUBR WVD	POLICY NUMBER	POLICY EFF (MM/DD/YYYY)	POLICY EXP (MM/DD/YYYY)	LIMITS
A	<input checked="" type="checkbox"/> COMMERCIAL GENERAL LIABILITY <input type="checkbox"/> CLAIMS-MADE <input checked="" type="checkbox"/> OCCUR GEN'L AGGREGATE LIMIT APPLIES PER: <input checked="" type="checkbox"/> POLICY <input checked="" type="checkbox"/> PROJECT <input checked="" type="checkbox"/> LOC OTHER:			GLO 0244268-03	3/1/2022	3/1/2023	EACH OCCURRENCE \$ 2,000,000 DAMAGE TO RENTED PREMISES (Ea occurrence) \$ 1,000,000 MED EXP (Any one person) \$ 10,000 PERSONAL & ADV INJURY \$ 1,000,000 GENERAL AGGREGATE \$ 4,000,000 PRODUCTS - COMP/OP AGG \$ 4,000,000 \$
A	<input checked="" type="checkbox"/> AUTOMOBILE LIABILITY <input checked="" type="checkbox"/> ANY AUTO <input type="checkbox"/> OWNED AUTOS ONLY <input type="checkbox"/> SCHEDULED AUTOS NON-OWNED AUTOS ONLY <input type="checkbox"/> HIRED AUTOS ONLY			BAP 0244269-03	3/1/2022	3/1/2023	COMBINED SINGLE LIMIT (Ea accident) \$ 2,000,000 BODILY INJURY (Per person) \$ BODILY INJURY (Per accident) \$ PROPERTY DAMAGE (Per accident) \$ \$
B	<input type="checkbox"/> UMBRELLA LIAB <input checked="" type="checkbox"/> OCCUR <input checked="" type="checkbox"/> EXCESS LIAB <input type="checkbox"/> CLAIMS-MADE <input type="checkbox"/> DED <input checked="" type="checkbox"/> RETENTION \$ 0			P-001-000288768	3/1/2022	3/1/2023	EACH OCCURRENCE \$ 3,000,000 AGGREGATE \$ 3,000,000 \$
A	<input checked="" type="checkbox"/> WORKERS COMPENSATION AND EMPLOYERS' LIABILITY ANY PROPRIETOR/PARTNER/EXECUTIVE OFFICER/MEMBER EXCLUDED? (Mandatory in NH) If yes, describe under DESCRIPTION OF OPERATIONS below			WC 0244267-03	3/1/2022	3/1/2023	<input checked="" type="checkbox"/> PER STATUTE <input type="checkbox"/> OTHER E.L. EACH ACCIDENT \$ 1,000,000 E.L. DISEASE - EA EMPLOYEE \$ 1,000,000 E.L. DISEASE - POLICY LIMIT \$ 1,000,000

DESCRIPTION OF OPERATIONS / LOCATIONS / VEHICLES (ACORD 101, Additional Remarks Schedule, may be attached if more space is required)
 OTHER EXCESS LIABILITY

Excess Liability-Westfield Specialty Insurance Company
 Policy # XSL-00004XW
 3/1/22-3/1/23
 Limits Shown Are Excess of the Axis \$3,000,000 Umbrella
 \$5,000,000 Each Occurrence Limit
 \$5,000,000 General Aggregate Limit
 See Attached...

CERTIFICATE HOLDER**CANCELLATION**

Hickman County School System
 115 Murphree Avenue
 Centerville TN 37033

SHOULD ANY OF THE ABOVE DESCRIBED POLICIES BE CANCELLED BEFORE THE EXPIRATION DATE THEREOF, NOTICE WILL BE DELIVERED IN ACCORDANCE WITH THE POLICY PROVISIONS.

AUTHORIZED REPRESENTATIVE

© 1988-2015 ACORD CORPORATION. All rights reserved.



ADDITIONAL REMARKS SCHEDULE

AGENCY Arthur J. Gallagher Risk Management Services, Inc.		NAMED INSURED South Western Communications, Inc. 4871 Rosebud Lane Newburg IN 47630	
POLICY NUMBER		EFFECTIVE DATE:	
CARRIER	NAIC CODE		

ADDITIONAL REMARKS

THIS ADDITIONAL REMARKS FORM IS A SCHEDULE TO ACORD FORM,
FORM NUMBER: 25 **FORM TITLE:** CERTIFICATE OF LIABILITY INSURANCE

\$5,000,000 Products & Completed Operations Aggregate Limit
 Excess Liability-Everest Indemnity Insurance Company
 Policy # XC1EX00464-221
 3/1/22-3/1/23
 Limits Shown Are Excess of the Axis and Westfield \$8,000,000 Umbrella's
 \$7,000,000 Each Occurrence Limit
 \$7,000,000 General Aggregate Limit
 \$7,000,000 Products & Completed Operations Aggregate Limit



STATE OF TENNESSEE
DEPARTMENT OF
COMMERCE AND INSURANCE



SOUTH WESTERN COMMUNICATIONS, INC.

382071

ID NUMBER: 29581
LIC STATUS: ACTIVE
EXPIRATION DATE: September 30, 2023

BOARD FOR LICENSING CONTRACTORS
CONTRACTOR

THIS IS TO CERTIFY THAT ALL REQUIREMENTS
OF THE STATE OF TENNESSEE HAVE BEEN MET

SOUTH WESTERN COMMUNICATIONS, INC.
4871 ROSEBUD LANE
NEWBURGH, IN 47630

State of Tennessee

382071

12717913

BOARD FOR LICENSING CONTRACTORS
CONTRACTOR

SOUTH WESTERN COMMUNICATIONS, INC.

This is to certify that all requirements of the State of Tennessee have been met.

ID NUMBER: 29581
LIC STATUS: ACTIVE
EXPIRATION DATE: September 30, 2023
UNLIMITED; CE



IN-1313
DEPARTMENT OF
COMMERCE AND INSURANCE

BOARD FOR LICENSING CONTRACTORS

AREAS OF CERTIFICATION/MONEY LIMITS

UNLIMITED; CE

Hickman County HS Auditorium

Sound System

Speakers

Sound system to consist of all JBL speakers. SWC will keep the two SRX800 speakers that are left and right of stage in place. Two new SRX 18 inch subwoofers will be added to the left and right of stage adjacent to the existing SRX800 main speakers. The 4 side wall Peavey speakers will be removed and changed out to JBL Architectural series dual 8 inch full range speakers (4) with wall brackets.

Amplifiers & Signal Processing

SWC to install 2 new Lab Gruppen 1200w 2 channel amplifiers (Mains and subs) and two 800w Lab Gruppen amps for the delay side speakers. The existing Crown DCI amp can be utilized to run any stage monitors if needed. Amplifiers will be moved to the room behind the mix area into a new Middle Atlantic equipment rack with sequencing and power conditioning. Customer will be responsible for provide 3 dedicated 15 amp circuits to power the new equipment. A new Symetrix 8x8 Digital audio processor will be installed to provide signal processing such as equalization, crossover, delay, etc.

Digital Mixer

A new 24 channel Allen & Heath QU 24C mixer will be installed at the mix position. Mixer has ability to connect to customer provided IPAD. for remote control of mixer. Main features include:

- Inputs: 24 Mono / 3 Stereo
- Mixes: 4 Mono / 5 Stereo / LR
- Matrix: 2 Stereo
- 32x30 USB Audio Interface
- Comprehensive Channel Processing and FX
- Intuitive Interface with Full Color Touchscreen

A new digital snake is included in the price and will replace the Horizon wall mounted snake box on the side stage. The snake is a 16 x8 channel box to give you inputs for any stage hardwire mics or other inputs or monitor aux outputs. The existing rack sitting by the mixer will be removed to free up tabletop space. A dedicated 110VAC outlet will be required to power the mic snake and wireless mic receivers. Preferred the outlet to be on the same breaker box and phase as the audio amplifiers at rear of room.

Wireless Mics

12 new Audix wireless mic receivers with 12 belt packs and flesh colored headset mics (Provdor Series equivalents to the Countryman E6 elements) to be installed in new wall mounted equipment rack on side stage. 2 additional belt packs with lapel mics and 2 handheld transmitters to be provided for connection to the 12 receivers. An antenna distribution system will be added with directional paddles for optimal signal reception.

SWC to provide a line diagram of the system as installed and system training at completion.



SRX818S

18" Passive Subwoofer System

Key Features:

- ▶ Premium JBL Transducer with extremely high power handling
- ▶ Rugged, versatile enclosures
- ▶ Full Integration into Audio Architect
- ▶ Maximum SPL Output: 135dB
- ▶ System Type: Passive 18", subwoofer
- ▶ Frequency Range (-10dB): 28Hz - 150Hz
- ▶ Frequency Response (-3dB): 45Hz - 150Hz
- ▶ JBL Professional Tunings available for Crown I-Tech HD
- ▶ Accepts JBL WK-45 Caster Kit
- ▶ M20 Threaded Pole Cup
- ▶ Indexing feet for stacking and cardioid deployment
- ▶ Lightweight poplar plywood cabinets made structurally sound with tongue and groove joints and protected by JBL's tour proven DuraFlex™ finish

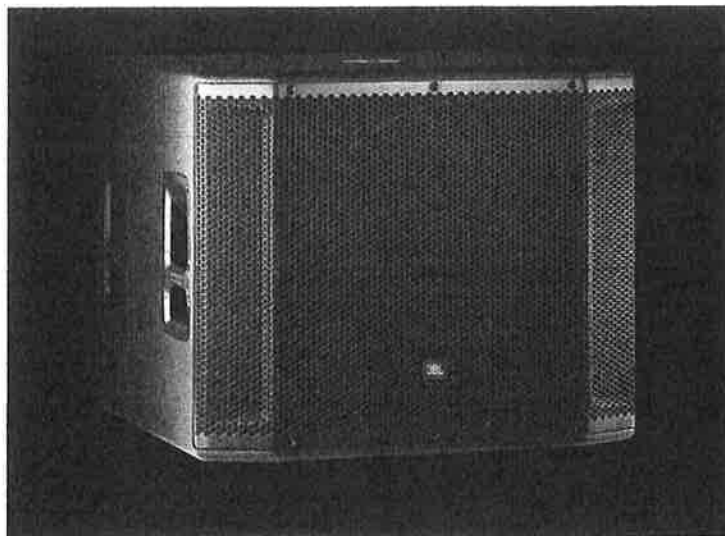

Applications:

- ▶ The SRX818S is a passive portable subwoofer in the SRX800 series from JBL Professional. It has been designed to deliver class leading performance in a variety of applications including small and medium sized installations and tours. When used in conjunction with the SRX800 full range systems and other SRX800 subs, SRX818S in an integral part of a high performance, fully configurable loudspeaker system.
- ▶ With and M20 pole cup and indexed feet, the SRX818S can be configured for a variety of applications, including being stacked in a cardioid configuration for large shows on stage.
- ▶ For incredible extended low frequency response, the SRX818S uses an 18-inch woofer with JBL's patented Differential Drive Technology for reduced weight while maximizing power amp efficiency. 3" voice coils and dual ferrite drivers deliver exceptionally low distortion and extended low frequency response.
- ▶ The SRX818S is supported with tunings for Crown I-Tech HD amplifiers, which can be controlled as part of a comprehensive system with Harman Audio Architect.

With best in class 18mm wooden enclosures, 14 gauge steel grilles, and JBL's Patented DuraFlex finish, SRX800 speakers are built to last and withstand a lifetime of hard tour use.

Specifications:

System:	
System Type:	Passive 18", subwoofer system
Maximum SPL Output:	135 dB
Frequency Range (-10 dB):	28Hz - 150Hz
Frequency Response (-3 dB):	45Hz - 150Hz
Power:	
System Power Rating:	2400W Peak, 1200W Program, 600W Continuous
Nominal Impedance:	8 Ohm
Connectors:	NL4 Input, NL4 Loop-thru (+/-1 or +/-2 Selectable)
Operational Modes:	Passive
Speaker:	
LF Driver:	2279H
Crossover Frequency:	80hz
Enclosure:	
Material:	18mm plywood
Suspension/Mounting:	M20 Threaded Pole Mount
Handles:	4
Finish:	Obsidian Duraflex™ finish
Grille:	Powder coated, Obsidian, 14-gauge perforated steel with acoustically transparent black cloth backing
Dimensions (L x W x H):	26.89" x 26.92" x 22.62" (683mm x 684mm x 575mm)
Weight:	78.0 lbs (35.4 kg)

SRX818S 18" Passive Subwoofer System

Frequency Response (Main Tuning)

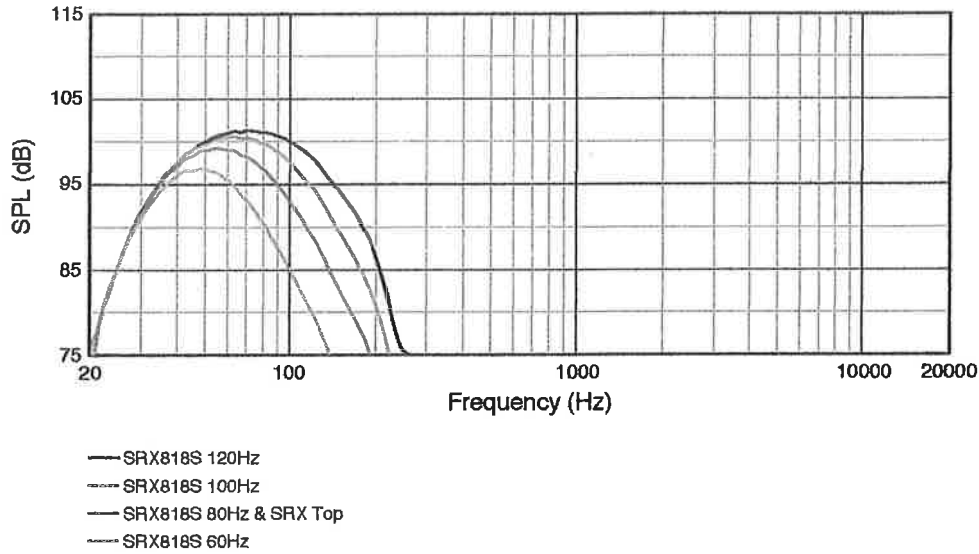

Frequency Response (80Hz)

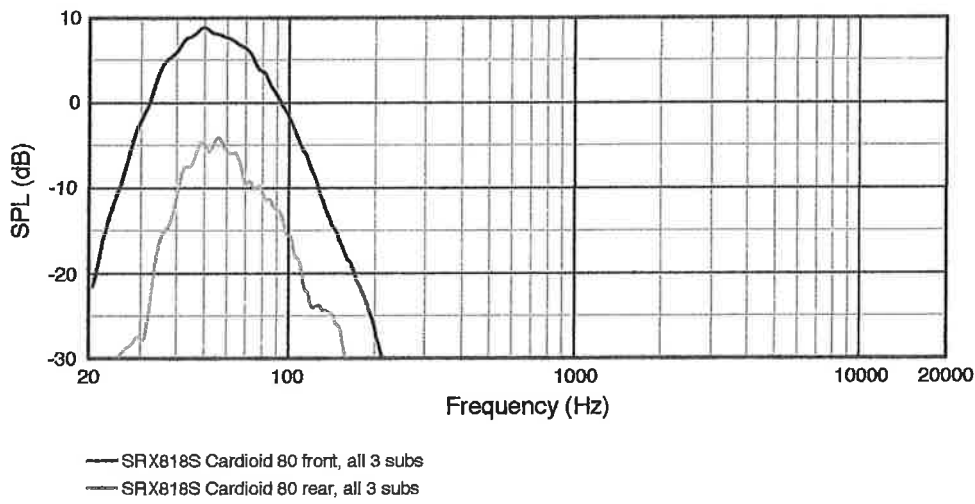

► SRX818S 18" Passive Subwoofer System

Dimensions:

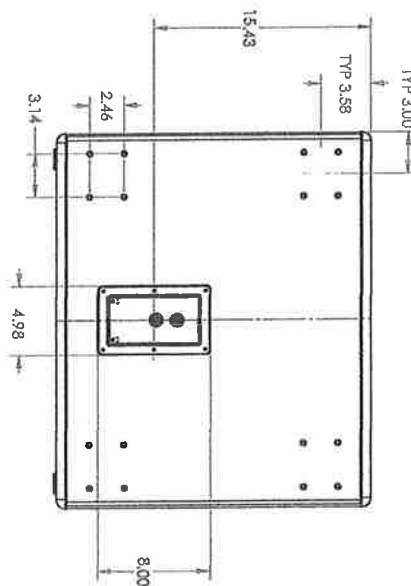
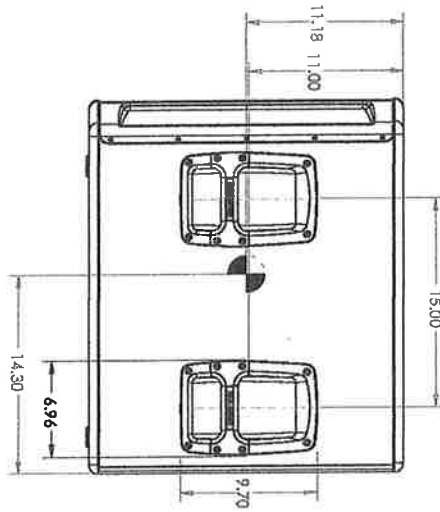
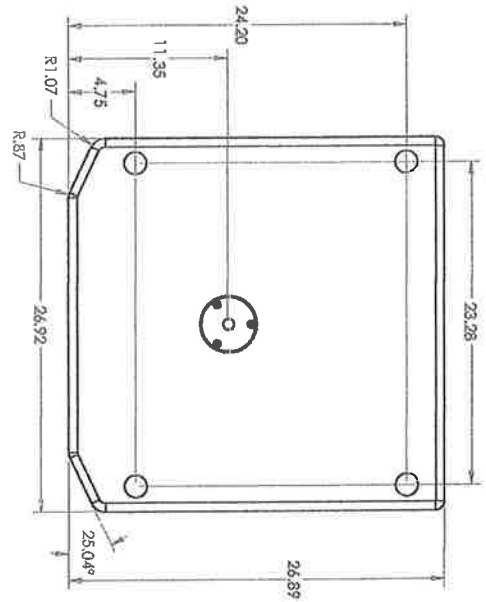
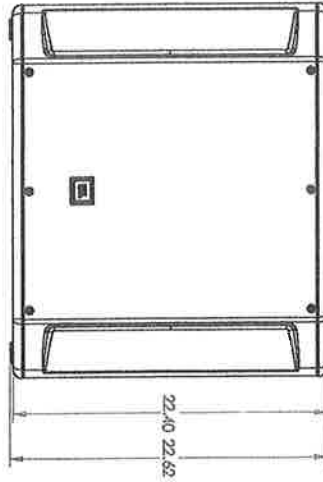
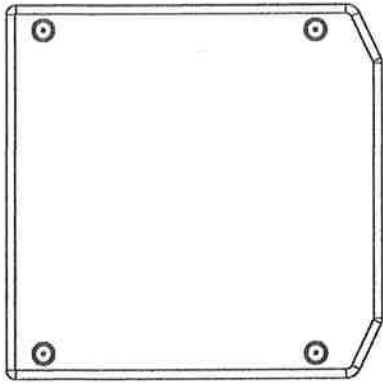

JBL Professional
 8500 Balboa Boulevard, P.O. Box 2200
 Northridge, California 91329 U.S.A.
 © Copyright 2015 JBL Professional
www.jblpro.com



AC28/95

Compact 2-way Loudspeaker System with 2 - 8" LF

Key Features:

- ▶ Compact enclosure
- ▶ Dual 205 mm (8 in) LF transducers
- ▶ 90° x 50° Progressive Transition™ Field Rotatable Waveguide with a 25 mm (1 in) exit compression driver
- ▶ Dual Neutrik NLA connectors plus screw terminals
- ▶ Multiple Attachment Points for Ultimate Flexibility

Applications:

- ▶ Performing Arts Facilities
- ▶ Houses of Worship
- ▶ Sports Facilities
- ▶ Multi Media Spaces
- ▶ Retail Spaces
- ▶ Presentation Suites
- ▶ Educational Facilities
- ▶ Portable Audio-Visual Systems

The AC28/95 is a compact full-range loudspeaker system designed to provide maximum bandwidth and SPL in a single system package and yet be visually unobtrusive. The enclosure design allows for installation very close to walls and ceilings making it an ideal choice for under balcony, column, or wall mounting. The high frequency device is a 1" exit compression driver integrated into a newly designed 90° x 50° rotatable PT™ (Progressive Transition) waveguide providing even coverage throughout the intended listening area. The combination exhibits smooth power response resulting in extremely natural voicing. The AC28/95 utilizes dual 8" Symmetrical Field Geometry (SFG™) LF Transducers each with a copper-clad aluminum edge wound 2.5" voice coil and a copper-clad pole piece that improves performance by reducing voice coil inductance and distortion. Filtered Array Technology (FAT™) is utilized to independently control the dual woofers for magnitude and phase response resulting in smoother power response and constant coverage. To further enhance the flexibility and performance of the AC28/95, JBL engineers have designed a user selectable crossover network to ensure complete accuracy of the high-frequency coverage pattern regardless of whether the loudspeaker is being used in the vertical or in the horizontal orientation when the horn is rotated.

The rugged multiply hardwood enclosure is designed to work in the vertical plane as well as in the horizontal plane. Mounting points are provided for an optional U-bracket and for an OmniMount® type bracket. The AC28/95 is also equipped with attachment points located on the bottom of the enclosure for a stand mount accessory.

The rugged plywood enclosure features JBL's textured DuraFlex™ finish and is equipped with a heavy duty powder coated steel, foam-backed grille.



Specifications:

System:	
Frequency Range (-10 dB):	53 Hz - 20 kHz
Frequency Response (+/-3 dB):	65 Hz - 20 kHz
Horizontal Coverage:	90°
Vertical Coverage:	50°
Directivity Factor (Q):	8.9 (avg. 500 Hz - 16 kHz)
Directivity Index (DI):	7.5 dB (avg. 500 Hz - 16 kHz)
System Sensitivity ¹ :	94 dB SPL/1W/1m
Rated Maximum SPL (1m) ² :	120 dB
System Nominal Impedance:	8 Ohms
Long-Term System Power Rating ³ :	
(Continuous/Program/Peak):	375 W / 750 W / 1500 W
AES Standard Power Rating ⁴ :	700 W
Crossover:	2 kHz
Transducers:	
Low Frequency Driver:	2 x JBL 228J, 205 mm (8 in) SFG™ driver with 64 mm (2.5 in) edge wound voice coil
High Frequency Driver:	1 x 2408H-1 25 mm (1 in) exit compression driver, 38 mm (1.5 in) voice coil
High-Frequency Waveguide:	PT-D95HF-1 (field rotatable)
Physical:	
Enclosure:	12 mm and 15 mm exterior grade multi-ply hardwood plywood
Suspension Attachment:	6 x M8 points; 1 top, 3 bottom, 2 rear. 4 x M8 rear for MultiMount® MM-120-BT.
Finish:	Black DuraFlex™ finish. White (-WH) available upon request.
Optional Weather Resistant Versions ⁵ :	WRC & WRX available upon request
Grille:	Powder coated 16 gauge perforated steel, acoustically transparent foam backing (grille cloth backing on white units)
Input Connectors:	Neutrik Speakone NLA (2 wired in parallel), plus CE-compliant covered barrier strip terminals. Barrier terminals accept up to 5.2 sq mm (10 AGW) wire or max width 9 mm (.375 in) spade lugs. NLA's +1/-1 in parallel with barrier strip (+2/-2 loop through).
Environmental Specifications:	Mil-Std 810; IPx3 per IEC529. For higher environmental ratings, use WRC or WRX.
Dimensions (H x W x D):	679.5 x 237.5 x 254.0 mm (26.8 x 9.4 x 10.0 in)
Weight:	18.6 kg (40.9 lb)
Optional Accessories:	MTU-28 U-Bracket 365469-001, M8 x 38mm Tee Knob Thumbscrew Kit for use with BMB-200k or K&M 195/8 stand mount accessory.

¹On axis SPL measured in far field and referenced to 1 meter by inverse square law. Average from 300 Hz to 16 kHz.

²Calculated based on system sensitivity and continuous power handling.

³IEC shaped pink noise, 6 dB crest factor, 100 hour duration.

⁴AES standard 2 hour duration, with IEC system noise spectrum.

⁵WRC for outdoor placement where the loudspeaker will be sheltered from direct exposure to the elements. WRX for direct exposure or extreme environments, such as tropical or beach, or in areas with salt air, extreme high humidity or rapid changes in temperatures. See WRC/WRX configuration sheet for details.

▶ AC28/95 Compact 2-way Loudspeaker System with 2 - 8" LF

Beamwidth

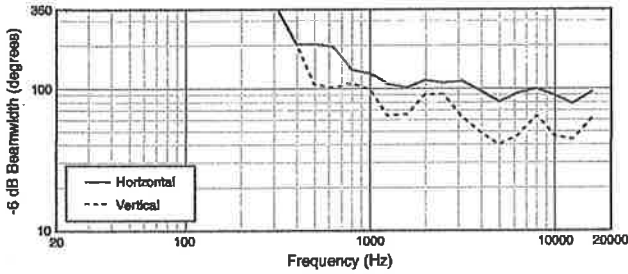

Vertical Orientation



Directivity Index, Q

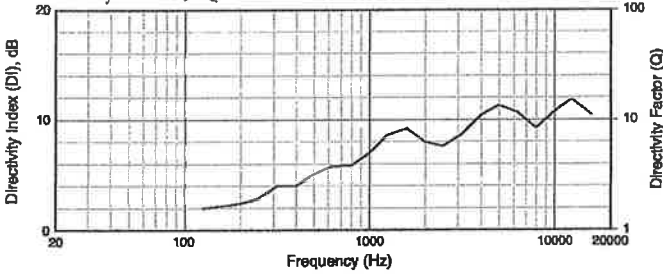

Horizontal Off-Axis Frequency Response

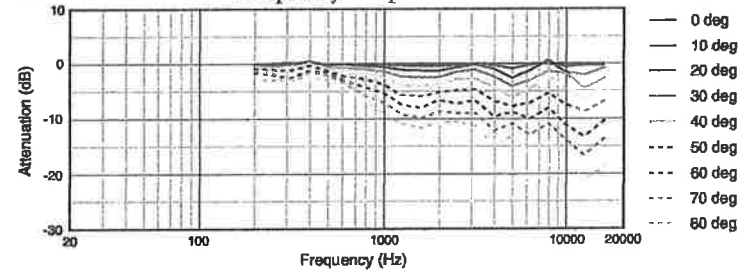

Frequency Response, 1W/1m

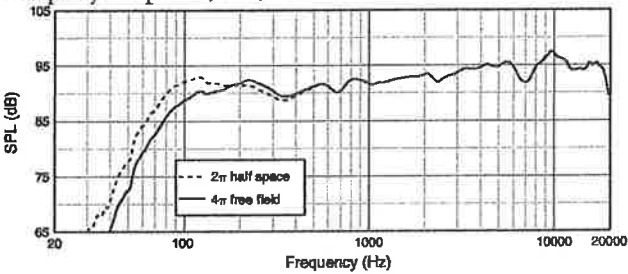

Vertical Up Off-Axis Frequency Response

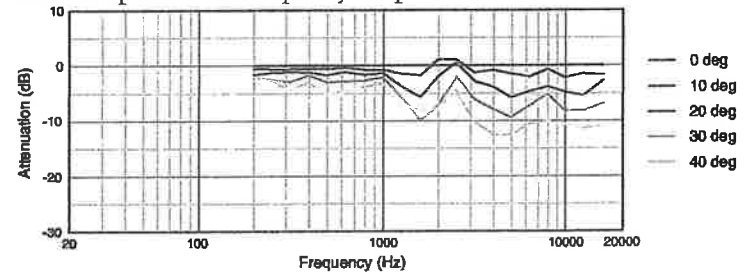

Impedance

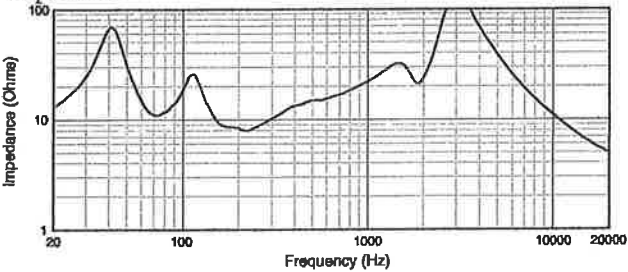

Vertical Down Off-Axis Frequency Response

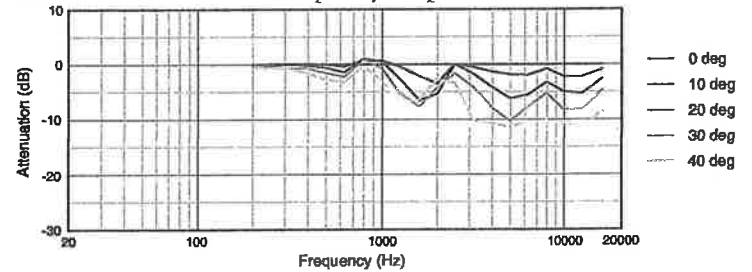

Measurements obtained in full passive crossover mode with no signal processing. Graphs are from unaltered measured data.

Beamwidth

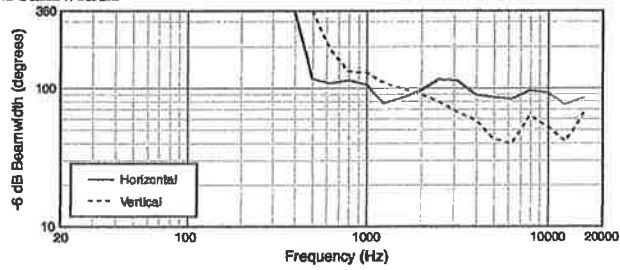

Horizontal Orientation

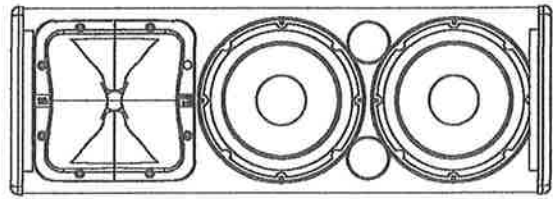

Directivity Index, Q

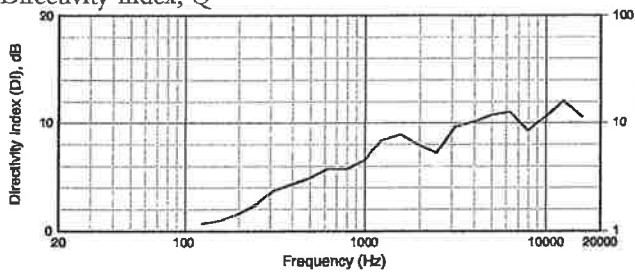

Vertical Off-Axis Frequency Response

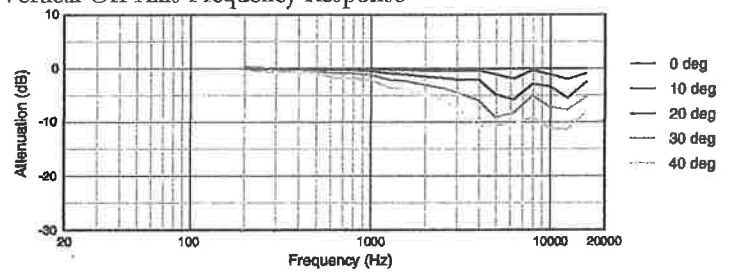

Frequency Response, 1W/1m

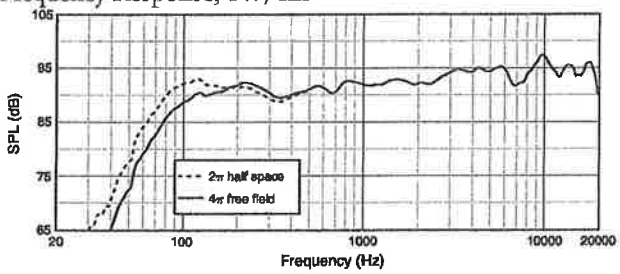

Horizontal Right Off-Axis Frequency Response

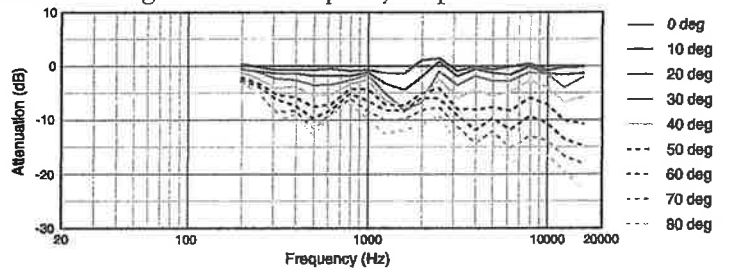

Impedance

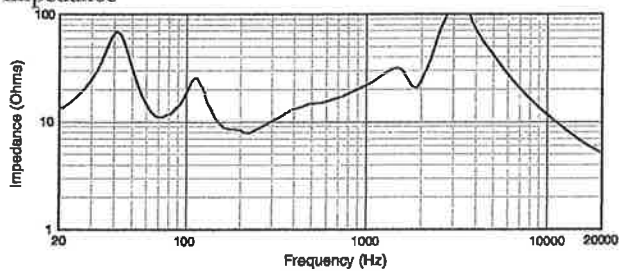

Horizontal Left Frequency Response

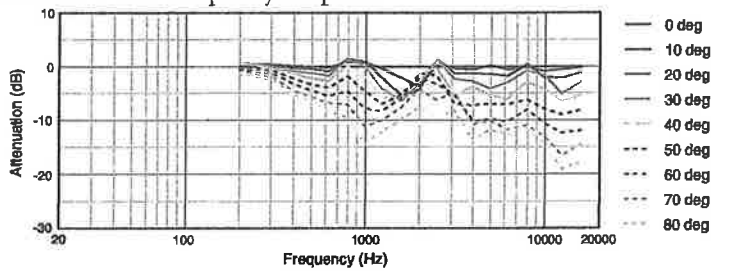

Measurements obtained in full passive crossover mode with no signal processing. Graphs are from unaltered measured data.

▶ AC28/95 Compact 2-way Loudspeaker System with 2 - 8" LF

Dimensions

Dimensions in "in" (mm)

For more detailed dimensional information, refer to Application Data Sheet.

For AE & AE Compact Series WRC and WRX versions please visit the JBL Pro website at <http://www.jblpro.com/www/products/installed-sound/ae-series#.V63kVfkrLIV> to download Drawings.

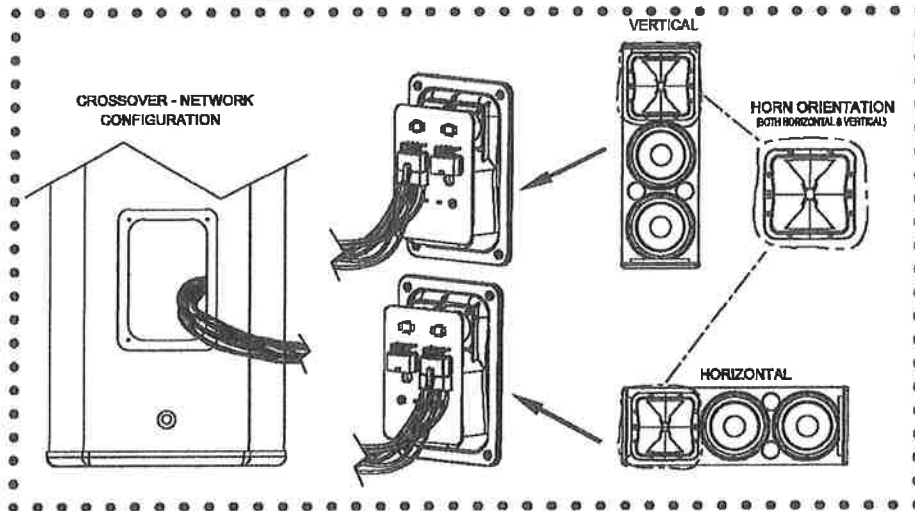
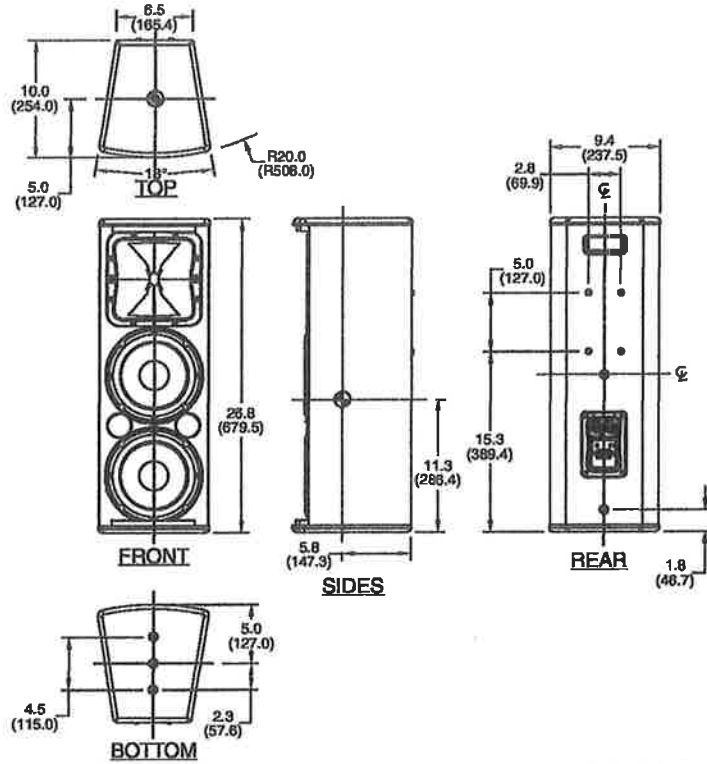

Attachment Points For Third Party Accessories:

Bottom: Ultimate Support™ BMB-200K; Konig & Meyer 195/8

Rear: MultiMount® MM-120-BT; Konig & Meyer 24480



JBL Professional
8500 Balboa Boulevard, P.O. Box 2200
Northridge, California 91329 U.S.A.

■ A Harman International Company
© Copyright 2016 JBL Professional

SS AC28/95
CRP 5M
8/16

QU-24

DIGITAL MIXER

The Qu digital mixer series is designed to be simple for any user to operate.

The Qu-24 has 24+1 faders in 3 layers, 24 mono & 3 stereo DSP channels, plus 4FX units with their own dedicated return, resulting in a total of 38 processing channels. 4 mono and 3 stereo auxiliaries and 2 stereo subgroup mix busses are available.

Every function has a dedicated hardware button to complement the touchscreen.

A dSNAKE remote audio port allows Qu-24 to connect to AB & AR AudioRacks as well the ME personal monitor system.

16 Channels of automatic mic mixing, 3 user levels, USB multi-track audio and a customisable fader layout make the Qu-24 a powerful mixer.

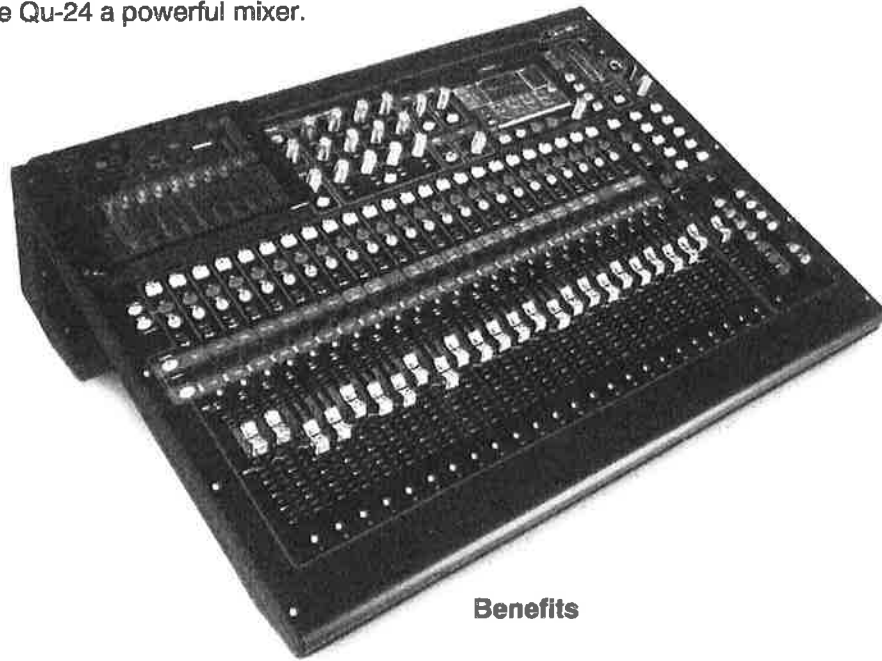

Key Features

- 24 Mono + 3 stereo inputs
- 16 channels of Auto Mic Mixing
- dSNAKE for AB & AR remote I/O
- External control drivers available
- DAW control
- 32x30 USB audio interface

Benefits

- 3 User levels
- Easy reset without data loss
- 4 Mono + 5 stereo mixes (3 auxes, 2 subgroups)
- Ducker on all inputs
- 25 faders
- Compatible with ME personal monitoring system

PSE9

Single Earset Microphone

The Provider Series PSE9 Earset Microphone is a low-profile, single-ear headworn microphone featuring a single ear design with replaceable cables. The PSE9 is built for exceptional sound quality around the popular Provider Series headset models. The PSE9 can be worn on the left or right side of the face and molded to fit any user.



Features

- Low Profile Look
- Can be molded and shaped
- Available in Black or Tan
- Available for Shure, Sennheiser, Audio Technica, EV and AKG



Specs

- Model: PSE9
- Element: Back Electret
- Polar Pattern: Omni-directional
- Frequency Response: 20-20,000 Hz
- Sensitivity: -46+3dB 1V/Pa
- SPL Max: 130 dB
- Cable: 1.4 mm
- Dimension: 3.5 mm

AP62 BP

WIRELESS MICROPHONE SYSTEM - R62 TWO CHANNEL TRUE DIVERSITY RECEIVER WITH TWO B60 BODYPACK TRANSMITTERS

A professional true diversity lavalier wireless system featuring the B60 bodypack transmitter. B60 bodypack transmitter. This bodypack may be used with any lavalier, head-worn, or instrument microphone in the Audix line, as well as guitar and bass.

A single space rackmount kit with BNC cables for front mounting antennas is included. Optional accessories include active directional antennas and antenna distribution systems for up to four systems (8 channels).

FREQUENCY RANGE

522 MHz - 586 MHz

FEATURES

R62 Two-Channel True Diversity Receiver

- 64 MHz Wide spectrum tuning receiver
- 2560 Tunable frequencies
- One-touch auto scan searches for clear channel
- One-touch sync links transmitter to the receiver via infrared beam

B60 Bodypack Transmitter

- 64 MHz Wide spectrum transmitter
- Durable metal housing
- 14 Hour run time - AA batteries



Prism: 0x0 4x4 8x8 12x12 16x16

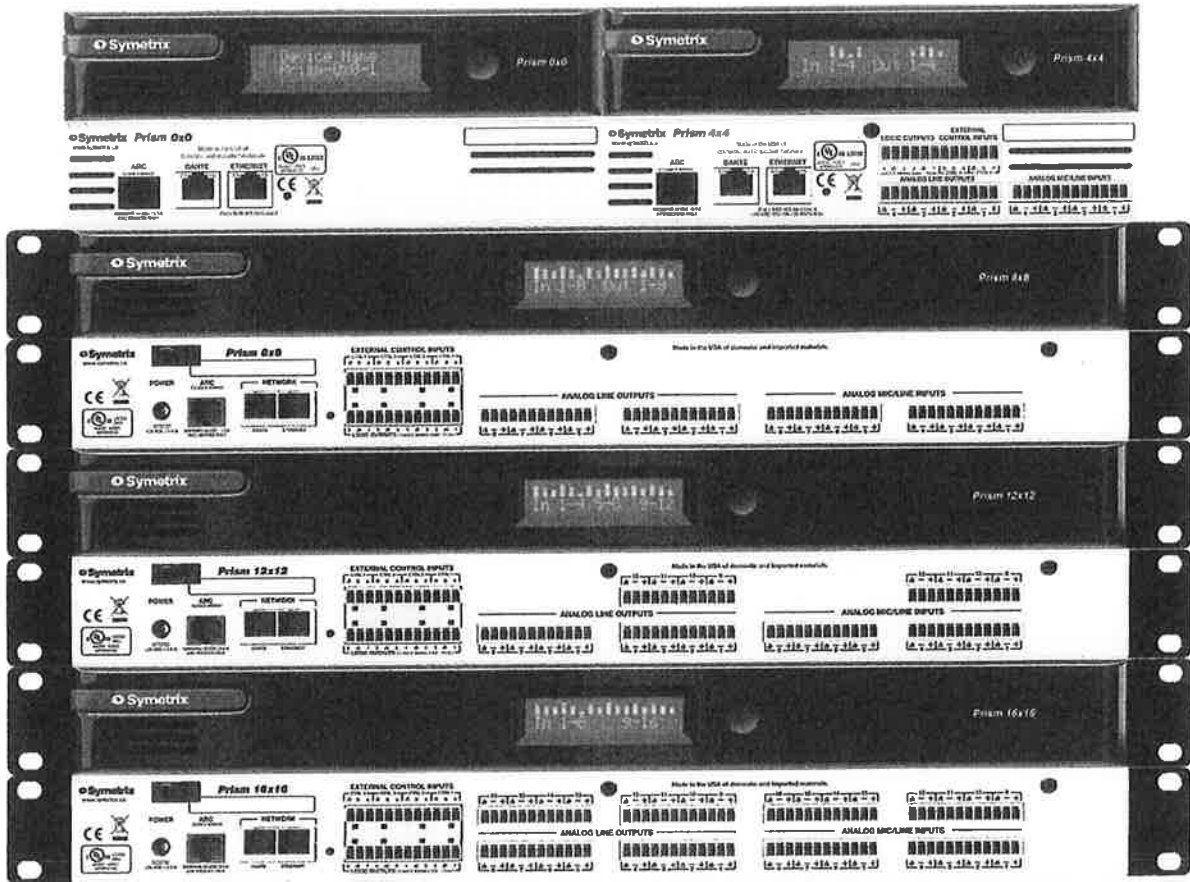

Prism 0x0, 4x4, 8x8, 12x12 and 16x16 DSPs provide sophisticated state of the art audio signal processing at price points that were unimaginable only a few short years ago. The same uncompromising analog and digital design found in the Symetrix top of the line DSPs is now available across the Prism family.

Dante™ in our DNA.

All Prism models are optionally available equipped with 64x64 Dante channels. Dante is an uncompressed multi-channel digital media technology. Symetrix designs and supports one, and only one, network audio protocol: Audinate's Dante. Symetrix and Dante provide the fastest way to implement, control and maintain a system of networked DSPs and accessories - including select third-party products.

Scale up.

Increase a Prism system's analog input and output count using Symetrix Dante-enabled xIn 4, xIO 4x4, xOut 4, xIn 12, and xOut 12 expanders.

Total design control.

Program Prism using Symetrix' award winning Composer open-architecture Windows CAD application.

Connect to the outside world.

Connect to Ethernet equipped touch panels, W Series wall remotes, and any of the Symetrix ARC wall panels including the ARC-3 with graphical menus and universal mounting options.

Form, fit and function.

Prism 8x8, 12x12 and 16x16 models are 19" x 1U. Prism 0x0 and 4x4 are 1/2 rack x 1U. (Surface and rack mount kits sold separately).

An embedded web server for status and control.

Prism's embedded web server displays analog I/O levels, diagnostics, and provides access to ARC-WEB, a remote interface accessible from any smart phone, tablet or computer. The embedded server is accessible using any popular web browser by entering Prism's local LAN, or publicly accessible IP address or its fully qualified domain name into the browser's address field.

Installed Sound DSP Quick Comparison															
	Mic/Line Inputs	Line Only Inputs	AEC Channels	Line Outputs	Expansion Slots	ARC Port	Control Inputs	Logic Outputs	Design Software	Dante	RS-232	10/100 Base-T Ethernet Ports	1000 Base-T Ethernet Ports	Power Supply	Form Factor
Edge	Up to 16	-	Up to 16	Up to 16	4	Yes	8 Closures 4 Pots	8	Composer	Optional	Yes	2	2	Internal and/or External	1U Full Rack
Radius NX 4x4	4	-	Up to 16	4	1	Yes	4 Closures 2 Pots	4	Composer	Optional	Yes	2	2	Internal	1U Full Rack
Radius NX 12x8	12	-	Up to 16	8	1	Yes	8 Closures 4 Pots	8	Composer	Optional	Yes	2	2	Internal	1U Full Rack
Prism 0x0	-	-	-	-	-	Yes	-	-	Composer	Yes	No	1	1	PoE+	1U Half Rack
Prism 4x4	4	-	-	4	-	Yes	4 Closures 2 Pots	4	Composer	Optional	No	1	1	PoE+	1U Half Rack
Prism 8x8	8	-	-	8	-	Yes	8 Closures 4 Pots	8	Composer	Optional	No	1	1	External	1U Full Rack
Prism 12x12	12	-	-	12	-	Yes	8 Closures 4 Pots	8	Composer	Optional	No	1	1	External	1U Full Rack
Prism 16x16	16	-	-	16	-	Yes	8 Closures 4 Pots	8	Composer	Optional	No	1	1	External	1U Full Rack
Jupiter 4	4	-	-	4	-	Yes	4 Closures 2 Pots	4	Jupiter	No	No	1	-	External	1U Full Rack
Jupiter 8	8	-	-	8	-	Yes	4 Closures 2 Pots	4	Jupiter	No	No	1	-	External	1U Full Rack
Jupiter 12	12	-	-	4	-	Yes	4 Closures 2 Pots	4	Jupiter	No	No	1	-	External	1U Full Rack
Zone Mix 761	4	8	-	6	-	Yes	4 Closures 2 Pots	4	761	No	Yes	1	-	External	1U Full Rack

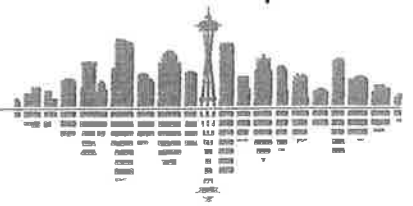



The Prism family is included in the Symetrix line of Dante™ enabled DSPs. Symetrix uses Dante, a multi-channel digital media networking technology, to interconnect multiple Symetrix DSPs, Symetrix I/O expanders, and select third-party Dante enabled devices. Prism is ideally suited for applications requiring powerful, extremely cost effective advanced signal processing coupled with a standardized means for future expansion.

- 64x64 Dante and powerful Symetrix DSP reduce overall system costs.
- Ultra low latency Dante network audio protocol uses standard IT infrastructure.
- Cost-effective processing, mixing, and routing for Dante-enabled end points.
- Configured using award winning Composer software. Controlled from W Series remotes, ARC wall panels, ARC-WEB and T Series touchscreens. Embedded web server enables remote metering and diagnostics.
- Compact ½ rack format. PoE+ injector included. Rack and surface mount kits sold separately.
- Front panel LCD provides configuration information, system status, and analog audio levels.

Electrical Specifications

ANALOG INPUTS	
Number of Inputs	None.
ANALOG OUTPUTS	
Number of Outputs	None.
SYSTEM	
Sampling Rate	48 kHz.
Processors	1 x Analog Devices SHARC 21489 @ 400 MHz SIMD.
Raw Processing Capacity	400 MIPS, 1.6 GFLOPS.
Delay Memory	174 mono seconds.
RS-485 Serial I/O	38.4 kbaud (default) 8 data bits, 1 stop bit, no parity, no flow control. May be broken out of ARC port.
Ethernet Cable	Standard CAT5e or CAT6, maximum device-to-device length = 100 meters.
Dante Cable	Standard CAT6, maximum device-to-device length = 100 meters.
ARC Cable	Standard CAT5, distance dependent upon load and number of devices. 8 Watts maximum power available.
Maximum Devices Per System	128 units per Site File.
Maximum Stored Presets	1000.



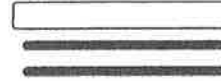
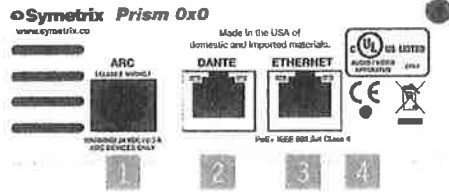

- 1 ARC:** Distributes power and RS-485 data to one or more ARC devices.
- 2 Dante:** 1000 Base-T Ethernet port provides 128 (64x64) channels of Dante network audio.
- 3 Ethernet:** 10/100 Base-T Ethernet port for Symetrix Composer host control, third-party accessory controllers over IP, and power. Features auto-crossover sensing for direct device-to-device connections.
- 4 Factory Reset Switch:** To be used under the supervision of technical support, it has the ability to reset the unit's network configuration and completely reset the unit to factory defaults.

Mechanical Specifications		
Items	Specifications	Remarks
Space Required	Half rack unit (WDH: 20.83 cm x 23.83 cm x 4.37 cm / 8.2 in. x 9.38 in. x 1.72 in.) Depth does not include connector allowance.	Allow at least 3 inches additional clearance for rear panel connections. Additional depth may be required depending upon your specific wiring and connections.
Electrical	PoE+ IEEE 802.3at Class 4, 7 Watts minimum to 25.5 Watts maximum. No line voltage switching required.	Note: Subject to change when actual power requirements are determined.
Ventilation	Maximum recommended ambient operating temperature is 30 C / 86 F.	Ensure that the left and right equipment sides are unobstructed (5.08 cm, 2 in minimum clearance). The ventilation should not be impeded by covering the ventilation openings with items such as newspapers, tablecloths, curtains, etc.
Certifications or Compliance	Safety: UL 60065, cUL 60065, IEC 60065. EMC: "Class A" device (applies to all of the following) EN 55032, EN 55103-2, EN 61000-3-2, EN 61000-3-3, FCC Part 15, ICES-003. Environmental: RoHS.	
Shipping Weight	5.1 lbs. (2.3 kg)	

Architect and Engineer Specifications: Prism 0x0.

The half rack device shall provide network audio processing, mixing, and routing using the Dante™ protocol with a capacity of 128 (64x64) channels. The connector shall be 1000 Base-T RJ45 utilizing CAT6 cable.

A designer software application shall be provided that operates on a Windows computer, with network interface installed, running Windows® 7 or higher operating system. Computer connection for configuration shall be via the device's rear panel Ethernet connector. All internal processing shall be digital (DSP). Available DSP components shall include (but not be limited to) various forms of: mixers, equalizers, filters, crossovers, dynamics/ gain controls, routers, delays, remote controls, meters, generators, and diagnostics.

The front panel shall include a LCD and momentary switch. The display shall indicate unit name, IP address, MAC address, Site File version, and fault messages and can be switched between system overview and meter displays.

External control shall include dedicated software screens as well as preset selection, level control and muting using the optional ARC wall panel remote controls via industry-standard CAT5 cable with RJ45 connectors. A built-in web server shall provide four instances of ARC-WEB, which allows for user control from nearly any web browser or mobile device. All program memory shall be non-volatile and provide program security should power fail. The device shall provide an on board real time clock to facilitate automatic, timed changing of presets and may sync to NTP. Third-party control systems may interface over IP using a published ASCII control protocol.

Internal processing shall be 32-bit or 40-bit floating point, 48 kHz.

The device shall be powered over Ethernet (PoE+) by an IEEE 802.3at Class 4 standard compliant switch, or the included injector. The device can be powered from either the Dante or Ethernet Port. The device shall meet UL/CSA and CE safety requirements and comply with CE and FCC Part 15 emissions limits. The device shall be RoHS compliant. The chassis shall be constructed of cold rolled steel, and may be surface mounted or mount into a standard 19" 1U EIA rack using an available bracket or rack tray. The device shall be a Symetrix Prism 0x0.

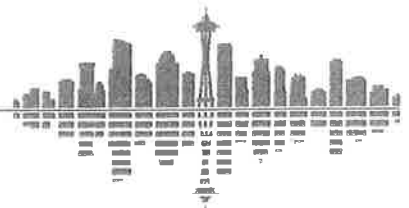



The Prism family is the workhorse series in Symetrix's DSP lineup. With all the core features needed for the most common applications, it provides powerful processing with flexible control, and optional Dante networking. Prism is ideally suited for applications requiring powerful, extremely cost effective advanced signal processing coupled with a standardized means for future expansion.

- 4 analog in and out, and powerful Symetrix DSP reduce overall system costs.
- Optional 64x64 Ultra low latency Dante network audio protocol uses standard IT infrastructure.
- Industry leading analog and A/D/D/A performance, 48 volt phantom mic power.
- Configured using award winning Composer software. Controlled from W Series remotes, ARC wall panels, ARC-WEB and T Series touchscreens. Embedded web server enables remote metering and diagnostics.
- Compact ½ rack format. PoE+ injector included. Rack and surface mount kits sold separately.
- Front panel LCD provides configuration information, system status, and analog audio levels.

Electrical Specifications	
ANALOG INPUTS	
Number of Inputs	Four (4) switchable balanced mic or line level.
Connectors	3.81 mm terminal blocks.
Nominal Input Level	+4 dBu.
Maximum Input Level	+23 dBu.
Mic Pre-amp gain	0, 12, 24, 44 or 54 dB switchable with ± 24 dB trim.
Mic Pre-amp EIN	< -125dB with 150 ohm source impedance. 22.4 kHz BW.
CMRR	> 79 dB @ 1 kHz, unity gain.
Input impedance	8k Ohms balanced, 4k Ohms unbalanced.
Phantom power (per input)	+48 VDC, 10 mA maximum.
Dynamic range	> 113 dB, A-weighted.
THD+Noise	< -100 dB; 22.4 kHz BW, unweighted; 1 kHz @ +15 dBu with 0 dB gain. Course gain is set to +4dBu.
A to D Latency	0.28 mS.
ANALOG OUTPUTS	
Number of Outputs	Four (4) balanced line level.
Connectors	3.81 mm terminal blocks.
Nominal Output Level	+4 dBu with 20 dB of headroom.
Maximum Output Level	+24 dBu (+22.8 dBu into a 2k Ohm minimum load).
Output Impedance	300 Ohms balanced, 150 Ohms unbalanced.
Dynamic Range	> 117 dB, A-weighted.
THD+Noise	< -97 dB; 22.4 kHz BW, unweighted; 1 kHz, 0 dB gain +8dBu output.
D to A Latency	0.60 mS.
SYSTEM	
Sampling Rate	48 kHz.
Frequency Response (A/D/A)	20 Hz – 20 kHz, ± 0.5 dB.
Dynamic Range (A/D/A)	> 113 dB, A-weighted.
Channel Separation (A/D/A)	> 110 dB @ 1 kHz, +24 dBu.
THD+Noise	< 95 dB (22.4 kHz BW, un-weighted); 1 kHz @ +15 dBu with 0 dB gain.
Latency (A/D/A)	1.04 mS, inputs routed to outputs.
Processors	1 x Analog Devices SHARC 21489 @ 400 MHz SIMD.
Raw Processing Capacity	400 MIPS, 1.6 GFLOPS.
Delay Memory	174 mono seconds.
Analog control inputs	0-3.3 VDC.



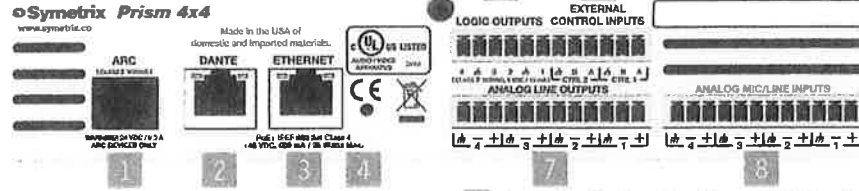

- 1 ARC:** Distributes power and RS-485 data to one or more ARC devices.
- 2 Dante:** 1000 Base-T Ethernet port provides 128 (64x64) channels of Dante network audio. Requires optional factory installed Dante card.
- 3 Ethernet:** 10/100 Base-T Ethernet port for Symetrix Composer host control, third-party accessory controllers over IP, and power. Features auto-crossover sensing for direct device-to-device connections.
- 4 Factory Reset Switch:** To be used under the supervision of technical support, it has the ability to reset the unit's network configuration and completely reset the unit to factory defaults.
- 5 Logic Outputs:** Four (4) logic outputs with two (2) paired common ground pins. Logic Outputs go low (0V) when active, and are internally pulled high (5V) when inactive and can drive external LED indicators directly.
- 6 External Control Inputs:** Four (4) analog control inputs able to be used as 2 potentiometer inputs or as 4 switch inputs (+3.3 VDC reference voltage supplied).
- 7 Analog Line Outputs:** Four (4) balanced analog line level audio outputs, with individually software-controllable +/- 24 dB of digital trim and mute.
- 8 Analog Mic/Line Inputs:** Four (4) balanced analog audio inputs, with individually software-controllable pre-amp gain (reference levels of -50 dBu, -40 dBu, -20 dBu, -10 dBV and +4 dBu), +/- 24 dB of digital trim, phantom power, signal inversion and mute.

SYSTEM (continued)	
Recommended External Control Potentiometer	10k Ohm, linear.
Logic Outputs	Low (0V) when active, pulled high (5V) when inactive.
Logic Output Maximum External Power Supply Voltage	24 VDC.
Logic Output Maximum External Power Supply Current Sinking	50 mA.
Logic Output Maximum Output Current	10 mA.
RS-485 Serial I/O	38.4 kbaud (default) 8 data bits, 1 stop bit, no parity, no flow control. May be broken out of ARC port.
Ethernet Cable	Standard CAT5e or CAT6, maximum device-to-device length = 100 meters.
Dante Cable	Standard CAT6, maximum device-to-device length = 100 meters.
ARC Cable	Standard CAT5, distance dependent upon load and number of devices. 8 Watts maximum power available.
Maximum Devices Per System	128 units per Site File.
Maximum Stored Presets	1000.

Mechanical Specifications		
Items	Specifications	Remarks
Space Required	Half rack unit (WDH: 20.83 cm x 23.83 cm x 4.37 cm / 8.2 in. x 9.38 in. x 1.72 in.) Depth does not include connector allowance.	Allow at least 3 inches additional clearance for rear panel connections. Additional depth may be required depending upon your specific wiring and connections.
Electrical	PoE+ IEEE 802.3at Class 4, 25.5 Watts maximum. No line voltage switching required.	Note: Subject to change when actual power requirements are determined.
Ventilation	Maximum recommended ambient operating temperature is 30 C / 86 F.	Ensure that the left and right equipment sides are unobstructed (5.08 cm, 2 in minimum clearance). The ventilation should not be impeded by covering the ventilation openings with items such as newspapers, tablecloths, curtains, etc.
Certifications or Compliance	Safety: UL 60065, cUL 60065, IEC 60065. EMC: "Class A" device (applies to all of the following) EN 55032, EN 55103-2, EN 61000-3-2, EN 61000-3-3, FCC Part 15, ICES-003. Environmental: RoHS.	
Shipping Weight	5.1 lbs. (2.3 kg)	

Architect and Engineer Specifications: Prism 4x4.

The half rack device shall provide four analog mic/line inputs that are adjustable from line to mic level with coarse gain, fine trim and phantom power plus four analog line outputs that are adjustable with fine trim. Levels, phantom powers, signal inversions and mutes shall be controllable via software. Audio connections shall be accessed via rear panel 3.81 mm terminal block connectors.

Network audio expansion shall be provided by an optional factory installed Dante™ card with a capacity of 128 (64x64) channels. The connector shall be 1000 Base-T RJ45 utilizing CAT6 cable.

A designer software application shall be provided that operates on a Windows computer, with network interface installed, running Windows® 7 or higher operating system. Computer connection for configuration shall be via the device's rear panel Ethernet connector. All internal processing shall be digital (DSP). Available DSP components shall include (but not be limited to) various forms of: mixers, equalizers, filters, crossovers, dynamics/gain controls, routers, delays, remote controls, meters, generators, onboard logic, and diagnostics.

The front panel shall include a LCD and momentary switch. The display shall indicate unit name, IP address, MAC address, Site File version, and fault messages and can be switched between system overview and meter displays.

External control shall include dedicated software screens as well as preset selection, I/O level control and muting using the optional ARC wall panel remote controls via industry-standard CAT5 cable with RJ45 connectors. A built-in web server shall provide four instances of ARC-WEB, which allows for user control from nearly any web browser or mobile device. Logic I/O shall consist of four contact closures or two potentiometer inputs along with four logic outputs. The logic outputs may be used to drive LEDs directly or control external relays or switches. All program memory shall be non-volatile and provide program security should power fail. The device shall provide an on board real time clock to facilitate automatic, timed changing of presets and may sync to NTP. Third-party control systems may interface over IP using a published ASCII control protocol.

Audio conversion shall be 24-bit, 48 kHz and internal processing shall be 32-bit or 40-bit floating point, 48 kHz. The dynamic range shall not be lower than 113 dB, A-weighted with a maximum input level of +23 dBu and maximum output level of +24 dBu.

The device shall be powered over Ethernet (PoE+) by an IEEE 802.3at Class 4 standard compliant switch, or the included injector. The device can be powered from either the Dante or Ethernet Port. The device shall meet UL/CSA and CE safety requirements and comply with CE and FCC Part 15 emissions limits. The device shall be RoHS compliant. The chassis shall be constructed of cold rolled steel, and may be surface mounted or mount into a standard 19" 1U EIA rack using an available bracket or rack tray. The device shall be a Symetrix Prism 4x4.



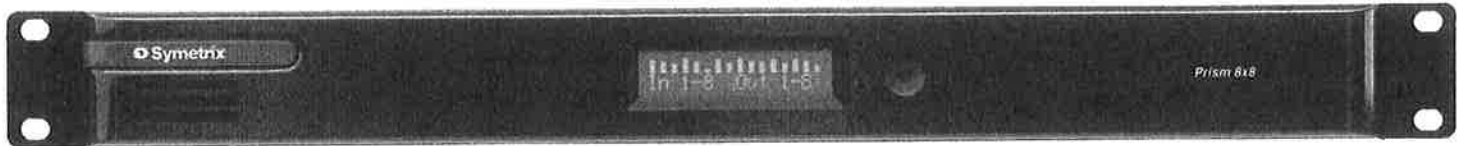

The Prism family is the workhorse series in Symetrix’s DSP lineup. With all the core features needed for the most common applications, it provides powerful processing with flexible control, and optional Dante networking. Prism is ideally suited for applications requiring powerful, extremely cost effective advanced signal processing coupled with a standardized means for future expansion.

- 8 analog in and out, and powerful Symetrix DSP reduce overall system costs.
- Optional 64x64 Ultra low latency Dante network audio protocol uses standard IT infrastructure.
- Industry leading analog and A/D/D/A performance, 48 volt phantom mic power.
- Configured using award winning Composer software. Controlled from W Series remotes, ARC wall panels, ARC-WEB and T Series touch-screens. Embedded web server enables remote metering and diagnostics.
- Front panel LCD provides configuration information, system status, and analog audio levels.

Electrical Specifications

ANALOG INPUTS	
Number of Inputs	Eight (8) switchable balanced mic or line level.
Connectors	3.81 mm terminal blocks.
Nominal Input Level	+4 dBu.
Maximum Input Level	+23 dBu.
Mic Pre-amp gain	0, 12, 24, 44 or 54 dB switchable with ± 24 dB trim.
Mic Pre-amp EIN	< -125dB with 150 ohm source impedance, 22.4 kHz BW.
CMRR	> 79 dB @ 1 kHz, unity gain.
Input impedance	8k Ohms balanced, 4k Ohms unbalanced.
Phantom power (per input)	+48 VDC, 10 mA maximum.
Dynamic range	> 113 dB, A-weighted.
THD+Noise	< -100 dB; 22.4 kHz BW, unweighted; 1 kHz @ +15 dBu with 0 dB gain. Course gain is set to +4dBu.
A to D Latency	0.28 mS.
ANALOG OUTPUTS	
Number of Outputs	Eight (8) balanced line level.
Connectors	3.81 mm terminal blocks.
Nominal Output Level	+4 dBu with 20 dB of headroom.
Maximum Output Level	+24 dBu (+22.8 dBu into a 2k Ohm minimum load).
Output Impedance	300 Ohms balanced, 150 Ohms unbalanced.
Dynamic Range	> 117 dB, A-weighted.
THD+Noise	< -97 dB; 22.4 kHz BW, unweighted; 1 kHz, 0 dB gain +8dBu output.
D to A Latency	0.60 mS.
SYSTEM	
Sampling Rate	48 kHz.
Frequency Response (A/D/A)	20 Hz – 20 kHz, ± 0.5 dB.
Dynamic Range (A/D/A)	> 113 dB, A-weighted.
Channel Separation (A/D/A)	> 110 dB @ 1 kHz, +24 dBu.
THD+Noise	< 95 dB (22.4 kHz BW, un-weighted); 1 kHz @ +15 dBu with 0 dB gain.
Latency (A/D/A)	1.04 mS, inputs routed to outputs.
Processors	1 x Analog Devices SHARC 21489 @ 400 MHz SIMD.
Raw Processing Capacity	400 MIPS, 1.6 GFLOPS.
Delay Memory	174 mono seconds.
Analog control inputs	0-3.3 VDC.



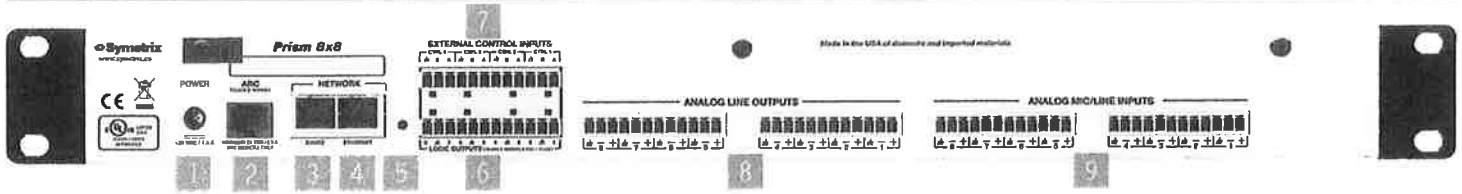

- 1 Power:** Switching power supply providing 24 VDC @ 1.4 amperes. *NOTE: Each power supply will accept a 100-240 VAC input.*
- 2 ARC:** Distributes power and RS-485 data to one or more ARC devices.
- 3 Dante:** 1000 Base-T Ethernet port provides 128 (64x64) channels of Dante network audio. Requires optional factory installed Dante card.
- 4 Ethernet:** 10/100 Base-T Ethernet port for Symetrix Composer host control, third-party accessory controllers over IP, and power. Features auto-crossover sensing for direct device-to-device connections.
- 5 Factory Reset Switch:** To be used under the supervision of technical support, it has the ability to reset the unit's network configuration and completely reset the unit to factory defaults.
- 6 Logic Outputs:** Eight (8) logic outputs with four (4) paired common ground pins. Logic Outputs go low (0V) when active, and are internally pulled high (5V) when inactive and can drive external LED indicators directly.
- 7 External Control Inputs:** Four (4) analog control inputs able to be used as 4 potentiometer inputs or as 8 switch inputs (+3.3 VDC reference voltage supplied).
- 8 Analog Line Outputs:** Eight (8) balanced analog line level audio outputs, with individually software-controllable +/- 24 dB of digital trim and mute.
- 9 Analog Mic/Line Inputs:** Eight (8) balanced analog audio inputs, with individually software-controllable pre-amp gain (reference levels of -50 dBu, -40 dBu, -20 dBu, -10 dBV and +4 dBu), +/- 24 dB of digital trim, phantom power, signal inversion and mute.

SYSTEM (continued)	
Recommended External Control Potentiometer	10k Ohm, linear.
Logic Outputs	Low (0V) when active, pulled high (5V) when inactive.
Logic Output Maximum External Power Supply Voltage	24 VDC.
Logic Output Maximum External Power Supply Current Sinking	50 mA.
Logic Output Maximum Output Current	10 mA.
RS-485 Serial I/O	38.4 kbaud (default) 8 data bits, 1 stop bit, no parity, no flow control. May be broken out of ARC port.
Ethernet Cable	Standard CAT5e or CAT6, maximum device-to-device length = 100 meters.
Dante Cable	Standard CAT6, maximum device-to-device length = 100 meters.
ARC Cable	Standard CAT5, distance dependent upon load and number of devices. 8 Watts maximum power available.
Maximum Devices Per System	128 units per Site File.
Maximum Stored Presets	1000.

Mechanical Specifications		
Items	Specifications	Remarks
Space Required	1U (WDH: 18.91 in. x 9.88 in. x 1.72 in. / 48.02 cm x 25.1 cm x 4.37 cm). Depth does not include connector allowance.	Allow at least 3 inch additional clearance for rear panel connections. Additional depth may be required depending upon your specific wiring and connections.
Electrical	24V 1.4A, 34W Maximum.	Symetrix Part Number 12-0034. CUI part number SDI65-24-U-P5.
Ventilation	Maximum recommended ambient operating temperature is 30 C / 86 F.	Ensure that the left and right equipment sides are unobstructed (5.08 cm, 2 in minimum clearance). The ventilation should not be impeded by covering the ventilation openings with items such as newspapers, tablecloths, curtains, etc.
Certifications or Compliance	Safety: UL 60065, cUL 60065, IEC 60065. EMC: "Class A" device (applies to all of the following) EN 55032, EN 55103-2, EN 61000-3-2, EN 61000-3-3, FCC Part 15, ICES-003 Environmental: RoHS.	
Shipping Weight	9.4 lbs. (4.2 kg).	

Architect and Engineer Specifications: Prism 8x8.

The device shall provide eight analog mic/line inputs that are adjustable from line to mic level with coarse gain, fine trim and phantom power plus eight analog line outputs that are adjustable with fine trim. Levels, phantom powers, signal inversions and mutes shall be controllable via software. Audio connections shall be accessed via rear panel 3.81 mm terminal block connectors.

Network audio expansion shall be provided by an optional factory installed Dante™ card with a capacity of 128 (64x64) channels. The connector shall be 1000 Base-T RJ45 utilizing CAT6 cable.

A designer software application shall be provided that operates on a Windows computer, with network interface installed, running Windows® 7 or higher operating system. Computer connection for configuration shall be via the device's rear panel Ethernet connector. All internal processing shall be digital (DSP). Available DSP components shall include (but not be limited to) various forms of: mixers, equalizers, filters, crossovers, dynamics/gain controls, routers, delays, remote controls, meters, generators, onboard logic, and diagnostics.

The front panel shall include a LCD and momentary switch. The display shall indicate unit name, IP address, MAC address, Site File version, and fault messages and can be switched between system overview and meter displays.

External control shall include dedicated software screens as well as preset selection, I/O level control and muting using the optional ARC wall panel remote controls via industry-standard CAT5 cable with RJ45 connectors. A built-in web server shall provide four instances of ARC-WEB, which allows for user control from nearly any web browser or mobile device. Logic I/O shall consist of eight contact closures or four potentiometer inputs along with eight logic outputs. The logic outputs may be used to drive LEDs directly or control external relays or switches. All program memory shall be non-volatile and provide program security should power fail. The device shall provide an on board real time clock to facilitate automatic, timed changing of presets and may sync to NTP. Third-party control systems may interface over IP using a published ASCII control protocol.

Audio conversion shall be 24-bit, 48 kHz and internal processing shall be 32-bit or 40-bit floating point, 48 kHz. The dynamic range shall not be lower than 113 dB, A-weighted with a maximum input level of +23 dBu and maximum output level of +24 dBu.

The device shall have a power plug that accepts power from Symetrix part number 12-0034, CUI power supply part number SDI65-24-U-P5. The device shall meet UL/CSA and CE safety requirements and comply with CE and FCC Part 15 emissions limits. The device shall be RoHS compliant. The chassis shall be constructed of cold rolled steel, and mounts into a standard 19" 1U EIA rack. The device shall be a Symetrix Prism 8x8.



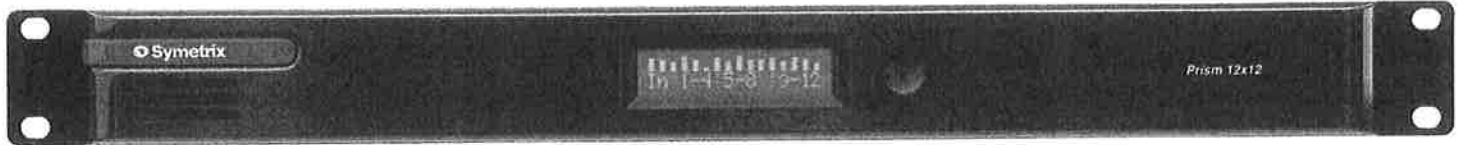

The Prism family is the workhorse series in Symetrix's DSP lineup. With all the core features needed for the most common applications, it provides powerful processing with flexible control, and optional Dante networking. Prism is ideally suited for applications requiring powerful, extremely cost effective advanced signal processing coupled with a standardized means for future expansion.

- 12 analog in and out, and powerful Symetrix DSP reduce overall system costs.
- Optional 64x64 Ultra low latency Dante network audio protocol uses standard IT infrastructure.
- Industry leading analog and A/D/D/A performance, 48 volt phantom mic power.
- Configured using award winning Composer software. Controlled from ARC wall panels, W Series remotes, ARC-WEB and T Series touch-screens. Embedded web server enables remote metering and diagnostics.
- Front panel LCD provides configuration information, system status, and analog audio levels.

Electrical Specifications

ANALOG INPUTS	
Number of Inputs	Twelve (12) switchable balanced mic or line level.
Connectors	3.81 mm terminal blocks.
Nominal Input Level	+4 dBu.
Maximum Input Level	+23 dBu.
Mic Pre-amp gain	0, 12, 24, 44 or 54 dB switchable with ± 24 dB trim.
Mic Pre-amp EIN	< -125dB with 150 ohm source impedance, 22.4 kHz BW.
CMRR	> 79 dB @ 1 kHz, unity gain.
Input impedance	8k Ohms balanced, 4k Ohms unbalanced.
Phantom power (per input)	+48 VDC, 10 mA maximum.
Dynamic range	> 113 dB, A-weighted.
THD+Noise	< -100 dB; 22.4 kHz BW, unweighted; 1 kHz @ +15 dBu with 0 dB gain. Course gain is set to +4dBu.
A to D Latency	0.28 mS.
ANALOG OUTPUTS	
Number of Outputs	Twelve (12) balanced line level.
Connectors	3.81 mm terminal blocks.
Nominal Output Level	+4 dBu with 20 dB of headroom.
Maximum Output Level	+24 dBu (+22.8 dBu into a 2k Ohm minimum load).
Output Impedance	300 Ohms balanced, 150 Ohms unbalanced.
Dynamic Range	> 117 dB, A-weighted.
THD+Noise	< -97 dB; 22.4 kHz BW, unweighted; 1 kHz, 0 dB gain +8dBu output.
D to A Latency	0.60 mS.
SYSTEM	
Sampling Rate	48 kHz.
Frequency Response (A/D/A)	20 Hz – 20 kHz, ± 0.5 dB.
Dynamic Range (A/D/A)	> 113 dB, A-weighted.
Channel Separation (A/D/A)	> 110 dB @ 1 kHz, +24 dBu.
THD+Noise	< 95 dB (22.4 kHz BW, un-weighted); 1 kHz @ +15 dBu with 0 dB gain.
Latency (A/D/A)	1.04 mS, inputs routed to outputs.
Processors	1 x Analog Devices SHARC 21489 @ 400 MHz SIMD.
Raw Processing Capacity	400 MIPS, 1.6 GFLOPS.
Delay Memory	174 mono seconds.
Analog control Inputs	0-3.3 VDC.



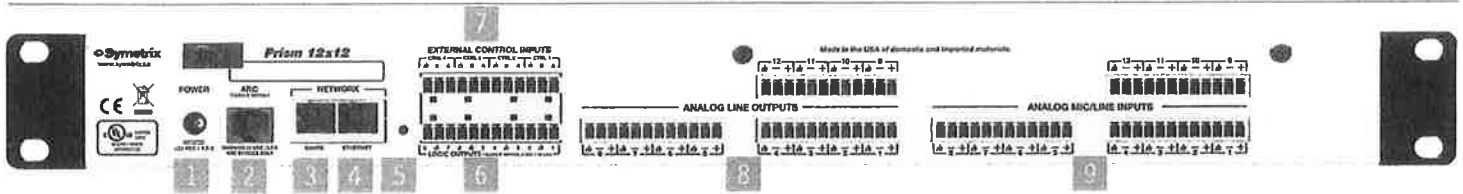

- 1 Power:** Switching power supply providing 24 VDC @ 1.9 amperes. *NOTE: Each power supply will accept a 100-240 VAC input.*
- 2 ARC:** Distributes power and RS-485 data to one or more ARC devices.
- 3 Dante:** 1000 Base-T Ethernet port provides 128 (64x64) channels of Dante network audio. Requires optional factory installed Dante card.
- 4 Ethernet:** 10/100 Base-T Ethernet port for Symetrix Composer host control, third-party accessory controllers over IP, and power. Features auto-crossover sensing for direct device-to-device connections.
- 5 Factory Reset Switch:** To be used under the supervision of technical support, it has the ability to reset the unit's network configuration and completely reset the unit to factory defaults.
- 6 External Control Inputs:** Four (4) analog control inputs able to be used as 4 potentiometer inputs or as 8 switch inputs (+3.3 VDC reference voltage supplied).
- 7 External Control Inputs:** Four (4) analog control inputs able to be used as 4 potentiometer inputs or as 8 switch inputs (+3.3 VDC reference voltage supplied).
- 8 Analog Line Outputs:** Twelve (12) balanced analog line level audio outputs, with individually software-controllable +/- 24 dB of digital trim and mute.
- 9 Analog Mic/Line Inputs:** Twelve (12) balanced analog audio inputs, with individually software-controllable pre-amp gain (reference levels of -50 dBu, -40 dBu, -20 dBu, -10 dBV and +4 dBu), +/- 24 dB of digital trim, phantom power, signal inversion and mute.

SYSTEM (continued)	
Recommended External Control Potentiometer	10k Ohm, linear.
Logic Outputs	Low (0V) when active, pulled high (5V) when inactive.
Logic Output Maximum External Power Supply Voltage	24 VDC.
Logic Output Maximum External Power Supply Current Sinking	50 mA.
Logic Output Maximum Output Current	10 mA.
RS-485 Serial I/O	38.4 kbaud (default) 8 data bits, 1 stop bit, no parity, no flow control. May be broken out of ARC port.
Ethernet Cable	Standard CAT5e or CAT6, maximum device-to-device length = 100 meters.
Dante Cable	Standard CAT6, maximum device-to-device length = 100 meters.
ARC Cable	Standard CAT5, distance dependent upon load and number of devices. 8 Watts maximum power available.
Maximum Devices Per System	128 units per Site File.
Maximum Stored Presets	1000.

Mechanical Specifications		
Items	Specifications	Remarks
Space Required	1U (WDH: 18.91 in. x 9.88 in. x 1.72 in. / 48.02 cm x 25.1 cm x 4.37 cm). Depth does not include connector allowance.	Allow at least 3 inch additional clearance for rear panel connections. Additional depth may be required depending upon your specific wiring and connections.
Electrical	24V 1.9A, 45W Maximum.	Symetrix Part Number 12-0034. CUI part number SDI65-24-U-P5.
Ventilation	Maximum recommended ambient operating temperature is 30 C / 86 F.	Ensure that the left and right equipment sides are unobstructed (5.08 cm, 2 in minimum clearance). The ventilation should not be impeded by covering the ventilation openings with items such as newspapers, tablecloths, curtains, etc.
Certifications or Compliance	Safety: UL 60065, cUL 60065, IEC 60065. EMC: "Class A" device (applies to all of the following) EN 55032, EN 55103-2, EN 61000-3-2, EN 61000-3-3, FCC Part 15, ICES-003. Environmental: RoHS.	
Shipping Weight	9.4 lbs. (4.2 kg)	

Architect and Engineer Specifications: Prism 12x12.

The device shall provide twelve analog mic/line inputs that are adjustable from line to mic level with coarse gain, fine trim and phantom power plus twelve analog line outputs that are adjustable with fine trim. Levels, phantom powers, signal inversions and mutes shall be controllable via software. Audio connections shall be accessed via rear panel 3.61 mm terminal block connectors.

Network audio expansion shall be provided by an optional factory installed Dante™ card with a capacity of 128 (64x64) channels. The connector shall be 1000 Base-T RJ45 utilizing CAT6 cable.

A designer software application shall be provided that operates on a Windows computer, with network interface installed, running Windows® 7 or higher operating system. Computer connection for configuration shall be via the device's rear panel Ethernet connector. All internal processing shall be digital (DSP). Available DSP components shall include (but not be limited to) various forms of: mixers, equalizers, filters, crossovers, dynamics/gain controls, routers, delays, remote controls, meters, generators, onboard logic, and diagnostics.

The front panel shall include a LCD and momentary switch. The display shall indicate unit name, IP address, MAC address, Site File version, and fault messages and can be switched between system overview and meter displays.

External control shall include dedicated software screens as well as preset selection, I/O level control and muting using the optional ARC wall panel remote controls via industry-standard CAT5 cable with RJ45 connectors. A built-in web server shall provide four instances of ARC-WEB, which allows for user control from nearly any web browser or mobile device. Logic I/O shall consist of eight contact closures or four potentiometer inputs along with eight logic outputs. The logic outputs may be used to drive LEDs directly or control external relays or switchers. All program memory shall be non-volatile and provide program security should power fail. The device shall provide an on-board real time clock to facilitate automatic, timed changing of presets and may sync to NTP. Third-party control systems may interface over IP using a published ASCII control protocol.

Audio conversion shall be 24-bit, 48 kHz and internal processing shall be 32-bit or 40-bit floating point, 48 kHz. The dynamic range shall not be lower than 113 dB, A-weighted with a maximum input level of +23 dBu and maximum output level of +24 dBu.

The device shall have a power plug that accepts power from Symetrix part number 12-0034, CUI power supply part number SDI65-24-U-P5. The device shall meet UL/CSA and CE safety requirements and comply with CE and FCC Part 15 emissions limits. The device shall be RoHS compliant. The chassis shall be constructed of cold rolled steel, and mounts into a standard 19" 1U EIA rack. The device shall be a Symetrix Prism 12x12.



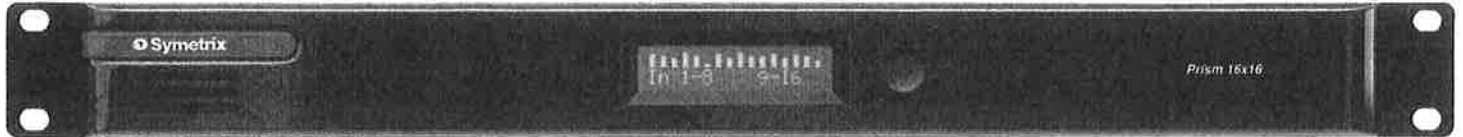

The Prism family is the workhorse series in Symetrix's DSP lineup. With all the core features needed for the most common applications, it provides powerful processing with flexible control, and optional Dante networking. Prism is ideally suited for applications requiring powerful, extremely cost effective advanced signal processing coupled with a standardized means for future expansion.

- 16 analog in and out, and powerful Symetrix DSP reduce overall system costs.
- Optional 64x64 Ultra low latency Dante network audio protocol uses standard IT infrastructure.
- Industry leading analog and A/D/D/A performance, 48 volt phantom mic power.
- Configured using award winning Composer software. Controlled from W Series remotes, ARC wall panels, ARC-WEB and T Series touchscreens. Embedded web server enables remote metering and diagnostics.
- Front panel LCD provides configuration information, system status, and analog audio levels.

Electrical Specifications	
ANALOG INPUTS	
Number of Inputs	Sixteen (16) switchable balanced mic or line level.
Connectors	3.81 mm terminal blocks.
Nominal Input Level	+4 dBu.
Maximum Input Level	+23 dBu.
Mic Pre-amp gain	0, 12, 24, 44 or 54 dB switchable with ± 24 dB trim.
Mic Pre-amp EIN	< -125dB with 150 ohm source impedance. 22.4 kHz BW.
CMRR	> 79 dB @ 1 kHz, unity gain.
Input impedance	8k Ohms balanced, 4k Ohms unbalanced.
Phantom power (per input)	+48 VDC, 10 mA maximum.
Dynamic range	> 113 dB, A-weighted.
THD+Noise	< -100 dB; 22.4 kHz BW, unweighted; 1 kHz @ +15 dBu with 0 dB gain. Course gain is set to +4dBu.
A to D Latency	0.28 mS.
ANALOG OUTPUTS	
Number of Outputs	Sixteen (16) balanced line level.
Connectors	3.81 mm terminal blocks.
Nominal Output Level	+4 dBu with 20 dB of headroom.
Maximum Output Level	+24 dBu (+22.8 dBu into a 2k Ohm minimum load).
Output Impedance	300 Ohms balanced, 150 Ohms unbalanced.
Dynamic Range	> 117 dB, A-weighted.
THD+Noise	< -97 dB; 22.4 kHz BW, unweighted; 1 kHz, 0 dB gain +8dBu output.
D to A Latency	0.60 mS.
SYSTEM	
Sampling Rate	48 kHz.
Frequency Response (A/D/A)	20 Hz – 20 kHz, ± 0.5 dB.
Dynamic Range (A/D/A)	> 113 dB, A-weighted.
Channel Separation (A/D/A)	> 110 dB @ 1 kHz, +24 dBu.
THD+Noise	< 95 dB (22.4 kHz BW, un-weighted); 1 kHz @ +15 dBu with 0 dB gain.
Latency (A/D/A)	1.04 mS, inputs routed to outputs.
Processors	1 x Analog Devices SHARC 21489 @ 400 MHz SIMD.
Raw Processing Capacity	400 MIPS, 1.6 GFLOPS.
Delay Memory	174 mono seconds.
Analog control inputs	0-3.3 VDC.

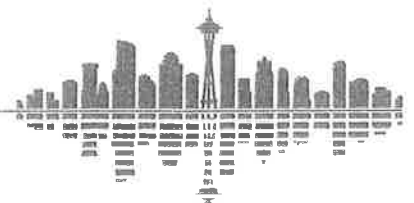

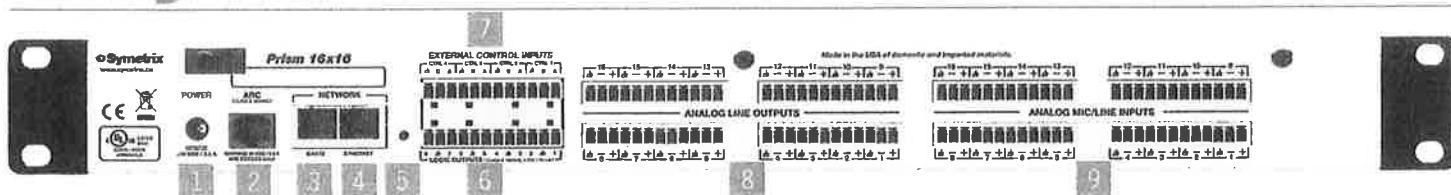

- 1 Power:** Switching power supply providing 24 VDC @ 2.3 amperes. *NOTE: Each power supply will accept a 100-240 VAC input.*
- 2 ARC:** Distributes power and RS-485 data to one or more ARC devices.
- 3 Dante:** 1000 Base-T Ethernet port provides 128 (64x64) channels of Dante network audio. Requires optional factory installed Dante card.
- 4 Ethernet:** 10/100 Base-T Ethernet port for Symetrix Composer host control, third-party accessory controllers over IP, and power. Features auto-crossover sensing for direct device-to-device connections.
- 5 Factory Reset Switch:** To be used under the supervision of technical support, it has the ability to reset the unit's network configuration and completely reset the unit to factory defaults.
- 6 Logic Outputs:** Eight (8) logic outputs with four (4) paired common ground pins. Logic Outputs go low (0V) when active, and are internally pulled high (5V) when inactive and can drive external LED indicators directly.
- 7 External Control Inputs:** Four (4) analog control inputs able to be used as 4 potentiometer inputs or as 8 switch inputs (+3.3 VDC reference voltage supplied).
- 8 Analog Line Outputs:** Sixteen (16) balanced analog line level audio outputs, with individually software-controllable +/- 24 dB of digital trim and mute.
- 9 Analog Mic/Line Inputs:** Sixteen (16) balanced analog audio inputs, with individually software-controllable pre-amp gain (reference levels of -50 dBu, -40 dBu, -20 dBu, -10 dBV and +4 dBu), +/- 24 dB of digital trim, phantom power, signal inversion and mute.

SYSTEM (continued)	
Recommended External Control Potentiometer	10k Ohm, linear.
Logic Outputs	Low (0V) when active, pulled high (5V) when inactive.
Logic Output Maximum External Power Supply Voltage	24 VDC.
Logic Output Maximum External Power Supply Current Sinking	50 mA.
Logic Output Maximum Output Current	10 mA.
RS-485 Serial I/O	38.4 kbaud (default) 8 data bits, 1 stop bit, no parity, no flow control. May be broken out of ARC port.
Ethernet Cable	Standard CAT5e or CAT6, maximum device-to-device length = 100 meters.
Dante Cable	Standard CAT6, maximum device-to-device length = 100 meters.
ARC Cable	Standard CAT5, distance dependent upon load and number of devices. 8 Watts maximum power available.
Maximum Devices Per System	128 units per Site File.
Maximum Stored Presets	1000.

Mechanical Specifications		
Items	Specifications	Remarks
Space Required	1U (WDH: 18.91 in. x 9.88 in. x 1.72 in. / 48.02 cm x 25.1 cm x 4.37 cm). Depth does not include connector allowance.	Allow at least 3 inch additional clearance for rear panel connections. Additional depth may be required depending upon your specific wiring and connections.
Electrical	24V 2.3A, 56W Maximum.	Symetrix Part Number 12-0034. CUI part number SDI65-24-U-P5.
Ventilation	Maximum recommended ambient operating temperature is 30 C / 86 F.	Ensure that the left and right equipment sides are unobstructed (5.08 cm, 2 in minimum clearance). The ventilation should not be impeded by covering the ventilation openings with items such as newspapers, tablecloths, curtains, etc.
Certifications or Compliance	Safety: UL 60065, cUL 60065, IEC 60065. EMC: *Class A* device (applies to all of the following) EN 55032, EN 55103-2, EN 61000-3-2, EN 61000-3-3, FCC Part 15, ICES-003 Environmental: RoHS.	
Shipping Weight	9.4 lbs. (4.2 kg)	

Architect and Engineer Specifications: Prism 16x16.

The device shall provide sixteen analog mic/line inputs that are adjustable from line to mic level with coarse gain, fine trim and phantom power plus sixteen analog line outputs that are adjustable with fine trim. Levels, phantom powers, signal inversions and mutes shall be controllable via software. Audio connections shall be accessed via rear panel 3.81 mm terminal block connectors.

Network audio expansion shall be provided by an optional factory installed Dante™ card with a capacity of 128 (64x64) channels. The connector shall be 1000 Base-T RJ45 utilizing CAT6 cable.

A designer software application shall be provided that operates on a Windows computer, with network interface installed, running Windows® 7 or higher operating system. Computer connection for configuration shall be via the device's rear panel Ethernet connector. All internal processing shall be digital (DSP). Available DSP components shall include (but not be limited to) various forms of: mixers, equalizers, filters, crossovers, dynamics/gain controls, routers, delays, remote controls, meters, generators, onboard logic, and diagnostics.

The front panel shall include a LCD and momentary switch. The display shall indicate unit name, IP address, MAC address, Site File version, and fault messages and can be switched between system overview and meter displays.

External control shall include dedicated software screens as well as preset selection, I/O level control and muting using the optional ARC wall panel remote controls via industry-standard CAT5 cable with RJ45 connectors. A built-in web server shall provide four instances of ARC-WEB, which allows for user control from nearly any web browser or mobile device. Logic I/O shall consist of eight contact closures or four potentiometer inputs along with eight logic outputs. The logic outputs may be used to drive LEDs directly or control external relays or switches. All program memory shall be non-volatile and provide program security should power fail. The device shall provide an on board real time clock to facilitate automatic, timed changing of presets and may sync to NTP. Third-party control systems may interface over IP using a published ASCII control protocol.

Audio conversion shall be 24-bit, 48 kHz and internal processing shall be 32-bit or 40-bit floating point, 48 kHz. The dynamic range shall not be lower than 113 dB, A-weighted with a maximum input level of +23 dBu and maximum output level of +24 dBu.

The device shall have a power plug that accepts power from Symetrix part number 12-0034, CUI power supply part number SDI65-24-U-P5. The device shall meet UL/CSA and CE safety requirements and comply with CE and FCC Part 15 emissions limits. The device shall be RoHS compliant. The chassis shall be constructed of cold rolled steel, and mounts into a standard 19" 1U EIA rack. The device shall be a Symetrix Prism 16x16.

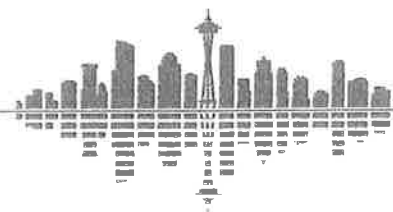

Technical Datasheet

Overview

- Compatible with SQ, Qu, Avantis, AHM-64, GLD
- 16 Mic Preamps on XLR
- Phantom Power LED per Input
- 8 XLR Line Outs
- dSNAKE Connection with locking Ethercon port
- Additional locking Ethercon port for daisy chaining / ME personal mixing system
- Rubber bumpers
- Carry handle
- Optional rack mount kit available

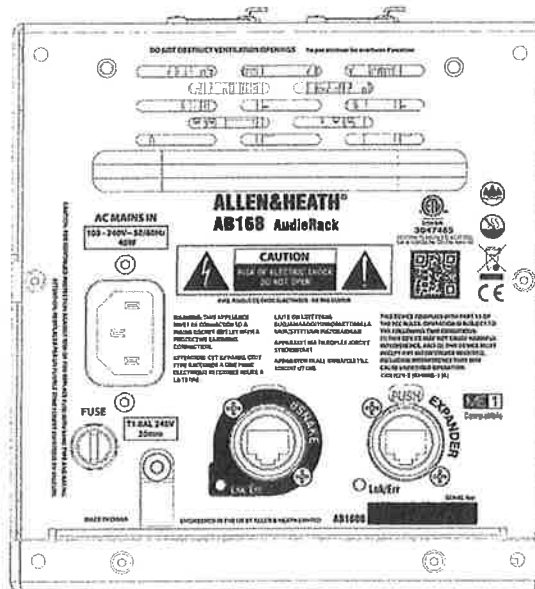
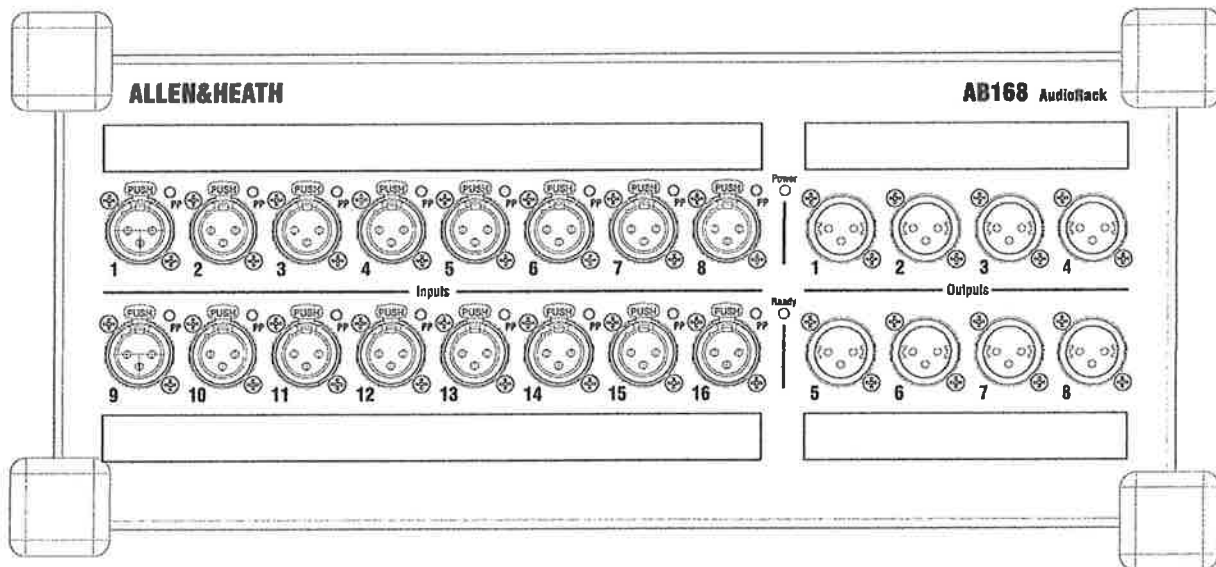

Dimensions

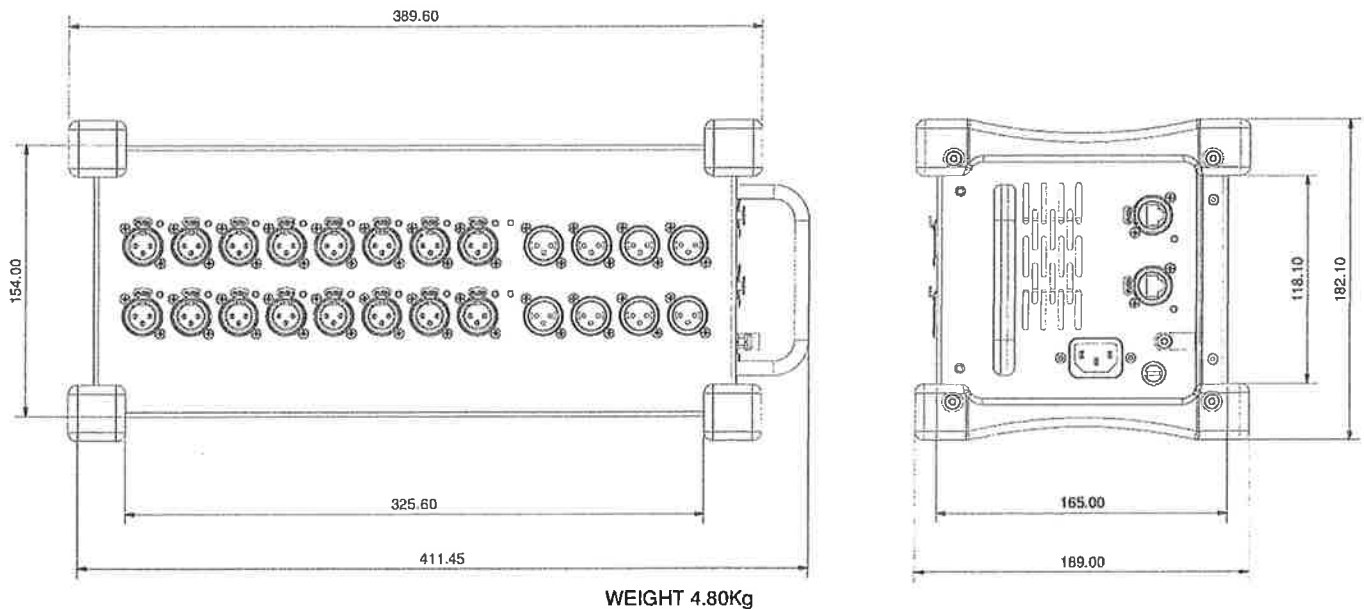

A&E Specifications

The unit shall be a portable remote audio rack for a digital mixing system. The remote audio rack shall provide 16 XLR inputs and 8 XLR outputs and shall be connected to add a further inputs and outputs. The XLR sockets shall be the same or higher quality and specification as those located on the digital mixing system, and shall appear in the digital mixing system soft patch for assignment to channels.

Audio connection shall be over Cat5 cable using Allen & Heath's dSNAKE Ethernet protocol, allowing the remote audio rack to be positioned up to 100m from the mixer or expanded audio rack. The Ethernet protocol shall provide control to the remote preamp, and all mic preamps are scene recallable by the digital mixing system. Phantom power LED indicators shall be provided per input socket on the remote audio rack. Unit firmware shall automatically be updated when connected to the digital mixing system. The local Ethernet port shall be an RJ45 socket with EtherCon locking ring.

It shall also be possible to connected the remote audio rack to a main AudioRack unit to add a further 16 XLR inputs and 8 XLR outputs from that location. This connection shall be via an 'Expander' connection and shall also be an RJ45 socket with EtherCon locking ring.

The remote audio rack shall provide an 'Expander' port to allow the connection of an additional remote audio rack from that location. This connection shall also be a 'dSNAKE' RJ45 socket with EtherCon locking ring. This port shall also provide 40 channels to Allen&Heath ME personal monitoring solution hardware and the remote audio rack shall be compatible with Allen&Heath digital mixers.

The remote audio rack shall have a robust steel chassis and shall be designed to be portable and to be placed horizontally or vertically on the stage or performance environment. A carrying handle shall be provided to facilitate

lifting and holding the device when moving and an optional padded dust cover shall be available. The remote audio rack shall also be mounted in a 19" equipment rack or case using an optional remote audio rack kit.

The remote audio rack shall have a built in power supply accepting AC mains voltages of 100~240V, 50/60 Hz, 40W max via an earthed 3-pin IEC male connector mounted on the rear chassis.

Recommended operating temperature for the remote audio rack shall be 5 to 35 degrees Celsius.

The unit shall be the Allen&Heath AB168 Portable AudioRack.

System Specifications

Inputs

XLR Mic/Line Inputs	Balanced
Mic/Line Preamp	Fully recallable
Input Sensitivity	-60 to +15dBu
Analogue Gain	+5 to +60dB, 1dB steps
Pad	-20dB
Maximum Input Level	+32dBu
Input Impedance	>4k Ω (Pad out), >10k Ω (Pad in)
Mic/Line Channel noise	20-20kHz, Direct Out @ unbalanced out
Mic EIN	-127dB with 150 Ω source
Unity gain (Pad in)	-90dBu
Low gain (5dB, Pad out)	-93dBu
Mid gain (30dB, Pad out)	-89dBu
Mic/Line Channel THD+N	20-20kHz, Direct Out @ unbalanced out
Unity gain (Pad in)	0.005% -86dBu @ 1kHz, 0dBu output
Low gain (5dB, Pad out)	0.003% -89dBu @ 1kHz, 0dBu output
Mid gain (30dB, Pad out)	0.004% -88dBu @ 1kHz, 0dBu output

Outputs

XLR Outputs	Balanced, Relay protected
Output Impedance	<75 Ω
Nominal Output	+4dBu = 0dB meter reading
Maximum Output Level	+22dBu
Residual Output Noise	-91dBu (muted, 20-20kHz)
Operating Temperature	0 deg C to 35 deg C (32 deg F to 95 deg F)
Mains Power	100-240V, 50/60 Hz, 40W max

Hickman County HS Auditorium

Video System

Video system to consist of a Vivitek Large Venue 8000 Lumen DLP laser projector WUXGA resolution 10,000:1 contrast ratio. Laser light source up to 20,000 hours. Projector will be mounted in ceiling opening in front of the stage by the catwalk. A CAT transmitter receiver will be provided to feed the video over IP to the projector from the booth. The two old electric screens will be removed from back stage wall and a new Da-Lite electric tensioned screen will be mounted in the old screen(s) location. On the stage (podium side) will have a HDMI connection for laptop or other video player connection back to the booth. The booth will have a 2nd HDMI connection that will be connected to a six input scaler video switcher to select between the stage or rear of room devices. For system control a 3.5" FSR touch panel will be installed to turn projector on/off and raise and lower electric screen. An audio output will be sent from the video switcher into an open channel on the audio mixer. Customer to provide power for projector in the ceiling and wire the power into the new screen. A training session will be conducted after completion of installation, date and time TBD.

Projector Info

Native Resolution	WUXGA (1920 x 1200)
Brightness	8000 ANSI Lumens
Contrast Ratio	10,000:1
Max. Supported Resolution	WUXGA (1920 x 1200) @60Hz
Native Aspect Ratio	16:10
Lamp Life and Type	Lamp free design. Laser light source last up to 20,000 hours
Display Type	Single chip DLP® Technology by Texas Instruments
Chip Size	0.67" DMD

DU8090Z

LARGE VENUE PROJECTORS



Laser Projector with High Brightness and Low Maintenance

FEATURES

- DLP® technology with BrilliantColor™ for vibrant and rich picture quality
- 8,000 ANSI lumens of brightness, WUXGA resolution, and 10,000:1 contrast ratio for clear, crisp and bright projection
- Laser light source up to 20,000 hours Operations
- Designed for heavy duty 24/7 Operations
- 3G-SDI & HDBaseT for robustness and long signal transmission
- 8 optional lenses from 0.38:1 to 5.31-8.26:1 throw ratio range
- Lens Position Memory
- Built-in Edge-Blending and Warping features

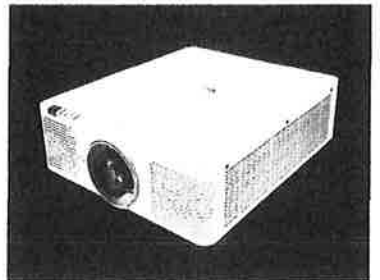
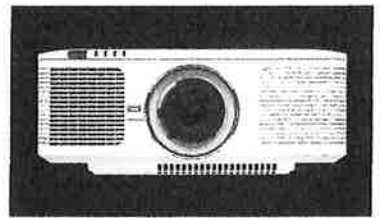



Lamp-Free and Eco-Friendly

The DU8090Z features a WUXGA resolution, an amazing 8000 ANSI Lumens brightness and 10,000:1 contrast ratio for a clear and bright projection. The projector is equipped with a laser light source which offers up to 20,000 hours of operation. The DU8090Z is specifically designed for large venues which need power, flexibility and a durable solution.



DU8090Z SPECIFICATIONS

Image	Display Type	Single chip DLP® Technology by Texas Instruments	
	Brightness	8000 ANSI Lumens	
	Native Resolution	WUXGA (1920 x 1200)	
	Max. Supported Resolution	WUXGA (1920 x 1200) @60Hz	
	Contrast Ratio	10,000:1	
	Native Aspect Ratio	16:10	
	Keystone Correction	Vertical +/- 40°, Horizontal +/- 60°	
	Optical	Throw Ratio	8 optional lenses from 0.38:1 to 5.31-8.26:1 throw ratio range
		Image Size (Diagonal)	40" - 500" (Standard lens)
		Projection Distance	depending on lens selection
Projection Lens		8 optional lenses from 0.38:1 to 5.31-8.26:1 throw ratio range	
Zoom Ratio		Motorized Zoom & Focus	
Offset		Motorized Lens Shift	
Features	Lens Shift Range	Vertical: +64%. -33%; Horizontal: +24%. -14%	
	Features	3D Ready(DLP link, PC+Video), Direct 3D (HDMI 1.4a), 3D Mandatory Formats supported (top/bottom, right/left, frame sequential), Instant On/Off	
Compatibility	Video	SDTV (480i, 576i) / EDTV (480p, 576p) / HDTV (720p, 1080i, 1080p), NTSC (M, 3.58/4.43 MHz), PAL (B,D,G,H,I,M,N) SECAM (B,D,G,K,K1,L)	
Connectivity	I/O Connection Ports	VGA-In (15pin D-Sub), HDMI Number of Ports v.1.4 (x2), DVI-D, Component (5 BNC) (RGBHV), VGA-Out (15pin D-Sub), RJ45 (1: HDBaseT/LAN), RS-232, 3D-Sync (x2: In and Out), Remote Jack(wire remote)	
General	Lamp Life and Type	Lamp free design. Laser light source last up to 20,000 hours	
	Dimensions (W x D x H)	500 x 580 x 205 mm	
	Weight	28 kg	
	Noise Level	40dB (Normal Mode)	
	Power	Supply: AC 100-240V, 50/60Hz Consumption: 675W (Eco. Mode), 850W (Normal Mode), <0.5W (Standby)	
	Control Software	PJ - Control V3.0.0.4	
	Warranty	Large Venue Laser Phosphor Warranty: 5 Year projector / 5 years or 20.000h on the Laser Phosphor illumination source.(Whichever comes first)	
	Standard Accessories	VGA Cable, User Manual (CD), Quick Start Guide, Warranty Card (by region), Remote Controller (with battery), AC Power Cord, Remote Control Cable	
	Optional Accessories	Remote Control P/N (5042221900)	
	UPC Code	DU8090Z BK: 813097021953; DU8090Z WH: 813097021786	

OPTIONAL LENSES

Lens Name	Ultra Wide Zoom	Ultra Short Throw	Standard Lens	Wide Pix	Wide Zoom	Short Long Zoom	Long Zoom 1	Long Zoom 2
Aspect Ratio	16:10	16:10	16:10	16:10	16:10	16:10	16:10	16:10
Throw Ratio	0.75-0.93:1	0.38:1	1.73-2.27:1	0.76:1	1.25-1.79:1	2.22-3.67:1	3.58-5.38:1	5.31-8.26:1
Projection Distance	0.62-10.36	0.85-2.74	1.45-24.85	0.64-8.50	1.05-19.59	1.87-40.33	3.01-59.02	4.42-91.54
Image Size	40-500	100-350	40-500	40-500	40-500	40-500	40-500	40-500
Zoom	1.25	1	1.3	1	1.41	1.65	1.5	1.55
F Number	1.96 - 2.3	2.0	1.7-1.9	1.85	1.85-2.5	1.86-2.48	1.85-2.41	1.85-2.48
Focal Length	11.3 - 14.1 mm	5.64 mm	26 - 34 mm	11.6 mm	18.7 - 26.5 mm	32.9 - 54.2 mm	52.8 - 79.1 mm	78.5 - 121.9 mm
Part Number	3797804200-SVK (D88-UWZ01)	3797866500-SVK (D88-UST01B)	3797744200-SVK (D88-ST001)	3797745100-SVK (D88-WF18501)	3797745200-SVK (D88-WZ01)	3797745000-SVK (D88-SMLZ01)	3797745400-SVK (D88-LOZ101)	3797744900-SVK (D88-LOZ201)



DESCRIPTION

The switcher allows selection of six different sources (three HDMI inputs, one USB-C input, one DisplayPort input and one VGA input), and will switch the selected video to HDMI output. It supports video resolution up to 4Kx2K@60Hz 4:4:4 8bit, 1080P, and 3D. In addition, there is the smart built-in EDID setting can be selected by the 4-pin DIP switch on the rear panel. The switcher supports stereo and multichannel audio on the HDMI inputs.

In addition to the audio embedded in the HDMI output stream, the audio is simultaneously de-embedded to an optical digital audio output and a balanced analog audio output.

The switcher features multiple methods of control. When in the AUTO mode, the switcher will automatically switch to the first detected source device. When the active source is removed, the switcher will switch from input 1 to 6. The switcher can be manually controlled by the front panel buttons, IR remote and RS232 command. CEC allows the display device can be controlled by the front panel buttons and RS232 CEC commands.

FEATURES

- Supports HDMI 2.0 and video resolution up to 4K@60Hz 4:4:4 8bit, 1080P, and 3D
- 18Gbps high bandwidth and supports HDR 10
- HDCP 2.3 compliant
- Supports automatic switching
- CEC control for display volume and ON/OFF
- Controllable via RS232 and IR
- VGA resolution is selectable on the front panel
- Optical and balanced analog audio for audio de-embedding
- Smart EDID management for various application and customized setting



FLEX

CONTROL SYSTEM



Manufactured
in the USA

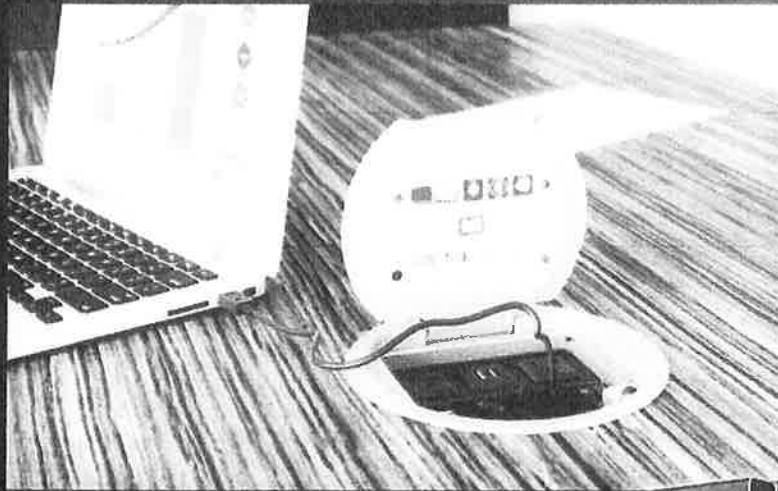

Control systems
make our everyday
lives easier.

Like the universal
remotes in our homes,
control systems allow
us to manipulate nearly
any aspect of technology
around us with the touch
of a button.

The Flex Control System
places a sophisticated
level of control within
everyone's reach.

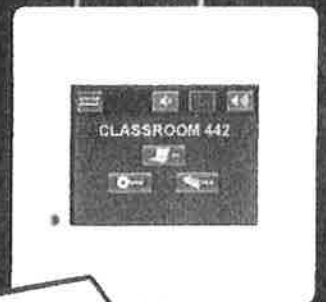
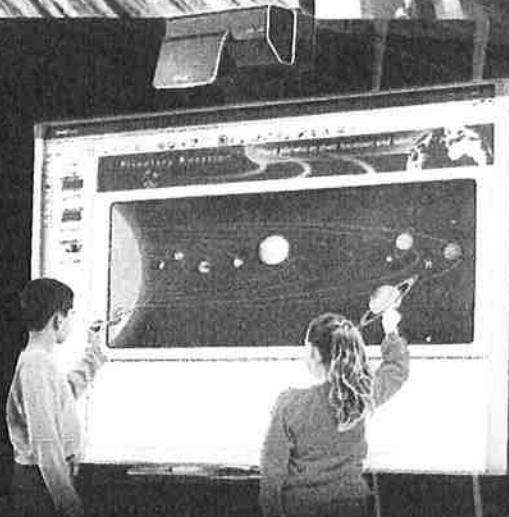

FLEX-LT Wallplate



CT6-FLEX

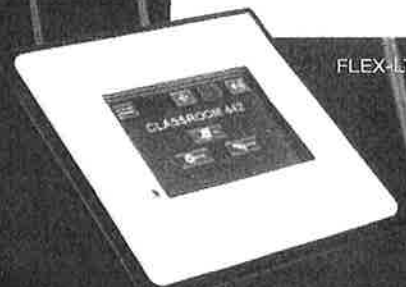

FLEX-LT Mounted
In a DSKB
Desktop Housing



THE

FLEX CONTROL SYSTEM



Manufactured
in the USA

Every AV equipped boardroom & classroom can benefit from a control system. With one, the entire room can be manipulated from a simple touch.

The Flex control system is a small, powerful and affordable solution perfect for nearly any installation. It features a 3.5" color LCD touchscreen and all of the connectivity needed to control the lighting, shades and every piece of AV equipment installed all from one central location.

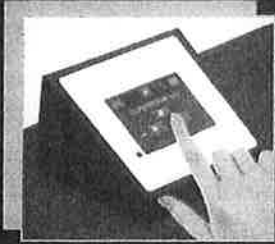

The Flex can be mounted in a wall, podium, desktop or boardroom table. Multiple Flex panels can be used within a room so that room control is always convenient.

A Flex can also be remotely controlled from a Windows computer using the Flex Remote Control software. The software connects to the Flex installed in the room and replicates the screen on the desktop. The Flex remote is available for: Windows 10®, 8, 7, xp; Windows RT®; Windows Phone®; Android®; iPad® and iPhone®.



With the touch of a finger or a click of the mouse, Flex places control of your room at your fingertip.

THE FLEX SOFTWARE



FLEX CONTROL BUILDER

Flex Control builder features an easy-to-use method to get the most out of the system with it's drag 'n drop programming methodology; no need to learn another programming language. Flex-LT offers IR libraries or if a library is not available, the Flex-IR learner is a snap to use. Serial libraries are also available or can be entered in either ASCII or Hex. Attractive, intuitive user interface screens can be designed, tested and loaded using the built-in developer features. Custom as well as standard supplied graphics can be utilized to personalize each project design.

A few of the many Flex Control Builder features include:

- Projects can be saved and retrieved to any location
- Drag 'n Drop compatibility
- Custom and Resizable buttons and graphics
- Built-in Diagnostics
- Project History
- Single click Firmware and Software updates
- Full size Clock Displays and Timers on Splash Screens, smaller on other screens
- Update Firmware & load projects to multiple panels or all panels as a batch request
- Up to 16 Bar Graphs with simplified setup

LIGHTING



SOUND



DOC CAM



DVD/BLU



Free Webinar Classes
for Flex Control Builder
Visit www.certrac.com
to view up.

A PEEK UNDER THE HOOD

SHADES

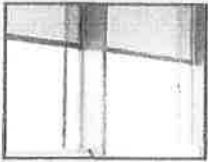

SCREEN



PROJECTOR



CABLE/DVR



• **Small Footprint** – The Flex Control Panel can be mounted in a wall in a standard 2 gang opening or mounted on a desk, shelf or podium with the optional DSKB-2 mounting bracket.

• **Network Port** – The Network Port on the Flex can serve many purposes. First, it can supply power to the Flex via Power over Ethernet or PoE. Attach a Flex to a PoE switch and there is no need to attach an additional power supply. The second function of the Network Port is to give the Flex the capability to communicate with other Network equipped devices including other Flex Panels. The third function of the Network Port is to allow 3rd party applications and our mobile app to communicate with the Flex panel.

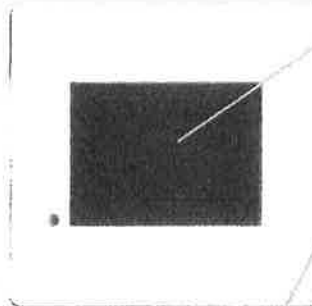

• **3.5" Color LCD Touchscreen** – Provides a bright, interactive, easy to use and engaging interface for the simplest or most complex task.

• **Up to 4 Serial Ports** – Serial is still the most common way to control a device such as a projector, audio / video switcher and much more. With up to 4 Serial Ports a Flex control system is ready to meet your needs.

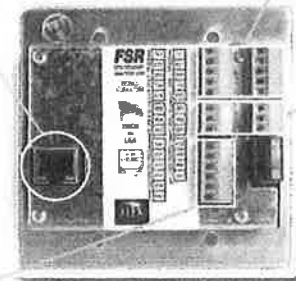

• **Up to 4 IR Ports** – While serial has many advantages, several devices such as DVD players, DVR's and cable boxes require IR control. The Flex Control Panel has up to 4 IR ports and each is capable of driving multiple emitters.

• **4 GPIO Ports** – GPIO ports are unique in that they can be inputs or outputs and can be very handy. When set as an input, a GPIO port can be triggered from a contact closure or a switch to tell the Flex to do something. As an output, a GPIO port can control devices with compatible inputs such as screens, drapes, etc...

Flex Control Builder version 1.17.0.100 For use with Firmware version 2.10 or Higher. 1 MB Memory, 3729.018 User Obj, 428 / 100,000 GD1 Obj, 215 / 100,000

Action Objects = 68 / 1,910
Global Objects = 74 / 947
Touch Objects = 59 / 474
Calendar Objects = 2 / 256
Memory Lists/Items = 412 / 4,096

Images, Fonts, Aliases, Device Commands = 435 / 2,304

Library Tree: Ethernet Devs, IP Cameras, Serial Devices, Screens, Screen empty 0, Screen Template, Screen 1, Screen 2, Screen 3, Screen 4, Screen 5, Screen 6, Windows, Message Box, Event, Alias

Project Tree: Test 4-11-15*, Project Properties, Devices, Serial Ports, General Purpose IO, Global Banner, Screens, Screen 1, HOME, Button 1, Button 2, Button 3, Button 4, Button 5, Button 6, Button 7, Label 1, Label 2, Label 3, BLUERAY, VPRESS, Screen 5, Screen 6, Windows, Window 1, Message Boxes, Events, Aliases, Email Aliases

Preview Window: HOME, BLUERAY, BULER, PC, PHONE, TOOLS

Screen 2, Button 4

Go To Parent...

Flag: NO

Group: None

- Send Command
- Go To Screen
- Wait
- Sleep
- Virtual Button Press
- Set Button State
- Assign
- Flags
- Counters
- Conditional
- Open/Close Window
- Open/Close MsgBox
- Send Intra Serial Message
- Send Intra IP Command
- Log Command
- Set/Clear GPIO
- LCD Brightness/Contrast
- Touch Lockout
- Open Date/Time Window
- Send To Input Window
- Send To Output Window
- IR Repetition

Check out our Flex App available at the App Store



For iPad®, iPhone®, Android® and Windows® phones and tablets.

Available from the app store.

SELECTING YOUR FLEX

There are five members of the Flex family, each with a slightly different set of connectivity options.

Model #	Screen	Serial Ports	IR Ports	GPIO Ports	Network
FLEX-LT100	3.5" Color Touchscreen	2	2	N/A	N/A
FLEX-LT150	3.5" Color Touchscreen	N/A	N/A	N/A	10/100 w/PoE
FLEX-LT200	3.5" Color Touchscreen	4	4	4	10/100 w/PoE
FLEX-LT300	N/A	4	4	4	10/100 w/PoE
CT6-FLEX Table Box	3.5" Color Touchscreen	4	4	4	10/100 w/PoE

FLEX-LT100 – The entry level member of the Flex Family. The LT100 has 2 serial ports and 2 IR ports making it perfect to control a small, stand-alone room.

FLEX-LT150 – The LT150 is a specialized member of the Flex Family. It is intended to be used when only Ethernet equipped devices need to be controlled, or as an additional touch panel for the LT200 or LT300.

FLEX-LT200 – The LT200 is the fully equipped member of the Flex Family. It features the full complement of serial, IR, GPIO and Ethernet ports and is the right choice for larger installations or where network connectivity is required.

CT6-FLEX has the same features as the LT200 with addition of being encased in one of our elegant CT6 table boxes. The interior compartment can be populated with a variety of AC and AV connector plates available from FSR.

Remote Control

FLEX LT-300

FLEX-LT300 – The LT300 is another specialty member of the Flex Family. The LT300 is basically an LT-200 in a box without a touchscreen. The LT300 can be mounted in a rack or Ceiling Box and connected to all of the devices that need to be controlled. The user interface to the LT300 is provided either by a FLEX-LT200 or LT150 or the Flex Remote Windows application.

ACCESSORIES

Mud Rings
1/2" and 5/8" depths

8 Ohm and 70 volt Amplifiers

Serial Controlled Relay and Volume Modules

Adds relay control capability to FLEX systems for automated window treatments, lighting, etc.

Desktop Mounting Brackets

Locking Wall Plate Covers



Front cover photo: Copyright SMART Technologies. All rights reserved.
LIT1359F



244 Bergen Blvd. · Woodland Park, NJ 07424
www.fsrinc.com · sales@fsrinc.com · 973-998-2300

Scaler/Switcher Info

- Supports HDMI 2.0 and video resolution up to 4K@60Hz
- 4:4:4 8bit, 1080P, and 3D •
- 18Gbps high bandwidth and supports HDR 10 • HDCP 2.3 compliant
- • Supports automatic switching •
- CEC control for display volume and ON/OFF •
- Controllable via RS232 and IR •
- VGA resolution is selectable on the front panel •
- Optical and balanced analog audio for audio de-embedding
- • Smart EDID management for various application and customized setting

Video System Controller

NEW FLEX CONTROL BUILDER FEATURES

- Built in Flex Panel Remote Viewer
- View and Press on the Actual Panel Graphic for Remote Testing and Support
 - Device Command Checking and Direct Control
 - Test any Library Command; IR, Serial or IP
 - View Device Responses and Response Timing
 - Direct Input Commands to Test Device or Command Syntax
 - Display Clocks and Timers:
- Can be the full size on the splash, or smaller in a window or on other screens.
- Various formats with or without seconds and military time.
 - Actions can associate at the terminus of the timer.
 - Time can be offset to show multiple time zones.



Misty Shelton
Director of Accountability
Hickman County Schools
115 Murphree Avenue
Centerville, Tennessee 37033

To: School Board Members
From: Misty Shelton
Date: October 2022

1st reading:

4.210 - Credit Recovery

In June, the State Board of Education made changes to their grading scale. These changes conflicted with the policy impacting credit recovery. Policy update on lines 10-12 of page 2 to reflect that students completing credit recovery shall receive a grade of 60%. Changes are noted on the policy.

4.402 Reconsideration of Instructional Materials and Textbooks- remove lines 1-6 references the Library Bill of Rights and library materials. TSBA recommends that all information regarding library materials be maintained in policy 4.403

4.403 Library Materials- the policy has been revised by adding 8 and 9 to page 2.

4.603 - Promotion and Retention

A new state law on promotion and retention will impact students this school year. The State Board of Education has updated a regulation that goes into more detail on the process. While much focus has been placed on third and fourth grader. TSBA encourages district staff to review this process for all students as it is important to understand how this policy applies at different grade levels. Changes are noted on the policy. Appeal process should be put in place. The recommendation would be for this to be at the school level with the assistant principal/principal. There is a sample process in the model policy that would be to the board.

4.605- Graduation Requirements-

Lines 11 – 12, page 1, state that special education students must obtain 24 credits to graduate. However, per state law, these students are required to only receive 22 credits.

6.200- Attendance- recommendation to remove lines 30-36 on page 4 since this information is covered in board policy 6. 506

931-729-3391 ext. 2226

misty.shelton@hickmank12.org

fax 931-729-3834

2nd reading:

Policy 4.400 Instructional Materials- add lines 29 of page 1 to line 2 of page 2 from 4.402 to policy 4.400- footnote added and superscript changed to a 1

Policy 4.601 Reporting Student Progress- Removal of lines 11-17

Policy 6.310 Dress Code- clarification to the policy see attached

Up for Review:

- 5.100 Personnel Goals**
- 5.101 Line and Staff Relations**
- 5.102 Personnel Classification and Qualifications**
- 5.103 Job Descriptions**
- 5.104 Equal Opportunity Employment**
- 5.105 Recruitment**
- 5.1051 Job Sharing Guidelines**
- 5.106 Application and Employment**
- 5.108 Supervision**
- 5.109 Evaluation**
- 5.110 Compensation Guides and Contracts**

Thank you in advance for your careful consideration of these policies.

931-729-3391 ext. 2226

misty.shelton@hickmank12.org

fax 931-729-3834

Hickman County Board of Education

	Descriptor Term: Credit Recovery	Descriptor Code: 4.210	Issued Date: 05/02/22
		Rescinds: 4.210	Issued: 02/03/20

1 **GENERAL¹**

2 The director of schools shall ensure that credit recovery facilitators receive training regarding course
3 organization, online instruction management and related technology.

4 Credit recovery teachers shall comply with all State Board of Education certification requirements.¹

5 **ADMISSION AND REMOVAL²**

6 No student shall be admitted to or otherwise enrolled in credit recovery courses unless:

- 7 1. The student's parent/guardian gives written consent for the student to enroll in the proposed
8 credit recovery course. Parents/guardians should be informed that not all postsecondary
9 institutions will accept credit recovery courses for credit and that the NCAA Clearinghouse will
10 not accept credit recovery courses for credit; and
- 12 2. The student has previously taken an initial, non-credit recovery section of the proposed course
13 and received a grade of at least fifty percent (50%). Students who receive a grade of below fifty
14 percent (50%) in the non-credit recovery section of the course must re-take the course.

15 If a student is seeking to recover credit for the first semester of a two-semester course, the student may
16 not receive the full credit for the course until he/she has enrolled in and passed the second semester of
17 the course and taken any applicable End of Course examinations.

18 The board shall track students enrolled in credit recovery courses as directed by the Tennessee
19 Department of Education.

20 **INSTRUCTION AND CONTENT²**

21 Credit recovery teachers shall work closely with credit recovery facilitators to correlate class content
22 and instruction.

23 The director of schools shall ensure that all credit recovery courses:

- 24 1. Align with Tennessee's current academic standards for the relevant course content area, as
25 approved by the State Board of Education; and
- 26
27 2. Differentiate instruction to address individual student growth needs based on diagnostic
assessment or End of Course data.

1 Students in credit recovery programs shall:

- 2 1. Complete a course skill-specific diagnostic to determine skill-specific goals;
- 3
- 4 2. Meet individual skill-specific goals in a flexible time frame as established by identified student
- 5 need; and
- 6
- 7 3. Master all individualized skill-specific goals as established by the diagnostic process in order to
- 8 earn credit.

9 **GRADES²**

10 Students passing credit recovery shall receive a grade of sixty percent (60%) under the state uniform
11 grading system. If the district utilizes a locally-adopted grading scale that differs from the uniform
12 grading scale, a student passing credit recovery shall receive a D.³

Legal References

1. State Board of Education Policy 2.103; TRR/MS 0520-01-03-.03(13)
2. State Board of Education Policy 2.103
3. State Board of Education Policy 3.301

Cross References

Virtual Education Program 4.212
Grading System 4.600
Promotion and Retention 4.603

Hickman County Board of Education

	Descriptor Term:	Descriptor Code: 4.402	Issued Date: 08/01/22
	Reconsideration of Instructional Materials and Textbooks	Rescinds: 4.402	Issued: 06/05/22

1 ~~The Board supports principles of intellectual freedom inherent in the First Amendment of the~~
2 ~~Constitution of the United States¹ and expressed in the *Library Bill of Rights* of the American Library~~
3 ~~Association.~~

4 ~~Because opinions differ, there may be questions concerning some instructional and library materials~~
5 ~~despite the quality of the selection process. If a complaint is made, the following procedure is to be~~
6 ~~followed:¹~~

- 7 1. Inform the complainant of the selection procedures and make no commitments.
- 8 2. Request the complainant to submit a formal “Request for Reconsideration of Instructional
9 Materials”.
- 10 3. Inform the director of schools (and other appropriate personnel).
- 11 4. Keep challenged materials available for use during the reconsideration process.²
- 12 5. Upon receipt of the completed form, the principal requests review of the challenged materials
13 by an ad hoc materials review committee within fifteen (15) working days, and notifies the
14 appropriate supervisor and director of schools that such review is being done. The review
15 committee is appointed by the principal, and includes certificated library media personnel,
16 representatives from classroom teachers, one or more parents, and may include one or more
17 students.
- 18 6. The review committee shall take the following steps after receiving the challenged materials:
 - 19 a. Read, view or listen to the material in its entirety;
 - 20 b. Check general acceptance of the material by reading recognized and evaluative reviews;
 - 21 c. Determine the extent to which the material supports the curriculum;
 - 22 d. Complete the appropriate “Checklist for Reconsideration of Instructional Materials”,
23 judging the material for its strength and value; and
 - 24 e. Present recommendation to principal for further action and to the director of schools for
25 purposes of information.

- 1 7. If the complainant desires further action after receiving the recommendation of the committee and the decision of the principal, an appeal may be made to the Board.

Legal References

1. *Board of Education, Island Trees Union Free School District No. 26 v. Pico*, 457 U.S. 853, 102 S. Ct. 2799 (1982)
2. TCA 49-1-302(a)(8); TCA 49-1-314; TCA 49-6-2206; Public Acts of 2022, Chapter No. 1085

Cross References

Instructional Standards 4.101
Textbooks and Instructional Materials 4.400
School and System Websites 4.407
Controversial Materials 4.801

Hickman County Board of Education

Monitoring: Review: Annually, in November	Descriptor Term: Library Materials	Descriptor Code: 4.403	Issued Date: 08/01/22
		Rescinds:	Issued:

1 *General*

2 The Director of Schools shall be responsible for library collection development. Library materials shall
3 be reviewed to ensure the content aligns with state law.¹ The library collection shall adhere to the
4 following criteria:

- 5 1. Materials shall be suitable for and consistent with the educational mission of the school;
6
- 7 2. Materials shall be appropriate for the age and maturity levels of the students who may access
8 them. The determining factor will be based on an assessment of any mature themes or content
9 (i.e., violence, sexual content, vulgar language, substance abuse);
10
- 11 3. Materials shall contain literary, historical, and/or artistic value and merit; and
12
- 13 4. The collection as a whole shall offer a variety of viewpoints.

14 Grade level supervisors shall be responsible for periodically reviewing the district's library collection
15 in line with these established standards.

16 **COMPLAINTS**

17 If a complaint is made by an employee, student, or parent/guardian, this process is to be followed:

- 18 1. Inform the complainant of the selection procedures and make no commitments.
19
- 20 2. Request the complainant to submit a Request for Reconsideration of Library Materials form.
21
- 22 3. Inform the principal (and other appropriate personnel).
23
- 24 4. Keep challenged materials available for use during the reconsideration process.
25
- 26 5. Upon receipt of the completed form, the principal shall notify the Director of Schools.
27
- 28 6. The principal shall request review of the challenged materials by an ad hoc materials review
29 committee within ten business days. The review committee is appointed by the principal and
30 includes certified library media personnel, representatives from classroom teachers, one or
31 more parents, and may include one or more students. The principal will inform the Director of

1 Schools of the review committee's progress.

3 7. The review committee shall take the following steps after receiving the challenged materials:

- 4
5 a. Read, view, or listen to the contested material in its entirety;
6 b. Check general acceptance of the material by reading recognized and evaluative reviews;
7 c. Determine the extent to which the material supports the educational mission of the
8 school;
9 d. Complete the appropriate Checklist for Reconsideration of Library Materials, judging
10 the material for its strength and value; and
11 e. Present recommendation to principal for further action and to the Director of Schools
12 for purposes of information.

13 8. The Board shall review the recommendation presented by the review committee and make the
14 determination whether the material is appropriate for the age and maturity levels of the students
15 who have access to the materials and whether the material is suitable for, and consistent with,
16 the educational mission of the school.

17
18 9. If it is determined that the material is not appropriate for the age and maturity levels of the
19 students who have access to them or is not suitable for, and consistent with, the educational
20 mission of the school, the Board shall require the school to remove the material from the library
21 collection.
22

Legal References

1. *Board of Education, Island Trees Union Free School District No. 26 v. Pico*, 457 U.S. 853, 102 S. Ct. 2799 (1982); Public Acts of 2022, Chapter No. 744

Cross References

Textbooks and Instructional Materials 4.400
School and System Websites 4.407
Controversial Materials 4.801

Hickman County Board of Education

	Descriptor Term: Promotion and Retention	Descriptor Code: 4.603	Issued Date: 07/11/22
		Rescinds: 4.603	Issued: 05/04/20

1 **PROMOTION**¹

2 The director of schools/designee shall promote students to the next grade level based on the successful
3 completion of required academic work and on the satisfactory progress in each of the relevant
4 academic areas. However, no student enrolled in the third grade shall be promoted unless the student
5 has shown a basic understanding of curriculum and the ability to perform the skills required in the
6 subject of reading as demonstrated by the student's grades or standardized test results. This
7 requirement shall not apply to students who are participating in a board-approved, research-based
8 intervention prior to the beginning of the next school year or to students who have an individualized
9 education program (IEP).²

10 Students who have difficulty in achieving the requirements for promotion may be considered for
11 retention. Schools shall identify these students by February 1st. Factors used to identify students for
12 retention shall include:¹

- 13 1. The student's ability to perform at the current grade level;
- 14 2. The results of local assessments, if applicable;
- 15 3. State assessments, as applicable;
- 16 4. Home Literacy Reports;³
- 17 5. The overall academic achievement of the student;
- 18 6. The student's chance for success with more difficult material if promoted to the next grade;
- 19 7. Attendance; and
- 20 8. Social and emotional maturity.

21 Students may be identified for retention after the February 1st deadline if the delay in identifying a
22 student is due to:⁴

- 23 1. Date of enrollment;

24
25
26
27
28
29
30
31

- 1 2. Additional information acquired after results of local assessment, screening, or monitoring are
2 released; or
- 3
- 4 3. Decisions made by a student's IEP team or extenuating medical or psychological information
5 on a case by case basis.

6 **PROMOTION PLANS⁵**

7 When a student is identified for retention, the student's parent(s)/guardian(s) shall be notified within
8 fifteen (15) calendar days, and an individualized promotion plan shall be developed to help the student
9 avoid retention. The plan shall be developed in coordination with the student's teachers, IEP or 504
10 team, if applicable, and may also include input from the student's parent(s)/guardian(s), school
11 counselor, or other appropriate school personnel.

12 Promotion plans shall incorporate evidence-based strategies, including expectations and measurements
13 that will verify whether a student has made sufficient progress to be promoted to the next grade level,
14 and be tailored to the student's learning needs. Promotion plans for students in third and fourth grade
15 will include additional requirements for promoting students in these grades. A copy of the plan will be
16 provided to the student's parent(s)/guardian(s), and the school shall offer the opportunity for a parent-
17 teacher conference to discuss the plan. If a student is not making progress on the promotion plan, then
18 the strategies shall be modified. Parent(s)/guardian(s) shall be provided with any changes to the
19 promotion plan.

20 A student who demonstrates sufficient academic progress according to his/her promotion plan shall be
21 promoted to the next grade level unless retention is required per additional requirements for students in
22 third and fourth grade.⁶

23 If a student has not demonstrated sufficient academic progress according to his/her promotion plan by
24 the end of the school year, the student shall be eligible to enroll in a summer reading or learning
25 program, if available. Parent(s)/guardian(s) shall be notified of a decision for retention at least ten (10)
26 calendar days prior to the start of the next school year if the student was enrolled in a summer program.
27 However, if the student wasn't enrolled in a summer program, the parent(s)/guardian(s) shall be
28 notified of a decision for retention at least thirty (30) calendar days prior to the start of the next school
29 year.⁷

30 **RETENTION⁶**

31 A student may be retained when, in the judgment of the student's teacher and/or the student's IEP
32 team, such retention is in the best interest of the student or when retention is required per additional
33 requirements for students in third and fourth grade. However, a student shall not be retained more than
34 once in any grade.

35 *Decision of Retention⁸*

36 If a student is retained, the director of schools/designee shall develop an individualized academic
37 remediation plan within thirty (30) calendar days after the beginning of the next school year. A copy of
38 the plan shall be provided to the student's parent/guardian within ten (10) days of its development.
39 This plan shall include at least one of the following strategies:

1. Adjustment to the current instructional strategies or materials;
2. Additional instructional time;
3. Individual tutoring outside of school hours;
4. Modification to the student's classroom assignment to ensure the student receives instruction from a highly effective teacher; or
5. Attendance or truancy interventions.

The director of schools shall develop procedures to ensure proper monitoring of students who are retained and appropriate recordkeeping.

For the purpose of determining the effectiveness of retention toward improving student achievement, the progress of retained students shall be closely monitored and reported to parent(s)/guardian(s) at least three (3) times during the school year in which the student is retained.

Decision of Retention – Third Grade⁹

Third grade students shall not be promoted to the next grade unless they are determined to be proficient (i.e., receive a performance level rating of "Met" or "Exceeded") in English language arts (ELA) based on the student's most recent TCAP test.

Students who are not proficient in ELA may still be promoted if the following conditions are met:

1. A student in third grade receiving a performance level rating of "approaching" on the ELA portion of the student's most recent TCAP test may be promoted if:
 - a. The student is an English language learner and has received less than two (2) full years of ELA instruction;
 - b. The student was previously retained in grades K-3;
 - c. The student is retested before the next school year and scores proficient in ELA;
 - d. The student attends a learning loss bridge camp before the next school year, maintains a ninety percent (90%) attendance rate, and demonstrates adequate growth on the post-test at the end of the camp; or
 - e. The student receives tutoring for the entirety of the next school year in accordance with state law.
2. A student in third grade receiving a performance level rating of "below" on the ELA portion of the student's most recent TCAP test may be promoted if:
 - a. The student is an English language learner and has received less than two (2) full years of ELA instruction;

- 1 b. The student was previously retained in grades K-3;
- 2 c. The student is retested before the next school year and scores proficient in ELA; or
- 3 d. The student attends a learning loss bridge camp before the next school year, maintains a
- 4 ninety percent (90%) attendance rate, and receives tutoring for the entirety of the next
- 5 school year in accordance with state law.

6 *Decision of Retention – Fourth Grade⁹*

7 Students in the following categories shall show adequate growth in the following ways before being
8 promoted to the fifth grade:

- 9 1. A student who is promoted to the fourth grade due to receiving tutoring for the entirety of the
- 10 next school year in accordance with state law or because of attending a learning loss bridge
- 11 camp must maintain a ninety percent (90%) attendance rate; and
- 12
- 13 2. A student receiving tutoring for the entirety of the next school year in accordance with state law
- 14 shall be required to show adequate growth on the fourth grade ELA portion of TCAP before the
- 15 student may be promoted to fifth grade.

16 A student shall not be retained more than once in fourth grade.

17 *Decision of Retention – Students with Disabilities¹⁰*

18 Retention and promotion decisions shall be made on a case-by-case basis and in consultation with the
19 student's IEP and/or 504 team to determine whether the student's performance on the ELA portion of
20 TCAP was due to the student's disability. The school district shall not retain a student with a disability
21 or a suspected disability that impacts their ability to read.

22 APPEALS^{7,11}

23 When a student is identified for retention, the parent(s)/guardian(s) shall be notified about the decision
24 to retain the student and provided with information on the right to appeal the decision. Appeals shall be
25 made to the assistant principal or principal of the school within (5) business days. The student and
26 his/her parent(s)/guardian(s) shall be provided written or actual notice of the appeal hearing and shall
27 be given the opportunity to address the assistant principal or principal. They shall conduct a hearing
28 within (5) business days to determine if the student will be promoted and issue such decision within (5)
29 business days. Upon notification of the committee decision, the principal shall send written notification
30 to the Director of Schools/designee and the parent(s)/guardian(s).

31 For students where retention is required per the additional requirements for students in third and fourth
32 grade, parent(s)/guardian(s) may appeal this decision directly to the Department of Education in
33 accordance with state law.¹²

Legal References

1. 20 USCA § 1400 *et seq.*; 29 U.S.C. § 794 (Section 504); TRR/MS 0520-01-03-.16; TCA 49-6-3115
2. TRR/MS 0520-01-03-.16(5)
3. TCA 49-1-905(e)
4. TRR/MS 0520-01-03-.16(4)
5. TRR/MS 0520-01-03-.16(6)
6. TRR/MS 0520-01-03-.16(6)(f)
7. TRR/MS 0520-01-03-.16(6)(e)
8. TRR/MS 0520-01-03-.16(6)(g)
9. TRR/MS 0520-01-03-.16(7)
10. 29 U.S.C. § 794 (Section 504); 20 USCA § 1400 *et seq.*; TRR/MS 0520-01-03-.16(7)(e)
11. TRR/MS 0520-01-03-.16(3); TRR/MS 0520-01-02-.17(7); TCA 49-6-3102(e)(1)
12. TRR/MS 0520-01-03-.16(7)(f)

Cross References

Credit Recovery 4.210
Grading System 4.600
Reporting Student Progress 4.601
Attendance 6.200
Student Assignments 6.205
Homeless Students 6.503
Student Records 6.600

1 1. A student who is promoted to the fourth grade due to receiving tutoring for the entirety of the
 2 next school year in accordance with state law or because of attending a learning loss bridge
 3 camp must maintain a ninety percent (90%) attendance rate; and
 4

5 2. A student receiving tutoring for the entirety of the next school year in accordance with state law
 6 shall be required to show adequate growth on the fourth grade ELA portion of TCAP before the
 7 student may be promoted to fifth grade.

8 A student shall not be retained more than once in fourth grade.

9 *Decision of Retention – Students with Disabilities*¹⁰

10 Retention and promotion decisions shall be made on a case-by-case basis and in consultation with the
 11 student's IEP and/or 504 team to determine whether the student's performance on the ELA portion of
 12 TCAP was due to the student's disability. The school district shall not retain a student with a disability
 13 or a suspected disability that impacts their ability to read.

14 **APPEALS**^{7,11}

Sample from model policy

15 When a student is identified for retention, the parent(s)/guardian(s) shall be notified about the decision
 16 to retain the student and provided with information on the right to appeal the decision. Appeals shall be
 17 made to a committee appointed by the principal within **[insert number of days]**. The student and
 18 his/her parent(s)/guardian(s) shall be provided written or actual notice of the appeal hearing and shall
 19 be given the opportunity to address the committee. The committee shall conduct a hearing within
 20 **[insert number of days]** to determine if the student will be promoted and issue such decision within
 21 **[insert number of days]**. Upon notification of the committee decision, the principal shall send written
 22 notification to the Director of Schools/designee and the parent(s)/guardian(s). The notification shall
 23 advise parent(s)/guardian(s) of their right to appeal such action within **[insert number of days]** to the
 24 Director of Schools/designee.

25 The appeal shall be heard no later than ten (10) business days after the request for appeal is received. A
 26 decision shall be issued within **[insert number of days]**.

27 Within five (5) business days of the Director of Schools/designee rendering a decision, the student's
 28 parent(s)/guardian(s) may request a hearing by the Board, and the Board shall review the record.
 29 Following the review, the Board may affirm or overturn the decision of the Director of
 30 Schools/designee. The action of the Board shall be final.

31 For students where retention is required per the additional requirements for students in third and fourth
 32 grade, parent(s)/guardian(s) may appeal this decision directly to the Department of Education in
 33 accordance with state law.¹²

Hickman County Board of Education

	Descriptor Term: Graduation Requirements	Descriptor Code: 4.605	Issued Date: 07/11/22
		Rescinds: 4.605	Issued: 08/02/21

1 *General*

2 The program of studies shall include areas required by the State Board of Education.

3 Before high school graduation, every student shall:¹

- 4 1. Achieve the specified twenty-four (24) units of credit;
- 5 2. Have satisfactory records of attendance and conduct;
- 6 3. Take the ACT or SAT prior to graduation;² and
- 7 4. Pass a United States civics test.³

8 Students achieving the minimum twenty-two credits will be awarded a state diploma. In order to
9 receive a Hickman County diploma, students shall obtain twenty-four credits.

10 **SPECIAL EDUCATION STUDENTS⁴**

11 Special education students who earn the prescribed twenty-four (22) credit minimum shall be awarded
12 a regular high school diploma.

13 *Special Education Diploma*

14 A special education diploma shall be awarded to students who have not met the requirements for a
15 regular high school diploma but have:⁵

- 16 1. Completed four (4) years of high school;
- 17 2. Made satisfactory progress on their IEP; and
- 18 3. Maintained satisfactory records of attendance and conduct.

19 *Occupational Diploma*

20 Special education students who do not meet the requirements for a regular high school diploma may be
21 awarded an occupational diploma if the student has:^{1,4}

- 22 1. Completed at least four (4) years of high school;
- 23 2. Made satisfactory progress on their IEP;
- 24 3. Maintained satisfactory records of attendance and conduct;
- 25 4. Completed the occupational diploma Skills, Knowledge, and Experience Mastery Assessment
26 (SKEMA); and
- 27 5. Has two (2) years of paid or non-paid work experience.

1 The decision to attain an occupational diploma shall be made at the conclusion of the student's 10th
2 grade year or two (2) academic years prior to the expected graduation date.

3 Students who have received a special education diploma or an occupational diploma shall continue to
4 make progress towards a regular high school diploma until the end of the school year in which they
5 turn twenty-two (22) years old.

6 *Alternate Academic Diploma*

7 Special education students who do not meet the requirements for a regular high school diploma may be
8 awarded an alternate academic diploma if the student has:⁴

- 9 1. Completed at least four (4) years of high school;
- 10 2. Participated in the high school alternate assessments;
- 11 3. Earned the prescribed twenty-two (22) credit minimum;
- 12 4. Made satisfactory progress on their IEP;
- 13 5. Maintained satisfactory records of attendance and conduct; and
- 14 6. Completed a transition assessment that measures postsecondary education and training,
15 employment, independent living, and community involvement.

16 **STUDENT LOAD**

17 All full time students in grades 9-12 shall be enrolled each semester in subjects that produce a
18 minimum of five (5) units of credit for graduation per year. Students with hardships and gifted students
may appeal this requirement to the director of schools and then to the board.⁶

20 **EARLY GRADUATION⁷**

21 High school students shall be permitted to complete an early graduation program. Students intending to
22 graduate early shall inform the school principal of this intent prior to the beginning of 9th grade or as
23 soon thereafter as the intent is known.

24 In order to graduate early, students must meet the following requirements:

- 25 1. Earn the required seventeen (17) credits;
- 26 2. Achieve a benchmark score for each required end-of-course exam;
- 27 3. Attain a cumulative GPA of at least 3.2 on a 4.0 scale;
- 28 4. Meet the minimum ACT or SAT benchmark score;
- 29 5. Obtain a qualifying benchmark score on a world language proficiency assessment; and
- 30 6. Complete at least two (2) types of the following courses:
 - 31 a. AP;
 - 32 b. IB;
 - 33 c. Dual enrollment; or
 - 34 d. Dual credit.

35 The director of schools shall develop administrative procedures to ensure that the early graduation
36 program is conducted in accordance with state law.

Legal References

1. TCA 49-6-6001; State Board of Education Policy 2.103; TRR/MS 0520-01-03-.06
2. TCA 49-6-6001(b); State Board of Education Policy 2.103
3. TCA 49-6-408; State Board of Education Policy 2.103
4. TRR/MS 0520-01-03-.06; State Board of Education Policy 2.103
5. TCA 49-6-6005; State Board of Education Policy 2.103
6. TRR/MS 0520-01-03-.06
7. TCA 49-6-8103; State Board of Education Policy 2.103

Cross References

Class Size Ratios 4.201
Alternative Credit Options 4.209
Honor Roll, Awards, & Class Ranking 4.602

Hickman County Board of Education

	Descriptor Term: Attendance	Descriptor Code: 6.200	Issued Date: 08/01/22
		Rescinds: 6.200	Issued: 08/02/21

1 Attendance is a key factor in student achievement and therefore, students are expected to be present
2 each day school is in session. The official school day for students begins at 8:00 a.m. and concludes at
3 3:00 p.m. unless so noted on the Board approved calendar.

4 The attendance supervisor shall oversee the entire attendance program which shall include: ¹

- 5 1. All accounting and reporting procedures and their dissemination;
6
- 7 2. Alternative program options for students who severely fail to meet minimum attendance
8 requirements;
9
- 10 3. Ensuring that all school age children attend school;
11
- 12 4. Providing documentation of enrollment status upon request for students applying for new or
reinstatement of driver's permit or license; and
- 14
15 5. Notifying the Department of Safety whenever a student with a driver's permit or license
16 withdraws from school.²

17 Student attendance records shall be given the same level of confidentiality as other student records.
18 Only authorized school officials with legitimate educational purposes may have access to student
19 information without the consent of the student or parent/guardian.³

20 Absences shall be classified as either excused or unexcused as determined by the principal/designee.
21 Excused absences shall include:⁴

- 22 1. Personal illness;
23
- 24 2. Illness of immediate family member;
25
- 26 3. Death in the family;
27
- 28 4. Extreme weather conditions;
29
- 30 5. Religious observances;⁵
31
- 32 6. Pregnancy;

1 Students with three (3) unexcused absences shall be subject to the progressive truancy intervention
2 framework outlined below.

3 **Tier I**

4 Tier I of the progressive truancy plan shall apply to all students within the district and include
5 schoolwide prevention-oriented supports to assist with satisfactory attendance. These supports shall
6 include, but are not limited to,

- 7 1. A conference with the student and the student's parent/guardian;
8
- 9 2. An attendance contract, based on the conference, signed by the student, the parent/guardian,
10 and an attendance officer. The contract shall include:
 - 11 a. A specific description of the school's attendance expectations for the student;
 - 12 b. The period for which the contract is effective. The term of the contract must not exceed
13 ninety (90) school days or continue beyond the last day of the semester, whichever
14 comes first; and
 - 15 c. Penalties for additional absences and alleged school offenses, including additional
16 disciplinary action and potential referral to juvenile court; and
17
- 18 3. Regularly scheduled follow-up meetings to discuss the student's progress.
19

20 If the student accumulates additional unexcused absences in violation of the attendance contract, in
21 Tier I, he/she shall be subject to Tier II.

22 **Tier II**

23 An individualized assessment by a school employee of the reasons a student has been absent from
24 school. This may result in referral to counseling, community-based services, or other services to
25 address the student's attendance problems.

26 **Tier III**

27 This tier shall be implemented if the truancy interventions under Tier II are unsuccessful.

28 Tier III interventions must include a review of the previous individualized assessment and an amended
29 attendance contract but may also result in further action including but not limited to a review of grades
30 and the discipline record, a referral to restorative justice programs, a referral to community-based
31 services, or a referral to the Department of Children's Services.

32 These interventions shall be determined by a team formed at each school. The interventions shall
33 address student needs in an age-appropriate manner. Finalized plans shall be approved by the Director
34 of Schools/designee.

1 MAKE-UP WORK

2 All missed class work or tests (whether from excused or unexcused absence) may be made up provided
3 the student makes the request immediately upon returning to school and provided instruction time is
4 not taken from other students.

5 A grade of incomplete will be received for any work missed until the work is completed. A student
6 may have up to three (3) days to make up work from a single absence and up to five (5) days to make
7 up work from an absence longer than a single day. It is the student's responsibility to make
8 arrangements for make-up work, and if not completed in the allotted time, a grade of zero (0) will be
9 recorded for the assignments.

10 For school-sponsored activities, the student will be required to make up all work missed and will
11 receive full credit for the assignment or upon completion of a test. The student will not be counted
12 absent for a school sponsored event (school planned, school-directed, and teacher supervised).

13 STATE-MANDATED TESTS/END OF COURSE EXAMS

14 Students who are absent the day of the scheduled End of Course Exams must present a signed doctor's
15 excuse or must have been given an excused release by the principal prior to testing to receive an
16 excused absence. Students who have excused absences will be allowed to take a make-up exam that
17 will count as 15% of their grade. Excused students will receive an incomplete in the course until they
18 have taken the End of Course Exam.

19 Students who have an unexcused absence shall receive a failing grade on the course exam which shall
20 be averaged into their final grade at 15%.

21 CREDIT/PROMOTION DENIAL

22 Credit/promotion denial determinations may include student attendance, however, student attendance
23 may not be the sole criterion.¹² However, if attendance is a factor, prior to credit/promotion denial, the
24 following shall occur:

- 25
- 26 1. Parents and students shall be advised if a student is in danger of credit/promotion denial due
27 to excessive absenteeism.
- 28 2. Procedures in due process are available to the student when credit or promotion is denied.

29 DRIVER'S LICENSE REVOCATION²

30 More than ten (10) consecutive or fifteen (15) reported unexcused absences by a student during any
31 semester renders a student ineligible to retain a driver's permit or license, or to obtain such if of age.

32 ATTENDANCE HEARING¹³

33 Students with excessive (more than 5) unexcused absences or those in danger of credit/promotion
34 denial shall have the opportunity to appeal to an attendance hearing committee appointed by the
principal. If the student chooses to appeal, the student or their parent/guardian shall be provided



Misty Shelton
Director of Accountability
Hickman County Schools
115 Murphree Avenue
Centerville, Tennessee 37033

To: School Board Members
From: Misty Shelton
Date: October 2022

1st reading:

4.210 - Credit Recovery

In June, the State Board of Education made changes to their grading scale. These changes conflicted with the policy impacting credit recovery. Policy update on lines 10-12 of page 2 to reflect that students completing credit recovery shall receive a grade of 60%. Changes are noted on the policy.

4.402 Reconsideration of Instructional Materials and Textbooks- remove lines 1-6 references the Library Bill of Rights and library materials. TSBA recommends that all information regarding library materials be maintained in policy 4.403

4.403 Library Materials- the policy has been revised by adding 8 and 9 to page 2.

4.603 - Promotion and Retention

A new state law on promotion and retention will impact students this school year. The State Board of Education has updated a regulation that goes into more detail on the process. While much focus has been placed on third and fourth grader. TSBA encourages district staff to review this process for all students as it is important to understand how this policy applies at different grade levels. Changes are noted on the policy. Appeal process should be put in place. The recommendation would be for this to be at the school level with the assistant principal/principal. There is a sample process in the model policy that would be to the board.

4.605- Graduation Requirements-

Lines 11 – 12, page 1, state that special education students must obtain 24 credits to graduate. However, per state law, these students are required to only receive 22 credits.

6.200- Attendance- recommendation to remove lines 30-36 on page 4 since this information is covered in board policy 6. 506

931-729-3391 ext. 2226

misty.shelton@hickmank12.org

fax 931-729-3834

2nd reading:

Policy 4.400 Instructional Materials- add lines 29 of page 1 to line 2 of page 2 from 4.402 to policy 4.400- footnote added and superscript changed to a 1

Policy 4.601 Reporting Student Progress- Removal of lines 11-17

Policy 6.310 Dress Code- clarification to the policy see attached

Up for Review:

- 5.100 Personnel Goals**
- 5.101 Line and Staff Relations**
- 5.102 Personnel Classification and Qualifications**
- 5.103 Job Descriptions**
- 5.104 Equal Opportunity Employment**
- 5.105 Recruitment**
- 5.1051 Job Sharing Guidelines**
- 5.106 Application and Employment**
- 5.108 Supervision**
- 5.109 Evaluation**
- 5.110 Compensation Guides and Contracts**

Thank you in advance for your careful consideration of these policies.

931-729-3391 ext. 2226

misty.shelton@hickmank12.org

fax 931-729-3834

Hickman County Board of Education

	Descriptor Term: Instructional Materials	Descriptor Code: 4.400	Issued Date: 06/05/22
		Rescinds: 4.400	Issued: 03/02/20

1 All classrooms and learning centers shall be equipped with the instructional materials needed to
2 provide quality learning experiences for students.

3 The Board seeks to provide a wide range of instructional materials that cover all levels of difficulty,
4 generate critical thinking, and support the educational programs. The director of schools shall develop
5 procedures to review and reconsider instructional materials that are allegedly inappropriate.

6 A list of instructional materials adopted for use across the school system shall be revised annually by
7 building administrators under the direction of the director of schools.

8 Upon request, parents/guardians shall have the ability to inspect the following items: instructional
9 materials; teaching materials; teaching aids; handouts; and tests that are developed by and graded by
10 their child's teacher. The director of schools shall develop procedures for the inspection of materials
11 and distribute these procedures to each principal.

12 There is included in the Tennessee BEP an amount of money sufficient to pay two hundred dollars
13 (\$200) for every teacher in kindergarten through grade twelve (K-12). This money shall be used by the
14 teachers for instructional supplies and shall be given to each teacher by October 31 of each school year
15 so that the teacher may spend it at any time during that school year on instructional supplies as
16 determined necessary by the teacher.¹ \$200.00 BEP allocations will be distributed by August 1st of
17 each school year, unless otherwise explained by the Director of Schools.

Legal References

1. TCA 49-3-359

Hickman County Board of Education

	Descriptor Term: <h2 style="text-align: center;">Reporting Student Progress</h2>	Descriptor Code: <h3 style="text-align: center;">4.601</h3>	Issued Date: <h3 style="text-align: center;">07/11/22</h3>
		Rescinds: <h3 style="text-align: center;">4.601</h3>	Issued: <h3 style="text-align: center;">05/04/20</h3>

Student report cards shall be provided once every nine (9) weeks during the school year. The reporting procedure shall be in writing and shall be uniform for all reporting periods during each school year.¹ Each report shall be signed by the parents and returned promptly to the school.

Student progress reports shall indicate the students' conduct, attendance and academic progress and other information necessary to communicate effectively with the parents.

In addition to the regular progress reports, principals and teachers are encouraged to confer with parents on the educational progress of their children. Teachers shall consult with parents of students who are working at an unsatisfactory level or whose performance shows a marked or sudden deterioration. Parents shall be notified by the teacher as early in the school year as possible if the retention of a student is being considered.

~~DRIVER'S LICENSE REVOCATION³~~

~~Any student fifteen (15) years of age or older who becomes academically deficient shall be reported to the Department of Safety for driver's license revocation.~~

~~A student shall be deemed academically deficient if he/she has not received passing grades in at least three (3) full unit subjects or their equivalency at the end of semester grading.~~

~~A copy of the notice sent to the Department of Safety by the attendance teacher or the director of schools or his/her designee shall also be mailed to the student's parent or guardian.~~

PARENT CONFERENCES

At least two (2) times during the school year, conferences shall be scheduled in which parents and teachers may discuss any pertinent problems or other matters of concern regarding the development and education of each student. These scheduled conferences shall not use any portion of the 180 days of classroom instruction.³ The director of schools shall be responsible for scheduling and coordinating systemwide conferences.

Conferences shall be physically accessible to all students, parents and/or guardians.⁴

Legal References

1. TRR/MS 0520-01-03-.03(5); TCA 49-6-901
2. TCA 49-6-3017
3. TCA 49-6-7002
4. 28 CFR § 36.201

Cross References

- School Calendar 1.800
- Section 504 & ADA Grievance Procedures 1.802
- Grading System 4.600
- Promotion and Retention 4.603
- Staff Time Schedules 5.602
- Attendance 6.200

Hickman County Board of Education

Descriptor Term: Dress Code	Descriptor Code: 6.310	Issued Date: 03/01/21
	Rescinds: 6.310	Issued: 01/07/19

1 Students shall dress and groom in a clean, neat and modest manner so as not to distract or interfere
2 with the operation of the school.

3 More specific guidelines appropriate for each type of school (elementary, intermediate, middle, and
4 high) may be developed.¹ Principals, faculty members and students shall be involved in the
5 development of each appropriate set of guidelines. These guidelines must receive Board approval prior
6 to implementation, and shall be published in each school's student handbook.

7 When a student is attired in a manner which is likely to cause disruption or interference with the
8 operation of the school, the principal shall administer appropriate punishment, which may include
9 suspension and/or expulsion.

10 The following guidelines shall apply:

11 Any clothing which is disruptive to classroom routine is inappropriate for school wear. Included as
12 disruptive are the following:

- 13 • Wearing pajamas/house shoes (except on days designated by the school administration)
- 14 • Low cut, revealing blouses/tops
- 15 • Clothing not size appropriate (no sagging, bagging, or revealed undergarments);
- 16 • Clothing bearing obscene words or pictures;
- 17 • Clothing bearing endorsements for alcohol or tobacco products;
- 18 • See-through clothing;
- 19 • Undergarments worn as outer garments (boxer shorts, long-johns);
- 20 • Clothing denoting students' membership in or affiliation with any gang associated with criminal
21 activities; and
- 22 • Any jewelry that could be considered dangerous or disruptive will not be permitted. This
23 includes but not limited to tongue rings, nose rings or eyebrow rings.

24 ~~The trunk of the body should be entirely covered from the shoulders to the point on the legs three~~
25 ~~inches above the knee.~~ Covering the trunk of the body includes making sure that:

- 26 • There shall be no holes in pants above the knee. Holes in the pants above the knee shall be
27 patched with similar or like material of the pants. ~~Simply wearing an item of clothing under the~~
28 ~~hole is not acceptable.~~
- 29 • Underclothing is not exposed by slits or holes; and
- 30 • No part of the body between shoulders and mid thigh shall be exposed.
- 31 • Leggings and other compression-style garments may be worn so long as an opaque top garment
covers the private body parts;

- 1 Any questionable attire would be left to the discretion of the principal.
- 2 The above rules would allow shorts for both girls and boys and sleeveless tops which cover the
- 3 shoulders (but not tank tops). Skirts would have to be at least as long as shorts in order to be
- 4 acceptable.
- 5 Administrative policies are to be developed by each school to address options and penalties for
- 6 violation of the above guidelines.

Legal References

1. TCA 49-6-4215

Cross References

Discipline Procedures 6.313
Suspension/Expulsion/Remand 6.316

Hickman County Board of Education

	Descriptor Term: Personnel Goals	Descriptor Code: 5.100	Issued Date: 07/06/20
		Rescinds: 5.100	Issued: 04/02/18

1 The general purpose of the administration shall be to coordinate and supervise, under Board policies, the
2 creation and operation of an environment in which students learn most effectively. The Board shall rely
3 on the director of schools to provide the professional administrative leadership.

4 The Board of Education shall clearly specify its requirements and expectations of the director of schools,
5 then holding the director of schools accountable by evaluating how well those requirements and
6 expectations have been met. In turn, the director of schools shall clearly specify requirements and
7 expectations for all administrators who report to him, then holding each accountable by evaluating how
8 well requirement and expectations have been met.

9 Major goals of administration will be:

- 10 1. To manage the system's various resources effectively and efficiently;
- 11
- 12 2. To provide professional advice and counsel to the Board and to advisory groups established
13 by Board action; and
- 14
- 15 3. To assure effective learning programs by:
 - 16
 - 17 a. Keeping abreast of current educational developments;
 - 18 b. Arranging for staff development;
 - 19 c. Coordinating efforts to improve learning programs, facilities, equipment, and materials;
20 and
 - 21 d. Providing access to the decision-making process to staff, students, parents, and others.

22 The Board recognizes that high morale in the teaching staff is essential if education of the finest
23 quality is to prevail for the pupils of the school system. Teaching is a profession, and the interest of
24 the educational program is best served when mutual understanding, cooperation and communication
25 exist among the Board, the administration, and the instructional staff.

Cross References

School District Goals 1.700

Hickman County Board of Education

	Descriptor Term: Line and Staff Relations	Descriptor Code: 5.101	Issued Date: 07/06/20
		Rescinds: 5.101	Issued: 04/02/18

- 1 The director of schools shall establish lines of authority which shall be approved by the Board and
2 shown on the system organization chart.
- 3 All personnel are expected to keep the person to whom they are immediately responsible informed of
4 their activities and shall refer matters requiring administrative action to the administrator to whom they
5 are responsible. That administrator shall refer such matters to the next higher administrative authority
6 when necessary.
- 7 All personnel shall have the right to appeal any decision made by an administrative officer through
8 grievance procedures established through board policy.
- 9 Lines of authority do not restrict the cooperative, sensible working together of all staff members at all
10 levels. The established lines of authority represent direction of authority and responsibility and
11 avenues for a two-way flow of ideas to improve the program and operations of the school system.

Cross References

Assignment/Transfer 5.115
Complaints and Grievances 5.501

Hickman County Board of Education

	Descriptor Term: Classification and Qualifications	Descriptor Code: 5.102	Issued Date: 07/06/20
		Rescinds: 5.102	Issued: 04/02/18

1 ADMINISTRATIVE AND SUPERVISORY PERSONNEL

2 All administrative and supervisory positions in the school system are established initially by the Board,
3 by state law, or State Board Rule, Regulations, and Minimum Standards.

4 To be considered for certificated administrative or supervisory positions, the applicant must show the
5 following qualifications:

- 6 1. Professional teaching certification; and
7
- 8 2. Administrative or supervisory certification and experience in accordance with state law and
9 State Board Rules and Regulations in the appropriate area based on the minimum of a
10 master's degree.

11 Non-certified administrative and supervisory personnel shall possess sufficient training and experience
12 to perform the services required and such additional qualifications as the Board and director shall
determine.

14 PROFESSIONAL PERSONNEL

15 The professional staff members are the personnel whose employment status requires certification in
16 accordance with the rules and regulations of the State Board of Education.

17 It is the responsibility of the employee to secure a certificate and to maintain its validity and for
18 registering it with the Board. Teaching contracts are automatically invalid if a certificate is allowed to
19 lapse.

20 SUPPORT PERSONNEL

21 The non-certificated staff members are personnel whose regular employment does not require
22 certification in accordance with rules and regulations of the State Department of Education. Non-
23 certificated personnel include the following employees: bookkeepers, secretaries, clerks, maintenance
24 employees, custodial employees, cafeteria employees, teacher assistants and bus personnel.

25 FULL TIME EMPLOYMENT

26 Full time employment is defined as working a minimum of thirty hours per week for a minimum of
27 thirty-six weeks. Benefits are not available to part time employees except as recommended by the
28 director and approved by the Board.

Hickman County Board of Education

	Descriptor Term: Job Descriptions	Descriptor Code: 5.103	Issued Date: 07/06/20
		Rescinds: 5.103	Issued: 04/02/18

- 1 The Board will approve the broad purpose and function of the position in accord with state laws and
2 state regulations, approve a statement of duties as recommended by the director of schools, and
3 delegate to the director of schools the task or writing, or causing to be written, a job description for the
4 position.
- 5 A copy of each job description shall be provided to the employee, the immediate supervisor and
6 included in the employee's personnel record. A copy of all job descriptions shall be maintained in the
7 director of schools' office. Copies of position description shall be made available to the public upon
8 request. Job descriptions shall be used as guides in annual employee evaluations.
- 9 The director of schools shall maintain a comprehensive, coordinated set of job descriptions for all such
10 positions so as to promote efficiency and economy in the staff's operations.

Cross References

Supervision 5.108
Evaluation 5.109
Assignment/Transfer 5.115
Qualifications and Duties of the Director of Schools 5.802

Hickman County Board of Education

	Descriptor Term: Equal Opportunity Employment	Descriptor Code: 5.104	Issued Date: 07/06/20
		Rescinds: 5.104	Issued: 04/02/18

- 1 Opportunity for employment, as well as continuation and advancement in employment, shall be
- 2 afforded equally to members of all races, creeds, colors, sexes, religions, ages, national origins, and
- 3 individuals with disabilities or veteran status with regard only for qualifications for the positions
- 4 involved.¹

Legal References

1. U.S. Constitution, Amendment XIV; Title VII, Civil Rights Act of 1964; Title VI, Civil Rights Act of 1964; Title IX, Education Amendments of 1972; Age Discrimination Act of 1967; Section 504 of the Rehabilitation Act of 1973; and 42 USCA § 12101-12213

Cross References

Section 504 & ADA Grievance Procedures 1.802
Discrimination/Harassment of Employees 5.500
Complaints and Grievances 5.501

Hickman County Board of Education

	Descriptor Term: Recruitment of Employees	Descriptor Code: 5.105	Issued Date: 07/06/20
		Rescinds: 5.105	Issued/ 04/02/18

- 1 The authorization of all school system positions rests with the Board. Personnel employment shall be
2 within the discretion of the director of schools.¹
- 3 The director of schools is responsible for the development of a program for the recruitment of licensed
4 personnel.²
- 5 Identification of personnel needs shall be the responsibility of the director of schools, supervisors, and
6 building principal. Effort shall be made to include representation of academic and professional
7 experience, age, ethnic backgrounds, race, and sex.
- 8 Vacancies will be advertised locally and through the closest placement offices. A deadline for
9 receiving applications will be established and disseminated with the vacancy notice.

Legal References

1. TCA 49-2-301(b)(1)(EE); TCA 49-2-203(a)(1)
2. TRR/MS 0520-01-02-.14

Cross References

Equal Opportunity Employment 5.104
Assignment/Transfer 5.115
Staff Positions 5.116

Hickman County Board of Education

	Descriptor Term: Job-Sharing Guidelines	Descriptor Code: 5.1051	Issued Date: 07/06/20
		Rescinds: 5.1051	Issued: 04/02/18

1 **BENEFITS**

2 State regulations do not allow a part-time employee to participate in the state insurance scheme. All
3 employees must work at least 30 hours a week in order to qualify for insurance benefits. Teachers who
4 job share will not meet this criteria.

5 **REQUIRED ATTENDANCE**

6 Each teacher will be paid for 100 days of work even though their attendance may be required for
7 additional time.

8 Each teacher will attend all required in-service days and both parent-teacher conferences. A
9 principal/supervisor may assign other days for required attendance outside of the scheduled paid days
10 if it is deemed in the best interest of the student, teacher, school, and/or the system. Each will
11 complete six (6) hours of optional in-service education.

12 **PERMISSION FROM BOARD**

13 Teachers must submit a proposal letter to the Board outlining their reasons for requesting job sharing.
14 This request will be accompanied by an outline of anticipated shared duties and responsibilities which
15 must be approved by the Board.

16 **APPROVAL PROCESS**

17 Job sharing for each team will be on a year-to-year approval basis by the Board. Request for
18 continuation of job sharing for the next school year must be submitted in writing by the June meeting
19 of the Board.

20 **RESIGNATIONS**

21 If one of the job sharing team members resigns during the year, the remaining teacher must agree to
22 work full time for the remainder of the school year if a suitable replacement cannot be found.

23 **REPLACEMENT TEACHER**

24 A teacher who is hired to fill the full-time position vacated by a tenured job-sharing teacher will do so
25 with the knowledge that the position is for one year only.

1 **TENURE**

2 A non-tenured teacher will receive half-a-year's credit toward tenure for each year of job sharing.

3 **CAREER LADDER**

4 Career Ladder teachers will receive half of the state supplement.

5 **RETIREMENT**

6 Each teacher will receive one-half year's service credit toward retirement with the Tennessee
7 Consolidated Retirement System.

8 **LICENSURE**

9 An apprentice teacher must work 100 days (based on payroll records) to be eligible to receive a year's
10 credit toward the next license level. The principal will be required to evaluate each teacher according
11 to state regulations for full-time teachers in order for the teacher to advance to the next license.

12 **HICKMAN COUNTY PAY SCHEDULE**

13	Regular	Job Sharing
14		
15 Days of Instruction	180	90
16 In-Service Training	5	2 1/2
17 Annual Leave (holidays)	10	5
18 Administrative Days	5	2 1/2
19	_____	_____
20	200 days	100 days

21

22 *Each teacher will receive one personal and five sick days per school year. State regulations require*
23 *one month of work for one sick day, and one hundred days for one personal day. Each teacher will*
24 *work five months or 100 days and thereby qualify for these days.*

Hickman County Board of Education

	Descriptor Term: Application and Employment	Descriptor Code: 5.106	Issued Date: 08/02/21
		Rescinds: 5.106	Issued: 07/06/20

1 APPLICATION

2 An individual desiring a position shall make application to the Director of Schools on forms developed
3 by his/her office. To ensure the safety and welfare of students and staff, the district shall require
4 criminal history background checks and fingerprinting of applicants for teaching positions and any
5 other positions that require proximity to children.¹ If applying for a teaching position, the Director of
6 Schools shall also check the applicant's license status in the State Board of Education's database to
7 determine if there is a hold on that applicant's license, and if so, the reasoning behind the hold.²

8 Knowingly falsifying information shall be sufficient grounds for termination of employment and shall
9 also constitute a Class A misdemeanor which shall be reported to the District Attorney General for
10 prosecution.³

11 Any costs incurred to perform these background checks and fingerprinting shall be paid by the
12 applicant. The Board shall reimburse the applicant if a position is offered and accepted.⁴

Professional Employees

14 The application shall include a transcript of credits earned at the colleges or universities attended along
15 with references from persons such as previous employers, college professors, and supervisors of
16 student teachers. Other information shall include whether such applicant has been dismissed for cause
17 from a school district.⁵ If previously employed by a local board of education, the applicant shall
18 provide evidence of acceptable resignation.

19 No person shall be employed:

- 20 1. Who does not hold a valid license to teach or a temporary permit to teach from the State Board
21 of Education;⁶
- 22 2. Who has been identified by the Department of Children's Services as a perpetrator of child
23 abuse, severe child abuse, child sexual abuse, or child neglect or who poses an immediate threat
24 to the health, safety, or welfare of children;⁷
- 25 3. Who is listed on the state's abuse of vulnerable persons registry maintained by the Department
26 of Health;⁷
- 27 4. Who does not present a physician's certificate showing a satisfactory health record or has any
28 contagious or communicable disease in such form that might endanger the health of school
29 children;⁸
- 30 5. Who refuses to take and subscribe to an oath to support the Constitution of the State of
31 Tennessee and of the United States of America;⁹

- 1 6. Who fails to make a full disclosure of any prior criminal record and any prior dismissals from
2 employment for cause; or
3 7. Who does not receive a satisfactory background check.¹⁰

4 *Support Employees*

5 No person shall be employed:

- 6 1. Who has any contagious or communicable disease in such form that might endanger the health
7 of school children;⁸
8 2. Who has been identified by the Department of Children's Services as a perpetrator of child
9 abuse, severe child abuse, child sexual abuse, or child neglect or who poses an immediate threat
10 to the health, safety, or welfare of children;⁷
11 3. Who is listed on the state's abuse of vulnerable persons registry maintained by the Department
12 of Health;⁷
13 4. Who has not complied with the Immigration Reform and Control Act of 1986;¹¹
14 5. Who fails to make a full disclosure of any prior criminal record and any prior dismissals from
15 employment for cause; or
16 6. Who does not receive a satisfactory background check.¹⁰

17 **EMPLOYMENT**

18 After checking references and receiving written recommendations, the Director of Schools shall hire
19 and assign qualified applicants.

20 *Initial Employment for Professional Employees*

21 The Director of Schools shall notify such person, in writing, of the offer and conditions of
22 employment. Upon receipt of employment notification, such person shall respond within the timeline
23 established by state law.¹² From the date of the written acceptance, such person is considered to be
24 under employment with the district and is subject to all rights, privileges, and duties.

Legal References

1. TCA 49-5-406
2. State Board of Education Policy 5.501
3. TCA 49-5-406(a)(2)(A)
4. TCA 49-5-413(c)
5. TCA 49-2-131
6. TCA 49-5-403; TCA 49-5-101; Public Acts of 2021, Chapter No. 211
7. TCA 49-5-413(e)
8. TCA 49-5-404
9. TCA 49-5-405
10. TCA 49-5-413(a), (f)
11. Immigration Reform and Control Act of 1986; Pub. L. No. 99-603, 100 Stat. 3359, 8 USCA § 1101 *et seq.*
12. TCA 49-5-406(b)

Cross References

Orientation and Probation 5.107
Compensation Guides & Contracts 5.110
Background Investigations 5.118
Recommendations and File Transfers 5.203
Interim Employees 5.700
Qualifications and Duties of the Director of Schools 5.802

Hickman County Board of Education

	Descriptor Term: <b style="text-align: center;">Supervision	Descriptor Code: <b style="text-align: center;">5.108	Issued Date: <b style="text-align: center;">07/06/20
		Rescinds: <b style="text-align: center;">5.108	Issued: <b style="text-align: center;">04/02/18

- 1 Supervision of administrative and supervisory personnel shall be provided by the director of schools.
- 2 Apprentice teachers shall be assisted by supervising teachers in the development of competencies
- 3 required by the Board.¹
- 4 Professional supervision has two major purposes: to promote and insure the coordination, quality and
- 5 continuity necessary for the operation of a good school system and to provide staff members with
- 6 assistance designed to improve their job performance.
- 7 Supervision is provided from the building level in the person of the principal and from the system level
- 8 through the supervisory staff and the office of the director of schools.
- 9 Support personnel shall be supervised by the person designated on the approved job description.
- 10 The immediate supervisor and director of schools' office share the responsibility for providing
- 11 desirable orientation experience for newly hired employees. Periodic training sessions may be
- provided for employees or employee groups as deemed necessary.
- 13 The immediate supervisor has the responsibility of assigning specific duties and for giving guidance to
- 14 the employee for the satisfactory performance of those duties.

Legal References

1. TCA 49-6-3004(c)(2)

Cross References

- Nepotism 1.108
- Drug-Free Workplace 1.804
- Job Descriptions 5.103
- Staff Positions 5.116

Hickman County Board of Education

Descriptor Term: Evaluation	Descriptor Code: 5.109	Issued Date: 07/06/20
	Rescinds: 5.109	Issued: 04/02/18

- 1 The evaluation of performance and its effectiveness must be a cooperative and shared endeavor on the
2 part of the director of schools and administrative and supervisory personnel.
- 3 The Board shall use a state-approved model for evaluating administrative and supervisory personnel
4 and shall approve standard forms to be used in evaluating support personnel.
- 5 The director of schools is responsible for ensuring that all administrative and supervisory personnel are
6 evaluated annually.

7 **LICENSED TEACHING PERSONNEL**

- 8 The Board adopts the TEAM evaluation model. The director shall draft procedures to ensure that the
9 model is implemented throughout the school system. Additionally, the director shall provide
10 information to all licensed teaching personnel regarding the nature of the evaluation and the grievance
11 procedures prescribed by the Tennessee State Board of Education.¹

Local Level Grievance Procedure

- 13 The director of schools shall develop procedures, consistent with State law, for processing evaluation
14 grievances.²

15 **NON-LICENSED PERSONNEL**

- 16 Non-licensed administrative/support personnel shall be evaluated once during the evaluation period
17 and at least one (1) additional time following successful completion of the probation period during the
18 first year of employment. Support personnel employed for more than one (1) year shall be evaluated at
19 least once a year.

- 20 Evaluations shall be used as an aid in improving an employee's performance and as a basis for
21 continuing employment. Evaluation reports shall be discussed with the evaluated employee. Each
22 employee shall be given a copy of the evaluation and shall sign the supervisor's copy as evidence it has
23 been discussed.

Legal References

1. TRR/MS 0520-02-.01-.01; TRR/MS 0520-02-01-.02
2. TRR/MS 0520-02-.01-.01(4)

Cross References

- Evaluations of Instructional Programs 4.702
Job Descriptions 5.103
Orientation and Probation 5.107

Hickman County Board of Education

	Descriptor Term: Compensation Guides & Contracts	Descriptor Code: 5.110	Issued Date: 07/06/20
		Rescinds: 5.110	Issued: 04/02/18

1 All licensed personnel must make a written contract with the Board at a fixed salary per month before
 2 entering upon their duties.¹

3 The director of schools shall establish the salary rating of each person employed and shall recommend
 4 such salary rating to the Board for its approval.²

5 Salaries of all employees, including substitute and supplemental pay, shall be paid by the Board. No
 6 payment to any employee for service performed on behalf of the school system shall be made from any
 7 source other than the Board.

8 Contracts for administrators and system-wide professional personnel shall include two-hundred (200)
 9 days of responsibility, plus twenty (20) days for each additional month assigned by the Board. Each
 10 contract shall provide:³

- 11 1. A minimum of one hundred and eighty (180) working days;
2. A minimum of five (5) days for in-service education;
- 13 3 Ten (10) annual days; and
- 14 4. Five (5) days as designated by the Board. (Teachers shall use one (1) day for parent
 15 teacher conferences.)

16 The school calendar adopted by the Board each year shall become part of each employee's contract.

17 Salaries and supplements may be paid from revenue derived from sources other than taxes, provided
 18 the revenue is deposited with and salaries paid through the Board. This includes donations or
 19 contributions from individual, civic or other non-school related sources of funds from individual
 20 school activity funds, such as gate receipts and concessions.^{1,4}

Legal References

1. TCA 49-2-203(a)(1); TCA 49-5-408
2. TCA 49-5-402
3. TCA 49-6-3004
4. TCA 49-6-2006(a)

Cross References

- School Calendar 1.800
- Revenues 2.400
- Payroll Procedures 2.802
- Salary Deductions 2.803
- Application and Employment 5.106

PROPOSED FUNDRAISING ACTIVITIES

Fund/account name CES Library

Proposed fundraising activities: Fall Book Fair
10/28 - 11/4

Purposed Uses of funds raised Library books + supplies

Expected student involvement (school-wide or specific school organization) _____

Method by which school will receive profit Profit calculated and withheld
from amount paid to Scholastic

Requested by Lori Cochran/Librarian Date 7/28/22
Name/Title

Approved by Jennifer Hudson Date 8/9/22
Principal

Approved by Michelle Gilbert Date 8/10/22
Director of Schools*

* The Director of Schools must approve all fundraising activities that involve the participation of the general student population in the marketing process of the fundraising effort.

Brian Storer (Mcquire management)

Exhibit 1

PROPOSED FUNDRAISING ACTIVITIES

Fund/account name "M^C School Night" Aug 30th 5-8 PM

Proposed fundraising activities: Local McDonald's
will donate 20% of a la carte sales

Purposed Uses of funds raised PBIS supplies

Expected student involvement (school-wide or specific school organization) _____

any community members

Method by which school will receive profit McDonald's
will send a check

Requested by MI Boy / PBIS Chair Date 8-22-22
Name/Title

Approved by [Signature] Date 8/22/22
Principal

Approved by [Signature] Date 8/25/22
Director of Schools*

* The Director of Schools must approve all fundraising activities that involve the participation of the general student population in the marketing process of the fundraising effort.

PROPOSED FUNDRAISING ACTIVITIES

Fund/account name Back to School Bash

Proposed fundraising activities: 8-26-22

to sell Eagle Spirit Stuflo . shirts, magementis

Purposed Uses of funds raised Instructional use

Expected student involvement (school-wide or specific school organization) _____

Community & School wide

Method by which school will receive profit Cash or check

Requested by Darlene Saleh / Bookkeeper Date 8-10-22
Name/Title

Approved by Leigha Coble Date 8-10-22
Principal

Approved by Michelle Shiver Date 8/11/22
Director of Schools*

* The Director of Schools must approve all fundraising activities that involve the participation of the general student population in the marketing process of the fundraising effort.

PROPOSED FUNDRAISING ACTIVITIES

Fund/account name Library

Proposed fundraising activities: Book Fair (~~Fall~~) Oct/Nov

Purposed Uses of funds raised

Library items supplies

Expected student involvement (school-wide or specific school organization) _____

to purchase item from Book Fair

Method by which school will receive profit 25% net profit

Requested by Rebekah Sorensen / Librarian
Name/Title _____ Date 8-10-22

Approved by Leisha Coble
Principal _____ Date 8-10-22

Approved by Mickie Hibert
Director of Schools* _____ Date 8/11/22

* The Director of Schools must approve all fundraising activities that involve the participation of the general student population in the marketing process of the fundraising effort.

PROPOSED FUNDRAISING ACTIVITIES

Fund/account name Yearbooks

Proposed fundraising activities: raise money for General
Funds

Purposed Uses of funds raised teacher supplies.

Expected student involvement (school-wide or specific school organization) Students will preorder yearbooks

Method by which school will receive profit School will receive a percentage of sales

Requested by Penny Wilson / teacher Date 8-10-22
Name/Title

Approved by Leigha Coble Date 8-10-22
Principal

Approved by Michelle Hivent Date 8/11/22
Director of Schools*

* The Director of Schools must approve all fundraising activities that involve the participation of the general student population in the marketing process of the fundraising effort.

PROPOSED FUNDRAISING ACTIVITIES

Fund/account name Fundraising

Proposed fundraising activities: Kona Ice - Food truck

Purposed Uses of funds raised Instructional Supplies

Expected student involvement (school-wide or specific school organization) parents
can purchase shaved ice @ our Back to School Bash

Method by which school will receive profit School will receive a percentage of sales

Requested by Penny Wilson / teacher Date 8-10-22
Name/Title

Approved by Leigha Coble Date 8-10-22
Principal

Approved by Michelle Gilbert Date 8/11/22
Director of Schools*

* The Director of Schools must approve all fundraising activities that involve the participation of the general student population in the marketing process of the fundraising effort.

PROPOSED FUNDRAISING ACTIVITIES

Fund/account name School Store. (Fundraising)

Proposed fundraising activities: School Store
(online shopping mall)

Purposed Uses of funds raised Instructional Supplies

Expected student involvement (school-wide or specific school organization) Parents can purchase items online from various participating stores. Examples Walmart, Old Navy, Kohls, etc over 400 stores for teachers classroom supplies

Method by which school will receive profit School will receive a percentage of sales

Requested by Darlene Saleh / Book Keeper Date 8-10-22
Name/Title

Approved by Leigha Coble Date 8-10-22
Principal

Approved by Michelle Silver Date 8/11/22
Director of Schools*

* The Director of Schools must approve all fundraising activities that involve the participation of the general student population in the marketing process of the fundraising effort.

PROPOSED FUNDRAISING ACTIVITIES

Fund/account name Pictures

Proposed fundraising activities: Fall and Spring pictures

Purposed Uses of funds raised General Fund

Expected student involvement (school-wide or specific school organization) Students
Will have pictures made and parents can order
from proofs

Method by which school will receive profit Will receive 30% of
net profit

Requested by Penny Wilson/teacher Date 8-10-22
Name/Title

Approved by Reigha Coble Date 8-10-22
Principal

Approved by Michelle Trivett Date 8/11/22
Director of Schools*

* The Director of Schools must approve all fundraising activities that involve the participation of the general student population in the marketing process of the fundraising effort.

TIMELESS TREASURES
PHOTOGRAPHY BY WAYNE BAKER
(931) 623-3470
Timeless.treasures.photography@live.com

BID TO PERFORM ALL SCHOOL PHOTOGRAPHY NEEDS FOR
EAST HICKMAN ELEMENTARY SCHOOL
FOR THE 2022-2023 SCHOOL YEAR

The School will receive:

1. I will pay 30% of net profit from both fall and spring picture sales to the school within 30 days of completion.
2. Each teacher, that requests it, will be given the smallest photo package offered, to be used by them or their student children.
3. Each teacher will receive an 8 x 10 print of their class photo.
4. Yearbook Company will receive all photos in their format in a timely manner.
5. I will be available to yearbook staff for any photo assistance they request.
6. School has the right to demand any work that isn't acceptable be performed again at no extra expense to them.

The photographer will receive:

1. Space to safely locate equipment necessary for taking school pictures.

Timeless Treasures/Wayne Baker
EHES/Leigha Coble

Wayne Baker
Leigha Coble

PROPOSED FUNDRAISING ACTIVITIES

Fund/account name CIS Bookfair

Proposed fundraising activities: Scholastic Bookfair and stickers/erasers - October 19 - November 1

Purposed Uses of funds raised New books for the library and cover the Bus Cost for the AR Field Trip

Expected student involvement (school-wide or specific school organization) School Wide

Method by which school will receive profit Scholastic Dollars and cash profit from stickers and erasers

Requested by Bethany Powers / Librarian Date 8/15/22
Name/Title

Approved by [Signature] Date 8/15/20
Principal

Approved by Michelle Silvert Date 8/17/22
Director of Schools*

* The Director of Schools must approve all fundraising activities that involve the participation of the general student population in the marketing process of the fundraising effort.

PROPOSED FUNDRAISING ACTIVITIES

Fund/account name CIS Fundraiser

Proposed fundraising activities: Walk the Dawg - October 1st

Purposed Uses of funds raised

rewards/materials

Expected student involvement (school-wide or specific school organization) _____

School wide

Method by which school will receive profit Students earn money

by gaining pledges for completed laps

Requested by [Signature]
Name/Title

Date 9/14/22

Approved by [Signature]
Principal

Date 9/14/22

Approved by Michelle Hewitt
Director of Schools*

Date 9/15/22

* The Director of Schools must approve all fundraising activities that involve the participation of the general student population in the marketing process of the fundraising effort.

PROPOSED FUNDRAISING ACTIVITIES

Fund/account name CIS Fundraiser

Proposed fundraising activities: Boo Bash - Oct 28 after school
Oct 31 during school day

Purposed Uses of funds raised
PBIS /rewards /instructional materials

Expected student involvement (school-wide or specific school organization) _____
School-wide

Method by which school will receive profit concessions - both
participation is extras - after school
(some activities will be free)

Requested by Rose Kate Oites /Principal Date 9/14/22
Name/Title

Approved by Rose [Signature] Date 9/14/22
Principal

Approved by Michelle Helvert Date 9/15/22
Director of Schools*

* The Director of Schools must approve all fundraising activities that involve the participation of the general student population in the marketing process of the fundraising effort.

PROPOSED FUNDRAISING ACTIVITIES

Fund/account name Golf

Proposed fundraising activities: DBC Golf Scramble

Weekend of August 26th + 27th

Purposed Uses of funds raised

Bags, balls, course fees, equipment

Expected student involvement (school-wide or specific school organization)

HCHS & HCHS Golf Teams & Various Community Members

Method by which school will receive profit Registration Fees

Requested by Zach Bentley/Golf
Name/Title Coach

Date 7-27-22

Approved by Iman A. Shug
Principal

Date 7-28-22

Approved by Michelle Hiver
Director of Schools*

Date 8/5/22

* The Director of Schools must approve all fundraising activities that involve the participation of the general student population in the marketing process of the fundraising effort.

PROPOSED FUNDRAISING ACTIVITIES

Fund/account name Golf

Proposed fundraising activities: Golf skills Day
September 14th

Purposed Uses of funds raised
Bags, Pulos, course fees, equipment

Expected student involvement (school-wide or specific school organization) 60 CIS students, Heas & HCBHS Golf Teams

Method by which school will receive profit \$10 charge to participate

Requested by Zach Bentley / Golf Coach Date 7-27-22
Name/Title

Approved by [Signature] Date 7-28-22
Principal

Approved by [Signature] Date 8/5/22
Director of Schools*

* The Director of Schools must approve all fundraising activities that involve the participation of the general student population in the marketing process of the fundraising effort.

PROPOSED FUNDRAISING ACTIVITIES

Fund/account name Boys Basketball

Proposed fundraising activities: Bulldog Basketball Camp
week of October 3rd-7th

Purposed Uses of funds raised
shoes, apparel, basketballs, court cleaning supplies

Expected student involvement (school-wide or specific school organization)
CIS students + CES students

Method by which school will receive profit \$5 charge to participate

Requested by Zach Bentley / Basketball Date 7-27-22
Name/Title Coach

Approved by Uma S. Shupp Date 7-28-22
Principal

Approved by Michelle Gilvert Date 8/5/22
Director of Schools*

* The Director of Schools must approve all fundraising activities that involve the participation of the general student population in the marketing process of the fundraising effort.

PROPOSED FUNDRAISING ACTIVITIES

Fund/account name Rewards

Proposed fundraising activities: Sell "World's Finest Chocolates" as well as other concession items during Reward times.

Purposed Uses of funds raised
Purchase rewards for students and teachers throughout the school year.

Expected student involvement (school-wide or specific school organization) School-wide (those who wish to participate)

Method by which school will receive profit Currency

Requested by [Signature] Date 7-20-22
Name/Title

Approved by [Signature] Date 7-20-22
Principal

Approved by [Signature] Date 8/9/22
Director of Schools*

* The Director of Schools must approve all fundraising activities that involve the participation of the general student population in the marketing process of the fundraising effort.

Policy 3.500

states
an policy must follow guidelines for nutrition during school day. Doesn't regulate sales after school. Make sure to follow policy.

PROPOSED FUNDRAISING ACTIVITIES

Fund/account name Rewards

Proposed fundraising activities: Kona Ice on certain WIN Days & other reward days (as it accomodates our schedules)

Purposed Uses of funds raised
Rewards for students + teachers throughout the year.

Expected student involvement (school-wide or specific school organization) School-wide – those wishing to participate

Method by which school will receive profit Currency

Requested by Paul Gilbert PBIS Committee Chair Date 8/22/22
Name/Title

Approved by Lina S. Shipper Date 8-22-22
Principal

Approved by Michelle Gilbert Date 8/25/22
Director of Schools*

* The Director of Schools must approve all fundraising activities that involve the participation of the general student population in the marketing process of the fundraising effort.

use the options that follow nutrition policy

PROPOSED FUNDRAISING ACTIVITIES

Fund/account name Beta (HCMS)

Proposed fundraising activities: Sell spirit links for homecoming competition (9/19-9/22)

Purposed Uses of funds raised
lower the cost of convention, help with community service projects

Expected student involvement (school-wide or specific school organization) school-wide

Method by which school will receive profit cash

Requested by Faith Tanner/Beta Date 8/16/22
Name/Title Sponsor

Approved by Jina S. Shupin Date 8-18-22
Principal

Approved by Michele Sivert Date 8/25/22
Director of Schools*

* The Director of Schools must approve all fundraising activities that involve the participation of the general student population in the marketing process of the fundraising effort.

PROPOSED FUNDRAISING ACTIVITIES

Fund/Account Name: ETHOS GOLF

Proposed Fundraising Activities: LITTLE CAESAR PIZZA KITS

Proposed Uses of Funds Raised: Indoor practice / training equipment

Expected Student Involvement (school-wide or specific school organization):
GOLF TEAM

Method by which school will receive profit: CASH / CHECK

Requested by (Name/Title): Preston Hobb / ^{PG}Head Golf _{Coach} Date: 8/8/22

Approved by (Principal): Boya Arif Date: 8/8/22

Approved by (Director of Schools): Michelle Stewart Date: 8/22/22

Exhibit 1

PROPOSED FUNDRAISING ACTIVITIES

Fund/account name East Hickman Middle School Girls Soccer

Proposed fundraising activities: Krispy Kreme

Purposed Uses of funds raised Referee fees

Expected student involvement (school-wide or specific school organization) Team Only

Method by which school will receive profit Cash & Check

Requested by Wendell Gordon - Coach
Name/Title

Date 8-17-2022

Approved by Boya Ayl
Principal

Date 8/17/22

Approved by Michelle Hwert
Director of Schools*

Date 8/20/22

* The Director of Schools must approve all fundraising activities that involve the participation of the general student population in the marketing process of the fundraising effort.

PROPOSED FUNDRAISING ACTIVITIES

Fund/Account Name: EHMS Gen. Fund

Proposed Fundraising Activities: Selling OHS Spunkmeyer Cookies

Proposed Uses of Funds Raised: Supplies / Equipment / Fees

Expected Student Involvement (school-wide or specific school organization):

School wide

Method by which school will receive profit: Percentage of total sales at the end of the fundraiser

Requested by (Name/Title): Bryan Anglin Date: 9/2/22

Approved by (Principal): Bryan Anglin Date: 9/2/22

Approved by (Director of Schools): Michelle Gilbert Date: 9/6/22

PROPOSED FUNDRAISING ACTIVITIES



East Hickman High School
7700 Hwy 7, Lyles, TN 37098
Phone 931-670-1366 Fax 931-670-1039

Fund/Account Name CDC

Account Number 824

Proposed fundraising activities: Monthly Lunches

Purposed Uses of funds raised: Classroom rewards / supplies

Expected Student involvement (school-wide or specific school organization): ELC class + peer helpers

Method by which school will receive profit: \$6.00 a plate cash or check

Open Period to 7/29/22

Requested by: Sheryl Robinson / ELC Teacher
Name/Title

7-28-22
Date

Approved by: Kimberly Williams
Principal

7/29/22
Date

Approved by: Michelle Albert
Director of Schools*

8/2/22
Date

* The Director of Schools must approve all fundraising activities that involve the participation of the general student population in the marketing process of the fundraising effort.

PROPOSED FUNDRAISING ACTIVITIES



East Hickman High School
7700 Hwy 7, Lyles, TN 37098
Phone 931-670-1366 Fax 931-670-1039

Fund/Account Name Class of 2024

Account Number _____

Proposed fundraising activities: Shirt sale for class

Purposed Uses of funds raised: Class materials / grad fund

Expected Student involvement (school-wide or specific school organization): Students in EHHS

Method by which school will receive profit: cash, check, Debit card

Jeff Nordke 7/29/22

Requested by: Sheryl Robinson / Lead class sponsor
Name/Title _____ Date 7-29-22

Approved by: Kimberly Williams
Principal _____ Date 7/29/22

Approved by: Michelle Fivert
Director of Schools* _____ Date 8/2/22

* The Director of Schools must approve all fundraising activities that involve the participation of the general student population in the marketing process of the fundraising effort.

PROPOSED FUNDRAISING ACTIVITIES



East Hickman High School
7700 Hwy 7, Lyles, TN 37098
Phone 931-670-1366 Fax 931-670-1039

Fund/Account Name FCS

Account Number 835

Proposed fundraising activities: collection of dues

Purposed Uses of funds raised: club expenses, veteran's day

Expected Student involvement (school-wide or specific school organization): FCS

Students only

Method by which school will receive profit: checks ; cash

Requested by: Robyn Emerson / Teacher
Name/Title

8-2-22
Date

Approved by: Kimberly Williams
Principal

8-2-22
Date

Approved by: Michelle Hivent
Director of Schools*

8/5/22
Date

* The Director of Schools must approve all fundraising activities that involve the participation of the general student population in the marketing process of the fundraising effort.

Joe Nordke 8/3/22

PROPOSED FUNDRAISING ACTIVITIES



East Hickman High School
7700 Hwy 7, Lyles, TN 37098
Phone 931-670-1366 Fax 931-670-1039

Fund/Account Name FCS

Account Number 835

Proposed fundraising activities: Sell t-shirts / sweatshirts

Purposed Uses of funds raised: club expenses, veterans day

Expected Student involvement (school-wide or specific school organization): FCS
students only

Method by which school will receive profit: cash, check

Requested by: Robyn Emerson / Teacher 8-2-22
Name/Title Date

Approved by: Kimberly Williams 8-2-22
Principal Date

Approved by: Michelle Helvert 8/5/22
Director of Schools* Date

* The Director of Schools must approve all fundraising activities that involve the participation of the general student population in the marketing process of the fundraising effort.

Joe Nordiko 8/3/22

PROPOSED FUNDRAISING ACTIVITIES

Fund/account name Freshman Class 2024

Proposed fundraising activities: class t-shirt sale

Purposed Uses of funds raised
end of year plaques, senior trip, graduation,
(class fund)

Expected student involvement (school-wide or specific school organization) _____

Entire class of 2026 - about 100 students

Method by which school will receive profit \$1 5.00 to \$1 7.00 added
to actual cost of shirt

Requested by Tracy Poth (class sponsor) Date August 2, 2022
Name/Title

Approved by Kimberly Coleman Date 08/3/22
Principal

Approved by Michelle Hwert Date 8/5/22
Director of Schools*

* The Director of Schools must approve all fundraising activities that involve the participation of the general student population in the marketing process of the fundraising effort.

Jojo Nordke 8/3/22

PROPOSED FUNDRAISING ACTIVITIES

Fund/account name Boys & Girls Cross Country

Proposed fundraising activities: Annual smart card sale

Purposed Uses of funds raised
Funds are used to pay for
MSCCA and TSSAA meet fees

Expected student involvement (school-wide or specific school organization) Our teams
will be working in conjunction with our middle school teams.

Method by which school will receive profit We keep money collected and
issue Innovative Funding a check for their cut.

Requested by [Signature] Date 7/29/22
Name/Title

Approved by [Signature] Date 8/2/22
Principal

Approved by [Signature] Date 8/5/22
Director of Schools*

* The Director of Schools must approve all fundraising activities that involve the participation of the general student population in the marketing process of the fundraising effort.

[Signature] 7/29/22

PROPOSED FUNDRAISING ACTIVITIES



East Hickman High School
7700 Hwy 7, Lyles, TN 37098
Phone 931-670-1366 Fax 931-670-1039

Fund/Account Name Class of 2023

Account Number 703

Proposed fundraising activities: Class T-shirt Sale

Purposed Uses of funds raised: Graduation Expenses

Expected Student involvement (school-wide or specific school organization): purchase t-shirts

Method by which school will receive profit: cost \$8.00 sell \$12.00

Requested by: Crystal Wilson Senior Class Sponsor 8-3-22
Name/Title Date

Approved by: Kimberly Williams 8-3-22
Principal Date

Approved by: Michelle River 8/8/22
Director of Schools* Date

* The Director of Schools must approve all fundraising activities that involve the participation of the general student population in the marketing process of the fundraising effort.

Jojo Nordke

PROPOSED FUNDRAISING ACTIVITIES



East Hickman High School
7700 Hwy 7, Lyles, TN 37098
Phone 931-670-1366 Fax 931-670-1039

Fund/Account Name

Sophomore Class

Account Number

Proposed fundraising activities:

Country Meats

Purposed Uses of funds raised:

The sell of Country meat sticks will allow the sophomores to raise money toward graduation.

Expected Student involvement (school-wide or specific school organization):

Michaiah Mathis will sell the sticks from his classroom to the student body.

Method by which school will receive profit:

Cash

Requested by:

Robert Castalbey
Name/Title

8/4/22

Date

Approved by:

Kimberly Williams
Principal

8/4/22

Date

Approved by:

Michelle Hiett
Director of Schools*

8/8/22

Date

* The Director of Schools must approve all fundraising activities that involve the participation of the general student population in the marketing process of the fundraising effort.

Jojo Nordke



AMY BRYANT
9589 S. Lick Creek Rd., Lyles, TN 37098

JACKIE DEITMEN
1911 Deitmen Ln., Nunnally, TN 37137

TIM HOBBS
9220 Old Bon Aqua Rd., Bon Aqua, TN 37025

JIM HUDGINS
1297 E. Grinders Switch Rd., Centerville, TN 37033

JEWELL PRINCE
2439 Skyview Dr., Centerville, TN 37033

KATHY REDDEN
11379 Moss Branch Rd., Bon Aqua, TN 37025

MIKE THOMASSON
105 Hickory Trace, Lyles, TN 37098

Michelle Gilbert
SUPERINTENDENT
115 MURPHREE AVENUE
CENTERVILLE, TN 37033

**School Support Organization
Request For Fundraising Activities**

Organization EHHS Band + Choir Boosters

Proposed Fundraising Activity Lollipop Fundraiser

Date(s) 10/10 - 10/21, 2022

Location(s) School + Community

Requested By DeAnna Heald
President/Chair of Organization

Date 3/may/2022

Recommended By Kimberly Williams
Principal

Date 06/8/2022

Approved Michelle Gilbert
Director of Schools or Designee

Date 8/10/22

Not Approved _____
Director of Schools or Designee

Date _____

Jojo Nordke

* Must follow school nutrition policy during school hours

A signed copy will be mailed to the organization and forwarded to the school



AMY BRYANT
9589 S Lick Creek Rd., Lyles, TN 37098

JACKIE DEITMEN
1911 Deitmen Ln., Nunnely, TN 37137

TIM HOBBS
9220 Old Bon Aqua Rd., Bon Aqua, TN 37025

JIM HUDGINS
1297 E Grinders Switch Rd., Centerville, TN 37033

JEWELL PRINCE
2439 Skyview Dr., Centerville, TN 37033

KATHY REDDEN
11379 Moss Branch Rd., Bon Aqua, TN 37025

MIKE THOMASSON
105 Hickory Trace, Lyles, TN 37098

Michelle Gilbert
SUPERINTENDENT
115 MURPHREE AVENUE
CENTERVILLE, TN 37033

**School Support Organization
Request For Fundraising Activities**

Organization EHTS Band + Choir Boosters

Proposed Fundraising Activity Football Game Concessions Tent

Date(s) 8/19, 9/9, 9/30, 10/7, 10/28 + any post season games, 2022

Location(s) EHTS Stadium

Requested By DeAnna Heald
President/Chair of Organization

Date 3 May 2022

Recommended By Kimberly Williams
Principal

Date 06/08/22

Approved Michelle Gilbert
Director of Schools or Designee

Date 8/11/22

Not Approved _____
Director of Schools or Designee

Date _____

Jordan Nordike

A signed copy will be mailed to the organization and forwarded to the school



AMY BRYANT
9589 S Lick Creek Rd., Lyles, TN 37098

JACKIE DEITMEN
1911 Deitmen Ln., Nunnally, TN 37137

TIM HOBBS
9220 Old Bon Aqua Rd., Bon Aqua, TN 37025

JIM HUDGINS
1297 E. Grinders Switch Rd., Centerville, TN 37033

JEWELL PRINCE
2439 Skyview Dr., Centerville, TN 37033

KATHY REDDEN
11379 Moss Branch Rd., Bon Aqua, TN 37025

MIKE THOMASSON
105 Hickory Trace, Lyles, TN 37098

Michelle Gilbert
SUPERINTENDENT
115 MURPHREE AVENUE
CENTERVILLE, TN 37033

**School Support Organization
Request For Fundraising Activities**

Organization EHHS Band + Choir Boosters

Proposed Fundraising Activity Pancake Breakfast

Date(s) 4/2 + presell tickets starting 1 month prior, 2023

Location(s) East Hickman Community Center

Requested By DeAnna Heald
President/Chair of Organization

Date 3 May 2022

Recommended By Kimberly Williams
Principal

Date 06/08/2022

Approved Michelle Gilbert
Director of Schools or Designee

Date 8/11/22

Not Approved _____
Director of Schools or Designee

Date _____

Jane Nordke

A signed copy will be mailed to the organization and forwarded to the school



AMY BRYANT
9589 S Lick Creek Rd., Lyles, TN 37098

JACKIE DEITMEN
1911 Deitmen Ln., Nunnely, TN 37137

TIM HOBBS
9220 Old Bon Aqua Rd., Bon Aqua, TN 37025

JIM HUDGINS
1297 E. Grinders Switch Rd., Centerville, TN 37033

JEWELL PRINCE
2439 Skyview Dr., Centerville, TN 37033

KATHY REDDEN
11379 Moss Branch Rd., Bon Aqua, TN 37025

MIKE THOMASSON
105 Hickory Trace, Lyles, TN 37098

Michelle Gilbert
SUPERINTENDENT
115 MURPHREE AVENUE
CENTERVILLE, TN 37033

School Support Organization
Request For Fundraising Activities

Organization EHTS Band + Choir Boosters

Proposed Fundraising Activity Concert Concessions

Date(s) Fall - O'-Ween, winter, Spring - Dates TBA

Location(s) EHTS Foyer

Requested By DeAnna Heald
President/Chair of Organization

Date 3 May 2022

Recommended By Kimberly W. Adams
Principal

Date 06/08/2022

Approved Michelle Gilbert
Director of Schools or Designee

Date 8/11/22

Not Approved _____
Director of Schools or Designee

Date _____

A signed copy will be mailed to the organization and forwarded to the school



AMY BRYANT
9589 S Lick Creek Rd., Lyles, TN 37098

JACKIE DEITMEN
1911 Deitmen Ln., Nunnely, TN 37137

TIM HOBBS
9220 Old Bon Aqua Rd., Bon Aqua, TN 37025

JIM HUDGINS
1297 E. Grinders Switch Rd., Centerville, TN 37033

JEWELL PRINCE
2439 Skyview Dr., Centerville, TN 37033

KATHY REDDEN
11379 Moss Branch Rd., Bon Aqua, TN 37025

MIKE THOMASSON
105 Hickory Trace, Lyles, TN 37098

Michelle Gilbert
SUPERINTENDENT
115 MURPHREE AVENUE
CENTERVILLE, TN 37033

School Support Organization Request For Fundraising Activities

Organization EHTS Band + Choir Boosters

Proposed Fundraising Activity Donation Calendar ^{"March Madness"} Donation Drive

Date(s) 3/3 - 3/17, 2023

Location(s) Community

Requested By DeAnna Heald Date 3 May 2022
President/Chair of Organization

Recommended By Kimberly Williams Date 06/08/2022
Principal

Approved Michelle Stewart Date 8/11/22
Director of Schools or Designee

Not Approved _____ Date _____
Director of Schools or Designee

John Nordke

A signed copy will be mailed to the organization and forwarded to the school

PROPOSED FUNDRAISING ACTIVITIES



East Hickman High School
7700 Hwy 7, Lyles, TN 37098
Phone 931-670-1366 Fax 931-670-1039

Fund/Account Name Construction Annual Sale

Account Number 816

Proposed fundraising activities: Building Items to sell - Table, shelves, Picture frames, bird Houses

Purposed Uses of funds raised: Class Supplies

Expected Student involvement (school-wide or specific school organization): Only Construction

Method by which school will receive profit: Cash from selling items

Requested by: Wesley Whitlam
Name/Title

7-7-22
Date

Approved by: Kimberly Williams
Principal

8/8/22
Date

Approved by: Michelle Hivent
Director of Schools*

8/10/22
Date

* The Director of Schools must approve all fundraising activities that involve the participation of the general student population in the marketing process of the fundraising effort.

Jojo Nordhe

AMY BRYANT
9589 S. Lick Creek Rd., Lyles, TN 37098

RONALD GAMMONS
6419 Rice Ln., Lyles, TN 37098

TIM HOBBS
9220 Old Bon Aqua Rd., Bon Aqua, TN 37025

JIM HUDGINS
1297 E. Grinders Switch Rd., Centerville, TN 37033



Michelle Gilbert
Director of Schools
115 MURPHREE AVENUE
CENTERVILLE, TN 37033

JANE HERRON
1222 Hwy. 100., Centerville, TN 37033

STEVE GIANAKOS
9792 Dogwood Dr., Bon Aqua, TN 37025

VANCE WILLIS
2868 Hwy 48 N., Nunnely, TN 37137

School Support Organization Request For Fundraising Activities

Organization EH Southern Cheer Booster Club

Proposed Fundraising Activity Bake Sale

Date(s) August / Sept ish

Location(s) Walmart (Fairview 3 Dickson)

Requested By Tonya England Richardson 8.8.22
President/Chair of Organization Date

Recommended By Kimberly Williams 8/8/22
Principal Date

Approved Michelle Gilbert 8/12/22
Director of Schools or Designee Date

Not Approved _____
Director of Schools or Designee Date

**** A signed copy will be mailed to the organization and forwarded to the school****

Jojo Nordke 8/9/22

PROPOSED FUNDRAISING ACTIVITIES



East Hickman High School
7700 Hwy 7, Lyles, TN 37098
Phone 931-670-1366 Fax 931-670-1039

Fund/Account Name Book store

Account Number 845

Proposed fundraising activities: School Bookstore

Purposed Uses of funds raised: Funds are used to purchase inventory to restock. Excess funds are used for FBLA & CTE Activities

Expected Student Involvement (school-wide or specific school organization):
Work based learning students

Method by which school will receive profit: as items are sold

Requested by: Cindi Morgan
Name/Title

8-9-22
Date

Approved by: Kimberly Williams
Principal

8/10/22
Date

Approved by: Michelle Hilt
Director of Schools*

8/11/22
Date

* The Director of Schools must approve all fundraising activities that involve the participation of the general student population in the marketing process of the fundraising effort.

revised 4/2019

JJ Nordk

AMY BRYANT
9589 S. Lick Creek Rd., Lyles, TN 37096

RONALD GAMMONS
8419 Rice Ln., Lyles, TN 37098

TIM HOBBS
9220 Old Bon Aqua Rd., Bon Aqua, TN 37025

JIM HUDGINS
1297 E. Grinders Switch Rd., Centerville, TN 37033



Michelle Gilbert
Director of Schools
115 MURPHREE AVENUE
CENTERVILLE, TN 37033

JANE HERRON
1222 Hwy. 100., Centerville, TN 37033

STEVE GIANAKOS
8792 Dogwood Dr., Bon Aqua, TN 37025

VANCE WILLIS
2888 Hwy 48 N., Nunnally, TN 37137

**School Support Organization
Request For Fundraising Activities**

Organization EH Southern Cheer Booster Club

Proposed Fundraising Activity Sweetheart Pageant

Date(s) February 12th 2023

Location(s) EHHS Auditorium

Requested By Tonya Richardson 3.3.22
President/Chair of Organization Date

Recommended By Kimberly Williams 3/17/22
Principal Date

Approved Michelle Gilbert 3/16/22
Director of Schools or Designee Date

Not Approved _____
Director of Schools or Designee Date

**** A signed copy will be mailed to the organization and forwarded to the school****

AMY BRYANT
9599 S. Uck Creek Rd., Lyles, TN 37098

RONALD GAMMONS
8418 Rice Ln., Lyles, TN 37098

TIM HOBBS
9220 Old Bon Aqua Rd., Bon Aqua, TN 37025

JIM HUGGINS
1297 E. Grinders Switch Rd., Centerville, TN 37033



Michelle Gilbert
Director of Schools
115 MURPHREE AVENUE
CENTERVILLE, TN 37033

JANE HERRON
1222 Hwy. 100., Centerville, TN 37033

STEVE GIANAKOS
8792 Dogwood Dr., Bon Aqua, TN 37025

VANCE WILLIS
2888 Hwy 48 N., Nunnely, TN 37137

School Support Organization
Request For Fundraising Activities

Organization EH Southern Cheer Booster Club

Proposed Fundraising Activity Christmas Movie Night

Date(s) December 16th 2022

Location(s) FHHS Grand Hall

Requested By Tonya Richardson 3-3-22
President/Chair of Organization Date

Recommended By Kimberly Williams 3/17/22
Principal Date

Approved Michelle Gilbert 8/16/22
Director of Schools or Designee Date

Not Approved _____
Director of Schools or Designee Date

** A signed copy will be mailed to the organization and forwarded to the school**

PROPOSED FUNDRAISING ACTIVITIES



East Hickman High School
7700 Hwy 7, Lyles, TN 37098
Phone 931-670-1366 Fax 931-670-1039

Fund/Account Name FBLA

Account Number 846

Proposed fundraising activities: FBLA Yearly Membership Dues

Purposed Uses of funds raised: \$1 EHHS FBLA Dues

\$3 TN Dues

\$6 National Dues

Expected Student involvement (school-wide or specific school organization): FBLA members

Method by which school will receive profit: No Profit

Requested by: Cindi Morgan
Name/Title

8-16-22
Date

Approved by: Kimberly Williams
Principal

8-17-22
Date

Approved by: Michelle Silver
Director of Schools*

8/22/22
Date

* The Director of Schools must approve all fundraising activities that involve the participation of the general student population in the marketing process of the fundraising effort.

Opp Nordke

PROPOSED FUNDRAISING ACTIVITIES



East Hickman High School
7700 Hwy 7, Lyles, TN 37098
Phone 931-670-1366 Fax 931-670-1039

Fund/Account Name FCCLA

Account Number 832

Proposed fundraising activities: Sell spirit socks and eye blacks

Purposed Uses of funds raised: Help pay for FCCLA blazers

Expected Student involvement (school-wide or specific school organization):

Spirit socks and eye blacks will be sold school wide to students and staff.

Method by which school will receive profit: Cash or check from students and staff

Jo Nozdrick
Requested by: Charlotte Boehms

Name/Title

8/19/2022

Date

Approved by: *Kimberly Williams*

Principal

8/22/22

Date

Approved by: *Michelle Hivert*

Director of Schools*

8/22/22

Date

* The Director of Schools must approve all fundraising activities that involve the participation of the general student population in the marketing process of the fundraising effort.

PROPOSED FUNDRAISING ACTIVITIES



East Hickman High School
7700 Hwy 7, Lyles, TN 37098
Phone 931-670-1366 Fax 931-670-1039

Fund/Account Name FCCLA

Account Number 832

Proposed fundraising activities: Collect dues, money for cords, and money for Titans Tickets

Purposed Uses of funds raised: Pay for dues, cords, and Titans' Tickets

Expected Student involvement (school-wide or specific school organization):

Members will pay for their own dues, cords, and Titans' Tickets

Method by which school will receive profit: Cash or check from students

Joe Nerdino

Requested by: Charlotte Boehms

Name/Title

8/19/2022

Date

Approved by:

Kimberly Williams

Principal

8/22/22

Date

Approved by:

Michelle Hix

Director of Schools*

8/22/22

Date

* The Director of Schools must approve all fundraising activities that involve the participation of the general student population in the marketing process of the fundraising effort.

PROPOSED FUNDRAISING ACTIVITIES



East Hickman High School
7700 Hwy 7, Lyles, TN 37098
Phone 931-670-1366 Fax 931-670-1039

Fund/Account Name **FACS**

Account Number **820**

Proposed fundraising activities: **Create a project and submit on DonorsChoose**

Purposed Uses of funds raised:

**Supplies including cleaning and organizational supplies and some small equipment will be .
donated to the classroom**

Expected Student involvement (school-wide or specific school organization): **None.**

Method by which school will receive profit: **Materials will be shipped if project is funded.**

Jan Nardone

Requested by: **Charlotte Boehms**

Name/Title

8/19/2022

Date

Approved by:

Kimberly W. Lewis

Principal

8/22/22

Date

Approved by:

Michelle Hilvert

Director of Schools*

8/22/22

Date

* The Director of Schools must approve all fundraising activities that involve the participation of the general student population in the marketing process of the fundraising effort.

PROPOSED FUNDRAISING ACTIVITIES



East Hickman High School
7700 Hwy 7, Lyles, TN 37098
Phone 931-670-1366 Fax 931-670-1039

Fund/Account Name FACS and FCCLA

Account Number 820 and 832

Proposed fundraising activities: Make banana pudding to sell.

Purposed Uses of funds raised: Materials for labs, competition fees, travel for trips, rewards for classroom and FCCLA

Expected Student involvement (school-wide or specific school organization):

Students will make the banana pudding and scoop banana pudding at the National Banana Pudding Festival

Method by which school will receive profit: Check from NBPF

Requested by: Charlotte Boehms

08/19/2022

Name/Title

Date

Approved by:

Principal

Date

Approved by:

Director of Schools*

Date

* The Director of Schools must approve all fundraising activities that involve the participation of the general student population in the marketing process of the fundraising effort.

PROPOSED FUNDRAISING ACTIVITIES



East Hickman High School
7700 Hwy 7, Lyles, TN 37098
Phone 931-670-1366 Fax 931-670-1039

Fund/Account Name **FCCLA**

Account Number **832**

Proposed fundraising activities: **Sell Elf on the Shelf Kits**

Purposed Uses of funds raised: **Use funds to pay for travel, competition fees, and FCCLA blazers for state conference.**

Expected Student involvement (school-wide or specific school organization):

Students will create the Elf on the Shelf scenes and put kits together.

Method by which school will receive profit: **School will receive profit through Elf on the Shelf Kit sales.**

Students will collect money and turn in to teacher.

Charlotte Boehms
Requested by: **Charlotte Boehms**

8/19/2022

Name/Title

Date

Approved by:

Kimberly Williams

Principal

8/22/22
Date

Approved by:

Michelle Silbert

Director of Schools*

8/22/22
Date

* The Director of Schools must approve all fundraising activities that involve the participation of the general student population in the marketing process of the fundraising effort.

PROPOSED FUNDRAISING ACTIVITIES



East Hickman High School
7700 Hwy 7, Lyles, TN 37098
Phone 931-670-1366 Fax 931-670-1039

Fund/Account Name **FACS**

Account Number **820**

Proposed fundraising activities: **Collect money for Chef Coats for Culinary**

Purposed Uses of funds raised: **Pay for Chef Coats**

Expected Student involvement (school-wide or specific school organization):

None

Method by which school will receive profit: **Cash or check from student**

Requested by: **Charlotte Boehms**

Name/Title

8/19/2022

Date

Approved by:

Principal

8/22/22

Date

Approved by:

Director of Schools*

8/22/22

Date

* The Director of Schools must approve all fundraising activities that involve the participation of the general student population in the marketing process of the fundraising effort.



PROPOSED FUNDRAISING ACTIVITIES

East Hickman High School
7700 Hwy 7, Lyles, TN 37098
Phone 931-670-1366 Fax 931-670-1039

Fund/Account Name EHHS FFA

Account Number _____ Spring Semester

Proposed fundraising activities: Annual plant sale

Purposed Uses of funds raised: To earn funds for FFA activities and the operation of the Green House at EHHS. To purchase seeds and materials needed for the green house.

Expected Student involvement (school-wide or specific school organization): students will prepare a variety of garden and ornamental plants to be sold to the community.

Method by which school will receive profit: From sales of Ferns, mixed baskets and garden plants.

Requested by: Myles Keogh Williams EHHS AS
Name/Title

8-19-2022
Date

Approved by: Kimberly Williams
Principal

8/22/22
Date

Approved by: Michelle Hivent
Director of Schools*

8/22/22
Date

* The Director of Schools must approve all fundraising activities that involve the participation of the general student population in the marketing process of the fundraising effort.

[Handwritten signature]



PROPOSED FUNDRAISING ACTIVITIES

East Hickman High School
7700 Hwy 7, Lyles, TN 37098
Phone 931-670-1366 Fax 931-670-1039

Fund/Account Name EHHS FFA

Account Number Fall Semester

Proposed fundraising activities: Annual FFA Meat Sale with Southern Heritage in Fairhope AL

Purposed Uses of funds raised: To earn funds for FFA activities such as competitions, community relations, and state convention. To promote FFA within the school and community.

Expected Student involvement (school-wide or specific school organization): Students will sale a variety of meats for thanksgiving.

Method by which school will receive profit: Profit comes from sales. The company takes orders and FFA will receive a percentage.

Requested by: Myles Keogh Williams, EHHS AS 8-19-2022
Name/Title Date

Approved by: Kimberly Williams 8/19/22
Principal Date

Approved by: Michelle Hivert 8/22/22
Director of Schools* Date

* The Director of Schools must approve all fundraising activities that involve the participation of the general student population in the marketing process of the fundraising effort.

Joe Mordeko



PROPOSED FUNDRAISING ACTIVITIES

East Hickman High School
7700 Hwy 7, Lyles, TN 37098
Phone 931-670-1366 Fax 931-670-1039

Fund/Account Name Student Council

Account Number 838

Proposed fundraising activities: Ticket sales for homecoming skits

Purposed Uses of funds raised: Money raised to pay for homecoming expenses (flowers, crowns, etc.); any remaining money used for student rewards/teacher appreciation.

Expected Student involvement (school-wide or specific school organization):
Any student may purchase a ticket.

Method by which school will receive profit: Ticket sales - \$2.00 per ticket.

Requested by: Beth Roberts - Student Council
Name/Title SP/NSR

8-30-22
Date

Approved by: Kimberly Williams
Principal

8-30-22
Date

Approved by: Michelle Hewitt
Director of Schools*

9/1/22
Date

* The Director of Schools must approve all fundraising activities that involve the participation of the general student population in the marketing process of the fundraising effort.



PROPOSED FUNDRAISING ACTIVITIES

East Hickman High School
7700 Hwy 7, Lyles, TN 37098
Phone 931-670-1366 Fax 931-670-1039

Fund/Account Name Student Council

Account Number 838

Proposed fundraising activities: Spirit link sales during homecoming week

Purposed Uses of funds raised: Funds used to pay homecoming expenses (flowers, crowns, etc); any remaining money used for student rewards/teacher appreciation.

Expected Student involvement (school-wide or specific school organization):

Any student may purchase links

Method by which school will receive profit: Students purchase individual links

at 10¢ each or \$1.00 to steal 10 links from another class.

Requested by: Ben Robinson - Student Council
Name/Title Sponsor

8-30-22
Date

Approved by: Kimberly Williams
Principal

8-30-22
Date

Approved by: Michelle Albert
Director of Schools*

9/1/22
Date

* The Director of Schools must approve all fundraising activities that involve the participation of the general student population in the marketing process of the fundraising effort.



AMY BRYANT
9589 S. Lick Creek Rd., Lyles, TN 37096

RONALD GANNONS
6419 Rice Ln., Lyles, TN 37098

TIM HOBBS
9220 Old Bon Aqua Rd., Bon Aqua, TN 37025

JIM HUDGINS
1297 E. Grinders Switch Rd., Centerville, TN 37033

Michelle Gilbert
Director of Schools
115 MURPHREE AVENUE
CENTERVILLE, TN 37033

JANE HERRON
1222 Hwy. 100., Centerville, TN 37033

STEVE GIANAKOS
9792 Dogwood Dr., Bon Aqua, TN 37025

VANCE WILLIS
2868 Hwy 48 N., Nannelly, TN 37137

School Support Organization Request For Fundraising Activities

Organization EHHS Goal Football Booster

Proposed Fundraising Activity: Bake Goods @ game

Date(s) games

Location(s) EHHS Field

Requested By Tonya Richardson / Treasurer 8-30-22
President/Chair of Organization Date

gof no date
Recommended By Russell Williams 8-30-22
Principal Date

Approved Michelle Gilbert 9/1/22
Director of Schools or Designee Date

Not Approved _____
Director of Schools or Designee Date

**** A signed copy will be mailed to the organization and forwarded to the school****

PROPOSED FUNDRAISING ACTIVITIES



East Hickman High School
7700 Hwy 7, Lyles, TN 37098
Phone 931-670-1366 Fax 931-670-1039

Fund/Account Name

Art Club

Account Number

Proposed fundraising activities:

Face Painting for home games
(primarily homecoming)

Purposed Uses of funds raised:

Supplies for art club activities.

Expected Student involvement (school-wide or specific school organization):

Art club will be providing the service.

Method by which school will receive profit:

Cash

Requested by:

Samantha Avery / Art Teacher
Name/Title

Date

9/2/2022

Approved by:

Kimberly Williams
Principal

Date

9/2/2020

Approved by:

Michelle Gilbert
Director of Schools*

Date

9/6/22

* The Director of Schools must approve all fundraising activities that involve the participation of the general student population in the marketing process of the fundraising effort.



PROPOSED FUNDRAISING ACTIVITIES

East Hickman High School
7700 Hwy 7, Lyles, TN 37098
Phone 931-670-1366 Fax 931-670-1039

Fund/Account Name Student Council; classes of 2023, 2024, 2025, 2026

Account Number 838 (transfer to classes)

Proposed fundraising activities: Homecoming Glow Party (see attached sheet)

Purposed Uses of funds raised: Ticket revenue w(after expenses) will be distributed to classes. Money raised from food sales will go to Student Council to cover cost of food purchase and decorations

Expected Student involvement (school-wide or specific school organization):
Any EHHS student 9-12 - may bring one guest.

Method by which school will receive profit: Tickets - each class will receive a percentage of tickets purchased by their class. Pre-sale tickets are \$10.00; at the door, \$15.00.

Requested by: Beth Robinson Student Council
Name/Title Sponsor

8-30-22
Date

Approved by: Kimberly Williams
Principal

8-30-22
Date

Approved by: Michelle Hillert
Director of Schools*

9/1/22
Date

* The Director of Schools must approve all fundraising activities that involve the participation of the general student population in the marketing process of the fundraising effort.

Hello Eagles! The Student Council is excited to announce that we are planning an after school event to celebrate Homecoming. This event will be a casual after party following the Homecoming game. Details are as follows:

Date: September 9 from 9:30 pm to 11pm.

- **Tickets will be sold the week of Homecoming in Miss Robinson's room from 7:30 am to 8 am.**
- **They will cost \$10 for admittance. Tickets will also be sold at the door, but will cost \$15 if purchased at the door.**
- **Tickets will include 2 glow sticks. Additional glow sticks and other glow accessories will be sold at the party.**
- **Students must follow dress code and all other school rules to attend.**
- **Only those from 9th grade students to those age 21 can attend. EHHS students are permitted one guest only.**
- **This event is a fundraiser. Once expenses for the party are paid, the money raised will be split based on percentage between the classes. It will go to their graduation fund.**
- **The party will be held in the Grand Hall. The gym and cafeteria will not be used.**
- **Pizza will be sold at the party for \$2 a slice. A variety of chips will be sold for \$1 each.**
- **Drinks will be \$1 each.**
- **We will have neon decorations and music.**
- **Games such as glow in the dark musical chairs, cornhole, karaoke, limbo, and a photo booth will be at the party.**
- **Once students leave the party, they may not reenter.**

Please plan to come out and celebrate our Eagle football team!

PROPOSED FUNDRAISING ACTIVITIES

Fund/account name Bulldog Bakery / ELC

Proposed fundraising activities: Students run all aspects of a Bakery/
store learning vocational & social skills selling homemade & handmade items

Purposed Uses of funds raised
Develop & grow program. purchase classroom supplies

Expected student involvement (school-wide or specific school organization) ELC
class & peer helpers

Method by which school will receive profit _____

Requested by Levi Griego ELC Teacher
Name/Title

Date 8.4.22

Approved by [Signature]
Principal

Date 8/4/22

Approved by Michelle Hivert
Director of Schools*

Date 8/5/22

* The Director of Schools must approve all fundraising activities that involve the participation of the general student population in the marketing process of the fundraising effort.

PROPOSED FUNDRAISING ACTIVITIES

Fund/account name ELC

Proposed fundraising activities: Collection of used ink cartridge
& selling to DazzCycle.com

Purposed Uses of funds raised
Classroom supplies

Expected student involvement (school-wide or specific school organization) ELC students
will collect, separate, package, & ship

Method by which school will receive profit _____

Requested by Levi Griego ELC Teacher Date _____
Name/Title

Approved by [Signature] Date 8/4/22
Principal

Approved by Michelle Levitt Date 8/5/22
Director of Schools*

* The Director of Schools must approve all fundraising activities that involve the participation of the general student population in the marketing process of the fundraising effort.

PROPOSED FUNDRAISING ACTIVITIES

Fund/account name HCHS Volleyball

Proposed fundraising activities: Alumni Game

Purposed Uses of funds raised
Officials, Transportation, End-of-Season Plaques

Expected student involvement (school-wide or specific school organization)
Volleyball players "host" the evening

Method by which school will receive profit \$5 donations (admission) at the gate

Requested by Matthew Dotson/Head Coach Date 8/2/22
Name/Title

Approved by [Signature] Date 8/2/22
Principal

Approved by Michelle Shiver Date 8/2/22
Director of Schools*

* The Director of Schools must approve all fundraising activities that involve the participation of the general student population in the marketing process of the fundraising effort.

AMY BRYANT
9589 S Lick Creek Rd, Lyles, TN 37098

RONALD GAMMONS
8419 Rice Ln, Lyles, TN 37098

TIM HOBBS
9220 Old Bon Aqua Rd., Bon Aqua, TN 37025

JIM HUDGINS
1297 E Grinders Switch Rd, Centerville, TN 37033



Michelle Gilbert
Director of Schools
115 MURPHREE AVENUE
CENTERVILLE, TN 37033

JANE HERRON
1222 Hwy 100, Centerville, TN 37033

STEVE GIANAKOS
9792 Dogwood Dr, Bon Aqua, TN 37025

VANCE WILLIS
2868 Hwy 48 N, Nunnely, TN 37137

**School Support Organization
Request For Fundraising Activities**

Organization HCHS Quarterback Club

Proposed Fundraising Activity 3rd Annual Golf Tournament

Date(s) June 11, 2022

Location(s) Centerville Municipal Golf Course

Requested By Greg McRee
President/Chair of Organization

04-05-2022
Date

Recommended By [Signature]
Principal

7/18/22
Date

Approved Michelle Gilbert
Director of Schools or Designee

8/8/22
Date

Not Approved _____
Director of Schools or Designee

Date

**** A signed copy will be mailed to the organization and forwarded to the school****



AMY BRYANT
9589 S Lick Creek Rd , Lyles, TN 37098

RONALD GAMMONS
6419 Rice Ln , Lyles, TN 37098

TIM HOBBS
9220 Old Bon Aqua Rd., Bon Aqua, TN 37025

JIM HUDGINS
1297 E Grinders Switch Rd , Centerville, TN 37033

JANE HERRON
1222 Hwy 100., Centerville, TN 37033

STEVE GIANAKOS
9792 Dogwood Dr , Bon Aqua, TN 37025

VANCE WILLIS
2868 Hwy 48 N , Nunnely, TN 37137

Michelle Gilbert
Director of Schools
116 MURPHREE AVENUE
CENTERVILLE, TN 37033

School Support Organization Request For Fundraising Activities

Organization HCHS Quarterback Club

Proposed Fundraising Activity Promotion of 22-23 season to include:
Spirit wear sales, sponsorship banners, season programs, advertisements for programs,
Bulldog merchandise, and parking spaces.

Date(s) Football Season

Location(s) HCHS

Requested By Greg McRee
President/Chair of Organization

07-13-2022
Date

Recommended By [Signature]
Principal

7/18/22
Date

Approved Michelle Gilbert
Director of Schools or Designee

8/8/22
Date

Not Approved _____
Director of Schools or Designee

Date

**** A signed copy will be mailed to the organization and forwarded to the school****

PROPOSED FUNDRAISING ACTIVITIES

Fund/account name General Fund

Proposed fundraising activities: Kona Ice (arguing for the year)

Purposed Uses of funds raised reimburse the general fund

Expected student involvement (school-wide or specific school organization) Ø

Method by which school will receive profit (partial) sales from kona ice

Requested by [Signature]
Name/Title

Date 8/26/22

Approved by [Signature]
Principal

Date 8/26/22

Approved by Michelle Hebert
Director of Schools*

Date 8/26/22

* The Director of Schools must approve all fundraising activities that involve the participation of the general student population in the marketing process of the fundraising effort.

AMY BRYANT
9589 S Lick Creek Rd., Lyles, TN 37088

RONALD GAMMONS
8418 Rice Ln., Lyles, TN 37098

TIM HOBBS
9220 Old Bon Aqua Rd., Bon Aqua, TN 37025

JIM HUDGINS
1297 E Grinders Switch Rd., Centerville, TN 37033



Michelle Gilbert
Director of Schools
115 MURPHREE AVENUE
CENTERVILLE, TN 37033

JANE HERRON
1222 Hwy 100., Centerville, TN 37033

STEVE GIANAKOS
9792 Dogwood Dr., Bon Aqua, TN 37025

VANCE WILLIS
2068 Hwy 48 N., Nunnally, TN 37137

School Support Organization
Request For Fundraising Activities

Organization Above the Fun, Inc.

Proposed Fundraising Activity Autumn Basketball Game Concessions

Date(s) 10.22-22

Location(s) HCHS Gym

Requested By Joseph C. Holt, President 8-10.22
President/Chair of Organization Date

Recommended By D. P. [Signature] 8/11/22
Principal Date

Approved Michelle Gilbert 8/25/22
Director of Schools or Designee Date

Not Approved _____
Director of Schools or Designee Date

**** A signed copy will be mailed to the organization and forwarded to the school****

PROPOSED FUNDRAISING ACTIVITIES

Fund/account name 618 Girls Soccer

Proposed fundraising activities: Calendar

Purposed Uses of funds raised
pay for officials, replace soccer balls,

Expected student involvement (school-wide or specific school organization)
School-wide

Method by which school will receive profit cash, check directly

Requested by [Signature] 156, USA Lily, Barry Date 8/31/2022
Name/Title

Approved by [Signature] Date 8/31/22
Principal

Approved by Michelle Gilbert Date 9/6/22
Director of Schools*

* The Director of Schools must approve all fundraising activities that involve the participation of the general student population in the marketing process of the fundraising effort.



HCHS Girls Soccer Calendar Fundraiser



Player Name: _____

	1	2	3	4	5	6
7	8	9	10	11	12	13
14	15	16	17	18	19	20
21	22	23	24	25	26	27
28	29	30	31			

1. Pick a date and donate that amount!
2. You can pick more than one date!
3. Write your name in the square to claim it

Donations help the soccer team pay for:

- Referees
- Paint
- Fertilizer
- Trophies
- New Soccer Balls

Team Goal: \$900

Checks can be made payable to HCHS Girls Soccer



AMY BRYANT
9589 S Lick Creek Rd., Lyles, TN 37098

RONALD GAMBONS
6419 Rice Ln., Lyles, TN 37098

TIM HOBBS
9220 Old Bon Aqua Rd., Bon Aqua, TN 37025

JIM HUDGINS
1297 E Genders Switch Rd., Centerville, TN 37033

Michelle Gilbert
Director of Schools
115 MURPHREE AVENUE
CENTERVILLE, TN 37033

JANE HERRON
1222 Hwy 100., Centerville, TN 37033

STEVE GIANAKOS
9792 Dogwood Dr., Bon Aqua, TN 37025

VANCE WILLIS
2688 Hwy 48 N., Nunnally, TN 37137

School Support Organization
Request For Fundraising Activities

Organization Above the Rim Club, Inc.

Proposed Fundraising Activity BANNER SALES

Date(s) 9-20-22 thru 11-15-22

Location(s) Community

Requested By Josiah Hunt 9-20-22
President/Chair of Organization Date

Recommended By R. P. 9/20/22
Principal Date

Approved Michelle Gilbert 9/20/22
Director of Schools or Designee Date

Not Approved _____
Director of Schools or Designee Date

** A signed copy will be mailed to the organization and forwarded to the school**

PROPOSED FUNDRAISING ACTIVITIES

Fund/account name Schoolwide Fundraiser

Proposed fundraising activities: Spike Hike 9/23/22

Purposed Uses of funds raised

Raise money for outdoor equipment that can be used during recess by students & teachers

Expected student involvement (school-wide or specific school organization) _____

School wide - Those that wish to participate

Method by which school will receive profit Currency

Requested by Cynthia Gasparro Date 9-19-22
Name/Title

Approved by Jina S. Hughes Date 9-19-22
Principal

Approved by Michelle Hebert Date 9/22/22
Director of Schools*

* The Director of Schools must approve all fundraising activities that involve the participation of the general student population in the marketing process of the fundraising effort.

PROPOSED FUNDRAISING ACTIVITIES

Fund/account name _____

Proposed fundraising activities: Fall Festival

Purposed Uses of funds raised Playground Equipment

Expected student involvement (school-wide or specific school organization) _____

School-wide, community

Method by which school will receive profit Cash, ticket sales

Requested by Shelda Qualls, AP Date 9-16-2022
Name/Title

Approved by Jennifer Hudgins Date 9-16-2022
Principal

Approved by Michelle Stever Date 9/22/22
Director of Schools*

* The Director of Schools must approve all fundraising activities that involve the participation of the general student population in the marketing process of the fundraising effort.

PROPOSED FUNDRAISING ACTIVITIES

Fund/account name _____

Proposed fundraising activities: KONA Ice truck

Purposed Uses of funds raised playground equipment

Expected student involvement (school-wide or specific school organization) School-wide, fall festival event

Method by which school will receive profit check

Requested by Shelda Qualls AP Date 9-22-22
Name/Title

Approved by Jennifer Hudgin Date 9-22-22
Principal

Approved by Michelle Shiver Date 9/20/22
Director of Schools*

* The Director of Schools must approve all fundraising activities that involve the participation of the general student population in the marketing process of the fundraising effort.

PROPOSED FUNDRAISING ACTIVITIES

Fund/account name Hems Library

Proposed fundraising activities: Scholastic Book Fair

Purposed Uses of funds raised
TO buy books and supplies for the library

Expected student involvement (school-wide or specific school organization) Specific organization
Students will not be involved selling anything just coming to the fair and buying. ☺

Method by which school will receive profit Cash

Requested by Robin DeVault / Library media Specialist Date 9/8/22
Name/Title

Approved by Jina S. Juggi Date 9-8-22
Principal

Approved by Michelle Hebert Date 9/12/22
Director of Schools*

* The Director of Schools must approve all fundraising activities that involve the participation of the general student population in the marketing process of the fundraising effort.

PROPOSED FUNDRAISING ACTIVITIES

Fund/account name FCCLA

Proposed fundraising activities: Sell breast cancer t-shirts for club & class supplies

Purposed Uses of funds raised Purchase lab supplies & funds for competition materials & charges

Expected student involvement (school-wide or specific school organization) All FACS classes & FCCLA members (25-30)

Method by which school will receive profit Students will collect \$ & we will use an online store via Grandy/Ink (Supplier) for ordering
*opens us to credit card sales

Requested by Raven Davidson Date 9-14-22
Name/Title

Approved by [Signature] Date 9/14/2022
Principal

Approved by Michelle Helvert Date 9/23/22
Director of Schools*

* The Director of Schools must approve all fundraising activities that involve the participation of the general student population in the marketing process of the fundraising effort.

PROPOSED FUNDRAISING ACTIVITIES

Fund/account name Book Club

Proposed fundraising activities: Chocolate bars

Purposed Uses of funds raised To buy books

Expected student involvement (school-wide or specific school organization) Book Club members will sell to school

Method by which school will receive profit sell chocolate bars

Requested by Kristin Carter
Name/Title

Date 9/19/22

Approved by R. Pol
Principal

Date 9/21/22

Approved by Michelle Hivert
Director of Schools*

Date 9/23/22

* The Director of Schools must approve all fundraising activities that involve the participation of the general student population in the marketing process of the fundraising effort.

PROPOSED FUNDRAISING ACTIVITIES



East Hickman High School
7700 Hwy 7, Lyles, TN 37098
Phone 931-670-1366 Fax 931-670-1039

Fund/Account Name Boys Basketball

Account Number 606

Proposed fundraising activities: Alumni basketball game

Purposed Uses of funds raised: To help cover team expenses such as travel, practice gear, etc.

Expected Student involvement (school-wide or specific school organization):
Boys basketball team

Method by which school will receive profit: Through revenue brought in from entry fees, admissions, and concessions.

Requested by: [Signature] Boys basketball coach
Name/Title

9/22/22
Date

Approved by: [Signature]
Principal

9/22/22
Date

Approved by: [Signature]
Director of Schools*

9/23/22
Date

* The Director of Schools must approve all fundraising activities that involve the participation of the general student population in the marketing process of the fundraising effort.