

Regular Board of Education Meeting

November 28, 2023 5:00 PM

Robert J. Smallridge School Administration Building

I. Call to Order

II. Pledge of Allegiance and Presentation of Colors

III. School Program by Willow Brook Elementary School

IV. Approval of Agenda

V. Special Reports/Presentations

A. Good News

B. ESG Report

VI. Public Forum

VII. Consent Agenda

A. Board Minutes: 10-23-23

VIII. Items for Action

A. FY24 Budget Transfer #1 & Budget Amendment #1 - Second Reading

B. FY23 LEA Compliance Report

C. FY24 TISA Accountability Report

D. FY24 Comparability Report

E. Board Policy 1.105 School Board Legislative Involvement - First and Second Reading

F. Board Policy 1.701 School District Planning - First and Second Reading

G. Board Policy 2.601 Fundraising Activities - First and Second Reading

H. Board Policy 2.8051 Debit Cards, Credit Cards & Credit Lines - First and Second Reading

I. Board Policy 4.603 Promotion and Retention - First and Second Reading

J. Purchase of Fleet Service Truck

K. Purchase and Installation of Intercom System at ORHS

L. Locker Replacement at Robertsville Middle School

M. Purchase of New Website and Hosting Platform

N. Purchase of Classroom and Parent Communication Platform

O. ORPSEF Donation of a HAAS High Performance Mill

P. FY25 Proposed Budget Timeline

Q. Addition of 1.0 FTE ESL Teaching Assistant

R. Robertsville Middle School Step Club

IX. Items for Information

A. Enrollment and Attendance Reports

B. Financial Report

C. Head Start/Preschool Community Assessment Update

X. Items for Discussion

A. Board Self-Evaluation

XI. Old Business

XII. New Business

XIII. Communications

XIV. Adjournment



Oak Ridge High School

On Tuesday, November 7, cadets from Oak Ridge High School NJROTC Wildcat Battalion competed in the Tennessee Valley Junior ROTC League Drill Competition at Farragut High School. Oak Ridge placed fourth for Personnel Inspection and Air Rifle, second in Color Guard and first in Armed Drill, Unarmed Drill and Academics. Overall meet placement, Oak Ridge High School placed first! We have increased our lead over second place Farragut to a 9-point lead overall in the league!

ORHS had 238 students volunteer at the *Wildcats for Change* community-wide Trunk or Treat event last month. We doubled our student volunteers from last year. In total, 307 students, staff and ORHS parents helped with this event.

The ORHS Marching Band recently concluded another great season that focused around their 2023 show titled, *Metal*. With a journey that began at Band Camp in July, the 116 member Wildcat Marching Band put in 198 total hours of group rehearsal time. The band performed at ten football games and three marching competitions, where they received straight superior ratings and were three-time first divisional winners with one grand champion award. Congratulations to the students, staff, and community of the Oak Ridge High School Marching Band!

Willow Brook Elementary

WBES partnered with *Tennessee Tech University* Professors and Students to put on a day of STEM for our students! TTU students/staff prepared various lessons for each grade level to experience life as engineers who solve real world problems. A huge shout out to our STEM coaches, Dr. Tiffany Collins, Mrs. Michelle Chenot and Christopher Bruce. Each grade level had an activity with a Portrait of a Graduate theme and technology integration:

- Kindergarten – What will the weather be using Beebots & practicing the 4 C's.
- 1st grade – Earth, moon, and sun patterns using Dash Robots and practice self-discipline, awareness, and empathy.
- 2nd grade - Sheep in a jeep using Spheros and exploring STEM related careers.
- 3rd grade - bionic animal prosthetic designs using 3D printers and practicing digital citizenship with technology tools
- 4th grade - Environmental/Ocean clean up (oil spills & recycling) using the Dash Robots and preparing students for college, career, and life success.



Willow Brook Elementary (cont'd)

WBES hosted author Raul the Third to campus earlier this month! His books have won multiple awards for illustration and story, and he tells his stories in both English and Spanish! A great time was had by all students!

WBES hosted their Annual Veteran's Day Breakfast on November 10th. We had over 40 Veteran's join us for a breakfast to salute their Service!

WBES hosted their *Annual Thanksgiving Day Family Luncheon* in partnership with Food Service Provider SFE! We had over 250 loved ones join their children for lunch! It was a wonderful day of family, and fellowship.

WBES Administration began meeting with 2nd, 3rd and 4th grade parents regarding the 3rd grade retention law! Over 30 meetings have occurred thus far to ensure our parents understand the law and how they can partner with our staff to ensure student success.

Robertsville Middle School

The RMS CDC Bridge classroom is offering coffee delivery for staff on Monday, Wednesday, and Friday during first period. The RMS Daily Drip provides a wonderful opportunity for Bridge students to learn work-based learning skills while providing staff with that all-important mainline of caffeine. Students enjoy working with their classmates to improve their adaptive skills in a secure, comfortable environment while preparing and delivering the orders. The CDC classroom teacher and sponsor of The RMS Daily Drip is Ms. Alissa Jenkins.

Woodland Elementary School

Second graders performed "Woodland Salutes Our Veterans – Honoring All Who Served" on November 11. The musical tribute honored veterans and friends of the Woodland family in the matinee and evening concerts.

Students met the award-winning author and illustrator, Raul the Third, best known for his *Vamos!* picture books and *Stuntboy* graphic novels. During his visit, he shared stories about growing up on the Mexican border and how he drew inspiration from the world around him. He seamlessly integrates Spanish words and phrases, giving our Spanish speakers the opportunity to share their knowledge of a language with pride and joy. He spoke about the art of illustrating and storytelling and encouraged students to keep on reading.

Good News



Nov 28, 2023

Jefferson Middle School

Congratulations to the following students for having their artwork selected to be included in the Eighteenth Annual East Tennessee Regional Student Art Exhibition. Founded by Oak Ridge Art Teacher, Jim Dodson, in cooperation with the Knoxville Museum of Art the exhibit will run from November 24 through January 7. The following students will have their artwork displayed with some winning major awards: Ellie Linthicum, Hayden Nelson, Heidi Mohamed, Ruby Melton, and Tucker Campbell. Macy Ball was awarded Honorable Mention in the 8th grade while Polina Maltseva was awarded Honorable Mention in the 6th grade. Kate Pickel was named Middle School Best of Show! Way to go!



Oak Ridge Schools

OFFICE OF
Finance Director

Telephone (865) 425-9004

MEMORANDUM

To: Dr. Bruce Borchers, Superintendent of Schools
From: Jenifer Van Dyke, Finance Director *JVD*
Subject: **FY'24 Budget Transfer #1 & Budget Amendment #1**
Date: October 16, 2023

The attached FY'24 Budget Transfer #1 & Budget Amendment #1 includes the following budget requests for Board of Education approval:

- Addition of \$347,172.15 to the General Fund (Fund 141) budget to establish the Innovative Schools Model Grant Carryover Budget. This budget amendment will be taken to the City of Oak Ridge in Spring 2024.
- Addition of \$2,277,596.47 to the Federal Programs (Fund 142) budget to establish the ESSER 3 Grant Carryover Budget and the needed funds for the IDEA B Grant Budget. This budget amendment will be taken to the City of Oak Ridge in Spring 2024.
- All routine budget transfers and revisions from July 1, 2023 through October 16, 2023 for Board Approval.

FY 24 FYTD Budget Summary - Budget Transfer #1 & Amendment #1

Fund	FY24 Original Approved Budget	Budget Amendment #1	Budget Transfer #1	FY23 Revised & Amended Budget Amounts
Fund 141 (General Fund)	\$ 72,537,161.00	\$ 347,172.15	\$ (108,045.78)	\$ 72,776,287.37
Fund 142 (Federal)	\$ 5,087,614.00	\$ 2,277,596.47	\$ 108,045.78	\$ 7,473,256.25
Fund 143 (Food Service)	\$ 3,004,294.00			\$ 3,004,294.00
Fund 145 (Other Education)	\$ 155,021.00			\$ 155,021.00
Fund 146 (Extended Child Care)	\$ 448,337.00			\$ 448,337.00
TOTAL All Funds	\$ 81,232,427.00	\$ 2,624,768.62	\$ -	\$ 83,857,195.62

Fund 141 Budget Transfers

Fund 141 REVENUES	Account Number	Decrease	Increase
-------------------	----------------	----------	----------

Reduce Pre-K State Grant Budget	141 R 46515 000 011 00000 000	\$ 4,585.80	\$ -
	141 R 46980 000 000 00000 000	\$ -	\$ 4,585.80

Establish Resilient School Communities Grant Budget (to Fund 142)	141 R 46980 000 000 00000 000	\$ 25,045.78	\$ -
--	-------------------------------	--------------	------

Establish HQIM Literacy Implementation Networks Grant Budget (to Fund 142)	141 R 46980 000 000 00000 000	\$ 72,793.93	\$ -
	141 R 44570 000 000 00000 000	\$ 10,206.07	\$ -

Establish Public Schools Security Grant Budget	141 R 46980 000 000 00000 000	\$ 193,837.09	\$ -
	141 R 46980 000 044 00000 000	\$ -	\$ 193,837.09

Establish TN SySTEM Grant Budget	141 R 46980 000 000 00000 000	\$ 12,909.00	\$ -
	141 R 44570 000 022 00000 000	\$ -	\$ 12,909.00

Fund 141 EXPENDITURES	Account Number	Increase	Decrease
-----------------------	----------------	----------	----------

Establish Resilient School Communities Grant Budget (to Fund 142)	141 E 71900 599 000 00000 000	\$ -	\$ 25,045.78
--	-------------------------------	------	--------------

Establish Public Schools Security Grant Budget	141 E 72130 399 044 00000 000	\$ 100,000.00	\$ -
	141 E 72620 790 044 00000 000	\$ 93,837.09	\$ -
	141 E 71900 599 000 00000 000	\$ -	\$ 193,837.09

Establish HQIM Literacy Implementation Networks Grant Budget (to Fund 142)	141 E 71900 599 000 00000 000	\$ -	\$ 83,000.00
---	-------------------------------	------	--------------

Reduce Pre-K State Grant Budget	141 E 73400 116 011 00043 000	\$ -	\$ 23,214.18
	141 E 73400 116 011 00043 031	\$ -	\$ 3,727.00
	141 E 73400 163 011 00043 000	\$ 2,844.80	\$ -
	141 E 73400 201 011 00043 031	\$ -	\$ 198.00
	141 E 73400 201 011 00043 000	\$ -	\$ 1,094.96
	141 E 73400 204 011 00043 000	\$ -	\$ 1,944.52
	141 E 73400 204 011 00043 031	\$ -	\$ 1,027.00
	141 E 73400 206 011 00043 000	\$ -	\$ 23.64
	141 E 73400 207 011 00043 000	\$ -	\$ 3,860.00
	141 E 73400 207 011 00043 031	\$ -	\$ 11.00
	141 E 73400 208 011 00043 000	\$ -	\$ 53.60
	141 E 73400 212 011 00043 000	\$ -	\$ 285.52
	141 E 73400 212 011 00043 031	\$ -	\$ 40.00
	141 E 73400 217 011 00043 000	\$ -	\$ 103.34
	141 E 73400 299 011 00043 000	\$ -	\$ 13.84
	141 E 71900 599 000 00000 000	\$ 32,751.80	\$ -

Transfer for Other Contracted Services	141 E 72250 399 000 00000 000	\$ 64,350.00	\$ -
	141 E 71900 121 000 00000 000	\$ -	\$ 64,350.00

Transfer for Bowling Coach Stipends	141 E 71100 116 000 00035 000	\$ 6,594.00	\$ -
	141 E 71900 599 000 00000 001	\$ -	\$ 6,594.00

Establish Additional COPS Grant Local Match Budget	141 E 76100 707 000 00000 499	\$ 7,244.00	\$ -
	141 E 71900 599 000 00000 004	\$ -	\$ 35.66
	141 E 71900 599 000 00000 001	\$ -	\$ 7,208.34

Transfer for Welding Remodel - from Contingency	141 E 76100 707 023 00000 499	\$ 168,000.00	\$ -
	141 E 71900 599 000 00000 002	\$ -	\$ 100,000.00
	141 E 71900 599 000 00000 004	\$ -	\$ 68,000.00

Establish TN SySTEM Grant Budget	141 E 72230 399 022 00000 000	\$	12,116.00	\$	-
	141 E 72230 504 022 00000 000	\$	793.00	\$	-
	141 E 71900 599 000 00000 000	\$	-	\$	12,909.00
Establish Budget for FY23 POs Re-Opened in FY24 - from Contingency	141 E 76100 707 001 00000 429	\$	14,356.00	\$	-
	141 E 72620 718 001 00000 000	\$	64,517.08	\$	-
	141 E 72620 335 001 00000 000	\$	9,977.00	\$	-
	141 E 72610 499 001 00000 450	\$	1,220.00	\$	-
	141 E 76100 707 001 00000 436	\$	23,649.30	\$	-
	141 E 72620 418 001 00000 000	\$	1,920.00	\$	-
	141 E 72410 499 001 00035 000	\$	3,257.00	\$	-
	141 E 72210 599 001 00000 306	\$	2,290.00	\$	-
	141 E 72250 709 001 00000 000	\$	10,777.96	\$	-
	141 E 71900 599 000 00000 004	\$	-	\$	131,964.34
Transfer for SCA - CTE Renovation	141 E 72620 701 046 00000 000	\$	-	\$	19,630.00
	141 E 76100 707 000 00000 412	\$	19,630.00	\$	-
Establish Budget for PreK Insurance Claim	141 E 72620 426 000 00000 000	\$	535.00	\$	-
	141 E 71900 599 000 0000 000	\$	-	\$	535.00
TOTAL		\$	960,037.70	\$	960,037.70

Fund 141 Budget Amendment To Be Presented to City Spring 2024

Fund 141 REVENUES	Account Number	Decrease	Increase
Establish Innovative Schools Model Grant Budget	141 R 46790 000 023 00000 000	\$ -	\$ 347,172.15

Fund 141 EXPENDITURES	Account Number	Increase	Decrease
	141 E 71300 399 023 00025 000	\$ -	\$ 3,000.00
	141 E 71300 399 023 00035 000	\$ -	\$ 102,300.00
	141 E 71300 399 023 00040 000	\$ -	\$ 3,000.00
	141 E 71300 311 023 00035 000	\$ 5,000.00	\$ -
	141 E 71300 429 023 00025 000	\$ 65,000.00	\$ -
	141 E 71300 429 023 00040 000	\$ 55,000.00	\$ -
	141 E 71300 429 023 00035 000	\$ 8,500.00	\$ -
	141 E 71300 524 023 00025 000	\$ -	\$ 2,500.00
	141 E 71300 524 023 00040 000	\$ -	\$ 2,500.00
Establish Innovative Schools Model Grant Budget	141 E 71300 599 023 00035 000	\$ -	\$ 508,000.00
	141 E 71300 730 023 00025 000	\$ 140,000.00	\$ -
	141 E 71300 730 023 00040 000	\$ 120,000.00	\$ -
	141 E 71300 730 023 00035 000	\$ 292,972.15	\$ -
	141 E 72130 524 023 00025 000	\$ 10,000.00	
	141 E 72130 524 023 00035 000	\$ 5,000.00	
	141 E 72130 524 023 00040 000	\$ 10,000.00	
	141 E 76100 399 023 00025 000	\$ -	\$ 30,000.00
	141 E 76100 399 023 00040 000	\$ 50,000.00	\$ -
	141 E 76100 399 023 00035 000	\$ 237,000.00	\$ -

TOTAL		\$ 998,472.15	\$ 998,472.15
--------------	--	----------------------	----------------------

Fund 142 Budget Transfers

Fund 142 REVENUES	Account Code	Decrease	Increase
Establish Carl Perkins Grant Budget	142 R 47590 000 000 00000 000	\$ 6,145.54	\$ -
	142 R 47131 000 801 00000 000	\$ -	\$ 6,145.54
Establish IDEA Preschool Grant Budget	142 R 47131 000 802 00000 000	\$ 12,113.63	\$ -
	142 R 47145 000 911 00000 000	\$ -	\$ 12,113.63
Establish Title I Grant Budget	142 R 47141 000 101 00000 000	\$ 76,831.36	\$ -
	142 R 47590 000 000 00000 000	\$ -	\$ 76,831.36
Establish Title IV Grant Budget	142 R 47590 000 411 00000 000	\$ -	\$ 16,246.10
	142 R 47590 000 000 00000 000	\$ 16,246.10	\$ -
Establish TN All Corps Grant Budget	142 R 47401 000 938 00000 000	\$ -	\$ 280,147.28
	142 R 47590 000 000 00000 000	\$ 280,147.28	\$ -
Establish Budget for Title II Grant	142 R 47189 000 202 00000 000	\$ -	\$ 196,176.13
	142 R 47590 000 000 00000 000	\$ 196,176.13	\$ -
Establish HQIM Literacy Implementation Networks Grant Budget (from 141 Contingency)	142 R 47309 000 954 00000 000	\$ -	\$ 83,000.00
Establish Head Start Budget	142 R 47590 000 000 00000 000	\$ 46,673.00	\$ -
	142 R 47990 000 031 00000 000	\$ -	\$ 46,673.00
Reclass Carl Perkins Reserve Grant Budget	142 R 47131 000 802 00000 000	\$ 37,886.37	\$ -
	142 R 47590 000 000 00000 000	\$ -	\$ 37,886.37
Establish Title III Grant Budget	142 R 47146 000 303 00000 000	\$ -	\$ 5,134.63
	142 R 47590 000 000 00000 000	\$ 5,134.63	\$ -

Establish Head Start Grant Budget	142 R 47990 000 030 00000 000	\$	-	\$	417.00
	142 R 47590 000 000 00000 000	\$	417.00	\$	-
Establish Math Implementation Support Grant Budget	142 R 47590 000 000 00000 000	\$	73,250.00	\$	-
	142 R 47307 000 979 00000 000	\$	-	\$	73,250.00
Establish Innovative High Schools Carryover Grant Budget	142 R 47590 000 000 00000 000	\$	14,883.63	\$	-
	142 R 47310 000 951 00000 000	\$	-	\$	14,883.63
Establish Resilient School Communities Grant Budget (from 141 Contingency)	142 R 47590 000 000 00000 000	\$	235,146.52	\$	-
	142 R 47590 000 942 00000 000	\$	-	\$	260,192.30
Establish ARP Homeless Grant Budget	142 R 47590 000 000 00000 000	\$	518.53	\$	-
	142 R 47404 000 701 00000 000	\$	-	\$	518.53
Establish TSW Grant Revenue Budget	142 R 47189 000 202 00000 000	\$	191,690.00	\$	-
	142 R 47590 000 045 00000 000			\$	141,668.00
	142 R 47590 000 000 00000 000	\$	-	\$	50,022.00
Establish COPS Grant Budget	142 R 47590 000 000 00000 000	\$	175,594.00	\$	-
	142 R 47710 000 970 00000 000	\$	-	\$	175,594.00

FUND 142 EXPENDITURES		Account Code	Increase	Decrease
Establish Carl Perkins Grant Budget		142 E 71300 163 801 00035 000	\$ -	\$ 622.00
		142 E 71300 201 801 00035 000	\$ -	\$ 47.00
		142 E 71300 212 801 00035 000	\$ -	\$ 7.00
		142 E 71300 429 801 00000 000	\$ 5,000.00	\$ -
		142 E 71300 429 801 00000 090	\$ 524.73	\$ -
		142 E 71300 499 801 00000 000	\$ 7,700.00	\$ -
		142 E 71300 730 801 00000 000	\$ 11,000.00	\$ -
		142 E 72130 355 801 00000 000	\$ 8,000.00	\$ -
		142 E 72130 399 801 00000 000	\$ 500.00	\$ -
		142 E 72130 524 801 00000 000	\$ 10,000.00	\$ -
		142 E 72230 524 801 00000 000	\$ 4,000.00	\$ -
		142 E 99100 504 801 00000 000	\$ 3,624.81	\$ -
		142 E 71300 000 000 00000 000	\$ -	\$ 23,548.73
		142 E 72230 000 000 00000 000	\$ -	\$ 4,000.00
		142 E 71900 000 000 00000 000	\$ -	\$ 18,500.00
		142 E 99100 000 000 00000 000	\$ -	\$ 3,624.81
Establish IDEA Preschool Grant Budget		142 E 71200 163 911 00043 000	\$ 8,487.38	\$ -
		142 E 71200 201 911 00043 000	\$ 46.00	\$ -
		142 E 71200 204 911 00043 000	\$ 521.80	\$ -
		142 E 71200 206 911 00043 000	\$ -	\$ 9.00
		142 E 71200 212 911 00043 000	\$ -	\$ 29.00
		142 E 71200 725 911 00000 000	\$ 5,000.00	\$ -
		142 E 99100 504 911 00000 000	\$ 2,313.45	\$ -
		142 E 71200 163 901 00040 000	\$ -	\$ 16,330.63
Establish Title III Grant Budget		142 E 72210 499 303 00000 000	\$ 14,049.08	\$ -
		142 E 72210 499 303 00008 000	\$ 3,298.47	\$ -
		142 E 72210 524 303 00000 000	\$ 10,000.00	\$ -
		142 E 99100 504 303 00000 000	\$ 392.08	\$ -
		142 E 72210 599 303 00000 000	\$ 5,000.00	\$ -
		142 E 99100 000 000 00000 000	\$ -	\$ 32,739.63

Establish Title I Grant Budget

142 E 71100 116 101 00043 000	\$	-	\$	1.50
142 E 71100 163 101 00015 000	\$	-	\$	7,350.31
142 E 71100 163 101 00030 000	\$	-	\$	17,984.98
142 E 71100 163 101 00043 000	\$	-	\$	1.22
142 E 71100 163 101 00045 000	\$	-	\$	0.06
142 E 71100 163 101 00050 000	\$	-	\$	12,899.65
142 E 71100 189 101 00015 000	\$	792.00	\$	-
142 E 71100 189 101 00030 000	\$	792.00	\$	-
142 E 71100 189 101 00045 000	\$	792.00	\$	-
142 E 71100 189 101 00050 000	\$	792.00	\$	-
142 E 71100 201 101 00015 000	\$	-	\$	454.60
142 E 71100 201 101 00030 000	\$	-	\$	0.13
142 E 71100 201 101 00043 000	\$	-	\$	1.41
142 E 71100 201 101 00045 000	\$	0.20	\$	-
142 E 71100 201 101 00050 000	\$	-	\$	800.28
142 E 71100 204 101 00015 000	\$	-	\$	554.07
142 E 71100 204 101 00043 000	\$	674.94	\$	-
142 E 71100 204 101 00045 000	\$	0.93	\$	-
142 E 71100 206 101 00015 000	\$	-	\$	46.00
142 E 71100 206 101 00045 000	\$	-	\$	0.50
142 E 71100 206 101 00043 000	\$	-	\$	2.00
141 E 71100 207 101 00015 000	\$	-	\$	0.22
142 E 71100 207 101 00043 000	\$	0.30	\$	-
142 E 71100 207 101 00045 000	\$	0.20	\$	-
142 E 71100 208 101 00015 000	\$	-	\$	131.70
142 E 71100 208 101 00043 000	\$	-	\$	2.23
142 E 71100 208 101 00045 000	\$	-	\$	0.73
142 E 71100 212 101 00015 000	\$	-	\$	107.39
142 E 71100 212 101 00030 000	\$	0.33	\$	-
142 E 71100 212 101 00043 000	\$	-	\$	2.77
142 E 71100 212 101 00045 000	\$	0.50	\$	-
142 E 71100 212 101 00050 000	\$	-	\$	160.80
142 E 71100 217 101 00015 000	\$	-	\$	108.00
142 E 71100 217 101 00043 000	\$	-	\$	720.00

**Establish Title I Grant Budget
(Cont)**

142 E 71100 299 101 00015 000	\$	-	\$	39.50
142 E 71100 299 101 00043 000	\$	2.77	\$	-
142 E 71100 299 101 00045 000	\$	0.87	\$	-
142 E 71100 429 101 00015 000	\$	10,000.00	\$	-
142 E 71100 429 101 00030 000	\$	8,331.26	\$	-
142 E 71100 429 101 00043 000	\$	5,000.00	\$	-
142 E 71100 429 101 00045 000	\$	10,000.00	\$	-
142 E 71100 429 101 00050 000	\$	5,000.00	\$	-
142 E 72130 189 101 00015 000	\$	7,350.31	\$	-
142 E 72130 189 101 00045 000	\$	-	\$	0.17
142 E 72130 201 101 00015 000	\$	455.72	\$	-
142 E 72130 201 101 00045 000	\$	-	\$	0.47
142 E 72130 204 101 00000 000	\$	661.53	\$	-
142 E 72130 204 101 00045 000	\$	0.39	\$	-
142 E 72130 206 101 00015 000	\$	45.56	\$	-
142 E 72130 207 101 00045 000	\$	-	\$	0.34
142 E 72130 208 101 00015 000	\$	132.09	\$	-
142 E 72130 208 101 00045 000	\$	0.30	\$	-
142 E 72130 212 101 00015 000	\$	106.58	\$	-
142 E 72130 212 101 00045 000	\$	0.36	\$	-
142 E 72130 299 101 00015 000	\$	39.23	\$	-
142 E 72130 299 101 00045 000	\$	-	\$	0.50
142 E 72130 399 101 00008 000	\$	13,247.34	\$	-
142 E 72130 499 101 00015 000	\$	2,314.52	\$	-
142 E 72130 499 101 00030 000	\$	2,314.52	\$	-
142 E 72130 499 101 00045 000	\$	2,314.52	\$	-
142 E 72130 499 101 00050 000	\$	2,314.52	\$	-
142 E 72130 499 101 00008 000	\$	133.81	\$	-
142 E 72130 599 101 00000 000	\$	2,000.00	\$	-
142 E 72130 599 101 00008 000	\$	16,838.03	\$	-
142 E 72210 189 101 00045 000	\$	-	\$	1.00
142 E 72210 201 101 00000 000	\$	-	\$	0.39
142 E 72210 204 101 00000 000	\$	0.36	\$	-
142 E 72210 207 101 00000 000	\$	0.20	\$	-

Establish Title I Grant Budget (Cont)	142 E 72210 208 101 00000 000	\$	-	\$	0.70
	142 E 72210 212 101 00000 000	\$	0.07	\$	-
	142 E 72210 299 101 00000 000	\$	0.50	\$	-
	142 E 72210 524 101 00015 000	\$	10,000.00	\$	-
	142 E 72210 524 101 00030 000	\$	8,000.00	\$	-
	142 E 72210 524 101 00043 000	\$	5,000.00	\$	-
	142 E 72210 524 101 00045 000	\$	10,000.00	\$	-
	142 E 72210 524 101 00050 000	\$	5,000.00	\$	-
	142 E 99100 504 101 00000 000	\$	55,548.50	\$	-
	142 E 71900 000 000 00000 000	\$	-	\$	144,625.64

Establish TN All Corps Grant Budget	142 E 72210 189 938 00000 000	\$	221,000.00	\$	-
	142 E 72210 201 938 00000 000	\$	13,735.15	\$	-
	142 E 72210 204 938 00000 000	\$	22,817.60	\$	-
	142 E 72210 212 938 00000 000	\$	3,212.30	\$	-
	142 E 72710 399 938 00000 000	\$	19,382.23	\$	-
	142 E 71900 000 000 00000 000	\$	-	\$	275,323.01
	142 E 73300 000 000 00000 000	\$	-	\$	4,824.27

Establish Title IV Grant Budget	142 E 72120 189 411 00025 000	\$	38,359.50	\$	-
	142 E 72120 201 411 00025 000	\$	2,378.29	\$	-
	142 E 72120 204 411 00025 000	\$	2,612.28		
	142 E 72120 206 411 00025 000	\$	63.00		
	142 E 72120 208 411 00025 000	\$	179.70		
	142 E 72120 212 411 00025 000	\$	566.22		
	142 E 72120 299 411 00025 000	\$	54.25		
	142 E 72120 399 411 00008 000	\$	835.69	\$	-
	142 E 72120 499 411 00000 000	\$	1,500.00	\$	-
	142 E 72130 189 411 00025 000	\$	39,730.00		
	142 E 72130 201 411 00025 000	\$	2,463.26		
	142 E 72130 204 411 00025 000	\$	2,705.61	\$	-
	142 E 72130 206 411 00025 000	\$	63.00	\$	-
	142 E 72130 208 411 00025 000	\$	179.70	\$	-
	142 E 72130 212 411 00025 000	\$	576.00	\$	-

Establish Title IV Grant Budget (cont)	142 E 72130 599 411 00000 000	\$	7,500.00	\$	-
	142 E 72210 499 411 00000 000	\$	2,506.21	\$	-
	142 E 72250 499 411 00000 000	\$	4,000.00	\$	-
	142 E 72250 524 411 00000 000	\$	7,000.00	\$	-
	142 E 99100 504 411 00000 000	\$	2,169.14	\$	-
	142 E 72130 299 411 00000 000	\$	54.25	\$	-
	142 E 71900 000 000 00000 000	\$	-	\$	26,860.54
	142 E 99100 000 000 00000 000	\$	-	\$	88,635.56

Establish Title IIA Grant Budget	142 E 71900 000 000 00000 000	\$	-	\$	165,892.13
	142 E 72210 189 202 00000 000	\$	2,139.00	\$	-
	142 E 72210 196 202 00000 000	\$	10,000.00	\$	-
	142 E 72210 201 202 00000 000	\$	1,090.00	\$	-
	142 E 72210 204 202 00000 000	\$	1,426.00	\$	-
	142 E 72210 206 202 00000 000	\$	43.00	\$	-
	142 E 72210 207 202 00000 000	\$	2,541.00	\$	-
	142 E 72210 208 202 00000 000	\$	34.00	\$	-
	142 E 72210 212 202 00000 000	\$	220.00	\$	-
	142 E 72210 299 202 00000 000	\$	48.00	.	-
	142 E 72210 399 202 00000 000	\$	90,000.00	\$	-
	142 E 72210 524 202 00000 000	\$	45,409.83	\$	-
	142 E 99100 504 202 00000 000	\$	10,158.74	\$	-
	142 E 72210 524 202 00008 000	\$	2,782.56	\$	-

Reclass IDEA ARP Grant Budget to Contingency (grant eliminated)	142 E 71900 000 000 00000 000	\$	34,055.00	\$	-
	142 E 71200 163 905 00000 000	\$	-	\$	6,196.00
	142 E 71200 163 905 00050 000	\$	-	\$	22,719.00
	142 E 71200 201 905 00000 000	\$	-	\$	384.00
	142 E 71200 201 905 00050 000	\$	-	\$	1,409.00
	142 E 71200 204 905 00000 000	\$	-	\$	467.00
	142 E 71200 204 905 00050 000	\$	-	\$	1,711.00
	142 E 71200 206 905 00000 000	\$	-	\$	32.00
	142 E 71200 206 905 00050 000	\$	-	\$	126.00

Reclass IDEA ARP Grant Budget to Contingency (cont)	142 E 71200 208 905 00000 000	\$	-	\$	91.00
	142 E 71200 208 905 00050 000	\$	-	\$	365.00
	142 E 71200 212 905 00000 000	\$	-	\$	90.00
	142 E 71200 212 905 00050 000	\$	-	\$	329.00
	142 E 71200 299 905 00000 000	\$	-	\$	27.00
	142 E 71200 299 905 00050 000	\$	-	\$	109.00

Establish HQIM Literacy Implementation Networks Grant Budget (from 141 Contingency)	142 E 71100 429 954 00000 000	\$	6,000.00	\$	-
	142 E 72210 399 954 00000 000	\$	73,000.00	\$	-
	142 E 72210 524 954 00000 000	\$	4,000.00	\$	-

Establish Head Start Budget	142 E 73300 104 031 00043 000	\$	0.15	\$	-
	142 E 73300 116 031 00043 000	\$	21,347.54	\$	-
	142 E 73300 119 031 00043 000	\$	0.08	\$	-
	142 E 73300 161 031 00043 000	\$	0.22	\$	-
	142 E 73300 163 031 00043 000	\$	7,921.47	\$	-
	142 E 73300 189 031 00043 000	\$	1,068.82	\$	-
	142 E 73300 201 031 00043 000	\$	2,190.28	\$	-
	142 E 73300 204 031 00043 000	\$	2,296.30	\$	-
	142 E 73300 206 031 00043 000	\$	12.60	\$	-
	142 E 73300 207 031 00043 000	\$	-	\$	4,716.21
	142 E 73300 208 031 00043 000	\$	54.80	\$	-
	142 E 73300 212 031 00043 000	\$	457.25	\$	-
	142 E 73300 217 031 00043 000	\$	-	\$	1,060.00
	142 E 73300 299 031 00043 000	\$	19.10	\$	-
	142 E 73300 348 031 00043 000	\$	200.00	\$	-
	142 E 73300 355 031 00043 000	\$	500.00	\$	-
	142 E 73300 399 031 00043 000	\$	26,000.00	\$	-
	142 E 73300 429 031 00043 000	\$	24,000.00	\$	-
	142 E 73300 499 031 00043 000	\$	6,000.00	\$	-
	142 E 73300 524 031 00043 000	\$	14,636.60	\$	-
142 E 73300 000 000 00000 000	\$	-	\$	100,929.00	

Establish Head Start Allocation Budget	142 E 73300 399 030 00043 000	\$	4,083.00	\$	-
	142 E 73300 524 030 00043 000	\$	5,234.00	\$	-
	142 E 73300 000 000 00000 000	\$	-	\$	9,317.00

Establish Math Implementation Support Grant Budget	142 E 72210 399 979 00000 000	\$	73,250.00	\$	-
	142 E 71900 000 000 00000 000	\$	-	\$	73,250.00

Establish ARP Homeless Budget	142 E 72120 399 701 00000 000	\$	5,800.00	\$	-
	142 E 72130 399 701 00000 000	\$	22,391.53	\$	-
	142 E 72130 499 701 00000 000	\$	4,827.00	\$	-
	142 E 72130 599 701 00000 000	\$	12,500.00	\$	-
	142 E 71900 000 000 00000 000	\$	-	\$	45,518.53

Establish Innovative High Schools Carryover Grant Budget	142 E 71300 429 951 00000 090	\$	1,853.92	\$	-
	142 E 71300 730 951 00000 000	\$	12,918.47	\$	-
	142 E 99100 504 951 00000 000	\$	111.24	\$	-
	142 E 71900 000 000 00000 000	\$	-	\$	14,883.63

Establish Resilient School Communities Grant Budget (from 141 Contingency)	142 E 72130 399 942 00000 000	\$	224,000.00	\$	-
	142 E 72210 499 942 00000 000	\$	2,000.00	\$	-
	142 E 72210 524 942 00000 000	\$	34,192.30	\$	-
	142 E 71900 000 000 00000 000	\$	-	\$	235,146.52

Establish COPS Grant Budget	142 E 76100 790 970 00000 000	\$	175,594.00	\$	-
	142 E 73300 000 000 00000 000	\$	-	\$	175,594.00

Reclass ARP IDEA PreK Grant Budget to Contingency (grant eliminated)	142 E 71200 163 912 00043 000	\$	-	\$	18,587.00
	142 E 71200 201 912 00043 000	\$	-	\$	1,152.00
	142 E 71200 204 912 00043 000	\$	-	\$	1,399.00
	142 E 71200 206 912 00043 000	\$	-	\$	95.00
	142 E 71200 208 912 00043 000	\$	-	\$	274.00
	142 E 71200 212 912 00043 000	\$	-	\$	270.00
	142 E 71900 000 000 00000 000	\$	21,858.00	\$	-
	142 E 71200 299 912 00043 000	\$	-	\$	81.00

	142 E 73300 105 431 00015 000	\$	10,000.00	\$	-
	142 E 73300 105 431 00045 000	\$	17,550.00	\$	-
	142 E 73300 116 431 00015 000	\$	33,000.00	\$	-
	142 E 73300 116 431 00045 000	\$	5,820.00	\$	-
	142 E 73300 169 431 00015 000	\$	1,815.00	\$	-
	142 E 73300 189 431 00015 000	\$	11,037.50	\$	-
	142 E 73300 189 431 00045 000	\$	28,995.00	\$	-
	142 E 73300 201 431 00015 000	\$	3,374.21	\$	-
	142 E 73300 201 431 00045 000	\$	3,358.86	\$	-
	142 E 73300 204 431 00015 000	\$	3,555.53	\$	-
	142 E 73300 204 431 00045 000	\$	3,953.77	\$	-
	142 E 73300 212 431 00015 000	\$	789.02	\$	-
	142 E 73300 212 431 00045 000	\$	785.44	\$	-
	142 E 73300 399 431 00015 000	\$	1,596.28	\$	-
Establish 21st CCLC Grant Budget	142 E 73300 399 431 00045 000	\$	1,482.26	\$	-
	142 E 73300 429 431 00015 000	\$	466.98	\$	-
	142 E 73300 429 431 00045 000	\$	214.78	\$	-
	142 E 73300 599 431 00015 000	\$	420.00	\$	-
	142 E 73300 599 431 00045 000	\$	390.00	\$	-
	142 E 73300 524 431 00015 000	\$	780.59	\$	-
	142 E 73300 524 431 00045 000	\$	655.00	\$	-
	142 E 99100 504 431 00015 000	\$	4,486.39	\$	-
	142 E 99100 504 431 00045 000	\$	4,486.39	\$	-
	142 E 71100 000 000 00000 000	\$	-	\$	304.00
	142 E 71300 000 000 00000 000	\$	-	\$	66,373.27
	142 E 72230 000 000 00000 000	\$	-	\$	1,000.00
	142 E 72250 000 000 00000 000	\$	-	\$	2,000.00
	142 E 72710 000 000 00000 000	\$	-	\$	10,000.00
	142 E 73300 000 000 00000 000	\$	-	\$	59,335.73

TOTAL		\$	3,179,232.96	\$	3,179,232.96
--------------	--	-----------	---------------------	-----------	---------------------

Fund 142 Budget Amendment To Be Presented to City Spring 2024

Fund 142 REVENUES	Account Number	Decrease	Increase
Establish IDEA B Grant Budget	141 R 47143 000 901 00000 000	\$ -	\$ 359,512.40
Establish ESSER 3.0 Grant Budget	142 R 47401 000 936 00000 000	\$ -	\$ 1,918,084.07

Fund 142 EXPENDITURES	Account Number	Increase	Decrease
Establish ESSER 3.0 Grant Budget	142 E 71100 449 936 00000 000	\$ 500,000.00	\$ -
	142 E 71100 471 936 00000 000	\$ 222,500.00	\$ -
	142 E 71100 722 936 00000 000	\$ 10,000.00	\$ -
	142 E 72130 790 936 00000 000	\$ 960,499.07	\$ -
	142 E 72210 524 936 00000 000	\$ 174,890.57	\$ -
	142 E 72210 524 936 00000 000	\$ 50,194.43	\$ -

	142 E 71200 116 901 00000 000	\$ 62,100.00	\$ -
	142 E 71200 171 901 00000 000	\$ 17,728.00	\$ -
	142 E 71200 188 901 00000 000	\$ 30,000.00	\$ -
	142 E 71200 201 901 00000 000	\$ 7,116.00	\$ -
	142 E 71200 204 901 00000 000	\$ -	\$ 515.00
	142 E 71200 207 901 00000 000	\$ 67,969.70	\$ -
	142 E 71200 725 901 00000 000	\$ 12,000.00	\$ -
	142 E 72220 131 901 00000 000	\$ -	\$ 1,316.00
	142 E 72220 189 901 00000 000	\$ 547.00	\$ -
	142 E 72220 201 901 00000 000	\$ 84.00	\$ -
	142 E 72220 204 901 00000 000	\$ -	\$ 3,815.00
Establish IDEA B Grant Budget	142 E 72220 207 901 00000 000	\$ 111.00	\$ -
	142 E 72220 208 901 00000 000	\$ -	\$ 384.60
	142 E 72220 212 901 00000 000	\$ 512.00	\$ -
	142 E 72220 299 901 00000 000	\$ -	\$ 17.10
	142 E 72220 499 901 00000 000	\$ 2,000.00	\$ -
	142 E 72220 524 901 00000 000	\$ 36,494.40	\$ -
	142 E 99100 504 901 00000 000	\$ 82,850.00	\$ -
	142 E 71200 163 901 00040 000	\$ -	\$ 8,175.37
	142 E 71200 206 901 00040 000	\$ -	\$ 315.00
	142 E 71200 208 901 00040 000	\$ -	\$ 1,705.00
	142 E 71200 212 901 00040 000	\$ -	\$ 1,858.00
	142 E 71200 299 901 00040 000	\$ -	\$ 393.00
	142 E 71900 000 000 00000 000	\$ 58,494.37	\$ -

TOTAL		\$ 2,296,090.54	\$ 2,296,090.54
--------------	--	------------------------	------------------------



MEMORANDUM

Dr. Kelly Williams

Executive Director, Office of Teaching and Learning

TO: Board of Education

DATE: 11/10/23

SUBJECT: Item for Action: Approval of the 2023 LEA Compliance Report

I recommend the board approval of the 2023 Local Education Agency Compliance Report. This annual compliance report is one mechanism the Tennessee Department of Education uses to ensure education laws and rules are faithfully executed.

Oak Ridge Schools is in compliance with all federal and state education laws and State Board of Education rules.

2023 Local Education Agency Compliance Report

Local education agencies (LEAs) are required to comply with all federal and state education laws and State Board of Education (SBE) rules. This annual compliance report is one mechanism the department uses to ensure education laws and rules are faithfully executed. The commissioner of education is charged with taking corrective action when an LEA is noncompliant with those laws and rules or is not following a department-approved compliance plan.

Each LEA must submit this report and, if applicable, the corresponding corrective action plan, to the department by **November 30, 2023**. During completion, an LEA should carefully check the status of its compliance with all federal and state education laws and SBE rules. The department monitors and verifies LEA compliance via multiple data sources (e.g., Education Information System, internal program managers) and will consider those sources in making a final determination of an LEA's compliance. Please be advised annual compliance report data may inform an LEA's approval classification.

I certify that the LEA is in compliance with all federal and state education laws and SBE rules.

I certify that, with the exception of areas indicated in the **attached corrective action plan**, the LEA is in compliance with all federal and state education laws and SBE rules.

LEA Name:

Director of Schools/Superintendent Name:

Director of Schools/Superintendent **Signature:**

School Board Chair Name:

School Board Chair **Signature:**

Date of School Board Approval:

UPLOAD COMPLETED REPORT TO ePlan BY **NOVEMBER 30, 2023**

(including the corresponding corrective action plan if applicable).

Upload instructions are accessible [here](#).



MEMORANDUM

Dr. Kelly Williams

Executive Director, Office of Teaching and Learning

TO: Board of Education

DATE: 11/10/23

SUBJECT: Item for Action: Approval of the TISA Accountability Report

I recommend the board approval of the Tennessee Investment in Student Achievement (TISA) Accountability Report. This new annual report is one mechanism the Tennessee Department of Education uses to ensure accountability with the new TISA funding formula.



Tennessee Investment in Student Achievement

Accountability Report Template

The Tennessee Investment in Student Achievement (TISA) public school funding formula marks a significant change in how Tennessee invests in public education. The TISA funding formula updates the way Tennessee funds public education for the first time in over 30 years to empower each student to read proficiently by third grade, prepare each high school graduate for postsecondary success, and provide resources needed for all students to ensure they succeed.

As part of TISA, T.C.A. § 49-3-112 requires each school district, starting in the 2023-24 school year, to submit an annual accountability report to the Tennessee Department of Education (department). This report must include:

- Goals for student achievement
 - One of the goals must include the district's plan to pursue the goal of seventy percent (70%) or more of the district's third grade students to score "met expectations" or "exceeded expectations" on the English Language Arts (ELA) portion of the TCAP tests. This goal must also detail the district's goal to increase 3rd grade ELA proficiency rates by 15% of the gap over the next three years (starting with the 2022-23 TCAP results) to achieve the district's stated goal of at least 70% of 3rd grade students proficient in ELA.¹
- Explanation how the district's stated goals can be met within the district's budget.
- For reports submitted **starting in the 2024-25** school year, a description of how the district's budget and expenditures from the prior school year enabled the district to make progress toward the stated student achievement goals.

Each district's TISA accountability report is required to be presented to the public for review and comment before the report is submitted to the department. The report must be submitted annually to the department by November 1st.

Furthermore, each district's TISA accountability report is required to be reviewed annually by the TISA Progress Review Board pursuant to T.C.A. § 49-3-114 to determine whether the school district is taking the proper steps to achieve their stated goal.

This template is intended to assist districts in submitting their accountability reports to the department.

For questions, please contact tnedu.funding@tn.gov

Completed reports should be submitted in ePlan by **November 1, 2023**.

¹ T.C.A. § 49-3-114 requires the TISA Progress Review Board to review district TISA accountability reports and set a district's minimum goal to increase the district's 3rd grade proficiency by 15% of the gap to 70% in 3 years, starting with the 2022-23 TCAP results. This does not apply to districts who have 70% or more of 3rd grade students proficient in ELA.

DISTRICT INFORMATION		
District Name	Oak Ridge	
Director of Schools Name	Dr. Bruce Borchers	
District Point of Contact for TISA Accountability Report	Name	Dr. Kelly Williams
	Phone Number	865-425-9016
	Email Address	kmwilliams@ortn.edu
Percent of 3 rd grade students who scored proficient (“met expectations” or “exceeded expectations”) on the English Language Arts (ELA) portion of the spring TCAP	59%	

DISTRICT GOAL STATEMENT(S)	
Goal Statement 1: 3 rd Grade ELA Proficiency ²	70 % of students will score proficient on the 3 rd grade ELA TCAP by 2026 year
Goal Statement 2:	65% of students will score proficient on the Math TCAP by 2028.
Goal Statement 3:	97% of students will graduate from Oak Ridge Schools by 2028.
Goal Statement 4:	
Goal Statement 5:	

² **Note:** This is a required goal pursuant to T.C.A. § 49-3-112 and must include 70% or more of 3rd grade students proficient on the ELA TCAP. If your district already has 70% or more of 3rd grade students proficient in ELA, please state a goal that either maintains or increases that proficiency rate.

School Year	Annual Outcome(s)	Associated Metrics/Data	Action Steps This may include descriptions of district-based programs, staffing, and intervention services for students.	Describe how your district intends to use their budget to execute the action steps and meet the stated goal. <i>Optional:</i> Provide a copy of your district's budget when submitting this report to the department.
Goal Statement 1: 3 rd grade ELA proficiency ³		Seventy percent of third grade students will score proficient on the third grade ELA TCAP by 2026		
Year 1: 2023-24 school year	63%	TCAP + District Benchmarks	1.High Quality Instructional Materials adoption and implementation support	District Budget & Federal Programs Budget provided
Year 2: 2024-25 school year	67%	TCAP + District Benchmarks	2. Professional Learning	District Budget & Federal Programs Budget provided
Year 3: 2025-26 school year	70%	TCAP + District Benchmarks	3.Professional Learning Communities (PLCs)	District Budget & Federal Programs Budget provided
Year 4: 2026-27 school year				
Year 5: 2027-28 school year				
Goal Statement 2:		Sixty-five percent of ORS students will score proficient on the math TCAP by 2028.		
Year 1: 2023-24 school year	50%	TCAP + District Benchmarks	1.High Quality Instructional Materials adoption and implementation support	District Budget & Federal Programs Budget provided

³ The annual outcome for 3rd grade ELA proficiency must include, but is not limited to, the district's goal to increase 3rd grade ELA proficiency rates by 15% of the gap over the next 3 years, starting with the 2022-23 TCAP results, to achieve the district's stated goal of at least 70% of 3rd grade students proficient in ELA. If the district already has 70% or more of 3rd grade students proficient in ELA, it is not required to state in your annual outcomes the 15% gap closure, but must still detail annual outcomes and metrics to either maintain or increase your district's 3rd grade ELA proficiency rates and other stated district goals.

School Year	Annual Outcome(s)	Associated Metrics/Data	Action Steps This may include descriptions of district-based programs, staffing, and intervention services for students.	Describe how your district intends to use their budget to execute the action steps and meet the stated goal. <i>Optional:</i> Provide a copy of your district's budget when submitting this report to the department.
Year 2: 2024-25 school year	55%	TCAP + District Benchmarks	2. Professional Learning	District Budget & Federal Programs Budget provided
Year 3: 2025-26 school year	60%	TCAP + District Benchmarks	3. Professional Learning Communities (PLCs)	District Budget & Federal Programs Budget provided
Year 4: 2026-27 school year	65%	TCAP + District Benchmarks		District Budget & Federal Programs Budget provided
Year 5: 2027-28 school year	70%	TCAP + District Benchmarks		District Budget & Federal Programs Budget provided
Goal Statement 3:	Ninty-seven percent of ORS students will graduate from high school by 2028.			
Year 1: 2023-24 school year	95%	Graduation Rate, Ready Grad, Course Completion	Attendance tracking	District Budget & Federal Programs Budget provided
Year 2: 2024-25 school year	95.5%	Graduation Rate, Ready Grad, Course Completion	Course completion action steps	District Budget & Federal Programs Budget provided
Year 3: 2025-26 school year	96%	Graduation Rate, Ready Grad, Course Completion	scorecard tracking	District Budget & Federal Programs Budget provided
Year 4: 2026-27 school year	96.5%	Graduation Rate, Ready Grad, Course Completion	AP and guidance counselor alignment	District Budget & Federal Programs Budget provided
Year 5: 2027-28 school year	97%	Graduation Rate, Ready Grad, Course Completion		District Budget & Federal Programs Budget provided

School Year	Annual Outcome(s)	Associated Metrics/Data	Action Steps This may include descriptions of district-based programs, staffing, and intervention services for students.	Describe how your district intends to use their budget to execute the action steps and meet the stated goal. <i>Optional:</i> Provide a copy of your district's budget when submitting this report to the department.
Goal Statement 4:				
Year 1: 2023-24 school year				
Year 2: 2024-25 school year				
Year 3: 2025-26 school year				
Year 4: 2026-27 school year				
Year 5: 2027-28 school year				
Goal Statement 5:				
Year 1: 2023-24 school year				
Year 2: 2024-25 school year				
Year 3: 2025-26 school year				
Year 4: 2026-27 school year				
Year 5: 2027-28 school year				

Public Comment	
The TISA accountability report must be presented for public comment to parents, educators, and local community members prior to its submission to the department by November 1 each year.	
Date(s) of opportunity for local public comment.	10/19/23 Superintendents' PTO Meeting 10/18/23 - 10/30/23 ORS Website with survey link and email to ORS families.
Description of public comment opportunities (e.g. collection of	Public comments recorded during PTO meeting. Staff advisory comments recorded at monthly meeting. Survey comments reviewed by executive and leadership team.

Public Comment

The TISA accountability report must be presented for public comment to parents, educators, and local community members prior to its submission to the department by November 1 each year.

written comments, public hearing, local board meeting discussion, etc.)	
Summary of public comment received, if any.	No feedback received.
Description of how your district did or did not incorporate public comment received into the final accountability report submission.	No feedback received.



MEMORANDUM

Dr. Kelly Williams

Executive Director, Office of Teaching and Learning

TO: Board of Education

DATE: 11/10/23

SUBJECT: Item for Action: Approval of the Comparability Report

I recommend the board approval of the FY24 Comparability Report. Demonstrating comparability is a prerequisite for receiving Title I, Part A funds. The basic premise of comparability is to ensure that an LEA can demonstrate that state and local funds used to provide services in Title I, Part A schools are at least comparable to the services in non-Title I schools. Because Title I, Part A allocations are made annually, comparability is an annual requirement.

Comparability Overview

Heather Farley

Division of Federal Programs and Oversight

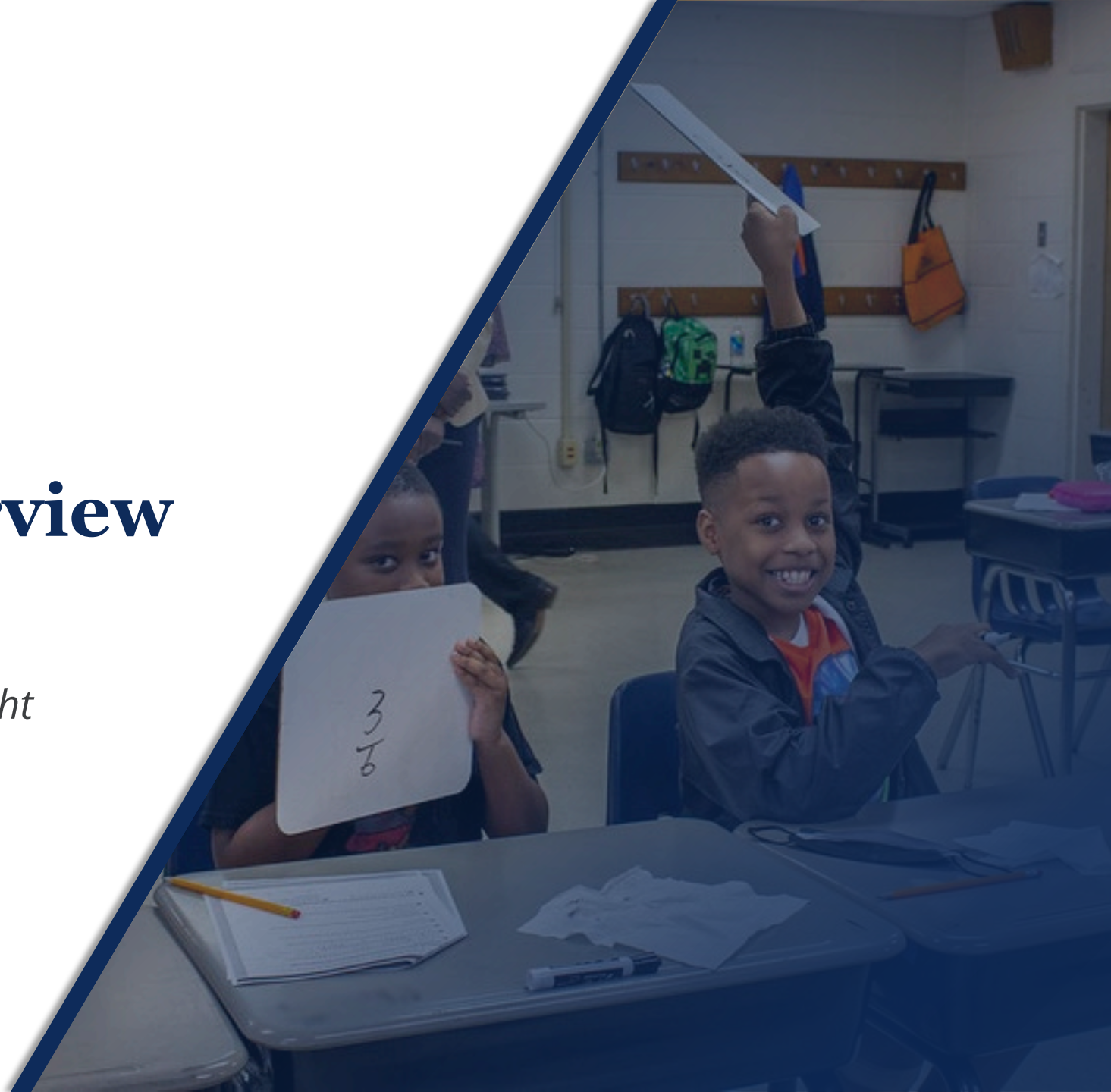



BEST FOR ALL

We will set all students on a path to success.

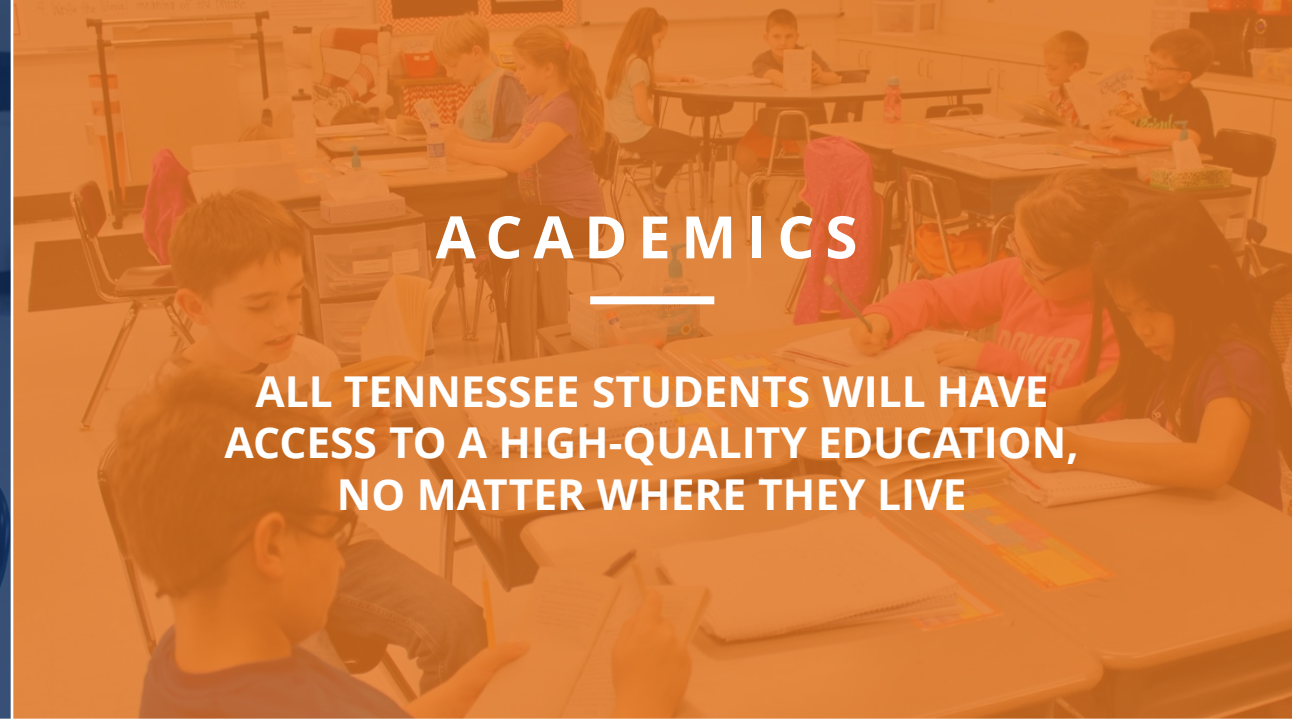

ACADEMICS

ALL TENNESSEE STUDENTS WILL HAVE ACCESS TO A HIGH-QUALITY EDUCATION, NO MATTER WHERE THEY LIVE

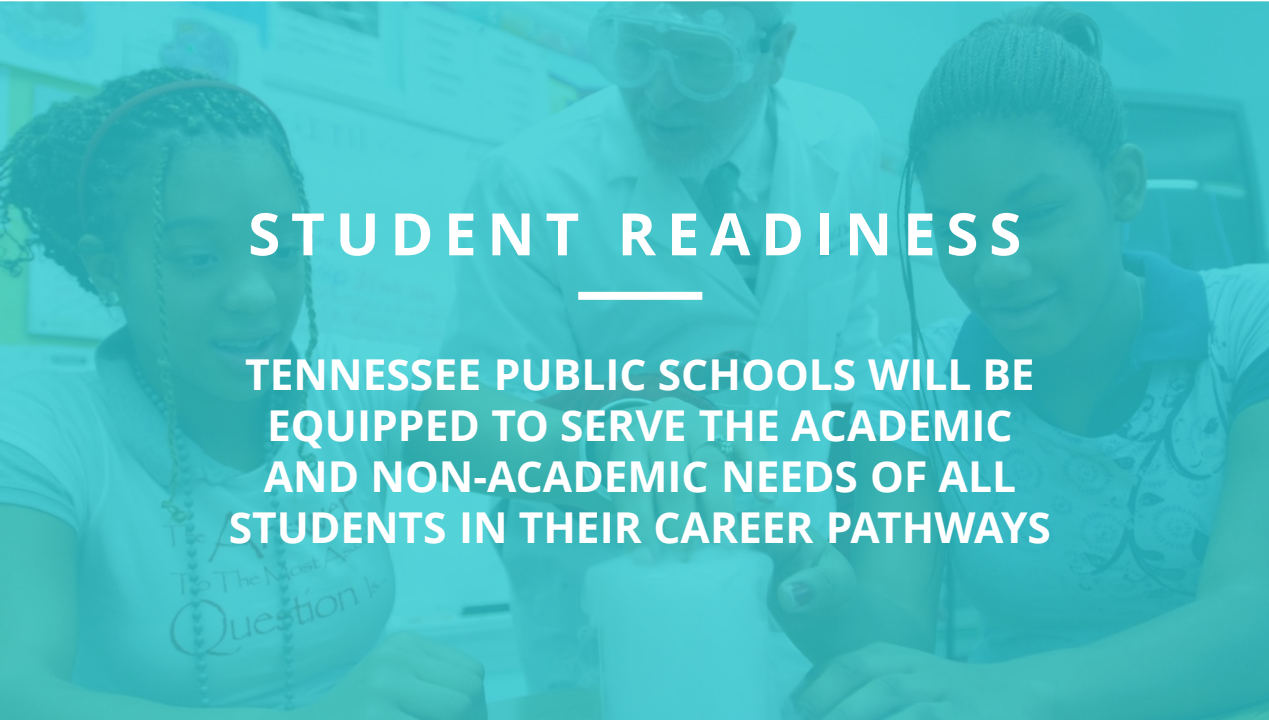

STUDENT READINESS

TENNESSEE PUBLIC SCHOOLS WILL BE EQUIPPED TO SERVE THE ACADEMIC AND NON-ACADEMIC NEEDS OF ALL STUDENTS IN THEIR CAREER PATHWAYS

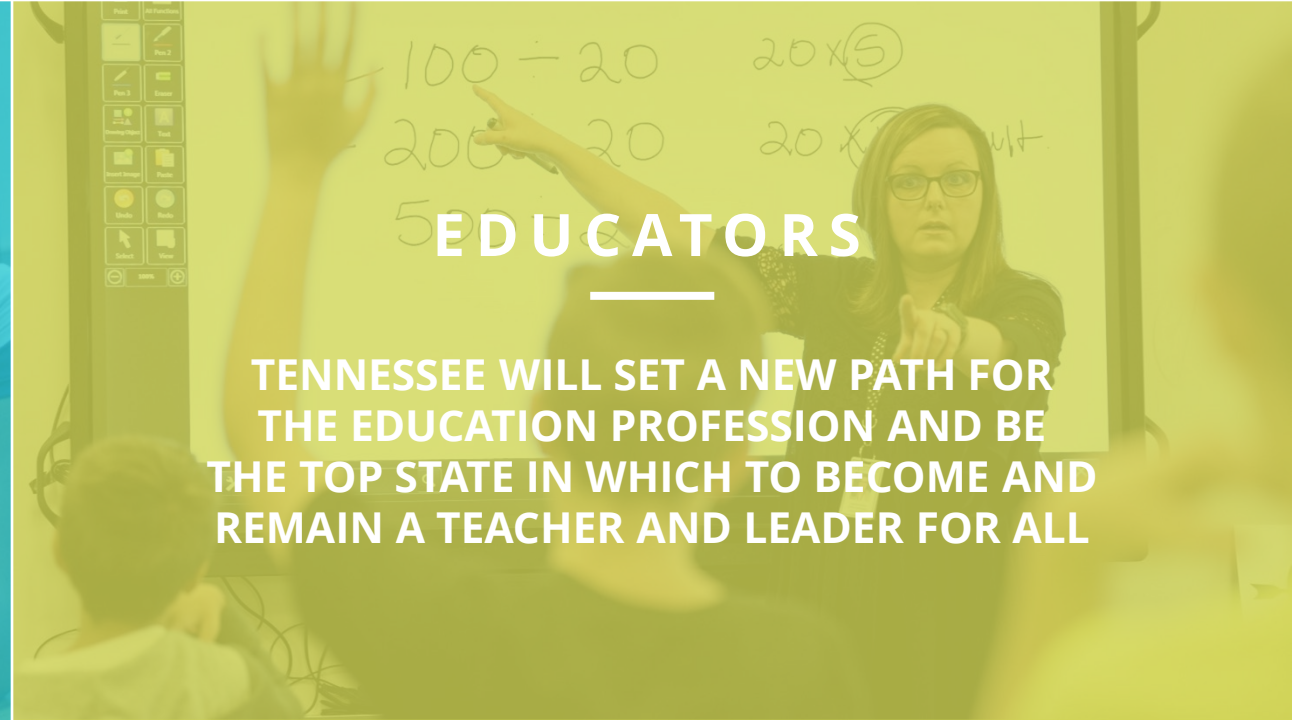

EDUCATORS

TENNESSEE WILL SET A NEW PATH FOR THE EDUCATION PROFESSION AND BE THE TOP STATE IN WHICH TO BECOME AND REMAIN A TEACHER AND LEADER FOR ALL



- Required Process
- Comparability Application Supplement
- Technical Assistance



Basic Premise of Comparability

- The basic premise of comparability is to ensure that an LEA can demonstrate that state and local funds used to provide services in Title I, Part A schools are *at least comparable* to the services in non-Title I schools.
- Grade span groupings used to demonstrate comparability are very important.
 - Grade span groupings must match the basic organization of schools in the LEA.
Note: Pre-K is not included in comparability.
- Groupings should also reflect the organization on the ***School Eligibility*** page in the LEA's **current fiscal year Consolidated Funding Application (CFA)**.



Prerequisite for Receiving Title I, Part A Funds

- Demonstrating comparability is a prerequisite for receiving Title I, Part A funds.
- Because **Title I, Part A allocations are made annually**, comparability is an **annual requirement**.
- Each LEA must perform comparability calculations annually to demonstrate that all Title I schools within the LEA are, in fact, comparable and adjust if any are not comparable.



Required Forms





Uploading a File to ePlan

- **Form III** is an Excel file that must be completed and uploaded to the ***Related Documents section*** of the Comparability Application Supplement which contains support personnel for each school.
- **Note:** Other forms in the ***Related Documents section*** are for alternative methods.
- **Please do not print and scan in Excel files.** If Excel files are printed and scanned, the department will contact the LEA to upload the completed Excel files.

LEA Written Procedures

- An LEA must develop procedures for complying with comparability requirements.
- These procedures should be in writing and should, at a minimum, include:
 - identification of the office responsible for making comparability calculations,
 - timeline for demonstrating comparability,
 - method and process for collecting data required to demonstrate comparability,
 - selected basis for demonstrating comparability, and
 - how and when the LEA makes adjustments in schools that are not comparable.



Maintaining Source Documentation

- **The LEA must maintain source documentation** to support the calculations and form submitted to demonstrate comparability and any needed adjustments made to staff assignments.

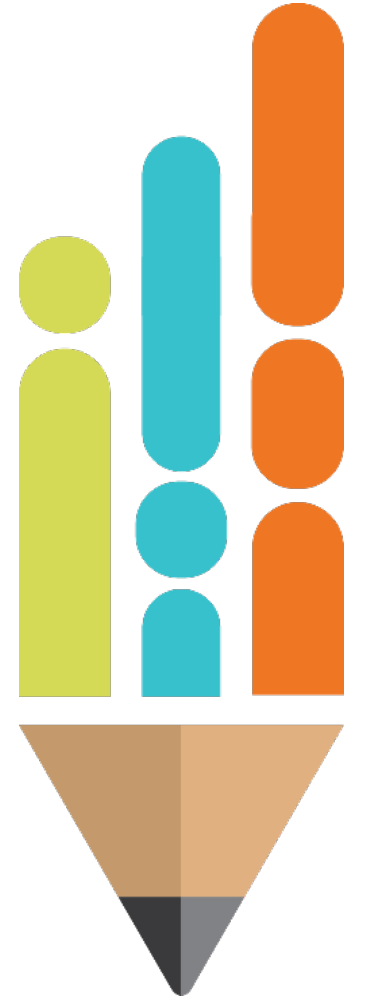

Comparability Application Supplement



Location of Comparability Application Supplement



- <http://eplan.tn.gov>
- **Data and Information**

The screenshot shows the ePlan website interface. On the left is a vertical navigation menu with blue buttons and right-pointing arrows. The 'Data and Information' button is highlighted with an orange border. The main content area on the right has a white background with a blue header 'Data and Information'. Below the header, there is a breadcrumb trail 'Public District - FY 2023'. A red warning message states: 'This is the TEST site. Please be sure to complete the page you are attempting to view has expired.' Below the message are two dropdown menus: '2023' and 'Active'. A second blue header 'Data and Information' is present, followed by a list of links: 'Comparability' (highlighted with an orange border), 'Continuous Learning Plan', 'Continuous Learning Plan' (with a sub-link 'Continuous Learning Plan'), 'Coordinated School Health Action Plan', and 'CTE FAUPL Target Negotiations'.

Comparability Application Supplement: Section Page



Comparability Sections		
Public District - FY 2021 - Comparability - Rev 0		
This is the TEST site. Please be sure to complete your work on the LIVE site.		
Status:	Draft Started	
Change Status To:	LEA Consolidated Director Draft Completed	
Description (View Sections Only View All Pages)	Validation	Print Select Items
All	Messages	Print
<input type="checkbox"/> History Log		Print
History Log		Print
Create Comment		Print
<input type="checkbox"/> Comparability	Messages	Print
Program Details	Messages	Print
Assurances	Messages	Print
Grade Spans		Print
School Information	Messages	Print
Form II		Print
Comparability Method	Messages	Print
Related Documents	Messages	Print
All	Messages	Print





Comparability Application Supplement: Grade Spans

- Grade Spans: Allows the LEA to set up the grade span groupings for the LEA.
- **Note:** Grade span groupings must match the *School Eligibility* page in the LEA's **current fiscal year CFA**.

Grade Spans

Public District - FY 2020 - Comparability - Rev 0

Save And Go To ▶

Actions	Grade Span
 ↑ ↓	<input type="text" value="K-5"/>
 ↑ ↓	<input type="text" value="6-8"/>
 ↑ ↓	<input type="text" value="9-12"/>
 ↑ ↓	<input type="text" value="K-12"/>

[Add Grade Span](#)

Save And Go To ▶

Comparability Application Supplement: Student Counts

- Input this data in the **School Information** section.
- School lists will auto-populate from the CFA.
- Grade span drop-down menus will generate from the previous page.
- Student counts **from the current school year:**
 - Enrollment
 - Low Income

School Information				
- FY 2020 - Comparability - Rev 0				
Save And Go To ▶				
School Name	* Grade Span	Service Type	Student Counts	
			* Enrollment	* Low Income
Anderson County Career Technical Center	9-12 ▼	None	411	253
Anderson County High School	9-12 ▼	None	1069	341
Andersonville Elementary	K-5 ▼	GF (SW)	309	120
Briceville Elementary	K-5 ▼	SW	117	70
Claxton Elementary	K-5 ▼	SW	448	233
Clinch River Community School	K-12 ▼	None	68	47
Clinton High School	9-12 ▼	None	1083	480
Clinton Middle School	6-8 ▼	None	667	273
Dutch Valley Elementary	K-5 ▼	SW	103	55
Fairview Elementary	K-5 ▼	SW	284	125
Grand Oaks Elementary	K-5 ▼	SW	275	111
Lake City Elementary	K-5 ▼	SW	421	221
Lake City Middle School	6-8 ▼	None	284	141
Norris Elementary	K-5 ▼	None	211	53
Norris Middle School	6-8 ▼	None	488	149
Norwood Elementary	K-5 ▼	SW	237	126
Norwood Middle School	6-8 ▼	None	188	95
Totals:			6663	2893

The above is a test example, not actual LEA results.

Comparability Application Supplement: Licensed Instructional Staff

- This data is in the **School Information** section.
- Licensed Instructional Staff will pull from the **Form II** section within the *Comparability Application Supplement*.
- Ensure all data pulled from the Education Information System (EIS) is correct within the **Form II** section.

School Name	Licensed Instruction Personnel		
	* Excluded State/Local FTE (LEP/SWD)	* Federal FTE	* State/Local FTE
Anderson County Career Technical Center	0.00	0.00	33.00
Anderson County High School	0.00	0.00	54.10
Andersonville Elementary	0.00	2.00	21.11
Briceville Elementary	0.00	1.50	10.20
Claxton Elementary	0.00	5.00	31.00
Clinch River Community School	0.00	0.00	13.57
Clinton High School	0.00	0.00	53.50
Clinton Middle School	0.00	0.00	40.50
Dutch Valley Elementary	0.00	1.50	9.60
Fairview Elementary	0.00	2.00	19.63
Grand Oaks Elementary	0.00	1.00	18.20
Lake City Elementary	0.00	4.00	29.13
Lake City Middle School	0.00	0.00	19.77
Norris Elementary	0.00	0.00	15.97
Norris Middle School	0.00	0.00	30.38
Norwood Elementary	0.00	3.50	17.99
Norwood Middle School	0.00	0.00	17.01
	0.00	20.50	434.66

The above is a test example, not actual LEA results.



Comparability Application Supplement: Support Staff

- This page must correspond to the uploaded **Form III**.
- **Form III** must be uploaded into the **Related Documents** section within the *Comparability Application Supplement*.
- Ensure consistency for exclusions among each school.
- **Note:** LEAs can exclude staff utilizing the check box beside each row for support staff.

School Name	Other Personnel Supporting Instruction			
	* Excluded State/Local FTE (LEP/SWD)	* Actual Federal FTE	* Actual State/Local FTE	State/Local FTE for Comparability (1 FTE = .5 FTE)
Black Fox Elementary School	<input type="checkbox"/> <input type="text"/>	<input type="checkbox"/> <input type="text" value="2.00"/>	<input type="checkbox"/> <input type="text" value="3.00"/>	<input type="text" value="1.500"/>
Bradley Central High School	<input type="checkbox"/> <input type="text"/>	<input type="checkbox"/> <input type="text" value="3.00"/>	<input type="checkbox"/> <input type="text" value="1.50"/>	<input type="text" value="0.750"/>
Bradley County Virtual School	<input type="checkbox"/> <input type="text"/>	<input type="checkbox"/> <input type="text" value="0.00"/>	<input type="checkbox"/> <input type="text" value="3.50"/>	<input type="text" value="1.750"/>
Charleston Elementary School	<input type="checkbox"/> <input type="text"/>	<input type="checkbox"/> <input type="text" value="5.80"/>	<input type="checkbox"/> <input type="text" value="4.00"/>	<input type="text" value="2.000"/>
Hopewell Elementary School	<input type="checkbox"/> <input type="text"/>	<input type="checkbox"/> <input type="text" value="2.00"/>	<input type="checkbox"/> <input type="text" value="4.00"/>	<input type="text" value="2.000"/>
Lake Forest Middle School	<input type="checkbox"/> <input type="text"/>	<input type="checkbox"/> <input type="text" value="0.00"/>	<input type="checkbox"/> <input type="text" value="3.00"/>	<input type="text" value="1.500"/>
Michigan Avenue Elementary School	<input type="checkbox"/> <input type="text"/>	<input type="checkbox"/> <input type="text" value="1.00"/>	<input type="checkbox"/> <input type="text" value="2.00"/>	<input type="text" value="1.000"/>

The above is a test example, not actual LEA results.



Comparability Application Supplement: Form II

- **Form II** is populated with names and assignments for K-12 licensed instructional staff with assignments in EIS.
- The data is pulled from the Oct. 1 count from EIS.
- Staff is listed by school.
- The data from this page pulls into the instructional staff counts on the *School Information* page.

Form II

Public District - FY 2021 - Comparability - Rev 0

This is the TEST site. Please be sure to complete your work on the LIVE site.

Save And Go To 

Black Fox Elementary School 

LAST Name of Employee	FIRST Name of Employee	Position (Please be specific)	Excluded State/Local FTE (LEP/SWD)	Federal FTE	State/Local FTE
 Zebra	* Apple	* Teacher	* 0.00	* 0.00	* 0.00
Totals:			0.00	0.00	0.00

Save And Go To 



Comparability Application Supplement: Form II

- LEAs can manipulate staff for each school that was pulled from EIS.
 - Use the trash can to remove staff.
 - Use *Add New Personnel* to add staff.
- Once a school is completed, click **Save And Go To** to save the information.
- Go to another school via the *Comparability Application Supplement* drop-down arrow to check for accuracy and add the FTE count for each staff member.
- Repeat for each school in the LEA.

LAST Name of Employee	FIRST Name of Employee	Position (Please be specific)	Excluded State/Local FTE (LEP/SWD)	Federal FTE	State/Local FTE
			0.00	0.00	0.00
Zebra	Apple	Teacher	0.00	0.00	0.00
Totals:			0.00	0.00	0.00

Comparability Application Supplement: Comparability Method



Public District - FY 2020 - Comparability - Rev 0

Go To

School Name	Grade Span	Service Type	110% Student/Staff Ratio for Non-Title I Schools		
			Test Value	Actual Value	Test Result
Andersonville Elementary	K-5	GF (SW)	17.27	13.98	Passed
Briceville Elementary	K-5	SW	17.27	10.60	Passed
Claxton Elementary	K-5	SW	17.27	12.99	Passed
Dutch Valley Elementary	K-5	SW	17.27	9.72	Passed
Fairview Elementary	K-5	SW	17.27	13.13	Passed
Grand Oaks Elementary	K-5	SW	17.27	13.96	Passed
Lake City Elementary	K-5	SW	17.27	13.63	Passed
Norwood Elementary	K-5	SW	17.27	12.32	Passed
Passing Schools:					8 / 8

The above is a test example, not actual LEA results.



Comparability Application Supplement: Comparability Method

School Name	Grade Span	Service Type	110% Student/Staff Ratio for Non-Title I Schools Within Grade Span		
			Test Value	Actual Value	Test Result
Andersonville Elementary	K-5	GF (SW)	13.29	13.98	Failed
Briceville Elementary	K-5	SW	13.29	10.60	Passed
Claxton Elementary	K-5	SW	13.29	12.99	Passed
Dutch Valley Elementary	K-5	SW	13.29	9.72	Passed
Fairview Elementary	K-5	SW	13.29	13.13	Passed
Grand Oaks Elementary	K-5	SW	13.29	13.96	Failed
Lake City Elementary	K-5	SW	13.29	13.63	Failed
Norwood Elementary	K-5	SW	13.29	12.32	Passed
Passing Schools:					5 / 8

The above is a test example, not actual LEA results.

If Schools Are Not Comparable

- **If the LEA is unable to demonstrate comparability by the November deadline, the LEA must still upload all required forms by the November deadline *and* a letter** stating that the LEA was not able to demonstrate comparability and understands it must make necessary adjustments within the same school year.
 - Upload documents to the **Related Documents** section of the *Comparability Application Supplement*.
- If, after review by the department, the LEA's first submission shows comparability has not been met due to an error in data, calculation or procedure, and adjustments are required, the LEA will be notified.





Comparability Deadlines

- If adjustments are required to demonstrate comparability, **all new comparability forms *and* a letter** stating what adjustments were made must be uploaded to ePlan in the *Comparability Application Supplement* **Related Documents** section no later than **Dec. 1** of the same school year.

Technical Assistance



Comparability Guidance

- **Comparability Procedures Guide and Data**
 - ePlan.tn.gov > [TDOE Resources](#) > 7. Data and Information Tools > Comparability > Year
- **Recorded Webinars**
 - ePlan.tn.gov > [TDOE Resources](#) > Federal Programs and Oversight (FPO) > Federal Programs Professional Development > 2020-21 Federal Programs Webinar Series > ESEA Title I, Part A Comparability
- **Contact Divisional Coordinators**
 - Heather Farley | Top 20 Most Populous LEAs and Middle (vacant)
 - Heather.Farley@tn.gov
 - Lynn Dotson | West TN
 - Lynn.Dotson@tn.gov
 - Henry LaFollette | East TN
 - Henry.LaFollette@tn.gov

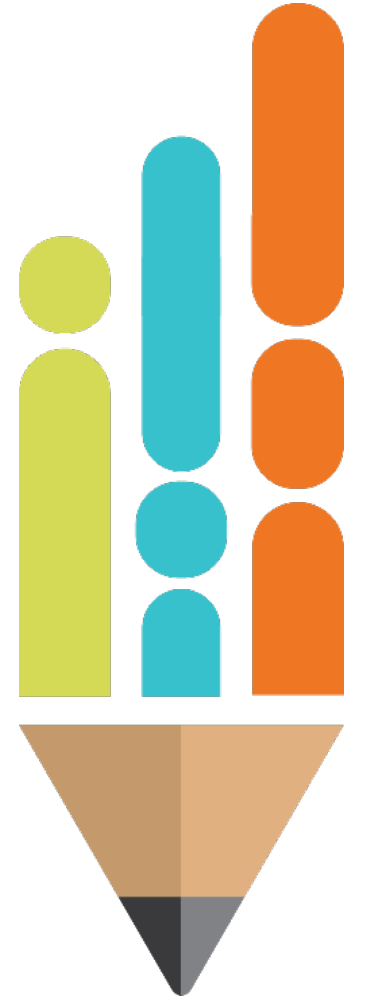

Fraud, Waste or Abuse

Citizens and agencies are encouraged to report fraud, waste, or abuse in State and Local government.

NOTICE: This agency is a recipient of taxpayer funding. If you observe an agency director or employee engaging in any activity which you consider to be illegal, improper or wasteful, please call the state Comptroller's toll-free Hotline:

1-800-232-5454

Notifications can also be submitted electronically at:

<http://www.comptroller.tn.gov/hotline>

Oak Ridge Board of Education

Monitoring: Review: Annually, in September	Descriptor Term: School Board Legislative Involvement	Descriptor Code: 1.105	Issued Date: 08/01/22
		Rescinds:	Issued: <u>08/01/22</u> 04/28/14

1 The Board shall work for the passage of new laws designed to advance the cause of improving public
2 education in Tennessee. Likewise, the Board shall work for the repeal or modification of existing laws
3 and for the defeat of proposed laws that impede this cause.

4 To accomplish this:

- 5 1. The Board shall stay informed of pending legislation and actively communicate its concerns
6 and make its position known to their elected representatives at both the state and national level;
- 7 2. The Board shall work with other school boards in the state, other local officials, and the
8 community groups in creating public awareness and support for legislative priorities;
- 9 3. The Board shall annually select one (1) of its members to serve as its legislative ~~representative~~
10 liaison;
- 11 4. The Board shall work with its legislative ~~representative~~liaison, TSBA, and other concerned
12 groups in developing an annual legislative program; and
- 13 5. The Board shall include in its budget appropriate resources to cover costs, including travel
14 expenses, necessary to ensure active participation in the legislative process.

Cross References

Board Member Development Opportunities 1.204

Oak Ridge Board of Education

Monitoring: Review: Annually, in September	Descriptor Term: School District Planning	Descriptor Code: 1.701	Issued Date: 10/22/18
		Rescinds:	Issued: <u>10/22/18</u> <u>04/28/14</u>

1 *General*

2 The Board shall develop and implement a written five (5) year strategic plan that addresses identified
3 priority needs and provides for continuous student growth and improvement. The plan shall be updated
4 every two (2) years and shall align with requirements of the State Board of Education.¹

5 The Superintendent of Schools shall develop necessary procedures, forms, or other measures to
6 implement this policy.

7 **BOARD IMPROVEMENT PLAN FOR THE DISTRICT¹**

8 The Board shall develop annual plans with specific goals for improving student performance and that
9 operationalize the district's five (5) year strategic plan. This will be incorporated into the TISA
10 accountability report that must be approved by the Board and filed with the Department of Education
11 each November 1st.²

12 The Board shall plan an annual retreat with the Superintendent of Schools and appropriate staff. The
13 purpose of the retreat shall be to:

- 14 1. Review progress on the implementation of priorities, initiatives, and long-range plans;
- 15 2. Determine which goals have been achieved and whether any new efforts are needed;
- 16 3. Review major issues that may affect the school system in the future; and
- 17 4. Create an annual plan for district improvement.

21 **SCHOOL IMPROVMENT PLAN¹**

22 The principal of each school shall work with the Superintendent of Schools/designee to develop and
23 implement a school improvement plan that is student focused and in support of the board improvement
24 plan. The plan shall be updated annually and address the long-range strategic plan of the school
25 district.¹

Legal References

~~1. TRR/MS-0520-01-03-.03(14); State Board of
Education Policy 2.101; TCA 49-1-613~~

Cross References

~~Role of the Board of Education 1.101~~

~~Qualifications and Duties of the Director of Schools
5.802~~

1

Legal References

1. TCA 49-1-613; TRR/MS 0520-01-02-.31(8); State Board of Education Policy 2.101
2. TCA 49-3-112

Cross References

Role of the Board of Education 1.101
In-Service and Professional Learning Opportunities 5.113
Qualifications and Duties of the Director of Schools 5.802

Oak Ridge Board of Education

Monitoring: Review: Annually, in April <u>Review: Annually, in September</u>	Descriptor Term: Fundraising Activities	Descriptor Code: 2.601	Issued Date: 08/26/19
		Rescinds: 6.701 III-41	Issued: 08/26/19 01/02/17 09/28/15

1 *General*

2 The following general guidelines shall be followed:¹

- 3 1. Fundraising activities shall be authorized by the Board and shall be for the purpose of
4 supplementing funds for established school programs and not for supplementing funds which are
5 the responsibility of the Board.
- 6 2. Fundraising companies and other salespersons shall obtain permission in writing from the
7 Superintendent or designee's office in order to visit the schools.
- 8 3. Any commission payable by companies shall be paid in the form of reduced prices to the students
9 or paid into the activity fund of the school for use by the school. No school employee shall
10 personally benefit from any fundraising activity.
- 11 4. The principal must obtain written approval from the Superintendent or designee for all
12 fundraising activities, including online fundraising activities, that involve the participation of the
13 general student population in the marketing process of the fundraising effort. All other
14 fundraising activities, including online fundraising activities, must have written approval from
15 the principal and comply with all administrative procedures issued by the Superintendent or
16 designee. The authorization request shall contain the following information:²
- 17 a. A list of the proposed fundraising activities;
- 18 b. Purpose of the fundraising activity;
- 19 c. Proposed uses of funds raised;
- 20 d. Expected student involvement in fundraising activity (school-wide or individual class or
21 club); and
- 22 e. Margin of profit and how it is to be paid to the school.
- 23 5. The Superintendent or designee shall determine whether or not the activity will benefit the school,
24 contribute to the welfare of the student body, and supplement, not replace, funds necessary to
25 fulfill the Board's required contributions.

1 6. Students shall not be excused from a regular class to participate in a fundraising activity. No
2 grade in a subject or course shall be affected by a student's participation in a fundraising activity.

3 7. No quotas shall be imposed on students involved, and their efforts shall be voluntary. Students
4 who do not participate in fundraising activities shall not be punished or discriminated against in
5 any way.

6 This policy shall not be construed as preventing a teacher from using instructional or informational
7 materials even though the materials might include reference to a brand, a product, or a service.

8 **LOTTERIES**

9 No fundraising activity shall be conducted which distributes prizes or makes awards to winners from
10 among purchasers of chances by means of tickets through a random selection process.³

11 **ONLINE FUNDRAISING¹**

12 The school district is authorized to utilize online fundraising (e.g., crowdfunding). The
13 Superintendent/designee shall ensure that adequate internal controls are established and will determine,
14 on a case-by-case basis, when using online fundraising is appropriate.

15 ~~Individual schools may establish school-wide online fundraising accounts. The accounts must meet all~~
16 ~~fundraising requirements established by the board and the *Internal School Uniform Accounting Policy*~~
17 ~~*Manual*. The principal/designee of each school shall have access to the established fundraising account~~
18 ~~to ensure all funds are properly accounted for, and the information is recorded in the school's~~
19 ~~accounting records by the designated personnel. Online fundraising shall not be used on behalf and for~~
20 ~~the benefit of an outside party.~~

21 Employees shall not engage in online fundraising for educational purposes in their official capacity as
22 district employees nor make any reference to non-school sponsored fundraisers, online or otherwise,
23 that would lead another to believe such activity is an approved school fundraiser. Online fundraising
24 shall not be used on behalf and for the benefit of an outside party.

25 *Individual Schools*

26 Individual schools may establish school-wide online fundraising accounts. The accounts shall meet all
27 fundraising requirements established by the Board and the *Tennessee Internal School Funds Manual*.
28 The principal/designee of each school shall have access to the established fundraising account to
29 ensure all funds are properly accounted for, and the information is recorded in the school's accounting
30 records by the designated personnel.

31 **FUNDRAISING FOR NONEDUCATIONAL PURPOSES⁴**

32 On approval of the principal, an employee may be authorized to raise and use funds for the following
33 noneducational purposes:

34 1. Bereavement support;

35

- 1 2. Award recognition;
- 2
- 3 3. Employee morale; or
- 4
- 5 4. Banquets.

6 These funds shall be derived from vending machine revenue or donations.

7 The Superintendent of Schools or designee shall develop administrative procedures regarding the
 8 receipt, disbursement, accounting, and auditing of these noneducational funds. The Superintendent of
 9 Schools or designee shall ensure that the procedures are consistent with board policy and state law and
 10 disseminate them to all employees.

11 **RECORDKEEPING¹**

12 The Superintendent of Schools/designee shall ensure that the appropriate records are maintained for
 13 each fundraising activity and shall be responsible for collecting and maintaining the appropriate
 14 documents that show the approving, tracking, and monitoring of each fundraising activity from
 15 beginning to end.

16

Legal References

1. ~~Tennessee Internal School Uniform Accounting Policy Manual, Section 4-30, 4-31~~
2. ~~Tennessee Internal School Uniform Accounting Policy Manual, Section 4-32~~
3. ~~Tenn. Op. Att'y Gen. No. 03-049 (Apr. 22, 2003)~~
4. ~~Public Acts of 2019, Chapter No. 134~~

Legal References

1. Tennessee Internal School Funds Manual, Section 4-30, 4-31
2. Tennessee Internal School Funds Manual, Section 4-28
3. Tenn. Att'y Gen. Op. No. 03-049 (Apr. 22, 2003)
4. TCA 49-2-134

Cross References

~~Revenues 2.400~~
~~School Support Organization 2.404~~
~~Audits 2.703~~
~~Vendor Relations 2.809~~
~~Student Activity Funds Management 2.900~~
~~Staff Gifts and Solicitations 5.605~~

Cross References

Revenues 2.400
School Support Organization 2.404
Audits 2.703
Vendor Relations 2.809
Student Activity Funds Management 2.900
Staff Gifts and Solicitations 5.605
Gifts 6.710

Oak Ridge Board of Education

Monitoring: Review: Annually, in September	Descriptor Term: Credit Cards & Credit Lines	Descriptor Code: 2.8051	Issued Date: Click here to enter a date.
		Rescinds:	Issued:

1 *General*

2 District credit cards shall be maintained by the Superintendent/designee through procedures developed
3 and maintained in the Business Office for the purchase of appropriate goods and services for district or
4 school related purposes only.¹ The credit cards will be kept in a secure location, and account numbers
5 will remain confidential. The Finance Director shall be the only employee authorized to apply for a
6 credit card on a school's behalf.

7 Superintendent/designee shall review and approve card transactions. Purchases which are not approved
8 by the Superintendent or the Finance Director will be reimbursed to the district within ten (10) days of
9 notification.

10 **AUTHORIZED USE**

11 Credit cards may be used for transactions in which the use of a standard purchase order is either
12 impossible or would result in a delay of the delivery of goods or services during an emergency. Credit
13 cards may also be used to facilitate out-of-town travel for official school business.

14 Card users shall be held accountable for appropriate use of credit cards. Unauthorized use of a credit
15 card or credit line shall be grounds for disciplinary action, including termination of employment.
16 Employees will be required to reimburse the district or school for any unauthorized purchases. Failure
17 to reimburse the district within ten (10) days of notification will result in a reduction of pay equal to
18 the amount due the district.

19 Any school employee that purchases items with the credit card or any approved credit line shall follow
20 the guidelines outlined below:

- 21 1. Original receipts for each purchase shall be turned into the bookkeeper within three (3) working
22 days of purchase;
- 23 2. If the credit card is used to pay for a conference or training, a copy of the registration form shall
24 be turned in;
- 25 3. The bookkeeper, administrative assistant, or a separate employee shall check off on purchases
26 and the physical inventory that is purchased;
- 27 4. All purchases shall be district or school related purchases;
- 28
- 29
- 30
- 31

- 1 5. Cash advances using district credit cards are prohibited;
- 2
- 3 6. If there is any incurred finance or late charges, the responsibility will belong to the person or
- 4 program associated with said charges; and
- 5
- 6 7. Under no circumstances will the credit card or credit line be used to make personal purchases.

Legal References

1. *Tennessee Internal School Funds Manual*,
Section 4-8; Section 4-11 through 4-13

Cross References

Executive Committee 1.301
Purchasing 2.805
Purchase Orders and Contracts 2.808

Oak Ridge Board of Education			
Monitoring: Review: Annually, in November	Descriptor Term: Promotion and Retention	Descriptor Code: 4.603	Issued Date: 09/26/22
		Rescinds:	Issued: <u>09/26/22</u> 04/22/19 04/23/18

1 *General*

2 All promotion and retention decisions shall be made on a case-by-case basis and comply with state and
3 federal law. All decisions shall be made in consultation with a student’s IEP and/or 504 team, if
4 applicable.¹

5 Students who have difficulty in achieving the requirements for promotion may be considered for
6 retention. Schools shall identify these students by February 1. Factors used to identify students for
7 retention shall include:²

- 8 1. Ability to perform at the current grade level;
- 9
- 10 2. Results of local assessments, screening, or monitoring tools;
- 11
- 12 3. State assessments, as applicable;
- 13
- 14 4. Home Literacy Reports;³
- 15
- 16 5. Overall academic achievement of the student;
- 17
- 18 6. Likelihood of success with more difficult material if promoted to the next grade;
- 19
- 20 7. Attendance record; and
- 21
- 22 8. The student’s maturity.

23 Students may be identified for retention after the February 1st deadline if the delay in identifying a
24 student is due to:⁴

- 25 1. Date of enrollment;
- 26
- 27 2. Additional information acquired after results of local assessment, screening, or monitoring are
28 released; or
- 29
- 30 3. Unexpected long-term illness.

1 **PROMOTION PLANS⁵**

2 When a student is identified for retention, the student's parent(s)/guardian(s) shall be notified within
3 fifteen (15) calendar days, and an individualized promotion plan shall be developed to help the student
4 avoid retention. The plan shall be developed in coordination with the student's teachers, IEP or 504
5 team and may also include input from the student's parent(s)/guardian(s), school counselor, or other
6 appropriate school personnel.

7 Promotion plans shall incorporate evidence-based strategies, including expectations and measurements
8 that will verify whether a student has made sufficient progress to be promoted to the next grade level,
9 and be tailored to the student's learning needs. Promotion plans for students in third and fourth grade
10 will include additional requirements for promoting students in these grades. A copy of the plan will be
11 provided to the student's parent(s)/guardian(s), and the school shall offer the opportunity for a parent-
12 teacher conference to discuss the plan. If a student is not making progress on the promotion plan, then
13 the strategies shall be modified. Parent(s)/guardian(s) shall be provided with any changes to the
14 promotion plan.

15 A student who demonstrates sufficient academic progress according to his/her promotion plan shall be
16 promoted to the next grade level unless retention is required per additional requirements for students in
17 third and fourth grade.⁶

18 If a student has not demonstrated sufficient academic progress according to his/her promotion plan by
19 the end of the school year, the student shall be eligible to enroll in a summer reading or learning
20 program, if available. Parent(s)/guardian(s) shall be notified of a decision for retention at least ten (10)
21 calendar days prior to the start of the next school year if the student was enrolled in a summer program.
22 However, if the student wasn't enrolled in a summer program, the parent(s)/guardian(s) shall be
23 notified of a decision for retention at least thirty (30) calendar days prior to the start of the next school
24 year.⁷

25 **RETENTION⁶**

26 A student may be retained when such retention is in the best interest of the student or when retention is
27 required per additional requirements for students in third and fourth grade.

28 *Decision of Retention – General⁸*

29 If a student is retained, the Superintendent of Schools/designee shall develop an individualized
30 academic remediation plan within thirty (30) calendar days after the beginning of the next school year.
31 A copy of the plan shall be provided to the student's parent(s)/guardian(s) within ten (10) calendar
32 days of its development. The plan shall include at least one of the following strategies:

- 33 1. Adjustment to the current instructional strategies or materials;
- 34
- 35 2. Additional instructional time;
- 36
- 37 3. Individual tutoring;
- 38

- 1 4. Modification to the student’s classroom assignment to ensure the student receives
2 instruction from a teacher with a level of overall effectiveness of above expectations (level
3 4) or significantly above expectations (level 5); or
4
- 5 5. Attendance or truancy interventions.

6 A student shall not be retained more than once in any grade. The progress of students who are retained
7 shall be closely monitored and reported to parent(s)/guardian(s) at least three (3) times during the
8 school year in which the student is retained. The Superintendent or designee shall develop procedures
9 to ensure appropriate recordkeeping of students who are retained.

10 Decision of Retention – Third Grade⁹

11 Third grade students shall not be promoted to the next grade unless they are determined to be
12 proficient (i.e., receive a performance level rating of “on track” or “mastered”) in English language arts
13 (ELA) based on the student’s most recent TCAP test.

14 Students who are not proficient in ELA may still be promoted if the following conditions are met:

15 1. A student in third grade receiving a performance level rating of “approaching” on the ELA
16 portion of the student’s most recent TCAP test may be promoted if:

- 17
- 18 a. The student is an English language learner and has received less than two (2) full years
19 of ELA instruction;
- 20 b. The student was previously retained in grades K-3;
- 21 c. The student is retested before the next school year and scores proficient in ELA;
- 22 d. The student attends a learning loss bridge camp before the next school year, maintains a
23 ninety percent (90%) attendance rate, and demonstrates adequate growth on the post-
24 test at the end of the camp;
- 25 e. The student receives tutoring for the entirety of the next school year in accordance with
26 state law; or
- 27 f. Beginning with the 2023-2024 school year, the student demonstrates proficiency in
28 ELA standards by scoring within the fiftieth percentile on the most recently
29 administered state-provided benchmark assessment and the district provides tutoring
30 services to the student during the entire fourth grade school year and notifies the
31 student’s parent/guardian, in writing, of the benefits of enrolling the student in summer
32 programming.

33

34 2. A student in third grade receiving a performance level rating of “below” on the ELA portion of
35 the student’s most recent TCAP test may be promoted if:

- 36
- 37 a. The student is an English language learner and has received less than two (2) full years
38 of ELA instruction;
- 39 b. The student was previously retained in grades K-3;
- 40 c. The student is retested before the next school year and scores proficient in ELA; or

- 1 d. The student attends a learning loss bridge camp before the next school year, maintains a
2 ninety percent (90%) attendance rate, and receives tutoring for the entirety of the next
3 school year in accordance with state law.

Decision of Retention – Fourth Grade⁹

Students in the following categories shall show adequate growth in the following ways before being promoted to the fifth grade:

1. A student who is promoted to the fourth grade due to receiving tutoring for the entirety of the next school year in accordance with state law or because of attending a learning loss bridge camp must maintain a ninety percent (90%) attendance rate; and
2. A student receiving tutoring for the entirety of the next school year in accordance with state law shall be required to show adequate growth on the fourth grade ELA portion of TCAP before the student may be promoted to fifth grade.

A student shall not be retained more than once in fourth grade.

Decision of Retention – Students with Disabilities¹⁰

Retention and promotion decisions shall be made on a case-by-case basis and in consultation with the student's IEP and/or 504 team to determine whether the student's performance on the ELA portion of TCAP was due to the student's disability. The school district shall not retain a student with a disability or a suspected disability that impacts their ability to read.

APPEALS^{7,11}

When a student is identified for retention, the parent(s)/guardian(s) shall be notified about the decision to retain the student and provided with information on the right to appeal the decision. Appeals shall be made to a committee appointed by the principal within ten (10) days. The student and his/her parent(s)/guardian(s) shall be provided written or actual notice of the appeal hearing and shall be given the opportunity to address the committee. The committee shall conduct a hearing within ten (10) days to determine if the student will be promoted and issue such decision within ten (10) days. Upon notification of the committee decision, the principal shall send written notification to the Superintendent of Schools/designee and the parent(s)/guardian(s). The notification shall advise parent(s)/guardian(s) of their right to appeal such action within five (5) days to the Superintendent of Schools/designee.

The appeal shall be heard no later than ten (10) business days after the request for appeal is received. A decision shall be issued within ten (10) business days.

Within five (5) business days of the Superintendent of Schools/designee rendering a decision, the student's parent(s)/guardian(s) may request a hearing by the Board, and the Board shall review the record. Following the review, the Board may affirm or overturn the decision of the Superintendent of Schools/designee. The action of the Board shall be final.

For students where retention is required per the additional requirements for students in third and fourth grade, parent(s)/guardian(s) may appeal this decision **directly to the Department of Education** in accordance with state law.¹²

Legal References

1. 20 USCA § 1400 *et seq.*; 29 U.S.C. § 794 (Section 504); TRR/MS 0520-01-03-.16; TCA 49-6-3115
2. TRR/MS 0520-01-03-.16(5)
3. TCA 49-1-905(e)
4. TRR/MS 0520-01-03-.16(4)
5. TRR/MS 0520-01-03-.16(6)
6. TRR/MS 0520-01-03-.16(6)(f)
7. TRR/MS 0520-01-03-.16(6)(e)
8. TRR/MS 0520-01-03-.16(6)(g)
9. TRR/MS 0520-01-03-.16(7)
10. 29 U.S.C. § 794 (Section 504); 20 USCA § 1400 *et seq.*; TRR/MS 0520-01-03-.16(7)(e)
11. TRR/MS 0520-01-03-.16(3); TRR/MS 0520-01-02-.17(7); TCA 49-6-3102(e)(1)
12. TRR/MS 0520-01-03-.16(7)(f)

Cross References

Credit Recovery 4.210
Grading System 4.600
Reporting Student Progress 4.601
Attendance 6.200
Student Assignments 6.205
Homeless Students 6.503
Student Records 6.600



Oak Ridge

SCHOOLS

Maintenance and Operations

OFFICE OF MAINTENANCE AND OPERATIONS

DATE: October 2, 2023

TO: Bruce Lay, Executive Director of School Leadership

FROM: Allen Thacker, Director of Maintenance and Operations

SUBJECT: Purchase of New District Fleet Maintenance Truck

Mr. Lay,

I am recommending that the Oak Ridge Schools Board of Education approve the purchase of a new maintenance truck with service body from Freeland Automotive LLC of Antioch TN in the amount of \$61,975.00. This purchase will serve as a scheduled replacement for a fleet vehicle that has reached or exceeded its service life. This project was bid in accordance with state guidelines with two vendors submitting a bids ranging from a high bid of \$79,390.00 to a low bid of \$61,975.00.

Funding for this vehicle is from the Motor Vehicles budget line 72620 718.

Thank you,

Allen Thacker

Supervisor of Maintenance and Operations

Maintenance Office

100 Woodbury, Oak Ridge, TN 37830

(865) 425-3171

www.ortn.edu



Oak Ridge Schools

OFFICE OF
Business & Support Services

Telephone (865) 425-9005
Fax: (865) 425-9060

Bid Minutes
09/28/2023
Service Truck (RFP 24-003)
Business Services Conference Room
Administration Building

Present for the bid opening were:

Kim Farmer
Mary Ann Riley
Dana Paolucci

Oak Ridge Schools Maintenance
Oak Ridge Schools Purchasing
Oak Ridge Schools Business Services Coordinator

Bid responses were received from the following companies:

	<u>Bid Amount</u>
Freeland Automotive, LLC Antioch, TN	\$61,975.00 (2024 Chevrolet Silverado with Reading service)
Lee Smith, Inc. Chattanooga, TN	\$79,390.00 (2024 Ford F250 reg cab with Reading service)

**** Recommended Bid Winner**



**Business
Department**

School Administration Building
304 New York Ave
Oak Ridge, Tennessee 37830
Phone (865) 425-9005
Fax (865) 425-9060

Request for Proposal

Description of items/services requested:

The Oak Ridge Schools Board of Education is soliciting proposals for a truck for the district
(RFP 24-003) 2024 4x4 Regular Cab Truck with Reading Service Package.

General Requirements:

Proposals, bids, or responses will be accepted by the Oak Ridge Schools Business Department no later than **2:30 PM EDT, September 28, 2023**. Every document must be enclosed in an envelope clearly marked as a bid document. Two full copies of the proposal must be submitted each with original signatures on both Bid Forms (included in this packet). Any response, bid, or proposal received after the above deadline shall be considered late, and will not be opened or considered. Bid prices must be valid for no less than sixty (60) days from the date of the bid.

All documents shall be submitted to the following address:

Mary Ann Riley, Purchasing Specialist
Re: 2024 4x4 Truck with Service Package
(RFP 24-003)
Oak Ridge Schools
304 New York Ave
Oak Ridge, TN 37830

SPECIFICATIONS: (Specs are from a previous year truck – we are desiring this truck or an equivalent)

2024 Ford F-250 XL 4x4 SD Regular Cab 8 ft. box 142 in. WB SRW

Warranty

- Standard warranty
- Basic Warranty 36 mon/36,000 miles
- Powertrain Warranty 60 mon/60,000 miles
- Corrosion Perforation 60 mon/60,000 miles
- Roadside Assistance Warranty 60 mon/60,000 miles

Basic vehicle F2B price

- Engine: 6.8L 2 Valve DEVCT NA PFI V8 Gas Engine
- Transmission: TorqShift®-G Ten-Speed Automatic with Selectable Drive Modes with 6.8L gas engine Includes Selectshift and selectable drive modes: normal, eco, slippery roads, tow/haul and off-road.
- GVWR: 10,000 lb payload package
- Wheels: 17" argent painted steel, includes painted hub covers/center ornament
- Seat Type: Heavy-Duty Vinyl 40/20/40 Split Bench Seats with Center Armrest, cupholder, storage and driver's side manual lumbar

- Radio: Am/FM stereo / MP3 player, 4 speakers
- SYNC 4 Includes 8"LCD capacitive touchscreen with swipe capability, wireless phone connection, cloud connected, AppLink with app catalog, 911 Assist, Apple carplay and Android auto compatibility and digital owner's manual.
- Electronic locking w/3.73 axle ratio
- Tires:LT245/75Rx17E BSW A/T
- 142" Wheelbase
- Monotone paint application
- XL Chrome package: Boxlink, 4 premium locking cleats and interface brackets, bright chrome hub covers and center ornament, chrome front bumper, chrome rear step bumper and halogen fog lamp
- Snow Plow prep package, Computer-selected springs for snowplow application, includes 190 amp alternator
- Dual 68 AH/65 AGM Batteries
- 190 amp alternator
- 410 Amp dual alternators
- Platform running boards
- LED Roof Clearance lights
- 120V/400W outlet, 1 in-dash mounted outlet
- Upfitter switches (6)
- Fleet customer Powertrain limited warranty
- 50-State Emission system
- Oxford white
- Medium dark slate w/HD vinyl 40/20/40 Split Bench Seats
- Reading service body
- Front and rear LED's 2 front grill, LED strip under tailgate
- Mini LED Lightbar

Submission Requirements:

1. A detailed bid form, which includes quantity and unit cost must be included in the bid package. Please include specification sheets on all products/terms.
2. Two full copies of the proposal must be submitted, with original Bid Forms included with each copy.
3. A detailed description of all warranties and support for equipment and software must be included.
4. A copy of your W-9 should be included with bid documents.
5. Any questions should be directed to Mary Ann Riley via email: orspurchasing@ortn.edu

Schedule

1. Sealed bids will be opened at the School Administration Building, 304 New York Avenue, Oak Ridge, TN 37830 at **2:30 PM EDT September 28, 2023.**

Bidding Procedures

Location: All bids must be submitted to the Oak Ridge Schools Business Department at or before the announced deadline.

Mary Ann Riley,
Purchasing Specialist
2024 4x4 Truck
(RFP 24-003)
304 New York Ave.
Oak Ridge, TN 37830

Award of Contract: The owner (Oak Ridge Schools) further reserves the right to reject any and all bids, to waive any and all informalities and to negotiate contract terms with the successful bidder, and the right to disregard all non-conforming, non-responsive, or conditional bids. Oak Ridge Schools may conduct such investigations, as it deems necessary, to assist in the evaluation of any bid to establish the responsibility, qualifications, and financial ability of the bidder, proposed subcontractors and other persons and organizations to perform the work in accordance with the contract documents to the bidder who does not pass any such evaluation to the owner's satisfaction. The contract shall be awarded to the bidder whose evaluation by the owner indicates to the owner that the award will be in the best interest of Oak Ridge Schools. It is also understood that the "apparent low bidder" will be announced at the bid opening; however, the "successful bidder," who may or may not be the lowest bidder, will not be announced until all issues, which include, but are not limited to quality, service, conformity to specifications, etc. have been resolved and until a period of review has been completed by the owner. Price will be the primary factor when determining the successful bidder assuming all bid specifications are met. Oak Ridge Schools does not enter into contracts that provide for mediation or arbitration. The owner (Oak Ridge Schools) further reserves the right to reject any and all bids, to waive any and all informalities, and to negotiate contract terms with the successful bidder (e.g., product line-item deletions or adjustments), and the right to disregard all non-conforming, non-responsive, or conditional bids.

Bid Document: For certain projects the Owner will supply a bid form to be completed by the bidder. When such forms are issued, only bids returned with the proper forms will be accepted. Envelopes must be sealed and marked as a bid document. Any bid may be withdrawn prior to the date and time as set forth in the "bid invitation."

EDGAR Certification: The EDGAR certifications and provisions are required and applied when Oak Ridge Schools expends federal funds for any contract resulting from this procurement process. Pursuant to 2 C.F.R. § 200.326, all contracts, including small purchases, awarded by the District and the District's subcontractors shall contain the procurement provisions of Appendix II to Part 200, as applicable.

Errors in Bids: When an error is made in extending total prices, the unit bid price will govern. Carelessness in quoting prices or in preparation of bid otherwise, will not relieve the bidder. Erasures or changes to bids must be initialed. Any alteration, erasure, addition to or omission of required information, change of the specifications, or bidding schedule, is made at the risk of the bidder.

Facsimile transmissions: Electronic transmissions will not be accepted, except when in the course of the bidding process addendums or other notifications of errors on behalf of the owner places an undue hardship upon prospective bidders. Written notification by the owner must precede the acceptance of Facsimile transmissions.

Hold Harmless Agreement: Bidders shall be required to complete the attached Hold Harmless Agreement.

Laws and Regulations: The bidder's attention is directed to the fact that all applicable state laws, municipal ordinances, and the rules and regulations of all authorities having jurisdiction over construction of the project shall apply to the contract throughout, and they will be deemed to be included in the contract the same as though herein written out in full.

Legal Issues: Contracts with Oak Ridge Schools will be subject to the laws of Tennessee. Disputes will be tried in the State of Tennessee and in the Court of Anderson County. Bids will be denied if these provisions are not included in the contract.

Non-Boycott of Israel Affidavit: Concerning the Non-Boycott of Israel Act (TCA 12-4-1 et seq.), by submission of this bid/quote/proposal, each supplier and each person signing on behalf of any supplier certifies, and in the case of a joint bid/quote/proposal, each party thereto certifies as to its own organization, under penalty of perjury, that to the best of its knowledge and belief that each supplier is not boycotting Israel pursuant to TCA 12-4-1 and will not during the term of any award. Note: Applicable only to contracts of \$250,000 or more and to suppliers with 10 or more employees.

Non-Collusion Affidavit: Bidder shall be required to complete the attached Non-Collusion Affidavit.

Payments: Invoices that are submitted by the awarded bidder are required to provide accurate and current addresses. Payment terms shall be specified in the bid response, including any discounts for early payment. The Oak Ridge Schools Business Department discourages the practice of picking up checks in person unless there is an emergency situation.

Purchase: No purchase or contract is authorized or valid until the issuance of a Purchase Order from Oak Ridge Schools and the Board of Education approval of project in accordance with Oak Ridge Schools Policy. No employee is authorized to purchase equipment, supplies or services prior to the issuance of such Purchase Order and Board of Education approval.

Sub-contracts: The Bidder is specifically advised that any person, firm, or other party to whom it is proposed to award a sub-contract under this contract must be acceptable to the Owner.

Subcontractors and employees: If work is to be performed during regular school hours when children are present, the BOE reserves the right to require background checks, dress codes, and certain ethical standards of all employees on school property.

Taxes: Oak Ridge Schools is tax exempt.

Tie Bids: If two or more bidders submit identical bids and is equally qualified; selection shall be made at the discretion of the owner.

Title VI of the Civil Rights Act of 1964: All interested parties, without regard of race, color, or national origin, shall be afforded the opportunity to bid and shall receive equal consideration. Title VI states "No person in the United States shall, on the ground of race, color, or national origin, be excluded from participation in, be denied the benefits of, or be subjected to discrimination under any program activity receiving Federal financial assistance." Oak Ridge Schools strives to protect individuals' civil rights through active compliance with the requirements of Title VI.

Vendor Indemnify: Oak Ridge Schools will indemnify vendor to the extent Tennessee law allows.

Warranty: The vendor shall provide warranty information on the equipment, components and items bid with the bid submittal.

Bid Form

Owner: Oak Ridge Schools Board of Education
Mary Ann Riley, Purchasing Specialist
School Administration Building
304 New York Ave
Oak Ridge, TN 37830

Project: **2024 4x4 Truck**
RFP 24-003

Bid Opening: **2:30 PM EDT, Sept.28, 2023**

Company Name: Freeland Automotive LLC

Address: 5333 Hickory Hollow Parkway

Antioch, TN 37013

Phone Number: 512-740-2272

Email: ben.rotz@freelandauto.com

Main Bid: ***This Price is to be for the complete package including delivery. ALL COSTS ARE TO BE INCLUDED IN THE FINAL PRICE.***

Bid Amount: \$ 61,975 USD

Company: Freeland Automotive LLC

Signature: *Benjamin Rotz*

Title: Government Fleet Specialist

Date: 9/26/2023

Please attach detailed specifications.

HOLD HARMLESS AGREEMENT

This Hold Harmless Agreement is between Freeland Automotive LLC
Name of Contractor
(Hereinafter Contractor), and Oak Ridge Schools named in this bid.

Contractor agrees that as a condition precedent to "Contractor" being awarded a contract from Oak Ridge Schools, "Contractor" agrees to indemnify, protect, defend, and hold harmless Oak Ridge Schools, its Board Members, agents, and employees from all judgments, claims, demands for payment, suits or actions of every nature and description brought against Oak Ridge Schools, its Board Members, agents, and employees alleging injuries or damages sustained by any person arising out of or in the course of "Contractor's" providing goods or services to Oak Ridge Schools.

Name of Contractor: Freeland Automotive LLC

By: Jordan Frey

Title: Director of Fleet

STATE OF TN

County of Davidson

Jordan Frey personally appeared before me, the undersigned, with whom I am personally acquainted and who, upon oath, acknowledged that he/she/it executed the within instrument for the purposes therein contained, and who further acknowledge that he/she/it is authorized to execute this instrument on behalf of

[Handwritten Signature]
Signature

Witness by hand and Notaries seal at office this 27th day of Sept
year of 2023.

[Handwritten Signature]
Notary Public

My Commission Expires: 1-1-25

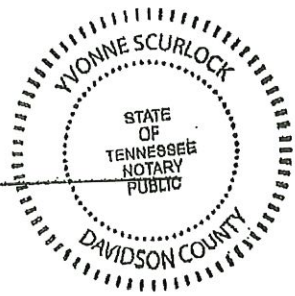

NON-COLLUSION AFFIDAVIT

NON-COLLUSION AFFIDAVIT TO BE EXECUTED
BY DESIGN-BUILDER

State of Tennessee

County of Davidson

Jordan Frey, being first duly sworn, deposes and says that he or she is of the party making the foregoing bid is not made in the interest of, or on behalf of, any undisclosed person, partnership, company, association, organization, or corporation; that the bid is genuine and not collusive or sham; that the bidder neither possesses a business relationship with any employee of the District which may be involved in the award or administration of the project nor has received or solicited either directly or indirectly any inside information from an employee of the District which would give the bidder an advantage over any other bidder; that the bidder has not directly or indirectly induced or solicited any other bidder to put in a false or sham bid, and has not directly or indirectly colluded, conspired, connived, or agreed with any bidder or anyone else to put in a sham bid, or that anyone shall refrain from bidding; that the bidder has not in any manner, directly or indirectly, sought by agreement, communication, or conference with anyone to fix the bid price of the bidder or any other bidder, or to fix any overhead, profit, or cost element of the bid price, or of that of any other bidder, or to secure any advantage against the public body awarding the contract or any interested in the proposed contract; that all statements contained in the bid are true; and, further, that the bidder has not, directly or indirectly, submitted his or her bid price of any breakdown thereof, or the contents thereof, or divulged information or data relative thereto, or paid, and will not pay, any fee to any corporation, partnership, company, association, organization, bid depository, or to any member or agent thereof to effectuate a collusive or sham bid.

Subscribed and sworn to (or affirmed) before me this 21st day

of Sept, 23.

[Signature]
Signature of Officer

Jordan Frey
Typed Name of Officer

Director of Fleet
Office

[Signature]
Notary Signature

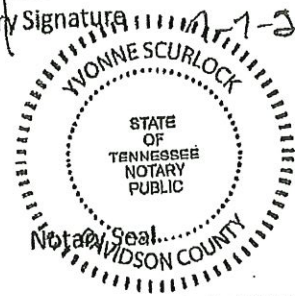

WARNING! PROPOSALS WILL NOT BE CONSIDERED UNLESS THIS AFFIDAVIT IS COMPLETED AND EXECUTED, INCLUDING THE AFFIDAVIT OF THE NOTARY AND THE NOTORIAL SEAL.

IRAN DIVESTMENT ACT REQUIREMENTS

Pursuant to Tennessee Code Annotated § 12-12-106 (as enacted by Chapter 817 of the Public Acts of 2016) the chief procurement officer for the State of Tennessee shall publish a list of persons determined to be engaging in investment activities in Iran. The list is posted on the website of the Tennessee General Services Department's Central Procurement Office*. When competitive bidding is required, Tennessee Code Annotated § 12-12-111 requires every bid or proposal submitted to a local government for goods or services to include the following statement, subscribed or affirmed by the bidder as true under the penalty of perjury:

CERTIFICATION

By submission of this bid, each bidder and each person signing on behalf of any bidder certifies, and in the case of a joint bid each party thereto certifies as to its own organization, under penalty of perjury, that to the best of its knowledge and belief that each bidder is not on the list created pursuant to T.C.A. § 12-12-106.

Benjamin Rotz
Signature

9/26/2023
Date

Benjamin Rotz
Printed Name

Government Fleet Specialist
Title

Freeland Automotive LLC
Name of Firm/Company

*https://tn.gov/assets/entities/generalservices/cpo/attachments/List_of_persons_pursuant_to_Tenn._Code_Annotation_12-12-106_Iran_Divestment_Act-July.pdf



2024 Chevrolet 2500HD Silverado

Body Style: CK20953-LWB, 4WD, Double Cab Pickup

PEG: 1WT-Work Truck Preferred Equipment Group

Primary Color: GAZ-Summit White

Trim: H2G-1WT-Vinyl, Jet Black, Interior Trim

Engine: L8T-Engine: 6.6L, V-8, SIDI

Transmission: MKM-10-Speed Automatic

Options:

Body Type Description - Service Truck

On Lot Notes - Summit White 2024 Chevrolet Silverado 2500HD Work Truck 4WD 6.6L V8 10-Speed Automatic Double Cab**Price Includes \$750 Finance Coupon W.A.C. See Dealer For Details**, 10-Speed Automatic, 4WD, Jet Black Vinyl. We will beat any Middle Tennessee dealer's price on new Chevrolet's. One Low Price! Great Selection! Find Your New Road! *** Text us now at 615-293-5047 to schedule your test drive.

Upfit Model Description - Silverado 2500

5N5 - Rear Camera Kit for ZW9 Box Delete or Chassis Cab (SEO)

9L7 - Upfilter / Accessory Electrical Switches

AQQ - Keyless Remote Entry

B3P - Special Vehicle Sales

C49 - Defogger, Rear Window, Electric

DD8 - ISRV Mirror, Electro-chromatic

FE9 - Federal Emissions

GAZ - Summit White

H2G - 1WT-Vinyl, Jet Black, Interior Trim

JL1 - Integrated Trailer Brake Controller

K47 - Heavy Duty Air Filter

KC4 - Cooler, Engine Oil

KNP - Transmission Cooling System

L8T - Engine: 6.6L, V-8, SIDI

N37 - Steering Column, Manual Tilt & Telescoping

NZZ - Skid Plate

PRF - 3 Years of OnStar Remote Access

QXT - Tires: LT265/70 R17 All Terrain, Blackwall

TQ5 - Headlamps, IntelliBeam

U2K - SiriusXM Satellite Radio (subscription)

UE4 - Following Distance Indicator

UHY - Automatic Emergency Braking

V46 - Bumper, Front, Chrome

VK3 - Front License Plate Mounting Provisions

YK6 - SEO Processing Option

Body Manufacturer - Reading

Fuel Type - Gasoline

Upfit Condition - New

1WT - Work Truck Preferred Equipment Group

9J4 - Bumper: Rear Delete

AKO - Glass, Deep Tinted

AZ3 - Seats: Front 40/20/40 Split-Bench, Full Feature

BG9 - Floor Covering: Rubberized Vinyl, Black

C7G - GVW Rating 10,500 Lbs

DWI - Mirrors, O/S: Pwr Fold, Man. Ext., Heat, Turn Indicator

G80 - Auto Locking Differential, Rear

GT4 - Rear Axle: 3.73 Ratio

IOR - Chevrolet Infotainment, 7" Color Screen

K34 - Cruise Control

K4Z - Battery, Auxiliary, 700 CCA

KI4 - 120 Volt Electrical Receptacle, In Cab

KW5 - Alternator, 220 AMP

MKM - 10-Speed Automatic

NQF - Transfer Case: w/ Rotary Dial Control, Electronic Shift

PCV - 1WT Convenience 1 Package

PYN - Wheels: 17" Steel, Painted

SFW - Back-Up Alarm Calibration (SEO)

U01 - Roof Marker Lamps

UE1 - OnStar Communication System

UEU - Sensor, Forward Collision Alert

UKJ - Sensor, Front Pedestrian Braking

V76 - Recovery Hooks

VYU - Snow Plow Prep / Camper Package

ZW9 - Delete: Pick-Up Box

Warranty Information:

- Vehicle meets warranty commitments

Delivery:

- Truck is currently with upfitter.
- Truck will be delivered by December 31, 2023 at the latest

Body Details



Manufacturer	READING TRUCK
Body Type	Service Truck
Body Line	SL Service Truck
Body Model	SLU98-SWs
Body Material	Steel
Body Height	40"
Body Width	77.5"
Body Length	98"
Body Inside Width	48.5"
Body Weight	1046 lbs.
Bulkhead Description	Reinforced
Bulkhead Height	Full
Compartment Description	"A" Compartment Layout - R/S and C/S, Spring Loaded Door Holders, Standard Shelf and Divider Equipment - All Removable and Adjustable
Compartment Depth	14.5"
Floor Description	Treadplate
Floor Material	Steel

Lighting Type	LED
Lighting Location	Exterior
Lock System Type	Rotary Locks
Lock System Material	Stainless Steel
Tailgate Type	Slam Action
Tailgate Description	Knee Braced Tailgate
Bumper Type	Pooched Recessed
Bumper Color	White
Camera Description	Factory Backup Camera
Hitch Type	Receiver
Hitch Description	Tube
Hitch Size	2"
Trailer Plug Description	7-Way Round Socket Flat Pin RV Style

SL Service Truck Features

Reading's SL service bodies feature the premium materials and quality construction Reading is famous for at an exceptional value. The SL is available in 98" single rear wheel, 108" and 132" dual rear wheel configurations. Both are available in standard and low-profile designs. You can get even more storage space with the Reading Spacemaker[®] option.

Every SL service truck body moves through our exclusive E-coat primer and powder coat finish process for outstanding rust and corrosion resistance. In addition, the SL service body offers numerous standard features and options, including Dual-Pro[®] door seals, an Alumina-Fill fuel cup, stainless steel rotary locks, a slam-action tailgate and much more.

Made in America and backed by our 6-year warranty, the SL service body offers unbeatable value.

Request for Taxpayer Identification Number and Certification

Give Form to the
requester. Do not
send to the IRS.

▶ Go to www.irs.gov/FormW9 for instructions and the latest information.

1 Name (as shown on your income tax return). Name is required on this line; do not leave this line blank.
Free Land Chevrolet LLC

2 Business name/disregarded entity name, if different from above

3 Check appropriate box for federal tax classification of the person whose name is entered on line 1. Check only one of the following seven boxes.

Individual/sole proprietor or single-member LLC

Limited liability company. Enter the tax classification (C=C corporation, S=S corporation, P=Partnership) ▶ _____

Other (see instructions) ▶ _____

4 Exemptions (codes apply only to certain entities, not individuals; see instructions on page 3):
Exempt payee code (if any) _____
Exemption from FATCA reporting code (if any) _____
(Applies to accounts maintained outside the U.S.)

5 Address (number, street, and apt. or suite no.) See instructions.
5333 Hickory Hollow Pkwy

6 City, state, and ZIP code
Antioch, TN 37013

7 List account number(s) here (optional)

Requester's name and address (optional)

Part I Taxpayer Identification Number (TIN)

Enter your TIN in the appropriate box. The TIN provided must match the name given on line 1 to avoid backup withholding. For individuals, this is generally your social security number (SSN). However, for a resident alien, sole proprietor, or disregarded entity, see the instructions for Part I, later. For other entities, it is your employer identification number (EIN). If you do not have a number, see *How to get a TIN*, later.

Note: If the account is in more than one name, see the instructions for line 1. Also see *What Name and Number To Give the Requester* for guidelines on whose number to enter.

Social security number	
[] [] [] - [] [] [] - [] [] []	
or	
Employer identification number	
26 - 3207095	

Part II Certification

Under penalties of perjury, I certify that:

- The number shown on this form is my correct taxpayer identification number (or I am waiting for a number to be issued to me); and
- I am not subject to backup withholding because: (a) I am exempt from backup withholding, or (b) I have not been notified by the Internal Revenue Service (IRS) that I am subject to backup withholding as a result of a failure to report all interest or dividends, or (c) the IRS has notified me that I am no longer subject to backup withholding; and
- I am a U.S. citizen or other U.S. person (defined below); and
- The FATCA code(s) entered on this form (if any) indicating that I am exempt from FATCA reporting is correct.

Certification instructions. You must cross out item 2 above if you have been notified by the IRS that you are currently subject to backup withholding because you have failed to report all interest and dividends on your tax return. For real estate transactions, item 2 does not apply. For mortgage interest paid, acquisition or abandonment of secured property, cancellation of debt, contributions to an individual retirement arrangement (IRA), and generally, payments other than interest and dividends, you are not required to sign the certification, but you must provide your correct TIN. See the instructions for Part II, later.

Sign Here Signature of U.S. person ▶ [Signature] Date ▶ 5-16-23

General Instructions

Section references are to the Internal Revenue Code unless otherwise noted.

Future developments. For the latest information about developments related to Form W-9 and its instructions, such as legislation enacted after they were published, go to www.irs.gov/FormW9.

Purpose of Form

An individual or entity (Form W-9 requester) who is required to file an information return with the IRS must obtain your correct taxpayer identification number (TIN) which may be your social security number (SSN), individual taxpayer identification number (ITIN), adoption taxpayer identification number (ATIN), or employer identification number (EIN), to report on an information return the amount paid to you, or other amount reportable on an information return. Examples of information returns include, but are not limited to, the following:

- Form 1099-INT (interest earned or paid)
- Form 1099-DIV (dividends, including those from stocks or mutual funds)
- Form 1099-MISC (various types of income, prizes, awards, or gross proceeds)
- Form 1099-B (stock or mutual fund sales and certain other transactions by brokers)
- Form 1099-S (proceeds from real estate transactions)
- Form 1099-K (merchant card and third party network transactions)
- Form 1098 (home mortgage interest), 1098-E (student loan interest), 1098-T (tuition)
- Form 1099-C (canceled debt)
- Form 1099-A (acquisition or abandonment of secured property)

Use Form W-9 only if you are a U.S. person (including a resident alien), to provide your correct TIN.

If you do not return Form W-9 to the requester with a TIN, you might be subject to backup withholding. See What is backup withholding, later.



Phone: 423-622-4161

2600 8th Ave. • P.O. Box 72843 • Chattanooga, TN 37407
TRUCKS • PARTS • SERVICE • SOLUTIONS

Fax: 423-629-9540

To: Oak Ridge Schools
304 New York Ave
Oak Ridge, TN. 37830
ATTN: Mary Ann Riley
REF: RFP 24-003 4x4 pickup trk w/service body

Salesperson: Andy Ashford

Date: September 28, 2023

We are pleased to quote you, for acceptance within ten days from this date, prices on equipment described below.

Quantity	Description	Amount
1	2024 Ford F250 4x4 regular cab with reading service body delivered to Oak Ridge TN	\$79,390.00
	NOTE: 410 AMP DUAL ALTERNATORS NOW HAS TO BE A DIESEL ENGINE	
	SERVICE BODY LEAD TIME IS LATE Q2 2024 AT BID TIME COULD BE EXTENDED OUT AFTER RECEIPT OF ORDER	
	TRUCK IS 18 TO 32 WEEKS OUT AFTER ORDERED	
	Del of Complete Unit could be	
	AS Late as OCT 2024	
	Detailed Specifications Attached	
		\$79,390.00



Business

Department

School Administration Building
304 New York Ave
Oak Ridge, Tennessee 37830
Phone (865) 425-9005
Fax (865) 425-9060

Request for Proposal

Description of items/services requested:

The Oak Ridge Schools Board of Education is soliciting proposals for a truck for the district
(RFP 24-003) 2024 4x4 Regular Cab Truck with Reading Service Package.

General Requirements:

Proposals, bids, or responses will be accepted by the Oak Ridge Schools Business Department no later than **2:30 PM EDT, September 28, 2023**. Every document must be enclosed in an envelope clearly marked as a bid document. Two full copies of the proposal must be submitted each with original signatures on both Bid Forms (included in this packet). Any response, bid, or proposal received after the above deadline shall be considered late, and will not be opened or considered. Bid prices must be valid for no less than sixty (60) days from the date of the bid.

All documents shall be submitted to the following address:

Mary Ann Riley, Purchasing Specialist
Re: 2024 4x4 Truck with Service Package
(RFP 24-003)
Oak Ridge Schools
304 New York Ave
Oak Ridge, TN 37830

SPECIFICATIONS: (Specs are from a previous year truck – we are desiring this truck or an equivalent)

2024 Ford F-250 XL 4x4 SD Regular Cab 8 ft. box 142 in. WB SRW

✓ Warranty

- ✓ • Standard warranty
- ✓ • Basic Warranty 36 mon/36,000 miles
- ✓ • Powertrain Warranty 60 mon/60,000 miles
- ✓ • Corrosion Perforation 60 mon/60,000 miles
- ✓ • Roadside Assistance Warranty 60 mon/60,000 miles

✓ Basic vehicle F2B price

- ✓ • Engine: 6.8L 2 Valve DEVCT NA PFI V8 Gas Engine
- ✓ • Transmission: TorqShift®-G Ten-Speed Automatic with Selectable Drive Modes with 6.8L gas engine Includes Selectshift and selectable drive modes: normal, eco, slippery roads, tow/haul and off-road.
- ✓ • GVWR: 10,000 lb payload package
- ✓ • Wheels: 17" argent painted steel, includes painted hub covers/center ornament
- ✓ • Seat Type: Heavy-Duty Vinyl 40/20/40 Split Bench Seats with Center Armrest, cupholder, storage and driver's side manual lumbar

- ✓ • Radio: Am/FM stereo / MP3 player, 4 speakers
- ✓ • SYNC 4 Includes 8" LCD capacitive touchscreen with swipe capability, wireless phone connection, cloud connected, AppLink with app catalog, 911 Assist, Apple carplay and Android auto compatibility and digital owner's manual.
- ✓ • Electronic locking w/3.73 axle ratio
- ✓ • Tires: LT245/75R17E BSW A/T
- ✓ • 142" Wheelbase
- ✓ • Monotone paint application
- ✓ • XL Chrome package: Boxlink, 4 premium locking cleats and interface brackets, bright chrome hub covers and center ornament, chrome front bumper, chrome rear step bumper and halogen fog lamp
- ✓ • Snow Plow prep package, Computer-selected springs for snowplow application, includes 190 amp alternator
- ✓ • Dual 68 AH/65 AGM Batteries
- ✓ • 190 amp alternator
- ~~✓~~ • 410 Amp dual alternators NONE TO DO Diesel eng.
- ✓ • Platform running boards
- ✓ • LED Roof Clearance lights
- ✓ • 120V/400W outlet, 1 in-dash mounted outlet
- ✓ • Upfitter switches (6)
- ✓ • Fleet customer Powertrain limited warranty
- ✓ • 50-State Emission system
- ✓ • Oxford white
- ✓ • Medium dark slate w/HD vinyl 40/20/40 Split Bench Seats
- ✓ • Reading service body
- ✓ • Front and rear LED's 2 front grill, LED strip under tailgate
- ✓ • Mini LED Lightbar

Submission Requirements:

1. A detailed bid form, which includes quantity and unit cost must be included in the bid package. Please include specification sheets on all products/terms.
2. Two full copies of the proposal must be submitted, with original Bid Forms included with each copy.
3. A detailed description of all warranties and support for equipment and ~~software~~ ^{N/A} must be included.
4. A copy of your W-9 should be included with bid documents.
5. Any questions should be directed to Mary Ann Riley via email: orspurchasing@ortn.edu

Schedule

1. Sealed bids will be opened at the School Administration Building, 304 New York Avenue, Oak Ridge, TN 37830 at **2:30 PM EDT September 28, 2023.**

Bidding Procedures

Location: All bids must be submitted to the Oak Ridge Schools Business Department at or before the announced deadline.

Mary Ann Riley,
Purchasing Specialist
2024 4x4 Truck
(RFP 24-003)
304 New York Ave.
Oak Ridge, TN 37830

Award of Contract: The owner (Oak Ridge Schools) further reserves the right to reject any and all bids, to waive any and all informalities and to negotiate contract terms with the successful bidder, and the right to disregard all non-conforming, non-responsive, or conditional bids. Oak Ridge Schools may conduct such investigations, as it deems necessary, to assist in the evaluation of any bid to establish the responsibility, qualifications, and financial ability of the bidder, proposed sub-contractors and other persons and organizations to perform the work in accordance with the contract documents to the bidder who does not pass any such evaluation to the owner's satisfaction. The contract shall be awarded to the bidder, whose evaluation by the owner indicates to the owner that the award will be in the best interest of Oak Ridge Schools. It is also understood that the "apparent low bidder" will be announced at the bid opening; however, the "successful bidder," who may or may not be the lowest bidder, will not be announced until all issues, which include, but are not limited to quality, service, conformity to specifications, etc. have been resolved and until a period of review has been completed by the owner. Price will be the primary factor when determining the successful bidder assuming all bid specifications are met. Oak Ridge Schools does not enter into contracts that provide for mediation or arbitration. The owner (Oak Ridge Schools) further reserves the right to reject any and all bids, to waive any and all informalities, and to negotiate contract terms with the successful bidder (e.g., product line-item deletions or adjustments), and the right to disregard all non-conforming, non-responsive, or conditional bids.

Bid Document: For certain projects the Owner will supply a bid form to be completed by the bidder. When such forms are issued, only bids returned with the proper forms will be accepted. Envelopes must be sealed and marked as a bid document. Any bid may be withdrawn prior to the date and time as set forth in the "bid invitation."

EDGAR Certification: The EDGAR certifications and provisions are required and applied when Oak Ridge Schools expends federal funds for any contract resulting from this procurement process. Pursuant to 2 C.F.R. § 200.326, all contracts, including small purchases, awarded by the District and the District's subcontractors shall contain the procurement provisions of Appendix II to Part 200, as applicable.

Errors in Bids: When an error is made in extending total prices, the unit bid price will govern. Carelessness in quoting prices or in preparation of bid otherwise, will not relieve the bidder. Erasures or changes to bids must be initialed. Any alteration, erasure, addition to or omission of required information, change of the specifications, or bidding schedule, is made at the risk of the bidder.

Facsimile transmissions: Electronic transmissions will not be accepted, except when in the course of the bidding process addendums or other notifications of errors on behalf of the owner places an undue hardship upon prospective bidders. Written notification by the owner must precede the acceptance of Facsimile transmissions.

Hold Harmless Agreement: Bidders shall be required to complete the attached Hold Harmless Agreement.

Laws and Regulations: The bidder's attention is directed to the fact that all applicable state laws, municipal ordinances, and the rules and regulations of all authorities having jurisdiction over construction of the project shall apply to the contract throughout, and they will be deemed to be included in the contract the same as though herein written out in full.

Legal Issues: Contracts with Oak Ridge Schools will be subject to the laws of Tennessee. Disputes will be tried in the State of Tennessee and in the Court of Anderson County. Bids will be denied if these provisions are not included in the contract.

Non-Boycott of Israel Affidavit: Concerning the Non-Boycott of Israel Act (TCA 12-4-1 et seq.), by submission of this bid/quote/proposal, each supplier and each person signing on behalf of any supplier certifies, and in the case of a joint bid/quote/proposal, each party thereto certifies as to its own organization, under penalty of perjury, that to the best of its knowledge and belief that each supplier is not boycotting Israel pursuant to TCA 12-4-1 and will not during the term of any award. Note: Applicable only to contracts of \$250,000 or more and to suppliers with 10 or more employees.

Non-Collusion Affidavit: Bidder shall be required to complete the attached Non-Collusion Affidavit.

Payments: Invoices that are submitted by the awarded bidder are required to provide accurate and current addresses. Payment terms shall be specified in the bid response, including any discounts for early payment. The Oak Ridge Schools Business Department discourages the practice of picking up checks in person unless there is an emergency situation.

Purchase: No purchase or contract is authorized or valid until the issuance of a Purchase Order from Oak Ridge Schools and the Board of Education approval of project in accordance with Oak Ridge Schools Policy. No employee is authorized to purchase equipment, supplies or services prior to the issuance of such Purchase Order and Board of Education approval.

Sub-contracts: The Bidder is specifically advised that any person, firm, or other party to whom it is proposed to award a sub-contract under this contract must be acceptable to the Owner.

Subcontractors and employees: If work is to be performed during regular school hours when children are present, the BOE reserves the right to require background checks, dress codes, and certain ethical standards of all employees on school property.

Taxes: Oak Ridge Schools is tax exempt.

Tie Bids: If two or more bidders submit identical bids and is equally qualified; selection shall be made at the discretion of the owner.

Title VI of the Civil Rights Act of 1964: All interested parties, without regard of race, color, or national origin, shall be afforded the opportunity to bid and shall receive equal consideration. Title VI states "No person in the United States shall, on the ground of race, color, or national origin, be excluded from participation in, be denied the benefits of, or be subjected to discrimination under any program activity receiving Federal financial assistance." Oak Ridge Schools strives to protect individuals' civil rights through active compliance with the requirements of Title VI.

Vendor Indemnify: Oak Ridge Schools will indemnify vendor to the extent Tennessee law allows.

Warranty: The vendor shall provide warranty information on the equipment, components and items bid with the bid submittal.

Bid Form

Owner: Oak Ridge Schools Board of Education
Mary Ann Riley, Purchasing Specialist
School Administration Building
304 New York Ave
Oak Ridge, TN 37830

Project: **2024 4x4 Truck**
RFP 24-003

Bid Opening: **2:30 PM EDT, Sept.28, 2023**

Company Name: LEE-Smith Inc.

Address: 2600 8TH AVE
CHATTANOOGA TN 37407

Phone Number: 423-622-4161

Email: cashford@lee-smith.com

Main Bid: *This Price is to be for the complete package including delivery. ALL COSTS ARE TO BE INCLUDED IN THE FINAL PRICE.*

Bid Amount: \$ 79390⁰⁰ USD

Company: LEE-Smith Inc.

Signature: Andy Crawford

Title: Sales

Date: 9/28/2023

Please attach detailed specifications.

IRAN DIVESTMENT ACT REQUIREMENTS

Pursuant to Tennessee Code Annotated § 12-12-106 (as enacted by Chapter 817 of the Public Acts of 2016) the chief procurement officer for the State of Tennessee shall publish a list of persons determined to be engaging in investment activities in Iran. The list is posted on the website of the Tennessee General Services Department's Central Procurement Office*. When competitive bidding is required, Tennessee Code Annotated § 12-12-111 requires every bid or proposal submitted to a local government for goods or services to include the following statement, subscribed or affirmed by the bidder as true under the penalty of perjury:

CERTIFICATION

By submission of this bid, each bidder and each person signing on behalf of any bidder certifies, and in the case of a joint bid each party thereto certifies as to its own organization, under penalty of perjury, that to the best of its knowledge and belief that each bidder is not on the list created pursuant to T.C.A. § 12-12-106.

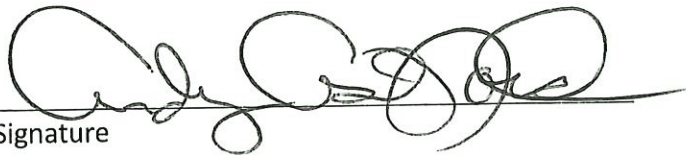
Signature

Andy Ashford
Printed Name

Lee-Smith Inc
Name of Firm/Company

9/28/2023
Date

Sales
Title

*https://tn.gov/assets/entities/generalservices/cpo/attachments/List_of_persons_pursuant_to_Tenn._Code_An_n_12-12-106._Iran_Divestment_Act-July.pdf

NON-COLLUSION AFFIDAVIT

NON-COLLUSION AFFIDAVIT TO BE EXECUTED
BY DESIGN-BUILDER

State of Tennessee

County of Hamilton

_____ being first duly sworn, deposes and says that he or she is of the party making the foregoing bid is not made in the interest of, or on behalf of, any undisclosed person, partnership, company, association, organization, or corporation; that the bid is genuine and not collusive or sham; that the bidder neither possesses a business relationship with any employee of the District which may be involved in the award or administration of the project nor has received or solicited either directly or indirectly any inside information from an employee of the District which would give the bidder an advantage over any other bidder; that the bidder has not directly or indirectly induced or solicited any other bidder to put in a false or sham bid, and has not directly or indirectly colluded, conspired, connived, or agreed with any bidder or anyone else to put in a sham bid, or that anyone shall refrain from bidding; that the bidder has not in any manner, directly or indirectly, sought by agreement, communication, or conference with anyone to fix the bid price of the bidder or any other bidder, or to fix any overhead, profit, or cost element of the bid price, or of that of any other bidder, or to secure any advantage against the public body awarding the contract or any interested in the proposed contract; that all statements contained in the bid are true; and, further, that the bidder has not, directly or indirectly, submitted his or her bid price of any breakdown thereof, or the contents thereof, or divulged information or data relative thereto, or paid, and will not pay, any fee to any corporation, partnership, company, association, organization, bid depository, or to any member or agent thereof to effectuate a collusive or sham bid.

Subscribed and sworn to (or affirmed) before me this 21st day

of September, 2023.

[Signature]
Signature of Officer

[Signature]
Notary Signature

ANNY ASHFORD
Typed Name of Officer

Sales
Office

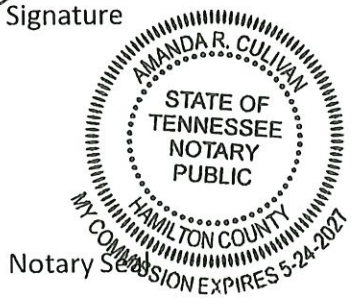

WARNING! PROPOSALS WILL NOT BE CONSIDERED UNLESS THIS AFFIDAVIT IS COMPLETED AND EXECUTED, INCLUDING THE AFFIDAVIT OF THE NOTARY AND THE NOTORIAL SEAL.

HOLD HARMLESS AGREEMENT

This Hold Harmless Agreement is between Lee-Smith Inc.
Name of Contractor

(Hereinafter Contractor), and Oak Ridge Schools named in this bid.

Contractor agrees that as a condition precedent to "Contractor" being awarded a contract from Oak Ridge Schools, "Contractor" agrees to indemnify, protect, defend, and hold harmless Oak Ridge Schools, its Board Members, agents, and employees from all judgments, claims, demands for payment, suits or actions of every nature and description brought against Oak Ridge Schools, its Board Members, agents, and employees alleging injuries or damages sustained by any person arising out of or in the course of "Contractor's" providing goods or services to Oak Ridge Schools.

Name of Contractor: Lee-Smith Inc.

By: Andy Ashford

Title: Sales

STATE OF Tennessee
County of Hamilton

Andy Ashford personally appeared before me, the undersigned, with whom I am personally acquainted and who, upon oath, acknowledged that he/she/it executed the within instrument for the purposes therein contained, and who further acknowledge that he/she/it is authorized to execute this interment on behalf of Lee-Smith Inc.

[Signature]
Signature

Witness by hand and Notaries seal at office this 24th day of September
year of 2023.

[Signature]
Notary Public

My Commission Expires: 5/24/2027

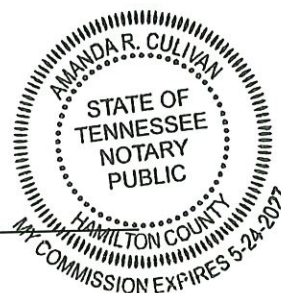

Prepared for: Mary Ann Riley
Purchasing Specialist, Oak Ridge Schools
Prepared by: Andy Ashford
09/20/2023



Lee-Smith, Inc. | 2600 Eighth Avenue Chattanooga Tennessee | 374071156

2023 F-250 4x4 SD Regular Cab 8' box 142" WB SRW XL (F2B)

Price Level: 350

As Configured Vehicle

Code	Description	MSRP
Base Vehicle		
F2B	Base Vehicle Price (F2B)	\$46,760.00
Packages		
600A	Order Code 600A <i>Includes:</i> - Engine: 6.8L 2V DEVCT NA PFI V8 Gas - Transmission: TorqShift-G 10-Speed Automatic Includes SelectShift and selectable drive modes: normal, eco, slippery roads, tow/haul and off-road. - GVWR: 10,000 lb Payload Package - Tires: LT245/75Rx17E BSW A/S Spare may not be the same as road tire. - Wheels: 17" Argent Painted Steel Includes painted hub covers/center ornaments. - HD Vinyl 40/20/40 Split Bench Seat Includes center armrest, cupholder, storage and driver's side manual lumbar. - Radio: AM/FM Stereo w/MP3 Player Includes 4 speakers. - SYNC 4 Includes 8" LCD capacitive touchscreen with swipe capability, wireless phone connection, cloud connected, AppLink with app catalog, 911 Assist, Apple CarPlay and Android Auto compatibility and digital owner's manual.	N/C
Powertrain		
99A	Engine: 6.8L 2V DEVCT NA PFI V8 Gas	Included
44F	Transmission: TorqShift-G 10-Speed Automatic <i>Includes SelectShift and selectable drive modes: normal, eco, slippery roads, tow/haul and off-road.</i>	Included
X3E	Electronic-Locking w/3.73 Axle Ratio	\$430.00
STDGV	GVWR: 10,000 lb Payload Package	Included
Wheels & Tires		
TD8	Tires: LT245/75Rx17E BSW A/S Spare may not be the same as road tire.	Included
64A	Wheels: 17" Argent Painted Steel <i>Includes painted hub covers/center ornaments.</i>	Included
Seats & Seat Trim		
A	HD Vinyl 40/20/40 Split Bench Seat	Included

Prices and content availability as shown are subject to change and should be treated as estimates only. Actual base vehicle, package and option pricing may vary from this estimate because of special local pricing, availability or pricing adjustments not reflected in the dealer's computer system. See salesperson for the most current information.

Prepared for: Mary Ann Riley
Purchasing Specialist, Oak Ridge Schools
Prepared by: Andy Ashford
09/20/2023



Lee-Smith, Inc. | 2600 Eighth Avenue Chattanooga Tennessee | 374071156

2023 F-250 4x4 SD Regular Cab 8' box 142" WB SRW XL (F2B)

Price Level: 350

As Configured Vehicle (cont'd)

Code	Description	MSRP
	<i>Includes center armrest, cupholder, storage and driver's side manual lumbar.</i>	
Other Options		
142WB	142" Wheelbase	STD
PAINT	Monotone Paint Application	STD
587	Radio: AM/FM Stereo w/MP3 Player <i>Includes 4 speakers.</i>	Included
	<i>Includes:</i> - SYNC 4 <i>Includes 8" LCD capacitive touchscreen with swipe capability, wireless phone connection, cloud connected, AppLink with app catalog, 911 Assist, Apple CarPlay and Android Auto compatibility and digital owner's manual.</i>	
96V	XL Chrome Package <i>Includes:</i> - BoxLink <i>Includes 4 premium locking cleats and interface brackets.</i> - Bright Chrome Hub Covers & Center Ornaments - Chrome Front Bumper - Chrome Rear Step Bumper - Halogen Fog Lamps	\$225.00
473	Snow Plow Prep Package <i>Includes computer selected springs for snowplow application. Note 1: Restrictions apply; see supplemental reference or body builders layout book for details. Note 2: May result in deterioration of ride quality when vehicle is not equipped with snowplow. Note 3: Dual battery (86M) recommended with 6.8L or 7.3L gasoline engines; see body builders layout book for details.</i>	\$250.00
67E	250 Amp Alternator (Gas)	\$85.00
18B	Platform Running Boards	\$320.00
592	LED Roof Clearance Lights	\$95.00
43C	120V/400W Outlet <i>Includes 1 in-dash mounted outlet.</i>	\$175.00
66S	Upfitter Switches (6) <i>Located in overhead console.</i>	\$165.00
Fleet Options		
WARANT	Fleet Customer Powertrain Limited Warranty Requires valid FIN code.	N/C

Prices and content availability as shown are subject to change and should be treated as estimates only. Actual base vehicle, package and option pricing may vary from this estimate because of special local pricing, availability or pricing adjustments not reflected in the dealer's computer system. See salesperson for the most current information.

Prepared for: **Mary Ann Riley**
 Purchasing Specialist, Oak Ridge Schools
 Prepared by: Andy Ashford
 09/20/2023



Lee-Smith, Inc. | 2600 Eighth Avenue Chattanooga Tennessee | 374071156

2023 F-250 4x4 SD Regular Cab 8' box 142" WB SRW XL (F2B)

Price Level: 350

As Configured Vehicle (cont'd)

Code	Description	MSRP
<p><i>Ford is increasing the 5-year 60,000-mile limited powertrain warranty to 5-years, 100,000 miles. Only Fleet purchasers with a valid Fleet Identification Number (FIN code) will receive the extended warranty. When the sale is entered into the sales reporting system with a sales type fleet along with a valid FIN code, the warranty extension will automatically be added to the vehicle. The extension will stay with the vehicle even if it is subsequently sold to a non-fleet customer before the expiration. This extension applies to both gas and diesel powertrains. Dealers can check for the warranty extension on eligible fleet vehicles in OASIS. Please refer to the Warranty and Policy Manual section 3.13.00 Gas Engine Commercial Warranty. This change will also be reflected in the printed Warranty Guided distributed with the purchase of every new vehicle.</i></p>		
Emissions		
425	50-State Emissions System	STD
Exterior Color		
Z1_01	Oxford White	N/C
Interior Color		
AS_03	Medium Dark Slate w/HD Vinyl 40/20/40 Split Bench Seat	N/C
SUBTOTAL		\$48,505.00
Destination Charge		\$1,995.00
TOTAL		\$50,500.00

Prices and content availability as shown are subject to change and should be treated as estimates only. Actual base vehicle, package and option pricing may vary from this estimate because of special local pricing, availability or pricing adjustments not reflected in the dealer's computer system. See salesperson for the most current information.

Prepared for: **Mary Ann Riley**
 Purchasing Specialist, Oak Ridge Schools
 Prepared by: Andy Ashford
 09/20/2023



Lee-Smith, Inc. | 2600 Eighth Avenue Chattanooga Tennessee | 374071156

2023 F-250 4x4 SD Regular Cab 8' box 142" WB SRW XL (F2B)

Price Level: 350

Pricing Summary - Single Vehicle

	MSRP
<i>Vehicle Pricing</i>	
Base Vehicle Price	\$46,760.00
Options	\$1,745.00
Colors	\$0.00
Upfitting	\$0.00
Fleet Discount	\$0.00
Fuel Charge	\$0.00
Destination Charge	\$1,995.00
Subtotal	\$50,500.00

Pre-Tax Adjustments

Code	Description	MSRP
NICHOLS	Reading 98, Classic II aluminum, service body NOT AVL TILL LATE 2ND QTR 2024	\$23,500.00
LIGHTS	Frt & rear flashing lights-mini light bar--LED strip under tailgate	\$4,200.00
SAFETY EQUIP	Triangle kit and Fire extinguisher	\$295.00
DRIVER FUEL	driver and fuel pick up and deliver to customer	\$500.00
DOT Inspection	DOT inspection	\$390.00
TN FEE 5	ENVIRONMENTAL FEE ON TIRES	\$5.00
<i>4 OR LESS WHEELS</i>		
Total		\$79,390.00

 Customer Signature

 Acceptance Date

Prices and content availability as shown are subject to change and should be treated as estimates only. Actual base vehicle, package and option pricing may vary from this estimate because of special local pricing, availability or pricing adjustments not reflected in the dealer's computer system. See salesperson for the most current information.

Prepared for: Mary Ann Riley

Purchasing Specialist, Oak Ridge Schools

Prepared by: Andy Ashford

09/20/2023

Lee-Smith, Inc. | 2600 Eighth Avenue Chattanooga Tennessee | 374071156



2023 F-250 4x4 SD Regular Cab 8' box 142" WB SRW XL (F2B)

Price Level: 350

Selected Equip & Specs

Dimensions

- Conventional Capacity: 14,400 lbs.
- Fifth-wheel towing capacity: 14,100 lbs.
- Cargo box length: 98.1"
- Cargo box volume: 78.5 cu.ft.
- Cargo box max width: 66.9"
- Cargo box length feet: 8.0
- Vehicle body width: 80.0"
- Wheelbase: 142.0"
- Rear track: 67.2"
- Cab to axle: 56.1"
- Frame yield strength (psi): 50000.0
- Front bumper to back of cab: 123.7"
- Rear brake diameter: 14.3"
- Max interior rear cargo volume: 11.6 cu.ft.
- Headroom first-row: 40.8"
- Shoulder room first-row: 66.7"
- GCWR: 21,000 lbs.
- Gooseneck towing capacity: 14,300 lbs.
- Cargo box min width: 50.5"
- Pickup box depth: 21.1"
- Cargo box tailgate width: 60.5"
- Vehicle body length: 231.8"
- Vehicle body height: 81.3"
- Front track: 68.3"
- Vehicle turning radius: 23.8'
- Frame section modulus: 10.7 cu.in.
- Front bumper to front axle: 38.2"
- Front brake diameter: 14.3"
- Interior rear cargo volume: 11.6 cu.ft.
- Total passenger volume: 64.6 cu.ft.
- Leg room first-row: 43.9"
- Hip room first-row: 62.5"

Powertrain

- 6.8L V-8 variable valve control, engine with 405HP
- Injection Type: sequential MPI
- Horsepower: 405 HP@5000 RPM
- Radiator
- Part-time 4WD
- Recommended fuel: regular unleaded
- Auto locking hub control
- * **Driver selectable rear locking differential**
- Engine cylinders: V-8
- Spark ignition system
- Torque: 445 lb.-ft.@4000 RPM
- TorqShift 10-speed automatic
- Four-wheel drive
- All-speed ABS and driveline traction control
- Electronic transfer case shift

Fuel Economy and Emissions

- Gasoline secondary fuel type
- Federal emissions

Suspension and Handling

- Firm ride suspension
- Heavy-duty rear shock absorbers
- Heavy-duty front shock absorbers

Driveability

- 4-wheel disc brakes
- 4-wheel antilock (ABS) brakes
- Brake assist system
- Mono-beam rigid axle front suspension
- Front and rear ventilated disc brakes
- Four channel ABS brakes
- Hill Start Assist
- Front anti-roll bar

Prices and content availability as shown are subject to change and should be treated as estimates only. Actual base vehicle, package and option pricing may vary from this estimate because of special local pricing, availability or pricing adjustments not reflected in the dealer's computer system. See salesperson for the most current information.

Prepared for: Mary Ann Riley
Purchasing Specialist, Oak Ridge Schools
Prepared by: Andy Ashford
09/20/2023



Lee-Smith, Inc. | 2600 Eighth Avenue Chattanooga Tennessee | 374071156

2023 F-250 4x4 SD Regular Cab 8' box 142" WB SRW XL (F2B)

Price Level: 350

Selected Equip & Specs (cont'd)

- Front coil springs
- Leaf spring rear suspension
- Re-circulating ball steering

- Rigid axle rear suspension
- Hydraulic power-assist steering system
- 2-wheel steering system

Body Exterior

- Trailer wiring harness
- 2 doors
- Pickup bed-rail protectors
- Monotone paint
- Black windshield trim
- * **Chrome front bumper**
- 2 front tow hooks
- Rear bumper step
- Black door mirrors
- Convex spotter in driver and passenger side door mirrors
- Tailgate
- 17 x 7.5-inch front and rear argnt steel wheels

- * **Running boards**
- Standard style pickup box
- Clearcoat paint
- Black side window trim
- Black door handles
- * **Body-coloured front bumper rub strip**
- * **Chrome rear bumper**
- Black grille
- Manual extendable trailer mirrors
- Turn signal indicator in door mirrors

- LT245/75RS17 AS BSW front and rear tires

Convenience

- Power door locks with 2 stage unlocking
- All-in-one remote fob and ignition key
- Cruise control with steering wheel mounted controls
- Day/Night rearview mirror
- Integrated side steps
- Illuminated locking glove box
- Front beverage holders
- Instrument panel covered bin
- Retained accessory power
- Trip computer
- Over the air updates

- Keyfob activated door locks
- Power tailgate/rear door lock
- FordPass Connect smart device vehicle start control
- Power first-row windows
- Fixed rear windshield
- Illuminated glove box
- 6 beverage holders
- Dashboard storage
- PRND in IP
- * **Upfitter switches**

Comfort

- Manual climate control
- Cloth headliner material
- Full vinyl floor covering
- Manual tilting steering wheel
- Urethane steering wheel

- Cabin air filter
- Full headliner coverage
- Full floor coverage
- Manual telescopic steering wheel

Seats and Trim

- Seating capacity: 3

- 40-20-40 split-bench front seat

Prices and content availability as shown are subject to change and should be treated as estimates only. Actual base vehicle, package and option pricing may vary from this estimate because of special local pricing, availability or pricing adjustments not reflected in the dealer's computer system. See salesperson for the most current information.



2023 F-250 4x4 SD Regular Cab 8' box 142" WB SRW XL (F2B)

Price Level: 350

Selected Equip & Specs (cont'd)

- Split-bench front seat
- Front passenger seat with 4-way directional controls
- Manual front seat head restraint control
- Front seat armrest storage
- Manual driver seat fore/aft control
- Manual passenger seat fore/aft control
- Vinyl front seat upholstery
- Driver seat with 4-way directional controls
- Height adjustable front seat head restraints
- Front seat center armrest
- Manual reclining driver seat
- Manual reclining passenger seat
- Manual driver seat lumbar

Entertainment Features

- 2 total number of 1st row displays
- Primary touchscreen display
- In-vehicle audio
- FM radio
- SYNC 4 external memory control
- Standard grade speakers
- SYNC 4 voice activated audio controls
- Bluetooth wireless audio streaming
- 8 inch primary LCD display
- AM/FM stereo radio
- AM radio
- Seek scan
- Speakers number: 4
- Steering wheel mounted audio controls
- Speed sensitive volume
- Fixed audio antenna

Lighting, Visibility and Instrumentation

- Digital/analog instrumentation display
- Trip odometer
- Compass
- Driver information center
- Tachometer
- Engine/electric motor temperature gauge
- Engine hour meter
- Aero-composite headlights
- Autolamp auto on/off headlight control
- Delay-off headlights
- Variable intermittent front windshield wipers
- Illuminated entry
- Daytime running lights
- * **Cab clearance lights**
- Pickup box cargo light
- Fade interior courtesy lights
- Configurable instrumentation gauges
- In-radio display clock
- Exterior temperature display
- Gauge cluster display size (inches): 4.20
- Oil pressure gauge
- Transmission fluid temperature gauge
- Light tinted windows
- Halogen headlights
- Multiple enclosed headlights
- DRL preference setting
- Front reading lights
- Variable instrument panel light
- * **Front fog lights**
- High mounted center stop light
- Remote activated perimeter approach lighting

Technology and Telematics

- SYNC 4 911 Assist emergency SOS system via mobile device
- Applink/Apple CarPlay and Android Auto smart device wireless mirroring
- SYNC 4 handsfree wireless device connectivity
- FordPass Connect 5G mobile hotspot internet access



Prepared for: Mary Ann Riley
 Purchasing Specialist, Oak Ridge Schools
 Prepared by: Andy Ashford
 09/20/2023

Lee-Smith, Inc. | 2600 Eighth Avenue Chattanooga Tennessee | 374071156

2023 F-250 4x4 SD Regular Cab 8' box 142" WB SRW XL (F2B)

Price Level: 350

Selected Equip & Specs (cont'd)

- 2 USB ports

Safety and Security

- Driver front impact airbag
- Safety Canopy System curtain first-row overhead airbags
- Seat mounted side impact front passenger airbag
- Front height adjustable seatbelts
- Remote panic alarm
- AdvanceTrac w/Roll Stability Control electronic stability control system with anti-roll
- Seat mounted side impact driver airbag
- Cancellable front passenger air bag
- 6 airbags
- SecuriLock immobilizer
- Rear mounted camera

Dimensions

General Weights

Curb weight	6,148 lbs.	Rear curb weight	2,517 lbs.
GVWR	10,000 lbs.	Payload	3,814 lbs.

Trailer Weights

Fifth-wheel towing capacity	14,100 lbs.	Gooseneck towing capacity	14,300 lbs.
Conventional capacity	14,400 lbs.	GCWR	21,000 lbs.

Front Weights

Front curb weight	3,631 lbs.	* GAWR front	5,990 lbs.
Axle capacity front	6,000 lbs.	* Spring rating front	5,990 lbs.
Tire/wheel capacity front	6,390 lbs.		

Rear Weights

GAWR rear	6,340 lbs.	Axle capacity rear	6,200 lbs.
Spring rating rear	6,340 lbs.	Tire/wheel capacity rear	6,390 lbs.

Off Road

Min ground clearance	8.5"	Loading floor height	37.6"
Approach angle	17.2	Departure angle	21.6

Exterior Measurements

Vehicle body length	231.8"	Vehicle body width	80.0"
Vehicle body height	81.3"	Wheelbase	142.0"
Cargo box length	98.1"	Front brake diameter	14.3"
Cargo box min width	50.5"	Rear brake diameter	14.3"
Cargo box volume	78.5 cu.ft.	Pickup box depth	21.1"
Cargo box max width	66.9"	Cargo box tailgate width	60.5"
Cargo box length feet	8.0	Front track	68.3"
Rear track	67.2"	Vehicle turning radius	23.8'
Cab to axle	56.1"	Frame section modulus	10.7 cu.in.

Prices and content availability as shown are subject to change and should be treated as estimates only. Actual base vehicle, package and option pricing may vary from this estimate because of special local pricing, availability or pricing adjustments not reflected in the dealer's computer system. See salesperson for the most current information.

Prepared for: Mary Ann Riley



Purchasing Specialist, Oak Ridge Schools

Prepared by: Andy Ashford

09/20/2023

Lee-Smith, Inc. | 2600 Eighth Avenue Chattanooga Tennessee | 374071156

2023 F-250 4x4 SD Regular Cab 8' box 142" WB SRW XL (F2B)

Price Level: 350

Selected Equip & Specs (cont'd)

Frame yield strength (psi)	50000.0	Front bumper to front axle	38.2"
Front bumper to back of cab	123.7"		
<i>Interior Measurements</i>			
Interior rear cargo volume	11.6 cu.ft.	Max interior rear cargo volume	11.6 cu.ft.
<i>Interior Volume</i>			
Total passenger volume	64.6 cu.ft.		
<i>Headroom</i>			
Headroom first-row	40.8"		
<i>Legroom</i>			
Leg room first-row	43.9"		
<i>Shoulder Room</i>			
Shoulder room first-row	66.7"		
<i>Hip Room</i>			
Hip room first-row	62.5"		

Powertrain

Engine

Engine 6.8L V-8 variable valve control, engine with 405HP		Valves per cylinder	2
Engine cylinders	V-8	Injection type	sequential MPI
Engine location	Front mounted engine	Ignition	Spark ignition system
Engine mounting direction	Longitudinal mounted engine	Engine block material	Iron engine block
Cylinder head material	Aluminum cylinder head		

Engine Specs

Displacement	6.8L	cc	415 cu.in.
Bore	4.22"	Stroke	3.68"
Compression ratio	10.8	SAEJ1349	AUG2004 compliant

Engine Power

Horsepower	405 HP@5000 RPM	Torque	445 lb.-ft.@4000 RPM
------------	-----------------	--------	----------------------

Alternator

* Alternator amps	250A	* Alternator type	Heavy-duty alternator
-------------------	------	-------------------	-----------------------

Battery

Battery amps	78Ah	Battery type	HD lead acid battery
Battery rating	750CCA	Battery run down protection	Battery run down protection

Prices and content availability as shown are subject to change and should be treated as estimates only. Actual base vehicle, package and option pricing may vary from this estimate because of special local pricing, availability or pricing adjustments not reflected in the dealer's computer system. See salesperson for the most current information.

Prepared for: **Mary Ann Riley**
 Purchasing Specialist, Oak Ridge Schools
 Prepared by: Andy Ashford
 09/20/2023



Lee-Smith, Inc. | 2600 Eighth Avenue Chattanooga Tennessee | 374071156

2023 F-250 4x4 SD Regular Cab 8' box 142" WB SRW XL (F2B)

Price Level: 350

Selected Equip & Specs (cont'd)

Engine Extras

Radiator Radiator

Transmission

Transmission TorqShift 10-speed automatic

Overdrive transmission Overdrive transmission

First gear ratio 4.696

Third gear ratio 2.146

Fifth gear ratio 1.52

Reverse gear ratio 4.866

Eighth gear ratio 0.854

Tenth gear ratio 0.636

Selectable mode transmission Selectable mode transmission

Transmission oil cooler Transmission oil cooler

Drive Type

4WD type Part-time 4WD

Drivetrain

Axle ratio 3.73

Exhaust

Tailpipe Stainless steel single exhaust

Fuel

Fuel type regular unleaded

Fuel Tank

Fuel tank capacity 34.00 gal.

Drive Feature

Traction control All-speed ABS and driveline

traction control

Transfer case Electronic transfer case shift

Transmission electronic control Transmission
 electronic control

Lock-up transmission Lock-up transmission

Second gear ratio 2.985

Fourth gear ratio 1.769

Sixth gear ratio 1.275

Seventh gear ratio 1

Ninth gear ratio 0.689

Stall ratio 1.97

Sequential shift control SelectShift Sequential
 shift control

Drive type Four-wheel drive

Locking hub control Auto locking hub control

*** Rear locking differential Driver selectable rear
 locking differential**

Provisions

* Provisions Snow plow provisions

Fuel Economy and Emissions

Fuel Economy

Secondary fuel type Gasoline secondary fuel
 type

Prices and content availability as shown are subject to change and should be treated as estimates only. Actual base vehicle, package and option pricing may vary from this estimate because of special local pricing, availability or pricing adjustments not reflected in the dealer's computer system. See salesperson for the most current information.



Prepared for: Mary Ann Riley

Purchasing Specialist, Oak Ridge Schools

Prepared by: Andy Ashford

09/20/2023

Lee-Smith, Inc. | 2600 Eighth Avenue Chattanooga Tennessee | 374071156

2023 F-250 4x4 SD Regular Cab 8' box 142" WB SRW XL (F2B)

Price Level: 350

Selected Equip & Specs (cont'd)

Emissions

Emissions

Federal emissions

Suspension and Handling

Suspension

Suspension

Firm ride suspension

Front shock absorbers
absorbers

Heavy-duty front shock

Rear shock absorbers
absorbers

Heavy-duty rear shock

Driveability

Brakes

Brake type

4-wheel disc brakes

Ventilated brakes Front and rear ventilated disc
brakes

ABS brakes

Four channel ABS brakes

ABS brakes

4-wheel antilock (ABS) brakes

Brake Assistance

Hill start assist

Hill Start Assist

Brake assist system

Brake assist system

Front Suspension

Anti-roll bar front

Front anti-roll bar

Suspension ride type front Mono-beam rigid axle
front suspension

Front Spring

* HD front springs

Heavy-duty front springs

Springs front

Front coil springs

Rear Spring

Springs rear

Rear leaf springs

Rear springs

Heavy-duty rear springs

Rear Suspension

Suspension type rear
suspension

Leaf spring rear

Suspension ride type rear
suspension

Rigid axle rear

Steering

Steering
system

Hydraulic power-assist steering

Steering type

Re-circulating ball steering

Steering type number of wheels 2-wheel steering
system

Exterior

Front Wheels

Front wheels diameter

17"

Front wheels width

7.5"

Rear Wheels

Prices and content availability as shown are subject to change and should be treated as estimates only. Actual base vehicle, package and option pricing may vary from this estimate because of special local pricing, availability or pricing adjustments not reflected in the dealer's computer system. See salesperson for the most current information.



2023 F-250 4x4 SD Regular Cab 8' box 142" WB SRW XL (F2B)

Price Level: 350

Selected Equip & Specs (cont'd)

Rear wheels diameter	17"	Rear wheels width	7.5"
<i>Front And Rear Wheels</i>			
Appearance	argent	Material	steel
<i>Front Tires</i>			
Aspect	75	Diameter	17"
Sidewalls	BSW	Speed	S
Tread	AS	Type	LT
Width	245mm	Front wheel - RPM	649
<i>Rear Tires</i>			
Aspect	75	Diameter	17"
Sidewalls	BSW	Speed	S
Tread	AS	Type	LT
Width	245mm	Rear wheel - RPM	649

Body Exterior

Trailering

Towing capability	Trailer towing capability	Towing class	Class V tow rating
Towing hitch	Trailer hitch	Towing wiring harness	Trailer wiring harness
Towing brake controller	Trailer brake controller	Towing trailer sway	Trailer sway control

Exterior Features

Box style	Standard style pickup box	Number of doors	2 doors
* Running boards	Running boards		

Body

Body panels Aluminum body panels with side impact beams

Mirrors

Convex spotter	Convex spotter in driver and passenger side door mirrors	Turn signal in door mirrors	Turn signal indicator in door mirrors
----------------	--	-----------------------------	---------------------------------------

Spare Tire

Spare tire	Full-size spare tire with steel wheel	Spare tire location	Crank-down spare tire
------------	---------------------------------------	---------------------	-----------------------

Tires

Front tires LT load rating	E	Rear tires LT load rating	E
----------------------------	---	---------------------------	---

Wheels

* Wheel covers	Chrome hub wheel covers
-----------------------	--------------------------------

Convenience

Prepared for: **Mary Ann Riley**

Purchasing Specialist, Oak Ridge Schools

Prepared by: Andy Ashford

09/20/2023

Lee-Smith, Inc. | 2600 Eighth Avenue Chattanooga Tennessee | 374071156



2023 F-250 4x4 SD Regular Cab 8' box 142" WB SRW XL (F2B)

Price Level: 350

Selected Equip & Specs (cont'd)

Door Locks

Door locks Power door locks with 2 stage unlocking
All-in-one key All-in-one remote fob and ignition key

Keyfob door locks Keyfob activated door locks

Tailgate control Power tailgate/rear door lock

Cruise Control

Cruise control Cruise control with steering wheel mounted controls

Key Fob Controls

Fob remote vehicle controls FordPass Connect smart device vehicle start control

Rear View Mirror

Day/Night rearview mirror Day/Night rearview mirror

Exterior Mirrors

Door mirrors Power door mirrors
Heated door mirrors Heated driver and passenger side door mirrors

Folding door mirrors Manual folding door mirrors

Front Side Windows

First-row windows Power first-row windows

Overhead Console

Overhead console Full overhead console

Overhead console storage Overhead console storage

Passenger Visor

Visor passenger mirror Passenger visor mirror

Power Outlets

12V power outlets 2 12V power outlets

* 120V AC power outlets 1 120V AC power outlet

Pickup Box

Boxside steps Integrated side steps

Rear Windshield

Rear windshield Fixed rear windshield

Storage

Number of beverage holders 6 beverage holders
Glove box Illuminated locking glove box

Beverage holders
Illuminated glove box

Front beverage holders
Illuminated glove box

Prices and content availability as shown are subject to change and should be treated as estimates only. Actual base vehicle, package and option pricing may vary from this estimate because of special local pricing, availability or pricing adjustments not reflected in the dealer's computer system. See salesperson for the most current information.



2023 F-250 4x4 SD Regular Cab 8' box 142" WB SRW XL (F2B)

Price Level: 350

Selected Equip & Specs (cont'd)

Instrument panel storage covered bin	Instrument panel	Dashboard storage	Dashboard storage
<i>Windows Feature</i>			
One-touch up window one-touch up windows	Driver and passenger	One-touch down window one-touch down windows	Driver and passenger
<i>Miscellaneous</i>			
Trip computer	Trip computer	PRND in IP	PRND in IP
* Upfitter switches	Upfitter switches	Accessory power	Retained accessory power
Over the air updates	Over the air updates		

Comfort

<i>Climate Control</i>			
Climate control	Manual climate control	Cabin air filter	Cabin air filter
<i>Headliner</i>			
Headliner material	Cloth headliner material	Headliner coverage	Full headliner coverage
<i>Floor Trim</i>			
Floor covering	Full vinyl floor covering	Floor coverage	Full floor coverage
<i>Steering Wheel</i>			
Steering wheel telescopic steering wheel	Manual telescopic steering wheel	Steering wheel material	Urethane steering wheel
Steering wheel tilt	Manual tilting steering wheel		

Seats and Trim

<i>Seat Capacity</i>			
Seating capacity		3	
<i>Front Seats</i>			
Front seat type	Split-bench front seat	Driver seat direction	Driver seat with 4-way directional controls
Driver seat fore/aft control	Manual driver seat fore/aft control	Passenger seat direction	Front passenger seat with 4-way directional controls
Split front seats	40-20-40 split-bench front seat	Reclining passenger seat	Manual reclining passenger seat
Passenger seat fore/aft control	Manual passenger seat fore/aft control	Front head restraints	Height adjustable front seat head restraints
Front head restraint control	Manual front seat head restraint control	Armrests front center	Front seat center armrest
Armrests front storage	Front seat armrest storage	Reclining driver seat	Manual reclining driver seat



Prepared for: Mary Ann Riley

Purchasing Specialist, Oak Ridge Schools

Prepared by: Andy Ashford

09/20/2023

Lee-Smith, Inc. | 2600 Eighth Avenue Chattanooga Tennessee | 374071156

2023 F-250 4x4 SD Regular Cab 8' box 142" WB SRW XL (F2B)

Price Level: 350

Selected Equip & Specs (cont'd)

Lumbar Seats

Driver lumbar Manual driver seat lumbar

Front Seat Trim

Front seat upholstery Vinyl front seat upholstery Front seatback upholstery Vinyl front seatback upholstery

Interior Accents

Interior accents Chrome interior accents

Gearshifter Material

Gearshifter material Urethane gear shifter material

Entertainment Features

LCD Displays

Primary touchscreen display Primary touchscreen display Number of first-row LCD displays 2 total number of 1st row displays
LCD primary display size 8 inch primary LCD display

Radio Features

External memory control SYNC 4 external memory Seek scan Seek scan

Speakers

Speakers Standard grade speakers Speakers number 4

Audio Features

Steering mounted audio control Steering wheel mounted audio controls Speed sensitive volume Speed sensitive volume
Voice activated audio SYNC 4 voice activated audio controls Wireless streaming Bluetooth wireless audio streaming

Lighting, Visibility and Instrumentation

Instrumentation

Trip odometer Trip odometer Instrumentation display Digital/analog instrumentation display

Configurable instrumentation gauges Configurable instrumentation gauges

Instrumentation Displays

Temperature display Exterior temperature display Driver information center Driver information center
Clock In-radio display clock Compass Compass

Prices and content availability as shown are subject to change and should be treated as estimates only. Actual base vehicle, package and option pricing may vary from this estimate because of special local pricing, availability or pricing adjustments not reflected in the dealer's computer system. See salesperson for the most current information.

Prepared for: Mary Ann Riley
 Purchasing Specialist, Oak Ridge Schools
 Prepared by: Andy Ashford
 09/20/2023



Lee-Smith, Inc. | 2600 Eighth Avenue Chattanooga Tennessee | 374071156

2023 F-250 4x4 SD Regular Cab 8' box 142" WB SRW XL (F2B)

Price Level: 350

Selected Equip & Specs (cont'd)

Instrumentation Gauges

Tachometer	Tachometer	Oil pressure gauge	Oil pressure gauge
Transmission temperature gauge	Transmission	Engine/electric motor temperature gauge	Engine/electric motor temperature gauge
fluid temperature gauge		Engine/electric motor temperature gauge	
Gauge cluster display size (inches)	4.20	Engine hour meter	Engine hour meter

Instrumentation Warnings

Engine temperature warning	Engine temperature warning	Oil pressure warning	Oil pressure warning
Low fuel warning	Low fuel warning	Low brake fluid warning	Low brake fluid warning
Battery charge warning	Battery charge warning	Headlights on reminder	Headlights on reminder
Key in vehicle warning	Key in vehicle warning	Door ajar warning	Door ajar warning
Service interval warning	Service interval indicator	Low tire pressure warning	Tire specific low air pressure warning

Glass

Tinted windows	Light tinted windows
----------------	----------------------

Headlights

Headlights	Halogen headlights	Headlight type	Aero-composite headlights
Auto headlights	Autolamp auto on/off headlight control	Multiple headlights	Multiple enclosed headlights
Delay off headlights	Delay-off headlights	DRL preference setting	DRL preference setting

Front Windshield

Wipers	Variable intermittent front windshield wipers
--------	---

Interior Lighting

Illuminated entry	Illuminated entry	Variable panel light	Variable instrument panel light
Front reading lights	Front reading lights		

Lights

Running lights	Daytime running lights	Interior courtesy lights	Fade interior courtesy lights
* Fog lights	Front fog lights	* Clearance lights	Cab clearance lights
High mount stop light	High mounted center stop light	Pickup box cargo light	Pickup box cargo light
Perimeter approach lighting	Remote activated perimeter approach lighting		

Technology and Telematics

Prices and content availability as shown are subject to change and should be treated as estimates only. Actual base vehicle, package and option pricing may vary from this estimate because of special local pricing, availability or pricing adjustments not reflected in the dealer's computer system. See salesperson for the most current information.

Prepared for: Mary Ann Riley

Purchasing Specialist, Oak Ridge Schools

Prepared by: Andy Ashford

09/20/2023

Lee-Smith, Inc. | 2600 Eighth Avenue Chattanooga Tennessee | 374071156



2023 F-250 4x4 SD Regular Cab 8' box 142" WB SRW XL (F2B)

Price Level: 350

Selected Equip & Specs (cont'd)

Connectivity

Handsfree SYNC 4 handsfree wireless device connectivity

Smart device integration AppLink/Apple CarPlay and Android Auto smart device wireless mirroring

Emergency SOS SYNC 4 911 Assist emergency SOS system via mobile device

Internet Access

Internet access FordPass Connect 5G mobile hotspot internet access

USB Ports

USB ports 2 USB ports

Safety and Security

Airbags

Front impact airbag driver Driver front impact airbag

Number of airbags 6 airbags

Front impact airbag passenger Cancellable front passenger air bag

Front side impact airbag driver Seat mounted side impact driver airbag

Front side impact airbag passenger Seat mounted side impact front passenger airbag

Overhead airbags Safety Canopy System curtain first-row overhead airbags

Seatbelts

Height adjustable seatbelts Front height adjustable seatbelts

Security System

Immobilizer SecuriLock immobilizer

Remote panic alarm Remote panic alarm

Cameras

Rear camera Rear mounted camera

Traction Control

Electronic stability control AdvanceTrac w/Roll Stability Control electronic stability control system with anti-roll



Prepared for: Mary Ann Riley
 Purchasing Specialist, Oak Ridge Schools
 Prepared by: Andy Ashford
 09/20/2023

Lee-Smith, Inc. | 2600 Eighth Avenue Chattanooga Tennessee | 374071156

2023 F-250 4x4 SD Regular Cab 8' box 142" WB SRW XL (F2B)

Price Level: 350

Warranty

Standard Warranty

<i>Basic Warranty</i>	36 months/36,000 miles
Basic warranty	
<i>Powertrain Warranty</i>	60 months/60,000 miles
Powertrain warranty	
<i>Corrosion Perforation</i>	60 months/unlimited
Corrosion perforation warranty	
<i>Roadside Assistance Warranty</i>	60 months/60,000 miles
Roadside warranty	

Prices and content availability as shown are subject to change and should be treated as estimates only. Actual base vehicle, package and option pricing may vary from this estimate because of special local pricing, availability or pricing adjustments not reflected in the dealer's computer system. See salesperson for the most current information.

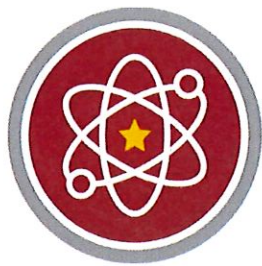

Oak Ridge

SCHOOLS

Maintenance and Operations

OFFICE OF MAINTENANCE AND OPERATIONS

DATE: November 10, 2023

TO: Bruce Lay, Executive Director of School Leadership

FROM: Allen Thacker, Director of Maintenance and Operations

SUBJECT: Purchase and Installation of ORHS Intercom System

Mr. Lay,

I am recommending that the Oak Ridge Schools Board of Education approve the purchase and installation of a replacement intercom system for Oak Ridge High School by Commercial Building Systems of Knoxville TN for \$89,000.00. The current system is no longer supported by the manufacturer and replacement parts are either no longer available or in short supply. The new system is compatible with our most recent intercom upgrades and the server will operate as a redundancy for the new system installed at JMS.

Funding for this purchase is from 76100 Capital Outlay. Bids were advertised in accordance with state guidelines and made available on the Oak Ridge Schools' website and Vendor Registry.

Thank you,

Allen Thacker

Director of Maintenance and Operations

Maintenance Office

100 Woodbury, Oak Ridge, TN 37830

(865) 425-3171

www.ortn.edu



Oak Ridge Schools

OFFICE OF
Business & Support Services

Telephone (865) 425-9005
Fax: (865) 425-9060

Bid Minutes
11/09/2023
ORHS Intercom System (RFP 23-005)
Business Services Conference Room
Administration Building

Present for the bid opening were:

Kim Farmer
Mary Ann Riley
Dana Paolucci

Oak Ridge Schools Maintenance
Oak Ridge Schools Purchasing
Oak Ridge Schools Business Services Coordinator

Bid responses were received from the following companies:

	<u>Bid Amount</u>
Commercial Building Systems, Inc. Knoxville, TN 37932	\$89,000.00 **

**** Recommended Bid Winner**



Oak Ridge Schools

OFFICE OF
Business & Support Services

Telephone (865) 425-9005
Fax: (865) 425-9060

DATE: June 12, 2023

TO: Jenifer Van Dyke, Finance Director

cc: Dana Paolucci

FROM: Mary Ann Riley, Purchasing Specialist, Oak Ridge Schools

SUBJECT: Recommendation of RFP 24-005 ORHS Intercom Systems

I recommend that the Oak Ridge Board of Education choose Commercial building Systems for the above-mentioned bid in the amount of \$89,000.00. One company responded with a bid.

Bids were advertised in accordance with state guidelines and made available on the Oak Ridge Schools' website and Vendor Registry.

Attachment: Bid Minutes

Bid Form

Owner: Oak Ridge Schools Board of Education
Mary Ann Riley, Purchasing Specialist
School Administration Building
304 New York Ave
Oak Ridge, TN 37830

Project: ORHS Intercom System
RFP 24-005

Bid Opening: 2:00 PM EST, Nov. 9, 2023

Company Name: Commercial Building Systems Inc

Address: 9821 Cogdill Road suite 4A
Knoxville, TN 37932

Phone Number: 865-824-3063

Email: awilson@cbainc.com

Main Bid: *This Price is to be for the complete specified equipment and installation as outlined within this RFP 24-005. ALL COSTS ARE TO BE INCLUDED IN THE FINAL PRICE.*

Bid Amount: \$ 89,000 USD

Company: Commercial Building Systems Inc,

Signature: [Signature]

Title: President

Date: 11-8-23

Please attach detailed specifications.



Commercial Building Systems Inc

9821 Cogdill Rd. Suite 4A
Knoxville, TN 37932
Phone: 865-824-3063
Fax: 865-824-3064
TN License # ASC-1113

PROPOSAL

Customer #
10017

Estimate Date:
11/8/23

Estimate #
18328

Bill To:

Oak Ridge Schools
Maintenance & Operations
P.O. Box 6677
Oak Ridge, TN 37830

Install Location:

Oak Ridge High School
1450 Oak Ridge Turnpike
Oak Ridge, TN 37830

Contract Details

This quote is for updating the intercom system. The existing call buttons will remain.

Qty	Description	Unit Amount	Tax	Total
17	VE1225 12 Port 25-Volt / 45ohm Talkback Gateway	\$5,000.00	Y	\$68,000.00
3	6-Channel Amplifier	\$1,000.00	Y	\$3,000.00
1	Installation	\$5,000.00	Y	\$5,000.00
1	Installation Material	\$1,250.00	Y	\$1,250.00
1	VE6030-1 IP6K Communication Redundat Server	\$11,750.00	Y	\$11,750.00

By accepting this proposal you agree to all of Commercial Building Systems Inc.'s standard terms and conditions.

Subtotal: \$89,000.00

Sales Tax: \$0.00

Estimate Total: \$89,000.00

Representative Signature

Date

Customer Signature

Date

Request for Taxpayer Identification Number and Certification

**Give Form to the
 requester. Do not
 send to the IRS.**

▶ Go to www.irs.gov/FormW9 for instructions and the latest information.

1 Name (as shown on your income tax return). Name is required on this line; do not leave this line blank.
Commercial Building Systems, INC

2 Business name/disregarded entity name, if different from above

3 Check appropriate box for federal tax classification of the person whose name is entered on line 1. Check only one of the following seven boxes.

Individual/sole proprietor or single-member LLC

C Corporation S Corporation Partnership Trust/estate

Limited liability company. Enter the tax classification (C=C corporation, S=S corporation, P=Partnership) ▶ _____

Note: Check the appropriate box in the line above for the tax classification of the single-member owner. Do not check LLC if the LLC is classified as a single-member LLC that is disregarded from the owner unless the owner of the LLC is another LLC that is not disregarded from the owner for U.S. federal tax purposes. Otherwise, a single-member LLC that is disregarded from the owner should check the appropriate box for the tax classification of its owner.

Other (see instructions) ▶ _____

4 Exemptions (codes apply only to certain entities, not individuals; see instructions on page 3):

Exempt payee code (if any) _____

Exemption from FATCA reporting code (if any) _____

(Applies to accounts maintained outside the U.S.)

5 Address (number, street, and apt. or suite no.) See instructions.
9821 Cogdill Road Suite 4A

6 City, state, and ZIP code
Knoxville, TN 37932

7 List account number(s) here (optional)

Requester's name and address (optional)

Print or type.
See Specific Instructions on page 3.

Part I Taxpayer Identification Number (TIN)

Enter your TIN in the appropriate box. The TIN provided must match the name given on line 1 to avoid backup withholding. For individuals, this is generally your social security number (SSN). However, for a resident alien, sole proprietor, or disregarded entity, see the instructions for Part I, later. For other entities, it is your employer identification number (EIN). If you do not have a number, see *How to get a TIN*, later.

Note: If the account is in more than one name, see the instructions for line 1. Also see *What Name and Number To Give the Requester* for guidelines on whose number to enter.

Social security number									
or									
Employer identification number									
2	0	-	0	0	7	0	0	9	5

Part II Certification

Under penalties of perjury, I certify that:

- The number shown on this form is my correct taxpayer identification number (or I am waiting for a number to be issued to me); and
- I am not subject to backup withholding because: (a) I am exempt from backup withholding, or (b) I have not been notified by the Internal Revenue Service (IRS) that I am subject to backup withholding as a result of a failure to report all interest or dividends, or (c) the IRS has notified me that I am no longer subject to backup withholding; and
- I am a U.S. citizen or other U.S. person (defined below); and
- The FATCA code(s) entered on this form (if any) indicating that I am exempt from FATCA reporting is correct.

Certification instructions. You must cross out item 2 above if you have been notified by the IRS that you are currently subject to backup withholding because you have failed to report all interest and dividends on your tax return. For real estate transactions, item 2 does not apply. For mortgage interest paid, acquisition or abandonment of secured property, cancellation of debt, contributions to an individual retirement arrangement (IRA), and generally, payments other than interest and dividends, you are not required to sign the certification, but you must provide your correct TIN. See the instructions for Part II, later.

Sign Here Signature of U.S. person ▶ Date ▶ 11-8-23

General Instructions

Section references are to the Internal Revenue Code unless otherwise noted.

Future developments. For the latest information about developments related to Form W-9 and its instructions, such as legislation enacted after they were published, go to www.irs.gov/FormW9.

Purpose of Form

An individual or entity (Form W-9 requester) who is required to file an information return with the IRS must obtain your correct taxpayer identification number (TIN) which may be your social security number (SSN), individual taxpayer identification number (ITIN), adoption taxpayer identification number (ATIN), or employer identification number (EIN), to report on an information return the amount paid to you, or other amount reportable on an information return. Examples of information returns include, but are not limited to, the following.

- Form 1099-INT (interest earned or paid)
- Form 1099-DIV (dividends, including those from stocks or mutual funds)
- Form 1099-MISC (various types of income, prizes, awards, or gross proceeds)
- Form 1099-B (stock or mutual fund sales and certain other transactions by brokers)
- Form 1099-S (proceeds from real estate transactions)
- Form 1099-K (merchant card and third party network transactions)
- Form 1098 (home mortgage interest), 1098-E (student loan interest), 1098-T (tuition)
- Form 1099-C (canceled debt)
- Form 1099-A (acquisition or abandonment of secured property)

Use Form W-9 only if you are a U.S. person (including a resident alien), to provide your correct TIN.

If you do not return Form W-9 to the requester with a TIN, you might be subject to backup withholding. See What is backup withholding, later.

IRAN DIVESTMENT ACT REQUIREMENTS

Pursuant to Tennessee Code Annotated § 12-12-106 (as enacted by Chapter 817 of the Public Acts of 2016) the chief procurement officer for the State of Tennessee shall publish a list of persons determined to be engaging in investment activities in Iran. The list is posted on the website of the Tennessee General Services Department's Central Procurement Office*. When competitive bidding is required, Tennessee Code Annotated § 12-12-111 requires every bid or proposal submitted to a local government for goods or services to include the following statement, subscribed or affirmed by the bidder as true under the penalty of perjury:

CERTIFICATION

By submission of this bid, each bidder and each person signing on behalf of any bidder certifies, and in the case of a joint bid each party thereto certifies as to its own organization, under penalty of perjury, that to the best of its knowledge and belief that each bidder is not on the list created pursuant to T.C.A. § 12-12-106.



Signature

11-8-23

Date

Anthony Wilson

Printed Name

President

Title

Commercial Building Systems

Name of Firm/Company

*https://tn.gov/assets/entities/generalservices/cpo/attachments/List_of_persons_pursuant_to_Tenn._Code_An_n._12-12-106._Iran_Divestment_Act-July.pdf

CRIMINAL BACKGROUND COMPLIANCE AFFIDAVIT

STATE OF TN

COUNTY OF KNOX

The undersigned, principal officer of Commercial Building Systems, an Employer contracting with the Oak Ridge School Board of Education to provide services having direct contact with children or access to grounds of an Oak Ridge public school while students are on grounds, hereby states under oath as follows:

1. The undersigned is a principal officer of Commercial Building Systems (hereafter referred to as the "Company") and is duly authorized to execute this Affidavit on behalf of the Company.
2. The Company submits this Affidavit pursuant to T.C.A. § 49-5-413 as amended effective September 1, 2007, for entities entering into contracts with a local board of education where the Company's employees will have direct contact with school children or access to the grounds of a school when children are present. It is the duty of the Company to require applicants supply a fingerprint sample and submit to a criminal history records check to be conducted by the Tennessee Bureau of Investigation and the Federal Bureau of Investigation prior to permitting the person to have contact with such children or enter school grounds and to take certain other actions based upon the results of the records check.
3. The Company is in compliance with the terms of T.C.A. § 49-5-413.

Further affiant saith naught.
Principal Officer

STATE OF TN

COUNTY OF KNOX

Before me personally appeared Anthony Williams with whom I am personally acquainted (or proved to me on the basis of satisfactory evidence), and who acknowledged that he/she is the President of Commercial Building Systems and is authorized to execute this instrument on behalf of the principal for the purposes therein contained.

Witness my hand and seal at office this 8 day of November 2023.

Notary Public
My commission expires: 11/1/25

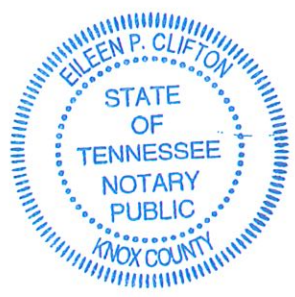

NON-COLLUSION AFFIDAVIT

NON-COLLUSION AFFIDAVIT TO BE EXECUTED
BY DESIGN-BUILDER

State of TN

County of Knox

Anthony Wilson, being first duly sworn, deposes and says that he or she is of the party making the foregoing bid is not made in the interest of, or on behalf of, any undisclosed person, partnership, company, association, organization, or corporation; that the bid is genuine and not collusive or sham; that the bidder neither possesses a business relationship with any employee of the District which may be involved in the award or administration of the project nor has received or solicited either directly or indirectly any inside information from an employee of the District which would give the bidder an advantage over any other bidder; that the bidder has not directly or indirectly induced or solicited any other bidder to put in a false or sham bid, and has not directly or indirectly colluded, conspired, connived, or agreed with any bidder or anyone else to put in a sham bid, or that anyone shall refrain from bidding; that the bidder has not in any manner, directly or indirectly, sought by agreement, communication, or conference with anyone to fix the bid price of the bidder or any other bidder, or to fix any overhead, profit, or cost element of the bid price, or of that of any other bidder, or to secure any advantage against the public body awarding the contract or any interested in the proposed contract; that all statements contained in the bid are true; and, further, that the bidder has not, directly or indirectly, submitted his or her bid price of any breakdown thereof, or the contents thereof, or divulged information or data relative thereto, or paid, and will not pay, any fee to any corporation, partnership, company, association, organization, bid depository, or to any member or agent thereof to effectuate a collusive or sham bid.

Subscribed and sworn to (or affirmed) before me this 8 day

of November 2023.

[Signature]

Signature of Officer

[Signature]

Notary Signature

Anthony Wilson

Typed Name of Officer

Office



Notary Seal

WARNING! PROPOSALS WILL NOT BE CONSIDERED UNLESS THIS AFFIDAVIT IS COMPLETED AND EXECUTED, INCLUDING THE AFFIDAVIT OF THE NOTARY AND THE NOTORIAL SEAL.

HOLD HARMLESS AGREEMENT

This Hold Harmless Agreement is between Commercial Building Systems Inc
Name of Contractor
(Hereinafter Contractor), and Oak Ridge Schools named in this bid.

Contractor agrees that as a condition precedent to "Contractor" being awarded a contract from Oak Ridge Schools, "Contractor" agrees to indemnify, protect, defend, and hold harmless Oak Ridge Schools, its Board Members, agents, and employees from all judgments, claims, demands for payment, suits or actions of every nature and description brought against Oak Ridge Schools, its Board Members, agents, and employees alleging injuries or damages sustained by any person arising out of or in the course of "Contractor's" providing goods or services to Oak Ridge Schools.

Name of Contractor: Commercial Building Systems Inc

By: Anthony Wilson

Title: President

STATE OF TN

County of Knox

Anthony Wilson personally appeared before me, the undersigned, with whom I am personally acquainted and who, upon oath, acknowledged that he/she/it executed the within instrument for the purposes therein contained, and who further acknowledge that he/she/it is authorized to execute this interment on behalf of

Commercial Building Systems Inc

[Signature]
Signature

Witness by hand and Notaries seal at office this 8 day of November,
year of 2023.

Eileen P Clifton
Notary Public

My Commission Expires: 11/1/25

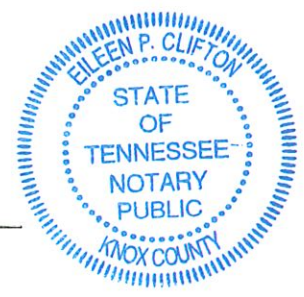

EDGAR CERTIFICATIONS
ADDENDUM FOR AGREEMENT FUNDED BY U.S. FEDERAL GRANT

TO WHOM IT MAY CONCERN:

Oak Ridge Schools is in the process of ensuring that all policies and procedures involving the expenditure of federal funds are compliant with the new Education Department General Administrative Guidelines ("EDGAR"). Part of this process involves ensuring that all current vendors agree to comply with EDGAR. You must complete this form and return to Oak Ridge Schools along with your proposal.

The following certifications and provisions are required and apply when Oak Ridge Schools expends federal funds for any contract resulting from this procurement process. Pursuant to 2 C.F.R. § 200.326, all contracts, including small purchases, awarded by the District and the District's subcontractors shall contain the procurement provisions of Appendix II to Part 200, as applicable.

REQUIRED CONTRACT PROVISIONS FOR NON-FEDERAL ENTITY CONTRACTS UNDER FEDERAL AWARDS
APPENDIX II TO 2 CFR PART 200

(A) Contracts for more than the simplified acquisition threshold currently set at \$150,000, which is the inflation adjusted amount determined by the Civilian Agency Acquisition Council and the Defense Acquisition Regulations Council (Councils) as authorized by 41 U.S.C. 1908, must address administrative, contractual, or legal remedies in instances where contractors violate or breach contract terms, and provide for such sanctions and penalties as appropriate.

Pursuant to Federal Rule (A) above, when Oak Ridge Schools expends federal funds, Oak Ridge Schools reserves all rights and privileges under the applicable laws and regulations with respect to this procurement in the event of breach of contract by either party.

Does Vendor agree? YES AW Initials of Authorized Representative of Vendor

(B) Termination for cause and for convenience by the grantee or subgrantee including the manner by which it will be effected and the basis for settlement. (All contracts in excess of \$10,000)

Pursuant to Federal Rule (B) above, when Oak Ridge Schools expends federal funds, Oak Ridge Schools reserves the right to immediately terminate any agreement in excess of \$10,000 resulting from this procurement process in the event of a breach or default of the agreement by Vendor in the event Vendor fails to: (1) meet schedules, deadlines, and/or delivery dates within the time specified in the procurement solicitation, contract, and/or a purchase order; (2) make any payments owed; or (3) otherwise perform in accordance with the contract and/or the procurement solicitation. Oak Ridge Schools also reserves the right to terminate the contract immediately, with written notice to vendor, for convenience, if Oak Ridge Schools believes, in its sole discretion that it is in the best interest of the District to do so. Vendor will be compensated for work performed and accepted and goods accepted by the District as of the termination date if the contract is terminated for convenience of the District. Any award under this procurement process is not exclusive and Oak Ridge Schools reserves the right to purchase goods and services from other vendors when it is in the District's best interest.

Does Vendor agree? YES AW Initials of Authorized Representative of Vendor

(C) Equal Employment Opportunity. Except as otherwise provided under 41 CFR Part 60, all contracts that meet the definition of "federally assisted construction contract" in 41 CFR Part 60-1.3 must include the equal opportunity clause provided under 41 CFR 60-1.4(b), in accordance with Executive Order 11246, "Equal Employment Opportunity" (30 FR 12319, 12935, 3 CFR Part, 1964-1965 Comp., p. 339), as amended by Executive Order 11375, "Amending Executive Order 11246 Relating to Equal Employment Opportunity," and implementing regulations at 41 CFR part 60, "Office of Federal Contract Compliance Programs, Equal Employment Opportunity, Department of Labor."

Pursuant to Federal Rule (C) above, when Oak Ridge Schools expends federal funds on any federally assisted construction contract the equal opportunity clause is incorporated by reference herein.

Does Vendor agree to abide by the above? YES AW Initials of Authorized Representative of Vendor

(D) Davis-Bacon Act, as amended (40 U.S.C. 3141-3148). When required by Federal program legislation, all prime construction contracts in excess of \$2,000 awarded by non-Federal entities must include a provision for compliance with the Davis-Bacon Act (40 U.S.C. 3141-3144, and 3146-3148) as supplemented by Department of Labor regulations (29 CFR Part 5, "Labor Standards Provisions Applicable to Contracts Covering Federally Financed and Assisted Construction"). In accordance with the statute, contractors must be required to pay wages to laborers and mechanics at a rate not less than the prevailing wages specified in a wage determination made by the Secretary of Labor. In addition, contractors must be required to pay wages not less than once a week. The non-Federal entity must place a copy of the current prevailing wage determination issued by the Department of Labor in each solicitation. The decision to award a contract or subcontract must be conditioned upon the acceptance of the wage determination. The non-Federal entity must report all suspected or reported violations to the Federal awarding agency. The contracts must also include a provision for compliance with the Copeland "Anti-kickback" Act (40 U.S.C. 3145), as supplemented by Department of Labor regulations (29 CFR Part 3, "Contractors and Subcontractors on Public Building or Public Work Financed in Whole or in Part by Loans or Grants from the United States"). The Act provides that each contractor or subrecipient must be prohibited from inducing, by any means, any person employed in the construction, completion, or repair of public work, to give up any part of the compensation to which he or she is otherwise entitled. The non-Federal entity must report all suspected or reported violations to the Federal awarding agency.

Pursuant to Federal Rule (D) above, when Oak Ridge Schools expends federal funds during the term of an award for all contracts and subgrants for construction or repair, Vendor will be in compliance with all applicable Davis-Bacon Act provisions.

Does Vendor agree? YES AW Initials of Authorized Representative of Vendor

(E) Contract Work Hours and Safety Standards Act (40 U.S.C. 3701-3708). Where applicable, all contracts awarded by the non-Federal entity in excess of \$100,000 that involve the employment of mechanics or laborers must include a provision for compliance with 40 U.S.C. 3702 and 3704, as supplemented by Department of Labor regulations (29 CFR Part 5). Under 40 U.S.C. 3702 of the Act, each contractor must be required to compute the wages of every mechanic and laborer on the basis of a standard work week of 40 hours. Work in excess of the standard work week is permissible provided that the worker is compensated at a rate of not less than one and a half times the basic rate of pay for all hours worked in excess of 40 hours in the work week. The requirements of 40 U.S.C. 3704 are applicable to construction work and provide that no laborer or mechanic must be required to work in surroundings or under working conditions which are unsanitary, hazardous or dangerous. These requirements do not apply to the purchases of supplies or materials or articles ordinarily available on the open market, or contracts for transportation or transmission of intelligence.

Pursuant to Federal Rule (E) above, when SAISD expends federal funds, Vendor certifies that Vendor will be in compliance with all applicable provisions of the Contract Work Hours and Safety Standards Act during the term of an award for all contracts by SAISD resulting from this procurement process.

Does Vendor agree? YES AW Initials of Authorized Representative of Vendor

(F) Rights to Inventions Made Under a Contract or Agreement. If the Federal award meets the definition of "funding agreement" under 37 CFR §401.2 (a) and the recipient or subrecipient wishes to enter into a contract with a small business firm or nonprofit organization regarding the substitution of parties, assignment or performance of experimental, developmental, or research work under that "funding agreement," the recipient or subrecipient must comply with the requirements of 37 CFR Part 401, "Rights to Inventions Made by Nonprofit Organizations and Small Business Firms Under Government Grants, Contracts and Cooperative Agreements," and any implementing regulations issued by the awarding agency.

Pursuant to Federal Rule (F) above, when federal funds are expended by Oak Ridge Schools, the vendor certifies that during the term of an award for all contracts by SAISD resulting from this procurement process, the vendor agrees to comply with all applicable requirements as referenced in Federal Rule (F) above.

Does Vendor agree? YES AW Initials of Authorized Representative of Vendor

(G) Clean Air Act (42 U.S.C. 7401-7671q) and the Federal Water Pollution Control Act (33 U.S.C. 1251-1387), as amended— Contracts and subgrants of amounts in excess of \$150,000 must contain a provision that requires the non-Federal award to agree to comply with all applicable standards, orders or regulations issued pursuant to the Clean Air Act (42 U.S.C. 7401-7671q) and the Federal Water Pollution Control Act as amended (33 U.S.C. 1251- 1387). Violations must be reported to the Federal awarding agency and the Regional Office of the Environmental Protection Agency (EPA).

Pursuant to Federal Rule (G) above, when federal funds are expended by Oak Ridge Schools, the vendor certifies that during the term of an award for all contracts by Oak Ridge Schools member resulting from this procurement process, the vendor agrees to comply with all applicable requirements as referenced in Federal Rule (G) above.

Does Vendor agree? YES AW Initials of Authorized Representative of Vendor

(H) Debarment and Suspension (Executive Orders 12549 and 12689)—A contract award (see 2 CFR 180.220) must not be made to parties listed on the government wide exclusions in the System for Award Management (SAM), in accordance with the OMB guidelines at 2 CFR 180 that implement Executive Orders 12549 (3 CFR part 1986 Comp., p. 189) and 12689 (3 CFR part 1989 Comp., p. 235), "Debarment and Suspension." SAM Exclusions contains the names of parties debarred, suspended, or otherwise excluded by agencies, as well as parties declared ineligible under statutory or regulatory authority other than Executive Order 12549.

Pursuant to Federal Rule (H) above, when federal funds are expended by Oak Ridge Schools, the vendor certifies that during the term of an award for all contracts by Oak Ridge Schools resulting from this procurement process, the vendor certifies that neither it nor its principals is presently debarred, suspended, proposed for debarment, declared ineligible, or voluntarily excluded from participation by any federal department or agency.

Does Vendor agree? YES AW Initials of Authorized Representative of Vendor

(I) Byrd Anti-Lobbying Amendment (31 U.S.C. 1352)—Contractors that apply or bid for an award exceeding \$100,000 must file the required certification. Each tier certifies to the tier above that it will not and has not used Federal appropriated funds to pay any person or organization for influencing or attempting to influence an officer or employee of any agency, a member of Congress, officer or employee of Congress, or an employee of a member of Congress in connection with obtaining any Federal contract, grant or any other award covered by 31 U.S.C. 1352. Each tier must also disclose any lobbying with non-Federal funds that takes place in connection with obtaining any Federal award. Such disclosures are forwarded from tier to tier up to the non-Federal award.

- (1) Pursuant to Federal Rule (I) above, when federal funds are expended by Oak Ridge Schools, the vendor certifies that during the term and after the awarded term of an award for all contracts by Oak Ridge Schools resulting from this procurement process, the vendor certifies that it is in compliance with all applicable provisions of the Byrd Anti-Lobbying Amendment (31 U.S.C. 1352). The undersigned further certifies that:
- (2) No Federal appropriated funds have been paid or will be paid for on behalf of the undersigned, to any person for influencing or attempting to influence an officer or employee of any agency, a Member of Congress, an officer or employee of congress, or an employee of a Member of Congress in connection with the awarding of a Federal contract, the making of a Federal grant, the making of a Federal loan, the entering into a cooperative agreement, and the extension, continuation, renewal, amendment, or modification of a Federal contract, grant, loan, or cooperative agreement.
- (3) If any funds other than Federal appropriated funds have been paid or will be paid to any person for influencing or attempting to influence an officer or employee of any agency, a Member of Congress, an officer or employee of congress, or an employee of a Member of Congress in connection with this Federal grant or cooperative agreement, the undersigned shall complete and submit Standard Form-LLL "Disclosure Form to Report Lobbying", in accordance with its instructions.
- (4) The undersigned shall require that the language of this certification be included in the award documents for all covered sub-awards exceeding \$100,000 in Federal funds at all appropriate tiers and that all subrecipients shall certify and disclose accordingly.

Does Vendor agree? YES AW Initials of Authorized Representative of Vendor

EMPLOYMENT VERIFICATION
FAR 22.18

As applicable, and as a condition for the award of any Federal contract at \$50,000 or greater, Vendor certifies that vendor is enrolled in, and is currently participating in, E-Verify or any other equivalent electronic verification of work authorization program operated by the U.S. Department of Homeland Security and does not knowingly employ any person who is an unauthorized alien in conjunction with the contracted services. A breach in compliance with immigration laws and regulations shall be deemed a material breach of the contract and may be subject to penalties up to and including termination of the contract.

Does vendor agree? YES AW Initials of Authorized Representative of vendor

RECORD RETENTION REQUIREMENTS FOR CONTRACTS INVOLVING FEDERAL FUNDS

When federal funds are expended by Oak Ridge Schools for any contract resulting from this procurement process, Vendor certifies that it will comply with the record retention requirements detailed in 2 CFR § 200.333. The Vendor further certifies that Vendor will retain all records as required by 2 CFR § 200.333 for a period of three years after grantees or subgrantees submit final expenditure reports or quarterly or annual financial reports, as applicable, and all other pending matters are closed.

Does Vendor agree? YES AW Initials of Authorized Representative of Vendor

CERTIFICATION OF COMPLIANCE WITH EPA REGULATIONS
APPLICABLE TO GRANTS, SUBGRANTS, COOPERATIVE AGREEMENTS, AND CONTRACTS
IN EXCESS OF \$50,000 OF FEDERAL FUNDS

When federal funds are expended by Oak Ridge Schools, and/or its cooperative members, for any contract resulting from this procurement process in excess of \$50,000, the vendor certifies that the vendor is in compliance with all applicable standards, orders, regulations, and/or requirements issued pursuant to the Clean Air Act of 1970, as amended (42 U.S.C. 1857(h)), Section 508 of the Clean Water Act, as amended (33 U.S.C. 1368), Executive Order 117389 and Environmental Protection Agency Regulation, 40 CFR Part 15.

Does Vendor agree? YES AW Initials of Authorized Representative of Vendor

CERTIFICATION OF COMPLIANCE WITH THE ENERGY POLICY AND CONSERVATION ACT

When Oak Ridge Schools expends federal funds for any contract resulting from this procurement process, Vendor certifies that it will comply with the mandatory standards and policies relating to energy efficiency which are contained in the state energy conservation plan issued in compliance with the Energy Policy and Conservation Act (42 U.S.C. 6321 et seq.; 49 C.F.R. Part 18).

Does Vendor agree? YES AW Initials of Authorized Representative of Vendor

CERTIFICATION OF COMPLIANCE WITH BUY AMERICA PROVISIONS

Vendor certifies that it is in compliance with all applicable provisions of the Buy America Act. Purchases made in accordance with the Buy America Act must still follow the applicable procurement rules calling for free and open competition.

Does Vendor agree? YES AW Initials of Authorized Representative of Vendor

CERTIFICATION OF ACCESS TO RECORDS — 2 C.F.R. § 200.336

Vendor agrees that the Inspector General of the District or any of their duly authorized representatives shall have access to any books, documents, papers and records of Vendor that are directly pertinent to Vendor's discharge of its obligations under the Contract for the purpose of making audits, examinations, excerpts, and transcriptions. The right also includes timely and reasonable access to Vendor's personnel for the purpose of interview and discussion relating to such documents.

Does Vendor agree? YES AW Initials of Authorized Representative of Vendor

CERTIFICATION OF APPLICABILITY TO SUBCONTRACTORS

Vendor agrees that all contracts it awards pursuant to the Contract shall be bound by the foregoing terms and conditions.

Does Vendor agree? YES AW Initials of Authorized Representative of Vendor

Vendor agrees to comply with all federal, state, and local laws, rules, regulations and ordinances, as applicable. It is further acknowledged that vendor certifies compliance with all provisions, laws, acts, regulations, etc. as specifically noted above.

Corporate/Company Name: Commercial Building Systems Inc

Authorized Signature: [Signature]

Printed Name: Anthony Wilson

Title: President

Date: 11-9-23

Address: 9821 Cogdill Rd Suite 414

City, State, Zip Code: Knoxville, TN 37932

Phone #: 865-824-3063

Fax #: 865-824-3064

Email Address: awilson@cbainc.com

Corporate/Company Website: cbainc.com

DUNS #: 145599580

CAGE#:

Oak Ridge Schools RFP #: 24-009

Technical Specifications

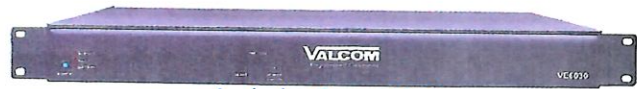

Includes Smart UPS

VE6030-1 Communication/Notification Server

- Web browser access to setup, schedules, and real-time control functions
- 3RU Total (2RU Communication / Notification Package) - (1RU Smart UPS)
- Multiple simultaneous schedules, multiple events per schedule, up to 12 simultaneous events
- One second event resolution
- An event may send audio to any number of page groups
- Events may control paging, relays, and/or streaming audio -Event types: Audio File, Streaming Audio, Relay
- Control, Test Room, Stop, Delay
- Cascading events from a single time trigger, example 10:01 AM, event A then B then C
- Page broadcast to Valcom ES IP endpoints by zone, groups, or all call
- Calendar view showing day, year, and months with tabs for other options
- "Normal", "Calendar Date", and "Override" schedules
 - Calendar date programming takes precedence over normal weekday schedules
 - Override takes precedence over calendar date
- Set feature permissions per user (feature access yes/no, if yes limited or full control)
- Define default screen view after login, per user
- Playlist for easy origination of unscheduled events -Similar to a schedule, but without an event time, and with a name for each row.
 - Permits execution of a selection manually via the browser, VE8048 input or CAP Message
- Import and convert audio files from many Wav formats
- Built-in Icons and audio files
- Unlimited graphical interfaces
- User log-in with permissions and roles
- Text-To-Speech with unlimited use
- Option to enhance audio files during import
- Record page audio to a file
 - File can be used in an event, schedule, and/or playlist
 - File may be date and time stamped and kept as history
- -Option for immediate playback: program playback zone(s) and number of repeats
- System backup and restore (with various restore options)
- Software update options
- View system software version number
- Programmable pre/post page delays
- Volume control per event
- Master volume control (system-wide)
- Control VE8001/8002/8004BR IP Audio Gateways to provide streaming audio to page group(s)
- Use VE8048 inputs to execute events from the playlist
- Control VE8048 relays from events
- Communicates with built-in VIP-102B setup tool for initial setup and speaker dial codes
- User entered names for displaying dial codes, page groups, inputs, events, and schedules
- Test rooms (receive high priority pages only)
- Maximum size of a single audio file is 20MB (uLaw = approximately 40 minutes)
- Audio storage is 25,000 seconds
- Maximum number of audio files for simultaneous playback is twelve
- Includes Smart UPS (1RU) for software/hardware services
- High availability redundancy with tandem VE6030-1, VE6030, and VE6090
- CAP 1.2 receiver to monitor emergency alerts (local - state - national - weather)
- CAP 1.2 sender to send daily and emergency alerts to 3rd party devices and systems
- RSS and ATOM feed sender for 3rd party devices and systems
- Email post for daily and emergency alerts
- 3rd party system network monitoring triggers audio and text broadcast to IP endpoints
- Valcom Earthquake Early Warning (VEEWS) enabled
- Valcom District Software compatible
- Broadcast audio and visual messaging to speakers, speakers with text, strobes, and threat level indicators

2022 Rev. 1.6.2

Technical Specifications

Description:

The VE6030-1 Communication/Notification Server with UPS, when used as part of a Valcom Engineered Solutions IP6000 Communications System, provides daily communication, emergency notification, calendar event scheduling, graphical interface, and clock control capability. The VE6030-1 sends audio and text to up to 25 simultaneous groups of speakers, speakers with text, IP strobes, and threat level indicators. The simple browser-based interface broadcasts pre-recorded messages, wav files, and text for class change tones/messaging and emergency notification alerts. The VE6030-1 includes text-to-speech and provides on demand access to pre-loaded audio files via web browser or remote contact closures. Schedules may be automated based upon day of the week, calendar date up to one year in advance, or software controlled daily as needed.

SPECIFICATIONS

NOMINAL SPECIFICATIONS

Protocols: DHCP, IGMP v3, TCP, HTTP, Telenet, FTP, UDP and RTP

Dell Server Power Requirements:
100-240 Vac, 1.6A

Smart UPS Power Requirements:
120 Vac, 12A

DIMENSIONS AND WEIGHT

Server:: 1.75in H x 19.00in W x 12.00in D
(4.45cm x 48.26cm x 30.48cm)

Weight: 11.30lbs (5.12kg)

Smart UPS: 1.75in H x 19.00in W x 9.00in D
(4.45cm x 48.26cm x 22.86cm)

Weight: 23.75 (10.77kg)

Shipping Weight: 35.00lbs (15.75kg)

ARCHITECTS AND ENGINEERS

The Communication/Notification Server, Model VE6030-1, when used in a Valcom Engineered Solutions IP6000 Communications System, shall provide daily communication, emergency notification, calendar event scheduling, graphical interface, clock control, and on demand distribution of WAV files, pre-recorded audio, and text to simultaneous groups of speakers, speakers with text, strobes, and threat level indicators. The Communication/Notification Server shall feature a simple browser-based interface including graphics, icons, and calendar. Schedule control shall be via automatic initiation (based upon day of the week, calendar date up to one year in advance) or software controlled daily as needed. The Communication/Notification Server shall provide multiple simultaneous schedules, multiple events per schedule and up to 12 simultaneously occurring events. The schedules shall feature one-second resolution. Events shall be capable of controlling paging, relays, text, and streaming audio. The Communication/Notification Server shall allow cascading events from a single time trigger. Schedules shall be presented to the user in a calendar view showing day, date, year and months. The Communication/Notification Server shall provide for default screen view, permissions based log-in, and roles..

Additionally, the VE6030-1 Communication/Notification Server shall provide Common Alert Protocol (send and receive), RSS feeds, ATOM feeds, and Email post. The VE6030-1 shall manually initiate origination of unscheduled events and shall import and convert

audio files from wav files with an option to enhance the wav file audio during import and an option to pre-record messages to be utilized for daily communication and emergency alerts. Events shall feature programmable pre/post page delays and volume control per event. A master volume control (system-wide) shall also be available. The server shall control VE8001A/8002A/8004As to provide streaming audio to page group(s) and shall use VE8048 inputs to execute events from the Playlist. Controlling VE8048 relays from events shall be inherent. The VE6030-1 shall be capable of sending and receiving CAP (Common Alert Protocol) messages and executing multiple emergency voice messages and text from key words of one or more CAP message files. The server shall communicate with VIP-102B setup tool for setup and dial code information. The ability to control receipt of messages based upon priority shall be inherent. Audio storage capacity shall be 25,000 seconds. The Communication/Notification Server shall include a Smart UPS (Uninterrupted over Supply) to provide continued communication during power loss and brown-outs. The smart UPS shall automatically and gracefully shut down the Communication/Notification Server after an extended power loss so when power is restored, the Communication/Notification Software shall be fully operational.

Warranty information may be found on our website at www.valcom.com/warranty.

VE6030-1 is a direct replacement for a VE6025

V-6120 6-Channel Amplifier

INTRODUCTION

The V-6120 6-Channel Amplifier is designed as a replacement amplifier for existing 25-Volt Speaker Lines. When used with Valcom's 25-Volt retrofit intercom systems, the V-6120 eliminates the need to install separate amplifiers for each one-way zone. Most of Valcom's 25-Volt compatible station cards feature a line level output suitable for connection to the line level inputs of the V-6120. This allows users to provide audio to up to 6 zones of common area paging per V-6120.

Features:

- 2u 19" Rack Mounting
- 6 Independent Amplifier Channels
- 3 Convenient Strain Relief Points
- LED Activity Indicator per channel

Power Requirements:

120 VAC/1.7A; 165W

Weight:

21.0 lbs (9.53 kg)

Dimensions:

3.5" H x 17.0" W x 15.0" D
(8.89 cm x 43.18 cm x 38.1 cm)

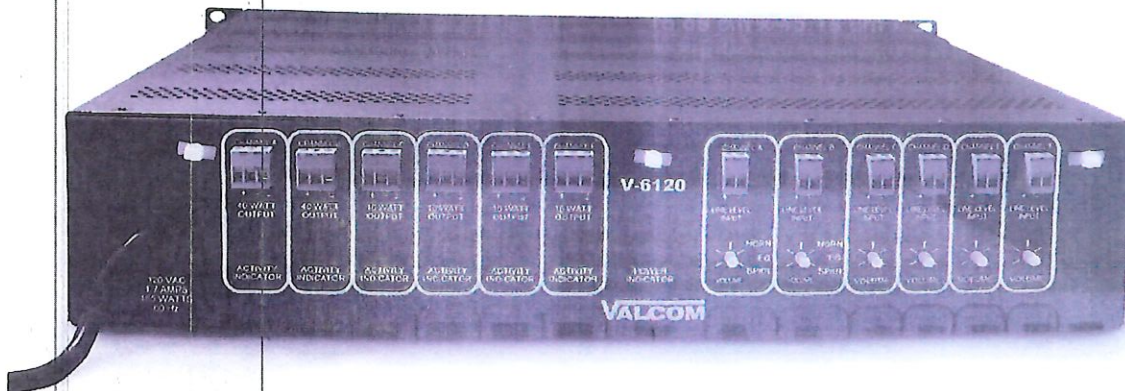

INSTALLATION

All connections to the V-6120 are made on the rear of the amplifier. There are 6 line level (-10dBm) inputs, each featuring an independent volume control, and 6 corresponding speaker outputs. Channels A and B are designed to drive up to a 40 watt load of 25-Volt speakers each or horn loudspeakers. These 2 channels also feature a switch selectable EQ to enhance the amplifier's output for horn or speaker loads. Channels C, D, E and F are designed to drive up to a 10 watt load of 25-Volt speakers each. The inputs may be bridged together, providing multiple outputs from a single input signal. The V-6120 Amplifiers outputs may not be bridged together.

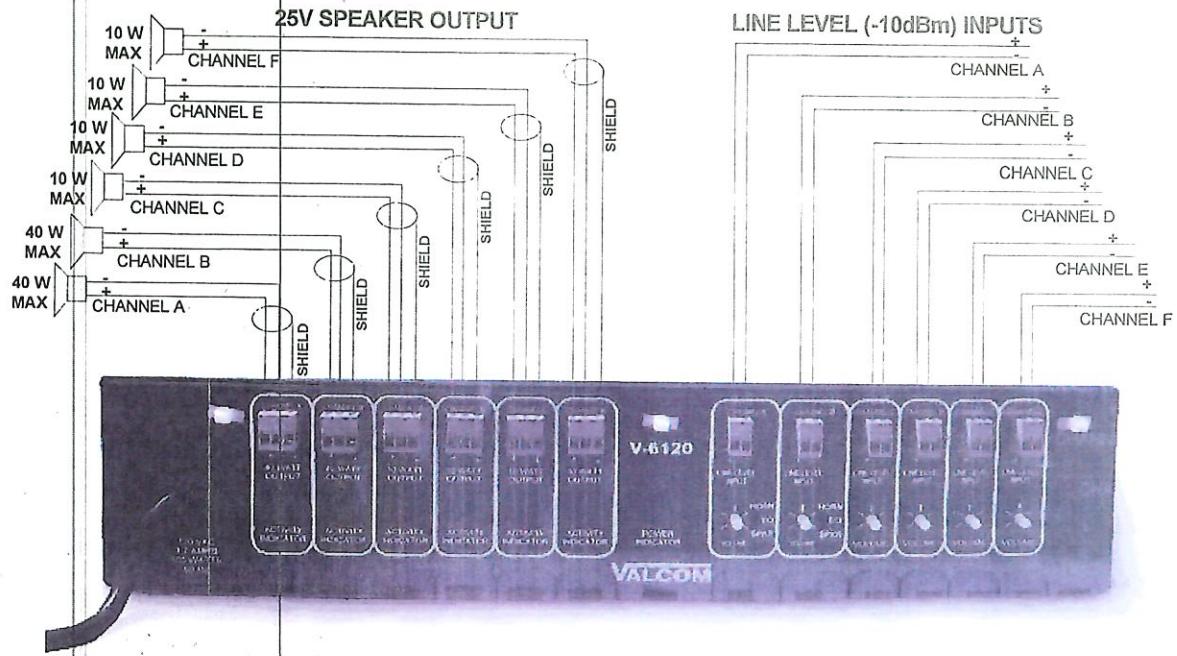

REAR VIEW

VALCOM LIMITED WARRANTY

Valcom, Inc. warrants its products to be free from defects in materials and workmanship under conditions of normal use and service for a period of one year from the date of shipment. The obligation under this warranty shall be limited to the replacement, repair or refund of any such defective device within the warranty period, provided that:

1. inspection by Valcom, Inc. indicates the validity of the claim;
2. the defect is not the result of damage, misuse or negligence after the original shipment;
3. the product has not been altered in any way or repaired by others and that factory sealed units are unopened (a service charge plus parts and labor will be applied to units defaced or physically damaged);
4. freight charges for the return of products to Valcom are prepaid;
5. all units 'out of warranty' are subject to a service charge. The service charge will cover minor repairs (major repairs will be subject to additional charges for parts and labor).

This warranty is in lieu of and excludes all other warranties, expressed or implied and in no event shall Valcom, Inc. be liable for any anticipated profits, consequential damages, loss of time or other losses incurred by the buyer in connection with the purchase, operation or use of the product.

This warranty specifically excludes damage incurred in shipment. In the event a product is received in damaged condition, the carrier should be notified immediately. Claims for such damage should be filed with the carrier involved in accordance with the F.O.B. point.

Headquarters:
 Valcom, Inc.
 5614 Hollins Road
 Roanoke, VA 24019-5056
 Phone: (540) 563-2000
 FAX: (540) 362-9300

Technical Specifications

VE1225 Talkback Gateway

- Replaces most analog school intercoms
- 12 port 25 V or 45 Ohm speaker connection
- 12 inputs for call switches
- 2 line level outputs for direct connection to one-way audio systems
- 2 Form A relay contacts
- 120 – 240 V 50/60 Hz AC powered
- Easy Windows based setup
- No server required
- 1 to 11 digit dial plans
- Front panel status led
- Compatible with most existing speaker cable
- Scalable to thousands of intercom stations/zones
- 19in rack mount design (1 unit)
- Convenient screw terminal and amphenol connectors
- Software volume control per zone
- SIP compatible

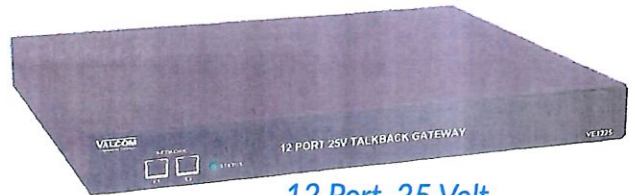

12 Port, 25 Volt

Description:

The VE1225 12 Port Talkback Gateway allows for the ultimate modernization of old-fashioned analog intercom systems. Each VE1225 provides 12 two-way intercom channels each supporting either 2 x 45 Ohm speakers or a 15-Watt load of 25 V speakers. The unit conveniently features 12 call button inputs as well as dual line level outputs. These line level outputs may be connected to amplifiers or self-amplified speakers in order to provide one-way audio to common areas. AC power makes installation as easy as plugging in a common AC receptacle. System relays may be utilized for visual signaling during announcements or for door unlock functionality. 12 port retrofit gateway channels may be directly accessed via Session Initiation Protocol (SIP).

SPECIFICATIONS

NOMINAL SPECIFICATIONS

Line Out Impedance: 50 Ohms
Line Out Audio Level: Software adjustable
Relay Contact Rating: 1 Amp @ 30 Vdc
Protocols: DHCP, IGMP v3, UDP, TCP, HTTP, Telnet, FTP
25 Volt Power Out: Up to a 15-Watt load/station (Maximum 60-Watt total)

ENVIRONMENT

Temperature: +32 to 104 °F (0 to +40) °C
Humidity: 0-85% non-condensing

DIMENSIONS AND WEIGHT

1 Standard 19in Rack Unit
1.75in H x 16.50in W x 15.00in D
(4.50cm x 41.90cm W x 38.10cm)
Weight: 5.20lbs (2.36kg)
Shipping Weight: 11.00lbs (4.95kg)

2022 Rev.2.5.31

Technical Specifications

ARCHITECTS AND ENGINEERS

The 12 Port Talkback Gateway, model VE1225, shall allow for the ultimate modernization of old-fashioned analog intercom systems. Each VE1225 port shall support either 2 x 45 Ohm speakers or a 15-watt load of 25 V speakers. The unit shall feature 12 call button inputs. The VE1225 shall additionally offer dual line level outputs. These line level outputs may be connected to amplifiers or self-amplified speakers to provide one-way audio to common areas. The VE1225 shall be powered via 120-240 V 50/60 Hz AC. System relays may

be available for visual signaling during announcements or for door unlock functionality.

Maximum dimensions shall be: 1.75in H x 16.50in W x 15.00in D (4.50cm x 41.90cm W x 38.10cm). Weight shall be approximately: 5.20lbs (2.36kg).

Warranty information may be found on our website at www.valcom.com/warranty.



Commercial Building Systems Inc

9821 Cogdill Rd. Suite 4A
Knoxville, TN 37932
Phone: 865-824-3063
Fax: 865-824-3064
TN License # ASC-1113

The warranty will be one year on parts and labor.



Warranty

Valcom, Inc. warrants its products only to the original purchaser, for its own use, to be free from defects in materials and workmanship under conditions of normal use and service for a period of one year from the date of shipment. This Limited Warranty obligation shall be limited to the replacement, repair or refund of any such defective device within the warranty period, provided that:

1. inspection by Valcom, Inc. indicates the validity of the claim;
2. the defect is not the result of damage, misuse or negligence after the original shipment;
3. the product has not been altered in any way or repaired by others and that factory sealed units are unopened (a service charge plus parts and labor will be applied to units defaced or physically damaged);
4. freight charges for the return of products to Valcom are prepaid;
5. all units 'out of warranty' are subject to a service charge. The service charge will cover minor repairs (major repairs will be subject to additional charges for parts and labor).

This Limited Warranty is in lieu of and excludes all other warranties, expressed or implied and in no event shall Valcom, Inc. be liable for any anticipated profits, consequential damages, loss of time or other losses incurred by the buyer in connection with the purchase, operation, maintenance, installation, removal or use of the product. The maximum liability of Valcom under this warranty is limited to the purchase price of the specific Product covered by the warranty.

Disclaimer. Except for the Limited Warranty provided herein, the product is provided "as-is" without any warranty of any kind whatsoever including, without limitation, any WARRANTY OF MERCHANTABILITY, FITNESS FOR A PARTICULAR PURPOSE OR NON-INFRINGEMENT.

This warranty specifically excludes damage incurred in shipment. In the event a product is received in damaged condition, the carrier should be notified immediately. Claims for such damage should be filed with the carrier involved in accordance with the F.O.B. point.

Headquarters:

Valcom, Inc.

5614 Hollins Road

Roanoke VA 24019-5056

Phone: (540) 563-2000 FAX: (540) 362-9800

Email: is@valcom.com

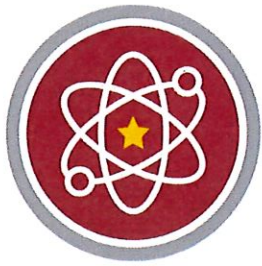

Oak Ridge

SCHOOLS

Maintenance and Operations

OFFICE OF MAINTENANCE AND OPERATIONS

DATE: November 1, 2023

TO: Bruce Lay, Executive Director of School Leadership

FROM: Allen Thacker, Director of Maintenance and Operations

SUBJECT: Purchase and Installation of RMS Lockers

Mr. Lay,

I am recommending that the Oak Ridge Schools Board of Education approve the purchase and installation of new lockers for Robertsville Middle School from School and Office Supply of Knoxville TN in the amount of \$122,170.15. The current lockers are original to the building and are in serious disrepair due to lack of replacement parts. The replacement lockers will be installed over spring break, providing the manufacturer is able to deliver within that time frame, if not the installation will be moved to summer break. The lockers will be heavy duty, double stacked with integrated combination locks, and will occupy one side of the hallway, providing 846 locker openings. Installation includes a measured amount of ADA openings and trim. Maintenance will remove the remaining lockers and do final finish work to close the open space.

The lockers will be purchased through a "piggyback" of the University of Tennessee Contract #5500007702. Funding for this purchase is from 76100 Capital Outlay and CIP funds.

Thank you,

Allen Thacker

Director of Maintenance and Operations

Maintenance Office

100 Woodbury, Oak Ridge, TN 37830

(865) 425-3171

www.ortn.edu



Jonathan Johnson
 School & Office Supply
 10653 Dutchtown Road
 Knoxville, TN 37932
 865-218-7936

Date: 11/2/2023

PROPOSAL

RMS - Lockers

PREPARED FOR: Allen Thacker
 Supervisor of Maintenance and
 Operations
 Oak Ridge City Schools
 245 Robertsville Rd

INSTALL AT: Allen Thacker
 Supervisor of Maintenance and Operations
 Oak Ridge City Schools
 245 Robertsville Rd
 Oak Ridge , TN 37830

Line #	Image	Part Number/Description	Qty	Unit List	Sell Unit	Sell Ext
1		PRICING NOTE	1	\$ 0.00	\$0.00	\$0.00
		The below Pricing is based on The University of Tennessee Contract Framework PO #5500007702. All applicable terms and conditions of the contract apply.				
2		List Industries Locker	1	\$ 0.00	\$122,170.15	\$122,170.15
		Build In Lockers(No Slope Top), Z Base, Double Tier,				
		Lock		Master Lock Built In w/Master Key (F148 System)		
		Size A		15"W x 12"D x 60"H Double Tier		
		Size B		12"W x 12"D x 60"H Double Tier(2)		
		Openings		846 Total Openings		
		Color:		Light Grey		
		Upgrade		Heavy Guage Bottom and Middle Shelf		
				Includes 5% ADA Openings		
				Includes Top and Recessed 3" Trim and Filler Panels		
3		Freight	1	\$ 0.00	\$0.00	\$0.00
		Included in Total Price				
4		Installation	1	\$ 0.00	\$0.00	\$0.00
		Included in Total Price				

Subtotal: \$122,170.15

Grand Total: \$122,170.15

Line #	Image	Part Number/Description	Qty	Unit List	Sell Unit	Sell Ext
--------	-------	-------------------------	-----	-----------	-----------	----------

Overview /of Terms and Conditions

- Client has reviewed proposal, drawings, material selections and has clear understanding of products and services being provided.
- SOS will place all orders upon approval with vendor(s) and may not be cancelled without prior approval.
- All furnishings are custom produced products to the client's specifications and cannot be returned.
- Standard delivery and installation are quoted during normal business hours (M-F 8am to 5pm) in one contiguous install, unless stated otherwise. Any Client directed changes after order may incur additional charges.
- Client agrees to have authorized personnel available to sign proof of delivery the day delivery is scheduled.
- Client is responsible for all phone and data wiring and termination as wells as all hard-wired electrical connections.

By signing the below, the Client authorizes SOS to proceed in procuring the furnishings on the above Proposal at the price stated. The Client agrees to the full "Terms and Conditions". This agreement supersedes any terms that may appear on the clients purchase order, unless agreed upon in writing.

CLIENT: _____
 APPROVED BY: _____
 TITLE: _____

SIGNED: _____
 DATE: _____

Grand Total: \$122,170.15

Framework Order Terms

Purchasing Agreement #: 5500007702

1. **Term of Agreement:** 11/5/2018 – 10/31/2028
2. **Extensions:** none
3. **General Description:** Supplier will furnish, deliver and install various furnishings.
4. **Cooperative Procurement:** This agreement is open to any institution provided supplier agrees. See section 19, subsections g and h.
5. **Pricing Structure:** Supplier will provide pricing to University as follows:
Supplier offers cost + 16% for all manufacturers listed. For orders exceeding \$200,000.00 pricing will be cost + 12%. At time of invoicing, School & Office Supply will provide copies of both the invoices and the costs from the manufacturer.
6. **Pricing Accuracy:** Supplier shall make reasonable efforts to ensure that the Supplier charges the University accurate pricing for 100% of University's order. Supplier shall take the following steps to self-audit Supplier's pricing: Vendor will review pricing for each order to make sure we are charging the proper amount. All quotes/orders will be presented on an excel spreadsheet, so our gross-profit/mark-up formula is a simple keystroke in excel.
7. **Pricing Transparency:** The University will not be responsible for paying any costs, unless the costs are specifically stated in this agreement.
 - a. Deposit: 50% on all orders over \$50,000 and a line item stating 'deposit fee' will be listed on the invoice.
 - b. Re-design: \$50 per person per hour with a line item stating hourly fee and total hours will be listed on the invoice.
 - c. Re-install: \$45 per person per hour with a line item stating hourly fee and total hours will be listed on the invoice.
 - d. Labor/installation: each project is evaluated and the price will be presented to UT before the order. Labor and installation charges will not exceed 15% of the order. Item will be listed as 'install charges' on the invoice.
 - e. Rush order/expedite shipping: UT will be charged the same price the manufacturer charges the supplier and a copy of the manufacturer's invoice will be available.
 - f. Surcharge: UT will only be charged a surcharge if the manufacturer charges the supplier. The Invoice will contain a line item for the surcharge with an explanation.
 - g. Travel: Only if the delivery location is outside a 125 mile radius from the vendor's location. Travel cost will be reimbursed per the UT Travel Policy. To view travel

policy:

<https://universitytennessee.policytech.com/docview/?docid=408&public=true>

8. **Ordering & Delivery:** Orders can be placed by fax or email. - Fax # (865)671-1126;
Email: rob.johnson@awos.com or jonathan.johnson@awos.com.
9. **Cancelling Orders:** In order to cancel an order, UT will need to contact School & Office Supply. Supplier will then contact the specific manufacturer to determine if the order can be cancelled and report back to UT. Each manufacturer has their own cancellation policy. As a general rule, most orders cannot be cancelled unless the cancellation request is made before production/shipment of the product. Some vendors have a cancellation charge, others do not. Cancelling orders will be treated on a case by case basis.
10. **Restocking Fees:** When applicable, each manufacturer has their own policy and School and Office Supply will abide by that plus 5% and freight charges.
11. **Warranty:** Upon initial delivery, the installer would note any damages. Damages get reported back to the vendor in order to fix the issue with a reorder or parts replacement. UT would be notified as to what specific punch-list items need to be corrected as well as an estimated timeline to resolve the issue. If a warranty issue occurs after the install, then the University would report that to either School & Office Supply. If it is something that can be fixed in the field, then vendor's installer will correct the issue on-site. If not, then vendor sends pictures of the issue back to the manufacturer in order to correct the issue. Supplier will track the status and report back to the University the estimated time of resolution.
12. **Shipping:**
 - a. **Arrangement:** Supplier will arrange shipping goods to the University's specified locations.
 - b. **Costs:** UT pays shipping costs to the vendor, who then pays the manufacturer.
 - c. **Insurance:** Seller is beneficiary of the insurance which covers full replacement costs. The deductible is \$1,000.00, paid by the seller. There is no mark-up or extra fee charged by the supplier. Insurance policy provided by: Frankenmuth
 - d. **Third-Party:**
 - i. **Reporting Damages:** The seller who receives the furniture will report the damage. If damage is discovered by the University, report the damage to either Rob Johnson (rob.johnson@awos.com) or Jonathan Johnson (jonathan.johnson@awos.com).
 - ii. **Declared Value:** Seller will declare the value of the item to the carrier.

- e. **Title:** The University takes title of the goods upon University's physical receipt of goods.
 - f. **Damages:** Carrier/shipper is responsible for all damages that occur during shipment, regardless of cause, until the University takes title of the goods.
 - g. **Inspection and Rejection:** If it is a drop ship that the University receives directly, then upon the time of receipt and note it on the Bill of Lading. Concealed damage allows 10 days. Otherwise, the seller is responsible for reporting all damage as they receive the product/s.
13. **Returns:** All returns must be approved by Supplier. As a general rule, School & Office Supply accepts returns under two conditions 1) School & Office Supply ordered the incorrect product or 2) Product is damaged.
14. **Refunds:** Once returned product has been "approved" and picked-up for return, School & Office Supply will issue a credit to the University of Tennessee. If no balance is due then UT will be issued a check.
15. **Insurance:** During the term of this agreement, Supplier shall maintain the following insurance levels, at a minimum:
Vendor must maintain a commercial general liability policy. The policy shall provide coverage which includes, but is not limited to, bodily injury, personal injury, death, property damage and medical claims, with minimum limits of \$1,000,000 per occurrence, \$2,000,000 in the aggregate. The University shall be named as an additional insured on any related policy. The Proposer shall maintain workers' compensation coverage or a self-insured program as required under Tennessee law. If any policy providing insurance required by the contract is cancelled prior to the policy expiration date, the Proposer, upon receiving a notice of cancellation, shall give immediate notice to the University.
16. **Licenses:** Tennessee Contractor's License No. 65626, Classification: BC-7; Monetary Limit: \$141,460.00.
17. **Bonds:** NA
18. **Agreement Based Upon:** Response to Furniture RFQ-S #2018-05-01.
19. **Miscellaneous:**
- a. **Additional Goods or Services:** The University may add supplier's additional goods or services as mutually agreed.
 - b. **Cancellation:** Notwithstanding any other cancellation provision, the University may cancel its purchase order, in whole or in part, by giving 10 days' prior written notice.

If the respondent fails to perform properly its obligations under this award or violates any term of this award, the University may terminate this agreement immediately and withhold payments in excess of fair compensation for completed services. If the University terminates an award, the University may seek all available remedies against the respondent.

- c. **Delivery:** The title and risk of loss for the goods will only pass to the University when the University actually receives the goods. The supplier must assume all responsibility for damage in transit. Any claim for loss of damage incurred during delivery will be between the respondent and the carrier. It is the supplier's responsibility to prevent shipments from being late and any additional charges for expedited delivery, shipments being routed to a point other than the one specified on the purchase order, special handling, or back orders will be incurred by the supplier. It is also understood and agreed that any item offered or shipped as a result of this bid shall be new (current production model), unless specified otherwise.
- d. **Inspection:** In the event of a dispute between the supplier and the University about the items supplier provides to the University, the University has sole and absolute discretion to determine whether the supplier's shipment conforms to the University's order. Supplier shall pay all costs for the University to return the rejected goods or replace missing goods. The respondent shall make immediate replacement of the damaged merchandise or be subject to damages for breach of contract. When University staff sign for a shipment, the signature does not constitute "acceptance." Rather, the signature is only acknowledgement of receipt.
- e. **Invoicing and Payment:** Unless stated otherwise, the University initiates payment for materials or services upon receipt of all goods and services and receipt of an original, itemized invoice that reflects accurate contract prices. Invoices failing to itemize the order, reference the purchase order, or undated may cause a delay in payment or rejection of the invoice.
- f. **Payment Terms:** Unless both parties agree in writing to other payment terms, the payment terms governing this award shall be a 2% discount, if payment is made within 10 days from the delivery of the goods or services or receipt of an itemized invoice, whichever is later.
- g. **Cooperative Procurement:** Any University, college, school, or government agency (third-party entity) may purchase under this agreement. The third-party entity may negotiate its own terms with the supplier.
- h. **Extension of Terms to Other Institutions:** The successful proposer will provide the requested services for the University of Tennessee entity described in the bid. Additionally, if the successful proposer is agreeable, these services/products may also be provided to the other University of Tennessee departments and/or campuses. Similarly, The State of Tennessee and entities from The Tennessee Board of Regents may also purchase goods and/or services from this agreement, if the winning proposal is agreeable. It should be noted that these institutions, departments and campuses are not required to use this agreement. If any these

institutions elect to participate under the terms and conditions of this resulting agreement, the University of Tennessee reserves the right to re-negotiate favorable incentive, and cost terms with the successful proposer that are reflective of the additional volume added as a result of participation by these institutions. Note: The offer to extend contract terms and conditions to these other institutions is at the discretion of the winning proposal and they should not be extended if it would affect your ability to offer the most favorable prices and terms to The University of Tennessee.

- i. **Non-Exclusivity:** The University will promote the use of any established contract; however, the University does not guarantee that all purchases for the products and/or services available under any award will be made exclusively from the supplier. Also, an award does not obligate the University to make any purchases from the awarded respondent and the University may elect to award contracts or purchase orders for like products or services to multiple suppliers.
- j. **Assignment:** Neither party may assign this agreement, or any right or duty hereunder, or enter into a subcontract for any of the services performed under this agreement, without the prior written approval of an authorized official of both parties.
- k. **Default:** In case of default of the supplier, the University may procure the articles or services from other sources and hold the supplier responsible for any excess costs incurred in remedying such default, including reasonable attorneys' fees, in addition to any other remedies to which the University may be entitled at law or in equity.
- l. **Governmental Restrictions:** In the event any governmental restrictions are imposed which would necessitate alteration of the material, quality workmanship or performance of the items offered on this bid prior to their delivery, it shall be the responsibility of the supplier to notify the University promptly regarding the potential impact. The University may accept any such alteration, including any price adjustments occasioned thereby, or to cancel the order at no expense to the University.
- m. **Audits** The supplier shall maintain documentation for all charges against the University under this procurement. The books, records and documents of the supplier, insofar as they relate to work performed or money received under the procurement, shall be maintained for a period of three (3) full years from the date of the final payment, and shall be subject to audit, at any reasonable time and upon reasonable notice, by the University or the Comptroller of the Treasury for the State of Tennessee, or their duly appointed representatives. These records shall be maintained in accordance with generally accepted accounting principles. If pricing is based on cost plus or discounts, the respondent shall maintain records supporting and detailing that the prices being charge to the University comply with the award.
- n. **Extension:** The University may extend the period of this agreement. Extension of the agreement period will be by mutual agreement in writing.
- o. **Better Pricing:** If, during the term of this award, supplier enters into a contract with the state of Tennessee which has lower prices, or the University identifies

consortium/cooperative pricing that is lower, the supplier must offer the lower pricing to the University without the University demanding the lower pricing. If respondent fails to offer the University the lower pricing, the University may terminate this award immediately and without advanced notice.

- p. **Vendor Adherence to Agreement:** Supplier may only sell goods or services listed in the University's purchase order. If respondent sells items not listed in the University's purchase order, the University may terminate the purchase order immediately and without advanced notice.
- q. **No Third-Party Beneficiaries:** There are no third-party beneficiaries to this agreement.
- r. **Iran Divestment Act:** The Supplier certifies, under penalty of perjury, that to the best of its knowledge and belief the Supplier is not on the list created pursuant to Tenn. Code Ann. § 12-12-106. The Supplier further certifies that it shall not utilize any subcontractor that is on the list created pursuant to Tenn. Code Ann. §12-12-106.
- s. **Illegal Immigrants:** In compliance with the requirements of Tenn. Code Ann. § 12-3-309, Supplier hereby attests that it shall not knowingly utilize the services of an illegal immigrant in the United States in the performance of this agreement and shall not knowingly utilize the services of any subcontractor who will utilize the services of an illegal immigrant in the United States in the performance of this agreement.
- t. **Registration with the Tennessee Department of Revenue:** The Supplier must register with, or receive an exemption from, the Tennessee Department of Revenue for the collection of Tennessee sales and use tax. This registration requirement is a material requirement of this agreement. The Supplier shall comply, and shall require any sub-contractor to comply, with all laws and regulations governing the remittance of sales and use taxes on the sale of goods and services made by the Supplier, or the Supplier's sub-contractor.
- u. **Governing Law:** The internal laws of the State of Tennessee (without regard to its conflict of law principles) govern all matters arising under or relating to this agreement.
- v. **Severability:** The parties intend as follows:
 - i. that if any provision of this agreement is held to be unenforceable, then that provision will be modified to the minimum extent necessary to make it enforceable, unless that modification is not permitted by law, in which case that provision will be disregarded;
 - ii. that if an unenforceable provision is modified or disregarded in accordance with this section, then the rest of the agreement will remain in effect as written; and
 - iii. that any unenforceable provision will remain as written in any circumstances other than those in which the provision is held to be unenforceable.
- w. **Click-Through Agreements:** In the event the supplier enters into terms of use, end users agreements, or other agreements or understandings, whether electronic, click-through, or shrink-wrap and whether verbal or written, with University employees,

such agreements shall be null, void, and without effect and the terms of this award apply.

- x. **Entire Agreement:** This agreement constitutes the entire understanding between the parties with respect to the subject matter of this agreement and supersedes all other agreements, whether written or oral, between the parties. In the event Supplier's invoices, order forms, or other Supplier-provided items contain terms, Supplier acknowledges that Supplier's terms do not apply to the Customer. Further, in the event Supplier's website, mobile applications, or other platforms contain click-wrap, browse-wrap, or shrink-wrap terms and conditions, Supplier states that such terms and conditions do not apply to Customer.

Agreed:

The University of Tennessee

Signature: Lisa Pate

Name: Lisa Pate

Title: Buyer

Date: November 20, 2018

Supplier

Signature: Robert L. Johnson

Name: Co-Owner Rob Johnson

Title: Co-Owner

Date: 11/18/18

School & Office Supply
Rob Johnson / Jonathan Johnson

Manufacturers Represented

Website

Manufacturers that provide a broad range of products

Versteel	http://www.versteel.com/
KI	https://www.ki.com/
Jasper Group (JSI, JOFCO, Community)	http://www.jaspergroup.us.com/
Hon	www.hon.com
Global Furniture Group	https://www.globalfurnituregroup.com/
OFS	https://ofs.com/
Arcadia	http://www.arcadiacontract.com/products/

Auditorium / Lecture Hall

KI	https://www.ki.com/
Sitmatic	http://sitmatic.com/
Enwork	http://www.enwork.com/

Custom Cabinetry / Millwork

Wisconsin Bench	https://www.wibenchmfg.com/
Fleetwood	https://www.fleetwoodfurniture.com/
Lacasse	https://www.grounelacasse.com/
Forma Space	https://formaspace.com/
Paul Downs Custom Conference Tables	https://www.custom-conference-tables.com/
Leonard Peterson-Science Lab	http://www.lpc.com/

Casegoods / Conference Tables / Training Tables

Jasper Group (JSI, JOFCO, Community) <http://www.jaspergroup.us.com/>
KI <https://www.ki.com/>
Nevers <http://www.nevers.com/>
Darran <https://www.darran.com/>
Trendway www.trendway.com
Paul Downs Custom Conference Tables <https://www.custom-conference-tables.com/>
Lacasse <https://www.grounelacasse.com/>
Tayco <https://www.tayco.com/>
Special T <https://www.specialt.net/>
Mayline <https://www.mayline.com/>
Flexsteel <https://www.flexsteel.com/>
Liat Furniture <http://liatfurniture.com/>
Enwork <http://www.enwork.com/>
Arcadia <http://www.arcadiacontract.com/products/>

Classroom Furniture

KI <https://www.ki.com/>
Smith Systems <https://smithsystem.com/>
Fleetwood <https://www.fleetwoodfurniture.com/>
Versteel <http://www.versteel.com/>
Scholarcraft <https://www.scholarcraft.com/>
Liat Furniture <http://liatfurniture.com/>

Dining

KI <https://www.ki.com/>
Hon www.hon.com
Palmer Hamilton <http://www.palmerhamilton.com/>
Harden Contract <http://www.hardenfurniture.com/>
Daniel Paul Banquet/Dining Furniture <https://www.danielpaulchairs.com/>
Special T <https://www.specialt.net/>
Hickory Contract <https://hickorycontract.com/>
David Edward <http://www.davidedward.com/>

KFI Seating <https://www.kfiseating.com/>
Flexsteel <https://www.flexsteel.com/>
MityLite <https://mitylite.com/>
MTS <https://www.mtsseating.com/>

Ergonomics
Humanscale <https://www.humanscale.com/>
Workright <http://workriteergo.com/>
Right Angle <https://www.raproducts.com/>
ESI Ergonomics <https://www.esiergo.com/>
Symmetry Office www.symmetryoffice.com

Glassboards / Markerboards

Clarus Glassboards www.clarus.com
Claridge <https://claridgeproducts.com/>
Ghent <https://ghent.com/>
Platinum Visual Systems <https://pvsusa.com/>
Egan Visual <https://egan.com/>

Healthcare

Haworth Health Environments <http://healthcare.haworth.com/>
Lacasse <https://www.grounelacasse.com/en/market/3-healthcare.html>
Hickory Contract <https://hickorycontract.com/>
David Edward <http://www.davidedward.com/>
Wieland www.wielandhealthcare.com

Library

Liat Furniture (Library) <http://liatfurniture.com/>
KI <https://www.ki.com/>
Fleetwood <https://www.fleetwoodfurniture.com/>
Tesco Library <https://tesco-learning-environments.myshopify.com/>
Jasper Chair <http://jasperchair.com/>
Arcadia <http://www.arcadiacontract.com/products/>

Lockers

List Industries-Lockers-Superior Lockers
Wisconsin Bench

<http://www.listindustries.com/>
<https://www.wibenchmfg.com/>

Lounge Seating / Commons / Soft Seating

KI
Jasper Group (JSI, JOFCO, Community)
Lesro
Fairfield
Hickory Contract
David Edward
Flexsteel
Leland/ Fresh Coast
Arcadia

<https://www.ki.com/>
<http://www.jaspergroup.us.com/>
<http://lesro.com/>
<http://www.fairfieldchair.com/>
<https://hickorycontract.com/>
<http://www.davidedward.com/>
<https://www.flexsteel.com/>
<http://lelandinternational.com/freshcoast/>
<http://www.arcadiacontract.com/products/>

Metal Storage / Industrial

Tennsco
Hirsh
Hon
Fireking
Lacasse
Forma Space
Diversified Wood Crafts
Mayline
Phoenix Safe
Wisconsin Bench

<http://www.tennsco.com/>
<https://www.hirshindustries.com/>
www.hon.com
<https://www.fireking.com/>
<https://www.grounelacasse.com/>
<https://formaspace.com/>
<https://www.diversifiedwoodcrafts.com/>
<https://www.mayline.com/>
<http://www.phoenixsafe.com/>
<https://www.wibenchmfg.com/>

Music Room / Band

Fleetwood (music furniture, mobile storage)
National Public Seating
Wenger

<https://www.fleetwoodfurniture.com/>
<https://www.nationalpublicseating.com/>
<https://www.wengercorp.com/>

Midwest Folding

<https://www.midwestfolding.com/>

Outdoor Furniture

Webcoat

<https://webcoat.com/>

KFI Seating

<https://www.kfiseating.com/>

Flexsteel

<https://www.flexsteel.com/>

Palmer Hamilton

<http://www.palmerhamilton.com/>

Homecrest

<http://www.homecrest.com/?AspxAutoDetectCookieSupport=1>

Playground Equipment

Playworld

<https://playworld.com/>

SportsPlay

<https://www.sportsplayinc.com/>

Science Lab

Biofit (Lab Seating)

<https://www.biofit.com/>

Leonard Peterson-Lab Stations

<http://www.lpc.com/>

Fleetwood (music furniture, mobile storage)

<https://www.fleetwoodfurniture.com/>

Wisconsin Bench

<https://www.wibenchmfg.com/>

Hann

<http://www.hannmfg.com/products.html>

Forma Space

<https://formaspace.com/>

Diversified Wood Crafts

<https://www.diversifiedwoodcrafts.com/>

Seating

KI

<https://www.ki.com/>

Jasper Group (ISI, JOFCO, Community)

<http://www.jaspergroup.us.com/>

Via Seating

<https://www.viaseating.com/#/>

9to5 Seating

<https://9to5seating.com/>

Sit-On-It

<https://www.sitonit.net/>

Fairfield

<http://www.fairfieldchair.com/>

United Chair

<https://www.groupelacasse.com/>

Eurotech

<http://www.eurotechseating.com/>

Hon

www.hon.com

Global Furniture Group	https://www.globalfurnituregroup.com/
OFS	https://ofs.com/
Hickory Contract	https://hickorycontract.com/
David Edward	http://www.davidedward.com/
Emeco	https://www.emeco.net/
Sit-matic	http://sitmatic.com/
Neutral Posture	http://www.neutralposture.com/
Jasper Chair	http://jasperchair.com/
Sitmatic	http://sitmatic.com/
HPFI	https://www.hpfi.com/
Arcadia	http://www.arcadiacontract.com/products/
Stage Curtains	
Roberts Stage	https://robertscurtains.tumblr.com/
Signage	
2/90 Signs	http://www.290signs.com/
Appenx	http://appenx.com/
Specialty	
Harden Contract	http://www.hardenfurniture.com/
Lacasse	https://www.groupe-lacasse.com/
Hickory Contract	https://hickorycontract.com/
Waddell- Display Cases/ Trophy Cases	https://www.waddellfurniture.com/
Fireking Fireproof Files	https://www.fireking.com/
Phoenix Safe	https://www.phoenixsafeusa.com/
Koncept-Lighting	https://www.koncept.com/
Speech Privacy Systems	https://speechprivacysystems.com/
Tech Lab	
Forma Space	https://formaspace.com/
Mayline	https://www.mayline.com/

Workstations / Panel Systems

Tayco

<https://www.tayco.com/>

Hon

www.hon.com

Trendway

www.trendway.com

KI

<https://www.ki.com/>



Framework Order Terms Amendment

This amendment # 5, effective 02/20/2022 amends Purchase Order # 5500007702 between The University of Tennessee and School & Office Supplies dated 11/05/2018 Except as amended below, all other terms remain unchanged.

The parties agree as follows:

Supplier will supply pricing to the University as follows:

Supplier offers cost plus to achieve 16% gross profit for all manufacturers listed. Orders reaching a minimum subtotal of \$200,000 (Before the Addition of Freight & Installation), will receive product invoiced at 12% gross profit. The \$200,000 minimum will need to be reached by using one manufacturer.

DocuSigned by:
Signature: Billy J Roberts
EE9EEAA7F892480...

Name: Billy J Roberts

Title: Buyer

2/21/2023 | 07:55:18 PST

DocuSigned by:
Signature: Rob Johnson
11789E6CDC264F6...

Name: Rob Johnson

Title: Co-Owner / Sales

2/21/2023 | 12:23:41 PST

Purchasing Department
505 Summer Pl - UT Tower #1044
Knoxville, TN 37902

Ship To:

C/O Department
All University of TN Campuses
Address designated by Dept.
Details designated by Dept.
City to be given at order placement , TN 37996

Vendor Address

Vendor No. 1018460
ROB JOHNSON
SCHOOL & OFFICE SUPPLY
10653 DUTCHTOWN RD
KNOXVILLE TN 37927

Framework Purchase Order**Information**

Date: 02/21/2023
Framework PO #: 5500007702
Payment Terms: Payable immediately Due net
Delivery Date: 11/05/2018
F.O.B.: FOB Shipping Point PP & Add
Buyer: BJ Roberts
Phone: 865-974-2569
Fax: 865-974-2973
Validity Dt: From 11/05/2018 **To** 10/31/2028
Collective Number: 1317289

Bill To:

All University of TN Campuses
Address designated by Dept.
Details designated by Dept.
City to be given at order placement

Item	QTY	UM	Material/Description	Price Per Unit	Net Amount
00001	1	LOT	<p>Please see attached purchase order terms.</p> <p>Contact information: Rob Johnson Phone: (865)386-5803 Email: rob.johnson@awos.com</p> <p>or</p> <p>Jonathan Johnson Phone: (865)386-5801 Email: jonathan.johnson@awos.com</p> <p>School & Office services primarily the East TN region of the state from Chattanooga, to Bristol/Kingsport, to Cookeville.</p> <p>Furnish, deliver and install various furnishings per the attached list of manufacturers with links to the manufacturers website.</p> <p>The following types of furnishings are offered: Office Classroom Auditorium Seating</p>	1,000,000.00	1,000,000.00

This purchase order is subject to the University's purchasing terms and conditions which can be found at: <https://procurement.tennessee.edu/gbc/>

Purchasing Department
505 Summer Pl - UT Tower #1044
Knoxville, TN 37902

Ship To:

C/O Department
All University of TN Campuses
Address designated by Dept.
Details designated by Dept.
City to be given at order placement , TN 37996

Vendor Address

Vendor No. 1018460
ROB JOHNSON
SCHOOL & OFFICE SUPPLY
10653 DUTCHTOWN RD
KNOXVILLE TN 37927

Bill To:

All University of TN Campuses
Address designated by Dept.
Details designated by Dept.
City to be given at order placement

Framework Purchase Order**Information**

Date: 02/21/2023
Framework PO #: 5500007702
Payment Terms: Payable immediately Due net
Delivery Date: 11/05/2018
F.O.B.: FOB Shipping Point PP & Add
Buyer: BJ Roberts
Phone: 865-974-2569
Fax: 865-974-2973
Validity Dt: From 11/05/2018 **To** 10/31/2028
Collective Number: 1317289

Item	QTY	UM	Material/Description	Price Per Unit	Net Amount
			Laboratory Lounge Dorm Outdoor Healthcare Lockers Stage Curtains Playground equipment Pricing: Cost 16% gross profit for all manufacturers listed Freight and installation will be quoted as a separate line item. Refurbishing: Cost of the parts: cost + 16% Man hours for removal & reinstallation: \$45 an hour per man Refurbishing work off-site: cost + 16% Transportation costs: cost + 5% Design fee: \$50 an hour per person; re-installation is \$45 an hour per person		
			Total Net Amount without Tax USD		1,000,000.00

This purchase order is subject to the University's purchasing terms and conditions which can be found at: <https://procurement.tennessee.edu/gbc/>

Purchasing Department
 505 Summer Pl - UT Tower #1044
 Knoxville, TN 37902

Ship To:

C/O Department
 All University of TN Campuses
 Address designated by Dept.
 Details designated by Dept.
 City to be given at order placement , TN 37996

Vendor Address

Vendor No. 1018460
 ROB JOHNSON
 SCHOOL & OFFICE SUPPLY
 10653 DUTCHTOWN RD
 KNOXVILLE TN 37927

Framework Purchase Order

Information

Date: 02/21/2023
Framework PO #: 5500007702
Payment Terms: Payable immediately Due net
Delivery Date: 11/05/2018
F.O.B. FOB Shipping Point PP & Add
Buyer: BJ Roberts
Phone: 865-974-2569
Fax: 865-974-2973
Validity Dt: From 11/05/2018 **To** 10/31/2028
Collective Number: 1317289

Bill To:

All University of TN Campuses
 Address designated by Dept.
 Details designated by Dept.
 City to be given at order placement

Item	QTY	UM	Material/Description	Price Per Unit	Net Amount
			The University of Tennessee conforms to all applicable rules, regulations and relevant orders of the Secretary of Labor. Affirmative action clauses and supporting regulations are incorporated by reference. 41 C.F.R. 60:1,4 sections 60-250.22, 60-741.22 and C.F.R. 61-250.10.		

This purchase order is subject to the University's purchasing terms and conditions which can be found at: <https://procurement.tennessee.edu/gbc/>

DocuSigned by:
 Signature Billy J Roberts
 EE9EEAA7F892480...

THE UNIVERSITY OF TENNESSEE

Purchasing Department
5723 Middlebrook Pike
Knoxville, TN 37921

Ship To:

C/O Department
All University of TN Campuses
Address designated by Dept.
Details designated by Dept.
City to be given at order placement , TN 37996

Framework Purchase Order

Information

Date: 11/14/2018
Framework PO #: 5500007702
Payment Terms: within 40 days Due net
Delivery Date: 11/05/2018
F.O.B.: FOB Shipping Point PP & Add
Buyer: Lisa Pate
Phone: 865-974-3101
Fax: 865-974-2973
Validity Dt: From 11/05/2018 **To** 10/31/2028
Collective Number: 1317289

Vendor Address

Vendor No. 1018460
 ROB JOHNSON
 SCHOOL & OFFICE SUPPLY
 10603 DUTCHTOWN RD
 KNOXVILLE TN 37927

Bill To:

All University of TN Campuses
 Address designated by Dept.
 Details designated by Dept.
 City to be given at order placement

Item	QTY	UM	Material/Description	Price Per Unit	Net Amount
00001	1	LOT	Please see attached purchase order terms. Contact information: Rob Johnson Phone: (865)386-5803 Email: rob.johnson@awos.com or Jonathan Johnson Phone: (865)386-5801 Email: jonathan.johnson@awos.com School & Office services primarily the East TN region of the state from Chattanooga, to Bristol/Kingsport, to Cookeville. Furnish, deliver and install various furnishings per the attached list of manufacturers with links to the manufacturers website. The following types of furnishings are offered: Office Classroom Auditorium Seating Laboratory Lounge	1,000,000.00	1,000,000.00

This purchase order is subject to the University's general bid condition which can be found at:
<https://procurement.tennessee.edu/gbc/>

Signature _____

THE UNIVERSITY OF TENNESSEE

Purchasing Department
5723 Middlebrook Pike
Knoxville, TN 37921

Ship To:

C/O Department
All University of TN Campuses
Address designated by Dept.
Details designated by Dept.
City to be given at order placement , TN 37996

Framework Purchase Order

Information

Date: 11/14/2018
Framework PO #: 5500007702
Payment Terms: within 40 days Due net
Delivery Date: 11/05/2018
F.O.B. FOB Shipping Point PP & Add
Buyer: Lisa Pate
Phone: 865-974-3101
Fax: 865-974-2973
Validity Dt: From 11/05/2018 **To** 10/31/2028
Collective Number: 1317289

Vendor Address

Vendor No. 1018460
ROB JOHNSON
SCHOOL & OFFICE SUPPLY
10603 DUTCHTOWN RD
KNOXVILLE TN 37927

Bill To:

All University of TN Campuses
Address designated by Dept.
Details designated by Dept.
City to be given at order placement

Item	QTY	UM	Material/Description	Price Per Unit	Net Amount
			Dorm Outdoor Healthcare Lockers Stage Curtains Playground equipment Pricing: Cost + 16% for all manufacturers listed. Freight and installation will be quoted as a separate line item. Reburbinging: Cost of the parts: cost + 16% Man hours for removal & reinstallation: \$45 an hour per man Refurbishing work off-site: cost + 16% Transporation costs: cost + 5% Design fee: \$50 an hour per person; re-installation is \$45 an hour per person Total Net Amount without Tax USD		===== 1,000,000.00

This purchase order is subject to the University's general bid condition which can be found at:
<https://procurement.tennessee.edu/gbc/>

Signature *Lisa Pate*

THE UNIVERSITY OF TENNESSEE

Purchasing Department
5723 Middlebrook Pike
Knoxville, TN 37921

Ship To:

C/O Department
All University of TN Campuses
Address designated by Dept.
Details designated by Dept.
City to be given at order placement , TN 37996

Framework Purchase Order

Information

Date: 11/14/2018
Framework PO #: 5500007702
Payment Terms: within 40 days Due net
Delivery Date: 11/05/2018
F.O.B. FOB Shipping Point PP & Add
Buyer: Lisa Pate
Phone: 865-974-3101
Fax: 865-974-2973
Validity Dt: From 11/05/2018 **To** 10/31/2028
Collective Number: 1317289

Vendor Address

Vendor No. 1018460
ROB JOHNSON
SCHOOL & OFFICE SUPPLY
10603 DUTCHTOWN RD
KNOXVILLE TN 37927

Bill To:

All University of TN Campuses
Address designated by Dept.
Details designated by Dept.
City to be given at order placement

Item	QTY	UM	Material/Description	Price Per Unit	Net Amount
			The University of Tennessee conforms to all applicable rules, regulations and relevant orders of the Secretary of Labor. Affirmative action clauses and supporting regulations are incorporated by reference. 41 C.F.R. 60:1,4 sections 60-250.22, 60-741.22 and C.F.R. 61-250.10.		

This purchase order is subject to the University's general bid condition which can be found at:
<https://procurement.tennessee.edu/gbc/>

Signature _____



MEMORANDUM

Dr. Kelly Williams

Executive Director, Office of Teaching and Learning

TO: Board of Education

DATE: 11/13/23

SUBJECT: Item for Action: Approval to Purchase New Website and Hosting Platform

I recommend board approval to purchase a new website and hosting platform. FinalSite is recommended for the new website and hosting platform based on committee feedback. This decision was made based on the vendor's ability to meet the needs of the district, as identified by the Communications Specialist and members of the committee and scored using a standardized rubric. This project is included as part of the FY24 Communications budget line 141-72290-399.

The website review committee included:

Molly Gallagher Smith

Heather Henderlight

Jeffrey Edmonds

Allen Etheridge

Jenifer Laurendine

Jennifer Milligan

Julie Kinder-McMillan

Website

Content Management System	1	2	3	4	5
<i>User Friendly, Preview Pages, User Management</i>					
Technical Requirements	1	2	3	4	5
<i>Adaptive for multiple devices, Server Security, Server Downtime</i>					
Content Organization	1	2	3	4	5
<i>Staff Directory Functionality</i>					
Search Functionality	1	2	3	4	5
Accessibility	1	2	3	4	5
Website Design	1	2	3	4	5
Training	1	2	3	4	5
Technical Support	1	2	3	4	5
Migration Process	1	2	3	4	5
Intranet	1	2	3	4	5

Parent Communication Platform

User Friendly/Intuitive	1	2	3	4	5
Hierarchy/Organization of Information	1	2	3	4	5
Accessibility	1	2	3	4	5
Translations	1	2	3	4	5
Mobile App	1	2	3	4	5
Technical Support	1	2	3	4	5
Calendars	1	2	3	4	5
Forms	1	2	3	4	5
Consolidation of Platforms	1	2	3	4	5

Comments:

From: [Molly Gallagher Smith](#)
To: [Elizabeth McFall](#)
Subject: Website/Comm Platform Info
Date: Monday, October 16, 2023 4:36:30 PM
Attachments: [Parent Square Comm Platform and Website.pdf](#)
[image001.png](#)
[Parent Square Comm Platform.pdf](#)
[Finalsite Oak Ridge Composer Proposal \(1\).pdf](#)

I have linked to [Apptegy's Pricing Structure site](#), which is the most official "quote" they will provide unless we move forward with them. It comes to \$52,250 without the optional training for teachers, which would be roughly an additional \$11,500

Committee Members:

Heather Henderlight
Jeffrey Edmonds
Allen Etheridge
Jenifer Laurendine
Jennifer Milligan
Julie Kinder-McMillan

Based on the committees review and feedback, we have decided to proceed with FinalSite as our website hosting vendor, and ParentSquare for our Classroom and Parent Communication Platform. This decision was made based on the vendor's abilities to meet the needs of the district, as identified by the Communications Specialist and members of the committee, and scored using a standardized rubric. The vendors are specialized in the K-12 education industry and are well-known and widely-accepted as industry leaders. Based on feedback from colleagues at comparable districts, the needs of the district, and fiscal responsibility we propose to move forward with a FinalSite website, and Parent Square's Engage communication platform.

Molly Gallagher Smith
Communications Specialist
304 New York Avenue | Oak Ridge, TN 37830
mgsmith@ortn.edu | O: (865) 425-9014 | C: (865) 601-6139
Every student prepared for college, career, and life success



FINALSITE ORDER

This **Finalsite Order (the 'Order')** is entered into by and between Active Internet Technologies, dba Finalsite ('Finalsite') and Oak Ridge School District ("Customer") and sets forth the terms of Customer's use of the products and services set forth below ("**Pricing Summary**"). This Order, together with the Master Terms and Conditions for Services (the "**Master Terms**") located at <http://www.finalsite.com/masterterms/useducationagencies> and incorporated herein by this reference, form the entire agreement between the parties in respect of the products and services set forth below. Each of the individuals executing this Order represent and warrant that he or she is authorized to execute this Order on behalf of Customer or Finalsite, as applicable. Unless otherwise specified herein, any capitalized terms used in this Order shall have the meaning defined in the Master Terms. The "**Effective Date**" of this Order is the date on which both parties have signed this Order as reflected in the signature lines below.

In consideration of the promises set forth herein, and other good and valuable consideration, the receipt of which are hereby acknowledged, the parties hereby agree as follows:

A. Pricing Summary

* Indicates products added

[x] Indicates products removed

CMS Platform

Platform	
* Communications Core Platform - Districts View a detailed description of what is included in your software package here http://www.finalsite.com/dcc	

Setup and Creative and Professional Services	
* Public School Theme View a detailed description of what is included in your software package here https://www.finalsite.com/sowpt	

Add-Ons	
* Athletics Manager	* LDAPS/Active Directory Integration
* Integration: GG4L	* Advanced Search

Training	
* School Webmaster Training [2 hour-Virtual Instructor]	

Products Included in Communications Core Platform - Districts	
Basic Site Search	HTTPS Implementation
Basic Support with integrated ticketing	LDAP/Google Authentication (Network SSO)
Blog, News and Subscriptions with Finalsite Posts (Unlimited)	Live Webinar Training
Data Imports through Finalsite Support (4/year)	Mobile-Friendly, Responsive Design
Digital Asset Management & Document Library with Resources	Website cloud storage (120 GB)
District Site and 10 Additional Sites	Page-Based Notifications (Page Pops)

FERPA-compliant Hosting, Security and Integrated CDN	Searchable Knowledge Base and Video Access
Finalsite Composer Content Management System	Social Media Feeds (11)
Faculty/Staff Directory & Role	Tiered Permissions and User Management
Finalsite Payments by BlueSnap	Unlimited Calendars (Incl. Integration)
Forms (Unlimited)	Unlimited Published Pages

Translation

Translation	
* Weglot Pro (5 languages, 200K words)	

Special Provisions:

Oak Ridge School anticipated launch date is Spring 2024.

Services: Initial Term and Fees:

The initial term of this Order is for the (5) year period beginning from the Effective Date, unless otherwise outlined in the schedule below (the "Initial Term").

Fees for the Initial Term for the Services specified in the table above are set forth below:

Total Setup Cost (USD)
\$7,900

Schedule	Amount
Period 1 - Nov 01 2023	\$ 11,700
Period 2 - Nov 01 2024	\$ 11,700
Period 3 - Nov 01 2025	\$ 11,700
Period 4 - Nov 01 2026	\$ 11,700
Period 5 - Nov 01 2027	\$ 11,700

B. Payment Terms

1. All fees for the initial year of this Order shall be due as follows: (i) Set Up fees shall be invoiced on the Effective Date of this Order and shall be due and payable upon receipt of invoice; (ii) fees for Year 1 (described in the fee table above) shall be invoiced on the Effective Date of this Order or the first day of Year 1, whichever is later, and shall be due and payable upon receipt of invoice; (iii) fees for each subsequent Year of the Initial Term, and for each Renewal Term, shall be invoiced on the commencement of such Year or Renewal Term (as applicable) and shall be due and payable upon receipt of invoice. Fees for any other Services, and for reimbursable expenses, shall be invoiced in accordance with the Master Terms or this Order and shall be due and payable upon receipt of invoice.
2. Unless otherwise specified in the Special Provisions above, this Order Form shall be renewed automatically for successive periods of (5) years (each a "Renewal Term") after the expiration of the Initial Term and any subsequent Renewal Term, unless Client provides Finalsite, or Finalsite provides Client, with a written notice to the contrary ninety (90) days prior to the end of the Initial Term or Renewal Term, as applicable.
3. Unless otherwise specified, all dollars (\$) are United States currency.
4. Sales/VAT Tax: If applicable, a copy of Customer's Sales/VAT Tax Direct Pay Certificate or its Sales/VAT Tax Exemption Certificate must be returned with this Order Form. Otherwise, Finalsite will invoice Customer for applicable sales, use and other transactional taxes due in connection with the Services or the fees due therefor.
5. Except as otherwise specified in this Order, fees are subject to increase in accordance with the applicable provisions of the Master Terms.

Any SOWs to which links are provided above in Section A, "Pricing Summary," are incorporated into this Order by reference, and any professional services described therein are included as part of your software package. By signing below, Finalsite and Customer each agree to the terms and conditions of this Order, the Master Terms, and any SOWs incorporated by reference. By signing below, Finalsite and Customer each agree to the terms and conditions of this Order and the Master Terms.

On Behalf Of: Oak Ridge School District
Signature
Name (printed)
Title (printed)
Date

Active Internet Technologies ('Finalsite')
Signature
Name (printed)
Title (printed)
Date

C. Client Contact Information

Please fill out the following information, which will be used by our deployment & accounting teams.

Billing Contact
Title
Address PO Box 6588
City, State Zip Oak Ridge, TN 37831
Phone
Email

Project Contact
Title
Phone
Email

*Executive Sponsor (Superintendent, Head of School, CFO, etc.)
Title
Email

*The Executive Sponsor should be separate from the Project Contact and is typically the Superintendent, Head of School, Business Manager, CFO, etc.



Oak Ridge, TN - 4703240 - New Deal

Pricing Term Start Date: October 1, 2023 | **Pricing Term End Date:** September 30, 2024 | **Quote Create Date:** September 18, 2023 | **Reference:** 20230918-114109681

Oak Ridge, TN - 4703240

P. O. Box 6588 AVE
Oak Ridge, TN 37831
United States

Molly Gallagher Smith

Communications Specialist
mgsmith@ortn.edu
(865) 425-9014

Comments

Ben Craft - Regional Director ParentSquare, Inc.



Products & Services

Item & Description	Billing Start Date	Term (Months)	Quantity	Unit Price	Total
--------------------	--------------------	---------------	----------	------------	-------

Items due now

Item & Description	Billing Start Date	Term (Months)	Quantity	Unit Price	Total
District Onboarding (5 - 14.9K) <ul style="list-style-type: none"> • Coordination between ParentSquare Implementation Team and Points of Contact • Creation & configuration of the ParentSquare site • Data migration and review of Staff, Student, Parent and Roster data • Digital training opportunities including recurring webinars, digital training modules, and videos • Access to “Resource Kit” and Best Practice materials to support Launch • Ongoing help and support for Admins via email, chat, and voice • Discovery call with Implementation Manager • District walkthrough videos w/ Q&A option • 1 hour of training or CS consultation (Engagement Team) • Launch check in meeting • Ongoing engagement with Customer Success Team 			1	\$2,500.00	\$2,000.00 after \$500.00 discount

Item & Description	Billing Start Date	Term (Months)	Quantity	Unit Price	Total
Smart Sites Onboarding - Standard w/ Content Migration <ul style="list-style-type: none"> · Project Management · Site Launch Consultation · Staff Directory · Template Configuration · Activation · Content Migration (500 pages) 			1	\$6,750.00	\$6,750.00
Smart Sites - Content Migration (100 pages)			5	\$750.00	\$3,750.00
Items due later					
Engage 2023 <ul style="list-style-type: none"> · Mobile App & Web Portal · Language Translation · Analytics, Reporting & Archiving · SIS Integrations, SSO (API, SFTP, other) · Smart & Urgent Alerts · Posts & Newsletters · Social Media & Website Share · Attendance & Auto Notices (includes lunch balances) · Direct Messaging · Appointments (including parent-teacher conferences) · Volunteering & Sign Ups · Directory · StudentSquare · Calendar & Event RSVP · Forms & Permission Slips (includes Surveys) 	October 1, 2023	12	5,000	\$4.50 / year	\$22,500.00 / year for 1 year
Payment starts: October 1, 2023					

Item & Description	Billing Start Date	Term (Months)	Quantity	Unit Price	Total
Community Groups Payment starts: October 1, 2023	October 1, 2023	12	5,000	\$1.00 / year	\$1,875.00 / year after \$3,125.00 discount for 1 year
Secure Documents Payment starts: October 1, 2023	October 1, 2023	12	5,000	\$1.00 / year	\$1,875.00 / year after \$3,125.00 discount for 1 year
Smart Sites (Multi-site) Payment starts: October 1, 2023	October 1, 2023	12	5,000	\$1.89 / year	\$9,450.00 / year for 1 year
Smart Sites - Monsido Economy <ul style="list-style-type: none"> • Web Accessibility • Mobile Accessibility • Site Inventory • Quality Assurance • Uptime Monitoring • Policies • SEO • Analytics Payment starts: October 1, 2023	October 1, 2023	12	1	\$3,850.00 / year	\$3,850.00 / year for 1 year

Future Payments Summary

Item	Payment
Engage 2023	\$22,500.00 / year starting on October 1, 2023 for 1 payment
Community Groups	\$1,875.00 / year starting on October 1, 2023 for 1 payment
Secure Documents	\$1,875.00 / year starting on October 1, 2023 for 1 payment
Smart Sites (Multi-site)	\$9,450.00 / year starting on October 1, 2023 for 1 payment

Item

Payment

Smart Sites - Monsido Economy

\$3,850.00 / year starting on October 1, 2023 for 1 payment

Signature

Before you sign this quote, an email must be sent to you to verify your identity. Find your profile below to request a verification email.

Molly Gallagher Smith

mgsmith@ortn.edu

[sig|req|signer1]

Lindsey Fishback

lindsey.fishback@parentsquare.com

[sig|req|signer2]

This quote expires on October 18, 2023

Purchase terms

District/School Agreement -- The Services are subject to the terms contained in this Order Form and School Agreement which are located at www.parentsquare.com/agreement, and incorporated by reference into this Order Form ("ParentSquare School Agreement").

By executing this Order Form, the undersigned certifies that (i) the undersigned is a duly authorized agent of District/School, and (ii) the undersigned has read the ParentSquare School Agreement and will take all reasonable measures to enforce them within the District/School.

NOTE: Pricing above does not reflect ParentSquare's right to increase pricing up to 5% each annual period. Pricing above also does not include applicable tax, which will be applied upon invoicing.

Privacy Policy -- The ParentSquare Privacy Policy may be reviewed here - <https://www.parentsquare.com/privacy>

Terms of Use -- The ParentSquare Terms of Use may be reviewed here - <https://www.parentsquare.com/terms>

StudentSquare Consent -- Pursuant to Children's Online Privacy and Protection Act ("COPPA"), ParentSquare relies on the School's consent on behalf of students in order to allow those under 13 years of age to use our services.

Questions? Contact me



Ben Craft

Regional Director

ben.craft@parentsquare.com

+17049427410

ParentSquare, Inc.

PO Box 841604,

Los Angeles, CA 90084-1604

United States

Simple and Transparent Pricing

Thrillshare Media + Rooms

\$12,250 + \$6/student

- ✓ Thrillshare Platform & Mobile
- ✓ Native iOS App
- ✓ Native Android App
- ✓ Text & Voice Alerts
- ✓ Email & Push Notifications
- ✓ CMS & Integrated Websites
- ✓ SIS Integration
- ✓ Training & Support
- ✓ Unlimited Classes
- ✓ Class Stream for Announcements
- ✓ Assignment creation and turn-in
- ✓ Visibility into Parent-Teacher comms
- ✓ Content & User migration
- ✓ Marketing Package

Cost/Year

Professional Development

\$4000 + \$25/teacher

Unlimited training and support for every teacher

First Year

Setup/App Development

\$9500 + \$500/organization

One Time

Testimonials

"Best customer service of any company I've ever worked with anywhere! Our teachers and parents are saying the app is making their lives easier, and that literally makes my heart soar!"



Alisha Evans

Communications Coordinator

"This has been the best and most positive experience I've had with a vendor in a school district. Hands down. 100%"



Joshua Silver

District Chief Technology Officer

"As much as I wanted to keep you guys a secret (so we might look good to our neighbors) the product is just too good. I must have stopped 7-8 superintendents at our state conference last week and kept showing them your work. You guys are very good at what you do - thank you!"



Dr. Seth Miller

Superintendent



SOLUTIONS

CAREERS

GUIDES

SCHEDULE A DEMO

-\$1000/year Thrillshare Suite Bundle

CONTACT US

Explore

- Thrillshare
- Mobile Apps
- Websites
- Alerts
- ADA Compliance

- Careers
- Contact
- Guides
- Terms of Use
- Privacy policy

Contact

2201 Brookwood Drive, Suite 115
 Little Rock, AR 72202
 Sales: 501-222-3447
 Support: 501-613-0370
 hello@apptegy.com
 Press inquiries:
 press@apptegy.com

Send us a message

First name*

Last name*

Email*

Phone Number*

Message

protected by reCAPTCHA
[Privacy](#) - [Terms](#)

SUBMIT

COPYRIGHT ©2023 APPTEGY. ALL RIGHTS RESERVED.



MEMORANDUM

Dr. Kelly Williams

Executive Director, Office of Teaching and Learning

TO: Board of Education

DATE: 11/13/23

SUBJECT: Item for Action: Approval to Purchase Classroom and Parent Communication Platform

I recommend board approval to purchase a new classroom and parent communication platform. ParentSquare is recommended for the our classroom and parent communication platform based on committee feedback. This decision was made based on the vendor's ability to meet the needs of the district, as identified by the Communications Specialist and members of the committee and scored using a standardized rubric. This project is included as part of the FY24 Communications budget line 141-72290-399.

The website review committee included:

Molly Gallagher Smith

Heather Henderlight

Jeffrey Edmonds

Allen Etheridge

Jenifer Laurendine

Jennifer Milligan

Julie Kinder-McMillan

Website

Content Management System	1	2	3	4	5
<i>User Friendly, Preview Pages, User Management</i>					
Technical Requirements	1	2	3	4	5
<i>Adaptive for multiple devices, Server Security, Server Downtime</i>					
Content Organization	1	2	3	4	5
<i>Staff Directory Functionality</i>					
Search Functionality	1	2	3	4	5
Accessibility	1	2	3	4	5
Website Design	1	2	3	4	5
Training	1	2	3	4	5
Technical Support	1	2	3	4	5
Migration Process	1	2	3	4	5
Intranet	1	2	3	4	5

Parent Communication Platform

User Friendly/Intuitive	1	2	3	4	5
Hierarchy/Organization of Information	1	2	3	4	5
Accessibility	1	2	3	4	5
Translations	1	2	3	4	5
Mobile App	1	2	3	4	5
Technical Support	1	2	3	4	5
Calendars	1	2	3	4	5
Forms	1	2	3	4	5
Consolidation of Platforms	1	2	3	4	5

Comments:



Oak Ridge Schools, TN

Pricing Term Start Date: December 1, 2023 | **Pricing Term End Date:** November 30, 2024 | **Quote Create Date:** September 18, 2023 | **Reference:** 20230918-113419611

Oak Ridge, TN - 4703240

304 New York Avenue
Oak Ridge, TN 37830
United States

Bruce Borchers

Superintendent
btborchers@ortn.edu
(865) 425-9001

Comments

Section 10.1 (Governing Law) of the ParentSquare School Agreement, which is made part of this Sales Quote and agreement, is amended to replace the existing language in Section 10.1 in its entirety with the following: **"10.1 Governing Law and Venue.** Unless the laws governing School require otherwise, the laws of the State of Tennessee govern all matters arising out of the Agreement, without regard to conflict of law principles, and federal courts in the Eastern District of Tennessee and the state courts located in Anderson County, Tennessee, will have non-exclusive jurisdiction in respect of disputes arising in connection with the Agreement. The United Nations Convention for the International Sale of Goods shall not apply."

Ben Craft - Regional Director ParentSquare, Inc.



Products & Services

Item & Description	Billing Start Date	Term (Months)	Quantity	Unit Price	Total
<p>Engage Premium 2023</p> <ul style="list-style-type: none"> · Mobile App & Web Portal · Language Translation · Analytics, Reporting & Archiving · SIS Integrations, SSO (API, SFTP, other) · Smart & Urgent Alerts · Posts & Newsletters · Social Media & Website Share · Attendance & Auto Notices (includes lunch balances) · Direct Messaging · Appointments (including parent-teacher conferences) · Volunteering & Sign Ups · Directory · StudentSquare · Calendar & Event RSVP · Forms & Permission Slips (includes Surveys) · Community Groups · Secure Documents 	December 1, 2023	12	5,000	\$6.00 / year	<p>\$27,500.00 / year</p> <p>after \$2,500.00 discount for 1 year</p>
<p>Payment starts: December 1, 2023</p>					

Item & Description	Billing Start Date	Term (Months)	Quantity	Unit Price	Total
District Onboarding (5 - 14.9K) • Coordination between ParentSquare Implementation Team and Points of Contact • Creation & configuration of the ParentSquare site • Data migration and review of Staff, Student, Parent and Roster data • Digital training opportunities including recurring webinars, digital training modules, and videos • Access to "Resource Kit" and Best Practice materials to support Launch • Ongoing help and support for Admins via email, chat, and voice • Discovery call with Implementation Manager • District walkthrough videos w/ Q&A option • 1 hour of training or CS consultation (Engagement Team) • Launch check in meeting • Ongoing engagement with Customer Success Team Payment due: December 1, 2023	December 1, 2023		1	\$2,500.00	\$2,000.00 after \$500.00 discount

Future Payments Summary

Item	Payment
District Onboarding (5 - 14.9K)	\$2,000.00 on December 1, 2023
Engage Premium 2023	\$27,500.00 / year starting on December 1, 2023 for 1 payment

Signature

Before you sign this quote, an email must be sent to you to verify your identity. Find your profile below to request a verification email.

<p>Bruce Borchers btborchers@ortn.edu</p>	<p>Verify to sign</p>
--	-----------------------

<p>Lindsey Fishback lindsey.fishback@parentsquare.com</p>	<p>Verify to sign</p>
--	-----------------------

This quote expires on November 30, 2023

Purchase terms

District/School Agreement -- The Services are subject to the terms contained in this Order Form and School Agreement which are located at www.parentsquare.com/agreement, and incorporated by reference into this Order Form ("ParentSquare School Agreement").

By executing this Order Form, the undersigned certifies that (i) the undersigned is a duly authorized agent of District/School, and (ii) the undersigned has read the ParentSquare School Agreement and will take all reasonable measures to enforce them within the District/School.

NOTE: Pricing above does not reflect ParentSquare's right to increase pricing up to 5% each annual period. Pricing above also does not include applicable tax, which will be applied upon invoicing.

Privacy Policy -- The ParentSquare Privacy Policy may be reviewed here - <https://www.parentsquare.com/privacy>

Terms of Use -- The ParentSquare Terms of Use may be reviewed here - <https://www.parentsquare.com/terms>

StudentSquare Consent -- Pursuant to Children's Online Privacy and Protection Act ("COPPA"), ParentSquare relies on the School's consent on behalf of students in order to allow those under 13 years of age to use our services.

Questions? Contact me



Ben Craft

Regional Director

ben.craft@parentsquare.com

+17049427410

ParentSquare, Inc.

PO Box 841604,
Los Angeles, CA 90084-1604
United States



MEMORANDUM

Dr. Kelly Williams

Executive Director, Office of Teaching and Learning

TO: Board of Education

DATE: 11/13/23

SUBJECT: Item for Action: Approval of ORPSEF Donation of HAAS

I recommend board approval to accept the donation from the Oak Ridge Public Schools Education Foundation (ORPSEF) of a Haas VM3 high-performance CNC 3-Axis Mill for mold making, tool & die work, and other high -precision projects. This machine will be used, in part to create statues for the “Giants of Oak Ridge” community project as well as future projects requiring its generous build capacity.

The attached quote shows the pricing for build, purchase, delivery, and setup to be cover by the donation from ORPSEF.



Date: November 13, 2023

To: Kelly Williams, Executive Director of Teaching and Learning

From: Holly Cross, Supervisor of College, Career, and Technical Education

Subject: **Recommendation of Approval of ORPSEF Donation of HAAS**

Dr. Williams,

I recommend the Oak Ridge Schools Board of Education accept the donation from the Oak Ridge Public Schools Education Foundation (ORPSEF) of a Haas VM3 high-performance CNC 3-Axis Mill for mold making, tool & die work, and other high-precision projects. This machine will be used, in part to create statues for the "Giants of Oak Ridge" community project, as well as future projects requiring its generous work cube, multi-fixturing table, 12,000-rpm inline direct-drive spindle, high-speed control with full look-ahead, side-mount tool changer, programmable coolant nozzle, and automatic air gun.

The Haas site states that the "control hardware and software is designed and built in-house and optimized specifically for Haas machine tools. If there is a problem, Haas Automation takes full responsibility for the entire machine. The Haas control is easy to learn and use, and it is the same across the entire product line. Haas machines are used extensively in educational institutions around the world, so graduating students are already familiar with the Haas control, which makes finding new operators and programmers easier, and simplifies training." Our students have already been trained on our current 5-axis CNC mill, so transfer of learning will be streamlined.

The attached quote shows the pricing for build, purchase, delivery, and setup, to be covered by the donation from ORPSEF.

Thank you,

A handwritten signature in black ink that reads "Holly Cross". The signature is fluid and cursive, with the first name being more prominent.

Holly Cross



HAAS FACTORY OUTLET
A DIVISION OF PHILLIPS

VM-3

PROPOSAL

PROPOSAL: HFO-PC1635270

DATE: NOVEMBER 6, 2023

PREPARED FOR:

MARK BUCKNER

OAKRIDGE HIGHSCHOOL

1450 OAKRIDGE TURNPIKE

OAKRIDGE TN 37830

PREPARED BY:

BILL WALSH

HAAS FACTORY OUTLET | A DIVISION OF PHILLIPS CORPORATION

865-599-3372

bwalsh@phillipscorp.com



QUOTATION

VM-3

\$112,295.00

Travels

X Axis	1016 mm / 40.0 in
Y Axis	660 mm / 26.0 in
Z Axis	635 mm / 25.0 in
Spindle Nose to Table (~ max)	742 mm / 29.2 in
Spindle Nose to Table (~ min)	107 mm / 4.2 in

Options

12,000-rpm Spindle	Included
Standard Program Memory, 1 GB	Included
55-Gallon Coolant Tank	Included
Automatic Air Gun	Included
Chip Auger	Included
Coordinate Rotation and Scaling	Included
Early Power-Failure Detection Module	Included
Ethernet Interface	Included
HaasConnect: Remote monitoring	Included
HaasDrop	Included
High-Speed Machining	Included
Lifting Provision	Included
User-Definable Macros	Included
Media Display M-Code; M130	Included
Programmable Coolant Nozzle	Included
Large Remote Jog Handle with Touchscreen Display	Included
Rigid Tapping	Included
Safe Run	Included
30+1 Side-Mount Tool Changer	Included
Power Surge Protection	Included
Table Auxiliary Air Supply	Included
Control Touch Screen	Included
WiFi Connection for the Haas Control	Included
Window Air Blast	Included
Visual Part Programming System	Included
Spindle Orientation	Included
CT-Style Tool Changer Grippers	Included
*Through-Spindle Coolant	\$ 6,295.00
Wireless Intuitive Probing System	\$ 5,795.00
Auto Door for Mills	\$ 2,095.00
*Internal High-Voltage Isolated Transformer	\$ 3,695.00
Auxiliary Coolant Filter	\$ 2,795.00
1-Year Extended Warranty	\$ 7,895.00

Machine & Options Total \$ 140,865.00

MACHINE TOTAL \$ 140,865.00

ADDITIONAL ITEMS

Haas School Discount: Includes FREE 2nd-Year Warranty \$ -27,840.50

SUB TOTAL \$ 113,024.50

Mill Probe Installation & Calibration \$ 500.00

VM Freight: from Oxnard CA to Customer \$ 4,320.00

Rigging: Gillespie, Inc \$ 2,200.00

** Not available for field installation*

TOTAL INVESTMENT

\$120,044.50

Shipping FOB Oxnard, CA

Point Delivery 4-6 Weeks. Tooling items could be backordered. Please consult with your sales engineer prior to ordering. Tooling will be shipped separately from machine.

Payment Terms School terms, net 30 days

Customs/Duty/Taxes Final invoice will include any applicable sales tax, Please be aware: If we have not received a current sales tax resale/exempt certificate from your organization by April 7th, 2023 you will be charged and expected to pay for any applicable sales tax on your order. Certificates may be emailed to Phillipscorp@certcapture.com to avoid taxation on your order. If there are any question related to this matter, please contact Pcexemptions@phillipscorp.com

Validity Pricing can change without notice

Warranty One-Year Standard (Parts & Labor)

Title Transfer The day your machine leaves the Haas Automation Facility, the ownership/title of the machine automatically transfers to your company.

Machine Storage Please note that machines held in storage may be subject to a storage charge.

Voltage 208-230 VAC, 3 Phase, 60 Hz (unless High-Voltage Transformer is added)

Purchase Orders PO for above should be made out to Phillips Corporation



TERMS AND CONDITIONS

1. **STANDARD TERMS:** This document contains the standard terms and conditions (the "Terms") applicable to dealings between Phillips Corporation (Haas Factory Outlet Phillips Corporation) ("SELLER") and its customers, including the customer signing this document below ("BUYER"). The Terms are incorporated into, and a material part of: (a) each proposal to sell goods ("Goods") and, if applicable, ancillary services ("Services") made by SELLER to BUYER (a "Proposal"), (b) each order to purchase Goods and/or Services submitted by BUYER to Seller (an "Order"), (c) each acceptance of an Order by SELLER (an "Acceptance"), (d) each invoice issued by SELLER (an "Invoice"), and (e) all other documents exchanged between SELLER and BUYER pertaining to any ORDER (each Proposal, Order, Acceptance, Invoice or other relevant document is a "Document"); in each case regardless of whether the Terms are referred to in the Document and regardless of whether the Document is submitted or provided electronically, on paper or otherwise. The Terms shall control over any contrary terms or conditions set forth in any Document, regardless of when the Document may be provided by BUYER to SELLER or SELLER to BUYER, except as expressly agreed by SELLER and BUYER in a writing specifically described as an amendment of the Terms, and SELLER and BUYER expressly object to any contrary terms or conditions.

2. PROPOSALS AND ORDERS:

- a) A Proposal is valid for 30 days from the date shown on it unless otherwise specified in it.
- b) A Proposal does not constitute a firm offer, but is rather an invitation to BUYER to place an Order.
- c) All Orders shall be in writing. All Orders shall be subject to written Acceptance by SELLER.
- d) SELLER is not the manufacturer of any of the Goods. All weights, measurements and other specifications of Goods set forth in Proposals, Orders and Acceptances are estimates based on information provided by the manufacturer, and SELLER shall not be responsible for any deviations therefrom. Brochures, photographs and other illustrations depicting or describing Goods are non-binding in detail, and BUYER acknowledges that such brochures, photographs and other illustrations may have been superseded since being provided by the manufacturer. BUYER acknowledges further that manufacturers reserve the right to discontinue or to make changes to their products at any time, and that Goods are subject to specification and/or design changes without prior notice. Nothing contained in any descriptions of the Goods set forth in any Proposal, Order, Acceptance or other Document shall expand or otherwise affect SELLER's warranty obligations as set forth in Section 7.
- e) Any production estimates provided by SELLER are not guarantees of actual production unless specifically so stated in writing and signed by a duly authorized officer of SELLER. All time study figures relating to Goods are only estimates based on information provided to SELLER pertaining to finish required, machine-ability of the Goods, amount of material to be removed, BUYER's operating conditions and similar factors.
- f) SELLER retains the right to correct in its Acceptance any clerical error contained in a Proposal or an Order. BUYER agrees to promptly notify SELLER of any suspected clerical error in a Proposal.

3. PRICES:

- a) All prices listed in a Proposal are F.O.B. Ship Point (i.e., manufacturer's factory, port of entry or stocking warehouse) unless otherwise specified. Prices are subject to change without notice until confirmed by SELLER in its Acceptance.
- b) Prices quoted in a Proposal do not include sales, use, excise, property or similar taxes arising out of or relating to the sale, purchase, ownership or use of Goods or Services, and all sales are made subject to applicable taxes, the entire amount of which BUYER agrees to pay. BUYER shall provide SELLER with any applicable tax exemption certificates acceptable to appropriate taxing authorities together with an Order. BUYER shall indemnify and hold SELLER harmless from and against the imposition and payment of such taxes. SELLER may in any Invoice or separately bill BUYER at any time for any such taxes, in which case BUYER shall pay the same to SELLER, but SELLER shall not be obligated to do so.
- c) All freight and rigging quoted in a Proposal is subject to change until confirmed by SELLER in its corresponding Invoice.
- d) SELLER will be compensated for all service work performed by SELLER on Goods not covered by manufacturer's warranty or after the manufacturer's warranty period has expired at SELLER's then prevailing rate, plus all expenses, transportation, material and parts.

4. PAYMENT TERMS: Subject to SELLER's credit approval of BUYER:

- a) The terms of payment with respect to any Order shall be as specified in the Proposal or the Acceptance applicable to the Order (with the Acceptance controlling if differing terms are specified). If terms of payment are not specified in a Proposal or Acceptance, then BUYER shall pay 25% of purchase price as a non-refundable deposit at time of transmitting an Order (the "Deposit") and 75% of purchase price net 15 days from SELLER'S shipment of Goods (the "Final Payment"). In the case of leased and financed Orders, the Final Payment is due upon the sooner of BUYER's signing the delivery slip or acceptance or installation of Goods, but in no event later than 15 days from SELLER's shipment of Goods. Any unpaid amount shall bear interest from the due date until payment at a rate equal to the lesser of 2% per month or the maximum percentage permitted by law. Delays in installation and/or delays in operation of Goods caused by damage, warranty service or warranty replacement of parts or otherwise shall not extend or alter time for payment.
- b) BUYER shall pay all of SELLER's costs (including without limitation court costs and reasonable attorney fees) incurred in collecting past due amounts (whether purchase price or other amounts owing pursuant to the Terms) regardless of whether litigation is commenced.
- c) To secure the Obligations, BUYER hereby grants SELLER a first priority security interest in all Goods sold by SELLER to BUYER, any accessions thereto and any insurance, sale or other proceeds of the foregoing (the "Collateral"). For these purposes, the "Obligations" means all amounts due to SELLER in connection with Goods and/or Services sold to BUYER, including without limitation purchase price, taxes and all fees, expenses and reasonable attorneys' fees incurred by SELLER pursuant to or in connection with the Terms, the Obligations or the Collateral. BUYER agrees to insure the Collateral against loss or damage by fire or other risks and hazards in an amount no less than the replacement value of the Collateral, and upon request to provide SELLER with evidence of such insurance identifying SELLER as loss payee as its interests may appear. BUYER authorizes SELLER to file with applicable governmental authorities financing statements and similar instruments describing the Collateral without the signature of BUYER. Upon BUYER's default in any payment or other performance under the Terms, SELLER may, in its sole and absolute discretion, declare all Obligations immediately due and payable without demand, protest or other notice of any kind, and

SELLER shall have the right to repossess the Collateral (BUYER hereby granting SELLER a right of access to BUYER's premises for such purposes) and all other remedies of a secured party under the Uniform Commercial Code as in from time to time in effect in the state origin of purchase.

5. SHIPPING:

- a) Goods subject to an accepted Order shall be sent to the address listed in the applicable Proposal.
- b) Shipping schedules identified in a Proposal are approximate and subject to confirmation by SELLER with the manufacturer following SELLER's issuance of its Acceptance, despite anything set forth in an Order or other Document.
- c) SELLER shall endeavor to accommodate BUYER's requested delivery schedule, but shall have no liability for loss to BUYER, whether direct, incidental and/or consequential, as a result of delays.

6. RISK OF LOSS: The risk of loss or damage to Goods shall pass to BUYER when Goods are placed with a carrier for delivery to BUYER. The carrier shall be deemed to be acting for and on behalf of BUYER, and the terms of payment for Goods shall not be affected by damage to or destruction of Goods.

7. WARRANTIES; REMEDIES:

a) Goods -- SELLER is NOT a manufacturer, and all Goods are manufactured by others. Accordingly, SELLER is not making and shall not make any warranties with respect to Goods other than that SELLER shall convey to BUYER good and marketable title to Goods. Other warranties available to BUYER are those, if any, extended by the manufacturer, to the extent they are in force and effect and may be assigned to BUYER. SELLER shall, upon written request, assign to BUYER any assignable rights SELLER has under the manufacturer's warranties. THE MANUFACTURER'S WARRANTY, IF ANY, AND SELLER'S WARRANTY OF TITLE, SHALL BE EXCLUSIVE AND IN LIEU OF ALL OTHER WARRANTIES WHETHER WRITTEN, ORAL OR IMPLIED BY LAW OR OTHERWISE, INCLUDING ANY WARRANTY OF MERCHANTABILITY OR WARRANTY OF FITNESS FOR ANY PARTICULAR PURPOSE, ALL OF WHICH ARE DISCLAIMED BY SELLER.

b) Services -- SELLER warrants that Services will be performed in a workmanlike manner. THIS WARRANTY IS EXCLUSIVE AND IS IN LIEU OF ALL OTHER WARRANTIES WHETHER WRITTEN, ORAL OR IMPLIED BY LAW OR OTHERWISE, ALL OF WHICH ARE DISCLAIMED BY SELLER.

c) Remedies -- If SELLER breaches any warranty granted by SELLER with respect to the Goods, SELLER'S sole responsibility shall be to repair, replace or refund the purchase price for the applicable Goods, as determined in SELLER'S sole and absolute discretion. If SELLER breaches any warranty granted by SELLER with respect to Services, Seller shall either refund the portion of the purchase price relating to the defective Services or correct the defective Services, as determined in SELLER'S sole and absolute discretion.

d) Limitation of Damages -- If SELLER breaches any of the Terms (including by breach of its warranties), BUYER'S remedies shall be limited as set forth in Section 7c) and this Section 7d). SELLER shall not be liable for any of BUYER'S indirect, incidental, special or consequential damages relating to or arising from the breach, or punitive damages of any nature, and BUYER'S recovery in connection with any Order shall in no event exceed the purchase price actually paid to SELLER with respect to that Order. Without limiting the generality of the foregoing sentence, in no event shall SELLER be liable to BUYER for BUYER'S loss of profits, loss of use, or damages of any nature based upon a claim for breach of warranty or for faulty workmanship or materials or otherwise, whether or not SELLER has been advised of the potential for any such damages. BUYER acknowledges that the purchase price at which SELLER has agreed to provide Goods and/or Services reflects the SELLER'S disclaimer of warranties and limitation of remedies set forth in this Section 7 and further acknowledges that the purchase price would be substantially higher without such disclaimer and limitation.

8. CANCELLATION: All Orders are non-cancelable by BUYER except as approved in writing by SELLER in its discretion. It is agreed that any cancellation, whether or not approved by SELLER, shall damage SELLER. Accordingly, SELLER shall be entitled to retain the Deposit, and BUYER shall pay to SELLER the following (against which the Deposit shall be credited):

- a) SELLER'S purchase price for the Goods delivered to BUYER prior to cancellation;
- b) SELLER'S costs incurred in connection with Services provided prior to cancellation (including compensation costs and overhead);
- c) All other out of pocket costs incurred by SELLER in connection with the Order, including without limitation cancellation or restocking charges that SELLER has or will incur; and
- d) In the case the cancellation is not approved by SELLER, any other amounts to which SELLER may be entitled at law for BUYER'S breach, it being understood that unapproved cancellation shall be a breach by BUYER of the contractual relationship existing between SELLER and BUYER.

9. BUYER'S USE: BUYER agrees that its employees, contractors and invitees when operating Goods will comply with all operating procedures set forth in the manufacturer's operators manuals and instruction sheets relating to such Goods, and BUYER further agrees not to remove or modify any safety device, warning sign, operators manual or work handling tools. BUYER shall immediately notify SELLER of any accident or injury connected with use of the Goods and agrees, upon SELLER'S request, to cooperate with SELLER in investigating and determining the cause of the same. BUYER agrees to indemnify and hold harmless SELLER from and against any and all claims, suits, damages of any nature, losses, costs or expenses, including without limitation all fees and expenses of counsel and other professional advisors arising from use of any Goods or BUYER'S failure to comply with the Terms.

10. PERFORMANCE IN THE EVENT OF DEFAULT; NON-WAIVER OF DEFAULT: In addition to the rights and remedies conferred on SELLER by law and the Terms, SELLER will not be required to respond to or perform an Order (even if previously accepted) if BUYER is in default with respect to any other Order. If SELLER at anytime, in SELLER'S sole and absolute discretion, doubts BUYER'S ability to pay for Goods consistent with the Terms, SELLER may ship the Goods C.O.D. In the event of any default by BUYER under the Terms, SELLER may decline, in its sole and absolute discretion, to make further shipments of Goods to BUYER without in any way affecting its rights under the Terms. If, despite any default by BUYER, SELLER elects to continue to make shipments, SELLER'S actions shall not constitute a waiver of any default by BUYER or in any way affect SELLER'S remedies for such default under the Terms or otherwise.

11. CONFIDENTIALITY: All drawings, designs, specifications, manuals, programs and prices furnished to BUYER by SELLER shall remain the confidential and proprietary property of SELLER. All such information, except as may be found in the public domain, shall be held in strict confidence by BUYER and shall not be disclosed by BUYER to any third parties. As between BUYER and SELLER, all copyright interests in all

material made available by SELLER shall remain in SELLER at all times, and BUYER waives any property or privacy rights BUYER may have with respect to all such information.

12. EMPLOYEES: BUYER agrees that neither it nor any of its affiliates will solicit for hire, hire or recommend for hire any employee of SELLER or any affiliate of SELLER during the period from SELLER's issuance of a Proposal until the first anniversary of the date on which Goods purchased pursuant to an Order are finally installed or Services obtained pursuant to an Order are fully provided. This Section 12 is a material inducement to SELLER to transact business with BUYER. This Section 12 shall cease to apply to any former employee of SELLER or an affiliate of SELLER on the date such employee has ceased to be employed by SELLER or an affiliate for six (6) months, and it shall not apply to the hiring of any employee of SELLER or an affiliate of SELLER whose initial contact with BUYER is such employee's response to a general public solicitation of employment applications by BUYER.

13. FORCE MAJEURE: SELLER shall not be responsible for nonperformance or late performance due to orders, regulations and/or ordinances by any government or governmental agency, act of God, war, terrorism, blockade, insurrection, mobilization, riots, fire, work stoppage, civil insurrection, flood, earthquake or any other circumstance beyond SELLER's reasonable control. Without limiting the preceding sentence, BUYER acknowledges that Goods originating from foreign countries are subject to export permit by the governmental authorities of the country from which such Goods originate.

14. REVISIONS: SELLER, in its sole and absolute discretion, may modify the Terms at any time and from time to time. The Terms as in effect at the time of SELLER's Acceptance shall govern the terms of sale of the Goods and Services contemplated by the Order so accepted, provided SELLER has provided BUYER with a copy of such Terms prior to or contemporaneously with the Acceptance.

15. SEVERABILITY: If any provision(s) of the Terms are held by any court of competent jurisdiction to be unenforceable or invalid, the remaining provisions of the Terms shall not be rendered invalid or unenforceable as a result thereof.

16. APPLICABLE LAW; VENUE: The Terms are governed by, and shall be construed in accordance with, the law of the State of Maryland without reference to the conflict of laws principles thereof. BUYER and SELLER agree that the State and Federal courts sitting in the City of Hanover, Maryland shall be the exclusive forums for resolving any dispute pertaining in any way to their dealings, the Terms, any Goods or any Services. BUYER consents to the jurisdiction of such courts and agrees that any such court is a convenient forum for the resolution of any such dispute, and agrees that it may be served with process for any suit in any such court by first class registered mail, return receipt requested and postage pre-paid, sent to BUYER at its address identified in an Order or by any other lawful means. BUYER acknowledges that Maryland is the headquarters state of SELLER's parent entity, and that this Section 16 is a material inducement to SELLER to transact business with BUYER.

17. NO DELEGATION OR ASSIGNMENT: BUYER may not assign or delegate any of its rights or obligations under or in connection with the Terms or the Order without the prior written consent of SELLER, and any purported assignment or delegation in violation of this sentence shall be void ab initio, without force or effect, and a material violation of the Terms by BUYER.

Phillips Corporation requires receipt of the 25% down payment before any Haas machine is ordered.
25% payments can be made via bank wire or ACH.

Bank Wires

Account Name: Phillips Corporation

Acct#: 1233252889

ACH ABA Number: 121000358

Wire ABA Number: 026009593

Routing Number: 122000030

Swift Code: BOFAUS3N

Bank of America

6000 Feldwood Rd

College Park, Ga 30349

*REQUIRED: All ACH Wire Remittance notifications should be sent to: pcar@phillipscorp.com.

Please address all Purchase Orders to the following:

Phillips Corporation

8500 Triad Drive

Colfax, NC 27235

Acknowledged and agreed as of the date indicated below:

PROPOSAL NUMBER: _____

BUYER SIGNATURE: _____

PRINTED NAME: _____ DATE: _____

TITLE: _____

Please email signed accepted proposal to pcmachineorders@phillipscorp.com or fax 336-665-1980.



Phillips®

HAAS SERVICE TRAINING

JOIN US FOR A HAAS TRAINING EXPERIENCE LIKE NO OTHER IN THE INDUSTRY

Haas Service Training will teach you how to **TROUBLESHOOT, REPAIR** and **MAINTAIN** your Haas *in hours, not days.*



LOCATIONS Knoxville, TN - Bensalem, PA - Rock Hill, SC **CONTACT** hfooster@phillipscorp.com - (800) 989-9181



"I wouldn't keep sending so many of our Techs (nearly 30 so far) if I didn't think the course was a great investment."

~ **Michael Goode**,
General Electric



"This is the best machine learning environment I've ever seen. You should take this class, it's a no brainer. You're going to benefit"

~ **Dale Miller**,
Southern Cast Products

Bottom-Line Benefits

This class more than pays for itself with fewer service calls, reduced downtime, and real gains in part quality.

For more information, email hfooster@phillipscorp.com or call (800) 989-9181.

****Interested in Mill and Lathe Crash Recovery Training?** Let us know and we can send information on those classes as well.



CLASSES RUN MONTHLY, YEAR-ROUND.
CALL (800) 989-9181 TO RESERVE YOUR SPOT
TODAY! OR VISIT US AT:
PHILLIPSCORP.COM/SERVICE-TRAINING

SKILLS COVERED



In just five days, participants will take their service game to the next level by learning to perform the following skills

- Lathe Alignment
- Turret Repair (ST, SL & BMT)
- Tool Changer Repairs
- Ball Screw Replacement
- Spindle Replacement
- I/O Board & Vector Drive Troubleshooting
- Best Practices & MUCH MORE!!!

HANDS-ON LEARNING



This is a roll-up-your-sleeves, get inside-the-machine learning experience.

WORLD-CLASS FACILITIES



Training takes place in state-of-the-art facilities with more than a million dollars worth of Haas equipment - just like the ones on your floor.

EXPERIENCED INSTRUCTORS



Our teachers have spent years in the field. No question too basic. No problem too complex. Small class sizes mean you have plenty of one-on-one time for all your questions.

Plus every participant receives a free Haas Service Key, which unlocks the service parameters on any Next-Gen Control so you can take ownership of your Haas service and maintenance!



**HUNDREDS HAVE ATTENDED,
RATING THE COURSE 9.9/10**

**Disclaimer - In order to attend any Advanced Courses, students must have already completed the basic Phillips Haas Service Training course. Please call/email for more information.



ADVANCED MILL SERVICE TRAINING

Phillips
HAAS SERVICE TRAINING

LOCATION Knoxville, TN **CONTACT** hfooster@phillipscorp.com - (800) 989-9181

JOIN US FOR A HAAS TRAINING EXPERIENCE LIKE NO OTHER IN THE INDUSTRY

From replacing guide rails to inspecting geometry, Advanced Mill Service Training will help you **repair your Haas mill if it crashes** and **uncover hidden problems before they affect quality** or slow production.

■ SKILLS COVERED



In just five days, participants will take their mill service skills to the next level by learning how to:

- Conduct a detailed geometry inspection
- Read ball bar information
- Use a granite square
- Correct machine geometry
- Replace machine guide rails
- Change out drawbars
- Replace different styled encoders

Contact us about training grants that could cover your tuition!

■ HANDS-ON LEARNING

This is a roll-up-your-sleeves, get inside-the-machine learning experience.

■ WORLD-CLASS FACILITIES

Training takes place in state-of-the-art facilities with more than a million dollars worth of Haas equipment - just like the ones on your floor.

■ EXPERIENCED INSTRUCTORS

Our teachers have spent years in the field (If it's happened, they've seen it!). No question too basic. No problem too complex. Small class sizes mean you have plenty of one-on-one time for all your questions.



"This class takes the mystery out of these bigger mill repairs, which can be daunting. I think it's going to be a game changer for companies and on-site service techs."

~ Todd Price, Head Service Instructor

**CLASSES RUN MONTHLY, YEAR-ROUND.
CALL (800) 989-9181 TO RESERVE YOUR SPOT
TODAY! OR VISIT US AT:
PHILLIPSCORP.COM/ADVANCEDMILL**

Bottom-Line Benefits

This class more than pays for itself with fewer service calls, reduced downtime, and real gains in part quality.

For more information,
email hfooster@phillipscorp.com or call
(800) 989-9181.

****Not quite ready for an advanced class?** Contact us to find out more about Phillips Haas Service Training - our introductory Haas Service Training class.

****Disclaimer - In order to attend any Advanced Courses, students must have already completed the basic Phillips Haas Service Training course. Please call/email for more information.**



Phillips®



*OPTO CAN HELP YOU IMPROVE PROCESSES & MAXIMIZE PROFITS
THROUGH REDUCED CYCLE TIME & MANUFACTURING IMPROVEMENTS.
RESULTING IN THE REALIZATION OF NEW CAPABILITIES.*

SERVICES OFFERED

■ SPECIALIZED TRAINING



Put our industry-leading know-how to work and gain cutting edge skills through our training programs.

Advanced Lathe Training

Learn the techniques needed to be able to program and set up live tooling, sub spindles, bar feeders as well as utilize tool management and automatic probing. Plus, many more tips and tricks when using your Haas Lathes.



Advanced Mill Training

Learn productive programming skills enabling you to produce parts faster. Here we address things like how to eliminate the need to indicate a vise or how to streamline your set-ups. Let us tailor a class to fit your needs and provide you with the tools necessary to maximize your production.

Advanced Probe Training

Learn about the hidden potential your probing system has to offer. A full overview of how a probing system operates, how to automate common shop tasks, and how to integrate probing routines into your current programs.

Introduction to Macros Training

Our training covers theory, discipline, potential, and practical application. Let us shift your programming mentality to a level that makes your machine automate the critical thinking for you.

Advanced Macros Training

Take your knowledge of logical programming to the next level and maximize the use of your machine like never before. Learn how to eliminate every bottleneck you can think of by programming it out of the equation.

Multi-Axis Training

Want to make the move into 5-axis machining but do not know where to start? Let us teach you the ins and outs of multi-axis machining so you can be more competitive in your industry. Learn how to plan for, setup, and diagnose machining at an expert level.

(Continued on back)

Find out how we can help you reduce cycle time and cost.



phillipscorp.com/phillips-opto

SERVICES OFFERED (CONTINUED)

■ APPLICATIONS SUPPORT



Maximize your machine's potential and increase efficiency with Phillips' application support services.

Machine Programming Services

Our OPTO Team has the best programmers the industry has to offer and are experts in a wide variety of CAM platforms. Let our engineers help you get the most out of your machine investment.

Tooling Selection Optimization

Looking to improve your production runs or are you developing a new process and need to revamp your tooling? Our experts constantly work with the best tooling vendors to stay on top of the industry's latest technology and know how to implement them on your machines.

Fixture Design

Whether you are trying to fit more parts into your machine at once or just struggling to conceive a method on how to hold that awkward part, we have the experience on how to make your needs a reality.



Manufacturing Efficiency Assistance

Are your cycle times longer than you hoped, or are you simply needing more throughput? Do you have downtime due to out-dated tooling or program selection? Let the OPTO Team pinpoint the bottlenecks and eliminate them for good.

First Part Qualification Assistance

Whether you need to produce a prototype or qualify a process for production, let us help your team develop a new application and process. Planning for and achieving goals is what we do best.

Software Assistance

Reduce waste, increase throughput, and realize improved efficiency with software assistance. We can help you program more effective toolpaths and cutting parameters ensuring that you are maximizing your machine.

■ AUTOMATION & ROBOTICS



Overcome labor shortages, take on more work and run machines unattended with a Phillips' robotic solution.

Haas Robot Packages

Phillips is a distributor of Haas Robot Packages. These automation solutions offer plug-and-play capabilities and integrate directly with the Haas control. Our OPTO engineers can get this automation solution up and running in a matter of days.



Universal Robotics

Collaborative robots provide a cost-effective, flexible, and safe automation solution for a wide range of production tasks. Phillips can assist with Universal Robot integrations and provide training and programming assistance for your robot application.

Experience, expertise, and engagement — that's what you get when an OPTO engineer steps on your shop floor and is the edge your business needs.

Contact us at Opto@PhillipsCorp.com to get started



phillipscorp.com/phillips-opto

Installed Dimensions

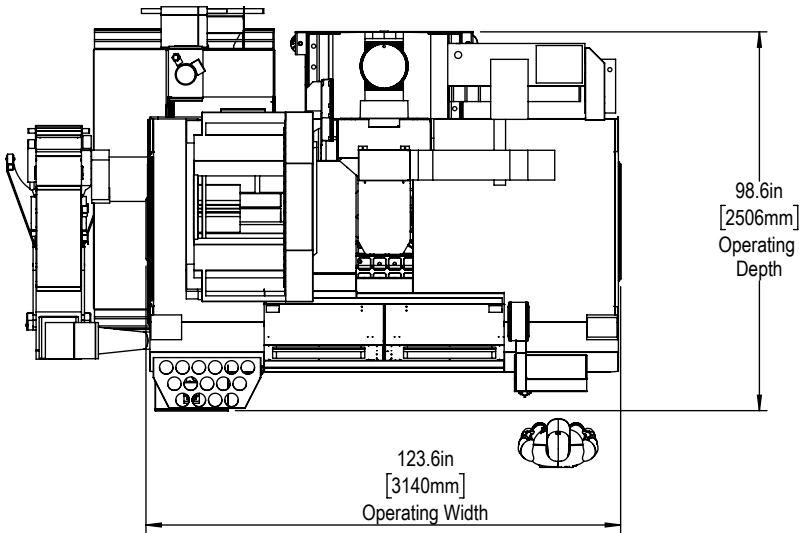
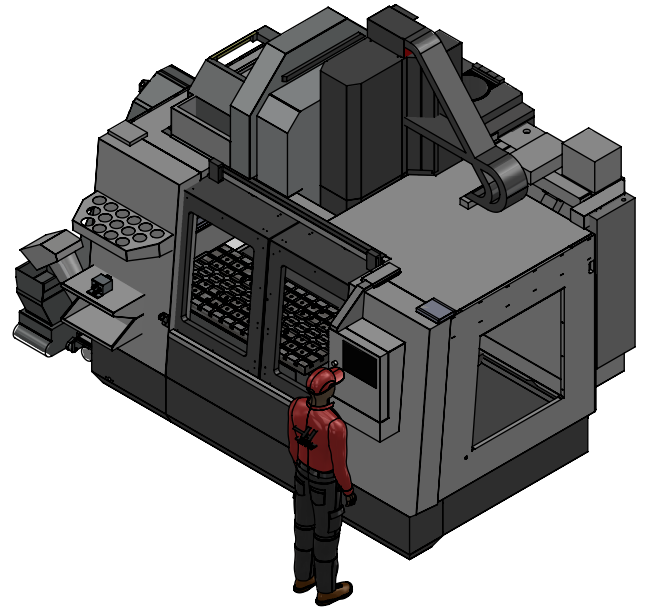
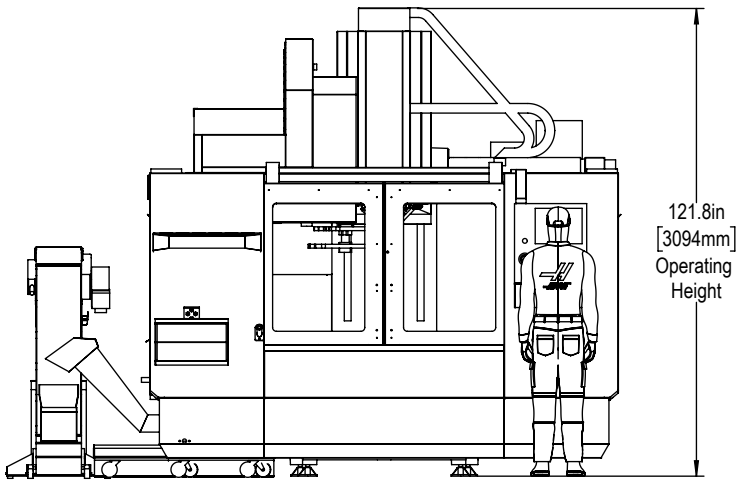

Leveling Pad Height

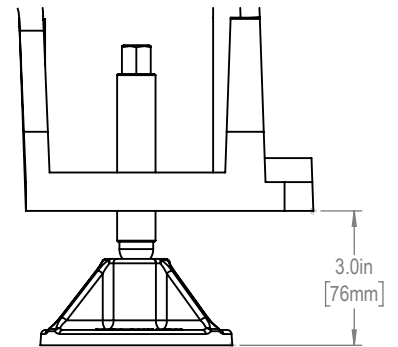

*All Height Dimensions Based on Suggested Leveling Pad Height

Shipping Dimensions

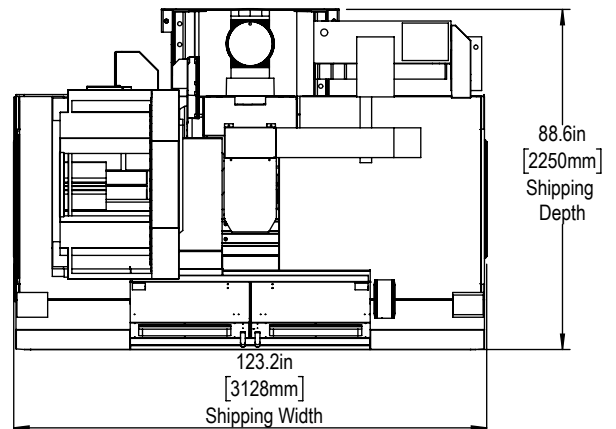
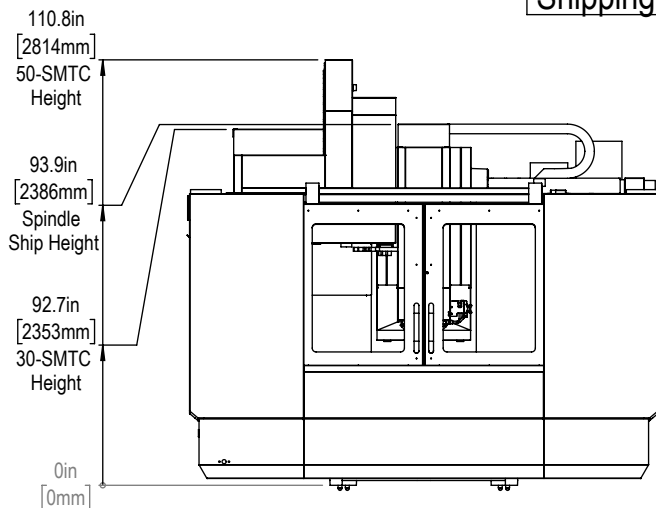

Air & Power

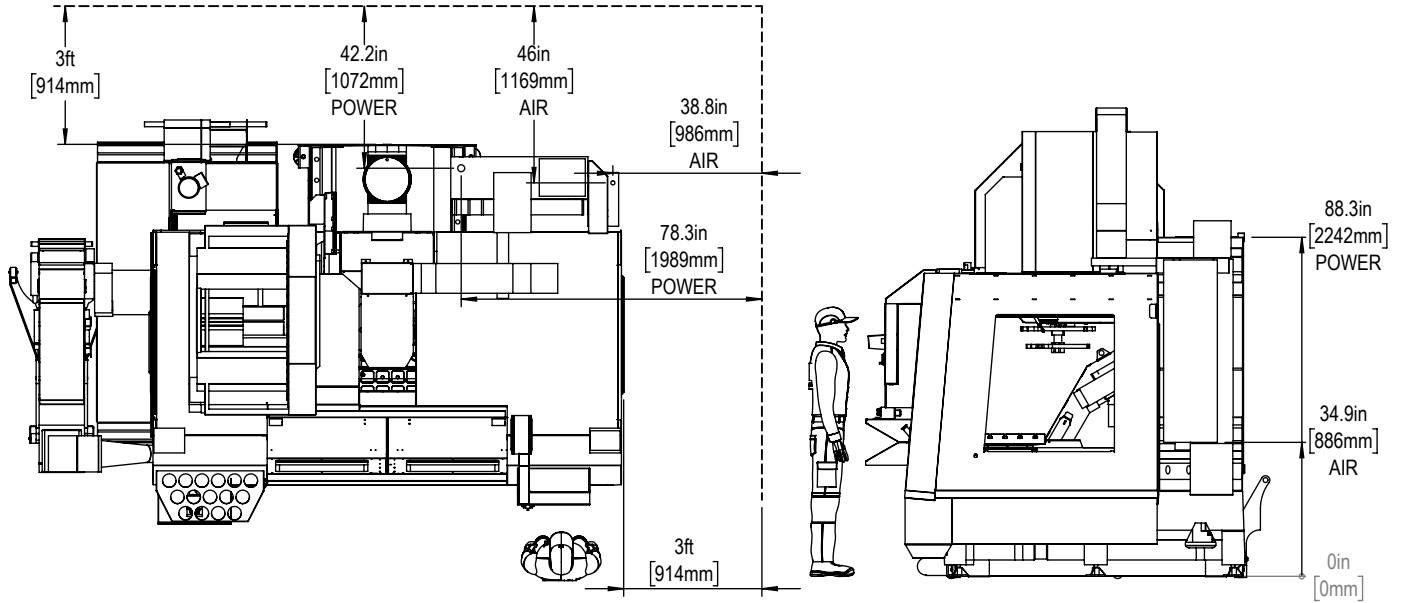

Maintain 3 feet [915mm] clearance to the nearest obstruction around all sides of machine perimeter for maintenance access

Note:
Machine must be placed on one continous concrete slab. Slab should extend 12in [305mm] beyond anchor holes in all directions

Anchor Pattern

Anchor Hole Detail
Ø0.625in
▽2.00in-2.25in

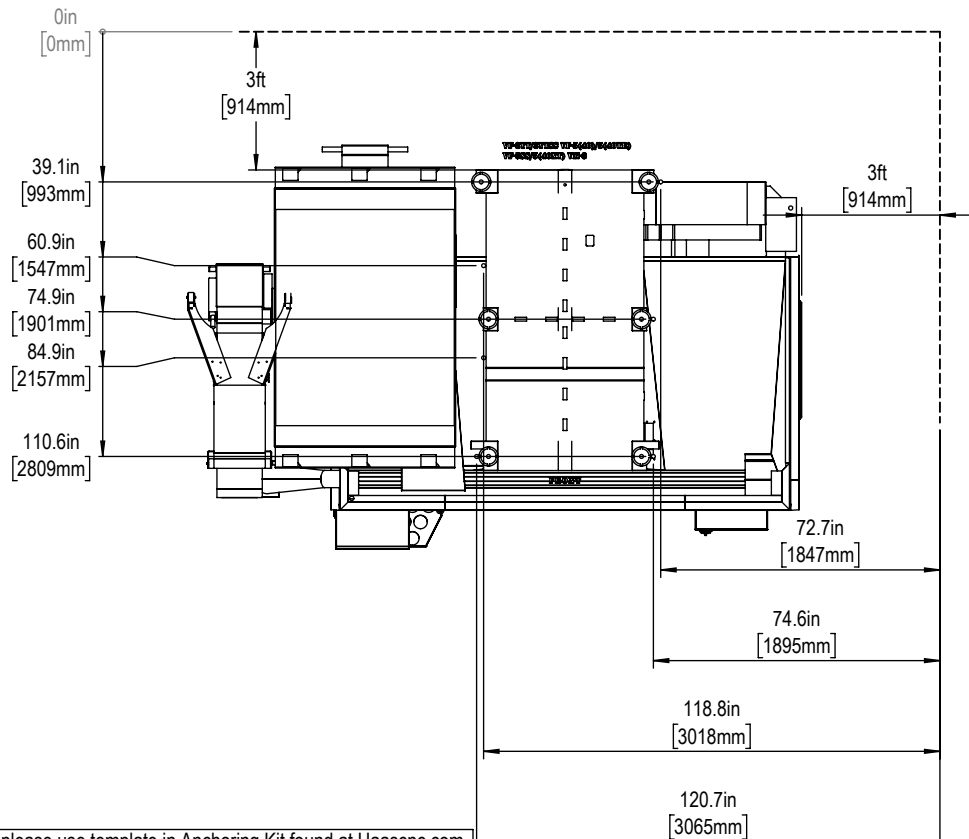

For precise locations and specifications please use template in Anchoring Kit found at Haascnc.com



Height Breakdown

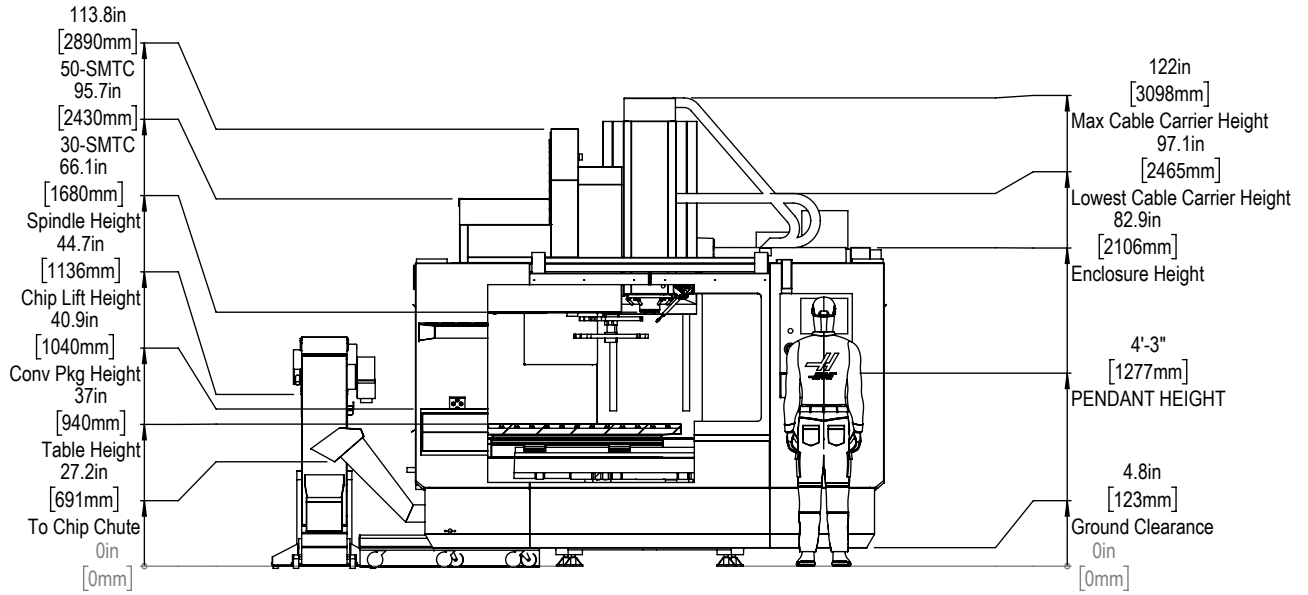

Width Breakdown

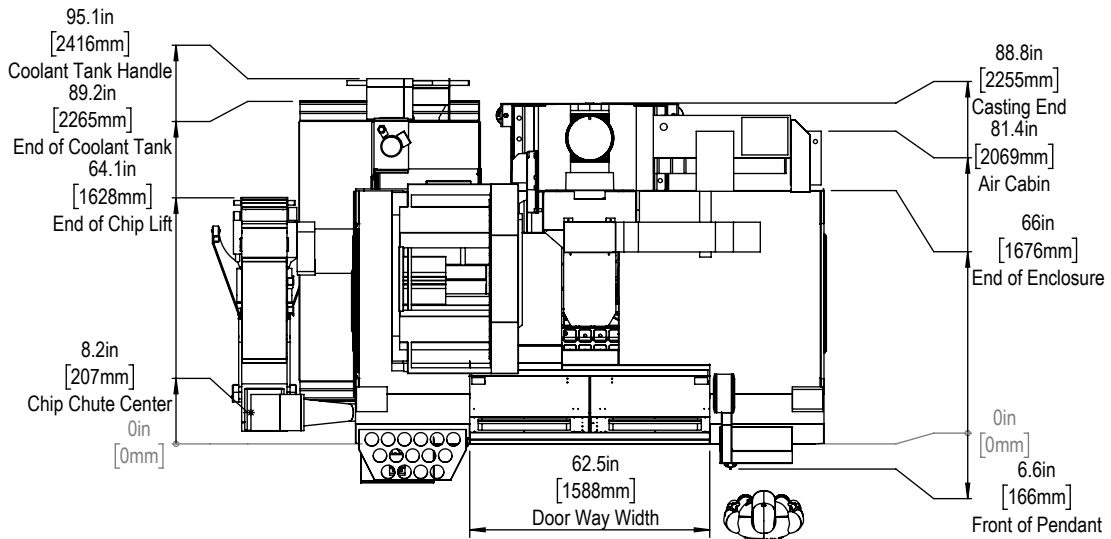

X&Y-Axis Travel and Clearance

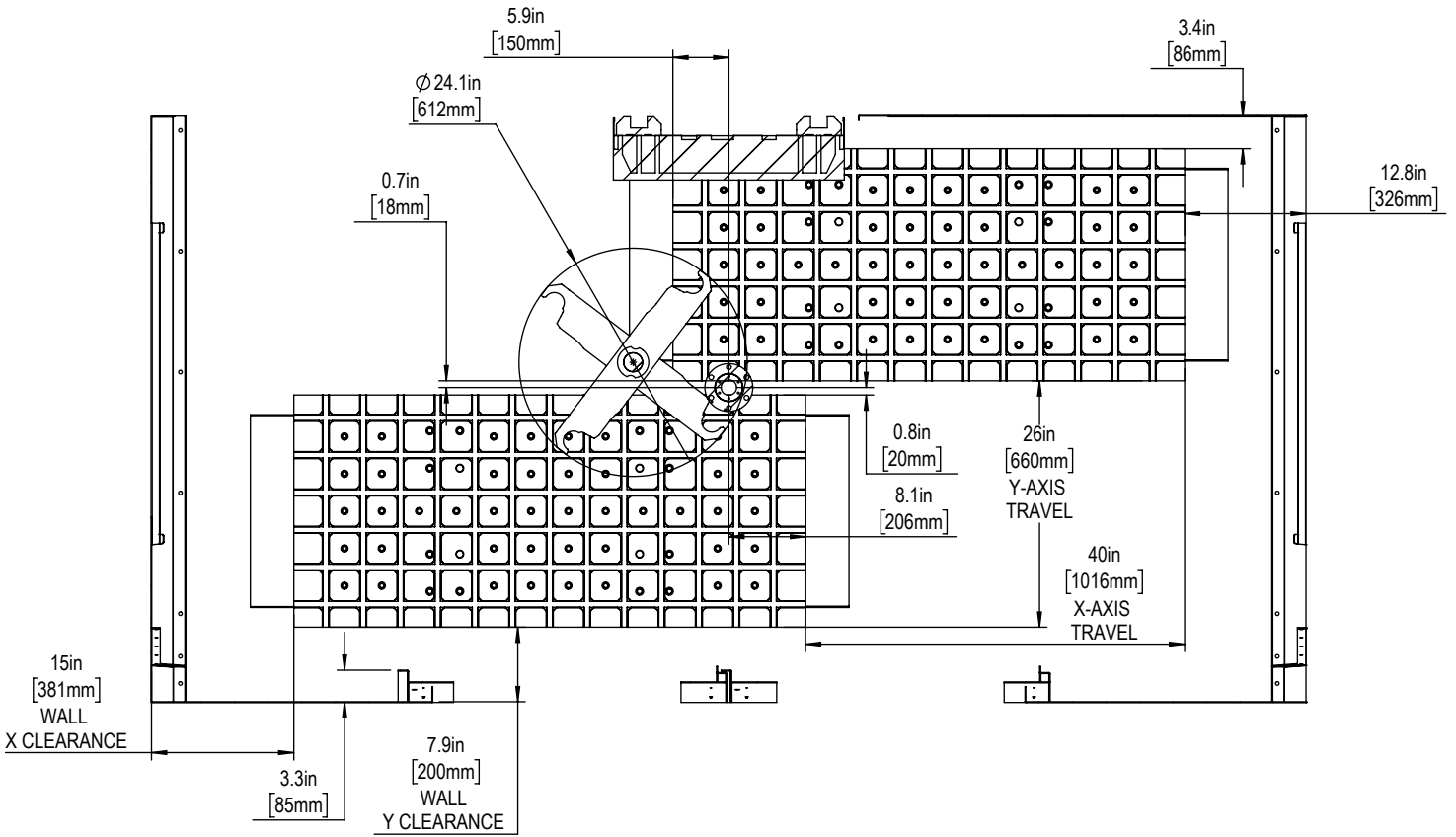

Z-Axis Travel and Clearance

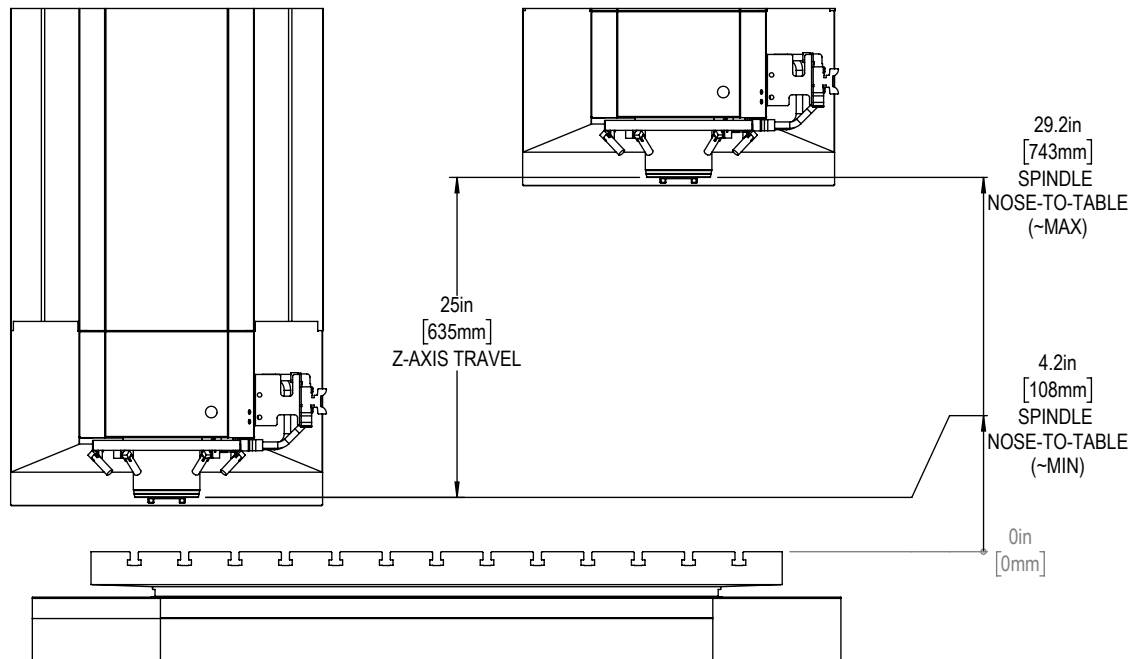



Optional Table With X T-Slot Only

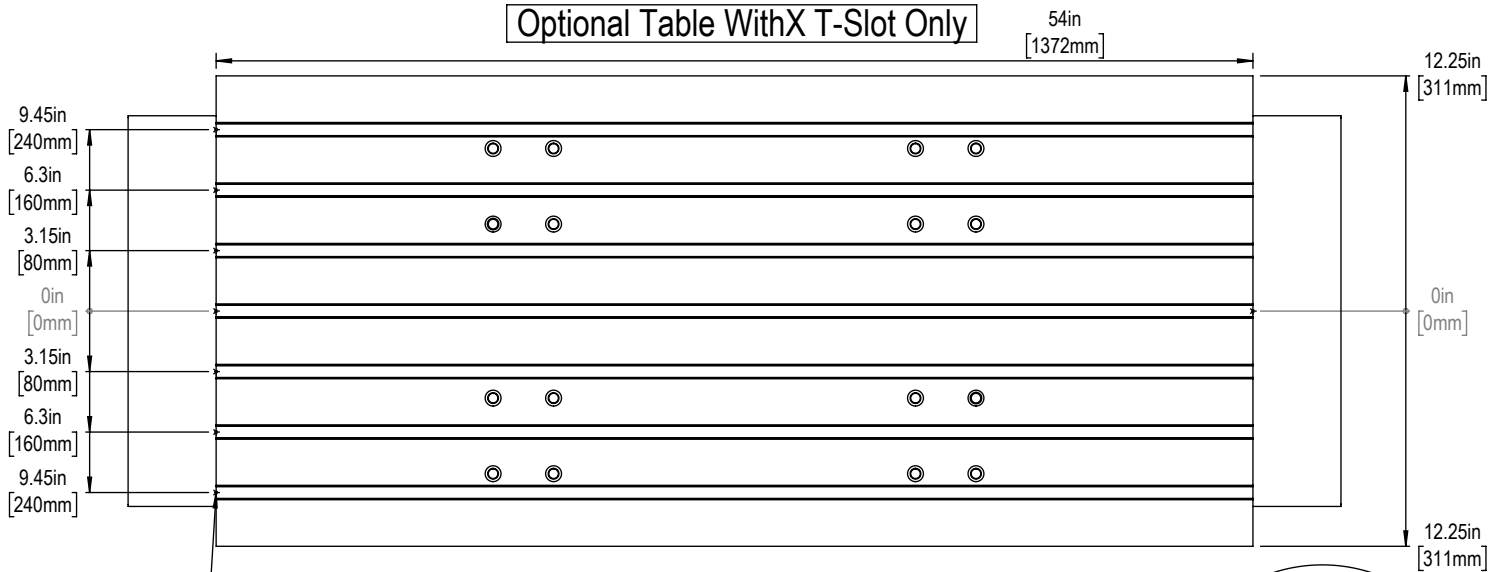

16mm T-Slots

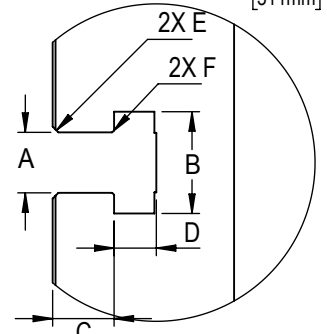

T-Slot Dimensions in inches

Slot Size	A	B	C	D	E	F
12mm	$0.438 \begin{smallmatrix} +.002 \\ -.000 \end{smallmatrix}$	0.76 ± 0.02	0.310 ± 0.010	0.318 ± 0.010	$0.03 \times 45^\circ$	$0.020 \times 45^\circ$
16mm	0.628 ± 0.002	1.06 ± 0.02	0.640 ± 0.010	0.420 ± 0.010	$0.06 \times 45^\circ$	$0.020 \times 45^\circ$

Tool Changer

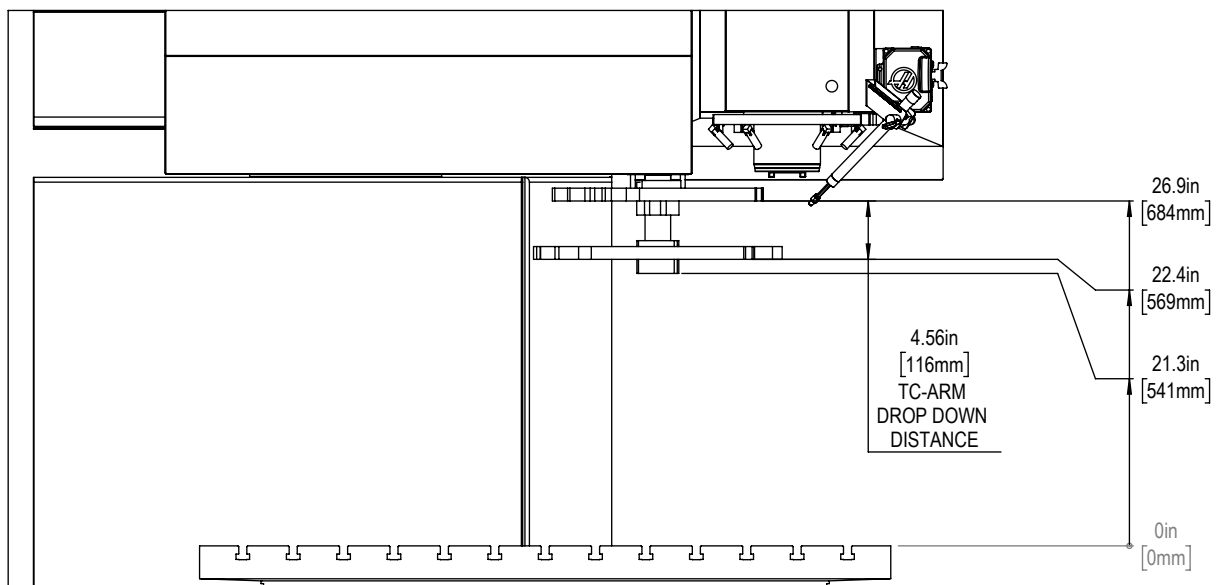



X-Y Table

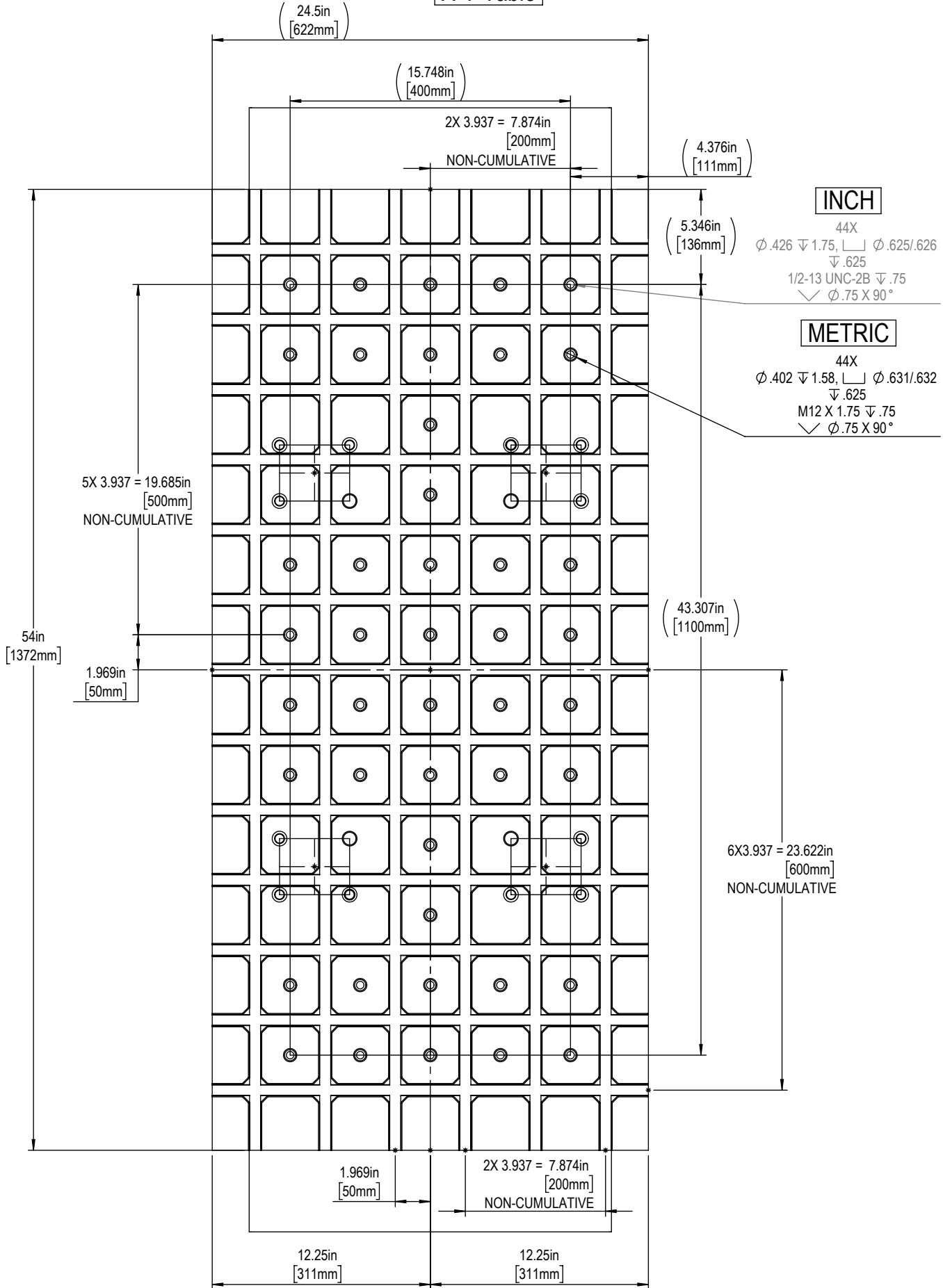



Budget Development Timeline...

Fiscal Year 2024-2025

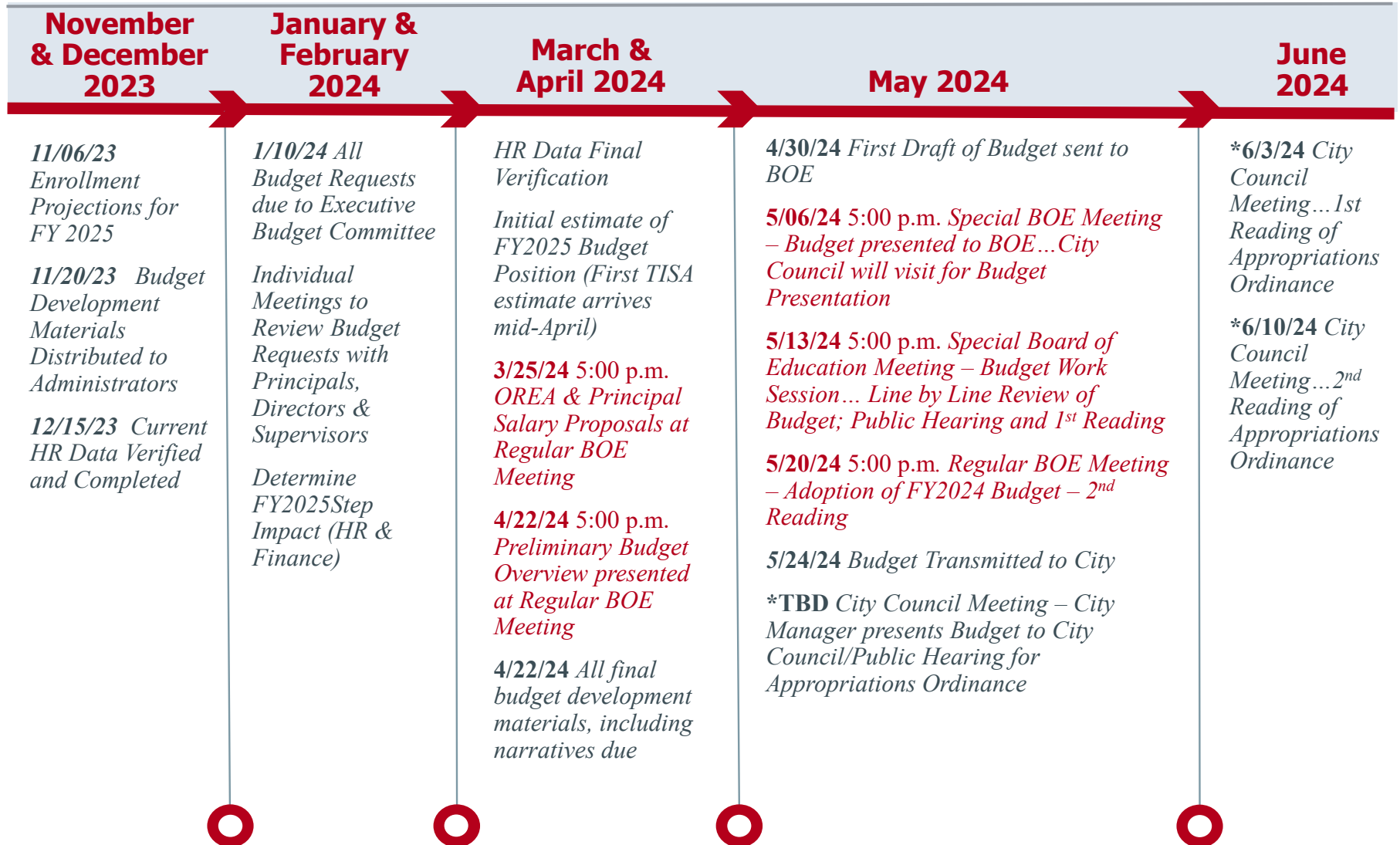

Superintendent’s Budget Committee Meetings Occur Throughout Budget Development Process

Revision Date 11/10/2023
 * Dates Subject to Change



MEMORANDUM

Dr. Kelly Williams

Executive Director, Office of Teaching and Learning

TO: Board of Education

DATE: 11/13/23

SUBJECT: Item for Action: Approval of 1.0 FTE ESL Teaching Assistant

I recommend the addition of a 1.0 FTE ESL Teaching Assistant (0.75 Woodland, 0.25 Willow Brook) due to the increased enrollment of English Learners. This position will be funded with the FY24 teacher contingency funds. Enrollment data below shows the number of students receiving ESL instruction from 2022 and 2023 at Willow Brook Elementary and Woodland Elementary.

EL Students Served	Oct-22	Nov-23
Willow Brook	34 Direct Service	40 Direct Service (42 Total)
Woodland	27 Direct Service	35 Direct Service (46 Total)

The attached description shows the purpose, guidelines, and job details of the ESL Teaching Assistant. The continuation of the ESL Teaching Assistant position after the 2023-2024 school year will be dependent upon enrollment and budgetary needs.

EL Teaching Assistant

Purpose:

- Support EL students and work closely with supervising EL teachers.
- Enhance the participation of the limited English proficient students in the classroom.
- Serve as a stopgap for the remainder of this school year for schools understaffed and schools with an increased ratio of 1:35 including active, T1/T2, and waivers.
- Support schools with a part-time EL teacher or no EL teacher.

Guidelines:

- Should not replace the required 1 hour of direct ELL service by a licensed EL teacher.
- Provide instructional support only and not allowed to plan direct instruction.
- Should serve as a supporting role for ELL students and are limited to classroom support (e.g., small groups, all contents areas, additional intervention pull-out).

Job Description Details:

- Work under the direct supervision of the ELL teacher unless otherwise assigned by the appropriate supervisor.
- Maintain student records as directed by the ELL teacher.
- Administer all diagnostic tools as directed by the teacher.
- Support multilingual families if appropriate.
- Assist with preparing the classroom and organizing all instructional materials and equipment as directed by the teacher.
- Required to monitor the classroom when the teacher must attend staff meetings, provide consultation, etc.

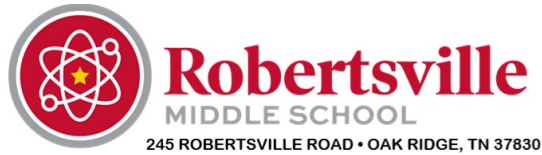

A school community that creates a sense of belonging and promotes excellence.

DATE: November 14, 2023
TO: Mr. Bruce Lay, Executive Director of School Leadership
FROM: Nick Corrigan, Principal
SUBJECT: Board Approval for new Step Club

Mr. Lay,

I would like to request Board approval for a prospective new club at Robertsville Middle School entitled the RMS Step Club. The club would be sponsored by staff member, Mrs. Amy Phillips.

The RMS Step Club will be open to all RMS students and pending approval will begin in January, with after- school practice held one day per week. Once the club is established, the members would like to hold tryouts to build a step team. The step team would participate in activities such as the RMS Talent Show and hopefully join with other teams to compete in local competition.

Please reach out with any questions of concerns, and thank you for your continued support of our students.

Respectfully,

Nick Corrigan
Principal

Oak Ridge Schools

3rd Attendance Period

November 2, 2023

These numbers reflect the **2023-2024** Skyward Student Management System (Entity) active student enrollment count as of **November 2, 2023**.

The total includes **30** private school and home-schooled students receiving Special Ed services.



Oak Ridge Schools

Enrollment Entity Counts 3rd RP 2023-24

November 2, 2023

School	P3	P4	K	1	2	3	4	5	6	7	8	9	10	11	12	Total PK-12 2023-24	Previous 2nd RP 2023-24	Diff
Preschool	104	124														228	227	1
Glenwood			74	82	74	60	79									369	365	4
Linden			104	101	104	98	117									524	525	-1
Willow Brook			90	74	87	83	80									414	414	0
Woodland			79	83	99	101	93									455	448	7
JMS								167	180	159	205					711	707	4
RMS								193	171	178	205					747	745	2
ORHS												412	411	391	385	1599	1606	-7
Enrollment 2023-24	104	124	347	340	364	342	369	360	351	337	410	412	411	391	385	5047	5037	10
Prev. 2nd RP 2023-24	103	124	348	339	363	336	366	356	352	340	405	412	416	393	384	5037		
Difference	1	0	-1	1	1	6	3	4	-1	-3	5	0	-5	-2	1	10		

This report compares the 2023-24 3rd RP period enrollment with the 2023-24 2nd RP period.

Attendance Graphs

The graphs below display excused and unexcused absence totals, entity counts, and attendance percentages by grade and reporting period. The data was compiled using information from attendance detail and summary reports and entity counts reports.
Reporting Period 3: 9/19/2023-10/31/2023

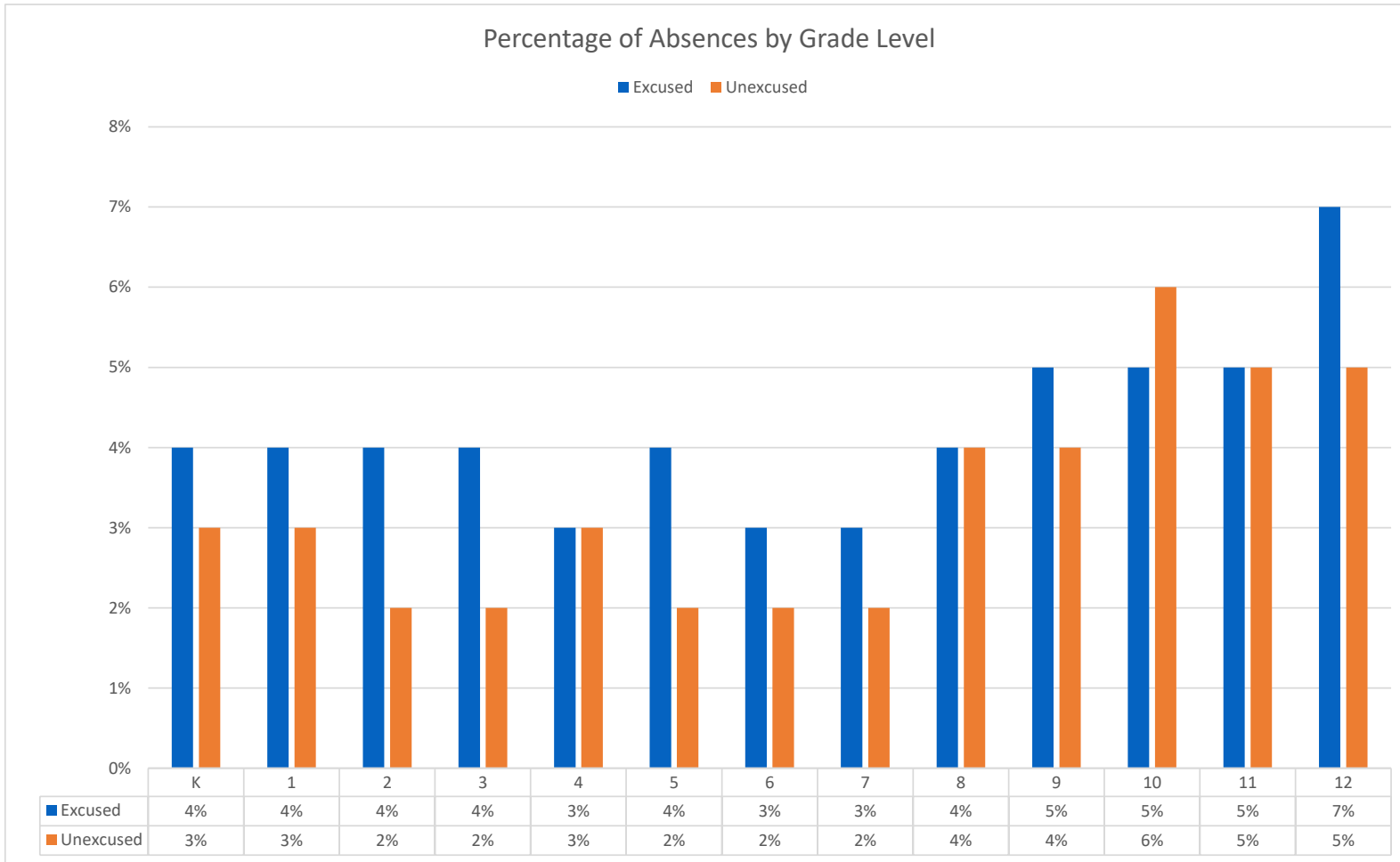

* Percentages have been rounded to the nearest whole number.

2019-20	RP1: 4%	RP2: 4%	RP3: 5%	RP4: 5.6%	RP5: 6%	RP6: 8.8%	RP7: 4.9%	Covid-19	Covid-19
2020-21	RP1: 7.3%	RP2: 5.8%	RP3: 8.1%	RP4: 11.6%	RP5: 9.9%	RP6: 7.5%	RP7: 5.3%	RP8: 8%	RP9: 5.4%
2021-22	RP1: 6.3%	RP2: 6.7%	RP3: 6.3%	RP4: 7.7%	RP5: 6.9%	RP6: 5.8%	RP7: 6.3%	RP8: 8%	RP9: 5.9%
2022-23	RP1: 4.9%	RP2: 4.4%	RP3: 5.5%	RP4: 11%	RP5: 4.7%	RP6: 6.1%	RP7: 4.8%	RP8: 4.9%	RP9: 4.9%
2023-24	RP1: 4.3%	RP2: 4.2%	RP3: 5%						

Glenwood

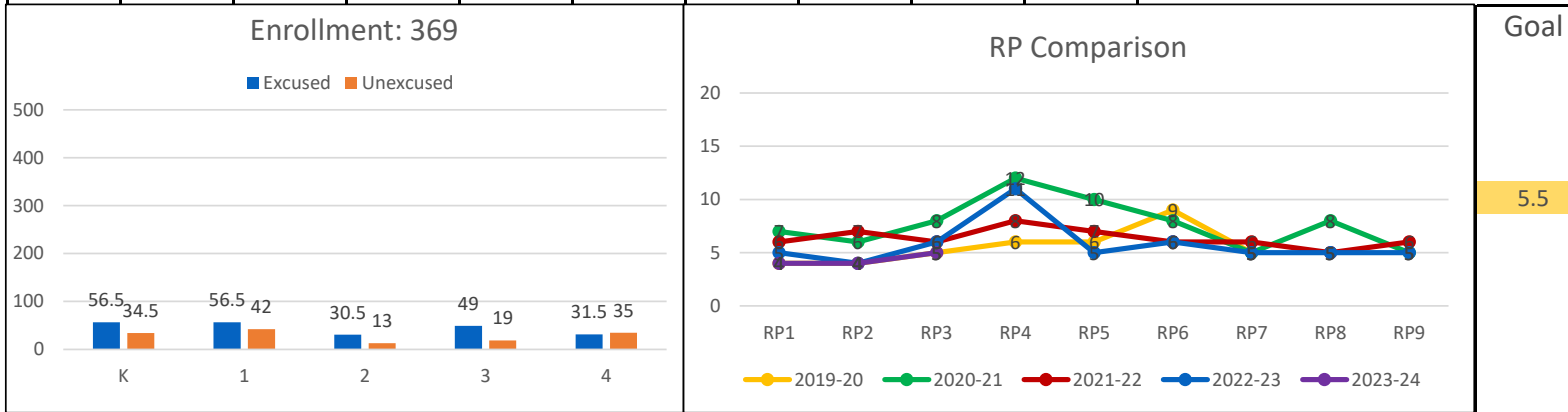

2019-20	RP1: 3%	RP2: 4%	RP3: 5%	RP4: 5.6%	RP5: 6.8%	RP6: 7.7%	RP7: 6.4%	Covid-19	Covid-19
2020-21	RP1: 4.3%	RP2: 4.3%	RP3: 6.1%	RP4: 7.7%	RP5: 9.1%	RP6: 7.9%	RP7: 6.2%	RP8: 5.6%	RP9: 5.3%
2021-22	RP1: 4.4%	RP2: 4.2%	RP3: 4.8%	RP4: 6.4%	RP5: 5.8%	RP6: 4.6%	RP7: 5.5%	RP8: 5.4%	RP9: 5%
2022-23	RP1: 3.2%	RP2: 4%	RP3: 4.4%	RP4: 8.9%	RP5: 5.4%	RP6: 5.8%	RP7: 4.5%	RP8: 4.1%	RP9: 7.1%
2023-24	RP1: 3.3%	RP2: 3.7%	RP3: 4.1%						

Linden

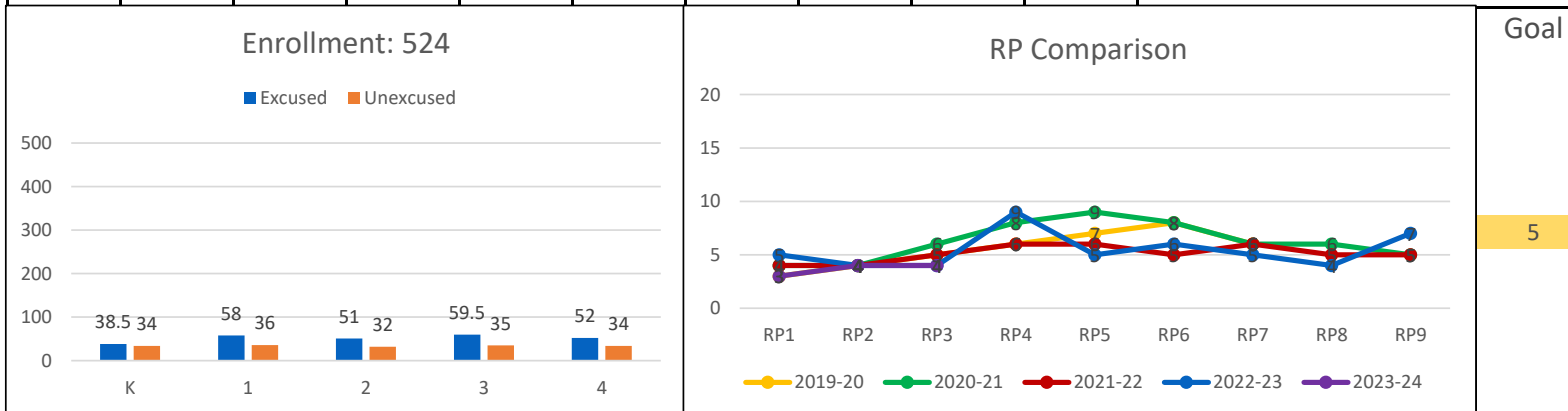

2019-20	RP1: 4%	RP2: 5%	RP3: 6%	RP4: 6.6%	RP5: 7.8%	RP6: 8.4%	RP7: 7.5%	Covid-19	Covid-19
2020-21	RP1: 6.1%	RP2: 7.1%	RP3: 7.3%	RP4: 11%	RP5: 11.7%	RP6: 8.9%	RP7: 6.9%	RP8: 7.5%	RP9: 6.4%
2021-22	RP1: 6.1%	RP2: 6%	RP3: 6.4%	RP4: 6.9%	RP5: 6.6%	RP6: 6.5%	RP7: 8%	RP8: 6.6%	RP9: 7.4%
2022-23	RP1: 3.6%	RP2: 4.7%	RP3: 7%	RP4: 10%	RP5: 6.4%	RP6: 8.1%	RP7: 5.3%	RP8: 5.3%	RP9: 6.9%
2023-24	RP1: 4.9%	RP2: 4.4%	RP3: 5.5%						

Willow Brook

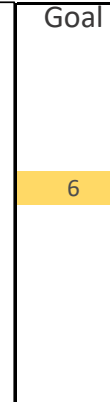
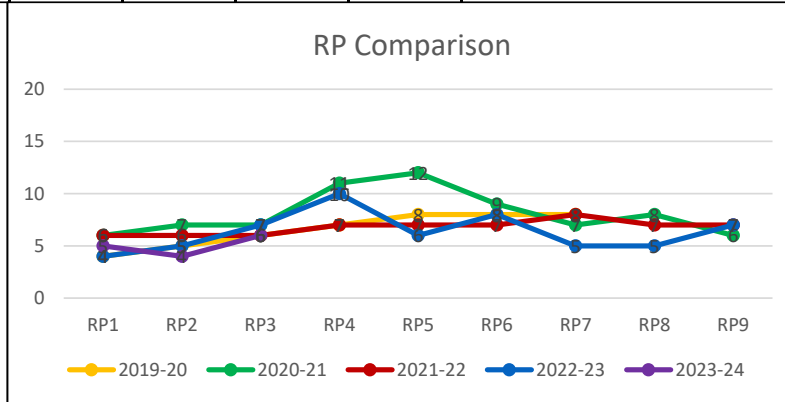
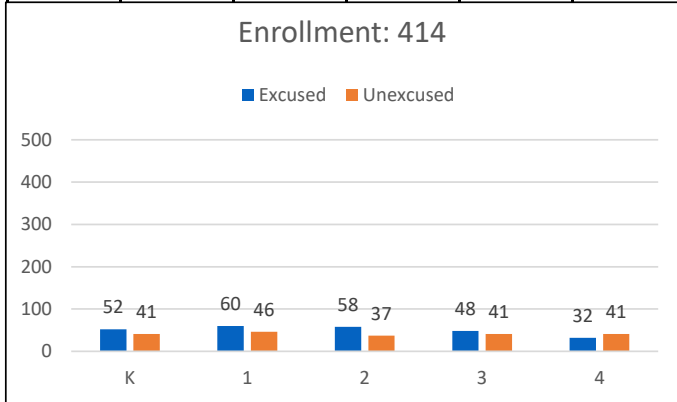

2019-20	RP1: 4%	RP2: 4%	RP3: 5%	RP4: 5.6%	RP5: 6.2%	RP6: 8.4%	RP7: 6.6%	Covid-19	Covid-19
2020-21	RP1: 4.1%	RP2: 4.9%	RP3: 6.2%	RP4: 7.1%	RP5: 7.1%	RP6: 5.9%	RP7: 5.5%	RP8: 5.9%	RP9: 5.3%
2021-22	RP1: 4.5%	RP2: 4.1%	RP3: 4.8%	RP4: 6.7%	RP5: 5.9%	RP6: 5%	RP7: 4.7%	RP8: 4.5%	RP9: 5.2%
2022-23	RP1: 2.6%	RP2: 3.7%	RP3: 5.2%	RP4: 6.6%	RP5: 4.5%	RP6: 6.7%	RP7: 5.4%	RP8: 3.7%	RP9: 4.9%
2023-24	RP1: 3.1%	RP2: 3.5%	RP3: 4.3%						

Woodland

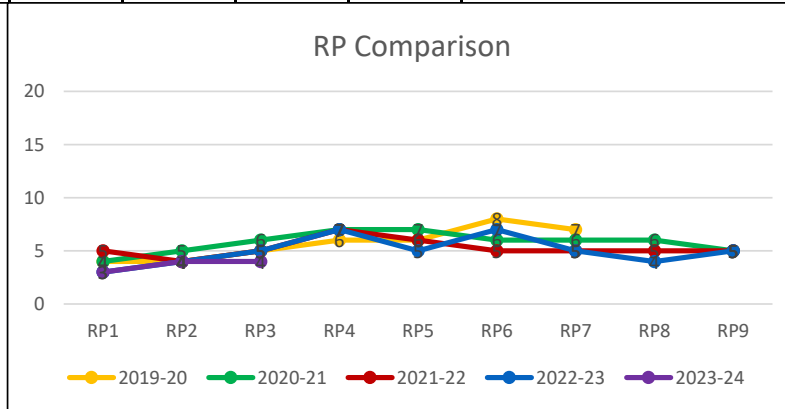
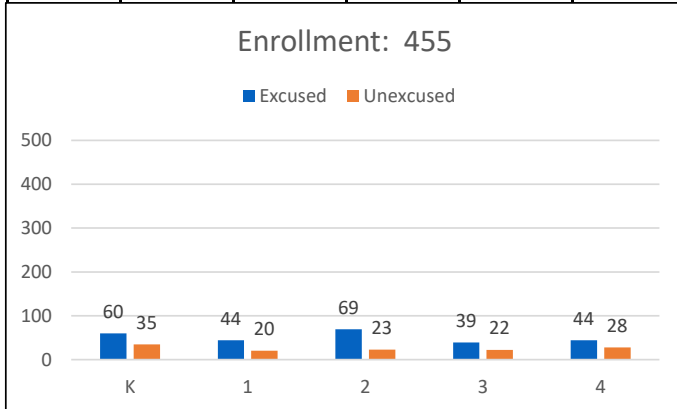

2019-20	RP1: 3%	RP2: 3%	RP3: 4%	RP4: 5%	RP5: 4.9%	RP6: 8.4%	RP7: 5.2%	Covid-19	Covid-19
2020-21	RP1: 2.2%	RP2: 4.1%	RP3: 3.4%	RP4: 4.5%	RP5: 3.8%	RP6: 5.7%	RP7: 3.7%	RP8: 5.1%	RP9: 4.7%
2021-22	RP1: 5.1%	RP2: 4.2%	RP3: 4.9%	RP4: 5.9%	RP5: 6.8%	RP6: 5.4%	RP7: 5.3%	RP8: 4.9%	RP9: 6.1%
2022-23	RP1: 3.1%	RP2: 4.6%	RP3: 5%	RP4: 8.7%	RP5: 4.7%	RP6: 5.5%	RP7: 5.1%	RP8: 4.3%	RP9: 5.3%
2023-24	RP1: 3.8%	RP2: 4.4%	RP3: 4.5%						

Jefferson

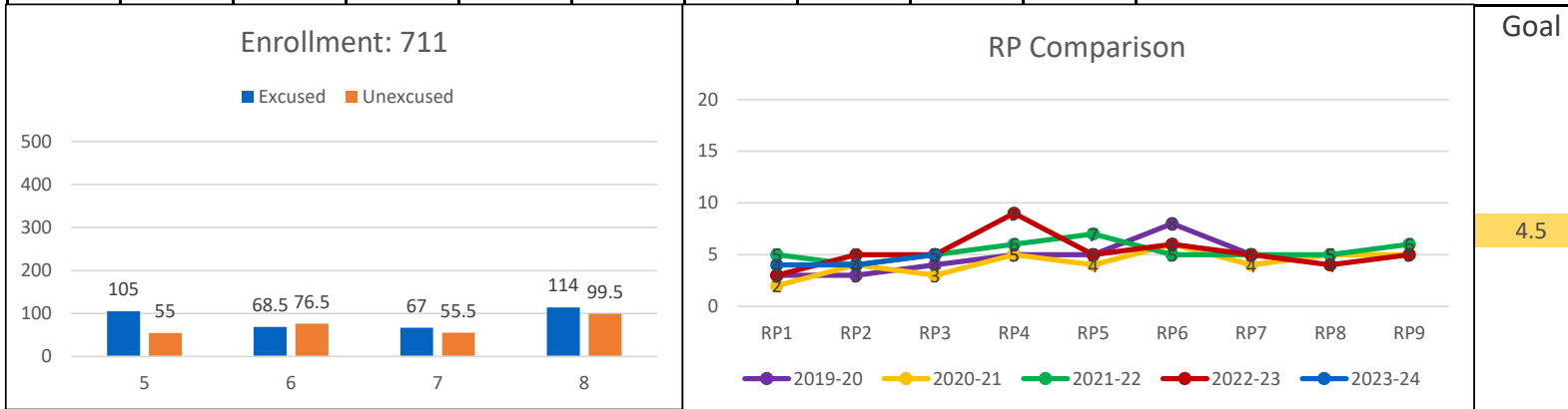

2019-20	RP1: 4%	RP2: 4%	RP3: 5%	RP4: 5.7%	RP5: 5.6%	RP6: 7.9%	RP7: 5.7%	Covid-19	Covid-19
2020-21	RP1: 2%	RP2: 2.3%	RP3: 3.4%	RP4: 4%	RP5: 2.7%	RP6: 3.3%	RP7: 2.8%	RP8: 5.6%	RP9: 5.1%
2021-22	RP1: 4.2%	RP2: 4.7%	RP3: 5.4%	RP4: 5.8%	RP5: 5.9%	RP6: 5.5%	RP7: 5.6%	RP8: 5%	RP9: 5.3%
2022-23	RP1: 4.4%	RP2: 4.5%	RP3: 5.4%	RP4: 9.7%	RP5: 6.1%	RP6: 6.8%	RP7: 5.5%	RP8: 4.8%	RP9: 5.8%
2023-24	RP1: 3.9%	RP2: 4.2%	RP3: 4.4%						

Robertsville

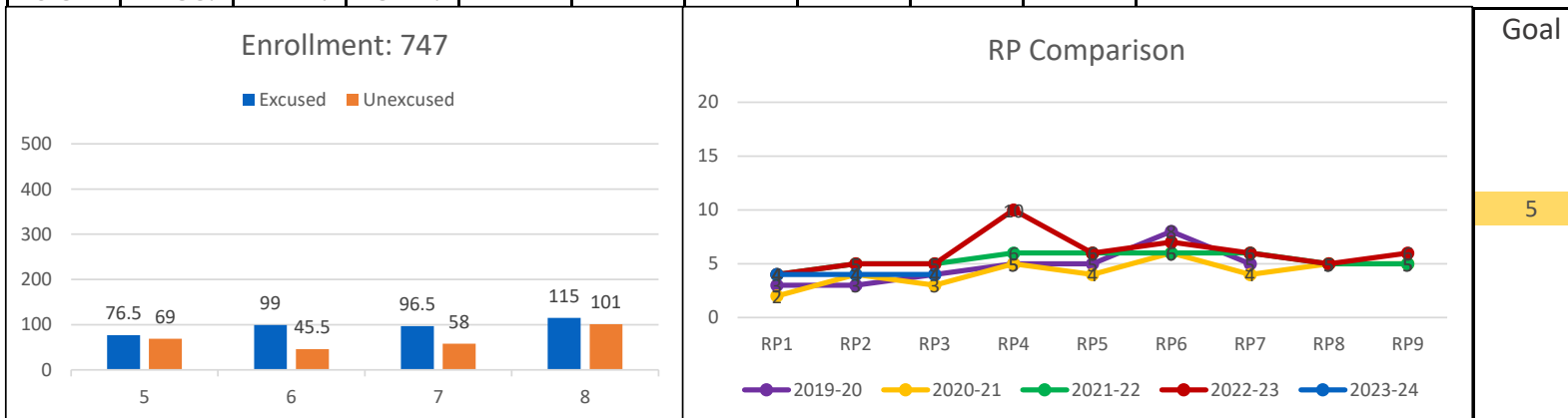

2019-20	RP1: 4%	RP2: 5%	RP3: 6%	RP4: 6.2%	RP5: 6.4%	RP6: 7.6%	RP7: 6.4%	Covid-19	Covid-19
2020-21	RP1: 3.6%	RP2: 4.6%	RP3: 5.5%	RP4: 9.9%	RP5: 6.8%	RP6: 3.8%	RP7: 5.8%	RP8: 7.1%	RP9: 5.1%
2021-22	RP1: 7.2%	RP2: 6.2%	RP3: 6.9%	RP4: 7.3%	RP5: 9.2%	RP6: 8.2%	RP7: 7%	RP8: 8.2%	RP9: 6%
2022-23	RP1: 6%	RP2: 6.3%	RP3: 6.6%	RP4: 9.8%	RP5: 6.6%	RP6: 8.7%	RP7: 6.5%	RP8: 8.2%	RP9: 6.3%
2023-24	RP1: 5.8%	RP2: 6.3%	RP3: 7.1%						

ORHS

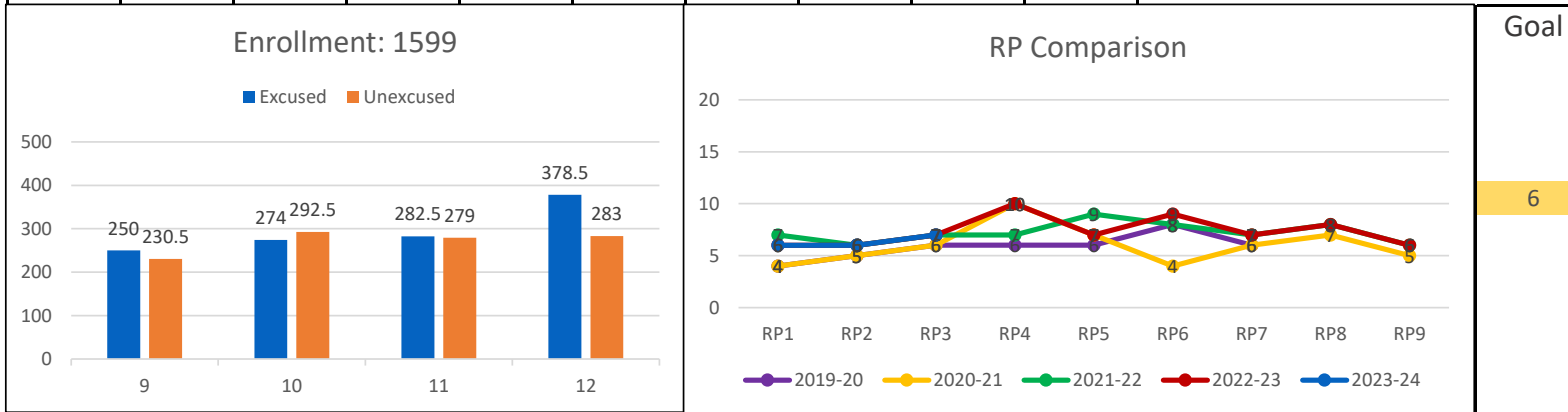

Acct	Acct	2023-24 FYTD Budget	October 2023-24 Monthly Activity	2023-24 Year-To-Date	2023-24 Percent of Budget	2023-24 Variance from Bud	Encumbered Amount	Unencumbered Budget Remaining
40110	Current Property Tax	12,993,941.00	41,131.69	182,937.90	1.41%	12,811,003.10		12,811,003.10
40210	Local Option Sales Tax	7,200,000.00	754,166.52	2,385,699.69	33.13%	4,814,300.31		4,814,300.31
40275	Mixed Drink Tax	125.00	53.29	142.69	114.15%	-17.69		-17.69
40280	Mineral Severance Tax	125.00				125.00		125.00
43511	Tuition - Regular Day Students	300,000.00	12,461.77	173,165.56	57.72%	126,834.44		126,834.44
43513	Tuition - Summer School			150.00		-150.00		-150.00
43533	Transportation Fees	3,000.00	1,035.00	1,585.00	52.83%	1,415.00		1,415.00
44110	Interest Earned	220,000.00	56,593.77	223,730.09	101.70%	-3,730.09		-3,730.09
44120	Lease/Rentals	10,000.00	1,675.00	3,550.00	35.50%	6,450.00		6,450.00
44170	Miscellaneous Refunds	3,000.00				3,000.00		3,000.00
44530	Sale of Equipment	20,000.00	260.00	5,962.51	29.81%	14,037.49		14,037.49
44570	Contributions & Gifts	202,702.93	2,550.00	2,550.00	1.26%	200,152.93		200,152.93
44990	Other Local Revenues	62,000.00		21,042.13	33.94%	40,957.87		40,957.87
46510	TN Investment in Student Achv	30,250,000.00	3,026,523.39	9,079,570.19	30.02%	21,170,429.81		21,170,429.81
46515	Early Childhood Education	455,414.20	36,640.50	70,451.54	15.47%	384,962.66		384,962.66
46610	Career Ladder Program	84,600.00	44,998.97	44,998.97	53.19%	39,601.03		39,601.03
46790	Other Vocational	1,191,172.15	624,311.51	821,272.48	68.95%	369,899.67		369,899.67
46980	Other State Grants	193,837.09				193,837.09		193,837.09
46990	Other State Revenues	45,189.00				45,189.00		45,189.00
47630	Public Law 874 - Maint/Operat.			23,692.00		-23,692.00		-23,692.00
47640	ROTC Reimbursement	79,600.00		9,511.59	11.95%	70,088.41		70,088.41
49700	Insurance Recovery	2,500.00		535.00	21.40%	1,965.00		1,965.00
49800	Transfers In	125,000.00				125,000.00		125,000.00
49810	City General Fund Transfer	15,493,963.00	1,291,163.58	5,164,654.32	33.33%	10,329,308.68		10,329,308.68
-----	Revenue	68,936,169.37	5,893,564.99	18,215,201.66	26.42%	50,720,967.71		50,720,967.71
=====								
71100	Regular Instruction Prgm	30,646,124.00	2,496,144.85	7,682,635.30	25.07%	22,963,488.70	21,494,955.73	1,468,532.97
71150	Alternative Instruction Prgm	970,766.00	76,346.16	222,121.20	22.88%	748,644.80	652,896.28	95,748.52
71200	Special Education Prgm	5,288,964.00	444,917.23	1,283,430.44	24.27%	4,005,533.56	3,812,668.18	192,865.38
71300	Career/Technical Education Prg	2,841,892.15	296,041.91	908,201.34	31.96%	1,933,690.81	1,383,003.10	550,687.71
71900	Contingency	569,622.59				569,622.59		569,622.59
72120	Health Services	738,520.00	63,890.90	197,573.53	26.75%	540,946.47	505,711.06	35,235.41
72130	Other Student Support	2,168,257.00	166,936.12	589,357.21	27.18%	1,578,899.79	1,149,783.26	429,116.53
72210	Regular Inst. Support	4,206,488.00	328,489.04	1,162,537.10	27.64%	3,043,950.90	2,461,240.21	582,710.69
72220	Special Education Support	885,352.00	77,924.19	269,339.86	30.42%	616,012.14	684,646.01	-68,633.87
72230	Career & Technical Prg Support	258,348.00	17,815.71	76,806.36	29.73%	181,541.64	140,335.75	41,205.89
72250	Technology Services	3,178,119.96	286,898.97	1,066,371.04	33.55%	2,111,748.92	1,592,048.35	519,700.57
72260	Adult Programs		2,424.41	6,532.78		-6,532.78	19,395.10	-25,927.88

Acct	Acct	2023-24 FYTD Budget	October 2023-24 Monthly Activity	2023-24 Year-To-Date	2023-24 Percent of Budget	2023-24 Variance from Bud	2023-24 Encumbered Amount	Unencumbered Budget Remaining
72290	Communications	215,578.00	16,402.69	45,936.88	21.31%	169,641.12	79,738.20	89,902.92
72310	Board of Education	1,183,507.00	63,782.16	470,924.89	39.79%	712,582.11	9,238.32	703,343.79
72320	Director of Schools	408,770.00	33,629.95	137,893.02	33.73%	270,876.98	248,258.35	22,618.63
72410	Office of the Principal	4,390,188.00	367,515.01	1,427,283.51	32.51%	2,962,904.49	2,920,765.54	42,138.95
72510	Fiscal Services	1,029,454.00	78,840.60	357,381.01	34.72%	672,072.99	609,388.03	62,684.96
72520	Human Resources/ Personnel	478,093.00	36,342.42	171,956.21	35.97%	306,136.79	260,033.92	46,102.87
72610	Operation of Plant	4,880,262.00	378,925.17	1,566,362.20	32.10%	3,313,899.80	1,686,847.89	1,627,051.91
72620	Maintenance of Plant	2,518,210.89	262,840.70	801,519.42	31.83%	1,716,691.47	1,233,584.59	483,106.88
72710	Transportation	1,978,790.00	404,005.94	558,331.75	28.22%	1,420,458.25		1,420,458.25
73400	Early Childhood Education	455,414.20	38,457.04	108,908.58	23.91%	346,505.62	340,930.61	5,575.01
73401	Pre-K General Fund	814,892.00	87,586.51	233,365.74	28.64%	581,526.26	458,653.94	122,872.32
76100	Regular Capital Outlay	2,541,203.58	456,037.97	1,161,830.89	45.72%	1,379,372.69	570,950.60	808,422.09
82130	Education Principal on Debt	6,843.00	6,843.00	6,843.00	100.00%			
82230	Education Interest on Debt	157.00	157.00	157.00	100.00%			
99100	Transfers Out	122,471.00				122,471.00		122,471.00
-----	Expense	72,776,287.37	6,489,195.65	20,513,600.26	28.19%	52,262,687.11	42,315,073.02	9,947,614.09
-----	General Purpose School Fund	-3,840,118.00	-595,630.66	-2,298,398.60	27.33%	-1,541,719.40	-42,315,073.02	40,773,353.62
	Grand Revenue Totals	68,936,169.37	5,893,564.99	18,215,201.66	26.42%	50,720,967.71		50,720,967.71
	Grand Expense Totals	72,776,287.37	6,489,195.65	20,513,600.26	28.19%	52,262,687.11	42,315,073.02	9,947,614.09
	Grand Totals	3,840,118.00	595,630.66	2,298,398.60	59.85%	1,541,719.40	42,315,073.02	40,773,353.62
		Loss	Loss	Loss		Loss	Loss	Profit

Number of Accounts: 1302

***** End of report *****

General Fund Revenue Budget to Actual Summary - October, 2023

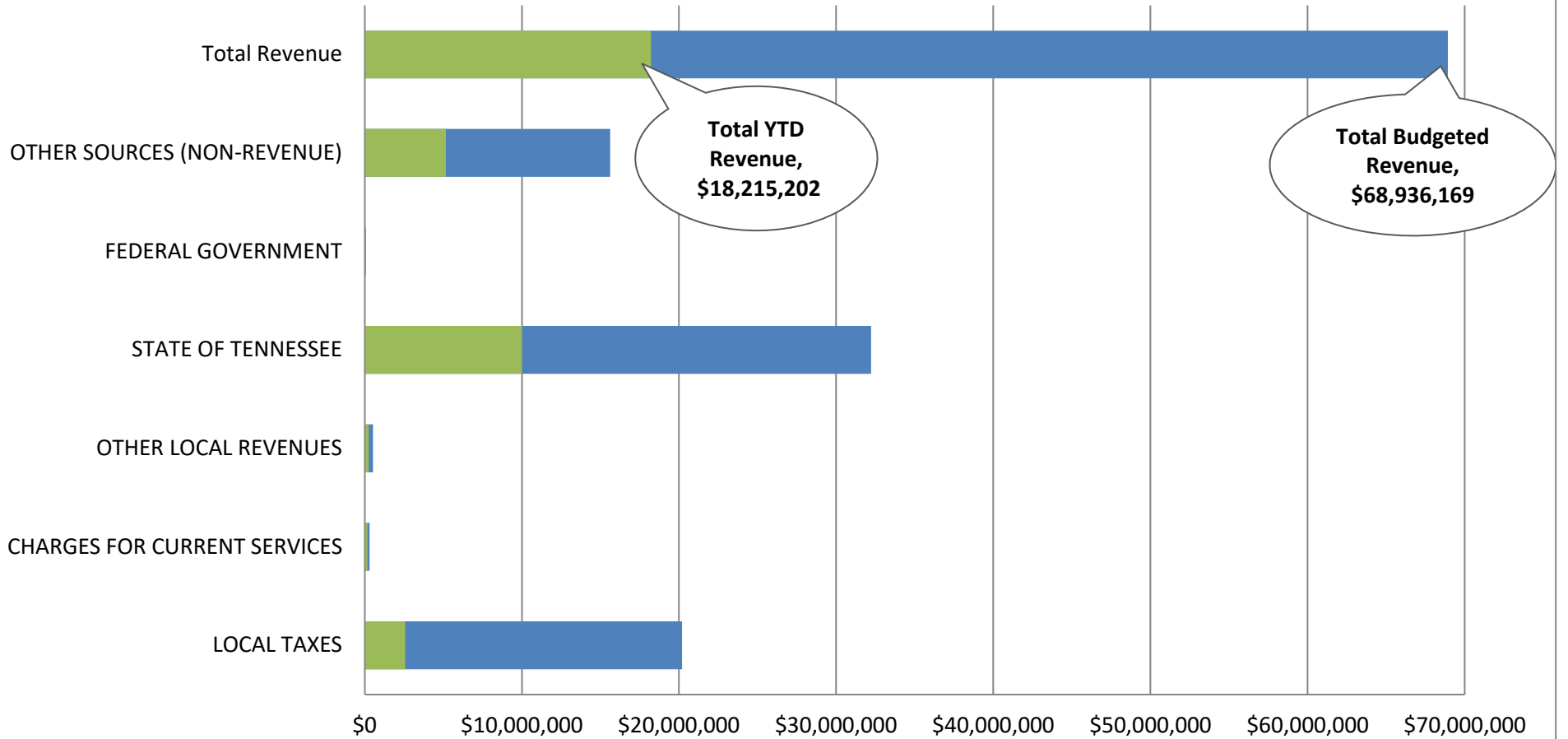

	LOCAL TAXES	CHARGES FOR CURRENT SERVICES	OTHER LOCAL REVENUES	STATE OF TENNESSEE	FEDERAL GOVERNMENT	OTHER SOURCES (NON-REVENUE)	Total Revenue
Percent of Budget	12.72%	57.72%	49.61%	31.09%	41.71%	33.06%	26.42%
Year-To-Date	2,568,780.28	174,900.56	256,834.73	10,016,293.18	33,203.59	5,165,189.32	\$18,215,202
FYTD Budget	20,194,191.00	303,000.00	517,702.93	32,220,212.44	79,600.00	15,621,463.00	\$68,936,169

General Fund Expenditure Budget to Actual Summary by Object October, 2023

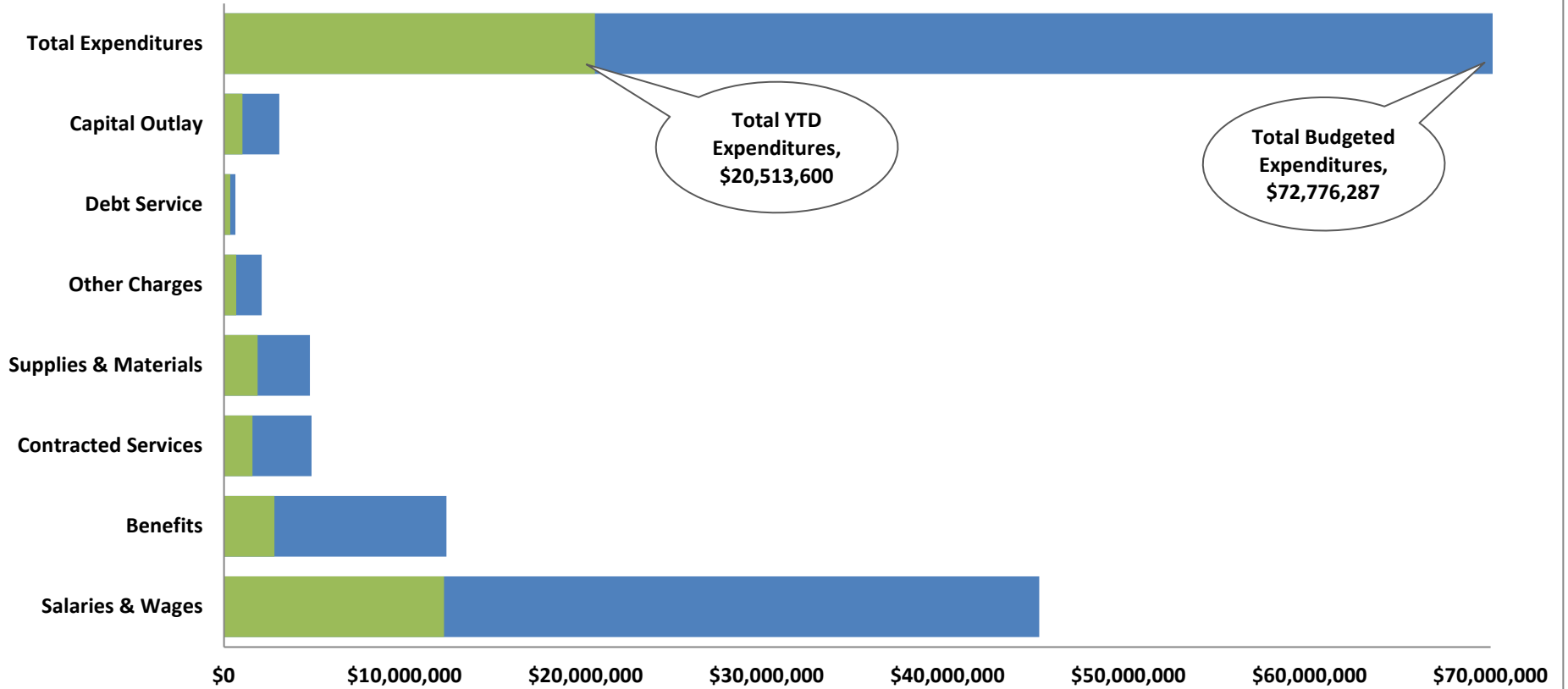

	Salaries & Wages	Benefits	Contracted Services	Supplies & Materials	Other Charges	Debt Service	Capital Outlay	Total Expenditures
FYTD %	26.98%	22.73%	32.55%	39.44%	34.86%	55.42%	33.5%	28.19%
FYTD Activity	12,177,871.66	2,804,479.62	1,580,543.87	1,874,233.81	694,123.19	357,000.00	1,025,348.11	\$20,513,600
FYTD Revised Bdgt	45,070,732.62	12,303,121.58	4,851,238.00	4,756,773.00	2,089,247.59	644,205.00	3,060,969.58	\$72,776,287

General Fund "Undesignated" Fund Balance Summary

FY21 FY22 FY23 FY24

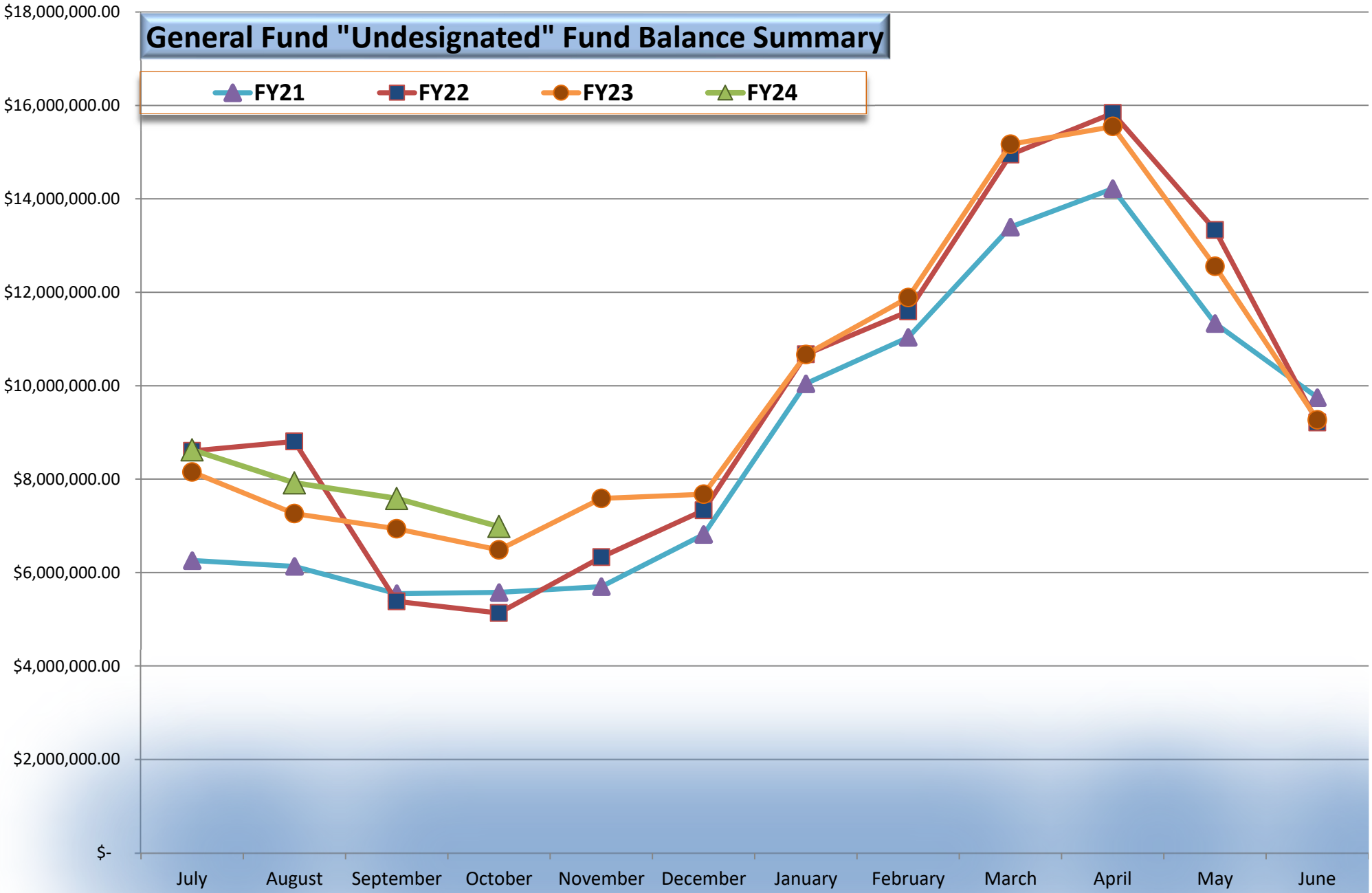

Acct	Acct	2023-24 FYTD Budget	October 2023-24 Monthly Activity	2023-24 Year-To-Date	2023-24 Percent of Budget	2023-24 Variance from Bud	Encumbered Amount	Unencumbered Balance Remaining
142	School Federal Projects							
R	Revenue							
47131	Vocational Program Improvement	75,299.54	11,491.78	26,603.37	35.33%	48,696.17		48,696.17
47141	Title I	1,018,977.64	72,908.47	140,500.82	13.79%	878,476.82		878,476.82
47143	Special Education Grants	1,479,520.40	103,382.22	197,305.07	13.34%	1,282,215.33		1,282,215.33
47145	Special Ed Pre-School Grants	47,613.63	2,844.08	5,685.04	11.94%	41,928.59		41,928.59
47146	English Lang Acq Grants	32,739.63	2,117.31	2,117.31	6.47%	30,622.32		30,622.32
47147	Title IV Part B, 21st Century	152,625.00	15,742.40	15,742.40	10.31%	136,882.60		136,882.60
47189	Title II	196,176.13	19,755.38	23,169.26	11.81%	173,006.87		173,006.87
47307	COVID-19 Grant B	73,250.00				73,250.00		73,250.00
47309	COVID-19 Grant D	83,000.00				83,000.00		83,000.00
47310	COVID-19 Grant E	14,883.63				14,883.63		14,883.63
47401	ESSER 3.0	2,198,231.35	84,628.92	823,466.69	37.46%	1,374,764.66		1,374,764.66
47404	ARP Homeless Grant	45,518.53	3,439.36	3,439.36	7.56%	42,079.17		42,079.17
47590	Other Federal Through State	631,763.77	13,330.22	27,776.95	4.40%	603,986.82		603,986.82
47710	Public Safety Prtnrshp & Comm	373,217.00	11,715.45	188,312.34	50.46%	184,904.66		184,904.66
47990	Other Direct Fedral Revenue	1,050,440.00	82,099.65	201,459.39	19.18%	848,980.61		848,980.61
-----	Revenue	7,473,256.25	423,455.24	1,655,578.00	22.15%	5,817,678.25		5,817,678.25
E	Expense							
71100	Regular Instruction Prgm	1,439,700.25	78,554.50	866,120.48	60.16%	573,579.77	488,331.95	85,247.82
71200	Special Education Prgm	1,148,682.88	86,646.05	248,049.55	21.59%	900,633.33	727,386.38	173,246.95
71300	Career/Technical Education Prg	63,947.12	2,464.76	26,958.20	42.16%	36,988.92	33,188.02	3,800.90
71900	Contingency	114,407.37				114,407.37		114,407.37
72120	Health Services	52,348.93	-8,194.00			52,348.93		52,348.93
72130	Other Student Support	1,406,774.27	363,565.34	440,902.89	31.34%	965,871.38	404,984.88	560,886.50
72210	Regular Inst. Support	1,070,976.11	98,756.92	252,378.68	23.57%	818,597.43	233,993.81	584,603.62
72220	Special Education Support	358,392.70	42,911.71	101,200.02	28.24%	257,192.68	236,458.74	20,733.94
72230	Career & Technical Prg Support	3,750.00		578.17	15.42%	3,171.83	90.98	3,080.85
72250	Technology Services	11,000.00		1,400.00	12.73%	9,600.00	3,024.00	6,576.00
72710	Transportation	19,382.23	4,446.78	4,446.78	22.94%	14,935.45		14,935.45
73100	Food Service						1,000.00	-1,000.00
73300	Community Services	1,194,092.22	94,195.75	334,874.29	28.04%	859,217.93	716,998.09	142,219.84
76100	Regular Capital Outlay	373,217.00	155,172.90	343,485.24	92.03%	29,731.76	29,731.76	
99100	Transfers Out	216,585.17				216,585.17		216,585.17

Acct	Acct	2023-24 FYTD Budget	October 2023-24 Monthly Activity	2023-24 Year-To-Date	2023-24 Percent of Budget	2023-24 Variance from Bud	Encumbered Amount	Unencumbered Balance Remaining
142	School Federal Projects							
E	Expense							
-----	Expense	7,473,256.25	918,520.71	2,620,394.30	35.06%	4,852,861.95	2,875,188.61	1,977,673.34
-----	School Federal Projects		-495,065.47	-964,816.30	28.61%	964,816.30	-2,875,188.61	3,840,004.91
=====								
143	Central Cafeteria							
R	Revenue							
43521	Lunch Payments - Children	314,000.00	27,606.80	137,971.00	43.94%	176,029.00		176,029.00
43522	Lunch Payments - Adults	3,292.00	132.00	652.00	19.81%	2,640.00		2,640.00
43523	Income From Breakfast	70,659.00	3,693.15	20,273.90	28.69%	50,385.10		50,385.10
43525	A la Carte Sales	80,151.00	4,564.60	26,580.28	33.16%	53,570.72		53,570.72
43990	Other Charges for Food Service	35,000.00	6,176.92	13,445.22	38.41%	21,554.78		21,554.78
44110	Interest Earned	20,000.00	3,608.98	13,747.70	68.74%	6,252.30		6,252.30
46520	School Food Service	20,560.00				20,560.00		20,560.00
47111	USDA School Lunch Program	1,166,632.00	97,359.50	235,457.60	20.18%	931,174.40		931,174.40
47112	USDA Commodities	155,000.00				155,000.00		155,000.00
47113	Breakfast	339,000.00	29,826.48	71,166.09	20.99%	267,833.91		267,833.91
47114	USDA - Other	300,000.00	21,052.77	77,484.91	25.83%	222,515.09		222,515.09
-----	Revenue	2,504,294.00	194,021.20	596,778.70	23.83%	1,907,515.30		1,907,515.30
E	Expense							
73100	Food Service	3,004,294.00	536,540.63	783,179.02	26.07%	2,221,114.98	149,658.10	2,071,456.88
-----	Expense	3,004,294.00	536,540.63	783,179.02	26.07%	2,221,114.98	149,658.10	2,071,456.88
-----	Central Cafeteria	-500,000.00	-342,519.43	-186,400.32	25.05%	-313,599.68	-149,658.10	-163,941.58
=====								

Acct	Acct	2023-24 FYTD Budget	October 2023-24 Monthly Activity	2023-24 Year-To-Date	2023-24 Percent of Budget	2023-24 Variance from Bud	Encumbered Amount	Unencumbered Balance Remaining
145	Other Education Funds							
R	Revenue							
44990	Other Local Revenues	35,000.00	1,650.00	3,900.00	11.14%	31,100.00		31,100.00
49800	Transfers In	120,021.00				120,021.00		120,021.00
-----	Revenue	155,021.00	1,650.00	3,900.00	2.52%	151,121.00		151,121.00
E	Expense							
73300	Community Services	155,021.00	12,108.98	38,553.99	24.87%	116,467.01	71,350.95	45,116.06
-----	Expense	155,021.00	12,108.98	38,553.99	24.87%	116,467.01	71,350.95	45,116.06
-----	Other Education Funds		-10,458.98	-34,653.99	13.69%	34,653.99	-71,350.95	106,004.94
=====								
146	Extended School Program							
R	Revenue							
43581	Community Services Fees Child	446,100.00	33,656.00	189,905.51	42.57%	256,194.49		256,194.49
-----	Revenue	446,100.00	33,656.00	189,905.51	42.57%	256,194.49		256,194.49
E	Expense							
73300	Community Services	438,337.00	34,494.54	121,293.45	27.67%	317,043.55	174,710.86	142,332.69
99100	Transfers Out	10,000.00				10,000.00		10,000.00
-----	Expense	448,337.00	34,494.54	121,293.45	27.05%	327,043.55	174,710.86	152,332.69
-----	Extended School Program	-2,237.00	-838.54	68,612.06	34.79%	-70,849.06	-174,710.86	103,861.80
=====								

<u>Acct</u>	<u>Acct</u>	<u>2023-24</u>	<u>October 2023-24</u>	<u>2023-24</u>	<u>2023-24</u>	<u>2023-24</u>	<u>Encumbered</u>	<u>Unencumbered</u>
		<u>FYTD Budget</u>	<u>Monthly Activity</u>	<u>Year-To-Date</u>	<u>Percent of Budget</u>	<u>Variance from Bud</u>	<u>Amount</u>	<u>Balance Remaining</u>
Grand Revenue Totals		10,578,671.25	652,782.44	2,446,162.21	23.12%	8,132,509.04		8,132,509.04
Grand Expense Totals		11,080,908.25	1,501,664.86	3,563,420.76	32.16%	7,517,487.49	3,270,908.52	4,246,578.97
Grand Totals		502,237.00	848,882.42	1,117,258.55	222.46%	615,021.55	3,270,908.52	3,885,930.07
		Loss	Loss	Loss		Profit	Loss	Profit

Number of Accounts: 420

***** End of report *****

Combined Fund Balance and YTD Operating Statement Summary

October, 2023

Description	General Fund 141	Federal Fund 142	Food Service Fund 143	Special Fund 145	ECC Fund 146
Beginning Fund Balance July 1, 2023	16,158,657.76	0.00	2,070,826.26	29,790.62	223,533.17
Plus YTD Revenue per books 10/31/23	18,215,201.66	1,655,578.00	596,778.70	3,900.00	189,905.51
Less YTD Expenditures per books 10/31/23	(20,513,600.26)	(2,620,394.30)	(783,179.02)	(38,553.99)	(121,293.45)
Revenues Over (Under) Expenditures as of 10/31/23	(2,298,398.60)	(964,816.30)	(186,400.32)	(34,653.99)	68,612.06
Ending Fund Balance per books as of 10/31/23	13,860,259.16	(964,816.30)	1,884,425.94	(4,863.37)	292,145.23

Fund Balance Restricted/Committed/Assigned Status

Encumbrances and Deferred Revenue	\$ -		\$ 58,113.28		
Inventory					
Restricted for Career Ladder Program	-942.34				
Restricted for Operation of Non-Instructional Services (CCI)	16,200.00		1,326,312.66		292,145.23
Committed for Other Purposes (Vehicles- ERR Fund)	0.00				
Committed for Other Purposes (Device Replacement)	3,000,000.00				
Assigned for Instruction- Coordinated School Health	3,298.08				
Assigned for other local grants					
Assigned for Instruction - Education Foundation Grant	4,048.73				
Assigned for Instruction (APSI-ORHS)	8,524.41				
Assigned for Support Services FRC Local Funds (56)				-4,863.37	
Nonspendable-Prepaid Expenditures					
Assigned to Balance FY24 Budget	3,840,118.00	0.00	500,000.00		
Unassigned Fund Balance 10/31/23	\$ 6,989,012.28	-964,816.30	0.00	0.00	
Total Fund Balance 10/31/23	13,860,259.16	\$(964,816.30)	\$ 1,884,425.94	\$(4,863.37)	\$ 292,145.23

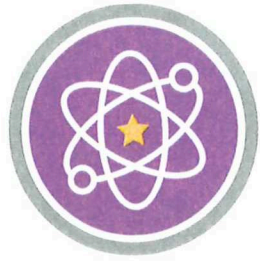

Oak Ridge Schools

PRESCHOOL

Rationale for Item for Information

Head Start/Preschool Community Assessment Update

2023-2024

Every five years, the program must conduct a complete Community Assessment. Each year in-between, an update for community information must be conducted. The update was completed with the collaborative efforts from the Recipient (Anderson County) management team, policy council, and community partners along with our program's managers, policy committee, and community partners.

The document included here reflects the updates to the community assessment along with areas of focus. This document, along with the self-assessment, is used to guide the Head Start Grant goals and objectives.

If you have any questions, please do not hesitate to contact me.

Respectfully,

Mrs. Lisa M Downard

Principal

157 Carver Ave | Oak Ridge, TN 37830

lmdownard@ortn.edu | (865) 425-9101

www.ortn.edu

Every student prepared for college, career, and life success



Oak Ridge Schools

PRESCHOOL

Recipient/Delegate 2023-2024 Community Assessment Update

The Anderson County Board of Education Head Start completed a Community Assessment update. The Community Assessment team was structured to match, as closely as possible, the original team from the 2019-2020 Community Assessment. The team met and shared information in-person, electronically, and virtually.

Program Services: The program was fully enrolled and opened all classrooms in August, 2022. The program continued to offer parent training, parent meetings, and policy council meetings through a hybrid model in order for stakeholders to attend either in-person or virtually to best meet their needs. Additionally, the program continued to provide remote services and utilized a virtual platform to support at-home learning should a classroom experience a temporary closure due to inclement weather.

1. There are no changes to the availability of publicly-funded Pre-Kindergarten. The community's Pre-Kindergarten meets the needs of parents and children served by the program by offering a full school day with an extended hour for working parents and those enrolled in school.
2. Rates of family and childhood homelessness:
According to information from community partners and the Tennessee Valley Coalition for the Homeless:
 - a. Over 30% of the renters in Anderson County pay more than 35% of their income toward rent.
 - b. The average cost of rent has increased by \$500.00 per month.
 - c. Anderson County has the highest fair market rental value.
 - d. Less than 70% of individuals with housing vouchers were able to find housing.
 - e. Two housing agencies no longer accept housing vouchers.
 - f. Many families are having to separate and "double-up" with other friends or family members just to have a place to stay.
 - g. The Scarboro Community is interested in building housing. However, the community lacks buy-in due to the stigma around individuals experiencing homelessness.
3. Significant shifts in community demographics and resources:
 - a. Anderson County Schools served 144 students who were English Language Learners (ELL) during the 2022 school year as compared to 79 ELL students during the 2021 school year. This is an increase of 65 students. The increase of ELL students and families includes many languages including Spanish.
 - b. Anderson County, Tennessee's estimated population is 78,913 with a growth rate of 2.3% since 2021.
 - c. The poverty rate in Anderson County increased slightly, from 13.3% in 2021, to 14.3% in 2022. Additionally, 19.3% of children under the age of 5 are living in poverty.
 - d. The 2022 census data shows an increase of 5.6% to the median household income of Anderson County residents from \$52,338 in 2021, to \$55,414 in 2022.
 - e. The unemployment rate for Anderson County showed a slight decrease from 4.9% in 2021, to 3.2% in 2022.

- f. According to County Health Rankings in 2022, Tennessee's ratio of dentists-per-resident was 1 to 1,340 in Anderson County. This does not reflect the new dental service offered through Core Dental Health that opened in 2022.
 - g. 11.3% of Anderson County's residents have less than a 9th grade education and/or do not have a high school diploma.
4. Demographic, economic, environmental, and/or resource changes that impact the program and the community:
- a. From the 2022 Anderson County Community Health Assessment, the top 10 most severe problems facing Anderson County in ranked order were:
 - 1. Lack of affordable housing
 - 2. Substance misuse
 - 3. Poverty
 - 4. Mental illness
 - 5. Youth tobacco use and vaping
 - 6. Access to mental health care
 - 7. Reliable and affordable transportation
 - 8. Lack of physical exercise and obesity
 - 9. Diabetes
 - 10. Lack of good-paying jobs
 - b. In 2022, Anderson County's premature death rate (the years of potential life lost before age 75 per 100,000 residents) was 10,800.
 - c. The uninsured population in Anderson County increased slightly, from 12% to 13%.
 - d. New data is not yet released for 2022 on the total number of teen births in Anderson County. The rate in 2021 was 9 per 1000. This is a decrease of 27.8% from 11.5 per 1000 in 2020. While this decrease is moving in a positive direction, there continues to be a lack of sex education within the community. Current programs offered focus on abstinence rather than on preventative education/resources.
 - e. Data from the Kids Count Data Center by the Tennessee Department of Health (Office of Vital Records and Statistics) in 2021, in Anderson County, 79.8% of live births were to mothers who received adequate prenatal care (adequacy of care is based on the Kessner Index). This was a slight increase from the previous year's data.
 - f. Children with Neonatal Abstinence Syndrome decreased from 29.3% to 15.9% from 2021 to 2022.
 - g. The total number of deaths involving opioids in Anderson County for 2022 was 52.4 per 100,000. This is a 21.8% increase from 2021's rate of 41 per 100,000.
 - h. According to County Health Rankings in 2022, Anderson County's ratio of mental health providers per resident was 1 to 994.
 - i. The number of children receiving SNAP benefits increased from 26% in 2021, to 33.5% in 2022.
 - j. 26.5% of children enrolled in the Women, Infants, and Children (WIC) were considered to be obese in 2022. This is a decrease from 30.1% in 2021.
 - k. Food insecurity continues to be a concern due to the rising food costs.
 - l. The lack of public transportation continues to be a concern.
5. New legislation impacting housing, medical, educational, and transportation services to low-income families:

- a. Under Tennessee's House Bill 0978, it is now a felony for anyone in Tennessee to camp on public property. While it was already illegal for someone to sleep on private or state property, under this new bill, there is almost nowhere someone experiencing homelessness can sleep without the risk of being arrested and/or fined.
 - b. According to ECLKC, "the U.S. Department of Health and Human Services (HHS), through the Administration for Children and Families (ACF), released nearly \$3.7 billion in Low Income Home Energy Assistance Program (LIHEAP) funding to help households with their home energy costs. The funding will help ensure households across the country have the support they need to maintain safe and healthy indoor temperatures, especially as the winter season approaches."
 - c. NARCAN (Save a Life) Training continues to be provided throughout the community to educate individuals and families on the purpose and usage of NARCAN kits and receive a NARCAN kit and Medication Lock Box. Community members are still able to dispose of medication that is no longer needed through medication drop boxes located throughout the community.
 - d. Anderson County continues to have a Safe Baby Court (SBC) site. SBC helps parents identify needs, access necessary resources, and empowers parents and families to advocate for themselves and to flourish long term. The goal is to provide best practices for babies, toddlers, and families in order to reduce the incidence of child abuse and neglect and to minimize the effects of childhood trauma on our younger children.
 - e. As reported on the Officer of the Governor's website, "Tennessee Governor Bill Lee signed the Transportation Modernization Act, historic legislation that will create a new strategy and invest \$3.3 billion to accommodate Tennessee's record growth, address traffic congestion and meet transportation needs across rural and urban communities."
6. While Coronavirus Disease 2019 (COVID-19) has greatly impacted the health of our community in previous years, the community has reverted to pre-COVID-19 standards. Anderson County Schools' Preschool has created a mitigation plan to ensure that if cases rise in the community, the program remains diligent in protecting the health of its staff and students.
7. Strengths of the Community:
- a. Anderson County had a decrease in the substantiated cases of reported child abuse, from 6.6% to 5.9%.
 - b. The community of Lake City/Rocky Top now has a Dollar General Market helping alleviate the issues with being a food desert.
 - c. Anderson County is unique in the wrap around services offered by community agencies.

In summary, the items listed below will be considered as priorities for goals and objectives as they continue to be the most notable needs in our community:

1. Continue to provide resources to families experiencing homelessness and make appropriate referrals to support these families to establish adequate housing.
2. Keep up to date with community partners so that appropriate referrals for children and families are made to support a healthy and safe life.