

Regular Board of Education Meeting

November 25, 2019 6:00 PM

Robert J. Smallridge School Administration Building

I. Call to Order

II. Pledge of Allegiance and Program

III. Approval of Agenda

IV. Special Reports/Presentations

- A. Good News
- B. Volunteer Recognitions
- C. ESG Report
- D. OR 2020 Report

V. Public Forum

VI. Consent Agenda

- A. Board Minutes: 10-28-19

VII. Items for Action

- A. ESG Performance Contract Project Development Agreement
- B. FY'20 Budget Transfer #2 - Second Reading
- C. Board Policy 6.200 Attendance - First Reading
- D. Board Policy 6.200 Attendance - Second Reading
- E. ELA Textbook Adoption Committee
- F. Student Discipline Code Handbook Addendum
- G. ORHS NJROTC Trip to Pearl Harbor Memorial Parade
- H. Preschool Playground Surfacing and Equipment
- I. FY20 Budget Transfer #3 - First Reading
- J. Purchase of Linden Gymnasium HVAC Equipment
- K. Removal and Replacement of the ORHS Soccer Dugouts

VIII. Items for Information

- A. Enrollment and Attendance Reports
- B. Financial Reports

IX. Items for Discussion

- A. Board of Education Evaluation
- B. TSBA Leadership and Annual Conference

X. Old Business

XI. New Business

XII. Communications

XIII. Adjournment



OFFICE OF MAINTENANCE AND OPERATIONS

DATE: November 15, 2019

TO: Bruce Lay, Executive Director of School Leadership

FROM: Allen Thacker, Supervisor of Maintenance and Operations

SUBJECT: Performance Based Contract Project Development Agreement

Mr. Lay,

I am recommending that the Oak Ridge Schools Board of Education enter into an agreement with Energy Systems Group (ESG) for the purpose of developing a second phase of capital projects funded from performance based savings. The work ESG has performed with the first phase of performance contracting has vastly improved the conditions in several schools at an affordable cost. ESG originally planned a larger project, however due to funding restrictions, many parts of the larger project were left out of the project. With the proven savings from the first phase, a second phase of work is now able to be planned and executed, including several of the items that were excluded from the original project scope.

If the engineering work is approved, but a contract to perform the work is not able to be executed, the district would agree to pay for the engineering services of ESG at a rate of \$.05 per square foot of facilities analyzed for the project totaling \$49,469.00. If a project is agreed upon and we enter second phase of performance based contracting with ESG, the fee would be part of the scope of the project engineering.

Thank You,

Allen Thacker
Supervisor of Maintenance and Operations



Performance Based Contract
Project Development Agreement

Oak Ridge Schools

Between
AND

Energy Systems Group, LLC.

Based on the quality of work that ESG has provided the schools in our first project and the very positive savings results to date, the Board of Education voted on November 25, 2019, to authorize ESG to proceed with development of a second phase of performance contracting improvements for Oak Ridge Schools (ORS).

It is expected that ESG will work diligently to accomplish the following:

- Solutions to upgrade HVAC systems
- Solutions to upgrade lighting systems to LED
- Solutions to upgrade water consuming devices
- Solutions to upgrade building envelop systems
- Solutions to address specific areas of concern
- Calculate utility savings, maintenance savings and other positive impacts
- Define specific costs for the implementation of solutions
- Develop a guarantee of utility savings for the term of the project financing

It is expected that ORS will assist ESG by providing:

- Access to all areas of the facilities to be included
- Assistance from staff as available and within staff's capabilities
- Operating cost data
- Timely feedback on project scope decisions and contract evaluation

The facilities that will be included are listed in Attachment #1.

It is the intent of ORS to enter into a contract with ESG based on the following criteria:

Financial:

- The project should demonstrate significant short-term and long-term costs savings from energy, maintenance, capital avoidance and other viable savings such that project costs are able to be funded from savings impacts.
- ESG will provide an annual guarantee of energy, utility and operational cost savings for the term of project financing

Anticipated Project Scope:

- HVAC upgrades
- LED lighting system upgrades
- Window replacements/ envelope improvements
- Water conservation improvements



- Other improvement measures that reduce operating costs and provide enhancements to the learning environment

Please begin your project development efforts immediately and schedule your work to meet the overall timeline of events (Attachment #2) that will allow improvement work to begin as close as possible to the beginning of summer break for the schools.

Based on the above criteria being met, it is the intent of ORS to enter into good faith negotiations for a contract following completion of the project development activities and final scope selection review.

The project development will be complete prior to the parties entering into a contract so this letter shall govern such development activities. This letter will then be superseded by a contract executed between the parties, which will incorporate and govern the proposed scope of work. All project development costs borne by ESG in development of a contract and scope evaluation will be included within the total cost of the contract.

If a contract is executed, all services provided and development costs incurred under this letter agreement will become part of the overall project. If a contract is not executed within sixty (60) calendar days of delivery of ESG's final proposal which meets the criteria stated in this letter, ORS agree to compensate ESG for project development costs in the amount of \$.05 per square foot for the facilities analyzed in Attachment #1

ESG and ORS will use best reasonable efforts to work together to meet the overall timeline of events (attachment #2).

Energy Systems Group, LLC	Oak Ridge Schools
Authorized Signature:	Authorized Signature:
Print Name:	Print Name:
Title:	Title:
Date:	Date:



ATTACHMENT #1

The following facilities will be included in the development process to be conducted by Energy Systems Group, LLC.

OAK RIDGE SCHOOLS	
Oak Ridge HS	423,068
Jefferson Middle	137,300
Robertsville Middle	124,960
Glenwood Elem	70,400
Linden Elem	86,250
Willowbrook Elem	84,112
Woodland Elem	63,290
TOTAL SQUARE FOOTAGE	989,380



ATTACHMENT #2

The following timeline of events will act as an anticipated guide and goal for the development of a successful performance contract project for ORS:

<u>PROCESS STEP</u>	<u>ANTICIPATED DATES</u>
1. APPROVAL OF PROJEC DEVELOPMENT AGREEMENT	11/25/19
2. SCOPE REVIEW MEETINGS	
• 75% review and scope of work guidance	January 2020
• Final project review and scope selection	February 2020
3. APPROVALS TO EXECUTE ESG CONTRACT	March 2020
4 CONSTRUCTION BEGINS	April 2020

**OAK RIDGE SCHOOLS
FY 2019-20 FYTD BUDGET**

All Funds Summary Revenue

<u>ACCOUNT</u>	<u>2018-2019 Audit Report</u>	<u>2019-2020 Original Budget</u>	<u>2019-2020 Revised Budget</u>	<u>Chg from 2019-2020 Final Budget</u>	<u>Percentage of Increase (Decrease)</u>
30000 Reserves and/or Fund Balances					
39000 Unassigned Fund Balance	449,521	1,866,151	1,866,151	-	0.00%
Total 30000 Reserves and/or Fund Balances	\$ 449,521	\$ 1,866,151	\$ 1,866,151	\$ -	0.00%
40000 Local Revenues					
40110 Current Property Tax	10,592,827	11,048,443	11,048,443	-	0.00%
40210 Local Option Sales Tax	5,879,500	5,787,581	5,787,581	-	0.00%
40275 Mixed Drink Tax	162	250	250	-	0.00%
40280 Mineral Severance Tax	72	250	250	-	0.00%
Total 40000 Local Revenues	\$ 16,472,561	\$ 16,836,524	\$ 16,836,524	\$ -	0.00%
43500 Charges for Current Services					
43511 Tuition - Regular Day Students	239,192	240,000	240,000	-	0.00%
43513 Tuition - Summer School	10,900	12,000	12,000	-	0.00%
43533 Transportation Fees	4,010	10,000	10,000	-	0.00%
Total 43500 Charges for Current Services	\$ 254,102	\$ 262,000	\$ 262,000	\$ -	0.00%
44000 Other Local Revenues					
44110 Interest Earned	174,056	150,000	150,000	-	0.00%
44120 Lease/Rentals	14,059	18,000	18,000	-	0.00%
44170 Miscellaneous Refunds	7,922	2,500	2,500	-	0.00%
44530 Sale of Equipment	42,893	35,000	35,000	-	0.00%
44570 Contributions & Gifts	104,927	200,000	200,000	-	0.00%
44990 Other Local Revenues	84,645	75,000	75,000	-	0.00%
Total 44000 Other Local Revenues	\$ 429,416	\$ 480,500	\$ 480,500	\$ -	0.00%

**OAK RIDGE SCHOOLS
FY 2019-20 FYTD BUDGET**

All Funds Summary Revenue

<u>ACCOUNT</u>	<u>2018-2019 Audit Report</u>	<u>2019-2020 Original Budget</u>	<u>2019-2020 Revised Budget</u>	<u>Chg from 2019-2020 Final Budget</u>	<u>Percentage of Increase (Decrease)</u>
46000 State Revenues					
46511 Basic Education Progam	22,210,310	22,809,000	22,809,000	-	0.00%
46515 Early Childhood Education	465,349	461,500	460,771	(729)	(-0.16%)
46520 School Food Service	-	-	-	-	
46590 Other State Education Funds	196,236	75,000	75,000	-	0.00%
46610 Career Ladder Program	137,405	150,000	150,000	-	0.00%
46640 Vocational Equipment	-	-	-	-	
46980 Other State Grants	5,220	500,000	454,671	(45,329)	(-9.07%)
46990 Other State Revenues	5,807	7,500	7,500	-	0.00%
Total 46000 State Revenues	\$ 23,020,328	\$ 24,003,000	\$ 23,956,943	\$ (46,057)	(-0.19%)
47000 Federal Revenues					
47143 Special Education Grants	79,300	80,000	80,000	-	0.00%
47590 Other Federal Through State	-	-	-	-	
47630 Public Law 874 - Maint/Operat.	57,578	55,000	55,000	-	0.00%
Total 47000 Federal Revenues	\$ 136,878	\$ 135,000	\$ 135,000	\$ -	0.00%
49000 Other Sources					
49300 Capital Leases Issued	-	-	-	-	
49700 Insurance Recovery	67,894	2,500	2,500	-	0.00%
49800 Transfers In	122,532	125,000	125,000	-	0.00%
49810 City General Fund Transfer	15,493,963	15,493,963	15,493,963	-	0.00%
Total 49000 Other Sources	\$ 15,684,388	\$ 15,621,463	\$ 15,621,463	\$ -	0.00%
48991 Cert SRT Investment Income					
48991 Cert SRT Investment Income	-	-	-	-	

**OAK RIDGE SCHOOLS
FY 2019-20 FYTD BUDGET**

All Funds Summary Revenue

<u>ACCOUNT</u>	<u>2018-2019 Audit Report</u>	<u>2019-2020 Original Budget</u>	<u>2019-2020 Revised Budget</u>	<u>Chg from 2019-2020 Final Budget</u>	<u>Percentage of Increase (Decrease)</u>
Total 48991 Cert SRT Investment Income	\$ -	\$ -	\$ -		
48992 NonCert SRT Investment Income					
48992 NonCert SRT Investment Income	-	-	-	-	
Total 48992 NonCert SRT Investment Income	\$ -	\$ -	\$ -		
Total Fund 141 General Purpose School Fund Revenue	<u>\$ 56,447,193</u>	<u>\$ 59,204,638</u>	<u>\$ 59,158,581</u>	<u>(\$46,057)</u>	<u>(-0.08%)</u>
Total Fund 142 School Federal Projects Revenue	<u>\$ 3,464,619</u>	<u>\$ 3,861,611</u>	<u>\$ 3,861,611</u>	<u>\$0</u>	<u>0.00%</u>
Total Fund 143 Central Cafeteria Revenue	<u>\$ 2,241,825</u>	<u>\$ 2,358,891</u>	<u>\$ 2,358,891</u>	<u>\$0</u>	<u>0.00%</u>
Total Fund 145 Other Education Funds Revenue	<u>\$ 156,735</u>	<u>\$ 181,848</u>	<u>\$ 227,905</u>	<u>\$46,057</u>	<u>25.33%</u>
Total Fund 146 Extended School Program Revenue	<u>\$ 386,137</u>	<u>\$ 473,067</u>	<u>\$ 473,067</u>	<u>\$0</u>	<u>0.00%</u>
Total Revenue All Funds	<u><u>\$ 62,696,509</u></u>	<u><u>\$ 66,080,055</u></u>	<u><u>\$ 66,080,055</u></u>	<u><u>\$ 0</u></u>	<u><u>0.00%</u></u>

**OAK RIDGE SCHOOLS
FY 2019-20 FYTD BUDGET**

All Funds Summary Expenditures

<u>ACCOUNT</u>	<u>2018-2019 Audit Report</u>	<u>2019-2020 Original Budget</u>	<u>2019-2020 Revised Budget</u>	<u>Chg from 2019-2020 Final Budget</u>	<u>Percentage of Increase (Decrease)</u>
71000 Instruction					
71100 Regular Instruction Prgm	26,046,462	26,870,319	26,970,123	99,804	0.37%
71150 Alternative Instruction Prgm	748,627	820,705	820,705	-	0.00%
71200 Special Education Prgm	4,079,164	4,460,027	4,459,917	(110)	(0.00%)
71300 Career/Technical Education Prg	1,123,496	1,265,333	1,295,523	30,190	2.39%
71900 Contingency	-	1,010,000	736,825	(273,175)	(-27.05%)
72000 Support Services					
72120 Health Services	575,773	604,107	604,107	-	0.00%
72130 Other Student Support	1,508,367	1,680,410	1,681,844	1,434	0.09%
72210 Regular Inst. Support	2,599,460	2,765,556	2,781,457	15,901	0.57%
72220 Special Education Support	847,702	828,745	828,745	-	0.00%
72230 Career & Technical Prg Support	106,065	111,349	113,109	1,760	1.58%
72250 Technology Services	2,533,227	2,763,113	2,772,379	9,266	0.34%
72290 Communications	97,828	114,349	116,214	1,865	1.63%
72310 Board of Education	953,863	1,061,487	1,050,750	(10,737)	(-1.01%)
72320 Director of Schools	336,039	356,796	356,796	-	0.00%
72410 Office of the Principal	3,419,741	3,567,705	3,567,705	-	0.00%
72510 Fiscal Services	738,696	806,626	806,626	-	0.00%
72520 Human Resources/ Personnel	352,288	429,455	429,455	-	0.00%
72610 Operation of Plant	4,272,898	4,627,396	4,635,502	8,106	0.18%
72620 Maintenance of Plant	1,753,950	1,642,702	1,642,702	-	0.00%
72710 Transportation	1,240,818	1,522,347	1,524,978	2,631	0.17%
73000 Non-Instuctional Services					
73400 Early Childhood Education	465,349	461,499	460,771	(728)	(-0.16%)
73401 Pre-K General Fund	536,095	654,054	653,943	(111)	(-0.02%)

**OAK RIDGE SCHOOLS
FY 2019-20 FYTD BUDGET**

All Funds Summary Expenditures

<u>ACCOUNT</u>	<u>2018-2019 Audit Report</u>	<u>2019-2020 Original Budget</u>	<u>2019-2020 Revised Budget</u>	<u>Chg from 2019-2020 Final Budget</u>	<u>Percentage of Increase (Decrease)</u>
76100 Capital Outlay					
76100 Regular Capital Outlay	750,720	707,205	775,051	67,846	9.59%
82000 Capital Leases					
82130 Education Principal on Debt	411,755	-	-	-	
82230 Education Interest on Debt	13,245	-	-	-	
99000 Other Uses					
99100 Transfers Out	71,950	73,353	73,353	-	0.00%
Total Fund 141 General Purpose School Fund Expenditures	<u>\$ 55,583,579</u>	<u>\$ 59,204,638</u>	<u>\$ 59,158,581</u>	<u>(\$46,057)</u>	<u>(-0.08%)</u>
Total Fund 142 School Federal Projects Expenditures	<u>\$ 3,464,619</u>	<u>\$ 3,861,611</u>	<u>\$ 3,861,611</u>	<u>\$0</u>	<u>0.00%</u>
Total Fund 143 Central Cafeteria Expenditures	<u>\$ 2,099,640</u>	<u>\$ 2,358,891</u>	<u>\$ 2,358,891</u>	<u>\$0</u>	<u>0.00%</u>
Total Fund 145 Other Education Funds Expenditures	<u>\$ 160,902</u>	<u>\$ 181,848</u>	<u>\$ 227,905</u>	<u>\$46,057</u>	<u>25.33%</u>
Total Fund 146 Extended School Program Expenditures	<u>\$ 398,595</u>	<u>\$ 473,067</u>	<u>\$ 473,067</u>	<u>\$0</u>	<u>0.00%</u>
Total Expenditures All Funds	<u>\$ 61,707,334</u>	<u>\$ 66,080,055</u>	<u>\$ 66,080,055</u>	<u>\$ 0</u>	<u>0.00%</u>

**OAK RIDGE SCHOOLS
FY 2019-20 FYTD BUDGET**

**Fund 141 General Purpose School
Fund Revenue Summary**

<u>ACCOUNT</u>	<u>2018-2019</u> <u>Audit</u> <u>Report</u>	<u>2019-2020</u> <u>Original</u> <u>Budget</u>	<u>2019-2020</u> <u>Revised</u> <u>Budget</u>	<u>Chg from</u> <u>2019-2020 Final</u> <u>Budget</u>	<u>Percentage of</u> <u>Increase</u> <u>(Decrease)</u>
30000 Reserves and/or Fund Balances					
39000 Unassigned Fund Balance	449,521	1,866,151	1,866,151	-	0.00%
40000 - 44000 Local Funds					
40110 Current Property Tax	10,592,827	11,048,443	11,048,443	-	0.00%
40210 Local Option Sales Tax	5,879,500	5,787,581	5,787,581	-	0.00%
40275 Mixed Drink Tax	162	250	250	-	0.00%
40280 Mineral Severance Tax	72	250	250	-	0.00%
43511 Tuition - Regular Day Students	239,192	240,000	240,000	-	0.00%
43513 Tuition - Summer School	10,900	12,000	12,000	-	0.00%
43533 Transportation Fees	4,010	10,000	10,000	-	0.00%
44110 Interest Earned	174,056	150,000	150,000	-	0.00%
44120 Lease/Rentals	14,059	18,000	18,000	-	0.00%
44170 Miscellaneous Refunds	7,922	2,500	2,500	-	0.00%
44530 Sale of Equipment	42,893	35,000	35,000	-	0.00%
44570 Contributions & Gifts	104,927	200,000	200,000	-	0.00%
44990 Other Local Revenues	84,645	75,000	75,000	-	0.00%
46000 State Funds					
46511 Basic Education Program	22,210,310	22,809,000	22,809,000	-	0.00%
46515 Early Childhood Education	465,349	461,500	460,771	(729)	(-0.16%)
46590 Other State Education Funds	196,236	75,000	75,000	-	0.00%
46610 Career Ladder Program	137,405	150,000	150,000	-	0.00%
46640 Vocational Equipment	-	-	-	-	-
46980 Other State Grants	5,220	500,000	454,671	(45,329)	(-9.07%)
46990 Other State Revenues	5,807	7,500	7,500	-	0.00%
47000 Federal Funds					

**OAK RIDGE SCHOOLS
FY 2019-20 FYTD BUDGET**

**Fund 141 General Purpose School
Fund Revenue Summary**

<u>ACCOUNT</u>	<u>2018-2019 Audit Report</u>	<u>2019-2020 Original Budget</u>	<u>2019-2020 Revised Budget</u>	<u>Chg from 2019-2020 Final Budget</u>	<u>Percentage of Increase (Decrease)</u>
47143 Special Education Grants	79,300	80,000	80,000	-	0.00%
47630 Public Law 874 - Maint/Operat.	57,578	55,000	55,000	-	0.00%
49000 Other Sources					
49300 Capital Leases Issued	-	-	-	-	
49700 Insurance Recovery	67,894	2,500	2,500	-	0.00%
49800 Transfers In	122,532	125,000	125,000	-	0.00%
49810 City General Fund Transfer	15,493,963	15,493,963	15,493,963	-	0.00%
99000 Other Uses					
48991 Cert SRT Investment Income	-	-	-	-	
48992 NonCert SRT Investment Income	-	-	-	-	
Total Fund 141 General Purpose School Fund Revenue	\$ 56,447,193	\$ 59,204,638	\$ 59,158,581	-\$46,057	(-0.08%)

**OAK RIDGE SCHOOLS
FY 2019-20 FYTD BUDGET**

**Fund 141 General Purpose School
Fund Expenditures Summary**

<u>ACCOUNT</u>	<u>2018-2019</u> <u>Audit</u> <u>Report</u>	<u>2019-2020</u> <u>Original</u> <u>Budget</u>	<u>2019-2020</u> <u>Revised</u> <u>Budget</u>	<u>Chg from</u> <u>2019-2020 Final</u> <u>Budget</u>	<u>Percentage of</u> <u>Increase</u> <u>(Decrease)</u>
71000 Instruction					
71100 Regular Instruction Prgm	26,046,462	26,870,319	26,970,123	99,804	0.37%
71150 Alternative Instruction Prgm	748,627	820,705	820,705	-	0.00%
71200 Special Education Prgm	4,079,164	4,460,027	4,459,917	(110)	(0.00%)
71300 Career/Technical Education Prg	1,123,496	1,265,333	1,295,523	30,190	2.39%
71900 Contingency	-	1,010,000	736,825	(273,175)	(-27.05%)
72000 Support Services					
72120 Health Services	575,773	604,107	604,107	-	0.00%
72130 Other Student Support	1,508,367	1,680,410	1,681,844	1,434	0.09%
72210 Regular Inst. Support	2,599,460	2,765,556	2,781,457	15,901	0.57%
72220 Special Education Support	847,702	828,745	828,745	-	0.00%
72230 Career & Technical Prg Support	106,065	111,349	113,109	1,760	1.58%
72250 Technology Services	2,533,227	2,763,113	2,772,379	9,266	0.34%
72290 Communications	97,828	114,349	116,214	1,865	1.63%
72310 Board of Education	953,863	1,061,487	1,050,750	(10,737)	(-1.01%)
72320 Director of Schools	336,039	356,796	356,796	-	0.00%
72410 Office of the Principal	3,419,741	3,567,705	3,567,705	-	0.00%
72510 Fiscal Services	738,696	806,626	806,626	-	0.00%
72520 Human Resources/ Personnel	352,288	429,455	429,455	-	0.00%
72610 Operation of Plant	4,272,898	4,627,396	4,635,502	8,106	0.18%
72620 Maintenance of Plant	1,753,950	1,642,702	1,642,702	-	0.00%
72710 Transportation	1,240,818	1,522,347	1,524,978	2,631	0.17%
73000 Non-Instructional Services					
73400 Early Childhood Education	465,349	461,499	460,771	(728)	(-0.16%)
73401 Pre-K General Fund	536,095	654,054	653,943	(111)	(-0.02%)

**OAK RIDGE SCHOOLS
FY 2019-20 FYTD BUDGET**

**Fund 141 General Purpose School
Fund Expenditures Summary**

<u>ACCOUNT</u>	<u>2018-2019</u> <u>Audit</u> <u>Report</u>	<u>2019-2020</u> <u>Original</u> <u>Budget</u>	<u>2019-2020</u> <u>Revised</u> <u>Budget</u>	<u>Chg from</u> <u>2019-2020 Final</u> <u>Budget</u>	<u>Percentage of</u> <u>Increase</u> <u>(Decrease)</u>
76100 Capital Outlay					
76100 Regular Capital Outlay	750,720	707,205	775,051	67,846	9.59%
82000 Capital Leases					
82130 Education Principal on Debt	411,755	-	-	-	
82230 Education Interest on Debt	13,245	-	-	-	
99000 Other Uses					
99100 Transfers Out	71,950	73,353	73,353	-	0.00%
Total Fund 141 General Purpose School Fund Expenditures	<u>\$ 55,583,579</u>	<u>\$ 59,204,638</u>	<u>\$ 59,158,581</u>	<u>-\$46,057</u>	<u>(-0.08%)</u>

**OAK RIDGE SCHOOLS
FY 2019-20 FYTD BUDGET**

**Fund 142 School Federal Projects
Revenue Detail**

<u>ACCOUNT</u>	<u>2018-2019 Audit Report</u>	<u>2019-2020 Original Budget</u>	<u>2019-2020 Revised Budget</u>	<u>Chg from 2019-2020 Original Budget</u>	<u>Percentage of Increase (Decrease)</u>
142 School Federal Projects					
Certain federal funds are allocated to local school systems by the State Department of Education for special federal program initiatives. Such funds are highly restricted in their use and must be account in a separate Federal Projects Fund. FY20 projections are based on preliminary award amounts received from the State in April 2019. (Any carryover amounts will be budgeted from Grant Contingency.)					
47131 Vocational Program Improvement	67,711	71,724	131,707	59,983	83.63%
47139 Other Vocational	-	-	-	-	
47141 Title I	972,289	928,795	946,271	17,476	1.88%
47143 Special Education Grants	1,052,421	998,832	1,153,395	154,563	15.47%
47145 Special Ed Pre-School Grants	32,489	29,791	29,791	-	0.00%
47146 English Lang Acq Grants	13,839	15,065	19,520	4,455	29.57%
47147 Title IV Part B, 21st Century	186,196	187,000	152,625	(34,375)	(-18.38%)
47189 Title II	131,543	121,555	125,016	3,461	2.85%
47590 Other Federal Through State	124,548	568,849	302,104	(266,745)	(-46.89%)
47990 Other Direct Fedral Revenue	883,583	940,000	1,001,182	61,182	6.51%
49800 Transfers In	-	-	-	-	
Total 142 School Federal Projects Revenue	\$ 3,464,619	\$ 3,861,611	\$ 3,861,611	\$0	0.00%

**OAK RIDGE SCHOOLS
FY 2019-20 FYTD BUDGET**

**Fund 142 School Federal Projects
Expenditures Detail**

<u>ACCOUNT</u>	<u>2018-2019 Audit Report</u>	<u>2019-2020 Original Budget</u>	<u>2019-2020 Revised Budget</u>	<u>Chg from 2019-2020 Original Budget</u>	<u>Percentage of Increase (Decrease)</u>
Original Account Distribution	\$ -	\$ 1,145,932	\$ 198,695	\$ (947,237)	(-82.66%)
71100 Regular Instruction Prgm	-	79,474	-	(79,474)	(-100.00%)
71200 Special Education Prgm	-	2,928	-	(2,928)	(-100.00%)
71300 Career/Technical Education Prg	-	26,420	-	(26,420)	(-100.00%)
71900 Contingency	-	500,000	198,695	(301,305)	(-60.26%)
72120 Health Services	-	23	-	(23)	(-100.00%)
72130 Other Student Support	-	4,403	-	(4,403)	(-100.00%)
72210 Regular Inst. Support	-	126,025	-	(126,025)	(-100.00%)
72220 Special Education Support	-	2,826	-	(2,826)	(-100.00%)
72230 Career & Technical Prg Support	-	3,500	-	(3,500)	(-100.00%)
72250 Technology Services	-	-	-	-	
72710 Transportation	-	25,000	-	(25,000)	(-100.00%)
73300 Community Services	-	250,333	-	(250,333)	(-100.00%)
99100 Transfers Out	-	125,000	-	(125,000)	(-100.00%)
030 Head Start PA20	\$ 9,054	\$ -	\$ 8,984	\$ 8,984	
73300 Community Services	9,054	-	8,984	8,984	
031 Head Start PA22	\$ 808,402	\$ 782,808	\$ 818,153	\$ 35,345	4.52%
71100 Regular Instruction Prgm	-	-	-	-	
71200 Special Education Prgm	-	-	-	-	
72210 Regular Inst. Support	-	-	-	-	
73300 Community Services	808,402	782,808	818,153	35,345	4.52%
032 Start-up Head Start Grant	\$ -	\$ -	\$ -	\$ 0	
73300 Community Services	-	-	-	-	
047 Safe Schools Act	\$ -	\$ -	\$ -	\$ 0	
71100 Regular Instruction Prgm	-	-	-	-	

**OAK RIDGE SCHOOLS
FY 2019-20 FYTD BUDGET**

**Fund 142 School Federal Projects
Expenditures Detail**

<u>ACCOUNT</u>	<u>2018-2019</u> <u>Audit</u> <u>Report</u>	<u>2019-2020</u> <u>Original</u> <u>Budget</u>	<u>2019-2020</u> <u>Revised</u> <u>Budget</u>	<u>Chg from</u> <u>2019-2020</u> <u>Original Budget</u>	<u>Percentage</u> <u>of Increase</u> <u>(Decrease)</u>
72210 Regular Inst. Support	-	-	-	-	
73300 Community Services	-	-	-	-	
101 Title I Part A	\$ 972,289	\$ 831,506	\$ 946,271	\$ 114,765	13.80%
71100 Regular Instruction Prgm	709,675	670,526	713,061	42,535	6.34%
72120 Health Services	-	-	-	-	
72130 Other Student Support	41,052	40,597	44,769	4,172	10.28%
72210 Regular Inst. Support	167,666	120,383	119,690	(693)	(-0.58%)
72710 Transportation	10,384	-	14,000	14,000	
73300 Community Services	-	-	-	-	
99100 Transfers Out	43,512	-	54,750	54,750	
202 Title II Part A	\$ 131,543	\$ 26,592	\$ 125,016	\$ 98,424	370.13%
71100 Regular Instruction Prgm	-	-	-	-	
72130 Other Student Support	-	-	-	-	
72210 Regular Inst. Support	125,688	26,592	117,927	91,335	343.47%
72250 Technology Services	1,061	-	-	-	
99100 Transfers Out	4,795	-	7,090	7,090	
303 Title III Part A	\$ 13,839	\$ -	\$ 19,520	\$ 19,520	
71100 Regular Instruction Prgm	-	-	-	-	
71200 Special Education Prgm	-	-	-	-	
72130 Other Student Support	-	-	-	-	
72210 Regular Inst. Support	13,210	-	18,660	18,660	
99100 Transfers Out	629	-	860	860	
411 Title IV Part A	\$ 53,612	\$ 15,077	\$ 82,941	\$ 67,864	450.12%
72120 Health Services	12,278	13,077	12,754	(323)	(-2.47%)
72130 Other Student Support	11,375	-	15,000	15,000	
72210 Regular Inst. Support	26,361	-	51,301	51,301	
72250 Technology Services	1,145	2,000	-	(2,000)	(-100.00%)

**OAK RIDGE SCHOOLS
FY 2019-20 FYTD BUDGET**

**Fund 142 School Federal Projects
Expenditures Detail**

<u>ACCOUNT</u>	<u>2018-2019</u> <u>Audit</u> <u>Report</u>	<u>2019-2020</u> <u>Original</u> <u>Budget</u>	<u>2019-2020</u> <u>Revised</u> <u>Budget</u>	<u>Chg from</u> <u>2019-2020</u> <u>Original Budget</u>	<u>Percentage</u> <u>of Increase</u> <u>(Decrease)</u>
99100 Transfers Out	2,452	-	3,887	3,887	
431 Title IV Part B - 21st Century	\$ 186,196	\$ 11,870	\$ 152,625	\$ 140,755	1,185.80%
73300 Community Services	178,249	11,870	143,468	131,598	1,108.66%
99100 Transfers Out	7,947	-	9,158	9,158	
720 Read to be Ready Summer Grant	\$ 70,936	\$ -	\$ 20,467	\$ 20,467	
71100 Regular Instruction Prgm	56,513	-	14,739	14,739	
72130 Other Student Support	709	-	110	110	
72210 Regular Inst. Support	2,207	-	510	510	
72710 Transportation	10,527	-	5,108	5,108	
73100 Food Service	979	-	-	-	
801 Carl Perkins Act	\$ 62,753	\$ 23,580	\$ 71,707	\$ 48,127	204.10%
71300 Career/Technical Education Prg	45,575	23,580	48,415	24,835	105.32%
72130 Other Student Support	14,108	-	16,000	16,000	
72230 Career & Technical Prg Support	1,076	-	4,190	4,190	
99100 Transfers Out	1,993	-	3,102	3,102	
802 Carl Perkins Secondary Reserve	\$ 4,958	\$ -	\$ 60,000	\$ 60,000	
71300 Career/Technical Education Prg	4,958	-	60,000	60,000	
72130 Other Student Support	-	-	-	-	
72230 Career & Technical Prg Support	-	-	-	-	
892 IDEA Part B Discretionary Supp	\$ 9,384	\$ -	\$ -	\$ 0	
72220 Special Education Support	9,384	-	-	-	
893 IDEA Part B Discretionary	\$ 111,135	\$ 56,330	\$ 95,000	\$ 38,670	68.65%
71200 Special Education Prgm	83,316	56,330	40,000	(16,330)	(-28.99%)
72710 Transportation	23,852	-	55,000	55,000	
99100 Transfers Out	3,967	-	-	-	

**OAK RIDGE SCHOOLS
FY 2019-20 FYTD BUDGET**

**Fund 142 School Federal Projects
Expenditures Detail**

<u>ACCOUNT</u>	<u>2018-2019</u> <u>Audit</u> <u>Report</u>	<u>2019-2020</u> <u>Original</u> <u>Budget</u>	<u>2019-2020</u> <u>Revised</u> <u>Budget</u>	<u>Chg from</u> <u>2019-2020</u> <u>Original Budget</u>	<u>Percentage</u> <u>of Increase</u> <u>(Decrease)</u>
901 IDEA-B	\$ 931,902	\$ 941,894	\$ 1,058,395	\$ 116,501	12.37%
71200 Special Education Prgm	666,164	704,720	763,003	58,283	8.27%
72220 Special Education Support	223,444	237,174	235,829	(1,345)	(-0.57%)
99100 Transfers Out	42,295	-	59,563	59,563	
911 IDEA-B Preschool	\$ 31,165	\$ 26,022	\$ 29,791	\$ 3,769	14.48%
71200 Special Education Prgm	29,824	26,022	28,168	2,146	8.25%
72120 Health Services	-	-	-	-	
99100 Transfers Out	1,341	-	1,623	1,623	
Total 142 School Federal Projects Expenditures	\$ 3,464,619	\$ 3,861,611	\$ 3,861,611	\$0	0.00%

**OAK RIDGE SCHOOLS
FY 2019-2020 FYTD BUDGET**

**Fund 143 Central Cafeteria
Revenue Summary**

<u>ACCOUNT</u>	<u>2018-2019 Audit Report</u>	<u>2019-2020 Original Budget</u>	<u>2019-2020 Revised Budget</u>	<u>Chg from 2019-2020 Original Budget</u>	<u>Percentage of Increase (Decrease)</u>
39000 Unassigned Fund Balance	(5,191)	180,000	180,000	-	0.00%
43521 Lunch Payments - Children	252,303	263,736	263,736	-	0.00%
43522 Lunch Payments - Adults	3,781	4,000	4,000	-	0.00%
43523 Income From Breakfast	25,457	35,951	35,951	-	0.00%
43525 A la Carte Sales	181,743	315,872	315,872	-	0.00%
43990 Other Charges for Food Service	58,930	10,000	10,000	-	0.00%
44110 Interest Earned	4,119	3,000	3,000	-	0.00%
46520 School Food Service	16,455	16,455	16,455	-	0.00%
47111 USDA School Lunch Program	964,331	907,812	907,812	-	0.00%
47112 USDA Commodities	137,666	117,824	117,824	-	0.00%
47113 Breakfast	385,847	342,887	342,887	-	0.00%
47114 USDA - Other	216,384	161,354	161,354	-	0.00%
47590 Other Federal Through State	-	-	-	-	0.00%
Total 143 Central Cafeteria Revenue	<u>\$ 2,241,825</u>	<u>\$ 2,358,891</u>	<u>\$ 2,358,891</u>	<u>\$0</u>	<u>0.00%</u>
73100 Food Service	2,099,640	2,358,891	2,358,891	-	0.00%
Total 143 Central Cafeteria Expenditures	<u>\$ 2,099,640</u>	<u>\$ 2,358,891</u>	<u>\$ 2,358,891</u>	<u>\$0</u>	<u>0.00%</u>

**OAK RIDGE SCHOOLS
FY 2019-20 FYTD BUDGET**

**Fund 145 Other Education Funds
Summary**

<u>ACCOUNT</u>	<u>2018-2019 Audit Report</u>	<u>2019-2020 Original Budget</u>	<u>2019-2020 Revised Budget</u>	<u>Chg from 2019-2020 Original Budget</u>	<u>Percentage of Increase (Decrease)</u>
44990 Other Local Revenues	11,791	32,929	32,929	-	0.00%
46590 Other State Education Funds	72,994	75,545	121,602	46,057	60.97%
49800 Transfers In	71,950	73,374	73,374	-	0.00%
Total Fund 145 Other Education Funds Revenue	<u>\$ 156,735</u>	<u>\$ 181,848</u>	<u>\$ 227,905</u>	<u>\$46,057</u>	<u>25.33%</u>
72130 Other Student Support	102,561	103,986	102,986	(1,000)	(-0.96%)
72210 Regular Inst. Support	21,725	249	3,500	3,251	1,305.62%
72620 Maintenance of Plant	20,658	44,684	88,491	43,807	98.04%
73300 Community Services	15,958	32,929	32,929	-	0.00%
Total Fund 145 Other Education Funds Expenditures	<u>\$ 160,902</u>	<u>\$ 181,848</u>	<u>\$ 227,905</u>	<u>\$46,057</u>	<u>25.33%</u>

**OAK RIDGE SCHOOLS
FY 2019-20 FYTD BUDGET**

**Fund 146 Extended School
Program Revenue Summary**

ACCOUNT		<u>2018-2019</u> <u>Audit</u> <u>Report</u>	<u>2019-2020</u> <u>Original</u> <u>Budget</u>	<u>2019-2020</u> <u>Final</u> <u>Budget</u>	<u>Chg from</u> <u>2019-2020</u> <u>Final Budget</u>	<u>Percentage</u> <u>of Increase</u> <u>(Decrease)</u>
39000	Unassigned Fund Balance	-	-	-		
43581	Community Services Fees Child	385,637	473,067	473,067	-	0.00%
Total 146 Extended School Program Revenue		\$ 385,637	\$ 473,067	\$ 473,067	\$ -	0.00%
73300	Community Services	388,595	463,067	463,067	-	0.00%
99100	Transfers Out	10,000	10,000	10,000	-	0.00%
Total 146 Extended School Program Expenditures		\$ 398,595	\$ 473,067	\$ 473,067	\$ -	0.00%



Oak Ridge Schools

OFFICE OF
Finance Director

Telephone (865) 425-9004

MEMORANDUM

To: Dr. Bruce Borchers, Superintendent of Schools
From: Pat Smith, Finance Director *Pat*
Subject: **FY'20 Budget Transfer #2**
Date: October 21, 2019

The attached FY'20 Budget Transfer #2 includes the following budget transfer requests for Board of Education approval:

- All routine budget transfers and revisions from August 15, 2019 through October 21, 2019 (routine transfers, mostly grants) for Board Approval
- Preschool Building Technology – Smart Boards Project (from Contingency)

The attached FY20 Current Revised Budget Summary provides an overview of the FY20 Revised Budget once these transfers have been approved by the Board of Education.

FY 20 FYTD Budget Summary - Budget Transfer #2

Fund	FY20 Revised Approved Budget (After Approval of Budget Transfer #1)	Budget Transfer #2	FY20 Revised	Budget Total
Fund 141 (General Fund)	\$ 59,205,638.35	\$ (47,057.68)	\$	59,158,580.67
Fund 142 (Federal)	\$ 3,861,611.00	\$ -	\$	3,861,611.00
Fund 143 (Food Service)	\$ 2,358,891.00		\$	2,358,891.00
Fund 145 (Other Education)	\$ 180,847.65	\$ 47,057.68	\$	227,905.33
Fund 146 (Extended Child Care)	\$ 473,067.00		\$	473,067.00
TOTAL All Funds	\$ 66,080,055.00	\$ -	\$	66,080,055.00

Fund 141 Budget Transfers

Fund 141 REVENUES	Account Number	Decrease	Increase
-------------------	----------------	----------	----------

Establish Safe Schools Grant Budget (from 141 Contingency to 145)	141 R 46980 000 000 00000 000	\$ 47,057.68	\$ -
---	-------------------------------	--------------	------

Fund 141 EXPENDITURES	Account Number	Increase	Decrease
-----------------------	----------------	----------	----------

Math & Science Transfer from Supplies to Teacher Stipends	141 E 72210 196 000 00081 000	\$ 1,600.00	\$ -
	141 E 72210 429 000 00081 000	\$ -	\$ 1,600.00

Establish Safe Schools Grant Budget (from 141 Contingency to 145)	141 E 71900 599 000 00000 000	\$ -	\$ 47,057.68
---	-------------------------------	------	--------------

Unused Naka Funds Transfer to Teacher Stipends	141 E 72210 196 000 00068 000	\$ 1,130.63	\$ -
	141 E 72130 599 000 00052 000	\$ -	\$ 1,130.63

Unused Community Tour Funds Transfer to Teacher Stipends	141 E 72210 196 000 00068 000	\$ 3,000.00	\$ -
	141 E 72210 599 000 00000 351	\$ -	\$ 3,000.00

	141 E 71300 116 000 00035 000	\$ 23,350.00	\$ -
	141 E 71300 201 000 00000 000	\$ 205.00	\$ -
	141 E 71300 212 000 00000 000	\$ 50.00	\$ -
	141 E 72130 123 000 00015 000	\$ 827.00	\$ -
	141 E 72130 123 000 00025 000	\$ 828.00	\$ -
	141 E 72130 123 000 00035 000	\$ 910.00	\$ -
	141 E 72210 138 000 00015 000	\$ 7,550.00	\$ -
	141 E 72210 138 000 00050 000	\$ 7,550.00	\$ -
	141 E 72230 105 000 00000 000	\$ 1,760.00	\$ -
	141 E 72230 201 000 00000 000	\$ 55.00	\$ -
Increase Salaries & Benefits Lines for added positions and lane increases for advanced degrees. From Instructional Contingency	141 E 72230 201 000 00035 000	\$ 30.00	\$ -
	141 E 72230 212 000 00000 000	\$ 15.00	\$ -
	141 E 72230 212 000 00035 000	\$ 10.00	\$ -
	141 E 72250 105 000 00000 000	\$ 8,606.00	\$ -
	141 E 72290 105 000 00000 000	\$ 1,755.00	\$ -
	141 E 72290 201 000 00000 000	\$ 55.00	\$ -
	141 E 72290 201 000 00035 000	\$ 30.00	\$ -
	141 E 72290 212 000 00000 000	\$ 15.00	\$ -
	141 E 72290 212 000 00035 000	\$ 10.00	\$ -
	141 E 71100 116 000 00030 000	\$ 49,667.00	\$ -
	141 E 71100 116 000 00000 000	\$ 50,137.00	\$ -
	141 E 71300 207 000 00000 000	\$ 6,585.00	\$ -
	141 E 71900 599 000 00000 000	\$ -	\$ 160,000.00

Transfer Salaries from Teachers to TA lines to align with Budgeted PreK Needs	141 E 73401 163 000 00043 000	\$ 9,100.00	\$ -
	141 E 73401 116 000 00043 000	\$ -	\$ 9,100.00

Preschool Classroom Technology (Smart Boards)	141 E 76100 707 000 00000 438	\$ 47,808.00	\$ -
	141 E 76100 707 000 00000 426	\$ -	\$ 47,808.00

TOTAL		\$ 269,696.31	\$ 269,696.31
--------------	--	----------------------	----------------------

Fund 142 Budget Transfers

Fund 142 REVENUES	Account Code	Decrease	Increase
Establish Title II Carryover Budget	142 R 47590 000 000 00000 000	\$ 3,461.24	\$ -
	142 R 47189 000 202 00000 000	\$ -	\$ 3,461.24
Establish Title III Carryover Budget	142 R 47590 000 000 0000 000	\$ 4,455.22	\$ -
	142 R 47146 000 303 00000 000	\$ -	\$ 4,455.22
Establish Title IV Carryover Budget	142 R 47590 000 000 00000 000	\$ 14,092.18	\$ -
	142 R 47590 000 411 00000 000	\$ -	\$ 14,092.18
Reduction of Title I Budget	142 R 47141 000 101 00000 000	\$ 21,965.00	\$ -
	142 R 47590 000 000 00000 000	\$ -	\$ 21,965.00
Establish CRESO Budget	142 R 47590 000 000 00000 000	\$ 32,240.20	\$ -
	142 R 47990 000 058 00000 000	\$ -	\$ 32,240.20
Establish Head Start Safety Grant Budget	142 R 47590 000 000 00000 000	\$ 141,805.00	\$ -
	142 R 47990 000 034 00000 000	\$ -	\$ 141,805.00
Establish IDEA Discretionary Grant Budget	142 R 47590 000 000 00000 000	\$ 95,000.00	\$ -
	142 R 47143 000 893 00000 000	\$ -	\$ 95,000.00
Establish 21st Century Grant Budget	142 R 47147 000 431 00000 000	\$ 34,375.00	\$ -
	142 R 47590 000 000 00000 000	\$ -	\$ 34,375.00

FUND 142 EXPENDITURES

Increase Decrease

	142 E 72210 196 202 00000 000	\$	12,000.00	\$	-
Establish Title II Carryover Budget	142 E 72210 504 202 00000 000	\$	233.91	\$	-
	142 E 72210 524 202 00000 000	\$	-	\$	8,772.67
	142 E 73300 000 000 00000 000	\$	-	\$	3,461.24

	142 E 72210 499 303 00000 000	\$	1,314.82	\$	-
Establish Title III Carryover Budget	142 E 72210 524 303 00000 000	\$	3,000.00	\$	-
	142 E 99100 504 303 00000 000	\$	140.00	\$	-
	142 E 73300 000 000 00000 000	\$	-	\$	4,454.82

	142 E 72210 189 411 00000 000	\$	1,000.00	\$	-
Establish Title IV Carryover Budget	142 E 72210 499 411 00000 000	\$	1,675.61	\$	-
	142 E 72210 524 411 00000 000	\$	11,602.74	\$	-
	142 E 72250 524 411 00000 000	\$	-	\$	2,000.00
	142 E 99100 504 411 00000 000	\$	-	\$	186.17
	142 E 73300 000 000 00000 000	\$	-	\$	12,092.18

	142 E 71900 000 000 00000 000	\$	21,965.00	\$	-
Reduction & Reallocation of Title I Budget	142 E 71100 429 101 00015 000	\$	500.00	\$	-
	142 E 71100 429 101 00030 000	\$	1,000.00	\$	-
	142 E 71100 429 101 00043 000	\$	213.07	\$	-
	142 E 71100 429 101 00050 000	\$	1,000.00	\$	-
	142 E 72210 524 101 00030 000	\$	3,000.00	\$	-
	142 E 72210 524 101 00050 000	\$	3,000.00	\$	-
	142 E 99100 504 101 00000 000	\$	1,821.93	\$	-
	142 E 72710 399 101 00030 000	\$	-	\$	3,000.00
	142 E 72710 399 101 00050 000	\$	-	\$	3,000.00
	142 E 71100 189 101 00030 000	\$	-	\$	5,000.00
	142 E 71100 189 101 00050 000	\$	-	\$	5,500.00
	142 E 71100 195 101 00043 000	\$	-	\$	16,000.00

Establish CRESO Budget	142 E 73300 399 058 00000 000	\$	25,500.00	\$	-
	142 E 73300 201 058 00000 000	\$	31.00	\$	-
	142 E 73300 204 058 00000 000	\$	50.20	\$	-
	142 E 73300 212 058 00000 000	\$	7.25	\$	-
	142 E 73300 429 058 00000 000	\$	6,651.75	\$	-
	142 E 73300 000 000 00000 000	\$	-	\$	32,240.20

Establish Head Start Safety Grant Budget	142 E 73300 499 034 00043 000	\$	10,668.00	\$	-
	142 E 73300 790 034 00043 000	\$	130,741.00	\$	-
	142 E 99100 504 034 00043 000	\$	396.00	\$	-
	142 E 73300 000 000 00000 000	\$	-	\$	126,554.59
	142 E 71900 000 000 00000 000	\$	-	\$	15,250.41

Establish IDEA Discretionary Grant Budget	142 E 71200 163 893 00035 000	\$	12,318.00	\$	-
	142 E 72710 729 893 00000 000	\$	55,000.00	\$	-
	142 E 71200 163 893 00040 094	\$	-	\$	23,721.00
	142 E 71200 201 893 00040 094	\$	-	\$	1,471.00
	142 E 71200 204 893 00040 094	\$	-	\$	2,522.00
	142 E 71200 206 893 00040 094	\$	-	\$	126.00
	142 E 71200 208 893 00040 094	\$	-	\$	355.00
	142 E 71200 212 893 00040 094	\$	-	\$	344.00
	142 E 71200 299 893 00040 094	\$	-	\$	109.00
	142 E 71900 000 000 00000 000	\$	-	\$	38,670.00

Transfer within Head Start Grant to Meet Program Needs	142 E 73300 116 031 00043 000	\$	-	\$	9,000.00
	142 E 73300 163 031 00043 000	\$	-	\$	11,000.00
	142 E 73300 204 301 00043 000	\$	-	\$	5,000.00
	142 E 73300 207 031 00043 000	\$	530.00	\$	-
	142 E 73300 429 031 00043 000	\$	7,000.00	\$	-
	142 E 73300 499 031 00000 000	\$	3,000.00	\$	-
	142 E 73300 524 031 00043 000	\$	3,470.00	\$	-
	142 E 73300 195 031 00043 000	\$	11,000.00	\$	-

	142 E 73300 105 431 00015 000	\$	11,000.00	\$	-
	142 E 73300 105 431 00045 000	\$	11,700.01	\$	-
	142 E 73300 116 431 00015 000	\$	26,420.00	\$	-
	142 E 73300 116 431 00045 000	\$	6,150.00	\$	-
	142 E 73300 162 431 00015 000	\$	1,800.00	\$	-
	142 E 73300 169 431 00015 000	\$	3,840.00	\$	-
	142 E 73300 169 431 00045 000	\$	7,680.00	\$	-
	142 E 73300 189 431 00015 000	\$	7,340.00	\$	-
	142 E 73300 189 431 00045 000	\$	23,385.00	\$	-
	142 E 73300 201 431 00015 000	\$	3,488.00	\$	-
	142 E 73300 201 431 00045 000	\$	3,395.42	\$	-
	142 E 73300 204 431 00015 000	\$	5,241.00	\$	-
	142 E 73300 204 431 00045 000	\$	4,172.84	\$	-
Establish 21st Century Grant Budget	142 E 73300 212 431 00015 000	\$	731.00	\$	-
	142 E 73300 212 431 00045 000	\$	709.09	\$	-
	142 E 73300 399 431 00015 000	\$	3,470.00	\$	-
	142 E 73300 399 431 00045 000	\$	4,615.88	\$	-
	142 E 73300 429 431 00015 000	\$	328.75	\$	-
	142 E 73300 429 431 00045 000	\$	1,935.51	\$	-
	142 E 73300 524 431 00015 000	\$	600.00	\$	-
	142 E 73300 524 431 00045 000	\$	600.00	\$	-
	142 E 73300 599 431 00015 000	\$	1,540.00	\$	-
	142 E 73300 599 431 00045 000	\$	1,455.00	\$	-
	142 E 99100 504 431 00015 000	\$	4,578.75	\$	-
	142 E 99100 504 431 00045 000	\$	4,578.75	\$	-
	142 E 71900 000 000 00000 000	\$	-	\$	140,755.00

TOTAL		\$	817,979.12	\$	817,979.12
--------------	--	----	-------------------	----	-------------------

Fund 145 Budget Transfers

Fund 145 REVENUES	Account Code	Decrease	Increase
Establish Safe Schools Grant Budget (from 141 Contingency)	145 R 46590 000 047 00000 000	\$ -	\$ 47,057.68

Fund 145 EXPENDITURES	Account Code	Increase	Decrease
Establish Safe Schools Grant Budget (from 141 Contingency)	145 E 72210 524 047 00000 000	\$ 3,251.00	\$ -
	145 E 72620 701 047 00000 000	\$ 43,806.68	\$ -

TOTAL		\$ 47,057.68	\$ 47,057.68
--------------	--	---------------------	---------------------

Oak Ridge Board of Education

Monitoring: Review: Annually, in April	Descriptor Term: <h2 style="margin: 0;">Attendance</h2>	Descriptor Code: 6.200	Issued Date: 10/28/19
		Rescinds: 6.200	Issued: 08/27/18 09/28/15 02/25/13

1 Attendance is a key factor in student achievement and therefore, students are expected to be present
 2 each day school is in session. The Superintendent of Schools/designee shall develop appropriate
 3 administrative procedures to implement this policy.

4
 5 The attendance supervisor shall oversee the entire attendance program which shall include: ¹

- 6
- 7 1. All accounting and reporting procedures and their dissemination;
- 8 2. Alternative program options for students who severely fail to meet minimum attendance
- 9 requirements;
- 10 3. Ensuring that all school age children attend school;
- 11 4. Providing documentation of enrollment status upon request for students applying for new or
- 12 reinstatement of driver's permit or license; and
- 13 5. Notifying the Department of Safety whenever a student with a driver's permit or license
- 14 withdraws from school. ²
- 15

16 Student attendance records shall be given the same level of confidentiality as other student records. Only
 17 authorized school officials with legitimate educational purposes may have access to student information
 18 without the consent of the student or parent(s)/guardian(s). ³

19
 20 Absences shall be classified as either excused or unexcused as determined by the principal/designee.

21
 22 Excused absences shall include:⁴

- 23 1. Personal illness/injury;
- 24 2. Verifiable family emergency;
- 25 3. Death in the family;
- 26 4. Extreme weather conditions;
- 27 5. Religious observances;⁵
- 28 6. ~~College visits;~~
- 29 7. Pregnancy;
- 30 8. School ~~sponsored or school~~-endorsed activities
- 31 9. Summons, subpoena, or court order; or
- 32 10. Circumstances which in the judgment of the principal create emergencies over which the
- 33 student has no control.
- 34
- 35

SCHOOL SPONSORED ACTIVITIES AND POSTSECONDARY SCHOOL VISITS

Students participating in a school sponsored field trip, excursion, competition or postsecondary school visit will be counted present. Board Policy 6.2001 provides specific information regarding postsecondary school visits as well as the required documentation to be counted present during a postsecondary school visit.

The principal shall be responsible for ensuring that:⁶

1. Attendance is checked and reported daily for each class;
2. Daily absentee sheets contain sign in/sign out sheets and indicate students present or absent for the majority of the day;
3. All student absences are verified;
4. Written excuses are submitted for absences and tardiness; and
5. System-wide procedures for accounting and reporting are followed.

TRUANCY

Annually, the Superintendent of Schools/designee will provide written notice to parent(s)/guardian(s) that attendance at school is required. Students shall be present at least fifty percent (50%) of the scheduled school day in order to be counted present. Students may attend part-time days, alternating days, or for a specific amount of time as indicated in their Individualized Education Plan or 504 Plan and shall be considered present for school attendance purposes.⁸ If a student is required to participate in a remedial instruction program outside of the regular school day where there is no cost to the parent(s)/guardian(s) and the school system provides transportation, unexcused absences from these programs shall be reported in the same manner.⁷

A student who is absent five (5) days without adequate excuse shall be reported to the Superintendent of Schools/designee who will, in turn, provide written notice to the parent(s)/guardian(s) of the student's absence. If a parent does not provide documentation within adequate time excusing those absences, or request an attendance hearing, then the Superintendent of Schools/designee shall implement the progressive truancy intervention plan described below prior to referral to juvenile court.

*Progressive Truancy Intervention Plan*⁸

Prior to referral to juvenile court, the following progressive truancy intervention plan will be implemented.

Tier I

Tier I of the progressive truancy intervention plan shall include the following:

1. A conference with the student and the student's parent(s)/guardian(s);
2. An attendance contract, based on the conference, signed by the student, the parent(s)/guardian(s), and an attendance supervisor or designee. The contract shall include:
 - a. A specific description of the school's attendance expectations for the student;
 - b. The period for which the contract is effective; and

1 c. Penalties for additional absences and alleged school offenses, including additional
2 disciplinary action and potential referral to juvenile court; and
3

4 3. Regularly scheduled follow-up meetings to discuss the student's progress.
5

6 **Tier II**

7

8 If a student accumulates additional unexcused absences in violation of the attendance contract in Tier I,
9 the student will be subject to Tier II.
10

11 Under this tier, a school employee shall conduct an individualized assessment detailing the reasons a
12 student has been absent from school. The employee may refer the student to counseling, community-
13 based services, or other services to address the student's attendance problems.
14

15 **Tier III**

16

17 This tier shall be implemented if the truancy interventions under Tier II are unsuccessful.
18

19 These interventions shall be determined by a team formed at each school. The interventions shall
20 address student needs in an age-appropriate manner. Finalized plans shall be approved by the
21 Superintendent of Schools/designee.
22

23 **NON-SCHOOL SPONSORED EXTRACURRICULAR ACTIVITY⁹**

24

25 A principal/designee may excuse a student to participate in non-school sponsored extracurricular
26 activities. The principal shall document the approval in writing and shall excuse no more than ten (10)
27 absences each school year. No later than seven (7) business days prior to the student's absence, the
28 student shall provide documentation to the school as proof of the student's participation along with a
29 written request for the excused absence from the student's parent/guardian. The request shall include
30 the following:
31

- 32 1. Student's name and personal identification number;
- 33
- 34 2. Student's grade;
- 35
- 36 3. The dates of the student's absence;
- 37
- 38 4. The reason for the student's absence; and
- 39
- 40 5. The signatures of the student and parent/guardian.
41
42

43 **RELEASED TIME COURSE¹⁰**

44

1 A principal/designee may excuse a student to attend a course in religious moral instruction for up to
2 one (1) class period per school day. Students shall not be excused during any class which requires an
3 examination for state or federal accountability purposes.

4
5 The student shall submit a written consent form signed by the student's parent/guardian prior to
6 participation in the released time course. The principal/designee shall document the approval in
7 writing. The student shall provide documentation to the principal/designee as proof of the student's
8 participation in the released time course.

9
10 The district shall not be responsible for transporting students to and from the place of instruction.
11

12 Upon submission of the student's transcript from the entity that provided the released time course, the
13 student may be awarded one-half (1/2) unit of elective credit.

14 The Superintendent of Schools/designee shall develop procedures with secular criteria for determining
15 whether credit shall be awarded.
16

17 **MAKE-UP WORK**

18 Make up work for excused or unexcused absences must be requested by the student or parent no later
19 than three (3) days after returning to school.

20 **STATE-MANDATED TESTS/END OF COURSE EXAMS**

21
22 Students who are absent the day of the scheduled End of Course Exams must present a signed doctor's
23 excuse or must have been given an excused release by the principal prior to testing to receive an excused
24 absence. Students who have excused absences will be allowed to take a make-up exam. Excused
25 students will receive an incomplete in the course until they have taken the End of Course Exam.
26

27 Students who have an unexcused absence shall receive a failing grade on the EOC exam which shall be
28 averaged into their final grade.
29

30 **CREDIT/PROMOTION DENIAL**

31
32 Credit/promotion denial determinations may include student attendance, however, student attendance
33 may not be the sole criterion.¹¹ If attendance is a factor prior to credit/promotion denial, the following
34 shall occur:
35

- 36 1. Parents and students shall be advised if a student is in danger of credit/promotion denial due
37 to excessive absenteeism.
- 38 2. Procedures in due process are available to the student when credit or promotion is denied.
39

40 **DRIVER'S LICENSE REVOCATION²**

41
42 More than ten (10) consecutive or fifteen (15) reported unexcused absences by a student during any
43 semester renders a student ineligible to retain a driver's permit or license or to obtain such if of age.

In order to qualify for reclaiming a driver's permit or license, the student must make a passing grade in at least three (3) full unit subjects or their equivalency at the conclusion of a subsequent grading period.

ATTENDANCE HEARING ¹²

Students with excessive (more than five (5)) unexcused absences or those in danger of credit/promotion denial shall have the opportunity to appeal to an attendance hearing committee appointed by the principal. If the student chooses to appeal, the student or his/her parent(s)/guardian(s) shall be provided written or actual notice of the appeal hearing and shall be given the opportunity to address the committee. The committee will conduct a hearing to determine if any extenuating circumstances exist to excuse an absence(s) or to determine if the student has met attendance requirements that will allow him/her to pass the course or be promoted. Upon notification of the attendance committee decision, the principal shall send written notification to the Superintendent of Schools/designee and the parent(s)/guardian(s) of the student of any action taken regarding the excessive unexcused absences. The notification shall advise parent(s)/guardian(s) of their right to appeal such action within two (2) school days to the Superintendent of Schools/designee.

The appeal shall be heard no later than ten (10) school days after the request for appeal is received.

Within five (5) school days of the Superintendent of schools/designee rendering a decision, the student's parent(s)/guardian(s) may request a hearing by the Board, and the Board shall review the record. Following the review, the Board may affirm or overturn the decision of the Superintendent of schools/designee. The action of the Board shall be final.

The Superintendent of schools/designee shall ensure that this policy is posted in each school building and disseminated to all students, parents, teachers and administrative staff.

Legal References

1. TRR/MS 0520-01-03-.08(1)(a); TCA 49-6-3006
2. TCA 49-6-3017(c)
3. 20 USCA § 1232g
4. TRR/MS 0520-01-02-.17(1)(c)
5. TCA 49-6-2904(b)(5)
6. TCA 49-6-3007
7. TCA 49-6-3021
8. TCA 49-6-3007; TCA 49-6-3009
9. TCA 49-6-3022
10. TCA 49-2-130; Public Acts of 2019, Chapter No. 272
11. TCA 49-2-203(b)(7); TCA 49-6-3002(b)
12. TRR/MS 0520-01-02-.17

Cross References

- School Calendar 1.800
- Extracurricular Activities 4.300
- Interscholastic Athletics 4.301
- Field Trips/Excursions/Competitions 4.302
- Reporting Student Progress 4.601
- Promotion and Retention 4.603
- Recognition of Religious Beliefs, Customs, & Holidays 4.803
- Voluntary Pre-K Attendance 6.2011
- Students in Foster Care 6.505
- Students from Military Families 6.506
- Student Records 6.600

Oak Ridge Board of Education

Monitoring: Review: Annually, in April	Descriptor Term: <h2 style="margin: 0;">Attendance</h2>	Descriptor Code: 6.200	Issued Date: 10/28/19
		Rescinds: 6.200	Issued: 08/27/18 09/28/15 02/25/13

1 Attendance is a key factor in student achievement and therefore, students are expected to be present
 2 each day school is in session. The Superintendent of Schools/designee shall develop appropriate
 3 administrative procedures to implement this policy.

4
 5 The attendance supervisor shall oversee the entire attendance program which shall include: ¹

- 6
- 7 1. All accounting and reporting procedures and their dissemination;
- 8 2. Alternative program options for students who severely fail to meet minimum attendance
- 9 requirements;
- 10 3. Ensuring that all school age children attend school;
- 11 4. Providing documentation of enrollment status upon request for students applying for new or
- 12 reinstatement of driver's permit or license; and
- 13 5. Notifying the Department of Safety whenever a student with a driver's permit or license
- 14 withdraws from school. ²
- 15

16 Student attendance records shall be given the same level of confidentiality as other student records. Only
 17 authorized school officials with legitimate educational purposes may have access to student information
 18 without the consent of the student or parent(s)/guardian(s). ³

19
 20 Absences shall be classified as either excused or unexcused as determined by the principal/designee.

21
 22 Excused absences shall include:⁴

- 23 1. Personal illness/injury;
- 24 2. Verifiable family emergency;
- 25 3. Death in the family;
- 26 4. Extreme weather conditions;
- 27 5. Religious observances;⁵
- 28 6. ~~College visits;~~
- 29 7. Pregnancy;
- 30 8. School ~~sponsored or school~~-endorsed activities
- 31 9. Summons, subpoena, or court order; or
- 32 10. Circumstances which in the judgment of the principal create emergencies over which the
- 33 student has no control.
- 34
- 35

SCHOOL SPONSORED ACTIVITIES AND POSTSECONDARY SCHOOL VISITS

Students participating in a school sponsored field trip, excursion, competition or postsecondary school visit will be counted present. Board Policy 6.2001 provides specific information regarding postsecondary school visits as well as the required documentation to be counted present during a postsecondary school visit.

The principal shall be responsible for ensuring that:⁶

1. Attendance is checked and reported daily for each class;
2. Daily absentee sheets contain sign in/sign out sheets and indicate students present or absent for the majority of the day;
3. All student absences are verified;
4. Written excuses are submitted for absences and tardiness; and
5. System-wide procedures for accounting and reporting are followed.

TRUANCY

Annually, the Superintendent of Schools/designee will provide written notice to parent(s)/guardian(s) that attendance at school is required. Students shall be present at least fifty percent (50%) of the scheduled school day in order to be counted present. Students may attend part-time days, alternating days, or for a specific amount of time as indicated in their Individualized Education Plan or 504 Plan and shall be considered present for school attendance purposes.⁸ If a student is required to participate in a remedial instruction program outside of the regular school day where there is no cost to the parent(s)/guardian(s) and the school system provides transportation, unexcused absences from these programs shall be reported in the same manner.⁷

A student who is absent five (5) days without adequate excuse shall be reported to the Superintendent of Schools/designee who will, in turn, provide written notice to the parent(s)/guardian(s) of the student's absence. If a parent does not provide documentation within adequate time excusing those absences, or request an attendance hearing, then the Superintendent of Schools/designee shall implement the progressive truancy intervention plan described below prior to referral to juvenile court.

*Progressive Truancy Intervention Plan*⁸

Prior to referral to juvenile court, the following progressive truancy intervention plan will be implemented.

Tier I

Tier I of the progressive truancy intervention plan shall include the following:

1. A conference with the student and the student's parent(s)/guardian(s);
2. An attendance contract, based on the conference, signed by the student, the parent(s)/guardian(s), and an attendance supervisor or designee. The contract shall include:
 - a. A specific description of the school's attendance expectations for the student;
 - b. The period for which the contract is effective; and

1 c. Penalties for additional absences and alleged school offenses, including additional
2 disciplinary action and potential referral to juvenile court; and
3

4 3. Regularly scheduled follow-up meetings to discuss the student's progress.
5

6 **Tier II**

7

8 If a student accumulates additional unexcused absences in violation of the attendance contract in Tier I,
9 the student will be subject to Tier II.
10

11 Under this tier, a school employee shall conduct an individualized assessment detailing the reasons a
12 student has been absent from school. The employee may refer the student to counseling, community-
13 based services, or other services to address the student's attendance problems.
14

15 **Tier III**

16

17 This tier shall be implemented if the truancy interventions under Tier II are unsuccessful.
18

19 These interventions shall be determined by a team formed at each school. The interventions shall
20 address student needs in an age-appropriate manner. Finalized plans shall be approved by the
21 Superintendent of Schools/designee.
22

23 **NON-SCHOOL SPONSORED EXTRACURRICULAR ACTIVITY⁹**

24

25 A principal/designee may excuse a student to participate in non-school sponsored extracurricular
26 activities. The principal shall document the approval in writing and shall excuse no more than ten (10)
27 absences each school year. No later than seven (7) business days prior to the student's absence, the
28 student shall provide documentation to the school as proof of the student's participation along with a
29 written request for the excused absence from the student's parent/guardian. The request shall include
30 the following:
31

- 32 1. Student's name and personal identification number;
- 33
- 34 2. Student's grade;
- 35
- 36 3. The dates of the student's absence;
- 37
- 38 4. The reason for the student's absence; and
- 39
- 40 5. The signatures of the student and parent/guardian.
41
42

43 **RELEASED TIME COURSE¹⁰**

44

1 A principal/designee may excuse a student to attend a course in religious moral instruction for up to
2 one (1) class period per school day. Students shall not be excused during any class which requires an
3 examination for state or federal accountability purposes.

4
5 The student shall submit a written consent form signed by the student's parent/guardian prior to
6 participation in the released time course. The principal/designee shall document the approval in
7 writing. The student shall provide documentation to the principal/designee as proof of the student's
8 participation in the released time course.

9
10 The district shall not be responsible for transporting students to and from the place of instruction.
11

12 Upon submission of the student's transcript from the entity that provided the released time course, the
13 student may be awarded one-half (1/2) unit of elective credit.

14 The Superintendent of Schools/designee shall develop procedures with secular criteria for determining
15 whether credit shall be awarded.
16

17 **MAKE-UP WORK**

18 Make up work for excused or unexcused absences must be requested by the student or parent no later
19 than three (3) days after returning to school.

20 **STATE-MANDATED TESTS/END OF COURSE EXAMS**

21
22 Students who are absent the day of the scheduled End of Course Exams must present a signed doctor's
23 excuse or must have been given an excused release by the principal prior to testing to receive an excused
24 absence. Students who have excused absences will be allowed to take a make-up exam. Excused
25 students will receive an incomplete in the course until they have taken the End of Course Exam.

26
27 Students who have an unexcused absence shall receive a failing grade on the EOC exam which shall be
28 averaged into their final grade.
29

30 **CREDIT/PROMOTION DENIAL**

31
32 Credit/promotion denial determinations may include student attendance, however, student attendance
33 may not be the sole criterion.¹¹ If attendance is a factor prior to credit/promotion denial, the following
34 shall occur:
35

- 36 1. Parents and students shall be advised if a student is in danger of credit/promotion denial due
37 to excessive absenteeism.
- 38 2. Procedures in due process are available to the student when credit or promotion is denied.
39

40 **DRIVER'S LICENSE REVOCATION²**

41
42 More than ten (10) consecutive or fifteen (15) reported unexcused absences by a student during any
43 semester renders a student ineligible to retain a driver's permit or license or to obtain such if of age.

In order to qualify for reclaiming a driver's permit or license, the student must make a passing grade in at least three (3) full unit subjects or their equivalency at the conclusion of a subsequent grading period.

ATTENDANCE HEARING ¹²

Students with excessive (more than five (5)) unexcused absences or those in danger of credit/promotion denial shall have the opportunity to appeal to an attendance hearing committee appointed by the principal. If the student chooses to appeal, the student or his/her parent(s)/guardian(s) shall be provided written or actual notice of the appeal hearing and shall be given the opportunity to address the committee. The committee will conduct a hearing to determine if any extenuating circumstances exist to excuse an absence(s) or to determine if the student has met attendance requirements that will allow him/her to pass the course or be promoted. Upon notification of the attendance committee decision, the principal shall send written notification to the Superintendent of Schools/designee and the parent(s)/guardian(s) of the student of any action taken regarding the excessive unexcused absences. The notification shall advise parent(s)/guardian(s) of their right to appeal such action within two (2) school days to the Superintendent of Schools/designee.

The appeal shall be heard no later than ten (10) school days after the request for appeal is received.

Within five (5) school days of the Superintendent of schools/designee rendering a decision, the student's parent(s)/guardian(s) may request a hearing by the Board, and the Board shall review the record. Following the review, the Board may affirm or overturn the decision of the Superintendent of schools/designee. The action of the Board shall be final.

The Superintendent of schools/designee shall ensure that this policy is posted in each school building and disseminated to all students, parents, teachers and administrative staff.

Legal References

1. TRR/MS 0520-01-03-.08(1)(a); TCA 49-6-3006
2. TCA 49-6-3017(c)
3. 20 USCA § 1232g
4. TRR/MS 0520-01-02-.17(1)(c)
5. TCA 49-6-2904(b)(5)
6. TCA 49-6-3007
7. TCA 49-6-3021
8. TCA 49-6-3007; TCA 49-6-3009
9. TCA 49-6-3022
10. TCA 49-2-130; Public Acts of 2019, Chapter No. 272
11. TCA 49-2-203(b)(7); TCA 49-6-3002(b)
12. TRR/MS 0520-01-02-.17

Cross References

- School Calendar 1.800
- Extracurricular Activities 4.300
- Interscholastic Athletics 4.301
- Field Trips/Excursions/Competitions 4.302
- Reporting Student Progress 4.601
- Promotion and Retention 4.603
- Recognition of Religious Beliefs, Customs, & Holidays 4.803
- Voluntary Pre-K Attendance 6.2011
- Students in Foster Care 6.505
- Students from Military Families 6.506
- Student Records 6.600

ELA Textbook Adoption Committee

ELEMENTARY	Glenwood	Linden	Willow Brook	Woodland
Kindergarten	Shannon Cupp	Steffanie Greer	Jessica Martin	Amanda Tiller
1 st grade	Jennifer Lanfair	Ginger Adams	Marti Overton	Michelle Large
2 nd grade	Trudy Cartagena	Todd Koob	Liane Aldridge	Amy Brewer
3 rd grade	Amy Kennedy	Jen Cantrell	Jackie Cohn	Leslie Hagan
4 th grade	Katy Miller	Christine Wade	Gary Grimac	Amanda Binder
Rdg Specialist		Stephanie Smith		
ITC Consultant	Heather Henderlight			
Parent		Angela Patterson		

MIDDLE	Jefferson	Robertsville
5 th grade	Melissa Fox	Kathy Douglas
6 th grade	Greta Hensley	Laura Scott
7 th grade	Carmey Sears	Michelle Scott
8 th grade	Chandler Sprouse	Julie Kinder-McMillan
Parent	Vidiya Barnes	Danielle Scott

HIGH	
	Michael Feuer
	Jenny Jordan
	Ginger Flanders
	Elisabeth Denisar
	Jammie Robbin



MEMORANDUM
OAK RIDGE SCHOOLS

Bruce Lay
Office of the Executive Director of School Leadership
Memorandum No. 004

TO: Board of Education

DATE: November 7, 2019

SUBJECT: Student Discipline Code Addendum

To effectively address and discourage student vaping we are recommending the following addendum to the 2019-2020 Oak Ridge Schools Discipline Code. Multiple discussions have been held to develop this addendum, which is supported by all building principals and Dr. Henderson. We are requesting that the addendum be approved at this time but will not enforce the changes until January 1, 2020. This delay implementation will allow us adequate time to communicate the specifics changes of the addendum to students and parents.

Smoking/Tobacco Citations/Electronic Cigarettes

Smoking or the possession or use of any tobacco product including smokeless tobacco and electronic cigarettes in school buildings, on school premises, or at school-related activities is prohibited. (BEP SEC. I-5, TCA 39-17-1601 and school board policy 1.803) Students who are found in possession of tobacco or tobacco products including smokeless tobacco, and electronic cigarettes will be issued a tobacco citation for a court hearing. (T.C.A. 39-17-1505). Electronic cigarettes mean an electronic device that converts nicotine into a vapor that is inhaled by the user. Nicotine vapors or oils will be considered as paraphernalia for the electronic cigarettes. All uses of tobacco including electronic/battery operated nicotine delivery devices, vapor products, and all other associated paraphernalia are prohibited in all of the school district's buildings and in all vehicles that are owned, leased, or operated by the district. Smoking and vaping shall be prohibited in any public seating areas including, but not limited to, bleachers used for sporting events or public restrooms. (School Board policy 1.803)

Student who are vaping or found to be in possession of tobacco or tobacco products on school property including smokeless tobacco, and electronic cigarettes, will be assigned the following consequences:

. First Offense – Student will be *assigned five* days of out of school suspension, receive a tobacco citation and be required to attend a tobacco/vaping education class. The length of the suspension may be

reduced pending the successful completion of the tobacco/vaping education class.

. Second Offense – Student will be assigned seven days of out of school suspension.

. Third Offense – Student will be assigned a long term suspension (10 days or more).

Students who are found to be distributing tobacco or tobacco products, including smokeless tobacco and electronic cigarettes, will be assigned the following consequences:

. 1st Offense – Student will be assigned seven days of out of school suspension, receive a tobacco citation and be required to attend a tobacco/vaping education class. The length of the suspension may be reduced pending the successful completing of the tobacco /vaping education class.

. 2nd Offense – Student will be assigned a long term suspension (10 days or more).

Vaping products containing THC – Student activity involving possession or distribution of products containing THC will be addressed as a Zero Tolerance Offense.

Oak Ridge Schools
CAMPUS LEAVE REQUEST – Overnight Trip

School: Oak Ridge H.S. Date: 7-9-19

The following group requests permission to leave the school campus to participate in the educational activity indicated below. Parental permission will be obtained for each student.

Class/Group Requesting Permission: NJROTC

Educational Activity: Community support and state Representation

Destination: Pearl Harbor, H.I.

Purpose of Trip: Represent the State of Tennessee and the USS Tennessee in the 2020 Pearl Harbor Memorial Parade.

Departure Date: 12-2-20 Departure Time: 0700

Return Date: 12-9-20 Return Time: 0330

Name of School Sponsor: Ryan Nicholls Cell #: 865-712-1924

of Students: 30 # of Adults: 20 Chaperone/Student Ratio: 1:1.5

[The required student/chaperone ratio is one chaperone for each 6 students in grades Pre-K-4 and one chaperone for each 10 students in grades 5-12]

Professional Staff Chaperone(s):

1. Name: Ryan Nicholls Cell #: 865-712-1924

2. Name: Todd Livesay Cell #: 865-924-5590

3. Name: _____ Cell #: _____

4. Name: _____ Cell #: _____

Other Chaperone(s):

1. Name: Tiffany Nicholls Cell #: 865-399-0211

2. Name: Susan Debord Cell #: 865-388-8995

3. Name: George Julian Cell #: 865-805-5225

4. Name: Ben Arnold Cell #: 865-566-5093

Oak Ridge Schools

CAMPUS LEAVE REQUEST – Overnight Trip

Field Trips which exceed \$25,000 must be approved by the School Board, regardless of fund raising, Booster Club participation or other contributions. Please follow these guidelines when requesting approval of such trip:

- 1. Submit an "Item for Action" for the Board Agenda (Principals have directions on submitting Board Agenda Items).
2. Attach as documentation the following items:
- Completed Campus Leave Request
- Details of Trip/Itinerary
- Justification/Explanation of Cost (per student/chaperone/total)
- Financial Arrangements for students who cannot afford trip (if any)
- Insurance Details
- Out of country travel requires a release for each student participant.

Financial Arrangements: (please indicate method)

No Cost [X] Paid by Students [] Paid by School [] Paid by School System

[X] Substitute Required Acot to be charged for Substitute

\$ 3,100 Per Student TOTAL TRIP AMOUNT: \$ 93,000

Provisions for those students unable to pay: Cadets must participate in fundraising to cover the cost of their trip or they may choose to pay out of pocket the entire amount or the difference of fundraising money raised and the total cost of their share.

Other information, comments, and special arrangements: (foreseeable hazards must be identified)

THIS IS NOT A MANDATORY TRIP, strictly voluntary. Cadets will have ample opportunities to fundraise to cover their cost if they wish to attend.

Mode of Transportation: (circle below)

First Student

Transportation Contractor

School System Van

Air Travel

Note: Only ORS employees are authorized to drive school system vans.

School System Van - Name of Driver

Valid Driver's License Verified? Yes No Verified by:

Attach copy/copies of driver's license

Transportation Contractor: Phone #:

(Only approved transportation companies may be used; see ORS website for a list of approved companies)

* Air Travel Flight #'s:

Do not have this information yet, probably Jan. 2020.

Oak Ridge Schools
CAMPUS LEAVE REQUEST – Overnight Trip

Accommodations: Overnight lodging for students must be appropriately selected with student safety, quality of accommodations, cost and location to events as central considerations. Students should be appropriately assigned to rooms and an overnight adult supervision and contact plan should be established and communicated to students.

Hotel/Motel Name: Do not have at this time

Address: _____

City: _____ State: _____ Zip: _____

Phone: _____ Contact Person: _____

Number of Nights: 7 Hotel Rating: _____

School Sponsor Signature: [Signature]

Date: 7-9-19

This Section for Athletic Trip Only

At the high school level up to three events and/or tournaments per season can involve an overnight trip. However, no more than one day of school may be missed for these trips. (Under certain conditions, the Superintendent of Schools or designee may approve additional events.) These trips must be paid entirely from funds outside the Oak Ridge High School Athletic Department. TSSAA Tournament games would be an exception to this policy. (All overnight trips involving middle school athletics require Superintendent or designee approval.)

Number of overnight trips (including this request) requested during the current school year: _____

Athletic Director Signature: _____

Date: _____

Principal's Action: Approved: Disapproved: _____

Principal's Signature: [Signature] Date: 11/14/19

Superintendent or Designee's Action: Approved: _____ Disapproved: _____

Superintendent or Designee's Signature: _____ Date: _____

Board Approval Date (if required): _____

CAMPUS LEAVE / FIELD TRIP PERMISSION FORM



NJ ROTC will take a trip to:
(Name of Group)
Pearl Harbor, HI by Air
(Destination) (mode of transportation)

for the purpose of: Pearl Harbor Memorial Parade

Date: 12/2/20 to: 12/9/20 Expected number of Participants: 30
Time: 0700 to: 0330 Expected number of Chaperones: 20

[Signature]
Teacher/Sponsor of Trip

[Signature]
Principal

Fee Requested (If any)* \$ 0

**In the course of learning throughout the school year, there are always opportunities to go above and beyond what the basic curriculum requires. In such cases, it is customary for the school to request a fee in order to cover the cost of these enhancements. These fees are in no way required and your child will not be denied the opportunity to participate or benefit from any curricular offering as a result of not paying a requested fee. The fees simply allow the district to offset the cost of any additional opportunities.*

Parent: Please ~~complete this form~~ return to: Cheryl Nocholls (teacher) by: 11-1-19 (date).

My child _____ has my permission to go on the Oak Ridge Schools field trip as described above. She/he will abide by the rules of Oak Ridge School and any special rules of the sponsor.

I have read and understand the activities my child will be involved with on this field trip. I understand that the Oak Ridge School System will provide adequate supervision, but as with any activity, injuries may occur. The School System is responsible only for injuries that result from the result from the negligence of their staff. With my signature, I also authorize emergency medical treatment for my child.

I will be responsible for the damage to personal property of others or injury to other people caused by my son/daughter.

Parent/Guardian Name (printed) _____ Parent/Guardian Signature _____ Date _____

Please provide 2 emergency contact phone numbers:

Name/Relationship _____ Number _____
Name/Relationship _____ Number _____



DECEMBER 2, 2020 - ARRIVAL

- Depart US Mainland - Arrive in
- **Honolulu**
- Meet your Local tour escort at the airport baggage claim
- Transfer via private motorcoach to the hotel in Waikiki
- Check in Spend a relaxing evening on **Waikiki Beach** – Dinner on own

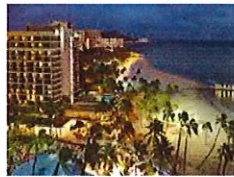

DECEMBER 3 – CIRCLE ISLAND TOUR

- Breakfast provided
- Depart on a circle Island tour where you will see **Diamond Head, Pali Lookout, Dole Plantation, North Shore Beaches and the World famous Banzai Pipeline, Waimea Bay and Sunset Beach**
- Island cooking demonstration with Chief Seilu
- Return to Waikiki in the afternoon
- Dinner and evening to enjoy Waikiki and the Waikiki Beach Walk

DECEMBER 4 – PEARL HARBOR VISIT

- Breakfast provided
- Depart to **Pearl Harbor**. Visit Museum, documentary, board Navy Launch to **USS Arizona Memorial**
- After tour of Pearl Harbor, depart for Ford Island
- Lunch on own
- Visit the **USS Missouri**
- Return to Hotel - Dinner on own then evening to explore the famous **International Market Place**



DECEMBER 5 – FREE DAY TO ENJOY HAWAII

- Breakfast provided
- Day to enjoy optional activities at the discretion of your leaders
- Lunch and dinner on own

DECEMBER 6 – PCC

- Breakfast provided
- Moring at leisure in Waikiki
- Transfer to **Polynesian Cultural Center**
- Lunch on own
- Enjoy the seven Polynesian villages
- **Pageant of the Long Canoes**
- Buffet Dinner at Polynesian Cultural Center –
- Spectacular **HA: The Breath of Life** evening show



DECEMBER 7 – PEARL HARBOR PARADE

- Breakfast provided
- Morning in Waikiki for optional beach activities
- Lunch on own
- 4 pm Gather at **Fort DeRussy**
- 5 pm **Opening Ceremony**
- 6 pm **Pearl Harbor Memorial Parade** down Kalakaua Ave.
- Post Parade Picnic provided



DECEMBER 8 – DEPART FOR HOME

- Breakfast provided
- Morning to spend in Waikiki for optional activities
- Check out of your hotel
- Meet bus for transfer to the airport
- Depart for the Mainland
- Late night arrival (or possible arrival the following morning, December 9)

COMMEMORATIVE PARTNERS



DECEMBER 7
PEARL HARBOR 1941
MEMORIAL PARADE



Dear Ryan Nicholls, MAC (ret) and the Oak Ridge High School JROTC:

2020 will mark the 79th Anniversary of the “day that will live in infamy” – the attack on Pearl Harbor, and the 75th anniversary of the end of WWII. Perhaps unlike any moment in our modern history Americans felt the call of duty to help preserve the freedoms we enjoy in this great country. The sacrifices that were made by so many should be cherished, honored and never forgotten.

We want to take this opportunity to congratulate you and the **Oak Ridge High School JROTC** for being selected as the official ambassador from your state in the 2020 *Pearl Harbor Memorial Parade and 75th anniversary of WWII commemoration*. *Your JROTC Cadets would not only represent the state of Tennessee, but you would represent the veterans of the USS Tennessee during the Pearl Harbor events*. This selection was based on your outstanding reputation and a recommendation from a member of our selection Committee

The Pearl Harbor Memorial Parade is fortunate to have the support from both the *State of Hawaii and the City of Honolulu*. We are also proud to be associated with our partners including the *Pearl Harbor Memorial Fund, the American Veterans Center, Pacific Historic Parks, the Battleship Missouri, Pearl Harbor, The Navy League and the Military Order of the Purple Heart*.

On behalf of the Pearl Harbor Parade Committee we congratulate you and look forward to having the **Oak Ridge HS JROTC** join us in our island state in 2020. Your participation will do much to demonstrate your support for America’s men and women who serve in our military.

Mahalo and we look forward to working with you in 2020!

Sincerely,

Earl T. Hurrey

Earl T. Hurrey
MGySgt USMC (ret)
Selection Committee Chair
Pearl Harbor Memorial Parade Committee

Tour Contract

Ryan Nicholls, ROTC Instructor
 Oak Ridge High School
 1450 Oak Ridge Turnpike
 Oak Ridge, TN 37830

Pearl Harbor Memorial Parade
 7255 E Hampton Avenue, Suite 127
 Mesa, AZ 85209
 FAX: 928.348.7970

PRICE - The price of the performance tour is based on rates in effect on 06/13/2019 for a minimum of 40 persons. Space is reserved for 50 persons. If in the event the total group number falls below 40 persons, an additional charge from \$20 to \$60 per person will be added to your final invoice. Package price includes arrangements for one performing ensemble only. Additional ensembles will incur an additional fee. Statements are adjusted as the group size increases or decreases reflecting rate changes caused by changing the number of participants. Rates of hotel, food cost, transportation cost, etc. are based on your total number traveling. It is the customer's responsibility to keep us informed as these numbers change.

TOUR INCLUSIONS & OPTIONS - The list of package inclusions and options selected by the customer is shown below

7 day/6 night Package	\$1,389.00 / Person
Registration Fee	\$1,000.00 / Group

PAYMENT SCHEDULE - Pearl Harbor Memorial Parade has agreed on a deposit schedule with suppliers in your behalf, to provide the experience you expect at the price we have agreed upon. Prices and services are guaranteed only on the condition that deposits are received from the customer in accordance with the payment schedule above, and are otherwise subject to change. If the customer anticipates any delays, it is important to contact Pearl Harbor Memorial Parade immediately. Notice will be sent 14 days prior to a payment becoming due. Schedule of payments is as follows.

7/1/2019	\$1000 / Group
9/1/2019	\$200 / Person
12/1/2019	\$200 / Person
3/1/2020	\$200 / Person
6/1/2020	\$400 / Person
10/15/2020	100% of total

If an invoice becomes 30 days past due, the customer will incur a \$100 late fee. If an invoice becomes 60 days past due, the customer will incur a \$200 late fee. If an invoice becomes 90 days past due, the customer will incur a \$300 late fee. If full payment is not received by 14 days prior to departure, the customer will incur a \$500 late fee.

CANCELLATION SCHEDULE - Deposits to suppliers, including hotels, bear cancellation penalties in their contracts with Pearl Harbor Memorial Parade. These cancellation penalties and certain administrative expenses result in cancellation penalties as indicated below. The percentages indicated are the percentages of gross billing. Cancellations must be made in writing and are effective on the date of receipt by Pearl Harbor Memorial Parade. The cancellation schedule applies unless modifications are authorized in writing by Pearl Harbor Memorial Parade management.

Ground & Package Cancellation Schedule

\$200 per person	09/01/2019
\$400 per person	01/01/2020
50% of the tour cost	08/01/2020
100% of the tour cost	11/01/2020

Supplemental Hotel Charges (based on)

Supplemental Charges	Per Person	Sub-total
Total Supplemental Charges		\$0.00

SUBSTITUTIONS AND CHANGES IN GROUP SIZE - Substitutions will be allowed up to and including 11/3/2020 at no additional charge. A list of names of all travelers must be submitted by 10/4/2020 to Pearl Harbor Memorial Parade. This will certify the number for billing. In the event this name list is not received by Pearl Harbor Memorial Parade, then the last number submitted to Pearl Harbor

Memorial Parade in writing will be the number certified for billing. The cancellation of a person after 10/4/2020, with no substitution, will follow the cancellation schedule above. The addition of a new participant will be charged at the best price available at the time with all efforts being made by Pearl Harbor Memorial Parade to keep the new participant at the group rate.

OTHER INFORMATION - Capital Management Group, Inc., Pearl Harbor Memorial Parade, and its and their employees, shareholders, subsidiaries, affiliates, officers, directors, agents and assigns (collectively 'Pearl Harbor Memorial Parade') does not own or operate any entity which is to or does provide goods or services for your trip, including, for example, lodging facilities, transportation companies, local ground handlers, food service or entertainment providers, etc. As a result, Pearl Harbor Memorial Parade is not liable for any negligent or willful act or failure to act of any such person, or any other third party not under its control. Without limiting the foregoing, Pearl Harbor Memorial Parade accepts no responsibility for any risk or resulting injury, delay, inconvenience, damage, or death which results from criminal activity, weather or other acts of God, accidents, disease, epidemics, illness, the provision of inappropriate or no medical attention, the demands of indoor or outdoor activities, strikes, political or civil unrest, overbooking, structural or other defective conditions in hotels or other lodging facilities, acts of terrorism, insurrection or revolt, or any other event beyond its direct control. Pearl Harbor Memorial Parade in its sole discretion reserves the right to decline to accept any participant as a member of these trips. Pearl Harbor Memorial Parade reserves the right in its sole discretion to terminate any participant who does not abide by its rules and regulations, and /or whose conduct is deemed to be such as to endanger the participant; the success of the program; or the welfare of other participants, staff members and/or third parties. In the event of such termination, the participant will be sent home at the expense of the participant the amount of which shall be determined exclusively by Pearl Harbor Memorial Parade. In the event of such termination, there will be no refund whatsoever. The participant is personally liable to Pearl Harbor Memorial Parade for any damages caused by improper conduct. Each participant agrees to be video taped and/or photographed and authorizes Pearl Harbor Memorial Parade to use such material in any advertising in any form, and releases Pearl Harbor Memorial Parade from any claims for compensation based on the use of such material. Pearl Harbor Memorial Parade may cancel any trip because of insufficient enrollment or for any other reason. In the event a trip is canceled by Pearl Harbor Memorial Parade, the participant shall have the option of either taking a complete refund of all deposits, and moneys paid, or of selecting an alternate program as full compensation. The school and ensemble understand and agree to be responsible for receiving any permissions or licenses required by copyright for the performance of their music selections. Pearl Harbor Memorial Parade and its partners, owner's officers and affiliates are neither liable nor responsible for any unlicensed music performance and shall be indemnified by the ensemble, and school for any action resulting in unauthorized use of music. The terms set forth in this agreement supersede any oral agreement or any information that may be found on sales brochures, invoices, statements, or other documentation. Any amendment to this agreement must be made in writing and signed by both parties. No refunds can be granted for features in the trip not utilized. The cost of replacing lost or stolen tickets is the responsibility of the passenger. If a flight or transfer by motorcoach or train is missed, participant is responsible to make his or her own arrangements and to pay all charges associated therewith.

ARBITRATION - Any dispute concerning this contract, the brochure or any other advertising material concerning the trip or the trip itself must be resolved exclusively by binding arbitration in Maricopa County, Arizona pursuant to the commercial rules of the American Arbitration Association.

ACCEPTANCE OF CONTRACT - All of the terms of this contract are considered accepted by the customer 30 days after Pearl Harbor Memorial Parade receives the first deposit, whether or not this Letter of Agreement is eventually signed by either party.

I have read and consent to the terms found in this Letter of Agreement.

Ryan Nicholls

Date



Joel Biggs, President, Capital Management Group, Inc.

06/13/2019

Date



OFFICE OF MAINTENANCE AND OPERATIONS

DATE: November 13, 2019

TO: Bruce Lay, Executive Director of Leadership

FROM: Allen Thacker, Supervisor of Maintenance and Operations

SUBJECT: Approval of Preschool Playground Equipment and Surfacing

Mr. Lay,

I am recommending for the Oak Ridge Schools Board of Education approve the purchase and installation of playground surfacing, sun shades, and the disassembly, transport, and reinstallation of existing playground structure for the new Preschool by Great Southern Recreation LLC. Great Southern Recreation has provided a proposal of \$109,483.63 for services and materials based on pricing from the Knox County Schools contract bid 15-646/2286. Knox County Schools was contacted and approved for Oak Ridge Schools to "piggy back" on this contract. In addition, Great Southern Recreation was the original vendor and installer of the equipment on the current Preschool Playground.

Funds for this project are made available through a grant from Head Start and Regular Capital Outlay Site Development 76100 724.

Thank you,

Allen Thacker,
Supervisor of Maintenance and Operations



1-800-390-8438
www.GreatSouthernRec.com

Beautiful Outdoor Spaces, we can ALL be proud of.

ORGANIZATION:	Oak Ridge Schools
CONTACT:	
ADDRESS:	
PHONE:	

PROJECT TITLE:	Oak Ridge Preschool
REVISION:	
OPTION:	Turf and Shade

Official Quote from Great Southern Recreation

TERRITORY MANAGER	DATE	TERRITORY	COUNTY	TERMS	COLORS
Jake Peterman	11/11/2019	2	Anderson	Net 10	TBD

PART NUMBER	QUANTITY	DESCRIPTION	UNIT PRICE	TOTAL	
SD141410IN-AF	1	Superior 14'x14'x10' Pyramid Hip End Shade	\$ 3,234.00	\$ 3,234.00	
Custom	1	Superior Custom 35'x35' Hyperbolic Shade	\$ 15,535.00	\$ 15,535.00	
				\$ -	
				\$ -	
				\$ -	
SUBTOTAL FOR EQUIPMENT				\$ 18,769.00	
Certified Southern-built™ Installation				\$ 15,953.65	
SAFETY SURFACE	5010	Artificial Turf Safety Surface	\$ 10.00	\$ 50,100.00	
		<i>Install into existing surface.</i>			
SUBSTRATE	5010	3" Compacted Crushed Stone Substrate	\$ 2.25	\$ 11,272.50	
BORDER		12" Interlocking Playground Borders		\$ -	
ACCESSIBILITY		6" Interlocking Accessibility Ramp		\$ -	
SAFETY MATS		40" x 40" Black Rubber Swing Mats		\$ -	
MISCELLANEOUS				\$ -	
MISCELLANEOUS				\$ -	
SITework		<i>Sitework Details</i>		\$ -	
DISCOUNT	8%		DISCOUNT	\$ (1,501.52)	
				SUBTOTAL	\$ 94,593.63

TAX RATE	
SALES TAX	-

BONDS	
EQUIPMENT FREIGHT	640.00
SURFACE FREIGHT	1,250.00

TOTAL	\$ 96,483.63
-------	--------------

Please Note Exclusions and Expectations on Attached Contract Form



1-800-390-8438
www.GreatSouthernRec.com

Beautiful Outdoor Spaces, we can ALL be proud of.

ORGANIZATION:	Oak Ridge Schools
CONTACT:	
ADDRESS:	
PHONE:	

PROJECT TITLE:	Oak Ridge Preschool
REVISION:	
OPTION:	Removal, Transport & Reinstall

Official Quote from Great Southern Recreation

TERRITORY MANAGER	DATE	TERRITORY	COUNTY	TERMS	COLORS
Jake Peterman	11/7/2019	2	Anderson	Net 10	TBD

PART NUMBER	QUANTITY	DESCRIPTION	UNIT PRICE	TOTAL
		***Labor Quote ONLY**		\$ -
				\$ -
				\$ -
SUBTOTAL FOR EQUIPMENT				\$ -
Certified Southern-built™ Installation				\$ -
SAFETY SURFACE		Engineered Wood Fiber Safety Surface		\$ -
		<i>Install into existing surface.</i>		
SUBSTRATE		3" Compacted Crushed Stone Substrate		\$ -
BORDER		12" Interlocking Playground Borders		\$ -
ACCESSIBILITY		6" Interlocking Accessibility Ramp		\$ -
SAFETY MATS		40" x 40" Black Rubber Swing Mats		\$ -
MISCELLANEOUS	1	<i>Disassembly, Transport and Reinstallation of Existing Playground.</i>	\$ 13,000.00	\$ 13,000.00
MISCELLANEOUS				\$ -
SITWORK		<i>Sitework Details</i>		\$ -
SUBTOTAL				\$ 13,000.00

TAX RATE	
SALES TAX	-
BONDS	
EQUIPMENT FREIGHT	
SURFACE FREIGHT	
TOTAL	\$ 13,000.00

Please Note Exclusions and Expectations on Attached Contract Form



OFFICE OF COUNTY MAYOR GLENN JACOBS

Procurement Division, 1000 N. Central Street, Suite 100, Knoxville, TN 37917

**Knox County Procurement Division
Extension of Purchase Contract**

Knox County Government desires the extension of the following described Contract with your company.

Vendor: **Great Southern Recreation** Date: **Friday, November 02, 2018**
Phone Number: **678-674-8272** Fax Number:
Contact: **Dustin Graham** Email: **dustin@greatsouthern.com**
Name of Bid: **Playground Equipment**

Contract/Bid Number: **15-646/2285**

Date of Original Award: **02/01/2016**

Buyer: **Tom Seagle** Phone Number: **865-215-5603** Fax Number: **865-215-5778**

Length of Contract Extension: **02/01/2019 through 01/31/2020**

Additional Options to Renew: **Yes** Number of Renewals: **1** (after this renewal)

Please sign and fax back to the Procurement Division indicating your intent to renew or not to renew as indicated below immediately. Please return this signature page to tom.seagle@knoxcounty.org or you may fax it to **865-215-5778**. By signing this document you have agreed to the terms and conditions established in Contract/Bid 15-646/2285 for the contract period stated above. **This contract requires a new Certificate of Insurance naming Knox County as additional insured, a copy of your current Knox County business license (if Applicable) and a new Criminal History Records Check Affidavit.**

Note: Pricing pursuant to Contract/Bid 16-646/2285. All requests for price increases must be approved by the Procurement Division and the using Department.

- Yes, I agree to extend the Contract specified above.
- Yes, with amendment. I agree to extend the contract specified above with amendment. Please attach amendment to this extension.
- No, I Do Not wish to extend the Contract specified above.

I have attached a new Certificate of Insurance naming Knox County as additional insured. Yes _____ No TBD

I have attached a copy of my current Knox County business license. Yes _____ No TBD

I have attached a copy of the Criminal History Records Check affidavit. Yes _____ No TBD

Print Name: Justin Van Title: Buyer
Signature: [Signature] Date: 2/1/18

knoxcounty.org/procurement • phone 865.215.5777 • fax 865.215.5778

AFFIDAVIT OF COMPLIANCE

WITH

TENNESSEE CRIMINAL HISTORY RECORDS CHECK

TENNESSEE CODE ANNOTATED, SECTION 49-5-413

(To be submitted with bid by contractor)

I, [Signature], President or other Principal
Officer of Great Southern Rec, swear or affirm that the
Name of Company

Company is in compliance with Public Chapter 587 of 2007, codified at Tennessee Code Annotated 49-5-413, in effect at the time of this bid submission at least to the extent required of governmental entities. I further swear or affirm that the company is in compliance with Tennessee Code Annotated, § 49-5-413.

[Signature]
President or Principal Officer
For: Great Southern Rec
Name of Company

STATE OF TENNESSEE }
COUNTY OF Davidson

Subscribed and sworn before me by Justin Vance,
President or Principal Officer of Great Southern Recreation

On this 1st day of February, 2019.

[Signature]
Notary Public

My Commission expires: Nov 5, 2019

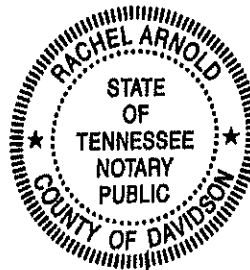

SECTION V VENDOR INFORMATION FOR BID #2285, PLAYGROUND EQUIPMENT

The following pages should be attached as a portion of the bid response. Bidders are welcome to attach additional documentation to fully address any required responses. Please clearly reference any attachments to the appropriate subsection.

- 5.1 Vendor: Great Southern Recreation
 - 5.2 Vendor number as assigned by Knox County: 73348
 - 5.3 Street Address: 2441-A Old Fort Pkwy #462 (*Note: Territory Office located in Knoxville)
 - 5.4 City: Murfreesboro State: TN Zip: 37128
 - 5.5 Telephone Number: 615-671-1809
 - 5.6 Fax Number: _____
 - 5.7 Contact Person: Chris Beaman
 - 5.8 Contact Person's e-mail address: Chris@greatsouthernrec.com
 - 5.9 Authorizing Signature: Chris Beaman
 - 5.10 Vendor's Knox County Business License Number: N/A We can obtain a Knox Co Business Lic if awarded
 - 5.11 State of Tennessee sales tax number: 106526869
 - 5.12 Guaranteed business days for delivery after receipt of a signed purchase order: N/A days
Due to the range of items priced with multiple manufacturers, it is impossible to list anything on this list.
 - 5.13 May other government agencies in Tennessee purchase these items at the same prices per Section 1.9 of this bid? Yes No
 - 5.14 Will you accept payment via e-commerce card as per Section 1.19? Yes No
 - 5.15 Did you include authorized dealer/reseller documentation as per Section 3.6? Yes No
 - 5.16 Did you include the detailed submittal as per Section 4.6? Yes No
 - 5.17 Did you include warranty information as per Section 4.11? *Not 4.11* Yes No
 - 5.18 I acknowledge the receipt of: (please write "yes" if you received one)
Addendum 1 _____ Addendum 2 _____ Addendum 3 _____ Addendum 4 _____
 - 5.19 Do you accept the terms and conditions of the bid? YES NO YES WITH EXCEPTION
(Please circle your answer)
- If you do not fully accept the terms and conditions, please note the exceptions below:

- 5.20 Vendor offers a discount of N/A % if payment is made within 30 days.
 - 5.21 Vendor certifies that the equipment to be provided under this contract will be neither refurbished nor remanufactured.
- Signed: Chris Beaman

SECTION VI PRICING FOR BID #2185, PLAYGROUND EQUIPMENT

- 6.1 Provide percentage discount offered to Knox County Schools from MSRP pricing to purchase playground equipment. 3% Catalog 12% Custm%
- 6.2 Provide a unit price for the purchase and delivery of playground borders to any Knox County School facility. (price per standard section). \$ 8" \$5.85/foot 12" \$7.00/foot
80' minimum
- 6.3 Provide a unit price for the purchase and delivery of gravel drainage fill to any Knox County School facility. (price per cubic yard). \$ 28.00/yd (5 yd min.)
- 6.4 Provide a unit price for the installation of gravel drainage fill. (price per cubic yard). Note: Installation price shall include necessary equipment and transporting material up to 100 yards where necessary. \$ 133/yd (5 yd min.)
- 6.5 Provide a unit price for the purchase and delivery of loose-fill protective surface material to any Knox County School facility. (price per cubic yard). \$ 16/yd + \$375 Freight
- 6.6 Provide a unit price for the installation of loose-fill protective surface material. (price per cubic yard). Note: Installation price shall include necessary equipment and transporting material up to 100 yards where necessary. \$ 127/yd
- 6.7 Provide a unit price for the installation of unitary protective surface material. (price per square foot). Note: Installation price shall include necessary material and equipment required for a complete installation. \$ 10.00/sq ft 50' Epdm
- 6.8 Provide a unit price for the purchase, delivery and installation of surface mats to any Knox County School facility. (price each). \$ 220/per mat
- 6.9 Provide regular hourly labor costs to provide supervisory personnel for equipment/border and/or protective surface installation. \$ 50.00
- 6.10 Provide overtime hourly labor costs to provide supervisory personnel for equipment/border and/or protective surface installation. \$ 75.00
- 6.11 Provide regular hourly labor costs to provide laborers for equipment/border and/or protective surface installation. \$ 100.00 (5 hr min)
- 6.12 Provide overtime hourly labor costs to provide laborers for equipment/border and/or protective surface installation. \$ 1 1/2 original
- 6.13 **INDIVIDUAL PROJECT COST PREPARATION**

Contractor may be required upon request to prepare and submit (prior to commencing work) a written quotation to provide a turn-key project. The quotation shall include all cost required to provide a complete and full installation at a given location. The pricing shall include but not be limited to the cost of design, permits, labor, materials, a detailed description of the scope of work, inspection services, and any required subcontracted services. The quotation shall remain firm for ninety (90) days from the date of receipt by Knox County. All estimation and quotation preparation shall be provided at no cost or obligation to Knox County.

**OFFICIAL FILE DOCUMENT
DO NOT REMOVE OR MARK**



Thank you for the opportunity to bid on #2285 Playground Equipment. We have a lot of experience with district wide school contracts involving playground equipment. We currently handle all things playgrounds for the City of Huntsville School District. We have successfully installed over 12 playgrounds with various unitary surfacing types. We have also become the go to contractor for Murfreesboro City Schools as well as Rutherford County Schools. We take great pride in servicing district wide playground contracts and would thoroughly enjoy the opportunity to perform the same quality service for Knox County.

Great Southern Recreation services 5 states with a home office in Murfreesboro TN and a territory office in Knoxville TN.

I would encourage a meeting after the bids have been submitted to further discuss our capabilities and approach to our methods of servicing district wide playground contracts.

If you have any questions regarding our proposal or would like to set up a meeting, please feel free to contact Chris Berrong. We look forward to your decision.

I am pleased to authorize our proposal for Bid #2285.

Chris Berrong

A handwritten signature in black ink, appearing to read "Chris Berrong", with a long horizontal flourish extending to the right.

615-631-1809

chris@greatsouthernrec.com

OFFICIAL FILE DOCUMENT
DO NOT REMOVE OR MARK

ATTACHMENT A

Knox County Purchasing Division
Insurance Checklist
Proposal Number 2221

THE CERTIFICATE OF INSURANCE MUST SHOW ALL COVERAGES & ENDORSEMENTS WITH "YES" AND ITEMS 20 TO 26

REQUIRED	NUMBER	TYPE OF COVERAGE	COVERAGE LIMITS
YES	1.	WORKERS COMPENSATION	STATUTORY LIMITS OF TENNESSEE
YES	2.	EMPLOYERS LIABILITY	\$100,000 PER ACCIDENT \$100,000 PER DISEASE \$500,000 DISEASE POLICY LIMIT
YES	3.	AUTOMOBILE LIABILITY <input checked="" type="checkbox"/> ANY AUTO-SYMBOL (1)	COMBINE SINGLE LIMIT \$ 1,000,000 (Per -Accident) BODY INJURY (Per -Person) BODY INJURY (Per-Accident) PROPERTY DAMAGE (Per-Accident)
YES	4.	COMMERCIAL GENERAL LIABILITY	LIMITS
		CLAIM MADE <input checked="" type="checkbox"/> OCCUR	EACH OCCURRENCE \$ 1,000,000
			FIRE LEGAL LIABILITY \$ 100,000
			MED EXP (Per person) \$ 5,000
		GEN'L AGGREGATE LIMITS APPLIES PER	PERSONAL & ADV INJURY \$ 1,000,000
		POLICY <input checked="" type="checkbox"/> PROJECT <input type="checkbox"/> LOG <input type="checkbox"/>	GENERAL AGGREGATE \$ 2,000,000 PRODUCTS-COMPLETED OPERATIONS/ AGGREGATE \$ 2,000,000
YES	5.	PREMISES/OPERATIONS	\$1,000,000 CSL BI/PPD EACH OCCURRENCE \$2,000,000 ANNUAL AGGREGATE
YES	6.	INDEPENDENT CONTRACTOR	\$1,000,000 CSL BI/PPD EACH OCCURRENCE \$1,000,000 ANNUAL AGGREGATE
YES	7.	CONTRACTUAL LIABILITY (MUST BE SHOWN ON CERTIFICATE)	\$1,000,000 CSL BI/PPD EACH OCCURRENCE \$1,000,000 ANNUAL AGGREGATE
NO	8.	XCU COVERAGE	NOT TO BE EXCLUDED
YES	9.	UMBRELLA LIABILITY COVERAGE	\$1,000,000
		PROFESSIONAL LIABILITY	
NO	10.	ARCHITECTS & ENGINEERS	\$1,000,000 PER OCCURRENCE/CLAIM
NO		ASBESTOS & REMOVAL LIABILITY	\$2,000,000 PER OCCURRENCE/CLAIM
NO		MEDICAL MALPRACTICE	\$1,000,000 PER OCCURRENCE/CLAIM
NO		MEDICAL PROFESSIONAL LIABILITY	\$1,000,000 PER OCCURRENCE/CLAIM
NO	11.	MISCELLANEOUS E & O	\$500,000 PER OCCURRENCE/CLAIM
NO	12.	MOTOR CARRIER AGT ENDORSEMENT	\$1,000,000 BI/PPD EACH OCCURRENCE UNINSURED MOTORIST (MCS-90)
NO	13.	MOTOR CARGO INSURANCE	
NO	14.	GARAGE LIABILITY	\$1,000,000 BODILY INJURY, PROPERTY DAMAGE PER OCCURRENCE
NO	15.	GARAGEKEEPER'S LIABILITY	\$500,000 COMPREHENSIVE; \$500,000 COLLISION
NO	16.	INLAND MARINE BAILEE'S INSURANCE	\$
NO	17.	DISHONESTY BOND	\$
NO	18.	BUILDERS RISK	PROVIDE COVERAGE IN THE FULL AMOUNT OF THE CONTRACT UNLESS PROVIDED BY OWNER.
NO	19.	USL&H	FEDERAL STATUTORY LIMITS

*Hired and Non Owned Only
Insured has no Owned Autos

20. CARRIER RATING SHALL BE BEST'S RATING OF A-V OR BETTER OR ITS EQUIVALENT.

21. NOTICE OF CANCELLATION, NON-RENEWABLE OR MATERIAL CHANGES IN COVERAGE SHALL BE PROVIDED TO COUNTY AT LEAST 30 DAYS PRIOR TO ACTION. THE WORDS "ENDEAVOR TO" AND "BUT FAILURE TO" (TO END OF SENTENCE) ARE TO BE ELIMINATED FROM THE NOTICE OF CANCELLATION PROVISION ON STANDARD ACCORD CERTIFICATES.

OFFICIAL FILE DOCUMENT 14
DO NOT REMOVE OR MARK

22. THE COUNTY SHALL BE NAMED AS AN ADDITIONAL NAMED INSURED ON ALL POLICIES EXCEPT WORKERS' COMPENSATION AND AUTO.
23. GERTIFICATE OF INSURANCE SHALL SHOW THE PROPOSAL NUMBER AND TITLE.
24. OTHER INSURANCE REQUIRED _____
25. THE CONTRACTOR AGREES TO SAVE, DEFEND, KEEP HARMLESS, INDEMNIFY AND PAY ON BEHALF OF THE COUNTY AND ALL OF ITS AGENTS AND EMPLOYEES (COLLECTIVELY THE COUNTY) FROM AND AGAINST ANY AND ALL CLAIMS, LOSS, DAMAGE, INJURY, COST (INCLUDING COURT COSTS AND ATTORNEY'S FEES), CHARGES, LIABILITY OR EXPOSURE, HOWEVER CAUSED, RESULTING FROM, ARISING OUT OF OR IN ANY WAY CONNECTED WITH THE CONTRACTOR'S PERFORMANCE OF THE AGREEMENT TERMS ON ITS OBLIGATIONS UNDER THE AGREEMENT.

INSURANCE AGENT'S STATEMENT AND CERTIFICATION: I HAVE REVIEWED THE ABOVE REQUIREMENTS WITH THE PROPOSERS NAMED BELOW.

AGENCY NAME:

Miller Laughlin Beach Insurance Services Inc.

AUTHORIZING SIGNATURE:

[Signature]

PROPOSER'S STATEMENT AND CERTIFICATION: IF AWARDED THE CONTRACT, I WILL COMPLY WITH THE CONTRACT INSURANCE REQUIREMENTS.

PROPOSER'S NAME:

Great Southern Recreation

AUTHORIZING SIGNATURE:

Chris Ruy

OFFICIAL FILE DOCUMENT
DO NOT REMOVE OR MARK

ATTACHMENT A
CERTIFICATE OF EXPERIENCE
IFB 2221

I Chds Berrang hereby certify that (company) Great Southern Recreation
has performed the following services within the last three (3) years.

NAME OF BUSINESS THAT WAS SERVICED: Mt. Juliet Park & Rec
CONTACT NAME: Roger Lee
ADDRESS: 2425 N Mt. Juliet Rd EMAIL: rlee@cityofmtjuliet.org
AMOUNT OF CONTRACT: \$ 319,000 PHONE: 615 754 2552 FAX: 615 754 5742
TYPE OF WORK: Planet Playground (Playcraft, Net Climber, Freezones, EWF, matted rubber)

NAME OF BUSINESS THAT WAS SERVICED: City of Knoxville
CONTACT NAME: Mike Harris
ADDRESS: 400 Main Street Knoxville TN 37902 EMAIL: mharris@knoxville.gov
AMOUNT OF CONTRACT: \$ 35,225 PHONE: 865-216-0303 FAX: _____
TYPE OF WORK: E.V. Davidson Playground

NAME OF BUSINESS THAT WAS SERVICED: Huntsville City Schools
CONTACT NAME: Andy Bernard
ADDRESS: 200 White St SE Huntsville AL 35890 EMAIL: andy@tcuconsulting.com
AMOUNT OF CONTRACT: \$ 50K-180K PHONE: 256-520-9890 FAX: _____
TYPE OF WORK: Playgrounds at multiple locations with bonded rubber and artificial turf

OFFICIAL FILE DOCUMENT
DO NOT REMOVE OR MARK

CE-001

State of Tennessee

BOARD FOR LICENSING CONTRACTORS
CONTRACTOR

GREAT SOUTHERN RECREATION, LLC

Please verify the validity that all requirements of the State of Tennessee have been met

ID NUMBER: 00067831

LIC STATUS: ACTIVE

EXPIRATION DATE: 05/31/2016

EC-21

\$500.000.00



IN 1313
DEPARTMENT OF
COMMERCE AND INSURANCE

3105691

299812

OFFICIAL FILE DOCUMENT
DO NOT REMOVE OR MARK



123 North Valley Dr, Grants Pass Oregon
541-955-9199 www.playcraftsystems.com

Great Southern Recreation is the authorized dealer and installer of Playcraft Systems in the states of Tennessee, Mississippi, Georgia, and Alabama.

Great Southern Recreation contain key staff that have been Playcraft certified to install any product manufactured by Playcraft Systems.

CJ Schatza

COO Playcraft Systems

A handwritten signature in black ink, appearing to read "CJ Schatza", is written over the printed name and title.

OFFICIAL FILE DOCUMENT
DO NOT REMOVE OR MARK

AFFIDAVIT OF COMPLIANCE

WITH

TENNESSEE CRIMINAL HISTORY RECORDS CHECK

TENNESSEE CODE ANNOTATED, SECTION 49-5-413

(To be submitted with bid by Contractor)

I, Chris Berrong, President or other Principal

Officer of Great Southern Recreation, swear or affirm that the
Name of Company

Company is in compliance with Public Chapter 587 of 2007, codified at Tennessee Code Annotated 49-5-413, in effect at the time of this bid submission at least to the extent required of governmental entities. I further swear or affirm that the company is in compliance with Tennessee Code Annotated, § 49-5-413.

[Signature]
President or Principal Officer

For: Great Southern Recreation
Name of Company

STATE OF TENNESSEE }
COUNTY OF Knox }

Subscribed and sworn before me by Chris Berrong

President or Principal Officer of Great Southern Recreation

On this 21st day of October 2015.

[Signature]
Notary Public

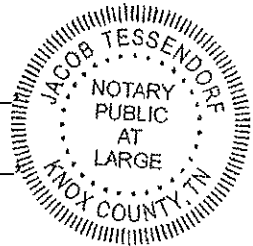

My Commission expires: 07/06/2016

OFFICIAL FILE DOCUMENT
DO NOT REMOVE OR MARK

AFFIDAVIT OF COMPLIANCE
WITH
DRUG-FREE WORKPLACE REQUIREMENTS OF
TENNESSEE CODE ANNOTATED, § 50-9-113

(To be submitted with bid by construction contractor with five (5) or more employees)

I, Chris Berrong, President or other Principal Officer of
Great Southern Recreation, swear or affirm that the
Name of Company

Company has a drug-free workplace program that complies with Title 50, Chapter 9, Tennessee Code Annotated, in effect at the time of this bid submission at least to the extent required of governmental entities. I further swear or affirm that the company is in compliance with Tennessee Code Annotated, § 50-9-113.

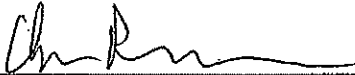
President or Principal Officer
For: Great Southern Recreation
Name of Company

STATE OF TENNESSEE {COUNTY OF Knox }

Subscribed and sworn before me by Chris Berrong
President or Principal Officer of Great Southern Recreation
On this 21st day of October, 2015

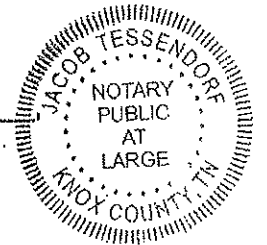
Notary Public
My Commission expires: 07/06/2016



OFFICIAL FILE DOCUMENT
DO NOT REMOVE OR MARK



SHOCK & DRAINAGE PAD

PlayLite™ is the premier Shock & Drainage pad for synthetic turf, pour-in-place and other permanent install play areas and playgrounds. Achieve superior HIC impact protection and stability with our composite panels or rolls.

- Patented Manufacturing Technology
- HIC testing in house - to support playground system design.
- ASTM F1292 + 9 foot fall heights achieved with 2 layers.

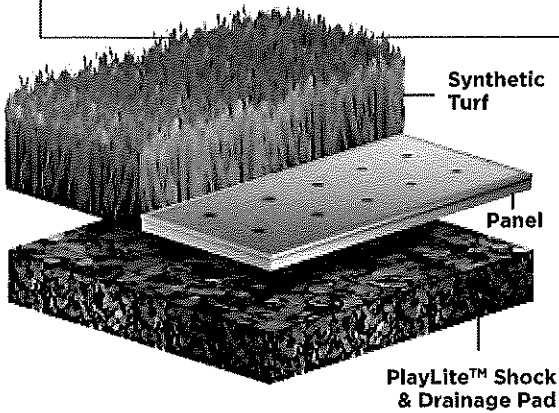
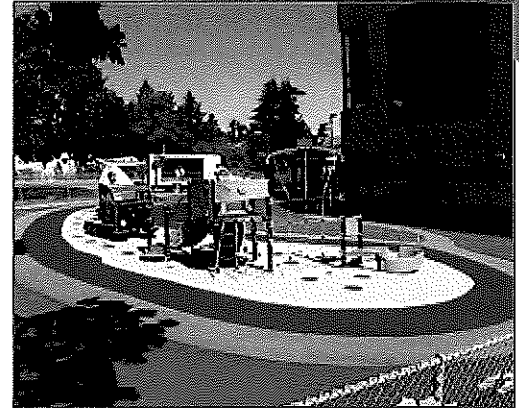

Safety: Properly installed and tested, PlayLite™ will help surpass the shock attenuation properties required for your playground under ASTM F1292 and ASTM F355A for HIC and GMAX ratings.

Sustainability and the Environment:

- Non-toxic
- Synthetic Precipitation Leaching Procedure (SPLP) approved.
- California Proposition 65 compliant.
- LEED® points qualification (Leadership in Energy and Environmental Design)

ThermaGreen SportLite and PlayLite Shock and Drainage Products - New Equipment, expanded Operations and Product Development.

ThermaGreen Environmental has invested significantly over the past 5 years to enhance the quality and overall performance of our products. Participation in ASTM committees and input from architects, designers and our Customers, our products are a seamless component of an integrated system.

New Equipment! To meet increased demand for our products, we have installed production line upgrades and new equipment additions throughout 2017, providing an increase to production capacity. Also, we have expanded our supply and distribution capabilities in the USA, to effectively serve our growth in Customer demand in this market.

To learn more about us and how we may best help you with your next project.

Blu Alexander, Director of Business Development - 1 (647) 216-9021
ThermaGreen Corporate Office - info@thermagreen.com

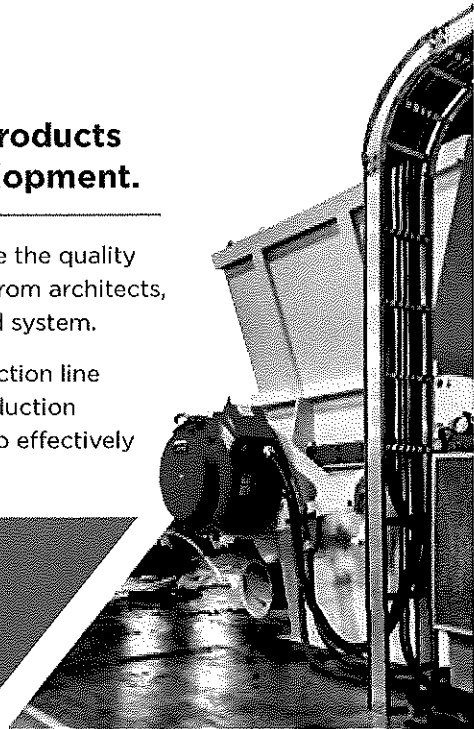



SYNTHETIC TURF
INTERNATIONAL
EXPERIENCE A GREENER WORLD

200 Howell Drive
Dalton, Georgia 30722-2008

LIMITED LIFETIME MANUFACTURER'S WARRANTY

Synthetic Turf International®, LLC, an American company doing business since 1995, stands by its synthetic grass landscape products with this LIMITED LIFETIME MANUFACTURER'S WARRANTY.

Warranty: Synthetic Turf International® warrants that its synthetic grass landscape products will be free from defects in materials and workmanship resulting in significant fiber fading or degradation for the natural and useful life of the products. For the purpose of this warranty, "significant fiber fading or degradation" means a reduction in the original tensile strength of the product by more than fifty percent or a loss of more than fifty percent of the product's original weight. This warranty is provided only to the retail dealer or installer who purchases the products directly from Synthetic Turf International®, and to no other party.

Remedies: For any warranty claim not excluded by the exclusions below, the remedy for such claim is for Synthetic Turf International®, in its sole discretion, to either: (a) provide replacement product of equal or similar construction, style, and value, at a discount corresponding to the prorated value of the warranted product, in a volume sufficient to replace the affected product; or (b) to issue a credit, equal to the prorated value of the affected product, for the purchase of product of equal or similar construction, style, and value. The prorated value of the product is expressed in Exhibit A, which is attached to this warranty and made a part hereof.

Warranty Effectiveness: For this warranty to be effective, the retailer dealer or installer purchasing the products directly from Synthetic Turf International® must sign and date this warranty below, and return the original or a copy thereof to Synthetic Turf International® at the address indicated above. Any claim under this warranty must be made to Controll Products in writing within one (1) year after the date the party provided this warranty knows or has reason to know of the claim.

Other Exclusions: Any coverage under this warranty shall be excluded when the affected products are damaged by:

- Improper installation, improper maintenance (e.g., aeration or heavy raking), or lack of basic maintenance and reasonable upkeep.
- Matting, modest fading, occasional turf shedding, and other normal results of product aging.
- Application of chemicals such as insecticides, herbicides, or fertilizers.
- Excessive or unusual wear and tear from humans, pets, tools, vehicles, or regular sports play.
- Fiber shrinkage or melting due to exposure to reflect light from low-e glass or any other reflective object.
- Accidents, misuse, abuse, neglect, fire, floods, water submersion, vandalism, animal or pest damage, or acts of God.

This warranty is non-transferrable. Synthetic Turf International® **hereby disclaims all other warranties, express or implied, including warranties of merchantability and fitness for a particular purpose.** Synthetic Turf International® hereby also disclaims liability for incidental, consequential, or punitive damages. This document contains the entire warranty for this product. The exclusive venue for any dispute arising out of this warranty shall be the state and federal courts encompassing Dalton, Georgia.

Retail Dealer/Installer (Signature)

Retailer Dealer/Installer (Printed name, date, address,
and telephone number)

EXHIBIT A

<u>Warranty Period</u>	<u>Prorated Value</u>
Years 1 through 4	100%
Years 5 through 6	50%
Years 7 through 10	25%
Years 11 through 12	15%
Years 13 and beyond	5%





PlayLite™, developed by ThermaGreen Environmental, is the Shock & Drainage pad critical for indoor and outdoor play areas. Our pad is manufactured in North America, approved under the NAFTA agreement, and is produced by re-purposing virgin non-contaminated post-industrial cross-linked (closed cell) PEX foam. It is bonded to a non-woven geotextile to create a pad that accommodates a variety of synthetic surface treatments.

ThermaGreen Play products meet energy absorption standards under ASTM F1292 & ASTM F355A for HIC and G_{MAX}. PlayLite™ does not contain or use any toxic substances (i.e. CFC & HCFC) during the manufacturing process; it has passed the Synthetic Precipitation Leaching Procedure (SPLP) for metals, and is compliant under NSF 61 US/Canadian drinking water quality. It is inert, environmentally friendly, resistant to mold and most chemicals (including petroleum products), and helps you obtain LEED credits!

TESTED PROPERTY	TEST METHOD	TYPICAL VALUES	
		SI units	Imperial units

FOAM / GEOTEXTILE COMPOSITE			
Mass per Unit Area	ASTM D3776M-09a	3.0 kg/m ²	0.78 lb/ft ²
Overall Density	ASTM D3575-08-W (A)	120 kg/m ³	7.7 lb/ft ³
Ply Adhesion (200 mm wide specimens)	ASTM D7005-03 mod	0.2 kN/m	1.3 lbf/in
Thermal Stability	ASTM D3575-08-S	< 0.5 %	< 0.5 %

PERFORMANCE PROPERTIES			
Compression Set	ASTM D3575-08-B	8.2 %	8.2 %
Compressive Strength at 25% Deflection	ASTM D3575-08-D	80 kPa	12 psi
In-Plane Flow Rate ⁽¹⁾	ASTM D4716-08	16.6 l/min/m	1.34 gal/min/ft
Permeability ⁽²⁾	ASTM D4491-09	0.31 cm/s	7 inch/min.
Shock Attenuation – 8' fall height ⁽³⁾	ASTM F1292-99	110 - 130 G _{MAX}	630 -780 HIC

GEOTEXTILE (prior to lamination)			
Grab Tensile Strength	ASTM D4632	400 N	90 lb
Grab Tensile Elongation	ASTM D4632	75 %	75 %
Tear Resistance	ASTM D4533	130 N	30 lb
Puncture Resistance	ASTM D6241	1100 N	250 lb
Permittivity	ASTM D4491	2.0 s ⁻¹	2.0 s ⁻¹

DURABILITY AND ENDURANCE PROPERTIES			
Residual properties after 4000 hours water immersion			
Compression Set	ASTM D5322-98 / D3575-08-B	100% retained	
Compressive Strength at 25% Deflection	ASTM D5322-98 / D3575-08-D	> 75% retained	
Residual properties after 4000 hours aging at 85°C/185°F			
Compression Set	ASTM D3045-92 / D3575-08-B	100% retained	
Compressive Strength at 25% Deflection	ASTM D3045-92 / D3575-08-D	> 75% retained	

DIMENSIONS			
Thickness +/- 2 mm (0.08")	ASTM D5199-01	> 25 mm	> 1.0 in
Panel Weight		8.6 kg	19 lbs
Panel Width	-	1.22 m	4 ft
Panel Length (custom lengths available) +/- 1%	-	1.82 m	6 ft
Panel Area	-	2.22 m ²	24 ft ²

(1) In-Plane Flow Rate measured between rigid plates after 15 min seating under 10 kPa and a hydraulic gradient of 0.01

(2) Permeability measured on 4" diameter specimens

(3) Shock attenuation measured using Triax Head-Form Tests. Results will vary depending on actual field configuration and final cross-section design

The technical information is provided by ThermaGreen and to the best of our knowledge, is true and accurate; ThermaGreen assumes no legal responsibility for use or reliance of data.



PlayLite™ MD50PL-NW3-S

PlayLite™, developed by ThermaGreen Environmental, is the Shock & Drainage pad critical for indoor and outdoor play areas. Our pad is manufactured in North America, approved under the NAFTA agreement, and is produced by re-purposing virgin non-contaminated post-industrial cross-linked (closed cell) PEX foam. It is bonded to a non-woven geotextile to create a pad that accommodates a variety of synthetic surface treatments.

ThermaGreen Play products meet energy absorption standards under ASTM F1292 & ASTM F355A for HIC and G_{MAX} . PlayLite™ does not contain or use any toxic substances (i.e. CFC & HCFC) during the manufacturing process; it has passed the Synthetic Precipitation Leaching Procedure (SPLP) for metals, and is compliant under NSF 61 US/Canadian drinking water quality. It is inert, environmentally friendly, resistant to mold and most chemicals (including petroleum products), and helps you obtain LEED credits!

TESTED PROPERTY	TESTED METHOD	TYPICAL VALUES	
		SI units	Imperial units

FOAM / GEOTEXTILE COMPOSITE			
Mass per Unit Area	ASTM D3776M-09a	6.0 kg/m ²	1.2 lb/ft ²
Overall Density	ASTM D3575-08-W (A)	120 kg/m ³	7.7 lb/ft ³
Ply Adhesion (200 mm wide specimens)	ASTM D7005-03 mod	0.2 kN/m	1.3 lbf/in
Thermal Stability	ASTM D3575-08-S	< 0.5 %	< 0.5 %

PERFORMANCE PROPERTIES			
Compression Set	ASTM D3575-08-B	7.4 %	7.4 %
Compressive Strength at 25% Deflection	ASTM D3575-08-D	70 kPa	10 psi
In-Plane Flow Rate ⁽¹⁾	ASTM D4716-08	30.4 l/min/m	2.4 gal/min/ft
Permeability ⁽²⁾	ASTM D4491-09	2.7 cm/s	1.06 inch/s
Shock Attenuation – up to 9' fall height ⁽³⁾	ASTM F1292-99	98.5 G_{MAX}	607 HIC

GEOTEXTILE (prior to lamination)			
Grab Tensile Strength	ASTM D4632	400 N	90 lb
Grab Tensile Elongation	ASTM D4632	75 %	75 %
Tear Resistance	ASTM D4533	130 N	30 lb
Puncture Resistance	ASTM D6241	1100 N	250 lb
Permittivity	ASTM D4491	2.0 s ⁻¹	2.0 s ⁻¹

DURABILITY AND ENDURANCE PROPERTIES			
Residual properties after 4000 hours water immersion			
Compression Set	ASTM D5322-98 / D3575-08-B	100% retained	
Compressive Strength at 25% Deflection	ASTM D5322-98 / D3575-08-D	> 75% retained	
Residual properties after 4000 hours aging at 85°C/185°F			
Compression Set	ASTM D3045-92 / D3575-08-B	100% retained	
Compressive Strength at 25% Deflection	ASTM D3045-92 / D3575-08-D	> 75% retained	

DIMENSIONS			
Thickness +/- 2 mm (0.08")	ASTM D5199-01	> 50 mm	> 2 in
Panel Weight	-	13 kg	29 lbs
Panel Width	-	1.22 m	4 ft
Panel Length (custom lengths available) +/- 1%	-	1.82 m	6 ft
Panel Area	-	2.22 m ²	24 ft ²

(1) In-Plane Flow Rate measured between rigid plates after 15 min seating under 10 kPa and a hydraulic gradient of 0.01

(2) Permeability measured on 4" diameter specimens

(3) Test was performed by independent IPEMA certified Lab using 50mm (2") foam underlay & 50mm (2") synthetic turf over 3" compacted stone base

The technical information is provided by ThermaGreen and to the best of our knowledge, is true and accurate; ThermaGreen assumes no legal responsibility for use or reliance of data.

Section 02790 SYNTHETIC TURF SYSTEMS

Artificial Turf – PL921 SoftLawn Bluegrass Blend

PART 1 – GENERAL

1.01 WORK

- A. Furnishing, delivery, installation and warranty of a complete synthetic turf system including drainage, synthetic turf, and resilient infill material.

1.02 RELATED SECTIONS

- A. Section 02300 – Earthwork
- B. Section 321123 – Aggregate subbase

1.03 REFERENCES

- A. ATSM Standard Test Methods
 - **D1577** – Standard Test Method for Linear Density of Textile Fiber
 - **D5848** – Standard Test Method for Mass Per Unit Area of Pile Yarn Floor Covering
 - **D418** – Standard Test Method for Testing Pile Yarn Floor Covering Construction
 - **D1338** – Standard Test Method for Tuft Bind of Pile Yarn Floor Coverings
 - **D1682** – Standard Method of Test for Breaking Load and Elongation of Textile Fabrics
 - **D5034** – Standard Test Method of Breaking Strength and Elongation of Textile Fabrics (Grab Test)
 - **F1551** – Standard Test Methods for Water Permeability
 - **D2859** – Standard Test Method for Ignition Characteristics of Finished Textile Floor Covering Materials
 - **F355** – Standard Test Method for Shock-Absorbing Properties of Playing Surfaces
 - **D1557** – Test Method for Laboratory Compaction Characteristics of Soil Using Modified Effort.
- B. STC Suggested Guidelines for the Essential Elements of Synthetic Turf Systems

1.04 PROJECT CONDITIONS

- A. Coordinate all work with the work of other sections to avoid delay and interference with other work.

Section 02790 SYNTHETIC TURF SYSTEMS

Artificial Turf – PL921 SoftLawn Bluegrass Blend

- B. Protect excavations by shoring, bracing sheeting, underpinning, or other methods as required to prevent cave-ins or loose dirt from entering excavations. Barricade open excavations and post warning lights at work adjacent to public streets and walks.

1.05 SITE INSPECTION

- A. The inspection shall include a check for planarity. The finished surface shall not vary from a true plane more than 1/4" in 10 feet when measured in any direction. The Contractor shall provide all required tools and materials needed for the planarity check, which may include but not be limited to, a laser level, string line, straight edge and/or other assessment materials. The Contractor shall mark in the field any deviations from grade in excess of those specified above, as well as provide a marked up plan locating the deviations. The Contractor shall correct any deviations to the satisfaction of the Engineer and Synthetic Turf installer.
- B. The compaction of aggregate base shall be 95% to Standard Proctor and surface tolerances shall not exceed 1/4" over 10 feet.
- C. The Contractor shall have a state registered surveyor conduct an elevation survey of the area in a 25' grid to determine and verify that subgrade elevations and slopes are within previously specified tolerances. This elevation survey may require further verification of smaller areas within the 25' grid if determined necessary by the Engineer.
- D. When any or all corrective procedures have been completed, the finished sub-base surface must be re-inspected, with the same representatives attending as the initial inspection. If required, additional repair and inspections are to be conducted until the subbase surface is deemed acceptable by the Engineer and Synthetic Turf Installer
- E. Once the sub-base surface has been deemed acceptable, the Contractor shall submit a written certificate indicating the acceptance of:
 - 1. The sub-base construction finished surface as totally suitable for the application of the selected synthetic turf system, and
 - 2. The sub-base construction as totally suitable for work under this section to proceed with the final installation and fully warrant the athletic surface installation for the period and conditions specified herein.
- F. Commencement of work under this section shall constitute acceptance of the work completed under other sections by the Contractor, acceptance of dimensions of the subbase, and hence, no claims for extra work based upon these conditions will be permitted.

Section 02790 SYNTHETIC TURF SYSTEMS

Artificial Turf – PL921 SoftLawn Bluegrass Blend

1.06 ENVIRONMENTAL CONDITIONS

- A. Install synthetic turf surfacing only when ambient air temperature is 35 F or above and the relative humidity is below 35% or as specified by the product manufacturer. Installation will not proceed if rain is imminent.
- B. Install product only when prepared base is suitably free of dirt, dust, and petroleum products, is moisture free and sufficiently secured to prevent unwanted pedestrian and vehicular access.
- C. Maintain all benchmarks, monuments, and other reference points. If disturbed or destroyed, replace as directed.
- D. Adjacent streets, sidewalks, and property shall be kept free of mud, dirt, or similar nuisances resulting from earthwork operations.

1.07 QUALITY CONTROL

- A. **Manufacturer Qualifications:** Company specializing in manufacturing products specified in this section. The Turf Manufacturer:
 - 1. Basis of design shall be “SoftLawn Bluegrass Blend” synthetic turf system as provided by STI™. Contact: Nathan Chance – (615) 796-9891
 - 2. Materials other than those listed must be approved 15 days prior by written addendum. Materials from non-approved manufacturers will not be accepted.
 - 3. Must be experienced in the manufacturing of tall pile synthetic infill grass systems with the same fiber as specified.
 - 4. Manufacturer must be a member in good standing with the STC.
 - 5. Manufacturer must utilize best practices as certified by ISO-9001 and ISO-14001.
 - 6. Manufacturer must be owned and operated in the U.S.A.
 - 7. Manufacturer must have no periods of insolvency over the last 25 years.
- B. **Installer Qualifications:** Company specializing in performing the work of this section.
 - 1. The Synthetic Turf Installer must provide competent workmen skilled in this type of synthetic grass installation. All technicians must have installed similar synthetic turf.
- C. Prior to the beginning of installation, the Synthetic Turf Installer shall inspect the subbase. The installer will accept the sub-base in writing when the general contractor provides test results for compaction, planarity and permeability that are in compliance with the synthetic turf manufacturer’s recommendations and as stated herein.

Section 02790 SYNTHETIC TURF SYSTEMS

Artificial Turf – PL921 SoftLawn Bluegrass Blend

- D. Remove defective Work, whether the result of poor workmanship, defective products or damage, which has been rejected by the Engineer as unacceptable. Replace defective work in conformance with the Contract Documents.

1.08 SUBMITTALS

A. Submit the following with Proposal:

1. Submit the exact product name/description as well as the name and location of the manufacturers and suppliers of each component. Manufacturers and suppliers must not be changed after the contract is awarded unless approved by the Owner in writing.
2. Submit two (2) samples, 12"x12" minimum size, illustrating details of finished product as bid, including full cross section of subbase, turf, and infill material.
3. Product Literature: Submit two (2) copies of manufacturer's recommended installation and maintenance information, including any technical criteria for evaluation of the installed product. Descriptions of all equipment recommended for the maintenance and repair of turf product, as well as a list of any activities not recommended relative to the warranty.
4. Submit a 1-lb sample of the selected bid infill material(s).
5. A letter and specification sheet certifying that the products of this section meet or exceed specified requirements.
6. Certified copies of independent (third-party) laboratory reports on ASTM tests as follows:
 - a. Pile Height, Face Width & Total Fabric Weight, ASTM D418 or D5848
 - b. Primary & Secondary Backing Weights, ASTM D418 or D5848
 - c. Tuft Bind, ASTM D1335
 - d. Grab Tear Strength, ASTM D1682 or D5034
7. ASTM test submittals may vary by no more than ¼" and 6 oz. of the specified product to bid. Bid winner must show NEW ASTM TESTS with contract submittals.
8. Name and experience of the designated supervisory personnel assigned to this project shall be submitted with the proposal. Changes to this assignment after contract can only be made if approved in writing by the Owner. Include a listing of other on-site personnel and their experience.
9. The Synthetic Turf Installer and Turf Manufacturer shall provide evidence that the turf system does not violate any other manufacturer's patents, patents allowed or patents pending.

Section 02790 SYNTHETIC TURF SYSTEMS

Artificial Turf – PL921 SoftLawn Bluegrass Blend

1.09 WARRANTY

- A. The Contractor shall provide a minimum eight (8) year warranty policy by the manufacturer, against defects in materials and workmanship. Defects shall include, but not be limited to ultraviolet ray fading, degradation, or excessive wear of fiber.
- B. Warranty shall be for full replacement of any damaged product within the warranty period. Warranty shall be comprehensive and sufficient to replace all turf if necessary.
- C. Warranty shall become effective from the date of substantial completion.
- D. The Warranty shall contain no usage limits for warranted turf.
- E. Submit Manufacturer Warranty and ensure that forms have been completed in Owner's name and registered with Manufacturer.

PART 2 PRODUCTS

2.01 SUPPLIER QUALIFICATIONS

- A. The Owner has conducted an extensive review of synthetic turf products, including visiting installed sites and review of other agencies' review criteria. Based upon their research, they have established the following criteria for acceptance of a synthetic turf product. No variation from these criteria shall be allowed. The Owner's review is considered final.
- B. The Synthetic Turf Installer shall have minimum experience of at least 5 years, actively selling, installing and maintaining in-fill synthetic turf project of similar size.
- C. The Synthetic Turf Installer must provide a list of references based on previous installations.
- D. Installation team shall be established, insured installation firm experienced as a premium turf installer with suitable equipment and supervisory personnel, with a minimum of 5 years' experience with 15 foot wide tufted materials.

2.02 TURF SYSTEM

- A. **Turf Fiber:**
 - 1. The turf fiber must be tufted to the backing with a minimum tuft bind of 10 pounds.
 - 2. The tufted fiber weight shall be a minimum of 55 ounces per square yard.
 - 3. The turf fiber shall be non-abrasive and a minimum of 100 microns thick.
 - 4. The turf fiber must contain less than 100 ppm of lead chromate in all colors.
 - 5. The turf fibers must be from the same dye lots.

Section 02790 SYNTHETIC TURF SYSTEMS

Artificial Turf – PL921 SoftLawn Bluegrass Blend

6. The turf fibers must be guaranteed for a period of Eight Years not to fade or fail (as distinguished from a change in texture) or have a pile height decrease to 50% of pile height as result of UV degradation.
7. The turf fiber must retain a minimum of 75% of its original fibril width after 10,000 cycles on the Lisport Studded Roll Test Machine.
8. The pile fiber shall possess the following characteristics:

Characteristic	Value	Test
Linear Density (Denier)	13600	ASTM D 1577
Yarn Thickness	100 Microns (PE mono); 100 Microns (PP)	ASTM D 3218
Tensile Strength	71 N (PE Mono); 16 N (PP)	ASTM D 2256
Pile Weight*	55 oz./yd ²	ASTM D 5848
Fiber manufacturer must be from the same source		
The above specifications are nominal. *Values are +/- 5%.		

9. The pile fabric shall possess the following physical characteristics

Characteristic	Value	Test
Finished Pile Height*	1.75" (45mm)	ASTM D 5823
Product Weight (total)*	82 oz./yd ²	ASTM D 3218
Primary Backing Weight*	7.4 oz./yd ²	ASTM D 2256
Secondary coating Weight**	20 oz./yd ²	ASTM D 5848
Fabric Width	15' (4.57m)	ASTM D 5793
Tuft Gauge	3/8"	ASTM D 5793
Grab Tear Strength	200-1b-F	ASTM D 5034
Tuft Bind	>10-1b-F	ASTM D 1335
Infill (Sand)	2 lbs Silica Sand	None
Infill (Rubber)	N/A	None
Except where noted as a minimum, the above specifications are nominal.		
* Values are +/- 5%. **All values are +/- 3 oz./yd ² .		

B. Backing Material

a. Primary Backing:

Section 02790 SYNTHETIC TURF SYSTEMS

Artificial Turf – PL921 SoftLawn Bluegrass Blend

- i. Primary backing must be a dual layered woven polypropylene material, ArmorLoc™3L.
 - ii. Primary backing system weight must be a minimum of 7.0 ounces/square yard.
- b. Secondary Backing:**
- i. Secondary backing system weight must be a minimum of 20 ounces/square yard.
 - ii. Secondary backing SilverBack™ shall saturate the primary backing and effectively lock the fiber tufts in place to the primary backing.
 - iii. Secondary backing must be a heat activated polyurethane coating with **no vegetable based polyols**.
 - iv. Secondary backing system shall have minimum tuft bind strength of 10 pounds.
 - v. Secondary backing must have Drainage Perforations: 3/16" to ¼" diameter at 4 inches or less on center each way. Non-perforated backing is not acceptable.
- C. Turf roll seams:** to be sewn or glued on site so that no openings larger than the porous backing mat openings are created. All turf fabric edges to be securely bound as per the perimeter detail design. Adhesives for joining seams of turf together shall be Nordot 34G Glue, Mapei 2K, Turf Claw, hot melt technology or equivalent. No substitutions.
- D. Fabric surface:** shall be constructed and installed in minimum widths of 15 feet with no longitudinal or transverse seams.
- E.** The entire system shall be resistant to weather, including ultra-violet light and heat degradation; insects, rot, mildew and fungus growth and be non-allergenic and non-toxic.
- F.** The turf material shall be non-combustible and pass the DIN standard Pill Burn test or ASTM D 2859.

2.03 SYNTHETIC GLUE MATERIAL

- A. Adhesive products shall be Nordot 34G, Mapei 2K, Turf Claw, hot melt technology or equivalent as approved by the engineer.
- B. Any adhesive products required for the installation of a proposed turf system shall be purpose-suited to the system. The material and application methods shall be as recommended by the adhesive manufacturer.
- C. Disposal of adhesive containers and unused adhesives as well as any fees resulting from such disposal shall be the responsibility of the Contractor.

Section 02790 SYNTHETIC TURF SYSTEMS

Artificial Turf – PL921 SoftLawn Bluegrass Blend

2.04 INFILL MATERIAL

- A. The synthetic infill material shall consist of a blend of graded, silica sand and treated and mixed ground rubber.
1. Sand: specially-graded, dust-free silica sand shall be placed on the turf in a minimum quantity of 1 pound/ square foot and shall include test results that demonstrate the following minimum properties:
 - a. Color – tan
 - b. Sand shall be round non-angular in shape
 - c. Roundness – 0.6+
 - d. Hardness - 0.6-0.8 on the Mohs Scale
 - e. Size – 1.00 mm ± 0.15 mm
 - f. Density – 90 – 95 lbs/ cu ft.
 - g. Dust - < 0.001 %
 - h. Angle of Repose - < 30°
 - i. Sand shall be heavy metal safe
 2. Rubber: Rubber is SBR ambient (styrene butadiene rubber) rubber, color black, 10-18 mesh, that is 99% fiber free and is heavy metal safe. Rubber shall be placed on the turf in a minimum quantity as referenced the table in Section 2.02 in this document and shall be of the following Mesh Size Distribution:

Mesh Size	% Retained
a. 10	0-15%
b. 12	5-30%
a. 16	40-70%
b. 20	15-35%
c. 30	0-10%
d. 40	0-1%
e. Pan	0-1%

PART 3 EXECUTION

3.01 GENERAL

- A. Installation of the synthetic turf system is to comply with the manufacturer's recommendations, requirements and the reviewed and approved shop drawings.
- B. Perform all work in strict accordance with the Contract Documents and the manufacturer's specifications and instructions. Only those skilled technicians proposed in the bid phase are to be assigned to this project by the Contractor.

Section 02790 SYNTHETIC TURF SYSTEMS

Artificial Turf – PL921 SoftLawn Bluegrass Blend

- C. The designated Supervisor for the Synthetic Turf Installer must be present during any and all construction activity associated with the field installation, including testing, cleanup and training.
- D. All products and equipment are to be from sources approved by the authorized turf manufacturer and conform to the specifications.

3.02 PRODUCT DELIVERY, STORAGE & HANDLING

- A. Deliver products to site in original containers and wrappers as agreed between the Engineer and Contractor. Inspect products upon delivery for damage.
- B. Store products in a location and in a position that protects them from crush damage or any other defects.
- C. Handle and store (on and off site) all materials safely to ensure their physical properties are not adversely affected and that they are not subject to vandalism or damage.
- D. Rubber and sand infill shall arrive dry and loose.
- E. Adhesives shall arrive in dry, sealed containers.

3.03 TURF INSTALLATION

- A. Install synthetic turf system in accordance with the manufacturer's written installation instructions.
- B. Turf shall be attached to the perimeter edge as shown in the construction plans and as per the manufacturer.
- C. All seams shall be brushed thoroughly before infill materials are installed.
- D. All terminations shall be as detailed and approved in the shop drawings.

3.04 INFILL INSTALLATION

- A. The synthetic turf shall be thoroughly brushed prior to installation of infill materials to remove wrinkles.
- B. Turf shall remain free draining at all times before, during and after the infill materials are installed.

3.05 CLEANING AND COMPLETION

- A. Protect all installed work from other construction activities as installation progresses.
- B. The Contractor shall keep the area clean throughout the construction period and free from the installation process, including track surfaces.
- C. Upon completion of the installation, thoroughly clean surfaces and site of all refuse resulting from the installation process, including track surfaces.

Section 02790 SYNTHETIC TURF SYSTEMS

Artificial Turf – PL921 SoftLawn Bluegrass Blend

- D. Any damage to existing fixtures or facilities resulting from the installation of the synthetic turf system shall be repaired to original condition at the Contractor's expense prior to Substantial Completion and commencement of the Warranty Period.
- E. A deficiency list will be produced by the Engineer at the conclusion of the project. All installation project deficiencies not in dispute must be remedied by the Contractor prior to the issuance of a certificate of Substantial Completion.
- F. Contractor to provide a written acceptance by the Turf Manufacturer that the turf and base system is installed in accordance with their recommendations prior to final completion.

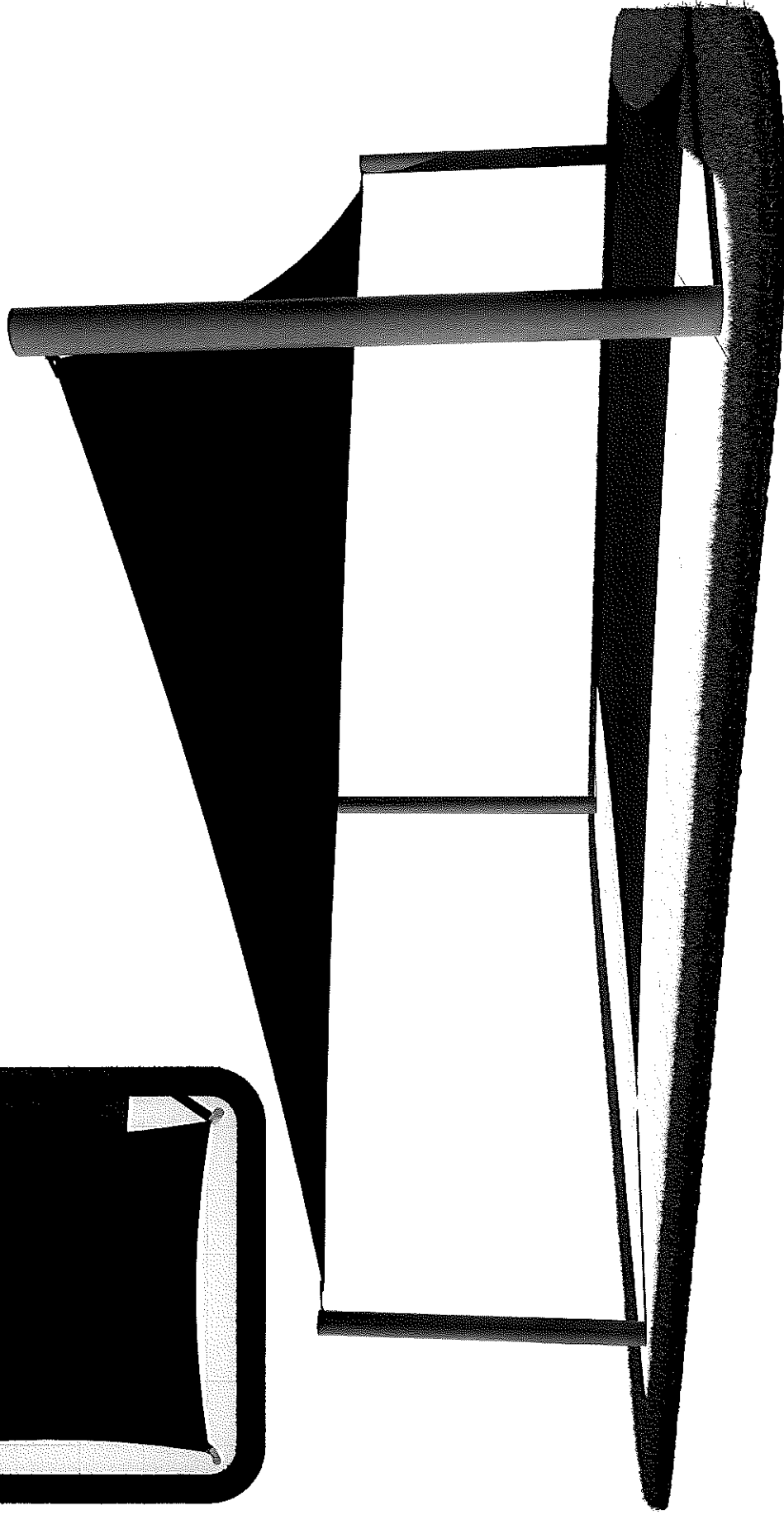
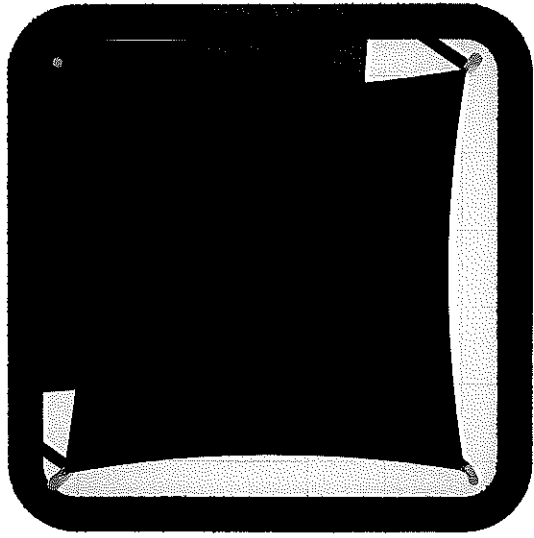

CUSTOM SQUARE HYPERBOLIC SAIL SHADE

FRAME ICED COFFEE | FABRIC FOREST GREEN

For illustration purposes only. Colors may vary.



SUPERIOR
EXCEPTIONAL PRODUCTS
9089 75th Ave

SQUARE HIP SHADE

14' X 14' X 10'

MODEL #:

SD141410IG (With Glide Elbows)

SD141410IN (Without Glide Elbows)

REF.#	PART DESCRIPTION	QTY.
1	Ø5.0" Capped Embedded Column	4
2	Angled Elbow	4
3	Ø2.5" Hip Rafter w/ Swaged End	4
4	Ø2.5" Ridge Pole w/ Swaged Ends	1
5	Square "Y" Connection	2
6	Fabric Cover w/ Cable Insert	1
7	Frame Hardware Kit	1

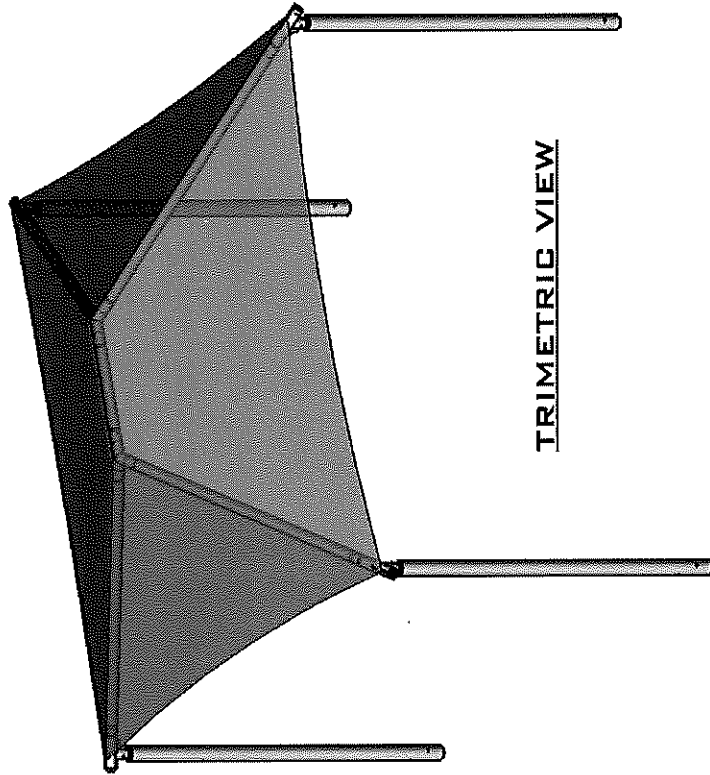
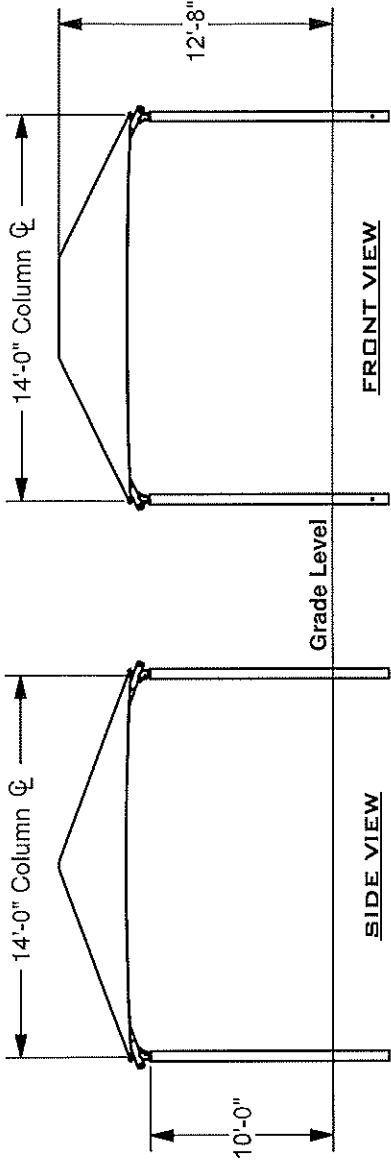

TRIMETRIC VIEW

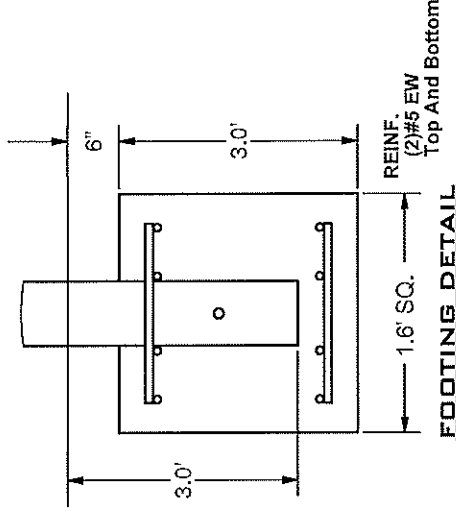

FOOTING DETAIL

*Footing design based on 1500 PSF soil bearing pressure.



SUPERIOR
INTERNATIONAL PRODUCTS

1050 Columbia Drive
Carrollton, Georgia

1.888.829.3997 | 770.894.2764 (f)

These drawings are for reference only and should not be used as construction details. Materials, fasteners, and foundations are subject to change if professionally sealed engineering drawings are required. Designed for 93 MPH Basic Wind Speed.

OAK RIDGE HEAD START TOP VIEW

ADA ACCESSIBILITY GUIDELINE - ADAAG CONFORMANCE

ELEVATED	ACCESSIBLE	RAMP ACCESSIBLE	GROUND	TYPES
8	8/4	0	6/3	4/3

R35

FOR KIDS
AGES
2-12

GENERAL NOTES:

This conceptual plan is based on information provided prior to construction. Detailed site information, including the following, should be obtained, evaluated, and utilized in the final project design. Exact site dimensions, topography, existing utilities, soil conditions and drainage solutions.

WARNING: Accessible safety surfacing material is required beneath and around this equipment that has a critical height value (fall height) appropriate for the highest accessible part of this equipment. Refer to the CPSC's Handbook For Public Playground Safety, Section 4: Surfacing.

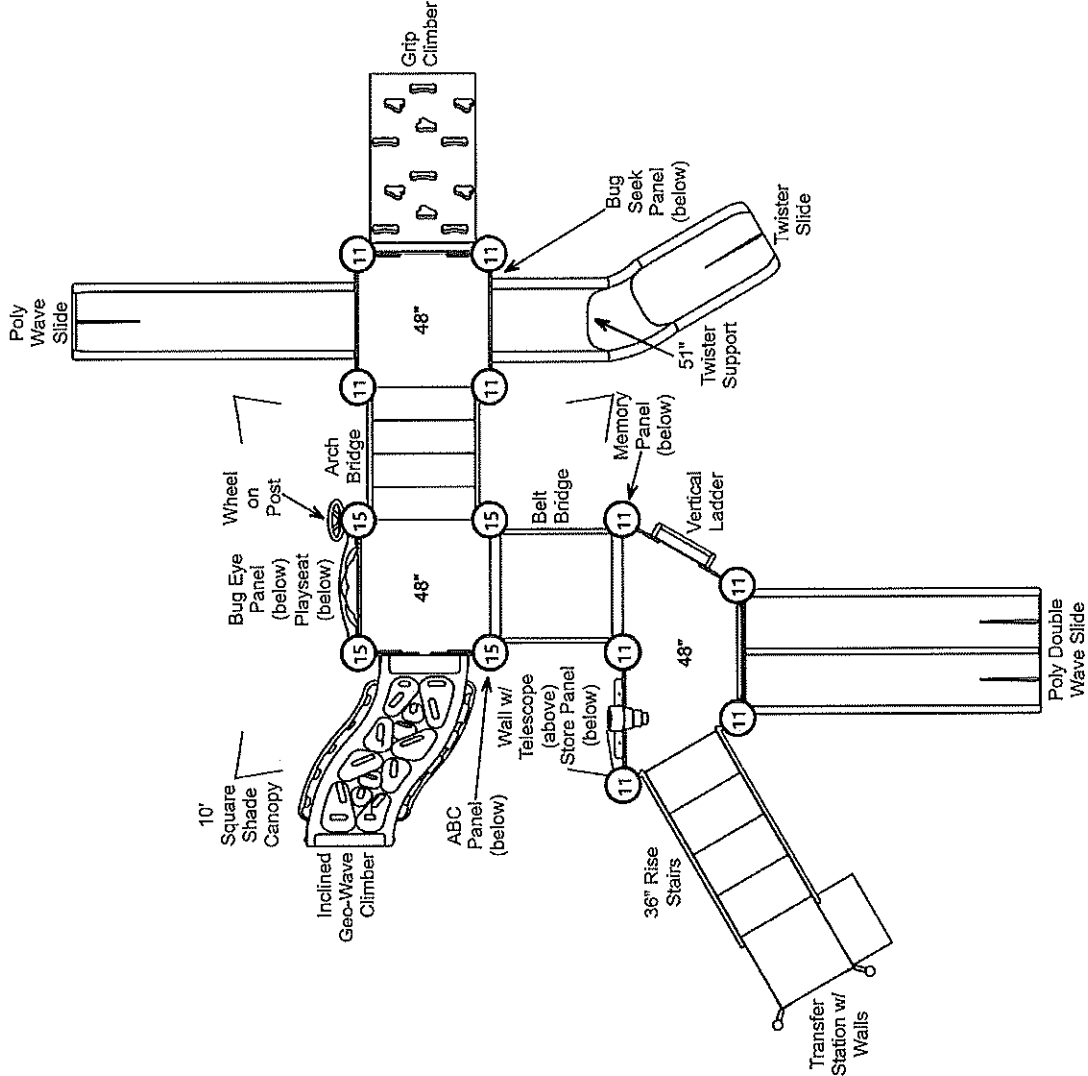

NOTES:

1. Post footing dimensions are from centers of support posts.
2. Deck heights shown are finished heights at top of decks above ground cover. Adjust footing depth of support posts, compensating for required ground cover depth.
3. This structure is accessible by transfer point.
4. It is the opinion of the manufacturer that this design meets the accessibility requirements of the ADAAG and ASTM F1487-17 when properly installed over accessible surfacing.
5. This structure meets the USCPSC and ASTM guidelines for playground safety.
6. This equipment was designed for use by children 2-12 years of age.
7. **WARNING:** An impact absorbing safety surfacing is required under and around all playground equipment.

STRUCTURE#: R351C7288

PROJECT#: 5771120

DATE: 6/5/2018 | DRAWN BY: JDE

MIN. USE ZONE: 38' x 38'

PLAYCRAFT REP:

Great Southern Recreation



ELEVATED	ACCESSIBLE	RAMP	ACCESSIBLE	GROUND	TYPES
8	8/4	0	6/3	4/3	

R35

FOR KIDS
AGES
2-12

OAK RIDGE HEAD START TOP VIEW (Footings)

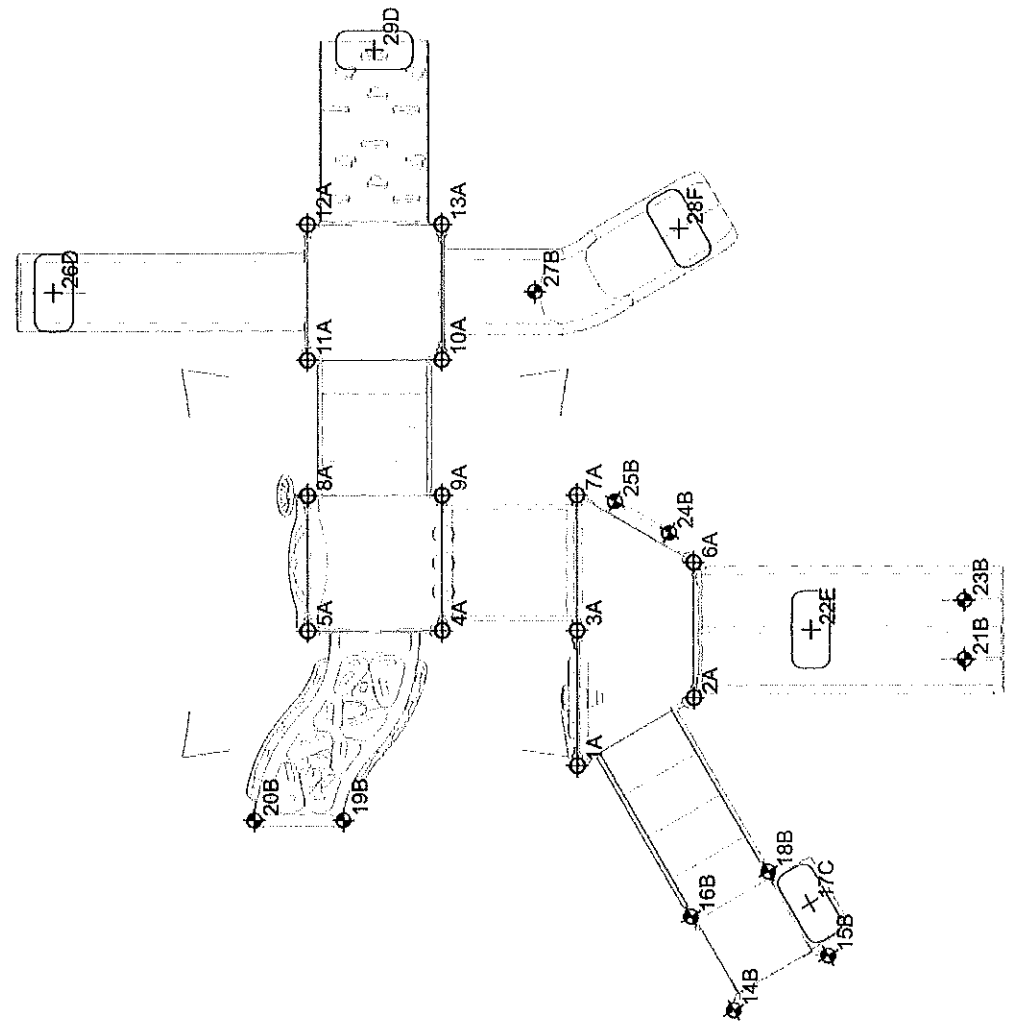

#	TYPE	SIZE/DEPTH	QTY
A	PostFooting	W:18" x L:18" x D:30"	13
B	EF12	W:12" x L:12" x D:18"	11
C	EFO	W:12" x L:24" x D:21.5"	1
D	EFO	W:12" x L:24" x D:18"	2
E	EFO	W:12" x L:24" x D:26"	1
F	EFO	W:12" x L:24" x D:25"	1

#	X	Y	DIAG	#	X	Y	DIAG
1	0'-0"	0'-0"	0'-0"	16	-3'-11"	-2'-11"	4'-11"
2	1'-9"	-3'-0"	3'-6"	17	-3'-7"	-6'-0"	7'-0"
3	3'-6"	0'-0"	3'-6"	18	-2'-9"	-4'-11"	5'-8"
4	3'-6"	3'-6"	4'-11"	19	-1'-5"	6'-1"	6'-3"
5	3'-6"	7'-0"	7'-10"	20	-1'-5"	8'-5"	8'-6"
6	5'-3"	-3'-0"	6'-1"	21	2'-9"	-10'-0"	10'-5"
7	7'-0"	0'-0"	7'-0"	22	3'-6"	-6'-1"	7'-0"
8	7'-0"	7'-0"	9'-11"	23	4'-3"	-10'-0"	10'-11"
9	7'-0"	3'-6"	7'-10"	24	6'-0"	-2'-5"	6'-6"
10	10'-6"	3'-6"	11'-1"	25	6'-10"	-1'-0"	6'-11"
11	10'-6"	7'-0"	12'-7"	26	12'-3"	13'-7"	18'-4"
12	14'-0"	7'-0"	15'-8"	27	12'-3"	1'-1"	12'-4"
13	14'-0"	3'-6"	14'-5"	28	13'-11"	-2'-8"	14'-2"
14	-6'-4"	-4'-1"	7'-6"	29	18'-6"	5'-3"	19'-3"
15	-4'-11"	-6'-6"	8'-2"				

STRUCTURE#: R351C7288
PROJECT#: 5771120
DATE: 6/5/2018 | DRAWN BY: JDE

PLAYCRAFT REP:
Great Southern Recreation



MIN. USE ZONE: 38' x 38'

OAK RIDGE HEAD START SITE PLAN

ADA ACCESSIBILITY GUIDELINE - ADAAG CONFORMANCE

ELEVATED	ACCESSIBLE	RAMP ACCESSIBLE	GROUND	TYPES
8	8/4	0	6/3	4/3



FOR KIDS
AGES
2-12

GENERAL NOTES:

This Preliminary Site Plan is based on measurements that were provided in the initial planning phase. All dimensions must be verified prior to the submission of a purchase order. Playcraft Systems will not be held responsible for any discrepancies between actual dimensions and dimensions submitted in the planning phase.

The Minimum Use Zone for a play structure is based on the product design at the time of proposal. Components and structure designs may be subject to change which may affect dimensions. Therefore, before preparing the site, we strongly recommend obtaining final drawings from the factory (available after the order is placed and included in the Assembly Manual).

WARNING: Accessible safety surfacing material is required beneath and around this equipment that has a critical height value (Fall Height) appropriate for the highest accessible part of this equipment. Refer to the CPSC's Handbook For Public Playground Safety, Section 4: Surfacing.

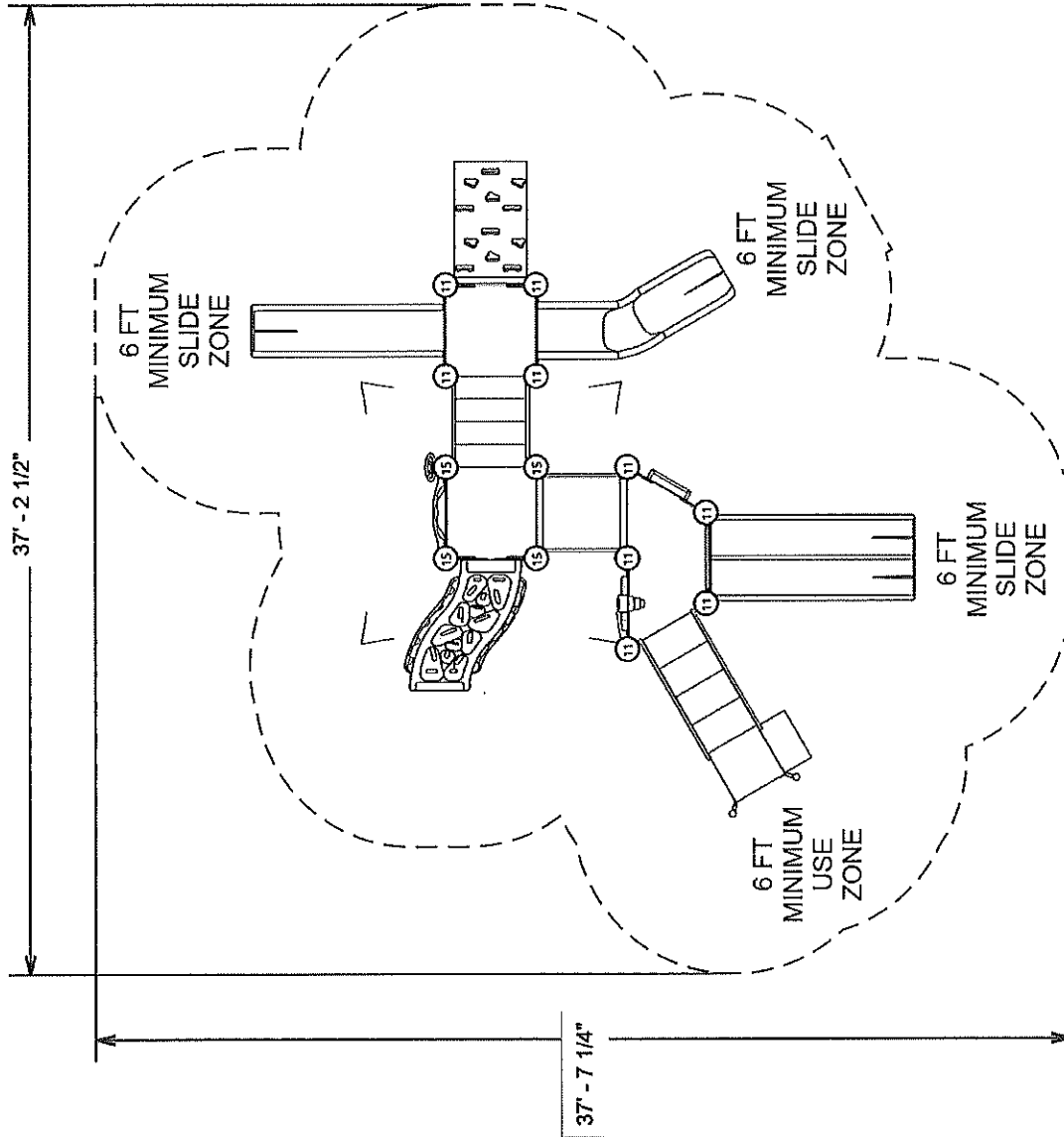

PROJECT#: 5771120
DATE: 6/5/2018

PLAYCRAFT REP:
Great Southern Recreation

MIN. USE ZONE: 38' x 38'

PLAYCRAFT
SYSTEMS



OAK RIDGE HEAD START
SW VIEW

R35

FOR KIDS
AGES
2-12

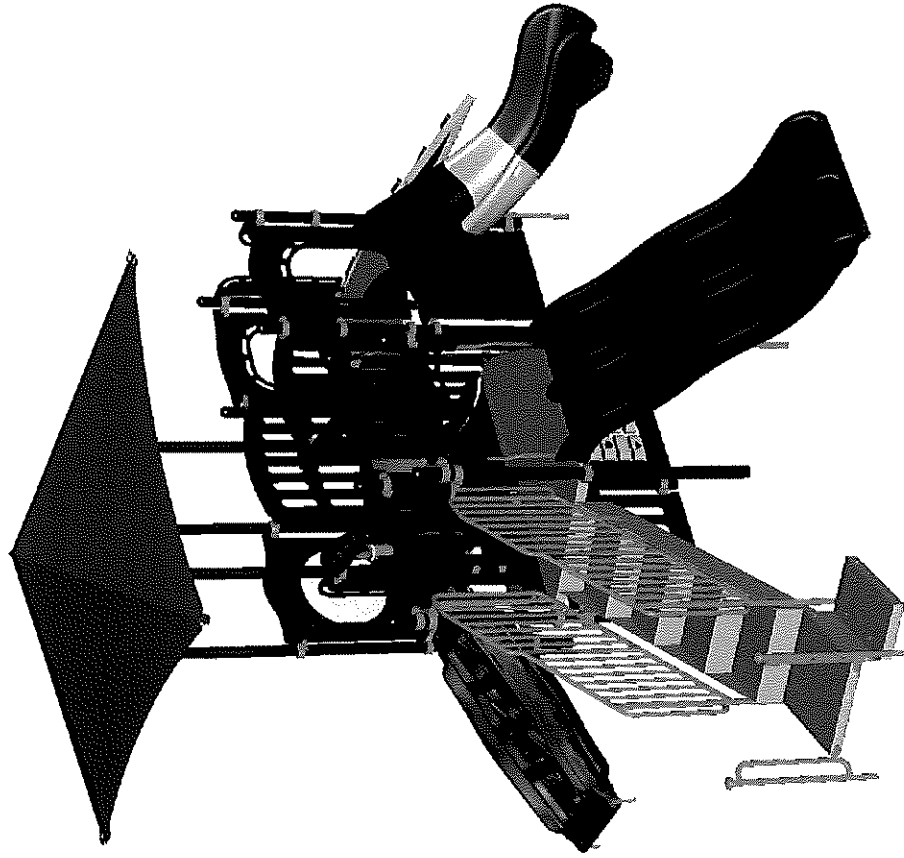

STRUCTURE#: R351C728B

PROJECT#: 5771120

DATE: 6/5/2018 | DRAWN BY: JDE



**OAK RIDGE HEAD START
SE VIEW**

R35

FOR KIDS
AGES
2-12

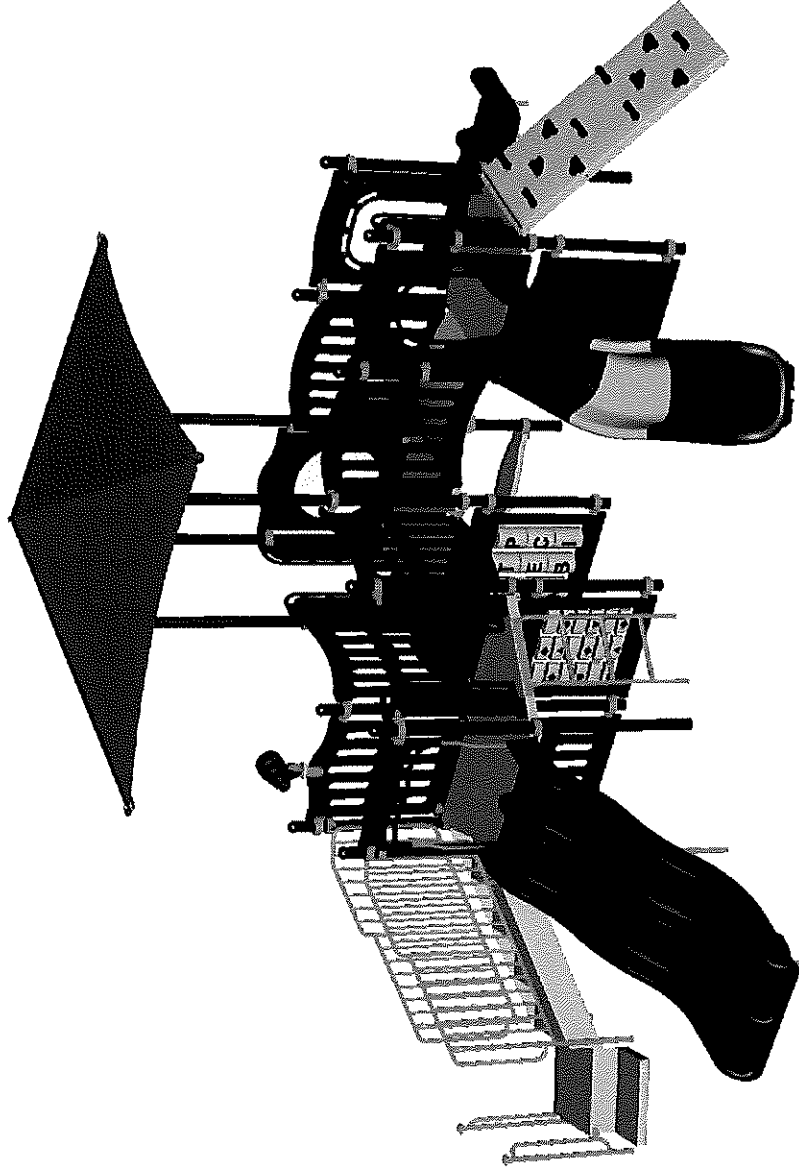

STRUCTURE#: R351C728B

PROJECT#: 5771120

DATE: 6/5/2018 | DRAWN BY: JDE

**OAK RIDGE HEAD START
NE VIEW**

R35

FOR KIDS
AGES
2-12

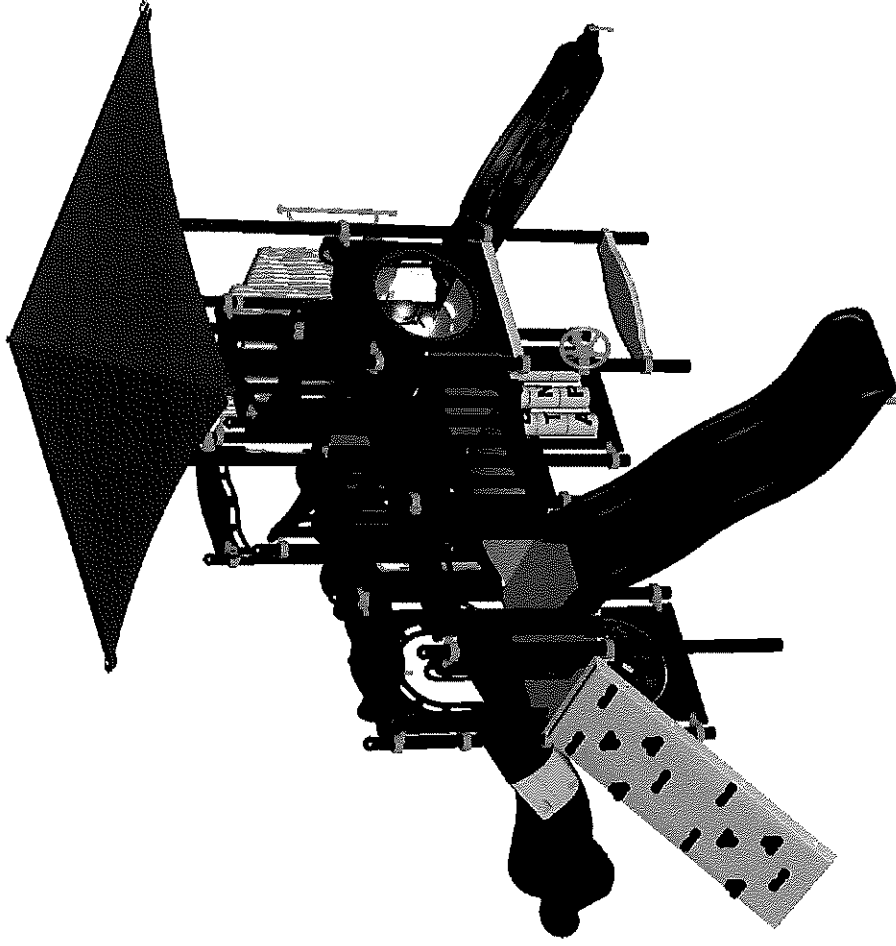

STRUCTURE#: R351C728B

PROJECT#: 5771120

DATE: 6/5/2018 | DRAWN BY: JDE



**OAK RIDGE HEAD START
NW VIEW**

R35

FOR KIDS
AGES
2-12

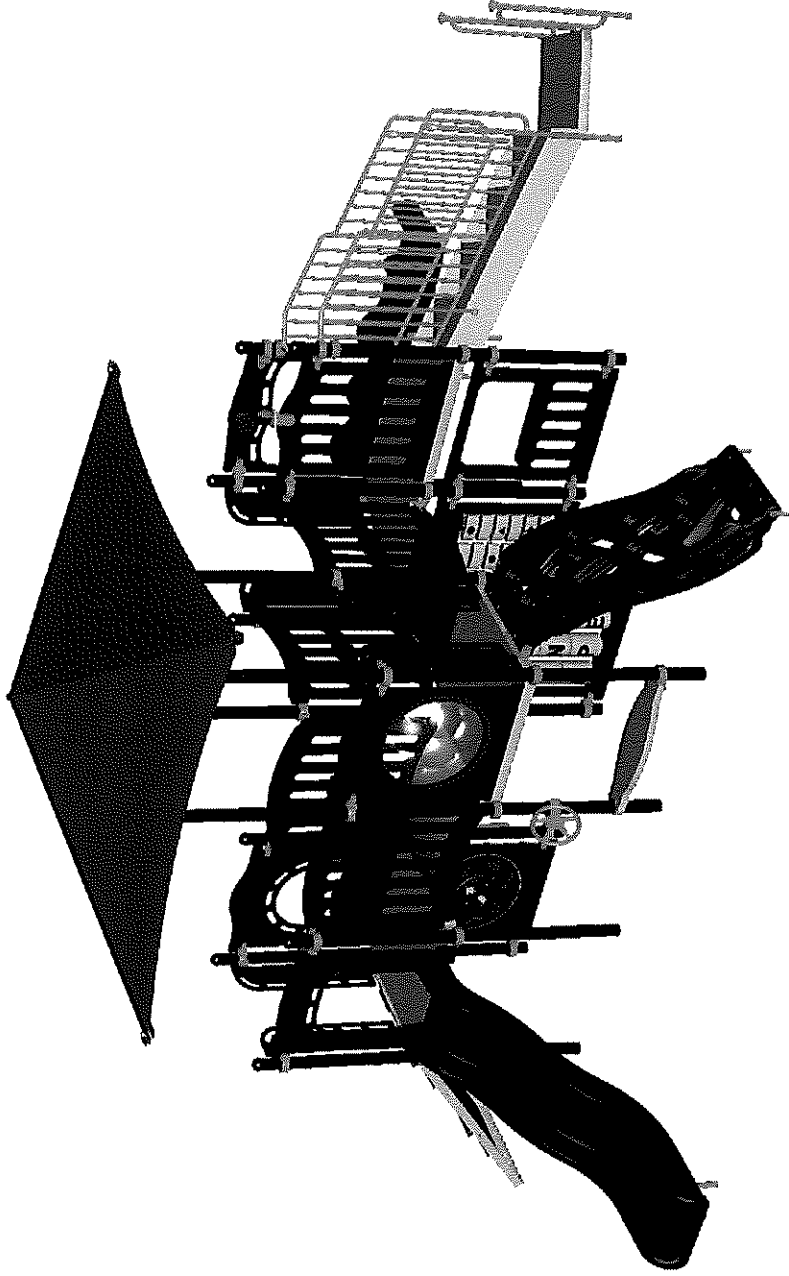

STRUCTURE#: R351C728B

PROJECT#: 5771120

DATE: 6/5/2018 | DRAWN BY: JDE

PLAYCRAFT
SYSTEMS



Oak Ridge Schools

OFFICE OF
Finance Director

Telephone (865) 425-9004

MEMORANDUM

To: Dr. Bruce Borchers, Superintendent of Schools
From: Pat Smith, Finance Director *Pat*
Subject: Budget Transfer #3
Date: November 15, 2019

In order to cover the entire cost of the new Preschool Playground Equipment and Resurfacing Contract, I recommend that the \$26,015.03 necessary to complete the project be funded through a budget transfer from the "other contingency funds" allocated in the FY20 Budget. With the Board of Education approval of the Playground Equipment and Surfacing as presented in the total amount of \$109,483.63, the following budget transfer is proposed to allow for this purchase.

Account	Description	Increase	Decrease
141-76100-707---426	Capital Outlay- Building Improvements	\$26,015.03	
141-71900-599---002	Instructional Contingency		(\$26,015.03)

Please let me know if you have questions or need additional information.



OFFICE OF MAINTENANCE AND OPERATIONS

DATE: November 15, 2019

TO: Bruce Lay, Executive Director of School Leadership

FROM: Allen Thacker, Supervisor of Maintenance and Operations

SUBJECT: Recommendation of Purchase of HVAC Equipment for Linden Gym

Mr. Lay,

I am recommending that the Oak Ridge Schools Board of Education approve the purchase of HVAC equipment for the Linden Gymnasium from Team Air Distributing, Inc for \$36,297.00. Bids were advertised in accordance with state guidelines with four bids submitted ranging from \$36,297.00 to \$46,245.00. The new equipment will replace the existing units that have exceeded their life expectancy and has developed leaks in the water coils. The units drip water on the gym floor when in use posing a safety hazard and could potentially damage the wood floor. The noise level of the units prevents them from being used during instructional time or during stage performances. The new equipment includes heating and cooling for the stage area that is currently without any conditioning. Equipment will be installed by the Maintenance and Operations Department. Preliminary work will start over winter break and will continue as possible around the classroom schedule once the equipment arrives.

Funding for the HVAC equipment was allocated in Capital Outlay 76100 707.

Thank You,

Allen Thacker,

Supervisor of Maintenance and Operations

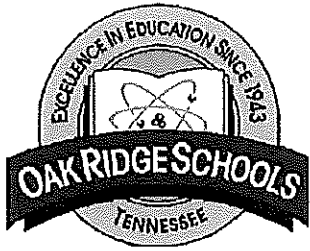

Oak Ridge Schools
OFFICE OF
Business & Support Services

Telephone (865) 425-9005
Fax: (865) 425-9060

DATE: November 15, 2019

TO: Pat Smith, Finance Director

cc: Jennifer VanDyke, Allen Thacker, Sandi Jones

FROM: Mary Ann Riley, Purchasing Specialist, Oak Ridge Schools

SUBJECT: Recommendation of RFP 20-005 – Linden Elementary Gym HVAC Equipment

I recommend that the Oak Ridge Board of Education accept the bid from Team Air, for the above mentioned bid. Their bid of \$36,297.00 was the lowest bid that met all of the specifications. Bids ranged from \$36,297.00 - \$46,245.00.

Bids were advertised in accordance with state guidelines and also available on the Oak Ridge Schools' website and Vendor Registry. Four companies responded with bids.

Attachment: Bid Minutes

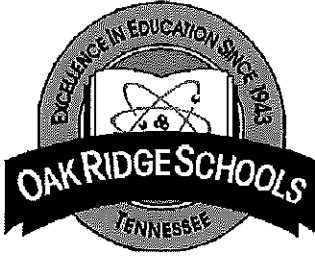

Oak Ridge Schools

OFFICE OF
Business & Support Services

Telephone (865) 425-9005
Fax: (865) 425-9060

Bid Minutes

11/15/2019

Linden Elementary School Gym HVAC Equipment (RFP 20-005)
Business Services Conference Room
Administration Building

Present for the bid opening were:

Allen Thacker	Oak Ridge Schools
Jenifer VanDyke	Oak Ridge Schools
Andrew Bosse	Trane
Mary Ann Riley	Oak Ridge Schools

Bid responses were received from the following companies:

Partner's Supply Chattanooga, TN	\$37,878.52**
Team Air Nashville, TN	\$36,297.00*
Technology International, Inc. Lake Mary, FL	\$42,995.00
Trane Knoxville, TN	\$46,245.00

***Recommended Bidder**

**This bid was disqualified due to incomplete compliance affidavits.



Business
Department
School Administration
Building 304 New York Ave
Oak Ridge, Tennessee 37830
Phone (865) 425-9003
Fax (865) 425-9060

Request for Proposal

Description of items/services requested:

The Oak Ridge Schools Board of Education is soliciting proposals for the purchase of **Linden Elementary School Gym HVAC Equipment**.

General Requirements:

Proposals, bids, or responses will be accepted by the Oak Ridge Schools Business Department no later than **03:00PM, November 15, 2019 EDT**. Every document must be enclosed in a sealed envelope clearly marked as a bid document and include TN contractor license information. **Two full copies** of the proposal must be submitted, each with original signatures on both Bid Forms (included in this packet). Any response, bid, or proposal received after the above deadline shall be considered late, and will not be opened or considered. Facsimile or emailed responses will not be considered. Bid prices must be valid for no less than thirty (60) days from the date of the bid.

All documents shall be submitted to the following address:

Mary Ann Riley, Purchasing Specialist
RE: Linden Elementary School Gym HVAC Equipment-RFP 20-005
School Administration Building
304 New York Avenue
Oak Ridge, TN 37830

Device Specifications:

We are specifying Mitsubishi equipment with no substitute.

ITEM	DESCRIPTION	QUANTITY	UM
PUZ-HA42NKA	OUTDOOR UNIT HIP HYPER 42 BTU SN	5	EA
PCA-A42KA7.TH	INDOOR UNIT HIP HYPER 42 BTU DELUXE	5	EA
PAR-33MAAA-J	MA REMOTE CONTROL	5	EA
PUZ-HA36NHA5	Hyper Heat Outdoor (H2i) SN	2	EA
PCA-A36KA7.TH	INDOOR UNIT HIP HYPER 36 BTU	2	EA
PAR-33MAA-J	DELUXE MA REMOTE CONTROL	2	EA
WB-PA3	WIND BAFFLE (P-SERIES) *LARGE	10	EA
WB-PA5	WIND BAFFLE (P-SERIES)	4	EA
BACnet and Modbus	BACNET INTERFACE MELCO BEMS	7	EA

Purchasing Terms:

Oak Ridge Schools will order on the following schedule: Board of Education approval and funding availability.

Shipping & Receiving:

If there are shipping costs in your proposal (**EXAMPLE**, etc.), please indicate and describe them in detail in your proposal.

Submission Requirements:

1. A detailed bid form, which includes quantity and unit cost must be included in the bid package. Please include specification sheets on all products/terms.

2. Two full copies of the proposal must be submitted, with original Bid Forms included with each copy.
3. A detailed description of all warranties and support for equipment and software must be included.
4. Any license or renewal costs (if any) shall be included in notes on Bid Form. Specifically, anticipated annually recurring costs for maintenance, support, and software updates and upgrades, if any, must be listed.
5. The amount listed on the Bid Form should reflect the total implementation costs of this project as submitted.

Bidding Procedures/Requirements

Award of Contract: The owner (Oak Ridge Schools) further reserves the right to reject any and all bids, to waive any and all informalities and to negotiate contract terms with the successful bidder, and the right to disregard all non-conforming, non-responsive, or conditional bids. Oak Ridge Schools may conduct such investigations as it deems necessary to assist in the evaluation of any bid to establish the responsibility, qualifications, and financial ability of the bidder, proposed sub-contractors and other persons and organizations to perform the work in accordance with the contract documents to the bidder who does not pass any such evaluation to the owner's satisfaction. The contract shall be awarded to the bidder, whose evaluation by the owner indicates to the owner that the award will be in the best interest of Oak Ridge Schools. It is also understood that the "apparent low bidder" will be announced at the bid opening; however, the "successful bidder," who may or may not be the lowest bidder, will not be announced until all issues, which include, but are not limited to quality, service, conformity to specifications, etc. have been resolved and until a period of review has been completed by the owner. Oak Ridge Schools does not enter into contracts that provide for mediation or arbitration. The owner (Oak Ridge Schools) further reserves the right to reject any and all bids, to waive any and all informalities, and to negotiate contract terms with the successful bidder (e.g., product line-item deletions or adjustments), and the right to disregard all non-conforming, non-responsive, or conditional bids.

Bid Document: For certain projects Oak Ridge Schools will supply a bid form to be completed by the bidder. When such forms are issued, only bids returned with the proper forms will be accepted. Envelopes must be sealed and marked as a bid document. Any bid may be withdrawn prior to the date and time as set forth in the "bid invitation."

Conflict of Interest: All bidders must disclose with their bid the name of any

officer, director, or agent who is also an employee of the State of Tennessee, or any of its agencies (which includes Oak Ridge Schools). Further, all bidders must disclose the name of any state or Oak Ridge School employee who owns, directly or indirectly, an interest in the bidder's firm or any of its branches. Bidding by Oak Ridge School employees is prohibited.

Contractors, Subcontractors and employees: If work is to be performed during regular school hours when children are present, the BOE reserves the right to require background checks, dress codes, and certain ethical standards of all employees on school property.

Controlling Documents: Compliance with Oak Ridge Schools' purchase order will be subject to all terms and conditions which comprise Oak Ridge Schools' General and Special Bid Conditions, if any, unless an exception is taken by the bidder to which Oak Ridge Schools has concurred in writing.

Criminal Background Compliance: Bidders shall be required to complete the attached Criminal Background Compliance Affidavit form in compliance with the provisions of Tennessee Code Annotated § 49-5-413.

Deadline: Any responses received after the scheduled closing time for the receipt for responses will not be considered.

Default of Contractor: In the event the Contractor defaults in performing this Contract, the Contractor agrees to pay Oak Ridge Schools all reasonable costs incurred in remedying such default, including a reasonable Attorney's fee.

Drug Free Work Place Affidavit (Attached Herewith): Bidders shall be required to complete the attached Drug Free Workplace Affidavit form in compliance with the provisions of Tennessee Code Annotated § 50-9-113.

Errors in Bids: When an error is made in extending total prices, the unit bid price will govern. Carelessness in quoting prices or in preparation of bid otherwise, will not relieve the bidder. Erasures or changes to bids must be initialed. Any alteration, erasure, addition to or omission of required information, change of the specifications, or bidding schedule, is made at the risk of the bidder.

Exceptions: If the bidder takes exception to anything in the specifications or terms and conditions, the exception must be listed in bid. If necessary, you may supplement with an attachment. If no exceptions are taken, mark bid "No Exceptions Are Taken". If no comments or exceptions are furnished, it will be assumed that no exceptions are being taken.

Facsimile or Electronic transmissions: Electronic transmissions will not be accepted except when in the course of the bidding process addendums or other notifications of errors on behalf of the owner places an undue hardship upon prospective bidders. Written notification by the owner must precede the

acceptance of Facsimile transmissions.

Hold Harmless Agreement: Bidders shall be required to complete the attached Hold Harmless Agreement.

Laws and Regulations: The bidder's attention is directed to the fact that all applicable state laws, municipal ordinances, and the rules and regulations of all authorities having jurisdiction over construction of the project and shall apply to the contract throughout, and they will be deemed to be included in the contract the same as though herein written out in full.

Legal Issues: Contracts with Oak Ridge Schools will be subject to the laws of Tennessee. Disputes will be tried in the State of Tennessee and in the Court of Anderson County. Bid will be denied if these provisions are not included in the contract.

Legal Requirements: The successful bidder shall be responsible for compliance with all federal, state and local laws, ordinances, rules and regulations that in any manner affect the items covered herein. Lack of knowledge by the bidder will in no way be a cause for relief from responsibility for their bid.

Location: All bids must be submitted to the Oak Ridge Schools Business Department at or before the announced deadline.

Mary Ann Riley, Purchasing Specialist
RE: **Linden Elementary School Gym HVAC Equipment**
RFP 20-005
304 New York Avenue
Oak Ridge, TN 37830

Non-Collusion Affidavit: Bidder shall be required to complete the attached Non-Collusion Affidavit.

Payments: Invoices that are submitted to Oak Ridge Schools Business Department will be approved and processed for payment. The awarded bidder is required to provide accurate and current addresses. Payment terms shall be specified in the bid response, including any discounts for early payment. Payment will not be made by Oak Ridge Schools to contractor until the said Epson Projector Refresh equipment are inspected and approved as meeting all specifications by persons appointed by Oak Ridge Schools.

Public Acts of 2006: In compliance with the requirements of Chapter 878, Public Acts of 2006, the Contractor hereby attests that the Contractor shall not knowingly utilize the services of an illegal immigrant

in the performance of this contract and shall not knowingly utilize the services of any subcontractor who will utilize the services of an illegal immigrant in the performance of this contract.

Purchase: No purchase or contract is authorized or valid until the issuance of a Purchase Order from Oak Ridge Schools and the Board of Education approval of project in accordance with Oak Ridge Schools Policy. No employee is authorized to purchase equipment, supplies or services prior to the issuance of such Purchase Order and Board of Education approval.

Sub-contracts: The Bidder is specifically advised that any person, firm, or other party to whom it is proposed to award a sub-contract under this contract must be acceptable to the Owner.

Taxes: Oak Ridge Schools is exempt from federal excise taxes and from state sales taxes on purchases of tangible personal property. Copies of the appropriate exemption documentation will be provided upon request. Contractors are responsible for the payment of taxes on tangible personal property which they use in the completion of their contracts, for which sales taxes have not otherwise been paid, irrespective of who holds title to the property or for whom the work is done.

Tie Bids: If two or more bidders submit identical bids and is equally qualified; selection shall be made at the discretion of the owner.

Title VI of the Civil Rights Act of 1964: All interested parties, without regard of race, color, or national origin, shall be afforded the opportunity to bid and shall receive equal consideration. Title VI states "No person in the United States shall, on the ground of race, color, or national origin, be excluded from participation in, be denied the benefits of, or be subjected to discrimination under any program activity receiving Federal financial assistance." Oak Ridge Schools strives to protect individuals' civil rights through active compliance with the requirements of Title VI.

Vendor Indemnify: Oak Ridge Schools will indemnify vendor to the extent Tennessee law allows.

Warranty: The vendor shall provide warranty information on the equipment, components and items bid with the bid submittal.

Bid Form

Owner: Oak Ridge Schools Board of Education
Mary Ann Riley, Purchasing Specialist
RE: **Linden Elementary School Gym HVAC Equipment**
RFP 20-005
304 New York Avenue
Oak Ridge, TN 37830

Project: Oak Ridge Schools : **Linden Elementary School Gym HVAC Equipment: RFP 20-005**

Bid Opening: **Friday, November 15, 2019, 03:00PM EDT**
Business Services Conference Room

Company Name: TEAM AIR DISTRIBUTING, INC

Address: 631 Hamilton Avenue
Nashville, TN 37203

Phone Number: 615 - 297-8523

Main Bid: ***This price is to be for the complete package, materials, licenses and labor to complete this project.***

Bid Amount: \$ 36,297.00 USD.

Option 1: _____

Option 2: _____

Option 3: _____

Option 4: _____

Company: TEAM AIR DISTRIBUTING, INC

Signature: James Murphy

Title: Corporate Secretary

Date: 11/6/2019

Please attach detailed specifications.

DRUG-FREE WORKPLACE AFFIDAVIT

STATE OF Tennessee
COUNTY OF Davidson

The undersigned, principal officer of TEAM AIR DISTRIBUTING INC., an employer of five (5) or more employees contracting with Oak Ridge School District to provide construction services, hereby states under oath as follows:

1. The undersigned is a principal officer of TEAM AIR DISTRIBUTING INC. (hereafter referred to as the "Company"), and is duly authorized to execute this Affidavit on behalf of the Company.
2. The Company submits this Affidavit pursuant to T.C.A. § 50-9-113 which requires each employer with no less than five (5) employees receiving pay who contracts with the state or any local government to provide construction services to submit an affidavit stating that such employer has a drug-free workplace program that complies with Title 50, Chapter 9, of the Tennessee Code Annotated.
3. The Company is in compliance with the terms of T.C.A. § 50-9-113.

Further affiant saith naught.

Principal Officer

STATE OF Tennessee
COUNTY OF Davidson

Before me personally appeared JAMES MURPHY with whom I am personally acquainted (or proved to me on the basis of satisfactory evidence), and who acknowledged that he/she is the Secretary of TEAM AIR DISTRIBUTING INC. and is authorized to execute this instrument on behalf of the principal for the purposes therein contained.

Witness my hand and seal at office this 6th day of November, 2019.

Notary Public

My commission expires: 7-5-2021

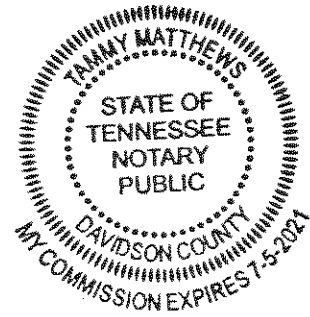

CRIMINAL BACKGROUND COMPLIANCE AFFIDAVIT

STATE OF Tennessee
COUNTY OF Davidson

The undersigned, principal officer of TEAM AIR DISTRIBUTING INC, an Employer contracting with the Oak Ridge School Board of Education to provide services having direct contact with children or access to grounds of an Oak Ridge public school while students are on grounds, hereby states under oath as follows:

1. The undersigned is a principal officer of TEAM AIR DISTRIBUTING INC (hereafter referred to as the "Company"), and is duly authorized to execute this Affidavit on behalf of the Company.
2. The Company submits this Affidavit pursuant to T.C.A. § 49-5-413 as amended effective September 1, 2007, for entities entering into contracts with a local board of education where the Company's employees will have direct contact with school children or access to the grounds of a school when children are present. It is the duty of the Company to require applicants supply a fingerprint sample and submit to a criminal history records check to be conducted by the Tennessee Bureau of Investigation and the Federal Bureau of Investigation prior to permitting the person to have contact with such children or enter school grounds and to take certain other actions based upon the results of the records check.
3. The Company is in compliance with the terms of T.C.A. § 49-5-413.

Further affiant saith naught.

Principal Officer

STATE OF TENNESSEE
COUNTY OF Davidson

Before me personally appeared James Murphy with whom I am personally acquainted (or proved to me on the basis of satisfactory evidence), and who acknowledged that he/she is the Secretary of TEAM AIR DISTRIBUTING INC and is authorized to execute this instrument on behalf of the principal for the purposes therein contained.

Witness my hand and seal at office this 6th day of November, 2019.

Notary Public Tammy Matthews
My commission expires: 7-5-2021

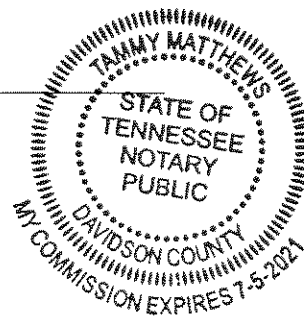

HOLD HARMLESS AGREEMENT

This Hold Harmless Agreement is between TEAM AIR DISTRIBUTING INC.
Name of Contractor

(hereinafter Contractor), and Oak Ridge Schools named in this bid.

Contractor agrees that as a condition precedent to "Contractor" being awarded a contract from Oak Ridge Schools, "Contractor" agrees to indemnify, protect, defend, and hold harmless Oak Ridge Schools, its Board Members, agents, and employees from all judgments, claims, demands for payment, suits or actions of every nature and description brought against Oak Ridge Schools, its Board Members, agents, and employees alleging injuries or damages sustained by any person arising out of or in the course of "Contractor's" providing goods or services to Oak Ridge Schools.

Name of Contractor: TEAM AIR DISTRIBUTING INC.

By: James Murphy

Title: Corporate Secretary

STATE OF TENNESSEE

County of Anderson

James Murphy personally appeared before me, the undersigned, with whom I am personally acquainted and who, upon oath, acknowledged that he/she/it executed the within instrument for the purposes therein contained, and who further acknowledge that he/she/it is authorized to execute this interment on behalf of TEAM AIR DISTRIBUTING, INC.

[Signature]
Signature

Witness by hand and Notaries seal at office this 10th day of November, year of 2019.

[Signature]
Notary Public

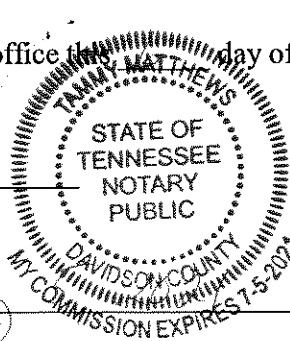

My Commission Expires: July

NON-COLLUSION AFFIDAVIT

NON-COLLUSION AFFIDAVIT TO BE EXECUTED
BY DESIGN-BUILDER

State of Tennessee

County of Davidson

James Murphy, being first duly sworn, deposes and says that he or she is of the party making the foregoing bid is not made in the interest of, or on behalf of, any undisclosed person, partnership, company, association, organization, or corporation; that the bid is genuine and not collusive or sham; that the bidder neither possesses a business relationship with any employee of the District which may be involved in the award or administration of the project nor has received or solicited either directly or indirectly any inside information from an employee of the District which would give the bidder an advantage over any other bidder; that the bidder has not directly or indirectly induced or solicited any other bidder to put in a false or sham bid, and has not directly or indirectly colluded, conspired, connived, or agreed with any bidder or anyone else to put in a sham bid, or that anyone shall refrain from bidding; that the bidder has not in any manner, directly or indirectly, sought by agreement, communication, or conference with anyone to fix the bid price of the bidder or any other bidder, or to fix any overhead, profit, or cost element of the bid price, or of that of any other bidder, or to secure any advantage against the public body awarding the contract or any interested in the proposed contract; that all statements contained in the bid are true; and, further, that the bidder has not, directly or indirectly, submitted his or her bid price of any breakdown thereof, or the contents thereof, or divulged information or data relative thereto, or paid, and will not pay, any fee to any corporation, partnership, company, association, organization, bid depository, or to any member or agent thereof to effectuate a collusive or sham bid.

Subscribed and sworn to (or affirmed) before me this 6th day

of November, 2019.

James Murphy
Signature of Officer

James Murphy
Typed Name of Officer

Secretary

Office

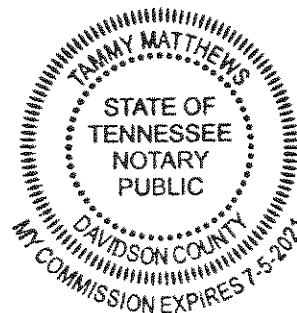

NON-COLLUSION AFFIDAVIT Page 2

STATE OF TENNESSEE
County of Anderson

James Murphy personally appeared before me, the undersigned, with whom I am personally acquainted and who, upon oath, acknowledged that he/she/it executed the within instrument for the purposes therein contained, and who further acknowledge that he/she/it is authorized to execute this interment on behalf of TEAM AND DISTRIBUTING INC

James Murphy
Signature

Witness by hand and Notaries seal at office this 6th day of November year of 2019.

Tammy Matthews
Notary Public

My Commission Expires: 7-5-2021

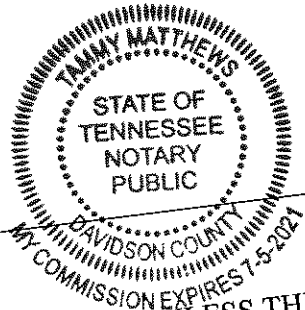

WARNING! PROPOSALS WILL NOT BE CONSIDERED UNLESS THIS AFFIDAVIT IS COMPLETED AND EXECUTED, INCLUDING THE AFFIDAVIT OF THE NOTARY AND THE NOTORIAL SEAL.

IRAN DIVESTMENT ACT REQUIREMENTS

Pursuant to *Tennessee Code Annotated* § 12-12-106 (as enacted by Chapter 817 of the Public Acts of 2016) the chief procurement officer for the State of Tennessee shall publish a list of persons determined to be engaging in investment activities in Iran. The list is posted on the website of the Tennessee General Services Department's Central Procurement Office*. When competitive bidding is required, *Tennessee Code Annotated* § 12-12-111 requires every bid or proposal submitted to a local government for goods or services to include the following statement, subscribed or affirmed by the bidder as true under the penalty of perjury:

CERTIFICATION

By submission of this bid, each bidder and each person signing on behalf of any bidder certifies, and in the case of a joint bid each party thereto certifies as to its own organization, under penalty of perjury, that to the best of its knowledge and belief that each bidder is not on the list created pursuant to *T.C.A.* § 12-12-106.

James Murphy
Signature

11/6/2019
Date

James Murphy
Printed Name

Secretary
Title

Team Air Distributing, Inc.
Name of Firm/Company

*[https://tn.gov/assets/entities/generalservices/cpo/attachments/List of persons pursuant to Tenn. Code Ann. 12-12-106. Iran Divestment Act-July.pdf](https://tn.gov/assets/entities/generalservices/cpo/attachments/List_of_persons_pursuant_to_Tenn._Code_Ann._12-12-106_Iran_Divestment_Act-July.pdf)

P-SERIES

SUBMITTAL DATA: PCA-A42KA7 & PUZ-HA42NKA
42,000 BTU/H CEILING-SUSPENDED HEAT PUMP SYSTEM



Job Name:

System Reference:

Date:

Indoor Unit:
PCA-A42KA7

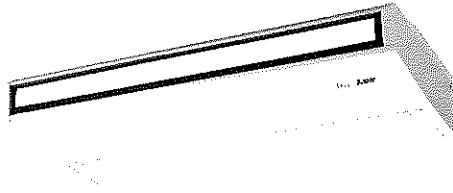

Outdoor Unit:
PUZ-HA42NKA

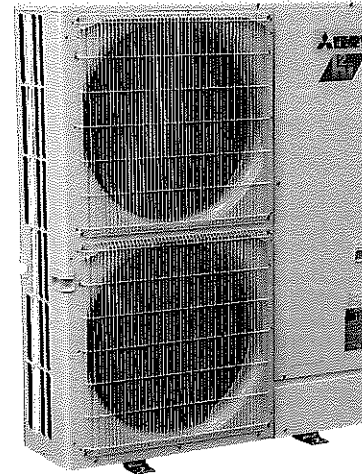

INDOOR UNIT FEATURES

- Airflow settings for high and low ceiling applications
- Knock-out for outside-air intake
- Optional i-see Sensor™ for air distribution and energy saving
- Auto fan speed mode
- Filter status indicator
- Easy-to-clean, washable filter
- Suspends from ceiling for quick and easy installation
- Ideal for larger retail stores, classrooms, and restaurants

OUTDOOR UNIT FEATURES

- Variable speed INVERTER-driven compressor
- High heating capacity: flash injection circuit maintains 100% heating capacity at 5°F outdoor temperature
- Wide heating range: heating performance down to -13°F (average of 80% heating capacity)
- High speed heating at start up: Hyper-Heating INVERTER® reduces the time for heating at start up by about half compared to standard models
- Suction accumulator pre-charged with refrigerant volume for piping length up to 100 ft.
- Twinning of two indoor units possible with the 36 kBtu/h model
- High pressure/temperature protection

SPECIFICATIONS: PCA-A42KA7 & PUZ-HA42NKA

Model Number	Indoor Unit Outdoor Unit	PCA-A42KA7 PUZ-HA42NKA	
Cooling ¹	Maximum Capacity	Btu/h	42,000
	Rated Capacity	Btu/h	42,000
	Minimum Capacity	Btu/h	19,000
	Maximum Power Input	W	4,200
	Rated Power Input	W	4,200
	Moisture Removal	Pints/h	11.7
	Sensible Heat Factor		0.69
	Power Factor	%	95.6
Heating at 47°F ²	Maximum Capacity	Btu/h	54,000
	Rated Capacity	Btu/h	48,000
	Minimum Capacity	Btu/h	21,000
	Maximum Power Input	W	5,860
	Rated Power Input	W	4,150
	Power Factor	%	95.5
Heating at 17°F ³	Maximum Capacity	Btu/h	48,000
	Rated Capacity	Btu/h	44,000
	Maximum Power Input	W	7,020
	Rated Power Input	W	5,480
Heating at 5°F ⁴	Maximum Capacity	Btu/h	48,000
	Maximum Power Input	W	7,580
Efficiency	SEER		14.5
	EER ¹		10.0
	HSPF (IV)		10.4
	COP at 47°F ²		3.39
	COP at 17°F in Maximum Capacity		2.00
	COP at 5°F in Maximum Capacity		1.85
Electrical	Voltage, Phase, Frequency		208 / 230V, 1-phase, 60 Hz
	Guaranteed Voltage Range	V AC	198 – 253
	Voltage: Indoor - Outdoor, S1-S2	V AC	208V / 230
	Voltage: Indoor - Outdoor, S2-S3	V DC	24
	Voltage: Indoor - Remote controller	V DC	12
	Recommended Fuse/Breaker Size	A	40
	Recommended Wire Size (Indoor - Outdoor)	AWG	14
Indoor Unit	MCA	A	2.00
	Fan Motor Full Load Amperage	A	0.97
	Fan Motor Output	W	160
	Airflow Rate, Dry	CFM	810-885-955-1025
	Airflow Rate, Wet	CFM	740-810-885-955
	External Static Pressure	in.WG	n/a

SPECIFICATIONS: PCA-A42KA7 & PUZ-HA42NKA

Model Number	Indoor Unit		PCA-A42KA7
	Outdoor Unit		PUZ-HA42NKA
	Sound Pressure Level	dB(A)	39-41-43-45
	Drain Pipe Size	In. (mm)	1-1/32 (26)
	Condensate Lift Mechanism, Maximum Distance	Ft. (m)	n/a
	Heat Exchanger Type		Plate fin coil
	External Finish Color		White Munsell 6.4Y 8.9/0.4
	Unit Dimensions // Grille Dimensions	W: In. (mm)	63 (1600)
		D: In. (mm)	26-3/4 (680)
		H: In. (mm)	9-1/16 (230)
	Package Dimensions // Grille Dimensions	W: In. (mm)	53-2/16
		D: In. (mm)	29-15/16
		H: In. (mm)	13-12/16
	Unit Weight	Lbs. (kg)	86 (39)
	Package Weight	Lbs. (kg)	102
Indoor Unit Operating Temperature Range	Cooling Intake Air Temp (Maximum / Minimum)	°F	90 DB, 73 WB / 66 DB, 59 WB
	Heating Intake Air Temp (Maximum / Minimum)	°F	82 DB / 50 DB
Outdoor Unit	MCA	A	37
	MOCP	A	44
	Fan Motor Full Load Amperage	A	0.4+0.4
	Fan Motor Output	W	86+86
	Airflow Rate	CFM	3,320
	Refrigerant Control		Electronic Expansion Valve
	Defrost Method		Reverse Cycle
	Heat Exchanger Type		Cross fin
	Sound Pressure Level, Cooling ¹	dB(A)	49
	Sound Pressure Level, Heating ²	dB(A)	51
	Compressor Type		Inverter-driven twin rotary
	Compressor Model		ANB42FJTMT
	Compressor Rated Load Amps	A	19
	Compressor Locked Rotor Amps	A	28
	Compressor Oil Type // Charge	oz.	FVC68D // 54
	External Finish Color		Ivory Munsell 3Y 7.8/1.1
	Base Pan Heater		Option (PAC-SJ20BH-E)
	Unit Dimensions	W: In. (mm)	41-3/8[1,050]
		D: In. (mm)	13 + 1-3/16 (330 + 30)
		H: In. (mm)	52-11/16 (1,338)
Package Dimensions	W: In. (mm)	42-15/16 (1,090)	
	D: In. (mm)	17-11/16 (450)	
	H: In. (mm)	56-1/4 (1,428)	
Unit Weight	Lbs. (kg)	287 (130)	

SPECIFICATIONS: PCA-A42KA7 & PUZ-HA42NKA

Model Number	Indoor Unit		PCA-A42KA7
	Outdoor Unit		PUZ-HA42NKA
	Package Weight	Lbs. (kg)	313 (142)
Outdoor Unit Operating Temperature Range	Cooling Intake Air Temp (Maximum / Minimum)	°F	115 DB / 0° DB
	Heating Intake Air Temp (Maximum / Minimum)	°F	70 DB, 59 WB / -13 DB, -13 WB
	Thermal Lock-out / Re-start Temperatures**	°F	n/a
Refrigerant	Type		R410A
	Charge	Lbs, oz	13, 4
Piping	Gas Pipe Size O.D. (Flared)	In.(mm)	5/8 (15.88)
	Liquid Pipe Size O.D. (Flared)	In.(mm)	3/8 (9.52)
	Maximum Piping Length	Ft. (m)	245 (75)
	Maximum Height Difference	Ft. (m)	100 (30)
	Maximum Number of Bends		15

Notes

AHRI Rated Conditions (Rated data is determined at a fixed compressor speed)	¹ Cooling (Indoor // Outdoor)	°F	80 DB, 67 WB // 95 DB, 75 WB
	² Heating at 47°F (Indoor // Outdoor)	°F	70 DB, 60 WB // 47 DB, 43 WB
	³ Heating at 17°F (Indoor // Outdoor)	°F	70 DB, 60 WB // 17 DB, 15 WB
Conditions	⁴ Heating at 5°F (Indoor // Outdoor)	°F	70 DB, 60 WB // -4 DB, -5 WB

*Wind baffles required to operate below 23°F DB in cooling mode. PUZ with wind baffle: 0°F - 115°F.

**System cuts out in heating mode to avoid thermistor error and automatically restarts at these temperatures.

ACCESSORIES: PCA-A42KA7

High Efficiency (MERV 8) Filter Element	□ PAC-SE81KF-E
High-efficiency Filter Element	□ PAC-SH90KF-E
Signal Receiver	□ PAR-SA9CA-E
Wireless Remote Controller	□ PAR-FL32MA-E
Wireless Remote Receiver	□ PAR-FA32MA-E
Controller Kit (Sender & Receiver)	□ PAR-SL93B-E
Controller Kit with I-see Sensor	□ PAR-SA92MW-E
Backlit, Wall-mounted, Wireless Controller	□ MHK1
Portable Central Controller	□ MCCH1
Wired MA Controller	□ PAR-33MAA
Simple MA Controller	□ PAC-YT53CRAU
Touch MA Controller	□ PAR-CT01MAU-SB
Lockdown Bracket for Wireless, Hand-held, Remote Controller	□ RCMKP1CB
Wireless Temperature and Humidity Sensor	□ PAC-USWHS003-TH-1
Outside Air Sensor for MHK1	□ MOS1
Flush Mount Remote Temperature Sensor	□ PAC-USSEN001-FM-1
Wireless Interface	□ PAC-USWHS002-WF-1
Thermostat Interface	□ PAC-US444CN-1
kumo station®	□ PAC-WHS01HC-E
USNAP Interface	□ PAC-WHS01UP-E
IT Extender	□ PAC-WHS01IE-E
BACnet® and Modbus Interface	□ PAC-UKPRC001-CN-1
External Fan / Heater Control Relay Adapter	□ CN24RELAY-KIT-CM3
Remote Operation Adapter (with wire terminals for remote ON/OFF and operation status/ error) ¹	□ PAC-SF40RM-E
I-see Sensor™	□ PAC-SH91MK-E
External Drain Pump	□ PAC-SH84DM-E
Blue Diamond Sensor Extension Cable—15 Ft.	□ C13-103
MegaBlue Advanced Blue Diamond Condensate Pump w/ Reservoir & Sensor	□ X87-835 - 110 to 250V
MaxiBlue Advanced Blue Diamond Mini Condensate Pump w/ Reservoir & Sensor (208/230V) up to 48,000 Btu/h [recommended]	□ X87-721 - 208/230V
Drain Pan Level Sensor (Control for indoor unit shut off to prevent drain pan overflow)	□ DPLS2
3 Pole Disconnect Switch (30A/600VUL) [fits 2"X4" utility] - Black	□ TAZ-MS303
3 Pole Disconnect Switch (30A/600VUL) [fits 2"X4" utility] - White	□ TAZ-MS303W

¹ Unable to use with wireless remote controller

ACCESSORIES: PUZ-HA42NKA

Air Outlet Guide	<input type="checkbox"/> PAC-SH96SG-E (two pieces are required)
Front Wind Baffle	<input type="checkbox"/> WB-PA3 (two pieces are required)
Drain Socket	<input type="checkbox"/> PAC-SG61DS-E
Defrost Heater	<input type="checkbox"/> PAC-SJ20BH-E
Centralized Drain Pan	<input type="checkbox"/> PAC-SH97DP-E
M-NET Converter	<input type="checkbox"/> PAC-SF83MA-E
M-NET Converter	<input type="checkbox"/> PAC-SJ95MA-E
Control/Service Tool	<input type="checkbox"/> PAC-SK52ST
Hail Guard	<input type="checkbox"/> HG-A2
Condensing Unit Mounting Pad 24" x 42" x 3"	<input type="checkbox"/> ULTRILITE2
Outdoor Unit Stand—12" High	<input type="checkbox"/> QSMS1202M
Outdoor Unit Stand—18" High	<input type="checkbox"/> QSMS1802M
Outdoor Unit Stand—24" High	<input type="checkbox"/> QSMS2402M
Heavy Duty Wall Mounting Bracket for Outdoor Units—Coated Steel	<input type="checkbox"/> QSWB2000M-1
Heavy Duty Wall Mounting Bracket for Outdoor Units—316 Series Stainless Steel	<input type="checkbox"/> QSWBSS
3/8" x 5/8" x 10' / 1/2" Lineset (Twin-Tube Insulation)	<input type="checkbox"/> MPLS385812T-10
3/8" x 5/8" x 15' / 1/2" Lineset (Twin-Tube Insulation)	<input type="checkbox"/> MPLS385812T-15
3/8" x 5/8" x 30' / 1/2" Lineset (Twin-Tube Insulation)	<input type="checkbox"/> MPLS385812T-30
3/8" x 5/8" x 50' / 1/2" Lineset (Twin-Tube Insulation)	<input type="checkbox"/> MPLS385812T-50
3/8" x 5/8" x 65' / 1/2" Lineset (Twin-Tube Insulation)	<input type="checkbox"/> MPLS385812T-65
3/8" x 5/8" x 100' / 1/2" Lineset (Twin-Tube Insulation)	<input type="checkbox"/> MPLS385812T-100

DIMENSIONS: PCA-A42KA7 & PUZ-HA42NKA

PCA-A42KA7

Unit: in (mm)

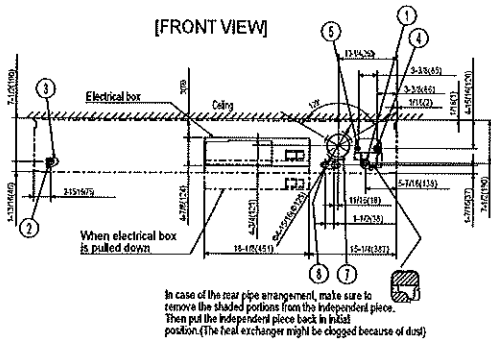

NOTES.

1. Use M10 or W3/8 screw for anchor bolt.
2. Please be sure when installing the drain pump (option parts), refrigerant pipe will be only upward.

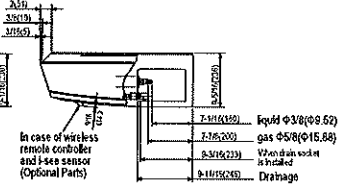
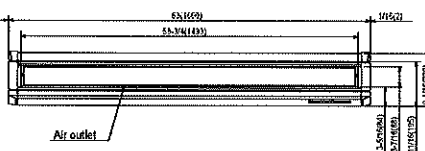
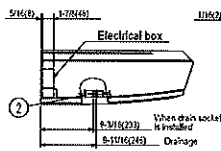
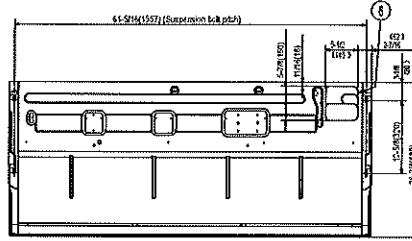

- ① Drainage pipe connection(1(26mm)I.D.)
 - ② Drainage pipe connection(for the left arrangement)
 - ③ Knockout hole for left drain-piping arrangement
 - ④ Refrigerant-pipe connection (gas pipe side/flared connection)
 - ⑤ Refrigerant-pipe connection (liquid pipe side/flared connection)
 - ⑥ Knockout hole for upper drain pipe arrangement
 - ⑦ Knockout hole for fresh air intake $\Phi 3-15/16(\Phi 100)$
 - ⑧ Knockout hole for wiring arrangement $\Phi 7/8(\Phi 22)$
- Accessory...Drain socket (1(26mm)I.D.)

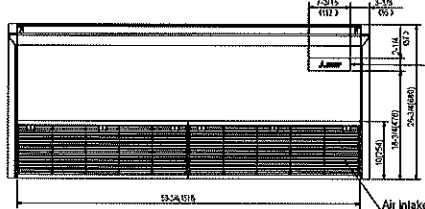

In case of wireless remote controller and I-see sensor(Optional Parts)

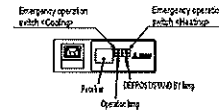

DIMENSIONS: PCA-A42KA7 & PUZ-HA42NKA

PUZ-HA42NKA

Unit mm/inch

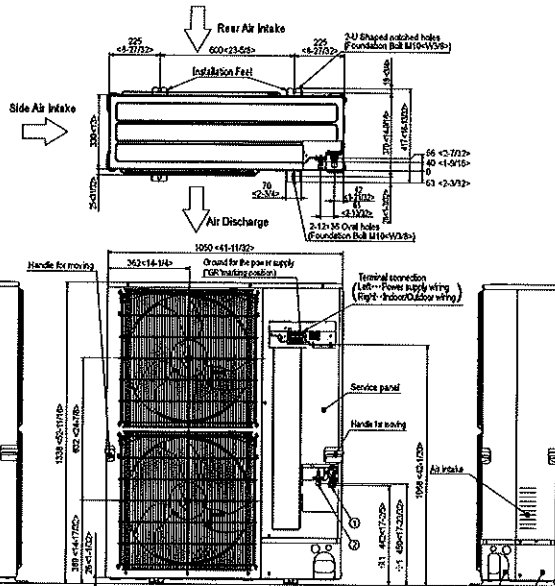
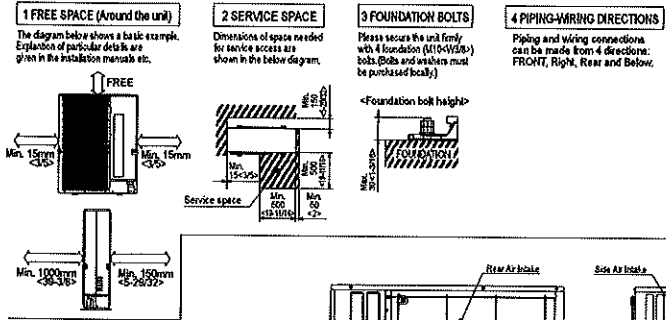

Example of Notes

- ① Refrigerant GAS pipe connection (FLARE) (Ø15.88 (5/8")
- ② Refrigerant LIQUID pipe connection (FLARE) (Ø 9.52 (3/8")
- F1 - Indication of STOP VALVE connection location.

Piping Knock-Out Hole Details

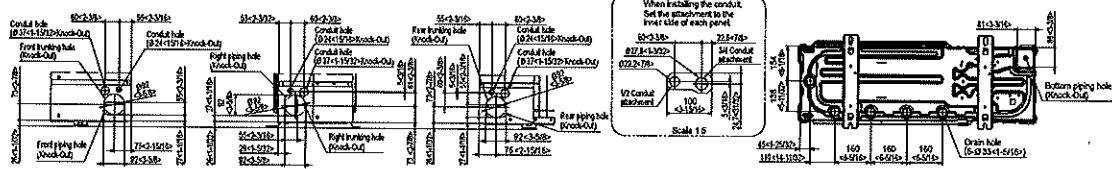

1340 Satellite Boulevard, Suwanee, GA 30024
Toll Free: 800-433-4822 www.mehvac.com



FORM# PCA-A42KA7 / PUZ-HA42NKA - 201810

P-SERIES

SUBMITTAL DATA: PCA-A36KA7 & PUZ-HA36NHA5 36,000 BTU/H CEILING-SUSPENDED HEAT PUMP SYSTEM



Job Name:

System Reference:

Date:

Indoor Unit:
PCA-A36KA7



Outdoor Unit:
PUZ-HA36NHA5

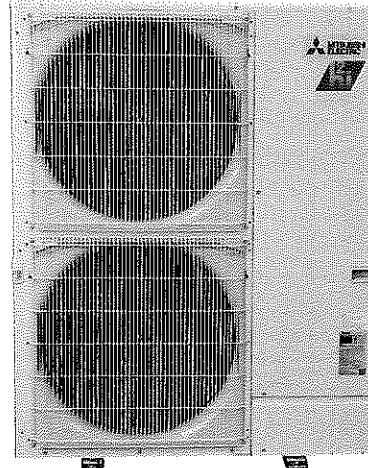

INDOOR UNIT FEATURES

- Airflow settings for high and low ceiling applications
- Knock-out for outside-air intake
- Optional I-see Sensor™ for air distribution and energy saving
- Auto fan speed mode
- Filter status indicator
- Easy-to-clean, washable filter
- Suspends from ceiling for quick and easy installation
- Ideal for larger retail stores, classrooms, and restaurants

OUTDOOR UNIT FEATURES

- Variable speed INVERTER-driven compressor
- High heating capacity: flash injection circuit maintains 100% heating capacity at 5°F outdoor temperature
- Wide heating range: heating performance down to -13°F (average of 80% heating capacity)
- High speed heating at start up: Hyper-Heating INVERTER® reduces the time for heating at start up by about half compared to standard models
- Suction accumulator pre-charged with refrigerant volume for piping length up to 100 ft.
- Twinning of two indoor units possible with the 36 kBTU/h model
- High pressure/temperature protection

SPECIFICATIONS: PCA-A36KA7 & PUZ-HA36NHA5

Model Number	Indoor Unit		PCA-A36KA7
	Outdoor Unit		PUZ-HA36NHA5
Cooling ¹	Maximum Capacity	Btu/h	36,000
	Rated Capacity	Btu/h	34,000
	Minimum Capacity	Btu/h	18,000
	Maximum Power Input	W	3,170
	Rated Power Input	W	2,810
	Moisture Removal	Pints/h	8.2
	Sensible Heat Factor		0.73
	Power Factor	%	93.3
Heating at 47°F ²	Maximum Capacity	Btu/h	40,000
	Rated Capacity	Btu/h	38,000
	Minimum Capacity	Btu/h	18,000
	Maximum Power Input	W	3,730
	Rated Power Input	W	3,270
	Power Factor	%	94.2
Heating at 17°F ³	Maximum Capacity	Btu/h	38,000
	Rated Capacity	Btu/h	27,000
	Maximum Power Input	W	5,720
	Rated Power Input	W	3,480
Heating at 5°F ⁴	Maximum Capacity	Btu/h	38,000
	Maximum Power Input	W	6,550
Efficiency	SEER		16.6
	EER ¹		12.1
	HSPF (IV)		10.3
	COP at 47°F ²		3.41
	COP at 17°F in Maximum Capacity		1.95
	COP at 5°F in Maximum Capacity		1.70
Electrical	Voltage, Phase, Frequency		208 / 230V, 1-phase, 60 Hz
	Guaranteed Voltage Range	V AC	198 – 253
	Voltage: Indoor - Outdoor, S1-S2	V AC	208V / 230
	Voltage: Indoor - Outdoor, S2-S3	V DC	24
	Voltage: Indoor - Remote controller	V DC	12
	Recommended Fuse/Breaker Size	A	30
	Recommended Wire Size (Indoor - Outdoor)	AWG	14
Indoor Unit	MCA	A	2.00
	Fan Motor Full Load Amperage	A	0.97
	Fan Motor Output	W	160
	Airflow Rate, Dry	CFM	775-850-920-990
	Airflow Rate, Wet	CFM	705-775-850-920
	External Static Pressure	in.WG	n/a

SPECIFICATIONS: PCA-A36KA7 & PUZ-HA36NHA5

Model Number	Indoor Unit	Outdoor Unit	PCA-A36KA7 PUZ-HA36NHA5
	Sound Pressure Level	dB(A)	37-39-41-43
	Drain Pipe Size	In. (mm)	1-1/32 (26)
	Condensate Lift Mechanism, Maximum Distance	Ft. (m)	n/a
	Heat Exchanger Type		Plate fin coil
	External Finish Color		White Munsell 6.4Y 8.9/0.4
	Unit Dimensions // Grille Dimensions	W: In. (mm)	63 (1600)
		D: In. (mm)	26-3/4 (680)
		H: In. (mm)	9-1/16 (230)
	Package Dimensions // Grille Dimensions	W: In. (mm)	53-2/16
		D: In. (mm)	29-15/16
H: In. (mm)		13-12/16	
Unit Weight	Lbs. (kg)	79 (36)	
Package Weight	Lbs. (kg)	93	
Indoor Unit Operating Temperature Range	Cooling Intake Air Temp (Maximum / Minimum)	°F	90 DB, 73 WB / 66 DB, 59 WB
	Heating Intake Air Temp (Maximum / Minimum)	°F	82 DB / 50 DB
Outdoor Unit	MCA	A	28
	MOCP	A	40
	Fan Motor Full Load Amperage	A	0.4+0.4
	Fan Motor Output	W	86+86
	Airflow Rate	CFM	3,530
	Refrigerant Control		Electronic Expansion Valve
	Defrost Method		Reverse Cycle
	Heat Exchanger Type		Cross fin
	Sound Pressure Level, Cooling ¹	dB(A)	52
	Sound Pressure Level, Heating ²	dB(A)	53
	Compressor Type		INVERTER-Driven Twin Rotary
	Compressor Model		ANB33FJEMT
	Compressor Rated Load Amps	A	18
	Compressor Locked Rotor Amps	A	27.5
	Compressor Oil Type // Charge	oz.	FV50S // 45
	External Finish Color		Ivory Munsell 3Y 7.8/1.1
	Base Pan Heater		n/a
	Unit Dimensions	W: In. (mm)	37-3/8 (950)
		D: In. (mm)	13 + 1-3/16 (330 + 30)
		H: In. (mm)	53-1/8 (1,350)
Package Dimensions	W: In. (mm)	40-15/16 (1,040)	
	D: In. (mm)	17-11/16 (450)	
	H: In. (mm)	56-11/16 (1,440)	
Unit Weight	Lbs. (kg)	265 (120)	

SPECIFICATIONS: PCA-A36KA7 & PUZ-HA36NHA5

Model Number	Indoor Unit		PCA-A36KA7
	Outdoor Unit		PUZ-HA36NHA5
	Package Weight	Lbs. (kg)	289 (131)
Outdoor Unit Operating Temperature Range	Cooling Intake Air Temp (Maximum / Minimum)	°F	115 DB / 0° DB
	Heating Intake Air Temp (Maximum / Minimum)	°F	70 DB, 59 WB / -13 DB, -13 WB
	Thermal Lock-out / Re-start Temperatures**	°F	n/a
Refrigerant	Type		R410A
	Charge	Lbs, oz	12
Piping	Gas Pipe Size O.D. (Flared)	In.(mm)	5/8 (15.88)
	Liquid Pipe Size O.D. (Flared)	In.(mm)	3/8 (9.52)
	Maximum Piping Length	Ft. (m)	245 (75)
	Maximum Height Difference	Ft. (m)	100 (30)
	Maximum Number of Bends		15

Notes

AHRI Rated Conditions (Rated data is determined at a fixed compressor speed)	¹ Cooling (Indoor // Outdoor)	°F	80 DB, 67 WB // 95 DB, 75 WB
	² Heating at 47°F (Indoor // Outdoor)	°F	70 DB, 60 WB // 47 DB, 43 WB
	³ Heating at 17°F (Indoor // Outdoor)	°F	70 DB, 60 WB // 17 DB, 15 WB
Conditions	⁴ Heating at 5°F (Indoor // Outdoor)	°F	70 DB, 60 WB // -4 DB, -5 WB

*Wind baffles required to operate below 23°F DB in cooling mode. PUZ with wind baffle: 0°F - 115°F.

**System cuts out in heating mode to avoid thermistor error and automatically restarts at these temperatures.

ACCESSORIES: PCA-A36KA7

High Efficiency (MERV 8) Filter Element	<input type="checkbox"/> PAC-SE81KF-E
High-efficiency Filter Element	<input type="checkbox"/> PAC-SH90KF-E
Signal Receiver	<input type="checkbox"/> PAR-SA9CA-E
Wireless Remote Controller	<input type="checkbox"/> PAR-FL32MA-E
Wireless Remote Receiver	<input type="checkbox"/> PAR-FA32MA-E
Controller Kit (Sender & Receiver)	<input type="checkbox"/> PAR-SL93B-E
Controller Kit with i-see Sensor	<input type="checkbox"/> PAR-SA92MW-E
Backlit, Wall-mounted, Wireless Controller	<input type="checkbox"/> MHK1
Portable Central Controller	<input type="checkbox"/> MCCH1
Wired MA Controller	<input type="checkbox"/> PAR-33MAA
Simple MA Controller	<input type="checkbox"/> PAC-YT53CRAU
Touch MA Controller	<input type="checkbox"/> PAR-CT01MAU-SB
Lockdown Bracket for Wireless, Hand-held, Remote Controller	<input type="checkbox"/> RCMKP1CB
Wireless Temperature and Humidity Sensor	<input type="checkbox"/> PAC-USWHS003-TH-1
Outside Air Sensor for MHK1	<input type="checkbox"/> MOS1
Flush Mount Remote Temperature Sensor	<input type="checkbox"/> PAC-USSEN001-FM-1
Wireless Interface	<input type="checkbox"/> PAC-USWHS002-WF-1
Thermostat Interface	<input type="checkbox"/> PAC-US444CN-1
kumo station®	<input type="checkbox"/> PAC-WHS01HC-E
USNAP Interface	<input type="checkbox"/> PAC-WHS01UP-E
IT Extender	<input type="checkbox"/> PAC-WHS01IE-E
BACnet® and Modbus Interface	<input type="checkbox"/> PAC-UKPRC001-CN-1
External Fan / Heater Control Relay Adapter	<input type="checkbox"/> CN24RELAY-KIT-CM3
Remote Operation Adapter (with wire terminals for remote ON/OFF and operation status/ error) ¹	<input type="checkbox"/> PAC-SF40RM-E
i-see Sensor™	<input type="checkbox"/> PAC-SH91MK-E
External Drain Pump	<input type="checkbox"/> PAC-SH84DM-E
Blue Diamond Sensor Extension Cable—15 Ft.	<input type="checkbox"/> C13-103
MegaBlue Advanced Blue Diamond Condensate Pump w/ Reservoir & Sensor	<input type="checkbox"/> X87-835 - 110 to 250V
MaxiBlue Advanced Blue Diamond Mini Condensate Pump w/ Reservoir & Sensor (208/230V) up to 48,000 Btu/h [recommended]	<input type="checkbox"/> X87-721 - 208/230V
Drain Pan Level Sensor (Control for indoor unit shut off to prevent drain pan overflow)	<input type="checkbox"/> DPLS2
3 Pole Disconnect Switch (30A/600VUL) [fits 2"X4" utility] - Black	<input type="checkbox"/> TAZ-MS303
3 Pole Disconnect Switch (30A/600VUL) [fits 2"X4" utility] - White	<input type="checkbox"/> TAZ-MS303W

¹ Unable to use with wireless remote controller

ACCESSORIES: PUZ-HA36NHA5

Air Outlet Guide	<input type="checkbox"/> PAC-SG59SG-E
Front Wind Baffle	<input type="checkbox"/> WB-PA5
Drain Socket	<input type="checkbox"/> PAC-SG61DS-E
Centralized Drain Pan	<input type="checkbox"/> PAC-SG63DP-E
M-NET Converter	<input type="checkbox"/> PAC-SF83MA-E
M-NET Converter	<input type="checkbox"/> PAC-SJ95MA-E
Control/Service Tool	<input type="checkbox"/> PAC-SK52ST
Hail Guard	<input type="checkbox"/> HG-A2
Condensing Unit Mounting Pad 24" x 42" x 3"	<input type="checkbox"/> ULTRILITE2
Outdoor Unit Stand—12" High	<input type="checkbox"/> QSMS1202M
Outdoor Unit Stand—18" High	<input type="checkbox"/> QSMS1802M
Outdoor Unit Stand—24" High	<input type="checkbox"/> QSMS2402M
Heavy Duty Wall Mounting Bracket for Outdoor Units—Coated Steel	<input type="checkbox"/> QSWB2000M-1
Heavy Duty Wall Mounting Bracket for Outdoor Units—316 Series Stainless Steel	<input type="checkbox"/> QSWBSS
3/8" x 5/8" x 10' / 1/2" Lineset (Twin-Tube Insulation)	<input type="checkbox"/> MPLS385812T-10
3/8" x 5/8" x 15' / 1/2" Lineset (Twin-Tube Insulation)	<input type="checkbox"/> MPLS385812T-15
3/8" x 5/8" x 30' / 1/2" Lineset (Twin-Tube Insulation)	<input type="checkbox"/> MPLS385812T-30
3/8" x 5/8" x 50' / 1/2" Lineset (Twin-Tube Insulation)	<input type="checkbox"/> MPLS385812T-50
3/8" x 5/8" x 65' / 1/2" Lineset (Twin-Tube Insulation)	<input type="checkbox"/> MPLS385812T-65
3/8" x 5/8" x 100' / 1/2" Lineset (Twin-Tube Insulation)	<input type="checkbox"/> MPLS385812T-100

DIMENSIONS: PCA-A36KA7 & PUZ-HA36NHA5

PCA-A36KA7

Unit: in (mm)

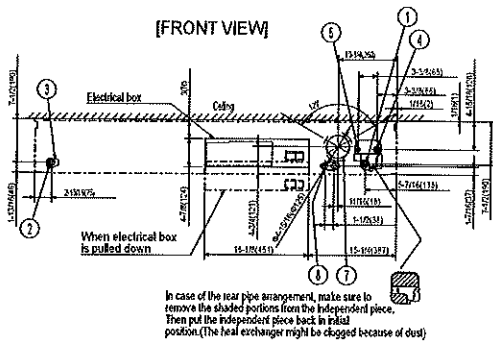

NOTES.

1. Use M10 or W3/8 screw for anchor bolt.
2. Please be sure when installing the drain pump (option parts), refrigerant pipe will be only upward.

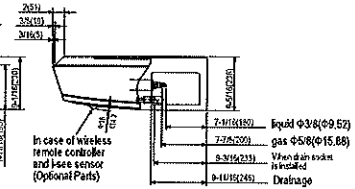
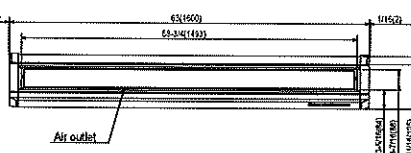
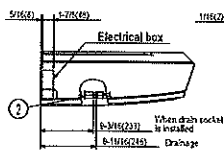
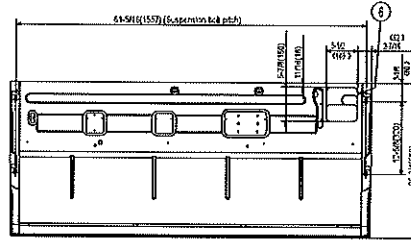

- ① Drainage pipe connection (1/26mm) I.D.
 - ② Drainage pipe connection (for the left arrangement)
 - ③ Knockout hole for left drain-piping arrangement
 - ④ Refrigerant-pipe connection (gas pipe side/flared connection)
 - ⑤ Refrigerant-pipe connection (liquid pipe side/flared connection)
 - ⑥ Knockout hole for upper drain pipe arrangement
 - ⑦ Knockout hole for fresh air intake $\Phi 3-15/16$ ($\Phi 100$)
 - ⑧ Knockout hole for wiring arrangement $\Phi 7/8$ ($\Phi 22$)
- Accessory...Drain socket (1/26mm) I.D.)

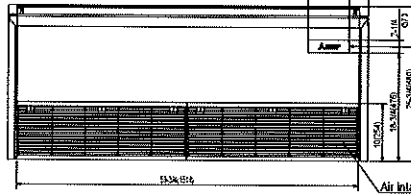

In case of wireless remote controller and face sensor (Optional Parts)

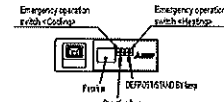

DIMENSIONS: PCA-A36KA7 & PUZ-HA36NHA5

PUZ-HA36NHA5

1 FREE SPACE (Around the unit) | 2 SERVICE SPACE | 3 FOUNDATION BOLTS | 4 PIPING-WIRING DIRECTIONS

The diagram below shows a basic example. Explanation of particular details are given in the installation manuals, etc.

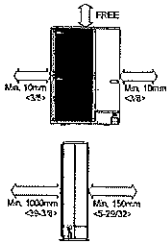

Dimensions of space needed for service access are shown in the below diagram.

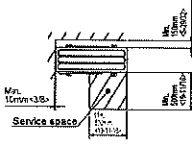

Please secure the unit firmly with 4 foundation (M10\times120\times6) bolts. (Bolts and washers must be purchased locally.)

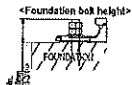

Piping and wiring connections can be made from 4 directions: front, right, rear and below.

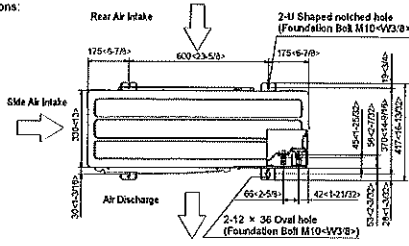

Unit : mm$\langle S \rangle$-inch

Example of Notes

- ① --- Refrigerant GAS pipe connection (FLARE) ϕ15.88\times5.8
- ② --- Refrigerant LIQUID pipe connection (FLARE) ϕ6.52\times3.8
- * --- Indication of STOP VALVE connection location.

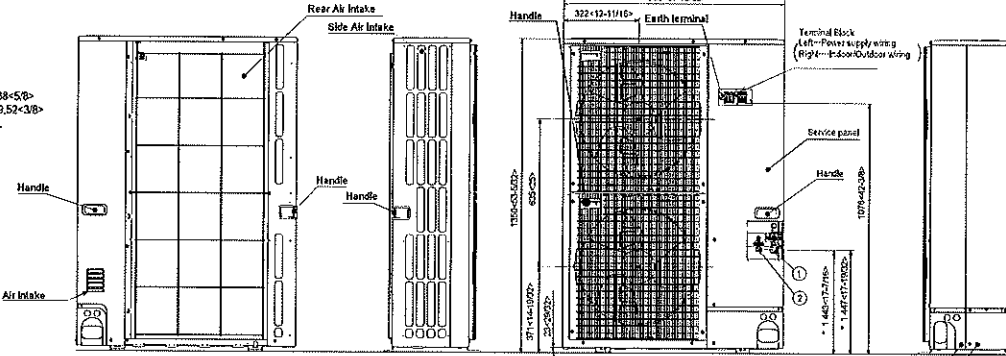

Piping Knockout Hole Details

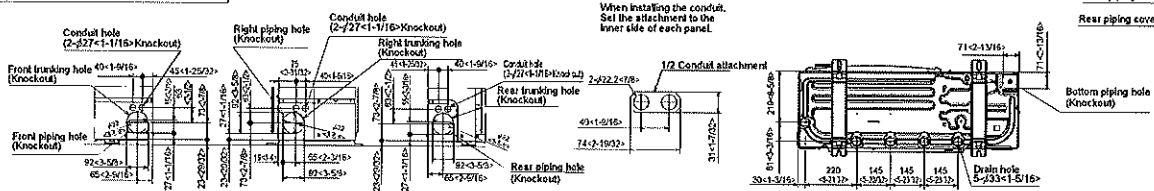

When installing the conduit, Set the attachment to the inner side of each panel.



1340 Satellite Boulevard, Suwanee, GA 30024
Toll Free: 800-433-4822 www.mehvac.com





Permanent Structure of Facility Alteration Request Form

Date of Request: April 2, 2019

Location/Building: Pro 2 Serve Soccer Complex

Name of person or group making request: Oak Ridge High School Athletic Department

Description of proposed project: Remove and replace soccer dugouts

Total Project Cost: \$60,000.00

District/School Cost: -0-

Donated Amount: \$60,000

Projected Operation/Maintenance Cost: _____

Name of Group or Individual making the donation: Pro2Serve Barry Goss, CEO

People/Group that will do the work: _____

If contract labor will be used, please complete the following:

Name of Contractor: _____

Address: _____

Phone: _____

Background check of contracted labor has been verified by:

_____ Date: _____

Attach any pictures, diagrams or blueprints for the proposed project.

Approval Signatures:

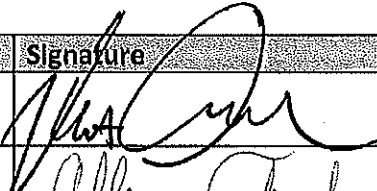
Date	Title	Signature
4/2/19	Principal or Building Administrator	
11/15/19	Supervisor of Maintenance and Operations	Allen Tracker
11-18-19	Executive Director of Business and Operations	Pete Smith
11/18/19	Executive Director of School Leadership	Bruce Long
11-18-19	Superintendent of Schools	Ben Brubaker

Project work may not begin prior to ORS Board of Education approval.

Board Approval Date: _____



Professional Project Services, Inc.

1100 Bethel Valley Road
Oak Ridge, TN 37830
(865) 220-4300
Fax: (865) 220-4310
www.p2s.com

April 1, 2019

Mike Mullins
Athletic Director
Oak Ridge School Systems
Oak Ridge, TN 37830

Reference: Pro2Serve/Oak Ridge High School Corporate Partnership – Construction of Soccer Dugouts and Extension of Naming Rights Agreement

Dear Mr. Mullins:

The Pro2Serve Board of Directors has approved the funding for the construction of two soccer dugouts as detailed in Attachment 1 at the Pro2Serve/Oak Ridge High School Soccer Complex. Upon approval from Oak Ridge Schools extending our naming rights agreement for an additional five (5) years, Pro2Serve will manage the construction of the dugouts, working closely with you to schedule construction activities. This will extend the current ten year Soccer Complex naming rights agreement through December 31, 2027.

Please have Dr. Borchers sign below and return to me for signature. We will return a fully executed copy of the agreement for your files.

We are pleased to have the opportunity to extend our current corporate partnership with Oak Ridge Schools and, as you have stated, make the best soccer complex in the state even better!

IN WITNESS WHEREOF, the authorized representatives of the Parties, acting within their authority, have executed this Agreement signifying their concurrence and confirming the commitment of the organizations that they represent to be bound thereby.



L. Barry Goss, Ph.D. 4/2/19 Date
Chairman and CEO
Pro2Serve



Dr. Bruce Borchers 4.2.19 Date
Superintendent
Oak Ridge Schools,

"An Employee-Owned Company"

ORHS Soccer Shelters

Summary

Use Steel beam to span opening to eliminate columns for the two team shelters. Provide Split-face block to match existing concession stand. Shelter will have concrete block side walls with window to support the steel and still allow view of field.

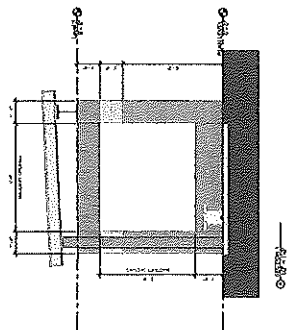
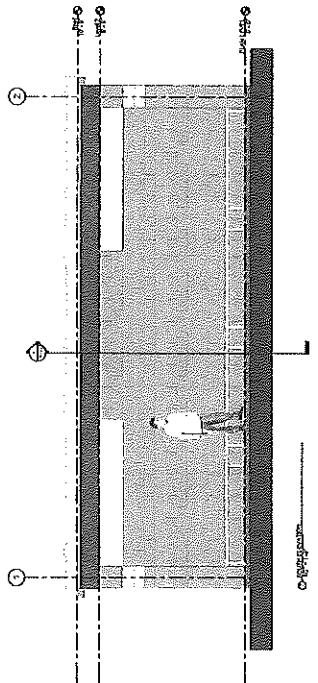
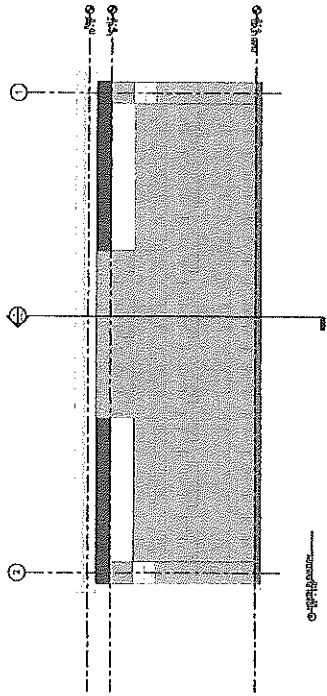

© 2012 [unreadable]

© 2012 [unreadable]

© 2012 [unreadable]

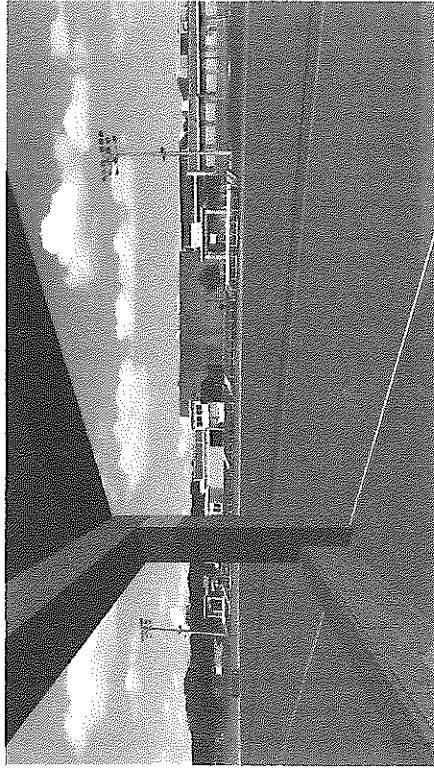
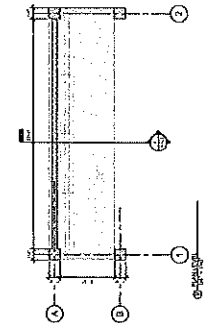
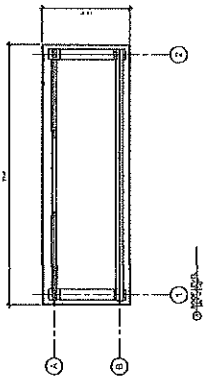

© 2012 [unreadable]

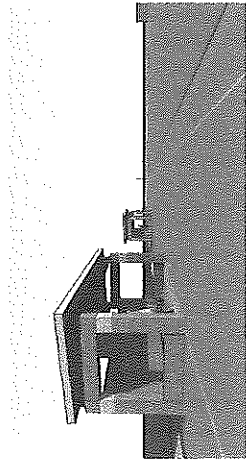

© 2012 [unreadable]

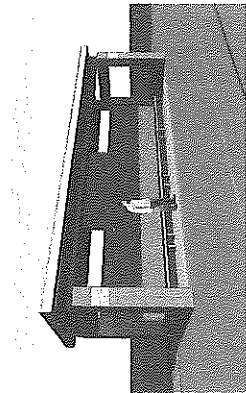

© 2012 [unreadable]

Agreed Configuration

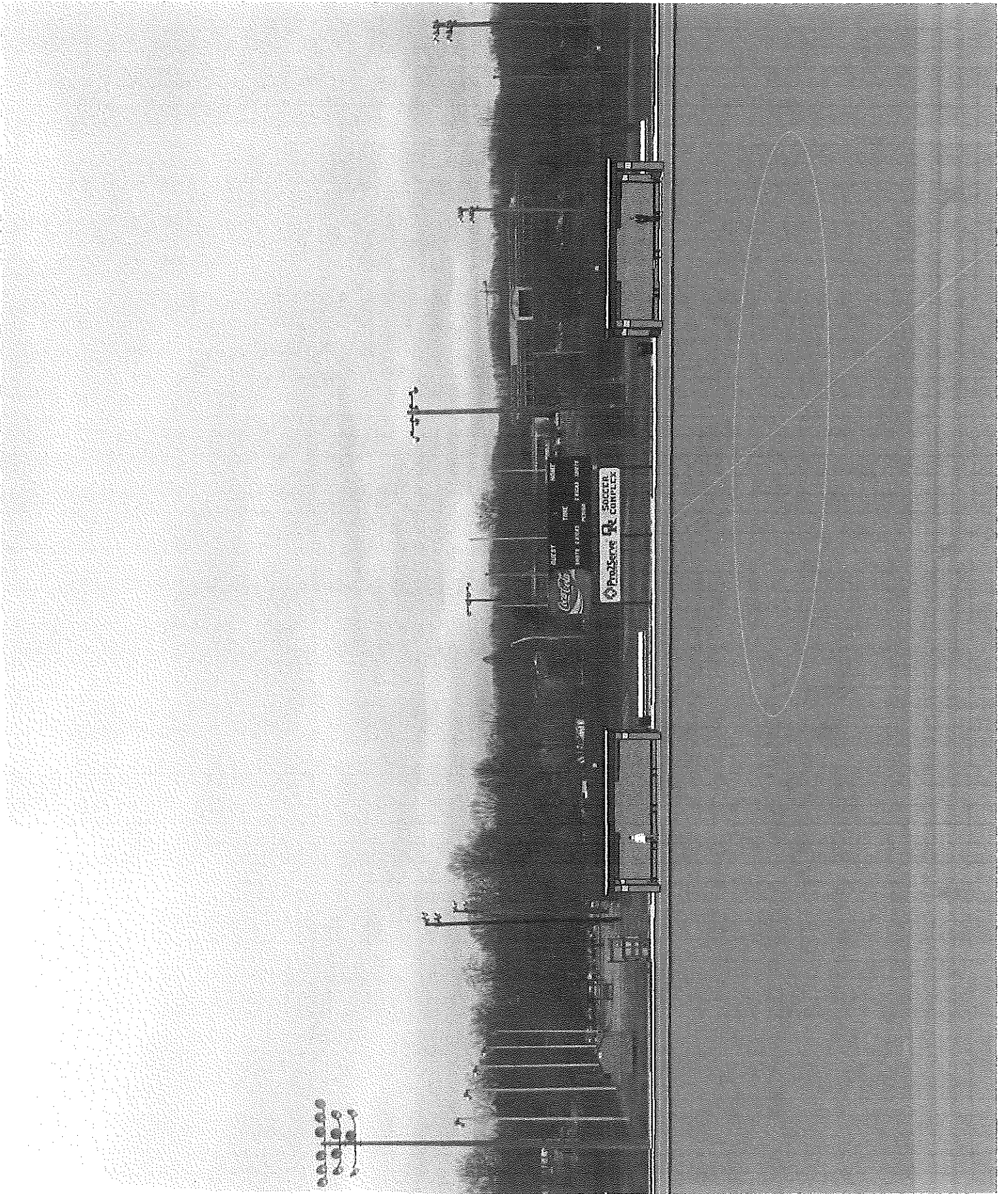

Attendance Graphs

The graphs below display excused and unexcused absence totals, total enrollment, and attendance percentages by grade and reporting period. The data was compiled using information from attendance detail and summary reports and entity counts reports.

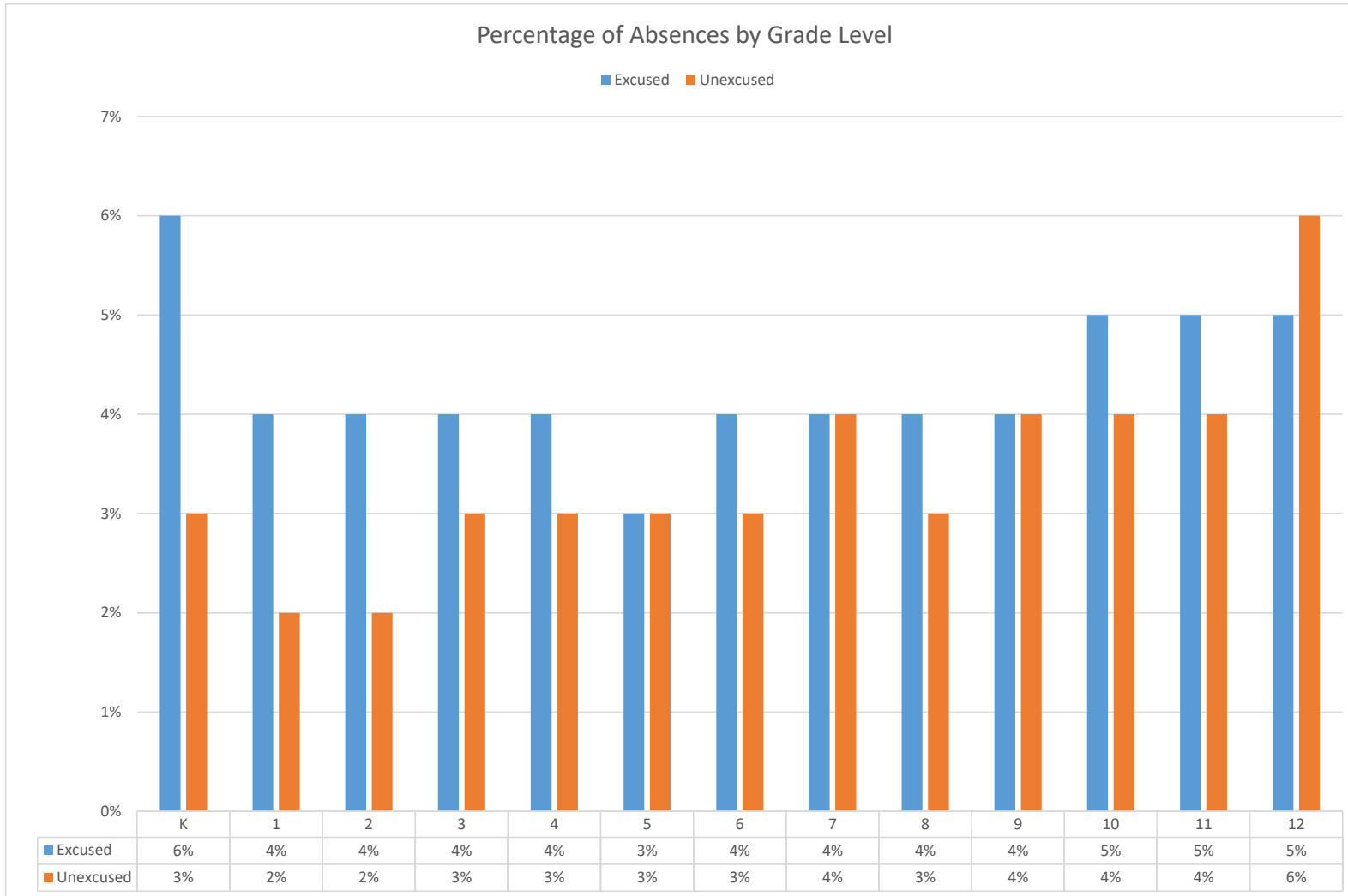

2015-16	RP1: 3%	RP2: 3%	RP3: 5%	RP4: 5%	RP5: 5%	RP6: 5%	RP7: 4%	RP8: 6%	RP9: 6%
2016-17	RP1: 4%	RP2: 5%	RP3: 6%	RP4: 6%	RP5: 6%	RP6: 7%	RP7: 6%	RP8: 6%	RP9: 6%
2017-18	RP1: 4%	RP2: 5%	RP3: 5%	RP4: 5%	RP5: 6%	RP6: 10%	RP7: 5%	RP8: 4%	RP9: 5%
2018-19	RP1: 3%	RP2: 4%	RP3: 5%	RP4: 5%	RP5: 6%	RP6: 5%	RP7: 7%	RP8: 4%	RP9: 5%
2019-20	RP1: 4%	RP2: 4%	RP3: 5%						

Glenwood

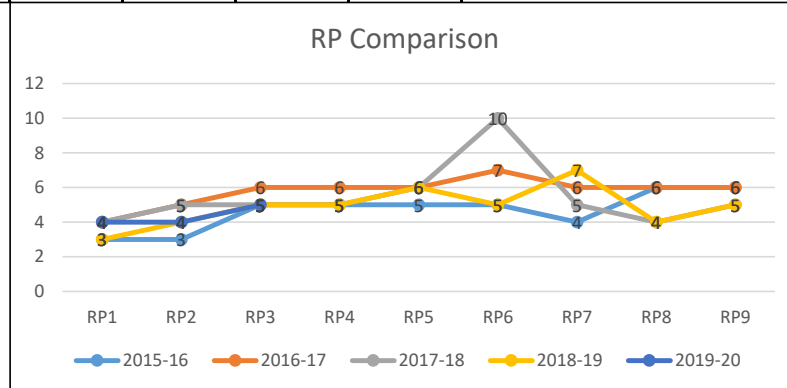
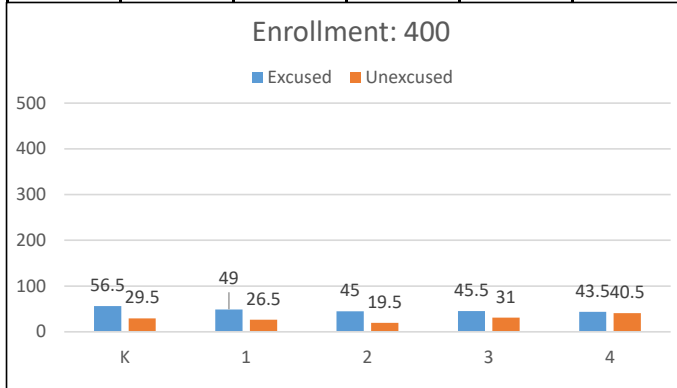

Goal
5.5

2015-16	RP1: 3%	RP2: 3%	RP3: 4%	RP4: 5%	RP5: 5%	RP6: 3%	RP7: 4%	RP8: 4%	RP9: 4%
2016-17	RP1: 4%	RP2: 5%	RP3: 5%	RP4: 7%	RP5: 6%	RP6: 8%	RP7: 6%	RP8: 5%	RP9: 5%
2017-18	RP1: 3%	RP2: 4%	RP3: 7%	RP4: 6%	RP5: 7%	RP6: 8%	RP7: 5%	RP8: 5%	RP9: 5%
2018-19	RP1: 3%	RP2: 5%	RP3: 6%	RP4: 5%	RP5: 5%	RP6: 8%	RP7: 6%	RP8: 6%	RP9: 6%
2019-20	RP1: 3%	RP2: 4%	RP3: 5%						

Linden

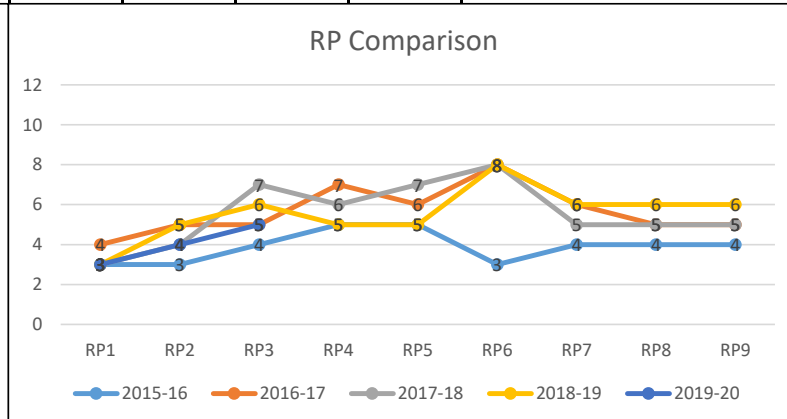
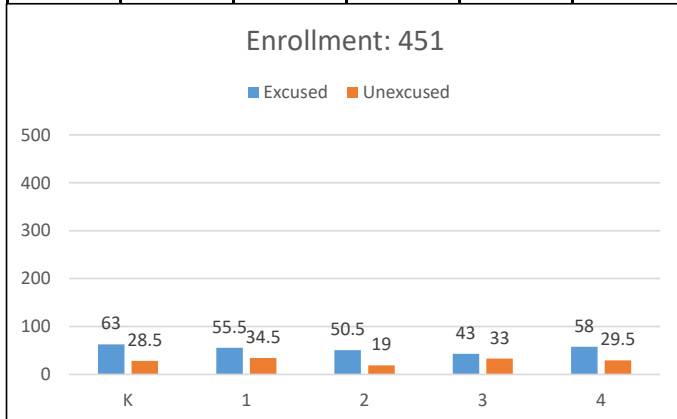

Goal
5

2015-16	RP1: 4%	RP2: 4%	RP3: 5%	RP4: 5%	RP5: 6%	RP6: 6%	RP7: 6%	RP8: 6%	RP9: 5%
2016-17	RP1: 5%	RP2: 5%	RP3: 5%	RP4: 5%	RP5: 6%	RP6: 7%	RP7: 5%	RP8: 5%	RP9: 6%
2017-18	RP1: 5%	RP2: 6%	RP3: 6%	RP4: 6%	RP5: 7%	RP6: 9%	RP7: 5%	RP8: 6%	RP9: 6%
2018-19	RP1: 5%	RP2: 5%	RP3: 5%	RP4: 6%	RP5: 6%	RP6: 6%	RP7: 9%	RP8: 5%	RP9: 5%
2019-20	RP1: 4%	RP2: 5%	RP3: 6%						

Willow Brook

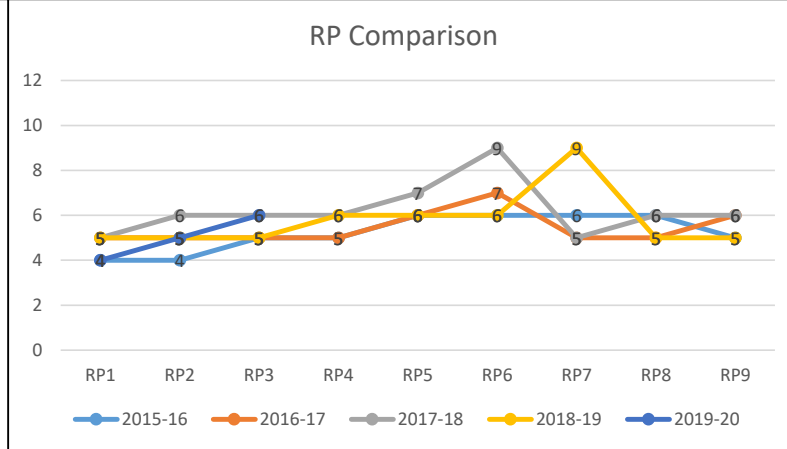
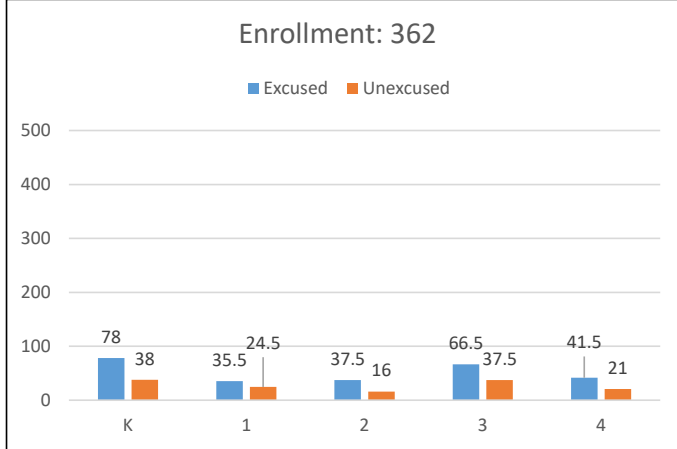

Goal

6

2015-16	RP1: 3%	RP2: 3%	RP3: 4%	RP4: 4%	RP5: 4%	RP6: 5%	RP7: 4%	RP8: 4%	RP9: 4%
2016-17	RP1: 3%	RP2: 4%	RP3: 4%	RP4: 4%	RP5: 5%	RP6: 5%	RP7: 4%	RP8: 4%	RP9: 4%
2017-18	RP1: 3%	RP2: 4%	RP3: 4%	RP4: 5%	RP5: 5%	RP6: 9%	RP7: 4%	RP8: 4%	RP9: 3%
2018-19	RP1: 3%	RP2: 5%	RP3: 5%	RP4: 6%	RP5: 5%	RP6: 6%	RP7: 5%	RP8: 5%	RP9: 5%
2019-20	RP1: 4%	RP2: 4%	RP3: 5%						

Woodland

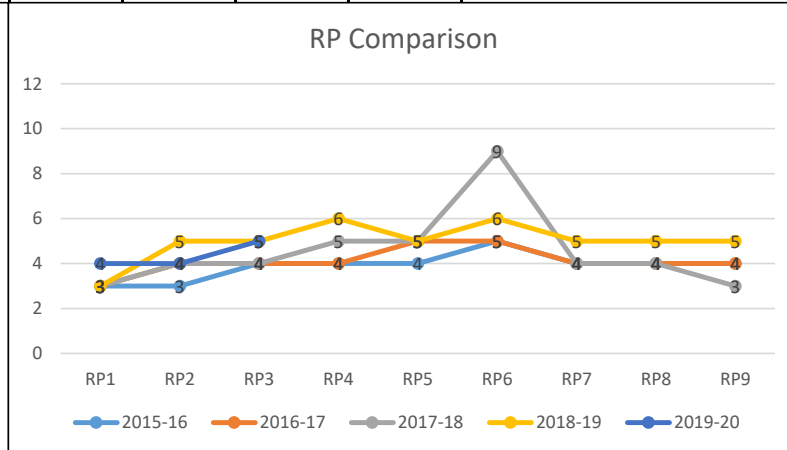
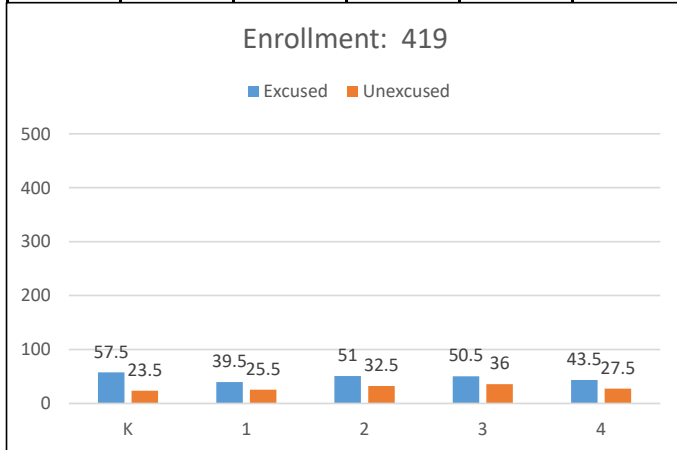

Goal

4

2015-16	RP1: 3%	RP2: 4%	RP3: 4%	RP4: 4%	RP5: 5%	RP6: 5%	RP7: 4%	RP8: 4%	RP9: 4%
2016-17	RP1: 3%	RP2: 3%	RP3: 4%	RP4: 5%	RP5: 7%	RP6: 8%	RP7: 5%	RP8: 5%	RP9: 6%
2017-18	RP1: 3%	RP2: 4%	RP3: 5%	RP4: 6%	RP5: 6%	RP6: 8%	RP7: 4%	RP8: 4%	RP9: 5%
2018-19	RP1: 3%	RP2: 4%	RP3: 5%	RP4: 4%	RP5: 5%	RP6: 6%	RP7: 5%	RP8: 4%	RP9: 4%
2019-20	RP1: 3%	RP2: 3%	RP3: 4%						

Jefferson

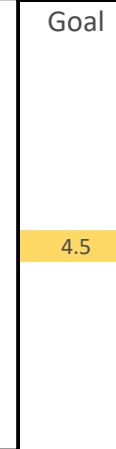
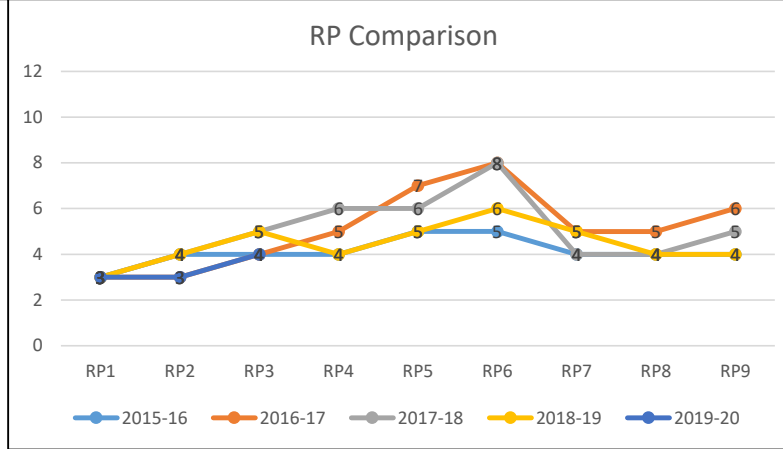
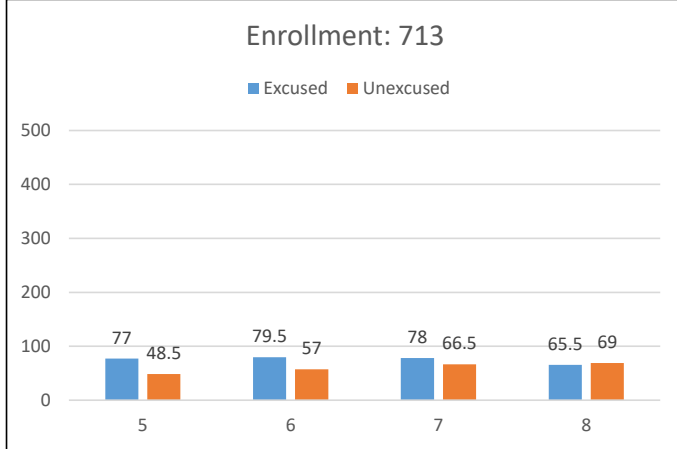

2015-16	RP1: 3%	RP2: 4%	RP3: 4%	RP4: 5%	RP5: 7%	RP6: 6%	RP7: 5%	RP8: 6%	RP9: 8%
2016-17	RP1: 4%	RP2: 4%	RP3: 5%	RP4: 6%	RP5: 5%	RP6: 8%	RP7: 5%	RP8: 4%	RP9: 7%
2017-18	RP1: 3%	RP2: 5%	RP3: 5%	RP4: 5%	RP5: 8%	RP6: 8%	RP7: 6%	RP8: 5%	RP9: 7%
2018-19	RP1: 4%	RP2: 5%	RP3: 6%	RP4: 5%	RP5: 5%	RP6: 8%	RP7: 6%	RP8: 5%	RP9: 6%
2019-20	RP1: 4%	RP2: 4%	RP3: 5%						

Robertsville

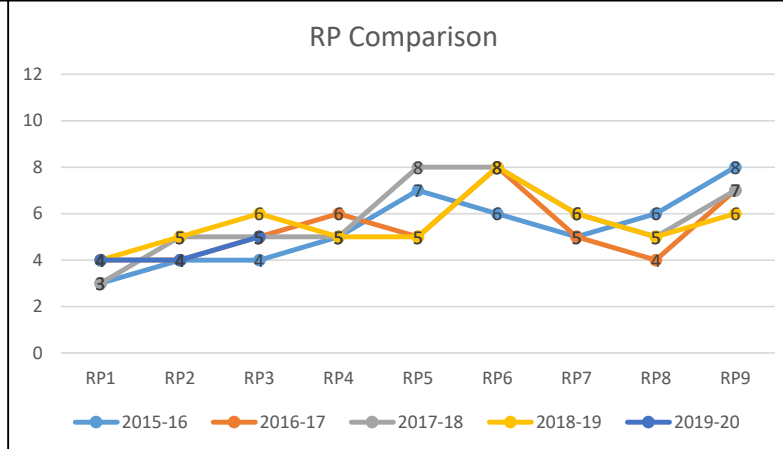
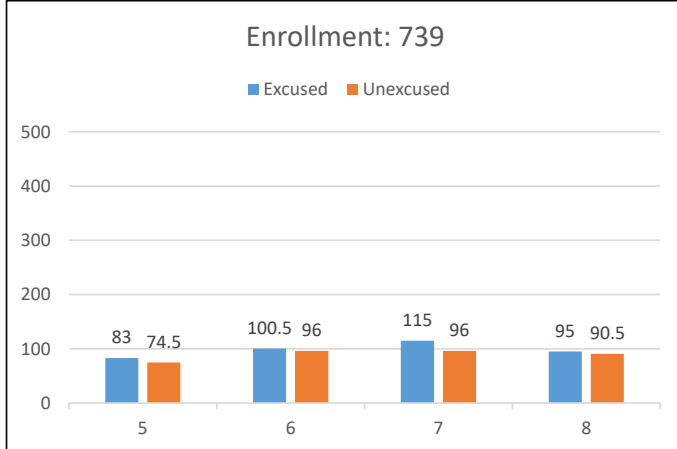

2015-16	RP1: 5%	RP2: 7%	RP3: 7%	RP4: 8%	RP5: 9%	RP6: 8%	RP7: 8%	RP8: 9%	RP9: 8%
2016-17	RP1: 5%	RP2: 6%	RP3: 6%	RP4: 7%	RP5: 8%	RP6: 9%	RP7: 7%	RP8: 7%	RP9: 9%
2017-18	RP1: 5%	RP2: 5%	RP3: 6%	RP4: 7%	RP5: 7%	RP6: 11%	RP7: 6%	RP8: 6%	RP9: 5%
2018-19	RP1: 4%	RP2: 4%	RP3: 5%	RP4: 6%	RP5: 6%	RP6: 7%	RP7: 6%	RP8: 6%	RP9: 5%
2019-20	RP1: 4%	RP2: 5%	RP3: 6%						

ORHS

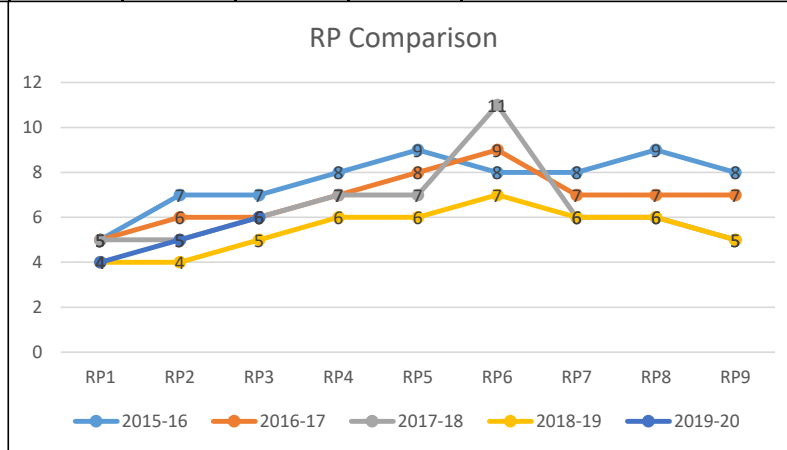
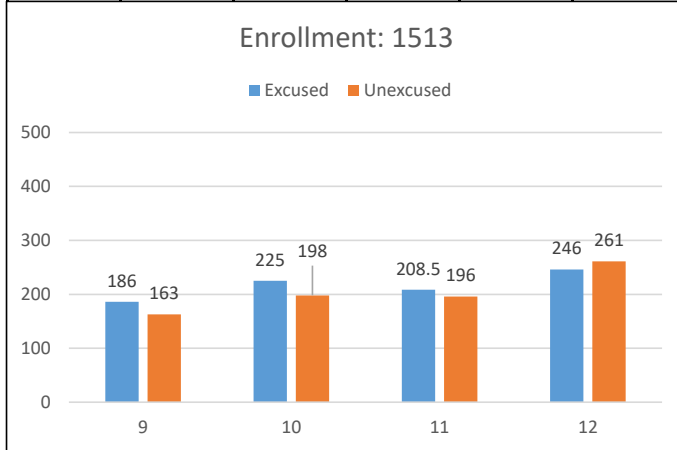

Goal

6

Oak Ridge Schools

3rd Attendance Period

November 8, 2019

These numbers reflect the **2019-2020** Skyward Student Management System (Entity) active student enrollment count as of **November 8, 2019**.

The total includes **28** private school and home schooled students receiving Special Ed services.



Oak Ridge Schools

Enrollment Entity Counts 3rd RP 2019-20

November 8, 2019

School	P3	P4	K	1	2	3	4	5	6	7	8	9	10	11	12	Total PK-12 2019-20	Previous 2nd RP 2019-20	Diff
Preschool	73	141														214	211	3
Glenwood			75	76	78	83	88									400	400	0
Linden			96	104	82	69	100									451	446	5
Willow Brook			78	65	66	80	73									362	356	6
Woodland			83	81	77	86	92									419	417	2
JMS								178	177	175	183					713	711	2
RMS								160	190	189	200					739	736	3
ORHS												395	384	387	347	1513	1513	0
Enrollment 2019-20	73	141	332	326	303	318	353	338	367	364	383	395	384	387	347	4811	4790	21
Prev. 2nd RP 2019-20	69	142	325	321	305	315	353	339	363	365	380	395	383	388	347	4790		
Difference	4	-1	7	5	-2	3	0	-1	4	-1	3	0	1	-1	0	21		

This report compares the 2019-20 3rd RP period enrollment with the 2019-20 2nd RP period.

Acct	Acct	2019-20 FYTD Budget	October 2019-20 Monthly Activity	2019-20 Year-To-Date	2019-20 Percent of Budget	2019-20 Variance from Bud	Encumbered Amount	Unencumbered Budget Remaining
40110	Current Property Tax	11,048,443.00	34,581.46	222,137.39	2.01%	10,826,305.61		10,826,305.61
40210	Local Option Sales Tax	5,787,581.00	573,340.95	1,695,906.79	29.30%	4,091,674.21		4,091,674.21
40275	Mixed Drink Tax	250.00	17.75	75.19	30.08%	174.81		174.81
40280	Mineral Severance Tax	250.00				250.00		250.00
43511	Tuition - Regular Day Students	240,000.00	19,784.20	147,035.50	61.26%	92,964.50		92,964.50
43513	Tuition - Summer School	12,000.00		780.00	6.50%	11,220.00		11,220.00
43533	Transportation Fees	10,000.00	375.00	1,315.00	13.15%	8,685.00		8,685.00
44110	Interest Earned	150,000.00	9,913.79	48,878.00	32.59%	101,122.00		101,122.00
44120	Lease/Rentals	18,000.00	1,000.00	4,206.00	23.37%	13,794.00		13,794.00
44170	Miscellaneous Refunds	2,500.00		3,420.46	136.82%	-920.46		-920.46
44530	Sale of Equipment	35,000.00		395.80	1.13%	34,604.20		34,604.20
44560	Damages Recovered from Individ			110.40		-110.40		-110.40
44570	Contributions & Gifts	200,000.00	900.00	14,450.00	7.23%	185,550.00		185,550.00
44990	Other Local Revenues	75,000.00	1,611.00	8,215.40	10.95%	66,784.60		66,784.60
46511	Basic Education Program	22,809,000.00	2,274,800.00	6,824,400.00	29.92%	15,984,600.00		15,984,600.00
46515	Early Childhood Education	460,771.37	38,974.78	74,045.61	16.07%	386,725.76		386,725.76
46590	Other State Education Funds	75,000.00	6,774.80	12,823.76	17.10%	62,176.24		62,176.24
46610	Career Ladder Program	150,000.00				150,000.00		150,000.00
46980	Other State Grants	454,671.30				454,671.30		454,671.30
46990	Other State Revenues	7,500.00				7,500.00		7,500.00
47143	Special Education Grants	80,000.00				80,000.00		80,000.00
47630	Public Law 874 - Maint/Operat.	55,000.00				55,000.00		55,000.00
49700	Insurance Recovery	2,500.00				2,500.00		2,500.00
49800	Transfers In	125,000.00				125,000.00		125,000.00
49810	City General Fund Transfer	15,493,963.00	1,291,163.58	5,164,654.32	33.33%	10,329,308.68		10,329,308.68
-----	Revenue	57,292,429.67	4,253,237.31	14,222,849.62	24.83%	43,069,580.05		43,069,580.05
=====								
71100	Regular Instruction Prgm	26,970,123.00	2,223,832.96	7,100,219.18	26.33%	19,869,903.82	18,949,162.62	920,741.20
71150	Alternative Instruction Prgm	820,705.00	66,836.63	196,474.37	23.94%	624,230.63	573,632.92	50,597.71
71200	Special Education Prgm	4,459,917.00	364,117.82	1,061,036.37	23.79%	3,398,880.63	3,124,197.90	274,682.73
71300	Career/Technical Education Prg	1,295,523.00	106,689.26	324,209.77	25.03%	971,313.23	919,324.94	51,988.29
71900	Contingency	736,824.95				736,824.95		736,824.95
72120	Health Services	604,107.00	50,373.93	148,297.33	24.55%	455,809.67	391,384.47	64,425.20
72130	Other Student Support	1,681,844.37	123,668.00	549,745.02	32.69%	1,132,099.35	1,089,350.60	42,748.75
72210	Regular Inst. Support	2,781,456.63	243,129.83	800,701.14	28.79%	1,980,755.49	1,521,238.73	459,516.76
72220	Special Education Support	828,745.00	69,827.39	236,435.98	28.53%	592,309.02	558,173.14	34,135.88
72230	Career & Technical Prg Support	113,109.00	8,076.45	31,557.42	27.90%	81,551.58	63,368.27	18,183.31
72250	Technology Services	2,772,379.00	271,228.24	914,625.16	32.99%	1,857,753.84	1,171,526.43	686,227.41

<u>Acct</u>	<u>Acct</u>	2019-20 FYTD Budget	October 2019-20 Monthly Activity	2019-20 Year-To-Date	2019-20 Percent of Budget	2019-20 Variance from Bud	Encumbered Amount	Unencumbered Budget Remaining
72290	Communications	116,214.00	8,163.89	35,910.32	30.90%	80,303.68	65,067.72	15,235.96
72310	Board of Education	1,050,750.00	63,476.22	498,213.94	47.42%	552,536.06	7,661.21	544,874.85
72320	Director of Schools	356,796.00	26,743.08	115,531.95	32.38%	241,264.05	219,818.33	21,445.72
72410	Office of the Principal	3,567,705.00	292,511.53	1,066,501.09	29.89%	2,501,203.91	2,390,633.08	110,570.83
72510	Fiscal Services	806,626.00	62,382.17	272,280.40	33.76%	534,345.60	445,217.57	89,128.03
72520	Human Resources/ Personnel	429,455.00	21,791.84	147,477.92	34.34%	281,977.08	165,473.78	116,503.30
72610	Operation of Plant	4,635,502.00	341,930.62	1,388,481.74	29.95%	3,247,020.26	1,500,534.08	1,746,486.18
72620	Maintenance of Plant	1,642,702.00	141,747.26	608,186.17	37.02%	1,034,515.83	813,143.86	221,371.97
72710	Transportation	1,524,978.00	288,458.99	358,866.57	23.53%	1,166,111.43		1,166,111.43
73400	Early Childhood Education	460,771.37	38,974.78	113,020.39	24.53%	347,750.98	347,521.73	229.25
73401	Pre-K General Fund	653,943.00	72,211.30	166,794.61	25.51%	487,148.39	321,854.72	165,293.67
76100	Regular Capital Outlay	775,051.35	33,118.02	123,767.38	15.97%	651,283.97	94,048.18	557,235.79
99100	Transfers Out	73,353.00				73,353.00		73,353.00
-----	Expense	59,158,580.67	4,919,290.21	16,258,334.22	27.48%	42,900,246.45	34,732,334.28	8,167,912.17
-----	General Purpose School Fund	-1,866,151.00	-666,052.90	-2,035,484.60	26.18%	169,333.60	-34,732,334.28	34,901,667.88
Grand Revenue Totals		57,292,429.67	4,253,237.31	14,222,849.62	24.83%	43,069,580.05		43,069,580.05
Grand Expense Totals		59,158,580.67	4,919,290.21	16,258,334.22	27.48%	42,900,246.45	34,732,334.28	8,167,912.17
Grand Totals		1,866,151.00	666,052.90	2,035,484.60	109.07%	169,333.60	34,732,334.28	34,901,667.88
		Loss	Loss	Loss		Profit	Loss	Profit

Number of Accounts: 1253

***** End of report *****

General Fund Revenue Budget to Actual Summary - OCTOBER, 2019

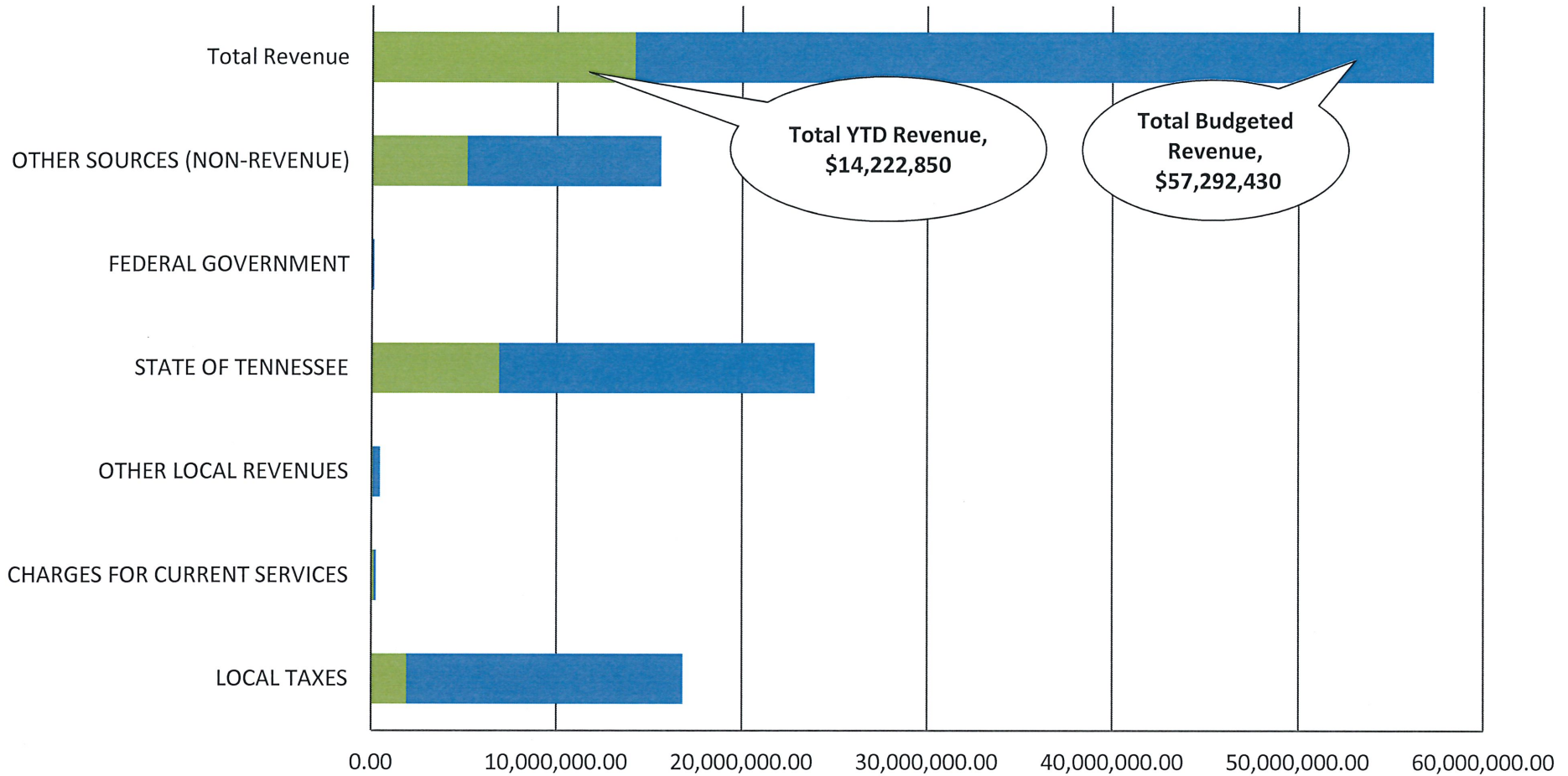

	LOCAL TAXES	CHARGES FOR CURRENT SERVICES	OTHER LOCAL REVENUES	STATE OF TENNESSEE	FEDERAL GOVERNMENT	OTHER SOURCES (NON-REVENUE)	Total Revenue
■ Percent of Budget	11.39%	56.92%	16.58%	28.85%	0	33.06%	24.83%
■ Year-To-Date	1,918,119.37	149,130.50	79,676.06	6,911,269.37	0	5,164,654.32	\$14,222,850
■ FYTD Budget	16,836,524.00	262,000.00	480,500.00	23,956,942.67	135,000.00	15,621,463.00	\$57,292,430

General Fund Expenditure Budget to Actual Summary by Object OCTOBER, 2019

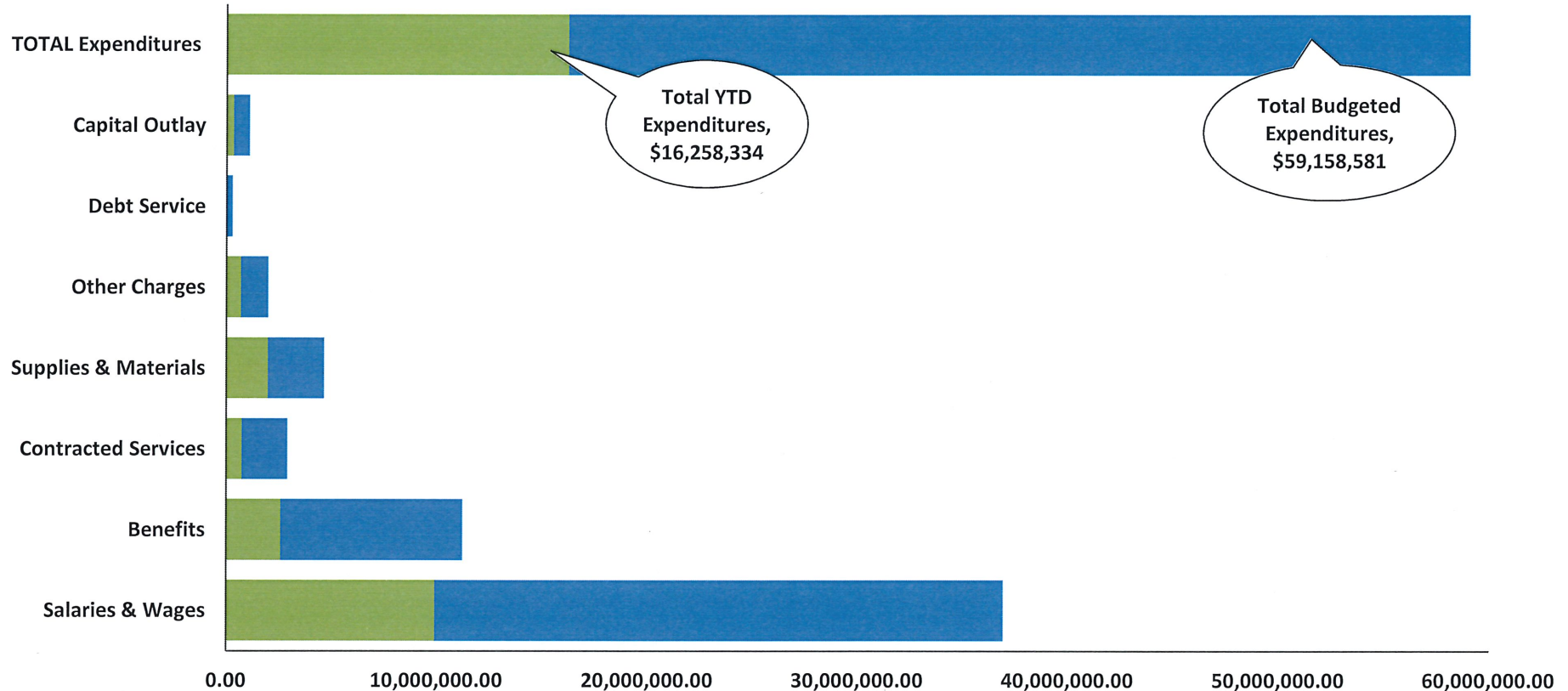

	Salaries & Wages	Benefits	Contracted Services	Supplies & Materials	Other Charges	Debt Service	Capital Outlay	TOTAL Expenditures
FYTD %	26.84%	23.07%	25.22%	42.57%	34.43%		30.96%	27.48%
FYTD Activity	9,920,088.66	2,596,818.98	735,226.77	1,982,180.69	684,503.23	0	339,515.89	\$16,258,334
FYTD Revised Bdg	36,956,600.63	11,255,027.00	2,915,813.00	4,658,947.37	1,988,298.32	287,205.00	1,096,689.35	\$59,158,581

General Fund "Undesignated" Fund Balance Summary

FY17 FY18 FY19 FY20

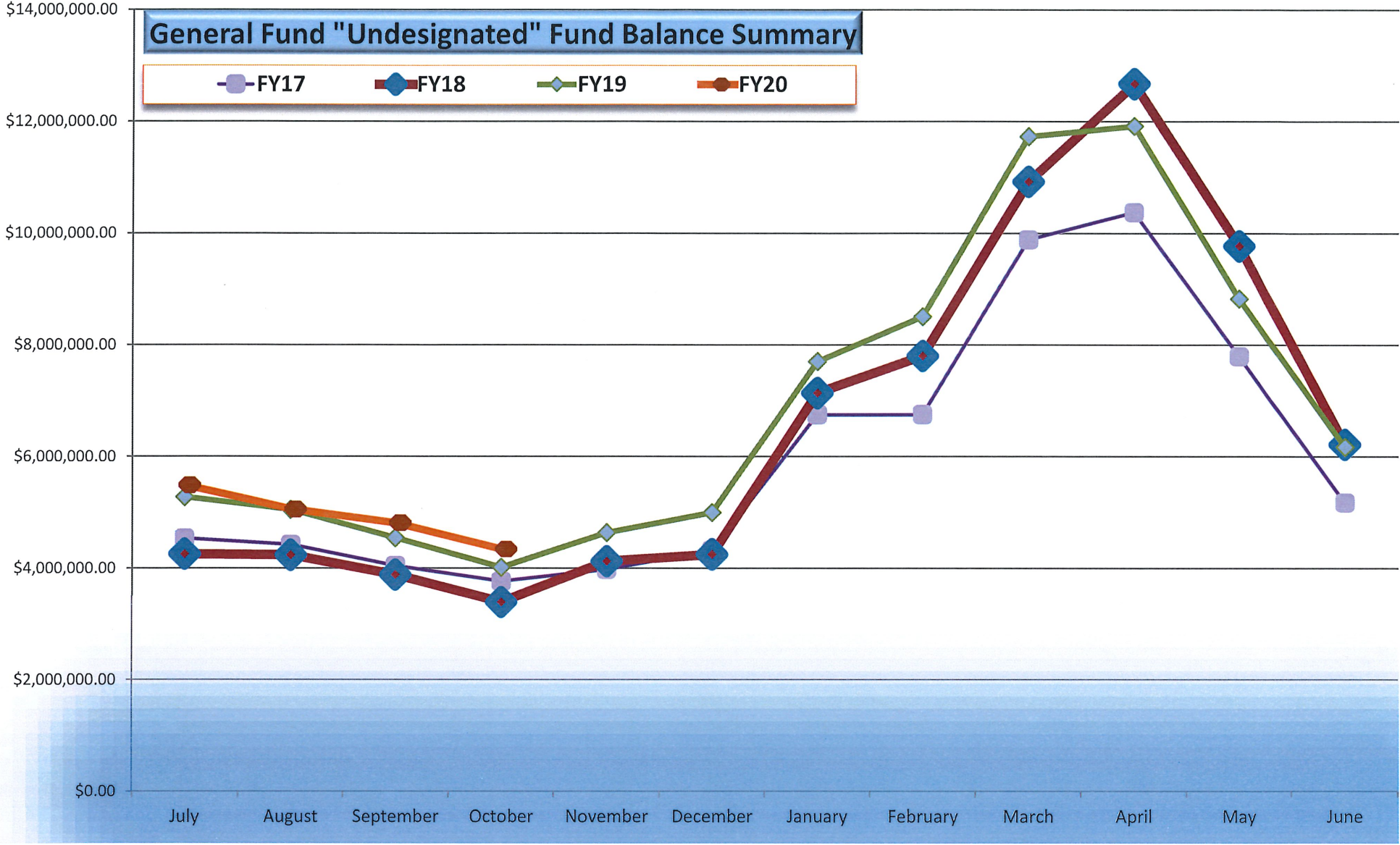

Acct	Acct	2019-20 FYTD Budget	October 2019-20 Monthly Activity	2019-20 Year-To-Date	2019-20 Percent of Budget	2019-20 Variance from Bud	Encumbered Amount	Unencumbered Balance Remaining
142	School Federal Projects							
R	Revenue							
47131	Vocational Program Improvement	131,707.20	4,371.89	20,233.39	15.36%	111,473.81		111,473.81
47141	Title I	946,270.61	79,829.59	152,187.06	16.08%	794,083.55		794,083.55
47143	Special Education Grants	1,162,972.51	63,354.61	116,978.02	10.06%	1,045,994.49		1,045,994.49
47145	Special Ed Pre-School Grants	29,791.00	2,536.86	5,070.58	17.02%	24,720.42		24,720.42
47146	English Lang Acq Grants	19,520.22	493.80	493.80	2.53%	19,026.42		19,026.42
47147	Title IV Part B, 21st Century	152,625.00				152,625.00		152,625.00
47189	Title II	125,016.24	29,052.48	44,650.98	35.72%	80,365.26		80,365.26
47590	Other Federal Through State	292,526.02	11,588.04	34,368.79	11.75%	258,157.23		258,157.23
47990	Other Direct Federal Revenue	1,001,182.20	67,446.14	139,811.78	13.96%	861,370.42		861,370.42
-----	Revenue	3,861,611.00	258,673.41	513,794.40	13.31%	3,347,816.60		3,347,816.60
E	Expense							
71100	Regular Instruction Prgm	727,800.13	55,915.91	184,541.10	25.36%	543,259.03	478,281.79	64,977.24
71200	Special Education Prgm	831,171.88	60,176.26	174,922.43	21.05%	656,249.45	539,171.55	117,077.90
71300	Career/Technical Education Prg	108,415.00	3,120.41	19,588.83	18.07%	88,826.17	60,490.80	28,335.37
71900	Contingency	189,117.74				189,117.74		189,117.74
72120	Health Services	12,754.00	1,170.30	3,496.16	27.41%	9,257.84	9,521.19	-263.35
72130	Other Student Support	75,879.41	5,445.00	16,443.48	21.67%	59,435.93	30,648.56	28,787.37
72210	Regular Inst. Support	308,087.41	27,041.71	128,350.21	41.66%	179,737.20	106,050.31	73,686.89
72220	Special Education Support	245,406.08	21,372.17	67,230.67	27.40%	178,175.41	175,254.01	2,921.40
72230	Career & Technical Prg Support	4,189.77		337.92	8.07%	3,851.85	226.92	3,624.93
72710	Transportation	74,108.20		5,108.20	6.89%	69,000.00	54,820.00	14,180.00
73300	Community Services	1,144,253.70	87,438.48	260,046.77	22.73%	884,206.93	668,417.28	215,789.65
99100	Transfers Out	140,427.68				140,427.68		140,427.68
-----	Expense	3,861,611.00	261,680.24	860,065.77	22.27%	3,001,545.23	2,122,882.41	878,662.82
-----	School Federal Projects		-3,006.83	-346,271.37	17.79%	346,271.37	-2,122,882.41	2,469,153.78

Acct	Acct	2019-20 FYTD Budget	October 2019-20 Monthly Activity	2019-20 Year-To-Date	2019-20 Percent of Budget	2019-20 Variance from Bud	Encumbered Amount	Unencumbered Balance Remaining
143	Central Cafeteria							
R	Revenue							
43521	Lunch Payments - Children	263,736.00	17,849.36	68,424.31	25.94%	195,311.69		195,311.69
43522	Lunch Payments - Adults	4,000.00	258.40	969.00	24.23%	3,031.00		3,031.00
43523	Income From Breakfast	35,951.00	2,145.00	8,764.85	24.38%	27,186.15		27,186.15
43525	A la Carte Sales	315,872.00	10,673.30	50,355.15	15.94%	265,516.85		265,516.85
43990	Other Charges for Food Service	10,000.00	8,234.90	13,882.40	138.82%	-3,882.40		-3,882.40
44110	Interest Earned	3,000.00	449.08	1,990.59	66.35%	1,009.41		1,009.41
46520	School Food Service	16,455.00				16,455.00		16,455.00
47111	USDA School Lunch Program	907,812.00	187,708.08	322,586.40	35.53%	585,225.60		585,225.60
47112	USDA Commodities	117,824.00				117,824.00		117,824.00
47113	Breakfast	342,887.00	88,703.05	151,839.64	44.28%	191,047.36		191,047.36
47114	USDA - Other	161,354.00	3,968.68	56,892.45	35.26%	104,461.55		104,461.55
-----	Revenue	2,178,891.00	319,989.85	675,704.79	31.01%	1,503,186.21		1,503,186.21
E	Expense							
73100	Food Service	2,358,891.00	77,651.95	141,760.46	6.01%	2,217,130.54	178,674.99	2,038,455.55
-----	Expense	2,358,891.00	77,651.95	141,760.46	6.01%	2,217,130.54	178,674.99	2,038,455.55
-----	Central Cafeteria	-180,000.00	242,337.90	533,944.33	18.01%	-713,944.33	-178,674.99	-535,269.34
=====								
145	Other Education Funds							
R	Revenue							
44990	Other Local Revenues	32,929.00	3,263.00	9,312.60	28.28%	23,616.40		23,616.40
46590	Other State Education Funds	121,602.33	6,717.06	18,491.84	15.21%	103,110.49		103,110.49
49800	Transfers In	73,374.00				73,374.00		73,374.00
-----	Revenue	227,905.33	9,980.06	27,804.44	12.20%	200,100.89		200,100.89

Acct	Acct	2019-20 FYTD Budget	October 2019-20 Monthly Activity	2019-20 Year-To-Date	2019-20 Percent of Budget	2019-20 Variance from Bud	Encumbered Amount	Unencumbered Balance Remaining
145	Other Education Funds							
E	Expense							
72130	Other Student Support	102,985.65	8,344.97	30,453.01	29.57%	72,532.64	68,883.83	3,648.81
72210	Regular Inst. Support	3,500.00				3,500.00		3,500.00
72620	Maintenance of Plant	88,490.68				88,490.68	25,755.40	62,735.28
73300	Community Services	32,929.00	1,636.75	5,385.63	16.36%	27,543.37		27,543.37
-----	Expense	227,905.33	9,981.72	35,838.64	15.73%	192,066.69	94,639.23	97,427.46
-----	Other Education Funds		-1.66	-8,034.20	13.96%	8,034.20	-94,639.23	102,673.43
=====								
146	Extended School Program							
R	Revenue							
43581	Community Services Fees Child	473,067.00	31,146.80	160,311.92	33.89%	312,755.08		312,755.08
-----	Revenue	473,067.00	31,146.80	160,311.92	33.89%	312,755.08		312,755.08
E	Expense							
73300	Community Services	463,067.00	33,863.37	118,295.56	25.55%	344,771.44	188,195.80	156,575.64
99100	Transfers Out	10,000.00				10,000.00		10,000.00
-----	Expense	473,067.00	33,863.37	118,295.56	25.01%	354,771.44	188,195.80	166,575.64
-----	Extended School Program		-2,716.57	42,016.36	29.45%	-42,016.36	-188,195.80	146,179.44
=====								
Grand Revenue Totals		6,741,474.33	619,790.12	1,377,615.55	20.43%	5,363,858.78		5,363,858.78
Grand Expense Totals		6,921,474.33	383,177.28	1,155,960.43	16.70%	5,765,513.90	2,584,392.43	3,181,121.47
Grand Totals		180,000.00	236,612.84	221,655.12	-123.14%	401,655.12	2,584,392.43	2,182,737.31
		Loss	Profit	Profit		Loss	Loss	Profit

**Combined Fund Balance and YTD Operating Statement Summary
October, 2019**

Description	General Fund 141	Federal Fund 142	Food Service Fund 143	Special Fund 145	ECC Fund 146
Beginning Fund Balance July 1, 2019	8,570,807.16	0.00	808,715.52	2,508.79	88,759.66
Plus YTD Revenue per books 10/31/19	14,222,849.62	513,794.40	675,704.79	27,804.44	160,311.92
Less YTD Expenditures per books 10/31/19	(16,258,334.22)	(860,065.77)	(141,760.46)	(35,838.64)	(118,295.56)
Revenues Over (Under) Expenditures as of 10/31/19	(2,035,484.60)	(346,271.37)	533,944.33	(8,034.20)	42,016.36
Ending Fund Balance per books as of 10/31/19	6,535,322.56	(346,271.37)	\$1,342,659.85	(5,525.41)	130,776.02

*Beginning Balance decreased due to State required adjusting entry of Grant funds

Fund Balance Restricted/Committed/Assigned Status

Encumbrances and Deferred Revenue			\$ 34,435.93		
Inventory			27,364.59		
Restricted for Career Ladder Program	-1,040.32				
Restricted for Operation of Non-Instructional Services			1,100,859.33		130,776.02
Committed for Other Purposes (Vehicles- ERR Fund)	483,570.52				
Assigned for Instruction- Coordinated School Health	16,194.84				
Assigned for other local grants					
Assigned for Instruction - Education Foundation Grant	10,950.30				
Assigned for Instruction - TN Early Literacy Network	5,070.52				
Assigned for Instruction (APSI-ORHS)	14,019.95				
Assigned for Support Services FRC Local Funds (56)				6,435.76	
Nonspendable-Prepaid Expenditures					
Assigned to Balance FY20 Budget	1,666,151.00		180,000.00		
Unassigned Fund Balance 10/31/19	\$ 4,340,405.75	-346,271.37		-11,961.17	
Total Fund Balance 10/31/19	6,535,322.56	(\$346,271.37)	\$ 1,342,659.85	(\$5,525.41)	\$ 130,776.02