



**Morgan County Schools Board of Education Meeting  
April 1, 2010 6:30 PM  
Central Office**

1. **Prayer**
2. **Pledge**
3. **Good News - Robotics Program Demonstration; "Save the Children" Award; E4000TN Grant - \$20,000**
4. **Agenda**
5. **MCEA**
6. **Audience Participation**
7. **Consent Agenda**
  - A. Approval of Minutes
  - B. Workshop, April 26, 6:30 pm. @ Central Office
  - C. Regular Board Meeting, May 3, 6:30 p.m. Central Office
  - D. Approval of Field Trips
  - E. Distance Learning Course Approval
8. **Discussion of Coalfield Roof Repairs - (Firestone, CM Hensley Roofing) - Joe Fielden, Cope & Associates**
9. **Budget Amendments (#74-Corrected; #80-87)**
10. **Approval of "High Schools That Work" Grant Proposal - Maximum \$7,000**
11. **Review of Bids**
  - A. Security Cameras for MCCTC, Petros Joyner
  - B. Septic System at Coalfield - Tim Kazmire, Representative for Manufacturer - Aeromond - Jack Southard, Installer
12. **Financial Assistance with Educator's Banquet - Thursday, April 22, 2010**
13. **Eligibility and Vote on Tenure for Teachers**

14. **Consider bids for gym floor re-finish and repair**
15. **Policy Revisions**
  - A. Mental Health Policy (2nd Reading)
  - B. IHC Class Ranking (1st reading)
  - C. Discussion of GBL - Procedures for Granting Tenure (Consideration more than once per year)
16. **Maintenance and Transportation Building (Revised Drawing)**
17. **Formal Request for Assistance From Morgan County Commission for Capital Projects**
18. **Director's Performance Contract Report/Announcements**
  - A. Budget Workshop #4 - Monday, April 19th 6:00 p.m. at Central Office
  - B. Monthly Financial Report
  - C. Planning - A Joint Venture (May 23-24 - Pigeon Forge) (Registration Confirmed)
  - D. TN Race to the Top (4 yr - \$857,856; \$214,464 Annually)
  - E. Update - Refinancing of Debt Service Obligations
19. **Adjourn**
  - A. Workshop, April 26, 2010, 6:30 p.m. @ Central Office
  - B. Regular Board Meeting, May 3, 2010, 6:30 p.m. @ Central Office

March 5, 2010

Morgan County Career and Technical Center has significantly benefited from the recent Engineering/Computer Integrated Manufacturing Reserve Grant. The Robotics component of the grant has sparked wide student interest in this course. We expect next term enrollments to have full classes when the word gets out.

The students have developed a robot with a camera system that has a range of 150 feet. They had an idea to use these as an intruder locator device for school safety issues to reduce threatening situations in areas where the schools have no cameras. The Morgan County School Health Coordinator offered to provide a grant for \$2,000 this year for the class to build a robot for each of our 4 high schools. She will also provide funding for the other 4 schools next year. The teacher and students will give a robot demonstration to the Morgan County School Board on March 29, 2010.

The Mastercam Program, which was a part of this grant, has enabled the class to assist our technology department in reducing costs for the installation of LCD Projectors for teachers. The students write a program for a mount bracket design for the LCD projectors and then they are manufactured in the machine technology shop and powder coated. By using our school maintenance to install them and our machine technology students to manufacture them we can save \$350.00 per unit. With 23 units to install this year, we can save the school system over \$8,000.00.



Mitchell Heidel, CTE Director  
Morgan County Career & Technical Center  
132 Flat Fork Rd.  
Wartburg, TN 37887  
423-346-6285 / 423-346-5857 Fax  
[heidelm@mcsmail.net](mailto:heidelm@mcsmail.net)

# *Guided Independent Reading Awards Criteria*



As a way to recognize hard work and success, Save the Children awards various certificates for outstanding achievement in reading practice. Certificates are awarded based on *monthly* Accelerated Reader Diagnostic Report criteria.

## ***Gold Star Award***

Recipients of this award have reached or maintained all of the following goals:

- The average percent of quizzes passed. Goal: 90% or higher
- The percent of children scoring below 85% correct on quizzes. Goal: 15% or fewer
- The percent of children with A codes. Goal: 5% or fewer
- The percent of children reading independently. Goal: 90% or higher

## ***Platinum Award***

Recipients of this award have maintained Gold Star status for three or more consecutive months.

## ***Super Star Status***

To attain this status, all of the children have maintained an AR quiz average of 85% or higher for an entire month.

**Morgan County Board of Education  
Regular Meeting  
March 01, 2010 06:30PM  
Central Office**

**Attendance Taken at 6:23 PM:**

Present Board Members:

Mr. Terry Armes  
Mrs. Louise Coleman  
Wendy Collins  
Randy Harlan  
Mr. Glen Moore  
Mr. Jim Rivers

**1. Prayer**

**2. Pledge**

**3. "Good News"**

Discussion:

Mr. Mitchell Heidel was selected for the regional Career and Technical Trailblazer Award for extraordinary leadership. Wanda Lane was selected as regional Supervisor of the Year. She will also receive consideration for the State level award.

**4. Agenda**

**Primary Motion Passed:** Motion by Mr. Jim Rivers and a second by Randy Harlan to approve the Agenda as presented.

**5. MCEA - Letter of Intent to Negotiate**

**6. Audience Participation**

Discussion:

Ronnie LaRue presented the Board with a GED diploma he received from the military in 1966. He said the POST committee in Nashville would not recognize it as an official GED diploma. Mr. LaRue is requesting the Board of Education to acknowledge that the GED he acquired is legal and should be accepted.

**Primary Motion Passed:** Pending legal approval, the executive committee will work with Mr. Larue on this request. Motion by Randy Harlan and a second by Wendy Collins.

**7. Consent Agenda**

**Primary Motion Passed:** Motion by Randy Harlan and a second by Mr. Glen Moore to approve the following consent agenda.

**7.a. Approval of Minutes**

**7.b. Workshop, March 29, 6:30 p.m.@ Central Office**

**7.c. Regular Board Meeting, April 1, 6:30 p.m. Central Office**

**8. Budget Amendments (#68-74) (#75-78)**

**Primary Motion Passed:** Motion by Mr. Jim Rivers and a second by Randy Harlan to approve budget amendments as presented.

Mr. Terry Armes	Yes
Mrs. Louise Coleman	Yes
Wendy Collins	Yes
Randy Harlan	Yes
Mr. Glen Moore	Yes
Mr. Jim Rivers	Yes

**Morgan County Board of Education  
General Purpose  
February 11, 2010  
Budget Amendment #68**

Debit:			
	71200-312	(Contracts with Priv. Agency)	\$74,103.26
	71200-599	(Other Charges)	\$33.01
	72220-725	(Sp. Ed. Equipment)	\$47.09
		Total:	\$74,183.36

Credit:			
	71200-116	(Teachers)	\$74,183.36

Explanation: Re-adjustment to balance out G.P. Budget.

**Morgan County Board of Education  
General Purpose  
February 11, 2010  
Budget Amendment #69**

Debit:			
	71200-312	(Contracts with Priv. Agency)	\$13,425.36
Credit:			
	71200-399	(Other Contracted Serv.)	\$10,708.94
	71200-429	(Instructional Supplies)	\$2,716.42

Explanation: Transfer of money to necessary line items because of over expenditures in Other Contracted Services, and Instructional Supplies.

**Morgan County Board of Education  
Carl Perkins  
February 11, 2010  
Budget Amendment #70**

Credit:			
	71300-399	(Other Contracted Serv.)	\$500.00
Debit:			
	71300-429	(Instructional Supplies)	\$500.00

Explanation:

More hours needed for my EIS employee to deal with problems in e-tiger with primary and service schools sharing of class rosters in addition to correcting data which was incorrectly transferred. We can use funds from this account because we have used less than 10% of available funds in this line item and at this point I feel it will not affect our estimated budgeted uses.

**Morgan County Board of Education  
Title I  
February 17, 2010  
Budget Amendment #71**

Debit: 142-39000 (Fund Balance) \$40,737.00

Credit: 142-72210-499-011-650 (Other Charges) \$40,737.00

Explanation:

Transfer money from Fund Balance to Consolidated Admin.

**Morgan County Board of Education  
IDEA Part B  
February 17, 2010  
Budget Amendment #72**

Debit: (Fund Balance) \$22,306.00

Credit: 47143 \$22,306.00

Explanation:

This revenue should have been received in June but wasn't received and posted till July.

**Morgan County Board of Education  
IDEA Preschool  
February 17, 2010  
Budget Amendment #73**

Debit: (Fund Balance) \$1,123.00

Credit: Revenue 47145 \$1,123.00

Explanation:

This revenue should have been received in June but wasn't received and posted till July.

**Morgan County Board of Education  
SRO  
February 26, 2010  
Budget Amendment #74**

Credit: (Increase)			
	141-72130-599-4001	(Other Charges)	\$22,800.00
Debit (Increase)			
	141-46590		\$22,800.00

Explanation: Funds received as a SRO grant of \$21,100 and a match of \$1,700.00.

**Morgan County Board of Education  
G.P.  
March 1, 2010  
Budget Amendment #75**

Debit:			
	44520	(Insurance Recovery)	\$7,998.69
Credit:			
	72710-453	(Vehicle Parts)	\$7,998.69

Explanation: Insurance payment for bus accident.

**Morgan County Board of Education  
G.P.  
March 1, 2010  
Budget Amendment #76**

Debit:			
	141-44530	(Sale of Equipment)	\$39.00
Credit:			
	141-72210-790	(Other Equipment)	\$39.00

Explanation: Additional revenue from sale of surplus equipment.

**Morgan County Board of Education  
G.P.  
March 1, 2010  
Budget Amendment #77**

Debit:			
	141-44170	(Misc. Refunds)	\$34.02
Credit:			
	141-72710-412	(Diesel Fuel)	\$34.02

Explanation: Reimbursement for use of bus.

**Morgan County Board of Education**  
**G.P.**  
**March 1, 2010**  
**Budget Amendment #78**

Debit:	141-44170	(Misc. Refunds)	\$31.50
Credit:	72710-453	(Vehicle Parts)	\$31.50

Explanation:  
Payment for fire extinguisher.

**9. Discussion of Coalfield Roof - (Firestone, CM Hensley Roofing) - Joe Fielden, Cope & Associates- Board requested documentation that all bonding adhesives used were approved.**

**10. Update on Bids**

**10.a. Security cameras for MCCTC, Petros Joyner (Opening - Thursday, March 11, 2010 at 10:00 a.m.)**

**10.b. Septic system at Coalfield (Opening - Friday, March 5, 2010 at 9:00 a.m.)**

**11. Approval of Distance Learning/Green Technology Proposal (Perkins Reserve Grant - \$98,693)**

**Primary Motion Passed:** Motion by Mr. Jim Rivers and a second by Mr. Glen Moore to approve application process.

Mr. Terry Armes	Yes
Mrs. Louise Coleman	Yes
Wendy Collins	Yes
Randy Harlan	Yes
Mr. Glen Moore	Yes
Mr. Jim Rivers	Yes

**12. Approval of Title IID ARRA E4TN Distance Learning Grant - \$20,000**

Rationale:

\$10,000 funding to district for improvement of distance learning program.

\$10,000 in funds to pay for students to take course through the E4TN state-wide network.

**Primary Motion Passed:** Motion by Mr. Jim Rivers and a second by Randy Harlan to approve E4TN Distance Learning Grant.

**13. Update on drainage project at Oakdale School - Sample Contract**

**14. Policy Revisions**

**14.a. JCCC - Suspension/Expulsion (2nd reading)**

**Primary Motion Passed:** Motion by Randy Harlan and a second by Mr. Jim Rivers to approve Policy JCCC on 2<sup>nd</sup> reading.

<b>SUSPENSION/EXPULSION/REMAND</b>	<b>Descriptor Code:</b>  <b>JCCC</b>	<b>Issued Date:</b>  <b>10-02-2000</b>
------------------------------------	--	--

**DEFINITIONS:<sup>1</sup>**

**Suspension:** dismissed from attendance at school for any reason not more than ten (10) consecutive days. Multiple suspensions shall not run consecutively nor shall multiple suspensions be applied to avoid expulsion from school.

**Expulsion:** removal from attendance for more than ten (10) consecutive days or more than fifteen (15) days in a month of school attendance. Multiple suspensions that occur consecutively shall constitute expulsion.

**Remand:** assignment to an alternative school.

**REASONS FOR SUSPENSION/EXPULSION:**

Any principal or assistant principal (herein called principal) may suspend/expel any student from attendance at school or any school-related activity on or off campus (out-of-school suspension) or from attendance at a specific class or classes, or from riding a school bus, without suspending such student from attendance at school (in-school suspension), for good and sufficient reasons including, but not limited to:<sup>2</sup>

1. Willful and persistent violation of the rules of the school or truancy;
2. Immoral or disreputable conduct, including vulgar or profane language;
3. Violence or threatened violence against the person of any personnel attending or assigned to any school;
4. Willful or malicious damage to real or personal property of the school, or the property of any person attending or assigned to the school;
5. Inciting, advising or counseling of others to engage in any of the acts herein enumerated;
6. Possession of a pistol, gun or firearm on school property;<sup>3</sup>
7. Possession of a knife, etc., as defined in TCA 39-6-1701, on school property;
8. Assaulting a principal or teacher with vulgar, obscene or threatening language;
9. Unlawful use or possession of barbitol or legend drugs, as defined in TCA 53-10-101;<sup>3</sup>
10. Engaging in behavior which disrupts a class or school-sponsored activity;
11. Off-campus criminal behavior resulting in felony charges; when behavior poses a danger to persons or property or disrupts the education process;
12. Inadequate proof of immunization.<sup>6</sup>
13. Any other conduct prejudicial to good order or discipline in any school.

**IN-SCHOOL SUSPENSION:<sup>4</sup>**

1. Students given an in-school suspension in excess of one (1) day from classes shall attend either special classes attended only by students guilty of misconduct or be placed in an isolated area appropriate for study, and
2. Personnel responsible for in-school suspension will see that each student is supervised at all times and has textbooks and classwork assignments from his/her regular teachers. Students given in-school suspension shall be required to complete academic assignments and shall receive credit for work completed.

**PROCEDURES FOR IN-SCHOOL AND OUT-OF-SCHOOL SUSPENSION:<sup>5</sup>**

Unless the student’s continued presence in the school, class, or school-related activity presents an immediate danger to the student or other persons or property, no principal shall suspend/expel any student until that student has been given due process by advising them of the nature of his/her misconduct, questioned about it, and allowed to give an explanation;

Upon suspension/expulsion of any student (in-school suspension in excess of one (1) day), the principal shall make an immediate attempt to contact the parent or guardian to inform them of the suspension/expulsion. The student shall not be sent home before the end of the school day unless the parent or guardian has been contacted;

The principal shall notify the parent or guardian and the director of schools or designee in writing of the suspension/expulsion and the cause for it, the length of suspension/expulsion, and terms of readmission.

If at the time of the suspension the principal determines that an offense has been committed which, in the judgment of the principal would justify a suspension/expulsion for more than ten (10) days, he/she may suspend the student unconditionally for a specified period of time or upon such terms and conditions as are deemed reasonable.

The principal shall immediately give written or actual notice to the parent or guardian and the student of the right to appeal the decision to suspend/expel/remand for more than ten (10) days. All appeals must be filed, orally or in writing, within five (5) days after receipt of the notice and may be filed by the parent or guardian, the student or any person holding a teaching license who is employed by the school system if requested by the student.

If the suspension/expulsion occurs during the last ten (10) days of any term or semester, the student shall be permitted to take such final examinations or submit such required work as necessary to complete the course of instruction for that semester, subject to conditions prescribed by the principal.

Students under suspension from one (1) school in the school system cannot attend or enter another school in the system. (Ex. Career and Technical Center and high school)

---

Legal References:

1. TCA 49-6-3007(g)
2. TCA 49-2-203(a)(8);TCA 49-6-3401(a)
3. TCA 49-6-4216; TCA 39-17-1309; TCA 39-17-417
4. TCA 49-6-3401(b)(1)
5. TCA 49-6-3401(4)-(6); Goss v. Lopez, 419 U.S. 565 (Ohio, 1975); Individuals with Disabilities Act Amendments of 1997 § 615
6. TCA 49-6-5007

---

Cross References:

- Procedural Due Process 6.302
- Interference/Disruption of School Activities 6.306
- Bus Conduct 6.308
- Zero Tolerance Offenses 6.309
- Dress Codes 6.310
- Discipline Procedures 6.313
- Disciplinary Hearing Authority 6.317

**14.b. Mental Health Policy (1st Reading)**

**Primary Motion Passed:** Motion by Randy Harlan and a second by Wendy Collins to approve Mental Health Policy on 1<sup>st</sup> reading.

**15. Consideration of Classification and Compensation Study for Support Staff (Budget Amendment #79)**

**Primary Motion Passed:** Motion by Mr. Jim Rivers and a second by Wendy Collins to approve the Classification and Compensation Study for support staff.

Mr. Terry Armes	Yes
Mrs. Louise Coleman	Yes
Wendy Collins	Yes
Randy Harlan	Yes
Mr. Glen Moore	Yes
Mr. Jim Rivers	Yes

**Primary Motion Passed:** Motion by Mr. Jim Rivers and a second by Wendy Collins to approve budget amendment #79 to cover cost of Classification and Compensation Study.

Mr. Terry Armes	Yes
Mrs. Louise Coleman	Yes
Wendy Collins	Yes
Randy Harlan	Yes
Mr. Glen Moore	Yes
Mr. Jim Rivers	Yes

**Morgan County Board of Education  
General Purpose  
March 1, 2010  
Budget Amendment #79**

Debit:

46851 – State Revenue Sharing-TVA	\$35,299.00
-----------------------------------	-------------

Credit:

141-72310-399 (Other Contracted Services)	\$21,000.00
141-72310-355 (Travel, Training-Board)	\$5,000.00
141-72130-322 (Evaluation: Testing)	\$5,000.00
141-72210-524 (In-Service/Staff Development)	\$4,299.00

Explanation: (Unanticipated revenue increase)

399: Classification and Compensation Study (\$16,000)
TSBA Services – Policy Revisions; eMeeting Service (\$5,000)
355: Travel – Board Training, registration, lodging etc. (\$5,000)
322: Increased cost of testing program (\$5,000)
524: In-Service/Staff Development – Leadership training (\$4,299)

**16. Revised Job Descriptions for Supervisors (Connection to TILS Standards)**

Discussion:

Present at future date

**16.a. GCBI – Qualifications and Duties of the Federal Projects Coordinator**

**16.b. GCBP – Grant Writer**

**16.c. CGBB – Qualifications and Duties of Supervisor of Grants and Special Projects**

**16.d. CBBC – Duties of Attendance Supervisor (Supervisor of Student Services)**

**17. Appoint Board Member to County Planning Committee**

**Primary Motion Passed:** Motion by Mr. Jim Rivers and a second by Randy Harlan to appoint Terry Armes as member of the County Planning Committee.

**18. Facility Needs – Maintenance and Transportation (Revised drawing)**

Discussion:

Vocational School to draw up building plans as presented. Board suggested a contact be made with Industrial Board concerning previous land transaction.

**19. Schedule Budget Workshop(s)**

Discussion:

Special Budget workshop scheduled for March 9, 2010.

**20. Director's Performance Contract Report/Announcements**

**20.a. Monthly Financial Report**

**20.b. Overview of CTE Report Card – Mitchell Heidel, CTE Director**

- 20.c. TSBA Day on the Hill - February 23, 2010
- 20.d. March 12, 2010 - SCOPE Conference
- 20.e. TSBA Facilities Workshop - April 30th
- 20.f. Planning - A Joint Venture (May 23-24 - Pigeon Forge)
- 20.g. Update - Refinancing of Debt Service Obligations
- 20.h. Plan to Make-up Missed School Days

21. Adjourn

**Primary Motion Passed:** Motion by Randy Harlan and a second by Wendy Collins.

21.a. Workshop, March 29, 2010, 6:30 p.m. @ Central Office

21.b. Regular Board Meeting, April 1, 2010, 6:30 p.m. @ Central Office

---

Chairperson

---

Superintendent

Morgan County Schools  
Request for Field Trip Approval

Tammy Rogers  
Name of Teacher

Grade HS

Beta Club  
Subject Area (s)

Request permission to take 17 students who will have written permission from their parents

to Opryland Hotel & Convention Center  
Name of Place (s) you intend to visit

Proposed date of trip: April 5-7, 2010

Objectives of Trip (Should correlate with teaching objectives):

To attend the State Beta Convention & participate in the talent and banner competitions.

How will cost of trip be finance? by Sr. Beta Club & students

What arrangements will be made for substitute teacher for your students who are left with at school? worksheets

The means of transportation will be school bus

Name (s) of bus driver (s): Robin Greer

Names of parents (or staff) who will help supervise students on this trip: Mike Barber

Time of departure: 12:30pm April 5, 2010

Time of arrival back: 4:00pm April 7, 2010

Signature of teachers requesting approval: Tammy Rogers

Approval of Principal: Diana Smith

Wanda Lane

3-5-10

3-30-10 (sealed)

# MORGAN COUNTY SCHOOLS

## Request for Field Trip Approval

Jessica Mee Grade 9-12 Subject Area Business  
(Name of teacher)

requests permission to take 11 students in her/his classroom. Who will have written permission from their parents to \_\_\_\_\_

FBhA State Competition in Chattahoochee (Convention center)  
(Name of place you intend to visit)

Proposed date of trip: April 19-21, 2010

Objectives of trip (should correlate with teaching objectives): \_\_\_\_\_

How will cost of trip be financed? students, CTE

What arrangements will be made for substitute teacher for your students who are left at school?  
sub lesson plans will be left for each day

The means of transportation will be: Bus - ~~none~~ will be riding with Oakdale

Name or names of bus drivers: \_\_\_\_\_

Names of parents who will help supervise students on this trip: Rebecca Owens

Time of departure: 4/19 - 8:00 Time of arrival back: 4/21 - 3:00

Signature of teacher requesting approval: Jessica Mee

Approval of Principal: Bob Bennett

3-29-10  
Pending Board Approval

Morgan County Schools  
Request for Field Trip Approval

*file*

Darlene Headrick Name of Teacher    Grade 9-12    Subject Area (s) Business Technology

Request permission to take 8 students who will have written permission from their parents to Convention Center - Chattanooga, TN  
Name of Place (s) you intend to visit

Proposed date of trip: April 19-21, 2010

Objectives of Trip (Should correlate with teaching objectives):

- FBLA State Conference
1. Compete in business-related activities.
  2. Leadership Workshops.

How will cost of trip be finance? Vocational money and donation

What arrangements will be made for substitute teacher for your students who are left with at school? Substitute - Official

The means of transportation will be bus (traveling with Coalfield)

Name (s) of bus driver (s): Billy Nichols

Names of parents (or staff) who will help supervise students on this trip: \_\_\_\_\_

Time of departure: April 19 - 8:00 a.m.

Time of arrival back: April 21 - 1:00 p.m.

Signature of teachers requesting approval: Darlene Headrick

Approval of Principal: Diana Smith

Janda Lane 3-16-10  
Pending Board Approval

Morgan County Schools  
Request for Field Trip Approval

JOHN HICKS

Name of Teacher

Grade 9-12

Subject Area (s)

OAKDALE

BOY'S BASKETBALL

Request permission to take 15 students who will have written permission from their parents

to DISNEY WORLD, ORLANDO, FL  
Name of Place (s) you intend to visit

Proposed date of trip: 12/27-12/31, 2010

Objectives of Trip (Should correlate with teaching objectives):

THE TEAM HAS BEEN INVITED TO PARTICIPATE IN  
A BASKETBALL TOURNAMENT.

How will cost of trip be finance? FUND RAISERS & DONATIONS

What arrangements will be made for substitute teacher for your students who are left with at school? N/A

The means of transportation will be TRAVEL BY AIRPLANE

Name (s) of bus driver (s): N/A

Names of parents (or staff) who will help supervise students on this trip:

JOHN HICKS (HEAD COACH), JAN CURRIER, GOOSE LINDSAY

Time of departure: TBA ON 12/27/10

Time of arrival back: TBA ON 12/31/10

Signature of teachers requesting approval:

John Hicks

Approval of Principal:

Diana Smith

Handa Jane 3-25-10  
Pending Board approval

I. APPLICATION FOR APPROVAL OF Distance and e-Learning COURSES

Academic       Vocational       Special Education

**Section A – SYSTEM INFORMATION** (This section is to be completed for all Distance/e-Learning requests.)

Date of Application 1-15-2010

School System Morgan      State System Number 63

Contact Person Kathy Carroll

E-mail carrollk@mcsmail.net

Phone Number 423-346-9730      Fax Number 423-346-6043

Date of Approval by Local Board of Education April 1, 2010 (Must be approved annually)

The information on this application is complete and accurate. Assigning the proposed instructor to this special course will not preclude having all State Board approved courses taught by appropriately endorsed teachers.

Director of Schools Signature *Edward J. Duda*

1. Grade level(s) eligible to enroll: 10, 11, 12

2. Can course be counted as one of the core credits in the total number of units required by the State Board of Education for graduation.      Yes  No

3. Can course be counted as one of the elective credits in the total number of units required by the State Board of Education for graduation.      Yes  No



**Section B – COURSE INFORMATION** (This section is to be completed for all Distance/e-Learning requests.)

**NOTE: Correlation and Alignment with Tennessee Standards, Learning Expectations, and Performance Indicators must be attached to this application. These should follow the same format as those for current State-Board approved courses. If career and technical education credit is requested, correctly formatted competency profiles must also be attached.** (See Note on page 5.)

1. Name of Course: Reading In The Content Area 03081

2. Total units of credit available through course: 1

3. Pre-requisite(s):

4. Justification for including this Distance/e-Learning Course in the school program: (type below)  
 Test preparation courses can be very expensive and many times are not available in rural areas.

5. Describe briefly the nature of this Distance/e-Learning Course: (type below)  
 ACT prep work such as: test preparation techniques and practices.

6. Total estimated number of hours of Distance/e-Learning instruction: 135

7. Check one area of curriculum in which credit is awarded. Credit must be awarded in a specific area, and cannot be requested simply as "core or elective credit".

<input type="checkbox"/>	Arts	<input type="checkbox"/>	Science
<input type="checkbox"/>	Business	<input type="checkbox"/>	Social Studies
<input type="checkbox"/>	Computer Technology	<input type="checkbox"/>	Special Education
<input type="checkbox"/>	Foreign Language	<input type="checkbox"/>	Career and Technical Education Specify program area: _____
<input checked="" type="checkbox"/>	Language Arts	<input type="checkbox"/>	Wellness & P. E.
<input type="checkbox"/>	Math	<input type="checkbox"/>	Other (please specify) _____



8. Names/titles of individuals or Vendor(s) who developed the course: (Type Response beginning with (a.) below.)  
(a.) State Curriculum Standards

9. Resources (electronic or print) used to develop the course: (Type Response beginning with (a.) below.)  
(a.) State Curriculum Standards

10. Goals of course/program (student learning goals): (Type Response beginning with (a.) below.)  
(a.) State Curriculum Standards

11. Major units of instruction of e-Learning Course: (Type Response beginning with (a.) below.)  
(a.) State Curriculum Standards

12. Electronic or print texts and/or supplementary materials to be used: (Type Response beginning with (a.) below.)  
(a.)



13. Procedure for evaluating student progress: (Type Response beginning with (a.) below.)

(a.) Class participation, tests, homework

14. Procedure for evaluating success of course: (Type Response beginning with (a.) below.)

(a.) ACT prep scores.

(b.) ACT SCORES

**Section C – Career and Technical Education Course** – (Complete this section only if you are seeking to award credit in career and technical education Distance/e-Learning courses.)

1. **Outline how this course fits into a career and technical program sequence.** (Type Response beginning with (a.) below.)

(a.)

2. Interpret and summarize and attach labor market data to support the proposed course in the local area. Cite the source of data. (Type Response beginning with (a.) below.)

(a.)



**Section D – Technology-Based Course** – This section is to be completed for all Technology Based, e-Learning or Video-based Distance Learning requests.

1. This course is:

- (A) Technology-Based Intervention  
Tech Based Intervention 3645
- (B) e-Learning Courses (Academic) (core or elective)  
8000 Series
- (C) e-Learning Courses (Career and Technical)  
7000 Series
- (D) Video-based Distance Learning

2. For Technology-based Intervention, check appropriate area(s):

- Algebra (Math)     Biology (Science)     English (Language Arts)

3. For e-Learning and video-based distance learning courses **ONLY**, who will evaluate coursework submitted by students enrolled? (type below)

Distance Learning Instructor

4. Origination of course:

**Type:**

- Satellite     On-Line     CD-ROM-based

Provider/Vendor: PCS

**Note:**

**\*For technology-based intervention courses a correlation of the Gateway standards with the provided program must be attached.**

**\*\*For Distance/e-Learning courses (academic, special education or vocational) a Correlation and Alignment with Tennessee Standards, Learning Expectations, and Performance Indicators must be attached to this application with documentation of instructional resources to fill any identified gaps. Curriculum Standards must be listed with corresponding units of instruction from the Distance/e-Learning course of study. (e.g. textbooks, on-line resources, etc...)**



**SECTION E – COURSE SITE INFORMATION** – This section is to be completed for all Technology Based, e-Learning or Video-based Distance Learning requests.

School Site	State School #	Years Course Offered at this School (1, 2, 3, or 4+)	School Year Course to be Offered	Semester Offered Fall or Spring Both Full Year Summer	School Format: Traditional Block Modified Block	For Video Distance Learning: Base Site Receiving Site	Facilities available for Course/program (Required for Career and Technical courses)
Sunbright	0070	2	2009-10	S	B	R	
Coalfield	0030	1	2009-10	S	B	R	
Central	0015	2	2009-10	S	B	B	



**SECTION F – INSTRUCTION INFORMATION** – This section is to be completed for all Distance/e-Learning requests.

System and/or School and/or Vendor Name	Teacher Name	Teacher #	Teacher Role		Highly Qualified Status		Endorsement Code(s)	Industry Certifications	e-Learning Training	
			Main/ Base	Instructor/ Facilitator	Yes	No			Yes	No
Central High	Duane Yeary	410373693	M	I	Yes	Math, Science Reading, Lang. Arts	460		Yes	
Sunbright	Becky Douglas	414964908	B	F	Yes		002 101		Yes	
Coalfield	Teena Stewart	410086828	B	F	No		N/A		Yes	





## Ballast Paver®

### Firestone Item Number:

- W56RACPV01 (Natural Grey)
- W56RACPVTC (Adobe)
- W56RACPVCG (Sable)
- W56RACPVCR (Canyon Red)
- W56RACPVSD (Desert Sand)

### DESCRIPTION:

The Firestone Ballast Paver is a 1.34 sq. ft. durable interlocking concrete paver with radius bearing pads to protect the membrane from abrasion. Designed as an engineered system, the Ballast Paver provides superior roof top wind resistance and because of their unique design, allows four-way water drainage.

### PREPARATION OF SUBSTRATES:

1. Prior to application of roofing membrane substrates must be clean, dry, smooth, free of sharp edges, fins, loose or foreign materials, oil, grease, and other materials which may damage the membrane.
2. All rough surfaces which could damage the membrane shall be repaired prior to installing the membrane, as specified.
3. All surface voids greater than 1/4" wide shall be properly filled with an acceptable fill material.
4. Reference Firestone details regarding appropriate flashing details to be used with the Firestone Ballast Paver system.

### METHOD OF APPLICATION:

1. Firestone Ballast Pavers are installed as a continuous ballasting overlay layer on the roof. Ballast Pavers are overlapped (shiplaps), and mechanically clipped as described in the Firestone Ballast Paver Design Guide.
2. Face upper shiplap edge of Ballast Paver at roof edge.
3. Install pavers in straight bond or staggered bond.
4. Maintain 1 ¼" inch maximum distance between the upper shiplap and/or the 11 ¾" inch dimension of the Ballast Paver where they meet the first roofing element.
5. Install mechanical clips where Ballast Pavers meet any roof protrusions (HVAC equipment, roof drains, structural members, roof curbs, etc.) and where there are any pavers less than full size. Firestone AP Sealant may be substituted for mechanical clips.



### PRODUCT DATA

6. At ridges or valleys, the cut to fit pavers are adhered to the adjacent full size paver with a one part polyurethane.
7. Install the Firestone Ballast Paver system in accordance with current Firestone Ballast Paver specifications, details and workmanship requirements.

Please contact Firestone Roofing Solutions for additional technical information.

### PHYSICAL PROPERTIES:

Size:	11 ¾" x 16 ½" x 1 ½"
Weight:	12 ± 0.75 lb per sq. ft.
Compressive Strength:	5000 psi @ 28 days
Flexural Strength:	400 lb
Density:	125 pcf
Water Absorption:	5% (nominal)

### PRODUCT DATA:

Packaging:	Palletized, banded, stretch wrapped, and labeled
Pieces Per Square:	75 pavers per square
Pieces Per Pallet:	144 pavers per pallet
Pallets Per Truck:	20

### PRECAUTIONS:

1. Store materials on raised platforms.
2. Handle materials to prevent damage.
3. Do not exceed the structural capacity of deck if placing Firestone Ballast Paver units on the roof.
4. Protect membrane and installed areas of the Firestone Ballast Paver from damage when transporting pallets of Firestone Ballast Paver or other material. Recommended to place ¾" plywood sheets in traffic path or use carts with pneumatic tires.

### LEED INFORMATION:

Post Consumer Recycled Content:	0%
Post Industrial Recycled Content:	0%
Manufacturing Location:	Littleton, CO

Ballast Paver® is a Registered trademark of Oldcastle.

**Firestone Building Products Company**  
A Division of BFS Diversified Products, LLC  
310 E. 96<sup>th</sup> Street, Indianapolis, IN 46240  
Sales: (800) 428-4442 • Technical (800) 428-4511  
[www.firestonebpco.com](http://www.firestonebpco.com)

This sheet is meant only to highlight Firestone's products and specifications. Information is subject to change without notice. Firestone takes responsibility for furnishing quality materials, which meet Firestone's published product specification. As neither Firestone itself nor its representatives practice architecture, Firestone offers no opinion on, and expressly disclaims any responsibility for the soundness of any structure on which its products may be applied. If questions arise as to the soundness of a structure, or its ability to support a planned installation properly, the Owner should obtain opinions of competent structural engineers before proceeding. Firestone accepts no liability for any structural failure or for resultant damages, and no Firestone Representative is authorized to vary this disclaimer.



## Ballast Paver® Mat

**Firestone Item Number: W5635890PV**

**DESCRIPTION:**

Firestone Ballast Paver Mat is composed of high-tenacity polypropylene yarns, which are woven into a stable network such that the yarns retain their relative position. Ballast Paver Mat is inert to biological degradation and resistant to naturally encountered chemicals, alkalis, and acids.

**METHOD OF APPLICATION:**

Install Ballast Paver Mat where required by Firestone's Ballast Paver Design and Installation Guide. Mat may be cut to desired dimensions and laid in direct contact with the EPDM membrane. Mat is held down by the Ballast Paver weight and requires no adhesive to keep in place.

**PHYSICAL PROPERTIES:**

<u>Property</u>	<u>Test Method</u>	<u>Typical Performance (MD)</u>
Weight	ASTM D 5261	6.0 oz./sq. yd. (203 g/m <sup>2</sup> )
Thickness	ASTM D 5199	0.025" (0.64 mm)
Wide Width Tensile Strength	ASTM D 4595	175 lb/in (30.6 kN/m)
Grab Tensile Strength	ASTM D 4632	315 lb (1.4 kN/m)
Grab Tensile Elongation	ASTM D 4632	15%
Trapezoid Tear Strength	ASTM D 4533	120 lb (0.53 kN)
Mullen Burst Strength	ASTM D 3786	600 psi (4,134 kPa)
Puncture Strength	ASTM D 4833	120 lb (0.53 kN)
Percent Open Area	COE-02215-86	1%
Apparent Opening Size (AOS)	ASTM D 4751	U.S. Sieve 40 (0.425 mm)
Permittivity	ASTM D 4491	0.05 sec. <sup>-1</sup>
Flow Rate	ASTM D 4491	4 gal/min/sq. ft. (163 l/min/m <sup>2</sup> )
UV Resistance at 500 Hrs.	ASTM D 4355	70% strength retained

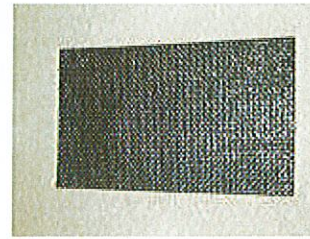

### PRODUCT DATA

**PHYSICAL CHARACTERISTICS:**

1. Material is .025" x 12.5' wide x 360' long (0.64 mm x 3.8 m x 110 m).
2. Roll weight is approximate 240 lb (109 kg).
3. Roll area is 500 sq. yd. (418 sq. m).
4. Rolls are individually wrapped with black polyethylene film.

**PRECAUTIONARY DATA:**

1. Do not expose Ballast Paver Mat to any open flames or ignition sources.
2. Refer to Material Safety Data Sheets (MSDS).

**LEED INFORMATION:**

Post Consumer Recycled Content: 0%  
 Post Industrial Recycled Content: 0%  
 Manufacturing Location: Cornelia, GA

Ballast Paver® is a Registered Trademark of Oldcastle.

This sheet is meant only to highlight Firestone's products and specifications. Information is subject to change without notice. Firestone takes responsibility for furnishing quality materials, which meet Firestone's published product specification. As neither Firestone itself nor its representatives practice architecture, Firestone offers no opinion on, and expressly disclaims any responsibility for the soundness of any structure on which its products may be applied. If questions arise as to the soundness of a structure, or its ability to support a planned installation properly, the Owner should obtain opinions of competent structural engineers before proceeding. Firestone accepts no liability for any structural failure or for resultant damages, and no Firestone Representative is authorized to vary this disclaimer.

**Firestone Building Products Company**  
 A Division of BFS Diversified Products, LLC  
 310 E. 96<sup>th</sup> Street, Indianapolis, IN 46240  
 Sales: (800) 428-4442 • Technical (800) 428-4511  
[www.firestonebpc.com](http://www.firestonebpc.com)

**Morgan County Board of Education**  
**SRO**  
**March 29, 2010**  
**Budget Amendment #74**  
**(Correction)**

Credit: (Increase)  
141-72130-599-4001 (Other Charges) \$22,800.00

Debit (Increase)  
141-46981 (Safe Schools-ARRA) \$21,100.00

Debit (Increase)  
141-39000 (Undesignated Fund) \$1,700.00

Explanation:  
Correction to Budget Amendment #74.

\_\_\_\_\_  
Edward L. Diden, Director of Schools

\_\_\_\_\_  
Date

\_\_\_\_\_  
Terry Armes, Board Chairman

\_\_\_\_\_  
Date

**Morgan County Board of Education  
Career In Mind  
March 8, 2010  
Budget Amendment #80**

Debit:

141-72210-355-0041	(Travel)	\$5,000.00
--------------------	----------	------------

Credit:

141-73400-198-0041	(Subs)	\$4,000.00
141-73400-201-0041	(Social Security)	\$500.00
141-73400-204-0041	(State Retirement)	<u>\$500.00</u>
	Total:	\$5,000.00

Explanation:

The above journal entry is for transferring of funds from a Travel line item to Subs, Social Security, and Retirement line items.

\_\_\_\_\_  
Edward L. Diden, Director of Schools

\_\_\_\_\_  
Date

\_\_\_\_\_  
Terry Armes, Board Chairman

\_\_\_\_\_  
Date

**Morgan County Board of Education**  
**Title I**  
**March 22, 2010**  
**Budget Amendment #81**

Debit:		
	142-39000 Fund Balance	\$4,000.00
Credit:		
	142-72210-499-011-650	\$4,000.00

Explanation:  
Transfer of money from Fund Balance to Consolidated Administration to correct Budget Amendment.

\_\_\_\_\_  
Edward L. Diden, Director of Schools

\_\_\_\_\_  
Date

\_\_\_\_\_  
Terry Armes, Board Chairman

\_\_\_\_\_  
Date

**Morgan County Board of Education**  
**Title I**  
**March 22, 2010**  
**Budget Amendment #82**

Debit:

Undesignated funds	\$35,000.00
--------------------	-------------

Credit:

47171 Revenue	\$35,000.00
---------------	-------------

Explanation:

To correct budget after audit adjustments.

\_\_\_\_\_  
Edward L. Diden, Director of Schools

\_\_\_\_\_  
Date

\_\_\_\_\_  
Terry Armes, Board Chairman

\_\_\_\_\_  
Date

**Morgan County Board of Education  
Title II  
March 22, 2010  
Budget Amendment #83**

Credit:

Fund Balance	\$3,887.78
--------------	------------

Debit:

142-72210-599-201	\$2,274.00
142-72210-355-201	\$1,613.78

Explanation:

To correct budget after audit adjustments.

\_\_\_\_\_  
Edward L. Diden, Director of Schools

\_\_\_\_\_  
Date

\_\_\_\_\_  
Terry Armes, Board Chairman

\_\_\_\_\_  
Date

**Morgan County Board of Education**  
**G.P.**  
**March 29, 2010**  
**Budget Amendment #84**

Debit:

141-49700 (Insurance Recovery) \$2,614.82

Credit:

141-72710-453 (Vehicle Parts) \$2,614.82

Explanation:

Insurance Recovery Funds.

\_\_\_\_\_  
Edward L. Diden, Director of Schools

\_\_\_\_\_  
Date

\_\_\_\_\_  
Terry Armes, Board Chairman

\_\_\_\_\_  
Date

**Morgan County Board of Education  
G.P.  
March 29, 2010  
Budget Amendment #85**

Debit:

141-44170 (Misc. Refunds) \$3,965.00

Credit:

141-72710-412 (Diesel Fuel) \$3,965.00

Explanation:

Reimbursement for use of buses.

\_\_\_\_\_  
Edward L. Diden, Director of Schools

\_\_\_\_\_  
Date

\_\_\_\_\_  
Terry Armes, Board Chairman

\_\_\_\_\_  
Date

**Morgan County Board of Education  
Carl Perkins  
March 29, 2010  
Budget Amendment #86**

Debit:

Revenue 47131-801	\$1,411.00
-------------------	------------

Credit:

142-71300-730-801-REAP	\$1,411.00
------------------------	------------

Explanation:

Reappropriated funds from 2009 State-Wide  
Carl Perkins.

\_\_\_\_\_  
Edward L. Diden, Director of Schools

\_\_\_\_\_  
Date

\_\_\_\_\_  
Terry Armes, Board Chairman

\_\_\_\_\_  
Date

**Morgan County Board of Education  
G.P.  
March 29, 2010  
Budget Amendment #87**

Debit:

141-44170      (Misc. Refunds)      \$1,000.00

Credit:

141-71100-116 (Teachers)      \$1,000.00

Explanation:

Supplemental Pay Funded by Grant.

\_\_\_\_\_  
Edward L. Diden, Director of Schools

\_\_\_\_\_  
Date

\_\_\_\_\_  
Terry Armes, Board Chairman

\_\_\_\_\_  
Date

## ***HIGH SCHOOLS THAT WORK KEY PRACTICES***

*HSTW* has identified a set of ten Key Practices that impact student achievement. The following *HSTW* Key Practices provide direction and meaning to comprehensive school improvement and student learning:

1. **High expectations**—Motivate more students to meet high expectations by integrating high expectations into classroom practices and by giving students frequent feedback.
2. **Program of study**—Require each student to complete an upgraded academic core and a career/technical, mathematics/science, and/or humanities concentration.
3. **Academic studies**—Teach more students the essential concepts of the college-preparatory curriculum by encouraging them to apply academic content and skills to real-world problems and projects.
4. **Career and technical studies**—Provide more students access to intellectually challenging career and technical studies in high-demand fields that emphasize the higher-level mathematics, science, literacy, and problem-solving skills needed in the workplace and in further education.
5. **Work-based learning**—Enable students and their parents to choose from programs that integrate challenging high school studies and work-based learning and are planned by educators, employers, and students.
6. **Teachers working together**—Provide teams of teachers from several disciplines the time and support to work together to help students succeed in challenging academic and career and technical studies. Integrate reading, writing, and speaking as strategies for learning into all parts of the curriculum and integrate mathematics into science and career and technical classrooms.
7. **Students actively engaged**—Engage students in academic and career and technical classrooms in rigorous and challenging proficient-level assignments using research-based instructional strategies and technology.
8. **Guidance**—Involve students and their parents in a guidance and advisement system that develops positive relationships and ensures completion of an accelerated plan of study with a career/technical, mathematics/science, and/or humanities concentration. Provide each student with the same mentor throughout middle or high school to assist with setting goals, selecting courses, reviewing the student's progress, and suggesting appropriate interventions as necessary.
9. **Extra help**—Provide a structured system of extra help to assist students in completing accelerated plans of study with high-level core academic and technical content.
10. **Culture of continuous improvement**—Use student assessment and program evaluation data to continuously improve school culture, organization, management, curriculum, and instruction to advance student learning.

## **Morgan County Schools**

### **1. Application for Improvement**

Morgan County strives to be creative and innovative in our approach to delivering high quality educational services. In this process, we face challenges between the need to improve student achievement and a desire to provide educational opportunities that engage each learner. It is clear in rural schools that students do not have the same opportunities as those in more urban areas. A great way to capitalize on the rural setting is through the effort-based school improvement initiative High Schools That Work. This program would initiate a cross county movement to challenge middle and high school students academically.

The ever-changing state graduation goal constitutes a continuing challenge for Morgan County Schools. The graduation rate for 2009 is 94.7%, which exceeds the state goal of 90%. Yet, many who graduate from high school lack preparation for further study and the recognized credentials needed to acquire good jobs. Historically, students have scored below state averages on the ACT Test.

Morgan County's 2009 projected performance in Gateway English II for grades 9-10 show 321 students out of 490 in need of instructional interventions. It is most evident that wide gaps in reading preparedness exist. Another identified area of need is shown in 2009 projected performance to Gateway Algebra I for grades 9-10 where better than half of students are in need of intervention. School and teacher leaders are not satisfied if only a small portion of students completing the recommended academic core are college and or career ready. U.S. 2000 Census American Fact Finder for Morgan County provides a brief snapshot of who we are and why: 16.0% families living in poverty, 35% individuals living in poverty, and 6.0% obtain a 4 year degree.

Could it be our schools do not create learning experiences that link high-level academic content to the unique talents, interests, and goals of MC students? This grant will assist in connecting Central Middle and High School students to the real world, and to show the relevance of high school graduation and the importance of pursuing post-secondary learning opportunities.

The HSTW principles integrate well with the district mission and will pave the way to meeting the requirements of the New High School Transition Policy of the Tennessee State Board of Education.

### **2. Current Promising Practices (Not Currently a HSTW site)**

Central High School currently provides a successful Credit Recovery Program through collaboration with a 21<sup>st</sup> Century After-School Program and Career Ladder funding. During the 2008-09 school year twenty-seven students successfully recovered required academy credit. The CHS faculty and administration have familiarity with an advisory system as one has been in use for several years. Additional training will assist this program to align more precisely with the principles of HSTW.

Morgan County Schools Independent Study (ISP) is a non-traditional classroom designed to serve at-risk students who are in danger of not graduating or not graduating with their peer group. The program is conducted daily at the Morgan County Career and Technical Center and provides opportunity for students who are need of an alternative setting to reach a personal goal of high school graduation. The ISP approach employs the use of Nova Net as an individualized computer-based curriculum delivery system. Since implementing the ISP program in the fall of 2008, 48 students have completed their graduation requirements. Another 20 students are

expected to graduate in the spring semester. The ISP Program has played a huge role in our 94.7% graduation rate. Recently, Nova Net has been purchased for the Alternative Program at Central High and Central Middle Schools.

Students achieve at higher levels when they use knowledge and skills to solve problems as they would in a real job. A partnership between Morgan County Career and Technical Center and Habitat for Humanity resulted in carpentry students building a three-bedroom house for a local student's family. For several years, the Career and Technical Center has also made available to the community beautiful flowers planted and harvested in greenhouses maintained by Agriculture students. Money from plant sales covers the cost of materials for the next growing season. Students will be more successful if they make the connection between classroom skills and a real-world context.

The Morgan County Career and Technical Center has renewable wind and solar energy programs as an integral part of the curriculum. This work has become cross-curricular in scope involving hundreds of students across multiple disciplines. Several local partners have provided in-kind support to bring these projects to fruition. The programs have garnered regional, state, and national attention. In January, the CTC faculty began to further engage the community by teaching a class entitled, "Wind and Solar Power for Home Use." External grant funds of \$75,000+ have been acquired to support these programs. Two students were awarded third place in the nation on their sustainability solutions competition this past summer in Kansas City.

The excitement of hands-on learning can motivate students to overcome their academic weaknesses. Through the greater use of project and problem-based learning, students are permitted to experiment in areas of interest and to discover that they can handle complex assignments with real-life components and consequences.

### **3. Current Challenges for School Improvement**

Morgan County has the following prioritized list of goals in the current school improvement plan:

- a.) Maintain at or above NCLB required percentage of students graduates
- b.) Students will score at or above TVAAS predicted scores on the Gateway Algebra I
- c.) Students will score at or above TVAAS predicated scores on the Gateway English II
- d.) Improve student preparation and student work habits

The High School That Work initiative will help with these challenges by familiarizing all members of the faculty with the key practices and how these principles have proven effective in other school settings. Training to implement those key practices will be a focus of the work that will be done by faculty at Central High. Middle grade teachers and counselors from Central Middle School will also be included in this training.

The expanded use of work-based learning and more access to Career and Technical studies will improve the graduation rate by giving students curriculum that is more relevant for their future career plans. School leaders will overcome the focus on deficits, minimum standards, and boring work assignments that cause a downward spiral in enthusiasm and interest the longer students remain in school. Students will be guided to discover what gives them the most satisfaction and assist them in setting career goals in anticipation of a rewarding career. Teachers will be provided with training, time for collaboration, and other resource support.

### **4. Action Plans for School Improvement**

- a. Graduation Rate

1. Early identification and intervention for 9<sup>th</sup> grade students who are struggling socially and academically.
  2. Involve students and their parents in a guidance and advisement system that develops positive relationships and ensures completion of an accelerated program of study with an academic or career/technical concentration beginning with 0<sup>th</sup> grade students.
  3. Continue to give students access to opportunities such as Credit Recovery, Dual Credit, and ISS Program for all students who encounter academic difficulty.
- b. Focus on ACT/Work Readiness
1. Achievement in Math/Science/Reading-Using student assessment and program evaluation data to continuously improve school culture, organization, management, curriculum and instruction to advance student learning.
  2. Work-based learning- Enable students and their parents to choose from programs that integrate challenging high school studies and work-based learning that are planned by educators, employers, and students.
  3. Motivate more students to meet high expectations by integrating high expectations into classroom practices and giving students frequent feedback.
- c. Staff development for teachers and administrators in the HSTW key practices
1. Provide teachers the time and support to work together to help students Succeed in challenging academic and career/technical studies, Integrate reading, writing, and speaking strategies for learning into all parts of the curriculum and integrate math into science and career/technical classrooms.
  2. Attendance at HSTW national and state conferences.
  3. Provide teachers with instructional materials, planning time and professional development for implementing new curriculums and research-based instructional methods.

## 5. Process to Inform New Teachers and Staff

New teacher orientation in HSTW key factors; new teachers attending conferences and workshops; District level appointee to foster communication among all new personnel. Scheduling to promote collaborative planning with partner schools and integration of curriculum cross content areas.

**Other Reform Initiatives:** Dual Credit Classes are offered through with Roane State Community College and the Tennessee Technology Centers. Through a collaborative grant proposal with Grainger County, distance learning has become a reality for Morgan County students. Courses include Algebra I for 8<sup>th</sup> grade, Physics, College Algebra, and ACT Prep. Distance learning opportunities will be expanding during the 2010-11 school year.

The Morgan County Career and Technical Center received a Carl Perkins Reserve Grant for \$91,700 to implement an Engineering/CIM Program of Study. The students are involved in hands-on projects, and much interested is being generated in this course of study for next year.

In August, 2010, educators in grades 6-12 will receive training on project-based learning with connection to local communities. These sessions will include a component on Professional Learning Communities to encourage all educators to work collaboratively to address student needs and achievement challenges. This process will engage students and educators in academic work connected to state learning standards, 21<sup>st</sup> century workforce skills, and community development issues of the local place.

GAI, 3351 Regal Drive, Alcoa, TN 37934		Phone: 865-970-2471 Fax: 865-970-7889	
<b>Proposal submitted to:</b>		<b>Description of Job:</b>	
Morgan County Schools		<b>Job</b> Vocational School – CCTV System pricing	
<b>Address</b>		132 Flat Fork Road	
136 Flat Fork Road		<b>City</b>	<b>State</b>
Wartburg, Tennessee 37887		Wartburg	Tennessee
<b>Attention:</b>		<b>Phone</b>	<b>Date:</b>
Chris R. Rogers		423-346-6214 – Office	March 11, 2010

GAI hereby submits specifications and estimates to:

Provide the following CCTV equipment and cabling for the Morgan County Schools – Vocational School CCTV project in Wartburg, Tennessee. Prices below are base on GAI's understanding of RFI provide by Morgan County Schools. As of this date, no addenda or written clarifications have been given for this project.

GAI will provide the following CCTV equipment for this project:

(2) GE Security 16 channel TruVison Digital Video Recorder with 3TB hard drive storage, (10) GE TruVison IR Color Dome Cameras for outdoor locations, (22) GE TruVison Plastic Color Dome Cameras for indoor locations, (1) 32 channel / 10A rack mounted power supply, (1) wall mounted double hinged 12RU cabinet, (1) ceiling mounted microphone and on/off switch for principals office, (1) lot installation labor, programming, testing and certification of CCTV system, and (1) one-warranty on GAI provided equipment and labor.

**GE CCTV EQUIPMENT ONLY, Installed = \$14,375.00, use tax included.**

GAI will provide the following CCTV Cabline for this project:

(100') Non-plenum rated RG59/18-2 Siamese cable for cameras listed above, (100) j-hooks, (10) sleeve penetrations, and (1) one-warranty on GAI provided equipment and labor.

Cable amount is based on an average of 250' per cable run for each camera.

**GE CCTV CABLING ONLY, Installed = \$5,575.00, use tax included.**

GAI will install the systems with the following qualifications:

- 1) Prices below are subject change pending system review and approval of Morgan County Schools and final camera locations at school.
- 2) Morgan County Schools shall provide and install all 120VAC power at head end location for system.
- 3) GAI will provide fire caulking, sleeves, standard device boxes and complete conduit raceway as required per specifications.
- 4) Install price below includes freight, taxes, programming, testing and certification of system.

We Hereby Propose to furnish the above in accordance with the information received, for the sum of

**\$ Combined totals = 19,950.00, installed, use tax included.**

with payment to be made as follows: Net 10 days after draw request.

All material is guaranteed to be as specified. Any alteration or deviation from above specifications involving extra costs will be executed only upon written orders, and will become an extra charge over and above the estimate. All agreements are contingent upon strikes, accidents or delays beyond our control. Owner is to carry fire, tornado and other necessary insurance.

Authorized  
GAI Signature

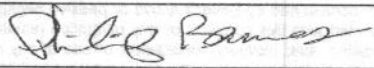
  
Philip Barnes

Note: This proposal may be withdrawn by GAI if not accepted within **180** days.

Acceptance of this proposal: The above prices, specifications and conditions are satisfactory and are hereby accepted within the scope of GAI's terms and conditions. You are authorized to do the work specified. Payment will be made as outlined above.

P.O. Number: \_\_\_\_\_

Name: \_\_\_\_\_

Date Accepted: \_\_\_\_\_

Signature: \_\_\_\_\_

GAI, 3351 Regal Drive, Alcoa, TN 37934		Phone: 865-970-2471 Fax: 865-970-7889	
<b>Proposal submitted to:</b>		<b>Description of Job:</b>	
Morgan County Schools		<b>Job</b> Pertos-Joyner School – CCTV System pricing	
136 Flat Fork Road		<b>Address</b> 125 Petros-Joyner School Road	
Wartburg, Tennessee 37887		<b>City</b> Oliver Springs	<b>State</b> Tennessee
<b>Attention:</b> Chris R. Rogers		<b>Phone</b> 423-346-6214 – Office	<b>Date:</b> March 11, 2010

GAI hereby submits specifications and estimates to:

Provide the following CCTV equipment and cabling for the Morgan County Schools – Pertos-Joyner School CCTV project in Oliver Springs, Tennessee. Prices below are base on GAI's understanding of RFI provide by Morgan County Schools. As of this date, no addenda or written clarifications have been given for this project.

GAI will provide the following CCTV equipment for this project:

(1) GE Security 16 channel TruVison Digital Video Recorder with 3TB hard drive storage, (5) GE TruVison IR Color Dome Cameras for outdoor locations, (11) GE TruVison Plastic Color Dome Cameras for indoor locations, (1) 16 channel / 8A rack mounted power supply, (1) wall mounted double hinged 12RU cabinet, (1) ceiling mounted microphone and on/off switch for principals office, (1) lot installation labor, programming, testing and certification of CCTV system, and (1) one-warranty on GAI provided equipment and labor.

**GE CCTV EQUIPMENT ONLY, Installed = \$8,100.00, use tax included.**

GAI will provide the following CCTV Cabling for this project:

300' Non-plenum rated RG59/18-2 Siamese cable for cameras listed above, (100) j-hooks, (10) sleeve penetrations, and (1) one-warranty on GAI provided equipment and labor.

Cable amount is based on an average of 250' per cable run for each camera.

**GE CCTV CABLING ONLY, Installed = \$3,025.00, use tax included.**

GAI will install the systems with the following qualifications:

- Prices below are subject change pending system review and approval of Morgan County Schools and final camera locations at school.
- Morgan County Schools shall provide and install all 120VAC power at head end location for system.
- GAI will provide fire caulking, sleeves, standard device boxes and complete conduit raceway as required per specifications.
- Install price below includes freight, taxes, programming, testing and certification of system.

We Hereby Propose to furnish the above in accordance with the information received, for the sum of

**\$ Combined totals = 11,125.00, installed, use tax included.**

with payment to be made as follows: Net 10 days after draw request.

All material is guaranteed to be as specified. Any alteration or deviation from above specifications involving extra costs will be executed only upon written orders, and will become an extra charge over and above the estimate. All agreements are contingent upon strikes, accidents or delays beyond our control. Owner is to carry fire, tornado and other necessary insurance.

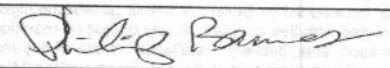
Authorized  
GAI Signature   
Philip Barnes

Note: This proposal may be withdrawn by GAI if not accepted within **180** days.

Acceptance of this proposal: The above prices, specifications and conditions are satisfactory and are hereby accepted within the scope of GAI's terms and conditions. You are authorized to do the work specified. Payment will be made as outlined above.

P.O. Number: \_\_\_\_\_

Name: \_\_\_\_\_

Date Accepted: \_\_\_\_\_

Signature: \_\_\_\_\_

**Morgan County Schools - VO TECH & Petros-Joyner  
School CCTV System - per each price**

<b>GE SECURITY TRUVISON CCTV EQUIPMENT TYPE</b>	<b>UNIT PRICES</b>
GE Security TVR-3016-3T TruVison DVR	\$ 2,350.00
GE Security TVD-DOME-HR plastic TV Color dome & t-bar	\$ 250.00
GE Security TVD-TIR-HR - IR Color Dome	\$ 350.00
32 channel - 10A rack mounted power supply	\$ 750.00
16 channel - 8A rack mounted power supply	\$ 550.00
1000' Siamese Coax cable with 100 J-hooks and 10 sleeves	\$ 950.00
GE Security CCTV LCD 17" Monitor	\$ 325.00
Double Hinged wall cabinet	\$ 725.00
principal microphone and on/off switch	\$ 200.00
A/B video switch for Votech school monitor connection to (2) DVR's	\$ 150.00
misc install materials	\$ 650.00

**This prices are good for 180 days from date of bid opening.**



# TruVision DVR 30 Calculator (NTSC)

INPUTS	
Number of Days of Storage	30
Numbers of Cameras	16
Frames Per Second (per ch)	3.75
Quality Setting	highest
% Motion Detection Rec.	40%

\*Please note the values calculated are +/- 5% accurate.

This calculator was used to determine the hard drive size for the DVR's at both schools based on GAI's understanding of RFP requirements. The 40% listed above is for motion recording for approximately 40% of a 24 hour day.

### Storage Requirements:

D1	2CIF	CIF
1457 GB	845 GB	361 GB
1.5 TB	0.8 TB	0.4 TB

### Bandwidth Usage:

D1		2CIF		CIF	
11.25	Mbps	6.52	Mbps	2.79	Mbps
11245.8	kbps	6518.6	kbps	2785.2	kbps

[Advanced](#)

[Back to Cover](#)

March 11, 2010

Mr. Chris Rogers  
Morgan County Schools  
136 Flat Fork Road  
Wartburg, Tennessee 37887

CCTV Reference list for Gallagher and Associates, Inc.:

Morgan County Schools  
136 Flat Fork Road  
Wartburg, Tennessee 37887  
Contact: Mr. Chris Rogers  
Phone: (423) 346-6214

Blount County Schools  
831 Grandview Drive  
Maryville, Tennessee 37803  
Contact: Dr. Brian Bell  
Phone: (865) 930-1012

Denso Manufacturing  
1720 Robert C Jackson Dr  
Maryville, Tennessee 37801-3748  
Contact: Ron Cobb  
Phone: (865) 932-7000

Additional references available upon request.

## Overview

The TruVision™ DVR 30 (TVR 30) digital video recorder brings the benefits of digital security monitoring to small and mid-sized commercial applications. A user-friendly interface and more than a month of hard disk recording make the TVR 30 easy to install, use and maintain. Users can efficiently view, record, and play back recorded high-quality video that is transmitted based on alarms, events and recording attributes like schedules. For added convenience, users can configure the DVR, view live video or search and play back video through the IR remote control, mouse, front-panel buttons or the remote browser.

A cost-effective surveillance solution, the TVR 30 features H.264 video compression technology that allows users to save high-quality images into smaller file sizes for easier storage and streaming over an Ethernet network. Any range of recorded video can be easily copied to a blank recordable CD or DVD and played back without installing any software on the playback PC.

The Record Wizard makes programming easy—by entering the number of days to store video, the DVR programs itself. Up to 16 channels of audio can be recorded for applications requiring audio which is played in sync with video. The dual-streaming feature makes it easier to transmit video and audio over low-bandwidth networks.

The TVR 30 is a fit-and-forget solution, with a simple search function for reviewing video. External alarm inputs and motion detection trigger an alarm when movement in a user-definable area of the image is detected. The feature set includes complete search by alarm, motion, and time and date. Video evidence is easily archived to an external device connected through a USB 2.0 port—and because USB 2.0 is hot-swappable, an external device can be connected at any time. Transferring video information is quick and easy, as the TVR 30 creates a file that can be viewed by any PC with a TVR 30 player, making it ideal for retail, education, police interrogation rooms and small commercial applications.

## Standard Features

- Network-friendly dual-streaming means more efficient and flexible video transmission
- Simple one-button archive video via USB 2.0, CD/DVD or download allows convenient remote access to archived video
- Record Wizard facilitates quick, easy configuration and installation—program DVR to record by number of days or by frame rate
- High-quality recording resolutions—CIF, 2CIF, D1—deliver clear images for quick decision making
- Record up to 120 fps NTSC (100 PAL) at D1 for clear images and quick decision making
- Simple, free, pre-configured DDNS makes remote access easy
- Video Authentication ensures video authenticity that can be verified in browser
- Motion-detection recording saves storage space and time required to search for events
- Network capable via Ethernet (TCP/IP) to provide remote monitoring, searching, playback, archiving, configuration, alarm notifications and firmware upgrades
- 16 channels of audio recording
- Bi-directional audio—1 channel allows users to carry on a conversation via remote software over network to DVR
- POS and ATM text insertion (requires ProBridge accessory, sold separately)

## TruVision Line

# DVR 30

H.264 Digital Video  
Recorder, Dual-Streaming



Overview

TruVision™ LCD monitors from GE Security represent a cost-effective CCTV solution designed for years of trouble-free operation and clear, reliable viewing.

Available in 15-inch, 17-inch and 19-inch models, these high-quality monitors come equipped with comb filters for optimum picture quality particularly when capturing motion video. A 500:1 contrast ratio delivers sharp, clear images and a panel lamp life of up to 50,000 hours offers a long-lasting, effective monitor to meet a full range of video surveillance needs.

Standard Features

TruVision LCD 17" and TruVision LCD 19"

- Comb filter (2D-17", 3D-19") improves video with motion
- Multi-language On Screen Display (OSD) in 7 languages
- 2/6 ms of fast response time
- Up to 50,000 hours of long panel lamp life
- 500:1 high-contrast ratio for darker blacks and whiter whites
- Multiple inputs including 1 x BNC In/Out, 1 x S-video In/Out, VGA input
- S-video input/output for improved video compared to composite

TruVision LCD 15"

- Comb filter (2D) improves video with motion
- Multi-language On Screen Display (OSD) in 7 languages
- 5/11 ms of fast response time
- 30,000 hours of long panel lamp life
- 500:1 high-contrast ratio for darker blacks and whiter whites
- Multiple inputs including 1 x BNC In/Out, 1 x S-video In/Out, VGA input
- S-video input/output for improved video compared to composite

TruVision LCD 17" VGA

- VGA only
- 800:1 high-contrast ratio offers excellent definition; darker blacks and whiter whites
- Up to 30,000 hours of long panel lamp life

TruVision™ Line  
LCD Monitors  
(15", 17" and 19")

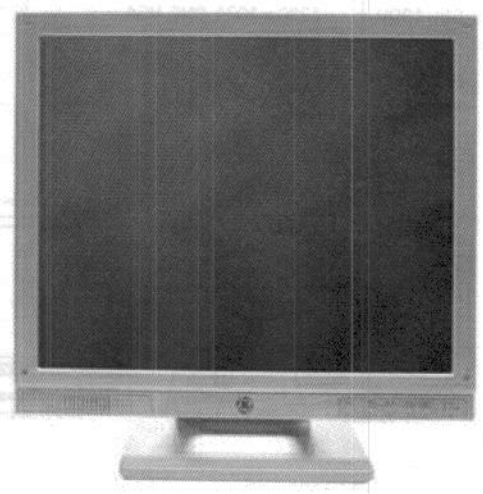

Imagination at work

# TruVision™ Line IR cameras

## Standard-Res Fixed Lens Cameras

- TruVision™ Cam IR Bullet (TVC-BIR-SR)
- TruVision™ Dome IR (TVD-TIR-SR)

## Mid-Res Varifocal Lens Cameras

- TruVision™ Cam IR Bullet (TVC-BIR-MR)
- TruVision™ Dome IR (TVD-TIR-MR)

## High-Res Varifocal Lens Cameras

- TruVision™ Cam IR Bullet (TVC-BIR-HR)
- TruVision™ Dome IR (TVD-TIR-HR)

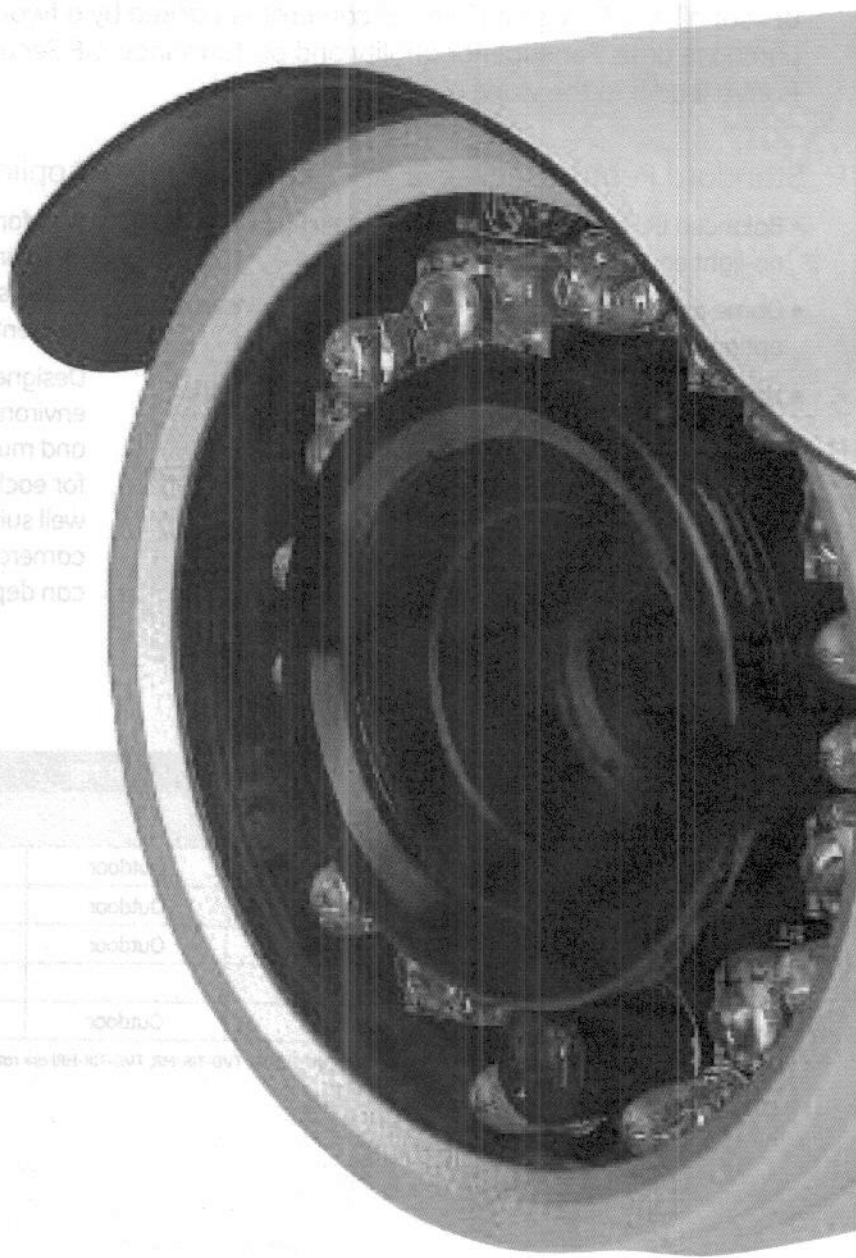







Resolution	Field of View	Mounting	Application
Standard-Res	Fixed	Indoor/Outdoor	General Purpose
Mid-Res	Varifocal	Indoor/Outdoor	Wide Area Monitoring
High-Res	Varifocal	Indoor/Outdoor	High Detail Monitoring



# TruVision™ IR Camera Comparisons



GE SKU	TVC-BIR-SR	TVD-TIR-SR	TVC-BIR-MR	TVD-TIR-MR	TVC-BIR-HR	TVD-TIR-HR
<b>GE Description</b>	 TruVision™ Cam IR Bullet, Standard-Res Fixed Lens Camera, 12VDC only	 TruVision™ Dome IR, Standard-Res Fixed Lens Camera, 12VDC only	 TruVision™ Cam IR Bullet, Mid-Res Varifocal Lens Camera, 24VAC/12VDC	 TruVision™ Dome IR, Mid-Res Varifocal Lens Camera, 12VDC only	 TruVision™ Cam IR Bullet, High-Res Varifocal Lens Camera, 24VAC/12VDC	 TruVision™ Dome IR, High-Res Varifocal Lens Camera, 12VDC only
<b>Pick-up device</b>	1/3" Interline transfer CCD	1/3" Interline transfer CCD	1/3" Interline transfer CCD	1/3" Interline transfer CCD	1/3" Interline transfer CCD	1/3" Interline transfer CCD
<b>Total pixels</b>	NTSC: 537(H) x 505(V) PAL: 537(H) x 505(V)	NTSC: 537(H) x 505(V) PAL: 537(H) x 505(V)	NTSC: 811(H) x 508(V) PAL: 795(H) x 596(V)	NTSC: 811(H) x 508(V) PAL: 795(H) x 596(V)	NTSC: 811(H) x 508(V) PAL: 795(H) x 596(V)	NTSC: 811(H) x 508(V) PAL: 795(H) x 596(V)
<b>Effective pixels</b>	NTSC: 510(H) x 492(V) PAL: 500(H) x 582(V)	NTSC: 510(H) x 492(V) PAL: 500(H) x 582(V)	NTSC: 768(H) x 494(V) PAL: 752(H) x 582(V)	NTSC: 768(H) x 494(V) PAL: 752(H) x 582(V)	NTSC: 768(H) x 494(V) PAL: 752(H) x 582(V)	NTSC: 768(H) x 494(V) PAL: 752(H) x 582(V)
<b>Resolution</b>	380 TV lines	380 TV lines	480 TV lines	480 TV lines	530 TV lines	530 TV lines
<b>Sync. system</b>	2.1 internal	2.1 internal	2.1 internal	2.1 internal	2.1 internal	2.1 internal
<b>Scanning system</b>	NTSC 525 Lines/30 Fields PAL 625 Lines/50 Fields	NTSC 525 Lines/30 Fields PAL 625 Lines/50 Fields	NTSC 525 Lines/30 Fields PAL 625 Lines/50 Fields	NTSC 525 Lines/30 Fields PAL 625 Lines/50 Fields	NTSC 525 Lines/30 Fields PAL 625 Lines/50 Fields	NTSC 525 Lines/30 Fields PAL 625 Lines/50 Fields
<b>S/N ratio</b>	More than 48dB (AGC OFF)	More than 52dB (AGC OFF)	More than 48dB (AGC OFF)	More than 49dB (AGC OFF)	More than 48dB (AGC OFF)	More than 49dB (AGC OFF)
<b>Electronic shutter</b>	Auto 1/60 (1/50)-1/100,000 sec.	Auto 1/60 (1/50)-1/100,000 sec.	Auto 1/60 (1/50)-1/100,000 sec.	Auto 1/60 (1/50)-1/100,000 sec.	Auto 1/60 (1/50)-1/100,000 sec.	Auto 1/60 (1/50)-1/100,000 sec.
<b>Min. illumination</b>	0.4 lux color / F2.0 0.00 lux IR ON	0.4 lux color / F2.0 0.00 lux IR ON	0.3 lux color / F2.0 0.00 lux IR ON	0.3 lux color / F2.0 0.00 lux IR ON	0.5 lux color / F2.0 0.00 lux IR ON	0.5 lux color / F2.0 0.00 lux IR ON
<b>Video output</b>	Composite 1.0 Vp-p / 75 ohm	Composite 1.0 Vp-p / 75 ohm	Composite 1.0 Vp-p / 75 ohm	Composite 1.0 Vp-p / 75 ohm	Composite 1.0 Vp-p / 75 ohm	Composite 1.0 Vp-p / 75 ohm
<b>IR distance</b>	50 ft./15 m (18 pcs IR LED)	33 ft./10 m (14 pcs IR LED)	82 ft./25 m (20 pcs IR LED)	66 ft./20 m (28 pcs IR LED)	180 ft./55 m (40 pcs IR LED)	66 ft./20 m (28 pcs IR LED)
<b>IR trigger</b>	2.6 lux/2.7 lux IR ON/OFF	2.6 lux/2.7 lux IR ON/OFF	2.6 lux/2.7 lux IR ON/OFF	3.1 lux/3.7 lux IR ON/OFF	3.1 lux/3.7 lux IR ON/OFF	3.1 lux/3.7 lux IR ON/OFF
<b>Lens type</b>	Board lens: 4.3 mm	Board lens: 4.3 mm	Varifocal lens: 3.5-12 mm	Varifocal lens: 3.5-8 mm	Varifocal lens: 6-50 mm	Varifocal lens: 3.5-8 mm
<b>Single gang mounting plate</b>	N/A	No	N/A	Yes	N/A	Yes
<b>Power source</b>	12VDC	12VDC	24VAC/12VDC	12VDC	24VAC/12VDC	12VDC
<b>Power consumption</b>	6.0W (Max)	5.9W (Max)	10W (Max)	5.9W (Max)	14.3W (Max)	6.2W (Max)
<b>Current</b>	110mA (IR OFF) 350mA (Max)	110mA (IR OFF) 250mA (Max)	12VDC: 250mA (IR OFF) 12VDC: 740mA (Max) 24VAC: 290mA (IR OFF) 24VAC: 650mA (Max)	120mA (IR OFF) 400mA (Max)	12VDC: 260mA (IR OFF) 12VDC: 1.2A (Max) 24VAC: 290mA (IR OFF) 24VAC: 960mA (Max)	150mA (IR OFF) 430mA (Max)
<b>Weight</b>	11 oz./ .31 kg	14 oz./ .39 kg	26 oz./ .75 kg	26 oz./ .76 kg	33 oz./ .93 kg	26 oz./ .76 kg
<b>Dimensions</b>	2.24 in. (W) x 2.42 in. (H) x 3.95 in. (D) (57 mm x 61.5 mm x 100.3 mm)	3.7 in. (W) x 2.72 in. (H) (94 mm x 69 mm)	2.99 in. (W) x 3.27 in. (H) x 6.14 in. (D) (76 mm x 83 mm x 156 mm)	4.69 in. (W) x 3.25 in. (H) (119 mm x 82.5 mm)	3.46 in. (W) x 3.74 in. (H) x 6.93 in. (D) (88 mm x 95 mm x 176 mm)	4.69 in. (W) x 3.25 in. (H) (119 mm x 82.5 mm)
<b>Operation temperature</b>	-10 to 50° C 14 to 122° F	-10 to 50° C 14 to 122° F	-10 to 50° C 14 to 122° F	-10 to 50° C 14 to 122° F	-10 to 50° C 14 to 122° F	-10 to 50° C 14 to 122° F
<b>Storage temperature</b>	-20 to 70° C -4 to 158° F	-20 to 70° C -4 to 158° F	-20 to 70° C -4 to 158° F	-20 to 70° C -4 to 158° F	-20 to 70° C -4 to 158° F	-20 to 70° C -4 to 158° F
<b>Weather resistant</b>	IP67	IP67	IP67	IP66	IP67	IP66
<b>Regulatory certification</b>	CE/FCC RoHS DecaBDE C-Tick	CE/FCC RoHS DecaBDE C-Tick	CE/FCC RoHS DecaBDE C-Tick	CE/FCC RoHS DecaBDE C-Tick	CE/FCC RoHS DecaBDE C-Tick	CE/FCC RoHS DecaBDE C-Tick

### Overview

The TruVision™ dome camera provides outstanding video surveillance performance while offering a cost-effective security solution. Equipped with a varifocal lens and engineered for superior resolution, this camera delivers crisp, detailed images while being flexible enough to meet the needs of most applications.

Small and lightweight, the TruVision plastic dome camera represents a strong value for users looking for reliable security in smaller venues. With 500TVL color and a 2.6mm–6.0mm autoiris lens, this TruVision dome is well suited to secure a variety of applications including quick-service restaurants, retail and small-business environments.

### Standard Features

- Superior image performance
- 500 TVL color
- Flexible form factor
- Varifocal auto-iris lens
- 0.2 lux @ F2.0
- 2.6mm to 6.0mm AI lens
- 12VDC or 24VAC power input



## TruVision Dome Hi-Res, Varifocal Lens Camera

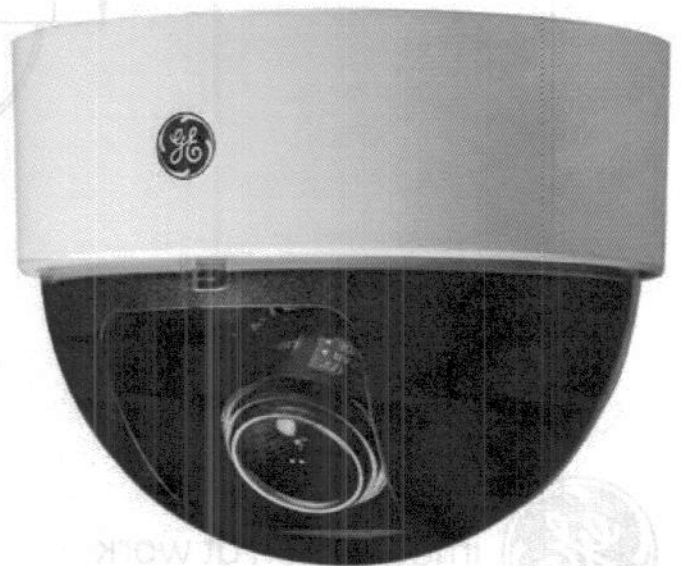

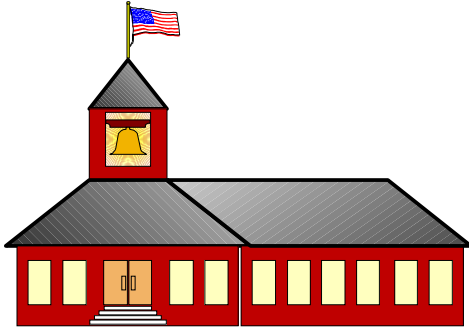

# Morgan County Schools

136 Flat Fork Road

Wartburg, Tennessee 37887

---

Chris R. Rogers – Technology Coordinator

Central Office Phone: (423) 346-6214 FAX: (423) 346-5583

---

## **VTC Bid Review:**

Gallaher's total bid of \$19,950.00 is \$3,625.00 less than Massey Electric's bid of \$23,575.00

Both bids include 32 cameras, DVR, cable installation, microphones in the principal's office and 1 year warranty parts and labor.

We recommend Gallaher. Gallaher has installed all the current camera systems in Oakdale, Central High, Central Elementary, Coalfield, and Sunbright. We also have a Camera Server at the Central Office that this equipment can be intergraded with.

Copies of the bid are available for review. They should also be included in the TSBA board website.

## **PJ Bid Review:**

Gallaher's total bid of \$11,125.00 is \$1,450.00 less than Massey Electric's bid of \$12,575.00

Both bids include 16 cameras, DVR, cable installation, microphones in the principal's office and 1 year warranty parts and labor.

We recommend Gallaher. Gallaher has installed all the current camera systems in Oakdale, Central High, Central Elementary, Coalfield, and Sunbright. We also have a Camera Server at the Central Office that this equipment can be intergraded with.

Copies of the bid are available for review. They should also be included in the TSBA board website.

Thanks,

Chris R. Rogers  
Technology Coordinator  
Morgan County Schools



**MASSEY ELECTRIC**  
C O M P A N Y

March 10, 2010

To: Morgan County Schools  
Attn: Chris Rogers  
Re: Vocational School

Dear Sir,

Thank you for giving Massey Electric the opportunity to quote on this project. We hope that you will find our price acceptable to your budget.

Massey Electric will install a CCTV Camera system that will include (1) Crest Electronics 32 Channel DVR with 4-TB of storage PN. CDVS-7532-4T, (32) Crest Electronics Vandal Proof Dome cameras PN. CP-48ES. (2) Crest Electronics Power Supply PN. CPS-1624AC, (1) Crest Electronics 19" LCD Monitor PN. VGA-19TL and (1) Crest Electronics 1050-VA UPS PN. UPS-1050. All cameras will be connected via a Homerun Siamese RG-59, 18/2 cable from the individual camera back to the power supply and DVR to complete the connection. (1) Microphone will be connected to the DVR and located in the Principal's office for recording conversation upon request.

The indoor cameras will be strategically located in the ceiling for optimum viewing and coverage. The outdoor cameras will be mounted to a wall mount bracket and placed to accommodate the required viewing areas for each camera.

The total cost to complete this work which includes all labor and materials will be **\$23,575.00** this does not include any conduit that maybe required to complete this project.

Additional Cameras will be at a cost of **\$480.00** each for the camera and cabling to connect each camera.

The cabling for this project will cost **\$4450.00** which is included in the total bid.

Please allow 7 working days for materials once the notice to proceed has been given.

This quote is valid for 6 months from the above date.

Massey Electric will provide a One Year warranty from the date of installation that will be backed by Crest electronics.

If you have any questions regarding this quote, please feel free to contact me at your convenience.

Thank you,  
Andy Fadnek, RCDD  
Communications Project Manager  
Massey Electric  
865-273-8139  
865-216-0863



**MASSEY ELECTRIC**  
C O M P A N Y

March 10, 2010

To: Morgan County Schools  
Attn: Chris Rogers  
Re: References for CCTV Systems

Dear Sir,

The following is a list of references and systems that Massey Electric has recently installed:

- 1) Comcast Communications  
5720 Asheville Hwy  
Knoxville, Tn. 37924  
Attn. David Petko  
865-740-7482
- 2) P. Graham Dunn  
606 Parkway  
Gatlinburg, Tn. 37738  
Attn. Peter Graham
- 3) Cherokee Millwright  
1034 Ross Drive  
Maryville, Tn. 37802  
Attn. Dale Pearson  
865-379-1500

Thank you,  
Andy Fadnek, RCDD  
Communications Project Manager  
Massey Electric  
865-273-8139  
865-216-0863

# CP-48 Series 1/3" Color EDR Hi-Res Vandal Dome Cameras



- ☞ 550 lines of resolution
- ☞ 0.3 lux with f1.2 lens
- ☞ Vari-focal auto iris lens,  
2.8 to 11mm (CP-48ES & CP-48DS-36),  
6 to 60mm (CP-48ET)
- ☞ 36 infrared LED array (CP-48DS-36)
- ☞ Selectable on/off back light compensation
- ☞ Selectable on/off gain control
- ☞ Hi-speed auto electronic shutter –  
switchable
- ☞ Dual voltage – 24vAC / 12vDC
- ☞ High impact polycarbonate construction
- ☞ Weatherproof housing (IP-66)
- ☞ Service monitor connection
- ☞ Recessed or surface mount
- ☞ Compact size – 5 3/4" dia x 3 7/8" h

 **CREST**  
ELECTRONICS INC  
Video Security Since 1974

3706 Alliance Drive | Greensboro, NC 27407 | 1-888-50-CREST | [www.crestelectronics.com](http://www.crestelectronics.com)

# Product Data: CP-48 Series 1/3" Color EDR Hi-Res Vandal Domes

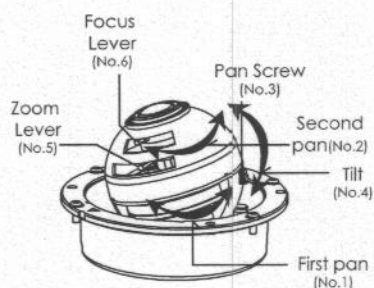
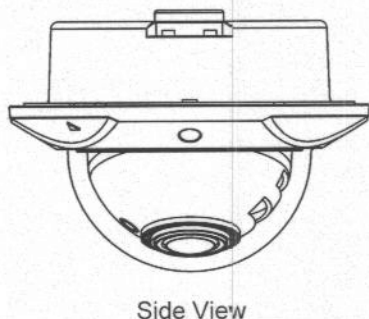
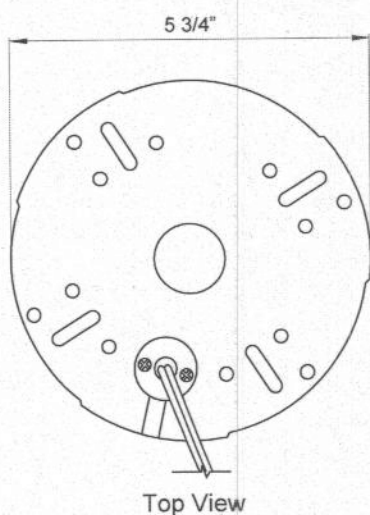

<b>Model Number</b>	<b>CP-48ES, CP-48ET, CP-48DS-36</b>
<b>Image Pick-Up Device</b>	1/3" CCD Sony Super HAD
<b>Effective Picture Elements</b>	NTSC: 768x494 (HxV)
<b>Horizontal Resolution</b>	550 TV Lines
<b>Minimum Illumination</b>	0.3 Lux @ F1.2
<b>S/N Ratio</b>	More than 48dB (AGC Off)
<b>Auto Electronic Shutter</b>	NTSC: 1/60-1/100,000s, ON/OFF Switchable
<b>Auto Iris Control</b>	DC Drive Iris Control
<b>Flickerless Mode</b>	NTSC: 1/100s, ON/OFF Switchable
<b>Gamma Characteristic</b>	0.45
<b>Lens Furnished</b>	2.8-11mm DCAI (ES & DS-36); 6-60mm DCAI (ET)
<b>Focal Length/Aperture Ratio</b>	f=2.8~11mm / F1.2~360 (ES & DS-36); f=6~60mm / F1.2~360 (ET);
<b>Angle Field of View</b>	2.8~11mm = Wide=82.2°x62°; Tele=28.6°x21.5° (ES & DS-36); 6~60mm = Wide=72.0°x54.2°; Tele=4.8°x3.2° (ET);
<b>Auto Gain Control</b>	High / Low Switchable
<b>Auto White Balance</b>	Auto / Manual Selectable
<b>Back Light Compensation</b>	ON/OFF Selectable
<b>Scanning System</b>	Interlace 2:1
<b>Synchronous System</b>	Internal, negative sync
<b>Video Output</b>	1 Vp-p / 75 ohms
<b>Power Supply</b>	DC 12v / AC 24v dual voltage
<b>Power Consumption</b>	DC 12v, 50/60Hz, 180mA; AC 24v, 50/60Hz, 2.7w
<b>Operating Temperature</b>	14 ~ 122°F
<b>Dimensions</b>	5 3/4" dia x 3 7/8" h

<b>IR MODEL SPECIFICATIONS</b>	
<b>Model Number</b>	<b>CP-48DS-36</b>
<b>Infrared Luminary</b>	36 pieces IR LED; 6000 Hrs
<b>Wave Length</b>	850nm
<b>Projection Distance</b>	Up to 30 meters
<b>Illumination Activation Limit</b>	Under 10 lux
<b>Power Consumption</b>	0.7 Amp, 12vDC/24vAC (LED on)

Specifications subject to change

**CREST**  
ELECTRONICS INC  
Video Security Since 1974

# CDVS-7532 Digital Video Recorder

- 32 video inputs with looping outputs
- MPEG4 compression / real-time display
- REAL Hybrid Technology Ready – view and record any combination of 32 IP or analog cameras, simply by utilizing the available CNVS-Hybrid Software Activation Key\*
- 720 x 480 (4 CIF) resolution
- 960fps display and 480fps record rates
- 16 audio channels
- Two-way communication
- Multi-zone motion detection for every camera
- Adjustable sensitivity per motion zone
- Utilizes SATA HDD technology
- Exclusive CrestLink™ multiplatform remote software allows administration of embedded and PC based DVRs & NVRs
- On-site/remote multi-plex operation – view live, record, back-up video & playback – all simultaneously

\* Sold separately

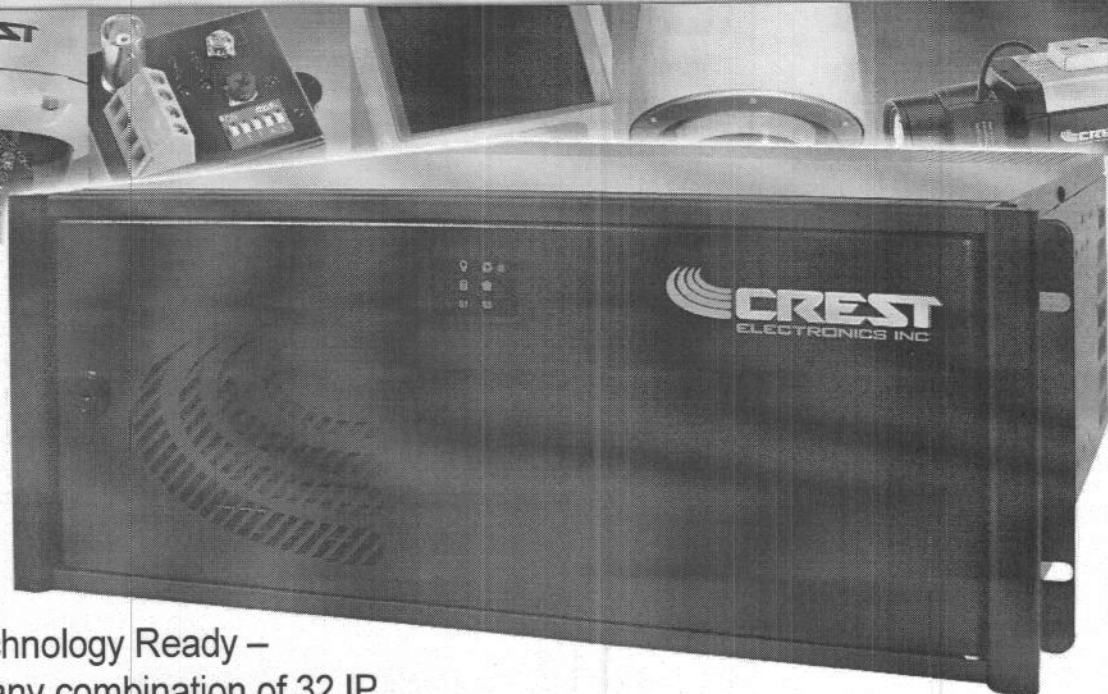

 **CREST**  
ELECTRONICS INC  
**Video Security Since 1974**

3706 Alliance Drive | Greensboro, NC 27407 | 1-888-50-CREST | [www.crestelectronics.com](http://www.crestelectronics.com)

# Product Data: VGA & VMC LCD Monitor Series

Model Number	VGA-17TL	VGA-19TL	VMC-17TLV	VMC-19TLV
Screen Size	17"	19"	17"	19"
Pixel Type	Active Matrix TFT			
Max Resolution	1280x1024 @ 75Hz			
Dot Pitch	0.264mm x 0.264mm			
Brightness	250cd/m2	300cd/m2		
Contrast Ratio	600:1	700:1	1000:1	
Viewing Angle (H/V)	85°/85°		160°/160°	
Display Color	16.2 Million			
Response Time	8 ms		< 5 ms	
Video System	NTSC/PAL			
Panel Lamp Life	40,000 hours			
Video Input	VGA 15 pin		VGA/BNC/S-Video	
Built-in Speakers	Yes	N/A		Yes
VESA Mounting	75mm x 75mm		100mm x 100mm	
Cabinet Dimensions	17 3/4"w x 18 1/2"h x 9 3/8"d	19 3/8"w x 21 5/8"h x 6 1/8"d	15 1/8"w x 13"h x 2 3/8"d	16 7/8"w x 14 5/8"h x 2 3/8"d
Weight	7 lbs, 15 oz	13 lbs, 3 oz	13 lbs, 1 oz	14 lbs, 10 oz
Power Type	110-230vAC (50/60Hz)			
Power Consumption	Max 35w	Max 45w	Max 36w	Max 42w

Specifications subject to change



# VGA & VMC LCD Monitor Series

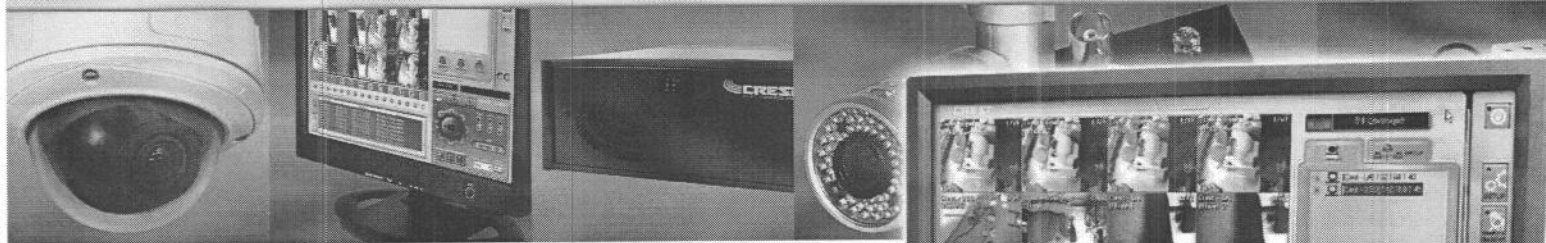

- Hi-definition .264mm dot pitch LCD display
- 17" & 19" screen sizes available
- Easy OSD Menu for adjusting monitor
- Anti-glare & hard-coated glass display screen
- Multiple source inputs on VMC models
- Available with composite input
- Designed specifically for the security CCTV industry

 **CREST**  
ELECTRONICS INC  
Video Security Since 1974

3706 Alliance Drive | Greensboro, NC 27407 | 1-888-50-CREST | [www.crestelectronics.com](http://www.crestelectronics.com)

# CPS-ACS Series Power Supplies

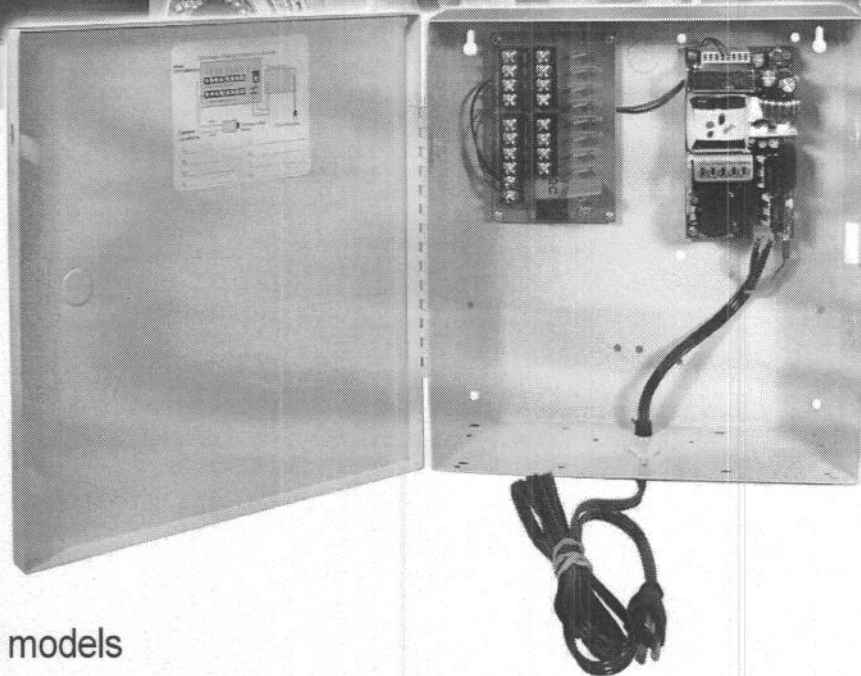
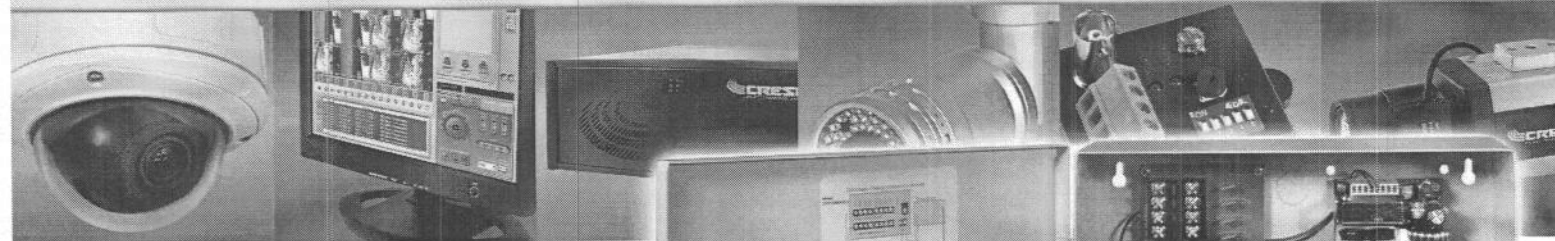

- Available in 4, 8 and 16 output models
- Heavy duty models provide higher amperage outputs for powering high consumption models such as heater/blowers, PTZs, etc.
- Each output individually protected by a self-restoring Smartfuse
- All models UL listed
- Output terminals for both 24 and 28vAC provide greater flexibility in meeting cable length requirements
- Oversized metal cans with multiple knock outs for easy installation

 **CREST**  
ELECTRONICS INC  
Video Security Since 1974

3706 Alliance Drive | Greensboro, NC 27407 | 1-888-50-CREST | [www.crestelectronics.com](http://www.crestelectronics.com)

# Product Data: CPS-ACS Series Power Supplies

	CPS-ACS Series
Model Number	
Input Voltage	110vAC
Available Outputs	4, 8, 16
Output Voltage	24 or 28vAC (individually selectable)
Total Power Output (Amps)	8A (All ACS Models)
Maximum Amps per Output	3A
Surge Protection	Self-restoring Smartfuse
Smartfuse Rating	2A
Output Wire Size	12-22 AWG Solid or Stranded Wire
Dimensions	11 1/4" w x 11 1/4" h x 3 1/2" d (All ACS Models)

*Specifications subject to change*





**MASSEY ELECTRIC**  
C O M P A N Y

March 10, 2010

To: Morgan County Schools  
Attn: Chris Rogers  
Re: Petros-Joyner CCTV System

Dear Sir,

Thank you for giving Massey Electric the opportunity to quote on this project. We hope that you will find our price acceptable to your budget.

Massey Electric will install a CCTV Camera system that will include (1) Crest Electronics 16 Channel DVR with 3-TB of storage PN. CDVS-7316-3T, (16) Crest Electronics Vandal Proof Dome cameras PN. CP-48ES. (1) Crest Electronics Power Supply PN. CPS-1624AC, (1) Crest Electronics 19" LCD Monitor PN. VGA-19TL and (1) Crest Electronics 900-VA UPS PN. UPS-900. All cameras will be connected via a Homerun Siamese RG-59, 18/2 cable from the individual camera back to the power supply and DVR to complete the connection. (1) Microphone will connected to the DVR and located in the Principal's for recording conversation upon request.

The indoor cameras will be strategically located in the ceiling for optimum viewing and coverage. The outdoor cameras will be mounted to a wall mount bracket and placed to accommodate the required viewing areas for each camera.

The total cost to complete this work which includes all labor and materials will be **\$12,575.00** this does not include any conduit that maybe required to complete this project.

Additional Cameras will be at a cost of **\$480.00** each for the camera and cabling to connect each camera.

The cabling for this project will cost **\$2365.00** which is included in the total bid.

Please allow 7 working days for materials once the notice to proceed has been given.

This quote is valid for 6 months from the above date.



**MASSEY ELECTRIC**  
C O M P A N Y

March 10, 2010

To: Morgan County Schools  
Attn: Chris Rogers  
Re: References for CCTV Systems

Dear Sir,

The following is a list of references and systems that Massey Electric has recently installed:

- 1) Comcast Communications  
5720 Asheville Hwy  
Knoxville, Tn. 37924  
Attn. David Petko  
865-740-7482
- 2) P. Graham Dunn  
606 Parkway  
Gatlinburg, Tn. 37738  
Attn. Peter Graham
- 3) Cherokee Millwright  
1034 Ross Drive  
Maryville, Tn. 37802  
Attn. Dale Pearson  
865-379-1500

Thank you,  
Andy Fadnek, RCDD  
Communications Project Manager  
Massey Electric  
865-273-8139  
865-216-0863

# CP-48 Series 1/3" Color EDR Hi-Res Vandal Dome Cameras



- ☞ 550 lines of resolution
- ☞ 0.3 lux with f1.2 lens
- ☞ Vari-focal auto iris lens,  
2.8 to 11mm (CP-48ES & CP-48DS-36),  
6 to 60mm (CP-48ET)
- ☞ 36 infrared LED array (CP-48DS-36)
- ☞ Selectable on/off back light compensation
- ☞ Selectable on/off gain control
- ☞ Hi-speed auto electronic shutter –  
switchable
- ☞ Dual voltage – 24vAC / 12vDC
- ☞ High impact polycarbonate construction
- ☞ Weatherproof housing (IP-66)
- ☞ Service monitor connection
- ☞ Recessed or surface mount
- ☞ Compact size – 5 3/4" dia x 3 7/8" h

 **CREST**  
ELECTRONICS INC  
Video Security Since 1974

3706 Alliance Drive | Greensboro, NC 27407 | 1-888-50-CREST | [www.crestelectronics.com](http://www.crestelectronics.com)

# Product Data: CP-48 Series 1/3" Color EDR Hi-Res Vandal Domes

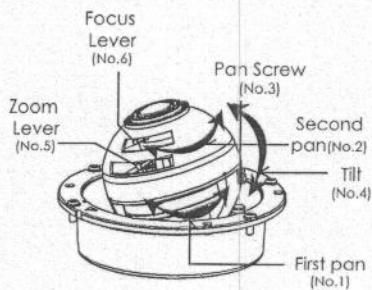
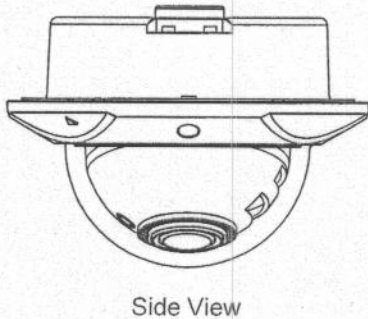
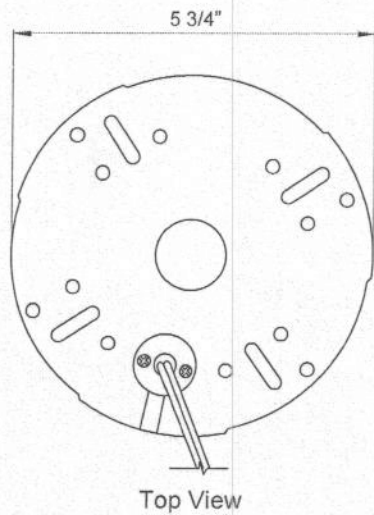

Model Number	CP-48ES, CP-48ET, CP-48DS-36
Image Pick-Up Device	1/3" CCD Sony Super HAD
Effective Picture Elements	NTSC: 768x494 (HxV)
Horizontal Resolution	550 TV Lines
Minimum Illumination	0.3 Lux @ F1.2
S/N Ratio	More than 48dB (AGC Off)
Auto Electronic Shutter	NTSC: 1/60-1/100,000s, ON/OFF Switchable
Auto Iris Control	DC Drive Iris Control
Flickerless Mode	NTSC: 1/100s, ON/OFF Switchable
Gamma Characteristic	0.45
Lens Furnished	2.8-11mm DCAI (ES & DS-36); 6-60mm DCAI (ET)
Focal Length/Aperture Ratio	f=2.8~11mm / F1.2~360 (ES & DS-36); f=6~60mm / F1.2~360 (ET);
Angle Field of View	2.8~11mm = Wide=82.2°x62°; Tele=28.6°x21.5° (ES & DS-36); 6~60mm = Wide=72.0°x54.2°; Tele=4.8°x3.2° (ET);
Auto Gain Control	High / Low Switchable
Auto White Balance	Auto / Manual Selectable
Back Light Compensation	ON/OFF Selectable
Scanning System	Interlace 2:1
Synchronous System	Internal, negative sync
Video Output	1 Vp-p / 75 ohms
Power Supply	DC 12v / AC 24v dual voltage
Power Consumption	DC 12v, 50/60Hz, 180mA; AC 24v, 50/60Hz, 2.7w
Operating Temperature	14 ~ 122°F
Dimensions	5 3/4" dia x 3 7/8" h

Model Number	CP-48DS-36
Infrared Luminary	36 pieces IR LED; 6000 Hrs
Wave Length	850nm
Projection Distance	Up to 30 meters
Illumination Activation Limit	Under 10 lux
Power Consumption	0.7 Amp, 12vDC/24vAC (LED on)

## IR MODEL SPECIFICATIONS

Model Number	CP-48DS-36
Infrared Luminary	36 pieces IR LED; 6000 Hrs
Wave Length	850nm
Projection Distance	Up to 30 meters
Illumination Activation Limit	Under 10 lux
Power Consumption	0.7 Amp, 12vDC/24vAC (LED on)

Specifications subject to change

**CREST**  
ELECTRONICS INC  
Video Security Since 1974

# VGA & VMC LCD Monitor Series

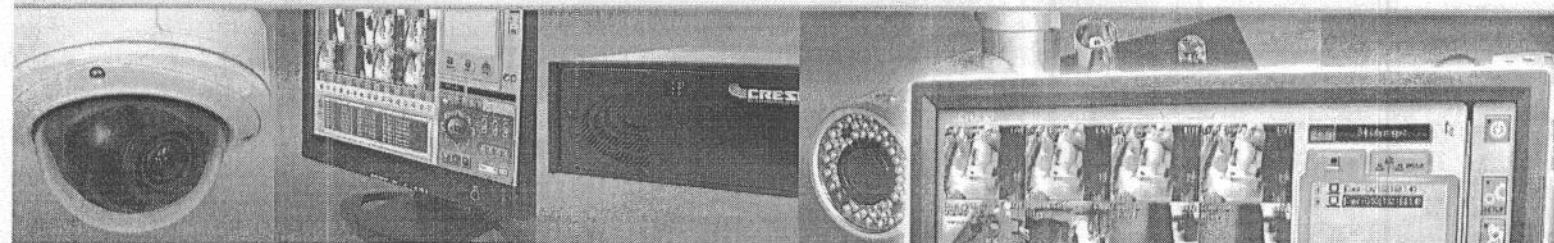

- Hi-definition .264mm dot pitch LCD display
- 17" & 19" screen sizes available
- Easy OSD Menu for adjusting monitor
- Anti-glare & hard-coated glass display screen
- Multiple source inputs on VMC models
- Available with composite input
- Designed specifically for the security CCTV industry

 **CREST**  
ELECTRONICS INC  
Video Security Since 1974

3706 Alliance Drive | Greensboro, NC 27407 | 1-888-50-CREST | [www.crestelectronics.com](http://www.crestelectronics.com)

# Product Data: VGA & VMC LCD Monitor Series

Model Number	VGA-17TL	VGA-19TL	VMC-17TLV	VMC-19TLV
Screen Size	17"	19"	17"	19"
Pixel Type	Active Matrix TFT			
Max Resolution	1280x1024 @ 75Hz			
Dot Pitch	0.264mm x 0.264mm			
Brightness	250cd/m2	300cd/m2		
Contrast Ratio	600:1	700:1	1000:1	
Viewing Angle (H/V)	85°/85°		160°/160°	
Display Color	16.2 Million			
Response Time	8 ms		< 5 ms	
Video System	NTSC/PAL			
Panel Lamp Life	40,000 hours			
Video Input	VGA 15 pin		VGA/BNC/S-Video	
Built-In Speakers	Yes		N/A	Yes
VESA Mounting	75mm x 75mm		100mm x 100mm	
Cabinet Dimensions	17 3/4"w x 18 1/2"h x 9 3/8"d	19 3/8"w x 21 5/8"h x 6 1/8"d	15 1/8"w x 13"h x 2 3/8"d	16 7/8"w x 14 5/8"h x 2 3/8"d
Weight	7 lbs, 15 oz	13 lbs, 3 oz	13 lbs, 1 oz	14 lbs, 10 oz
Power Type	110-230vAC (50/60Hz)			
Power Consumption	Max 35w	Max 45w	Max 36w	Max 42w

Specifications subject to change



# CDVS-7316 Digital Video Recorder

- 16 video inputs with looping outputs
- MPEG4 compression / real-time display
- REAL Hybrid Technology Ready – view and record any combination of 16 IP or analog cameras, simply by utilizing the available CNVS-Hybrid Software Activation Key\*
- 720 x 480 (4 CIF) resolution
- 480fps display/240fps record rate
- 16 audio channels
- Two-way communication
- Multi-zone motion detection for every camera
- Adjustable sensitivity per motion zone
- Utilizes SATA HDD technology
- Exclusive CrestLink™ multiplatform remote software allows administration of embedded and PC based DVRs & NVRs
- On-site/remote multi-plex operation – view live, record, back-up video & playback – all simultaneously

\* Sold separately

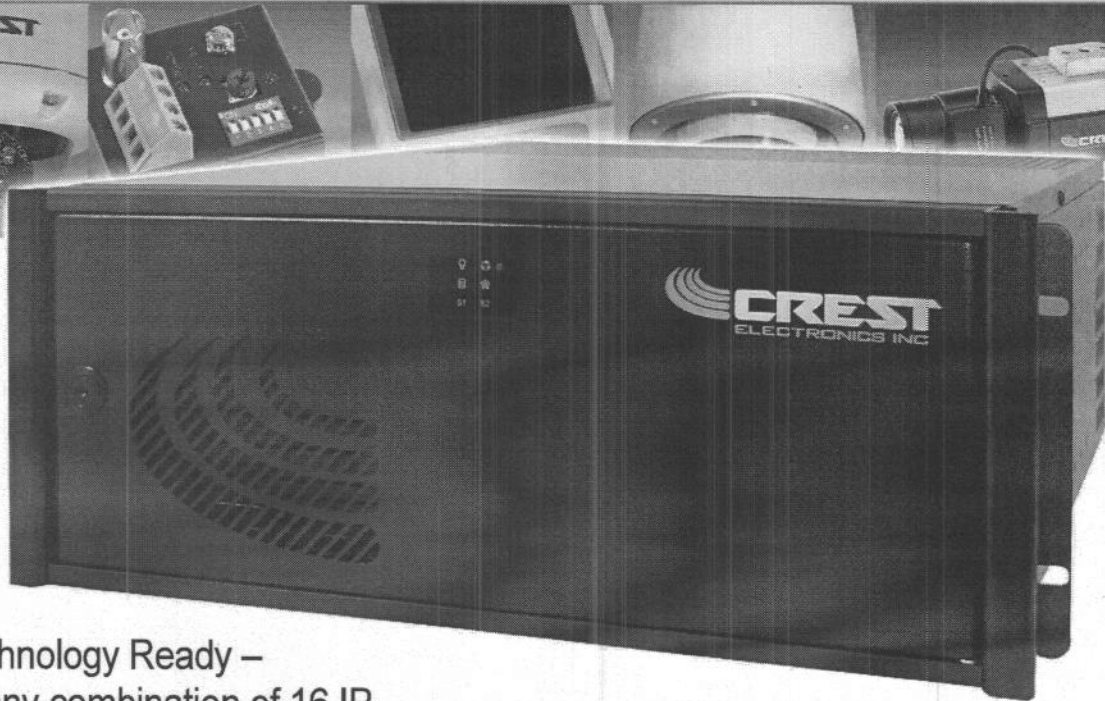

 **CREST**  
ELECTRONICS INC  
Video Security Since 1974

3706 Alliance Drive | Greensboro, NC 27407 | 1-888-50-CREST | [www.crestelectronics.com](http://www.crestelectronics.com)

# CPS-ACS Series Power Supplies

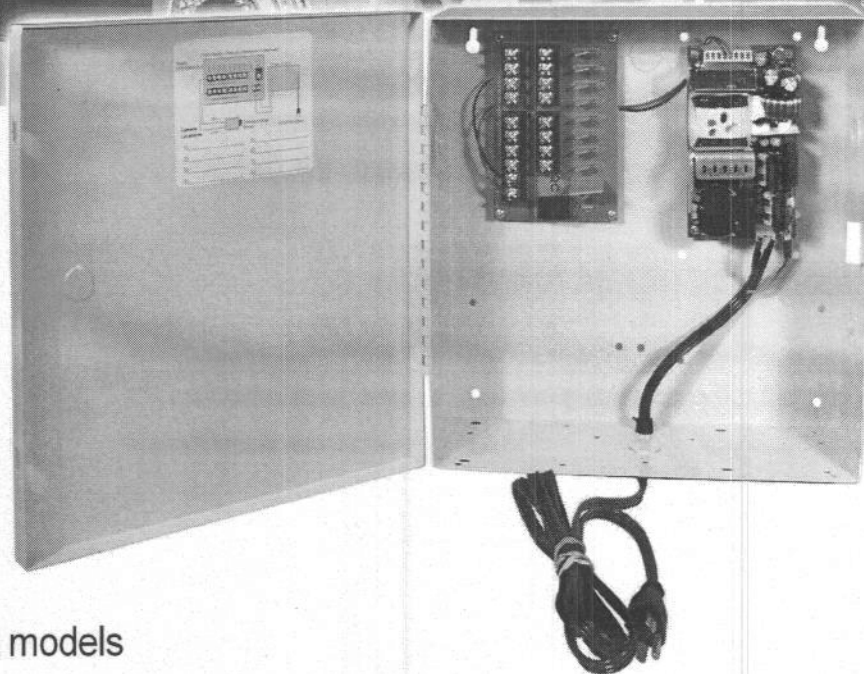

- Available in 4, 8 and 16 output models
- Heavy duty models provide higher amperage outputs for powering high consumption models such as heater/blowers, PTZs, etc.
- Each output individually protected by a self-restoring Smartfuse
- All models UL listed
- Output terminals for both 24 and 28vAC provide greater flexibility in meeting cable length requirements
- Oversized metal cans with multiple knock outs for easy installation

 **CREST**  
ELECTRONICS INC

**Video Security Since 1974**

3706 Alliance Drive | Greensboro, NC 27407 | 1-888-50-CREST | [www.crestelectronics.com](http://www.crestelectronics.com)

# Product Data: CPS-ACS Series Power Supplies

	CPS-ACS Series
Model Number	
Input Voltage	110vAC
Available Outputs	4, 8, 16
Output Voltage	24 or 28vAC (individually selectable)
Total Power Output (Amps)	8A (All ACS Models)
Maximum Amps per Output	3A
Surge Protection	Self-restoring Smartfuse
Smartfuse Rating	2A
Output Wire Size	12-22 AWG Solid or Stranded Wire
Dimensions	11 1/4"w x 11 1/4"h x 3 1/2"d (All ACS Models)

*Specifications subject to change*



## BID PROPOSAL SUMMARY PAGE

**Bid Opening March 11, 2010 @ 10:00 a.m.**

**Morgan County Schools, Central Office**

Company #1:	Gallaher & Associates, Inc. 3351 Regal Drive, Alcoa, TN 37701 Phone: 865-970-2471 Fax: 865-970-7889
Company #2:	Massey Electric Company 3204 Regal Drive, Alcoa, TN 37701 Phone: 865-573-4200 Fax: 865-577-7671
Project Name:	Security Camera System for Petros Joyner and MCCTC Schools
Bid from Company #1	\$19,950 – MCCTC \$11,125 – Petros Joyner
Bid from Company #2	\$23,575 – MCCTC \$12,575 – Petros Joyner

**Present:**

**Andy Fadnek – Massey Electric**  
**Ronnie Wilson**  
**Gary Howard – Finance Director**  
**Chris Roger**

**James Burgess**  
**Brian Peddicord**  
**Vickie Bullen**





February 25, 2010

TO: **Morgan County Board of Education**  
**136 Flat Fork Road**  
**Wartburg, TN 37887**

RE: **Scope of Services – Septic System - Coalfield School**

FROM: **Aero-Mod, Inc. - Manhattan, Kansas**

CC: **Tim Kazmier – Kazmier & Associates**

The following scope of services is based upon past drawings and site visits to the facility. Aero-Mod proposes to provide the following equipment for the referenced project. The equipment is quoted FOB with freight allowed to the job site. Off-loading of the equipment on-site will be the responsibility of the general contractor and will require a crane to be on-site upon the arrival of the equipment. **NO SALES TAX is included in the pricing.**

Unless otherwise noted, all bolts and brackets required to install the equipment are supplied. The following items are **not** included in our scope of services and are to be supplied by others.

1. **Locally supplied PVC materials, if necessary, to replace any defective existing piping.**
2. **Any yard and or interior piping that is DIP, steel, or galvanized.**
3. **Electrical connections.**

**Labor, installation materials and tools, and all exterior yard piping are not included in our pricing. No field painting or field welding is required with the equipment.**

Included as part of our Scope of Services is mechanical start-up of the equipment and also operator training.

### **Mechanical Start-up Services**

An Aero-Mod representative will be on site at the time of the installation of the new ClarAstor clarifier module. We estimate a maximum of two days to remove the existing module and install the new ClarAstor and associated control panel. Upon completion of the installation, training on the new control panel will be conducted. Aero-Mod personnel will do on-site review of the operational procedures for the plant at this time.

If any additional trips are requested for assistance to the operator or to train new operators, then additional days and/or trips will be charged at a \$500/day rate plus travel expenses.

## **TREATMENT PLANT EQUIPMENT**

### **I. Clarifier Module**

- (1) ClarAator clarifier, Model 2090 as provided by Aero-Mod. This equipment is installed in the aeration tank and will perform the operations of clarification, sludge return, skimmer as well as aeration. The module is equipped with aluminum grating and a two-rail aluminum handrail system. Six (6) model WA-PS2 aerators will be included with the module. Each aerator will have two (2) 12" stainless steel coarse bubble diffusers. The module will be fully fabricated and ready to set on the walls of the existing tank. Skimmers integral to the clarification portion are included.

#### **The contractor will need to:**

1. Disconnect pipe and pneumatic tubing connections and remove old clarifier module from aeration basin.
2. Install new clarifier module and anchor to wall.
3. Re-connect one (1) PVC air pipe connection
4. Re-connect one PVC effluent pipe connection
5. Run new nylon tubing from the plant control panel to the RAS pneumatic valve and WAS pneumatic valve.

### **II. Controls**

- (1) Plant Control Panel, Model CC-100. This NEMA 4X panel will control the Aero-Mod process. The panel requires 110 V power. The panel will activate solenoid valves contained within the panel. Timers to control the RAS and WAS actuated valves are included in the panel.
- (1) An air compressor and desiccant tower will supply dry air to the pneumatic system. The air compressor and desiccant tower will be located in the Plant Control Panel. An auto-drain will also be supplied within this panel to keep the compressor tank empty.

#### **The contractor will need to:**

1. Remove existing plant control panel and install new plant control panel. The new panel will be larger, and may be "floor-standing", and will need to be supported by the existing uni-strut.
2. Bring 110V / 15 A service to the panel.

### III. Screening Equipment

- (1) An aluminum influent screen rack will be supplied, which will bolt to the wall of the equalization basin over the inlet pipe. The rack itself will be a retrievable basket that can be brought to the surface for cleaning on a guiderail. The guiderail and supports will bolt to the concrete wall with 1/2" stainless steel expansion bolts (supplied by Aero-Mod).
- (1) A davit crane and wall mounted base will be supplied for retrieval of the influent screen rack basket.

#### The contractor will need to:

1. Install influent screen rack to wall over the influent pipe to the equalization basin.
2. Install davit crane base to wall near influent screen rack.

### IV. Wall-Mounted Handrail

- (LS) Approximately **80** LF of two-rail aluminum handrail for the aeration basin. A 1-1/2" NU-Rail aluminum handrail system will be used, which will be the same as the handrail used on the ClarAstor clarifier mentioned above. Surface mount sockets will be used for mounting to the tankage wall. At the intersection with the ClarAstor clarifier, the handrail will tie into the clarifier's handrail.

#### The contractor will need to:

1. Install surface-mount handrail sockets with supplied anchor bolts.
2. Assembly and install handrail around tankage.
3. Connect wall-mounted handrail to handrail on ClarAstor clarifier.

### IV. Miscellaneous

- (LS) All required SS wall brackets and U-bolts for installation of the Aero-Mod supplied equipment.
- (LS) Nylon pneumatic tubing to be run from plant control panel to the RAS pneumatic valve and WAS pneumatic valve.
- (6) O&M Manuals

**ANY ITEMS NOT LISTED ABOVE ARE NOT INCLUDED IN OUR PRICE**

### Equipment Pricing

This Scope of Supply does not include the installation of the equipment listed in this document. AERO-MOD will supply all of the aforementioned equipment and start-up services including freight to the jobsite for the lump sum of **\$72,900.00**.

**Equipment Delivery**

Equipment will be ready for shipment within 8 weeks of purchase order and approved submittal drawings.

**Payment Terms**

Terms shall be 90% due within 30 days of equipment delivery to jobsite.

The remaining 10% balance shall be due within 30 days of the equipment startup.

**Standard Terms and Conditions of Sale**

Aero-Mod's standard Terms and Conditions of Sale, as stated on the attached sheets, shall apply.

If you have any questions concerning this scope, please feel free to call our office.

Respectfully Submitted,



Todd L. Steinbach, PE  
Regional Sales Manager, Aero-Mod, Inc.

Accepted by the Morgan County Board of Education this \_\_\_\_\_ day of  
\_\_\_\_\_, 2010

By: \_\_\_\_\_

Printed: \_\_\_\_\_

Title: \_\_\_\_\_

## Terms and Conditions of Aero-Mod, Inc. ("Seller")

1. **Pricing Policies.** All prices are good until June 4, 2010. After that date, the pricing is subject to change without notice and shall not be binding on Seller until reduced to writing and signed by Seller. All orders are subject to written acceptance and approval by an authorized representative of Seller. All prices are F.O.B. to the job site. Prices quoted include standard packing according to Seller's specifications. All costs and taxes for special packing requested by Purchaser, including packing for exports, shall be paid by Purchaser as an additional charge.

2. **Taxes.** The price for the goods does not include any applicable sales, use, excise, GST, VAT, or similar tax. The purchaser shall have the responsibility for the payment of such taxes if applicable.

3. **Payment Terms.** See Scope of Services.

4. **Effect of Purchaser's Financial Condition.** If, during the performance of the contract with Purchaser, the financial responsibility or condition of Purchaser is such that Seller in good faith deems itself insecure, or if Purchaser becomes insolvent, or if a material change in the ownership of the Purchaser occurs, or if Purchaser fails to make any payments in accordance with the terms of its contract with Seller, then, in any such event, Seller is not obligated to continue performance under the contract and may stop goods in transit and defer or decline to make delivery of goods, except upon receipt of satisfactory security or cash payments in advance, or Seller may terminate the order without further obligation to Purchaser whatsoever. If the Purchaser fails to make payments or fails to furnish security satisfactory to Seller then Seller shall also have the right to enforce payment to the full contract price of the work completed and in process. Upon default by Purchaser in payment when due, Purchaser shall immediately pay to Seller the entire unpaid amounts for any and all shipments made to Purchaser irrespective of the terms of said shipment and whether said shipments are made pursuant to this proposal or any other contract of sale between Seller and Purchaser, and Seller may withhold all subsequent shipments until the full amount is settled. Acceptance by the Seller of less than full payment shall not be a waiver of any of its rights hereunder.

5. **Risk of Loss, Title.** The risk of loss of the goods shall pass to the Purchaser as soon as they are deposited with the carrier for shipment to the Purchaser, but title to the goods shall remain in the Seller until the full purchase price therefor has been paid, unless otherwise agreed by Seller.

6. **Shipment.** Any stated shipment or delivery dates are approximate only and are contingent upon purchaser's prompt acceptance of Seller's offer. Seller will use every reasonable effort to meet estimated shipment or delivery dates. Seller's obligation with respect to shipment of the goods shall not extend beyond a) putting the goods in the possession of a suitable carrier and making a contract for the transportation thereof as may be reasonable, having due regard for the nature of the goods and b) delivering, within a reasonable time, such documents as may be necessary for Purchaser to obtain possession of the goods. Seller shall have the right to ship all of the goods at one time or in portions from time to time within the shipment period. This contract shall be deemed separable as to the goods sold. Purchaser may not refuse to accept any lot or portion of the goods shipped hereunder on the grounds that there has been a failure to ship any other lot or that goods in any other lot were nonconforming. Any such default by Seller will not substantially impair the value of this contract as a whole and will not constitute a breach of the contract as a whole.

7. **Testing, Inspection, and Acceptance.** Purchaser shall have the right to inspect the goods upon their receipt. Purchaser's failure to inspect the goods or failure to notify the Seller in writing that the goods are nonconforming within ten (10) days of their receipt, shall constitute a waiver of Purchaser's right to inspect and/or reject the goods for nonconformity and shall be equivalent to an irrevocable acceptance of the goods by Purchaser.

8. **Seller's Performance.** Seller shall not be responsible or liable for any delay directly or indirectly resulting from or contributed by limitations on Seller's production capabilities beyond its reasonable control, or to delays due to fires, explosions, acts of God, strikes or other differences with workers, shortage of utility, facility, components or labor, delay in transportation, breakdown or accident, war and acts of war, compliance with or actions taken to carry out the intent or purposes of any law or regulation, changes in goods or materials, or any other causes or contingencies not caused by Seller or over which Seller had no reasonable control. In the event that any one or more deliveries hereunder is suspended or delayed by reason of any one or more of the occurrences or contingencies stated above, any and all deliveries so suspended or delayed shall be made after such occurrences or contingencies have ceased to exist, and nothing herein contained shall be construed in any way as lessening the full amount of goods herein being purchased and sold, but only as deferring delivery and payment on the event(s) and to the extent herein provided for. Neither shall any delay in shipment be considered as a default under this contract nor

give rise to any liability on the part of Seller for any incidental, special or consequential damage.

9. **Statement of Limited Warranty; Disclaimer and Limitation of Remedies.** Seller warrants that the goods purchased hereunder (with the exception of membranes, seals, gaskets, elastomer materials, coatings and "wear parts" all of which are not warranted) will be built in accordance with the specifications referred to in this quotation of confirmation of sale, as the case may be, and will be free from defects in material and workmanship for a period of one (1) year from the date of installation or eighteen (18) months from the date of shipment, whichever shall occur first. Seller warrants the clarifier equipment purchased hereunder will be free from defects in material and workmanship for a period of five (5) years from the date of installation or five and one-half (5 ½) years from the date of shipment, whichever shall occur first. In no event shall Seller be liable for any loss, damage, injury or expense, resulting from the use or operation of, or from the erosion or corrosion of the goods or from ordinary wear and tear of the goods unless otherwise agreed in writing. Parts or products manufactured by others and provided by Seller are warranted only to the extent of the manufacturer's original warranty. Seller makes no independent warranty or representation with respect to these products.

Purchaser must give written notice to Seller of any defects in material or workmanship of warranted goods within ten (10) days of the date when any defects are first manifest. **UPON SUCH NOTICE, THE SOLE RESPONSIBILITY OF SELLER UNDER THIS LIMITED WARRANTY SHALL BE TO REPAIR OR REPLACE, AT ITS OPTION, A DEFECT IN THE MATERIAL OR WORKMANSHIP DURING THE WARRANTY PERIOD. ALL LABOR REQUIRED TO MAKE SUCH REPAIRS OR REPLACEMENT SHALL BE MADE BY PURCHASER AND AT PURCHASER'S EXPENSE UNLESS OTHERWISE AGREED IN WRITING.**

This limited warranty is void unless the installation, operation and maintenance of the goods are done in accordance with the Seller's instructions. Further, Seller's warranty is void if Purchaser makes any repairs to the goods without Seller's prior written authorization.

**THE FOREGOING WARRANTY IS EXCLUSIVE AND IN LIEU OF ALL OTHER EXPRESS OR IMPLIED WARRANTIES, GUARANTIES, AGREEMENTS, CONDITIONS OR REPRESENTATIONS MADE BY ANY PERSON WITH RESPECT TO THE GOODS COVERED BY THIS OFFER, INCLUDING ANY IMPLIED WARRANTY OF MERCHANTABILITY OR FITNESS FOR A PARTICULAR PURPOSE WHICH ARE HEREBY SPECIFICALLY DISCLAIMED. IN NO CASE WILL SELLER BE LIABLE FOR ANY DIRECT, INDIRECT, SPECIAL, INCIDENTAL OR CONSEQUENTIAL DAMAGES RESULTING FROM A BREACH OF WARRANTY OR ANY OTHER CAUSE INCLUDING, BUT NOT LIMITED TO, LOSS OF USE OF THE PRODUCT, LOSS OF TIME, INCONVENIENCE, INJURY, LOSS OR DAMAGE TO PERSON OR PROPERTY, COMMERCIAL LOSS, LOSS OF PROFITS, LIABILITIES OF PURCHASER TO ITS CUSTOMERS OR THIRD PERSONS OR OTHER MATTERS NOT SPECIFICALLY STATED, WHETHER BASED ON CONTRACT, TORT OR ANY OTHER LEGAL THEORY.**

It is specifically agreed that any action for breach of warranty or other action against Seller under this contract shall be commenced within one (1) year and one (1) day after such cause of action accrued.

10. **Installation and Start-up.** Unless otherwise agreed to in writing by Seller, installation shall be the sole responsibility of Purchaser. Where start-up service is required with respect to the goods purchased hereunder, it must be performed by Seller's authorized personnel or agents, otherwise, Seller's limited warranty is void. In the event Purchaser has engaged Seller to provide an engineer for start-up supervision, such engineer will function in supervisory capacity only and Seller shall have no responsibility for the quality of workmanship of the installation. In any event, Purchaser understands and agrees that it shall furnish, at Purchaser's expense, all necessary foundations, supplies, labor and facilities which might be required to install and operate the equipment.

11. **Cancellation.** No order may be canceled unless requested in writing by either party and accepted in writing by the other. In the event of a cancellation by Purchaser, Purchaser shall, within thirty days of such cancellation, pay Seller a cancellation fee which shall include all costs and expenses incurred by Seller prior to the receipt of the request for cancellation including, but not limited to, all commitments to its suppliers, subcontractors and others, all labor and overhead expended by Seller in the preparation of the Equipment prior to the cancellation, plus an amount equal to 15% of the aggregate of all the foregoing.

12. **Specifications.** Changes in specifications requested by Purchaser are subject to approval in writing by Seller. In the event such changes are approved, the price for the goods and the delivery schedule shall be changed to reflect such changes.

## BID PROPOSAL SUMMARY PAGE

Company:	Jack Southard Company 278 Joe Byrd Lane Clinton, TN 37716 Phone: (865) 457-0012 Fax: (865) 457-9950
Project Name:	Septic System Coalfield School
Date Submitted:	03/05/2010
Base Bid Amount:	
Bid #1 Amount:	Installation Only \$12,500
Bid #2 Amount:	Equipment and Labor (price to include sales tax \$101,950.00
Bid #3 Amount:	

**Bid Opening March 5, 2010 @ 9:00 a.m.  
Morgan County Schools, Central Office**

**Employees Present:**

**Vickie Bullen  
Gary Howard  
Jim Aytes  
Glinn Phillips  
Edd Diden**

### Teachers Recommended for Tenure (2009-10)

		Hire Date
<u>Crystal Tompkins</u>	CES	08/06/2007
Sara Goss	CHS	07/09/2007
<u>Laura Stowers</u>	CHS	06/29/2007
Shirley Quigley	CMS	08/06/2007
Renee Gamble Davis	CMS	08/20/2007
<u>Erin Clabough</u>	CMS	08/20/2007
Robert Bennett	Coalfield	10/15/2007
Jennifer Laurendine	Coalfield	07/23/2007
Stacie Shanks	Coalfield	08/09/2007
<u>Steffany Korte</u>	Coalfield	10/20/2007
Buddy Tharp	MCCTC	08/06/2007
<u>Jocelyn Potter</u>	MCCTC	08/06/2007
Jim Morris	Oakdale	07/20/2007
Tessa Tate Headrick	Oakdale	08/13/2007
Jeffery Kidd	Oakdale	08/06/2007
<u>Kate Hale</u>	Oakdale	08/09/2007
Erin Chapman Miller	Petros Joyner	08/06/2007
Star Adcock	Petros Joyner	08/13/2007
<u>Susan Chamblee Bates</u>	Petros Joyner	08/06/2007
Marty Maxfield	Sunbright	08/09/2007
Paula Winn	Sunbright	08/06/2007
Tara Y. England	Sunbright	07/07/2006
<u>Dwight Hamby</u>	Sunbright	08/05/2005

## **Morgan County Schools Mental Health Policy**

The Morgan County School Board of Education recognizes that the social and emotional wellbeing of students should be addressed and promoted in order to maximize academic achievement. In accordance with this principle, protocols and policies will be adopted that address the prevention, early identification, referral, and follow up of student mental health needs.

The Mental Health Policy is designed to improve student achievement by reducing fragmentation of services and aligning and integrating mental health services to children. The policy addresses the infrastructure necessary to coordinate, improve, and evaluate support programs currently offered in school and in the community. It does not require new program development, but calls on our school system to consider how best to support resilience in youth, identify students who need mental health support, and provide a family driven and seamless integration within established community systems of care.

1. The Morgan County Schools will align systems and available resources to enable all pupils to have an equal opportunity for success at school by addressing barriers to and promoting engagement in learning and teaching. This includes prevention, early intervention, referral and follow up policies and procedures within a system of care.<sup>1</sup>

2. The Morgan County School system shall develop and maintain a positive school climate in all schools ensuring a global approach to addressing barriers to learning and promoting resilience in children. Current laws regarding the prevention of hazing, bullying, and intimidation will be fully implemented as an essential element in the protection of student mental health and the fostering of a positive school climate.<sup>2</sup>

3. According to the Tennessee Comprehensive School Counseling Model and other curriculum standards<sup>3</sup>, Morgan County School staff will provide students with effective early intervention activities such as social and emotional learning, positive behavior supports and strength-based developmental assets.

4. School personnel shall create a plan whereby appropriate staff can provide proactive on-site support services to students having social, emotional, and mental health concerns, including those students that do not meet criteria for special education services.<sup>4</sup>

5. The Morgan County School administration will require staff and administrators to attend professional development on how to identify warning signs of emotional and behavioral barriers to learning, how to address such barriers, and promote engagement in learning.<sup>5</sup> School staff new to the district shall receive this professional development in a timely manner.

6. Morgan County School staff will utilize clearly identified referral protocols for in-school student support that is easily accessible to all students, families, and school personnel. Intentional effort will be made to reduce stigma, keep the

referral process simple and user friendly, and provide a variety of strategies to assist students in need.

7. Memorandums of Understanding (MOUs) between schools and community resources will be created to enable effective linkages for services. These MOUs will include agreements regarding the responsibility of both entities with respect to working together (e.g. formal linkages, weaving resources together, sharing information, making and accepting referrals, intervention during and after a crisis).<sup>6</sup> The MOUs will be reviewed and updated as needed.

8. Consistent with HIPAA<sup>7</sup> and FERPA<sup>8</sup> standards, all materials will protect the confidentiality of each student throughout the referral process.

9. As prescribed by existing policy unless otherwise specified by law, <sup>9</sup> policies will assure parental consent prior to making a student referral.

10. Morgan County School staff will facilitate smooth transitions for students who are entering and exiting the classroom due to involvement with community mental health treatment, Department of Children's Services including juvenile justice services, or other child serving programs.

11. Morgan County School Director of Schools shall maintain a Mental Health Team and will appoint a team leader to oversee overall implementation of the Mental Health policy. The Mental Health team will meet regularly to review the integration and alignment of services.

12. Successful strategies used to address barriers to learning include promoting a positive school climate, providing in-school support to students that enhance their social and emotional development, establishing clear and effective relationships with community agencies, and developing effective transition practices between schools and community programs and therefore will be incorporated into the continuous school improvement plan as well as the Tennessee Comprehensive System-wide Planning Process.

<sup>1</sup> See T.C.A. §49-1-1002

<sup>2</sup> See T.C.A. §49-6-801, §49-6-1016, §49-6-4216, §49-2-120

<sup>3</sup> Tennessee School Counseling Model, Policy 5.103, pp. 60-74

<sup>4</sup> See T.C.A. §49-5-302, §49-6-303, TN Dept. of Ed. SBOE rule 0520-2-2-.26, SBOE

Standards and Guidelines 5.103

<sup>5</sup> See T.C.A. §49-6-3004(c) (1)

<sup>6</sup> See T.C.A. §33-1-308

<sup>7</sup> See Public Law 104-191

<sup>8</sup> See 20 U.S.C. § 1232g; 34 CFR Part 99

<sup>9</sup> See T.C.A. §10-7-504(4) (A), §§33-3-206—33-3-209, §37-1-403, §37-1-605, §33-8-202

<sup>10</sup> See TN SBOE Policy, Standards, and Guidelines 4.207

## **Additional resources:**

### **State**

Tennessee Office of Coordinated School Health, Tennessee Department of Education

[www.tennessee.gov/education/schoolhealth](http://www.tennessee.gov/education/schoolhealth)

Tennessee Model for Comprehensive School Counseling Guidelines

[www.state.tn.us/education/ci/doc/tncomschconsmdl.doc](http://www.state.tn.us/education/ci/doc/tncomschconsmdl.doc)

Tennessee Voices for Children

[www.tnvoices.org](http://www.tnvoices.org)

Tennessee Suicide Prevention Network

[www.tspn.org](http://www.tspn.org)

### **National**

Center for Disease Control and Prevention – Mental Health

<http://www.cdc.gov/HealthyYouth/mentalhealth/index.htm>

Center for School Mental Health, University of Maryland School of Medicine

<http://csmh.umaryland.edu/>

Collaborative for Academic, Social, and Emotional Learning

<http://www.casel.org/>

National Community of Practice on Collaborative School Behavioral Health

<http://www.sharedwork.org/section.cfm?as=4&ms=4>

National Registry of Evidence-Based Programs and Practices

<http://www.nrepp.samhsa.gov/find.asp>

Office of Juvenile Justice and Delinquency Prevention

<http://www.ojjdp.ncjrs.org/>

Office of Juvenile Justice and Delinquency Prevention’s Model Program Guide

[http://www.dsgonline.com/mpg2.5/mpg\\_index.htm](http://www.dsgonline.com/mpg2.5/mpg_index.htm)

Positive Behavior Interventions and Supports

<http://www.pbis.org/main.htm>

Search Institute – Developmental Assets

[www.search-institute.org](http://www.search-institute.org)

Substance Abuse and Mental Health Services Administration

<http://www.samhsa.gov>

Tennessee National Alliance for the Mentally Ill

<http://www.namitn.org/>

UCLA Center for Mental Health in Schools

<http://smhp.psych.ucla.edu/>

**MORGAN COUNTY BOARD OF EDUCATION**  
**CLASS RANKING** Descriptor Code: IHC  
Issued Date: ????

This policy applies to incoming Freshmen (9<sup>th</sup> grade) for 2010-2011 school year.

Students must be enrolled full time at the home base school to be eligible for ranking among the top high school seniors.

All grades earned in grades 9, 10, 11, and the first semester of grade 12 will be counted toward the grade point average and the rank in class.

Honor roll students will be determined by standards approved by the Board. Students who meet these standards, and who do not request otherwise, will have their names submitted to the principal for release to the news media.

Each school department or club which presents honors or awards or conducts contests will file with the principal the name of the honor, award, or contest; the basis for selection of the award and honor; the method of participation; and the reason for the contest.

To become valedictorian or salutatorian, a student must be enrolled in the high school at least four (4) of the seven (7) semesters preceding the final semester. The final semester will not be used in determining class standing. The senior(s) with the highest Grade Point Average (GPA) with the highest ACT score will be the valedictorian. The senior(s) with the second highest GPA and ACT score will be the salutatorian.

GPA (Grade Point Average) is based on a four point scale [4.0 = A, 3.0 = B, 2.0 = C, 1.0 = D, Below 1.0 = F] carried out to three (3) decimal points.

# Morgan County Board of Education

Descriptor Term:

## Procedure for Granting Tenure

Descriptor Code:

GBL

Issued Date:

06/06/94

Rescinds:

Issued:

1 The Board of Education will grant tenure only to those teachers who can present documentation of a record  
2 of excellence as a teacher. The superintendent is responsible for documenting and presenting the  
3 recommendation for tenure to the Board of Education.  
4

5 Documentation of a record of excellence in teaching must include:  
6

- 7 1. Consistently high ratings on evaluations conducted by the principal and/or other evaluators
- 8
- 9 2. Specific evidence of effectiveness in teaching students:  
10 (a) test scores  
11 (b) narrative descriptions of specific examples of effectiveness with students  
12 (c) letters from parents  
13
- 14 3. Record of attendance for the last three years
- 15
- 16 4. Documentation of strongly favorable student response
- 7
- 19 5. Other indicators of effectiveness may be included
- 20

21 The following additional guidelines will apply:  
22

- 23 1. The decision as to whether or not to grant tenure is solely within the discretion of the Board  
24 of Education.
- 25
- 26 2. The superintendent will present the names of all persons eligible for tenure including an  
27 indication of which are recommended for tenure at a board meeting in ample time for the  
28 superintendent to provide notice of non-renewal to each teacher not granted tenure prior  
29 to April 15 of the year of eligibility.
- 30
- 31 3. Only those teachers who receive a majority vote of the membership of the Board will be  
32 granted tenure.
- 33
- 34 4. Teachers who earn tenure will be honored by the Board in a special ceremony, either at  
35 a board meeting or in some other special public event.
- 36
- 37 5. No person who is eligible for tenure who has not been granted tenure by the Board of  
38 Education shall be employed in the school system in any position which requires a license.  
39
- 40
- 41
- 42
- 43
- ..

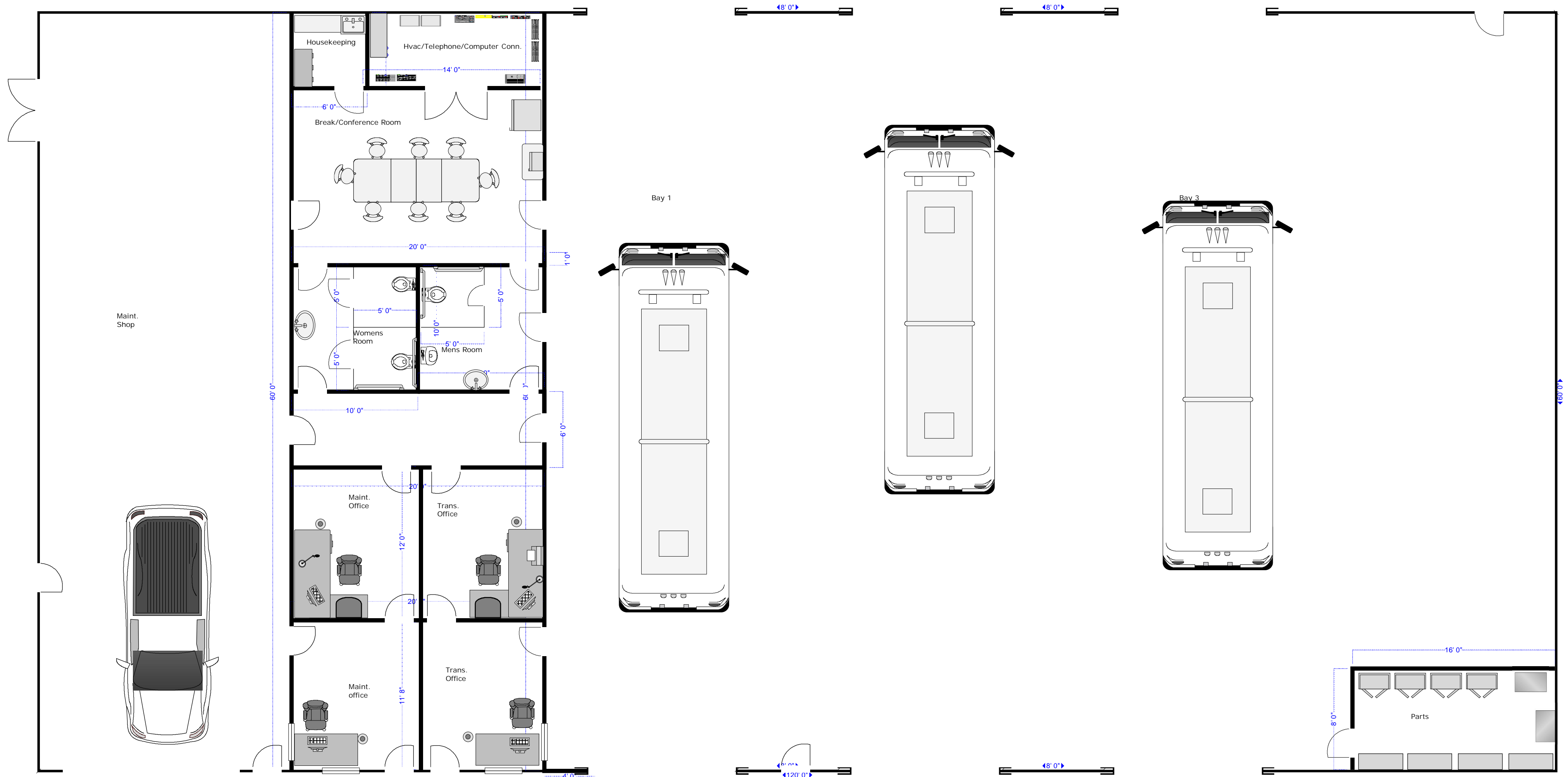

Footprint of building is 60' X 120'  
 The building will feature:  
 7 14' roll up doors  
 4 exterior entry doors  
 17 interior doors  
 2 double doors one interior one exterior  
 4 windows

The busses illustrated are drawn 30' in length

**Director's Performance Contract Report**  
**April 1, 2010**

**Performance Goal 1: Improved Student Achievement**

**Performance Indicators:** The performance objective is complete when the Director of Schools provides evidence of the following:

- h.) An on-going staff development plan to prepare educators and students to meet the more rigorous requirements of the revised state K-12 curriculum standards and assessment system.

**Our leadership team (principals and supervisors) have completed considerable work on a staff development plan for 2010-11. With the additional of RTTT funds, this plan will be revised and enriched. The Tennessee Department of Education is planning several summer sessions on teaching strategies related to the new curriculum standards. Educators not previously attending will be encouraged to participate.**

**Performance Goal 2: Improved organizational efficiency and effectiveness.**

**Objective 1: Continuous evaluation of the organizational structure of the central office to achieve maximum efficiency and effectiveness.**

**Performance Indicators:** The performance objective is complete when the Director of Schools provides:

- a.) a continual analysis of the duties of all central office personnel and any recommendations for changes to the board, and
- b.) if necessary, a fiscal review with budgetary recommendations.

**A re-organization plan for the Central Office staff will be presented as a part of the budget process at the next workshop on Monday, April 19, 2010.**

**Performance Goal 3: Assure quality performance of all personnel.**

**Objective 2: Expanded professional growth opportunities for current and future instructional leaders.**

**A. "Aspiring Administrators" Program for Morgan County Schools.**

**Performance Indicators:** The performance objective is complete when the Director of Schools:

- a.) researches "best practices" and provide an update to the board on

- similar programs in other school districts,
- b.) develops an implementation plan (including program content, selection of staff, recruitment of participants, schedule of sessions),
  - c.) demonstrates collaboration with other school districts and local universities in the development on these programs,
  - d.) provides an evaluation of the program at the end of the 2009-10 school year.

**Letter of Support for UTK Leadership Grant**

**Service on UTK Steering Committee for Educational Leadership Program**

**UTK Center for Educational Leadership**

**Summer Institute for Beginning & Novice Administrators**

**Educational Leadership Institute – Supervisors & Directors**

**Objective 3: Attract and retain the best faculty, staff, and administrators.**

**Performance Indicators:** The performance objective is complete when the Director of Schools presents:

- a.) an analysis of compensation packages of school system employees and offer suggestions for improvements;
- b.) a plan that has reviewed the compensation packages provided by adjacent school systems and those that have a per capita income, fiscal capacity, and demographics similar to Morgan County; and
- c.) a funding proposal is prepared and presented to the school board and county commission on the cost of competitive compensation for all categories of school employees.

**Classification and Compensation Study has begun. The focus of this study is non-certified support staff, but it will include technology and nursing. Results to be considered as a part of 2010-11 budget process.**

**Performance Goal 5: Funding - Budget development and pursuit of external funding for system-wide school improvement.**

**Objective 2: Develop an annual budget for the school board.**

**Performance Indicators:** The performance objective is complete when the Director of Schools presents a budget document that is consistent with the five year strategic plan, Tennessee Comprehensive System-wide Planning Process

**(TCSPP), school board policies, and other guidelines established by the State Department of Education.**

**Three board budget workshops held year to date. Next workshop is Monday, April 19, 2010. Principals have submitted the required BEP 2.0 budget requests which have been distributed to board members for review.**

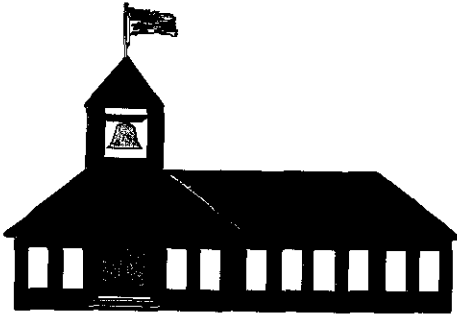

# Morgan County Schools

136 Flat Fork Rd

Wartburg, Tennessee 37887-0348

Dr. Edd Diden, Director of Schools  
Wanda Lane, Asst. Director of Schools

Central Office Phone: (423) 346-6214 FAX: (423) 346-6043

## Board Of Education:

Terry Armes, Chairman P.O. Box 295 Oakdale, TN 37829	James Rivers 145 Gouge Hollow Rd Oliver Springs, TN 37840	Randy Harlan 326 Lakeshore Dr Wartburg, TN 37887	Wendell Collins P.O. Box 865 Wartburg, TN 37887	Glen Moore 156 Clear Creek Road Lancing, TN 37770	Louise Coleman P.O. Box 485 Sunbright, TN 37872
--	---	--	---	---	---

March 2, 2010

To Whom It May Concern:

As the Director of Schools for the Morgan County district, I recognize the need for high quality school leaders in the schools in our district. Leadership preparation programs must answer the call to graduate aspiring leaders fully ready to step into the role of principal and be successful. To accomplish this, we have established a partnership with The University of Tennessee Educational Administration and Supervision Program.

Like many other rural school districts, the lack of a diverse tax base and the struggling economy has created great challenges in financing education. The percentage of students on free-reduced meals in our district has increased to 62.7%. Our district also struggles to attract and retain effective educators including aspiring administrators. Our district desperately needs effective educational administrators who are eager to meet the challenges of educating our youth.

This letter is written in support of The University of Tennessee's School Leadership Grant proposal. If funded, we will support application of our teacher leaders to UT's Leadership Academy. We also agree to provide a site where Leadership Academy aspiring leaders may complete their full time internship under the mentoring of an exemplary principal.

Morgan County Schools fully supports and strongly endorses The University of Tennessee's School Leadership Grant Proposal. We look forward to the successful grant award.

Sincerely,

Edward L. Diden, Ed.D.  
Director of Schools – Morgan County  
136 Flat Fork Rd.  
Wartburg, TN 37887

# MORGAN COUNTY SCHOOLS

## EXPENDITURE REPORT

For Month Ended March 31, 2010

	MONTH OF MARCH			MARCH YEAR-TO-DATE		
	Activity	Bdgt (1/12th)	Prct	Activity	Budget	Prct
<b>141 - G.P. SCHOOLS</b>						
71100 - REGULAR INSTRUCTION	824,722	857,072	96%	5,786,604	10,284,862	56%
71100 - REGULAR INSTR (MOE)	21,108	0		284,769	0	
71100 - REGULAR INSTR (ARRA)	0	0		594,700	0	
71200 - SPECIAL EDUC PROG	119,415	123,100	97%	1,052,291	1,477,195	71%
71300 - VOCATIONAL EDUC PROG	79,566	78,758	101%	627,092	945,100	66%
72110 - ATTENDANCE	6,818	13,946	49%	142,399	167,352	85%
72120 - HEALTH SERVICES	19,749	19,931	99%	147,212	239,170	62%
72310 - OTHER STUDENT SUPP	48,782	42,123	116%	331,056	505,480	65%
72210 - REGULAR INSTR PROG	81,070	71,478	113%	545,294	857,738	64%
72220 - SPECIAL EDUC PROG	11,996	12,633	95%	109,098	151,590	72%
72230 - VOCATIONAL EDUC PROG	6,344	6,799	93%	56,431	81,590	69%
72310 - BOARD OF EDUCATION	36,637	47,541	77%	363,377	570,490	64%
72320 - OFFICE SUPERINTENDENT	31,234	22,922	136%	198,759	275,060	72%
72410 - OFFICE OF PRINCIPAL	94,328	102,321	92%	845,304	1,227,850	69%
72610 - OPERTATION OF PLANT	152,975	127,668	120%	1,128,301	1,532,019	74%
72620 - MAINT. OF PLANT	32,405	51,396	63%	327,961	616,750	53%
72710 - TRANSPORTATION	94,871	79,892	119%	643,445	958,705	67%
73100 - FOOD SERVICE	0	2,583	0%	0	31,000	0%
73400 - EARLY CHILDHOOD EDUC	553	0		553	0	
76100 - CAPITAL OUTLAY	0	1,667	0%	13,026	20,000	65%
82000 - DEBT SERVICE	0	78,844	0%	743,757	946,124	79%
99100 - OTHER USES	0	0		0	0	
<b>Grants</b>						
0003 - CO-ORDINATED SCH HLTH	10,126	10,167	100%	84,842	122,000	70%
0041 - CAREER IN MIND (TnACHE)	32	1,667	2%	254	20,000	1%
0053 - SAVE-THE-CHILDREN	10,670	8,833	121%	61,672	106,000	58%
0319 - FAMILY RESOURCE	1,420	4,919	29%	23,056	59,026	39%
0501 - DISTANCE LEARNING	219	833	26%	957	10,000	10%
7009 - PRE K LOTTERY	38,685	0		332,223	830,590	40%
7016 - 21st CENTURY LEARNING	2,991	16,936	18%	47,846	203,238	24%
7019 - PRE K EXPANSION	0	0		0	0	
TOTAL G.P.Schools:	1,726,718	1,784,028	97%	14,492,277	22,238,929	65%
<b>142 - FEDERAL SCHOOLS</b>						
011 - TITLE I & II ADMIN	37,585	15,013	250%	123,822	180,159	69%
101 - TITLE I	98,362	87,968	112%	687,417	1,055,612	65%
10S - TITLE I ARRA	15,454	47,458	33%	211,313	569,496	37%
201 - TITLE 2A	247	23,190	1%	150,839	278,280	54%
231 - TITLE 2D	700	1,218	57%	6,347	14,610	43%
23S - TITLE 2D ARRA	1,526	1,749	87%	5,303	20,991	25%
401 - TITLE 4	3,778	1,381	274%	11,294	16,567	68%
501 - TITLE 5	0	23	0%	272	272	100%
601 - TITLE 6	-20,856	9,056		72,141	108,676	66%
801 - CARL PERKINS	1,689	12,867	13%	142,637	154,408	92%
901 - IDEA	56,565	59,775	95%	618,406	717,295	86%
911 - IDEA PreSCHOOL	2,475	2,655	93%	25,476	31,855	80%
90S - IDEA ARRA	67,207	63,557	106%	433,248	762,679	57%
91S - IDEA PreSCH ARRA	-738	1,418		0	17,020	0%
TOTAL Federal School Project:	263,993	327,327	81%	2,488,514	3,927,921	63%
<b>143 - CENTRAL CAFETERIA</b>						
73100 - FOOD SERVICE	118,777	144,144	82%	1,069,858	1,729,723	62%
73300 - COMMUNTIY SERVICES	2,139	7,571	28%	47,977	90,850	53%
TOTAL Cafeteria:	120,915	151,714	80%	1,117,836	1,820,573	61%

# MORGAN COUNTY SCHOOLS

## EXPENDITURE REPORT

For Month Ended March 31, 2010

	JULY	AUG	SEPT	OCT	NOV	DEC	JAN	FEB	MAR	APR	MAY	JUNE	Y-T-D TOTAL	BUDGET	PRCT
<b>141 - G.P. SCHOOLS</b>															
71100 - REGULAR INSTRUCTION	20,976	547,741	871,422	878,926	934,842	264,002	824,807	619,166	824,722				5,786,604	10,284,862	64.8%
71100 - REGULAR INSTR - MOE	0	0	0	0	0	0	0	263,661	21,108				284,769	0	
71100 - REGULAR INSTR - ARRA	0	0	0	0	0	594,700	0	0	0				594,700	0	
71200 - SPECIAL EDUC PROG	49,030	82,351	155,991	148,430	125,891	123,409	128,182	119,593	119,415				1,052,291	1,477,195	71.2%
71300 - VOCATIONAL EDUC PROG	10,201	44,736	79,262	80,659	84,171	87,647	81,292	79,558	79,566				627,092	945,100	66.4%
72110 - ATTENDANCE	14,230	74,840	6,616	6,767	7,200	6,629	6,671	12,629	6,818				142,399	167,352	85.1%
72120 - HEALTH SERVICES	0	9,390	20,706	19,190	19,966	19,126	19,539	19,546	19,749				147,212	239,170	61.6%
72310 - OTHER STUDENT SUPP	9,441	20,912	47,159	40,806	42,178	39,896	40,593	41,289	48,782				331,056	505,480	65.5%
72210 - REGULAR INSTR PROG	17,348	43,039	57,935	127,423	53,596	51,730	58,127	55,026	81,070				545,294	857,738	63.6%
72220 - SPECIAL EDUC PROG	7,854	11,208	10,747	13,337	13,737	13,835	13,908	12,475	11,996				109,098	151,590	72.0%
72230 - VOCATIONAL EDUC PROG	5,801	6,092	6,376	6,376	6,376	6,376	6,344	6,344	6,344				56,431	81,590	69.2%
72310 - BOARD OF EDUCATION	268,198	11,118	13,121	8,869	22,858	-10,797	999	12,376	36,637				363,377	570,490	63.7%
72320 - OFFICE SUPERINTENDEN	20,042	20,795	21,802	20,673	20,718	23,158	19,903	20,434	31,234				198,759	275,060	72.3%
72410 - OFFICE OF PRINCIPAL	90,655	80,265	93,504	92,338	100,508	91,433	106,651	95,622	94,328				845,304	1,227,850	68.8%
72610 - OPERTATION OF PLANT	108,120	112,890	119,290	131,675	99,769	111,810	116,070	175,704	152,975				1,128,301	1,532,019	73.6%
72620 - MAINT. OF PLANT	20,703	33,508	45,037	50,581	38,345	27,075	35,717	44,590	32,405				327,961	616,750	53.2%
72710 - TRANSPORTATION	12,255	40,725	81,577	74,660	103,132	73,608	91,755	70,862	94,871				643,445	958,705	67.1%
73100 - FOOD SERVICE	0	0	0	0	0	0	0	0	0				0	31,000	0.0%
73400 - EARLY CHILDHOOD EDUC	0	0	0	0	0	0	0	0	553				553	0	
76100 - CAPITAL OUTLAY	0	0	0	0	0	0	10,294	2,732	0				13,026	20,000	65.1%
82000 - DEBT SERVICE	0	113,632	0	630,124	0	0	0	0	0				743,757	946,124	78.6%
99100 - OTHER USES	0	0	0	0	0	0	0	0	0				0	0	
<b>Grants</b>															
0003 - CO-ORDINATED SCH HLTH	8,136	8,673	9,464	10,813	11,098	9,833	7,905	8,793	10,126				84,842	122,000	69.5%
0041 - CAREER IN MIND (TRACHE)	0	0	0	0	0	0	0	222	32				254	20,000	1.3%
0053 - SAVE-THE-CHILDREN	0	2,787	5,695	11,598	7,706	11,852	5,664	5,700	10,670				61,672	106,000	58.2%
0319 - FAMILY RESOURCE	1,919	3,647	3,343	2,703	794	4,388	1,658	3,185	1,420				23,056	59,026	39.1%
0501 - DISTANCE LEARNING	0	0	0	0	0	0	0	737	219				957	10,000	9.6%
7009 - PRE K LOTTERY	2	18,221	40,401	38,063	40,254	39,711	80,490	36,397	38,685				332,223	830,590	40.0%
7016 - 21ST CENTURY LEARNING	202	6	2,259	1,326	658	39,944	188	272	2,991				47,846	203,238	23.5%
7019 - PRE K EXPANSION	0	0	0	0	0	0	0	0	0				0	0	
<b>TOTAL G.P.Schools:</b>	<b>665,111</b>	<b>1,286,574</b>	<b>1,691,705</b>	<b>2,395,338</b>	<b>1,733,797</b>	<b>1,629,365</b>	<b>1,656,756</b>	<b>1,706,913</b>	<b>1,726,718</b>				<b>14,492,277</b>	<b>22,238,929</b>	
	3.0%	5.8%	7.6%	10.8%	7.8%	7.3%	7.4%	7.7%	7.8%				65.2%		
<b>142 - FEDERAL SCHOOLS</b>															
011 - TITLE I & II ADMIN	8,832	10,322	9,448	9,914	10,089	18,430	10,182	9,022	37,585				123,822	180,159	68.7%
101 - TITLE I	1,833	40,385	200,176	65,113	70,871	63,899	67,354	79,424	98,362				687,417	1,055,612	65.1%
10S - TITLE I ARRA	14,332	15,829	77,827	17,265	16,536	22,564	15,471	16,036	15,454				211,313	569,496	37.1%
201 - TITLE 2A	27,915	14,551	13,337	40,037	8,060	35,369	7,667	3,657	247				150,839	278,280	54.2%
231 - TITLE 2D	1,254	0	0	1,534	1,416	1,443	0	0	700				6,347	14,610	43.4%
23S - TITLE 2D ARRA	0	0	60	0	0	0	2,445	1,272	1,526				5,303	20,991	25.3%
401 - TITLE 4	655	111	1,190	950	500	732	100	3,278	3,778				11,294	16,567	68.2%
501 - TITLE 5	0	0	182	0	0	90	0	0	0				272	272	100.0%
601 - TITLE 6	22,243	0	44,770	2,000	0	1,289	22,695	0	-20,856				72,141	108,676	66.4%
801 - CARL PERKINS	36	7,729	3,280	9,392	20,665	82,081	9,782	7,984	1,689				142,637	154,408	92.4%
901 - IDEA	1,162	27,351	84,389	91,315	111,868	109,192	78,472	58,093	56,565				618,406	717,295	86.2%
911 - IDEA PreSCHOOL	66	1,244	2,481	6,012	4,727	3,522	2,475	2,475	2,475				25,476	31,855	80.0%
90S - IDEA ARRA	0	3,025	60,363	45,131	16,314	122,358	39,225	79,625	67,207				433,248	762,679	56.8%
91S - IDEA PreSCH ARRA	0	0	0	0	485	253	0	0	-738				0	17,020	0.0%
<b>TOTAL Federal School Project:</b>	<b>78,327</b>	<b>120,547</b>	<b>497,502</b>	<b>288,663</b>	<b>261,531</b>	<b>461,220</b>	<b>255,867</b>	<b>260,864</b>	<b>263,993</b>				<b>2,488,514</b>	<b>3,927,921</b>	
	2.0%	3.1%	12.7%	7.3%	6.7%	11.7%	6.5%	6.6%	6.7%				63.4%		
<b>143 - CENTRAL CAFETERIA</b>															
73100 - FOOD SERVICE	12,230	36,630	166,169	175,629	163,501	169,514	103,500	123,908	118,777				1,069,858	1,729,723	61.9%
73300 - COMMUNITY SERVICES	22,920	9,873	2,139	2,674	2,138	2,352	1,604	2,139	2,139				47,977	90,850	52.8%
<b>TOTAL Cafeteria:</b>	<b>35,150</b>	<b>46,503</b>	<b>168,308</b>	<b>178,302</b>	<b>165,639</b>	<b>171,866</b>	<b>105,104</b>	<b>126,047</b>	<b>120,915</b>				<b>1,117,836</b>	<b>1,820,573</b>	
	1.9%	2.6%	9.2%	9.8%	9.1%	9.4%	5.8%	6.9%	6.6%				61.4%		

## **PLANNING: A JOINT VENTURE** **PART I AND PART II**

✧ Pigeon Forge	✧ May 23-24, 2010 (Su-M)
Paris Landing	June 13-14, 2010 (Su-M)

### **Objectives:**

- *To develop practical skills and increase knowledge in the planning process*
- *To provide superintendents and board members with methods to develop a common vision and mission statement*
- *To develop strategies for setting system goals*
- *To monitor/evaluate results to bring about systemic change*
- *To provide follow-up and support in Part II for boards who have previously attended a Joint Venture session*

### **Special Considerations:**

- The superintendent and a majority of the school board must attend.
- Superintendents and school board members meet in large group, presentation, and discussion sessions with other systems as well as with team members in small group settings throughout the two-day workshop experience. The casual meeting site facilitates a relaxed atmosphere and open communication.

### **Description:**

#### ***Planning: A Joint Venture I***

The importance of planning for a school system's future is the major focus of this institute. The Tennessee Department of Education and the Tennessee School Boards Association present the steps for establishing a school system's mission and vision. Also included are strategies to help you plan for school improvement through goal setting, and definitions of strategies, as well as methods to monitor and evaluate results to help you modify plans over time. Participants discuss how to incorporate the State Board of Education's Performance Standards and *Master Plan for Tennessee Schools* into a school system's plan.

#### ***Planning: A Joint Venture II***

For those boards that have attended Planning: A Joint Venture I, Planning: A Joint Venture II is available. In this session, boards review their beliefs and mission statement and report the progress they have made toward their goals. Prior to the sessions, board members are asked to complete a board self-evaluation instrument and mail it back to TSBA to tabulate and analyze. During the session, the facilitator shares the results with the board and leads members through a process to discover ways to improve. Each board has the opportunity to further develop its strategic plan, including in-depth exploration of a board project, or the board may focus exclusively on plans for board improvement.

**Maximum Enrollment:** 5 school boards

# Planning: A Joint Venture

## Part I

Integration of State Board of Education Master Plan and the  
No Child Left Behind Act into Five-Year Plans.

Day 1 \_\_\_\_\_

12:30-1:00 p.m.	Registration/Coffee	
<b>General Session #1</b>		
1:00-1:15 p.m.	Welcome & Introductions Objectives for the Academy	<b>Dr. Tammy Grissom</b>
1:15-2:15 p.m.	The Planning Process: Why Do We Need to Plan? How Beliefs Affect Our Plans Creating a Vision	<b>Dr. Tammy Grissom</b>
2:15-2:30 p.m.	BREAK	
<b>Breakout Session #1 in individual breakout rooms</b>		
2:30-4:00 p.m.	Identifying Beliefs Developing Vision Statements	<b>Facilitators</b>
4:00-4:15 p.m.	BREAK	
<b>General Session #2</b>		
4:15-5:00 p.m.	Reports from boards: Beliefs and Vision Statements Identifying Our Mission	<b>Dr. Tammy Grissom</b>
5:00-5:15 p.m.	BREAK	
<b>Breakout Session #2 in individual breakout rooms</b>		
5:15-6:00 p.m.	Developing a Mission Statement	<b>Facilitators</b>
6:00-7:00 p.m.	DINNER (on your own)	
<b>Breakout Session #3 in individual breakout rooms</b>		
7:00-8:30 p.m.	Planning for Involvement for the Community, Staff & Students	<b>Facilitators</b>
8:30 p.m.	ADJOURN	

## Day 2

---

### General Session #3

- 8:00-9:15 a.m.      - Reports from each board on Mission Statements      **Dr. Tammy Grissom**  
- Review of No Child Left Behind Act  
- Integration of SBOE Master Plan & NCLB into  
the Five-Year Plan  
- Writing objectives & strategies  
- Using goal development teams

### Breakout Session #4 in individual breakout rooms

- 9:15-10:15 a.m.      - No Child Left Behind Worksheet      **Facilitators**  
- Goal Setting

10:15-10:30 a.m.      BREAK

10:30-11:00 a.m.      Goal Setting      **Facilitators**

11:00-11:30 a.m.      Writing Objectives & Strategies      **Facilitators**

### General Session #4

- 11:30 a.m. - Noon      - Monitoring, Evaluating & Modifying      **Dr. Tammy Grissom**  
- Report from Boards  
- Wrap-up and Evaluation

Noon-1:00 p.m.      LUNCH

1:00-3:30 p.m.      Special Session: Where Do We Go From Here?



TO: Key Stakeholders  
FROM: Brad Smith, Executive Director, Tennessee SCORE  
SUBJECT: Tennessee’s Race to the Top Application  
DATE: February 4, 2010

Below is a summary of Tennessee’s Race to the Top (RTTT) application. This summary in no way reflects SCORE’s opinion on the various components of the state’s application. The summary follows the layout of the application and is broken down into seven sections: (1) governance and oversight (2) standards and assessments (3) data systems (4) teachers and leaders (5) low-performing schools (6) STEM and (7) budget.

**Governance and Oversight**

- The RTTT grant will be managed by a “**First to the Top Oversight Team,**” which will be led by a new \$120,000 a year employee at the Tennessee Department of Education (TDOE). This employee will report to the Governor’s Office of State Planning and Policy.
- If Tennessee wins RTTT, districts will have 90 days to submit **scopes of work** to TDOE outlining how they will locally implement the state’s RTTT application. TDOE and field service centers will provide technical assistance to districts in completing these scopes of work.
- The Tennessee Consortium on Research, Evaluation, and Development (TN CRED) will be created to identify best practices and research the impact of the RTTT grant. **TN CRED** will be led by Matthew Springer, Director of the National Center for Performance Incentives at Vanderbilt University, and the Center for Business and Economic Research (CBER) at the University of Tennessee.

**Standards and Assessments**

- The Tennessee State Board of Education will adopt the new **Common Core Standards** in July 2010. The RTTT application suggests these standards will be closely aligned with the new standards Tennessee adopted as part of the Tennessee Diploma Project.
- TDOE will provide significant **professional development on the Common Core Standards** including statewide Summer Institutes (similar to those held the past two summers on the Tennessee Diploma Project), regional trainings at field service centers, annual trainings for new administrators and teachers, and additional training through the Electronic Learning Center. TDOE will also provide additional training to high priority schools and districts.

- TDOE will develop a **comprehensive item bank** for formative assessments, interim assessments, benchmark assessments and summative assessments. Teachers and principals will be able to administer tests based on this item bank either online or by printing the test. All tests will be scored electronically, and the results will be automatically imported into the new State Longitudinal Data System (see below).

### Data Systems

- TDOE, in partnership with SAS, THEC, and CBER, will create a **P-20 State Longitudinal Data System (SLDS)** that combines data from existing TDOE, THEC, TennCare, and Department of Children’s Services, Health, Human Services, Mental Health, and Corrections databases. The SLDS is intended to provide educators with a “360-degree view of the student” and increase teacher, administrator, and district use of student data.
- SAS will expand the existing **data dashboard** teachers and principals currently use to view students’ Tennessee Value-Added Assessment System (TVAAS) data. This new dashboard will include a “360-degree view of the student” based on the SLDS discussed above.
- SAS and a non-profit organization, such as Battelle for Kids, will provide teachers and principals **training on how to use the state’s new assessment system and data dashboard** to improve classroom instruction and to inform teacher and principal evaluation and compensation systems. This non-profit will conduct much of its training via the Electronic Learning Center and interactive WebEx™ sessions.
- **Teacher pre-service programs** will be required to incorporate an eight-hour module into their research methods courses on how teachers can use the Tennessee Value-Added Assessment System (TVAAS) to improve classroom instruction.

### Teachers and Leaders

- TDOE will fund the expansion of traditional and alternative teacher training programs focused on **increasing the supply of teachers in hard-to-staff subjects**. This includes funding to replicate the UTeach program in Chattanooga and Memphis, the expansion of both Teach for America and The New Teacher Project, and \$8 million in competitive grants to expand principal and teacher residency programs.
- The state will create a 15-member **Teacher Evaluation Advisory Committee** to develop new teacher and principal evaluation systems based on multiple measures. Evaluations will be based 50% on student achievement data, with at least 35% being based on TVAAS data for teachers and principals who possess TVAAS data. Evaluations will be conducted annually and will include summative rankings that place every teacher and principal in one of four or five performance categories.

- The state will **annually publish** the percent of principals and teachers in each performance category by district as well as the tenure granting rate by district. The state will ask LEAs to ensure at least 15% of educators move up at least one performance category each year.
- TDOE will create a \$12 million competitive fund to assist districts in designing and/or implementing **alternative salary schedules**. To be eligible for the fund, districts must have the agreement of their local teachers association (if applicable) and be able to show how the local funding body will sustain the alternative salary schedule after Race to the Top funding expires.
- TDOE will also create an additional competitive fund of \$375,000 a year for **innovation in small school districts** (technically districts in the bottom 20% in terms of state BEP funding). These districts can apply for this funding to develop alternative salary schedules or turnaround low-performing schools.
- TDOE will create and administer a **Teacher Working Conditions Survey** to gauge principals' effectiveness in creating positive working conditions within their schools.
- The State Board of Education will redesign the existing Teacher Preparation Program Report Card to make it more informative and user-friendly and create new **report cards** for school leadership preparation programs and all professional development courses.
- THEC and the State Board of Education will commission a **School Leader Supply and Demand Study** to help the state and individual school districts project their future human capital needs.
- TDOE will create a **Leadership Action Tank** to identify and disseminate best practices that district and school leaders use to improve student achievement. This Action Tank will focus on high-poverty, high-performing schools, particularly schools in rural areas.

### **Low-Performing Schools**

- **Focus Schools:** Schools in School Improvement I or School Improvement II will be known as focus schools and will receive the state's current accountability interventions including Exemplary Educators, Achievement Gap consultants, and System Targeted Assistance Teams. TDOE will also provide \$6,000 a year to each focus school to fund additional supports.
- **Renewal Schools:** Schools in Corrective Action or Restructuring I will be known as renewal schools and required to partner with a private provider, higher education organization, or a collaboration of non-profits to develop and implement a school turnaround strategy. TDOE will provide \$300,000 a year to each renewal school to fund these additional supports.
- **Achievement School District (ASD):** The Commissioner of Education will have the authority to place schools in Restructuring II or beyond or schools meeting the federal definition of "persistently low-achieving schools" in a newly created ASD (however, the Commissioner could choose to leave these schools as renewal schools). Currently, 13 schools are eligible for the ASD including eight schools in Memphis, two in Nashville, and one each in Chattanooga, Jackson, and Knoxville. The Commissioner

has wide leeway over schools in the ASD and can do everything from providing them additional funding to implement existing turnaround strategies to turning these schools over to a charter management organization. TDOE has identified several national non-profit organizations it might partner with to turnaround these schools. TDOE is currently looking to hire a Superintendent of the ASD (salary: \$250,000 a year). Schools will remain in the ASD for at least five years.

- THEC will establish a statewide **college access network** to provide a central set of resources to help students apply to and receive financial aid for college.

**STEM**

- TDOE will partner with Battelle, who in partnership with the University of Tennessee runs Oak Ridge National Laboratory, to establish a statewide **STEM Innovation Network**. This network will work with Oak Ridge Associated Universities, existing higher education STEM Centers of Excellence, and several new regional STEM hubs to share best practices in STEM education and deliver professional development for STEM teachers across the state. This network will be modeled on a similar STEM effort led by Battelle in Ohio.
- TDOE will expand the STEM training offerings on the Electronic Learning Center (ELC) by uploading content from **PBS’s Digital Learning Library** onto the ELC.

**Budget**

<b>Line-Item</b>	<b>Description</b>	<b>Cost</b>
First to the Top Oversight Team	One full-time employee to oversee the First to the Top oversight team plus \$600,000 in consulting services	\$2,362,605
Tennessee Department of Education Delivery Unit	Consulting contract with an organization, such as the U.S. Education Delivery Institute, to increase the efficiency of TDOE	\$538,000
Tennessee Consortium on Research, Evaluation, and Development	The Center for Business and Economic Research at the University of Tennessee will evaluate the effectiveness of Race to the Top programs and identify best practices	\$3,240,000
Common Core Standards Professional Development	TDOE will provide training on the Common Core Standards similar to training provided on the Tennessee Diploma Project in Summer 2008 and Summer 2009	\$1,614,000
Integrating Common Core Standards into Pre-Service	THEC will contract to provide training to teacher and school leadership preparation program faculty on the Common Core Standards and the new teacher and principal evaluation systems	\$1,350,000
State Longitudinal Data System	The state will expand its P-12 State Longitudinal Data System (SLDS) to a P-20 SLDS by integrating TDOE data with data from THEC, the Tennessee Department of Children Services, and other state agencies	\$19,470,491
Data Dashboard	TDOE will expand its current contract with SAS to provide an improved data dashboard for teachers; this dashboard will build on the current TVAAS database	\$645,600

Integrating Data to Improve Instruction	TDOE will contract with a non-profit (e.g., Battelle for Kids) to provide training on how to use TVAAS to improve classroom instruction and how to integrate data into teacher and principal evaluation and compensation systems	\$26,387,683
Integrating TVAAS into Pre-Service	The state will issue an RFP to develop an 8-hour module to teach pre-service teachers how to use TVAAS data to improve instruction	\$1,350,000
UTeach	TDOE would provide funding to replicate the UTeach program at both the University of Memphis and University of Tennessee - Chattanooga	\$4,104,000
Teach Tennessee	Teach Tennessee will train an additional 35 teachers per year in high-needs fields	\$645,600
Distinguished Professionals	Distinguished Professionals will expand from Knoxville to at least three additional urban sites; possible sites listed are Chattanooga, Clarksville, Memphis, Nashville, and Tri-Cities	\$400,000
Teacher and Principal Residencies	TDOE will create a competitive grant pool to support universities and/or districts in developing and expanding teacher or principal residency programs	\$8,000,000
Teacher Preparation Program Report Card	THEC will be provided one new employee to annually produce the Teacher Preparation Program Report Card	\$432,000
Teacher and Principal Evaluation Development	TDOE will contract with national and state experts to develop the new teacher and principal evaluation systems	\$2,569,488
Electronic Learning Center	TDOE will hire 17 new employees on a contract basis to expand the content of the Electronic Learning Center	\$4,734,400
Teacher Working Conditions Survey	TDOE will conduct an annual survey of teacher working conditions	\$1,127,648
Innovation Acceleration Fund	TDOE will create a competitive grant pool to develop and implement alternative pay systems	\$12,000,000
Competitive Supplemental Fund	TDOE will create a competitive grant pool for the state's smallest districts (the smallest 20% of districts by BEP funding) to implement alternative pay systems and school turnaround strategies	\$1,500,000
Rural Literacy Programs	TDOE will contract with Save the Children to expand its existing rural literacy efforts in Tennessee	\$1,673,835
School Leaders Supply and Demand Study	The Center for Business and Economic Research at the University of Tennessee will conduct a study of the supply and demand for new school leaders in Tennessee	\$172,800
Leadership Action Tank	TDOE will contract with a non-profit to identify and share best practices in school leadership (10% of funding) and train a cohort of 20-25 new principals a year to turnaround the state's lowest performing schools (90% of funding)	\$10,404,932

Achievement School District	Tennessee will contract with nationally recognized non-profits (e.g., Teach for America, The New Teacher Project, New Leaders for New Schools) to turnaround 13 of the state's lowest performing schools	\$49,168,869
Renewal Schools	Each school in Corrective Action or Restructuring I will be given \$300,000 to purchase school support services from an outside provider	\$52,650,000
Focus Schools	Each school in School Improvement I or School Improvement II will be given \$6,000 to purchase school support services from an outside provider (e.g., 20 days of services at \$300 per day)	\$3,745,090
College Access Network	THEC's Office of P-16 initiatives will be given funding to create a statewide college access network	\$3,240,336
STEM Innovation Network	TDOE will partner with Battelle to establish a STEM Innovation Network for sharing best practices in STEM education and coordinating STEM professional development opportunities for teachers	\$1,667,800
STEM Centers of Excellence	TDOE will contract with existing STEM Centers of Excellence to provide additional STEM professional development for teachers	\$6,480,000
STEM Regional Hubs	TDOE will contract with several regional organizations (e.g. higher education institutions) to provide additional STEM professional development for teachers	\$5,380,000
STEM Platform Schools	TDOE will provide funding to expand existing STEM programs in Knoxville and Nashville; additional districts will be eligible in Years 3 and 4 of the grant	\$9,000,000
SITES -M	SITES-M, which forms STEM partnerships between universities and elementary/middle schools, will double its number of university sites from five to ten	\$8,608,000
Oak Ridge Associated Universities STEM Training	Oak Ridge Associated Universities will provide training to 150 lead STEM teachers from across the state	\$1,604,316
PBS Digital Learning Library	TDOE will contract with PBS to place the content of PBS's Digital Learning Library on the Electronic Learning Center	\$4,628,952
LEA Funding	TDOE will distribute 50% of all RTTT funding to school districts by Title I formula	\$250,896,446
	<b>Total</b>	<b>\$501,792,892</b>