



**Lawton Public Schools Board of Education
Special Meeting
June 1, 2020 5:00 PM
Shoemaker Center Auditorium
753 NW Fort Sill Blvd**

Lawton, Oklahoma 73507

AGENDA

The Board reserves the right to consider, take up and take action on any agenda item in any order, except as to items 1-4. The Board may discuss, make motions, and vote on all matters appearing on the agenda. Such vote may be to adopt, reject, table, reaffirm, rescind, or to take no action on any item. Any person with a disability who needs special accommodations to attend the Board of Education meeting should notify the Clerk of the Board at least 24 hours, to the extent possible, prior to the scheduled time of the Board meeting. The telephone number is 580-357-6900. At the time and place designated, the Board will consider and act upon the matters set out on the Agenda for this meeting as follows:

1. Call to Order
2. Pledge of Allegiance - Kevin Hime
3. Roll Call to Establish Quorum
4. Special Guests/Special Recognition - Kevin Hime and Carla Clodfelter
5. Architect and Construction Manager at Risk Update
6. Departmental Reports
 - a. Information Item: Update - Business Operations and Educational Services Reports
7. Report of the Superintendent
 - a. Information Item: COVID-19 Update
 - b. Superintendent's Announcement(s)
8. Consent Agenda
(The following matters may be approved in their entirety by the Board upon motion made, seconded and passed by a majority vote of the Board members. However, upon request of any Board member, any one or more matters will be removed from the consent agenda and acted upon separately. Contracts are approved subject to review by the District's legal counsel. Any or all of the public record items included within the consent agenda, i.e. minutes to be submitted for approval; purchase orders to be submitted for acceptance; financial report; proposed transfer of funds between activity accounts; and fund-raising event listings, may be examined at the Office of the Clerk of the Board of Education at the Shoemaker Center, 753 Fort Sill Blvd., Lawton, OK. An appointment to review records is requested.)
 - a. Item(s) Removed from the Consent Agenda for Separate Action
 - b. Approval of the Balance of the Consent Agenda

- c. Approval of the Minutes of the May 19, 2020 Special Board Meeting
- d. Report of the Purchasing Agent/Encumbrance Clerk - Sheila Relf
 - 1. Increase, Decrease and Issue Purchase Orders
 - 2. Encumbrances/Partial Payments
- e. Report of the Comptroller - Lance Gibbs
 - 1. Application for 2020-2021 Temporary Appropriations
- f. Report of the Activity Fund Custodian - Nancy McQuaide
 - 1. Activity Fund Transfers, Expenditures, Establishments, and Amendments
- g. Report of the Clerk - Kathy Bentley
 - 1. Construction Related Contracts/Agreements
 - A. Crossland Construction Company, Change Order #12, EMS new construction
 - 2. Contracts / Agreements
 - A. Certification of Children's Internet Protection Act (CIPA) and E-Rate Requirements
 - B. Herff Jones, LHS Yearbook Printing Agreement 2020-2021
- 9. Proposed Executive Session to Discuss [Authorized by 25 OKLA.STAT. Section 307 (B)(1) of the Oklahoma Open Meeting Act]:
 - a. The employing, promoting, or receiving resignation(s) of individual certified and support salaried personnel as listed on the Certified and Support Personnel Reports
- 10. Vote to Convene in Executive Session
- 11. Vote to Acknowledge Return to Open Session
- 12. Statement of Executive Session Minutes
- 13. Superintendent's Personnel Report / Items Discussed in Executive Session
 - a. Approval of Certified and Support Personnel Reports
- 14. New Business - This refers to any matter not known about or which could not have been reasonably foreseen prior to the time of posting of the agenda. Okla. Stat. tit. 25 Sec. 311(A)(9)
- 15. The next regular board meeting date is Thursday, June 25, 2020, at 5:00 p.m., in the Shoemaker Center Auditorium.
- 16. Setting New Board Meeting Dates
- 17. Board Announcements
- 18. Adjournment

Time of Posting: 3:30 p.m.

Date of Posting: May 14, 2021

Place of Posting: Foyer of Shoemaker Center, 753 NW Fort Sill Blvd.

Posted by: _____
 Kevin Hime, Superintendent



Lawton Public Schools BOE Update for 6/1/2020

1715A New Eisenhower Middle School:

- Crossland is continuing to track any risks and cost impacts associated with potential delays due to COVID-19.
- Crossland will present a schedule for LPS's review showing all activities leading up to building occupancy and teacher move-in planned for the week of 8/10/20.
- AIP has submitted Change Order #12 to LPS for consideration.

1715C Whittier Safe Room:

- AIP and the civil engineer are investigating solutions for runoff.

1715D Eisenhower Middle School Furniture:

- Furniture delivery is scheduled for 7/20/20.

1901 Food Service Warehouse Freezer & Refrigerator Replacement:

- Demolition is complete.
- Freezer installer is repairing misaligned panels and replacing damaged skins.
- Electrician is pulling wire in preparation for startup.

1903B&C Carriage Hills & Crosby Park Gym Repair:

- Permit documents have been approved by the City.
- Construction is awaiting LPS approval.

1911 MacArthur High School Auditorium, Gym & Admin HVAC:

- Ductwork and equipment installation are complete.
- Controls and fire alarm are in progress.
- Screenwall awaits brick delivery.

1911B MacArthur High School Gym HVAC:

- Utility distribution is in progress.
- Contractor has set some of the small units.
- Contractor is awaiting equipment delivery.

1914 Central Middle School HVAC Repair:

- Submittal packet is under review.

1916 Cameron Stadium Field Turf Replacement:

- Demolition and perimeter nailer replacement are complete.
- Turf delivery and installation to begin 6/3/20.

1917 Lawton High School Entry Vestibule:

- LPS has postponed design until further notice.

1918 Douglas Learning Center Window Replacement:

- AIP and mechanical engineer met with LPS for a pre-proposal walk-through on 6/1/20.
- AIP is preparing a proposal for services on the HVAC design with preliminary estimate.

2002 MHS Gym Foyer & Locker Room, Pat Henry, Woodland Hills & Food Service Warehouse Reroofs:

- Pre-Construction Conference was held on 6/1/20.

2003 Ron Stephens Stadium Wall Repair:

- AIP to schedule final review with LPS for the week of June 8.

2004 Lawton High School Gym & Auditorium HVAC:

- LPS to consider Contract for Construction at upcoming Board meeting.

2005 Tomlinson Middle School Gym HVAC:

- Pre-Construction Conference was held on 6/1/20.

Project: LPS Eisenhower Middle School
Date: 1 June 2020

408 NE 145th Place
Oklahoma City, OK 73013
tel 405.748.5043
fax 405.748.7214

Subject: Eisenhower Middle School update

1. The new Eisenhower Middle School is 89% complete.
 - a. Classroom punch list scheduled for 6.16.2020.
 - b. Gym and locker rooms punch list scheduled for 7.8.2020.
 - c. School furniture delivery and installation 7.20.2020
 - d. Building completion 8.03.2020.
Auditorium will not be completed
2. Recently completed work:
 - a. Courtyard stamped concrete.
 - b. Fine grading on East side for landscaping
 - c. Kitchen / Admin Ductwork
3. On-going work:
 - a. Plumbing fixture installation on 1st floor B and C.
 - b. HVAC ductwork in the Music / Arts, and Auditorium.
 - c. Sidewalks and maintenance strip around the school.
 - d. Phase 02 of Asbestos Abatement on existing EMS.
 - e. Telescoping bleachers in Area D Gym.
 - f. Frame ceilings in the Auditorium.
 - g. Parking lot on West side.
 - h. Terrazzo flooring in Kitchen.
 - i. Resinous showers and flooring
 - j. Crossland preliminary punch list.
 - k. Plumbing fixture installation.
4. Up-coming work
 - a. Sod and Landscaping on East parking and bus loop.
 - b. Top-coat asphalt on East side.
 - c. Radius glass wall installation (media center wall).
 - d. Sheetrock walls / tape-texture-paint in Admin offices and Auditorium

If there are any questions or concerns regarding the current status of the new Eisenhower Middle School, please contact me at (405) 748-5043 or by e-mail at jjacox@crossland.com

Joshua Jacox
Project Manager
Crossland Construction Company Inc.



BUSINESS OPERATIONS
Board Meeting Update
June 1, 2020

Paula Diehl – Payroll

- Processing payrolls for all employees to include extended leave for the cessation – COVID-19.
- Preparing/Submitting Employer Retirement Verifications as needed for end of FY20.
- Running end-of-year reports and auditing for closing of 2019-20.

Jean Hastings – Personnel

- Accessing our first Virtual Career Fair that was May 12 from 9-noon and 1 – 4 pm. It was successful – currently we have only 32 positions to fill (14 are SPED, 18 are regular ed)
- Completing scan of employment files to push out Frontline Central this fall. This is the software that will allow employees access to their employment file and allow for many communications to take place online that has been paper previously such as contracts, W2 changes, salary entitlements, etc)

Daniel Ghrrayeb - Child Nutrition

- We are starting summer feeding at seven schools and utilizing six bus routes to make over 70 stops.
- Training for summer feeding with the SDE has been completed for all administrative positions.
- We received a \$2,000 grant for Pat Henry Elementary from Gen Youth / Dairy Max for Covid-19 Feeding.

AJ Watson - Information Technology

Technology Maintenance:

- Moved 12 Offices at Shoemaker Center.
- Delivered 98 flat panel smart interactive devices to district.
- Repaired or swapped out 70 +/- teacher computers and issued 39 USB webcams.

Network:

- Installed door stations on all safe rooms.
- Repaired inoperable cameras at the maintenance area.
- Repaired the internet at Ridgecrest Elementary

Systems:

- Created 35 email accounts for newly hired employees and 70 Resigned/ Retired user accounts will be removed this month.
- Purged 1800 risk emails.
- Updated JAMF, created DMZ server to access apple devices from outside of the district network.

Information Systems:

- Processed report cards for Print Shop.
- Created reports for the different departments.
- Processing new enrollment applications.

Educational Technology:

- Worked with Curriculum Team to put together LPS' first virtual Professional Development.

Dave McDermott – Media Operations

- We continue to receive all packages for the district.
- Printed 8th grade certificates and programs, and mailed.
- Printed, folded, stuffed, addressed all report cards for the district.

Jack Hanna – Facilities Operations/Maintenance

- Grounds crew is working at all facilities to maintain grounds.
- All custodians are reporting to assigned buildings on a split shift schedule to perform essential obligations and maintain a level of standards according to LPS guidelines.
- Work at Brockland is moving forward to enable the Special Services to move into the building.
- Window vents are near completed for all safe rooms to avoid any further vandalism. Once this is completed they will be installed by the LPS maintenance team.
- Transportation continues to support the Child Nutrition department with delivery sites.



EDUCATIONAL SERVICES
Board Meeting Update
June 1, 2020

Brenda Hatch – Elementary Ed. / Professional Development

Karen Cooksey – Elementary Education

Donna Catlin – Elementary Ed. / Early Childhood

Rick Owens – Secondary Education

Carol McPhail – Middle Schools

Chris Sharkey – Special Services

Teresa Jackson – High Schools

- Working with the Ed Tech Team to continue developing technology resource professional development for teachers, students, and parents.
- Conducting goal setting meetings for the Teaching and Learning Team.
- Relocating Teaching and Learning Team offices for close proximity and effective collaboration.
- Preparing for state reports
- Coordinated Food 4 Kids backpack overages at sites and distributed them to sites needing more food bags.
- Conducted elementary counselor interviews.
- Zoom meetings with principals and counselors.
- Special Services is preparing for distance learning Extended School Year (ESY), to start June 2 - June 18, 2020.
- Special Services is working on the OSDE End of the Year report, due June 30, 2020.
- Planning for next year keeping in mind various delivery methods to our students
- Yearbook Curbside Pickups – Week of May 22, (LHS/EHS - Late June-July, but dates may be delayed due to publisher closed for business)
- High School and Gateway Virtual Graduation Ceremonies – May 22, aired for the public 1:00 p.m. – 4:00 p.m.
- Senior Recognition Activities - Senior picture signs placed at each high school. Students were asked to take a picture with their sign and submit it on the LPS FB page. EHS's front lawn was generously mowed by "B Mowers". They were driving by as signs were being placed and asked if they could mow the lawn as a gift to the seniors. A HUGE Thank You to "B Mowers".
- Diploma Delivery - Diplomas to be given out in June.
- Teacher Appreciation Day - Each high school provided lunch to teachers as a drive up and go.
- Student Locker Clean-out - Curbside pick-up at each high school
- Teacher Classroom Clean-out - Appointment schedule following CDC Guidelines

Joan Gabelmann – Student Assessment and Accountability

- Researching vetted progress monitoring/interim assessment options for 2020 - 2021
- Meeting with state and local entities regarding assessment, accountability, and district planning
- Collaborating with grading team to help implement appropriate grading instructions and expectations for spring 2020 semester.

Teresa Donahue – Federal Programs

- Providing guidance to all school site Title I Schoolwide Planning teams for completing a Needs Assessment and writing a Title I Schoolwide Plan.
- Providing guidance, templates and communicating the need for Time & Effort documentation for all federally funded employees.
- Maintaining the financial operations of all federal grants

Diana Landoll - Grants

- Receiving and distributing inventory to sites: DoDEA Elementary Schools- Test Prep Books, Middle and High Schools - Special Education Writing Curriculum, and High Schools - EL Newcomer Curriculum, High Interest/Low Readability Readers
- Revising DoDEA budgets and requisitioning school site software, professional development, and instructional materials for the 2020-2021 School Year
- Working on OEM (Oklahoma Emergency Management)/FEMA grant application for reimbursement of district's COVID 19 expenses.



**Minutes of the Lawton Public Schools
Board of Education Special Meeting
Held on Tuesday, May 19, 2020**

The Board of Education of Independent School District I-8, Comanche County, Oklahoma, met on Tuesday, May 19, 2020 at 5:00 PM in Shoemaker Center Auditorium, 753 NW Fort Sill Blvd, Lawton, Oklahoma.

CALL TO ORDER, PLEDGE OF ALLEGIANCE AND ROLL CALL

Carla Clodfelter, President, called the meeting to order. Interim Superintendent Dr. Tom Thomas led the flag salute. Roll call indicated the following board members were present:

(Note: All were present at Shoemaker Center, none by videoconferencing)

Carla Clodfelter, President
Patty Neuwirth, Vice-President
Kelly Edwards
Mary Bradley
Zeldon Rice

*Col. Don King, Ex-Officio, was absent.

SPECIAL GUESTS/SPECIAL RECOGNITION

Academic excellence for the 2019-2020 school year was celebrated via video presentation recognizing students from all three high schools in the following categories:

National Merit Scholars:

MHS – Eric Wang, Ryan Bolin (finalist)

Oklahoma Academic Scholars:

LHS: Keayla Anderson, Jacob Compton, Johnathan Hoffmann, Jadeyn Perry

EHS: Katelynn Clouse, Simon Gibson, Elizabeth High, Kyle Nethercot, Kaylynn Risley, Dominique Smalls, David Yun

MHS: Austin Aguilera, Ian Anderson, Robert Bausch, Brooklynn Baxter, Ryan Bolin, Erika Brock, Andrew Celedon, Brandon Craig, Divina DHaiti, Kelsey Ferguson, Brianna Heckert-Smith, Hannag Hively, David Jeffalone, Makinley Kennedy, Elizabeth Kopsky, Jada Lawson, Kamyla McCormick, Clay Pritchett, Evan Rafferty, Andrew Saliba, Jesse Smith, Stephen Smith, Jacob Swedlund, Eric Wang, Chandler Lugo

Oklahoma Academic All-State:

MHS: Eric Wang

ACT 30+:

LHS: Keayla Anderson - 30, Jacob Compton - 32, Johnathan Hoffmann - 30

EHS: Simon Gibson – 35, Kyle Nethercot – 34, Dominique Smalls – 32, Kaylynn Risley – 30

MHS: Ryan Bolin – 34, Ericka Brock – 31, Andrew Celedon -30, Kylor Day – 30, Makinley Kennedy – 30, Evan Rafferty – 34, Stephen Smith – 34, Eric Wang - 35

ARCHITECT AND CONSTRUCTION MANAGER UPDATE

Architect Cory Miller of Architects in Partnership presented an overview via videoconference of the written updates he and Josh Jacox of Crossland Construction provided the board on the status of the various district

projects. He noted that the estimated date of completion for the Eisenhower Middle School project is August 1, 2020 with the auditorium to be delayed beyond August 1 due to the chair factory being closed due to Covid-19. He stated that the project is slightly behind schedule due to driver shortages causing delays in deliveries of construction items as well as several inclement weather days. Furniture deliveries are expected July 20. He also noted that the Cameron Stadium turf is expected to be delivered to the site June 3. Mr. Jacox was unable to attend the meeting.

DEPARTMENTAL REPORTS

As an informational item, Child Nutrition Manager, Daniel Ghrayyeb, presented an update via videoconference on how the district’s child nutrition department has been running since the Covid-19 lockdown took place immediately following spring break. He noted that the district began serving meals on Monday, March 23 at 21 school sites, adding 50 bus stops to accommodate the plan. He added that each meal consists of a lunch and a breakfast for the next day. Since that time, the district has served just under 200,000 meals to students in Lawton. He explained that they plan to begin their summer schedule Tuesday, May 26, switching to servicing just 7 schools, running approximately 70 bus stops, and the schools that were previously served will meals will become bus stops. Mr. Ghrayyeb thanked all those that assisted with getting the program underway during this time.

Executive Director of Human Resources, Jean Hastings, presented proposed changes to the FY21 Extra Duty Salary Schedule for approval, noting salary increases were comparative to other districts the size of LPS, although still below some of the smaller area districts. Ms. Bradley noted that although she does support the changes, she wanted to share with the district’s certified staff that the district does need to increase the salaries of district administrators in order to be competitive with other districts, and she hoped they did not feel slighted.

Motion Passed: Motion to approve the proposed FY21 Extra Duty Salary Schedule passed with a motion by Patty Neuwirth and a second by Mary Bradley. Roll call was:

Mary Bradley	Yes
Carla Clodfelter	Yes
Kelly Edwards	Yes
Patty Neuwirth	Yes
Zeldon Rice	Yes

REPORT OF THE INTERIM SUPERINTENDENT

Interim Superintendent Dr. Tom Thomas discussed with the board the change in Title I designation of the district with the options to go either site-based or school-wide. He recommended that the district go “school-wide” based on the number of advantages in doing so. All district school sites will then be designated Title 1. Superintendent Kevin Hime stated he has found no reason not to do so and assured everyone that no jobs will be cut or any effective programs lost due to the change.

Motion Passed: Motion to approve the change to “school-wide” Title I designation of the school district passed with a motion by Kelly Edwards and a second by Patty Neuwirth. Roll call was:

Mary Bradley	Yes
Carla Clodfelter	Yes
Kelly Edwards	Yes
Patty Neuwirth	Yes
Zeldon Rice	Yes

SUPERINTENDENT'S ANNOUNCEMENT(S)

- Dr. Thomas announced that this was his last board meeting. He thanked the board for the privilege and honor to serve the district. Board members also thanked him for his time and service.
- Congratulations to Eisenhower Middle School 6th grade Academic Team, winning the district, regional, and area competitions without losing a single match! They were slated to attend nationals; however, the competition was canceled due to the pandemic. Team members included Eesha Katta, Milo Wyatt, Jaylen Carter, and Austin Barteck.
- Lawton Virtual Academy will expand to middle school for the 2020-2021 school year.
- Professional Development for the district staff is going well.

CONSENT AGENDA

Motion Passed: Approval of the consent agenda as presented passed with a motion by Patty Neuwirth and a second by Kelly Edwards. Roll call was:

Mary Bradley	Yes
Carla Clodfelter	Yes
Kelly Edwards	Yes
Patty Neuwirth	Yes
Zeldon Rice	Yes

EXECUTIVE SESSION

There was no executive session.

SUPERINTENDENT'S PERSONNEL REPORT

Ms. Bradley thanked the retirees and employees leaving the district for their time and service. Dr. Thomas made note of two corrections needed on the Personnel Reports:

- Certified – Teacher Amanda Mack, noted as a resignation, however she will be reassigned from Whittier Elementary to Crosby Park Elementary for 2020-2021.
- Extra Duty Salary Schedule – typo on page 2, Johnson-O’Malley Coordinator salary should be \$6,600, not \$660.00 as noted.

Motion Passed: Motion to approve the Certified and Support Personnel Reports as amended passed with a motion by Kelly Edwards and a second by Zeldon Rice. Roll call was:

Mary Bradley	Yes
Carla Clodfelter	Yes
Kelly Edwards	Yes
Patty Neuwirth	Yes
Zeldon Rice	Yes

There was no recommendation at this time regarding Middle School Principal.

NEW BUSINESS

There was no new business.

FUTURE BOARD MEETING DATES

The next regular board meeting date is Monday, June 1, 2020, at 5:00 p.m., in the Shoemaker Center Auditorium. No new meeting dates were set.

BOARD ANNOUNCEMENTS

Ms. Clodfelter made note of how nice the senior graduation photo cards look that have been placed in front of each high school. She also thanked the Oklahoma Sports Network for streaming all high school virtual graduations for the district.

ADJOURNMENT

Motion Passed: Motion to adjourn the meeting passed with a motion by Patty Neuwirth and a second by Mary Bradley. The time was 5:31 p.m. Roll call was:

Mary Bradley	Yes
Carla Clodfelter	Yes
Kelly Edwards	Yes
Patty Neuwirth	Yes
Zeldon Rice	Yes

I, the undersigned clerk of the Board of Education of Lawton Public Schools, District I-8, Comanche County, Oklahoma, do hereby certify that prior notice of this meeting was given to the County Clerk of Comanche County, Oklahoma, listing the time, place, and date of the meeting. I also certify that at least 24 hours prior to the meeting, notice of the time and place and the agenda were posted in prominent view of the location of the meeting and in all respects Title 25, O.S. (Supp.) both inclusive, have been complied with fully.

Witness my hand and seal of the school district this _____ day of _____, 2020.

School Seal:

Kathy Bentley, Clerk of the Board

Denise Duffy, Minutes Clerk

Carla Clodfelter, President

Lawton Public Schools
Lawton, Oklahoma

Administrative Services Division
Purchasing Department

PURCHASING SECTION

June 1, 2020

- I. Request permission to increase, issue purchase orders, and to make related encumbrances.
- II. Encumbrance Approval/Partial Payment

Lawton Public Schools
Lawton, Oklahoma

Administrative Services Division
Purchasing Department

Request to Increase Purchase Orders

June 1, 2020

Request permission to increase the following purchase orders:

iNET Communications LLC
\$25,746.60 to \$32,246.60

Shoemaker - **Watson**
Acct. #0-26-185

#20000499

An increase on standing purchase order of \$6,500.00 is due to an increase in the number of channels needed to make calls to parents during the cessation of schools because of the coronavirus outbreak.

Lawton Public Schools
Lawton, Oklahoma

Administrative Services Division
Purchasing Department

Request to Issue Purchase Orders and Make Related Encumbrances

June 1, 2020

Shoemaker - Gibbs

Bedrock Irrigation & Nursery

Irrigation system and landscaping
at Shoemaker. This project was
started by Sodexo on LPS's behalf
prior to contract termination.

\$34,631.12

BEGINNING DATE: 5/12/2020
 ENDING DATE: 5/22/2020

LAWTON PUBLIC SCHOOLS
 PURCHASE ORDER ENCUMBRANCE LIST

PAGE 1

Qty	DESCRIPTION	PO DATE	VENDOR NAME	ACCOUNT NO	AMOUNT	PO NO
FUND 11 GENERAL FUNDS						
PROJECT 101 ADMINISTRATIVE SERVICES						
SITE 050 DISTRICT WIDE SERVICES						
1	CUSTOMIZING OF CURRENT POLICY MANUAL/FY20 STAND/BD APVD 5-19-2020	05/21/20	OSSBA	0-11-101-52319-337-000-0000-000-050	6,000.00	20005028
SITE Total 050 DISTRICT WIDE SERVICES					6,000.00	
PROJECT Total 101 ADMINISTRATIVE SERVICES					6,000.00	
PROJECT 107 MEDIA/TECHNOLOGY SERVICES						
SITE 399 TECHNOLOGY SERVICES_AJ WATSON						
1	SOLE SOURCE/TECHNOLOGY ITEMS PER ATTACHED	05/14/20	APPLE INC	0-11-107-52520-653-000-0000-000-399	6,622.00	20005021
SITE Total 399 TECHNOLOGY SERVICES_AJ					6,622.00	
PROJECT Total 107 MEDIA/TECHNOLOGY					6,622.00	
PROJECT 109 TRANSPORTATION SERVICES						
SITE 381 TRANSPORTATION_						
1	SOLE SOURCE/LABOR & MATLS TO REPAIR BUS 625	05/22/20	WEBER'S DIESEL	0-11-109-52740-439-000-0000-000-381	1,310.05	20005038
5	GPS LIGHT DUTY CABLE KITS	05/21/20	ZONAR SYSTEMS INC	0-11-109-52720-612-000-0000-000-381	149.75	20005037
1	SHIPPING	05/21/20	ZONAR SYSTEMS INC	0-11-109-52720-612-000-0000-000-381	26.25	20005037
SITE Total 381 TRANSPORTATION_					1,486.05	
PROJECT Total 109 TRANSPORTATION					1,486.05	
PROJECT 621 FLOW THRU, PL 101-476,IDEA/B						
SITE 368 SPECIAL SERVICES_CHRIS SHARKEY						
25	BANKERS BOX CORRUGATED STORAGE/FILE 20 PACK	05/21/20	STAPLES BUSINESS ADVANTAGE	0-11-621-52330-619-239-0000-000-368	1,250.50	20005034
SITE Total 368 SPECIAL SERVICES_CHRIS					1,250.50	
PROJECT Total 621 FLOW THRU, PL 101-					1,250.50	
PROJECT 766 SUMMER FOOD SERVICE PROGRAM						
SITE 392 CHILD NUTRITION_						
1	LOCAL TRAVEL/FY20 STAND/BD APVD 5-19-2020/SUMMER FEED PROGRAM	05/21/20	SAMPLEY PATSY	0-11-766-53140-581-700-0000-000-392	200.00	20005029
1	FOOD ITEMS/FY20 STAND/BD APVD 5-19-2020/SUMMER FEED PROGRAM	05/21/20	SYSCO OF OKLAHOMA INC	0-11-766-53150-630-700-0000-000-392	25,000.00	20005030

BEGINNING DATE: 5/12/2020
 ENDING DATE: 5/22/2020

**LAWTON PUBLIC SCHOOLS
 PURCHASE ORDER ENCUMBRANCE LIST**

PAGE 2

Qty	DESCRIPTION	PO DATE	VENDOR NAME	ACCOUNT NO	AMOUNT	PO NO
1	NON-FOOD ITEMS/FY20 STAND/BD APVD 5-19-2020/SUMMER FEED PROGRAM	05/21/20	SYSCO OF OKLAHOMA INC	0-11-766-53140-618-700-0000-000-392	10,000.00	20005030
1	MILK/FY20 STAND/BD APVD 5-19-2020/SUMMER FEED PROGRAM	05/21/20	HILAND DAIRY FOODS COMPANY, LLC	0-11-766-53150-630-700-0000-000-392	15,000.00	20005031
1	BREAD/FY20 STAND/BD APVD 5-19-2020/SUMMER FEED PROGRAM	05/21/20	BIMBO BAKERIES USA INC	0-11-766-53150-630-700-0000-000-392	5,500.00	20005032
1	PRODUCE/FY20 STAND/BD APVD 5-19-2020/SUMMER FEED PROGRAM	05/21/20	FRESHPOINT OKLAHOMA CITY LLC	0-11-766-53150-630-700-0000-000-392	5,500.00	20005033
					SITE Total 392 CHILD NUTRITION_	61,200.00
					PROJECT Total 766 SUMMER FOOD SERVICE	61,200.00
					FUND Total 11 GENERAL FUNDS	76,558.55
FUND 21 BUILDING FUND						
PROJECT 108 MAINTENANCE SERVICES						
SITE 380 MAINTENANCE_KEN BADEN						
5	CUSTODIAL/DOODLE SCRUB PADS	05/14/20	EMPIRE PAPER CO INC	0-21-108-52620-618-000-0000-000-380	163.15	20005017
					SITE Total 380 MAINTENANCE_KEN BADEN	163.15
					PROJECT Total 108 MAINTENANCE SERVICES	163.15
					FUND Total 21 BUILDING FUND	163.15
FUND 26 MUNICIPAL TAX FUND (2015)						
PROJECT 181 BLDG REPAIR/RENOVATIONS						
SITE 380 MAINTENANCE_KEN BADEN						
2	SOLE SOURCE/1 TON AC UNIT	05/22/20	LENNOX INDUSTRIES	0-26-181-52620-651-000-0000-000-380	2,705.10	20005039
1	BROCKLAND PROJECT/RENTAL OF ROLL-OFF/BUILDING CLEAN-UP	05/21/20	WASTESOLUTIONS LLC	0-26-181-52620-420-000-0000-000-380	275.00	20005036
1	BROCKLAND PROJECT/BOARDS FOR WINDOW UNITS PER ATTACHED	05/14/20	ARROW SIGN COMPANY INC	0-26-181-52620-618-000-0000-000-380	2,520.10	20005020
					SITE Total 380 MAINTENANCE_KEN BADEN	5,500.20
					PROJECT Total 181 BLDG	5,500.20
PROJECT 185 GROUNDS REPAIR/RENOVATIONS						
SITE 353 BUSINESS OFFICE_LANCE GIBBS						
1	SHOEMAKER CENTER/QUOTES/LABOR & MATLS TO REMOVE TREES AND GRING STUMPS	05/21/20	SULLIVAN TREE SERVICE	0-26-185-52630-420-000-0000-000-353	2,500.00	20005035

BEGINNING DATE: 5/12/2020
 ENDING DATE: 5/22/2020

**LAWTON PUBLIC SCHOOLS
 PURCHASE ORDER ENCUMBRANCE LIST**

PAGE 3

Qty	DESCRIPTION	PO DATE	VENDOR NAME	ACCOUNT NO	AMOUNT	PO NO
SITE Total 353 BUSINESS OFFICE_LANCE					2,500.00	
PROJECT Total 185 GROUNDS					2,500.00	
FUND Total 26 MUNICIPAL TAX FUND (2015)					8,000.20	
FUND 33 BOND FUND (2017)						
PROJECT 165 BOND-FURNITURE						
SITE 122 EDISON ELEMENTARY						
1	BID BD APVD 5-19-2020/AMTAB ADA CAFETERIA TABLES	05/21/20	MERRIFIELD OFFICE & SCHOOL SUPPLY CORP	0-33-165-53190-651-239-0000-000-122	1,255.13	20005026
14	BID BD APVD 5-19-2020/AMTAB CAFETERIA TABLES	05/21/20	MERRIFIELD OFFICE & SCHOOL SUPPLY CORP	0-33-165-53190-651-000-0000-000-122	17,141.04	20005026
SITE Total 122 EDISON ELEMENTARY					18,396.17	
SITE 127 FREEDOM ELEMENTARY						
4	BID BD APVD 5-19-2020/COOPER CABINET SHELVING/42H X 24D X37W	05/21/20	MERRIFIELD OFFICE & SCHOOL SUPPLY CORP	0-33-165-51000-651-100-1050-000-127	3,806.80	20005024
SITE Total 127 FREEDOM ELEMENTARY					3,806.80	
SITE 530 MACARTHUR MIDDLE SCHOOL						
2	BID BD APVD 5-19-2020/AMTAB ADA CAFETERIA TABLES	05/21/20	MERRIFIELD OFFICE & SCHOOL SUPPLY CORP	0-33-165-53190-651-239-0000-000-530	2,728.20	20005026
28	BID BD APVD 5-19-2020/AMTAB CAFETERIA TABLES	05/21/20	MERRIFIELD OFFICE & SCHOOL SUPPLY CORP	0-33-165-53190-651-000-0000-000-530	37,297.40	20005026
SITE Total 530 MACARTHUR MIDDLE SCHOOL					40,025.60	
PROJECT Total 165 BOND-FURNITURE					62,228.57	
FUND Total 33 BOND FUND (2017)					62,228.57	

APPLICATION FOR TEMPORARY APPROPRIATIONS

WHEREAS: The needs of the Board of Education of Lawton Independent School District I-8 of Comanche County requires the immediate approval of temporary appropriations for the fiscal year 2020-2021.

NOW, THEREFORE, BE IT RESOLVED, that the County Excise Board of Comanche County be requested to approve temporary appropriations to the extent of and not to exceed one-hundred percent (100%) of the total estimated needs as submitted to said Board as follows:
As published for annual mill election.

REQUESTED APPROPRIATIONS

General Fund (11)	\$ <u>139,000,000</u>
Building Fund (21)	\$ <u>3,000,000</u>
Municipal Tax Fund - 2010 (25) Municipal	\$ <u>255,000</u>
Tax Fund - 2015 (26)	\$ <u>5,500,000</u>
Bond Fund - 2004 (31)	\$ <u>15,000</u>
Bond Fund - 2014 (32)	\$ <u>7,600,000</u>
Bond Fund – 2017 (33)	\$ <u>20,000,000</u>
Lease Note Fund – 2017 (34)	\$ <u>4,760,000</u>
Sinking Fund (41)	\$ <u>6,500,000</u>

APPROVED AND ADOPTED THIS 1st day of June, 2020.

THE BOARD OF EDUCATION
Lawton School District I-008
Comanche County, Oklahoma

ATTEST:

Clerk – Board of Education

President - Board of Education

APPROVED by the Comanche County Excise Board this _____ day of _____, 2020.

THE COUNTY EXCISE BOARD
Comanche County, Oklahoma

Chairman - County Excise Board

ATTEST:

Member

County Clerk

Member

**Lawton Public Schools
Business Operations**

**Report of Activity Fund Custodian
June 1, 2020**

REQUEST PERMISSION TO MAKE THE FOLLOWING ACTIVITY FUND TRANSFERS:

	<u>Acct. Credited</u>	<u>Acct. Debited</u>	<u>Purpose</u>	<u>Amount</u>
1	LHS Robotics	LHS Girls Soccer	Jersey Decorations	\$100.00
2	LHS Commission	LHS Student Council	Partial Repayment from November	\$2,000.00

**Lawton Public Schools
Business Operations**

**Report of the Clerk
June 1, 2020**

REQUEST APPROVAL OF THE FOLLOWING CONSTRUCTION-RELATED DOCUMENTS:

Crossland Construction Company
EMS New Construction

Change Order #12

2017 Bond (33)
Use \$23,511.23 from Contingency

REQUEST APPROVAL OF THE FOLLOWING CONTRACTS/AGREEMENTS:

Certification of Children's Internet Protection Act (CIPA) and E-Rate Requirements

Herff Jones
LHS Yearbook

Printing Agreement 2020-2021

Activity Fund (60)

Kathy Bentley

From: Cory Miller <cory.miller@aipok.com>
Sent: Thursday, May 21, 2020 9:49 AM
To: Kathy Bentley
Cc: Kevin Hime; Tom Thomas; Jack Hanna; Don McCaig; Lance Gibbs; 'Joshua Jacox (jjacox@crossland.com)'
Subject: LPS New EMS - Change Order #12
Attachments: 1715A - Change Order 12.pdf

*****CAUTION: EXTERNAL EMAIL - Think before you click or open attachments! *****

Kathy,

I am attaching Change Order #12 for approval. This authorizes the use of \$23,511.23 from contingency for the following items:

Exhaust Registers at C122, C124, C204, and C206 \$192.89

During construction the contractor discovered that these restroom exhaust registers were undersized for the air volume they were to provide.

Interlocked Masonry Credit (\$22,640.00)

The specifications required interlocked corners where CMU walls intersected. When construction began, the subcontractor did not interlock the first walls that were erected at the gyms. The subcontractor was given notice of the requirement and told to interlock the CMU moving forward. The subcontractor neglected to do so which led to quality control problems in some areas. The architect requested that the subcontractor return the cost savings to the Owner for the method of installation that was used. A portion of this credit was used to coordinate the masonry at a door jamb as required by the fire rated coiling door manufacturer. Refer to the breakdowns attached in the Change Order.

Column Covers \$10,509.00

The exterior aluminum column covers at the west entrance were shown in the Construction Documents but were not included in the bid packages. The Construction Manager received two proposals for this work, and this is the less expensive of the two.

Transfer Grille Coordination with New Millwork at Kiln Storage B118 \$2,281.43

During construction ASI-020 was issued with Owner requested changes that included adding millwork at Kiln Storage B118. An air transfer grille must be raised to coordinate with this millwork. This mechanical cost was not included in the previous price of Change Order #6.

Courtyard Foundation Skirt Transition Angle \$438.50

AIP recommends adding a trim angle to transition the foundation skirt where the concrete paving rises to meet the storefront window framing in the Courtyard.

Coordinate Mechanical with Wrestling Room Furr Down \$796.95

A furr down was added at the Wrestling Room to cover spray-applied fireproofing in Change Order #10. This cost to coordinate the mechanical ductwork adjacent to the furr down was not included at that time.

Stainless Steel Cover Plates for Data Blanks \$400.00

An RFI answered during bidding allowed the use of hard plastic blank cover plates for the data ports which were rough-in only with the expectation that the district may add data ports in the near future. Since the district is mostly using Wi-Fi, we don't expect for these blanks to be modified for some time. The rest of the electrical and data cover plates are stainless steel. AIP recommends approving this cost increase to include stainless steel blank data cover plates that will match the rest.

Stainless Steel Shrouds over FACS Hood Exhaust \$2,650.46

During construction it was discovered that the exhaust ductwork would be exposed from the kitchen hood to the ceiling at the FACS kitchenettes. AIP recommends approval of this cost increase to provide stainless steel shrouds to cover this ductwork as an extension of the stainless steel hoods. The contractor expects that this option will be less expensive than a painted gypsum board furr down.

New Communications Vault \$3,857.00

The Construction Documents originally called for reusing an existing communications vault. During construction it was discovered that the vault contained a fiber connection from a vendor other than who the district currently uses for data service. Change Order #6 included a new fiber building entry from the district's current vendor and relocating the existing vault as required by the vendor. When the contractor attempted to relocate the vault, it was found to be unusable, and a new vault is needed.

Second Round of Asbestos Abatement – Subtotal: \$25,025.00

1. Air monitoring of the school while abatement is being conducted (Assuming 15 days of actual abatement at \$535 per day): \$8,025.00
This is a State requirement that was not included in the GMP.
2. State required air testing (\$100 per test and 5 tests per area at 6 areas): \$3,000.00
This is a State requirement for buildings that will be reoccupied after asbestos abatement. During design the asbestos design plan excluded re-occupancy of the building after asbestos abatement. As part of the contingency planning around COVID-19, LPS decided that we should maintain the option to re-occupy the existing EMS building just in case the new building is not ready for school in August.
3. Additional fittings (Assuming 200 fittings that are 3" in diameter or smaller @ \$60 a fitting): \$12,000.00
The original design plan included 200 fittings that were noted in the Owner's asbestos report. The contractor discovered additional asbestos that was concealed within plumbing chases and were not included in the asbestos report nor the design plan for abatement. This quantity and size is being used as an allowance for the Change Order. Any unused portion will be returned to the Owner by Change Order after abatement is complete.
4. Interior demolition for access: \$2,000.00
The asbestos that is concealed in plumbing chases will require additional interior demolition for access and State inspection.

Feel free to contact me with any questions.

Thank you,
Cory S. Miller, NCARB
Sr. Project Manager/ Associate



Architects in Partnership



AIA® Document G701™ – 2017

Change Order

PROJECT: <i>(Name and address)</i> Lawton Public Schools - New Eisenhower Middle School Lawton, Oklahoma	CONTRACT INFORMATION: Contract For: General Construction Date: January 19, 2018	CHANGE ORDER INFORMATION: Change Order Number: 12 Date: May 21, 2020
OWNER: <i>(Name and address)</i> Lawton Public Schools 753 NW Ft. Sill Blvd. Lawton, Oklahoma 73507	ARCHITECT: <i>(Name and address)</i> Architects in Partnership, LLC 3220 Marshall Avenue Norman, Oklahoma 73072	CONTRACTOR: <i>(Name and address)</i> Crossland Construction Company 408 N.E. 145th Place Edmond, Oklahoma 73013

THE CONTRACT IS CHANGED AS FOLLOWS:

(Insert a detailed description of the change and, if applicable, attach or reference specific exhibits. Also include agreed upon adjustments attributable to executed Construction Change Directives.)

Contingency Amount: \$456,425.25

Exhaust Registers at C122, C124, C204, and C206	\$192.89
Interlocked Masonry Credit	(\$22,640.00)
Column Covers	\$10,509.00
Transfer Grille Coordination with New Millwork at Kiln Storage B118	\$2,281.43
Courtyard Foundation Skirt Transition Angle	\$438.50
Coordinate Mechanical with Wrestling Room Furr Down	\$796.95
Stainless Steel Cover Plates for Data Blanks	\$400.00
Stainless Steel Shrouds over FACS Hood Exhaust	\$2,650.46
New Communications Vault	\$3,857.00
Second Round of Asbestos Abatement - Subtotal	\$25,025.00
1. Air monitoring of the school while abatement is being conducted (Assuming 15 days of actual abatement at \$535 per day):	\$8,025.00
2. State required air testing (\$100 per test and 5 tests per area at 6 areas)	: \$3,000.00
3. Additional fittings (Assuming 200 fittings that are 3" in diameter or smaller @ \$60 a fitting):	\$12,000.00
4. Interior demolition for access:	\$2,000.00

Remaining Contingency: \$432,914.02

The original Contract Sum was	\$	10,939,373.00
The net change by previously authorized Change Orders	\$	26,997,127.44
The Contract Sum prior to this Change Order was	\$	37,936,500.44
The Contract Sum will be decreased by this Change Order in the amount of	\$	0.00
The new Contract Sum including this Change Order will be	\$	37,936,500.44

The Contract Time will be unchanged by Zero (0) days.

The new date of Substantial Completion will be May 11, 2020

NOTE: This Change Order does not include adjustments to the Contract Sum or Guaranteed Maximum Price, or the Contract Time, that have been authorized by Construction Change Directive until the cost and time have been agreed upon by both the Owner and Contractor, in which case a Change Order is executed to supersede the Construction Change Directive.

NOT VALID UNTIL SIGNED BY THE ARCHITECT, CONTRACTOR AND OWNER.

Architects in Partnership, LLC
ARCHITECT *(Firm name)*

Crossland Construction Company
CONTRACTOR *(Firm name)*

Lawton Public Schools
OWNER *(Firm name)*

SIGNATURE

Cory Miller, Senior Project
Manager/Associate
PRINTED NAME AND TITLE

May 21, 2020
DATE

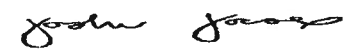
SIGNATURE

Josh Jacox, Project Manager
PRINTED NAME AND TITLE

May 21, 2020
DATE

SIGNATURE

PRINTED NAME AND TITLE

DATE

1715A - Lawton Public Schools New Eisenhower Middle School
Trend Log



Last Update: MAY 21, 2020

	Closed Issue (Accepted - No)
	Active Issue (Pending)
	New Issue (Issue Item Needs)
	Not Accepted

Original Contract Amount: \$10,939,373.00
Construction Occupancy: 09/17/2018
Original Completion Date: 05/11/2020

Item	ASI No.	Date	Description	Proposed	Acceptance Required Date	LPS Acceptance Date	Accepted Change Amount	Working Estimate	PCO No.	CO No.	CO Date	Comments
01			Original Contingency	(\$546,000.00)		2/21/2019	(\$546,000.00)	(\$546,000.00)				As of GMP #4
02	ASI-001	10/5/2018	Art Room & Vocal Windows	\$0.00			\$0.00	\$0.00				Concur
03	ASI-002	10/25/2018	Landing at Door B101	\$0.00		3/12/2019	\$0.00	\$0.00				Concur
04	ASI-003	11/30/2018	Sanitary Sewer & Gas Utility	\$540.32		3/12/2019	\$540.32	\$540.32		3	3/15/2019	Concur. \$ included in Pier Log (Trend Log Item 15)
05	ASI-004	1/10/2019	Water Loop	\$51,541.11		2/21/2019	\$51,541.11	\$51,541.11				Concur
06	Email	12/14/2018	Non-proprietary Fire Alarm	\$1,959.00		1/17/2019	\$1,959.00	\$1,959.00		1	12/27/2018	Owner Requested - Concur
07	ASI-005	12/28/2018	Muscle Walls to Deck & Elevator Coordination	\$22,163.00		3/12/2019	\$22,163.00	\$22,163.00		3	3/11/2019	Concur
08	Submittal	1/4/2019	Additional Roller Shades	\$16,720.00		3/12/2019	\$16,720.00	\$16,720.00		3	3/11/2019	Concur
09	Submittal	12/20/2018	Door Hardware Coordination	\$5,400.00		3/12/2019	\$5,400.00	\$5,400.00		3	3/11/2019	Concur
10	Email	1/21/2019	MotORIZED Small Gym Bleacher	\$3,662.00		3/12/2019	\$3,662.00	\$3,662.00		3	3/11/2019	Concur
11	ASI-006	1/25/2019	RCP Coordination with Mechanical	\$0.00			\$0.00	\$0.00				Classification only
12	ASI-007	2/6/2019	FD-1 in RR C122 & C124	\$2,461.26		2/21/2019	\$2,461.26	\$2,461.26		2	2/15/2019	Concur
13	ASI-008	2/7/2019	Auditorium Ramp ADA Clearance	\$0.00			\$0.00	\$0.00				Classification only
14	ASI-009	2/11/2019	Electrical Coordination	\$0.00			\$0.00	\$0.00				Classification only
15	Pier Log	2/12/2019	Actual Pier Depths	(\$51,269.51)		3/12/2019	(\$51,269.51)	(\$51,269.51)		3	3/11/2019	Concur
16	ASI-010	5/3/2019	Kitchen Security Closure	\$10,995.00		6/27/2019	\$10,995.00	\$10,995.00		4	6/13/2019	Owner Requested - Concur
17	ASI-011	3/8/2019	Fire Sprinkler Crossing at A131	\$0.00			\$0.00	\$0.00				Classification only
18	ASI-012	3/12/2019	Auditorium Aisle Dimension	\$0.00			\$0.00	\$0.00				Classification only
19	Email	2/27/2019	Building Fiber Connection	\$25,362.00		9/19/2019	\$25,362.00	\$25,362.00		6	9/19/2019	Owner's Vendor - Omitted from GMP - Concur
20	Email	5/11/2019	Rough-in to Exterior Cameras	\$6,047.00		9/3/2019	\$6,047.00	\$6,047.00		5	9/3/2019	Owner Requested - Concur
21	Email	5/3/2019	Access Control Hardware Coordination	(\$236.00)		6/27/2019	(\$236.00)	(\$236.00)		4	6/13/2019	Concur
22	ASI-013	5/9/2019	Gym Dimension Clarification	\$0.00			\$0.00	\$0.00				Classification only
23	Email	2/4/2019	Audio System Coordination	\$8,153.60		6/27/2019	\$8,153.60	\$8,153.60		4	6/13/2019	Concur
24	ASI-014 P2	5/24/2019	IFACS & Career Tech Coordination	\$35,581.00		9/3/2019	\$35,581.00	\$35,581.00		5	9/3/2019	Owner Requested - Concur
25	Submittal	3/21/2019	Omit Motorized Bases for Light Fixture M2	(\$1,000.00)		1/16/2020	(\$1,000.00)	(\$1,000.00)		3	1/16/2020	Concur
26	RFI #082	4/10/2019	Translucent Panel Steel Angle	\$0.00			\$0.00	\$0.00				Use \$400 of allowance per S-000 Structural Steel Note 6
27	Email	6/12/2019	Additional Slab Reinforcement for Terrace Area	\$4,016.00		6/27/2019	\$4,016.00	\$4,016.00		4	6/13/2019	Concur - Uses reinforcing allowance per S-000 Structural Steel Note 6
28	Email	6/12/2019	Hook-up Commercial Washer & Dryer in Existing Cafeteria Dishroom	\$3,200.00								Owner Requested - Awaiting Plumbing Fixing
29	Email	6/12/2019	Irrigation for Football Practice Field	\$20,034.41		9/3/2019	\$20,034.41	\$20,034.41		5	9/3/2019	Owner Requested - Concur
30	Email	6/21/2019	Substitute DecoFloor for Primecoat Resinous Flooring	(\$2,000.00)		9/3/2019	(\$2,000.00)	(\$2,000.00)		5	9/3/2019	Concur
31	ASI-015 R1	6/25/2019	Media Center Coordination	\$9,368.30		9/3/2019	\$9,368.30	\$9,368.30		5	9/3/2019	Owner Requested - Concur
32	RFI #090	6/27/2019	Add 4 Floor Drains to Second Floor at Restrooms	\$4,426.09		9/3/2019	\$4,426.09	\$4,426.09		5	9/3/2019	Concur
33	ASI-016 R1	6/28/2019	Median Paving Section	\$1,725.00		9/19/2019	\$1,725.00	\$1,725.00		6	9/19/2019	Concur
34	Email	7/2/2019	Omit FACs Teaching Station Sink	(\$761.23)		9/3/2019	(\$761.23)	(\$761.23)		5	9/3/2019	Concur
35	Email	6/5/2019	Custom Metal Casing Color	\$10,300.00		9/3/2019	\$10,300.00	\$10,300.00		5	9/3/2019	Concur
36	ASI-017 R1	7/23/2019	Foundation Vapor Barrier Details & Stage Ramp Landing Dimension	\$0.00			\$0.00	\$0.00				Classification only
37	ASI-018	7/29/2019	ID/ MID MOD Electrical Receptacles	\$0.00			\$0.00	\$0.00				Classification only
38	Email	7/24/2019	Resinous Seamless Shower Wall System	\$28,064.10		9/3/2019	\$28,064.10	\$28,064.10		5	9/3/2019	Omitted from GMP - Concur
39	Email	8/6/2019	Irrigation for Soccer Practice Fields	\$18,267.55		9/3/2019	\$18,267.55	\$18,267.55		5	9/3/2019	Owner Requested - Concur
40	ASI-019	8/9/2019	TrueTouch Coordination	\$2,398.00		9/19/2019	\$2,398.00	\$2,398.00		6	9/19/2019	Owner Requested - Concur
41	Email	8/15/2019	Add one flammable storage cabinet at Science Lab C143 and C219	\$1,845.00		9/19/2019	\$1,845.00	\$1,845.00		6	9/19/2019	Owner Requested - Concur
42	ASI-020	8/20/2019	Art & Testing Storage Shelving	\$7,353.00		9/19/2019	\$7,353.00	\$7,353.00		6	9/19/2019	Owner Requested - Concur
43	RFI #108	8/20/2019	Additional Data Bores	\$497.00		9/19/2019	\$497.00	\$497.00		6	9/19/2019	Concur
44		10/4/2019	Transfer Contingency to Furniture Project	\$27,018.56		10/14/2019	\$27,018.56	\$27,018.56		7	10/14/2019	Concur
45	Email	7/6/2019	Water Line Repairs on Gore Blvd.	\$2,613.94		1/16/2020	\$2,613.94	\$2,613.94		3	1/16/2020	Concur
46	Email	12/9/2019	Deduct for Gyp. Bd. Headers Above Corridor Lockers	(\$7,319.00)		1/16/2020	(\$7,319.00)	(\$7,319.00)		8	1/16/2020	Concur
47	ASI-025	11/6/2019	Vestibule C127 Furr Down	\$2,705.44		1/16/2020	\$2,705.44	\$2,705.44		5	1/16/2020	Concur
48	RFI #145	11/25/2019	Safe Room Wall Types J and JA	\$5,000.00		1/16/2020	\$5,000.00	\$5,000.00		3	1/16/2020	Concur

Item	ASI No.	Date	Description	Proposed	Acceptance Required Date	LPS Acceptance Date	Accepted Change Amount	Working Estimate	PCO No.	CO No.	CO Date	Comments
49	Email	10/23/2019	Commons Canopy	\$68,440.00		1/16/2020	\$68,440.00	\$68,440.00		8	1/16/2020	Omitted from GMP - Concur
50	Email	12/17/2019	Concrete Basculid Board	\$14,311.35		1/16/2020	\$14,311.35	\$14,311.35		8	1/16/2020	Omitted from GMP - Concur
51	Email	12/17/2019	Welded Academic Lockers	\$47,478.00		1/16/2020	\$47,478.00	\$47,478.00		6	1/16/2020	Concur
52	Email	11/22/2019	Aggregate Base for Courtyard Paving	\$23,838.63		1/16/2020	\$23,838.63	\$23,838.63		5	1/16/2020	Concur
53	RFI # 163	1/7/2020	Stainless Steel Fittings for Storm Sewer	\$3,165.50		2/3/2020	\$2,185.50	\$3,165.50		9	2/2/2020	Concur
54	Email	12/12/2019	Omit Exhaust Ductwork Insulation	\$7,524.00		4/16/2020	\$7,524.00	\$7,524.00		10	4/16/2020	Concur
55	Email	11/13/2020	Blair-In Combination Locks for All Academic and Athletic Lockers	\$16,908.00		2/3/2020	\$16,908.00	\$16,908.00		9	2/3/2020	Owner Requested - Concur
56	Email	11/13/2020	Center Court Logs at Both Gyms	\$6,260.00		2/3/2020	\$6,260.00	\$6,260.00		9	2/2/2020	Owner Requested - Concur
57	Email	1/3/2020	Wheel Stops at 20 Parking Stalls Adjacent to Light Poles	\$1,697.40		2/3/2020	\$1,697.40	\$1,697.40		9	2/3/2020	Concur
58	Email	1/15/2020	8' Long Marker Boards in Lieu of 4'	\$10,523.00		2/3/2020	\$10,523.00	\$10,523.00		9	2/3/2020	Owner Requested - Concur
59	RFI # 166	1/26/2020	MOA Disconnects for L7A, L7B, and L7C	\$9,522.00		4/16/2020	\$9,522.00	\$9,522.00		10	4/16/2020	Concur
60	ASI-026	1/28/2020	Ceiling Coordination	\$495.00		4/16/2020	\$495.00	\$495.00		10	4/16/2020	Concur
61	ASI-027	2/3/2020	Projector Screen	\$4,105.97		4/16/2020	\$4,105.97	\$4,105.97		10	4/16/2020	Concur
62	Email	2/17/2020	Impact Resistant Gyp Above Lockers	\$12,279.20		4/16/2020	\$12,279.20	\$12,279.20		10	4/16/2020	Concur
63	Email	2/17/2020	Furr Down in Wrestling Room	\$4,551.51		4/16/2020	\$4,551.51	\$4,551.51		10	4/16/2020	Concur
64	Email	2/17/2020	Kitchen Equipment Crest	\$3,475.00		4/16/2020	\$3,475.00	\$3,475.00		10	4/16/2020	Concur
65	Email	2/17/2020	Panic Device for Door B102a	\$941.60		4/16/2020	\$941.60	\$941.60		10	4/16/2020	Concur
66	RFI # 165a	2/24/2020	Water Connection to ASF	\$679.95		4/16/2020	\$679.95	\$679.95		10	4/16/2020	Concur
67	RFI # 174	2/24/2020	Gas Pot Backflow	\$1,178.98		4/16/2020	\$1,178.98	\$1,178.98		10	4/16/2020	Concur
68	Email	2/26/2020	Data Port for Triax SC Panels	\$300.00		4/16/2020	\$300.00	\$300.00		10	4/16/2020	Concur
69	ASI-029	2/26/2020	Roof Details	\$7,396.09		4/16/2020	\$7,396.09	\$7,396.09		10	4/16/2020	Concur
70	ASI-031	3/18/2020	LPD Antenna Mounting	\$5,636.40		4/16/2020	\$5,636.40	\$5,636.40		10	4/16/2020	Owner Requested - Concur
71	Email	3/26/2020	Replace Natural Gas Cocks with Open Ball Valves	\$1,273.52		4/16/2020	\$1,273.52	\$1,273.52		10	4/16/2020	Concur
72	RFI # 157	12/17/2019	Provide Power to Ranges in B156 & C135	\$5,268.00		4/16/2020	\$5,268.00	\$5,268.00		10	4/16/2020	Concur
73	Email	3/24/2020	Ten 4G CONEY for Moving Storage Through July 31, 2020	\$7,360.00		4/16/2020	\$7,360.00	\$7,360.00		10	4/16/2020	Owner Requested - Concur
74	Email	4/16/2020	First Round of Asbestos Abatement: Air Monitoring, State Testing, and Additional 100 Fittings	\$15,850.00		4/20/2020	\$15,850.00	\$15,850.00		11	4/20/2020	Concur
75	RFI # 169	4/14/2020	Exhaust Registers at C122, C124, C204, and C208	\$192.89			\$192.89	\$192.89		12		Concur
76	ASI-032	4/16/2020	Stair Guards and Thermostat Covers	\$13,747.52			\$13,747.52	\$13,747.52		12		Awaiting Revised ASI for Pricing
77	Email	4/27/2020	Interlocked Masonry Credit	\$10,509.00			\$10,509.00	\$10,509.00		12		Omitted from GMP - Concur
78	Email	5/15/2020	Column Covers	\$2,281.43			\$2,281.43	\$2,281.43		12		Owner Requested per ASI-020 - Concur
79	RFI # 184	5/15/2020	Transfer Gite Coordination with New Millwork at Kin Storage B113	\$438.50			\$438.50	\$438.50		12		Concur
80	Email	5/15/2020	Courtyard Foundation Skirt Transition Angle	\$796.95			\$796.95	\$796.95		12		Concur
81	Email	5/15/2020	Coordinate Mechanical with Wrestling Room Furr Down	\$400.00			\$400.00	\$400.00		12		Concur
82	Email	5/15/2020	Stainless Steel Cover Plates for Data Banks	\$2,650.46			\$2,650.46	\$2,650.46		12		Concur
83	Email	5/15/2020	Stainless Steel Shrouds over FACS Hood Exhaust	\$3,857.00			\$3,857.00	\$3,857.00		12		Concur
84	Email	5/15/2020	New Communications Vault	\$25,025.00			\$25,025.00	\$25,025.00		12		Concur
85	Email	5/20/2020	Second Round of Asbestos Abatement: Air Monitoring, State Testing, Additional 200 Fittings, and Demolition for Access	\$25,025.00			\$25,025.00	\$25,025.00		12		Concur
Totals To Date				\$223,511.23			\$223,511.23	\$223,511.23				Negative = Remaining Contingency Amount
				\$1,959.00	CO #1		\$1,959.00	\$1,959.00				Use of contingency; No Change to Contract Sum
				\$54,002.37	CO #2		\$54,002.37	\$54,002.37				Use of contingency; No Change to Contract Sum
				\$1,759,150.00	CO #3		\$1,759,150.00	\$1,759,150.00				Increase contingency; No Change to Contract Sum
				\$22,928.00	CO #4		\$22,928.00	\$22,928.00				Use of contingency; No Change to Contract Sum
				\$132,507.22	CO #5		\$132,507.22	\$132,507.22				Use of contingency; No Change to Contract Sum
				\$59,180.00	CO #6		\$59,180.00	\$59,180.00				Use of contingency; No Change to Contract Sum
				\$37,018.56	CO #7		\$37,018.56	\$37,018.56				Use of contingency; No Change to Contract Sum
				\$155,078.28	CO #8		\$155,078.28	\$155,078.28				Use of contingency; Deduct from Contract Sum
				\$38,653.99	CO #9		\$38,653.99	\$38,653.99				Use of contingency; No Change to Contract Sum
				\$38,431.01	CO #10		\$38,431.01	\$38,431.01				Use of contingency; No Change to Contract Sum
				\$15,850.00	CO #11		\$15,850.00	\$15,850.00				Use of contingency; No Change to Contract Sum
				\$23,511.23	CO #12		\$23,511.23	\$23,511.23				Use of contingency; No Change to Contract Sum
Original Contract Amount				\$10,939,373.00		5/11/2020						
Change Order Summary					Date Executed		New Completion Date					
GMP #1					10/22/2013	\$16,599,241.00	5/11/2020					
GMP #3					11/15/2016	\$7,941,005.00	5/11/2020					
GMP #4					2/21/2019	\$2,493,900.00	5/11/2020					



Trade Mechanical Contractors, Inc.

136 N.E. 48th Street • Oklahoma City, OK 73106

Office: (405) 521-1497 • Fax: (405) 521-1499

REQUEST for CHANGE ORDER #00 Exhaust Registers

Date: 4/14/2020
To: Crossland Construction
Attn: Joshua Jacox
Project: Eisenhower Middle School

Description of Change:

This cost is for the air devices as outlined in RFI 169 - MEP Response. We had already received the ones per plan sheets M-101c & M-102c. We will turn these (4) devices over to LPS.

Direct Labor Subtotal:	\$ <u>80.00</u>	Labor Hrs:	1
Material Subtotal:	\$ <u>0.00</u>		
Equipment Subtotal:	\$ <u>87.00</u>		
Sub-Contractors:	\$ <u>0.00</u>		
Total Direct Cost:	\$ 167.00		
10% Overhead:	\$ 16.70		
Direct Cost & OH:	\$ 183.70		
5% Profit:	\$ 9.19		
Total Change Amount:	\$ 192.89		

Sincerely,

Gary Jones
Estimator / Project manager
Trade mechanical Contractors, Inc.

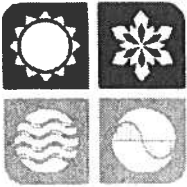

r. b. akins
company
ENVIRONMENTAL EQUIPMENT
FOR BUSINESS & INDUSTRY

1125 N. Santa Fe Ave.
Oklahoma City, OK 73102

PHONE 405 961-1887
FAX 405 961-1419

Date: January 27, 2019

No. of Pages Including This Page: 1

To: Trade Mechanical

From: Timothy Mincey

Attn: Gary Jones

Subject: Lawton PS Eisenhower MS - RFI-169

Size change to (4) Titus Air Distribution Devices.

Net Price:.....\$87.00 Freight Inc.

Terms

F.O.B. SHIPPING POINT FULL FREIGHT ALLOWED

NET 30 DAYS

PLEASE CALL IMMEDIATELY IF ALL PAGES ARE NOT RECEIVED

Thank You

Timothy Mincey

CROSSLAND
CONSTRUCTION COMPANY, INC.

408 NE 145th Place
Oklahoma City, OK 73013
tel 405.748.5043
fax 405.748.7214

Project: LPS Eisenhower Middle School
Date: 7 May 2020

Subject: Masonry Credit

Below is a breakdown of the credit from the DMG Masonry for placing CMU walls that didn't adhered to the specifications and outstanding change orders.

1. CMU wall placement credit: (\$25,031.00)
2. Outstanding change orders:
 - a. Additional 4 inches of CMU blow for Corridor Fire Rated Coiling Door: \$2,391.00
3. Total Credit to LPS: (\$22,640.00)

Should you have any questions or concerns regarding the letter please contact me at (405) 748-5043 or by e-mail at jjacox@crossland.com

Thanks,

Joshua Jacox
Project Manager
Crossland Construction Company Inc.

Eisenhower Middle School
CHANGE ORDER REQUEST

Contractor: Crossland
Subcontractor: 0 Date: 5/5/2020
Subcontractor COR Number: 0 Change Order Document / RFI: 0

Description of Change: Intersecting walls non intersecting walls

Intersecting walls	Subtotal: \$ 34,232.00	Onsite Man-hours: <u>714</u>
Non intersecting walls	Subtotal: \$ 12,560.00	
	Equipment Subtotal: \$ -	
	Vendor/Subcontracts Subtotal: \$ -	

Total Direct Cost: (\$21,672.00)
10% Overhead: \$ (2,167.20)

Direct Cost & Overhead: \$ (23,839.20)
5% Profit: \$ (1,191.96)

Total Change Amount: \$ (25,031)

Schedule Impact: _____ additional work days are requested.
Schedule Impact Description:

Exclusions: _____

Thank you,

Estimator /PM
Shawn Daffern
817-748-0880

Subcontractor Change Proposal / Cost Breakdown Form

Date : 5/5/2020 Architect Name: _____
 Contractor Name: Crossland Subcontractor Name: _____
 Project Name: Eisenhower middle School (Check One)
 Subcontractor COR : _____ Initiated By: Owner/Architect
 GC Job Number: _____ GC
 Reference Change Proposal Request Number: _____ Subcontractor

Brief Description of Proposed Change:

Non Intersecting walls

Item/Description	Quantity	Unit	Unit Cost	Amount		
				Material	Labor	Equip/Sub
Labor						
Foreman	33	HR	\$60.00		\$1,980.00	
Bricklayer	66	HR	\$38.00		\$2,508.00	
Operator	68	HR	\$35.00		\$2,380.00	
Laborer	69	HR	\$30.00		\$2,070.00	
Safety Coordinator	0	HR	\$42.00		\$1,750.00	
per diem	234	HR	\$8.00		1872	
Material						
Brick	0	EA	\$0.65	\$0.00		
8" Double burnish CMU	0	EA	\$12.00	\$0.00		
CMU Mortar	0	YD	\$310.00	\$0.00		
Brick Mortar	0	YD	\$300.00	\$0.00		
Grout	0	YD	\$180.00	\$0.00		
Rebar	0	TON	\$900.00	\$0.00		
Reinforcing Wire	0	LF	\$0.50	\$0.00		
Wall Ties/Fasteners	0	EA	\$1.75	\$0.00		
Mortar Net/Weeps	0	LF	\$3.00	\$0.00		
Anchors/Fasteners	0	EA	\$7.50	\$0.00		
Cast Stone/GFRC Material	0	LS	\$0.00	\$0.00		
Franklin Stone	0	EA	\$15.00	\$0.00		
Tools/Equipment						
Forklift	0	DAY	\$150.00			\$0.00
Scaffold	0	SF	\$0.75			\$0.00
Misc. Equipment (ie. mixers, saws, etc.)	0	DAY	\$20.00			\$0.00
saw & mixer	0	DAY	\$150.00			\$0.00
hamer drill & bits	0	DAY	\$10.00			\$0.00
Sub Contract						
		LS				\$0.00
Sub Totals:				\$0.00	\$12,560.00	\$0.00
Sales Tax:					\$0.00	
Sub Totals:				\$0.00	\$12,560.00	\$0.00

Subcontractor Change Proposal / Cost Breakdown Form

Date : 5/5/2020 Architect Name: _____
 Contractor Name: Crossland Subcontractor Name: _____
 Project Name: Eisenhower middle School
 Subcontractor COR : _____ (Check One)
 GC Job Number: _____ Initiated By: Owner/Architect
 Reference Change Proposal Request Number: _____ GC
 Subcontractor

Brief Description of Proposed Change:

Intersecting walls

Item/Description	Quantity	Unit	Unit Cost	Amount		
				Material	Labor	Equip/Sub
Labor						
Foreman	95	HR	\$60.00		\$5,700.00	
Bricklayer	195	HR	\$38.00		\$7,410.00	
Operator	196	HR	\$35.00		\$6,860.00	
Laborer	228	HR	\$30.00		\$6,840.00	
Safety Coordinator	0	HR	\$42.00		\$1,710.00	
per diem	714	HR	\$8.00		5712	0
Material						
Brick	0	EA	\$0.65	\$0.00		
8" Double burnish CMU	0	EA	\$12.00	\$0.00		
CMU Mortar	0	YD	\$310.00	\$0.00		
Brick Mortar	0	YD	\$300.00	\$0.00		
Grout	0	YD	\$180.00	\$0.00		
Rebar	0	TON	\$900.00	\$0.00		
Reinforcing Wire	0	LF	\$0.50	\$0.00		
Wall Ties/Fasteners	0	EA	\$1.75	\$0.00		
Mortar Net/Weeps	0	LF	\$3.00	\$0.00		
Anchors/Fasteners	0	EA	\$7.50	\$0.00		
Cast Stone/GFRC Material	0	LS	\$0.00	\$0.00		
Franklin Stone	0	EA	\$15.00	\$0.00		
Tools/Equipment						
Forklift	0	DAY	\$150.00			\$0.00
Scaffold	0	SF	\$0.75			\$0.00
Misc. Equipment (ie. mixers, saws, etc.)	0	DAY	\$20.00			\$0.00
saw & mixer	0	DAY	\$150.00			\$0.00
hamer drill & bits	0	DAY	\$10.00			\$0.00
Sub Contract						
		LS				\$0.00
Sub Totals:				\$0.00	\$34,232.00	\$0.00
Sales Tax:					\$0.00	
Sub Totals:				\$0.00	\$34,232.00	\$0.00

Eisenhower Middle School
CHANGE ORDER REQUEST

Contractor: Crossland
Subcontractor: 0 Date: 1/22/2020
Subcontractor COR Number: 0 Change Order Document / RFI: 0

Description of Change: Demo block and adding 4" to door RFI 137

Direct Labor Subtotal:	\$ 1,660.00	Onsite Man-hours:	<u>37</u>
Material Subtotal:	\$ 100.50		
Equipment Subtotal:	\$ 310.00		
Vendor/Subcontracts Subtotal:	\$ -		
Total Direct Cost:	\$ 2,070.50		
10% Overhead:	\$ 207.05		
Direct Cost & Overhead:	\$ 2,277.55		
5% Profit:	\$ 113.88		
Total Change Amount:	\$ 2,391		

Schedule Impact: _____ additional work days are requested.
Schedule Impact Description:

Exclusions: _____

Thank you,

Estimator /PM
Shawn Daffern
817-748-0880

Subcontractor Change Proposal / Cost Breakdown Form

Date : 1/22/2020

Architect Name: _____

Contractor Name: Crossland

Subcontractor Name: _____

Project Name: Eisenhower Middle School

Subcontractor COR : _____

(Check One)

Initiated By: Owner/Architect

GC

GC Job Number: _____

Subcontractor

Reference Change Proposal Request Number: _____

Brief Description of Proposed Change:

Demo block and adding 4" to door RFI 137

Item/Description	Quantity	Unit	Unit Cost	Amount		
				Material	Labor	Equip/Sub
Labor						
Foreman	5	HR	\$60.00		\$300.00	
Bricklayer	8	HR	\$38.00		\$304.00	
Operator	8	HR	\$35.00		\$280.00	
Laborer	16	HR	\$30.00		\$480.00	
Safety Coordinator	0	HR	\$42.00		\$0.00	
per diem	37	HR	\$8.00		296	
Material						
Brick	0	EA	\$0.65	\$0.00		
4" block	35	EA	\$1.50	\$52.50		
CMU Mortar	0.3	YD	\$160.00	\$48.00		
Brick Mortar	0	YD	\$300.00	\$0.00		
Grout	0	YD	\$180.00	\$0.00		
Rebar	0	TON	\$900.00	\$0.00		
Reinforcing Wire	0	LF	\$0.50	\$0.00		
Wall Ties/Fasteners	0	EA	\$1.75	\$0.00		
Mortar Net/Weeps	0	LF	\$3.00	\$0.00		
Anchors/Fasteners	0	EA	\$7.50	\$0.00		
Cast Stone/GFRC Material	0	LS	\$0.00	\$0.00		
Granite Material	0	LS	\$0.00	\$0.00		
Tools/Equipment						
Forklift	1	DAY	\$150.00			\$150.00
Scaffold	0	SF	\$0.75			\$0.00
Misc. Equipment (ie. mixers, saws, etc.)	0	DAY	\$20.00			\$0.00
saw & mixer	1	DAY	\$150.00			\$150.00
hamer drill & bits	1	DAY	\$10.00			\$10.00
Sub Contract						
		LS				\$0.00
Sub Totals:				\$100.50	\$1,660.00	\$310.00
Sales Tax:					\$0.00	
Sub Totals:				\$100.50	\$1,660.00	\$310.00

Request for Information 137a

Detailed, RFIs Grouped by RFI Number

Lawton Public Schools 2017 Eisenhower Middle S
5702 W Gore Blvd.
Lawton, OK 73505

Project # 18OK06-MLA

RFI #: 137a

Date Created: 11/14/2019

Answer Company	Answered By	Author Company	Authored By
		Crossland Construction Company, Inc. 408 NE 145th Place Edmond, OK 73013	Matthew Henderson

Co-Respondent	Author RFI Number
---------------	-------------------

Subject	Discipline	Category
Coiling Door at L-20.1	Architectural	Clarifications

Cc: Company Name	Contact Name	Copies	Notes
------------------	--------------	--------	-------

Question **Date Required: 11/21/2019**

After reviewing the response from RFI 137 there is still not enough room to mount the glides. In reference to detail 5, Plan Page A-613 it shows the guides to be 6" wide, but the actual shop drawings from the manufacturer show the guides are 6 3/16", but the column is 5" from the edge of jamb, so neither will work. Please advise.

Suggestion

Answer **Date Answered:**

At the southern jambs of doors C101a and C101b, it is acceptable to add a 4" course of block in the opening, reducing the opening to 10'-2" to allow installation of the bracket and rail. Coordinate the door widths with the new rough opening.
CSM 1/15/20

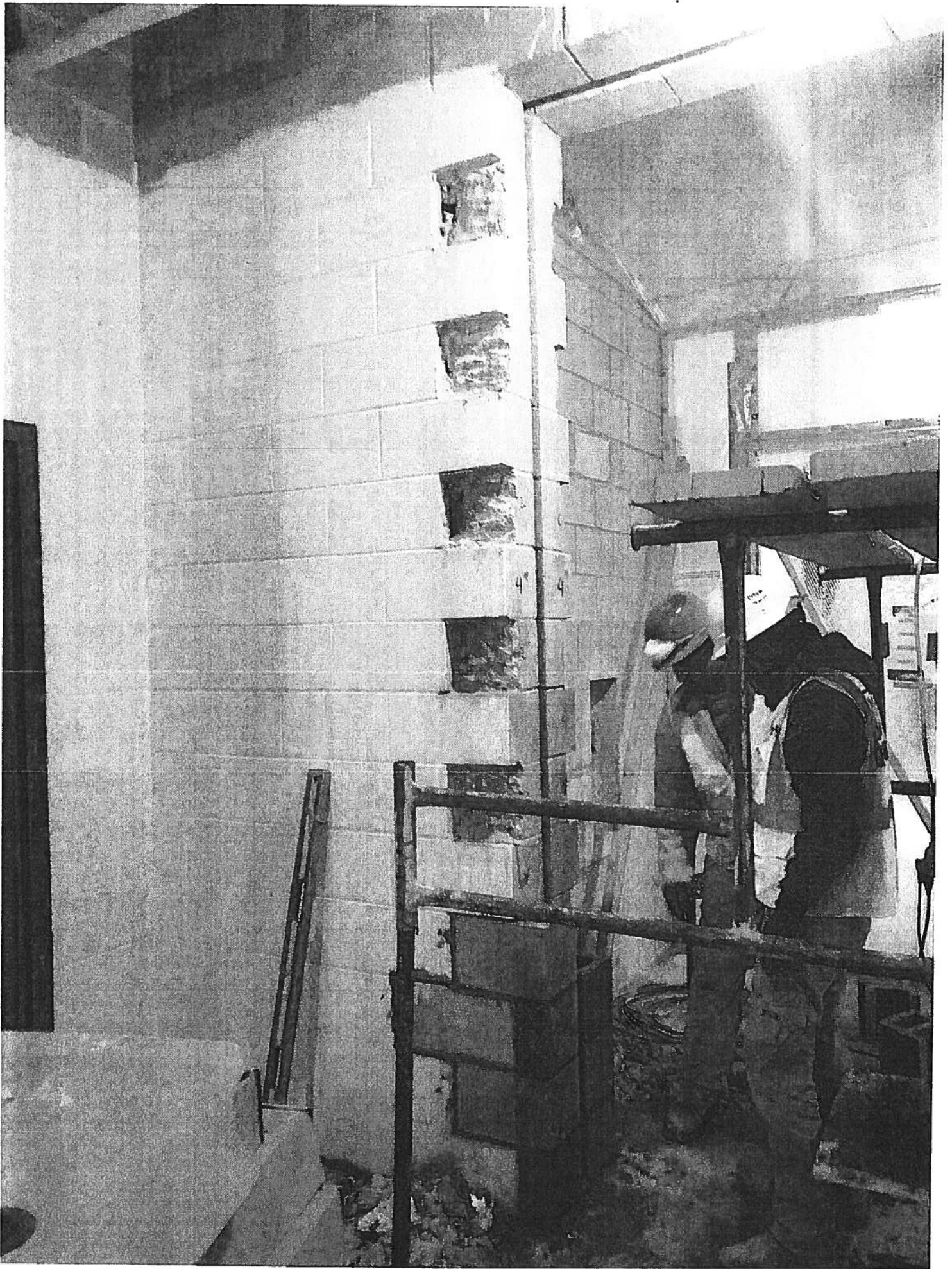

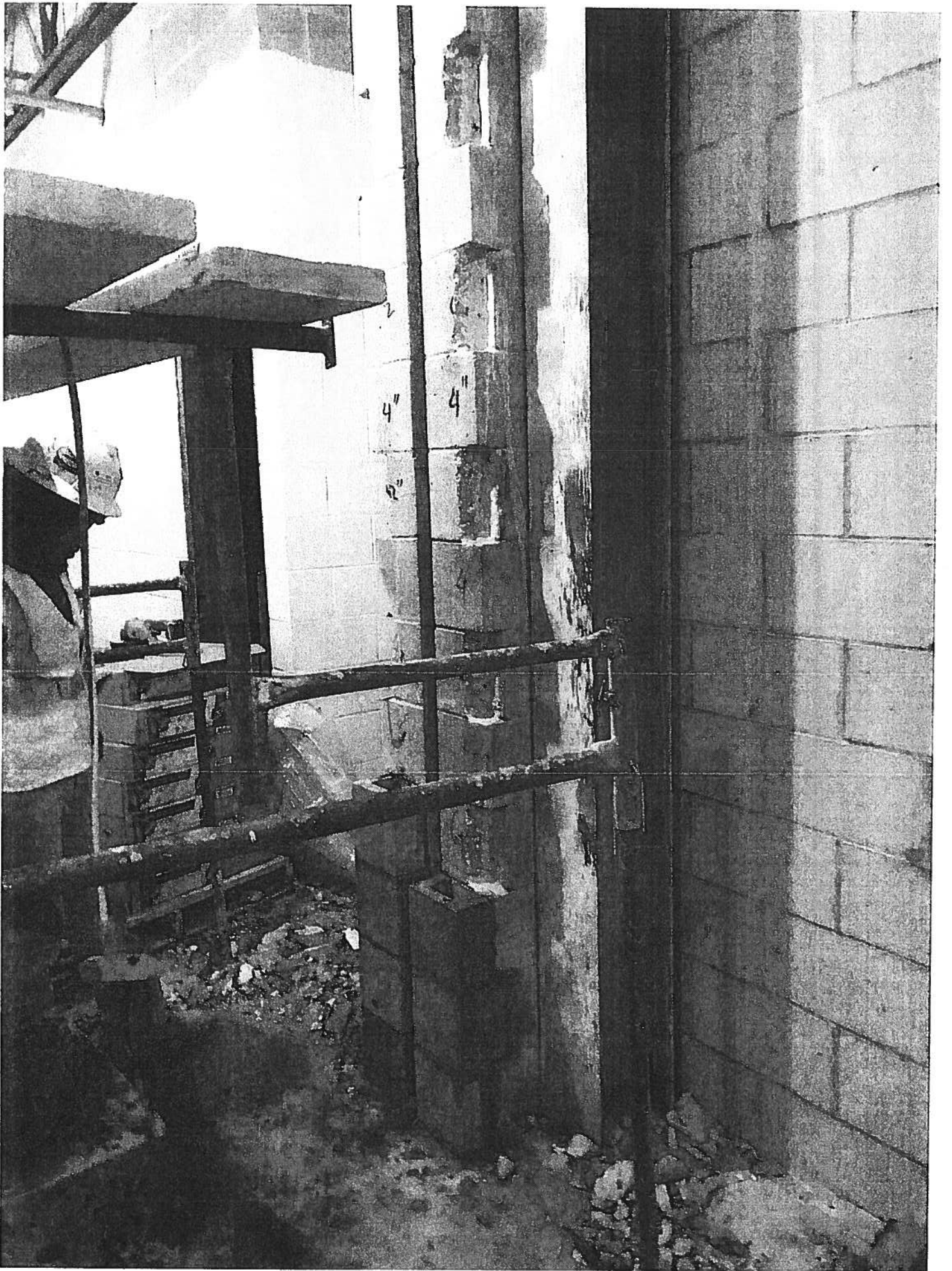



SOUTHWEST

DRYWALL

Phone: (405)463-7171. FAX: (405)463-7173. 11609-A North Santa Fe Ave; OKC, OK 73114

Request for Change Order

<u>To:</u> Josh Jacox	<u>Project Manager:</u> Daniel Mendell	<u>Cell Phone:</u> (405)464-5737	<u>Email Address:</u> daniel@southwestdrywall.com
<u>Firm:</u> Crossland Construction	<u>Project Name & Location:</u> Eisenhower Middle School Lawton, OK	<u>Date Submitted:</u> May 15, 2020	

Add for 2 Column Covers per attached spec. Covers approximately 22' tall with a clear anodized finish.

Request for Change Order #022:

Material	\$6,724.00
Labor	\$1,544.00
OH & P	\$1,241.00
Equipment	\$1,000.00
Total	\$10,509.00

Thank You,

Daniel Mendell
Estimator
Southwest Drywall



QUOTATION
SAF METAL FABRICATION
 Metals Distribution, Finishing, and Fabricating

Be more profitable by staying informed!
Sign up for our e-newsletter at www.saf.com

QUOTE NO	QUOTE DATE
194348	5/11/2020

S
O
L
D
T
O

Southwest Drywall
Daniel Mendell
13919 N Harvey Ave
 -
Edmond OK 73013-2431

S
H
I
P
T
O

SAME

sou73013 Ph: 405-463-7171 Fax:

SALESPERSON	ESTIMATED SCHEDULE	SHIP VIA	TERMS
kjt	3-4 weeks	TBD	To be determined
QUANTITY	PART #	DESCRIPTION	\$ / EA
			AMOUNT

To Furnish Fabricated Material

FINISH: SAF 215 / Clear Anodize

2	CC1-M1 .125" M2000 16D x 132H plus splice (male half)		96 #
2	CC1-F1 .125" M2000 16D x 132H plus splice (female half)		89 #
2	CC1-M2 .125" M2000 16D x 132H (male half)		96 #
2	CC1-F2 .125" M2000 16D x 132H (female half)		89 #
			370 #

Freight: FOB Factory. Prepaid and Allowed

Finishing Summary: 209 Square Feet

NOTES:

- *Prices good for thirty days.
- *Changes in quantity may change price per unit.
- *On custom colors, customer approval of SAF color chip required prior to finishing.
- *Final terms and conditions are established by SAF's acknowledgment and invoice.
- *To grip these parts for finishing, anodized parts will have rack marks and painted parts will have holes for hanging.
- *Defective goods returned will be replaced or repaired without charge, but SAF will not be responsible for labor backcharges or consequential damages.
- *Freight charges are based on ground shipment to locations in the U.S., excluding Alaska and Hawaii.
- *This quotation is based on the quantities, number of items, and dimensions shown.
- *This price is based on receiving a priced purchase order and complete release for these items as quoted.
- *If this order is being delivered to a job site and requires a flat bed truck, there will be an additional freight charge. Please contact us for that freight charge.
- *Any and all materials or services not specifically noted herein are expressly excluded from the scope of this proposal. If, for any reason, the scope listed herein does not match your expectations, please contact me for adjustment.
- *A more accurate estimate of the schedule will depend on SAF's backlog at the time of receipt of your written purchase order, complete dimensions and color.



QUOTATION

Be more profitable by staying informed! Sign up for our e-newsletter at www.saf.com

SOUTHERN ALUMINUM FINISHING CO INC

Metals Distribution, Finishing, and Fabricating

QUOTE NO	QUOTE DATE
194348	5/11/2020

SOLD TO

Southwest Drywall Daniel Mendell 13919 N Harvey Ave Edmond OK 73013-2431

SHIP TO

SAME

sou73013 Ph: 405-463-7171 Fax:

SALESPERSON	ESTIMATED SCHEDULE	SHIP VIA	TERMS
kjt	3-4 weeks	TBD	To be determined
QUANTITY	PART #	DESCRIPTION	\$ / EA
			AMOUNT

CONTINUED: PAGE 2

*The schedule for SAF's Estimated Shipment date begins after SAF receives a completed release from you which shall include approved shop drawings, production drawings, field dimensions, approved color samples or any other information SAF needs from you to manufacture this order.

*I certify that the product I am ordering from SAF on my purchase order _____ is for an essential purpose under my local civil authority's guidelines. My firm can take delivery of it on approximately _____ (date). We do not have a sales tax exemption form for OK. Please send your exemption form if applicable.

QUOTE COMMENTS:

*Quotation is based on SAF Series M-2000 Reveal column covers. See attached details for more information.

*MATERIAL: .125" Class I Clear anodized aluminum 5005 alloy.

*This price does not include cutouts - not by SAF.

*Price excludes backer rods, sealant, steel studs, fasteners, shims, etc. Installation not by SAF.

*This quotation does not include any shop drawings, engineering, design, or structural calculations. Compliance with building codes is the responsibility of others and is beyond the scope of the undertaking of SAF.

*Products are packed in crates with approximate dimensions of 48" x 48" x 126". Crates may weigh up to 1200 lbs when fully packed. Claims for shortages must be made within 5 days of delivery.

*A more accurate estimate of the schedule will depend on SAF's backlog at the time of receipt of your written purchase order, complete dimensions and color.

*Any and all materials or services not specifically noted herein are expressly excluded from the scope of this proposal. If, for any reason, the scope listed herein does not match your expectations, please contact me for adjustment.



QUOTATION

SOUTHERN ALUMINUM FINISHING CO INC

Metals Distribution, Finishing, and Fabricating

Be more profitable by staying informed! Sign up for our e-newsletter at www.saf.com

QUOTE NO	QUOTE DATE
194348	5/11/2020

S
O
L
D
T
O

Southwest Drywall
Daniel Mendell
13919 N Harvey Ave
-
Edmond OK 73013-2431

S
H
I
P
T
O

SAME
-

sou73013 Ph: 405-463-7171 Fax:

SALESPERSON		ESTIMATED SCHEDULE		SHIP VIA		TERMS	
kjt		3-4 weeks		TBD		To be determined	
QUANTITY	PART #	DESCRIPTION			\$ / EA	AMOUNT	

CONTINUED: PAGE 3

*This quotation is not based on a review for compliance with the Contract Document Specifications. The materials and finishes provided by SAF are solely as expressly ordered by you through the relevant and specific information provided to SAF and which information is incorporated by specific reference in this quotation. SAF disclaims any larger undertaking, such as, but not limited to, review of the Contract Document Specifications with regard to your order.

Thank you for the opportunity to quote.

Very truly yours,

Kelly J. Torline
770-942-1207 x 807
kjt@saf.com

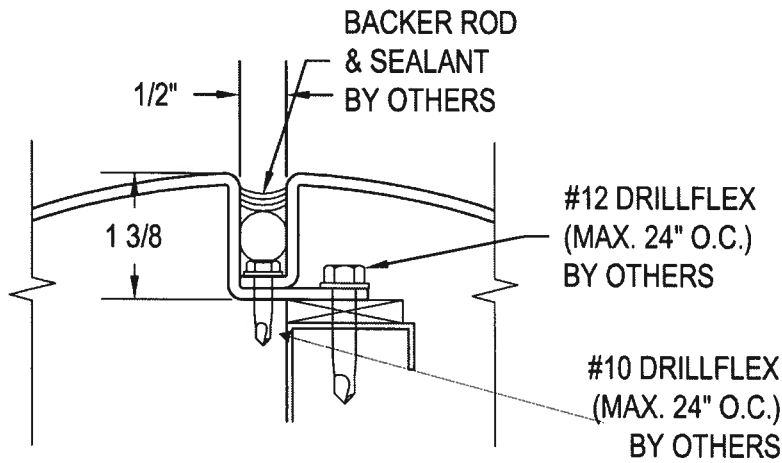

2 VERTICAL JOINT DETAIL

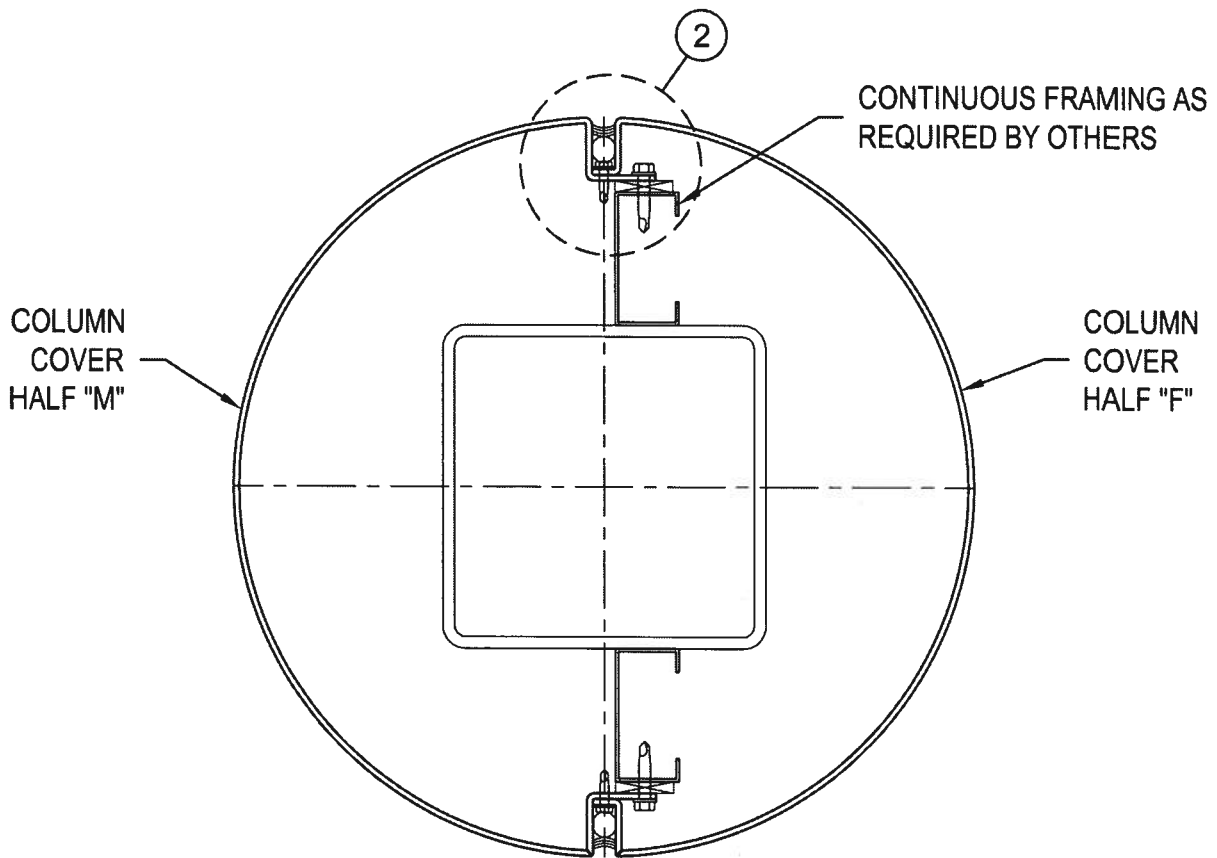

1 COLUMN COVER SECTION

SERIES M-2000 (Reveal)

SAF Metal Fabrication

8370 HIGHWAY 78E www.saf.com PHONE: (770) 942-1207
VILLA RICA, GEORGIA 30180 FAX: (877) 949-4759

TYPICAL DETAILS

SCALE: NTS

REVISION: 11 JUN 10

SAF *Expressions*

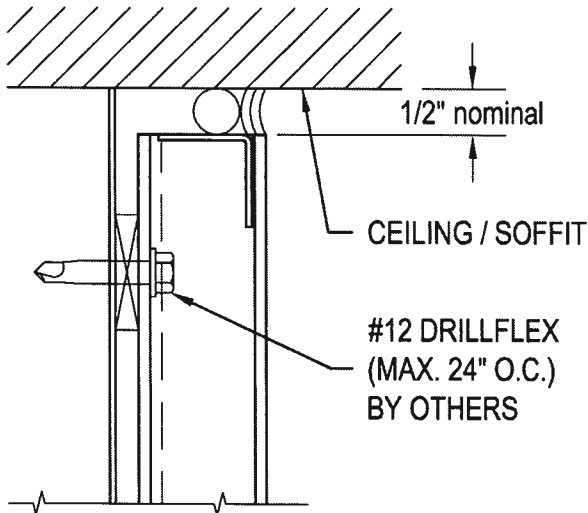

4 CEILING/SOFFIT DETAIL

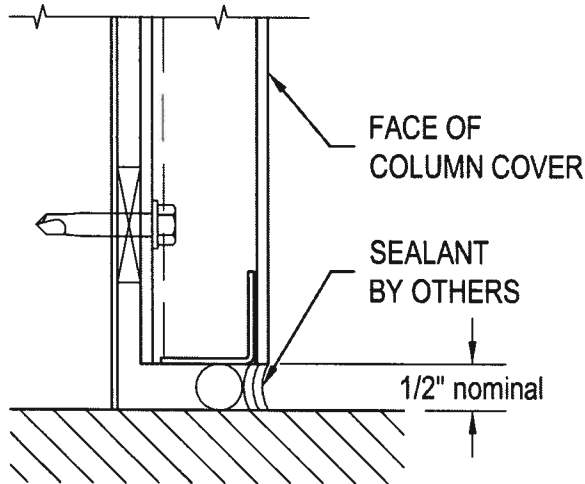

3 BASE DETAIL

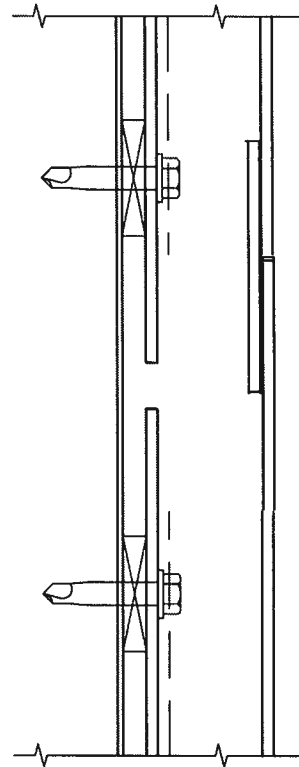

5 SPLICE @
HORIZONTAL
JOINT DETAIL

SERIES M-2000 (Reveal)



Metal Fabrication

8370 HIGHWAY 78E www.saf.com PHONE: (770) 942-1207
VILLA RICA, GEORGIA 30180 FAX: (877) 949-4759

TYPICAL DETAILS

SCALE: NTS

REVISION: 11 JUN 10



Expressions

SOUTHERN ALUMINUM FINISHING CO., INC
TERMS AND CONDITIONS OF SALE

Page 6 of 6

PRICES, CONTRACT AND DELIVERY

Prices are subject to change without notice unless otherwise stated in writing. Stenographic or clerical errors are subject to correction. Any customs, sales use, excise or other transactional tax or charges imposed upon the sale, shipment or use of the materials shall be paid by the buyer. We will not be liable for nondelivery of goods or delay in the performance of orders or contracts or in the delivery shipment of goods, or for any damages suffered by buyer by reason of such nondelivery or delay when such nondelivery or delay is directly or indirectly caused by or in any manner arises from acts of God, casualties of wars, shortage of materials or suppliers or interruption or delay in the delivery thereof, plant breakdown or disability or interruptions for any cause whatsoever, strikes or other labor disturbances, delays or interruption in transportation facilities, requirements or regulations or policies of any government, or any other disabling causes or contingencies or any condition causing delays in our plant or otherwise affecting our production which is reasonably beyond our control. The materials are sold for delivery at buyer's expense. All prices are F.O.B. seller's factory.

PAYMENT-CANCELLATION

The term of payment are subject at all times to our approval and in case of doubt arising as to Customer's financial responsibility, production may be stopped, and shipments may be suspended or sent draft attached to negotiable or other bill of lading, until satisfactory assurance of Customer's responsibility is received. Invoices for material delivered under this order are payable only to our office in Atlanta, GA. If the invoice is not paid when due, the outstanding balance shall bear interest at the rate of 1.5% per month or the highest interest rate allowed by law from the date when due. If legal process is necessary to enforce this indebtedness then the customer agrees to pay all reasonable attorney's fees necessary to enforce the indebtedness. Orders placed with us cannot be cancelled or countermanded without our consent.

CUSTOMER'S METAL

We do not count Customer's metal until we begin processing the metal. We reserve the right to revise our acknowledgment if we do not receive all items listed, because quantity frequently governs the price.

WARRANTY

All goods sold hereunder are warranted to be free from defects in material and workmanship, and this express warranty is in lieu of and EXCLUDES ALL OTHER WARRANTIES, EXPRESSED OR IMPLIED BY OPERATION OF LAW OR OTHERWISE. Defective material may be returned to us after inspection by our representative and upon receipt of definite shipping instructions for us. Goods returned will be replaced or repaired by us without charge, but we shall not be liable for loss, damage, or expense directly, or indirectly arising from the use of the material or from any other cause, our liability being expressly limited to the replacement or repair of defective material. Seller's liability shall not exceed the purchase price of the goods. All claims for shortage and damage shall be waived unless buyer notifies seller of the same within ten days after receipt of the materials to which the claim relates. In no event shall seller have any liability for any such claim unless seller verifies that shortages represent a difference between the quantity shipped and the quantity determined by an inspection by a representative. Every claim on account of defective material, workmanship, non-conformity, or for any other cause shall be deemed waived by Customer unless made in writing within sixty (60) days from the date of the receipt by the customer of goods to which such claim relates. If the Customer's metal fabrication is damaged in the finishing process our liability shall be limited to the repair of fabrication but in no case to exceed \$0.50 per pound unless a higher valuation is declared by the customer on purchase order and agreed to by us. Such excess valuation shall be cause for adjustment of any quoted price which we may have made.

ENTIRE AGREEMENT-MODIFICATION-GOVERNING LAW

These conditions of sale and any other written contract executed by seller, under which this sale is made, constitute the full understanding of the parties and a complete and exclusive statement of the terms of the agreement. No modification or waiver of such agreement shall be of any force or effect unless made in writing and signed by an authorized officer of seller. Seller accepts buyer's order for material on the express condition that buyer assent to any different or additional terms contained herein. If seller does not receive buyer's assent and seller nevertheless delivers the material, such delivery constitutes seller's counter-offer to sell the material to buyer on these terms and conditions only. Acceptance of seller's counter-offer is limited to its terms and may be made by buyer in any reasonable manner, including execution of a packing list, or accepting, using or paying for the material. This contract shall be governed by and construed in accordance with the laws of Georgia.

EXCEPT AS SET FORTH IN THIS ENTIRE WARRANTY, SOUTHERN ALUMINUM FINISHING COMPANY MAKES NO OTHER WARRANTIES, EXPRESS OR IMPLIED, WITH RESPECT TO THE PRODUCT, INCLUDING ANY WARRANTY OF MERCHANTABILITY OR FITNESS FOR A PARTICULAR PURPOSE OR OTHERWISE. UNDER NO CIRCUMSTANCES SHALL SAFF BE RESPONSIBLE FOR ANY INCIDENTAL OR CONSEQUENTIAL DAMAGE OF ANY KIND OR NATURE.

WAIVER

No provision hereof and no breach of any provision shall be deemed waived by reason of any previous waiver of such provision or of any breach thereof. Our failure to object to provisions contained in any communication from customer shall not be deemed a waiver of the provisions of our acknowledgment of order.

Revised 01/05/06

Southern Plains Electric, Inc.

2006 NW Williams Drive

Lawton, OK 73507

580-355-2517

License # 19913

Change order Quote

May 13, 2020

To: Crossland

Attn: Josh

Southern Plains Electric, Inc. is pleased to price changing the single gang blank plates from plastic to stainless steel on Eisenhower Project.

If you have any questions, please call Dustin Self at 580-678-7467

Total: \$400.00

Sincerely,

Dustin Self

VP

May 21, 2020

TO: Members of the Board of Education

SUBJECT: Certification of the Children's Internet Protection Act (CIPA) and E-rate Requirements

The purpose of this letter is to help better educate you and to certify one of the requirements that must be met each year that we file for E-rate funds. These funds assist in offsetting the cost of our internet, intranet, and based on funding, the purchasing of hardware such as switches, routers, and wireless access points.

We must certify compliance with the Children's Internet Protection Act (CIPA) to be eligible for Schools and Libraries (E-rate) Program discounts on Category One internet access and all Category Two services – internal connections, managed internal broadband services, and basic maintenance of internal connections.

There are three basic requirements:

1. *Internet Safety Policy*: This is covered under policy EFBCA – Internet and Other Computer Networks, Acceptable Use and Internet Safety Policy, dated June 27, 2017, that each student and staff member sign each year.
2. *Technology Protection Measure*: The district utilizes an active internet filter that blocks or prevents access to content that is inappropriate or harmful to minors. This service is provided by GoGuardian Admin (K-12), a content web filtering service. It is also covered under the requirements of EFBCA R2 – Internet Filtering (Regulation), dated March 9, 2010.
3. *Public Notice and Hearing or Meeting*: Which is being met as this information is displayed in the agenda and provided to the Board of Education.

I have included a CIPA fact sheet with those requirements to further explain each of them.

By reviewing this letter and attached CIPA fact sheet, the Board of Education is certifying that all Federal Communications Commissions (FCC), Universal Service Administrative Company (USAC), and CIPA requirements are being met.

For further information, please contact me or AJ Watson, our district IT Director.

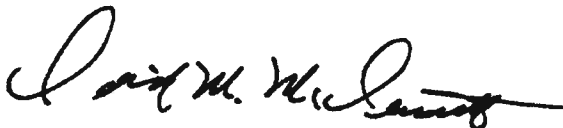

Dave McDermott

Children's Internet Protection Act (CIPA)

The Children's Internet Protection Act (CIPA) was enacted by Congress in 2000 to address concerns about children's access to obscene or harmful content over the Internet. CIPA imposes certain requirements on schools or libraries that receive discounts for Internet access or internal connections through the E-rate program – a program that makes certain communications services and products more affordable for eligible schools and libraries. In early 2001, the FCC issued rules implementing CIPA and provided updates to those rules in 2011.

What CIPA requires

Schools and libraries subject to CIPA may not receive the discounts offered by the E-rate program unless they certify that they have an Internet safety policy that includes technology protection measures. The protection measures must block or filter Internet access to pictures that are: (a) obscene; (b) child pornography; or (c) harmful to minors (for computers that are accessed by minors). Before adopting this Internet safety policy, schools and libraries must provide reasonable notice and hold at least one public hearing or meeting to address the proposal.

Schools subject to CIPA have two additional certification requirements: 1) their Internet safety policies must include monitoring the online activities of minors; and 2) as required by the Protecting Children in the 21st Century Act, they must provide for educating minors about appropriate online behavior, including interacting with other individuals on social networking websites and in chat rooms, and cyberbullying awareness and response. Schools and libraries subject to CIPA are required to adopt and implement an Internet safety policy addressing:

- Access by minors to inappropriate matter on the Internet;
- The safety and security of minors when using electronic mail, chat rooms and other forms of direct electronic communications;
- Unauthorized access, including so-called "hacking," and other unlawful activities by minors online;
- Unauthorized disclosure, use, and dissemination of personal information regarding minors; and

Measures restricting minors' access to materials harmful to them.

Schools and libraries must certify they are in compliance with CIPA before they can receive E-rate funding.

- CIPA does not apply to schools and libraries receiving discounts only for telecommunications service only;
- An authorized person may disable the blocking or filtering measure during use by an adult to enable access for bona fide research or other lawful purposes.
- CIPA does not require the tracking of Internet use by minors or adults.



HERFF JONES

Charles Cook
1191 Oxford Rd - Davis, OK 73030-5501
(580) 369-1671 - cwcook@herffjones.com

PRINTING AGREEMENT

Year(s) Covered: 2021 2022 2023 2024 2025
 New Renewal

Date: 2/5/2019

Subject to the terms hereof, the Customer (school) named below hereby engages HERFF JONES, Inc., and Herff Jones agrees, to print and bind the specified publication during the Years Covered (specified above).

School Name: Lawton Senior High School

Address: 601 NW FORT SILL BLVD

City/State/Zip: Lawton, OK 73507

Job Number: 14916

Title/Publication:

Current Enrollment: 1812

Specifications

Program: 900 All Color

Trim Size: 9 X 12

Pages: 232

Copies: 250

Submission Method: Web (eDesign)

Cover: Vista Custom Embossed + Vista Litho
Cover Proof 4-C (100% to size)
Gloss Lamination (Vista Litho)

Binding: Squarebacked

Endsheet: Vibracolor
Four-Color Litho Different Front and Back

Paper: 100# Gloss

Proofs: Self Proof (eDesign)

Correspond With

Name: Mr. Jay DeSilver

Title: Yearbook Advisor

Address: 601 Nw Fort Sill Blvd

City/State/Zip: Lawton, OK 73507-6601

Phone Number: 580-355-5170

Fax Number: 580-585-6433

Email: jay.desilver@lawtonps.org

Send Invoice To

Name: Mr. Jay DeSilver

Title: Yearbook Advisor

Address: 601 Nw Fort Sill Blvd

City/State/Zip: Lawton, OK 73507-6601

Phone Number: 580-355-5170

Tax Exemption Number:

Pre-Payment Option Desired: Yes No

Base Price: \$20,000.00

Printing Agreement Total: \$20,000.00

Shipping Information

Requested Book Ship Date: May 01, 2021

Ship Book To: Mr. Jay DeSilver

Requested Kit Ship Date: April 25, 2020

Ship Kit To: Mr. Jay DeSilver

If Printing Agreement is for multiple years, annual increase to Printing Agreement Total not to exceed _____ for same specifications.

This agreement is subject to the terms shown on the reverse side and is binding on Herff Jones and the Customer for the Years Covered, subject to such terms.

YEARBOOK PLANT USE

Customer Number _____

Date Received _____

Jay DeSilver

Yearbook Advisor

Charles Cook

Principal

Representing Herff Jones

HUMAN RESOURCES
Certified Personnel
June 1, 2020

The following resignations are recommended:

***Denotes Retirement**

****Resigned without having worked**

NAME	ASSIGNMENT	END DATE
Aguilar, Denise	Activities Director, CMS	05-10-2020
Ayers, Ronald	Teacher, EHS	05-22-2020
Beard, Tammy	Certified Tutor, Washington	05-08-2020
Boydston, Brenda	Certified Tutor, Lincoln	05-12-2020
Boydston, Steven	Certified Tutor, Lincoln	05-11-2020
Chambers, Paula	Certified Tutor, Cleveland	05-11-2020
Cooper, Katie	SPED Teacher, Whittier	05-22-2020
Dunlap, Kathleen	Certified Tutor, Washington	05-11-2020
Griesback, Kari	Teacher, Lincoln	05-22-2020
Hill, Holly	Teacher, Freedom	05-22-2020
Hill, Holly	Staff Route Driver, Transportation	05-22-2020
King, Karisa	Title I Supplemental Teacher, Cleveland	05-22-2020
Kirk, Marsha	Certified Tutor, Washington	05-12-2020
Leseney, Katherine	SPED Teacher, Almor West	05-22-2020
Phariss, Greg*	Teacher, EMS	05-22-2020
Prestidge, Casey	Teacher, EMS	05-22-2020
Prestidge, Casey	Wrestling Coach, EMS	05-22-2020
McKelvey, Terry	Certified Tutor, Ridgecrest	05-11-2020
Short, Allyson	Teacher, Whittier	05-22-2020
Spangler, Janice	Certified Tutor, Washington	05-11-2020
Sullivan, Joshua**	Teacher, MHS	05-22-2020
Taylor, Melissa	Teacher, Ridgecrest	05-22-2020

The following employment is recommended for the 2020-2021 school year:

NAME	ASSIGNMENT	START DATE
Alkire, Sharayah	Teacher, EMS	08-18-2020
Aman, Azura	Teacher, Freedom	08-18-2020
Ford, Alexis	Teacher, Whittier	08-18-2020
Griffin, Erin	Teacher, Woodland Hills	08-18-2020
Higdon, LeShondre	Teacher, CMS	08-18-2020
James, Rachel	Teacher, EMS	08-18-2020
Janek, Karie	Teacher, Freedom	08-18-2020
Johns, Ashley	Teacher, CMS	08-18-2020
Landoll, Laura	Teacher, Pioneer Park	08-18-2020
McMillin, Kristi	Teacher, Edison	08-18-2020
Medders, Mary	SPED Resource Teacher, Crosby Park	08-18-2020
Stevens, Kristen	Teacher, Freedom	08-18-2020
Squire, Derrick	Teacher, CMS	08-18-2020
Tate, Alyssa	Teacher, TMS	08-18-2020

Walters, Dorthea	SPED Teacher, EMS	08-18-2020
Yokeum, Danene	Teacher, Sullivan Village	08-18-2020
Young, Bryan	Teacher, LHS	08-18-2020

The following employments are recommended for duration of need:

NAME	ASSIGNMENT	START DATE
Arter, Brandi	ESY Summer Teacher, Distance Learning	06-02-2020
Foxx, Stephanie	ESY Summer Teacher, Distance Learning	06-02-2020
Givens, Michelle	ESY Summer Teacher, Distance Learning	06-02-2020
Hagans, Cynthia	ESY Summer Teacher, Distance Learning	06-02-2020
Kimbrell, Angela	ESY Summer Teacher, Distance Learning	06-02-2020
Knottek, Liza	ESY Summer Teacher, Distance Learning	06-02-2020
Meyer, Kari	ESY Summer Speech Pathologist, Distance Learning	06-02-2020
Owens, Debbie	ESY Summer Teacher, Distance Learning	06-02-2020
Palmer, Maris	ESY Summer Teacher, Distance Learning	06-02-2020
Parra, Brenda	ESY Summer Teacher, Distance Learning	06-02-2020
Pugh, Amanda	ESY Summer Teacher, Distance Learning	06-02-2020
Shiple, Stephanie	ESY Summer Teacher, Distance Learning	06-02-2020

The following changes are recommended for the 2020-2021 school year:

NAME	ASSIGNMENT	START DATE
Booth, Ron	From: Asst. Boys' Basketball Coach, LHS To: Head Girls' Basketball Coach, LHS	08-18-2020
Garcia, Joshua	From: Teacher, Almor West To: Teacher, Ridgecrest	08-18-2020
Jones, Jerrold	From: Principal, B.R.I.D.G.E. To: Principal, CMS	06-01-2020
Jung, Lauren	From: Pre-K Teacher, Carriage Hills To: SPED Teacher, Carriage Hills	08-18-2020
Keene, Brandon	From: SPED Resource, Ridgecrest To: SPED Co-Teacher, MMS	08-18-2020
Lafferty, Jade	From: SPED Resource, Sullivan Village To: SPED Resource, Ridgecrest	08-18-2020
Mack, Amanda	From: Teacher, Whittier To: Teacher, Crosby Park	08-18-2020
McMillin, Kristi	From: Teacher, Freedom To: Teacher, Edison	08-18-2020
Shiple, Stephanie	From: SPED Co-Teacher, MMS To: SPED Teacher, CMS	08-18-2020
Webster, Nasaussja	From: Teacher, LHS To: Career Adviser, LHS	08-18-2020

The following employee has rescinded their resignation for the 2020-2021 school year:

NAME	ASSIGNMENT	START DATE
Robertson, John	Teacher Tech Trainer, Media Center	05-14-2020

HUMAN RESOURCES
Support Personnel
June 1, 2020

The following resignations are recommended:

***Denotes Retirement**

NAME	ASSIGNMENT	STOP DATE
Bushong, Jessica	School Nurse, CMS	05-22-2020
Carroll, Monika	Title I Non Certified Tutor, Cleveland	05-12-2020
Guilford, Johanna	Special Ed Class Assistant, Freedom	05-21-2020
Guilford, Johanna	Staff Route Driver, Freedom	05-21-2020
Janek, Karie	Special Ed Class Assistant, Freedom	05-23-2020
Martinez, Mally	Parent Coordinator, Pat Henry	05-08-2020
Matte, Jeffrey	Custodian, MMS	06-30-2020
Milner, Kathlyn	Speech Language Pathology Assistant, Hugh Bish	05-22-2020
Rivera-Gatliff, Maddie	10 Month Secretary, Crosby Park	05-29-2020
Rivera, Mayda	Special Ed Teacher Assistant, Crosby Park	05-21-2020
Smith, Evan	Assistant Boys Basketball Coach, LHS	05-19-2020
Vance, Jamie	Library Assistant, Pioneer Park	05-23-2020

The following employment is recommended:

NAME	ASSIGNMENT	START DATE
Baker, Debra	Summer Feeding Assistant, Pioneer Park	05-26-2020
Beartrack, Camina	Summer Feeding Manager, MHS	05-26-2020
Bernard, Tammy	Summer Feeding Manager, Pioneer Park	05-26-2020
Brantley, Rebecca	Summer Feeding Assistant, Edison	05-26-2020
Burwell, Maya	Summer Feeding Assistant, CMS	05-26-2020
Conner, Marion	Summer Feeding Manager, Crosby Park	05-26-2020
Conner, Michaelae	Summer Feeding Assistant, Crosby Park	05-26-2020
Diaz, Andrew	Summer Feeding Bus Driver, Transportation	05-26-2020
Fernandez, Gloria	Summer Feeding Assistant, CMS	05-26-2020
Higgins, Denise	Summer Feeding Assistant, Edison	05-26-2020
Hutto, Tanja	Summer Feeding Assistant, Freedom	05-26-2020
Jackson, Carolyn	Summer Feeding Assistant, Pat Henry	05-26-2020
Jensen, Dana	Summer Feeding Bus Driver, Transportation	05-26-2020
Jung, Laura	Summer Feeding Assistant, CMS	05-26-2020
Keefer, James	Summer Feeding Police Officer, District Wide	05-26-2020
Kittle, Sylvia	Summer Feeding Assistant, Edison	05-26-2020
Kraft, Mark	Summer Feeding Police Officer, District Wide	05-26-2020
Leday, Maryan	Summer Feeding Assistant, MHS	05-26-2020
Liggins, Deborah	Summer Feeding Bus Driver, District Wide	05-26-2020
Macias, Alicia	Summer Feeding Manager, Pat Henry	05-26-2020
McCarter, Larry	Custodian, Edison	07-01-2020
McGhee, Traci	Summer Feeding Assistant, Crosby Park	05-26-2020
Mozie, Joyce	Summer Feeding Manager, Edison	05-26-2020
Oliver, Otis	Summer Feeding Assistant, CMS	05-26-2020
O'Neal, Marion	Summer Feeding Assistant, Freedom	05-26-2020

Reyes, Edwina Marie	Secretary, 12 month, MMS	05-27-2020
Rhea, Kim	Summer Feeding Manager, Freedom	05-26-2020
Schaffer, Daisha	Summer Feeding Assistant, Freedom	05-26-2020
Siaca, Kristie	Summer Feeding Assistant, Pat Henry	05-26-2020
Small, Deborah	ESY, Occupation Therapist, EHS	06-02-2020
Suttles, Bernette	Summer Feeding Assistant, MHS	05-26-2020
Taylor, Jacqueline	Summer Feeding Bus Driver, District Wide	05-26-2020
Wheeler, Amber	10 Month Secretary, Learning Tree Academy	07-28-2020
Winfry, Tanasha	Summer Feeding Manager, CMS	05-26-2020
Zimmerman, James	Summer Feeding Assistant, MHS	05-26-2020

The following changes are recommended:

NAME	ASSIGNMENT	START DATE
Aikens, Rhonda	From: Cafeteria Manager, Freedom To: Secretary, Freedom	07-28-2020
Allen, Brenda	From: Personal Care Assistant, Freedom To: Special Education Class Assistant, Freedom	08-20-2020
Ferebee, Staphne	From: Personal Care Assistant, Freedom To: Special Education Class Assistant, Freedom	08-20-2020
File, Brittany	From: Personal Care Assistant, Cleveland To: Pre-K Assistant, Cleveland	08-20-2020
Lewis, Michael	From: Bus Driver, Transportation To: Lead Driver/Trainer Supervisor, Transportation	07-01-2020