



Regular Board of Education Meeting Garden City Public Schools USD 457

Monday, January 15, 2024 - 6:00 PM

Board Meeting Room, Educational Support Center, 1205 Fleming Street, Garden City, KS 67846

Board of Education Members:

Andy Fahrmeier; Jackie Gigot; John Wiese; Mark Hinde; Nathan Haeck; Randy Ralston; Robin Bergkamp

AGENDA

A. PLEDGE

B. APPROVAL OF AGENDA with the following amendments:

- B.1. Additional certified and classified personnel actions for consideration, Item# E.3.
- B.2. Remove Item C.3. - Recognition of Megan Brungardt, school nurse at Buffalo Jones Elementary and Plymell Elementary, recipient of the Outstanding Oral Health Volunteer Award.
- B.3. Remove Item F.1. - Music Department Presentation

C. DELEGATIONS, Q & A, PUBLIC COMMENTS, RECOGNITIONS, COMMITTEE REPORTS

(a speaker or group will be allotted five minutes to speak after signing a request to address the Board of Education)

- C.1. Election of Board of Education Officers and Consider Resolution to Establish Election of School Board Officers
- C.2. Recognition of Board of Education Members - School Board Recognition Month
Dr. Mike Dominguez, Superintendent

D. CORRESPONDENCE

E. CONSENT AGENDA

- E.1. Minutes
 - E.1.a. December 21, 2023, Regular Board of Education Meeting
- E.2. ACCOUNTS PAYABLE totaling \$204,887.76 noting that all major accounts contain adequate balances to meet current obligations.
- E.3. Personnel
 - E.3.a. Certified
 - E.3.b. Classified
- E.4. Bids
 - E.4.a. Floor covering - Charles Stones Intermediate Center - to accept the bid of Star Commercial Flooring in the amount of \$23,702.44
Colleen Drees, Chief Financial Officer
 - E.4.b. Floor covering - Gertrude Walker Elementary School - to accept the bid of Star Commercial Flooring in the amount of \$42,091.73

Colleen Drees, Chief Financial Officer

E.4.c. Floor covering - Plymell Elementary School - to accept the bid of Country Carpet in the amount of \$49,450.00

Colleen Drees, Chief Financial Officer

E.4.d. Floor covering - Victor Ornelas Elementary School - to accept the bid of Star Commercial Flooring in the amount of \$76,855.65

Colleen Drees, Chief Financial Officer

E.5. The Board of Education is asked to consider and approve Wazer - Sole Source Purchase of GCHS Welding Waterjet - in the amount of \$11,999.00.

Colleen Drees, Chief Financial Officer

E.6. Other

E.6.a. The Board of Education is asked to consider and approve a State Contract - Pur O Zone - Custodial Equipment - in the amount of \$31,207.82

Colleen Drees, Chief Financial Officer

E.6.b. The Board of Education is asked to consider and approve a State Contract - Alta Brown Playground - in the amount of \$95,998.90

Colleen Drees, Chief Financial Officer

E.6.c. The Board of Education is asked to consider and approve a State Contract - Next Generation Recreation - Victor Ornelas Playground - in the amount of \$124,294.83

Colleen Drees, Chief Financial Officer

E.6.d. The Board of Education is asked to consider and approve a Taylor True Value Hardware quote for the purchase of a fence at Georgia Matthews Elementary School - in the amount of \$16,171.20.

Colleen Drees, Chief Financial Officer

E.6.e. The Board of Education is asked to consider and approve a State Contract - Greenbush - Bulk Copy Paper - in the amount of \$28,812.00

E.6.f. The Board of Education is asked to consider and approve the Board of Education Standards

E.6.g. The Board of Education is asked to consider and adopt a Resolution to Establish Board Meeting Dates and Times

E.6.h. The Board of Education is asked to consider and approve the scheduling of Board Meeting dates for July: July 8 and July 22, 2024.

F. NEW BUSINESS

F.1. The Board of Education is asked to consider and approve the purchase of Harris Solutions eTriton Front of House and Back of House Software - in the amount of \$28,876.00, with an annual maintenance fee of \$17,341.00.

Josh Guymon, Assistant Superintendent and Tracy Johnson, Nutrition Director

F.2. The Board of Education is asked to consider and approve the purchase of a new walk-in freezer at Gertrude Walker Elementary School.

Josh Guymon, Assistant Superintendent and Tracy Johnson, Nutrition Director

F.3. Boundary Study - Enrollment Analysis - RSP

Colleen Drees, Chief Financial Officer, Josh Guymon, Assistant Superintendent, and RSP Consultants

F.4. Abe Hubert Elementary School HVAC

Shane Faurot, Plant Facilities Director

F.5. Board of Education Committee Assignments

G. BOARD OPEN DISCUSSION

H. NEXT BOARD MEETING

The next meeting of the Board of Education will take place on February 5, 2024, at 6:00 p.m. in the Board Meeting Room at the Educational Support Center, 1205 Fleming St., Garden City, Kansas.

I. ACCOUNTS PAYABLE REVIEW - Jackie Gigot and John Wiese

J. ADJOURNMENT



**RESOLUTION TO EXTEND TERM OF BOARD OFFICERS
Resolution Number 2024-004**

BE IT RESOLVED THAT the Board of Education of Unified School District No. 457, Garden City Public Schools, Finney County, Kansas hereby extends the term of current Board President, John Wiese and current Board Vice President, Jackie Gigot, until successors for such positions are elected by the board at the organizational meeting in July 2024.

By:

Board Member

Board Member

Board Member

Board Member

Board Member

Board Member

Board Member

CERTIFICATE

This is to certify that the above resolution was duly adopted by the Board of Education of Unified School District No. 457, Garden City Public Schools, Finney County, Kansas, on the 15th day of January, 2024.

Jennifer Ramos, Clerk of the Board of Education

BOARD OF EDUCATION

Addendum to Certified Personnel Actions

January 8, 2024

APPOINTMENT:

Gene Juno, Scott City, Kansas, is recommended for a sixth grade communications position at Charles Stones Intermediate Center with effective date to be determined. He has fourteen years’ experience and is a former USD 457 teacher.

TRANSFER:

Casey Wise – from 205-day instructional technology coordinator position to a 260-day instructional technology coordinator position at the Educational Support Center effective January 4, 2024.

CONTRACT RECOMMENDATION:

Requesting that the recommendation on April 17, 2023 for Jeffrey Dunlap be changed from non-renewal to renewal effective January 4, 2024. He has completed requirements for Kansas teaching license.

SUPPLEMENTAL CONTRACTS:

- Ana Urrutia GE Bilingual, Level 2
- Ana Urrutia GE Supplemental SPED

SUPPLEMENTAL ADDENDUM CONTRACT:

- Violet Johnson HG Spring Activity Supplemental

TUITION REIMBURSEMENT AGREEMENT:

Kristopher Bussen – Special Education

BOARD OF EDUCATION

Addendum to Certified Personnel Actions

January 15, 2024

APPOINTMENT:

Mary Morton, Ingalls, Kansas, is recommended for a second grade position at Jennie Barker Elementary School effective January 4, 2024. She is a first year teacher.

SUPPLEMENTAL ADDENDUM CONTRACTS:

James Beard	HS	Supplemental Overload NS
James Burnfin	HS	Supplemental Overload NS
Rebecca Burnfin	HS	Supplemental Overload NS
Rajneesh Devgan	HS	Supplemental Overload NS
Emily Hamlin DeLoach	HS	Supplemental Overload NS
Biju Kalarikkal	HS	Supplemental Overload NS
Karan Long	HS	Supplemental Overload NS
Kelsi Shannon	GW	School Counselor Elementary
Kelsi Shannon	GW	SAT Team Member
Curtis Wedel	HG	Supplemental Overload

BOARD OF EDUCATION
Classified Personnel Actions

January 8, 2024

RETIREMENTS	POSITION	BUILDING	DATE
Denise Guerrero	Special Education Paraprofessional	Bernadine Sitts Intermediate Center	12/5/23

RESIGNATIONS	POSITION	BUILDING	DATE
Alaina Ferrell	Special Education Paraprofessional	Garfield Early Childhood Center	1/10/24
Dolores Huffman	Intervention Paraprofessional	Garfield Early Childhood Center	12/20/23

ASSIGNMENTS	POSITION	BUILDING	DATE
Ada Chanthavong	After School Program Supervisor	Florence Wilson Elementary School and Victor Ornelas Elementary School	1/3/24
Mariela Rodriguez	Special Education Paraprofessional	Garfield Early Childhood Center	1/8/24

TRANSFERS	FROM	TO	DATE
Janet Kruleski	Special Education Paraprofessional - Garfield Early Childhood Center	Intervention Paraprofessional – Garfield Early Childhood Center	1/8/24

OTHER

- Drew Thon, Chief HR Officer requests the following changes for Garden City High School
- Change the Office Specialist position currently held by Aaron Riojas from 205 days to 260 days
 - Change open Career Services Administrative Assistant position from 260 days to 205 days
 - Change current .5 Bilingual/Migrant paraprofessional position to 1.0

BOARD OF EDUCATION
Classified Personnel Actions Addendum

January 8, 2024

RESIGNATIONS	POSITION	BUILDING	DATE
Lorena Meraz De Castillo	Nutrition Assistant	Garden City High School	1/10/24

ASSIGNMENTS	POSITION	BUILDING	DATE
Alyssa Kelley	Special Education Paraprofessional	Bernadine Sitts Intermediate Center	1/8/24
Nevaeh Robinson- Dailing	Special Education Paraprofessional	Garden City Achieve	1/8/24

BOARD OF EDUCATION
Classified Personnel Actions Addendum

January 15, 2024

RETIREMENTS	POSITION	BUILDING	DATE
Santa Ana Lopez	Custodian	Garden City High School	1/10/24

RESIGNATIONS	POSITION	BUILDING	DATE
Kyle Crum	Mechanic	Transportation	1/8/24
Austin Longoria	In School Suspension Paraprofessional	Garden City Achieve	1/11/24
Jenny Lopez	Special Education Paraprofessional	Garfield Early Childhood Center	1/19/24
Norma Morales	Custodian	Garden City High School	1/19/24

TRANSFERS	FROM	TO	DATE
Marissa Hernandez	Long-term substitute Edith Scheuerman Elementary School	Special Education Paraprofessional Edith Scheuerman Elementary School	1/8/24
Martha Arteaga	Special Education Paraprofessional Edith Scheuerman Elementary	Special Education Paraprofessional Victor Ornelas Elementary School	1/8/24

OTHER:

Michael Burns, Director of Transportation, requests approval of Temporary Transportation Driver Agreements with Mayra Varela and Aidan Sparks

Steve Nordby, Principal at Garden City High School, is requesting to transfer Alma Garcia from her current .5 Bilingual/Migrant Paraprofessional/.5 Office Assistant position to the open 1.0 Career Services Office Assistant in the Career Center.

MEMORANDUM

TO: Board of Education
THRU: Dr. Mike Dominguez, Superintendent
FROM: Colleen Drees, Chief Financial Officer
DATE: January 8th, 2024
RE: Floorcovering - Charles Stones Intermediate Center

ISSUE:

The Board of Education is asked to approve the replacement of existing carpet in Charles Stones Intermediate Center

BACKGROUND:

Bid packet is attached for your review. Charles Stones has been identified as one of this year's flooring priorities. This bid has been completed to replace aging carpet in the library and two offices.

ALTERNATIVES:

No other alternatives applicable.

RECOMMENDATION:

1. Approve the lowest bid for the purchase and installation of carpet tiles to Star Commercial Flooring.
2. Deny the purchase and installation.
3. Re-bid the flooring to alternative vendors.

FISCAL NOTE:

The total cost of this purchase and installation is \$23,702.44. This purchase has been budgeted for this fiscal year from the following account: 016 E 4700 21 0550 056 06 610 with adequate balances remaining for this purchase

ATTACHMENTS:

Board Packet – CSIC
Floorcovering Plan - CSIC

**Bid Tabulations
Library and Office Areas
Charles Stones Intermediate Center**

Bid Opening: January 4th, 2024

Bid 2024-12

Vendor	Base Bid (Area N) J&J Carpet Tile Floor	Bid Bond	Base Bid Duration
J&M	no bid		
Country Carpet-Wichita	\$27,000.00	Yes	4 days
Star Commercial Flooring	\$23,702.44	Yes	3-4 days
Vitztum	no bid		
F & A Flooring	no bid		
Milliken Design, Inc	no bid		

RECOMMENDATION: To accept the bid of Star Commercial Flooring in the amount of \$23,702.44.

Payment to be made from budgeted funds in account:

016 E 4700 21 0550 056 06 610

DW Flooring

Bidders List
Library and Office Areas
Charles Stones Intermediate Center

J&M Paint and Decorating Center

Daryl
1615 Buffalo Jones Ave.
Garden City, KS 67846
620.276.3811
jandmpaint@gmail.com

Country Carpet-Wichita

Mallory Minor
505 S. Broadway Ave. Ste 122
Wichita, KS 67202
316-351-2420
mallory@countrycarpetceramic.com

Star Commercial Flooring

Cliff Means
325 S. West Street
Wichita, KS 67213
316.946.1586 P
316.554.4212 C
cliff.means@starlumber.com

Vitztum Commercial Flooring

Brian Vitztum
PO Box 642
Hays, KS 67601
785.623.7453
brian@vitztum.com

F & A Flooring

Amber
19 N. Main
Hutchinson, KS 67501
620.500.6808
faflooringks@gmail.com

Milliken Design, Inc

Jennifer Wolff
Kansas City, MO
816.814.5890
jennifer.wolff@milliken.com

Base Bid Area N (Turquoise)

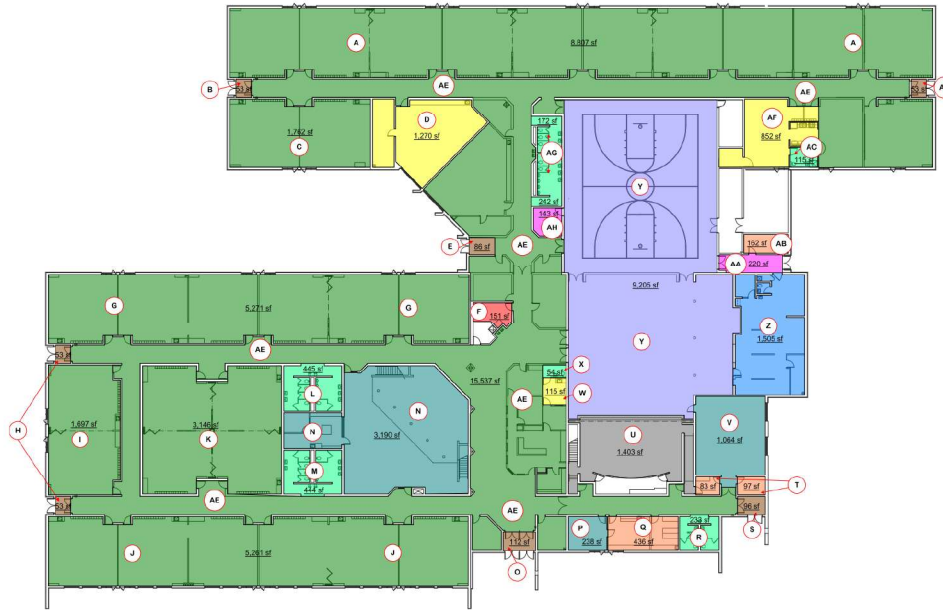

- LEGEND**
- CARPET
 - KITCHEN TILE
 - RESTROOM TILE
 - VCT 1
 - CARPET TILE 1
 - VCT 2
 - VCT 3
 - CARPET TILE 2
 - VCT 4
 - CARPET TILE 3
 - CARPET TILE 4

1 CHARLES O STONE
1" = 20'-0"



PROGRESS
PRINT
NOT FOR CONSTRUCTION
DATE: 2/20/24

Project Number

GMCN
ARCHITECTS • PLANNERS
11511 AUBURN • GARDEN CITY, KS 67844 • (620) 274-5244
www.gmcncn.com

DISTRICT FLOOR - ASSESSMENT
USD 457
Enter address here

ISSUE:
No. Date Description

SHEET TITLE
CHARLES O STONE
DATE:
Issue Date

CSIC

MEMORANDUM

TO: Board of Education
THRU: Dr. Mike Dominguez, Superintendent
FROM: Colleen Drees, Chief Financial Officer
DATE: January 8th, 2024
RE: Floor covering - Gertrude Walker Elementary School

ISSUE:

The Board of Education is asked to approve the replacement of existing carpet in Gertrude Walker Elementary School

BACKGROUND:

Bid packet is attached for your review. Gertrude Walker has been identified as one of this year's flooring priorities. This bid has been completed to replace aging tile with LVT tile in the gym and hallways.

ALTERNATIVES:

No other alternatives applicable.

RECOMMENDATION:

1. Approve the lowest bid for the purchase and installation of carpet tiles to Star Commercial Flooring.
2. Deny the purchase and installation.
3. Re-bid the flooring to alternative vendors.

FISCAL NOTE:

The total cost of this purchase and installation is \$42,091.73. This purchase has been budgeted for this fiscal year from the following account: 016 E 4700 21 0550 056 06 610 with adequate balances remaining for this purchase

ATTACHMENTS:

Board Packet – GW
Floorcovering Plan - GW

**Bid Tabulations
Gym and Entry Way
Gertrude Walker Elementary School**

Bid Opening: January 4th, 2024

Bid 2024-13

Vendor	Base Bid (Area G) J&J LVT1	Bid Bond	Duration
J&M Paint & Decorating Center	no bid		
Country Carpet-Wichita	\$46,180.00	Yes	8 days
Star Commercial Flooring	\$42,091.73	Yes	9-11 days
Vitztum Commerical Flooring	no bid		
F & A Flooring	no bid		
Milliken Design, Inc	no bid		

RECOMMENDATION: To accept the bid of Star Commercial Flooring in the amount of \$42,091.73.

Payment to be made from budgeted funds in account:

016 E 4700 21 0550 056 06 610

DW Flooring

Bidders List
Gym and Entry Way
Gertrude Walker Elementary School

J&M Paint and Decorating Center

Daryl
1615 Buffalo Jones Ave.
Garden City, KS 67846
620.276.3811
jandmpaint@gmail.com

Country Carpet-Wichita

Mallory Minor
505 S. Broadway Ave. Ste 122
Wichita, KS 67202
316-351-2420
mallory@countrycarpetceramic.com

Star Commercial Flooring

Cliff Means
325 S. West Street
Wichita, KS 67213
316.946.1586 P
316.554.4212 C
cliff.means@starlumber.com

Vitztum Commercial Flooring

Brian Vitztum
PO Box 642
Hays, KS 67601
785.623.7453
brian@vitztum.com

F & A Flooring

Amber
19 N. Main
Hutchinson, KS 67501
620.500.6808
faflooringks@gmail.com

Milliken Design, Inc.

Jennifer Wolff
Kansas City, MO
816.814.5890
jennifer.wolff@milliken.com

BID OPENING: January 4, 2024

Base Bid Area G (Yellow)

LVT1 Classic II V5023 1000 Notable

- LEGEND**
- CARPET 1
 - CARPET TILE 1
 - VCT 1
 - CARPET TILE 2
 - VCT 2
 - CARPET 2
 - KITCHEN TILE
 - CARPET 3
 - TILE 4
 - TILE 2
 - REST ROOM TILE 1
 - RESTROOM TILE 2
 - RESTROOM TILE 3
 - RESTROOM TILE 4
 - RESTROOM TILE 5



1 GERTRUDE WALKER
1" = 20'-0"



Project Number



DISTRICT FLOOR - ASSESSMENT
USD 457
Enter address here

ISSUE:
No. Date Description

SHEET TITLE:
GERTRUDE WALKER
DATE:
Issue Date
GWES

MEMORANDUM

TO: Board of Education
THRU: Dr. Mike Dominguez, Superintendent
FROM: Colleen Drees, Chief Financial Officer
DATE: January 8th, 2024
RE: Floor covering - Plymell Elementary School

ISSUE:

The Board of Education is asked to approve the replacement of existing carpet in Plymell Elementary School

BACKGROUND:

Bid packet is attached for your review. Plymell has been identified as one of this year's flooring priorities. This bid has been completed to replace aging carpet with carpet tiles in classrooms

ALTERNATIVES:

No other alternatives applicable.

RECOMMENDATION:

1. Approve the lowest bid for the purchase and installation of carpet tiles to Country Carpet - Wichita
2. Deny the purchase and installation.
3. Re-bid the flooring to alternative vendors.

FISCAL NOTE:

The total cost of this purchase and installation is \$49,450.00. This purchase has been budgeted for this fiscal year from the following account: 016 E 4700 21 0550 056 06 610 with adequate balances remaining for this purchase

ATTACHMENTS:

Board Packet – PLY
Plymell Floorcovering Plan

**Bid Tabulations
Classroom Flooring
Plymell Elementary School**

Bid Opening: January 4th, 2024

Bid 2024-14

Vendor	Base Bid (Area P) J&J Carpet Tile Floor	Alt. Bid (Areas D, G, N) J&J Carpet Tile Floor	Total	Bid Bond	Base Bid Duration
J&M	no bid				
Country Carpet-Wichita	\$41,260.00	\$8,190.00	\$49,450.00	Yes	5 Days
Star Commercial Flooring	\$42,411.05	\$11,226.92	\$53,637.97	Yes	7-8 Days
Vitztum	no bid				
F & A Flooring	no bid				
Milliken Design, Inc	no bid				

RECOMMENDATION: To accept the bid of Country Carpet-Wichita in the amount of \$49,450.00.

Payment to be made from budgeted funds in account:

016 E 4700 21 0550 056 06 610

DW Flooring

Bidders List
Classroom Flooring
Plymell Elementary School

J&M Paint and Decorating Center

Daryl
1615 Buffalo Jones Ave.
Garden City, KS 67846
620.276.3811
jandmpaint@gmail.com

Country Carpet-Wichita

Mallory Minor
505 S. Broadway Ave. Ste 122
Wichita, KS 67202
316-351-2420
mallory@countrycarpetceramic.com

Star Commercial Flooring

Cliff Means
325 S. West Street
Wichita, KS 67213
316.946.1586 P
316.554.4212 C
cliff.means@starlumber.com

Vitztum Commercial Flooring

Brian Vitztum
PO Box 642
Hays, KS 67601
785.623.7453
brian@vitztum.com

F & A Flooring

Amber
19 N. Main
Hutchinson, KS 67501
620.500.6808
faflooringks@gmail.com

Milliken Design, Inc

Jennifer Wolff
Kansas City, MO
816.814.5890
jennifer.wolff@milliken.com

BID OPENING: January 4, 2024

**Bids and Quotations
Classroom Flooring
Plymell Elementary School**

Bid Opening: January 4th, 2024
Board Meeting: January 8th, 2024

Bid 2024-14

Item, Material and/or Service that is being bid:

1. Classrooms

2. Brief description of the item, material, or service listed above:

Removal of existing flooring and replace with new

3. Period of time item, material or service bid will cover:

10+ years

4. Reason that the item, material or service is needed:

Floors have reached the end of their serviceable life

5. Department and person responsible for the expenditure of the budget:

Plant Facilities - Shane Faurot

6. Line item and amount budgeted for this item:

DW Flooring

016 E 4700 21 0550 056 06 610

Base Bid is Area P (Yellow)

Alternate Bid for Areas D (Green), G (Brown) and N (Brown)



LEGEND

- VCT 1
- CARPET 1
- CARPET TILE 1
- CARPET 2
- CARPET TILE 2
- MOSAIC TILE 1
- MOSAIC TILE 2
- VCT 2
- VCT 3
- VCT 4
- CARPET TILE 3
- VCT 5
- CERAMIC TILE

1 PLYMELL
1" = 10'-0"



Project Number



DISTRICT FLOOR - ASSESSMENT
USD 457
Enter address here

ISSUE:
No. Date Description

SHEET TITLE:
PLYMELL
DATE:
Issue Date

PES

MEMORANDUM

TO: Board of Education
THRU: Dr. Mike Dominguez, Superintendent
FROM: Colleen Drees, Chief Financial Officer
DATE: January 8th, 2024
RE: Floorcovering – Victor Ornelas Elementary School

ISSUE:

The Board of Education is asked to approve the replacement of flooring in Victor Ornelas Elementary School

BACKGROUND:

Bid packet is attached for your review. Victor Ornelas has been identified as one of this year's flooring priorities. This bid has been completed to replace aging tile with LVT in the Gym and Dining Room

ALTERNATIVES:

No other alternatives applicable.

RECOMMENDATION:

1. Approve the lowest bid for the purchase and installation of carpet tiles to Star Commercial Flooring.
2. Deny the purchase and installation.
3. Re-bid the flooring to alternative vendors.

FISCAL NOTE:

The total cost of this purchase and installation is \$76,855.65. This purchase has been budgeted for this fiscal year from the following account: 016 E 4700 21 0550 056 06 610 with adequate balances remaining for this purchase

ATTACHMENTS:

Board Packet – VO
Floorcovering Plan - VO

**Bid Tabulations
Gym and Dining Room
Victor Ornelas Elementary School**

Bid Opening: January 4th, 2024

Bid 2024-15

Vendor	Base Bid (Area AB) J&J 3 mm LVT1 & LVT2	Alternate Base Bid (Area AB)	Total	Bid Bond	Base Bid Duration
J&M	no bid				
Country Carpet-Wichita	\$67,460.00	\$10,025.00	\$77,485.00	Yes	10 days
Star Commercial Flooring	\$60,696.60	\$16,159.05	\$76,855.65	Yes	10-12 days
Vitztum	no bid				
F & A Flooring	no bid				
Milliken Design, Inc	no bid				

RECOMMENDATION: To accept the bid of Star Commercial Flooring in the amount of \$76,855.65.

Payment to be made from budgeted funds in account:

016 E 4700 21 0550 056 06 610

DW Flooring

Bidders List
Gym and Dining Room
Victor Ornelas Elementary School

J&M Paint and Decorating Center

Daryl
1615 Buffalo Jones Ave.
Garden City, KS 67846
620.276.3811
jandmpaint@gmail.com

Country Carpet-Wichita

Mallory Minor
505 S. Broadway Ave. Ste 122
Wichita, KS 67202
316-351-2420
mallory@countrycarpetceramic.com

Star Commercial Flooring

Cliff Means
325 S. West Street
Wichita, KS 67213
316.946.1586 P
316.554.4212 C
cliff.means@starlumber.com

Vitztum Commercial Flooring

Brian Vitztum
PO Box 642
Hays, KS 67601
785.623.7453
brian@vitztum.com

F & A Flooring

Amber
19 N. Main
Hutchinson, KS 67501
620.500.6808
faflooringks@gmail.com

Milliken Design, Inc

Jennifer Wolff
Kansas City, MO
816.814.5890
jennifer.wolff@milliken.com

BID OPENING: January 4, 2024

**Bids and Quotations
Gym and Dining Room
Victor Ornelas Elementary School**

Bid Opening: January 4th, 2024
Board Meeting: January 8th, 2024

Bid 2024-15

Item, Material and/or Service that is being bid:

1. Replacing Gym and Dining Room VCT with LVT
2. Brief description of the item, material, or service listed above:
Removal of existing flooring and replace with new
3. Period of time item, material or service bid will cover:
10+ years
4. Reason that the item, material or service is needed:
Floors have reached the end of their serviceable life
5. Department and person responsible for the expenditure of the budget:
Plant Facilities - Shane Faurot
6. Line item and amount budgeted for this item:
DW Flooring 016 E 4700 21 0550 056 06 610

Base Bid Area AB(Yellow)

LVT1 1119 Pebble Dining Room and Basketball Court in Gym

LVT2 1118 Mosaic Border around Gym

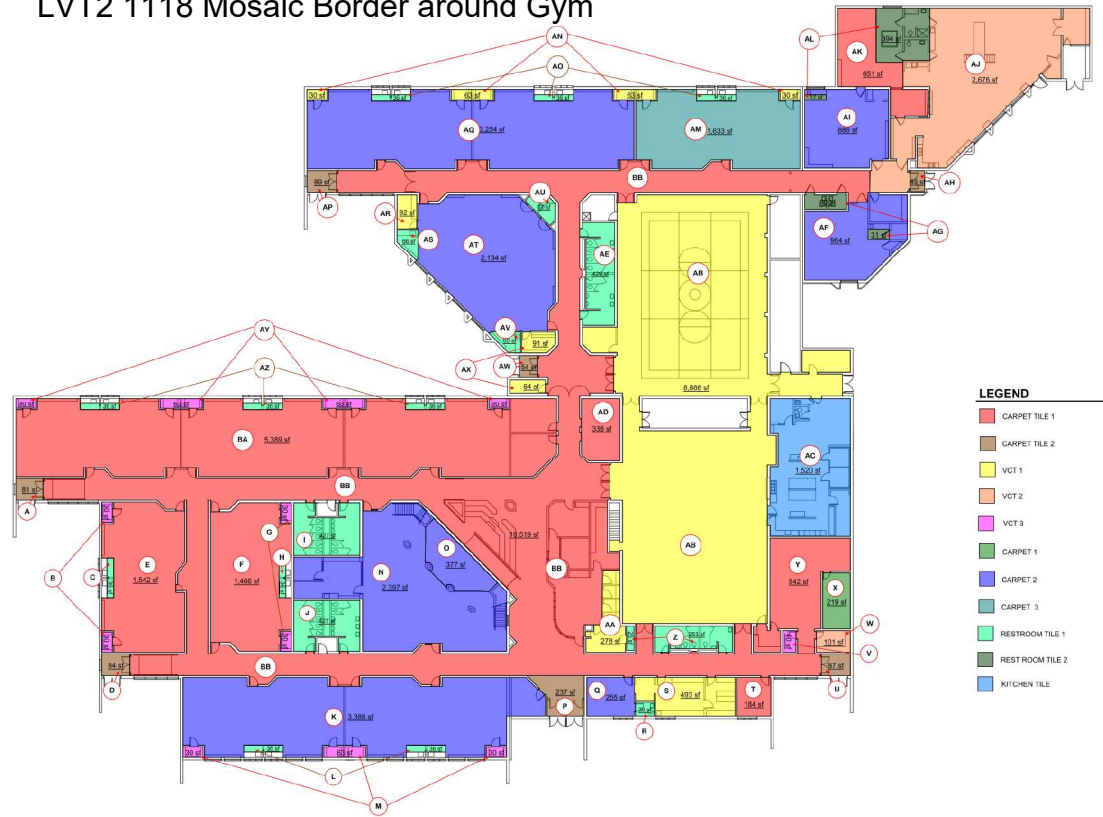

1 VICTOR ORNELAS
1" = 20'-0"



PROGRESS PRINT
NOT FOR CONSTRUCTION
DATE: 2/20/2022

Project Number

GMCN
ARCHITECTS • PLANNERS
11511 AUBURN • GARDEN CITY, KS 67844 • (620) 274-5244
www.gmcncorp.com

DISTRICT FLOOR - ASSESSMENT
USD 457
Enter address here

ISSUE:
No. Date Description

SHEET TITLE:
VICTOR ORNELAS
VOES
DATE:
Issue Date

MEMORANDUM

TO: Board of Education
THRU: Dr. Mike Dominguez, Superintendent
FROM: Colleen Drees, Chief Financial Officer
DATE: January 8th, 2024
RE: Wazer – Welding Waterjet

ISSUE:

The Board of Education is asked to approve the purchase of a Wazer Welding Waterjet

BACKGROUND:

This purchase is being completed via a sole source vender. This purchase is for the welding shop at Garden City High School. This purchase is being completed utilizing a grant award to Don Murrell to use for his classroom.

ALTERNATIVES:

No other alternatives applicable.

RECOMMENDATION:

1. Approve the state contract to purchase the Wazer Waterjet.
2. Deny the purchase and installation.
3. Re-bid the flooring to alternative vendors.

FISCAL NOTE:

The total cost of this purchase is \$11,999.00. This purchase has been funded from a grant that Don Murrell received for his welding shop. The account number is: 004 L 5750 50 0010 130 00 000 Harbor Freight Grant

ATTACHMENTS:

Garden City High School Welding
Sole Source Letter

WAZER INVOICE: 16402182511

Garden City Public Schools

1205 Fleming Street
Garden City, KS 67846
United States

Don Murrell

dmurrell@gckschools.com
+1 620 272 7163

WAZER Inc

4 Executive Plaza, Suite 175
Yonkers, NY 10701

Prepared by:

Tyler Keppler
tyler.keppler@wazer.com
+1-929-265-5163

Invoice Date: December 7, 2023

PRODUCTS & SERVICES	SKU	QUANTITY	BILLING FREQUENCY	PRICE	TOTAL
110V / 60Hz WAZER Starter Bundle	WZR-107	1		\$11,999.00	\$11,999.00
SUBTOTALS					TOTAL
One-time subtotal					\$11,999.00

Total	\$11,999.00
--------------	-------------

Ship To:

Garden City High School Welding - Deal

Total	\$11999
Amount Paid	\$0
Balance Due	\$11999

Payment Terms:**Invoice Notes:**

Payment Terms: net30

Lead Time: 2-3 weeks

Shipping included for contiguous United States

Payments Method Accepted: Check, ACH, or Wire Transfer.

Contact Sales for Credit Card Payments or for Financing options.

Orders Subject to WAZER's Terms of Service:

<https://www.wazer.com/terms-of-service>

Please include the invoice number with all payments

Check Payment	ACH Payment	Wire Transfer	Credit Card
WAZER INC Attn: Accounts Receivable 4 Executive Plaza, Ste 175 Yonkers, NY 10701	Bank of America Account #: 483070940021 Routing #: 021000322	Bank of America Account #: 483070940021 Routing #: 026009593 Swift Code: BOFAUS3N	Contact Sales +1-929-265-5163 info@wazer.com



WAZER Inc.
4 Executive Plaza
Suite 175
Yonkers, NY 10701
www.wazer.com

07/20/2022

Letter of Availability

To Whom It May Concern

WAZER Inc. is the sole designer and manufacturer of the WAZER waterjet products, including the WAZER Desktop, WAZER Stand Up, WAZER Starter Bundle and related accessories.

Wazer products are available directly from Wazer Inc or in some regions Wazer has appointed authorized resellers. The list of locations and resellers can be found at this link :

<https://wazer.com/contact/>

Wazer Inc and its resellers offer the same base pricing to all customers which is openly published on the wazer.com web site at shop.wazer.com/products

Sincerely,

Tom Herd
Vice President, WAZER Inc.
(929) 265-5163
info@wazer.com

MEMORANDUM

TO: Board of Education
THRU: Dr. Mike Dominguez, Superintendent
FROM: Colleen Drees, Chief Financial Officer
DATE: December 4th, 2023
RE: State Contract – Pur-O-Zone Custodial Equipment

ISSUE:

The Board of Education is asked to approve the purchase of new custodial equipment for the High School.

BACKGROUND:

Plant Facilities is moving our custodial process to a “Team Cleaning” approach. So as we are replacing old equipment we are changing the type of equipment we’re purchasing.

ALTERNATIVES:

No other alternatives applicable

RECOMMENDATION:

1. Approve the bid to purchase the custodial equipment from Pur-O-Zone
2. Deny the purchase of the equipment
3. Re-bid the equipment to alternative vendors

FISCAL NOTE:

The total expense for this purchase is \$31,207.82. This purchase has been budgeted in the current fiscal year from the following account: 016 E 2630 19 0000 056 02 730. Adequate balances are remaining for this purchase.

ATTACHMENTS:

Pur-O-Zone Inc Quote



P.O. Box 727
 Lawrence, KS 66044-0727
 Telephone: 785-843-0771
 Fax: 785-843-0798

QUOTE VALID FOR 30 DAYS

QUOTE

QUOTE NO.	QUOTE DATE	CUST NO.
51095	12/07/23	12164

12164

PAGE 1

S
O
L
D
T
O

U.S.D. #457
 1205 FLEMING STREET
 GARDEN CITY, KS 67846

S
H
I
P
T
O

U.S.D. #457
 SERVICE CENTER
 4665 EAST US 50 HIGHWAY PLAZA
 GARDEN CITY, KS 67846

SPECIAL INSTRUCTIONS			CONTACT	SHIP VIA	TERMS	
				U.P.S.	Net 10 E.O.M.	
LINE	QUOTED	PRODUCT CODE	DESCRIPTION	UNIT	UNIT PRICE	EXTENDED PRICE
1	2	KV1750	KAIVAC CLEANING MACHINE KV1750 **KV1750 SN_____ EA	EA	4906.36	9812.72
2	6	XCV17PG	MAKITA BACKPACK BATTERY VACUUM SN_____	EA	1104.29	6625.74
3	6	BL1860B-2	MAKITA BATTERY PACK 18V 6.0AH LITHIUM-ION BATTERY 2/PK	PK	360.00	2160.00
4	3	LQFC425K	LOTUS PRO HIGH CAP UNIT SER. I TERSANO SER:_____	EA	3050.00	9150.00
5	6	Q755	HANDLE 48"-72" FOR MICRO FRAME Q755 QUICK CONNECT HYGEN 6/CS	EA	30.63	183.78
6	6	Q560	MOPMICRO 18" MICROFIBER FRAME Q560 QUICK-CONNECT HYGEN 6/CS	EA	41.65	249.90
7	6	10969	CHARGING BUCKET/LID 16" BLUE FILMOP SE1322AA KT	KT	63.78	382.68
8	6	EDPBR	DUST PAN, LOBBY, WITH BROOM UNGER EDPBR ERGO DUST PAN 33"	EA	66.88	401.28
9	6	2642	BRUTE CADDY BAG YELLOW RUBBERMAID 2642 6/CS	EA	70.83	424.98
10	6	2643GRAY	BRUTE 44 GAL. GRAY CONTAINER RUBBERMAID 2643 4/CS	EA	67.16	402.96
11	6	3120	DUSTER POLY WOOL 52-84" WASHBL IMPACT 3120 TELESCOPING 12/CS	EA	12.12	72.72
12	6	101532	DUSTER SLEEVES PRODUSTER PRO-TEAM YELLOW 50/PK 500/CS	PK	36.91	221.46

TOTAL QUANTITY		NO RETURN OF GOODS ACCEPTED WITHOUT WRITTEN AUTHORIZATION.	SUBTOTAL FRGT/MISC	
			TAX	
			QUOTE TOTAL	

WE APPRECIATE YOUR BUSINESS AND LOOK FORWARD TO PROVIDING THE CARE AND SERVICE YOU DESERVE.

BEST REGARDS,
 RON CHADWICK



P.O. Box 727
 Lawrence, KS 66044-0727
 Telephone: 785-843-0771
 Fax: 785-843-0798

QUOTE VALID FOR 30 DAYS

QUOTE

QUOTE NO.	QUOTE DATE	CUST NO.
51095	12/07/23	12164

12164

PAGE 2

S
O
L
D
T
O

U.S.D. #457
 1205 FLEMING STREET
 GARDEN CITY, KS 67846

S
H
I
P
T
O

U.S.D. #457
 SERVICE CENTER
 4665 EAST US 50 HIGHWAY PLAZA
 GARDEN CITY, KS 67846

SPECIAL INSTRUCTIONS			CONTACT	SHIP VIA	TERMS	
				U.P.S.	Net 10 E.O.M.	
LINE	QUOTED	PRODUCT CODE	DESCRIPTION	UNIT	UNIT PRICE	EXTENDED PRICE
13	6	SICEM2-QT	SIC-EM2 MULTI-PURP CLEANER QT PUR-O-ZONE RTU QUART 12/CS	CS	58.10	348.60
14	6	7708	7708 GATOR ANCHOR DOLLY	EA	128.50	771.00

TOTAL QUANTITY	77	NO RETURN OF GOODS ACCEPTED WITHOUT WRITTEN AUTHORIZATION.	SUBTOTAL	31207.82
			FRGT/MISC	0.00
			TAX	0.00
			QUOTE TOTAL	31207.82

WE APPRECIATE YOUR BUSINESS AND LOOK FORWARD TO PROVIDING THE CARE AND SERVICE YOU DESERVE.

BEST REGARDS,
 RON CHADWICK

MEMORANDUM

TO: Board of Education
THRU: Dr. Mike Dominguez, Superintendent
FROM: Colleen Drees, Chief Financial Officer
DATE: January 8th, 2024
RE: State Contract – Alta Brown

ISSUE:

The Board of Education is asked to approve the purchase and installation of additional playground equipment at Alta Brown.

BACKGROUND:

We have allocated capital funds per our long-range plan to improve the playground equipment at this school. This playground equipment is being purchased via a state contract and is identical to the equipment that was installed at Garden City Achieve (GCA). The equipment and surfacing is designed to be inclusive for students with special needs.

ALTERNATIVES:

No other alternatives applicable

RECOMMENDATION:

1. Approve the state contracted purchases for the playground equipment
2. Deny the proposals for new playground equipment
3. Recommend an alternative solution

FISCAL NOTE:

The total expense for the playground equipment and turf at Alta Brown is \$95,998.90. This purchase has been budgeted in the current fiscal year from the following accounts: 016 E 1000 21 0000 002 04 730 and 030 E 1000 21 0000 002 04 730. Adequate balances are remaining for these purchases.

ATTACHMENTS:

Alta Brown Playground



Alta Brown Elementary School (Green Area) - Gardent City USD457

Garden City USD 457

1205 Fleming Street
Garden City, KS 67846
United States

Shane Faurot

tfaurot@gckschools.com
620-214-4050

Reference: 20231117-224450878

Quote created: November 17, 2023

Quote expires: January 16, 2024

Quote created by: Chuck Green

"Recreation Design Specialist"

chuck.green@nextgenerationrecreation.com

Comments from Chuck Green

Sourcewell Cooperative Purchase Program - Dicount Applied

Playworld Systems - #010521-LTS-8

**All Equipment and Materials are shipped direct to client - Please see attached document named:
"How to Receive a Shipment"**

******ALL Quotes are good for 30-Days only******

Due to uncontrollable and ongoing changes directly effecting cost of goods, shipping, and material costs, If order placed more than 30-Days past original date, a new quote must be requested and updated before placing order. If new quote not requested, we will update all quotes, and invoices prior to ordering.

Products & Services

Item & Description	Quantity	Unit Price	Total
PLAYWORLD ZZXX0346 - Unit Slide Climber	1	\$15,497.00	\$15,497.00
<p>The thrill of a slide and so much more! Unity features different climbers for a variety of challenge levels. The tube at the top is an entry to the slide and a gathering point. Children use the space underneath to socialize and play games.</p>			
PLAYWORLD ZZXX0911 - Cone Spinner W/Floor	1	\$15,374.00	\$15,374.00
<p>The Cone Spinner presents a unique play experience each time a child interacts with the product. Children can test their courage by climbing to the top, increasing their strength, balance, and independence. The Cone Spinner also presents an inclusive play experience by being easy to access at the bottom. Children can sit and spin while their legs dangle creating a unique spinning experience. Multiple children can enjoy the product at once increasing the play value of this unique addition to any playground.</p>			
INSTALLATION Complete Installation of all NEW Playworld Equipment/or whatever item listed at above mentioned address only. Including all materials and use of heavy equipment required, and all concrete supplies and labor for all inground footings. Includes disposal of all containers/cardboard/packaging used for shipping of equipment.	1	\$9,980.44	\$9,980.44
SHIPPING Freight and delivery cost for Playworld Equipment.	1	\$1,850.00	\$1,850.00
One-time subtotal			\$42,701.44
Total			\$42,701.44

Purchase terms

50% Deposit/Payment due prior to ordering materials, equipment, or replacement parts, and due prior to mobilization for project. The remaining **50%** will be due **NET 30 Days after invoiced and prior to delivery of equipment and installation.**

Any order cancelled more than **15 Business Days** after placement will result in a 30% Restocking fee due immediately upon cancellation which will be deducted from all deposits, and remaining balance returned.

Next Generation Recreation **MUST be notified at least 15-days prior** to due date noted on invoice regarding any, and all delays in payment with good reason. Otherwise late fees of 18% will accrue at 45 days past due.

Signature

Signature

Date

Printed name

Questions? Contact me



Chuck Green
"Recreation Design Specialist"
chuck.green@nextgenerationrecreation.com

Next Generation Recreation
P.O. Box 902008
Kansas City , MO 64190
USA



Alta Brown Elementary School (Yellow Area) - Gardent City USD457 (copy)

Garden City USD 457

1205 Fleming Street
Garden City, KS 67846
United States

Reference: 20231120-191247782
Quote created: November 20, 2023
Quote expires: January 16, 2024
Quote created by: Chuck Green
"Recreation Design Specialist"
chuck.green@nextgenerationrecreation.com

Shane Faurot

tfaurot@gckschools.com
620-214-4050

Comments from Chuck Green

**Sourcewell Cooperative Purchase Program - Dicount Applied
Playworld Systems - #010521-LTS-8**

**All Equipment and Materials are shipped direct to client - Please see attached document named:
"How to Receive a Shipment"**

******ALL Quotes are good for 30-Days only******

Due to uncontrollable and ongoing changes directly effecting cost of goods, shipping, and material costs, If order placed more than 30-Days past original date, a new quote must be requested and updated before placing order. If new quote not requested, we will update all quotes, and invoices prior to ordering.

Products & Services

Item & Description	Quantity	Unit Price	Total
PLAYWORLD ZZXX0911 - Cone Spinner W/Floor The Cone Spinner presents a unique play experience each time a child interacts with the product. Children can test their courage by climbing to the top, increasing their strength, balance, and independence. The Cone Spinner also presents an inclusive play experience by being easy to access at the bottom. Children can sit and spin while their legs dangle creating a unique spinning experience. Multiple children can enjoy the product at once increasing the play value of this unique addition to any playground.	1	\$15,374.00	\$15,374.00
REX BORDER TIMBERS QTY: 20 Up to 20 Next Generation Recreation Bordering system – Plastic Border Timbers. ** SEE PURCHASE AGREEMENT**	1	\$942.12	\$942.12
REX CRUMBLE RUBBER MULCH Delivery and installation of High-Quality Rubber Crumb Mulch made with Recycled Playground Compliant Rubber Materials up to 6 Inches in Depth to meet up to a 9 ft Fall Height.	1	\$1,890.20	\$1,890.20
INSTALLATION Complete Installation of all NEW Playworld Equipment/or whatever item listed at above mentioned address only. Including all materials and use of heavy equipment required, and all concrete supplies and labor for all inground footings. Includes disposal of all containers/cardboard/packaging used for shipping of equipment.	1	\$5,280.00	\$5,280.00
SHIPPING Freight and delivery cost for Playworld items, all Border Timbers, and Crumble Rubber Mulch	1	\$2,550.00	\$2,550.00
		One-time subtotal	\$26,036.32
		Total	\$26,036.32

Purchase terms

50% Deposit/Payment due prior to ordering materials, equipment, or replacement parts, and due prior to mobilization for project. The remaining **50%** will be due **NET 30 Days after invoiced and prior to delivery of equipment and installation.**

Any order cancelled more than **15 Business Days** after placement will result in a 30% Restocking fee due immediately upon cancellation which will be deducted from all deposits, and remaining balance returned.

Next Generation Recreation **MUST be notified at least 15-days prior** to due date noted on invoice regarding any, and all delays in payment with good reason. Otherwise late fees of 18% will accrue at 45 days past due.

Signature

Signature

Date

Printed name

Questions? Contact me



Chuck Green
"Recreation Design Specialist"
chuck.green@nextgenerationrecreation.com

Next Generation Recreation
P.O. Box 902008
Kansas City , MO 64190
USA



FL INSTALL REVISION "PLAYGROUND PROJECT" USD 457 - ALTA BROWN ELEMENTARY

**USD 457 GARDEN CITY PUBLIC SCHOOLS
1205 FLEMING ST
GARDEN CITY, KS 67846**

Sales: Andrew Manion

**FL Install Revision "Playground Project" USD 457 -
Alta Brown Elementary EST4305514 1110 E Pine St
1110 E Pine St Garden City, Kansas 67846**

Est ID: EST4305514 2

Date: Dec-07-2023

FL Install - USD 457 - Alta Brown Elem Revision "Playground Project"

Scope of Work:

- Removal and disposal of the existing soil or mulch surface
- Gravel base
- Composite nailer boards
- Approx. 1000 Ft² Playground Academy Grass
- Rubber infill•3" SafetyFoam
- 1" SafetyFoam
- Approx 140 playground timbers/borders
- 15-year warrantry for the turf and foam

Subtotal	\$27,261.14
Taxes	\$0.00
Estimate Total	\$27,261.14

Commercial Lawn Management
3215 East 9th Street North
Wichita, Kansas
67208

P.316-688-0722

www.commercialawnmgmt.com
cmlawn@gmail.com

Payment Terms and Conditions

Upon the acceptance of the work, payment of the unpaid balance Contract Price when due together with such Value Added Taxes as may be applicable to such payment.

- Should the Client fail to make payments as they become due under the terms of the Contract or in the event of any claim, interest at eighteen percent (18%) per annum above the prime rate on such unpaid amounts shall also become due and payable until payment.

Exclusions

The Following matters are excluded from the Work, unless specified in writing to the contrary:

- Electrical Work is to be done by a certified electrician only and is always additional to the Contract.
- Iron railings removed during construction are always re-attached at an additional cost.
- Damage to existing irrigation lines during construction is considered to be an additional cost.
- Drainage: Should the Client's property be the lowest elevation in relation to surrounding property or buildings, the Contractor, Inc. reserves the right to retain a Soil Engineer to evaluate and propose drainage solutions. All costs for engineering services, as well as the actual drainage work will be at the Client's expense. Unless the Client has a detailed Topographical survey completed, the above clause may come into effect.
- Conduit and connections for electrical, gas, and all other utilities and services
- Site Unknowns: Including, but not limited to, sub-surface conditions/obstacles that create unforeseen labor, equipment, material or disposal charges

Procedure for Extra Work and Changes

If it shall become necessary for the Contractor to make changes in any designs, drawings, plans, software, reports or specifications for any part of the project or reasons over which we have no control, or we are put to any extra work, cost or expense by reason of any act or matter over which it has no control, the Customer will pay to the Contractor a fee for such changed or extra Work calculated on a time and materials basis. All changes to Work or pricing or the terms of this Agreement will be read and understood within the context and meanings of this Agreement unless stated explicitly to the contrary. Extras to the Contract are payable by the Owner forthwith upon receipt of the Company's invoice.

Change Notice: Any Contract change in scope in excess of one thousand dollars (\$1,000.00) requires a Contract Change Notice under which Work is to proceed. Work will not commence under a Contract Change Notice (CNN) unless with written Owner approval.

For Changes in scope of less than one thousand dollars (\$1,000.00), the Contractor will provide the Customer notification by way of its Progress Report. In either instance, such notification shall be plain and clear in terms of scope and reason. Any record, telephone conversation or meeting in which such change in scope was introduced, shall be attached as supporting documentation.

Warranty and Tolerances

- Payments Received: The Warranty for the contract is only valid if payment is received in full on acceptance of the work.
- Diligence: the Contractor agrees to carry out its Work diligently and to provide sufficient supervision and inspection of its staff and subcontractors and that its work will be of proper and professional quality, and in full conformity with the requirements of the contract.
- Competence: the Contractor warrants that it is competent to perform the Work and that it has the necessary qualifications including knowledge and skill with the ability to use them effectively.
- Site Unknowns: It is the responsibility of the Client or the Client's Representative to fully inform the Contractor of all the information regarding site unknowns that may include difficult buried materials, cables, and pipes, tree stumps, drainage or water table issues, rock and shale sub-surfaces and/or other impediments, issues or factors that could otherwise impact the quality, cost and timeliness of project completion. Failure to notify the Contractor may lead to additional costs to the Client (at the Contractor's discretion) and schedule time not included in the Quotation in Schedule 1, and may require changes in design and construction to overcome such problems – all for which the Client will be responsible. Client can avoid such risks by permitting the Contractor to do appropriate soil and ground tests, review the site, and to secure additional required site information from appropriate government and other authorities. The cost(s) of such additional work is not included in the Quotation in Schedule 1 attachment.
- Damaged Utilities: Should damage occur to utilities during construction, the Contractor is only liable for the cost of the repair. the Contractor is not liable in any way for inconvenience to the Client caused by damage to the utilities.
- Damage to neighbors buried utilities, on the Client's property, are the responsibility of the Client.
- Building/Window/Vehicle Washing: Buildings, windows, or vehicles of the Client, including neighbors, are not intended to be kept clean due to dust during Construction or Work performed by the Contractor. Any necessary cleaning due to Construction or Work by the Contractor will be the responsibility of the Client.



Material Tolerances

- Wood: Pressure treated wood cannot be guaranteed against warp age, checking, or cupping.
- Stone: Natural stone has color variations that vary from stone to stone. In addition, mineral deposits such as lime, iron, etc. can change the stone and even bleed. This is the nature of the product and the Client accepts this as a natural and acceptable quality of the stone.
- Metal: Metal, which is not galvanized, is not guaranteed from rusting commencing immediately after installation.
- Concrete: Spider cracks (hairline stress-fractures) are considered a normal characteristic of all types of concrete. Concrete may crack substantially over time due to proximity of tree roots.
- Warranty Time Period: the Contractor warrants all construction and installation for a period of one (1) season, providing that they have been maintained properly. All construction materials are subject to manufacturer's specific warranties/guarantees. Planting is warranted for one (1) season if there is an approved irrigation system.
- Client Responsibilities: The Client recognizes and agrees that they have a responsibility to maintain constructions, plants, bushes, trees, and other installations in keeping with standard quality maintenance requirements in order for the Warranty to remain in affect. Failure to properly maintain materials or horticulture installations will void the warranty. Client further recognizes and agrees that damage to construction, materials, horticulture elements and other warrantable items of the project will not be warranted if the damage or loss is due to elements beyond the control of the Contractor. For example, flooding eaves troughs that damage plants, fallen branches, animal caused damage, frozen/ burst irrigation or drainage pipes that were not seasonally drained at the proper time, use of improper chemicals, improper maintenance, extreme or unusual weather conditions, and similar and/or related situations – void all warranties provided by the Contractor.
- Use of Client Selected and Approved Substandard Materials: Client recognized and agrees that if the Client has chosen and approved the use of substandard materials for any application that the one year warranty will be void or otherwise limited in writing on those items so impacted, but will remain in affect for all other elements of the project not impacted directly or indirectly by use of substandard materials. the Contractor will notify in writing to the Client any material that the Client has selected that would negatively impact the one year warranty of the Contractor – prior to purchasing and/or installing such materials.
- Material Grades: The Client recognizes that all materials come in a range of grades of quality and finishes, and that natural materials are not perfect. Natural wood have knots, and other natural materials have variability in color due

Untitled Map

Write a description for your map.

Legend

-  AB Playground Area 1
-  AB Playground Area 2
-  Untitled Polygon

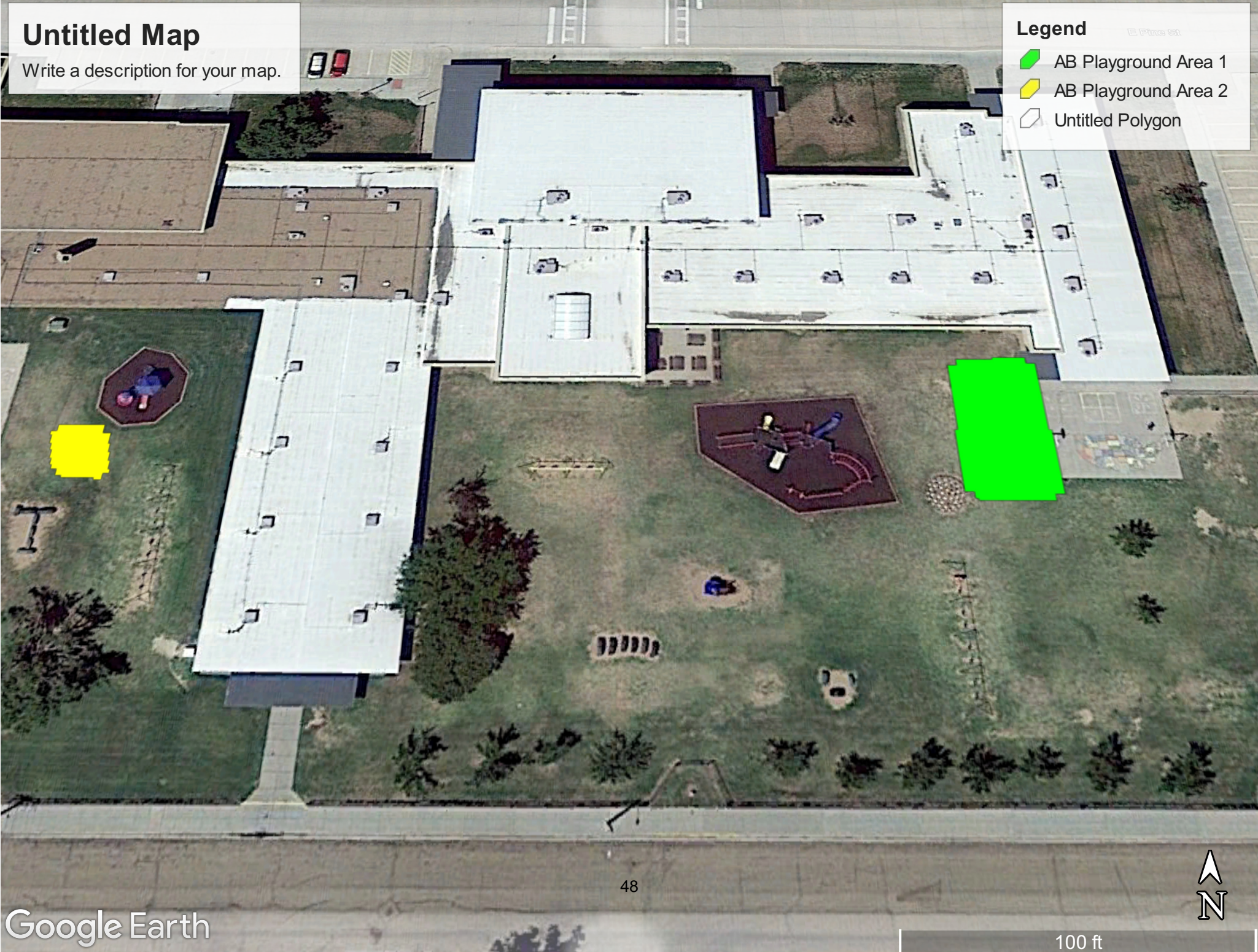

48



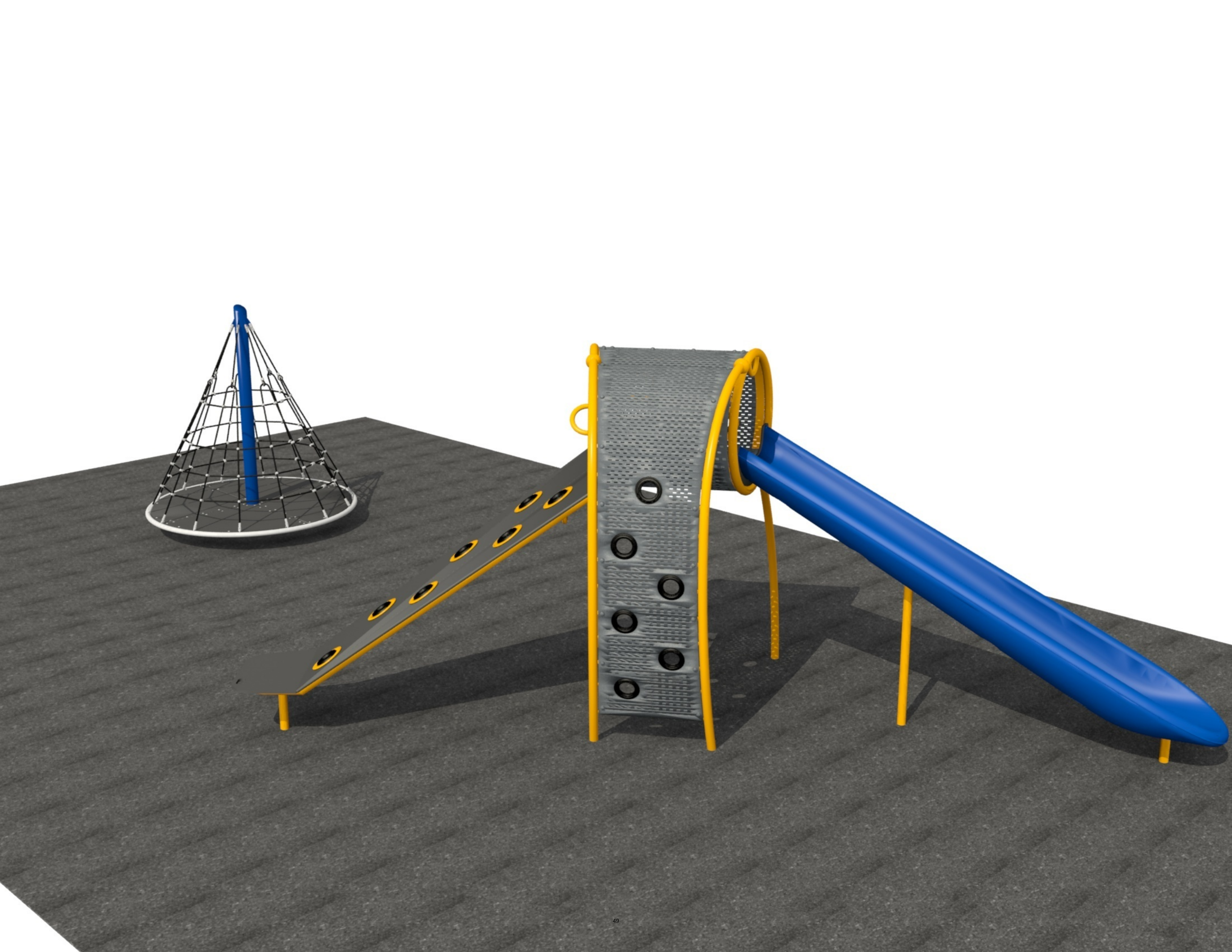

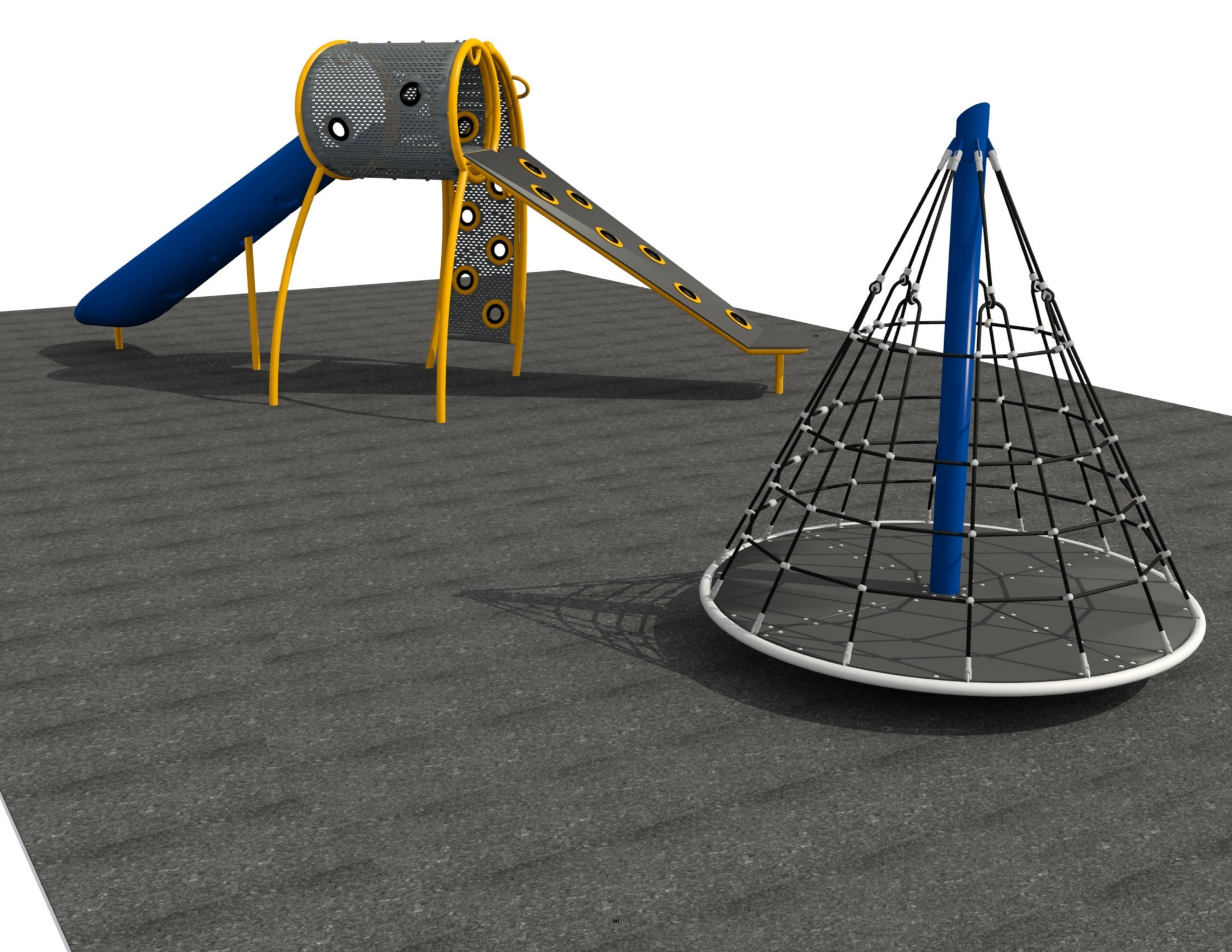

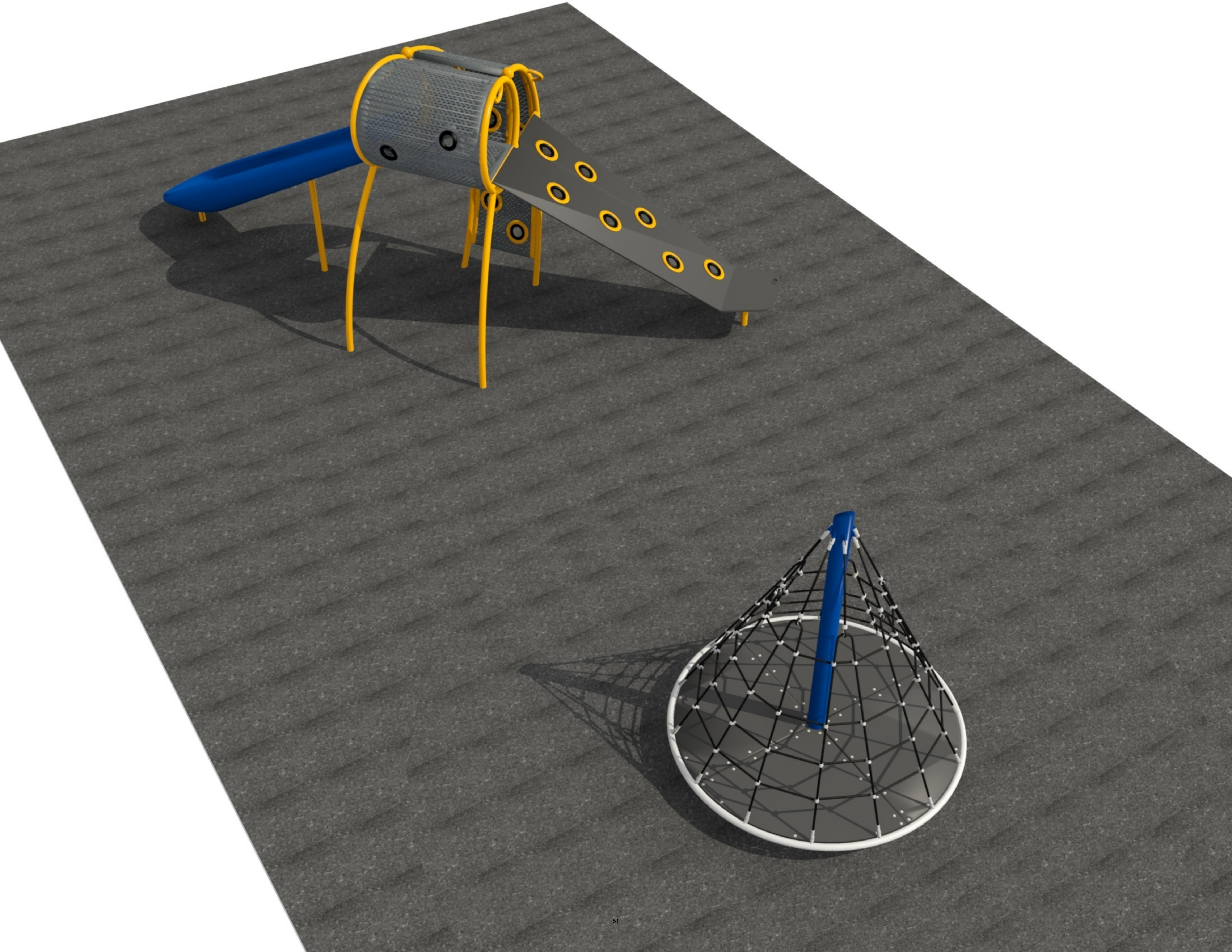

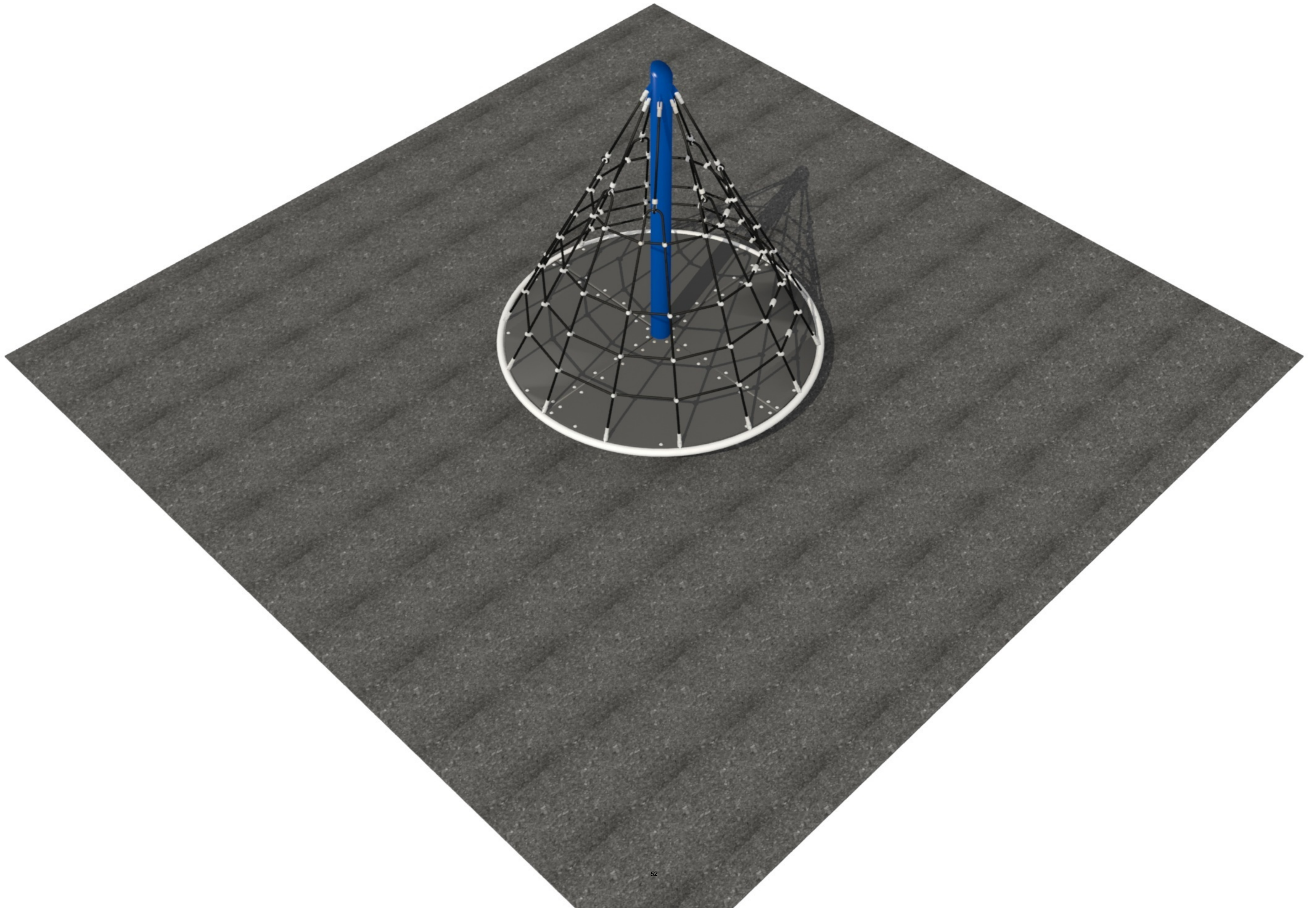

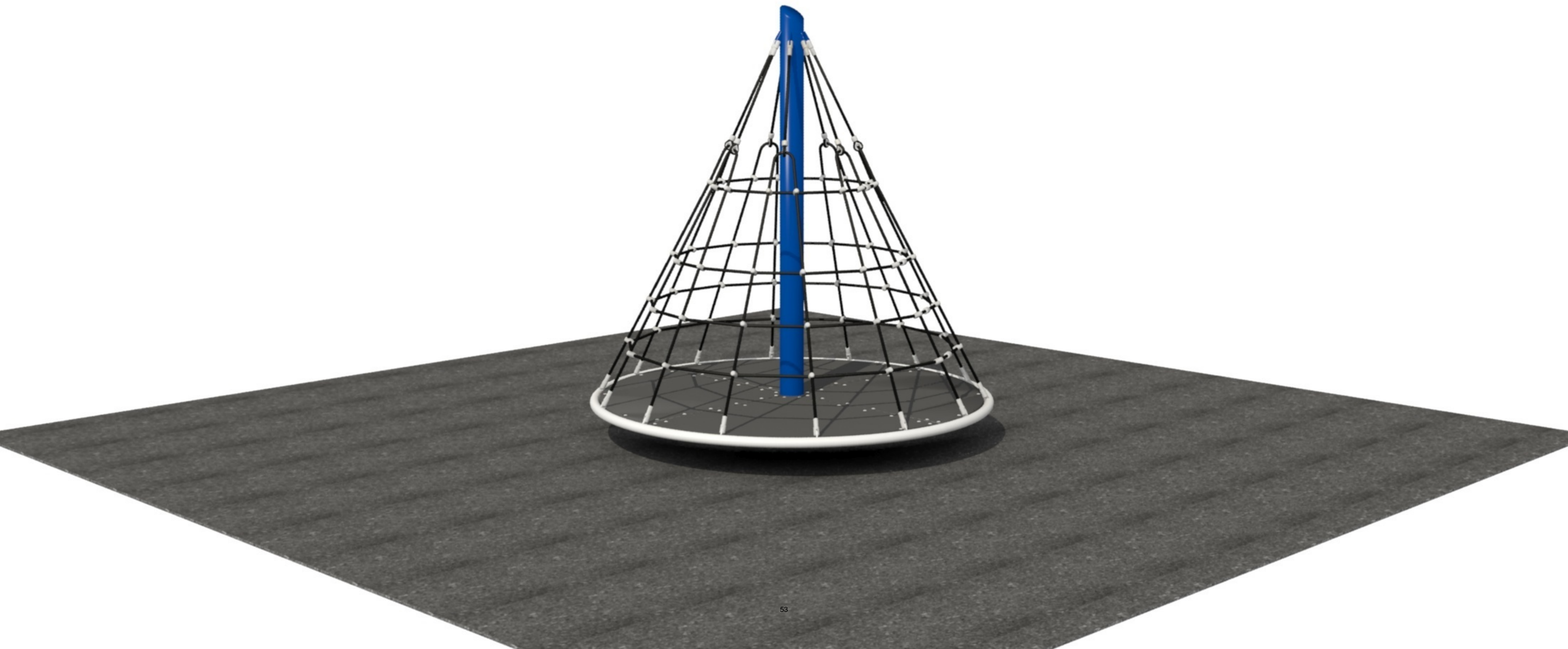

MEMORANDUM

TO: Board of Education
THRU: Dr. Mike Dominguez, Superintendent
FROM: Colleen Drees, Chief Financial Officer
DATE: January 8th, 2024
RE: State Contract – Victor Ornelas Playground

ISSUE:

The Board of Education is asked to approve the purchase and installation of additional playground equipment at Victor Ornelas (VO).

BACKGROUND:

We have allocated capital funds per our long-range plan to improve the playground equipment at this school. This playground equipment is being purchased via a state contract and is identical to the equipment that was installed at Garden City Achieve (GCA). The equipment and surfacing is designed to be inclusive for students with special needs. Two of the four areas will include the artificial turf like installed at GCA. The east side playground at VO will include a fence enclosure to create a safe environment for our RISE classroom.

ALTERNATIVES:

No other alternatives applicable

RECOMMENDATION:

1. Approve the state contracted purchases for the playground equipment
2. Deny the proposals for new playground equipment
3. Recommend an alternative solution

FISCAL NOTE:

The total expense for the playground equipment and turf at Victor Ornelas is \$124,294.83. This purchase has been budgeted in the current fiscal year from the following accounts: 016 E 1000 21 0000 002 04 730 and 030 E 1000 21 0000 002 04 730. Adequate balances are remaining for these purchases.

ATTACHMENTS:

Victor Ornelas Playground



REVISED USD 457 - VICTOR ORNELAS ELEMENTARY HGAC

**USD 457 GARDEN CITY PUBLIC SCHOOLS
1205 FLEMING ST
GARDEN CITY, KS 67846**

Sales: Andrew Manion

**FL Install - Revised USD 457 - Victor Ornelas
Elementary HGAC EST4301635 3401 East Spruce St
3401 East Spruce St Garden City, Kansas 67846**

Est ID: EST4301635 2

Date: Dec-05-2023

FL Install - USD 457 Victor Ornelas Elem REVISED

Scope of Work Includes:

- Removal and disposal of the existing soil or mulch surface
- Gravel base
- Composite nailer boards
- Approx. 780 Ft² Playground Academy Grass
- Rubber infill
- 3" Safetyfoam

15-year warranty for the turf and foam

Subtotal	\$20,500.03
Taxes	\$0.00
Estimate Total	\$20,500.03

Payment Terms and Conditions

Upon the acceptance of the work, payment of the unpaid balance Contract Price when due together with such Value Added Taxes as may be applicable to such payment.

- Should the Client fail to make payments as they become due under the terms of the Contract or in the event of any claim, interest at eighteen percent (18%) per annum above the prime rate on such unpaid amounts shall also become due and payable until payment.

Exclusions

The Following matters are excluded from the Work, unless specified in writing to the contrary:

- Electrical Work is to be done by a certified electrician only and is always additional to the Contract.
- Iron railings removed during construction are always re-attached at an additional cost.
- Damage to existing irrigation lines during construction is considered to be an additional cost.
- Drainage: Should the Client's property be the lowest elevation in relation to surrounding property or buildings, the Contractor, Inc. reserves the right to retain a Soil Engineer to evaluate and propose drainage solutions. All costs for engineering services, as well as the actual drainage work will be at the Client's expense. Unless the Client has a detailed Topographical survey completed, the above clause may come into effect.
- Conduit and connections for electrical, gas, and all other utilities and services
- Site Unknowns: Including, but not limited to, sub-surface conditions/obstacles that create unforeseen labor, equipment, material or disposal charges

Procedure for Extra Work and Changes

If it shall become necessary for the Contractor to make changes in any designs, drawings, plans, software, reports or specifications for any part of the project or reasons over which we have no control, or we are put to any extra work, cost or expense by reason of any act or matter over which it has no control, the Customer will pay to the Contractor a fee for such changed or extra Work calculated on a time and materials basis. All changes to Work or pricing or the terms of this Agreement will be read and understood within the context and meanings of this Agreement unless stated explicitly to the contrary. Extras to the Contract are payable by the Owner forthwith upon receipt of the Company's invoice.

Change Notice: Any Contract change in scope in excess of one thousand dollars (\$1,000.00) requires a Contract Change Notice under which Work is to proceed. Work will not commence under a Contract Change Notice (CNN) unless with written Owner approval.

For Changes in scope of less than one thousand dollars (\$1,000.00), the Contractor will provide the Customer notification by way of its Progress Report. In either instance, such notification shall be plain and clear in terms of scope and reason. Any record, telephone conversation or meeting in which such change in scope was introduced, shall be attached as supporting documentation.

Warranty and Tolerances

- Payments Received: The Warranty for the contract is only valid if payment is received in full on acceptance of the work.

- Diligence: the Contractor agrees to carry out its Work diligently and to provide sufficient supervision and inspection of its staff and subcontractors and that it's work will be of proper and professional quality, and in full conformity with the requirements of the contract.
- Competence: the Contractor warrants that it is competent to perform the Work and that it has the necessary qualifications including knowledge and skill with the ability to use them effectively.
- Site Unknowns: It is the responsibility of the Client or the Client's Representative to fully inform the Contractor of all the information regarding site unknowns that may include difficult buried materials, cables, and pipes, tree stumps, drainage or water table issues, rock and shale sub-surfaces and/or other impediments, issues or factors that could otherwise impact the quality, cost and timeliness of project completion. Failure to notify the Contractor may lead to additional costs to the Client (at the Contractor's discretion) and schedule time not included in the Quotation in Schedule 1, and may require changes in design and construction to overcome such problems – all for which the Client will be responsible. Client can avoid such risks by permitting the Contractor to do appropriate soil and ground tests, review the site, and to secure additional required site information from appropriate government and other authorities. The cost(s) of such additional work is not included in the Quotation in Schedule 1 attachment.
- Damaged Utilities: Should damage occur to utilities during construction, the Contractor is only liable for the cost of the repair. the Contractor is not liable in any way for inconvenience to the Client caused by damage to the utilities.
- Damage to neighbors buried utilities, on the Client's property, are the responsibility of the Client.
- Building/Window/Vehicle Washing: Buildings, windows, or vehicles of the Client, including neighbors, are not intended to be kept clean due to dust during Construction or Work performed by the Contractor. Any necessary cleaning due to Construction or Work by the Contractor will be the responsibility of the Client.

Material Tolerances

- Wood: Pressure treated wood cannot be guaranteed against warp age, checking, or cupping.
- Stone: Natural stone has color variations that vary from stone to stone. In addition, mineral deposits such as lime, iron, etc. can change the stone and even bleed. This is the nature of the product and the Client accepts this as a natural and acceptable quality of the stone.
- Metal: Metal, which is not galvanized, is not guaranteed from rusting commencing immediately after installation.
- Concrete: Spider cracks (hairline stress-fractures) are considered a normal characteristic of all types of concrete. Concrete may crack substantially over time due to proximity of tree roots.
- Warranty Time Period: the Contractor warrants all construction and installation for a period of one (1) season, providing that they have been maintained properly. All construction materials are subject to manufacturer's specific warranties/guarantees. Planting is warranted for one (1) season if there is an approved irrigation system.
- Client Responsibilities: The Client recognizes and agrees that they have a responsibility to maintain constructions, plants, bushes, trees, and other installations in keeping with standard quality maintenance requirements in order for the Warranty to remain in affect. Failure to properly maintain materials or horticulture installations will void the warranty. Client further recognizes and agrees that damage to construction, materials, horticulture elements and other warrantable items of the project will not be warranted if the damage or loss is due to elements beyond the control of the Contractor. For example, flooding eaves troughs that damage plants, fallen branches, animal caused damage, frozen/ burst irrigation or drainage pipes that were not seasonally drained at the proper time, use of improper chemicals, improper maintenance, extreme or unusual weather conditions, and similar and/or related situations – void all warrantees provided by the Contractor.
- Use of Client Selected and Approved Substandard Materials: Client recognized and agrees that if the Client has chosen and approved the use of substandard materials for any application that the one year warranty will be void or otherwise limited in writing on those items so impacted, but will remain in affect for all other elements of the project not impacted directly or indirectly by use of substandard materials. the Contractor will notify in writing to the Client any material that the Client has selected that would negatively impact the one year warranty of the Contractor – prior to purchasing and/or installing such materials.
- Material Grades: The Client recognizes that all materials come in a range of grades of quality and finishes, and that natural materials are not perfect. Natural wood have knots, and other natural materials have variability in color due to a wide range of factors, and that sample while useful in material selection decision-making, cannot be expected to accurately represent the total completed surface of a given construction or installation. the Contractor shall endeavor to enable the Client to see or understand the representative range of color, surface texture, and related of all materials begin seriously considered for installation on a project, however, it will be responsibility of the Client



Victor Ornelas Elementary School (Yellow Area) - Gardent City USD457

Garden City USD 457

1205 Fleming Street
Garden City, KS 67846
United States

Reference: 20231117-224212291

Quote created: November 17, 2023

Quote expires: January 16, 2024

Quote created by: Chuck Green

"Recreation Design Specialist"

chuck.green@nextgenerationrecreation.com

Shane Faurot

tfaurot@gckschools.com
620-214-4050

Comments from Chuck Green

Sourcewell Cooperative Purchase Program - Dicount Applied
Playworld Systems - #010521-LTS-8

All Equipment and Materials are shipped direct to client - Please see attached document named: "How to Receive a Shipment"

******ALL Quotes are good for 30-Days only******

Due to uncontrollable and ongoing changes directly effecting cost of goods, shipping, and material costs, If order placed more than 30-Days past original date, a new quote must be requested and updated before placing order. If new quote not requested, we will update all quotes, and invoices prior to ordering.

Products & Services

Item & Description	Quantity	Unit Price	Total
PLAYWORLD ZZXX0346 - Unit Slide Climber The thrill of a slide and so much more! Unity features different climbers for a variety of challenge levels. The tube at the top is an entry to the slide and a gathering point. Children use the space underneath to socialize and play games.	1	\$15,497.00	\$15,497.00
BORDER TIMBERS QTY: 28 Up to 28 Next Generation Recreation Bordering system – Plastic Border Timbers. ** SEE PURCHASE AGREEMENT**	1	\$1,288.00	\$1,288.00
REX CRUMBLE RUBBER MULCH Delivery and installation of High-Quality Rubber Crumb Mulch made with Recycled Playground Compliant Rubber Materials up to 6 Inches in Depth to meet up to a 9 ft Fall Height.	1	\$3,105.10	\$3,105.10
INSTALLATION Complete Installation of all NEW Playworld Equipment/or whatever item listed at above mentioned address only. Including all materials and use of heavy equipment required, and all concrete supplies and labor for all inground footings. Includes disposal of all containers/cardboard/packaging used for shipping of equipment.	1	\$5,388.00	\$5,388.00
SHIPPING Freight and delivery cost for Playworld Equipment, Border Timbers, and Rubber Crumble Mulch	1	\$2,890.00	\$2,890.00
One-time subtotal			\$28,168.10
Total			\$28,168.10

Purchase terms

50% Deposit/Payment due prior to ordering materials, equipment, or replacement parts, and due prior to mobilization for project. The remaining **50%** will be due **NET 30 Days after invoiced and prior to delivery of equipment and installation.**

Any order cancelled more than **15 Business Days** after placement will result in a 30% Restocking fee due immediately upon cancellation which will be deducted from all deposits, and remaining balance returned.

Next Generation Recreation **MUST be notified at least 15-days prior** to due date noted on invoice regarding any, and all delays in payment with good reason. Otherwise late fees of 18% will accrue at 45 days past due.

Signature

Signature

Date

Printed name

Questions? Contact me



Chuck Green
"Recreation Design Specialist"
chuck.green@nextgenerationrecreation.com

Next Generation Recreation
P.O. Box 902008
Kansas City , MO 64190
USA



Victor Ornelas Elementary School (Blue Area) - Gardent City USD457

Garden City USD 457

1205 Fleming Street
Garden City, KS 67846
United States

Shane Faurot

tfaurot@gckschools.com
620-214-4050

Reference: 20231117-115117433

Quote created: November 17, 2023

Quote expires: January 16, 2024

Quote created by: Chuck Green

"Recreation Design Specialist"

chuck.green@nextgenerationrecreation.com

Comments from Chuck Green

Sourcewell Cooperative Purchase Program - Dicount Applied

Playworld Systems - #010521-LTS-8

**All Equipment and Materials are shipped direct to client - Please see attached document named:
"How to Receive a Shipment"**

******ALL Quotes are good for 30-Days only******

Due to uncontrollable and ongoing changes directly effecting cost of goods, shipping, and material costs, If order placed more than 30-Days past original date, a new quote must be requested and updated before placing order. If new quote not requested, we will update all quotes, and invoices prior to ordering.

Products & Services

Item & Description	Quantity	Unit Price	Total
PLAYWORLD ZZXX0911 - Cone Spinner W/Floor The Cone Spinner presents a unique play experience each time a child interacts with the product. Children can test their courage by climbing to the top, increasing their strength, balance, and independence. The Cone Spinner also presents an inclusive play experience by being easy to access at the bottom. Children can sit and spin while their legs dangle creating a unique spinning experience. Multiple children can enjoy the product at once increasing the play value of this unique addition to any playground.	1	\$15,374.00	\$15,374.00
PLAYWORLD ZZXX0346 - Unit Slide Climber The thrill of a slide and so much more! Unity features different climbers for a variety of challenge levels. The tube at the top is an entry to the slide and a gathering point. Children use the space underneath to socialize and play games.	1	\$15,897.00	\$15,897.00
PLAYWORLD ZZXX1115 - Unity Web (Small) Unity Web's innovative design provides the ultimate climbing experience! Designed for maximum climbing room in less space and for any budget, Unity Web allows children of all abilities to join in the fun.	1	\$18,143.00	\$18,143.00
PLAYWORLD ZZXX1117 - Footing Kit for Unity Web	1	\$0.00	\$0.00
BORDER TIMBERS QTY: 40 Up to 40 Next Generation Recreation Bordering system – Plastic Border Timbers.	1	\$1,840.20	\$1,840.20
** SEE PURCHASE AGREEMENT**			

Item & Description	Quantity	Unit Price	Total
REX CRUMBLE RUBBER MULCH Delivery and installation of 1870 S.F. of High-Quality Rubber Crumb Mulch made with Recycled Playground Compliant Rubber Materials up to 6 Inches in Depth to meet up to a 9 ft Fall Height.	1	\$5,242.10	\$5,242.10
INSTALLATION Complete Installation of all NEW Playworld Equipment/or whatever item listed at above mentioned address only. Including all materials and use of heavy equipment required, and all concrete supplies and labor for all inground footings. Includes disposal of all containers/cardboard/packaging used for shipping of equipment.	1	\$15,788.40	\$15,788.40
SHIPPING Freight and delivery cost for items above. Playworld, Border Timbers, and Chunk Rubber Mulch	1	\$3,342.00	\$3,342.00
REX GUARANTEE At Next Gen Rec we believe in Service and Respect. We believe in going out of our way to respect the property of the project always cleaning up after each day, and once we are completed with our part of the project, we will make sure we leave the area cleaner, and better than we found it. That is our guarantee to you!	1	\$0.00	\$0.00
One-time subtotal			\$75,626.70
Total			\$75,626.70

Purchase terms

50% Deposit/Payment due prior to ordering materials, equipment, or replacement parts, and due prior to mobilization for project. The remaining **50%** will be due **NET 30 Days after invoiced and prior to delivery of equipment and installation.**

Any order cancelled more than **15 Business Days** after placement will result in a 30% Restocking fee due immediately upon cancellation which will be deducted from all deposits, and remaining balance returned.

Next Generation Recreation **MUST be notified at least 15-days prior** to due date noted on invoice regarding any, and all delays in payment with good reason. Otherwise late fees of 18% will accrue at 45 days past due.

Signature

Signature

Date

Printed name

Questions? Contact me



Chuck Green

"Recreation Design Specialist"

chuck.green@nextgenerationrecreation.com

Next Generation Recreation

P.O. Box 902008



Kansas City , MO 64190

USA

Untitled Map

Write a description for your map.

Legend

-  AB Playground Area 1
-  AB Playground Area 2
-  Untitled Polygon

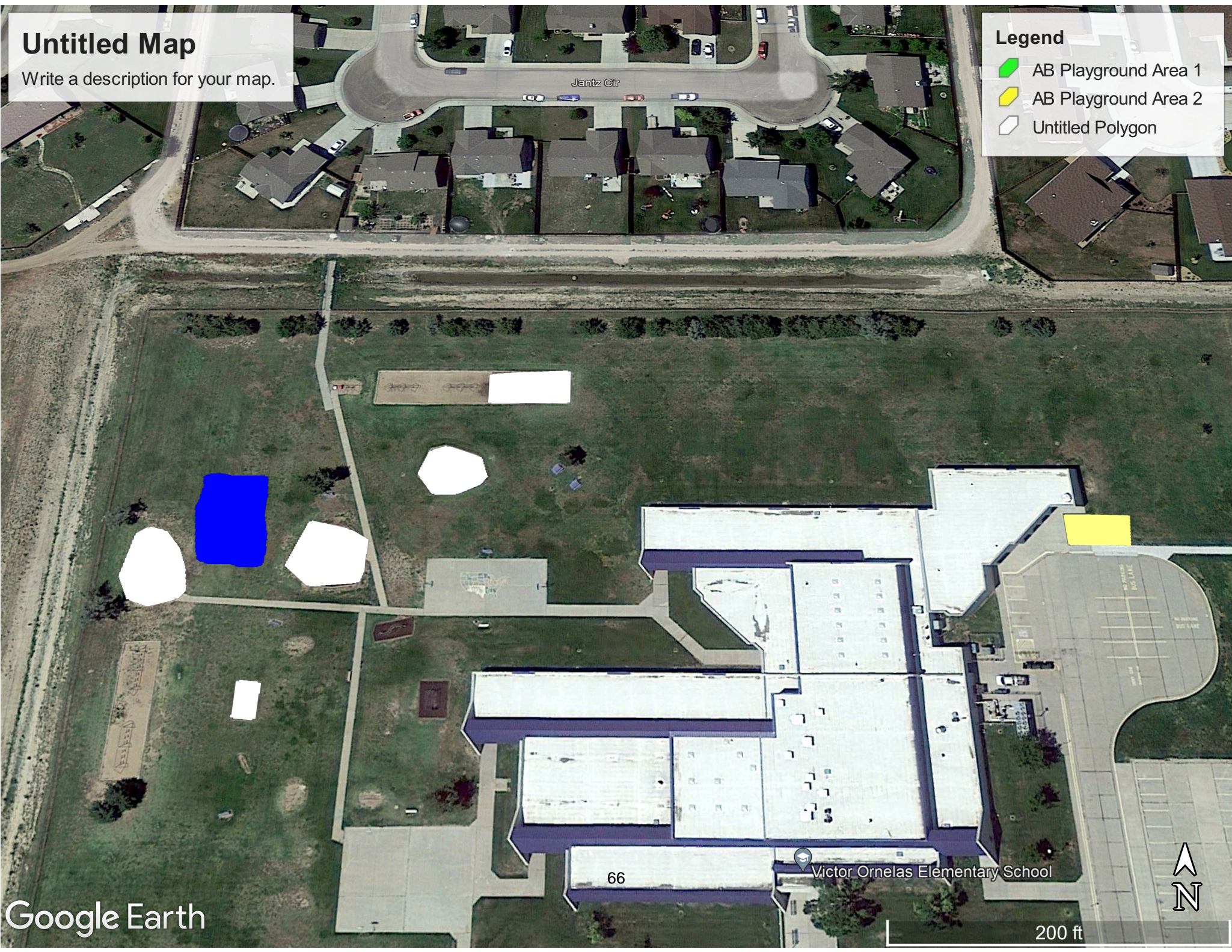

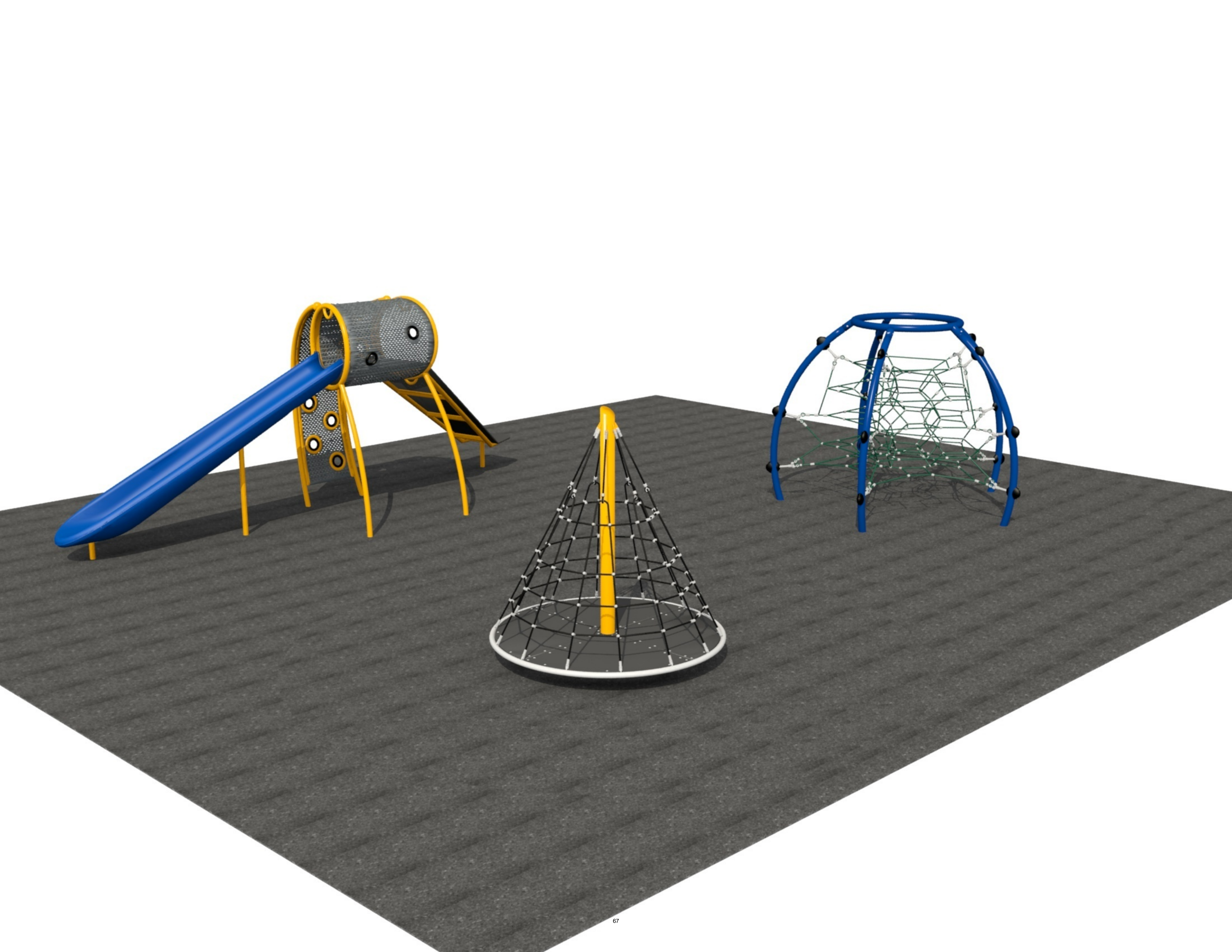

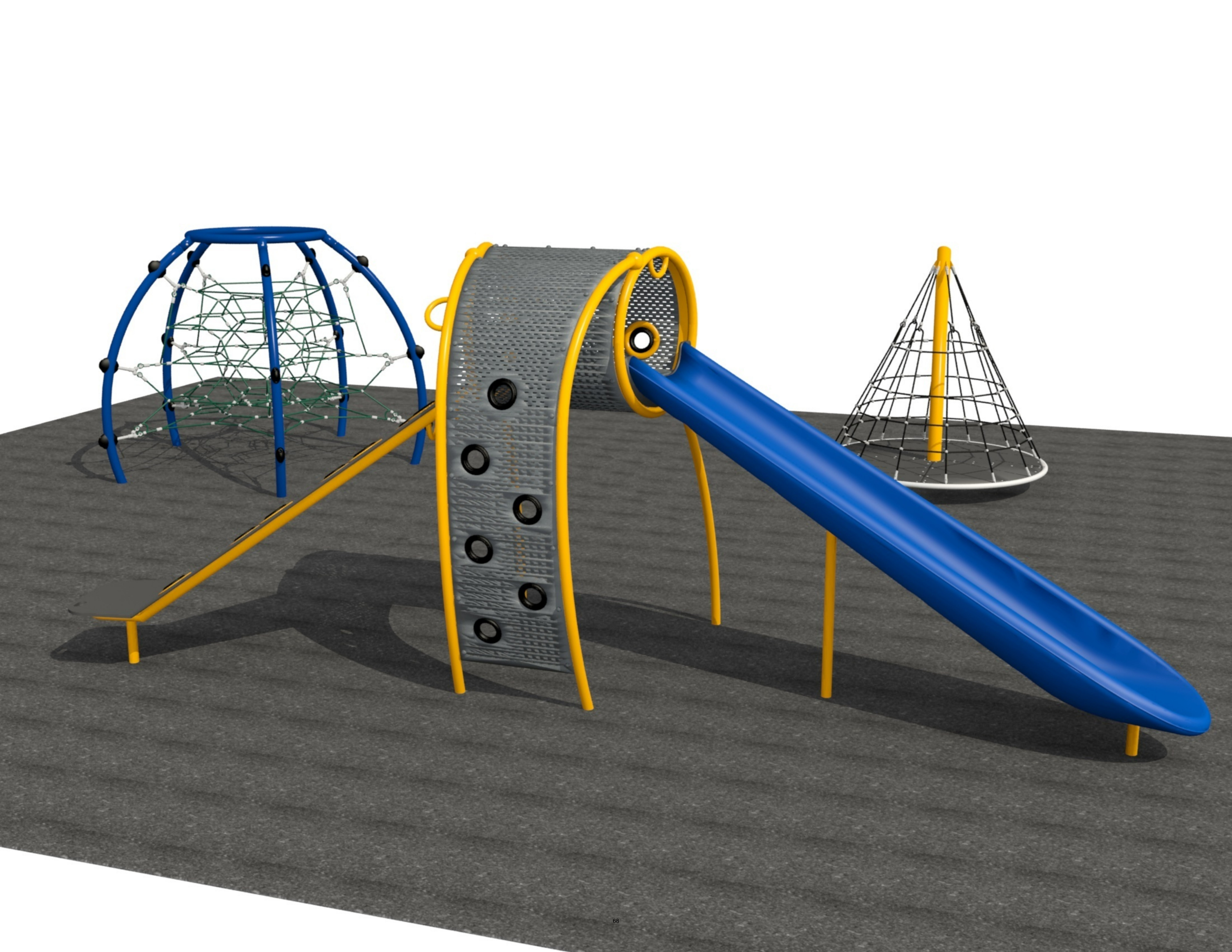

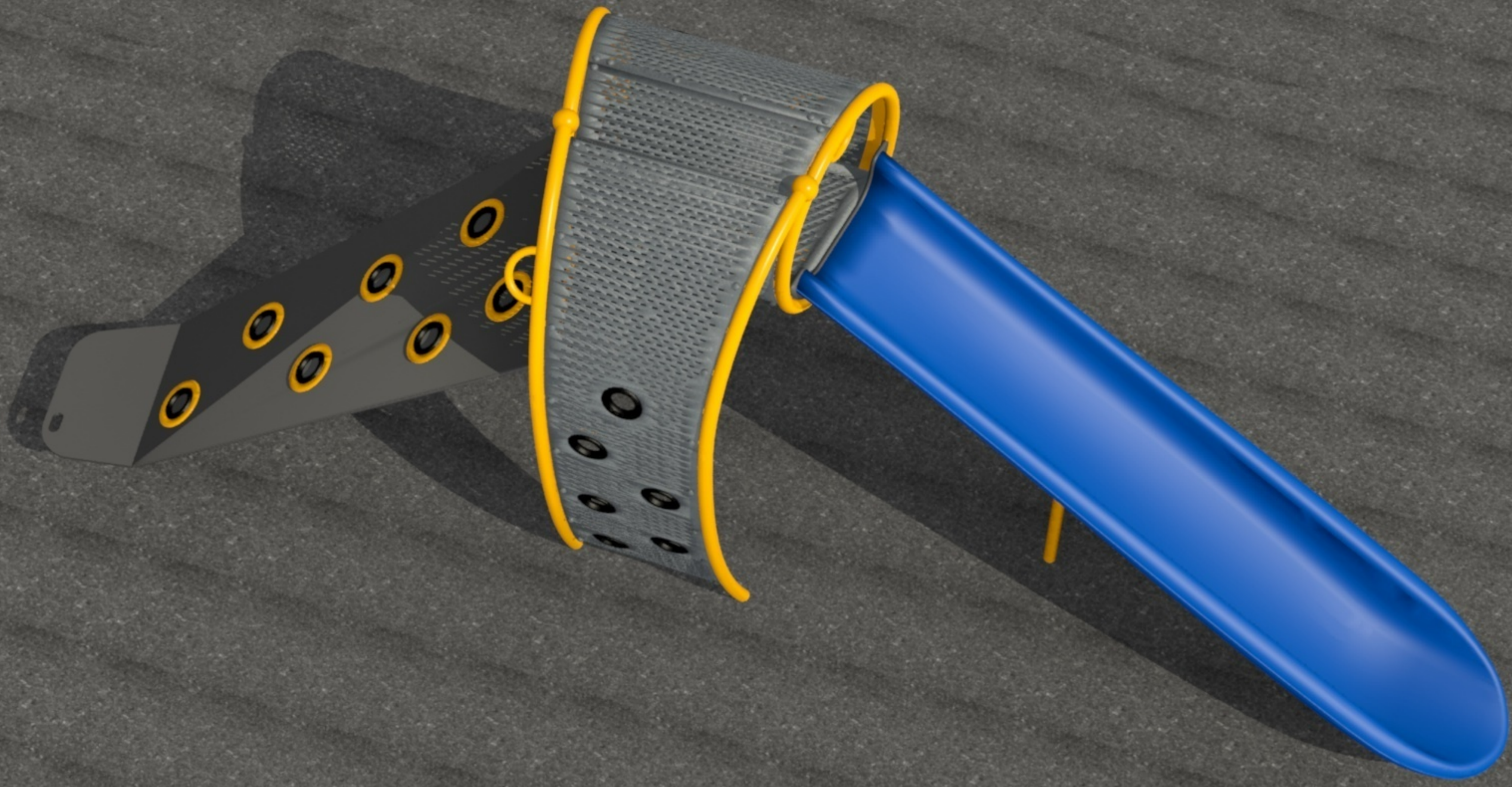
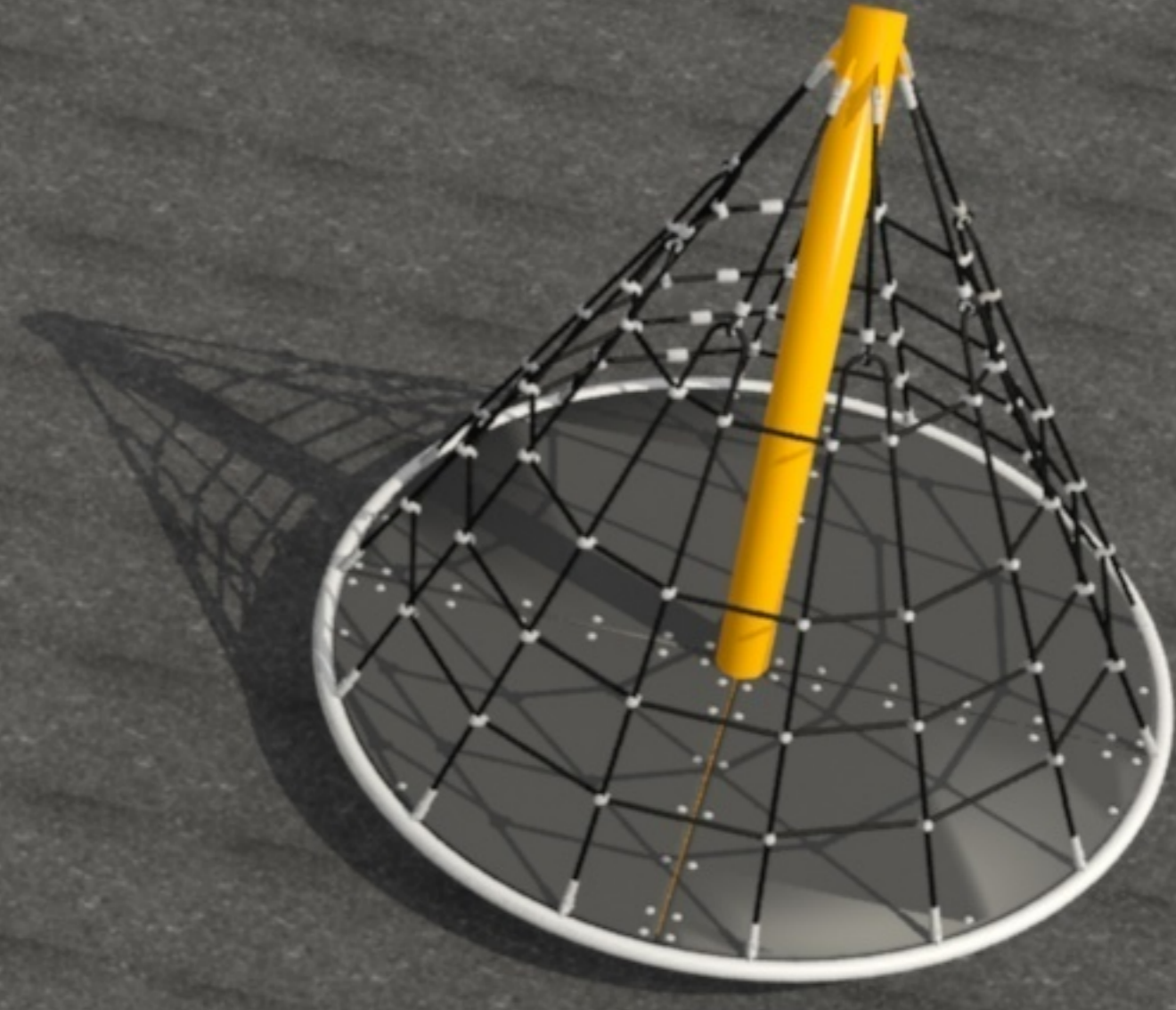
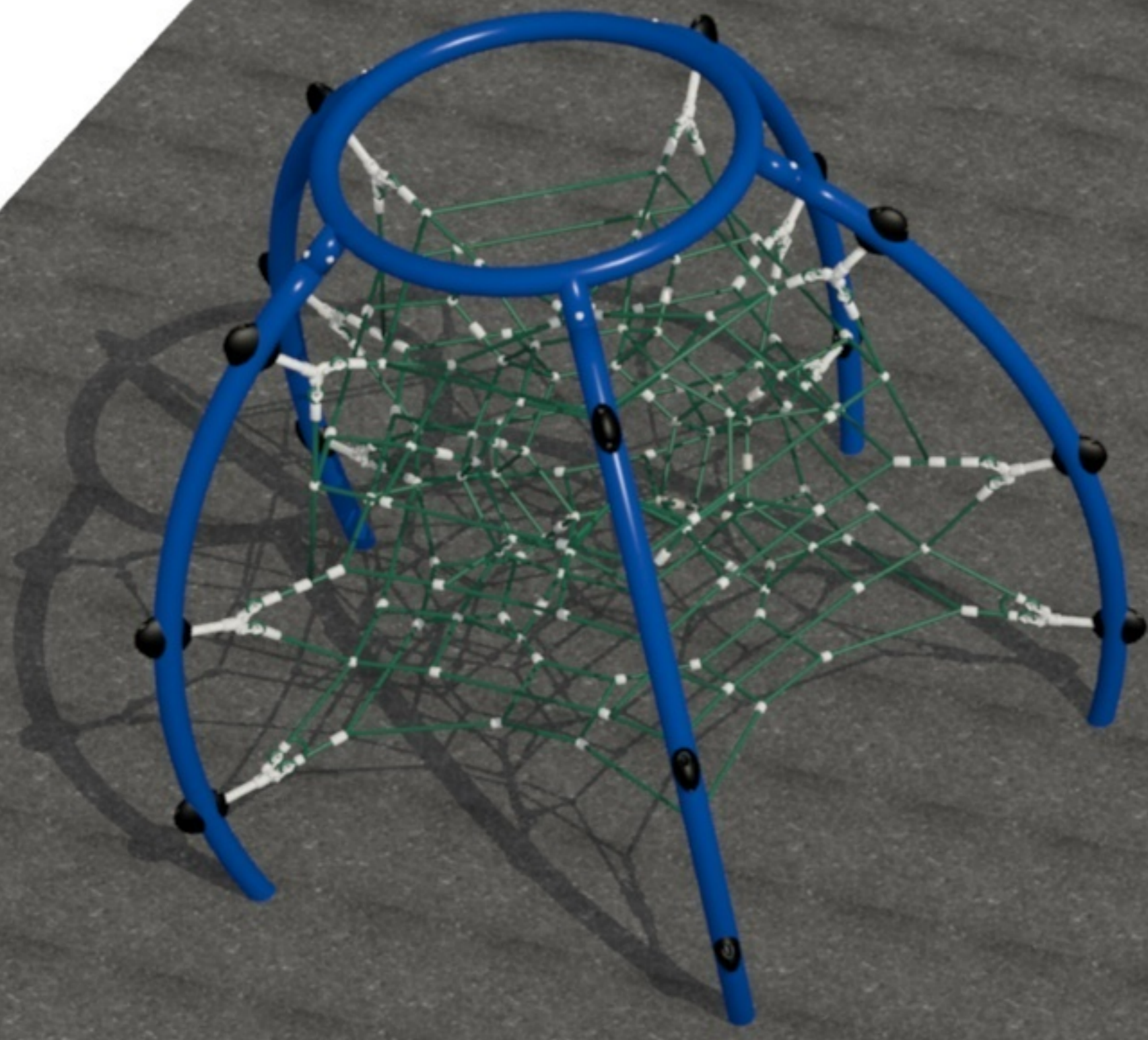

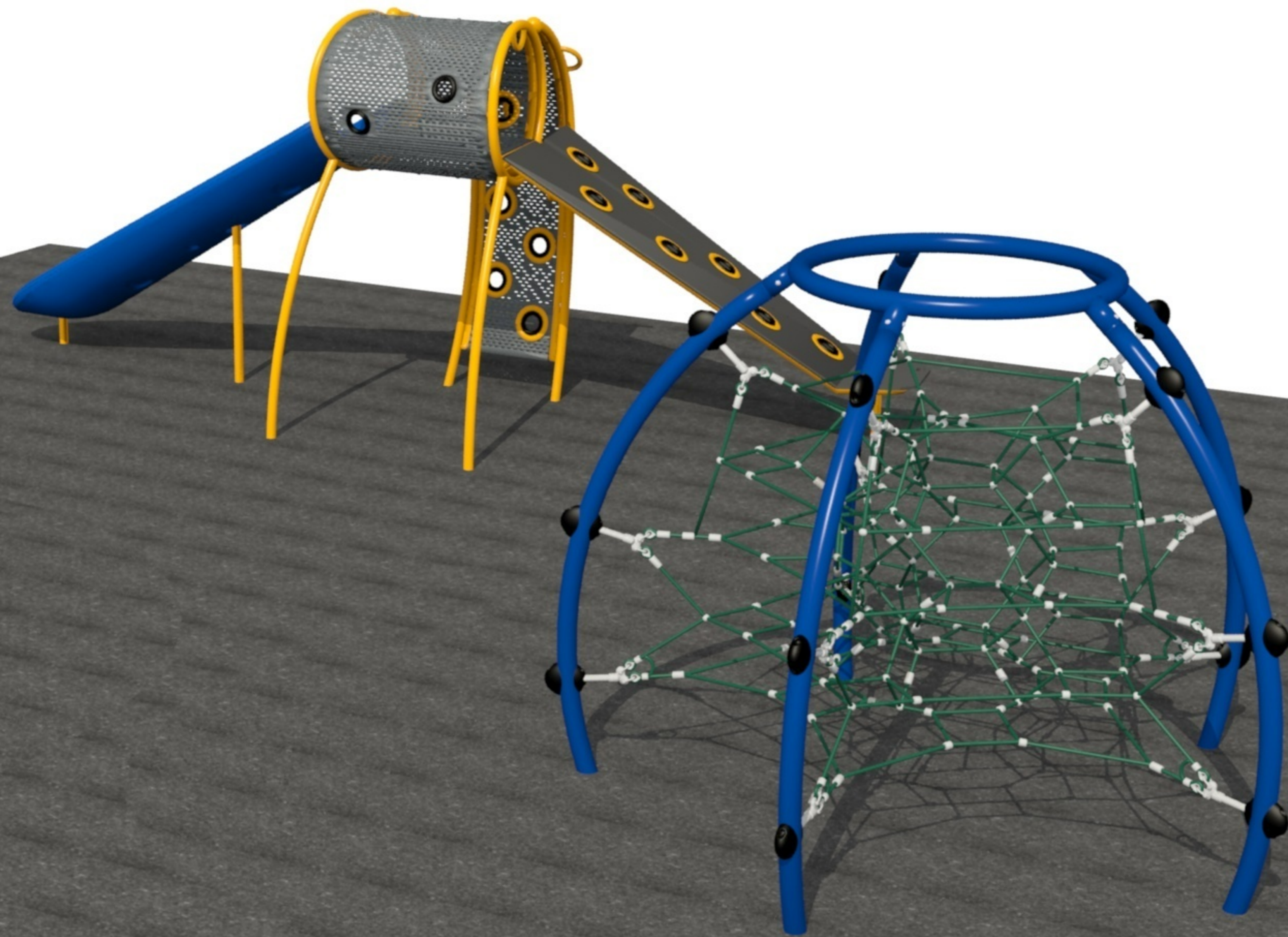
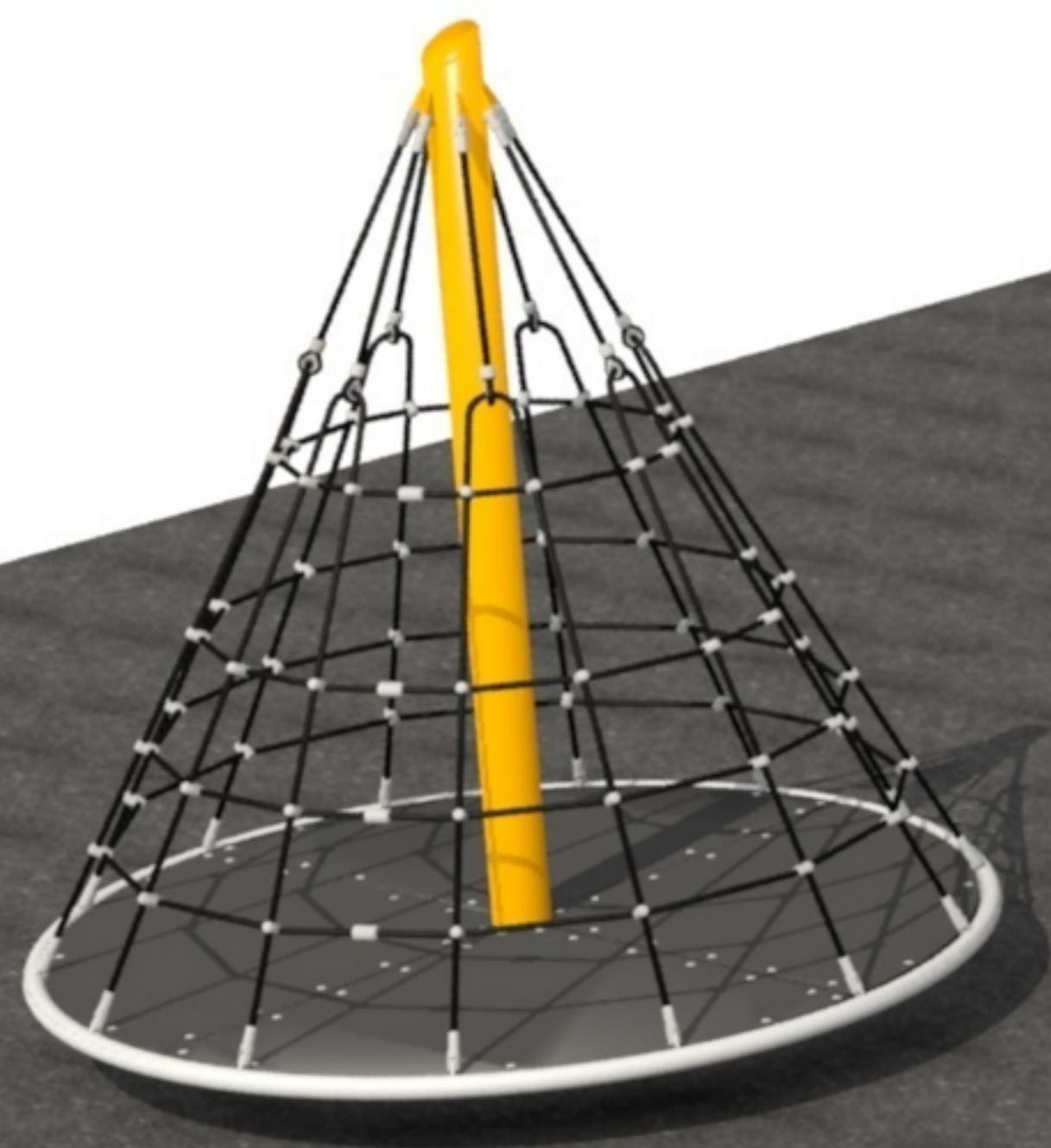



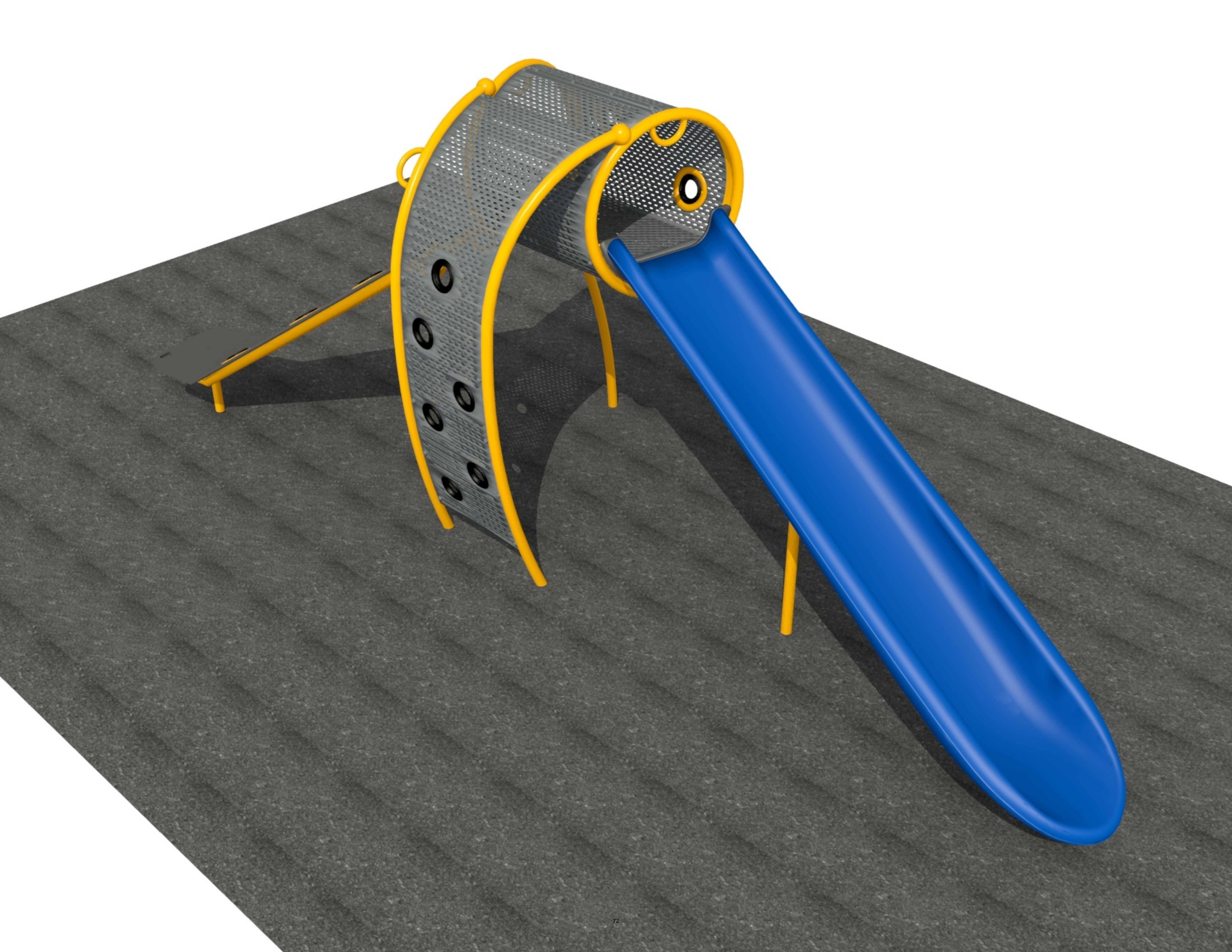

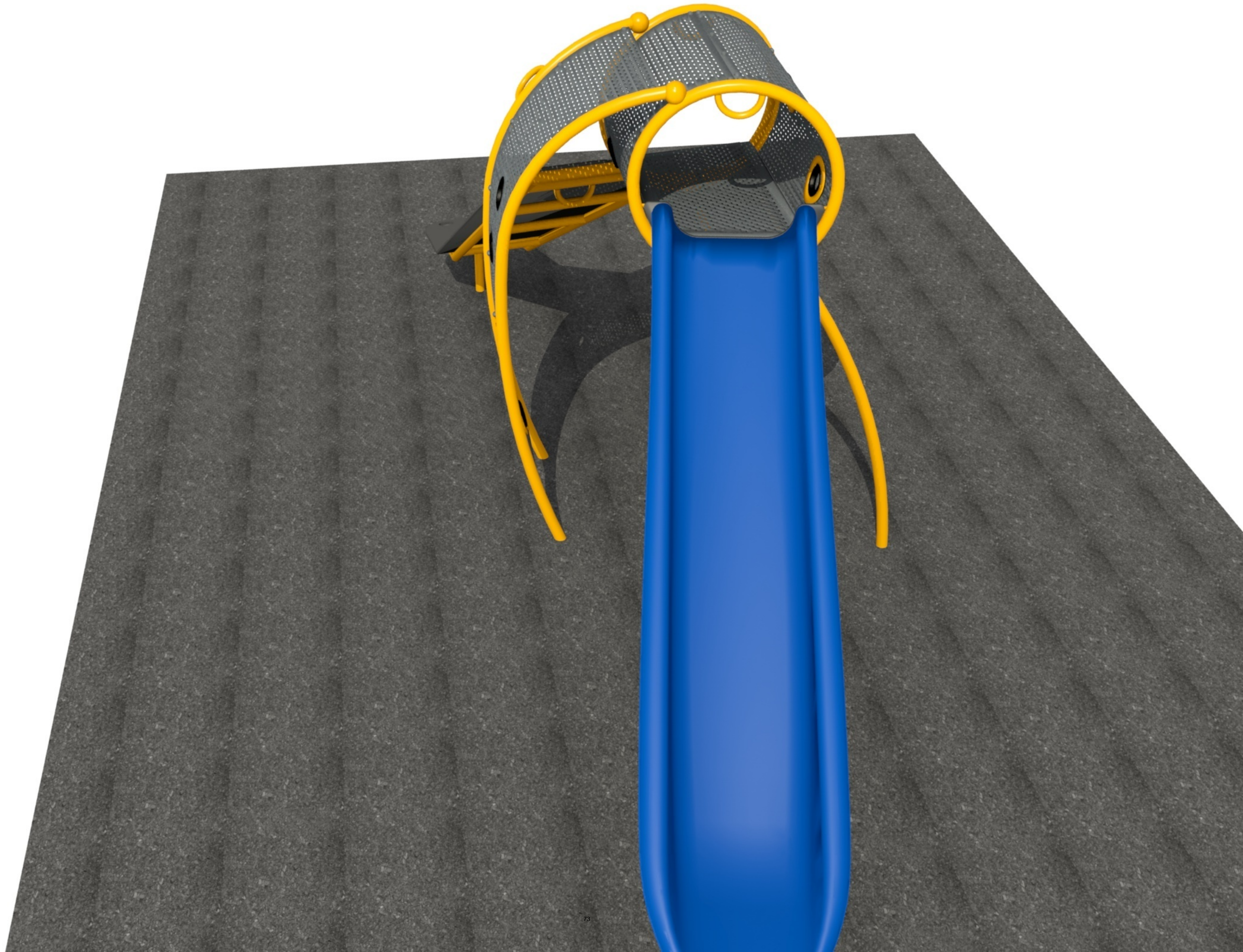

MEMORANDUM

TO: Board of Education
THRU: Dr. Mike Dominguez, Superintendent
FROM: Colleen Drees, Chief Financial Officer
DATE: January 8th, 2024
RE: Additional Fence at Georgia Matthews East Playground

ISSUE:

The Board of Education is asked to approve the cost of 400 feet of playground fence to complete the closure of the playground at Georgia Matthews. This fence will be installed on the east playground – on the north and east sides. The costs include a pedestrian gate and a double gate for mower access.

BACKGROUND:

The current playground is located right against the Talley Trail and is open on the north and east side of the playground. This fencing allows for the playground to be enclosed from the Talley Trail, which limits outside access to the playground during school hours.

ALTERNATIVES:

No other alternatives applicable.

RECOMMENDATION:

1. Approve the purchase of the new fence from Garden True Value.
2. Deny the purchase
3. Recommend an alternative solution

FISCAL NOTE:

This purchase has been budgeted for this fiscal year from the following account: 016 E 4700 21 7126 056 00 610 with adequate balances remaining for this purchase.

Total - \$16,717.20

ATTACHMENTS:

Garden True Value Quotation

TAYLOR TRUE VALUE HARDWARE
 1615 TAYLOR PLAZA
 GARDEN CITY, KS 67846
 (620)275-4136 OR 1-800-865-5641

Q U O T A T I O N

12/6/2023	DATE
JS	SALES PERSON

To:

USD 457
GEORGIA MATTHEWS
bknight@gckschools.com

QTY	SKU	DESCRIPTION	PRICE	TOTAL
8	650	6' X 50' 9 GUAGE KT FABRIC	459.99	3,679.92
9	97060	2-7/8" X 10.5' SP40 TERMINAL POSTS	124.99	1,124.91
37	72590	1-7/8" X 8' SP20 LINE POSTS	41.99	1,553.63
10	271676	72" TENSION BAR	11.99	119.90
40	72660	2-7/8" TENSION BAND	2.99	119.60
19	72640	1-5/8" TOPRAIL	74.99	1,424.81
10	72650	1-5/8" RAILEND	3.99	39.90
10	72670	2-7/8" BRACE BAND	2.49	24.90
3	270454	(20 PK) BOLT/NUT	10.99	32.97
2	70060	(100 PK) TIE WIRE	40.99	81.98
90	233049	QUIKCRETE	6.29	566.10
9	12230	2-7/8" POST CAP	3.99	35.91
37	72695	1-7/8" EYE TOP	2.99	110.63
2	FM	4'W X 6'H COMMERCIAL WALK GATE W/HARDWARE	674.56	1,349.12
1	FM	8'W X 6'H COMMERCIAL DOUBLE GATE W/HARDWARE		1,202.92
1	FL	LABOR TO CONSTRUCT APPROXIMATELY 400' X 6'		
		CHAIN LINK FENCE WITH TWO 4' WALK GATES AND		4,000.00
		ONE 8' DD GATE		-
				-
		EQUIPMENT EXPENSE		1,250.00
				-
		DOES NOT INCLUDE PERMIT FEES		-
				16,717.20

WE ARE PLEASED TO SUBMIT THE ABOVE QUOTATION FOR YOUR CONSIDERATION. SHOULD YOU PLACE AN ORDER, BE ASSURED IT WILL RECEIVE OUR PROMPT ATTENTION. THIS QUOTATION IS VALID FOR 30 DAYS. THEREAFTER IT IS SUBJECT TO CHANGE WITHOUT NOTICE.

ACCEPTED

75

DATE:

MEMORANDUM

TO: Board of Education
THRU: Dr. Mike Dominguez, Superintendent
FROM: Colleen Drees, Chief Financial Officer
DATE: January 8th, 2024
RE: State Contract – Bulk Copy Paper

ISSUE:

The Board of Education is asked to approve the purchase of bulk copy paper from Veritiv.

BACKGROUND:

This purchase is being completed via a GreenBush state contract. We are ordering a total of 840 cases of copy paper that the district then supplies to the various schools across the district. This purchase is completed annually as needed.

ALTERNATIVES:

No other alternatives applicable.

RECOMMENDATION:

1. Approve the state contract to Veritiv for copy paper.
2. Deny the purchase and installation.
3. Re-bid the flooring to alternative vendors.

FISCAL NOTE:

The total cost of this purchase and installation is \$28,812.00. This purchase has been budgeted for this fiscal year from the following account: 006 E 2530 21 1000 007 15 610 with adequate balances remaining for this purchase

ATTACHMENTS:

Veritiv Copy Paper

INTERNAL USE ONLY



Quote number: Q-3316333

Customer Account # 123463	Customer Name USD #457
Billing Address 1205 FLEMING ST GARDEN CITY, KS 67846	Contact Name Dianne Geist
Division Name UNISOURCE - WICHITA	Phone Number
Sales Rep Name Glenn Galvin	Shipping Address
Sales Rep Email glenn.galvin@veritivcorp.com	Expiration Date 2/29/2024

Product Code	Product Description	Mill Item #	Qty	Qty UOM	Price	Price UOM	Cost	Extended Price	GTM \$	GTM %	LDC	Projected Delivery	Min Mfg Qty
10802527	8 1/2X11 10M 20# WHITE COMET MULTIPURPOSE 5000/CT U31473		840.00	CT	\$34.30	CT	\$0.000	\$28,812.00	\$28,812.00	100.0%			
Total								\$28,812.00					

Customer Comments	
Vendor Comments	Greenbush contract # SAN - 0006039005
ATTENTION!	Seller's Terms and Conditions are incorporated by reference and are available at www.veritivcorp.com/termsandconditions-sellers . Buyer's acceptance of Seller's Terms and Conditions is a condition precedent to Seller's acceptance of customers order.

USD 457 Board of Education Standards

A school board member has no legal powers unless participating at a properly noticed school board meeting, or acting on behalf of the school board after the board formally grants authority to do so. Thus, it is essential that every school board member work as a member of the broader leadership team to perform board duties and act in a manner consistent with the Standards.

Board members can demonstrate personal commitment to the Standards by signing this document signifying agreement to uphold the principles of the Standards, both, in letter and spirit.

As citizens of the United States, board members have certain Constitutional rights, including freedom of speech that cannot be taken away, whether or not you choose to sign this document. The only sections of the Standards that require legal compliance are the “*conflict of interest*” and “*act only as a member of the board*”. All other sections represent effective practice.

Garden City Public Schools Board of Education members will promote the best interests of the school district as a whole and make decisions that place student learning and the success of all students first by adhering to the following educational and ethical standards:

BOARD GOVERNANCE

- Recognize that the role of the board is to govern and oversee the management of the district. Board members will delegate authority to the superintendent for the day-to-day operations of the district and will not seek to participate in the day-to-day operations.
- Act only as a member of the board and do not assume any individual authority when the board is not in session, unless otherwise directed by the board.
- Make decisions based on the educational welfare of all children.
- Make attendance at all regularly scheduled board meetings a priority, insofar as possible, review advance materials about the issues to be considered on each agenda, and give full attention to meeting presentations.
- Maintain confidentiality of information and discussion.
- Rely on school policies that are continually updated and aligned with Kansas and federal education laws, as well as, guidance from the superintendent, when making board decisions.
- Request recommendations from the superintendent and seek legal counsel, when required for full and informed board consideration of issues requiring legal expertise.

BOARD-ADMINISTRATION RELATIONS

- Provide policy support for school administrators in the performance of their duties and delegate authority commensurate with those responsibilities.
- Expect the superintendent to keep the board adequately informed through regular written and oral reports.
- Maintain open and candid communication between the board and the superintendent with the understanding that the board will keep the superintendent adequately informed of any issues or concerns that they have with regard to the district or they wished to have discussed during a board meeting.
- Refer complaints, requests, and concerns to the superintendent or other appropriate staff members.
- Avoid making commitments that may compromise the decision-making ability of the board or administrators.
- Hold the superintendent accountable by jointly creating job performance standards and, at least annually, perform a comprehensive evaluation process based on the job description, contract, and identified performance standards.
- Recognize that a board member’s responsibility is to see that schools are well run, but not to run them.

BOARD MEMBER RELATIONS/UNITY

- Understand that board members have not only the right, but the duty, to express their views, opinions and ask questions at the board table, as well as, make a good faith effort to understand the views of others.
- Voice opinions respectfully, maintain good relations with other board members, and respect and support the decisions made by the majority of the board.
- Retain independent judgment and refuse to surrender that judgement to individuals or special interest groups.

PERSONNEL RELATIONS

- Individual board members should not give directives to any school administrator or employee, publicly or privately.
- Support school personnel in the proper performance of their duties.
- Work fairly, ethically, and truthfully with employees.

COMMUNITY RELATIONS

- Encourage collaboration between the district and community.
- Believe firmly in the democratic process and the right of all groups to be heard.
- Treat stakeholders fairly and ethically – listen to their concerns and refer them to the appropriate school personnel.

BOARD PREPARATION AND TRAINING

- Be informed about educational issues through individual study and by participating in board development opportunities.
- Support new school board members by sharing experience and knowledge.
- Ensure that adequate board orientation and team building opportunities are available for board members and administrators.

I agree to abide by the principles outlined in the Board of Education Standards and will do everything in my power to work as a productive member of the governance team.

Board Member

Board Member

Board Member

Board Member

Board Member

Board Member

Board Member

Attest:

Clerk, Board of Education

Date



**RESOLUTION TO ESTABLISH BOARD MEETING DATES AND TIMES
RESOLUTION 2024-005**

WHEREAS, K.S.A. 72-1138 requires boards of education, at the first meeting on or after the second Monday in January or at a later date during that calendar year if so determined by the board at that first meeting, to adopt a resolution to establish its regular board meeting dates, times and location;

WHEREAS, the board of education must act each year on or after the second Monday in January and before February 1st of each year or at a later date during the calendar year to establish its meeting dates, times and location;

BE IT RESOLVED that pursuant to K.S.A. 72-1138, the Board of Education of Unified School District No. 457, Finney County, Kansas at its meeting on January 8, 2024 does hereby adopt this resolution to set its board meeting dates and times at its first meeting of the Board of Education in July, 2024.

By:

Board Member

Board Member

Board Member

Board Member

Board Member

Board Member

Board Member

CERTIFICATE

This is to certify that the above resolution was duly adopted by the Board of Education of Unified School District No. 457, Finney County, Kansas, on the 15th day of January, 2024.

Jennifer Ramos, Clerk of the Board of Education

MEMORANDUM

TO: Board of Education
THRU: Dr. Mike Dominguez, Superintendent
FROM: Tracy Johnson, Director of Nutrition Services
DATE: January 8, 2024
RE: Harris Solutions eTriton Quote

ISSUE:

The Board of Education is asked to consider and approve the purchase of Harris Solutions eTriton Front of House and Back of House Software.

BACKGROUND:

The software that Nutrition Services is currently utilizing will no longer be supported in the 2024-2025 school year. In this regard, the department had to search for a new software solution. A committee of 10 stakeholders, including technology took part in live online demos and visited several other districts to explore the right software solution for the department and district. Functionality, technology, support, ease of use and price were the main contributing factors in selecting the software package.

ALTERNATIVES:

No other alternatives applicable.

RECOMMENDATION:

1. Approve the purchase of Harris Solutions eTriton agreement
2. Deny the purchase of the Harris Solutions eTriton agreement

FISCAL NOTE:

The quote is in the amount of \$28,876.00 subscription and start-up services, with an annual estimated maintenance free of \$17,341.00. This has been budgeted out of the Nutrition Office Supply account, 024 E 3111 21 1000 054 00 610.

ATTACHMENTS:

Harris Solutions eTriton Quote



QUOTE FOR
Garden City Unified School District 457

Quote # HRS-25368

Created Date: Jan 5, 2024

Expiration Date: Feb 5, 2024



Corporate Address: Harris School Solutions
 2429 Military Road
 Suite 300
 Niagara Falls, NY 14304

Quote ID: HRS-25368
 Quote Date: Jan 5, 2024
 Valid Through: Feb 5, 2024
 GPID: NEW

Prepared By: Bobby Roy
 Email: broy@harriscomputer.com
 Phone:

Contact Name:

Bill To: Garden City Unified School District 457
 1205 FLEMING ST.
 GARDEN CITY KS 67846-4751

Ship To: Garden City Unified School District 457
 1205 FLEMING STREET
 GARDEN CITY, KS 67846

Annual Renewal Items

Quantity	Code	Description	Period Start	Period End	Unit Cost	Annual Cost
1	PLSS001	eTriton 7 Central	Jul 1, 2024	Jun 30, 2025	\$1,000.00	0
18	PLSS100	eTriton 7 POS Site License w/1 Serv Line (Per Site)	Jul 1, 2024	Jun 30, 2025	\$599.00	\$9,703.80
6	PLSS101	eTriton 7 POS Serving Line (Per add'l serving line)	Jul 1, 2024	Jun 30, 2025	\$199.00	\$1,074.60
1	PLSS103	eTriton 7 F/R Application Manager - SaaS	Jul 1, 2024	Jun 30, 2025	\$249.00	\$249.00
1	PLOAUNL	EZMealApp Module Unlimited Applications	Jul 1, 2024	Jun 30, 2025	\$125.00	\$125.00
1	PLSS700	eTriton 7 Extended Benefits Utility	Jul 1, 2024	Jun 30, 2025	\$950.00	\$950.00
1	Transactional Revenue	EZSchoolPay	Jul 1, 2024	Jun 30, 2025	\$0.00	0
1	PLSSEZMTE	EZSchoolMate	Jul 1, 2024	Jun 30, 2025	\$0.00	0
1	PLSS301	eTriton 7 Menu Planning - SaaS	Jul 1, 2024	Jun 30, 2025	\$199.00	\$199.00
1	PLSS311	eTriton 7 Production - SaaS	Jul 1, 2024	Jun 30, 2025	\$305.00	\$305.00
1	PLSS201	eTriton 7 Central Office Inventory - SaaS	Jul 1, 2024	Jun 30, 2025	\$950.00	\$950.00
18	PLSS202	eTriton 7 Site Inventory (per add'l inventory site)	Jul 1, 2024	Jun 30, 2025	\$175.00	\$2,835.00



Quantity	Code	Description	Period Start	Period End	Unit Cost	Annual Cost
1	PLSS221	eTritition 7 Central Office Purchasing	Jul 1, 2024	Jun 30, 2025	\$950.00	\$950.00
18	PLSS222	eTritition 7 Site Purchasing (Per add'l Purchasing Site)	Jul 1, 2024	Jun 30, 2025	\$175.00	0
					Total List Price	\$23,004.00
					Discount	24.62%
					Total Net Price	\$17,341.40

Service Fees

Quantity	Code	Product Name	Description	List Price/Unit	Net Price	
1	PSEB100	One-Time Activation/Training: Extended Benefits Utility	One-Time Activation/Training: Extended Benefits Utility	\$495.00	\$495.00	
1	PSMP103	Meal Planning Setup & Training	Meal Planning Setup & Training	\$595.00	\$595.00	
1	PSOA100	Online Application Setup	One Time Set Up Fee	\$595.00	\$595.00	
1	EZSPSETUP	EZSchoolPay: One-Time Setup	EZSchoolPay: One-Time Setup	\$595.00	\$595.00	
5	PSPM101	Project Management	Project Management	\$185.00	\$925.00	
18	PSRS102	Remote Services	services are estimates - if additional time is needed it will be invoiced in 30 minute increments at the hourly rate.	\$185.00	\$3,330.00	
					Total List Price	\$6,535.00
					Total Net Price	\$6,535.00

Summary

Total Annual Subscription Fees:	\$17,341.40
Total License Fees:	\$0.00
Total Professional Service Fees:	\$6,535.00
Total Hardware Fees:	\$0.00
Tax*:	\$0.00
Grand Total:	\$23,876.40

* All charges are exclusive of out of pocket expenses for Professional Services performed. Charges for actual and reasonable out-of-pocket expenses including, but not limited to, travel and lodging expenses will be billed monthly as incurred. All pricing is exclusive of applicable sales, use or similar taxes. Customer is responsible for any such taxes that may apply; if Customer is tax exempt, evidence of such tax exemption



must be provided. Lapsed payments may lead to denial of access to the Service in accordance with Section 16(b)(ii) of the Agreement.

Notes:

This is an 18 for 12 offer. Software cost will not be due until July 1st 2024. Training costs will be due when services are rendered.

(1) Annual Maintenance is due in Year 1 and each year thereafter. Annual maintenance fees are subject to annual increase. Annual Maintenance will be assessed at (\$)17,341.40 for the first year of service. Annual Maintenance will be assessed to the Customer in each year and shall be subject to an annual increase not to exceed three percent (3%) over the cost of Annual Maintenance from the previous year, for up to the first three (3) years of service from date of go-live. After the initial three-year period, annual increase percentages will be re-assessed with Customer and agreed upon by both parties, in writing, ahead of the year four renewal term.

(2) Travel expenses are estimates and will be based on actual travel required.

(3) Any amounts included on this document for Shipping/Freight are only provided as estimates - actual shipping/freight invoiced can vary. Some of the factors that cause estimates to vary include the destination of the shipment, the warehouse locations, the package 3/4 value, multiple and/or oversized packages as well as insurance. Please feel free to request an estimate if they are needed for your Purchase Order. We are always happy to help and strive to keep shipping costs as minimal as possible. Actual shipping charges will be calculated and added when your order is invoiced.

Name: _____ Signature: _____

Title: _____ Date: _____

Harris School Solutions ... Experience ... Expertise ... Solutions



EZSCHOOLPAY PARTICIPATION AGREEMENT

THIS EZSCHOOLPAY PARTICIPATION AGREEMENT (this "Agreement") is entered into this Jan 5, 2024 (the "Effective Date") by and between N. Harris Computer Corporation ("Harris") and Garden City Unified School District 457 ("Customer").

In consideration of the mutual promises contained herein and for other goods and valuable consideration, the receipt and sufficiency of which is hereby acknowledged, the parties agree as follows:

1. **Definitions.** As used in this Agreement, the following terms have the following meaning:
 - (a) "N. Harris Computer Corporation" is the operator of the Payment Service and the licensor of the SPOS.
 - (b) "Business Day" means any day in which Harris is open for the regular conduct of its business, and specifically excluding Harris holidays.
 - (c) "License Agreement" means the Harris End User License Agreement between Harris and Customer for Customer's use and the support and maintenance of the SPOS.
 - (d) "Notice" means any notice or communication between the parties required or allowed hereunder and made in accordance with the requirements of Section 8(d). (e) "Payment Service" means the service offered by Harris to Users that allows Users to make on-line payments to Harris for credit to Student's meal accounts with Customer, currently known as the EZSchoolPay.com payment service.
 - (f) "Customer" means the school, school district, or other organization who is a party to this Agreement and who is a licensee of the SPOS and the provider of meals and meal services to Students.
 - (g) "SPOS" means the Meal Tracker® or eTrition® Site Point of Sale software used by and licensed to Customer under the License Agreement.
 - (h) "Student" means a person enrolled at Customer and to whose benefit a User has utilized the Payment Services.
 - (i) "Term" means that period defined in Section 7(a).
 - (j) "User" means the parent or guardian of a Student or other person legally authorized to use and who has entered into an agreement with Harris for the Payment Service for the benefit of a Student.

2. **Online Credits & Other Payments.** Upon receipt by Harris of a User payment request conforming to Harris' criteria, Harris shall initiate a credit entry in the amount of the payment from such User (Harris less any convenience fee and/or other charges assessed by the Customer) to the account of the Student in the SPOS. Customer agrees to accept such credit in the full amount for immediate access and use by the Student in accordance with Customer's agreement with the Student and/or the Student's parent, guardian, or other authorized person concerning the purchase of meals and/or other Customer payments. Customer agrees that it will not discriminate against credits and payments from or through Harris and will honor such payments on the same basis as any other payments or form of payments received by Customer for the purchase of meals and/or other Customer payments.

3. **Customer Obligations.** In addition to such other obligations of the Customer as outlined herein during the Term, Customer shall:
 - (a) Sell meals and provide meal services to Students in accordance with Customer's agreement with the Student and/or the Student's parent, guardian, or other authorized person concerning the same, including, without limitation, handling complaints and addressing disputes, providing appropriate credits, and, as between Customer and Harris, Customer shall be solely responsible for the same;
 - (b) Provide Harris with full and complete access to the SPOS (including, without limitation, providing a means of remote access as specified in Harris' policies and providing Harris with passwords and other secured access to the hardware and systems upon which the SPOS resides) and such information as contained or used therein, as required by Harris to provide the Payment Service and to properly administer, account for, and credit User payments with Customer;



- (c) Maintain and not default in any obligation under the License Agreement or any other agreement between Harris and Customer;
 - (d) Promptly apply all upgrades, updates, patches, and bug-fixes supplied by Harris in accordance with its policies; maintain the SPOS and all hardware, software, and communication systems associated therewith in accordance with Harris' policies; and keep the SPOS up to date with information concerning Students and Users; and
 - (e) Apply the credit and payments hereunder exclusively for meals and/or other payments in accordance with Customer's agreement with Students and/or Users, and not take any action that jeopardizes or interferes with the proper processing and collection of User payments, including, without limitation, cooperation with bank or payment systems rules and regulations.
 - (f) Maintain an active merchant account for the purpose of processing payment cards. It is understood that the merchant agreement is solely between the Customer and the bank or other agent.
 - (g) Be responsible for all maintenance and processing fees associated with maintaining a merchant account.
 - (h) Be responsible for any financial settlement resulting from payment card user chargebacks.
 - (i) Allow Harris and its agents access to the payment gateway for the purpose of providing initial set up on behalf of the Customer
 - (j) Not assess a convenience fee as a percentage of an online transaction amount (must be a flat-dollar amount).
 - (k) Pay a monthly fee for each transaction processed through EZSchoolPay.com.
4. **Indemnification.** Subject to section 5, each party agrees to indemnify, defend, and hold the other party harmless from and against any and all claims, suits, liability, costs, and expenses (including – but not limited to – attorneys' fees) arising out of or related to (a) any claim that the other party has breached an obligation under this Agreement; and (b) any dispute with a Student or User concerning the provision of Customer's goods or services, the application of a User credit or payment, or any other claim of a Student or User other than (c) a claim that Harris failed to process a credit or payment of a User in accordance with the agreement between Harris and a User or (d) a claim that relates to a process, procedure, or form required by Customer that is a cause of the claim, suit, liability, cost, or expense.
5. **Disclaimers and Limitations of Liability.** Customer understands and agrees that:
- (a) Harris is only a provider of the Payment Service, and Harris is not a bank, financial institution; a trustee, escrow agent, or fiduciary with respect to any funds; or a guarantor or other form of surety of Users' or Students' payments or obligations.
 - (b) Except as expressly stated herein, Harris owes Customer no duty. Whether or not Harris offers the Payment Services and the manner, terms, and conditions upon which Harris offers the Payment Services are within Harris' sole and absolute discretion.
 - (c) THE SERVICES PROVIDED HEREUNDER ARE ON AN "AS IS" AND "AS AVAILABLE" BASIS. HARRIS MAKES NO WARRANTY AND DISCLAIMS LIABILITY THAT SUCH SERVICES WILL BE UNINTERRUPTED, ERROR FREE OR FREE FROM VIRUSES OR OTHER DEFECTS OR HARMFUL COMPONENTS, NOR DOES HARRIS MAKE ANY WARRANTY AS TO THE RESULTS THAT MAY BE OBTAINED FROM USE OF, OR AS TO THE ACCURACY, RELIABILITY OR CONTENT OF ANY INFORMATION OR SERVICE PROVIDED THROUGH SUCH SERVICES. HARRIS MAKES NO WARRANTIES OF ANY KIND, EITHER EXPRESS OR IMPLIED, INCLUDING, BUT NOT LIMITED TO, WARRANTIES OF TITLE, NONINFRINGEMENT, MERCHANTABILITY, OR FITNESS FOR A PARTICULAR PURPOSE.
 - (d) Harris shall use its reasonably commercial efforts to process User credits and payments in a timely manner in accordance with the terms and conditions of this Agreement. OTHER THAN FOR FOREGOING SENTENCE, NEITHER HARRIS, ITS DESIGNEES, EMPLOYEES, AGENTS, OR AFFILIATES WILL BE LIABLE FOR CLAIMS, LOSSES, ACTIONS, DAMAGES, OR INJURY RESULTING FROM ANY FAILURE OF PERFORMANCE, ERROR, OMISSION, INACCURACY, INTERRUPTION, DEFECT, UNTIMELINESS OR UNAUTHENTICITY OF ANY INFORMATION, DELAY OR INTERRUPTION IN OPERATION OR



TRANSMISSION, INTERCEPTION OF TRAFFIC SENT OR RECEIVED, COMMUNICATION LINE FAILURE, SECURITY BREACH, EAVESDROPPING, THEFT OR DESTRUCTION OR UNAUTHORIZED ACCESS TO, ALTERATION OF, OR USE OF INFORMATION, OR THE USE OF THE FACILITIES.

- (e) IN NO EVENT WILL HARRIS, ITS DESIGNEES, EMPLOYEES, AGENTS, OR AFFILIATES BE LIABLE FOR ANY PUNITIVE DAMAGES, OR ANY INDIRECT, INCIDENTAL, SPECIAL, CONSEQUENTIAL OR SIMILAR DAMAGES ARISING OUT OF OR RELATED TO THIS AGREEMENT. IN ALL CASES HARRIS' MAXIMUM LIABILITY SHALL NOT EXCEED THE LESSER OF CUSTOMER'S ACTUAL, DIRECT DAMAGES RESULTING FROM HARRIS' BREACH OR HARRIS' NET PROFITS RELATED TO THE BREACH.

6. Term and Termination.

- (a) This Agreement shall begin on the Effective Date and unless earlier terminated as provided herein, shall continue for a period of one (1) year after the Effective Date. Unless terminated hereunder, this Agreement shall automatically renew for successive periods of one (1) year each.
- (b) Either party may terminate this Agreement: (i) at any time, with or without cause, by giving the other party sixty (60) days prior written Notice of such termination; (ii) immediately and without Notice in the event of bankruptcy, insolvency, liquidation, winding up, reorganization, protection or relief of the other party (whether voluntary or involuntary) under any law of any jurisdiction, or upon issuance of any order for relief or the appointment of a receiver, trustee, or other similar official for the other party; and (iii) ten (10) Business Days after Notice by a party of a breach of this Agreement by the other party and such other party has not cured such breach within such 10-day period.
- (c) Harris, at its option, may immediately terminate this Agreement upon termination or expiration of the License Agreement.
- (d) The termination or expiration of this Agreement shall not impact and this Agreement shall still apply to any transaction between Harris and a User entered into prior to the effective date of the termination or expiration and for a reasonable period thereafter as necessary for Harris to make the credits and payments applicable thereto and for Customer to honor such credits as outlined herein. The provisions of Sections 4, 5, 6, and 7 shall survive the termination or expiration of this Agreement.

7. Generally.

- (a) Independent Parties. The parties acknowledge each is independent of the other, and Harris may engage in other business activities at its sole discretion. This Agreement does not in any way create or constitute a relationship of agency, employment, partnership, or a joint venture between the parties.
- (b) Non-Assignment. Customer's rights and obligations under this Agreement may not be assigned without the prior written consent of Harris. This Agreement shall benefit the parties and their respective successors and permitted assigns.
- (c) Force Majeure. Customer agrees that Harris shall not be liable for any losses and damage, including consequential damages, detention, or delay or failure to perform resulting from causes beyond the control of Harris including, but not limited to, acts of God, acts or omissions on the part of Customer, delays in transportation or communications, failure to obtain supplies and services not caused by the negligence of Harris, changes in governmental regulations, war, or civil disturbance.
- (d) Notices. All Notices shall be in writing and delivered personally, or by certified mail, email, postage prepaid, addressed to the parties at the addresses set forth on the signature page below, or such other address as a party shall provide by notice. Notices shall be deemed received three (3) days after mailing when the above procedures are followed or when actually received.
- (e) Severability. In the event that any of the provisions of this Agreement shall be held by a court or other tribunal of competent jurisdiction to be unenforceable, the remaining portions of this Agreement shall remain in full force and effect, provided that in such event the parties agree to negotiate in good faith enforceable substitute provisions which most nearly effect the parties' intent in entering into this Agreement.



- (f) Governing Law; Venue. This Agreement shall be construed in accordance with the laws of the State of Kansas, applicable to contracts entered into and solely performed therein, without regard to that body of law pertaining to conflicts of law, with proper venue with respect to any dispute hereunder being exclusively in the City of Wichita, County of Sedgwick, State of Kansas.
- (g) Waiver. No waiver of any breach or default hereunder shall be considered valid unless in writing and signed by the party giving such waiver, and no such waiver shall be deemed a waiver of any subsequent breach or default of the same or similar nature.
- (h) Counterparts. This Agreement may be executed in one or more counterparts, all of which taken together shall be deemed one original.
- (i) No Third Party Beneficiaries. Nothing expressed or implied in this Agreement is intended, or shall be construed, to confer upon or give any party other than the parties hereto and their respective corporate affiliates, heirs, successors and assigns, any rights or remedies under or by reason of this Agreement.
- (j) Integration and Amendment. This Agreement and all documents referenced herein constitutes the entire Agreement of the parties superseding and extinguishing all prior agreements or understandings, representations or warranties, relating to the subject matter hereof. This Agreement may not be modified, or amended except by written agreement specifically referring to this Agreement signed by the parties hereto.

Please select which credit card processor the school district would like to use:

Stripe

A 4.9% additional fee will be added to each transaction and paid for by the individual making the purchase.

Chargebacks / Bank Fees

Credit card company chargebacks and associated fees imposed on Harris will be reimbursed to Harris by an equivalent chargeback to the District, with written notice to the District. A credit card chargeback occurs when a depositor alleges an unauthorized debit to his/her credit card and the credit card company subsequently debits Harris' account, without recourse, for the "unauthorized" dollar amount. Such chargebacks universally occur after Harris has transferred payment to the District's account. Reimbursement to Harris will be accomplished by Harris' withholding of the chargeback and the chargeback processing fee amount from a subsequent fund transfer to the District. The District shall be responsible for reconciling the subject patron's meal account within the District's meal service application.

Clover Connect

Note: In addition to the Harris pricing below, a separate agreement will need to be signed with Clover Connect and they will also charge the district an additional fee per transaction.

With regard to pricing, because EZSchoolPay.com is not the merchant of record and Clover Connect is, we cannot charge the parents a fee, however, the school district has the ability to add on an additional convenience fee, if desired. Therefore we derive our revenue by invoicing the school or school district a per transaction fee on a monthly basis. The rates are as follows.

N. Harris Computer Corporation pricing (per month):

- Up to 249 transactions: \$1.25 per transaction
- 250 – 749 transactions: \$1.22 per transaction
- 750 – 1,499 transactions: \$1.17 per transaction
- 1,500 – 2,249 transactions: \$1.12 per transaction



- 2,250+ transactions: \$1.05 per transaction

IN WITNESS WHEREOF, Harris and the Customer have duly executed this Agreement to be effective on the Effective Date first written above.

N. HARRIS COMPUTER CORPORATION

Garden City Unified School District 457

Signature

Signature

Name

Name

Title

Title

Date

Date



Software As A Service Agreement

This **Software As A Service Agreement** (the “**Agreement**”) is entered into on Jan 5, 2024 (the “**Effective Date**”) by and between Garden City Unified School District 457 (“**Customer**”) of 1205 FLEMING ST., GARDEN CITY, KS, 67846-4751, and N. Harris Computer Corporation of 1 Antares Drive, Suite 400, Ottawa, Ontario K2E 8C4 (“**Harris**”).

NOW THEREFORE, in consideration of the mutual covenants and obligations contained here and other good and valuable consideration, the receipt and sufficiency of which are hereby acknowledged, the parties agree as follows:

1. Definitions

The following terms shall have the meaning set out below; all other capitalized terms not otherwise defined in this Section shall have the meaning set forth in the Agreement:

- (a) “**Annual Subscription Fees**” means the annual subscription fees set out in Schedule “A” to this Agreement.
- (b) “**Change Order**” means any written documentation between the Customer and Harris evidencing their agreement to change particular aspects of this Agreement.
- (c) “**Completion of Services**” means the Professional Services are complete and shall be deemed to have occurred on the date which the Customer commences using the Services.
- (d) “**Confidential Information**” means, with respect to a party hereto, all information or material which: is (A) marked "Confidential," "Restricted," or "Proprietary Information" or other similar marking, (B) known by the parties to be considered confidential, proprietary, or is confidential under federal or state law or (C) which should be known or understood to be confidential or proprietary by an individual exercising reasonable commercial judgment in the circumstances. Confidential Information of Harris shall include, without limitation, the Software, the Documentation, and any information with respect to the Services that Harris may provide to Customer from time to time, including without limitation, all information disclosed by Harris relating to the security of its facilities, computer systems and products. Confidential Information does not include information to the extent that such information: (i) is or becomes generally known to the public by any means other than a breach of the obligations of a receiving party hereunder; (ii) was previously known to the receiving party as evidenced by its written records; (iii) is rightly received by the receiving party from a third party who is not under an obligation of confidentiality; or (iv) is independently developed by the receiving party without reference to or use of the other party's Confidential Information and which such independent development can be established using evidence that would be acceptable to a court of competent jurisdiction. Confidential Information of Harris shall include, without limitation, the Services, the Software, Documentation, and any information with respect to the Services that Harris may provide to Customer from time to time, including without limitation, the terms and conditions of this Agreement and all information disclosed by Harris relating to the security of its facilities, computer systems and products.
- (e) “**Data Conversion Fees**” shall have the meaning set forth in Section 10 of this Agreement.



- (f) **“Data”** means all data that is provided by Customer to Harris and all other content transmitted, posted, received or created through Customer’s use of the Services or the Software.
- (g) **“Documentation”** means user guides, operating manuals, education materials, product descriptions and specifications, technical manuals, supporting materials, and other information relating to the Software or used in conjunction with the Software, whether distributed in print, magnetic, electronic, or video format, in effect as of the date the Software are provided to the Customer.
- (h) **“Fees”** means the Annual Subscription Fees, Professional Services Fees, Conversion Costs and other Fees as may be further described and listed in Schedule “A” of this Agreement.
- (i) **“Professional Service(s)”** means those implementation, training, consulting and professional service(s) provided by the Harris Professional Services team as further described in Schedule “A” and Schedule “C” to this Agreement.
- (j) **“Professional Services Fees”** means the Professional Service(s) fees set out in Schedule “A” to this Agreement.
- (k) **“Services” and “Software Services”** each means the web-based service(s) commonly referred to as a “Software as a Service” (SaaS) solution to be provided by or on behalf of Harris under this Agreement that includes hosting, monitoring, operating and maintaining the Software as a service at a site owned or controlled by Harris and the delivery of non-exclusive access via the Internet to Customer to use the Software, as a service, granted to Customer pursuant to Section 2 hereof. The Services shall also include storing all data entered and maintained by Users through use of the Services.
- (l) **“Software”** means the software product(s) that are owned by Harris, including those products that are delivered as a SaaS solution and the Terminal Software, as listed in Schedule “A”.
- (m) **“Support Services”** means those support services to be provided by the Harris Support team as further described in Schedule “D” to this Agreement.
- (n) **“Terminal Software”** means that portion of the eTriton software product that is downloaded on each point of sale terminal in order to access the Services.
- (o) **“Third Party Components”** means any third party telecommunications, energy/utility transportation, managed facilities and/or software applications and services that Harris or its service providers have licensed or purchased and provided access to or otherwise made available as part of the Services.
- (p) **“User”** means an employee or agent of Customer that has been authorized by the Customer in writing to access and use the Services.

2. Authorization

Subject to the terms and conditions of this Agreement, including without limitation, payment by Customer of the Professional Services Fees required for set-up and the Annual Subscription Fees, Harris hereby grants to Customer a personal, non-exclusive, non-transferable limited right during the Term (a) to install and use the Terminal Software on the number of serving lines and at the number of sites specified in Schedule “A” (the **“Serving Lines”** and **“Sites”**, respectively); (b) to allow Users to access and use the Services on an annual subscription basis from the Serving Lines solely at the Sites and in accordance with the Documentation solely for Customer’s internal business purposes; and (c) to use, copy and modify the Documentation solely for the purpose of creating and using internal training



materials relating to the Services.

3. Fees

In consideration of receiving the Terminal Software, Services and the Professional Services, Customer agrees to pay to Harris the Fees and all applicable travel and lodging expenses as described in Section 4 of this Agreement in accordance with the payment terms as defined in Schedule "A".

The Annual Subscription Fees, Professional Services Fees and any other fees set out in this Agreement are exclusive of taxes. Customer agrees to pay all foreign, federal, state, provincial, county or local income taxes, value added taxes, use, personal, property sales and any other taxes, tariff, duty or similar charges that may be levied by a taxing authority (excluding taxes on Harris' net income).

If any Fees are not paid when due, then at Harris' discretion, (a) such Fees may accrue late interest at the rate of 1.5% (18% per annum) of the outstanding balance per month, or the maximum rate permitted by law, whichever is lower, from the date such fee was due until the date paid, and/or (b)] Harris may suspend the Service, including all Customer access to the Service, pursuant to Section 16(b).

4. Travel and Lodging Expenses

Travel and lodging expenses will be billed in conjunction with any Professional Services work performed at Customer's offices by any Harris personnel. Harris travel expenses are billed to Customer for each Harris employee providing Professional Services as follows:

- Lodging and Hotel expenses: If the Harris employee must spend the evening.
- Airfare expenses: If the Harris employee must travel by air to reach Customer's offices.
- Rental Car or Taxi fees: As appropriate to travel to / from Customer's offices.
- Personal Vehicle expenses: If a Harris employee uses his/her personal vehicle, mileage will be charged at the currently published IRS reimbursement rate.
- Per Diem expenses: Fifty-five dollars (\$55) per day will be charged to cover meals and incidentals when an employee is at or traveling to and from Customer's offices. If an employee must travel on Saturday, Sunday, or a holiday, or is at Customer's office on a holiday, the Per Diem rate shall increase to one hundred ten dollars (\$110) per day for the corresponding days. Harris reserves the right to change the rates charged for reimbursable meals and incidentals.

Harris will use its reasonable efforts to minimize all travel and lodging expenses. Only actual travel and lodging expenses will be billed to the Customer.

5. Term

Unless terminated earlier in accordance with the terms hereof, this Agreement shall commence on the Effective Date and shall continue for a period of one (1) year from the date that the initial Software Services listed in Schedule "A" are installed and configured in Harris' hosted environment (the "Initial Term"); with evidence of said installation and configuration being by the issuance of an Invoice by Harris to Customer for the applicable Fees. After the Initial Term, the Agreement shall be automatically renewed for successive one (1) year periods (each a "Renewal Term") subject to Harris' then-current price structure unless either party provides written notice to the other party of its intention not to renew within one hundred and twenty (120) days of the end of the then current term. The Initial Term and Renewal



Term(s) shall collectively be referred to as the "Term".

6. Restrictions on Use

- (a) Except as expressly provided herein, Customer may not give away, rent, lease or otherwise sell, re-sell, sublicense, distribute or transfer the license rights granted under this Agreement or otherwise use the Software or Services except as expressly permitted by this Agreement without the prior written consent of Harris.
- (b) Customer agrees that it will not reverse engineer, decompile, translate or otherwise attempt to derive, or permit or help others to derive the source code relating to all or any part of the Software or Software Services, or attempt to otherwise convert or alter the Software or Software Services into human readable code, except to the extent applicable law expressly prohibits the foregoing restriction.
- (c) Customer may duplicate Documentation, at no additional charge, for Customer's internal use so long as all required proprietary markings are retained on all duplicated copies.
- (d) No third party, other than duly authorized agents or employees of Customer authorized pursuant to Section 2 hereunder, shall have access to or use of the Software or Services.
- (e) Customer shall not copy, frame or mirror any part or content of the Services, other than copying or framing on Customer's own intranets or otherwise for Customer's own internal business purposes.
- (f) Customer shall not access the Services in order to (i) build a competitive product or service; (ii) copy any features, functionality or graphics of the Software; or (iii) knowingly allow access to any competitor of Harris.
- (g) The Customer shall not transmit, upload, post, distribute, store or otherwise publish, through use of the Services, any data, material or Information that: (i) contains a software virus, Trojan horse, worm or other harmful or deleterious computer code, files or programs that may adversely affect any hardware or software, or that intercepts or misappropriates any data or information; (ii) is threatening, defamatory, libelous, harassing, profane, is an invasion of privacy, offensive, obscene or harmful; (iii) infringes or otherwise violates any patent, copyright, trademark, trade secret or other intellectual property or proprietary right of any third party; (iv) violates any law, statute, ordinance or regulation; or (v) includes unsolicited bulk e-mails, advertisements or solicitations.
- (h) Customer shall not knowingly transmit any data to the system used by Harris to provide the Services that contains software viruses or other harmful or deleterious computer code, files or programs.
- (i) Customer shall not interfere with or disrupt services or networks connected to the system used to provide the Services and shall not attempt to gain unauthorized access to the Services or such services or networks connected to the system used to provide the Services.
- (j) Customer shall not use the Services to store or transmit any material that is infringing, libelous, an invasion of privacy, obscene, offensive, harmful, illegal or would otherwise violate or infringe the rights of any third party.
- (k) Customer shall not provide the results of using the Services for the purposes of monitoring its availability, performance, functionality, benchmarking or competitive analysis to any third party.



- (l) In addition to its termination rights under Section 16, Harris may restrict or limit Customer's access to the Services if Harris reasonably determines that Customer has engaged in or is likely to engage in (whether knowingly or unknowingly) any prohibited conduct described herein and such conduct, in Harris' reasonable opinion poses any risk of any kind or nature to Harris or its service providers' network, business or other customers. As promptly as practicable after becoming aware of Customer's engagement in any such prohibited conduct, Harris will use reasonable efforts to notify Customer of the restriction or limitation to Customer's access to the Services and will promptly restore Customer's access after Harris has had reasonable assurance that such conduct has been permanently discontinued. In addition to and without limiting the foregoing, Harris reserves the right to refuse to post or to remove in whole or in part any information or materials provided or submitted by or on behalf of Customer in connection with its use of the Services that Harris determines, in its reasonable discretion, are either in violation of this Agreement or pose any risk of any kind or nature to Harris or its service provider's network, business or other customers.

7. Services Availability (SaaS)

- (a) Harris shall provide all facilities, equipment, and software required to make the Software Services available.
- (b) Harris shall use commercially reasonable efforts to make the Software Services available to Users twenty four (24) hours per day, seven (7) days per week; subject to the terms further defined in Schedule "B".
- (c) Harris reserves the right to have additional User acceptance criteria that may be applied to Users prior to their ability to have access to the Software Services. Harris shall inform Customer of such criteria but Harris shall be free to implement such criteria at any time without prior written warning to the Customer and/or to Users. Where Users do not accept such and/or agree to such criteria, Harris reserves its rights to not grant to such Users access to the Software Services. Harris reserves its rights to restrict access to the Software Services to Users for any violation of any additional terms and conditions to which such Users accept/agree to access the Software Services.
- (d) Harris shall provide installation, configuration, system administration and maintenance of the facilities and equipment and software required to operate and ensure availability of the Software Services. Customer, not Harris, shall be responsible for creating and maintaining all User account information and for performing all other application level system administration functions that are available within the Software Services.
- (e) Harris shall comply with the terms and conditions regarding access and use of Data as set out in Section 18 of this Agreement.
- (f) Customer acknowledges that in order to provide the Services Harris may be required to purchase access the Third Party Components. Customer further acknowledges that the availability of such Third Party Components is based solely on the best information available to Harris and its service providers as of the Effective Date including third party representations and government regulations and is subject to change during the Term with little or no advance notice. If any necessary Third Party Components are determined by Harris to be unavailable as a result of changes to any third party availability, governmental regulations or other condition or circumstance outside of Harris' control, then (a) Harris shall not be in breach hereof or otherwise liable for any failure or inability to provide the Services as a result of such unavailability of any Third Party Components; and (b) Harris may in its sole discretion modify, change or replace the applicable Third Party Components and otherwise attempt to mitigate the impact of the such unavailability of Third Party Components, subject to the right to terminate set out in Section 16.

8. Customer Responsibilities

- (a) **Cooperation by Customer.** Customer acknowledges that the success and timeliness of the implementation process shall require the active participation and collaboration of Customer and its staff and agrees to act



reasonably and co-operate fully with Harris to achieve the Completion of Services related to any Professional Services provided by Harris. To enable Harris to provide effective Support Services, the Customer will establish auto remote access based on remote access procedures compatible with Harris' practices.

- (b) **Project Manager.** Customer shall appoint a project manager who shall work closely with Harris to facilitate the successful completion of the implementation process and who shall be responsible for supervising Customer staff and ensure their co-operation with and participation in such process during any Professional Services engagement.
- (c) **Customer Equipment.** Customer agrees that it shall be responsible, at its sole expense, for providing all Internet access, including but not limited to obtaining, installing and maintaining all equipment, hardware, network, Internet or direct telecommunications connections and software applications (e.g. web browser) at Customer's facilities required for Users to access and use the Services. Harris shall not be responsible for the operation of any Internet, network or other communication services. Customer further acknowledges that access to and the operation of the Services requires Customer's and Users' hardware to be of sufficient quality, condition and repair, and Customer agrees to and/or to ensure that Users' maintain their applicable hardware in the appropriate quality, condition and repair at its sole cost and expense. These requirements may also be necessary in order to facilitate the achievement of Completion of Services related to any Professional Services supplied by Harris.
- (d) **Passwords.** Customer agrees to comply with all Harris security policies and procedures as provided to it and amended from time to time. Customer and its Users shall be responsible for keeping any and all passwords and user ID's assigned to it its Users secret and confidential. Customer agrees that it is and shall remain solely and completely liable for any communications or other uses that are made using Customer's or its Users' passwords and user ID's, as well as any obligation that may result from such use. Customer agrees to notify Harris in writing to change Customer or User's password(s) for any reason, including without limitation if it believes that a password has been stolen or might otherwise be misused. Customer agrees to notify Harris immediately of any unauthorized use of any password or user ID or any other breach of security suspected by Customer.
- (e) **Users.** The Customer is responsible for: (i) the actions of Users using the Services in accordance with this Agreement; (ii) ensuring that Users agree to any further terms and conditions as may be provided by Harris from time to time for Users; and (iii) informing Harris of any information about Users' actions that may affect either the Services or third party data contained in or used by the Services, or Harris' ability to provide the Services as contemplated by this Agreement.
- (f) **Compliance with Laws.** Customer represents and warrants to Harris that it and its Users will at all times be in compliance with all applicable local, state, provincial, federal and international laws including but not limited to those laws regarding restrictions on exports, defamation, libel, harm to reputation, invasion of privacy, misuse or failure to protect personal information, violation of secrecy, confidentiality, unfair competition and other situations which could generate liability.
- (g) **Data Security.** Customer acknowledges and agrees that use of or connection to the Internet is inherently insecure and provides opportunity for unauthorized access by a third party to Customer's and its Users' (as well as Harris') computer systems, networks and any and all information stored therein. Customer is solely responsible for ensuring that (i) Customer's computer systems are secure and protected from unwanted interference (such as "hackers" and viruses), (ii) all transmissions are screened for viruses or other harmful code prior to transmission to Harris' servers; and (iii) Data is encrypted.

HARRIS DOES NOT GUARANTEE THE PRIVACY, SECURITY, AUTHENTICITY, AND NON-CORRUPTION OF ANY INFORMATION TRANSMITTED OR STORED IN ANY SYSTEM CONNECTED TO THE INTERNET. WE SHALL NOT BE RESPONSIBLE FOR ANY ADVERSE CONSEQUENCES WHATSOEVER OF CUSTOMER'S OR ITS USERS' CONNECTION TO OR USE OF THE INTERNET, AND HARRIS SHALL NOT BE RESPONSIBLE



FOR ANY USE BY CUSTOMER OR ANY USER OF CUSTOMER'S INTERNET CONNECTION IN VIOLATION OF ANY LAW, RULE OR REGULATION.

9. Delivery Schedule

The parties will mutually agree in writing upon a delivery schedule based on, among other things, the purchased modules, required training and availability of both Customer and Harris staff members.

10. Data Conversion Fees

Harris may offer data conversion services for the purpose of migrating existing Customer data to a format usable by the Purchased Service. The success of the data conversion effort is largely based on the format and quality of the Customer provided data. Unless otherwise indicated, converted data is strictly limited to non-dollar amounts and typically includes information such as names, addresses, and phone numbers. Only information explicitly listed in this Agreement will be converted. In certain instances, initial cost estimates for a data conversion may have been included in a Professional Services pricing proposal. Unless specifically included in this Agreement as part of Schedule "A", said cost estimates, and all prior data conversion cost estimates, are not binding nor are they incorporated into this Agreement. Accordingly, Harris shall notify Customer of the final data conversion fees and costs after the Customer provided sample data is examined by Harris to verify existing Customer data formats and data integrity; but before data conversion efforts are commenced. In such event, and upon receipt by Harris of notice in writing from Customer that said data conversion fees are acceptable, such data conversion fees (Data Conversion Fees) shall be in addition to all fees currently stated in this Agreement.

Any costs associated with obtaining the data from an existing Customer vendor are the responsibility of the Customer. Sample data shall be provided in standard fixed length format, CSV format, or another mutually agreed upon format with ASCII display characters only. Data must be on a media formats readable by Harris.

Wherever possible, the data extraction shall be done twice. The first extraction is to test and create the conversion tools.

The second extraction is done when the implementation is ready to go live.

In the event a data re-conversion is required, for whatever reason, Customer will be billed at the Professional Services Fee rate set out in Schedule "A" to this Agreement.

11. Forms

The use of Harris standard forms ensures compatibility with the Software Services. Customer agrees to use standard Harris forms for use with the Services. Customer may purchase standard forms from Harris and Harris agrees to provide said forms to Customer at a competitive price. Customer must notify Harris in writing in the event that Customer elects to order forms from a third-party forms provider so that Harris is able to confirm that said third-party provider forms are compatible with the Software Services. In the event that Customer purchases non-compatible forms and has not received written confirmation from Harris that said forms are compatible with the Services, Harris may be required to modify the Services to be compatible with the third-party provided forms. In such event, Harris may issue a Change Order to Customer for the purpose of completing modifications to the Services and underlying software. Said modifications shall be billed to Customer at the rate of one hundred-seventy five dollars (\$185) per hour; with a minimum of four (4) hours effort. Said Change Order must be executed by both parties prior to commencement of the corresponding Professional Services.



12. Professional Services & Support Services

- (a) **Professional Services and Support Services.** Subject to the terms and conditions of this Agreement, Harris shall provide the Professional Services to Customer in accordance with Schedules "A" and "C" and the Support Services in accordance with Schedule "D".
- (b) **Manner of Performance.** Harris shall perform the Professional Services in an efficient, competent and timely manner and exercise reasonable care, skill and diligence in the performance thereof. Harris shall determine in its sole discretion the manner and means by which the Professional Services shall be performed, with due consideration of adequate knowledge transfer to Customer personnel. Harris will communicate openly with Customer in its methodology, manner and means.
- (c) **Conduct on Customer's Premises.** In the event that Harris is required to perform Professional Services on Customer's premises, any such Professional Services shall be performed with Customer's full cooperation and on the premises of Customer or, if agreed to by both parties, at an alternate location. Harris agrees that, while working on Customer's premises, each of its employees shall observe Customer's rules and policies provided to Harris in writing relating to conduct thereon.

13. Warranty and Warranty Disclaimer

- a) **Limited Warranty.** Harris warrants to Customer that the Services shall be performed at a level and shall substantially conform to the specifications, as stated in Harris' manuals and other documentation provided to Customer, provided that all use of the Services is for the purposes and in the environment for which they were designed and in accordance with such specifications. Customer's sole remedy in the event the Services do not conform to the foregoing limited warranty is for Harris to use commercially reasonable efforts to correct such non-conformance and the right to terminate this Agreement in accordance with Section 16(b).
- b) **Warranty Disclaimer.** TO THE GREATEST EXTENT PERMITTED BY LAW, EXCEPT FOR THE EXPRESS LIMITED WARRANTY SET OUT IN SECTION 13(A), THE SERVICES, THE SOFTWARE, THE PROFESSIONAL SERVICES AND ANY OTHER PRODUCTS OR SERVICES PROVIDED UNDER THIS AGREEMENT ARE PROVIDED TO CUSTOMER "AS IS" AND THERE ARE NO OTHER WARRANTIES, REPRESENTATIONS OR CONDITIONS, EXPRESSED OR IMPLIED, WRITTEN OR ORAL, ARISING BY STATUTE, OPERATION OF LAW, COURSE OF DEALING, USAGE OF TRADE OR OTHERWISE, REGARDING THEM OR ANY OTHER PRODUCT, SERVICE OR MATERIAL PROVIDED HEREUNDER OR IN CONNECTION HERewith.

HARRIS, ITS LICENSORS AND SUPPLIERS DISCLAIM ANY IMPLIED WARRANTIES OR CONDITIONS REGARDING THE SOFTWARE, THE SERVICES, THE PROFESSIONAL SERVICES AND ANY OTHER PRODUCTS, SERVICES AND MATERIALS PROVIDED HEREUNDER OR IN CONNECTION HERewith, INCLUDING, BUT NOT LIMITED TO, WARRANTIES OF MERCHANTABILITY, DURABILITY, FITNESS FOR A PARTICULAR PURPOSE, TITLE OR NON-INFRINGEMENT.

HARRIS DOES NOT REPRESENT OR WARRANT THAT THE SERVICES OR THE SOFTWARE SHALL OPERATE ERROR FREE OR UNINTERRUPTED, SHALL MEET ANY OR ALL OF CUSTOMER'S



PARTICULAR REQUIREMENTS, THAT ALL ERRORS OR DEFECTS IN THE SERVICES OR SOFTWARE CAN BE FOUND OR CORRECTED.

WITHOUT LIMITING THE FOREGOING, HARRIS DOES NOT MAKE ANY REPRESENTATIONS OR WARRANTIES WHATSOEVER WITH REGARD TO PRODUCTS OR SERVICES FROM THIRD PARTIES (INCLUDING WITHOUT LIMITATION THE THIRD PARTY COMPONENTS, THE HARDWARE, THE OPERATION OF THE INTERNET, NETWORK OR OTHER COMMUNICATION SERVICES) AND ASSUMES NO RESPONSIBILITY OR LIABILITY WITH RESPECT TO THE FOREGOING OR THE APPROPRIATENESS OF YOUR DATA MANAGEMENT SYSTEM OR THE ACCURACY OF DATA CONTAINED IN SUCH SYSTEM.

NO AGREEMENTS VARYING OR EXTENDING ANY EXPRESS WARRANTIES SET FORTH IN THIS AGREEMENT SHALL BE BINDING ON EITHER PARTY UNLESS IN WRITING AND SIGNED BY AN AUTHORIZED SIGNING OFFICER OF HARRIS.

14. Limitations on Liability

TO THE GREATEST EXTENT PERMITTED BY APPLICABLE LAW, CUSTOMER AGREES THAT THE ENTIRE LIABILITY OF HARRIS AND CUSTOMER'S EXCLUSIVE REMEDY WITH RESPECT TO THE SERVICES, THE SOFTWARE, THE SOFTWARE SERVICES, THE PROFESSIONAL SERVICES AND ANY OTHER PRODUCTS, MATERIALS OR SERVICES SUPPLIED BY HARRIS IN CONNECTION WITH THIS AGREEMENT FOR DAMAGES FOR ANY CAUSE AND REGARDLESS OF THE FORM OF ACTION, WHETHER IN CONTRACT OR IN TORT, INCLUDING FUNDAMENTAL BREACH OR NEGLIGENCE, SHALL BE LIMITED TO ACTUAL DIRECT DAMAGES AND SHALL NOT EXCEED IN THE AGGREGATE THE ANNUAL SUBSCRIPTION FEES PAID IN THE **THEN-CURRENT YEAR** BY CUSTOMER TO HARRIS UNDER THIS AGREEMENT

CUSTOMER FURTHER AGREES THAT IN NO EVENT SHALL HARRIS BE LIABLE, REGARDLESS OF THE FORM OF ACTION, WHETHER IN CONTRACT OR IN TORT, INCLUDING FUNDAMENTAL BREACH OR NEGLIGENCE, FOR ANY INDIRECT, PUNITIVE, CONSEQUENTIAL, INCIDENTAL, SPECIAL, OR EXEMPLARY DAMAGES WHATSOEVER, INCLUDING WITHOUT LIMITATION FOR LOST PROFITS, LOSS OF REVENUE, FAILURE TO REALIZE ANTICIPATED SAVINGS, LOST OR DAMAGED DATA, LOSS OF GOODWILL, BUSINESS OPPORTUNITIES OR REPUTATION, OR ECONOMIC LOSS, ARISING OUT OF OR IN CONNECTION WITH THIS AGREEMENT, EVEN IF IT HAS BEEN ADVISED OF THE POSSIBILITY OF SUCH POTENTIAL LOSS OR DAMAGES, OR SUCH LOSSES OR DAMAGES ARE FORESEEABLE.

15. Change Order Process

With respect to any proposed changes to the Professional Services defined by this Agreement, the parties will cooperate in good faith to execute Change Orders in respect thereof, and will not unreasonably withhold approval of such proposed changes. If either party causes or requests a change in the allocation of the resources of Harris applied to a task, changes in completion schedules for individual tasks or for overall implementation, and changes in staffing that require Harris to provide additional work hours, Harris may propose a change to cover the additional work effort required of it. Approval of any such proposed changes will not be unreasonably withheld (it being acknowledged that any such material changes may require modifications to the consideration paid, and timelines governing the Professional Services), and any disputes regarding changes shall be handled initially by discussions between the parties which will be convened in good faith by the parties to resolve any such matters in dispute.

The following individuals are authorized to sign off on Change Orders on the Customer's behalf:

Name: _____ Title: _____



Name: _____ Title: _____

16. Cancellations and Termination

(a) Professional Services may be cancelled as follows:

Cancellation of any on-site Professional Services by Customer is allowed for any reason if done in writing more than fourteen (14) days in advance of such Professional Services. In the case of cancellation of Professional Services within fourteen (14) days or less of scheduled on-site Professional Services, Customer will be billed for any on-site fees, plus any non-recoverable costs incurred by Harris due to advance scheduling of travel. Additionally, Customer hereby acknowledges that cancellation of on-site services means that such on-site services will be rescheduled as Harris' then current schedule permits. Harris is not responsible for any delay in Customer's project resulting from Customer's cancellation of Professional Services. If additional services are required because the Customer was not adequately prepared for the on-site services, Harris will provide a Change Order to the Customer for the additional services.

(b) This Agreement may be terminated as follows:

- i. If either party is in material breach of any of its obligations or any provision under this Agreement, the other party must notify the breaching party in writing of such default (a "**Default Notice**"). Upon receipt of a Default Notice, the breaching party must correct the default at no additional cost to the other party within ninety (90) days, or issue a written notice of its own disputing the alleged default within thirty (30) days, of the date of receipt of a Default Notice. If the breaching party fails to correct the default within such ninety (90) day period, and did not issue a notice disputing the alleged default within such thirty (30) day period, the other party may terminate this Agreement upon written notice to the other party to that effect.
- ii. If Customer has failed to pay any amounts when due under this Agreement, Harris shall have the right to (i) suspend performance of the Services (including Customer access to the Services) until all amounts are paid in full; and/or (ii) terminate this Agreement effective immediately upon written notice to Customer to that effect.
- iii. Harris may terminate this Agreement effective immediately upon written notice to Customer if Customer has breached its obligations of confidentiality or any intellectual property right or proprietary right of Harris.
- iv. Either party may terminate this Agreement effective immediately upon written notice to the other party if the other party: (i) becomes insolvent; (ii) becomes the subject of any proceeding under any bankruptcy, insolvency or liquidation law, whether domestic or foreign, and whether voluntary or involuntary, which is not resolved favorably to the subject party within ninety (90) days of commencement thereof; or (iii) becomes subject to property seizure under court order, court injunction or other court order which has a material adverse effect on its ability to perform hereunder.

17. Effects of Termination

In the event of termination or expiration of this Agreement:

- a) All rights granted to Customer in this Agreement shall immediately terminate and Harris will immediately cease to perform or provide the Services.



- b) Customer will pay all amounts due under this Agreement up to and through the date of termination and all costs reasonably incurred in collecting the amounts due to Harris (including court costs, attorney fees, and repossession charges to the extent not prohibited by law).
- c) Customer shall return to Harris or at Harris' option purge or destroy all copies of any Confidential Information of Harris in its possession or under its control (except as required under any statute or legislation related to retention requirements), and provide a duly authorized certificate of an officer of Customer confirming same within thirty (30) days.
- d) Except as otherwise provided in this Agreement, termination of this Agreement shall not affect any right of action of either party arising from anything which was done or not done, as the case may be, prior to the termination taking effect.
- e) Any cancellation and/or termination of this Agreement prior to the end of the Initial Term shall result in the following: an acceleration of all Annual Subscription Fees due for each year of the Initial Term not already invoiced and/or paid, which amount will be due immediately. This section will not affect Harris's right to collect any further invoiced amounts for other Professional Service Fees.
- f) Conditional upon Customer's payment of all Fees that are due to Harris, Harris will furnish the Customer with a copy of the Data in a format to be mutually agreed upon between the parties in writing (typically a .csv file). The anticipated services to provide a copy of the Data are one to two days and will be billed at Harris' then current daily rate. Upon receipt of notice from Customer confirming receipt of the Data, Harris shall have the right to destroy all copies of the Data and delete all Data on the database in accordance with this Section 17(f) and upon request an Officer of Harris shall certify the destruction and deletion to the Customer. Subject to any legal requirement that Harris must retain a copy of the Data, Harris shall not delete the Data for 90 days from the date of termination except: (i) where Harris has provided the Data to Customer pursuant to this Subsection; or (ii) where it has received written instructions from Customer to delete the Data. Following 90 days from the date of termination if Customer has not communicated with Harris regarding the Data, Harris shall have the right to delete all Data at any time as either required by law or as determined by Harris in its sole discretion. Notwithstanding the foregoing, Harris shall be permitted to delete all Data without providing notification to Customer and Harris shall not be required to adhere to the time frames detailed above where Harris is required by law to delete such Data.

18. Ownership

- (a) **By Harris.** Harris its service providers and licensors are and shall at all times remain the owner of all copyright, trademarks, trade secrets, patents and any other intellectual property rights in and to the Software, the Services, and related documentation, materials, logos, names and other support materials provided pursuant to the terms of this Agreement. Customer shall acquire no right whatsoever to all or any part of the Services, Software, or underlying software except the limited right to access and use the Software and Services in accordance with the terms of this Agreement and Harris and its licensors reserve all rights not expressly granted to Customer. Customer must fully reproduce any copyright or other notice marked on any part of the documentation or other materials on all authorized copies and must not alter or remove any such copyright or other notice. Customer hereby grants to Harris a royalty-free, worldwide, irrevocable, perpetual license to use and incorporate into the Services and Software any suggestions, ideas, enhancement requests, recommendations or other feedback provided by Customer relating to the operation of the Services or Software.
- (b) **Customer Data.** As between Harris and Customer, all Data will remain the sole and exclusive property of Customer. Customer is solely responsible for ensuring the accuracy, quality, integrity, reliability, appropriateness and right to view and use the Data. Subject to the terms and conditions of the Agreement, Customer grants to



Harris a world-wide, non-exclusive, royalty-free license to access the Data for the purpose of performing the Services. Access to the Data shall only be by Harris’s employees and/or subcontractors whose job function requires access. Except as specified in this Agreement, Harris may not access the Data for any other purpose without the express written consent of Customer. Access to Data by any outside party shall only be in accordance with the terms of this Agreement or where required by law.

Customer grants to Harris a world-wide, non-exclusive, royalty-free license to aggregate or compile Data with the customer data of other customers using the Services so long as such aggregation or compilation omits any data that would enable the identification of Customer, its clients or any individual, company or organization (“Aggregated Data”). Harris shall have a worldwide, perpetual, royalty-free license to use, modify, distribute and create derivative works based on such Aggregated Data, including all reports, statistics or analyses created or derived therefrom. Additionally, Customer grants Harris the right to access Data to provide feedback to Customer concerning its use of the Services.

In the event that Harris will have access to “education records” for the Customer’s students as defined under the Family Educational Rights and Privacy Act (FERPA), Harris acknowledges that for the purposes of this Agreement it will be designated as a “school official” with “legitimate educational interests” in the Client’s Education records, as those terms have been defined under FERPA and its implementing regulations, and Harris agrees to abide by the FERPA limitations and requirements imposed on school officials. Harris will use the Education records only for the purpose of fulfilling its duties under this Agreement, and will not share such Data with or disclose it to any third party except as provided for in this Agreement, where required by law, or authorized in writing by Customer.

(c) Data and Privacy Policy of Customer

The Customer represents and warrants to Harris that:

- i. Data that is either provided to or acquired by Harris from Customer is owned exclusively by Customer and that the Customer has full right and title to provide the Data to Harris;
- ii. Data that is either provided to or acquired by Harris is subject to a privacy policy in effect as of the Effective Date and Customer’s customers have provided to Customer their written consent for its collection, use and storage by Harris and its third-party service providers in accordance with this Agreement and in any jurisdiction in North America;
- iii. Customer complies with all applicable privacy legislation as of the Effective Date in the performance of its obligations hereunder in respect of any Data collected, used, transferred, created or disclosed pursuant to this Agreement; and
- iv. Customer will not provide Harris with data of any kind for which Harris either has no need or does not have the right to collect, use and store under the terms of this Agreement.

19. Confidential Information

The parties agree to keep confidential any and all Confidential Information with respect to the other party which it has received or may in the future receive in connection with this Agreement and shall only disclose such Confidential Information of the other party (i) to its agents, employees or representatives who have a need to know such information, for the purpose of performance under this Agreement and exercising the rights granted under this Agreement, and who have entered into a non-disclosure agreement at least as protective of the other party’s Confidential Information as this Agreement, or (ii) to the extent required by applicable law or during the course of or



in connection with any litigation, arbitration or other proceeding based upon or in connection with the subject matter of this Agreement, provided that the receiving party shall give the disclosing party reasonable notice prior to such disclosure and shall comply with any applicable protective order or equivalent. The parties each agree to hold the other party's Confidential Information in confidence and to take all reasonable steps, which shall be no less than those steps it takes to protect its own confidential and proprietary information, to protect the Confidential Information of the other party.

In addition to any other restrictions on Harris' use of the Data, the confidentiality obligations above apply except to the extent that both parties agree that the Data may be subject to privacy laws providing for the owners of the Data to review such Data or to challenge the collection and storage of the Data. Customer shall indemnify and reimburse Harris in relation to all reasonable fees and other disbursements paid by Harris to comply with such requests, whether by an individual or a government body, or to challenge such requests at either Harris' or Customer's request. Customer represents and warrants to Harris that as of the Effective Date no individual, government body or third party has requested a review of the Data or challenged the collection and storage of the Data to be stored in the Software.

20. Indemnity

Customer is solely responsible for its Data, its use, and its Users' use, of the Services in any way, and all legal liability arising out of or relating thereto. Customer shall defend, indemnify and hold Harris and its third party service providers, if applicable, and each of their respective officers, directors, employees and agents (the "Indemnities") harmless from and against any and all losses, costs, damages and expenses (including reasonable attorney's fees) that the Indemnities may suffer in connection with any demands, claims, actions, suits or proceedings arising out of or in connection with (i) the use of the Services including but not limited to any Third Party Components by Customer or its Users; (ii) any breach by Customer or its Users of this Agreement; or (iii) Customer's Data, including but not limited to any third party claims that the inclusion, use, reference, incorporation of or linking to any third party materials or the Customer's Data violates such third party's copyright and/or other intellectual property, privacy or other rights, or that such use is illegal.

21. General

(a) Governing Law; Venue: This Agreement shall be governed by and construed in accordance with the laws of the state of Delaware and the federal laws of the United States applicable therein. This Agreement expressly excludes that body of law applicable to choice of law, the Uniform Commercial Code and the United Nations Convention on Contracts for the International Sale of Goods and any legislation implementing such Convention, if otherwise applicable. Customer and Harris hereby waive, to the fullest extent permitted by applicable law, the right to trial by jury in any action, proceeding or counterclaim filed by any party, whether in contract, tort or otherwise, relating directly or indirectly to this Agreement or any acts or omissions of Harris in connection therewith or contemplated thereby.

(b) Mediation: Except where this Agreement explicitly states that this Section does not apply, the parties agree to submit any claim, controversy or dispute arising out of or relating to this Agreement or the relationship created by this Agreement to non-binding mediation before bringing a claim, controversy or dispute in a court or before any other tribunal. The mediation is to be conducted by either an individual mediator or a mediator appointed by mediation services mutually agreeable to the parties. Such mediator shall be knowledgeable in software system agreements. The mediation shall take place at a time and location which is also mutually agreeable; provided; however, in no event shall the mediation occur later than ninety (90) days after either party notified



the other of its desire to have a dispute be placed before a mediator. The costs and expenses of mediation, including compensation and expenses of the mediator (and except for the attorneys' fees incurred by either party), is to be shared by the parties equally. If the parties are unable to resolve the claim, controversy or dispute within ninety (90) days after the date either party provides the other notice of mediation, then either party may bring and initiate a legal proceeding to resolve the claim, controversy or dispute unless the time period is extended by a written agreement of the parties. Nothing in this Section shall inhibit a party's right to seek injunctive relief at any time.

(c) Notice

Any notice required or permitted to be given to any party to this Agreement shall be given in writing and shall be delivered either personally, mailed by prepaid registered post or sent by facsimile to the appropriate address or facsimile number set out below. Any such notice shall be conclusively deemed to have been given and received on the day on which it is delivered or transmitted (or on the next succeeding business day if delivered or received by facsimile after 5:00 p.m. local time on the date of delivery or receipt, or if delivered or received by facsimile on a day other than a business day), if personally delivered or sent by facsimile or, if mailed, on the third business day following the date of mailing, and addressed, in the case of the Consultant, to:

N. HARRIS COMPUTER CORPORATION
1 Antares Drive, Suite 400
Ottawa, Ontario K2E 8C4
Attention: CEO
Telephone: 613-226-5511, extension 2149

and in the case of the Customer, to:
Garden City Unified School District 457
1205 FLEMING ST.
GARDEN CITY,KS 67846-4751

Each party may change its particulars respecting notice, by issuing notice to the other party in the manner described in this Section 21(c).

- (d) Currency:** Unless otherwise indicated, all dollar amounts referred in this Agreement are in lawful money of the United States of America.
- (e) Use of Name.** Customer agrees to the following promotional activities in relation to the purchase of Harris' solutions, products and services: (i) Customer permits Harris to issue a mutually agreed upon press release announcing Customer's purchase of Harris' products and services; and (ii) Customer grants Harris the right to reasonably include the Customer's name and logo in published lists referencing the users of the products and services of Harris. Customer may unilaterally withdraw their consent to the above promotional activities at any time by providing written notice to Harris of said revocation.
- (f) Entire Agreement:** This Agreement together with the Schedules attached to this Agreement constitute the entire agreement between the parties with respect to the subject matter hereof and supersedes all prior and contemporaneous agreements, representations, negotiations, understandings, arrangements, and communications between the parties, both written and oral, relating to the subject matter hereof. No terms and conditions in any Customer orders, or in any other documentation employed by or on behalf of Customer in connection with this Agreement, regardless of the date of such documentation, will affect the terms of this Agreement, even if such document is accepted by the receiving party, with such provisions being deemed deleted. This Agreement may only be modified by a written amendment signed by an authorized



representative of each of the parties.

- (g) Waiver.** No waiver of any breach of any provision of this Agreement shall constitute a waiver of any prior, concurrent, or subsequent breach of the same or any other provisions hereof, and no waiver shall be effective unless made in writing and signed by an authorized representative of the waiving party.
- (h) Assignment:** Customer may not assign any of its rights or duties under this Agreement without the prior written consent of Harris, such consent not to be unreasonably withheld. This Agreement shall inure to the benefit of and be binding upon the parties to this Agreement and their respective successors and permitted assigns.
- (i) Severability:** If any provision of this Agreement is determined by a court of competent jurisdiction to be invalid or unenforceable under any applicable law, then such provision shall be deemed modified to the extent necessary in order to render such provision valid and enforceable. If such provision may not be so saved, it shall be severed and the remainder of this Agreement shall remain in full force and effect.
- (j) Allocation of Risk:** Customer acknowledges and agrees that the warranty disclaimer and limitation of liability contained in this Agreement are fundamental elements of the basis of the bargain between Harris and Customer and set forth an allocation of risk reflected in the fees and payments due hereunder.
- (k) Relationship:** The parties are and shall at all times remain independent contractors in the performance of this Agreement and nothing herein shall be deemed to create a joint venture, partnership or agency relationship between the parties. Neither party will have the power to bind the other party or to contract in the name of or create any liability against the other party in any way for any purpose. Neither party will be responsible for the acts or defaults of the other party or of those for whom the other party is law responsible.
- (l) Equitable Relief:** Customer acknowledges and agrees that it would be difficult to compute the monetary loss to Harris arising from a breach or threatened breach of this Agreement by Customer and that, accordingly, Harris will be entitled to specific performance, injunctive or other equitable relief in addition to or instead of monetary damages in the event of a breach or threatened breach of this Agreement by Customer.
- (m) Force Majeure:** No default, delay or failure to perform on the part of Harris shall be considered a breach of this Agreement where such default, delay or failure is due to a force majeure or to circumstances beyond its control. Such circumstances will include, without limitation, strikes, riots, civil disturbances, actions or inactions concerning government authorities, epidemics, war, terrorist acts, embargoes, severe weather, fire, earthquakes, acts of God or the public enemy or default of a common carrier, unavailability of Third Party Components or other disasters or events.
- (n) Survival:** Sections 1 (Definitions), 3 (Fees), 4 (Travel and Lodging Expenses), 6 (Restrictions on Use), 8(f) (Compliance with Laws), 8(g) (Security), 13 (Warranty and Warranty Disclaimer), 14 (Limitations of Liability), 17 (Effects of Termination), 18 (Ownership), 19 (Confidential Information), 20 (Indemnity), 21 (General) and any other provision of this Agreement which is required to ensure that the parties fully exercise their rights and their obligations hereunder shall survive any termination or expiration of this Agreement unless and until waived expressly in writing by the party to whom they are the benefit.
- (o) Counterparts:** This Agreement may be executed in counterparts (whether by facsimile signature, PDF via email, or otherwise), each of which when so executed shall constitute an original and all of which together shall constitute one and the same instrument.



IN WITNESS WHEREOF, Harris and the Customer have duly executed this Agreement to be effective on the Effective Date first written above.

N. HARRIS COMPUTER CORPORATION

Garden City Unified School District 457

NAME

NAME

TITLE

TITLE

SIGNATURE

SIGNATURE

DATE

DATE



Schedule "A"
Fees and Payment Schedule *

Software, Products, Services, Hardware and applicable pricing that are referenced/listed in Quote ID (HRS-25368) are included as part of this Agreement, and are subject to the following terms:

Annual Maintenance, License and Professional Services will be invoiced, in full, upon signing and due within thirty (30) days from the invoice date. Hardware will be invoiced, in full, once all purchased items are shipped. All invoices are due within thirty (30) days from invoice date. Any applicable travel and lodging expenses will be invoiced as incurred and shall be due and payable thirty (30) days from the date of invoice

ADDITIONAL PROFESSIONAL SERVICE(S) FEES:

Additional Professional Services may be provided on-site or via the telephone. Professional Service work provided via telephone is billed at the rate of one hundred-eighty five dollars (\$185) per hour. On-site work is billed at the rate of one thousand four-hundred eighty five (\$1,485) per day plus travel, lodging and per diem expenses. Professional Services performed one year or more after the execution date of this Agreement shall be billed at the then current Harris Professional Services rate. Help line support and Support Services do not include training or other Professional Services.

Customer shall incur a seven-hundred fifty dollar (\$750) daily surcharge for any Professional Services provided on weekends or Harris recognized holidays; plus the corresponding standard Professional Services fees and any applicable travel charges per paragraph 4.

Professional Services include, but are not limited to, the following: software installation, configuration, data validation, system setup, system balancing, interface setup, interface testing, process training, application training and business requirements gathering.

RESET OF TERM TO MATCH FISCAL YEAR:

Customer may request that Harris match the annual invoicing of the Annual Subscription Fees with Customer's fiscal year. In order for Customer to elect to match annual invoicing with their fiscal year, Customer must make said request to Harris in writing and during the Initial Term of this Agreement. If such election is made Harris shall, a) issue a prorated invoice for any Subscription Fees due for the portion of the year remaining in Customer's current fiscal year, b) extend the then current term to expire at the end of the Customer's subsequent fiscal year, c) issue an annual invoice thereafter on the annual anniversary date of Customer's fiscal year for any Subscription Fees due, and d) reset future annual terms to expire at the end of Customer's fiscal year. Annual Subscription Fees are invoiced in advance of an upcoming annual term. Subscription fees shall be due and payable thirty (30) days from date of invoice.



Schedule "B" **Service Availability**

Availability and Uptime Objectives:

1. Availability of the Services is defined as when the Software Services are operational and accessible via a public internet connection. The Services shall be unavailable during certain scheduled downtime periods for the purpose of conducting maintenance and upgrades to the Services.
2. Uptime is defined as the time that the Services are either available or in scheduled downtime. Specific Service Level Objectives relating to Uptime are as follows:
 - a. Routine scheduled downtime shall not exceed eight (8) hours per month, averaged over twelve (12) months. Scheduled downtimes shall occur, to the extent practicable, during the weekend hours from 10:00 p.m. Friday to 3:00 a.m. Monday Eastern Time.
 - b. Harris shall notify Customer a minimum of five (5) calendar days prior to any period of scheduled downtime.
 - c. Harris reserves the right to schedule downtime for emergency situations with less than five (5) advance calendar days' notice.

Harris shall make commercially reasonable efforts to achieve the service level objectives described herein.

3. Harris will not be responsible for any failure to meet the above Service Level Objectives if the failure is caused by:
 - a. Customer's network infrastructure (equipment, software or other technology), Customer's connection to the Internet or an Internet failure beyond the control of Harris;
 - b. A breach of the Agreement by Customer, its employees, subcontractors or agents ("Customer Representatives");
 - c. The negligence or intentional acts or omissions of Customer Representatives or Users;
 - d. Scheduled maintenance or other mutually agreed upon downtime; or



e. Any other force majeure event, as set out in Section 21(l) of the Agreement.

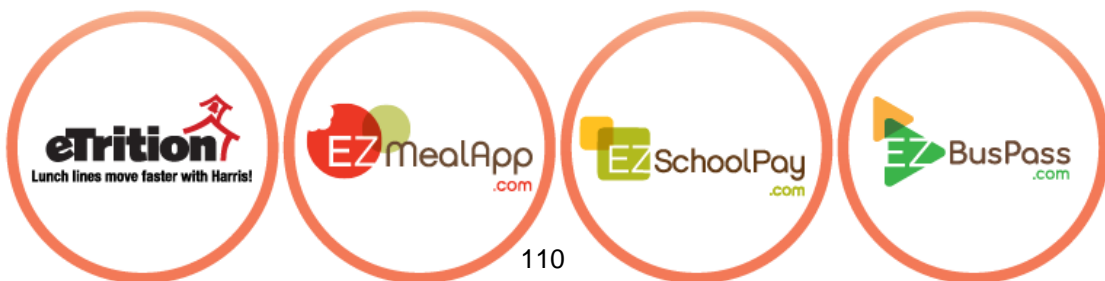

Schedule "C"
Professional Services

In order to achieve the Completion of Services, Harris agrees, subject to the terms and conditions of this Agreement, to perform the following Professional Services for Customer:

1. If applicable, oversee and implement the conversion of Customer's existing software application data and migration to the purchased Harris Services substantially in accordance with the below Implementation Process Timetable.
2. Install the purchased Software Services in Harris' hosted environment, perform the necessary set up and configuration operations, perform initial testing and parallel testing in accordance with below Implementation Process Timetable.
3. Provide the training substantially in accordance with the below Implementation Process Timetable.

IMPLEMENTATION PROCESS AND TIMETABLE

COMPLETION OF SERVICES – GLOBAL TIMETABLE

1. Project Commencement Date: TBD at Implementation Planning Meeting
2. Estimated Project Completion Date: TBD at Implementation Planning Meeting
3. Project Schedule: TBD at Implementation Planning Meeting

The parties shall each assign a project manager responsible for driving tasks and deliverables for their respective teams.

COMPLETION OF SERVICES – KEY PHASE TIMETABLES

1. Conversion Process

Projected Commencement Date:	TBD at Implementation Planning Meeting
Projected Completion Date:	TBD at Implementation Planning Meeting
Estimated Hours Required:	TBD at Implementation Planning Meeting

2. Installation/Setup

Projected Commencement Date:	TBD at Implementation Planning Meeting
Projected Completion Date:	TBD at Implementation Planning Meeting
Estimated Hours Required:	TBD at Implementation Planning Meeting

3. Training

The parties will mutually agree upon an appropriate training schedule based upon the purchased modules and the corresponding required skills and availability of Customer staff members.



- (a) Harris recommends a class size of eight (8) students. Customer may be assessed an additional charge at the then current Harris rates for class sizes larger than eight (8) students where it has been determined by Harris that an additional instructor is required.
- (b) Customer is required to make copies of the training manuals for the training classes. Photocopy, electronic duplication and distribution is subject to the confidentiality restrictions and obligations contained in this Agreement.
- (c) On-line reference documentation is available and may be printed by Customer solely for its internal use in accordance with Section 2 of this Agreement.



Schedule “D” Support Services

Standard Guidelines

The purpose of this Schedule “D” is to define:

- Harris’ standard Support Services coverage (i.e. the Support Services that are included with the annual recurring subscription and hosting fees listed in Schedule “A”),
- Harris’ call priorities process and escalation procedures, and
- Other relevant Support information.

Harris reserves the right to make modifications to this Schedule as required; provided, however, Harris shall not reduce the scope of Support Services provided hereunder without the prior consent of the Customer.

STANDARD SUPPORT AND MAINTENANCE SERVICES

The following services are included as part of Harris’ software support contract:

- Toll-free telephone support
- Seamless and cost-effective upgrade solutions to leverage technological advances
- Technical troubleshooting, including assessment, diagnosis, documentation, and ultimate resolution of issues that pertain specifically to the customer’s software (troubleshooting does **not** extend to any hardware or operating system components, unless the customer has a hardware support contract)
- Email support call logging and notification
- Online access 24 hours a day, 7 days a week (“24 x 7”). Harris’ online portal (the “Hub”) can be used to log support issues and check for status updates on issues. Access to published documentation pertaining to a customer’s particular software line (if available) may be contained in the Knowledge Base article section within the Hub. The Hub also enables the customer to assign a specific priority based on the specific level of urgency for a particular circumstance. In summary, the Hub benefits include the ability to:
 - Log, view, update and close support tickets
 - Update contact information
 - Access published documentation
 - Access available downloads
 - Access Knowledge Base
- Standard software releases and updates, which include defect corrections (as warranted), planned enhancements, state- or federally-mandated changes, and release notes
- Limited training questions (15 minutes) – questions pertaining to a customer’s software line that Harris deems as training-related, i.e., information that has already been covered and/or reviewed with the customer will be considered training-related in scope and is limited to a 15-20 minute timeframe. Anything going beyond the aforementioned timeframe may be classified as a billable service for which the customer will receive a quotation prior to the service being administered
- Customer Care Program, which includes technical support notifications and communications on new products and services
- Outstanding Calls Report, which details outstanding calls and the respective status of those calls
- Design review for potential enhancements or custom modifications – based on the customer’s needs and requests, Harris will determine, document and program changes, as needed. Modifications that result from an inherent flaw in the customer’s software package will be rectified at no additional charge to the



customer. Modifications which are performed as a result of a customer request and are not determined to be a result of an inherent flaw will be considered a billable service for which the customer will receive a quotation prior to the service being delivered

BILLABLE SUPPORT SERVICES

The services listed below are outside the scope of the customer's standard software support contract and are therefore considered billable services, as deemed by Harris:

- Extended telephone training
- Forms/reports (re-design or creation)
- Setup and changes to handheld interface, or creation of new interface
- Setup of new services, or changes to existing services
- File imports/exports
- Interfaces to other applications
- Setting up test areas, database refreshes, backups, restores
- Setup of new printers, printer setup changes (if available)
- Custom modifications (reports, forms, software customizations)
- Reversal of custom code
- Data conversions/global modifications to setup table data
- Integrity issues due to database updates by non-Harris personnel
- Hardware and Operating System support
- Installations and/or re-installations (workstations, servers)
- "On-Call," after-hours support (scheduled assistance for installations, upgrades and other special projects, may include charges depending on scope of work)

STANDARD COVERAGE

Harris' standard hours of telephone and email support across all product lines are from 7:00 AM to 8:00 PM EST, Monday through Friday, excluding designated statutory holidays, as detailed in the next section ("HOLIDAY SCHEDULE"). Harris' online Hub is, however, available and accessible 24 hours a day, 7 days a week.

HOLIDAY SCHEDULE

Please note that our offices will be **closed** on designated days, as outlined below. In instances where the Statutory Holiday falls on a weekend, Harris offices will be closed on either the preceding Friday or following Monday:

- New Year's Day
- President's Day
- Memorial Day
- Independence Day
- Labor Day
- Columbus Day
- Thanksgiving Day
- Day After Thanksgiving
- Christmas Eve
- Christmas Day

CALL PROCESSES

All support issues or questions reported to Harris are tracked via a support ticket. Harris' Support Analysts cannot provide assistance unless a support ticket is logged. The current process for logging tickets is outlined below.

A support ticket must be placed through one of the following methods:



- 🌀 **Online (Hub):** <https://schoolnutritionsolutions.na2.teamsupport.com>
- 🌀 **Email:** support@harriscomputer.com
- 🌀 **Phone:** 1-877-387-4846, option 1
- 🌀 **Fax:** 613-226-3377

Customer ticket information must contain the following:

- 🌀 School District Name
- 🌀 Contact Person
- 🌀 Software Product and/or Version
- 🌀 Module and/or Menu Selection
- 🌀 Nature of the question or issue
- 🌀 Detailed Description of the question or issue
- 🌀 Serial Number / Patron Number / Account Number / Serving Date, etc. (where applicable)

Harris' online Hub, or the Support Call Coordinator, for those customers who email and/or telephone for support, will provide the customer with the Ticket Number to track the issue and the customer ticket will be logged in to our support tracking database (TeamSupport).

The customer's call will be stored in a queue, and the first available Harris Support Analyst will be assigned to review the issue.

As the Harris Support Analyst assigned to the ticket investigates the issue, the customer will be contacted and advised as to where the issue stands, and the course of action that will be taken for resolution. If the Harris Support Analyst requires additional information, the customer will be contacted by the assigned Harris Support Analyst to supply the information required.

All correspondence and actions associated with the customer ticket will be tracked in Harris' support database. At any time, the customer may log onto the Hub to see the status of the ticket.

Once the customer issue has been resolved, the customer will receive an automated notification via email that the ticket has been closed. This email will contain the entire event history of the call from the time the call was created leading up to the resolution of the ticket. The customer also has the option of viewing both open and closed tickets online through the Hub.

RESPONSE TIMES

Response times will vary, and are dependent upon the priority of the ticket. Harris will do its best to ensure that Harris Support Analysts deal with incoming tickets in the order that they are received, however, calls will be escalated based on the urgency of the issue reported. Harris' targeted response times are as follows:

- 🌀 Priority 1 (Urgent): First available Harris Support Analyst
- 🌀 Priority 2 (Normal): 1 to 8 business hours
- 🌀 Priority 3 (Low): 1 to 24 business hours

CALL PRIORITIES

In an effort to assign resources to incoming tickets as effectively as possible, Harris has identified three types of call priorities (1 / 2 / 3). A Priority 1 ticket is deemed by Harris Support Analysts to be an Urgent, or "High Priority," ticket; Priority 2 is classified as Medium, or "Normal" priority; Priority 3 is deemed to be Low priority. The criteria used to establish guidelines for these tickets are as follows:

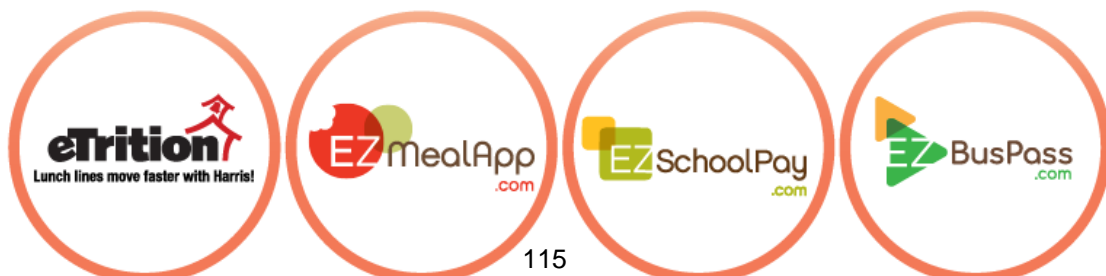

Priority 1 (High):

- System down (all users unable to access/use software)
- POS Serving Line(s) down
- Incorrect calculation errors impacting a majority of records
- Trainer on-site
- Auditor on-site
- Program errors without workarounds
- Performance issues of severe nature, impacting critical processes

Priority 2 (Medium):

- Workstation down (individual user unable to use software)
- Calculation errors impacting a minority of records
- Report calculation issues
- Tech/Contact person on-site
- System errors / issues that have workarounds
- Printer-related issues (related to interfaces with Harris' software and not the printer itself)
- Performance issues not impacting critical processes
- Security issues
- Usability issues
- Workstation connectivity issues (workstation-specific)

Priority 3 (Low):

- Training questions, how-to, or implementing new processes
- Report formatting issues
- Aesthetic issues
- Issues with workarounds for large majority of accounts
- Recommendations for enhancements on system changes
- Questions on documentation

ESCALATION PROCEDURES

Harris' escalation process is defined below. This process has been put in to place to ensure that issues are dealt with appropriately. If, at any time, the customer is not satisfied with the resolution of the issue, or the response to the ticket, they are encouraged to escalate with Harris' Support Services organization as follows:

- Level 1:** Contact the Support Analyst assigned to working on the issue
- Level 2:** Contact the Support Supervisor / Team Lead
- Level 3:** Contact the Director / Manager of Support
- Level 4:** Contact the Vice-President of Support
- Level 5:** Contact the Executive Vice-President of Harris School Nutrition Solutions

Escalation Process within our Internal Ticket Tracking System:

- Customer ticket is logged with Harris Support
- If a customer ticket is a Priority 1 and has not been responded to within 4 hours, the Harris Support Analysts responsible for the ticket are notified via email, and the ticket is escalated internally. Priority 2 tickets will be escalated if not responded to within 8 hours, and Priority 3 tickets will be escalated if not responded to within 12 hours
- If a customer's Priority 1 ticket has not been responded to 4 hours after the designated timeframe, Harris' Support Supervisor(s) are notified and the call is escalated
- If a customer's Priority 1 ticket has not been responded to after 6 hours from the designated timeframe, Harris' Vice-President of Support is notified and the call is escalated



- 🌀 If a customer's Priority 1 ticket has not been responded to after 7 hours from the designated timeframe, Harris' Executive Management Team is notified and the call is escalated

CONNECTION METHODS

To ensure Harris can effectively support the customer, Harris asks that a communication link is established and maintained between Harris and the customer site. It is the customer's responsibility to ensure the connection is valid at its location so that Harris can connect to the customer site and resolve the issue at hand. Harris' supported methods of connection are:

- 🌀 Harris School Nutrition Solutions' Remote Support Portal, powered by ConnectWise Control (**preferred**)
- 🌀 VPN
- 🌀 Remote Desktop Connection
- 🌀 WebEx

HARDWARE AND "THIRD-PARTY" SUPPORT (if applicable)

Harris is not responsible for providing support on third-party components, plug-ins or hardware systems.

CONFIDENTIALITY

During the course of this Agreement, either party may have or may be provided access to the other's proprietary items or confidential information ("Confidential Information"). Except as may be otherwise required by law, each party agrees to maintain the confidentiality of the other's Confidential Information in accordance with this provision and any separate non-disclosure agreement that expressly references the disclosure(s) between the customer and Harris. At a minimum, each party agrees that, except as otherwise required by law, it shall not make the other's Confidential Information available to any third-party without the expressed written consent of the other, and that title and ownership of the Confidential Information provided by one party to the other shall remain the exclusive property of the party who has the right to possess the Confidential Information.

MAINTENANCE CONTRACT PRICING

In order to keep pace with the increasing cost of doing business within our industry (including, but not limited to: increased overhead and production development costs, inflation, staff salaries, etc.), Harris, as a standard practice, reviews the software maintenance contracts of each client every year. In light of the aforementioned, Harris reserves the right to raise annual maintenance charges in accordance with industry standards and/or increased costs that are incurred. Such costs may vary within any given year. Customer acknowledges these outlined variances and reserves the right to discuss any disagreements with members of the Harris School Nutrition Solutions management team.

PAYMENT TERMS

Maintenance amounts will be billed and due no later than thirty (30) days after the renewal date of the current term. Lapses in annual maintenance will be monitored and will lead to denial of support, upgrade privileges and termination of licenses, provided, however, that Harris provides the customer with written notice of any such lapse and customer shall have the right to cure any such lapse within thirty (30) days of such notice.

REFUNDS

Harris, as a standard practice, does not issue refunds for full or unused portions of any paid maintenance fees. Circumstances, such as an error in billing, or billing disputes, are handled on a case-by-case basis, at the discretion of the Harris School Nutrition Solutions management team.

PRORATIONS

Certain circumstances may require a prorated invoice to be issued for annual maintenance fees. As a standard practice, Harris will issue a prorated invoice with a minimum six- (6) month term. In instances where a prorated invoice is issued, a fifteen (15%) processing/handling fee will be applied to the overall invoice total.

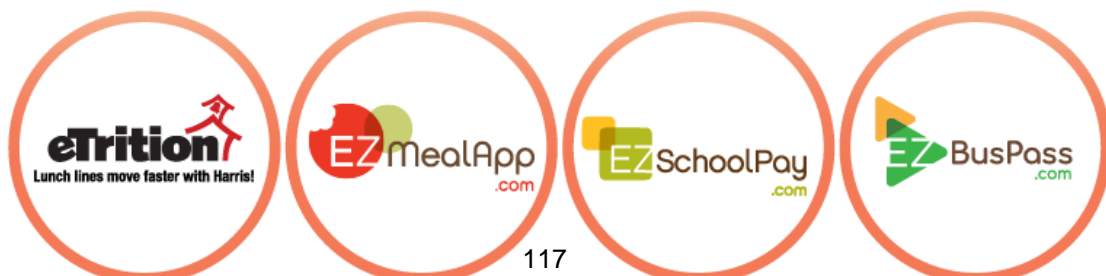

Schedule "E" Security

1. Harris shall store and process Data in accordance with commercially reasonable practices, including appropriate safeguards, to secure such Data from unauthorized access, disclosure, alteration and use.
2. Harris shall ensure that its employees and subcontractors who have potential access to Data have undergone appropriate background screening and possess the required qualifications to comply with the terms of this Agreement.
3. Response to Legal Orders, Demands or Requests for Data.
 - a. Where permitted by law Harris shall:
 - i. Promptly notify the Customer of any subpoenas, warrants, or other legal orders, demands or requests received by Harris seeking Data;
 - ii. Consult with the Customer regarding its response;
 - iii. Cooperate with the Customer's reasonable requests, at Customer's expense, in connection with efforts by the Customer to intervene and quash or modify the legal order, demand or request; and
 - iv. Upon the Customer's request, provide the Customer with a copy of its response.
 - b. If the Customer receives a subpoena, warrant, or other legal order, demand ("requests") or request seeking Data maintained by Harris, Customer will promptly provide a copy of the request to Harris. Harris will, where permitted by law, promptly supply Customer with copies of records or information required for the Customer to respond, and will cooperate with Customer's reasonable requests, and at Customer's expense, in connection with its response.



MEMORANDUM

TO: Board of Education
THRU: Dr. Mike Dominguez, Superintendent
FROM: Tracy Johnson, Director of Nutrition Services
DATE: January 8, 2024
RE: Gertrude Walker Walk in

ISSUE:

The Board of Education is asked to consider and approve the purchase of a new walk-in freezer unit along with a condenser/evaporator for Gertrude Walker.

BACKGROUND:

The walk-in freezer which was installed July, 1993 at Gertrude Walker floor has settled and is no longer air tight and not in repairable condition.

This purchase is being completed via a formal bid process. The bid specifications were sent to three vendors.

Weber's Refrigeration was the only company to submit a complete bid packet on an indoor unit.

Please refer to attached bid packet for further details.

ALTERNATIVES:

1. Approve the purchase of the walk-in freezer
2. Deny the purchase of the walk-in freezer

RECOMMENDATION:

The Nutrition Department recommends that the Board of Education consider and approve the purchase of a new walk-in freezer and condenser/evaporator from Weber's Refrigeration for \$25,700.00.

FISCAL NOTE:

The quote is in the amount of \$25,700.00. This will be paid out of Nutrition's Equipment Account, 024 E 3141 21 0000 054 01 730.

ATTACHMENTS:

Quotes as presented.

USD 457, Garden City Public Schools

Large Equipment Bid

Due: 12/19/2023 by 10:00 am

The District reserves the right to accept or reject all or any part of any quote, to waive technicalities, and to accept the offer that the District considers to be the most advantageous.

Requirement	Condenser
Manufacturer:	Russell
Model	Condenser: RF0250L4SDANT Evaporator: RL6E090DDARE
Price (unit Cost)	(1) Condenser and (1) Indoor Evaporator for \$8700.00
Price (total)	\$8700.00 for both Furnish Only
Estimated Delivery Date	1 Week

1 Year Compressor/Parts Warranty add 2nd through 5th years to Compressor for \$1200.00

Requirement	Walk in Freezer Box
Manufacturer:	AmeriKooler
Model	6' 7 5/8" x 8' 9" x 7' 7" Interior Freezer with Floor, Door, LED Light
Price (unit Cost)	\$17,000.00
Price (total)	\$17,000.00 Furnish Only
Estimated Delivery Date	3-4 Weeks

15 Year Panel Warranty and 1 Year Parts Warranty

Requirement	
Manufacturer:	
Model	
Price (unit Cost)	
Price (total)	
Estimated Delivery Date	

WE HEREBY AGREE TO FURNISH THE ITEMS ON WHICH PRICES ARE QUOTED ABOVE IN ACCORDANCE WITH ALL TERMS AND CONDITIONS PREVIOUSLY LISTED AND ANY ATTACHED SPECIFICATOINS.

BY:  **Brian Weber**
 TITLE: Business Manager
 PHONE: 620-275-2187

DATE: 12/12/2023
 FIRM: Weber Refrigeration
 EMAIL: BrianWeberGC@gmail.com

Walk-in: Indoor freezer**Actual Overall Dimension: 6'-7 5/8" x 8'-9" x 7'-7" (Rectangular)**

Description:	Indoor Freezer, with Floor
Interior Dim:	5'-11 5/8" x 8'-1" x 6'-11" (w x l x h)
Temperature:	-10°F (100°F ambient)
Insulation:	4" thick AK-XPS4 extruded foam with R-values of R-29 for coolers and R-32 for freezers with a 50 Year Thermal Warranty. UL Classified Core Flame Spread 15, Smoke Rating less than 165.
Warranty:	15 Year Panel Warranty and 1 Year Parts Warranty
Finishes:	Interior walls: 26 Ga. Stucco Embossed Acrylume Exterior walls: 26 Ga. Stucco Embossed Acrylume Interior ceiling: 26 Ga. Stucco Embossed Acrylume Exterior ceiling: 26 Ga. Stucco Embossed Acrylume
Floor	Type: Type F2-DT Application: Pan Rolling Racks , Dunnage Racks NSF Floor panel rated for 900 LBS/ SQ. FT. Diamond tread plate .090" Integral - Not Reinforced
Door:	(1) Standard 36" x 76" Right hinged flush door with brushed hardware. Interior & Exterior finish: 26 Ga. Stucco Embossed Acrylume. 36" kickplates to interior and exterior of door. Energy saving temperature regulating thermostat heater wire and heated relief vent. Heavy duty deadbolt handle latch. Digital LED Thermometer with pilot light switch. 1807 11w, Vapor Proof, 120V. LED fixture. 82 Lumens /watt Angled face . Requires 115vac. 2.2 amps. With third hinge, Internal Ramp 24" deep x 36" wide
Freight:	Freight included to GARDEN CITY KS 67846



USD 457 FREEZER



SYS-1 - Box Load Calculation

General Requirements

Room Temperature: **-10 °F** Ambient Temperature: **100 °F** Design Run-time: **18 Hrs** Required Capacity: **8,092 BTUH**

Area Load

Section	Material	Thickness	X - Factor	Surface Temp	Dim. 1	Dim. 2	Load
Wall 1	Polyurethane	4 in	0.1	85 °F	9 ft	7.5 ft	5,386.5 BTU
Wall 2	Polyurethane	4 in	0.1	85 °F	7 ft	7.5 ft	4,189.5 BTU
Wall 3	Polyurethane	4 in	0.1	85 °F	9 ft	7.5 ft	5,386.5 BTU
Wall 4	Polyurethane	4 in	0.1	85 °F	7 ft	7.5 ft	4,189.5 BTU
Ceiling	Polyurethane	4 in	0.1	110 °F	9 ft	7 ft	6,350.4 BTU
Floor	Polyurethane	4 in	0.1	65 °F	9 ft	7 ft	3,969 BTU

Total Area Load: **29,471.4 BTU**

Product Load - Auto Usage Selected

Total Product Load: **10,206 BTU**

Air Change Load

Dry Bulb: 96.4 °F	Wet Bulb: 69.3 °F	
Door Type 1: Man	Number of Door Type 1: 1	Door Usage: Average
Door Type 1: Curtains: None	Door Type 1 Curtain Efficiency: 0%	Total Door Type 1 Load: 16,800 BTU
Total Air Change Load:		53,966.8 BTU

Miscellaneous Load

People Load: 33,600 BTU	Lighting Load: 5,163.5 BTU	Motor Load: 0 BTU
Other Load: 0 BTU	Total Misc. Load: 38,763.5 BTU	

Load Calculation Summary

Total Design Load: 132,407.7 BTU	Safety Factor: 10%	Total Required Load: 145,648.5 BTU
---	---------------------------	---

SYS-1 - System Design Summary

General Requirements

Room Temperature: -10 °F	Ambient Temperature: 100 °F	Design Run-time: 18 Hrs	Required Capacity: 8092 BTUH
Design TD: 10 °F	Refrigerant: R-404A	Altitude: 1000 FT	

Selected Equipment

Line Item	Quantity	Type	Tag	Description
1.0	1	System	SYS-1	R-404A - Refrigeration Equipment Match 1
1.1	1	Condensing Unit	CDU-1	RFO250L4SDA
1.2	1	Unit Cooler	UC-1	RL6E090DDA

System Balance

Balanced Capacity: 8,630.4 BTUH	Evap. T.D.: 9.9 °F	Line Loss: 2 °F	Suction Temp: -21.9 °F	Calc. Run-Time: 16.9 Hrs
--	---------------------------	------------------------	-------------------------------	---------------------------------

SYS-1 - CDU-1 - Product Information**General Data**

Model Line: NEXT-GEN MINI-CON	Model Number: RFO250L4SDA	Flooded: Yes
Refrigerant: R-404A	Voltage: 208-230/1/60	Compressor Type: SCROLL

Performance Data

Ambient Temp: 100 °F	Suction Temp: -22 °F	Capacity: 8,264 BTUH
-----------------------------	-----------------------------	-----------------------------

Electrical Data

Compressor RLA: 14.7	Compressor LRA: 73	Total Condenser Fan FLA: 1
MCA: 20.4	MOPD: 35	

Physical Data

Number of Compressors: 1	Compressor Model: ZF08K4E	Compressor HP: 2.5
Number of Condenser Fans: 2	Approx. Ship Weight: 240 lbs	Sound Data: 73 dBA
Liquid Line: 3/8 in.	Suction Line: 7/8 in.	
Pump Down Capacity (%): 90	Pump Down Capacity: 13.6 lbs	

Option Data

Mounted Option	NO STANDARD DEFROST KIT
Mounted Option	LIQUID LINE WITH COMPONENTS: SEALED FILTER & SIGHT GLASS
Mounted Option	STANDARD RECEIVER
Mounted Option	FIXED HIGH/ADJUSTABLE LOW PRESSURE CONTROL

Compliance Data

AWEF: **3.15**

Notes

Dimensional Drawing

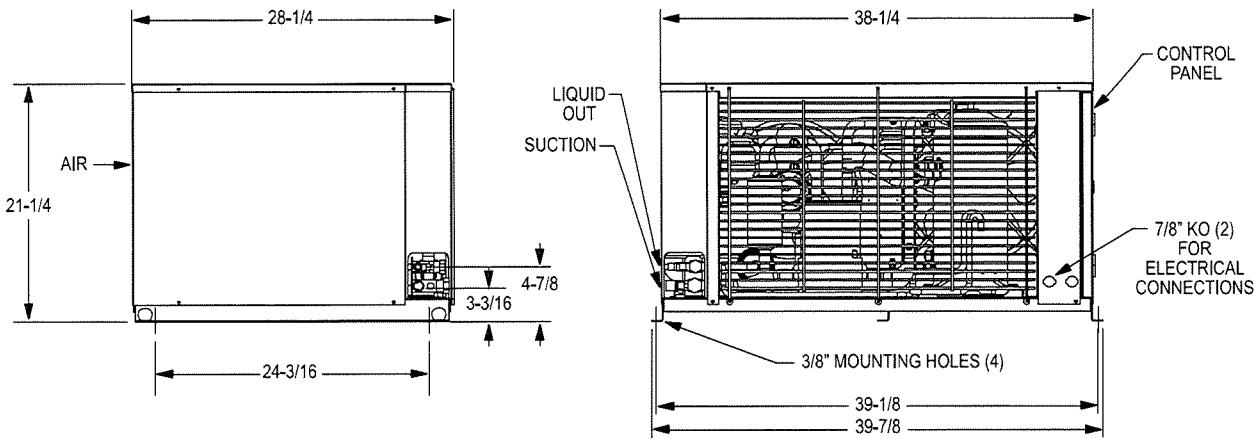

Standard Features

- All-weather Galvanized steel painted housing
- Generously sized high efficiency condenser, enhanced copper tubes/aluminum fins
- Integral Liquid Subcooling Circuit provides subcooled liquid to the expansion device
- Crankcase heater
- Large electrical panel with hinged/removable door
- Color coded point-to-point wiring
- Quick access to shut off valves from exterior
- UL/cUL certified for use with multiple refrigerants
- UL/cUL listed for outdoor use
- Flooded models include flooded head pressure control
- Non flooded models include mild ambient fan cycle control

Certifications



SYS-1 - UC-1 - Product Information

General Data

Model Line: NEXT-GEN ALL-TEMP	Model Number: RL6E090DDA	Motors: DUAL SPEED EC MOTOR
Unit Voltage: 208-230/1/60	Defrost Type: ELECTRIC DEFROST	Refrigerant: R-404A
Fins Per Inch: 6	Number of Fans: 2	

Performance Data

Suction Temp: -20 °F	T.D: 9.9 °F	Capacity: 8,890 BTUH	CFM: 1550
-----------------------------	--------------------	-----------------------------	------------------

Electrical Data

Motor Voltage: 208-230/1/60	Total Unit Fan Motor Amps: 1	
Heater Voltage: 208-230/1/60	Heater Amps: 9.8	Heater Watts: 2250
MCA: 15	MOPD: 20	

Physical Data

Liquid Line: 3/8 in.	Suction Line: 7/8 in.	Approx. Ship Weight: 58 lbs
-----------------------------	------------------------------	------------------------------------

Option Data

Mounted Option	EcoNet Control Package
----------------	------------------------

Compliance Data

AWEF: 4.15

Notes

Dimensional Drawing

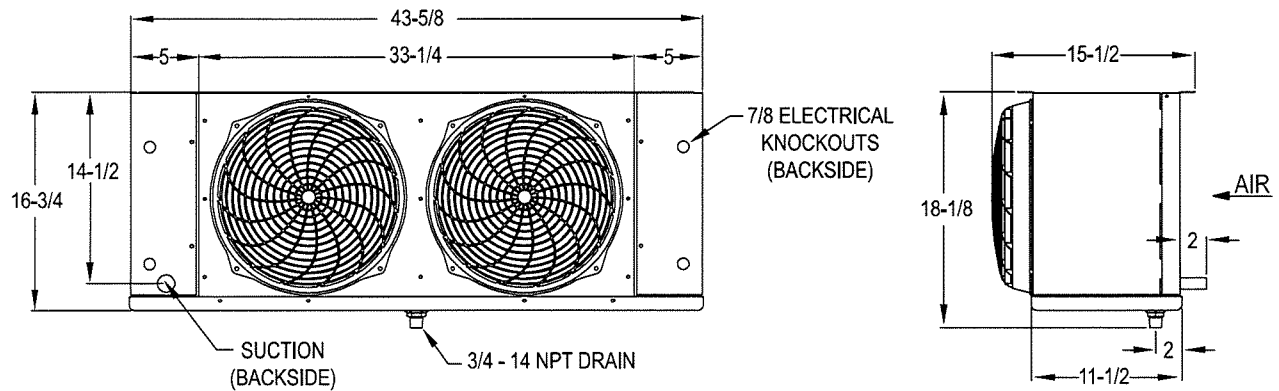

Standard Features

- Embossed aluminum housing
- Enhanced copper tube and aluminum fin coil construction
- Sweat connections
- Thermal overload protection
- High efficiency fan guard design and deep draw venturi
- Heavy-duty fans are balanced for vibration-free operation
- Fan sections are baffled to prevent short cycling of air
- Slide out end panels
- Removable drain pan
- Mounts flush to the ceiling
- Top pan includes 1/2" wide slotted mounting points
- UL/cUL certified for use with multiple refrigerants
- NSF approved for use in food preparation areas

Certifications



Garden City Child Nutrition and Wellness Department Request for Proposal
1205 Fleming
Garden City, KS 67846
620-805-7080

Electronic bid due December 19, 2023

Description of Proposal

Items: Walk-in Freezer

Mail or Deliver bids to: Garden City School District
Child Nutrition and Wellness Dept.
1205 Fleming
Garden City, KS 67846

Contact: Tracy Johnson, Director at trjohnson@gckschools.com

Bid Timeline: RFP Opening – December 19 @ 10:00 AM
Award Notification January 9, 2024

Garden City School District will be accepting electronic proposal for walk in freezer box and Condenser. Only proposals received by the date and time specified will be considered. Bid results will be presented to the USD 457 Board of Education on January 8, 2024.

Per attached specifications listed in this invitation to bid. Bidders must specify manufacturer/model number/delivery days, and unit price on each item or bid may be determined to be non-responsive.

- Pricing shall be FOB Garden City, KS (freight and fuel expenses included).
- Line item. Award will go to most qualified bidder on each line item.
- The District reserves the right to reject any or all bids, to waive any informalities, irregularities or technical defects in bids, and unless otherwise specified by the District to accept any item or groups of items in the bid, as may be in the best interest of the District.
- Time (days, weeks, etc.) required for delivery is a significant consideration with respect to this award process. The time required for delivery must be indicated in the space provided or your bid may be found non-responsive and may not be considered.
- Bid shall include copies of pertinent warranty information pertaining to the product offered. The bidder agrees that equipment furnished under any resultant purchase order issued by Garden City Public Schools shall be covered by commercial warranties the contractor gives to any customer for such supplies. All warranty information and certificates shall be furnished and become the property of the District upon delivery and acceptance of said items and/or the contractor must honor services and all rights and remedies stated in the warranties.
- All items are new manufacture unless otherwise specifically stated in this bid.
- All products must have passed the first line quality standard as set by the manufacturer and no seconds, blemished articles or items having defective workmanship are included.
- Bidder shall notify the District immediately of any changes to specifications made by the manufacturer for the equipment listed.
- Bid may not be considered if a service charge, minimum dollar or minimum quantity order is applied.
- Bidder shall acknowledge all addenda for this bid and include the form acknowledgements with their bid.

Specifications:

The following specifications are to serve as the minimum requirements for this solicitation, and should not be construed to exclude any other make or model of comparably equipped item of the same class designation. Any substitute must be approved in advance by the District.

Item 1

Outside Condenser with Indoor Evaporator
 2.5 Horsepower
 208/20V
 Single Phase

Item 2

Insulated Walk-In Freezer Box, 6'-7 5/8" x 8'-9" 7'7" height. Include 4" panels, door, LED fixture and floor.

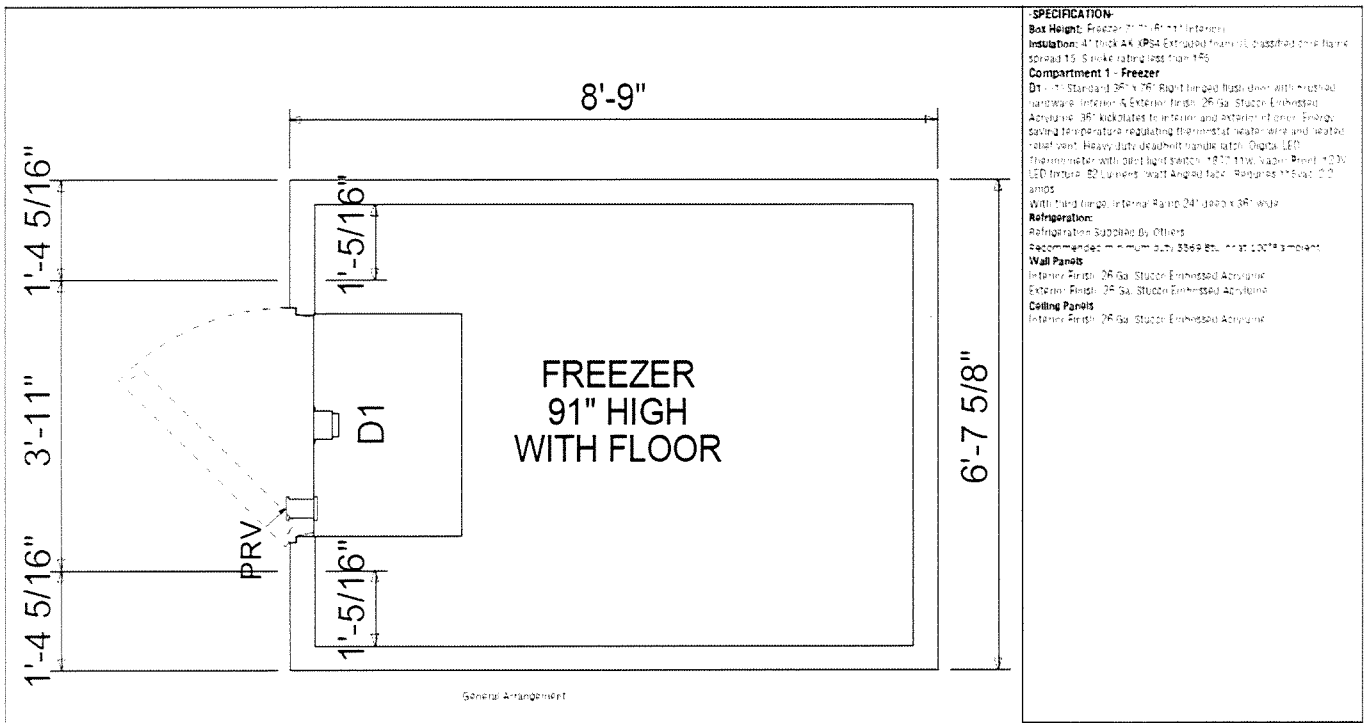

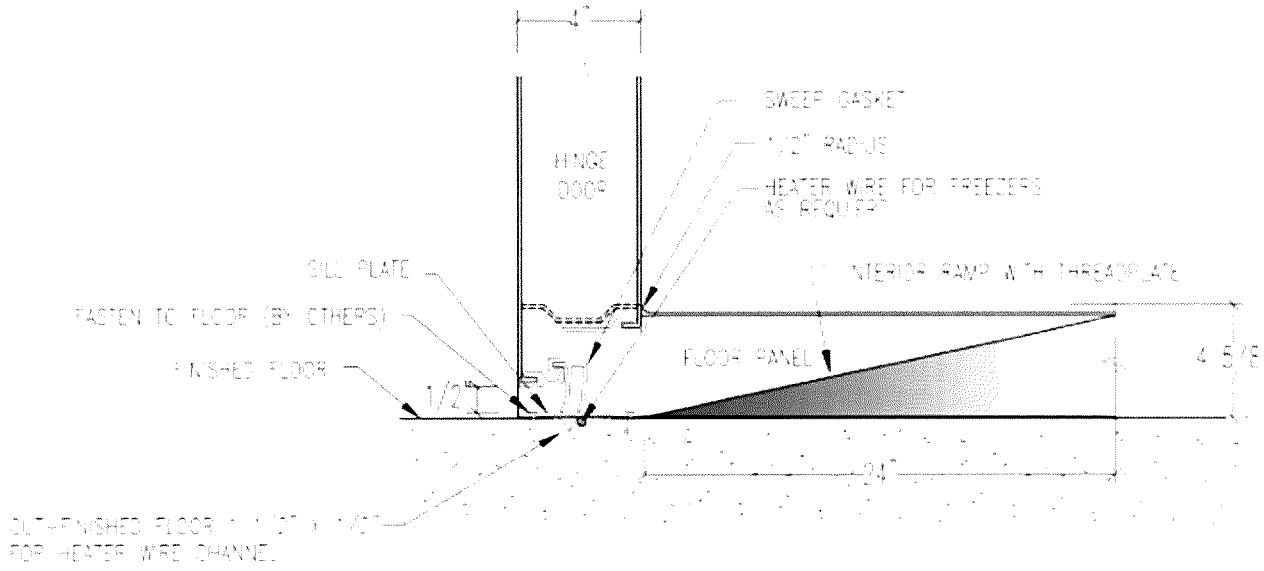
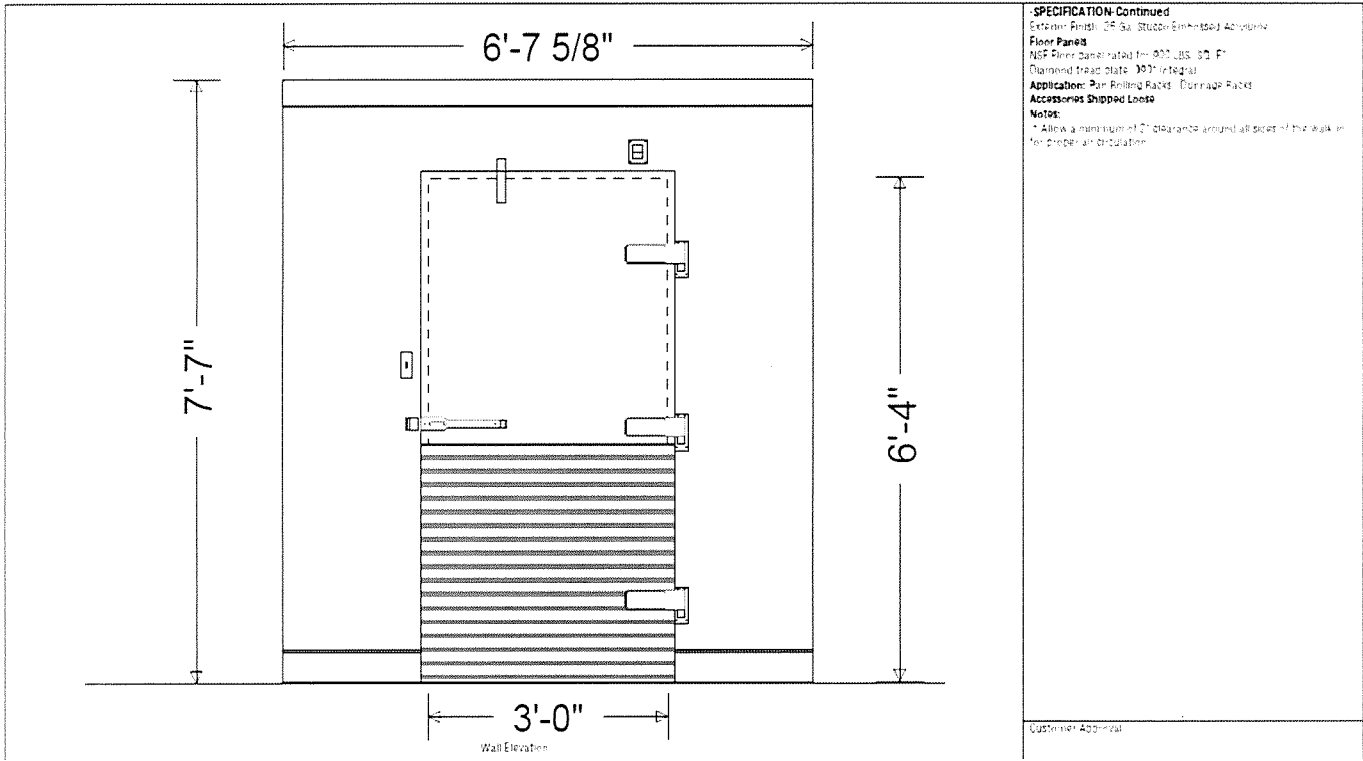

INTERIOR RAMP 24" DEEP X 36" WIDE

10064: INTERIOR RAMP 24" DEEP X 36" WIDE OPENING FOR FREEZER (E.T. 3-MS HEATER WIRE

USD 457, Garden City Public Schools

Large Equipment Bid

Due: 12/19/2023 by 10:00 am

The District reserves the right to accept or reject all or any part of any quote, to waive technicalities, and to accept the offer that the District considers to be the most advantageous.

Requirement	Condenser
Manufacturer:	AmeriKooler
Model	BCH0022LBACZA0200
Price (unit Cost)	\$6,534
Price (total)	\$6,534
Estimated Delivery Date	2/16/24

Requirement	Walk in Freezer Box
Manufacturer:	AmeriKooler
Model	CUSTOM
Price (unit Cost)	\$12,665
Price (total)	\$12,665
Estimated Delivery Date	2/16/24

Requirement	
Manufacturer:	
Model	
Price (unit Cost)	
Price (total)	
Estimated Delivery Date	

WE HEREBY AGREE TO FURNISH THE ITEMS ON WHICH PRICES ARE QUOTED ABOVE IN ACCORDANCE WITH ALL TERMS AND CONDITIONS PREVIOUSLY LISTED AND ANY ATTACHED SPECIFICATOINS.

BY: Phillip Schmidt
TITLE: Equipment Specialist
PHONE: (785) 823-6394

DATE: 12/19/23
FIRM: Sunflower Restaurant Supply
EMAIL: phillips@sunflowersrs.com

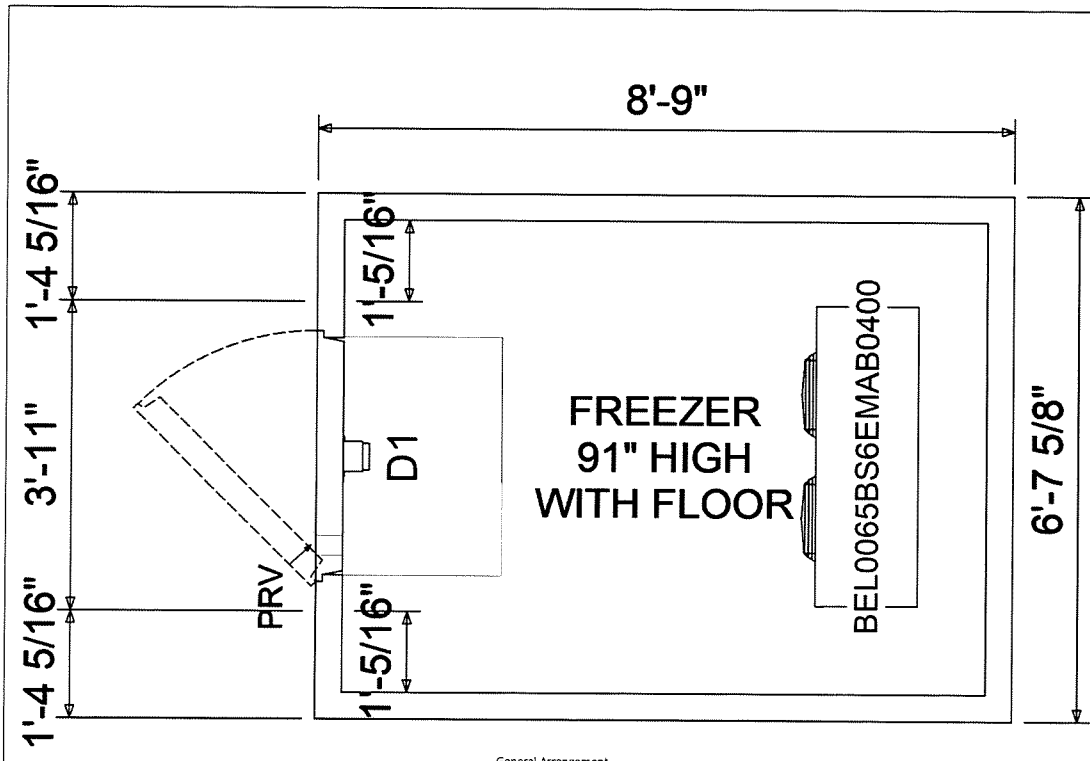

General Arrangement

-SPECIFICATION-
Box Height: Freezer 7'-7" (6'-11" Interior)
Insulation: 4" thick AX-XPS4 Extruded foam UL classified core flame spread 15, Smoke rating less than 165
Compartment 1 - Freezer
 D1 - (1) Standard 36" x 76" Right hinged flush door with brushed hardware. Interior & Exterior finish: 26 Ga. Stucco Embossed Acrylume. 36" kickplates to interior and exterior of door. Energy saving temperature regulating thermostat heater wire and heated relief vent. Heavy duty deadbolt handle latch. Digital LED Thermometer with pilot light switch. 1807 11w, Vapor Proof, 120V, LED fixture. 82 Lumens/watt Angled face. Requires 115vac. 2.2 amps.
 With third hinge, Internal Ramp 24" deep x 36" wide
Refrigeration:
 (1) 2 HP Bohn DOE Compliant Outdoor Condensing Unit, Model BCH0022LBACZA0200, 208-230/1/60, MCA 21 Amps, Low Temperature, Scroll, Air-cooled, R-404A. This refrigeration system is designed and certified for use in walk-in freezer applications - AWEF3.1, 1 yea (7259 Btu/hr @ -10°F room temperature and 100°F ambient)
 (1) Bohn DOE Compliant BEL0065BS6EMAB0400, 208-230/1/60, Low Profile Electric Defrost, 1 Fan Amps with Fixed Speed EC motor
 (1) Extended 4 year compressor Warranty

Customer Approval: _____

Quote No : 23-35979 Revision :	Project : Garden City School District	Date : 12/13/2023
Customer : Sunflower Restaurant Supply (PRIDE)	Page 1 of 4	



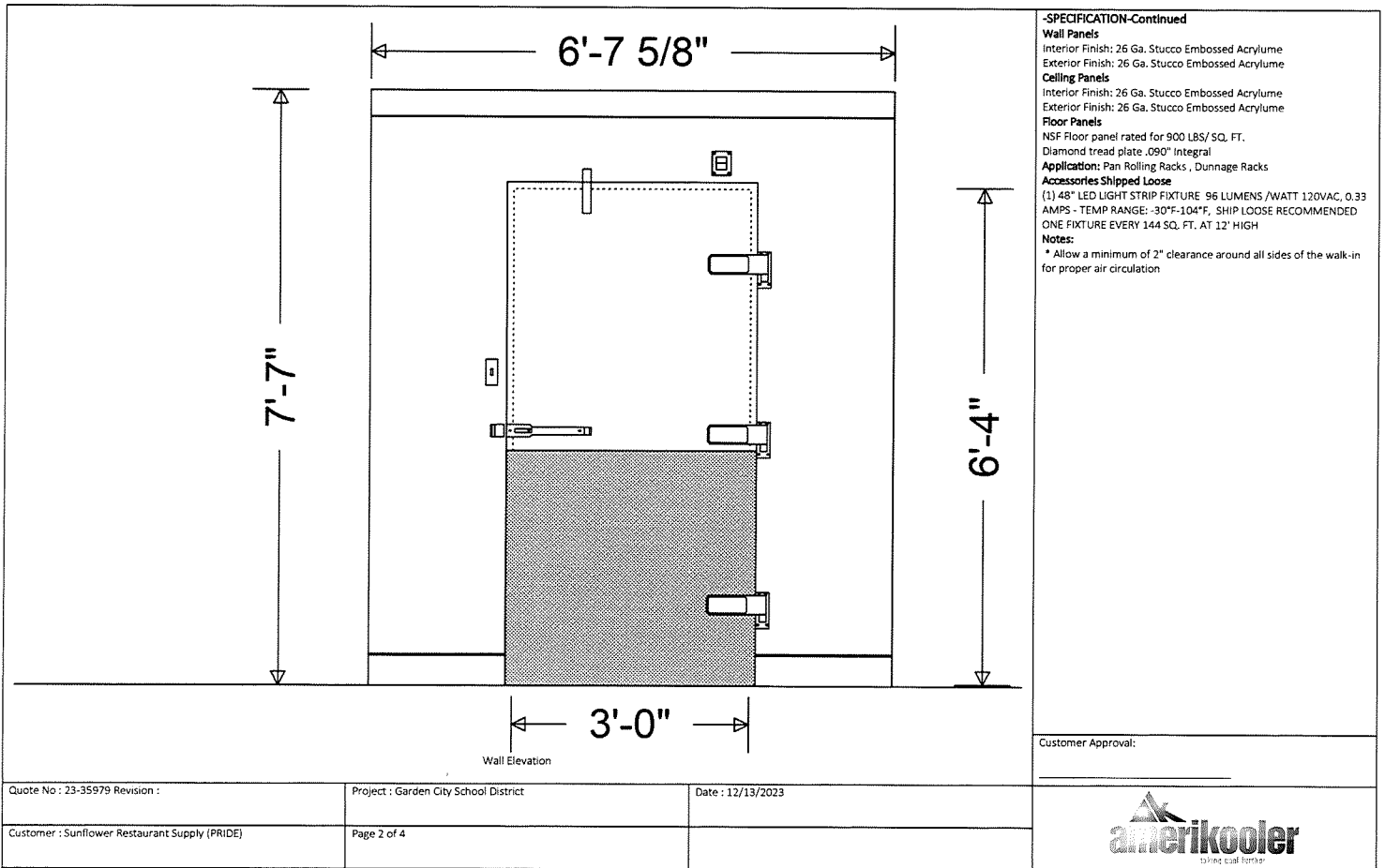

-SPECIFICATION-Continued
Wall Panels
 Interior Finish: 26 Ga. Stucco Embossed Acrylume
 Exterior Finish: 26 Ga. Stucco Embossed Acrylume
Ceiling Panels
 Interior Finish: 26 Ga. Stucco Embossed Acrylume
 Exterior Finish: 26 Ga. Stucco Embossed Acrylume
Floor Panels
 NSF Floor panel rated for 900 LBS/ SQ. FT.
 Diamond tread plate .090" Integral
Application: Pan Rolling Racks , Dunnage Racks
Accessories Shipped Loose
 (1) 48" LED LIGHT STRIP FIXTURE 96 LUMENS /WATT 120VAC, 0.33 AMPS - TEMP RANGE: -30°F-104°F, SHIP LOOSE RECOMMENDED ONE FIXTURE EVERY 144 SQ. FT. AT 12' HIGH
Notes:
 * Allow a minimum of 2" clearance around all sides of the walk-in for proper air circulation

Customer Approval: _____

Quote No : 23-35979 Revision :

Project : Garden City School District

Date : 12/13/2023

Customer : Sunflower Restaurant Supply (PRIDE)

Page 2 of 4



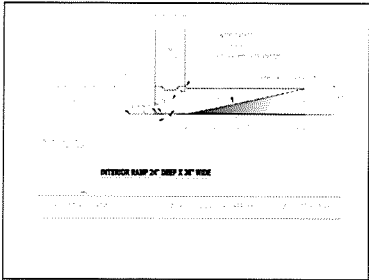

Quote No : 23-35979 Revision :	Project : Garden City School District	Date : 12/13/2023	
Customer : Sunflower Restaurant Supply (PRIDE)	Page 3 of 4		



Quote

12/19/2023

Project:
53266 Garden City Public School
District

From:
Douglas Equipment
Cale Veneri
301 North St.
Bluefield, WV 24701-4048
304-327-0149

Job Reference Number: 127967

Item	Qty	Description	Sell	Sell Total
1	1 ea	RECTANGULAR OUTDOOR FREEZER Imperial Brown Model No. RECTANGULAR OUTDOOR FREEZER Walls Exterior finish: STUCCO GALVALUME — Interior finish: STUCCO GALVALUME Connection to ceiling: CAMLOCK — Connection to floor: CAMLOCK — Ceiling caps: MOUNTED 4 section 4" urethane NSF wall panels [LDU400] Ceilings Exterior finish: METAL — Interior finish: STUCCO GALVALUME 1 section 4" urethane NSF ceiling panels (45 #/sf. live load) [LDU400] Floors Int. Finish: .080 ALUMINUM DIAMOND TREAD over 1/2" PLYWOOD — Ext. Finish: METAL 1 section 3 1/2" high density urethane NSF Hand-Truck Floor panels model #HTFN (NSF) [HDU350] Doors **STAINLESS STEEL AND TAMPER-PROOF FASTENERS** FRAME: 4" high density urethane door section, 3-sided, 4-sided heat cable LEAF: 4" thick, 3-side lap, Magnetic gasket, 2 1/4" black neoprene sweep RAISED 1/4" for flooring HARDWARE: (3) W59 hinge, (1) 27C deadbolt handle, (1) 27C knob ins. Rel., (1) Kason 'PUSH' pad, (1) 1094 closer, (1) IB locking hasp FINISH: Stucco galvalume / 24 ga. stainless steel 430 (magnetic) liners	\$20,483.10	\$20,483.10

Item	Qty	Description	Sell	Sell Total
		<p>KICKPLATES: 36" high, .063 aluminum diamond tread (LP) (ext. leaf) / 36" high, .063 aluminum diamond tread (LP) (int. leaf) w/ (1) ea. Weiss 24DT-L, single pole switch and thermometer combo @ ext. w/ (1) ea. Vapor proof light fixture base only for E26 LED lamp w/ concealed conduit w/ (1) ea. Kason 1825LE heated air vent (4W, 120V, .04A) w/ (1) ea. Rain drip cover w/ (1) ea. .080 smooth aluminum threshold w/ Electrical components to be pre-wired 1 ea. 34" x 78" flush model G3 self-closing freezer swing door (RIGHT hinge) [A] Parts (Fixture ships loose for field installation.) 1 ea. 4' LED light fixture #LED-440079 for cooler or freezer application (65W, 120-277V, 0.6- 0.3A) 1 ea. 24" deep model #HTFi interior ramp, w/ non-skid strips Simpson Titen or similar concrete screws @ 24" o/c 17 ea. Prefabricated floor seismic restraint system (2" x 2") x 96" x Stucco galvalume 5 ea. Interior seismic tie-down @ ceiling level Cut size: 11ft x 9ft - High end: 11ft side - Rise: 1 3/8 in. (Attaches to building on 8' - 9" side of box.) [QBRCS-59] 1 Pkg. Sloped roof - Membrane roofing [3 AA, 3 A, 0 B, 0 C, 0 Flat] 1 Pkg. Sloped roof - ISO boards Refrigeration 6567 BTU/H @ 11F TD with 16.2 hr runtime @ -10F inside/95F outside room, 101F @ cond. unit, 2832ft altitude 1 ea. Freezer - Outdoor R404a split system w/ EcoNET 1-year refrigeration system labor warranty (Freezer) 208-230V/1ϕ/60Hz/2.3HP Scroll compressor MCA=32, MOPD =35, AWEF: 3.14 39.875W x 28.25D x 18.75H x 230lbs. (1) Russell R404a air cooled condensing unit #RFO230L4SDA-NT w/ (2) 2-speed EC motors (1A) & electric defrost (9.8A) 208-230V/1ϕ/60Hz 43.625W x 15.5D x 18.125H x 42lbs. (1) Russell R404a Next-Gen All-Temp evaporator model #RL6E066DDARE 4-year extended compressor warranty (Freezer) FOB Factory, Imperial Brown does not offer FOB destination** - Quote based on RFQ - no specs available at time of quote. - Nominal sizes quoted. Contact factory if exact sizes is required - price may vary.</p>		

Douglas Equipment

12/19/2023

Item	Qty	Description	Sell	Sell Total
		<ul style="list-style-type: none"> - Engineering and seismic restraints (if needed) are not included. - Doors are pre-wired to interior terminal j-boxes. Final connection, penetrations by others. - Refrigeration (if quoted) is sized for holding only - no product or pulldown loads are assumed. - Verify all electrical requirements prior to placing order. - Upon ordering please include jobsite name, and job site address. Also please include shipping instructions if not specified. - Pricing is good for items ordered and approved within 30 days of this quote, and shipped within IB standard lead time. Once this quote expires, IB will have to update the quote. No pricing, with or without a PO in hand, will be valid if shipment is beyond 6 months of this quote date. <p>SPECIAL NOTES: STANDARD NOTES:</p> <ul style="list-style-type: none"> -Options, if any, are shown on the following detail pages for each item. OPTIONS ARE NOT INCLUDED IN FOB PRICE. -Please place a check mark next to each desired option. -This offer is limited to the items explicitly incorporated into the written specifications contained herein. It is the customer's responsibility to review this quotation for accuracy and completeness in all aspects. No additional responsibility or liability is hereby assumed for errors and/or omissions. -LOIs will not hold pricing under any circumstances. After 90 days, if the job has not shipped, the project will need to be re-quoted. -Installation quote, when provided, is based on non-union labor unless otherwise specified. -Freight quote is estimated only; current freight will be billed. -If, after production is complete, the customer requests the delivery date to be moved by more than 7 days past the original date, a \$200 storage fee will be charged per pallet per week for goods stored in our factory. -Meets 2009 Federal Energy Independence and Security Act Requirements. -All panel and door assemblies should be installed by a qualified and experienced contractor. To ensure proper installation and avoid potential loss of warranty resulting from poor installation, the Manufacturer can arrange to handle your installation for you. 		
			Freight: \$1,523.00	\$1,523.00
			Installation: \$11,620.00	\$11,620.00
			ITEM TOTAL:	\$33,626.10
			Total	\$33,626.10

Acceptance: _____ Date: _____

Printed Name: _____

Project Grand Total: \$33,626.10

SPECIFICATIONS

Outdoor freezer (-10°F) (with floor)
Vinyl NSF gasket (1/16" joint thickness), Cam-lock layout SHI

SPECIAL INSTRUCTIONS

Tamper-proof fasteners
Standard crating

WALL PANELS

Construction: 4" urethane
Exterior Finish: Stucco galvalume
Interior Finish: Stucco galvalume
Ceiling connections: Camlock
Floor connections: Camlock

CEILING PANELS

Construction: 4" urethane
Exterior Finish: Metal
Interior Finish: Stucco galvalume
Ceiling Cages: Factory mounted
Live Load: 45 psf

FLOOR PANELS

Model: Hand-Truck Floor panels model #HTFN (NSF)
Construction: 3 1/2" high density urethane
w/ .080 aluminum diamond tread @ interior
over 1/2" plywood
w/ Metal @ exterior

DOORS

(A) 34" x 78" flush model G3 self-closing freezer door
*** TAMPER-PROOF FASTENERS ***
*** STAINLESS STEEL TAMPER-PROOF FASTENERS ***
*** STAINLESS STEEL FASTENERS ***
*** ELECTRICAL COMPONENTS PRE-WIRED ***
Brand: Imperial Brown
Frame: 4" high density urethane, 3-sided
w/ Stucco galvalume both sides
w/ 24 ga. stainless steel 430 (magnetic) liners
w/ 4-sided heat cable in frame (FL-4-117M)
(24'-9" x 5 ohms/ft (124 total) @ 4.8 W/ft - Pepi - 120V, 1A)
Leaf: 4" thick, 3-side lap, raised 1/4"
w/ Stucco galvalume both sides
w/ Magnetic gasket
w/ 2 1/4" black neoprene sweep
(3) Component Hardware #W59 spring assisted adjustable hinge
(1) Kason #27C cylinder locking deadbolt handle
(1) Kason #27C twist-off knob inside release
(1) Kason "PUSH" pad
(1) Kason #1094 hydraulic door closer (polished chrome)
(1) IB locking hasp w/ inside release
(1) Weiss 24DT-L, single pole switch and thermostat combo @ ext.
(1) Vapor proof light fixture base only for E26 LED lamp w/ concealed

conduit
(1) Terminal J-Box @ int.
(1) Kason 1825LE heated air vent (4W, 120V, .04A)
(1) rain drip cover
(1) .080 smooth aluminum threshold for interior ramp
(1) 36" high AFP .063 aluminum diamond tread (LP) kickplates (leaf, ext. & int.)

PARTS

(1) ea. Vapor proof light globe & E26 LED bulb
(1) ea. 4' LED light fixture #LED-440079 for cooler or freezer application (65W, 120-277V, 0.6-0.3A) - (Fixture ships loose for field installation.)
(17) ea. Prefabricated floor seismic restraint system-Simpson Titen or similar concrete screws @ 24"/c
(5) ea. Interior seismic tie-down @ ceiling level-(2" x 2") x 96" x Stucco galvalume
(1) Pkg. Sloped roof - Membrane roofing-Cut size: 11ft x 9ft - High end: 11ft side - Rise: 1 3/8 in.
(Attaches to building on 8" - 9" side of box.) (QBRC3-59)
(1) Pkg. Sloped roof - 150 boards-13 AA, 3 A, 0 B, 0 C, 0 Flat)

REFRIGERATION

(1) ea. Freezer - Outdoor R404a split system w/ EconET
6567 BTU/H @ 11F TD with 16.2 hr runtime @ -10F inside/95F outside room
101F @ cond. unit, 2832ft altitude
(1) Russe11 R404a air cooled condensing unit #RFO230L45DA-N7
208-230V/1ø/60Hz/2.3HP Scroll compressor
MCA=32, MOPD =35, AWEF: 3.14
39.875W x 28.25D x 18.75H x 230lbs.
(1) Russe11 R404a Next-Gen All-Temp evaporator model #RL6R066DDARE
w/ (2) 2-speed EC motors (1A) & electric defrost (9.8A)
208-230V/1ø/60Hz
43.625W x 15.5D x 18.125H x 42lbs.

SPECIAL PANELS

XXX w/ (1) ea. 24" deep model #HTPI interior ramp, w/ non-skid strips

NOTES

Meets 2009 Federal Energy Independence and Security Act Requirements.

STANDARD NOTES

To prevent condensation, a minimum 2" from the walk-in exterior surface is required. High humidity conditions may require force ventilation in addition to clearance.

Installation site floor must be true and level within 3/16" per 10' or additional costs may be incurred.

R-Plus Doors sliding and vertical lift doors shall not be considered means of egress. Check code egress requirements for your application.

ELECTRICAL

Field electrician to verify maximum acceptable load for light switches. If load is too high, then relay type controls should be used.
After wiring devices, ALL conduits must be sealed to stop moisture transfer through electrical raceways.
Failure to seal device per NEC codes WILL VOID WARRANTY.

REVISIONS

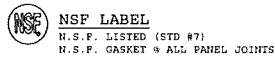

- PRELIMINARY DRAWING -
Customer Note: This is a preliminary drawing only. Approving this drawing only indicates that you agree with overall dimensions and door and opening locations. Panel sizes and layout is subject to change. If "Nominal Size" has been quoted, then actual dimensions may end up a bit smaller than drawn herein. Actual drawings will be shown on subsequent non-preliminary drawings. Should discrepancies be found between drawing and sales order, customer may be asked to approve standard Submittal drawings.
The customer or their representative in signing these drawings is taking responsibility for overall size and fit around building walls, columns and existing restrooms, door locations, openings for equipment supplied by others, specifications and accessories listed.
 APPROVED FOR FABRICATION WITH NO CHANGES
 APPROVED FOR FABRICATION WITH CHANGES
 REVERSE AND RESUBMIT
Signature: _____

23-IB-96161-01
23-IB-96161.001-1-00

NOT FOR CONSTRUCTION

PRELIMINARY

DOUGLAS FOOD STORES, INC.
BLUEFIELD, WV
GARDEN CITY SCHOOL DISTRICT CHILD NUTRITION
GARDEN CITY, KS

NOTE TO PREVENT CONDENSATION, ALL CRACKS/FITTING CLEARANCE AROUND THE EXTERIOR OF THIS UNIT SHALL BE SEALED WITH AN APPROPRIATE POLYURETHANE SEALANT.
OR FORCED VENTILATION MAY BE REQUIRED IN ADDITION TO CLEARANCE.
NOTE: FLOORS OF INSTALLATION SITES SHALL BE TRUE AND LEVEL WITHIN 3/16" PER 10' OR ADDITIONAL COSTS MAY BE INCURRED.
NOTE: MANUFACTURER IS NOT RESPONSIBLE FOR ELECTRICAL, PLUMBING, PERMITS OR CONCRETE WORK UNLESS LISTED ON THE QUOTE.

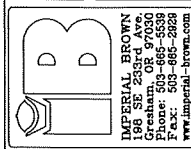

DO NOT SCALE THIS DRAWING
SCALE: 3/16" = 1'-0"
DATE DRAWN: 12/15/2023
DATE PRINTED: 12/15/2023
BY: PDX-Assistant
CHKD BY:
DRW#: 23-IB-96161-01
BOX: 1 OF 1
SHEET: 1 OF 6

CONSTRUCTION LEGEND:
 [] 4" urethane
 [] 4" high density urethane
 [] 3 1/2" high density urethane

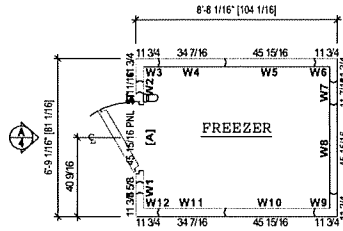

WALL PANELS

--- Stucco galvalume

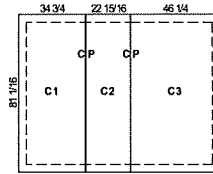

CEILING PANELS

23-IB-96161-01
 23-IB-96161.00.01-00

NOT FOR CONSTRUCTION

PRELIMINARY

DOUGLAS FOOD STORES, INC.
 BLUEFIELD, WV
 GARDEN CITY SCHOOL DISTRICT CHILD NUTRITION
 GARDEN CITY, KS

NOTE: TO PREVENT CONDENSATION, ALLOW 2" MIN. CLEARANCE AROUND THE EXTERIOR OF
 INDOOR WALLS. MAINTAIN THE TEMPERATURE BELOW 70°F
 AND THE HUMIDITY BELOW 70% RELATIVE HUMIDITY.
 NOTE: FLOORS OF INSTALLATION SITES SHALL BE TRUE AND LEVEL WITHIN 3/16" PER 10' OR
 ADDITIONAL COSTS MAY BE INCURRED.
 NOTE: MANUFACTURER IS NOT RESPONSIBLE FOR ELECTRICAL, PLUMBING, PERMITS OR
 CONCRETE WORK UNLESS LISTED ON THE QUOTE

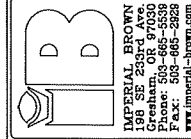

IMPERIAL BROWN
 198 SE 233rd Ave.
 Gretna, NE 68645-5539
 Phone: 402-685-5539
 Fax: 402-685-2928
 www.imperial-brown.com

DO NOT SCALE THIS DRAWING

SCALE: 3/16" = 1'-0"
 DATE DRAWN: 12/15/2023
 DATE PRINTED: 12/15/2023
 BY: PDX-Assistant
 CHK'D BY:

DRW# 23-IB-96161-01
 BOX: 1 OF 1
 SHEET: 2 OF 6

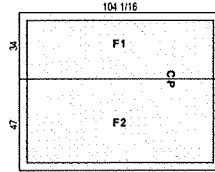

FLOOR PANELS

23-IB-96161-01
23-IB-96161.00.01-00

NOT FOR CONSTRUCTION

PRELIMINARY

DOUGLAS FOOD STORES, INC.
BLUEFIELD, WV

GARDEN CITY SCHOOL DISTRICT CHILD NUTRITION
GARDEN CITY, KS

NOTE: PERMIT CONSTRUCTION ALL OUT 2" MIN. CLEARANCE AROUND THE EXTERIOR OF
THIS PRODUCT IS REQUIRED. MAINTAIN RELATIVE HUMIDITY BELOW 65% AND TEMPERATURE BELOW 75°F
OR FORCED VENTILATION MAY BE REQUIRED IN ADDITION TO CLEARANCE.
NOTE: FLOORS OF INSTALLATION SITES SHALL BE TRUE AND LEVEL WITHIN 3/16" PER 10' OR
ADDITIONAL COSTS MAY BE INCURRED.
NOTE: MANUFACTURER IS NOT RESPONSIBLE FOR ELECTRICAL, PLUMBING, PERMITS OR
CONCRETE WORK UNLESS LISTED ON THE QUOTE.

IMPERIAL BROWN
188 S.E. 253rd Ave.
P.O. Box 1000
Phone: 500-685-5539
Fax: 500-685-2628
www.imperial-brown.com

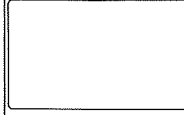

DO NOT SCALE THIS DRAWING

SCALE: 3/16" = 1'-0"

DATE DRAWN: 12/15/2023
DATE PRINTED: 12/15/2023
BY: PDX-Assistant
CHK'D BY:

DRW#: **23-IB-96161-01**
BOX: 1 OF 1
SHEET: 3 OF 6

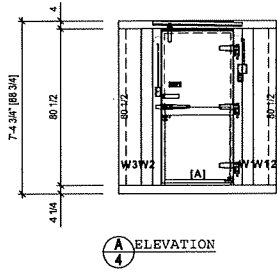

23-IB-96161-01
 23-IB-96161.0001-00

NOT FOR CONSTRUCTION

PRELIMINARY

DOUGLAS FOOD STORES, INC.
 BLUEFIELD, WV
 GARDEN CITY SCHOOL DISTRICT CHILD NUTRITION
 GARDEN CITY, KS

NOTE: TO PREVENT CONDENSATION, ALLOW 2" MIN. CLEARANCE AROUND THE EXTERIOR OF THIS ASU WALK-IN. MAINTAIN RELATIVE HUMIDITY BELOW 85% AND TEMPERATURE BELOW 75°F OR FORCED VENTILATION MAY BE REQUIRED IN ADDITION TO CLEARANCE.
 NOTE: FLOORS OF INSTALLATION SITES SHALL BE TRUE AND LEVEL WITHIN 3/16" PER 17' OR ADDITIONAL COSTS MAY BE INCURRED.
 NOTE: MANUFACTURER IS NOT RESPONSIBLE FOR ELECTRICAL, PLUMBING, PERMITS OR CONCRETE WORK UNLESS LISTED ON THE QUOTE.

IB
 IMPERIAL BROWN
 188 SE 230TH AVE.
 OAKLAND, MO 64450
 Phone: 503-665-5539
 Fax: 503-665-2828
 www.imperial-brown.com

DO NOT SCALE THIS DRAWING

SCALE: 3/16" = 1'-0"
 DATE DRAWN: 12/15/2023
 DATE PRINTED: 12/15/2023
 BY: PDX-Assistant
 CHK'D BY:

DRW#: **23-IB-96161-01**
 BOX: 1 OF 1
 SHEET: 4 OF 6

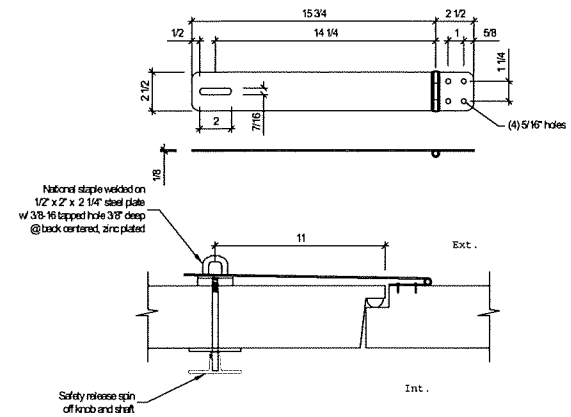

5 LOCKING HASP FOR FLUSH DOOR
Outswing

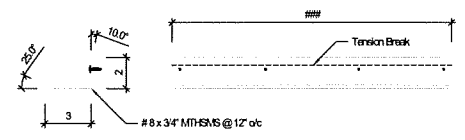

NOTE: Rain drip cover should be mounted @5 degrees to drain toward the hinge side of the door opening

6 RAIN DRIP COVER

23-IB-96161-01
23-IB-96161.00.01-00

NOT FOR CONSTRUCTION

PRELIMINARY

DOUGLAS FOOD STORES, INC.
BLUEFIELD, WV
GARDEN CITY SCHOOL DISTRICT CHILD NUTRITION
GARDEN CITY, KS

NOTE: PROVIDE CLEARANCE AROUND THE EXTERIOR OF THE WORKING UNIT TO MAINTAIN RELATIVE HUMIDITY BELOW 75% OR FORCED VENTILATION MAY BE REQUIRED IN ADDITION TO CLEARANCE.
NOTE: FLOORS OF INSTALLATION SITES SHALL BE TRUE AND LEVEL WITHIN 3/16" PER 10' OR ADDITIONAL COSTS MAY BE INCURRED.
NOTE: MANUFACTURER IS NOT RESPONSIBLE FOR ELECTRICAL, PLUMBING, PERMITS OR CONCRETE WORK UNLESS LISTED ON THE QUOTE.

IMPERIAL BROWN
198 SE 203rd Ave.
Imperial, MO 64502
Phone: 503-665-5539
Fax: 503-665-2828
www.imperial-brown.com

DO NOT SCALE THIS DRAWING
SCALE: 3/16" = 1'-0"
DATE DRAWN: 12/15/2023
DATE PRINTED: 12/15/2023
BY: PDX-Assistant
CHK'D BY:
DRW#: **23-IB-96161-01**
BOX: 1 OF 1
SHEET: 6 OF 6



Box Load Calculation

Quote/Order #
23-IB-96161

Imperial Brown (Prague Division) - 2115 West Main Street - Prague, OK 74864
 Phone: (800) 238.4093 - Fax: (503) 665.2929
 Internet: imperialbrown.com

CCB #0091759

Box #: 1
Box Description: 6' - 9 1/16" x 8' - 8 1/16" x 7' - 4 3/4" rectangular outdoor freezer (-10°F) (with floor)

System Name: Freezer
Holding Temp. (° F): -10 **Ambient Temp. @ Chamber (° F):** 95
Altitude (Ft.): 2832 **Ambient Temp. @ Cond. Unit (° F):** 101
RH %: 90%

System Summary: (1) RFO230L4SDA-NT w/ (1) RL6E066DDARE - 6567
 BTU/H Capacity @ 11° F TD @ 16.2 hour runtime
 @ 95°F ambient / -10°F room temp. / 2832ft altitude

Load Summary:	Surfaces	1,641	27.83%	
(BTU/H)	Infiltration	3,615	61.31%	2.00 times ASHRAE's recommended infiltration load
	Product	90	1.53%	ASHRAE recommended values for holding load only
	Misc.	550	9.33%	
	Total	5,896		

Product Data	
Product Weight (lbs.)	324
Pull Down Time (Hours)	24
Entering Temp. (° F)	0
Final Temp. (° F)	-10
Freezing Point (° F)	29
Specific Heat - Above	0.90
Specific Heat - Below	0.40
Latent Heat of Fusion	115.00
Respiration Load	0.00
Heat of Respiration	0.00

Misc. Data	
Motor HP Equivalence	0.03
Lighting Watts / Ft. ²	1.11
Occupancy	0.01
Forklift	0.00
Misc. BTUH	0.00

Physical Data

Refrigerant	Compressor		Connections		Receiver Capacity (90%)	Sound Data	Net Weight (lbs.)	Altitude (Feet)	Ambient Temp (°F)
	Model #	HP	Liquid	Suction					
R404a	ZF07KAE	2.3	3/8"	7/8"	11.6	71	230	2832	101

Electrical Data

Power Supply			Compressor		MCA		MOP		Notes
Volts	Phase	Hz	RLA	LRA	Air Def.	Elec. Def.	Air Def.	Elec. Def.	
208-230	1	60	12.44	75	17.5	32	25	35	MCA = Minimum Circuit Ampacity MOP = Maximum Overcurrent Protection

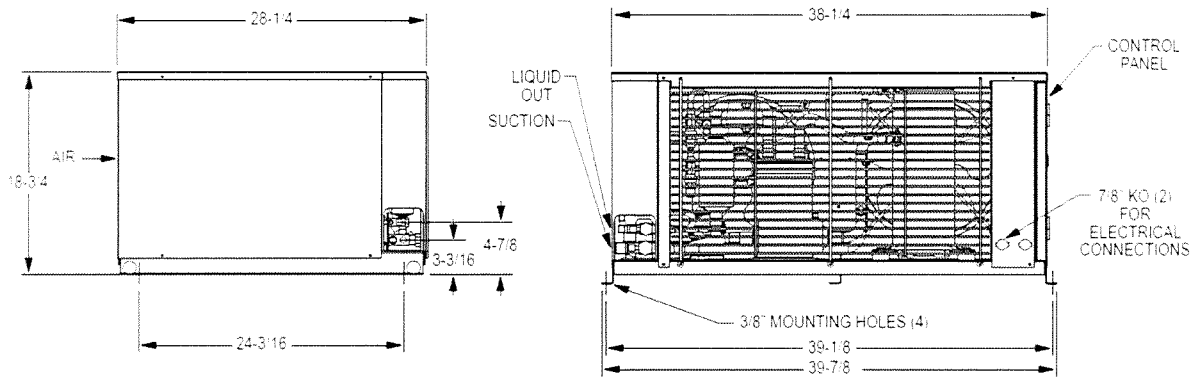

Capacity (BTUH) @ Designated Saturated Suction Temperatures

+40° F	+35° F	+30° F	+25° F	+20° F	+15° F	+10° F	+5° F	+0° F
0	0	0	0	0	0	0	0	10,289
-5° F	-10° F	-15° F	-20° F	-25° F	-30° F	-35° F	-40° F	
9,450	8,307	7,311	6,408	5,587	4,831	4,117	3,402	

Physical and Electrical Data

Defrost Type	Air Flow	Capacity (BTUH)	Net Weight (lbs.)	Altitude (Feet)
Electric	1600	5,973	42	2832

Power Supply			Fans			Heaters		Connections		
Volts	Phase	Hz	Qty	Amps	Motor Type	Amps	Watts	Inlet	Outlet	Drain
208-230	1	60	2	1.0	EC2	9.8	2250	3/8"	7/8"	3/4"

Front and Right Views

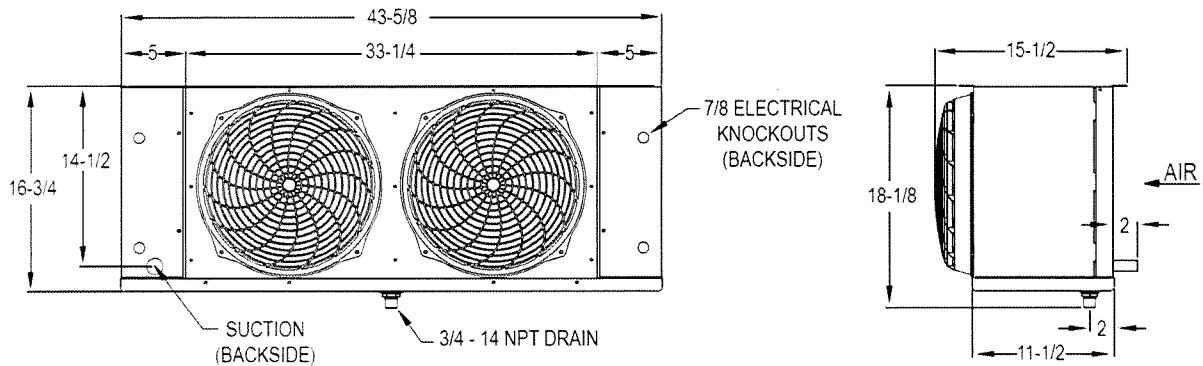

Bidders List Large Equipment

Webers Refrigeration

Brian Weber
711 N Main
Garden City, KS 67846
BrianWeberGC@gmail.com

Douglas Equipment

Cale Veneri
301 North St
Bluefield, WV 2401
cale@dougleasequipment.us

Sunflower Restaurant Supply

Phillip Schmidt
P.O. Box 1277
Salina, KS 67401
phillips@sunflowersrs.com

**Bid Tabulations
Large Equipment**

Bid Opening: December 19, 2023

Bid 2023 - 24

Vendor	Condenser/ Evaporator	Unit	Unit Condenser/ Evaporator	Total
1. Webers	8,700.00	17,000.00		25,700.00
2. Sunflower Restaurant Supply*	6,534.00	12,665.00		19,199.00
3. Douglas**			22,006.10	22,006.10

*Sunflower did not include written Specs for unit

**Douglas bid an outside unit.

RECOMMENDATION: Purchase Condenser/Evaporator and Unit from Webers Refrigeration for 25,700.00

Payment to be made from budgeted funds in account:

024 E 3151 21 0000 054 01 630 Equipment

MEMORANDUM

TO: Board of Education
THRU: Dr. Mike Dominguez, Superintendent
FROM: Colleen Drees, Chief Financial Officer
DATE: January 8th, 2024
RE: Boundary Study – Enrollment Analysis - RSP

ISSUE:

The Board of Education is asked to receive a presentation from RSP on our Boundary Study.

BACKGROUND:

RSP will be presenting on the boundary study and provide an analysis of our student population then the board will need to vote to identify the top three priorities for the Boundary Study. These top three priorities will then be utilized by District Site Council to make recommendations to the board at the April 15th board meeting. The draft presentation is attached.

ALTERNATIVES:

No other alternatives applicable.

RECOMMENDATION:

Not Applicable

FISCAL NOTE:

No Fiscal impact.

ATTACHMENTS:

RSP Presentation 1.8.24



Planning for the Future

Garden City Public Schools

Enrollment Analysis

December 2023

RSP & Associates

RSP Quick Facts:

- Founded in 2003
- Professional educational planning firm
- Expertise in multiple disciplines (GIS, Planning, Facilitation)
- Over 20 years of planning experience
- Over 80 years of education experience
- Over 20 years of GIS experience
- Projection accuracy of 97% or greater

RSP Planning Team:

Robert Schwarz, CEO

- Military, County, City, and School District Planner
- University of Kansas – Master of Urban Planning (MUP)
- American Institute of Certified Planners (AICP)
- Accredited Learning Environment Planner (ALEP)

Ginna Wallace, Planner

- University of Kansas – Master of Urban Planning (MUP)
- American Institute of Certified Planners (AICP)

Company was started with the desire and commitment to assist school districts in long-range planning. RSP has served over **130** clients in:

- Arkansas
- Colorado
- Iowa
- Illinois
- Kansas
- Minnesota
- Missouri
- Nebraska
- North Dakota
- Oklahoma
- South Dakota
- Tennessee
- Wisconsin

RSP Recent Projects:

Dodge City USD 443

- Enrollment Analysis, 2022/23

Hutchinson USD 308

- Enrollment Analysis, 2021/22
- Facility Master Plan, 2021/22

Maize USD 266

- Board Member Rezone, 2022/23

Our Partners:



154

Expectations

Thank you to Garden City Public School, Finney County, City of Garden City, Census Bureau, and ESRI for assisting in this analysis!

Things to Consider...

- **Timeline** – Project timeline is a result of ensuring student data could represent as close as possible to the Official County Data with attributes that would allow RSP to forecast enrollment at a parcel level geography.
- **Findings** – The findings were not focused on supporting or contradicting any past internal or outsourced studies. This analysis is based on data, data, and more data.
- **Study** – This study factored in many different data sets to provide data driven analysis that is the foundation to the RSP Statistical Forecast Model (SFM).
- **Change** – Enrollment change in the community is influenced by, but not limited to, the birth rate, demographics, types of development and/or housing affordability.
- **Facts:**
 - 1) The study does not provide specific information about which site would be best suited for a new facility or for that matter should the district build any new facility – this analysis is one portion of how to make that decision
 - 2) This analysis is based on the same grade configuration and educational programming expectations the patrons have for each student
 - 3) Projecting enrollment is not a science – like life in general some assumptions happen that may lead to greater enrollment while others toward a smaller enrollment
 - 4) Student data does not include Preschool, virtual, or 18-21 special education population. Enrollment best aligns with district Official Count Day data. Presented enrollment may vary from state reported enrollment (KSDE).

Helpful Hints to Read the Report:

- 1) Slides that have the flagged star symbol are SIGNATURE SLIDES and are the most important variables in this unique analysis



- 2) Each variable is analyzed as an indicator of future student population. Use the PLUS (student growth) and MINUS (student loss) icons to note how each indicator contributes to the analysis:



- 3) Click the APPENDIX symbol on a page to reference additional analysis on this topic



The goal of this study is to help the board, administration, and public understand how to make the best decision for the students at the classroom level.

Discussion Points

Part 1 Enrollment & Demographics



- Things to Consider
- Maps & Data
- Sophisticated Forecast Model
- Demographics
- Past Enrollment & Change

Part 2 Development



- Population, Development, & Enrollment Trends
- Yield Rate
- Maps & Data

Part 3 Projections



- Past, Current, & Future Enrollment
- Building Projections

Part 4 Next Steps



- Moving Forward
- Next Steps & Key Consideration

Appendix



- Demographics
- Intra-transfer Tables
- Student Density Maps

Part One: Past Enrollment and Demographics



100,000 Foot Perspective



Enrollment is projected to decrease by about 160 students, totaling 6,360 total students

- **Elementary enrollment is projected to increase by about 60 students**
- **Middle school enrollment is projected to decrease by about 45 students**
- **High school enrollment is projected to decrease by about 180 students**



Capacity was provided by district administration and analyze in regard to projection enrollment

- Capacity challenges are expected to continue at Jennie Barker Elementary School as the number of students residing within the boundary is projected to exceed the building's capacity
- Most of the facilities in the district are forecasted to occupy less than 70% of available capacity resulting in potential under-utilization challenges



Development in the northeast is a driver to future enrollment growth at the elementary level

- There are almost 1,850 units identified for development over the next 10 years
- 2023 has seen 3 single-family and 4 multi-family units built
- Continue monitoring local economic indicators to gauge likelihood of future residential development and timing of identified projects

District Boundary



District Boundary

- District Boundary
- District Office
- Early Childhood
- Elementary School
- Intermediate School
- Middle School
- High School
- Lee Richardson Zoo
- Garden City Community College
- Park
- Recreation

- School List:**
- Elementary List (K-4):
1. Abe Hubert (K-6)
 2. Alta Brown
 3. Buffalo Jones
 4. Edith Scheurman
 5. Florence Wilson
 6. Georgia Matthews
 7. Gertrude Walker
 8. Jennie Barker (K-6)
 9. Jennie Wilson
 10. Plymell (K-6)
 11. Victor Ornelas
- Intermediate List (5-6):
12. Bernadine Sitts
 13. Charles O Stones
- Middle List (7-8):
14. Horace Good
- High List (9-12):
15. Kenneth Henderson
 16. Garden City

- Cities:**
- Garden City
 - Holcomb
 - Pierceville

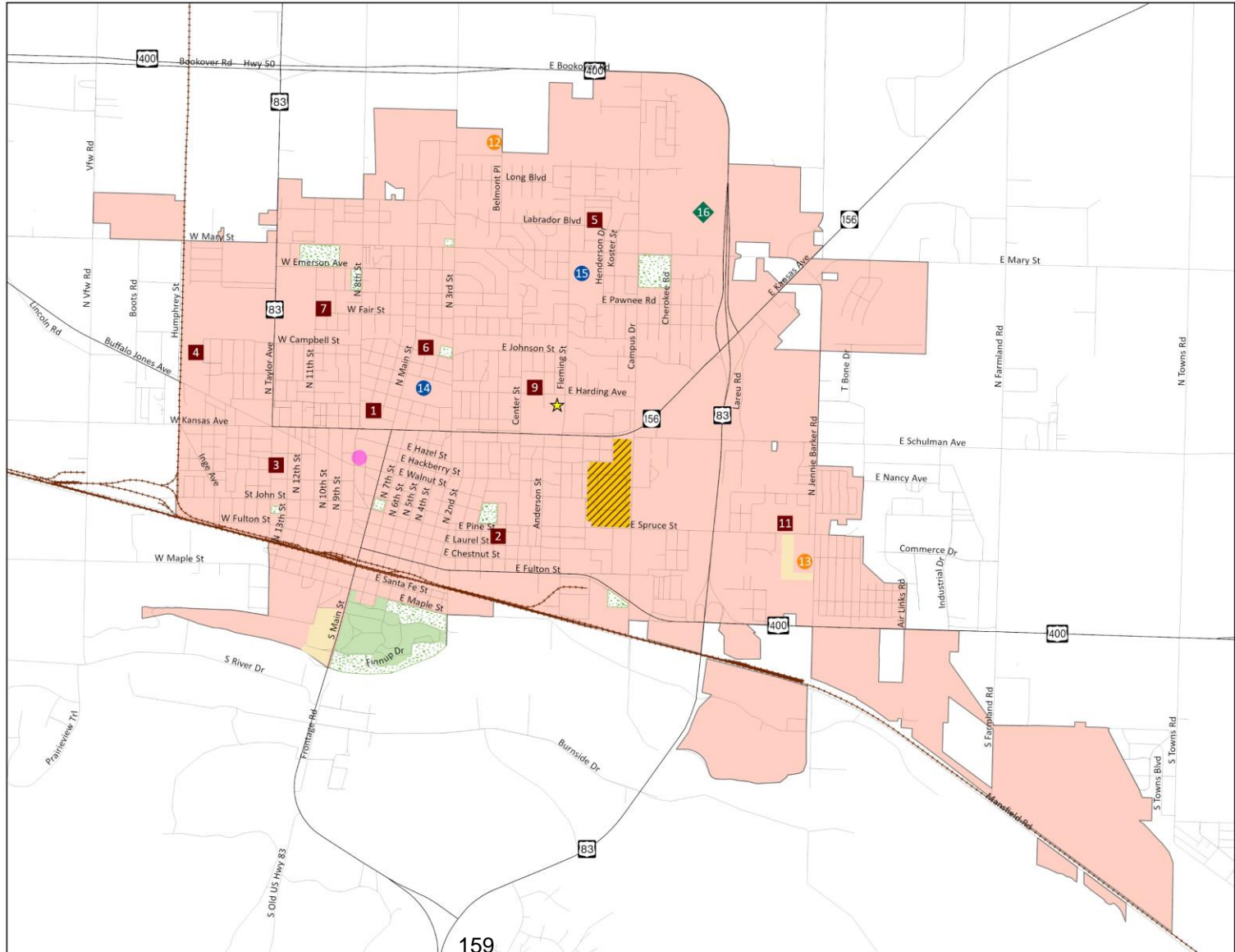

159

Map data provided by USD 457, Garden City, Finney County, USGS, and ESRI. Map created by RSP & Associates in December 2023.

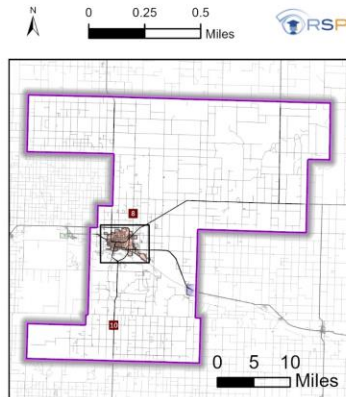

Elementary Boundary Map



Elementary School Attendance Areas

- District Boundary
- District Office
- Early Childhood
- Elementary School
- Intermediate School
- Middle School
- High School
- Lee Richardson Zoo
- Garden City Community College
- Park
- Recreation

- School List:**
- Elementary List (K-4):**
1. Abe Hubert (K-6)
 2. Alta Brown
 3. Buffalo Jones
 4. Edith Scheuerman
 5. Florence Wilson
 6. Georgia Matthews
 7. Gertrude Walker
 8. Jennie Barker (K-6)
 9. Jennie Wilson
 10. Phyllis (K-6)
 11. Victor Ornelas
- Intermediate List (5-6):**
12. Bernadine Sitts
 13. Charles O Stones
- Middle List (7-8):**
14. Horace Good
- High List (9-12):**
15. Kenneth Henderson
 16. Garden City

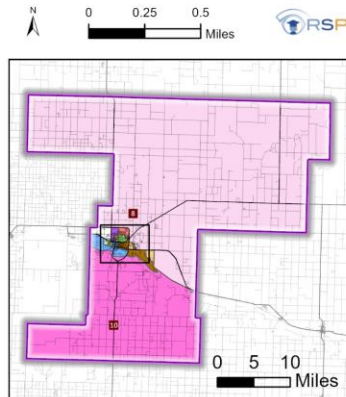
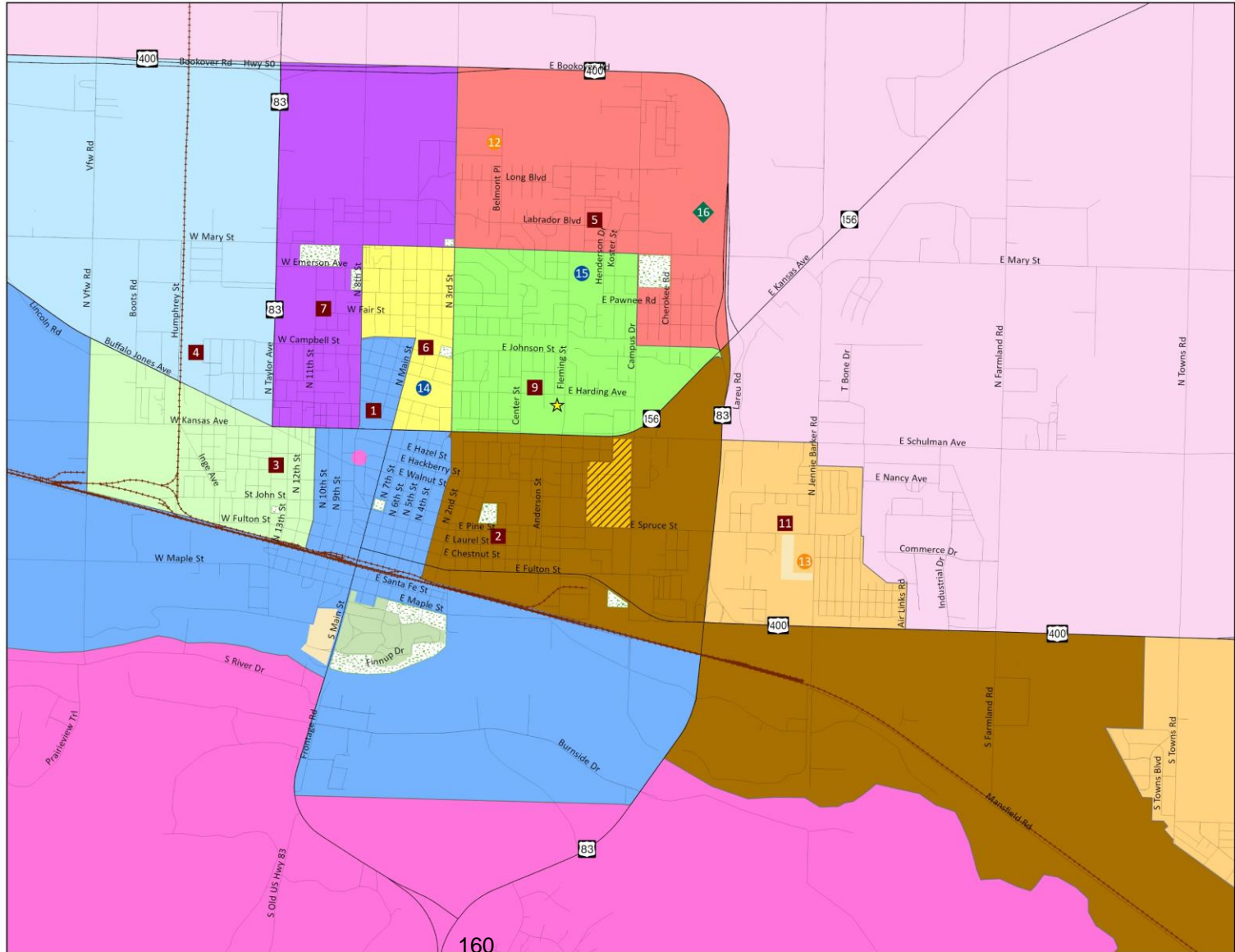

Map data provided by USD 457, Garden City, Finney County, USGS, and ESRI. Map created by RSP & Associates in December 2023.

Intermediate Boundary Map



Intermediate School Attendance Areas

- District Boundary
- District Office
- Early Childhood
- Elementary School
- Intermediate School
- Middle School
- High School
- Lee Richardson Zoo
- Garden City Community College
- Park
- Recreation

- School List:**
- Elementary List (K-4):**
1. Abe Hubert (K-6)
 2. Alta Brown
 3. Buffalo Jones
 4. Edith Scheurman
 5. Florence Wilson
 6. Georgia Matthews
 7. Gertrude Walker
 8. Jennie Barker (K-6)
 9. Jennie Wilson
 10. Phyllis (K-6)
 11. Victor Ornelas
- Intermediate List (5-6):**
12. Bernadine Sitts
 13. Charles O Stones
- Middle List (7-8):**
14. Horace Good
- High List (9-12):**
15. Kenneth Henderson
 16. Garden City

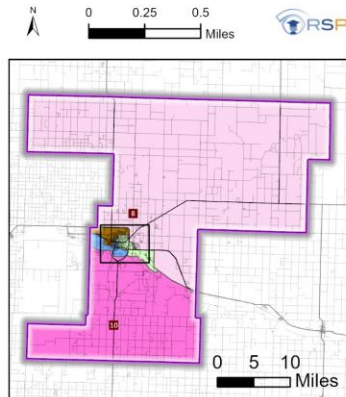
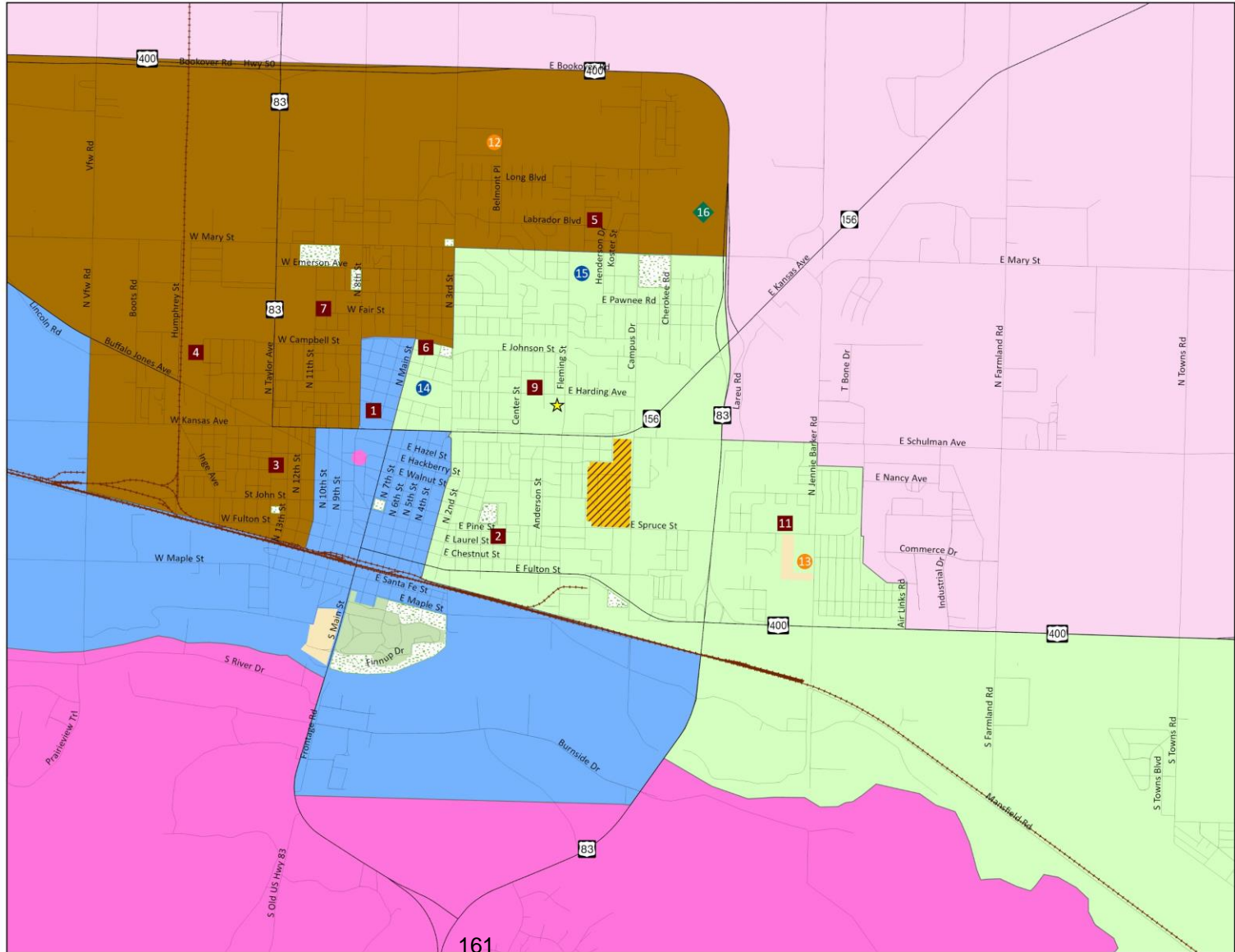

Map data provided by USD 457, Garden City, Finney County, USGS, and ESRI. Map created by RSP & Associates in December 2023.

RSP Planning Areas Map



Planning Areas-Detail

- District Boundary
- ★ District Office
- Early Childhood
- Elementary School
- Intermediate School
- Middle School
- ◆ High School
- Lee Richardson Zoo
- Garden City Community College
- Park
- Recreation

- School List:**
- Elementary List (K-4):
1. Abe Hubert (K-6)
 2. Alta Brown
 3. Buffalo Jones
 4. Edith Scheuerman
 5. Florence Wilson
 6. Georgia Matthews
 7. Gertrude Walker
 8. Jennie Barker (K-6)
 9. Jennie Wilson
 10. Phyllis (K-6)
 11. Victor Ornelas
- Intermediate List (5-6):
12. Bernadine Sitts
 13. Charles O Stones
- Middle List (7-8):
14. Horace Good
- High List (9-12):
15. Kenneth Henderson
 16. Garden City

- Year Built**
- Planning Areas
 - Before 2000
 - 2001 to 2005
 - 2006 to 2010
 - 2011 to 2015
 - After 2015

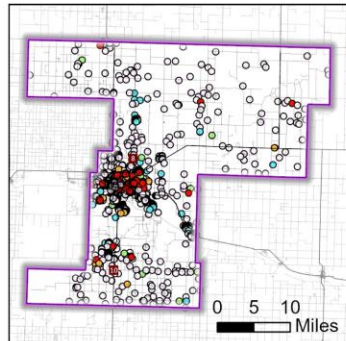
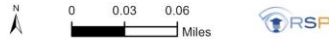

163

Map data provided by USD 457, Garden City, Finney County, USGS, and ESRI. Map created by RSP & Associates in December 2023.

Sophisticated Forecast Model Methodology

Built-Out $S_{c,t,x} = S_{c-1,t-1,x} * GC$

Let:
 S = The number of students, either an actual count or a projected count
 x = A subscript denoting an attendance area in the School District
 c = Grade level
 t = Time (years)
 GC = Growth component either modeling enrollment increase or decrease based on historical information, expressed as a real number

Developing $S_{c,t,x} = S_{c-1,t-1,x} + (BP_{t,x} * R_{c,x})$

Where: $BP_{t,x} = \left(\frac{(CP_x)(BT_x)(A_x)}{\sum_x (CP_x)(BT_x)(A_x)} \right) * CT$

Let:
 S = The number of students, either an actual count or a projected count
 x = A subscript denoting an attendance area in School District
 c = Grade level
 t = Time (years)
 BP = Building permit forecast as given by the Building Permit Allocation Model (BPAM) model
 R_{c,x} = Student Enrollment ratio of cohort c in planning area x
 CP = Capacity of a planning area as expressed by available housing units
 BT = Building history trend of planning area
 A = An index which models the likelihood of development
 CT = Building permit control total forecast

This is the **central focus** of everything RSP does.

The model is based on what is happening in a school district. The best data is statistically analyzed to provide an accurate enrollment forecast. The District will be able to use RSP's report and maps to better understand demographic trends, school utilization, and the timing of construction projects.

The SFM is...

- a social science... not an exact science; it identifies behavior trends to determine the propensity of them to be recreated
- valuable in how our team created and analyzes the geography at a planning area level for any commonality which while help produce an accurate forecast

Some variables examined for each planning area (but not limited to) are...

- natural cohort (district data)
- planning area subdivision lifecycle (a RSP variable)
- the value of homes (county assessor data)
- type of residential units like single-family, multi-family, townhome, mobile home, etc. (county assessor data)
- year units were built
- estimated female population (census data)
- estimated 0-4 population (census data)
- existing land use (county and city data)
- future land use (county and city data)
- capital improvement plan (county and city data)
- future development (county and city data)
- in-migration of students (district data) & out-migration of students (district data)

Birth Rate Information



Finney County Live Births and Garden City Kindergarteners 5 Years Later

Calendar Year	# Live Births	Birth Change	% Birth Change	School Year	# Kdg	%Kdg of Live Births
2014	690			2019/20	656	95.1%
2015	725	35	5.1%	2020/21	480	66.2%
2016	655	-70	-9.7%	2021/22	499	76.2%
2017	625	-30	-4.6%	2022/23	576	92.2%
2018	621	-4	-0.6%	2023/24	548	88.2%
2019	576	-45	-7.2%	2024/25	381	548
2020	548	-28	-4.9%	2025/26	363	521
2021	552	4	0.7%	2026/27	365	525
2022	563	11	2.0%	2027/28	373	535
3-Year Average	554.3	-4				
3-Year Weighted Average	556.8	2.2				

Low Range
 High Range

Source: Kansas Department of Health and Environment (KDHE) and USD 457

Live Birth Observations

- Tracks the number of live births and the corresponding number of kindergarten students five years later
- The number of live births have been decreasing. This is consistent with national and state trends.
- 3-year average of 4 less live births per year – the past four years there has been less than 600 live births per year
- Garden City enrolls around 70-90% of county live births in kindergarten five years later
- When live births were at the highest in 2015, kindergarten share of live births was at its lowest
- Kindergarten enrollment has varied between 480-656 students over the past five years

Main Takeaway: The decline of live births in the Finney County can potentially result in smaller kindergarten classes.

RSP recommends continuing to monitor this variable for more understanding on demographic trends as propensity of Finney County live births enrolling in Garden City Public Schools.

Past Enrollment by Grade

KANSAS SCHOOL DISTRICT - Dept of Education

Enrollment By Grade

Year	K	1st	2nd	3rd	4th	5th	6th	7th	8th	9th	10th	11th	12th	K-12		
														Total	Change	% Change
2007/08	609	622	559	559	578	513	501	523	515	558	508	454	381	6,880		
2008/09	618	566	595	563	551	573	491	533	524	579	473	437	400	6,903	23	0.3%
2009/10	664	567	544	597	566	546	570	535	520	610	514	422	404	7,059	156	2.3%
2010/11	645	622	536	549	609	586	559	585	546	581	516	472	404	7,210	151	2.1%
2011/12	694	596	584	535	527	619	570	573	594	563	528	454	416	7,253	43	0.6%
2012/13	676	615	570	545	519	512	594	584	566	665	507	475	418	7,246	-7	-0.1%
2013/14	617	627	575	545	531	514	496	613	575	612	588	477	423	7,193	-53	-0.7%
2014/15	663	580	621	582	539	523	512	534	610	619	589	545	423	7,340	147	2.0%
2015/16	643	604	563	615	568	529	536	545	553	634	601	529	496	7,416	76	1.0%
2016/17	601	645	575	548	606	556	516	539	546	582	601	547	475	7,337	-79	-1.1%
2017/18	544	535	627	549	534	593	556	544	531	576	577	566	447	7,179	-158	-2.2%
2018/19	548	504	519	608	546	523	589	587	541	565	558	529	483	7,100	-79	-1.1%
2019/20	533	518	468	515	571	538	509	614	580	560	539	496	439	6,880	-220	-3.1%
2020/21	542	504	485	455	511	548	525	527	588	602	533	483	412	6,715	-165	-2.4%
2021/22	552	505	491	480	449	500	538	549	513	662	511	482	414	6,646	-69	-1.0%
2022/23	495	538	482	476	476	439	504	561	530	519	575	525	443	6,563	-83	-1.2%
2023/24	502	478	534	486	470	468	449	524	551	547	521	557	440	6,527	-36	-0.5%

Source: Kansas Department of Education (2007/08 to 2018/19) and Garden City Public Schools (2019/20 to 2023/24) Note: Virtual Students are not included in enrollment.

Observations:

- Largest K-12 class in 2023/24 – 11th grade with 557 Students
- Smallest K-12 class in 2023/24 – 12th grade with 440 Students
- Graduating senior class is smaller than the incoming Kindergarten class which tends to increase total enrollment; however, enrollment has decreased every year since 2016/17
- Largest historical increase was from 2013/14 to 2014/15 with increase of 2.0%
- 2023/24 has the smallest grades since 2007/08 in: 1st, 6th, and 7th grades

Cohort Change by Grade

Enrollment Grade Change

From	To	K	1st	2nd	3rd	4th	5th	6th	7th	8th	9th	10th	11th	K-12	
		1st	2nd	3rd	4th	5th	6th	7th	8th	9th	10th	11th	12th	Change	% Change
2007/08	2008/09	-43	-27	4	-8	-5	-22	32	1	64	-85	-71	-54	23	0.3%
2008/09	2009/10	-51	-22	2	3	-5	-3	44	-13	86	-65	-51	-33	156	2.2%
2009/10	2010/11	-42	-31	5	12	20	13	15	11	61	-94	-42	-18	151	2.0%
2010/11	2011/12	-49	-38	-1	-22	10	-16	14	9	17	-53	-62	-56	43	0.6%
2011/12	2012/13	-79	-26	-39	-16	-15	-25	14	-7	71	-56	-53	-36	-7	-0.1%
2012/13	2013/14	-49	-40	-25	-14	-5	-16	19	-9	46	-77	-30	-52	-53	-0.7%
2013/14	2014/15	-37	-6	7	-6	-8	-2	38	-3	44	-23	-43	-54	147	1.9%
2014/15	2015/16	-59	-17	-6	-14	-10	13	33	19	24	-18	-60	-49	76	1.0%
2015/16	2016/17	2	-29	-15	-9	-12	-13	3	1	29	-33	-54	-54	-79	-1.0%
2016/17	2017/18	-66	-18	-26	-14	-13	0	28	-8	30	-5	-35	-100	-158	-2.0%
2017/18	2018/19	-40	-16	-19	-3	-11	-4	31	-3	34	-18	-48	-83	-79	-1.0%
2018/19	2019/20	-30	-36	-4	-37	-8	-14	25	-7	19	-26	-62	-90	-220	-2.9%
2019/20	2020/21	-29	-33	-13	-4	-23	-13	18	-26	22	-27	-56	-84	-165	-2.2%
2020/21	2021/22	-37	-13	-5	-6	-11	-10	24	-14	74	-91	-51	-69	-69	-1.0%
2021/22	2022/23	-14	-23	-15	-4	-10	4	23	-19	6	-87	14	-39	-83	-1.2%
2022/23	2023/24	-17	-4	4	-6	-8	10	20	-10	17	2	-18	-85	-36	-0.5%
3-Year Average		-22.7	-13.3	-5.3	-5.3	-9.7	1.3	22.3	-14.3	32.3	-58.7	-18.3	-64.3	-62.7	-0.9%
3-Year Weighted Average		-19.3	-11.8	-3.8	-5.3	-9.2	4.7	21.7	-13.7	22.8	-43.2	-12.8	-67.0	-57.2	-0.8%

Source: Kansas Department of Education (2007/08 to 2018/19) and Garden City Public Schools (2019/20 to 2023/24)

Observations:

- Largest 3-year average K-12 class cohort increase – 8th to 9th grade **(+32.3)**
- Largest 3-year average K-12 class cohort decrease – 11th to 12th grade **(-64.3)**
- Overall percent change from previous year of -0.5% **(decrease of -36 students)**
- Over past 5 years, cohorts have decreased on average by more than 200+ students between starting kindergarten and graduating 12th grade

167

3-Year Student Migration Trend

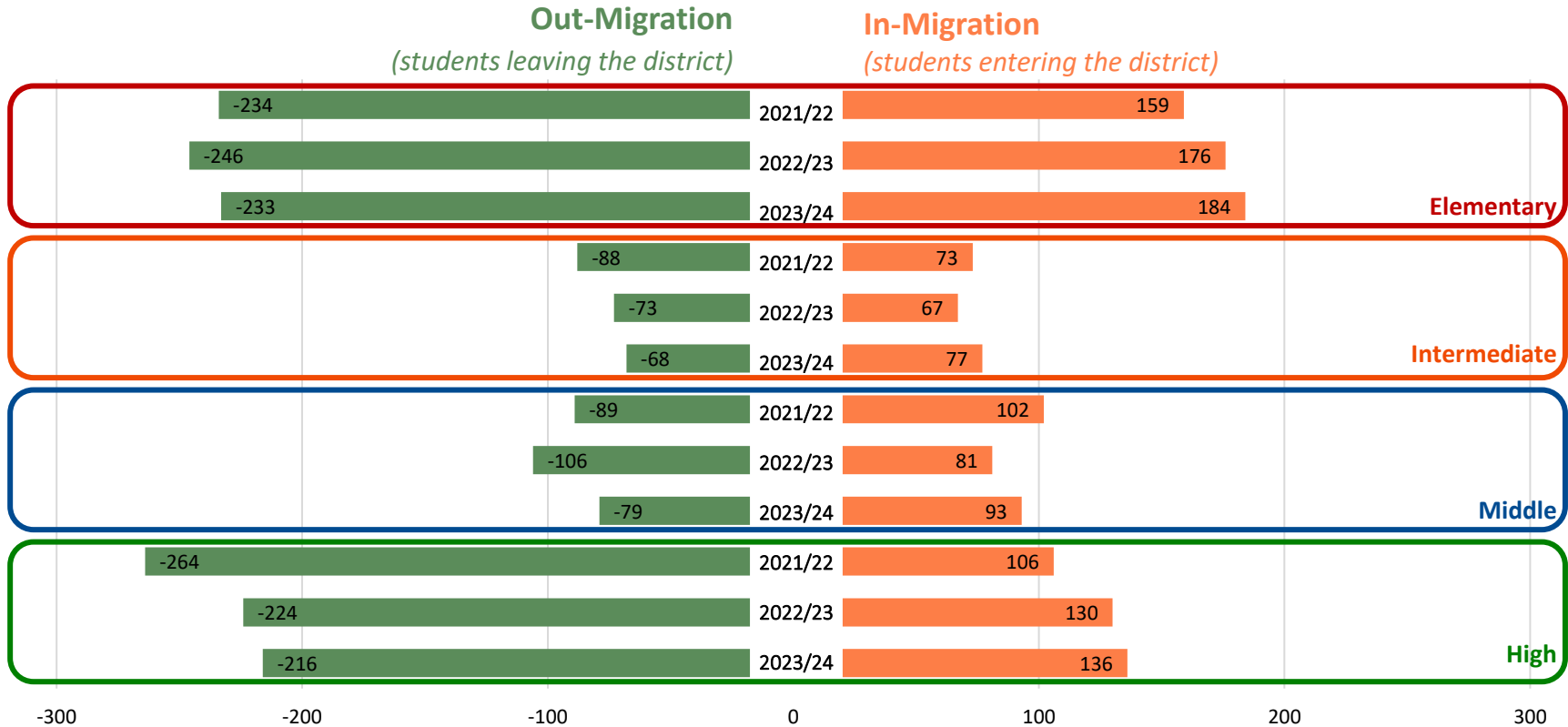

Source: Garden City Public Schools and RSP

Definition

Out-Migration: Shows number of students in grade K to 11th that were attending the District in the previous year, but are not attending the District in the current year.

In-Migration: Shows number of students in grade 1st to 12th that are attending the District in the current year, but were not attending the District in the previous year.

Observations

- 2021/22 lost 675 students and gained 440 students; **NET: -235**
- 2022/23 lost 649 students and gained 454 students; **NET: -195**
- 2023/24 lost 596 students and gained 490 students; **NET: -106**

Main Takeaway: The district had a negative loss of transfer students in for the past three years. High School and Elementary levels to have more than 200 student migrating out each year.

Out of District Student Analysis

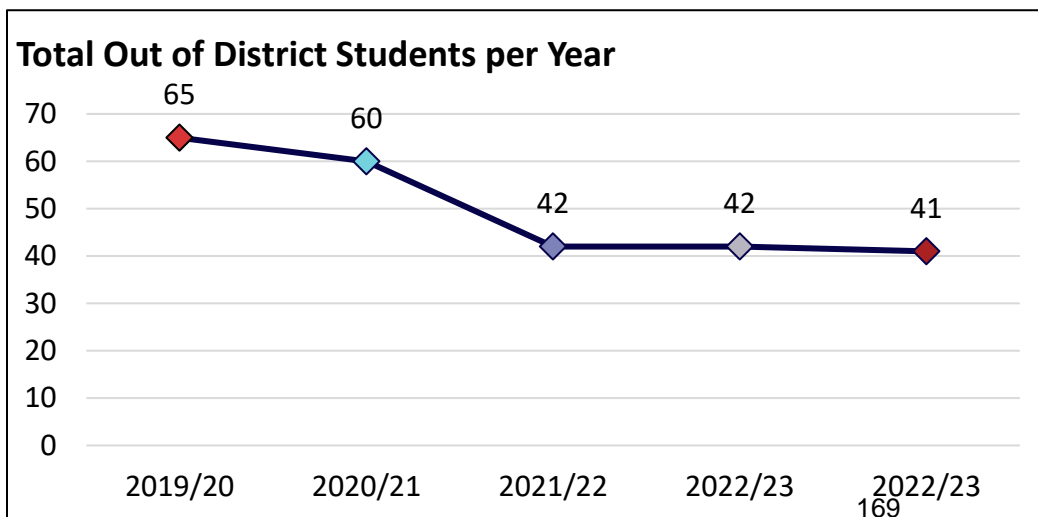
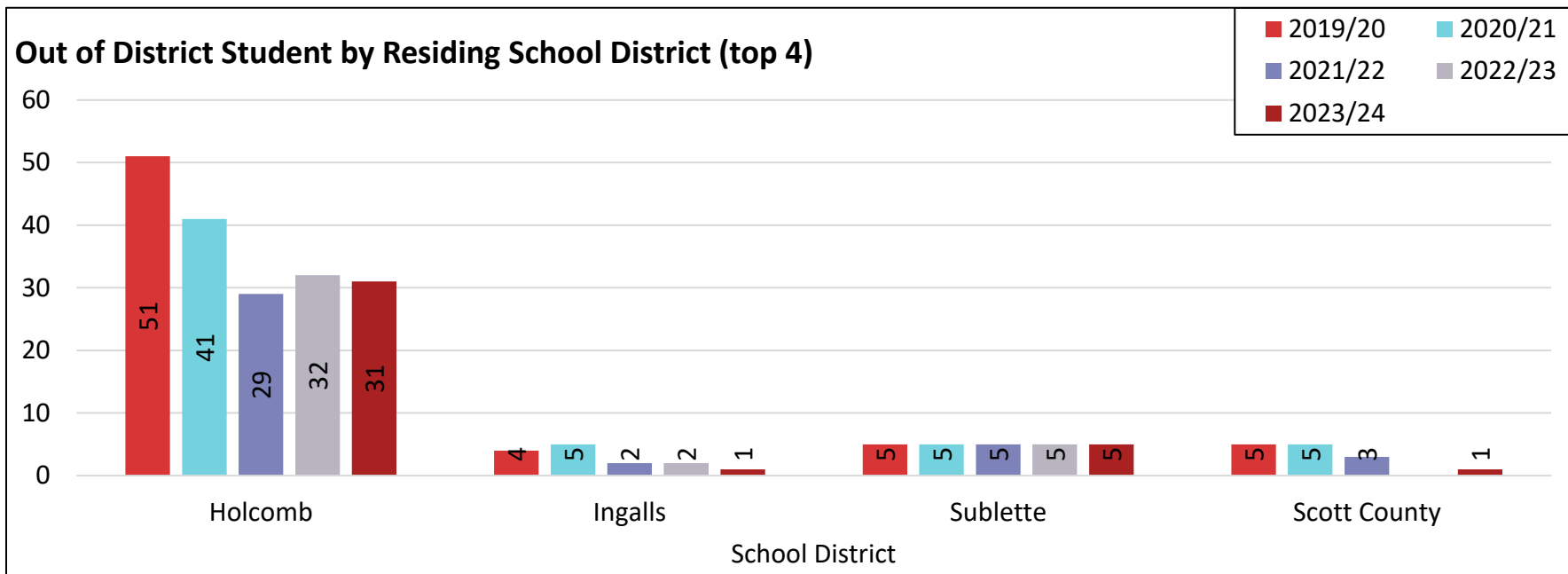

Source: Garden City Public Schools and RSP

Observations

- The number of student out of the district enrolling in Garden City has been decreasing
- Holcomb School District tends to contribute the largest share of out of district students
- 41 total students this year reside out of the district boundary

Main Takeaway: Understanding this variable is important in knowing how future Open Enrollment policy changes may impact future students.

Student Count Change Map



Student Count Change from 2019/20 to 2023/24 in Grades K-12

- District Boundary
- District Office
- Early Childhood
- Elementary School
- Intermediate School
- Middle School
- High School
- Lee Richardson Zoo
- Garden City Community College
- Park
- Recreation

- School List:**
- Elementary List (K-4):
1. Abe Hubert (K-6)
 2. Alta Brown
 3. Buffalo Jones
 4. Edith Scheurman
 5. Florence Wilson
 6. Georgia Matthews
 7. Gertrude Walker
 8. Jennie Barker (K-6)
 9. Jennie Wilson
 10. Phyllis (K-6)
 11. Victor Ornelas
- Intermediate List (5-6):
12. Bernadine Sitts
 13. Charles O Stines
- Middle List (7-8):
14. Horace Good
- High List (9-12):
15. Kenneth Henderson
 16. Garden City

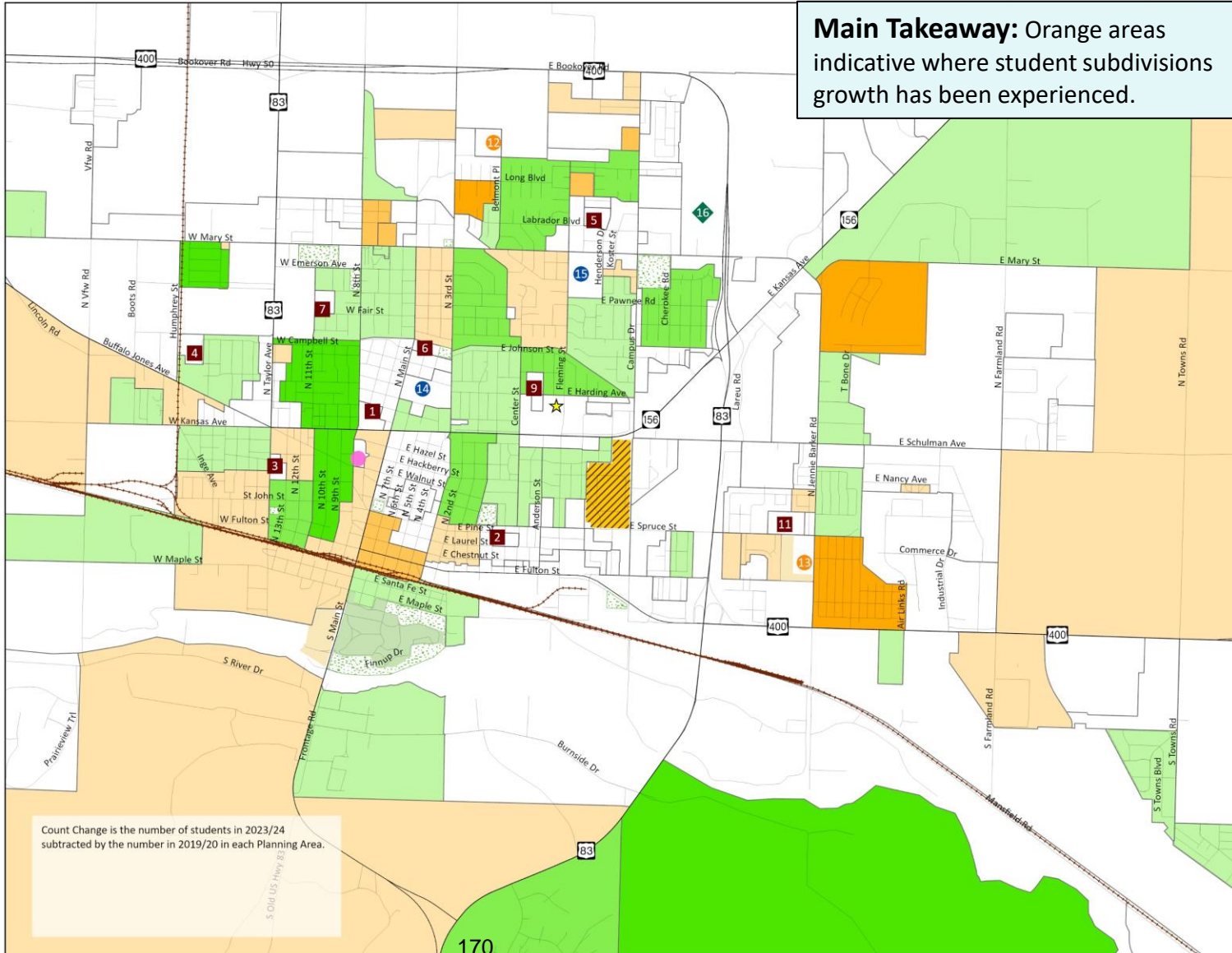
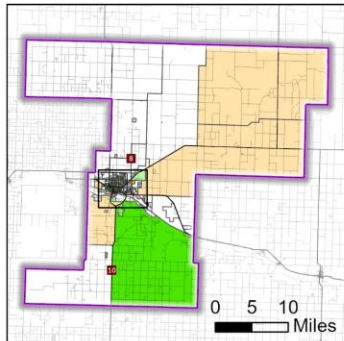
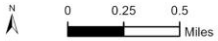

Count Change is the number of students in 2023/24 subtracted by the number in 2019/20 in each Planning Area.

Map data provided by USD 457, Garden City, Finney County, USGS, and ESRI. Map created by RSP & Associates in December 2023.

Heat Map



Student "Heat" Density in 2023/24 in Grades K-12

- District Boundary
- District Office
- Early Childhood
- Elementary School
- Intermediate School
- Middle School
- High School
- Lee Richardson Zoo
- Garden City Community College
- Park
- Recreation

- School List:**
- Elementary List (K-4):
1. Abe Hubert (K-6)
 2. Alta Brown
 3. Buffalo Jones
 4. Edith Scheurman
 5. Florence Wilson
 6. Georgia Matthews
 7. Gertrude Walker
 8. Jennie Barker (K-6)
 9. Jennie Wilson
 10. Plymell (K-6)
 11. Victor Ornelas
- Intermediate List (5-6):
12. Bernadine Sitts
 13. Charles O Stones
- Middle List (7-8):
14. Horace Good
- High List (9-12):
15. Kenneth Henderson
 16. Garden City

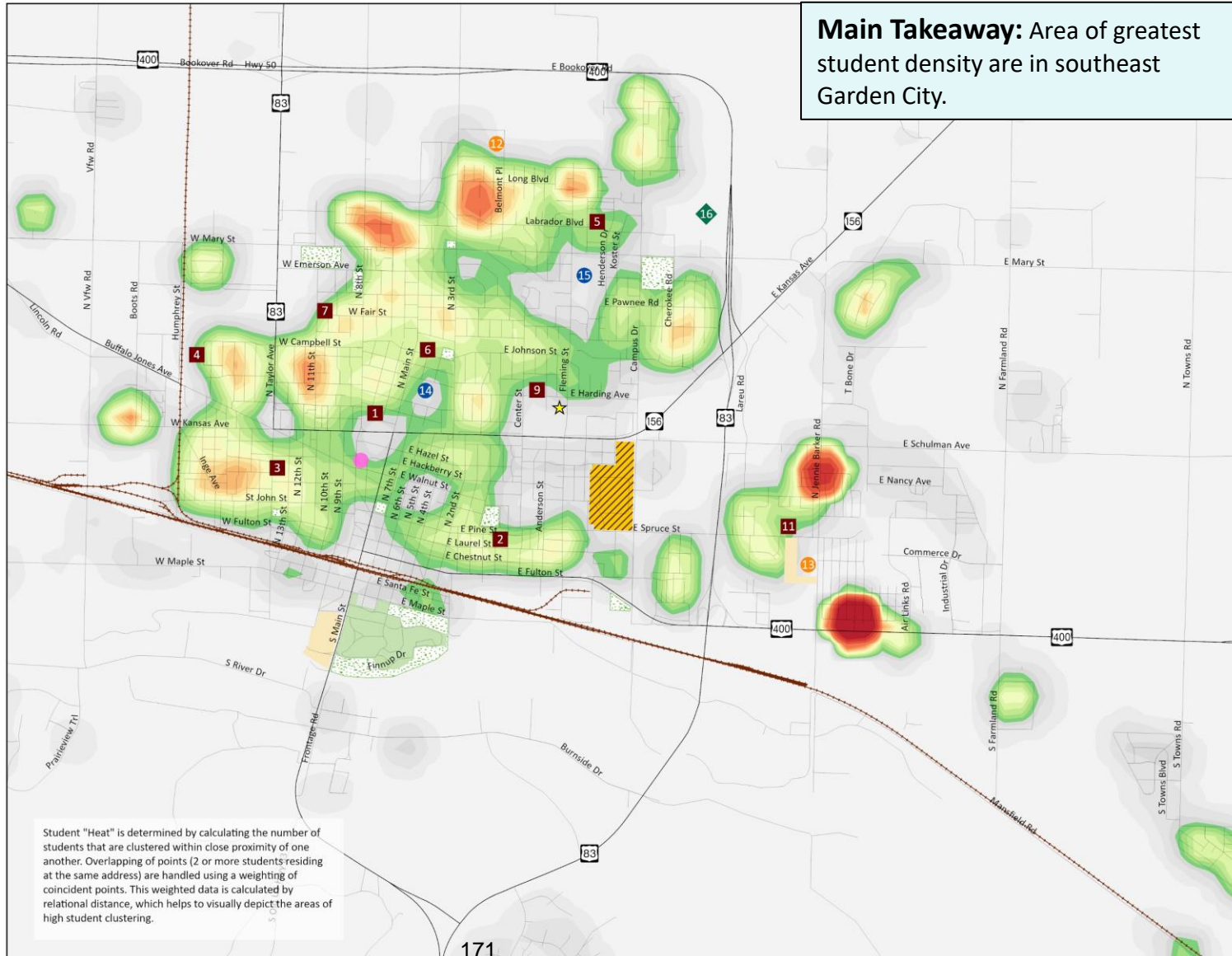
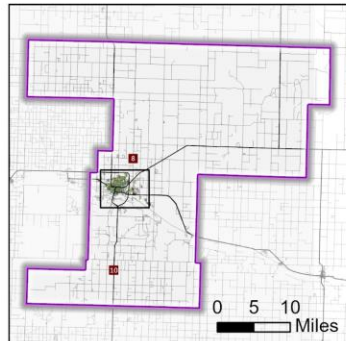
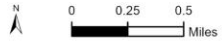
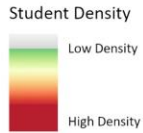

Student "Heat" is determined by calculating the number of students that are clustered within close proximity of one another. Overlapping of points (2 or more students residing at the same address) are handled using a weighting of coincident points. This weighted data is calculated by relational distance, which helps to visually depict the areas of high student clustering.

Map data provided by USD 457, Garden City, Finney County, USGS, and ESRI. Map created by RSP & Associates in December 2023.

Heat Density Change Map



Student "Heat" Density Difference from 2019/20 to 2023/24 in Grades K-12

- District Boundary
- District Office
- Early Childhood
- Elementary School
- Intermediate School
- Middle School
- High School
- Lee Richardson Zoo
- Garden City Community College
- Park
- Recreation

- School List:**
- Elementary List (K-4):
1. Abe Hubert (K-6)
 2. Alta Brown
 3. Buffalo Jones
 4. Edith Scheurman
 5. Florence Wilson
 6. Georgia Matthews
 7. Gertrude Walker
 8. Jennie Barker (K-6)
 9. Jennie Wilson
 10. Plymell (K-6)
 11. Victor Ornelas
- Intermediate List (5-6):
12. Bernadine Sitts
 13. Charles O Stones
- Middle List (7-8):
14. Horace Good
- High List (9-12):
15. Kenneth Henderson
 16. Garden City

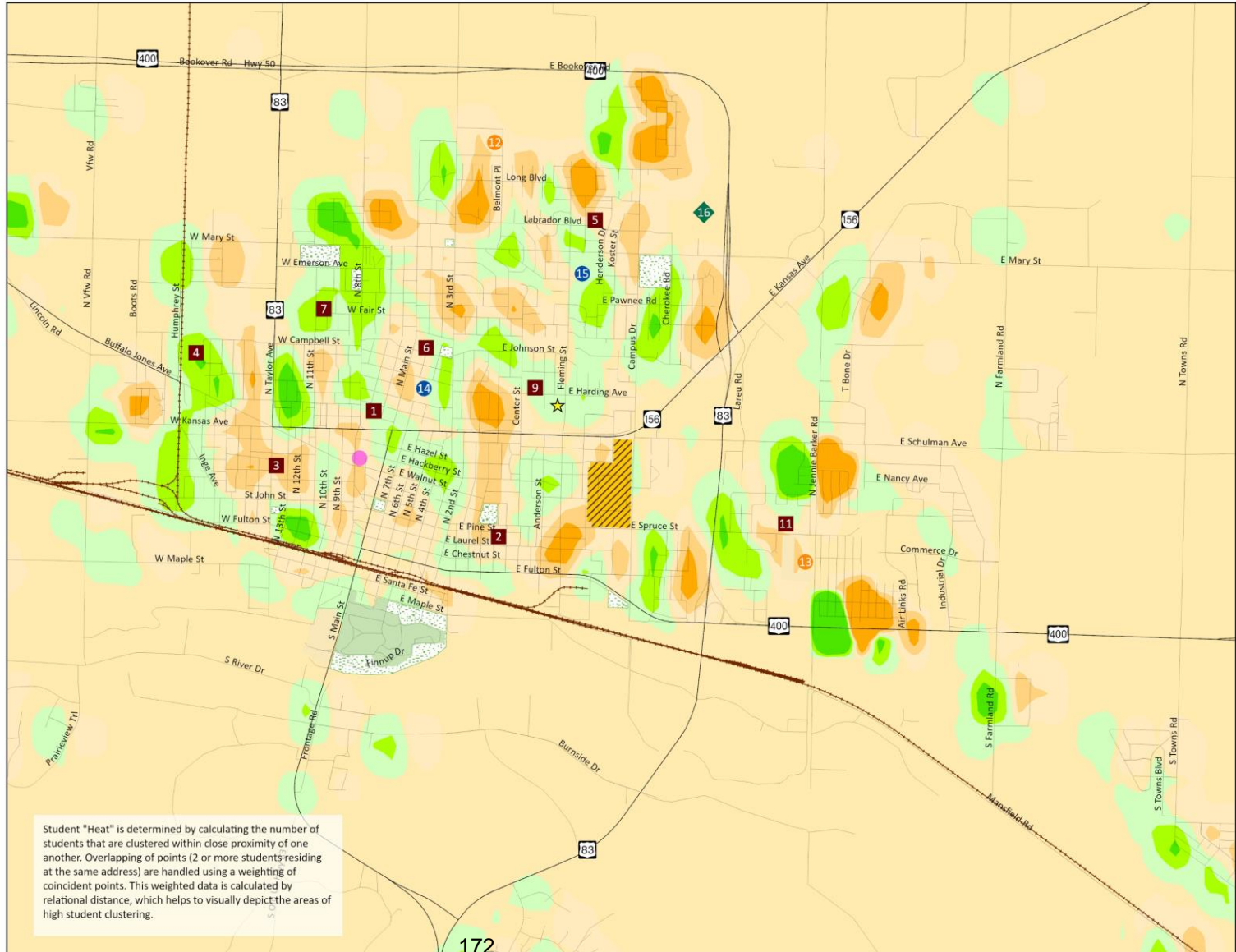
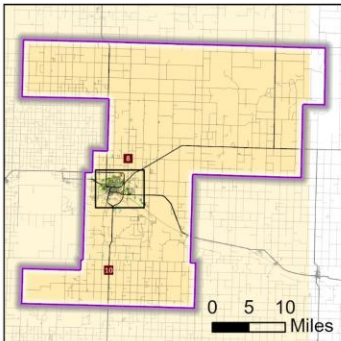
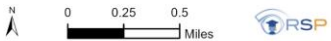

Student "Heat" is determined by calculating the number of students that are clustered within close proximity of one another. Overlapping of points (2 or more students residing at the same address) are handled using a weighting of coincident points. This weighted data is calculated by relational distance, which helps to visually depict the areas of high student clustering.

Map data provided by USD 457, Garden City, Finney County, USGS, and ESRI. Map created by RSP & Associates in December 2023.

Enrollment Observation and Conclusion

The following are some general enrollment observations:

- RSP & Associates monitors almost 250 planning areas for demographic, development, and enrollment data sets
- Live births in Finney County have decreased to less than 600 births per year the past four years
- District enrollment decreased by 36 students from last year
 - District enrollment has decreased consecutively since 2016/17
 - Most grade levels decrease as they work their way through the system
- Graduating senior classes are similar in size to the incoming kindergarten classes indicating a stabilization of enrollment
- District tends to have more students migrating out than new students migrating into the district
- Greatest student density is southeast of Charles O Stones intermediate Schools
- Open enrollment trends should continually be analyzed as change to open enrollment policy have impact on enrollment outlook
- If negative migration and lower live births continue, the district will have some difficulties in having a larger future enrollment

Part Two: Development and Growth Trends



Population, Development, & Enrollment

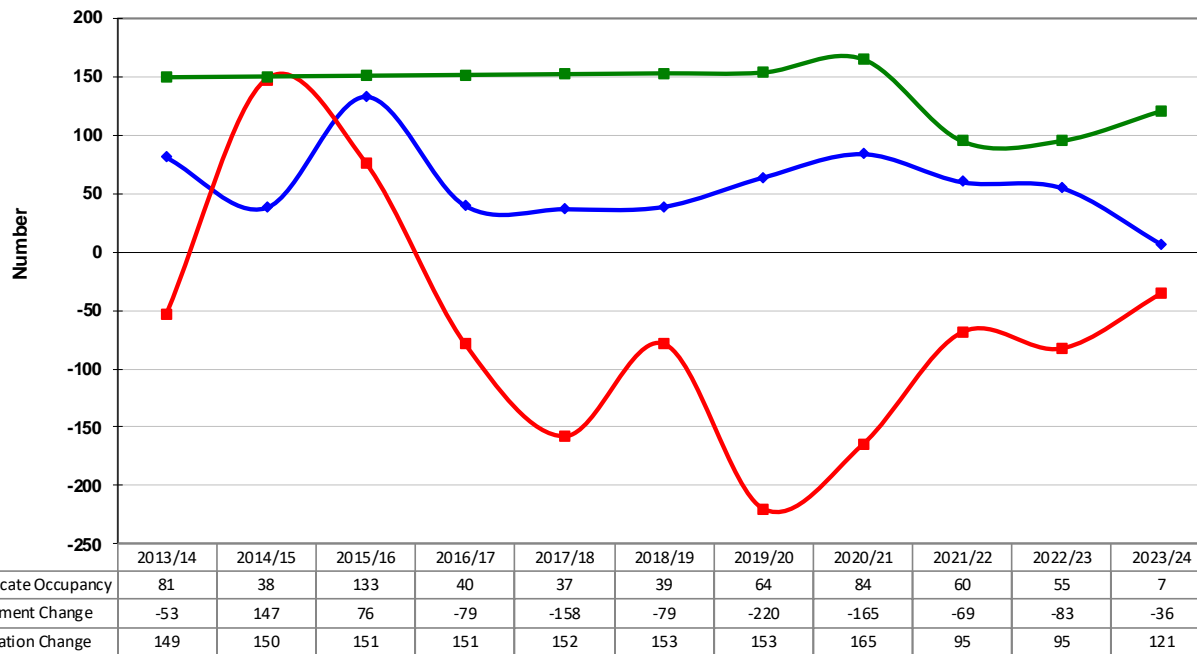

Source: Finney County, Census, Garden City, Garden City Public Schools and RSP

Benchmark data to determine if there is a correlation between:

- Population change
- Building activity
- School enrollment

Graphic Explanation

- **BLUE LINE:** Building activity has averaged about 55+ units a year (Limited residential development in the past)
- **GREEN LINE:** Census data indicates a stable, increasing population
 - Population shows the estimate growth of the whole decade
 - New decennial census often affect year-to-year change
- **RED LINE:** Student enrollment has been generally decreasing year to year
 - Average loss of 65 students per year since 2013/14

Student Yield Rate: Single-Family



Schools	2019	2020	2021	2022	2023	Avg
Abe Hubert Elementary	19	17	17	17	16	17.2
Alta Brown Elementary	18	17	16	17	17	17
Buffalo Jones Elementary	20	20	19	20	21	20
Edith Scheurman Elementary	23	22	20	19	18	20.4
Florence Wilson Elementary	22	20	19	19	18	19.6
Georgia Matthews Elementary	23	22	19	20	19	20.6
Gertrude Walker Elementary	21	21	22	21	20	21
Jennie Barker Elementary	20	22	20	19	19	20
Jennie Wilson Elementary	18	16	17	17	16	16.8
Plymell Elementary	26	22	22	19	17	21.2
Victor Ornelas Elementary	28	28	30	28	27	28.2
District (K-4):	21	20	19	19	19	19.6

Source: Finney County, Garden City Public Schools, and RSP

Single-Family Yield Rate Observations

- Table shows the number of students per 100 single-family (SF) units by year and by elementary boundary
- District sees on average 19.6 K-4 students per 100 single-family households
- Victor Ornelas Elementary has the largest 2023 SF yield rate with 27 students per 100 single-family households
- Abe Hubert and Jennie Wilson have the smallest 2023 SF Yield rate with 16 students per 100 single-family households
- The district average yield rate has been decreasing over the past five years indicating less students are being generated from the single-family housing inventory
- Adding new housing inventory can increase the yield rate – **There were 421 single-family homes built from 2013 to 2023**

Table Legend

-  +3 and greater from District Average
-  -3 and greater from District Average

176

Student Yield Rate: Multi-Family



Schools	2019	2020	2021	2022	2023	Avg
Abe Hubert Elementary	23	24	23	22	23	23
Alta Brown Elementary	19	19	20	22	19	19.8
Buffalo Jones Elementary	23	23	23	21	20	22
Edith Scheurman Elementary	29	32	30	27	27	29
Florence Wilson Elementary	16	15	15	15	20	16.2
Georgia Matthews Elementary	9	13	11	7	0	8
Gertrude Walker Elementary	26	23	25	26	25	25
Jennie Barker Elementary	3	3	3	1	6	3.2
Jennie Wilson Elementary	3	4	4	4	5	4
Plymell Elementary	29	22	20	16	14	20.2
Victor Ornelas Elementary	36	36	39	39	40	38
District (K-4):	21	21	21	21	22	21.2

Source: Finney County, Garden City Public Schools, and RSP

Multi-Family Yield Rate Observations

- Table shows the number of students per 100 multi-family (MF) units by year and by elementary boundary
- District sees on average 21.2 K-4 students per 100 multi-family households
- Victor Ornelas Elementary has the largest 2023 MF yield rate with 40 students per 100 multi-family households
- Georgia Matthews Elementary has the smallest 2023 MF yield rate with 0 students per 100 multi-family households
- The district average yield rate has been stable around 21 students per 100 MF units
- Adding new housing inventory can increase the yield rate – **There was 217 multi-family homes built from 2013 to 2023**

Table Legend

-  +3 and greater from District Average
-  -3 and greater from District Average

Average Year Built Map



Average Year Built

- District Boundary
- District Office
- Early Childhood
- Elementary School
- Intermediate School
- Middle School
- High School
- Lee Richardson Zoo
- Garden City Community College
- Park
- Recreation

- School List:**
- Elementary List (K-4):
1. Abe Hubert (K-6)
 2. Alta Brown
 3. Buffalo Jones
 4. Edith Scheuerman
 5. Florence Wilson
 6. Georgia Matthews
 7. Gertrude Walker
 8. Jennie Barker (K-6)
 9. Jennie Wilson
 10. Plymell (K-6)
 11. Victor Ornelas
- Intermediate List (5-6):
12. Bernadine Sitts
 13. Charles O Stones
- Middle List (7-8):
14. Horace Good
- High List (9-12):
15. Kenneth Henderson
 16. Garden City

Average Year Built

- No Residential Data
- < 1990
- 1991 to 2000
- 2001 to 2010
- > 2010

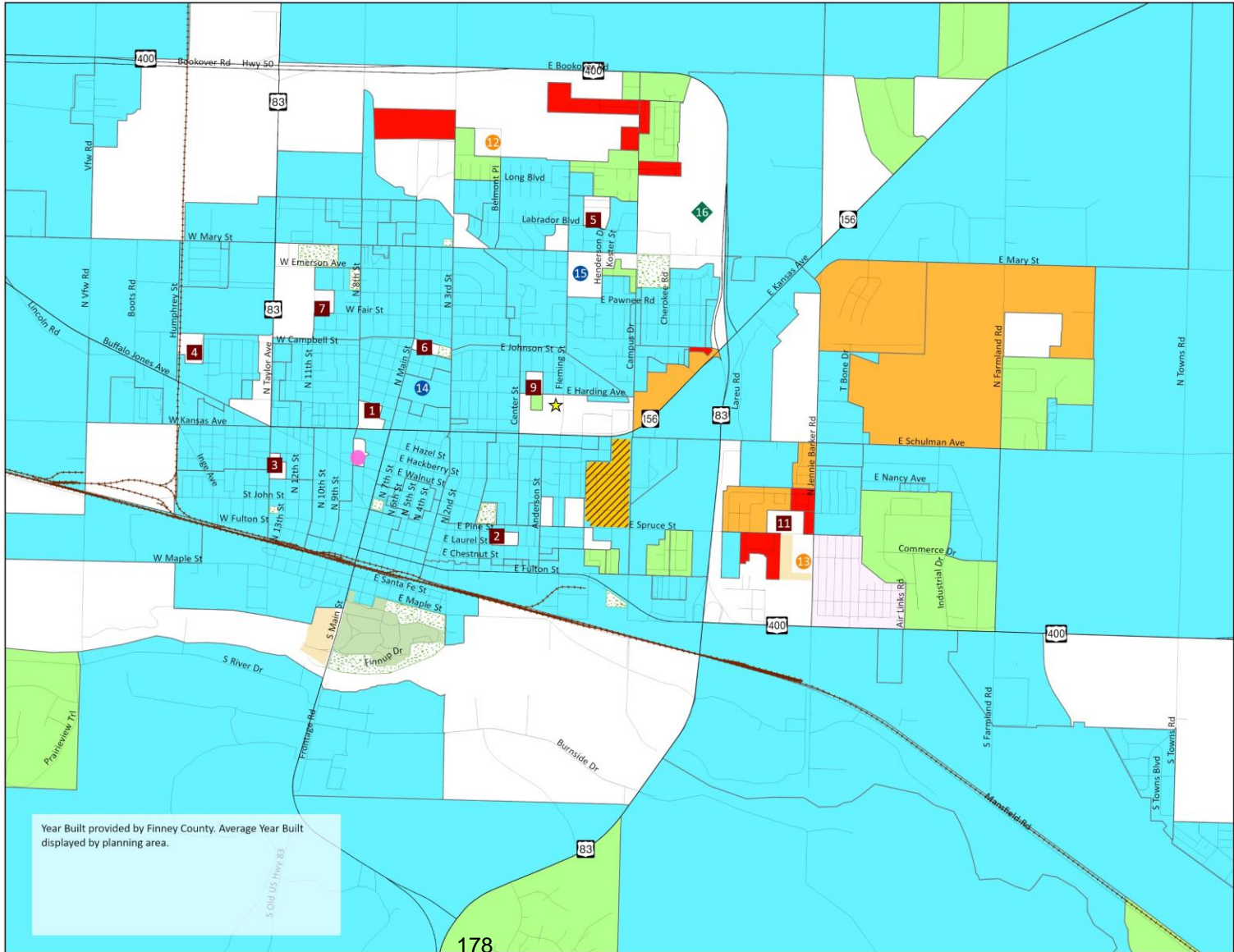

Year Built provided by Finney County. Average Year Built displayed by planning area.

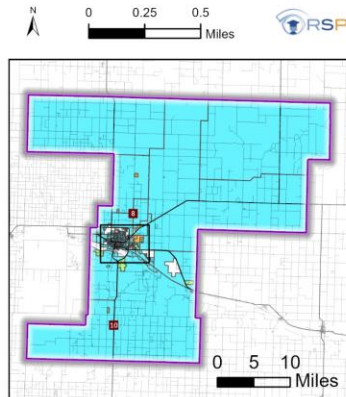

Map data provided by USD 457, Garden City, Finney County, USGS, and ESRI. Map created by RSP & Associates in December 2023.

Median Home Value Map



Median Home Value

- District Boundary
- District Office
- Early Childhood
- Elementary School
- Intermediate School
- Middle School
- High School
- Lee Richardson Zoo
- Garden City Community College
- Park
- Recreation

- School List:**
- Elementary List (K-4):
1. Abe Hubert (K-6)
 2. Alta Brown
 3. Buffalo Jones
 4. Edith Scheurman
 5. Florence Wilson
 6. Georgia Matthews
 7. Gertrude Walker
 8. Jennie Barker (K-6)
 9. Jennie Wilson
 10. Plymell (K-6)
 11. Victor Ornelas
- Intermediate List (5-6):
12. Bernadine Sitts
 13. Charles O Stones
- Middle List (7-8):
14. Horace Good
- High List (9-12):
15. Kenneth Henderson
 16. Garden City

- Median Home Value**
- No Residential Value
 - < \$75,000
 - \$75,000 to \$125,000
 - \$125,001 to \$200,000
 - \$200,001 to \$300,000
 - > \$300,000

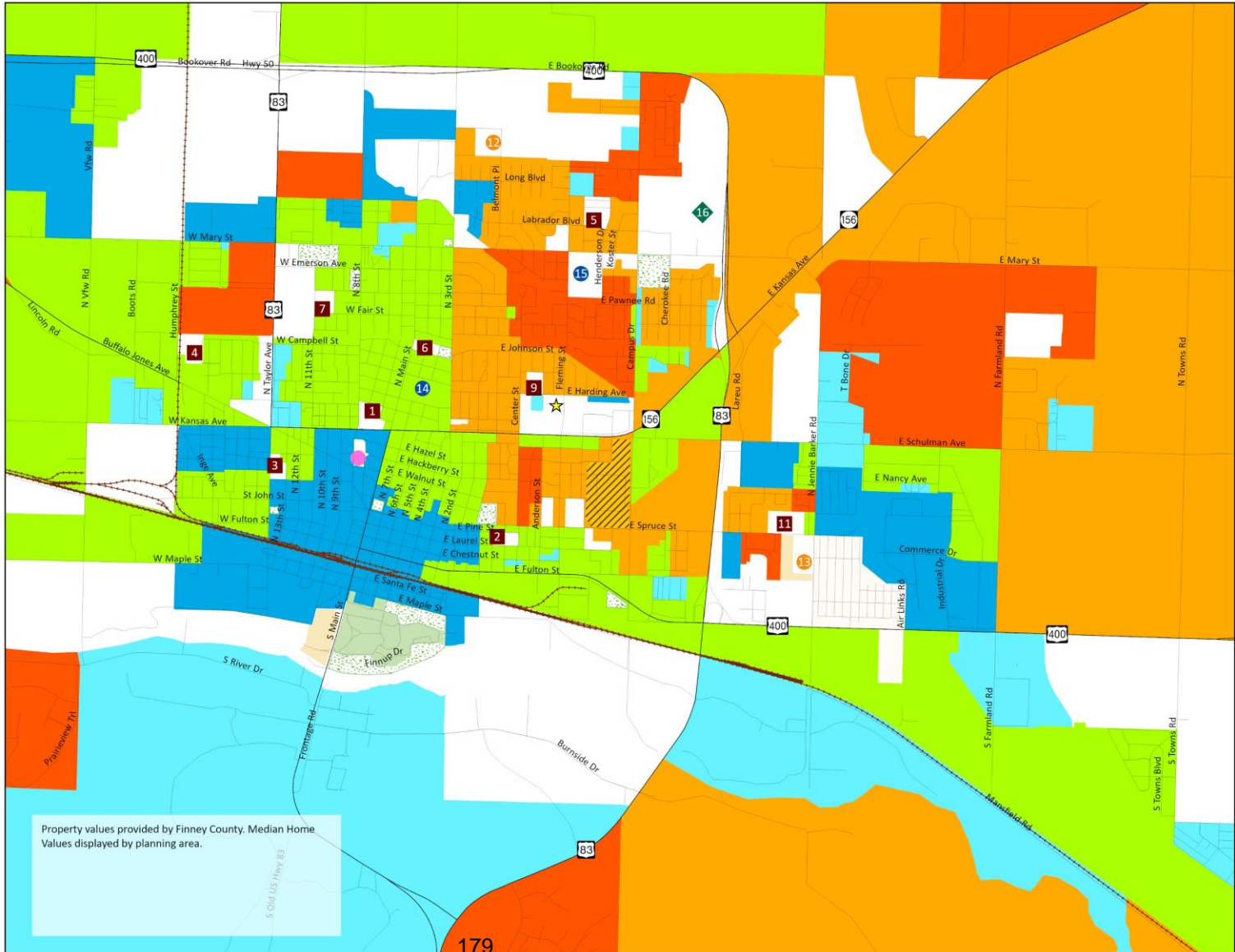
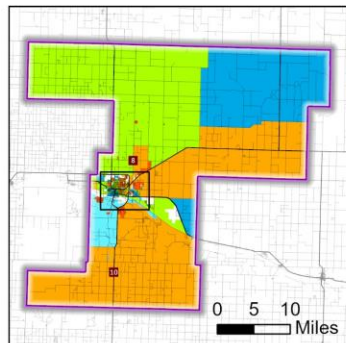
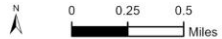

Map data provided by USD 457, Garden City, Finney County, USGS, and ESRI. Map created by RSP & Associates in December 2023.

Recent Year Built Map



Residential Year Built

- District Boundary
- ★ District Office
- Early Childhood
- Elementary School
- Intermediate School
- Middle School
- ◆ High School
- Lee Richardson Zoo
- Garden City Community College
- Park
- Recreation

- School List:**
- Elementary List (K-4):
1. Abe Hubert (K-6)
 2. Alta Brown
 3. Buffalo Jones
 4. Edith Scheuerman
 5. Florence Wilson
 6. Georgia Matthews
 7. Gertrude Walker
 8. Jennie Barker (K-6)
 9. Jennie Wilson
 10. Plymell (K-6)
 11. Victor Ornelas
- Intermediate List (5-6):
12. Bernadine Sitts
 13. Charles O Stones
- Middle List (7-8):
14. Horace Good
- High List (9-12):
15. Kenneth Henderson
 16. Garden City

Year Built

- 2019: 64 units
- 2020: 84 units
- 2021: 60 units
- 2022: 55 units
- 2023: 7 units

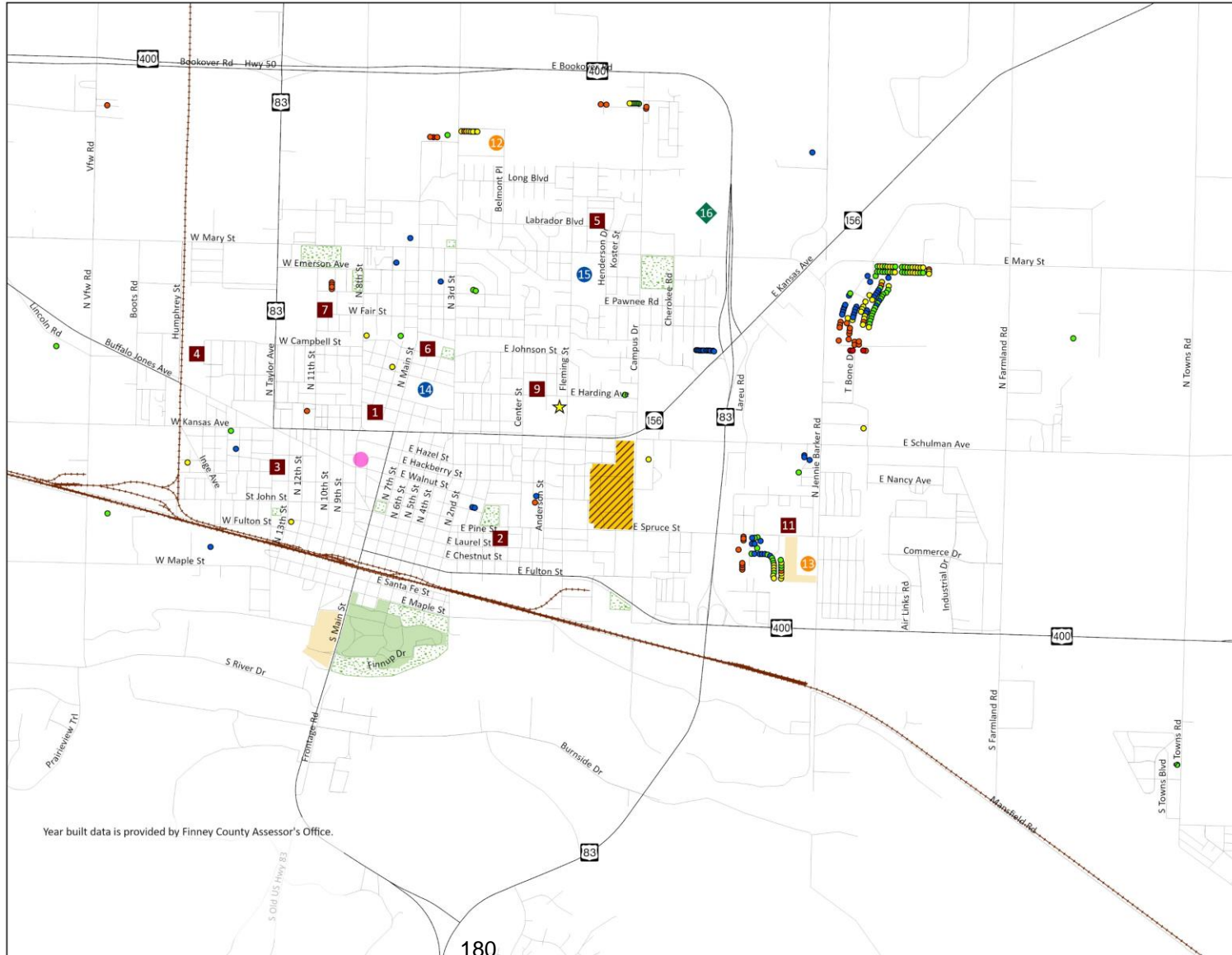
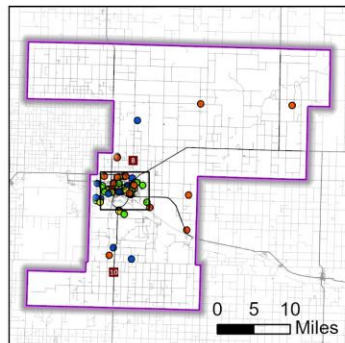

Year built data is provided by Finney County Assessor's Office.

180

Map data provided by USD 457, Garden City, Finney County, USGS, and ESRI. Map created by RSP & Associates in December 2023.

Development Activity Over Time

New V.S. Existing Units by Decade Built

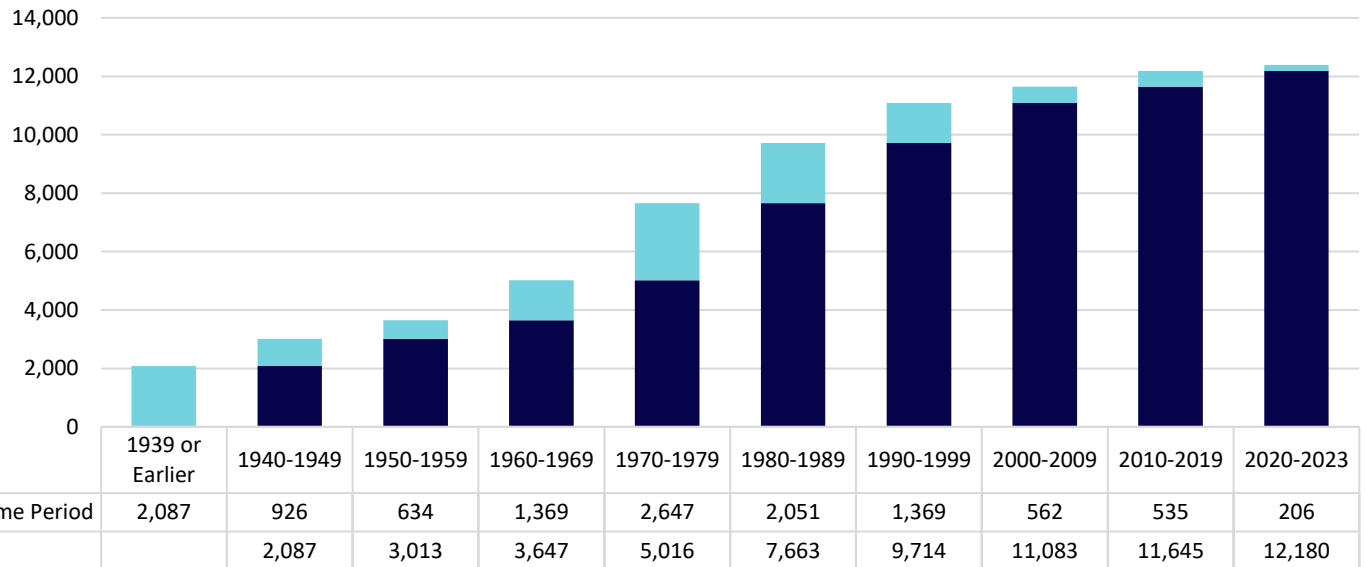

Source: Finney County and ESRI

Observations:

- Table has been created to illustrate the number of units by year built
- The average number of units built per year from 2010 to 2019 (53.5 per year) is lower than from 2000 to 2009 (56.2 per year)
- The decade with the most units built was 1970 to 1979 with over 2,500 new units built
- The average year for all units built was 1967 and median year built is 1974
- Development activity in the past 30 years has been minimal¹⁸¹ in comparison to the 1960-1990s

Growth Area Map



Growth Areas

- District Boundary
- District Office
- Early Childhood
- Elementary School
- Intermediate School
- Middle School
- High School
- Lee Richardson Zoo
- Garden City Community College
- Park
- Recreation

- School List:**
- Elementary List (K-4):
1. Abe Hubert (K-6)
 2. Alta Brown
 3. Buffalo Jones
 4. Edith Scheurman
 5. Florence Wilson
 6. Georgia Matthews
 7. Gertrude Walker
 8. Jennie Barker (K-6)
 9. Jennie Wilson
 10. Plymell (K-6)
 11. Victor Ornelas
- Intermediate List (5-6):
12. Bernadine Sitts
 13. Charles O Stines
- Middle List (7-8):
14. Horace Good
- High List (9-12):
15. Kenneth Henderson
 16. Garden City

Growth Areas

- Current
- 5 Year
- 10 Year

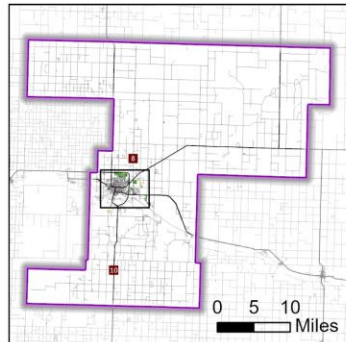
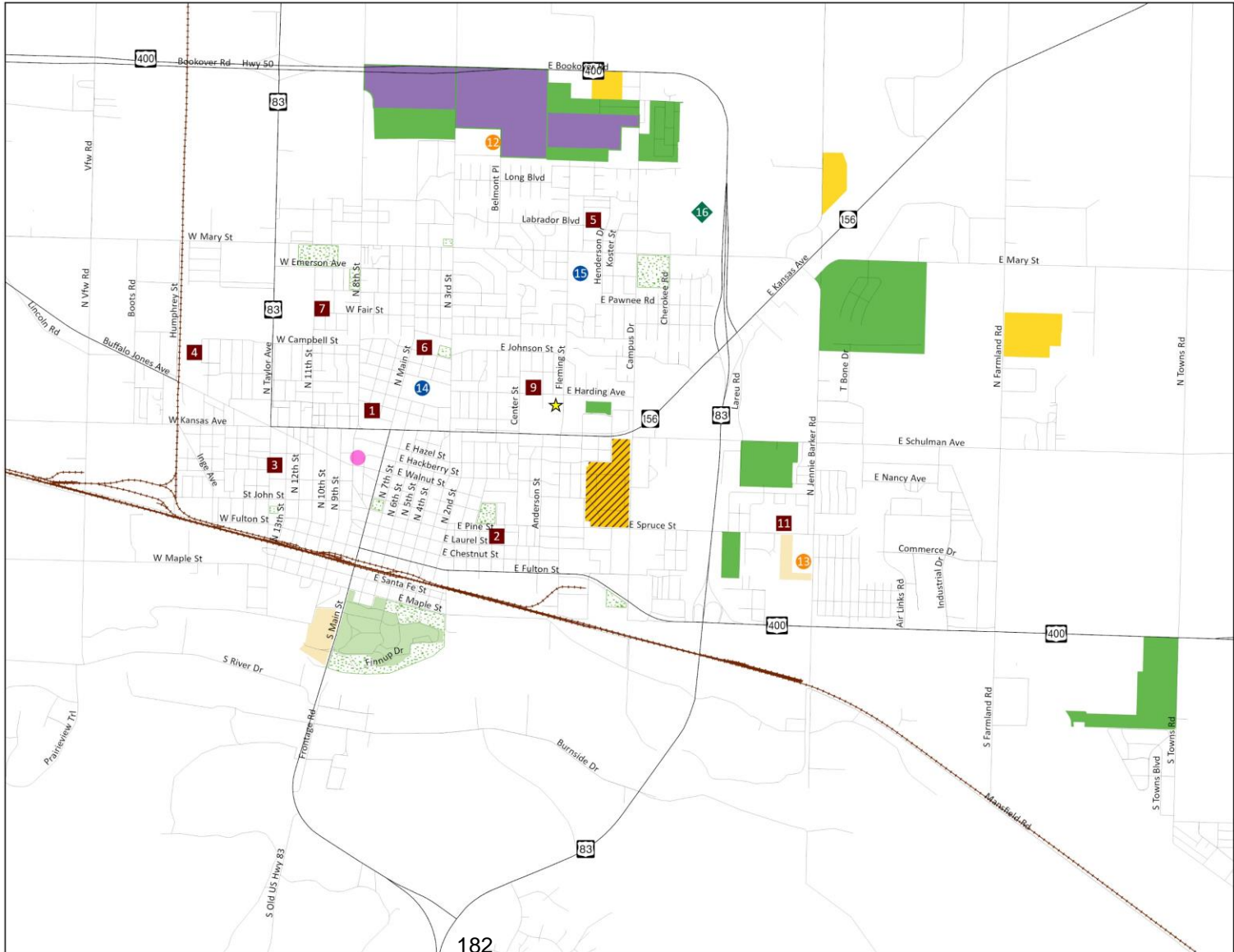

Map data provided by USD 457, Garden City, Finney County, USGS, and ESRI. Map created by RSP & Associates in December 2023.

Development Table

RSP Planning Area Name	Type of Development	Timing of Growth	Existing Units	Potential Units	Acres
Garden City Apartments	Multi-Family	Current	2	140	47.63
Sligo Station	Multi-Family	Current	0	200	5.70
Sunflower Crossing	Single-Family	Current	11	51	16.01
Pheasant Valley	Single-Family	Current	66	38	39.69
Chappel Heights	Single-Family	Current	155	39	183.14
Lost Rivers	Single-Family	Current	0	37	14.54
Sunset Terrace Estates	Single-Family	Current	0	68	83.13
Prairie View Acres	Townhomes	Current	15	111	31.89
Hunters Glen	Townhomes	Current	32	86	46.01
Trails Replat 1	Mixed-Use	5 Year	0	50	16.32
Petra Residences	Multi-Family	5 Year	0	348	22.88
Speers Acres	Single-Family	5 Year	2	14	58.26
Patriot Land and Development	Single-Family	5 Year	0	35	45.56
N of Sitts Intermediate	Agriculture	10 Year	0	240	129.89
N of Hunters Glen	Single-Family	10 Year	0	90	72.54
W of Reserves at Prairie Ridge	Vacant	10 Year	0	300	54.19
Current Development Potential:			281	770	
5 Year Development Potential:			2	447	
10 Year Development Potential:			0	630	
Total Development Potential:			283	1,847	

Main Takeaway:

Almost 1,850 units identified for development in this analysis.

Most of the units are in current development stages. The 5-10 year potential developments are contingent on developer interests, infrastructure expansion, and market economic factors.

Source: City of Garden City, Finney County, and RSP

Definition

- Table has been created to illustrate the type and amount of potential development. The speed in which any developments are built are influenced by who owns the property, access to infrastructure, and economic indicators.
- Growth Areas are created from existing land use, future land use, capital improvement plan, zoning, and city staff input

- Empirical Foods has broken ground on a new ground beef facility
- Expected to generate 250 new jobs and more than \$250 million in capital investment to Garden City and Finney County
- Expected increase ground beef production by **50%**
 - Phase II expansion would double production – up to 80 million pounds annually



Sources:

- <https://businessfacilities.com/empirical-foods-breaks-ground-250m-facility-garden-city-kansas/#:~:text=Empirical%20Foods%20has%20broken%20ground,Garden%20City%20and%20Finney%20County>
- <https://www.hpr.org/hpr-news/2021-11-01/kansas-meatpacking-workers-fueled-an-economic-boom-but-many-need-food-pantries-to-get-by>
- <https://empiricalfoods.com/gardencityks/>

Main Takeaway:

Economic development opportunity is factored into the analysis as an attraction variable for future population and housing growth in the community.

Development Observations and Conclusions

The following are some general development observations:

- Over 1,800 units identified for potential development within the next 10+ years
- Single-family residential has the highest propensity to have school aged students, yield rates of this development type are higher than that of multi-family
 - Minimal residential development was experienced in 2023 (7 new units)
 - Single-family yield rates have been decreasing while multi-family yield rates have remained stable over the past five years
 - Tracking the types of development is important to understand the yield rate of students for every part of the community – there are varying yield rates with all developments
- Building activity has been decreased the past couple of years
 - Opportunities of residential growth still exist – however the speed of the activity is forecasted to continue decreasing
 - Monitor local factors that may affect development timing and economic outlook to gauge how the new decade of residential growth will play out
- Growth areas are mostly located to the northeast

Notes:

Residential development will continue if the housing product is affordable and have active residential projects – infrastructure connectivity also plays a role in the desirability and timing of residential development. Potential for a slight decrease in unit production with a national election year (2024).

As of February 2022, construction costs have increased over 100% from August 2020 and supply chain challenges impact the potential of new development and where new developments will occur in the district

Part Three: Enrollment Projections



Past, Current, & Future Enrollment

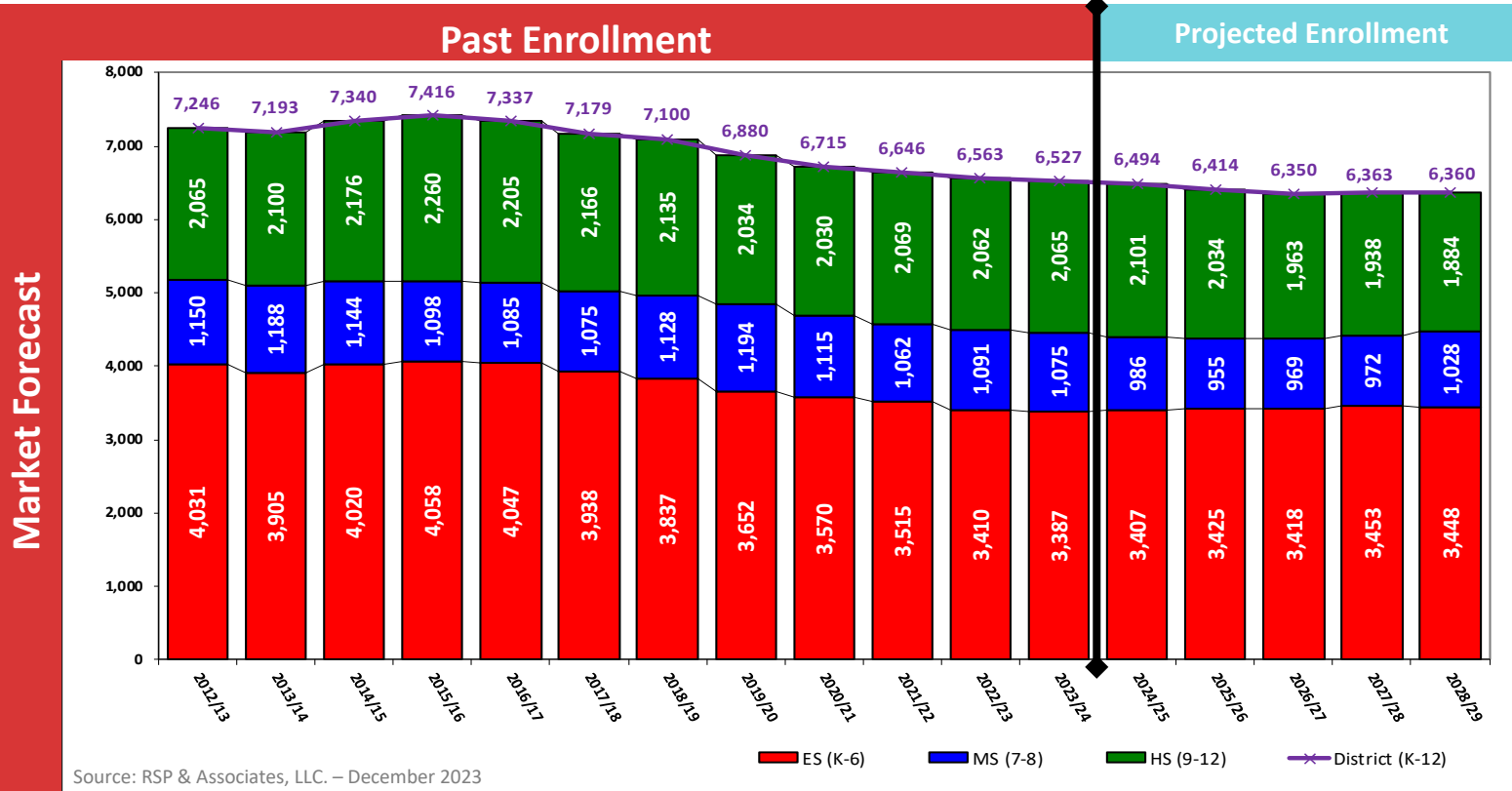

Observations

- Overall enrollment forecasted to decrease by 167 students to enroll around 6,360 students by 2028/29
- **Elementary/Intermediate increases by 61 students (+1.8%) (Annual Range: -0.2% to +1.0% a year)**
- **Middle School decreases by 47 students (-4.4%) (Annual Range: -8.3% to +5.8% a year)**
- **High School decreases by 181 students (-8.7%) (Annual Range: -3.5% to +1.7% a year)**

187

Projection Notes & Clarifications

Past Enrollment and Projections are shown three ways:

1. Reside (Based on where a student Resides in relation to the district boundary)
2. Attend (Based on both a student residing in the district and attending and students not residing in the district attending)
3. Reside/Attend (Subset of Reside to know how many of the Reside attend the school based on the attendance area they are assigned to)

Other Items:

- Enrollment Grade Configuration in Student Forecast Model follows current grade configuration by building (K-4, 5-6, 7-8, 9-12)
- Open enrollment trends are assumed to follow District policy and follow similar trends as the last few years
- Projection accuracy is limited by the number of years of student data which matches the State enrollment
- Out of District trends are assumed to follow District policy and may continue or may take place like those trends during the projection
- Integrated potential outcomes as a result of potential continued impact of COVID-19
- Housing challenges that may result in a slowdown in new housing starts and challenges with the economy as it adapts to a “New Normal” of supply challenges, cost increases, and other housing policy changes
- Virtual students are not included in past or projected enrollment numbers

Projection By Elementary Buildings

Garden City School District Projections By School (Based on Student Reside)

School	Functional Capacity	Enrollment Type (Past)	Past School Enrollment				Projections Based on Residence				
			2020/21	2021/22	2022/23	2023/24	2024/25	2025/26	2026/27	2027/28	2028/29
Abe Hubert Elementary K to 6th	646	Reside/Attend	231	254	254	245					
		Reside	334	323	308	301	292	288	289	291	280
		Attend	321	349	337	308	244	309	310	312	301
Alta Brown Elementary K to 4th	558	Reside/Attend	186	207	242	255					
		Reside	282	271	297	280	296	297	297	293	303
		Attend	295	307	308	323	350	327	327	323	333
Buffalo Jones Elementary K to 4th	384	Reside/Attend	144	164	169	196					
		Reside	219	216	218	231	228	227	226	228	221
		Attend	208	250	228	240	237	245	244	246	239
Edith Scheuerman Elementary K to 4th	325	Reside/Attend	102	102	109	109					
		Reside	144	133	127	124	122	110	112	115	112
		Attend	174	180	180	178	178	161	163	166	163
Florence Wilson Elementary K to 4th	729	Reside/Attend	222	255	276	333					
		Reside	348	337	335	382	389	413	419	438	445
		Attend	296	324	335	361	364	402	408	427	434
Georgia Matthews Elementary K to 4th	248	Reside/Attend	90	82	88	92					
		Reside	143	121	128	121	121	109	108	101	105
		Attend	311	107	109	126	127	100	99	92	96
Gertrude Walker Elementary K to 4th	392	Reside/Attend	141	154	173	191					
		Reside	224	235	237	224	212	208	200	205	212
		Attend	198	198	208	216	198	183	175	180	187
Jennie Barker Elementary K to 6th	180	Reside/Attend	127	149	159	167					
		Reside	221	217	224	228	229	226	223	228	234
		Attend	136	160	165	172	149	169	166	171	177
Jennie Wilson Elementary K to 4th	336	Reside/Attend	149	186	196	197					
		Reside	216	226	223	220	218	215	200	218	229
		Attend	196	227	223	213	215	213	198	216	227
Plymell Elementary K to 6th	154	Reside/Attend	122	136	132	120					
		Reside	180	183	157	137	134	131	132	136	132
		Attend	132	144	141	127	107	109	110	114	110
Victor Ornelas Elementary K to 4th	484	Reside/Attend	288	338	361	368					
		Reside	397	423	414	414	405	419	402	412	425
		Attend	392	420	411	385	366	407	390	400	413
ELEMNTARY SCHOOL TOTAL K to 4th	3,456	Reside/Attend	1,322	1,488	1,614	1,741					
		Reside	1,973	1,962	1,979	1,996	1,991	1,998	1,964	2,010	2,052
		Attend	2,070	2,013	2,002	2,042	2,031	2,038	2,004	2,050	2,092
ELEMNTARY SCHOOL TOTAL K to 6th	980	Reside/Attend	480	539	545	532					
		Reside	735	723	689	666	655	645	644	655	646
		Attend	589	653	643	607	597	587	586	597	588

Source: RSP & Associates, LLC - December 2023

Note 1: Student Projections are based on the residence of the student. Virtual Students are not included in enrollment.

Note 2: The Enrollment Model is based on a Head count of students by Planning Area at each facility

Note 3: Transfers between Facilities are shown with Attend Projections

Note 4: The Enrollment Model assumes ES(K-6) MS(7-8) and HS (9-12)

Note 5: Each planning area is assigned the 2023/24 boundary

Note 6: School capacity provided by the District as Functional Capacity

Note 7: Reside is based on the student home address

Note 8: Attend is based on which facility the student attends

Note 9: Res/Att (Reside/Attend) are the students who reside in the attendance area that they have chosen to attend

School Utilization Legend

- Over 100% functional design capacity
- Under 70% functional design capacity

Main Takeaway:

Most of the elementary schools are forecasted to enroll less than 70% of facility capacities

Jennie Barker Elementary may see capacity challenges between reside/attend enrollment over the next five years

District wide the elementary enrollment is forecasted to occupy 60% of elementary capacity

Projection By Secondary Buildings

Garden City School District Projections By School (Based on Student Reside)

School	Functional Capacity	Enrollment Type (Past)	Past School Enrollment				Projections Based on Residence				
			2020/21	2021/22	2022/23	2023/24	2024/25	2025/26	2026/27	2027/28	2028/29
Bernadine Sitts Intermediate 5th to 6th	881	Reside/Attend	370	377	347	317					
		Reside	422	423	378	341	363	386	381	365	373
		Attend	460	448	404	351	373	406	401	385	393
Charles O Stones Intermediate 5th to 6th	712	Reside/Attend	363	331	304	332					
		Reside	428	392	348	368	380	379	414	406	361
		Attend	442	391	343	362	378	375	410	402	357
Horace J Good Middle 7th to 8th	1,144	Reside/Attend	556	539	612	610					
		Reside	627	590	656	645	545	524	515	512	537
		Attend	685	657	699	689	565	575	566	563	588
Kenneth Henderson Middle 7th to 8th	650	Reside/Attend	353	345	336	346					
		Reside	483	466	425	425	438	424	447	456	487
		Attend	422	394	384	390	425	375	398	407	438
Garden City High School 9th to 12th	2,845	Reside/Attend	1,971	1,985	1,973	1,976					
		Reside	1,971	1,985	1,973	1,976	2,006	1,957	1,894	1,865	1,806
		Attend	1,971	1,985	1,973	1,976	2,006	1,957	1,894	1,865	1,806
Garden City Achieve K to 12th		Reside/Attend	76	105	115	110					
		Reside	76	105	115	110	116	101	91	94	98
		Attend	76	105	115	110	116	101	91	94	98
ELEMENTARY SCHOOL TOTAL K to 4th	3,456	Reside/Attend	1,322	1,488	1,614	1,741					
	Reside	1,973	1,962	1,979	1,996	1,991	1,998	1,964	2,010	2,052	
	Attend	2,070	2,013	2,002	2,042	2,031	2,038	2,004	2,050	2,092	
ELEMENTARY SCHOOL TOTAL K to 6th	980	Reside/Attend	480	539	545	532					
	Reside	735	723	689	666	655	645	644	655	646	
	Attend	589	653	643	607	597	587	586	597	588	
INTERMEDIATE SCHOOL TOTAL 5th to 6th	1,593	Reside/Attend	733	708	651	649					
	Reside	850	815	726	709	743	765	795	771	734	
	Attend	902	839	747	713	759	781	811	787	750	
MIDDLE SCHOOL TOTAL 7th to 8th	1,794	Reside/Attend	909	884	948	956					
	Reside	1,110	1,056	1,081	1,070	983	948	962	968	1,024	
	Attend	1,107	1,051	1,083	1,079	985	950	964	970	1,026	
HIGH SCHOOL TOTAL 9th to 12th	2,845	Reside/Attend	1,971	1,985	1,973	1,976					
	Reside	1,971	1,985	1,973	1,976	2,006	1,957	1,894	1,865	1,806	
	Attend	1,971	1,985	1,973	1,976	2,006	1,957	1,894	1,865	1,806	
K-12 TOTAL K-12th		Reside/Attend	76	105	115	110					
	Reside	76	105	115	110	116	101	91	94	98	
	Attend	76	105	115	110	116	101	91	94	98	
DISTRICT TOTALS K to 12th	8,095	Reside/Attend	5,491	5,709	5,846	5,964					
	Reside	6,715	6,646	6,563	6,527	6,494	6,414	6,350	6,363	6,360	
	Attend	6,715	6,646	6,563	6,527	6,494	6,414	6,350	6,363	6,360	

Source: RSP & Associates, LLC - December 2023

Note 1: Student Projections are based on the residence of the student. Virtual Students are not included in enrollment.

Note 2: The Enrollment Model is based on a Head count of students by Planning Area at each facility

Note 3: Transfers between Facilities are shown with Attend Projections

Note 4: The Enrollment Model assumes ES(K-6) MS(7-8) and HS (9-12)

Note 5: Each planning area is assigned the 2023/24 boundary

Note 6: School capacity provided by the District as Functional Capacity

Note 7: Reside is based on the student home address

Note 8: Attend is based on which facility the student attends

Note 9: Res/Att (Reside/Attend) are the students who reside in the attendance area that they have chosen to attend

School Utilization Legend

- Over 100% functional design capacity
- Under 70% functional design capacity

Main Takeaway:

Most of the secondary schools are forecasted to enroll less than 70% of facility capacities

District capacity utilization:

- ES (K-4 and K-6): 60.3%
- IS (5-6): 47.1%
- MS (7-8): 57.2%
- HS (9-12): 63.5%

Projection Observations & Conclusions

Enrollment at all levels is expected to slightly increase:

1. District-wide enrollment to decreased by 162 students in five years totaling 6,365
2. Elementary School enrollment to increase by 63 students in five years to total 3,450
3. Middle School enrollment to decrease by 45 students in five years to total 1,030
4. High School enrollment to decrease by 180 students in five years to total 1,885

Driving forces of enrollment forecast:

2023/24 Student population

Indicators:

- *Smallest classes in history*
- *Average cohort loss of 200+ students between Kindergarten and 12th grade*
- *Average class size decreasing*

Development Activity

Indicators:

- *Decreasing/stable yield rates*
- *2020 to 2023 building trends*
- *Potential new developments*

Migration Trends

Indicators:

- *Negative student migration*
- *Cohort loss year to year*
- *Decreasing number of out of district students*

Enrollment Analysis Conclusion

RSP Recommended to continually monitor the following indicators:

Enrollment may decrease more than forecasted if...	Enrollment may increase more than forecasted if...
<ul style="list-style-type: none"> ⊖ Decreasing share of live births 	<ul style="list-style-type: none"> ⊕ Increasing share of live births
<ul style="list-style-type: none"> ⊖ Current housing stock does not re-green (continues to age) 	<ul style="list-style-type: none"> ⊕ Current housing stock re-greens (turns over)
<ul style="list-style-type: none"> ⊖ Housing development experiences minimal potential growth 	<ul style="list-style-type: none"> ⊕ Housing development experience more potential growth
<ul style="list-style-type: none"> ⊖ Economic indicators challenge the ability for new homeowners and affordability aspects of the district 	<ul style="list-style-type: none"> ⊕ Economic indicators improve the ability for new homeowners and the affordability aspects of the district
<ul style="list-style-type: none"> ⊖ Demographic shifts in community and/or surrounding communities 	<ul style="list-style-type: none"> ⊕ Demographic shifts in community and/or surrounding communities
<ul style="list-style-type: none"> ⊖ Incoming Kindergarten class smaller than outgoing senior class 	<ul style="list-style-type: none"> ⊕ Incoming Kindergarten class larger than outgoing senior class

- These factors are not all positive or negative. Each have a different impact on future outlooks.
- State education policy change may impact enrollment outlook. This analysis assumes policies will continue as they currently operate throughout the projection time frame.
- It is important to continue to monitor these factors – RSP modeling attempts to find the most likely outcome:
 - District 5-year growth: **-2.5%**
 - Elementary 5-year growth: **+1.9%**
 - Middle School 5-year growth: **-4.2%**
 - High School 5-year growth: **-8.7%**

The goal of this study is to help the board, administration, and public understand how to make the best decision for the students at the classroom level.

Key Considerations

The following items will assist the district advance its educational goals:

- Annually review enrollment projections, demographics, and development trends
- District administration and the Board of Education further study the enrollment, demographic, and development information presented
- Utilize the enrollment model to assist with planning for staffing needs at each facility for the following school year which will address how quickly areas are “Regreening” and “Emerging”
- The type of residential development and how affordable it is will determine likely location and number of students
- Annually monitor the impact of future educational programming that will be integrated into each facility to ensure equitable and appropriate space is utilized in the building which will experience enrollment change
- Recent economic indicators have been in-flux (interest rates, housing prices, supply chain). Continued economic changes will impact the likelihood of new people moving into the district and increasing enrollment.
- RSP Enrollment forecasting is based on the best-known information at the time

Key Considerations Impacting Enrollment Forecast:

1. Number of live births in Finney County (continue to monitor)... *see page 13*
2. Size of outgoing senior class compared to the incoming Kindergarten and PK classes... *see page 14*
3. Migration trends (In-Migration tends to be less than Out-Migration)... *see page 16*
4. Development trends and timing of identified projects... *see pages 30-31*

Part Four: Next Steps



Boundary Analysis

TASKS AT HAND:

- BOE to enhance/approve Guiding Principles (verbal feedback)
- BOE to prioritize Boundary Criteria (PollEverywhere activity)

Importance of these activities:

- ✓ Provides the committee the framework to analyze the challenges
- ✓ Ensure the committee works toward a solution that the Board feels comfortable in approving
- ✓ Provides the community the context to understand the values and metrics to be used in this process
- ✓ Opportunity for any guiding measures to be created in the beginning of the process
- ✓ Sets the process up for success

Guiding Principles - *DRAFT*

- The Board will consider this boundary work as part of district wide long-range planning.
- The future boundary should provide even better educational opportunities at each school to ensure an equitable student experience at each school.
- Neighborhoods/Planning areas are influential in how attendance areas are created and accepted by the community.
- Future boundaries can anticipate future change of the neighborhood.
 - May consider assigning new growth areas to noncontiguous attendance areas
- The focus of the Boundary Process will be at elementary, intermediate, and middle school level
- The boundary proposed should continue to effectively utilize District resources.
- Boundary lines that follow natural/manmade boundaries are desired in how attendance areas are created.
- Consider the future ideas of building utilization and grade configuration changes with the creation of a new attendance area
 - The community will likely need to support a bond referendum to make these building and grade configuration changes
- Grandfathering/Student Options will be a recommendation from Administration to the Board according to Board policy.

Choose **THREE** boundary criteria you believe should have the most influence in the creation of new attendance areas.



A. Contiguous Attendance Areas



B. Demographic Considerations



C. Duration of Boundaries



D. Feeder Systems



E. Fiscal Consideration – Capital



F. Fiscal Consideration – Operational



G. Neighborhoods Intact



H. Projected Enrollment/Utilization



I. Students Impacted Boundary Change



SEE MORE ¹⁹⁷ ✓

Boundary Analysis Process

4 Committee Meetings

- February 1st

1 Opportunity for Public Input

- Two nights in March

3 BOE Meeting

- Meeting 1 and 2 complete
- Next meeting on April 15th to review boundary recommendation



Garden City Public Schools 2023/24 Comprehensive Boundary Process

Boundary plan implementation 2024/25 school year

Note: Meeting dates are subject to availability of when contract is signed.

BOE MEETING #1

RSP via Zoom
Board of Education receives homework of Boundary Criteria

Tuesday, December 5

BOE MEETING #2

RSP in-person
Board of Education receives RSP Enrollment Analysis and prioritizes Boundary Criteria

Monday, January 8

Enrollment Analysis

RSP provides 5-Year Enrollment Forecast and student data analysis

BOUNDARY COMMITTEE MEETING #1

RSP in-person
Boundary team receive charge, process, and EA overview

Thursday, February 1 5:30

BOUNDARY COMMITTEE MEETING #2

RSP in-person
Refine scenarios, discuss options, achieve consensus

Thursday, February 22 5:30

BOUNDARY COMMITTEE MEETING #3

RSP in-person
Refine scenarios, discuss options, achieve consensus

Thursday, March 7 5:30

PUBLIC INPUT

RSP in-person
Opportunity for patron feedback

March 20 - March 21 5:30

BOUNDARY COMMITTEE MEETING #4

RSP in-person
Refine scenarios, discuss options, achieve consensus

Thursday, April 4 5:30

BOE MEETING #3

Board of Education adopts boundary plan for 2024/25 implementation

Monday, April 15

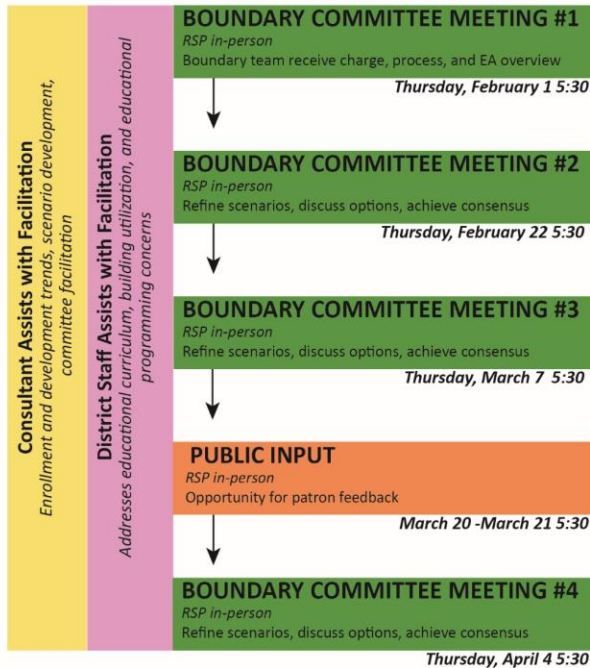

Appendix

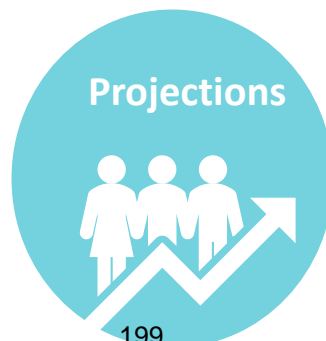

199

Note: Presentation slide heading color in the appendix matches the section in which the information corresponds

Demographic Summary



Population

Percent Change of Annual Rate

2000 to 2010: -1.05%
2010 to 2020: 0.44%
2020 to 2023: 0.29%
2022 to 2028: 0.04%

Observations:



Housing

Percent Change of Annual Rate of Housing Inventory

2000 to 2010: -0.43%
2010 to 2020: 0.67%
2020 to 2022: 0.62%
2023 to 2028: 0.22%

Observations:



Income

Percent Change of Income per Capita

2023: \$28,624
2028: \$32,840
2023 to 2028: 2.79%

Observations:



Workforce

Unemployment Rate

4.2% as of July 2023

Observations:

Demographics

	USD 457 Garden City	USD 363 Holcomb	USD443 Dodge City	Garden City	Finney County	Kansas
Unemployment Rate	4.2%	1.8%	4.2%	3.9%	4.0%	4.3%
Average Household Size	2.86	3.20	2.97	2.82	2.88	2.46
Median Age	31.7	31.5	32.1	31.7	31.7	37.9
Total Population	35,506	3,073	31,478	28,144	38,673	2,952,421
Median Household Income	\$63,731	\$74,068	\$59,570	\$63,646	\$64,419	\$65,296
Total Housing Units	13,348	1,026	11,467	10,577	14,426	1,295,571
Owner Occupied Housing	7,885	827	6,525	6,212	8,735	796,078
Renter Occupied Housing	4,343	132	3,853	3,562	4,489	368,302
Vacancy Rate	8.4%	6.5%	9.5%	7.6%	8.3%	10.1%

	USD 457 Garden City	USD 363 Holcomb	USD443 Dodge City	Garden City	Finney County	Kansas
White	34.3%	57.0%	30.2%	32.8%	36.2%	71.4%
Black	3.7%	0.9%	2.7%	4.3%	3.4%	5.6%
American Indian/Alaskan	0.4%	1.0%	0.3%	0.3%	0.4%	0.8%
Asian	4.2%	0.4%	1.2%	4.9%	3.8%	2.9%
Pacific Islander	0.0%	0.0%	0.0%	0.0%	0.0%	0.1%
Other Race	0.4%	0.2%	0.3%	0.4%	0.4%	0.3%
Two or More Races	2.1%	4.0%	1.9%	2.1%	2.3%	5.2%
Hispanic	54.9%	36.5%	63.5%	55.1%	53.4%	13.7%

Source; U.S. Census, ESRI BAO

Notes:

1. Median Household Income is slightly lower than the State of Kansas
2. USD457 has similar demographics with USD443, Garden City, and Finney County.
3. The Median Age is tied for second lowest when comparing all neighboring geographies.

Employment Information

	USD 457 Garden City	USD 363 Holcomb	USD443 Dodge City	Garden City	Finney County	Kansas
2023 Agriculture/Mining (SIC01-14) Employees	2.6%	0.9%	1.1%	1.2%	2.3%	1.8%
2023 Construction (SIC15-17) Employees	3.4%	1.0%	2.2%	1.9%	3.0%	4.2%
2023 Manufacturing (SIC20-39) Employees	3.2%	84.8%	28.3%	1.8%	17.9%	10.5%
2023 Transportation (SIC40-47) Employees	2.8%	1.1%	2.0%	2.4%	2.5%	2.8%
2023 Communication (SIC48) Employees	1.2%	0.0%	1.0%	1.4%	1.0%	0.8%
2023 Utility (SIC49) Employees	1.3%	0.4%	1.4%	0.4%	1.2%	0.6%
2023 Wholesale Trade (SIC50-51) Employees	4.3%	2.3%	3.0%	1.9%	4.0%	4.2%
2023 Home Improvement (SIC52) Employees	2.8%	0.0%	1.1%	3.2%	2.3%	1.4%
2023 General Merchandise (SIC53) Employees	5.0%	0.0%	3.5%	5.9%	4.1%	2.3%
2023 Food Stores (SIC54) Employees	2.7%	0.0%	1.5%	3.1%	2.2%	2.2%
2023 Auto Dealer/Gas Station (SIC55) Employees	3.0%	0.7%	3.5%	2.9%	2.6%	2.2%
2023 Apparel/Accessory (SIC56) Employees	0.6%	0.1%	0.4%	0.8%	0.5%	0.8%
2023 Furniture/Home Furnishings (SIC57) Employees	0.3%	0.1%	0.3%	0.4%	0.3%	0.9%
2023 Eating & Drinking (SIC58) Employees	8.4%	0.6%	5.7%	9.5%	7.0%	6.6%
2023 Miscellaneous Retail (SIC59) Employees	3.5%	0.2%	2.0%	3.9%	2.9%	2.6%
2023 Banks (SIC60-61) Employees	1.7%	0.4%	2.0%	2.0%	1.5%	1.9%
2023 Securities Broker (SIC62) Employees	0.4%	0.0%	0.3%	0.4%	0.3%	0.9%
2023 Insurance (SIC63-64) Employees	0.7%	0.0%	0.5%	0.8%	0.5%	1.5%
2023 Real Estate/Holding (SIC65-67) Employees	0.9%	0.1%	0.9%	0.9%	0.8%	2.6%
2023 Hotel/Lodging (SIC70) Employees	1.5%	0.0%	1.4%	1.7%	1.2%	0.9%
2023 Auto Services (SIC75) Employees	1.1%	0.2%	1.2%	0.6%	1.0%	0.9%
2023 Movie/Amusement (SIC78-79) Employees	1.9%	0.5%	3.8%	2.1%	1.7%	2.2%
2023 Health Services (SIC80) Employees	11.9%	0.1%	5.1%	13.8%	9.8%	11.3%
2023 Legal Services (SIC81) Employees	0.5%	0.0%	0.3%	0.6%	0.4%	0.7%
2023 Education/Library (SIC82) Employees	12.0%	4.9%	9.3%	13.1%	10.7%	10.0%
2023 Other Service (SIC72-89SEL) Employees	11.2%	0.5%	11.4%	11.1%	9.3%	15.2%
2023 Government (SIC91-97) Employees	10.8%	0.9%	6.8%	12.1%	9.0%	7.4%
2023 Unclassified Establishments (SIC99) Employees	0.2%	0.1%	0.1%	0.2%	0.2%	0.5%

Source; U.S. Census, ESRI BAO

- Notes:
1. Largest Percentage of Employees are in Education/Library services (12%)
 2. Has the highest percentage when compared to all other geographies in Wholesale Trade (4.29%)²⁰²

Class Size Comparisons

Kindergarten and 12th Grade Class Size

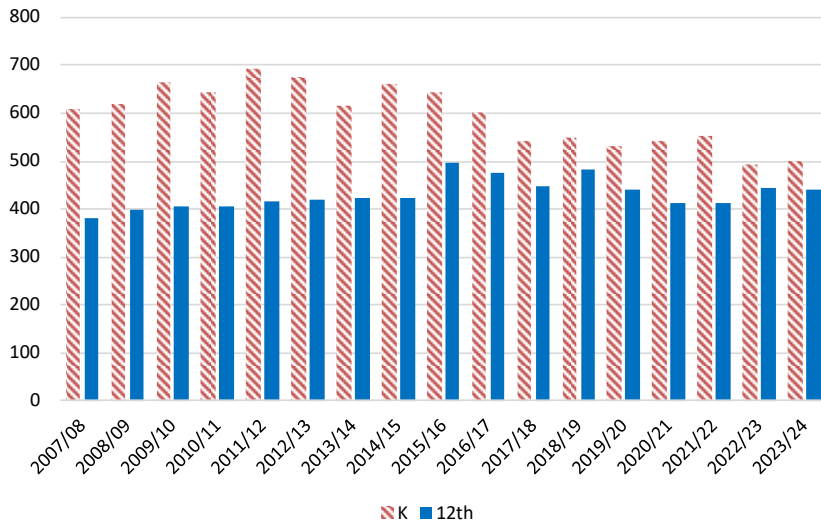

Observations:

- Kindergarten and 12th Grade Class Size: Kindergarten class sizes have been larger than the outgoing 12th grade class since 2007/08
- Average Class Size: District class size has been decreasing since its peak in 2015/16
 - Last year, 2022/23, represented the smallest average class size at the elementary level since 2007/08
- K-12 Cohort Enrollment: There has been consistent losses in cohort change since 2016/17
 - The 12th grade classes have been averaging a loss of 60 students each year since 2007/08
 - The average class is losing about 200 students between kindergarten and 12th grade

Average Class Size

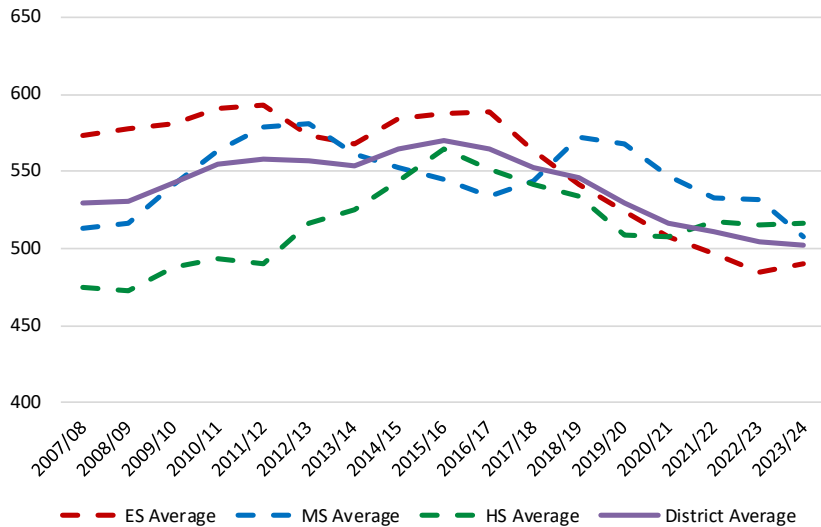

K-12 Cohort Enrollment Change

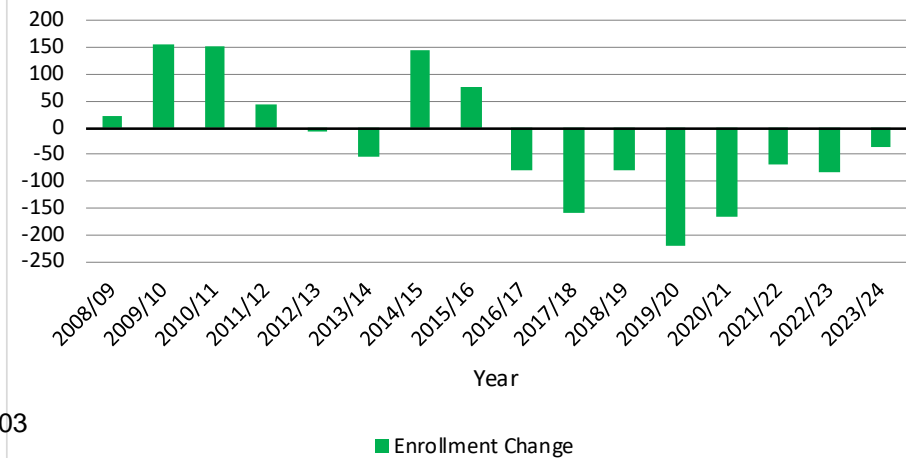

203

Elementary Intra-District Transfer Table

K-4	Attend											
Reside	Abe Hubert	Alta Brown	Buffalo Jones	Edith Scheuerman	Florence Wilson	Georgia Matthews	Gertrude Walker	Jennie Barker	Jennie Wilson	Plymell	Victor Ornelas	Attend Total
Abe Hubert Elementary	0	9	9	11	2	5	10	1	0	0	0	47
Alta Brown Elementary	6	0	3	3	0	2	3	0	2	0	6	25
Buffalo Jones Elementary	3	11	0	14	2	2	3	0	0	0	0	35
Edith Scheuerman Elementary	0	3	6	0	3	1	0	0	0	2	0	15
Florence Wilson Elementary	9	10	6	5	0	6	2	0	6	3	2	49
Georgia Matthews Elementary	4	4	4	8	2	0	5	0	2	0	0	29
Gertrude Walker Elementary	5	9	4	6	2	5	0	0	1	0	1	33
Jennie Barker Elementary	6	2	4	12	6	3	0	0	1	2	6	42
Jennie Wilson Elementary	2	2	0	6	5	7	1	0	0	0	0	23
Plymell Elementary	4	4	2	0	0	0	0	0	0	0	2	12
Victor Ornelas Elementary	7	13	6	4	6	3	1	2	4	0	0	46
Grand Total	46	67	44	69	28	34	25	3	16	7	17	356

Note: Table contains K-4 students only. Produced by RSP & Associates.

Observations:

- Illustrates school choice that could be impacted by location of educational programming
- Reviewed on an annual basis and approved based on capacity availability
- Edith Scheuerman ES had the most transferring in (+69)
- Florence Wilson ES had the most transferring out (-49)
- 356 total elementary students did not attend the facility in which they reside this year

UNDERSTANDING THE TABLE: The schools in the left column are associated with the current attendance area. Reading to the right indicates a school choice change from where they are assigned based on the Reside attendance area.

For example: Abe Hubert ES has 47 students attending a different elementary school and 46 students from another elementary school choosing to attend Abe Hubert ES. This results in a 1 less student attending Abe Hubert than what reside in that attendance area.

Secondary Intra-District Transfer Table

5-6	Attend								
Reside	Abe Hubert	Alta Brown	Jennie Barker	Plymell	Bernadine Sitts	Charles O Stones	Kenneth Henderson	Attend Total	
Abe Hubert Elementary	0	0	0	0	6	1	2	9	
Alta Brown Elementary	0	0	0	0	0	0	0	0	
Jennie Barker Elementary	1	0	0	0	6	12	0	19	
Plymell Elementary	1	0	0	0	2	2	0	5	
Bernadine Sitts Intermediate	8	0	0	0	0	13	3	24	
Charles O Stones Intermediate	7	1	2	0	20	0	6	36	
Kenneth Henderson Middle	0	0	0	0	0	0	0	0	
Grand Total	17	1	2	0	34	28	11	93	

Observations:

- Illustrates school choice that could be impacted by location of educational programming
- Reviewed on an annual basis and approved based on capacity availability
- 93 5th to 6th grade students attended a school where they do not reside
- 114 7th to 8th grade students attended a school where they do not reside

Notes:

1. Table contains 5-6 students only. No Virtual students or students who attend Garden City Achieve.
2. Some students attend schools above or below their designated grade configuration. These are included as Intra-Transfers since they don't attend their residing school.

7-8	Attend			
Reside	Charles O Stones	Horace J Good	Kenneth Henderson	Attend Total
Charles O Stones Intermediate	0	0	0	0
Horace J Good Middle	2	0	33	35
Kenneth Henderson Middle	0	79	0	79
Grand Total	2	79	33	114

Note:

1. Table contains 7-8 students only. No Virtual students or students who attend Garden City Achieve.
2. Some students attend schools above or below their designated grade configuration. These are included as Intra-Transfers since they don't attend their residing school.

205

K to 4th Grade Student Count Change Map



Student Count Change from 2019/20 to 2023/24 in Grades K-4

- District Boundary
- District Office
- Early Childhood
- Elementary School
- Intermediate School
- Middle School
- High School
- Lee Richardson Zoo
- Garden City Community College
- Park
- Recreation

- School List:**
- Elementary List (K-4):
1. Abe Hubert (K-6)
 2. Alta Brown
 3. Buffalo Jones
 4. Edith Scheurman
 5. Florence Wilson
 6. Georgia Matthews
 7. Gertrude Walker
 8. Jennie Barker (K-6)
 9. Jennie Wilson
 10. Plymell (K-6)
 11. Victor Ornelas
- Intermediate List (5-6):
12. Bernadine Sitts
 13. Charles O Stones
- Middle List (7-8):
14. Horace Good
- High List (9-12):
15. Kenneth Henderson
 16. Garden City

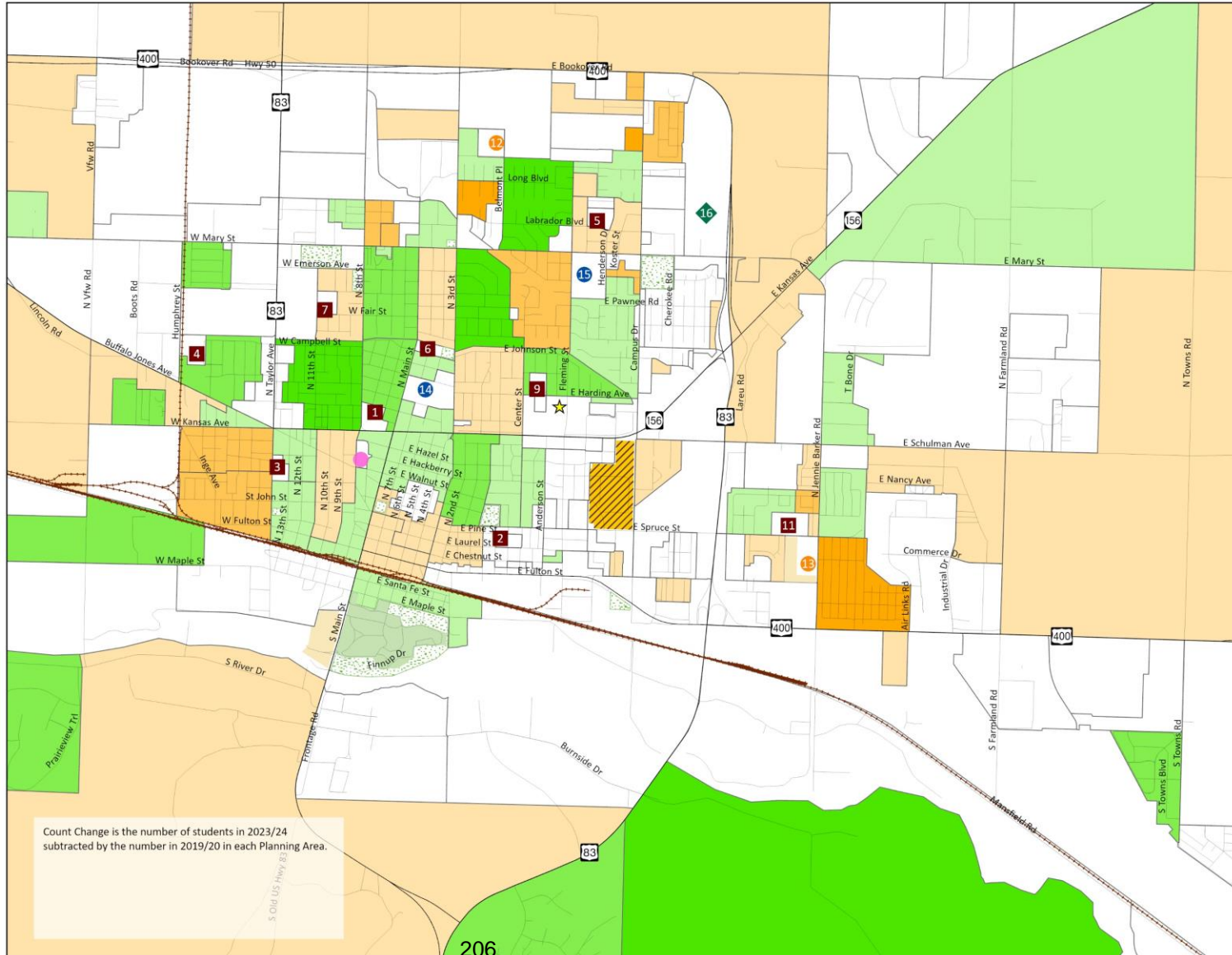
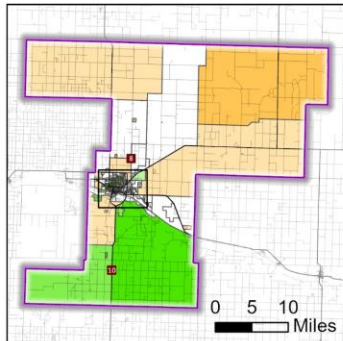
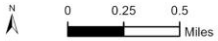

Count Change is the number of students in 2023/24 subtracted by the number in 2019/20 in each Planning Area.

Map data provided by USD 457, Garden City, Finney County, USGS, and ESRI. Map created by RSP & Associates in December 2023.

5th to 6th Grade Student Count Change Map



Student Count Change from 2019/20 to 2023/24 in Grades 5-6

- District Boundary
- District Office
- Early Childhood
- Elementary School
- Intermediate School
- Middle School
- High School
- Lee Richardson Zoo
- Garden City Community College
- Park
- Recreation

- School List:**
- Elementary List (K-4):
1. Abe Hubert (K-6)
 2. Alta Brown
 3. Buffalo Jones
 4. Edith Scheurman
 5. Florence Wilson
 6. Georgia Matthews
 7. Gertrude Walker
 8. Jennie Barker (K-6)
 9. Jennie Wilson
 10. Plymell (K-6)
 11. Victor Ornelas
- Intermediate List (5-6):
12. Bernadine Sitts
 13. Charles O Stones
- Middle List (7-8):
14. Horace Good
- High List (9-12):
15. Kenneth Henderson
 16. Garden City

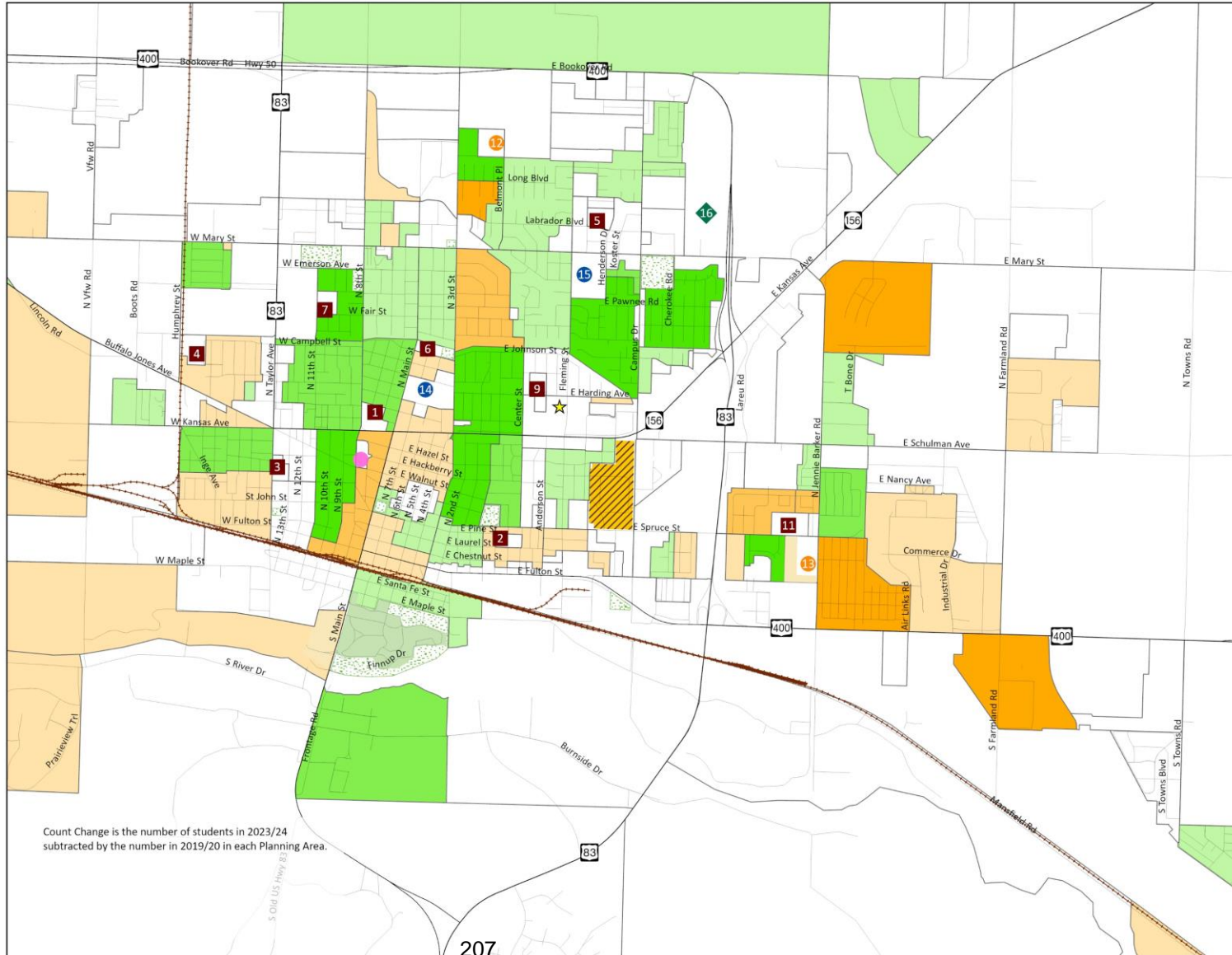
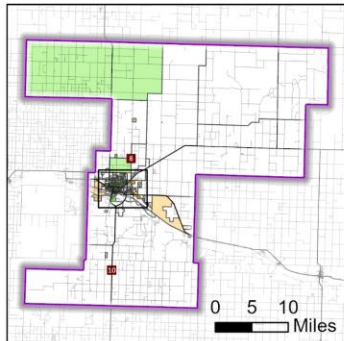
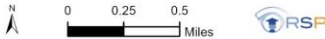

Count Change is the number of students in 2023/24 subtracted by the number in 2019/20 in each Planning Area.

Map data provided by USD 457, Garden City, Finney County, USGS, and ESRI. Map created by RSP & Associates in December 2023.

7th to 8th Grade Student Count Change Map



Student Count Change from 2019/20 to 2023/24 in Grades 7-8

- District Boundary
- District Office
- Early Childhood
- Elementary School
- Intermediate School
- Middle School
- High School
- Lee Richardson Zoo
- Garden City Community College
- Park
- Recreation

- School List:**
- Elementary List (K-4):
1. Abe Hubert (K-6)
 2. Alta Brown
 3. Buffalo Jones
 4. Edith Scheurman
 5. Florence Wilson
 6. Georgia Matthews
 7. Gertrude Walker
 8. Jennie Barker (K-6)
 9. Jennie Wilson
 10. Plymell (K-6)
 11. Victor Ornelas
- Intermediate List (5-6):
12. Bernadine Sitts
 13. Charles O Stones
- Middle List (7-8):
14. Horace Good
- High List (9-12):
15. Kenneth Henderson
 16. Garden City

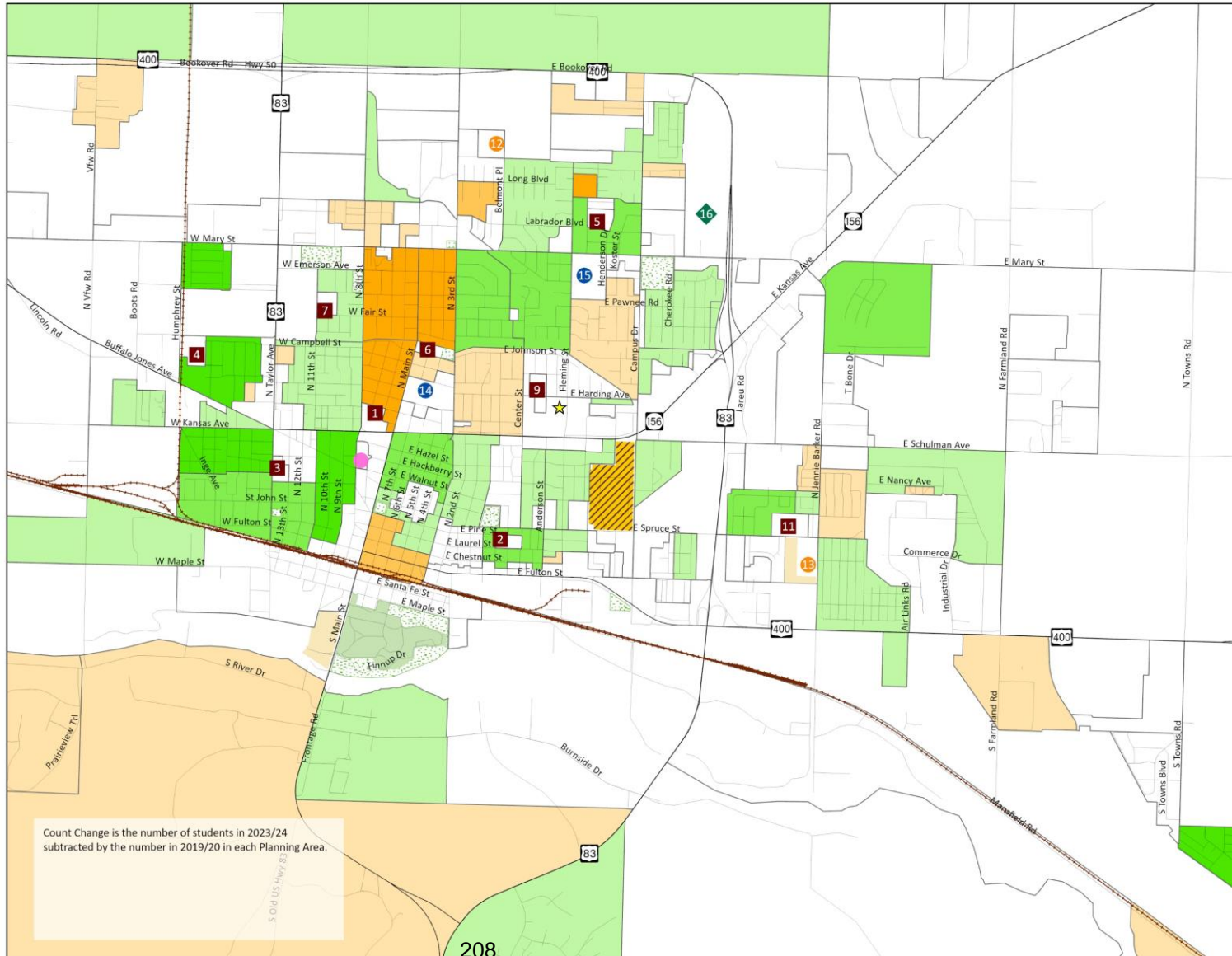
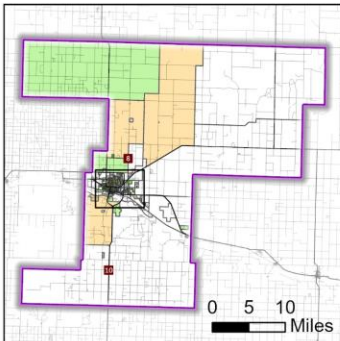
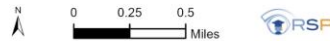

Count Change is the number of students in 2023/24 subtracted by the number in 2019/20 in each Planning Area.

208

Map data provided by USD 457, Garden City, Finney County, USGS, and ESRI. Map created by RSP & Associates in December 2023.

9th to 12th Grade Student Count Change Map



Student Count Change from 2019/20 to 2023/24 in Grades 9-12

- District Boundary
- District Office
- Early Childhood
- Elementary School
- Intermediate School
- Middle School
- High School
- Lee Richardson Zoo
- Garden City Community College
- Park
- Recreation

- School List:**
- Elementary List (K-4):
1. Abe Hubert (K-6)
 2. Alta Brown
 3. Buffalo Jones
 4. Edith Scheurman
 5. Florence Wilson
 6. Georgia Matthews
 7. Gertrude Walker
 8. Jennie Barker (K-6)
 9. Jennie Wilson
 10. Plymell (K-6)
 11. Victor Ornelas
- Intermediate List (5-6):
12. Bernadine Sitts
 13. Charles O Stones
- Middle List (7-8):
14. Horace Good
- High List (9-12):
15. Kenneth Henderson
 16. Garden City

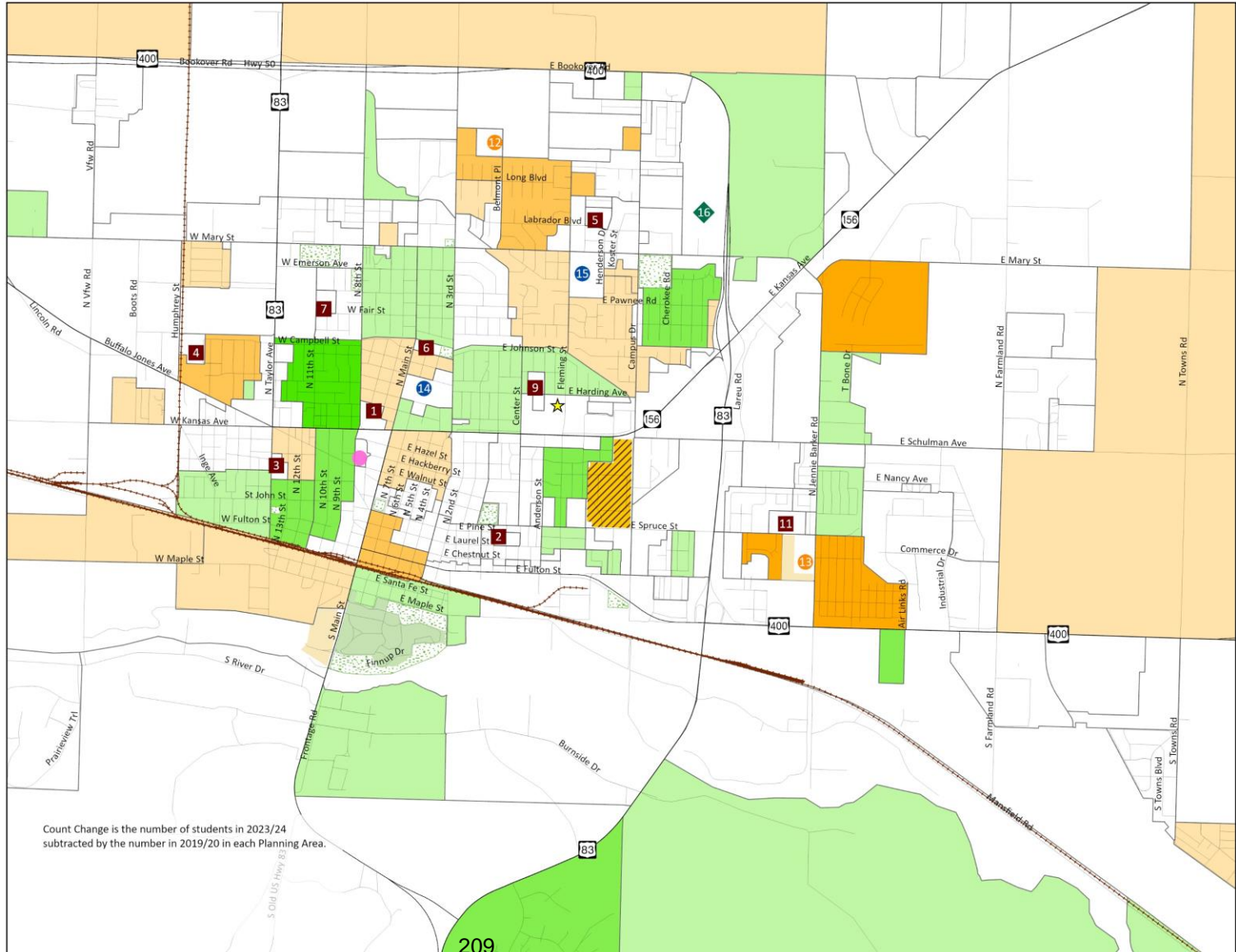
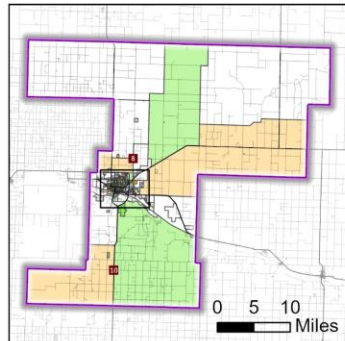
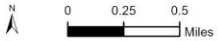

Count Change is the number of students in 2023/24 subtracted by the number in 2019/20 in each Planning Area.

209

Map data provided by USD 457, Garden City, Finney County, USGS, and ESRI. Map created by RSP & Associates in December 2023.

Student Density Map in 2023/24



2023/24 Student Density in Grades K-12

- District Boundary
- District Office
- Early Childhood
- Elementary School
- Intermediate School
- Middle School
- High School
- Lee Richardson Zoo
- Garden City Community College
- Park
- Recreation

- School List:**
- Elementary List (K-4):
1. Abe Hubert (K-6)
 2. Alta Brown
 3. Buffalo Jones
 4. Edith Scheuerman
 5. Florence Wilson
 6. Georgia Matthews
 7. Gertrude Walker
 8. Jennie Barker (K-6)
 9. Jennie Wilson
 10. Phyllis (K-6)
 11. Victor Ornelas
- Intermediate List (5-6):
12. Bernadine Sitts
 13. Charles O Stones
- Middle List (7-8):
14. Horace Good
- High List (9-12):
15. Kenneth Henderson
 16. Garden City

Student Density

- 0
- 1 to 50
- 51 to 250
- 251 to 1,000
- 1,001 to 2,500
- > 2,500

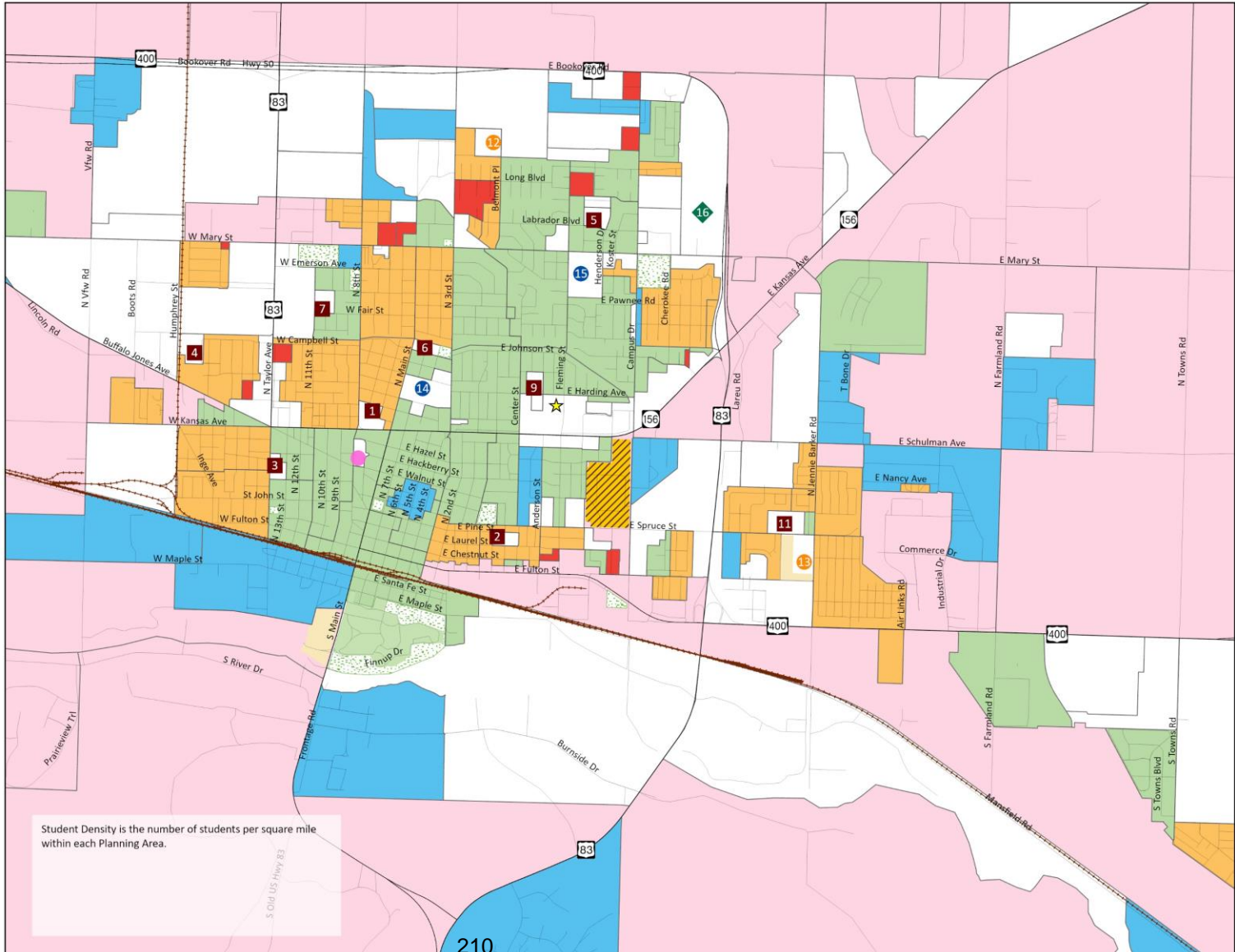
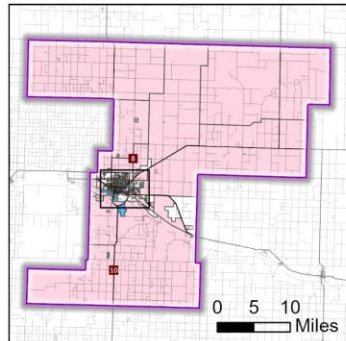
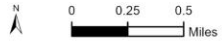

Map data provided by USD 457, Garden City, Finney County, USGS, and ESRI. Map created by RSP & Associates in December 2023.

Student Density Map in 2019/20



2019/20 Student Density in Grades K-12

- District Boundary
- District Office
- Early Childhood
- Elementary School
- Intermediate School
- Middle School
- High School
- Lee Richardson Zoo
- Garden City Community College
- Park
- Recreation

- School List:**
- Elementary List (K-4):
1. Abe Hubert (K-6)
 2. Alta Brown
 3. Buffalo Jones
 4. Edith Scheuerman
 5. Florence Wilson
 6. Georgia Matthews
 7. Gertrude Walker
 8. Jennie Barker (K-6)
 9. Jennie Wilson
 10. Plymell (K-6)
 11. Victor Ornelas
- Intermediate List (5-6):
12. Bernadine Sitts
 13. Charles O Stones
- Middle List (7-8):
14. Horace Good
- High List (9-12):
15. Kenneth Henderson
 16. Garden City

Student Density

- 0
- 1 to 50
- 51 to 250
- 251 to 1,000
- 1,001 to 2,500
- > 2,500

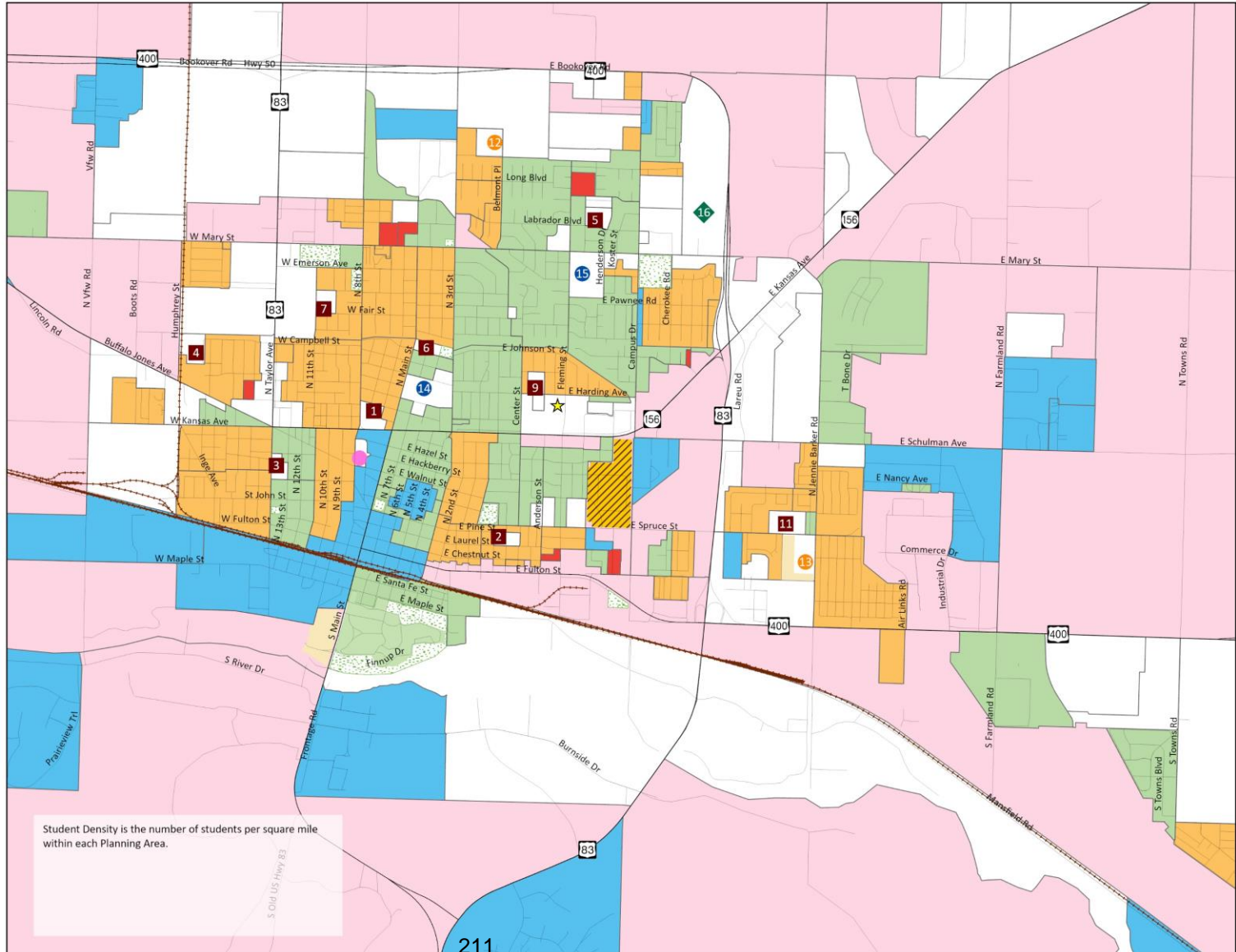
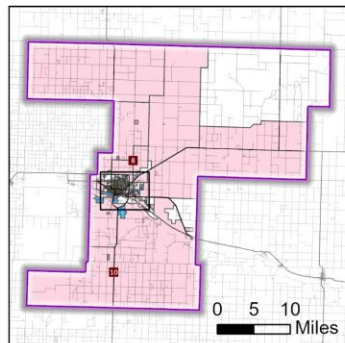
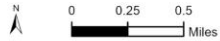

Map data provided by USD 457, Garden City, Finney County, USGS, and ESRI. Map created by RSP & Associates in December 2023.

Student Density Change Map



Student Density Change from 2019/20 to 2023/24 in Grades K-12

- District Boundary
- District Office
- Early Childhood
- Elementary School
- Intermediate School
- Middle School
- High School
- Lee Richardson Zoo
- Garden City Community College
- Park
- Recreation

- School List:**
- Elementary List (K-4):
1. Abe Hubert (K-6)
 2. Alta Brown
 3. Buffalo Jones
 4. Edith Scheurman
 5. Florence Wilson
 6. Georgia Matthews
 7. Gertrude Walker
 8. Jennie Barker (K-6)
 9. Jennie Wilson
 10. Plymell (K-6)
 11. Victor Ornelas
- Intermediate List (5-6):
12. Bernadine Sitts
 13. Charles O Stones
- Middle List (7-8):
14. Horace Good
- High List (9-12):
15. Kenneth Henderson
 16. Garden City

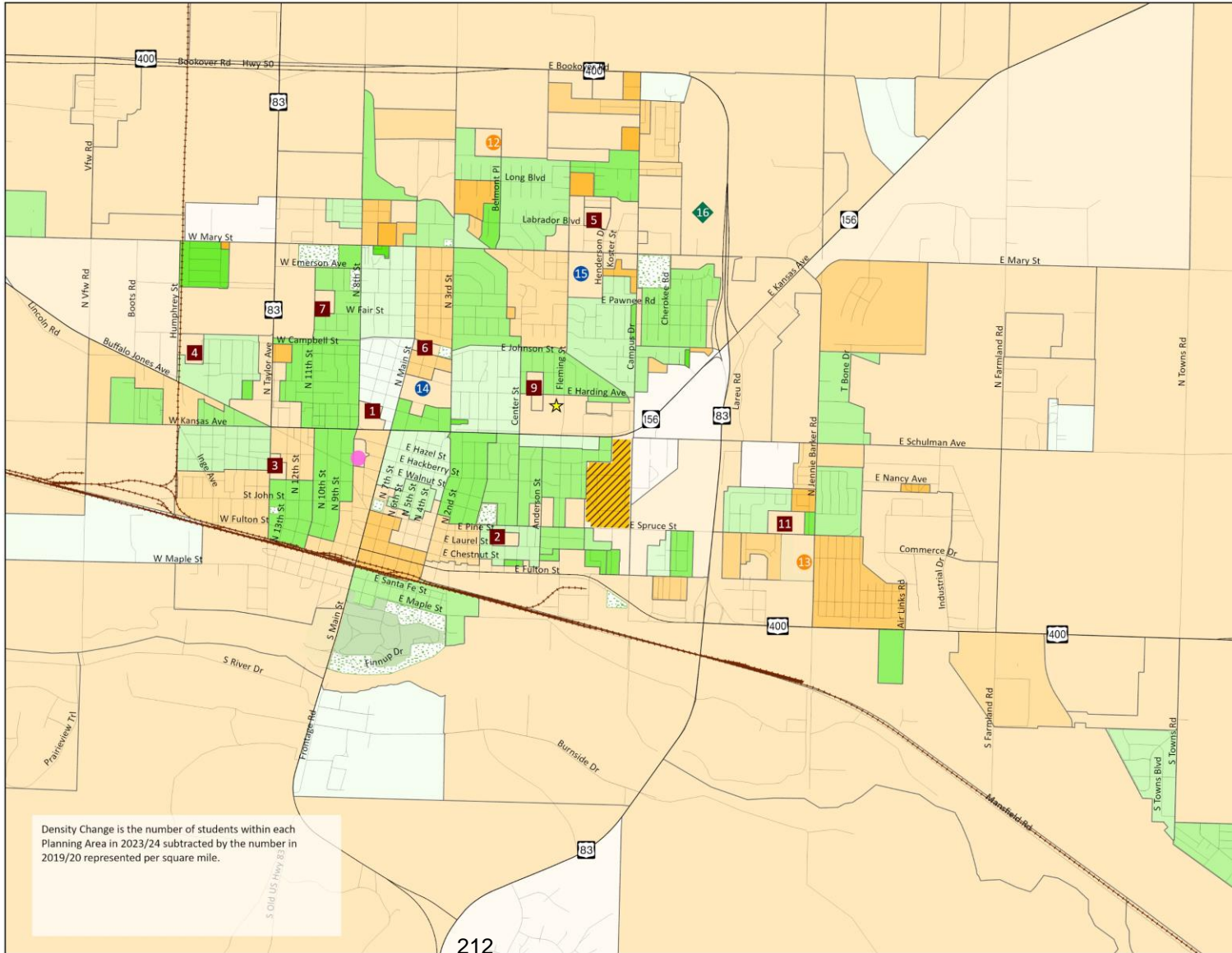
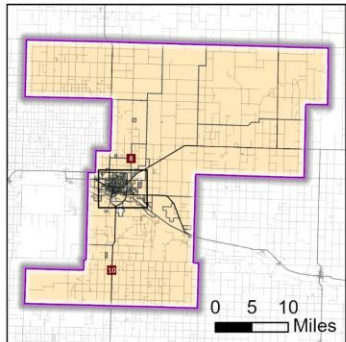
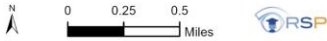

212

Map data provided by USD 457, Garden City, Finney County, USGS, and ESRI. Map created by RSP & Associates in December 2023.

Yield Rate Analysis Map



Yield Rate

- District Boundary
- District Office
- Early Childhood
- Elementary School
- Intermediate School
- Middle School
- High School
- Lee Richardson Zoo
- Garden City Community College
- Park
- Recreation

- School List:**
- Elementary List (K-4):
1. Abe Hubert (K-6)
 2. Alta Brown
 3. Buffalo Jones
 4. Edith Scheurman
 5. Florence Wilson
 6. Georgia Matthews
 7. Gertrude Walker
 8. Jennie Barker (K-6)
 9. Jennie Wilson
 10. Plymell (K-6)
 11. Victor Ornelas
- Intermediate List (5-6):
12. Bernadine Sitts
 13. Charles O Stones
- Middle List (7-8):
14. Horace Good
- High List (9-12):
15. Kenneth Henderson
 16. Garden City

Yield Rate

- < 5
- 6 to 25
- 26 to 35
- 36 to 60
- > 60

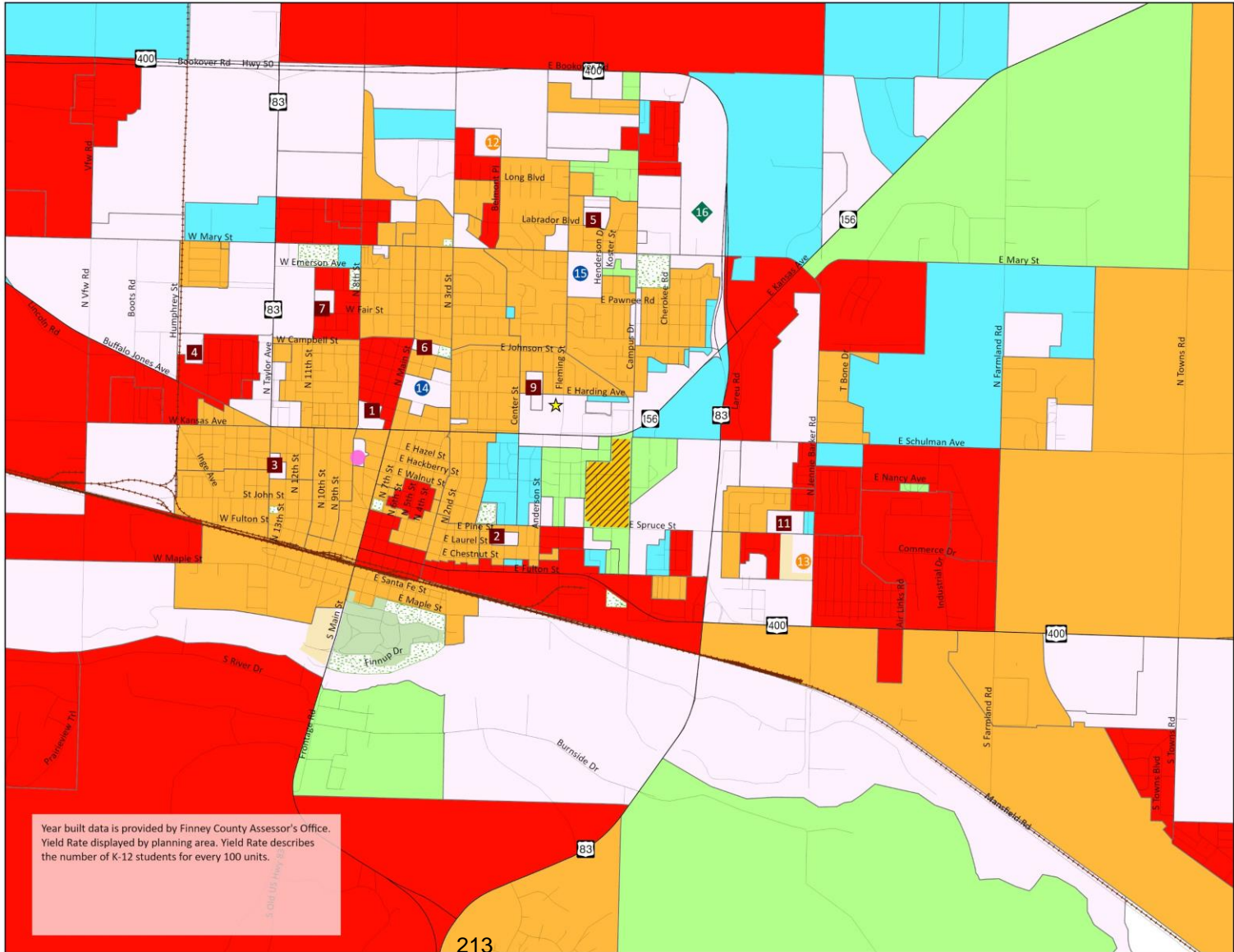

Year built data is provided by Finney County Assessor's Office. Yield Rate displayed by planning area. Yield Rate describes the number of K-12 students for every 100 units.

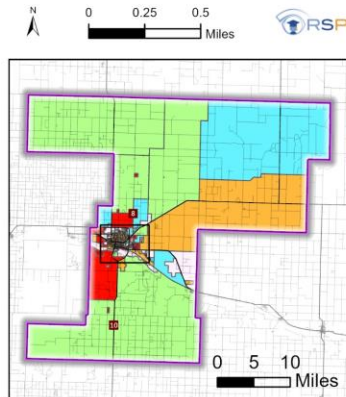

Map data provided by USD 457, Garden City, Finney County, USGS, and ESRI. Map created by RSP & Associates in December 2023.

Central Growth Area Map



Growth Areas

- District Boundary
- District Office
- Early Childhood
- Elementary School
- Intermediate School
- Middle School
- High School
- Lee Richardson Zoo
- Garden City Community College
- Park
- Recreation

- School List:**
- Elementary List (K-4):
1. Abe Hubert (K-6)
 2. Alta Brown
 3. Buffalo Jones
 4. Edith Scheuerman
 5. Florence Wilson
 6. Georgia Matthews
 7. Gertrude Walker
 8. Jennie Barker (K-6)
 9. Jennie Wilson
 10. Plymell (K-6)
 11. Victor Ornelas
- Intermediate List (5-6):
12. Bernadine Sitts
 13. Charles O Stones
- Middle List (7-8):
14. Horace Good
 15. Kenneth Henderson
- High List (9-12):
16. Garden City

Growth Areas

- Current
- 5 Year
- 10 Year



Population growth Areas are defined as areas that display a high propensity for growth; however, development is not guaranteed. Additionally, it is possible that areas not designated for growth may develop.

214

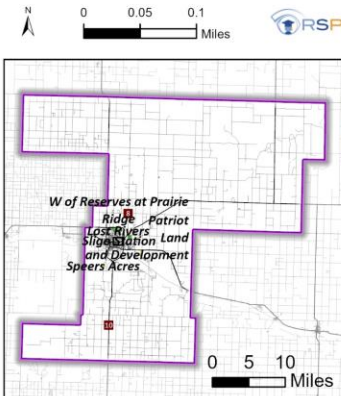

Map data provided by USD 457, Garden City, Finney County, USGS, and ESRI. Map created by RSP & Associates in December 2023.

Northern Growth Area Map



Growth Areas

- District Boundary
- District Office
- Early Childhood
- Elementary School
- Intermediate School
- Middle School
- High School
- Lee Richardson Zoo
- Garden City Community College
- Park
- Recreation

- School List:**
- Elementary List (K-4):
1. Abe Hubert (K-6)
 2. Alta Brown
 3. Buffalo Jones
 4. Edith Scheurman
 5. Florence Wilson
 6. Georgia Matthews
 7. Gertrude Walker
 8. Jennie Barker (K-6)
 9. Jennie Wilson
 10. Plymell (K-6)
 11. Victor Ornelas
- Intermediate List (5-6):
12. Bernadine Sitts
 13. Charles O Stones
- Middle List (7-8):
14. Horace Good
- High List (9-12):
15. Kenneth Henderson
 16. Garden City

Growth Areas

- Current
- 5 Year
- 10 Year



Population growth Areas are defined as areas that display a high propensity for growth; however, development is not guaranteed. Additionally, it is possible that areas not designated for growth may develop.

215

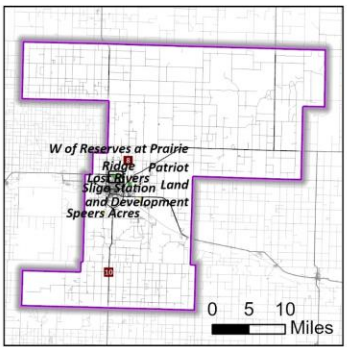

Map data provided by USD 457, Garden City, Finney County, USGS, and ESRI. Map created by RSP & Associates in December 2023.

Northeast Growth Area Map



Growth Areas

- District Boundary
- District Office
- Early Childhood
- Elementary School
- Intermediate School
- Middle School
- High School
- Lee Richardson Zoo
- Garden City Community College
- Park
- Recreation

- School List:**
- Elementary List (K-4):
1. Abe Hubert (K-6)
 2. Alta Brown
 3. Buffalo Jones
 4. Edith Scheuerman
 5. Florence Wilson
 6. Georgia Matthews
 7. Gertrude Walker
 8. Jennie Barker (K-6)
 9. Jennie Wilson
 10. Plymell (K-6)
 11. Victor Ornelas
- Intermediate List (5-6):
12. Bernadine Sitts
 13. Charles O Stones
- Middle List (7-8):
14. Horace Good
 15. Kenneth Henderson
- High List (9-12):
16. Garden City

Growth Areas

- Current
- 5 Year
- 10 Year

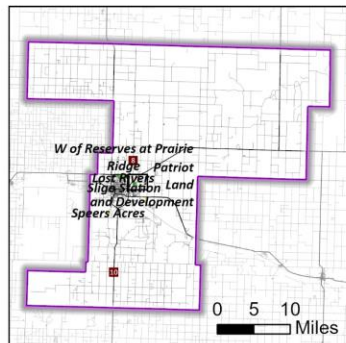
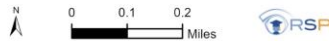

Population growth Areas are defined as areas that display a high propensity for growth; however, development is not guaranteed. Additionally, it is possible that areas not designated for growth may develop.

Map data provided by USD 457, Garden City, Finney County, USGS, and ESRI. Map created by RSP & Associates in December 2023.

South Growth Area Map



Growth Areas

- District Boundary
- District Office
- Early Childhood
- Elementary School
- Intermediate School
- Middle School
- High School
- Lee Richardson Zoo
- Garden City Community College
- Park
- Recreation

- School List:**
- Elementary List (K-4):
1. Abe Hubert (K-6)
 2. Alta Brown
 3. Buffalo Jones
 4. Edith Scheuerman
 5. Florence Wilson
 6. Georgia Matthews
 7. Gertrude Walker
 8. Jennie Barker (K-6)
 9. Jennie Wilson
 10. Plymell (K-6)
 11. Victor Ornelas
- Intermediate List (5-6):
12. Bernadine Sitts
 13. Charles O Stones
- Middle List (7-8):
14. Horace Good
- High List (9-12):
15. Kenneth Henderson
 16. Garden City

Growth Areas

- Current
- 5 Year
- 10 Year

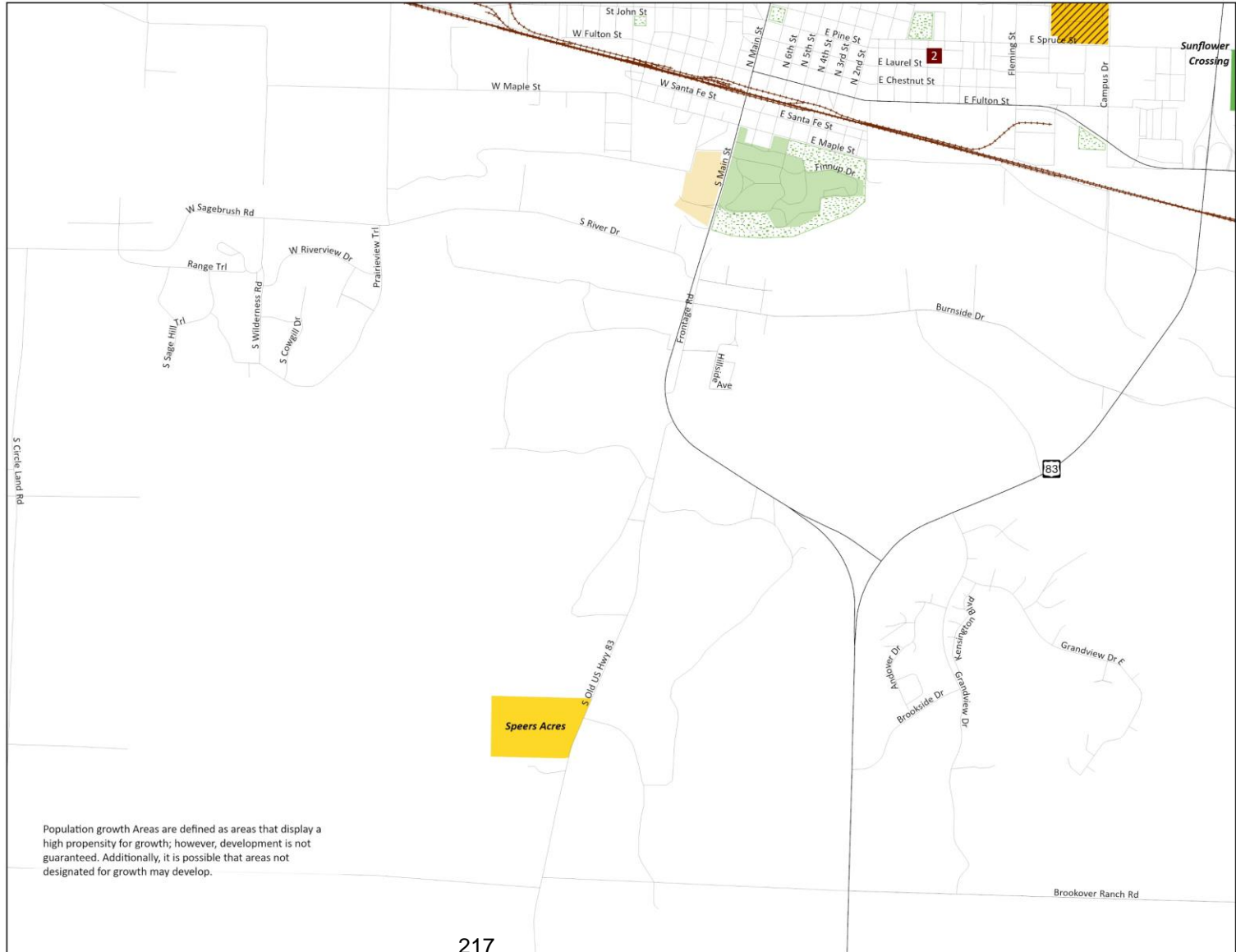
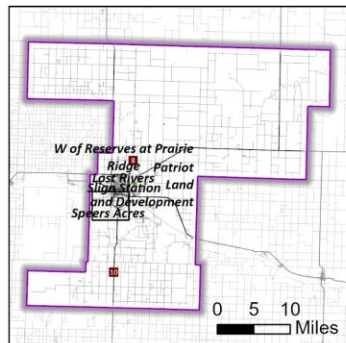

Map data provided by USD 457, Garden City, Finney County, USGS, and ESRI. Map created by RSP & Associates in December 2023.

Southeastern Growth Area Map



Growth Areas

- District Boundary
- District Office
- Early Childhood
- Elementary School
- Intermediate School
- Middle School
- High School
- Lee Richardson Zoo
- Garden City Community College
- Park
- Recreation

- School List:**
- Elementary List (K-4):
1. Abe Hubert (K-6)
 2. Alta Brown
 3. Buffalo Jones
 4. Edith Scheurman
 5. Florence Wilson
 6. Georgia Matthews
 7. Gertrude Walker
 8. Jennie Barker (K-6)
 9. Jennie Wilson
 10. Phyllis (K-6)
 11. Victor Ornelas
- Intermediate List (5-6):
12. Bernadine Sitts
 13. Charles O Stones
- Middle List (7-8):
14. Horace Good
- High List (9-12):
15. Kenneth Henderson
 16. Garden City

Growth Areas

- Current
- 5 Year
- 10 Year

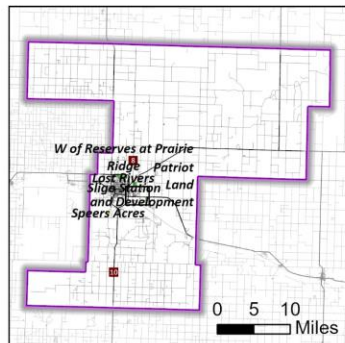
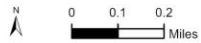

Population growth Areas are defined as areas that display a high propensity for growth; however, development is not guaranteed. Additionally, it is possible that areas not designated for growth may develop.

218

Map data provided by USD 457, Garden City, Finney County, USGS, and ESRI. Map created by RSP & Associates in December 2023.

Definitions

- Cohort: a group of individuals having a statistical factor (such as grade level) in common in a demographic study
- Out-migration: shows number of students in grade Kindergarten to 11th that are attending the district in the previous year, but were not attending the district in the current year
- In-migration: shows number of students in grade 1st to 12th that are attending the district in the current year, but were not attending the district in the previous year
- Yield-rate: ratio of students that attend each school to the number of housing units in that school's attendance area
- Single-family: a house that is may be fully detached or semi-detached occupied by one household or family
- Multi-family: a classification of housing where multiple separate housing units for residential inhabitants are contained within one building or several buildings within one complex
- Town Homes: Side by side housing units that do not meet the definition of single-family houses
- Mobile Home Park: movable dwelling, 8 feet or more wide and 40 feet or more long, designed to be towed on its own chassis, with transportation gear integral to the unit when it leaves the factory, and without need of a permanent foundation.
- Vacant Land: means any undeveloped land/ erf within a proclaimed township or a land development area and will continue to be rated as vacant until such time as a certificate of occupancy
- Mixed-use development: development that blends two or more residential, commercial, cultural, institutional, and/or industrial uses
- Median Year Built: equal to the middle point of all reported years when each dwelling unit was built based on information from the local assessor's office
- Median Home Value: equal to the middle point of all reported home values from the assessor's office in the district

MEMORANDUM

TO: Board of Education
THRU: Dr. Mike Dominguez, Superintendent
FROM: Shane Faurot, Plant Facilities Director
DATE: January 8th, 2024
RE: Abe Hubert Elementary School HVAC

ISSUE:

The Board of Education is asked to receive a presentation from Shane Faurot, our Plant Facilities Director.

BACKGROUND:

Our Plant Facilities Director will be discussing with the board a future HVAC project at Abe Hubert. There are a couple of opportunities to consider with this project that will impact the overall timeline for completion. This will be discussion only, with a follow-up presentation in February.

ALTERNATIVES:

No other alternatives applicable.

RECOMMENDATION:

Not Applicable

FISCAL NOTE:

No Fiscal impact.

ATTACHMENTS: