

**AGENDA
OURAY CITY COUNCIL**

Monday, April 21, 2025 - 6:00 PM

**Ouray Community Center
320 6th Ave
Ouray, CO 81427**

VIRTUAL OPTION - <https://zoom.us/j/9349389230>

Meeting ID: 934 938 9230 Passcode: 491878 Or dial: 408 638 0968 or 669 900 6833

Ouray City Council Regular Meeting

- Changes to this agenda can be found on the bulletin board at City Hall
- Electronic copies of the Council Packet are available on the City website at www.cityofouray.com. A hard copy of the Packet is also available at the Administrative Office for interested citizens.
- Notice is hereby given that a majority or quorum of the Planning Commission, Ouray Economic Development Committee, Beautification Committee, Tourism Advisory Committee, Main Streets Committee, and/or Parks and Recreation Committee may be present at the above noticed City Council meeting to discuss any or all of the matters on the agenda below for Council consideration

1. CALL TO ORDER
2. ROLL CALL
3. Consideration of a Request from Councilor Peggy Lindsey to Participate in this Meeting Remotely, per Resolution 4, Series 2022 - Remote Participation Policy for Council Members
4. PLEDGE OF ALLEGIANCE
5. CEREMONIAL/INFORMATIONAL
 - a. Proclamation 1, Series 2025 - Making May Mental Health Awareness Month in Ouray
 - b. Presentation from EPA Regarding Governor Basin Rehabilitation Project
6. APPROVAL OF MINUTES - Meeting of March 3, 2025
7. CITIZENS' COMMUNICATION
8. CITY COUNCIL REPORTS/INFORMATION - Tamara Gulde, Peggy Lindsey, Michael Underwood, Josh Smith, and Ethan Funk
9. DEPARTMENT REPORTS
 - a. City Administrator
 - b. Director of Finance and Administration
 - c. Information Technology Director
 - d. Communications and Community Engagement Coordinator
10. CONSENT AGENDA - Liquor License Renewal for Ouray Brewery, LLP dba Ouray Brewery
11. ACTION ITEMS
 - a. Agreement to Amend-Extend Contract; 333 6th Ave
 - b. Resolution 8, Series 2025 - Approving the Purchase of 333 6th Avenue
 - c. Appeal of Non-renewal of Short-term Rental License for 318 6th Avenue by Scott and Rebecca Yale
 - d. Identity Signage Design Contract - Ouray Hot Springs & Rotary Park
 - e. Department of Local Affairs (DOLA) Mini Grant Historic Sign Bases Contract Approval
 - f. Letter of Support for Funding Request of Home Trust of Ouray County River Walk Rentals (1507 Oak Street Affordable Housing Project)
 - g. Letter of Support for Congressional Directed Spending for Ouray Waterview Phase 2 Project
12. DISCUSSION ITEMS
 - a. Coordination of PIO with Ouray County for Wildfire Messaging

- b. Future Agenda Items
13. ADJOURNMENT



**A PROCLAMATION BY THE MAYOR OF
THE CITY OF OURAY, COLORADO**

**PROCLAMATION NO. 1, 2025
MENTAL HEALTH AWARENESS MONTH**

WHEREAS, mental health is essential to the well-being of our community;

WHEREAS, Colorado ranks 50th in prevalence of mental illness, indicating Coloradans experience more mental health challenges and substance use challenges than every state except one (Mental Health America);

WHEREAS, according to a Colorado Health Foundation poll in 2024, 3 in 5 Coloradans (59%) reported experiencing a mental health challenge in the past year;

WHEREAS, stigma persists in being a barrier to accessing care, with nearly 50% of Coloradans who needed mental health support reporting they did not seek out care due to stigma (Mental Health America);

WHEREAS, the most recent data on suicide death in our combined region of Delta, Montrose, Ouray, San Miguel, Gunnison, and Hinsdale Counties indicates 33 community members died by suicide in 2023 (CO Vital Statistics);

WHEREAS, organizations such as Tri-County Health Network are dedicated to shining a light on mental health and bringing hope to those experiencing a mental health challenge through research, education, advocacy, and resources and urge that we:

1. Recognize mental health challenges affect all members of our community.
2. Normalize conversations about mental health, suicide, and substance use in open and understanding ways to erase stigma and remind community members they are not alone in anything they may be experiencing.
3. Acknowledge that there is no one size fits all program or effort that will be appropriate for all populations or communities, and address the disparity in access to mental healthcare for underserved and underrepresented groups while advocating to end these disparities.
4. Support the efforts of social movements like We Are The Ones that build upon the innate ability of every individual to take meaningful action to strengthen our communities.

NOW THEREFORE, I, Ethan Funk, the Mayor of the City of Ouray, do hereby proclaim **May 2025 as Mental Health Awareness Month** in the City of Ouray.

April 21, 2025

Ethan Funk, Mayor

ATTEST: _____

Melissa M. Drake, City Clerk

WE ARE THE ONES

In times of challenge and change, TCHNetwork is launching We Are the Ones—a movement that empowers each of us to take meaningful action, big or small, to strengthen our communities. If we want things to improve, We Are the Ones who will make it happen—together.

If we want to address the mental health crisis, We Are the Ones who must normalize open conversations about mental health. If bullying is a problem in our schools and neighborhoods, We Are the Ones who can stand up, support each other, and create safer spaces. If someone in our community is struggling, We Are the Ones who can step up with kindness and support.

Taking action isn't always easy—sometimes, it takes courage to speak up, reach out, or be vulnerable. But when we do, we create a ripple effect of connection and support, making our community stronger for everyone.

This movement is about recognizing the power of individual actions in shaping a more connected and compassionate community. It's a reminder that each of us has the ability to make a difference—by fostering connection, encouraging resilience, and creating a sense of belonging. In our community, no one should feel alone.

Join us in We Are the Ones. Together, we can build a future where support, courage, and kindness lead the way.



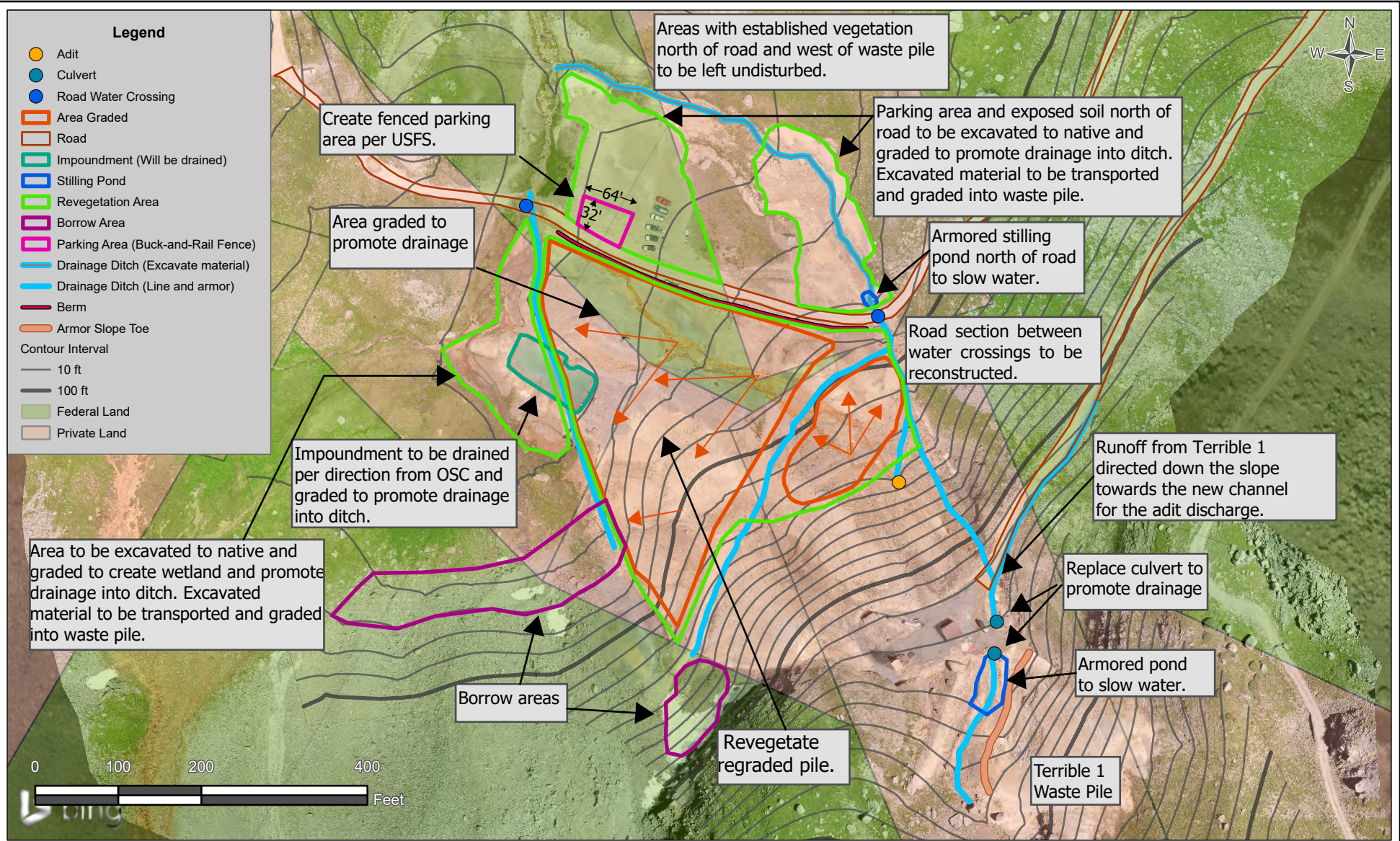

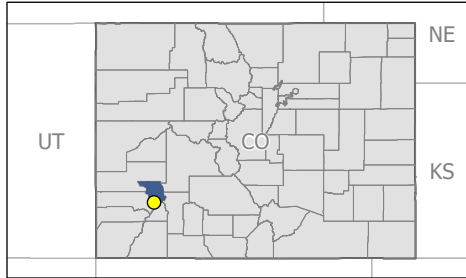

Notes:
Contour lines derived from UAV digital terrain model (DTM).

Source:
Background: UAV Orthomosaic (ERRS 7/30/24)/Bing Maps Hybrid
Spatial Reference: NAD 1983 StatePlane Colorado South FIPS 0503 Feet Coordinate System



 United States Environmental Protection Agency
 Region 8 START V
 TD: 2359-2407-03

TETRA TECH
 Analyst: S. DeNeice
 Date: 9/25/2024

Governor Basin
 Ouray, Ouray County, Colorado
Operations Plan



Ouray City Council Regular Meeting

Monday, March 3, 2025 6:00 PM

Ouray Community Center, 320 6th Ave, Ouray, CO 81427

Ethan Funk: Present
Tamara Gulde: Present
Peggy Lindsey: Present
Josh Smith: Present
Michael Underwood: Present

Also present were: City Administrator Michelle Metteer, Finance and Administration Director Melissa Drake, Public Works Director Joe Coleman, Parks and Recreation Director Joe Brown, Interim Police Chief Gary Ray, Tourism and Destination Marketing Director Kailey Rhoten, IT Director Rich Willis and City Attorney Carol Viner.

1. CALL TO ORDER

Mayor Funk called the meeting to order at 6:00 pm

2. ROLL CALL

3. PLEDGE OF ALLEGIANCE

The Pledge of Allegiance was recited.

4. PUBLIC HEARING - Ordinance 1, Series 2025 - Adding Chapter 7-7-K of the Ouray Municipal Code Regulating Affordable, Attainable, or Workforce Housing

Mayor Funk opened the public hearing. Kevin Schiffer thanked the council for making these changes. Mayor Funk closed the floor.

5. CITIZENS' COMMUNICATION

Mayor Funk opened the floor for public comment. Since there were no comments, Mayor Funk closed the floor.

6. CITY COUNCIL REPORTS/INFORMATION - Tamara Gulde, Peggy Lindsey, Michael Underwood, Josh Smith, and Ethan Funk

Councilor Gulde - attended FOHS meeting and Ouray Chamber After Hours meeting. Attended February 26th BOCC work session on affordable housing.

Councilor Lindsey - Beautification Committee will be meeting March 5th

Councilor Underwood - PARC will meet tomorrow. Attended pasta fundraiser for Ouray School. A modified Cabin Fever Day happened on March 1st at Fellin Park.

Mayor Pro Tem Smith - Main Street Committee meeting will be held on March 12th

Mayor Funk - Reminded councilors about the CML Conference in June. Attended BOCC work session as mayor.

Met with Ouray High School Government class about local government.

7. DEPARTMENT REPORTS

a. City Administrator

Ms. Metteer highlighted some items on her report.

b. Acting Police Chief

Acting Chief Ray gave an overview of his report, adding that Councilor Underwood spent two days riding along with officers on their shifts.

c. Fire Chief

Report in packet

d. Public Works Director

Mr. Coleman highlighted some items on his department report.

e. Parks and Recreation Director

Mr. Brown gave an overview of his report.

f. Tourism and Destination Marketing Director

Ms. Rhoten gave an overview of her report.

8. CONSENT AGENDA

Motion to approve the Consent Agenda. This motion, made by Peggy Lindsey and seconded by Tamara Gulde, Carried.

Ethan Funk: Yea, Tamara Gulde: Yea, Peggy Lindsey: Yea, Josh Smith: Yea, Michael Underwood: Yea

a. Liquor License Renewal - TABJ Company dba The Silver Eagle Saloon

b. Liquor License Renewal & Trade Name Change - The Gray LLC dba Cahoots Tavern

9. ACTION ITEMS

a. Ordinance 1, Series 2025 - Adding Chapter 7-7-K of the Ouray Municipal Code Regulating Affordable, Attainable, or Workforce Housing - Second Reading

Motion to approve Ordinance 1, Series 2025. This motion, made by Tamara Gulde and seconded by Peggy Lindsey, Carried.

Ethan Funk: Yea, Tamara Gulde: Yea, Peggy Lindsey: Yea, Josh Smith: Yea, Michael Underwood: Yea

b. Ordinance 2, Series 2025 - Repealing and Replacing Chapter 7-8-B of the Ouray Municipal Code to Correct the Formula for Determining the Maximum Density for a Given Lot - First Reading

Motion to approve Ordinance 2, Series 2025. Motion made by Councilor Gulde and seconded by Councilor Underwood.

Amended motion to approve the first reading of Ordinance 2, Series 2025, adding "to" after "necessary" in the final whereas. This motion, made by Tamara Gulde and seconded by Michael Underwood, Carried.

Ethan Funk: Yea, Tamara Gulde: Yea, Peggy Lindsey: Yea, Josh Smith: Yea, Michael Underwood: Yea

c. Resolution 6, Series 2025 - Adopting a 2025 Sidewalk Replacement Program

Motion to adopt Resolution 6, Series 2025. This motion, made by Josh Smith and seconded by Tamara Gulde, Carried.

Ethan Funk: Nay, Tamara Gulde: Yea, Peggy Lindsey: Yea, Josh Smith: Yea, Michael Underwood: Yea

d. Resolution 7, Series 2025 - Modifying the City of Ouray Personnel Regulations to Include Police Department Employees in Standard Overtime, Vacation, Holiday, and Sick Time Policies

Motion to adopt Resolution 7, Series 2025. This motion, made by Peggy Lindsey and seconded by Michael Underwood, Carried.

Ethan Funk: Yea, Tamara Gulde: Yea, Peggy Lindsey: Yea, Josh Smith: Yea, Michael Underwood: Yea

e. Addendum 4 to Agreement with KEO Studioworks for Fellin Park Stage Design

Motion to approve Addendum 4 to Agreement with KEO Studioworks. This motion, made by Peggy Lindsey and seconded by Josh Smith, Carried.

Ethan Funk: Yea, Tamara Gulde: Yea, Peggy Lindsey: Yea, Josh Smith: Yea, Michael Underwood: Yea

f. Letter of Intent to Contribute \$100,000 to Home Trust of Ouray County from Affordable Housing Funds for a Triplex Located at 835 2nd Street, Ouray

Kevin Schiffer asked what the fund balance would need to be for contributions to be temporarily stopped, and when contributions would resume, and suggested making guidelines for council contributions for affordable housing projects. Mr. Schiffer also asked if this project would come before the Planning Commission in the future. Mayor Funk said it would not because of the new 7-7-K adoption that would allow this renovation by right. Mayor Funk said the affordable housing fund is not only used for outside requests to fund affordable housing, and the city can use it internally for affordable housing goals, meaning a spending policy focused on outside requests would be unnecessarily limiting. Mr. Schiffer said he's trying to protect the positive perception of this fund by the community by ensuring that there are rules dictating how the money can be used to avoid any situations that seem unfair. City Attorney Viner advised against creating a set of rules for one line item in the budget, and said the budget itself is the guideline for spending in that fund, and every fund.

Motion to approve the Letter of Intent for 835 2nd St. This motion, made by Tamara Gulde and seconded by Peggy Lindsey, Carried.

Ethan Funk: Yea, Tamara Gulde: Yea, Peggy Lindsey: Yea, Josh Smith: Yea, Michael Underwood: Yea

10. DISCUSSION ITEMS

a. City Administrator Down Payment Assistance Funding Source

Council felt that taking \$250,000 from the General Fund made the most sense.

b. Deed Restrictions for Swiss Village

Kevin Schiffer asked what the goal of the deed restrictions is. Paul Smith asked if the County is obligated to follow the 3% appreciation rule. Mayor Funk said they were. Mayor Pro Tem Smith suggested allowing rentals for the second homeowner units, and for the owner-occupied units in the 4 months each year that they don't have to live at the property. Jay Lauderdale said the current covenants do not allow renting out of any units, and that would likely carry forward into the Co-Op's covenants. Paul Smith asked if there was a way to appeal any of the rules if someone in the future can't stay in Ouray for 8 months of the year due to health reasons. Mayor Funk confirmed that there is an appeals process for extenuating circumstances like this.

c. Future Agenda Items

11. EXECUTIVE SESSION - For a Conference with the City Attorney for the Purpose of Receiving Legal Advice on Specific Legal Questions Under C.R.S. 24-6-402(4)(b), Concerning Crystal Reservoir Dispute; 24CV30020 OH v. Little Switzerland, and Rosevelt Placer Land Donation and Boundary Adjustment Application; Then for Discussion of a Personnel Matter Under C.R.S. 24-6-402(2)(f) and not Involving any Specific Employees who have Requested Discussion of the Matter in Open Session, any Member of this Body or any Elected Official, the Appointment of any Person to Fill an Office of this Body or of an Elected Official, or Personnel Policies that do not Require the Discussion of Matters Personal to Particular Employees.

Motion to move into executive session at 7:45 pm. This motion, made by Michael Underwood and seconded by Peggy Lindsey, Carried.

Ethan Funk: Yea, Tamara Gulde: Yea, Peggy Lindsey: Yea, Josh Smith: Yea, Michael Underwood: Yea

12. ADJOURNMENT

Executive session concluded at 9:12 pm

Motion to adjourn at 9:12 pm. This motion, made by Tamara Gulde and seconded by Josh Smith, Carried.

Ethan Funk: Yea, Tamara Gulde: Yea, Peggy Lindsey: Yea, Josh Smith: Yea, Michael Underwood: Yea

Ethan Funk, Mayor

ATTEST:

Melissa M. Drake, City Clerk

CERTIFICATION

I, Melissa M. Drake, do hereby certify that I am the City Clerk of the City of Ouray, Ouray County, State of Colorado, and that the above minutes are a true and correct summary of the meeting of the Ouray City Council held on Monday, March 3, 2025. I further certify that the meeting was duly called and held, and that a quorum was present.

Dated this Monday, March 3, 2025.

Melissa M. Drake, City Clerk



P.O. Box 468
320 6th Avenue
Ouray, CO 81427
(970) 325-7211

Date: April 21, 2025
To: Ouray City Council
From: Michelle Metteer, City Administrator
Re: City Updates

Budget/Capital Review

Finance Director Melissa Drake and I took some time to review the 2025 Capital Improvement Budget for potential areas of cost savings. With the unbudgeted purchase of 333 6th Ave, it seemed prudent to look for separate areas within the general fund for saving opportunities. I will now be meeting with department heads to determine progress on each of the capital improvements budgeted for 2025 to understand if cost savings can be achieved.

In-Town Shuttle

The RFP for an in-town shuttle service is being prepared for publication. This effort began last year with the goal of providing shuttle service seven days a week throughout the summer. \$120,000 has been budgeted for this service. Josh Smith has been incredibly valuable with bringing me up to speed on this project and the goals of facilitating additional multi-modal forms of transportation throughout the community.

Regional Housing Administrator

Work continues toward the selection of a Regional Housing Administrator. This is a tri-agency effort between the City, County and Town of Ridgway. Previously, an RFP had been published with a single proposal submitted. The City, County and Town are looking to conduct a more robust RFP process with hopefully multiple proposals submitted to ensure a thoroughly-vetted process. We are now collaboratively working to make any updates to the RFP and republish, including notice in both local and regional outlets.

Bath House Remodel Funding

City staff will be researching funding options for the upcoming remodel to the Ouray Hot Springs Bath House. The USDA option originally considered is limited as they do not fund recreational infrastructure. This research effort will most likely involve the use of a municipal financial advisor and it is my understanding the City has contracted with Troy Berneberg of Northland Securities.

Colorado Association of Ski Towns (CAST)

CAST is currently organizing the October 8 & 9 meeting which will be held in Breckenridge, CO. This meeting will be coordinated with the [Mountain Towns 2030 Summit](#). For any Council members interested in attending MT2030 and the CAST meeting, please let staff know so we can coordinate.

City Administrator Community Reception

The Wright Opera House has been kind enough to host the City Administrator Community Reception which will be held on Friday, May 2nd from 5 to 7 PM. This is a time for community members to have a few appetizers, enjoy good company and get to know their new City Administrator. I'm hopeful a wide variety of stakeholders will attend. If this time doesn't work for anyone, please let me know as I'm happy to meet at other times as convenient.



City of Ouray
February 2025 Sales Tax Revenues by Business Category
(received in April 2025)

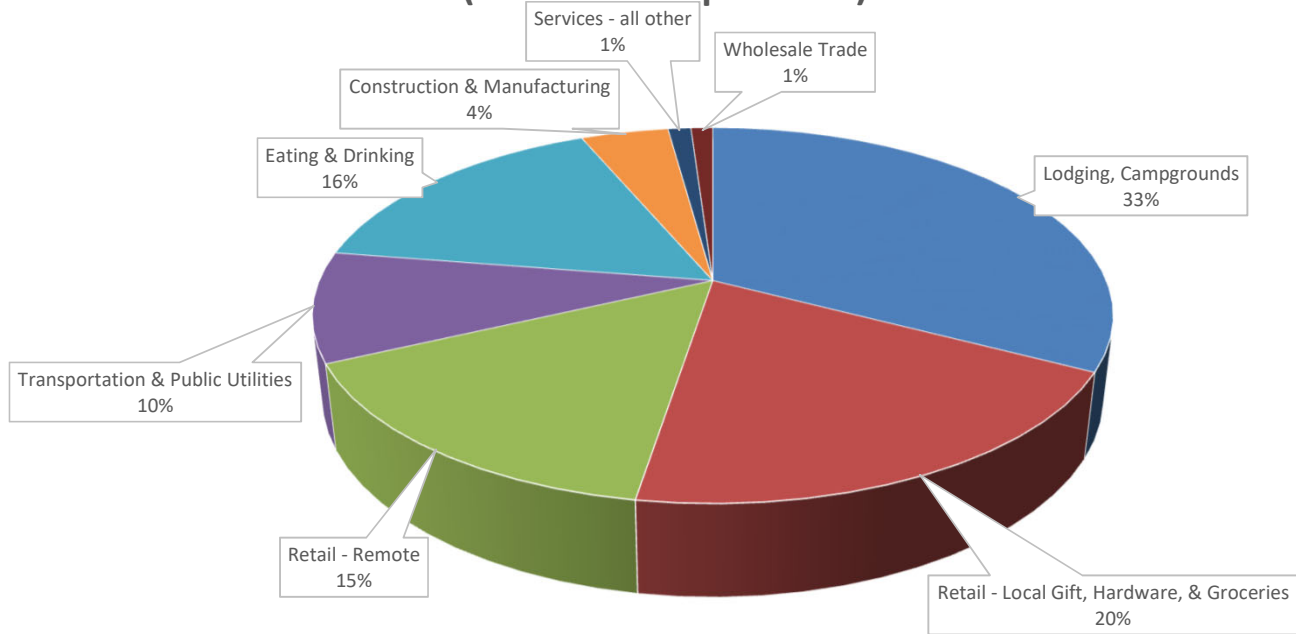

CITY OF OURAY
2025 MONTHLY SALES TAX REVENUES BY BUSINESS CATEGORY

(1) Month tax received from State of Colorado, representing sales from two months earlier (e.g. tax shown as APRIL is mostly from FEBRUARY)

2025 SALES TAX REVENUES BY BUSINESS CATEGORY							
(1) Funds received by City in: July (mostly re: May)							
Business Category	January	February	March	April	May	June	
Lodging, Campgrounds	\$ 32,707.60	\$ 61,038.62	\$ 52,880.88	\$ 47,165.36			
Retail - Local Gift, Hardware, & Groceries	\$ 27,124.53	\$ 33,924.66	\$ 29,458.68	\$ 28,756.14			
Retail - Remote	\$ 22,614.06	\$ 31,898.09	\$ 24,812.28	\$ 22,337.10			
Transportation & Public Utilities	10,901.88	13,647.55	14,514.51	13,677.96			
Eating & Drinking	18,360.30	27,751.32	28,404.66	23,271.59			
Construction & Manufacturing	7,048.89	6,716.06	4,621.87	6,097.70			
Services - all other	1,882.55	3,060.50	2,443.60	1,598.30			
Wholesale Trade	1,038.43	1,568.99	1,779.29	1,518.80			
TOTAL	\$ 121,678.24	\$ 179,605.79	\$ 158,915.77	\$ 144,422.95	\$ -	\$ -	
Business Category	July	August	September	October	November	December	Year-to-date
Lodging, Campgrounds							\$ 193,792.46
Retail - Local Gift, Hardware, & Groceries							\$ 119,264.01
Retail - Remote							\$ 101,661.53
Transportation & Public Utilities							52,741.90
Eating & Drinking							97,787.87
Construction & Manufacturing							24,484.52
Services - all other							8,984.95
Wholesale Trade							5,905.51
TOTAL	\$ -	\$ -	\$ -	\$ -	\$ -	\$ -	\$ 604,622.75

CITY OF OURAY FEBRUARY SALES TAX REVENUE COMPARISON Over Past 10 Years

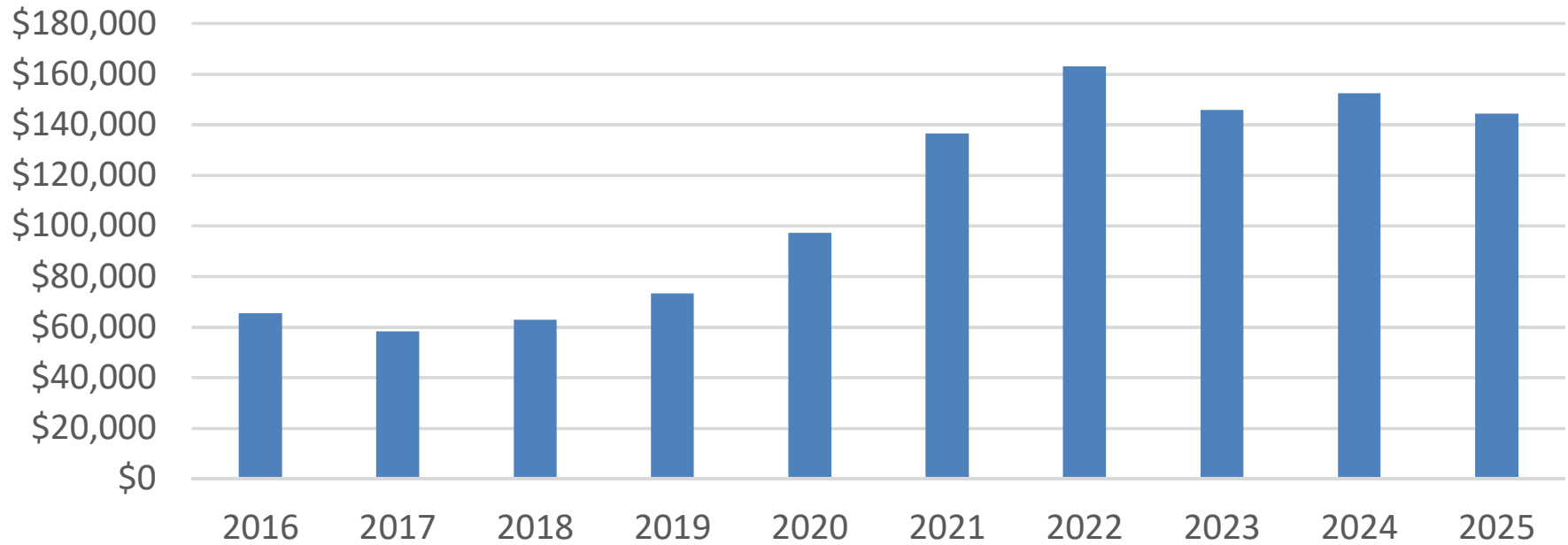

Notes: Figures represent revenue received in April
Sales Tax increased from 3% to 4% on January 1, 2016

CITY OF OURAY
SALES TAX REVENUES BY BUSINESS CATEGORY 2016-2025

SALES TAX REVENUES BY BUSINESS CATEGORY

Business Category	2016	2017	2018	2019	2020	2021	2022	2023	2024	2025
Lodging, campgrnds.	\$ 19,715.80	\$ 15,912.22	\$ 19,077.49	\$ 23,081.46	\$ 26,580.81	\$ 37,873.92	\$ 57,820.63	\$ 55,728.49	\$ 53,525.63	\$ 47,165.36
Retail - Local Gift, Hardware, & Groceries					\$ 17,147.45	\$ 23,627.21	\$ 27,054.56	\$ 26,647.60	\$ 25,475.53	\$ 28,756.14
Retail - Remote					\$ 15,352.60	\$ 24,933.67	\$ 20,865.37	\$ 17,585.84	\$ 19,000.83	\$ 22,337.10
Retail - groceries, liquor, candy, hardw	12,255.70	11,214.99	10,942.86	21,912.81						
Retail - gift, souvenir, variety, books	5,819.29	4,652.93	7,363.15	1,264.87						
Trans & Pub. Util.	6,400.62	7,942.73	8,182.18	8,674.18	12,276.40	12,631.99	14,646.02	15,749.48	13,914.72	13,677.96
Eating & Drinking	13,393.00	12,463.99	11,100.93	11,248.23	22,111.84	31,787.40	30,031.16	24,642.34	33,719.56	23,271.59
Const. & Manufacturing	6,329.68	4,905.28	5,028.85	5,624.30	1,661.83	2,448.18	9,370.64	1,735.20	3,241.48	6,097.70
Services - all other	485.56	520.70	911.04	197.56	1,194.72	1,615.88	1,292.90	2,079.81	1,955.06	1,598.30
Finance, Ins. Real Estate	1,071.57	623.61	217.43	899.22						
Wholesale Trade	78.22	47.00	168.00	565.13	964.13	1,658.85	2,019.23	1,767.56	1,737.68	1,518.80
Mining		-								
All Other		-								
TOTAL	\$ 65,549.44	\$ 58,283.45	\$ 62,991.93	\$ 73,467.76	\$ 97,289.78	\$ 136,577.10	\$ 163,100.51	\$ 145,936.32	\$ 152,570.49	\$ 144,422.95
			\$1,501.70 out-of-period	\$2,700.82 out-of-period	\$4,613.53 out-of-period	\$7,518.92 out-of-period	\$14,671.86 out-of-period	\$9,211.74 out-of-period	\$13,062.06 out-of-period	\$4,210.72 out-of-period

Year to Date Sales Tax Comparison

Percentage Change
from 2024

February 2024 Activity	\$	152,570.49	
February 2025 Activity	\$	144,422.95	-5.34%
Jan-Feb 2024 Activity	\$	308,753.96	
Jan-Feb 2025 Activity	\$	303,338.72	-1.75%

Ouray Lodging Occ. Tax Collection Summary

ROOMS	2015	2016	2017	2018	2019	2020	2021	2022	2023	2024	2025	25 vs 24
Month												
January	5712	5826	5113	5782	6196	6245	5936	7718	7609	6942	6791	-2.18%
February	4816	5226	4509	5085	5593	4641	7189	7776	5906	6328	5914	-6.54%
March	3394	3638	3499	4763	4152	1952	6993	6782	7341	5953		
April	2236	2660	2411	3080	2857	32	4941	4172	3836	4057		
May	5047	5850	5939	7396	7894	3111	11093	10002	9560	8475		
June	12015	13521	14494	14578	15026	12736	17520	16180	17231	16096		
July	19171	19960	20248	19802	19482	20444	20509	16551	19482	19504		
August	16477	16949	17344	17613	18629	16919	20798	17825	18657	18449		
September	15478	16149	16526	17743	18498	17564	13517	18930	18234	17807		
October	7937	7691	7762	7462	9407	12877	12038	12080	12388	13750		
November	2141	2113	2674	2856	3237	3864	3199	3196	3691	3727		
December	3656	3382	4226	5038	4268	5153	5237	3998	4776	5091		
Total Rooms	98080	102965	104745	111198	115239	105538	128970	125210	128711	126179		-4.26%

DOLLARS												
January	\$15,867	\$15,819	\$13,795	\$16,294	\$22,444	\$25,204	\$27,107	\$29,038	\$36,828	\$34,062	\$36,301	6.57%
February	\$12,468	\$13,908	\$12,648	\$14,021	\$19,580	\$18,464	\$28,191	\$36,284	\$30,377	\$31,294	\$31,566	0.87%
March	\$9,240	\$9,505	\$9,529	\$12,884	\$14,526	\$6,834	\$27,858	\$30,334	\$30,554	\$27,551		
April	\$5,701	\$6,633	\$6,294	\$8,090	\$8,312	\$107	\$18,324	\$18,466	\$17,063	\$16,915		
May	\$13,876	\$15,372	\$15,734	\$19,031	\$22,068	\$7,922	\$41,033	\$43,131	\$39,992	\$45,459		
June	\$31,431	\$34,498	\$36,654	\$36,236	\$62,392	\$51,634	\$100,852	\$98,839	\$107,693	\$107,890		
July	\$47,884	\$49,767	\$50,344	\$49,371	\$110,244	\$114,230	\$138,864	\$131,139	\$142,596	\$157,254		
August	\$41,643	\$41,801	\$42,090	\$43,236	\$90,952	\$92,809	\$127,157	\$122,778	\$127,552	\$136,115		
September	\$40,336	\$41,704	\$41,965	\$44,480	\$79,505	\$93,050	\$98,575	\$119,099	\$123,174	\$127,337		
October	\$21,385	\$20,717	\$20,355	\$19,711	\$37,511	\$60,690	\$54,480	\$74,824	\$74,823	\$82,632		
November	\$5,136	\$5,802	\$7,079	\$7,000	\$10,367	\$15,399	\$14,134	\$14,566	\$15,480	\$18,071		
December	\$9,571	\$9,590	\$11,882	\$13,622	\$17,593	\$24,892	\$29,038	\$23,554	\$27,242	\$28,857		
Total Dollars	\$254,538	\$265,116	\$268,369	\$283,976	\$495,494	\$511,234	\$705,613	\$742,052	\$773,373	\$813,436		3.84%

Data represents rooms and dollars for month in which lodging activity occurred.
 LOT report and payment are due by 20th of following month.
 "ROOMS" data includes exempt rooms.

OURAY LODGING OCCUPANCY TRENDS
Based on Lodging Occupation Tax Collections

	2022				2023				2024				2025			
	Avail. Rooms	Rooms Rented	Occ.%	Exempt Rooms	Avail. Rooms	Rooms Rented	Occ.%	Exempt Rooms	Avail. Rooms	Rooms Rented	Occ.%	Exempt Rooms	Avail. Rooms	Rooms Rented	Occ.%	Exempt Rooms
	+ RVs, Unfurnished Cabins				+ RVs, Unfurnished Cabins				+ RVs, Unfurnished Cabins				+ RVs, Unfurnished Cabins			
January	18142	7718	42.5%	0	20375	7609	37.3%	469	19064	6942	36.4%	304	19568	6791	34.7%	321
February	16580	7776	46.9%	0	17183	6022	35.0%	386	17656	6328	35.8%	357	17806	5914	33.2%	233
March	17657	6782	38.4%	7	19519	7341	37.6%	341	18223	5953	32.7%	92				
April	16620	4172	25.1%	31	18168	3836	21.1%	0	16435	4057	24.7%	47				
May	21206	10002	47.2%	57	21360	9560	44.8%	110	20998	8475	40.4%	212				
June	20577	16180	78.6%	13	21111	17231	81.6%	122	20685	16096	77.8%	212				
July	20677	16551	80.0%	432	21195	19482	91.9%	499	21420	19504	91.1%	205				
August	21613	17825	82.5%	53	21504	18657	86.8%	481	21934	18449	84.1%	213				
September	21327	18930	88.8%	47	21086	18234	86.5%	413	20994	17807	84.8%	390				
October	20398	12080	59.2%	10	20094	12388	61.7%	261	20419	13750	67.3%	305				
November	15776	3196	20.3%	260	16283	3691	22.7%	254	17140	3727	21.7%	87				
December	17828	5050	28.3%	4	17320	4776	27.6%	215	19365	5091	26.3%	41				
Total	228401	126262	53.2%	914	235198	128827	52.9%	3551	234333	126179	51.9%	2465	37374	12705	34.0%	554

Data represents rooms for month in which lodging activity occurred.
 LOT report and payment are due by 20th of following month.
 "Rooms Rented" columns includes exempt rooms.
 "Exempt Rooms" columns are for memo purposes only.

2025 Lodging Occupation Tax, By Business Category

AVAILABLE ROOMS	Jan	Feb	Mar	Apr	May	Jun	Jul	Aug	Sep	Oct	Nov	Dec	Total
Hotel, Motel	12,668	11,451											24,119
Bed and Breakfast	713	786											1,499
House, Townhouse, Condo (1)	3,614	3,245											6,859
RV Space, Unfurnished Cabin	2,573	2,324											4,897
Total Rooms	19,568	17,806	-	-	-	-	-	-	-	-	-	-	37,374

Prior YTD 36,720

ROOMS RENTED	Jan	Feb	Mar	Apr	May	Jun	Jul	Aug	Sep	Oct	Nov	Dec	Total
Hotel, Motel	4,864	4,410											9,274
Bed and Breakfast	341	214											555
House, Townhouse, Condo (1)	1,073	880											1,953
RV Space, Unfurnished Cabin	513	410											923
Total Rooms	6,791	5,914	-	-	-	-	-	-	-	-	-	-	12,705

Prior YTD 13,270

DOLLARS	Jan	Feb	Mar	Apr	May	Jun	Jul	Aug	Sep	Oct	Nov	Dec	Total
Hotel, Motel	\$ 23,937.36	\$ 22,123.00											46,060
Bed and Breakfast	\$ 1,059.49	\$ 842.27											1,902
House, Townhouse, Condo (1)	\$ 10,312.02	\$ 7,878.04											18,190
RV Space, Unfurnished Cabin	\$ 992.57	\$ 722.29											1,715
Total Dollars	\$ 36,301.44	\$ 31,565.60	\$ -	\$ -	\$ -	\$ -	\$ -	\$ -	\$ -	\$ -	\$ -	\$ -	\$ 67,867.04

Prior YTD 65,355.86

(1) For a property that is marketed as a stand-alone short-term rental, for which there are no hotel/motel amenities offered.
 Data represents rooms for month in which lodging activity occurred.
 LOT report and payment are due by 20th of following month.
 "Rooms Rented" columns includes exempt rooms.

Excise Tax on Short Term Rentals

Activity Month	2022	2023	2024	2025	% Change from 2024	YTD % Change
January	\$ 27,661.19	\$ 37,085.48	\$ 35,761.19	\$ 39,059.77	9.2%	9.2%
February	\$ 32,883.88	\$ 27,662.57	\$ 28,192.46	\$ 28,043.85	-0.5%	4.9%
March	\$ 28,220.99	\$ 23,074.54	\$ 21,027.21			
April	\$ 7,217.41	\$ 6,674.51	\$ 7,558.36			
May	\$ 23,933.67	\$ 21,653.38	\$ 27,989.28			
June	\$ 72,625.26	\$ 84,017.25	\$ 89,007.15			
July	\$ 109,220.30	\$ 128,885.01	\$ 141,496.13			
August	\$ 90,863.82	\$ 99,257.44	\$ 118,757.19			
September	\$ 83,065.86	\$ 92,170.25	\$ 87,286.84			
October	\$ 41,028.93	\$ 55,796.90	\$ 49,490.66			
November	\$ 9,274.82	\$ 13,210.01	\$ 10,581.26			
December	\$ 29,333.34	\$ 29,200.58	\$ 27,874.27			
Grand Total	\$ 555,329.47	\$ 618,687.92	\$ 645,022.01	\$ 67,103.62		

Revenue by Fund	2022	2023	2024	2025	Cumulative
Affordable/Attainable Housing	\$ 277,664.74	\$ 309,343.96	\$ 322,511.00	\$ 33,551.81	\$ 943,071.51
Water Capital Improvements	\$ 138,832.37	\$ 154,671.98	\$ 161,255.50	\$ 16,775.91	\$ 471,535.75
Sewer Capital Improvements	\$ 138,832.37	\$ 154,671.98	\$ 161,255.50	\$ 16,775.91	\$ 471,535.75
Cumulative Total Raised					\$ 1,886,143.02

Affordable Housing Revenue and Expenses	2022	2023	2024	2025	Cumulative
Total Raised	\$ 277,664.74	\$ 309,343.96	\$ 322,511.00	\$ 33,551.81	\$ 943,071.51
Total Spent	\$ (110,000.00)	\$ (67,849.69)	\$ (132,882.16)	\$ -	\$ (310,731.85)
Total Remaining	\$ 167,664.74	\$ 241,494.27	\$ 189,628.84	\$ 33,551.81	\$ 632,339.66

Check Date	Payee	Amount	Description
4/20/2022	Home Trust of Ouray County	\$ 10,000.00	2022 Operating funds
1/4/2023	Home Trust of Ouray County	\$ 100,000.00	734 4th St
2/1/2023	Home Trust of Ouray County	\$ 20,000.00	2023 Operating funds
4/26/2023	Economic & Planning Systems Inc	\$ 3,847.50	Housing needs analysis
5/24/2023	Economic & Planning Systems Inc	\$ 3,505.00	Housing needs analysis
6/7/2023	Buckhorn Engineering	\$ 3,426.25	Cascade Park Geohazard Assessment
7/5/2023	Economic & Planning Systems Inc	\$ 1,557.50	Housing needs analysis
8/2/2023	Economic & Planning Systems Inc	\$ 7,692.50	Housing needs analysis
9/6/2023	Buckhorn Engineering	\$ 6,293.75	Cascade Park Geohazard Assessment
9/27/2023	Economic & Planning Systems Inc	\$ 4,237.50	Housing needs analysis
11/1/2023	Economic & Planning Systems Inc	\$ 1,930.00	Housing needs analysis
11/29/2023	Economic & Planning Systems Inc	\$ 9,257.19	Housing needs analysis
1/23/2024	Economic & Planning Systems Inc	\$ 6,102.50	Housing needs analysis
1/23/2024	Home Trust of Ouray County	\$ 30,000.00	2024 Operating funds
4/17/2024	Ouray County Clerk & Recorder	\$ 382.16	Recording fee
8/28/2024	Economic & Planning Systems Inc	\$ 2,500.00	Housing needs analysis
9/18/2024	Home Trust of Ouray County	\$ 100,000.00	River Walk Rentals

City of Ouray Hot Springs Pool and Fitness Center - Visitor and Revenue Trends

(Source: Point of Sale Software)

VISITORS	2016	2017	2018	2019	2020	2021	2022	2023	2024	2025	% change from 2024
January	9,287	36	9,392	8,553	8,149	4,961	5,258	6,871	7,152	7,958	11.27%
February	9,095	13	7,342	5,970	7,836	4,824	6,660	5,599	5,592	7,369	31.78%
March	10,087	58	10,468	9,118	3,638	7,697	8,621	7,148	8,426	10,250	21.65%
April	6,195	16	7,048	5,481	-	7,104	5,249	4,693	6,578		
May	12,065	2,984	13,346	11,397	-	11,580	9,549	10,602	11,201		
June	22,404	18,175	24,764	24,525	1,540	25,977	20,156	23,206	22,419		
July	36,116	37,483	35,943	36,986	6,416	30,994	26,286	32,117	32,654		
August	22,353	25,486	23,936	23,274	12,622	22,179	19,101	21,170	20,874		
September	9,258	16,065	16,397	14,833	11,946	13,612	14,652	15,634	15,208		
October	62	9,834	8,771	9,596	10,699	9,368	10,135	11,035	12,238		
November	49	7,077	7,043	6,920	4,644	6,782	5,354	6,326	6,851		
December	47	10,753	9,046	8,174	4,439	6,317	6,510	8,152	8,816		
TOTAL YEAR	137,018	127,980	173,496	164,827	71,929	151,395	137,531	152,553	158,009		

REVENUE	2016	2017	2018	2019	2020	2021	2022	2023	2024	2025	% change from 2024
January	\$ 85,983.09	\$ 2,189.00	\$ 89,885.46	\$ 95,701.53	\$ 99,306.81	\$ 66,989.85	\$ 63,150.43	\$ 96,783.56	\$ 121,260.10	\$ 140,810.60	16.12%
February	\$ 78,569.69	\$ 724.00	\$ 70,970.13	\$ 65,918.59	\$ 97,215.12	\$ 61,086.55	\$ 85,924.20	\$ 112,926.04	\$ 105,565.18	\$ 152,827.35	44.77%
March	\$ 84,745.80	\$ 1,012.00	\$ 102,232.15	\$ 108,526.39	\$ 47,810.30	\$ 106,419.45	\$ 126,759.01	\$ 120,467.93	\$ 145,888.18	\$ 190,605.89	30.65%
April	\$ 52,112.54	\$ 2,234.00	\$ 72,957.12	\$ 62,025.47	\$ -	\$ 98,819.49	\$ 152,003.71	\$ 133,097.92	\$ 119,178.58	\$ -	
May	\$ 108,047.29	\$ 123,474.60	\$ 155,881.40	\$ 138,237.34	\$ -	\$ 162,720.12	\$ 143,279.82	\$ 208,335.74	\$ 275,871.30	\$ -	
June	\$ 211,853.56	\$ 166,974.02	\$ 317,542.31	\$ 311,093.17	\$ 19,273.04	\$ 352,538.72	\$ 321,377.13	\$ 469,321.85	\$ 469,363.01	\$ -	
July	\$ 332,026.16	\$ 479,802.39	\$ 455,519.84	\$ 474,330.32	\$ 74,169.01	\$ 428,489.09	\$ 452,460.99	\$ 646,348.28	\$ 660,284.72	\$ -	
August	\$ 198,465.34	\$ 326,151.96	\$ 308,882.04	\$ 295,953.46	\$ 165,977.58	\$ 312,872.14	\$ 316,183.52	\$ 419,353.80	\$ 423,754.26	\$ -	
September	\$ 80,149.87	\$ 184,807.92	\$ 200,777.07	\$ 188,131.33	\$ 158,666.78	\$ 186,412.51	\$ 238,796.90	\$ 283,459.93	\$ 278,649.03	\$ -	
October	\$ 2,737.00	\$ 82,537.92	\$ 99,235.68	\$ 120,843.43	\$ 145,302.53	\$ 131,806.01	\$ 170,555.12	\$ 211,284.83	\$ 223,633.93	\$ -	
November	\$ 1,796.25	\$ 62,435.74	\$ 84,885.49	\$ 83,976.37	\$ 58,403.16	\$ 88,639.21	\$ 84,930.60	\$ 107,867.28	\$ 119,193.83	\$ -	
December	\$ 1,957.00	\$ 112,212.40	\$ 111,645.98	\$ 105,050.32	\$ 60,304.81	\$ 79,891.78	\$ 94,844.99	\$ 156,882.10	\$ 163,777.30	\$ -	
TOTAL YEAR	\$ 1,238,443.59	\$ 1,544,555.95	\$ 2,070,414.67	\$ 2,049,787.72	\$ 926,429.14	\$ 2,076,684.92	\$ 2,250,266.42	\$ 2,966,129.26	\$ 3,106,419.42		

CITY OF OURAY VISITOR CENTER - REVENUE TRENDS

REVENUES

	2022		2023			2024			2025			Incr./Decr.	25 vs. 24
	Concessions	Non-Profit	Concessions	Non-Profit	OHV	Concessions	Non-Profit	OHV	Concessions	Non-Profit	OHV		
January			\$ 228.95	\$ 53.00		\$ 284.11	\$ 25.00	\$ -	\$ 149.25	\$ 95.00	\$ -	\$ (64.86)	-21%
February			\$ 150.89	\$ 85.95		\$ 438.62	\$ 36.00	\$ -	\$ 519.70	\$ 140.00	\$ -	\$ 185.08	39%
March			\$ 395.38	\$ 4.00		\$ 773.27	\$ 111.00	\$ -	\$ 764.72	\$ 95.00	\$ -	\$ (24.55)	-3%
April			\$ 403.25	\$ 2.00	\$ 50.50	\$ 713.73	\$ 25.00	\$ -					
May			\$ 1,098.28	\$ 611.60	\$ 126.25	\$ 2,281.10	\$ 88.00	\$ 126.25					
June			\$ 1,627.77	\$ 690.75	\$ 202.00	\$ 3,035.75	\$ 498.00	\$ 325.25					
July	\$ 910.80	\$ 215.00	\$ 2,517.75	\$ 664.60	\$ 782.75	\$ 3,369.09	\$ 277.00	\$ 252.50					
August	\$ 1,281.05	\$ 684.85	\$ 2,669.69	\$ 648.85	\$ 378.75	\$ 2,360.70	\$ 387.00	\$ 378.75					
September	\$ 1,814.71	\$ 676.95	\$ 2,834.91	\$ 698.00	\$ 75.75	\$ 3,482.57	\$ 360.00	\$ 277.75					
October	\$ 1,383.05	\$ 275.00	\$ 1,096.11	\$ 253.00	\$ 227.25	\$ 1,636.08	\$ 225.00	\$ 50.50					
November	\$ 380.36	\$ 121.00	\$ 354.94	\$ 40.00	\$ -	\$ 160.37	\$ 60.00	\$ -					
December	\$ 516.45	\$ 79.00	\$ 233.25	\$ -	\$ -	\$ 477.79	\$ -	\$ -					
TOTAL \$	\$ 6,286.42	\$ 2,051.80	\$ 13,611.17	\$ 3,751.75	\$ 1,843.25	\$ 19,013.18	\$ 2,092.00	\$ 1,411.00	\$ 1,433.67	\$ 330.00	\$ -	\$ 95.67	
		\$ 8,338.22			\$ 19,206.17			\$ 22,516.18			\$ 1,763.67		

percent of sales earning profit

75%

71%

84%

81%

March - April 2025 IT Highlights

- Main and Backup Servers were rebuilt to enable disk mirroring for better redundancy. This allowed us to test the hardware recovery backups that worked well. A secondary backup server was available just in case and had the latest data in the event that it was needed.
- The secondary backup server was repurposed as a replication server for network management and monitoring virtual machines. Backups were happening but we now have replicas ready for use for quicker recovery.
- Operations continued during a three hour Internet outage from a fiber cut by using internal capabilities and cell phone hot spots. As a stop gap solution, we set up and tested a satellite Internet service to keep the Hot Springs point of sale 3 terminals and membership computer running. Cell phone hot spots will be used for essential staff as long as the cellular services are available. For a long term solution, the city will partner with Region 10 when they are capable of providing a secondary Internet connection to cover all City of Ouray needs for a redundant Internet connection.
- The Ouray Fire Department now has a new laptop computer and an Internet capable mini satellite dish for use in the field to provide mapping and reporting. This configuration includes a backpack for portability and aligns Ouray with Ridgway fire departments remote capabilities.
- New camera added to Police Department office.
- Keyfob access is added to both police department doors, the library, parks building, public works shop, box canon, waste water, and water treatment. This will allow staff simpler controlled access while also providing a history of access. This will also provide simpler onboarding and offboarding access control.
- A credit card machine was replaced with a backup credit card machine over a weekend and then the error prone device was brought back online with support assistance on a weekday. We maintain critical backup devices like this for just an event.
- Two backup computers are prepared for POS Box Canon, Hot Springs or Visitor Center.
- Further Backup and Replication reporting was started to ensure backups and replicas occur successfully on a daily basis.
- One camera was replaced and brought back online after the power supply issue was corrected.
- Server and Security Systems updates completed.



CCEC Report

Thursday, 4.17.2025

Communications

Press Release: Main Street Cleaning & Striping

1. A press release was sent out to a distribution list on Wednesday, April 16, 2025. This was provided on our website's "[Latest News](#)", the alert pop-up, as well as on Facebook and Instagram for both city feeds and stories. This year we created a map to go with this information. The map has been posted at City Hall, the Post Office, and Ouray Grocery.

Mass Communications

1. April Newsletter: <https://conta.cc/4ck5AXM>
2. Registered Business owners received an email update containing [Business Funding & Technical Assistance](#) and upcoming events

Website Alert Pop-Up

3. Updated with Save the Date for Community Cleanup Day
4. Updated with Visitor Center closure
5. Updated with Tourism Stakeholder Survey & Resident Sentiment Survey
6. Updated with Ouray PD Scholarship for Seniors information
7. Updated with Temporary Alley Closure information
8. Updated with Main Street Cleaning and Striping

Website Pages

1. Attended a meeting with Revize on April 16th to discuss items found throughout website that need assistance, i.e. link and button colors are not working properly,



“ghost” pages still seem to exist in search engines, mobile page cuts out the accessibility translator and social media buttons.

2. Updated Latest News
3. Corrected Express Bill Pay link to land on Ouray’s custom landing page
4. Uploaded upcoming agendas for multiple committees
5. Archived approved minutes for multiple committees to Public Records & Documents
6. Updated Staff directory
7. Updated Email Contact form
8. Updated Parks & Recreation page
9. Updated Community Development page
10. Updated Business Resources page
11. Created Committee page for Ice Park Advisory Team
12. Updated Public Records & Documents
13. Updated Police page

Social Media - City

1. Event created: Upcoming City Council meetings
2. Event created: City - Save the Date for Ouray Community Cleanup Day on June 7th
3. Event created: City - Offices Closed May 26th
4. Event created: City - Offices Closed June 19th
5. Post regarding Visitor Center temporary closure
6. Post regarding weather-related issues
7. Post regarding availability of April newsletter
8. Event created: Ouray Hot Springs Bathhouse Final Meeting on April 22nd
9. Post regarding new Business Bulletin board
10. Event created: City - Love Your Trail on May 31st

11. Post regarding Love Your Trail event
12. Post regarding the [Tourism Stakeholder Survey](#)
13. Post regarding the [Resident Sentiment Survey](#)
14. Post regarding press release for Main Street Cleaning & Striping

Social Media - Police Department

1. Post regarding Brady Suppeland
2. Post regarding Cocoa with a Po-Po event
3. Post regarding CDOT Travel Alert
4. Post regarding Cocoa with a Po-Po event
5. Post weather-related issues 🔥 4.4k+ reactions, 213 comments, 783 shares
6. Post with weather-related driving tips and thank you's to all those who were working hard to clear the snow: Danny, Clark, Stefen, Corey, Cliff, Tony, Joe, JB, Brian, Tim, Kris, Cruz, Brad, and Ouray County Road & Bridge Crew
7. Post regarding CDOT Travel Alert
8. Post regarding April Newsletter
9. Post regarding Ouray PD Scholarship for Ouray School seniors
10. Post regarding upcoming temporary alley closure to thru traffic
11. Post regarding PD is hiring
12. Post regarding press release for Main Street Cleaning & Striping

Social Media - Parks and Community Center

1. Event created: Free Zumba on April 12th
2. Event created: Arts & Crafts on April 15th

Ouray County Alerts

1. Genasys Message sent April 9th to targeted area: City of Ouray - Alley Temporarily Closed to Thru Traffic



2. Genasys messaging is planned for Main Street Cleaning & Striping

City Planned Community Events

1. Join us Friday, May 2nd: The City of Ouray and the Wright Tavern invite everyone to a Meet & Greet with the new City Administrator in The Tavern on Friday, May 2, from 5 to 7 p.m. Michelle Metteer, along with the City Council and various other City staff and officials, will be in attendance. This is a chance for the Ouray community to come together before the rush of the summer season and enjoy some music and entertainment! An ad was placed in the Plaindealer for this event.
2. The Ouray Police Department has been holding Cocoa with a Po-Po on the fourth Wednesday of each month. Thank you to 1886 Coffee at the Beaumont Hotel for hosting us on March 26th, and to all community members who joined us! The next one will again be at 1886 Coffee at the Beaumont Hotel on April 23. No agenda, just warm conversation. Please feel free to join us! Ask questions, voice concerns, and enjoy some free Java.



- Held the first Multi-Agency City of Ouray 4th of July Planning meeting on April 7th. Working on updating our maps and paperwork for the CDOT Special Event Permit for scheduled highway closures. Working with Interim Police Chief, Daric Harvey.

City of Ouray Website Analytics

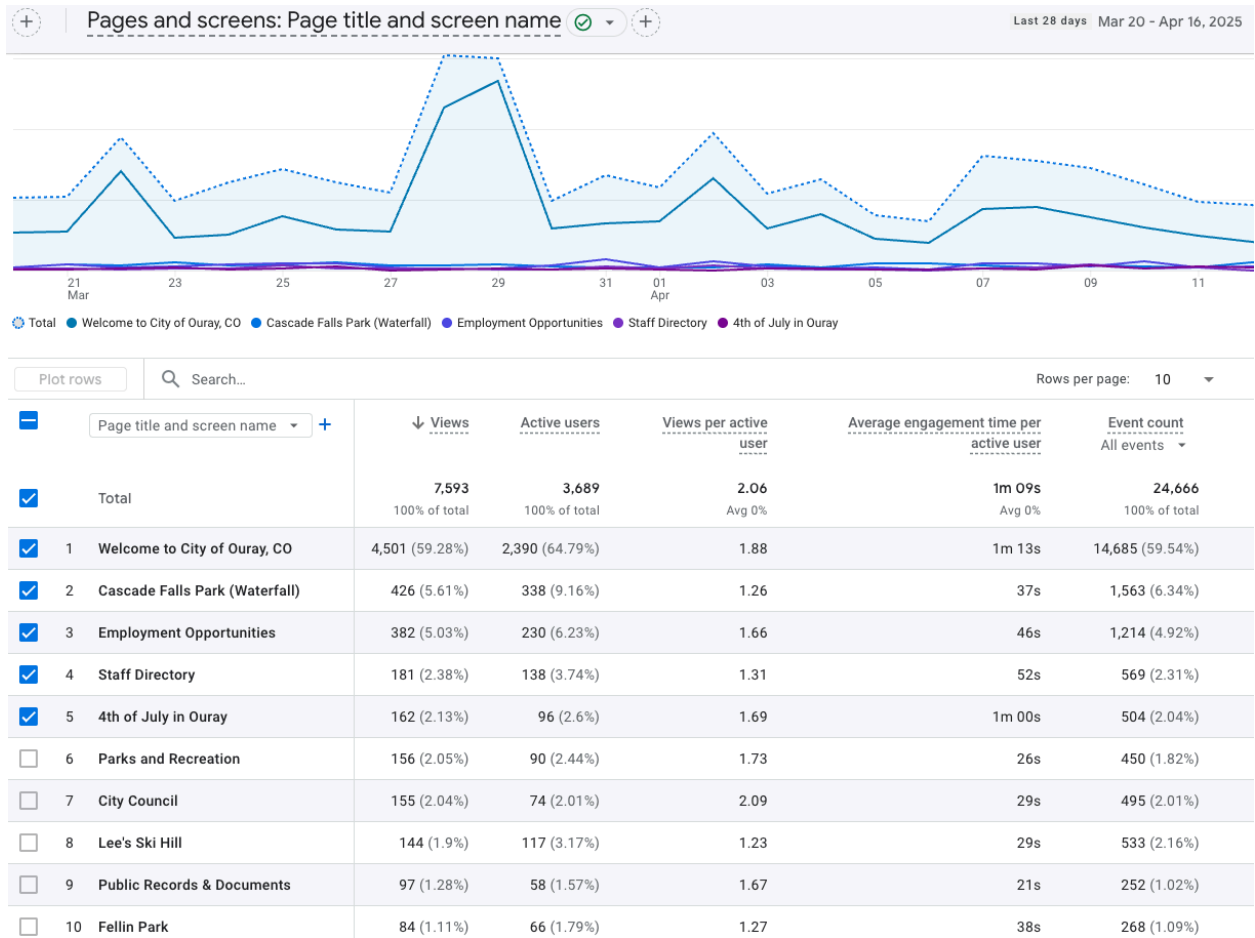

Communication Creations

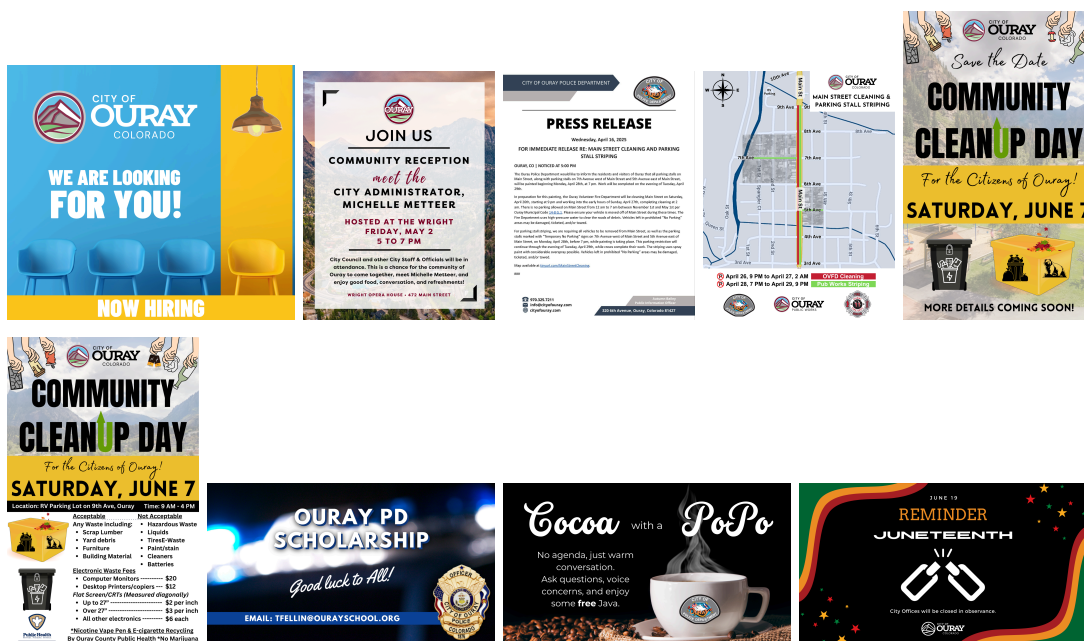

Meetings/Trainings

1. Attended West Region PIO Call on March 20th
2. Attended ACTIVENet Training on April 2nd
3. Attended July 4th planning meeting on April 7th
4. Attended Ouray County CEPA Session on April 10th
5. Attended Ouray Wildfire Outreach meeting on April 15th
6. Attended meeting with Revize on April 16th
7. Attended West Region PIO Call on April 17th

DR 8400 (02/16/24)
COLORADO DEPARTMENT OF REVENUE
Liquor Enforcement Division
PO BOX 17087
Denver CO 80217-0087
(303) 205-2300

Submit to Local Licensing Authority

OURAY BREWERY
PO BOX 811
Ouray CO 81427

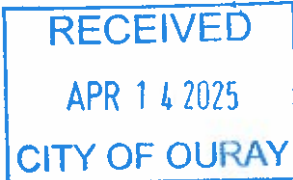

Fees Due		
Annual Renewal Application Fee		\$
Renewal Fee		1000.00
Storage Permit	\$100 X _____	\$
Sidewalk Service Area	\$75.00	\$
Additional Optional Premise Hotel & Restaurant	\$100 X _____	\$
Related Facility - Campus Liquor Complex	\$160.00 per facility	\$
Amount Due/Paid		\$

Make check payable to: Colorado Department of Revenue. The State may convert your check to a one-time electronic banking transaction. Your bank account may be debited as early as the same day received by the State. If converted, your check will not be returned. If your check is rejected due to insufficient or uncollected funds, the Department may collect the payment amount directly from your banking account electronically.

Retail Liquor License Renewal Application

Please verify & update all information below. Return to city or county licensing authority by due date.

Note that the Division will not accept cash.

 Paid by check
 Paid Online

Uploaded to Movelt on Date

Licensee Name

OURAY BREWERY LLP

Doing Business As Name (DBA)

OURAY BREWERY

Liquor License Number

15-75245-0001

License Type

Brew Pub (city)

Sales Tax License Number

15752450001

Expiration Date

07/27/2025

Due Date

06/12/2025

Business Address

Street Address

607 - 609 MAIN STREET

Phone Number

9703181376

City, State, ZIP Code

Ouray CO 81427-9903

Mailing Address

Street Address

PO BOX 811

City, State, ZIP Code

Ouray CO 81427

Email

OURAYBREW@GMAIL.COM

Operating Manager

ERIN EDDY

Date of Birth

888888888888

Home Address

Street Address		Phone Number
609 MAIN ST.		970.318.1376
City	State	ZIP Code
OURAY	CO	81427

1. Do you have legal possession of the premises at the street address?..... Yes No

Are the premises owned or rented? Owned Rented*

*If rented, expiration date of lease
[Empty box]

2. Are you renewing a storage permit, additional optional premises, sidewalk service area, or related facility?..... Yes No

If yes, please see the table in the upper right hand corner and include all fees due.

3. Are you renewing a takeout and/or delivery permit?..... Yes No

(Note: must hold a qualifying license type and be authorized for takeout and/or delivery license privileges) If selecting 'Yes', an additional \$11.00 is required to renew the permit.

If so, which are you renewing?..... Delivery Takeout Both Takeout and Delivery

4. Since the date of filing of the last application, has the applicant, including its manager, partners, officer, directors, stockholders, members (LLC), managing members (LLC), or any other person with a 10% or greater financial interest in the applicant, been found in final order of a tax agency to be delinquent in the payment of any state or local taxes, penalties, or interest related to a business?..... Yes No

Since the date of filing of the last application, has the applicant, including its manager, partners, officer, directors, stockholders, members (LLC), managing members (LLC), or any other person with a 10% or greater financial interest in the applicant failed to pay any fees or surcharges imposed pursuant to section 44-3-503, C.R.S.?..... Yes No

5. Since the date of filing of the last application, has there been any change in financial interest (new notes, loans, owners, etc.) or organizational structure (addition or deletion of officers, directors, managing members or general partners)?..... Yes No

If yes, explain in detail and attach a listing of all liquor businesses in which these new lenders, owners (other than licensed financial institutions), officers, directors, managing members, or general partners are materially interested.

ERIN EDDY'S OWNERSHIP INTEREST INCREASED FROM 40% TO 44% ON 1/1/2025

6. Since the date of filing of the last application, has the applicant or any of its agents, owners, managers, partners or lenders (other than licensed financial institutions) been convicted of a crime? Yes No

If yes, attach a detailed explanation.

7. Since the date of filing of the last application, has the applicant or any of its agents, owners, managers, partners or lenders (other than licensed financial institutions) been denied an alcohol beverage license, had an alcohol beverage license suspended or revoked, or had interest in any entity that had an alcohol beverage license denied, suspended or revoked? Yes No

If yes, attach a detailed explanation.

8. Does the applicant or any of its agents, owners, managers, partners or lenders (other than licensed financial institutions) have a direct or indirect interest in any other Colorado liquor license, including loans to or from any licensee or interest in a loan to any licensee? Yes No

If yes, attach a detailed explanation.

Affirmation & Consent

I declare under penalty of perjury in the second degree that this application and all attachments are true, correct and complete to the best of my knowledge.

Type or Print Name of Applicant/Authorized Agent of Business

ERIN EDDY

Title

MANAGER

Signature

[Handwritten Signature]

Date (MM/DD/YY)

4/14/2025

Report & Approval of City or County Licensing Authority

The foregoing application has been examined and the premises, business conducted and character of the applicant are satisfactory, and we do hereby report that such license, if granted, will comply with the provisions of Title 44, Articles 4 and 3, C.R.S., and Liquor Rules.

Therefore this application is approved.

Local Licensing Authority For

Title

Attest

Signature

Date (MM/DD/YY)



The printed portions of this form, except differentiated additions, have been approved by the Colorado Real Estate Commission. (AE41-8-24) (Mandatory 8-24)

THIS FORM HAS IMPORTANT LEGAL CONSEQUENCES AND THE PARTIES SHOULD CONSULT LEGAL AND TAX OR OTHER COUNSEL BEFORE SIGNING.

AGREEMENT TO AMEND/EXTEND CONTRACT

Date: 4/18/2025

1. This agreement amends the contract dated 3/19/2025 (Contract) between **RICHARD A LANE & MARY V LANE 1988 TRUST** (Seller) and **Michelle Metteer-City of Ouray** (Buyer) relating to the sale and purchase of the following legally described real estate in the County of **Ouray**, Colorado (insert legal description):

Subd: GREENHOUSE SUBDIVISION Lot: 2 S: 31 T: 44 R: 7
known as: **333 6th Avenue, Ouray, CO 81427** (Property).

NOTE: If the table is omitted, or if any item is left blank or is marked in the "No Change" column, it means no change to the corresponding provision of the Contract. If any item is marked in the "Deleted" column, it means that the corresponding provision of the Contract to which reference is made is deleted.

2. **§ 3.1. Dates and Deadlines. [Omitted as inapplicable]**

3. Other dates or deadlines set forth in the Contract are changed as follows:
n/a

4. Additional amendments:
A. It's agreed that Closing shall be Friday, April 25, 2025.

All other terms and conditions of the Contract remain the same.

This proposal expires unless accepted in writing by Seller and Buyer as evidenced by their signatures below and the offering party to this document receives notice of such acceptance on or before Closing.

Date Time

Date: 4/18/2025

Seller: **RICHARD A LANE & MARY V LANE 1988 TRUST**
By: Mary V. Lane, Trustee

Seller: _____ Date: _____

Address:

31 _____ Date: _____
Buyer: **Michelle Metteer-City of Ouray**

32

33 Buyer: _____ Date: _____

34 Address:

35

AE41-8-24. AGREEMENT TO AMEND/EXTEND CONTRACT

CTM eContracts - ©2025 CTM Software Corp.

RESOLUTION NO. 8 (SERIES 2025)

A RESOLUTION OF CITY COUNCIL OF THE CITY OF OURAY, COLORADO AUTHORIZING THE EXECUTION OF ALL NECESSARY DOCUMENTS TO EFFECUATE THE PURCHASE OF 333 6TH AVENUE, OURAY, COLORADO.

WHEREAS Council for the City of Ouray is duly authorized to purchase real property pursuant to its Home Rule Charter dated May 5, 2009, Section 1.2(B);

WHEREAS City Council unanimously approved the Contract to Buy and Sell Real Estate (Commercial) dated March 20, 2025 (Contract) in accordance with the contingency clause in paragraph 30 on April 7, 2025, in a regularly scheduled City Council meeting;

WHEREAS, On April 11, 2025, Land Title issued an updated commitment which requires a certified copy of resolution of the governing board of the City of Ouray, Colorado, a Colorado home rule municipality, authorizing the execution of necessary documents; and

WHEREAS City Council finds that the purchase of 333 6th Avenue advances the health, safety and welfare of the general public.

BE IT ORDAINED BY THE COUNCIL OF THE CITY OF OURAY, COLORADO as follows:

1. On April 7, 2025, City Council unanimously approved by vote the Contract to purchase 333 6th Avenue and a Post-Closing Occupancy Agreement.
2. Ethan Funk, the Mayor, is authorized to execute any necessary documents related to the purchase of 333 6th Avenue, Ouray, Colorado on April 25, 2025, at 9:15 a.m.. If the closing does not occur for any reason and must be extended beyond that date, the City Administrator is authorized to execute the closing documents on behalf of the City.
3. The purchase money shall be from the general fund and the City Clerk is authorized to wire the purchase money to Land Title on or before the closing date.

ADOPTED this 21st day of April 2025 by the Ouray City Council.

CITY OF OURAY, COLORADO

Ethan Funk, Mayor

ATTEST:

Melissa M. Drake, City Clerk

The printed portions of this form, except differentiated additions, have been approved by the Colorado Real Estate Commission.
(CBS3-8-24) (Mandatory 8-24)

THIS FORM HAS IMPORTANT LEGAL CONSEQUENCES AND THE PARTIES SHOULD CONSULT LEGAL AND TAX OR OTHER COUNSEL BEFORE SIGNING.

**CONTRACT TO BUY AND SELL REAL ESTATE
(COMMERCIAL)
(Property with No Residences)
(Property with Residences-Residential Addendum Attached)**

Date: March 19, 2025

AGREEMENT

1. AGREEMENT. Buyer agrees to buy and Seller agrees to sell the Property described below on the terms and conditions set forth in this contract (Contract).

2. PARTIES AND PROPERTY.

2.1. Buyer. CITY OF OURAY (Buyer) will take title to the Property described below as **Joint Tenants** **Tenants In Common** **Other** _____.

2.2. No Assignability. This Contract **IS NOT** assignable by Buyer unless otherwise specified in **Additional Provisions**.

2.3. Seller. RICHARD A LANE & MARY V LANE 1988 TRUST, dated December 9, 1988 (Seller) is the current owner of the Property described below.

2.4. Property. The Property is the following legally described real estate in the County of Ouray, Colorado (insert legal description):

Lot 2, Greenhouse Subdivision, according to the plat recorded at Reception No. 122978, City of Ouray, State of Colorado.

known as: 333 6th Avenue Ouray CO 81427
Street Address City State Zip

together with the interests, easements, rights, benefits, improvements and attached fixtures appurtenant thereto and all interest of Seller in vacated streets and alleys adjacent thereto, except as herein excluded (Property).

2.5. Inclusions. The Purchase Price includes the following items (Inclusions):

2.5.1. Inclusions – Attached. If attached to the Property on the date of this Contract, the following items are included unless excluded under **Exclusions**: lighting, heating, plumbing, ventilating and air conditioning units, TV antennas, inside telephone, network and coaxial (cable) wiring and connecting blocks/jacks, plants, mirrors, floor coverings, intercom systems, built-in kitchen appliances, sprinkler systems and controls, built-in vacuum systems (including accessories) and garage door openers (including _____ remote controls). If checked, the following are owned by the Seller and included: **Solar Panels** **Water Softeners** **Security Systems** **Satellite Systems** (including satellite dishes). Leased items should be listed under § 2.5.8. (Leased Items). If any additional items are attached to the Property after the date of this Contract, such additional items are also included in the Purchase Price.

2.5.2. Inclusions – Not Attached. If on the Property, whether attached or not, on the date of this Contract, the following items are included unless excluded under **Exclusions**: storm windows, storm doors, window and porch shades, awnings, blinds, screens, window coverings and treatments, curtain rods, drapery rods, fireplace inserts, fireplace screens, fireplace grates, heating stoves, storage sheds, carbon monoxide alarms, smoke/fire detectors and all keys.

2.5.3. Other Inclusions. The following items, whether fixtures or personal property, are also included in the Purchase Price:

54 **2.5.4. Encumbered Inclusions.** Any Inclusions owned by Seller (e.g., owned solar panels) must be conveyed at
55 Closing by Seller free and clear of all taxes (except personal property and general real estate taxes for the year of Closing), liens and
56 encumbrances, except:
57
58
59
60

61 Buyer **Will** **Will Not** assume the debt and obligations on the Encumbered Inclusions subject to Buyer's review under §10.6.
62 (Encumbered Inclusion Documents) and Buyer's receipt of written approval by such lender before Closing. If Buyer does not receive
63 such approval this Contract terminates.
64

65 **2.5.5. Personal Property Conveyance.** Conveyance of all personal property will be by bill of sale or other
66 applicable legal instrument.

67 **2.5.6. Parking and Storage Facilities.** The use or ownership of the following parking facilities:
68 _____; and the use or ownership of the following storage facilities: _____.

69 Note to Buyer: If exact rights to the parking and storage facilities is a concern to Buyer, Buyer should investigate.

70 **2.5.7. Trade Fixtures.** With respect to trade fixtures, Seller and Buyer agree as follows:
71
72
73

74 The trade fixtures to be conveyed at Closing will be conveyed by Seller free and clear of all taxes (except personal
75 property taxes for the year of Closing), liens and encumbrances, except . Conveyance will be by bill of sale or other applicable legal
76 instrument.

77 **2.5.8. Leased Items.** The following personal property is currently leased to Seller which will be transferred to Buyer
78 at Closing (Leased Items):
79
80
81
82

83 Buyer **Will** **Will Not** assume Seller's debt and obligations under such leases for the Leased Items subject to Buyer's review
84 under §10.6. (Leased Items Documents) and Buyer's receipt of written approval by such lender before Closing. If Buyer does not
85 receive such approval this Contract terminates.
86

87 **2.5.9. Solar Power Plan.** If the box is checked, Seller has entered into a solar power purchase agreement, regardless
88 of the name or title, to authorize a third-party to operate and maintain a photovoltaic system on the Property and provide electricity
89 (Solar Power Plan) that will remain in effect after Closing. Buyer **Will** **Will Not** assume Seller's obligations under such Solar
90 Power Plan subject to Buyer's review under §10.6. (Solar Power Plan) and Buyer's receipt of written approval by the third-party
91 before Closing. If Buyer does not receive such approval this Contract terminates.
92

93 **2.6. Exclusions.** The following items are excluded (Exclusions):
94
95
96

97 **2.7. Water Rights/Well Rights.**

98 **2.7.1. Deeded Water Rights.** The following legally described water rights:
99
100
101

102 Any deeded water rights will be conveyed by a good and sufficient _____ deed at Closing.

103 **2.7.2. Other Rights Relating to Water.** The following rights relating to water not included in §§ 2.7.1., 2.7.3. and
104 2.7.4., will be transferred to Buyer at Closing:
105
106
107
108

109 **2.7.3. Well Rights.** Seller agrees to supply required information to Buyer about the well. Buyer understands that if
110 the well to be transferred is a "Small Capacity Well" or a "Domestic Exempt Water Well" used for ordinary household purposes,
111 Buyer must, prior to or at Closing, complete a Change in Ownership form for the well. If an existing well has not been registered
112 with the Colorado Division of Water Resources in the Department of Natural Resources (Division), Buyer must complete a

113 registration of existing well form for the well and pay the cost of registration. If no person will be providing a closing service in
 114 connection with the transaction, Buyer must file the form with the Division within sixty days after Closing. The Well Permit # is
 115 _____.

116 **2.7.4. Water Stock.** The water stock to be transferred at Closing are as follows:
 117
 118
 119

120 **2.7.5. Conveyance.** If Buyer is to receive any rights to water pursuant to § 2.7.2. (Other Rights Relating to Water),
 121 § 2.7.3. (Well Rights), or § 2.7.4. (Water Stock Certificates), Seller agrees to convey such rights to Buyer by executing the applicable
 122 legal instrument at Closing.

123 **2.7.6. Water Rights Review.** Buyer has a Right to Terminate if examination of the Water Rights is unsatisfactory
 124 to Buyer on or before the **Water Rights Examination Deadline**.

125 **3. DATES, DEADLINES AND APPLICABILITY.**

126 **3.1. Dates and Deadlines.**

Item No.	Reference	Event	Date or Deadline
1	§ 3	Time of Day Deadline	6:00 p.m. MDT
2	§ 4	Alternative Earnest Money Deadline	MEC + 3 days
		Title	
3	§ 8	Record Title Deadline (and Tax Certificate)	MEC + 7 days
4	§ 8	Record Title Objection Deadline	MEC + 10 days
5	§ 8	Off-Record Title Deadline	MEC + 7 days
6	§ 8	Off-Record Title Objection Deadline	MEC + 10 days
7	§ 8	Title Resolution Deadline	MEC + 14 days
8	§ 8	Third Party Right to Purchase/Approve Deadline	
		Owners' Association	
9	§ 7	Association Documents Deadline	
10	§ 7	Association Documents Termination Deadline	
		Seller's Disclosures	
11	§ 10	Seller's Property Disclosure Deadline	MEC + 7 days
12	§ 10	Lead-Based Paint Disclosure Deadline (if Residential Addendum attached)	
		Loan and Credit	
13	§ 5	New Loan Application Deadline	
14	§ 5	New Loan Terms Deadline	
15	§ 5	New Loan Availability Deadline	
16	§ 5	Buyer's Credit Information Deadline	
17	§ 5	Disapproval of Buyer's Credit Information Deadline	
18	§ 5	Existing Loan Deadline	
19	§ 5	Existing Loan Termination Deadline	
20	§ 5	Loan Transfer Approval Deadline	
21	§ 4	Seller or Private Financing Deadline	
		Appraisal	
22	§ 6	Appraisal Deadline	
23	§ 6	Appraisal Objection Deadline	
24	§ 6	Appraisal Resolution Deadline	
		Survey	
25	§ 9	New ILC or New Survey Deadline	
26	§ 9	New ILC or New Survey Objection Deadline	
27	§ 9	New ILC or New Survey Resolution Deadline	
		Inspection and Due Diligence	
28	§ 2	Water Rights Examination Deadline	
29	§ 8	Mineral Rights Examination Deadline	
30	§ 10	Inspection Termination Deadline	MEC + 14 days
31	§ 10	Inspection Objection Deadline	MEC + 10 days
32	§ 10	Inspection Resolution Deadline	MEC + 14 days
33	§ 10	Property Insurance Termination Deadline	

34	§ 10	Due Diligence Documents Delivery Deadline	
35	§ 10	Due Diligence Documents Objection Deadline	
36	§ 10	Due Diligence Documents Resolution Deadline	
37	§ 10	Environmental Inspection Termination Deadline	
38	§ 10	ADA Evaluation Termination Deadline	
39	§ 10	Conditional Sale Deadline	
40	§ 10	Lead-Based Paint Termination Deadline (if Residential Addendum attached)	
41	§ 11	Estoppel Statements Deadline	
42	§ 11	Estoppel Statements Termination Deadline	
		Closing and Possession	
43	§ 12	Closing Date	MEC + 30 days
44	§ 17	Possession Date	Closing
45	§ 17	Possession Time	Closing
46	§ 27	Acceptance Deadline Date	March 20, 2025
47	§ 27	Acceptance Deadline Time	6:00 p.m. MDT

127 **3.2. Applicability of Terms.** If any deadline blank in § 3.1. (Dates and Deadlines) is left blank or completed with “N/A”,
128 or the word “Deleted,” such deadline is not applicable and the corresponding provision containing the deadline is deleted. Any box
129 checked in this Contract means the corresponding provision applies. If no box is checked in a provision that contains a selection of
130 “None”, such provision means that “None” applies.

131 The abbreviation “MEC” (mutual execution of this Contract) means the date upon which both parties have signed this Contract. The
132 abbreviation “N/A” as used in this Contract means not applicable.

133 **3.3. Day; Computation of Period of Days; Deadlines.**

134 **3.3.1. Day.** As used in this Contract, the term “day” means the entire day ending at 11:59 p.m., United States
135 Mountain Time (Standard or Daylight Savings, as applicable). Except however, if a **Time of Day Deadline** is specified in § 3.1.
136 (Dates and Deadlines), all Objection Deadlines, Resolution Deadlines, Examination Deadlines and Termination Deadlines will end
137 on the specified deadline date at the time of day specified in the **Time of Day Deadline**, United States Mountain Time. If **Time of**
138 **Day Deadline** is left blank or “N/A” the deadlines will expire at 11:59 p.m., United States Mountain Time.

139 **3.3.2. Computation of Period of Days.** In computing a period of days (e.g., three days after MEC), when the
140 ending date is not specified, the first day is excluded and the last day is included.

141 **3.3.3. Deadlines.** If any deadline falls on a Saturday, Sunday or federal or Colorado state holiday (Holiday), such
142 deadline **Will** **Will Not** be extended to the next day that is not a Saturday, Sunday or Holiday. Should neither box be checked,
143 the deadline will not be extended.

144 **4. PURCHASE PRICE AND TERMS.**

145 **4.1. Price and Terms.** The Purchase Price set forth below is payable in U.S. Dollars by Buyer as follows:

Item No.	Reference	Item	Amount	Amount
1	§ 4.1.	Purchase Price	\$ 675,000.00	
2	§ 4.3.	Earnest Money		\$
3	§ 4.5.	New Loan		\$5,000.00
4	§ 4.6.	Assumption Balance		\$
5	§ 4.7.	Private Financing		\$
6	§ 4.7.	Seller Financing		\$
7				
8				
9	§ 4.4.	Cash at Closing		\$670,000.00
10		TOTAL	\$675,000.00	\$675,000.00

146 **4.2. Seller Concession.** At Closing, Seller will credit to Buyer \$_____ (Seller Concession). The Seller
147 Concession may be used for any Buyer fee, cost, charge or expenditure to the extent the amount is allowed by the Buyer’s lender
148 and is included in the Closing Statement or Closing Disclosure at Closing. Examples of allowable items to be paid for by the Seller
149 Concession include, but are not limited to: Buyer’s closing costs, loan discount points, loan origination fees, prepaid items and any
150 other fee, cost, charge, expense or expenditure. Seller Concession is in addition to any sum Seller has agreed to pay or credit Buyer
151 elsewhere in this Contract.

152 **4.3. Earnest Money.** The Earnest Money set forth in this Section, in the form of a check, will be
153 payable to and held by Land Title Guaranty Co. (Earnest Money Holder), in its trust account, on behalf of
154 both Seller and Buyer. The Earnest Money deposit must be tendered, by Buyer, with this Contract unless the parties mutually agree
155 to an **Alternative Earnest Money Deadline** for its payment. The parties authorize delivery of the Earnest Money deposit to the
156 company conducting the Closing (Closing Company), if any, at or before Closing. In the event Earnest Money Holder has agreed to
157 have interest on Earnest Money deposits transferred to a fund established for the purpose of providing affordable housing to Colorado
158 residents, Seller and Buyer acknowledge and agree that any interest accruing on the Earnest Money deposited with the Earnest
159 Money Holder in this transaction will be transferred to such fund.

160 **4.3.1. Alternative Earnest Money Deadline.** The deadline for delivering the Earnest Money, if other than at the
161 time of tender of this Contract, is as set forth as the **Alternative Earnest Money Deadline**.

162 **4.3.2. Disposition of Earnest Money.** If Buyer has a Right to Terminate and timely terminates, Buyer is entitled
163 to the return of Earnest Money as provided in this Contract. If this Contract is terminated as set forth in § 24 and, except as provided
164 in § 23 (Earnest Money Dispute), if the Earnest Money has not already been returned following receipt of a Notice to Terminate,
165 Seller agrees to execute and return to Buyer or Broker working with Buyer, written mutual instructions (e.g., Earnest Money Release
166 form), within three days of Seller's receipt of such form. If Seller is entitled to the Earnest Money, and, except as provided in § 23
167 (Earnest Money Dispute), if the Earnest Money has not already been paid to Seller, following receipt of an Earnest Money Release
168 form, Buyer agrees to execute and return to Seller or Broker working with Seller, written mutual instructions (e.g., Earnest Money
169 Release form), within three days of Buyer's receipt.

170 **4.3.2.1. Seller Failure to Timely Return Earnest Money.** If Seller fails to timely execute and return the
171 Earnest Money Release Form, or other written mutual instructions, Seller is in default and liable to Buyer as set forth in "**If Seller
172 is in Default**", § 20.2. and § 21, unless Seller is entitled to the Earnest Money due to a Buyer default.

173 **4.3.2.2. Buyer Failure to Timely Release Earnest Money.** If Buyer fails to timely execute and return the
174 Earnest Money Release Form, or other written mutual instructions, Buyer is in default and liable to Seller as set forth in "**If Buyer
175 is in Default**", § 20.1. and § 21, unless Buyer is entitled to the Earnest Money due to a Seller Default.

176 **4.4. Form of Funds; Time of Payment; Available Funds.**

177 **4.4.1. Good Funds.** All amounts payable by the parties at Closing, including any loan proceeds, Cash at Closing
178 and closing costs, must be in funds that comply with all applicable Colorado laws, including electronic transfer funds, certified
179 check, savings and loan teller's check and cashier's check (Good Funds).

180 **4.4.2. Time of Payment.** All funds, including the Purchase Price to be paid by Buyer, must be paid before or at
181 Closing or as otherwise agreed in writing between the parties to allow disbursement by Closing Company at Closing **OR SUCH
182 NONPAYING PARTY WILL BE IN DEFAULT**.

183 **4.4.3. Available Funds.** Buyer represents that Buyer, as of the date of this Contract, **Does** **Does Not** have
184 funds that are immediately verifiable and available in an amount not less than the amount stated as Cash at Closing in § 4.1.

185 **4.5. New Loan.**

186 **4.5.1. Buyer to Pay Loan Costs.** Buyer, except as otherwise permitted in § 4.2. (Seller Concession), if applicable,
187 must timely pay Buyer's loan costs, loan discount points, prepaid items and loan origination fees as required by lender.

188 **4.5.2. Buyer May Select Financing.** Buyer may pay in cash or select financing appropriate and acceptable to
189 Buyer, including a different loan than initially sought, except as restricted in § 4.5.3. (Loan Limitations) or § 30 (Additional
190 Provisions).

191 **4.5.3. Loan Limitations.** Buyer may purchase the Property using any of the following types of loans:
192 **Conventional** **Other** _____.

193 **4.6. Assumption.** Buyer agrees to assume and pay an existing loan in the approximate amount of the Assumption Balance
194 set forth in § 4.1. (Price and Terms), presently payable at \$ _____ per _____ including principal and interest
195 presently at the rate of _____% per annum and also including escrow for the following as indicated: **Real Estate Taxes**
196 **Property Insurance Premium** and _____.

197 Buyer agrees to pay a loan transfer fee not to exceed \$ _____. At the time of assumption, the new interest rate will
198 not exceed _____% per annum and the new payment will not exceed \$ _____ per _____ principal and
199 interest, plus escrow, if any. If the actual principal balance of the existing loan at Closing is less than the Assumption Balance, which
200 causes the amount of cash required from Buyer at Closing to be increased by more than \$ _____, or if any other terms or
201 provisions of the loan change, Buyer has the Right to Terminate under § 24.1. on or before **Closing Date**.

202 Seller **Will** **Will Not** be released from liability on said loan. If applicable, compliance with the requirements for release
203 from liability will be evidenced by delivery on or before **Loan Transfer Approval Deadline** at **Closing** of an appropriate
204 letter of commitment from lender. Any cost payable for release of liability will be paid by _____ in an amount
205 not to exceed \$ _____.

206 This Contract terminates if written consent from Seller's lender for Buyer's assumption of Seller's existing loan is not received
207 by all parties and the Closing Company on or before Closing.

208 **4.7. Seller or Private Financing.**

209 **WARNING:** Unless the transaction is exempt, federal and state laws impose licensing, other requirements and restrictions on sellers
210 and private financiers. Contract provisions on financing and financing documents, unless exempt, should be prepared by a licensed

211 Colorado attorney or licensed mortgage loan originator. Brokers should not prepare or advise the parties on the specifics of financing,
212 including whether or not a party is exempt from the law.

213 **4.7.1. Seller Financing.** If Buyer is to pay all or any portion of the Purchase Price with Seller financing, **Buyer**
214 **Seller** will deliver the proposed Seller financing documents to the other party on or before _____ days before **Seller or**
215 **Private Financing Deadline.**

216 **4.7.1.1. Seller May Terminate.** If Seller is to provide Seller financing, this Contract is conditional upon
217 Seller determining whether such financing is satisfactory to the Seller, including its payments, interest rate, terms, conditions, cost,
218 and compliance with the law. Seller has the Right to Terminate under § 24.1., on or before **Seller or Private Financing Deadline**,
219 if such Seller financing is not satisfactory to Seller, in Seller's sole subjective discretion.

220 **4.7.2. Buyer May Terminate.** If Buyer is to pay all or any portion of the Purchase Price with Seller or private
221 financing, this Contract is conditional upon Buyer determining whether such financing is satisfactory to Buyer, including its
222 availability, payments, interest rate, terms, conditions, and cost. Buyer has the Right to Terminate under § 24.1, on or before **Seller**
223 **or Private Financing Deadline**, if such Seller or private financing is not satisfactory to Buyer, in Buyer's sole subjective discretion.

224

TRANSACTION PROVISIONS

225 **5. FINANCING CONDITIONS AND OBLIGATIONS.**

226 **5.1. New Loan, Assumption Application.** If Buyer is to pay all or part of the Purchase Price by obtaining one or more
227 new loans (New Loan), or if an existing loan is not to be released at Closing, Buyer, if required by such lender, must make an
228 application verifiable by such lender, on or before **New Loan Application Deadline** and exercise reasonable efforts to obtain such
229 loan or approval.

230 **5.2. New Loan Terms; New Loan Availability.**

231 **5.2.1. New Loan Terms.** If Buyer is to pay all or part of the Purchase Price with a New Loan, this Contract is
232 conditional upon Buyer determining, in Buyer's sole subjective discretion, whether the proposed New Loan's payments, interest
233 rate, conditions and costs or any other loan terms (New Loan Terms) are satisfactory to Buyer. This condition is for the sole benefit
234 of Buyer. Buyer has the Right to Terminate under § 24.1., on or before **New Loan Terms Deadline**, if the New Loan Terms are not
235 satisfactory to Buyer, in Buyer's sole subjective discretion.

236 **5.2.2. New Loan Availability.** If Buyer is to pay all or part of the Purchase Price with a New Loan, this Contract is
237 conditional upon Buyer's satisfaction with the availability of the New Loan based on the lender's review and underwriting of Buyer's
238 New Loan Application (New Loan Availability). Buyer has the Right to Terminate under § 24.1., on or before the **New Loan**
239 **Availability Deadline** if the New Loan Availability is not satisfactory to Buyer. Buyer does not have a Right to Terminate based on the
240 New Loan Availability if the termination is based on the New Loan Terms, Appraised Value (defined below), the Lender Property
241 Requirements (defined below), Insurability (§ 10.5. below) or the Conditional Upon Sale of Property (§ 10.7. below). **IF SELLER IS**
242 **NOT IN DEFAULT AND DOES NOT TIMELY RECEIVE BUYER'S WRITTEN NOTICE TO TERMINATE, BUYER'S**
243 **EARNEST MONEY WILL BE NONREFUNDABLE**, except as otherwise provided in this Contract (e.g., Appraisal, Title,
244 Survey).

245 **5.3. Credit Information.** This Contract is conditional (for the sole benefit of Seller) upon Seller's approval of Buyer's
246 financial ability and creditworthiness, which approval will be in Seller's sole subjective discretion. Accordingly: (1) Buyer must
247 supply to Seller by **Buyer's Credit Information Deadline**, at Buyer's expense, information and documents (including a current
248 credit report) concerning Buyer's financial, employment and credit condition; (2) Buyer consents that Seller may verify Buyer's
249 financial ability and creditworthiness; and (3) any such information and documents received by Seller must be held by Seller in
250 confidence and not released to others except to protect Seller's interest in this transaction. If the Cash at Closing is less than as set
251 forth in § 4.1. of this Contract, Seller has the Right to Terminate under § 24.1., on or before Closing. If Seller disapproves of Buyer's
252 financial ability or creditworthiness, in Seller's sole subjective discretion, Seller has the Right to Terminate under § 24.1., on or
253 before **Disapproval of Buyer's Credit Information Deadline.**

254 **5.4. Existing Loan Review.** Seller must deliver copies of the loan documents (including note, deed of trust and any
255 modifications) to Buyer by **Existing Loan Deadline**. For the sole benefit of Buyer, this Contract is conditional upon Buyer's review
256 and approval of the provisions of such loan documents. Buyer has the Right to Terminate under § 24.1., on or before **Existing Loan**
257 **Termination Deadline**, based on any unsatisfactory provision of such loan documents, in Buyer's sole subjective discretion. If the
258 lender's approval of a transfer of the Property is required, this Contract is conditional upon Buyer obtaining such approval without
259 change in the terms of such loan, except as set forth in § 4.6. If lender's approval is not obtained by **Loan Transfer Approval**
260 **Deadline**, this Contract will terminate on such deadline. Seller has the Right to Terminate under § 24.1., on or before Closing, in
261 Seller's sole subjective discretion, if Seller is to be released from liability under such existing loan and Buyer does not obtain such
262 compliance as set forth in § 4.6.

263 **6. APPRAISAL PROVISIONS.**

264 **6.1. Appraisal Definition.** An "Appraisal" is an opinion of value prepared by a licensed or certified appraiser, engaged on
265 behalf of Buyer or Buyer's lender, to determine the Property's market value (Appraised Value). The Appraisal may also set forth

266 certain lender requirements, replacements, removals or repairs necessary on or to the Property as a condition for the Property to be
267 valued at the Appraised Value.

268 **6.2. Appraised Value.** The applicable appraisal provision set forth below applies to the respective loan type set forth in
269 § 4.5.3., or if a cash transaction (i.e., no financing), § 6.2.1. applies.

270 **6.2.1. Conventional/Other.** Buyer has the right to obtain an Appraisal. If the Appraised Value is less than the
271 Purchase Price, or if the Appraisal is not received by Buyer on or before **Appraisal Deadline** Buyer may, on or before **Appraisal**
272 **Objection Deadline:**

273 **6.2.1.1. Notice to Terminate.** Notify Seller in writing, pursuant to § 24.1., that this Contract is terminated;
274 or

275 **6.2.1.2. Appraisal Objection.** Deliver to Seller a written objection accompanied by either a copy of the
276 Appraisal or written notice from lender that confirms the Appraised Value is less than the Purchase Price (Lender Verification).

277 **6.2.1.3. Appraisal Resolution.** If an Appraisal Objection is received by Seller, on or before **Appraisal**
278 **Objection Deadline** and if Buyer and Seller have not agreed in writing to a settlement thereof on or before **Appraisal Resolution**
279 **Deadline**, this Contract will terminate on the **Appraisal Resolution Deadline**, unless Seller receives Buyer's written withdrawal of
280 the Appraisal Objection before such termination, (i.e., on or before expiration of **Appraisal Resolution Deadline**).

281 **6.3. Lender Property Requirements.** If the lender imposes any written requirements, replacements, removals or repairs,
282 including any specified in the Appraisal (Lender Property Requirements) to be made to the Property (e.g., roof repair, repainting),
283 beyond those matters already agreed to by Seller in this Contract, this Contract terminates on the earlier of three days following
284 Seller's receipt of the Lender Property Requirements, or Closing, unless prior to termination: (1) the parties enter into a written
285 agreement to satisfy the Lender Property Requirements; (2) the Lender Property Requirements have been completed; or (3) the
286 satisfaction of the Lender Property Requirements is waived in writing by Buyer.

287 **6.4. Cost of Appraisal.** Cost of the Appraisal to be obtained after the date of this Contract must be timely paid by **Buyer**
288 **Seller**. The cost of the Appraisal may include any and all fees paid to the appraiser, appraisal management company, lender's
289 agent or all three.

290 **7. OWNERS' ASSOCIATIONS.** This Section is applicable if the Property is located within one or more Common Interest
291 Communities and subject to one or more declarations (Association).

292 **7.1. Common Interest Community Disclosure.** **THE PROPERTY IS LOCATED WITHIN A COMMON**
293 **INTEREST COMMUNITY AND IS SUBJECT TO THE DECLARATION FOR THE COMMUNITY. THE OWNER OF**
294 **THE PROPERTY WILL BE REQUIRED TO BE A MEMBER OF THE OWNERS' ASSOCIATION FOR THE**
295 **COMMUNITY AND WILL BE SUBJECT TO THE BYLAWS AND RULES AND REGULATIONS OF THE**
296 **ASSOCIATION. THE DECLARATION, BYLAWS AND RULES AND REGULATIONS WILL IMPOSE FINANCIAL**
297 **OBLIGATIONS UPON THE OWNER OF THE PROPERTY, INCLUDING AN OBLIGATION TO PAY ASSESSMENTS**
298 **OF THE ASSOCIATION. IF THE OWNER DOES NOT PAY THESE ASSESSMENTS, THE ASSOCIATION COULD**
299 **PLACE A LIEN ON THE PROPERTY AND POSSIBLY SELL IT TO PAY THE DEBT. THE DECLARATION, BYLAWS**
300 **AND RULES AND REGULATIONS OF THE COMMUNITY MAY PROHIBIT THE OWNER FROM MAKING**
301 **CHANGES TO THE PROPERTY WITHOUT AN ARCHITECTURAL REVIEW BY THE ASSOCIATION (OR A**
302 **COMMITTEE OF THE ASSOCIATION) AND THE APPROVAL OF THE ASSOCIATION. PURCHASERS OF**
303 **PROPERTY WITHIN THE COMMON INTEREST COMMUNITY SHOULD INVESTIGATE THE FINANCIAL**
304 **OBLIGATIONS OF MEMBERS OF THE ASSOCIATION. PURCHASERS SHOULD CAREFULLY READ THE**
305 **DECLARATION FOR THE COMMUNITY AND THE BYLAWS AND RULES AND REGULATIONS OF THE**
306 **ASSOCIATION.**

307 **7.2. Association Documents to Buyer.** Seller is obligated to provide to Buyer the Association Documents (defined below),
308 at Seller's expense, on or before **Association Documents Deadline**. Seller authorizes the Association to provide the Association
309 Documents to Buyer, at Seller's expense. Seller's obligation to provide the Association Documents is fulfilled upon Buyer's receipt
310 of the Association Documents, regardless of who provides such documents.

311 **7.3. Association Documents.** Association documents (Association Documents) consist of the following:

312 **7.3.1.** All Association declarations, articles of incorporation, bylaws, articles of organization, operating agreements,
313 rules and regulations, party wall agreements and the Association's responsible governance policies adopted under § 38-33.3-209.5,
314 C.R.S.;

315 **7.3.2.** Minutes of: (1) the annual owners' or members' meeting and (2) any executive boards' or managers' meetings;
316 such minutes include those provided under the most current annual disclosure required under § 38-33.3-209.4, C.R.S. (Annual
317 Disclosure) and minutes of meetings, if any, subsequent to the minutes disclosed in the Annual Disclosure. If none of the preceding
318 minutes exist, then the most recent minutes, if any (§§ 7.3.1. and 7.3.2., collectively, Governing Documents); and

319 **7.3.3.** List of all Association insurance policies as provided in the Association's last Annual Disclosure, including,
320 but not limited to, property, general liability, association director and officer professional liability and fidelity policies. The list must
321 include the company names, policy limits, policy deductibles, additional named insureds and expiration dates of the policies listed
322 (Association Insurance Documents);

323 7.3.4. A list by unit type of the Association's assessments, including both regular and special assessments as
324 disclosed in the Association's last Annual Disclosure;

325 7.3.5. The Association's most recent financial documents which consist of: (1) the Association's operating budget
326 for the current fiscal year, (2) the Association's most recent annual financial statements, including any amounts held in reserve for
327 the fiscal year immediately preceding the Association's last Annual Disclosure, (3) the results of the Association's most recent
328 available financial audit or review, (4) list of the fees and charges (regardless of name or title of such fees or charges) that the
329 Association's community association manager or Association will charge in connection with the Closing including, but not limited
330 to, any fee incident to the issuance of the Association's statement of assessments (Status Letter), any rush or update fee charged for
331 the Status Letter, any record change fee or ownership record transfer fees (Record Change Fee), fees to access documents, (5) list of
332 all assessments required to be paid in advance, reserves or working capital due at Closing and (6) reserve study, if any (§§ 7.3.4. and
333 7.3.5., collectively, Financial Documents);

334 7.3.6. Any written notice from the Association to Seller of a "construction defect action" under § 38-33.3-303.5,
335 C.R.S. within the past six months and the result of whether the Association approved or disapproved such action (Construction
336 Defect Documents). Nothing in this Section limits the Seller's obligation to disclose adverse material facts as required under § 10.2.
337 (Disclosure of Adverse Material Facts; Subsequent Disclosure; Present Condition) including any problems or defects in the common
338 elements or limited common elements of the Association property.

339 7.4. **Conditional on Buyer's Review.** Buyer has the right to review the Association Documents. Buyer has the Right to
340 Terminate under § 24.1., on or before **Association Documents Termination Deadline**, based on any unsatisfactory provision in
341 any of the Association Documents, in Buyer's sole subjective discretion. Should Buyer receive the Association Documents after
342 **Association Documents Deadline**, Buyer, at Buyer's option, has the Right to Terminate under § 24.1. by Buyer's Notice to
343 Terminate received by Seller on or before ten days after Buyer's receipt of the Association Documents. If Buyer does not receive
344 the Association Documents, or if Buyer's Notice to Terminate would otherwise be required to be received by Seller after **Closing**
345 **Date**, Buyer's Notice to Terminate must be received by Seller on or before Closing. If Seller does not receive Buyer's Notice to
346 Terminate within such time, Buyer accepts the provisions of the Association Documents as satisfactory and Buyer waives any Right
347 to Terminate under this provision, notwithstanding the provisions of § 8.6. (Third Party Right to Purchase/Approve).

348 8. TITLE INSURANCE, RECORD TITLE AND OFF-RECORD TITLE.

349 8.1. Evidence of Record Title.

350 8.1.1. **Seller Selects Title Insurance Company.** If this box is checked, Seller will select the title insurance
351 company to furnish the owner's title insurance policy at Seller's expense. On or before **Record Title Deadline**, Seller must furnish
352 to Buyer, a current commitment for an owner's title insurance policy (Title Commitment), in an amount equal to the Purchase Price,
353 or if this box is checked, an **Abstract of Title** certified to a current date. Seller will cause the title insurance policy to be issued
354 and delivered to Buyer as soon as practicable at or after Closing.

355 8.1.2. **Buyer Selects Title Insurance Company.** If this box is checked, Buyer will select the title insurance
356 company to furnish the owner's title insurance policy at Buyer's expense. On or before **Record Title Deadline**, Buyer must furnish to
357 Seller, a current commitment for owner's title insurance policy (Title Commitment), in an amount equal to the Purchase Price.
358 If neither box in § 8.1.1. or § 8.1.2. is checked, § 8.1.1. applies.

359 8.1.3. **Owner's Extended Coverage (OEC).** The Title Commitment **Will** **Will Not** contain Owner's
360 Extended Coverage (OEC). If the Title Commitment is to contain OEC, it will commit to delete or insure over the standard exceptions
361 which relate to: (1) parties in possession, (2) unrecorded easements, (3) survey matters, (4) unrecorded mechanics' liens, (5) gap
362 period (period between the effective date and time of commitment to the date and time the deed is recorded) and (6) unpaid taxes,
363 assessments and unredeemed tax sales prior to the year of Closing. Any additional premium expense to obtain OEC will be paid by
364 **Buyer** **Seller** **One-Half by Buyer and One-Half by Seller** **Other** _____.

365 Regardless of whether the Contract requires OEC, the Title Insurance Commitment may not provide OEC or delete or insure over
366 any or all of the standard exceptions for OEC. The Title Insurance Company may require a New Survey or New ILC, defined below,
367 among other requirements for OEC. If the Title Insurance Commitment is not satisfactory to Buyer, Buyer has a right to object under
368 § 8.7. (Right to Object to Title, Resolution).

369 8.1.4. **Title Documents.** Title Documents consist of the following: (1) copies of any plats, declarations, covenants,
370 conditions and restrictions burdening the Property and (2) copies of any other documents (or, if illegible, summaries of such
371 documents) listed in the schedule of exceptions (Exceptions) in the Title Commitment furnished to Buyer (collectively, Title
372 Documents).

373 8.1.5. **Copies of Title Documents.** Buyer must receive, on or before **Record Title Deadline**, copies of all Title
374 Documents. This requirement pertains only to documents as shown of record in the office of the clerk and recorder in the county
375 where the Property is located. The cost of furnishing copies of the documents required in this Section will be at the expense of the
376 party or parties obligated to pay for the owner's title insurance policy.

377 8.1.6. **Existing Abstracts of Title.** Seller must deliver to Buyer copies of any abstracts of title covering all or any
378 portion of the Property (Abstract of Title) in Seller's possession on or before **Record Title Deadline**.

379 8.2. **Record Title.** Buyer has the right to review and object to the Abstract of Title or Title Commitment and any of the
380 Title Documents as set forth in § 8.7. (Right to Object to Title, Resolution) on or before **Record Title Objection Deadline**. Buyer's

381 objection may be based on any unsatisfactory form or content of Title Commitment or Abstract of Title, notwithstanding § 13, or
382 any other unsatisfactory title condition, in Buyer's sole subjective discretion. If the Abstract of Title, Title Commitment or Title
383 Documents are not received by Buyer on or before the **Record Title Deadline**, or if there is an endorsement to the Title Commitment
384 that adds a new Exception to title, a copy of the new Exception to title and the modified Title Commitment will be delivered to
385 Buyer. Buyer has until the earlier of Closing or ten days after receipt of such documents by Buyer to review and object to: (1) any
386 required Title Document not timely received by Buyer, (2) any change to the Abstract of Title, Title Commitment or Title Documents,
387 or (3) any endorsement to the Title Commitment. If Seller receives Buyer's Notice to Terminate or Notice of Title Objection,
388 pursuant to this § 8.2. (Record Title), any title objection by Buyer is governed by the provisions set forth in § 8.7. (Right to Object
389 to Title, Resolution). If Seller has fulfilled all Seller's obligations, if any, to deliver to Buyer all documents required by § 8.1.
390 (Evidence of Record Title) and Seller does not receive Buyer's Notice to Terminate or Notice of Title Objection by the applicable
391 deadline specified above, Buyer accepts the condition of title as disclosed by the Abstract of Title, Title Commitment and Title
392 Documents as satisfactory.

393 **8.3. Off-Record Title.** Seller must deliver to Buyer, on or before **Off-Record Title Deadline**, true copies of all existing
394 surveys in Seller's possession pertaining to the Property and must disclose to Buyer all easements, liens (including, without
395 limitation, governmental improvements approved, but not yet installed) or other title matters not shown by public records, of which
396 Seller has actual knowledge (Off-Record Matters). This Section excludes any **New ILC** or **New Survey** governed under § 9 (New
397 ILC, New Survey). Buyer has the right to inspect the Property to investigate if any third party has any right in the Property not shown
398 by public records (e.g., unrecorded easement, boundary line discrepancy or water rights). Buyer's Notice to Terminate or Notice of
399 Title Objection of any unsatisfactory condition (whether disclosed by Seller or revealed by such inspection, notwithstanding § 8.2.
400 (Record Title) and § 13 (Transfer of Title)), in Buyer's sole subjective discretion, must be received by Seller on or before **Off-
401 Record Title Objection Deadline**. If an Off-Record Matter is received by Buyer after the **Off-Record Title Deadline**, Buyer has
402 until the earlier of Closing or ten days after receipt by Buyer to review and object to such Off-Record Matter. If Seller receives
403 Buyer's Notice to Terminate or Notice of Title Objection pursuant to this § 8.3. (Off-Record Title), any title objection by Buyer is
404 governed by the provisions set forth in § 8.7. (Right to Object to Title, Resolution). If Seller does not receive Buyer's Notice to
405 Terminate or Notice of Title Objection by the applicable deadline specified above, Buyer accepts title subject to such Off-Record
406 Matters and rights, if any, of third parties not shown by public records of which Buyer has actual knowledge.

407 **8.4. Special Taxing and Metropolitan Districts. Intentionally Deleted.**

408 **8.5. Tax Certificate.** A tax certificate paid for by Seller Buyer, for the Property (Tax Certificate) must be delivered
409 to Buyer on or before **Record Title Deadline**. If the content of the Tax Certificate is unsatisfactory to Buyer, in Buyer's sole
410 subjective discretion, Buyer may terminate, on or before **Record Title Objection Deadline**. Should Buyer receive the Tax Certificate
411 after **Record Title Deadline**, Buyer, at Buyer's option, has the Right to Terminate under § 24.1. by Buyer's Notice to Terminate
412 received by Seller on or before ten days after Buyer's receipt of the Tax Certificate. If Buyer does not receive the Tax Certificate, or
413 if Buyer's Notice to Terminate would otherwise be required to be received by Seller after **Closing Date**, Buyer's Notice to Terminate
414 must be received by Seller on or before Closing. If Seller does not receive Buyer's Notice to Terminate within such time, Buyer
415 accepts the content of the Tax Certificate as satisfactory and Buyer waives any Right to Terminate under this provision. If Buyer's
416 loan specified in § 4.5.3. (Loan Limitations) prohibits Buyer from paying for the Tax Certificate, the Tax Certificate will be paid for
417 by Seller.

418 **8.6. Third Party Right to Purchase/Approve.** If any third party has a right to purchase the Property (e.g., right of first
419 refusal on the Property, right to purchase the Property under a lease or an option held by a third party to purchase the Property) or a
420 right of a third party to approve this Contract, Seller must promptly submit this Contract according to the terms and conditions of
421 such right. If the third-party holder of such right exercises its right this Contract will terminate. If the third party's right to purchase
422 is waived explicitly or expires, or the Contract is approved, this Contract will remain in full force and effect. Seller must promptly
423 notify Buyer in writing of the foregoing. If the third party right to purchase is exercised or approval of this Contract has not occurred
424 on or before **Third Party Right to Purchase/Approve Deadline**, this Contract will then terminate. Seller will supply to Buyer, in
425 writing, details of any Third Party Right to Purchase the Property on or before the Record Title Deadline.

426 **8.7. Right to Object to Title, Resolution.** Buyer has a right to object or terminate, in Buyer's sole subjective discretion,
427 based on any title matters including those matters set forth in § 8.2. (Record Title), § 8.3. (Off-Record Title), § 8.5. (Tax Certificate)
428 and § 13 (Transfer of Title). If Buyer exercises Buyer's rights to object or terminate based on any such title matter, on or before the
429 applicable deadline, Buyer has the following options:

430 **8.7.1. Title Objection, Resolution.** If Seller receives Buyer's written notice objecting to any title matter (Notice of
431 Title Objection) on or before the applicable deadline and if Buyer and Seller have not agreed to a written settlement thereof on or
432 before **Title Resolution Deadline**, this Contract will terminate on the expiration of **Title Resolution Deadline**, unless Seller receives
433 Buyer's written withdrawal of Buyer's Notice of Title Objection (i.e., Buyer's written notice to waive objection to such items and
434 waives the Right to Terminate for that reason), on or before expiration of **Title Resolution Deadline**. If either the Record Title
435 Deadline or the Off-Record Title Deadline, or both, are extended pursuant to § 8.2. (Record Title) or § 8.3. (Off-Record Title) the
436 Title Resolution Deadline also will be automatically extended to the earlier of Closing or fifteen days after Buyer's receipt of the
437 applicable documents; or

438 **8.7.2. Title Objection, Right to Terminate.** Buyer may exercise the Right to Terminate under § 24.1., on or before
439 the applicable deadline, based on any title matter unsatisfactory to Buyer, in Buyer's sole subjective discretion.

440 **8.8. Title Advisory.** The Title Documents affect the title, ownership and use of the Property and should be reviewed
441 carefully. Additionally, other matters not reflected in the Title Documents may affect the title, ownership and use of the Property,
442 including, without limitation, boundary lines and encroachments, set-back requirements, area, zoning, building code violations,
443 unrecorded easements and claims of easements, leases and other unrecorded agreements, water on or under the Property and various
444 laws and governmental regulations concerning land use, development and environmental matters.

445 **8.8.1. OIL, GAS, WATER AND MINERAL DISCLOSURE. THE SURFACE ESTATE OF THE**
446 **PROPERTY MAY BE OWNED SEPARATELY FROM THE UNDERLYING MINERAL ESTATE AND TRANSFER OF**
447 **THE SURFACE ESTATE MAY NOT NECESSARILY INCLUDE TRANSFER OF THE MINERAL ESTATE OR WATER**
448 **RIGHTS. THIRD PARTIES MAY OWN OR LEASE INTERESTS IN OIL, GAS, OTHER MINERALS, GEOTHERMAL**
449 **ENERGY OR WATER ON OR UNDER THE SURFACE OF THE PROPERTY, WHICH INTERESTS MAY GIVE THEM**
450 **RIGHTS TO ENTER AND USE THE SURFACE OF THE PROPERTY TO ACCESS THE MINERAL ESTATE, OIL,**
451 **GAS OR WATER.**

452 **8.8.2. SURFACE USE AGREEMENT. THE USE OF THE SURFACE ESTATE OF THE PROPERTY TO**
453 **ACCESS THE OIL, GAS OR MINERALS MAY BE GOVERNED BY A SURFACE USE AGREEMENT, A**
454 **MEMORANDUM OR OTHER NOTICE OF WHICH MAY BE RECORDED WITH THE COUNTY CLERK AND**
455 **RECORDER.**

456 **8.8.3. OIL AND GAS ACTIVITY. OIL AND GAS ACTIVITY THAT MAY OCCUR ON OR ADJACENT**
457 **TO THE PROPERTY MAY INCLUDE, BUT IS NOT LIMITED TO, SURVEYING, DRILLING, WELL COMPLETION**
458 **OPERATIONS, STORAGE, OIL AND GAS, OR PRODUCTION FACILITIES, PRODUCING WELLS, REWORKING**
459 **OF CURRENT WELLS AND GAS GATHERING AND PROCESSING FACILITIES.**

460 **8.8.4. ADDITIONAL INFORMATION. BUYER IS ENCOURAGED TO SEEK ADDITIONAL**
461 **INFORMATION REGARDING OIL AND GAS ACTIVITY ON OR ADJACENT TO THE PROPERTY, INCLUDING**
462 **DRILLING PERMIT APPLICATIONS. THIS INFORMATION MAY BE AVAILABLE FROM THE COLORADO OIL**
463 **AND GAS CONSERVATION COMMISSION.**

464 **8.8.5. Title Insurance Exclusions.** Matters set forth in this Section and others, may be excepted, excluded from, or
465 not covered by the owner's title insurance policy.

466 **8.9. Mineral Rights Review.** Buyer has a Right to Terminate if examination of the Mineral Rights is unsatisfactory to
467 Buyer on or before the **Mineral Rights Examination Deadline**.

468 **9. NEW ILC, NEW SURVEY.**

469 **9.1. New ILC or New Survey.** If the box is checked, (1) **New Improvement Location Certificate (New ILC)**; or, (2)
470 **New Survey** in the form of _____; is required and the following will apply:

471 **9.1.1. Ordering of New ILC or New Survey.** **Seller** **Buyer** will order the New ILC or New Survey. The
472 New ILC or New Survey may also be a previous ILC or survey that is in the above-required form, certified and updated as of a date
473 after the date of this Contract.

474 **9.1.2. Payment for New ILC or New Survey.** The cost of the New ILC or New Survey will be paid, on or before
475 Closing, by: **Seller** **Buyer** or:

476
477
478 **9.1.3. Delivery of New ILC or New Survey.** Buyer, Seller, the issuer of the Title Commitment (or the provider of
479 the opinion of title if an Abstract of Title) and _____ will receive a New ILC or New Survey on or before **New**
480 **ILC or New Survey Deadline**.

481 **9.1.4. Certification of New ILC or New Survey.** The New ILC or New Survey will be certified by the surveyor to
482 all those who are to receive the New ILC or New Survey.

483 **9.2. Buyer's Right to Waive or Change New ILC or New Survey Selection.** Buyer may select a New ILC or New
484 Survey different than initially specified in this Contract if there is no additional cost to Seller or change to the **New ILC or New**
485 **Survey Objection Deadline**. Buyer may, in Buyer's sole subjective discretion, waive a New ILC or New Survey if done prior to
486 Seller incurring any cost for the same.

487 **9.3. New ILC or New Survey Objection.** Buyer has the right to review and object based on the New ILC or New Survey.
488 If the New ILC or New Survey is not timely received by Buyer or is unsatisfactory to Buyer, in Buyer's sole subjective discretion,
489 Buyer may, on or before **New ILC or New Survey Objection Deadline**, notwithstanding § 8.3. or § 13:

490 **9.3.1. Notice to Terminate.** Notify Seller in writing, pursuant to § 24.1, that this Contract is terminated; or

491 **9.3.2. New ILC or New Survey Objection.** Deliver to Seller a written description of any matter that was to be
492 shown or is shown in the New ILC or New Survey that is unsatisfactory and that Buyer requires Seller to correct.

493 **9.3.3. New ILC or New Survey Resolution.** If a **New ILC or New Survey Objection** is received by Seller, on or
494 before **New ILC or New Survey Objection Deadline** and if Buyer and Seller have not agreed in writing to a settlement thereof on
495 or before **New ILC or New Survey Resolution Deadline**, this Contract will terminate on expiration of the **New ILC or New Survey**
496 **Resolution Deadline**, unless Seller receives Buyer's written withdrawal of the New ILC or New Survey Objection before such
497 termination (i.e., on or before expiration of **New ILC or New Survey Resolution Deadline**).

499 **10. PROPERTY DISCLOSURE, INSPECTION, INDEMNITY, INSURABILITY, DUE DILIGENCE AND SOURCE OF**
 500 **WATER.**

501 **10.1. Seller's Property Disclosure.** On or before **Seller's Property Disclosure Deadline**, Seller agrees to deliver to Buyer
 502 the most current version of the applicable Colorado Real Estate Commission's Seller's Property Disclosure form completed by Seller
 503 to Seller's actual knowledge and current as of the date of this Contract.

504 **10.2. Disclosure of Adverse Material Facts; Subsequent Disclosure; Present Condition.** Seller must disclose to Buyer
 505 any adverse material facts actually known by Seller as of the date of this Contract. Seller agrees that disclosure of adverse material
 506 facts will be in writing. In the event Seller discovers an adverse material fact after the date of this Contract, Seller must timely
 507 disclose such adverse fact to Buyer. Buyer has the Right to Terminate based on the Seller's new disclosure on the earlier of Closing
 508 or five days after Buyer's receipt of the new disclosure. Except as otherwise provided in this Contract, Buyer acknowledges that
 509 Seller is conveying the Property and Inclusions to Buyer in an "**As Is**" condition, "**Where Is**" and "**With All Faults.**"

510 **10.3. Inspection.** Unless otherwise provided in this Contract, Buyer, acting in good faith, has the right to have inspections
 511 (by one or more third parties, personally or both) of the Property, Leased Items, and Inclusions (Inspection), at Buyer's expense. If
 512 (1) the physical condition of the Property, including, but not limited to, the roof, walls, structural integrity of the Property, the
 513 electrical, plumbing, HVAC and other mechanical systems of the Property, (2) the physical condition of the Inclusions and Leased
 514 Items, (3) service to the Property (including utilities and communication services), systems and components of the Property (e.g.,
 515 heating and plumbing), (4) any proposed or existing transportation project, road, street or highway, or (5) any other activity, odor or
 516 noise (whether on or off the Property) and its effect or expected effect on the Property or its occupants is unsatisfactory, in Buyer's
 517 sole subjective discretion, Buyer may:

518 **10.3.1. Inspection Termination.** On or before the **Inspection Termination Deadline**, notify Seller in writing,
 519 pursuant to § 24.1., that this Contract is terminated due to any unsatisfactory condition, provided the Buyer did not previously deliver
 520 an Inspection Objection. Buyer's Right to Terminate under this provision expires upon delivery of an Inspection Objection to Seller
 521 pursuant to § 10.3.2.; or

522 **10.3.2. Inspection Objection.** On or before the **Inspection Objection Deadline**, deliver to Seller a written
 523 description of any unsatisfactory condition that Buyer requires Seller to correct.

524 **10.3.3. Inspection Resolution.** If an Inspection Objection is received by Seller, on or before **Inspection Objection**
 525 **Deadline** and if Buyer and Seller have not agreed in writing to a settlement thereof on or before **Inspection Resolution Deadline**,
 526 this Contract will terminate on **Inspection Resolution Deadline** unless Seller receives Buyer's written withdrawal of the Inspection
 527 Objection before such termination (i.e., on or before expiration of **Inspection Resolution Deadline**). Nothing in this provision
 528 prohibits the Buyer and the Seller from mutually terminating this Contract before the Inspection Resolution Deadline passes by
 529 executing an Earnest Money Release.

530 **10.4. Damage, Liens and Indemnity.** Buyer, except as otherwise provided in this Contract or other written agreement
 531 between the parties, is responsible for payment for all inspections, tests, surveys, engineering reports, or other reports performed at
 532 Buyer's request (Work) and must pay for any damage that occurs to the Property and Inclusions as a result of such Work. Buyer
 533 must not permit claims or liens of any kind against the Property for Work performed on the Property. Buyer agrees to indemnify,
 534 protect and hold Seller harmless from and against any liability, damage, cost or expense incurred by Seller and caused by any such
 535 Work, claim, or lien. This indemnity includes Seller's right to recover all costs and expenses incurred by Seller to defend against
 536 any such liability, damage, cost or expense, or to enforce this Section, including Seller's reasonable attorney fees, legal fees and
 537 expenses. The provisions of this Section survive the termination of this Contract. This § 10.4. does not apply to items performed
 538 pursuant to an Inspection Resolution.

539 **10.5. Insurability.** Buyer has the Right to Terminate under § 24.1., on or before **Property Insurance Termination**
 540 **Deadline**, based on any unsatisfactory provision of the availability, terms and conditions and premium for property insurance
 541 (Property Insurance) on the Property, in Buyer's sole subjective discretion.

542 **10.6. Due Diligence.**

543 **10.6.1. Due Diligence Documents.** Seller agrees to deliver copies of the following documents and information
 544 pertaining to the Property and Leased Items (Due Diligence Documents) to Buyer on or before **Due Diligence Documents Delivery**
 545 **Deadline**:

546 **10.6.1.1. Occupancy Agreements.** All current leases, including any amendments or other occupancy
 547 agreements, pertaining to the Property. Those leases or other occupancy agreements pertaining to the Property that survive Closing
 548 are as follows (Leases):

549
 550
 551
 552 **10.6.1.2. Leased Items Documents.** If any lease of personal property (§ 2.5.8., Leased Items) will be
 553 transferred to Buyer at Closing, Seller agrees to deliver copies of the leases and information pertaining to the personal property to
 554 Buyer on or before **Due Diligence Documents Delivery Deadline**.

555 **10.6.1.3. Encumbered Inclusions Documents.** If any Inclusions owned by Seller are encumbered
556 pursuant to § 2.5.4. (Encumbered Inclusions) above, Seller agrees to deliver copies of the evidence of debt, security and any other
557 documents creating the encumbrance to Buyer on or before **Due Diligence Documents Delivery Deadline.**

558 **10.6.1.4. Solar Power Plan.** Copy of any Solar Power Plan not included in Leased Items (regardless
559 of its name or title).

560 **10.6.1.5. Septic Use Permit.** If required by the local health department or other applicable government
561 entity, on or before the local health department's applicable deadline, Seller must pay for and furnish to Buyer a Septic Use Permit.

562 **10.6.1.6. Other Documents.** If the respective box is checked, Seller agrees to additionally deliver copies
563 of the following:

564 **10.6.1.6.1.** All contracts relating to the operation, maintenance and management of the
565 Property;

566 **10.6.1.6.2.** Property tax bills for the last _____ years;

567 **10.6.1.6.3.** As-built construction plans to the Property and the tenant improvements, including
568 architectural, electrical, mechanical and structural systems; engineering reports; and permanent Certificates of Occupancy, to the
569 extent now available;

570 **10.6.1.6.4.** A list of all Inclusions to be conveyed to Buyer;

571 **10.6.1.6.5.** Operating statements for the past _____ years;

572 **10.6.1.6.6.** A rent roll accurate and correct to the date of this Contract;

573 **10.6.1.6.7.** A schedule of any tenant improvement work Seller is obligated to complete
574 but has not yet completed and capital improvement work either scheduled or in process on the date of this Contract;

575 **10.6.1.6.8.** All insurance policies pertaining to the Property and copies of any claims which
576 have been made for the past ____ years;

577 **10.6.1.6.9.** Soils reports, surveys and engineering reports or data pertaining to the Property (if
578 not delivered earlier under § 8.3.);

579 **10.6.1.6.10.** Any and all existing documentation and reports regarding Phase I and II
580 environmental reports, letters, test results, advisories and similar documents respective to the existence or nonexistence of asbestos,
581 PCB transformers, or other toxic, hazardous or contaminated substances and/or underground storage tanks and/or radon gas. If no
582 reports are in Seller's possession or known to Seller, Seller warrants that no such reports are in Seller's possession or known to
583 Seller;

584 **10.6.1.6.11.** Any *Americans with Disabilities Act* reports, studies or surveys concerning the
585 compliance of the Property with said Act;

586 **10.6.1.6.12.** All permits, licenses and other building or use authorizations issued by any
587 governmental authority with jurisdiction over the Property and written notice of any violation of any such permits, licenses or use
588 authorizations, if any; and

589 **10.6.1.6.13.** Other:

590
591
592
593
594

595 **10.6.2. Due Diligence Documents Review and Objection.** Buyer has the right to review and object based on the Due
596 Diligence Documents. If the Due Diligence Documents are not supplied to Buyer or are unsatisfactory, in Buyer's sole subjective
597 discretion, Buyer may, on or before **Due Diligence Documents Objection Deadline:**

598 **10.6.2.1. Notice to Terminate.** Notify Seller in writing, pursuant to § 24.1., that this Contract is
599 terminated; or

600 **10.6.2.2. Due Diligence Documents Objection.** Deliver to Seller a written description of any
601 unsatisfactory Due Diligence Documents that Buyer requires Seller to correct.

602 **10.6.2.3. Due Diligence Documents Resolution.** If a Due Diligence Documents Objection is received
603 by Seller, on or before **Due Diligence Documents Objection Deadline** and if Buyer and Seller have not agreed in writing to a
604 settlement thereof on or before **Due Diligence Documents Resolution Deadline**, this Contract will terminate on **Due Diligence**
605 **Documents Resolution Deadline** unless Seller receives Buyer's written withdrawal of the Due Diligence Documents Objection
606 before such termination (i.e., on or before expiration of **Due Diligence Documents Resolution Deadline**).

607 **10.6.2.4. Automatic Due Diligence Extension.** If a Due Diligence Document is not delivered on or
608 before the Due Diligence Documents Deadline, Buyer has until the earlier of Closing or ten days after receipt by Buyer to review
609 and object to such Due Diligence Document. If Buyer's right to review and object to such Due Diligence Document is extended due
610 to such Due Diligence Document not being delivered on or before the Due Diligence Documents Deadline, the Due Diligence
611 Document Resolution Deadline will also be extended to the earlier of Closing or fifteen days after Buyer's receipt of such Due
612 Diligence Document.

613 **10.6.3. Zoning.** Buyer has the Right to Terminate under § 24.1., on or before Due Diligence Documents **Objection**
614 **Deadline**, based on any unsatisfactory zoning and any use restrictions imposed by any governmental agency with jurisdiction over
615 the Property, in Buyer's sole subjective discretion.

616 **10.6.4. Due Diligence – Environmental.** Buyer has the right to obtain environmental inspections of the Property
617 including a Phase I Environmental Site Assessment. **Seller** **Buyer** will order or provide a current Phase I Environmental
618 Site Assessment (compliant with the most current version of the applicable ASTM E1527 standard practices for Environmental Site
619 Assessments) and/or _____, at the expense of **Seller** **Buyer**
620 (Environmental Inspection).

621 If the Phase I Environmental Site Assessment recommends a Phase II Environmental Site Assessment, the **Environmental**
622 **Inspection Termination Deadline** will be extended by _____ days (Extended Environmental Inspection
623 Termination Deadline) and if such Extended Environmental Inspection Termination Deadline extends beyond the Closing **Date**, the
624 **Closing Date** will be extended a like period of time. In such event, **Seller** **Buyer** must pay the cost for such Phase II
625 Environmental Site Assessment.

626 Notwithstanding Buyer's right to obtain additional environmental inspections of the Property in this § 10.6.4., Buyer has the
627 Right to Terminate under § 24.1., on or before **Environmental Inspection Termination Deadline**, or if applicable, the Extended
628 Environmental Inspection Termination Deadline, based on any unsatisfactory results of Environmental Inspection, in Buyer's sole
629 subjective discretion.

630 **10.6.5. Due Diligence – ADA.** Buyer, at Buyer's expense, may also conduct an evaluation whether the Property
631 complies with the *Americans with Disabilities Act* (ADA Evaluation). All such inspections and evaluations must be conducted at
632 such times as are mutually agreeable to minimize the interruption of Seller's and any Seller's tenants' business uses of the Property,
633 if any.

634 Buyer has the Right to Terminate under § 24.1., on or before **ADA Evaluation Termination Deadline**, based on any unsatisfactory
635 ADA Evaluation, in Buyer's sole subjective discretion.

636 **10.7. Conditional Upon Sale of Property.** This Contract is conditional upon the sale and closing of that certain property
637 owned by Buyer and commonly known as _____. Buyer has
638 the Right to Terminate under § 24.1. effective upon Seller's receipt of Buyer's Notice to Terminate on or before **Conditional Sale**
639 **Deadline** if such property is not sold and closed by such deadline. This Section is for the sole benefit of Buyer. If Seller does not
640 receive Buyer's Notice to Terminate on or before **Conditional Sale Deadline**, Buyer waives any Right to Terminate under this
641 provision.

642 **10.8. Source of Potable Water (Residential Land and Residential Improvements Only).** [Intentionally Deleted - See
643 **Residential Addendum if applicable]**

644 **10.9. Existing Leases; Modification of Existing Leases; New Leases.** Seller states that none of the Leases to be assigned
645 to the Buyer at the time of Closing contain any rent concessions, rent reductions or rent abatements except as disclosed in the Lease
646 or other writing received by Buyer. Seller will not amend, alter, modify, extend or cancel any of the Leases nor will Seller enter into
647 any new leases affecting the Property without the prior written consent of Buyer, which consent will not be unreasonably withheld
648 or delayed.

649 **10.10. Lead-Based Paint.** [Intentionally Deleted - See Residential Addendum if applicable]

650 **10.11. Carbon Monoxide Alarms.** [Intentionally Deleted - See Residential Addendum if applicable]

651 **10.12. Methamphetamine Disclosure.** [Intentionally Deleted - See Residential Addendum if applicable]

652 **11. TENANT ESTOPPEL STATEMENTS.**

653 **11.1. Estoppel Statements Conditions.** Buyer has the right to review and object to any Estoppel Statements. Seller must
654 request from all tenants of the Property and if received by Seller, deliver to Buyer on or before **Estoppel Statements Deadline**,
655 statements in a form and substance reasonably acceptable to Buyer, from each occupant or tenant at the Property (Estoppel Statement)
656 attached to a copy of the Lease stating:

657 **11.1.1.** The commencement date of the Lease and scheduled termination date of the Lease;

658 **11.1.2.** That said Lease is in full force and effect and that there have been no subsequent modifications or
659 amendments;

660 **11.1.3.** The amount of any advance rentals paid, rent concessions given and deposits paid to Seller;

661 **11.1.4.** The amount of monthly (or other applicable period) rental paid to Seller;

662 **11.1.5.** That there is no default under the terms of said Lease by landlord or occupant; and

663 **11.1.6.** That the Lease to which the Estoppel Statement is attached is a true, correct and complete copy of the Lease
664 demising the premises it describes.

665 **11.2. Seller Estoppel Statement.** In the event Seller does not receive from all tenants of the Property a completed signed
666 Estoppel Statement, Seller agrees to complete and execute an Estoppel Statement setting forth the information and documents
667 required in §11.1. above and deliver the same to Buyer on or before **Estoppel Statements Deadline**.

668 **11.3. Estoppel Statements Termination.** Buyer has the Right to Terminate under § 24.1., on or before **Estoppel**
669 **Statements Termination Deadline**, based on any unsatisfactory Estoppel Statement, in Buyer's sole subjective discretion, or if

670 Seller fails to deliver the Estoppel Statements on or before **Estoppel Statements Deadline**. Buyer also has the unilateral right to
671 waive any unsatisfactory Estoppel Statement.

672

CLOSING PROVISIONS

673 **12. CLOSING DOCUMENTS, INSTRUCTIONS AND CLOSING.**

674 **12.1. Closing Documents and Closing Information.** Seller and Buyer will cooperate with the Closing Company to enable
675 the Closing Company to prepare and deliver documents required for Closing to Buyer and Seller and their designees. If Buyer is
676 obtaining a loan to purchase the Property, Buyer acknowledges Buyer's lender is required to provide the Closing Company, in a
677 timely manner, all required loan documents and financial information concerning Buyer's loan. Buyer and Seller will furnish any
678 additional information and documents required by Closing Company that will be necessary to complete this transaction. Buyer and
679 Seller will sign and complete all customary or reasonably required documents at or before Closing.

680 **12.2. Closing Instructions.** Colorado Real Estate Commission's Closing Instructions **Are** **Are Not** executed with
681 this Contract.

682 **12.3. Closing.** Delivery of deed from Seller to Buyer will be at closing (Closing). Closing will be on the date specified as
683 the **Closing Date** or by mutual agreement at an earlier date. At Closing, Seller must provide Buyer with the ability to access the
684 Property (e.g. keys, access code, garage door opener). The hour and place of Closing will be as designated by
685 mutual agreement of parties and closing agent _____.

686 **12.4. Disclosure of Settlement Costs.** Buyer and Seller acknowledge that costs, quality and extent of service vary between
687 different settlement service providers (e.g., attorneys, lenders, inspectors and title companies).

688 **12.5. Assignment of Leases.** Seller must assign to Buyer all Leases at Closing that will continue after Closing and Buyer
689 must assume Seller's obligations under such Leases. Further, Seller must transfer to Buyer all Leased Items and assign to Buyer such
690 leases for the Leased Items accepted by Buyer pursuant to § 2.5.8. (Leased Items).

691 **13. TRANSFER OF TITLE.** Subject to Buyer's compliance with the terms and provisions of this Contract, including the tender
692 of any payment due at Closing, Seller must execute and deliver the following good and sufficient deed to Buyer, at Closing:
693 special warranty deed general warranty deed bargain and sale deed quit claim deed personal representative's deed
694 _____ deed. Seller, provided another deed is not selected, must execute and deliver a good and
695 sufficient special warranty deed to Buyer, at Closing.

696 Unless otherwise specified in § 30 (Additional Provisions), if title will be conveyed using a special warranty deed or a general
697 warranty deed, title will be conveyed "subject to statutory exceptions" as defined in §38-30-113(5)(a), C.R.S.

698 **14. PAYMENT OF LIENS AND ENCUMBRANCES.** Unless agreed to by Buyer in writing, any amounts owed on any liens
699 or encumbrances securing a monetary sum against the Property and Inclusions, including any governmental liens for special
700 improvements installed as of the date of Buyer's signature hereon, whether assessed or not, and previous years' taxes, will be paid
701 at or before Closing by Seller from the proceeds of this transaction or from any other source.

702 **15. CLOSING COSTS, FEES, ASSOCIATION STATUS LETTER AND DISBURSEMENTS, TAXES AND**
703 **WITHHOLDING.**

704 **15.1. Closing Costs.** Buyer and Seller must pay, in Good Funds, their respective closing costs and all other items required
705 to be paid at Closing, except as otherwise provided herein.

706 **15.2. Closing Services Fee.** The fee for real estate closing services must be paid at Closing by **Buyer** **Seller**
707 **One-Half by Buyer and One-Half by Seller** **Other** _____.

708 **15.3. Association Fees and Required Disbursements.** At least fourteen days prior to **Closing Date**, Seller agrees to
709 promptly request that the Closing Company or the Association deliver to Buyer a current Status Letter, if applicable. Any fees
710 associated with or specified in the Status Letter will be paid as follows:

711 **15.3.1. Status Letter Fee.** Any fee incident to the issuance of Association's Status Letter must be paid by Seller.

712 **15.3.2. Record Change Fee.** Any Record Change Fee must be paid by **Buyer** **Seller** **One-Half by Buyer**
713 **and One-Half by Seller** **N/A.**

714 **15.3.3. Reserves or Working Capital.** Unless agreed to otherwise, all reserves or working capital due (or other
715 similar cost not addressed in § 16.2. (Association Assessments)) at Closing must be paid by **Buyer** **Seller** **One-Half by**
716 **Buyer and One-Half by Seller** **N/A.**

717 **15.3.4. Other Fees.** Any other fee listed in the Status Letter as required to be paid at Closing will be paid by
718 **Buyer** **Seller** **One-Half by Buyer and One-Half by Seller** **N/A.**

719 **15.4. Local Transfer Tax.** Any Local Transfer Tax must be paid at Closing by **Buyer** **Seller** **One-Half by**
720 **Buyer and One-Half by Seller** **N/A.**

721 **15.5. Sales and Use Tax.** Any sales and use tax that may accrue because of this transaction must be paid when due by
722 **Buyer** **Seller** **One-Half by Buyer and One-Half by Seller** **N/A.**

723 **15.6. Private Transfer Fee.** Any private transfer fees and other fees due to a transfer of the Property, payable at Closing,
724 such as community association fees, developer fees and foundation fees, must be paid at Closing by Buyer Seller
725 One-Half by Buyer and One-Half by Seller N/A.

726 **15.7. Water Transfer Fees.** Water Transfer Fees can change. The fees, as of the date of this Contract, do not exceed
727 \$ 25.00 for:

728 Water District/Municipality Water Stock
729 Augmentation Membership Small Domestic Water Company _____
730 and must be paid at Closing by Buyer Seller One-Half by Buyer and One-Half by Seller N/A.

731 **15.8. Utility Transfer Fees.** Utility transfer fees can change. Any fees to transfer utilities from Seller to Buyer must be
732 paid by Buyer Seller One-Half by Buyer and One-Half by Seller N/A.

733 **15.9. FIRPTA and Colorado Withholding.**

734 **15.9.1. FIRPTA.** The Internal Revenue Service (IRS) may require a substantial portion of the Seller's proceeds be
735 withheld after Closing when Seller is a foreign person. If required withholding does not occur, the Buyer could be held liable for the
736 amount of the Seller's tax, interest and penalties. If the box in this Section is checked, Seller represents that Seller IS a foreign
737 person for purposes of U.S. income taxation. If the box in this Section is not checked, Seller represents that Seller is not a foreign
738 person for purposes of U.S. income taxation. Seller agrees to cooperate with Buyer and Closing Company to provide any reasonably
739 requested documents to verify Seller's foreign person status. If withholding is required, Seller authorizes Closing Company to
740 withhold such amount from Seller's proceeds. Seller should inquire with Seller's tax advisor to determine if withholding applies or
741 if an exemption exists.

742 **15.9.2. Colorado Withholding.** The Colorado Department of Revenue may require a portion of the Seller's proceeds
743 be withheld after Closing when Seller will not be a Colorado resident after Closing, if not otherwise exempt. Seller agrees to
744 cooperate with Buyer and Closing Company to provide any reasonably requested documents to verify Seller's status. If withholding
745 is required, Seller authorizes Closing Company to withhold such amount from Seller's proceeds. Seller should inquire with Seller's
746 tax advisor to determine if withholding applies or if an exemption exists.

747 **16. PRORATIONS AND ASSOCIATION ASSESSMENTS.**

748 **16.1. Prorations.** The following will be prorated to the **Closing Date**, except as otherwise provided:

749 **16.1.1. Taxes.** Personal property taxes, if any, special taxing district assessments, if any, and general real estate taxes
750 for the year of Closing, based on Taxes for the Calendar Year Immediately Preceding Closing Most Recent Mill Levy
751 and Most Recent Assessed Valuation, adjusted by any applicable qualifying seniors property tax exemption, qualifying disabled
752 veteran exemption or Other _____.

753 **16.1.2. Rents.** Rents based on Rents Actually Received Accrued. At Closing, Seller will transfer or credit
754 to Buyer the security deposits for all Leases assigned to Buyer, or any remainder after lawful deductions, and notify all tenants in
755 writing of such transfer and of the transferee's name and address.

756 **16.1.3. Other Prorations.** Water and sewer charges, propane, interest on continuing loan and _____.

757 **16.1.4. Final Settlement.** Unless otherwise specified in Additional Provisions, these prorations are final.

758 **16.2. Association Assessments.** Current regular Association assessments and dues (Association Assessments) paid in
759 advance will be credited to Seller at Closing. All Association Assessments accrued before Closing must be paid by Seller and all
760 Association Assessments accrued after Closing must be paid by Buyer. Cash reserves held out of the regular Association Assessments
761 for deferred maintenance by the Association will not be credited to Seller except as may be otherwise provided by the Governing
762 Documents. Any special assessment assessed prior to **Closing Date** by the Association will be the obligation of Buyer
763 Seller. Except however, any special assessment by the Association for improvements that have been installed as of the date of
764 Buyer's signature hereon, whether assessed prior to or after Closing, will be the obligation of Seller unless otherwise specified in
765 Additional Provisions. Seller represents there are no unpaid regular or special assessments against the Property except the current
766 regular assessments and _____. Association Assessments are subject to change as provided in the
767 Governing Documents.

768 **17. POSSESSION.** Possession of the Property and Inclusions will be delivered to Buyer on **Possession Date** at **Possession Time**,
769 subject to the Leases as set forth in § 10.6.1.1.

770 If Seller, after Closing occurs, fails to deliver possession as specified, Seller will be subject to eviction and will be additionally
771 liable to Buyer, notwithstanding § 20.2. (If Seller is in Default), for payment of \$ 300.00 per day (or any part of a day
772 notwithstanding § 3.3., Day) from **Possession Date** and **Possession Time** until possession is delivered. Additionally, Buyer may
773 pursue a claim against Seller for any of Buyer's actual additional damages incurred by Buyer in excess of such amount.

774

GENERAL PROVISIONS

775 **18. CAUSES OF LOSS, INSURANCE; DAMAGE TO INCLUSIONS AND SERVICES; CONDEMNATION; AND**
776 **WALK-THROUGH.** Except as otherwise provided in this Contract, the Property and Inclusions will be delivered in the condition
777 existing as of the date of this Contract, ordinary wear and tear excepted.

778 **18.1. Causes of Loss, Insurance.** In the event the Property or Inclusions are damaged by fire, other perils or causes of loss
779 prior to Closing (Property Damage) in an amount of not more than ten percent of the total Purchase Price and if the repair of the
780 damage will be paid by insurance (other than the deductible to be paid by Seller), then Seller, upon receipt of the insurance proceeds,
781 will use Seller's reasonable efforts to repair the Property before **Closing Date**. Buyer has the Right to Terminate under § 24.1., on
782 or before **Closing Date**, if the Property is not repaired before **Closing Date**, or if the damage exceeds such sum. Should Buyer elect
783 to carry out this Contract despite such Property Damage, Buyer is entitled to a credit at Closing for all insurance proceeds that were
784 received by Seller (but not the Association, if any) resulting from damage to the Property and Inclusions, plus the amount of any
785 deductible provided for in the insurance policy. This credit may not exceed the Purchase Price. In the event Seller has not received
786 the insurance proceeds prior to Closing, the parties may agree to extend the **Closing Date** to have the Property repaired prior to
787 Closing or, at the option of Buyer, (1) Seller must assign to Buyer the right to the proceeds at Closing, if acceptable to Seller's
788 insurance company and Buyer's lender; or (2) the parties may enter into a written agreement prepared by the parties or their attorney
789 requiring the Seller to escrow at Closing from Seller's sale proceeds the amount Seller has received and will receive due to such
790 damage, not exceeding the total Purchase Price, plus the amount of any deductible that applies to the insurance claim.

791 **18.2. Damage, Inclusions and Services.** Should any Inclusion or service (including utilities and communication services),
792 system, component or fixture of the Property (collectively Service) (e.g., heating or plumbing), fail or be damaged between the date
793 of this Contract and Closing or possession, whichever is earlier, then Seller is liable for the repair or replacement of such Inclusion
794 or Service with a unit of similar size, age and quality, or an equivalent credit, but only to the extent that the maintenance or
795 replacement of such Inclusion or Service is not the responsibility of the Association, if any, less any insurance proceeds received by
796 Buyer covering such repair or replacement. If the failed or damaged Inclusion or Service is not repaired or replaced on or before
797 Closing or possession, whichever is earlier, Buyer has the Right to Terminate under § 24.1., on or before **Closing Date**, or, at the
798 option of Buyer, Buyer is entitled to a credit at Closing for the repair or replacement of such Inclusion or Service. Such credit must
799 not exceed the Purchase Price. If Buyer receives such a credit, Seller's right for any claim against the Association, if any, will survive
800 Closing.

801 **18.3. Condemnation.** In the event Seller receives actual notice prior to Closing that a pending condemnation action may
802 result in a taking of all or part of the Property or Inclusions, Seller must promptly notify Buyer, in writing, of such condemnation
803 action. Buyer has the Right to Terminate under § 24.1., on or before **Closing Date**, based on such condemnation action, in Buyer's
804 sole subjective discretion. Should Buyer elect to consummate this Contract despite such diminution of value to the Property and
805 Inclusions, Buyer is entitled to a credit at Closing for all condemnation proceeds awarded to Seller for the diminution in the value
806 of the Property or Inclusions, but such credit will not include relocation benefits or expenses or exceed the Purchase Price.

807 **18.4. Walk-Through and Verification of Condition.** Buyer, upon reasonable notice, has the right to walk through the
808 Property prior to Closing to verify that the physical condition of the Property and Inclusions complies with this Contract.
809

810 **19. RECOMMENDATION OF LEGAL AND TAX COUNSEL.** By signing this Contract, Buyer and Seller acknowledge that
811 their respective broker has advised that this Contract has important legal consequences and has recommended: (1) legal examination
812 of title; (2) consultation with legal and tax or other counsel before signing this Contract as this Contract may have important legal
813 and tax implications; (3) to consult with their own attorney if Water Rights, Mineral Rights or Leased Items are included or excluded
814 in the sale; and (4) to consult with legal counsel if there are other matters in this transaction for which legal counsel should be
815 engaged and consulted. Such consultations must be done timely as this Contract has strict time limits, including deadlines, that must
816 be complied with.
817

818 **20. TIME OF ESSENCE, DEFAULT AND REMEDIES.** Time is of the essence for all dates and deadlines in this Contract.
819 This means that all dates and deadlines are strict and absolute. If any payment due, including Earnest Money, is not paid, honored
820 or tendered when due, or if any obligation is not performed timely as provided in this Contract or waived, the non-defaulting party
821 has the following remedies:

822 **20.1. If Buyer is in Default:**

823 **20.1.1. Specific Performance.** Seller may elect to cancel this Contract and all Earnest Money (whether or not paid
824 by Buyer) will be paid to Seller and retained by Seller. It is agreed that the Earnest Money is not a penalty, and the parties agree the
825 amount is fair and reasonable. Seller may recover such additional damages as may be proper. Alternatively, Seller may elect to treat
826 this Contract as being in full force and effect and Seller has the right to specific performance or damages, or both.

827 **20.1.2. Liquidated Damages, Applicable.** **This § 20.1.2. applies unless the box in § 20.1.1. is checked.** Seller may
828 cancel this Contract. All Earnest Money (whether or not paid by Buyer) will be paid to Seller and retained by Seller. It is agreed that
829 the Earnest Money amount specified in § 4.1. is LIQUIDATED DAMAGES and not a penalty, which amount the parties agree is
830 fair and reasonable and (except as provided in §§ 10.4. and 21), such amount is SELLER'S ONLY REMEDY for Buyer's failure to
831 perform the obligations of this Contract. Seller expressly waives the remedies of specific performance and additional damages.

832 **20.2. If Seller is in Default:**

833 **20.2.1. Specific Performance, Damages or Both.** Buyer may elect to treat this Contract as canceled, in which case
834 all Earnest Money received hereunder will be returned to Buyer and Buyer may recover such damages as may be proper.
835 Alternatively, in addition to the per diem in § 17 (Possession) for failure of Seller to timely deliver possession of the Property after
836 Closing occurs, Buyer may elect to treat this Contract as being in full force and effect and Buyer has the right to specific performance
837 or damages, or both.

838 **20.2.2. Seller's Failure to Perform.** In the event Seller fails to perform Seller's obligations under this Contract, to
839 include, but not limited to, failure to timely disclose Association violations known by Seller, failure to perform any replacements or
840 repairs required under this Contract or failure to timely disclose any known adverse material facts, Seller remains liable for any such
841 failures to perform under this Contract after Closing. Buyer's rights to pursue the Seller for Seller's failure to perform under this
842 Contract are reserved and survive Closing.

843 **21. LEGAL FEES, COST AND EXPENSES.** Anything to the contrary herein notwithstanding, in the event of any arbitration
844 or litigation relating to this Contract, prior to or after **Closing Date**, the arbitrator or court must award to the prevailing party all
845 reasonable costs and expenses, including attorney fees, legal fees and expenses.

846 **22. MEDIATION.** If a dispute arises relating to this Contract (whether prior to or after Closing) and is not resolved, the parties
847 must first proceed, in good faith, to mediation. Mediation is a process in which the parties meet with an impartial person who helps
848 to resolve the dispute informally and confidentially. Mediators cannot impose binding decisions. Before any mediated settlement is
849 binding, the parties to the dispute must agree to the settlement, in writing. The parties will jointly appoint an acceptable mediator
850 and will share equally in the cost of such mediation. The obligation to mediate, unless otherwise agreed, will terminate if the entire
851 dispute is not resolved within thirty days of the date written notice requesting mediation is delivered by one party to the other at that
852 party's last known address (physical or electronic as provided in § 26). Nothing in this Section prohibits either party from filing a
853 lawsuit and recording a *lis pendens* affecting the Property, before or after the date of written notice requesting mediation. This
854 Section will not alter any date in this Contract, unless otherwise agreed.

855 **23. EARNEST MONEY DISPUTE.** Except as otherwise provided herein, Earnest Money Holder must release the Earnest
856 Money following receipt of written mutual instructions, signed by both Buyer and Seller. In the event of any controversy regarding
857 the Earnest Money, Earnest Money Holder is not required to release the Earnest Money. Earnest Money Holder, in its sole subjective
858 discretion, has several options: (1) wait for any proceeding between Buyer and Seller; (2) interplead all parties and deposit Earnest
859 Money into a court of competent jurisdiction (Earnest Money Holder is entitled to recover court costs and reasonable attorney and
860 legal fees incurred with such action); or (3) provide notice to Buyer and Seller that unless Earnest Money Holder receives a copy of
861 the Summons and Complaint or Claim (between Buyer and Seller) containing the case number of the lawsuit (Lawsuit) within one
862 hundred twenty days of Earnest Money Holder's notice to the parties, Earnest Money Holder is authorized to return the Earnest
863 Money to Buyer. In the event Earnest Money Holder does receive a copy of the Lawsuit and has not interpleaded the monies at the time
864 of any Order, Earnest Money Holder must disburse the Earnest Money pursuant to the Order of the Court. The parties reaffirm the
865 obligation of § 22 (Mediation). This Section will survive cancellation or termination of this Contract.

866 **24. TERMINATION.**

867 **24.1. Right to Terminate.** If a party has a right to terminate, as provided in this Contract (Right to Terminate), the
868 termination is effective upon the other party's receipt of a written notice to terminate (Notice to Terminate), provided such written
869 notice was received on or before the applicable deadline specified in this Contract. If the Notice to Terminate is not received on or
870 before the specified deadline, the party with the Right to Terminate accepts the specified matter, document or condition as satisfactory
871 and waives the Right to Terminate under such provision. Any Notice to Terminate delivered after the applicable deadline specified
872 in the Contract is ineffective and does not terminate this Contract.

873 **24.2. Effect of Termination.** In the event this Contract is terminated, all Earnest Money received hereunder must be timely
874 returned to Buyer and the parties are then relieved of all obligations hereunder, subject to §§ 10.4. and 21.

875 **25. ENTIRE AGREEMENT, MODIFICATION, SURVIVAL; SUCCESSORS.** This Contract, its exhibits and specified
876 addenda, constitute the entire agreement between the parties relating to the subject hereof and any prior agreements pertaining
877 thereto, whether oral or written, have been merged and integrated into this Contract. No subsequent modification of any of the terms
878 of this Contract is valid, binding upon the parties, or enforceable unless made in writing and signed by the parties. Any right or
879 obligation in this Contract that, by its terms, exists or is intended to be performed after termination or Closing survives the same.
880 Any successor to a party receives the predecessor's benefits and obligations of this Contract.

881 **26. NOTICE, DELIVERY AND CHOICE OF LAW.**

882 **26.1. Physical Delivery and Notice.** Any document or notice to Buyer or Seller must be in writing, except as provided in
883 § 26.2. and is effective when physically received by such party, any individual named in this Contract to receive documents or
884 notices for such party, Broker, or Brokerage Firm of Broker working with such party (except any notice or delivery after Closing
885 must be received by the party, not Broker or Brokerage Firm).

886 **26.2. Electronic Notice.** As an alternative to physical delivery, any notice may be delivered in electronic form to Buyer or
887 Seller, any individual named in this Contract to receive documents or notices for such party, Broker or Brokerage Firm of Broker
888 working with such party (except any notice or delivery after Closing, cancellation or Termination must be received by the party, not
889 Broker or Brokerage Firm) at the electronic address of the recipient by facsimile, email or _____.

890 **26.3. Electronic Delivery.** Electronic Delivery of documents and notice may be delivered by: (1) email at the email address
891 of the recipient, (2) a link or access to a website or server provided the recipient receives the information necessary to access the
892 documents, or (3) facsimile at the facsimile number (Fax No.) of the recipient.

893 **26.4. Choice of Law.** This Contract and all disputes arising hereunder are governed by and construed in accordance with
894 the laws of the State of Colorado that would be applicable to Colorado residents who sign a contract in Colorado for real property
895 located in Colorado.

896 **27. NOTICE OF ACCEPTANCE, COUNTERPARTS.** This proposal will expire unless accepted in writing, by Buyer and
897 Seller, as evidenced by their signatures below and the offering party receives notice of such acceptance pursuant to § 26 on or before
898 **Acceptance Deadline Date and Acceptance Deadline Time.** If accepted, this document will become a contract between Seller and
899 Buyer. A copy of this Contract may be executed by each party, separately and when each party has executed a copy thereof, such
900 copies taken together are deemed to be a full and complete contract between the parties.

901 **28. GOOD FAITH.** Buyer and Seller acknowledge that each party has an obligation to act in good faith including, but not limited
902 to, exercising the rights and obligations set forth in the provisions of **Financing Conditions and Obligations; Title Insurance,**
903 **Record Title and Off-Record Title; New ILC, New Survey; and Property Disclosure, Inspection, Indemnity, Insurability and**
904 **Due Diligence.**

905 **29. BUYER'S BROKERAGE FIRM COMPENSATION.** Buyer's brokerage firm's compensation will be paid, at Closing, as
906 follows:

907 **29.1.** ____% of the Purchase Price or \$ _____ by Seller. Buyer's brokerage firm is an intended third-party
908 beneficiary under this provision only. The amount paid by Seller under this provision is in addition to any other amounts Seller is
909 paying on behalf of Buyer elsewhere in this Contract.

910 **29.2.** ____% of the Purchase Price or \$ _____ by Buyer pursuant to a separate agreement between Buyer and
911 Buyer's brokerage firm. This amount may be modified between Buyer and Buyer's brokerage firm outside of this Contract.

912 **29.3.** ____% of the Purchase Price or \$ _____ by a separate agreement between Buyer's brokerage firm and
913 Seller's brokerage firm.

914

ADDITIONAL PROVISIONS AND ATTACHMENTS
--

915 **30. ADDITIONAL PROVISIONS.** (The following additional provisions have not been approved by the Colorado Real Estate
916 Commission.)

917 This Contract is contingent upon ratification by the City of Ouray City Council at the next regularly scheduled City Council meeting on April 7, 2025. If not ratified, Buyer shall
918 provide a Notice to Terminate to Seller by April 8, 2025 and this contract shall terminate and all earnest money shall be refundable.
919
920
921
922
923
924
925
926

927 **31. OTHER DOCUMENTS.**

928 **31.1. Documents Part of Contract.** The following documents **are a part** of this Contract:
929
930
931

932 **31.2. Documents Not Part of Contract.** The following documents have been provided but are **not** a part of this Contract:
933
934
935

936

SIGNATURES

937

Buyer's Name: CITY OF OURAY
By Michelle Metteer, City Administrator

Buyer's Name: _____

Michelle Metteer

3/19/2025

Buyer's Signature _____ Date _____

Buyer's Signature _____ Date _____

Address: 320 6th St.

Ouray, CO 81427

Address: _____

Phone No.: 970-325-7211

Phone No.: _____

Fax No.: _____

Fax No.: _____

Email Address: _____

Email Address: _____

938 [NOTE: If this offer is being countered or rejected, do not sign this document.]

Seller's Name: RICHARD A LANE & MARY V LANE 1988 TRUST,
dated December 9, 1988

Seller's Name: _____

Mary V. Lane

03/20/2025

Seller's Signature _____ Date _____

Seller's Signature _____ Date _____

Address: 11013 Shaw St.

Alta Loma, CA 91701-7702

Address: 11013 Shaw St.

Alta Loma, CA 91701-7702

Phone No.: _____

Phone No.: _____

Fax No.: _____

Fax No.: _____

Email Address: _____

Email Address: _____

939

940

END OF CONTRACT TO BUY AND SELL REAL ESTATE

BROKER'S ACKNOWLEDGMENTS AND COMPENSATION DISCLOSURE.

A. Broker Working With Buyer

Broker Does Does Not acknowledge receipt of Earnest Money deposit. Broker agrees that if Brokerage Firm is the Earnest Money Holder and, except as provided in § 23, if the Earnest Money has not already been returned following receipt of a Notice to Terminate or other written notice of termination, Earnest Money Holder will release the Earnest Money as directed by the written mutual instructions. Such release of Earnest Money will be made within five days of Earnest Money Holder's receipt of the executed written mutual instructions, provided the Earnest Money check has cleared.

Broker is working with Buyer as a Buyer's Agent Transaction-Broker in this transaction.

Customer. Broker has no brokerage relationship with Buyer. See § B for Broker's brokerage relationship with Seller.

Brokerage Firm's compensation or commission is to be paid as specified in §29 above.

This Broker's Acknowledgments and Compensation Disclosure is for disclosure purposes only and does NOT create any claim for compensation. Any compensation agreement between the brokerage firms must be entered into separately and apart from this provision.

Brokerage Firm's Name: United Country Sneffels Realty
Brokerage Firm's License #: _____
Broker's Name: Todd R. Schroedel

Broker's License #:

Todd Schroedel 03/19/2025
Broker's Signature Date

Address:

150 Liddell Street
Ridgway, CO 81432

Phone No.:

970-318-2160

Fax No.:

Email Address:

Todd@sneffelsrealty.com

B. Broker Working with Seller

Broker Does **Does Not** acknowledge receipt of Earnest Money deposit. Broker agrees that if Brokerage Firm is the Earnest Money Holder and, except as provided in § 23, if the Earnest Money has not already been returned following receipt of a Notice to Terminate or other written notice of termination, Earnest Money Holder will release the Earnest Money as directed by the written mutual instructions. Such release of Earnest Money will be made within five days of Earnest Money Holder's receipt of the executed written mutual instructions, provided the Earnest Money check has cleared.

Broker is working with Seller as a **Seller's Agent** **Transaction-Broker** in this transaction.

Customer. Broker has no brokerage relationship with Seller. See § A for Broker's brokerage relationship with Buyer.

Brokerage Firm's compensation or commission is to be paid by **Seller** **Buyer** **Other** _____.

This Broker's Acknowledgments and Compensation Disclosure is for disclosure purposes only and does NOT create any claim for compensation. Any agreement to pay compensation must be entered into separately and apart from this provision.

Brokerage Firm's Name:

United Country Sneffels Realty

Brokerage Firm's License #:

Broker's Name:

Todd R. Schroedel

Broker's License #:

Todd Schroedel 03/19/2025
Broker's Signature Date

Address:

150 Liddell Street
Ridgway, CO 81432

Phone No.:

9703182160

Fax No.:

Email Address:

todd@sneffelsrealty.com

Appeal for Reconsideration Due to Extenuating Circumstances

Dear Melissa,

I hope this message finds you well. I am writing to formally appeal the decision regarding the nonrenewal of Short-Term Rental (STR) License #2024-1147 due to failure to rent/use the licensed STR for a minimum of 30 or more days by the annual renewal deadline of February 28th. This is due to extenuating circumstances that have significantly impacted our ability to meet the required obligations.

Over the last year, our family has experienced a series of unfortunate events. We have suffered the loss of a dear family member, which has been a profound emotional challenge and has required my immediate attention and presence to support my grieving family. Additionally, another family member has been battling a severe illness, further demanding my time and care.

These circumstances have created an overwhelming situation, making it difficult for us to focus on our short-term rental. Despite my best efforts to manage these personal challenges alongside my responsibilities, I have found it necessary to prioritize our family's urgent needs.

Given these extenuating circumstances, I kindly request reconsideration of the decision concerning the nonrenewal of our STR license. I assure you that, under normal conditions, I would have met all the requirements and expectations. We have had short-term rentals here in Ouray since 2020 and have always met the 30 or more days requirement until this past year. However, the current situation has been beyond my control and has also created great financial hardship on us.

I am more than willing to provide any necessary documentation or further details to support my appeal. I genuinely hope for your understanding and compassion in light of the hardships my family and I are enduring.

Thank you very much for considering our appeal. We look forward to your favorable response.

Sincerely,

Scott & Rebecca Yale

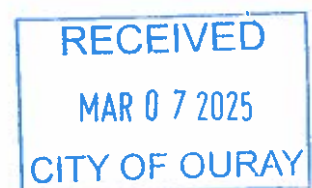

7-7 H. *Short-Term Rentals*

1. *Purpose.* To prevent adverse impacts attributable to short-term rentals in dwelling units; preserve the current character and ambiance of City neighborhoods; protect public health, safety, and welfare; and ensure compatibility with surrounding land uses.

2. *Applicability.* These regulations apply to any owner of real property with dwelling unit (dwelling units) used as an STR, whether directly or indirectly, in R-2, C-1, and C-2 Zone Districts, for less than thirty (30) consecutive days.

3. *Prohibitions and Conditions.*

a. STRs are prohibited in the R-1 Zone District.

b. STRs are prohibited in accessory dwelling units.

c. A maximum number of STR licenses, also known as a Cap, may be adopted by City Council from time to time.

d. Dwelling units with an STR license must use the dwelling unit as a STR for thirty (30) or more days each annual license period.

4. *Exemptions.*

a. Any STR within the R-1 Zone District in existence and use as an STR prior to July 17, 2019, must obtain an STR license and upon the granting of a license such use shall be deemed as legal nonconforming. Upon nonrenewal, or transfer in ownership of the real property of any kind, such license and use shall cease.

b. Dwelling units located within a lodging business premises are exempt but those located outside the lodging business premises must have an STR license if the property is assessed with a residential tax rate.

c. *STR Cap and Trade.* Any real property owner who provides three (3) new dwelling units for rent for more than 30 consecutive days on the same parcel, after adoption of the ordinance codified in this chapter, may obtain one (1) STR license for a fourth dwelling unit on the same parcel and shall be considered exempt from any STR license cap, so long as the policies concerning this exemption are met, as determined by City Council from time to time. When using the STR Cap and Trade program, a real property owner may use one (1) of the three (3) dwelling units as their primary residence and be excluded from the cap. The real property owner shall execute an affidavit when the STR license is issued stating that three (3) dwelling units are being utilized as rentals with a minimum lease agreement of six (6) months, excluding, if applicable, the real property owner's primary residence, and shall provide the City, upon request, proof of lease agreements. All other requirements of these regulations apply, including policies and procedures, adopted by City Council from time to time.

5. *Registration, Licensing, and Renewals.*

- a. An application is required to be submitted in accordance with the STR administrative policies and fee schedules, as City Council may adopt from time to time.
- b. The City Administrator, or any authorized staff, may issue and regulate short-term rental licenses, administratively.
- c. Upon submittal of a new STR application, a site inspection will be conducted to ensure the dwelling unit meets the City's adopted building codes.
- d. License renewals may require an additional inspection if substantial changes to the premises were made or complaints arose during the previous licensing period, as determined administratively.
- e. An STR license is issued to the real property owner and is not transferable, except if the real property for which a valid STR license has been issued is transferred pursuant to a deed meeting any of the following conditions (these exceptions do not apply to any STRs within R-1):
 - i. The transfer of title to real property if the grantee is a member of the grantor's family.
 - ii. The transfer of title to real property from a grantor to a trust established by the grantor.
 - iii. The transfer of title to real property from a grantor to a limited liability company or another form of business entity recognized by Colorado law so long as the grantor has a controlling interest in such limited liability company or other business entity.
 - iv. Any transfer of the property between the same parties creating or terminating a joint tenancy in such property.
 - v. The transfer of title or change of interest in real property by reason of death, pursuant to a will, the law of descent and distribution, or otherwise.
 - vi. The transfer of title to make effective any plan confirmed or ordered by a court of competent jurisdiction under the bankruptcy code or in an equity receivership proceeding.
 - vii. The transfer of title without consideration for the purpose of confirming, correcting, modifying, or supplementing a transfer previously recorded; making minor boundary adjustments; removing clouds on titles, or granting rights-of-way, easements, or licenses.
 - viii. The transfer of title pursuant to any decree or order of a court of record quieting, determining, or vesting title, including a final order awarding title pursuant to a condemnation proceeding.
 - ix. The transfer of title between spouses or former spouses made pursuant to a separation agreement, decree of legal separation, or dissolution of marriage.

f. The real property owner remains solely responsible for compliance with these regulations and any policies adopted by City Council from time to time.

g. Licenses are valid for one (1) year; and all license renewals shall be due on or before February 28 of each year.

h. Real property owners who have an STR license must maintain liability insurance during the licensing period, as set forth in the administrative policies adopted by City Council from time to time.

6. *Signs and Advertising Standards.*

a. External signs are prohibited for short-term rentals in the R-2 zone district and within the R-1 zone district on any nonconforming STRs.

b. One (1) internal sign no larger than 8 1/2" x 11" is allowed in R-1 and R-2 to identify a particular dwelling unit.

c. Signs in the C-1 and C-2 zone districts shall comply with the City Sign Code.

d. All short-term rentals shall clearly post the correct address on the exterior of the building in accordance with City addressing and street numbering requirements.

7. *Rules.*

a. The maximum number of persons per short-term rental shall be two (2) per bedroom, plus two (2) additional persons.

b. Noise Ordinance shall be followed.

c. The real property owner is responsible to remit all applicable local, state, and federal taxes, along with applicable Lodging Occupation Tax, Sales Tax, or any other applicable local tax, unless exempt.

d. Real property owner shall designate a responsible party who is located within a forty-five (45) minute drive of the City and available for immediate response to issues or emergencies that arise from the short-term rental.

8. *Parking Standards.* Parking shall meet any applicable provisions of the Ouray Municipal Code and any specific parking requirements of the underlying zone district.

9. *Snow Removal.* Real property owner shall comply with all City requirements for snow removal on public sidewalks, in addition to the requirement to remove snow from STR parking spaces, walkways, and the entrance to the short-term rental.

10. *Building Code Requirements.*

a. An STR shall only be used for one party that occupies the entire dwelling unit. Individual rooms within a single-family dwelling short-term rental shall not be rented out unless (i) the dwelling unit is separate, attached, or detached and it complies with the City of Ouray Municipal Code requirements; or (ii) the short-term rental has a separate entrance from the primary dwelling, no more than one short-term rental bedroom is provided on the property, and the building use and design complies with the underlying zone district requirements.

b. The short-term rental shall meet all applicable local, state, and federal regulations, including the requirement for carbon monoxide detectors under C.R.S. § [38-45-101](#) et seq.; lighting; one (1) wall-mounted, certified, five (5) pound ABC Fire Extinguisher within the short-term rental kitchen area; smoke detector requirements; and all other life-safety requirements, such as egress from sleeping areas.

c. When assessing this provision, the City Administrator or delegee will consider if the following items were built and approved according to the City's adopted codes at the time of development if these items do not meet current adopted building codes and do not cause a life-safety hazard:

- i. Fire separation of short-term rental unit.
- ii. Ingress and egress from dwelling and bedrooms.
- iii. Handrails on stairs.
- iv. Guardrails off decks or porches 30 inches off-grade.
- v. Sanitation, bathroom and hot water.
- vi. Stairway and landing requirements.
- vii. Hazardous location of windows.

11. *Refuse.*

a. The real property owner is responsible for proper disposal of garbage, refuse and trash collection in accordance with the Ouray Municipal Code.

b. STRs will be charged the residential rate for trash removal unless there are two or more trash violations within a six (6) month period and then the real property owner may be required to provide for two residential trash services at the same address to manage trash (paying for two cans at the residence), or to provide for a commercial trash pickup of trash if two residential service pickups do not resolve the trash complaints.

c. All trash shall be properly stored within containers that are not visible from any public street or sidewalk.

12. *Other General Requirements.*

- a. Short-term rentals must replace any exterior open light fixtures with dark sky compliant lighting.
- b. Real property owner must abide by all other applicable local, state, and federal laws and regulations.

13. *License Posting Requirements.*

- a. The STR License must be posted in a conspicuous place and contain the following items:
 - i. Contact information for the owner or responsible party.
 - ii. The STR address and license number.
 - iii. Maximum number of guests.
 - iv. Location of fire extinguishers.
 - v. A copy of the noise ordinance.
 - vi. Parking and snow storage rules.
 - vii. Trash disposal information.
 - viii. How to sign up for emergency notifications.
 - ix. Information on any City fire bans or water use restrictions.
 - xi. Map showing locations where trailer and large vehicle parking is allowed.

14. *Revocation or Suspension of License.*

- a. A license may be revoked after notice to the real property owner and opportunity to be heard for violations which result in more than two suspensions or serious violations which affect the health, safety, and welfare of the public.
- b. An STR license in the R-1 Zone District is a legal nonconforming use and upon the nonrenewal, suspension, revocation, abandonment of use or any transfer of ownership interest in the real property containing the dwelling unit with the STR license, the STR license is revoked immediately. There are no exceptions, and no affirmative or other defenses of any kind.
- c. A license may be suspended after notice to the real property owner for:

- i. One or more violations of any condition of the license or of any provision of these regulations during the licensing period.
- ii. Written notice of any violation shall be mailed to real property owner at the address provided in the most recent application.
- iii. The suspension is effective seven (7) days after the date of the notice.
- iv. This suspension procedure does not apply when an emergency arises which affects the health, safety, and welfare of the public under the City's police powers.

15. *Violations and Penalties.*

- a. It shall be unlawful to operate a short-term rental without a valid license or to violate any provision in these short-term rental regulations or any other City ordinance, resolution or official policy regarding short-term rentals or any state law or federal law.
- b. Violations are declared to be a nuisance, which may be abated in any lawful manner, including Section [10-4](#).
- c. Enforcement and penalties for violations of these Short-term Rental regulations shall be as provided for in Section [7-2](#).

16. *Appeals.* Appeals of administrative decisions under these regulations shall be pursuant to Section [7-5-C-7](#), and an appeal will be heard by City Council and not the Planning Commission.

Bid Assist and Construction Administration Cost Proposal



REQUEST FOR ADDITIONAL SERVICES

Project Title: Design two New Identity Signs for the Ouray Hot Springs and Pool and Rotary Park

Date: 05/20/2024

Scope of Work

Fee Proposal

The below chart provides work hours, hourly rates, and total cost per each task. Hourly rates are based on an average sum of the principal and staff hourly **un-loaded rates** combined. This proposal is a Time and Materials proposal. Cost is subject to change if requirements of the project scope are altered or revised.

TASK	WORK HOURS	HOURLY RATE	TOTAL COST
1. Concept / Design Development			
Concept Design (Produce three 3 concepts min.)	20	\$80	\$1,600
Concept Presentation	2	\$80	\$160
Design Development (After one concept has been chosen)	20	\$80	\$1,600
Final design presentation	2	\$80	\$160
Total Cost for Task 2			\$3,520
2. Implementation			
Design Intent Drawings	20	\$80	\$1,600
Bid Assist	10	\$80	\$800
Construction Administration (CA)	20	\$80	\$1,600
Total Cost for Task 3			\$4,000
Sub Total of all Tasks			\$7,520
REIMBURSABLE EXPENSES		RATE	TOTAL COST
Flights 6 total flights (2 Round trip flights x 3 people)		\$450 / Flight	\$2,700
Rental Car (6 Days)		\$100 / day	\$600
Lodging (6 nights GSA Rate)		\$110 / day	\$660
Meals and Incidentals (6 days GSA Rate)		\$68 / day	\$408
Parking (Public Parking Garages and Lots) (6 Days)		\$18 / day	\$108
Miscellaneous Project Expenses		N/A	\$500
Total for Reimbursable Expenses			\$4,976
TOTAL COST			\$12,496

Approved by _____

Date _____



FIVE-YEAR MINI-GRANT CONTRACT, 2020-2025

LATEST APPLICATION DATE: JUNE 30, 2024

MAIN STREET MINI-GRANT: PROJECT PROPOSAL

City of Ouray

City or Town

Michelle Metteer

Main Street Manager

Principal Representative/Main Street Manager

mmetteer@cityofouray.com

Title

970-318-9701

Email

Michelle Metteer

Phone

City Administrator

Responsible Administrator (from Local Government)

mmetteer@cityofouray.com

Title

970-318-9701

Email

Phone

QUESTIONS

1. How is this project part of your transformational strategy? Is it included in your annual work plan?

This partnership with the Ouray County Historical Society will allow these historic block signs to continue benefitting Ouray's downtown Main Street. Our transformational strategy states that we collaborate and leverage the good work of existing community organizations while also supporting physical beautification efforts downtown to help increase the economic success of local businesses.

2. In no more than 200 words, provide a brief description of the proposed project (scope of work), planned outcomes, and benefit to your downtown district.

The historic signage bases have sustained damage from snow removal operations over time. This initiative involves a collaboration with the Ouray County Historical Society, a local architectural firm, and a local artist to design and construct new multimedia bases comprised of steel and wood. The design adheres to Ouray's updated Wayfinding standards and will incorporate the "Powered by Main Street" logo, thereby highlighting both historical narratives and structures, as well as the work of local artisans. This will increase the amount of time visitors spend at these signs along the downtown corridor, consequently fostering interest in the buildings featured in the signs' historical information.

BUDGET AND MATCHING FUNDS

Please contact DOLA staff if you believe a match waiver is merited.

Project Task/Item	Total Cost	DOLA Funds	Local Match
HISTORICAL SIGN-POST REPLACEMENT	\$6,400.00	/	/
Totals:			

SIGNATURES

Chief Elected Official

 - 4/10/25
Local Main Street Chair/President



Historical Sign-Post Replacement Proposal

Dear Michelle Metteer:

Fresh Air Custom Creations is pleased to provide this proposal to replace the signposts for the seven historical interpretive signs along the Ouray's Main Street. These new signposts will be consistent with the upcoming way-finding signs to be installed in the city over the next three years.

The scope of this proposal includes:

- Procurement of all materials
- Remove all interpretive sign plaques from each sign post
- Remove and dispose of existing 3 x 3 aluminum signposts
- Repair sidewalk with concrete patching compound
- Provide new signpost assemblies
- Install new signpost assemblies at existing locations
- Reinstall interpretive sign plaques
- *Modification of sign plaque is not included in this scope*

Location of Signs:

			9th Ave
		★	SJPG
			8th Ave
		★	Brick House
			7th Ave.
Post Office	★		
			6th Ave.
Rockin' P	★	★	CO Boy
			5th Ave.
		★	
		★	Elks
			4th Ave.

Picture of Existing Sign (example):

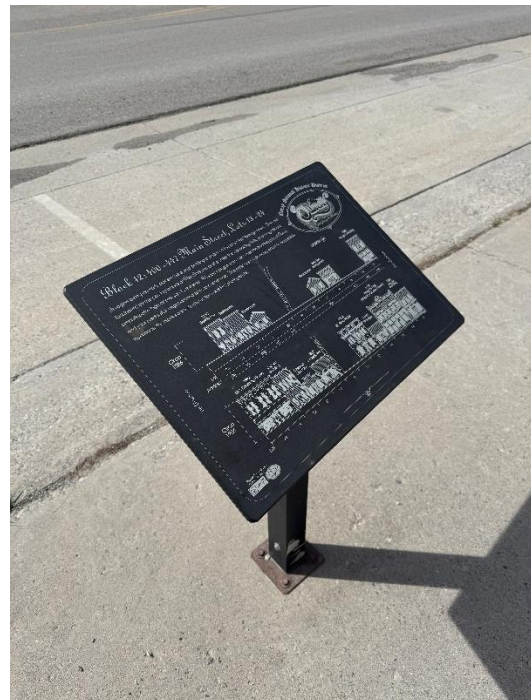

Sign Post Drawings:

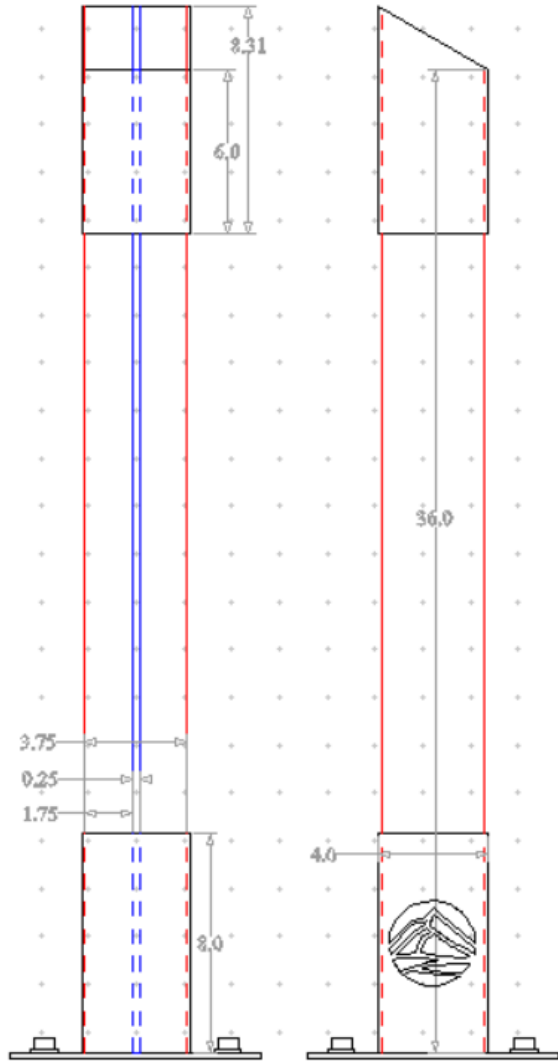

Post Assembly – Elevation Views

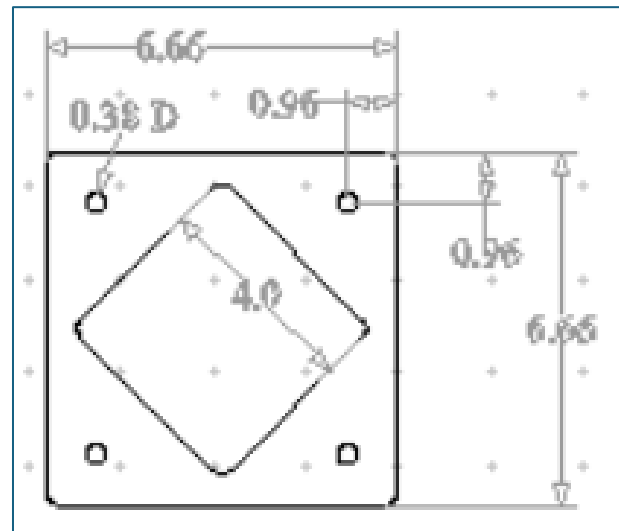

Base Plate with Post Footprint

Cost:

The scope described above will cost \$6,400.00 for all seven signs (no sales tax will be collected as the city is tax exempt). Payment terms are to provide \$3,200.00 at the beginning of the project (prior to purchase of materials) and the remainder upon completion.

Schedule:

Fresh Air Custom Creations will make every effort to complete this project prior to June 1st, 2025. This delivery date is contingent upon approval of the proposal at the April 21st Ouray city council meeting. All subcontractors used on this project are within the region (western slope) and have committed to timely execution.



P.O. Box 468
320 6th Avenue
Ouray, CO 81427
(970) 325-7211

April 21, 2025

Home Trust of Ouray County
95 Meadows Circle
Ridgway, Colorado, 81432

RE: Affordable Housing – Proposed River Walk Rentals Project at 1507 Oak St., Ouray, Colorado

To whom it may concern,

Home Trust of Ouray County is applying for CHFA’s Equity Program requesting \$3.2M for their River Walk Rentals Project at 1507 Oak St. in Ouray, Colorado.

There is a significant and increasing need for workforce and affordable housing in the City of Ouray and surrounding areas. Recognizing this issue, the City of Ouray supports the Home Trust’s request for funding to fill the need in the community.

Sincerely,

Ethan Funk
Mayor
City of Ouray



320 6th Avenue
PO Box 468
Ouray, Colorado 81427



970.325.7211
Fax 970.325.7212
www.cityofouray.com

April 21, 2025

The Honorable John Hickenlooper
Unites States Senators
Washington, D.C. 20510

Dear Honorable John Hickenlooper:

I am writing to express my strong support for the Paradox Community Trust's affordable homes Ouray Waterview Phase 2 project Congressional Directed Spending request. Ouray Waterview will serve a critical affordable housing need for the citizens of our City and the surround communities. The Waterview phase 1 neighborhood has been a great success meeting the affordable workforce housing needs of Ouray. Phase 1 has provided affordable homeownership opportunities for our local teachers, government employees and other critical members of our workforce.

We are proud to be their partner.

The City of Ouray is committed to helping our citizens solve the acute and increasing threatening, lack of affordable quality homeownership opportunities. Paradox through its Ouray Waterview is just that opportunity.

Along with Waterview phase 1, Paradox has completed two affordable housing developments in the nearby communities of Norwood and Ridgway. They look great and are life changing for the new homeowners. Ouray Waterview phase 2 will be two- and three-bedroom homes priced between \$250,000 to \$450,000 and are permanently deed restricted for households making from 60-120% AMI. The average AMI in the developments has been 79% with a significant number of new homeowners that are school district, and town employees. Paradox prioritizes employees who live and work in these communities and are given added priority in the lottery process.

Paradox's rural homeownership project is a model approach to entitle, construct and sell affordable housing in Colorado rural communities.

In order to support the construction of the Ouray Waterview affordable homes' neighborhoods in Ouray, the Paradox Community Trust is requesting a Congressional Directed Spending.

I appreciate your favorable consideration for the Paradox Community Trust's Ouray Waterview for a congressional directed investment.

Sincerely,

Ethan Funk
Mayor, City of Ouray

Future Agenda Items/Work Sessions

- Emergency Operations Plan Action Item – May 5
- Evacuation Plan Action Item – May 5
- School District/City of Ouray MOU Renewal – May 5
- Ouray Recreational Buildings & Facilities 501(c)(3) Work Session – (Date TBD, possibly May 19)
- Hazard Mitigation Plan
- Community Wildfire Protection Plan
- Huckstering Permit, Fees and Fine Schedule/Enforcement - May
- Joint Work Session with OIPI on Water Agreement & Long-term Planning for the Ice Park - June
- Parking Study and Bicycle usage on municipal trails (regulations for Ebikes) - June
- Restroom Cleaning and Vault Pumping Agreement Between City, OIPI, and FOVF (City to supply toilet paper but OIPI & FOVF will stock & clean)
- Dark Sky Ordinance – August/September
- Review of City Committees – October
- Business License Renewals – having issues with business's not registering/renewing
- Bed & Breakfast Discussion – wait for Community Development Director