

**GRANTON AREA SCHOOL DISTRICT
217 NORTH MAIN STREET
REGULAR SCHOOL BOARD MEETING
MONDAY, JULY 11, 2022 @ 6:45 PM
GRANTON COMMUNITY LIBRARY**

I. REGULAR BUSINESS

- A. Call to Order
- B. Roll Call
- C. Verification of Notice to Public
- D. Pledge of Allegiance
- E. Approval of Agenda
- F. Consent Agenda
 - a. Previous Minutes
 - b. Financial Reports
- G. Other

II. STUDENT COUNCIL REPRESENTATIVE INPUT/REMARKS

III. PUBLIC COMMENTS

IV. AGENDA ITEMS

- A. Check Register
- B. Athletic Coach Position(s)
- C. Academic Standards for 2022-23
- D. 2022-23 Student Handbooks
- E. Seclusion & Restraint Report
- F. Athletic Participation Fees
- G. 2022-23 Athletic Code/Handbook
- H. 2022-23 Preliminary Expenditures
- I. Staff Needs
- J. Principal's Office Reception Area
- K. Personnel

V. OTHER REPORTS

- A. School Board Committee Reports
- B. Principal's Report
- C. Superintendent's Report
- D. Other

VI. CORRESPONDENCE

VII. EXECUTIVE SESSION

- A. Convene in Executive Session for the purpose of discussing/taking action under Wisconsin Statute 19.85 (1)(c) Considering employment, promotion, compensation or performance evaluation data of any public employee over which the governmental body has jurisdiction or exercises responsibility.
- B. Return to Open Session

VIII. ADJOURNMENT

This meeting notice may be supplemented in order to comply with Wisconsin's open meetings law. If this notice is supplemented, the final notice will be posted and provided to the media no later than 24 hours prior to the meeting or no later than 2 hours prior to the meeting, in the event of an emergency.

TREASURERS REPORT

06302022

- Net of Funds 10, 21, 27, 29, 50, 80
\$ 465,733.04
- Fund 21 Trust & Agency
\$ 15,025.96
- Fund 38 & 39 Debt Service
\$ 97,890.57
- Fund 46 Capital Improvements
\$ 83,493.54
- Fund 21 Activity Account
\$ 77,511.91
- Fund 72 Scholarships
\$ 93,393.14
- Fund 73 Trust Fund
\$ 261,527.66

GRANTON AREA SCHOOL DISTRICT BANK BALANCE
AS OF 6-30-2022

FUND	COMPUTER ACCOUNT	BANK STATEMENT	
FUND 10-GENERAL	10-7110	15,985.67	
FUND 21-SPECIAL REVENUE TRUST	21-7110	5,340.88	
FUND 27-PACKAGE CONTRACT	27-7110	-62,667.51	
FUND 50- FOOD SERVICE	50-7110	35,698.00	
FUND 80-COMMUNITY SERVICE	80-7110	71,772.07	
TOTAL IN GENERAL CHECKING ACCOUNT		109,710.48	
TOTAL IN RESERVE ACCOUNT		<u>356,022.56</u>	
TOTAL OF FUNDS 10,21,27,29,50 & 80		\$465,733.04	
			GENERAL \$78,206.47
			RESERVE \$387,526.57
FUND 21 TRUST AND AGENCY	21-7121	\$15,025.96	NET CASH \$465,733.04
FUND 38 & 39-DEBT SERVICE	39-7110	\$97,890.57	
FUND 46 CAPITAL IMPROVEMENTS	46-7110	\$83,493.54	
FUND 49 CONSTRUCTION PROJECT	49-71100	\$0.00	
FUND 60 ACTIVITY ACCOUNTS	21-7110	\$77,511.91	
FUND 72 SCHOLARSHIPS	72-7110	\$93,393.14	
FUND 73 EXPENDABLE TRUST FUND	73-71100	\$261,527.66	

I. REGULAR BUSINESS

I.A. Call to Order

Meeting called to order at 6:45 pm by President Theresa Hasz.

I.B. Roll Call

Doug Eichten - absent, Mark Elmhorst - here, Dennis Kuehn - here, Theresa Hasz - here, Sheryl Young - here. Also present was District Administrator James Kuchta, Principal Amanda Kraus, District Administrative Assistant Sheila Kind, and nine community/staff members.

I.C. Verification of Notice to Public

Notice to Public was posted at the Granton School, Citizen's State Bank, Granton Post Office, the school website and published in the TRG.

I.D. Pledge of Allegiance

Pledge of Allegiance was led by President Theresa Hasz.

I.E. Approval of Agenda

Motion to approve the agenda as presented. This motion, made by Dennis Kuehn and seconded by Mark Elmhorst. Voice vote. Motion carried.

I.F. Consent Agenda

Motion to approve the consent agenda, which includes minutes of the May 9, 2022 regular board meeting, minutes of the May 19, 2022 special board meeting with revision, and review of financial reports. This motion, made by Dennis Kuehn and seconded by Sheryl Young. Voice vote. Motion carried.

<u>FINANCIAL REPORT:</u>	Net of Funds 10, 21, 27, 29, 50, 80	\$ 383,507.09
	Fund 21 Trust & Agency	\$ 15,025.96
	Fund 38 & 39 Debt Service	\$ 97,867.78
	Fund 46 Capital Improvements	\$ 83,474.10
	Fund 21 Activity Account	\$ 78,583.68
	Fund 72 Scholarships	\$ 93,344.46
	Fund 73 Trust Fund	\$ 261,527.66

I.G. Other

II. STUDENT COUNCIL REPRESENTATIVE INPUT/REMARKS

There was no Student Council report this month.

III. PUBLIC COMMENTS

Community members commented on the all-day 4K program, fully utilizing all resources for providing education for students, staffing, and child care center.

IV. AGENDA ITEMS

IV.A. Check Register

Motion to approve checks 44434-44505 for \$122,139.22, Fund 21 Activity Account 20294-20325 for \$9,564.61, and payroll for \$76,620.48. This motion, made by Dennis Kuehn and seconded by Mark Elmhorst. Voice vote. Motion carried.

IV.B. Achievement Gap Reduction Report Review

Kim Aumann reviewed the Achievement Gap Reduction (AGR) report.

IV.C. 2024 Trip to Spain

Motion to approve the 2024 student trip to Spain. This motion, made by Dennis Kuehn and seconded by Sheryl Young. Voice vote. Motion carried.

IV.D. Food Service

Motion to approve the Community Eligibility Provision (CEP) Program for the 2022-23 school year. This motion, made by Mark Elmhorst and seconded by Sheryl Young. Voice vote. Motion carried.

IV.E. Board Policy Review

No school board policies were reviewed.

IV.F. Personnel

Discussion on personnel items moved to Executive Session.

V. OTHER REPORTS

V.A. School Board Committee Reports

Mark Elmhorst reported on the Granton Area School Foundation Sweet Treat Social that was held on June 11, 2022.

V.B. Principal's Report

1) End of school celebration of learning events; 2) Foreign exchange student opportunities; 3) Wisconsin RTI/DPI Recognition; 4) Summer activities.

V.C. Superintendent's Report

1) Parking lot update; 2) Granton Community Child Care Center (GCCCC) new app, Bright Wheel; 3) Sold old chrome books and iPads; 4) COPS Technology Grant application; 5) Breakfast Grant; 6) Finances update; 7) CESA 10 refund.

V.D. Other

VI. CORRESPONDENCE

There was no correspondence this month.

VII. EXECUTIVE SESSION

VII.A. Convene in Executive Session under Wisconsin Statute 19.85 (1)(c)(f)

Motion to convene in Executive Session at 7:24 pm for the purpose of discussing/taking action under Wisconsin Statute 19.85 (1)(c)(f) Considering employment, promotion, compensation or performance evaluation data of any public employee over which the governmental body has jurisdiction or exercises responsibility; considering financial, medical, social or personal histories or disciplinary data of specific persons, preliminary consideration of specific personnel problems or the investigation of charges against persons except where par. (b) applies which, if discussed in public, would be likely to have a substantial adverse effect upon the reputation of any person referred to in such histories or data, or involved in such problems or investigations. This motion, made by Sheryl Young and seconded by Dennis Kuehn. Roll call vote. Douglas Eichten: Absent, Mark Elmhorst: Yea, Theresa Hasz: Yea, Dennis Kuehn: Yea, Sheryl Young: Yea

VII.B. Return to Open Session

Motion to move from Executive Session to Regular Session at 9:59 pm. This motion, made by Mark Elmhorst and seconded by Dennis Kuehn. Roll call vote. Douglas Eichten: Absent, Mark Elmhorst: Yea, Theresa Hasz: Yea, Dennis Kuehn: Yea, Sheryl Young: Yea

School Board Treasurer Sheryl Young reported no action was taken in Executive Session.

Motion to approve the resignation of Ryan Westaby and thank him for his service. This motion, made by Dennis Kuehn and seconded by Mark Elmhorst. Voice vote. Motion carried.

Motion to approve the resignation of Kim Hokenson and thank her for her service. This motion, made by Dennis Kuehn and seconded by Sheryl Young. Voice vote. Motion carried.

Motion to approve hiring Stina Jansen for the Math Interventionist position. This motion, made by Sheryl Young and seconded by Dennis Kuehn. Voice vote. Motion carried.

Motion to approve the contract with CESA for James Kuchta's services as District Administrator. This motion, made by Sheryl Young and seconded by Dennis Kuehn. Voice vote. Motion carried.

Motion to approve addendum for Special Education Director, through CESA, for James Kuchta. This motion, made by Sheryl Young and seconded by Dennis Kuehn. Voice vote Motion carried.

Motion to approve contract for Principal Amanda Kraus for 2022-24. This motion, made by Mark Elmhorst and seconded by Dennis Kuehn. Voice vote. Motion carried.

VIII. ADJOURNMENT

Motion to adjourn at 10:07 pm. This motion, made by Sheryl Young and seconded by Dennis Kuehn. Voice vote. Motion carried.

Sheryl Young, Treasurer

Theresa Hasz, President

VENDOR	CHECK		AMOUNT	INVOICE	INVOICE
	NUMBER	DATE		NUMBER	DESCRIPTION
ADVANCE AUTO PARTS	44506	06/13/2022	106.81	2219-42300	MAIN PARTS
AMAZON WEB SERVICES	44507	06/13/2022	423.50	1047716581	MAY 2022
BASCHE, PATRICIA	44508	06/13/2022	671.00	MAY 7-JUNE	WORK HOURS IEP'S
BLUUM OF MINNESOTA,	44509	06/13/2022	2,836.00	869693	INTERACTIVE
BLUUM OF MINNESOTA,	44509	06/13/2022	17,082.00	868529	INTERACTIVE
BLUUM OF MINNESOTA,	44509	06/13/2022	5,934.00	868638	WALL MOUNT/TOUCH DISPLAY/CART/BALANCE BOX
CARQUEST AUTO PARTS	44510	06/13/2022	312.92	2219-ID-41	BUS PARTS
CESA # 10	44511	06/13/2022	57,896.75	0002200525	4TH QTR SHARED SERVICES
CESA # 10	44511	06/13/2022	10,858.87	6002200213	2ND GRANT SHARED SERVICES
CHESTNUT CONSULTING	44512	06/13/2022	1,833.33	MSP-10156	JUNE 22 BILLING
CITIZEN'S STATE BANK	44513	06/13/2022	46.00	THE MAPLE	GROWING GRANTON STRONG
CITIZEN'S STATE BANK	44513	06/13/2022	65.00	FANNIES	GROWING GRANTON STRONG/GIFTS
CITIZEN'S STATE BANK	44513	06/13/2022	59.01	TURNPIKE G	GROWING GRANTON STRONG/GIFTS
CITIZEN'S STATE BANK	44513	06/13/2022	42.00	SHEAR PERF	GROWING GRANTON STRONG/GIFTS
CITIZEN'S STATE BANK	44513	06/13/2022	65.00	MAPLEWORKS	GROWING GRANTON STRONG/GIFTS
CITIZEN'S STATE BANK	44513	06/13/2022	20.00	ROGER'S	GROWING GRANTON STRONG/GIFTS
CITIZEN'S STATE BANK	44513	06/13/2022	40.00	GRANTON CE	GROWING GRANTON STRONG/GIFTS
CITIZEN'S STATE BANK	44513	06/13/2022	55.00	LYNN DAIRY	GROWING GRANTON STRONG/GIFTS
CITIZEN'S STATE BANK	44513	06/13/2022	99.27	WAL*MART	SUMMER SCHOOL SUPPLIES-MARQUEZ
DEPARTMENT OF ADMINI	44514	06/13/2022	1,500.00	505-000006	TEACH 2ND HALF
FOLLETT SCHOOL SOLUT	44515	06/13/2022	4,500.00	10945807	LIB BOOKS
GRANTON HARDWARE	44516	06/13/2022	103.23	897636 761	CONNECTOR/TUBING/HOOKS
GRANTON PARK	44517	06/13/2022	50.00	DONATION	GROWING GRANTON STRONG/GIFTS
GRANTON BULLDOG COMM	44518	06/13/2022	45.00	TRANSFER	GROWING GRANTON STRONG/GIFTS
HUBERT COMPANY	44519	06/13/2022	373.71	727767	COLD-SELL REPLACEMENT COOLING PANEL FOR BARREL, 2PK
HUEBSCH	44520	06/13/2022	57.86	10231357	BAGS/MOPS
HUEBSCH	44520	06/13/2022	57.86	10233437	BAGS/MOPS
HUEBSCH	44520	06/13/2022	57.86	10239922	BAGS/MOPS
JOSTENS	44521	06/13/2022	247.28	N003035213	HEBERT SUPPLIES
KLEIN, DANA	44522	06/13/2022	20.00	JANEEN'S C	GROWING GRANTON STRONG/GIFTS
LAB MIDWEST	44523	06/13/2022	1,785.00	S00063	DRONE KIT
LOOKOUT BOOKS	44543	06/13/2022	317.22	ARU0331978	COLLECTION OF 20 BOOKS
MARSHFIELD BOOK & ST	44524	06/13/2022	7,722.00	361462	INTERIOR CONCEPTS RECEPTION STATION
MSA PROFESSIONAL SER	44525	06/13/2022	9,160.00	R14866002.	WETLAND SURVEY
NASSCO INC	44526	06/13/2022	145.84	6151911	FLOOR FINISH/DEFOAMER
NEILLSVILLE SCHOOL D	44527	06/13/2022	371.75	0002013	APRIL BUS SERVICE
NEILLSVILLE SCHOOL D	44527	06/13/2022	903.75	0002014	MAY BUS SERVICE
PENWORTHY COMPANY	44528	06/13/2022	1,376.92	0087262	39 BOOKS
PROVISION PARTNERS C	44529	06/13/2022	3,114.49	189025	FUEL MAY 1-31
ROGERS GROCERY	44530	06/13/2022	14.18	29235	SUMMER SCHOOL SUPPLIES-MARQUEZ
ROGERS GROCERY	44530	06/13/2022	10.56	29232	SS-MARQUEZ
ROGERS GROCERY	44530	06/13/2022	42.36	29206	5-18 GROC/ENRICH
ROGERS GROCERY	44530	06/13/2022	36.72	28283	GROC/ENRICH-5-10 & 11
ROGERS GROCERY	44530	06/13/2022	8.63	29210	FREEZER BAGS
SELK ELECTRONICS	44531	06/13/2022	455.00	114777	MIC WIRING
SKYWARD ACCOUNTING D	44532	06/13/2022	200.00	SIGNS	E-SIGN FOR CHECKS
STREY, LINDSEY	44533	06/13/2022	60.00	183101	GROWING GRANTON STRONG/GIFTS
SUPREME SCHOOL SUPPL	44534	06/13/2022	70.02	142717	HIGH SCHOOL SUPPLIES
THE LIFE GUARD STORE.	44535	06/13/2022	333.30	INV0011879	SWIMMING PROGRAM SUPPLIES
TP PRINTING COMPANY	44536	06/13/2022	474.61	196345	MAY 2022 ADV
TRIMLINE LAWN CARE L	44537	06/13/2022	1,465.00	1650 1640	LAWN TREATMENT GRASS CUTTING

21-22 FY

VENDOR	CHECK		AMOUNT	INVOICE	INVOICE
	NUMBER	DATE		NUMBER	DESCRIPTION
WE ENERGIES	44538	06/13/2022	448.08	0708921108	GAS-MAY 22
WISCONSIN BUS SALES	44539	06/13/2022	184.24	06BP48870	BUS PARTS
WISCONSIN VALLEY LIB	44540	06/13/2022	2,000.00	2022-2161	EBOOKS
WOLLER, ANNETTE	44541	06/13/2022	89.83	REMBSE	SUMMER SCHOOL SUPPLIES
XCEL ENERGY	44542	06/13/2022	4,487.44	783215542	MAY 9-JUNE 8
AMAZON	44544	06/15/2022	46.69	5449653445	MAGNETIC WHITE BOARD
AMAZON	44544	06/15/2022	179.98	7659389367	HORSHOD PONYO OFFICE CHAIR
AMAZON	44544	06/15/2022	12.79	7566544636	FUSE KIT
AMAZON	44544	06/15/2022	81.95	5738884466	6 INCH MIDDLE BLACK PLASTIC POTS
AMAZON	44544	06/15/2022	327.61	6883573666	GLOVES
AMAZON	44544	06/15/2022	252.97	6658883535	TECH SUPPLIES
AMAZON	44544	06/15/2022	285.81	6447477583	SWIMMING SUPPLIES
AMAZON	44544	06/15/2022	21.48	9654678844	ICE MACHINE CLEANER
AMAZON	44544	06/15/2022	13.74	7978875478	TECH SUPPLIES
AMAZON	44544	06/15/2022	82.62	5937886936	DRAWING PAPER-DC 624
AMAZON	44544	06/15/2022	249.99	114-353418	CLIMBER-DAYCARE 624
AMAZON	44544	06/15/2022	304.99	114-192259	CABINET-DC 624
AMAZON	44544	06/15/2022	48.99	114-263471	CABINET-DC 624
AMAZON	44544	06/15/2022	57.48	114-269557	MASKS-DC 624
BAUERNFEIND BUSINESS	44545	06/15/2022	58.79	INV136517	TONER
BERNIES EQUIPMENT CO	44546	06/15/2022	628.23	357542	ANNUAL INSPECTION
BOARDMAN & CLARK LLP	44547	06/15/2022	4,640.50	251926	LEGAL
BURT TROPHY & AWARDS	44548	06/15/2022	69.95	25300	TROPHY
BUSHMAN DAIRY DIST I	44549	06/15/2022	8.20	L-410137	DAIRY SUPPLIES
BUSHMAN DAIRY DIST I	44549	06/15/2022	8.10	L-410106	DAIRY SUPPLIES
BUSHMAN DAIRY DIST I	44549	06/15/2022	8.10	L-410033	DAIRY SUPPLIES
BUSHMAN DAIRY DIST I	44549	06/15/2022	8.10	L-409974	DAIRY SUPPLIES
BUSHMAN DAIRY DIST I	44549	06/15/2022	5.30	L-410091	DAIRY
CESA # 10	44550	06/15/2022	525.00	4002200100	DIAGNOSTIC MAIN FOR DL EQUIP
CHESTNUT CONSULTING	44551	06/15/2022	1,833.33	MSP-10007	MAY SERVICES
CITIZEN'S STATE BANK	44552	06/15/2022	68.26	WAL	SS SUPPLIES-MARQUEZ
CITIZEN'S STATE BANK	44552	06/15/2022	125.28	WAL.	KITS FOR SPANISH CLUB TRAVEL
CLARK COUNTY PUBLIC	44553	06/15/2022	150.00	138 HSAT-7	LICENSE FEE
CLARK COUNTY PUBLIC	44553	06/15/2022	440.00	138 HSAT-7	SCHOOL INSPECTION
COMPLETE CONTROL INC	44554	06/15/2022	1,356.35	SRVCE04552	REPLACED BLOWER MOTOR THERMOSTAT IN HS OFFICE
COMPLETE CONTROL INC	44554	06/15/2022	9,930.00	PB1152	KITCHEN VENTILATION
GUMDROP BOOKS	44555	06/15/2022	1,633.66	PINV133629	LIB BOOKS
INDIANHEAD FOOD SERV	44556	06/15/2022	1,393.88	INV-291300	FOOD SUPPLY
INDIANHEAD FOOD SERV	44556	06/15/2022	188.59	INV-291292	FOOD SUPPLY
INDIANHEAD FOOD SERV	44556	06/15/2022	303.84	INV-291296	FOOD SUPPLY
INDIANHEAD FOOD SERV	44556	06/15/2022	654.51	INV-291305	FOOD SUPPLY
INDIANHEAD FOOD SERV	44556	06/15/2022	431.52	INV-293616	FOOD SUPPLY
INDIANHEAD FOOD SERV	44556	06/15/2022	105.07	INV-293617	FOOD SUPPLY
INDIANHEAD FOOD SERV	44556	06/15/2022	480.67	INV-293624	FOOD SUPPLY
INDIANHEAD FOOD SERV	44556	06/15/2022	3,286.55	INV-293629	FS-DAYCARE
INDIANHEAD FOOD SERV	44556	06/15/2022	422.54	INV-289017	BREAK SUPPLY
INDIANHEAD FOOD SERV	44556	06/15/2022	597.47	INV-286641	LUNCH SUPPLY
INDIANHEAD FOOD SERV	44556	06/15/2022	84.36	INV-286639	LUNCH SUPPLY
INDIANHEAD FOOD SERV	44556	06/15/2022	7.00	INV-286640	LUNCH SUPPLY
INDIANHEAD FOOD SERV	44556	06/15/2022	449.36	INV-286655	LUNCH SUPPLY
INDIANHEAD FOOD SERV	44556	06/15/2022	1,374.97	INV-286660	LUNCH SUPPLY
INDIANHEAD FOOD SERV	44556	06/15/2022	3,552.46	INV-291298	SUMMER SCHOOL FOOD
INDIANHEAD FOOD SERV	44556	06/15/2022	599.98	INV-293626	SUMMER SCHOOL FOOD
INDIANHEAD FOOD SERV	44556	06/15/2022	988.51	INV-295410	SUMMER SCHOOL FOOD

VENDOR	CHECK		AMOUNT	INVOICE	INVOICE
	NUMBER	DATE		NUMBER	DESCRIPTION
JOSTENS	44557	06/15/2022	18.89	28636140	COVERS FOR DIPLOMAS
JOSTENS	44557	06/15/2022	16.18	28768854	DIPLOMAS
KOWAL, JENNIFER	44558	06/15/2022	20.00	REMBSE	HAIRCUT 6-8-22
MENARDS	44559	06/15/2022	71.62	41629	ROEHL SUPPLIES
MISSISSIPPI WELDERS	44560	06/15/2022	39.06	1468099	TANK RENTAL
NAPA MARSHFIELD	44561	06/15/2022	57.48	401898	HORN-BUS
NDSM HOLDINGS, LLC	44562	06/15/2022	386.33	781365	MILK ORDER
NDSM HOLDINGS, LLC	44562	06/15/2022	212.84	781163	MILK ORDER
NDSM HOLDINGS, LLC	44562	06/15/2022	556.65	781131	MILK ORDER
NDSM HOLDINGS, LLC	44562	06/15/2022	418.54	781248	MILK ORDER
ROBERT W BAIRD & CO	44563	06/15/2022	500.00	PF-2200277	MINI WORKSHOPS
ROGERS GROCERY	44564	06/15/2022	30.87	29205	SPANISH CLUB SUPPLIES
SCHMITT MUSIC	44565	06/15/2022	19.79	4636729	REEDS
SCHOOL DISTRICT OF B	44566	06/15/2022	3,404.07	2021-010	21-22 HOCKEY COOP FEES
SUDA PLUMBING	44567	06/15/2022	553.60	14599	INSPECTION-BACKFLOW PREVENTER
SYMMETRY ENERGY SOLU	44568	06/15/2022	1,229.34	13622574	MAY 2022
VONBRIESEN.COM	44569	06/15/2022	5,192.00	393045	LEGAL
WASB	44570	06/15/2022	420.26	93110 9321	LEGAL
WISCONSIN DRUG TESTI	44571	06/15/2022	535.50	50948	BACK CHECK 5-22
CITIZEN'S STATE BANK	44572	06/21/2022	690.00	20220603AD	Payroll accrual
CITIZEN'S STATE BANK	44572	06/21/2022	690.00	20220617AD	Payroll accrual
CITIZEN'S STATE BANK	44574	06/21/2022	690.00	20220630AD	Payroll accrual
CITIZEN'S STATE BANK	44572	06/21/2022	690.00	20220602BD	Payroll accrual
CITIZEN'S STATE BANK	44572	06/21/2022	690.00	20220602CD	Payroll accrual
CITIZEN'S STATE BANK	44572	06/21/2022	30.00	20220617BD	Payroll accrual
GURSTEL LAW FIRM	44573	06/21/2022	27.02	6-17-22 PA JK 389829103	GARN
CITIZEN'S STATE BANK	44575	06/22/2022	358.77	ARC755735	LIFEGUARD PARTICIPANT MANUAL
CITIZEN'S STATE BANK	44575	06/22/2022	46.55	PICK N SAV	ROGGENBAUER SUPPLIES
CITIZEN'S STATE BANK	44575	06/22/2022	1,390.00	BRIGHTWHEEL	NICKEL SUB-GRANT
CITIZEN'S STATE BANK	44575	06/22/2022	52.97	GRANTON CE	TRACK PARTY
CITIZEN'S STATE BANK	44575	06/22/2022	21.98	FLEET FARM	WIRE CLIPS-GARDEN
CITIZEN'S STATE BANK	44575	06/22/2022	15.00	ABBYLAND	SPITS-RETIREMENT MTG
CITIZEN'S STATE BANK	44575	06/22/2022	41.51	KWIK TRIP	COLOR RUN SUPPLIES
INDIANHEAD FOOD SERV	44576	06/22/2022	16.53	252686 SP	SHORT PAY INVOICE
INDIANHEAD FOOD SERV	44576	06/22/2022	-13.35	CM-39150	CREDIT ON ACCOUNT
GRANTON SCHOOL FS	44578	06/23/2022	1,018.65	LUNCHES	TEACHER SUBS
HILL ROAD LLC	44580	06/23/2022	7,200.00	1062	EXCAVATING
HILL ROAD LLC	44580	06/23/2022	3,000.00	1063	REMOVE STUMPS BEHIND SCHOOL SHOP
LAB MIDWEST	44582	06/23/2022	1,235.00	BALANCE	PO 0012200239
T-MOBILE	44583	06/23/2022	30.00	972889166	HOTSPOTS 6-22
WI DPI	44584	06/23/2022	500.00	255-000004	WIS IMPROVEMENT PROGRAM
AMAZON	44585	06/30/2022	-103.96	114-531690	CREDIT-ADAPTER
AMAZON	44585	06/30/2022	786.24	0012200290	COLOR RUN SUPPLIES
AT&T	44589	06/30/2022	551.26	1808899603	MAY 22 SERVICES
B&D LIQUID WASTE HAU	44590	06/30/2022	110.00	06012022	PORT TOILET
BLUUM OF MINNESOTA,	44591	06/30/2022	1,418.00	870789	WALL MOUNT/TOUCH DISPLAY/CART/BALANCE BOX
BOARDMAN & CLARK LLP	44592	06/30/2022	5,842.50	253049	0004 LEGAL MATTER
BRACK THERMAL SYSTEM	44593	06/30/2022	6,430.00	06152022	ASBESTOS
BUSHMAN DAIRY DIST I	44594	06/30/2022	8.20	L-410167	DAIRY
CDW-G	44595	06/30/2022	2,159.19	BB09785	WORKSTATION/MONITOR
CESA # 10	44596	06/30/2022	530.00	2002200511	3YR-AHERA INSPECT/REPORTING
CESA # 10	44596	06/30/2022	4,416.15	6002200243	ELEM/SEC AIDE
CESA # 6	44597	06/30/2022	1,000.00	39839	CMS4SCHOOLS TOUCH SETUP FEE
CITIZEN'S STATE BANK	44586	06/30/2022	16.77	SALLY BEAU	ROGGENBAUER SUPPLIES

VENDOR	CHECK		AMOUNT	INVOICE	INVOICE
	NUMBER	DATE		NUMBER	DESCRIPTION
COMPLETE CONTROL INC	44598	06/30/2022	7,188.80	JC10225	PHASE 4 CONTROLS
COMPLETE CONTROL INC	44598	06/30/2022	7,772.00	JC10235	BOILER ROOM-HVAC UPGRADE
COMPLETE CONTROL INC	44598	06/30/2022	37,792.50	JC10243	PHASE 3-1955 ADDITION
COMPLETE CONTROL INC	44598	06/30/2022	24,223.70	JC10244	APP 1-1991 ADDITION
COMPLETE CONTROL INC	44598	06/30/2022	25,707.40	PB1175	PHASE 5-1990 ADDITION
COMPLETE CONTROL INC	44598	06/30/2022	7,586.00	PB1177	APP 6-CLASSROOM UNIT VENTS
COMPLETE CONTROL INC	44598	06/30/2022	7,229.25	PB1181	PHASE 3 0-1955 ADD
DELTA DENTAL OF WI	44587	06/30/2022	899.84	20220603AF	Payroll accrual
DELTA DENTAL OF WI	44587	06/30/2022	91.71	20220603AF	Payroll accrual
DELTA DENTAL OF WI	44587	06/30/2022	899.84	20220617AF	Payroll accrual
DELTA DENTAL OF WI	44587	06/30/2022	91.71	20220617AF	Payroll accrual
DELTA DENTAL OF WI	44587	06/30/2022	899.84	20220630AF	Payroll accrual
DELTA DENTAL OF WI	44587	06/30/2022	91.71	20220630AF	Payroll accrual
DELTA DENTAL OF WI	44587	06/30/2022	91.71	20220602AF	Payroll accrual
DELTA DENTAL OF WI	44587	06/30/2022	899.84	20220602BF	Payroll accrual
DELTA DENTAL OF WI	44587	06/30/2022	91.71	20220602BF	Payroll accrual
DELTA DENTAL OF WI	44587	06/30/2022	899.84	20220602CF	Payroll accrual
DELTA DENTAL OF WI	44587	06/30/2022	91.71	20220602CF	Payroll accrual
DELTA DENTAL OF WI	44587	06/30/2022	532.14	20220603BF	Payroll accrual
DELTA DENTAL OF WI	44587	06/30/2022	97.18	20220603BF	Payroll accrual
DELTA DENTAL OF WI	44587	06/30/2022	327.79	20220617BF	Payroll accrual
DELTA DENTAL OF WI	44587	06/30/2022	91.72	20220617BF	Payroll accrual
EAST SIDE JERSEY DAI	44599	06/30/2022	157.96	9070967	MILK
EAST SIDE JERSEY DAI	44599	06/30/2022	110.36	9067549	MILK
ECOLAB PEST	44600	06/30/2022	170.33	7104467	PEST CONTROL
EID, MARY	44601	06/30/2022	104.00	MILES	JUNE 15-29
FOLLETT LIBRARY RESO	44602	06/30/2022	100.43	501884	LIB BOOKS
GRANTON FFA ALUMNI	44604	06/30/2022	425.88	JUNE 12-15	FFA RETREAT
GRANTON HARDWARE	44605	06/30/2022	51.85	771944	PAINT/ROLLER/GLOVES/APPLIANCE CORD
GREENWOOD SCHOOL	44606	06/30/2022	240.00	22002	SHARED ROOM AG CONF
GROSS MOTORS INC	44607	06/30/2022	54.60	SO475336	OIL CHANGE
GURSTEL LAW FIRM	44608	06/30/2022	55.59	GARN PMT	389829103 JK
HANDT ELECTRIC	44609	06/30/2022	227.97	751	CONTROLLERS IN FIELDHOUSE
HUEBSCH	44610	06/30/2022	51.68	10246270	MAIN SUPPLIE
INDIANHEAD FOOD SERV	44611	06/30/2022	234.97	INV-298690	SUMMER SCHOOL SUPPLIES
INDIANHEAD FOOD SERV	44611	06/30/2022	674.82	INV-301617	SUMMER SCHOOL SUPPLIES
INDIANHEAD FOOD SERV	44611	06/30/2022	810.75	INV-298687	SUMMER SCHOOL SUPPLIES
INDIANHEAD FOOD SERV	44611	06/30/2022	449.68	INV-298686	SUMMER SCHOOL SUPPLIES
INDIANHEAD FOOD SERV	44611	06/30/2022	629.14	INV-300143	SUPPLIES FOR KIT
JANSEN, STINA	44612	06/30/2022	49.74	REMBSE	SS SUPPLIES-RUSSELL'S/FAMILY FARE
JBC SCREENPRINTING	44613	06/30/2022	124.98	13240	T-SHIRTS/GARMENTS-GGS
KIND, SHEILA	44614	06/30/2022	18.98	REMBSE-HAR	DOLLY FOR FILE CABINET
KUCHTA, JAMES	44615	06/30/2022	77.22	MAY 26-JUN	SPITS/MSTC
LAKEVIEW BOOKS	44616	06/30/2022	571.19	ARU0338957	31 BOOKS
LEGEND TECHNICAL SER	44617	06/30/2022	1,419.42	22WI084	ASBESTOS PROJECT
MADISON NATIONAL LIF	44588	06/30/2022	134.36	20220603AF	Payroll accrual
MADISON NATIONAL LIF	44588	06/30/2022	134.52	20220617AF	Payroll accrual
MADISON NATIONAL LIF	44588	06/30/2022	134.52	20220630AF	Payroll accrual
MADISON NATIONAL LIF	44588	06/30/2022	134.52	20220602BF	Payroll accrual
MADISON NATIONAL LIF	44588	06/30/2022	134.52	20220602CF	Payroll accrual
MADISON NATIONAL LIF	44588	06/30/2022	91.51	20220603BF	Payroll accrual
MADISON NATIONAL LIF	44588	06/30/2022	64.58	20220617BF	Payroll accrual
MID-STATE TRUCK	44618	06/30/2022	552.01	301077	SENSOR REPAIR/LABOR
MID-STATE TRUCK	44618	06/30/2022	1,275.28	301618	REPAIR/LABOR

VENDOR	CHECK		AMOUNT	INVOICE	
	NUMBER	DATE		NUMBER	DESCRIPTION
NEILLSVILLE SCHOOL D	44619	06/30/2022	4,694.85	0002019	CO-OP MS GB/BB CO-OP MSGSB CO-OP HS BASEBALL
OAK RIDGE CHEMICAL I	44620	06/30/2022	672.71	076390	VACUUM KIT/BAGS
OAK RIDGE CHEMICAL I	44620	06/30/2022	2,367.00	076279	VACUUM KIT/BAGS
PIONEER VALLEY BOOKS	44621	06/30/2022	122.10	I225929	TITLE 1 SUPPLIES
ROGERS GROCERY	44622	06/30/2022	14.67	29234	SUMMER SCHOOL SUPPLIES
ROGERS GROCERY	44622	06/30/2022	17.60	28644	ENRICH CLASS
ROGERS GROCERY	44622	06/30/2022	3.98	29722	KITCH GROCS
ROGERS GROCERY	44622	06/30/2022	6.58	29201	KIT GROCS 5-2-22
ROGERS GROCERY	44622	06/30/2022	21.24	29658	SUPPLIES FOR ADMIN
SCHOFIELD, AMANDA	44623	06/30/2022	37.70	REMBSE-WAL	THANK YOU CARDS-GGS
SECURITY HEALTH PLAN	44624	06/30/2022	22,738.46	20220520AF	Payroll accrual
SECURITY HEALTH PLAN	44624	06/30/2022	3,063.85	20220520AF	Payroll accrual
SECURITY HEALTH PLAN	44624	06/30/2022	13,742.00	20220603AF	Payroll accrual
SECURITY HEALTH PLAN	44624	06/30/2022	1,283.56	20220603AF	Payroll accrual
SECURITY HEALTH PLAN	44624	06/30/2022	13,742.00	20220617AF	Payroll accrual
SECURITY HEALTH PLAN	44624	06/30/2022	1,283.56	20220617AF	Payroll accrual
SECURITY HEALTH PLAN	44624	06/30/2022	13,742.00	20220630AF	Payroll accrual
SECURITY HEALTH PLAN	44624	06/30/2022	1,283.56	20220630AF	Payroll accrual
SECURITY HEALTH PLAN	44624	06/30/2022	13,742.00	20220602AF	Payroll accrual
SECURITY HEALTH PLAN	44624	06/30/2022	1,283.56	20220602AF	Payroll accrual
SECURITY HEALTH PLAN	44624	06/30/2022	13,742.00	20220602BF	Payroll accrual
SECURITY HEALTH PLAN	44624	06/30/2022	1,283.56	20220602BF	Payroll accrual
SECURITY HEALTH PLAN	44624	06/30/2022	13,742.00	20220602CF	Payroll accrual
SECURITY HEALTH PLAN	44624	06/30/2022	1,283.56	20220602CF	Payroll accrual
SECURITY HEALTH PLAN	44624	06/30/2022	8,996.46	20220603BF	Payroll accrual
SECURITY HEALTH PLAN	44624	06/30/2022	1,780.29	20220603BF	Payroll accrual
SECURITY HEALTH PLAN	44624	06/30/2022	4,606.64	20220617BF	Payroll accrual
SECURITY HEALTH PLAN	44624	06/30/2022	1,250.64	20220617BF	Payroll accrual
US POSTAL SERVICE	44625	06/30/2022	1,650.70	E90293150	ENVELOPE ORDER
VERIZON WIRELESS	44626	06/30/2022	320.14	MAY 24-JUN	SERVICES
VONBRIESEN.COM	44627	06/30/2022	4,188.10	394424	045679-00001 LEGAL MATTER
WALTER, CAROLINE	44628	06/30/2022	60.00	REMBSE	GAS FOR TRIP
WAUSAU CHEMICAL CORP	44629	06/30/2022	2,979.18	INV-327029	POOL SUPPLIES
WOLLER, ANNETTE	44630	06/30/2022	90.62	REMBSE	GAS FOR TRIP
Totals for checks			517,291.89		

FUND SUMMARY

<u>FUND</u>	<u>DESCRIPTION</u>	<u>BALANCE SHEET</u>	<u>REVENUE</u>	<u>EXPENSE</u>	<u>TOTAL</u>
10	GENERAL FUND	129,559.28	0.00	287,842.70	417,401.98
21	TRUST FUNDS	0.00	0.00	238.10	238.10
27	SPECIAL EDUCATION	10,283.45	0.00	57,518.40	67,801.85
50	FOOD SERVICE FUND	1,815.17	0.00	20,280.55	22,095.72
80	COMMUNITY SERVICE FUND	1,421.23	0.00	8,333.01	9,754.24
*** Fund Summary Totals ***		143,079.13	0.00	374,212.76	517,291.89

***** End of report *****

VENDOR	CHECK		AMOUNT	INVOICE	
	NUMBER	DATE		NUMBER	DESCRIPTION
CITIZEN'S STATE BANK	20326	06/02/2022	27.50	TURNPIKE G	CLASS OF 22 GRADUATION
FRIEMOTH, FAYE	20327	06/02/2022	120.95	STORE SALE	FEB 5-MAY 7
GRANTON PTO	20328	06/02/2022	25.00	STORE SALE	LONG SLEEVE SHIRT
HALL, LOIS	20329	06/02/2022	28.50	STORE SALE	T-SHIRTS
KUHEN, JEANNIE	20330	06/02/2022	12.83	STORE SALE	SCARF/MAGNETS
MCCONKEY, THERESA	20331	06/02/2022	34.23	STORE SALE	FEB 5-APR 2
PREMIER PRINTING	20332	06/02/2022	220.00	45613	SENIOR YARD SIGNS
STREY, LINDSEY	20333	06/02/2022	9.50	STORE SALE	SMALL BLUE BOWL
WOLLER, ANNETTE	20334	06/02/2022	72.18	REMBSE	YEARBOOKS
GRANTON AREA SCHOOL	20335	06/08/2022	20.00	REMBSE	KITCHEN-ACADEMIC AWARDS NIGHT
GRANTON FFA ALUMNI	20336	06/08/2022	500.00	REMBSE	UNITY BANK-FFA DAIRY BREAKFAST
KRAUS, AMANDA	20337	06/08/2022	72.76	REMBSE	PICK N SAVE-ACADEMIC AWARDS NIGHT
GRANTON FFA ALUMNI	20338	06/21/2022	38.17	REMBSE	WALMART-SCRAPBOOK
JOSTENS	20339	06/21/2022	1,242.87	1298750	YEARBOOKS
REIDER, KATHRYN	20340	06/21/2022	43.75	REMBSE	CHAPTER BOOTH/RAFFLE BASKET
TEAM SPORTING GOODS	20341	06/21/2022	1,221.00	AAG023369	APPAREL-GRANTON STORE
CITIZEN'S STATE BANK	20342	06/22/2022	141.48	WALMART	TABLE TENNIS-MARQUEZ
Totals for checks			3,830.72		

FUND SUMMARY

<u>FUND</u>	<u>DESCRIPTION</u>	<u>BALANCE SHEET</u>	<u>REVENUE</u>	<u>EXPENSE</u>	<u>TOTAL</u>
21	TRUST FUNDS	0.00	0.00	3,830.72	3,830.72
*** Fund Summary Totals ***		0.00	0.00	3,830.72	3,830.72

***** End of report *****

22-23 PY

VENDOR	CHECK CHECK		AMOUNT	INVOICE	INVOICE
	NUMBER	DATE		NUMBER	DESCRIPTION
1ST AGENCY	44631	07/05/2022	4,012.00	4243149	NEW BUSINESS PREMIUM
ASSOCIATION FOR EQUI	44632	07/05/2022	125.00	0-250 STUD	22-23 RENEWAL MEMBERSHIP
AWSA-WFEA	44633	07/05/2022	765.00	27979	MEMBERSHIP RENEWAL
CEV	44634	07/05/2022	870.00	QTE044777	AG INSTR RENEW
CITIZEN'S STATE BANK	44635	07/05/2022	30.00	20220701AD	Payroll accrual
EMC INSURANCE COMPAN	44636	07/05/2022	4,778.77	7000325618	WC/COMM/AUTO/LIAB INS
FIRE & SAFETY EQUIPM	44637	07/05/2022	890.42	62408	ANNUAL FIRE EXT SERVICE
INTEGRATED SYSTEMS C	44638	07/05/2022	2,400.00	0724490	SKYWARD HOSTING 22-23
NASSP	44639	07/05/2022	385.00	9001580967	NATIONAL HONOR SOCIETY AFFILIATION
SECURITY HEALTH PLAN	44647	07/05/2022	212.76	ARACO21311	WILLIAMS, D
SECURITY HEALTH PLAN	44647	07/05/2022	241.15	ARACO21311	WILLIAMS, G
SERGEANT LABORATORIE	44640	07/05/2022	3,197.17	051322-AH	LICENSE 22-23
SKYWARD ACCOUNTING D	44641	07/05/2022	4,542.00	0000218495	LICENSES-22-23
WASB	44642	07/05/2022	145.00	27103	WI SCHOOL LAWS SUB
WASB	44642	07/05/2022	2,347.00	26405	WASB MEMBERSHIP DUES 22-23
WASBO	44643	07/05/2022	260.00	20223126	WASBO DISTRICT PROF MEMBERSHIP
WASDA	44644	07/05/2022	275.00	200011844	SUMMER LEGAL REG FEE-
WASPA	44645	07/05/2022	1,290.00	5461	MEMBERSHIP RENEWAL
WIRSA	44646	07/05/2022	500.00	22-23	WIRSA MEMBERSHIP
Totals for checks			27,266.27		

FUND SUMMARY

<u>FUND</u>	<u>DESCRIPTION</u>	<u>BALANCE SHEET</u>	<u>REVENUE</u>	<u>EXPENSE</u>	<u>TOTAL</u>
10	GENERAL FUND	30.00	0.00	27,236.27	27,266.27
*** Fund Summary Totals ***		30.00	0.00	27,236.27	27,266.27

***** End of report *****

BENEFIT EXPENDITURES-PAYROLL

June 3, 2022 Payroll

Medicare	\$ 1,209.98
FICA	\$ 5,173.66
WRS	\$ 5,638.82
Dental	\$ 1,620.87
Health	\$ 25,802.31
LTD	<u>\$ 225.87</u>
	\$39,671.51

June 17, 2022 Payroll

Medicare	\$ 1,400.82
FICA	\$ 5,989.59
WRS	\$ 6,458.58
Dental	\$ 1,628.22
Health	\$ 20,882.84
LTD	<u>\$ 199.10</u>
	\$36,559.15

AMOUNT TO BE APPROVED:

07-11-2022

FUND10-80-GENERAL \$544,558.16

FUND 21-ACTIVITY \$3,830.72

**GENERAL 44506-44647
ACTIVITY 20326-20342**

The following are the Academic Standards utilized by the Granton Area School District for the 2022-2023 school year:

Common Core Standards

Wisconsin Standards

Next Generation Science Standards

Wisconsin eSchool Network Standards

Odysseyware Standards

GRANTON Elementary School PARENT AND STUDENT HANDBOOK 2022-2023



Welcome to....

Granton Elementary School

Dear Granton Community,

It is with great excitement that we welcome you to the start our 2022-2023 Granton Elementary School Year! The teachers and staff at Granton Elementary are a skilled team who enjoy working with students and are dedicated to supporting the vision and mission of the Granton Area School District.

We offer amazing opportunities for all students to be successful in every aspect of their lives and we hope our students take advantage of every program, course, activity and sport that can maximize their educational involvement.

We know a strong partnership with you will make a difference in your child's education. As partners, we share the responsibility for your child's success and want you to know we will do our very best to carry out our responsibilities. As parents, we hope you continually encourage and support your child to be involved as they embark on their once in a lifetime school journey. Please use this parent/student handbook (also available on our website), communication with our teachers and staff, and an open invitation to visit us to learn more about the wonderful opportunities available with Granton Schools.

An amazing school year awaits your child! On behalf of our Elementary School faculty and staff; *Thank you for your partnership in your child's learning and welcome to the 2022-2023 School Year!*



Table Of Contents



Granton Area School District Educational Philosophy and Goals.....4-5

Non-Discrimination Policy.....5-6

Daily Elementary Schedules.....6

School Calendar.....7

Academic Information.....8-9

Attendance Information.....10-14

Behavior Information.....15-22

General Information.....22-34

Questions.....35

Nondiscrimination Statement: The Granton Area School District complies with all state and federal laws and regulations prohibiting discrimination, and with all requirements and regulations of the Department of Public Instruction of the State of Wisconsin and U.S. Department of Education. It is the policy of the Granton Area School District that no person, on the basis of sex, race, religion, color, national origin (including a student whose primary language is not English), ancestry, creed, pregnancy, parental status, marital status, sexual orientation, or physical, mental, emotional or learning disability shall be discriminated against, excluded from participation in, or denied the benefit of any curricular, extra-curricular, pupil services, recreational or other program or activity, or employment, for which it is responsible.

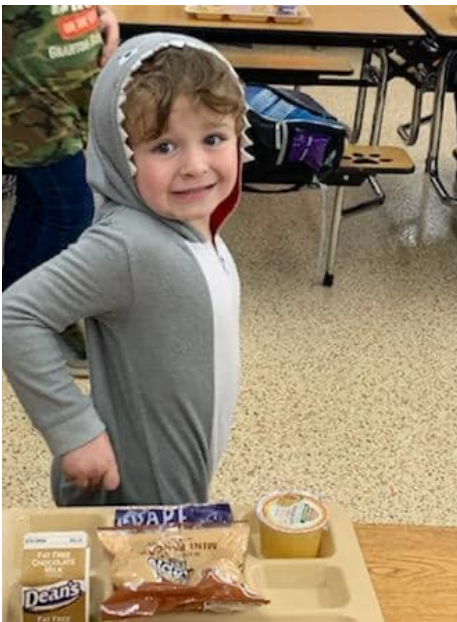

Educational Philosophy and Goals

As per Granton Area School District Board Policy code Chapter 1: Section B

Interests, attitudes, skills and habits developed during the school years of a person's life greatly influence the individual's behavior as an adult. The educational opportunities provided at Granton Area Schools are designed to enable students to gain knowledge, work skills, learn acceptable social concepts, and develop appreciations and values, which shall help them become responsible members of their community.

The opportunity to participate in the programs of the school shall be extended to all residents of the community provided statutory and school board regulations and requirements have been fulfilled. For the individual to realize maximum benefits from these programs, the student must be willing to accept the responsibilities, which go along with the educational privileges.

All aspects of the school's program of studies and activities shall be concerned with the total development of the individual student. It is recognized that students have differing interests, needs, and abilities. Therefore, course offerings, school activities, and teaching methods shall be planned which will

enable each student to develop according to his or her capability. Every effort shall be made to help the students experience success in their search for personal improvement.

The goals of education may best be achieved through cooperation and understanding among students, parents, faculty and members of the community. The working relationships shall be purposeful and business-like with mutual respect for individuals and their ideas, accomplishments and objectives. Each person involved in the educational process shall work towards the overall goal of maximum educational advancement for each child.

Therefore, we believe the district goals to be to:

1. Provide a safe learning environment.
2. Provide a well-rounded curriculum for teaching students the fundamentals that will prepare them for a four-year college, technical college, or the work world.
3. Provide a learning environment that will maximize the potential of all students.
4. Provide opportunities to develop each student's imagination, creativity and constructive and critical thinking.
5. Provide the skill each student needs to become a functioning, self-supporting, productive adult.
6. Provide opportunities that showcase the importance of a lifelong love for learning.
7. Provide opportunities to share their own cultures and to be aware of other cultural expressions and heritage.

8. Provide opportunities to develop an awareness of our political system starting at the school level and moving through all levels of government.
9. Provide opportunities to develop knowledge and responsibility concerning global resources.
10. Provide opportunities for career education and occupational awareness.
11. Provide the opportunity to develop each individual's abilities, goals, and self-concept.

Non-Discrimination Policy

As per Granton Area School District Board Policy Chapter 1: Section C & D

The Granton Area School District complies with all state and federal laws and regulations prohibiting discrimination, and with all requirements and regulations of the Department of Public Instruction of the State of Wisconsin and the U.S. Department of Education. It is the policy of the Granton Area School District that no person, on the basis of sex, race, religion, color, national origin (including a student whose primary language is not English), ancestry, creed, pregnancy, parental status, marital status, sexual orientation, or physical, mental, emotional or learning disability shall be discriminated against, excluded from participation in, or denied the benefit of any curricular, extra-curricular, pupil services, recreational or other program or activity, or employment, for which it is responsible.

DISCRIMINATION COMPLAINT PROCEDURE

If any person believes that the Granton Area School District, or any part of the school organization has inadequately applied the principles and/or regulations of Titles VI, IX, s118.13, Wis. Stats., or Section 504 or is in some way discriminatory on the basis of sex, race, religion, color, national origin (including Limited English Proficiency), ancestry, creed, pregnancy, parental status, marital status, sexual orientation, or physical, mental, emotional, or learning disability, he/she may bring forward a complaint to the office of the District Administrator in the Granton Area School District office at 217 North Main St., Granton, Wisconsin 54436.

INFORMAL PROCEDURE

The person who believes he/she has a valid basis for complaint shall discuss the concern with the District Administrator, who shall in turn investigate the complaint and reply to the complainant in writing within five (5) business days. If this reply is not acceptable to the complainant, he/she may initiate formal procedures according to the steps listed below.

FORMAL NON-DISCRIMINATION COMPLAINT PROCEDURE

STEP 1: A written statement of the grievance shall be prepared by the complainant and signed. This grievance shall be presented to the District Administrator within five (5) business days of receipt of the written reply to the informal complaint. The District Administrator shall further investigate the matters of the grievance and reply in writing to the complainant within five (5) business days by certified mail.

FORMAL NON-DISCRIMINATION COMPLAINT PROCEDURE; CONTINUED

- STEP 2: If the complainant remains unsatisfied, he/she may appeal through a signed, written statement to the Board of Education within five (5) business days of her/his receipt of the District Administrator's response in step 1. In an attempt to resolve the grievance, the Board of Education shall meet with the concerned parties and their representatives within fifteen (15) business days of the receipt of such an appeal. A copy of the Board's disposition of the appeal shall be sent by the Board Secretary to each concerned party within ten (10) business days of this meeting by certified mail.
- STEP 3: If a complainant wishes to appeal a negative determination by the Board regarding S.118.23, he/she has the right to appeal the decision to the State Superintendent within thirty (30) days of the Board's decision. In addition, the complainant may appeal directly to the State Superintendent if the Board has not provided written acknowledgement within forty-five (45) days of receipt of the complaint or made a determination within ninety (90) days of receipt of the written complaint. Appeals should be addressed to: State Superintendent, Wisconsin Department of Public Instruction, P.O. Box 7841, Madison, Wisconsin 53707-7841.
- STEP 4: If, at this point, the grievance has not been satisfactorily settled, further appeal may be made to the Office of Civil Rights, U.S. Department of Education, Citigroup Center, 500 W Madison St - Suite 1475, Chicago, IL 60661-4544.

Nothing in this procedure shall preclude individual from filing a complaint directly with the Office of Civil Rights at the address above as authorized by federal law.

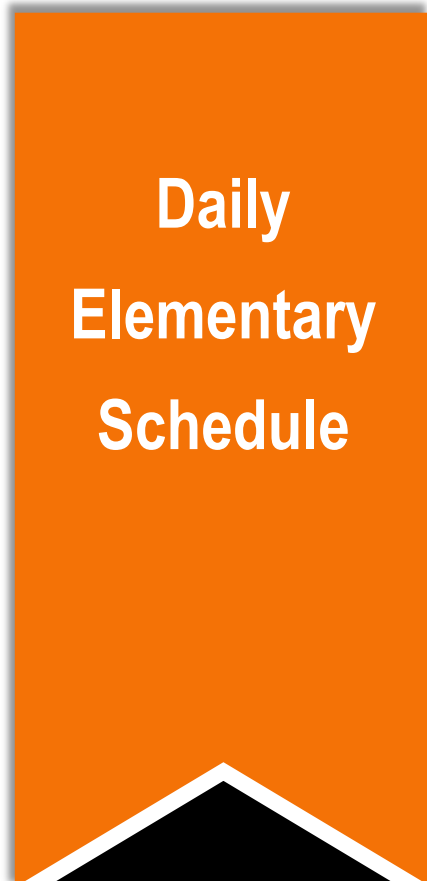

7:30 a.m. - We ask that students not be dropped off prior to this as teachers are often in meetings and unable to supervise children. This can create an unsafe situation for students and school personnel. Students are encouraged to report to the cafeteria for breakfast and/or the playground for supervision.

7:30 a.m.. - Buses begin to release students into the building

8:00 a.m. - Class begins.

Elementary Lunch Times:

K	11:00-11:30
1	11:00-11:30
2	11:05-11:35
3	11:10-11:40
4	11:15-11:45
5	11:20-11:50

Elementary Recess Times:

	AM Recess	PM Recess
4K-2	10:10-10:25	1:19-1:34
3-5	9:50-10:05	1:47-2:02

3:15 p.m. - School dismisses for elementary students.



GRANTON AREA SCHOOL 2022-2023 CALENDAR

AUGUST 2022

S	M	T	W	Th	F	S
	1	2	3	4	5	6
7	8	9	10	11	12	13
14	15	16	17	18	19	20
21	22	23	24	25	26	27
28	29	30	31			

15 New Teacher In-Service
16-17 Teacher PD/Work Day
18 All Staff PD 12-8pm
 Open house 6-8pm
22 Teacher ½ Work Day
23 First Day of School

7 Student Days

FEBRUARY 2023

S	M	T	W	Th	F	S
			1	2	3	4
5	6	7	8	9	10	11
12	13	14	15	16	17	18
19	20	21	22	23	24	25
26	27	28				

23 Student Day Early Release at Noon
 P/T Conferences 1-8pm
24 Teacher PD ½ Day
 No School

19.5 Student Days

SEPTEMBER 2022

S	M	T	W	Th	F	S
				1	2	3
4	5	6	7	8	9	10
11	12	13	14	15	16	17
18	19	20	21	22	23	24
25	26	27	28	29	30	

2 No School
5 Labor Day
 No School
23 All Staff PD Day
 No School

19 Student Days

MARCH 2023

S	M	T	W	Th	F	S
			1	2	3	4
5	6	7	8	9	10	11
12	13	14	15	16	17	18
19	20	21	22	23	24	25
26	27	28	29	30	31	

17 End of 3rd Quarter
20 Teacher PD/Work Day
 No School

22 Student Days

OCTOBER 2022

S	M	T	W	Th	F	S
						1
2	3	4	5	6	7	8
9	10	11	12	13	14	15
16	17	18	19	20	21	22
23	24	25	26	27	28	29
30	31					

13 Student Day Early Release at Noon
 P/T Conferences 1-8pm
14 No School
28 End of 1st Quarter
31 Teacher PD/Work Day
 No School

19.5 Student Days

APRIL 2023

S	M	T	W	Th	F	S
						1
2	3	4	5	6	7	8
9	10	11	12	13	14	15
16	17	18	19	20	21	22
23	24	25	26	27	28	29
30						

7-10 Easter Holiday Break
 No School
21 All Staff PD Day
 No School

17 Student Days

NOVEMBER 2022

S	M	T	W	Th	F	S
		1	2	3	4	5
6	7	8	9	10	11	12
13	14	15	16	17	18	19
20	21	22	23	24	25	26
27	28	29	30			

23-25 Thanksgiving Break
 No School

19 Student Days

MAY 2023

S	M	T	W	Th	F	S
	1	2	3	4	5	6
7	8	9	10	11	12	13
14	15	16	17	18	19	20
21	22	23	24	25	26	27
28	29	30	31			

12 Reinforcement Day
26 End of 4th Quarter
 Last Day of School
27 Graduation
29 Memorial Day
30 Teacher PD/Work Day

20 Student Days

DECEMBER 2022

S	M	T	W	Th	F	S
				1	2	3
4	5	6	7	8	9	10
11	12	13	14	15	16	17
18	19	20	21	22	23	24
25	26	27	28	29	30	31

23-31 Holiday Break
 No School

16 Student Days

JUNE 2023

S	M	T	W	Th	F	S
				1	2	3
4	5	6	7	8	9	10
11	12	13	14	15	16	17
18	19	20	21	22	23	24
25	26	27	28	29	30	

5-30 Summer School

JANUARY 2023

S	M	T	W	Th	F	S
1	2	3	4	5	6	7
8	9	10	11	12	13	14
15	16	17	18	19	20	21
22	23	24	25	26	27	28
29	30	31				

2 Holiday Break
 No School
13 End of 2nd Quarter
16 Teacher PD/Work Day
 No School

20 Student Days

Quarter 1 45.5 Days
 Quarter 2 44 Days
 Quarter 3 43.5 Days
 Quarter 4 46 Days
 Total 179 Days

Approved 2/14/2022

Color Key

- Teacher PD/Work Day
- 1st Day of School/End of Quarter
- No School
- Early Release P/T Conferences
- Reinforcement Day
- Graduation
- Summer School

Academic Information

- Cheating/Plagiarism
- Contacting teachers
- Grading periods
- Progress reports
- Student records
- Homework
- Internet/ On-line services
- Student promotion/retention
- Student absences
- Work missed during absence
- Tardiness
- Truancy
- Perfect attendance

CHEATING AND PLAGIARISM

Cheating of any kind (plagiarism, forgery, copying another person's work, allowing another person to copy one's own work, doing another person's work, creating additional copies of one's work for distribution, intentionally accessing another's material for personal use, downloading information from other sources and presenting it as one's own, unauthorized use of hard copy or software to develop one's own software) will not be tolerated. Possible disciplinary actions may include: redoing test or assignment, receiving a reduced grade (as low as zero), written referral to office, or any other action that a teacher and administration deem necessary and appropriate. It is expected that all schoolwork submitted for the purpose of meeting course requirements represent the original efforts of the individual student.

CONTACTING TEACHER INFORMATION

All teachers have email through the school and telephones in every classroom. Parents are encouraged to contact them often. This information is distributed at open house and is also available via the school website and elementary office.

GRADING PERIODS, PROGRESS REPORTS, STUDENT RECORDS

Students will receive grades and credits four times per year at the end of every nine-week grading period. The grades on the report cards issued at the nine-week period will be the recorded grade for student achievement (credit) and will become part of the student's permanent record. The progress report can, and should, be used at any time during the nine-week quarter when staff have information or concerns they wish to share with a parent(s). The progress report will indicate the reason for concern or commendation. Any student with a grade of "M" or below at the mid-quarter will be sent home a progress report (a.k.a. Minimal Performance report). Teachers are encouraged to communicate with parents on a regular basis. No parent or student should ever be surprised by the grade received at the end of any grading period as proper communication should take place prior to the end of a grading period.

HOMEWORK

Our programs are planned so that if each student makes wise use of their time during regular school hours the amount of work outside of school should be minimal. A reasonable amount of homework is a part of the educational process and should be expected. Every student is different and should not be compared to others regarding this issue.

INTERNET/ON-LINE SERVICES

The Granton Area School District has developed specific policies regarding student use of the Internet or other on-line computer services. Students in district classes are encouraged to explore the Internet or other on-line services for educational purposes under the careful direction and supervision of district staff. All student use of the Internet must be based on specific planned educational purpose and/or topic and must take place in a supervised setting such as a classroom, lab, or media center. School Board Policy clearly defines user rules. Students violating those rules may be subject to school discipline, up to and including expulsion.



STUDENT PROMOTION/RETENTION

As per Granton Area School District Board Policy Code Chapter 10

The Granton Area School District is dedicated to the total and continuous development of each pupil enrolled. The professional staff is expected to place pupils at the grade level best suited to them academically, socially and emotionally.

Children seem to do their best work in school when they are placed at a grade level with other children of their chronological age. Because of the following factors, it will occasionally be desirable for a child to be placed in a grade above or below his/her actual chronological age:

- ◆ Physical maturity
- ◆ Social/emotional maturity
- ◆ Attitudes/work habits
- ◆ Level of academic achievement, particularly in basic skill areas, and in reference to grade level outcomes
- ◆ Ability in relation to achievement
- ◆ Attendance patterns
- ◆ Potential benefit/success for the student
- ◆ Previous retention
- ◆ EEN status
- ◆ Extenuating circumstances, if any

Parents wishing to explore the advisability of retention or acceleration for their child may do so by first contacting the teacher of their son/daughter. The teacher will then initiate a review of the child's records beginning at Step 1 of the guidelines outlined in the rules associated with the appropriate policy.

Pupils will normally progress annually from grade to grade. Exceptions may be made only when, in the judgement of the professional staff, such exceptions are in the best educational interest of the pupils involved. Exceptions will always be made after prior notification and explanation to each pupil's parents, but the final decision will rest with the school authorities.

All retention and promotion decisions will follow the guidelines of the following Board Policies:

Chapter 10, Section PA, "Fourth, Eighth, and Tenth Grade Advancement Guidelines"

Chapter 10, Section Q, "Student Retention - Elementary"

Chapter 10, Section R, "Student Acceleration - Elementary"

Chapter 10, Section S, "Junior High Promotion and Retention"

Chapter 10, Section T, "Student Retention and Promotion - High School (9-12)"



Attendance Information

The Board of Education encourages a strong partnership between the home, school, and community. It recognizes a positive relationship between good school attendance and success in school and employment. If student learning and growth are to take place, parents/guardians, students and school personnel must recognize their responsibilities to assure regular attendance.

The Board, in recognition of the statutory requirements for school attendance and the overwhelming public need for an educated society, believes school attendance should take precedence over non-school activities. State law requires every child between 6 and 18 years of age to be in school attendance unless he/she:

1. Is excused temporarily for physical or mental reasons, or other reasons defined by the Board;
2. Has graduated
3. Has been authorized to attend an alternative educational program; or
4. Has been excused by his/her parent/guardian prior to an absence in accordance with state law.

It is the responsibility of any person having under his/her control such a child to ensure regular attendance during the full period and hours that school is in session until the end of grading period in which the child becomes 18 years of age. Parent/guardian(s) are responsible for notifying the school of student absences in accordance with established district procedures. When students are absent, parents/guardians assume full responsibility for their child's activities. It is the responsibility of the principal or designee to determine whether the absence is acceptable (excused) or not acceptable (truant).

As per Granton Area School District Board Policy Code Chapter 10: Section J

School attendance is crucial in order for students to have success in school. The Granton Board of Education has established, and the administration endorses, the following policy:

1. Parents must accept the responsibility for requiring their children to attend school so as to comply with school policy and Wisconsin law. When it is necessary for a student to be absent for "good cause" during the school day, parents are encouraged to contact school officials and inform them. The office will be open at 7:30 A.M. to receive these calls. When a student is absent and a call has not been received, school personnel will telephone the home. In case of no phone call, a note from the parent is necessary before an absence will be excused.
2. Wisconsin State Statutes 118.15 (Compulsory School Attendance) and 118.16 (School Attendance Enforcement) deal with student attendance. All children are subject to compulsory school attendance and law requires a record of attendance through the end of the school term in which they become 18 years of age.

STUDENT ABSENCES

The responsibility for regular school attendance of a child rests upon the child's parents or guardian. No absence shall be recorded when a child is physically away from school because he/she is participating in school sponsored activities, teacher chaperoned field trips, athletic events, workshops, contests, etc. Each teacher shall submit daily attendance reports to the attendance officer on all students under his/her charge. Each building principal shall adopt specific procedures for handling absences subject to the district attendance policies and the approval of the School Board. A written copy of these procedures shall be provided for each student and/or his/her parent(s) or guardian.

Advanced Makeup Form:

Granton Area Schools recognize the occasional need for extended absence or emergency situations that may arise. Students who are planning to be absent and know in advance that they will be missing work should pick up an advance makeup sheet from the office. A parent request is necessary to receive an advanced makeup. The student will be required to obtain signatures and assignments from their teachers. All work should be made up prior to dates that the student will be missing unless specific arrangements have been made with the classroom teacher. The completed advanced makeup form should be returned to the principal's office.

Excused Student Absences:**• Personal Illness**

A student who is absent due to illness is to have a parent/guardian call the school the morning of the absence. If this is not possible, a note signed by the parent/guardian explaining the absence should be brought to the office on the day the student returns. A student will be allowed five sickness or injury related absences per semester that do not require a doctor's verification. These absences will be recorded as IL. If a student requires more than five separate days per semester due to sickness or injury, a doctor's excuse will be necessary. These absences will be recorded as DR. When the illness or injury causes the student to miss three or more consecutive days of school, documentation from a doctor's office will be necessary to excuse the absences. These absences will be recorded as M.

• Medical Appointments

A student who has a medical, dental, chiropractic, optometric, or other valid professional appointment will need to provide documentation of the appointment from the medical facility to have the absence be marked "excused". These absences will be recorded as DR. If possible, please schedule appointments outside the school day. The office will accept a fax from the facility on company letterhead that provides verification of the appointment date and time. The elementary fax number is 715-238-7288.

• Family Emergencies

Any student who has a severely ill or injured family member or who has experienced the death of a family member should have a parent/guardian contact the office as soon as possible after the initial first absence with a description of the circumstances. These absences will be recorded as F. A student requiring more than ten days' absence from school must have a parent/guardian contact the office to give an estimated date for the return of the student to school.

• Family Religious Services

Any student requesting time off for the observance of a religious holiday must bring a note from a parent/guardian or have the parent/guardian call the office prior to the holiday. (These days do not count toward the five parent-excused days in a semester.) These absences will be recorded as R.

• Other Excused Type Absences

- * A court appearance or other legal procedure, which requires the attendance of the student. These absences will be recorded as CA
- * Quarantine as imposed by the Public Health Officer. These absences will be recorded as CDC.
- * Student sent home per CDC guidelines. We ask parents to keep children who are ill home for a full 24 hours after they are free of fever, vomiting, or diarrhea without the aid of fever reducing medications such as Tylenol, Ibuprofen, Advil, etc., because people are very contagious for 24 hours after they are completely symptom free. These absences will be recorded as CDC.
- * Attendance at special events of educational value approved in advance by the principal or attendance officer. These absences will be recorded as SA
- * Approved school activities during class time. These absences will be recorded as SA.
- * Special circumstances that show good cause and is approved in advance by the principal.

STUDENT ABSENCES, CONTINUED

- **Pre-arranged Absences**

Pre-arranged absences do not fall under the category of “parent request” unless an advanced makeup form has been filled out and approved. Individual parent requests that his/her child should be excused from an absence will not be honored unless it falls under the guidelines previously stated for excused absences and parent responsibilities. Faculty reserves the right to excuse a student from an absence when the absence has been deemed either justified or unavoidable.

- **Parent/Student Responsibilities**

All other absences must be cleared with the office and will be excused only if the absence falls within the guidelines stated above. It is the responsibility of the parent and student to provide the office with the proper documentation stated in the four reasons for excused absences. The parent/guardian or student will have five school days to clear the absence with the office. Documentation and/or phone calls received after five days will not be accepted, and the absence will be considered unexcused. Upon the student’s return to school, the student has the responsibility to confer with his/her teachers for those classes missed to determine work to be completed. The student may have the number of days absent plus one to make up missed assignments/class work to be completed. A longer period may be granted by teacher or administrator for extenuating circumstances.

Unexcused Student Absences:

- Children who are absent from school with the consent of their parents and/or guardian, but whose absence does not fall under the reasons listed above for excused absences, or children who skip, or are absent for no particular reason, shall be considered unexcused.
- Students marked with unexcused absences may be required to serve a 30 minute after-school detention for each period unexcused.



Attendance Information

Policies may be revised during the course of the year.

WORK MISSED DURING STUDENT ABSENCE

Unexcused Absence:

- Work missed during an unexcused absence may be made up upon request from the teacher. Students may or may not be permitted to make up daily class work missed and may be denied credit for unexcused absences. Tests are an exception and may be made up at a time mutually agreed upon by the teacher and student.
- A student may receive a zero for class participation for all classes missed if participation grades were given the day the student was marked as unexcused by the school attendance officer.
- Students have the obligation to obtain, understand, and retain for future reference and use, all materials presented during their unexcused absence.

WORK MISSED DURING STUDENT ABSENCE, CONTINUED

Excused Absence:

- It is the student's responsibility to contact his/her teachers to make arrangements for making up any work missed resulting from the absence.
- Students who miss class for reasons that are excusable will be given the opportunity, whenever possible, to make up work missed when they return to school.
- Teachers will grant the number of days absent plus one for make-up time. This provision applies to all work assigned during the student's absence unless an exception is granted by the principal due to extenuating circumstances.
- Exams missed during an excused absence will be taken at a time agreed upon by the student and teacher.

Any time a student is absent, parents are encouraged to call school and have the student's homework collected for pickup by the parent or another sibling.

TARDINESS

Tardiness is a two-way problem. First, tardiness is disturbing to other students and the teacher of the class being interrupted. Secondly, tardiness results in a loss of education for the tardy student. Students are expected to be in their proper classroom and in their designated seat when the bell rings at the beginning of each hour. Students are responsible for their movement throughout the building and planning ahead as to avoid tardiness. If at any time a student must be in the hallway, they are to have a hall pass from a staff member or the office. Student tardiness is kept on file by the school office and the attendance officer. Failure to comply with this policy may result in any of the following:

- Consequences as determined by the staff member or administration

TRUANCY

"Truancy" means any absence of part or all of one or more days from school during which the school attendance officer (Dean of Students) and/or High School Principal has not been notified of the legal cause of such absence by the parent or guardian of the absent student, and also means intermittent attendance carried on for the purpose of defeating the intent of the state attendance statutes (118.15).

Truancy Guidelines:

1. Part or all of 2 unexcused days absent in a school semester, or 4 excused absences in a school year:
Phone call to parent/guardian discussing attendance.
2. Part or all of 3 unexcused days absent in a school semester or 6 excused absences in a school year:
Letter to parent/ guardian giving notification of check list for habitual truant.
Referral to school counselor for: Review of school records to consider possible PBIS Team meeting.
3. Part or all of 4 unexcused days absent in a school semester or 8 excused absences in a school year:
Certified letter to parent/guardian giving notification of checklist for habitual truant.
Meeting with parents, principal, counselor, and student to consider/discuss placement in PBIS Tier 2 intervention.
4. Part or all of 5 unexcused days absent in a school semester or 10 excused absences in a school year: Certified letter to parent/guardian giving notification of checklist for habitual truant
Possible referral to Clark County Social Services.
Clark County notification for administration of Truancy Ordinance.

A "habitual truant" means a student who is absent from school without an acceptable excuse, based on the district attendance policies for either of the following:

- Part or all of 5 or more unexcused days in which school is held during a semester whether consecutive or not.
- Part or all of 5 or more days in which school was held which exceed 10 days excused absence in a school year.

TRUANCY, CONTINUED

If a student becomes a habitual truant the attendance officer shall notify the parent/guardian of the child by registered or certified mail, when the child initially becomes habitually truant. The notice shall include the following checklist:

- A statement of the parent's responsibility under the law to cause the child to attend school regularly.
- A statement that the parent/guardian or child may request program or curriculum modifications for the child and that the child may be eligible for any at-risk program.
- A request that the parent/guardian meet with appropriate school personnel to discuss the child's truancy.
- A statement of the penalties under the law that may be imposed on the parent/guardian if he/she fails to cause the child to attend school regularly.

CLARK COUNTY/GRANTON TRUANCY POLICY

Granton has partnered with Clark County as of June 2019 to respond to Granton Area School District Truancy cases. Under this ordinance, any student that is considered truant from school can be subject to any or all of the following actions:

- An order for the person to attend school
- Cumulative fines to be assessed against the person, the parents or guardian, or both
- Suspension of driver's license for not less than 30 day nor more than one year
- An order to participate in counseling or other supervised work program; the costs may be assessed against the person and/or family
- An order to attend an educational program
- An order from the Wisconsin Dept. of Work Force Development to revoke a work permit for up to one year
- An order for the person to be placed in a teen court program
- An order placing the person under formal or informal supervision for up to one year
- An order for the person's parent, guardian or legal custodian to participate in counseling at their expense
- Any other reasonable conditions with this Section including a curfew and other restrictions

The Granton Area School District is willing to work with students/families to resolve attendance issues if at all possible. The above is the end result of unresolved attendance issues and will be determined by Clark County Court Services.

PERFECT ATTENDANCE

Perfect Attendance Awards will be presented to students with perfect attendance at the end of the 2nd semester.



Behavior Information

- Behavior Philosophy
- Behavior Expectations
- Manners
- Consequences (PBIS)
- Code of student conduct
- Harassment
- Loitering
- PAWS
- Prohibited Items
- Searches
- Student/Staff Interactions
- Vandalism/theft

BEHAVIOR PHILOSOPHY

The Granton Area School District has high expectations for all students and recognizes the potential of all students. To help reach that potential for each student, it is necessary to have a school and classroom free of disruption. The District requires that students respect the rights of all members of the school family - teachers, administrators, support staff, parents, and other students.

Behavior procedures are necessary so the rights of each member of the school family are protected. They are designed to preserve an orderly school atmosphere and to help prepare students for productive and meaningful adult lives. Any student, who, through actions, conduct, dress, appearance or presence, disrupts the normal routines of the educational process of the school or who follows a course of conduct which may reasonably be anticipated to become disruptive of the educational process, shall be subject to the discipline of the school.

BEHAVIOR EXPECTATIONS FOR STUDENTS

Students at Granton are expected to conduct themselves in a positive manner and show respect towards all students and staff. Behavioral guidelines include:

- **Be Respectful** - For self, others, community, school, parent, etc.
- **Be Responsible** - To family, to self, and to school.
- **Be Safe**-To be free from danger or injury; physically and emotionally.

BEHAVIOR GUIDELINES

Please see additional information in this handbook and under board policies on our website.

- Respectful hallway behavior is expected, including being on time, not running and having a hall pass when in the hall during class times.
- Excessive public displays of affection are discouraged. Please be respectful of those around you.
- Keep the lunch room clean.
- Respectful and appropriate language is expected during the school day and at school events.
- Dangerous behaviors such as pushing, inappropriate physical contact, and other irresponsible behaviors are not allowed.
- Student dress, appearance, and grooming should not affect the health and safety of student nor disrupt the learning process within the classroom or school grounds.
- Be your best self; academically, socially, and behaviorally.

MANNERS

All behaviors exhibited by the individual while at school and school related activities are a reflection of that individual and the school. In our desire to create an environment of mutual respect supported by families and community, students are expected to employ common courtesy and good manners. Words such as please, thank you, along with the proper address of staff as "Mr." and "Mrs." are expected.

Behavior Expectations

CONSEQUENCES FOR INAPPROPRIATE BEHAVIOR

School officials are limited in the punishment that can be given to a student. In most cases, the Granton Area School District uses a progression of behavioral consequences. As in life, the best way for a student to avoid possible consequences is to make good choices. Possible consequences include verbal warnings, detentions, suspension, expulsion, and the possible contacting of law enforcement. Representing the School Board, a school administrator will decide the consequences for breaking school rules. The following is a listing of common consequences:

Classroom Managed - PBIS Tier 1

Teacher Detention - Teachers may assign detentions at their discretion and according to their classroom management plan that should be referenced in their course syllabus, which is given to every student upon their entering the course. Teachers will call the parent/guardian to discuss the problem. Teacher detentions may be served at the teacher's preference either before school, during the lunch hour, or after school. Teacher detentions may vary in length of time served and the tasks assigned to be performed. Students must be given a 24-hour notice to serve unless the teacher has contacted and made arrangements with the parents that same day. A behavioral log will be kept by the classroom teacher as a way of documenting problems in the classroom that may lead to a student's violation of the code of conduct which may result in a removal from the classroom.

Office Managed -PBIS Tier 2 and 3

Step system

- Behavioral plan

When actions taken by the teacher have failed or the rule infraction is of a serious nature, the incident will be reported to the principal or dean of students for investigation and action. The consequences of the infraction will depend upon the severity of the offense and the previous discipline record of the student. In order to incorporate these two factors, a progression of consequences called The Step System will be utilized. A student who is referred for violating a rule contained within the student handbook will receive the consequences that correspond to the entry-level step for that offense. With each successive referral the student may advance up the step system at least one step depending upon the severity of the offense. Placement on the step system will be at the discretion of the dean of students.

1. Referral to dean of students for a conference and/or mediation meeting with parties involved, incident in student file; parents should be notified by the teacher.
2. Dean of student's conference and/or mediation meeting with parties involved, student assigned one detention; initial notification to parents by the teacher, dean of students follow up contact with parents by phone or email.
3. Student assigned two detentions; initial notification to parents by the teacher, dean of students follow up contact with parents by phone or email to schedule conference with parent, teacher, HR teacher, guidance counselor, PBIS coordinator, and student to complete a behavior intervention plan (See PBIS Handbook for description of BIP).
4. Student assigned half day in school suspension; initial notification to parents by the teacher, dean of students follows up contact with parents by phone or email to schedule conference with parent, teacher, HR teacher, guidance counselor, PBIS coordinator and student to revisit BIP.
5. One day in school suspension; initial notification to parent by the teacher, dean of students follows up contact with parents by phone or email to schedule conference with parent, teacher, guidance counselor, PBIS coordinator and student to revisit BIP.
6. Two days in school suspension; initial notification to parent by the teacher, dean of students follow up contact with parents by phone or email to schedule conference with parent, teacher, guidance counselor, PBIS coordinator and student to complete a behavior contract (See PBIS Handbook for description of behavior contract).
7. One day out of school suspension; initial notification to parent by the teacher, principal/dean of students follow up contact with parents by phone to schedule conference with parent, teacher, guidance counselor, PBIS coordinator and student to revisit behavior contract.

CONSEQUENCES FOR INAPPROPRIATE BEHAVIOR, CONTINUED

8. 1-3 days out of school suspension; initial notification to parent by the teacher, principal/dean of students follow up contact with parents by phone to schedule conference to gain re-admittance. Meeting scheduled with PBIS team to revisit behavior contract is deemed necessary.
9. 3 days out of school suspension, all succeeding violations will be treated as a step 8 or higher. Parent conference required for pre-expulsion behavior contract prior to re-admittance.
10. 5 day out of school suspension pending pre-expulsion hearing before school superintendent.

- Good conduct clause

A student may work his/her way off the step system by demonstrating good behavior. Each period of 20 school days without a referral will result in the reduction of one step. Successful completion of a behavioral contract will result in the student being placed on one lower step.

- Severe Infraction Clause

A list of possible reasons for student suspension and/or expulsion is on page 14 of the Parent and Student Handbook. These severe infractions may lead to a student being placed on Step 4 or higher in the discipline step system on a first offense.

Office Detention - These can only be assigned by the superintendent, principal or behavior/academic interventionist. Office detentions can be earned for a variety of infractions including, but not limited to: disrespect or insubordination to any staff member or student, school disruption, inappropriate language, harassment, and inappropriate lunchroom behavior.

- Detentions are approximately 30 minutes long and are held in a predetermined location at the conclusion of the school day. The office will notify students if they have detention on any given day and parents will also be contacted.
- Detention will be held from approximately 3:30-4:00pm.

The following are the blanket expectations for students in after school detention:

1. You **MUST** have academic materials (schoolwork, school appropriate reading material, etc.) with you to work from the time you arrive for detention until the time you are released.
 2. Talking is **NOT** allowed.
 3. Food and drinks are **NOT** allowed.
 4. **NO** electronics (except for calculators) are permitted in detention.
 5. **ALL** simple directives and requests of the detention supervisor will be followed.
 6. Speaking as the student: If I choose to serve my detention inappropriately I realize that I may be assessed additional detentions, face possible suspension, and/or be referred to local law enforcement for a disorderly conduct citation by the building principal.
 7. Other expectations for behavior, so long as they are academically and socially fair, reasonable, and just, are left at the discretion of the detention supervisor and are supported by the building principal.
- When given a detention a student will be assigned the next possible detention date. It will be up to the student to deal with any meeting time that may be missed as a result of their actions.
 - Students will bring academic materials to work on. Homework, a book from the school library, or materials sent by the classroom teacher are the only materials deemed acceptable.
 - Any student with an un-served detention is not eligible to attend any school related activity including practice.
 - After school detentions for high school students may not be planned in advance and will be assigned as necessary by the principal/dean of students.



CONSEQUENCES, CONTINUED

As per Granton Area School District Board Policy Code Chapter 10: Section K & L

In School/Out of School Suspension - the power to suspend is limited to the Principal, District Administrator, or any teacher designated by the District Administrator. Such a suspension shall not exceed five days for any one occurrence. If a notice of expulsion has been sent, then suspension may not exceed more than 15 consecutive days, but must be in compliance with State Statute 119.25. Any student failing to abide by the policies of the Board of Education, or any of the other reasonable rules and regulations of the school, may be suspended. If and when a suspension is prescribed, the Principal or District Administrator shall immediately notify the parents. Prior to the suspension, the pupil shall be advised of the reason for the proposed suspension. In all cases of suspension, pupils can be readmitted only upon fulfilling the requirements set down for his/her return and with permission for the Principal or District Administrator.

- The suspended pupil or the pupil's parent or guardian may, within five school days following the commencement of the suspension, have a conference with the school district administrator. If the school district administrator finds that the pupil was suspended unfairly or unjustly, or that the suspension was inappropriate, given the nature of the alleged offense, or that the pupil suffered undue consequences or penalties as a result of the suspension, reference to the suspension on the pupil's school record shall be expunged. The administrator shall make a finding within 15 days of the conference.
- A pupil suspended shall not be denied the opportunity to take any quarterly, semester or grading period examinations or to complete course work missed during the suspension period.

Expulsion - the power to expel a student from school rests with the Board of Education. The school board may expel a pupil from school whenever it finds the pupil guilty of repeated refusal or neglect to obey the rules, or finds that a pupil knowingly conveyed or caused to be conveyed any threat or false information concerning an attempt or alleged attempt being made or to be made to destroy any school property by means of explosives, or finds that the pupil engaged in conduct while at school or while under the supervision of a school authority which endangered the property, health or safety of others, or finds that a pupil while not at school or while not under the supervision of a school authority or endangered the property, health or safety of any employee or school board member of the school district in which the pupil is enrolled, and is satisfied that the interest of the school demands the pupil's expulsion. In this subdivision, conduct that endangers a person or property includes making a threat to the healthy or safety of a person or making a threat to damage property.

Possible reasons for student suspension and/or expulsion:

- Failure to comply with reasonable rules and regulations.
- Insubordination to any staff member.
- The use of indecent or abusive language.
- The malicious marring or destruction of school property.
- The possession or use of weapons, intoxicants, narcotics, tobacco, inhalants, or prescription drugs at school and any related function. Local law enforcement will also be notified.
- Conduct at school sponsored functions that reflect unfavorably on the reputation of the school and community.
- Fighting.

Police Referral - It is the philosophy and belief of the administration at Granton High School that the primary responsibility for dealing with student discipline violations rests with us. Thus, we will make every effort to handle all problems in-house according to the policies and procedures established by the school board. However, when violations of state laws or municipal ordinances occur, or when students or parents/guardians refuse to work within the established policies of the district and school, or where security of person or property appears to be in jeopardy, we will involve the police as we have a responsibility to provide all members of our educational community with a safe school. Acts that are illegal under the Criminal Code of Wisconsin are report-

Behavior Expectations

CODE OF STUDENT CONDUCT/REMOVAL FROM CLASS

As per Granton Area School District Board Policy Code Chapter 10: Section HH

The Wisconsin state legislature has mandated that all Wisconsin schools has a board approved "Code of Conduct." This policy allows a teacher to remove a pupil from their class if the pupil violates the terms of Granton's Code of Student Conduct.

The Code of Conduct has a statement of principle, which states the district recognizes and accepts its responsibility to create, foster and maintain an orderly and safe educational environment. Therefore, beginning with the 1999-2000 school year, a teacher may temporarily remove a pupil from their class, if the pupil violates the terms of Granton's Code of Student Conduct. The removal from class may be "short term" or "long term."

The Code is quite extensive and describes behaviors for student removal from class. It discusses the documentation that is necessary by the teacher and administration or designee. It further describes placement procedures, guidelines, and decisions. The parent will be notified of the incident and may/may not be involved in the placement decision. The Code discusses the different rules and considerations for students identified as requiring special education services.

This booklet does not cover all existing policies of the Board of Education. Additional policies and regulations will be presented and discussed with the student body as they become pertinent in terms of timing. Should any questions arise on any topic not covered in this handbook, in this or other sections, students are encouraged to converse with school personnel for facts and opinions. Students are expected to follow rules of good behavior at all times.

HARASSMENT

As per Granton Area School District Board Policy Code Chapter 10: Section QQ

Harassment and/or bullying of students will not be tolerated in the Granton Area District which includes any property or vehicles owned, leased, or used by the school district. The School Board considers these actions to be detrimental to the health and safety of students, and disruptive to the education environment. The educational environment is defined as consisting of every activity under the supervision of the school. For purposes of this policy, harassment and/or bullying are defined as any conscious, willful, or deliberate act or attempted act, through the use of words or actions, which are intended to cause physical injury, emotional distress/suffering, or property damage, that impacts the learning environment.

Harassment and/or bullying could include acts motivated by, but not limited to, hostility toward the victim's real or perceived sex, race, color, religion, national origin, ancestry, creed, pregnancy, marital status, sexual orientation, gender identity, social, socio-economic or family status, physical attributes, disability/handicap or any other basis protected by state or federal law. Examples of acts of harassment and/or bullying include physical intimidation, force or assault, humiliation, bigoted epithets, vandalism, extortion, oral or written threats, taunting, put downs name calling, threatening looks or gestures, false accusations, social isolation, retaliating against another student for reporting harassment or bullying, or any other behavior that substantially interferes with a student's school performance or creates an intimidating, hostile, or offensive school environment.

All forms of harassment in cyberspace commonly referred to as cyber bullying are unacceptable and viewed as a violation of this policy. Cyber bullying includes, but is not limited to, the following misuses of technology: harassment, teasing, intimidation, threatening, or terrorizing another person or group of people by sending or posting inappropriate and hurtful e-mail messages, instant messages, text messages, digital pictures or images, or website postings, including blogs or any other messages sent via cyberspace. For purposes of this policy, "cyberspace" is defined as a global domain within the information environment consisting of the independent network of information technology infrastructures, including the Internet, telecommunication networks, computer systems, and embedded processors and controllers.

In situations in which cyber bullying originated off school or property or from a non-school computer or telecommunications device, but is brought to the attention of school officials, any disciplinary action shall be based upon whether the conduct is determined to be severely disruptive of the educational process so that it markedly impedes the day to day operations of the school. Such conduct includes, but is not limited to harassment, bullying or making a threat off school grounds through cyberspace that is intended to endanger the health, safety, or property of others at school, a District employee or a school board member.

Behavior Expectations

HARASSMENT, CONTINUED

Any student who believes he/she has been subject to harassment and/or bullying may file a complaint in accordance with established complaint procedures or may complain directly to the building principal or their designee. Filing a complaint or otherwise reporting harassment and/or bullying in good faith will not reflect upon the individual's status nor will it affect his/her grades or benefits provided by the District. The District shall respect the confidentiality of both the complainant and accused consistent with the District's legal obligations and with the necessity to investigate allegations of misconduct and to take corrective and/or disciplinary action when this conduct has occurred. Any student or parent/guardian who becomes aware of or witnesses harassment and/or bullying has an obligation to report and will be supported by involved staff members in reporting the bullying/harassment to the proper authorities. Any District employee who becomes aware of or witnesses harassment and/or bullying has an obligation to intervene and report the incident.

Students who engage in harassment and/or bullying in violation of this policy and/or retaliating against an individual for reporting harassment and/or bullying shall be subject to counseling, corrective school disciplinary measures consistent with District policies and procedures up to and including suspension, expulsion, and/or police referral. This includes appropriate intervention(s), restoration of a positive climate, and support for victims and others impacted by the violation. False reports or retaliation for harassment, intimidation or bullying also constitutes violations of this policy.

This policy will be: circulated to all school staff at the start of every school year, published in the August Newsletter, and incorporated into all District approved handbooks.

LOITERING

Any unauthorized person found in the building shall be referred to local law enforcement and prosecuted under the proper county ordinances, if they do not leave immediately upon request. You must leave the building when the school day is over, unless you are required to stay after - which will require you to be under faculty supervision. Any student refusing to comply faces disciplinary procedures including detention, restriction from being on campus after 3:30 P.M. and before 8:00 A.M., suspension, citation for trespassing, and expulsion.

PAWS (Positive Attitude + Work = Success) & "PAWS"-itive Behavior Awards

PAWS is a service learning and community service program that includes all students and staff! Each month we have scheduled times for school or community based projects that encourage students and staff of varying levels to work together in performing some type of project. Each quarter a school-wide celebration is held in which students are nominated by their teachers and recognized for good citizenship, attendance, and academic success. Students can also be nominated by a staff member for a "PAWS"-itive Behavior Award and they will receive some kind of prize from the Student Services Department. For more information on PAWS, please contact Mrs. Woller.

PROHIBITED ITEMS

Problems arise each year because students bring articles which are hazards to the safety of others or interfere in some way with school procedure. Such items include, but are not limited to: toy guns, water pistols, water balloons, bean shooters, sling shots, knives, hardballs, laser pointers. The items if brought to school as playthings are undesirable and will be confiscated. Parents are requested to help children understand the necessity for such regulations. Boom boxes, radios, personal/portable compact disc player, and TV's are not permitted. Cell phones, pagers, iPods, MP3s or other electronic devices are not to be used in the classrooms UNLESS authorized by the classroom teacher. Authorized use during classroom time is for ACADEMIC purposes only. In these cases of occasional use, the device(s) shall be put back into the students pocket or school issued locker for the remainder of the school day.

PROCEDURES FOR POSSESSION OF ALCOHOL, OTHER DRUGS OR ALTERING SUBSTANCES, INHALANTS, E-CIGARETTES, TOBACCO, STREET DRUGS, DRUG PARAPHERNALIA, CONTROLLED OR PERFORMANCE ENHANCING SUBSTANCES

Granton School District strictly forbids use, sale, or possession on any items listed above or look-a-like substances. The possession and/or use or sale of chemicals in our schools, our parking lots, on school buses, at athletic events and/or other school sponsored functions is strictly prohibited. School board policy and procedures have been established to respond to individuals possessing, distributing, and/or selling alcohol and other controlled chemicals/substances or their look-a-like counter parts. Disciplinary action will result if a student is involved in use, possession, and/or sale of any altering substances. Students refusing to comply with a breath test given by school officials or law enforcement will be treated as an admission of guilt.

SEARCHES

Desks, lockers, books, and equipment loaned to students remain school property while in possession of the students. Such property is provided for the convenience of the students and shall be used only for authorized school purposes. Lockers are not safe deposit boxes. Granton Schools cannot guarantee full security to items stored in lockers. Students that suspect their lock is malfunctioning or that another student knows their combination should report it to the office so that a new lock/combination can be provided to the student. Only locks issued by the school may be used on lockers. Personal locks will be cut and removed by school personnel. The school district is not responsible for any items taken from a student locker even if it is locked. Students are expected to clean their lockers and remove all tape, photos, etc. at the end of the school year.

Other pertinent information relating to searches:

- Student lockers are provided for the use and convenience of students but remain under the jurisdiction and control of the school authorities. If inspection of lockers, either individually or on a group basis, is deemed necessary, such inspections can and will take place by school administrators or their designee. If a locker is used to store personal items, (coats, purses, school bags, tec.) those items may also be inspected.
- When a locker is occupied anywhere in the building, it is understood that the occupant assumes all responsibility for contents therein. The Board of Education and its employees cannot be liable for losses that may occur. To protect their locker contents, the Board highly recommends that students use combination locks, which are available upon request. Personal locks of any type are not permitted. If the lock is ruined, lost, or not turned into the office at the end of the school year, the student will be responsible for the cost of the lock. The school authorities reserve the right to use drug dog inspections of students lockers.
- Student parking is provided on school grounds for the use and convenience of students but remain under the jurisdiction and control of school authorities. If inspection of vehicles, either individually or on a group basis, is deemed necessary, such inspections can and will take place by school administrators or their designee. The school authorities reserve the right to use drug dog inspections of the parking lot.

STUDENT/STAFF INTERACTIONS

Students and staff have a right to work, study, and teach in an atmosphere of mutual respect. Students also have the right to free and reasonable inquiry and expression while having the responsibility to respect the authority, feelings, physical well-being and property of school staff members. The following are considered infractions of student-to-staff relationships:

- **Insubordination:** The willful failure to respond or carry out a reasonable request by authorized school personnel. Disciplinary action will range from detention, suspension, possible police referral, and possible expulsion.
- **Disrespect:** To insult, call derogatory names, use obscenity toward, dishonor, or in another manner abuse verbally or in writing any member of the school staff. Disciplinary actions will range from detentions to suspension, possible police referral and possible expulsion. Profanity directed at a staff member will result in suspension and/or possible further disciplinary actions.
- **Threatening or Intimidating Acts:** Verbally or by gesture threatening the well-being, health, or safety of any member of the school staff. Disciplinary action will result in suspension, possible police referral and possible recommendation for expulsion.

STUDENT/STAFF INTERACTIONS, CONTINUED

- **Physical Attack:** The act of physically assaulting any member of the school staff on school property or at any activity under school sponsorship. Disciplinary action will result in automatic suspension, recommendation for expulsion to the school board, and police referral as a felony offense.

VANDALISM, THEFT & THE DESTRUCTION OF SCHOOL/STUDENT PROPERTY

The citizens of the Granton Area School District, including you parents, have provided you with an excellent facility containing excellent buildings and modern equipment. It is your duty to help maintain that appearance of the school. Anyone found willfully damaging school property would be required to pay for the damages and/or replacement of any item. That student may be suspended from school or possibly expelled. Any student caught stealing or destroying either school property, or a fellow student's property, will be required to pay for the loss and also faces suspension from school and possibly expulsion. Appropriate authorities will also be notified and the strongest legal action will be taken. Parents of the parties involved will also be notified.

A vertical orange banner with a white and black triangular shape at the bottom. The text "General Information" is written in white, bold, sans-serif font.

General Information

ACCIDENTS

Every accident in the school building, on the school grounds, or at any athletic event sponsored by the school must be reported immediately to the person in charge and to the school office. The teacher supervising the activity must fill out an accident report form that can be acquired in the office.

Accident Benefit Plan/Insurance:

The school participates in the First Agency, Inc., accident benefit plan. All injuries to students are to be reported to the school office immediately. Authorization for treatment forms, including arrangements for medical treatment, will be completed by parents(s)/guardian and kept on file in the school office. It should be remembered that this coverage only supplements your family's health and insurance coverage. It will not extend payment for bills paid by your own insurance. All athletes need to be aware that they can purchase supplemental insurance.

ANIMALS AT SCHOOL

Everyone enjoys a pet and pets can be educational. However, pets in school can also be distracting. Students are not to bring pets to school unless requested by the teacher as part of a unit or unless the student has made specific arrangements with his/her teacher and has approval from the principal. Usually, parents will be requested to bring the pet to school and take it home again when it has fulfilled its purpose in the classroom.

BULLETIN BOARD INFORMATION

A wide array of information is posted on the bulletin boards outside of the elementary and high school offices. All information posted is to be approved by the building principal and verified with his/her initials. Materials not approved will be removed.

BUS EXPECTATIONS

The school bus is an extension of the classroom. The bus driver, like the teacher in the classroom, has the responsibility for the safety and welfare of the students under his/her charge. It is highly recommended that drivers stop the bus, if necessary, to address student behaviors. If such action is taken, routes may be delayed. The inconvenience is something we apologize for in advance, but the safety of every person on the bus is the district's top priority. School bus transportation is a privilege - not a right. Be informed that misbehavior of any kind will not be tolerated. Pupils who misbehave can be suspended from school or the bus and can be denied bus-riding privileges. Buses are subject to videotaping and students are subject to discipline based on what the tape shows.

General Information

- Accidents
- Animals at school
- Bulletin board information
- Bus rules and regulations
- Cafeteria
- Cell Phone/Electronics
- Child abuse/neglect
- Church night
- Clothing/dress code
- Concerns/chain of command
- Fees/Fines
- Field trips/chaperones
- Library/IMC
- Medication
- Physical Education - Medical exemption
- Parental Involvement-title 1
- Recess
- Safety Drills
- School Board Meetings
- School closing information
- Sickroom/sick students
- Student Services
- Student surveys
- Technology
- Telephone
- Teacher Qualifications
- Visitors

BUS EXPECTATIONS, CONTINUED

Pupil and Parent Responsibilities

- **What if my son/daughter wants to get off at somebody else's bus stop?**
 - ⇒ Bring a note signed by **BOTH** families stating who wants to go where. All notes must have a current date, the child(ren's) name(s), and a parental signature from both families. This will require advanced planning, but it will help us to keep all children safe.
 - ⇒ The note(s) must be copied and kept on file in the office and a bus note will be given to the bus driver.
- **Prior to loading - on the road and at school**
 - ⇒ Be on time at the designated school bus stop. Help keep the bus on schedule.
 - ⇒ Stay off the road until the bus has come to a complete stop before attempting to board the school bus. Line up in an orderly, single file manner. For the safety of all, do not rush to get on the bus.
 - ⇒ Be courteous. Don't take advantage of younger children in order to get a seat.
 - ⇒ If there is no sidewalk or path, you should walk to the side of the road facing traffic to get to the bus stop.
 - ⇒ Use the handrail and watch your step when boarding the school bus.
- **While on the bus**
 - ⇒ Keep the bus safe and sanitary at all times (no open or closed soda, or eating is permitted on the bus).
 - ⇒ Loud talking, laughing, or unnecessary confusion is disturbing to the driver and is not permitted. (Boom boxes and radios are not permitted on the bus).
 - ⇒ Keep head, hands, and feet in the bus at all times.
 - ⇒ Treat bus equipment as valuable furniture found in your home. Offenders must pay for any damages.
 - ⇒ Never tamper with the bus or any of its equipment.
 - ⇒ Don't leave books, lunches, or other personal articles on the bus.
 - ⇒ Keep books, packages, coats, and all other objects out of the aisles.
 - ⇒ Remain in the bus in case of road emergency, unless directed otherwise by the bus driver.
 - ⇒ Do not throw anything out of the bus window.
 - ⇒ Always remain in your seats while the bus is in motion.
 - ⇒ Always be courteous to fellow pupils, the bus driver, the driver's assistant, and to passers-by.
 - ⇒ Keep absolutely quiet when approaching and crossing a railroad crossing.
 - ⇒ The driver is responsible for controlling the bus riders. All riders must obey their driver promptly.
 - ⇒ Parents will be notified if there is continuous misconduct on the bus. Bus riders may be denied the privilege of riding.

BUS EXPECTATIONS, Cont'd

- **After leaving the bus**

- ⇒ Cross the road at least 10 feet in front of the bus, but only after checking to be sure no traffic is approaching and/or after receiving a signal from the driver that it is safe to cross.
- ⇒ Help look after the safety and comfort of small children.
- ⇒ Be alert to the danger signal from the driver. Note: Pre-arranged signal.
- ⇒ Riders are not permitted to leave the bus other than regular stops unless school officials have given proper authorization in advance.

- **Extra curricular activity trips**

- ⇒ The above rules and regulations will apply to any trip under school sponsorship.
- ⇒ Pupils shall respect the wishes of chaperones appointed by the school officials to accompany the bus

- **Spectator buses**

- ⇒ Our school encourages your enthusiastic support and spirit at events scheduled out of town. A spectator bus will be provided if there is sufficient student demand. Students are encouraged to take advantage of this opportunity.
- ⇒ Students who ride the spectator bus to the event must return on the bus unless the principal has approved other arrangements in advance.
- ⇒ All school rules will be strictly adhered to while in attendance at events held at other schools as well as the transportation process.
- ⇒ Students are to remain at the game site from the time of arrival until the departure of the bus.
- ⇒ The cost of the bus is only \$5.00 and must be paid in advance and is not refundable.

CAFETERIA

The school cafeteria serves breakfast and lunch under guidelines set forth by the federal government's programs. Meals are planned to meet nutritional requirements set forth by the U.S. Government for balanced class "A" lunch programs. All Granton Area School students are eligible for meals in the cafeteria. Eating in the lunchroom is a privilege and all school rules and policies apply. Failure to comply with these reasonable requests may result in the loss of this privilege. Currently, the Granton School District participates in a Community Eligibility Provision (CEP). This allows us to serve breakfast and lunch to students at no charge. Students will be charged for second entrees. Money can be deposited into student accounts for second entrees. One family can make one lunch payment. All payments will be entered into the family account. Any unused money will be refunded or credited to the following year's account. Students are not allowed to share their account with other students. If there comes a time where the Granton Area School District is not eligible for CEP, families will be notified of Breakfast and lunch prices, and applications for free and reduced lunch prices would be available in the district office.

General Lunchroom rules and procedures

- Do not rush or push to get in line. This is for your safety and all other persons as well.
- Books and other personal belongings belong in your locker or room during this time.
- Eat all of your food in the lunchroom and return all trays, dirty dishes, and milk cartons to the dishwasher window in the cafeteria.
- Pick up any trash in your area - even if it's not yours!
- Each student is issued a lunch ID number. Students are responsible for the security of this number. If the number is lost, stolen, or forgotten, notify the kitchen staff immediately for a new number.
- When the student goes through the lunch line, he/she will type their ID number into a keypad monitored by lunchroom personnel. When the computer reads the number, it will automatically deduct the correct amount (1 day) from the student's account balance. When the account reaches a certain point (\$5.00) they will be notified that their account is nearing a zero balance.

A vertical orange banner with a white border and a white triangular shape at the bottom. The text "General Information" is written in white, bold, sans-serif font, centered on the banner.

General
Information

CAFETERIA, CONTINUED

Lunch period guidelines/smart snacks

All users of the lunchroom facility are expected to follow the rules of that facility. Students that take part in the school sponsored lunch program are to consume all food taken in the lunch room. At no time is food to leave the lunchroom. Students who bring their own lunch from home are to consume them in the lunchroom. No food or drink is to be consumed in the gymnasiums at any time during the school day. GASD follows the USDA "Smart Snack" Guidelines, therefore students are NOT allowed to have open bags of chips, energy drinks, and or soda in their lockers.

CHILD ABUSE/NEGLECT

Any teacher, administrator, counselor, psychologist, social worker, or other certified school staff member who suspects that a child has been, may be, or is being abused or neglected is required by law to immediately report such suspicions. These suspicions, true or not, will be reported to social services that will do the investigating. The school's legal obligation is to report the matter.

CLOTHING/DRESS CODE

Discretion of what is excessive or in bad taste will be left up to faculty and administration, as defined by the Wisconsin Statute 120.13 (1). It is the responsibility of the school to prohibit students from attending school when their personal appearance or attire is of a nature that interferes with the instructional purpose of the school or attracts undue attention that is detrimental to the normal operation of the Granton School District. By school board direction students shall dress appropriately for all occasions. **The board, with the administration as their representatives, will determine what appropriate dress is.** Students will be sent home unless corrective action is taken. Any exceptions to this dress code can only be made with prior office approval.

The following are guidelines for this policy:

- Clothing endorsing alcohol, drugs, foul language, or sex is unacceptable.
- The wearing of coats, hats, caps, bandannas, hoods, or any type of head covering is prohibited upon entrance into the school and exiting of the building at the end of the regular school day. If you chill easily dress warmer.
- Students are not permitted to display any article of clothing or item that may be interpreted as identification with a gang. These may include, but are not limited to: caps, coats, tattoos, hand signals, graffiti, jewelry, haircuts, belt buckles bandannas, handkerchiefs, gloves, raised pant legs, and straps. A school official will determine if something is a gang identifier. The first instance will result in a warning and the student will immediately remove or cover the identifier. The second violation will result in school discipline.
- Students must wear footwear, and footwear that causes excessive floor marking is prohibited.
- The wearing of arm bands, buttons, or badges bearing slogans or sayings shall be permitted unless they are found to be obscene, libelous, or in direct violation of current legal standards.
- Dark glasses may only be worn with approved medical documentation that is on file with the office.
- Backpacks or briefcases are not to be carried during the school day. There is enough time between classes for students to get the necessary material for their next class. Students will be allowed to bring backpacks to school, however they must leave them in their lockers.
- Clothing is expected to cover your stomach, chest, back, buttocks, and all undergarments. Skirts must extend a minimum or mid-thigh length. Shorts must reasonably cover the buttocks and undergarments as determined by staff. Tank top straps should be at least two fingers wide and should cover undergarments as well.



CLOTHING/DRESS CODE, CONTINUED

What clothing is not permissible?

- Spaghetti straps, bare mid-ribs, open back shirts, strapless shirt, mini-skirts, pants worn below the waist line.
- Any clothing that exposes undergarments (tank tops, loose fitting shirts and pants, sheer clothing)
- Other questionable dress should be referred to the principal or superintendent for a determination.
- Clothing or accessories that are deemed a danger to self or others must be removed. This included but is not limited to long chains, spikes, loose fitting clothing (worn around machines) etc.

CONCERNS/CHAIN OF COMMAND

Our society has a “chain of command.” If you experience a problem of some kind at school with another student, teacher, parent, coach, etc. please go to the root of the problem and work your way up from there. Calling the principal to address an issue with a teacher, when the teacher has never been contacted, is not the proper way to handle the problem. Contacting the teacher first is the appropriate step.

ELECTRONIC DEVICES; INCLUDING CELL PHONES

Possession and/or use of personal telecommunication devices, including mobile phones, pagers, iPods, iTouch, MP3 or other electronic devices may be used before or after school. If a device is being used during the school day, school personnel may confiscate it. If your child must have a personal telecommunication device, it must remain in their backpack, and TURNED OFF throughout the school day. Texting and/or videotaping are not permitted at any time during the school day.

The use of mobile telephones or any device capable of capturing images is strictly prohibited in locker rooms, or restroom areas while at school and at school-related/sponsored events. The district is not responsible for any damaged, lost or stolen electronic device.

We ask that families and students use the main office when communicating messages from home or school. Failure to follow these guidelines will result in the confiscation of that device, along with disciplinary action.

Devices may be used in conjunction with medical necessity and/or used in the classroom for educational unit purposes if pre-approved by administration

- **1st offense:** Student will be asked to surrender his/her device to school personnel and can pick up at the conclusion of the school day.
- **2nd offense:** The device will need to be picked up by a parent/guardian in the main office and the student will receive disciplinary action related to our behavioral system
- **3rd offense:** There will be a meeting with administration to create a personal electronics plan/contract for the remainder of the school year.

FEES AND FINES

- **Fee** - Some courses require the student to purchase materials for project that they will keep. Students are subject to fines for library books, textbook abuse, lost materials, and breakage. All student fees and fines must be paid before the student will be cleared for the school year.
- **Textbook Fee/Fine** -Student may be charged replacement costs if the materials are lost or defaced. Simply, once given the book, or item in question, the student is responsible for its return in a very similar condition as when it was issued. Students may be fined for damages to textbooks that are above and beyond routine wear. Students are encouraged to write their name in the space provided inside the cover and also place a book cover on all of their textbooks to serve as added protection. The classroom teacher will record all pertinent information including the number and condition of the book at the time of issuance. Should a student be fined for a textbook upon signing out with their instructor, the student will **a)** be told of the fine, **b)** the teacher will attempt to contact the parent by phone within 24 hours to inform them of the fine as it may be substantial, and **c)** the fine information will be written on the student's sign-out sheet. The School Board believes that textbooks have a quality use for seven years. Any book that is not fined for replacement will be levied a fine that will be prorated.

General
Information

General Information

FIELD TRIPS/CHAPERONES

No more than two school-approved chaperones will attend a classroom field trip; additional chaperones may be added at the discretion of the administration for longer trips that involve a significant number of students. All chaperones are subject to background checks as well. If other parents wish to attend the trips they must do so at their own expense. All school policies are in place while students and staff are off school grounds for a school related activity.

LIBRARY/IMC

The school library/IMC is a learning resource center available to all students K-12. The library is intended to be a quiet area where students can go, when time permits, to use the available resources. Students are expected to obey all established library rules as set forth by the IMC coordinator.

MEDICATION

As per Granton Area School District Board Policy Code Chapter 5: Section C

Efforts are to be made to avoid medication administration at school. Medication, prescription or over the counter, must be maintained in the high school office. Medication administered by the office must have a Parent/Guardian Medical authorization form sent with medication. If the medication is prescribed, a Doctor's form is also required.

At no time are school staff to distribute medications of any kind, including aspirin, to a student without a signed parent authorization form that is on file with the office. The school will assume responsibility for:

- Being aware of students who are on medication. **(It is the parent/guardian's responsibility to inform the school if their child is in possession of prescription drugs while at school.)**
- Checking the type, dosage, and purpose of these medications.
- Appointing an appropriate person to assist in administering medication.
- Keeping accurate and confidential records of pupils receiving medication.
- Providing a safe place to keep medication.

If your child is to receive medication at school, the following must be on file:

- A completed school medication form available in the school office signed by the parent, and physician, if it is a prescription medication.
- All prescription medications must be in a properly labeled bottle with the following information:
Name and phone number of pharmacy

PHYSICAL EDUCATION – MEDICAL EXEMPTION

Students who temporarily cannot participate actively in the program must present their physical education teacher with a written excuse from a licensed physician or doctor. It is the student's responsibility to return to active participation at the prescribed time on the medical excuse. Students who are unable to participate may remain with the physical education class or may be temporarily scheduled into a study hall until the student is able to return and participate in physical education. To receive a medical exemption for physical education a student must face scheduling conflicts that do not allow the credit requirements to be met because of medical conditions that were/are beyond the individual's control. However, should the student's schedule allow for the scheduling of physical education the course must be taken.

PARENTAL INVOLVEMENT/TITLE1

As per Granton Area School District Board Policy code Chapter 9: Section M

The Granton School Board recognizes the importance of parent/guardian input into the education of their children. The Board further recognizes parent participation in the design and implementation of the district's educational curriculum to allow for comprehensive programs for their children. As evidence of the school board's commitment to parent involvement in Title I, we are adopting the following activities as a response to regulation 200.53 of the May 19, 1986, Federal Register.

The Granton School District designates the Title 1 teachers to coordinate parent activities in order to ensure that parents of the children being served have an adequate opportunity to participate in the design and implementation of the Title I Project.

The following activities will be adopted:

- Training parents to promote the education of their children at home
- Facilitating volunteer or paid participation by parents in school activities
- Designating LEA parent coordinators
- Holding an annual meeting of parents of all eligible Title I students
- Implement and review the school-parent compact
- Provide parent representation during school wide committee meetings

RECESS

Weather permitting, and if their behavior allows, all students will be required to go out for recess. The only acceptable reason for a student remaining indoors is a written excuse **from a physician** indicating the medical reason for exclusion. This excuse should indicate the time period involved and any other restrictions placed on the student. Generally, the rule of thumb is that if the student is well enough to be in school, he/she is well enough to participate in recess. Coats are required of all students if the outside temperature is below 50 degrees. During the winter months, appropriate outside clothing is required. As a general policy sleds are not to be brought from home; however, the roll up sleds may be allowed. Please check with the classroom teacher as winter begins.

SAFETY DRILLS

All classrooms are to have emergency directions posted by the classroom door. These directions will point you in the proper direction in the event of an emergency. In the event of a fire drill you will leave the building by walking (not running) in a single file line. You are to leave all personal belongings in the building and leave immediately. Exit the building at a minimum distance of 100 feet. Always keep quiet listening for instructions from school and safety personnel. Additional safety drills will occur during the year. Please always listen to your teacher's instructions and remain calm.

SCHOOL BOARD MEETINGS

Unless announced otherwise, school board meetings are held the second Monday of every month in the Library/IMC at 6:45pm. If you have something you wish to discuss at a board meeting please contact the district administrator to discuss the items as it may be placed on the agenda. Your attendance is encouraged as only informed citizens can make an informed decision.

SCHOOL CLOSING & EMERGENCY INFORMATION

The district administrator and bus supervisor will weigh all pertinent factors and may consult with all appropriate resources in making the decision to close or delay the start of school. Students, parents, and staff will be informed of school closing as early as practical by announcements on: 1 Notice will be made through an *automated telephone system*. 2 Radio Stations including WCCN, WAXX, WDLB, etc. 3. *Television stations 7,9, and 13*. Please do not call the school to ask if the school will be, or is, closed. This ties up the phone lines and prevents its use in the case of an emergency; tune into the local media outlets for that information. Information will also be posted on the school web page as quickly as possible. You, as parents, may decide that the weather is too severe to send your child to school (especially a younger child). The school respects your decision in this matter. If you do keep your child home, please contact the school of the absence and send a note to school with the child when they return. If the school closes, all athletic, after-school, and evening events related to the school are canceled.

SICKROOM/SICK STUDENTS

The school does not employ a full time nurse or have somebody on call to deal with ill children. If a student does not feel well prior to leaving for school, you are encouraged to keep them home. If a student believes they are too ill to attend class they should go home. Arrangements will be made by the parents to get the student home.

STUDENT SERVICES INFORMATION

The professionals in our Student Service office are here to serve all students and their families. Our goal is to help students achieve their personal and academic best. Our philosophy is that all students can and will excel with support from within the school and their home.

Services that are offered through the student services staff are: special education consultation and evaluation, 504 coordination, classroom development guidance lessons for all students, small group work, individual career, academic, personal and social counseling, parent support and resources, college planning, scholarship information and class scheduling. Please see guidance counselor for more information.

STUDENT SURVEYS

The School Board respects the privacy rights of parent and their children. No student shall be required to participate in any survey associated with a school program or the District's curriculum, or which is administered by a third party in the schools if the survey includes one or more of the following items:

- political affiliations or beliefs of the student or the student's parent;
- mental and psychological problems of the student or the student's family;
- sex behavior or attitudes;
- illegal, anti-social, self-incriminating or demeaning behavior;
- critical appraisals of other individuals with whom students have close family relationships; legally recognized privileged or analogous relationships such as those of lawyers, physicians and ministers;
- religious practices, affiliations or beliefs of the student or the student's parent;
- Income, other than that required by law to determine eligibility for participation in a program or for receiving financial assistance under such a program.

Parents/guardians shall be given the opportunity to request that their child not participate in a survey containing the above information. If a survey containing any of the above information is funded in whole or in part by a program administered by the U.S. Department of Education, written consent shall be obtained from the student or in the case of a minor student, the student's parent/guardian before the student participates in the survey. Please refer to board policy for further details.

TECHNOLOGY

The Granton Area School District supports the use of technology by its students, staff and community. It recognizes that computer, computer networks, and databases are resources for educational and training opportunities for all citizens. (At present, community classes are limited to scheduled courses with the potential for more individualized sessions in the future.) Its primary mission being the education of youth, students (and staff involved in local educational purposes) will be given priority use of all computer equipment in the buildings and software program access.

General Information

TECHNOLOGY, CONTINUED

DISTRICT WEB PAGE

There shall be one authorized web page for the *Granton Area School District*. The purposes for developing a World Wide Web page for Granton are: (1) to provide an opportunity for staff to highlight their programs, courses, objectives, and curriculum openly with those interested in learning more about what is offered at Granton Schools; (2) to provide an opportunity for students; and (3) to provide information about Granton schools for public viewing.

Student photos or student's work may be featured unless the school district has on file written notice stating that they do not wish to have this type of information made available to the public. For more information regarding directory information families should contact the District Office. A directory information release form is sent out annually in the August newsletter.

INTERNET SAFETY & COMPUTER USE

Use of District computers and computer networks shall be in support of education and research and consistent with the educational objectives of the *Granton Area School District*. District staff users may use the District's e-mail and Internet system for informal or personal purposes within reasonable limits, consistent with the guides set forth in the policy. Students may access the Internet via District computers as part of classroom activities or for class projects. Student internet use in the classroom shall be under the direct supervision of the classroom teacher, and internet use by students at other locations within the school shall be under the direct supervision of the designated supervisor of that area. **Use of the Internet is a privilege, not a right.** No student or adult user may use District computers or computer networks to access the Internet unless they have signed a computer/internet acceptable use agreement. Student acceptable use agreements shall also be signed by the student's parent/guardian.

Internet filtering software will be used on District computers in an effort to limit access to inappropriate or harmful material on the Internet. The District acknowledges that even with a filtering system, complete control and/or access to objectionable material cannot be assured. The *Granton Area School District* is not liable for information contained or accessed on the Internet.

All who access the Internet through the *Granton Area School District's* system are responsible for lawful and appropriate behavior on computer networks. The following are guides for acceptable use of District computer networks, including the Internet; they are not meant to be all-inclusive:

1. Users may not access, copy or modify the files or data of another user. Users will access their own files and accounts only.
2. Network access may not be used for commercial purposes, nor for any illegal activities exemplified by (but not limited to) the following:
 - copying or circulating copyrighted materials.
 - Writing and transmitting messages that threaten, harass, frighten, intimidate or annoy others.
 - Accessing unauthorized services, or attempting to circumvent security measures.
 - Circulating files, which may corrupt the integrity of the network (e.g., viruses).
3. Users will not access internet sites, chat rooms, or use e-mail that contain pornography or materials that are obscene, harmful to minors or otherwise inappropriate. If such sites are accessed accidentally, the user is to exit immediately.
4. Users are expected to help maintain the integrity of the system. Modifications, additions to, or abuses of hardware or software are not allowed. Use of personal removable disks is allowed by district staff. Student use of removable disks is allowed with **prior approval**. The interface of personal devices (palm pilots, hand-held computers, etc.) with district equipment is prohibited. Individuals will be personally liable for any virus or destructive acts that cause damage to any portion of a computer or the network system. If there are problems, they should be reported to the Computer Specialist.
5. Because of the potential for viruses, hostile programs, unauthorized software, and limitations on hard disk space, files from the internet are not to be downloaded into the system. Downloading to removable disk is prohibited except **with prior approval** from the Computer Specialist.
6. Users are expected to limit their printing to that which is absolutely necessary. Printed pages for non-class-related activities may be made at the current per page charge.

General Information

TECHNOLOGY, CONTINUED

7. As a personal safety issue, users are cautioned not to reveal personal information (address, phone number, location, passwords, etc.) over the Internet. **Chat room use must be authorized** by the building principal. Student e-mail use will be allowed within the district network of school sanctioned distance learning. Adult users must adhere to the conditions of the computer/internet use policy.
8. Users are expected to follow all rules that are posted in the lab and classroom areas in which computer access is available.
9. Users are reminded that all electronic communication systems (e-mail) and all information transmitted by, received from, or stored in, the systems are the property of the *Granton Area School District*. **Users have no expectation of privacy in connection with the use of this equipment or with the transmission, receipt, or storage of information in this equipment.** The District reserves the right to access all files in the course of normal maintenance or when there is cause to suspect misuse of the system.
10. Users are reminded that Internet access is a shared resource, and it may be necessary to limit access time or put priorities in place for equipment use.
11. Uploading of any materials is permissible only under staff supervision and with prior approval from the Computer Specialist.

USE OF THE INTERNET

The Granton Area School District recognizes the need to provide technology to further the educational goals and mission of the District. The internet and other computer networks provide unique educational and communication opportunities and challenges to a learning community. Teachers and library media specialists have a professional responsibility to blend thoughtful use of such information with the curriculum and to provide guidance and instruction to students in the appropriate use of such resources. Staff will be responsible for enforcing the guidelines for instructional resources and the goals for the selection of instructional materials contained in Board policy. Use of the Internet and similar communications networks by staff and students is a privilege. Access will be given as consistent with District policies and educational objectives.

Conditions of Use:

1. All users will comply with legal requirements regarding the use, reproduction and distribution of copyrighted works.
2. All users will be expected to comply with privacy and security standards.
3. All users will be expected to demonstrate ethical behavior in using network facilities and to avoid any illegal activities, including tampering with hardware or software, vandalism, destruction of computer files or transmission of any material in violation of any state or federal law or regulation. The latter includes, but is not limited to, copyrighted material, threatening, inflammatory or obscene material, or material protected by trade secret.
4. Students will be granted access upon written permission by their parent or guardian.
5. Access to network services will be provided to all users who act in a considerate and responsible manner and conduct themselves in accordance with rules outlined in their handbooks. Failure to obey rules or directions will result in disciplinary action.
6. It is the responsibility of the entire educational community and the Library/Media Technology Coordinator to oversee the use of the District's computers. Violations of the policies, rules or procedures will be reported to the building principal.
7. Students and staff violating the above rules may be subject to school discipline, up to and including expulsion. They also may be denied future Internet/on-line service access and will be reported to the police or proper authority if in violation of law.

TECHNOLOGY, CONTINUED

Access to Global Information resources Procedure

Students and staff are reminded that the use of Internet is a privilege, not a right. The purpose of Internet is to facilitate communications in support of research and education by providing access to unique resources and an opportunity for collaborative work. Some material on the Internet may contain items that are inaccurate or potentially offensive to some people. Parents/guardians who wish to exempt their child from having access to or using the Internet should submit a written statement to that effect to the building principal.

General Use Rules:

1. Students and staff must adhere to the same standards of conduct expected and required in the classroom.
2. Transmission or reproduction of any material in violation of any United States or state regulation is prohibited. This includes but is not limited to copyrighted material, threatening or obscene material, or material protected by trade secret.
3. Students must always get permission from the instructors or library staff before using the network or accessing any specific file or application. Written and oral classroom instructions must be followed.
4. Students who have a need to use a given computer for academic reasons will have priority over any non-academic use of that computer.
5. E-mail at school is for school related use only. It is NOT for personal use.
6. Designated school personnel may conduct random checks of users who are on line with the Internet or other computer network.

Rules of Network Etiquette

All students and staff are expected to abide by the generally accepted rules of network etiquette. These rules include the following:

1. Appropriate language must be used at all times. Network users will not swear, use vulgarities or any other inappropriate language, or engage in activities which are prohibited under state or federal law.
2. Harassment and vandalism will not be tolerated. Harassment is defined as the persistent annoyance of another user or the interference of another user's work. Vandalism is defined as any malicious attempt to harm, modify or destroy data of another user or network equipment. Vandalism and harassment will result in disciplinary action.
3. It is the user's responsibility to avoid inappropriate materials.
4. Users must remember that electronic mail (e-mail) is not private.
5. Students and staff will not reveal any personal address or phone number or those of any other person.
6. Users will not use the network in such a way that would disrupt the use of the network by others users.

Penalties for Improper Use

Violation of these rules, applicable state and federal laws or classroom and/or district rules will result in loss of network privileges and/or other disciplinary action. Violations could also lead to referral to legal authorities.

1:1 Technology Policy

In this policy, "Chromebook/iPad" will be referred to as "device". The devices and bags/cases are issued to all students and are the property of the GASD. The device is on loan and must be used in accordance with the following policies and procedures.

1. The device and bag/case should be kept clean and free of marks at all times. Placing stickers, writing or drawing on, engraving or otherwise defacing the device and bag/case are not allowed.
2. When transporting a device to and from school, students should always be sure it is placed in the device bag/case. Device labels must remain on the device at all times.
3. Devices should be placed on the top shelf when stored in lockers.
4. Devices are assigned to individual students. Students should never "swap" or "share" their device with another student.
5. Students are responsible for bringing their device, fully charged, to school each day.
6. Devices will be randomly check to determine if students have the appropriate device and are using the device appropriately .

TECHNOLOGY, CONTINUED

INTERNET SAFETY POLICY

Introduction - It is the Policy of the Granton Area School District to:

- Prevent user access over its computer network to, or transmission of, inappropriate material via Internet, electronic mail, or other forms of direct electronic communications;
- Prevent unauthorized access and other unlawful online activity;
- Prevent unauthorized online disclosure, use, or dissemination of personal identification information of minors, and;
- Comply with the Children’s Internet Protection Act [Pub. L. No. 106-554 and 47 USC 254 (h)].

Definitions - Key terms are as defined in the Children’s Internet Protection Act.

Access to Inappropriate Material -To the extent practical, technology protection measures (or “Internet filters”) shall be used to block or filter Internet, or other forms of electronic communications, access to inappropriate information. Specifically, as required by the Children’s Internet Protection Act, blocking shall be applied to visual depiction of material deemed obscene or child pornography, or in any material harmful to minors. Subject to staff supervision, technology protection measures may be disabled or, in the case of minors, minimized only for bona fide research or other lawful purposes.

Inappropriate Network Usage - To the extent practical, steps shall be taken to promote the safety and security of users of the Granton Area School District online computer network when using electronic mail, chat rooms, instant messaging, and other forms of direct electronic communications. Specifically, as required by the Children’s Internet Protection Act, prevention of inappropriate network usage includes:

1. Unauthorized access, including so-called ‘hacking,’ and other unlawful activities; and
2. Unauthorized disclosure, use, and dissemination of personal identification information regarding minors.

Supervision and Monitoring - It shall be the responsibility of all members of the Granton Area School District staff to supervise and monitor usage of the online computer network and access to the Internet in accordance with this policy and the Children’s Internet Protection Act. Procedures for the disabling or otherwise modifying any technology protection measures shall be the responsibility of the district.

DISCIPLINARY PROCEDURES FOR INTERNET AND COMPUTER USE POLICY VIOLATIONS

As per Granton Area School District Board Policy Code Chapter 9: Section IC

The building principal or designee shall have discretion to deal with violations of this policy. Misuse of District computer networks, including the Internet, may result in school disciplinary action, including loss of computer network use privileges. If the misuse constitutes a criminal offense, appropriate legal action may also be taken.

Student Violations; Students who violate the District’s computer/internet use policy shall be subject to the following disciplinary actions:

- **First Offense** - Loss of all computer/internet access for no less than ten (10) school days. Parent(s)/guardian(s) will be notified of loss of computer network use privileges.
- **Second Offense** - Loss of all computer/internet access for no less than forty-five (45) school days. Parents(s)/guardians(s) will be notified of loss of computer network use privileges. Computer network use privileges will be restored on a conditional basis following the revocation period and parent/guardian meeting.
- **Third Offense;** Loss of all computer/internet access for the remainder of the year. Parents(s)/guardian(s) will be notified of loss of computer network use privileges. A meeting with the parent/guardian must be held before consideration of restoring computer network use privileges, which may be restored on a conditional basis following the revocation period and the parent/guardian meeting.

Employee Violations; Abuse of the District’s computer/Internet use policy by District employees may result in disciplinary action up to and including termination from employment.

Citizen Violations; Citizens who violate the District’s computer/internet use policy may lose their computer network use privileges.

Accidental Damage

1. On an annual basis, the student will incur a \$10.00 fee the first time a device has to be repaired.
2. If a device has to be repaired a second time, a \$25.00 fee will be charged. The student will not be allowed to take device home until the fee is paid.
3. For the third incident and any incident thereafter, the student will be charged the cost of associated with fixing and/or replacement of the technology. An administrative decision will be made regarding the student's take-home privileges for the remainder of the year.

If a student loses or destroys beyond repair any of the following components , they will be charged full replacement costs for those items.

1. Power module/cord
2. Bag/Case
3. Any device (Full Replacement Cost)

The use of any district technology is a privilege and not a right. Students are expected to use their device in accordance with these policies and procedures, and District Acceptable Use Policy and any applicable laws. Failure to use the device in an appropriate manner will result in the following consequences, as determined by the staff and administration of the Granton Area School District.

1. Cancellation of student use or privileges, including the privilege of taking the device home.
2. Suspension from school
3. Expulsion from school
4. Civil or criminal liability under applicable laws.

TELEPHONE

A telephone for student use is available in the elementary office. This telephone is available for emergency calls only. Permission must be obtained by office staff before any calls are made. All other telephones in the building are off limits to student use.

TEACHER QUALIFICATIONS

It is required by federal law that you are given access to information regarding the qualifications of teachers within the Granton Area School District. You might have questions, such as:

- Is my child's teacher licensed to teach the grades or subjects he/she teaches?
- Has the state waived any requirements for my child's teacher?
- What was the college major of my child's teacher?
- What degree(s) does my child's teacher hold?
- Are there instructional aides working with my child? If so, what their qualifications?

In Wisconsin, all teachers are required to have at least a bachelor's degree. If you are interested in seeing the state qualifications for your child's teacher, you may contact the school or check the Wisconsin Department of public Instruction's website at www.dpi.state.wi.us/dpi/dlsis/tel/liserach.html

VISITORS

Due to safety concerns, students are not allowed to bring visitors to school. However, the principal or superintendent may make exceptions to this rule. **Parents are encouraged to attend and are welcome at all times.** However, parents must check in at the office as is policy for any visitor to the school.

Will my child eat breakfast and lunch?

We sure hope so! Both are available and free to all Granton students.

What should I do if my child is absent?

Please fill out the Google Form in our Granton App and on our Website.

Be sure to check out attendance/truancy guidelines in this handbook for additional details on absences.

What if I need to pick up my child early?

Please fill out the Google Form in our Granton App and on our Website. All bus changes need to be communicated with the office before 2pm so that we have time to communicate your child's transportation plan. Your child will need to check out in the Principal's Office.

If you come into school, you will need to sign in as well.

What if I need to get a hold of my child Immediately?

Please call the Principal's office (715-238-7175). Students are not allowed to use their phones during the school (other than lunch).

What if I have concerns about what my child is learning?

Please encourage your child to talk to his/her teacher. If after your child tries to resolve the issue, please reach out to your child's teacher. Our staff is a great group of dedicated professionals who enjoy working with secondary students and want the same thing for your child that you do; success! The best way to get a hold of our teachers are via email (emails are located in infinite campus) or telephone (715-238-7175).

How can I help my child be more successful in school?

Have conversations with your child about their day, their homework, up-coming tests and events and of course, always encourage your child to read, read, read!

Who is my child's teacher?

Our high quality staff are a mix of experienced and new educators who are proud to be Granton Bulldogs! We have an eight period day with homeroom, so your child will have a variety of our dedicated professionals. Your child should provide more information to you as school starts and teachers will be handing out syllabi the first week as well. As always, please partner with your child's teachers to bring out the best in your child.

Please contact us with any questions.

*Thank you for you partnership in
your child's learning!*

Go Bulldogs!

GRANTON MIDDLE & HIGH SCHOOL STUDENT AND PARENT HANDBOOK 2022-2023

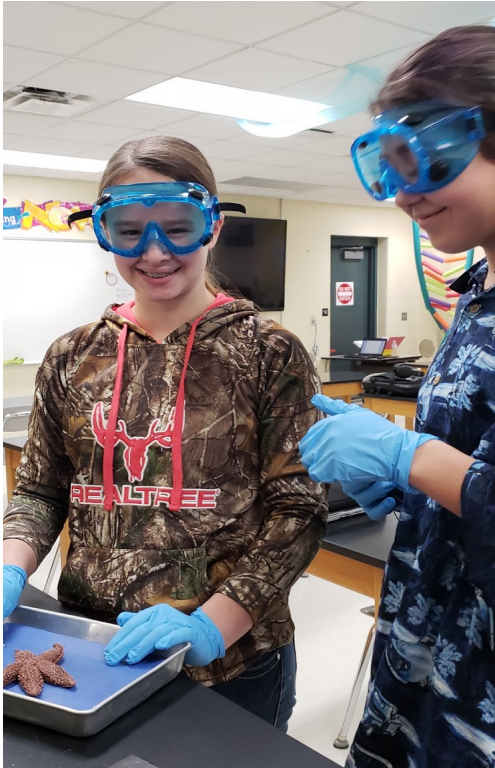

Dear Granton Community,

It is with great excitement that we welcome you to the start our 2022-2023 Granton Middle and High School Year! The teachers and staff at Granton Middle and High School are a skilled team who enjoy working with secondary students and are dedicated to supporting the vision and mission of the Granton Area School District. We offer amazing opportunities for all students to be successful in every aspect of their lives and we hope our students take advantage of every program, course, activity and sport that can maximize their educational involvement.

We know a strong partnership with you will make a difference in your child's education. As partners, we share the responsibility for your child's success and want you to know we will do our very best to carry out our responsibilities. As parents, we hope you continually encourage and support your child to be involved as they embark on their once in a lifetime school journey. Please use this parent/student handbook (also available on our website), communication with our teachers and staff, and an open invitation to visit us to learn more about the wonderful opportunities available with Granton Schools.

An amazing school year awaits your child! On behalf of our Middle school and High School faculty and staff; *Thank you for your partnership in your child's learning and welcome to the 2022-2023 School Year!*



Principal Office:

715-238-7175

Principal : Mrs. Amanda Kraus

4K-12 Secretary: Mrs. Tammie Cramer

Guidance Counselor: Mrs. Shelly Schmitz



Table Of Contents

Calendar.....4

Faculty and Staff.....5

Schedules & Extra Curriculars6

Educational Philosophy.....7

Academic Information.....9

Attendance Information.....16

Behavior Expectations/Information.....20

General Information.....27

Frequently Asked Questions.....40

Nondiscrimination Statement: The Granton Area School District complies with all state and federal laws and regulations prohibiting discrimination, and with all requirements and regulations of the Department of Public Instruction of the State of Wisconsin and U.S. Department of Education. It is the policy of the Granton Area School District that no person, on the basis of sex, race, religion, color, national origin (including a student whose primary language is not English), ancestry, creed, pregnancy, parental status, marital status, sexual orientation, or physical, mental, emotional or learning disability shall be discriminated against, excluded from participation in, or denied the benefit of any curricular, extra-curricular, pupil services, recreational or other program or activity, or employment, for which it is responsible.

GRANTON AREA SCHOOL 2022-2023 CALENDAR

AUGUST 2022

S	M	T	W	Th	F	S
	1	2	3	4	5	6
7	8	9	10	11	12	13
14	15	16	17	18	19	20
21	22	23	24	25	26	27
28	29	30	31			

15 New Teacher In-Service
16-17 Teacher PD/Work Day
18 All Staff PD 12-8pm
 Open house 6-8pm
22 Teacher ½ Work Day
23 First Day of School

7 Student Days

FEBRUARY 2023

S	M	T	W	Th	F	S
			1	2	3	4
5	6	7	8	9	10	11
12	13	14	15	16	17	18
19	20	21	22	23	24	25
26	27	28				

23 Student Day Early Release at Noon
 P/T Conferences 1-8pm
24 Teacher PD ½ Day
 No School

19.5 Student Days

SEPTEMBER 2022

S	M	T	W	Th	F	S
				1	2	3
4	5	6	7	8	9	10
11	12	13	14	15	16	17
18	19	20	21	22	23	24
25	26	27	28	29	30	

2 No School
5 Labor Day
 No School
23 All Staff PD Day
 No School

19 Student Days

MARCH 2023

S	M	T	W	Th	F	S
			1	2	3	4
5	6	7	8	9	10	11
12	13	14	15	16	17	18
19	20	21	22	23	24	25
26	27	28	29	30	31	

17 End of 3rd Quarter
20 Teacher PD/Work Day
 No School

22 Student Days

OCTOBER 2022

S	M	T	W	Th	F	S
						1
2	3	4	5	6	7	8
9	10	11	12	13	14	15
16	17	18	19	20	21	22
23	24	25	26	27	28	29
30	31					

13 Student Day Early Release at Noon
 P/T Conferences 1-8pm
14 No School
28 End of 1st Quarter
31 Teacher PD/Work Day
 No School

19.5 Student Days

APRIL 2023

S	M	T	W	Th	F	S
						1
2	3	4	5	6	7	8
9	10	11	12	13	14	15
16	17	18	19	20	21	22
23	24	25	26	27	28	29
30						

7-10 Easter Holiday Break
 No School
21 All Staff PD Day
 No School

17 Student Days

NOVEMBER 2022

S	M	T	W	Th	F	S
		1	2	3	4	5
6	7	8	9	10	11	12
13	14	15	16	17	18	19
20	21	22	23	24	25	26
27	28	29	30			

23-25 Thanksgiving Break
 No School

19 Student Days

MAY 2023

S	M	T	W	Th	F	S
	1	2	3	4	5	6
7	8	9	10	11	12	13
14	15	16	17	18	19	20
21	22	23	24	25	26	27
28	29	30	31			

12 Reinforcement Day
26 End of 4th Quarter
 Last Day of School
27 Graduation
29 Memorial Day
30 Teacher PD/Work Day

20 Student Days

DECEMBER 2022

S	M	T	W	Th	F	S
				1	2	3
4	5	6	7	8	9	10
11	12	13	14	15	16	17
18	19	20	21	22	23	24
25	26	27	28	29	30	31

23-31 Holiday Break
 No School

16 Student Days

JUNE 2023

S	M	T	W	Th	F	S
				1	2	3
4	5	6	7	8	9	10
11	12	13	14	15	16	17
18	19	20	21	22	23	24
25	26	27	28	29	30	

5-30 Summer School

JANUARY 2023

S	M	T	W	Th	F	S
1	2	3	4	5	6	7
8	9	10	11	12	13	14
15	16	17	18	19	20	21
22	23	24	25	26	27	28
29	30	31				

2 Holiday Break
 No School
13 End of 2nd Quarter
16 Teacher PD/Work Day
 No School

20 Student Days

Quarter 1 45.5 Days
 Quarter 2 44 Days
 Quarter 3 43.5 Days
 Quarter 4 46 Days
 Total 179 Days

Approved 2/14/2022

Color Key

- Teacher PD/Work Day
- 1st Day of School/End of Quarter
- No School
- Early Release P/T Conferences
- Reinforcement Day
- Graduation
- Summer School

Faculty and Staff

Faculty & staff may have changed since this handbook has been printed. Please check our website and refer to each class's syllabi from the first week of school for the most updated information.



AGRICULTURE

Katie Reider

ART

Dana Klein

ENGLISH

Blair Necas

HEALTH

Angela Schier

LIBRARIAN/ASSISTANT

Kay Heiting, Librarian

Missy Walz

Janet Boh

MATHEMATICS

Cody Roggenbauer

MIDDLE SCHOOL

Olyvia Pierce

John Legrid

Stina Jansen (interventions)

Laura Hanna (Interventions)

MUSIC ARTS

Autumn Lloyd— Choir

Keaton Wegner—Band

PHYSICAL EDUCATION

Angela Schier

SCIENCE

Lisa Larsen

Katie Reider

SOCIAL STUDIES

Lindsey Halverson

SPANISH

Cristopher Marquez

TECHNOLOGY EDUCATION

Kevin Pankratz

SPECIAL EDUCATION

SERVICES

Steven Johansen

Alison Painter

Stina Jansen

WORK-BASED LEARNING COORDINATOR

Kevin Pankratz

SCHOOL COUNSELOR

Shelly Schmitz

ASSESSMENT COORDINATOR

Shelly Schmitz

SCHOOL ASSESSMENT/ DISTANCE LEARNING COORDINATOR

Lindsey Halverson

TECHNOLOGY COORDINATOR

Steve Rowe

ACADEMIC / BEHAVIOR INTERVENTIONIST

Dale Rollins

TEACHER ASSISTANTS

Laurie Falk

Caroline Walter

Ruth Buettner

Mathew Tarlecki

Ryan Johnson

4K-12 OFFICE SECRETARY

Tammie Cramer

PRINCIPAL

Amanda Kraus

FOOD SERVICE

Kimmer Butts, Manager

Sheila Roehl

Cindy Gotz

Kimberly Ganther

CUSTODIANS

Tim Steinbach

Robby Roehl

Tim Luchterhand

Kimberly Ganther

DISTRICT OFFICES

Sheila Kind, Admin. Assistant

Char Johnson, Admin. Assistant/

Food Service Director

Joseph Andrashie, Bookkeeper

James Kuchta, Superintendent

Schedules & Extra- Curriculars

BELL SCHEDULE

Doors Open: 7:30

Breakfast: 7:30-8:00

Homeroom: 8:00-8:29

1st Hour: 8:32-9:17

2nd Hour 9:20-10:05

3rd Hour: 10:08-10:53

4th Hour: 10:56-11:41

HS 5th Hour: 11:44-12:29

MS 5th Hour: 12:11-12:56

6th Hour: 12:59-1:44

7th Hour: 1:47-2:32

8th Hour WIN Time: 2:35-3:20

Lunch A: 11:41-12:11 (MS)

Lunch B: 12:29-12:59 (HS)

ATHLETICS

Dan Hebert ; Athletic
Director

Baseball - Andy Radloff

Basketball (boys) - Omar Young

Basketball (girls) - Andy Radloff

Track - Cody Roggenbauer and Katie
Reider

Wrestling– Parker Vivoda & Darrell
Laschen

Volleyball– Keaton Wegner

Cross Country (Neillsville Co-op)

Football (Neillsville Co-op)

Softball (Neillsville Co-op)

INSTRAMURAL SPORTS

Basketball, volleyball, kickball -
Angela Schier

STUDENT SERVICES

On-line Learning Center –Steve
Rowe

Teen Leadership - Shelly Schmitz

BLAST - Shelly Schmitz

COMMUNICATIONS

Yearbook -

Facebook - Annette Woller

Webpage - Dana Klein

STUDENT ORGANIZATIONS

Visioneers -Dana Klein

FFA - Katie Reider

Forensics - Kay Heiting

Student Council - Lindsey Halverson

Spanish Club - Cristopher Marquez

STUDENT GOVERNMENT

OPPORTUNITIES

Freshman Class advisors -
Lindsey Halverson, Autumn Lloyd &
Cristopher Marquez

Sophomore Class advisors -

Cody Roggenbauer & Katie Reider

Junior Class advisors -

Blair Necas, Keaton Wegner & Kevin
Pankratz

Senior Class advisors -

Lisa Larson & Angela Schier

HONORS

National Honor Society -

Scholar Athlete– Dan Hebert

PERFORMING ARTS

Concert Choir - Autumn Lloyd

MEETING TIMES

Co-curricular meeting
Times will vary
throughout the year and
may include; before
school (7:40), Fridays
during homeroom, lunch,
rolling class periods,
and/or after school.

*If class time is missed, students are
responsible to get the work prior and
turn it in on time. Please be sure
students communicate with
advisors/coaches about
arrangements.*

Educational Philosophy

Policies may be revised during the course of the year. When that occurs a notification will be sent out and updated copy of this Student Handbook will be available in the high school office.

Please see <http://www.granton.k12.wi.us/Boardpolicy.cfm> for specific school board policies.



HANDBOOK PURPOSE

Rules are regulation are necessary to ensure an organization runs smoothly. Granton rules and regulations for students are written with this intention. The procedures outlined here also ensure students enjoy the rights accorded to them as responsible Bulldog citizens. Violations of these rules and regulations infringe upon the rights of others or creates a disruption of our common goals. As a Granton Middle or High School Citizen you are responsible to accept your obligations as a member of our student body. Faculty members and other adults have been given the responsibility to supervise student compliance with these rules and regulations. Students are responsible for recognizing this assigned authority.

BOARD POLICY;CHAPTER 1, SEC.B

Interests, attitudes, skills and habits developed during the school years of a person's life greatly influence the individual's behavior as an adult. The educational opportunities provided at Granton Area Schools are designed to enable students to gain knowledge, work skills, learn acceptable social concepts, and develop appreciations and values, which shall help them become responsible members of their community.

The opportunity to participate in the programs of the school shall be extended to all residents of the community provided statutory, and school board regulations and requirements have been fulfilled. For

the individual to realize maximum benefits from these programs, the student must be willing to accept the responsibilities, which go along with the educational privileges. All aspects of the school's program of studies and activities shall be concerned with the total development of the individual student. It is recognized that students have differing interests, needs, and abilities. Therefore, course offerings, school activities, and teaching methods shall be planned which will provide for individual differences and which will enable each student to develop according to his or her capability. Every effort shall be made to help the students experience success in their search for personal improvement.

The goals of education may best be achieved through cooperation and understanding among students parents, faculty and members of the community. The working relationships shall be purposeful and business-like with mutual respect for individuals and their ideas, accomplishments and objectives. Each person involved in the educational process shall work towards the overall goal of maximum educational advancement for each child.

Therefore, we believe the district goals are to be:

1. Provide a safe learning environment.

2. Provide a well-rounded curriculum for teaching students the fundamentals that will prepare them for a four-year college, technical college, or the work world.
3. Provide a learning environment that will maximize the potential of all students.
4. Provide opportunities to develop each student's imagination, creativity and constructive and critical thinking.
5. Provide the skill each student needs to become a functioning, self-supporting, productive adult.
6. Provide opportunities that showcase the importance of a lifelong love for learning.
7. Provide opportunities to share their own cultures and to be aware of other cultural expressions and heritage.
8. Provide opportunities to develop an awareness of our political system starting at the school level and moving through all levels of government.
9. Provide opportunities to develop knowledge and responsibility concerning global resources.
10. Provide opportunities for career education and occupational awareness.
11. Provide the opportunity to develop each individual's abilities, goals, and self-concept.

Our Vision: Granton Area School District believes that we will provide a high-quality education through a strong partnership with community and parents to instill a lifelong love of learning and success in our student's future.

DISCRIMINATION COMPLAINT PROCEDURE

If any person believes that the Granton Area School District, or any part of the school organization has inadequately applied the principles and/or regulations of Titles VI, IX S118.13, Wis. Stats., or Section 504 or Is in some way discriminatory on the basis of sex, race, religion, color, National origin (including Limited English Proficiency), ancestry, creed, pregnancy, parental status, marital status, sexual orientation, or physical, mental, emotional, or learning disability, he/she may bring forward a complaint to the office of The District Administrator in the Granton Area School District Office at 217 North Main, Granton, Wisconsin 54436.

Please see the district website for further details on both informal and formal complaint procedures.

Educational Philosophy

Policies may be revised during the course of the year. When that occurs a notification will be sent out and an updated copy of this Student Handbook will be available in the high school office.

Our Vision: EXCELLENCE, INNOVATION, INSPIRATION; Every day. Every way.



Academic Information

-Grading Information

- Graduation Requirements
- Grading System
- Homework
- Schedules Changes
- Withdraw/ Incompletes
- Course Retakes
- Mid-Quarter Progress
- Final Exams
- Academic Honesty
- Academic Awards
- Student Promotion

Multi-Level Systems of Support (RTI/PBIS)

- MS: Intervention, ZAP
- Reinforcement Days
- WIN Time
- Content/Strategy Core Labs
- English/Math Support
- Homework Help Center
- Alternative Education
- Student Services
- Student Recognition

Accelerated Programs On-line/Virtual Education School to Work/Youth Apprenticeship

(See course handbook for

GRADUATION REQUIREMENTS

Please refer to the Granton High School course book for further details on available courses, programs, and frequently asked questions.

1. GHS will issue diplomas to all students who complete the requirements for graduation and whose conduct warrants such recognition. The high school Principal and/or District Administrator shall be the judge of this accomplishment.
2. The minimum number of credits required and credit requirements shall be as follows:
 - English - 4 credits (Required; English 1, English II)
 - Social Studies -3 credits (Required: AH 1, AH 2, Poli. Sci)
 - Mathematics - 3 credits (Required: Algebra 1, Geometry)
 - Science - 3 Credits (Required; Biology)
 - Physical Education - 1.5 credits
 - Health - .5 credit
 - Electives - 9.5 credits plus required .5 credit course in personal finance & 1 credit (.25/year) in Academic and Career Planning
 - TOTAL———— 25 CREDITS
1. All 9-12 students will be required to register for 7 or more credits per year. Freshmen, sophomores, and juniors will not be demoted or retained in their class, but a student will not be considered a senior unless he/she has successfully completed 17 credits.
2. Students receiving diplomas from Granton High School must have attended 8 semesters prior to graduation. However, the Board may approve early graduation requests on an individual basis, if all graduation requirements have been met.
 - Home Based Instruction and Transfer Students should view School Board Policy, Chapter 10, Section Y for further information regarding placement and completion. Students transferring into Granton will be evaluated for semester and credit compliance. Students will be held accountable for the number of credits under their former school requirements. (i.e. A school with 24 credits required would need 6 credits per year of attendance.) A proportional number of credits will be required based on the year of graduation and number of years in the district. All required courses under 118.33(1) are required for graduation.
3. Any student that does not show satisfactory progress toward the completion of the required credits for graduation or the required courses as specified in this policy by the end of the third quarter, or have not met other obligations, including detentions, will be notified that they will not be able to participate in the graduation ceremonies. If the student can show satisfactory progress by 15 school days from graduation, they will be notified that they may participate in graduation ceremonies, however, if their grades drop within that 15 days, and they fail to meet the graduation requirements or other obligations, they will not receive a diploma, and will be given the opportunity to complete their graduation requirements and receive their diploma at a later date.

Academic Information

GRADING INFORMATION

- Any senior showing satisfactory progress at the end of the third quarter but is not showing satisfactory progress by 15 school days from graduation toward the completion of the required credits for graduation or the required courses, as specified in this policy, or have not met their other obligation including detentions, will be notified that they will have two options toward the graduation ceremonies. First, they may participate in the ceremony but there will be a notation on the program that they have not met the requirements for graduation. Secondly, they may have the option to not participate in the graduation ceremony. For either option, the student will receive their diploma only upon successful completion of their requirements.

GRADING SYSTEM

Please visit Infinite Campus on our school website routinely to keep up with your child's grades. Students will receive grades and credits four times per year at the end of every Nine-week grading period. The grades on the report cards issued at the nine-week period will be the recorded grade for student achievement (credit) and will become part of the student's permanent record. The progress report can, and should, be used at any time during the nine-week quarter when staff have information or concerns they wish to share with a parent(s). The progress report will indicate the reason for concern or commendation. Please reference individual teacher syllabi's for individual grading policies.

HOMework

A reasonable amount of homework is part of the educational process and should be expected. Though every student is different and should not be compared to others regarding this issue, our programs are planned so that if each student makes wise use of their time during regular school hours the amount of work outside of school should be minimal. As such, students are expected to make every effort to turn their homework in on time and contact their teacher(s) if they have questions or concerns. Middle School students who do not complete their assignments on time will be provided additional time during "ZAP" until they complete assignments. (Additional information regarding ZAP can be found in our MLSS section of handbook).

SCHEDULE CHANGES

Students may request to add or drop courses without penalty only up to the three days following the start of a semester. Adding any course after the 3rd day of the quarter or semester will require consent of the instructor. This will not apply to transfer students. If a course is dropped after the third day of the semester, the student will be awarded a grade of "WD", or withdrawal. A "WD" has the same honor point value as an "F", and will negatively impact the students' class rank and grade point average and remain on the permanent academic transcript. The adding or dropping of a course three days after the start of a semester requires signatures from the student, parent, teachers and school counselor on an Add/Drop form, available in the Counseling Office. Requesting to add or drop does not guarantee the change will be made. School officials (school counselor, staff and administration) will examine the impact this decision may have on the student's academic standing. (In accordance with school board policy, no student will be allowed to drop a course that will lower the student's credit attempts to below seven (7) credits for any one year.) When there are multiple sections of a course students may be assigned to a different section to balance class sizes and resolve staffing and scheduling problems.

WITHDRAWALS/INCOMPLETES

Students who are transferring out of the school district or leaving school must have the principal's approval or obtain a withdrawal form from the main office. This form must be signed by all the student's teachers, librarian, student services office, athletic director, and principal. Refunds are made after the form is returned to the main office.

COURSE RETAKE

Please see the graduation requirements section of this handbook, Granton Course book, and/or contact our student services office for further information on courses required for graduation. In the case of failing a required course, students may retake the course in an effort to earn a passing or higher grade. In certain situations, elective choices may be limited due to the necessity of retaking previously failed courses.

GRADING SCALE

(For Non-standards based class-- Please see your teacher's syllabi for further details on grading for each class.)

93%-100%; A

90%-93%; A-

87%-93%; B+

83%-87%; B

80%-83%; B-

77%-80%; C+

73%-77%; C

70%-73%; C-

67%-70%; D+

63%-67%; D

Below 60%; F

MID-QUARTER PROGRESS

Please partner with your child's teacher if you are concerned about their social, emotional, and/or academic progress at any time. Please visit Infinite Campus on school website routinely to keep up with your child's grades. Teachers will contact parents at mid-quarters to discuss any grades of a "D" or below. Both teachers and parents are encouraged to communicate with one another on a regular basis.

FINAL EXAMS

At the end of each semester, Granton High School Students will have two days for semester final exams. Teachers may use traditional written exams, presentations, projects, or other activities during the exam period. The final exam schedule will be posted near the end of each semester. Due to early graduation, seniors must make arrangements with their teachers prior to the second semester finals period for completion of final exams. Granton Middle school students may have final exams.

ACADEMIC HONESTY

Granton High and Middle School consider academic honesty as a cornerstone of its educational mission it is expected that all schoolwork submitted for the purpose of meeting course requirements represents the original efforts of the student. This includes, but is not limited to; test taking, homework, class assignments -- allowing others to copy one's work/doing another one's work, the original creation of essays, compositions, term papers, and scientific research. If such is not the case, then the student has demonstrated unacceptable academic behavior and subject to disciplinary action. Possible disciplinary actions may include; redoing test or assignment, receiving a reduced grade (as low as zero), written referral to office/athletic/co-curriculars, or any other action that a teacher and administration deem necessary an appropriate.

ACADEMIC AWARDS/HONOR ROLL

A list of honor roll students will be posted in the High School office and published in the local newspaper. Honor roll and high honor roll are computed each quarter and semester. Students in grades 9-12 can earn academic achievement points every quarter. This program was designed to recognize students for their academic accomplishments, reward them for excelling in the classroom, and provide them with incentive to succeed. A student earns "high honors" by attaining a 3.6 average or higher and "honors" if they attain a 3.0-3.59 average in all academic areas for a grading period.

The criteria for earning academic awards are as follows:

1. Only full-time students will be eligible for the awards.
2. All classes that count for honor roll tabulation/computation will count toward the awards.
3. The student must be enrolled in at least six(6) credits per year.
4. The GPA of transfer students will count toward the awards. Transfer students must be enrolled at Granton High School for at least one (1) semester to be eligible for any award recognition.
5. The computation to the GPA will be retroactive to the start of each student's freshman year.

STUDENT PROMOTION/RETENTION

The Granton Area School District is dedicated to the total and continuous development of each pupil enrolled. Children seem to do their best work in school when they are placed at a grade level with other children of their chronological age. Pupils will normally progress annually from grade to grade. Exceptions may be made only when, in the judgment of the professional staff, such exceptions are in the best educational interest of the pupils involved. The professional staff is expected to place pupils at the grade level best suited to them academically, socially and emotionally. Exceptions will always be made after prior notification and explanation to each pupil's parents, with the final decision resting with the school authorities. Parents wishing to explore the advisability of retention or acceleration for their child may do so by first contacting the teacher of their son/daughter. Because of the following actors, it will occasionally be desirable for a child to be placed in a grade above or below his/her actual chronological age:

Physical maturity, social/emotional maturity, attitudes/work habits, level of academic achievement, particularly in basic skill areas, and in reference to grade level outcomes, ability in relation to achievement, attendance patterns, potential benefit/success for the student, previous retention, EEN status, extenuating circumstances, if any.

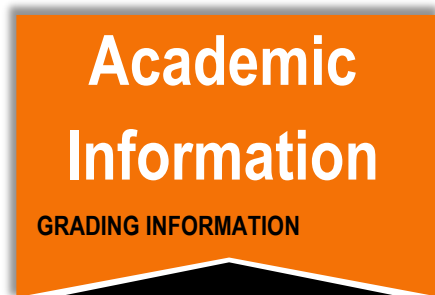

Academic Information

Multi-Level Systems of Support (RTI/PBIS)

- MS; Interventions, ZAP
- Content/Strategy Core Labs
- English/Math Support
- Homework Help Center
- Reinforcement Days
- WIN Time
- Alternative programs
- Student Services
- Student Recognition

Accelerated Programs

School to Work/Youth

Apprenticeship

On-line/ Virtual Education

(See course handbook for additional

MULTI-LEVEL SYSTEMS OF SUPPORT

In an effort to meet the needs of all our students, Granton MS/HS provides additional support for our students. Students needing support are identified using a team approach based on a balanced assessment system, which may include but is not limited to grades, teacher/parent recommendation, and student achievement on screening and monitoring tests.

Students who do not meet expectations will have either support labs and/or “intervention” as part of their educational programming. Intervention includes individual and/or small group instruction and is designed to increase skills in a particular area of need. Those students will continue to be monitored and based on how they progress may be exited from the small group/individual intervention or entered into additional interventions. If a student is assigned to an intervention, they are expected to follow the instructions laid out according to the Intervention Plan. Should a student choose not to do so, behavioral consequences will occur.

Students who meet or exceed academic expectations will have opportunities for enrichment and accelerated programming. The professional staff is expected to place pupils in support best suited to them academically, socially and emotionally and the final decision rests with school authorities. These support times occur throughout the day. Specific programs include, but are not limited to;

Middle School Intervention/Enrichment Periods, ZAP, Content Specific Core lab, Strategy Specific Core Lab, Homework Help Center, Support Lab, Study Hall, English Support Intervention, Math Support Intervention, At-Risk Programming, Accelerated Programming.

ZAP

Granton MS has implemented a program called Z.A.P (Zeros Are not Permitted). This program is designed to:

- Increase expectations of students who fail to complete and turn in assignments on time.
- Emphasize the belief that assignments/projects are important and must be completed.
- Direct students to utilize their abilities to acquire self-discipline/work habits that will serve them in the educational setting and in the future when they enter college and/or the workplace.
- The ZAP program is a program to help students understand failure is not acceptable.

How does the program work?

- ZAP will meet five days per week during the students lunch hour.
- Students will be assigned by their classroom teacher for not completing work by the required due date.
- The teacher assigning the ZAP will meet briefly with students when assigning the ZAP to provide the student with necessary information to complete his/her missing assignment.
- The student will then be directed to the ZAP room to complete the homework.

Grading/Consequences:

- Completed assignments will be collected and placed in the teachers' mailbox for their review the next day.
- Completed assignments will be a minimum of 75% or original assignment.
- Participation in extracurricular activities or rewards may be suspended until ZAP work is completed.

Families can help in assisting their children to be successful by:

- Scheduling a consistent time for homework
- Creating a quiet workplace away from distractions (such as Facebook and other social media)
- Whenever possible, participate in the experience by being available for help and/or encouragement
- Reinforce the importance of responsibility and time management
- Give praise when you child display good work habits.

MS INTERVENTION/ ENRICHMENT

Middle school students who have been identified as needing additional support in math and/or English, will have one to two intervention periods in their schedule. These periods are designed to help students gain the necessary skills and knowledge to achieve at or above grade level norms. Please contact Amy Hanna for further details.

STRATEGY SPECIFIC CORE LABS

Every day high school students attend a “homeroom” period. During Mondays, Wednesdays, and Fridays, students identified in need of organizational, social, and/or behavior support are in a strategy specific homeroom with a teacher designed to support their needs. Tuesdays and Thursdays of homeroom are ACP (Academic and Career Planning). Please contact Amanda Kraus for further details.

REINFORCEMENT DAY INTERVENTION (Ketchup/Mustard Day)

Throughout the year Reinforcement Days (Ketchup/Mustard Days) will be utilized as extra support for students that have fallen behind. These days will be scheduled on staff professional development days and/or assigned as reinforcement on the school calendar. All students are able to participate but those that are deemed as drastically behind will be highly encouraged to join on these support days. Breakfast, Lunch and transportation will be provided for all students involved on this support day.

WIN SUPPORT INTERVENTION

The purpose of WIN Time is to give our students more opportunities to be successful. Utilize this time for small group support that the everyday classroom does not always allow. This support period allows staff to pull students for support as well as students request small group support time with a specific teacher. WIN Time will be done on a daily basis throughout the school year.

HOMEWORK HELP CENTER(HHC)

A modification of the ZAP Program, HHC is designed to meet the needs of our high school students. Students are welcome to bring their lunch and work with one of our highly qualified staff on study skills, homework assistance, test retakes, and just about anything our students may need assistance with. Students who meet academic expectations may attend, and students who are not meeting academic expectations may be required to attend until those expectations are met. Morning (AM) HHC will be available to all secondary students from 7:40-8:00 A.M. in Room 312 starting second semester. AM HHC is designed to meet the needs of our students and is staffed by our faculty. Students are welcome to work on study skills, homework assistance, test retakes, and just about anything they may need assistance with and/ or just a place to work. Additional opportunities for all our students to be successful!

Granton Middle School and Granton High School continue to be the leaders in offering a welcoming and supportive environment for students of all backgrounds. Through a commitment to a continuous improvement plan aimed at providing a successful educational experience for all of our students, we have several academic support systems in place for our students.

ALTERNATIVE PROGRAMMING

Students must meet state and/ or district criteria to eligible for these programs. For more information, contact Nate Johnson.

Level 1: Credit Recovery This program is designed to serve students identified as at-risk of not meeting graduation requirements. Students enrolled in this program will have a Personal Education Plan to meet the individual needs of each Student. The program is devoted to the success of each student and should include strong parental/adult involvement. The PEP may incorporate school and partner agencies to address students who need intervention in the areas of behavior, mental health, academic needs, attendance, and/or AODA issues. Instruction may be in the regular classroom with support or it maybe specialized. Specializations may include; pull-out classes for core subjects of difficulty, project based learning for greater understanding and engagement, specialized reading/writing intervention, and/or on line school courses. Study/social skills will be emphasized as well as planning for post high school goals and objectives.

Level 2: HSED This program is designed for students with severe credit deficiencies who are unable to meet graduation Requirements through other means such as the Credit Recovery Program. Please see Nate Johnson or Shelly Schmitz for more information.

STUDENT SERVICES

The professionals in our Student Service office are here to serve all students and their families. Our goal is to help all students achieve their personal and academic best. Our philosophy is that all students can and will excel with support from within the school and their home. Services that are offered through the student service staff are: special education consultation and evaluation, 504 coordination, classroom development guidance lessons for all students, small group work, individual career, academic, personal and social counseling, parent support and resources, college planning, scholarship information and class scheduling. Please see our guidance counselor for more information.

STUDENT RECOGNITION

Students are routinely recognized for their positive academic, social, and behavioral choices. In addition to the reward of high grades, our student reward programs include but are not limited to; perfect attendance, honor roll, academic/athletic awards, PAWS awards, field trips. PAWS is a service learning and community service program that includes all students and staff! Each month we have scheduled times for school or community based projects that encourage students and staff or varying levels to work together in performing some type of project. Each quarter a school-wide celebration is held in which students are nominated by their teachers and recognized for good citizenship, attendance, and academic success. Students can also be nominated by a staff member for a "PAWS"itive Behavior Award and they will receive some kind of prize from the MS/HS office. For more information on PAWS please contact Ms. Woller.

ACCELERATED PROGRAMMING

Students have the opportunity to take rigorous course designed to challenge, Motivate, and improve their knowledge and skills. Middle school students are identified via our Multi Level System of Support Programming. Please contact Amy Hanna for further information for our middle school students. Please see our academic course book and/or contact Shelly Schmitz for further details for our high school students.

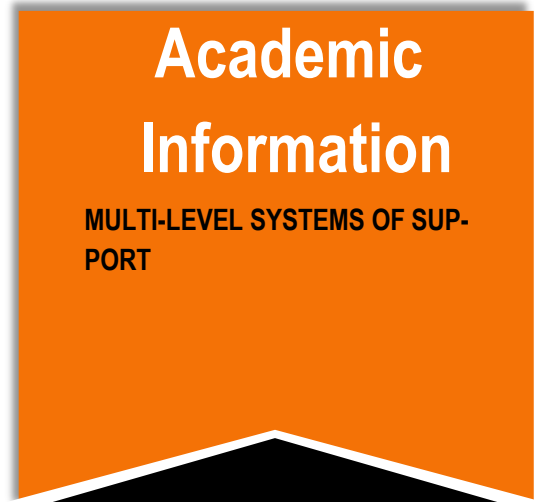

SCHOOL TO WORK PROGRAMMING

Please see our academic course book and/or contact Cheryl Steinbach for further details for our high school students.

1. A school day release program is available to qualifying students. An application for the program is available in the guidance office. The following rules govern the school day release program:
2. Students, parents, employers, and school personnel are all involved in the supervised work release or work release program. Students must be earning a passing grade in all subjects. An "F" or two "D's" automatically cancels the program and you return to the regular school day schedule.
3. Qualified student requests will be reviewed by the principal and guidance counselor or supervised work coordinator.
4. Students asking for a school day work release must be carrying a full schedule of classes where graduation requirements and standards can be achieved.
5. Students must leave school grounds immediately and not loiter in town. Students must furnish own transportation.
6. When all required documents have been approved, the student will be notified of the date they begin.
7. This program is to be considered a privilege. Abuse of this privilege can be reason to lose this opportunity to participate in the program. The program will be revoked if it not productive.

ON LINE/VIRTUAL/DISTANCE LEARNING PROGRAMMING

Distance learning is an instructional delivery model and refers to the method in which courses not offered as face-to-face Courses at Granton High School may be taught. Students in grades 9-12 may be eligible to take a distance-learning course. Please see the course handbook and/or contact our guidance department for further information. There are specific deadlines that must be met.

All students requesting enrollment in a DL course will be evaluated by the high school principal, school counselor and/ or district DL coordinator to determine if such a placement is academically appropriate. The interactive web-cam allows a teacher to see and interact students with students during their scheduled time. These courses may be high school to high school courses, early college credit courses, and/or start college now courses. Students must receive prior approval from the school counselor or building principal, and the course must comply with graduation requirements. Because coursework is completed remotely and their teacher is typically not on site at Granton, this format of education requires a high level of maturity and self-motivation. The cost for a DL course is paid for by the Granton Area School District. The District is not responsible for home instruction, home Internet access, or technical assistance. In the event that a student does not successfully complete a college level or Wisconsin Virtual School course, the student/parent is responsible for the cost of the course. Students taking courses to replace failed course will pay the cost of the course and the District will reimburse upon successful completion of the course.



Attendance Information

Compulsory School
Attendance Information
-Truancy/Ordinances
-Student Absence Procedure
-Excused Absences
 -Make-Up Work
-Pre-Arranged Absences
-Unexcused Absences
 -Make-Up Work
-Tardiness
-Attendance for Seniors
-Adult Students
-Perfect Attendance

The Board of Education encourages a strong partnership between the home, school, and community. It recognizes a positive relationship between good school attendance and success in school and employment. If student learning and growth are to take place, parents/guardians, students and school personnel must recognize their responsibilities to assure regular attendance.

The Board, in recognition of the statutory requirements for school attendance and the overwhelming public need for an educated society, believes school attendance should take precedence over non-school activities. State law requires every child between 6 and 18 years of age to be in school attendance unless he/she:

1. Is excused temporarily for physical or mental reasons, or other reasons defined by the Board;
1. Has graduated
3. Has been authorized to attend an alternative educational program; or
4. Has been excused by his/her parent/guardian prior to an absence in accordance with state law.

It is the responsibility of any person having under his/her control such a child to ensure regular attendance during the full period and hours that school is in session until the end of grading period in which the child becomes 18 years of age. Parent/guardian(s) are responsible for notifying the school of student absences in accordance with established district procedures. When students are absent, parents/guardians assume full responsibility for their child's activities. It is the responsibility of the principal or designee to determine whether the absence is acceptable (excused) or not acceptable (truant).

CLARK COUNTY/GRANTON TRUANCY POLICY

Granton has partnered with Clark County as of June 2019 to respond to Granton Area School District Truancy cases. Under this ordinance any student that is considered truant from school can be subject to any or all of the following actions:

- An order for the person to attend school
- Cumulative fines to be assessed against the person, the parents or guardian, or both.
- Suspension of driver's license for not less than 30 days nor more than one year
- An order to participate in counseling or other supervised work program: the cost may be assessed against the person and/or family
- An order to attend an educational program
- An order from the Wisconsin Dept. of Work Force Development to revoke a work permit for up to one year
- An order for the person to be placed in a teen court program
- An order placing the person under formal or informal supervision for up to one year
- An order for the person's parent, guardian or legal custodian to participate in counseling at their expense
- Any other reasonable conditions with this Section including a curfew and other restrictions

The Granton Area School District is willing to work with students/families to resolve attendance issues if at all possible. The above is the end result of unresolved attendance issues and will be determined by Clark County Court Services.

TRUANCY

“Truancy” means any absence of part or all of one or more days from school during which the school attendance officer and/or High School Principal has not been notified of the legal cause of such absence by the parent or guardian of the absent student, and also means intermittent attendance carried on for the purpose of defeating the intent of the state attendance statutes(118.15).

Truancy Guidelines:

1. Part or all of 2 unexcused days absent in a school semester, or 4 excused absences in a school year: *Phone call to Parent/guardian discussing attendance.*
2. Part or all of 3 unexcused days absent in a school semester or 6 excused absences in a school year: *Letter to parent/guardian giving notification of check list for habitual truant, Referral to school counselor for: Review of school records to consider possible PBIS Team Meeting.*
3. Part or all of 4 unexcused days absent in a school semester or 8 excused absences in a school year: *Certified letter to parent/guardian giving notification of checklist for habitual truant, Meeting with parents, principal, counselor, and student to consider/discuss placement in PBIS Tier 2 intervention*
4. Part or all of 5 unexcused days absent in a school semester or 10 excused absences in a school year: *Certified letter to parent/guardian giving notification of checklist for habitual truant, Possible referral to Clark County Social Services, Clark county notification for administration of Truancy Ordinance*

A “habitual truant” means a student who is absent from school without an acceptable excuse, based on the district attendance policies for either of the following:

- I. Part or all of 5 or more unexcused days in which school is held during a semester whether consecutive or not.
- II. Part or all of 5 or more days in which school was held which exceed 10 days excused absence in a school year.

If a student becomes a habitual truant the attendance officer shall notify the parent/guardian of the child by registered or certified mail, when the child initially becomes habitually truant. The notice shall include the following checklist:

- *A statement of the parent’s responsibility under the law to cause the child to attend school regularly*
- *A statement that the parent/guardian or child may request program or curriculum modifications for the child and that the child may be eligible for any at-risk program*
- *A request that the parent/guardian meet with appropriate school personnel to discuss the child’s truancy*
- *A statement of the penalties under the law that may be imposed on the parent/guardian if he/she fails to cause the child to attend school regularly*

STUDENT ABSENCE PROCEDURE

The responsibility for regular school attendance of a child rests upon the child’s parents or guardian. No absence shall be recorded when a child is physically away from school because he/she is participating in school sponsored activities, teacher chaperoned field trips, athletic events, workshops, contests, etc. Each teacher shall submit daily attendance reports to the attendance officer on all students under his/her charge.

All other absences must be cleared with the office and will be excused only the absence falls within the guidelines in board policy. It is the responsibility of the parent and student to provide the office with the proper documentation. The parent/guardian or student will have five school days to clear the absence with the office. Documentation and/or phone calls received after five days will not be accepted, and the absence will be considered unexcused. Office number is 715-238-7175

STUDENT ABSENCE PROCEDURE FOR PARTIAL DAY

All students (and visitors) attending or leaving during the school day, must sign in and out of the office. Students Should use a hall pass from staff whenever in the halls as well. If your child will need to leave/be late, please send a note and/or call the office at 715-238-7175 with proper documentation.

EXCUSED STUDENT ABSENCES

Personal Illness

A student who is absent due to illness is to have a parent/guardian call the school the morning of the absence. If this is not possible, a note signed by the parent/guardian explaining the absence should be brought to the office on the day the student returns. A student will be allowed five sickness or injury related absences per semester that do not require a doctor's verification. These absences will be recorded as IL. If a student requires more than five separate days per semester due to sickness or injury a doctor's excuse will be necessary. These absences will be recorded as DR. When the illness or injury causes the student to miss three or more consecutive days of school, documentation from a doctor's office will be necessary to excuse the absences. These absences will be recorded as M.

Medical Appointments

A student who has a medical, dental, chiropractic, optometric, or other valid professional appointment will need to provide documentation of the appointment from the medical facility to have the absence be marked "excused". These absences will be recorded as DR. If possible, please schedule appointments outside the school day. The office will accept a fax from the facility on company letterhead that provides verification of the appointment date and time. The High school fax number is (715) 238-7827.

Family Emergencies

Any student who has a severely ill or injured family member or who has experienced the death of a family member should have a parent/guardian contact the office as soon as possible after the initial first absence with a description of the circumstances. These absences will be recorded as F. A student requiring more than ten days absence from school must have a parent/guardian contact the office to give an estimated date for the return of the student to school.

Family Religious Services

Any student requesting time off for the observance of a religious holiday must bring a note from a parent/guardian or have the parent/guardian call the office prior to the holiday. (These days do not count toward the five parent-excused days in a semester.) These absences will be recorded as R.

Other Excused Type Absences

- A court appearance or other legal procedure, which requires the attendance of the student. These absences will be recorded as CA
- Quarantine as imposed by the Public Health Officer. These absences will be recorded M.
- Student sent home per CDC guidelines. We ask parents to keep children who are ill home for a full 24 hours after they are free of fever, vomiting, or diarrhea without the aid of fever reducing medications such as Tylenol, Ibuprofen, Advil, etc., because people are very contagious for 24 hours after they are completely symptom free. These absences will be recorded as CDC.
- Attendance at special events of educational value approved in advance by the principal or attendance officer. These absences will be recorded as SA
- Approved school activities during class time. These absences will be recorded as SA.
- Special circumstances that show good cause and is approved in advance by the principal.
- Pre-arranged Absences

Pre-arranged absences do not fall under the category of "parent request" unless an advanced makeup form has been filled out and approved. Individual parent requests that his/her child should be excused from an absence will not be honored unless it falls under the guidelines previously stated for excused absences and parent responsibilities. Faculty reserves the right to excuse a student from an absence when the absence has been deemed either justified or unavoidable.

EXCUSED ABSENCE MAKE-UP WORK

Upon the student's return to school, the student has the responsibility to confer with his/her teachers for those classes missed to determine work to be completed. The student may have the number of days absent plus one to make up missed assignments/class work to be completed. A longer period may be granted by teacher or administrator for extenuating circumstances.

PRE-ARRANGED ABSENCES

Granton Area Schools recognize the occasional need for extended absence or emergency situations that may arise. Students who are planning to be absent and know in advance that they will be missing work should pick up an advance makeup sheet from the office. A parent request is necessary to receive an advanced makeup. The student will be required to obtain signatures and assignments from their teachers. All work should be made up prior to dates that the student will be missing unless specific arrangements have been made with the classroom teacher. The completed advanced makeup form should be com-

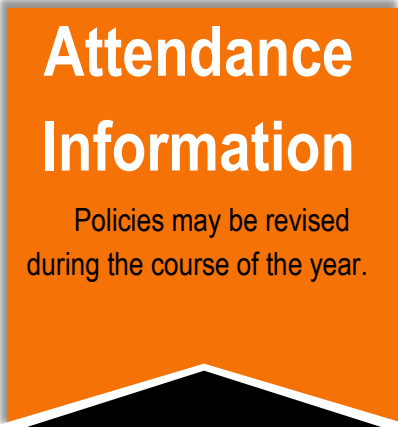

UNEXCUSED STUDENT ABSENCES

Children who are absent from school with the consent of their parents and/or guardian, but whose absence does not fall under the reasons listed above for excused absences, or children who skip, or are absent for no particular reason, shall be considered unexcused.

- Students marked with unexcused absences will serve a 30 minute after-school detention for each period unexcused
- Once a student accumulates three unexcused absences (all or part of a day) in one semester, a truancy warning letter will be sent home. Unexcused absences beyond five days in a semester may result in a truancy referral to Clark County Social Services, law enforcement and violation of village ordinance filed with the Village of Granton.

UNEXCUSED ABSENCE MAKE-UP WORK

Students have the obligation to obtain, understand, and retain for future reference and use, all materials presented during their unexcused absence as well as contact each of their teachers. Work missed during an unexcused absence may be made up upon request from the teacher. Students may or may not be permitted to make up daily class work missed and may be denied credit for unexcused absences. Tests are an exception and may be made up at a time mutually agreed upon by the teacher and student. A student may receive a zero for class participation for all classes missed if participation grades were given the day the student was marked as unexcused by the school attendance officer.

TARDIES

Students will be assigned a lunch detention for accumulating three tardies during a quarter. For every tardy after three in a semester, additional lunch detentions will be assigned. Students who accumulate three additional tardies in a semester will also be subject to after-school detention and parent meeting if tardies continue.

ATTENDANCE FOR STUDENTS

All seniors are required to maintain 90% attendance second semester in order to participate in the commencement ceremony. In other words, if a senior has missed more than 9 days or more than 72 class periods (even if parent permission was granted) he/she would not be allowed to participate in the graduation ceremony. Note: medical, funerals, court appearances, school activities, and college visits (with documentation) are exceptions to this rule.

ATTENDANCE FOR ADULT STUDENTS (18 YEAR OLD STUDENTS)

All school rules apply unless otherwise noted in the student handbook. Being 18 does not allow you to come and go as you please. Adults may write their own excuse to leave school for any reason that is excused as per the school attendance policy provided a written statement to that affect is on file. The principal must approve all notes and requests to leave the building. Administration may restrict any privilege if abused. Adult students are expected to be in school every day and comply with attendance policies set forth by the Board of Education and the State of Wisconsin. Adult students that fail to comply with school rules may be referred to the school board, and board action may result in expulsion.

PERFECT ATTENDANCE

Perfect attendance awards will be presented to students with perfect attendance at the end of 1st quarter, at the end of second semester, at the end of third quarter, and at the end of second semester.

Behavior Expectations

- Behavior Philosophy
- Academic Honesty
- Altering Substances
- Bus Expectations
- Proper Dress
- Electronic Devices
- Harassment
- Loitering
- Lunch/Snack Expectations
- Parking lot/Driving
- Prohibited Items
- Public Displays of Affection
- School Functions
- Searches
- Student/Staff Interactions
- Theft/Vandalism
- Consequences
- Legal Referrals
- Suspension/Expulsion

The Granton Area School District has high expectations for all students and recognizes the potential of all students. To help reach that potential for each student, it is necessary to have a school and classroom free of disruption. The District requires that students respect the rights of all members of the school family--teachers, administrators, support staff, parents, and other students.

Behavior procedures are necessary so the rights of each member of the school family are protected. They are designed to preserve an orderly school atmosphere and to help prepare students for productive and meaningful adult lives. Any student, who, through actions, conduct, dress, appearance or presence, disrupts the normal routines of the educational process of the school or who follows a course of conduct which may reasonably be anticipated to become disruptive of the educational process, shall be subject to the discipline of the school.

BEHAVIOR EXPECTATIONS

Students at Granton are expected to conduct themselves in a positive manner and show respect towards all students and staff. Behavioral guidelines include;

- Be Respectful; For self, others, community, school, parent.,etc
- Be Responsible-To family, to self, and to school.
- Be Safe-To be from danger or injury; physically and emotionally

BEHAVIOR GUIDELINES

Please see additional information in this handbook and under board policies on our website.

- Respectful hallway behavior is expected, including being on time, not running and having a hall pass when in hall during class times.
- Excessive public displays of affection are discouraged. Please be respectful of those around you.
- Keep the lunch room clean.
- Respectful and appropriate language is expected during the school day and at school events.
- Dangerous behaviors such as pushing, inappropriate physical contact, and other irresponsible behaviors are not allowed
- Student dress, appearance, and grooming should not affect the health and safety of student nor disrupt the learning process within the classroom or school grounds
- Be your best self; academically, socially, and behaviorally.

ACADEMIC HONESTY

Granton High and Middle School consider academic honesty as a cornerstone of its educational mission. It is expected that all schoolwork submitted for the purpose of meeting course requirements represents the original efforts of the student. This includes, but is not limited to; test taking, homework, class assignments--allowing others to copy one's work/doing another one's work, the original creation of essays, compositions, term papers, and scientific research. If such is not the case, then the student has demonstrated unacceptable academic behavior and is subject to disciplinary action. Possible disciplinary action may include; redoing test or assignment, receiving a reduced grade (as low as a zero), written referral to office/athletics/co-curriculars, or any other action that a teacher and administration deem necessary and appropriate.



Behavior Expectations

ALTERING SUBSTANCES;DRUGS/ALCOHOL/INHALANTS/ E-CIGARETTES/TOBACCO/STREET DRUGS/DRUG PARAPHERNALIA/ CONTROLLED OR PERFORMANCE ENHANCING SUBSTANCES

Granton School District strictly forbids use, sale, or possession on any items listed above or look-a-like substances. The possession and/or use or sale of chemicals in our schools, our parking lots, on school buses, at athletic events and/or other school sponsored functions is strictly prohibited.

School board policy and procedures have been established to respond to individuals possessing, distributing, and/or selling alcohol and other controlled chemicals/substances or their look-a-like counter parts. Disciplinary action will result if a student is involved in use, possession, and/or sale of any altering substances. Students refusing to comply with a breath test given by school officials or law enforcement will be treated as an admission of guilt.

BUS EXPECTATIONS

The school bus in an extension of the classroom. The bus driver, like the teacher in the classroom, has the responsibility for the safety and welfare of the students under his/her charge. It is highly recommended that drivers stop the bus, if necessary, to address student behaviors. If such action is taken routes may be delayed. The inconvenience is something we apologize for in advance, but the safety of every person on the bus is the district's top priority. School bus transportation is a privilege - not a right. Be informed that misbehavior of any kind will not be tolerated. Pupils who misbehave can be suspended from school or the bus and can be denied bus-riding privileges. Buses are subject to videotaping and students are subject to discipline based on what the tape shows.



- Riders are not permitted to leave the bus other than regular stops unless school officials have given proper authorization in advance.
Extra-Curricular Activity Trips:
- The above rules and regulations will apply to any trip under school sponsorship.
- Pupils shall respect the wishes chaperones appointed by the school officials to accompany the bus.
- Spectator Buses:
- Our school encourages your enthusiastic support and spirit at events scheduled out of town. A spectator bus will be provided if there is sufficient student demand. Students are encouraged to take advantage of this opportunity.
- Students who ride the spectator bus to the event must return on the bus unless the principal has approved other arrangements in advance.
- All school rules will be strictly adhered to while in attendance at events held at other schools as well as the transportation process
- Students are to remain at the game site from the time of arrival until the departure of the bus. Student violations will result in consequences.
- The cost of the bus is only \$5.00 and must be paid in advance and is not refundable.

DRESS CODE

Discretion of what is excessive or in bad taste will be left up to faculty and administration, as defined by the Wisconsin Statute 120.13 (1). It is the responsibility of the school to prohibit students from attending school when their personal appearance or attire is of a nature that interferes with the instructional purpose of the school or attracts undue attention that is detrimental to the normal operation of the Granton School District. By school board direction students shall dress appropriately for all occasions. **The board, with the administration as their representatives, will determine what appropriate dress is.** Students will be sent home unless corrective action is taken. Any exceptions to this dress code can only be made with prior office approval. The following are guidelines for this policy:

DRESS CODE CONTINUED

- Clothing endorsing alcohol, drugs, foul language, or sex is unacceptable.
- The wearing of coats, hats, caps, bandannas, hoods, or any type of head covering is prohibited upon entrance into the school and exiting of the building at the end of the regular school day. If you chill easily dress warmer.
- Students are not permitted to display any article of clothing or item that may be interpreted as identification with a gang. These may include, but are not limited to: caps, coats, tattoos, hand signals, graffiti, jewelry, haircuts, belt buckles, bandannas, handkerchiefs, gloves, raised pant legs, and straps. A school official will determine if something is a gang identifier. The first instance will result in a warning and the student will immediately remove or cover the identifier. The second violation will result in school discipline.
- Students must wear footwear, and footwear that causes excessive floor marking is prohibited.
- The wearing of arm bands, buttons, or badges bearing slogans or sayings shall be permitted unless they are found to be obscene, libelous, or in direct violation of current legal standards.
- Dark glasses may only be worn with approved medical documentation that is on file with the office.
- Backpacks or briefcases are not to be carried during the school day. There is enough time between classes for students to get the necessary material for their next class. Students will be allowed to bring backpacks to school, however they must leave them in their lockers.
- Clothing is expected to cover your stomach, chest, back, buttocks, and all undergarments. Skirts must extend a minimum or mid-thigh length. Shorts must reasonably cover the buttocks and undergarments as determined by staff. Tank top straps should be at least two fingers wide and should cover undergarments as well.

What clothing is not permissible?

- Spaghetti straps, bare mid-ribs, open back shirts, strapless shirt, mini-skirts, pants worn below the waist line.
- Any clothing that exposes undergarments (tank tops, loose fitting shirts and pants, sheer clothing)
- Other questionable dress should be referred to the principal or superintendent for a determination.
- Clothing or accessories that are deemed a danger to self or others must be removed. This included but is not limited to long chains, spikes, loose fitting clothing (worn around machines) etc.

ELECTRONIC DEVICES; INCLUDING CELL PHONES

Possession and/or use of personal telecommunication devices, including mobile phones, pagers, iPods, iTouch, MP3 or other electronic devices may be used before, during lunch, after school or during class if approved for a specific academic reason. If a device and/or ear buds are being used during the school day, other than the previously approved times, school personnel may confiscate and turn into the Principal's Office. If your child must have a personal telecommunication device, it must remain in their backpack, and TURNED OFF throughout the school day. Texting and/or videotaping are not permitted at any time during the school day.

The use of mobile telephones or any device capable of capturing images is strictly prohibited in locker rooms, or restroom areas while at school and at school-related/sponsored events. The district is not responsible for any damaged, lost or stolen electronic device.

We ask that families and students use the main office when communicating messages from home or school. Failure to follow these guidelines will result in the confiscation of that device along with disciplinary action.

Devices may be used in conjunction with medical necessity and/or used in the classroom for educational unit purposes if pre-approved by administration

1st Offense: Student will be asked to surrender his/her device to school personnel and can pick up at the conclusion of the school day.

2nd Offense: The device will need to be picked up by a parent/guardian in the main office and the student will receive disciplinary action related to our behavioral system.

3rd Offense: There will be a meeting with administration to create a personal electronics plan/contract for the remainder of the school year.

HARASSMENT

Harassment and/or bullying of students will not be tolerated in the Granton Area District which includes any property or vehicles owned, leased, or used by the school district. The School Board considers these actions to be detrimental to the health and safety of students, and disruptive to the education environment. The educational environment is defined as consisting of every activity under the supervision of the school. For purposes of this policy, harassment and/or bullying are defined as any conscious, willful, or deliberate act or attempted act, through the used of words or actions, which are intended to cause physical injury, emotional distress/suffering, or property damage, that impacts the learning environment.

Harassment and/or bullying could include acts motivated by, but not limited to, hostility toward the victim's real or perceived sex, race, color, religion, national origin, ancestry, creed, pregnancy, marital status, sexual orientation, gender identity, social, socio-economic or family status, physical attributes, disability/handicap or any other basis protected by state or federal law. Examples of acts of harassment and/or bullying include physical intimidation, force or assault, humiliation, bigoted epithets, vandalism, extortion, oral or written threats, taunting, put downs name calling, threatening looks or gestures, false accusations, social isolation, retaliating against another student for reporting harassment or bullying, or any other behavior that substantially interferes with a student's school performance or creates an intimidating, hostile, or offensive school environment.

All forms of harassment in cyberspace commonly referred to as cyber bullying are unacceptable and viewed as a violation of this policy. Cyber bullying includes, but is not limited to, the following misuses of technology: harassment, teasing, intimidation, threatening, or terrorizing another person or group of people by sending or posting inappropriate and hurtful e-mail messages, instant messages, text messages, digital pictures or images, or website postings, including blogs or any other messages sent via cyberspace. For purposes of this policy, "cyberspace" is defined as a global domain within the information environment consisting of the independent network of information technology infrastructures, including the Internet, telecommunication networks, computer systems, and embedded processors and controllers.

In situations in which cyber bullying originated off school or property or from a non-school computer or telecommunications device, but is brought to the attention of school officials, any disciplinary action shall be based upon whether the conduct is determined to be severely disruptive of the educational process so that it markedly impedes the day to day operations of the school. Such conduct includes, but is not limited to harassment, bullying or making a threat off school grounds through cyberspace that is intended to endanger the health, safety, or property of others at school, a District employee or a school board member.

Any student who believes he/she has been subject to harassment and/or bullying may file a complaint in accordance with established complaint procedures or may complain directly to the building principal or their designee. Filing a complaint or otherwise reporting harassment and/or bullying in good faith will not reflect upon the individual's status nor will it affect his/her grades or benefits provided by the District. The District shall respect the confidentiality of both the complainant and accused consistent with the District's legal obligations and with the necessity to investigate allegations of misconduct and to take corrective and/or disciplinary action when this conduct has occurred. Any student or parent/guardian who becomes aware of or witnesses harassment and/or bullying has an obligation to report and will be supported by involved staff members in reporting the bullying/harassment to the proper authorities. Any District employee who becomes aware of or witnesses harassment and/or bullying has an obligation to intervene and report the incident.

Students who engage in harassment and/or bullying in violation of this policy and/or retaliating against an individual for reporting harassment and/or bullying shall be subject to counseling, corrective school disciplinary measures consistent with District policies and procedures up to and including suspension, expulsion, and/or police referral. This includes appropriate intervention(s), restoration of a positive climate, and support for victims and others impacted by the violation. False reports or retaliation for harassment, intimidation or bullying also constitutes violations of this policy.

Behavior Expectations

LOITERING

Any unauthorized person found in the building shall be referred to local law enforcement and prosecuted under the proper county ordinances, if they do not leave immediately upon request. You must leave the building when the school day is over, unless you are required to stay after - which will require you to be under faculty supervision. Any student refusing to comply faces disciplinary procedures including detention, restriction from being on campus after 3:30 P.M. and before 8:00 A.M., suspension, citation for trespassing, and expulsion.

LUNCH PERIOD EXPECTATIONS/SMART SNACKS

All users of the lunchroom facility are expected to follow the rules of that facility. Students that take part in the school sponsored lunch program are to consume all food taken in the lunch room. At no time is food to leave the lunchroom unless students are participating in an academic support session in a staff directed location. Students who bring their own lunch from home are to consume them in the lunchroom. No food or drink is to be consumed in the gymnasiums at any time during the school day. GASD follows the USDA "Smart Snack" Guidelines, therefore students are NOT allowed to have open bags of chips, energy drinks, and or soda in their lockers.

PARKING LOTS; DRIVING TO SCHOOL

Driving to school is a privilege and any violation of this policy will result in forfeiture of that privilege and possible citation by law enforcement. School Board policy prohibits any student of the Granton School District from driving/riding/sitting in or on any motor vehicle during the hours of 8:00 A.M to 3:30 P.M of a school day. If necessary to drive or ride between these hours, you must receive permission from the principal to leave the parking lot. Each student must sign out in the high school office and be witnessed by the office staff. Students may not loiter in the parking lot before school or during the noon hour. All student vehicles must be parked in an orderly manner within the designated areas in the school parking lot. Any violation of this may result in the loss of parking privileges. Students must enter and leave the parking lot in an appropriate and lawful manner. Students who drive to school must purchase a parking permit and park their vehicles in the student parking lot. Parking permits can be obtained in the high school office. Each student will receive one permit. The permits can easily be moved from one vehicle to another. A \$5.00 fee will be assessed for any lost permits as well as for permits not returned at the end of the school year at check out.

PROHIBITED ITEMS

Problems arise each year because students bring articles which are hazards to the safety of others or interfere in some way with school procedure. Such items include, but are not limited to: toy guns, water pistols, water balloons, bean shooters, sling shots, knives, hardballs, laser pointers. The items if brought to school as playthings are undesirable and will be confiscated. Parents are requested to help children understand the necessity for such regulations. Boom boxes, radios, personal/portable compact disc player, and TV's are not permitted. Cell phones, pagers, iPods, MP3s or other electronic devices are not to be used in the classrooms UNLESS authorized by the classroom teacher. Authorized used during classroom time is for ACADEMIC purposes only. In these cases of occasional use, the device(s) shall be put back into the students pocket or school issued locker for the remainder of the school day.



Behavior Expectations

PUBLIC DISPLAYS OF AFFECTION

Friendship is great, but overly affectionate in school is in extremely poor taste. Kissing, hugging and other similar displays of affection are inappropriate for the school environment. Students are expected to exercise self-control and respect for others. Holding hands will be the extent of affection allowed. Student behavior that is outlined in the Sexual Assault Statutes of Wisconsin will result in disciplinary action and possible referral to law enforcement.

SCHOOL FUNCTIONS

It is important to remember that school activities occurring after the regular school days are considered an “extension” of the school day, and school rules, guidelines, and consequences apply. Such activities may include, but are not limited to the following: *Athletic events, dances, homecoming activities, formals, graduation, music and drama performances, and other school sponsored events.*

SEARCHES

Desks, lockers, books, and equipment loaned to students remain school property while in possession of the students. Such property is provided for the convenience of the students and shall be used only for authorized school purposes. Lockers are not safe deposit boxes. Granton Schools cannot guarantee full security to items stored in lockers. Students that suspect their lock is malfunctioning or that another student knows their combination should report it to the office so that a new lock/combination can be provided to the student. Only locks issued by the school may be used on lockers. Personal locks will be cut and removed by school personnel. The school district is not responsible for any items taken from a student locker even if it is locked. Students are expected to clean their lockers and remove all tape, photos, etc. at the end of the school year.

Other pertinent information relating to searches:

- Student lockers are provided for the use and convenience of students but remain under the jurisdiction and control of the school authorities. If inspection of lockers, either individually or on a group basis, is deemed necessary, such inspections can and will take place by school administrators or their designee. If a locker is used to store personal items (coats, purses, school bags, tec.) those items may also be inspected.
- When a locker is occupied anywhere in the building, it is understood that the occupant assumes all responsibility for contents therein. The Board of Education and its employees cannot be liable for losses that may occur. To protect their locker contents, the Board highly recommends that students use combination locks, which available upon request. Personal locks of any type are not permitted. If the lock is ruined, lost, or not turned into the office at the end of the school year, the student will be responsible for the cost of the lock. The school authorities reserve the right to use drug dog inspections of students lockers.
- Student parking is provided on school grounds for the use and convenience of students but remain under the jurisdiction and control of school authorities. If inspection of vehicles, either individually or on a group basis, is deemed necessary, such inspections can and will take place by school administrators or their designee. The school authorities reserve the right to use drug dog inspections of the parking lot.

STUDENT/STAFF RELATIONS

Students and staff have a right to work, study, and teach in an atmosphere of mutual respect. Students also have the right to free and reasonable inquiry and expression while having the responsibility to respect the authority, feelings, physical well-being and property of school staff members. The following and considered infractions of student-to-staff relationships:

- **Insubordination:** The willful failure to respond or carry out a reasonable request by authorized school personnel. Disciplinary action will range from detention, suspension, possible police referral, and possible expulsion.
- **Disrespect:** To insult, call derogatory names, use obscenity toward, dishonor, or in another manner abuse verbally or in writing any member of the school staff. Disciplinary actions will range from detentions to suspension, possible police referral and possible expulsion. Profanity directed at a staff member will result in suspension and/or possible further disciplinary actions.
- **Threatening or Intimidating Acts:** Verbally or by gesture threatening the well-being, health, or safety or any member of the school staff. Disciplinary action will result in suspension, possible police referral and possible recommendation for expulsion.
- **Physical Attack:** The act of physically assaulting any member of the school staff on school property or at any activity under school sponsorship. Disciplinary action will result in automatic suspension, recommendation for expulsion to the school board, and police referral as a felony offense.

Behavior Expectations

If you do not find what you need here, please also check the “academic information” section, the “behavioral expectations” section, the “attendance information” section at the beginning of the handbook and/or check frequently asked questions at the end.

Policies and procedures in this handbook are subject to change. Please refer to the board policies on our website and/or contact the high school office with any questions.



THEFT/VANDALISM/DESTRUCTION OF SCHOOL PROPERTY

Anyone found willfully damaging school property would be required to pay for the damages and/or replacement of any item. That student may be suspended from school or possibly expelled. Any student caught stealing or destroying either school property, or a fellow students property, will be required to pay for the loss and also faces suspension from school and possibly expulsion

BEHAVIOR CONSEQUENCES

Students who do not meet behavioral expectations will have consequences. Possible consequences include, but are not limited to: verbal warnings, removal from class, behavior program/plan, lunch detentions, after-school detentions, suspension, expulsion, possible contact of law enforcement, juvenile citations. Please see board policy for details on students code of conduct.

JUVENILE CITATIONS/POLICE REFERRALS

A revised Wisconsin State Statute places our students within the age bracket to receive citations/fines for breaking laws within the schools. Examples of incidents where citations may be issued include; theft, smoking, possession of cigarettes or tobacco, truancy, harassment, profane language, fighting, and disorderly conduct. The revised statute also allows for mandatory course appearance where the judge sets the fine amount for certain offenses. We want students and parents to be aware this is another option in dealing with students who choose to disrupt the school.

When violations of state laws or municipal ordinances occur, or when students or parents/guardians refuse to work within the established policies of the district and school, or where security of person or property appears to be in jeopardy, we will involve the police as we have a responsibility to provide all members of our educational community with a safe school. Acts that are illegal under the Criminal Code of Wisconsin are reported to the police. This referral does not replace the application of school disciplinary action for the same incident.

SUSPENSION/EXPULSIONS

A suspended student, whether in school or out of school, shall not be denied the opportunity to take any quarterly, semester or grading period examinations or to complete course work missed during the suspension period and is expected to complete the work during suspension. In all cases of suspension, pupils can be readmitted only upon fulfilling the requirements set down for his/her return and with permission from the Principal or District Administrator.

The power to expel a student from school rests with the Board of Education. The school board may expel a pupil from school whenever it finds the pupil guilty of repeated refusal or neglect to obey the rules, or finds that a pupil knowingly conveyed or caused to be conveyed any threat or false information concerning an attempt or alleged attempt being made or to be made to destroy any school property by means of explosives, or finds that the pupil engaged in conduct while at school or while under the supervision of a school authority which endangered the property, health or safety of others, or finds that a pupil while not at school or while not under the supervision of a school authority engaged in conduct which endangered the property, health or safety of others at school or under the supervision of a school authority or endangered the property, health or safety of any employee or school board member of the school district in which the pupil is enrolled, and is satisfied that the interest of the school demands the pupils expulsion. Conduct that endangers a person or property includes making a threat to the health or safety of a person or making a threat to damage property.

General Information

Please see the headings to the right for the information in this section.

If you do not find what you need here, please also check the “academic information,” section, the behavioral expectations” section, the “attendance information” section at the beginning of the handbook and/or check frequently asked questions at the end.

Policies and procedures in this handbook are subject to change. Please refer to the board policies on our website and/or contact the high school office with any questions.

ACCIDENTS
ANNOUNCEMENTS
ATHLETIC EVENTS/TICKETS
CAFETERIA
CHILD ABUSE/NEGLECT
CLOSING/EMERGENCY INFO.
CONCERNS
FEES AND FINES
FIELD TRIPS
FUND RAISING
HALL PASSES
HOMEROOM
ILLNESS
LEAVING SCHOOL GROUNDS
LIBRARY/IMC
LOCKERS/LOCKS
MEDICATION
OPEN CAMPUS
PARENTAL INVOLVEMENT
PHYSICAL EDUCATION-MEDICAL EXEMPTION
SAFETY DRILLS
SCHOOL BOARD MEETINGS
STUDENT MEETINGS
STUDENT SURVEYS
TECHNOLOGY
TELEPHONE
TEACHER QUALIFICATIONS
VISITORS
WEDNESDAY NIGHT
WORK PERMITS

BELL SCHEDULE

Doors Open: 7:30
Breakfast: 7:30-8:00
Homeroom: 8:00-8:29
1st Hour: 8:32-9:17
2nd Hour: 9:20-10:05
3rd Hour: 10:08-10:53
4th Hour: 10:56-11:41
HS 5th Hour: 11:44-12:29
MS 5th Hour: 12:11-12:56
6th Hour: 12:59-1:44
7th Hour: 1:47-2:32
8th Hour WIN Time: 2:35-3:20

Lunch A: 11:41-12:11 (MS)
Lunch B: 12:29-12:59 (HS)



ACCIDENTS

Every accident in the school building, on the school grounds, or at any athletic event sponsored by the school must be reported immediately to the person in charge and to the school office. The teacher supervising the activity must fill out an accident report form that can be acquired in the office.

Accident Benefit Plan/Insurance:

The school participates in the First Agency, Inc., accident benefit plan. All injuries to students are to be reported to the school office immediately. Authorization for treatment forms, including arrangements for medical treatment, will be completed by parents(s)/guardian and kept on file in the school office. It should be remembered that this coverage only supplements your family's health and insurance coverage. It will not extend payment for bills paid by your own insurance. All athletes need to be aware that they can purchase supplemental insurance.

ANNOUNCEMENTS

Announcements are read at the start of the homeroom period. All announcements must be turned into the high school office prior to 3:00 pm the day before or the announcement will not be posted for the next day. Students that arrive late to school can view the announcements posted in the high school commons area or via the school web page under the "District Information" link.

ATHLETIC EVENTS/TICKETS

Students are offered a variety of co-curricular activities at Granton Area Schools. All students are encouraged to participate in these activities as they serve an important function in the educational process. Season athletic tickets are available for purchase.

There are three different types of season tickets available:

- Family Pass – Parents/ Guardians and all school age family members will be admitted under this family pass.
- Single Adult Pass– Any single adult will be admitted under this pass.
- Student Pass – These are available for all students K-12
- Senior citizens and non-school aged children will be admitted free of charge.
- The single game price of admission: Set by the Conference
- Students that are suspended, expelled, have unserved detentions, or had an unexcused absence on the day of the event are not allowed to attend the event.



The Board of Education has the responsibility for crowd control at on-site school sponsored games, activities, and events. This responsibility is delegated to the district administrator and to his/her designee(s). The district has the right to set reasonable crowd control rules and enforcement procedures to ensure the health and safety of the crowd and participants. A ticket or invitation is a license to attend and not a property right. Loitering in the field-house lobby while games are in action is prohibited. All students should be prepared to leave the gymnasium within 20 minutes after the completion of the activity. Board Policy, Ch. 11, Sec. M, describes acceptable behavior and consequences. Remember to practice good sportsmanship at all times. You are there for the support of the team, or individual participant, not to be critical of the players or officials.

CAFETERIA

The school cafeteria serves breakfast and lunch under guidelines set forth by the federal governments programs. Meals are planned to meet nutritional requirements set forth by the U.S. Government for balances class "A" lunch programs. All Granton Area School students are eligible for meals in the cafeteria. Eating in the lunchroom is a privilege and all school rules and policies apply. Failure to comply with these reasonable requests may result in the loss of this privilege. Breakfast and lunch prices have not been established at the time of this printing. One family can make one lunch payment. All payments will be entered into the family account. Any unused money will be refunded or credited to the following year's account. Students are not allowed to share their account with other students.

General Information

CHILD ABUSE/NEGLECT

Any teacher, administrator, counselor, psychologist, social worker, or other certified school staff member who suspects that a child has been, may be, or is being abused or neglected is required by law to immediately report such suspicions. These suspicions, true or not, will be reported to social services that will do the investigating. The school's legal obligation is to report the matter.

CLOSING/EMERGENCY INFO.

The district administrator and bus supervisor will weigh all pertinent factors and may consult with all appropriate resources in making the decision to close or delay the start of school. Students, parents, and staff will be informed of school closing as early as practical by announcements on: 1 Notice will be made through an *automated telephone system*. 2 Radio Stations including WCCN, WAXX, WDLB, etc. 3. *Television stations 7,9, and 13.*

CONCERNS/CHAIN OF COMMAND

Our society has a "chain of command." If you experience a problem of some kind at school with another student, teacher, parent, coach, etc. please go to the root of the problem and work your way up from there. Calling the principal to address an issue with a teacher, when the teacher has never been contacted, is not the proper way to handle the problem. Contacting the teacher first is the appropriate step.

FEES AND FINES

- **Fee** - Some courses require the student to purchase materials for project that they will keep. Students are subject to fines for library books, textbook abuse, lost materials, and breakage. All student fees and fines must be paid before the student will be cleared for the school year.
- **Textbook Fee/Fine** - Student may be charged replacement costs if the materials are lost or defaced. Simply, once given the book, or item in question, the student is responsible for its return in a very similar condition as when it was issued. Students may be fined for damages to textbooks that are above and beyond routine wear. Students are encouraged to write their name in the space provided inside the cover and also place a book cover on all of their textbooks to serve as added protection. The classroom teacher will record all pertinent information including the number and condition of the book at the time of issuance. Should a student be fined for a textbook upon signing out with their instructor, the student will **a)** be told of the fine, **b)** the teacher will attempt to contact the parent by phone within 24 hours to inform them of the fine as it may be substantial, and **c)** the fine information will be written on the students sign-out sheet. The School Board believes that textbooks have a quality use for seven years. Any book that is not fined for replacement will be levied a fine that will be prorated.
- **Locker Fines** – Lockers are the property of the school and are not to be written on or in. Any Student that places tape, stickers, or other material to the inside or outside of the locker is responsible for its removal. Students who fail to clean all markings and materials from their locker, do not checkout appropriately at the end of the year or simply do not clean out their locker(s) will be assessed a cleaning fee of \$10.00 per locker; including Phy. Ed. Lockers.

FIELD TRIPS

No more than two school-approved chaperones will attend a classroom field trip; additional chaperones may be added at the discretion of the administration for longer trips that involve a significant number of students. All chaperones are subject to background checks as well. If other parents wish to attend the trips they must do so at their own expense. All school policies are in place while students and staff are off school grounds for a school related activity.



FUND-RAISING

Students are responsible for all funds collected on behalf of an organization. A fund-raising form must be completed for all fund-raising activities and approved by the principal before any fund-raiser can take place. The audit form must be completed at the conclusion of the fund-raiser. All fund-raising monies are to be placed in the school safe and at no time left in the teacher's/advisor's classroom. No organization shall spend monies for any purpose until written approval is given by the class or club advisor(s). Proper procedure must be followed in depositing monies in a class or club account or in obtaining a check for payment of due bills. Check with the office for informational procedure. All class or club funds will become the property of the school district one year after a class graduates and one year following the dissolving or disbanding of a club or organization.



HALL PASSES

The hallways should be free of heavy traffic during the school day, except between periods, as students are to be in class. Any student in the hallway during regularly scheduled class time without a hall pass is subject to punishment (detention) by the building principal. No more than one student from any given class is to be in the halls at one time. Please plan ahead and be organized to avoid problems in this area.

HOMEROOM

Students are assigned to a homeroom teacher and will attend homeroom with this teacher in a predetermined room (generally that teacher's classroom) every day. There are very specific behavioral guidelines that all students in every homeroom are expected to adhere to at all times. Each day during homeroom the teacher will have the opportunity to touch base with these students, check their grades and homework on infinite campus, and help with their schoolwork. Receiving help from another teacher is called academic intervention. This system of academic intervention is essential to helping students achieve success if they are struggling. They will be able to get help before it is too late. Students will be put on intervention if they are earning any grade less than a D+. They may also be placed on intervention if they have been absent and need to make up work or need to review with a teacher for a test or need help with organizational and/or behavioral strategies. Students who need additional intervention academically will have an additional period termed "ZAP" and/or "HHC" to work on the skills they are deficient in. There are many ways intervention time can be utilized. Also during Friday homerooms, meetings may be called for various co-curricular activities.

The exception to the above homeroom schedule is Tuesdays and Thursdays when there will be no interventions and no meetings. All middle and high school students will stay in their homeroom and work with their teacher/mentor on ACP. One Thursday of each month will be set aside for P.A.W.S activities.

ILLNESS

The school does not employ a full time nurse or have somebody on call to deal with ill children. If a student does not feel well prior to leaving for school you are encouraged to keep them home. If a student believes they are too ill to attend class they should go home. Arrangements will be made by the parents to get the student home. Please be sure to review the "attendance information" section of this handbook for a description of excused and unexcused absences.

LEAVING SCHOOL GROUNDS

All students are required to sign in and out of the high school office when entering or exiting the school building during school hours. All students should only enter and exit the building through the main high school entrance. Granton High School is a closed campus. Upon arrival in the morning, students may not leave the building without permission. If it is necessary to leave school during the day, a student must present a note from a parent indicating the reason for the request. Each request will be handled individually.

General Information



LIBRARY/IMC

The school library/IMC is a learning resource center available to all students K-12. The library is intended to be a quiet area where students can go, when time permits, to use the available resources. Students are expected to obey all established library rules as set forth by the IMC coordinator.

LOCKERS/ LOCKS

All students are encouraged to lock their lockers. Having an unlocked locker is an invitation to theft and if you choose not to lock your locker then you assume any and all responsibility for that choice. The school does provide combination locks free of charge and they are to be returned at the end of the school year; for security reasons, personal locks are not allowed for use at school. The outside of your locker is to be bare except for pre-approved decorations and/or signs.

MEDICATION

Efforts are to be made to avoid medication administration at school. Medication, prescription or over the counter, must be maintained in the high school office. Medication administered by the office must have a Parent/Guardian Medical authorization form sent with medication. If the medication is prescribed, a Doctor's form is also required.

At no time are school staff to distribute medications of any kind, including aspirin, to a student without a signed parent authorization form that is on file with the office. The school will assume responsibility for:

- Being aware of students who are on medication. **(It is the parent/guardian's responsibility to inform the school if their child is in possession of prescription drugs while at school.)**
- Checking the type, dosage, and purpose of these medications.
- Appointing an appropriate person to assist in administering medication.
- Keeping accurate and confidential records of pupils receiving medication.
- Providing a safe place to keep medication.

If your child is to receive medication at school, the following must be on file:

- A completed school medication form available in the school office signed by the parent, and physician, if it is a prescription medication.
- All prescription medications must be in a properly labeled bottle with the following information:
Name and phone number of pharmacy

OPEN/CLOSED CAMPUS

The Granton Area School District has a closed campus for all students in grades 4K-11; no exceptions to this portion of the policy will be granted. At the start of the 2022-2023 school year, it will be a closed campus through twelfth grade. If the closed campus is changed for 12th graders, notice will be made. If and when it's determined twelfth graders will have an open campus, the following guidelines are used;

1. Students in the 12th grade may leave school for lunch, and/or 8th period will certain conditions and understandings:
2. Open campus is for only graduating seniors.
3. The student brings the principal a signed note from his/her parent/guardian. This applies to all 12th grade students regardless of age.
4. The note must be approved by the building principal.
5. Seniors are required to follow all school rules while in the building or on the school grounds. Violation will result in a suspension from open campus in addition to other required penalties.
6. All seniors who qualify for open campus will be issued a laminated I.D. card. This card must be presented to any questioning school official upon leaving the school grounds for open campus. If you laminated card is lost, notify the office immediately. The cost to replace your I.D. will be \$1.00.

OPEN/CLOSED CAMPUS CONTINUED

7. Students must sign out at the high school office as well as leave and return from open campus through the front high school doors only. (ENTRANCE #4).
8. The lunch hour and approved open campus time period will be the time set as the lunch hour time period and 8th hour time period according to the daily school schedule.
9. **THE ADMINISTRATION HAS THE RIGHT TO CANCEL OPEN CAMPUS AT ANY TIME.**
10. Being tardy or having an unexcused absence as a result of leaving under the open campus premise is not acceptable and will result in revocation of the open campus privilege in addition to other required penalties.
11. Any senior that is absent 10 or more part or full days in a semester, excused or unexcused, will not have open campus privileges.
12. Negative reports from local citizens will be considered in evaluating any suspensions from open campus.
13. Any grades lower than a C- recorded for a marking period (quarter or semester) will result in suspension from open campus until the next marking period. The student will be reinstated if they have no failure notices.
14. Any deficiency will result in suspension from open campus for the remainder of the quarter. To resume open campus privileges, a student must not have any grade that would lead to a deficiency referral (any grade of D+ or below).
15. Through the high school principal, any teacher may recommend suspension from open campus at any time for any 12th grader whose grades noticeably drop or whose behavior degenerates.

PARENTAL INVOLVEMENT/TITLE 1

We know a strong partnership with you will make a difference in your child's education. As partners, we share the responsibility for your child's success and want you to know we will do our very best to carry our responsibilities. As parents, I hope you continually encourage and support your child to be involved in doing their best as they embark on their once in a lifetime school journey.

The Granton School Board recognizes the importance of parent/guardian input into the education of their children. The Board further recognizes parent participation in the design and implementation of the district's educational curriculum to allow for comprehensive programs for their children. As evidence of the school board's commitment to parent involvement in Title I, we are adopting the following activities as a response to regulation 200.53 of the May 19, 1986, Federal Register. The Granton School District designates the Title 1 teachers to coordinate parent activities in order to ensure that parents of the children being served have an adequate opportunity to participate in the design and implementation of the Title I Project.

The following activities will be adopted:

- Training parents to promote the education of their children at home
- Facilitating volunteer or paid participation by parents in school activities
- Designating LEA parent coordinators
- Holding an annual meeting of parents of all eligible Title I students
- Implement and review the school-parent compact
- Provide parent representation during school wide committee meetings



General Information

PHYSICAL EDUCATION – MEDICAL EXEMPTION

Students who temporarily cannot participate actively in the program must present their physical education teacher with a written excuse from a licensed physician or doctor. It is the student's responsibility to return to active participation at the prescribed time on the medical excuse. Students who are unable to participate may remain with the physical education class or may be temporarily scheduled into a study hall until the student is able to return and participate in physical education. To receive a medical exemption for physical education a student must face scheduling conflicts that do not allow the credit requirements to be met because of medical conditions that were/are beyond the individual's control. However, should the student's schedule allow for the scheduling of physical education the course must be taken.

SAFETY DRILLS

All classrooms are to have emergency directions posted by the classroom door. These directions will point you in the proper direction in the event of an emergency. In the event of a fire drill you will leave the building by walking (not running) in a single file line. You are to leave all personal belongings in the building and leave immediately. Exit the building at a minimum distance of 100 feet. Always keep quiet listening for instructions from school and safety personnel. Additional safety drills will occur during the year. Please always listen to your teacher's instructions and remain calm.

SCHOOL BOARD MEETINGS

Unless announced otherwise, school board meetings are held the second Monday of every month in the Library/IMC at 6:45pm. If you have something you wish to discuss at a board meeting please contact the district administrator to discuss the items as it may be placed on the agenda. Your attendance is encouraged as only informed citizens can make an informed decision.

STUDENT MEETINGS

Co-curricular meeting times will vary throughout the year and may include; before school (7:40), Fridays during homeroom, lunch, rolling class periods, and/or after school. If class time is missed, students are responsible to get the work prior and turn it in on time. If not possible to get prior, students must contact the teacher within 24 hours of the missed class and get the work. Please be sure students communicate with advisors/coaches about arrangements.

STUDENT SURVEYS

The School Board respects the privacy rights of parent and their children. No student shall be required to participate in any survey associated with a school program or the District's curriculum, or which is administered by a third party in the schools if the survey includes one or more of the following items:

- political affiliations or beliefs of the student or the student's parent;
- mental and psychological problems of the student or the student's family;
- sex behavior or attitudes;
- illegal, anti-social, self-incriminating or demeaning behavior;
- critical appraisals of other individuals with whom students have close family relationships; legally recognized privileged or analogous relationships such as those of lawyers, physicians and ministers;
- religious practices, affiliations or beliefs of the student or the student's parent;
- Income, other than that required by law to determine eligibility for participation in a program or for receiving financial assistance under such a program.

Parents/guardians shall be given the opportunity to request that their child not participate in a survey containing the above information. If a survey containing any of the above information is funded in whole or in part by a program administered by the U.S. Department of Education, written consent shall be obtained from the student or in the case of a minor student, the student's parent/guardian before the student participates in the survey. Please refer to board policy for further details.

General Information

TECHNOLOGY

The Granton Area School District supports the use of technology by its students, staff and community. It recognizes that computer, computer networks, and databases are resources for educational and training opportunities for all citizens. (At present, community classes are limited to scheduled courses with the potential for more individualized sessions in the future.) Its primary mission being the education of youth, students (and staff involved in local educational purposes) will be given priority use of all computer equipment in the buildings and software program access.

DISTRICT WEB PAGE

There shall be one authorized web page for the *Granton Area School District*. The purposes for developing a World Wide Web page for Granton are: (1) to provide an opportunity for staff to highlight their programs, courses, objectives, and curriculum openly with those interested in learning more about what is offered at Granton Schools; (2) to provide an opportunity for students; and (3) to provide information about Granton schools for public viewing.

Student photos or student's work may be featured unless the school district has on file written notice stating that they do not wish to have this type of information made available to the public. For more information regarding directory information families should contact the District Office. A directory information release form is sent out annually in the August newsletter.

INTERNET SAFETY & COMPUTER USE

Use of District computers and computer networks shall be in support of education and research and consistent with the educational objectives of the *Granton Area School District*. District staff users may use the District's e-mail and Internet system for informal or personal purposes within reasonable limits, consistent with the guides set forth in the policy. Students may access the Internet via District computers as part of classroom activities or for class projects. Student internet use in the classroom shall be under the direct supervision of the classroom teacher, and internet use by students at other locations within the school shall be under the direct supervision of the designated supervisor of that area. **Use of the Internet is a privilege, not a right.** No student or adult user may use District computers or computer networks to access the Internet unless they have signed a computer/internet acceptable use agreement. Student acceptable use agreements shall also be signed by the student's parent/guardian.

Internet filtering software will be used on District computers in an effort to limit access to inappropriate or harmful material on the Internet. The District acknowledges that even with a filtering system, complete control and/or access to objectionable material cannot be assured. The *Granton Area School District* is not liable for information contained or accessed on the Internet.

All who access the Internet through the *Granton Area School District's* system are responsible for lawful and appropriate behavior on computer networks. The following are guides for acceptable use of District computer networks, including the Internet; they are not meant to be all-inclusive:

1. Users may not access, copy or modify the files or data of another user. Users will access their own files and accounts only.
2. Network access may not be used for commercial purposes, nor for any illegal activities exemplified by (but not limited to) the following:
 - copying or circulating copyrighted materials.
 - Writing and transmitting messages that threaten, harass, frighten, intimidate or annoy others.
 - Accessing unauthorized services, or attempting to circumvent security measures.
 - Circulating files, which may corrupt the integrity of the network (e.g., viruses).
3. Users will not access internet sites, chat rooms, or use e-mail that contain pornography or materials that are obscene, harmful to minors or otherwise inappropriate. If such sites are accessed accidentally, the user is to exit immediately.

General Information

TECHNOLOGY; INTERNET SAFETY & COMPUTER USE CONTINUED

4. Users are expected to help maintain the integrity of the system. Modifications, additions to, or abuses of hardware or software are not allowed. Use of personal removable disks is allowed by district staff. Student use of removable disks is allowed with **prior approval**. The interface of personal devices (palm pilots, hand-held computers, etc.) with district equipment is prohibited. Individuals will be personally liable for any virus or destructive acts that cause damage to any portion of a computer or the network system. If there are problems, they should be reported to the Computer Specialist.
5. Because of the potential for viruses, hostile programs, unauthorized software, and limitations on hard disk space, files from the internet are not to be downloaded into the system. Downloading to removable disk is prohibited except **with prior approval** from the Computer Specialist.
6. Users are expected to limit their printing to that which is absolutely necessary. Printed pages for non-class-related activities may be made at the current per page charge through the Granton IMC.
7. As a personal safety issue, users are cautioned not to reveal personal information (address, phone number, location, passwords, etc.) over the Internet. **Chat room use must be authorized** by the building principal. Student e-mail use will be allowed within the district network of school sanctioned distance learning. Adult users must adhere to the conditions of the computer/internet use policy.
8. Users are expected to follow all rules that are posted in the lab and classroom areas in which computer access is available.
9. Users are reminded that all electronic communication systems (e-mail) and all information transmitted by, received from, or stored in, the systems are the property of the *Granton Area School District*. **Users have no expectation of privacy in connection with the use of this equipment or with the transmission, receipt, or storage of information in this equipment.** The District reserves the right to access all files in the course of normal maintenance or when there is cause to suspect misuse of the system.
10. Users are reminded that Internet access is a shared resource, and it may be necessary to limit access time or put priorities in place for equipment use.
11. Uploading of any materials is permissible only under staff supervision and with prior approval from the Computer Specialist.

Use of the internet

The Granton Area School District recognizes the need to provide technology to further the educational goals and mission of the District. The internet and other computer networks provide unique educational and communication opportunities and challenges to a learning community. Teachers and library media specialists have a professional responsibility to blend thoughtful use of such information with the curriculum and to provide guidance and instruction to students in the appropriate use of such resources. Staff will be responsible for enforcing the guidelines for instructional resources and the goals for the selection of instructional materials contained in Board policy. Use of the Internet and similar communications networks by staff and students is a privilege. Access will be given as consistent with District policies and educational objectives.

Conditions of Use:

1. All users will comply with legal requirements regarding the use, reproduction and distribution of copyrighted works.
2. All users will be expected to comply with privacy and security standards.

General Information

TECHNOLOGY, CONTINUED

3. All users will be expected to demonstrate ethical behavior in using network facilities and to avoid any illegal activities, including tampering with hardware or software, vandalism, destruction of computer files or transmission of any material in violation of any state or federal law or regulation. The latter includes, but is not limited to, copyrighted material, threatening, inflammatory or obscene material, or material protected by trade secret.
4. Students will be granted access upon written permission by their parent or guardian.
5. Access to network services will be provided to all users who act in a considerate and responsible manner and conduct themselves in accordance with rules outlined in their handbooks. Failure to obey rules or directions will result in disciplinary action.
6. It is the responsibility of the entire educational community and the Library/Media Technology Coordinator to oversee the use of the District's computers. Violations of the policies, rules or procedures will be reported to the building principal.
7. Students and staff violating the above rules may be subject to school discipline, up to and including expulsion. They also may be denied future Internet/on-line service access and will be reported to the police or proper authority if in violation of law.

Access to Global Information resources Procedure

Students and staff are reminded that the use of Internet is a privilege, not a right. The purpose of Internet is to facilitate communications in support of research and education by providing access to unique resources and an opportunity for collaborative work. Some material on the Internet may contain items that are inaccurate or potentially offensive to some people. Parents/guardians who wish to exempt their child from having access to or using the Internet should submit a written statement to that effect to the building principal.

General Use Rules:

1. Students and staff must adhere to the same standards of conduct expected and required in the classroom.
2. Transmission or reproduction of any material in violation of any United States or state regulation is prohibited. This includes but is not limited to copyrighted material, threatening or obscene material, or material protected by trade secret.
3. Students must always get permission from the instructors or library staff before using the network or accessing any specific file or application. Written and oral classroom instructions must be followed.
4. Students who have a need to use a given computer for academic reasons will have priority over any non-academic use of that computer.
5. E-mail at school is for school related use only. It is NOT for personal use.
6. Designated school personnel may conduct random checks of users who are on line with the Internet or other computer network.

1:1 Technology Policy

In this policy, "Chromebook/iPad" will be referred to as "device". The devices and bags/cases are issued to all students and are the property of the GASD. The device is on loan and must be used in accordance with the following policies and procedures.

1. The device and bag/case should be kept clean and free of marks at all times. Placing stickers, writing or drawing on, engraving or otherwise defacing the device and bag/case are not allowed.
2. When transporting a device to and from school, students should always be sure it is placed in the device bag/case. Device labels must remain on the device at all times.
3. Devices should be placed on the top shelf when stored in lockers.
4. Devices are assigned to individual students. Students should never "swap" or "share" their device with another student.
5. Students are responsible for bringing their device, fully charged, to school each day.
6. Devices will be randomly check to determine if students have the appropriate device and are using the device appropriately .
7. Students are not allowed to take a device home until the Student Chromebook Take Home Agreement is completed and permission is granted.

General Information

TECHNOLOGY: INTERNET (USE OF THE) CONTINUED

Rules of network Etiquette

All students and staff are expected to abide by the generally accepted rules of network etiquette. These rules include the following:

1. Appropriate language must be used at all times. Network users will not swear, use vulgarities or any other inappropriate language, or engage in activities which are prohibited under state or federal law.
2. Harassment and vandalism will not be tolerated. Harassment is defined as the persistent annoyance of another user or the interference of another user's work. Vandalism is defined as any malicious attempt to harm, modify or destroy data of another user or network equipment. Vandalism and harassment will result in disciplinary action.
3. It is the user's responsibility to avoid inappropriate materials.
4. Users must remember that electronic mail (e-mail) is not private.
5. Students and staff will not reveal any personal address or phone number or those of any other person.
6. Users will not use the network in such a way that would disrupt the use of the network by others users.

Penalties for Improper Use

Violation of these rules, applicable state and federal laws or classroom and/or district rules will result in loss of network privileges and/or other disciplinary action. Violations could also lead to referral to legal authorities.

Internet Safety Policy

Introduction - It is the Policy of the Granton Area School District to:

- Prevent user access over its computer network to, or transmission of, inappropriate material via Internet, electronic mail, or other forms of direct electronic communications;
- Prevent unauthorized access and other unlawful online activity;
- Prevent unauthorized online disclosure, use, or dissemination of personal identification information of minors, and;
- Comply with the Children's Internet Protection Act [Pub. L. No. 106-554 and 47 USC 254 (h)].

Definitions - Key terms are as defined in the Children's Internet Protection Act.

Access to inappropriate Material -To the extent practical, technology protection measures (or "Internet filters) shall be used to block or filter Internet, or other forms of electronic communications, access to inappropriate information. Specifically, as required by the Children's Internet Protection Act, blocking shall be applied to visual depiction of material deemed obscene or child pornography, or in any material harmful to minors. Subject to staff supervision, technology protection measures may be disabled or, in the case of minors, minimized only for genuine research or other lawful purposes.

Inappropriate Network Usage - To the extent practical, steps shall be taken to promote the safety and security of users of the Granton Area School District online computer network when using electronic mail, chat rooms, instant messaging, and other forms of direct electronic communications. Specifically, as required by the Children's Internet Protection Act, prevention of inappropriate network usage includes:

1. Unauthorized access, including so-called 'hacking,' and other unlawful activities; and
2. Unauthorized disclosure, use, and dissemination of personal identification information regarding minors.

Supervision and Monitoring - It shall be the responsibility of all members of the Granton Area School District staff to supervise and monitor usage of the online computer network and access to the Internet in accordance with this policy and the Children's Internet Protection Act. Procedures for the disabling or otherwise modifying any technology protection measures shall be the responsibility of the district.

General Information

TECHNOLOGY, CONTINUED

Disciplinary procedures for Internet and computer use policy violations

As per Granton Area School District Board Policy Code Chapter 9: Section IC

The building principal or designee shall have discretion to deal with violations of this policy. Misuse of District computer networks, including the Internet, may result in school disciplinary action, including loss of computer network use privileges. If the misuse constitutes a criminal offense, appropriate legal action may also be taken.

Student Violations; Students who violate the District's computer/internet use policy shall be subject to the following disciplinary actions:

- **First Offense** - Loss of all computer/internet access for no less than ten (10) school days. Parent(s)/guardian(s) will be notified of loss of computer network use privileges.
- **Second Offense** - Loss of all computer/internet access for no less than forty-five (45) school days. Parents(s)/guardians(s) will be notified of loss of computer network use privileges. Computer network use privileges will be restored on a conditional basis following the revocation period and/or parent/guardian meeting.
- **Third Offense;** Loss of all computer/internet access for the remainder of the year. Parents(s)/guardian(s) will be notified of loss of computer network use privileges. A meeting with the parent/guardian must be held before consideration of restoring computer network use privileges, which may be restored on a conditional basis following the revocation period and the parent/guardian meeting.

Employee Violations; Abuse of the District's computer/Internet use policy by District employees may result in disciplinary action up to and including termination from employment.

Citizen Violations; Citizens who violate the District's computer/internet use policy may lose their computer network use privileges.

Accidental Damage

1. On an annual basis, the student will incur a \$10.00 fee the first time a device has to be repaired.
2. If a device has to be repaired a second time, a \$25.00 fee will be charged. The student will not be allowed to take device home until the fee is paid.
3. For the third incident and any incident thereafter, the student will be charged the cost of associated with fixing and/or replacement of the technology. An administrative decision will be made regarding the student's take-home privileges for the remainder of the year.

If a student loses or destroys beyond repair any of the following components, they will be charged full replacement costs for those items.

1. Power module/cord
2. Bag/Case
3. Any device (Full Replacement Cost)

The use of any district technology is a privilege and not a right. Students are expected to use their device in accordance with these policies and procedures, and District Acceptable Use Policy and any applicable laws. Failure to use the device in an appropriate manner will result in the following consequences, as determined by the staff and administration of the Granton Area School District.

1. Cancellation of student use or privileges, including the privilege of taking the device home.
2. Suspension from school
3. Expulsion from school
4. Civil or criminal liability under applicable laws.

General Information

TELEPHONE

No calls are to be made from the office phone except for school related business (permission must be obtained from the high school office staff prior to calling out). Students will be allowed to use the office phone only in cases of emergency (forgetting swimming trunks, ball gloves, homework, etc. does not constitute as an emergency). The school reserves the right to prohibit student use of the phone when this use interferes with their academic success. Permission from the office must be obtained before any call can be made. All other telephones in the building are for staff use only. Students should not use their cell phones without permission from the office.

TEACHER QUALIFICATIONS

It is required by federal law that you are given access to information regarding the qualifications of teachers within the Granton Area School District. You might have questions, such as:

- Is my child's teacher licensed to teach the grades or subjects he/she teaches?
- Has the state waived any requirements for my child's teacher?
- What was the college major of my child's teacher?
- What degree(s) does my child's teacher hold?
- Are there instructional aides working with my child? If so, what their qualifications? In Wisconsin, all teachers are required to have at least a bachelor's degree. If you are interested in seeing the state qualifications for your child's teacher, you may contact the school or check the Wisconsin Department of public Instruction's website at www.dpi.state.wi.us/dpi/dlsis/tel/liserach.html.

VISITORS-DAY AND DANCES

Due to safety concerns, students are not allowed to bring visitors to school. Parents are encouraged to attend and are welcome at all times. However, parents must check in at the office as is policy for any visitor to the school. Only Granton students and their dates will be allowed to attend school dances. Guests must be enrolled in High School (or be one year out of HS) and are required to have their High School Principal sign the Dance Guest Pass form, stating they believe they will not be a discipline problem at our dance. Students coming to a school dance are to stay in the building where the dance is being held. Those leaving the building without special permission will not be permitted to return. Any disorderly conduct at a dance or extra-curricular activity will result in that student being removed from the facility and additional consequences may follow including referral to law enforcement.

WORK PERMITS

Before a work permit (ages 15 or younger) can be issued the following requirements must be presented to Tammie Cramer (school office): *Proof of age, birth record or baptismal certificate, Social Security card, Letter from employer stating his/her intention to employ a minor, Letter from parent or guardian consenting to employment, Required permit fee of \$10.00.*

Go Bulldogs!



What are the dates and times of school?

Tuesday, August 25th through Friday, May 28th; Monday through Friday 8:00-3:20: Doors Open; 7:30-8:00, MS Lunch; 11:41-12:11, HS Lunch 12:29-12:59. Check out the Calendar on page 4 of the handbook for other dates to be aware of.

Will my child eat breakfast and lunch?

We sure hope so! Both are available and free to all Granton students.

What should I do if my child is absent?

Please fill out the Google Form in our Granton App and on our Website. Be sure to check out attendance/truancy guidelines in this handbook for additional details on absences.

What if I need to pick up my child early?

Please fill out the Google Form in our Granton App and on our Website. All bus changes need to be communicated with the office before 2pm so that we have time to communicate your child's transportation plan. Your child will need to check out in the Principal's Office. If you come into school, you will need to sign in as well.

What if I need to get a hold of my child immediately?

Please call the Principal's office (715-238-7175). Students are not allowed to use their phones during the school (other than lunch).

What if I have concerns about what my child is learning?

Please encourage your child to talk to his/her teacher. If after your child tries to resolve the issue, please reach out to your child's teacher. Our staff is a great group of dedicated professionals who enjoy working with secondary students and want the same thing for your child that you do; success! The best way to get a hold of our teachers are via email (emails are located in infinite campus) or telephone (715-238-7175).

How can I help my child be more successful in school?

Have conversations with your child about their day, their homework, up-coming tests and events and of course, always encourage your child to read, read, read!

Who is my child's teacher?

Our high quality staff are a mix of experienced and new educators who are proud to be Granton Bulldogs! We have an eight period day with homeroom, so your child will have a variety of our dedicated professionals. Your child should provide more information to you as school starts and teachers will be handing out syllabi the first week as well. As always, please partner with your child's teachers to bring out the best in your child.

Questions?

Policies may be revised during the course of the year. When that occurs a notification will be sent out and an updated copy of this Student Handbook will be available in the high school office.

What if my son/daughter wants to get off at somebody else's bus stop?

Bring a note signed by BOTH families stating who wants to go where. All notes must have a current date, the child(ren's) name(s), and a parental signature from both families. This will require advanced planning, but it will help us to keep all children safe. The note(s) must be copied and kept on file in the office and the original is to be given to the bus driver.

What if my son/daughter is "dress coded"?

Any faculty or staff member may address improper attire with any student. Students will be requested to remedy the situation immediately. Requests are dependent on the situation and may include quickly find alternative apparel from the student's locker, the lost and found, turn the item inside out, cover up, etc. Each request comes with the understanding the item should not be worn again. Students who fail to comply or repeatedly violate the dress code will face disciplinary consequences.

*Please contact us with any
questions.*

*Thank you for you partnership in
your child's learning!*

Go Bulldogs!



In accordance with Wisconsin Act 118 the following data represents the Granton Area School District Seclusion and Restraint Written Report for the 2021-2022 school year.

Incident of Seclusion: 0

Students involved in Incident of Seclusion: 0

Students with disabilities involved in Incident of Seclusion: 0

Incident of Physical Restraint: 0

Students involved in Incident of Physical Restraint: 0

Students with disabilities involved in Incident of Physical Restraint: 0

FEES:

Student Athletes are required to pay a yearly \$35 fee (grades 9-12) or a \$25 fee (grades 6-8) in order to participate. The maximum fee per family is \$75. This fee covers the entire school year and does not change based on the number of sports participate in. This fee must be paid in order to practice.

PARENT INFORMATION

While spectators, at any extra/co-curricular events either at Granton or any other site, parents are expected to display sportsmanlike behavior. An individual or group who willfully interferes with or interrupts the proper order or management of a school sponsored extra/co-curricular event by an act of violence, boisterous conduct, threatening language, or unsportsmanlike conduct toward coaches, players, or officials, or disobeys board policies or administrative rules may be removed from the event and may be prohibited from further attendance for a period of up to six weeks. Individuals prohibited from attendance may follow the established grievance procedure.

At the conclusion of any sporting event there will be a 24-hour buffer period in which parents/guardians are to refrain from approaching any coaching staff with negative concerns regarding the sporting event.

Parents/Guardians need to be aware that injury, accidents, disability, and even death can result from athletic participation.

Granton Area School District

Athletic Code

Granton Bulldogs
2022-2023

District Office: 715-238-7292

Elementary/Middle/High School Office: 715-238-7175

Granton
AREA SCHOOL DISTRICT

HOME OF THE BULLDOGS



Check us out online @: www.granton.k12.wi.us

SPORTS:

Football, Cross-Country, Volleyball, Spirit Team, Basketball, Hockey, Baseball, Softball, Wrestling, and Track

ATHLETIC DIRECTOR:

Dan Hebert

SCHOOL COLORS:

Orange and Black

TEAM NAME:

Bulldogs

CONFERENCE:

Cloverbelt

CONFERENCE SCHOOLS:

Altoona, Cadott, Colby, Columbus (Marshfield), Fall Creek, Gilman, Granton, Greenwood, Loyal, McDonell, Neillsville, Osseo-Fairchild, Owen-Withee, Regis, Spencer, Stanley-Boyd, Thorp.

MEMBERSHIP

Wisconsin Interscholastic Athletic Association (WIAA)

ATHLETIC BOARD:

District Administrator, High School Principal, Athletic Director, Two coaches from different sport areas.

Granton Area School District Athletic Code

Each student and his/her parents should read the entire Athletic Code and be aware of its conditions. Each student must have a signed Athletic Code on file for the present school year before he/she is allowed to practice or participate. Each student participating in athletics must also have the appropriate physical card or alternate year card on file before practicing or participating.

As students decide to become a participant in athletic activities in Granton School District, they are reminded that involvement in co-curricular activity is a privilege, not a right. Certain privileges are given to those who participate in an athletic activity; therefore, the student's conduct is to be above the rest of the student body. In order to maintain that privilege, the students will be required to make some sacrifices, work hard, and follow certain rules. The rules and penalties that apply to a participant in athletic activities are as follows:

A. Eligibility Rules

1. In order to participate in the athletic program a student must be carried on the school's attendance roles for the purpose of state aid. The student must also be meeting the academic requirements put forth by the school district. A student must meet the districts requirement defining a full-time student. All participants in interscholastic athletics including managers and statisticians shall follow the Granton Athletic Code.
2. A student must be carrying a minimum of four classes per quarter. A senior who has acquired all necessary credits for graduation is not exempt from this rule. Students who are enrolled in a University or technical college must refer to the W.I.A.A. Handbook.
3. An Athlete enrolled in grades 9-12 will not be allowed to participate in the sports program after attending Eight (8) Semesters. An athlete has the potential of eight (8) consecutive semesters of athletic eligibility starting with the first semester of 9th grade unless there are extenuating circumstances that are documented with the WIAA office. The WIAA is the only entity that can wave this ruling. An athlete may not participate if he/she reaches their nineteenth (19) birthday before August 1st of that school year.
4. An athlete must be in attendance for at least a half day to be eligible to practice or play that day. *If an athlete has an unexcused absence for all or part of the day, he/she shall not be allowed to practice or play that day. School attendance for a half day is also required on the last day prior to a non-school day event (i.e. you must be in school all-day Friday to be eligible for Saturday). Some exceptions to the attendance rules could be a medical appointment, death in the family, or a funeral. The athletic director should clear other exception in advance. The discovery of a violation of the attendance eligibility rule after the practice or contest will result in suspension from participation on the next practice or contest date. A student who has been suspended is ineligible to practice or complete on the day(s) of the suspension.*
5. A pledge must be signed in person by the parent/guardian and athlete stating that the athlete will abide by the terms of this athletic code. The pledge must be filed with a school official before the student may participate in practice or athletic events. THE ATHLETIC CODE WILL APPLY YEAR AROUND. This means a 12 month, 365 or 366-day year.

B. Academic Eligibility Rules and Penalties

Grading checks will be completed on a bi-weekly basis. If an Athlete receives an F on the most recent grade check, the athlete will start the following eligibility process.

1. **Check 1: D/F = Warning (W)** – Teacher notify the student of possible suspension. There is no action taken at this time other than notification to student, parents and coaches.
2. **Check 2: F = Academic Support (S)** – Can practice and compete in games and/or other take part in performance related events. On M, W, F must report to Academic Support Homeroom, Athletic/Organization Director call home and notify the student.
3. **Check 3: F = Ineligible Practice (IP)** – Student must report to practice with homework, MWF Academic Support Study Hall and Homework Help. They may still participate in games/competition. Athletic/Organization Director call home and notify student. After one week the student can get staff approval to return to practice upon the improvement of grades. All failing grades must be improved for a student to return to competition and regular practice.

Teachers can make a call on moving a student up and down the scale based off of summative or inability for the student to make up the grade due to assigned work.

4. **Ineligibility for Competition (IC)** – Is determined off of the Final Semester Grade. This coincides with WIAA mandates. The student will be ineligible for 15 school days and must show passing grades in the next grading term to return after the completion of the ineligibility period.

C. Regaining Academic Eligibility

1. An athlete may regain eligibility status related to the semester grading period through summer school, courses which may include correspondence courses at the same school or alternate school when available, provided that the student's school gives credit towards graduation and the student successfully completes the same number of credits that caused the ineligibility. Upon successful completion of course(s) the ineligibility period shall then be reduced to the lesser of:

- a. Twenty-one (21) consecutive calendar days beginning with the date of earliest allowed competition in a sport, or
- b. One-third (1/3) of the maximum numbers of games/meets allowed in a sport (rounded-up if one-third results in a fraction).

During the ineligibility period (twenty-one (21) days or one-third (1/3) of the games) the athlete will practice, but not ride the team bus or compete; after which the athlete will be fully reinstated. The ineligibility status will be adjusted for students in fall sports in which the date of earliest allowed competition is before the first day students are in class.

D. Code of Conduct Rules

The following conduct rules shall be in effect on a year-round basis. These rules have been written in accordance with the basic guidelines mandated by the WIAA and must be followed at all times throughout an athlete's career. Violations of this code are cumulative for Middle School and High School. Athletes must attend practice. Absences must be excused. Skipping practice or unexcused absences will result in disciplinary action as decided by the coach.

- 1. Athletes shall not manufacture, distribute, dispense, possess, use, buy or sell alcohol, or tobacco products.
- 2. Athletes shall not participate in or be present at activities at which controlled substances are being used or alcoholic beverages are being unlawfully consumed.

Situation: A student finds him/herself in a situation where alcohol, drugs, and/or tobacco are being illegally consumed. The student is expected to leave immediately. Remaining in the presence of such activity will result in the same consequences as a violation of the code of conduct.

- 3. No use, consumption, possession, distribution or sale of illegal drugs or drug paraphernalia. The use of prescription drugs without a doctor's permission and the sale or attempted sale of prescription drugs is considered a violation.

WIAA: Article VII section 3:

B. The WIAA is against the use of anabolic-androgenic steroids and other performance enhancing substances (PES). Member schools shall devote time each year to positive programs which highlight prevention and education of the risks, benefits and adverse effects of PES. Coaches, teachers, sports medicine staff and school administrators who ignore or encourage the use of PES, provide and/or sell PES to athletes (including indirect distribution through a third party) shall be subject to their own school's provisions regarding discipline.

- 4. Athletes shall not commit acts of vandalism or fighting on school grounds or at any school function or any other serious violation of policies of the Granton School, The WIAA, State and/or Federal Laws. Such violations would include involvement in criminal activities such as theft, burglary, assault, and etcetera. A participant, who commits a legally punishable criminal act (misdemeanor or felony), whether or not governmental authority prosecutes the participant, is in violation of the code of conduct and subject to penalty.

- 5. Any athlete disqualified from a contest for a flagrant or unsportsmanlike conduct will be suspended from interscholastic competition for no less than the next competitive event.

- 6. Violations occurring during WIAA tournament competition will result in immediate disqualification of the athlete for the remainder of the tournament series in that sport.

E. Penalties for Violation of Conduct Rules

- 1. The athlete who violates the behavioral portion of the Athletic Code will be suspended as follows:

- a. First offense -----25% of season
- b. Second offense -----25% of season
- c. Third offense -----50% of season

d. Fourth offense -----Termination of the athlete's participation for the remainder of his/her entire high school career.

2. The suspension will be for all conference and non-conference events during the sport season in which he/she is presently participating.

3. If a violation occurred with less than one-quarter of the current season remaining, the remainder of the suspension will be carried into the next sport season in which the athlete participates.

4. In all cases, suspended athletes with behavioral violations will be required to attend practices, matches, meets or other competitive events, during the period of their suspension, if more than 25% of the pre-tournament season remains.

5. Once the athlete has served his/her period of suspension he/she may participate fully.

Honesty Clause: For a FIRST OFFENSE, should the athlete admit to having engaged in conduct that violated the Athletic Code when asked at the initial investigatory meeting, the penalty may be reduced 50%

F. Procedure for Violation of Conduct Rules

1. An alleged violation must be reported in writing and signed, within ninety (90) days of the violation to the school Superintendent, the Principal or the Athletic Director by:

- a. A non-student adult and/or
- b. Law Enforcement agencies and/or
- c. personal admission

2. Alcohol, tobacco, or other illegal drug convictions reported by the police authorities and/or public forum (i.e. newspaper, etc.) will be handled under the "violations of conduct rules" of this code.

3. School administrator, along with the Athletic Director, shall conduct an investigation into the alleged violation within five (5) days of receiving the violation report.

4. School administrator, along with the Athletic Director will meet with the accused athlete who has the right to have a parent present during questioning. If allegations are ADMITTED by the athlete, then the penalty for the stated violation will be followed.

5. If allegations are DENIED by the athlete and the athletic board after completing its investigation agrees that the violation did occur, the athlete may be disciplined according to the appropriate provision as outlined in the code.

6. If the Athletic Board members agree that any alleged violation did in fact occur, the suspension will be determined according to procedure, and the parent will be notified by telephone and written correspondence.

G. Appeal Process

1. If allegations are denied by the athlete, and disciplinary action has been imposed, a written appeal may be made by the athlete and/or his/her parent/guardian for a hearing by the Athletic Board. The request shall be made in writing to a school administrator.

2. A hearing shall be convened within three (3) days of receiving the appeal.

3. Those that may attend this hearing include the Athletic Board, athlete and parent/guardian, and witness to the alleged violation.

4. If the ruling of ineligibility has been sustained by the Athletic Board, the athlete and/or parent/guardian may formally appeal the decision in writing to the School Board within seven (7) days of the last decision. The decision of the School Board will be sent by certified mail.

5. Athletes may not participate in the athletic program during the appeal procedure.

6. The decision of the School Board shall be final.

ATHLETE INFORMATION

COACH'S PREROGATIVE:

Any coach has the right to discipline a player for behavior that is unbecoming an athlete, or for behavior that the coach deems detrimental to the team's moral. Such discipline can include, but may not be limited to, running or doing other exercises during or after practice, not competing during upcoming competitions, et cetera.

Any decision made by the coach in regard to disciplining a player will be consistent for all players who partake in the same behavior during the same season. Coached and athletes will discuss and set guidelines at first practice. The Granton School Board gives its full backing to the coach exercising such prerogative. If there are any questions regarding an athlete's discipline, the questioning individual will follow proper procedure for discussing questions and concerns.

A. Procedure

1. The following is the sequence to follow in discussing questions and concerns.
 - a. First, discuss concerns with the coach who disciplined the athlete.
 - b. Second, discuss concerns with the Varsity Coach of that sport.
 - c. Third, Discuss the matter with the Athletic Director.
 - d. Fourth, discuss the matter with the High School Principal.
 - e. Fifth, if matter is not resolved, questioning individual must express their concerns in writing, within five (5) working days, to the High School Principal.
 1. The High School Principal has five (5) days to respond by certified mail.
 - f. If matter is still not resolved, the questioning individual has five (5) working days after receiving the Principal's letter to put their concerns in a letter to the District Administrator.
 1. The District Administrator has five (5) days to respond by certified mail.
 - g. If not resolved the questioning individual has five (5) working days to respond to the Granton Area School Board.
 1. The Board has five (5) working days to respond by certified mail.
 - h. Finally, if questions or concerns still exist, the questioning individual may request a meeting with the Granton Area School District Board.

TRANSPORTATION

When the school provides transportation to away games, all participants are to travel to and from the event on the school transportation. No other means of transportation is allowed without prior approval of the coach and written parent/guardian permission. If a parent/guardian would like to alter transportation procedures, a request must be submitted in writing, by the parent/guardian and approved by the principal prior to that event. If approved the signed request must be given to his/her coach.

MEDICAL RELEASE:

If an athlete is injured and receives medical care he/she may not resume practice/competition until written permission is received by the coach, and signed by the attending physician or Licensed Athletic Trainer.

1. The written permission must include
 - a. the athlete's name,
 - b. date of injury,
 - c. injury diagnosis,
 - d. the earliest date the athlete may participate.

OUT OF TOWN EVENTS:

Athletes are reminded that they must stay within the host school's designated area. The coach's consent is required to leave this area at any time.

STATE TOURNAMENT PARTICIPATION:

In the event a team/individual(s) from Granton High School is participating at the state tournament level, accommodations will be provided by the Granton Area School District.

UNIFORMS AND EQUIPMENT:

Uniforms will be washed at school, by school personal. Any equipment issued is the athlete's responsibility. Lost or damaged equipment may have to be paid for by the athlete. Athletes must provide their own practice attire. Sports equipment, including uniforms and warm-ups, are to be used for athletic practice and events only during the designated sport season.

BLOOD – BORNE PATHOGENS:

Blood and other body fluids will be handled as regulated by the Department of Industry and Labor and Human Relations, The Department of Public Instruction and the Occupational Safety and Health Administration.

FEES:

Student Athletes are required to pay a yearly **\$35 fee (grades 9-12)** or a **\$25 fee (grades 6-8)** in order to participate. The maximum fee per family is \$75. This fee covers the entire school year and does not change based on the number of sports participate in. This fee must be paid in order to practice.

PARENT INFORMATION

While spectators, at any extra/co-curricular events either at Granton or any other site, parents are expected to display sportsmanlike behavior. An individual or group who willfully interferes with or interrupts the proper order or management of a school sponsored extra/co-curricular event by an act of violence, boisterous conduct, threatening language, or unsportsmanlike conduct toward coaches, players, or officials, or disobeys board policies or administrative rules may be removed from the event and may be prohibited from further attendance for a period of up to six weeks. Individuals prohibited from attendance may follow the established grievance procedure.

At the conclusion of any sporting event there will be a 24-hour buffer period in which parents/guardians are to refrain from approaching any coaching staff with negative concerns regarding the sporting event.

Parents/Guardians need to be aware that injury, accidents, disability, and even death can result from athletic participation.

**THESE FORMS MUST BE FILLED OUT AND RETURNED
BEFORE AN ATHLETE MAY PRACTICE**

PHYSICAL EXAMINATION/ALTERNATE YEAR ATHLETIC PERMIT CARD:

Every athlete involved in interscholastic activities must have a physical examination once every two (2) years. The physical permit card must be completed and signed by a licensed physician or qualified medical personal. The reverse side of this card is to be completed and signed by the parent/guardian. This card will be valid for two (2) years, if it is completed after April 1st. It is also recommended that the athlete's dental fitness be determined as well. /On the alternate year when a physical is not required, a parent/guardian giving the athlete permission to participate must sign an Alternate Year Card.

PLEDGE SHEET:

The student athlete and his/her parent/guardian must sign the Pledge Sheet at the back after reading the entire Athletic Code.

INSURANCE COVERAGE:

All athletes must document insurance coverage. The school district does not provide any type of insurance. Athletes must be covered by their family's insurance, purchase interscholastic competition insurance, or sign a waiver. The Granton Area School District needs evidence of how each athlete's health care needs are covered and strongly recommends that athletes have insurance coverage. Insurance is available through the District's Student Insurance carrier.

EMERGENCY FORM FOR ATHLETE'S:

This form lists any medical history that may be of value to the coaches if a medical emergency should occur. The athlete's insurance carrier and physician are also included on this form. The parent/guardian signatures on the form will GRANT PERMISSION TO THE COACH TO AUTHORIZE MEDICAL TREATMENT in the event that the parent/guardian cannot be reached.

WIAA Athletic Eligibility Form

This form must be signed by student athlete and a parent after reading the form. A student may not practice for or participate in interscholastic athletics until the school has written evidence on file in its office attesting to parental permission each school year including an acknowledgment of receiving the school athletic code and WIAA Rules of Eligibility.

PARENT/ATHLETE CONCUSSION ACKNOWLEDGEMENT

This form must be signed by student athlete and a parent after reading the form. A student may not practice or participate until the school district has on file acknowledgement of receipt of concussion information.

TRANSPORTATION LIABILITY AGREEMENT

This form must be signed by parent after reading the form and prior to the sporting event to allow alternative transportation for their child.

PLEDGE

I have a copy of, and I understand the rules of the Granton Athletic Code. I promise to conform to the Athletic Code.

I sign this document in good faith promising:

- to do my best for myself, my team, my school and my community by keeping myself in good physic condition
- to attend all practices and competitions,
- to work hard at my studies and grades, and
- to conduct myself at all times in an appropriate manner.

Date: _____

Athlete's signature: _____

Signature of parent/guardian: _____

Signature of parent/guardian: _____

HEALTH INSURANCE FORM

Dear Parent/Guardian:

The Granton School District does not provide interscholastic insurance coverage for athletic participation. We encourage all families to have accident/health coverage for their student-athlete prior to participation in any sporting activities. The school does provide you an opportunity to purchase athletic Insurance or to supplement your existing insurance through the Student Assurance Services, Inc. If you are interested in purchasing this insurance, please obtain an application form from the Athletic Director and pay the required fee before your student-athlete begins athletic participation. Please note that the fee varies according to which sport(s) your student-athlete participates in. Be sure to fill out the form completely and make your check payable to **STUDENT ASSURANCE SERVICES - INC.** If you feel you have adequate accident/health insurance coverage or if you intend to pay for any medical care that may be required due to athletic participation, **PLEASE SIGN WAIVER BELOW.**

INSURANCE WAIVER FOR INTERSCHOLASTIC SPORTS

Students Name: _____ Date: _____

Please Check One Below:

____ We, the undersigned, feel we have adequate insurance protection for our son or daughter for coverage while practicing or participating in interscholastic Sports.

____ We, the undersigned, have purchased Student Assurance insurance for our son or daughter for coverage while practicing or participating in Interscholastic Sports.

____ We, the undersigned, will pay for any medical cost that may incur while our son or daughter is practicing or participating in Interscholastic Sports.

Parent's/Guardian's Signature(s): _____

EMERGENCY FORM FOR ATHLETES

NAME OF STUDENT-ATHLETE: _____

We ask all of the parents/guardians of our athletes to fill out our Emergency Form for Athletes. This form will be kept in the Athletic Directors office, so it is available during athletic practices and/or competitions, in case medical care is required. Parents/guardians need to be made aware that injury, accidents, disability and even death can result from athletic participation. A parent's/guardian's signature on this form will grant permission to our coaches to authorize medical treatment in the event that a parent/guardian is not available and cannot be reached; this form also lists any medical history that may be of value to medical personnel that will be treating the athlete.

Athletes Medical Information

Athlete's Name _____ Athletes Birthdate _____

Parents' Names _____ Date _____

Address _____ Zip code _____

Home Phone _____ Work Phone(s) _____

Emergency Contact (if parents are unavailable) _____

(Name and Telephone)

Name of Family Health Insurance Carrier _____

Policy Number _____ Address _____

Preferred Hospital _____ Emergency Telephone _____

Preferred Doctor _____ Office Telephone _____

I hereby grant permission to the coaches for authorizing medical treatment of my student-athlete in the event that I (parent/guardian) are not available or cannot be reached.

I will not hold the Granton School District or the person or persons in charge, responsible in the case of injury, accident, disability, or death as a result of my student- athlete's participation.

Signature of parent/guardian:

Mother/Guardian: _____ Date _____

Father/Guardian: _____ Date _____



WISCONSIN INTERSCHOLASTIC ATHLETIC ASSOCIATION

P.O. Box 267, Stevens Point 54481

High School Athletic Eligibility Information Bulletin

To: Student-Athletes and Their Parents

From: Wisconsin Interscholastic Athletic Association and the Granton Area School District.

(School)

Your high school is a member of the Wisconsin Interscholastic Athletic Association. The following rules and regulations are developed by the member schools of the WIAA and govern the participation by boys and girls in school athletics and in some instances, impact upon sports activities outside the school.

This information bulletin is a **summary** of the WIAA OFFICIAL HANDBOOK as it pertains to those rules and regulations. Both student-athletes and their parents should have an understanding of these requirements. Equally important is that student-athletes and/or parents talk to their principal or athletic director if they have any question about these regulations. For additional information on Rules of Eligibility see the WIAA Handbook, or visit the WIAA website at www.wiaawi.org.

This bulletin does not discuss specific penalties for all violations. The reason is that penalties vary depending upon the nature of the violation. In addition, schools often have established penalties or periods of ineligibility which are greater than the minimum prescribed by WIAA rules.

There also are exceptions and other permissive provisions in some rules. Student-athletes and their parents should discuss all athletic eligibility related situations with the school principal or athletic director who, if necessary, will get a decision, interpretation, or opinion from the WIAA office.

Student-athletes, as well as parents are asked to read this bulletin, then sign it and have their signature statement (attached) on file at their school prior to practicing and competing.

These are WIAA eligibility rules:

AGE

A student shall be ineligible for interscholastic competition if he/she reaches his/her 19th birthday before August 1 of any given school year.

ACADEMICS

A student-athlete must meet school and DPI requirements defining a full-time student and have received no more than one failing grade (including incompletes) in the most recent school issued grade reporting period. Note: Some member schools adopt code and academic policies and other participation requirements which are more stringent than WIAA minimum requirements. In those instances the schools requirements prevail and must be applied as written.

ATTENDANCE

A student-athlete is eligible for interscholastic competition at a member school if he/she is carried on the attendance rolls as a duly enrolled full-time Grade 9, 10, 11 or 12 student in that member school. (Subject to satisfying all other eligibility requirements.)

Note: A full-time student is further defined as one where the member school is responsible for programming 100% of the student's school day. The student is eligible for like or similar awards, privileges and services as all the other students and meets all obligations and responsibilities as other students, without exception.

- A. A student must complete eligibility in the four consecutive years starting with Grade 9 and the three consecutive years starting with Grade 10, unless there are documented extenuating circumstances and a waiver has been provided.
- B. A student is ineligible if he/she has graduated from a school offering studies through Grade 12 or its equivalent.
- C. A student who graduated in May or June retains eligibility for (a) any portion of a spring athletic schedule not completed by the end of the academic year and (b) the school's summer athletic schedule.
- D. A student is ineligible if he/she has not been enrolled in some school by the 17th day of a semester or trimester, except upon request of a school in special cases involving sickness, accident, military service, social services assignment, e.g.
- E. A student-athlete may not participate in school sports in more than four different years, and a student-athlete may not participate in the same sport more than one season each school year.

DETERMINING RESIDENCE FOR PUBLIC SCHOOL STUDENTS

A full-time student, whether an adult or not, is eligible for varsity interscholastic competition only at the school within whose attendance boundaries his/her parents reside, within a given school district, with these additional provisions:

- A. Board of Education approved full-time student(s), paying their own tuition and residing full time with parents in their primary residence shall be afforded eligibility. Transfer students are subject to provisions outlined in the transfers section of this document and in the Senior High Handbook.
- B. The residence of a student's guardians shall determine eligibility in cases where both parents of a student are deceased. The execution of guardianship papers in situations where one or both parents are living does not by itself make a student eligible.
- C. In the event of a divorce or legal separation, whether pending or final, a student's residence at the beginning of the school year shall determine eligibility, except in situations involving transfer after the fourth consecutive semester following entry into grade 9. For the purpose of this rule, attendance at one day of school and/or attendance at one athletic practice shall determine 'beginning of school year.' Under this rule, a student who transfers after the beginning of the school year shall be ineligible at the new school unless approval is granted by the Board of Control in accordance with the transfer and/or waiver provisions as described in the WIAA HS Handbook.
- D. A student whose tuition is paid by the school within whose attendance boundaries parents reside or by the state and is enrolled in a district approved program may be eligible at either school (first priority to school of residence) but (a) may not participate at both schools in the same year and (b) academic ineligibility accompanies student upon transfer. Transfer restrictions may also apply.
- E. A student whose tuition is paid by the school within whose attendance boundaries parents reside or by the state or who is participating full time in a legislated open enrollment option must meet all statutory timeline requirements. This provision extends the opportunity to decline attendance at the new school and continue at his/her school of residence. If the student begins the school year at the new school and then transfers back to school of residence after attending one or more days of school or one or more athletic practices, he/she shall be subject to transfer provisions as outlined in the transfer Section of this document.
- F. A student may continue being eligible in the same school even though parent(s) and/or student move from within that school's attendance boundaries, provided enrollment is continuous (unbroken in that school).
- G. After a student-athlete has not participated and/or has had their eligibility restricted for one calendar year due to reasons relating to residence and/or transfer, he/she becomes eligible.
- H. A student-athlete will not be eligible if his/her attendance at a particular school resulted from undue influence (special consideration because of athletic ability) on the part of any person.
- I. A student-athlete who has been declared ineligible at a school for disciplinary reasons, academic reasons or due to another State Association's provision retains that ineligibility status if he/she transfers to another school.
- J. Except in situations involving transfer after a student's fourth consecutive semester, a full-time student whose residence in a given district and attendance at a member school does not conform with any of the provisions outlined above shall be eligible for nonvarsity competition only, for one calendar year, unless a waiver is provided as outlined in the WIAA HS Handbook under Waivers. Transfer students are subject to transfer provisions as outlined in the transfer section of this document and in the Senior High Handbook.

DETERMINING RESIDENCE FOR NONPUBLIC SCHOOL STUDENTS

A full-time student, whether an adult or not, is eligible for varsity interscholastic competition only if the student is residing full time with parents in their primary residence with these additional provisions:

- A. In the event of a divorce or legal separation, whether pending or final, a student's residence at the beginning of the school year shall determine eligibility except in situations involving transfer after a student's fourth consecutive semester. For the purpose of this rule, attendance at one day of school and/or attendance at one athletic practice shall determine 'beginning of school year'. Under this rule, a student who transfers after the beginning of the school year shall be ineligible at the new school unless approval is granted by the Board of Control in accordance with the waiver provisions as described in the WIAA HS Handbook under Waivers. Transfer restrictions may also apply.
- B. Residing full time with guardians shall determine eligibility in cases where both parents of a student are deceased. The execution of guardianship papers in situations where one or both parents are living does not by itself make a student eligible.
- C. A student may continue being eligible in the same school even though parent(s) and/or student move from within that school's traditional attendance area, provided enrollment is continuous (unbroken in that school).
- D. A student who has been in attendance in a nonpublic, self-contained school (i.e. grades K-12 or 7-12) for at least one complete school year prior to reaching Grade 9 and has not broken enrollment during that time is eligible in that nonpublic school upon entering Grade 9.
- E. Except in situations involving mid-year transfer and/or transfer after the fourth consecutive semester students attending member residential schools shall be eligible at the member school provided they reside at the school or reside full time with parents in their primary residence.
- F. Except in situations involving transfer after a student's fourth consecutive semester, a full-time student attending a nonpublic school but not residing in accordance with any of the provisions outlined above shall be eligible for nonvarsity competition only, for one calendar year, unless a waiver is provided as outlined in the WIAA HS Handbook under Waivers.

TRANSFERS

A full-time student may be afforded up to eight consecutive semesters of interscholastic eligibility upon entry into Grade 9.

Transferring schools at any time may result in restrictions being imposed on eligibility or in some cases a denial of eligibility.

For the purpose of this rule, attendance at one day of school and/or attendance at one athletic practice shall determine 'beginning of school year.' These additional provisions relate to transfer cases:

- A. A student who transfers from any school into a member school after the fourth consecutive semester following entry into Grade 9 shall be ineligible for practice and competition for one calendar year, unless the transfer is made necessary by a total change in residence by parent(s). The calendar year (365 days) will be determined from a student's first day of attendance at the new school.
- B. Open enrolled and/or tuition paying students entering 9th and/or 10th grade at the beginning of the school year and who are within the first four consecutive semesters of high school will be afforded unrestricted eligibility provided all other rules governing student eligibility are met.
- C. Open enrolled and/or tuition paying students entering 11th and/or 12th grade as transfer students are ineligible to practice and/or compete for one calendar year.
- D. 9th grade students who transfer after the beginning of the school year and with written consent from both schools directly involved may be provided nonvarsity opportunities for the remainder of the school year. Restrictions are removed upon entering 10th grade.
- E. 10th grade students who transfer after the beginning of the school year and with written consent from both schools directly involved may be provided nonvarsity opportunities for one calendar year (365 days beginning with first day of attendance at the new school).
- F. In the event of divorce or legal separation, whether pending or final, residence at the beginning of the school year shall determine eligibility for students entering 9th and/or 10th grade. In situations involving transfer after the fourth consecutive semester following entry into grade 9 the student is ineligible to compete for one calendar year, but may practice.
- G. District policies with respect to intra-district transfer do not supercede WIAA transfer rules in situations involving post-4th semester transfers. Intra-district transfers occurring after the fourth consecutive semester following entry into grade 9 result in the student being ineligible for practice and competition for one calendar year (365 days beginning with first day of attendance at the new school).
- H. Unless transfer, including an accompanying change of parent's residence, is effective at the outset of a semester, a student cannot establish eligibility at his/her new school until the fifth calendar day of such transfer.
- I. If within the first four consecutive semesters following entry into grade 9, a student who transfers more than once in any given school year shall be ineligible for all interscholastic competition for the remainder of that current school year and will be eligible for nonvarsity opportunities only for the balance of the calendar year. In situations involving transfer after the fourth consecutive semester following entry into grade 9 the student is ineligible to compete for one calendar year, but may practice.
- J. A student may not have eligibility in more than one-member school at the same time. A parent or parents who move from a primary residence within one school's attendance boundaries, to a secondary residence within another school's attendance boundary, may be required by the Board of Control to provide evidence of a total move.
- K. A student who transfers from any school, whether or not a member school, with a status of ineligibility for disciplinary reasons, academic reasons and/or as a result of another State Association's regulation or sanction, retains such status at his/her new school for the same period as decreed by the former school.
- L. No eligibility will be granted for a student whose residence within a school's attendance boundaries, with or without parents, or whose attendance at a school has been the result of undue influence (special consideration due to athletic ability or potential) on the part of any person, whether or not connected with the school.

PHYSICAL EXAMINATION and PARENT'S PERMISSION

A student-athlete whether an adult or not, must have written permission of parents to participate in school athletics and he/she must have a physical examination (signed by a licensed physician or advanced practice nurse prescriber) every other school year.

A physical examination taken April 1 and thereafter is valid for the following two school years. Physical examination taken before April 1 is valid only for remainder of that school year and the following school year.

TRAINING and CONDUCT

A student-athlete must follow his/her school's code of conduct (training rules) on a year-round basis.

- A. A student-athlete who violates his/her school's code of conduct during the season of a sport (start of practice to final game) must be suspended from competition for a period of time specified in the code (minimum of one meet) if the violation involves (a) possession and/or use of alcohol, (b) possession and/or use of tobacco, including chewing tobacco and (c) use, possession, buying or selling of controlled substances, street drugs and performance enhancing substances (PES).

- B. The member school will determine minimum penalties for violation of any other provisions of its code of conduct, including out of season offenses and for any other unacceptable conduct contrary to the ideals, principals and standards of the school and this Association including but not limited to criminal behavior.
- C. A student-athlete who violates his/her school's code of conduct at times other than during the actual season of a sport must be disciplined by the school, the nature of such discipline to be determined by the school as indicated in its code of conduct.
- D. A student-athlete who violates any part of the school or WIAA's code of conduct resulting in suspension of WIAA-sponsored tournament competition must be immediately declared ineligible for the remainder of tournament series in that sport. During the WIAA Tournament, an ineligible athlete may not suit up.
- E. A student-athlete, disqualified from a contest for flagrant or unsportsmanlike conduct, is also suspended from the next competitive event.
- F. Any player who spits on, strikes, slaps, kicks, pushes or intentionally and aggressively physically contacts an official at any time shall be immediately ineligible for competition a minimum of 90 calendar day from the date of the confrontation. In addition, the player is ineligible to compete for the first 25% of the next season in that same sport.
- G. A school must provide an opportunity for the student to be heard prior to a penalty being enforced. If a student appeals a suspension, according to the school's appeal procedure, the student is ineligible during the appeal process.
- H. Schools/individuals are prohibited during the regular season and the WIAA tournament series from practicing for regional, sectional, and state tournament preparation at sites and facilities hosting WIAA tournament.

AMATEUR STATUS

A student-athlete must be an amateur in all recognized sports of this association in order to compete in any WIAA sport.

- A. A student-athlete may not accept, receive or direct to another, reimbursement in any form of cash or merchandise such as shirts, jackets, sweaters, sweatshirts, jerseys, warm-ups, equipment, balls, duffelbags, backpacks, watches, rings, billfolds, coupons, gift certificates, regardless of their value for athletic accomplishments, such as being on a winning team, being selected for the school varsity team, or being a place winner in an individual tournament, e.g.
- B. A student-athlete may receive awards for school achievement which are symbolic (non utilitarian) in nature – badges, certificates, trophies, medals, banners, ribbons, pictures, plaques, event T-shirts, event hats, game balls, unattached emblems, letters, season highlight DVD or video, e.g.
- C. A student-athlete may not receive compensation or benefit, directly or indirectly, for the use of name, picture, and/or personal appearance, as an athlete. This includes receiving free and/or reduced rates on equipment, apparel, camps/clinics/instruction and competitive opportunities that are not identical for all other participants.
- D. A student-athlete may not be identified as an athlete, provide endorsement as an athlete or appear as an athlete in the promotion of a commercial/advertisement and/or profit-making event, item, plan, or service.
- E. A student-athlete may not participate in school athletics or in sports activities outside the school under a name other than his/her own name.

SPORTS ACTIVITIES OUTSIDE OF SCHOOL

A student-athlete in a given sport may not compete in that same sport outside of school either as a team member or an individual or independent entry during the same time he/she is participating with the school team.

- A. WIAA rules do not prevent athletes from practicing with nonschool teams or from receiving private skills instruction during the school season. However, they may not participate in any nonschool games, including scrimmages against other teams.
 - (1) This restriction applies to normal nonschool games as well as “gimmicks,” such as reduced numbers competition (3-on-3 basketball, 6 player soccer, e.g.), specific skill contests (punt, pass, and kick, shooting contests, free throws, 3 point, e.g.), fun runs, etc.
 - (2) A student who was a member of a school team during the previous year may not delay reporting for the school team beyond the school's official opening day of practice in order to continue nonschool training and/or competition.
- B. During the school year before and/or after the school season of a sport and in the summertime, members of a school's team may voluntarily assemble with their teammates (without school and/or school coach involvement) at their own discretion.
- C. A student-athlete or his/her parents must pay the fee for specialized training or instruction such as camps, clinics, and similar programs.
- D. A student-athlete may not be instructed except during the school season of a sport and approved summer contact days by the person who will be his/her coach in that sport in the following school season. The sports of baseball, cross country, golf, gymnastics, softball, swimming, tennis, track & field, and wrestling are exempt from this rule, BUT only (a) during the summer months and (b) if the program involved is not limited to individuals who are likely to be candidates for the school team in that sport in the following season.

- E. A student-athlete must not participate in an all-star game or similar contest except for summertime activities (a) within the same league or program (e.g., softball game between divisions of same league) or (b) in which a team is selected to represent a league in post-season play (e.g., Babe Ruth league team). Some post-season all-star opportunities may be permitted for 12th graders who have completed high school eligibility in a particular sport. Check with your Athletic Director to be certain.
- F. Schools/individuals are prohibited during the regular season and the WIAA tournament series from practicing for regional, sectional, and state tournament preparation at sites and facilities hosting WIAA tournaments.

USE OF STUDENT IMAGE

The participation of student-athletes in school and WIAA tournaments may result in the use of student-athlete images in promotion of school and WIAA events.

In order to facilitate good communication, all questions regarding athletic participation at your school should be addressed to your athletic administrator.

Detach and Return to Athletic Director

**PARENT-ATHLETE RULES OF ELIGIBILITY
SIGN-OFF FORM**

I certify that I have read, understand, and agree to abide by all of the information contained in this bulletin. I further certify that if I have not understood any information contained in this document, I have sought and received an explanation of the information prior to signing this statement.

School Name

Parent/Guardian's Signature

Student-Athlete's Signature

Date

Date

This form must be completed and submitted to the Athletic Director prior to a student being declared eligible to practice and compete.

PARENT & ATHLETE AGREEMENT

As a Parent and as an Athlete it is important to recognize the signs, symptoms, and behaviors of concussions. By signing this form, you are stating that you understand the importance of recognizing and responding to the signs, symptoms, and behaviors of a concussion or head injury.

1. Have you ever had a concussion? _____, if yes, how many? _____
2. Have you ever experienced concussion symptoms? _____ Did you report them? _____

Parent Agreement:

I _____ have **read** the Parent Concussion and Head Injury Information and **understand** what a concussion is and how it may be caused. I also understand the common signs, symptoms, and behaviors. I agree that my child must be removed from practice/play if a concussion is suspected.

I understand that it is my responsibility to seek medical treatment if a suspected concussion is reported to me.

I understand that my child cannot return to practice/play until providing written clearance from an appropriate health care provider to his/her coach.

I understand the possible consequences of my child returning to practice/play too soon.

Parent/Guardian Signature _____ Date _____

Athlete Agreement:

I _____ have **read** the Athlete Concussion and Head Injury Information and **understand** what a concussion is and how it may be caused.

I understand the importance of reporting a suspected concussion to my coaches and my parents/guardian.

I understand that I must be removed from practice/play if a concussion is suspected. I understand that I must provide written clearance from an appropriate health care provider to my coach before returning to practice/play.

I understand the possible consequence of returning to practice/play too soon and that my brain needs time to heal.

Athlete Signature _____ Date _____

GRANTON AREA SCHOOL DISTRICT
ATHLETIC TRANSPORTATION POLICY

If parents/guardians provide transportation to these events or allow their son/daughter to provide transportation to these events, they must be aware of the following:

- Where a parent/guardian provides transportation to their son/daughter to or from a scheduled event, the parent/guardian shall assume all resulting liability, and the school shall assume no liability.
- Where a parent/guardian or another adult designated by a parent/guardian transports students other than their own to or from a scheduled event, the parent/guardian or designated adult transporting the students shall assume all resulting liability and the school shall assume no liability.
- Where a student transports himself/herself to or from a scheduled event, the parents/guardians of that student shall assume all resulting liability, and the school shall assume no liability.
- Where a student transports other students to or from a scheduled event, the parents/guardians of the transporting student shall assume all resulting liability, and the school shall assume no liability.

TRANSPORTATION LIABILITY WAIVER

I have read the Athletic Transportation Policy and agree that I shall assume all liability for negligently caused injuries resulting from the following situations:

- *Where I transport my son/daughter to or from a scheduled event;*
- *Where I transport other students to or from a scheduled event, or I, as a parent/guardian, give permission to another adult to transport my son/daughter home from a scheduled event and have explained to the designated individual that s/he will assume all liability;*
- *Where my son/daughter transports himself/herself to or from a scheduled event; or*
- *Where my son/daughter transports other students to or from a practice or scheduled event.*

I also agree that Granton Area School District shall assume no liability whatsoever for negligently caused injuries resulting from the above situations or any other situation where contracted transportation is not being used to transport athletes.

Parent/Guardian Signature

Date

REQUEST FOR ALTERNATE ATHLETIC TRANSPORTATION

Sport: _____ Student-Athlete's Name: _____

My child, named above, has permission to ride (to-from-both) _____ event/contest.
(circle one) (Sport/Club)

I certify that I have personally arranged for the above named student to be transported with:

___ 1. Riding with his/her parent/guardian. ___ 3. Riding with a designated adult, _____, other than his/her parent/guardian.

___ 2. Driving. ___ 4. Riding with a designated minor, _____.

The reason for not riding the bus/van is:

(Reason must be sufficiently urgent to family needs to justify not riding the bus)

Parent/Guardian Signature

Date

Athletic Director/Head Coach Signature

Date

This form must be returned to the Athletic Director or Head Coach **NO LATER THAN 1 DAY** prior to the event.



Marshfield Book & Stationery, Inc.

Everything for the school and office.

109800 West McMillan St
Marshfield, WI 54449

Phone: 715-387-1286
marshfieldbook.com

PROJECT:

Granton HS Reception

Granton WI

ARCHITECT:

CONTRACTOR:

CUSTOMER:

SHIPPING ADDRESS:

ARCHITECT APPROVAL

REVIEWED BY: _____

DATE: _____

- APPROVE WITHOUT EXCEPTION
- APPROVED AS NOTED
- NOT APPROVED. REVISE AND RESUBMIT

STAMP (IF APPLICABLE) AND COMMENTS:

CONTRACTOR APPROVAL

REVIEWED BY: _____

DATE: _____

- APPROVE WITHOUT EXCEPTION
- APPROVED AS NOTED
- NOT APPROVED. REVISE AND RESUBMIT

STAMP (IF APPLICABLE) AND COMMENTS:

MBS CUSTOMER APPROVAL

REVIEWED BY: _____

DATE: _____

COMMENTS:

PROJECT NAME:

Granton HS Reception

Granton WI

PROJECT NUMBER:

20222615

COVER

NOTE: ADDITIONAL COLORS ARE AVAILABLE AT AN ADDED COST AND POTENTIAL ADDED LEADTIME.

*SOLID COMPLIMENTARY EDGE BANDING OPTION REQUIRED FOR THESE LAMINATES

1 CABINET (AVAILABLE HPL COLORS)

<input type="checkbox"/> AMERICAN CHERRY WC175-SD	<input type="checkbox"/> ASIAN NIGHT 7949K-38	<input type="checkbox"/> BANNISTER OAK 7806-58	<input type="checkbox"/> BLUE AGAVE 4919-60*	<input type="checkbox"/> BUKA BARK 7982-38
<input type="checkbox"/> BURN'T STRAND 6307-58	<input type="checkbox"/> EGGPLANT 4913-60*	<input type="checkbox"/> FUSION MAPLE 7909-60	<input type="checkbox"/> HONEY MAPLE WM951-SD	<input type="checkbox"/> KENSINGTON MAPLE 10776-60
<input type="checkbox"/> LITTLE BLK DRESS AE100-SD	<input type="checkbox"/> LOVE LETTERS AW300-SD*	<input type="checkbox"/> OILED CHERRY WC421-SD	<input type="checkbox"/> PICNIC IN THE PARK WA030-SD	<input type="checkbox"/> SLEEPING IN WT870-SD
<input type="checkbox"/> SPRROUT 4918-60*	<input type="checkbox"/> TANGERINE 4915-60*	<input type="checkbox"/> WALNUT GROVE WW050-SD	<input type="checkbox"/> ALMOND D30-60	<input type="checkbox"/> CASSIS 6903-58
<input type="checkbox"/> DOVE GREY D92-60	<input type="checkbox"/> FOLKSTONE SC241-SD	<input type="checkbox"/> FRESH PAPAYA S8001-SD	<input type="checkbox"/> HOLLYBERRY D307-60	<input type="checkbox"/> ISLAND D498-60
<input type="checkbox"/> LAPIS BLUE D417-60	<input type="checkbox"/> OCEAN D502-60	<input type="checkbox"/> SOL 3209-58	<input type="checkbox"/> SUMMER VACATION SB027-SD	<input type="checkbox"/> WROUGHT IRON S6054-SD
<input type="checkbox"/> BLACK 1595-60	<input type="checkbox"/> WHITE 1573-60	<input type="checkbox"/> BEACHCOMBER AT988-SD	<input type="checkbox"/> CHOCOLATE WARP 5881-58*	<input type="checkbox"/> CLASSIC LINEN 4943-38
<input type="checkbox"/> COOKIES & CREAM AG130-SD	<input type="checkbox"/> GREY NEBULA 4622-60	<input type="checkbox"/> WOOLAMAI BRUSH 4746-60	<input type="checkbox"/> VISION VAVA VA2002-SD*	

NOTE: COLORS SHOWN ARE FOR COMPARISON ONLY. FOR ACTUAL COLOR, PLEASE REQUEST PHYSICAL SAMPLES.

C:\Users\Frank_morano\Desktop\Granton HS 2022615_Granton_Reception_0615-22.dwg

PROJECT NAME: Granton HS Reception Granton WI	CUSTOMER:  Marshfield Book & Stationery, Inc. <small>Everything for the school and office.</small> 10980 West McMillan St Marshfield, WI 54449 Phone: 715-387-1286 marshfieldbook.com
REVISION HISTORY: DATE BY	DRAWN BY: DESCRIPTION: STANDARD COLORS
PROJECT NUMBER: 2022615	SHEET NUMBER: COLORS

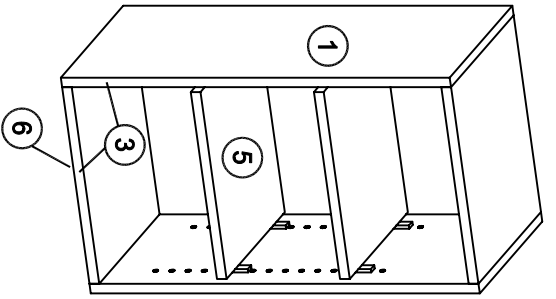

- 1 EXTERIOR, FINISHED END COLOR**
- WB WHITE
 - WB ALMOND
 - WB KHAKI BROWN
 - WB DOVE GREY
 - WB BLACK
 - WB GREY NEBULA
 - WB BANNISTER OAK
 - WB WILD CHERRY
 - WB MONTANA WALNUT
 - WB FUSION MAPLE

- INTERIOR COLOR**
- SEMI-EXPOSED:**
- WHITE 4**
- EXPOSED:**
- WHITE 5**
 - MATCH EXTERIOR COLOR**
- WALL CABINET BOTTOMS**
- WHITE 6**
 - MATCH EXTERIOR COLOR**

- LOCK:**
- NONE REQUIRED**
 - DEADBOLT**
 - ALL DOORS/DRAWERS**
 - ONLY WHERE NOTED**

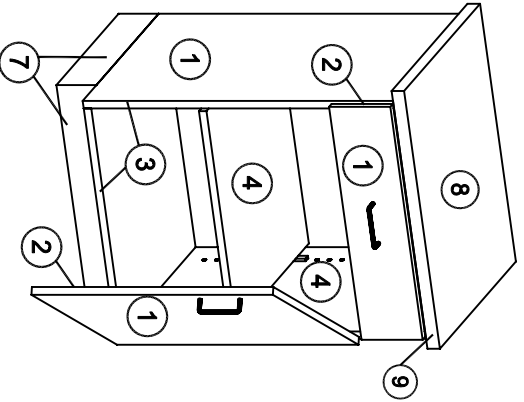
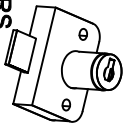

- 2 3mm DOOR / DRAWER EDGE**
- MATCH DOOR COLOR**

- 3 .020 BODY EDGE**
- MATCH DOOR EDGE**
 - MATCH DOOR FACE**

7 BASE / TOEKICK

CABINET APPLIED PLYWOOD

NOTE: THE TOE KICK SUPPLIED IS MOISTURE RESISTANT PLYWOOD, UNFINISHED. A VINYL OR OTHER FINISH MATERIAL IS TO BE SUPPLIED AND INSTALLED BY OTHERS.

- 8 COUNTERTOP COLOR**
- MATCH CABINET COLOR**

- 9 COUNTERTOP EDGE**
- 3mm EDGE**
 - SELF-EDGE**
- COLOR:**
- MATCH COUNTERTOP COLOR**



NOTE:
THE CABINETS SHOWN HERE MAY OR MAY NOT BE PART OF THIS PROJECT. THEY ARE SHOWN ONLY TO REFERENCE THE FINISHES USED.

CONSTRUCTION AND SPECIAL PROJECT NOTES:
CABINET CORE MATERIAL TO BE PARTICLE BOARD

FOR PULLS, HINGES, SLIDES AND OTHER HARDWARE, SEE FOLLOWING SHEET(S).

<p>DESCRIPTION: FINISH SECTIONS</p> <p>DRAWN BY: FCM 06-15-22</p> <p>PROJECT NUMBER: 2022615</p> <p>SHEET NUMBER: SEL</p>	<p>PROJECT NAME: Granton HS Reception</p> <p>Granton WI</p>	<p>CUSTOMER:</p>	<p>MBS Marshfield Book & Stationery, Inc. <i>Everything for the school and office.</i></p> <p>10980 West McMillan St Marshfield, WI 54449</p> <p>Phone: 715-387-1286 marshfieldbook.com</p>
---	--	-------------------------	--

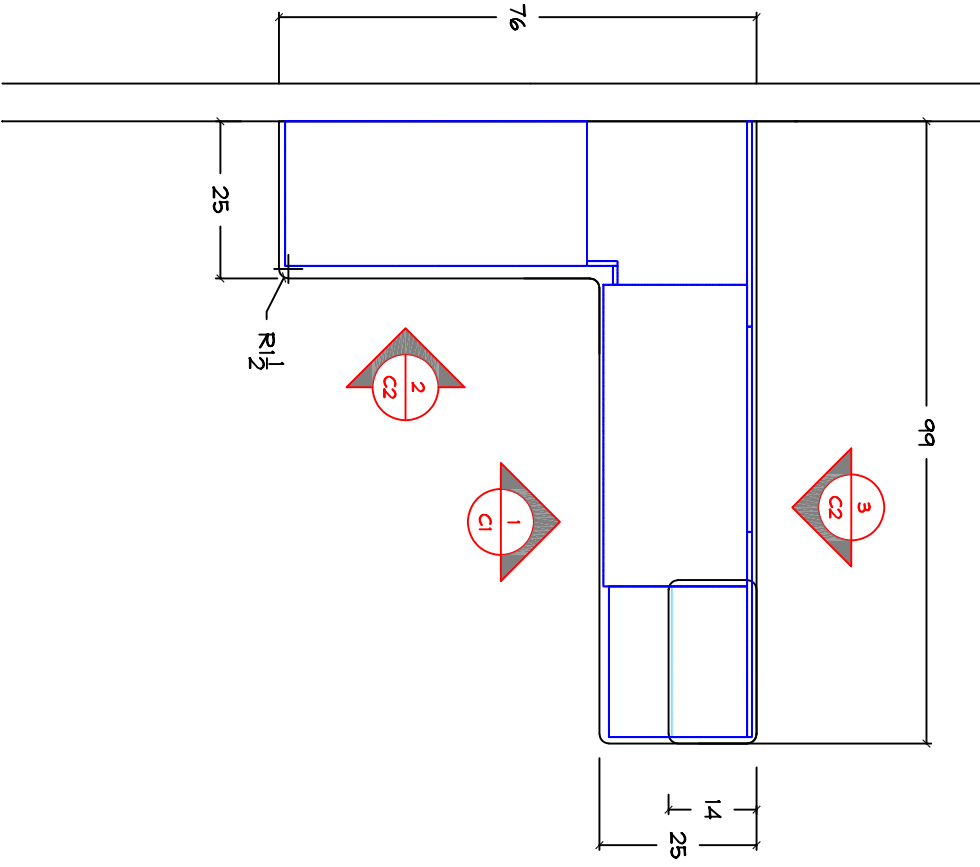
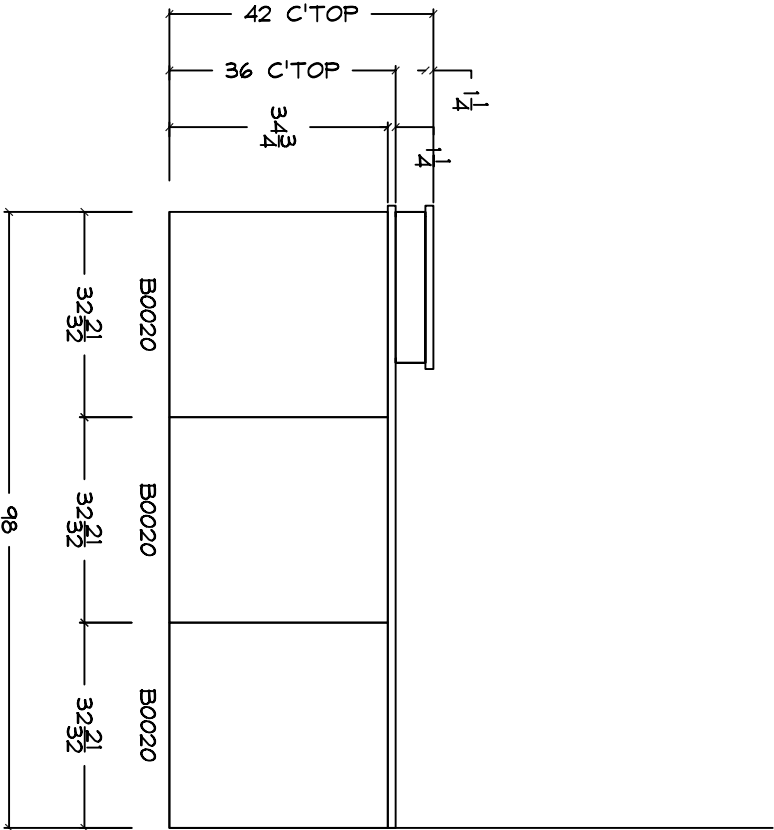

3	RECEPTION
C2	

SCALE: 3/8" = 1'-0" ARCHITECTURAL REF:

CABINET EXTERIOR: ADVISE
CABINET INT. (CLOSED): WHITE
CABINET INT. (OPEN): MATCH EXTERIOR
COUNTERTOP COLOR: ADVISE
COUNTERTOP EDGE: 3/16"



PROJECT NAME:
Granton HS Reception
Granton WI

CUSTOMER:

MBS Marshfield Book & Stationery, Inc.
Everything for the school and office.
10980 West McMillan St
Marshfield, WI 54449
Phone: 715-387-1286
marshfieldbook.com



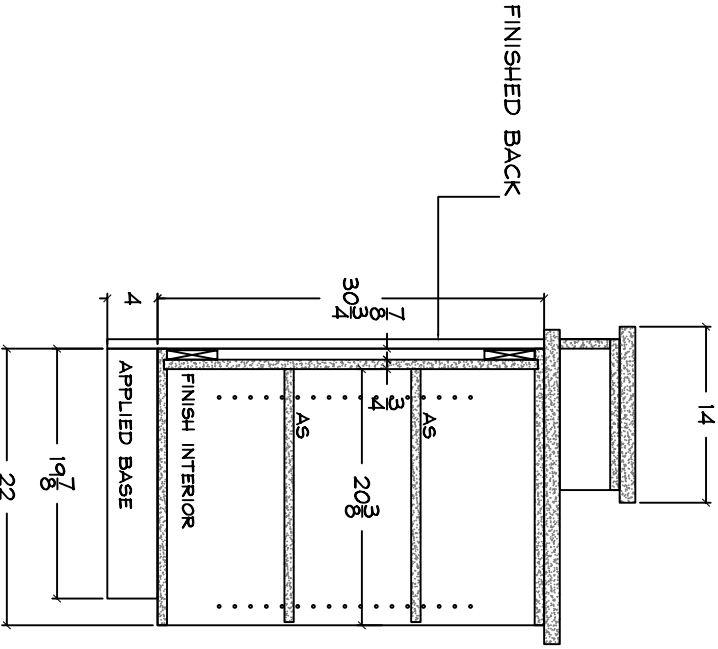



DESCRIPTION: ELEMENTS XREFRUDXX	DRAWN BY: FCM	DATE 06-15-22
PROJECT NUMBER: 2022615	SHEET NUMBER: C2	



1	SECTION
S1	SCALE: 3/4" = 1'-0"

SCALE:	
--------	--

STANDARD MATERIALS

-  PARTICLE BOARD
-  PLYWOOD
-  EPOXY RESIN
-  SOLID SURFACE
-  WOOD
-  STONE

REVISION HISTORY	DATE	BY

PROJECT NAME:
 Granton HS Reception
 Granton WI

CUSTOMER:

 **Marshfield Book & Stationery, Inc.**
Everything for the school and office.
 10980 West McMillan St
 Marshfield, WI 54449
 Phone: 715-387-1286
 marshfieldbook.com

DESCRIPTION:
SECTIONS
XX-TTRR/XX

DRAWN BY:
FCM
06-15-22

PROJECT NUMBER:
2022615

SHEET NUMBER:
S1

Marshfield Book & Stationery Inc.



EVERYTHING FOR THE SCHOOL AND OFFICE

Quote # 2022246
 Quote Date: 6/24/2022
 Quoted By: Greg Gunn (gunn.greg1@gmail.com)

Granton High School_WBM Reception Layout
 Granton, WI

Granton School District
 Granton, WI

Attention: Tammie Cramer, cramert@granton.k12.wi.us

Comments:

Quoted from WBM

Revision Notes:

None

Bid Scope:

<u>Qty</u>	<u>Item Description</u>	<u>Item Price</u>	<u>Net Price</u>
1	WBM Reception Layout as per attached drawings	\$ 5,477.00	\$ 5,477.00
1	Installation of WBM reception area	\$ 1,500.00	\$ 1,500.00

BID QUALIFICATIONS

Please indicate "Bid per Greg" and/or quote # when ordering.
 Installation is NOT included unless otherwise stated. Standard Colors only.
 Delivery IS included unless otherwise stated.
 Terms: Net-30 days Proposal Valid for **15 Days**.
 4 % fee added for credit card orders.
 Pricing subject to change per quantity ordered.

Sub Total: \$ 6,977.00

Quote Total: \$ 6,977.00

EXCLUSIONS: This quote excludes Tax and any item not in the scope of work above.
 I authorize MBS to proceed with the work outlined in this quote:

Signed: _____ Date: _____

109800 W McMillan St • Marshfield, WI 54449 • Ph. 715-387-1286 • Fax 715-387-1145 • marshfieldbook.com
 SERVICE WHEN YOU NEED IT!

Marshfield Book & Stationery Inc.



EVERYTHING FOR THE SCHOOL AND OFFICE

Quote # 2022246-1
 Quote Date: 7/5/2022
 Quoted By: Greg Gunn (gunn.greg1@gmail.com)

Granton High School_ Interior Concepts Reception Layout Rev 1
 Granton, WI

Granton School District
 Granton, WI

Attention: Tammie Cramer, cramert@granton.k12.wi.us

Comments:

Quoted from Interior Concepts

Revision Notes:

Revision 1 = change layout & update pricing

Bid Scope:

<u>Qty</u>	<u>Item Description</u>	<u>Item Price</u>	<u>Net Price</u>
1	IC Layout as per attached with colors as indicated, installation included	\$ 7,295.00	\$ 7,295.00

BID QUALIFICATIONS

Please indicate "Bid per Greg" and/or quote # when ordering.
 Installation is NOT included unless otherwise stated. Standard Colors only.
 Delivery IS included unless otherwise stated.
 Terms: Net-30 days Proposal Valid for **15 Days**.
 4 % fee added for credit card orders.
 Pricing subject to change per quantity ordered.

EXCLUSIONS: This quote excludes Tax and any item not in the scope of work above.

I authorize MBS to proceed with the work outlined in this quote:

Sub Total: \$ 7,295.00

Quote Total: \$ 7,295.00

Signed: _____ Date: _____

109800 W McMillan St • Marshfield, WI 54449 • Ph. 715-387-1286 • Fax 715-387-1145 • marshfieldbook.com

SERVICE WHEN YOU NEED IT!

AREA 01 - STATION

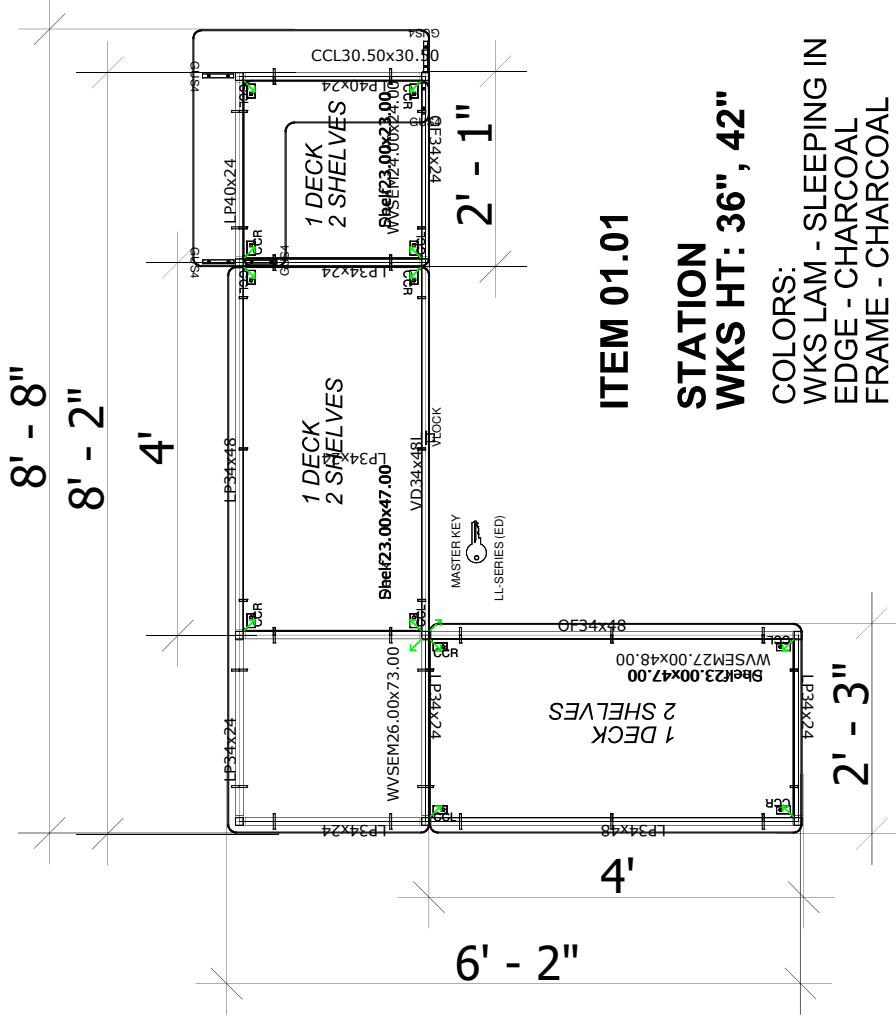

ITEM 01.01

**STATION
WKS HT: 36" , 42"**

COLORS:
 WKS LAM - SLEEPING IN
 EDGE - CHARCOAL
 FRAME - CHARCOAL
 PNL LAM - SLEEPING IN



© Interior Concepts Corporation Proprietary Information. No part may be used, disclosed or reproduced, in whole or in part, to any third party or for any purpose other than to evaluate the specific proposal without the prior written consent of Interior Concepts Corporation. This and ownership in and to the document and all information contained herein remains at all times in Interior Concepts Corporation.

Prepared for:
Marshfield Book & Stationary
 Product:
Granton HS Reception Area

Sales Representative:
E307

Drawn by:
JF

Date:
7/11/22

Quote:
IC020645 RevB

Customer: Marshfield Book & Stationary
Project: Granton HS Reception Area
Engineer: JF

Quote: IC020645
Rev: B
7/11/2022

AREA 01 – STATION
ITEM 01.01 – STATION

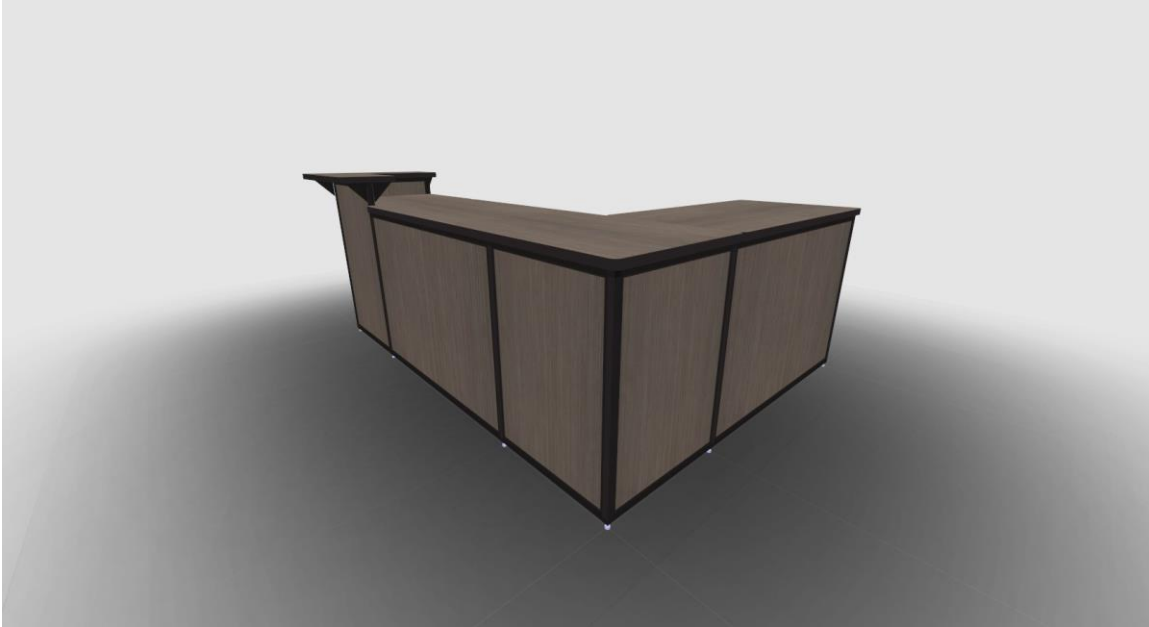

2021-22							
BUS MILEAGE REGISTER							
Bus #	Capacity	Identification	Driver	Miles Beg of Yr	Miles End of Yr	Org Cost	Miles Put on 2021-2022
1	72	2019 IC, VIN 4DRBUC8PXKB002177	Faye	19039	32362	\$ 82,721	13,323
20	65	2006 ICE, VIN 1DRBUAAP26B989989	Spare	150,769	151,772	\$ 57,989	1,003
21 (2WC)	50	2008 IC, VIN 4DRBUAAP18A490836		91,276	94,394	\$ 74,946	3,118
(1WC)	53						
22 (2WC)	17	2006 Chev, VIN 1GBJG31U261272138	4K Route	94,934	100,008	\$ 47,100	5,074
23 (old 53)	71	2009 IMC, VIN 4DRBUAAP89B67119	Janell	79,875	89,697	\$ 72,075	9,822
24	65	2007 Blue Bird, VIN 1BAKFCKH57F241131	Stina	132,478	141,346	\$ 37,000	8,868
TOTAL MILEAGE							41,208
VEHICLE MILEAGE REGISTER							
		1994 Dodge Truck VIN 1B7KF26W7RS716104		92,513	92,971	\$ 11,400	458
		2000 Ford Van (green) VIN 1FMRE11W5YHA62746		118,580	123,952	\$ 6,725	5,372
		2009 Chev Impala (red) VIN 2G1WT57N091158008		128,382	130,998	\$ 13,162	2,616
		2013 Chev Van (silver) VIN 1GNSHCF44D1106231		40,319	46,663	\$ 31,173	6,344
		2020 Dodge Van (maroon) VIN 2C4RDGBG7LR246861		1,156	4,871	\$ 25,095	3,715
TOTAL MILEAGE							18,505
7/8/2022							



AECOM 715 341 8110 tel
200 Indiana Avenue 715 341 7390 fax
Stevens Point, Wisconsin 54481
www.aecom.com

June 22, 2022

JUN 27 2022

Project ID: 7850-00-01
T York, Romadka Avenue
Middle Br O'Neill Creek Bridge B10-0399
Loc Str
Clark County

Please join us for a public involvement meeting to discuss the Romadka Avenue over Middle Branch O'Neill Creek Bridge, located in the Town of York, Clark County.

The meeting is scheduled for Monday, July 11th, 2022, as part of the regular Town of York Meeting starting at 8:00 p.m., at the York Town Hall, N5890 County Rd K, Granton, WI 54436.

The last bridge inspection in August of 2021 identified several areas of concrete deck, concrete abutment and steel structure deterioration, including concrete deck spalling and cracking; steel girder corrosion, rust, and section loss; and concrete abutment cracking and spalling. The current bridge railing does not meet current design standards.

An improvement project to address these needs on this section of Romadka Avenue is currently scheduled to be constructed in 2024. We are seeking your input on the needs of the facility, the proposed improvements to address the needs, and possible traffic control during any construction efforts.

Your input at the meeting, and throughout the design process, will help us deliver a successful project that will meet the safety and capacity requirements of the town roadway system, while enhancing the roadway's ability to serve the community's transportation needs.

Deaf or hard of hearing persons needing assistance should contact the Wisconsin Telecommunications Relay system (dial 711). To allow time to arrange for special accommodations needed to participate, please contact Matthew Thorsen at 715-225-4159 or matthew.thorsen@dot.wi.gov no later than three working days prior to the meeting.

If you have any questions, or if you cannot attend the meeting, but would like to find out more about the project, please contact me, Kevin Hagen, at 715-342-3053 or kevin.hagen@aecom.com.

Sincerely,
Kevin Hagen, P.E.
Project Manager

Enclosed: Project Location Map



WisDOT ID 7850-00-01 (71)
 P-10-185 over Middle Branch O'Neill Creek
 September 2021

Project Location
Clark County: Romadka Avenue Bridge