

AGENDA

TEXAS SOUTHERN UNIVERSITY BOARD OF REGENTS Standing Committee Meetings

Date: Wednesday, October 16, 2024
Time: 9:00 AM
Place: Texas Southern University - Library Learning Center, 5th Floor, 3100 Cleburne Street, Houston, TX 77004

Chair: Brandon L. Simmons
Vice Chair: James M. Benham
Second Vice Chair: Stephanie D. Nellons-Paige
Secretary: Marilyn A. Rose

I. Call to Order

- **Committee meetings are scheduled to start at approximately 9:00 A.M. and shall follow each other consecutively. Because any member of the Board may attend and participate in any committee meeting, committee meetings are posted as meetings of the full Board.**

II. Roll Call

III. Prayer

IV. Open Forum

V. Conflict of Interest

VI. Chairman's Comments

VII. Administration and Finance Committee

Presenters: Regent James M. Benham & Mr. John Pittman, Interim Chief Financial Officer/Vice President of Business & Administration

VII.A. Request Approval to Negotiate and Execute the Purchase of a Motor Coach Bus (56 Passengers)

Action Requested: Approval

VII.B. Request Approval Purchase Blanket Automobile, Directors & Officers, Employers Legal Liability, & Crime Insurance

Action Requested: Approval

VII.C. Request Approval to Renew Microsoft Corporation Products

Action Requested: Approval

VII.D. Request to Contract with TouchNet Information Inc. for Credit Card Processing Services

Action Requested: Approval

VII.E. Request Approval to Negotiate and Execute Contracts for Master Lease Agreements

Action Requested: Approval

VII.F. Request Approval for Executive Search Firm Services

Action Requested: Approval

VII.G. Request Approval to Purchase Four SUVs from the Department of Public Safety

Action Requested: Approval

VII.H. FY25 Operating Budget Amendment

Action Requested: Approval

VII.I. Endowment Performance Update (August 31, 2024)

Action Requested: Information

VIII. Academic Affairs, Research and Student Life Committee

Presenters: Regent Richard A. Johnson & Dr. Carl B. Goodman, Provost/Senior Vice President of Academic Affairs

VIII.A.A Review of Graduate Student Success Rates

Action Requested: Information

IX. Development and Legislative Affairs Committee

Presenters: Regent James M. Benham & Mr. Charlie W. Coleman, Associate Vice President of Development & Alumni Engagement

IX.A. Legislative Appropriations Request Update

Action Requested: Information

X. Personnel and Litigation Committee

Presenters: Regent Caroline Baker Hurley & Mr. Charlie T. Nhan, General Counsel

X.A. Litigation Update will be Presented in Executive Session under item XV.A. on this Agenda

Action Requested: Information

XI. Physical Facilities Committee

Presenters: Regent Dr. Richard A. Johnson & Mr. John Pittman, Interim Chief Financial Officer/Vice President of Business & Administration

XI.A. Request Approval for Water Treatment Services

Action Requested: Approval

XI.B. Request Approval to Purchase Auditorium-Style Seating in Charles P. Rhinehart Music Auditorium

Action Requested: Approval

XII. Audit & Compliance Committee

Presenters: Regent Marilyn A. Rose, Ms. Darlene Brown, Acting Chief Audit Executive, & Ms. Annette Linders, Compliance Partner

XII.A. Request Approval for FY 2025 Annual Internal Audit Plan

Action Requested: Approval

XIII. Athletics Committee

Presenters: Regent Stephanie D. Nellons-Paige & Dr. Kevin L. Granger, Vice President of Intercollegiate Athletics

XIII.A. No Agenda Items

XIV. Bylaws and Policies (Ad Hoc) Committee

Presenters: Regent Pamela A. Medina & Mr. Charlie T. Nhan, General Counsel

XIV.A. No Agenda Items

XV. Executive Session

XV.A. Texas Government Code - Section 551.071 - Consultation with University Attorneys on any matter in which the duty of the attorneys to the governmental body under the Texas Disciplinary Rules of Professional Conduct of the State Bar of Texas clearly conflicts with the Texas Open Meetings Act, including any matter listed on this notice/agenda, pending or contemplated litigation, and proposed settlement agreements.

XV.B. Texas Government Code - Section 551.072 - Deliberations concerning Purchase, Lease or Value of Real Property.

XV.C. Texas Government Code - Section 551.073 - Deliberations about Negotiated Contracts for Prospective Gifts or Donations.

XV.D. Texas Government Code - Section 551.074 - Personnel Matters: Deliberations Concerning the Appointments, Employment, Compensation, Duties, Responsibilities, Evaluations and/or Dismissal of Personnel (including but not limited to the Regents, President, General Officers, and Executive Management Employees) and as appropriate, any matter listed on this Agenda under the Personnel & Litigation Committee.

XVI. Reconvene in Open Session to Consider Actions on Executive Session Items as Necessary

XVII. Adjourn

**TEXAS SOUTHERN UNIVERSITY
BOARD OF REGENTS AGENDA**

COMMITTEE: Administration and Finance

ITEM: Request Approval to Negotiate and Execute the Purchase of a Motor Coach Bus (56 Passengers)

DATE PREVIOUSLY SUBMITTED: N/A

SUMMARY:

Approval is requested to negotiate and execute the purchase of a 56-passenger motor coach. This motor coach will benefit the university's students by providing transportation for TSU Athletics, the TSU band, drill teams, equipment, and shuttle services during various university events.

A Request for Proposal (RFP 717-25-704) was posted on the Electronic State Business Daily and TSU's website per Texas Government Code §2155.083.

Contracts are awarded to the bidder whose proposal offers the best value to the State of Texas and Texas Southern University, as outlined in Texas Government Code, § 2155.074.

SUPPORTING

DOCUMENTATION: Scope of Work (Under Separate Cover)

FISCAL IMPACT: NTE: \$875,000
University FOAP: 9104-61420-7372-80

ACTION REQUESTED: Administration recommends approval of this item

Legal Certification: Based on available information to date, this action item and its implementation will not be in violation of any applicable federal, state, or local law, or regulation.



GENERAL COUNSEL

10/07/2024

DATE

Fiscal Certification: This fiscal note shown above details the true and actual positive or negative fiscal effect that implementation of this proposal will achieve.



INTERIM CHIEF FINANCIAL OFFICER

10/08/2024

DATE



James Crawford (Oct 10, 2024 10:47 CDT)

PRESIDENT

10/10/2024

DATE

**TEXAS SOUTHERN UNIVERSITY
BOARD OF REGENTS AGENDA**

COMMITTEE: Administration and Finance

ITEM: Request Approval Purchase Blanket Automobile, Directors & Officers, Employers Legal Liability, & Crime Insurance

DATE PREVIOUSLY SUBMITTED: N/A

SUMMARY:

Approval is requested to purchase Blanket Automobile Insurance and Directors & Officers with Employers Legal Liability Insurance. A Blanket Automobile policy will be administered by American Southern and a Director & Officers policy will be administered through United Educators, Reciprocal Risk Retention Group. Each policy will be brokered by Arthur J. Gallagher Risk Management Services, Inc. (Gallagher). The State Office of Risk Management (SORM) maintains Gallagher as the broker of record.

Interests of the University insured for the coverage period beginning November 1, 2024, through November 1, 2025 and December 1, 2024, through December 1, 2025, respectively.

These policies add a layer of protection against direct and indirect losses from third-party claims. This purchase is available to State agencies via Chapter 412 of the Texas Labor Code. Arthur J. Gallagher is publicly traded, and Form 1295 is not required. Arthur J. Gallagher is not a HUB.

SUPPORTING

DOCUMENTATION: Summary of Proposed Coverage & Policy Updates (Under Separate Cover)

FISCAL IMPACT: Under Separate Cover
University FOAP: 1000-31001-7216-70 & 1000-31001-7204-70

ACTION REQUESTED: Administration recommends approval of this item

Legal Certification: Based on available information to date, this action item and its implementation will not be in violation of any applicable federal, state, or local law, or regulation.



GENERAL COUNSEL

10/10/2024

DATE

Fiscal Certification: This fiscal note shown above details the true and actual positive or negative fiscal effect that implementation of this proposal will achieve.



INTERIM CHIEF FINANCIAL OFFICER

10/10/2024

DATE



James Crawford (Oct 10, 2024 16:50 CDT)

PRESIDENT

10/10/2024

DATE

**TEXAS SOUTHERN UNIVERSITY
BOARD OF REGENTS AGENDA**

COMMITTEE: Administration and Finance
ITEM: Request Approval to Renew Microsoft Corporation Products
DATE PREVIOUSLY SUBMITTED: 10/2023

SUMMARY:

Request Approval to Renew Microsoft Corporation Products:

1. Microsoft Campus A3 Tenant License, which includes Office 365 (Word, Excel, PowerPoint, Outlook, One Drive, Teams, etc.), MS 365 Defender Suite, email archiving with e-discovery, SCCM for End Point Management.
2. Microsoft Premier Support provides Software Assurance, 24x7 technical support, planning services, end-user, and technical training.
3. Azure infrastructure for elastic public cloud computing platform used for Access Management (Azure AD), and backup for data storage, exchange server, etc.

Contracts are awarded to the bidder whose proposal offers the best value to the State of Texas and Texas Southern University, as outlined in Texas Government Code, § 2155.074.

In accordance with Texas Education Code § 51.9335, a cooperative contract (DIR CPO4471) was used to procure these services.

SUPPORTING

DOCUMENTATION: Monthly Azure Cloud Inf Cost - Actuals 2023, 2023 95K Microsoft Unified Support, 2024 95k MS A3 SHI Quote - 23477667 (BOA0001514) (Under Separate Cover)

FISCAL IMPACT: Cost Not to Exceed \$425,000 / FOAP: 1104-31200-7380-50

ACTION REQUESTED: Administration recommends approval of this item

Legal Certification: Based on available information to date, this action item and its implementation will not be in violation of any applicable federal, state, or local law, or regulation.



GENERAL COUNSEL

10/07/2024

DATE

Fiscal Certification: This fiscal note shown above details the true and actual positive or negative fiscal effect that implementation of this proposal will achieve.



INTERIM CHIEF FINANCIAL OFFICER

10/08/2024

DATE



James Crawford (Oct 10, 2024 10:53 CDT)

PRESIDENT

10/10/2024

DATE

**TEXAS SOUTHERN UNIVERSITY
BOARD OF REGENTS AGENDA**

COMMITTEE: Administration and Finance

ITEM: Request Approval to Negotiate and Execute Contracts for Master Lease Agreements

DATE PREVIOUSLY SUBMITTED: N/A

SUMMARY:

Approval is requested to execute master lease agreements for additional student housing (1500 beds) beginning Fall 2025.

A Request for Proposal (RFP 717-25-701) was posted on the Electronic State Business Daily and TSU's website per Texas Government Code §2155.083.

Contracts are awarded to the bidder whose proposal offers the best value to the State of Texas and Texas Southern University, as outlined in Texas Government Code, § 2155.074.

SUPPORTING

DOCUMENTATION: Scope of Work (Under Separate Cover)

FISCAL IMPACT: Pass-Through Charges
1601/2935

ACTION REQUESTED: Administration recommends approval of this item

Legal Certification: Based on available information to date, this action item and its implementation will not be in violation of any applicable federal, state, or local law, or regulation.



GENERAL COUNSEL

10/07/2024

DATE

Fiscal Certification: This fiscal note shown above details the true and actual positive or negative fiscal effect that implementation of this proposal will achieve.



INTERIM CHIEF FINANCIAL OFFICER

10/08/2024

DATE



James Crawford (Oct 10, 2024 10:53 CDT)

PRESIDENT

10/10/2024

DATE

**TEXAS SOUTHERN UNIVERSITY
BOARD OF REGENTS AGENDA**

COMMITTEE: Administration and Finance

ITEM: Request Approval for Executive Search Firm Services

DATE PREVIOUSLY SUBMITTED: N/A

SUMMARY:

Approval is requested to negotiate and execute search firm services to fulfill the critical roles of Vice President of Enrollment Services and Vice President of Student Services.

A Request for Proposal (RFP 717-24-724) was posted on Electronic State Business Daily and Texas Southern University's website per Texas Government Code §2155.083.

The University awards contracts to a respondent whose proposal provides the best value to the State of Texas and Texas Southern University, as defined by Texas Government Code, § 2155.074.

The University recommends Aces and TM2 for this award in accordance with Texas Education Code § 51.9335. Aces and TM2 are not registered HUB vendors. Form 1295 has been submitted.

SUPPORTING

DOCUMENTATION: Scope of Work (Under Separate Cover)

FISCAL IMPACT: NTE: \$150,000
University FOAP: 1000-31001-7253-70

ACTION REQUESTED: Administration recommends approval of this item

Legal Certification: Based on available information to date, this action item and its implementation will not be in violation of any applicable federal, state, or local law, or regulation.



GENERAL COUNSEL

10/07/2024

DATE

Fiscal Certification: This fiscal note shown above details the true and actual positive or negative fiscal effect that implementation of this proposal will achieve.



INTERIM CHIEF FINANCIAL OFFICER

10/08/2024

DATE



James Crawford (Oct 10, 2024 10:51 CDT)

PRESIDENT

10/10/2024

DATE

**TEXAS SOUTHERN UNIVERSITY
BOARD OF REGENTS AGENDA**

COMMITTEE: Administration and Finance

ITEM: Request Approval to Purchase Four SUVs for the Department of Public Safety

DATE PREVIOUSLY SUBMITTED:

SUMMARY:

Approval is requested to purchase four (4) SUVs for the Department of Public Safety from Parkway Chevrolet. This purchase will be made through the Sheriffs' Association of Texas (SAT) Cooperative Vehicle Program. The Sheriffs' Association of Texas conducts a statewide solicitation for dealer participation. The Department of Public Safety seeks to maintain quality, reliability, and efficiency within its vehicle fleet. These vehicles are equipped with advanced safety and security features, high-performance engines, and police-tuned technology.

Form 1295 is enclosed.

SUPPORTING

DOCUMENTATION: Current Fleet List & Quote (Under Separate Cover)

FISCAL IMPACT: Cost Not to Exceed \$250,000
FOAP: 9104/62000/7372/38627

ACTION REQUESTED: Administration recommends approval of this item

Legal Certification: Based on available information to date, this action item and its implementation will not be in violation of any applicable federal, state, or local law, or regulation.



GENERAL COUNSEL

10/08/2024

DATE

Fiscal Certification: This fiscal note shown above details the true and actual positive or negative fiscal effect that implementation of this proposal will achieve.



INTERIM CHIEF FINANCIAL OFFICER

10/09/2024

DATE



James Crawford (Oct 10, 2024 10:43 CDT)

PRESIDENT

10/10/2024

DATE

**TEXAS SOUTHERN UNIVERSITY
BOARD OF REGENTS AGENDA**

COMMITTEE: Administration and Finance

ITEM: Request Approval to Amend FY25 Operating Budget

DATE PREVIOUSLY SUBMITTED: N/A

SUMMARY:

The administration requests approval to amend the FY 25 Operating Budget.

The amendment includes additional budget for the following purposes:

1. Increased revenue projection due to registration
2. Increased revenue projection due to projections not included in the budget process
3. Increased expense projection due to errors and omissions in the budgeting process
4. Increased expense projection due to projections not included in the budgeting process

SUPPORTING

DOCUMENTATION: Budget Amendment

FISCAL IMPACT: Not to exceed \$ 30,000,000

ACTION REQUESTED: Administration recommends approval of this item

Legal Certification: Based on available information to date, this action item and its implementation will not be in violation of any applicable federal, state, or local law, or regulation.



GENERAL COUNSEL

10/10/2024

DATE

Fiscal Certification: This fiscal note shown above details the true and actual positive or negative fiscal effect that implementation of this proposal will achieve.



INTERIM CHIEF FINANCIAL OFFICER

10/10/2024

DATE



Darlene Brown (Oct 14, 2024 11:54 CDT)

ACTING CHIEF AUDIT EXECUTIVE

10/14/2024

DATE



James Crawford (Oct 17, 2024 15:48 CDT)

PRESIDENT

10/17/2024

DATE

Texas Southern University
Fiscal Year 2024-2025
Operating Budget

Source of Funds Operating Budget	FY 2024	FY 2025			Change over PY	
	Amended Budget	Board Approved	Amendment 1	Revised Budget	\$	%
State Appropriations	87,253,945.00	107,346,798.00		107,346,798.00	20,092,853.00	23%
Tuition and Fees	55,793,105.81	58,102,218.75	12,692,929.93	70,795,148.69	15,002,042.88	27%
Auxiliary Funds	20,887,940.59	29,561,227.60	100,000.00	29,661,227.60	8,773,287.01	42%
All Other Funds		42,477,412.29	1,217,299.59	43,694,711.88	43,694,711.88	
Total Operating Funds	163,934,991.40	237,487,656.64	14,010,229.52	251,497,886.16	87,562,894.76	53%
Grants (Research)	53,839,119.00	52,380,379.00		52,380,379.00	(1,458,740.00)	-3%
Capital Funds	11,719,335.00			-	(11,719,335.00)	-100%
Total Sources of Revenue	229,493,445.40	289,868,035.64	14,010,229.52	303,878,265.16	74,384,819.76	32%
Uses of Funds						
Operations						
Salaries and Benefits	85,975,687.00	111,851,340.15	6,116,768.51	117,968,108.66	31,992,421.66	37%
General Operating	38,390,317.00	64,590,627.04	8,297,642.26	72,888,269.29	34,497,952.29	90%
Debt Service - Bonds	15,372,288.00	12,716,900.00		12,716,900.00	(2,655,388.00)	-17%
Scholarships	17,060,486.00	18,397,868.51		18,397,868.51	1,337,382.51	8%
Utilities	6,454,285.00	6,584,731.67		6,584,731.67	130,446.67	2%
Other (PY Designated Reserves +Amend)	677,436.00			-	(677,436.00)	-100%
Budget Amendment-Operations	51,442,118.00			-		
Total Operational Uses of Funds	215,372,617.00	214,141,467.36	14,414,410.77	228,555,878.13	13,183,261.13	6%
Grants (Research)	53,839,119.00	52,380,379.00		52,380,379.00	(1,458,740.00)	-3%
Capital Funds	11,719,335.00	47,760,828.10	12,975,000.00	60,735,828.10	49,016,493.10	418%
Budget Amendment -Capital	94,918,423.00			-		
Total Uses of Funds	375,849,494.00	314,282,674.46	27,389,410.77	341,672,085.23	(34,177,408.77)	-9%
Net Increase/(Decrease) in Operational Sources and Uses of Funds	(51,437,625.60)	23,346,189.28	(404,181.25)	22,942,008.03	74,379,633.63	-145%
Net Increase/(Decrease) in Total Sources and Uses of Funds	(146,356,048.60)	(24,414,638.82)	(13,379,181.25)	(37,793,820.07)	108,562,228.53	-74%

Budget Amendment Notes

- \$12.1M settlement from Towers recorded in FY24. Repairs expected to begin FY25
- \$875K Source of funds for bus moving to HEF
- Includes additional \$2M for salary adjustments due to compensation study.
- Includes \$10M in expenditures not included in original budget.
- \$14M of expenses have cash already on hand to cover them
- Included \$500K for strategic plan

FY25 Budget

	FY Approved	Amended	Difference
per CH Statutory Fee			
per CH Designated Fee	42,266,874.00	44,666,712.49	2,399,838.49
per CH Student Service Fee	3,523,841.25	3,723,919.00	200,077.75
per CH Athletic Fee	2,135,661.36	2,256,920.00	121,258.64
per CH Library Service Fee	2,135,661.36	2,256,920.00	121,258.64
Headcount Student Center Fee	1,301,158.51	1,375,036.00	73,877.49
Headcount International Education Fee	52,046.34	55,001.00	2,954.66
Headcount Recreational Facility Fee	867,439.01	916,691.00	49,251.99
Headcount Medical Service Fee	607,207.30	641,683.00	34,475.70
Headcount Computer Service Fee	1,786,924.35	1,888,383.00	101,458.65
Headcount School Fees	1,804,273.13	1,906,717.00	102,443.87
Differential Tuition	5,180,141.97	4,342,255.77	(837,886.20)
Meal Plan Fee	6,108,709.38		
Housing Fee	13,816,077.10		
Lab Fee	-		
Equipment Fee	120,000.00		
			-
Total (less bad debt estimate)	81,706,015.06		
State General Rev	56,864,972.00		
State Statutory	23,567,126.00	33,891,046.25	10,323,920.25
Additional State Appropriations	26,385,944.00		
Adjusted Total	188,524,057.06		
Auxiliary and Cash Driven	3,168,780.00		
Fund Raising	17,500,000.00		
Grants	52,380,379.00		
Indirect Cost Recovery	1,800,000.00		
Revenue Other	2,327,651.29		
Settlement Fees	12,000,000.00		
Grand Total	<u>277,700,867.35</u>		<u>12,692,929.93</u>

FY25 Adj Amount	Comments
165,000.00	Earl Carl Institute not included in Final Budget
350,182.00	Earl Carl Institute not included in Final Budget
315,165.00	Earl Carl Institute not included in Final Budget
215,000.00	Earl Carl Institute not included in Final Budget
108,252.59	Earl Carl Institute not included in Final Budget
100,000.00	Athletic SWAC Grant
63,700.00	Reseach using Fund Balance- Museum
10,000.00	Corporate sponsorships
10,000.00	Corporate sponsorships
3,000.00	Donations
(10,000.00)	Reduced estimate
750,000.00	Homecoming
150,000.00	Event Services
75,000.00	New ECI grant

Total 2,305,299.59

Need Cash	Cash on Hand	Cash Coming	Capital	Comments
		\$14,995.68		Earl Carl Institute not included in Final Budget
		\$18,459.96		Earl Carl Institute not included in Final Budget
		\$117,955.00		Earl Carl Institute not included in Final Budget
		\$450.00		Earl Carl Institute not included in Final Budget
		\$527.16		Earl Carl Institute not included in Final Budget
		\$2,500.00		Earl Carl Institute not included in Final Budget
		\$6,200.00		Earl Carl Institute not included in Final Budget
		\$22,493.52		Earl Carl Institute not included in Final Budget
		\$32,004.16		Earl Carl Institute not included in Final Budget
		\$204,500.00		Earl Carl Institute not included in Final Budget
		\$29,991.36		Earl Carl Institute not included in Final Budget
		\$32,014.88		Earl Carl Institute not included in Final Budget
		\$220,768.00		Earl Carl Institute not included in Final Budget
		\$14,995.68		Earl Carl Institute not included in Final Budget
		\$25,345.18		Earl Carl Institute not included in Final Budget
		\$161,950.00		Earl Carl Institute not included in Final Budget
		\$7,497.84		Earl Carl Institute not included in Final Budget
		\$12,754.75		Earl Carl Institute not included in Final Budget
		\$88,000.00		Earl Carl Institute not included in Final Budget
	79,350.00			Athletic SWAC grant
	20,631.00			Athletic SWAC grant
28,937.62				BOR-Raise for Board Office Executive Director. Approved after final budget
42,000.00				HEC-Short-Term Clery Compliance Coordinator
4,500.00				HR - Ricoh lease Not included in final budget
26,179.00				HR-External job posting cost. Not included in final budget
322,092.00				KTSU-Salary accounts codes not copied into master spreadsheet
452,540.00				KTSU-Salary accounts codes not copied into master spreadsheet
	75,920.25			Endowment-Endowment distribution missed.
		63,700.00		Moving position from grant to Cash Driven. Funds coming from Foundation.
		266,000.00		Hurricane FEEMA reimbursable clean up
5,000,000.00				Insurane premiums not readded to budget
	15,000.00			Research-Request for Research Week
16,803.91				Research-Omitted Update on Reclassification for DRI staff (SAVP)
	57,178.39			7999, PLEASE RESTORE -Eliminated Research Expenditures and Collections Specialist
	117,195.00			Endowment distribution eliminated with reserve reduction
	140,349.00			Endowment distribution eliminated with reserve reduction

Need Cash	Cash on Hand	Cash Coming	Capital	Comments
	131,713.00			Endowment distribution eliminated with reserve reduction
	202,609.00			Endowment distribution eliminated with reserve reduction
	55,030.00			Endowment distribution eliminated with reserve reduction
65,000.00				Classification study for HR
85,355.48				Interim VP for Marketing
13,704.53				AVP Dr. Addison Increase
	12,100,000.00		X	Tower Residence Hall Repair
55,000.00				Homecoming-budget reduced in error.
50,000.00				Homecoming-budget reduced in error.
35,000.00				Homecoming-budget reduced in error.
60,000.00				Homecoming-budget reduced in error.
46,260.00				Band Director Increase
15,263.49				Assoc Band Dir
500,000.00				Strategic Plan
2,000,000.00				Compensation Study
230,000.00				Athletic Development
		55,000.00		Omitted in original budget development.
		55,000.00		Omitted in original budget development.
		10,000.00		Golf registration fees - Corporate sponsorships
		10,000.00		Golf registration fees - Corporate sponsorships
113,850.00				Director of Risk Mgt
57,825.00				Sr. AVP Development
40,000.00				Dean of SOPA
54,759.12				Sr. AVP University Planning & Analytics
2,000,000.00				University Contingency
426,100.10				six new Police Positions
180,161.72				Research request approved by Provost
1,800,000.00				Academic Affairs
		75,000.00		New ECI grant
\$13,721,331.96	\$12,994,975.64	\$1,548,103.17		\$28,264,410.77

Fund	FundTitle	Org	OrgDesc	Acct	AccDesc	Prog		Comments/Justification
1	State Apprc	21005	Accreditation of Prog	7203	Registration Fees	31510	19,008.77	20,000 increase to cover projected expenditures
1	State Apprc	21001	Promotion and Tenur	7008		30011	150,000.00	Estimate for FY25 Promotion and Tenure
1	State Apprc	21001	FY25 Mini Mesters	7008		30011	-	Revenue generating FY25 Projection for MiniMesters cash generated in to multiple accounts
1	State Apprc	21001	FY25 Summer Schoo	7008		30011	150,000.00	FY25 Adjuncts, Visiting Faculty and Graduate Students and FY25 Summer School
1000	Designated	21000	Academic Affairs Adr	7015	Professional/Administra	10	59,182.00	Sr. Administrative Assistant for Provost Office
1000	Designated	21000	Academic Affairs Adr	7010	Professional/Administra	50	553,303.00	Special Assistant, Executive Director, Director and Associate Omsbudman
1000	Designated	21000	Academic Affairs Adr	7116	Travel - Out of State Mea	50	79,999.68	Provost, Faculty Development, Staff 80,000
1000	Designated	21000	Academic Affairs Adr	7210	Fee and Other Charges	50	40,000.34	10 Programs External Reviews 40,000
1000	Designated	21000	Academic Affairs Adr	7211	Awards	10	80,000.00	8 Distinguished Professor Allocations 80,000
1000	Designated	21000	Academic Affairs Adr	7299	Purchased Temporary S	10	26,550.00	Student Success Initiative 30,000
1000	Designated	21000	Academic Affairs Adr	7300	Consumables	10	49,975.20	Supplies: SWAG, Rush the Court, Office 58,000
1000	Designated	21000	Academic Affairs Adr	7380	Reserve	10	147,476.00	Software for Promotion/Tenure, Courseleaf & Anthology 147,476 increase
1000	Designated	21001	General Academic Ad	7210	Fee and Other Charges	50	65,000.05	Fall/Spring Faculty Meetings, 4 Convocations 65,000 3 graduations expenditures
1000	Designated	21021	QEP	7300	Consumables	50	94,123.00	Costs associated with Transition to Major, Residential Life/QEP Plays 100,000
1000	Designated	21021	QEP	7382	Books, Pre-recorded Re	50	75,000.00	Cost of Common Read materials 100,000
1000	Designated	21020	Faculty Excellence Av	7211	Awards	50	15,600.00	FY25 Faculty Awards
1000	Designated	21021	QEP	7010	Professional/Administra	50	88,500.00	QEP Evaluator (if not on QEP) 100,000
1000	Designated	21021	QEP	7043	F.I.C.A. Employer Match	50	39,120.25	Stipends for QEP-engaged faculty 40,000
1000	Designated	21021	QEP	7252	Lecturers-Higher Educa	50	47,850.00	Alumni and National Speakers for Community Engagement 60,000
1000	Designated	21021	QEP	7116	Travel - Out of State Mea	50	-	
1000	Designated	21021	QEP	7203	Registration Fees	50	-	
1000	Designated	21021	QEP	7262	Maintenance and Repai	50	-	
1000	Designated	21021	QEP	7281	Advertising Services	50	-	
1000	Designated	21021	QEP	7299	Purchased Temporary S	50	-	
1000	Designated	21021	QEP	7315	Food Purchased By Loca	50	-	
1000	Designated	21021	QEP	7377	Computer Equipment- E	50	-	
1000	Designated	21021	QEP	7406	Rental of Furnishings an	50	-	
1000	Designated	21021	QEP	8001	Reserve	50	(95,575.30)	
1107	Graduate A	21021	QEP	7298	Purchased Temp Srvc	60	(500.00)	
1107	Graduate A	21021	QEP	7406	Rental of Furnishings an	60	(500.00)	
1000	Designated	21007	Commencments	7299	Reserve	50	119,999.40	

1,804,112.39

**TEXAS SOUTHERN UNIVERSITY
BOARD OF REGENTS AGENDA**

COMMITTEE: Administration and Finance

ITEM: Endowment Performance & Update (August 31, 2024)

DATE PREVIOUSLY SUBMITTED: N/A

SUMMARY:

The current endowment performance report is presented as information based on the requirements set forth in the Texas Southern University Endowment Investment Policy.

SUPPORTING

DOCUMENTATION: Atlanta Consulting Group TSU Endowment Reports
August 31, 2024 | BOA0001517

FISCAL IMPACT: None

ACTION REQUESTED: Information

Legal Certification: Based on available information to date, this action item and its implementation will not be in violation of any applicable federal, state, or local law, or regulation.



GENERAL COUNSEL

10/07/2024

DATE

Fiscal Certification: This fiscal note shown above details the true and actual positive or negative fiscal effect that implementation of this proposal will achieve.



INTERIM CHIEF FINANCIAL OFFICER

10/08/2024

DATE



James Crawford (Oct 10, 2024 10:48 CDT)

PRESIDENT

10/10/2024

DATE

TSU Recommendations Summary

- In reviewing the investment managers and asset allocation of the Texas Southern Endowment portfolio, ACG has a few recommendations to consider:
 - 1. Lengthen fixed income duration of the portfolio**
 - TSU's current fixed income positioning through Loop capital is to intermediate duration which has a lower sensitivity to interest rates. This allocation has outperformed relative to the broad fixed income markets during the period of the last few years as the Federal Reserve raised interest rates. With the Federal Reserve more likely to cut rates going forward, fixed income duration is now more attractive to portfolios. Duration is also viewed as a hedge to equity risk as in some periods of equity market volatility there is a flight to quality when investors rebalance assets into fixed income and increase bond prices. For the above reasons, we are recommending a change to the Loop Capital benchmark to the Bloomberg Aggregate which lengthens duration
 - As part of this transition, we also recommend termination of Brandywine fixed income. This fund has become too sensitive to changes in currencies vs. underlying fixed income selection. We recommend these proceeds go to Loop Capital
 - 2. Add an active small / mid cap manager to complement TSU's passive large cap ETF**
 - Small and mid cap is a significant part of the equity markets. While TSU has some exposure to small cap through the ETF, it is minimal. We have found that active managers in less efficient areas of the equity markets like small cap, tend to be more likely to outperform benchmarks over time
 - We recommend a 10% or \$9 million allocation to Atlanta Capital SMID - a small mid cap manager who we have used for over a decade and has one of the best long-term track records vs. peers
 - 3. Add additional private market investment**
 - To complement Golub (private credit) and Magnitude (hedge fund), we recommend TSU add a \$4 million commitment to Portfolio Advisors Secondaries Fund V (private equity). The current private equity market presents a good opportunity for secondaries funds. We have used Portfolio Advisors at ACG since the mid 2000s. Their prior secondaries strategies have all been successful

LOOP CAPITAL TRACK RECORD

Illustrative Only Performance Exhibit

Texas Southern University Broad FI

Below is an illustrative only performance exhibit that shows the linking of two performance track records from two separate investment managers: Smith Graham & Co. and Loop Capital Asset Management as of November 1st, 2022.

The below performance is not part the official performance reporting of Loop Capital Asset Management. The inception date of this account from Loop Capital Asset Management's management began on November 1st, 2022 and should be evaluated and measured as such.

As of June 30, 2024

	1 Month	3 Month	Year to Date	12 Months	3 Years Annualized	5 Years Annualized	Since Inception Annualized 5/31/2005
Texas Southern University Broad FI (Gross)	0.76	0.77	1.04	4.77	-0.78	1.23	3.51
Texas Southern University Broad FI (Net)	0.69	0.71	0.91	4.51	-1.04	0.94	3.23
Blended Index*	0.80	0.64	0.49	4.19	-1.17	0.74	3.21

*Bloomberg U.S. Aggregate Bond Index to 3/31/21, Bloomberg U.S. Intermediate Gov/Credit Index thereafter

Source:

Returns for the account and benchmark prior to 10/31/22 is from Smith Graham & Co.

Returns for the account and benchmark following 10/31/22 is from LCAM.

Texas Southern University Broad FI - Portfolio Characteristics

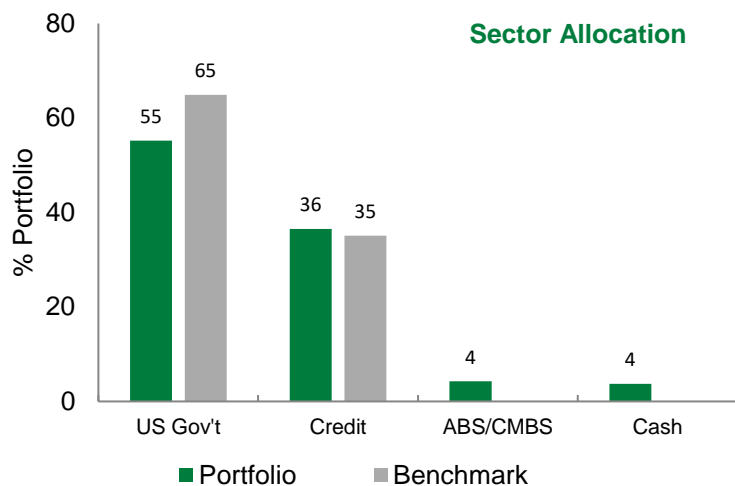

Portfolio characteristics	Texas Southern University Broad FI	Bloomberg Intermediate Gov/Credit Index
Market Value (M)	\$17.8	
Yield to Worst (%)	5.0	4.8
Average Years to Maturity	4.3	4.3
Effective Duration (Yrs)	3.7	3.8

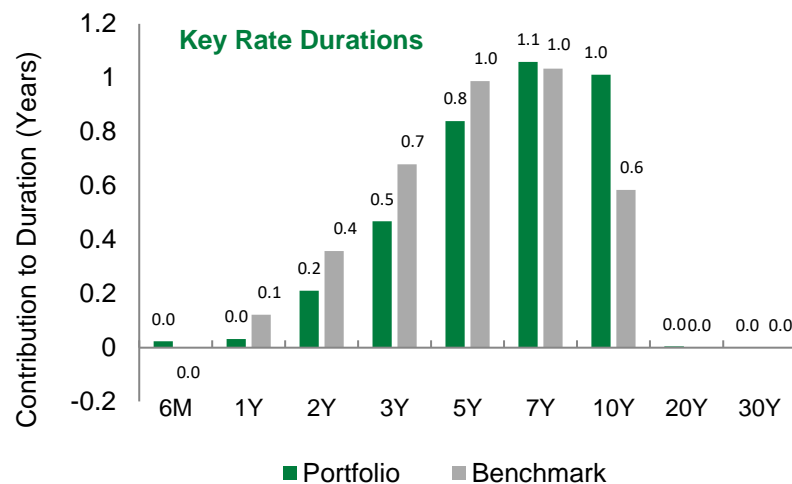
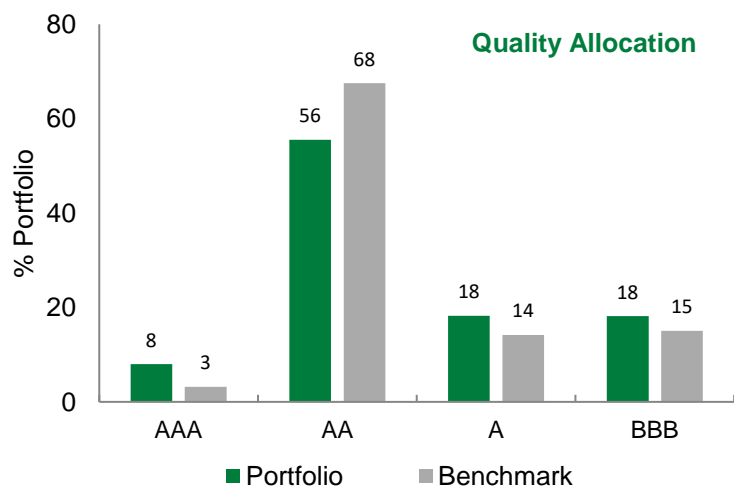

All data as of 6.30.24

Source for all data: BondEdge

Benchmark for all charts = Bloomberg Intermediate Gov/Credit Index

Fixed Income Rates

Performance Across Hiking Cycles

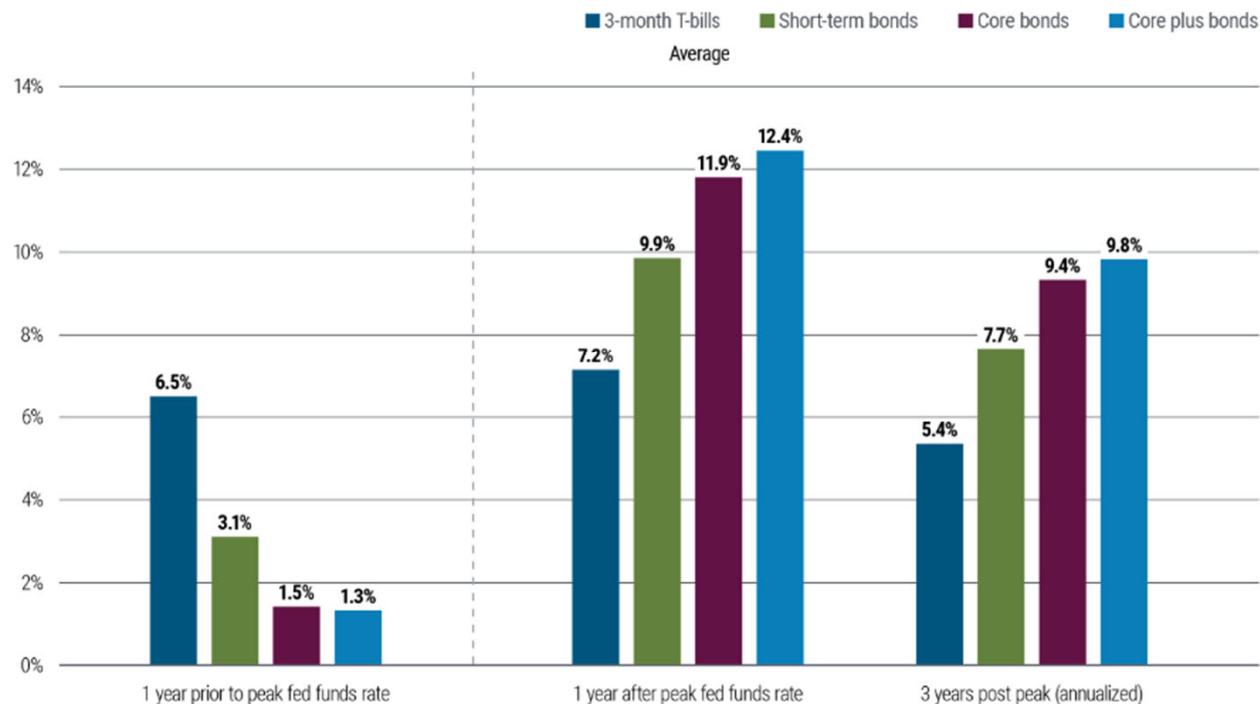

- Historically, cash has almost never outperformed bonds at this stage of the cycle, with policy rates at peak levels and the Federal Reserve poised to cut
 - Only in 1981 did bond investors have to wait a little more than a year from the initial rate cut to outperform cash
- In all other cycles dating back to 1980, it took a year or less for bonds to outperform cash. On average, core plus bond portfolios (or short and intermediate maturities) outperformed cash by about 5 percentage points over the year following the peak in the federal funds rate, and by about 4.5 percentage points annualized over the ensuing three years

Hiking cycles are defined as periods where the Federal Reserve embarks on a sustained path of increasing the target fed funds rate and/or target range. We define the end of a hiking cycle as the month where the Fed reaches its peak policy rate for that cycle (i.e., it either pauses rate hikes or cuts). Hiking cycles include (start to peak), 1980 (Jul '80 to May '81), 1983 (Feb '83 to Aug '84), May 1988 (Feb '88 to Mar '89), 1994 (Jan '94 to Feb '95), 1999 (May '99 to May '00), 2004 (May '04 to Jun '06) and 2015 (Nov '15 to Dec '18).

ATLANTA CAPITAL SMID ANALYSIS



Trailing Returns

As of Date: 6/30/2024 Peer Group: Open End Funds - U.S. - Mid-Cap Blend

	YTD	Peer group percentile	1 Year	Peer group percentile	3 Years	Peer group percentile	5 Years	Peer group percentile	7 Years	Peer group percentile	10 Years	Peer group percentile
Eaton Vance Atlanta Capital SMID-Cap I	6.34	22	15.45	19	5.78	17	9.85	33	11.61	7	11.73	1
Russell 2500 TR USD	2.35	83	10.47	73	-0.29	84	8.31	79	8.44	62	7.99	58

Calendar Year Returns

	2023	2022	2021	2020	2019	2018	2017	2016	2015	2014
Eaton Vance Atlanta Capital SMID-Cap I	14.01	-8.81	22.25	11.24	34.44	-5.35	24.73	11.21	9.74	5.17
Russell 2500 TR USD	17.42	-18.37	18.18	19.99	27.77	-10.00	16.81	17.59	-2.90	7.07

Three Year Risk-Reward

Time Period: 7/1/2021 to 6/30/2024

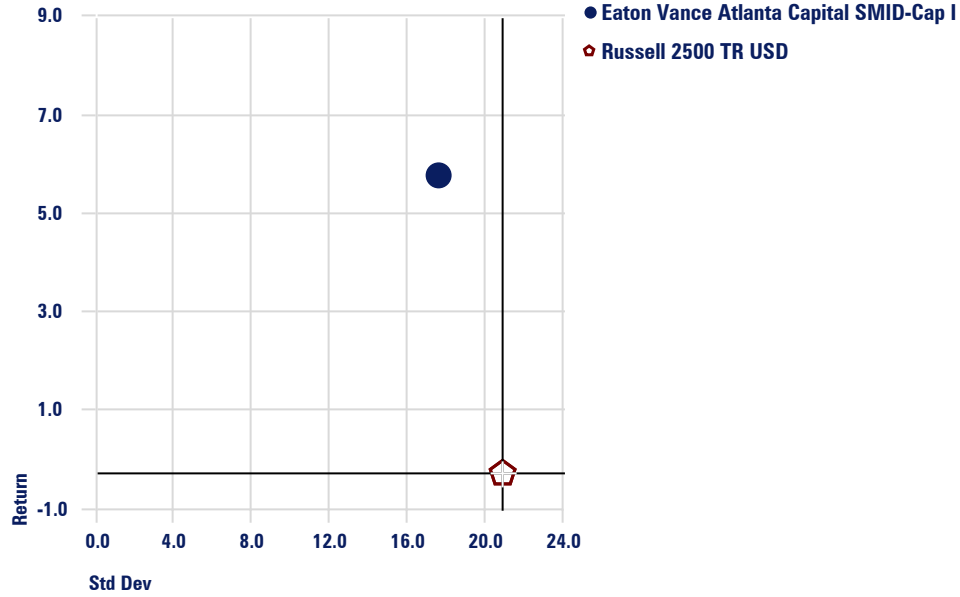

Five Year Risk-Reward

Time Period: 7/1/2019 to 6/30/2024

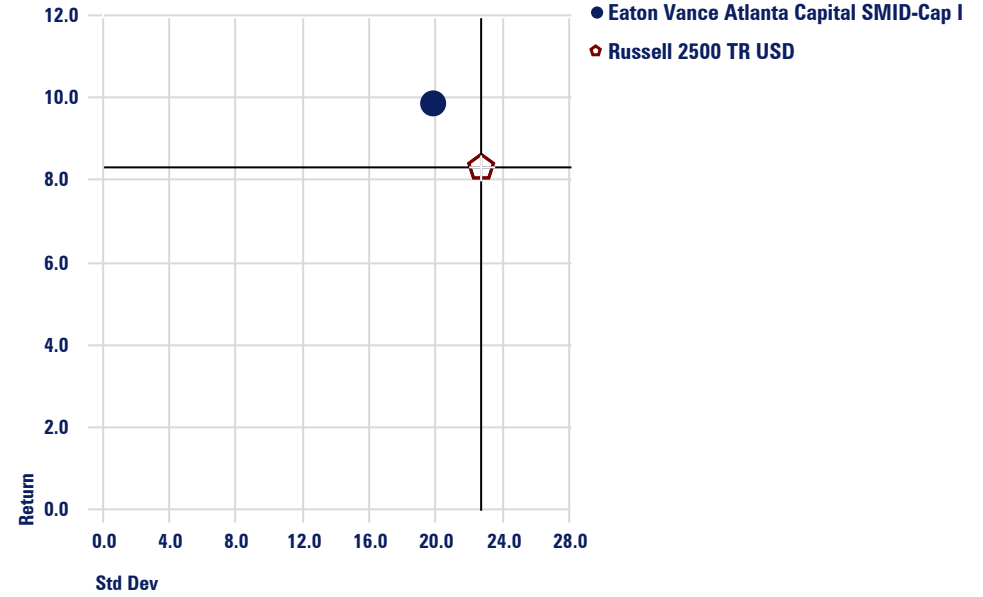

Three Year Risk

Time Period: 7/1/2021 to 6/30/2024

	Return	Std Dev	Loss Std Dev	Beta	Alpha	R2	Sharpe Ratio
Eaton Vance Atlanta Capital SMID-Cap I	5.78	17.57	7.87	0.80	4.99	90.05	0.13
Russell 2500 TR USD	-0.29	20.91	9.67	1.00	0.00	100.00	-0.17

Five Year Risk

Time Period: 7/1/2019 to 6/30/2024

	Return	Std Dev	Loss Std Dev	Beta	Alpha	R2	Sharpe Ratio
Eaton Vance Atlanta Capital SMID-Cap I	9.86	19.85	13.35	0.83	2.23	89.78	0.37
Russell 2500 TR USD	8.31	22.71	15.24	1.00	0.00	100.00	0.26

Seven Year Risk-Reward

Time Period: 7/1/2017 to 6/30/2024

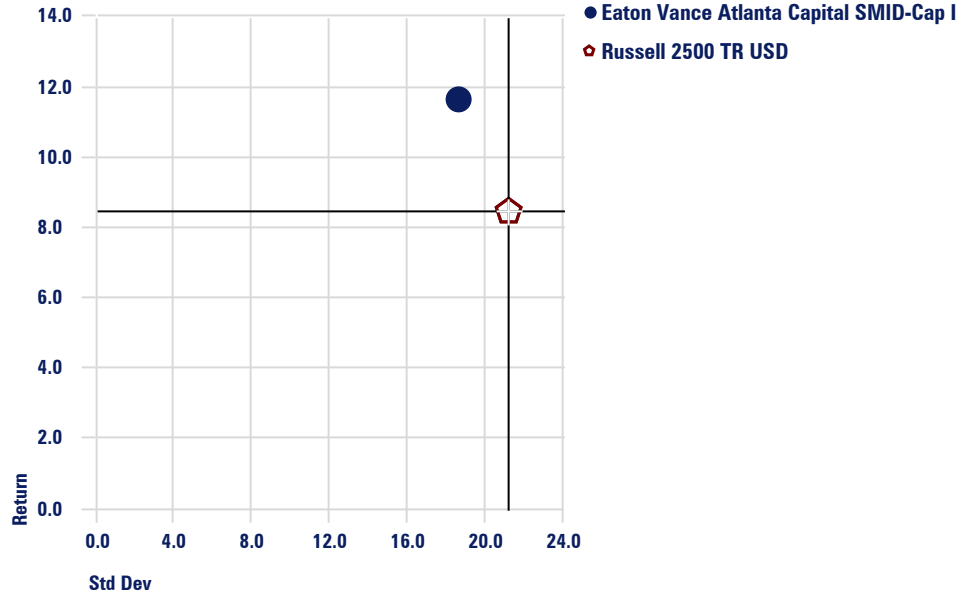

Ten Year Risk-Reward

Time Period: 7/1/2014 to 6/30/2024

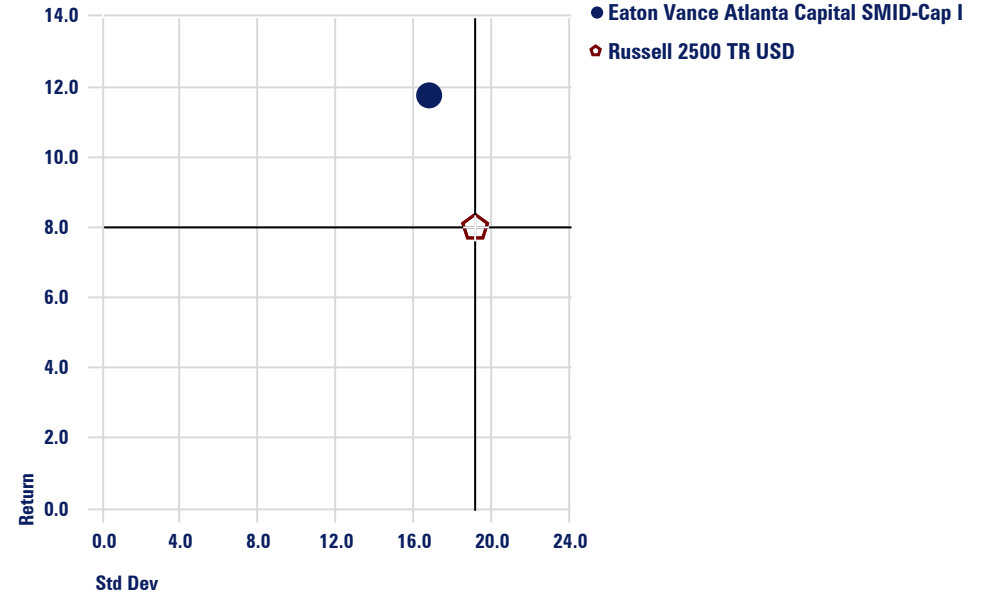

Seven Year Risk

Time Period: 7/1/2017 to 6/30/2024

	Return	Std Dev	Loss Std Dev	Beta	Alpha	R2	Sharpe Ratio
Eaton Vance Atlanta Capital SMID-Cap I	11.61	18.68	13.46	0.83	3.75	89.89	0.49
Russell 2500 TR USD	8.44	21.25	14.97	1.00	0.00	100.00	0.29

Ten Year Risk

Time Period: 7/1/2014 to 6/30/2024

	Return	Std Dev	Loss Std Dev	Beta	Alpha	R2	Sharpe Ratio
Eaton Vance Atlanta Capital SMID-Cap I	11.73	16.83	12.09	0.83	4.37	88.94	0.59
Russell 2500 TR USD	7.99	19.16	13.73	1.00	0.00	100.00	0.33

Three Year Excess Returns

Time Period: Since Common Inception (5/1/2002) to 6/30/2024

Rolling Window: 3 Years 1 Month shift



Performance

Time Period: Since Common Inception (5/1/2002) to 6/30/2024

	Annualized Return	Cumulative Return	Std Dev	Annualized Excess Return	Cumulative Excess Return	Rolling Batting Average
Eaton Vance Atlanta Capital SMID-Cap I	11.23	958.24	16.60	2.25	385.26	76.19
Russell 2500 TR USD	8.98	572.98	18.80	0.00	0.00	0.00

Five Year Excess Returns

Time Period: Since Common Inception (5/1/2002) to 6/30/2024

Rolling Window: 5 Years 1 Month shift

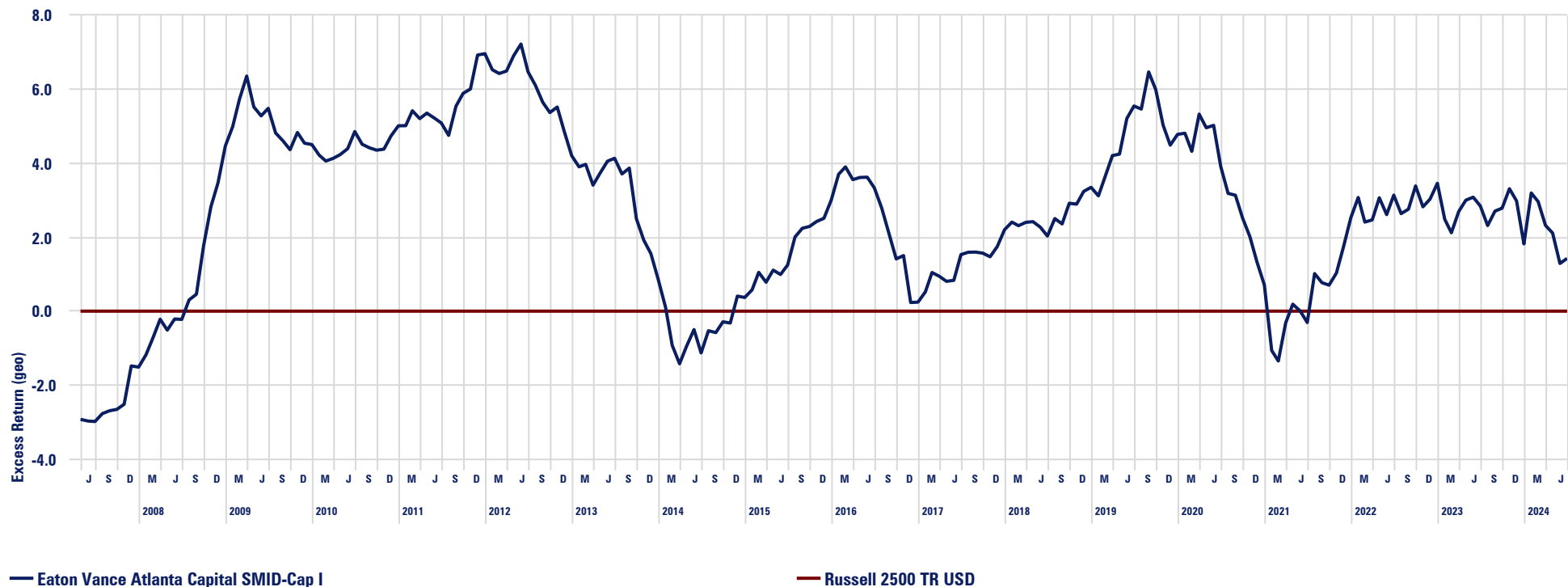

Performance

Time Period: Since Common Inception (5/1/2002) to 6/30/2024

	Annualized Return	Cumulative Return	Std Dev	Annualized Excess Return	Cumulative Excess Return	Rolling Batting Average
Eaton Vance Atlanta Capital SMID-Cap I	11.23	958.24	16.60	2.25	385.26	86.47
Russell 2500 TR USD	8.98	572.98	18.80	0.00	0.00	0.00

Risk Measures - Last Five Years

Time Period: 7/1/2019 to 6/30/2024

	# of Up Months	# of Down Months	Average Gain	Average Loss	Up Capture Return	Down Capture Return	Best Quarter	Worst Quarter	Up Capture Ratio	Down Capture Ratio	R2
Eaton Vance Atlanta Capital SMID-Cap I	35	25	4.62	-4.35	4.27	-4.22	22.21	-27.28	86.23	77.70	89.78
Russell 2500 TR USD	36	24	4.95	-5.43	4.95	-5.43	27.41	-29.72	100.00	100.00	100.00

Summary Statistics - Last Five Years

Time Period: 7/1/2019 to 6/30/2024

	Return	Std Dev	Sharpe Ratio	Loss Std Dev	Max Drawdown	Excess Return	Tracking Error	Batting Average	Information Ratio	Alpha
Eaton Vance Atlanta Capital SMID-Cap I	9.86	19.85	0.37	13.35	-27.28	1.54	7.46	48.33	0.19	2.23
Russell 2500 TR USD	8.31	22.71	0.26	15.24	-29.72	0.00	0.00	100.00	—	0.00

Risk Measures - Common Time Period

Time Period: Since Common Inception (5/1/2002) to 6/30/2024

	# of Up Months	# of Down Months	Average Gain	Average Loss	Up Capture Return	Down Capture Return	Best Quarter	Worst Quarter	Up Capture Ratio	Down Capture Ratio	R2
Eaton Vance Atlanta Capital SMID-Cap I	171	94	3.69	-4.00	3.59	-3.58	22.21	-27.28	89.97	76.86	90.92
Russell 2500 TR USD	168	98	3.99	-4.65	3.99	-4.65	27.41	-29.72	100.00	100.00	100.00

Summary Statistics - Common Time Period

Time Period: Since Common Inception (5/1/2002) to 6/30/2024

	Return	Std Dev	Sharpe Ratio	Loss Std Dev	Max Drawdown	Excess Return	Tracking Error	Batting Average	Information Ratio	Alpha
Eaton Vance Atlanta Capital SMID-Cap I	11.23	16.60	0.57	11.91	-38.50	2.25	5.83	53.38	0.35	3.06
Russell 2500 TR USD	8.98	18.80	0.39	13.77	-53.00	0.00	0.00	100.00	—	0.00

Over/Under Benchmark Performance

Time Period: 7/1/2014 to 6/30/2024 Rolling Window: 3 Years 3 Months shift Calculation Benchmark: Russell 2500 TR USD

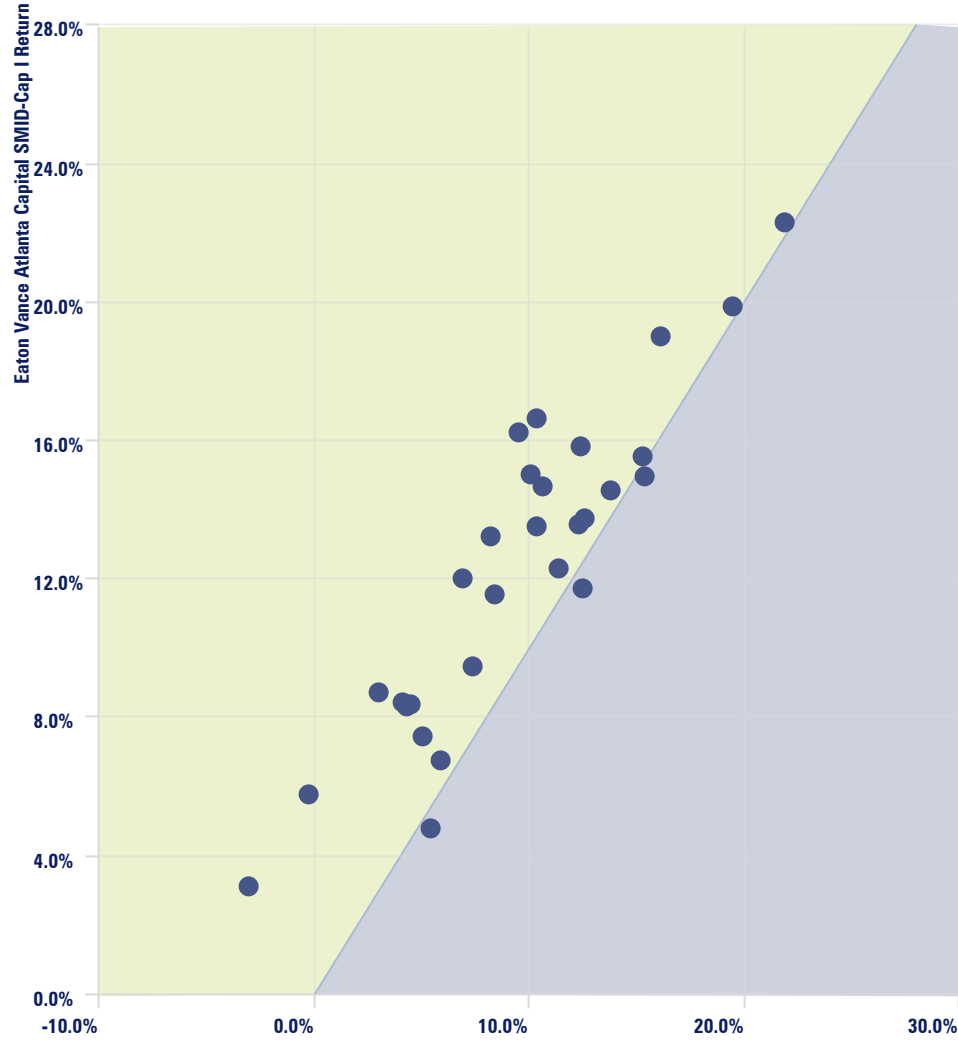

Russell 2500 TR USD Return

- 2017
- 2020
- 2023
- Eaton Vance Atlanta Capital SMID-Cap I outperforms 26 times (89.66%)
- Zero Excess Return

- 2018
- 2021
- 2024

Over/Under Benchmark Performance

Time Period: 7/1/2014 to 6/30/2024 Rolling Window: 5 Years 3 Months shift Calculation Benchmark: Russell 2500 TR USD

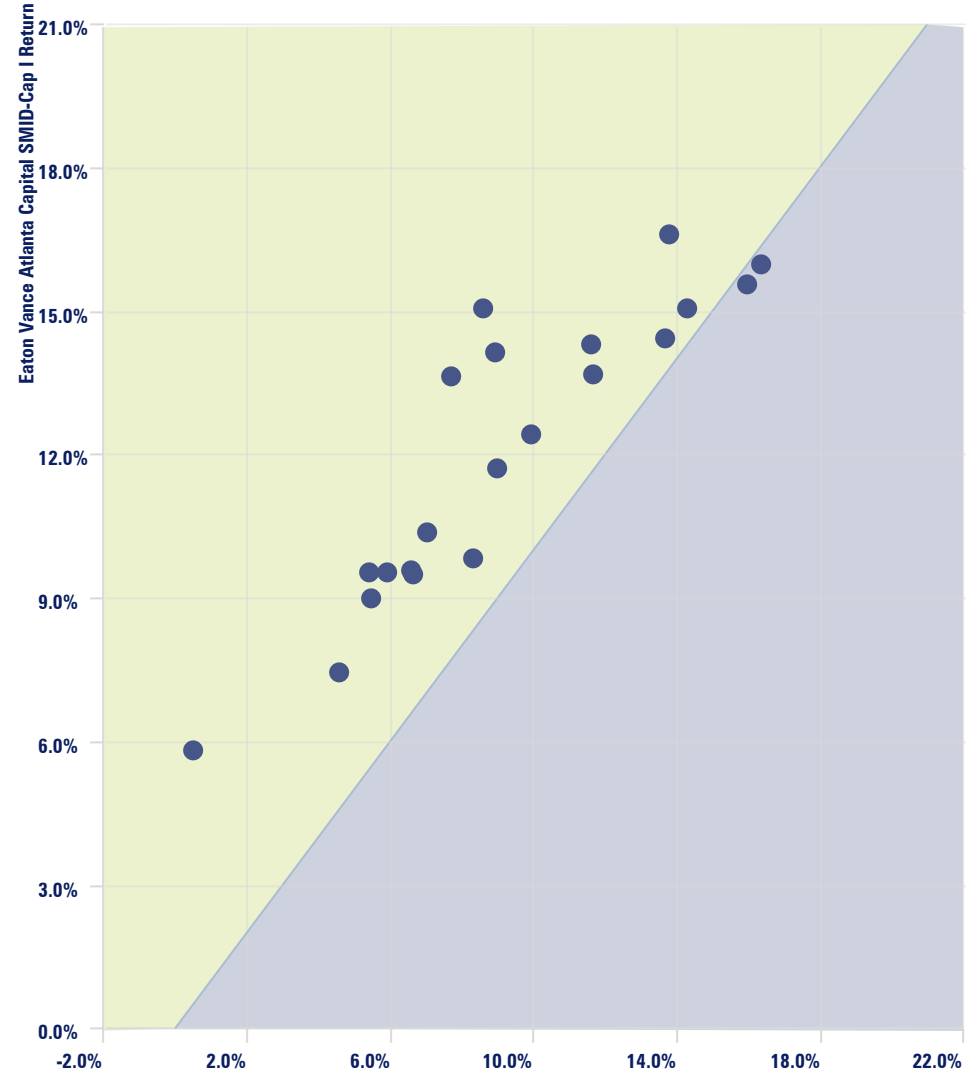

Russell 2500 TR USD Return

- 2019
- 2022
- Eaton Vance Atlanta Capital SMID-Cap I outperforms 19 times (90.48%)
- Zero Excess Return

- 2020
- 2023

- 2021
- 2024

PORTFOLIO ADVISORS SECONDARY FUND V

PORTFOLIO ADVISORS LLC

Portfolio Advisors Secondary Fund V ("PASF V")



TABLE OF CONTENTS

3	Portfolio Advisors (“PA”) overview
8	Team experience and track record
11	Secondary market overview
18	PASF V overview
23	PA Secondaries strategy
28	PASF V case studies
47	Appendix
53	Endnotes

Portfolio Advisors overview



25+ year leader in the mid-market



PORTFOLIO
ADVISORS LLC

Key Statistics

\$82B+

Assets Under
Management¹

600+

Professionals

30

Years of institutional
experience

300+

Sponsor
relationships

~250

Advisory Board
Seats

- **Mid-market specialist** with deep investment expertise across **private equity, private credit** and **private real estate**
- **Longstanding relationships** with **top-tier sponsors** provide access to differentiated, high-quality deal flow
- Average of **\$4.1B invested** in private markets **per year**
- In 2023, **Portfolio Advisors** joined forces with **FS Investments**

1. Total AUM estimated as of June 30, 2024. The AUM also includes the estimated AUM of FS Investments as of June 30, 2024, which merged with Portfolio Advisors on June 30, 2023. For additional information related to the total AUM, please visit our AUM Endnotes.

Portfolio Advisors key differentiators

Middle market focus	Broad access to top-tier, mid-market sponsors						
Extensive primary platform	PA commits \$4 billion annually to private equity sponsors						
Mid-size transactions	Majority of transactions are carve-outs of core sponsor relationships , with an average deal size of \$45 million allowing for high selectivity						
LP-led focus	Targeting 80% LP-led transactions to construct diversified portfolios with a focus on preserving capital and delivering consistent performance						
Low-leverage approach	In contrast to other secondary managers, PA does not rely on fund-level or transaction-level leverage to deliver returns						
Attractive fee structure	Market-leading, investor-friendly terms with management fees on invested capital, 10% carry and 10% preferred return						
Strong track record	<table border="0"> <tr> <td>PASF I: Net IRR 13% / TVPI 1.7x¹</td> <td>PASF IV: Net IRR 11% / TVPI 1.3x¹</td> </tr> <tr> <td>PASF II: Net IRR 15% / TVPI 1.6x¹</td> <td>PASF V: Net IRR NM² / TVPI 1.3x¹</td> </tr> <tr> <td>PASF III: Net IRR 19% / TVPI 1.7x¹</td> <td></td> </tr> </table>	PASF I: Net IRR 13% / TVPI 1.7x¹	PASF IV: Net IRR 11% / TVPI 1.3x¹	PASF II: Net IRR 15% / TVPI 1.6x¹	PASF V: Net IRR NM² / TVPI 1.3x¹	PASF III: Net IRR 19% / TVPI 1.7x¹	
PASF I: Net IRR 13% / TVPI 1.7x¹	PASF IV: Net IRR 11% / TVPI 1.3x¹						
PASF II: Net IRR 15% / TVPI 1.6x¹	PASF V: Net IRR NM² / TVPI 1.3x¹						
PASF III: Net IRR 19% / TVPI 1.7x¹							

1. As of March 31, 2024. Past performance is not indicative of future results and there can be no assurance that the Fund will achieve comparable results and/or its investment objective. Please see the "Secondary Performance Endnotes" as well as the Disclosure Statement, in the Appendix for additional information. The returns for each investor in the Fund(s) may be materially different from those shown herein due to different fee schedules and timing on investment. This performance information is estimated and unaudited.

2. PASF V is in its investment period and its Net IRR is not considered meaningful at this time.

Integrated private equity platform



Note: Numbers reflect historic limited partner commitments to each strategy as of July 1, 2024.

Responsible investment approach

Firm / mandates

- UNPRI signatory since 2015
- ILPA signatory since 2021
- Generous **parental leave policy** for all employees
- **\$6.9 billion¹ of AUM** in mandates prohibiting exposure to certain industries
- **Emerging / specialized manager investments** targeting 1st, 2nd and 3rd time funds as well as minority, woman, LGBTQX and disabled veteran funds



Investment process

- All fund managers required to complete **ESG due diligence** questionnaire prior to PA commitment
- PA's primary investment team then assesses fund managers' incorporation of **ESG principles** in their:
 - (i) investment process
 - (ii) value creation process; and
 - (iii) reporting to Limited Partners

Committees

- Two specialized committees with a diversified range of employee participation across the firm:
 - **ESG Committee**
 - **Diversity & Inclusion Committee**
- Committees tasked with two goals:
 - (i) improving the firm's ESG and D&I policies
 - (ii) encouraging and promoting new initiatives

Social & community engagement



Providing vital food and help to individuals and families in our local community



Creating opportunities for all, with a focus on education, income and health



Fulfilling wish lists for local area children this holiday season

1. As of December 31, 2022, assets under management is measured as adjusted reported value plus unfunded commitment.

Team experience and track record



Dedicated secondaries team

Portfolio Advisors Global Secondaries



Stephen Sloan
Managing Director
Global Head, Secondaries
Co-Head, GP Secondaries



Patrick Gerbracht
Managing Director
Co-Head, LP Secondaries



Hugh Perloff
Managing Director
Co-Head, LP Secondaries



Justin Lux
Managing Director
Co-Head, LP Secondaries



Brian Mooney
Managing Director
Co-Head, GP Secondaries



Briac Houtteville
Managing Director
Head, Europe Secondaries



Michael Liu
Managing Director
Asia Secondaries



Jorge Rossello
Sr. Vice President



Weibo Xiong
Sr. Vice President



Patrick Brown
Vice President



John Kennelly
Vice President



Dalton Potts
Vice President



Jay Tufts
Vice President



Cameron Dewey
Sr. Associate



Eric Li
Sr. Associate



August Oberbeck
Sr. Associate



Michael Bacon
Associate



Niyi Kelani
Associate



Benedict Lee
Associate



Karl Obi
Associate



Hayley Parsons
Associate



Ben Weinstock
Associate



Anish Arumala
Analyst

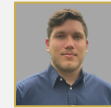

Ethan Butler
Analyst



Sam Jarvis
Analyst

Additional Secondaries Team Resources

Legal/Compliance

14 professionals

Marketing

14 professionals

Client Services

18 professionals

Finance

21 professionals

Administration

14 professionals

IT

5 professionals

Historical secondaries investment experience

- PA has executed more than **\$10.5B** of secondary transactions since **2002** across the spectrum of transaction types
- Within PASF I-IV, the average number of underlying funds is **>275** and the average number of underlying companies is **>3,400**
- PASF has generated strong returns over time **without relying on leverage to boost returns**

PASF secondaries track record (\$M)¹

Fund	Vintage Year	Fund Size	Contributions	Distributions	Reported Value	Gross			Net				
						DPI	TVPI	IRR	DPI	TVPI	Cash TVPI ²	IRR	Loss Ratio
PASF I	2008	\$1,128	\$1,021	\$1,833	\$8	1.8x	1.8x	16%	1.6x	1.7x	1.9x	13%	2.5%
PASF II	2012	\$910	\$797	\$1,272	\$104	1.6x	1.7x	19%	1.4x	1.6x	2.1x	15%	0.8%
PASF III	2016	\$1,518	\$1,512	\$1,489	\$1,267	1.0x	1.8x	23%	0.9x	1.7x	2.3x	19%	0.2%
PASF IV	2020	\$2,670	\$2,555	\$450	\$2,853	0.2x	1.3x	14%	0.0x	1.3x	1.3x	11%	0.7%
PASF V	2023	\$3,500 ³	\$269	\$-	\$354	-	1.3x	NM	-	1.3x	1.3x	NM	-

PASF historical value attribution¹

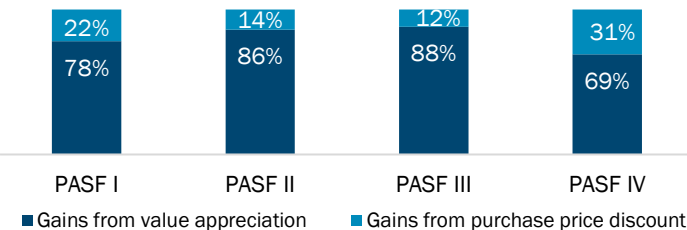

- While purchase price discount is an important contributor to value creation, most gains in the PASF portfolio are generated by appreciation in the underlying assets
- PA believes that investing in **high-quality companies managed by top-tier sponsors is the most sustainable path to value creation** over time

1. As of March 31, 2024. Past Performance is not a guarantee of future success. The Gross and Net Returns of other accounts and funds may be materially different from those shown herein. Please see the “Secondary Performance Endnotes” in the Appendix hereto for more information. Please see the defined terms in the “PASF Transaction Endnotes” in the Appendix hereto. Additional information available upon request. PASF V is young and unseasoned, and performance is not considered meaningful at this time.

2. Net Cash TVPI is a total value multiple (after expenses, taxes, management fees or carried interest borne by investors) calculated based on remaining value plus net distributions divided by net contributions. For this calculation, any contributions and distributions that are issued at the same time to investors are netted out, in effect, creating a net distribution or net contribution, but not both.

3. Represents the target fund size of PASF V.

Secondary market overview



PA's differentiated position in the secondary market

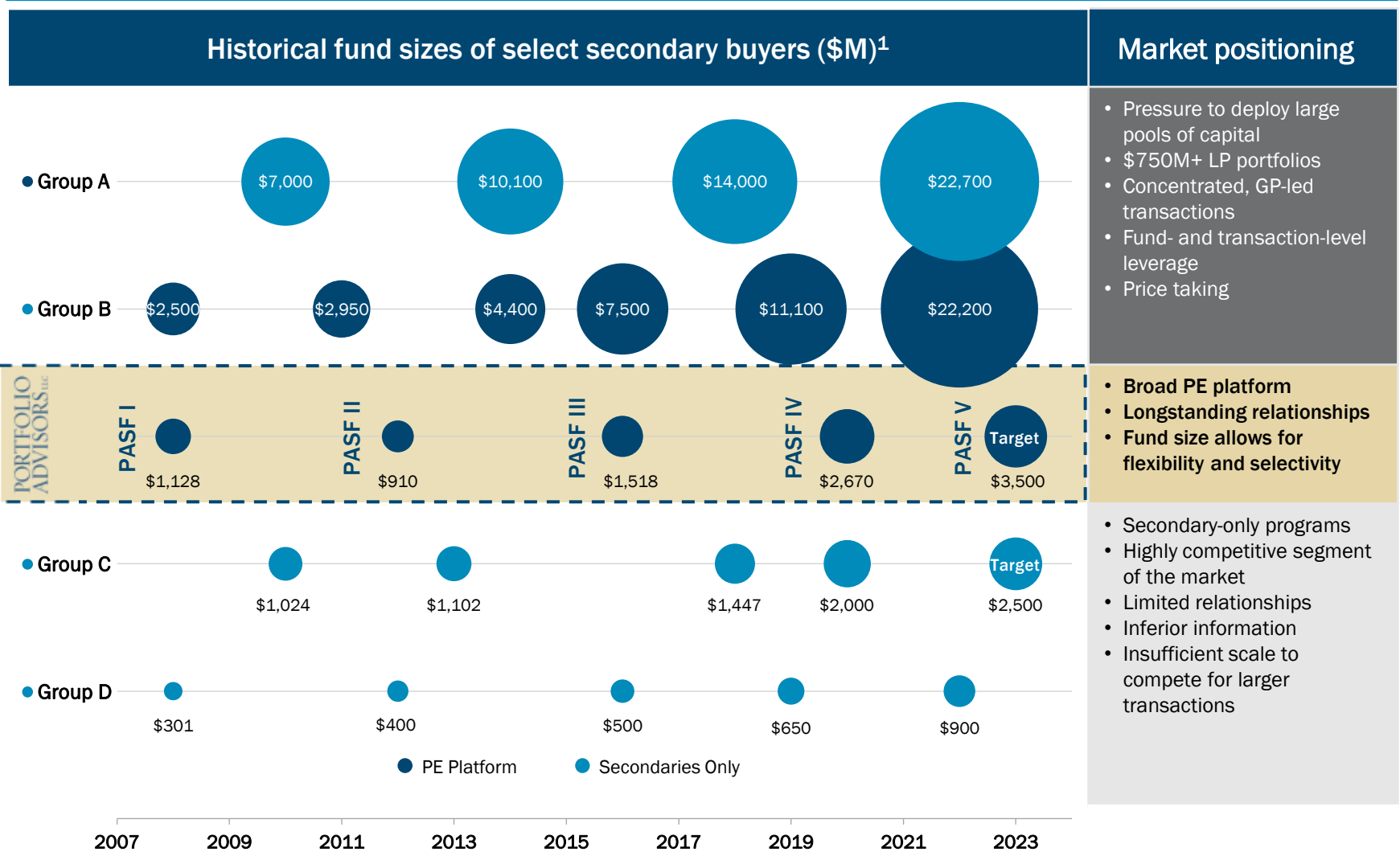

1. Sources: Preqin.com, last accessed June 2024, and Pitchbook.com, last accessed June 2024.

Note: Additional secondary funds and managers were in the market during the time period referenced above. Information on other managers is available upon request. Past performance is no guarantee of future success.

Secondary market growth provides attractive opportunities

Annual secondary market volume (\$B)

- H1 2024 volume was \$68 billion, surpassing the previous first half record of \$57 billion set in H1 2022.
- Market activity was robust, with LPs seeking liquidity across their portfolios and bringing larger and more diversified transactions to market.

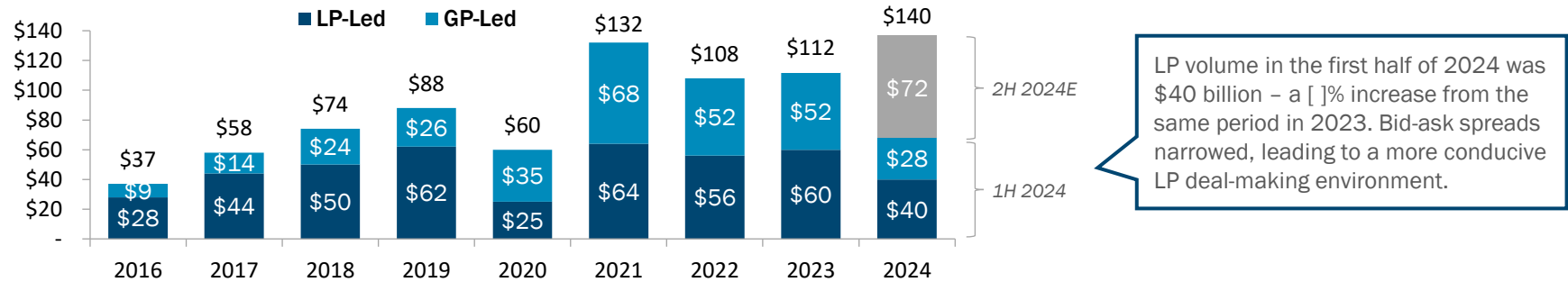

LP volume in the first half of 2024 was \$40 billion – a []% increase from the same period in 2023. Bid-ask spreads narrowed, leading to a more conducive LP deal-making environment.

PA's highly selective approach (\$M)

- As the growth of the secondary market accelerated over the last five years, many buyers increased fund sizes to record levels.
- PA's fund size and fee structure provide flexibility to selectively deploy capital (average market share of 1.0% since 2009).

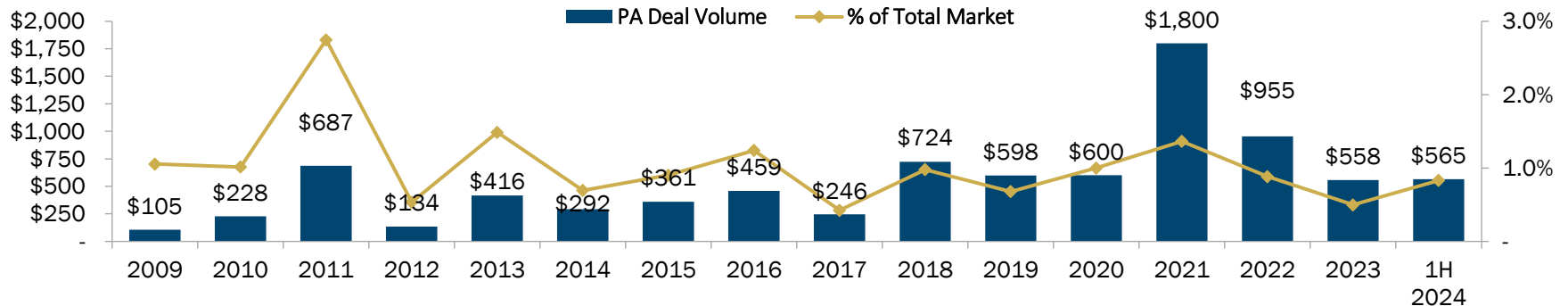

1. Historical volume and expected 2024 volume per Jefferies, "Global Secondary Market Review, July 2024".

Overallocation and liquidity issues persist for LPs

- Institutional investors with established alternatives programs are generally overallocated to private equity relative to targets. Concurrently, liquidity has dried up and is at a premium.

North American pension fund private-equity allocation²
(% above / (below) target allocation)

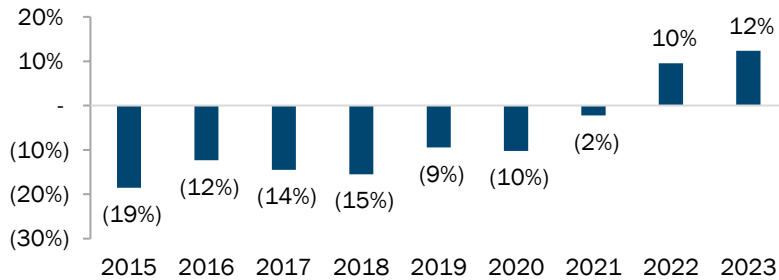

Limited partner net cash flows¹
(\$ in billions)

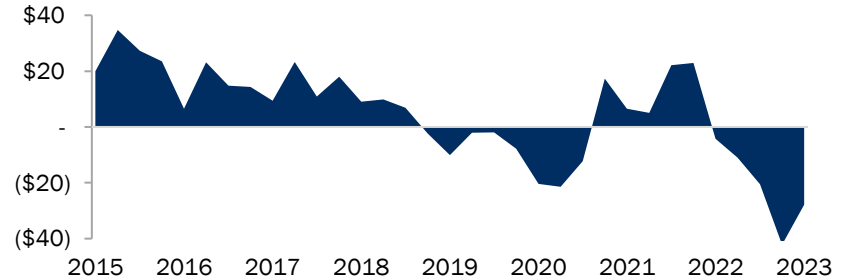

Options to address overallocation issues and access liquidity:

Sell public market exposure

- ✓ Solves liquidity issues
- ✗ Worsens denominator effect

Increase PE allocation threshold

- ✓ Solves private equity overallocation
- ✗ Worsens liquidity issues

Pause new commitments

- ✓ Solves private equity overallocation
- ✗ Does not generate new liquidity
- ✗ Leads to missed opportunities for outperformance

Selling private market exposure in the secondary market is a comprehensive solution that can solve both private equity overallocation and liquidity issues for LPs.

1. Per Capital IQ and MSCI Burgiss. As of December 31, 2023.

2. Per Preqin. As of December 31, 2023.

Market dislocation creates an opportunistic buyers' market

Types of deals LPs are pursuing to access liquidity

<p>Strip sales of select GPs</p>	<p>Sale of select assets to clear a dollar threshold</p>	<p>High quality funds alongside tail end interests</p>
<ul style="list-style-type: none"> Solves liquidity needs while maintaining GP relationship and upside potential. 	<ul style="list-style-type: none"> Solves liquidity needs while allowing buyers to maximize price on certain assets. 	<ul style="list-style-type: none"> Solves liquidity needs and helps clear portfolio at optically attractive pricing.

Pricing dislocation remains prevalent¹

- PASF V's current portfolio has an estimated effective purchase price of 77%² of NAV.
 - ~77% of the portfolio is buyout
 - ~78% of the investments are with existing sponsor relationships
- PA typically does not participate in the top end of the market which often consists of:
 - Price taking
 - Large cap funds
 - High deal level leverage
- The venture market is pricing well below historical levels.
 - PA views this as an opportunity and will strategically invest in venture funds at significant discounts

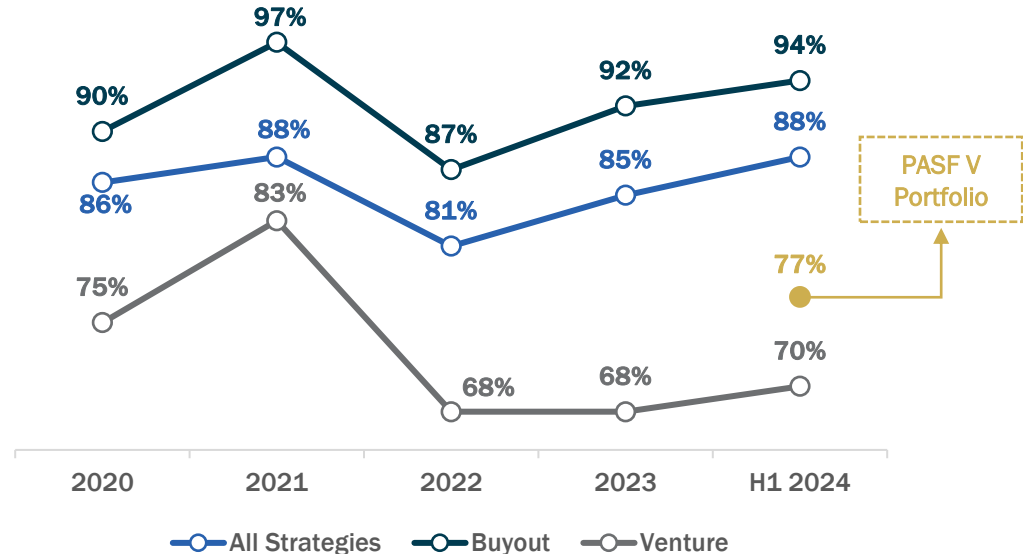

1. Source: Jefferies "Global Secondary Market Review, July 2024".
 2. Effective discount for deals closed after March 31, 2024, is estimated and has not yet been finalized.

Selectively executing transactions across market cycles

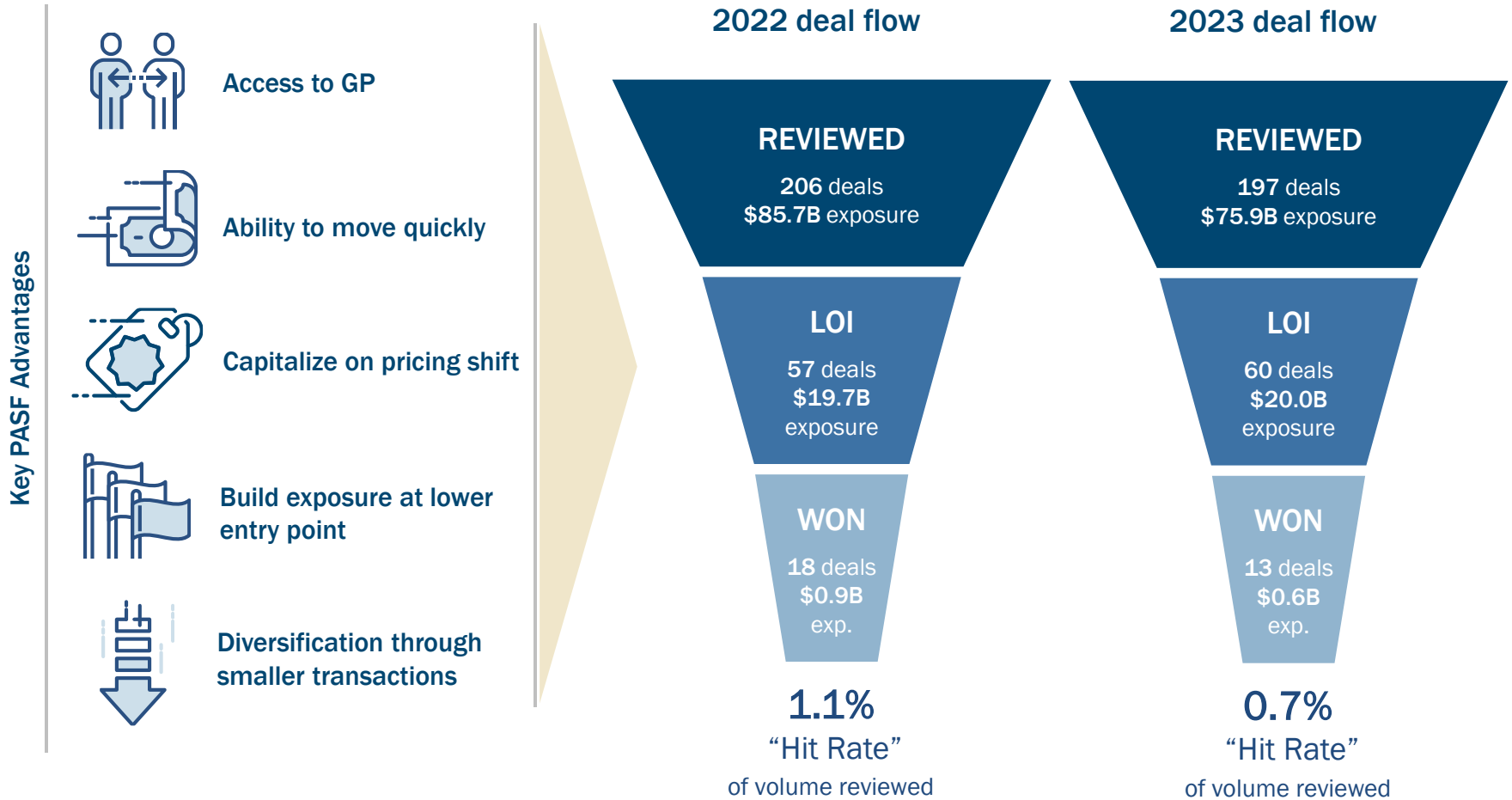

Consistent performance through economic cycles

- By maintaining its disciplined approach, PA seeks to achieve consistent returns **regardless of macroeconomic backdrop**.

PASF returns by investment vintage year¹

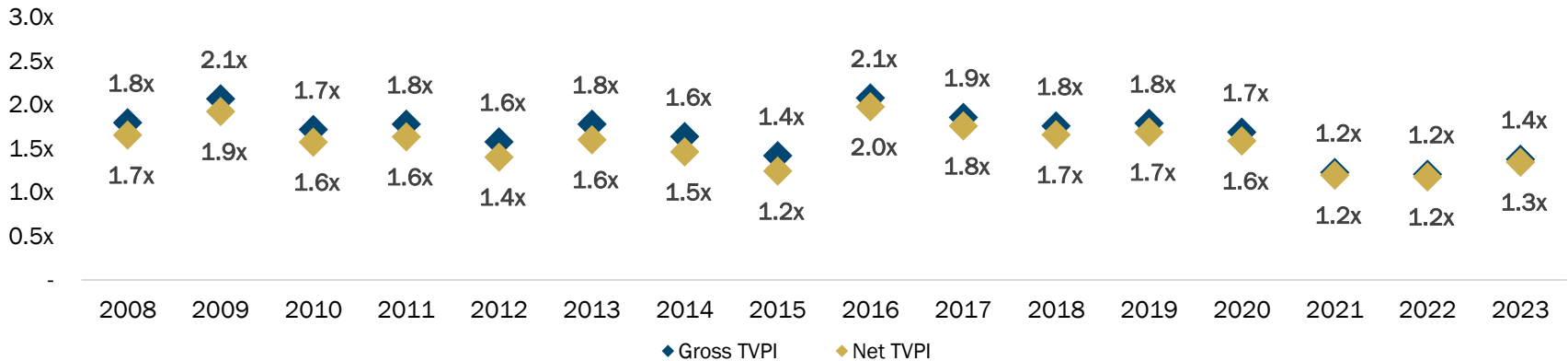

PASF III net multiple distribution (\$M)¹

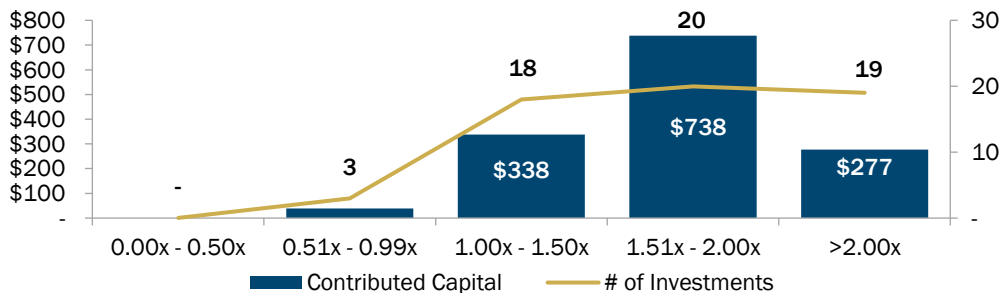

Commentary

- PASF III currently marked at a 1.8x gross TVPI and a 1.7x net TVPI.
- PASF III loss ratio: 0.2%.
- Investments representing 73% of contributed capital, are above a 1.50x net multiple.

1. As of March 31, 2024. Net returns for individual transactions and subtotals (sum of individual transactions) are estimations reflecting the difference between the Gross and Net returns in each relevant fund. Please see the "Secondary Performance Endnotes" as well as the Disclosure Statement, in the Appendix for additional information. Note: Past performance is not indicative of future results and there can be no assurance that the Fund will achieve comparable results and/or its investment objective. The returns for each investor in the Fund(s) may be materially different from those shown herein due to different fee schedules and timing on investment. This performance information is estimated and unaudited.

PASF V overview



PASF V target construction

Transaction type

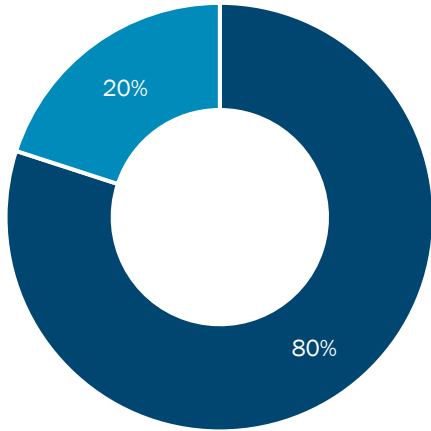

LP-Led Secondaries: 80%
GP-Led Secondaries: 20%

Geography

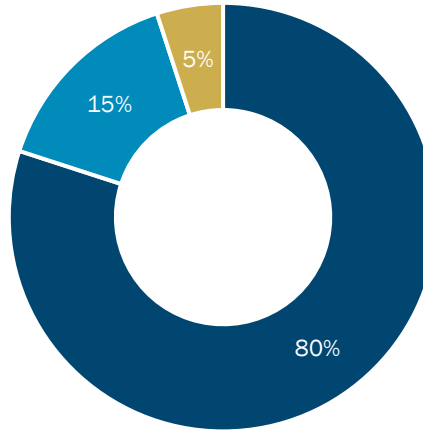

North America: 80%
Europe: 15%
Asia: 5%

Strategy

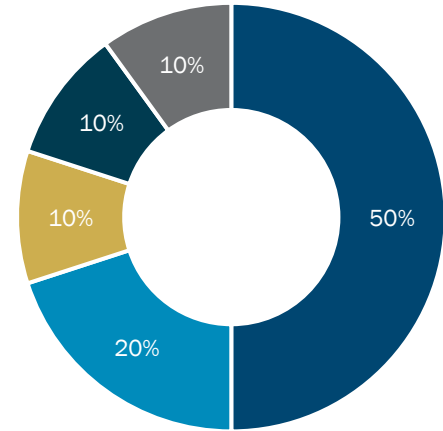

Middle Market Buyout: 50%
Growth / VC: 20%
Large Buyout: 10%
Special Situations / Distressed: 10%
Fund of Funds / Other: 10%

Note: Target allocations are shown for illustrative purposes only. The Fund's hypothetical portfolio composition based on current market conditions and potential investments evaluated by Portfolio Advisors. No assurance can be given that the Fund will have the same overall composition as shown above. The Fund's portfolio composition is subject to change anytime without notice as permitted by the Fund's offering and governing documents, as may be supplemented and amended.

PASF V portfolio construction

The PASF V initial portfolio consists of 18 transactions with high-quality sponsor relationships at attractive entry points.

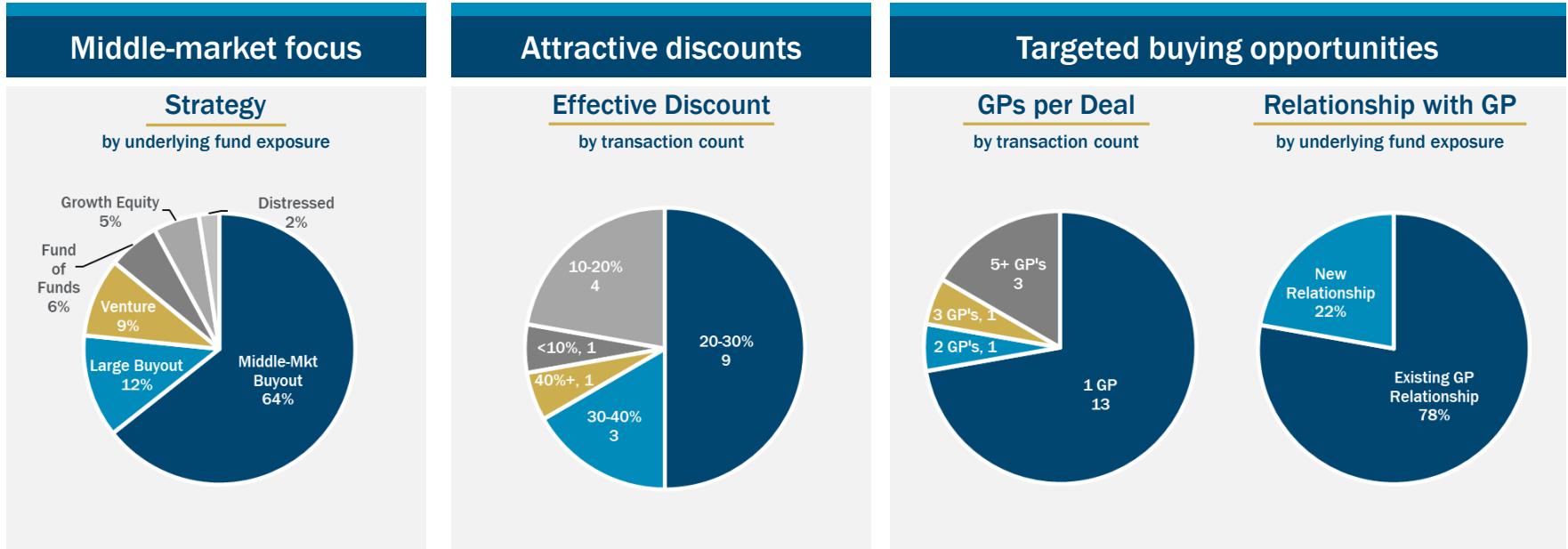

Select manager logos



Note: Past performance is not indicative of future results and there can be no assurance that the Fund will achieve comparable results and/or its investment objective. PASF V has closed on 18 deals to date, but there can be no assurance that they will close. Relationships shown represent the cross section of key GP relationships for the Secondaries sector. This is not an exclusive list and there is no guarantee that the fund will invest with one or more of these relationships in the future. No endorsement of PA has been made by any of the names shown herein.

PASF V portfolio

Transaction	# of Funds	Underlying Investments	Total Exposure (\$M) ¹	Type	% Funded At Close	Closing Date	Source	Headline Discount	Effective Discount	Gross TVPI ²	Net TVPI ²
Zipper	2	24	\$19.0	Buyout	87%	Dec-22	Limited Auction - Carve Out	14.0%	17.7%	1.27x	1.28x
Rady	1	5	\$15.3	Buyout	93%	Dec-22	Limited Auction - Carve Out	17.0%	33.5%	1.70x	1.71x
Chiron	3	19	\$16.7	Buyout	82%	Dec-22	Limited Auction - Carve Out	19.0%	20.5%	1.38x	1.39x
Sterling	2	29	\$17.5	Buyout	62%	Mar-23	Limited Auction - Carve Out	23.0%	22.0%	1.46x	1.47x
Taurus	1	9	\$10.1	Buyout	59%	Jun-23	Limited Auction - Carve Out	15.0%	21.9%	1.51x	1.52x
Georgian	1	29	\$10.8	Buyout	100%	Jun-23	Limited Auction - Carve Out	12.5%	20.6%	1.27x	1.28x
Saddle	4	14	\$26.8	Buyout	76%	Jun-23	Limited Auction - Carve Out	28.0%	27.7%	1.43x	1.44x
Viking	3	29	\$8.2	Mezzanine	92%	Sep-23	GP Directed	32.7%	32.3%	1.92x	1.93x
Thistle	6	35	\$17.0	Buyout	80%	Sep-23	Limited Auction - Carve Out	20.0%	21.4%	1.29x	1.30x
Electron	3	133	\$25.1	Fund of Funds	72%	Oct-23	Limited Auction - Carve Out	21.0%	24.9%	1.43x	1.44x
Lumberjack	9	107	\$23.7	Diversified	81%	Dec-23	Limited Auction - Carve Out	10.0%	15.0%	1.21x	1.22x
Amplify	1	22	\$20.5	Venture	100%	Dec-23	GP Directed	35.0%	44.6%	1.89x	1.90x
Lightning	2	12	\$59.7	Buyout	59%	Mar-24	Limited Auction - Carve Out	6.0%	8.9%	1.10x	1.11x
Star	1	17	\$7.6	Buyout	91%	Mar-24	Limited Auction - Carve Out	24.0%	23.2%	1.30x	1.31x
Cantaloupe	17	183	\$67.6	Diversified	85%	Mar-24	Limited Auction - Carve Out	17.0%	18.0% ³	1.23x	1.24x
Ocean	9	45	\$19.9	Diversified	91%	Mar-24	Limited Auction - Carve Out	30.0%	30.5% ³	1.59x	1.60x
Triton	3	18	\$23.3	Diversified	80%	Apr-24	Limited Auction - Carve Out	18.0%	26.0% ⁴	Reporting not yet available	
Niagara	1	10	\$22.5	Growth	60%	Jun-24	GP Directed	12.0%	12.0% ⁴	Reporting not yet available	
Total	69	740	\$411.2		78%			20.3%	23.1%	1.32x	1.33x

1. Total exposure in PASF V. Please see the defined term for "Total Exposure without adjustments" in the "Secondaries Transaction Endnotes" in the Appendix hereto.

2. As of March 31, 2024. Net returns for individual transactions are estimations reflecting the difference between the Gross and Net returns in PASF V. Please see the "Secondary Performance Endnotes" as well as the Disclosure Statement, in the Appendix for additional information. PASF V is young and unseasoned, and performance is not considered meaningful at this time.

3. Due to PTP issues, some funds in the underlying transaction have yet to close, so the effective discount is estimated and has not yet been finalized.

4. Effective discount for funds closed after March 31, 2024 is estimated and has not yet been finalized.

Note: Past performance is not indicative of future results and there can be no assurance that the Fund will achieve comparable results and/or its investment objective. The returns for each investor in the Fund(s) may be materially different from those shown herein due to different fee schedules and timing on investment. This performance information is estimated and unaudited.

PASF V key terms

Target Fund Size	Fee Structure	Fund Structures
\$3.5 billion	LP-friendly fee structure based on closed investments	Delaware (“Onshore”) vehicle, Cayman Islands (“Offshore”) vehicle, Luxembourg domiciled vehicle

PASF V Key Terms¹

Preferred Return	10.0% preferred return
Carried Interest	10.0% on net gains, payable only after full return of invested capital
GP Commitment	Minimum of 1.0% of total commitments

Management Fee	Series I Fees (Fees on invested capital)		Series II Fees (Fees on committed capital)	
	Investment Period (% of value of closed investments)	Thereafter (% of NAV of the Fund)	Investment Period (% of value of LP’s commitments)	Thereafter (% of NAV of the Fund)
Standard Fee Schedule	1.25%	1.25%	0.85%	1.25%
\$50M Commitment Discount	1.125%	1.125%	0.80%	1.125%
\$300M Commitment Discount	1.00%	1.00%	0.75%	1.00%

Note: See the PASF V LPA for complete details.

PA Secondaries strategy



The PASF mission

✓ Target transactions with favorable dynamics	47%	of deals sourced through a carve-out transaction	22%	of deals sourced in a broader auction process
✓ Utilize the full extent of the PA platform	76%	of closed investments represent existing sponsor relationships	31%	of deals exclusively sourced from GP or broker relationships
✓ Buy high-quality assets managed by top-tier sponsors	81%	of all PASF gains attributed to underlying value appreciation		
✓ Negotiate attractive effective discounts	20%	weighted average effective discount at entry for PASF I-IV secondary transactions		
✓ Construct a diversified underlying portfolio	1,200+	underlying funds in PASF I-IV	15,000+	underlying companies in PASF I-IV
✓ Manage downside and loss ratios	87 bps	loss ratio ¹ across all PASF vehicles	52 bps	loss ratio ¹ within latest four PASF vehicles
✓ Grow PASF responsibly to remain in the mid-market	~12%	total secondary volume annualized growth (2008 - 2023) ²	~8%	PASF fund size annualized growth ³

Note: As of March 31, 2024, unless otherwise specified. Past Performance is not a guarantee of future success.

1. Loss ratio calculated as loss (in dollars) of deals below 1.0x divided by total contributed capital (in dollars).

2. Calculated as secondary market volumes grew from \$20bn in 2008 to \$112bn in 2023 per Jefferies.

3. Calculated as PASF I (2008): \$1.1bn through PASF V target (2023): \$3.5bn.

PASF I-IV: Constructing highly-diversified portfolios

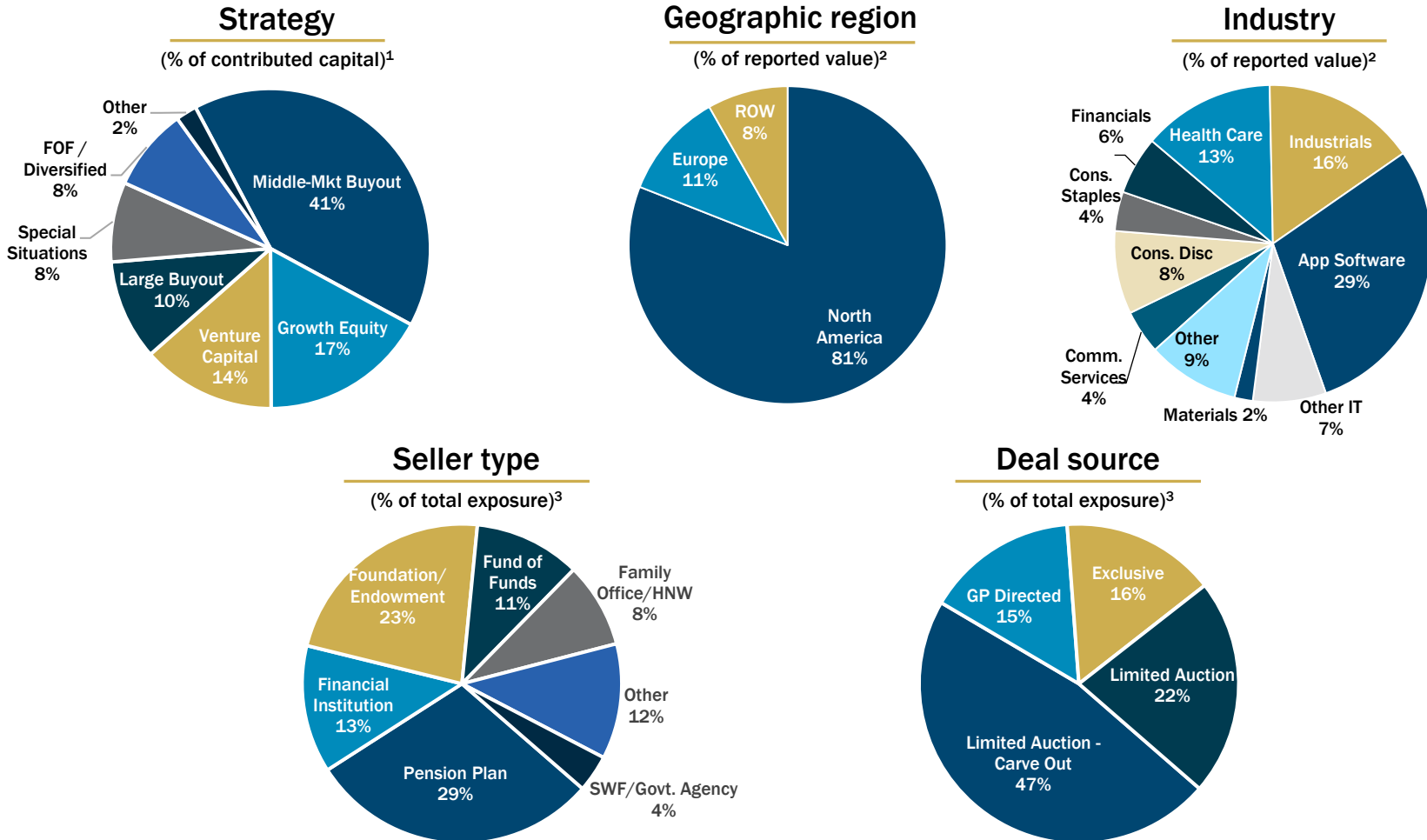

1. As of March 31, 2024. Please see the defined term for “Contributions” in the “PASF Transaction Endnotes” in the Appendix hereto.
 2. As of March 31, 2024. “Reported Value” reflects the value of PASF I-IV’s remaining underlying investments as of March 31, 2024, as reported on the underlying investments’ financial statements and includes co-investment transactions. As the foregoing chart presents the underlying investment industry and region composition of the remaining PASF I, III, III, and IV portfolio, note that the diversification percentages reported herein would differ if presented on the basis of ‘total exposure’ at the time each investment was made.
 3. As of March 31, 2024. Please see the defined term for “Total Exposure without adjustments” in the “PASF Transaction Endnotes” in the Appendix hereto.

Extensive general partner relationships

- 76% of closed investments represent existing sponsor relationships through our primary investing platform
- The 300+ GP relationships across the PA platform provide the secondaries team with both a higher probability of gaining transfer approvals and an information advantage to more accurately price and execute transaction

Select GP relationships



PA has longstanding relationships with top tier middle-market sponsors

Note: Relationships shown represent the cross section of key GP relationships for the Secondaries sector. This is not an exclusive list and there is no guarantee that the fund will invest with one or more of these relationships in the future. No endorsement of PA has been made by any of the names shown herein.

Targeting high-quality companies for risk-adjusted returns

Key investment criteria

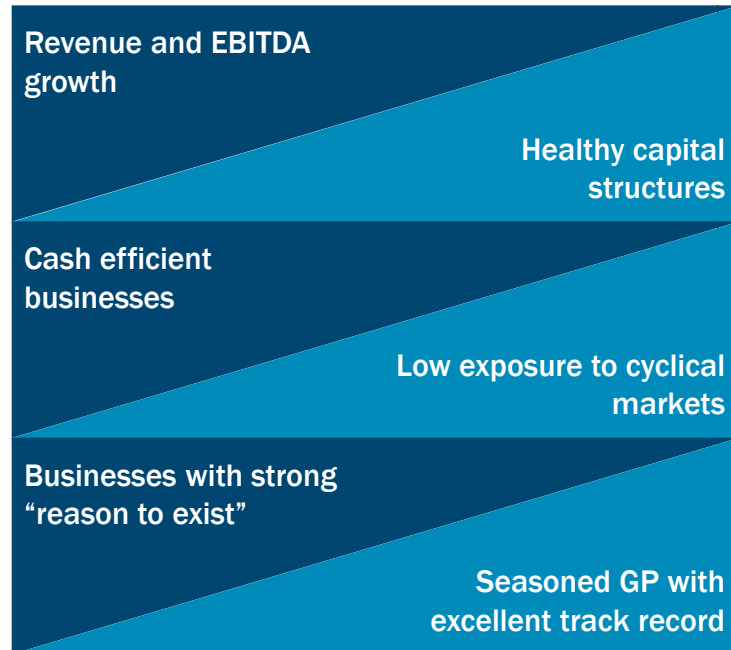

PASF targets investments in high-quality companies managed by top-tier sponsors at attractive entry prices

Value attribution analysis for seasoned funds

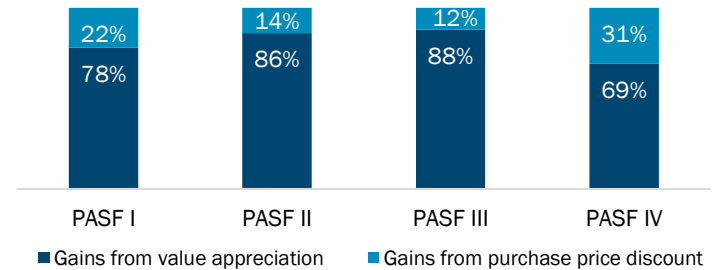

- PA believes that investing in **high-quality companies managed by top-tier sponsors** is the most sustainable path to value creation over time

Loss ratio analysis for seasoned funds

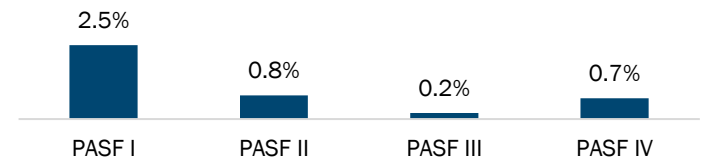

- PASF conservatively underwrites and selectively purchases assets at discounts, providing a significant cushion to **capital preservation**

Note: As of March 31, 2024. Past performance is not indicative of future results and there can be no assurance that the Fund will achieve comparable results and/or its investment objective. Please see the "Secondary Performance Endnotes" as well as the Disclosure Statement, in the Appendix for additional information. The returns for each investor in the Fund(s) may be materially different from those shown herein due to different fee schedules and timing on investment. This performance information is estimated and unaudited.

PASF V case studies



Project Zipper: restrictive carve out

Key Investment Data	
Closing Date	Dec. 2022
Total Exposure ⁽⁴⁾	\$19M
Sourcing	Limited Auction – Carve Out
Underlying Funds	2
Strategy	Buyout
Region	North America
Vintage Year	2016 – 2019

Highly Diversified Portfolio

Portfolio NAV by Vintage Year

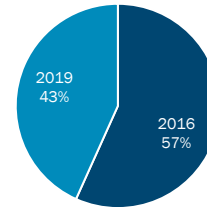

Portfolio NAV by Strategy

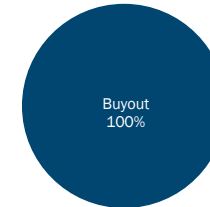

Portfolio NAV by Industry

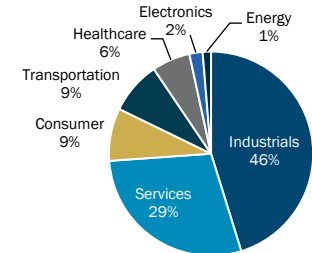

Portfolio Advisors Angle / Investment Rationale

Portfolio Advisors Sourcing Edge

- ✓ Restrictive Sponsor. Only two other competitors were approved to purchase the funds, so the seller was willing to carve them out from the broader transaction

Select Investment Rationale

- ✓ Information Advantage. PA is an existing investor in each of the funds in the portfolio and was able to conduct direct diligence with the sponsor, providing the firm with an information advantage
- ✓ Attractive Portfolio Composition. PA purchased a diversified portfolio of recent vintage buyout assets that are exhibiting significant growth and are conservatively held
- ✓ High-Quality Sponsor. PA has a longstanding relationship with the sponsor and has consistently supported its funds across the PA primary and directs platforms

Attractive Portfolio Composition

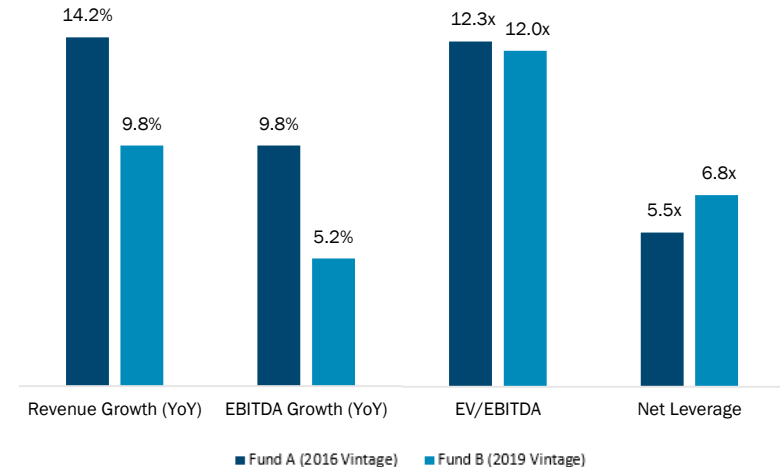

1. Please see the defined term for “Total Exposure without adjustments” in the “Secondaries Transaction Endnotes” in the Appendix hereto.

Project Rady: restrictive carve out

Key Investment Data

Closing Date	Dec. 2022
Total Exposure ⁽⁴⁾	\$15M
Sourcing	Limited Auction – Carve Out
Underlying Funds	1
Strategy	Buyout
Region	North America
Vintage Year	2014

Portfolio Advisors Angle / Investment Rationale

Portfolio Advisors Sourcing Edge

- ✓ *Restrictive Sponsor.* Only a few other competitors were approved to purchase the funds, so the seller was willing to carve them out from the broader transaction

Select Investment Rationale

- ✓ *High-Quality Sponsor.* PA has a longstanding relationship with the sponsor and benefited from a significant informational advantage during underwriting
- ✓ *Attractive Discount.* PA acquired the interest at an approximate net effective price of 66% of record date NAV, providing a sizable gain at close
- ✓ *Near-Term Liquidity.* The largest underlying company in the fund (25% of NAV) announced a partial sale at an uptick of value of 15%, which closed in Q1 2023

Effective Discount

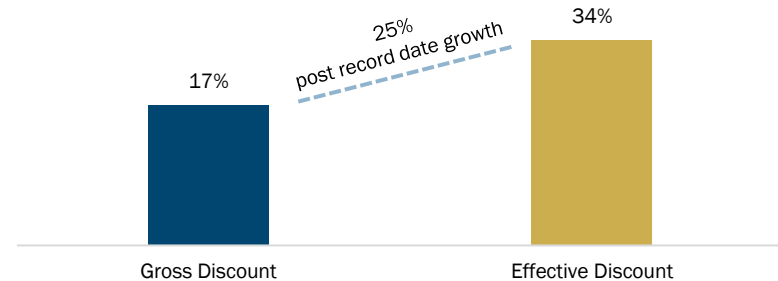

Attractive Portfolio Composition

Top Companies: Weighted Average Metrics

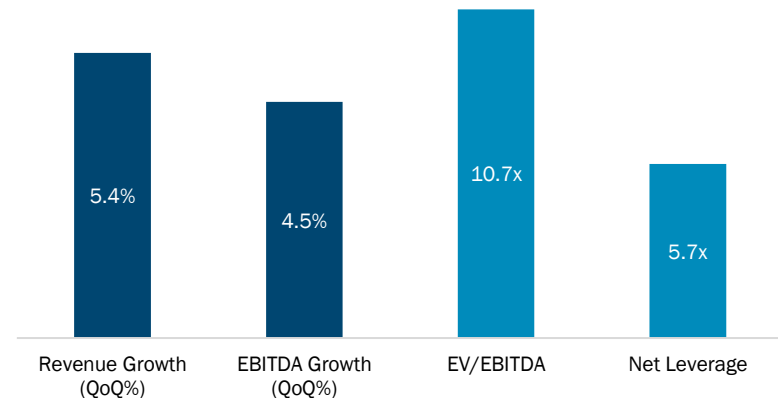

1. Please see the defined term for “Total Exposure without adjustments” in the “Secondaries Transaction Endnotes” in the Appendix hereto.

Project Chiron: restrictive carve out

Key Investment Data	
Closing Date	Dec. 2022
Total Exposure ⁽⁴⁾	\$17M
Sourcing	Limited Auction – Carve Out
Underlying Funds	3
Strategy	Buyout
Region	North America
Vintage Year	2008 – 2019

Highly Diversified Portfolio

Portfolio NAV by Vintage Year

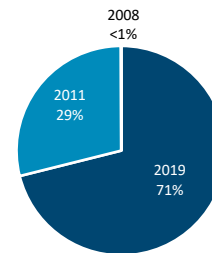

Portfolio NAV by Strategy

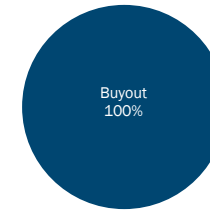

Portfolio NAV by Industry

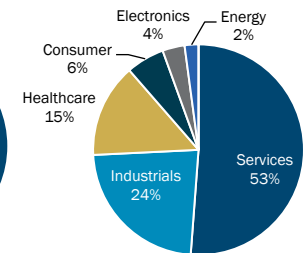

Portfolio Advisors Angle / Investment Rationale

Portfolio Advisors Sourcing Edge

- ✓ **Restrictive Sponsor.** Only two other competitors were approved to purchase the funds, so the seller was willing to carve them out from the broader transaction

Select Investment Rationale

- ✓ **Information Advantage.** PA is an existing investor in each of the funds in the portfolio and was able to conduct direct diligence with the sponsor, providing the firm with an information advantage
- ✓ **High-Quality Sponsor.** PA has a longstanding relationship with the sponsor and has consistently supported its funds across the PA primary and directs platforms
- ✓ **Attractive Discount.** PA purchased a diversified portfolio of growing buyout assets backed by a high-quality sponsor at an approximate net effective discount of 20%

Attractive Portfolio Composition

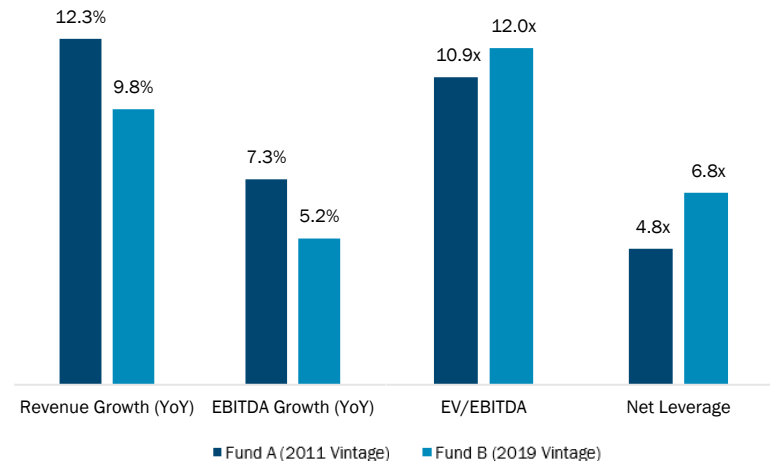

1. Please see the defined term for “Total Exposure without adjustments” in the “Secondaries Transaction Endnotes” in the Appendix hereto.

Project Sterling: limited auction carve out

Key Investment Data	
Closing Date	Mar. 2023
Total Exposure ⁽⁴⁾	\$18M
Sourcing	Limited Auction – Carve Out
Underlying Funds	2
Strategy	Buyout
Region	North America
Vintage Year	2017 – 2020

Portfolio Advisors Angle / Investment Rationale

Portfolio Advisors Sourcing Edge

- ✓ Carve Out Transaction. PA has an existing relationship with the sponsor, and the sale portfolio included an eclectic mix of strategies, which resulted in few buyers bidding on the portfolio as a whole

Select Investment Rationale

- ✓ High-Quality Sponsor. Top tier buyout sponsor, PA has acquired in the past
- ✓ Attractive Discount. PA acquired the portfolio at an approximate net effective price of 78% of record date NAV, providing a sizable gain at close
- ✓ Diversified Portfolio. The funds are diversified across 29 underlying investments, the largest of which only represents 12% of NAV
- ✓ High-Quality Underlying Assets. On a weighted average basis, the top nine portfolio companies generated 13% YoY revenue growth

1. Please see the defined term for “Total Exposure without adjustments” in the “Secondaries Transaction Endnotes” in the Appendix hereto.

2. Company H was a new investment and did not have financials at the time of purchase.

Highly Diversified Portfolio

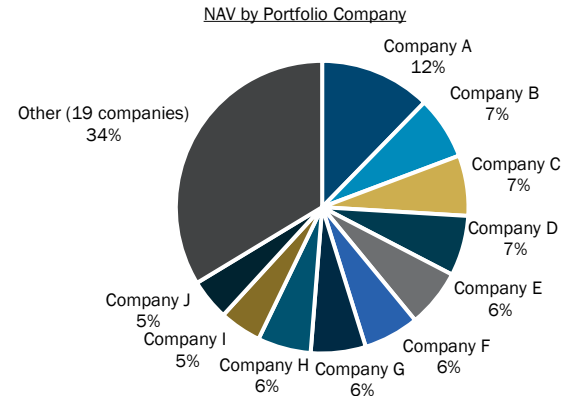

High-Quality Underlying Assets

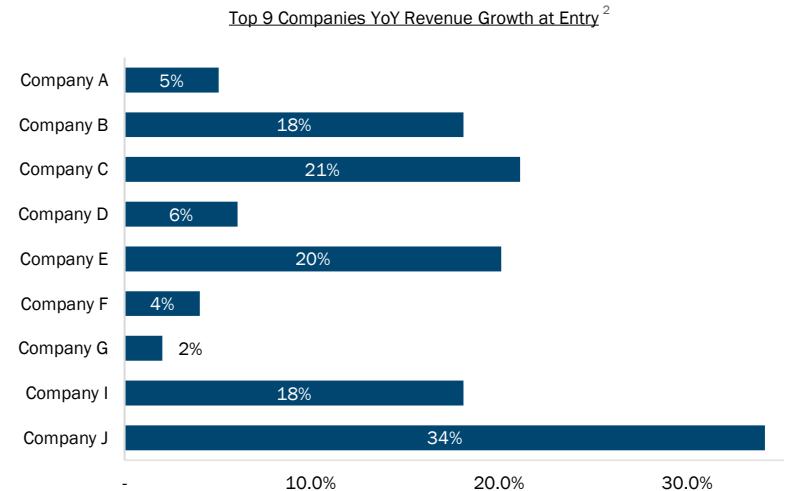

Project Taurus: restrictive carve out

Key Investment Data	
Closing Date	Jun. 2023
Total Exposure ⁽⁴⁾	\$10M
Sourcing	Limited Auction – Carve Out
Underlying Funds	1
Strategy	Buyout
Region	North America
Vintage Year	2019

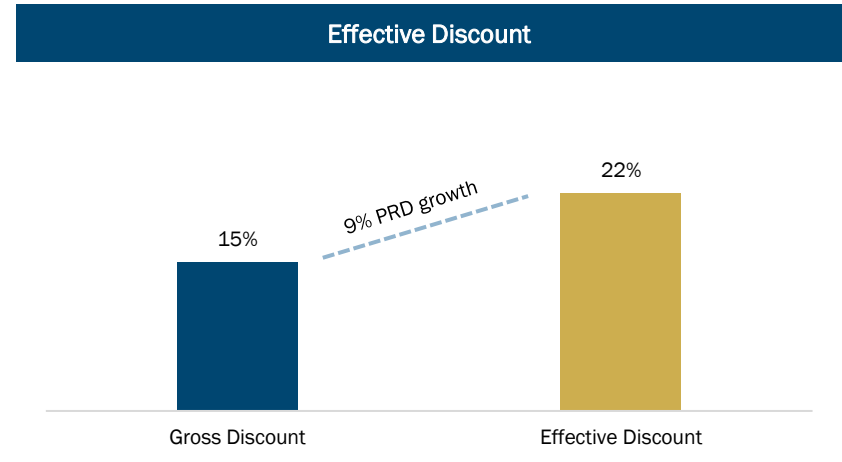

Portfolio Advisors Angle / Investment Rationale

Portfolio Advisors Sourcing Edge

- ✓ Restrictive Sponsor. The GP is very restrictive, and PA used its strong relationship with the GP to be one of the only buyers to obtain transfer approvals

Select Investment Rationale

- ✓ High-Quality Sponsor. PA has a longstanding relationship with the sponsor and benefitted from a significant informational advantage during underwriting
- ✓ Attractive Discount. PA acquired the interest at an approximate net effective price of 78% of record date NAV, providing a sizable gain at close
- ✓ High-Quality Underlying Assets. In the LTM period ended September 30, 2022, on a weighted average basis, the top six portfolio companies (87% of NAV) grew revenue 32% and grew EBITDA 37% compared to full year 2021

Attractive Portfolio Composition

Top Companies: Weighted Average Metrics

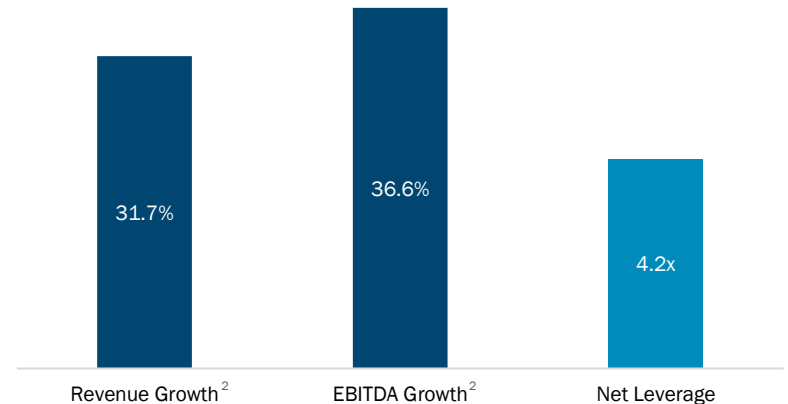

1. Please see the defined term for “Total Exposure without adjustments” in the “Secondaries Transaction Endnotes” in the Appendix hereto.

2. Revenue and EBITDA growth in the last twelve-month (LTM) period ended September 30, 2022 vs full year 2021.

Project Georgian: limited auction carve out

Key Investment Data	
Closing Date	Jun. 2023
Total Exposure ⁽⁴⁾	\$11M
Sourcing	Limited Auction – Carve Out
Underlying Funds	1
Strategy	Buyout
Region	North America
Vintage Year	2016

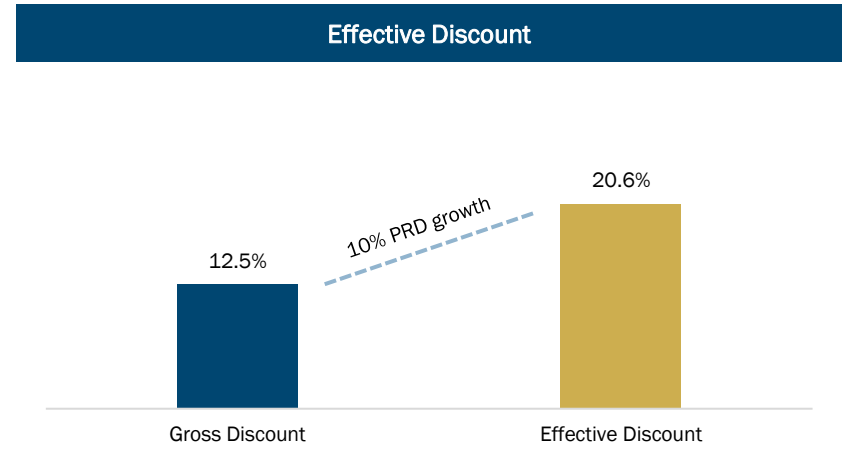

Portfolio Advisors Angle / Investment Rationale

Portfolio Advisors Sourcing Edge

- ✓ Access to Information. The seller did not provide underlying fund documents, and PA benefitted from access to information as an existing investor with the GP

Select Investment Rationale

- ✓ High-Quality Sponsor. PA has a longstanding relationship with the sponsor, which is considered a top tier buyout sponsor
- ✓ Attractive Discount. PA acquired the interest at an approximate net effective price of 79% of record date NAV, providing a sizable gain at closing
- ✓ High-Quality Underlying Assets. In the LTM period ended December 31, 2022, on a weighted average basis, the top 20 private portfolio companies (67% of NAV) grew revenue 9% and grew EBITDA nearly 11% compared to full year 2021

Attractive Portfolio Composition

Top 20 Private Companies (~67% of Portfolio NAV): Weighted Average Portfolio Metrics

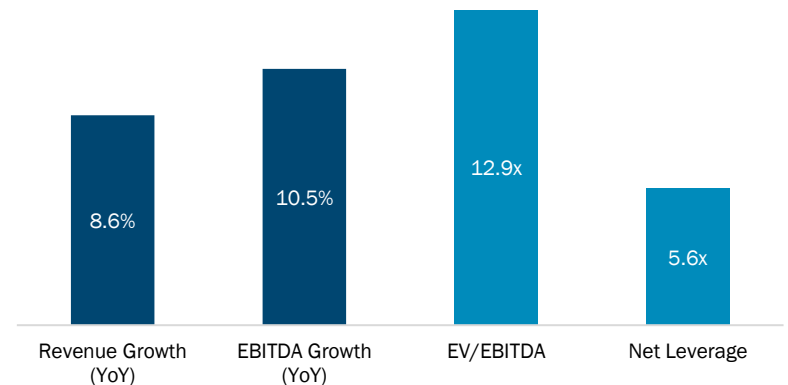

1. Please see the defined term for “Total Exposure without adjustments” in the “Secondaries Transaction Endnotes” in the Appendix hereto.

Project Saddle: restrictive carve out

Key Investment Data	
Closing Date	Jun. 2023
Total Exposure ⁽⁴⁾	\$27M
Sourcing	Limited Auction – Carve Out
Underlying Funds	4
Strategy	Buyout
Region	North America
Vintage Year	2016 – 2021

Attractive Portfolio Composition

Portfolio NAV by Vintage Year

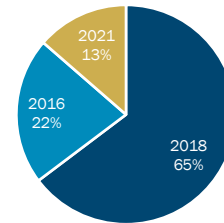

Portfolio NAV by Industry

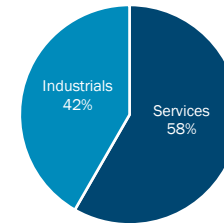

Portfolio NAV by Geography

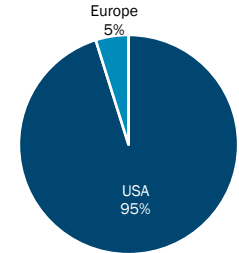

Portfolio Advisors Angle / Investment Rationale

Portfolio Advisors Sourcing Edge

- ✓ Carve Out Transaction. Only a few other competitors were approved to purchase the funds and PA was the only potential buyer to bid on this specific subset of funds

Select Investment Rationale

- ✓ Information Advantage. PA has a relationship with the sponsors and was able to conduct direct diligence with the sponsors, providing the firm with an information advantage
- ✓ Attractive Discount. PA acquired the portfolio at an approximate net effective price of 72% of record date NAV, providing a sizable gain at close
- ✓ High-Quality Underlying Assets. On a weighted average basis, the portfolio companies generated 14% YoY revenue growth as of Q1'23

High-Quality Underlying Assets

Top 10 Companies: YoY Revenue Growth at Entry

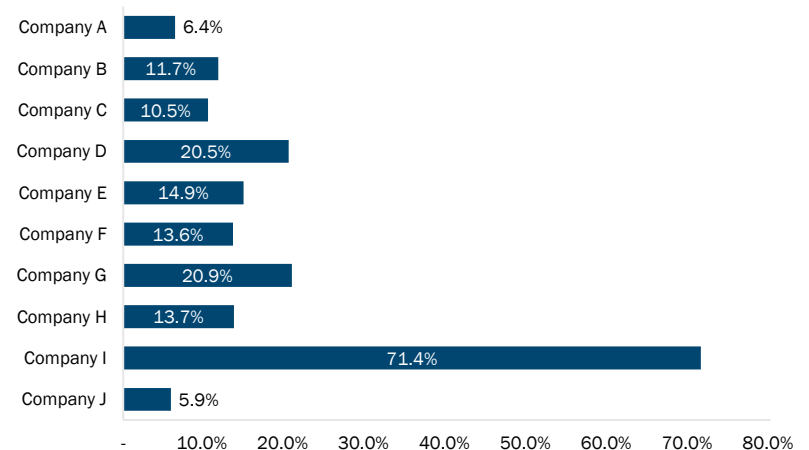

1. Please see the defined term for “Total Exposure without adjustments” in the “Secondaries Transaction Endnotes” in the Appendix hereto.

Project Viking: information advantage

Key Investment Data	
Closing Date	Sep. 2023
Total Exposure ⁽⁴⁾	\$8M
Sourcing	GP Directed
Underlying Funds	3
Strategy	Mezzanine
Region	North America
Vintage Year	2008 - 2023

Portfolio Advisors Angle / Investment Rationale

Portfolio Advisors Information Edge

- ✓ Access to Information. PA has a strong relationship with the broker in the process and obtained detailed information on the transaction dynamics as well as the underlying portfolio companies

Select Investment Rationale

- ✓ Large Transaction Discount. PA acquired the portfolio at an approximate headline price of 67% of Record Date NAV
- ✓ Attractive Risk/Reward Dynamic. Half of NAV is invested in sponsor-backed subordinated debt. Given the deal's size, it was priced with equity-like return expectations.
- ✓ Motivated Seller. The seller is required to divest all private equity and mezzanine exposure to its captive funds. The investment teams will be spun out into a separate business post-close.

Highly Diversified Portfolio

Portfolio Vintage by Total Exposure

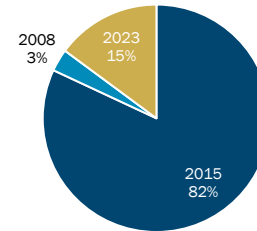

Portfolio NAV by Strategy

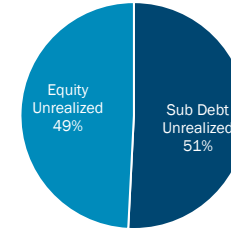

Portfolio NAV by Industry

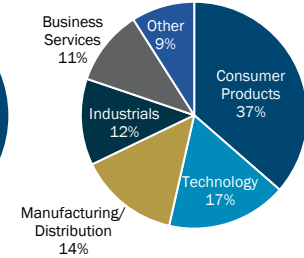

Attractive Portfolio Composition

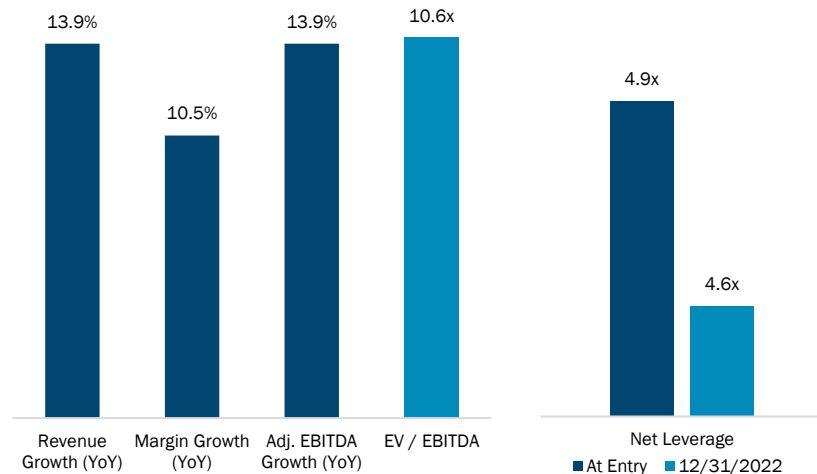

1. Please see the defined term for "Total Exposure without adjustments" in the "Secondaries Transaction Endnotes" in the Appendix hereto.

Project Thistle: limited auction carve out

Key Investment Data	
Closing Date	Sep. 2023
Total Exposure ⁽⁴⁾	\$17M
Sourcing	Limited Auction – Carve Out
Underlying Funds	6
Strategy	Buyout
Region	North America
Vintage Year	2013 - 2023

Attractive Portfolio Composition

Portfolio Vintage by Total Exposure

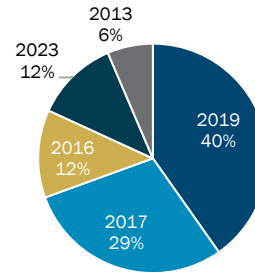

Portfolio NAV by Strategy

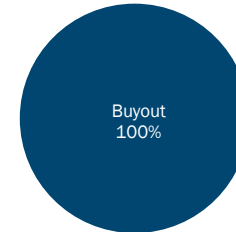

Portfolio NAV by Industry

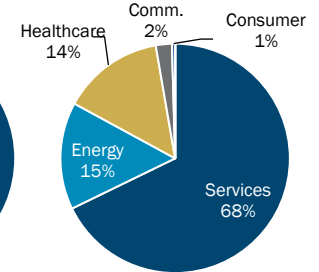

Portfolio Advisors Angle / Investment Rationale

Portfolio Advisors Sourcing Edge

- ✓ **Carve Out Transaction.** PA was the only buyer to bid on this specific subset of funds and leveraged the scope of the bid as well as certainty of quick closing to secure the assets

Select Investment Rationale

- ✓ **Information Advantage.** PA was able to conduct direct diligence with each sponsor, providing a strong informational advantage during underwriting
- ✓ **Attractive Discount.** PA is purchasing the fund at a headline price of 80% of Record Date NAV, which provides a sizable gain at close
- ✓ **High-Quality Underlying Assets.** In the latest available period, on a weighted average basis, the top portfolio companies (70% of NAV), grew revenue and EBITDA 19% and 23%, respectively

High-Quality Underlying Assets

Top Companies: Weighted Average Metrics

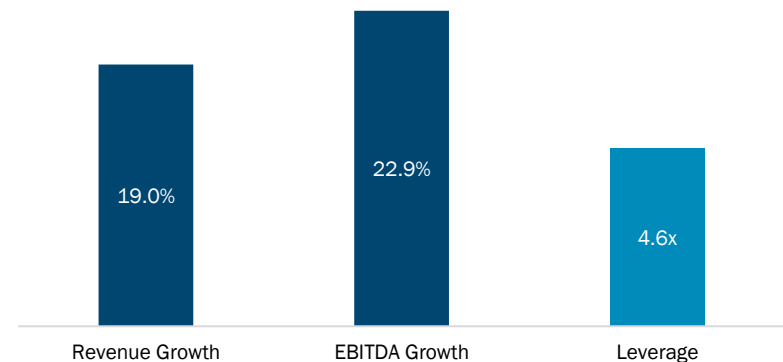

1. Please see the defined term for “Total Exposure without adjustments” in the “Secondaries Transaction Endnotes” in the Appendix hereto.

Project Electron: restrictive carve out

Key Investment Data	
Closing Date	Sep. 2023
Total Exposure ⁽⁴⁾	\$25M
Sourcing	Limited Auction – Carve Out
Underlying Funds	3
Strategy	Fund of Funds
Region	Europe
Vintage Year	2014 - 2017

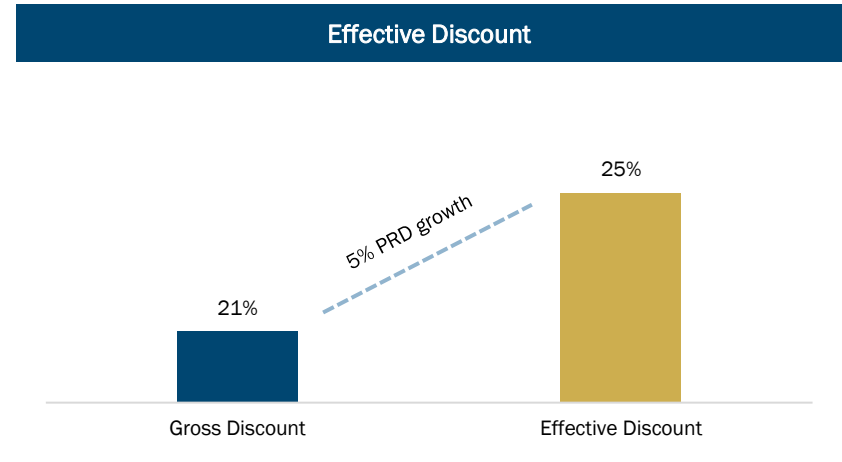

Portfolio Advisors Angle / Investment Rationale

Portfolio Advisors Sourcing Edge

- ✓ Carve Out Transaction. The GP (fund of funds manager) is highly restrictive, and PA leveraged its relationship to be one of the only buyers approved, hence limiting competition

Select Investment Rationale

- ✓ High-Quality, Diversified Exposure. Exposure to ~133 mid-market companies held through high-quality European mid-market managers
- ✓ Strong Near Term Cash Flow Visibility. Several of the portfolio companies are involved in ongoing sale processes with a large proportion of proceeds expected to be distributed in 2024/2025
- ✓ Information Advantage. Owing to its relationship, PA was able to conduct multiple diligence calls with the GP and gain an information advantage

Attractive Portfolio Composition

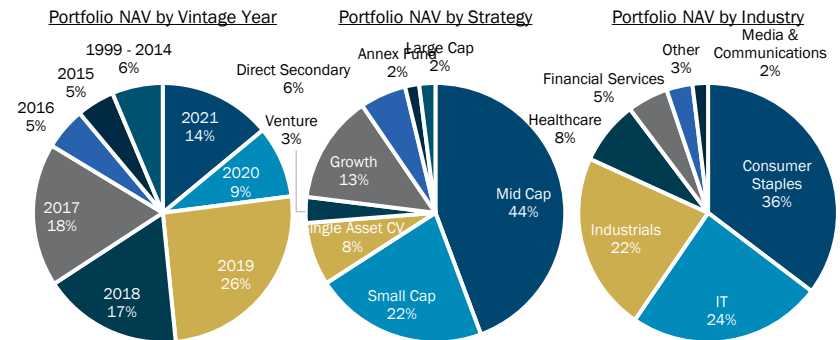

1. Please see the defined term for “Total Exposure without adjustments” in the “Secondaries Transaction Endnotes” in the Appendix hereto.

Project Lumberjack: limited auction carve out

Key Investment Data	
Closing Date	Dec. 2023
Total Exposure ⁽⁴⁾	\$24M
Sourcing	Limited Auction – Carve Out
Underlying Funds	9
Strategy	Diversified
Region	North America
Vintage Year	2008 - 2022

Attractive Portfolio Composition

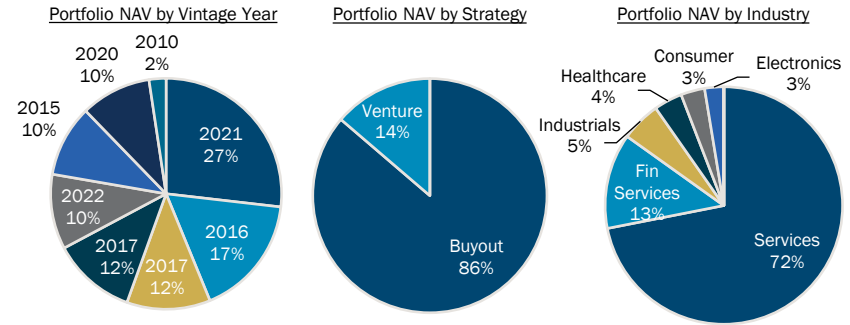

Portfolio Advisors Angle / Investment Rationale

Portfolio Advisors Sourcing Edge

- ✓ **Carve Out Transaction.** PA benefitted from its existing relationships with the GPs and its ability to work quickly towards a near-term close

Select Investment Rationale

- ✓ **Information Advantage.** PA was able to conduct direct diligence with key sponsors (over 70% of NAV), providing a strong informational advantage during underwriting
- ✓ **High-Quality, Diversified Exposure.** Exposure to ~107 underlying buyout and venture assets diversified across seven high-quality sponsors
- ✓ **Strong Momentum.** Revenue and EBITDA for the top portfolio companies is projected to grow approximately 21% and 49%, respectively in FY 2023

High-Quality Underlying Assets

Top Companies: Weighted Average Metrics

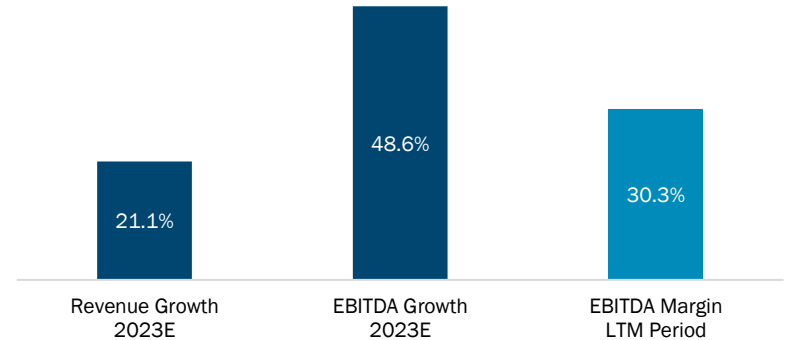

1. Please see the defined term for “Total Exposure without adjustments” in the “Secondaries Transaction Endnotes” in the Appendix hereto.

Project Amplify: GP relationship

Key Investment Data	
Closing Date	Dec. 2023
Total Exposure ⁽⁴⁾	\$20M
Sourcing	GP Directed
Underlying Funds	1
Strategy	Venture
Region	North America
Vintage Year	2009

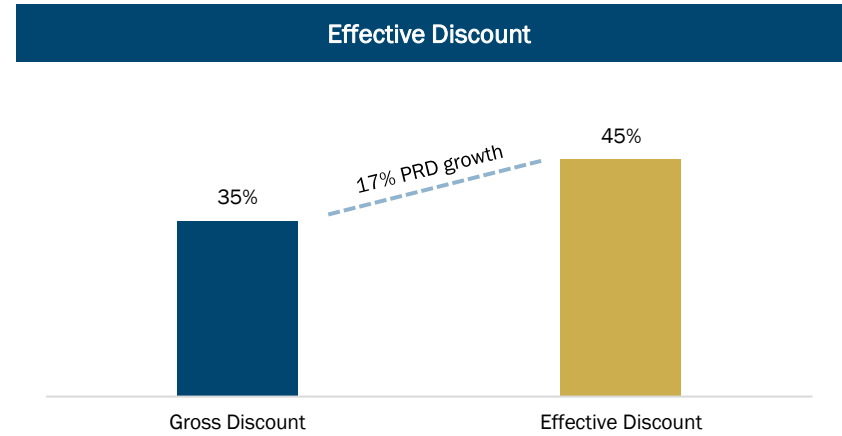

Portfolio Advisors Angle / Investment Rationale

Portfolio Advisors Information Edge

- ✓ Access to Information. As an existing investor with the GP, PA received direct access to the GP's investment team throughout due diligence and conducted reference calls with other sponsors and companies

Select Investment Rationale

- ✓ High-Quality Sponsor. PA has a longstanding relationship with the sponsor which is considered a top tier growth GP
- ✓ Attractive Discount. PA believes it is purchasing the interest at an approximate net effective price of 55% of record date NAV, which would provide a sizable gain at close
- ✓ Growth Profile. Attractive portfolio of companies with the top portfolio companies (85% of NAV) generating weighted average revenue growth of 79% YoY

High-Quality Underlying Assets

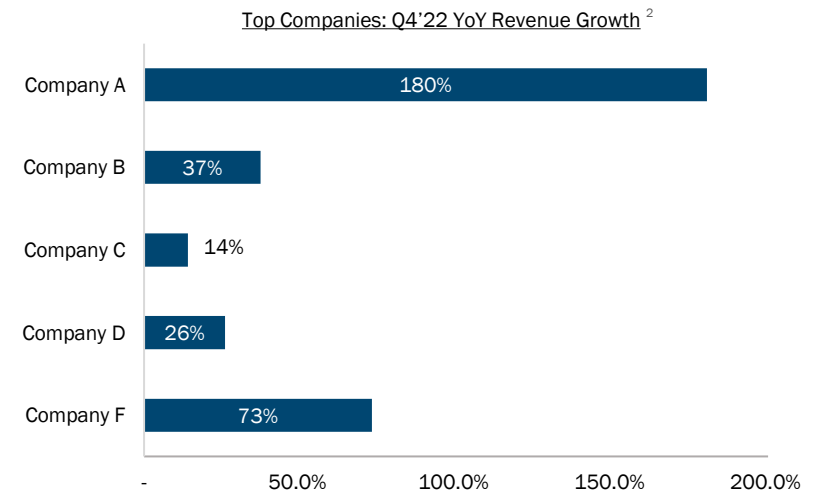

1. Please see the defined term for "Total Exposure without adjustments" in the "Secondaries Transaction Endnotes" in the Appendix hereto.

2. Company E was sold in Q4'22 and financials were not made available for FY 2022.

Project Lightning: restrictive carve out

Key Investment Data	
Closing Date	Mar. 2024
Total Exposure ⁽⁴⁾	\$60M
Sourcing	Limited Auction – Carve Out
Underlying Funds	2
Strategy	Buyout
Region	North America
Vintage Year	2019 - 2024

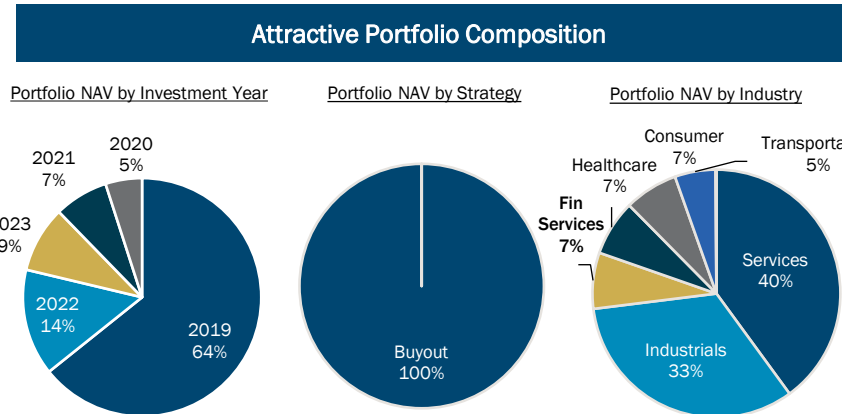

Portfolio Advisors Angle / Investment Rationale

Portfolio Advisors Sourcing Edge

- ✓ **Restrictive Sponsor.** The GP is very restrictive, and PA used its strong relationship with the GP to be one of the only buyers to obtain transfer approvals

Select Investment Rationale

- ✓ **Information Advantage.** PA is an existing investor and was able to conduct direct diligence with the sponsor, providing the firm with an information advantage
- ✓ **High-Quality Sponsor.** PA has a longstanding relationship with the sponsor and has consistently supported its funds across the PA primary and directs platforms
- ✓ **Strong Momentum.** In the LTM period ended December 31, 2023, on a weighted average basis, the top ten portfolio companies grew revenue 16% and grew EBITDA 8%. In addition, the top asset (33% of Record Date NAV) is in a sale process

High-Quality Underlying Assets

Top Companies: Weighted Average Metrics

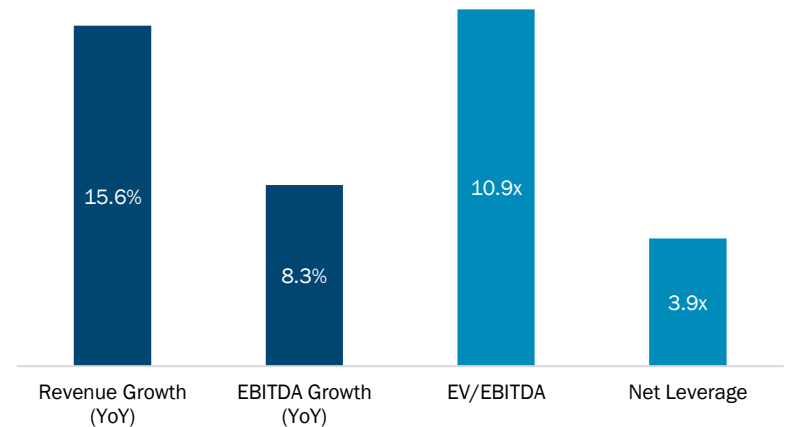

1. Please see the defined term for “Total Exposure without adjustments” in the “Secondaries Transaction Endnotes” in the Appendix hereto.

Project Cantaloupe: limited auction carve out

Key Investment Data	
Closing Date	Mar. 2024
Total Exposure ⁽⁴⁾	\$68M
Sourcing	Limited Auction – Carve Out
Underlying Funds	17
Strategy	Buyout / Venture
Region	North America
Vintage Year	2005 – 2019

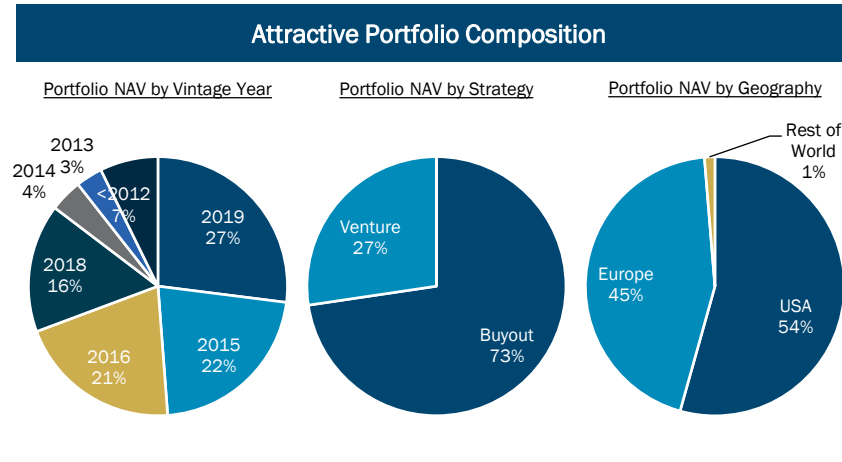

Portfolio Advisors Angle / Investment Rationale

Portfolio Advisors Sourcing Edge

- ✓ Carve Out Transaction. PA has existing relationships with the five sponsors purchased in Project Cantaloupe and benefitted from the scale of its sponsor relationships in the overall transaction

Select Investment Rationale

- ✓ Information Advantage. PA was able to conduct direct diligence with each of the five sponsors, providing a strong informational advantage during underwriting
- ✓ High-Quality, Diversified Exposure. Exposure to 183 underlying buyout and venture assets diversified across five high-quality sponsors, with the largest asset representing just 4.9% of NAV
- ✓ Attractive Composition. The Portfolio is comprised of predominantly private assets based in the US and Europe, insulating the transaction from public market volatility and diversifying end market exposure

High-Quality Underlying Assets

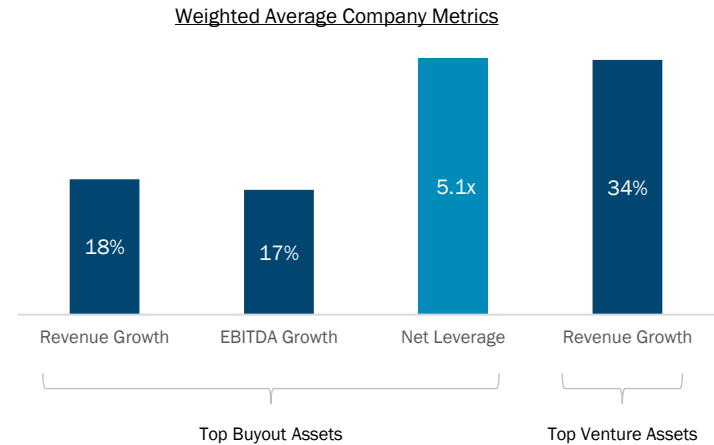

1. Please see the defined term for “Total Exposure without adjustments” in the “Secondaries Transaction Endnotes” in the Appendix hereto.

Project Star: restrictive carve out

Key Investment Data	
Closing Date	Mar. 2024
Total Exposure ⁽⁴⁾	\$8M
Sourcing	Limited Auction – Carve Out
Underlying Funds	1
Strategy	Buyout
Region	North America
Vintage Year	2016

Portfolio Advisors Angle / Investment Rationale

Portfolio Advisors Sourcing Edge

- ✓ Restrictive Sponsor. PA was one of very few buyers approved to purchase the interest and competed against only one other bidder in the second round

Select Investment Rationale

- ✓ Strong Near-Term Cash Flow Visibility. ~40% of NAV is expected to be realized this year owing to ongoing exit processes and sales that are pending closing
- ✓ Attractive Discount. PA purchased the interest at a 24% headline discount to record date NAV, providing a sizeable gain at close. Additional liquidity is expected shortly after closing
- ✓ High-Quality Underlying Assets. On a weighted average basis, the top ten portfolio companies have grown revenue and EBITDA at 3-year CAGRs of 15% and 13% respectively

Highly Diversified Portfolio

Portfolio NAV by Investment Year

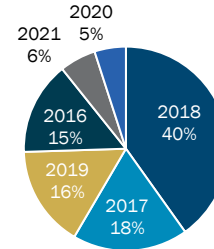

Portfolio NAV by Strategy

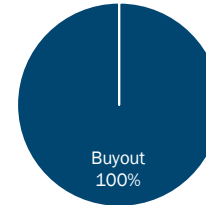

Portfolio NAV by Industry

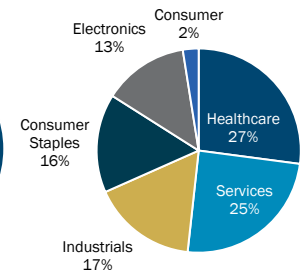

Attractive Portfolio Composition

Top Companies: 3-Year Revenue CAGR at Entry

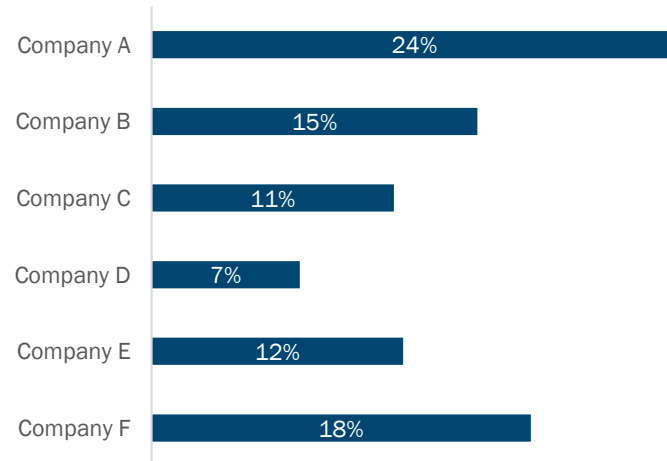

1. Please see the defined term for “Total Exposure without adjustments” in the “Secondaries Transaction Endnotes” in the Appendix hereto.

Project Ocean: limited auction carve out

Key Investment Data	
Closing Date	Mar. 2024
Total Exposure ⁽⁴⁾	\$20M
Sourcing	Limited Auction – Carve Out
Underlying Funds	9
Strategy	Diversified
Region	North America / Europe
Vintage Year	2008 - 2017

Portfolio Advisors Angle / Investment Rationale

Portfolio Advisors Sourcing Edge

- ✓ Carve Out Transaction. PA benefitted from its existing relationships with the GPs and its ability to work quickly towards a near-term close

Select Investment Rationale

- ✓ Attractive Discount. PA is purchasing the interest at a headline price of 70% of record date NAV, which would provide a sizable gain at close
- ✓ High-Quality, Diversified Exposure. Exposure to ~45 underlying buyout assets diversified across six high-quality sponsors
- ✓ Strong Momentum. On a weighted average basis, the top 10 companies (64.6% of NAV) increased 2023 revenues and EBITDA by 19.5% and 24.8% year over year respectively

Attractive Portfolio Composition

Portfolio NAV by Vintage Year

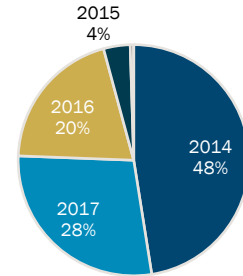

Portfolio NAV by Industry

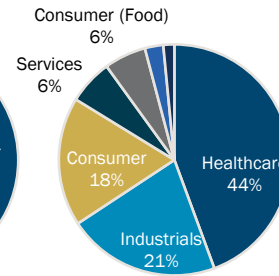

Portfolio NAV by Strategy

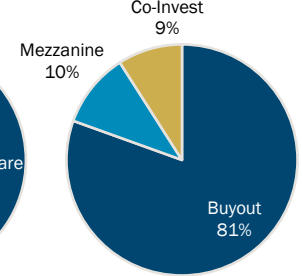

High-Quality Underlying Assets

Top Companies: Weighted Average Metrics

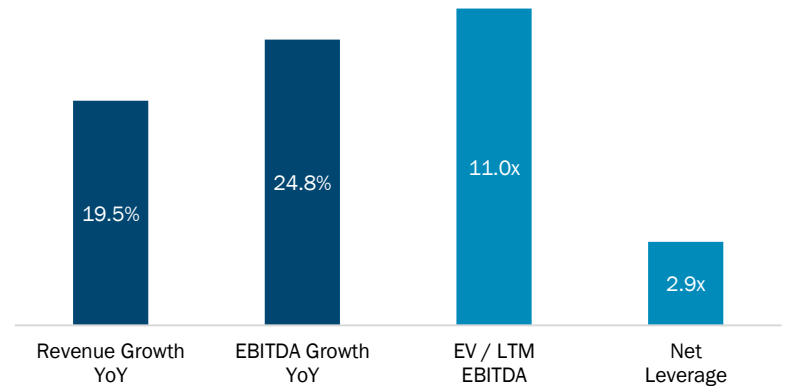

1. Please see the defined term for “Total Exposure without adjustments” in the “Secondaries Transaction Endnotes” in the Appendix hereto.

Project Triton: GP directed

Key Investment Data	
Closing Date	May 2024
Total Exposure ⁽⁴⁾	\$23M
Sourcing	GP Directed
Underlying Funds	3
Strategy	Co-investment
Region	North America
Vintage Year	2014 - 2024

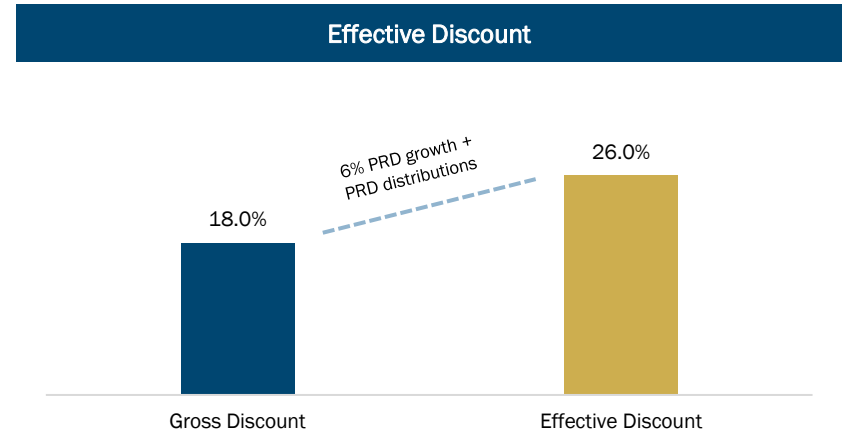

Portfolio Advisors Angle / Investment Rationale

Portfolio Advisors Sourcing Edge

- ✓ Limited Auction. PA benefitted from limited competition in the process and leveraged the scale of the bid as well as certainty of quick closing to secure the assets

Select Investment Rationale

- ✓ Attractive Discount. PA believes it is purchasing the interest at an approximate net effective price of 74% of record date NAV, which would provide a sizable gain at close
- ✓ Strong Near Term Cash Flow Visibility. 15% of Record Date NAV was distributed PRD and through due diligence, PA identified two near-term exits in the portfolio, which includes the largest asset
- ✓ Strong Momentum. On a weighted average basis, the top 10 value drivers in the portfolio (96% of NAV) generated weighted average YTD revenue and EBITDA growth of 16% and 23%, respectively

High-Quality Underlying Assets

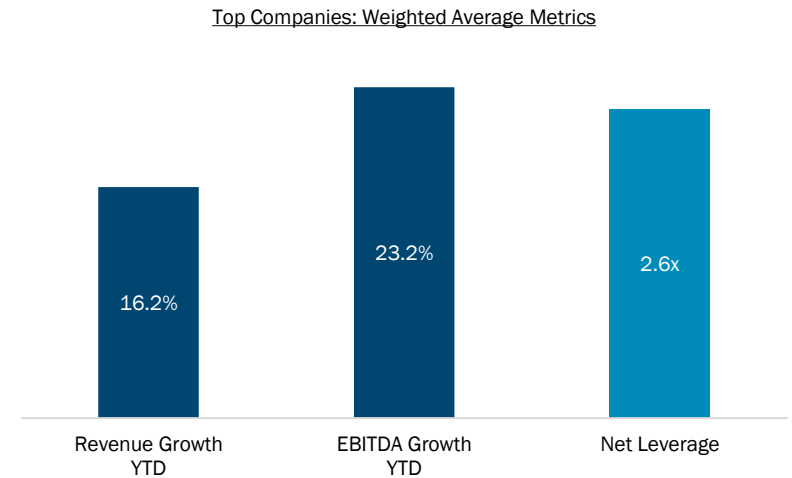

1. Please see the defined term for "Total Exposure without adjustments" in the "Secondaries Transaction Endnotes" in the Appendix hereto.

Project Niagara: GP directed

Key Investment Data	
Closing Date	Jun. 2024
Total Exposure ⁽⁴⁾	\$23M
Sourcing	GP Directed
Underlying Funds	1
Strategy	Growth Equity
Region	North America
Vintage Year	2023

Portfolio Advisors Angle / Investment Rationale

Portfolio Advisors Sourcing Edge

✓ Close Sponsor Relationship. PA benefitted from its close relationship with the Sponsor and was approached directly to purchase a targeted portfolio of secondary investments in high-growth assets at a discount

Select Investment Rationale

- ✓ Targeted Portfolio. The portfolio is the result of significant curation and negotiation by the Sponsor, who was highly selective in sourcing the portfolio through privately negotiated secondary sales
- ✓ Attractive Entry Point. The entry price into the companies represents an 32% headline discount to each company's most recent financing round and a significant discount to public peers
- ✓ High Quality Investor Syndicates. the companies within the portfolio are backed by other high-quality venture and growth investors with established track records

Attractive Entry Point

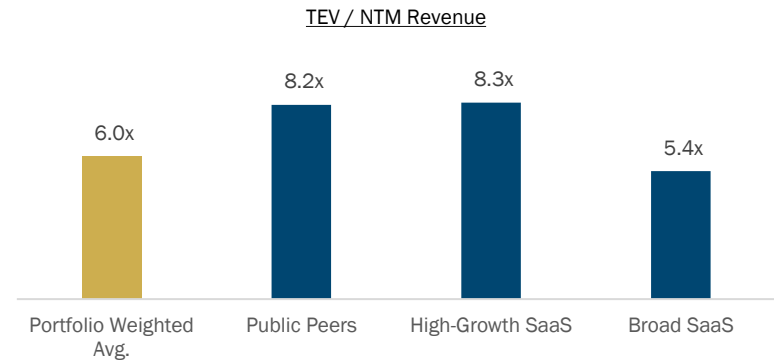

High-Quality Underlying Assets

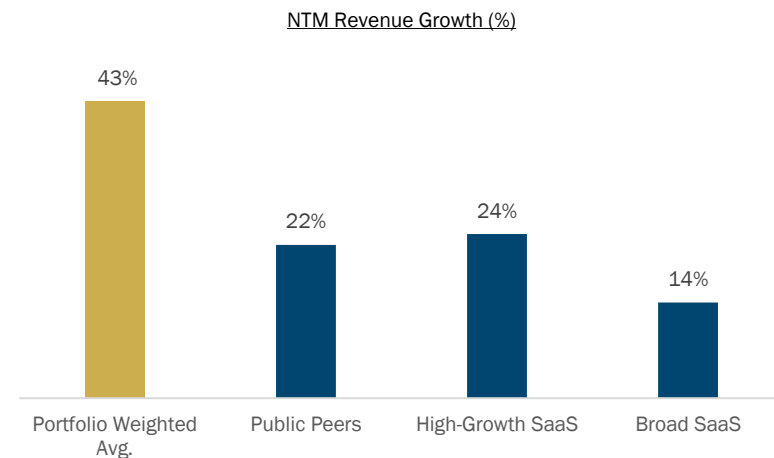

1. Please see the defined term for "Total Exposure without adjustments" in the "Secondaries Transaction Endnotes" in the Appendix hereto.

Appendix



PASF V partnership interests

Partnerships (Listed Alphabetically)

Abry Heritage Partners Cayman AIV	Greycroft Partners II
ABRY Heritage Partners I	JLL Partners Fund VII
ABRY Heritage Partners II	Luminate Capital Partners II, LP
ABRY Partners VIII (Cayman AIV), LP	Luminate Capital Partners III
ABRY Partners VIII	Luminate Capital Partners
Advent International GPE VIII-B	New Mountain Partners VI Direct Aggregator
Africa Top Invest	New Mountain Partners VI
American Securities Partners V	Norwest Mezzanine Partners III
American Securities Partners VII	Norwest Mezzanine Partners IV
American Securities Partners VIII	Norwest Mezzanine Partners V
American Securities Partners VIII	Olympus Growth Fund VII
American Securities VI	Olympus Growth Fund VII
Atlas Venture Fund VIII	Olympus VI (PROJECT RADY)
Bain Capital Fund X	Partners Group Direct Equity 2016
Bain Capital Venture Coinvestment Fund	Small Caps Opportunities Fund
Bain Capital Venture Fund 2005	Sparring Capital Fund
Bain Capital Venture Fund 2007	Spire Capital Partners III
Bain Capital Venture Fund 2012	Spire Capital Partners IV
Bain Capital Venture Fund 2014	Thoma Bravo Fund XII-A Global
Bain Capital Venture Fund 2016	Thoma Bravo Fund XII-A
Bertram Growth Capital III-A	Thoma Bravo Fund XIV-A Global
Centerbridge Capital Partners III	Thoma Bravo Fund XIV-A
Corealpha Private Equity Partners Co-Invest Fund V	Thoma Bravo Fund XV
COREalpha Private Equity Partners Co-Investment IV	Thoma Bravo Fund XV-P
EQT VII	TowerBrook Investors III Trust
EQT VIII Fund	TowerBrook Investors IV
Euro Choice Direct	Triton Fund IV L.P.
Euro Choice Secondary II	Triton Fund V
Euro Choice Secondary	VSS Structured Capital Parallel III
ForgePoint Cybersecurity Fund I	Warren Equity Partners II
Francisco Partners V-A	Waud Capital Partners QP IV
Francisco Partners V-B	Waud Capital Partners QP VI
Francisco Partners VI-B	Waud Capital Partners V
Genesis Park II LP	WHITE KNIGHT IX-1
Genstar Capital Partners X	WP COREalpha (Cayman) VII
Genstar X AIV	

Note: Represents closed investments as of March 31, 2024.

PASF IV portfolio

Transaction	# of Funds	Underlying Investments	Total Exposure (\$M) ¹	Type	% Funded at Close	Closing Date	Source	Gross IRR ²	Net IRR ²	Gross TVPI ²	Net TVPI ²
Gondola	1	8	\$13.1	Venture	55%	Jun-20	Limited Auction	23.5%	20.5%	2.06x	2.03x
Palisade	18	144	\$23.1	Diversified	86%	Jun-20	Exclusive	48.6%	45.6%	2.09x	2.06x
Nirvana	2	6	\$24.0	Growth	43%	Oct-20	GP Directed	19.0%	16.1%	1.64x	1.61x
Cougar	2	7	\$12.4	Growth	66%	Dec-20	GP Directed	16.4%	13.4%	1.39x	1.36x
Quadrangle	9	144	\$70.7	Buyout/Growth	70%	Dec-20	Limited Auction – Carve Out	32.8%	29.9%	2.04x	2.01x
Greylock	1	22	\$3.7	Growth	91%	Dec-20	GP Directed	16.3%	13.4%	1.49x	1.46x
Concord	4	68	\$21.2	Fund of Funds	80%	Feb-21	GP Directed	30.3%	27.3%	1.55x	1.52x
Galaxy	1	2	\$20.0	Venture	33%	Apr-21	GP Directed	(1.6%)	(4.6%)	0.95x	0.92x
Brooklyn	3	3	\$12.8	Venture	69%	Apr-21	GP Directed	(10.7%)	(13.6%)	0.74x	0.71x
Arctic	2	1	\$10.0	Growth	60%	Apr-21	GP Directed	29.1%	26.1%	1.95x	1.92x
Bloom	1	1	\$8.0	Growth	100%	Jun-21	GP Directed	36.0%	33.1%	2.33x	2.29x
Dragon	2	130	\$42.0	Growth	97%	Jun-21	Limited Auction – Carve Out	13.6%	10.6%	1.35x	1.32x
Bulwark	18	197	\$48.8	Diversified	61%	Jun-21	Exclusive	22.4%	19.5%	1.46x	1.43x
Dartmouth	1	1	\$23.2	Growth	100%	Aug-21	GP Directed	(0.6%)	(3.6%)	0.98x	0.95x
Chequers	1	3	\$1.2	Buyout	71%	Aug-21	GP Directed	19.6%	16.6%	1.25x	1.22x
Intrepid	2	36	\$10.3	Fund of Funds	45%	Aug-21	Exclusive	20.8%	17.8%	1.54x	1.51x
Diego	1	38	\$10.6	Buyout	74%	Sep-21	Limited Auction – Carve Out	19.1%	16.2%	1.47x	1.44x
Fairway	3	28	\$71.7	Buyout	58%	Sep-21	GP Directed	20.0%	17.1%	1.36x	1.33x
Osiris	20	189	\$563.8	Diversified	82%	Sep-21	Limited Auction – Carve Out	9.7%	6.8%	1.19x	1.16x
Sparta	9	105	\$112.1	Buyout/Growth	89%	Sep-21	Limited Auction – Carve Out	18.7%	15.8%	1.37x	1.34x
Victor	2	17	\$10.5	Buyout	92%	Sep-21	Limited Auction – Carve Out	27.1%	24.2%	1.68x	1.65x
Chevy	3	70	\$74.0	Venture	97%	Sep-21	Limited Auction – Carve Out	(2.2%)	(5.1%)	0.96x	0.93x
Typhoon	1	12	\$34.4	Buyout	90%	Nov-21	Limited Auction	5.9%	2.9%	1.09x	1.06x
Magnolia	2	83	\$77.3	Fund of Funds	74%	Dec-21	GP Directed	25.0%	22.1%	1.40x	1.36x
Lynx	2	15	\$49.6	Buyout/Growth	56%	Dec-21	Limited Auction – Carve Out	2.4%	(0.5%)	1.05x	1.02x
Rex	2	41	\$31.9	Buyout/Growth	96%	Dec-21	GP Directed	13.9%	10.9%	1.29x	1.26x
Canyon	10	162	\$175.8	Growth	94%	Dec-21	Limited Auction – Carve Out	(2.3%)	(5.3%)	0.95x	0.92x
Treble	4	165	\$15.5	Fund of Funds	87%	Dec-21	GP Directed	9.2%	6.2%	1.20x	1.17x
Space	6	284	\$49.5	Fund of Funds	73%	Mar-22	Limited Auction – Carve Out	4.5%	1.5%	1.09x	1.06x
Flare	4	75	\$68.7	Growth/Venture	87%	Mar-22	Limited Auction	6.6%	3.7%	1.13x	1.10x
Accent	1	5	\$31.8	Buyout	76%	Mar-22	GP Directed	9.5%	6.6%	1.18x	1.15x

1. Please see the defined term for “Total Exposure without adjustments” in the “PASF Transaction Endnotes” in the Appendix hereto.

2. As of March 31, 2024. Net returns for individual transactions are estimations reflecting the difference between the Gross and Net returns in each relevant fund. Please see the “Secondary Performance Endnotes” as well as the Disclosure Statement, in the Appendix for additional information.

Note: Past performance is not indicative of future results and there can be no assurance that the Fund will achieve comparable results and/or its investment objective. The returns for each investor in the Fund(s) may be materially different from those shown herein due to different fee schedules and timing on investment. This performance information is estimated and unaudited.

PASF IV portfolio (CONT'D)

Transaction	# of Funds	Underlying Investments	Total Exposure (\$M) ¹	Type	% Funded at Close	Closing Date	Source	Gross IRR ²	Net IRR ²	Gross TVPI ²	Net TVPI ²
Mound	1	1	\$9.0	Growth	100%	Apr-22	GP Directed	(26.9%)	(29.8%)	0.54x	0.51x
Ottoman	11	155	\$190.8	Buyout	75%	Jun-22	Limited Auction - Carve Out	8.8%	5.8%	1.14x	1.11x
Berkeley	1	22	\$24.1	Buyout	90%	Jun-22	Limited Auction - Carve Out	4.7%	1.8%	1.07x	1.04x
Nova	1	9	\$64.3	Growth	80%	Jun-22	GP Directed	1.9%	(1.0%)	1.03x	1.00x
Belmont	1	33	\$16.1	Buyout	83%	Sep-22	Limited Auction - Carve Out	29.0%	26.0%	1.44x	1.41x
Snow	3	27	\$25.9	Buyout/Special	70%	Sep-22	Limited Auction - Carve Out	15.5%	12.6%	1.21x	1.18x
Lantern	1	74	\$94.4	Diversified	83%	Sep-22	Limited Auction	25.3%	22.4%	1.36x	1.33x
Whaler	8	182	\$40.0	Fund of Funds	47%	Oct-22	GP Directed	36.4%	33.5%	1.45x	1.42x
Zipper	2	24	\$19.0	Buyout	87%	Dec-22	Limited Auction - Carve Out	24.4%	21.4%	1.27x	1.23x
Rady	1	5	\$15.3	Buyout	93%	Dec-22	Limited Auction - Carve Out	81.6%	78.7%	1.70x	1.66x
Chiron	3	19	\$16.7	Buyout	82%	Dec-22	Limited Auction - Carve Out	32.1%	29.2%	1.38x	1.34x
Icon	1	24	\$68.6	Growth	89%	Feb-23	GP Directed	53.4%	50.5%	1.33x	1.30x
Sterling	2	29	\$17.5	Buyout	62%	Mar-23	Limited Auction - Carve Out	49.7%	46.8%	1.46x	1.43x
Taurus	1	9	\$10.1	Buyout	59%	Jun-23	Limited Auction - Carve Out	52.8%	49.9%	1.51x	1.47x
Georgian	1	29	\$10.8	Buyout	100%	Jun-23	Limited Auction - Carve Out	32.3%	29.4%	1.27x	1.24x
Saddle	4	14	\$26.8	Buyout	76%	Jun-23	Limited Auction - Carve Out	44.6%	41.6%	1.43x	1.40x
Viking	3	29	\$8.2	Distressed	92%	Sep-23	GP Directed	121.3%	118.4%	1.92x	1.89x
Thistle	6	35	\$17.0	Buyout	80%	Sep-23	Limited Auction - Carve Out	32.3%	29.3%	1.29x	1.25x
Electron	3	133	\$25.1	Fund of funds	72%	Oct-23	Limited Auction - Carve Out	49.2%	46.2%	1.43x	1.40x
Amplify	1	22	\$39.3	Venture	100%	Dec-23	GP Directed	90.3%	87.4%	1.89x	1.85x
Lumberjack	9	107	\$23.7	Buyout/Venture	81%	Dec-23	Limited Auction - Carve Out	22.0%	19.1%	1.21x	1.18x
Celsius	10	191	\$37.3	Growth/Venture	93%	Mar-23	Limited Auction - Carve Out	NM	NM	1.81x	1.78x
Lightning	2	12	\$59.7	Buyout	59%	Mar-23	Limited Auction - Carve Out	NM	NM	1.10x	1.07x
Star	1	17	\$7.6	Buyout	90%	Mar-23	Limited Auction - Carve Out	NM	NM	1.30x	1.27x
Cantaloupe	17	183	\$67.6	Buyout/Venture	86%	Mar-23	Limited Auction - Carve Out	NM	NM	1.23x	1.20x
Ocean	9	45	\$19.9	Buyout	91%	Mar-23	Limited Auction	NM	NM	1.59x	1.56x
PA GPS	9	20	\$244.0	Buyout/Growth	100%	Various	GP Directed	5.9%	2.9%	1.12x	1.09x
Asia Secondaries	45	419	\$132.3	Diversified	100%	Various	Various	24.3%	21.4%	1.64x	1.61x
Co-Investments	-	43	\$367.0	Buyout	100%	Various	GP Directed	15.4%	12.5%	1.36x	1.32x
Total	302	3,986	\$3,436.7		84%			14.4%	11.5%	1.29x	1.26x

1. Please see the defined term for "Total Exposure without adjustments" in the "PASF Transaction Endnotes" in the Appendix hereto.

2. As of March 31, 2024. Net returns for individual transactions are estimations reflecting the difference between the Gross and Net returns in each relevant fund. Please see the "Secondary Performance Endnotes" as well as the Disclosure Statement, in the Appendix for additional information.

Note: Past performance is not indicative of future results and there can be no assurance that the Fund will achieve comparable results and/or its investment objective. The returns for each investor in the Fund(s) may be materially different from those shown herein due to different fee schedules and timing on investment. This performance information is estimated and unaudited.

PASF III portfolio

Transaction	# of Funds	Underlying Investments	Total Exposure (\$M) ¹	Type	% Funded at Close	Closing Date	Source	Gross IRR ²	Net IRR ²	Gross TVPI ²	Net TVPI ²
Adventure	20	225	\$31.2	Buyout/Growth/Venture	98%	Mar-16	Exclusive	32.6%	28.6%	2.50x	2.40x
Runway	2	41	\$13.6	Buyout	92%	Jun-16	Limited Auction - Carve Out	57.2%	53.3%	2.33x	2.23x
Pixel	2	27	\$6.8	Venture	82%	Nov-16	GP Directed	47.1%	43.1%	4.01x	3.91x
Hillary	1	4	\$3.3	Venture	84%	Nov-16	Exclusive	261.6%	>100%	2.64x	2.54x
Saffron	40	313	\$134.3	Diversified	96%	Dec-16	Limited Auction - Carve Out	149.9%	>100%	1.70x	1.60x
Beehive	1	25	\$18.3	Buyout	94%	Dec-16	Exclusive	36.2%	32.3%	2.17x	2.07x
Funnel	2	61	\$8.3	Fund of Funds	97%	Dec-16	Limited Auction - Carve Out	7.9%	4.0%	1.12x	1.02x
Dynamite	1	11	\$14.7	Distressed	96%	Mar-17	Limited Auction - Carve Out	61.1%	57.2%	2.51x	2.41x
Ursa	2	65	\$4.5	Growth	99%	Jun-17	Exclusive	18.1%	14.2%	1.83x	1.73x
Austin	7	140	\$49.1	Diversified	91%	Jun-17	Limited Auction - Carve Out	13.9%	10.0%	1.62x	1.52x
Community	3	53	\$7.0	Fund of Funds	98%	Dec-17	Limited Auction - Carve Out	15.3%	11.3%	1.52x	1.42x
Nepal	2	38	\$16.6	Buyout	79%	Dec-17	Exclusive	20.6%	16.6%	1.81x	1.71x
Navy	22	74	\$73.7	Buyout/Venture	95%	Dec-17	Limited Auction	20.0%	16.1%	1.40x	1.30x
Keiko	2	40	\$14.9	Fund of Funds/Venture	100%	Mar-18	Limited Auction - GP Directed	27.0%	23.1%	2.57x	2.47x
Pegasus	4	118	\$46.4	Buyout/Growth	84%	Mar-18	Limited Auction - Carve Out	14.2%	10.2%	1.82x	1.72x
Goldmine	19	276	\$35.8	Diversified	95%	Mar-18	Limited Auction	19.3%	15.3%	1.69x	1.59x
Foster	29	460	\$37.7	Diversified	96%	Jun-18	Limited Auction	21.3%	17.4%	1.52x	1.42x
Zeus	1	9	\$39.9	Buyout	62%	Jun-18	GP Directed	15.7%	11.8%	1.73x	1.63x
Wildcat	2	14	\$4.1	Buyout	96%	Jun-18	Exclusive	16.8%	12.8%	1.87x	1.77x
Clone	1	1	\$7.5	Growth	100%	Sep-18	GP Directed	73.1%	69.1%	2.56x	2.46x
Sierra	47	242	\$72.6	Diversified	91%	Sep-18	Limited Auction	13.9%	9.9%	1.54x	1.44x
Titan	47	294	\$26.4	Buyout/Growth/Venture	96%	Dec-18	Exclusive	12.8%	8.9%	1.50x	1.40x
Thunderbird	4	145	\$72.6	Fund of Funds	77%	Dec-18	Exclusive	24.2%	20.3%	2.18x	2.08x
Helix	1	31	\$50.0	Growth	73%	Dec-18	GP Directed	17.6%	13.6%	1.87x	1.77x
Haig	1	37	\$8.0	Fund of Funds	91%	Dec-18	Limited Auction - Carve Out	34.5%	30.5%	2.23x	2.14x
Blaze	11	150	\$16.1	Diversified	95%	Dec-18	Limited Auction - Carve Out	13.0%	9.1%	1.47x	1.37x
Orange	1	23	\$25.2	Fund of Funds	98%	Dec-18	Limited Auction - Carve Out	5.1%	1.1%	1.14x	1.04x
Diamond	17	152	\$39.0	Diversified	92%	Dec-18	Limited Auction - Carve Out	14.9%	10.9%	1.45x	1.35x
Rocky	3	28	\$23.1	Buyout/Special	67%	Jan-19	Limited Auction - Carve Out	3.5%	(0.5%)	1.08x	0.98x
Formula	2	107	\$5.0	Venture	93%	Mar-19	Exclusive	2.1%	(1.8%)	1.10x	1.00x

1. Please see the defined term for “Total Exposure without adjustments” in the “PASF Transaction Endnotes” in the Appendix hereto.

2. As of March 31, 2024. Net returns for individual transactions are estimations reflecting the difference between the Gross and Net returns in each relevant fund. Please see the “Secondary Performance Endnotes” as well as the Disclosure Statement, in the Appendix for additional information.

Note: Past performance is not indicative of future results and there can be no assurance that the Fund will achieve comparable results and/or its investment objective. The returns for each investor in the Fund(s) may be materially different from those shown herein due to different fee schedules and timing on investment. This performance information is estimated and unaudited.

PASF III portfolio (CONT'D)

Transaction	# of Funds	Underlying Investments	Total Exposure (\$M) ¹	Type	% Funded at Close	Closing Date	Source	Gross IRR ²	Net IRR ²	Gross TVPI ²	Net TVPI ²
Spectrum	13	147	\$82.5	Diversified	88%	Mar-19	Limited Auction - Carve Out	23.7%	19.8%	1.80x	1.70x
Buck	1	2	\$4.5	Venture	98%	Apr-19	GP Directed	251.4%	>100%	4.90x	4.80x
Coil	1	52	\$3.9	Venture	100%	May-19	Exclusive	220.2%	>100%	9.06x	8.96x
Twister	1	15	\$30.4	Buyout	78%	Jun-19	Limited Auction - Carve Out	12.9%	8.9%	1.42x	1.32x
Diver	1	1	\$10.0	Venture	100%	Jul-19	GP Directed	86.3%	82.3%	3.95x	3.85x
Laguna	5	40	\$33.9	Special	74%	Jul-19	Limited Auction - Carve Out	18.5%	14.6%	1.54x	1.44x
Violin	1	15	\$22.6	Venture	99%	Sep-19	Limited Auction - Carve Out	43.1%	39.1%	2.46x	2.36x
Graphite	2	10	\$22.4	Buyout	72%	Sep-19	Limited Auction	5.0%	1.0%	1.15x	1.05x
Bowie	26	172	\$167.9	Buyout/Growth/Venture	83%	Sep-19	Limited Auction - Carve Out	21.2%	17.3%	1.70x	1.61x
Stokes	2	97	\$36.2	Fund of Funds	87%	Jan-20	Limited Auction	22.3%	18.3%	1.46x	1.36x
Cardinal	7	47	\$15.2	Buyout/Venture	88%	Mar-20	Limited Auction	17.2%	13.3%	1.47x	1.37x
Regatta	1	10	\$14.7	Buyout	95%	Mar-20	Limited Auction - Carve Out	28.2%	24.2%	2.05x	1.95x
Coldstream	7	57	\$96.1	Diversified	62%	Mar-20	Limited Auction - Carve Out	23.4%	19.5%	1.77x	1.67x
Gondola	1	8	\$13.1	Venture	55%	Jun-20	Limited Auction	23.5%	19.5%	2.06x	1.96x
Palisade	18	144	\$23.1	Diversified	86%	Jun-20	Exclusive	48.6%	44.6%	2.09x	1.99x
Nirvana	2	6	\$24.0	Growth	52%	Oct-20	GP Directed	19.0%	15.1%	1.64x	1.54x
Cougar	2	7	\$12.4	Growth	81%	Dec-20	GP Directed	16.4%	12.4%	1.39x	1.29x
Quadrangle	9	144	\$70.7	Buyout/Growth	69%	Dec-20	Limited Auction - Carve Out	32.8%	28.9%	2.04x	1.94x
Greylock	1	22	\$3.7	Growth	91%	Dec-20	GP Directed	16.3%	12.4%	1.49x	1.39x
Concord	4	68	\$21.2	Fund of Funds	80%	Feb-21	GP Directed	30.3%	26.3%	1.55x	1.45x
Galaxy	1	2	\$20.0	Venture	33%	Apr-21	GP Directed	(1.6%)	(5.6%)	0.95x	0.85x
Brooklyn	3	3	\$12.8	Venture	75%	Apr-21	GP Directed	(10.7%)	(14.6%)	0.74x	0.64x
Arctic	2	1	\$10.0	Growth	100%	Apr-21	GP Directed	29.1%	25.1%	1.95x	1.85x
Bloom	1	1	\$8.0	Growth	100%	Jun-21	GP Directed	36.0%	32.1%	2.33x	2.23x
Dragon	2	130	\$42.0	Growth	97%	Jun-21	Limited Auction - Carve Out	13.6%	9.6%	1.35x	1.25x
Bulwark	18	197	\$48.8	Diversified	61%	Jun-21	Exclusive	22.4%	18.5%	1.46x	1.36x
Dartmouth	1	1	\$23.2	Growth	100%	Aug-21	GP Directed	(0.6%)	(4.6%)	0.98x	0.88x
Chequers	1	3	\$1.2	Buyout	71%	Aug-21	GP Directed	19.6%	15.6%	1.25x	1.15x
Intrepid	2	36	\$10.3	Fund of Funds	45%	Aug-21	Exclusive	20.8%	16.8%	1.54x	1.44x
Fairway	3	28	\$22.1	Buyout	57%	Sep-21	GP Directed	20.0%	16.1%	1.35x	1.26x
Co-Investments	-	73	\$227.7	Buyout	100%	Various	GP Directed	19.8%	15.8%	2.06x	1.96x
Total	437	4,757	\$2,040.1		85%			22.6%	18.7%	1.82x	1.72x

1. Please see the defined term for "Total Exposure without adjustments" in the "PASF Transaction Endnotes" in the Appendix hereto.

2. As of March 31, 2024. Net returns for individual transactions are estimations reflecting the difference between the Gross and Net returns in each relevant fund. Please see the "Secondary Performance Endnotes" as well as the Disclosure Statement, in the Appendix for additional information.

Note: Past performance is not indicative of future results and there can be no assurance that the Fund will achieve comparable results and/or its investment objective. The returns for each investor in the Fund(s) may be materially different from those shown herein due to different fee schedules and timing on investment. This performance information is estimated and unaudited.

Endnotes

PASF Transaction Endnotes

- a) **Inclusions.** The foregoing presents summaries of every transaction in each of the PASF fund's portfolio as of March 31, 2024 (and no transactions were excluded).
- b) **Certain definitions.** "Investment Date" represents, for each transaction, the date on which the respective purchase and sale agreement (or similar agreement) was executed. "Number of Underlying Funds" represents the number of distinct underlying partnerships within each PASF transaction. "Vintage Years" generally represents the year that each underlying fund first began to draw capital from its partners. "Total Exposure with adjustments" is calculated with adjustments made to account for any contributions and/or distributions after the "pricing date," but prior to the final closing, and represents (i) the total commitments to underlying secondary transactions (and co-investments, if applicable) in a given portfolio at a stated time for which a purchase and sale agreement and/or letter of intent was signed, valuing such investments at the purchase price stated in the applicable document, plus (ii) the unfunded commitment. "Total Exposure without adjustments" is calculated without adjustments made to account for any contributions and/or distributions after the "pricing date," but prior to the final closing, and represents (i) the total commitments to underlying secondary transactions (and co-investments, if applicable) in a given portfolio at a stated time for which a purchase and sale agreement and/or letter of intent was signed, valuing such investments at the purchase price stated in the applicable document, plus (ii) the unfunded commitment. "% Funded at Purchase" represents, with respect to each underlying fund, the total capital contributed by the partners to such fund divided by the total capital commitments by the partners to such fund, as of the Investment Date.
- c) **Transaction exposure by strategy.** The foregoing data represents information with respect to each PASF transaction, valuing such investments at the respective total exposure (i.e., the purchase price plus unfunded commitment) as of the respective Investment Date and the foregoing data does not take into account any subsequent liquidations thereto.

AUM calculation

Total AUM estimated as of June 30, 2024. References to "assets under management" or "AUM" represent the assets managed by FS Investments or its strategic partners as to which FS Investments is entitled to receive a fee or carried interest (either currently or upon deployment of capital) and general partner capital. FS Investments calculates the amount of AUM as of any date as the sum of: (i) the fair value of the investments of FS Investments' investment funds; (ii) uncalled capital commitments from these funds, including uncalled capital commitments from which FS Investments is currently not earning management fees or carried interest; (iii) the value of outstanding CLOs (excluding CLOs wholly-owned by FS Investments); (iv) the fair value of FS KKR Capital Corp. joint venture (JV) assets and FS Specialty Lending Fund JV assets; and (v) the fair value of other assets managed by FS Investments. The AUM also includes the estimated AUM of Portfolio Advisors, LLC as of June 30, 2024, which FS acquired through a merger on June 30, 2023. AUM for Portfolio Advisors, LLC is measured as adjusted reported value plus unfunded commitments. FS Investments' calculation of AUM may differ from the calculations of other asset managers and, as a result, FS Investments' measurements of its AUM may not be comparable to similar measures presented by other asset managers. FS Investments' definition of AUM is not based on any definition of AUM that may be set forth in agreements governing the investment funds, vehicles or accounts that it manages and is not calculated pursuant to any regulatory definitions.

Endnotes (CONT'D)

Secondary performance endnotes

- a) **IRRs. "IRR"** (the internal rate of return) is defined as the implied discount rate that will make the net present value of a stream of cash flows equal to zero. The IRRs shown are weighted based on drawn capital only. The "Gross IRRs" shown in this performance include (are net of) underlying fees, expenses and carried interest charged by underlying portfolio funds, but exclude (are gross of) fees, expenses and performance compensation charged by Portfolio Advisors. The Gross IRRs are calculated based on the last Reported Value received from the underlying portfolio funds. Additional information is available upon request.
- b) **Estimated Net IRR methodology.** The "Net IRR" of the PASF I, II, III, IV, and V Track Record is calculated based on information reported to investors by the underlying portfolio funds and is net of underlying fees, expenses and carried interest charged by such underlying portfolio funds and net of fees (including management fees), expenses and carried interest which investors pay to Portfolio Advisors. The actual Net IRR to any individual investor in any PA-sponsored fund would, however, differ slightly from the Net IRR presented based on certain factors, including, as applicable, the closing in which such investor participated and such investor's opt-out election. The Net IRR of the PASF I, II, III, IV, and V Track Record is calculated as of March 31, 2024, based on the last Reported Value received from the underlying portfolio funds and the cash flows between PASF I, II, III, IV, and V and their limited partners.
- c) **Certain definitions.** "Total Exposure" represents (i) the total commitments to underlying secondary transactions (and co-investments, if applicable) in a given portfolio at a stated time for which a purchase and sale agreement and/or letter of intent was signed, valuing such investments at the purchase price stated in the applicable document, plus (ii) the unfunded commitment. With respect to the PASF I, PASF II and PASF III Total Exposure, please note that in April 2011, PASF I committed \$100 million to PAPEF VII-D (the "Co-investment sector" of PAPEF VII). In September 2013 and September 2014, PASF II committed \$35 million and \$52 million, respectively. In March 2016, PASF III committed \$31 million to PAPEF VIII-D. In April 2017 and December 2017, PASF III committed \$64 million and \$86 million, respectively, to PAPEF IX-D. The foregoing Total Exposure with adjustments only includes PASF I, PASF II and PASF III's pro rata amount of the underlying co-investments made by PAPEF VII-D, PAPEF VIII-D and PAPEF IX-D. "Contributions" represents the total contributed capital by the client or applicable fund to the underlying secondary investments (and co-investments, if applicable). "Distributions" represents total distributions received from underlying secondary investments (and co-investments, if applicable) after closing the transaction. "Reported Value" represents the value of the underlying secondary investments' net assets (and co-investments' net assets, with respect to PASF I), as of December 31, 2023, as reported on the underlying funds' financial statements. The value of a fund's assets on its financial statements reflects the 'fair value', as determined by each underlying fund's general partner, in almost all cases, in accordance with U.S. Generally Accepted Accounting Principles or International Financial Reporting Standards and includes valuations of unrealized investments. Prospective investors must understand that (i) such valuations may be materially higher or lower than the cost of such investments and may vary over time, (ii) such valuations may or may not be based on valuations provided or verified by third parties independent of the underlying fund's general partner, and (iii) the ultimate realized value of any investment may be materially different from its fair value as reported in the underlying fund's financial statements. "Total Value" represents the sum of Distributions received and the Reported Value. "Gross DPI" is the Distributions divided by Contributions. "Gross TVPI" is the Total Value divided by Contributions. All numbers are "gross of fees" and do not reflect the deduction of any expenses, taxes, management fees or carried interest borne by investors, which may be substantial in the aggregate and which will reduce any returns presented. "Net DPI" is the Distributions divided by Contributions and account for the deduction of any expenses, taxes, management fees or carried interest borne by investors. "Net TVPI" is the Total Value divided by Contributions and account for the deduction of any expenses, taxes, management fees or carried interest borne by investors. Net TVPI for each individual transaction and subtotal (sum of individual transactions) is an estimation reflecting the difference between the Gross Multiple and the Net Multiple of each individual fund (Fund I, Fund II, Fund III, Fund IV), applied to each individual transaction and subtotal within a fund, unless otherwise noted. "Net Cash TVPI" is a total value multiple (after expenses, taxes, management fees or carried interest borne by investors) calculated based on remaining value plus net distributions divided by net contributions. For this calculation, any contributions and distributions that are issued in the same notice to investors are netted out, in effect, creating a net distribution or net contribution, but not both. "Average Headline Discount" represents the weighted average pricing date discount of the secondary transactions in each PASF Fund. "Gains from Discount" represents proportion of each respective PASF Fund's increase in value driven by purchasing assets for less than their current value. "Gains from Value Appreciation" represents the proportion of each respective PASF Fund's increase in value driven by appreciation of the underlying assets. "NM" Investments that recently closed and have not yet generated meaningful performance are deemed Not Meaningful (NM). "Loss Ratio" calculated as the gross dollar loss in deals below 1.0x Gross TVPI divided by total Contributions.
- d) **PAPEF VII, VIII and IX co-investment sector and PCIF IV and V commitment.** In April 2011, PASF I committed \$100 million to PAPEF VII-D (i.e., the "Co-investment sector" of PAPEF VII). In December 2012, PASF II committed \$50 million to PAPEF VII-D. In September 2013 and September 2014, PASF II committed \$35 million and \$52 million, respectively. In March 2016, PASF III committed \$31 million to PAPEF VIII-D. In April 2017 and December 2017, PASF III committed \$64 million and \$86 million, respectively, to PAPEF IX-D. In December 2019, March 2020, and June 2020, PASF IV committed \$267 million to PCIF IV. In August 2022, PASF IV committed \$100 million to PCIF V. No additional management fees or performance allocation are being charged by PAPEF VII-D, VIII-D and IX-D to PASF I, PASF II and PASF III with respect to these commitments.

Endnotes (CONT'D)

Secondary performance endnotes

- a) **PASA commitment.** Please note that PASF I, PASF II, PASF III, PASF IV, and PASF V achieved its exposure to certain secondary transactions cited herein through its investment in Portfolio Advisors Secondary Aggregator (“PASA I”), Portfolio Advisors Secondary Aggregator II (“PASA II”), Portfolio Advisors Secondary Aggregator III (“PASA III”), Portfolio Advisors Secondary Aggregator IV (“PASA IV”), Portfolio Advisors Secondary Aggregator V (“PASA V”), Portfolio Advisors Secondary Aggregator VI (“PASA VI”), Portfolio Advisors Secondary Aggregator VII (“PASA VII”), and Portfolio Advisors Secondary Aggregator VIII (“PASA VIII”). In September 2021 and April 2022, PASA VII committed \$160 million to PA GPS, \$144 million of which was from PASF IV. These are Portfolio Advisors-sponsored special purpose aggregator vehicles which consummate certain secondary transactions in order to maximize efficiencies and minimize expenses. With the foregoing in mind, PASF I, PASF II, PASF III, PASF IV, and PASF V’s portfolios are presented as including its respective portion of each underlying PASA, PASA II, PASA III, PASA IV, PASA V, PASA VI, PASA VII, and PASA VIII investments and transaction notwithstanding the fact that the exposure is indirect (via PASA, PASA II, PASA III, PASA IV, PASA V, PASA VI, PASA VII, and PASA VIII).
- b) **PAAF VI and PAASF VII commitment.** In January 2020, March 2020, and June 2020, PASF IV committed \$34 million to PAAF VI. In September 2020-September 2021 PASF IV committed \$98 million to PAASF VII. No additional management fees or performance allocation are being charged to PAAF VI and PAASF VII with respect to these commitments.
- c) **PA GPS commitment.** In March 2021, PASF IV committed \$100 million to the PA GPS Fund. No additional management fees or performance allocation are being charged to PA GPS with respect to these commitments.
- d) **Access to Information.** The PASF Funds’ performance figures are generally only available as of a date approximately six months behind the current date because, as a fund-of-funds, the PASF Funds are largely dependent upon the underlying portfolio funds to provide such information and because PASF information generally may not be finalized until all such reports are received and processed.

Disclosure statement

GENERAL DISCLAIMER

Past performance does not guarantee future results. The past performance presented in this document reflects the particular objectives and constraints of Portfolio Advisors' advisory clients and/or managed funds of funds at different points in time and is based on the actual historical performance of the private equity funds, co-investments or any other investments, as applicable (collectively or individually, as the context requires, "investments"), committed to on their behalf. No representation is made that the investments would have been selected for any Portfolio Advisors-sponsored fund during the period shown or that the performance of any Portfolio Advisors-sponsored fund would have been the same or similar to the performance reflected. Portfolio Advisors-sponsored funds make investments in different economic conditions than those prevailing in the past and in different investments than those reflected in the performance record(s) shown herein. Additionally, the performance described herein reflects the performance of certain investments over a limited period of time and does not necessarily reflect any such investments' performance in different market cycles. The performance record(s) shown herein were compiled, and reflect certain subjective assumptions and judgments, by Portfolio Advisors. It has not been audited or reviewed by any independent party for accuracy or reasonableness. Prospective investors should understand that the use of different underlying assumptions and judgments, and comparisons to different information, could result in material differences from the performance record(s) herein. Additional information can be provided by Portfolio Advisors upon request.

GENERAL DISCLOSURE

The summary description of any Portfolio Advisors-sponsored fund (each, the "Fund") included herein, and any other materials provided to you, are intended only for discussion purposes and are not intended as an offer to buy or a solicitation of an offer to buy or sell with respect to the purchase or sale of any security and should not be relied upon by you in evaluating the merits of investing in any securities. These materials are not intended for distribution to, or use by, any person or entity in any jurisdiction or country where such distribution or use is contrary to local law or regulation.

This summary is not intended to be complete and the description of the terms of any fund herein is qualified in its entirety by the terms contained in such fund's confidential private placement memorandum, partnership agreement and subscription agreement (the "Fund documents") similarly, any summaries of Portfolio Advisors' policies are qualified in their entirety by the terms of the actual policies. Material aspects of the descriptions contained herein may change at any time and if you express an interest in investing in the Fund you will be provided with a copy of the Fund documents. You must review the Fund documents and risk factors disclosed in the Fund documents prior to making a decision to invest. You should rely only on the information contained in the Fund documents in making your decision to invest.

The information herein is not intended to provide, and should not be relied upon for, accounting, legal or tax advice or investment recommendations. You should consult your tax, legal, accounting or other advisors about the matters discussed herein.

The Fund will not register as investment companies under the U.S. Investment Company Act of 1940, as amended (the "Company Act") in reliance upon the exemption under section 3(c)(7) thereunder, and, accordingly, the provisions of the Company Act will not be applicable to the Fund.

An investment in the Fund will be suitable only for certain sophisticated investors who have no need for immediate liquidity in their investment. Such an investment will provide limited liquidity because interests in the Fund will not be freely transferable and may generally not be withdrawn. There will be no public or secondary market for interests in the Fund, and it is not expected that a public or secondary market will develop.

Investing in financial markets involves a substantial degree of risk. There can be no assurance that the Fund's investment objectives or any of the Fund's (or its sectors' and sub-sectors', if any) investment objectives will be achieved or that there will be a return of capital. Investment losses may occur with respect to any investment in the Fund and investors could lose some or all of their investment. Nothing herein is intended to imply that an investment in the Fund or the Fund's investment strategies may be considered "conservative," "safe," "risk free" or "risk averse." No regulatory authority has passed upon or endorsed this summary or the merits of an investment in the Fund.

Disclosure statement (CONT'D)

Distribution of this information to any person other than the person to whom this information was originally delivered and to such person's advisors is unauthorized and any reproduction of these materials, in whole or in part, or the disclosure of any of the contents, without the prior consent of Portfolio Advisors, LLC. In each such instance is prohibited. Notwithstanding anything to the contrary herein, each recipient of this summary (and each employee, representative or agent of such recipient) may disclose to any and all persons, without limitation of any kind, the tax treatment and tax structure of (i) the Fund and (ii) any of its transactions, and all materials of any kind (including opinions or other tax analyses) relating to such tax treatment and tax structure.

Certain information contained herein constitutes forward-looking statements. Due to various uncertainties and actual events, including those discussed herein and in the Fund documents, actual results or performance of the Fund may differ materially from those reflected or contemplated in such forward-looking statements. As a result, investors should not rely on such forward-looking statements in making their investment decisions. Any target objectives are goals only, are not projections or predictions and are presented solely for your information. No assurance is given that the Fund will achieve its investment objectives.

Examples of investments described herein do not necessarily represent all or any of the investments that will be made by the Fund. It may not be assumed that any investments described herein would be profitable if implemented. Investment allocations may be changed or modified at any time without notice to you at the sole discretion of Portfolio Advisors, LLC. The information herein may not be relied on in making any investment decision. Investment decisions may only be made in reliance upon the information set forth in the Fund documents.

If the recipient of this document is or becomes subject to: (i) section 552(a) of Title 5 of the United States Code (commonly known as the "Freedom of Information Act") or any public disclosure law, rule or regulation of any governmental or non-governmental entity that could require similar or broader public disclosure of confidential information provided to such recipient; (ii) any public disclosure law, rule or regulation of any public company that could require similar or broader public disclosure of confidential information provided to such recipient; or (iii) any public disclosure law, rule or regulation of any pension fund (or similar entity) that could require similar or broader public disclosure of confidential information provided to such recipient (collectively, all such laws, rules or regulations, "FOIA"), then, to the extent that any such recipient receives a request for public disclosure of this document, such recipient agrees that: (i) it shall use its best efforts to (x) promptly notify Portfolio Advisors of such disclosure request and promptly provide Portfolio Advisors with a copy of such disclosure request or a detailed summary of the information being requested, (y) inform Portfolio Advisors of the timing for responding to such disclosure request, (z) consult with Portfolio Advisors regarding the response to such public disclosure request, including Portfolio Advisors' consideration of whether such disclosure is in the best interest of the fund and, to the fullest extent permitted by law, whether all or any part of this document may be withheld from such public disclosure request.

Nothing set forth in this document is intended to constitute a recommendation that any person take or refrain from taking any course of action within the meaning of U.S. Department of Labor Regulation §2510.3-21(b)(1), including without limitation buying, selling or continuing to hold any security. No information contained herein should be regarded as a suggestion to engage in or refrain from any investment-related course of action as none of Portfolio Advisors, LLC nor any of its affiliates is undertaking to provide investment advice, act as an adviser to any plan or entity subject to the Employee Retirement Income Security Act of 1974, as amended, individual retirement account or individual retirement annuity, or give advice in a fiduciary capacity with respect to the materials presented herein. You are advised to contact your own financial advisor or other fiduciary unrelated to Portfolio Advisors, LLC about whether any given course of action may be appropriate for your circumstances.

None of the information contained herein was prepared, reviewed or approved by the underlying portfolio funds identified herein, if any, the general partners thereof or any of their respective affiliates.

This document constitutes advertisement according to the Swiss Federal Act on Financial Services of 15 June 2018.

By accepting these materials, you hereby acknowledge and agree to all of the terms and conditions in this disclosure statement, specifically that the information contained herein is highly confidential and that you shall not disclose or cause to be disclosed any such information without the prior written consent of Portfolio Advisors, LLC.



Darien - HQ

9 Old Kings Highway South
Darien, CT 06820

+1 203 662 3456

Dallas

100 Crescent Court, Suite 800
Dallas, TX 75201

+1 469 761 5100

London

29 Farm Street
London W1J5RL

+44 20 3745 7847

Zurich

Brandschenkestrasse 47
8002 Zurich

+41 44 200 3500

Singapore

12 Marina Blvd. | MBFC Tower 3
Singapore 018982

+65 6809 5000

Hong Kong

33/F, Alexandra House
18 Chater Road, Central

+852 3184 9210

PORTFOLIO
ADVISORS LLC



Portad.com



InvestorRelations@Portad.com

Texas Southern University
August 2024

Atlanta Consulting Group | 5600 Glenridge Drive NE, Suite 230 - East | Atlanta, GA 30342

P 404.240.6747 | T 888.317.2810 | F 470.823.3178

acgconsulting.com

ACG Market Review – Second Quarter 2024

- **Economy – Growth is still positive, but slowing, while inflation continued to decelerate towards the Fed’s target**
 - After strong GDP readings in the second half of 2023, Q1 2024 GDP slowed to slightly over 1.0%. There have been some signs that the labor market is cooling, but consensus GDP estimates for Q2 currently point to a small reacceleration towards 2.0% growth.
 - Progress on inflation continued in Q2 as consumers spent less on discretionary items. Prices for non-discretionary items like shelter and health care continued to put some upward pressure on inflation numbers.
 - Given the overall slowing of inflation and some deceleration for the economy, markets have begun to price a Fed rate cut during the second half of the year. For their part, the Fed has signaled that more evidence of progress on inflation is needed to start cutting rates.

- **Equity – More all-time highs for the S&P 500 as mega-cap companies continue to buoy stocks**
 - The S&P 500 crossed the 5,500 mark for the first time in late June.
 - The largest companies in the index are driving returns, as the top 10% of stocks based on market cap drove most of the return in Q2.
 - US Small and Mid Cap stocks printed negative returns in Q2 and continue to lag Large Cap counterparts.
 - Emerging Markets have quietly rallied and enjoyed a strong Q2 by rising approximately +5.0% as measured by the MSCI EM Index.

- **Fixed Income – Bonds were mostly flat in Q2 as rates remained relatively range-bound**
 - The 10-year Treasury yield generally bounced between 4.0% and 4.5% during the quarter given near-term uncertainty over inflation and the path for the Fed.
 - The Bloomberg US Aggregate was essentially flat, rising +0.07% in Q2.

- **Risks/Other Considerations**
 - Excitement over AI has driven stock prices in some of the biggest names in major indexes. Any change in optimism could turn momentum the other direction for trades that have become crowded.
 - Elections across the globe, including in the US, add a layer of uncertainty. Especially if outcomes surprise markets.

Statistic	Last 10 Year Avg.	12 Month Prior	Prior Quarter	Current
Fed Funds Rate	1.53%	5.07%	5.33%	5.33%
Prime Rate	4.67%	8.25%	8.50%	8.50%
10-Year Treasury Yield	2.39%	3.81%	4.21%	4.36%
30-Year Fixed Mortgage Rate	4.37%	6.71%	6.79%	6.86%
S&P 500 P/E Ratio (Forward Earnings)	19.8x	18.9x	21.1x	21.2x
Projected Earnings Growth (S&P 500)	+8.4%	+8.4% (2024/2023) est.	+3.2% (year/year) est.	+8.8% (year/year) est.
U.S. GDP (Real, Quarterly)	2.40%	+1.7% (Q1 2023) est.	+2.5% (Q4 2023) est.	2.9% (Q1 2024) est.

Market Index Review – August 2024

Major Market Indices	MTD	QTD	YTD	1 Year	3 Years	5 Years	10 Years
S&P 500	2.43	3.67	19.53	27.13	9.38	15.92	12.98
Russell 2000	-1.49	8.51	10.39	18.47	0.60	9.68	8.03
Russell 3000	2.18	4.08	18.19	26.14	7.87	15.19	12.36
MSCI ACWI	2.54	4.19	15.97	23.44	5.77	12.14	8.78
MSCI ACWI ex USA	2.85	5.23	11.22	18.21	2.10	7.56	4.42
Bloomberg US Aggregate TR	1.44	3.81	3.07	7.30	-2.11	-0.04	1.64

Russell Indices	MTD	QTD	YTD	1 Year	3 Years	5 Years	10 Years
Russell 1000	2.37	3.86	18.64	26.60	8.34	15.55	12.66
Russell 1000 Growth	2.08	0.35	21.12	30.75	8.87	19.08	16.03
Russell 1000 Value	2.68	7.93	15.08	21.15	7.25	11.16	8.85
Russell MidCap	2.03	6.83	12.14	20.16	3.52	11.24	9.58
Russell MidCap Growth	2.48	3.11	9.27	19.07	-0.46	10.50	10.61
Russell MidCap Value	1.89	8.04	12.95	20.19	5.39	10.80	8.31
Russell 2000 Growth	-1.11	6.99	11.74	17.67	-2.07	8.35	8.21
Russell 2000 Value	-1.88	10.08	9.15	19.25	3.05	10.37	7.46

Sector Indices	MTD	QTD	YTD	1 Year	3 Years	5 Years	10 Years
S&P 500 Materials	2.40	6.89	11.21	16.15	5.49	13.11	8.66
S&P 500 Consumer Discretionary	-0.97	0.67	6.37	12.43	1.60	10.76	11.97
S&P 500 Consumer Staples	5.94	7.98	17.68	18.58	8.49	10.21	9.62
S&P 500 Energy	-1.70	0.38	11.35	6.35	29.10	15.37	3.45
S&P 500 Financials	4.51	11.26	22.58	35.39	8.07	13.55	11.47
S&P 500 Health Care	5.10	7.89	16.31	20.11	6.91	13.71	11.63
S&P 500 Industrials	2.86	7.90	16.26	23.60	9.80	13.68	11.24
S&P 500 Information Technology	1.25	-0.86	27.14	38.73	16.58	26.50	22.02
S&P 500 Real Estate	5.79	13.42	10.64	21.95	0.41	5.69	--
S&P 500 Communication Services	1.24	-2.82	23.11	32.13	2.50	13.66	9.33
S&P 500 Utilities	4.86	11.98	22.55	25.55	7.01	7.51	9.50

International Indices	MTD	QTD	YTD	1 Year	3 Years	5 Years	10 Years
MSCI EAFE	3.25	6.28	11.96	19.40	4.13	8.61	5.20
MSCI Europe	3.94	6.17	12.34	19.79	4.80	9.41	5.15
MSCI Pacific	1.83	6.36	11.03	18.37	2.91	7.13	5.35
MSCI EAFE Small Cap	1.98	7.79	8.34	15.08	-2.39	6.45	5.35
MSCI Emerging Markets	1.61	1.92	9.55	15.07	-3.06	4.79	2.56
MSCI Frontier Markets	1.99	3.89	10.05	10.08	-2.67	2.81	1.02

Bond Indices	MTD	QTD	YTD	1 Year	3 Years	5 Years	10 Years
FTSE T-Bill 3 Months	0.46	0.93	3.71	5.65	3.49	2.33	1.62
Bloomberg US Municipal TR	0.79	1.71	1.30	6.09	-0.48	1.02	2.43
Bloomberg US Govt/Credit TR	1.38	3.65	2.95	7.21	-2.31	-0.02	1.76
Bloomberg US Govt/Credit Int TR	1.15	3.05	3.55	7.11	-0.38	0.96	1.80
Bloomberg US Credit 1-3 Yr TR	0.94	2.20	4.02	7.04	1.70	2.01	2.04
Bloomberg US Credit Long TR	2.13	5.34	1.87	9.71	-5.70	-1.21	2.61
Bloomberg US Corporate High Yield TR	1.63	3.61	6.28	12.55	2.55	4.46	4.65
FTSE WGBI	2.30	5.23	1.06	5.68	-5.65	-2.63	-0.64

Other Indices	MTD	QTD	YTD	1 Year	3 Years	5 Years	10 Years
Morningstar US Long-Short Equity	1.12	2.68	10.42	14.79	4.13	6.68	4.24
Morningstar US Equity Market Neutral	1.06	2.26	9.54	13.00	8.06	4.33	2.85
Morningstar US Multistrategy	-0.48	0.08	4.62	6.86	2.75	3.48	2.47
Wilshire Liquid Alternative TR USD	0.69	1.62	5.35	8.46	1.71	2.96	1.80
FTSE EPRA/NAREIT Developed NR USD	6.26	12.67	8.50	17.45	-2.56	1.26	3.09
Alerian MLP TR USD	0.39	1.01	18.90	28.86	26.84	13.72	1.69
Bloomberg Commodity Index TR USD	0.05	-3.99	0.95	-4.39	3.70	7.02	-1.08
S&P Global Infrastructure TR USD	4.64	9.26	13.68	20.22	7.75	6.53	5.50
WTI Crude BL	-5.60	-9.80	2.65	-12.05	2.40	5.95	-2.62
US Dollar Index	-2.30	-3.94	0.36	-1.85	3.16	0.56	2.08
Consumer Price Index *	0.12	0.12	2.54	2.89	4.83	4.16	2.82

* Consumer Price Index returns will be reported as of the previous month end due to the delayed release of data.

Source: Morningstar, ACG

Returns include dividends; 3-year, 5-year and 10-year returns are annualized. Indices are unmanaged.

You cannot invest directly into an index. Past performance is not indicative of future results

Q2 2024: Market Strength Driven by Artificial Intelligence



“The impact of technology is often overestimated in the next two years and underestimated in the next ten.” – Bill Gates

Artificial Intelligence Boom Captivates Markets

of AI Mentions on S&P 500 Earnings Calls
(As % of GDP)

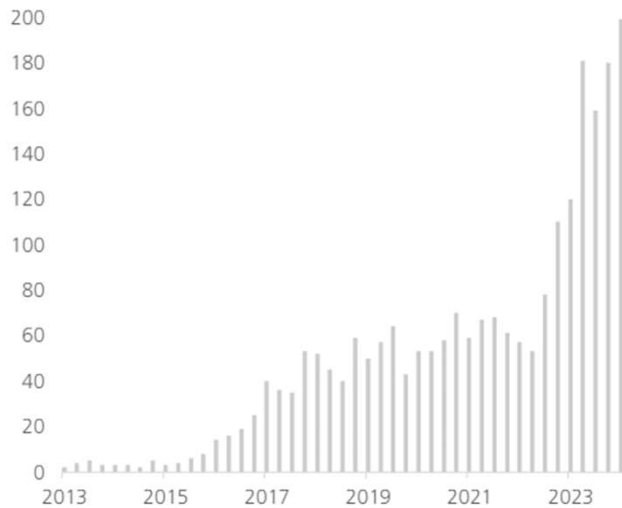

Data Center Capital Expenditures
(Mega Cap Companies)

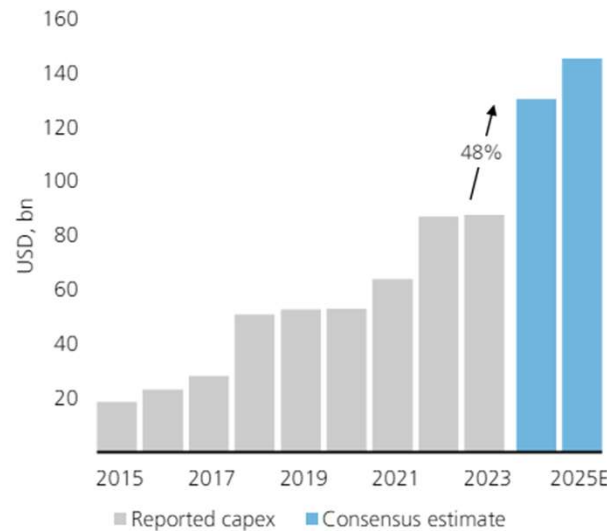

AI Related Investment
(As % of GDP)

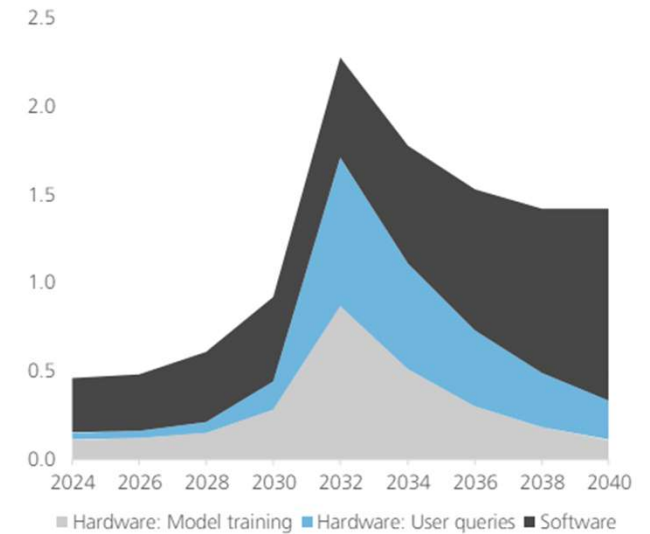

- Artificial Intelligence (or AI for short) has captured the imagination of investors as the new technology is being adopted across a wide range of industries in the hopes of new innovations, productivity gains, and ultimately profits
- Capital expenditures related to AI have also jumped. In the data center space, for example, capex in 2024 is expected to increase almost 50% vs. 2023 to well over \$120 billion per year
- AI related investment is expected to peak in the early 2030s at over 2.0% of GDP and remain a significant portion of the economy going forward

US Economic Growth: Slowing but Steady

U.S. Real GDP Change
(Seasonally Adjusted, Annual Rate)

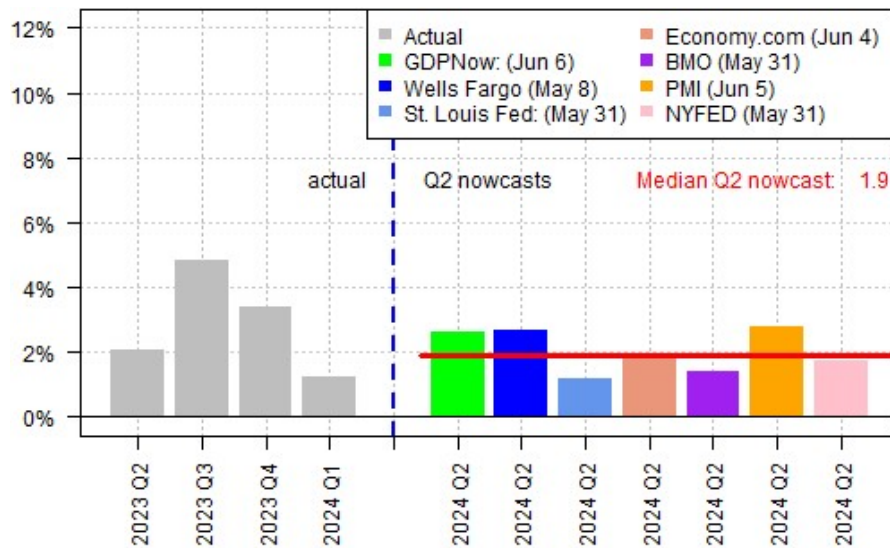

U.S. Real GDP Change
(Seasonally Adjusted, Annual Rate)

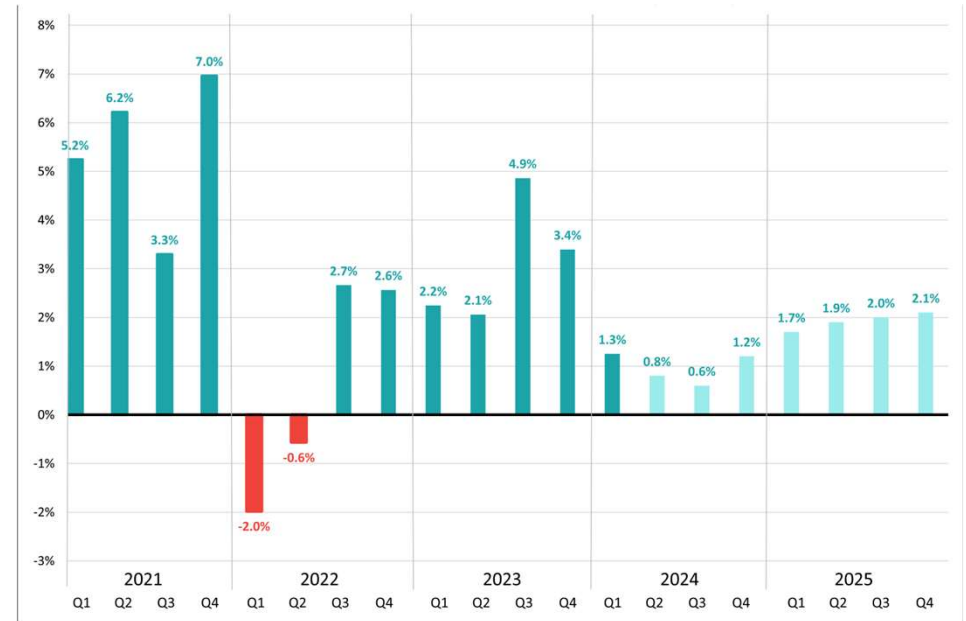

- U.S. economic growth, as measured by Gross Domestic Product (GDP), slowed during the first quarter of 2024. Most estimates of second quarter GDP growth show a slight reacceleration as compared to the first quarter slowdown

- Looking over the longer-term, consensus GDP forecasts expected a slowdown during 2024 and then projected a reacceleration towards the latter half of the year. This expected path is consistent with corporate earnings growth estimates as well

Maybe We've Already Had A Recession?

- The growth sector of the S&P 500 (dominated by technology) went through an EPS recession in 2022 and then recovered while other sectors were contracting. In 2024, estimates suggest defensive and cyclical stocks could emerge from their earnings contractions

S&P 500 Earnings growth by Sector
(Consensus, Year-over-Year Growth)

Quarter	Growth	Defensives	Cyclicals
Q1 2022	0%	15%	18%
Q2 2022	-10%	4%	30%
Q3 2022	-7%	0%	18%
Q4 2022	-17%	-1%	12%
Q1 2023	-5%	-12%	8%
Q2 2023	14%	-13%	-13%
Q3 2023	24%	-7%	-1%
Q4 2023	30%	-5%	-14%
Q1 2024E	21%	-1%	-8%
Q2 2024E	15%	10%	1%
Q3 2024E	12%	11%	1%
Q4 2024E	16%	15%	21%

- The market is currently priced for other companies to pick up the baton, after Nvidia and the other monopolistic tech platforms in the Magnificent 7 accounted for substantially all of the S&P 500's profits in the latter half of last year

Percent Contribution of S&P 500 Earnings
(Year-over-Year Growth)

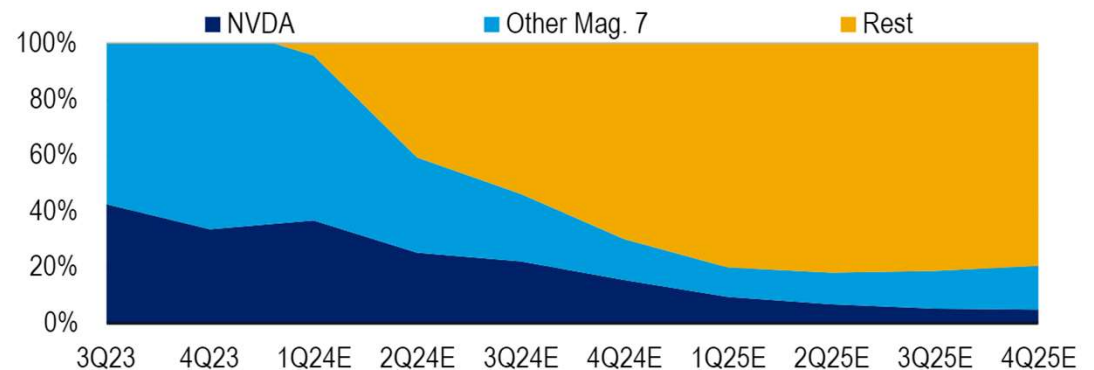

U.S. Corporate Profits Remain Strong

- U.S. corporate earnings remain resilient
- The amount of announced share buybacks in S&P 500 stocks is at a nearly two year high
- Companies continue to announce profitability that is better than analysts' estimates
- Overall margin levels remain elevated and with lower expected input costs, margins could potentially top the record highs seen during the pandemic

S&P 500 Announced Buybacks
(\$ Billion, Per Quarter)

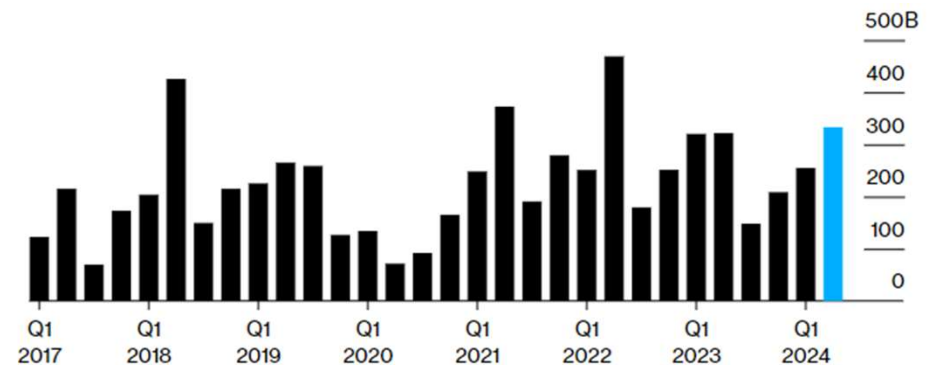

Percent of S&P 500 Companies Beating Estimates
(Vs. Net Margin Expectations)

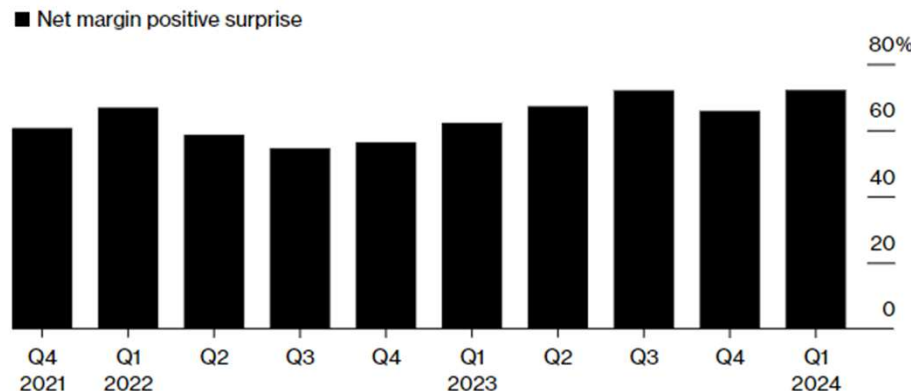

S&P 500 Profit Margins

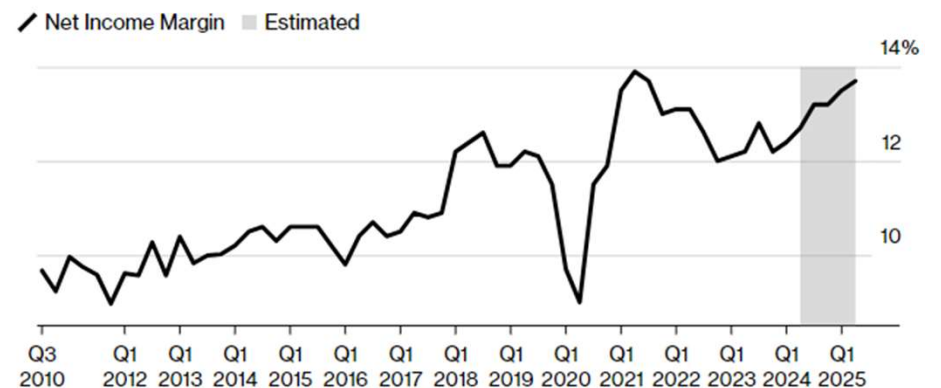

All-Time Highs Are At All-Time Highs!

- The S&P 500 Index closed at its 31st all-time high of the year in late June. This puts the index on pace for one of its best years ever
- The S&P 500 also moved above the 5,500 level for the first time during the second quarter of 2024 which was only 8 days after hitting 5,400. This was the 7th 100-point milestone achieved during 2024 for the index

S&P 500 Number of All-Time Highs
(# Days With Records Highs Through First 6 Months)

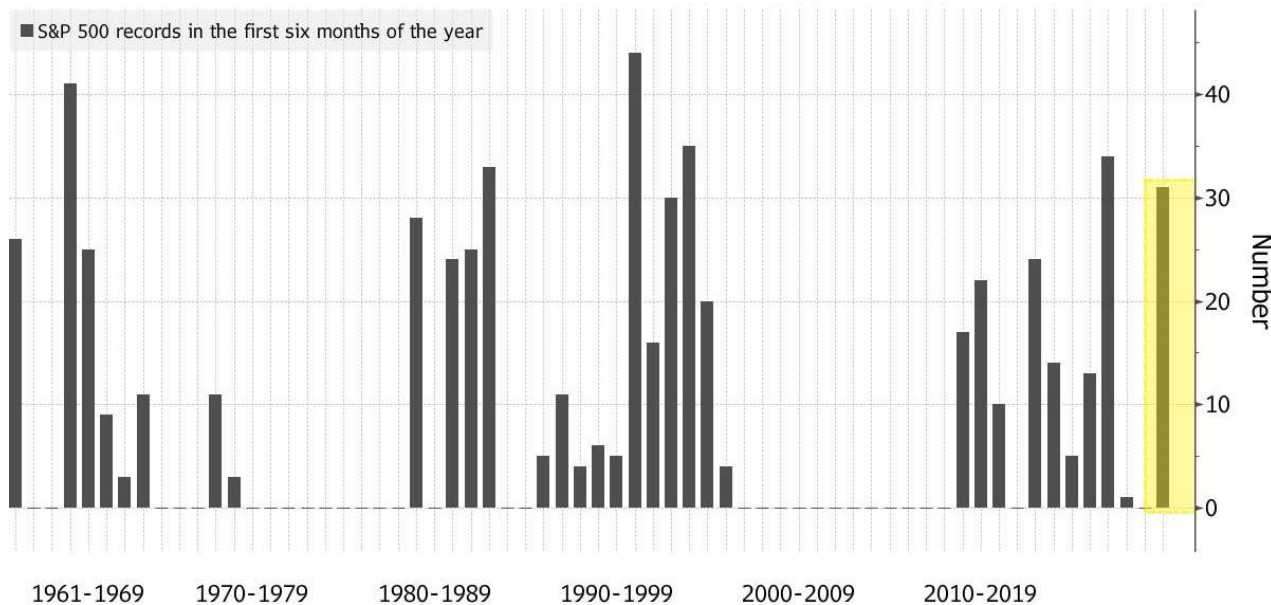

S&P 500 Level	% Change vs. Last Milestone	# Days Between Milestone	Date
5500	1.9%	8	6/20/2024
5400	1.9%	28	6/12/2024
5300	1.9%	56	5/15/2024
5200	2.0%	26	3/20/2024
5100	2.0%	15	2/23/2024
5000	2.0%	15	2/8/2024
4900	2.1%	757	1/24/2024
4800	2.1%	53	12/28/2021
4700	2.2%	7	11/5/2021
4600	2.2%	65	10/29/2021
4500	2.3%	33	8/25/2021
4400	2.3%	24	7/23/2021
4300	2.4%	62	6/29/2021
4200	2.4%	19	4/28/2021
4100	2.5%	8	4/9/2021
4000	2.6%	52	4/1/2021
3900	2.6%	32	2/8/2021
3800	2.7%	30	1/7/2021
3700	2.8%	29	12/8/2020
3600	2.9%	74	11/9/2020
3500	2.9%	3	8/27/2020
3400	3.0%	221	8/24/2020
3300	3.1%	28	1/16/2020
3200	3.2%	37	12/19/2019
3100	3.3%	125	11/12/2019
3000	3.4%	316	7/10/2019
2900	3.6%	224	8/28/2018
2800	3.7%	13	1/16/2018
2700	3.8%	43	1/3/2018
2600	4.0%	67	11/21/2017
2500	4.2%	198	9/15/2017
2400	4.3%	34	3/1/2017
2300	4.5%	65	1/26/2017
2200	4.8%	644	11/22/2016
2100	5.0%	176	2/17/2015
2000	5.3%	104	8/25/2014
1900	5.6%	176	5/13/2014
1800	5.9%	109	11/18/2013
1700	6.3%	90	8/1/2013
1600	6.7%	4790	5/3/2013
1500	7.1%	260	3/22/2000
1400	7.7%	117	7/6/1999
1300	8.3%	80	3/11/1999

Foreign Equity Markets Beginning to Perform

- International stocks continue to outperform the S&P 500 since the current bull market began in October 2022, as you can see in the chart to the right. The total return of the MSCI EAFE Index is outperforming the S&P 500 total return by about four percentage points, as measured in U.S. dollars. If the performance of the "Magnificent 7" stocks (Alphabet, Amazon, Apple, Meta, Microsoft, Nvidia, and Tesla) are excluded, the outperformance is closer to 20 percentage points, illustrating the concentration of gains in the U.S. market among just a handful of stocks.

Return Comparison
(Cumulative Return Since October 1, 2022)



- After the pandemic-induced global slowdown in 2020, economies bounced back sharply in 2021. In 2022 and 2023 most global economies continued to grow, albeit at a slower pace. In 2024 more than half of the world's largest economies started to reaccelerate

GDP Growth Breakdown
(45 Biggest Global Economies)

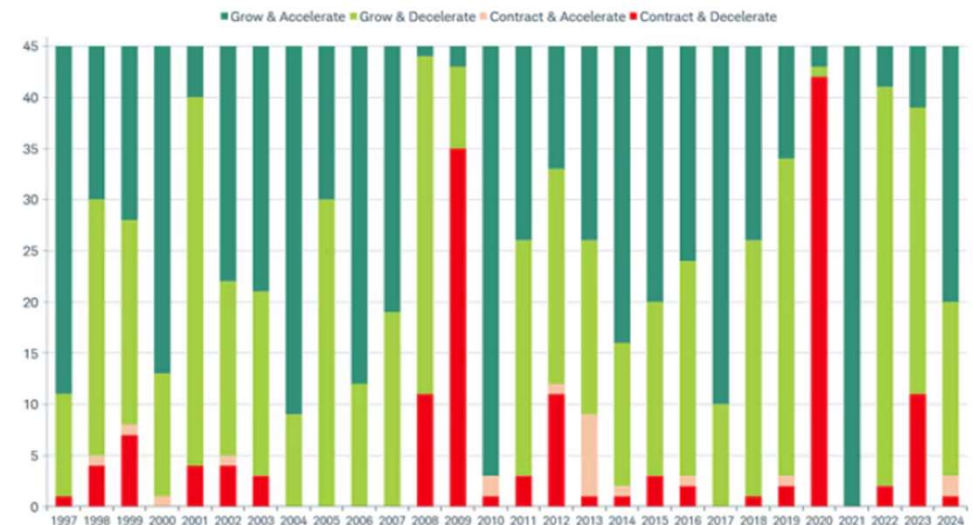

Valuation Update

- While stocks continue to rise, the driver of returns has shifted. Last year's gains were powered by higher valuations – following the sell-off in 2022. In 2024, a better-than-expected economy is powering stronger earnings, which are increasingly driving returns for US stocks

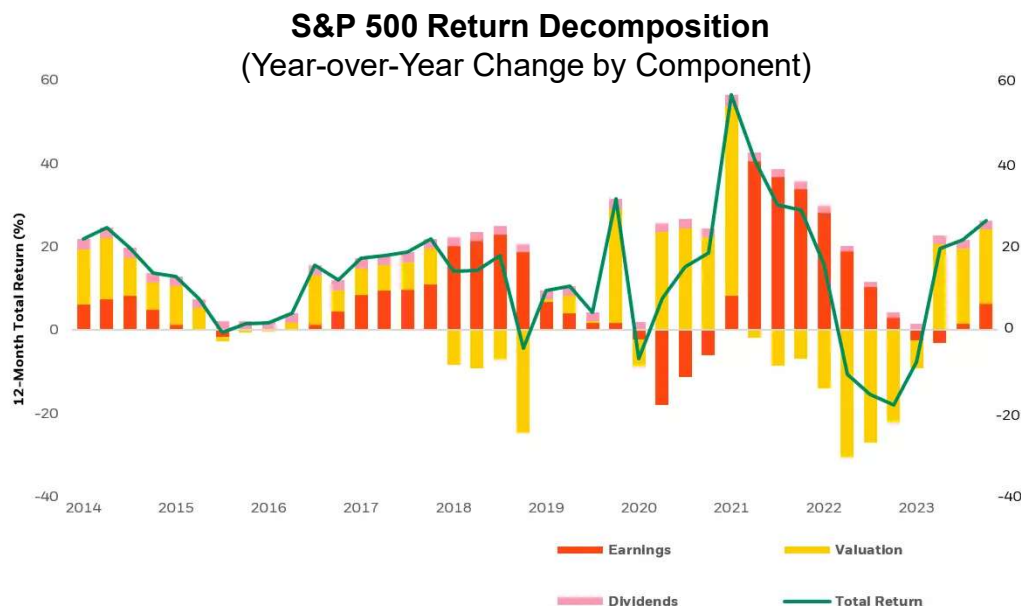

- On average, equity markets tend to exhibit a normal distribution of valuations across stocks. Currently, however, companies with relatively high valuations make up a far greater share of the MSCI World index of developed economies than on average for the last 25 years (a period that includes the dot-com bubble). This is a direct result of the high level of concentration in the equity markets today

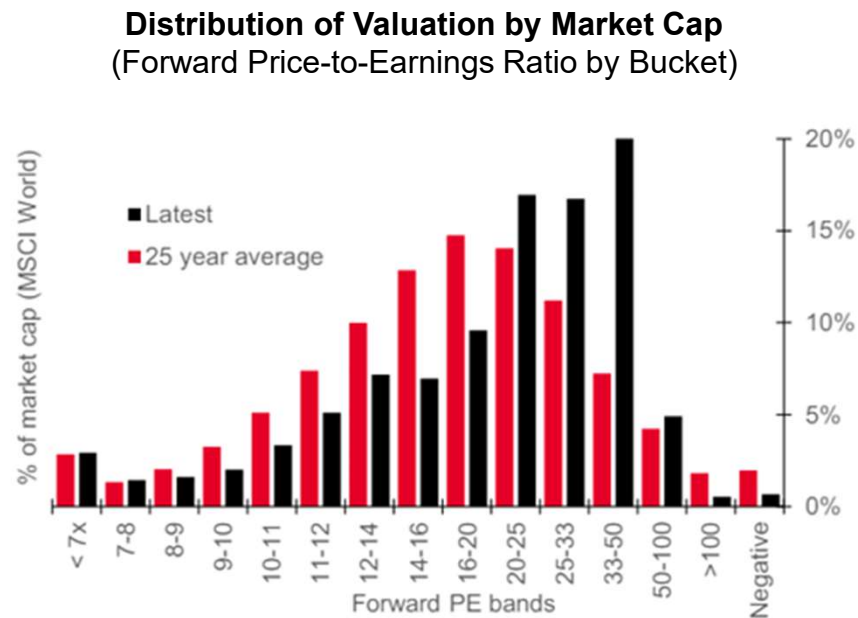

Performance Still Dependent on Company Size

- While the Magnificent Seven stocks have increased by a factor of five since the beginning of 2020, small cap stocks have lagged significantly. The average small cap stock, using the Russell 2000 equal weight index as a proxy, is up only 17% cumulative over the same period.

Magnificent 7 vs. Small Cap Performance (Index Performance Since 2020)



- This trend of performance being driven by company size was very much in place during Q2 2024. As you can see in the chart to the right, only the largest decile of stocks in the S&P 500 actually had positive returns. All other deciles were flat or negative – with notable relative underperformance from the bottom three deciles

S&P 500 Deciles by Market Cap (Q2 2024 Average Total Return)

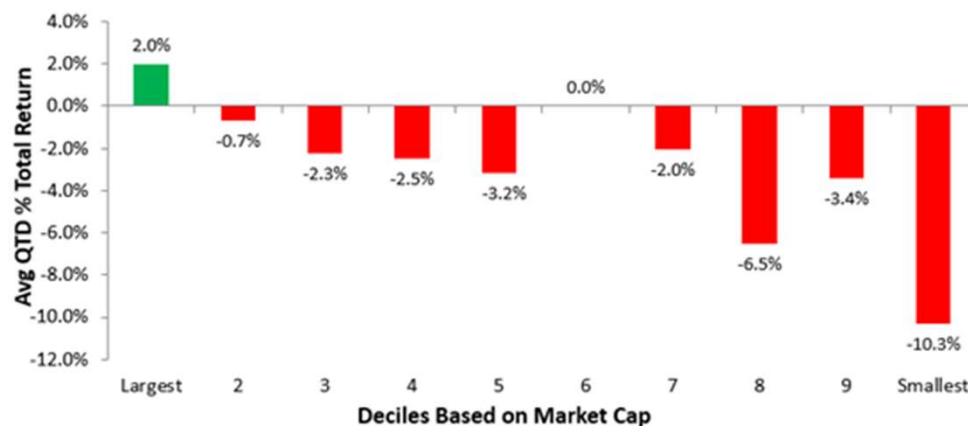

Inflation Update

- The overall rate of inflation continues to decelerate, albeit slowly. An interesting way to view inflation is comparing the discretionary vs. non-discretionary components. Piper Sandler recently separated the consumer price index (CPI) into discretionary (wants) and non-discretionary (needs) cohorts. Over the past two years, there has been a plunge in inflation of discretionary items; while the inflation rate in non-discretionary categories (like health care, shelter, insurance, etc.) has accelerated sharply to more than 6% year-over-year

Discretionary vs. Non-Discretionary Consumer Prices
(Year-over-year Change by Grouping)

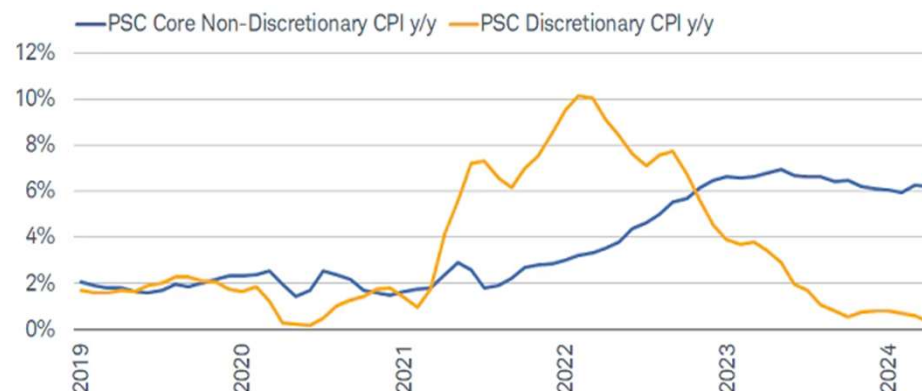

- Stubbornly high inflation has also started to change consumer behavior. A recent Nielsen study found an increase in spending on store brands relative to national brands. While consumers can change their behaviors to battle inflation to some degree, watching consumers for any signs of a pullback on overall spending will be key moving forward

National Brand vs. Store Brand Sales
(May 2024/ May 2023 Change)

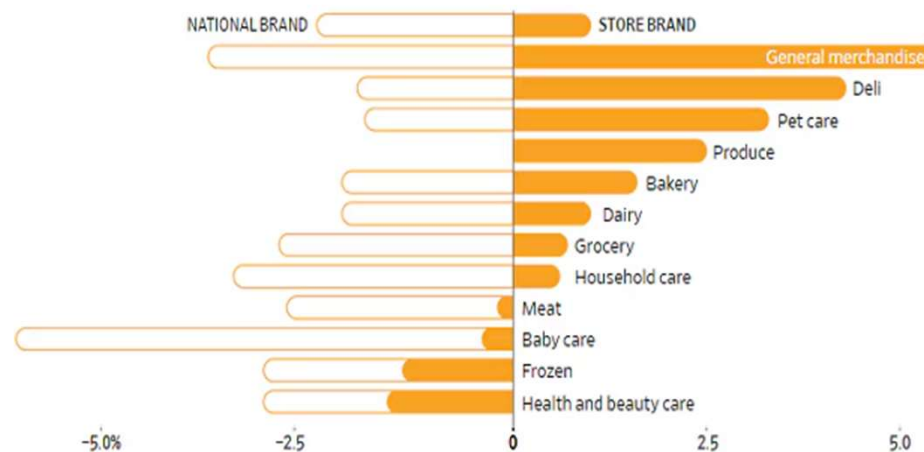

Source: Piper Sandler, Bureau of Labor Statistics, Nielsen, Wall Street Journal, ACG

Note: CPI indexes created by PSC. Core Non-Discretionary categories: Medical Care Commodities, Rent, Hospital Services, Motor Vehicle Maintenance, Motor Vehicle insurance, Motor Vehicle Fees, Day Care and Preschool, Wireless Telephone Services, Internet Services, Personal Care Products, Legal Services, Funeral Expenses, Haircuts & Other Personal Care Services, Financial Services, Pet Services including Veterinary.

(G)Rate Expectations

- Two years ago, the Federal Open Market Committee (FOMC) median projected Fed Funds Rate for the end of 2024 was near 2.75%. As the Federal Reserve kept short-term rates higher for longer, that projection has adjusted up to an expectation of near 5.0% at the end of 2024 as of today

Predicted vs. Actual Fed Funds Rate
(FOMC Median vs. Effective Rate)

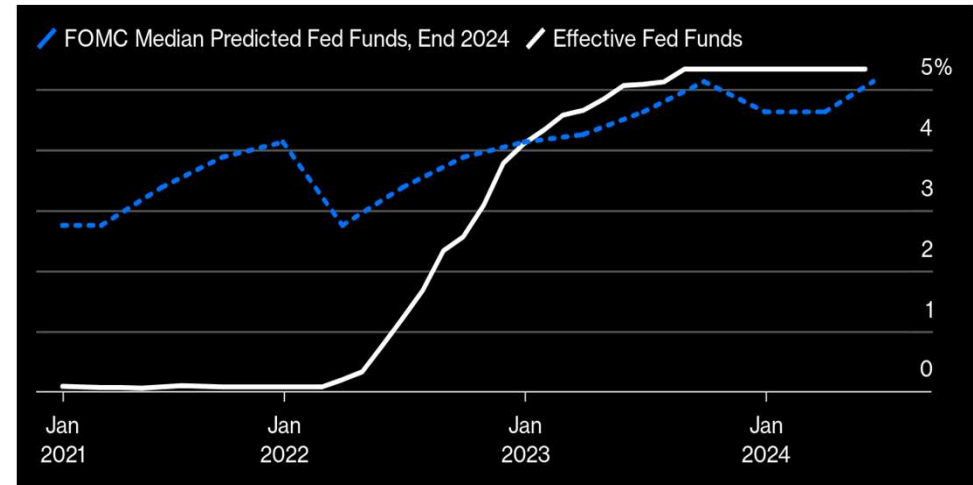

- Looking forward, both the Fed and the market see rate cuts ahead, but they differ on the expectations for the timing of those cuts. The Fed now projects a single 25 basis point (bps) cut by the end of 2024 and 125 bps in cuts by year end 2025. The market sees almost 50 bps of cuts by December 2024 and 145 bps of cuts by year end 2025

Fed Funds Rate Expectations
(Options Implied Rate vs. Fed Projection)

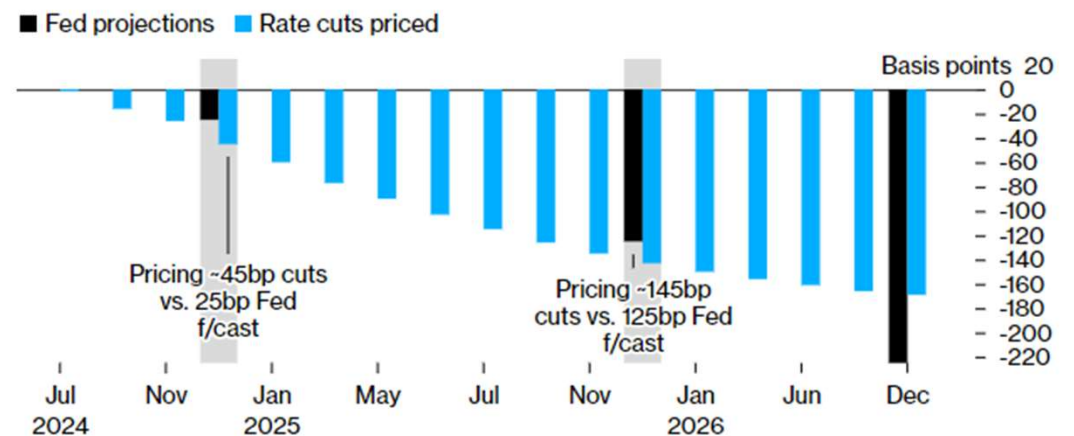

Election Year Influence on Fed?

- Many pundits have suggested the potential for election year influence by the Fed. The Federal Open Market Committee (FOMC), which sets rates, was chartered to be apolitical. Seven of the twelve members of the FOMC are Fed Governors and five are presidents of regional Federal Reserve Banks. Most come from outside the political sphere. Historically, rate decisions in the months leading up to an election during both election and non-election years were not notably different

FOMC Rate Decisions*
(1994 – Current)

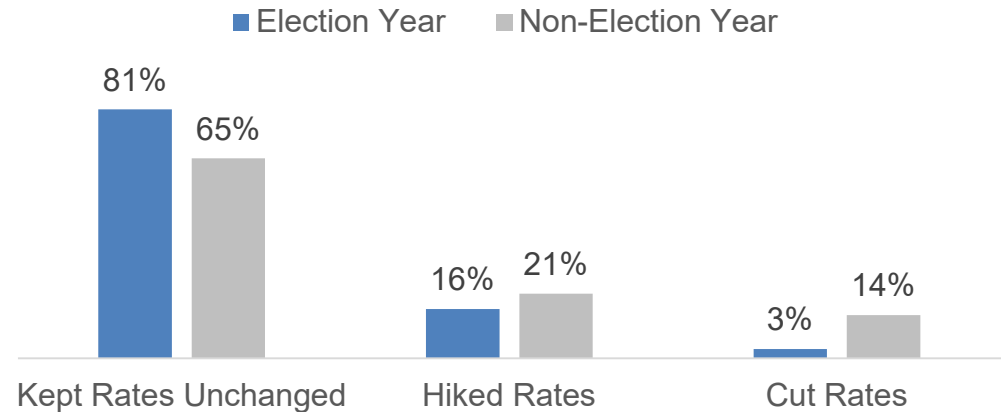

- Looking back and including the full election years, those years with large rate cuts were caused by significant events outside of the election. In 1992, the FOMC cut rates as a result of the fallout following the S&L crisis and early 1990s recession. In 2008, the FOMC cut rates due to the Global Financial Crisis. And in 2020, they were forced to cut due to the Pandemic

Fed Funds Target Rate
(1984 - 2020)

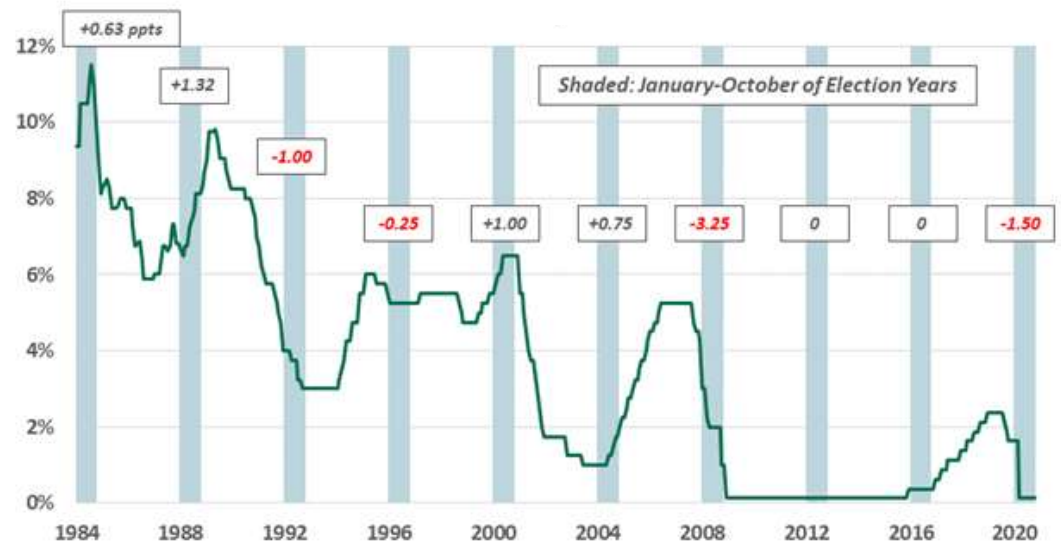

Source: Bloomberg, Bespoke Investment Group, ACG
* May to November

Fixed Income Rates

Performance Across Hiking Cycles

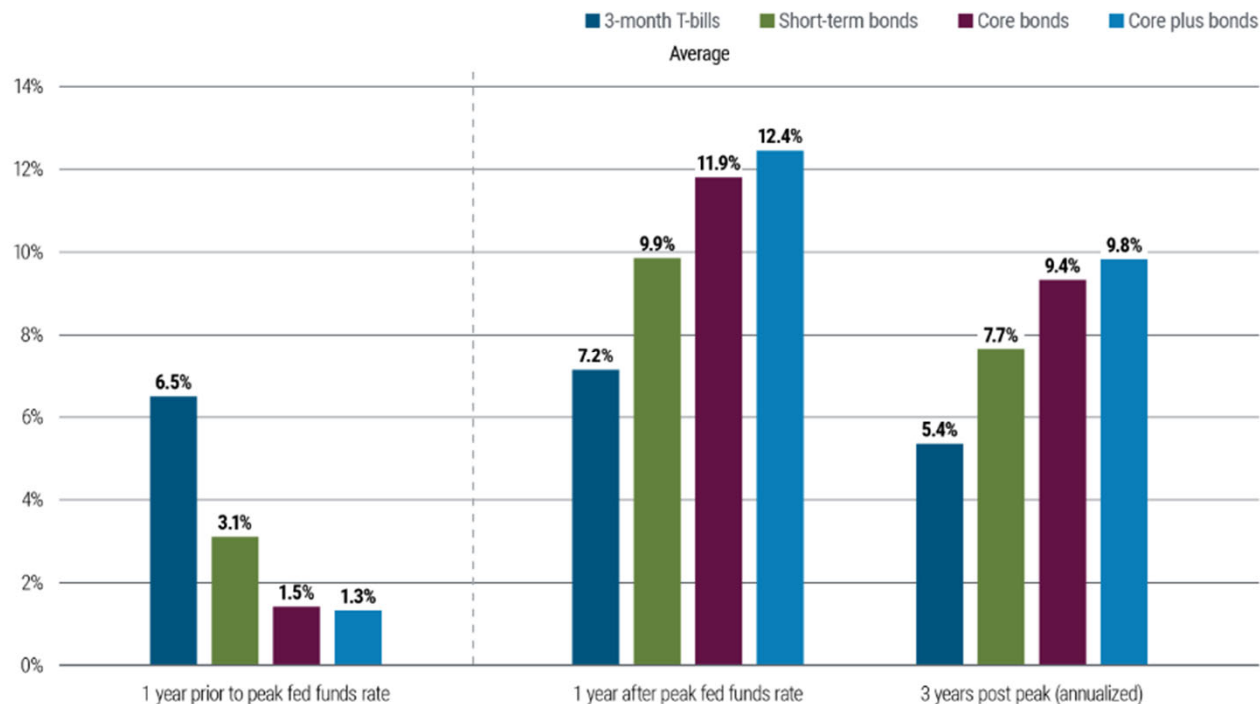

- Historically, cash has almost never outperformed bonds at this stage of the cycle, with policy rates at peak levels and the Federal Reserve poised to cut
 - Only in 1981 did bond investors have to wait a little more than a year from the initial rate cut to outperform cash
- In all other cycles dating back to 1980, it took a year or less for bonds to outperform cash. On average, core plus bond portfolios (or short and intermediate maturities) outperformed cash by about 5 percentage points over the year following the peak in the federal funds rate, and by about 4.5 percentage points annualized over the ensuing three years

Hiking cycles are defined as periods where the Federal Reserve embarks on a sustained path of increasing the target fed funds rate and/or target range. We define the end of a hiking cycle as the month where the Fed reaches its peak policy rate for that cycle (i.e., it either pauses rate hikes or cuts). Hiking cycles include (start to peak), 1980 (Jul '80 to May '81), 1983 (Feb '83 to Aug '84), May 1988 (Feb '88 to Mar '89), 1994 (Jan '94 to Feb '95), 1999 (May '99 to May '00), 2004 (May '04 to Jun '06) and 2015 (Nov '15 to Dec '18).

Appendix: T+1 Settlement Changes

T+5 to T+1: Transaction Settlement in History

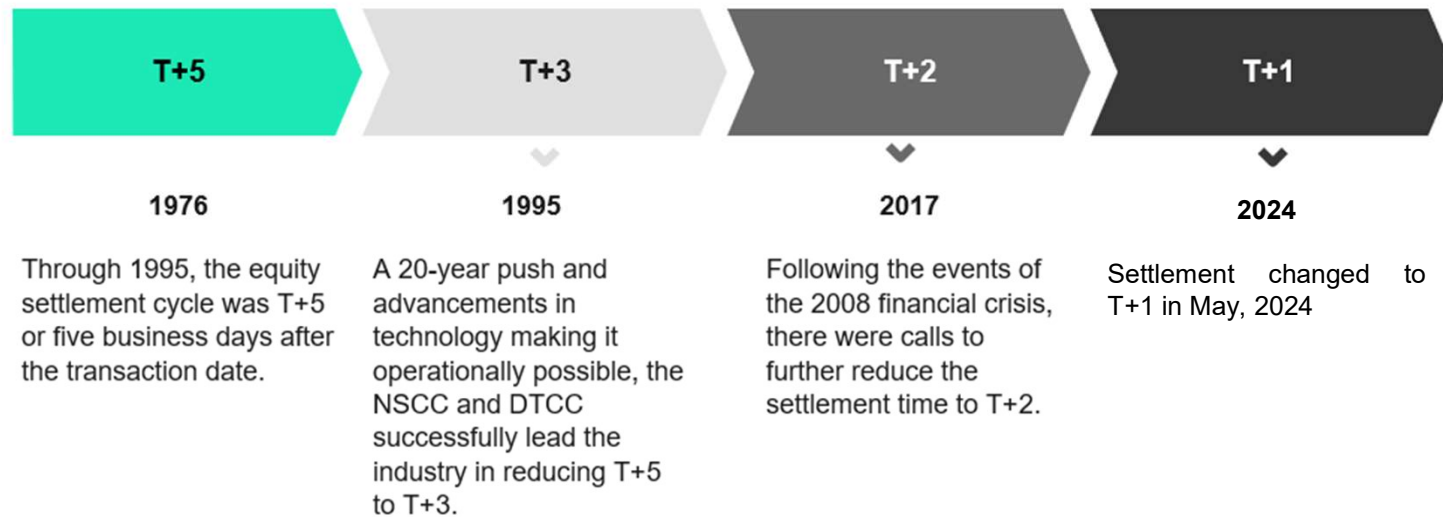

- The transaction date is the day you successfully execute a trade
- The settlement date is when that trade becomes official. It's the date when payment is due for purchases, when securities sold must be delivered, and the security's transfer agent has verified the new shareholder and removed the former one.
- The recent move to T+1 settlement reflects improvements in technology that allow trades to settle more quickly.
 - With most trading and banking activity occurring online, extra days to physically deliver securities or funds are no longer needed.
 - Under the new T+1 settlement cycle, most securities transactions will settle on the next business day following their transaction date. For example, if you sell shares of a stock on Tuesday, the transaction will now settle on Wednesday.

Appendix: Private Market Update

Global IPOs Recovering After Worst Year in a Decade

First-time share sales this year may surpass 2023's. That's a low bar

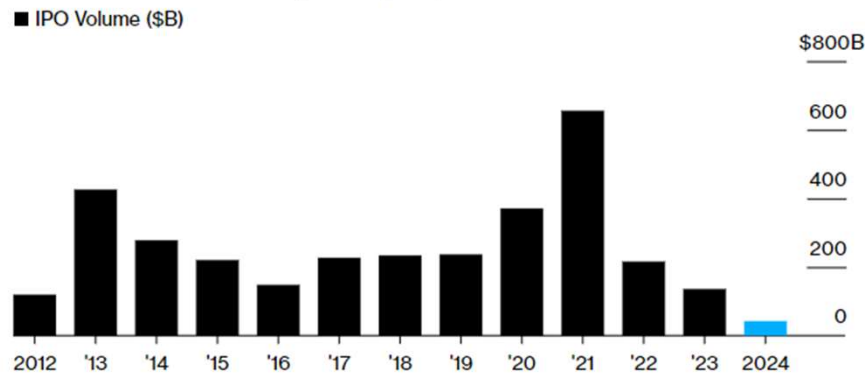

Source: Bloomberg
Note: 2024 figure is year to May 7 inclusive

Value of Unexited Companies Reaches \$3.2 Trillion Globally

Lack of IPO, M&A opportunity sends aging portfolio company value to record

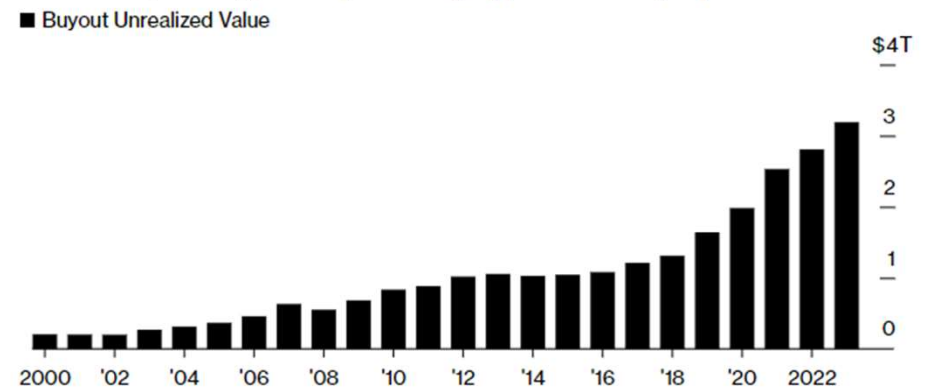

Source: Preqin, via Bain & Co.
Note: 2023 figure covers until September

- Initial Public Offerings (IPOs) are off to a slow start in 2024 following the slowest year for IPO volumes in a decade in 2023. This has both slowed distributions in existing private equity funds and also slowed the pace of fundraising in newer vintage year funds
- After a slowdown in exit activity through fewer IPOs and less M&A activity, the value of unexited private companies has hit a record.

Appendix: 2024 U.S. Elections

- Neither political party has appetite for additional large-scale fiscal stimulus, nor for reforms to long-term spending
- However, divergences in trade, tax, industrial, and other policy areas mean that consequences will vary based on the occupant of the White House and the makeup of Congress

Democrats Win	Republicans Win
<ul style="list-style-type: none">• Tariffs and export controls could be used tactically, but not to the extent they might under Republican leadership• Corporate taxes could rise, although an expansion of refundable tax credits for families could be pursued• A Democratic sweep would likely lead to expansion of Affordable Care Act subsidies, which would tend to benefit the health care sector• Financial sectors could face a tougher regulatory environment• Greater support for green energy – although fiscal space would tend to be constrained given the deficit and debt picture• Tighter restrictions on fossil fuel industries	<ul style="list-style-type: none">• Likely to see tariffs rise• Prohibitions on immigration pursued• Expiring tax cuts either all or mostly extended• Sectors likely to benefit under Republican leadership include oil and gas, pipelines, autos, financials, and areas linked to defense spending• Renewable energy would face headwinds• Consumer companies would face elevated tariff risk• Technology firms could be hit with negative headlines

DISCLOSURE

Investing is subject to a high degree of investment risk, including the possible loss of the entire amount of an investment. You should carefully read and review all information provided by The Atlanta Consulting Group Advisors, LLC (“ACG”), including ACG’s Form ADV, Part 2A brochure and all supplements thereto, before making an investment.

The information contained herein reflects the opinions and projections of the ACG as of the date of publication, which are subject to change without notice at any time subsequent to the date of issue. All information provided is for informational purposes only and should not be deemed as investment advice or a recommendation to purchase or sell any specific security. While the information presented herein is believed to be reliable, no representation or warranty is made concerning the accuracy of any data presented. You should not treat these materials as advice in relation to legal, taxation, or investment matters.

Various indices, including, but not limited to the S&P 500 Index, the FTSE 3-Month Treasury Bill Index, and the Russell 2000 index (each, an “Index”) are unmanaged indices of securities that are used as general measures of market performance, and their performance is not reflective of the performance of any specific investment. The Index comparisons are provided for informational purposes only and should not be used as the basis for making an investment decision. Further, the performance of an account managed by ACG and each Index may not be comparable. There may be significant differences between an account managed by ACG and each Index, including, but not limited to, risk profile, liquidity, volatility and asset comparison. The performance shown for each Index reflects no deduction for client withdrawals, fees or expenses. Accordingly, comparisons against the Index may be of limited use. Investments cannot be made directly into an Index.

Historical returns data has been compiled using data calculated by ACG and third parties (e.g., Morningstar and mutual funds). ACG has not independently verified data provided by third parties and cannot and does not guarantee the accuracy of data calculated by third parties. All information provided is for informational purposes only and should not be deemed as advice in relation to legal, taxation, or investment matters. No representations or warranties whatsoever are made by ACG or any other person or entity as to the future profitability of an account or the results of making an investment. Past performance is no guarantee of future results. An investment in an account is subject to a high degree of investment risk, including the possible loss of the entire amount of investment.

Statements herein that reflect projections or expectations of future financial or economic performance of the Fund are forward-looking statements. Such “forward-looking” statements are based on various assumptions, which assumptions may not prove to be correct. Accordingly, there can be no assurance that such assumptions and statements will accurately predict future events or ACG’s actual performance. No representation or warranty can be given that the estimates, opinions or assumptions made herein will prove to be accurate. Any projections and forward-looking statements included herein should be considered speculative and are qualified in their entirety by the information and risks disclosed in the confidential offering document. Actual results for any period may or may not approximate such forward-looking statements. You are advised to consult with your independent tax and business advisors concerning the validity and reasonableness of the factual, accounting and tax assumptions. No representations or warranties whatsoever are made by ACG any other person or entity as to the future profitability of investments recommended by ACG.

This report is based on transaction records, portfolio valuations, and performance supplied by the client, the custodian, the investment manager, and investment databases including Bloomberg and Morningstar. Due to the timeliness of this report performance information may be preliminary and therefore subject to audit. This report is complete and accurate to the best of our knowledge.

We urge you to take a moment to compare the account balances contained in this report to those balances reflected on the statements that you receive directly from your account’s custodian. Please contact us or the account custodian with any questions you may have. Also, please notify us promptly if you do not receive statements on all accounts from the custodian on at least a quarterly basis.

INDEX DESCRIPTIONS

Asset class and reference benchmarks:

ASSET CLASS	BENCHMARK
U.S. Equity	Russell 3000 TR
Non-U.S. Equity	MSCI ACWI ex US NR
U.S. Fixed Income	Bloomberg Barclays U.S. Aggregate Bond TR
Global Real Estate (prior to 2008)	NASDAQ Global Real Estate NR
Global Real Estate (2008-present)	FTSE EPRA/NAREIT Global Real Estate NR
Commodities	Bloomberg Commodity TR USD
Cash & Cash Alternatives	Citi Treasury Bill 3 Mon USD

Alerian MLP: The Alerian MLP Index is the leading gauge of large- and mid-cap energy Master Limited Partnerships (MLPs). The float-adjusted, capitalization-weighted index, which includes 50 prominent companies and captures approximately 75% of available market capitalization, is disseminated real-time on a price-return basis (AMZ) and on a total-return basis (AMZX).

Bloomberg 10-Year U.S. Treasuries: Measures the performance of U.S. Treasury securities that have a remaining maturity of 10 years.

Bloomberg U.S. Aggregate Index: Represents securities that are SEC-registered, taxable, and dollar denominated. The index covers the U.S. investment-grade fixed rate bond market, with index components for government and corporate securities, mortgage pass-through securities, and asset-backed securities.

Bloomberg Global Aggregate ex-U.S. Dollar Bond Index: Tracks an international basket of bonds that currently contains 65% government, 14% corporate, 13% agency and 8% mortgage-related bonds.

Bloomberg High Yield: Covers the universe of fixed-rate, non-investment grade debt. Pay-in-kind (PIK) bonds, Eurobonds, and debt issues from countries designated as emerging markets (e.g., Argentina, Brazil, Venezuela, etc.) are excluded, but Canadian and global bonds (SEC-registered) of issuers in non-EMG countries are included. Original issue zeroes, step-up coupon structures and 144-As are also included.

Bloomberg U.S. Corporate High Yield: Composed of fixed-rate, publicly issued, non-investment grade debt.

The Dow Jones Industrial Average is an unmanaged index of 30 widely held securities.

Dow Jones U.S. Total Stock Market Index, which comprises all U.S. equity securities with readily available prices.

FTSE 3-Month Treasury-Bill Index: This is an unmanaged index of three-month Treasury bills.

FTSE EPRA/NAREIT Global Real Estate Index: Designed to represent general trends in eligible listed real estate stocks worldwide. Relevant real estate activities are defined as the ownership, trading and development of income producing real estate.

INDEX DESCRIPTIONS

Gross Domestic Product (GDP) is the annual market value of all goods and services produced domestically by the US.

Morningstar US Equity-Market Neutral: These funds attempt to reduce systematic risk created by factors such as exposures to sectors, market-cap ranges, investment styles, currencies, and/or countries. They try to achieve this by matching short positions within each area against long positions. These strategies are often managed as beta-neutral, dollar-neutral, or sector-neutral. A distinguishing feature of funds in this category is that they typically have low beta exposures (less than 0.3 in absolute value) to equity market indexes such as the MSCI World. In attempting to reduce systematic risk, these funds put the emphasis on issue selection, with profits dependent on their ability to sell short and buy long the correct securities.

Morningstar US Event Driven : These funds attempt to profit from price changes related to a variety of corporate actions, including bankruptcy, emergence from bankruptcy, divestitures, stock buybacks, dividend issuance, major shifts in corporate strategy, and other atypical events. Many of these funds undertake activist techniques to spur further corporate changes at the underlying companies.

Morningstar US Long-Short Equity: These funds primarily take long and short positions in U.S. equities. These funds follow a strategy in which at least 75% of the fund's gross exposure is in equities, and 75% of equities exposure is in U.S. equities. The fund may also include some derivative instruments. These funds tend to have betas of 0.3 and higher relative to broad U.S. indexes like the S&P 500 and DJ Wilshire 5000.

Morningstar US Macro Trading: These funds base investment decisions on an assessment of the broad macroeconomic environment. They look for investment opportunities by studying such factors as the global economy, government policies, interest rates, inflation, and market trends. As opportunists, these funds are not restricted by asset class and may invest across such disparate assets as global equities, bonds, currencies, derivatives, and commodities. These funds primarily invest through derivatives markets. They typically make discretionary trading decisions rather than using a systematic strategy. At least 60% of the funds' exposure is obtained through derivatives.

Morningstar US Multistrategy: These funds offer investors exposure to several different hedge fund investment tactics. In most of these cases, all of the assets are managed in-house at the hedge fund, but the assets may be divided between multiple portfolio managers, each of whom focuses on a different strategy. This is not to be confused with a fund of funds, which uses external portfolio managers and strategies, as well as second layer of management and performance fees. An investor's exposure to different tactics may change slightly over time in response to market movements.

MSCI All Country World Index Ex-U.S Index.: A market-capitalization-weighted index maintained by Morgan Stanley Capital International (MSCI) and designed to provide a broad measure of stock performance throughout the world, with the exception of U.S.-based companies. It includes both developed and emerging markets.

MSCI EAFE Index (Europe, Australasia, Far East): A free-float adjusted market capitalization index that is designed to measure developed market equity performance, excluding the United States and Canada. The EAFE consists of the country indices of 21 developed nations.

MSCI EAFE Growth Index: Represents approximately 50% of the free-float adjusted market capitalization of the MSCI EAFE index, and consists of those securities classified by MSCI as most representing the growth style.

MSCI EAFE Small-Cap Index: An unmanaged, market-weighted index of small companies in developed markets, excluding the U.S. and Canada.

MSCI EAFE Value: Represents approximately 50% of the free-float adjusted market capitalization of the MSCI EAFE index, and consists of those securities classified by MSCI as most representing the value style.

MSCI Emerging Markets Index: Designed to measure equity market performance in 25 emerging market indexes. The three largest industries are materials, energy and banks.

The NASDAQ Composite Index is an unmanaged index of all stocks traded on the NASDAQ over-the-counter market.

Russell 1000 Index: Measures the performance of the 1,000 largest companies in the Russell 3000 Index, which represents approximately 90% of the investible U.S. equity market.

Russell 1000 Value Index: Measures the performance of those Russell 1000 companies with lower price-to-book ratios and lower forecasted growth values.

INDEX DESCRIPTIONS

Russell 1000 Growth Index: Measures the performance of those Russell 1000 companies with higher price-to-book ratios and higher forecasted growth values.

Russell Mid-Cap Index: Measures the performance of the 800 smallest companies of the Russell 1000 Index, which represent approximately 30% of the total market capitalization of the Russell 1000 Index.

Russell Mid-Cap Value Index: Measures the performance of those Russell Mid-cap companies with lower price-to-book ratios and lower forecasted growth values.

Russell Mid-Cap Growth Index: Measures the performance of those Russell Mid-cap companies with higher price-to-book ratios and higher forecasted growth values.

Russell 2000 Index: Measures the performance of the 2,000 smallest companies in the Russell 3000 Index, which represent approximately 8% of the total market capitalization of the Russell 3000 Index.

Russell 2000 Value Index: Measures the performance of those Russell 2000 companies with lower price-to-book ratios and lower forecasted growth values.

Russell 2000 Growth Index: Measures the performance of those Russell 2000 companies with higher price-to-book ratios and higher forecasted growth values.

Russell 3000 Index: Measures the performance of the 3,000 largest U.S. companies based on total market capitalization, which represents approximately 98% of the investable U.S. equity market.

Standard & Poor's 500 (S&P 500): Measures changes in stock market conditions based on the average performance of 500 widely held common stocks. Represents approximately 68% of the investable U.S. equity market.

Wilshire Liquid Alternative Index: The Wilshire Liquid Alternative IndexSM measures the collective performance of the five Wilshire Liquid Alternative strategies that make up the Wilshire Liquid Alternative Universe. The Wilshire Liquid Alternative Index (WLIQA) is designed to provide a broad measure of the liquid alternative market by combining the performance of the Wilshire Liquid Alternative Equity Hedge IndexSM (WLIQAEH), Wilshire Liquid Alternative Global Macro IndexSM (WLIQAGM), Wilshire Liquid Alternative Relative Value IndexSM (WLIQARV), Wilshire Liquid Alternative Multi-Strategy IndexSM (WLIQAMS), and Wilshire Liquid Alternative Event Driven IndexSM (WLIQAED).

Total Composite

As of August 31, 2024

Fiscal Year End: August

Current Allocation

Equity	\$49,399,814	48.37%
International	\$13,125,769	12.85%
Fixed	\$22,834,606	22.36%
Global Fixed Income	\$3,659,466	3.58%
Alternative Investments	\$5,464,693	5.35%
Cash	\$7,635,876	7.48%
Total	\$102,120,225	100.00%

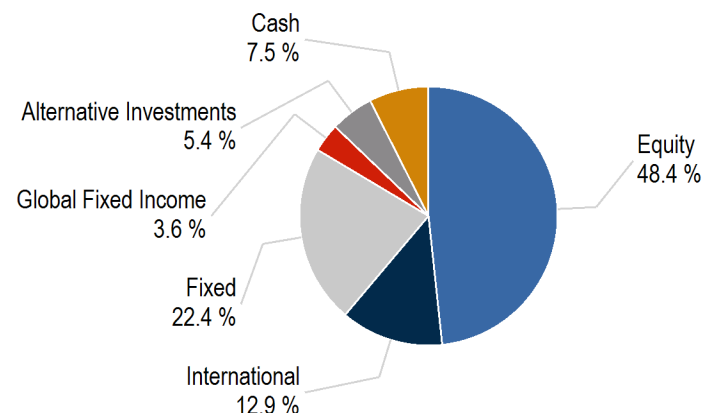

*Fixed market value contains transactional cash and accrued income held at Smith Graham

Summary of Cash Flows

	Last Month	Last Three Months	Year-To-Date
Beginning Market Value	\$98,901,911	\$95,616,294	\$89,937,316
Net Cash Flow	\$1,410,797	\$1,406,225	\$2,449,590
Net Investment Change	\$1,807,516	\$5,097,706	\$9,733,319
Income	\$124,759	\$523,278	\$1,299,178
Ending Market Value	\$102,120,225	\$102,120,225	\$102,120,225

Performance Summary

	1 Mo (%)	3 Mo (%)	YTD (%)	Fiscal YTD (%)	1 Yr (%)	3 Yrs (%)	5 Yrs (%)	10 Yrs (%)	15 Yrs (%)
Total Composite	1.83	5.33	10.89	16.84	16.84	3.36	9.92	8.28	9.63
Balanced Index	1.80	5.52	11.35	17.21	17.21	--	--	--	--
Total Fund Policy Index	1.87	6.27	13.68	20.28	20.28	5.59	11.01	9.43	10.78
Spliced Fixed Income Index	1.15	3.87	3.55	7.11	7.11	-0.38	0.78	2.06	2.86
Russell 3000	2.18	7.30	18.19	26.14	26.14	7.87	15.19	12.36	13.96

Total Composite

As of August 31, 2024

	Current Balance	Current Allocation	Policy Range	Within IPS Range?
US Equity	\$49,399,814	48.37%	25.00% - 75.00%	Yes
iShares Total U.S. Stock Market	\$49,399,814	48.37%		
Non-US Equity	\$13,125,769	12.85%	0.00% - 25.00%	Yes
Harding Loevner Intl	\$8,783,074	8.60%		
Delaware Emerging Markets Instl	\$4,342,695	4.25%		
US Fixed Income	\$22,834,606	22.36%	15.00% - 75.00%	Yes
Loop (Smith Graham)	\$18,319,854	17.94%		
Shenkman Short Duration High Income	\$4,514,752	4.42%		
Non-US Fixed Income	\$3,659,466	3.58%	0.00% - 25.00%	Yes
Brandywine Global Opp Bd	\$3,659,466	3.58%		
Alternatives	\$5,464,693	5.35%	0.00% - 15.00%	Yes
Golub Capital Partners 14	\$1,468,774	1.44%		
Magnitude International	\$3,995,919	3.91%		
Cash	\$7,635,876	7.48%	0.00% - 5.00%	No
Cash	\$7,635,637	7.48%		
Markston Accrued Income	\$239	0.00%		
Total	\$102,120,225	100.00%		

*Loop (Smith Graham) holds transactional cash and accrued income

Total Composite

As of August 31, 2024

Fiscal Year End: August

	Manager Status	Market Value (\$)	% of Portfolio	1 Mo (%)	3 Mo (%)	YTD (%)	Fiscal YTD (%)	1 Yr (%)	3 Yrs (%)	5 Yrs (%)	10 Yrs (%)	Inception (%)	Inception Date
Total Composite		102,120,225	100.00	1.83	5.33	10.89	16.84	16.84	3.36	9.92	8.28	8.03	Oct-94
Balanced Index				1.80	5.52	11.35	17.21	17.21	--	--	--	--	Oct-94
Equity Composite		62,525,583	61.23	2.25	6.72	15.37	23.18	23.18	5.15	13.55	10.75	9.11	Oct-94
Equity Balanced Index				2.23	6.88	16.55	24.18	24.18	7.00	14.63	12.09	10.56	Oct-94
iShares Total U.S. Stock Market		49,399,814	48.37	2.18	7.37	18.23	26.20	26.20	7.95	15.57	--	14.00	Sep-15
Russell 3000				2.18	7.30	18.19	26.14	26.14	7.87	15.19	12.36	13.78	Sep-15
Harding Loevner Intl		8,783,074	8.60	4.57	5.04	8.36	17.36	17.36	--	--	--	3.92	Mar-22
MSCI ACWI ex USA				2.85	5.13	11.22	18.21	18.21	2.10	7.56	4.42	5.46	Mar-22
Delaware Emerging Markets Instl		4,342,695	4.25	-1.34	2.88	13.71	24.44	24.44	--	--	--	3.44	Mar-22
MSCI Emerging Markets				1.61	5.94	9.55	15.07	15.07	-3.06	4.79	2.56	1.57	Mar-22
Fixed Income Composite		26,494,072	25.94	1.33	3.78	3.34	7.42	7.42	-0.21	0.95	2.08	3.44	Jun-05
Fixed Income Balanced Index				1.27	3.85	3.27	6.88	6.88	-0.77	0.54	1.94	3.28	Jun-05
Bloomberg US Aggregate TR				1.44	4.79	3.07	7.30	7.30	-2.11	-0.04	1.64	3.12	Jun-05
Loop (Smith Graham)		18,319,854	17.94	1.12	3.75	4.03	7.65	7.65	0.00	1.08	2.14	3.47	Jun-05
Spliced Fixed Income Index				1.15	3.87	3.55	7.11	7.11	-0.38	0.78	2.06	3.34	Jun-05
Shenkman Short Duration High Income		4,514,752	4.42	0.98	2.52	4.68	8.43	8.43	--	--	--	4.98	Mar-22
Bloomberg US Credit 1-3 Yr TR				0.94	2.72	4.02	7.04	7.04	1.70	2.01	2.04	3.43	Mar-22
Brandywine Global Opp Bd		3,659,466	3.58	2.85	5.56	-1.51	5.12	5.12	--	--	--	-3.69	Mar-22
FTSE WGBI TR				2.30	5.19	1.06	5.68	5.68	-5.65	-2.63	-0.64	-2.65	Mar-22
Alternatives Composite		5,464,693	5.35	0.93	2.52	7.72	11.79	11.79	--	--	--	9.53	Mar-22
Alternatives Balanced Index				1.08	3.26	5.28	9.34	9.34	--	--	--	5.78	Mar-22
Golub Capital Partners 14	1.6mm Committed	1,468,774	1.44	0.00	2.00	5.25	12.35	12.35	--	--	--	9.08	Mar-22
Cliffwater Direct Lending Index				0.00	2.64	5.74	12.31	12.31	9.81	9.22	8.83	9.25	Mar-22
Magnitude International		3,995,919	3.91	1.27	2.71	8.69	11.59	11.59	--	--	--	9.63	Mar-22
Hedge Fund Conservative				1.48	3.48	5.07	8.23	8.23	4.20	5.37	3.71	4.59	Mar-22
Cash Composite		7,635,876	7.48										
Cash		7,635,637	7.48										
Markston Accrued Income		239	0.00										

Total Composite

As of August 31, 2024

Fiscal Year End: August

Manager Status	Market Value (\$)	% of Portfolio	1 Mo (%)	3 Mo (%)	YTD (%)	Fiscal YTD (%)	1 Yr (%)	3 Yrs (%)	5 Yrs (%)	10 Yrs (%)	Inception (%)	Inception Date
----------------	----------------------	-------------------	-------------	-------------	------------	----------------------	-------------	--------------	--------------	---------------	------------------	-------------------

- *Balanced Index = Weighted Average of Russell 3000 / MSCI ACWI ex USA / MSCI Emerging Markets / Spliced Fixed Income Index / Bloomberg US Credit 1-3 Yr TR / FTSE WGBI TR / Cliffwater Direct Lending Index / Hedge Fund Conservative / FTSE T-Bill 1 Month TR*

- *Equity Balanced Index = Weighted Average of Russell 3000 / MSCI ACWI ex USA / MSCI Emerging Markets*

- *Fixed Income Balanced Index = Weighted Average of Spliced Fixed Income Index / FTSE WGBI TR / Bloomberg US Credit 1-3 Yr TR*

- *Spliced Fixed Income Index = Bloomberg US Govt/Credit Int TR*

- *Alternatives Balanced Index = Weighted Average of Cliffwater Direct Lending Index / Hedge Fund Conservative*

- *Cliffwater Direct Lending Index = Cliffwater Direct Lending Index*

- *Hedge Fund Conservative = Credit Suisse Equity Market Neutral USD 33.3% / Credit Suisse Convertible Arbitrage USD 33.3% / Credit Suisse Merg Arbtrg Liquid TR USD 33.3%*

iShares Total U.S. Stock Market

As of August 31, 2024

Universe Name: Large Blend MStar MF
 # of Observations: 332 (8/31/2024)

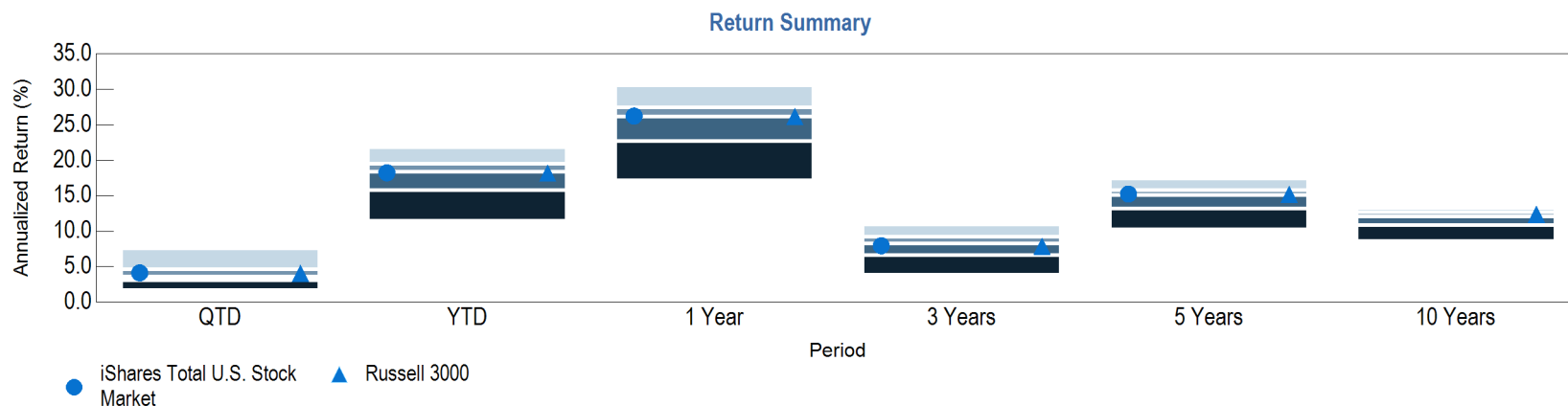

	QTD (%)	Rank	YTD (%)	Rank	1 Yr (%)	Rank	3 Yrs (%)	Rank	5 Yrs (%)	Rank	10 Yrs (%)	Rank
iShares Total U.S. Stock Market	4.14	34	18.23	52	26.20	51	7.95	55	15.57	38	--	--
Russell 3000	<u>4.08</u>	36	<u>18.19</u>	53	<u>26.14</u>	52	<u>7.87</u>	57	<u>15.19</u>	46	<u>12.36</u>	39
Over/Under	0.06		0.04		0.06		0.08		0.38			

	QTD (%)	Rank	YTD (%)	Rank	1 Yr (%)	Rank	3 Yrs (%)	Rank	5 Yrs (%)	Rank	10 Yrs (%)	Rank
iShares Total U.S. Stock Market	4.14	34	18.23	52	26.20	51	7.95	55	15.57	38	--	--
Russell 3000	<u>4.08</u>	36	<u>18.19</u>	53	<u>26.14</u>	52	<u>7.87</u>	57	<u>15.19</u>	46	<u>12.36</u>	39
Over/Under	0.06		0.04		0.06		0.08		0.38			

5 Years Statistics Summary

	Anlzd Std Dev	Anlzd Alpha	Beta	Up Mkt Cap Ratio	Down Mkt Cap Ratio	Sharpe Ratio	Tracking Error	Info Ratio
iShares Total U.S. Stock Market	18.59%	0.39%	1.00	101.60%	99.81%	0.72	0.71%	0.53
Russell 3000	18.59%	0.00%	1.00	100.00%	100.00%	0.70	0.00%	--

Harding Loevner Intl

As of August 31, 2024

Description:

The investment seeks long-term capital appreciation.

The fund invests in companies based in developed markets outside the U.S. as well as in companies in emerging and frontier markets. It normally invests at least 80% of its net assets (plus any borrowings for investment purposes) in common stocks, preferred stocks, rights and warrants issued by companies that are based outside the United States, securities convertible into such securities (including Depositary Receipts), and investment companies that invest in the types of securities in which the Portfolio would normally invest. The fund normally holds investments across at least 15 countries.

Return Summary

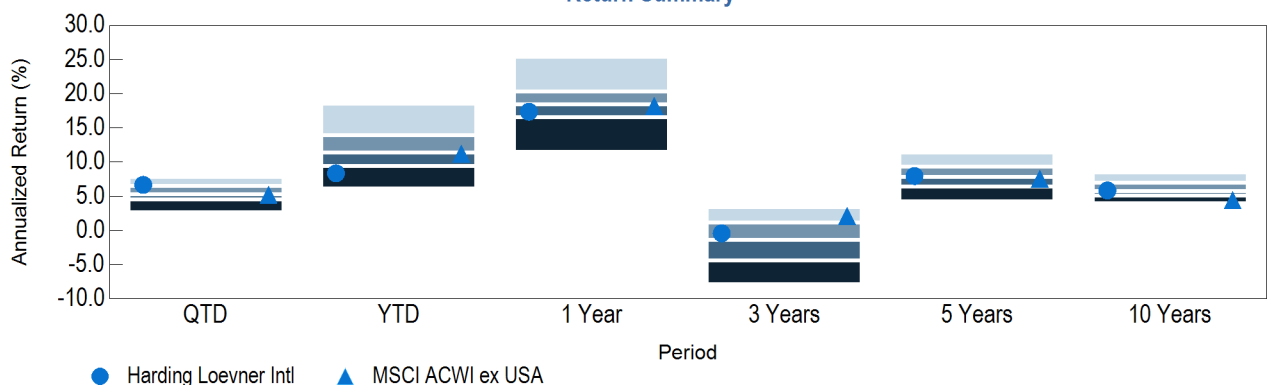

	QTD (%)	Rank	YTD (%)	Rank	1 Yr (%)	Rank	3 Yrs (%)	Rank	5 Yrs (%)	Rank	10 Yrs (%)	Rank
Harding Loevner Intl	6.68	20	8.36	87	17.36	69	-0.42	44	7.96	50	5.85	50
MSCI ACWI ex USA	<u>5.23</u>	55	<u>11.22</u>	51	<u>18.21</u>	53	<u>2.10</u>	11	<u>7.56</u>	56	<u>4.42</u>	92
Over/Under	1.45		-2.86		-0.85		-2.52		0.40		1.43	

	2023	2022	2021	2020	2019	2018	2017	2016	2015	2014
Harding Loevner Intl	15.06	-20.23	8.51	20.33	25.23	-13.96	29.90	5.30	-1.62	-1.61
MSCI ACWI ex USA	<u>15.62</u>	<u>-16.00</u>	<u>7.82</u>	<u>10.65</u>	<u>21.51</u>	<u>-14.20</u>	<u>27.19</u>	<u>4.50</u>	<u>-5.66</u>	<u>-3.87</u>
Over/Under	-0.56	-4.23	0.69	9.68	3.72	0.24	2.71	0.80	4.04	2.26

5 Years Statistics Summary

	Anlzd Std Dev	Anlzd Alpha	Beta	Up Mkt Cap Ratio	Down Mkt Cap Ratio	Sharpe Ratio	Tracking Error	Info Ratio
Harding Loevner Intl	18.32%	0.27%	1.02	112.96%	104.15%	0.31	5.51%	0.07
MSCI ACWI ex USA	17.19%	0.00%	1.00	100.00%	100.00%	0.31	0.00%	--

Universe Name:	Foreign Large Growth MStar MF
# of Observations:	98 (8/31/2024)

Fund Information as of 6/30/24

Fund Name	HARDING LOEVNER INTERNATIONAL EQ INSTL
Ticker	HLMIX
Morningstar Category	Foreign Large Growth
Benchmark	MSCI ACWI ex USA
Expense Ratio	0.82%
Fund Assets (\$mm)	11,267.98
Share Class Inception Date	5/11/1994
Manager Tenure	20

Top Holdings as of 6/30/24

TAIWAN SEMICONDUCTOR MANUFACTURING CO LTD ADR	4.14%
SAMSUNG ELECTRONICS CO LTD DR	3.74%
SHELL PLC	3.44%
DBS GROUP HOLDINGS LTD	3.19%
MANULIFE FINANCIAL CORP	3.19%
ROCHE HOLDING AG	3.15%
ALLIANZ SE	2.79%
SCHNEIDER ELECTRIC SE	2.76%
HALEON PLC	2.57%
CHUGAI PHARMACEUTICAL CO LTD	2.50%

Sector Allocation as of 6/30/24

BASIC MATERIALS	8.84%
COMMUNICATION SERVICES	2.31%
CONSUMER CYCLICAL	4.99%
CONSUMER DEFENSIVE	8.62%
ENERGY	3.47%
FINANCIAL SERVICES	21.64%
HEALTHCARE	16.52%
INDUSTRIALS	14.82%
REAL ESTATE	0.00%
TECHNOLOGY	18.03%
UTILITIES	0.75%

Delaware Emerging Markets

As of August 31, 2024

Description:

The investment seeks long-term capital appreciation.

The fund invests primarily in a broad range of equity securities of companies located in emerging market countries. Emerging market countries include those currently considered to be developing by the World Bank, the United Nations, or the countries' governments. These countries typically are located in the Asia-Pacific region, Eastern Europe, the Middle East, Central America, South America, and Africa. Under normal circumstances, at least 80% of the fund's net assets, plus the amount of any borrowings for investment purposes, will be invested in emerging market issuers (80% policy).

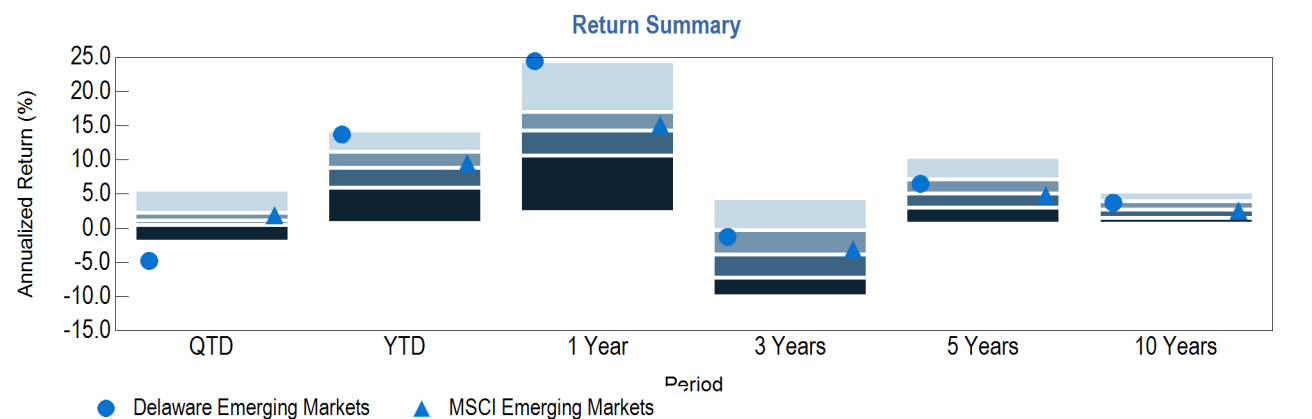

	QTD (%)	Rank	YTD (%)	Rank	1 Yr (%)	Rank	3 Yrs (%)	Rank	5 Yrs (%)	Rank	10 Yrs (%)	Rank
Delaware Emerging Markets	-4.77	99	13.71	9	24.44	5	-1.26	31	6.50	33	3.74	32
MSCI Emerging Markets	1.92	33	9.55	44	15.07	39	-3.06	42	4.79	57	2.56	56
Over/Under	-6.69		4.16		9.37		1.80		1.71		1.18	

	2023	2022	2021	2020	2019	2018	2017	2016	2015	2014
Delaware Emerging Markets	17.59	-28.66	-2.06	25.90	24.33	-17.09	41.97	17.89	-13.75	-8.18
MSCI Emerging Markets	9.83	-20.09	-2.54	18.31	18.44	-14.58	37.28	11.19	-14.92	-2.19
Over/Under	7.76	-8.57	0.48	7.59	5.89	-2.51	4.69	6.70	1.17	-5.99

5 Years Statistics Summary

	Anlzd Std Dev	Anlzd Alpha	Beta	Up Mkt Cap Ratio	Down Mkt Cap Ratio	Sharpe Ratio	Tracking Error	Info Ratio
Delaware Emerging Markets	22.11%	1.01%	1.15	130.17%	105.62%	0.19	6.96%	0.25
MSCI Emerging Markets	18.43%	0.00%	1.00	100.00%	100.00%	0.14	0.00%	--

Universe Name:	Diversified Emerging Mkts MStar MF
# of Observations:	210 (8/31/2024)

Fund Information as of 8/31/24

Fund Name	DELAWARE EMERGING MARKETS INSTL
Ticker	DEMIX
Morningstar Category	Diversified Emerging Mkts
Benchmark	MSCI Emerging Markets
Expense Ratio	1.17%
Fund Assets (\$mm)	2,886.60
Share Class Inception Date	6/10/1996
Manager Tenure	18

Top Holdings as of 8/31/24

TAIWAN SEMICONDUCTOR MANUFACTURING CO LTD	16.56%
SK HYNIX INC	8.25%
SK SQUARE	7.47%
RELIANCE INDUSTRIES LTD	6.82%
SAMSUNG ELECTRONICS CO LTD	5.21%
MEDIATEK INC	5.11%
RELIANCE INDUSTRIES LTD GDR - 144A	2.98%
ALIBABA GROUP HOLDING LTD ADR	2.92%
TENCENT HOLDINGS LTD	2.35%
SAMSUNG C&T CORP	2.06%

Sector Allocation as of 8/31/24

BASIC MATERIALS	3.42%
COMMUNICATION SERVICES	9.32%
CONSUMER CYCLICAL	5.14%
CONSUMER DEFENSIVE	6.63%
ENERGY	13.89%
FINANCIAL SERVICES	4.32%
HEALTHCARE	2.81%
INDUSTRIALS	4.17%
REAL ESTATE	0.33%
TECHNOLOGY	49.80%
UTILITIES	0.16%

Loop (Smith Graham)

As of August 31, 2024

Universe Name: Intermediate Core Bond MStar MF
 # of Observations: 127 (8/31/2024)

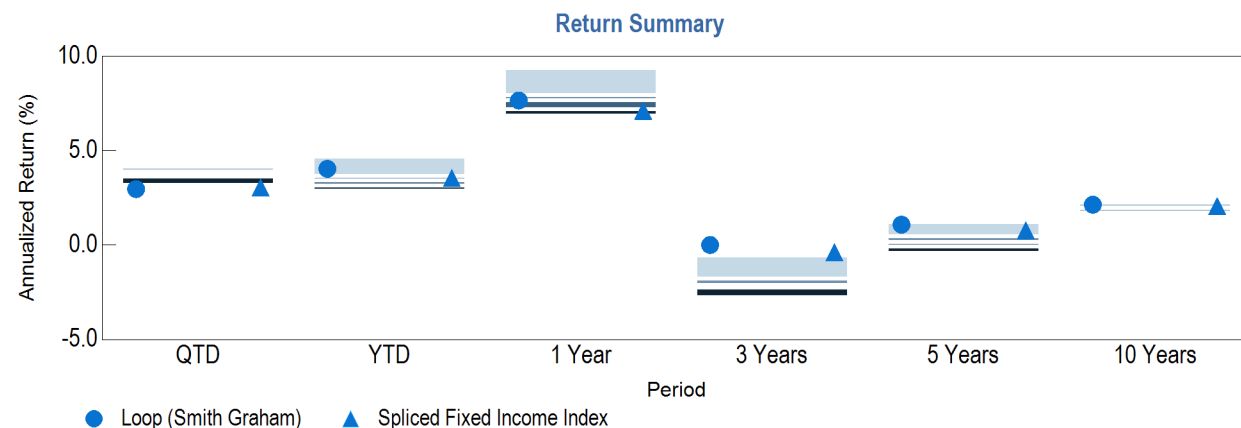

	QTD (%)	Rank	YTD (%)	Rank	1 Yr (%)	Rank	3 Yrs (%)	Rank	5 Yrs (%)	Rank	10 Yrs (%)	Rank
Loop (Smith Graham)	2.96	98	4.03	12	7.65	53	0.00	1	1.08	8	2.14	8
Spliced Fixed Income Index	3.05	96	3.55	38	7.11	84	-0.38	5	0.78	15	2.06	14
Over/Under	-0.09		0.48		0.54		0.38		0.30		0.08	

	2023	2022	2021	2020	2019	2018	2017	2016	2015	2014
Loop (Smith Graham)	6.04	-8.53	-2.51	7.67	8.88	-0.83	3.42	2.37	0.91	5.39
Spliced Fixed Income Index	5.24	-8.24	-2.96	7.51	8.72	0.01	3.54	2.65	0.55	5.97
Over/Under	0.80	-0.29	0.45	0.16	0.16	-0.84	-0.12	-0.28	0.36	-0.58

5 Years Statistics Summary

	Anlzd Std Dev	Anlzd Alpha	Beta	Up Mkt Cap Ratio	Down Mkt Cap Ratio	Sharpe Ratio	Tracking Error	Info Ratio
Loop (Smith Graham)	4.40%	0.30%	1.00	104.39%	99.12%	-0.27	0.90%	0.33
Spliced Fixed Income Index	4.32%	0.00%	1.00	100.00%	100.00%	-0.34	0.00%	--

Fixed Income Characteristics

	Portfolio Aug-24	Index Aug-24
Fixed Income Characteristics		
Number of Issues	105	6,096
Yield to Maturity	4.44	4.14
Years to Maturity	4.53	4.30
Average Duration	3.91	3.81
Effective Duration	3.87	3.81
Average Mod Duration	3.91	3.81
Average Quality	A	AA
Weighted Average Maturity	4.55	4.31
Maturity Allocation		
<1 Year	14.79	0.01
1-3 Years	24.97	38.18
3-5 Years	23.88	28.44
5-7 Years	4.41	17.28
7-10 Years	26.62	15.99
10-15 Years	1.99	--
Credit Quality Allocation		
AAA	1.78	3.14
AA	54.56	67.46
A	11.19	12.69
BBB	25.72	16.51
BB	--	0.21
Not Rated	6.75	--
US Sector Allocation		
UST/Agency	54.22	65.06
Corporate	37.47	29.89
MBS	1.67	--
ABS	3.31	0.07
Foreign	--	4.77
Muni	--	0.22
Cash	1.62	--

Shenkman Short Duration High Income

As of August 31, 2024

Description:

The investment seeks to generate a high level of current income.

Under normal market conditions, the fund will invest at least 80% of its net assets in fixed income securities, bank loans and other instruments issued by companies that are rated below investment grade. It generally invests in high yield instruments rated CCC or better by S&P or Moody's, but retains the discretion to invest in even lower rated instruments. The fixed income securities, bank loans and other instruments in which the fund invests include traditional corporate bonds, U.S. government obligations and bank loans to corporate borrowers, and may have fixed, floating or variable rates.

Return Summary

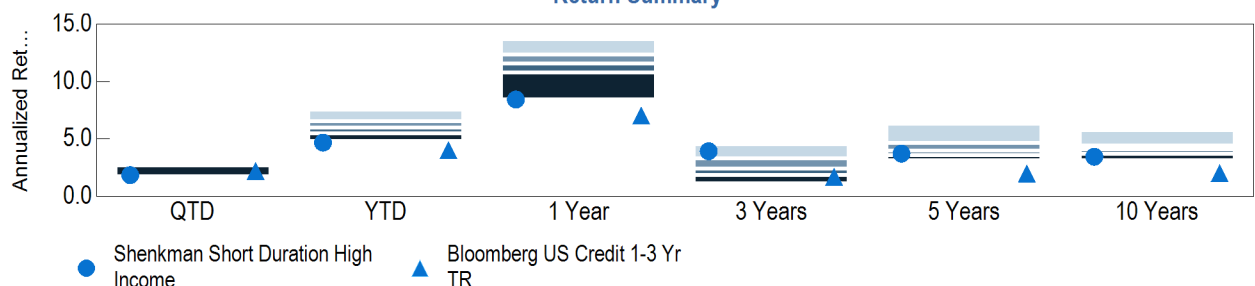

	QTD (%)	Rank	YTD (%)	Rank	1 Yr (%)	Rank	3 Yrs (%)	Rank	5 Yrs (%)	Rank	10 Yrs (%)	Rank
Shenkman Short Duration High Income	1.85	94	4.68	98	8.43	97	3.94	15	3.72	69	3.45	88
Bloomberg US Credit 1-3 Yr TR	<u>2.20</u>	86	<u>4.02</u>	99	<u>7.04</u>	99	<u>1.70</u>	82	<u>2.01</u>	99	<u>2.04</u>	99
Over/Under	-0.35		0.66		1.39		2.24		1.71		1.41	

	2023	2022	2021	2020	2019	2018	2017	2016	2015	2014
Shenkman Short Duration High Income	9.23	-2.52	2.85	3.36	7.61	0.85	3.54	5.15	0.87	1.59
Bloomberg US Credit 1-3 Yr TR	<u>5.28</u>	<u>-3.40</u>	<u>-0.18</u>	<u>3.68</u>	<u>5.01</u>	<u>1.64</u>	<u>1.66</u>	<u>2.11</u>	<u>0.85</u>	<u>1.12</u>
Over/Under	3.95	0.88	3.03	-0.32	2.60	-0.79	1.88	3.04	0.02	0.47

5 Years Statistics Summary

	Anlzd Std Dev	Anlzd Alpha	Beta	Up Mkt Cap Ratio	Down Mkt Cap Ratio	Sharpe Ratio	Tracking Error	Info Ratio
Shenkman Short Duration High Income	4.43%	0.93%	1.39	143.61%	95.33%	0.33	3.11%	0.55
Bloomberg US Credit 1-3 Yr TR	2.36%	0.00%	1.00	100.00%	100.00%	-0.11	0.00%	--

Universe Name: High Yield Bond MStar MF
 # of Observations: 176 (8/31/2024)

Fund Information as of 6/30/24

Fund Name	SHENKMAN CAPITAL SHORT DUR HI INC INST
Ticker	SCFIX
Morningstar Category	High Yield Bond
Benchmark	Bloomberg US Credit 1-3 Yr TR
Expense Ratio	0.65%
Fund Assets (\$mm)	1,049.20
Share Class Inception Date	10/31/2012
Manager Tenure	12

Fund Characteristics as of 6/30/24

Sharpe Ratio (3 Year)	0.06
Average Duration	1.63
Average Coupon	6.22%
Average Effective Maturity	2.55
R-Squared (3 Year)	0.50
Alpha (3 Year)	0.17%
Beta (3 Year)	1.33

Credit Quality as of 6/30/24

AAA	3.31%
AA	0.00%
A	0.00%
BBB	8.01%
BB	49.13%
B	32.64%
Below B	1.61%
Not Rated	5.30%

Fixed Income Sectors as of 6/30/24

GOVERNMENT	0.00%
MUNICIPAL	0.00%
CORPORATE	95.96%
SECURITIZED	0.00%
CASH & EQUIVALENTS	4.04%
DERIVATIVE	0.00%

Brandywine Global Opp Bd

As of August 31, 2024

Description:

The investment seeks to maximize total return consisting of income and capital appreciation.

The fund normally invests at least 80% of its net assets in fixed income securities of issuers located in developed market countries. It will invest in both investment grade and below investment grade fixed income securities, and the advisor intends to invest less than 35% of its net assets in below investment grade fixed income securities (commonly known as "high yield debt" or "junk bonds"). The fund may invest up to 25% of its net assets in convertible debt securities. It is non-diversified.

Return Summary

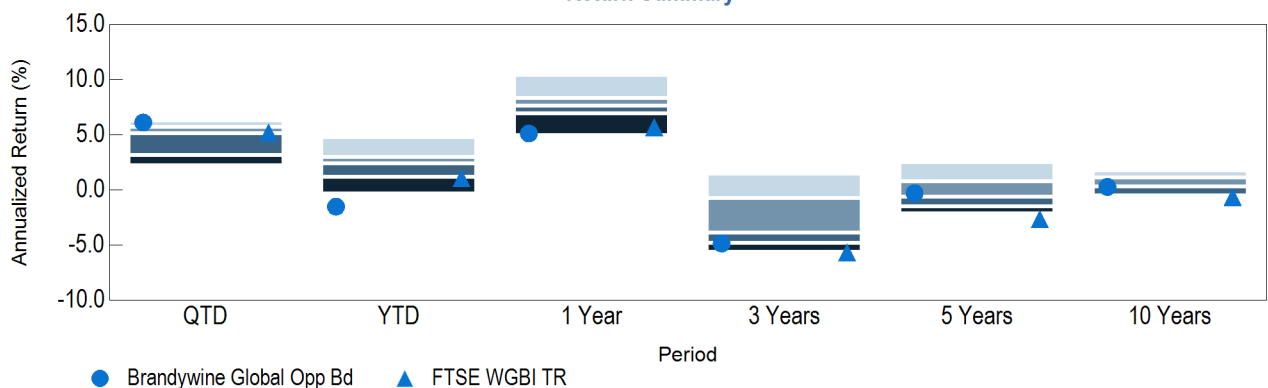

	QTD (%)	Rank	YTD (%)	Rank	1 Yr (%)	Rank	3 Yrs (%)	Rank	5 Yrs (%)	Rank	10 Yrs (%)	Rank
Brandywine Global Opp Bd	6.12	12	-1.51	98	5.12	95	-4.85	81	-0.28	42	0.28	57
FTSE WGBI TR	5.23	49	1.06	83	5.68	89	-5.65	98	-2.63	99	-0.64	89
Over/Under	0.89		-2.57		-0.56		0.80		2.35		0.92	

	2023	2022	2021	2020	2019	2018	2017	2016	2015	2014
Brandywine Global Opp Bd	7.22	-15.80	-5.36	12.52	9.14	-4.99	12.72	4.91	-8.63	6.13
FTSE WGBI TR	5.18	-18.26	-6.97	10.11	5.90	-0.84	7.49	1.60	-3.57	-0.48
Over/Under	2.04	2.46	1.61	2.41	3.24	-4.15	5.23	3.31	-5.06	6.61

5 Years Statistics Summary

	Anlzd Std Dev	Anlzd Alpha	Beta	Up Mkt Cap Ratio	Down Mkt Cap Ratio	Sharpe Ratio	Tracking Error	Info Ratio
Brandywine Global Opp Bd	12.61%	3.33%	1.37	196.72%	120.94%	-0.20	7.22%	0.33
FTSE WGBI TR	7.82%	0.00%	1.00	100.00%	100.00%	-0.63	0.00%	--

Universe Name:	Global Bond MStar MF
# of Observations:	36 (8/31/2024)

Fund Information as of 6/30/24

Fund Name	BRANDYWINEGLOBAL GLOBAL OPP BOND I
Ticker	GOBIX
Morningstar Category	Global Bond
Benchmark	FTSE WGBI TR
Expense Ratio	0.67%
Fund Assets (\$mm)	589.38
Share Class Inception Date	3/19/2009
Manager Tenure	18

Fund Characteristics as of 6/30/24

Sharpe Ratio (3 Year)	-0.76
Average Duration	9.06
Average Coupon	5.40%
Average Effective Maturity	16.76
R-Squared (3 Year)	0.87
Alpha (3 Year)	0.25%
Beta (3 Year)	1.38

Credit Quality as of 6/30/24

AAA	3.52%
AA	66.02%
A	3.25%
BBB	18.62%
BB	7.44%
B	1.16%
Below B	0.00%
Not Rated	-0.01%

Fixed Income Sectors as of 6/30/24

GOVERNMENT	32.02%
MUNICIPAL	0.00%
CORPORATE	3.87%
SECURITIZED	12.58%
CASH & EQUIVALENTS	1.44%
DERIVATIVE	50.10%

Total Composite

As of August 31, 2024

Investment Expense Analysis

As Of 8/31/24

Name	Market Value	% of Portfolio	Expense Ratio	Estimated Expense	Median Expense Ratio	Difference Fund v. Median Universe
iShares Total U.S. Stock Market	\$49,399,814	48.4%	0.02%	\$9,880	0.67%	-0.65% Large Blend MStar MF
Harding Loevner Intl	\$8,783,074	8.6%	0.82%	\$72,021	0.85%	-0.03% Foreign Large Growth MStar MF
Delaware Emerging Markets Instl	\$4,342,695	4.3%	1.17%	\$50,810	1.01%	0.16% Diversified Emerging Mkts MStar MF
Loop (Smith Graham)	\$18,319,854	17.9%	0.25%	\$45,800	0.45%	-0.20% Intermediate Core Bond MStar MF
Shenkman Short Duration High Income	\$4,514,752	4.4%	0.65%	\$29,346	0.70%	-0.05% High Yield Bond MStar MF
Brandywine Global Opp Bd	\$3,659,466	3.6%	0.67%	\$24,518	0.69%	-0.02% Global Bond MStar MF
Golub Capital Partners 14	\$1,468,774	1.4%	1.00%	\$14,688		
Magnitude International	\$3,995,919	3.9%	1.00%	\$39,959		
Cash	\$7,635,637	7.5%				
Markston Accrued Income	\$239	0.0%				
Total	\$102,120,225	100.0%	0.28%	\$287,022		
The Atlanta Consulting Group Fee			0.10%	\$101,696		
Total with ACG Fee			0.38%	\$388,718		

Atlanta Consulting Group Fee Schedule:

First \$100 Million: 10 basis points

Next \$100 Million: 8 basis points

Next \$200 Million: 6 basis points

Over \$400 Million: 4 basis points

Minimum annual fee of \$50,000

Texas Southern University
Quarterly Summary of Investments

	August 31, 2024	August 31, 2024	August 31, 2024
Investment Type	Book Value	Market Value	Gain/Loss
Non Endowment Investments*			
TexStar	1,516,826.01	1,516,826.01	-
Consolidated Revenue and Improvement Bonds	4,910,004.03	4,910,004.03	-
Chase-Tuition Revenue Bond 2016	2,088,561.88	2,088,561.88	-
Chase - LaFleur Trust	1,328,218.20	1,328,218.20	-
Chase Debt Service Reserve	1,513,377.61	1,513,377.61	-
Other (Restricted Cash)	7,733.35	7,733.35	-
Total Non Endowment Investments	11,364,721.08	11,364,721.08	-
Endowment Investments**			
Equity Securities**			
U.S. Common Stock			
Preferred Stock			
Foreign Stock			
Equity Mutual Funds	52,686,671.45	62,525,583.19	9,838,911.74
Total Equity Securities	52,686,671.45	62,525,583.19	9,838,911.74
Other Investments**			
Private Credit	1,280,000.00	1,468,774.00	188,774.00
Hedge Fund	3,200,000.00	3,995,919.48	795,919.48
Unity Bank	116,188.02	116,188.02	-
Total Other Investments	4,596,188.02	5,580,881.50	984,693.48
Debt Investments > 1 Year**			
U.S. Government	7,918,283.48	7,775,494.80	(142,788.68)
U.S. Government Agency	333,769.41	306,096.28	(27,673.13)
Mortgage Pass-Through			
CMOs:			
Interest Only Strips			
Principal Only Strips			
Inverse Floaters			
Foreign Issued Obligations	347,395.50	362,036.00	14,640.50
Municipal Obligations			
Corporate Obligations:			
Highly Rated (AAA/AA)			
Investment Grade (A/BBB)	6,308,166.33	6,241,112.75	(67,053.58)
NR/High Yield (<BBB)	669,854.11	628,319.35	(41,534.76)
Bond Mutual Funds	8,808,434.51	8,174,217.95	(634,216.56)
Other (list)			
Total Debt Investments > 1 year	24,385,903.34	23,487,277.13	(898,626.21)
Short Term Investments**			
U.S. Government	2,146,110.38	2,157,108.23	10,997.85
Other Money Market Funds and Pools	7,793,672.91	7,793,672.91	-
Other (list) - Corporate Obligations	537,364.26	552,816.92	15,452.66
Accrued Income	139,072.91	139,072.91	-
Total Short Term Investments	10,616,220.46	10,642,670.97	26,450.51
Summary of all Investments			
Total Non Endowment Investments*	11,364,721.08	11,364,721.08	-
Total Endowment Investments**	92,284,983.27	102,236,412.79	9,951,429.52
TOTAL INVESTMENTS	103,649,704.35	113,601,133.87	9,951,429.52

As of August 31, 2024

Summary of Cash Flows

	Last Three Months
Beginning Market Value	\$95,616,294
Net Cash Flow	\$1,406,225
Net Investment Change	\$5,097,706
Ending Market Value	\$102,120,225

Asset Allocation Over Time as of August 31, 2024

	% of Portfolio														Market Value (\$)	
	2/28/2021	5/31/2021	8/31/2021	11/30/2021	2/28/2022	5/31/2022	8/31/2022	11/30/2022	2/28/2023	5/31/2023	8/31/2023	11/30/2023	2/29/2024	5/31/2024	8/31/2024	As Of 8/31/2024
Equity	78.91	71.19	72.02	71.82	71.28	60.82	60.06	61.04	60.15	60.67	59.24	59.76	61.54	61.36	61.23	\$ 62,525,583
Fixed	18.24	26.08	24.77	24.97	24.99	31.91	32.25	31.41	31.62	31.27	28.79	28.76	27.58	26.70	25.94	\$ 26,494,072
Alternatives	0.00	0.00	0.00	0.00	0.00	5.37	5.93	5.82	6.2	6.29	5.67	5.90	5.62	5.57	5.35	\$ 5,464,693
Cash	2.85	2.73	3.21	3.20	3.74	1.90	1.75	1.73	2.03	1.78	6.29	5.59	5.25	6.36	7.48	\$ 7,635,876
Total Assets	100%	100%	100%	100%	100%	100%	100%	100%	100%	100%	100%	100%	100%	100%	100%	\$102,120,225

00372304
60- -01-B -62 -250-04
0101 -19-00883-04



Account Number: 001050970130
TEXAS SOUTHERN UNIVERSITY
DCM ADVISORS, LLC AS
INVESTMENT MANAGER

This statement is for the period from August 1, 2024 to August 31, 2024

Questions?

If you have any questions regarding your account or this statement, please contact your Account Manager.

Account Manager:
DANIELLE GROSS
1025 CONNECTICUT AVENUE SUITE 510
WASHINGTON DC 20036
Phone: 202-261-0782
E-mail: danielle.gross1@usbank.com

000001241 13 SP 000638792463441 S
ATLANTA CONSULTING GROUP
MATTHEW BAUDER
309 EAST PACES FERRY RD, SUITE 600
ATLANTA GA 30305

00372304
60- -01-B -62 -250-04
0101 -19-00883-04



TEXAS SOUTH UNIV, DCM ADVISORS
ACCOUNT 001050970130

Page 2 of 7
Period from August 1, 2024 to August 31, 2024

TABLE OF CONTENTS

Schedule	Page
Market And Cost Reconciliation	3
Cash Reconciliation	4
Income Accrual Detail	5
Investment Activity	6
Other Activity	7

00372304
 60- -01-B -62 -250-04
 0101 -19-00883-04



TEXAS SOUTH UNIV, DCM ADVISORS
 ACCOUNT 001050970130

Page 3 of 7
 Period from August 1, 2024 to August 31, 2024

MARKET AND COST RECONCILIATION

	08/31/2024 MARKET	08/31/2024 BOOK VALUE
Beginning Market And Cost	238.98	238.98
Investment Activity		
Interest	238.98	238.98
Net Accrued Income (Current-Prior)	- 238.98	- 238.98
Total Investment Activity	.00	.00
Other Activity		
Miscellaneous Receipts	6,605,752.43	6,605,752.43
Transfers Out	- 238.98	- 238.98
Miscellaneous Disbursements	- 6,605,752.43	- 6,605,752.43
Total Other Activity	- 238.98	- 238.98
Net Change In Market And Cost	- 238.98	- 238.98
Ending Market And Cost	.00	.00

00372304
60- -01-B -62 -250-04
0101 -19-00883-04



TEXAS SOUTH UNIV, DCM ADVISORS
ACCOUNT 001050970130

Page 4 of 7
Period from August 1, 2024 to August 31, 2024

CASH RECONCILIATION

Beginning Cash	.00
Investment Activity	
Interest	238.98
Total Investment Activity	238.98
Other Activity	
Miscellaneous Receipts	6,605,752.43
Transfers Out	- 238.98
Miscellaneous Disbursements	- 6,605,752.43
Total Other Activity	- 238.98
Net Change In Cash	.00
Ending Cash	.00

00372304
 60- -01-B -62 -250-04
 0101 -19-00883-04



TEXAS SOUTH UNIV, DCM ADVISORS
 ACCOUNT 001050970130

Page 5 of 7
 Period from August 1, 2024 to August 31, 2024

INCOME ACCRUAL DETAIL

SHARES/ FACE AMOUNT	DESCRIPTION	EX DATE	PAY DATE	ANN RATE	BEGINNING ACCRUAL	INCOME EARNED	INCOME RECEIVED	ENDING ACCRUAL
Cash And Equivalents								
.000	First Am Govt Ob Fd CI Z 31846V567		09/03/24	0.05	238.98	.00	238.98	.00
Total Cash And Equivalents					238.98	.00	238.98	.00
Grand Total					238.98	.00	238.98	.00

00372304
60- -01-B -62 -250-04
0101 -19-00883-04



TEXAS SOUTH UNIV, DCM ADVISORS
ACCOUNT 001050970130

Page 6 of 7
Period from August 1, 2024 to August 31, 2024

INVESTMENT ACTIVITY

DATE	DESCRIPTION	CASH
Interest		
First Am Govt Ob Fd CI Z 31846V567		
08/01/2024	Interest From 7/1/24 To 7/31/24	238.98
Total Interest		238.98

00372304
60- -01-B -62 -250-04
0101 -19-00883-04



TEXAS SOUTH UNIV, DCM ADVISORS
ACCOUNT 001050970130

Page 7 of 7
Period from August 1, 2024 to August 31, 2024

OTHER ACTIVITY

DATE	DESCRIPTION	CASH
Miscellaneous Receipts		
Transfer From Income		
08/30/2024	Zero Balance	6,605,752.43
Total Transfer From Income		6,605,752.43
Total Miscellaneous Receipts		6,605,752.43
Transfers Out		
Transfer To Another Account		
08/30/2024	Paid To # 001050970131 Trsf From Xxx0130 To Xxx0131	- 238.98
Total Transfer To Another Account		- 238.98
Total Transfers Out		- 238.98
Miscellaneous Disbursements		
Transfer To Principal		
08/30/2024	Zero Balance	- 6,605,752.43
Total Transfer To Principal		- 6,605,752.43
Total Miscellaneous Disbursements		- 6,605,752.43
Total Other Activity		- 238.98

00372604
60- -01-B -62 -250-04
0101 -19-00883-04



Account Number: 001050970131
TEXAS SOUTHERN UNIVERSITY
MUTUAL FUNDS

This statement is for the period from August 1, 2024 to August 31, 2024

Questions?

If you have any questions regarding your account or this statement, please contact your Account Manager.

Account Manager:
DANIELLE GROSS
1025 CONNECTICUT AVENUE SUITE 510
WASHINGTON DC 20036
Phone: 202-261-0782
E-mail: danielle.gross1@usbank.com

000001244 05 SP 000638792463444 S
ATLANTA CONSULTING GROUP
MATTHEW BAUDER
309 EAST PACES FERRY RD, SUITE 600
ATLANTA GA 30305

00372604
60- -01-B -62 -250-04
0101 -19-00883-04



TEXAS SOUTH UNIV, MUTUAL FUNDS
ACCOUNT 001050970131

Page 2 of 14
Period from August 1, 2024 to August 31, 2024

TABLE OF CONTENTS

Schedule	Page
Market And Cost Reconciliation	3
Cash Reconciliation	4
Asset Summary.....	5
Asset Detail	6
Income Accrual Detail	9
Investment Activity	10
Plan Expenses	11
Other Activity.....	12
Purchases	13
Sales And Maturities	14

00372604
 60- -01-B -62 -250-04
 0101 -19-00883-04



TEXAS SOUTH UNIV, MUTUAL FUNDS
 ACCOUNT 001050970131

Page 3 of 14
 Period from August 1, 2024 to August 31, 2024

MARKET AND COST RECONCILIATION

	08/31/2024 MARKET	08/31/2024 BOOK VALUE
Beginning Market And Cost	69,251,051.19	61,548,645.97
Investment Activity		
Interest	202.02	202.02
Dividends	24,511.31	24,511.31
Change In Unrealized Gain/Loss	1,502,288.96	.00
Net Accrued Income (Current-Prior)	232.43	232.43
Total Investment Activity	1,527,234.72	24,945.76
Plan Expenses		
Trust Fees	- 1,152.89	- 1,152.89
Total Plan Expenses	- 1,152.89	- 1,152.89
Other Activity		
Transfers In	238.98	238.98
Miscellaneous Receipts	24,511.31	24,511.31
Miscellaneous Disbursements	- 24,511.31	- 24,511.31
Total Other Activity	238.98	238.98
Net Change In Market And Cost	1,526,320.81	24,031.85
Ending Market And Cost	70,777,372.00	61,572,677.82

00372604
60- -01-B -62 -250-04
0101 -19-00883-04



TEXAS SOUTH UNIV, MUTUAL FUNDS
ACCOUNT 001050970131

Page 4 of 14
Period from August 1, 2024 to August 31, 2024

CASH RECONCILIATION

Beginning Cash	- 24,511.31
Investment Activity	
Interest	202.02
Dividends	24,511.31
Cash Equivalent Purchases	- 441.00
Purchases	- 21,208.84
Cash Equivalent Sales	1,152.89
Total Investment Activity	4,216.38
Plan Expenses	
Trust Fees	- 1,152.89
Total Plan Expenses	- 1,152.89
Other Activity	
Transfers In	238.98
Miscellaneous Receipts	24,511.31
Miscellaneous Disbursements	- 24,511.31
Total Other Activity	238.98
Net Change In Cash	3,302.47
Ending Cash	- 21,208.84

ASSET SUMMARY

ASSETS	08/31/2024 MARKET	08/31/2024 BOOK VALUE	% OF MARKET
Cash And Equivalents	77,136.41	77,136.41	0.11
Mutual Funds-Equity	62,525,583.19	52,686,671.45	88.34
Mutual Funds-Fixed Income	8,174,217.95	8,808,434.51	11.55
Miscellaneous	.00	1.00	0.00
Total Assets	70,776,937.55	61,572,243.37	100.00
Accrued Income	434.45	434.45	0.00
Grand Total	70,777,372.00	61,572,677.82	100.00

Estimated Annual Income 1,230,112.93

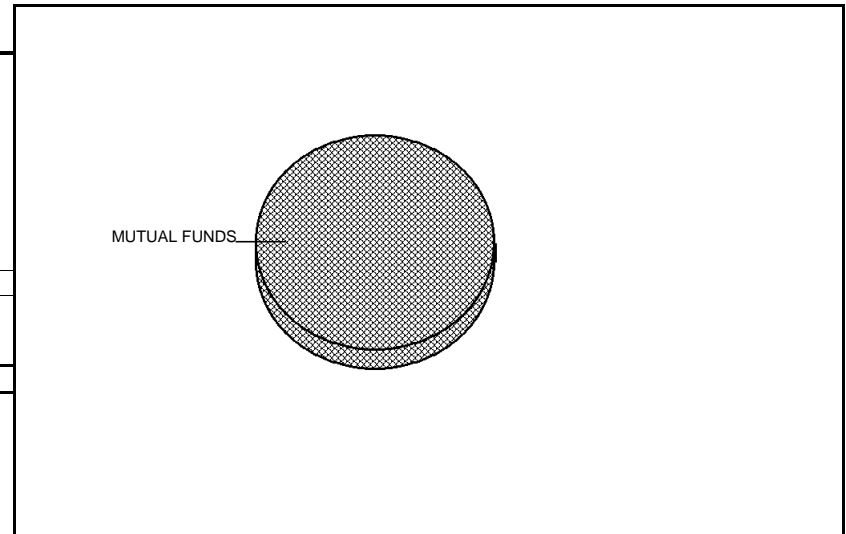

ASSET SUMMARY MESSAGES

Estimated Annual Income is an estimate provided for informational purposes only and should not be relied on for making investment, trading, or tax decisions. The estimates may not represent the actual value earned by your investments and they provide no guarantee of what your investments may earn in the future.

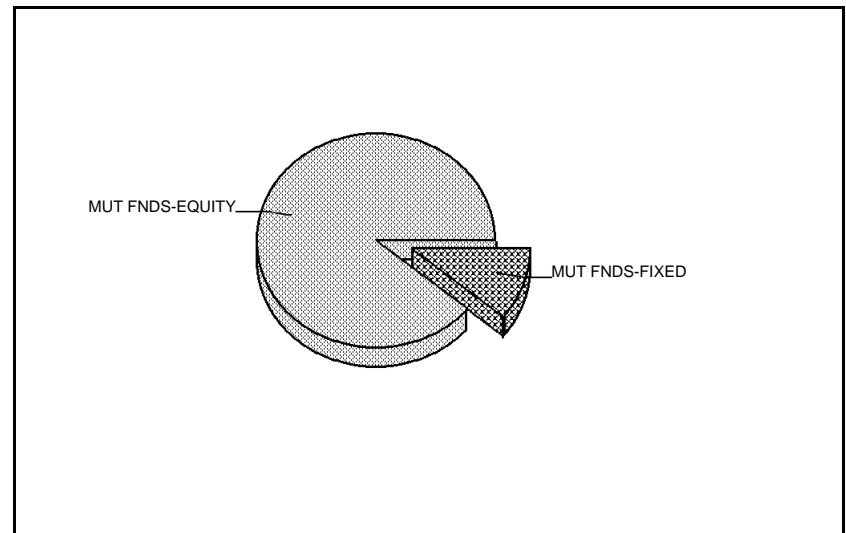

00372604
60- -01-B -62 -250-04
0101 -19-00883-04



TEXAS SOUTH UNIV, MUTUAL FUNDS
ACCOUNT 001050970131

Page 6 of 14
Period from August 1, 2024 to August 31, 2024

ASSET DETAIL

DESCRIPTION	SHARES/ FACE AMOUNT	MARKET PRICE/UNIT	BOOK VALUE	UNREALIZED GAIN (LOSS) SINCE INCEPTION/ CURRENT PERIOD	ENDING ACCRUAL	YIELD ON MARKET
Cash And Equivalents						
Money Markets						
First Am Govt Ob Fd Cl Z 31846V567 Asset Minor Code 1	98,345.250	98,345.25 1.0000	98,345.25	.00 .00	434.45	5.15
Total Money Markets	98,345.250	98,345.25	98,345.25	.00 .00	434.45	5.14
Cash						
Cash		- 21,208.84	- 21,208.84			
Total Cash	.000	- 21,208.84	- 21,208.84	.00 .00	.00	0.00
Total Cash And Equivalents	98,345.250	77,136.41	77,136.41	.00 .00	434.45	6.56
Mutual Funds						
Mutual Funds-Equity						
Ishares Total US Stock Mkt Ind Fd 091936153 Asset Minor Code 98	1,913,979.614	49,399,813.84 25.8100	40,049,152.38	9,350,661.46 1,052,688.79	.00	1.26
Delaware Emerging Markets Fund 245914817 Asset Minor Code 98	196,058.473	4,342,695.18 22.1500	4,169,470.00	173,225.18 - 58,817.54	.00	2.60
Harding Loevner International Equity 412295107 Asset Minor Code 98	312,342.609	8,783,074.17 28.1200	8,468,049.07	315,025.10 384,181.41	.00	1.84

00372604
60- -01-B -62 -250-04
0101 -19-00883-04



TEXAS SOUTH UNIV, MUTUAL FUNDS
ACCOUNT 001050970131

Page 7 of 14
Period from August 1, 2024 to August 31, 2024

ASSET DETAIL (continued)

DESCRIPTION	SHARES/ FACE AMOUNT	MARKET PRICE/UNIT	BOOK VALUE	UNREALIZED GAIN (LOSS) SINCE INCEPTION/ CURRENT PERIOD	ENDING ACCRUAL	YIELD ON MARKET
Total Mutual Funds-Equity	2,422,380.696	62,525,583.19	52,686,671.45	9,838,911.74 1,378,052.66	.00	1.43
Mutual Funds-Fixed Income						
Shenkman Short Duration High Income 00770X709 Asset Minor Code 99	458,350.465	4,514,752.08 9.8500	4,519,348.92	- 4,596.84 22,809.87	.00	5.68
Global Opportunities Bd Fd Cl I 524686334 Asset Minor Code 99	405,705.751	3,659,465.87 9.0200	4,289,085.59	- 629,619.72 101,426.43	.00	1.98
Total Mutual Funds-Fixed Income	864,056.216	8,174,217.95	8,808,434.51	- 634,216.56 124,236.30	.00	4.02
Total Mutual Funds	3,286,436.912	70,699,801.14	61,495,105.96	9,204,695.18 1,502,288.96	.00	1.73
Miscellaneous						
Miscellaneous Assets						
Esc Gci Liberty Inc Sr Esc 361ESC049 Asset Minor Code 91	1,627.000	.00 .0000	1.00	- 1.00 .00	.00	0.00
Total Miscellaneous Assets	1,627.000	.00	1.00	- 1.00 .00	.00	0.00
Total Miscellaneous	1,627.000	.00	1.00	- 1.00 .00	.00	0.00
Total Assets	3,386,409.162	70,776,937.55	61,572,243.37	9,204,694.18 1,502,288.96	434.45	1.73



ASSET DETAIL (continued)

DESCRIPTION	SHARES/ FACE AMOUNT	MARKET PRICE/UNIT	BOOK VALUE	UNREALIZED GAIN (LOSS) SINCE INCEPTION/ CURRENT PERIOD	ENDING ACCRUAL	YIELD ON MARKET
Accrued Income	.000	434.45	434.45			
Grand Total	3,386,409.162	70,777,372.00	61,572,677.82			

ASSET DETAIL MESSAGES

Time of trade execution and trading party (if not disclosed) will be provided upon request.

Publicly traded assets are valued in accordance with market quotations or valuation methodologies from financial industry services believed by us to be reliable. Assets that are not publicly traded may be reflected at values from other external sources. Assets for which a current value is not available may be reflected at a previous value or as not valued, at par value, or at a nominal value. Values shown do not necessarily reflect prices at which assets could be bought or sold. Values are updated based on internal policy and may be updated less frequently than statement generation.

For further information, please contact your account manager or relationship manager.

We provide a cash management administrative service for the temporary investment of principal and income balances in your account. The fee for providing this service will not exceed \$0.42 per month for each \$1,000 of the average daily balance invested under the cash management administrative service. The charge for this service has been deducted from your account.

Yield on Market and Accrued Income are estimates provided for informational purposes only and should not be relied on for making investment, trading, or tax decisions. The estimates may not represent the actual value earned by your investments and they provide no guarantee of what your investments may earn in the future.

The asset categories used in this statement may be general in nature. For example, assets listed under the "Mutual Funds" category may include open-end investment companies registered under the Investment Company Act of 1940 (which are commonly known as "mutual funds") but may also include closed-end investment companies, unit investment trusts, common trust funds, collective trust funds or other investments that are registered with (or not subject to registration with) the Securities and Exchange Commission.

00372604
 60- -01-B -62 -250-04
 0101 -19-00883-04



TEXAS SOUTH UNIV, MUTUAL FUNDS
 ACCOUNT 001050970131

Page 9 of 14
 Period from August 1, 2024 to August 31, 2024

INCOME ACCRUAL DETAIL

SHARES/ FACE AMOUNT	DESCRIPTION	EX DATE	PAY DATE	ANN RATE	BEGINNING ACCRUAL	INCOME EARNED	INCOME RECEIVED	ENDING ACCRUAL
Cash And Equivalents								
98,345.250	First Am Govt Ob Fd CI Z 31846V567		09/03/24	0.05	202.02	434.45	202.02	434.45
Total Cash And Equivalents					202.02	434.45	202.02	434.45
Mutual Funds-Fixed Income								
458,350.465	Shenkman Short Duration High Income 00770X709	08/30/24	08/30/24	0.56	.00	24,511.31	24,511.31	.00
Total Mutual Funds-Fixed Income					.00	24,511.31	24,511.31	.00
Grand Total					202.02	24,945.76	24,713.33	434.45

00372604
60- -01-B -62 -250-04
0101 -19-00883-04



TEXAS SOUTH UNIV, MUTUAL FUNDS
ACCOUNT 001050970131

Page 10 of 14
Period from August 1, 2024 to August 31, 2024

INVESTMENT ACTIVITY

DATE	DESCRIPTION	CASH
Interest		
First Am Govt Ob Fd CI Z 31846V567		
08/01/2024	Interest From 7/1/24 To 7/31/24	202.02
Total Interest		202.02
Dividends		
Shenkman Short Duration High Income 00770X709		
08/02/2024	0.054026 USD/Share On 453,696.129 Shares Due 7/31/24 Dividend Payable 07/31/24	24,511.31
Total Dividends		24,511.31

00372604
60- -01-B -62 -250-04
0101 -19-00883-04



TEXAS SOUTH UNIV, MUTUAL FUNDS
ACCOUNT 001050970131

Page 11 of 14
Period from August 1, 2024 to August 31, 2024

PLAN EXPENSES

<u>DATE</u>	<u>DESCRIPTION</u>	<u>CASH</u>
Trust Fees		
Trust Fees		
08/23/2024	Collected Charged For Period 07/01/2024 Thru 07/31/2024	- 1,152.89
Total Trust Fees		- 1,152.89
Total Trust Fees		- 1,152.89
Total Plan Expenses		- 1,152.89

00372604
60- -01-B -62 -250-04
0101 -19-00883-04



TEXAS SOUTH UNIV, MUTUAL FUNDS
ACCOUNT 001050970131

Page 12 of 14
Period from August 1, 2024 to August 31, 2024

OTHER ACTIVITY

DATE	DESCRIPTION	CASH
Transfers In		
Transfer From Another Account		
08/30/2024	Paid From Account # 001050970130 Trsf From Xxx0130 To Xxx0131	238.98
Total Transfer From Another Account		238.98
Total Transfers In		238.98
Miscellaneous Receipts		
Transfer From Income		
08/02/2024	Dividend Shenkman Short Duration High Income	24,511.31
Total Transfer From Income		24,511.31
Total Miscellaneous Receipts		24,511.31
Miscellaneous Disbursements		
Transfer To Principal		
08/02/2024	Dividend Shenkman Short Duration High Income	- 24,511.31
Total Transfer To Principal		- 24,511.31
Total Miscellaneous Disbursements		- 24,511.31
Total Other Activity		238.98

00372604
 60- -01-B -62 -250-04
 0101 -19-00883-04



TEXAS SOUTH UNIV, MUTUAL FUNDS
 ACCOUNT 001050970131

Page 13 of 14
 Period from August 1, 2024 to August 31, 2024

PURCHASES

DATE	DESCRIPTION	SHARES/ FACE AMOUNT	COMMISSION	CASH	BOOK VALUE
Cash And Equivalents					
08/02/2024	Purchased 202.02 Units Of First Am Govt Ob Fd CI Z Trade Date 8/2/24 31846V567	202.020	.00	- 202.02	202.02
08/30/2024	Purchased 238.98 Units Of First Am Govt Ob Fd CI Z Trade Date 8/30/24 31846V567	238.980	.00	- 238.98	238.98
Total First Am Govt Ob Fd CI Z		441.000	.00	- 441.00	441.00
Total Cash And Equivalents		441.000	.00	- 441.00	441.00
Mutual Funds-Fixed Income					
08/30/2024	Purchased 2,153.182 Shares Shenkman Short Duration High Income @ 9.85 USD Through Reinvestment Of Cash Dividend Due 8/30/24 00770X709	2,153.182	.00	- 21,208.84	21,208.84
Total Shenkman Short Duration High Income		2,153.182	.00	- 21,208.84	21,208.84
Total Mutual Funds-Fixed Income		2,153.182	.00	- 21,208.84	21,208.84
Total Purchases		2,594.182	.00	- 21,649.84	21,649.84

00372604
 60- -01-B -62 -250-04
 0101 -19-00883-04



TEXAS SOUTH UNIV, MUTUAL FUNDS
 ACCOUNT 001050970131

Page 14 of 14
 Period from August 1, 2024 to August 31, 2024

SALES AND MATURITIES

DATE	DESCRIPTION	SHARES/ FACE AMOUNT	COMMISSION	TRANSACTION PROCEEDS	BOOK VALUE	REALIZED GAIN/LOSS
Cash And Equivalents						
08/23/2024	Sold 1,152.89 Units Of First Am Govt Ob Fd CI Z Trade Date 8/23/24 31846V567	- 1,152.890	.00	1,152.89	- 1,152.89	.00
Total First Am Govt Ob Fd CI Z		- 1,152.890	.00	1,152.89	- 1,152.89	.00
Total Cash And Equivalents		- 1,152.890	.00	1,152.89	- 1,152.89	.00
Total Sales And Maturities		- 1,152.890	.00	1,152.89	- 1,152.89	.00

SALES AND MATURITIES MESSAGES

Realized gain/loss should not be used for tax purposes.

01360804
60- -01-B -62 -250-04
0105 -19-00883-04



Account Number: 1028785476
TEXAS SOUTH UNIV, LOOP CAPITAL
INVESTMENT MANAGER

This statement is for the period from August 1, 2024 to August 31, 2024

Questions?

If you have any questions regarding your account or this statement, please contact your Account Manager.

Account Manager:
DANIELLE GROSS
1025 CONNECTICUT AVENUE SUITE 510
WASHINGTON DC 20036
Phone: 202-261-0782
E-mail: danielle.gross1@usbank.com

00001126 25 SP 000638792473326 S
ATLANTA CONSULTING GROUP
MATTHEW BAUDER
309 EAST PACES FERRY RD, SUITE 600
ATLANTA GA 30305

01360804
60- -01-B -62 -250-04
0105 -19-00883-04



TEXAS SOUTH UNIV, LOOP CAP
ACCOUNT 1028785476

Page 2 of 53
Period from August 1, 2024 to August 31, 2024

TABLE OF CONTENTS

Schedule	Page
Market And Cost Reconciliation	3
Cash Reconciliation	4
Asset Summary.....	5
Asset Detail	6
Income Accrual Detail	23
Investment Activity.....	31
Plan Expenses	38
Other Activity.....	39
Corporate Changes And Adjustments	40
Purchases	41
Sales And Maturities	45
Bond Summary	52

01360804
 60- -01-B -62 -250-04
 0105 -19-00883-04



TEXAS SOUTH UNIV, LOOP CAP
 ACCOUNT 1028785476

Page 3 of 53
 Period from August 1, 2024 to August 31, 2024

MARKET AND COST RECONCILIATION

	08/31/2024 MARKET	08/31/2024 BOOK VALUE
Beginning Market And Cost	18,117,386.62	18,514,011.88
Investment Activity		
Interest	76,542.91	76,542.91
Realized Gain/Loss	468.22	468.22
Change In Unrealized Gain/Loss	158,666.12	.00
Net Accrued Income (Current-Prior)	- 32,510.44	- 32,510.44
Total Investment Activity	203,166.81	44,500.69
Plan Expenses		
Trust Fees	- 837.55	- 837.55
Total Plan Expenses	- 837.55	- 837.55
Other Activity		
Miscellaneous Receipts	77,543.03	77,543.03
Miscellaneous Disbursements	- 77,543.03	- 77,543.03
Other Non-Cash Transactions	138.00	138.00
Total Other Activity	138.00	138.00
Net Change In Market And Cost	202,467.26	43,801.14
Ending Market And Cost	18,319,853.88	18,557,813.02

01360804
60- -01-B -62 -250-04
0105 -19-00883-04



TEXAS SOUTH UNIV, LOOP CAP
ACCOUNT 1028785476

Page 4 of 53
Period from August 1, 2024 to August 31, 2024

CASH RECONCILIATION

Beginning Cash	- 224,640.00
Investment Activity	
Interest	76,542.91
Cash Equivalent Purchases	- 80,910.69
Purchases	- 472,628.25
Cash Equivalent Sales	682,455.42
Sales/Maturities	20,018.16
Total Investment Activity	225,477.55
Plan Expenses	
Trust Fees	- 837.55
Total Plan Expenses	- 837.55
Other Activity	
Miscellaneous Receipts	77,543.03
Miscellaneous Disbursements	- 77,543.03
Total Other Activity	.00
Net Change In Cash	224,640.00
Ending Cash	.00

ASSET SUMMARY

ASSETS	08/31/2024 MARKET	08/31/2024 BOOK VALUE	% OF MARKET
Cash And Equivalents	1,985,942.31	1,975,863.34	10.83
U.S. Government Issues	8,195,608.66	8,341,515.99	44.74
Corporate Issues	7,664,732.62	7,781,503.90	41.84
Foreign Issues	362,036.00	347,395.50	1.98
Total Assets	18,208,319.59	18,446,278.73	99.39
Accrued Income	111,534.29	111,534.29	0.61
Grand Total	18,319,853.88	18,557,813.02	100.00

Estimated Annual Income **666,420.92**

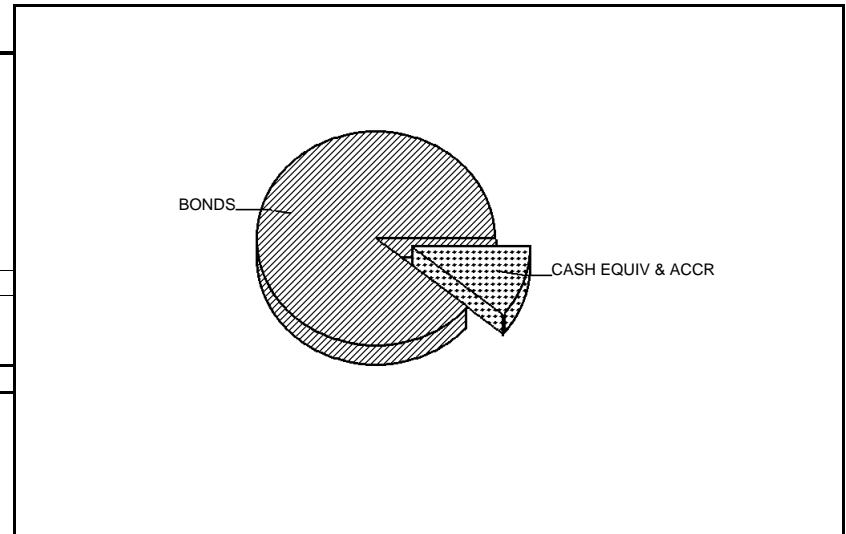

ASSET SUMMARY MESSAGES

Estimated Annual Income is an estimate provided for informational purposes only and should not be relied on for making investment, trading, or tax decisions. The estimates may not represent the actual value earned by your investments and they provide no guarantee of what your investments may earn in the future.

ASSET DETAIL

DESCRIPTION	SHARES/ FACE AMOUNT	MARKET PRICE/UNIT	BOOK VALUE	UNREALIZED GAIN (LOSS) SINCE INCEPTION/ CURRENT PERIOD	ENDING ACCRUAL	YIELD ON MARKET
Cash And Equivalents						
Money Markets						
First Am Govt Ob Fd Cl Z 31846V567 Asset Minor Code 1	185,335.260	185,335.26 1.0000	185,335.26	.00 .00	1,952.68	5.15
Total Money Markets	185,335.260	185,335.26	185,335.26	.00 .00	1,952.68	5.14
US Treas & Agency Short Term Obligat						
U S Treasury Bill 10/29/24 912797LV7 Asset Minor Code 4	1,815,000.000	1,800,607.05 .9921	1,790,528.08	10,078.97 8,639.40	.00	5.14
Total US Treas & Agency Short Term O	1,815,000.000	1,800,607.05	1,790,528.08	10,078.97 8,639.40	.00	5.14
Total Cash And Equivalents	2,000,335.260	1,985,942.31	1,975,863.34	10,078.97 8,639.40	1,952.68	5.14
US Government Issues						
F H L M C Gd G04715 6.000% 6/01/38 Standard & Poors Rating: N/A Moody's Rating: N/A 3128M6SC3 Asset Minor Code 24	3,386.930	3,559.46 105.0940	3,741.49	- 182.03 56.94	16.93	5.71
F H L M C Gd C03490 4.500% 8/01/40 Standard & Poors Rating: N/A Moody's Rating: N/A 31292K2X4 Asset Minor Code 24	2,727.310	2,732.85 100.2030	2,864.95	- 132.10 25.93	10.20	4.49

01360804
60- -01-B -62 -250-04
0105 -19-00883-04



TEXAS SOUTH UNIV, LOOP CAP
ACCOUNT 1028785476

Page 7 of 53
Period from August 1, 2024 to August 31, 2024

ASSET DETAIL (continued)

DESCRIPTION	SHARES/ FACE AMOUNT	MARKET PRICE/UNIT	BOOK VALUE	UNREALIZED GAIN (LOSS) SINCE INCEPTION/ CURRENT PERIOD	ENDING ACCRUAL	YIELD ON MARKET
F H L M C Gd A22005 4.500% 5/01/34 Standard & Poors Rating: N/A Moody's Rating: N/A 31296YGN7 Asset Minor Code 24	1,400.600	1,398.26 99.8330	1,394.02	4.24 12.96	5.22	4.51
F N M A #A11697 4.000% 10/01/41 Standard & Poors Rating: N/A Moody's Rating: N/A 3138EH3F7 Asset Minor Code 24	3,488.890	3,409.06 97.7120	3,697.69	- 288.63 43.15	11.63	4.09
F N M A #A14911 3.000% 10/01/27 Standard & Poors Rating: N/A Moody's Rating: N/A 3138EMN56 Asset Minor Code 24	4,173.910	4,091.35 98.0220	4,381.31	- 289.96 29.61	10.43	3.06
F N M A #725690 6.000% 8/01/34 Standard & Poors Rating: N/A Moody's Rating: N/A 31402DF70 Asset Minor Code 24	8,698.890	9,056.50 104.1110	10,011.88	- 955.38 114.50	43.49	5.76
F N M A #735676 5.000% 7/01/35 Standard & Poors Rating: N/A Moody's Rating: N/A 31402RJV2 Asset Minor Code 24	2,142.740	2,182.62 101.8610	2,332.19	- 149.57 19.37	9.05	4.91
F N M A #735925 5.000% 10/01/35 Standard & Poors Rating: N/A Moody's Rating: N/A 31402RSN0 Asset Minor Code 24	1,952.560	1,989.64 101.8990	2,121.55	- 131.91 17.36	8.14	4.91
F N M A #745516 5.500% 5/01/36 Standard & Poors Rating: N/A Moody's Rating: N/A 31403DGZ6 Asset Minor Code 24	4,284.990	4,418.08 103.1060	4,682.04	- 263.96 57.27	19.42	5.33

01360804
 60- -01-B -62 -250-04
 0105 -19-00883-04



TEXAS SOUTH UNIV, LOOP CAP
 ACCOUNT 1028785476

Page 8 of 53
 Period from August 1, 2024 to August 31, 2024

ASSET DETAIL (continued)

DESCRIPTION	SHARES/ FACE AMOUNT	MARKET PRICE/UNIT	BOOK VALUE	UNREALIZED GAIN (LOSS) SINCE INCEPTION/ CURRENT PERIOD	ENDING ACCRUAL	YIELD ON MARKET
F N M A #888219 5.500% 3/01/37 Standard & Poors Rating: N/A Moody's Rating: N/A 31410FYQ2 Asset Minor Code 24	6,292.540	6,475.28 102.9040	6,855.89	- 380.61 73.10	28.47	5.34
F N M A #888637 6.000% 9/01/37 Standard & Poors Rating: N/A Moody's Rating: N/A 31410GHN6 Asset Minor Code 24	9,574.330	10,052.95 104.9990	10,567.16	- 514.21 162.08	47.65	5.71
F N M A #889506 6.000% 3/01/37 Standard & Poors Rating: N/A Moody's Rating: N/A 31410KGP3 Asset Minor Code 24	2,330.410	2,446.91 104.9990	2,628.30	- 181.39 43.74	11.29	5.71
F N M A #889691 6.000% 7/01/38 Standard & Poors Rating: N/A Moody's Rating: N/A 31410KNG5 Asset Minor Code 24	1,714.360	1,798.74 104.9220	1,894.08	- 95.34 27.75	8.61	5.72
F N M A #889983 6.000% 10/01/38 Standard & Poors Rating: N/A Moody's Rating: N/A 31410KXL3 Asset Minor Code 24	2,042.930	2,144.77 104.9850	2,251.71	- 106.94 34.32	10.21	5.72
F N M A #Ae0395 4.500% 10/01/40 Standard & Poors Rating: N/A Moody's Rating: N/A 31419ANM5 Asset Minor Code 24	5,679.810	5,684.92 100.0900	5,883.04	- 198.12 54.99	21.27	4.50
G N M A II #004266 5.500% 10/20/38 Standard & Poors Rating: N/A Moody's Rating: N/A 36202EW39 Asset Minor Code 24	2,097.180	2,171.29 103.5340	2,342.91	- 171.62 9.86	9.63	5.31

01360804
60- -01-B -62 -250-04
0105 -19-00883-04



TEXAS SOUTH UNIV, LOOP CAP
ACCOUNT 1028785476

Page 9 of 53
Period from August 1, 2024 to August 31, 2024

ASSET DETAIL (continued)

DESCRIPTION	SHARES/ FACE AMOUNT	MARKET PRICE/UNIT	BOOK VALUE	UNREALIZED GAIN (LOSS) SINCE INCEPTION/ CURRENT PERIOD	ENDING ACCRUAL	YIELD ON MARKET
U S Treasury Nt 0.375% 1/31/26 Standard & Poors Rating: N/A Moody's Rating: Aaa 91282CBH3 Asset Minor Code 21	145,000.000	137,568.75 94.8750	141,998.04	- 4,429.29 1,120.85	47.28	0.40
U S Treasury Nt 1.375% 11/15/31 Standard & Poors Rating: N/A Moody's Rating: Aaa 91282CDJ7 Asset Minor Code 21	75,000.000	63,498.00 84.6640	72,263.67	- 8,765.67 796.50	305.45	1.62
U S Treasury Nt 1.250% 12/31/26 Standard & Poors Rating: N/A Moody's Rating: Aaa 91282CDQ1 Asset Minor Code 21	1,700,000.000	1,602,590.00 94.2700	1,682,118.92	- 79,528.92 14,416.00	3,657.79	1.33
U S Treasury Nt 1.875% 2/15/32 Standard & Poors Rating: N/A Moody's Rating: Aaa 91282CDY4 Asset Minor Code 21	330,000.000	288,284.70 87.3590	314,309.41	- 26,024.71 3,606.90	285.84	2.15
U S Treasury Nt 2.875% 5/15/32 Standard & Poors Rating: N/A Moody's Rating: Aaa 91282CEP2 Asset Minor Code 21	455,000.000	425,675.25 93.5550	448,903.71	- 23,228.46 4,873.05	3,874.61	3.07
U S Treasury Nt 2.625% 5/31/27 Standard & Poors Rating: N/A Moody's Rating: Aaa 91282CET4 Asset Minor Code 21	100,000.000	96,918.00 96.9180	98,011.72	- 1,093.72 805.00	667.01	2.71
U S Treasury Nt 3.250% 6/30/29 Standard & Poors Rating: N/A Moody's Rating: Aaa 91282CEV9 Asset Minor Code 21	345,000.000	337,306.50 97.7700	345,944.24	- 8,637.74 3,008.40	1,919.53	3.32

01360804
60- -01-B -62 -250-04
0105 -19-00883-04



TEXAS SOUTH UNIV, LOOP CAP
ACCOUNT 1028785476

Page 10 of 53
Period from August 1, 2024 to August 31, 2024

ASSET DETAIL (continued)

DESCRIPTION	SHARES/ FACE AMOUNT	MARKET PRICE/UNIT	BOOK VALUE	UNREALIZED GAIN (LOSS) SINCE INCEPTION/ CURRENT PERIOD	ENDING ACCRUAL	YIELD ON MARKET
U S Treasury Nt 3.250% 6/30/27 Standard & Poors Rating: N/A Moody's Rating: Aaa 91282CEW7 Asset Minor Code 21	355,000.000	349,785.05 98.5310	362,422.28	- 12,637.23 2,634.10	1,975.17	3.30
U S Treasury Nt 2.750% 8/15/32 Standard & Poors Rating: N/A Moody's Rating: Aaa 91282CFF3 Asset Minor Code 21	70,000.000	64,736.70 92.4810	65,980.47	- 1,243.77 774.20	84.08	2.97
U S Treasury Nt 4.125% 11/15/32 Standard & Poors Rating: N/A Moody's Rating: Aaa 91282CFV8 Asset Minor Code 21	230,000.000	234,303.30 101.8710	232,150.39	2,152.91 2,541.50	2,810.16	4.05
U S Treasury Nt 3.500% 2/15/33 Standard & Poors Rating: N/A Moody's Rating: Aaa 91282CGM7 Asset Minor Code 21	1,970,000.000	1,916,435.70 97.2810	1,942,475.56	- 26,039.86 22,320.10	3,185.19	3.60
U S Treasury Nt 4.375% 8/15/26 Standard & Poors Rating: N/A Moody's Rating: Aaa 91282CHU8 Asset Minor Code 21	325,000.000	327,616.25 100.8050	324,746.09	2,870.16 1,982.50	656.84	4.34
U S Treasury Bd 4.375% 7/15/27 Standard & Poors Rating: N/A Moody's Rating: Aaa 91282CKZ3 Asset Minor Code 21	525,000.000	533,079.75 101.5390	527,501.95	5,577.80 3,606.75	2,995.92	4.31
U S Treasury I P S 0.125% 4/15/25 Standard & Poors Rating: N/A Moody's Rating: Aaa 912828ZJ2 Asset Minor Code 30	364,890.000	356,501.18 97.7010	355,582.30	918.88 1,587.15	173.22	0.13

01360804
60- -01-B -62 -250-04
0105 -19-00883-04



TEXAS SOUTH UNIV, LOOP CAP
ACCOUNT 1028785476

Page 11 of 53
Period from August 1, 2024 to August 31, 2024

ASSET DETAIL (continued)

DESCRIPTION	SHARES/ FACE AMOUNT	MARKET PRICE/UNIT	BOOK VALUE	UNREALIZED GAIN (LOSS) SINCE INCEPTION/ CURRENT PERIOD	ENDING ACCRUAL	YIELD ON MARKET
U S Treasury Nt 2.375% 5/15/29 Standard & Poors Rating: N/A Moody's Rating: Aaa 9128286T2 Asset Minor Code 21	1,485,000.000	1,397,696.85 94.1210	1,359,457.03	38,239.82 14,092.65	10,446.45	2.52
Total US Government Issues	8,536,878.380	8,195,608.66	8,341,515.99	- 145,907.33 78,948.58	33,356.18	2.73
Corporate Issues						
American Express Co 3.950% 8/01/25 Standard & Poors Rating: BBB+ Moody's Rating: A2 025816CY3 Asset Minor Code 28	160,000.000	158,726.40 99.2040	157,520.00	1,206.40 598.40	526.67	3.98
Ameriprise Finl 5.700% 12/15/28 Standard & Poors Rating: A- Moody's Rating: A3 03076CAN6 Asset Minor Code 28	50,000.000	52,564.00 105.1280	49,916.50	2,647.50 631.00	601.67	5.42
Bank Of America Corp 3.419% 12/20/28 Standard & Poors Rating: A- Moody's Rating: A1 06051GHD4 Asset Minor Code 28	225,000.000	216,945.00 96.4200	236,142.35	- 19,197.35 1,903.50	1,517.18	3.55
Bk Of America Mtn 1.922% 10/24/31 Standard & Poors Rating: A- Moody's Rating: A1 06051GJL4 Asset Minor Code 28	125,000.000	106,382.50 85.1060	121,878.32	- 15,495.82 1,633.75	847.55	2.26
Bank New York Mtn 4.947% 4/26/27 Standard & Poors Rating: A Moody's Rating: A1 06406RBQ9 Asset Minor Code 28	125,000.000	125,683.75 100.5470	125,000.00	683.75 432.50	2,147.14	4.92

01360804
60- -01-B -62 -250-04
0105 -19-00883-04



TEXAS SOUTH UNIV, LOOP CAP
ACCOUNT 1028785476

Page 12 of 53
Period from August 1, 2024 to August 31, 2024

ASSET DETAIL (continued)

DESCRIPTION	SHARES/ FACE AMOUNT	MARKET PRICE/UNIT	BOOK VALUE	UNREALIZED GAIN (LOSS) SINCE INCEPTION/ CURRENT PERIOD	ENDING ACCRUAL	YIELD ON MARKET
Berkley WR Corp 6.250% 2/15/37 Standard & Poors Rating: BBB+ Moody's Rating: Baa1 084423AP7 Asset Minor Code 28	50,000.000	53,640.50 107.2810	53,441.00	199.50 199.50	138.89	5.83
Blackstone Private 2.625% 12/15/26 Standard & Poors Rating: BBB- Moody's Rating: Baa3 09261HAD9 Asset Minor Code 28	230,000.000	215,843.50 93.8450	230,000.00	- 14,156.50 2,313.80	1,274.58	2.80
Boeing Co 3.250% 2/01/35 Standard & Poors Rating: BBB- Moody's Rating: Baa3 097023CP8 Asset Minor Code 28	75,000.000	60,513.00 80.6840	59,286.00	1,227.00 986.25	203.13	4.03
Bristol Myers 5.100% 2/22/31 Standard & Poors Rating: A Moody's Rating: A2 110122EG9 Asset Minor Code 28	50,000.000	51,693.00 103.3860	49,921.50	1,771.50 443.00	63.75	4.93
Rixmor Operating LP 5.750% 2/15/35 Standard & Poors Rating: BBB Moody's Rating: Baa3 11120BAA5 Asset Minor Code 28	145,000.000	150,063.40 103.4920	143,871.90	6,191.50 1,754.50	370.56	5.56
Campbell Soup Co 5.400% 3/21/34 Standard & Poors Rating: BBB- Moody's Rating: Baa2 134429BP3 Asset Minor Code 28	60,000.000	61,966.80 103.2780	59,780.40	2,186.40 910.20	1,440.00	5.23
Cantor L P 7.200% 12/12/28 Standard & Poors Rating: BBB- Moody's Rating: N/A 138616AM9 Asset Minor Code 28	50,000.000	52,891.00 105.7820	49,903.00	2,988.00 283.50	790.00	6.81

01360804
60- -01-B -62 -250-04
0105 -19-00883-04



TEXAS SOUTH UNIV, LOOP CAP
ACCOUNT 1028785476

Page 13 of 53
Period from August 1, 2024 to August 31, 2024

ASSET DETAIL (continued)

DESCRIPTION	SHARES/ FACE AMOUNT	MARKET PRICE/UNIT	BOOK VALUE	UNREALIZED GAIN (LOSS) SINCE INCEPTION/ CURRENT PERIOD	ENDING ACCRUAL	YIELD ON MARKET
Capital One Finl 7.149% 10/29/27 Standard & Poors Rating: BBB Moody's Rating: Baa1 14040HDB8 Asset Minor Code 28	80,000.000	83,852.00 104.8150	80,000.00	3,852.00 440.80	1,938.17	6.82
Carmax Auto Owner 3.490% 2/16/27 Standard & Poors Rating: AAA Moody's Rating: Aaa 14317HAC5 Asset Minor Code 31	131,951.230	130,627.76 98.9970	129,064.80	1,562.96 141.16	204.67	3.53
Citigroup Inc 3.980% 3/20/30 Standard & Poors Rating: BBB+ Moody's Rating: A3 172967ME8 Asset Minor Code 28	70,000.000	67,961.60 97.0880	72,846.64	- 4,885.04 703.50	1,245.96	4.10
Citigroup Inc 3.785% 3/17/33 Standard & Poors Rating: BBB+ Moody's Rating: A3 172967NN7 Asset Minor Code 28	85,000.000	78,458.40 92.3040	85,000.00	- 6,541.60 955.40	1,465.64	4.10
Citigroup Inc Sub 6.174% 5/25/34 Standard & Poors Rating: BBB Moody's Rating: Baa2 17327CAR4 Asset Minor Code 28	75,000.000	79,170.00 105.5600	75,000.00	4,170.00 1,311.75	1,234.80	5.85
Concentrix Corp 6.650% 8/02/26 Standard & Poors Rating: BBB Moody's Rating: Baa3 20602DAA9 Asset Minor Code 28	125,000.000	128,463.75 102.7710	124,880.00	3,583.75 613.75	669.62	6.47
Continental Res 2.875% 4/01/32 Standard & Poors Rating: BBB- Moody's Rating: Baa3 212015AV3 Asset Minor Code 28	100,000.000	84,085.00 84.0850	80,291.00	3,794.00 1,075.00	1,197.92	3.42

ASSET DETAIL (continued)

DESCRIPTION	SHARES/ FACE AMOUNT	MARKET PRICE/UNIT	BOOK VALUE	UNREALIZED GAIN (LOSS) SINCE INCEPTION/ CURRENT PERIOD	ENDING ACCRUAL	YIELD ON MARKET
Cousins Pptys 5.875% 10/01/34 Standard & Poors Rating: BBB Moody's Rating: Baa2 222793AA9 Asset Minor Code 28	100,000.000	100,571.00 100.5710	100,475.00	96.00 96.00	244.79	5.84
Cummins Inc 5.150% 2/20/34 Standard & Poors Rating: A Moody's Rating: A2 231021AW6 Asset Minor Code 28	50,000.000	51,860.00 103.7200	49,834.00	2,026.00 617.50	78.68	4.97
Eastman Chem Co 5.000% 8/01/29 Standard & Poors Rating: BBB Moody's Rating: Baa2 277432AZ3 Asset Minor Code 28	125,000.000	126,832.50 101.4660	124,640.00	2,192.50 1,463.75	520.83	4.93
Exelon Corp 5.150% 3/15/29 Standard & Poors Rating: BBB Moody's Rating: Baa2 30161NBM2 Asset Minor Code 28	250,000.000	256,640.00 102.6560	249,452.50	7,187.50 2,562.50	6,580.56	5.02
Fifth Third Bancorp 4.772% 7/28/30 Standard & Poors Rating: BBB+ Moody's Rating: Baa1 316773DG2 Asset Minor Code 28	50,000.000	49,710.00 99.4200	46,477.00	3,233.00 575.50	218.72	4.80
Ge Healthcare 4.800% 8/14/29 Standard & Poors Rating: BBB Moody's Rating: Baa2 36266GAA5 Asset Minor Code 28	100,000.000	100,806.00 100.8060	99,881.00	925.00 925.00	226.67	4.76
General Mtrs Finl Co 2.700% 8/20/27 Standard & Poors Rating: BBB Moody's Rating: Baa2 37045XDA1 Asset Minor Code 28	175,000.000	165,947.25 94.8270	180,649.00	- 14,701.75 1,811.25	144.38	2.85

01360804
60- -01-B -62 -250-04
0105 -19-00883-04



TEXAS SOUTH UNIV, LOOP CAP
ACCOUNT 1028785476

Page 15 of 53
Period from August 1, 2024 to August 31, 2024

ASSET DETAIL (continued)

DESCRIPTION	SHARES/ FACE AMOUNT	MARKET PRICE/UNIT	BOOK VALUE	UNREALIZED GAIN (LOSS) SINCE INCEPTION/ CURRENT PERIOD	ENDING ACCRUAL	YIELD ON MARKET
Goldman Sachs Group 2.600% 2/07/30 Standard & Poors Rating: BBB+ Moody's Rating: A2 38141GXC4 Asset Minor Code 28	155,000.000	140,673.35 90.7570	162,612.65	- 21,939.30 1,884.80	268.67	2.86
Goldman Sachs Group 2.640% 2/24/28 Standard & Poors Rating: BBB+ Moody's Rating: A2 38141GZK3 Asset Minor Code 28	160,000.000	152,673.60 95.4210	149,715.20	2,958.40 1,620.80	82.13	2.77
Home Part Of Amer 2.200% 1/17/41 Standard & Poors Rating: N/A Moody's Rating: Aaa 43730XAA2 Asset Minor Code 31	104,944.080	94,560.91 90.1060	104,942.15	- 10,381.24 937.49	.00	2.44
Htundai Auto Rec Tr 0.600% 2/16/27 Standard & Poors Rating: AAA Moody's Rating: N/A 44934KAD6 Asset Minor Code 31	200,000.000	194,910.00 97.4550	183,601.56	11,308.44 1,092.00	50.00	0.62
Ingersoll Rand Inc 5.700% 8/14/33 Standard & Poors Rating: BBB Moody's Rating: Baa2 45687VAB2 Asset Minor Code 28	75,000.000	79,112.25 105.4830	74,425.50	4,686.75 483.00	201.88	5.40
Intel Corp 3.150% 5/11/27 Standard & Poors Rating: BBB+ Moody's Rating: Baa1 458140AX8 Asset Minor Code 28	150,000.000	143,631.00 95.7540	143,836.50	- 205.50 - 205.50	1,443.75	3.29
Intel Corp 1.600% 8/12/28 Standard & Poors Rating: BBB+ Moody's Rating: Baa1 458140BT6 Asset Minor Code 28	120,000.000	105,933.60 88.2780	119,755.20	- 13,821.60 - 927.60	101.33	1.81

01360804
60- -01-B -62 -250-04
0105 -19-00883-04



TEXAS SOUTH UNIV, LOOP CAP
ACCOUNT 1028785476

Page 16 of 53
Period from August 1, 2024 to August 31, 2024

ASSET DETAIL (continued)

DESCRIPTION	SHARES/ FACE AMOUNT	MARKET PRICE/UNIT	BOOK VALUE	UNREALIZED GAIN (LOSS) SINCE INCEPTION/ CURRENT PERIOD	ENDING ACCRUAL	YIELD ON MARKET
Jpmdb Commercial 3.1439% 6/15/49 Standard & Poors Rating: N/A Moody's Rating: Aaa 46590LAT9 Asset Minor Code 31	30,000.000	28,769.40 95.8980	30,899.76	- 2,130.36 156.30	78.60	3.28
Jpmorgan Chase Co 4.005% 4/23/29 Standard & Poors Rating: A- Moody's Rating: A1 46647PAR7 Asset Minor Code 28	170,000.000	166,809.10 98.1230	194,351.72	- 27,542.62 1,480.70	2,420.80	4.08
Jpmorgan Chase Co 2.069% 6/01/29 Standard & Poors Rating: A- Moody's Rating: A1 46647PCJ3 Asset Minor Code 28	190,000.000	173,882.30 91.5170	190,864.50	- 16,982.20 1,924.70	982.78	2.26
Jefferies Fin Group 6.200% 4/14/34 Standard & Poors Rating: BBB Moody's Rating: Baa2 47233WEJ4 Asset Minor Code 28	125,000.000	131,527.50 105.2220	124,798.75	6,728.75 1,802.50	2,906.25	5.89
Jones Lang Lasalle 6.875% 12/01/28 Standard & Poors Rating: BBB+ Moody's Rating: Baa1 48020QAB3 Asset Minor Code 28	50,000.000	53,857.00 107.7140	49,618.00	4,239.00 216.50	859.38	6.38
Kyndryl Hldgs Inc 3.150% 10/15/31 Standard & Poors Rating: BBB- Moody's Rating: Baa2 50155QAL4 Asset Minor Code 28	280,000.000	242,600.40 86.6430	184,489.76	58,110.64 2,119.60	3,332.00	3.64
Marsh McLennan Cos 5.150% 3/15/34 Standard & Poors Rating: A- Moody's Rating: A3 571748BW1 Asset Minor Code 28	75,000.000	77,703.75 103.6050	74,885.25	2,818.50 939.75	2,049.27	4.97

01360804
60- -01-B -62 -250-04
0105 -19-00883-04



TEXAS SOUTH UNIV, LOOP CAP
ACCOUNT 1028785476

Page 17 of 53
Period from August 1, 2024 to August 31, 2024

ASSET DETAIL (continued)

DESCRIPTION	SHARES/ FACE AMOUNT	MARKET PRICE/UNIT	BOOK VALUE	UNREALIZED GAIN (LOSS) SINCE INCEPTION/ CURRENT PERIOD	ENDING ACCRUAL	YIELD ON MARKET
Microchip Technology 5.050% 3/15/29 Standard & Poors Rating: N/A Moody's Rating: Baa1 595017BE3 Asset Minor Code 28	100,000.000	101,953.00 101.9530	99,823.00	2,130.00 840.00	2,440.83	4.95
Mohawk Industries 5.850% 9/18/28 Standard & Poors Rating: BBB+ Moody's Rating: Baa1 608190AM6 Asset Minor Code 28	75,000.000	78,487.50 104.6500	74,990.25	3,497.25 618.00	1,986.56	5.59
Morgan Stanley Baml 3.720% 12/15/49 Standard & Poors Rating: N/A Moody's Rating: Aaa 61691GAS9 Asset Minor Code 31	180,000.000	174,951.00 97.1950	194,021.58	- 19,070.58 1,148.40	558.00	3.83
Morgan Stanley Mtn 2.943% 1/21/33 Standard & Poors Rating: A- Moody's Rating: A1 61747YEL5 Asset Minor Code 28	185,000.000	162,700.10 87.9460	185,032.37	- 22,332.27 2,567.80	604.95	3.35
Morgan Stanley Baml 3.325% 5/15/49 Standard & Poors Rating: N/A Moody's Rating: Aaa 61766EBE4 Asset Minor Code 31	40,000.000	38,763.20 96.9080	41,197.86	- 2,434.66 220.40	110.83	3.43
National Oilwell 3.600% 12/01/29 Standard & Poors Rating: BBB Moody's Rating: Baa2 637071AM3 Asset Minor Code 28	260,000.000	246,620.40 94.8540	274,775.63	- 28,155.23 2,623.40	2,340.00	3.80
Oncor Elec Delivery 5.650% 11/15/33 Standard & Poors Rating: A+ Moody's Rating: A2 68233JCS1 Asset Minor Code 28	150,000.000	159,376.50 106.2510	157,387.50	1,989.00 1,686.00	2,495.42	5.32

01360804
60- -01-B -62 -250-04
0105 -19-00883-04



TEXAS SOUTH UNIV, LOOP CAP
ACCOUNT 1028785476

Page 18 of 53
Period from August 1, 2024 to August 31, 2024

ASSET DETAIL (continued)

DESCRIPTION	SHARES/ FACE AMOUNT	MARKET PRICE/UNIT	BOOK VALUE	UNREALIZED GAIN (LOSS) SINCE INCEPTION/ CURRENT PERIOD	ENDING ACCRUAL	YIELD ON MARKET
Owens Corning New 5.500% 6/15/27 Standard & Poors Rating: BBB Moody's Rating: Baa1 690742AN1 Asset Minor Code 28	75,000.000	76,872.00 102.4960	74,985.00	1,887.00 414.75	1,042.71	5.37
Paypal Hldgs Inc 5.150% 6/01/34 Standard & Poors Rating: A- Moody's Rating: A3 70450YAP8 Asset Minor Code 28	175,000.000	179,742.50 102.7100	173,864.25	5,878.25 2,873.50	2,328.23	5.01
Polaris Inc 6.950% 3/15/29 Standard & Poors Rating: BBB Moody's Rating: Baa3 731068AA0 Asset Minor Code 28	50,000.000	53,622.00 107.2440	49,509.00	4,113.00 502.00	1,602.36	6.48
Public Storage Sr 2.250% 11/09/31 Standard & Poors Rating: A Moody's Rating: A2 74460DAJ8 Asset Minor Code 28	260,000.000	222,346.80 85.5180	260,648.61	- 38,301.81 2,971.80	1,820.00	2.63
Schwab Charles Corp 5.643% 5/19/29 Standard & Poors Rating: A- Moody's Rating: A2 808513CD5 Asset Minor Code 28	150,000.000	155,194.50 103.4630	150,000.00	5,194.50 1,515.00	282.15	5.45
6297782 LLC Sr 5.026% 10/01/29 Standard & Poors Rating: BBB- Moody's Rating: Baa3 83007CAC6 Asset Minor Code 28	75,000.000	74,834.25 99.7790	74,994.75	- 160.50 - 160.50	31.41	5.04
Southern Cal Edison 4.200% 3/01/29 Standard & Poors Rating: A- Moody's Rating: A2 842400GQ0 Asset Minor Code 28	45,000.000	44,404.20 98.6760	47,070.45	- 2,666.25 526.50	945.00	4.26

01360804
60- -01-B -62 -250-04
0105 -19-00883-04



TEXAS SOUTH UNIV, LOOP CAP
ACCOUNT 1028785476

Page 19 of 53
Period from August 1, 2024 to August 31, 2024

ASSET DETAIL (continued)

DESCRIPTION	SHARES/ FACE AMOUNT	MARKET PRICE/UNIT	BOOK VALUE	UNREALIZED GAIN (LOSS) SINCE INCEPTION/ CURRENT PERIOD	ENDING ACCRUAL	YIELD ON MARKET
State Str Corp 5.159% 5/18/34 Standard & Poors Rating: A Moody's Rating: A1 857477CC5 Asset Minor Code 28	125,000.000	127,913.75 102.3310	125,000.00	2,913.75 1,286.25	1,845.06	5.04
Synchrony Financial 5.935% 8/02/30 Standard & Poors Rating: BBB- Moody's Rating: N/A 87165BAV5 Asset Minor Code 28	100,000.000	101,788.00 101.7880	100,000.00	1,788.00 1,497.20	478.10	5.83
Tapestry Inc 7.850% 11/27/33 Standard & Poors Rating: BBB Moody's Rating: Baa2 876030AF4 Asset Minor Code 28	30,000.000	32,100.90 107.0030	29,842.50	2,258.40 108.90	614.92	7.34
Targa Resources L P 6.875% 1/15/29 Standard & Poors Rating: BBB Moody's Rating: Baa3 87612BBN1 Asset Minor Code 28	175,000.000	179,838.75 102.7650	174,784.75	5,054.00 164.50	1,537.33	6.69
Towd Point Mortgage 3.250% 3/25/58 Standard & Poors Rating: N/A Moody's Rating: Aaa 89175VAA1 Asset Minor Code 31	18,647.080	18,195.26 97.5770	18,586.25	- 390.99 28.36	50.50	3.33
Toyota At Rec Own 1.230% 6/15/26 Standard & Poors Rating: N/A Moody's Rating: Aaa 89239KAC5 Asset Minor Code 31	51,165.920	50,357.50 98.4200	48,591.65	1,765.85 - 91.13	27.97	1.25
Triton Container 2.03967% 9/20/45 Standard & Poors Rating: A Moody's Rating: N/A 89680HAA0 Asset Minor Code 31	153,429.060	140,745.08 91.7330	152,517.97	- 11,772.89 1,489.53	98.92	2.30

ASSET DETAIL (continued)

DESCRIPTION	SHARES/ FACE AMOUNT	MARKET PRICE/UNIT	BOOK VALUE	UNREALIZED GAIN (LOSS) SINCE INCEPTION/ CURRENT PERIOD	ENDING ACCRUAL	YIELD ON MARKET
Trust Financial Mtn 7.161% 10/30/29 Standard & Poors Rating: A- Moody's Rating: Baa1 89788MAQ5 Asset Minor Code 28	80,000.000	86,925.60 108.6570	80,000.00	6,925.60 754.40	1,925.51	6.59
United Air 2016 1 3.100% 1/07/30 Standard & Poors Rating: N/A Moody's Rating: A1 90931LAA6 Asset Minor Code 31	83,244.350	78,145.63 93.8750	80,650.53	- 2,504.90 - 90.74	387.08	3.30
United Airlines Pt 3.500% 9/01/31 Standard & Poors Rating: N/A Moody's Rating: A1 909318AA5 Asset Minor Code 31	41,881.640	39,032.43 93.1970	41,055.96	- 2,023.53 - 226.58	732.94	3.76
Unitedhealth Group 5.000% 4/15/34 Standard & Poors Rating: A+ Moody's Rating: A2 91324PFB3 Asset Minor Code 28	60,000.000	60,964.80 101.6080	59,529.60	1,435.20 710.40	1,333.33	4.92
Viatis Inc 2.700% 6/22/30 Standard & Poors Rating: BBB- Moody's Rating: Baa3 92556VAD8 Asset Minor Code 28	85,000.000	74,827.20 88.0320	68,590.75	6,236.45 808.35	439.88	3.07
Vmware Inc 3.900% 8/21/27 Standard & Poors Rating: BBB Moody's Rating: N/A 928563AC9 Asset Minor Code 28	190,000.000	186,733.90 98.2810	205,105.28	- 18,371.38 1,977.90	205.83	3.97
Wells Fargo Co Mtn 5.574% 7/25/29 Standard & Poors Rating: BBB+ Moody's Rating: A1 95000U3E1 Asset Minor Code 28	115,000.000	118,753.60 103.2640	115,000.00	3,753.60 992.45	2,243.54	5.40

01360804
60- -01-B -62 -250-04
0105 -19-00883-04



TEXAS SOUTH UNIV, LOOP CAP
ACCOUNT 1028785476

Page 21 of 53
Period from August 1, 2024 to August 31, 2024

ASSET DETAIL (continued)

DESCRIPTION	SHARES/ FACE AMOUNT	MARKET PRICE/UNIT	BOOK VALUE	UNREALIZED GAIN (LOSS) SINCE INCEPTION/ CURRENT PERIOD	ENDING ACCRUAL	YIELD ON MARKET
Total Corporate Issues	7,875,263.360	7,664,732.62	7,781,503.90	- 116,771.28 66,664.64	71,178.73	4.20
Foreign Issues						
Icon Invts Six 5.849% 5/08/29 Standard & Poors Rating: BBB- Moody's Rating: Baa3 45115AAB0 Asset Minor Code 35	200,000.000	208,968.00 104.4840	200,000.00	8,968.00 2,138.00	3,671.87	5.60
Jbs USA Lux S A 5.500% 1/15/30 Standard & Poors Rating: BBB- Moody's Rating: Baa3 46590XAL0 Asset Minor Code 35	100,000.000	100,725.00 100.7250	97,333.00	3,392.00 1,079.00	702.78	5.46
Vale Overseas Ltd 6.125% 6/12/33 Standard & Poors Rating: BBB- Moody's Rating: Baa3 91911TAR4 Asset Minor Code 35	50,000.000	52,343.00 104.6860	50,062.50	2,280.50 1,196.50	672.05	5.85
Total Foreign Issues	350,000.000	362,036.00	347,395.50	14,640.50 4,413.50	5,046.70	5.59
Total Assets	18,762,477.000	18,208,319.59	18,446,278.73	- 237,959.14 158,666.12	111,534.29	3.67
Accrued Income	.000	111,534.29	111,534.29			
Grand Total	18,762,477.000	18,319,853.88	18,557,813.02			

01360804
60- -01-B -62 -250-04
0105 -19-00883-04



TEXAS SOUTH UNIV, LOOP CAP
ACCOUNT 1028785476

Page 22 of 53
Period from August 1, 2024 to August 31, 2024

ASSET DETAIL MESSAGES

Time of trade execution and trading party (if not disclosed) will be provided upon request.

Publicly traded assets are valued in accordance with market quotations or valuation methodologies from financial industry services believed by us to be reliable. Assets that are not publicly traded may be reflected at values from other external sources. Assets for which a current value is not available may be reflected at a previous value or as not valued, at par value, or at a nominal value. Values shown do not necessarily reflect prices at which assets could be bought or sold. Values are updated based on internal policy and may be updated less frequently than statement generation.

For further information, please contact your account manager or relationship manager.

We provide a cash management administrative service for the temporary investment of principal and income balances in your account. The fee for providing this service will not exceed \$0.42 per month for each \$1,000 of the average daily balance invested under the cash management administrative service. The charge for this service has been deducted from your account.

Yield on Market and Accrued Income are estimates provided for informational purposes only and should not be relied on for making investment, trading, or tax decisions. The estimates may not represent the actual value earned by your investments and they provide no guarantee of what your investments may earn in the future.

The asset categories used in this statement may be general in nature. For example, assets listed under the "Mutual Funds" category may include open-end investment companies registered under the Investment Company Act of 1940 (which are commonly known as "mutual funds") but may also include closed-end investment companies, unit investment trusts, common trust funds, collective trust funds or other investments that are registered with (or not subject to registration with) the Securities and Exchange Commission.

01360804
 60- -01-B -62 -250-04
 0105 -19-00883-04



TEXAS SOUTH UNIV, LOOP CAP
 ACCOUNT 1028785476

Page 23 of 53
 Period from August 1, 2024 to August 31, 2024

INCOME ACCRUAL DETAIL

SHARES/ FACE AMOUNT	DESCRIPTION	EX DATE	PAY DATE	ANN RATE	BEGINNING ACCRUAL	INCOME EARNED	INCOME RECEIVED	ENDING ACCRUAL
Cash And Equivalents								
185,335.260	First Am Govt Ob Fd CI Z 31846V567		09/03/24	0.05	3,981.36	1,952.68	3,981.36	1,952.68
Total Cash And Equivalents					3,981.36	1,952.68	3,981.36	1,952.68
US Government Issues								
3,386.930	F H L M C Gd G04715 6.000% 6/01/38 3128M6SC3				17.09	16.93	17.09	16.93
2,727.310	F H L M C Gd C03490 4.500% 8/01/40 31292K2X4				10.25	10.23	10.28	10.20
1,400.600	F H L M C Gd A22005 4.500% 5/01/34 31296YGN7				5.27	5.25	5.30	5.22
3,488.890	F N M A #A11697 4.000% 10/01/41 3138EH3F7				11.73	11.63	11.73	11.63
4,173.910	F N M A #A14911 3.000% 10/01/27 3138EMN56				10.92	10.43	10.92	10.43
8,698.890	F N M A #725690 6.000% 8/01/34 31402DF70				44.18	43.49	44.18	43.49
2,142.740	F N M A #735676 5.000% 7/01/35 31402RJV2				9.18	8.93	9.06	9.05
1,952.560	F N M A #735925 5.000% 10/01/35 31402RSN0				8.24	8.14	8.24	8.14
4,284.990	F N M A #745516 5.500% 5/01/36 31403DGZ6				19.66	19.64	19.88	19.42
6,292.540	F N M A #888219 5.500% 3/01/37 31410FYQ2				28.95	28.84	29.32	28.47
9,574.330	F N M A #888637 6.000% 9/01/37 31410GHN6				48.05	47.87	48.27	47.65

01360804
 60- -01-B -62 -250-04
 0105 -19-00883-04



TEXAS SOUTH UNIV, LOOP CAP
 ACCOUNT 1028785476

Page 24 of 53
 Period from August 1, 2024 to August 31, 2024

INCOME ACCRUAL DETAIL (continued)

SHARES/ FACE AMOUNT	DESCRIPTION	EX DATE	PAY DATE	ANN RATE	BEGINNING ACCRUAL	INCOME EARNED	INCOME RECEIVED	ENDING ACCRUAL
2,330.410	F N M A #889506 31410KGP3	6.000%	3/01/37		11.49	11.65	11.85	11.29
1,714.360	F N M A #889691 31410KNG5	6.000%	7/01/38		8.69	8.57	8.65	8.61
2,042.930	F N M A #889983 31410KXL3	6.000%	10/01/38		10.30	10.21	10.30	10.21
5,679.810	F N M A #Ae0395 31419ANM5	4.500%	10/01/40		21.45	21.30	21.48	21.27
2,097.180	G N M A I I #004266 36202EW39	5.500%	10/20/38		9.77	9.61	9.75	9.63
145,000.000	U S Treasury Nt 91282CBH3	0.375%	1/31/26		1.48	45.80	.00	47.28
75,000.000	U S Treasury Nt 91282CDJ7	1.375%	11/15/31		218.58	86.87	.00	305.45
1,700,000.000	U S Treasury Nt 91282CDQ1	1.250%	12/31/26		1,857.92	1,799.87	.00	3,657.79
330,000.000	U S Treasury Nt 91282CDY4	1.875%	2/15/32		2,855.77	523.82	3,093.75	285.84
455,000.000	U S Treasury Nt 91282CEP2	2.875%	5/15/32		2,772.66	1,101.95	.00	3,874.61
100,000.000	U S Treasury Nt 91282CET4	2.625%	5/31/27		444.67	222.34	.00	667.01
345,000.000	U S Treasury Nt 91282CEV9	3.250%	6/30/29		975.00	944.53	.00	1,919.53
355,000.000	U S Treasury Nt 91282CEW7	3.250%	6/30/27		1,003.26	971.91	.00	1,975.17
70,000.000	U S Treasury Nt 91282CFF3	2.750%	8/15/32		883.61	162.97	962.50	84.08

01360804
60- -01-B -62 -250-04
0105 -19-00883-04



TEXAS SOUTH UNIV, LOOP CAP
ACCOUNT 1028785476

Page 25 of 53
Period from August 1, 2024 to August 31, 2024

INCOME ACCRUAL DETAIL (continued)

SHARES/ FACE AMOUNT	DESCRIPTION	EX DATE	PAY DATE	ANN RATE	BEGINNING ACCRUAL	INCOME EARNED	INCOME RECEIVED	ENDING ACCRUAL
230,000.000	U S Treasury Nt 91282CFV8	4.125%	11/15/32		2,010.94	799.22	.00	2,810.16
1,970,000.000	U S Treasury Nt 91282CGM7	3.500%	2/15/33		31,823.08	5,837.11	34,475.00	3,185.19
325,000.000	U S Treasury Nt 91282CHU8	4.375%	8/15/26		6,562.50	1,203.72	7,109.38	656.84
525,000.000	U S Treasury Bd 91282CKZ3	4.375%	7/15/27		1,061.06	1,934.86	.00	2,995.92
364,890.000	U S Treasury I P S 912828ZJ2	0.125%	4/15/25		134.54	38.68	.00	173.22
1,485,000.000	U S Treasury Nt 9128286T2	2.375%	5/15/29		7,475.44	2,971.01	.00	10,446.45
Total US Government Issues					60,355.73	18,917.38	45,916.93	33,356.18
Corporate Issues								
160,000.000	American Express Co 025816CY3	3.950%	8/01/25		3,160.00	526.67	3,160.00	526.67
50,000.000	Ameriprise Finl 03076CAN6	5.700%	12/15/28		364.17	237.50	.00	601.67
225,000.000	Bank Of America Corp 06051GHD4	3.419%	12/20/28		876.12	641.06	.00	1,517.18
125,000.000	Bk Of America Mtn 06051GJL4	1.922%	10/24/31		647.34	200.21	.00	847.55
125,000.000	Bank New York Mtn 06406RBQ9	4.947%	4/26/27		1,631.82	515.32	.00	2,147.14
50,000.000	Berkley WR Corp 084423AP7	6.250%	2/15/37		.00	217.01	78.12	138.89
230,000.000	Blackstone Private 09261HAD9	2.625%	12/15/26		771.46	503.12	.00	1,274.58

01360804
60- -01-B -62 -250-04
0105 -19-00883-04



TEXAS SOUTH UNIV, LOOP CAP
ACCOUNT 1028785476

Page 26 of 53
Period from August 1, 2024 to August 31, 2024

INCOME ACCRUAL DETAIL (continued)

SHARES/ FACE AMOUNT	DESCRIPTION	EX DATE	PAY DATE	ANN RATE	BEGINNING ACCRUAL	INCOME EARNED	INCOME RECEIVED	ENDING ACCRUAL
75,000.000	Boeing Co 097023CP8	3.250%	2/01/35		1,218.75	203.13	1,218.75	203.13
50,000.000	Bristol Myers 110122EG9	5.100%	2/22/31		1,126.25	212.50	1,275.00	63.75
145,000.000	Rixmor Operating LP 11120BAA5	5.750%	2/15/35		1,459.06	694.80	1,783.30	370.56
60,000.000	Campbell Soup Co 134429BP3	5.400%	3/21/34		1,170.00	270.00	.00	1,440.00
50,000.000	Cantor L P 138616AM9	7.200%	12/12/28		490.00	300.00	.00	790.00
80,000.000	Capital One Finl 14040HDB8	7.149%	10/29/27		1,461.57	476.60	.00	1,938.17
131,951.230	Carmax Auto Owner 14317HAC5	3.490%	2/16/27		220.87	397.93	414.13	204.67
70,000.000	Citigroup Inc 172967ME8	3.980%	3/20/30		1,013.79	232.17	.00	1,245.96
85,000.000	Citigroup Inc 172967NN7	3.785%	3/17/33		1,197.53	268.11	.00	1,465.64
75,000.000	Citigroup Inc Sub 17327CAR4	6.174%	5/25/34		848.93	385.87	.00	1,234.80
125,000.000	Concentrix Corp 20602DAA9	6.650%	8/02/26		4,133.16	692.71	4,156.25	669.62
100,000.000	Continental Res 212015AV3	2.875%	4/01/32		958.33	239.59	.00	1,197.92
100,000.000	Cousins Pptys 222793AA9	5.875%	10/01/34		.00	195.83	- 48.96	244.79
50,000.000	Cummins Inc 231021AW6	5.150%	2/20/34		1,151.60	214.58	1,287.50	78.68

01360804
60- -01-B -62 -250-04
0105 -19-00883-04



TEXAS SOUTH UNIV, LOOP CAP
ACCOUNT 1028785476

Page 27 of 53
Period from August 1, 2024 to August 31, 2024

INCOME ACCRUAL DETAIL (continued)

SHARES/ FACE AMOUNT	DESCRIPTION	EX DATE	PAY DATE	ANN RATE	BEGINNING ACCRUAL	INCOME EARNED	INCOME RECEIVED	ENDING ACCRUAL
125,000.000	Eastman Chem Co 277432AZ3	5.000%	8/01/29		.00	520.83	.00	520.83
250,000.000	Exelon Corp 30161NBM2	5.150%	3/15/29		5,507.64	1,072.92	.00	6,580.56
50,000.000	Fifth Third Bancorp 316773DG2	4.772%	7/28/30		19.88	198.84	.00	218.72
100,000.000	Ge Healthcare 36266GAA5	4.800%	8/14/29		.00	226.67	.00	226.67
175,000.000	General Mtrs Finl Co 37045XDA1	2.700%	8/20/27		2,113.13	393.75	2,362.50	144.38
155,000.000	Goldman Sachs Group 38141GXF4	2.600%	2/07/30		1,947.83	335.84	2,015.00	268.67
160,000.000	Goldman Sachs Group 38141GZK3	2.640%	2/24/28		1,842.13	352.00	2,112.00	82.13
104,944.080	Home Part Of Amer 43730XAA2	2.200%	1/17/41		.00	192.90	192.90	.00
200,000.000	Htundai Auto Rec Tr 44934KAD6	0.600%	2/16/27		50.00	100.00	100.00	50.00
75,000.000	Ingersoll Rand Inc 45687VAB2	5.700%	8/14/33		1,983.13	356.25	2,137.50	201.88
150,000.000	Intel Corp 458140AX8	3.150%	5/11/27		.00	48.12	- 1,395.63	1,443.75
120,000.000	Intel Corp 458140BT6	1.600%	8/12/28		901.33	160.00	960.00	101.33
30,000.000	Jpmdb Commercial 46590LAT9	3.1439%	6/15/49		78.60	78.60	78.60	78.60
170,000.000	Jpmorgan Chase Co 46647PAR7	4.005%	4/23/29		1,853.43	567.37	.00	2,420.80

01360804
60- -01-B -62 -250-04
0105 -19-00883-04



TEXAS SOUTH UNIV, LOOP CAP
ACCOUNT 1028785476

Page 28 of 53
Period from August 1, 2024 to August 31, 2024

INCOME ACCRUAL DETAIL (continued)

SHARES/ FACE AMOUNT	DESCRIPTION	EX DATE	PAY DATE	ANN RATE	BEGINNING ACCRUAL	INCOME EARNED	INCOME RECEIVED	ENDING ACCRUAL
190,000.000	Jpmorgan Chase Co 46647PCJ3	2.069%	6/01/29		655.18	327.60	.00	982.78
125,000.000	Jefferies Fin Group 47233WEJ4	6.200%	4/14/34		2,260.42	645.83	.00	2,906.25
50,000.000	Jones Lang Lasalle 48020QAB3	6.875%	12/01/28		572.92	286.46	.00	859.38
280,000.000	Kyndryl Hldgs Inc 50155QAL4	3.150%	10/15/31		2,597.00	735.00	.00	3,332.00
75,000.000	Marsh McLennan Cos 571748BW1	5.150%	3/15/34		1,727.40	321.87	.00	2,049.27
100,000.000	Microchip Technology 595017BE3	5.050%	3/15/29		2,020.00	420.83	.00	2,440.83
75,000.000	Mohawk Industries 608190AM6	5.850%	9/18/28		1,620.94	365.62	.00	1,986.56
180,000.000	Morgan Stanley Baml 61691GAS9	3.720%	12/15/49		558.00	558.00	558.00	558.00
185,000.000	Morgan Stanley Mtn 61747YEL5	2.943%	1/21/33		151.24	453.71	.00	604.95
40,000.000	Morgan Stanley Baml 61766EBE4	3.325%	5/15/49		110.83	110.83	110.83	110.83
260,000.000	National Oilwell 637071AM3	3.600%	12/01/29		1,560.00	780.00	.00	2,340.00
150,000.000	Oncor Elec Delivery 68233JCS1	5.650%	11/15/33		1,789.17	706.25	.00	2,495.42
75,000.000	Owens Corning New 690742AN1	5.500%	6/15/27		698.96	343.75	.00	1,042.71
175,000.000	Paypal Hldgs Inc 70450YAP8	5.150%	6/01/34		1,577.19	751.04	.00	2,328.23

01360804
 60- -01-B -62 -250-04
 0105 -19-00883-04



TEXAS SOUTH UNIV, LOOP CAP
 ACCOUNT 1028785476

Page 29 of 53
 Period from August 1, 2024 to August 31, 2024

INCOME ACCRUAL DETAIL (continued)

SHARES/ FACE AMOUNT	DESCRIPTION	EX DATE	PAY DATE	ANN RATE	BEGINNING ACCRUAL	INCOME EARNED	INCOME RECEIVED	ENDING ACCRUAL
50,000.000	Polaris Inc 731068AA0	6.950%	3/15/29		1,312.78	289.58	.00	1,602.36
260,000.000	Public Storage Sr 74460DAJ8	2.250%	11/09/31		1,332.50	487.50	.00	1,820.00
150,000.000	Schwab Charles Corp 808513CD5	5.643%	5/19/29		3,809.03	- 3,526.88	.00	282.15
75,000.000	6297782 LLC Sr 83007CAC6	5.026%	10/01/29		.00	31.41	.00	31.41
45,000.000	Southern Cal Edison 842400GQ0	4.200%	3/01/29		787.50	157.50	.00	945.00
125,000.000	State Str Corp 857477CC5	5.159%	5/18/34		1,307.66	537.40	.00	1,845.06
100,000.000	Synchrony Financial 87165BAV5	5.935%	8/02/30		.00	478.10	.00	478.10
30,000.000	Tapestry Inc 876030AF4	7.850%	11/27/33		418.67	196.25	.00	614.92
175,000.000	Targa Resources L P 87612BBN1	6.875%	1/15/29		534.72	1,002.61	.00	1,537.33
18,647.080	Towd Point Mortgage 89175VAA1	3.250%	3/25/58		52.54	50.50	52.54	50.50
51,165.920	Toyota At Rec Own 89239KAC5	1.230%	6/15/26		31.28	55.34	58.65	27.97
153,429.060	Triton Container 89680HAA0	2.03967%	9/20/45		99.97	271.59	272.64	98.92
80,000.000	Trust Financial Mtn 89788MAQ5	7.161%	10/30/29		1,448.11	477.40	.00	1,925.51
83,244.350	United Air 2016 1 90931LAA6	3.100%	1/07/30		172.03	215.05	.00	387.08

01360804
60- -01-B -62 -250-04
0105 -19-00883-04



TEXAS SOUTH UNIV, LOOP CAP
ACCOUNT 1028785476

Page 30 of 53
Period from August 1, 2024 to August 31, 2024

INCOME ACCRUAL DETAIL (continued)

SHARES/ FACE AMOUNT	DESCRIPTION	EX DATE	PAY DATE	ANN RATE	BEGINNING ACCRUAL	INCOME EARNED	INCOME RECEIVED	ENDING ACCRUAL
41,881.640	United Airlines Pt 909318AA5	3.500%	9/01/31		610.78	122.16	.00	732.94
60,000.000	Unitedhealth Group 91324PFB3	5.000%	4/15/34		1,083.33	250.00	.00	1,333.33
85,000.000	Viatrix Inc 92556VAD8	2.700%	6/22/30		248.63	191.25	.00	439.88
190,000.000	Vmware Inc 928563AC9	3.900%	8/21/27		3,293.33	617.50	3,705.00	205.83
115,000.000	Wells Fargo Co Mtn 95000U3E1	5.574%	7/25/29		1,709.36	534.18	.00	2,243.54
Total Corporate Issues					76,349.32	21,474.03	26,644.62	71,178.73
Foreign Issues								
200,000.000	Icon Invts Six 45115AAB0	5.849%	5/08/29		2,697.04	974.83	.00	3,671.87
100,000.000	Jbs USA Lux S A 46590XALO	5.500%	1/15/30		244.44	458.34	.00	702.78
50,000.000	Vale Overseas Ltd 91911TAR4	6.125%	6/12/33		416.84	255.21	.00	672.05
Total Foreign Issues					3,358.32	1,688.38	.00	5,046.70
Grand Total					144,044.73	44,032.47	76,542.91	111,534.29

01360804
 60- -01-B -62 -250-04
 0105 -19-00883-04



TEXAS SOUTH UNIV, LOOP CAP
 ACCOUNT 1028785476

Page 31 of 53
 Period from August 1, 2024 to August 31, 2024

INVESTMENT ACTIVITY

DATE	DESCRIPTION	CASH
Interest		
American Express Co 3.950% 8/01/25 025816Cy3		
08/01/2024	American Express Co 3.950% 8/01/25 0.01975 USD/\$1 Pv On 160,000 Par Value Due 8/1/24	3,160.00
Berkley WR Corp 6.250% 2/15/37 084423Ap7		
08/06/2024	Paid Accrued Interest On Purchase Of Berkley WR Corp 6.250% 2/15/37 Income Debit 1,484.38- USD	- 1,484.38
08/15/2024	Berkley WR Corp 6.250% 2/15/37 0.03125 USD/\$1 Pv On 50,000 Par Value Due 8/15/24	1,562.50
Total Berkley WR Corp 6.250% 2/15/37		78.12
Boeing Co 3.250% 2/01/35 097023Cp8		
08/01/2024	Boeing Co 3.250% 2/01/35 0.01625 USD/\$1 Pv On 75,000 Par Value Due 8/1/24	1,218.75
Bristol Myers 5.100% 2/22/31 110122Eg9		
08/22/2024	Bristol Myers 5.100% 2/22/31 0.0255 USD/\$1 Pv On 50,000 Par Value Due 8/22/24	1,275.00
Carmax Auto Owner 3.490% 2/16/27 14317Hac5		
08/15/2024	Carmax Auto Owner 3.490% 2/16/27 \$0.00291/Pv On 142,394.25 Pv Due 8/15/24	414.13
Concentrix Corp 6.650% 8/02/26 20602Daa9		
08/02/2024	Concentrix Corp 6.650% 8/02/26 0.03325 USD/\$1 Pv On 125,000 Par Value Due 8/2/24	4,156.25

01360804
 60- -01-B -62 -250-04
 0105 -19-00883-04



TEXAS SOUTH UNIV, LOOP CAP
 ACCOUNT 1028785476

Page 32 of 53
 Period from August 1, 2024 to August 31, 2024

INVESTMENT ACTIVITY (continued)

DATE	DESCRIPTION	CASH
Cousins Pptys 5.875% 10/01/34		
222793AA9		
08/19/2024	Paid Accrued Interest On Purchase Of Cousins Pptys 5.875% 10/01/34 Income Debit 48.96- USD	- 48.96
Cummins Inc 5.150% 2/20/34		
231021Aw6		
08/20/2024	Cummins Inc 5.150% 2/20/34 0.02575 USD/\$1 Pv On 50,000 Par Value Due 8/20/24	1,287.50
F H L M C Gd A22005 4.500% 5/01/34		
31296Ygn7		
08/15/2024	F H L M C Gd A22005 4.500% 5/01/34 July FHLMC Due 8/15/24	5.30
F H L M C Gd C03490 4.500% 8/01/40		
31292K2X4		
08/15/2024	F H L M C Gd C03490 4.500% 8/01/40 July FHLMC Due 8/15/24	10.28
F H L M C Gd G04715 6.000% 6/01/38		
3128M6Sc3		
08/15/2024	F H L M C Gd G04715 6.000% 6/01/38 July FHLMC Due 8/15/24	17.09
F N M A #Ae0395 4.500% 10/01/40		
31419Anm5		
08/26/2024	F N M A #Ae0395 4.500% 10/01/40 July FNMA Due 8/25/24	21.48
F N M A #AI1697 4.000% 10/01/41		
3138Eh3F7		
08/26/2024	F N M A #AI1697 4.000% 10/01/41 July FNMA Due 8/25/24	11.73

01360804
60- -01-B -62 -250-04
0105 -19-00883-04



TEXAS SOUTH UNIV, LOOP CAP
ACCOUNT 1028785476

Page 33 of 53
Period from August 1, 2024 to August 31, 2024

INVESTMENT ACTIVITY (continued)

DATE	DESCRIPTION	CASH
F N M A #AI4911	3.000% 10/01/27	
3138Emn56		
08/26/2024	F N M A #AI4911 3.000% 10/01/27 July FNMA Due 8/25/24	10.92
F N M A #725690	6.000% 8/01/34	
31402Df70		
08/26/2024	F N M A #725690 6.000% 8/01/34 July FNMA Due 8/25/24	44.18
F N M A #735676	5.000% 7/01/35	
31402Rjv2		
08/26/2024	F N M A #735676 5.000% 7/01/35 July FNMA Due 8/25/24	9.06
F N M A #735925	5.000% 10/01/35	
31402Rsn0		
08/26/2024	F N M A #735925 5.000% 10/01/35 July FNMA Due 8/25/24	8.24
F N M A #745516	5.500% 5/01/36	
31403Dgz6		
08/26/2024	F N M A #745516 5.500% 5/01/36 July FNMA Due 8/25/24	19.88
F N M A #888219	5.500% 3/01/37	
31410Fyq2		
08/26/2024	F N M A #888219 5.500% 3/01/37 July FNMA Due 8/25/24	29.32
F N M A #888637	6.000% 9/01/37	
31410Ghn6		
08/26/2024	F N M A #888637 6.000% 9/01/37 July FNMA Due 8/25/24	48.27
F N M A #889506	6.000% 3/01/37	
31410Kgp3		

01360804
 60- -01-B -62 -250-04
 0105 -19-00883-04



TEXAS SOUTH UNIV, LOOP CAP
 ACCOUNT 1028785476

Page 34 of 53
 Period from August 1, 2024 to August 31, 2024

INVESTMENT ACTIVITY (continued)

DATE	DESCRIPTION	CASH
08/26/2024	F N M A #889506 6.000% 3/01/37 July FNMA Due 8/25/24	11.85
F N M A #889691 6.000% 7/01/38 31410Kng5		
08/26/2024	F N M A #889691 6.000% 7/01/38 July FNMA Due 8/25/24	8.65
F N M A #889983 6.000% 10/01/38 31410Kxl3		
08/26/2024	F N M A #889983 6.000% 10/01/38 July FNMA Due 8/25/24	10.30
First Am Govt Ob Fd CI Z 31846V567		
08/01/2024	Interest From 7/1/24 To 7/31/24	3,981.36
G N M A II #004266 5.500% 10/20/38 36202Ew39		
08/20/2024	G N M A II #004266 5.500% 10/20/38 July GNMA Due 8/20/24	9.75
General Mtrs Finl Co 2.700% 8/20/27 37045Xda1		
08/20/2024	General Mtrs Finl Co 2.700% 8/20/27 0.0135 USD/\$1 Pv On 175,000 Par Value Due 8/20/24	2,362.50
Goldman Sachs Group 2.600% 2/07/30 38141Gxg4		
08/07/2024	Goldman Sachs Group 2.600% 2/07/30 0.013 USD/\$1 Pv On 155,000 Par Value Due 8/7/24	2,015.00
Goldman Sachs Group 2.640% 2/24/28 38141Gzk3		
08/26/2024	Goldman Sachs Group 2.640% 2/24/28 0.0132 USD/\$1 Pv On 160,000 Par Value Due 8/24/24	2,112.00

01360804
 60- -01-B -62 -250-04
 0105 -19-00883-04



TEXAS SOUTH UNIV, LOOP CAP
 ACCOUNT 1028785476

Page 35 of 53
 Period from August 1, 2024 to August 31, 2024

INVESTMENT ACTIVITY (continued)

DATE	DESCRIPTION	CASH
Home Part Of Amer 2.200% 1/17/41		
43730Xaa2		
08/19/2024	Home Part Of Amer 2.200% 1/17/41 \$0.00183/Pv On 105,220.48 Pv Due 8/19/24	192.90
Htundai Auto Rec Tr 0.600% 2/16/27		
44934Kad6		
08/15/2024	Htundai Auto Rec Tr 0.600% 2/16/27 \$0.00050/Pv On 200,000.00 Pv Due 8/15/24	100.00
Ingersoll Rand Inc 5.700% 8/14/33		
45687Vab2		
08/14/2024	Ingersoll Rand Inc 5.700% 8/14/33 0.0285 USD/\$1 Pv On 75,000 Par Value Due 8/14/24	2,137.50
Intel Corp 1.600% 8/12/28		
458140Bi6		
08/12/2024	Intel Corp 1.600% 8/12/28 0.008 USD/\$1 Pv On 120,000 Par Value Due 8/12/24	960.00
Intel Corp 3.150% 5/11/27		
458140Ax8		
08/26/2024	Paid Accrued Interest On Purchase Of Intel Corp 3.150% 5/11/27 Income Debit 918.75- USD	- 918.75
08/30/2024	Paid Accrued Interest On Purchase Of Intel Corp 3.150% 5/11/27 Income Debit 476.88- USD	- 476.88
Total Intel Corp	3.150% 5/11/27	- 1,395.63
Jpmdb Commercial 3.1439% 6/15/49		
46590Lat9		
08/16/2024	Jpmdb Commercial 3.1439% 6/15/49 \$0.00262/Pv On 30,000.00 Pv Due 8/16/24	78.60

01360804
60- -01-B -62 -250-04
0105 -19-00883-04



TEXAS SOUTH UNIV, LOOP CAP
ACCOUNT 1028785476

Page 36 of 53
Period from August 1, 2024 to August 31, 2024

INVESTMENT ACTIVITY (continued)

DATE	DESCRIPTION	CASH
Morgan Stanley Baml 3.325% 5/15/49 61766Ebe4		
08/16/2024	Morgan Stanley Baml 3.325% 5/15/49 \$0.00277/Pv On 40,000.00 Pv Due 8/16/24	110.83
Morgan Stanley Baml 3.720% 12/15/49 61691Gas9		
08/16/2024	Morgan Stanley Baml 3.720% 12/15/49 \$0.00310/Pv On 180,000.00 Pv Due 8/16/24	558.00
Rixmor Operating LP 5.750% 2/15/35 11120BAA5		
08/15/2024	Rixmor Operating LP 5.750% 2/15/35 0.012299 USD/\$1 Pv On 145,000 Par Value Due 8/15/24	1,783.30
Towd Point Mortgage 3.250% 3/25/58 89175Vaa1		
08/26/2024	Towd Point Mortgage 3.250% 3/25/58 \$0.00271/Pv On 19,398.40 Pv Due 8/25/24	52.54
Toyota At Rec Own 1.230% 6/15/26 89239Kac5		
08/15/2024	Toyota At Rec Own 1.230% 6/15/26 \$0.00103/Pv On 57,221.81 Pv Due 8/15/24	58.65
Triton Container 2.03967% 9/20/45 89680Haa0		
08/20/2024	Triton Container 2.03967% 9/20/45 \$0.00176/Pv On 155,058.23 Pv Due 8/20/24	272.64
U S Treasury Nt 1.875% 2/15/32 91282Cdy4		
08/15/2024	U S Treasury Nt 1.875% 2/15/32 0.009375 USD/\$1 Pv On 330,000 Par Value Due 8/15/24	3,093.75
U S Treasury Nt 2.750% 8/15/32 91282Cff3		

01360804
60- -01-B -62 -250-04
0105 -19-00883-04



TEXAS SOUTH UNIV, LOOP CAP
ACCOUNT 1028785476

Page 37 of 53
Period from August 1, 2024 to August 31, 2024

INVESTMENT ACTIVITY (continued)

DATE	DESCRIPTION	CASH
08/15/2024	U S Treasury Nt 2.750% 8/15/32 0.01375 USD/\$1 Pv On 70,000 Par Value Due 8/15/24	962.50
	U S Treasury Nt 3.500% 2/15/33 91282Cgm7	
08/15/2024	U S Treasury Nt 3.500% 2/15/33 0.0175 USD/\$1 Pv On 1,970,000 Par Value Due 8/15/24	34,475.00
	U S Treasury Nt 4.375% 8/15/26 91282Chu8	
08/15/2024	U S Treasury Nt 4.375% 8/15/26 0.021875 USD/\$1 Pv On 325,000 Par Value Due 8/15/24	7,109.38
	Vmware Inc 3.900% 8/21/27 928563Ac9	
08/21/2024	Vmware Inc 3.900% 8/21/27 0.0195 USD/\$1 Pv On 190,000 Par Value Due 8/21/24	3,705.00
Total Interest		76,542.91

01360804
60- -01-B -62 -250-04
0105 -19-00883-04



TEXAS SOUTH UNIV, LOOP CAP
ACCOUNT 1028785476

Page 38 of 53
Period from August 1, 2024 to August 31, 2024

PLAN EXPENSES

<u>DATE</u>	<u>DESCRIPTION</u>	<u>CASH</u>
Trust Fees		
Trust Fees		
08/23/2024	Collected Charged For Period 07/01/2024 Thru 07/31/2024	- 837.55
Total Trust Fees		- 837.55
Total Trust Fees		- 837.55
Total Plan Expenses		- 837.55

01360804
60- -01-B -62 -250-04
0105 -19-00883-04



TEXAS SOUTH UNIV, LOOP CAP
ACCOUNT 1028785476

Page 39 of 53
Period from August 1, 2024 to August 31, 2024

OTHER ACTIVITY

DATE	DESCRIPTION	CASH
Miscellaneous Receipts		
Transfer From Income		
08/28/2024		77,543.03
Total Transfer From Income		77,543.03
Total Miscellaneous Receipts		77,543.03
Miscellaneous Disbursements		
Transfer To Principal		
08/28/2024		- 77,543.03
Total Transfer To Principal		- 77,543.03
Total Miscellaneous Disbursements		- 77,543.03
Total Other Activity		.00



CORPORATE CHANGES AND ADJUSTMENTS

DATE	DESCRIPTION	SHARES OR FACE AMOUNT	BOOK VALUE	MARKET VALUE	REALIZED/ UNREALIZED GAIN/LOSS
Adjustments					
08/13/2024	Book Value Of U S Treasury I P S 0.125% 4/15/25 Adjusted By 75.00 USD Old: 355,444.30 USD/New: 355,519.30 USD Units Increase To Adjust For Change In CPI 912828ZJ2	.00	75.00	.00	- 75.00
08/13/2024	Par Value Of U S Treasury I P S 0.125% 4/15/25 Adjusted By 75 Par Value Old Par Value 364,752/New Par Value 364,827 Units Increase To Adjust For Change In CPI 912828ZJ2	75.00	.00	.00	.00
08/28/2024	Book Value Of U S Treasury I P S 0.125% 4/15/25 Adjusted By 63.00 USD Old: 355,519.30 USD/New: 355,582.30 USD Units Increase To Adjust For Change In CPI 912828ZJ2	.00	63.00	.00	- 63.00
08/28/2024	Par Value Of U S Treasury I P S 0.125% 4/15/25 Adjusted By 63 Par Value Old Par Value 364,827/New Par Value 364,890 Units Increase To Adjust For Change In CPI 912828ZJ2	63.00	.00	.00	.00
Total Adjustments		138.00	138.00	.00	- 138.00
Total Corporate Changes And Adjustments		138.00	138.00	.00	- 138.00

01360804
 60- -01-B -62 -250-04
 0105 -19-00883-04



TEXAS SOUTH UNIV, LOOP CAP
 ACCOUNT 1028785476

Page 41 of 53
 Period from August 1, 2024 to August 31, 2024

PURCHASES

DATE	DESCRIPTION	SHARES/ FACE AMOUNT	COMMISSION	CASH	BOOK VALUE
Cash And Equivalents					
08/07/2024	Purchased 2,015 Units Of First Am Govt Ob Fd CI Z Trade Date 8/7/24 31846V567	2,015.000	.00	- 2,015.00	2,015.00
08/12/2024	Purchased 960 Units Of First Am Govt Ob Fd CI Z Trade Date 8/12/24 31846V567	960.000	.00	- 960.00	960.00
08/15/2024	Purchased 66,147.28 Units Of First Am Govt Ob Fd CI Z Trade Date 8/15/24 31846V567	66,147.280	.00	- 66,147.28	66,147.28
08/16/2024	Purchased 110.83 Units Of First Am Govt Ob Fd CI Z Trade Date 8/16/24 31846V567	110.830	.00	- 110.83	110.83
08/16/2024	Purchased 636.6 Units Of First Am Govt Ob Fd CI Z Trade Date 8/16/24 31846V567	636.600	.00	- 636.60	636.60
08/19/2024	Purchased 469.3 Units Of First Am Govt Ob Fd CI Z Trade Date 8/19/24 31846V567	469.300	.00	- 469.30	469.30
08/20/2024	Purchased 3,689.87 Units Of First Am Govt Ob Fd CI Z Trade Date 8/20/24 31846V567	3,689.870	.00	- 3,689.87	3,689.87

01360804
 60- -01-B -62 -250-04
 0105 -19-00883-04



TEXAS SOUTH UNIV, LOOP CAP
 ACCOUNT 1028785476

Page 42 of 53
 Period from August 1, 2024 to August 31, 2024

PURCHASES (continued)

DATE	DESCRIPTION	SHARES/ FACE AMOUNT	COMMISSION	CASH	BOOK VALUE
08/20/2024	Purchased 1,901.81 Units Of First Am Govt Ob Fd CI Z Trade Date 8/20/24 31846V567	1,901.810	.00	- 1,901.81	1,901.81
08/21/2024	Purchased 3,705 Units Of First Am Govt Ob Fd CI Z Trade Date 8/21/24 31846V567	3,705.000	.00	- 3,705.00	3,705.00
08/22/2024	Purchased 1,275 Units Of First Am Govt Ob Fd CI Z Trade Date 8/22/24 31846V567	1,275.000	.00	- 1,275.00	1,275.00
Total First Am Govt Ob Fd CI Z		80,910.690	.00	- 80,910.69	80,910.69
Total Cash And Equivalents		80,910.690	.00	- 80,910.69	80,910.69
Corporate Issues					
08/05/2024	Purchased 50,000 Par Value Of Berkley WR Corp 6.250% 2/15/37 Trade Date 8/5/24 Purchased Through J.P. Morgan Securities LLC Swift External Ref#: 8421903930589639 50,000 Par Value At 106.882 % 084423AP7	50,000.000	.00	- 53,441.00	53,441.00
Total Berkley WR Corp 6.250% 2/15/37		50,000.000	.00	- 53,441.00	53,441.00

01360804
60- -01-B -62 -250-04
0105 -19-00883-04



TEXAS SOUTH UNIV, LOOP CAP
ACCOUNT 1028785476

Page 43 of 53
Period from August 1, 2024 to August 31, 2024

PURCHASES (continued)

DATE	DESCRIPTION	SHARES/ FACE AMOUNT	COMMISSION	CASH	BOOK VALUE
08/16/2024	Purchased 100,000 Par Value Of Cousins Pptys 5.875% 10/01/34 Trade Date 8/16/24 Purchased Through J.P. Morgan Securities LLC Swift External Ref#: 8422903930602491 100,000 Par Value At 100.475 % 222793AA9	100,000.000	.00	- 100,475.00	100,475.00
Total Cousins Pptys 5.875% 10/01/34		100,000.000	.00	- 100,475.00	100,475.00
08/07/2024	Purchased 100,000 Par Value Of Ge Healthcare 4.800% 8/14/29 Trade Date 8/7/24 Purchased Through BofA Securities, Inc./Fxd Inc Swift External Ref#: 8422003930594967 100,000 Par Value At 99.881 % 36266GAA5	100,000.000	.00	- 99,881.00	99,881.00
Total Ge Healthcare 4.800% 8/14/29		100,000.000	.00	- 99,881.00	99,881.00
08/23/2024	Purchased 100,000 Par Value Of Intel Corp 3.150% 5/11/27 Trade Date 8/23/24 Purchased Through Bnp Paribas Sec Corp Swift External Ref#: 8423603930606763 100,000 Par Value At 95.927 % 458140AX8	100,000.000	.00	- 95,927.00	95,927.00
08/29/2024	Purchased 50,000 Par Value Of Intel Corp 3.150% 5/11/27 Trade Date 8/29/24 Purchased Through Wells Fargo Securities, LLC Swift External Ref#: 8424203930613079 50,000 Par Value At 95.819 % 458140AX8	50,000.000	.00	- 47,909.50	47,909.50
Total Intel Corp 3.150% 5/11/27		150,000.000	.00	- 143,836.50	143,836.50

01360804
 60- -01-B -62 -250-04
 0105 -19-00883-04



TEXAS SOUTH UNIV, LOOP CAP
 ACCOUNT 1028785476

Page 44 of 53
 Period from August 1, 2024 to August 31, 2024

PURCHASES (continued)

DATE	DESCRIPTION	SHARES/ FACE AMOUNT	COMMISSION	CASH	BOOK VALUE
08/14/2024	Purchased 75,000 Par Value Of 6297782 LLC Sr 5.026% 10/01/29 Trade Date 8/14/24 Purchased Through J.P. Morgan Securities LLC Swift External Ref#: 8422703930598972 75,000 Par Value At 99.993 % 83007CAC6	75,000.000	.00	- 74,994.75	74,994.75
Total 6297782 LLC Sr 5.026% 10/01/29		75,000.000	.00	- 74,994.75	74,994.75
Total Corporate Issues		475,000.000	.00	- 472,628.25	472,628.25
Total Purchases		555,910.690	.00	- 553,538.94	553,538.94

01360804
 60- -01-B -62 -250-04
 0105 -19-00883-04



TEXAS SOUTH UNIV, LOOP CAP
 ACCOUNT 1028785476

Page 45 of 53
 Period from August 1, 2024 to August 31, 2024

SALES AND MATURITIES

DATE	DESCRIPTION	SHARES/ FACE AMOUNT	COMMISSION	TRANSACTION PROCEEDS	BOOK VALUE	REALIZED GAIN/LOSS
Cash And Equivalents						
08/01/2024	Sold 120,261.25 Units Of First Am Govt Ob Fd CI Z Trade Date 8/1/24 31846V567	- 120,261.250	.00	120,261.25	- 120,261.25	.00
08/02/2024	Sold 91,862.39 Units Of First Am Govt Ob Fd CI Z Trade Date 8/2/24 31846V567	- 91,862.390	.00	91,862.39	- 91,862.39	.00
08/06/2024	Sold 54,925.38 Units Of First Am Govt Ob Fd CI Z Trade Date 8/6/24 31846V567	- 54,925.380	.00	54,925.38	- 54,925.38	.00
08/14/2024	Sold 97,743.5 Units Of First Am Govt Ob Fd CI Z Trade Date 8/14/24 31846V567	- 97,743.500	.00	97,743.50	- 97,743.50	.00
08/19/2024	Sold 100,523.96 Units Of First Am Govt Ob Fd CI Z Trade Date 8/19/24 31846V567	- 100,523.960	.00	100,523.96	- 100,523.96	.00
08/23/2024	Sold 837.55 Units Of First Am Govt Ob Fd CI Z Trade Date 8/23/24 31846V567	- 837.550	.00	837.55	- 837.55	.00
08/26/2024	Sold 92,920.26 Units Of First Am Govt Ob Fd CI Z Trade Date 8/26/24 31846V567	- 92,920.260	.00	92,920.26	- 92,920.26	.00

01360804
60- -01-B -62 -250-04
0105 -19-00883-04



TEXAS SOUTH UNIV, LOOP CAP
ACCOUNT 1028785476

Page 46 of 53
Period from August 1, 2024 to August 31, 2024

SALES AND MATURITIES (continued)

DATE	DESCRIPTION	SHARES/ FACE AMOUNT	COMMISSION	TRANSACTION PROCEEDS	BOOK VALUE	REALIZED GAIN/LOSS
08/28/2024	Sold 74,994.75 Units Of First Am Govt Ob Fd CI Z Trade Date 8/28/24 31846V567	- 74,994.750	.00	74,994.75	- 74,994.75	.00
08/30/2024	Sold 48,386.38 Units Of First Am Govt Ob Fd CI Z Trade Date 8/30/24 31846V567	- 48,386.380	.00	48,386.38	- 48,386.38	.00
Total First Am Govt Ob Fd CI Z		- 682,455.420	.00	682,455.42	- 682,455.42	.00
Total Cash And Equivalents		- 682,455.420	.00	682,455.42	- 682,455.42	.00
US Government Issues						
08/15/2024	Paid Down 12.38 Par Value Of F H L M C Gd A22005 4.500% 5/01/34 For Record Date Of July Due 8/15/24 July FHLMC Due 8/15/24 31296YGN7	- 12.380	.00	12.38	- 12.32	.06
Total F H L M C Gd A22005 4.500% 5/01/34		- 12.380	.00	12.38	- 12.32	.06
08/15/2024	Paid Down 13.05 Par Value Of F H L M C Gd C03490 4.500% 8/01/40 For Record Date Of July Due 8/15/24 July FHLMC Due 8/15/24 31292K2X4	- 13.050	.00	13.05	- 13.71	-.66
Total F H L M C Gd C03490 4.500% 8/01/40		- 13.050	.00	13.05	- 13.71	-.66

01360804
 60- -01-B -62 -250-04
 0105 -19-00883-04



TEXAS SOUTH UNIV, LOOP CAP
 ACCOUNT 1028785476

Page 47 of 53
 Period from August 1, 2024 to August 31, 2024

SALES AND MATURITIES (continued)

DATE	DESCRIPTION	SHARES/ FACE AMOUNT	COMMISSION	TRANSACTION PROCEEDS	BOOK VALUE	REALIZED GAIN/LOSS
08/15/2024	Paid Down 31.06 Par Value Of F H L M C Gd G04715 6.000% 6/01/38 For Record Date Of July Due 8/15/24 July FHLMC Due 8/15/24 3128M6SC3	- 31.060	.00	31.06	- 34.31	- 3.25
Total F H L M C Gd G04715 6.000% 6/01/38		- 31.060	.00	31.06	- 34.31	- 3.25
08/26/2024	Paid Down 47.8 Par Value Of F N M A #Ae0395 4.500% 10/01/40 For Record Date Of July Due 8/25/24 July FNMA Due 8/25/24 31419ANM5	- 47.800	.00	47.80	- 49.51	- 1.71
Total F N M A #Ae0395 4.500% 10/01/40		- 47.800	.00	47.80	- 49.51	- 1.71
08/26/2024	Paid Down 31.47 Par Value Of F N M A #AI1697 4.000% 10/01/41 For Record Date Of July Due 8/25/24 July FNMA Due 8/25/24 3138EH3F7	- 31.470	.00	31.47	- 33.35	- 1.88
Total F N M A #AI1697 4.000% 10/01/41		- 31.470	.00	31.47	- 33.35	- 1.88
08/26/2024	Paid Down 196.08 Par Value Of F N M A #AI4911 3.000% 10/01/27 For Record Date Of July Due 8/25/24 July FNMA Due 8/25/24 3138EMN56	- 196.080	.00	196.08	- 205.82	- 9.74
Total F N M A #AI4911 3.000% 10/01/27		- 196.080	.00	196.08	- 205.82	- 9.74



TEXAS SOUTH UNIV, LOOP CAP
 ACCOUNT 1028785476

Page 48 of 53
 Period from August 1, 2024 to August 31, 2024

SALES AND MATURITIES (continued)

DATE	DESCRIPTION	SHARES/ FACE AMOUNT	COMMISSION	TRANSACTION PROCEEDS	BOOK VALUE	REALIZED GAIN/LOSS
08/26/2024	Paid Down 137.44 Par Value Of F N M A #725690 6.000% 8/01/34 For Record Date Of July Due 8/25/24 July FNMA Due 8/25/24 31402DF70	- 137.440	.00	137.44	- 158.18	- 20.74
Total F N M A #725690 6.000% 8/01/34		- 137.440	.00	137.44	- 158.18	- 20.74
08/26/2024	Paid Down 31.67 Par Value Of F N M A #735676 5.000% 7/01/35 For Record Date Of July Due 8/25/24 July FNMA Due 8/25/24 31402RJV2	- 31.670	.00	31.67	- 34.47	- 2.80
Total F N M A #735676 5.000% 7/01/35		- 31.670	.00	31.67	- 34.47	- 2.80
08/26/2024	Paid Down 25.86 Par Value Of F N M A #735925 5.000% 10/01/35 For Record Date Of July Due 8/25/24 July FNMA Due 8/25/24 31402RSN0	- 25.860	.00	25.86	- 28.10	- 2.24
Total F N M A #735925 5.000% 10/01/35		- 25.860	.00	25.86	- 28.10	- 2.24
08/26/2024	Paid Down 51.11 Par Value Of F N M A #745516 5.500% 5/01/36 For Record Date Of July Due 8/25/24 July FNMA Due 8/25/24 31403DGZ6	- 51.110	.00	51.11	- 55.85	- 4.74
Total F N M A #745516 5.500% 5/01/36		- 51.110	.00	51.11	- 55.85	- 4.74

01360804
 60- -01-B -62 -250-04
 0105 -19-00883-04



TEXAS SOUTH UNIV, LOOP CAP
 ACCOUNT 1028785476

Page 49 of 53
 Period from August 1, 2024 to August 31, 2024

SALES AND MATURITIES (continued)

DATE	DESCRIPTION	SHARES/ FACE AMOUNT	COMMISSION	TRANSACTION PROCEEDS	BOOK VALUE	REALIZED GAIN/LOSS
08/26/2024	Paid Down 104.27 Par Value Of F N M A #888219 5.500% 3/01/37 For Record Date Of July Due 8/25/24 July FNMA Due 8/25/24 31410FYQ2	- 104.270	.00	104.27	- 113.61	- 9.34
Total F N M A #888219 5.500% 3/01/37		- 104.270	.00	104.27	- 113.61	- 9.34
08/26/2024	Paid Down 79.05 Par Value Of F N M A #888637 6.000% 9/01/37 For Record Date Of July Due 8/25/24 July FNMA Due 8/25/24 31410GHN6	- 79.050	.00	79.05	- 87.25	- 8.20
Total F N M A #888637 6.000% 9/01/37		- 79.050	.00	79.05	- 87.25	- 8.20
08/26/2024	Paid Down 38.43 Par Value Of F N M A #889506 6.000% 3/01/37 For Record Date Of July Due 8/25/24 July FNMA Due 8/25/24 31410KGP3	- 38.430	.00	38.43	- 43.34	- 4.91
Total F N M A #889506 6.000% 3/01/37		- 38.430	.00	38.43	- 43.34	- 4.91
08/26/2024	Paid Down 14.91 Par Value Of F N M A #889691 6.000% 7/01/38 For Record Date Of July Due 8/25/24 July FNMA Due 8/25/24 31410KNG5	- 14.910	.00	14.91	- 16.47	- 1.56
Total F N M A #889691 6.000% 7/01/38		- 14.910	.00	14.91	- 16.47	- 1.56

01360804
 60- -01-B -62 -250-04
 0105 -19-00883-04



TEXAS SOUTH UNIV, LOOP CAP
 ACCOUNT 1028785476

Page 50 of 53
 Period from August 1, 2024 to August 31, 2024

SALES AND MATURITIES (continued)

DATE	DESCRIPTION	SHARES/ FACE AMOUNT	COMMISSION	TRANSACTION PROCEEDS	BOOK VALUE	REALIZED GAIN/LOSS
08/26/2024	Paid Down 17.66 Par Value Of F N M A #889983 6.000% 10/01/38 For Record Date Of July Due 8/25/24 July FNMA Due 8/25/24 31410KXL3	- 17.660	.00	17.66	- 19.46	- 1.80
Total F N M A #889983 6.000% 10/01/38		- 17.660	.00	17.66	- 19.46	- 1.80
08/20/2024	Paid Down 30.12 Par Value Of G N M A I I #004266 5.500% 10/20/38 For Record Date Of July Due 8/20/24 July GNMA Due 8/20/24 36202EW39	- 30.120	.00	30.12	- 33.65	- 3.53
Total G N M A I I #004266 5.500% 10/20/38		- 30.120	.00	30.12	- 33.65	- 3.53
Total Government Issues		- 862.360	.00	862.36	- 939.40	- 77.04
Corporate Issues						
08/15/2024	Paid Down 10,443.02 Par Value Of Carmax Auto Owner 3.490% 2/16/27 Trade Date 8/15/24 14317HAC5	- 10,443.020	.00	10,443.02	- 10,214.58	228.44
Total Carmax Auto Owner 3.490% 2/16/27		- 10,443.020	.00	10,443.02	- 10,214.58	228.44
08/19/2024	Paid Down 276.4 Par Value Of Home Part Of Amer 2.200% 1/17/41 Trade Date 8/19/24 43730XAA2	- 276.400	.00	276.40	- 276.39	.01
Total Home Part Of Amer 2.200% 1/17/41		- 276.400	.00	276.40	- 276.39	.01

01360804
 60- -01-B -62 -250-04
 0105 -19-00883-04



TEXAS SOUTH UNIV, LOOP CAP
 ACCOUNT 1028785476

Page 51 of 53
 Period from August 1, 2024 to August 31, 2024

SALES AND MATURITIES (continued)

DATE	DESCRIPTION	SHARES/ FACE AMOUNT	COMMISSION	TRANSACTION PROCEEDS	BOOK VALUE	REALIZED GAIN/LOSS
08/26/2024	Paid Down 751.32 Par Value Of Towd Point Mortgage 3.250% 3/25/58 Trade Date 8/25/24 89175VAA1	- 751.320	.00	751.32	- 748.87	2.45
Total Towd Point Mortgage 3.250% 3/25/58		- 751.320	.00	751.32	- 748.87	2.45
08/15/2024	Paid Down 6,055.89 Par Value Of Toyota At Rec Own 1.230% 6/15/26 Trade Date 8/15/24 89239KAC5	- 6,055.890	.00	6,055.89	- 5,751.20	304.69
Total Toyota At Rec Own 1.230% 6/15/26		- 6,055.890	.00	6,055.89	- 5,751.20	304.69
08/20/2024	Paid Down 1,629.17 Par Value Of Triton Container 2.03967% 9/20/45 Trade Date 8/20/24 89680HAA0	- 1,629.170	.00	1,629.17	- 1,619.50	9.67
Total Triton Container 2.03967% 9/20/45		- 1,629.170	.00	1,629.17	- 1,619.50	9.67
Total Corporate Issues		- 19,155.800	.00	19,155.80	- 18,610.54	545.26
Total Sales And Maturities		- 702,473.580	.00	702,473.58	- 702,005.36	468.22

SALES AND MATURITIES MESSAGES

Realized gain/loss should not be used for tax purposes.

BOND SUMMARY

	PAR VALUE	MARKET VALUE	PERCENTAGE OF CATEGORY
MATURITY SUMMARY			
2024	.00	.00	0.00
2025	524,890.00	515,227.58	3.18
2026	2,576,165.92	2,462,439.75	15.18
2027	2,111,125.14	2,092,131.81	12.90
2028	730,000.00	713,351.70	4.40
2029	3,915,000.00	3,831,087.55	23.62
2030	643,244.35	613,830.78	3.79
2031	831,881.64	725,553.13	4.48
2032	1,185,000.00	1,097,084.95	6.76
2033	2,545,000.00	2,480,526.85	15.29
2034 - 2038	1,160,918.46	1,183,331.50	7.29
2039 - 2043	116,840.09	106,387.74	0.65
2044 - 2048	153,429.06	140,745.08	0.86
2049 - 2053	250,000.00	242,483.60	1.49
OVER 2053	18,647.08	18,195.26	0.11
Total	16,762,141.74	16,222,377.28	100.00

MOODY'S RATING

Aaa	9,031,598.31	8,668,221.01	53.44
A1	1,385,125.99	1,316,248.16	8.11
A2	1,240,000.00	1,197,913.15	7.38
A3	455,000.00	456,430.25	2.81
Baa1	830,000.00	834,862.20	5.15
Baa2	1,655,000.00	1,623,895.00	10.01
Baa3	1,410,000.00	1,384,126.85	8.53
N/A	755,417.44	740,680.66	4.57
Total	16,762,141.74	16,222,377.28	100.00

S&P RATING

AAA	331,951.23	325,537.76	2.01
A+	210,000.00	220,341.30	1.36
A	763,429.06	720,242.38	4.44
A-	1,470,000.00	1,423,253.55	8.77
BBB+	1,240,000.00	1,202,506.55	7.41

01360804
60- -01-B -62 -250-04
0105 -19-00883-04



TEXAS SOUTH UNIV, LOOP CAP
ACCOUNT 1028785476

Page 53 of 53
Period from August 1, 2024 to August 31, 2024

BOND SUMMARY (continued)

	PAR VALUE	MARKET VALUE	PERCENTAGE OF CATEGORY
BBB	2,155,000.00	2,178,773.60	13.43
BBB-	1,405,000.00	1,331,385.15	8.21
N/A	9,186,761.45	8,820,336.99	54.37
Total	16,762,141.74	16,222,377.28	100.00

01361304
60- -01-B -62 -250-04
0101 -19-00883-04



Account Number: 1028785485
TEXAS SOUTHERN UNIVERSITY CASH

This statement is for the period from August 1, 2024 to August 31, 2024

Questions?

If you have any questions regarding your account or this statement, please contact your Account Manager.

Account Manager:
DANIELLE GROSS
1025 CONNECTICUT AVENUE SUITE 510
WASHINGTON DC 20036
Phone: 202-261-0782
E-mail: danielle.gross1@usbank.com



000011131 04 SP 000638792473331 S
ATLANTA CONSULTING GROUP
MATTHEW BAUDER
309 EAST PACES FERRY RD, SUITE 600
ATLANTA GA 30305

01361304
60- -01-B -62 -250-04
0101 -19-00883-04



TEXAS SOUTH CASH
ACCOUNT 1028785485

Page 2 of 11
Period from August 1, 2024 to August 31, 2024

TABLE OF CONTENTS

Schedule	Page
Market And Cost Reconciliation	3
Cash Reconciliation	4
Asset Summary.....	5
Asset Detail	6
Income Accrual Detail	8
Investment Activity	9
Other Activity	10
Purchases	11

01361304
60- -01-B -62 -250-04
0101 -19-00883-04



TEXAS SOUTH CASH
ACCOUNT 1028785485

Page 3 of 11
Period from August 1, 2024 to August 31, 2024

MARKET AND COST RECONCILIATION

	08/31/2024 MARKET	08/31/2024 BOOK VALUE
Beginning Market And Cost	6,118,652.55	6,118,652.55
Investment Activity		
Interest	26,805.23	26,805.23
Net Accrued Income (Current-Prior)	59.96	59.96
Total Investment Activity	26,865.19	26,865.19
Other Activity		
Transfers In	1,412,548.69	1,412,548.69
Miscellaneous Receipts	26,805.23	26,805.23
Miscellaneous Disbursements	- 26,805.23	- 26,805.23
Total Other Activity	1,412,548.69	1,412,548.69
Net Change In Market And Cost	1,439,413.88	1,439,413.88
Ending Market And Cost	7,558,066.43	7,558,066.43

01361304
60- -01-B -62 -250-04
0101 -19-00883-04



TEXAS SOUTH CASH
ACCOUNT 1028785485

Page 4 of 11
Period from August 1, 2024 to August 31, 2024

CASH RECONCILIATION

Beginning Cash	.00
Investment Activity	
Interest	26,805.23
Cash Equivalent Purchases	- 26,805.23
Total Investment Activity	.00
Other Activity	
Transfers In	1,412,548.69
Miscellaneous Receipts	26,805.23
Miscellaneous Disbursements	- 26,805.23
Total Other Activity	1,412,548.69
Net Change In Cash	1,412,548.69
Ending Cash	1,412,548.69

01361304
 60- -01-B -62 -250-04
 0101 -19-00883-04



TEXAS SOUTH CASH
 ACCOUNT 1028785485

Page 5 of 11
 Period from August 1, 2024 to August 31, 2024

ASSET SUMMARY

ASSETS	08/31/2024 MARKET	08/31/2024 BOOK VALUE	% OF MARKET
Cash And Equivalents	7,531,201.24	7,531,201.24	99.64
Total Assets	7,531,201.24	7,531,201.24	99.64
Accrued Income	26,865.19	26,865.19	0.36
Grand Total	7,558,066.43	7,558,066.43	100.00
Estimated Annual Income	312,051.28		

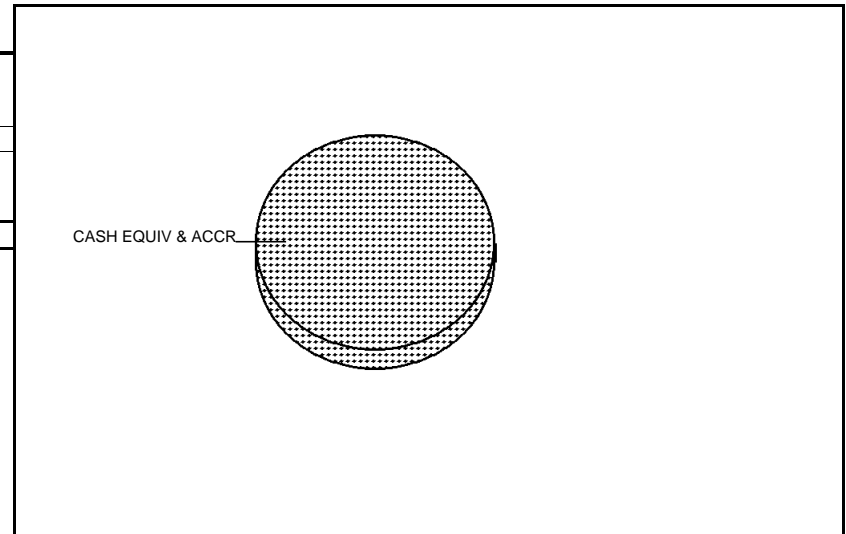

ASSET SUMMARY MESSAGES

Estimated Annual Income is an estimate provided for informational purposes only and should not be relied on for making investment, trading, or tax decisions. The estimates may not represent the actual value earned by your investments and they provide no guarantee of what your investments may earn in the future.

01361304
 60- -01-B -62 -250-04
 0101 -19-00883-04



TEXAS SOUTH CASH
 ACCOUNT 1028785485

Page 6 of 11
 Period from August 1, 2024 to August 31, 2024

ASSET DETAIL

DESCRIPTION	SHARES/ FACE AMOUNT	MARKET PRICE/UNIT	BOOK VALUE	UNREALIZED GAIN (LOSS) SINCE INCEPTION/ CURRENT PERIOD	ENDING ACCRUAL	YIELD ON MARKET
Cash And Equivalents						
Money Markets						
First Am Govt Ob Fd Cl Z 31846V567 Asset Minor Code 1	6,118,652.550	6,118,652.55 1.0000	6,118,652.55	.00 .00	26,865.19	5.15
Total Money Markets	6,118,652.550	6,118,652.55	6,118,652.55	.00 .00	26,865.19	5.14
Cash						
Cash		1,412,548.69	1,412,548.69			
Total Cash	.000	1,412,548.69	1,412,548.69	.00 .00	.00	0.00
Total Cash And Equivalents	6,118,652.550	7,531,201.24	7,531,201.24	.00 .00	26,865.19	4.18
Total Assets	6,118,652.550	7,531,201.24	7,531,201.24	.00 .00	26,865.19	4.18
Accrued Income	.000	26,865.19	26,865.19			
Grand Total	6,118,652.550	7,558,066.43	7,558,066.43			

01361304
60- -01-B -62 -250-04
0101 -19-00883-04



TEXAS SOUTH CASH
ACCOUNT 1028785485

Page 7 of 11
Period from August 1, 2024 to August 31, 2024

ASSET DETAIL MESSAGES

Time of trade execution and trading party (if not disclosed) will be provided upon request.

Publicly traded assets are valued in accordance with market quotations or valuation methodologies from financial industry services believed by us to be reliable. Assets that are not publicly traded may be reflected at values from other external sources. Assets for which a current value is not available may be reflected at a previous value or as not valued, at par value, or at a nominal value. Values shown do not necessarily reflect prices at which assets could be bought or sold. Values are updated based on internal policy and may be updated less frequently than statement generation.

For further information, please contact your account manager or relationship manager.

We provide a cash management administrative service for the temporary investment of principal and income balances in your account. The fee for providing this service will not exceed \$0.42 per month for each \$1,000 of the average daily balance invested under the cash management administrative service. The charge for this service has been deducted from your account.

Yield on Market and Accrued Income are estimates provided for informational purposes only and should not be relied on for making investment, trading, or tax decisions. The estimates may not represent the actual value earned by your investments and they provide no guarantee of what your investments may earn in the future.

The asset categories used in this statement may be general in nature. For example, assets listed under the "Mutual Funds" category may include open-end investment companies registered under the Investment Company Act of 1940 (which are commonly known as "mutual funds") but may also include closed-end investment companies, unit investment trusts, common trust funds, collective trust funds or other investments that are registered with (or not subject to registration with) the Securities and Exchange Commission.

01361304
60- -01-B -62 -250-04
0101 -19-00883-04



TEXAS SOUTH CASH
ACCOUNT 1028785485

Page 8 of 11
Period from August 1, 2024 to August 31, 2024

INCOME ACCRUAL DETAIL

SHARES/ FACE AMOUNT	DESCRIPTION	EX DATE	PAY DATE	ANN RATE	BEGINNING ACCRUAL	INCOME EARNED	INCOME RECEIVED	ENDING ACCRUAL
Cash And Equivalents								
6,118,652.550	First Am Govt Ob Fd CI Z 31846V567		09/03/24	0.05	26,805.23	26,865.19	26,805.23	26,865.19
Total Cash And Equivalents					26,805.23	26,865.19	26,805.23	26,865.19
Grand Total					26,805.23	26,865.19	26,805.23	26,865.19

01361304
60- -01-B -62 -250-04
0101 -19-00883-04



TEXAS SOUTH CASH
ACCOUNT 1028785485

Page 9 of 11
Period from August 1, 2024 to August 31, 2024

INVESTMENT ACTIVITY

DATE	DESCRIPTION	CASH
Interest		
First Am Govt Ob Fd Cl Z 31846V567		
08/01/2024	Interest From 7/1/24 To 7/31/24	26,805.23
Total Interest		26,805.23

01361304
60- -01-B -62 -250-04
0101 -19-00883-04



TEXAS SOUTH CASH
ACCOUNT 1028785485

Page 10 of 11
Period from August 1, 2024 to August 31, 2024

OTHER ACTIVITY

DATE	DESCRIPTION	CASH
Transfers In		
Incoming Wires		
08/30/2024	Jp Morgan-Tsu Cash Additions To Pool	1,412,548.69
Total Incoming Wires		1,412,548.69
Total Transfers In		1,412,548.69
Miscellaneous Receipts		
Transfer From Income		
08/28/2024		26,805.23
Total Transfer From Income		26,805.23
Total Miscellaneous Receipts		26,805.23
Miscellaneous Disbursements		
Transfer To Principal		
08/28/2024		- 26,805.23
Total Transfer To Principal		- 26,805.23
Total Miscellaneous Disbursements		- 26,805.23
Total Other Activity		1,412,548.69

01361304
60- -01-B -62 -250-04
0101 -19-00883-04



TEXAS SOUTH CASH
ACCOUNT 1028785485

Page 11 of 11
Period from August 1, 2024 to August 31, 2024

PURCHASES

<u>DATE</u>	<u>DESCRIPTION</u>	<u>SHARES/ FACE AMOUNT</u>	<u>COMMISSION</u>	<u>CASH</u>	<u>BOOK VALUE</u>
Cash And Equivalents					
08/02/2024	Purchased 26,805.23 Units Of First Am Govt Ob Fd CI Z Trade Date 8/2/24 31846V567	26,805.230	.00	- 26,805.23	26,805.23
Total First Am Govt Ob Fd CI Z		26,805.230	.00	- 26,805.23	26,805.23
Total Cash And Equivalents		26,805.230	.00	- 26,805.23	26,805.23
Total Purchases		26,805.230	.00	- 26,805.23	26,805.23

**TEXAS SOUTHERN UNIVERSITY
BOARD OF REGENTS AGENDA**

COMMITTEE: Academic Affairs, Research and Student Life

ITEM: A Review of Graduate Student Success Rates

DATE PREVIOUSLY SUBMITTED: NA

SUMMARY:

This information item will include a review of the graduation rates of Master's and Doctoral students over the most recent years. The definition of the graduation rate includes Master's students who complete their degrees within 5 years, and at the Doctoral level students have 10 years to complete their degrees.

A comparison of TSU's graduate student graduation rates will also be compared with other Texas peer institutions.

SUPPORTING

DOCUMENTATION: Graduate Student Graduation Rates PowerPoint

FISCAL IMPACT: NA

ACTION REQUESTED: Information

Legal Certification: Based on available information to date, this action item and its implementation will not be in violation of any applicable federal, state, or local law, or regulation.



GENERAL COUNSEL

10/08/2024

DATE

Fiscal Certification: This fiscal note shown above details the true and actual positive or negative fiscal effect that implementation of this proposal will achieve.



INTERIM CHIEF FINANCIAL OFFICER

10/09/2024

DATE



James Crawford (Oct 10, 2024 10:44 CDT)

PRESIDENT

10/10/2024

DATE

A Review of Graduate Student Success Rates

Raijanel S. Crockem, EdD

Associate Vice President

Institutional Assessment, Planning, & Effectiveness



TEXAS SOUTHERN UNIVERSITY

Enrollment and Degrees Awarded Summary

Fall 2023

Enrollment=8,469

78% Undergraduates

10% Master's

<1% Post Bacc.

2% Doctoral

7% Professional-Law

3% Professional-PharmD

2022-2023=1410 Degrees Awarded

64% UG

2% Doctoral-Research

19% Master's

15% Doctoral-Professional



R2 HBCU Comparison-2022-2023 Data

Degrees Awarded

Institution	City	State	Master's Degrees Awarded	Doctoral Research(PHD/EDD) Degrees Awarded
Clark Atlanta University	Atlanta	GA	145	36
Florida Agricultural and Mechanical University	Tallahassee	FL	235	33
Howard University	Washington	DC	312	102
Jackson State University	Jackson	MS	429	68
Morgan State University	Baltimore	MD	274	59
North Carolina A & T State University	Greensboro	NC	414	68
Prairie View A & M University	Prairie View	TX	295	26
Southern University and A & M College	Baton Rouge	LA	301	42
Tennessee State University	Nashville	TN	374	44
Texas Southern University	Houston	TX	265	28
University of Maryland Eastern Shore	Princess Anne	MD	61	16



Degrees Awarded July 1,2022 to June 30,2023

Data Source: IPEDS (Integrated Postsecondary Education Data System)

TX Peer Comparison- 2022-2023 Data

Degrees Awarded

Peers based on: Doctoral Classification and Region

Institution	City	State	Master's Degrees Awarded	Doctoral Research (PHD/EDD) Degrees Awarded
Prairie View A & M University	Prairie View	TX	295	26
Sam Houston	Huntsville	TX	1011	64
TX A&M Commerce	Commerce	TX	1478	59
TX A&M Corpus Christi	Corpus Christi	TX	1250	36
TX A&M Kingsville	Kingsville	TX	523	21
Texas Southern University	Houston	TX	265	28
TX Woman's University	Denton	TX	1692	233
UT Rio Grande Valley	Edinburg	TX	1990	45



Degrees Awarded July 1, 2022 to June 30, 2023

Data Source: IPEDS (Integrated Postsecondary Education Data System)

TX Peer Comparison- 2022 and 2023 Data

Master's Cohort 5-year Graduation Rate

Peers based on: Doctoral Classification and Region

Institution	City	State	Master's Degrees Awarded (2022) 2017 Cohort	Master's Degrees Awarded (2023) 2018 Cohort
Prairie View A & M University	Prairie View	TX	67% (257)	69% (205)
Sam Houston	Huntsville	TX	75% (556)	77% (595)
TX A&M Commerce	Commerce	TX	68% (767)	68% (618)
TX A&M Corpus Christi	Corpus Christi	TX	63% (516)	62% (527)
TX A&M Kingsville	Kingsville	TX	83% (418)	86% (417)
Texas Southern University	Houston	TX	62% (247)	59% (235)
TX Woman's University	Denton	TX	74% (686)	78% (798)
UT Rio Grande Valley	Edinburg	TX	76% (686)	77% (856)



Degrees Awarded July 1, 2022 to June 30, 2023

Data Source: IPEDS (Integrated Postsecondary Education Data System)

TX Peer Comparison- 2022 and 2023 Data

Doctoral Cohort 10-year Graduation Rate

Peers based on: Doctoral Classification and Region

Institution	City	State	Doctoral Rates (2022) 2012 Cohort	Doctoral Rates(2023) 2013 Cohort
Prairie View A & M University	Prairie View	TX	38% (34)	48% (23)
Sam Houston	Huntsville	TX	77% (22)	88% (24)
TX A&M Commerce	Commerce	TX	39% (44)	54% (23)
TX A&M Corpus Christi	Corpus Christi	TX	31% (32)	43% (28)
TX A&M Kingsville	Kingsville	TX	50% (24)	65% (17)
Texas Southern University	Houston	TX	44% (69)	38% (34)
TX Woman's University	Denton	TX	64% (81)	59% (85)
UT Rio Grande Valley	Edinburg	TX	54% (25)	52% (29)



TSU Master's Degree 2022 Graduation Rate by Major (Top 10)

school_or_college	Major_cipcode_description	Count of Major_cipcode_description	F17Cohort Masters Fall 2018 Persist.	F17Cohort 5yr Graduation Rate
Col of Science, Engr & Tech	Chemistry	2	100.00	100.00
Liberal Arts & Behavioral Scie	Human Services And Consumer Science	2	100.00	100.00
TM School of Law	Immigration Law	7	85.71	85.71
College Of Education	Health and Kinesiology	13	76.92	84.62
College Of Pharmacy/Hlth Sci.	Health Care Administration	13	69.23	76.92
College Of Education	Educational Administration	7	100.00	71.43
JHJ School Of Business	Management Information Systems	10	80.00	70.00
JHJ School Of Business	Business Administration/Management	51	78.43	68.63
The School of Public Affairs	Administration of Justice	9	66.67	66.67
Col of Science, Engr & Tech	Environmental Toxicology	3	100.00	66.67
Liberal Arts & Behavioral Scie	History	3	100.00	66.67
Liberal Arts & Behavioral Scie	Psychology	6	66.67	66.67
Liberal Arts & Behavioral Scie	Sociology	6	66.67	66.67



*ALL Degrees Awarded as of report run date from Banner 07.15.24

TSU Master's Degree 2023 Graduation Rate by Major (Top 10)

school_or_college	Major_cipcode_description	Count of Major_cipcode_description	F18Cohort Masters Fall 2019 Persist.	F18Cohort 5yr Graduation Rate
Col of Science, Engr & Tech	Transportation Planning And Management	5	100.00	100.00
College Of Education	Health and Kinesiology	9	100.00	100.00
Liberal Arts & Behavioral Scie	Human Services And Consumer Science	1	100.00	100.00
Col of Science, Engr & Tech	Computer Science	8	100.00	87.50
JHJ School Of Business	Management Information Systems	7	85.71	85.71
Col of Science, Engr & Tech	Biology	6	100.00	83.33
College Of Education	Curriculum & Instruction	5	100.00	80.00
JHJ School Of Business	Business Administration/Management	45	77.78	68.89
The School of Public Affairs	Administration of Justice	12	75.00	66.67
The School of Public Affairs	Urban Planning And Environmental Policy	3	100.00	66.67



*ALL Degrees Awarded as of report run date from Banner 07.15.24

TSU Doctoral Degree 2023 Graduation Rate by Major

school_or_college	Major_cipcode_description	Count of Major_cipcode_description	F13Cohort Fall 2014 Persist.	F13Cohort 10yr Graduation Rate
College Of Pharmacy/Hlth Sci.	Pharmaceutical Sciences	1	100.00	100.00
Col of Science, Engr & Tech	Environmental Toxicology	5	100.00	60.00
College Of Education	Curriculum & Instruction	4	100.00	50.00
College Of Education	Counselor Education	8	87.50	37.50
College Of Education	Educational Administration	5	80.00	20.00
The School of Public Affairs	Urban Planning And Environmental Policy	5	100.00	20.00



*ALL Degrees Awarded as of report run date from Banner 07.15.24

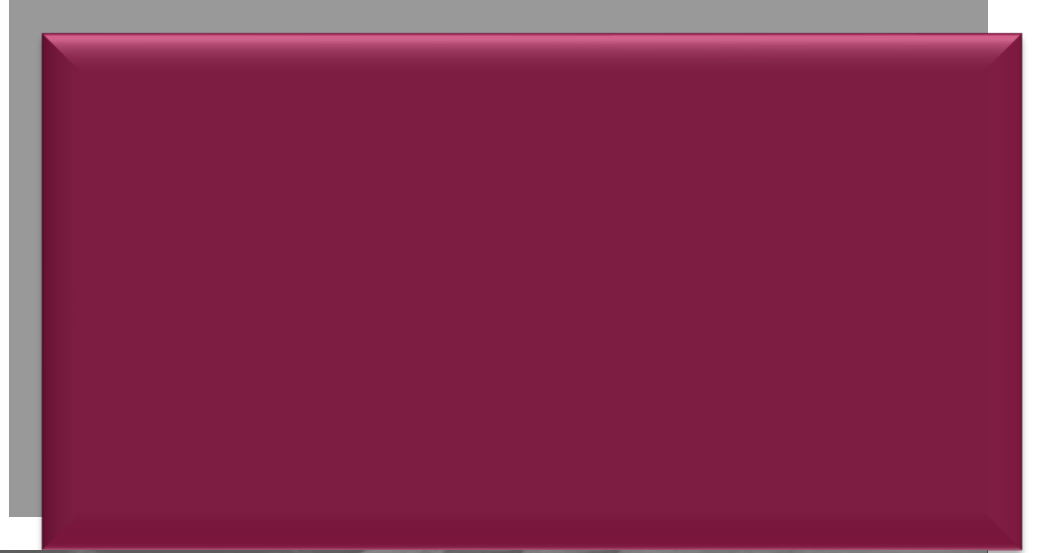

THANK YOU!



TSUPROUD

TEAMWORK

is our strength. We at TSU believe that working together, we achieve more.

STUDENT SUCCESS

FIRST in everything we undertake, if students see it, they can do it.

UNPRECEDENTED

In our resolve to succeed and be ACCOUNTABLE for what we do.

PROUD

To be an INDEPENDENT, URBAN UNIVERSITY, committed to SERVING OUR STUDENTS & COMMUNITY.

RESEARCH-DRIVEN

and resolved in our commitment to COLLABORATION and EXCELLENCE.

OPTIMISTIC

In our ability to be INNOVATIVE AND ENTREPRENEURIAL in deriving and advancing new ideas.

UNITED

In everything we do, UNBEATABLE at what we do, and UNRELENTING in our approach to progress.

DISTINCT

In our academic programs and in DIVERSITY of thought.

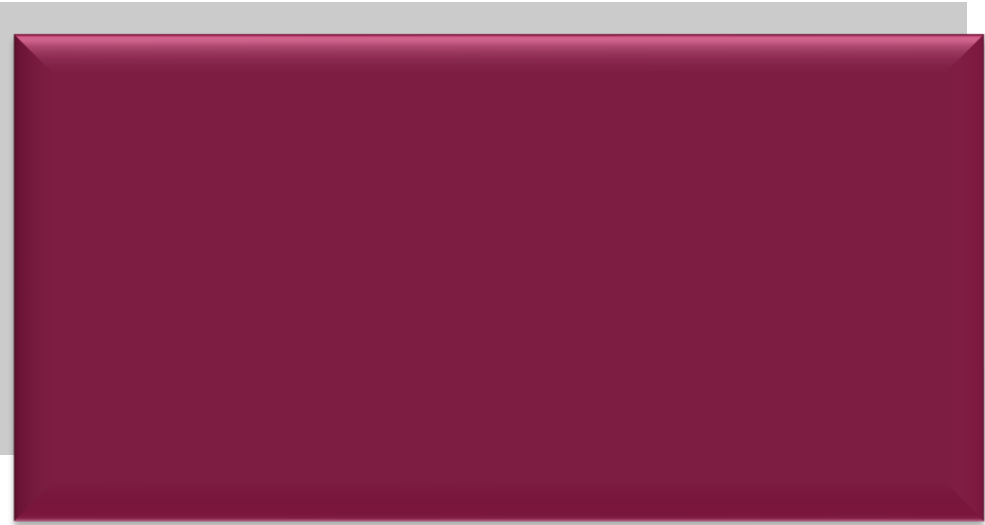

**TEXAS SOUTHERN UNIVERSITY
BOARD OF REGENTS AGENDA**

COMMITTEE: Development and Legislative Affairs

ITEM: Legislative Appropriations Request Update

DATE PREVIOUSLY SUBMITTED: N/A

SUMMARY:

Government Affairs and Civic Engagement will provide a briefing on the legislative approach to advocate the funding of exceptional items presented in the Legislative Appropriations Request.

This draft document is the primary document that the Government Affairs and Civic Engagement Office will use to inform members of the Legislature and other governmental stakeholders about our LAR exceptional item and C-CAP request.

SUPPORTING

DOCUMENTATION: Exceptional Item and C-CAP Request
BOA0001516

FISCAL IMPACT: Printing and Dissemination Costs are Absorbed with Current Resources

ACTION REQUESTED: Information

Legal Certification: Based on available information to date, this action item and its implementation will not be in violation of any applicable federal, state, or local law, or regulation.



GENERAL COUNSEL

10/07/2024

DATE

Fiscal Certification: This fiscal note shown above details the true and actual positive or negative fiscal effect that implementation of this proposal will achieve.



INTERIM CHIEF FINANCIAL OFFICER

10/08/2024

DATE



James Crawford (Oct 10, 2024 10:46 CDT)

PRESIDENT

10/10/2024

DATE

LEGISLATIVE APPROPRIATIONS REQUEST

Exceptional Item #1 | **Tiger Success Unlimited "TSU" = Texas Educator Excellence**

As directed by Governor Greg Abbott to all higher education institutions, Texas Southern University is asking the Texas Legislature to partner with our University to create the Tiger Success Unlimited ["TSU"] = Texas Educator Excellence to expand the number of candidates with exhibited academic achievement and a passion for learning and compassion for our K-12 students. This aggressive initiative relies on student engagement that includes recruitment, mentoring, modeling. By identify high achieving freshmen and sophomore students with the goal of significantly boosting student progression and graduation rates and increase the number of highly qualified educators for our K-12 classrooms, TSU will ensure that there are no institutional impediments that discourage or distract exceptionally promising TSU male students from taking advantage of the profession opportunities in K-12 education. This program will prepare our teacher candidates for success on the state certification exams, the financial resources to take the exams, and robust salary compensation while satisfying their student-internship in a Texas public school classroom.

Exceptional Item #2 | **TSU Center for Nursing Education Research and Maternal-Infant Health**

This initiative is a direct response to the directive from Governor Greg Abbott for the Texas higher education community to remove barriers that exist to expand healthcare programs in Texas. TSU will address the critical need for highly qualified nurses, who are well-prepared to provide competent and compassionate medical care in underserved communities and regions throughout Texas with a special emphasis in maternal and infant health. This program will leverage TSU's online instructional capabilities to enhance student access and nursing credentialing.

Exceptional Item #3 | **PharmD Satellite Campuses**

Adhering to Governor Greg Abbott's directive to expand healthcare programs, this initiative features an innovative program by the Texas Southern University's College of Pharmacy & Health Sciences (COPHS) to address the acute need for competent pharmaceutical healthcare professionals in Texas, and particularly, in our state's underserved communities. This satellite campus concept seeks to bring high quality pharmacy education closer to these underserved regions: thus, providing opportunities for future pharmacists to serve their fellow Texans in these communities: South Texas College (STC) and the University of Texas Medical Branch (UTMB) at Galveston. The satellite campus at STC will mimic the four-year curriculum offered at the main campus in Houston while the UTMB campus will offer a three-year accelerated curriculum. This accelerated program will be among the first in Texas and leverages instruction by other health sciences (nursing and medicine) available at UTMB to offer a unique inter-professional disciplinary curricula. Healthcare residents tend to accept positions and stay in the communities where they complete their residency training.

Exceptional Item #4 | **Aerospace Engineering (Drone/Rocket)**

In response to a directive from Governor Greg Abbott for higher education institutions immediately to include aerospace engineering in their curriculum, TSU has designed this initiative to cultivate the next generation of aerospace professionals foster innovation in aerospace education and contribute to the advancement of Texas' aerospace industry. TSU aims to provide students with innovative training, hands-on experiences and industry partnerships to prepare them for successful careers in aerospace and related fields. This proposal includes establishing the TSU Aerospace Institute at the Houston Spaceport, which presents a unique opportunity to leverage the expertise and resources within Texas Southern University's (TSU) Aviation Program, the geographic location relative the National Aeronautics Space Administration (NASA) in Houston, academic, commercial, and governmental partnerships, and previous stakeholder investments has positioned TSU to establish an Aerospace Institute at the Houston Spaceport.

Exceptional Item #5 | **Research Drone Netting Facility**

Within the College of Science, Engineering, and Technology, the Department of Transportation Studies has offered a degree program in Aviation Science Management with UAS (Drone) Concentration since Fall of 2023. This netted UAS facility will provide our students and faculty the appropriate simulated safety-conscious environment to conduct their academic studies and groundbreaking research.

Exceptional Item #6 | **Tiger Online Learning Expansion**

This Tiger Online Expansion will allow more prospective students opportunities to gain credentials in an affordable and convenient manner. Moreover, these online offerings will provide more flexibility to our residential student segment and enhance the transition of our Military Veterans to civilian life from their Military Service. These online offerings will also provide opportunities for high school students to begin their college experience and significantly decrease student debt.

Exceptional Item #7 | **AI-Driven Excellence: Transforming Student Success from Recruitment to Graduation**

This strategic AI initiative enhances operational efficiencies in student recruitment, admissions, progression, and successful graduation. This initiative aligns with TSU's mission to support underserved student populations and ensure their academic success and career readiness.

Capital Construction Assistance Projects

Aerospace Engineering Institute

This 21st century state of the art complex will facilitate TSU in the delivery of highly effective instruction and research as directed by Governor Abbott for institutions of higher education to develop aerospace engineering into their curriculum immediately. This includes the construction of research labs, classrooms, launch complexes (small rockets and drones), and storage facilities. The infrastructure will provide a conducive environment for students and faculty to engage in cutting-edge aerospace research and development. This facility will have classrooms and lecture halls equipped with modern teaching aids for theoretical instruction in subjects like astrophysics, aeronautical engineering, and space technology and specialized labs for various branches of aerospace studies such as propulsion lab, aerodynamics lab, materials lab, and avionics lab.

Aerospace Engineering Complex Furniture, Furnishings, and Equipment (FFE)

This CCAP request provides for the initial furniture, furnishings, and equipment that facilitate the engineering instructional and research activities for the Aerospace Engineering academic offering.

Critical Electrical Systems: Health and Safety

Critical Electrical Systems across campus require repairs and replacement, including two major circuits powering half of the campus buildings. In addition to new circuits to better balance and support building loads with more demand now compared to their original construction, back-up generators on priority buildings need repair and/or replacement to ensure safety and security in weather events.

Campus-Wide MEP Systems Upgrade Health & Safety

Deferred maintenance of plumbing, electrical, and mechanical systems in buildings across campus remains a top priority, and funding is requested to supplement other available funding sources, reducing the backlog created by aging facilities.

Active Learning Environments

Classroom spaces in older buildings on campus are in worse condition compared to high schools where our students attended. So therefore, upgrades are critical to student success. Upgrades are primarily for technology and furniture in older classrooms and lecture spaces to better facilitate active and engaged learning. Cost also includes deferred finishes replacement (floors, ceiling, and painted walls).

Exceptional Item #5 | **Research Drone Netting Facility**

Within the College of Science, Engineering, and Technology, the Department of Transportation Studies has offered a degree program in Aviation Science Management with UAS (Drone) Concentration since Fall of 2023. This netted UAS facility will provide our students and faculty the appropriate simulated safety-conscious environment to conduct their academic studies and groundbreaking research.

**TEXAS SOUTHERN UNIVERSITY
BOARD OF REGENTS AGENDA**

COMMITTEE: Physical Facilities

ITEM: Request Approval for Water Treatment Services

DATE PREVIOUSLY SUBMITTED: N/A

SUMMARY:

Approval is requested to execute a contract for water treatment services. The awarded contractor shall provide water chemicals and formulations to meet the needs for boilers, cooling towers, closed loop cooling systems, HVAC and water softening.

An Invitation to Bid (ITB 717-24-725) was posted on the Electronic State Business Daily and TSU's website per Texas Government Code §2155.083.

Contracts are awarded to the bidder whose proposal offers the best value to the State of Texas and Texas Southern University, as outlined in Texas Government Code, § 2155.074.

The University recommends Design Controls for this award in accordance with Texas Education Code § 51.9335. The contract term is October 2024 – September 2027 for an initial three-year period with an option for a one-year extension. Design Controls is a HUB vendor and Form 1295 has been submitted.

SUPPORTING

DOCUMENTATION: Scope of Work (Under Separate Cover)

FISCAL IMPACT: NTE: \$300,000
1000-61410-7310-80/BOA0001513

ACTION REQUESTED: Administration recommends approval of this item

Legal Certification: Based on available information to date, this action item and its implementation will not be in violation of any applicable federal, state, or local law, or regulation.



GENERAL COUNSEL

10/07/2024

DATE

Fiscal Certification: This fiscal note shown above details the true and actual positive or negative fiscal effect that implementation of this proposal will achieve.



INTERIM CHIEF FINANCIAL OFFICER

10/09/2024

DATE



James Crawford (Oct 10, 2024 09:36 CDT)

PRESIDENT

10/10/2024

DATE

**TEXAS SOUTHERN UNIVERSITY
BOARD OF REGENTS AGENDA**

COMMITTEE: Physical Facilities

ITEM: Request Approval to Purchase Auditorium-Style Seating in Charles P. Rhinehart Music Auditorium

DATE PREVIOUSLY SUBMITTED: N/A

SUMMARY:

Approval is requested Approval is requested to purchase auditorium-style seating in Rhinehart Auditorium.

Contracts are awarded to the bidder whose proposal offers the best value to the State of Texas and Texas Southern University, as outlined in Texas Government Code, § 2155.074.

In accordance with Texas Education Code § 51.9335, a cooperative contract (E & I Contract #EI00135) was used to procure these services.

The University recommends ECFS for this award. ECFS is a HUB vendor; form 1295 has been submitted.

SUPPORTING

DOCUMENTATION: Proposal

FISCAL IMPACT: NTE: \$135,000
University FOAP: 3333 21100-7373 - 70-1260

ACTION REQUESTED: Administration recommends approval of this item

Legal Certification: Based on available information to date, this action item and its implementation will not be in violation of any applicable federal, state, or local law, or regulation.

GENERAL COUNSEL

10/09/2024

DATE

Fiscal Certification: This fiscal note shown above details the true and actual positive or negative fiscal effect that implementation of this proposal will achieve.

INTERIM CHIEF FINANCIAL OFFICER

10/10/2024

DATE

James Crawford (Oct 10, 2024 16:48 CDT)

PRESIDENT

10/10/2024

DATE

**TEXAS SOUTHERN UNIVERSITY
BOARD OF REGENTS AGENDA**

COMMITTEE: Audit

ITEM: Request Approval for FY2025 Annual Internal Audit Plan

DATE PREVIOUSLY SUBMITTED: N/A

SUMMARY:

The FY2025 Annual Internal Audit Plan (audit plan) was prepared based upon a risk assessment. Texas Government Code Chapter 2102 (Texas Internal Audit Act) Sec.A2102.008.A requires the audit plan to be approved by the Board. The approved audit plan is required to be submitted to the Governor's Office, State Auditor's Office, and the Legislative Budget Board by November 1, 2024.

SUPPORTING

DOCUMENTATION: Internal Audit & Assurance Services Status Report & FY2025 Annual Audit Plan

FISCAL IMPACT: NTE: \$500,000
University FOAP: 0001-11200-7253-30677

ACTION REQUESTED: Administration recommends approval of this item

Legal Certification: Based on available information to date, this action item and its implementation will not be in violation of any applicable federal, state, or local law, or regulation.



GENERAL COUNSEL

10/08/2024

DATE

Fiscal Certification: This fiscal note shown above details the true and actual positive or negative fiscal effect that implementation of this proposal will achieve.



INTERIM CHIEF FINANCIAL OFFICER

10/09/2024

DATE



James Crawford (Oct 20, 2024 14:00 CDT)

PRESIDENT

10/20/2024

DATE

Texas Southern University

DEPARTMENT OF INTERNAL AUDIT & ASSURANCE SERVICES STATUS REPORT AND FY2025 ANNUAL AUDIT PLAN

PRESENTED BY:

DARLENE BROWN, CIA, CFE, CSM
ACTING CHIEF AUDIT EXECUTIVE

PRESENTED TO:

Texas Southern University
Board of Regents

October 17, 2024

Internal Audit Activities

Internal Audit Activities Since Last period:

Audits

- Budgeting Process – Completed
- Research & Grants – Completed
- Academic Advisory Services – In-Progress
- Student Fees – In-Progress

Audit Activities

- Prepared proposed FY2025 Annual Internal Audit Plan
- Prepared FY2024 Annual Internal Audit Report

FY 2024 Annual Internal Audit Plan Status
Contract Period: November 7, 2023 - November 6, 2024
17 Approved Audit Plan Activities

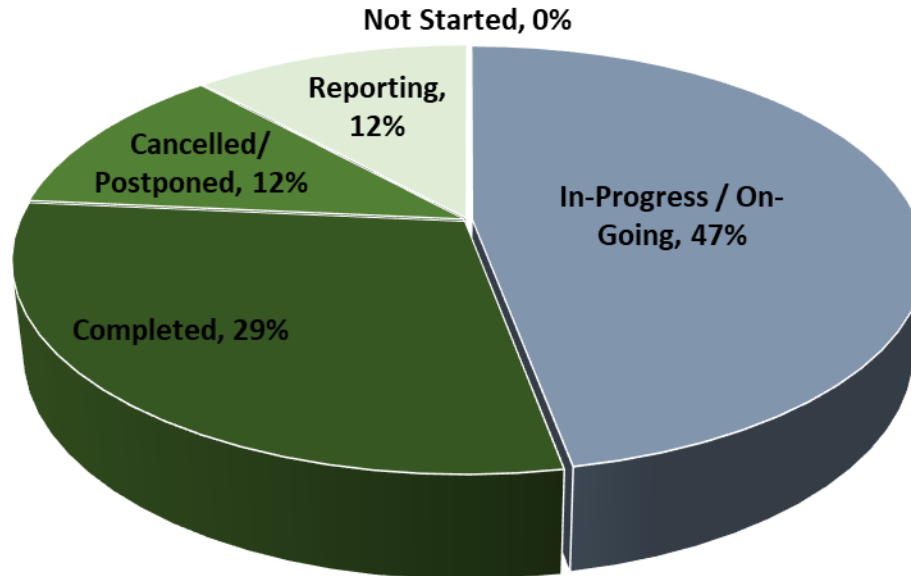

Contract Period Progress	75%
Percentage of Hours Expended	71%
Percentage of Fees Expended	65%

Proposed FY2025 Annual Internal Audit Plan – Action Item

Annual Internal Audit Plan Process:

- Identified the University's audit universe.
- Assigned risk rankings to each area.
- Prioritized the audit areas based upon the highest risk areas that could have the most impact on operations and provide value to management.

Audit Plan Summary:

- 9 audits planned.
- Perform follow-up on prior audit findings.
- Perform quarterly network access testing.
- Flexible to accommodate requests.