

**ACKNOWLEDGEMENT OF RECEIPT OF NOTICE OF MEETING  
OF THE MAYOR AND CITY COUNCIL OF  
THE CITY OF DAVID CITY, NEBRASKA**

The undersigned members of the governing body of the City of David City, Nebraska, hereby acknowledge receipt of advance notice of a regular meeting of said body and the agenda for such meeting to be held at 7:00 o'clock p.m. on the **Wednesday, November 12, 2025**, in the **meeting room of the City Office, 490 E Street, David City, Nebraska**.

This agenda is available on our Web site for public inspection and may be modified up to twenty-four hours prior to the opening of the meeting.

Dated this .

**AGENDA AS FOLLOWS:**

1. Roll Call;

\_\_\_\_\_  
Mayor Jessica Miller

2. Pledge of Allegiance;

3. Inform the Public about the location of the Open Meetings Act and the Citizens Participation Rules;

\_\_\_\_\_  
Council President Bruce Meysenburg

4. Minutes of the October 22, 2025, meeting of the Mayor and City Council;

\_\_\_\_\_  
Council member Thomas J. Kobus

5. Approval of Claim to Hein Construction;

\_\_\_\_\_  
Council member James Angell

6. Approval of Claim to D-Sign Shop;

7. Approval of Claims;

8. Committee and Officer Reports/Butler County Development Board Update;\*

\_\_\_\_\_  
Council member Patrick J. Meysenburg

9. Consider Change Order No. 7 for BRB Contractors, Inc. in the amount of \$135,701.87 for HVAC equipment in the headworks and storage buildings and SBR Air Piping Modifications & New Diffusers;

\_\_\_\_\_  
Council member Kevin Woita

10. Consider Pay Application No. 20 for BRB Contractors, Inc. in the amount of \$279,586.77 for the Wastewater Treatment Plant

\_\_\_\_\_  
Council member Keith Marvin

Improvement Project;

\_\_\_\_\_  
City Clerk Tami L. Comte

11. Consider Pay Application No. 1 for Rutjens Construction, Inc. in the amount of \$323,565.01 for the 2025 Water Main Improvements:  
North 7th Street from J Street to O Street;
12. Discuss/Consider bids for mowing services;
13. Discuss/Consider bids for Turf/Vegetation and Landscape Management (Chemical applications and treatments);
14. Discuss/Consider making West B Street from 1st Street west as a Dead-End Street;
15. Consider purchasing a new Backhoe with trade-in of the used Case 580SN Backhoe;
16. Consider purchasing an Alamo Rear mount Boom mower and a Water Tank trailer;
17. Consider the agreement with JEO Consulting Group, Inc. for Ballfield Restroom Addition;
18. Consider appointing JEO Consulting Group for the 2026 City Engineer;
19. Consider/approve health insurance for city employees;
20. Consider/adopt Resolution No. 24-2025 in pursuit of litigation;\*
21. Consider closed session for personnel, contracts, or pending litigation (as necessary);
22. Adjourn;

CITY COUNCIL PROCEEDINGS  
October 22, 2025

The City Council of the City of David City, Nebraska, met in open public session at 7:00 p.m. in the meeting room of the City Office at 490 "E" Street, David City, Nebraska. The Public had been advised of the meeting by posting in four public places (City Office, US Post Office, Butler County Courthouse and Hruska Public Library). The Mayor and members of the City Council acknowledged advance notice of the meeting by signing the Agenda which is a part of these minutes. The advance notice to the Public, Mayor, and Council members conveyed the availability of the agenda, which was kept continuously current in the office of the City Clerk and was available for public inspection on the City's website. No new items were added to the agenda during the twenty-four hours immediately prior to the opening of the Council meeting.

Present for the meeting were: Mayor Jessica Miller, Council President Bruce Meysenburg, Council members Jim Angell, Rick Holland, Keith Marvin, Kevin Woita, Jeremy Abel, City Administrator Alan Zavodny, City Administrator Intern Raiko Martinez and City Clerk-Treasurer Tami Comte. City Attorney Michael Sands attended via Zoom.

Also present for the meeting were: Police Sargeant Tristan Hilger, Police Officer Chris Baete, Deputy Clerk Lori Matchett, Johnny Matchett, Scott Steager, Nathan Styskal, Lisa Buntgen, Mary Lou Hilger and Marlene Hein. Ethan Joy with JEO and Alex Merten with V & K attended via Zoom.

The meeting opened with the Pledge of Allegiance.

Mayor Jessica Miller informed the public of the "Open Meetings Act" posted on the west wall of the meeting room and asked those present to please silence their cell phones. She also reminded the public that if they speak tonight in front of the Council, they must state their name and address for the record.

Council member Jim Angell made a motion to approve the minutes of the October 8, 2025 meeting of the Mayor and City Council as presented. Council Member Rick Holland seconded the motion. The motion carried.

Jeremy Abel: Yea, Jim Angell: Yea, Rick Holland: Yea, Keith Marvin: Yea, Bruce Meysenburg: Yea, Kevin Woita: Yea  
Yea: 6, Nay: 0

Council member Jim Angell made a motion to table the claim from Hein Construction to the next meeting. Council Member Keith Marvin seconded the motion. The motion carried.

Jeremy Abel: Yea, Jim Angell: Yea, Rick Holland: Yea, Keith Marvin: Yea, Bruce Meysenburg: Yea, Kevin Woita: Yea  
Yea: 6, Nay: 0

Council member Bruce Meysenburg made a motion to approve Pay Application #9 in the amount of \$15,059.07 for Municipal Pipe Tool for the South Area Sewer Rehabilitation Project. Council Member Kevin Woita seconded the motion. The motion carried.

Jeremy Abel: Yea, Jim Angell: Yea, Rick Holland: Yea, Keith Marvin: Yea, Bruce Meysenburg: Yea, Kevin Woita: Yea  
Yea: 6, Nay: 0





A Kleinfelder Company

**VEENSTRA & KIMM INC.**  
 6775 Vista Drive  
 West Des Moines, Iowa 50266  
 515.225.8000 // 800.241.8000  
 www.vknet

ESTIMATE OF CONSTRUCTION COMPLETED								
PARTIAL PAYMENT NO. 9								
PROJECT TITLE: South Area Sewer Rehabilitation								
Contractor: Municipal Pipe Tool Company			Date: October 17, 2025					
Original Contract Amount:			\$667,383.15					
Pay Period: July 25, 2025 to October 3, 2025								
BID ITEMS								
ITEM NO.	DESCRIPTION	UNIT	ESTIMATED (ORIG. CONT.)	QUANTITY AUTHORIZED (INCL. C.O.'S)	COMPLETED TO DATE	UNIT PRICE	VALUE COMPLETED TO DATE	
1.1	Mobilization	LS	1.00	1.10	0.90	\$39,917.50	\$35,925.75	
1.2	Traffic Control	LS	1.00	1.00	0.90	\$8,912.40	\$8,021.16	
1.3	Surface Restoration	LS	1.00	1.00	1.00	\$8,610.00	\$8,610.00	
1.4	PCC Pavement	SY	100.00	100.00	56.22	\$100.80	\$5,666.98	
1.5	HMA Pavement	SY	100.00	100.00	36.00	\$100.80	\$0.00	
1.6	PCC Sidewalk	SY	100.00	100.00	0.00	\$94.50	\$0.00	
1.7	Remove and Replace 8" Sewer	LF	110.00	110.00	131.00	\$47.25	\$6,189.75	
1.8	8" Sanitary Sewer Televising	LF	4,165.00	3,924.30	3,833.70	\$1.00	\$3,833.70	
1.9	8" Sanitary Sewer Cleaning	LF	4,165.00	3,924.30	3,833.70	\$2.00	\$7,667.40	
1.10	8" Sanitary Sewer Cured-in-Place Pipe	LF	4,165.00	3,924.30	3,833.70	\$34.00	\$130,345.80	
1.11	10" Sanitary Sewer Televising	LF	2,395.00	2,806.90	2,785.40	\$1.00	\$2,785.40	
1.12	10" Sanitary Sewer Cleaning	LF	2,395.00	2,806.90	2,785.40	\$2.00	\$5,570.80	
1.13	10" Sanitary Sewer Cured-in-Place Pipe	LF	2,395.00	2,386.90	2,363.60	\$39.00	\$92,180.40	
1.14	12" Sanitary Sewer Televising	LF	2,685.00	2,636.40	2,631.80	\$1.00	\$2,631.80	
1.15	12" Sanitary Sewer Cleaning	LF	2,685.00	2,636.40	2,631.80	\$3.00	\$7,895.40	
1.16	12" Sanitary Sewer Cured-in-Place Pipe	LF	2,685.00	1,358.40	1,402.20	\$42.00	\$58,892.40	
1.17	18" Sanitary Sewer Televising	LF	1,013.00	617.30	613.10	\$1.00	\$613.10	
1.18	18" Sanitary Sewer Cleaning	LF	1,013.00	617.30	613.10	\$4.00	\$2,452.40	
1.20	18" Sanitary Sewer Cured-in-Place Pipe	LF	1,013.00	617.30	613.10	\$74.00	\$45,369.40	
1.21	Point Repair No. 1	EA	1.00	0.00	0.00	\$3,528.00	\$0.00	
1.22	Point Repair No. 2	EA	1.00	0.00	0.00	\$3,528.00	\$0.00	
1.23	Point Repair No. 3	EA	1.00	0.00	0.00	\$3,528.00	\$0.00	
1.24	Point Repair No. 4	EA	1.00	0.00	0.00	\$3,024.00	\$0.00	
1.25	Point Repair No. 5	EA	1.00	1.00	1.00	\$3,391.50	\$3,391.50	
1.26	Point Repair No. 6	EA	1.00	0.00	0.00	\$10,185.00	\$0.00	
1.27	Point Repair No. 7	EA	1.00	0.00	0.00	\$12,731.25	\$0.00	
1.28	Point Repair No. 8	EA	1.00	0.00	0.00	\$3,024.00	\$0.00	
1.29	Point Repair No. 9	EA	1.00	0.00	0.00	\$3,024.00	\$0.00	
1.30	Heavy Cleaning / Root Cutting	LF	2,696.00	2,696.00	1,154.00	\$5.00	\$5,770.00	
1.31	Reinstate Service Connection	EA	103.00	90.00	98.00	\$90.00	\$8,820.00	
1.32	Grout Service Connection	EA	103.00	72.00	97.00	\$450.00	\$43,650.00	
1.33	Trim Protruding Service, Clay or PVC	EA	5.00	5.00	2.00	\$368.00	\$736.00	
CO1.1.33	Manhole, 48" Dia	EA	0.00	1.00	1.00	\$14,610.00	\$14,610.00	
CO1.2.1	PCC Pavement	SY	0.00	50.00	126.00	\$100.80	\$12,700.80	
CO1.2.2	Hot Mix Asphalt	SY	0.00	125.00	0.00	\$117.60	\$0.00	
CO1.2.3	8" Sanitary Sewer Televising	LF	0.00	923.00	936.00	\$1.00	\$936.00	
CO1.2.4	8" Sanitary Sewer Cleaning	LF	0.00	923.00	936.00	\$2.00	\$1,872.00	
CO1.2.5	8" Sanitary Sewer Cured-in-Place Pipe	LF	0.00	923.00	936.00	\$36.00	\$33,696.00	
CO1.2.6	Point Repair No. 10	EA	0.00	1.00	1.00	\$8,531.25	\$8,531.25	
CO1.2.7	Point Repair No. 11	EA	0.00	0.00	0.00	\$8,531.25	\$0.00	
CO1.2.8	Point Repair No. 12	EA	0.00	0.00	0.00	\$8,531.25	\$0.00	
CO1.2.9	Heavy Cleaning / Root Cutting	LF	0.00	488.00	0.00	\$5.00	\$0.00	
CO1.2.10	Reinstate Service Connection	EA	0.00	21.00	16.00	\$90.00	\$1,440.00	
CO1.2.11	Grout Service Connection	EA	0.00	21.00	12.00	\$500.00	\$6,000.00	
CO1.2.12	Trim Protruding Service, Clay or PVC	EA	0.00	2.00	0.00	\$368.00	\$0.00	
CO2.1.35	Compaction and PCC Testing	LS	0.00	1.00	0.00	\$2,000.00	\$0.00	
CO2.2.13	Point Repair No. 11 Add Manhole	EA	0.00	1.00	1.00	\$17,275.50	\$17,275.50	
CO2.2.14	Point Repair No. 12 Add Manhole	EA	0.00	1.00	1.00	\$19,195.00	\$19,195.00	
CO3.0.01	Chain Link Fence	LF	0.00	0.00	0.00	\$37.90	\$0.00	
CO4.0.01	Chain Link Fence, Full Replacement	LF	0.00	610.00	610.00	\$27.43	\$16,732.30	
<b>Total Value Completed - Bid Items</b>							<b>\$620,007.99</b>	

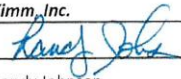

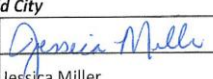
SUMMARY			
		Original Contract	Total Completed
<b>Bid Item Subtotal</b>		\$667,383.15	\$620,007.99
APPROVED CHANGE ORDERS			
Change Order No.	Description/Notes	Total Approved	Total Completed
1	Add and remove base bid item and Add Alternate 1 quantities. Item changes included in bid items.	-\$11,667.70	\$0.00
2	Remove and add bid items. Item changes included in bid items 1.13, 1.35, 2.7, 2.8, 2.13 and 2.14	\$5,028.00	\$0.00
3	Remove Point Repairs 7 and 8. Add partial replacement of chain link fence. Item changes included in bid items	-\$7,985.75	\$0.00
4	Remove partial replacement of chain link fence. Add full replacement of chain link fence at lower unit price. Item changes included in bid items	\$8,962.80	\$0.00
5		\$0.00	\$0.00
6		\$0.00	\$0.00
7		\$0.00	\$0.00
8		\$0.00	\$0.00
Total Change Orders		-\$5,662.65	\$0.00
		Total Approved	Total Completed
<b>Revised Contract Price</b>		\$661,720.50	\$620,007.99
			Total Completed
		Total Materials Stored	\$0.00
		Total Completed Plus Materials Stored	\$620,007.99
		Retainage (10%)	\$62,000.80
		Total Earned Less Retainage	\$558,007.19
APPROVED PARTIAL PAYMENTS			
Partial Payment No.	Period	Total Approved	
1	April 1, 2024 to April 26, 2024	\$45,845.59	
2	April 26, 2024 to July 30, 2024	\$216,338.13	
3	July 31, 2024 to August 11, 2024	\$17,543.70	
4	August 12, 2024 to September 24, 2024	\$11,281.95	
5	September 25, 2024 to December 2, 2024	\$9,855.64	
6	December 3, 2024 to December 18, 2024	\$774.90	
7	December 19, 2024 to May 21, 2025	\$55,759.55	
8	May 22, 2025 to July 24, 2025	\$185,548.66	
9		\$0.00	
10		\$0.00	
		Total Previously Approved	\$542,948.12
		<b>Amount Due This Request</b>	<b>\$15,059.07</b>
Note: The amount <b>\$15,059.07</b> is recommended for approval for payment in accordance with the terms of the Contract.			
<b>CONTRACT SUMMARY</b>			
		ORIGINAL CONTRACT AMOUNT	\$667,383.15
		TOTAL CONTRACT AMOUNT PLUS CHANGE ORDERS	\$661,720.50
		THIS PARTIAL PAYMENT	\$15,059.07
		TOTAL PARTIAL PAYMENTS INCL THIS PAYMENT	\$558,007.19
		BALANCE	\$103,713.31
		PERCENT COMPLETE	93.7%
<b>Recommended By:</b> Veenstra & Kimm, Inc.		<b>Contractor:</b> Municipal Pipe Tool Company	<b>Approved:</b> City of David City
Signature		Signature	
Name	Randy Johnson	Name	Matt Boggs
Title	Project Engineer	Title	Project Manager
Date	10/17/2025	Date	10/17/2025
Signature		Signature	
Name		Name	Jessica Miller
Title		Title	Mayor
Date		Date	10-22-25

Council member Rick Holland made a motion to table purchasing a new Backhoe with trade-in of the used Case580SN Backhoe. Council Member Bruce Meysenburg seconded the motion. The motion carried.

Jeremy Abel: Yea, Jim Angell: Yea, Rick Holland: Yea, Keith Marvin: Yea, Bruce Meysenburg: Yea, Kevin Woita: Yea  
Yea: 6, Nay: 0

Council member Kevin Woita made a motion to table purchasing an Alamo Rear mount Boom mower and a Water Tank trailer. Council Member Jim Angell seconded the motion. The motion carried.

Jeremy Abel: Yea, Jim Angell: Yea, Rick Holland: Yea, Keith Marvin: Yea, Bruce Meysenburg: Yea, Kevin Woita: Yea  
Yea: 6, Nay: 0

Council member Keith Marvin made a motion to table the agreement with JEO Consulting Group, Inc. for Ballfield Restroom Addition. Council Member Bruce Meysenburg seconded the motion. The motion carried.

Jeremy Abel: Yea, Jim Angell: Yea, Rick Holland: Yea, Keith Marvin: Yea, Bruce Meysenburg: Yea, Kevin Woita: Yea  
Yea: 6, Nay: 0

Council member Jim Angell made a motion to approve taking bids for mowing and spraying of city properties. Council Member Rick Holland seconded the motion. The motion carried.

Jeremy Abel: Yea, Jim Angell: Yea, Rick Holland: Yea, Keith Marvin: Yea, Bruce Meysenburg: Yea, Kevin Woita: Yea  
Yea: 6, Nay: 0

Council member Keith Marvin made a motion to approve the quote from Novak Construction for repairs on the building located at 569 E Street. Council Member Kevin Woita seconded the motion. The motion carried.

Jeremy Abel: Yea, Jim Angell: Yea, Rick Holland: Yea, Keith Marvin: Yea, Bruce Meysenburg: Yea, Kevin Woita: Yea  
Yea: 6, Nay: 0

[REMAINDER OF PAGE INTENTIONALLY LEFT BLANK]

T. NOVAK CONSTRUCTION, INC  
841 30 Road  
Rising City, Nebraska 68658  
402-542-2271 OR 402-367-2827

TO: City Office  
(OLD Legion Club)

DATE 10-13-25

QTY	DESCRIPTION	PRICE	AMOUNT
	Estimate to Complete west side of office by Bone Creek Museum.		\$ 5984.63

Includes  
Remove existing Housewrap - Remove All  
wet insulation - Check for Mold  
Re-Insulate exterior wall  
Install wall Sheathing  
Note: Install wall sheathing over existing  
BRICK - GRIND Mortar Smooth  
FRAME Upper Gable Structural wall  
Raise + Brace existing Roof at All Points  
Install TYVEK Housewrap over entire  
West wall  
Install Vertical LP SmartSide Corners for  
future Stucco.

Includes All Labor & Materials + Dump  
Fees for Above work.

Price Does Not Include

Stucco - still waiting on BIDS

SIGNATURE Tom Novak

City Council Proceedings

October 22, 2025

Page #7

Council member Keith Marvin made a motion to approve Certification of City Street Superintendent and Resolution No. 24-2025 signing of the Year End Certification of City Street Form 2025. Council Member Kevin Woita seconded the motion. The motion carried.

Jeremy Abel: Yea, Jim Angell: Yea, Rick Holland: Yea, Keith Marvin: Yea, Bruce Meysenburg:

Yea, Kevin Woita: Yea

Yea: 6, Nay: 0

[REMAINDER OF PAGE INTENTIONALLY LEFT BLANK]

Do not recreate or revise this document. Revisions and recreations will not be accepted. Copying this form is acceptable; see (3) below. Failure to complete and return the necessary documents per instructions will result in your municipality not receiving an Incentive Payment for Calendar Year 2025. Documents include the original Signing Resolution, Year-End Certification(s), and a copy of documentation of the appointment(s) of the City Street Superintendent(s). These must be received at the NDOT by December 31, 2025. RECORD KEEPING: NDOT recommends that the municipality keep a copy of everything you send to NDOT (the forms and meeting minutes) in a separate file for future reference.

### Year-End Certification of City Street Superintendent For Determining Incentive Payment in Calendar Year 2025

Separate forms may be needed to account for the entire year, see (3) below

This Form Covers the Following Period: January 1, 2025 to December 31, 2025

\*(1)(a) The municipality of David City certifies that: Andrew Wilshusen was the appointed City Street Superintendent during the above period. IF A NAME IS NOT ENTERED ABOVE (NO APPOINTED CITY STREET SUPERINTENDENT FOR THIS PERIOD), SKIP TO (2) BELOW.

(b) the superintending services of the above listed individual were provided by:  Employment with this Municipality  Contract (consultant) with this Municipality  Contract (interlocal agreement) between this Municipality and the following listed Municipality(ies) and/or County(ies)

(c) and the above listed individual assisted in the following: Reference Neb. Rev. Stat. §39-2512  
1. Developing and annually updating a long-range plan based on needs and coordinated with adjacent local governmental units,  
2. Developing an annual program for design, construction, and maintenance,  
3. Developing an annual budget based on programmed projects and activities,  
4. Submitting such plans, programs, and budgets to the local governing body for approval; and  
5. Implementing the capital improvements and maintenance activities provided in the approved plans, programs, and budgets,

(d) the above listed individual also served as city engineer  village engineer  public works director  city manager  city administrator  street commissioner

(e) If the above listed individual is a Licensed City Street Superintendent, enter their Superintendent's License Number S- 1696 and Class of License A, and/or

(f) If the above listed individual is a Licensed Engineer in Nebraska, enter their Engineer's License Number E- \_\_\_\_\_

(2) Signature of Mayor  Village Board Chairperson

\*(3) If during the calendar year your municipality (a) did not have an appointed City Street Superintendent for any portion(s) of the year; or (b) had one or more appointed City Street Superintendent(s) that were not licensed for any portion(s) of the year; or (c) had one or more appointed licensed City Street Superintendent(s) for any portion(s) of the year, please complete a separate Year-End Certification form for each period. Copy this form as needed to account for these separate periods.

(4) The payment amount will be computed based on (a) your most recent Federal Census as certified by the Tax Commissioner; (b) the number of full calendar months served by the appointed City Street Superintendent who is licensed or exempted from licensure under the Superintendents Act; (c) class of license, A or B if applicable; and (d) if the appointed City Street Superintendent assisted with the required duties in (1)(c) above. Reference Neb. Rev. Stat. §§39-2302 and 39-2511 through 39-2515.

(5) Failure to return by December 31, 2025, the Year-End Certification(s), Signing Resolution, and a copy of documentation of the appointment(s) of the superintendent(s) per the instructions will result in your municipality not receiving an Incentive Payment.



Return the completed original resolution and certification(s), and a copy of the documentation of appointment(s) by December 31, 2025 to:  
Highway Local Liaison Coordinator  
Boards-Liaison Services Section  
Local Assistance Division  
Nebraska Department of Transportation  
PO Box 94759  
Lincoln NE 68509-4759



Council member Keith Marvin made a motion to reappoint Tina Kirby to the Library Board of Trustees for another four-year term ending September 30, 2029. Council Member Jeremy Abel seconded the motion. The motion carried.

Jeremy Abel: Yea, Jim Angell: Yea, Rick Holland: Yea, Keith Marvin: Yea, Bruce Meysenburg: Yea, Kevin Woita: Yea  
Yea: 6, Nay: 0

Council member Keith Marvin made a motion to approve canceling the City Council meetings for November 26, 2025 and December 24, 2025. Council Member Rick Holland seconded the motion. The motion carried.

Jeremy Abel: Yea, Jim Angell: Yea, Rick Holland: Yea, Keith Marvin: Yea, Bruce Meysenburg: Yea, Kevin Woita: Yea  
Yea: 6, Nay: 0

Council member Bruce Meysenburg made a motion to enter into closed session to discuss legal and personnel matters at 7:35 p.m. Council Member Keith Marvin seconded the motion. The motion carried.

Jeremy Abel: Yea, Jim Angell: Yea, Rick Holland: Yea, Keith Marvin: Yea, Bruce Meysenburg: Yea, Kevin Woita: Yea  
Yea: 6, Nay: 0

Mayor Jessica Miller stated, "Now, at 7:35 p.m., we are going into closed session to discuss legal and personnel matters. Mayor Jessica Miller, all of the Council members, City Administrator Alan Zavodny, and City Administrator Intern Raiko Martinez went into closed session at 7:35 p.m. City Attorney Michael Sands joined the closed session via Zoom.

Council member Keith Marvin made a motion to reconvene in open session at 8:58 p.m. Council Member Rick Holland seconded the motion. The motion carried.

Jeremy Abel: Yea, Jim Angell: Yea, Rick Holland: Yea, Keith Marvin: Yea, Bruce Meysenburg: Yea, Kevin Woita: Yea  
Yea: 6, Nay: 0

Council member Bruce Meysenburg made a motion to adjourn. Council Member Keith Marvin seconded the motion. The motion carried and Mayor Jessica Miller declared the meeting adjourned at 8:58 p.m.

Jeremy Abel: Yea, Jim Angell: Yea, Rick Holland: Yea, Keith Marvin: Yea, Bruce Meysenburg: Yea, Kevin Woita: Yea  
Yea: 6, Nay: 0



CERTIFICATION OF MINUTES  
October 22, 2025

I, Tami Comte, duly qualified and acting City Clerk for the City of David City, Nebraska, do hereby certify with regard to all proceedings of October 22, 2025; that all of the subjects included in the foregoing proceedings were contained in the agenda for the meeting, kept continually current and available for public inspection at the office of the City Clerk; that such subjects were contained in said agenda for at least twenty-four hours prior to said meeting; that the minutes of the meeting of the City Council of the City of David City, Nebraska, were in written form and available for public inspection within ten working days and prior to the next convened meeting of said body; that all news media requesting notification concerning meetings of said body were provided with advance notification of the time and place of said meeting and the subjects to be discussed at said meeting.

---

Tami Comte, City Clerk

HEIN CONSTRUCTION LLC.

919 I STREET

FAIRBURY NEBRASKA, 68352

PHONE 402-239-9629

DAVID CITY, NEBRASKA

STATEMENT DATE 9-25-2025

PATCHING AND ARMOUR COAT

PATCHING

9870 SQ/FT MILL AND PATCH @ \$5.80 PER FT TOTAL \$57,246.00

ARMOUR COAT

31,251 SQ/YDS @ \$2.00 PER SQ/YD TOTAL \$62,502.00

E street 14 th to 14th OVERLAY

14,102 SQ/FT @ \$5.80 PER SQ/FT TOTAL \$81,791.60

M street 10<sup>th</sup> to 11<sup>th</sup> overlay

5742 sq/ft @ \$5.80 per sq/ft total \$33,303.60

PLEASE PAY THIS AMOUNT

TOTAL ~~\$234,849.20~~

**\$ 234,843.20**

21-2275  
CK

(Hold Check)

THANK YOU HEIN CONSTRUCTION LLC



# Invoice

PO Box 301  
David City, NE 68632

Date	Invoice #
10/28/2025	25-1065

<b>Bill To</b>
City of David City 490 E Sstreet David City, NE 68632

P.O. No.	Terms	Project

Quantity	Description	Rate	Amount
1	COST TO CLEAN UP FLAG LOGO AND REPRINT  <i>Rv Campground 49-2279</i>	265.00	265.00

Thank you for your business.

**Total**

\$265.00

# Check Approval List - Council

November 12, 2025

Page # 1

<u>Vendor Name</u>	<u>Invoice Description</u>	<u>Account Description</u>	<u>Amount</u>
<b>SALES TAX</b>			
JEO CONSULTING GROUP	Service	WATER SYSTEM IMPR	\$37,396.50
RUTJENS CONSTRUCTION INC.	Service - 2025 Water Main Improvements N	WATER SYSTEM IMPR	<u>\$323,565.01</u>
		Total SALES TAX	\$360,961.51
<b>GENERAL</b>			
ALLIED BENEFIT SYSTEMS, INC.	Employees Health Insurance	GROUP INSURANCE	\$3,794.62
AMAZON CAPITAL SERVICES	Supplies, Parts, Clothing	OFFICE SUPPLIES, PO	\$328.85
AMERICAN EXPRESS	Supplies, Books	OFFICE SUPPLIES, PO	\$84.34
APPLIED CONNECTIVE TECHNOLOGIE	Service	REPAIR & MAINT: OFFI	\$704.71
BEST CARE EMPLOYEE ASSISTANCE	Employee Assistance Program - Annual Fe	SUBSCRIPTION FEES	\$1,032.79
BUTLER COUNTY REGISTER OF DEED	Filing Fees	ATTORNEYS FEES	\$66.00
COLUMN SOFTWARE PBC	Publications and Legal Notices	PRINTING & PUBLISHI	\$159.90
TAMI COMTE	Reimbursement	MTGS, SCHOOL, TRAV	\$70.10
DALE'S FOOD PRIDE	Supplies	OFFICE SUPPLIES, PO	\$30.98
DAVID CITY ACE HARDWARE	Supplies, Small Tools	OFFICE SUPPLIES, PO	\$6.99
DAVID CITY PAYROLL ACCOUNT	Employees Payroll from 9/24/2025 to 10/23	SALARIES & WAGES: F	\$3,699.60
DAVID CITY PAYROLL ACCOUNT	Employees Payroll from 9/24/2025 to 10/23	SALARIES: OVERTIME	\$276.21
DAVID CITY PAYROLL ACCOUNT	Employees Payroll from 9/24/2025 to 10/23	SALARIES: ADMINISTR	\$1,377.65
DAVID CITY PAYROLL ACCOUNT	Employees Payroll from 9/24/2025 to 10/23	SALARIES: MAYOR, CI	\$1,937.50
DAVID CITY PAYROLL ACCOUNT	401 A Portion	RETIREMENT PLAN	\$1,075.21
DAVID CITY UTILITIES	Utility Bills	UTILITIES	\$75.27
DIDIER'S GROCERY, INC.	Supplies	OFFICE SUPPLIES, PO	\$32.88
FIRST NATIONAL BANK OF OMAHA	Webhosting, Adobe Subscription, Lodging,	MTGS, SCHOOL, TRAV	\$13.95
FIRST NATIONAL BANK OF OMAHA	Webhosting, Adobe Subscription, Lodging,	SUBSCRIPTION FEES	\$165.49
FIRST NATIONAL BANK OF OMAHA	Webhosting, Adobe Subscription, Lodging,	REPAIR & MAINT: OFFI	\$163.72
HOMETOWN LEASING	Copier Leases	CAPITAL OUTLAY- OFF	\$470.40
J.P. COOKE COMPANY	2026 Dog Tags & Dangerous Dog Tags	MISCELLANEOUS	\$154.95
RACHEL KAHNK	Reimbursement	MISCELLANEOUS	\$42.67
KOBZA MOTORS	Service	NUISANCE PROPERTI	\$85.50
LINCOLN JOURNAL-STAR	Publication and Legal Notices	PRINTING & PUBLISHI	\$180.94
LINCOLN NATIONAL LIFE INSURANCE	Employee Life Insurance and LTD Insuranc	GROUP INSURANCE	\$17.58
LINCOLN NATIONAL LIFE INSURANCE	Employee Life Insurance and LTD Insuranc	DISABILITY INSURANC	\$40.13
NEBRASKA MUNICIPAL CLERKS ASSN	Fees	MTGS, SCHOOL, TRAV	\$150.00
CLARENCE NOVAK	Reimbursement	MISCELLANEOUS	\$33.39
PAR IV	Refund	MISCELLANEOUS	\$612.62
ELIZABETH PARKER	Reimbursement - Mileage to Clerk/Treasure	MTGS, SCHOOL, TRAV	\$116.06
PETTY CASH	Reimbursement	MTGS, SCHOOL, TRAV	\$30.00
PETTY CASH	Reimbursement	OFFICE SUPPLIES, PO	\$32.56
QUILL CORPORATION	Supplies	OFFICE SUPPLIES, PO	\$141.08
SMEJKAL & ELM PC	2025-2026 Budget	AUDIT	\$4,100.00
STEAGER LAWN SERVICE	Service	CONTRACT LABOR	\$500.00
TIME MANAGEMENT SYSTEMS, INC.	Monthly Software Subscription & Support	SUBSCRIPTION FEES	\$91.00
WASTE CONNECTIONS OF NE	Garbage Service	REPAIR & MAINTENAN	<u>\$17.09</u>
		Total GENERAL	\$21,912.73
<b>BUILDING PERMIT FUND</b>			
AMAZON CAPITAL SERVICES	Supplies, Parts, Clothing	OFFICE SUPPLIES, PO	\$707.51
APPLIED CONNECTIVE TECHNOLOGIE	Service	MISCELLANEOUS	\$103.33
BEST CARE EMPLOYEE ASSISTANCE	Employee Assistance Program - Annual Fe	SUBSCRIPTION FEES	\$93.89
DAVID CITY ACE HARDWARE	Supplies, Small Tools	OFFICE SUPPLIES, PO	\$109.99
DAVID CITY PAYROLL ACCOUNT	Employees Payroll from 9/24/2025 to 10/23	SALARIES: PART-TIME	\$6,036.25
DAVID CITY PAYROLL ACCOUNT	401 A Portion	RETIREMENT PLAN	\$305.67
NORTHSIDE INC.	Service & Supplies	VEHICLE - REPAIR & M	\$105.02
WEX BANK	Fuel	FUEL	<u>\$2.03</u>
		Total BUILDING PERMIT FUND	\$7,463.69
<b>CREATIVE DISTRICT</b>			
BUTLER PUBLIC POWER DISTRICT	Electric Service - Airport	UTILITIES	<u>\$30.25</u>
		Total CREATIVE DISTRICT	\$30.25
<b>SOCIAL SECURITY FUND</b>			
DAVID CITY PAYROLL ACCOUNT		REMITTANCES TO IRS	<u>\$7,391.65</u>
		Total SOCIAL SECURITY FUND	\$7,391.65
<b>TAX INCREMENT FINANC</b>			
BAIRD HOLM LLP	Service	ATTORNEYS FEES	<u>\$1,548.00</u>
		Total TAX INCREMENT FINANC	\$1,548.00

# Check Approval List - Council

November 12, 2025

Page # 2

<u>Vendor Name</u>	<u>Invoice Description</u>	<u>Account Description</u>	<u>Amount</u>
<b>COMMUNITY DEVEL. BLO</b>			
DAVE HENNING CARPENTRY	Service - 22-TFHO-16018	HOUSING DEVELOPME	\$20,000.00
MIT CONTRACTING	Service - Project 22-TFHO-16018	HOUSING DEVELOPME	\$70,415.26
NEUJAHR HOME CENTER	Service - City of David City 22-DTR-004	DOWNTOWN REVITAL	\$1,500.00
SOUTHEAST NEBRASKA DEVELOPME	Service - City Project 22-TFHO-16018	HOUSING DEVELOPME	\$63,153.83
SOUTHEAST NEBRASKA DEVELOPME	Service - Tourism Development	DOWNTOWN REVITAL	<u>\$1,998.16</u>
Total COMMUNITY DEVEL. BLO			\$157,067.25
<b>STREET</b>			
ALLIED BENEFIT SYSTEMS, INC.	Employees Health Insurance	GROUP INSURANCE	\$998.60
AMAZON CAPITAL SERVICES	Supplies, Parts, Clothing	CLOTHING	\$179.97
APPLIED CONNECTIVE TECHNOLOGIE	Service	REPAIR & MAINT: OFFI	\$176.33
ARPS	Concrete	MATERIALS: CONCRET	\$3,383.50
BEST CARE EMPLOYEE ASSISTANCE	Employee Assistance Program - Annual Fe	SUBSCRIPTION FEES	\$375.56
BUTLER COUNTY CLINIC, P.C.	Service - Random Drug Testing - Zrust	SAFETY EXPENSES	\$40.00
BUTLER COUNTY LANDFILL INC.	Industrial Waste - Trash from Recycling	MISCELLANEOUS	\$62.23
BUTLER COUNTY WELDING	Parts & Small Tools	REPAIR & MAINT: EQU	\$3.36
BUTLER COUNTY WELDING	Parts & Small Tools	SUPPLIES: SHOP & SM	\$23.76
BUTLER COUNTY WELDING	Parts & Small Tools	CULVERTS	\$8.88
CENTRAL SAND & GRAVEL CO.	Armor Coat	MATERIALS: ASPHALT	\$4,427.89
CINTAS	First Aid Supplies & Maintenance Services	SAFETY EXPENSES	\$274.41
DAVID CITY ACE HARDWARE	Supplies, Small Tools	REPAIR & MAINTENAN	\$101.32
DAVID CITY ACE HARDWARE	Supplies, Small Tools	REPAIR & MAINT: EQU	\$10.00
DAVID CITY ACE HARDWARE	Supplies, Small Tools	MATERIALS: CONCRET	\$35.98
DAVID CITY PAYROLL ACCOUNT	Employees Payroll from 9/24/2025 to 10/23	SALARIES & WAGES: F	\$19,331.54
DAVID CITY PAYROLL ACCOUNT	Employees Payroll from 9/24/2025 to 10/23	SALARIES: OVERTIME	\$32.42
DAVID CITY PAYROLL ACCOUNT	401 A Portion	RETIREMENT PLAN	\$1,186.21
DAVID CITY UTILITIES	VOIP Phone Services	UTILITIES	\$20.25
GEHRING CONSTRUCTION & READY	ADA Tiles	CAP. IMP.:SIDEWALK I	\$1,497.60
GRASS ROOTS LAWN CARE	Service	CONTRACT LABOR	\$50.00
JACKSON SERVICES, INC.	Supplies	SUPPLIES: SHOP & SM	\$21.54
JEO CONSULTING GROUP	Service	CONTRACT LABOR	\$57,078.75
JEO CONSULTING GROUP	Service	DRAINAGE (STORM SE	\$15,520.50
RACHEL KAHNK	Reimbursement	MISCELLANEOUS	\$42.67
KOBZA MOTORS	Service	VEHICLE - REPAIR & M	\$5,580.73
LINCOLN NATIONAL LIFE INSURANCE	Employee Life Insurance and LTD Insuranc	GROUP INSURANCE	\$11.72
LINCOLN NATIONAL LIFE INSURANCE	Employee Life Insurance and LTD Insuranc	DISABILITY INSURANC	\$26.55
MICHAEL TODD INDUSTRIAL SUPPLY	Traffic Control Signs	CLOTHING	\$26.16
MICHAEL TODD INDUSTRIAL SUPPLY	Traffic Control Signs	REPAIR & MAINT: EQU	\$607.63
MICHAEL TODD INDUSTRIAL SUPPLY	Traffic Control Signs	TRAFFIC CONTROL: SI	\$1,113.84
MID-AMERICAN RESEARCH CHEMICA	Supplies	REPAIR & MAINT: EQU	\$135.00
MIDWEST SERVICE & SALES CO.	Supplies	REPAIR & MAINT: EQU	\$3,172.40
MURPHY TRACTOR & EQUIPMENT CO	Service	REPAIR & MAINT: EQU	\$10,698.02
NEBRASKA DEPT. OF REVENUE	Sales Tax - September 2025	SALES TAX REMITTAN	\$48.09
NORTHSIDE INC.	Service & Supplies	TIRES & TIRE REPAIR	\$44.80
CLARENCE NOVAK	Reimbursement	MISCELLANEOUS	\$33.39
RON PALENSKY	Tree Removal Reimbursement - Permit # 4	TREE REMOVAL EXPE	\$1,562.50
PETTY CASH	Reimbursement	REPAIR & MAINTENAN	\$10.00
PETTY CASH	Reimbursement	MISCELLANEOUS	\$27.36
TED & CATHY POKORNY	Reimbursement	TREE REMOVAL EXPE	\$996.00
REHMER AUTO PARTS	Supplies & Small Tools, Parts	REPAIR & MAINT: EQU	\$80.84
REHMER AUTO PARTS	Supplies & Small Tools, Parts	MISCELLANEOUS	\$127.94
REHMER AUTO PARTS	Supplies & Small Tools, Parts	SUPPLIES: SHOP & SM	\$10.99
RERUCHA AG AND AUTO SUPPLY	Supplies, Small Tools, Parts	SUPPLIES: SHOP & SM	\$74.40
SACK LUMBER COMPANY	Supplies & Parts	MATERIALS: CONCRET	\$43.96
SCHMID & SONS ENTERPRISES	Service	REPAIR & MAINT: EQU	\$699.57
SCHMID & SONS ENTERPRISES	Service	REPAIR & MAINT: EQU	\$746.66
STAPLES	Supplies	OFFICE SUPPLIES, PO	\$41.99
STEAGER IRRIGATION LLC	Services	CAP. IMP.:SIDEWALK I	\$146.00
SURNALI LLC DBA DIVERSIFIED DRUG	Service	SAFETY EXPENSES	\$55.00
VANDENBERG ELECTRIC & COMMUNI	Service	REPAIR & MAINTENAN	\$1,773.71
VERIZON WIRELESS	Wireless Service	UTILITIES	\$40.01
WASTE CONNECTIONS OF NE	Garbage Service	REPAIR & MAINTENAN	\$66.92
WEX BANK	Fuel	FUEL	<u>\$249.88</u>
Total STREET			\$133,135.33

# Check Approval List - Council

November 12, 2025

Page # 3

<u>Vendor Name</u>	<u>Invoice Description</u>	<u>Account Description</u>	<u>Amount</u>
<b>AIRPORT</b>			
BUTLER PUBLIC POWER DISTRICT	Electric Service - Airport	UTILITIES	\$230.47
CITY OF DAVID CITY	Credit Card Charges	SUBSCRIPTION FEES	\$71.90
DAVID CITY PAYROLL ACCOUNT	Employees Payroll from 9/24/2025 to 10/23	SALARIES & WAGES: F	\$678.64
DAVID CITY PAYROLL ACCOUNT	Employees Payroll from 9/24/2025 to 10/23	SALARIES: OVERTIME	\$10.81
DAVID CITY WATER DEPARTMENT	Services - Water Service	UTILITIES	\$28.50
GRASS ROOTS LAWN CARE	Service	SAFETY EXPENSES	\$750.00
KIRKHAM MICHAEL	Service	CONTRACT LABOR	\$2,675.38
U. S. CELLULAR	Service - Phone and Data Service	UTILITIES	<u>\$68.76</u>
		Total AIRPORT	\$4,514.46
<b>LIBRARY</b>			
AMERICAN EXPRESS	Supplies, Books	OFFICE SUPPLIES, PO	\$223.49
AMERICAN EXPRESS	Supplies, Books	BOOKS, MAGAZINES,	\$833.08
APPLIED CONNECTIVE TECHNOLOGIE	Service	REPAIR & MAINT: EQU	\$89.00
BLACK HILLS ENERGY	Service	UTILITIES	\$52.30
BLACK HILLS ENERGY	Service	UTILITIES	\$52.30
CHARTER COMMUNICATIONS	Digital Phone and Roadrunner	UTILITIES	\$105.00
COAST TO COAST SOLUTIONS	Library Bags	OFFICE SUPPLIES, PO	\$189.32
DAVID CITY PAYROLL ACCOUNT	Employees Payroll from 9/24/2025 to 10/23	SALARIES: PART-TIME	\$9,488.16
DAVID CITY PAYROLL ACCOUNT	401 A Portion	RETIREMENT PLAN	\$318.83
DAVID CITY UTILITIES	VOIP Phone Services	UTILITIES	\$40.00
MICHAEL FREDERICK	Books	BOOKS, MAGAZINES,	\$50.00
HOMETOWN LEASING	Copier Leases	PRINTING & PUBLISHI	\$119.00
MIDWEST TAPE	Advanced Digital Library	BOOKS, MAGAZINES,	\$409.48
PRESTO X COMPANY	Commercial Insect Control	REPAIR & MAINTENAN	\$174.84
WASTE CONNECTIONS OF NE	Garbage Service	REPAIR & MAINTENAN	<u>\$17.09</u>
		Total LIBRARY	\$12,161.89
<b>POLICE DEPARTMENT</b>			
ALLIED BENEFIT SYSTEMS, INC.	Employees Health Insurance	GROUP INSURANCE	\$6,715.47
AMAZON CAPITAL SERVICES	Supplies, Parts, Clothing	CLOTHING	\$29.99
AMAZON CAPITAL SERVICES	Supplies, Parts, Clothing	VEHICLE - REPAIR & M	\$231.65
AMAZON CAPITAL SERVICES	Supplies, Parts, Clothing	SAFETY EXPENSES	\$125.68
AMAZON CAPITAL SERVICES	Supplies, Parts, Clothing	MISCELLANEOUS	\$751.90
AMAZON CAPITAL SERVICES	Supplies, Parts, Clothing	OFFICE SUPPLIES, PO	\$1,162.41
APPLIED CONNECTIVE TECHNOLOGIE	Service	REPAIR & MAINT: OFFI	\$270.71
BEST CARE EMPLOYEE ASSISTANCE	Employee Assistance Program - Annual Fe	SUBSCRIPTION FEES	\$1,501.12
BUTLER COUNTY HEALTH	Service	MISCELLANEOUS SUP	\$95.00
BUTLER COUNTY WELDING	Parts & Small Tools	SAFETY EXPENSES	\$18.90
DAVID CITY ACE HARDWARE	Supplies, Small Tools	VEHICLE - REPAIR & M	\$56.97
DAVID CITY ACE HARDWARE	Supplies, Small Tools	OFFICE SUPPLIES, PO	\$34.98
DAVID CITY ACE HARDWARE	Supplies, Small Tools	OPERATING & TRAIING	\$112.63
DAVID CITY PAYROLL ACCOUNT	Employees Payroll from 9/24/2025 to 10/23	SALARIES & WAGES: F	\$33,012.81
DAVID CITY PAYROLL ACCOUNT	Employees Payroll from 9/24/2025 to 10/23	SALARIES: OVERTIME	\$2,866.96
DAVID CITY PAYROLL ACCOUNT	Employees Payroll from 9/24/2025 to 10/23	SALARIES: PART-TIME	\$1,943.28
DAVID CITY PAYROLL ACCOUNT	401 A Portion	RETIREMENT PLAN	\$1,127.06
DAVID CITY UTILITIES	VOIP Phone Services	UTILITIES	\$48.75
FIRST NATIONAL BANK OF OMAHA	Webhosting, Adobe Subscription, Lodging,	CLOTHING	\$699.07
FIRST NATIONAL BANK OF OMAHA	Webhosting, Adobe Subscription, Lodging,	SUBSCRIPTION FEES	\$89.21
FIRST NATIONAL BANK OF OMAHA	Webhosting, Adobe Subscription, Lodging,	OPERATING & TRAIING	\$1,239.33
GUNSLINGERS LLC	Ammo	SAFETY EXPENSES	\$338.00
HARTMAN AUTO REPAIR	Service & Parts	VEHICLE - REPAIR & M	\$230.35
LINCOLN NATIONAL LIFE INSURANCE	Employee Life Insurance and LTD Insuranc	GROUP INSURANCE	\$17.58
LINCOLN NATIONAL LIFE INSURANCE	Employee Life Insurance and LTD Insuranc	DISABILITY INSURANC	\$44.50
NANCY A. KRENK LLC	Service	CONTRACT LABOR	\$80.00
NEBRASKA PUBLIC HEALTH ENVIRON	Service	MISCELLANEOUS SUP	\$105.00
NORTHSIDE INC.	Service & Supplies	VEHICLE - REPAIR & M	\$21.04
POLICE OFFICERS' ASSN. OF NE	POAN - 2025 Handbooks & Annual Membe	SUBSCRIPTION FEES	\$119.00
POLICE OFFICERS' ASSN. OF NE	POAN - 2025 Handbooks & Annual Membe	SUBSCRIPTION FEES	\$30.00
REHMER AUTO PARTS	Supplies & Small Tools, Parts	VEHICLE - REPAIR & M	\$43.48
SHAFFER COMMUNICATIONS	Service - Radios	RADIO EXPENSES	\$664.29
UNMC	Service	MISCELLANEOUS SUP	\$123.00
VERIZON WIRELESS	Wireless Service	UTILITIES	\$504.37
VILLAGE OF POTTER	Supplies	OFFICE SUPPLIES, PO	\$618.15
WEX BANK	Fuel	FUEL	<u>\$2,114.36</u>
		Total POLICE DEPARTMENT	\$57,187.00

# Check Approval List - Council

November 12, 2025

Page # 4

<u>Vendor Name</u>	<u>Invoice Description</u>	<u>Account Description</u>	<u>Amount</u>
<b>SWIMMING POOL</b>			
BLACK HILLS ENERGY	Service	UTILITIES	\$139.95
BLACK HILLS ENERGY	Service	UTILITIES	\$141.95
BUTLER COUNTY WELDING	Parts & Small Tools	REPAIR & MAINT: EQU	\$6.24
RECREATION SUPPLY COMPANY	Supplies	REPAIR & MAINT - BLD	\$764.18
		<b>Total SWIMMING POOL</b>	<b>\$1,052.32</b>
<b>PARK</b>			
BEST CARE EMPLOYEE ASSISTANCE	Employee Assistance Program - Annual Fe	SUBSCRIPTION FEES	\$375.52
COLUMN SOFTWARE PBC	Publications and Legal Notices	PRINTING & PUBLISHI	\$41.66
DAVID CITY ACE HARDWARE	Supplies, Small Tools	REPAIR & MAINT: EQU	\$25.97
DAVID CITY ACE HARDWARE	Supplies, Small Tools	REPAIR & MAINT - BLD	\$96.15
DAVID CITY PAYROLL ACCOUNT	Employees Payroll from 9/24/2025 to 10/23	SALARIES & WAGES: F	\$10,797.62
DAVID CITY PAYROLL ACCOUNT	Employees Payroll from 9/24/2025 to 10/23	SALARIES: OVERTIME	\$1,111.31
DAVID CITY UTILITIES	VOIP Phone Services	UTILITIES	\$40.25
GEMPLER'S	Glovs, Jacket, Soil Test,	INSURANCE: WORKME	\$149.99
GEMPLER'S	Glovs, Jacket, Soil Test,	REPAIR & MAINT - BLD	\$59.99
GRAINGER	Supplies & Parts	REPAIR & MAINT - BLD	\$410.65
HOLIDAY INN KEARNEY	Lodging - Nathan Styskal, Bill Buntgen	MTGS, SCHOOL, TRAV	\$539.80
RACHEL KAHNK	Reimbursement	MISCELLANEOUS	\$42.66
LINCOLN NATIONAL LIFE INSURANCE	Employee Life Insurance and LTD Insuranc	GROUP INSURANCE	\$7.76
LINCOLN NATIONAL LIFE INSURANCE	Employee Life Insurance and LTD Insuranc	DISABILITY INSURANC	\$17.60
NEBRASKA DEPT. OF REVENUE	Sales Tax - September 2025	SALES TAX REMITTAN	\$5.17
NEBRASKA DEPT. OF REVENUE	Lodging Tax	SALES TAX REMITTAN	\$3.44
CLARENCE NOVAK	Reimbursement	MISCELLANEOUS	\$33.39
REHMER AUTO PARTS	Supplies & Small Tools, Parts	VEHICLE - REPAIR & M	\$16.78
RERUCHA AG AND AUTO SUPPLY	Supplies, Small Tools, Parts	REPAIR & MAINT: EQU	\$53.55
SACK LUMBER COMPANY	Supplies & Parts	REPAIR & MAINT - BLD	\$246.78
STEAGER IRRIGATION LLC	Services	REPAIR & MAINT - BLD	\$275.00
ULINE	Foam Nitrle Gloves	SAFETY EXPENSES	\$93.49
VERIZON WIRELESS	Wireless Service	UTILITIES	\$55.13
WASTE CONNECTIONS OF NE	Garbage Service	REPAIR & MAINT - BLD	\$66.93
WEX BANK	Fuel	FUEL	\$345.08
		<b>Total PARK</b>	<b>\$14,911.67</b>
<b>AUDITORIUM</b>			
ALLIED BENEFIT SYSTEMS, INC.	Employees Health Insurance	GROUP INSURANCE	\$1,497.90
APPLIED CONNECTIVE TECHNOLOGIE	Service	REPAIR & MAINT: EQU	\$102.00
DAVID CITY ACE HARDWARE	Supplies, Small Tools	REPAIR & MAINTENAN	\$28.56
DAVID CITY ELECTRIC DEPT.	Electric Service	UTILITIES	\$461.62
DAVID CITY PAYROLL ACCOUNT	Employees Payroll from 9/24/2025 to 10/23	SALARIES & WAGES: F	\$2,473.70
DAVID CITY PAYROLL ACCOUNT	Employees Payroll from 9/24/2025 to 10/23	SALARIES: OVERTIME	\$1,170.65
DAVID CITY PAYROLL ACCOUNT	Employees Payroll from 9/24/2025 to 10/23	SALARIES: PART-TIME	\$67.50
DAVID CITY PAYROLL ACCOUNT	401 A Portion	RETIREMENT PLAN	\$479.71
DAVID CITY WATER DEPARTMENT	Services - Water Service	UTILITIES	\$236.46
DIDIER'S GROCERY, INC.	Supplies	SUPPLIES FOR RESAL	\$37.35
GEMPLER'S	Glovs, Jacket, Soil Test,	REPAIR & MAINTENAN	\$9.99
GRAINGER	Supplies & Parts	REPAIR & MAINTENAN	\$389.18
JACKSON SERVICES, INC.	Supplies	REPAIR & MAINTENAN	\$57.82
MID-AMERICAN RESEARCH CHEMICA	Supplies	REPAIR & MAINTENAN	\$750.14
PLUNKETTS PEST CONTROL	General Pest Control	REPAIR & MAINTENAN	\$72.22
WASTE CONNECTIONS OF NE	Garbage Service	REPAIR & MAINTENAN	\$66.92
		<b>Total AUDITORIUM</b>	<b>\$7,901.72</b>
<b>RECREATION PROGRAM</b>			
ALLIED BENEFIT SYSTEMS, INC.	Employees Health Insurance	GROUP INSURANCE	\$1,647.66
APPLIED CONNECTIVE TECHNOLOGIE	Service	REPAIR & MAINT: EQU	\$15.13
ARPS	Concrete	REPAIR & MAINT - BLD	\$568.13
BEST CARE EMPLOYEE ASSISTANCE	Employee Assistance Program - Annual Fe	SUBSCRIPTION FEES	\$93.88
COLUMBUS CUSTOM EMBROIDERY	Ball Team Shirts & Hats	CLOTHING	\$396.00
COLUMN SOFTWARE PBC	Publications and Legal Notices	PRINTING & PUBLISHI	\$13.47
DAVID CITY ACE HARDWARE	Supplies, Small Tools	REPAIR & MAINT - BLD	\$29.98
DAVID CITY ACE HARDWARE	Supplies, Small Tools	OFFICE SUPPLIES, PO	\$11.98
DAVID CITY PAYROLL ACCOUNT	Employees Payroll from 9/24/2025 to 10/23	SALARIES & WAGES: F	\$5,168.69
DAVID CITY PAYROLL ACCOUNT	Employees Payroll from 9/24/2025 to 10/23	SALARIES: PART-TIME	\$1,645.09
DAVID CITY PAYROLL ACCOUNT	401 A Portion	RETIREMENT PLAN	\$297.17
DAVID CITY UTILITIES	Utility Bills	UTILITIES	\$479.33
DAVID CITY UTILITIES	Utility Bills	UTILITIES	\$44.51
FIRST NATIONAL BANK OF OMAHA	Webhosting, Adobe Subscription, Lodging,	SMALL EQUIP / VEHICL	\$482.62

# Check Approval List - Council

November 12, 2025

Page # 5

<u>Vendor Name</u>	<u>Invoice Description</u>	<u>Account Description</u>	<u>Amount</u>
<b>RECREATION PROGRAM (Continued)</b>			
LINCOLN NATIONAL LIFE INSURANCE	Employee Life Insurance and LTD Insuranc	GROUP INSURANCE	\$2.93
LINCOLN NATIONAL LIFE INSURANCE	Employee Life Insurance and LTD Insuranc	DISABILITY INSURANC	\$6.65
NEBRASKA DEPT. OF REVENUE	Sales Tax - September 2025	SALES TAX REMITTAN	\$214.32
SACK LUMBER COMPANY	Supplies & Parts	REPAIR & MAINT - BLD	\$61.98
STEAGER LAWN SERVICE	Service	REPAIR & MAINT - BLD	\$331.25
TWEET'S SPORT SHOP	Supplies	REPAIR & MAINT - BLD	\$75.00
WASTE CONNECTIONS OF NE	Garbage Service	REPAIR & MAINTENAN	\$62.05
WEX BANK	Fuel	FUEL	<u>\$219.47</u>
		Total RECREATION PROGRAM	\$11,867.29
<b>RV CAMPGROUND</b>			
COLUMN SOFTWARE PBC	Publications and Legal Notices	PRINTING & PUBLISHI	\$13.46
D-SIGN SHOP	Service - Clean up and reprint charges for C	REPAIR & MAINT - BLD	\$265.00
DAVID CITY ELECTRIC DEPT.	Electric Service	UTILITIES	\$470.00
DAVID CITY PAYROLL ACCOUNT	Employees Payroll from 9/24/2025 to 10/23	SALARIES & WAGES: F	\$142.90
DAVID CITY PAYROLL ACCOUNT	Employees Payroll from 9/24/2025 to 10/23	SALARIES: PART-TIME	\$632.00
NEBRASKA DEPT. OF REVENUE	Sales Tax - September 2025	SALES TAX REMITTAN	\$525.62
NEBRASKA DEPT. OF REVENUE	Lodging Tax	SALES TAX REMITTAN	\$35.79
STEAGER LAWN SERVICE	Service	REPAIR & MAINT - BLD	\$331.25
WASTE CONNECTIONS OF NE	Garbage Service	REPAIR & MAINT - BLD	\$133.85
WEX BANK	Fuel	FUEL	<u>\$72.48</u>
		Total RV CAMPGROUND	\$2,622.35
<b>ELECTRIC PLANT</b>			
BLACK HILLS ENERGY	Natural Gas Service	GENERATING GAS	\$145.95
BLACK HILLS ENERGY	Natural Gas Service	GENERATING GAS	\$135.45
CLEARFLY	VOIP Phone Services	UTILITIES	\$49.75
DAVID CITY ACE HARDWARE	Supplies, Small Tools, Parts	SHOP & SMALL TOOLS	\$213.85
DAVID CITY WATER DEPT.	Water Service	UTILITIES	\$53.75
JACKSON SERVICES, INC.	Wet Mops, Mops, Mats, Shop Towels, Hand	SHOP & SMALL TOOLS	\$59.81
MOTOR-SERVICES HUGO STAMP, INC	Service - Service Engine, Mileage,	CONTRACT LABOR	\$2,728.70
NEBRASKA DEPT. OF REVENUE	Sales and Use Tax	VEHICLES: REPAIR &	\$1.61
PER MAR SECURITY SERVICES	Service - Hosting Access Control, Interactiv	REPAIR & MAINTENAC	\$7,323.43
SACK LUMBER COMPANY	Supplies & Parts	REPAIR & MAINT: EQU	<u>\$526.74</u>
		Total ELECTRIC PLANT	\$11,239.04
<b>SERVICE DEPOSITS</b>			
PAT DINGMAN	Service Deposit Refund	REFUNDS (WHEN MAI	\$162.05
JOSE ERICK	Service Deposit Refund	REFUNDS (WHEN MAI	\$275.50
KAITLYN KING	Service Deposit Refund	REFUNDS (WHEN MAI	\$199.50
NEBRASKA STATE TREASURER	Unclaimed Property - Service Deposit Refu	REFUNDS (WHEN MAI	\$25.86
NEBRASKA STATE TREASURER	Unclaimed Property - Service Deposit Refu	REFUNDS (WHEN MAI	\$200.38
NEBRASKA STATE TREASURER	Unclaimed Property - Service Deposit Refu	REFUNDS (WHEN MAI	\$215.56
NEBRASKA STATE TREASURER	Unclaimed Property - Service Deposit Refu	REFUNDS (WHEN MAI	\$137.96
MADISON O'DELL	Service Deposit Refund	REFUNDS (WHEN MAI	\$202.22
DEANNA POKORNY	Service Deposit Refund	REFUNDS (WHEN MAI	\$5.09
SAMUEL VENEGAS	Service Deposit Refund	REFUNDS (WHEN MAI	<u>\$227.75</u>
		Total SERVICE DEPOSITS	\$1,651.87
<b>ELECTRIC SYSTEM</b>			
ALLIED BENEFIT SYSTEMS INC.	Health Insurance	GROUP INSURANCE	\$5,741.92
AMAZON CAPITAL SERVICES	Supplies	OFFICE SUPPLIES	\$526.76
AMERICAN EXPRESS	Supplies	OFFICE SUPPLIES	\$18.61
APPLIED CONNECTIVE TECHNOLOGIE	Services - IT Maintenance & Subscriptions	REPAIR & MAINTENAC	\$946.37
BEST CARE EMPLOYEE ASSISTANCE	Employee Assistance Program	SUBSCRIPTION FEES	\$751.12
BORDER STATES INDUSTRIES, INC.	Clothing	SAFETY EXPENSES	\$121.48
BRYANT AIR CONDITIONING & HEATIN	Maintenance & Services	REPAIR & MAINT - BLD	\$919.13
BUTLER COUNTY CLINIC	Service	SAFETY EXPENSES	\$40.00
BUTLER PUBLIC POWER DISTRICT	Subtransmission line and transformation ch	POWER PURCHASES:	\$22,700.24
BUTLER PUBLIC POWER DISTRICT	2025 Pole Attachments - 72	LAND LEASES & EASE	\$576.00
CINTAS	First Aid Supplies and Maintenance	SAFETY EXPENSES	\$15.93
CLEARFLY	VOIP Phone Services	UTILITIES	\$211.59
DAVID CITY ACE HARDWARE	Supplies, Small Tools, Parts	REPAIR & MAINTENAC	\$20.39
DAVID CITY PAYROLL ACCOUNT	Employees Payroll from 9/24/2025 to 10/23	SALARIES & WAGES: F	\$48,324.45
DAVID CITY PAYROLL ACCOUNT	Employees Payroll from 9/24/2025 to 10/23	SALARIES: OVERTIME	\$1,157.06
DAVID CITY PAYROLL ACCOUNT	Employees Payroll from 9/24/2025 to 10/23	SALARIES: ADMINIST	\$2,755.29
DAVID CITY PAYROLL ACCOUNT	Employees Payroll from 9/24/2025 to 10/23	SALARIES: CLERICAL	\$11,420.09
DAVID CITY PAYROLL ACCOUNT	Employees Payroll from 9/24/2025 to 10/23	SALARIES: MAYOR, CI	\$775.00

# Check Approval List - Council

November 12, 2025

Page # 6

<u>Vendor Name</u>	<u>Invoice Description</u>	<u>Account Description</u>	<u>Amount</u>
<b>ELECTRIC SYSTEM (Continued)</b>			
DAVID CITY PAYROLL ACCOUNT	401a Portion	RETIREMENT PLAN	\$2,806.15
DAVID CITY PAYROLL ACCOUNT	Employees Payroll from 9/24/2025 to 10/23	GROUP INSURANCE	\$656.25
DAVID CITY PAYROLL ACCOUNT	Employees Payroll from 9/24/2025 to 10/23	SALARIES: INSURANC	\$88.75
DAVID CITY PAYROLL ACCOUNT	Social Security Remittance	SOCIAL SECURITY RE	\$4,729.79
DAVID CITY UTILITIES	Credit Card Charges	SUBSCRIPTION FEES	\$565.96
DUTTON-LAINSON COMPANY	100KVA Padmount	REPAIR & MAINTENAC	\$15,398.30
FRONTIER COOPERATIVE COMPANY	Fuel	VEHICLES: REPAIR &	\$626.59
GENERAL FUND	In Lieu of Tax and Occupation Fees	IN-LIEU-OF-TAX REMIT	\$9,227.81
GENERAL FUND	In Lieu of Tax and Occupation Fees	OCCUPATION FEE TO	\$7,650.21
HARTMAN AUTO REPAIR	Service	VEHICLES: REPAIR &	\$20.00
INTERNATIONAL WORKFORCE SERVI	Training - CDL	DUES, MTGS, MILEAG	\$875.00
JEO CONSULTING GROUP, INC	Service	CONTRACT LABOR	\$4,345.00
LINCOLN NATIONAL LIFE INSURANCE	Employee Life Insurance and LTD Insuranc	GROUP INSURANCE	\$26.37
LINCOLN NATIONAL LIFE INSURANCE	Employee Life Insurance and LTD Insuranc	DISABILITY INSURANC	\$71.38
NANCY A. KRENK LLC	Cleaning Services - October 2025	CONTRACT LABOR	\$770.00
NEBRASKA DEPT. OF REVENUE	Sales and Use Tax	SALES TAX REMITTAN	\$14,846.94
NEBRASKA DEPT. OF REVENUE	Sales and Use Tax	OFFICE SUPPLIES	\$2.40
NEBRASKA DEPT. OF REVENUE	Sales and Use Tax	SHOP & SMALL TOOLS	\$1.48
NEBRASKA PUBLIC POWER DISTRICT	Service for September, 2025	POWER PURCHASES:	\$297,039.60
C.J. NOVAK	Reimbursement	DUES, MTGS, MILEAG	\$33.00
C.J. NOVAK	Reimbursement	MISCELLANEOUS	\$33.39
ONE CALL CONCEPTS, INC.	Locate Requests	SUBSCRIPTION FEES	\$39.65
PER MAR SECURITY SERVICES	Service - Hosting Access Control, Interactiv	CONTRACT LABOR	\$5,914.65
POSTMASTER		OFFICE SUPPLIES	\$183.56
SACK LUMBER COMPANY	Supplies & Parts	SHOP & SMALL TOOLS	\$60.18
DEAN & KELLI STARA	Rebate - Heat Pump	HEAT INCENTIVE EXP	\$1,200.00
STEAGER LAWN SERVICE	Service	CONTRACT LABOR	\$1,000.00
SURNALI LLC DBA DIVERSIFID DRUG	Service - Random Drug Testing - Yoch	SAFETY EXPENSES	\$55.00
T. NOVAK CONSTRUCTION	Service	CAP IMPROVE: LAND &	\$4,978.60
TECHRADIUM, INC.	IRIS Software	SUBSCRIPTION FEES	\$885.00
TIME MANAGEMENT SYSTEMS, INC.	Monthly Software Subscription & Support	SUBSCRIPTION FEES	\$30.34
U.S. POSTAL SERVICE	Postage for postage meter	OFFICE SUPPLIES	\$333.34
VERIZON WIRELESS	Wireless Phone Service	UTILITIES	\$287.08
WASTE CONNECTIONS OF NE	Garbage Service	REPAIR & MAINT - BLD	\$66.93
WESCO DISTRIBUTION	Parts & Supplies	REPAIR & MAINT: EQU	\$499.88
WESCO DISTRIBUTION	Parts & Supplies	SHOP & SMALL TOOLS	\$150.50
WESTERN AREA POWER AGENCY	Electric Service for September, 2025	POWER PURCHASES:	\$13,955.83
WESTERN AREA POWER AGENCY	Electric Service for October 2025	POWER PURCHASES:	\$13,047.99
WEX BANK	Fuel	VEHICLES: REPAIR &	\$147.58
WOODS & AITKEN	Attorney's Fees	ATTORNEYS FEES & L	\$36.50
		<b>Total ELECTRIC SYSTEM</b>	<b>\$499,708.41</b>
<b>WATER SYSTEM</b>			
ALLIED BENEFIT SYSTEMS INC.	Health Insurance	GROUP INSURANCE	\$5,442.28
APPLIED CONNECTIVE TECHNOLOGIE	Services - IT Maintenance & Subscriptions	REPAIR & MAINT: EQU	\$502.86
BEST CARE EMPLOYEE ASSISTANCE	Employee Assistance Program	SUBSCRIPTION FEES	\$375.56
BLACK HILLS ENERGY	Natural Gas Service	UTILITIES	\$75.97
BLACK HILLS ENERGY	Natural Gas Service	UTILITIES	\$124.51
BNSF	Service	CAP. IMP.: ENGINEERI	\$2,416.15
BUTLER COUNTY WELDING	Bolt & Nut	SHOP & SMALL TOOLS	\$2.17
CINTAS	First Aid Supplies and Maintenance	SAFETY EXPENSES	\$161.10
CLEARFLY	VOIP Phone Services	UTILITIES	\$74.34
DALE'S FOOD PRIDE	Supplies	OFFICE SUPPLIES	\$28.41
DAVID CITY ACE HARDWARE	Supplies, Small Tools, Parts	REPAIR & MAINT - BLD	\$77.27
DAVID CITY ACE HARDWARE	Supplies, Small Tools, Parts	MISCELLANEOUS	\$2.78
DAVID CITY ACE HARDWARE	Supplies, Small Tools, Parts	OFFICE SUPPLIES	\$11.89
DAVID CITY ACE HARDWARE	Supplies, Small Tools, Parts	SHOP & SMALL TOOLS	\$488.97
DAVID CITY ACE HARDWARE	Supplies, Small Tools, Parts	PIPES, VALVES, FITTIN	\$75.81
DAVID CITY ELECTRIC DEPT.	Electric Service	UTILITIES	\$13,323.92
DAVID CITY PAYROLL ACCOUNT	Employees Payroll from 9/24/2025 to 10/23	SALARIES & WAGES: F	\$30,285.47
DAVID CITY PAYROLL ACCOUNT	Employees Payroll from 9/24/2025 to 10/23	SALARIES: OVERTIME	\$2,673.65
DAVID CITY PAYROLL ACCOUNT	Employees Payroll from 9/24/2025 to 10/23	SALARIES: ADMINIST	\$1,377.65
DAVID CITY PAYROLL ACCOUNT	Employees Payroll from 9/24/2025 to 10/23	SALARIES: CLERICAL	\$5,386.26
DAVID CITY PAYROLL ACCOUNT	Employees Payroll from 9/24/2025 to 10/23	SALARIES: MAYOR, CI	\$581.25
DAVID CITY PAYROLL ACCOUNT	401a Portion	RETIREMENT PLAN	\$816.84
DAVID CITY PAYROLL ACCOUNT	Social Security Remittance	SOCIAL SECURITY RE	\$2,922.76
DAVID CITY UTILITIES	Credit Card Charges	SUBSCRIPTION FEES	\$565.96

# Check Approval List - Council

November 12, 2025

Page # 7

<u>Vendor Name</u>	<u>Invoice Description</u>	<u>Account Description</u>	<u>Amount</u>
<b>WATER SYSTEM (Continued)</b>			
DWEE - PUBLIC WATER OPERATORS	Water Operator License Renewals	CONTRACT LABOR	\$460.00
GENERAL FUND	In Lieu of Tax and Occupation Fees	OCCUPATION FEE TO	\$3,328.91
GRAINGER	Supplies	SAFETY EXPENSES	\$196.81
HAMPTON INN KEARNEY	Lodging	SALARIES: ADMINIST	\$319.90
HAWKINS, INC.	Chemicals	CHEMICALS	\$33,595.19
JACKSON SERVICES, INC.	Wet Mops, Mops, Mats, Shop Towels, Hand	OFFICE SUPPLIES	\$143.93
JEO CONSULTING GROUP, INC	Service	CAP. IMP.: ENGINEERI	\$5,636.90
KELLY SUPPLY COMPANY	Supplies	PIPES, VALVES, FITTIN	\$271.23
LINCOLN NATIONAL LIFE INSURANCE	Employee Life Insurance and LTD Insuranc	GROUP INSURANCE	\$6.92
LINCOLN NATIONAL LIFE INSURANCE	Employee Life Insurance and LTD Insuranc	DISABILITY INSURANC	\$38.52
LINCOLN WINWATER WORKS	Supplies & Parts	SHOP & SMALL TOOLS	\$380.23
LINCOLN WINWATER WORKS	Supplies & Parts	PIPES, VALVES, FITTIN	\$6,438.37
MID-AMERICAN RESEARCH CHEMICA	Supplies	OFFICE SUPPLIES	\$1,051.35
MID-AMERICAN RESEARCH CHEMICA	Supplies	SHOP & SMALL TOOLS	\$1,223.63
MID-AMERICAN RESEARCH CHEMICA	Supplies	MISCELLANEOUS SUP	\$313.91
MIDWEST LABORATORIES, INC.	supplies for testing	LABORATORY FEES	\$860.60
NEBRASKA DEPT. OF REVENUE	Sales and Use Tax	SAFETY EXPENSES	\$6.40
NEBRASKA DEPT. OF REVENUE	Sales and Use Tax	SALES TAX REMITTAN	\$1,157.64
NEBRASKA PUBLIC HEALTH ENVIRON	Tests	LABORATORY FEES	\$64.00
NEBRASKA RURAL WATER ASSN.	Service - Valve Machine usage & Upkeep	REPAIR & MAINTENAC	\$190.00
NEBTECH CALIBRATION, INC.	Backflow Assembly Test Kits	REPAIR & MAINT: EQU	\$212.62
NORTHSIDE, INC.	Supplies	SHOP & SMALL TOOLS	\$1,287.11
C.J. NOVAK	Reimbursement	MISCELLANEOUS	\$33.38
ONE CALL CONCEPTS, INC.	Locate Requests	SUBSCRIPTION FEES	\$39.65
PER MAR SECURITY SERVICES	Service - Hosting Access Control, Interactiv	SUBSCRIPTION FEES	\$13,571.63
PER MAR SECURITY SERVICES	Service - Hosting Access Control, Interactiv	CAP IMPROVE: LAND &	\$4,503.18
PLUNKETTS PEST CONTROL	Service - Pest Control	REPAIR & MAINT - BLD	\$91.38
POSTMASTER		OFFICE SUPPLIES	\$183.56
RASMUSSEN AIR & GAS ENERGY, INC	Compressor	REPAIR & MAINT: EQU	\$2,010.77
RERUCHA AG & AUTO SUPPLY	Supplies, Small Tools, Parts	VEHICLES: REPAIR &	\$80.85
RERUCHA AG & AUTO SUPPLY	Supplies, Small Tools, Parts	SHOP & SMALL TOOLS	\$139.46
SACK LUMBER COMPANY	Supplies & Parts	MISCELLANEOUS	\$25.79
SACK LUMBER COMPANY	Supplies & Parts	SHOP & SMALL TOOLS	\$261.20
SACK LUMBER COMPANY	Supplies & Parts	PIPES, VALVES, FITTIN	\$26.87
SARGENT DRILLING	Services	REP & MAINT: WELLS	\$86,856.90
SARGENT DRILLING	Services	REP & MAINT: WELLS	\$450.00
ST. PJ SUPPLY INC.	Supplies	SAFETY EXPENSES	\$287.55
STAPLES	Supplies	OFFICE SUPPLIES	\$976.13
STEAGER LAWN SERVICE	Service	REPAIR & MAINT - BLD	\$1,225.00
TEHRADIUM, INC.	IRIS Software	SUBSCRIPTION FEES	\$885.00
TIME MANAGEMENT SYSTEMS, INC.	Monthly Software Subscription & Support	SUBSCRIPTION FEES	\$30.34
U.S. POSTAL SERVICE	Postage for postage meter	OFFICE SUPPLIES	\$333.33
USA BLUE BOOK	Supplies	LAB SUPPLIES	\$1,634.81
VERIZON WIRELESS	Wireless Phone Service	UTILITIES	\$225.45
WASTE CONNECTIONS OF NE	Garbage Service	REPAIR & MAINT - BLD	\$53.51
WEX BANK	Fuel	FUEL, OIL, GAS	\$492.57
WINDSTREAM	Service - Data & Internet	UTILITIES	\$407.81
WINDSTREAM	Service - Data & Internet	UTILITIES	\$638.51
WRIGHT-WAY DRAIN & SEWER	Service	REPAIR & MAINT - BLD	<u>\$300.00</u>
		Total WATER SYSTEM	\$240,724.63
<b>SEWER SYSTEM</b>			
ALLIED BENEFIT SYSTEMS INC.	Health Insurance	GROUP INSURANCE	\$2,621.29
AMAZON CAPITAL SERVICES	Supplies	OFFICE SUPPLIES	\$75.14
APPLIED CONNECTIVE TECHNOLOGIE	Services - IT Maintenance & Subscriptions	REPAIR & MAINT: EQU	\$448.21
BEST CARE EMPLOYEE ASSISTANCE	Employee Assistance Program	SUBSCRIPTION FEES	\$375.56
BRB CONTRACTORS INC	Service - Wastewater Treatment Plant Impr	CAP. IMP.: ENGINEERI	\$279,586.77
CINTAS	First Aid Supplies and Maintenance	SAFETY EXPENSES	\$258.86
CLEARFLY	VOIP Phone Services	UTILITIES	\$40.25
CONCRETE INDUSTRIES	Parts	REPAIR & MAINTENAC	\$802.08
DAVID CITY ELECTRIC DEPT.	Electric Service	UTILITIES	\$5,767.04
DAVID CITY PAYROLL ACCOUNT	Employees Payroll from 9/24/2025 to 10/23	SALARIES & WAGES: F	\$10,265.52
DAVID CITY PAYROLL ACCOUNT	Employees Payroll from 9/24/2025 to 10/23	SALARIES: OVERTIME	\$298.05
DAVID CITY PAYROLL ACCOUNT	Employees Payroll from 9/24/2025 to 10/23	SALARIES: ADMINIST	\$1,377.64
DAVID CITY PAYROLL ACCOUNT	Employees Payroll from 9/24/2025 to 10/23	SALARIES: CLERICAL	\$5,114.30
DAVID CITY PAYROLL ACCOUNT	Employees Payroll from 9/24/2025 to 10/23	SALARIES: MAYOR, CI	\$581.25

# Check Approval List - Council

November 12, 2025

Page # 8

## SEWER SYSTEM (Continued)

DAVID CITY PAYROLL ACCOUNT	401a Portion	RETIREMENT PLAN	\$242.67
DAVID CITY PAYROLL ACCOUNT	Social Security Remittance	SOCIAL SECURITY RE	\$1,268.69
DAVID CITY UTILITIES	Credit Card Charges	SUBSCRIPTION FEES	\$565.97
FIRST NATIONAL BANK OF OMAHA	Supplies	OFFICE SUPPLIES	\$16.05
GENERAL FUND	In Lieu of Tax and Occupation Fees	OCCUPATION FEE TO	\$4,187.09
GPM	Service - Service Call to Wastewater Treatm	REPAIR & MAINTENAC	\$5,211.00
GPM	Service - Service Call to Wastewater Treatm	CAP. IMPROVE - SYST	\$27,040.00
HAMPTON INN KEARNEY	Lodging	SALARIES: ADMINIST	\$319.90
JACKSON SERVICES, INC.	Wet Mops, Mops, Mats, Shop Towels, Hand	OFFICE SUPPLIES	\$43.68
JEO CONSULTING GROUP, INC	Service	CAP. IMP.: ENGINEERI	\$58,942.25
KOBZA MOTORS	Service - Tire Repair, Belt Pulley & Tension	REPAIR & MAINT: EQU	\$239.13
LINCOLN NATIONAL LIFE INSURANCE	Employee Life Insurance and LTD Insuranc	GROUP INSURANCE	\$5.86
LINCOLN NATIONAL LIFE INSURANCE	Employee Life Insurance and LTD Insuranc	DISABILITY INSURANC	\$13.43
LINCOLN WINWATER WORKS	Supplies & Parts	REPAIR & MAINTENAC	\$1,497.06
LINCOLN WINWATER WORKS	Supplies & Parts	LAB SUPPLIES	\$616.00
MID-AMERICAN RESEARCH CHEMICA	Supplies	MISCELLANEOUS SUP	\$2,020.50
MIDWEST LABORATORIES, INC.	supplies for testing	LABORATORY FEES	\$1,108.74
MUNICIPAL PIPE TOOL COMPANY	South Area Sewer Rehabilitation Payment E	CAP. IMP: WWTP IMPR	\$15,059.07
NEBRASKA DEPT. OF REVENUE	Sales and Use Tax	SALES TAX REMITTAN	\$3,669.01
C.J. NOVAK	Reimbursement	MISCELLANEOUS	\$33.38
SACK LUMBER COMPANY	Supplies & Parts	OFFICE SUPPLIES	\$53.96
STEAGER LAWN SERVICE	Service	REPAIR & MAINT - BLD	\$450.00
TIME MANAGEMENT SYSTEMS, INC.	Monthly Software Subscription & Support	SUBSCRIPTION FEES	\$30.32
U.S. POSTAL SERVICE	Postage for postage meter	OFFICE SUPPLIES	\$333.33
VANDENBERG ELECTRIC COMMUNIC	Service	REPAIR & MAINTENAC	\$682.00
VERIZON WIRELESS	Wireless Phone Service	UTILITIES	\$40.02
WASTE CONNECTIONS OF NE	Garbage Service	REPAIR & MAINT - BLD	\$117.80
WEX BANK	Fuel	FUEL, OIL, GAS	\$338.02
WINDSTREAM	Service - Data & Internet	UTILITIES	\$478.85
		<b>Total SEWER SYSTEM</b>	<b>\$432,235.74</b>

**TOTAL CLAIMS ALLOWED      \$1,987,288.80**



<b>Change Order Estimate - Lump Sum Work</b>		
JEO Project Name: <b>Wastewater Treatment Facility Improvements</b>		JEO Project Number: <b>251034.00</b>
Owner: <b>City of David City</b>		Change Order Number: <b>7</b>
Contractor: <b>BRB Contractors, Inc.</b>		Effective Date: <b>November 12, 2025</b>
Item		Change Order Information
Specification Section No.	Description	Scheduled Value
	WCD No. 7 - Headworks and Storage HVAC Modifications	\$62,807.32
	WCD No. 9 – SBR Air Piping Modifications & New Diffusers	\$72,894.55
		\$0.00
		\$0.00
		\$0.00
		\$0.00
		\$0.00
		\$0.00
		\$0.00
		\$0.00
		\$0.00
		\$0.00
		\$0.00
		\$0.00
		\$0.00
<b>Total:</b>		<b>\$135,701.87</b>



# Work Change Directive

**WORK CHANGE DIRECTIVE NO.** | 7

**DATE** | 10/23/2025

**PROJECT** | Wastewater Treatment Facility Improvements

**JEO PROJECT NO.** | 251034.00

**LOCATION** | David City, NE

**OWNER** | City of David City, NE

**CONTRACTOR** | BRB Contractors, Inc.

**You are directed to proceed promptly with the following change(s):**

**Description** The following is a change to the scope of work to provide required HVAC equipment in the Headworks and Storage buildings. The following is a summarized list of the changes:

Headworks Building:

- Upsize MAU-1
- Upsize EF-1
- Remove dampers
- Add 25 kW heater
- Add duct work to the Pump Pit
- Upsize ACU-1

Storage Building:

- Reduce exhaust fan size
- Add an exhaust fan
- Add a CO2 and NO2 detection system
- Add a 25 kW heater

**Purpose of Change Directive** These modifications are outlined in the Wastewater Treatment Facility Improvements Peer Review. See the attachments for details about each recommended modification.

**Attachment(s)** - Appendix Sheets from Wastewater Treatment Facility Improvements Peer Review for the mechanical evaluation in the Headworks, Blower building and Storage building.

- BRB proposal summary
- BRB cost breakdown
- Emails from this discussion

**If claim is made that the above changes have affected Contract Price or Contract Times, any claim for a Change Order based thereon will involve one or more of the following methods of determining the effect of the changes:**

**Method of Determining Change in Contract Price**

- Unit Prices
- Lump Sum
- Other N/A

**Estimated Increase (Decrease) in Contract Price**

\$ 62,807.32

**Method of Determining Change in Contract Times**

- CONTRACTOR's Records
- ENGINEER's Records
- Other N/A

**Estimated Increase (Decrease) in Contract Times**

0 Days

**If the change involves an increase, the estimated amount is not to be exceeded without further authorization.**



## Work Change Directive

**Recommended:**

**Authorized:**

**Accepted:**

\_\_\_\_\_  
**ENGINEER**

\_\_\_\_\_  
**OWNER**

\_\_\_\_\_  
**CONTRACTOR**

\_\_\_\_\_  
**Date**

\_\_\_\_\_  
**Date**

\_\_\_\_\_  
**Date**

cc: Project Manager, Resident Project Representative, Contractor, Owner

**David City Wastewater Treatment Plant****Peer Review and Evaluation****Element Name: Mechanical Evaluation – Headworks Building****STRUCTURE 10 - HEADWORKS BUILDING – SCREEN ROOM 101**

1. It appears the screen room was designed for approximately 10 ACH with a 1600 CFM make-up air unit MAU-1 and 1600 CFM exhaust fan EF-1. In order for the room to be Class 1, Division 2 it requires minimum 12 ACH continuous.
  - a. Recommendation<sup>1</sup>: Change make-up air unit MAU-1 from 1600 CFM to 2200 CFM and exhaust fan EF-1 from 1600 CFM to 2200 CFM to meet the required 12 ACH to be Class 1, Division 2.
2. Control dampers are located in outside air inlets and conditioned outside air discharge of make-up air unit MAU-1. Per Ten State Standards, dampers should not be used on exhaust or fresh air ducts and fine screens or other obstructions should be avoided to prevent clogging.
  - a. Recommendation<sup>1</sup>: Remove dampers from outside air inlet and conditioned outside air discharge of make-up air unit MAU-1.
3. Two 10 KW electric unit heaters are located within the room to cover the envelope load of approximately 21.7 MBH. If make-up air unit MAU-1 were to lose heating capacity and supply fan and/or exhaust fan EF-1 remain operating the room could reach freezing temperatures.
  - a. Recommendation<sup>2</sup>: Add 25 KW of additional heat to the room for a total of 45 KW of electric heat.
4. No fresh air is being supplied to Pump Pit 103 located on north end of Screen Room 101. Per Ten State Standards, fresh air shall be forced into enclosed screening device areas or open pits more than 4 feet deep. Pump Pit 103 is approximately 11'-0" deep.
  - a. Recommendation<sup>1</sup>: Route 8"x8" conditioned outside air duct down in pit and connect to 12"x12" conditioned outside air duct from make-up air unit MAU-1.

**STRUCTURE 10 - HEADWORKS BUILDING – ELECTRICAL ROOM 102**

1. Currently being served with a single Packaged Air Conditioning Unit ACU-1. The room has an electrical heat loss load of approximately 49.9 MBH sensible and an envelope load of approximately 4.8 MBH sensible for a total load of 54.7 MBH sensible.

Packaged Air Conditioning Unit ACU-1 Capacity:

ACU-1 Cooling Capacity = 36.0 Total MBH, 25.0 Sensible MBH

ACU-1 Heating Capacity = 6KW, 20.40 MBH

- a. Recommendation<sup>2</sup>: Provide a Packaged Air Conditioning Unit with the minimum capacities: 55.7 MBH Total / 54.7 MBH Sensible, 6KW, 20.40 MBH Heating

## David City Wastewater Treatment Plant

### Peer Review and Evaluation

#### **Element Name: Mechanical Evaluation – Storage Building**

#### **STRUCTURE 50 - STORAGE BUILDING**

1. Storage building is approximately 2,400 SF, and its ventilation is being provided with a 6400 CFM exhaust fan EF-2 and a 48"x48" Outside air louver. Per code the ventilation rate required is Full on rate of not less than 0.75 CFM per SF with a standby rate of not less than 0.05 CFM per SF. To conserve energy the system is allowed to modulate between full capacity and minimum standby capacity. In addition, this building will store vehicles, therefore, per International Fire Code, this system must operate automatically by the use of CO<sub>2</sub> and NO<sub>2</sub> detection devices.  
Full capacity will require 1,800 CFM (2,400 SF x 0.75 CFM = 1800 CFM)  
Standby rate will require 120 CFM (2,400 SF x 0.05 CFM = 120 CFM)
  - a. Recommendation<sup>1</sup>: Reduce the exhaust fan size from 6400 CFM to 1800 CFM to meet the required ventilation rate of 1,800 CFM at 0.75 CFM per SF. Provide an additional continuous operation exhaust fan sized for 120 CFM to meet the required ventilation rate of 0.05 CFM continuous. It is also required to add a CO<sub>2</sub> and NO<sub>2</sub> detection system capable of covering 2,400 SF.
2. Currently there are two 10 KW electric unit heaters located within the storage building, which provides approximately 34.1 MBH each for a total of 68.2 MBH. The building envelope load is approximately 45.3 MBH. If exhaust fan EF-2 (6400 CFM) were to operate in winter conditions, the two heaters would only be capable of providing a temperature rise of approximately 10°F. If exhaust fan EF-2 is reduced to 1800 CFM then the needed heat capacity would be approximately 29 KW, or 98.9 MBH to provide approximately a 50°F temperature rise. This would keep the building above freezing temperature during winter operation. This load combined with the envelope load would be approximately 144.2 MBH. The current design would not be able to provide sufficient heat to keep the building above freezing during winter.
  - a. Recommendation<sup>2</sup>: Add 25 KW of additional heat with more electric heaters to provide a total of 45 KW of electric heat, or a total of approximately 153.5 MBH. This would provide sufficient heating to the storage building, if the EF-2 is reduced to 1,800 CFM.

10/23/2025



To JEO and the City of David City,

Per WCD #7 dated 7/31/2025, BRB was asked to provide pricing for modifying the HVAC equipment in the headworks and storage buildings on the David City Wastewater Facility Improvements project. Modifications include the following:

- Upsizing the unit heater, fan, and air conditioner
- The existing MAU can still be used, but the motor needs to be upsized to increase the CFM
- Ductwork modifications
- Subcontractor labor
- Coring/modifying the existing blockouts for the new units

Modifying the air conditioning units at the blower building is NOT included in this proposal and will be sent separately. The air conditioning units that were previously purchased (qty 2) will be installed at the headworks building.

Electrical/instrumentation cost modifications to accommodate these HVAC modifications are NOT included as part of this proposal and will instead be sent separately as part of a proposal from the electrician for additional electrical modifications.

The cost of these modifications will be \$62,807.32 and will require an additional eight weeks to reorder parts and install new equipment at the headworks and storage building, to be added from the date of acceptance of this proposal. Updated submittal information showing the new units has been sent with this document. If you have any questions, or would like to discuss this further, please feel free to reach out.

Thank You,

Josh Klug  
Project Manager  
BRB Contractors, Inc  
785-477-3094

*Street Address:*  
4646 NW Fielding Rd  
Topeka, KS 66618

Phone: 785-232-1245



Fax: 785-235-8045

*Mailing Address:*  
PO Box 750940  
Topeka, KS 66675-0940

**David City**  
**JEO**

Cost Proposal: Modifications to the HVAC Units

Date: October 16, 2025

Class of Work	QTY.	Unit	Unit Labor	Labor	Total Labor	Unit Material	Extended Material	Equipment Cost	Sub Contract
Modifications to the HVAC Units	1.00	EA			0.00				51978.00
Additional Coring/Blockout Adjustments	1.00	EA			0.00				4000.00
	1.00	EA			0.00				
	1.00	EA			0.00				
	2.50	EA			0.00				
	3.50	EA			0.00				
	1.00	EA			0.00				
	1.00	EA			0.00				
<b>Sub Totals:</b>					\$0.00		\$0.00	\$0.00	\$55,978.00

<b>Material Sub-Total</b>		\$0.00
<b>Labor Sub-Total</b>		\$0.00
<b>Subcontractor-Total</b>		\$55,978.00
<b>Equipment Sub-Total</b>		\$0.00
<b>Sub-Total</b>		\$55,978.00
<b>Sub-Total Without Sub</b>		\$0.00
<b>Contractor's Fee</b>	15.00%	\$0.00
<b>Sub-Contractors Fee</b>	10.00%	\$5,597.80
<b>Sub-Total</b>		\$61,575.80
<b>Insurance and Bond</b>	2.00%	\$1,231.52
<b>Total</b>		\$62,807.32



---

**Fw: Fw: David City WWTP HVAC Submittal Information**

---

**From** Josh Klug <JoshKlug@brbcontractors.com>

**Date** Thu 10/23/2025 8:19 AM

**To** Josh Klug <JoshKlug@brbcontractors.com>

---

**From:** jerrod wasson <eventempks@gmail.com>

**Sent:** Wednesday, October 22, 2025 4:58 PM

**To:** Josh Klug <JoshKlug@brbcontractors.com>

**Subject:** Re: Fw: David City WWTP HVAC Submittal Information

\$51,978 without the acs

On Wed, Oct 22, 2025, 4:52 PM Josh Klug <[JoshKlug@brbcontractors.com](mailto:JoshKlug@brbcontractors.com)> wrote:

Jerrod,

See below. I forgot about this when you called earlier. In short, the city wants us to break out the AC Units at the blower building from this change order so that they can give the green light on everything else. Can you update your proposal to separate out that cost?

Thanks,

Josh Klug  
Project Manager



BRB Contractors

[4646 NW Fielding Rd](#)

PO Box 750940

Topeka, KS 66675

Phone: 785-290-1116

Cell: 785-477-3094

# ESTIMATE

## Even Temp LLC

748 N 100 Road  
BALDWIN CITY, KS 66006  
**(785) 218-2503**

**ORIGINAL QUOTE FOR  
REFERENCE ONLY: INCLUDES  
UNAPPROVED AC UNITS AT  
BLOWER BUILDING.**

BRB Contractors  
4646 NW Fielding Road  
Topeka, KS 66618

Estimate #: 94  
Date: 8/28/2025  
Expires On: 9/28/2025

DESCRIPTION	QUANTITY	PRICE	AMOUNT
Change order	1.00	\$81,978.00	<del>\$81,978.00</del>

Change order based on re submittals

### Project Description

The price includes installation and freight.  
price also includes any duct size increases  
duct sizing will need to be redrawn to handle  
the CFM increase price includes ~~two five time~~  
~~ACS for the blower building~~

**SUBTOTAL:** ~~\$81,978.00~~

**SALES TAX:** \$0.00

### Notes

Exclusions are concrete concrete sawing or  
boring and wiring in high voltage

**TOTAL:** ~~\$81,978.00~~



# Work Change Directive

**WORK CHANGE DIRECTIVE NO.** | 9  
**DATE** | 10/22/2025  
**PROJECT** | Wastewater Treatment Facility Improvements  
**JEO PROJECT NO.** | 251034.00  
**LOCATION** | David City, NE  
**OWNER** | City of David City, NE  
**CONTRACTOR** | BRB Contractors, Inc.

**You are directed to proceed promptly with the following change(s):**

**Description** The following is a change to the scope of work to modify the SBR air piping to add two air diffusers to each existing and new SBR basins. This change includes modifying the existing SBR air piping above grade to install the necessary fittings and piping to install eight (8) new diffusers in four (4) basins.

**Purpose of Change Directive** This change is to meet the recommendation from Aqua-Aerobic Systems during the submittal process and their design proposal.

**Attachment(s)** Figure - Proposed Air Piping Modifications  
- BRB Proposal  
- BRB Cost Breakdown

**If claim is made that the above changes have affected Contract Price or Contract Times, any claim for a Change Order based thereon will involve one or more of the following methods of determining the effect of the changes:**

**Method of Determining Change in Contract Price**  
 Unit Prices  
 Lump Sum  
 Other N/A

**Method of Determining Change in Contract Times**  
 CONTRACTOR's Records  
 ENGINEER's Records  
 Other N/A

**Estimated Increase (Decrease) in Contract Price**  
 \$ 72,894.55

**Estimated Increase (Decrease) in Contract Times**  
4 Days

**If the change involves an increase, the estimated amount is not to be exceeded without further authorization.**

**Recommended:**

**Authorized:**

**Accepted:**

\_\_\_\_\_  
**ENGINEER**

\_\_\_\_\_  
**OWNER**

\_\_\_\_\_  
**CONTRACTOR**

\_\_\_\_\_  
**Date**

\_\_\_\_\_  
**Date**

\_\_\_\_\_  
**Date**

cc: Project Manager, Resident Project Representative, Contractor, Owner

# SBR TANKS - ABOVE GRADE AIR PIPING MODIFICATIONS FOR ADDITIONAL DIFFUSERS

CONTRACTOR TO FIELD VERIFY FITTINGS AND PIPING REQUIRED TO ADD TWO NEW DIFFUSER ASSEMBLIES TO EACH BASIN. THE FITTINGS AND PIPING SHOWN MAY NOT ACCOUNT FOR WHAT'S NECESSARY TO ADD THE DIFFUSERS.

CONTRACTOR TO TRY TO ADD TWO NEW DIFFUSER ASSEMBLIES WITHOUT ADJUSTING THE LOCATION OF EXISTING DIFFUSERS. THE LOCATIONS SHOWN OF PROPOSED TWO NEW DIFFUSERS ARE APPROXIMATE. CONTRACTOR TO COORDINATE LOCATION WITH FIELD ENGINEER.

Remove existing 6" 90 and install 6" tee with 6" piping and two 6" 90's.

Remove existing 6" 90 and install 6" tee with 6" piping and two 6" 90's.

Remove existing 6" 90 and install 6" tee with 6" piping and two 6" 90's.

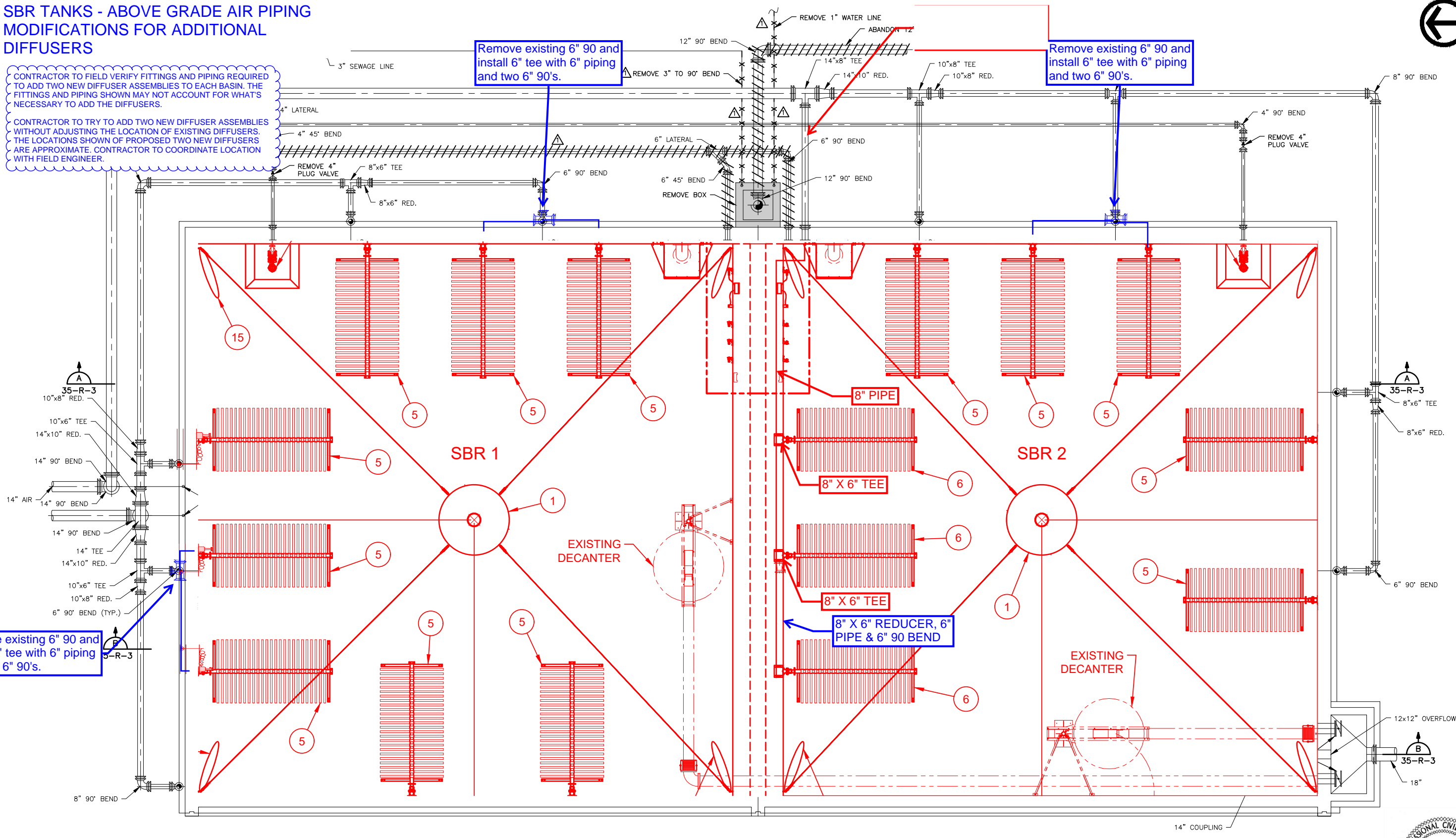

PIPING PLAN © 1613.40  
SCALE: 3/16" = 1'-0"

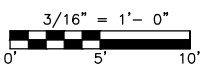

X-REFS: XSBRL100 & XSBRL101 & XSBRS  
 FILE PATH: \\VK-FS-WMSHARE\0600\0647-DAVID\_CITY\_NE\0647-0005\_WWTP\_IMP  
 S:\CADD\_PRODDRAWINGS\35\35-R REV 1  
 PLOTTED: Wednesday, November 29, 2023 12:22:13 PM

DATE	REVISIONS	SCALE	AS NOTED
11/29/2023	PER ADDENDUM 2	DRAWN	BSS
		CHECKED	MJS
		APPROVED	HRV
		DATE	11/3/2023
		ISSUED FOR	BIDDING



WASTEWATER TREATMENT PLANT IMPROVEMENTS  
DAVID CITY, NEBRASKA

3000 Westown Parkway • West Des Moines, Iowa 50266-1320  
515-225-8000 • 515-255-7848(FAX) • 800-241-8000(WATS)

EXISTING SBR PROCESS TANKS  
REMOVAL PLAN

DWG. NO.
35-R-1
75 OF 139
PROJECT 6475



10/16/2025

To JEO and the City of David City,

Per RFI #1 and RFI #37, there needs to be eight diffusers in each SBR basin instead of the six shown on the contract drawings. This affects several items:

- Additional air pipe beyond what was shown on the contract drawings will be needed to account for the eight additional diffusers.
- The existing buried piping at SBR #1 and #2 will need to be dug up and modified per JEO's updated drawing (attached).

The additional work will take an additional four days and the cost will be \$72,894.55. A breakdown of costs and proposed drawing is provided. If there are any questions about this proposal, feel free to reach out.

Thanks,

*Josh Klug*

Project Manager  
BRB Contractors, Inc  
785-477-3094

**Street Address:**  
4646 NW Fielding Rd  
Topeka, KS 66618

**Phone: 785-232-1245**



**Fax: 785-235-8045**

**Mailing Address:**  
PO Box 750940  
Topeka, KS 66675-0940

**David City**  
**JEO**

Cost Proposal: Modifications to the SBR diffuser pipe

Date: October 16, 2025

Class of Work	QTY.	Unit	Unit Labor	Labor	Total Labor	Unit Material	Extended Material	Equipment Cost	Sub Contract
Additional Pipe at Both SBR Basins	1.50	WK	130.00	160.00	20800.00		30843.69	3500.00	
Supervision	2.00	WK	175.00	40.00	7000.00				
	1.00	EA			0.00				
	2.50	EA			0.00				
	3.50	EA			0.00				
	1.00	EA			0.00				
	1.00	EA			0.00				
<b>Sub Totals:</b>					<b>\$27,800.00</b>		<b>\$30,843.69</b>	<b>\$3,500.00</b>	<b>\$0.00</b>

<b>Material Sub-Total</b>		\$30,843.69
<b>Labor Sub-Total</b>		\$27,800.00
<b>Subcontractor-Total</b>		\$0.00
<b>Equipment Sub-Total</b>		\$3,500.00
<b>Sub-Total</b>		\$62,143.69
<b>Sub-Total Without Sub</b>		\$62,143.69
<b>Contractor's Fee</b>	15.00%	\$9,321.55
<b>Sub-Contractors Fee</b>	10.00%	\$0.00
<b>Sub-Total</b>		\$71,465.24
<b>Insurance and Bond</b>	2.00%	\$1,429.30
<b>Total</b>		\$72,894.55

Four man crew for an additional 4 days for pipe  
Additional rock where digging around new SBR



**FERGUSON WATERWORKS #2923**  
 1251 N CENTURY AVE  
 KANSAS CITY, MO 64120-2923

Phone: 816-627-2706  
 Fax: 816-920-5723

<b>Deliver To:</b> .
<b>From:</b> Taylor Grover taylor.grover@ferguson.com
<b>Comments:</b>

14:58:16 OCT 15 2025

**FERGUSON WATERWORKS #2923**  
 Price Quotation  
 Phone: 816-627-2706  
 Fax: 816-920-5723

**Bid No:** B444241  
**Bid Date:** 10/14/25  
**Quoted By:** TXG

**Cust Phone:** 785-290-1128  
**Terms:** NET 10TH PROX

**Customer:** BRB CONTRACTORS INC  
 3805 NW 25TH ST  
 DAVID CITY WWTP IMPROVEME  
 (PLANT DIVISION)  
 TOPEKA, KS 66618

**Ship To:** BRB CONTRACTORS INC  
 3461 M RD  
 DAVID CITY WWTP IMPROVEMEN  
 .  
 DAVID CITY, NE 68632

**Cust PO#:** DIFT, DIFB, REST BID

**Job Name:**

Item	Description	Quantity	Net Price	UM	Total
DFTU	DOM 6 DI 125# C110 FLG TEE CUST ITEM: DFTU SEQ #: 820 6" FLG DI TEE C110 UNLINED/PRIMED ----	3	618.819	EA	1856.46
DFTXU	DOM 8X6 DI 125# C110 FLG TEE CUST ITEM: DFTXU SEQ #: 821 8" X 6" FLG DI TEE, C110 UNLINED / PRIMED ----	2	1266.088	EA	2532.18
DF9U	DOM 6 DI 125# C110 FLG 90 BEND CUST ITEM: DF9U SEQ #: 822 6" FLG DI 90 BEND C110 UNLINED / PRIMED ----	6	359.956	EA	<del>2879.65</del> <b>\$2,159.74</b>
DF9UM	DOM 6X3 DI 125# C110 FLG 90 BEND CUST ITEM: DF9UM SEQ #: 823 6" X 3" FLG DI C110 90 BEND UNLINED/PRIMED ----	8	358.026	EA	2864.21
DI350JJPX	8 DI CL350 TYTON JT PIPE CUST ITEM: DI350JJPX SEQ #: 824 8" TYTON X PE 350 SEAL COAT / SEAL COAT ----	18	41.724	FT	751.03
DI350TJPU	6 DI CL350 / CL50 TYTON JT PIPE CUST ITEM: DI350TJPU SEQ #: 825 6" TYTON X PE 350 SEAL COAT / SEAL COAT ----	54	31.693	FT	<del>4140.95</del> <b>\$1,711.42</b>



**HOW ARE WE DOING? WE WANT YOUR FEEDBACK!**

Scan the QR code or use the link below to  
 complete a survey about your bids:

<https://survey.medallia.com/?bidsorder&fc=2923&on=36419>



FERGUSON WATERWORKS #2923  
Price Quotation

Fax: 816-920-5723

14:58:16 OCT 15 2025

Reference No: B444241

Item	Description	Quantity	Net Price	UM	Total
SP-6DIPFABSPPOOL	6 DIP FAB SPL - DESCRIPTION BELOW CUST ITEM: SP-6DIPFABSPPOOL SEQ #: 826 6" X 12'-0" FLG X PE DI PIPE - CL53 SC / TN140-1211 RED ----	3	1271.719	EA	3815.16
DMJ9LAU	DOM 6 MJ C153 90 BEND L/A CUST ITEM: DMJ9LAU SEQ #: 827 6" MJ DI 90 BEND C153 / BIT COAT ----	3	188.188	EA	564.56
DMJTLAXU	DOM 8X6 MJ C153 TEE L/A CUST ITEM: DMJTLAXU SEQ #: 828 8" X 6" MJ TEE C153 / BIT COAT ----	3	337.755	EA	1013.27
DMJBGPU	DOM 6 MJ BLT & GSKT PK L/ GLAND CUST ITEM: DMJBGPU SEQ #: 829 6" MJ ACC PACK C153 6 ----	9	32.251	EA	290.26
IMJGPX	8 MJ GLAND PK ACCY KIT C153 CUST ITEM: IMJGPX SEQ #: 830 8" MJ ACC PACK C153 6 ----	3	37.778	EA	113.33
SP-8DIPFABSPPOOL	8 DIP FAB SPL - DESCRIPTION BELOW CUST ITEM: SP-8DIPFABSPPOOL SEQ #: 831 8" X 11'6" FLG X FLG CL53 UNLINED / TN-N140-1211 RED ----	2	2329.926	EA	4659.85
SP-6DIPFABSPPOOL	6 DIP FAB SPL - DESCRIPTION BELOW CUST ITEM: SP-6DIPFABSPPOOL SEQ #: 832 6" X 6'0" FLG X FLG CL53 UNLINED / TN-N140-1211 RED ----	6	1086.143	EA	6516.86
SP-6DIPFABSPPOOL	6 DIP FAB SPL - DESCRIPTION BELOW CUST ITEM: SP-6DIPFABSPPOOL SEQ #: 833 6" X 4'0" FLG X FLG CL53 UNLINED / TN-N140-1211 RED ----	2	922.960	EA	1845.92

**Net Total:** ~~\$30843.69~~  
**Tax:** \$0.00  
**Freight:** \$0.00  
**Total:** ~~\$30843.69~~

**\$30,694.25**



**HOW ARE WE DOING? WE WANT YOUR FEEDBACK!**

Scan the QR code or use the link below to complete a survey about your bids:

<https://survey.medallia.com/?bidsorder&fc=2923&on=36419>



FERGUSON WATERWORKS #2923  
Price Quotation

Fax: 816-920-5723

14:58:16 OCT 15 2025

**Reference No:** B444241

Quoted prices are based upon receipt of the total quantity for immediate shipment (48 hours). SHIPMENTS BEYOND 48 HOURS SHALL BE AT THE PRICE IN EFFECT AT TIME OF SHIPMENT UNLESS NOTED OTHERWISE. QUOTES FOR PRODUCTS SHIPPED FOR RESALE ARE NOT FIRM UNLESS NOTED OTHERWISE.

Due to the uncertain impact of potential tariffs, Ferguson's quotation/proposal has not included any provision or contingency for future tariffs or increase of existing tariffs. Ferguson reserves the right to adjust prices to reflect the impact of any new or increased tariffs that affect our costs at the time of shipment. Ferguson will provide notice of any such adjustments along with documentation supporting the changes.

CONTRACTOR CUSTOMERS: IF YOU HAVE DBE/MBE/WBE//VBE/SDVBE/SBE GOOD FAITH EFFORTS DIVERSITY GOALS/ REQUIREMENTS ON A FEDERAL, STATE, LOCAL GOVERNMENT, PRIVATE SECTOR PROJECT, PLEASE CONTACT YOUR BRANCH SALES REPRESENTATIVE IMMEDIATELY PRIOR TO RECEIVING A QUOTE/ORDER.

Seller not responsible for delays, lack of product or increase of pricing due to causes beyond our control, and/or based upon Local, State and Federal laws governing type of products that can be sold or put into commerce. This Quote is offered contingent upon the Buyer's acceptance of Seller's terms and conditions, which are incorporated by reference and found either following this document, or on the web at <https://www.ferguson.com/content/website-info/terms-of-sale>  
Govt Buyers: All items are open market unless noted otherwise.

LEAD LAW WARNING: It is illegal to install products that are not "lead free" in accordance with US Federal or other applicable law in potable water systems anticipated for human consumption. Products with \*NP in the description are NOT lead free and can only be installed in non-potable applications. Buyer is solely responsible for product selection.



**HOW ARE WE DOING? WE WANT YOUR FEEDBACK!**

Scan the QR code or use the link below to  
complete a survey about your bids:

<https://survey.medallia.com/?bidsorder&fc=2923&on=36419>

**Contractor's Application for Payment**

<b>Owner:</b> <u>City of David City</u>	<b>Owner's Project No.:</b> _____
<b>Engineer:</b> <u>JEO Consulting Group, Inc.</u>	<b>Engineer's Project No.:</b> <u>251034.00</u>
<b>Contractor:</b> <u>BRB Contractors, Inc.</u>	<b>Contractor's Project No.:</b> <u>NE3DAV</u>
<b>Project:</b> <u>David City Wastewater Treatment Facility Improvements</u>	
<b>Contract:</b> <u>David City Wastewater Treatment Facility Improvements</u>	
<b>Application No.:</b> <u>20</u>	<b>Application Date:</b> <u>11/7/2025</u>
<b>Application Period:</b> <b>From</b> <u>9/24/2025</u> <b>to</b> <u>10/21/2025</u>	

1. Original Contract Price	\$ 16,882,000.00
2. Net change by Change Orders	\$ 601,474.50
3. Current Contract Price (Line 1 + Line 2)	\$ 17,483,474.50
4. Total Work completed and materials stored to date (Sum of Column G Lump Sum Total and Column J Unit Price Total)	\$ 15,049,347.41
5. Retainage	
a. <u>5%</u> X <u>\$ 12,010,989.15</u> Work Completed =	\$ 600,549.46
b. <u>5%</u> X <u>\$ 3,038,358.26</u> Stored Materials =	\$ 151,917.91
c. Total Retainage (Line 5.a + Line 5.b)	\$ 752,467.37
6. Amount eligible to date (Line 4 - Line 5.c)	\$ 14,296,880.04
7. Less previous payments (Line 6 from prior application)	\$ 14,017,293.27
8. Amount due this application	\$ 279,586.77
9. Balance to finish, including retainage (Line 3 - Line 4 + Line 5.c)	\$ 3,186,594.46

**Contractor's Certification**

The undersigned Contractor certifies, to the best of its knowledge, the following:

(1) All previous progress payments received from Owner on account of Work done under the Contract have been applied on account to discharge Contractor's legitimate obligations incurred in connection with the Work covered by prior Applications for Payment;

(2) Title to all Work, materials and equipment incorporated in said Work, or otherwise listed in or covered by this Application for Payment, will pass to Owner at time of payment free and clear of all liens, security interests, and encumbrances (except such as are covered by a bond acceptable to Owner indemnifying Owner against any such liens, security interest, or encumbrances); and

(3) All the Work covered by this Application for Payment is in accordance with the Contract Documents and is not defective.

**Contractor:** BRB Contractors, Inc.

**Signature:**  **Date:** 11/7/2025

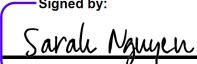
<b>Recommended by Engineer</b>	<b>Approved by Owner</b>
<b>By:</b> <u></u>	<b>By:</b> _____
<b>Title:</b> <u>Project Engineer</u>	<b>Title:</b> <u>Mayor</u>
<b>Date:</b> <u>11/7/2025</u>	<b>Date:</b> _____
<b>Approved by Funding Agency</b>	
<b>By:</b> <u>N/A</u>	<b>By:</b> <u>N/A</u>
<b>Title:</b> _____	<b>Title:</b> _____
<b>Date:</b> _____	<b>Date:</b> _____

**Progress Estimate - Lump Sum Work**

**Contractor's Application for Payment**

<b>Owner:</b>	City of David City	<b>Owner's Project No.:</b>	
<b>Engineer:</b>	JEO Consulting Group, Inc.	<b>Engineer's Project No.:</b>	251034.00
<b>Contractor:</b>	BRB Contractors, Inc.	<b>Contractor's Project No.:</b>	NE3DAV
<b>Project:</b>	David City Wastewater Treatment Facility Improvements		
<b>Contract:</b>	David City Wastewater Treatment Facility Improvements		

<b>Application No.:</b>	20	<b>Application Period:</b>	<b>From</b>	09/24/25	<b>to</b>	10/21/25	<b>Application Date:</b>	11/07/25
-------------------------	----	----------------------------	-------------	----------	-----------	----------	--------------------------	----------

A	B	C	D		E	F	G	H	I
Item No.	Description	Scheduled Value (\$)	Work Completed		Currently Stored (not in D or E) (\$)	Work Completed and Materials Stored to Date (D + E + F) (\$)	% of Scheduled Value (G / C) (%)	Balance to Finish (C - G) (\$)	
			(D + E) From Previous Application (\$)	This Period (\$)					

**Original Contract**

<b>GENERAL SITEWORK</b>									
						-			-
1	Mobilize	\$ 750,000.00	750,000.00			750,000.00	100%	-	
2	Bonds and Insurance	\$ 180,000.00	180,000.00			180,000.00	100%	-	
3	SWPP Items	\$ 25,000.00	23,200.00			23,200.00	93%	1,800.00	
4	Site Clearing	\$ 30,000.00	30,000.00			30,000.00	100%	-	
5	12" & 16" Forcemain Piping	\$ 300,000.00	214,557.08		63,893.68	278,450.76	93%	21,549.24	
6	Other Piping/Valves	\$ 1,395,000.00	413,000.00	160,000.00	574,291.45	1,147,291.45	82%	247,708.55	
7	Precast Manholes	\$ 65,000.00	60,000.00			60,000.00	92%	5,000.00	
8	Instrumentation & Control	\$ 50,000.00	15,000.00		15,096.14	30,096.14	60%	19,903.86	
9	Electrical/Generator Work	\$ 125,000.00	112,500.00			112,500.00	90%	12,500.00	
<b>HEADWORKS BUILDING</b>									
						-		-	
10	Excavation & Backfill	\$ 150,000.00	120,000.00			120,000.00	80%	30,000.00	
11	Concrete Base Structure	\$ 500,000.00	500,000.00			500,000.00	100%	-	
12	Concrete Walls Structure	\$ 1,207,000.00	1,160,000.00	47,000.00		1,207,000.00	100%	-	
13	Concrete Floor/Deck Structure	\$ 350,000.00	320,000.00			320,000.00	91%	30,000.00	
14	Misc. Metals Furnish/Install	\$ 50,000.00			38,975.00	38,975.00	78%	11,025.00	
15	Masonry Above Structure	\$ 225,000.00	225,000.00			225,000.00	100%	-	
16	Doors & Windows Furnish/Install	\$ 65,000.00		40,000.00		40,000.00	62%	25,000.00	
17	Roof Trusses Furnish/Install	\$ 45,000.00	45,000.00			45,000.00	100%	-	
18	Standing Seam Roof & Specialties	\$ 100,000.00	80,000.00			80,000.00	80%	20,000.00	
19	Slide Gates Furnish/Install	\$ 100,000.00	92,000.00			92,000.00	92%	8,000.00	
20	Bar Screen Furnish/Install	\$ 200,000.00	185,000.00			185,000.00	93%	15,000.00	
21	Grit Equipment, Valves, Flumes Furnish/Install	\$ 1,300,000.00	250,000.00	80,000.00	592,260.22	922,260.22	71%	377,739.78	
22	Parshall Flume	\$ 10,000.00				-	0%	10,000.00	
23	Indoor Sampler	\$ 20,000.00				-	0%	20,000.00	
24	Painting Structure	\$ 40,000.00				-	0%	40,000.00	
25	Instrumentation & Control Work	\$ 950,000.00	538,253.00		245,490.40	783,743.40	82%	166,256.60	
26	Mechanical Work (both buildings)	\$ 270,000.00	25,000.00		16,920.00	41,920.00	16%	228,080.00	
27	Electrical Work	\$ 700,000.00	364,500.00	40,000.00	85,762.85	490,262.85	70%	209,737.15	
<b>AGP FLUME NO. 20</b>									
						-		-	
28	Excavation & Backfill	\$ 15,000.00	13,000.00			13,000.00	87%	2,000.00	
29	Concrete Base	\$ 20,000.00	20,000.00			20,000.00	100%	-	
30	Concrete Walls	\$ 42,000.00	42,000.00			42,000.00	100%	-	

**Progress Estimate - Lump Sum Work**

**Contractor's Application for Payment**

<b>Owner:</b>	City of David City	<b>Owner's Project No.:</b>	
<b>Engineer:</b>	JEO Consulting Group, Inc.	<b>Engineer's Project No.:</b>	251034.00
<b>Contractor:</b>	BRB Contractors, Inc.	<b>Contractor's Project No.:</b>	NE3DAV
<b>Project:</b>	David City Wastewater Treatment Facility Improvements		
<b>Contract:</b>	David City Wastewater Treatment Facility Improvements		

<b>Application No.:</b>	20	<b>Application Period:</b>	<b>From</b>	09/24/25	<b>to</b>	10/21/25	<b>Application Date:</b>	11/07/25
-------------------------	----	----------------------------	-------------	----------	-----------	----------	--------------------------	----------

A	B	C	D	E	F	G	H	I
Item No.	Description	Scheduled Value (\$)	Work Completed		Currently Stored (not in D or E) (\$)	Work Completed and Materials Stored to Date (D + E + F) (\$)	% of Scheduled Value (G / C) (%)	Balance to Finish (C - G) (\$)
			(D + E) From Previous Application (\$)	This Period (\$)				
31	Misc. Metals Furnish/Install	\$ 10,000.00	8,500.00			8,500.00	85%	1,500.00
32	Equipment Flume Install	\$ 15,000.00	15,000.00			15,000.00	100%	-
	<b>INFLUENT PUMP STATION</b>					-		-
33	Excavation & Backfill	\$ 160,000.00	150,000.00			150,000.00	94%	10,000.00
34	Concrete Base	\$ 50,000.00	50,000.00			50,000.00	100%	-
35	Concrete Walls	\$ 327,000.00	327,000.00			327,000.00	100%	-
36	Concrete Roof	\$ 100,000.00	100,000.00			100,000.00	100%	-
37	Misc. Metals Funish/Install	\$ 50,000.00	50,000.00			50,000.00	100%	-
38	Furnish & Install Pumps	\$ 525,000.00	498,750.00			498,750.00	95%	26,250.00
39	Furnish & Install Jib Crane & Foundation	\$ 50,000.00			34,860.00	34,860.00	70%	15,140.00
40	Painting Work	\$ 35,000.00	20,000.00			20,000.00	57%	15,000.00
41	Electrical Work	\$ 50,000.00	9,000.00	5,000.00	6,633.43	20,633.43	41%	29,366.57
	<b>NEW SBR STRUCTURE</b>					-		-
42	Excavation & Backfill	\$ 350,000.00	260,000.00	45,000.00		305,000.00	87%	45,000.00
43	SBR Concrete Base Sections	\$ 520,000.00	520,000.00			520,000.00	100%	-
44	SBR Concrete Wall Sections	\$ 1,261,000.00	1,213,000.00	35,000.00		1,248,000.00	99%	13,000.00
45	SBR Basin Equipment Aeration	\$ 1,000,000.00	914,060.50	20,000.00		934,060.50	93%	65,939.50
46	SBR Basin Equipment Pumps	\$ 50,000.00	40,000.00	5,000.00		45,000.00	90%	5,000.00
47	Misc. Metals Furnish/Install	\$ 40,000.00			31,625.00	31,625.00	79%	8,375.00
48	Painting Work	\$ 15,000.00	15,000.00			15,000.00	100%	-
49	Electrical Work	\$ 50,000.00	30,795.00		5,000.00	35,795.00	72%	14,205.00
	<b>BLOWER BUILDING MODIFICATIONS</b>					-		-
50	Concrete Floor/Wall Demolition	\$ 15,000.00	10,000.00	4,000.00		14,000.00	93%	1,000.00
51	Excavation & Backfill	\$ 15,000.00	5,000.00	5,000.00		10,000.00	67%	5,000.00
52	New Concrete Floor and Blower Bases	\$ 35,000.00	20,000.00		4,203.29	24,203.29	69%	10,796.71
53	New Masonry Wall/Misc. Infill	\$ 7,500.00	7,500.00			7,500.00	100%	-
54	Furnish & Install Doors	\$ 7,500.00		7,500.00		7,500.00	100%	-
55	Funish & Install New/Existing SBR Blowers	\$ 400,000.00	150,000.00		225,103.16	375,103.16	94%	24,896.84
56	Painting Work	\$ 20,000.00	15,000.00			15,000.00	75%	5,000.00
57	Instrumentation & Control Work	\$ 150,000.00	26,000.00		114,060.50	140,060.50	93%	9,939.50
58	Electrical Work	\$ 100,000.00	78,625.00		9,681.02	88,306.02	88%	11,693.98
	<b>EXISTING SBR BASIN MODIFICATIONS</b>					-		-
59	Remove Existing Equipment & Piping	\$ 50,000.00				-	0%	50,000.00
60	Existing SBR Basin Equipment Aeration	\$ 1,000,000.00	5,000.00		882,316.62	887,316.62	89%	112,683.38

**Progress Estimate - Lump Sum Work**

**Contractor's Application for Payment**

<b>Owner:</b>	City of David City	<b>Owner's Project No.:</b>	
<b>Engineer:</b>	JEO Consulting Group, Inc.	<b>Engineer's Project No.:</b>	251034.00
<b>Contractor:</b>	BRB Contractors, Inc.	<b>Contractor's Project No.:</b>	NE3DAV
<b>Project:</b>	David City Wastewater Treatment Facility Improvements		
<b>Contract:</b>	David City Wastewater Treatment Facility Improvements		

<b>Application No.:</b>	20	<b>Application Period:</b>	<b>From</b>	09/24/25	<b>to</b>	10/21/25	<b>Application Date:</b>	11/07/25
-------------------------	----	----------------------------	-------------	----------	-----------	----------	--------------------------	----------

A	B	C	D	E	F	G	H	I
Item No.	Description	Scheduled Value (\$)	Work Completed		Currently Stored (not in D or E) (\$)	Work Completed and Materials Stored to Date (D + E + F) (\$)	% of Scheduled Value (G / C) (%)	Balance to Finish (C - G) (\$)
			(D + E) From Previous Application (\$)	This Period (\$)				
61	Existing SBR Basin Equipment Pumps	\$ 50,000.00			29,535.50	29,535.50	59%	20,464.50
62	Misc. Metals Furnish/Install	\$ 40,000.00			31,650.00	31,650.00	79%	8,350.00
63	Construct New SBR Splitter Box	\$ 174,000.00	174,000.00			174,000.00	100%	-
64	Painting Work	\$ 20,000.00				-	0%	20,000.00
65	Electrical Work	\$ 50,000.00	5,000.00			5,000.00	10%	45,000.00
	<b>STORAGE BUILDING</b>					-		-
66	Excavation & Backfill	\$ 35,000.00	35,000.00			35,000.00	100%	-
67	Building Drainage Piping & Oil Seperator	\$ 40,000.00	40,000.00			40,000.00	100%	-
68	Concrete Foundations	\$ 40,000.00	40,000.00			40,000.00	100%	-
69	Concrete Floor	\$ 56,000.00	56,000.00			56,000.00	100%	-
70	New Building Walls and Roof	\$ 270,000.00	229,259.00	10,000.00		239,259.00	89%	30,741.00
71	Doors & Windows	\$ 40,000.00			21,000.00	21,000.00	53%	19,000.00
72	Painting Work	\$ 30,000.00				-	0%	30,000.00
73	Electrical Work	\$ 75,000.00	7,000.00	5,000.00	10,000.00	22,000.00	29%	53,000.00
	<b>DEMO EXISTING HEADWORKS BUILDING</b>					-		-
74	Demolition of Existing Building Complete	\$ 30,000.00				-	0%	30,000.00
	<b>CLOSEOUT</b>					-		-
75	Site Grading	\$ 25,000.00				-	0%	25,000.00
76	SBR/Storage Building Sidewalks	\$ 25,000.00				-	0%	25,000.00
77	Concrete Paving	\$ 20,000.00				-	0%	20,000.00
78	Seeding & Mulch	\$ 15,000.00				-	0%	15,000.00
79	Crushed Rock Surfacing Roads	\$ 80,000.00				-	0%	80,000.00
80	Fence & Gate System	\$ 30,000.00				-	0%	30,000.00
<b>Original Contract Totals</b>		<b>\$ 16,882,000.00</b>	<b>\$ 10,902,499.58</b>	<b>\$ 508,500.00</b>	<b>\$ 3,038,358.26</b>	<b>\$ 14,449,357.84</b>	<b>86%</b>	<b>\$ 2,432,642.16</b>



**Stored Materials Summary**

**Contractor's Application for Payment**

<b>Owner:</b>	City of David City	<b>Owner's Project No.:</b>	
<b>Engineer:</b>	JEO Consulting Group, Inc.	<b>Engineer's Project No.:</b>	251034.00
<b>Contractor:</b>	BRB Contractors, Inc.	<b>Contractor's Project No.:</b>	NE3DAV
<b>Project:</b>	David City Wastewater Treatment Facility Improvements		
<b>Contract:</b>	David City Wastewater Treatment Facility Improvements		

**Application No.:** 20      **Application Period:** From 09/24/25 to 10/21/25      **Application Date:** 11/07/25

A	B	C	D	E	F	G	H	I	J	K	L	M
Item No. (Lump Sum Tab) or Bid Item No. (Unit Price Tab)	Supplier Invoice No.	Submittal No. (with Specification Section No.)	Description of Materials or Equipment Stored	Storage Location	Application No. When Materials Placed in Storage	Materials Stored			Incorporated in Work			Materials Remaining in Storage (I - L) (\$)
						Previous Amount Stored (\$)	Amount Stored this Period (\$)	Amount Stored to Date (G + H) (\$)	Amount Previously Incorporated in the Work (\$)	Amount Incorporated in the Work this Period (\$)	Total Amount Incorporated in the Work (J + K) (\$)	
	105795-1		Aqua Aerobics Down Payment			261,353.50		261,353.50	261,353.50		261,353.50	-
	50026177578		Rebar			19,091.30		19,091.30	19,091.30		19,091.30	-
	50026159555		Rebar			28,359.32		28,359.32	28,359.32		28,359.32	-
	50026147392		Rebar			26,753.09		26,753.09	26,753.09		26,753.09	-
	50026147072		Rebar			29,743.20		29,743.20	29,743.20		29,743.20	-
	50026147071		Rebar			29,743.20		29,743.20	29,743.20		29,743.20	-
	50026114832		Rebar			29,743.20		29,743.20	29,743.20		29,743.20	-
	50026127187		Rebar			22,299.72		22,299.72	22,299.72		22,299.72	-
	50026303876		Rebar			30,145.37		30,145.37	30,145.37		30,145.37	-
	0755219-1		Polywrap			1,964.40		1,964.40	500.00	1,464.40	1,964.40	-
	755226		Polywrap			420.00		420.00		420.00	420.00	-
	755219		Polywrap			3,170.72		3,170.72			-	3,170.72
	27693		HME Shop Drawings			6,675.00		6,675.00		6,643.95	6,643.95	31.05
	50026415841		Rebar			17,736.06		17,736.06	17,736.06		17,736.06	-
	50026367581		Rebar			26,960.24		26,960.24	26,960.24		26,960.24	-
	50026337203		Rebar			26,014.37		26,014.37	26,014.37		26,014.37	-
	50026192138		Rebar			18,469.82		18,469.82	18,469.82		18,469.82	-
	94020		SBR Wall Valves			76,643.95		76,643.95	76,643.95		76,643.95	-
	755902		Ductile Iron Pipe			18,451.18		18,451.18	18,451.18		18,451.18	-
	755171		Ductile Iron Pipe			15,132.60		15,132.60	14,000.00		14,000.00	1,132.60
	50026489471		Rebar			650.00		650.00	650.00		650.00	-
	50026599911		Rebar			5,675.00		5,675.00	5,675.00		5,675.00	-
	50026604462		Rebar			2,179.06		2,179.06	2,179.06		2,179.06	-
			Concrete Expansion Joints			5,892.80		5,892.80	5,892.80		5,892.80	-
	105795-2		Aqua Aerobics - Second Payment			522,707.00		522,707.00	522,707.00		522,707.00	-
	0756281-2		Ductile Iron Pipe and Accessories			1,975.74		1,975.74			-	1,975.74
	0756281-1		Ductile Iron Pipe and Accessories			10,440.99		10,440.99	1,830.82		1,830.82	8,610.17
	757833		24" PVC Pipe			83,203.12		83,203.12			-	83,203.12
	0755902-1		Ductile Iron Pipe and Accessories			21,275.08		21,275.08			-	21,275.08
	757699		Ductile Iron Pipe and Accessories			622.71		622.71			-	622.71
	755893		Ductile Iron Pipe and Accessories			22,446.17		22,446.17	22,446.17		22,446.17	-
	756281		Ductile Iron Pipe and Accessories			5,056.44		5,056.44			-	5,056.44
	94511		Butterfly Valves and Accessories			128,612.31		128,612.31	34,296.00		34,296.00	94,316.31
	94275		Air Release Valves			7,803.31		7,803.31			-	7,803.31
	27920		HME Shop Drawings			20,025.00		20,025.00	20,000.00		20,000.00	25.00
	0174120-IN		Hatches and Crane Equipment			30,750.00		30,750.00	21,605.00		21,605.00	9,145.00
	0756281-3		Ductile Iron Pipe and Accessories			3,181.29		3,181.29			-	3,181.29
	2022-113		Electrical Stored Materials			36,633.43		36,633.43			-	36,633.43
	759894		Ductile Iron Forcemain Pipe			184,557.08		184,557.08	184,557.08		184,557.08	-
	94711		Valves			116,428.37		116,428.37	116,428.37		116,428.37	-
	0755902-2		Ductile Iron Pipe			23,676.17		23,676.17	23,676.17		23,676.17	-
	50027906312		Rebar			27,202.03		27,202.03	27,202.03		27,202.03	-
	50027701696		Rebar			2,573.98		2,573.98	2,573.98		2,573.98	-
	50027633543		Rebar			14,510.75		14,510.75	14,510.75		14,510.75	-
	50027614897		Rebar			20,282.00		20,282.00	20,282.00		20,282.00	-

**Stored Materials Summary**

**Contractor's Application for Payment**

<b>Owner:</b>	City of David City	<b>Owner's Project No.:</b>	
<b>Engineer:</b>	JEO Consulting Group, Inc.	<b>Engineer's Project No.:</b>	251034.00
<b>Contractor:</b>	BRB Contractors, Inc.	<b>Contractor's Project No.:</b>	NE3DAV
<b>Project:</b>	David City Wastewater Treatment Facility Improvements		
<b>Contract:</b>	David City Wastewater Treatment Facility Improvements		

**Application No.:** 20      **Application Period:** From 09/24/25 to 10/21/25      **Application Date:** 11/07/25

A	B	C	D	E	F	G	H	I	J	K	L	M
Item No. (Lump Sum Tab) or Bid Item No. (Unit Price Tab)	Supplier Invoice No.	Submittal No. (with Specification Section No.)	Description of Materials or Equipment Stored	Storage Location	Application No. When Materials Placed in Storage	Materials Stored			Incorporated in Work			Materials Remaining in Storage (I - L) (\$)
						Previous Amount Stored (\$)	Amount Stored this Period (\$)	Amount Stored to Date (G + H) (\$)	Amount Previously Incorporated in the Work (\$)	Amount Incorporated in the Work this Period (\$)	Total Amount Incorporated in the Work (J + K) (\$)	
	95073		Gates/Valves/Flumes			10,622.32		10,622.32	10,622.32		10,622.32	-
	94913		Gates/Valves/Flumes			135,104.83		135,104.83	79,140.78		79,140.78	55,964.05
	0759894-2		Ductile Iron Pipe			89,965.26		89,965.26	40,000.00		40,000.00	49,965.26
	0759894-1		Ductile Iron Pipe			48,516.80		48,516.80	30,000.00		30,000.00	18,516.80
	760997		Ductile Iron Pipe			30,341.68		30,341.68	30,341.68		30,341.68	-
	0757692-1		Ductile Iron Pipe			6,545.67		6,545.67	6,545.67		6,545.67	-
	757692		Ductile Iron Pipe			34,436.37		34,436.37	34,436.37		34,436.37	-
	8635424-01		Electrical Stored Materials			1,893.10		1,893.10	1,893.10		1,893.10	-
	8653766-00		Electrical Stored Materials			1,344.01		1,344.01	1,344.01		1,344.01	-
	8635424-00		Electrical Stored Materials			1,029.30		1,029.30	1,029.30		1,029.30	-
	8651280-00		Electrical Stored Materials			249.97		249.97	249.97		249.97	-
	8602508-01		Electrical Stored Materials			5,846.58		5,846.58	5,846.58		5,846.58	-
	8602508-02		Electrical Stored Materials			18,107.44		18,107.44	18,107.44		18,107.44	-
	8634948-00		Electrical Stored Materials			10.92		10.92	10.92		10.92	-
	2022-119		Electrical Stored Materials			5,915.24		5,915.24	5,915.24		5,915.24	-
	95314		Valves			35,962.26		35,962.26		20,000.00	20,000.00	15,962.26
	95296		Valves			5,507.18		5,507.18	5,507.18		5,507.18	-
	95194		Valves			64,227.99		64,227.99	64,227.99		64,227.99	-
	0760997-1		Embedded Wall Pipe			10,490.00		10,490.00	10,490.00		10,490.00	-
	761001		Embedded Wall Pipe			10,763.56		10,763.56	10,763.56		10,763.56	-
	759887		Ductile Iron Fittings			14,654.75		14,654.75			-	14,654.75
	0760997-2		Ductile Iron Pipe			18,733.52		18,733.52			-	18,733.52
	50028222134		Headworks Area Rebar			17,661.05		17,661.05	17,661.05		17,661.05	-
	50028559050		Generator Pad Rebar			5,316.85		5,316.85	5,316.85		5,316.85	-
	95460		Valves			9,113.55		9,113.55		9,113.55	9,113.55	-
	765559		Ductile Iron Pipe			11,022.47		11,022.47		11,022.47	11,022.47	-
	765117		Ductile Iron Pipe			95,948.26		95,948.26		95,948.26	95,948.26	-
	764836		Ductile Iron Pipe			22,291.21		22,291.21			-	22,291.21
	764427		Ductile Iron Pipe			2,800.00		2,800.00			-	2,800.00
	0764836-1		Ductile Iron Pipe			9,449.42		9,449.42			-	9,449.42
	764846		Ductile Iron Pipe			21,007.67		21,007.67			-	21,007.67
	0765117-2		Ductile Iron Pipe			21,792.38		21,792.38			-	21,792.38
	8653766-01		Electrical Stored Materials			6,180.00		6,180.00	6,180.00		6,180.00	-
	8635424-02		Electrical Stored Materials			9,419.62		9,419.62	9,419.62		9,419.62	-
	8635424-03		Electrical Stored Materials			5,327.55		5,327.55	5,327.55		5,327.55	-
	8658232-00		Electrical Stored Materials			20,413.00		20,413.00	15,000.00		15,000.00	5,413.00
	8635424-04		Electrical Stored Materials			4,119.52		4,119.52	4,119.52		4,119.52	-
	8666003-00		Electrical Stored Materials			8,910.00		8,910.00	8,910.00		8,910.00	-
	8602508-03		Electrical Stored Materials			5,317.25		5,317.25	5,317.25		5,317.25	-
	8658232-02		Electrical Stored Materials			31,315.00		31,315.00	31,315.00		31,315.00	-
	8658232-01		Electrical Stored Materials			32,956.00		32,956.00			-	32,956.00
	NECOL256197		Electrical Stored Materials			301.18		301.18			-	301.18
	79795		Electrical Stored Materials			270.00		270.00			-	270.00
	12251		HOA Progress Billing			227,884.60		227,884.60			-	227,884.60
	27665		Submersible Pumps			432,500.00		432,500.00	432,500.00		432,500.00	-

**Stored Materials Summary**

**Contractor's Application for Payment**

<b>Owner:</b>	City of David City	<b>Owner's Project No.:</b>	
<b>Engineer:</b>	JEO Consulting Group, Inc.	<b>Engineer's Project No.:</b>	251034.00
<b>Contractor:</b>	BRB Contractors, Inc.	<b>Contractor's Project No.:</b>	NE3DAV
<b>Project:</b>	David City Wastewater Treatment Facility Improvements		
<b>Contract:</b>	David City Wastewater Treatment Facility Improvements		

**Application No.:** 20      **Application Period:** From 09/24/25 to 10/21/25      **Application Date:** 11/07/25

A	B	C	D	E	F	G	H	I	J	K	L	M
Item No. (Lump Sum Tab) or Bid Item No. (Unit Price Tab)	Supplier Invoice No.	Submittal No. (with Specification Section No.)	Description of Materials or Equipment Stored	Storage Location	Application No. When Materials Placed in Storage	Materials Stored			Incorporated in Work			Materials Remaining in Storage (I - L) (\$)
						Previous Amount Stored (\$)	Amount Stored this Period (\$)	Amount Stored to Date (G + H) (\$)	Amount Previously Incorporated in the Work (\$)	Amount Incorporated in the Work this Period (\$)	Total Amount Incorporated in the Work (J + K) (\$)	
	0174897-IN		Hoist			19,110.00		19,110.00			-	19,110.00
	0765117-6		Pipe and Fittings			9,402.29		9,402.29			-	9,402.29
	0765117-5		Pipe and Fittings			39,726.61		39,726.61			-	39,726.61
	0765117-4		Pipe and Fittings			6,442.13		6,442.13			-	6,442.13
	0760997-3		Pipe and Fittings			26,816.12		26,816.12			-	26,816.12
	0765117-3		Pipe and Fittings			578.28		578.28			-	578.28
	766259		Pipe and Fittings			21,663.44		21,663.44			-	21,663.44
	764818		Pipe and Fittings			25,146.59		25,146.59			-	25,146.59
	95755		Valves			33,531.00		33,531.00			-	33,531.00
	8635424-05		Electrical Stored Materials			386.20		386.20	386.20		386.20	-
	8658653-00		Electrical Stored Materials			1,335.00		1,335.00	1,335.00		1,335.00	-
	8602508-04		Electrical Stored Materials			373.10		373.10	373.10		373.10	-
	8694471-00		Electrical Stored Materials			266.93		266.93	266.93		266.93	-
	8602508-05		Electrical Stored Materials			2,328.26		2,328.26	2,328.26		2,328.26	-
	8635424-06		Electrical Stored Materials			12,514.95		12,514.95	6,000.00		6,000.00	6,514.95
	8792		Grit Pump			23,395.00		23,395.00			-	23,395.00
	29452		Handrail			12,300.00		12,300.00			-	12,300.00
	568		HVAC: Air Conditioners			16,920.00		16,920.00			-	16,920.00
	0765117-7		Pipe and Fittings			2,528.22		2,528.22			-	2,528.22
	766417		Piping System/Ball Valves			3,112.76		3,112.76			-	3,112.76
	770080		Pipe and Fittings			4,184.11		4,184.11			-	4,184.11
	765579		Pipe and Fittings			33,920.76		33,920.76			-	33,920.76
	0057750-IN		Sand/Oil Trap			10,900.00		10,900.00	10,900.00		10,900.00	-
	29678		Ladders			8,250.00		8,250.00			-	8,250.00
	769915		Pipe and Fittings			17,343.56		17,343.56			-	17,343.56
	1045880		Aqua Aerobics SBR Equipment			254,849.56		254,849.56	100,000.00		100,000.00	154,849.56
	1046052		Aqua Aerobics SBR Equipment			703,753.84		703,753.84			-	703,753.84
	24105-18870		Bar Screen			127,871.00		127,871.00	127,871.00		127,871.00	-
	92726-00		Generator			82,368.00		82,368.00	82,368.00		82,368.00	-
	8653766-02		Electrical Stored Materials			12,200.28		12,200.28			-	12,200.28
	1046371		Aqua Aerobics SBR Equipment			56,029.84		56,029.84			-	56,029.84
	448099		Precast Manholes			6,829.90		6,829.90	6,829.90		6,829.90	-
	448100		Precast Manholes			6,367.98		6,367.98	6,367.98		6,367.98	-
	1046768		Aqua Aerobic Equipment			456,848.92		456,848.92	208,871.77		208,871.77	247,977.15
	1046711		Aqua Aerobic Equipment			4,266.73		4,266.73			-	4,266.73
	769540		Pipe and Fittings			10,912.32		10,912.32			-	10,912.32
	777143		Pipe and Fittings			9,368.08		9,368.08			-	9,368.08
	50030735331		Blower Room Rebar			4,203.29		4,203.29			-	4,203.29
	SO113091		Doors and Frames			30,000.00		30,000.00		9,000.00	9,000.00	21,000.00
	1047062		Aqua Aerobic Equipment			75,103.16		75,103.16			-	75,103.16
	12687		Instrumentation Equipment			55,490.40		55,490.40			-	55,490.40
	97508		Slide Gates			277,359.52		277,359.52	80,000.00		80,000.00	197,359.52
	777559		Ductile Iron Pipe and Fittings (SBR)			33,415.07		33,415.07			-	33,415.07

**Stored Materials Summary**

**Contractor's Application for Payment**

<b>Owner:</b>	City of David City	<b>Owner's Project No.:</b>	
<b>Engineer:</b>	JEO Consulting Group, Inc.	<b>Engineer's Project No.:</b>	251034.00
<b>Contractor:</b>	BRB Contractors, Inc.	<b>Contractor's Project No.:</b>	NE3DAV
<b>Project:</b>	David City Wastewater Treatment Facility Improvements		
<b>Contract:</b>	David City Wastewater Treatment Facility Improvements		

**Application No.:** 20      **Application Period:** From 09/24/25 to 10/21/25      **Application Date:** 11/07/25

A	B	C	D	E	F	G	H	I	J	K	L	M
Item No. (Lump Sum Tab) or Bid Item No. (Unit Price Tab)	Supplier Invoice No.	Submittal No. (with Specification Section No.)	Description of Materials or Equipment Stored	Storage Location	Application No. When Materials Placed in Storage	Materials Stored			Incorporated in Work			Materials Remaining in Storage (I - L) (\$)
						Previous Amount Stored (\$)	Amount Stored this Period (\$)	Amount Stored to Date (G + H) (\$)	Amount Previously Incorporated in the Work (\$)	Amount Incorporated in the Work this Period (\$)	Total Amount Incorporated in the Work (J + K) (\$)	
	777526		Ductile Iron Pipe and Fittings (Blower)			7,835.01		7,835.01			-	7,835.01
	0777559-1		Ductile Iron Pipe and Fittings (SBR)			17,352.34		17,352.34			-	17,352.34
	30706		Misc Steel			81,605.00		81,605.00			-	81,605.00
	12743		Motor Control Centers and Drives			438,253.00		438,253.00	438,253.00		438,253.00	-
	97802		Slide Gate Actuator			22,576.82		22,576.82			-	22,576.82
	97966		Grit Removal System			227,316.00		227,316.00		30,000.00	30,000.00	197,316.00
6	781379		Ductile Iron Pipe and Fittings			6,995.20		6,995.20		6,995.20	6,995.20	-
6	0779486-1		Ductile Iron Pipe and Fittings			5,131.29		5,131.29		5,131.29	5,131.29	-
6	0799486-2		Ductile Iron Pipe and Fittings			93,081.78		93,081.78	93,081.78		93,081.78	-
6	0777559-2		Ductile Iron Pipe and Fittings			11,821.88		11,821.88		11,821.88	11,821.88	-
6	780229		14" SBR Pipe			4,492.31		4,492.31			-	4,492.31
	IN108191		Doors and Frames			16,637.14		16,637.14		16,637.14	16,637.14	-
	133739		Headworks Trusses (Partial)			4,925.00		4,925.00	4,925.00		4,925.00	-
	781551		Ductile Iron Pipe and Fittings			12,310.45		12,310.45	4,000.00		4,000.00	8,310.45
	0785422-1		Ductile Iron Fittings (Blower)			9,229.73		9,229.73	1,318.53		1,318.53	7,911.20
								-			-	-
								-			-	-
								-			-	-
								-			-	-
								-			-	-
<b>Totals</b>						<b>\$ 7,038,091.55</b>	<b>\$ -</b>	<b>\$ 7,038,091.55</b>	<b>\$ 3,775,535.15</b>	<b>\$ 224,198.14</b>	<b>\$ 3,999,733.29</b>	<b>\$ 3,038,358.26</b>

**Contractor's Application for Payment**

<b>Owner:</b> <u>City of David City</u>	<b>Owner's Project No.:</b> _____
<b>Engineer:</b> <u>JEO Consulting Group, Inc.</u>	<b>Engineer's Project No.:</b> <u>231471.00</u>
<b>Contractor:</b> <u>Rutjens Construction, Inc.</u>	<b>Contractor's Project No.:</b> _____
<b>Project:</b> <u>2025 Water Main Improvements: North 7th Street from J Street to O Street</u>	
<b>Contract:</b> <u>2025 Water Main Improvements: North 7th Street from J Street to O Street</u>	
<b>Application No.:</b> <u>1</u>	<b>Application Date:</b> <u>11/3/2025</u>
<b>Application Period:</b> <b>From</b> <u>9/2/2025</u> <b>to</b> <u>10/31/2025</u>	

1. Original Contract Price	\$	380,566.00
2. Net change by Change Orders	\$	-
3. Current Contract Price (Line 1 + Line 2)	\$	380,566.00
4. Total Work completed and materials stored to date (Sum of Column G Lump Sum Total and Column J Unit Price Total)	\$	340,594.75
5. Retainage		
a. <u>5%</u> X <u>\$ 340,594.75</u> Work Completed =	\$	17,029.74
b. <u>5%</u> X <u>\$ -</u> Stored Materials =	\$	-
c. Total Retainage (Line 5.a + Line 5.b)	\$	17,029.74
6. Amount eligible to date (Line 4 - Line 5.c)	\$	323,565.01
7. Less previous payments (Line 6 from prior application)		
8. Amount due this application	\$	323,565.01
9. Balance to finish, including retainage (Line 3 - Line 4 + Line 5.c)	\$	57,000.99

**Contractor's Certification**

The undersigned Contractor certifies, to the best of its knowledge, the following:

(1) All previous progress payments received from Owner on account of Work done under the Contract have been applied on account to discharge Contractor's legitimate obligations incurred in connection with the Work covered by prior Applications for Payment;

(2) Title to all Work, materials and equipment incorporated in said Work, or otherwise listed in or covered by this Application for Payment, will pass to Owner at time of payment free and clear of all liens, security interests, and encumbrances (except such as are covered by a bond acceptable to Owner indemnifying Owner against any such liens, security interest, or encumbrances); and

(3) All the Work covered by this Application for Payment is in accordance with the Contract Documents and is not defective.

**Contractor:** Rutjens Construction, Inc.

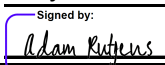
**Signature:**  **Date:** 11/5/2025

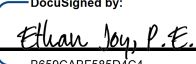
<b>Recommended by Engineer</b>	<b>Approved by Owner</b>
<b>By:</b> <u></u>	<b>By:</b> _____
<b>Title:</b> <u>Project Manager</u>	<b>Title:</b> _____
<b>Date:</b> <u>11/5/2025</u>	<b>Date:</b> _____
<b>Approved by Funding Agency</b>	
<b>By:</b> _____	<b>By:</b> _____
<b>Title:</b> _____	<b>Title:</b> _____
<b>Date:</b> _____	<b>Date:</b> _____

**Progress Estimate - Unit Price Work**

**Contractor's Application for Payment**

<b>Owner:</b>	City of David City	<b>Owner's Project No.:</b>	
<b>Engineer:</b>	JEO Consulting Group, Inc.	<b>Engineer's Project No.:</b>	231471.00
<b>Contractor:</b>	Rutjens Construction, Inc.	<b>Contractor's Project No.:</b>	
<b>Project:</b>	2025 Water Main Improvements: North 7th Street from J Street to O Street		
<b>Contract:</b>	2025 Water Main Improvements: North 7th Street from J Street to O Street		

**Application No.:** 1      **Application Period:** From 09/02/25 to 10/31/25      **Application Date:** 11/03/25

A	B	C	D	E	F	G	H	I	J	K	L
Bid Item No.	Description	Item Quantity	Units	Unit Price (\$)	Value of Bid Item (C X E) (\$)	Work Completed		Materials Currently Stored (not in G) (\$)	Work Completed and Materials Stored to Date (H + I) (\$)	% of Value of Item (J / F) (%)	Balance to Finish (F - J) (\$)
						Estimated Quantity Incorporated in the Work	Value of Work Completed to Date (E X G) (\$)				
<b>Original Contract</b>											
1	Mobilization	1	LS	17,000.00	17,000.00	1.00	17,000.00		17,000.00	100%	-
2	Bonding and Insurance	1	LS	1,500.00	1,500.00	1.00	1,500.00		1,500.00	100%	-
3	8" PVC Water Main, DR 18, RJ, Directionally Bored	1,808	LF	82.00	148,256.00	1,802.00	147,764.00		147,764.00	100%	492.00
4	8" PVC Water Main, DR 18	21	LF	70.00	1,470.00	21.00	1,470.00		1,470.00	100%	-
5	6" PVC Water Main, DR 18	18	LF	65.00	1,170.00	18.00	1,170.00		1,170.00	100%	-
6	4" PVC Water Main, DR 18	7	LF	65.00	455.00	7.00	455.00		455.00	100%	-
7	8" Gate Valve and Box, MJ	14	EA	2,515.00	35,210.00	14.00	35,210.00		35,210.00	100%	-
8	8" Cross, MJ	4	EA	1,104.00	4,416.00	4.00	4,416.00		4,416.00	100%	-
9	8" x 6" x 8" Tee, MJ	4	EA	885.00	3,540.00	4.00	3,540.00		3,540.00	100%	-
10	6" 90° Bend, MJ	2	EA	515.00	1,030.00	2.00	1,030.00		1,030.00	100%	-
11	4" 90° Bend, MJ	6	EA	495.00	2,970.00	6.00	2,970.00		2,970.00	100%	-
12	8" 45° Bend, MJ	2	EA	613.00	1,226.00	2.00	1,226.00		1,226.00	100%	-
13	10" x 8" Reducer, MJ	1	EA	687.00	687.00		-		-	0%	687.00
14	8" x 6" Reducer, MJ	1	EA	518.00	518.00	1.00	518.00		518.00	100%	-
15	8" x 4" Reducer, MJ	4	EA	505.00	2,020.00	4.00	2,020.00		2,020.00	100%	-
16	8" Plug, MJ	3	EA	300.00	900.00	3.00	900.00		900.00	100%	-
17	Connect to Existing Water Main	7	EA	1,121.00	7,847.00	7.00	7,847.00		7,847.00	100%	-
18	8" x 1" Saddle	36	EA	230.00	8,280.00	34.00	7,820.00		7,820.00	94%	460.00
19	1" Corporation Stop	36	EA	250.00	9,000.00	34.00	8,500.00		8,500.00	94%	500.00
20	1" Curb Stop	31	EA	300.00	9,300.00	29.00	8,700.00		8,700.00	94%	600.00
21	1" Curb Stop Box (Install Only)	31	EA	175.00	5,425.00		-		-	0%	5,425.00
22	1" Curb Stop and Box	5	EA	355.00	1,775.00	5.00	1,775.00		1,775.00	100%	-
23	1" PE Water Service (SDR 9)	1,296	EA	20.00	25,920.00	1,274.00	25,480.00		25,480.00	98%	440.00
24	Bore Water Service Line	420	LF	26.00	10,920.00	420.00	10,920.00		10,920.00	100%	-
25	Connect to Existing Water Service	36	EA	175.00	6,300.00	34.00	5,950.00		5,950.00	94%	350.00
26	Remove Pavement	110	SY	13.00	1,430.00	90.00	1,170.00		1,170.00	82%	260.00
27	7" Concrete Pavement	110	SY	89.00	9,790.00		-		-	0%	9,790.00
28	Remove driveway	75	SY	13.00	975.00	55.00	715.00		715.00	73%	260.00
29	5" Concrete Driveway	75	SY	87.00	6,525.00		-		-	0%	6,525.00
30	Remove Concrete Sidewalk	1,300	SF	2.00	2,600.00		-		-	0%	2,600.00
31	4" Concrete Sidewalk	1,300	SF	8.00	10,400.00		-		-	0%	10,400.00
32	Water Main Removals and Abandonments	1	LS	1,000.00	1,000.00		-		-	0%	1,000.00
33	Temporary Traffic Control Measures	1	LS	1,215.00	1,215.00	0.85	1,032.75		1,032.75	85%	182.25
<b>Group B - Fire Hydrants</b>											
1	6" Fire Hydrant Assembly	4	EA	9,874.00	\$ 39,496.00	4.00	39,496.00		39,496.00	100%	\$ -
<b>Original Contract Totals</b>					<b>\$ 380,566.00</b>		340,594.75	\$ -	<b>\$ 340,594.75</b>	<b>89%</b>	<b>\$ 39,971.25</b>

**Progress Estimate - Unit Price Work**

**Contractor's Application for Payment**

<b>Owner:</b>	City of David City	<b>Owner's Project No.:</b>	
<b>Engineer:</b>	JEO Consulting Group, Inc.	<b>Engineer's Project No.:</b>	231471.00
<b>Contractor:</b>	Rutjens Construction, Inc.	<b>Contractor's Project No.:</b>	
<b>Project:</b>	2025 Water Main Improvements: North 7th Street from J Street to O Street		
<b>Contract:</b>	2025 Water Main Improvements: North 7th Street from J Street to O Street		

Application No.: 1 Application Period: From 09/02/25 to 10/31/25 Application Date: 11/03/25

A	B	C	D	E	F	G	H	I	J	K	L	
Bid Item No.	Description	Item Quantity	Units	Unit Price (\$)	Value of Bid Item (C X E) (\$)	Work Completed		Materials Currently Stored (not in G) (\$)	Work Completed and Materials Stored to Date (H + I) (\$)	% of Value of Item (J / F) (%)	Balance to Finish (F - J) (\$)	
						Estimated Quantity Incorporated in the Work	Value of Work Completed to Date (E X G) (\$)					
<b>Change Orders</b>												
					-						-	
					-						-	
					-						-	
					-						-	
					-						-	
					-						-	
					-						-	
					-						-	
					-						-	
					-						-	
					-						-	
					-						-	
					-						-	
					-						-	
					-						-	
					-						-	
					-						-	
					-						-	
					-						-	
<b>Change Order Totals</b>					\$ -			\$ -	\$ -		\$ -	
<b>Original Contract and Change Orders</b>												
<b>Project Totals</b>					\$ 380,566.00			\$ 340,594.75	\$ -	\$ 340,594.75	89%	\$ 39,971.25

**Stored Materials Summary**

**Contractor's Application for Payment**

<b>Owner:</b>	City of David City	<b>Owner's Project No.:</b>	
<b>Engineer:</b>	JEO Consulting Group, Inc.	<b>Engineer's Project No.:</b>	231471.00
<b>Contractor:</b>	Rutjens Construction, Inc.	<b>Contractor's Project No.:</b>	
<b>Project:</b>	2025 Water Main Improvements: North 7th Street from J Street to O Street		
<b>Contract:</b>	2025 Water Main Improvements: North 7th Street from J Street to O Street		

**Application No.:** 1      **Application Period:** From 09/02/25 to 10/31/25      **Application Date:** 11/03/25

A	B	C	D	E	F	G	H	I	J	K	L	M	
Item No. (Lump Sum Tab) or Bid Item No. (Unit Price Tab)	Supplier Invoice No.	Submittal No. (with Specification Section No.)	Description of Materials or Equipment Stored	Storage Location	Application No. When Materials Placed in Storage	Materials Stored			Incorporated in Work			Materials Remaining in Storage (I - L) (\$)	
						Previous Amount Stored (\$)	Amount Stored this Period (\$)	Amount Stored to Date (G + H) (\$)	Amount Previously Incorporated in the Work (\$)	Amount Incorporated in the Work this Period (\$)	Total Amount Incorporated in the Work (J + K) (\$)		
<b>Totals</b>						\$	-	\$	-	\$	-	\$	-

## Request for Bids: Mowing Services

The City of David City is soliciting professional services for the mowing and maintenance of specified properties.

Mowing Services should be provided as needed throughout the mowing season.

Mowing locations include:

- 1) City Park (located south of Iowa Street between 7<sup>th</sup> and 9<sup>th</sup> Streets, and south of Ohio Street between 5<sup>th</sup> and 7<sup>th</sup> Streets, and South of Kansas Street between 4<sup>th</sup> and 10<sup>th</sup> Streets.
- 2) Jaycee Park (located at 9<sup>th</sup> and M Street)
- 3) David City Family Aquatic Center (located at 485 S. 9<sup>th</sup> Street)
- 4) Football Field (located south of Kansas Street between 5<sup>th</sup> and 7<sup>th</sup> Street)

Bagging of grass clippings is only required at the David City Family Aquatic Center and park areas as events require.

Contractor shall provide all required equipment to perform the Services, and all costs and expenses associated with the maintenance, repair, and replacement of such equipment shall be Contractor's responsibility.

Contractor shall provide and maintain bodily injury, property damage and liability insurance appropriate and/or required by law for the Services with a combined single limit of at least Three Hundred Thousand Dollars (\$300,000.00) per occurrence. The contractor shall provide the City with a certificate of insurance evidencing the coverage required.

For additional information, please contact City Administrator Alan Zavodny at [azavodny@davidcityne.gov](mailto:azavodny@davidcityne.gov) or City Administrator Intern Raiko Martinez at [cityadministrator@davidcityne.gov](mailto:cityadministrator@davidcityne.gov).

Bids will be received until 3 p.m., November 12, 2025, and will be opened and publicly read at the City Council meeting, 490 E Street, David City, NE at 7 p.m.

## **Request for Quotes: Turf and Landscape Management Services**

The City of David City is soliciting professional services for the vegetation and landscape management of specified park and public properties.

Vegetation and landscape management services shall be provided as needed throughout the growing season, excluding mowing.

### **Service Locations Include:**

City Park (located south of Iowa Street between 7th and 9th Streets, and south of Ohio Street between 5th and 7th Streets, and south of Kansas Street between 4th and 10th Streets)

Jaycee Park (located at 9th and M Street)

David City Family Aquatic Center (located at 485 S. 9th Street)

Football Field (located south of Kansas Street between 5th and 7th Streets)

Baseball/Softball fields (located on West H Street)

Soccer fields (located east of Elm Street and north of West H Street)

RV Campground (located on Elm Street)

### **Scope of Work:**

Apply turf fertilizer to maintain consistent nutrient throughout the growing season  
Pre-Emergent Herbicide applications to prevent the germination and establishment of grassy weeds such as crabgrass and foxtail  
Weed control in landscaped areas, paths, fence lines, and non-turf zones  
Broadleaf Weed Control to prevent broadleaf in all turf areas  
Sterilant Applications on walking trails and around playground equipment to control unwanted vegetation

All mowing activities are specifically excluded from this contract.

### **Contractor Responsibilities:**

Provide all products, equipment, tools, and materials necessary to perform the above services

Maintain all required licenses and certifications for pesticide and herbicide applications

Follow all safety and environmental regulations

### **Insurance Requirements:**

Contractor shall provide and maintain bodily injury, property damage, and liability insurance appropriate and/or required by law for the Services with a combined single limit of at least Three Hundred Thousand Dollars (\$300,000.00) per occurrence. The contractor shall provide the City with a certificate of insurance evidencing the coverage required.

**Contact Information:**

For additional information, please contact:

City Administrator Alan Zavodny – [azavodny@davidcityne.gov](mailto:azavodny@davidcityne.gov)

or

City Administrator Intern Raiko Martinez – [cityadministrator@davidcityne.gov](mailto:cityadministrator@davidcityne.gov)

**Submission Deadline:**

Quotes will be received until 3 p.m., November 12, 2025, and will be opened and publicly read at the City Council meeting, 490 E Street, David City, NE at 7 p.m.

## **Request for Quotes: Vegetation and Landscape Management Services**

The City of David City is soliciting professional services for the vegetation and landscape management of specified park and public properties.

Vegetation and landscape management services shall be provided as needed throughout the growing season, excluding mowing.

### **Service Locations Include:**

City Park (located south of Iowa Street between 7th and 9th Streets, and south of Ohio Street between 5th and 7th Streets, and south of Kansas Street between 4th and 10th Streets)

Jaycee Park (located at 9th and M Street)

David City Family Aquatic Center (located at 485 S. 9th Street)

Football Field (located south of Kansas Street between 5th and 7th Streets)

### **Scope of Work:**

Apply turf fertilizer to maintain consistent nutrient throughout the growing season

Pre-Emergent Herbicide applications to prevent the germination and establishment of grassy weeds such as crabgrass and foxtail

Weed control in landscaped areas, paths, fence lines, and non-turf zones

Broadleaf Weed Control to prevent broadleaf in all turf areas

Sterilant Applications on walking trails and around playground equipment to control unwanted vegetation

All mowing activities are specifically excluded from this contract.

### **Contractor Responsibilities:**

Provide all products, equipment, tools, and materials necessary to perform the above services

Maintain all required licenses and certifications for pesticide and herbicide applications

Follow all safety and environmental regulations

### **Insurance Requirements:**

Contractor shall provide and maintain bodily injury, property damage, and liability insurance appropriate and/or required by law for the Services with a combined single limit of at least Three Hundred Thousand Dollars (\$300,000.00) per occurrence. The contractor shall provide the City with a certificate of insurance evidencing the coverage required.

### **Contact Information:**

For additional information, please contact:

City Administrator Alan Zavodny – [azavodny@davidcityne.gov](mailto:azavodny@davidcityne.gov)

or

City Administrator Intern Raiko Martinez – [cityadministrator@davidcityne.gov](mailto:cityadministrator@davidcityne.gov)

**Submission Deadline:**

Quotes will be received until 3 p.m., November 12, 2025, and will be opened and publicly read at the City Council meeting, 490 E Street, David City, NE, at 7 p.m.



# QUOTATION

401 Northwest 56th Street  
 Lincoln, NE 68528  
 (888) 833-1455

**QUOTATION DATE** 10/31/2025  
**VALID UNTIL** 11/27/2025  
**QUOTATION ID** QTO111427-6

**Quoted To:**

City Of David City  
 557 N 4th St  
 David City, NE 68632-1623  
 USA

**Ship To:**

City Of David City - C/O  
 Clerk-Treasurer/Generators  
 557 N 4th St  
 David City, NE 68632-1623  
 USA

Invoice Account	Order Account	Customer PO	Delivery Method	Page
1575250	1575250			1 of 2
Salesperson		Phone Number	Email Address	
Travis Boyll		402-429-3450	travisboyll@nmccat.com	

**Item Information**

**Machine Model:** 416                      **Make:** Caterpillar  
**Machine Model:** 2193383\_BHL        **Make:** Caterpillar

**Machine Specification**

**Model:** 416  
**Description**  
 416 07A BHL DCA3B  
 LANE 1 ORDER  
 PRODUCT LINK, CELLULAR, PLE643  
 TIRES, 340 80-18/500 70-24, MX  
 INSTRUCTIONS, ANSI  
 BELT, SEAT, 2" SUSPENSION  
 STABILIZER PADS, FLIP-OVER  
 COUPLER, PG, MAN.D.LOCK, BHL  
 SERIALIZED TECHNICAL MEDIA KIT  
 SHIPPING/STORAGE PROTECTION  
 RUST PREVENTATIVE APPLICATOR  
 PACK, DOMESTIC TRUCK  
 GUARD, STABILIZER  
 PLATE GROUP, BOOM WEAR  
 STD RADIO (12V)  
 BUCKET-SOIL, 24", 8.5 FT3  
 BUCKET, LOADER (NONE)

**Machine Specification**

**Model:** 2193383\_BHL  
**Description**  
 BUCKET, 36", 10.3 FT3  
 PINS, BUCKET, BHL-F, 45MM-50MM

<b>Sell Price of 416</b>	112,430.00
<b>Less Gross Trade Allowance for 580</b>	-39200
<b>Document Fee</b>	0.00
<b>Net Balance Due</b>	<b>73,230.00</b>
<b>Sales Tax</b>	0.00
<b>After Tax Balance</b>	<b>73,230.00</b>



# QUOTATION

401 Northwest 56th Street  
Lincoln, NE 68528  
(888) 833-1455

**QUOTATION DATE** 10/31/2025  
**VALID UNTIL** 11/27/2025  
**QUOTATION ID** QTO111427-6

### Trade - Ins

Model	Make	Serial Number	Year	Trade Allowance
580	Case			39,200.00

All trade-ins are subject to equipment being in "as inspected condition" by customer at time of delivery of equipment purchase quoted above. Customer also warrants the trade-in equipment to be free and clear of all claims, liens, mortgages, and security interests except as already disclosed and noted.

### Notes

Includes 1.0CY PO Bucket

### DCA INCLUDES:

- 543-3339 416 07A BACKHOE LOADER CFG2
- 337-9696 COUNTERWEIGHT, 460 KGS (1015 LBS)
- 491-6734 WORKLIGHTS (8) HALOGEN LAMPS
- 542-7761 HYDRAULICS GP, 5FCN/7BNK, PT
- 542-7779 ENGINE, 70KW, C3.6 DITA, S5 (T4F)
- 542-7810 AIR CONDITIONER, S5 (T4F)
- 543-4282 STICK, EXTENDABLE, 4.3M, PILOT (14FT.)
- 543-4900 PT, 4WD/2WS STD SHIFT, PILOT
- 545-5047 DISPLAY, STANDARD
- 545-8548 LOADER BUCKET PINS
- 557-4932 CAB, STANDARD
- 611-0335 SEAT, FABRIC

### Additional Terms

This Quotation is provided for general information purposes only and is not binding upon either party. No binding agreement shall exist unless or until the parties enter into a Sales Agreement under NMC's standard Sales and Service Terms for Caterpillar Products (a copy of which is available at <https://www.nmccat.com/legal-terms>). Any terms and conditions provided by Buyer are expressly rejected and any purchase order or other terms provided by Buyer shall be considered solely as internal documentation of Buyer and not legally binding upon NMC regardless of NMC's signature upon any such document.

**Please Note:** NMC cannot guarantee availability of equipment. In addition, while NMC endeavors to provide accurate pricing, due to circumstances beyond its control, such pricing is considered an estimate only of the final price and may be subject to change as market, supply, or other circumstances require (including, without limitation, OEM pending steel surcharges and OEM tariffs) until such time as the product is shipped. Should the final price exceed the estimated price, customer shall have the option to terminate the order as its sole remedy.

Quote Id: 33479287

---

Prepared For:  
**CITY OF DAVID CITY**



Prepared By: **ZACH HAPPEL**

Murphy Tractor & Equipment  
6100 Arbor Road  
Lincoln, NE 68517

Tel: 402-467-1300  
Mobile Phone: 402-432-8314  
Fax: 402-467-1927  
Email: [zhappel@murphytractor.com](mailto:zhappel@murphytractor.com)

---

Date: 26 September 2025

Offer Expires: 31 October 2025

### Quote Summary

**Prepared For**

CITY OF DAVID CITY  
 451 N 5TH ST  
 DAVID CITY, NE 68632  
 Business: 402-367-7470

**Prepared By**

ZACH HAPPEL  
 Murphy Tractor & Equipment  
 6100 Arbor Road  
 Lincoln, NE 68517  
 Phone: 402-467-1300  
 Mobile: 402-432-8314  
 zhappel@murphytractor.com

\$8,447 Add and optional HYD Quick Coupler  
 \$3,069 Add an Full Machine 4 year/2000hr Warranty  
 Priced Per Sourcwell Contract#011723-JDC

**Quote Id:** 33479287  
**Created On:** 26 September 2025  
**Last Modified On:** 06 October 2025  
**Expiration Date:** 31 October 2025

**Equipment Summary**

	<b>Qty</b>		<b>Extended</b>
JOHN DEERE 310 P-Tier Backhoe Loader	X 1	=	

**Equipment Total** **\$ 128,400.00**

**Trade In Summary**

	<b>Qty</b>	<b>Each</b>	<b>Extended</b>
2013 CASECO 580 - JJGN58SNLDC585585	1	\$ 43,000.00	\$ 43,000.00
PayOff			\$ 0.00
Total Trade Allowance			\$ 43,000.00

**Trade In Total** **\$ 43,000.00**

**Quote Summary**

Equipment Total	\$ 128,400.00
Trade In	\$ (43,000.00)
SubTotal	\$ 85,400.00
Est. Service Agreement Tax	
Total	\$ 85,400.00
<b>Balance Due</b>	<b>\$ 85,400.00</b>

# Selling Equipment

**Quote Id:** 33479287

**Customer:** CITY OF DAVID CITY

## JOHN DEERE 310 P-Tier Backhoe Loader

**Hours:**
**Stock Number:**

Code	Description	Qty
17B1T	310 P-Tier Backhoe Loader	1
<b>Standard Options - Per Unit</b>		
183N	JDLink™	1
0202	United States	1
0259	English	1
0351	Translated Text Labels	1
0606	Level 2 Cab	1
0651	Level 1 Performance Package	1
0950	Less Vision System	1
1205	Basic Package Radio	1
3006	Powershift Transmission - Mechanical Front Wheel Drive (MFWD) with Open Differential	1
4006	John Deere 4.5L - FT4/Stage IV	1
5247	Galaxy 19.5L-24 12PR Rear & 12- 16.5 R4 12PR Front	1
6155	Dual Batteries with Disconnect and Jump Post	1
6576	1000 lb. (454 kg.) Front Counterweight	1
6752	Extendible Dipperstick	1
7001	Auxiliary Hydraulics with One Way Flow (Hammer)	1
7028	Pilot Controls, Two Lever, with Pattern Selection	1
7037	Two-Function Loader Hydraulics, Single Lever	1
7705	Multi-Brand Quick Coupler - Less Thumb	1
7806	24 in. (611 mm.) Heavy-Duty Bucket, 6.9 cu. ft. (0.20 cu. m.)	1
7870	86 in. (2.18 m.) General Purpose Bucket, 1.31 cu. yd. (1.00 cu. m.)	1
8089	Engine Coolant Heater	1

# Selling Equipment

**Quote Id:** 33479287**Customer:** CITY OF DAVID CITY

8096	Premium Mirrors - Exterior Rear View Mirrors (2) and Front View Mirror (1)	1
8109	Flip-down Front Sun Visor	1

<b>Customer:</b> DAVID CITY, CITY OF <b>Address:</b> CITY OF DAVID CITY PO BOX 191 DAVID CITY NE 68632-0191  <b>County:</b> BUTLER <b>PO:</b> <b>Phone:</b> 402-367-3109	<b>Seller:</b> TITAN MACHINERY-LINCOLN <b>Address:</b> 6310 N 56TH ST LINCOLN NE 68504-1764  <b>Phone:</b> 402-464-3711 <b>PLUTA, RYAN A.</b>
<b>Sales Tax Possession / Receiving Location:</b> <b>NE, BUTLER, DAVID CITY</b>	

**NOTICE TO PURCHASER**

1. Read this contract before you sign it.
2. You are entitled to an exact and completely filled in copy of this contract when you sign it. Keep it to protect your legal rights.
3. Purchaser acknowledges receipt of a fully completed copy of this contract and Purchaser waives notice of the acceptance or rejection of this order by the seller.
4. The Acknowledgments and Additional Terms and Conditions are a part of this contract and are incorporated herein by reference.

**Purchased Equipment Information**

Type	Product	PDI	Warranty	Unit #	Serial Number	Sales Price
New	CASE, 580SN, BACKHOE	No	STANDARD FACTORY	E00422104	JJGN58SNLRC785664	138,000.00
Addendum Subtotal Price						<b>0.00</b>

<b>Trade-In Equipment Information</b>	<b>1. Total Sales Price</b>	138,000.00
---------------------------------------	-----------------------------	------------

I (we) offer to sell, transfer and convey the following item(s) at or prior to the time of delivery of the above product, as a "trade-in" to be applied against the cash price. Such items shall be free and clear of all security agreements, liens, and encumbrances at the time of transfer to you. The following is a description and the price allowed for each item.

Description of Trade In	Unit #	Serial Number	Amount
CASE, 580SN, BACKHOE	E00404392	NDC585585	40,000.00
Addendum Subtotal Price			<b>0.00</b>

Tax Breakdown	Amount	2. Total Trade In Allowance	40,000.00
		<b>3. Balance</b>	98,000.00
		<b>4. Total Tax</b>	0.00
		<b>5. Other Options, Charges, Fees</b>	0.00
		<b>6. Trade Payoff / Pre Barter</b>	0.00
<b>Total Taxes</b>	0.00	<b>7. Total Due</b>	98,000.00
<b>Other Options, Charges, Fees</b>	<b>Amount</b>	<b>SETTLEMENT</b>	
FINANCE FEES	0.00	<b>8. Cash Payment</b>	0.00
		<b>9. Cash Due:</b>	0.00
		<b>10. Retail Installment Contract</b>	98,000.00
Addendum Subtotal Price	0.00	<b>11. Total Settlement</b>	98,000.00
<b>Total Other Options, Charges and Fees</b>	<b>0.00</b>		

**It is understood that this is the entire agreement between the parties**

Customer: \_\_\_\_\_ Date \_\_\_\_\_ Salesperson: \_\_\_\_\_  
PLUTA, RYAN A.

Customer: \_\_\_\_\_ Date \_\_\_\_\_ Accepted By: \_\_\_\_\_



Quotation Number: **RK1442786**  
 Quote Sent Date: **Oct 06, 2025**  
 Expiration Date: **Dec 05, 2025**  
 Prepared By: **Rick Kraft**  
 Phone: (308) 390-9010  
 Email: rick@cnebobcat.com

Customer  
**City of David City Water Dept.**  
 1220 E ST  
 DAVID CITY, NE, 68632-1825

Contact  
**ANTHONY ANTHONY**  
 Phone: 1-402-367-2340  
 Email: dcwatersup@davidcityne.gov

Dealer  
**Central Nebraska Bobcat, Grand Island, NE**  
 3809 WESTGATE ROAD

Item Name	Item Number	Quantity	Price Each	Total
<b>B760 T4 Bobcat Backhoe Loader</b>	M4816	1	112,317.00	112,317.00
<b>Standard Equipment:</b>				
96 HP 3.4L Tier 4 Bobcat Engine			Glow Plugs	
12 Volt power socket			Interior and Exterior Mirrors	
2" Retractable Seat Belt			Interior Storage Compartments	
Accelerator Pedal			Lift Arm Support	
Auto Throttle			Mechanical Self Leveling Loader	
Auxiliary Hydraulics: Loader and Backhoe			Multi Function Loader Joystick w/ Clutch Button, Loader Aux Control, and Differential Lock Button	
Back-up Alarm			Operator Canopy: Roll Over Protective Structure (ROPS) meets ISO 3471; Falling Object Protective Structure (FOPS) meets ISO 3449 Level II	
Battery Disconnect Switch			Pilot Backhoe controls w/Auxiliary Hydraulic and Extendable Arm selector	
Instrumentation: Standard 5" Display with Keyless Start, Engine Temperature & Fuel Gauges, Hour meter, RPM and Warning Indicators. Includes maintenance interval notification, fault display, job codes, quick start, and security lockouts.			Pin On Buckets	
Differential Lock			Return to Dig function	
USB Charger with Type A & C			Ride Control	
Engine and Hydraulics Systems De-rate			Rotating Beacon	
Extendable Arm			Tie Down Points	
Fold Down Backhoe Stabilizers			Tilt Steering Column	
Foot Control for Backhoe Auxiliary/Extendable Arm Control			Travel Direction Control Lever w/Four Gear selection	
Four Wheel Drive			Vinyl Suspension Seat	
Front Horn			Work lights - (2 front & 2 rear)	
			Warranty: 2 years, or 2000 hours whichever occurs first	
<b>Cabin w/HVAC</b>	M4816-R01-C02	1	9,450.00	9,450.00
<b>90" General Purpose bucket</b>	M4816-R04-C01	1	3,500.00	3,500.00
<b>24" Backhoe Bucket</b>	M4816-R05-C01	1	1,450.00	1,450.00
<b>32" Bucket Rear BH760</b>	7443866	1	1,500.00	1,500.00
<b>Total for B760 T4 Bobcat Backhoe Loader</b>				<b>128,217.00</b>
			Quote Subtotal	128,217.00
			Dealer PDI	650.00
			Tariff Surcharge	0.00
			Freight Charges	3,300.00
			Destination Charges	90.00
			State Contract Discount	-30,772.08
			2013yr Case 580 W/BKTS	-36,500.00
			Sales Total before Taxes	64,984.92
			Taxes	0.00

**Quote Total - USD**

**64,984.92**

**Customer Acceptance:**

Quotation Number: **RK1442786**

Purchase Order: \_\_\_\_\_

**Authorized Signature:**

Print: \_\_\_\_\_ Sign: \_\_\_\_\_

Date: \_\_\_\_\_ Email: \_\_\_\_\_ Tax Exempt: Y  / N

# Brothers Equipment, Inc.

Serving The Agriculture Industry Since 1975  
 1002 First Street, Friend, NE 68359  
 (800) 228-4582 FAX: (402) 947-2077

## Price Quotation

**Bill to:**  
 Chris  
 David City NE  
 402-367-3109  
 ckroesing@davidcityne.gov

**Ship to:**  
 Chris  
 David City NE  
 402-367-3109  
 ckroesing@davidcityne.gov

Ter 1

Quote # 004939

Quote Date: 7/17/2025

Expiration Date: 8/1/2025

Part #	Description	Price	Qty	Extend
MC1700	Dalton MC1700 SINGLE Nurse Trailer with 1700 gallon 15 Degree Cone Bottom Tank. Includes (4) 255/22.5 Tires mounted on 22.5 x 8.25 x 8 bolt wheel. (does not include Brakes, Step, Light Kit or Fenders)	\$12,350.00	1	\$12,350.00
PLUMBING	Plumbing Package including 2" Hypro Poly pump with 6.5HP Power Pro Motor, Plumbing to rear of Trailer with (2) Flood Nozzles controlled on/off by Hand Valve at the Pump, A Single 20ft x 1" Hose with Fire Style Nozzle Controlled on/off and Pattern by the Nozzle and A Single 1" Recirculation Circuit with Valve to have on/off when Using Other Functions.	\$1,824.00	1	\$1,824.00
	<b>Options</b>			
BOLTONSTEP	Bolt On Step add: \$108.00 net			
LIGHT KIT	DOT Light Kit Installed add: \$160.00 net			
FENDERS	Bolt On Fenders (pair) add: \$560.00 net			
(2)BRAKES	2 Wheel Brakes on Trailer add: \$1656.00 net			
(4)BRAKES	4 Wheel Brakes on Trailer add: \$2268.00 net			

Subject to Fuel Surcharge at the time of Delivery.

Sales Tax

Total **\$14,174.00**

I Accept the terms and conditions of this quotation

Signature: \_\_\_\_\_

Printed Name: \_\_\_\_\_

Title: \_\_\_\_\_

Terms: 20% Down w/Order, Net on Delivery

Prices Quoted are F.O.B.: FRIEND, NE

Delivery: As Available

(20% Security Deposit Down Payment is Non-Refundable)

**RM165**

# CUTTING YOUR

- Economically Priced
- Easy Installation
- Suitable for Municipal and Agricultural Markets

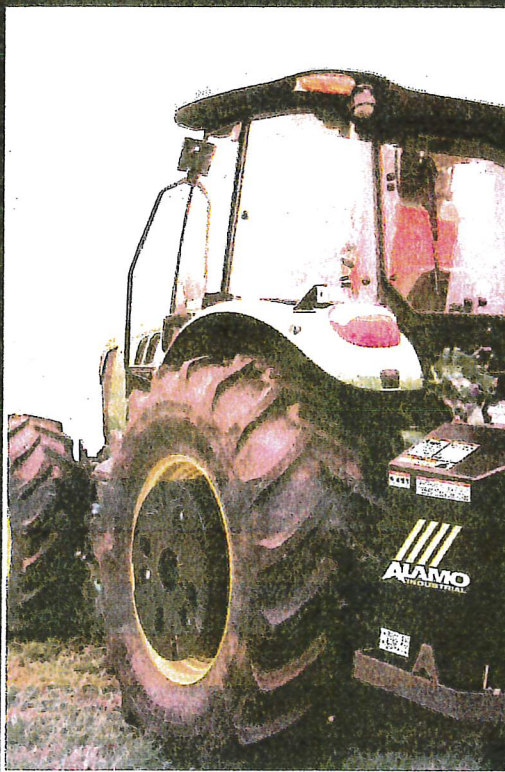

**RM180**

# BUDGET

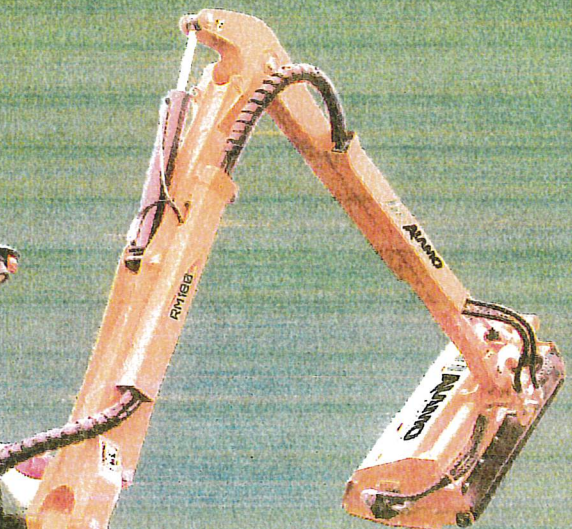

- Self-Contained Hydraulic System
- Integrated Safety Break-Away
- Standard Lift Float with Nitrogen Accumulator
- Electronic Joystick or Cable Controls

## REAR MOUNT BOOM MOWER

# REAR MOUNT BOOM MOWER

## RM165

## RM180

	RM165	RM180
Minimum Horsepower Requirement (PTO hp)	58	65
Minimum Tractor Weight (lbs)	6,615	7,715
Maximum Horizontal Reach (ft/in)	16' 4"	18' 1"
Maximum Vertical Reach (ft/in)	19' 8"	22' 4"
Machine Weight with Flail & Oil (lbs)	2,631	2,701
Output Horsepower (hp)	55	55
Oil Reservoir Capacity (gal)	53	53
Flail Head Option	48"	48"
Rotary Head Option	48" & 60"	48" & 60"
Cutting Capacity	4"	4"
Hitch Design	CAT II	CAT II

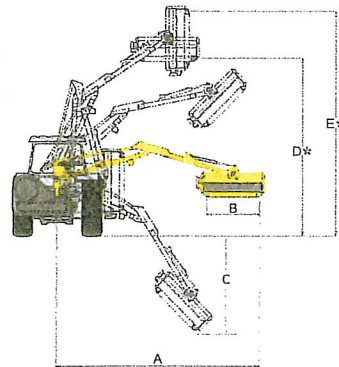

	RM165	RM180
A	16'4"	18'1"
B	48"	48"
C	6'11"	8'2"
D	15'9"	17'5"
E	19'8"	22'4"

This information is intended to be of a general nature only; specifications are subject to change without notice as we continue to improve our products.

© 2019 Alamo Group Inc. Registered trademarks identified are property of Alamo Group Inc.



Always purchase  
genuine OEM parts.  
1-800-882-5762

A Member of Alamo Group

# ALAMO INDUSTRIAL

## BUILT SHARPER

1502 East Walnut St. • Seguin, Texas 78155

1-800-882-5762

[www.alamo-industrial.com](http://www.alamo-industrial.com)



Please submit new orders to: mgras@alamo-group.com

Sourcwell Sales Price, Effective

Quote #	Q-062425-97	Quote Date	6/24/25	Order Date		Sales Order #		Terms	30 Days - XAB
Bill To	David City Street Department Nebraska. Chris Kroesing. (402) 367-3109. ckroesing@davidcityne.gov								
Ship To	TBD								
End User	David City Street Department Nebraska							Member ID	
Servicing Dealer	TBD								
Dealer PO#		End User PO#							
Dealer Contact		End User Contact							
Dealer Phone		End User Phone							
Dealer Email		End User Email							
<b>RM165 and RM180</b>									
Qty	Part Number	Description	List Price	Discount	Sales Price				
<b>Alamo Supplied Tractor</b>									
				17%	\$0.00				
				17%	\$0.00				
<b>Section 1 Base Unit</b>									
	04550004	Rear-mounted boom mower with a reach of 16' feet	\$33,681	17%	\$0.00				
1	04550002	Rear-mounted boom mower with a reach of 18' feet	\$35,506	17%	\$29,469.98				
		<b>Base Unit Includes:</b>							
<b>Section 2 Heads</b>									
	32121139	48" Rotary, Blade Pan	\$14,104	17%	\$0.00				
1	32120530	60" Rotary, Blade Bar	\$15,578	17%	\$12,929.74				
	32120414	48" Flail, Serrated 7 oz Blades (2" Cutting Capacity)	\$14,104	17%	\$0.00				
	02999801	48" Flail, F91 Knives (2" Cutting Capacity)	\$14,660	17%	\$0.00				
	32123213	69" Buzzbar <sup>®</sup> Saw Head, 3 Blade	\$21,874	17%	\$0.00				
<b>Section 3 Options</b>									
	32120917	Wheel Kit for RM Rotary	\$6,817	17%	\$0.00				
		500# Wheel Weight	\$2,300	17%	\$0.00				
<b>Section 4 Installation</b>									
	32123487	Factory mounting	\$2,919	17%	\$0.00				
<b>Section 5 Warranty</b>									
	32121066	Extended Warranty 1 additional year for a total of 2 years	\$2,894	17%	\$0.00				
<b>Section 6 Mount Kit</b>									
1		Wire Harness Adapter	\$0	17%	\$0.00				
0		Lexan Kit	\$0	17%	\$0.00				
<b>Section 7 Freight</b>									
1	ne	Freight from Alamo to Dealer	\$1,867	0%	\$1,867.00				
<b>Notes and Additional Items</b>									
		1. Prior to accepting an order we would like to see pictures of the tractor							
		2. Tractor must have a class 2 hitch and 540 pto.							
		2. Ballast is not included.							
		3. Due to the age of the tractor you will need to make an operator protective window for the right side and rear of the tractor. Lexan or Polycarbonate glass is recommended. Operator protection is needed and the city will be responsible for providing it.							
					<b>Totals</b>				<b>\$44,266.72</b>
Non-Alamo Tractor Information		Make	Model	Transmission	-Cab or ROPS-	-2wd or 4wd-	Front Tire	Rear Tire	ETA
SN:		1980 John Deere	4440		cab	2wd			

Accepted By: \_\_\_\_\_

Date: \_\_\_\_\_

Quotations are valid for 30 days, prices are subject without notice.  
 Dealer supplied tractors require a review of the build codes prior to accepting an order.  
 Standard Terms of Sale Apply.  
 Gov Mowing Territory Managers can supply standard tractor build codes upon request.  
 Refer to tractor adaptability list or consult a Gov Mowing TM for tractor / mower compatibility questions.



**AGREEMENT  
BETWEEN CLIENT AND JEO CONSULTING GROUP, INC.  
FOR  
PROFESSIONAL SERVICES**

THIS IS AN AGREEMENT effective as \_\_\_\_\_ (“Effective Date”) between David City, Nebraska (“Client”) and JEO Consulting Group, Inc. (“JEO”).

Client’s project, of which JEO’s services under this Agreement are a part, is generally identified as follows:

David City Ballfield Restroom Addition (“Project”).

JEO Project Number: 251890.00

Client and JEO further agree as follows:

**ARTICLE 1 - SERVICES OF JEO**

---

**1.01 Scope**

- A. JEO shall provide, or cause to be provided, the services set forth in Exhibit A.

**ARTICLE 2 - CLIENT’S RESPONSIBILITIES**

---

**2.01 Client Responsibilities**

- A. Client responsibilities are outlined in Exhibit A and Section 3 of Exhibit B.

**ARTICLE 3 - COMPENSATION**

---

**3.01 Compensation**

- A. Client shall pay JEO as set forth in Exhibit A and per the terms in Exhibit B.
- B. The fee for the Project is: \$40,000.00
- C. The Standard Hourly Rates Schedule shall be adjusted annually (as of approximately January 1st) to reflect equitable changes in the compensation payable to JEO. The current hourly rate schedule can be provided upon request.

**ARTICLE 4 - EXHIBITS AND SPECIAL PROVISIONS**

---

**4.01 Exhibits**

Exhibit A – Scope of Services  
Exhibit B – General Conditions

**4.02 Total Agreement**

- A. This Agreement (consisting of pages 1 to 2 inclusive, together with the Exhibits identified as included above) constitutes the entire agreement between Client and JEO and supersedes all prior written or oral understandings. This Agreement may only be amended, supplemented, modified, or canceled by a duly executed written instrument.

IN WITNESS WHEREOF, the parties hereto have executed this Agreement.

Client: David City, Nebraska

JEO Consulting Group, Inc.

---



---

By: Jessica J. Miller

By: Corey Brodersen

Title: Mayor

Title: Department Leader

Date Signed: \_\_\_\_\_

Date Signed: November 05, 2025

Address for giving notices:

Address for giving notices:

City of David City

JEO Consulting Group, Inc.

490 E. Street

2000 Q Street, Suite 500

David City, NE 68632

Lincoln, NE 68503

---

---



## Appendix A – Scope of Services David City Ballfield Restroom Addition

### **YOUR PROJECT:**

Your project consists of an addition and renovation to the existing concession and restroom building for the David City Ballfields. The scope of the addition and renovation is to add restroom space. The building addition dimensions are anticipated to be approximately 45'-0" x 12'-6". It is anticipated that the building addition will be a wood framed structure with exterior finishes consisting of masonry veneer to match the existing. The intent is to use the existing roof overhang as the ceiling assembly for the addition. The existing restrooms will be renovated to serve as accessible stalls. The building addition is not planned to follow any FEMA design regulations for storm shelter or tornado proofing. JEO's design services will include: limited site civil, architectural, structural, mechanical, plumbing, and electrical design for the building.

### **SCOPE OF SERVICES:**

Based on the project defined above, we propose to provide architectural and engineering services as defined herein.

#### **1) Design - Construction Documents**

JEO shall develop permit/design intent construction documents indicating the scope of work for the addition and renovation of the existing concession/restroom building.

Building design will include the following scope of work:

- Site Civil Design (limited to the area directly adjacent to the building)
  - Limited Pavement Design
- Architectural Design
  - Code review analysis
  - Demolition Plan
  - Design of the building addition layout (floor plan)
  - Design of the building façade (exterior elevations)
  - Development of building sections and details
  - Schedules
  - Overall coordination of the required disciplines
- Structural Design
  - Design of the footing/foundations
  - Footing/foundation details
  - Wall framing and connection details
  - Building concrete slab design
- Mechanical and Electrical Design
  - Design of the building addition's mechanical system
  - Design of the building addition's plumbing system
  - Design of the building addition's electrical system (power and lighting)

#### **2) Bidding (BN): JEO shall provide Bidding services as follows and as requested by the Owner:**

- a. JEO will provide Bidding services as needed based on standard hourly rates.
- b. JEO will assist the Owner in obtaining competitive bids for construction of the project defined above.

- c. JEO will provide construction documents (plans and specifications) to prospective bidders/contractors and suppliers. (see also reimbursable expenses)
- d. JEO will assist in answering Contractor questions and will issue any addenda prior to the bid date.
- e. JEO will assist in the opening of Contractor bids.
- f. JEO will review received bids and will provide the Owner with a recommendation for award of the contract.
- g. JEO will assist in awarding and preparing the contracts for construction.
- h. For this phase of the project JEO has included 1 site visit for the opening of bids.

**1. Construction Administration (CA):**

- a. JEO will provide Construction Administration services as needed on standard hourly rates.
- b. JEO shall provide customary services related to the administration of the Contract between the Owner and the Contractor.
- c. JEO shall be a representative of and shall advise and consult with the Owner during the provision of the Contract Administration Services.
- d. Typical services provided during construction often include but are not limited to the following:
  - i. Shop drawing review
  - ii. Pay request review/approval
  - iii. Change Orders
  - iv. Supplemental Instruction
  - v. Answer Contractor questions
  - vi. Monthly progress meetings
  - vii. Substantial completion
  - viii. Punch list
- e. For this phase of the project, JEO proposes to provide Construction Administration and project oversight services based on hourly rates. We anticipate 4-5 monthly progress meetings during construction along with performing other typical Construction Administration services identified above. In addition, JEO will be onsite to perform the services of a punch list to confirm the project's substantial completion.

The Owner and Architect may rely on this project information as a basis for the initial project scope and fee. Both parties, however, recognize that such information may materially change and, in that event, the Owner and the Architect shall appropriately adjust the Architect's services and compensation as an amendment if there's a change in project scope.

**TERMS AND CONDITIONS:**

- 1. Compensation
  - a. For the Design services described herein, JEO proposes to provide the services for a lump-sum fee of \$40,000.00
  - b. The fee for the services can be broken down as follows:
    - i. Design – Construction Documents = \$40,000.00
    - ii. Bidding = Hourly, with an estimated cost range of \$6,000.00-\$8,000.00
    - iii. Construction Administration = Hourly, with an estimated cost range of \$15,000.00-\$25,000.00.

**1) REIMBURSABLE EXPENSES**

- a) Reimbursable expenses shall be as defined below and will be invoiced to you at their cost.
  - i) Cost of reproduction of contract documents for bidding and/or construction.
  - ii) Any required permitting fees.
- b) Reimbursable expenses shall be billed monthly.

**2) ADDITIONAL SERVICES**

- a) For Additional Services requested by the Owner and as defined herein, work shall be completed at standard hourly rates:
- b) Typical additional services include but may not be limited to:
  - i) assistance during the construction/construction administration phase.
  - ii) evaluation of substitutions proposed by the Owner's consultants or contractors and making subsequent revisions to Instruments of Service resulting therefrom.
  - iii) increase in project scope.

**3) CONTRACT TIME**

- a) If the Basic Design / Construction Document Services covered by this Agreement have not been completed by May 1, 2026, through no fault of JEO, extension of JEO's services beyond that time shall be compensated as additional services.

**JEO CONSULTING GROUP INC ■ JEO ARCHITECTURE INC****GENERAL CONDITIONS**

**1. SCOPE OF SERVICES:** JEO Consulting Group, Inc. ("JEO") shall perform the services described in Exhibit A. JEO shall invoice the client for these services at the fee stated in Exhibit A.

**2. ADDITIONAL SERVICES:** JEO can perform work beyond the scope of services, as additional services, for a negotiated fee or at fee schedule rates.

**3. CLIENT RESPONSIBILITIES:** The client shall provide all criteria and full information as to the client's requirements for the project; designate and identify in writing a person to act with authority on the client's behalf in respect to all aspects of the project; examine and respond promptly to JEO's submissions; and give prompt written notice to JEO whenever the client observes or otherwise becomes aware of any defect in work.

Unless otherwise agreed, the client shall furnish JEO with right-of-access to the site in order to conduct the scope of services. Unless otherwise agreed, the client shall also secure all necessary permits, approvals, licenses, consents, and property descriptions necessary to the performance of the services hereunder. While JEO shall take reasonable precautions to minimize damage to the property, it is understood by the client that in the normal course of work some damage may occur, the restoration of which is not a part of this agreement.

Client is responsible for paying the sales tax/fees on services provided, if sales tax/fees are required by the jurisdiction of the project. This amount may not be included in the fee for the project.

**4. TIMES FOR RENDERING SERVICES:** JEO's services and compensation under this agreement have been agreed to in anticipation of the orderly and continuous progress of the project through completion. Unless specific periods of time or specific dates for providing services are specified in the scope of services, JEO's obligation to render services hereunder shall be for a period which may reasonably be required for the completion of said services.

If specific periods of time for rendering services are set forth or specific dates by which services are to be completed are provided, and if such periods of time or date are changed through no fault of JEO, the rates and amounts of compensation provided for herein shall be subject to equitable adjustment. If the client has

requested changes in the scope, extent, or character of the project, the time of performance of JEO's services shall be adjusted equitably.

**5. INVOICES:** JEO shall submit invoices to the client monthly for services provided to date and a final bill upon completion of services. Invoices are due and payable within 30 days of receipt. Invoices are considered past due after 30 days. Client agrees to pay a finance charge on past due invoices at the rate of 1.0% per month, or the maximum rate of interest permitted by law.

If the client fails to make any payment due to JEO for services and expenses within 30 days after receipt of JEO's statement, JEO may, after giving 7 days' written notice to the client, suspend services to the client under this agreement until JEO has been paid in full all amounts due for services, expenses, and charges.

**6. STANDARD OF CARE:** The standard of care for all services performed or furnished by JEO under the agreement shall be the care and skill ordinarily used by members of JEO's profession practicing under similar circumstances at the same time and in the same locality. JEO makes no warranties, express or implied, under this agreement or otherwise, in connection with JEO's services.

JEO shall be responsible for the technical accuracy of its services and documents resulting therefrom, and the client shall not be responsible for discovering deficiencies therein. JEO shall correct such deficiencies without additional compensation except to the extent such action is directly attributable to deficiencies in client furnished information.

**7. REUSE OF DOCUMENTS:** Reuse of any materials (including in part plans, specifications, drawings, reports, designs, computations, computer programs, data, estimates, surveys, other work items, etc.) by the client on a future extension of this project, or any other project without JEO's written authorization shall be at the client's risk and the client agrees to indemnify and hold harmless JEO from all claims, damages, and expenses including attorney's fees arising out of such unauthorized use.

**8. ELECTRONIC FILES:** Copies of Documents that may be relied upon by the client are limited to the printed copies (also known as hard copies) that are signed or sealed by JEO. Files in electronic media format of text,

# JEO CONSULTING GROUP INC ■ JEO ARCHITECTURE INC

## GENERAL CONDITIONS

data, graphics, or of other types that are furnished by JEO to the client are only for convenience of the client. Any conclusion or information obtained or derived from such electronic files shall be at the user's sole risk.

a. Because data stored in electronic media format can deteriorate or be modified inadvertently or otherwise without authorization of the data's creator, the party receiving electronic files agrees that it shall perform acceptance tests or procedures within 30 days, after which the receiving party shall be deemed to have accepted the data thus transferred. Any errors detected within the 30 day acceptance period shall be corrected by the party delivering the electronic files. JEO shall not be responsible to maintain documents stored in electronic media format after acceptance by the client.

b. When transferring documents in electronic media format, JEO makes no representations as to long term compatibility, usability, or readability of documents resulting from the use of software application packages, operating systems, or computer hardware differing from those used by JEO at the beginning of the project.

c. The client may make and retain copies of documents for information and reference in connection with use on the project by the client.

d. If there is a discrepancy between the electronic files and the hard copies, the hard copies govern.

e. Any verification or adaptation of the documents by JEO for extensions of the project or for any other project shall entitle JEO to further compensation at rates to be agreed upon by the client and JEO.

**9. SUBCONSULTANTS:** JEO may employ consultants as JEO deems necessary to assist in the performance of the services. JEO shall not be required to employ any consultant unacceptable to JEO.

**10. INDEMNIFICATION:** To the fullest extent permitted by law, JEO and the client shall indemnify and hold each other harmless and their respective officers, directors, partners, employees, and consultants from and against any and all claims, losses, damages, and expenses (including but not limited to all fees and charges of engineers, architects, attorneys, and other professionals, and all court or arbitration or other dispute resolution costs) to the extent such claims, losses, damages, or expenses are caused by the indemnifying parties' negligent acts, errors, or omissions. In the event claims, losses, damages, or expenses are caused by the joint or concurrent

negligence of JEO and the client, they shall be borne by each party in proportion to its negligence.

**11. INSURANCE:** JEO shall procure and maintain the following insurance with limits not less than shown during the performance of services under this agreement:

a. Workers' Compensation: Statutory

b. Employer's Liability

i. Each Accident: \$500,000

ii. Disease, Policy Limit: \$500,000

iii. Disease, Each Employee: \$500,000

c. General Liability

i. Each Occurrence (Bodily Injury and Property Damage): \$1,000,000

ii. General Aggregate: \$2,000,000

d. Auto Liability

i. Combined Single: \$1,000,000

e. Excess or Umbrella Liability

i. Each Occurrence: \$1,000,000

ii. General Aggregate: \$1,000,000

f. Professional Liability:

i. Each Occurrence: \$1,000,000

ii. General Aggregate: \$2,000,000

g. All policies of property insurance shall contain provisions to the effect that JEO and JEO's consultants' interests are covered and that in the event of payment of any loss or damage the insurers shall have no rights of recovery against any of the insureds or additional insureds thereunder.

h. For projects with construction services, the client shall require the contractor to purchase and maintain general liability and other insurance as specified in the Contract Documents and to cause JEO and JEO's consultants to be listed as additional insured with respect to such liability and other insurance purchased and maintained by the contractor for the project.

i. The client shall reimburse JEO for any additional limits or coverages that the client requires for the project.

**12. TERMINATION:** This agreement may be terminated by either party upon 7 days prior written notice. In the event of termination, JEO shall be compensated by client for all services performed up to and including the termination date. The effective date of termination may be set up to thirty (30) days later than otherwise provided to allow JEO to demobilize personnel and equipment from the site, to complete tasks whose value would otherwise be lost, to prepare notes as to the status of completed and uncompleted tasks, and to assemble project materials in orderly files.

# JEO CONSULTING GROUP INC ■ JEO ARCHITECTURE INC

## GENERAL CONDITIONS

**13. GOVERNING LAW:** This agreement is to be governed by the law of the state in which the project is located.

**14. SUCCESSORS, ASSIGNS, AND BENEFICIARIES:** The client and JEO each is hereby bound and the partners, successors, executors, administrators and legal representatives of the client and JEO are hereby bound to the other party to this agreement and to the partners, successors, executors, administrators and legal representatives (and said assigns) of such other party, with respect to all covenants, agreements and obligations of this agreement.

a. Neither the client nor JEO may assign, sublet, or transfer any rights under or interest (including, but without limitation, monies that are due or may become due) in this agreement without the written consent of the other, except to the extent that any assignment, subletting, or transfer is mandated or restricted by law. Unless specifically stated to the contrary in any written consent to an assignment, no assignment shall release or discharge the assignor from any duty or responsibility under this agreement.

b. Unless expressly provided otherwise in this agreement: Nothing in this agreement shall be construed to create, impose, or give rise to any duty owed by the client or JEO to any contractor, contractor's subcontractor, supplier, other individual or entity, or to any surety for or employee of any of them.

c. All duties and responsibilities undertaken pursuant to this agreement shall be for the sole and exclusive benefit of the client and JEO and not for the benefit of any other party.

**15. PRECEDENCE:** These standards, terms, and conditions shall take precedence over any inconsistent or contradictory language contained in any proposal, contract, purchase order, requisition, notice to proceed, or like document regarding JEO's services.

**16. SEVERABILITY:** Any provision or part of the agreement held to be void or unenforceable shall be deemed stricken, and all remaining provisions shall continue to be valid and binding upon the client and JEO, who agree that the agreement shall be reformed to replace such stricken provision or part thereof with a valid and enforceable provision that comes as close as possible to expressing the intention of the stricken provision.

**17. NON-DISCRIMINATION CLAUSE:** Pursuant to Neb. Rev. Stat. § 73-102, the parties declare, promise, and warrant that they have and will continue to comply fully with Title VI of the Civil Rights Act of 1964, as amended (42 U.S.C.A § 1985, et seq.) and the Nebraska Fair Employment Practice Act, Neb. Rev. Stat. § 48-1101, et seq., in that there shall be no discrimination against any employee who is employed in the performance of this agreement, or against any applicant for such employment, because of age, color, national origin, race, religion, creed, disability or sex.

**18. E-VERIFY:** JEO shall register with and use the E-Verify Program, or an equivalent federal program designated by the United States Department of Homeland Security or other federal agency authorized to verify the work eligibility status of a newly hired employee pursuant to the Immigration Reform and Control Act of 1986, to determine the work eligibility status of new employees physically performing services within the state where the work shall be performed. Engineer shall require the same of each consultant.

**19. WAIVER OF CONSEQUENTIAL DAMAGES:** Client and JEO expressly waive any and all claims for consequential damages for the Project including, but not limited to, loss of use, profits, business, reputation, financing, rental expenses, loss of income, and overhead.

**20. DISPUTE RESOLUTION:** In the event of any dispute between the Parties related to the Project, the Parties agree to first negotiate in good faith toward a resolution with participation by representatives of each Party holding sufficient authority to resolve the dispute. If such dispute cannot be resolved within fifteen (15) business days, before any action or litigation is initiated other than as required to secure lien rights, the dispute shall be submitted to mediation using a mediator mutually selected by the Parties. Such mediation shall be completed within forty-five (45) days of either the Party's written demand, with each Party to bear its share of the mediation fees and its own respective costs.



November 1, 2025

City of David City  
Mayor and City Council  
490 E Street  
David City, NE 68632

**RE: City of David City 2026 City Engineer Appointment Request**

Dear Mayor and City Council:

I ask that you appoint JEO Consulting Group, Inc. as the city engineer for 2026. We appreciate your confidence in JEO in the past, and we sincerely hope to continue our relationship.

JEO has provided services to the city in the past, and our staff has accumulated extensive "institutional knowledge" about your city and its infrastructure. This is extremely important as it provides the background information needed to evaluate what actions to take. Additionally, this knowledge often allows JEO staff to respond to questions about the city and its infrastructure without extensive investigation and research, reducing the time and cost involved in addressing routine matters.

Below is what you can expect from JEO as your city engineer. When a fee is involved for services, as noted in items two through four below, JEO will notify you before beginning work.

- **IDENTIFYING AND PRIORITIZING INFRASTRUCTURE PROJECTS:**  
If requested, JEO will attend a council or committee meeting to identify and prioritize infrastructure projects in the city. This planning may include prioritizing capital and infrastructure improvements, summary reviews of new permits and their potential impact, information on new regulations, recommendations on future planning, and input on potential funding sources. This does not entail detailed studies or evaluations but can be a valuable first step in assessing potential infrastructure projects' needs, priorities, and feasibility. There is no charge for JEO to attend this meeting or prepare and follow up on the meeting.
- **APPLYING AND SECURING FUNDING:** JEO will assist in applying for and securing funding, such as CDBG, USDA-RD, DWSRF, and CWSRF for potential infrastructure projects, as well as more non-traditional funding from both public and private sources. Additionally, JEO will provide the information necessary to complete the reporting requirements of any funding the city may secure. JEO has staff devoted to assisting municipalities in locating the funding that makes projects a reality. In some cases, having an appointed city engineer can expedite moving a project forward when grant and loan funding is involved. There may be a fee for some of these services, and we would be happy to discuss this with you.
- **ROUTINE INFRASTRUCTURE OPERATION AND MAINTENANCE:** JEO will respond to questions about the routine operation and maintenance of the city infrastructure based on our prior knowledge of these facilities/systems. There is typically no charge for this service. However, in some instances a fee may be involved, such as site visits or research.

- **COST OPINIONS:** Throughout the year, JEO will provide additional assistance with identifying, prioritizing, and providing rough cost opinions for potential infrastructure projects. Depending on some factors, such as the effort required to complete the requested task, there may be a fee involved for this service. However, as noted above, JEO's extensive institutional knowledge about the city and its infrastructure will be utilized to provide this service efficiently and effectively.

When requested, JEO will provide a scope of services and fees for specific projects that the city would desire to pursue.

JEO does not require a contract or retainer to serve as the city engineer. Instead, we strive to assist you in efficiently and effectively dealing with routine matters, so we will be the first firm considered by the city when you need consulting services for a project. In other words, all we request is the opportunity to earn your business.

We would appreciate you notifying us of your action on this request to keep our records up to date. Please take a few minutes to complete the form below. Then, please return the form along with a copy of your meeting minutes to Ava Dunne at [adunne@jeo.com](mailto:adunne@jeo.com). If appointed, please record the motion in your minutes as follows: **"We appoint JEO Consulting Group, Inc. as our City Engineer for 2026."**

If you have questions about this letter or want further information, don't hesitate to contact me. Thank you for your consideration.

Sincerely,

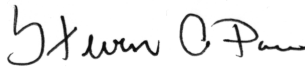

Steven A. Parr  
Principal  
JEO Consulting Group, Inc.

Mobile: 402.443.8003 | Email: [sparr@jeo.com](mailto:sparr@jeo.com)

---

## 2026 ENGINEER APPOINTMENT REQUEST

The City of David City has appointed JEO Consulting Group, Inc. as the city engineer:

Yes     No

Notes: \_\_\_\_\_

\_\_\_\_\_

Form Completed By (please print name)

Date

**\*Please include a copy of your meeting minutes.**

Illustration prepared by



**JONESGROUP**  
INSURANCE | FINANCIAL SERVICES

CITY OF DAVID CITY  
Group Health Plan Considerations  
1/1/2026 Effective Date

HSA PLAN *All benefits for in-network providers*	Current		Renewal		-----Guaranteed Issue Plans-----			
	Allstate Aetna ASA Network Embedded Ded	Allstate Aetna ASA Network Embedded Ded	Medica 3400-0% Embedded Ded	Medica 3400-0% + Rx Copays Embedded Ded	BCBS Chamber Choice CHF26 Aggregate Ded	UHC EPZS Aggregate Ded	Medica 3400-0% HSA Embedded Ded	
	Level Funded	Level Funded	Level Funded	Level Funded	Level Funded	Level Funded	Level Funded	
DEDUCTIBLE	\$3,500/\$7,000	\$3,500/\$7,000	\$3,400/\$6,800	\$3,400/\$6,800	\$3,000/6,000	\$2,500/5,000	\$3,400/\$6,800	
COINSURANCE	0%	0%	0%	0%	0%	0%	0%	
OOP MAXIMUM-with copays	\$3,500/\$7,000	\$3,500/\$7,000	\$3,400/\$6,800	\$4,300/\$8,600	\$3,000/6,000	\$7,000/\$14,000	\$3,400/\$6,800	
OFFICE VISIT - PCP	Deductible	Deductible	Deductible	Deductible	Deductible	Deductible	Deductible	
SPECIALIST VISIT	Deductible	Deductible	Deductible	Deductible	Deductible	Deductible	Deductible	
URGENT CARE VISIT	Deductible	Deductible	Deductible	Deductible	Deductible	Deductible	Deductible	
ER VISIT	Deductible	Deductible	Deductible	Deductible	Deductible	Ded, then \$500	Deductible	
RX COPAYS								
Generic	Deductible	Deductible	Deductible	Ded, then \$12	Deductible	Ded, then \$10	Deductible	
Preferred Brand	Deductible	Deductible	Deductible	Ded, then \$50	Deductible	Ded, then \$40	Deductible	
Non-Preferred Brand	Deductible	Deductible	Deductible	Ded, then \$90	Deductible	Ded, then \$105	Deductible	
Specialty	Deductible	Deductible	Deductible	Ded, then \$200 or 40%	Deductible	Ded, then \$250 or \$500	Deductible	
RATES				Prev Rx covered 100%				
Employee Only	\$665.73	\$1,211.73	\$698.24	\$682.20	\$667.46	AGE RATED	AGE RATED	
Employee + Spouse	\$1,697.59	\$3,089.90	\$1,536.12	\$1,500.83	\$1,368.29			
Employee + Children	\$1,298.17	\$2,362.86	\$1,326.65	\$1,296.18	\$1,168.05			
Employee + Family	\$2,196.88	\$3,998.70	\$2,234.34	\$2,183.02	\$1,935.63			
Total Monthly	\$35,083.66	\$63,858.04	\$35,609.96	\$34,792.00	\$31,837.79	\$53,992.44	\$44,145.09	
Total Yearly	\$421,003.92	\$766,296.48	\$427,319.52	\$417,504.00	\$382,053.48	\$647,909.28	\$529,741.08	
% change from current		82.02%	1.50%	-0.83%	-9.25%	53.90%	25.83%	

All rates subject to change with significant change in census. This is a summary illustration only and is not a binding contract or guarantee of rates. Please refer to individual proposals for terms and conditions.

**RESOLUTION NO. 24- 2025**

A RESOLUTION OF THE MAYOR AND CITY COUNCIL OF DAVID CITY, NEBRASKA, RATIFYING AND AUTHORIZING THE FILING AND PURSUIT OF CERTAIN LITIGATION RELATED TO THE CITY'S WASTEWATER TREATMENT PLAN IMPROVEMENT PROJECT.

WHEREAS, in accordance with Nebraska Revised Statutes section 84-1410(1)(a), the Mayor and City Council of the City of David City, Nebraska, a municipal corporation and city of the second class (the "City"), previously entered into and held a closed session meeting regarding certain litigation matters pertaining to claims and damages of the City as against Veenstra & Kimm, Inc., H. Robert Veenstra, Jr., and General Excavating, LLC in relation to that certain wastewater treatment plant improvement project undertaken by the City (the "Claims"); and

WHEREAS, in accordance with Nebraska Revised Statutes section 84-1410(2), the City did not take any formal action with respect to the Claims during the closed session; and

WHEREAS, following the closed session, on the advice and consent of the City's legal counsel pertaining to the preservation of the Claims, the City filed a complaint asserting the Claims against the above-named parties (the "Complaint"); and

WHEREAS, the Mayor and City Council of the City now wish to ratify and approve the filing of the Complaint, authorize City's legal counsel to initiate and pursue litigation of the Claims against the above-named parties on the City's behalf, and take other such actions as reasonably necessary to effectuate recovery by the City in relation to the Claims; and finds it in the best interest of the City and its residents to do so.

NOW, THEREFORE, BE IT RESOLVED BY THE MAYOR AND CITY COUNCIL OF THE CITY OF DAVID CITY, NEBRASKA:

1. The Complaint and filing thereof, as well as any other prior actions undertaken by the City or its legal counsel with respect thereto, is hereby ratified and approved.
2. The City's legal counsel is authorized to initiate and pursue litigation of the Claims against the parties named in the Complaint, and take other such actions as reasonably necessary to effectuate recovery by the City in relation to the Claims, all on the City's behalf and in the best interest of the City and its residents.
3. This resolution shall be in full force and effect from and after passage and approval.

PASSED AND APPROVED THIS 12th day of November, 2025.

---

Mayor Jessica Miller

ATTEST

---

Lori Matchett, Deputy City Clerk