

City Council Regular Meeting  
Monday, May 4, 2026 6:00 PM  
Columbus Community Building/Community Room  
2500 14 Street  
Columbus, NE 68601

The Mayor and City Council reserve the right to go into closed session as per Section 84-1410 of the Nebraska Revised Statutes. A current agenda is on file at City Hall, 2500 14 Street, Columbus, Nebraska. For more information, call 402-562-4224 or visit our website at [www.columbusne.us](http://www.columbusne.us).

**1. STATEMENT OF COMPLIANCE WITH OPEN MEETINGS ACT AND ROLL CALL**

#### **...4-1407. Act, how cited.**

Sections 84-1407 to 84-1414 shall be known and may be cited as the Open Meetings Act.

**Source:** Laws 2004, LB 821, § 34.

#### **84-1408. Declaration of intent; meetings open to public.**

It is hereby declared to be the policy of this state that the formation of public policy is public business and may not be conducted in secret.

Every meeting of a public body shall be open to the public in order that citizens may exercise their democratic privilege of attending and speaking at meetings of public bodies, except as otherwise provided by the Constitution of Nebraska, federal statutes, and the Open Meetings Act.

**Source:** Laws 1975, LB 325, § 1; Laws 1996, LB 900, § 1071; Laws 2004, LB 821, § 35.

## **Annotations**

- Nebraska's public meetings laws do not apply to school board deliberations pertaining solely to disputed adjudicative facts. *McQuinn v. Douglas Cty. Sch. Dist. No. 66*, 259 Neb. 720, 612 N.W.2d 198 (2000).
- The primary purpose of the public meetings law is to ensure that public policy is formulated at open meetings. *Marks v. Judicial Nominating Comm.*, 236 Neb. 429, 461 N.W.2d 551 (1990).
- The public meetings law is broadly interpreted and liberally construed to obtain the objective of openness in favor of the public, and provisions permitting closed sessions must be narrowly and strictly construed. *Grein v. Board of Education of Fremont*, 216 Neb. 158, 343 N.W.2d 718 (1984).
- Although a committee was a subcommittee of a natural resources district board, it was not subject to the Open Meetings Act because there was never a quorum of board members in attendance and the committee did not hold hearings, make policy, or take formal action on behalf of the board. *Koch v. Lower Loup NRD*, 27 Neb. App. 301, 931 N.W.2d 160 (2019).
- A county board of equalization is a public body whose meetings shall be open to the public. *Wolf v. Grubbs*, 17 Neb. App. 292, 759 N.W.2d 499 (2009).

#### **84-1409. Terms, defined.**

For purposes of the Open Meetings Act, unless the context otherwise requires:

(1)(a) Public body means (i) governing bodies of all political subdivisions of the State of Nebraska, (ii) governing bodies of all agencies, created by the Constitution of Nebraska, statute, or otherwise pursuant to law, of the executive department of the State of Nebraska, (iii) all independent boards, commissions, bureaus, committees, councils, subunits, or any other bodies created by the Constitution of Nebraska, statute, or otherwise pursuant to law, (iv) all study or advisory committees of the executive department of the State of Nebraska whether having continuing existence or appointed as special committees with limited existence, (v) advisory committees of the bodies referred to in subdivisions (i), (ii), and (iii) of this subdivision, and (vi) instrumentalities exercising essentially public functions; and

(b) Public body does not include (i) subcommittees of such bodies unless a quorum of the public body attends a subcommittee meeting or unless such subcommittees are holding hearings, making policy, or taking formal action on behalf of their parent body, except that all meetings of any subcommittee established under section 81-15,175 are subject to the Open Meetings Act, (ii) entities conducting judicial proceedings unless a court or other judicial body is exercising rulemaking authority, deliberating, or deciding upon the issuance of administrative orders, and (iii) the Judicial Resources Commission or subcommittees or subgroups of the commission;

(2) Meeting means all regular, special, or called meetings, formal or informal, of any public body for the purposes of briefing, discussion of public business, formation of tentative policy, or the taking of any action of the public body; and

(3) Virtual conferencing means conducting or participating in a meeting electronically or telephonically with interaction among the participants subject to subsection (2) of section 84-1412.

**Source:** Laws 1975, LB 325, § 2; Laws 1983, LB 43, § 1; Laws 1989, LB 429, § 42; Laws 1989, LB 311, § 14; Laws 1992, LB 1019, § 124; Laws 1993, LB 635, § 1; Laws 1996, LB 1044, § 978; Laws 1997, LB 798, § 37; Laws 2004, LB 821, § 36; Laws 2007, LB296, § 810; Laws 2011, LB366, § 2; Laws 2021, LB83, § 11; Laws 2022, LB922, § 12.

## Annotations

- A township is a political subdivision, and as such, a township board is subject to the provisions of the public meetings laws. *Steenblock v. Elkhorn Township Bd.*, 245 Neb. 722, 515 N.W.2d 128 (1994).
- A county agricultural society is a public body to which the provisions of the Nebraska public meetings law are applicable. *Nixon v. Madison Co. Ag. Soc'y*, 217 Neb. 37, 348 N.W.2d 119 (1984).
- Failure by a public governing body, as defined under section 84-1409, R.R.S.1943, to take and record a roll call vote on an action, as required by section 84-1413(2), R.S.Supp.,1980, grants any citizen the right to sue for the purpose of having the action declared void. In this case such failure could not be later corrected by a nunc pro tunc order because there was no showing that a roll call vote on the disputed action was actually taken, and even if it was the record showed it was not recorded until over a year later. Sections 23-1301, R.R.S.1943, and 23-1302, R.R.S.1943, make it the duty of the county clerk to record proceedings of the board of county commissioners. *State ex rel. Schuler v. Dunbar*, 208 Neb. 69, 302 N.W.2d 674 (1981).
- Although a committee was a subcommittee of a natural resources district board, it was not subject to the Open Meetings Act because there was never a quorum of board members in attendance and the committee did not hold hearings, make policy, or take formal action on behalf of the board. *Koch v. Lower Loup NRD*, 27 Neb. App. 301, 931 N.W.2d 160 (2019).
- Although the Open Meetings Act does not define "subcommittee," a subcommittee is generally defined as a group within a committee to which the committee may refer business. *Koch v. Lower Loup NRD*, 27 Neb. App. 301, 931 N.W.2d 160 (2019).
- The Open Meetings Act does not require policymakers to remain ignorant of the issues they must decide until the moment the public is invited to comment on a proposed policy. By excluding nonquorum subgroups from the definition of a public body, the Legislature

has balanced the public's need to be heard on matters of public policy with a practical accommodation for a public body's need for information to conduct business. *Koch v. Lower Loup NRD*, 27 Neb. App. 301, 931 N.W.2d 160 (2019).

- As an administrative agency of the county, a county board of equalization is a public body. *Wolf v. Grubbs*, 17 Neb. App. 292, 759 N.W.2d 499 (2009).
- The electors of a township at their annual meeting are a public body under the Open Meetings Act. *State ex rel. Newman v. Columbus Township Bd.*, 15 Neb. App. 656, 735 N.W.2d 399 (2007).
- The meeting at issue in this case was a "meeting" within the parameters of subsection (2) of this section because it involved the discussion of public business, the formation of tentative policy, or the taking of any action of the public power district. *Hansmeyer v. Nebraska Pub. Power Dist.*, 6 Neb. App. 889, 578 N.W.2d 476 (1998).
- Informational sessions in which the governmental body hears reports are briefings. *Johnson v. Nebraska Environmental Control Council*, 2 Neb. App. 263, 509 N.W.2d 21 (1993).

**84-1410. Closed session; when; purpose; reasons listed; procedure; right to challenge; prohibited acts; chance meetings, conventions, or workshops.**

(1) Any public body may hold a closed session by the affirmative vote of a majority of its voting members if a closed session is clearly necessary for the protection of the public interest or for the prevention of needless injury to the reputation of an individual and if such individual has not requested a public meeting. The subject matter and the reason necessitating the closed session shall be identified in the motion to close. Closed sessions may be held for, but shall not be limited to, such reasons as:

(a) Strategy sessions with respect to collective bargaining, real estate purchases, pending litigation, or litigation which is imminent as evidenced by communication of a claim or threat of litigation to or by the public body;

(b) Discussion regarding deployment of security personnel or devices;

(c) Investigative proceedings regarding allegations of criminal misconduct;

(d) Evaluation of the job performance of a person when necessary to prevent needless injury to the reputation of a person and if such person has not requested a public meeting;

(e) For the Community Trust created under section 81-1801.02, discussion regarding the amounts to be paid to individuals who have suffered from a tragedy of violence or natural disaster; or

(f) For public hospitals, governing board peer review activities, professional review activities, review and discussion of medical staff investigations or disciplinary actions, and any strategy session concerning transactional negotiations with any referral source that is required by federal law to be conducted at arms length.

Nothing in this section shall permit a closed meeting for discussion of the appointment or election of a new member to any public body.

(2) The vote to hold a closed session shall be taken in open session. The entire motion, the vote of each member on the question of holding a closed session, and the time when the closed session commenced and concluded shall be recorded in the minutes. If the motion to close

passes, then the presiding officer immediately prior to the closed session shall restate on the record the limitation of the subject matter of the closed session. The public body holding such a closed session shall restrict its consideration of matters during the closed portions to only those purposes set forth in the motion to close as the reason for the closed session. The meeting shall be reconvened in open session before any formal action may be taken. For purposes of this section, formal action shall mean a collective decision or a collective commitment or promise to make a decision on any question, motion, proposal, resolution, order, or ordinance or formation of a position or policy but shall not include negotiating guidance given by members of the public body to legal counsel or other negotiators in closed sessions authorized under subdivision (1)(a) of this section.

(3) Any member of any public body shall have the right to challenge the continuation of a closed session if the member determines that the session has exceeded the reason stated in the original motion to hold a closed session or if the member contends that the closed session is neither clearly necessary for (a) the protection of the public interest or (b) the prevention of needless injury to the reputation of an individual. Such challenge shall be overruled only by a majority vote of the members of the public body. Such challenge and its disposition shall be recorded in the minutes.

(4) Nothing in this section shall be construed to require that any meeting be closed to the public. No person or public body shall fail to invite a portion of its members to a meeting, and no public body shall designate itself a subcommittee of the whole body for the purpose of circumventing the Open Meetings Act. No closed session, informal meeting, chance meeting, social gathering, email, fax, or other electronic communication shall be used for the purpose of circumventing the requirements of the act.

(5) The act does not apply to chance meetings or to attendance at or travel to conventions or workshops of members of a public body at which there is no meeting of the body then intentionally convened, if there is no vote or other action taken regarding any matter over which the public body has supervision, control, jurisdiction, or advisory power.

**Source:** Laws 1975, LB 325, § 3; Laws 1983, LB 43, § 2; Laws 1985, LB 117, § 1; Laws 1992, LB 1019, § 125; Laws 1994, LB 621, § 1; Laws 1996, LB 900, § 1072; Laws 2004, LB 821, § 37; Laws 2004, LB 1179, § 1; Laws 2006, LB 898, § 1; Laws 2011, LB390, § 29; Laws 2012, LB995, § 17.

## Annotations

- There is no absolute discovery privilege for communications that occur during a closed session. *State ex rel. Upper Republican NRD v. District Judges*, 273 Neb. 148, 728 N.W.2d 275 (2007).
- If a person present at a meeting observes a public meetings law violation in the form of an improper closed session and fails to object, that person waives his or her right to object at a later date. *Wasikowski v. Nebraska Quality Jobs Bd.*, 264 Neb. 403, 648 N.W.2d 756 (2002).
- The public interest mentioned in this section is that shared by citizens in general and by the community at large concerning pecuniary or legal rights and liabilities. *Grein v. Board of Education*, 216 Neb. 158, 343 N.W.2d 718 (1984).
- Hearing in closed executive session was contrary to this section since there was no showing of necessity or reason under subdivision (1)(a), (b), or (c), but did not result in reversal of board decision. *Simonds v. Board of Examiners*, 213 Neb. 259, 329 N.W.2d 92

(1983).

- Negotiations for the purchase of land need not be conducted at an open meeting but the deliberations of a city council as to whether an offer to purchase real estate should be made should take place in an open meeting. *Pokorny v. City of Schuyler*, 202 Neb. 334, 275 N.W.2d 281 (1979).
- Public meeting law was not violated where the Board of Regents of the University of Nebraska voted to hold a closed session to consider the university president's resignation, and also discussed the appointment of an interim president during such session. *Meyer v. Board of Regents*, 1 Neb. App. 893, 510 N.W.2d 450 (1993).

**84-1411. Meetings of public body; notice; method; contents; when available; right to modify; duties concerning notice; virtual conferencing authorized; requirements; emergency meeting without notice; appearance before public body; applicability of section.**

(1)(a) Except as provided in subsection (9) of this section, each public body shall give reasonable advance publicized notice of the time and place of each meeting as provided in this subsection. Such notice shall be transmitted to all members of the public body and to the public.

(b)(i) Except as provided in subdivision (1)(b)(ii) of this section, in the case of a public body described in subdivision (1)(a)(i) of section 84-1409 or such body's advisory committees, such notice shall be given by:

(A)(I) Publication in a newspaper of general circulation within the public body's jurisdiction that is finalized for printing prior to the time and date of the meeting, (II) posting on such newspaper's website, if available, and (III) posting on a statewide website, if available, established and maintained as a repository for such notices by a majority of Nebraska newspapers. Such notice shall be placed in the newspaper and on the websites by the newspaper; or

(B)(I) Posting to the newspaper's website, if available, and (II) posting to a statewide website, if available, established and maintained as a repository for such notices by a majority of Nebraska newspapers if no edition of a newspaper of general circulation within the public body's jurisdiction is to be finalized for printing prior to the time and date of the meeting. Such notice shall be placed in the newspaper and on the websites by the newspaper.

(ii) In the case of the governing body of a city of the second class or village, any advisory committee of such governing body, or the governing body of a rural or suburban fire protection district, such notice shall be given by:

(A)(I) Publication in a newspaper of general circulation within the public body's jurisdiction that is finalized for printing prior to the time and date of the meeting, (II) posting on such newspaper's website, if available, and (III) posting on a statewide website, if available, established and maintained as a repository for such notices by a majority of Nebraska newspapers. Such notice shall be placed in the newspaper and on the websites by the newspaper;

(B)(I) Posting to the newspaper's website, if available, and (II) posting on a statewide website, if available, established and maintained as a repository for such notices by a majority of Nebraska newspapers if no edition of a newspaper of general circulation within the public body's jurisdiction is to be finalized for printing prior to the time and date of the meeting. Such notice shall be placed in the newspaper and on the websites by the newspaper; or

(C) Posting written notice in three conspicuous public places in such city, village, or district.

Such notice shall be posted by the public body in the same three places for each meeting.

(iii) In the case of a public body not described in subdivision (1)(b)(i) or (ii) of this section, such notice shall be given by a method designated by the public body.

(iv) In case of refusal, neglect, or inability of the newspaper to publish the notice, the public body shall (A) post such notice on its website, if available, (B) request the newspaper submit a post on a statewide website, if available, established and maintained as a repository for such notices by a majority of Nebraska newspapers, and (C) post such notice in a conspicuous public place in such public body's jurisdiction. The public body shall keep a written record of such posting pursuant to subdivision (1)(b)(iv)(A) and (C) of this section and a written record of the request to the newspaper pursuant to subdivision (1)(b)(iv)(B) of this section. The record of such posting shall be evidence that such posting was done as required and shall be sufficient to fulfill the requirement of publication.

(c) In addition to a method of notice required by subdivision (1)(b)(i) or (ii) of this section, such notice may also be provided by any other appropriate method designated by such public body or such advisory committee.

(d) Each public body shall record the methods and dates of such notice in its minutes.

(e) Such notice shall contain an agenda of subjects known at the time of the publicized notice or a statement that the agenda, which shall be kept continually current, shall be readily available for public inspection at the principal office of the public body during normal business hours. Agenda items shall be sufficiently descriptive to give the public reasonable notice of the matters to be considered at the meeting. Except for items of an emergency nature, the agenda shall not be altered later than (i) twenty-four hours before the scheduled commencement of the meeting or (ii) forty-eight hours before the scheduled commencement of a meeting of a city council or village board scheduled outside the corporate limits of the municipality. The public body shall have the right to modify the agenda to include items of an emergency nature only at such public meeting.

(2)(a) The following entities may hold a meeting by means of virtual conferencing if the requirements of subdivision (2)(b) of this section are met:

(i) A state agency, state board, state commission, state council, or state committee, or an advisory committee of any such state entity;

(ii) An organization, including the governing body, created under the Interlocal Cooperation Act, the Joint Public Agency Act, or the Municipal Cooperative Financing Act;

(iii) The governing body of a public power district having a chartered territory of more than one county in this state;

(iv) The governing body of a public power and irrigation district having a chartered territory of more than one county in this state;

(v) An educational service unit;

(vi) The Educational Service Unit Coordinating Council;

(vii) An organization, including the governing body, of a risk management pool or its advisory committees organized in accordance with the Intergovernmental Risk Management Act;

- (viii) A community college board of governors;
- (ix) The Nebraska Brand Committee;
- (x) A local public health department;
- (xi) A metropolitan utilities district;
- (xii) A regional metropolitan transit authority; and
- (xiii) A natural resources district.

(b) The requirements for holding a meeting by means of virtual conferencing are as follows:

(i) Reasonable advance publicized notice is given as provided in subsection (1) of this section, including providing access to a dial-in number or link to the virtual conference;

(ii) In addition to the public's right to participate by virtual conferencing, reasonable arrangements are made to accommodate the public's right to attend at a physical site and participate as provided in section 84-1412, including reasonable seating, in at least one designated site in a building open to the public and identified in the notice, with: At least one member of the entity holding such meeting, or his or her designee, present at each site; a recording of the hearing by audio or visual recording devices; and a reasonable opportunity for input, such as public comment or questions, is provided to at least the same extent as would be provided if virtual conferencing was not used;

(iii) At least one copy of all documents being considered at the meeting is available at any physical site open to the public where individuals may attend the virtual conference. The public body shall also provide links to an electronic copy of the agenda, all documents being considered at the meeting, and the current version of the Open Meetings Act; and

(iv) Except as otherwise provided in this subdivision, subsection (1) of section 70-1014, subsection (2) of section 70-1014.02, or subsection (4) of section 79-2204, no more than one-half of the meetings of the state entities, advisory committees, boards, councils, organizations, or governing bodies are held by virtual conferencing in a calendar year. In the case of (A) an organization created under the Interlocal Cooperation Act that sells electricity or natural gas, (B) an organization created under the Municipal Cooperative Financing Act, (C) a governing body of a risk management pool and any advisory committee of such governing body, or (D) any advisory committee of any state entity created in response to the Opioid Prevention and Treatment Act, such organization, governing body, or committee may hold more than one-half of its meetings by virtual conferencing if such organization holds at least one meeting each calendar year that is not by virtual conferencing.

(3) Virtual conferencing, emails, faxes, or other electronic communication shall not be used to circumvent any of the public government purposes established in the Open Meetings Act.

(4) The secretary or other designee of each public body shall maintain a list of the news media requesting notification of meetings and shall make reasonable efforts to provide advance notification to them of the time and place of each meeting and the subjects to be discussed at that meeting.

(5) When it is necessary to hold an emergency meeting without reasonable advance public notice, the nature of the emergency shall be stated in the minutes and any formal action taken in

such meeting shall pertain only to the emergency. Such emergency meetings may be held by virtual conferencing. The provisions of subsection (4) of this section shall be complied with in conducting emergency meetings. Complete minutes of such emergency meetings specifying the nature of the emergency and any formal action taken at the meeting shall be made available to the public by no later than the end of the next regular business day.

(6) A public body may allow a member of the public or any other witness to appear before the public body by means of virtual conferencing.

(7)(a) Notwithstanding subsections (2) and (5) of this section, if an emergency is declared by the Governor pursuant to the Emergency Management Act as defined in section 81-829.39, a public body the territorial jurisdiction of which is included in the emergency declaration, in whole or in part, may hold a meeting by virtual conferencing during such emergency if the public body gives reasonable advance publicized notice as described in subsection (1) of this section. The notice shall include information regarding access for the public and news media. In addition to any formal action taken pertaining to the emergency, the public body may hold such meeting for the purpose of briefing, discussion of public business, formation of tentative policy, or the taking of any action by the public body.

(b) The public body shall provide access by providing a dial-in number or a link to the virtual conference. The public body shall also provide links to an electronic copy of the agenda, all documents being considered at the meeting, and the current version of the Open Meetings Act. Reasonable arrangements shall be made to accommodate the public's right to hear and speak at the meeting and record the meeting. Subsection (4) of this section shall be complied with in conducting such meetings.

(c) The nature of the emergency shall be stated in the minutes. Complete minutes of such meeting specifying the nature of the emergency and any formal action taken at the meeting shall be made available for inspection as provided in subsection (5) of section 84-1413.

(8) In addition to any other statutory authorization for virtual conferencing, any public body not listed in subdivision (2)(a) of this section may hold a meeting by virtual conferencing if:

(a) The purpose of the virtual meeting is to discuss items that are scheduled to be discussed or acted upon at a subsequent non-virtual open meeting of the public body;

(b) No action is taken by the public body at the virtual meeting; and

(c) The public body complies with subdivisions (2)(b)(i) and (ii) of this section.

(9) This section does not apply to a meeting of the Nebraska Power Review Board or a public power district, a public power and irrigation district, an electric membership association, an electric cooperative company, a municipality having a generation and distribution system, or a registered group of municipalities if such meeting is subject to section 70-1034.

**Source:** Laws 1975, LB 325, § 4; Laws 1983, LB 43, § 3; Laws 1987, LB 663, § 25; Laws 1993, LB 635, § 2; Laws 1996, LB 469, § 6; Laws 1996, LB 1161, § 1; Laws 1999, LB 47, § 2; Laws 1999, LB 87, § 100; Laws 1999, LB 461, § 1; Laws 2000, LB 968, § 85; Laws 2004, LB 821, § 38; Laws 2004, LB 1179, § 2; Laws 2006, LB 898, § 2; Laws 2007, LB199, § 9; Laws 2009, LB361, § 2; Laws 2012, LB735, § 1; Laws 2013, LB510, § 1; Laws 2017, LB318, § 1; Laws 2019, LB212, § 5; Laws 2020, LB148, § 3; Laws 2021, LB83, § 12; Laws 2022, LB742, § 1;

Laws 2022, LB908, § 1; Laws 2022, LB922, § 13; Laws 2024, LB287, § 74;  
Laws 2024, LB399, § 4; Laws 2024, LB1370, § 8; Laws 2025, LB521, § 82.

**Operative Date: May 31, 2025**

## Cross References

- **Emergency Management Act**, see section 81-829.36.
- **Intergovernmental Risk Management Act**, see section 44-4301.
- **Interlocal Cooperation Act**, see section 13-801.
- **Joint Public Agency Act**, see section 13-2501.
- **Municipal Cooperative Financing Act**, see section 18-2401.
- **Opioid Prevention and Treatment Act**, see section 71-2485.

## Annotations

- Under subsection (1) of this section, the Legislature has imposed only two conditions on the public body's notification method of a public meeting: (1) It must give reasonable advance publicized notice of the time and place of each meeting and (2) it must be recorded in the public body's minutes. *City of Elkhorn v. City of Omaha*, 272 Neb. 867, 725 N.W.2d 792 (2007).
- An emergency is "(a)ny event or occasional combination of circumstances which calls for immediate action or remedy; pressing necessity; exigency; a sudden or unexpected happening; an unforeseen occurrence or condition." *Steenblock v. Elkhorn Township Bd.*, 245 Neb. 722, 515 N.W.2d 128 (1994).
- An agenda which gives reasonable notice of the matters to be considered at a meeting of a city council complies with the requirements of this section. *Pokorny v. City of Schuyler*, 202 Neb. 334, 275 N.W.2d 281 (1979).
- When notice is required, a notice of a special meeting of a city council posted in three public places at 10:00 p.m. on the day preceding the meeting is not reasonable advance publicized notice of a meeting as is required by this section. *Pokorny v. City of Schuyler*, 202 Neb. 334, 275 N.W.2d 281 (1979).
- Teacher waived right to object to lack of public notice in board of education employment hearing by voluntary participation in the hearing without objection. *Alexander v. School Dist. No. 17*, 197 Neb. 251, 248 N.W.2d 335 (1976).
- A county board of commissioners and a county board of equalization are not required to give separate notices when the notice states only the time and place that the boards meet and directs a citizen to where the agendas for each board can be found. *Wolf v. Grubbs*, 17 Neb. App. 292, 759 N.W.2d 499 (2009).
- A county board of equalization is a public body which is required to give advanced publicized notice of its meetings. *Wolf v. Grubbs*, 17 Neb. App. 292, 759 N.W.2d 499 (2009).
- Notice of recessed and reconvened meetings must be given in the same fashion as the original meeting. *Wolf v. Grubbs*, 17 Neb. App. 292, 759 N.W.2d 499 (2009).
- True notice of a meeting is not given by burying such in the minutes of a prior board proceeding. *Wolf v. Grubbs*, 17 Neb. App. 292, 759 N.W.2d 499 (2009).
- An agenda notice which merely stated "work order reports" was an inadequate notice under this section because it did not give interested persons knowledge that plans for a 345 kv transmission line through the district was going to be discussed and voted upon at the meeting. Inadequate agenda notice under this section meant there was a substantial

violation of the public meeting laws; however, later actions by the board of directors cured the defects in notice, and such actions were in substantial compliance with the statute. *Hansmeyer v. Nebraska Pub. Power Dist.*, 6 Neb. App. 889, 578 N.W.2d 476 (1998).

#### **84-1412. Meetings of public body; rights of public; public body; powers and duties.**

(1) Subject to the Open Meetings Act, the public has the right to attend and the right to speak at meetings of public bodies, and all or any part of a meeting of a public body, except for closed sessions called pursuant to section 84-1410, may be videotaped, televised, photographed, broadcast, or recorded by any person in attendance by means of a tape recorder, a camera, video equipment, or any other means of pictorial or sonic reproduction or in writing. Except for closed sessions called pursuant to section 84-1410, a public body shall allow members of the public an opportunity to speak at each meeting.

(2) It shall not be a violation of subsection (1) of this section for any public body to make and enforce reasonable rules and regulations regarding the conduct of persons attending, speaking at, videotaping, televising, photographing, broadcasting, or recording its meetings, including meetings held by virtual conferencing.

(3) No public body shall require members of the public to identify themselves as a condition for admission to the meeting nor shall such body require that the name of any member of the public be placed on the agenda prior to such meeting in order to speak about items on the agenda. The body shall require any member of the public desiring to address the body to identify himself or herself, including an address and the name of any organization represented by such person unless the address requirement is waived to protect the security of the individual.

(4) No public body shall, for the purpose of circumventing the Open Meetings Act, hold a meeting in a place known by the body to be too small to accommodate the anticipated audience.

(5) No public body shall be deemed in violation of this section if it holds its meeting in its traditional meeting place which is located in this state.

(6) No public body shall be deemed in violation of this section if it holds a meeting outside of this state if, but only if:

(a) A member entity of the public body is located outside of this state and the meeting is in that member's jurisdiction;

(b) All out-of-state locations identified in the notice are located within public buildings used by members of the entity or at a place which will accommodate the anticipated audience;

(c) Reasonable arrangements are made to accommodate the public's right to attend, hear, and speak at the meeting, including making virtual conferencing available at an in-state location to members, the public, or the press, if requested twenty-four hours in advance;

(d) No more than twenty-five percent of the public body's meetings in a calendar year are held out-of-state;

(e) Out-of-state meetings are not used to circumvent any of the public government purposes established in the Open Meetings Act; and

(f) The public body publishes notice of the out-of-state meeting at least twenty-one days before the date of the meeting in a legal newspaper of statewide circulation.

(7) Each public body shall, upon request, make a reasonable effort to accommodate the public's right to hear the discussion and testimony presented at a meeting.

(8) Public bodies shall make available at the meeting or the instate location for virtual conferencing as required by subdivision (6)(c) of this section, for examination and copying by members of the public, at least one copy of all reproducible written material to be discussed at an open meeting, either in paper or electronic form. Public bodies shall make available at least one current copy of the Open Meetings Act posted in the meeting room at a location accessible to members of the public. At the beginning of the meeting, the public shall be informed about the location of the posted information.

**Source:** Laws 1975, LB 325, § 5; Laws 1983, LB 43, § 4; Laws 1985, LB 117, § 2; Laws 1987, LB 324, § 5; Laws 1996, LB 900, § 1073; Laws 2001, LB 250, § 2; Laws 2004, LB 821, § 39; Laws 2006, LB 898, § 3; Laws 2008, LB962, § 1; Laws 2021, LB83, § 13; Laws 2024, LB43, § 21.

## Annotations

- To preserve an objection that a public body failed to make documents available at a public meeting as required by subsection (8) of this section, a person who attends a public meeting must not only object to the violation, but must make that objection to the public body or to a member of the public body. *Stoetzel & Sons v. City of Hastings*, 265 Neb. 637, 658 N.W.2d 636 (2003).

### **84-1413. Meetings; minutes; roll call vote; secret ballot; when; agenda and minutes; required on website; when.**

(1) Each public body shall keep minutes of all meetings showing the time, place, members present and absent, and the substance of all matters discussed.

(2) Any action taken on any question or motion duly moved and seconded shall be by roll call vote of the public body in open session, and the record shall state how each member voted or if the member was absent or not voting. The requirements of a roll call or viva voce vote shall be satisfied by a public body which utilizes an electronic voting device which allows the yeas and nays of each member of such public body to be readily seen by the public.

(3) The vote to elect leadership within a public body may be taken by secret ballot, but the total number of votes for each candidate shall be recorded in the minutes.

(4) The minutes of all meetings and evidence and documentation received or disclosed in open session shall be public records and open to public inspection during normal business hours.

(5) Minutes shall be written or kept as an electronic record and shall be available for inspection within ten working days or prior to the next convened meeting, whichever occurs earlier, except that cities of the second class and villages may have an additional ten working days if the employee responsible for writing or keeping the minutes is absent due to a serious illness or emergency.

(6) Beginning July 31, 2022, the governing body of a natural resources district, the city council of a city of the metropolitan class, the city council of a city of the primary class, the city council of a city of the first class, the county board of a county with a population greater than twenty-five thousand inhabitants, and the school board of a school district shall make available

on such entity's public website the agenda and minutes of any meeting of the governing body. The agenda shall be placed on the website at least twenty-four hours before the meeting of the governing body. Minutes shall be placed on the website at such time as the minutes are available for inspection as provided in subsection (5) of this section. This information shall be available on the public website for at least six months.

**Source:** Laws 1975, LB 325, § 6; Laws 1978, LB 609, § 3; Laws 1979, LB 86, § 9; Laws 1987, LB 663, § 26; Laws 2005, LB 501, § 1; Laws 2009, LB361, § 3; Laws 2015, LB365, § 2; Laws 2016, LB876, § 1; Laws 2021, LB83, § 14; Laws 2022, LB742, § 2.

## Annotations

- Under prior law, if a person present at a meeting observes and fails to object to an alleged public meetings laws violation in the form of a failure to conduct rollcall votes before taking actions on questions or motions pending, that person waives his or her right to object at a later date. *Hauser v. Nebraska Police Stds. Adv. Council*, 264 Neb. 944, 653 N.W.2d 240 (2002).
- Subsection (2) of this section does not require the record to state that the vote was by roll call, but requires only that the record show if and how each member voted. Neither does the statute set a time limit for recording the results of a vote, after which no corrections of the record can be made. If no intervening rights of third persons have arisen, a board of county commissioners has power to correct the record of the proceedings had at a previous meeting so as to make them speak the truth, particularly where the correction supplies some omitted fact or action and is done not to contradict or change the original record but to have the record show that a certain action was taken or thing done, which the original record fails to show. *State ex rel. Schuler v. Dunbar*, 214 Neb. 85, 333 N.W.2d 652 (1983).
- Failure by a public governing body, as defined under section 84-1409, R.R.S.1943, to take and record a roll call vote on an action, as required by section 84-1413(2), R.S.Supp.,1980, grants any citizen the right to sue for the purpose of having the action declared void. In this case such failure could not be later corrected by a nunc pro tunc order because there was no showing that a roll call vote on the disputed action was actually taken, and even if it was the record showed it was not recorded until over a year later. Sections 23-1301, R.R.S.1943, and 23-1302, R.R.S.1943, make it the duty of the county clerk to record proceedings of the board of county commissioners. *State ex rel. Schuler v. Dunbar*, 208 Neb. 69, 302 N.W.2d 674 (1981).
- There is no requirement that a public body make a record of where notice was published or posted. *Wolf v. Grubbs*, 17 Neb. App. 292, 759 N.W.2d 499 (2009).

### **84-1414. Unlawful action by public body; declared void or voidable by district court; when; duty to enforce open meeting laws; citizen's suit; procedure; violations; penalties.**

(1) Any motion, resolution, rule, regulation, ordinance, or formal action of a public body made or taken in violation of the Open Meetings Act shall be declared void by the district court if the suit is commenced within one hundred twenty days of the meeting of the public body at which the alleged violation occurred. Any motion, resolution, rule, regulation, ordinance, or formal action of a public body made or taken in substantial violation of the Open Meetings Act shall be voidable by the district court if the suit is commenced more than one hundred twenty days after but within one year of the meeting of the public body in which the alleged violation occurred. A suit to void any final action shall be commenced within one year of the action.

(2) The Attorney General and the county attorney of the county in which the public body ordinarily meets shall enforce the Open Meetings Act.

(3) Any citizen of this state may commence a suit in the district court of the county in which the public body ordinarily meets or in which the plaintiff resides for the purpose of requiring compliance with or preventing violations of the Open Meetings Act, for the purpose of declaring an action of a public body void, or for the purpose of determining the applicability of the act to discussions or decisions of the public body. It shall not be a defense that the citizen attended the meeting and failed to object at such time. The court may order payment of reasonable attorney's fees and court costs to a successful plaintiff in a suit brought under this section.

(4) Any member of a public body who knowingly violates or conspires to violate or who attends or remains at a meeting knowing that the public body is in violation of any provision of the Open Meetings Act shall be guilty of a Class IV misdemeanor for a first offense and a Class III misdemeanor for a second or subsequent offense.

**Source:** Laws 1975, LB 325, § 9; Laws 1977, LB 39, § 318; Laws 1983, LB 43, § 5; Laws 1992, LB 1019, § 126; Laws 1994, LB 621, § 2; Laws 1996, LB 900, § 1074; Laws 2004, LB 821, § 40; Laws 2006, LB 898, § 4.

## Annotations

- The Legislature has granted standing to a broad scope of its citizens for the very limited purpose of challenging meetings allegedly in violation of the Open Meetings Act, so that they may help police the public policy embodied by the act. *Schauer v. Grooms*, 280 Neb. 426, 786 N.W.2d 909 (2010).
- Any citizen of the state may commence an action to declare a public body's action void. *City of Elkhorn v. City of Omaha*, 272 Neb. 867, 725 N.W.2d 792 (2007).
- The reading of ordinances constitutes a formal action under subsection (1) of this section. *City of Elkhorn v. City of Omaha*, 272 Neb. 867, 725 N.W.2d 792 (2007).
- If a person present at a meeting observes a public meetings law violation in the form of an improper closed session and fails to object, that person waives his or her right to object at a later date. *Wasikowski v. Nebraska Quality Jobs Bd.*, 264 Neb. 403, 648 N.W.2d 756 (2002).
- Under the Public Meetings Act, a county lacks capacity to maintain an action to declare its official conduct "void" for noncompliance with the act. *County of York v. Johnson*, 230 Neb. 403, 432 N.W.2d 215 (1988).
- When a petitioner under this section is successful in the district court, that court may allow attorney fees. *Tracy Corp. II v. Nebraska Pub. Serv. Comm.*, 218 Neb. 900, 360 N.W.2d 485 (1984).
- Informal discussions between the Tax Commissioner and the State Board of Equalization in which instructions were clarified, with such clarification leading to the amendment of hearing notices, did not constitute a public meeting subject to the provisions of this section. *Box Butte County v. State Board of Equalization and Assessment*, 206 Neb. 696, 295 N.W.2d 670 (1980).
- The right to collaterally attack an order made in contravention of the Public Meeting Act must occur within a period of one year as is specifically provided by this section. *Witt v. School District No. 70*, 202 Neb. 63, 273 N.W.2d 669 (1979).
- Statutory change, requiring "publicized notice" for board of education employment hearings, occurring between dates meeting scheduled and conducted, held not to void

proceedings. *Alexander v. School Dist. No. 17*, 197 Neb. 251, 248 N.W.2d 335 (1976).

- Voiding an entire meeting is a proper remedy for violations of the Open Meetings Act. Once a meeting has been declared void pursuant to Nebraska's public meetings law, board members are prohibited from considering any information obtained at the illegal meeting. *Wolf v. Grubbs*, 17 Neb. App. 292, 759 N.W.2d 499 (2009).
- Actions by the board of directors were merely voidable under this section, and not void. Pursuant to subsection (3) of this section, the plaintiffs were awarded partial attorney fees because they were successful in having the court declare that the board of directors was in substantial violation of the statute, even though the plaintiffs did not get the relief requested of having the board's actions declared void. *Hansmeyer v. Nebraska Pub. Power Dist.*, 6 Neb. App. 889, 578 N.W.2d 476 (1998).

**2. PRAYER**

**3. NATIONAL ANTHEM AND PLEDGE OF ALLEGIANCE**

**4. CONSENT AGENDA - The following items are considered to be routine by the city council and will be enacted by one motion. There will be no separate discussion of these items unless a city council member or citizen so requests, in which event the item will be removed from consent status and considered in its normal sequence on the agenda.**

4.A. Minutes of April 20, 2026, City Council meeting.

PROCEEDINGS OF CITY COUNCIL  
April 20, 2026

A regular meeting of the mayor and council of the City of Columbus, Nebraska, was convened in open and public session on April 20, 2026, at 6 p.m. in the Columbus Community Building, Community Room, 2500 14 Street, Columbus, Nebraska. Notice of this meeting was given in advance thereof by publication in the Columbus Telegram on April 1, 2026, with a copy of the proof of publication being on file in the office of the city clerk. Notice of this meeting was given simultaneously to the mayor and members of the city council, with a copy of the acknowledgment of receipt of notice being on file in the office of the city clerk. Availability of the agenda was communicated in the advance notice and in the notice to the mayor and city council of this meeting. All proceedings hereafter shown were taken while the convened meeting was open to the public.

1. **STATEMENT OF COMPLIANCE WITH OPEN MEETINGS ACT:** Mayor Bulkley announced that a copy of the Open Meetings Act is posted in the meeting room. Present were Mayor James Bulkley and Council Members, Charlie Bahr, Troy Hiemer, Rich Jablonski, Kat Lopez, AJ Palensky, and Prent Roth. Council Members Cynthia Alarcòn and Ron Schilling were absent and excused. City staff members included City Attorney Neal Valorz, City Administrator Tara Vasicek, Director of General Services Betsy Eckhardt, City Clerk Shuraya Choat, City Engineer Rick Bogus, Public Works Director Chuck Sliva, Police Chief Bret Strecker, Finance Director Chris Norquest, Library Director Jeri Kay Hopkins, Chief Building and Code Official Andy Woehrer, Planning and Economic Development Coordinator Jean Van Iperen, and Communications Manager Matt Lindberg.
2. **PRAYER:** Hiemer led in prayer.
3. **NATIONAL ANTHEM AND PLEDGE OF ALLEGIANCE:** The National Anthem was played and the Pledge of Allegiance was recited.
4. **CONSENT AGENDA:** The following items are considered to be routine by the city council and will be enacted by one motion. There will be no separate discussion of these items unless a city council member or citizen so requests, in which event the item will be removed from consent status and considered in its normal sequence on the agenda. The items on the consent agenda were approved as presented with a motion by Hiemer and a second by Bahr. Bahr, Hiemer, Jablonski, Lopez, Palensky, and Roth voted "Aye" and none voted "Nay". Alarcòn and Schilling were absent.
  - 4.A. **Minutes of April 6, 2026, City Council meeting.**
  - 4.B. **Reappointment of Neil Carnes and Mark Bierman to the Board of Adjustment for three-year terms.**
  - 4.C. **Renewal of solid waste hauling licenses for Ace Sanitation Service, Inc., Beemer Lumber LLC dba Discount Dumpster, Hilltop Rolloff LLC dba Callaway Rolloff, S2 Roll-offs Refuse & Recycling, Smash the Trash Sanitation LLC, U & I Sanitation LLC, and Waste Connections of Nebraska, Inc., contingent on bond requirements being met.**

PROCEEDINGS OF CITY COUNCIL

April 20, 2026

Page 2

**4.D. Finance department report.**

**4.E. Payroll and bills on file.** B=Bnd Pymnts; CP=Capt'l Proj; E=Expns; G=Grnts; I=Insrnc; L=Lic; M=Mbrshp; P=Pymt; R=Rfnd; RT=Rent; S=Srvc & Supp; T=Trng; 4/24/26 payroll 915,407.51; 5 Star Pmpng 300.00 S; 911 Custom 137.00 S; A to Z Msgng 148.50 S; Ace Hdwr 427.78 S; Advnc Auto 162.00 S; All Star Auto 285.00 S; All Star Pro Golf 967.76; Amrcn Red Crss 144.00 T; Aqua-Chem 7,715.40 S; Aqua-Pure 9,043.33 S; Arnold Mtr Sup 1,182.38 S; AT&T 2,072.70 S; Auxiant 136,933.29 I; Baird Holm 216.00 S; Behlen Twng 1,050.00 S; Benchmark Gvrnmt 499.05 S; A Benesch 11,372.50 CP; Best Books 1,157.71 S; BGNE 20.30 S; Bierman Cntrctng 2,217.50 S; Black Hills 5,098.44 S; B McDonald Grg Door 2,895.32 S; Bound Tree Med 205.98 S; A Brauner 85.00 S; Carolina Sftwr 600.00 S; Casey's Mail Serv 6,273.26 S; CDW Gvrnmt 20,977.37 S; CCC Ag Club 2,069.35 S; CVA 231.25 S; Clay Hills Ag 487.50 S; CNC Rpr 4,645.87 S; CCH 1,189.37 S; Col Crdt Ser 556.62 S; Col Fam Rsrc Ctr 11,491.30 RT; Connoisseur Media 600.00 S; Core & Main 15,953.16 S; CPPD 505.31 S; Culligan 339.00 S; D & K Prod 7,183.75 S; D Johnson Trckng 4,869.07 S; Dnls Prod 809.44 S; Datavant 20.00 S; Dell Mrkng 2,240.06 S; D Dunbar 32,769.66 P; Eakes 1,303.01 S; FBI-LEEDA 2,385.00 T; FNBO 24,661.03 S; Frontier 2,442.03 S; Frontline Cnslng 1,350.00 S; Gehring Const 259.12 S; G Steffy Ford 1,766.06 S; Grainger 1,131.36 S; Granville Cstm Hms 24.30 R; Grt Plns Bldg Sup 19.54 S; Grt Plns Comm 1,509.47 S; H2 Equip 2,424.76 S; Havana Stone 245.00 S; Hawkins 11,620.03 S; HDR 85,067.80 CP; Hrtlnd Ntrl Gas 5,967.29 S; J Hopkins 705.45 E; M Howerter MD 1,303.75 S; Hutcheson Eng 3,695.78 S; Hy-Vee 248.83 S; Imagetrend 8,323.74 S; Indstrl Systems 10.68 S; Jackson Serv 2,349.96 S; Jaster Lndscpng 3,880.00 S; JEO 31,909.00 CP; Kelly Sup 143.79 S; Koch Excvtng 1,815.45 CP; A Laborde 1,700.00 S; Lakeview Small Eng 2,910.55 S; Language Ln Serv 390.70 S; Lncln Jrnl Str 326.56 S; Lncln Whwtr Wrks 9,556.86 S; Loup 104,160.63 S; Macqueen Equip 1,311.33 S; Mailbox 139.53 S; Matteo Sand 1,038.25 S; McMaster-Carr 428.25 S; Menards 1,265.52 S; Mettler-Toledo 1,265.03 S; MARC 149.00 S; Mdwst Alarm 1,230.96 S; Mdwst Lab 865.42 S; Mdwst Tape 547.94 S; Mdwst Turf 9,523.41 S; Mike's Auto 22,495.00 CP; Mike's Twng 600.00 S; Motion Pctr Lcnsng 410.66 S; Napa Auto 487.26 S; NE Law Enf 542.00 S; NE Rural Wtr Ass 1,335.00 T; NE State Fire Mrshl 144.00 S; NE UC Fnd 4,473.00 S; Newman Sgns 1,306.41 NE NE Clrks Assoc 20.00 M; NE NE Econ Dev Dstrct 28,016.37 M; NE NE Sld Wste 66,752.23 S; NoSwett 500.00 S; Occ Health 873.00 S; One Call Cncpt 346.06 S; One Source 38.00 S; O'Reilly 137.48 S; Pacific Wndw 140.00 S; Paper Tiger 38.00 S; Perception Sfty 2,926.00 S; Pete Lien 7,500.98 S; Petty Cash 166.36 S; Platte Cnty 4,267.54 S; Platte Cnty Reg of Dds 134.00 S; Platte Villy Comm 791.25 S; Port-A-Johns 450.00 S; Power Tech 2,349.00 S; Prestox 152.32 S; Quadiant 1,000.00 S; R & R Prod 585.05 S; K Reid 1,980.00 S; Rensenhouse 22.27 S; Rvrsd Prtbls 110.00 S; R Geilenkirchen 10,262.00 G; Rutt's 683.50 S; RVW 567.00 CP; Sapp Bros 49,492.19 S; Schieffer Sgns 48.00 S; Scrty Equip 680.00 S; Shvl'n Sup 1,170.33 S; Shirts R Us 112.00 S; State Dept of Rev 66,595.07 P; Super Svr 127.71 S; Sysco 9,771.88 S; Target Sol 10,120.98 S;

The Glf Shp 3,543.33 S; The Sprnklr Co 9,313.28 S; Tire Outlet 1,355.00 S; TK Elevator 272.17 S; Trittech Sftwr 496.41 S; Truck Cntr 455.26 S; Turfwerks 528.95 S; Twin Rvrs Vet 361.33 S; Two Lane Tctcs 90.00 S; USA Blue Bk 169.35 S; Utility Serv 23,497.38 S; Van Diest 225.41 S; C Van Dyke 175.00 S; Vandenberg Elec 890.00 S; C Wagner 32.00 S; Wanco 4,839.70 S; Waste Conn 691.53 S; Wemhoff Ref 4,669.15 S; White Cap 287.82 S; Wilson & Co 3,694.14 CP; Zimco 3,043.85. Total \$1,906,278.92.

5. **APPROVAL OF MINUTES:** Included in Consent Agenda

6. **SPECIAL PRESENTATIONS:**

6.A. **Proclamation declaring the week of April 26, 2026, as National Apprenticeship Week.** Bulkley read the proclamation.

6.B. **Proclamation declaring April 28, 2026, as Kind Columbus Day.** Bulkley read the proclamation.

7. **PUBLIC HEARINGS:**

7.A. **Public hearing - Application from Williams Midwest Housemovers, on behalf of Jim Connot, for a permit to move a house from 1808 E 23rd Street, Columbus, NE to land outside of city jurisdiction. (Planning Commission recommends approval.)** No public testimony was heard. The public hearing closed with a motion by Bahr and second by Lopez. The application from Williams Midwest Housemovers, on behalf of Jim Connot, for a permit to move a house from 1808 E 23rd Street, Columbus, NE, to land outside of city jurisdiction was approved with a motion by Palensky and a second by Bahr. Bahr, Hiemer, Jablonski, Lopez, Palensky, and Roth voted "Aye" and none voted "Nay". Alarcòn and Schilling were absent.

7.B. **Public hearing - Application from Advanced Consulting Engineering Services on behalf of Keyes Development, LLC for final plat and development agreement of Dubas Addition (extensions and connections of Isaiah Drive and 44th Avenue). (Planning Commission recommends approval.)** No public testimony was heard. The public hearing closed with a motion by Hiemer and second by Lopez. Bahr, Hiemer, Jablonski, Lopez, Palensky, and Roth voted "Aye" and none voted "Nay". Alarcòn and Schilling were absent.

7.B.1. **Resolution No. R26-54 approving final plat and development agreement.** Resolution No. R26-54 entitled: A RESOLUTION OF THE MAYOR AND COUNCIL OF THE CITY OF COLUMBUS, NEBRASKA, ACCEPTING THE DEED OF DEDICATION TO A PARCEL OF LAND LEGALLY DESCRIBED AS: A TRACT OF LAND LOCATED LOT 1, BLOCK A AND LOT 1, BLOCK B IN NEW HOPE 2ND SUBDIVISION TO THE CITY OF COLUMBUS, PLATTE COUNTY, NEBRASKA AND IN THE NORTH 1/2 OF THE NORTHEAST 1/4 OF THE SOUTHWEST 1/4 OF SECTION 24, T17N, R1W OF THE 6TH P.M., CITY OF COLUMBUS, PLATTE COUNTY, NEBRASKA, MORE PARTICULARLY DESCRIBED AS FOLLOWS: BEGINNING AT THE

SOUTHWEST CORNER OF NEW HOPE 2ND SUBDIVISION TO THE CITY OF COLUMBUS, PLATTE COUNTY, NEBRASKA; THENCE N 88°11'12" E ON THE SOUTH LINE OF LOT 1, BLOCK B, NEW HOPE 2ND SUBDIVISION, 88.17 FEET TO THE SOUTHEAST CORNER OF SAID LOT 1, BLOCK B; THENCE N 01°44'04" W ON THE EAST LINE OF SAID LOT 1, BLOCK B, 135.02 FEET TO THE NORTHEAST CORNER OF SAID LOT 1, BLOCK B; THENCE S 88°17'25" W ON THE NORTH LINE OF SAID LOT 1, BLOCK B, 88.28 FEET TO THE NORTHWEST CORNER OF SAID LOT 1, BLOCK B; THENCE N 01°44'07" W ON THE WEST LINE OF SAID NEW HOPE 2ND SUBDIVISION, 60.00 FEET TO THE SOUTHWEST CORNER OF LOT 1, BLOCK A OF SAID NEW HOPE 2ND SUBDIVISION; THENCE N 88°15'42" E ON THE SOUTH LINE OF SAID LOT 1, BLOCK A, 88.03 FEET TO THE SOUTHEAST CORNER OF SAID LOT 1, BLOCK A; THENCE N 01°34'59" W ON THE EAST LINE OF SAID LOT 1, BLOCK A, 134.98 FEET TO THE NORTHEAST CORNER OF SAID LOT 1, BLOCK A; THENCE S 88°15'00" W ON THE NORTH LINE OF SAID LOT 1, BLOCK A, 88.47 FEET; THENCE N 01°49'31" W ON THE WEST LINE OF SUNSET 2ND ADDITION TO THE CITY OF COLUMBUS, PLATTE COUNTY, NEBRASKA, 197.46 FEET TO THE SOUTHEAST CORNER OF SUNSET 4TH ADDITION TO THE CITY OF COLUMBUS, PLATTE COUNTY, NEBRASKA; THENCE S 88°10'27" W, ON THE SOUTH LINE OF SAID SUNSET 4TH ADDITION, 350.81 FEET TO THE NORTHEAST CORNER OF NEW HOPE ADDITION TO THE CITY OF COLUMBUS, PLATTE COUNTY, NEBRASKA; THENCE S 01°52'53" E ON THE EAST LINE OF SAID NEW HOPE ADDITION, 527.20 FEET TO THE NORTH LINE OF SOLAR GATE SUBDIVISION TO THE CITY OF COLUMBUS, PLATTE COUNTY, NEBRASKA; THENCE N 88°14'18" E ON THE NORTH LINE OF SAID SOLAR GATE SUBDIVISION, 349.96 FEET TO THE POINT OF BEGINNING, CONTAINING 4.79 ACRES, MORE OR LESS; HEREINAFTER TO BE KNOWN AS DUBAS ADDITION TO THE CITY OF COLUMBUS, PLATTE COUNTY, NEBRASKA; APPROVING THE PLAT THEREOF; APPROVING INCLUSION OF SAID PLAT INTO THE CITY CORPORATE LIMITS; AND APPROVING AND ACCEPTING THE DEVELOPMENT AGREEMENT BY AND BETWEEN THE CITY OF COLUMBUS, NEBRASKA, A MUNICIPAL CORPORATION, AND KEYES DEVELOPMENT, LLC, WHICH SETS FORTH THE AGREEMENT BETWEEN THE PARTIES INCLUDING THE DUTIES AND RESPONSIBILITIES OF SAID OWNER/SUBDIVIDER WITH RESPECT TO SAID ADDITION; AND AUTHORIZING THE MAYOR TO SIGN THE DEVELOPMENT AGREEMENT PROVIDING FOR PUBLIC IMPROVEMENTS TO SERVE THIS ADDITION was adopted with a motion by Hiemer and a second by Lopez. Bahr, Hiemer, Jablonski, Lopez, Palensky, and Roth voted "Aye" and none voted "Nay". Alarcón and Schilling were absent.

- 7.C. **Public hearing - Application from Clark Grant on behalf of Dr. Jeffrey Gotschall and Tammi Gotschall for final plat and development agreement of J.C. and T.L. Gotschall 2nd Subdivision (west side of 26th Avenue and 33rd Street). (Planning Commission recommends approval.)** No public

testimony was heard. The public hearing closed with a motion by Bahr and second by Lopez. Bahr, Hiemer, Jablonski, Lopez, Palensky, and Roth voted "Aye" and none voted "Nay". Alarcón and Schilling were absent.

**7.C.1. Resolution No. R26-55 approving final plat and development agreement.**

Resolution No. R26-55 entitled: A RESOLUTION OF THE MAYOR AND COUNCIL OF THE CITY OF COLUMBUS, NEBRASKA, ACCEPTING THE DEED OF DEDICATION TO A PARCEL OF LAND LEGALLY DESCRIBED AS: A TRACT OF LAND LOCATED IN PART OF LOT 1 AND ALL OF LOT 2, J.A. FEHRINGER 2ND SUBDIVISION TO THE CITY OF COLUMBUS AND IN THE N1/2 OF THE SE1/4 OF THE NW1/4 AND THE N1/2 OF THE N1/2 OF THE S1/2 OF THE SE1/4 OF THE NW1/4 ALL IN SECTION 18, T17N, R1E OF THE 6TH P.M., PLATTE COUNTY, NEBRASKA, MORE PARTICULARLY DESCRIBED AS FOLLOWS: REFERRING TO THE SOUTHEAST CORNER OF SAID N1/2 N1/2 S1/2 SE1/4 NW1/4; THENCE N 88°58'55" W, 30.01 FT. ON THE SOUTH LINE OF SAID N1/2 N1/2 S1/2 SE1/4 NW1/4 TO THE POINT OF BEGINNING; THENCE N 88°58'55" W, 473.23 FT. ON THE SOUTH LINE OF SAID N1/2 N1/2 S1/2 SE1/4 NW1/4 TO THE SOUTHEAST CORNER OF LOT 1 OF ASSISTED LIVING ESTATES; THENCE N 00°01'41" W, 436.03 FT. ON THE EAST LINE OF SAID LOT 1 AND OTHER SURVEYED SUBDIVISIONS TO THE SOUTHWEST CORNER OF J.C. AND T.L. GOTSCHALL SUBDIVISION; THENCE S 89°00'50" E, 473.61 FT. ON THE SOUTH LINE OF SAID J.C. AND T.L. GOTSCHALL SUBDIVISION TO THE WEST RIGHT-OF-WAY LINE OF 26TH AVENUE; THENCE S 00°01'21" W, 436.29 FT. ON THE WEST RIGHT-OF-WAY LINE OF SAID 26TH AVENUE TO THE POINT OF BEGINNING, CONTAINING 4.74 ACRES MORE OR LESS, HEREINAFTER TO BE KNOWN AS J.C. AND T.L. GOTSCHALL 2<sup>ND</sup> SUBDIVISION TO THE CITY OF COLUMBUS, PLATTE COUNTY, NEBRASKA; APPROVING THE PLAT THEREOF; AND APPROVING AND ACCEPTING THE DEVELOPMENT AGREEMENT BY AND BETWEEN THE CITY OF COLUMBUS, NEBRASKA, A MUNICIPAL CORPORATION, AND DR. JEFFREY C. GOTSCHALL AND TAMMI L. GOTSCHALL, WHICH SETS FORTH THE AGREEMENT BETWEEN THE PARTIES INCLUDING THE DUTIES AND RESPONSIBILITIES OF SAID OWNER/SUBDIVIDER WITH RESPECT TO SAID SUBDIVISION AND AUTHORIZING THE MAYOR TO SIGN THE DEVELOPMENT AGREEMENT PROVIDING FOR PUBLIC IMPROVEMENTS TO SERVE THIS SUBDIVISION was adopted with a motion by Roth and a second by Hiemer. Bahr, Hiemer, Jablonski, Lopez, Palensky, and Roth voted "Aye" and none voted "Nay". Alarcón and Schilling were absent.

**7.D. Public hearing - Application from Clark Grant on behalf of Dr. Jeffrey Gotschall and Tammi Gotschall to rezone property located in Lots 1, 2, 3, and 4, Block B, and lots 1, 2, 3, 4, 5, 6, and 7, Block C J.C. and T.L. Gotschall 2nd Subdivision to the City of Columbus, Platte County, Nebraska from "R-1" (Single-Family Residential) to "R-2" (Two-Family Residential) and to amend the Future Land Use Map of the Comprehensive Plan (west side of 26th Avenue and 33rd Street). (Planning Commission recommends approval.) No public testimony was**

heard. The public hearing closed with a motion by Hiemer and second by Lopez. Bahr, Hiemer, Jablonski, Lopez, Palensky, and Roth voted "Aye" and none voted "Nay". Alarcòn and Schilling were absent.

- 7.D.1. Ordinance No. 26-06 approving rezoning.** The rules were suspended and Ordinance No. 26-06 entitled: AN ORDINANCE OF THE MAYOR AND COUNCIL OF THE CITY OF COLUMBUS, NEBRASKA, AMENDING THE COLUMBUS LAND DEVELOPMENT ORDINANCE FOR THE CITY OF COLUMBUS, ZONING CHAPTER, PASSED AND ADOPTED NOVEMBER 18, 2024, AS THE ZONING CODE FOR THE CITY OF COLUMBUS, NEBRASKA, BY ORDINANCE NO. 24-32, AND AS AMENDED THEREAFTER, TO REZONE AND RECLASSIFY THE FOLLOWING DESCRIBED REAL ESTATE, TO-WIT: LOTS 1, 2, 3 AND 4, BLOCK B AND LOTS 1, 2, 3, 4, 5, 6 AND 7, BLOCK C, J.C. AND T.L. GOTSCHALL 2ND SUBDIVISION TO THE CITY OF COLUMBUS, PLATTE COUNTY, NEBRASKA., FROM THE PRESENT ZONING CLASSIFICATION OF "R-1" (SINGLE-FAMILY RESIDENTIAL DISTRICT) TO "R-2" (TWO-FAMILY RESIDENTIAL DISTRICT); TO AMEND THE ZONING MAP AND THE FUTURE LAND USE MAP WHICH HAVE BEEN ADOPTED AND MADE A PART OF SAID CITY OF COLUMBUS, NEBRASKA LAND DEVELOPMENT ORDINANCE TO SHOW SAID REZONING AND RECLASSIFICATION; TO REPEAL ALL ORDINANCES AND RESOLUTIONS OR PARTS THEREOF IN CONFLICT HEREWITH; TO PROVIDE FOR THE PUBLICATION OF THIS ORDINANCE IN PAMPHLET FORM; AND TO PROVIDE FOR THE EFFECTIVE DATE was read by number only with a motion by Jablonski and a second by Hiemer. Bahr, Hiemer, Jablonski, Lopez Palensky, and Roth voted "Aye" and none voted "Nay". Alarcòn and Schilling were absent. Ordinance No. 26-06 was adopted with a motion by Jablonski and a second by Hiemer. Bahr, Hiemer, Jablonski, Lopez, Palensky, and Roth voted "Aye" and none voted "Nay". Alarcòn and Schilling were absent.
- 7.E. Public hearing - Application from Dale and Patricia Labenz to rezone property located in Lots 1, 2, 3, and 4 Lying South of the Union Pacific Right-of-Way and all of Lots 5, 6, 7, and 8, Block 73 and Lot 1, Block 74, Original City of Columbus, Platte County, Nebraska from "R-3" (Multiple-Family Residential) to "ML/C-1" (Light Industrial District) and to amend the Future Land Use Map of the Comprehensive Plan (northwest corner of 12th Street and 14th Avenue). (Planning Commission recommends approval.)** No public testimony was heard. The public hearing closed with a motion by Lopez and second by Palensky. Bahr, Hiemer, Jablonski, Lopez, Palensky, and Roth voted "Aye" and none voted "Nay". Alarcòn and Schilling were absent.
- 7.E.1. Ordinance No. 26-07 approving rezoning.** The rules were suspended and Ordinance No. 26-07 entitled: AN ORDINANCE OF THE MAYOR AND COUNCIL OF THE CITY OF COLUMBUS, NEBRASKA, AMENDING THE COLUMBUS LAND DEVELOPMENT ORDINANCE FOR THE CITY OF COLUMBUS, ZONING CHAPTER, PASSED AND ADOPTED NOVEMBER 18,

2024, AS THE ZONING CODE FOR THE CITY OF COLUMBUS, NEBRASKA, BY ORDINANCE NO. 24-32, AND AS AMENDED THEREAFTER, TO REZONE AND RECLASSIFY THE FOLLOWING DESCRIBED REAL ESTATE, TO-WIT: LOTS 1, 2, 3, AND 4 LYING SOUTH OF THE UNION PACIFIC RAILROAD RIGHT-OF-WAY AND ALL OF LOTS 5, 6, 7 AND 8, BLOCK 73, ORIGINAL CITY OF COLUMBUS, PLATTE COUNTY NEBRASKA AND THE VACATED ALLEY ADJACENT THERETO AND THE E 1/2 OF VACATED 15TH AVENUE FROM THE NORTHERN BOUNDARY OF 12TH STREET TO THE SOUTHERN BOUNDARY OF THE BURLINGTON NORTHERN RAILROAD RIGHT-OF-WAY AND FROM THE SOUTHERN BOUNDARY OF THE BURLINGTON NORTHERN RIGHT-OF-WAY TO THE SOUTHERN BOUNDARY OF THE UNION PACIFIC RIGHT-OF-WAY, AND LOT 1, BLOCK 74, ORIGINAL CITY OF COLUMBUS, PLATTE COUNTY, NEBRASKA LYING SOUTH OF UNION PACIFIC RAILROAD RIGHT-OF-WAY AND ALL OF THE VACATED ALLEY LYING SOUTH OF AND ADJACENT TO SAID LOT 1, AND ALL OF THAT PORTION OF THE W 1/2 OF VACATED 15TH AVENUE LYING EAST OF AND ADJOINING SAID LOT 1 AND NORTH OF THE SOUTH LINE OF ALLEY TO THE SOUTH LINE OF THE UNION PACIFIC RAILROAD RIGHT-OF-WAY., FROM THE PRESENT ZONING CLASSIFICATION OF "R-3" (MULTIPLE-FAMILY RESIDENTIAL DISTRICT) TO "ML/C-1" (LIGHT INDUSTRIAL DISTRICT); TO AMEND THE ZONING MAP AND THE FUTURE LAND USE MAP WHICH HAVE BEEN ADOPTED AND MADE A PART OF SAID CITY OF COLUMBUS, NEBRASKA LAND DEVELOPMENT ORDINANCE TO SHOW SAID REZONING AND RECLASSIFICATION; TO REPEAL ALL ORDINANCES AND RESOLUTIONS OR PARTS THEREOF IN CONFLICT HEREWITH; TO PROVIDE FOR THE PUBLICATION OF THIS ORDINANCE IN PAMPHLET FORM; AND TO PROVIDE FOR THE EFFECTIVE DATE was read by number only with a motion by Palensky and a second by Bahr. Bahr, Hiemer, Jablonski, Lopez Palensky, and Roth voted "Aye" and none voted "Nay". Alarcòn and Schilling were absent. Ordinance No. 26-07 was adopted with a motion by Palensky and a second by Lopez. Bahr, Hiemer, Jablonski, Lopez, Palensky, and Roth voted "Aye" and none voted "Nay". Alarcòn and Schilling were absent.

8. **PETITIONS AND COMMUNICATIONS:** None
9. **REPORTS OF CITY OFFICES:** Finance department report included in Consent Agenda
- 9.A. **2025 tax increment financing report.** Norquest noted there are twenty-eight redevelopment projects utilizing \$63.5 million in tax increment financing with four new projects added this past year.
- 9.B. **Update on Nebraska Department of Transportation Loup River South Bridges project.** Bogus reported the project remains on schedule with crews finishing up work on the south three piers. He noted that the traffic bump on the north side of the east bridge is being monitored.

**9.C. Columbus in Focus - General Services.** Lindberg presented on behalf of the General Services team, which included Eckhardt, Van Iperen, Lindberg, Mroczek, and Hopkins. The team highlighted individual department accomplishments from the past 60 days as well as group projects, including Kind Columbus Day which is set for Tuesday, April 28, 2026.

**10. REPORTS OF COUNCIL COMMITTEES:**

**10.A. Public Property, Safety, and Works Committee - April 20, 2026.**

**10.A.1. Permanent Utility Easement located in Lot 1, JLO Subdivision, to the City of Columbus, Platte County, Nebraska (Howard Blvd and Evans Lane).** The committee recommended approval. The report was adopted with a motion by Lopez and a second by Bahr. Bahr, Hiemer, Jablonski, Lopez, Palensky, and Roth voted "Aye" and none voted "Nay". Alarcòn and Schilling were absent.

**10.A.2. Minutes of January 21, 2026, Americans with Disabilities Compliance Committee meeting.** The committee recommended approval. The report was adopted with a motion by Lopez and a second by Palensky. Bahr, Hiemer, Jablonski, Lopez, Palensky, and Roth voted "Aye" and none voted "Nay". Alarcòn and Schilling were absent.

**10.A.3. Traffic Control Device Committee report for 1st Quarter 2026.** The committee recommended approval. The report was adopted with a motion by Bahr and a second by Roth. Bahr, Hiemer, Jablonski, Lopez, Palensky, and Roth voted "Aye" and none voted "Nay". Alarcòn and Schilling were absent.

**11. REPORTS OF SPECIAL COMMITTEES:** None

**12. REPORTS ON LEGISLATION:** None

**13. NEW BUSINESS:**

**13.A. Appointment of Greg Sealock to the Civil Service Commission for five-year term.** The mayor's appointment of Greg Sealock to the Civil Service Commission was ratified with a motion by Jablonski and a second by Palensky. Bahr, Hiemer, Jablonski, Lopez, Palensky, and Roth voted "Aye" and none voted "Nay". Alarcòn and Schilling were absent.

**13.B. Appointment of Bret Kumpf to the Board of Adjustment for three-year term.** The mayor's appointment of Bret Kumpf to the Board of Adjustment was ratified with a motion by Roth and a second by Jablonski. Bahr, Hiemer, Jablonski, Lopez, Palensky, and Roth voted "Aye" and none voted "Nay". Alarcòn and Schilling were absent.

**13.C. Appointment of Russ Strehle to the Board of Adjustment for three-year term.** The mayor's appointment of Russ Strehle to the Board of Adjustment was ratified with a motion by Bahr and a second by Lopez. Bahr, Hiemer, Jablonski, Lopez, Palensky, and Roth voted "Aye" and none voted "Nay". Alarcòn and Schilling were absent.

- 13.D. Appointment of Michael Duesman as an alternate to the Board of Adjustment for three-year term.** The mayor's appointment of Michael Duesman as an alternate to the Board of Adjustment was ratified with a motion by Bahr and a second by Jablonski. Bahr, Hiemer, Jablonski, Lopez, Palensky, and Roth voted "Aye" and none voted "Nay". Alarcón and Schilling were absent.

Vasicek clarified that the Board of Adjustment is an independent body of construction professionals who review applications and determine if a variance or waiver may be granted.

- 13.E. Plans, specifications, estimate of cost in the amount of \$204,590, and authorization to advertise for bids for Columbus Loup River Bridge Mitigation 2026 (plans and specifications on file in the engineering department) CIP# 25-25** Bogus explained that because the Loup River southbound truss bridge is a historic bridge, the federal government requires that it be mitigated. He noted that the mitigation project will be 100% reimbursed through the Nebraska Department of Transportation and the display structure will be located in Pawnee Park over the existing trail. The plans, specifications, estimate of cost, and authorization to advertise for bids for Columbus Loup River Bridge Mitigation 2026 was approved with a motion by Palensky and a second by Lopez. Bahr, Hiemer, Jablonski, Lopez, Palensky, and Roth voted "Aye" and none voted "Nay". Alarcón and Schilling were absent.
- 13.F. Comments from mayor and city council members.** Bulkley reminded the public that he will be at the Columbus Public Library on Saturday, April 25, 2026, from 9 a.m. to 10 a.m., as part of "Open House with the Mayor" which is held on the last Saturday of each month.

**14. RESOLUTIONS:**

- 14.A. Resolution No. R26-56 approving and accepting permanent utility easement with JLO Properties, LLC located in Lot 1, JLO Subdivision, to the City of Columbus, Platte County, Nebraska (Howard Boulevard and Evans Lake).** Resolution No. R26-56 entitled: A RESOLUTION OF THE MAYOR AND COUNCIL OF THE CITY OF COLUMBUS, NEBRASKA, APPROVING AND ACCEPTING THE PERMANENT UTILITY EASEMENT AGREEMENT WITH JLO PROPERTIES, LLC, LOCATED IN LOT 1, JLO SUBDIVISION TO THE CITY OF COLUMBUS, PLATTE COUNTY, NEBRASKA, MORE PARTICULARLY DESCRIBED AS FOLLOWS: BEGINNING AT A POINT ON THE SOUTHEASTERLY LINE OF LOT 1, JLO SUBDIVISION TO THE CITY OF COLUMBUS, PLATTE COUNTY NEBRASKA, SAID POINT BEING 76.01 FEET NORTHEASTERLY OF THE SOUTHEAST CORNER OF ORIGINALLY PLATTED, LOT 1, BLOCK C, EVANS-PLUGGE SUBDIVISION, AND ON THE NORTHEASTERLY RIGHT OF WAY LINE OF U.S. HIGHWAY 81, AND ASSUMING THE SOUTHEASTERLY LINE OF SAID LOT 1 TO HAVE A BEARING OF N 40°15'21"E; THENCE N 50°46'20"W AND ON SAID NORTHEASTERLY RIGHT OF WAY LINE, 116.71 FEET; THENCE N 39°13'40"E, 10.00 FEET;

THENCE S 50°46'20"E AND PARALLEL TO SAID RIGHT OF WAY LINE, 116.89 FEET TO A POINT ON THE SOUTHEASTERLY LINE OF SAID LOT 1; THENCE S 40°15'21" W AND ON SAID SOUTHEASTERLY LINE, 10.00 FEET TO THE POINT OF BEGINNING CONTAINING 1168.0 SQUARE FEET MORE OR LESS. A COPY OF WHICH IS ATTACHED HERETO AND INCORPORATED HEREIN; AND TO REPEAL ALL RESOLUTIONS OR PORTIONS THEREOF IN CONFLICT HEREWITH was adopted with a motion by Lopez and a second by Roth. Bahr, Hiemer, Jablonski, Lopez, Palensky, and Roth voted "Aye" and none voted "Nay". Alarcón and Schilling were absent.

**14.B. Resolution R26-57 awarding contract to Midlands Contracting dba Johnson Service Co. in the amount of \$133,409.75 for Sanitary Sewer Rehabilitation 2026. CIP #20-94** Resolution No. R26-57 entitled: A RESOLUTION OF THE MAYOR AND COUNCIL OF THE CITY OF COLUMBUS, NEBRASKA, AWARDING A CONTRACT TO MIDLANDS CONTRACTING, INC. DBA JOHNSON SERVICE CO. IN THE AMOUNT OF \$133,409.75 FOR SANITARY SEWER REHABILITATION 2026 was adopted with a motion by Bahr and a second by Hiemer. Bahr, Hiemer, Jablonski, Lopez, Palensky, and Roth voted "Aye" and none voted "Nay". Alarcón and Schilling were absent.

**14.C. Resolution R26-58 approving professional engineering services agreement with Kirkham Michael & Associates, Inc. in the amount of \$125,384.19 for Airport Runway and Taxiway Lighting Improvements. Reallocated CIP #26-15** Resolution No. R26-58 entitled: A RESOLUTION OF THE MAYOR AND COUNCIL OF THE CITY OF COLUMBUS, NEBRASKA, APPROVING A PROFESSIONAL ENGINEERING SERVICES AGREEMENT WITH KIRKHAM MICHAEL & ASSOCIATES, INC. IN THE AMOUNT OF \$125,384.19 FOR AIRPORT RUNWAY AND TAXIWAY LIGHTING IMPROVEMENTS PROJECT; A COPY OF WHICH IS ATTACHED HERETO AND INCORPORATED HEREIN; TO AUTHORIZE THE MAYOR TO EXECUTE THE SAME ON BEHALF OF THE CITY OF COLUMBUS; AND TO REPEAL ALL RESOLUTIONS OR PORTIONS THEREOF IN CONFLICT HEREWITH was adopted with a motion by Hiemer and a second by Bahr. Bahr, Hiemer, Jablonski, Lopez, Palensky, and Roth voted "Aye" and none voted "Nay". Alarcón and Schilling were absent.

**14.D. Resolution R26-59 approving professional engineering services agreement with Kirkham Michael & Associates, Inc. in the amount of \$20,000 to provide geographical information system and AutoCAD files for runway approach zones for Columbus Municipal Airport. Reallocated CIP #26-15** Resolution No. R26-59 entitled: A RESOLUTION OF THE MAYOR AND COUNCIL OF THE CITY OF COLUMBUS, NEBRASKA, APPROVING A PROFESSIONAL ENGINEERING SERVICES AGREEMENT WITH KIRKHAM MICHAEL & ASSOCIATES, INC. IN THE AMOUNT OF \$20,000 TO PROVIDE GEOGRAPHICAL INFORMATION SYSTEM AND AUTOCAD FILES FOR RUNWAYS 14/32 AND 02/20 APPROACH ZONES FOR COLUMBUS MUNICIPAL AIRPORT; A COPY OF SAID AGREEMENT IS ATTACHED

PROCEEDINGS OF CITY COUNCIL

April 20, 2026

Page 11

HERETO; TO AUTHORIZE THE MAYOR TO EXECUTE THE SAME ON BEHALF OF THE CITY; AND TO REPEAL ALL RESOLUTIONS OR PORTIONS THEREOF IN CONFLICT HEREWITH was adopted with a motion by Palensky and a second by Lopez. Bahr, Hiemer, Jablonski, Lopez, Palensky, and Roth voted "Aye" and none voted "Nay". Alarcòn and Schilling were absent.

- 14.E. Resolution No. R26-60 amending award of Community Development Block Grant funds to the amount of \$19,126.70 to Melissa Spearman for downtown revitalization.** Resolution No. R26-60 entitled: A RESOLUTION OF THE MAYOR AND COUNCIL OF THE CITY OF COLUMBUS, NEBRASKA, APPROVING THE AWARD OF PROCEEDS IN THE AMENDED AMOUNT OF \$19,126.70 FROM COMMUNITY DEVELOPMENT BLOCK GRANT NO. 23-DTR-003 TO MELISSA SPEARMAN AS RECOMMENDED BY THE BUSINESS IMPROVEMENT BOARD, A COPY OF WHICH IS ATTACHED HERETO AND INCORPORATED HEREIN BY THIS REFERENCE; AND TO AUTHORIZE THE MAYOR TO EXECUTE THE SAME ON BEHALF OF THE CITY was adopted with a motion by Lopez and a second by Bahr. Bahr, Hiemer, Jablonski, Lopez, Palensky, and Roth voted "Aye" and none voted "Nay". Alarcòn and Schilling were absent.
- 15. ORDINANCES ON FIRST READING:** None
- 16. ORDINANCES ON SECOND READING:** None
- 17. ORDINANCES ON THIRD READING:** None
- 18. CONSIDERATION OF PAYROLL AND BILLS ON FILE:** Included in Consent Agenda.
- 19. UNFINISHED BUSINESS:** None
- 20. ADJOURNMENT:** The meeting adjourned at 6:51 p.m.

Presented and approved this 4th day of May 2026.

OFFICE OF THE CITY CLERK

: Shuraya Choat

4.B. Minutes of April 20, 2026, Community Development Agency meeting.

COMMUNITY DEVELOPMENT AGENCY  
April 20, 2026

A meeting of the mayor and city council, as the Community Development Agency, of the City of Columbus, Nebraska, was convened in open and public session on April 20, 2026, at 6:53 p.m. in the Columbus Community Building, Community Room, 2500 14 Street, Columbus, Nebraska. Notice of this meeting was given in advance thereof by publication in the Columbus Telegram on April 1, 2026, with a copy of the proof of publication being on file in the office of the city clerk. Notice of this meeting was given simultaneously to the mayor and members of the city council, with a copy of the acknowledgment of receipt of notice being on file in the office of the city clerk. Availability of the agenda was communicated in the advance notice and in the notice to the mayor and city council of this meeting. All proceedings hereafter shown were taken while the convened meeting was open to the public.

- 1. Statement of compliance with open meetings act and roll call.** Mayor Bulkley announced that a copy of the Open Meetings Act is posted in the meeting room. Present were Mayor James Bulkley and Council Members, Charlie Bahr, Troy Hiemer, Rich Jablonski, Kat Lopez, AJ Palensky, and Prent Roth. Council Member Cynthia Alarcòn and Ron Schilling were absent and excused. City staff members included City Attorney Neal Valorz, City Administrator Tara Vasicek, Director of General Services Betsy Eckhardt, City Clerk Shuraya Choat, City Engineer Rick Bogus, Public Works Director Chuck Sliva, Police Chief Bret Strecker, Chief Building and Code Official Andy Woehrer, Planning and Economic Development Coordinator Jean Van Iperen, and Communications Manager Matt Lindberg.
- 2. R26-61 approving redevelopment contract with Keyes Development LLC and authorizing issuance of tax increment revenue bond in the amount of \$918,895 for Keyes Development LLC Redevelopment Project.** Resolution No. R26-61 entitled: A RESOLUTION OF THE MAYOR AND CITY COUNCIL OF THE CITY OF COLUMBUS, NEBRASKA, AS THE GOVERNING BODY OF THE COMMUNITY DEVELOPMENT AGENCY OF THE CITY OF COLUMBUS, NEBRASKA, APPROVING A REDEVELOPMENT CONTRACT FOR A REDEVELOPMENT PROJECT UNDERTAKEN BY KEYES DEVELOPMENT, LLC, AS SET FORTH IN THE "REDEVELOPMENT PLAN FOR THE KEYES DEVELOPMENT, LLC, REDEVELOPMENT PROJECT"; AND AUTHORIZING ISSUANCE OF ITS TAX INCREMENT FINANCING BOND PURSUANT TO THE TERMS OF THE REDEVELOPMENT CONTRACT was adopted with a motion by Bahr and a second by Hiemer. Bahr, Hiemer, Jablonski, Lopez, Palensky, and Roth voted "Aye" and none voted "Nay". Alarcòn and Schilling were absent.
- 3. Adjournment:** The meeting adjourned at 6:55 p.m.

Presented and approved this 4th day of May 2026.

OFFICE OF THE CITY CLERK  
: Shuraya Choat

4.C. Resolution No. R26-62 authorizing payment of various improvement projects.

DRAFT

**RESOLUTION NO. R26-62**

A RESOLUTION OF THE MAYOR AND COUNCIL OF THE CITY OF COLUMBUS, NEBRASKA, TO AUTHORIZE AND DIRECT THAT A CHECK BE ISSUED AND MADE PAYABLE TO THE RESPECTIVE CONTRACTOR(S) FOR LABOR, EQUIPMENT, AND MATERIALS FURNISHED FOR IMPROVEMENTS IN THE FOLLOWING DESIGNATED DISTRICTS AND PROJECTS WITHIN THE CITY OF COLUMBUS, ALL AS SET FORTH ON THE ATTACHED CERTIFICATES OF PROGRESS PREPARED BY THE RESPECTIVE SPECIAL ENGINEER TO WIT: COMMONWEALTH ELECTRIC COMPANY, FRANKFORT SQUARE LIGHTING PROJECT, \$39,726.60.

WHEREAS, the mayor and council of the City of Columbus, Nebraska, hereby find and determine that pursuant to contract, labor, equipment, and materials have been furnished for improvements in the following designated districts and projects within said City, to wit:

Commonwealth Electric Co.          Frankfort Square Lighting    \$ 39,726.60

that the respective special engineer has prepared and filed with the city clerk a certificate of progress respecting said improvements, copies of which are attached and are hereby incorporated herein by reference and made a part hereof as if fully set forth herein; and that pursuant to said contract, the plans, specifications, and said certificate of progress, there is due the respective contractor on account the amount as set forth in the attached.

NOW, THEREFORE, BE IT RESOLVED BY THE MAYOR AND COUNCIL OF THE CITY OF COLUMBUS, NEBRASKA, that the said improvements in the aforesaid districts and projects and the respective certificate of progress be and are hereby accepted and adopted; that a check be issued and made payable to the respective contractor in the amount and in the manner as set forth in the respective certificate of progress; that each check shall be drawn on the appropriate and respective fund; that each check shall be redeemed and paid upon collection of special assessments and sale of various purpose bonds at the completion of each of said districts and projects.

INTRODUCED BY COUNCIL MEMBER \_\_\_\_\_

PASSED AND ADOPTED THIS \_\_\_\_ DAY OF \_\_\_\_\_, 2026.

\_\_\_\_\_  
MAYOR

APPROVED AS TO FORM:

ATTEST:

\_\_\_\_\_  
CITY ATTORNEY

\_\_\_\_\_  
CITY CLERK



# Contractor's Application and Certificate of Payment

100-100-57200-23001 - 39,726.60

|  |  |
|--|--|
| Contractor's Application for Payment No: <span style="float: right;">2</span>                |  |
| Application Period: (From - to) <span style="float: right;">April 1st thru April 30th</span> |  |
| To: City of Columbus (Owner)   | From (Contractor): Commonwealth Electric Co of the Midwest <span style="float: right;">Contractor's Project No.: 260039</span> |
| Project Name: Columbus Frankfort Square Lighting Project                                     | Via (Consulting Engineer / Architect):<br>City of Columbus   |
| Fiscal Year Budget Number: 100-100-57200-23001   |  |

## Application For Payment

### Field Order and Change Order Summary

| Field (FO#) and Change Orders (CO#) Approved: |             |            |
|---|-------------|------------|
| Number  | Additions   | Deductions |
| 1   | \$ 6,532.00 |            |
|   |             |            |
|   |             |            |
|   |             |            |
| TOTALS  | \$ 6,532.00 | \$ -       |
| NET CHANGE                                    | \$ 6,532.00 |            |

|  |    |            |
|--|----|------------|
| 1. ORIGINAL CONTRACT PRICE.....  | \$ | 125,000.00 |
| 2. Net change by Field Order and Change Orders.....  | \$ | 6,532.00   |
| 3. Current Contract Price (Line 1 ± 2).....  | \$ | 131,532.00 |
| 4. TOTAL COMPLETED AND STORED TO DATE<br>(Column H on Progress Estimate).....  | \$ | 49,974.00  |
| 5. RETAINAGE: (Capped at 10% at 50% of Line 3)<br>(When line 4 is over 50% of Line 3 do calculation of Line 3 x .5 x .1 to get Retainage)  | \$ | 4,997.40   |
| 6. AMOUNT ELIGIBLE TO DATE (Line 4 - Line 5).....  | \$ | 44,976.60  |
| 7. LESS PREVIOUS PAYMENTS (Line 6 from prior Application).....   | \$ | 5,250.00   |
| 8. AMOUNT DUE THIS APPLICATION (Line 6 - Line 7).....  | \$ | 39,726.60  |
| 9. BALANCE TO FINISH, PLUS RETAINAGE (Line 3- Line 6).....<br>(To double check Line 9 Take Column I + Line 5 should = Line 9 calculations) | \$ | 86,555.40  |

### Contractor's Certification

The undersigned Contractor certifies that to the best of the Contractor's knowledge, information and belief, the Work covered by this Application for Payment has been completed in accordance with the Contract Documents, that all amounts have been paid by the Contractor for Work for which previous Certificates for Payment were issued and payments received from the Owner, and that current payment shown herein is now due.

Contractor: Commonwealth Electric Company  
 By: [Signature] Date: 4/14/2026  
 Printed/Typed Name: Jake Gable

|                    |    |  |
|--------------------|----|--|
| Payment of:        | \$ | 39,726.60  |
|                    |    | (Line 8 or other - attach explanation of the other amount)   |
| is recommended by: |    | _____<br>(Consulting Engineer/Architect) <span style="float: right;">(Date)</span>                 |
| Payment of:        | \$ | 39,726.60  |
|                    |    | (Line 8 or other - attach explanation of the other amount)   |
| is approved by:    |    | <u>Ronald J. Bozler</u><br>(City Engineer) <span style="float: right;">4-27-2026<br/>(Date)</span> |
| Approved by:       |    | _____<br>Funding Agency (if applicable) <span style="float: right;">(Date)</span>                  |

# APPLICATION AND CERTIFICATE FOR PAYMENT

**Containing Contractor's signed Certification is attached**

| Project Name: Columbus Frankfort Square Lighting Project                        |                 |                 | Contractor's Pay Application: 2 |               |                 |                              |                 |                           |  |                   |                           |
|---|-----------------|-----------------|---------------------------------|---------------|-----------------|------------------------------|-----------------|---------------------------|--|-------------------|---------------------------|
| Application Period: (From - To) April 1st thru April 30th                       |                 |                 |                                 |               |                 |                              |                 |                           |  |                   |                           |
| A<br>Item   |                 |                 | B                               | C             | D               | E                            | F               | G                         | H  |                   | I                         |
| Bid Item No.  | Description     | Unit of Measure | Bid Quantity                    | Unit Price    | Bid Value (B*C) | Estimated Quantity Installed | Value Installed | Material Presently Stored | Total Completed and Stored to Date (F+G) | % (F) B (H/F*100) | Balance to Finish (D - H) |
| <b>PROJECT A: 33RD AVENUE FROM NORTH OF 30TH STREET TO SOUTH OF 38TH STREET</b> |                 |                 |                                 |               |                 |                              |                 |                           |  |                   |                           |
| 1   | Contract amount | GMP             | 1                               | \$ 125,000.00 | \$ 125,000.00   |                              | \$ 43,442.00    |                           | \$ 43,442.00                             | 34.7536           | \$ 81,558.00              |
| 2   | Field Order 1   |                 | 1                               | \$ 6,532.00   | \$ 6,532.00     |                              | \$ 6,532.00     |                           | \$ 6,532.00                              | 100               | \$ -                      |
|   |                 |                 |                                 |               | \$ 131,532.00   |                              | \$ 49,974.00    |                           | \$ 49,974.00                             |                   | \$ 81,558.00              |

4.D. Payroll and bills on file.

| Vendor Code<br>Post Date | Vendor Name<br>Activity      | Inv/Check #        | Description                                  | Invoice Amt | Check Amt |
|--------------------------|------------------------------|--------------------|--|-------------|-----------|
| 00116                    | ACE HARDWARE & GARDEN CNT    |                    |  |             |           |
| 05/05/2026               | INVOICE                      | 218827/5           | SHOP TOWEL, DRAIN CLEANER                    | 77.95       |           |
| 05/05/2026               | INVOICE                      | 218838/5           | WHIZ LOCK NUTS                               | 14.99       |           |
| 05/05/2026               | INVOICE                      | 218842/5           | PADLOCK, HOSE NOZLE, WATERING CAN            | 68.96       |           |
| 05/05/2026               | INVOICE                      | 218843/5           | BIT, NUTS, BOLTS, SCREWS                     | 14.53       |           |
| 05/05/2026               | INVOICE                      | 218853/5           | WATER HEATER CLEANER, ELBOW, HEX BUSINGS, N. | 31.56       |           |
| 05/05/2026               | INVOICE                      | 218854/5           | NIPPLE, COUPLING                             | 7.98        |           |
| 05/05/2026               | INVOICE                      | 218858/5           | NUTS, BOLTS, SCREWS                          | 9.30        |           |
| 05/05/2026               | INVOICE                      | 218864/5           | 2 CYCLE OIL, SCREW DRIVER, HAMMER, .095 PRO  | 108.41      |           |
| 05/05/2026               | INVOICE                      | 218869/5           | NUTS, BOLTS, SCREWS                          | 6.36        |           |
| 05/05/2026               | INVOICE                      | 218889/5           | CONTRACTOR BAG, LANDSCAPE PIN                | 19.58       |           |
| 05/05/2026               | INVOICE                      | 218891/5           | SPRINKLER                                    | 21.99       |           |
| 05/05/2026               | INVOICE                      | 218893/5           | NUTS, BOLTS, SCREWS                          | 6.64        |           |
| 05/05/2026               | INVOICE                      | 218899/5           | BULB MR16 XENON 20W                          | 38.97       |           |
| 05/05/2026               | INVOICE                      | 218962/5           | NUTS, BOLTS, SCREWS                          | 2.76        |           |
| 05/05/2026               | INVOICE                      | 218964/5           | BIT 2", HMMR BIT                             | 16.58       |           |
| 05/05/2026               | INVOICE                      | 218966/5           | FAUCT SPRAY HOSE, STRAIGHT VALVE             | 26.98       |           |
| 05/05/2026               | INVOICE                      | 218984/5           | ELBOW 1/2"                                   | 1.39        |           |
| 05/05/2026               | INVOICE                      | 218990/5           | PEX CLAMP, TUBING CUTTER, PIPE - PEX         | 72.96       |           |
| 05/05/2026               | INVOICE                      | 219048/5           | AA BATTERY                                   | 21.99       |           |
| 05/05/2026               | INVOICE                      | 219091/5           | PADLOCK                                      | 26.99       |           |
| 05/05/2026               | INVOICE                      | 219117/5           | GARDEN SPADE, INSECT KILLER                  | 46.98       |           |
| 05/05/2026               | INVOICE                      | 219130/5           | VACUM BREAKER REPAIR KIT                     | 8.59        |           |
|                          |                              |                    | Total:                                       | 652.44      |           |
|                          |                              |                    | Net of 22 Invoices / 0 Checks                | 652.44      |           |
| 00102                    | AG SPRAY EQUIPMENT           |                    |  |             |           |
| 05/05/2026               | INVOICE                      | 133227             | SUPER FOAM CONCENTRATE, AIR INDUCTION TIP    | 60.51       |           |
| 05/05/2026               | INVOICE                      | 131264             | HOSE, SUPER FOAM CONCENTRATE, CALIBRATION JI | 227.42      |           |
|                          |                              |                    | Total:                                       | 287.93      |           |
|                          |                              |                    | Net of 2 Invoices / 0 Checks                 | 287.93      |           |
| 11185                    | ALLO COMMUNICATONS           |                    |  |             |           |
| 05/05/2026               | INVOICE                      | 2034309            | TELEPHONE - S FIRE STATION, INTERNET - VAN 1 | 146.06      |           |
|                          |                              |                    | Total:                                       | 146.06      |           |
|                          |                              |                    | Net of 1 Invoices / 0 Checks                 | 146.06      |           |
| 00294                    | AMERITAS LIFE INSURANCE CORP |                    |  |             |           |
| 05/05/2026               | INVOICE                      | 20251231M122525404 | CITY ADMINISTRATOR 414(H) PLAN 245879        | 460.00      |           |
|                          |                              |                    | Total:                                       | 460.00      |           |
|                          |                              |                    | Net of 1 Invoices / 0 Checks                 | 460.00      |           |
| 02873                    | ARIAS ABEL                   |                    |  |             |           |
| 05/05/2026               | INVOICE                      | CLASS              | SNEAKER DECORATING CLASS MAY 2, 2026         | 500.00      |           |
|                          |                              |                    | Total:                                       | 500.00      |           |
|                          |                              |                    | Net of 1 Invoices / 0 Checks                 | 500.00      |           |
| 11180                    | ARMOR EQUIPMENT              |                    |  |             |           |
| 05/05/2026               | INVOICE                      | 0066195-IN         | BOLT EYE 1/2 IN                              | 48.63       |           |
| 05/05/2026               | INVOICE                      | 0066111-IN         | WATER FILL HOSE                              | 195.67      |           |

| Vendor Code<br>Post Date | Vendor Name<br>Activity     | Inv/Check #        | Description                                  | Invoice Amt | Check Amt |
|--------------------------|-----------------------------|--------------------|--|-------------|-----------|
|                          |                             |                    | Total:                                       | 244.30      |           |
|                          |                             |                    | Net of 2 Invoices / 0 Checks                 | 244.30      |           |
| 10561                    | ARNOLD MOTOR SUPPLY         |                    |  |             |           |
| 05/05/2026               | INVOICE                     | 78NV182587         | AIR & OIL FILTER, PM 5W20 SYN                | 55.02       |           |
| 05/05/2026               | INVOICE                     | 78NV182557         | PUMP LEVER ACTION                            | 87.99       |           |
| 05/05/2026               | INVOICE                     | 78NV182478         | AIR, CABIN AIR & OIL FILTERS                 | 39.60       |           |
| 05/05/2026               | INVOICE                     | 78NV182421         | BRAKE PADS & ROTORS, OIL SEAL, GAS-MAG TRUCI | 422.56      |           |
| 05/05/2026               | INVOICE                     | 78NV182384         | AIR & OIL FILTERS                            | 17.59       |           |
| 05/05/2026               | INVOICE                     | 78NV181584         | OIL & AIR FILTER                             | 23.02       |           |
| 05/05/2026               | INVOICE                     | 78NV181591         | PM 10W30                                     | 29.46       |           |
| 05/05/2026               | INVOICE                     | 78CR021586         | CREDIT - CORE, CABIN AIR FILTER              | (33.37)     |           |
| 05/05/2026               | INVOICE                     | 78NV181530         | 12V HIGH PERF BATTERY                        | 208.06      |           |
| 05/05/2026               | INVOICE                     | 78NV182336         | AIR FILTER                                   | 17.55       |           |
|                          |                             |                    | Total:                                       | 867.48      |           |
|                          |                             |                    | Net of 10 Invoices / 0 Checks                | 867.48      |           |
| 00107                    | AT&T MOBILITY               |                    |  |             |           |
| 05/05/2026               | INVOICE                     | 287354145770X04282 | CELL PHONE MAR 22 - APR 21                   | 201.42      |           |
| 05/05/2026               | INVOICE                     | 287358632498X04282 | CELL PHONE MAR 22 - APR 21                   | 221.20      |           |
| 05/05/2026               | INVOICE                     | 287358635002X04282 | CELL PHONE MAR 22 - APR 21                   | 91.12       |           |
|                          |                             |                    | Total:                                       | 513.74      |           |
|                          |                             |                    | Net of 3 Invoices / 0 Checks                 | 513.74      |           |
| 11513                    | AUTEN RYAN                  |                    |  |             |           |
| 05/05/2026               | INVOICE                     | 4.15.2026          | REIMBURSE - MEALS & DOG FOOD FOR K-9 TRAINII | 146.63      |           |
|                          |                             |                    | Total:                                       | 146.63      |           |
|                          |                             |                    | Net of 1 Invoices / 0 Checks                 | 146.63      |           |
| 11537                    | AUTOMATIC SYSTEMS GROUP LLC |                    |  |             |           |
| 05/05/2026               | INVOICE                     | 044907             | WELL #12 BATTERY CHARGER ISSUE               | 1,707.62    |           |
| 05/05/2026               | INVOICE                     | 044913             | SOUTH PLANT CHEMICAL FEED PUMPS FLOW REPORT  | 684.80      |           |
| 05/05/2026               | INVOICE                     | 044899             | SCADA CYBERSECURITY & REMOTE ACCESS          | 5,017.24    |           |
|                          |                             |                    | Total:                                       | 7,409.66    |           |
|                          |                             |                    | Net of 3 Invoices / 0 Checks                 | 7,409.66    |           |
| 10663                    | AUXIANT                     |                    |  |             |           |
| 05/05/2026               | INVOICE                     | 5012026            | STOPLOSS PREMIUM, FEES                       | 60,420.27   |           |
| 05/05/2026               | INVOICE                     | 4232026FLEX        | FLEX FUNDING                                 | 3,077.20    |           |
| 05/05/2026               | INVOICE                     | 4232026HEALTH      | HEALTH FUNDING                               | 143,448.98  |           |
|                          |                             |                    | Total:                                       | 206,946.45  |           |
|                          |                             |                    | Net of 3 Invoices / 0 Checks                 | 206,946.45  |           |
| 11541                    | BAD RIVER ARTWORKS          |                    |  |             |           |
| 05/05/2026               | INVOICE                     | 2026-2027          | SCULPTURE WALK FEES                          | 1,000.00    |           |
|                          |                             |                    | Total:                                       | 1,000.00    |           |
|                          |                             |                    | Net of 1 Invoices / 0 Checks                 | 1,000.00    |           |
| 11411                    | BALDWIN ZACH                |                    |  |             |           |
| 05/05/2026               | INVOICE                     | 4.21.2026          | REIMBURSE -MEALS                             | 89.41       |           |

| Vendor Code<br>Post Date | Vendor Name<br>Activity            | Inv/Check # | Description                             | Invoice Amt | Check Amt |
|--------------------------|------------------------------------|-------------|---|-------------|-----------|
|                          |                                    |             | Total:                                  | 89.41       |           |
|                          |                                    |             | Net of 1 Invoices / 0 Checks            | 89.41       |           |
| 11324                    | BENCHMARK GOVERNMENT SOLUTIONS LLC |             |   |             |           |
| 05/05/2026               | INVOICE                            | 23851       | MEALS - AUTEN                           | 27.90       |           |
| 05/05/2026               | INVOICE                            | 23787       | MEALS - AUTEN                           | 27.90       |           |
| 05/05/2026               | INVOICE                            | 23800       | MEAL - NE LETC SPECIAL CLASS            | 13.95       |           |
|                          |                                    |             | Total:                                  | 69.75       |           |
|                          |                                    |             | Net of 3 Invoices / 0 Checks            | 69.75       |           |
| 11455                    | BICE ERIC                          |             |   |             |           |
| 05/05/2026               | INVOICE                            | 4.17.2026   | MILEAGE                                 | 300.80      |           |
|                          |                                    |             | Total:                                  | 300.80      |           |
|                          |                                    |             | Net of 1 Invoices / 0 Checks            | 300.80      |           |
| MISC                     | BILLS MATTHEW                      |             |   |             |           |
| 05/05/2026               | INVOICE                            | 04/27/2026  | UB refund for account: 400-68520-01     | 30.02       |           |
|                          |                                    |             | Total:                                  | 30.02       |           |
|                          |                                    |             | Net of 1 Invoices / 0 Checks            | 30.02       |           |
| 11552                    | BLACKBURN MFG CO                   |             |   |             |           |
| 05/05/2026               | INVOICE                            | IN0030391   | FIELD FLAGS                             | 735.00      |           |
|                          |                                    |             | Total:                                  | 735.00      |           |
|                          |                                    |             | Net of 1 Invoices / 0 Checks            | 735.00      |           |
| 00917                    | BLACKSTONE PUBLISHING              |             |   |             |           |
| 05/05/2026               | INVOICE                            | 2231544     | CD'S                                    | 180.69      |           |
|                          |                                    |             | Total:                                  | 180.69      |           |
|                          |                                    |             | Net of 1 Invoices / 0 Checks            | 180.69      |           |
| 11538                    | BLUESTREAK K9 LLC                  |             |   |             |           |
| 05/05/2026               | INVOICE                            | 619         | POLICE K9                               | 13,500.00   |           |
|                          |                                    |             | Total:                                  | 13,500.00   |           |
|                          |                                    |             | Net of 1 Invoices / 0 Checks            | 13,500.00   |           |
| 00337                    | BOMGAARS                           |             |   |             |           |
| 05/05/2026               | INVOICE                            | 35672782    | KITCHEN BRUSH, STRAP                    | 22.98       |           |
| 05/05/2026               | INVOICE                            | 35677465    | TOMCAT PELLETS                          | 82.36       |           |
| 05/05/2026               | INVOICE                            | 35677625    | PINTLE MOUNT                            | 96.29       |           |
| 05/05/2026               | INVOICE                            | 35680937    | PTO PIN ASSORTMENT, SPRAY PAINT         | 35.28       |           |
| 05/05/2026               | INVOICE                            | 35687168    | RATCHETING TIE DOWN                     | 89.86       |           |
| 05/05/2026               | INVOICE                            | 35672890    | BRAKLEEN, GREASE FITTING, FASTENERS     | 24.77       |           |
| 05/05/2026               | INVOICE                            | 35673248    | MAPP TORCH KIT, MAP GAS CYLINDER        | 101.97      |           |
| 05/05/2026               | INVOICE                            | 35674591    | ORANGE SAFETY FLAG                      | 7.19        |           |
| 05/05/2026               | INVOICE                            | 35676638    | PIKSTIK, PAINT STICK, BLADE FUSES       | 51.52       |           |
| 05/05/2026               | INVOICE                            | 35677115    | BILK BOLTS                              | 11.50       |           |
| 05/05/2026               | INVOICE                            | 35677396    | BROMEGRASS, TALL FESCUE, JACKET, GLOVES | 551.35      |           |
| 05/05/2026               | INVOICE                            | 35679892    | SPRAY WAND                              | 49.99       |           |
| 05/05/2026               | INVOICE                            | 35679780    | THREADED ROD, BULK BOLTS, FASTENERS     | 13.29       |           |
| 05/05/2026               | INVOICE                            | 35679877    | HITCH PIN                               | 14.99       |           |

| Vendor Code<br>Post Date      | Vendor Name<br>Activity     | Inv/Check # | Description                                | Invoice Amt | Check Amt |
|-------------------------------|-----------------------------|-------------|--|-------------|-----------|
| 05/05/2026                    | INVOICE                     | 35683629    | GREASE                                     | 95.80       |           |
| 05/05/2026                    | INVOICE                     | 35686737    | DISPOSABLE GLOVES                          | 49.98       |           |
| 05/05/2026                    | INVOICE                     | 35686528    | OIL, GEAR LUBE                             | 53.98       |           |
| 05/05/2026                    | INVOICE                     | 35686600    | GLOVES, WD-40 SPRAY                        | 31.98       |           |
| Total:                        |                             |             |  | 1,385.08    |           |
| Net of 18 Invoices / 0 Checks |                             |             |  | 1,385.08    |           |
| 00240                         | BOUND TREE MEDICAL LLC      |             |  |             |           |
| 05/05/2026                    | INVOICE                     | 86171468    | ELECTRODES                                 | 964.40      |           |
| 05/05/2026                    | INVOICE                     | 86171469    | CURAPLEX TRANSPORT CHAIR                   | 419.80      |           |
| Total:                        |                             |             |  | 1,384.20    |           |
| Net of 2 Invoices / 0 Checks  |                             |             |  | 1,384.20    |           |
| MISC                          | BRANDT PAM                  |             |  |             |           |
| 05/05/2026                    | INVOICE                     | 04/22/2026  | UB refund for account: 300-57210-05        | 55.51       |           |
| Total:                        |                             |             |  | 55.51       |           |
| Net of 1 Invoices / 0 Checks  |                             |             |  | 55.51       |           |
| 11540                         | BRIGGS INC OF OMAHA         |             |  |             |           |
| 05/05/2026                    | INVOICE                     | 2485367-00  | HIGHCLIFF ULTRA BOWL, STRONGHOLD SEAT      | 141.26      |           |
| Total:                        |                             |             |  | 141.26      |           |
| Net of 1 Invoices / 0 Checks  |                             |             |  | 141.26      |           |
| 03092                         | BRITE                       |             |  |             |           |
| 05/05/2026                    | INVOICE                     | INV43988    | INSTALLATION OF COMPUTERS INTO PATROL CARS | 18,480.00   |           |
| 05/05/2026                    | INVOICE                     | INV44600    | LICENSE READER KIT                         | 419.00      |           |
| Total:                        |                             |             |  | 18,899.00   |           |
| Net of 2 Invoices / 0 Checks  |                             |             |  | 18,899.00   |           |
| 03018                         | BS&A SOFTWARE               |             |  |             |           |
| 05/05/2026                    | INVOICE                     | 167001      | ANNUAL SERVICE & SUPPORT                   | 35,303.00   |           |
| Total:                        |                             |             |  | 35,303.00   |           |
| Net of 1 Invoices / 0 Checks  |                             |             |  | 35,303.00   |           |
| 11548                         | CENTRAL NEBRASKA SOD SUPPLY |             |  |             |           |
| 05/05/2026                    | INVOICE                     | 21982       | SOD  | 280.00      |           |
| Total:                        |                             |             |  | 280.00      |           |
| Net of 1 Invoices / 0 Checks  |                             |             |  | 280.00      |           |
| 10795                         | CHESTERMAN COMPANY          |             |  |             |           |
| 05/05/2026                    | INVOICE                     | 12010039    | CONCESSIONS - POP, MONSTER                 | 170.12      |           |
| Total:                        |                             |             |  | 170.12      |           |
| Net of 1 Invoices / 0 Checks  |                             |             |  | 170.12      |           |
| 10398                         | CLAY HILLS AG               |             |  |             |           |
| 05/05/2026                    | INVOICE                     | 138991      | 15 BAGS PRO 18-0-4                         | 531.75      |           |
| Total:                        |                             |             |  | 531.75      |           |

| Vendor Code<br>Post Date | Vendor Name<br>Activity                  | Inv/Check # | Description                                  | Invoice Amt | Check Amt |
|--------------------------|--|-------------|--|-------------|-----------|
|                          |  |             | Net of 1 Invoices / 0 Checks                 | 531.75      |           |
| 00036<br>05/05/2026      | COLUMBUS CUSTOM EMBROIDERY<br>INVOICE    | 60542       | CLOTHING - MARCOE                            | 54.00       |           |
|                          |  |             | Total:                                       | 54.00       |           |
|                          |  |             | Net of 1 Invoices / 0 Checks                 | 54.00       |           |
| 01250<br>05/05/2026      | COMMONWEALTH ELECTRIC COMPANY<br>INVOICE | 2           | FRANKFURT SQUARE LIGHTING PROJECT            | 39,726.60   |           |
|                          |  |             | Total:                                       | 39,726.60   |           |
|                          |  |             | Net of 1 Invoices / 0 Checks                 | 39,726.60   |           |
| 02718<br>05/05/2026      | CORE & MAIN LP<br>INVOICE                | Y884388     | 45 - METER SPUDS                             | 1,672.65    |           |
| 05/05/2026               | INVOICE                                  | Y884391     | 18 - 510M M2 S/POINT WIRED                   | 3,685.32    |           |
| 05/05/2026               | INVOICE                                  | Y884393     | 18 - 510M M2 S/POINT WIRED                   | 3,685.32    |           |
| 05/05/2026               | INVOICE                                  | Y884394     | 18 - 510M M2 S/POINT WIRED                   | 3,685.32    |           |
| 05/05/2026               | INVOICE                                  | Y884395     | 12 - IPERL 1 100 CF                          | 3,743.16    |           |
| 05/05/2026               | INVOICE                                  | Y884399     | 6 - IPERL 1 100CF                            | 1,871.58    |           |
|                          |  |             | Total:                                       | 18,343.35   |           |
|                          |  |             | Net of 6 Invoices / 0 Checks                 | 18,343.35   |           |
| 00548<br>05/05/2026      | COX MATT<br>INVOICE                      | 255         | JUNE 6TH, 2026 PERFORMANCE                   | 600.00      |           |
|                          |  |             | Total:                                       | 600.00      |           |
|                          |  |             | Net of 1 Invoices / 0 Checks                 | 600.00      |           |
| 11551<br>05/05/2026      | CREATIVE PLANNING<br>INVOICE             | 1278726     | TWO WEEKS OF PROJECT PER AGREEMENT           | 5,000.00    |           |
| 05/05/2026               | INVOICE                                  | 1280369     | ASSESSMENT WORK                              | 2,500.00    |           |
|                          |  |             | Total:                                       | 7,500.00    |           |
|                          |  |             | Net of 2 Invoices / 0 Checks                 | 7,500.00    |           |
| 03149<br>05/05/2026      | CULLIGAN OF COLUMBUS<br>INVOICE          | 303868      | SALT SOLAR DELIVERED                         | 60.00       |           |
| 05/05/2026               | INVOICE                                  | 303879      | 5 GALLON WATER DELIVERED                     | 36.50       |           |
|                          |  |             | Total:                                       | 96.50       |           |
|                          |  |             | Net of 2 Invoices / 0 Checks                 | 96.50       |           |
| 01539<br>05/05/2026      | D & K PRODUCTS<br>INVOICE                | 100470IN    | LSC IGNITION SPORTS TURF                     | 996.00      |           |
| 05/05/2026               | INVOICE                                  | 100469IN    | ROTARY SPREADER, CREW HERBICIDE              | 990.00      |           |
| 05/05/2026               | INVOICE                                  | 07777CM     | CREDIT - MEMO SYNGENTA EARLY ORDER GT365 CRJ | (1,502.80)  |           |
|                          |  |             | Total:                                       | 483.20      |           |
|                          |  |             | Net of 3 Invoices / 0 Checks                 | 483.20      |           |
| 00061<br>05/05/2026      | DALE JOHNSON TRUCKING<br>INVOICE         | 43632       | 3 LOADS                                      | 375.00      |           |

| Vendor Code<br>Post Date | Vendor Name<br>Activity | Inv/Check # | Description                                | Invoice Amt | Check Amt |
|--------------------------|-------------------------|-------------|--|-------------|-----------|
|                          |                         |             | Total:                                     | 375.00      |           |
|                          |                         |             | Net of 1 Invoices / 0 Checks               | 375.00      |           |
| 03279                    | DAS STATE ACCOUNTING    |             |  |             |           |
| 05/05/2026               | INVOICE                 | 1522652     | MONTHLY NETWORK CHARGES                    | 1,356.79    |           |
| 05/05/2026               | INVOICE                 | 1522699     | MONTHLY NETWORK CHARGES                    | 537.60      |           |
|                          |                         |             | Total:                                     | 1,894.39    |           |
|                          |                         |             | Net of 2 Invoices / 0 Checks               | 1,894.39    |           |
| 11489                    | DIGITECH COMPUTER LLC   |             |  |             |           |
| 05/05/2026               | INVOICE                 | 618002667   | MARCH 2026                                 | 3,318.94    |           |
|                          |                         |             | Total:                                     | 3,318.94    |           |
|                          |                         |             | Net of 1 Invoices / 0 Checks               | 3,318.94    |           |
| 03065                    | DOWNEY DRILLING         |             |  |             |           |
| 05/05/2026               | INVOICE                 | 26-450-1    | SS SHAFTS COMPLETE W/SS SLEEVES & COUPLERS | 3,108.00    |           |
|                          |                         |             | Total:                                     | 3,108.00    |           |
|                          |                         |             | Net of 1 Invoices / 0 Checks               | 3,108.00    |           |
| MISC                     | DREESEN DON             |             |  |             |           |
| 05/05/2026               | INVOICE                 | 04/22/2026  | UB refund for account: 100-08870-14        | 27.27       |           |
|                          |                         |             | Total:                                     | 27.27       |           |
|                          |                         |             | Net of 1 Invoices / 0 Checks               | 27.27       |           |
| 11420                    | DWEE                    |             |  |             |           |
| 05/05/2026               | INVOICE                 | 4.23.2026   | WATER OPERATOR LICENSE - ZACH BALDWIN      | 115.00      |           |
|                          |                         |             | Total:                                     | 115.00      |           |
|                          |                         |             | Net of 1 Invoices / 0 Checks               | 115.00      |           |
| 03158                    | EAKES OFFICE SOLUTIONS  |             |  |             |           |
| 05/05/2026               | INVOICE                 | 9326398-0   | PAPER, LAMINATE, POSTER STRIP              | 73.22       |           |
| 05/05/2026               | INVOICE                 | 9324120-0   | PERFED PAPER - WATER OFFICE                | 566.00      |           |
|                          |                         |             | Total:                                     | 639.22      |           |
|                          |                         |             | Net of 2 Invoices / 0 Checks               | 639.22      |           |
| MISC                     | EARLEY BOB              |             |  |             |           |
| 05/05/2026               | INVOICE                 | 04/22/2026  | UB refund for account: 100-06590-06        | 30.29       |           |
|                          |                         |             | Total:                                     | 30.29       |           |
|                          |                         |             | Net of 1 Invoices / 0 Checks               | 30.29       |           |
| MISC                     | EARLEY RENTALS          |             |  |             |           |
| 05/05/2026               | INVOICE                 | 04/22/2026  | UB refund for account: 200-29990-09        | 25.83       |           |
|                          |                         |             | Total:                                     | 25.83       |           |
|                          |                         |             | Net of 1 Invoices / 0 Checks               | 25.83       |           |
| 03159                    | EBSCO INDUSTRIES INC    |             |  |             |           |
| 05/05/2026               | INVOICE                 | 1811374     | MAGAZINE SUBSCRIPTIONS                     | 2,133.88    |           |

| Vendor Code<br>Post Date          | Vendor Name<br>Activity                      | Inv/Check #    | Description                                  | Invoice Amt      | Check Amt |
|-----------------------------------|--|----------------|--|------------------|-----------|
|                                   |  |                | Total:                                       | 2,133.88         |           |
|                                   |  |                | Net of 1 Invoices / 0 Checks                 | 2,133.88         |           |
| 11553<br>05/05/2026               | ECHO ELECTRIC<br>INVOICE                     | S011906671.001 | FUSE 600V                                    | 173.00           |           |
|                                   |  |                | Total:                                       | 173.00           |           |
|                                   |  |                | Net of 1 Invoices / 0 Checks                 | 173.00           |           |
| 11244<br>05/05/2026               | EGAN SUPPLY CO<br>INVOICE                    | 414679         | MULTI FOLD PAPER TOWELS, TOILET BOWL CLEANER | 425.98           |           |
|                                   |  |                | Total:                                       | 425.98           |           |
|                                   |  |                | Net of 1 Invoices / 0 Checks                 | 425.98           |           |
| 03161<br>05/05/2026               | ELECTRICAL ENGINEERING &<br>INVOICE          | 9146192-00     | LED 13WA19                                   | 58.40            |           |
|                                   |  |                | Total:                                       | 58.40            |           |
|                                   |  |                | Net of 1 Invoices / 0 Checks                 | 58.40            |           |
| 11368<br>05/05/2026               | ELKHORN INDUSTRIES LLC<br>INVOICE            | 2274           | PRESSURE WASHER                              | 2,600.00         |           |
|                                   |  |                | Total:                                       | 2,600.00         |           |
|                                   |  |                | Net of 1 Invoices / 0 Checks                 | 2,600.00         |           |
| MISC<br>05/05/2026                | ERNESTI D & VAN DYKE BETTY<br>INVOICE        | 04/22/2026     | UB refund for account: 100-15760-00          | 26.26            |           |
|                                   |  |                | Total:                                       | 26.26            |           |
|                                   |  |                | Net of 1 Invoices / 0 Checks                 | 26.26            |           |
| 11534<br>05/05/2026               | EXTREME GLASS<br>INVOICE                     | 5887           | 2026 MACK DRIVER DOOR GLASS                  | 370.50           |           |
|                                   |  |                | Total:                                       | 370.50           |           |
|                                   |  |                | Net of 1 Invoices / 0 Checks                 | 370.50           |           |
| 02639<br>05/05/2026               | FIRST NATIONAL BANK OF OMAHA<br>INVOICE      | 2026037        | RESEARCH & COPIES                            | 51.60            |           |
|                                   |  |                | Total:                                       | 51.60            |           |
|                                   |  |                | Net of 1 Invoices / 0 Checks                 | 51.60            |           |
| 03172<br>05/05/2026               | GALLS LLC<br>INVOICE                         | 034842493      | HAYS REPLACEMENT PANT                        | 93.25            |           |
|                                   |  |                | Total:                                       | 93.25            |           |
|                                   |  |                | Net of 1 Invoices / 0 Checks                 | 93.25            |           |
| 03174<br>05/05/2026<br>05/05/2026 | GEHRING CONSTRUCTION &<br>INVOICE<br>INVOICE | 89823<br>89824 | 1840 NORTH PARK LANE<br>1840 NORTH PARK LANE | 190.50<br>190.50 |           |
|                                   |  |                | Total:                                       | 381.00           |           |

| Vendor Code<br>Post Date                        | Vendor Name<br>Activity                            | Inv/Check #                           | Description  | Invoice Amt               | Check Amt |
|---|--|---------------------------------------|--|---------------------------|-----------|
|   |  |                                       | Net of 2 Invoices / 0 Checks   | 381.00                    |           |
| 10756<br>05/05/2026                             | GRAY RYAN<br>INVOICE                               | 4.20.2026                             | MILEAGE  | 130.50                    |           |
|   |  |                                       | Total:   | 130.50                    |           |
|   |  |                                       | Net of 1 Invoices / 0 Checks   | 130.50                    |           |
| 02594<br>05/05/2026<br>05/05/2026               | GREAT PLAINS BUILDING SUPPLY<br>INVOICE<br>INVOICE | 2604-552557<br>2604-552660            | 2X4-12 ACQ TREATED<br>ATHLETIC FIELD MARKER  | 21.84<br>673.26           |           |
|   |  |                                       | Total:   | 695.10                    |           |
|   |  |                                       | Net of 2 Invoices / 0 Checks   | 695.10                    |           |
| 02075<br>05/05/2026                             | GREAT PLAINS COMMUNICATIONS<br>INVOICE             | 125755 996-426-002                    | INTERNET 5/01 - 5/31   | 209.95                    |           |
|   |  |                                       | Total:   | 209.95                    |           |
|   |  |                                       | Net of 1 Invoices / 0 Checks   | 209.95                    |           |
| 02904<br>05/05/2026<br>05/05/2026               | GUNSLINGERS LLC<br>INVOICE<br>INVOICE              | 30895<br>30896                        | OPTIC COMPATIBLE SIGHT SET<br>HOLOSUN RED CIRCLE MULTI, OPTIC COMPATIBLE :   | 47.00<br>262.00           |           |
|   |  |                                       | Total:   | 309.00                    |           |
|   |  |                                       | Net of 2 Invoices / 0 Checks   | 309.00                    |           |
| 03182<br>05/05/2026                             | HACH COMPANY<br>INVOICE                            | 14959518                              | MODIFIED AGAR PLATES   | 832.20                    |           |
|   |  |                                       | Total:   | 832.20                    |           |
|   |  |                                       | Net of 1 Invoices / 0 Checks   | 832.20                    |           |
| 00009<br>05/05/2026                             | HARRINGTON TIM<br>INVOICE                          | 4.27.2026                             | REFUND - OVERPAYMENT FOR GROUP MEMBERSHIP  | 25.00                     |           |
|   |  |                                       | Total:   | 25.00                     |           |
|   |  |                                       | Net of 1 Invoices / 0 Checks   | 25.00                     |           |
| 00272<br>05/05/2026                             | HAWKINS INC<br>INVOICE                             | 7393300                               | CHEMICALS  | 2,209.56                  |           |
|   |  |                                       | Total:   | 2,209.56                  |           |
|   |  |                                       | Net of 1 Invoices / 0 Checks   | 2,209.56                  |           |
| 10271<br>05/05/2026<br>05/05/2026<br>05/05/2026 | HD SUPPLY<br>INVOICE<br>INVOICE<br>INVOICE         | 9246819906<br>9248046724<br>876106691 | CENTERPULL TOWELS, BLEACH, LINERS<br>MULTIFOLD TOWELS, SOAP REFILL, LAUNDRY PODS,<br>MULTIFOLD PAPER TOWEL, FLOOR CLEANER, CENTE | 105.18<br>260.90<br>66.71 |           |
|   |  |                                       | Total:   | 432.79                    |           |
|   |  |                                       | Net of 3 Invoices / 0 Checks   | 432.79                    |           |
| 03185<br>05/05/2026                             | HDR ENGINEERING INC<br>INVOICE                     | 1200817355                            | 8TH STREET & 12TH AVE INTERSECTION DESIGN  | 16,174.62                 |           |

| Vendor Code<br>Post Date | Vendor Name<br>Activity                 | Inv/Check # | Description                                  | Invoice Amt | Check Amt |
|--------------------------|---|-------------|--|-------------|-----------|
|                          |   |             | Total:                                       | 16,174.62   |           |
|                          |   |             | Net of 1 Invoices / 0 Checks                 | 16,174.62   |           |
| 11549<br>05/05/2026      | HILMER MARK<br>INVOICE                  | 1           | USED CUSHMAN REAR END                        | 1,750.00    |           |
|                          |   |             | Total:                                       | 1,750.00    |           |
|                          |   |             | Net of 1 Invoices / 0 Checks                 | 1,750.00    |           |
| 00150<br>05/05/2026      | HOMETOWN LEASING<br>INVOICE             | 21          | COPIER LEASE                                 | 232.93      |           |
| 05/05/2026               | INVOICE                                 | 14          | COPIER LEASE                                 | 271.19      |           |
| 05/05/2026               | INVOICE                                 | 16          | COPIER LEASE                                 | 130.21      |           |
| 05/05/2026               | INVOICE                                 | 12          | COPIER LEASE                                 | 74.26       |           |
|                          |   |             | Total:                                       | 708.59      |           |
|                          |   |             | Net of 4 Invoices / 0 Checks                 | 708.59      |           |
| 02077<br>05/05/2026      | HUSKER STEEL INC<br>INVOICE             | 0-64C26     | 3" STD PIPE                                  | 672.00      |           |
|                          |   |             | Total:                                       | 672.00      |           |
|                          |   |             | Net of 1 Invoices / 0 Checks                 | 672.00      |           |
| 03194<br>05/05/2026      | INGRAM LIBRARY SERVICES, INC<br>INVOICE | 95097112    | CREDIT                                       | (11.77)     |           |
| 05/05/2026               | INVOICE                                 | 94858275    | MATERIALS                                    | 65.54       |           |
| 05/05/2026               | INVOICE                                 | 94936366    | MATERIALS                                    | 34.18       |           |
| 05/05/2026               | INVOICE                                 | 94967841    | MATERIALS                                    | 642.69      |           |
| 05/05/2026               | INVOICE                                 | 95035975    | MATERIALS                                    | 52.81       |           |
| 05/05/2026               | INVOICE                                 | 95171510    | MATERIALS                                    | 45.03       |           |
| 05/05/2026               | INVOICE                                 | 95203482    | MATERIALS                                    | 353.74      |           |
| 05/05/2026               | INVOICE                                 | 95254695    | MATERIALS                                    | 76.50       |           |
| 05/05/2026               | INVOICE                                 | 95299167    | MATERIALS                                    | 179.51      |           |
| 05/05/2026               | INVOICE                                 | 95329913    | MATERIALS                                    | 810.58      |           |
| 05/05/2026               | INVOICE                                 | 95438678    | MATERIALS                                    | 51.34       |           |
| 05/05/2026               | INVOICE                                 | 95453990    | MATERIALS                                    | 149.44      |           |
| 05/05/2026               | INVOICE                                 | 95468126    | MATERIALS                                    | 579.22      |           |
| 05/05/2026               | INVOICE                                 | 95495872    | MATERIALS                                    | 26.72       |           |
|                          |   |             | Total:                                       | 3,055.53    |           |
|                          |   |             | Net of 14 Invoices / 0 Checks                | 3,055.53    |           |
| 03199<br>05/05/2026      | JACKSON SERVICES INC<br>INVOICE         | 5795378     | SHOP TOWELS, UNIFORMS                        | 312.75      |           |
| 05/05/2026               | INVOICE                                 | 5793348     | UNIFORMS                                     | 84.27       |           |
| 05/05/2026               | INVOICE                                 | 5788702     | UNIFORMS                                     | 84.12       |           |
| 05/05/2026               | INVOICE                                 | 5790775     | UNIFORMS                                     | 162.82      |           |
| 05/05/2026               | INVOICE                                 | 5790777     | UNIFORMS                                     | 30.60       |           |
| 05/05/2026               | INVOICE                                 | 5790778     | UNIFORMS                                     | 98.58       |           |
| 05/05/2026               | INVOICE                                 | 5790779     | UNIFORMS                                     | 99.76       |           |
| 05/05/2026               | INVOICE                                 | 5790780     | MAT  | 3.30        |           |
| 05/05/2026               | INVOICE                                 | 5790781     | UNIFORMS                                     | 78.96       |           |
| 05/05/2026               | INVOICE                                 | 5790767     | SOAP FOAM - BAG, UNIFORMS                    | 339.70      |           |
| 05/05/2026               | INVOICE                                 | 5793341     | MATS   | 92.30       |           |
| 05/05/2026               | INVOICE                                 | 5797836     | MATS, MOPS, POLISH TOWEL, WINDSHIELD WIPE, : | 150.19      |           |

| Vendor Code<br>Post Date      | Vendor Name<br>Activity            | Inv/Check # | Description                                  | Invoice Amt | Check Amt |
|-------------------------------|------------------------------------|-------------|--|-------------|-----------|
| 05/05/2026                    | INVOICE                            | 5797841     | SHOP TOWELS, UNIFORMS                        | 312.75      |           |
| 05/05/2026                    | INVOICE                            | 5797851     | UNIFORMS                                     | 162.97      |           |
| 05/05/2026                    | INVOICE                            | 5797853     | MAT, UNIFORMS                                | 35.69       |           |
| 05/05/2026                    | INVOICE                            | 5797856     | MATS, ROLLER TOWELS, UNIFORMS                | 137.60      |           |
| 05/05/2026                    | INVOICE                            | 5797857     | UNIFORMS                                     | 99.92       |           |
| 05/05/2026                    | INVOICE                            | 5797858     | MAT, BAR TOWELS, SHOP TOWELS                 | 26.70       |           |
| 05/05/2026                    | INVOICE                            | 5797859     | UNIFORMS                                     | 79.11       |           |
| 05/05/2026                    | INVOICE                            | 5797865     | MOPS, MATS                                   | 65.74       |           |
| Total:                        |                                    |             |  | 2,457.83    |           |
| Net of 20 Invoices / 0 Checks |                                    |             |  | 2,457.83    |           |
| 03005                         | JONES AUTOMOTIVE                   |             |  |             |           |
| 05/05/2026                    | INVOICE                            | 2-65245     | FULL VEHICLE STRIP - VIN #7979               | 902.50      |           |
| Total:                        |                                    |             |  | 902.50      |           |
| Net of 1 Invoices / 0 Checks  |                                    |             |  | 902.50      |           |
| 11103                         | JONES GROUP                        |             |  |             |           |
| 05/05/2026                    | INVOICE                            | 16756       | NEW PBON EFFECTIVE 3/9/2026                  | 250.00      |           |
| Total:                        |                                    |             |  | 250.00      |           |
| Net of 1 Invoices / 0 Checks  |                                    |             |  | 250.00      |           |
| 10314                         | KEAST ENTERPRISES INC.             |             |  |             |           |
| 05/05/2026                    | INVOICE                            | INV36367    | SEAL, 2" BEARING DUCTILE HOUSING, COUPLING ( | 301.16      |           |
| Total:                        |                                    |             |  | 301.16      |           |
| Net of 1 Invoices / 0 Checks  |                                    |             |  | 301.16      |           |
| 03202                         | KELLY SUPPLY COMPANY               |             |  |             |           |
| 05/05/2026                    | INVOICE                            | S12312214-0 | O-RING                                       | 1.15        |           |
| 05/05/2026                    | INVOICE                            | S12312003-0 | PVC PIPE NIPPLE, BUSHING                     | 62.21       |           |
| Total:                        |                                    |             |  | 63.36       |           |
| Net of 2 Invoices / 0 Checks  |                                    |             |  | 63.36       |           |
| 11454                         | KINGS III EMERGENCY COMMUNICATIONS |             |  |             |           |
| 05/05/2026                    | INVOICE                            | 3403248     | VIDEO MONITORING, ELEVATOR PHONES            | 390.00      |           |
| Total:                        |                                    |             |  | 390.00      |           |
| Net of 1 Invoices / 0 Checks  |                                    |             |  | 390.00      |           |
| 03206                         | KOCH EXCAVATING CO INC             |             |  |             |           |
| 05/05/2026                    | INVOICE                            | 41064       | TOP DIRT                                     | 268.16      |           |
| Total:                        |                                    |             |  | 268.16      |           |
| Net of 1 Invoices / 0 Checks  |                                    |             |  | 268.16      |           |
| 00300                         | LACAL EQUIPMENT INC                |             |  |             |           |
| 05/05/2026                    | INVOICE                            | 0448764-IN  | 5 SEGMENT GUTTER BROOM                       | 1,440.96    |           |
| Total:                        |                                    |             |  | 1,440.96    |           |
| Net of 1 Invoices / 0 Checks  |                                    |             |  | 1,440.96    |           |
| 00012                         | LAKEVIEW SMALL ENGINE INC          |             |  |             |           |

| Vendor Code<br>Post Date | Vendor Name<br>Activity     | Inv/Check # | Description                                  | Invoice Amt | Check Amt |
|--------------------------|-----------------------------|-------------|--|-------------|-----------|
| 05/05/2026               | INVOICE                     | 059455      | OIL, AIR & FUEL FILTERS, SPARK PLUGS, DECK 1 | 909.66      |           |
| 05/05/2026               | INVOICE                     | 059645      | OXYGEN SENSOR, FUEL PUMP, SPARK PLUGS        | 503.83      |           |
|                          |                             |             | Total:                                       | 1,413.49    |           |
|                          |                             |             | Net of 2 Invoices / 0 Checks                 | 1,413.49    |           |
| 01183                    | LARM (LEAGUE ASSOCIATION OF |             |  |             |           |
| 05/05/2026               | INVOICE                     | 115912      | ENDORSEMENT #15                              | 208.76      |           |
| 05/05/2026               | INVOICE                     | 115743      | CREDIT - ENDORSEMENT #14                     | (168.26)    |           |
|                          |                             |             | Total:                                       | 40.50       |           |
|                          |                             |             | Net of 2 Invoices / 0 Checks                 | 40.50       |           |
| 02596                    | LAWSON PRODUCTS             |             |  |             |           |
| 05/05/2026               | INVOICE                     | 9313412517  | LOCK NUTS                                    | 27.16       |           |
|                          |                             |             | Total:                                       | 27.16       |           |
|                          |                             |             | Net of 1 Invoices / 0 Checks                 | 27.16       |           |
| 11388                    | LEGACY OUTDOOR ADVERTISING  |             |  |             |           |
| 05/05/2026               | INVOICE                     | MINV-814    | BILLBOARD HWY 30 6/15/26 TO 12/14/26         | 3,150.00    |           |
|                          |                             |             | Total:                                       | 3,150.00    |           |
|                          |                             |             | Net of 1 Invoices / 0 Checks                 | 3,150.00    |           |
| 11554                    | LIMON KENDRA                |             |  |             |           |
| 05/05/2026               | INVOICE                     | 5.05.2026   | PINATA DECORATING WORKSHOP MAY 16, 2026      | 500.00      |           |
|                          |                             |             | Total:                                       | 500.00      |           |
|                          |                             |             | Net of 1 Invoices / 0 Checks                 | 500.00      |           |
| 00822                    | LINCOLN WINWATER WORKS      |             |  |             |           |
| 05/05/2026               | INVOICE                     | 11988601    | 2' HYD EXT                                   | 813.57      |           |
|                          |                             |             | Total:                                       | 813.57      |           |
|                          |                             |             | Net of 1 Invoices / 0 Checks                 | 813.57      |           |
| MISC                     | MAGUIRE STEVE               |             |  |             |           |
| 05/05/2026               | INVOICE                     | 04/22/2026  | UB refund for account: 100-16440-31          | 27.63       |           |
|                          |                             |             | Total:                                       | 27.63       |           |
|                          |                             |             | Net of 1 Invoices / 0 Checks                 | 27.63       |           |
| 10499                    | MARCO TECHNOLOGIES LLC      |             |  |             |           |
| 05/05/2026               | INVOICE                     | INV14971723 | WIDE FORMAT PRINTER                          | 4,427.00    |           |
|                          |                             |             | Total:                                       | 4,427.00    |           |
|                          |                             |             | Net of 1 Invoices / 0 Checks                 | 4,427.00    |           |
| 11470                    | MATTEO SAND & GRAVEL CO INC |             |  |             |           |
| 05/05/2026               | INVOICE                     | 32837       | GOLF COURSE SAND                             | 2,072.00    |           |
|                          |                             |             | Total:                                       | 2,072.00    |           |
|                          |                             |             | Net of 1 Invoices / 0 Checks                 | 2,072.00    |           |
| 02101                    | MD SOLUTIONS INC            |             |  |             |           |

| Vendor Code<br>Post Date | Vendor Name<br>Activity     | Inv/Check #   | Description                                  | Invoice Amt | Check Amt |
|--------------------------|-----------------------------|---------------|--|-------------|-----------|
| 05/05/2026               | INVOICE                     | 0064880       | STRAPPING BRACKET                            | 260.00      |           |
|                          |                             |               | Total:                                       | 260.00      |           |
|                          |                             |               | Net of 1 Invoices / 0 Checks                 | 260.00      |           |
| 03220                    | MENARDS                     |               |  |             |           |
| 05/05/2026               | INVOICE                     | 46166         | FINAL CHARGE 50/50                           | 85.62       |           |
| 05/05/2026               | INVOICE                     | 46255         | WATER, BOUNTY PAPER TOWELS                   | 59.15       |           |
| 05/05/2026               | INVOICE                     | 46256         | STRUT 1/4" SPRING NUT, BEAM CLAMP, SQR WASHI | 37.04       |           |
| 05/05/2026               | INVOICE                     | 46273         | HOME DEF, BOUNTY, TOWELS, GLADE, NOZZLE, GRI | 110.56      |           |
| 05/05/2026               | INVOICE                     | 46267         | 1" BLACK COUPLING                            | 2.39        |           |
| 05/05/2026               | INVOICE                     | 46319         | GREASE FITTING ASST                          | 12.49       |           |
| 05/05/2026               | INVOICE                     | 46330         | INT/EXT PAINT                                | 22.97       |           |
| 05/05/2026               | INVOICE                     | 46318         | ROLLER, PAINT TRAY, SPREADER                 | 76.89       |           |
| 05/05/2026               | INVOICE                     | 46306         | DAWN   | 133.68      |           |
| 05/05/2026               | INVOICE                     | 46363         | INT/EXT PAINT                                | 22.97       |           |
| 05/05/2026               | INVOICE                     | 46387         | ELITE POST MOUNT, MAILBOX POST KIT, BIT SET  | 134.96      |           |
| 05/05/2026               | INVOICE                     | 46446         | POTHOLE PATCH                                | 137.88      |           |
| 05/05/2026               | INVOICE                     | 46430         | GLASS CLEANER, KITCHEN BRUSH, CLOROX WIPES,  | 27.30       |           |
| 05/05/2026               | INVOICE                     | 46422         | FUSION WEB, FERTILIZER, GARDEN STAPLE        | 48.17       |           |
| 05/05/2026               | INVOICE                     | 45904         | 1X4-10', CEILING PAINT, CONST ADH, TAPING KI | 57.87       |           |
| 05/05/2026               | INVOICE                     | 45966         | TIRE GAUGE, AA BATTERIES, WASHING MACH CLEA  | 115.74      |           |
| 05/05/2026               | INVOICE                     | 46120         | OIL DRI                                      | 124.35      |           |
| 05/05/2026               | INVOICE                     | 46033         | BOUNTY, ANGEL SOFT,PAPER DISC FILTER, PKG T  | 12.65       |           |
|                          |                             |               | Total:                                       | 1,222.68    |           |
|                          |                             |               | Net of 18 Invoices / 0 Checks                | 1,222.68    |           |
| MISC                     | MICKEY DANIEL               |               |  |             |           |
| 05/05/2026               | INVOICE                     | 04/22/2026    | UB refund for account: 200-38870-00          | 27.00       |           |
|                          |                             |               | Total:                                       | 27.00       |           |
|                          |                             |               | Net of 1 Invoices / 0 Checks                 | 27.00       |           |
| 03230                    | MOTION INDUSTRIES INC       |               |  |             |           |
| 05/05/2026               | INVOICE                     | NE07-00545188 | 15" OCTAGONAL LED MINI LIGHT                 | 477.58      |           |
| 05/05/2026               | INVOICE                     | NE07-00545524 | FITTING, FITTING - MALE CONN, GREASE FITTIN  | 85.01       |           |
|                          |                             |               | Total:                                       | 562.59      |           |
|                          |                             |               | Net of 2 Invoices / 0 Checks                 | 562.59      |           |
| 11550                    | MUELLER CON & MARLA         |               |  |             |           |
| 05/05/2026               | INVOICE                     | 5.05.2026     | CEMETERY PLOTS                               | 400.00      |           |
|                          |                             |               | Total:                                       | 400.00      |           |
|                          |                             |               | Net of 1 Invoices / 0 Checks                 | 400.00      |           |
| 10225                    | NAPA AUTO PARTS OF COLUMBUS |               |  |             |           |
| 05/05/2026               | INVOICE                     | 775334        | WATER PUMP                                   | 301.99      |           |
| 05/05/2026               | INVOICE                     | 775243        | AIR DOOR ACTUATOR                            | 20.54       |           |
|                          |                             |               | Total:                                       | 322.53      |           |
|                          |                             |               | Net of 2 Invoices / 0 Checks                 | 322.53      |           |
| 10877                    | NARANS STEVE                |               |  |             |           |
| 05/05/2026               | INVOICE                     | 4.27.2026     | BEATS & EATS - NE ALL STARS 5/30/2026        | 3,800.00    |           |

| Vendor Code<br>Post Date          | Vendor Name<br>Activity                           | Inv/Check #            | Description  | Invoice Amt      | Check Amt |
|-----------------------------------|---|------------------------|--|------------------|-----------|
|                                   |   |                        | Total:   | 3,800.00         |           |
|                                   |   |                        | Net of 1 Invoices / 0 Checks   | 3,800.00         |           |
| 11400<br>05/05/2026               | NDWEE<br>INVOICE                                  | BU84002256.475200      | GRADE 1 & 2 COURSE - SCHOENHOFER   | 200.00           |           |
|                                   |   |                        | Total:   | 200.00           |           |
|                                   |   |                        | Net of 1 Invoices / 0 Checks   | 200.00           |           |
| 00572<br>05/05/2026               | NE DEPT OF TRANSPORTATION<br>INVOICE              | 0650843                | PROJECT NO RRZ-TMT-6065 (5)  | 2,971.41         |           |
|                                   |   |                        | Total:   | 2,971.41         |           |
|                                   |   |                        | Net of 1 Invoices / 0 Checks   | 2,971.41         |           |
| 03233<br>05/05/2026<br>05/05/2026 | NEBRASKA LAW ENFORCEMENT<br>INVOICE<br>INVOICE    | 16534<br>16548         | WOTIPKA BENJAMIN - TUITION - FIREARMS INSTR<br>MCCLOUD, ZACHARY - TUITION - GROUND CONTROL | 400.00<br>160.00 |           |
|                                   |   |                        | Total:   | 560.00           |           |
|                                   |   |                        | Net of 2 Invoices / 0 Checks   | 560.00           |           |
| 00444<br>05/05/2026               | NEBRASKA PUBLIC HEALTH<br>INVOICE                 | 602450                 | WATER TESTING  | 468.00           |           |
|                                   |   |                        | Total:   | 468.00           |           |
|                                   |   |                        | Net of 1 Invoices / 0 Checks   | 468.00           |           |
| 00029<br>05/05/2026               | NEBRASKA STATE FIRE MARSHAL<br>INVOICE            | 138331                 | ANNUAL BOILER CERTIFICATE - AQUATIC CENTER   | 36.00            |           |
|                                   |   |                        | Total:   | 36.00            |           |
|                                   |   |                        | Net of 1 Invoices / 0 Checks   | 36.00            |           |
| 03241<br>05/05/2026               | NEWMAN SIGNS INC.<br>INVOICE                      | TRFINV066777           | SIGNS  | 1,791.56         |           |
|                                   |   |                        | Total:   | 1,791.56         |           |
|                                   |   |                        | Net of 1 Invoices / 0 Checks   | 1,791.56         |           |
| 03212<br>05/05/2026               | NIPPON SANZO MATHESON INC<br>INVOICE              | 0033178024             | CYLINDER RENTAL  | 71.91            |           |
|                                   |   |                        | Total:   | 71.91            |           |
|                                   |   |                        | Net of 1 Invoices / 0 Checks   | 71.91            |           |
| 10518<br>05/05/2026<br>05/05/2026 | NORTHEAST COMMUNITY COLLEGE<br>INVOICE<br>INVOICE | 200081128<br>200081128 | PARAMEDIC SCHOOL - THEODORE VAUGHN<br>PARAMEDIC SCHOOL - THEODORE VAUGHN                   | 292.00<br>556.75 |           |
|                                   |   |                        | Total:   | 848.75           |           |
|                                   |   |                        | Net of 2 Invoices / 0 Checks   | 848.75           |           |
| 03245<br>05/05/2026               | NORTHEAST NEBRASKA SOLID<br>INVOICE               | 3312026                | LANDFILL CHARGES   | 488.40           |           |

| Vendor Code<br>Post Date | Vendor Name<br>Activity        | Inv/Check # | Description                          | Invoice Amt | Check Amt |
|--------------------------|--------------------------------|-------------|--------------------------------------|-------------|-----------|
|                          |                                |             | Total:                               | 488.40      |           |
|                          |                                |             | Net of 1 Invoices / 0 Checks         | 488.40      |           |
| 03249                    | OCCUPATIONAL HEALTH SERV       |             |                                      |             |           |
| 05/05/2026               | INVOICE                        | 85564       | DRUG SCREEN                          | 530.00      |           |
| 05/05/2026               | INVOICE                        | 85565       | VACCINATIONS                         | 316.00      |           |
|                          |                                |             | Total:                               | 846.00      |           |
|                          |                                |             | Net of 2 Invoices / 0 Checks         | 846.00      |           |
| 00761                    | OLIVER PACKAGING & EQUIPMENT   |             |                                      |             |           |
| 05/05/2026               | INVOICE                        | 276437      | 2C TRAYS, FILM SEAL ROLLS FOR HDM    | 3,514.16    |           |
|                          |                                |             | Total:                               | 3,514.16    |           |
|                          |                                |             | Net of 1 Invoices / 0 Checks         | 3,514.16    |           |
| 00176                    | O'REILLY AUTOMOTIVE INC        |             |                                      |             |           |
| 05/05/2026               | INVOICE                        | 0681-397543 | WIPER BLADES                         | 45.88       |           |
| 05/05/2026               | INVOICE                        | 0681-397203 | RV ANTIFREEZE                        | 13.98       |           |
| 05/05/2026               | INVOICE                        | 0681-397396 | CREDIT - CORE RETURN                 | (55.00)     |           |
| 05/05/2026               | INVOICE                        | 0681-397371 | BRACKETED CAL                        | 118.62      |           |
| 05/05/2026               | INVOICE                        | 0681-397221 | NEW MASTER CYLINDER                  | 164.69      |           |
|                          |                                |             | Total:                               | 288.17      |           |
|                          |                                |             | Net of 5 Invoices / 0 Checks         | 288.17      |           |
| 03010                    | PACE ANALYTICAL SERVICES LLC   |             |                                      |             |           |
| 05/05/2026               | INVOICE                        | 2660245210  | WATER TESTING                        | 1,178.00    |           |
|                          |                                |             | Total:                               | 1,178.00    |           |
|                          |                                |             | Net of 1 Invoices / 0 Checks         | 1,178.00    |           |
| 11542                    | PEDERSEN RYAN                  |             |                                      |             |           |
| 05/05/2026               | INVOICE                        | 2026-2027   | SCULPTURE WALK FEES                  | 1,000.00    |           |
|                          |                                |             | Total:                               | 1,000.00    |           |
|                          |                                |             | Net of 1 Invoices / 0 Checks         | 1,000.00    |           |
| 00345                    | PETE LIEN & SONS INC.          |             |                                      |             |           |
| 05/05/2026               | INVOICE                        | CD99406093  | QUICKLIME FINES                      | 7,858.69    |           |
|                          |                                |             | Total:                               | 7,858.69    |           |
|                          |                                |             | Net of 1 Invoices / 0 Checks         | 7,858.69    |           |
| 03258                    | PETTY CASH                     |             |                                      |             |           |
| 05/05/2026               | INVOICE                        | 4.21.2026   | 2026 START UP CASH FOR PAWNEE PLUNGE | 2,600.00    |           |
|                          |                                |             | Total:                               | 2,600.00    |           |
|                          |                                |             | Net of 1 Invoices / 0 Checks         | 2,600.00    |           |
| 10413                    | PICTOMETRY INTERNATIONAL CORP. |             |                                      |             |           |
| 05/05/2026               | INVOICE                        | US450649    | 2026 FLIGHT EV CLOUD YEAR 1          | 18,150.00   |           |
|                          |                                |             | Total:                               | 18,150.00   |           |
|                          |                                |             | Net of 1 Invoices / 0 Checks         | 18,150.00   |           |

| Vendor Code<br>Post Date | Vendor Name<br>Activity              | Inv/Check # | Description                           | Invoice Amt | Check Amt |
|--------------------------|--------------------------------------|-------------|---------------------------------------|-------------|-----------|
| 01010<br>05/05/2026      | PLATTE VALLEY PRINTING<br>INVOICE    | 13461       | DOOR HANGERS                          | 141.12      |           |
|                          |                                      |             | Total:                                | 141.12      |           |
|                          |                                      |             | Net of 1 Invoices / 0 Checks          | 141.12      |           |
| 11195<br>05/05/2026      | PLAYAWAY PRODUCTS LLC<br>INVOICE     | 531328      | WONDERBOOKS                           | 2,528.58    |           |
|                          |                                      |             | Total:                                | 2,528.58    |           |
|                          |                                      |             | Net of 1 Invoices / 0 Checks          | 2,528.58    |           |
| 11526<br>05/05/2026      | POINTS CONSULTING LLC<br>INVOICE     | INV-0673    | HOUSING NEEDS ANALYSIS                | 17,250.00   |           |
|                          |                                      |             | Total:                                | 17,250.00   |           |
|                          |                                      |             | Net of 1 Invoices / 0 Checks          | 17,250.00   |           |
| MISC<br>05/05/2026       | PROSOSKI MIKE & MELVA<br>INVOICE     | 04/22/2026  | UB refund for account: 100-10740-15   | 40.13       |           |
| 05/05/2026               | INVOICE                              | 04/22/2026  | UB refund for account: 200-25040-19   | 25.53       |           |
|                          |                                      |             | Total:                                | 65.66       |           |
|                          |                                      |             | Net of 2 Invoices / 0 Checks          | 65.66       |           |
| 00138<br>05/05/2026      | R & R PRODUCTS INC<br>INVOICE        | CD3140264   | DAMPER CONTROL, ROLLER-ANTI SCALP     | 174.35      |           |
| 05/05/2026               | INVOICE                              | CD3142422   | FOOT EXTRACTION HOLE CUTTER           | 196.25      |           |
|                          |                                      |             | Total:                                | 370.60      |           |
|                          |                                      |             | Net of 2 Invoices / 0 Checks          | 370.60      |           |
| 03264<br>05/05/2026      | REARDON LAWN & GARDEN INC<br>INVOICE | 20999       | WHEEL                                 | 46.99       |           |
|                          |                                      |             | Total:                                | 46.99       |           |
|                          |                                      |             | Net of 1 Invoices / 0 Checks          | 46.99       |           |
| 11547<br>05/05/2026      | REESE BREANN<br>INVOICE              | 4.23.2026   | REFUND - ADULT SOFTBALL               | 175.00      |           |
|                          |                                      |             | Total:                                | 175.00      |           |
|                          |                                      |             | Net of 1 Invoices / 0 Checks          | 175.00      |           |
| 11138<br>05/05/2026      | REGINA'S KITCHEN<br>INVOICE          | 000031      | ASSORTED COOKIES                      | 120.00      |           |
|                          |                                      |             | Total:                                | 120.00      |           |
|                          |                                      |             | Net of 1 Invoices / 0 Checks          | 120.00      |           |
| 02551<br>05/05/2026      | RICHARD A COMI<br>INVOICE            | 74400-003   | COLUMBUS NE ATT - 3028 10TH ST MOD    | 700.00      |           |
| 05/05/2026               | INVOICE                              | 255898-003  | COLUMBUS NE ATT - 1868 E 29TH AVE MOD | 800.00      |           |
|                          |                                      |             | Total:                                | 1,500.00    |           |
|                          |                                      |             | Net of 2 Invoices / 0 Checks          | 1,500.00    |           |

| Vendor Code<br>Post Date | Vendor Name<br>Activity                  | Inv/Check # | Description                          | Invoice Amt | Check Amt |
|--------------------------|--|-------------|--------------------------------------|-------------|-----------|
| 02280<br>05/05/2026      | RITTER FRED<br>INVOICE                   | 4.27.2026   | BEATS & EATS - VOICE HOUSE 6/11/2026 | 350.00      |           |
|                          |  |             | Total:                               | 350.00      |           |
|                          |  |             | Net of 1 Invoices / 0 Checks         | 350.00      |           |
| 11543<br>05/05/2026      | S. L. JOHNSON STUDIOS LLC<br>INVOICE     | 2026-2027   | SCULPTURE WALK FEES                  | 1,000.00    |           |
|                          |  |             | Total:                               | 1,000.00    |           |
|                          |  |             | Net of 1 Invoices / 0 Checks         | 1,000.00    |           |
| MISC<br>05/05/2026       | SCHWARTZ DEBRA<br>INVOICE                | 04/22/2026  | UB refund for account: 400-80755-05  | 66.58       |           |
|                          |  |             | Total:                               | 66.58       |           |
|                          |  |             | Net of 1 Invoices / 0 Checks         | 66.58       |           |
| 01875<br>05/05/2026      | SCOTUS CENTRAL CATHOLIC<br>INVOICE       | 4.20.2026   | SHARE OF TRACK HURDLES (90)          | 4,500.00    |           |
|                          |  |             | Total:                               | 4,500.00    |           |
|                          |  |             | Net of 1 Invoices / 0 Checks         | 4,500.00    |           |
| 11184<br>05/05/2026      | SCP DISTRIBUTORS LLC<br>INVOICE          | 541588      | 4"X28" SELF ADHESIVE YELLOW & BLACK  | 594.00      |           |
|                          |  |             | Total:                               | 594.00      |           |
|                          |  |             | Net of 1 Invoices / 0 Checks         | 594.00      |           |
| 11539<br>05/05/2026      | SEESE KIRK<br>INVOICE                    | 2026-2027   | SCULPTURE WALK FEES                  | 1,000.00    |           |
|                          |  |             | Total:                               | 1,000.00    |           |
|                          |  |             | Net of 1 Invoices / 0 Checks         | 1,000.00    |           |
| 00465<br>05/05/2026      | SERVICEMASTER BY SHEVLIN<br>INVOICE      | 12813       | MONTHLY JANITORIAL SERVICE           | 2,661.00    |           |
|                          |  |             | Total:                               | 2,661.00    |           |
|                          |  |             | Net of 1 Invoices / 0 Checks         | 2,661.00    |           |
| MISC<br>05/05/2026       | SEVENTY ELEVEN PROPERTIES LLC<br>INVOICE | 04/22/2026  | UB refund for account: 100-10430-10  | 24.04       |           |
|                          |  |             | Total:                               | 24.04       |           |
|                          |  |             | Net of 1 Invoices / 0 Checks         | 24.04       |           |
| 01090<br>05/05/2026      | SHEVLIN SUPPLY<br>INVOICE                | 9311        | HAND SOAP, M/F TOWELS, BATH TISSUE   | 206.11      |           |
|                          |  |             | Total:                               | 206.11      |           |
|                          |  |             | Net of 1 Invoices / 0 Checks         | 206.11      |           |
| MISC<br>05/05/2026       | SINS RENEE & CHARLES TRUSTEES<br>INVOICE | 04/22/2026  | UB refund for account: 100-04990-03  | 57.40       |           |

| Vendor Code<br>Post Date | Vendor Name<br>Activity               | Inv/Check #    | Description                          | Invoice Amt | Check Amt |
|--------------------------|---------------------------------------|----------------|--------------------------------------|-------------|-----------|
|                          |                                       |                | Total:                               | 57.40       |           |
|                          |                                       |                | Net of 1 Invoices / 0 Checks         | 57.40       |           |
| MISC<br>05/05/2026       | SLAMA IAN & JESSICA<br>INVOICE        | 04/22/2026     | UB refund for account: 200-43240-11  | 40.65       |           |
|                          |                                       |                | Total:                               | 40.65       |           |
|                          |                                       |                | Net of 1 Invoices / 0 Checks         | 40.65       |           |
| 03278<br>05/05/2026      | STANLEY PETROLEUM<br>INVOICE          | 8633T          | PUMP 2 - NOT DISPENSING PRODUCT      | 402.50      |           |
|                          |                                       |                | Total:                               | 402.50      |           |
|                          |                                       |                | Net of 1 Invoices / 0 Checks         | 402.50      |           |
| 11294<br>05/05/2026      | STARGUARD ELITE LLC<br>INVOICE        | INV/2026/01140 | CERTIFICATIONS - STARGUARD LIFEGUARD | 1,380.00    |           |
|                          |                                       |                | Total:                               | 1,380.00    |           |
|                          |                                       |                | Net of 1 Invoices / 0 Checks         | 1,380.00    |           |
| 00244<br>05/05/2026      | STERICYCLE INC<br>INVOICE             | 8014052933     | BUDGET SUBSCRIPTION                  | 73.96       |           |
|                          |                                       |                | Total:                               | 73.96       |           |
|                          |                                       |                | Net of 1 Invoices / 0 Checks         | 73.96       |           |
| 11545<br>05/05/2026      | STONY CREEK LANDSCAPES INC<br>INVOICE | 2026-2027      | SCULPTURE WALK FEES                  | 1,000.00    |           |
|                          |                                       |                | Total:                               | 1,000.00    |           |
|                          |                                       |                | Net of 1 Invoices / 0 Checks         | 1,000.00    |           |
| 00105<br>05/05/2026      | SUPER SAVER<br>INVOICE                | 133074         | GROCERIES                            | 39.38       |           |
| 05/05/2026               | INVOICE                               | 133050         | GROCERIES                            | 22.68       |           |
| 05/05/2026               | INVOICE                               | 132876         | GROCERIES                            | 15.48       |           |
|                          |                                       |                | Total:                               | 77.54       |           |
|                          |                                       |                | Net of 3 Invoices / 0 Checks         | 77.54       |           |
| 11555<br>05/05/2026      | TAPIA ANGELICA<br>INVOICE             | 5.05.2026      | PRINTMAKING WORKSHOP MAY 23RD, 2026  | 500.00      |           |
|                          |                                       |                | Total:                               | 500.00      |           |
|                          |                                       |                | Net of 1 Invoices / 0 Checks         | 500.00      |           |
| 10660<br>05/05/2026      | TARNICK TIM<br>INVOICE                | 4.27.2026      | BEATS & EATS - 6/4/2026              | 1,500.00    |           |
|                          |                                       |                | Total:                               | 1,500.00    |           |
|                          |                                       |                | Net of 1 Invoices / 0 Checks         | 1,500.00    |           |
| 00313<br>05/05/2026      | T-BONE FUEL DELIVERY<br>INVOICE       | 1574           | FUEL                                 | 5,376.70    |           |

| Vendor Code<br>Post Date | Vendor Name<br>Activity   | Inv/Check #    | Description                                  | Invoice Amt | Check Amt |
|--------------------------|---------------------------|----------------|--|-------------|-----------|
| 05/05/2026               | INVOICE                   | 1575           | FUEL   | 2,991.50    |           |
| 05/05/2026               | INVOICE                   | 1576           | FUEL   | 4,464.80    |           |
|                          |                           |                | Total:                                       | 12,833.00   |           |
|                          |                           |                | Net of 3 Invoices / 0 Checks                 | 12,833.00   |           |
| 10997                    | T-BONE PD LLC             |                |  |             |           |
| 05/05/2026               | INVOICE                   | 2557           | PROPANE                                      | 68.98       |           |
|                          |                           |                | Total:                                       | 68.98       |           |
|                          |                           |                | Net of 1 Invoices / 0 Checks                 | 68.98       |           |
| 10326                    | THE LIFEGUARD STORE       |                |  |             |           |
| 05/05/2026               | INVOICE                   | INV001589590   | GUARD RESCUE TUBE, BACKBOARD KIT             | 895.66      |           |
| 05/05/2026               | INVOICE                   | INV001589865   | WHISTLES, LANYARD, GOOGLES,                  | 667.15      |           |
|                          |                           |                | Total:                                       | 1,562.81    |           |
|                          |                           |                | Net of 2 Invoices / 0 Checks                 | 1,562.81    |           |
| 01829                    | THE PITTSBURGH PAINTS CO  |                |  |             |           |
| 05/05/2026               | INVOICE                   | 836620011932   | PAINT  | 1,498.00    |           |
|                          |                           |                | Total:                                       | 1,498.00    |           |
|                          |                           |                | Net of 1 Invoices / 0 Checks                 | 1,498.00    |           |
| 11544                    | TIMOTHY PAUL JAMES        |                |  |             |           |
| 05/05/2026               | INVOICE                   | 2026-2027      | SCULPTURE WALK FEES                          | 1,000.00    |           |
|                          |                           |                | Total:                                       | 1,000.00    |           |
|                          |                           |                | Net of 1 Invoices / 0 Checks                 | 1,000.00    |           |
| 03128                    | TIRE OUTLET INC           |                |  |             |           |
| 05/05/2026               | INVOICE                   | 264848         | 5 - REPAIRS                                  | 175.00      |           |
| 05/05/2026               | INVOICE                   | 264854         | TIRE REPAIR                                  | 20.00       |           |
| 05/05/2026               | INVOICE                   | 264686         | USED TRUCK TIRE                              | 125.00      |           |
| 05/05/2026               | INVOICE                   | 264759         | REPAIR                                       | 35.00       |           |
| 05/05/2026               | INVOICE                   | 264811         | 5 - USED TIRES                               | 875.00      |           |
|                          |                           |                | Total:                                       | 1,230.00    |           |
|                          |                           |                | Net of 5 Invoices / 0 Checks                 | 1,230.00    |           |
| 01564                    | TOOLEY DRUG               |                |  |             |           |
| 05/05/2026               | INVOICE                   | 01302094       | F&T CHEW, CONTOUR NEXT                       | 71.36       |           |
|                          |                           |                | Total:                                       | 71.36       |           |
|                          |                           |                | Net of 1 Invoices / 0 Checks                 | 71.36       |           |
| 00550                    | TRUCK CENTER COMPANIES    |                |  |             |           |
| 05/05/2026               | INVOICE                   | XA111065292:01 | GASKET - WATER PUMP, GASKET CONNECTION, SEA: | 37.76       |           |
| 05/05/2026               | INVOICE                   | RA111008988:01 | PM AND REPAIRS ON LADDER TRUCK               | 1,107.17    |           |
|                          |                           |                | Total:                                       | 1,144.93    |           |
|                          |                           |                | Net of 2 Invoices / 0 Checks                 | 1,144.93    |           |
| 00289                    | UNION PACIFIC RAILROAD CO |                |  |             |           |
| 05/05/2026               | INVOICE                   | 90159384       | QUIET ZONES                                  | 14,880.26   |           |

| Vendor Code<br>Post Date | Vendor Name<br>Activity                        | Inv/Check # | Description                               | Invoice Amt | Check Amt |
|--------------------------|--|-------------|---|-------------|-----------|
|                          |  |             | Total:                                    | 14,880.26   |           |
|                          |  |             | Net of 1 Invoices / 0 Checks              | 14,880.26   |           |
| 11146<br>05/05/2026      | VANDENBERG ELE & COMMUNICATIONS LLC<br>INVOICE | 11398       | FIX LIGHT AT SOFTBALL FIELDS              | 656.15      |           |
|                          |  |             | Total:                                    | 656.15      |           |
|                          |  |             | Net of 1 Invoices / 0 Checks              | 656.15      |           |
| 11349<br>05/05/2026      | VANITII PRODUCTIONS<br>INVOICE                 | 3.01.2026   | WOMEN OF ROCK PERFORMANCE                 | 3,200.00    |           |
|                          |  |             | Total:                                    | 3,200.00    |           |
|                          |  |             | Net of 1 Invoices / 0 Checks              | 3,200.00    |           |
| MISC<br>05/05/2026       | VILLAGE CENTRE VENTURES LP<br>INVOICE          | 04/27/2026  | UB refund for account: 200-40361-07       | 70.39       |           |
|                          |  |             | Total:                                    | 70.39       |           |
|                          |  |             | Net of 1 Invoices / 0 Checks              | 70.39       |           |
| MISC<br>05/05/2026       | VOIGT VERNICE<br>INVOICE                       | 04/22/2026  | UB refund for account: 300-56260-19       | 23.02       |           |
|                          |  |             | Total:                                    | 23.02       |           |
|                          |  |             | Net of 1 Invoices / 0 Checks              | 23.02       |           |
| 11160<br>05/05/2026      | WAGNER CINDY<br>INVOICE                        | 6135-9      | 3 SHIRTS                                  | 48.00       |           |
|                          |  |             | Total:                                    | 48.00       |           |
|                          |  |             | Net of 1 Invoices / 0 Checks              | 48.00       |           |
| 03302<br>05/05/2026      | WEMHOFF REFRIGERATION INC<br>INVOICE           | 17652       | SERVICE CALL - HEAT PUMPS QUAIL RUN       | 226.42      |           |
| 05/05/2026               | INVOICE  | 17680       | SERVICE CALL - KEG COOLER QUAIL RUN       | 321.90      |           |
| 05/05/2026               | INVOICE  | 17684       | SERVICE CALL - ICE MACHINE SHED QUAIL RUN | 511.74      |           |
|                          |  |             | Total:                                    | 1,060.06    |           |
|                          |  |             | Net of 3 Invoices / 0 Checks              | 1,060.06    |           |
| 11546<br>05/05/2026      | WIELGUS PATRICE<br>INVOICE                     | 5.05.2026   | INSTRUCTOR FEE - GELLI PLATE WORKSHOP     | 105.00      |           |
|                          |  |             | Total:                                    | 105.00      |           |
|                          |  |             | Net of 1 Invoices / 0 Checks              | 105.00      |           |
| 00215<br>05/05/2026      | ZIMCO SUPPLY CO<br>INVOICE                     | INV-05183   | CONTEC DG, CORTEVA DIMENSION              | 3,689.72    |           |
| 05/05/2026               | INVOICE  | INV-01442   | ACELEPRYN XTRA                            | 5,560.00    |           |
|                          |  |             | Total:                                    | 9,249.72    |           |
|                          |  |             | Net of 2 Invoices / 0 Checks              | 9,249.72    |           |
|                          |  |             | invoices and 0 checks for 138 vendors:    | 556,431.16  |           |

| Inv Ref# | Vendor                      | Inv Date   | Due Date   | Inv Amt  | Amt Due  | Status | Jrnlized |
|----------|-----------------------------|------------|------------|----------|----------|--------|----------|
| 125900   | ZIMCO SUPPLY CO             | 10/31/2025 | 05/05/2026 | 5,560.00 | 5,560.00 | Open   | N        |
| 125962   | PETE LIEN & SONS INC.       | 04/14/2026 | 05/05/2026 | 7,858.69 | 7,858.69 | Open   | N        |
| 126011   | AUTOMATIC SYSTEMS GROUP LLC | 04/09/2026 | 05/05/2026 | 5,017.24 | 5,017.24 | Open   | N        |
| 126080   | T-BONE FUEL DELIVERY        | 04/23/2026 | 05/05/2026 | 5,376.70 | 5,376.70 | Open   | N        |
| 126131   | CREATIVE PLANNING           | 02/28/2026 | 05/05/2026 | 5,000.00 | 5,000.00 | Open   | N        |

|                    |   |        |   |         |           |           |
|--------------------|---|--------|---|---------|-----------|-----------|
| # of Invoices:     | 5 | # Due: | 5 | Totals: | 28,812.63 | 28,812.63 |
| # of Credit Memos: | 0 | # Due: | 0 | Totals: | 0.00      | 0.00      |

Net of Invoices and Credit Memos: 28,812.63      28,812.63

--- TOTALS BY FUND ---

|                           |           |           |
|---------------------------|-----------|-----------|
| 100 - GENERAL FUND        | 10,560.00 | 10,560.00 |
| 200 - STREETS/ENGINEERING | 5,376.70  | 5,376.70  |
| 500 - UTILITY SERVICE     | 7,858.69  | 7,858.69  |
| 520 - WATER               | 5,017.24  | 5,017.24  |

--- TOTALS BY DEPT/ACTIVITY ---

|                                |          |          |
|--------------------------------|----------|----------|
| 105 - FINANCE                  | 5,000.00 | 5,000.00 |
| 155 - VAN BERG GOLF COURSE     | 5,560.00 | 5,560.00 |
| 200 - STREETS                  | 5,376.70 | 5,376.70 |
| 501 - WASTEWATER TREATMENT FAC | 7,858.69 | 7,858.69 |
| 520 - WATER                    | 5,017.24 | 5,017.24 |

| Inv Ref# | Vendor                         | Inv Date   | Due Date   | Inv Amt   | Amt Due   | Status | Jrnlized |
|----------|--------------------------------|------------|------------|-----------|-----------|--------|----------|
| 125877   | UNION PACIFIC RAILROAD CO      | 04/13/2026 | 05/05/2026 | 14,880.26 | 14,880.26 | Open   | N        |
| 126034   | BRITE                          | 04/14/2026 | 05/05/2026 | 18,480.00 | 18,480.00 | Open   | N        |
| 126035   | BLUESTREAK K9 LLC              | 04/01/2026 | 05/05/2026 | 13,500.00 | 13,500.00 | Open   | N        |
| 126159   | POINTS CONSULTING LLC          | 04/22/2026 | 05/05/2026 | 17,250.00 | 17,250.00 | Open   | N        |
| 126161   | HDR ENGINEERING INC            | 04/22/2026 | 05/05/2026 | 16,174.62 | 16,174.62 | Open   | N        |
| 126162   | PICTOMETRY INTERNATIONAL CORP. | 04/21/2026 | 05/05/2026 | 18,150.00 | 18,150.00 | Open   | N        |

# of Invoices: 6 # Due: 6 Totals: 98,434.88 98,434.88

# of Credit Memos: 0 # Due: 0 Totals: 0.00 0.00

Net of Invoices and Credit Memos: 98,434.88 98,434.88

--- TOTALS BY FUND ---

|                           |           |           |
|---------------------------|-----------|-----------|
| 100 - GENERAL FUND        | 67,380.00 | 67,380.00 |
| 200 - STREETS/ENGINEERING | 31,054.88 | 31,054.88 |

--- TOTALS BY DEPT/ACTIVITY ---

|                              |           |           |
|------------------------------|-----------|-----------|
| 100 - GENERAL ADMINISTRATION | 35,400.00 | 35,400.00 |
| 110 - POLICE                 | 31,980.00 | 31,980.00 |
| 200 - STREETS                | 31,054.88 | 31,054.88 |

| GL Number                                 | Invoice Line Desc              | Vendor                     | Invoice Description                     | Amount    | Check # |
|---|--------------------------------|----------------------------|---|-----------|---------|
| Fund 100 GENERAL FUND                     |                                |                            |   |           |         |
| Dept 000                                  |                                |                            |   |           |         |
| 100-000-10111                             | PETTY CASH                     | PETTY CASH                 | 2026 START UP CASH FOR PAWNEE PLUNGE    | 2,600.00  |         |
| Total For Dept 000                        |                                |                            |   | 2,600.00  |         |
| Dept 100 GENERAL ADMINISTRATION           |                                |                            |   |           |         |
| 100-100-53200                             | PROFESSIONAL SERVICES          | CREATIVE PLANNING          | ASSESSMENT WORK                         | 2,500.00  |         |
| 100-100-53200-CREAT                       | PROFESSIONAL SERVICES          | ARIAS ABEL                 | SNEAKER DECORATING CLASS MAY 2, 2026    | 500.00    |         |
| 100-100-53200-CREAT                       | PROFESSIONAL SERVICES          | LIMON KENDRA               | PINATA DECORATING WORKSHOP MAY 16, 2026 | 500.00    |         |
| 100-100-53200-CREAT                       | PROFESSIONAL SERVICES          | TAPIA ANGELICA             | PRINTMAKING WORKSHOP MAY 23RD, 2026     | 500.00    |         |
| 100-100-53200-CREAT                       | PROFESSIONAL SERVICES          | WIELGUS PATRICIA           | INSTRUCTOR FEE - GELLI PLATE WORKSHOP   | 105.00    |         |
| 100-100-53200-SCULP                       | PROFESSIONAL SERVICES          | BAD RIVER ARTWORKS         | SCULPTURE WALK FEES                     | 1,000.00  |         |
| 100-100-53200-SCULP                       | PROFESSIONAL SERVICES          | PEDERSEN RYAN              | SCULPTURE WALK FEES                     | 1,000.00  |         |
| 100-100-53200-SCULP                       | PROFESSIONAL SERVICES          | S. L. JOHNSON STUDIOS LLC  | SCULPTURE WALK FEES                     | 1,000.00  |         |
| 100-100-53200-SCULP                       | PROFESSIONAL SERVICES          | SEESE KIRK                 | SCULPTURE WALK FEES                     | 1,000.00  |         |
| 100-100-53200-SCULP                       | PROFESSIONAL SERVICES          | STONY CREEK LANDSCAPES INC | SCULPTURE WALK FEES                     | 1,000.00  |         |
| 100-100-53200-SCULP                       | PROFESSIONAL SERVICES          | TIMOTHY PAUL JAMES         | SCULPTURE WALK FEES                     | 1,000.00  |         |
| 100-100-53400                             | COMPUTER SUPPORT/MAINT         | BS&A SOFTWARE              | ANNUAL SERVICE & SUPPORT                | 12,149.20 |         |
| 100-100-54310                             | BUILDING MAINTENANCE           | ACE HARDWARE & GARDEN CNT  | CONTRACTOR BAG, LANDSCAPE PIN           | 19.58     |         |
| 100-100-54310                             | BUILDING MAINTENANCE           | ECHO ELECTRIC              | FUSE 600V                               | 173.00    |         |
| 100-100-54310                             | BUILDING MAINTENANCE           | JACKSON SERVICES INC       | MATS                                    | 92.30     |         |
| 100-100-54310                             | BUILDING MAINTENANCE           | MENARDS                    | GLASS CLEANER, KITCHEN BRUSH, CLOROX WI | 27.30     |         |
| 100-100-54380                             | MAINTENANCE AGREEMENTS         | KINGS III EMERGENCY COMMUN | VIDEO MONITORING, ELEVATOR PHONES       | 390.00    |         |
| 100-100-55200                             | INSURANCE                      | JONES GROUP                | NEW PBON EFFECTIVE 3/9/2026             | 250.00    |         |
| 100-100-56010                             | SUPPLIES                       | ACE HARDWARE & GARDEN CNT  | NUTS, BOLTS, SCREWS                     | 6.64      |         |
| 100-100-56010                             | SUPPLIES                       | EGAN SUPPLY CO             | MULTI FOLD PAPER TOWELS, TOILET BOWL CI | 425.98    |         |
| 100-100-56010-CREAT                       | SUPPLIES                       | REGINA'S KITCHEN           | ASSORTED COOKIES                        | 120.00    |         |
| 100-100-56020                             | OFFICE SUPPLIES                | HOMETOWN LEASING           | COPIER LEASE                            | 271.19    |         |
| 100-100-57200-22002                       | CAPITAL-LAND & BUILDINGS       | POINTS CONSULTING LLC      | HOUSING NEEDS ANALYSIS                  | 17,250.00 |         |
| 100-100-57200-23001                       | CAPITAL-LAND & BUILDINGS       | COMMONWEALTH ELECTRIC COME | FRANKFURT SQUARE LIGHTING PROJECT       | 39,726.60 |         |
| 100-100-57510-20006                       | CAPITAL-EQUIPMENT              | PICTOMETRY INTERNATIONAL C | 2026 FLIGHT EV CLOUD YEAR 1             | 18,150.00 |         |
| Total For Dept 100 GENERAL ADMINISTRATION |                                |                            |   | 99,156.79 |         |
| Dept 103 COLUMBUS SENIOR CENTER           |                                |                            |   |           |         |
| 100-103-56010-III-C                       | SUPPLIES                       | OLIVER PACKAGING & EQUIPM  | 2C TRAYS, FILM SEAL ROLLS FOR HDM       | 3,514.16  |         |
| 100-103-56010-III-C                       | SUPPLIES                       | SUPER SAVER                | GROCERIES                               | 22.68     |         |
| 100-103-56300-III-C                       | FOOD COSTS                     | SUPER SAVER                | GROCERIES                               | 39.38     |         |
| Total For Dept 103 COLUMBUS SENIOR CENTER |                                |                            |   | 3,576.22  |         |
| Dept 104 CITY ADMINISTRATOR               |                                |                            |   |           |         |
| 100-104-55900                             | MISCELLANEOUS                  | AMERITAS LIFE INSURANCE CC | CITY ADMINISTRATOR 414(H) PLAN 245879   | 460.00    |         |
| Total For Dept 104 CITY ADMINISTRATOR     |                                |                            |   | 460.00    |         |
| Dept 105 FINANCE                          |                                |                            |   |           |         |
| 100-105-52710                             | EMPLOYEE RECRUITMENT/RETENTION | COLUMBUS CUSTOM EMBROIDER  | CLOTHING - MARCOE                       | 54.00     |         |
| 100-105-53200                             | PROFESSIONAL SERVICES          | CREATIVE PLANNING          | TWO WEEKS OF PROJECT PER AGREEMENT      | 5,000.00  |         |
| Total For Dept 105 FINANCE                |                                |                            |   | 5,054.00  |         |
| Dept 110 POLICE                           |                                |                            |   |           |         |
| 100-110-52700                             | TRAINING AND TUITION           | AUTEN RYAN                 | REIMBURSE - MEALS & DOG FOOD FOR K-9 TF | 146.63    |         |
| 100-110-52700                             | TRAINING AND TUITION           | BENCHMARK GOVERNMENT SOLU  | MEALS - AUTEN                           | 55.80     |         |
| 100-110-52700                             | TRAINING AND TUITION           | NEBRASKA LAW ENFORCEMENT   | WOTIPKA BENJAMIN - TUITION - FIREARMS I | 560.00    |         |
| 100-110-52800                             | UNIFORMS                       | WAGNER CINDY               | 3 SHIRTS                                | 48.00     |         |
| 100-110-53200                             | PROFESSIONAL SERVICES          | FIRST NATIONAL BANK OF OM  | RESEARCH & COPIES                       | 51.60     |         |
| 100-110-54320                             | EQUIPMENT MAINTENANCE          | GUNSLINGERS LLC            | OPTIC COMPATIBLE SIGHT SET              | 309.00    |         |

| GL Number                                    | Invoice Line Desc              | Vendor                     | Invoice Description                     | Amount    | Check # |
|--|--------------------------------|----------------------------|---|-----------|---------|
| Fund 100 GENERAL FUND                        |                                |                            |   |           |         |
| Dept 110 POLICE                              |                                |                            |   |           |         |
| 100-110-54330                                | VEHICLE MAINTENANCE            | JONES AUTOMOTIVE           | FULL VEHICLE STRIP - VIN #7979          | 902.50    |         |
| 100-110-54330                                | VEHICLE MAINTENANCE            | O'REILLY AUTOMOTIVE INC    | WIPER BLADES                            | 45.88     |         |
| 100-110-54380                                | MAINTENANCE AGREEMENTS         | DAS STATE ACCOUNTING       | MONTHLY NETWORK CHARGES                 | 1,356.79  |         |
| 100-110-55200                                | INSURANCE                      | LARM (LEAGUE ASSOCIATION C | ENDORSEMENT #15                         | 208.76    |         |
| 100-110-56010                                | SUPPLIES                       | SHEVLIN SUPPLY             | HAND SOAP, M/F TOWELS, BATH TISSUE      | 206.11    |         |
| 100-110-56030                                | CLEANING SUPPLIES/SERVICE      | SERVICEMASTER BY SHEVLIN   | MONTHLY JANITORIAL SERVICE              | 2,661.00  |         |
| 100-110-56240                                | TELEPHONE                      | AT&T MOBILITY              | CELL PHONE MAR 22 - APR 21              | 201.42    |         |
| 100-110-57510-26001                          | CAPITAL-EQUIPMENT              | BRITE                      | INSTALLATION OF COMPUTERS INTO PATROL C | 18,899.00 |         |
| 100-110-57510-26017                          | CAPITAL-EQUIPMENT              | BLUESTREAK K9 LLC          | POLICE K9                               | 13,500.00 |         |
| Total For Dept 110 POLICE                    |                                |                            |   | 39,152.49 |         |
| Dept 120 FIRE                                |                                |                            |   |           |         |
| 100-120-52710                                | EMPLOYEE RECRUITMENT/RETENTION | OCCUPATIONAL HEALTH SERV   | VACCINATIONS                            | 316.00    |         |
| 100-120-52800                                | UNIFORMS                       | GALLS LLC                  | HAYS REPLACEMENT PANT                   | 46.62     |         |
| 100-120-54310                                | BUILDING MAINTENANCE           | ACE HARDWARE & GARDEN CNT  | ELBOW 1/2"                              | 0.69      |         |
| 100-120-54320                                | EQUIPMENT MAINTENANCE          | MENARDS                    | TIRE GAUGE, AA BATTERIES, WASHING MACH  | 35.13     |         |
| 100-120-54330                                | VEHICLE MAINTENANCE            | BOMGAARS                   | ORANGE SAFETY FLAG                      | 3.60      |         |
| 100-120-54330                                | VEHICLE MAINTENANCE            | MENARDS                    | FINAL CHARGE 50/50                      | 46.80     |         |
| 100-120-54330                                | VEHICLE MAINTENANCE            | TRUCK CENTER COMPANIES     | PM AND REPAIRS ON LADDER TRUCK          | 1,107.17  |         |
| 100-120-55200                                | INSURANCE                      | LARM (LEAGUE ASSOCIATION C | CREDIT - ENDORSEMENT #14                | (168.26)  |         |
| 100-120-56020                                | OFFICE SUPPLIES                | HOMETOWN LEASING           | COPIER LEASE                            | 116.47    |         |
| 100-120-56030                                | CLEANING SUPPLIES/SERVICE      | HD SUPPLY                  | CENTERPULL TOWELS, BLEACH, LINERS       | 216.40    |         |
| 100-120-56030                                | CLEANING SUPPLIES/SERVICE      | JACKSON SERVICES INC       | MATS, MOPS, POLISH TOWEL, WINDSHIELD WI | 107.96    |         |
| 100-120-56030                                | CLEANING SUPPLIES/SERVICE      | MENARDS                    | TIRE GAUGE, AA BATTERIES, WASHING MACH  | 36.31     |         |
| 100-120-56240                                | TELEPHONE                      | ALLO COMMUNICATONS         | TELEPHONE - S FIRE STATION, INTERNET -  | 15.53     |         |
| 100-120-56240                                | TELEPHONE                      | AT&T MOBILITY              | CELL PHONE MAR 22 - APR 21              | 110.60    |         |
| Total For Dept 120 FIRE                      |                                |                            |   | 1,991.02  |         |
| Dept 121 RESCUE                              |                                |                            |   |           |         |
| 100-121-52700                                | TRAINING AND TUITION           | NORTHEAST COMMUNITY COLLEC | PARAMEDIC SCHOOL - THEODORE VAUGHN      | 848.75    |         |
| 100-121-52800                                | UNIFORMS                       | GALLS LLC                  | HAYS REPLACEMENT PANT                   | 46.63     |         |
| 100-121-53200                                | PROFESSIONAL SERVICES          | DIGITECH COMPUTER LLC      | MARCH 2026                              | 3,318.94  |         |
| 100-121-54310                                | BUILDING MAINTENANCE           | ACE HARDWARE & GARDEN CNT  | ELBOW 1/2"                              | 0.70      |         |
| 100-121-54330                                | VEHICLE MAINTENANCE            | BOMGAARS                   | ORANGE SAFETY FLAG                      | 3.59      |         |
| 100-121-54330                                | VEHICLE MAINTENANCE            | MENARDS                    | FINAL CHARGE 50/50                      | 46.80     |         |
| 100-121-56010                                | SUPPLIES                       | ACE HARDWARE & GARDEN CNT  | PADLOCK                                 | 26.99     |         |
| 100-121-56010                                | SUPPLIES                       | BOUND TREE MEDICAL LLC     | ELECTRODES                              | 1,384.20  |         |
| 100-121-56010                                | SUPPLIES                       | NIPPON SANZO MATHESON INC  | CYLINDER RENTAL                         | 71.91     |         |
| 100-121-56010                                | SUPPLIES                       | TOOLEY DRUG                | F&T CHEW, CONTOUR NEXT                  | 71.36     |         |
| 100-121-56020                                | OFFICE SUPPLIES                | HOMETOWN LEASING           | COPIER LEASE                            | 116.46    |         |
| 100-121-56030                                | CLEANING SUPPLIES/SERVICE      | HD SUPPLY                  | CENTERPULL TOWELS, BLEACH, LINERS       | 216.39    |         |
| 100-121-56030                                | CLEANING SUPPLIES/SERVICE      | JACKSON SERVICES INC       | MATS, MOPS, POLISH TOWEL, WINDSHIELD WI | 107.97    |         |
| 100-121-56030                                | CLEANING SUPPLIES/SERVICE      | MENARDS                    | TIRE GAUGE, AA BATTERIES, WASHING MACH  | 36.32     |         |
| 100-121-56030                                | CLEANING SUPPLIES/SERVICE      | STERICYCLE INC             | BUDGET SUBSCRIPTION                     | 73.96     |         |
| 100-121-56050                                | FUEL                           | GRAY RYAN                  | MILEAGE                                 | 130.50    |         |
| 100-121-56240                                | TELEPHONE                      | ALLO COMMUNICATONS         | TELEPHONE - S FIRE STATION, INTERNET -  | 15.53     |         |
| 100-121-56240                                | TELEPHONE                      | AT&T MOBILITY              | CELL PHONE MAR 22 - APR 21              | 110.60    |         |
| Total For Dept 121 RESCUE                    |                                |                            |   | 6,627.60  |         |
| Dept 125 VOLUNTEER FIRE DEPARTMENT           |                                |                            |   |           |         |
| 100-125-56010                                | SUPPLIES                       | BLACKBURN MFG CO           | FIELD FLAGS                             | 735.00    |         |
| Total For Dept 125 VOLUNTEER FIRE DEPARTMENT |                                |                            |   | 735.00    |         |

| GL Number                                   | Invoice Line Desc              | Vendor                     | Invoice Description                     | Amount    | Check # |
|---|--------------------------------|----------------------------|---|-----------|---------|
| Fund 100 GENERAL FUND                       |                                |                            |   |           |         |
| Dept 130 LIBRARY                            |                                |                            |   |           |         |
| 100-130-52710                               | EMPLOYEE RECRUITMENT/RETENTION | OCCUPATIONAL HEALTH SERV   | DRUG SCREEN                             | 260.00    |         |
| 100-130-56240-PATRN                         | TELEPHONE                      | GREAT PLAINS COMMUNICATION | INTERNET 5/01 - 5/31                    | 209.95    |         |
| 100-130-56400-YASRP                         | PROGRAMS                       | SUPER SAVER                | GROCERIES                               | 15.48     |         |
| 100-130-56410-ADULT                         | BOOKS AND PUBLICATIONS         | BLACKSTONE PUBLISHING      | CD'S                                    | 180.69    |         |
| 100-130-56410-ADULT                         | BOOKS AND PUBLICATIONS         | INGRAM LIBRARY SERVICES, I | CREDIT                                  | 1,563.38  |         |
| 100-130-56410-CHILD                         | BOOKS AND PUBLICATIONS         | INGRAM LIBRARY SERVICES, I | MATERIALS                               | 1,116.50  |         |
| 100-130-56410-FOUND                         | BOOKS AND PUBLICATIONS         | PLAYAWAY PRODUCTS LLC      | WONDERBOOKS                             | 2,528.58  |         |
| 100-130-56410-SUBSC                         | BOOKS AND PUBLICATIONS         | EBSCO INDUSTRIES INC       | MAGAZINE SUBSCRIPTIONS                  | 2,133.88  |         |
| 100-130-56410-YOUNG                         | BOOKS AND PUBLICATIONS         | INGRAM LIBRARY SERVICES, I | MATERIALS                               | 375.65    |         |
| 100-130-57510-26022                         | CAPITAL-EQUIPMENT              | MARCO TECHNOLOGIES LLC     | WIDE FORMAT PRINTER                     | 4,427.00  |         |
| Total For Dept 130 LIBRARY                  |                                |                            |   | 12,811.11 |         |
| Dept 140 CEMETERY                           |                                |                            |   |           |         |
| 100-140-44510                               | CEMETERY-LOTS                  | MUELLER CON & MARLA        | CEMETERY PLOTS                          | 400.00    |         |
| 100-140-53400                               | COMPUTER SUPPORT/MAINT         | BS&A SOFTWARE              | ANNUAL SERVICE & SUPPORT                | 1,762.00  |         |
| 100-140-56080                               | PLANTS SOD SEED FLOWERS        | CENTRAL NEBRASKA SOD SUPPI | SOD                                     | 140.00    |         |
| Total For Dept 140 CEMETERY                 |                                |                            |   | 2,302.00  |         |
| Dept 145 COMMUNITY DEVELOPMENT              |                                |                            |   |           |         |
| 100-145-53200                               | PROFESSIONAL SERVICES          | RICHARD A COMI             | COLUMBUS NE ATT - 3028 10TH ST MOD      | 1,500.00  |         |
| 100-145-53400                               | COMPUTER SUPPORT/MAINT         | BS&A SOFTWARE              | ANNUAL SERVICE & SUPPORT                | 490.00    |         |
| Total For Dept 145 COMMUNITY DEVELOPMENT    |                                |                            |   | 1,990.00  |         |
| Dept 150 PARKS                              |                                |                            |   |           |         |
| 100-150-52800                               | UNIFORMS                       | JACKSON SERVICES INC       | UNIFORMS                                | 66.29     |         |
| 100-150-53200                               | PROFESSIONAL SERVICES          | VANDENBERG ELE & COMMUNIC  | FIX LIGHT AT SOFTBALL FIELDS            | 656.15    |         |
| 100-150-54310                               | BUILDING MAINTENANCE           | BRIGGS INC OF OMAHA        | HIGHCLIFF ULTRA BOWL, STRONGHOLD SEAT   | 141.26    |         |
| 100-150-54310                               | BUILDING MAINTENANCE           | MENARDS                    | 1X4-10', CEILING PAINT, CONST ADH, TAPI | 57.87     |         |
| 100-150-54320                               | EQUIPMENT MAINTENANCE          | BOMGAARS                   | BRAKLEEN, GREASE FITTING, FASTENERS     | 74.76     |         |
| 100-150-54520                               | EQUIPMENT RENTAL/PURCHASE      | SCOTUS CENTRAL CATHOLIC    | SHARE OF TRACK HURDLES (90)             | 4,500.00  |         |
| 100-150-56010                               | SUPPLIES                       | ACE HARDWARE & GARDEN CNT  | AA BATTERY                              | 21.99     |         |
| 100-150-56010                               | SUPPLIES                       | GREAT PLAINS BUILDING SUPE | ATHLETIC FIELD MARKER                   | 673.26    |         |
| 100-150-56070                               | FERTILIZER                     | BOMGAARS                   | GLOVES, WD-40 SPRAY                     | 31.98     |         |
| 100-150-56080                               | PLANTS SOD SEED FLOWERS        | ACE HARDWARE & GARDEN CNT  | PADLOCK, HOSE NOZLE, WATERING CAN       | 68.96     |         |
| 100-150-56400                               | PROGRAMS                       | COX MATT                   | JUNE 6TH, 2026 PERFORMANCE              | 600.00    |         |
| 100-150-56400                               | PROGRAMS                       | NARANS STEVE               | BEATS & EATS - NE ALL STARS 5/30/2026   | 3,800.00  |         |
| 100-150-56400                               | PROGRAMS                       | REESE BREANN               | REFUND - ADULT SOFTBALL                 | 175.00    |         |
| 100-150-56400                               | PROGRAMS                       | RITTER FRED                | BEATS & EATS - VOICE HOUSE 6/11/2026    | 350.00    |         |
| 100-150-56400                               | PROGRAMS                       | TARNICK TIM                | BEATS & EATS - 6/4/2026                 | 1,500.00  |         |
| 100-150-56400                               | PROGRAMS                       | VANITII PRODUCTIONS        | WOMEN OF ROCK PERFORMANCE               | 3,200.00  |         |
| Total For Dept 150 PARKS                    |                                |                            |   | 15,917.52 |         |
| Dept 151 PAWNEE PLUNGE WATER PARK           |                                |                            |   |           |         |
| 100-151-52710                               | EMPLOYEE RECRUITMENT/RETENTION | OCCUPATIONAL HEALTH SERV   | DRUG SCREEN                             | 90.00     |         |
| 100-151-52800                               | UNIFORMS                       | THE LIFEGUARD STORE        | WHISTLES, LANYARD, GOOGLES,             | 272.95    |         |
| 100-151-54310                               | BUILDING MAINTENANCE           | ACE HARDWARE & GARDEN CNT  | BIT, NUTS, BOLTS, SCREWS                | 41.51     |         |
| 100-151-54310                               | BUILDING MAINTENANCE           | MENARDS                    | 1" BLACK COUPLING                       | 2.39      |         |
| 100-151-54320                               | EQUIPMENT MAINTENANCE          | ACE HARDWARE & GARDEN CNT  | WATER HEATER CLEANER, ELBOW, HEX BUSING | 39.54     |         |
| 100-151-54320                               | EQUIPMENT MAINTENANCE          | KELLY SUPPLY COMPANY       | O-RING                                  | 1.15      |         |
| 100-151-54520                               | EQUIPMENT RENTAL/PURCHASE      | THE LIFEGUARD STORE        | GUARD RESCUE TUBE, BACKBOARD KIT        | 815.76    |         |
| 100-151-56130                               | SUPPLIES FOR RESALE            | THE LIFEGUARD STORE        | WHISTLES, LANYARD, GOOGLES,             | 394.20    |         |
| Total For Dept 151 PAWNEE PLUNGE WATER PARK |                                |                            |   | 1,657.50  |         |

| GL Number                                | Invoice Line Desc         | Vendor                     | Invoice Description                     | Amount     | Check # |
|--|---------------------------|----------------------------|---|------------|---------|
| Fund 100 GENERAL FUND                    |                           |                            |   |            |         |
| Dept 152 AQUATIC CENTER POOL             |                           |                            |   |            |         |
| 100-152-52700                            | TRAINING AND TUITION      | STARGUARD ELITE LLC        | CERTIFICATIONS - STARGUARD LIFEGUARD    | 1,380.00   |         |
| 100-152-53200                            | PROFESSIONAL SERVICES     | NEBRASKA STATE FIRE MARSH  | ANNUAL BOILER CERTIFICATE - AQUATIC CEN | 36.00      |         |
| 100-152-54310                            | BUILDING MAINTENANCE      | ACE HARDWARE & GARDEN CNT  | SHOP TOWEL, DRAIN CLEANER               | 77.95      |         |
| 100-152-54320                            | EQUIPMENT MAINTENANCE     | SCP DISTRIBUTORS LLC       | 4"X28" SELF ADHESIVE YELLOW & BLACK     | 594.00     |         |
| 100-152-54320                            | EQUIPMENT MAINTENANCE     | THE LIFEGUARD STORE        | GUARD RESCUE TUBE, BACKBOARD KIT        | 79.90      |         |
| 100-152-54520                            | EQUIPMENT RENTAL/PURCHASE | HOMETOWN LEASING           | COPIER LEASE                            | 74.26      |         |
| 100-152-55930                            | REFUNDS                   | HARRINGTON TIM             | REFUND - OVERPAYMENT FOR GROUP MEMBERSH | 25.00      |         |
| 100-152-56020                            | OFFICE SUPPLIES           | EAKES OFFICE SOLUTIONS     | PAPER, LAMINATE, POSTER STRIP           | 73.22      |         |
| 100-152-56300                            | FOOD COSTS                | CHESTERMAN COMPANY         | CONCESSIONS - POP, MONSTER              | 170.12     |         |
| Total For Dept 152 AQUATIC CENTER POOL   |                           |                            |   | 2,510.45   |         |
| Dept 155 VAN BERG GOLF COURSE            |                           |                            |   |            |         |
| 100-155-53400                            | COMPUTER SUPPORT/MAINT    | ALLO COMMUNICATONS         | TELEPHONE - S FIRE STATION, INTERNET -  | 115.00     |         |
| 100-155-54350                            | GOLF CART/COURSE MAINT    | ELKHORN INDUSTRIES LLC     | PRESSURE WASHER                         | 2,600.00   |         |
| 100-155-54490                            | IRRIGATION MAINTENANCE    | KELLY SUPPLY COMPANY       | PVC PIPE NIPPLE, BUSHING                | 62.21      |         |
| 100-155-56060                            | CHEMICALS                 | ZIMCO SUPPLY CO            | CONTEC DG, CORTEVA DIMENSION            | 8,134.52   |         |
| Total For Dept 155 VAN BERG GOLF COURSE  |                           |                            |   | 10,911.73  |         |
| Dept 156 QUAIL RUN GOLF COURSE           |                           |                            |   |            |         |
| 100-156-53200                            | PROFESSIONAL SERVICES     | CULLIGAN OF COLUMBUS       | SALT SOLAR DELIVERED                    | 96.50      |         |
| 100-156-53200                            | PROFESSIONAL SERVICES     | JACKSON SERVICES INC       | UNIFORMS                                | 158.07     |         |
| 100-156-54310                            | BUILDING MAINTENANCE      | WEMHOFF REFRIGERATION INC  | SERVICE CALL - HEAT PUMPS QUAIL RUN     | 548.32     |         |
| 100-156-54320                            | EQUIPMENT MAINTENANCE     | BOMGAARS                   | OIL, GEAR LUBE                          | 53.98      |         |
| 100-156-54320                            | EQUIPMENT MAINTENANCE     | HILMER MARK                | USED CUSHMAN REAR END                   | 1,750.00   |         |
| 100-156-54320                            | EQUIPMENT MAINTENANCE     | R & R PRODUCTS INC         | DAMPER CONTROL, ROLLER-ANTI SCALP       | 174.35     |         |
| 100-156-54350                            | GOLF CART/COURSE MAINT    | MATTEO SAND & GRAVEL CO IN | GOLF COURSE SAND                        | 2,072.00   |         |
| 100-156-54350                            | GOLF CART/COURSE MAINT    | R & R PRODUCTS INC         | FOOT EXTRACTION HOLE CUTTER             | 196.25     |         |
| 100-156-55900                            | MISCELLANEOUS             | BICE ERIC                  | MILEAGE                                 | 300.80     |         |
| 100-156-56010                            | SUPPLIES                  | ACE HARDWARE & GARDEN CNT  | GARDEN SPADE, INSECT KILLER             | 46.98      |         |
| 100-156-56010                            | SUPPLIES                  | AG SPRAY EQUIPMENT         | SUPER FOAM CONCENTRATE, AIR INDUCTION T | 60.51      |         |
| 100-156-56010                            | SUPPLIES                  | D & K PRODUCTS             | ROTARY SPREADER, CREW HERBICIDE         | 990.00     |         |
| 100-156-56060                            | CHEMICALS                 | AG SPRAY EQUIPMENT         | HOSE, SUPER FOAM CONCENTRATE, CALIBRATI | 227.42     |         |
| 100-156-56060                            | CHEMICALS                 | D & K PRODUCTS             | CREDIT - MEMO SYNGENTA EARLY ORDER GT36 | (1,502.80) |         |
| 100-156-56070                            | FERTILIZER                | ZIMCO SUPPLY CO            | CONTEC DG, CORTEVA DIMENSION            | 1,115.20   |         |
| 100-156-56080                            | PLANTS SOD SEED FLOWERS   | CENTRAL NEBRASKA SOD SUPPI | SOD                                     | 140.00     |         |
| 100-156-56080                            | PLANTS SOD SEED FLOWERS   | D & K PRODUCTS             | LSC IGNITION SPORTS TURF                | 996.00     |         |
| 100-156-56110                            | PRO-SHOP SUPPLIES         | WEMHOFF REFRIGERATION INC  | SERVICE CALL - ICE MACHINE SHED QUAIL F | 511.74     |         |
| Total For Dept 156 QUAIL RUN GOLF COURSE |                           |                            |   | 7,935.32   |         |
| Total For Fund 100 GENERAL FUND          |                           |                            |   | 215,388.75 |         |
| Fund 200 STREETS/ENGINEERING             |                           |                            |   |            |         |
| Dept 200 STREETS                         |                           |                            |   |            |         |
| 200-200-52800                            | UNIFORMS                  | JACKSON SERVICES INC       | SHOP TOWELS, UNIFORMS                   | 840.58     |         |
| 200-200-53400                            | COMPUTER SUPPORT/MAINT    | BS&A SOFTWARE              | ANNUAL SERVICE & SUPPORT                | 2,678.00   |         |
| 200-200-54320                            | EQUIPMENT MAINTENANCE     | ARMOR EQUIPMENT            | WATER FILL HOSE                         | 195.67     |         |
| 200-200-54320                            | EQUIPMENT MAINTENANCE     | LACAL EQUIPMENT INC        | 5 SEGMENT GUTTER BROOM                  | 1,440.96   |         |
| 200-200-54450                            | STREET MAINTENANCE        | GREAT PLAINS BUILDING SUPP | 2X4-12 ACQ TREATED                      | 21.84      |         |
| 200-200-54450                            | STREET MAINTENANCE        | MENARDS                    | POTHOLE PATCH                           | 137.88     |         |
| 200-200-54460                            | LAND MAINTENANCE          | BOMGAARS                   | BROMEGRASS, TALL FESCUE, JACKET, GLOVES | 289.48     |         |
| 200-200-54460                            | LAND MAINTENANCE          | DALE JOHNSON TRUCKING      | 3 LOADS                                 | 375.00     |         |
| 200-200-56010                            | SUPPLIES                  | ACE HARDWARE & GARDEN CNT  | NUTS, BOLTS, SCREWS                     | 22.94      |         |
| 200-200-56010                            | SUPPLIES                  | CLAY HILLS AG              | 15 BAGS PRO 18-0-4                      | 531.75     |         |

| GL Number                              | Invoice Line Desc        | Vendor                     | Invoice Description                     | Amount    | Check # |
|--|--------------------------|----------------------------|---|-----------|---------|
| Fund 200 STREETS/ENGINEERING           |                          |                            |   |           |         |
| Dept 200 STREETS                       |                          |                            |   |           |         |
| 200-200-56010                          | SUPPLIES                 | MENARDS                    | INT/EXT PAINT                           | 257.79    |         |
| 200-200-56010                          | SUPPLIES                 | O'REILLY AUTOMOTIVE INC    | RV ANTIFREEZE                           | 13.98     |         |
| 200-200-56010                          | SUPPLIES                 | REARDON LAWN & GARDEN INC  | WHEEL                                   | 46.99     |         |
| 200-200-56010                          | SUPPLIES                 | T-BONE PD LLC              | PROPANE                                 | 68.98     |         |
| 200-200-56010                          | SUPPLIES                 | THE PITTSBURGH PAINTS CO   | PAINT                                   | 1,498.00  |         |
| 200-200-56050                          | FUEL                     | T-BONE FUEL DELIVERY       | FUEL                                    | 12,833.00 |         |
| 200-200-56090                          | SMALL TOOLS              | BOMGAARS                   | MAPP TORCH KIT, MAP GAS CYLINDER        | 101.97    |         |
| 200-200-56120                          | TRAFFIC SIGNS            | ACE HARDWARE & GARDEN CNT  | WHIZ LOCK NUTS                          | 53.96     |         |
| 200-200-56120                          | TRAFFIC SIGNS            | MD SOLUTIONS INC           | STRAPPING BRACKET                       | 260.00    |         |
| 200-200-56120                          | TRAFFIC SIGNS            | NEWMAN SIGNS INC.          | SIGNS                                   | 1,791.56  |         |
| 200-200-56190                          | PERSONAL PROTECTIVE SUPP | BOMGAARS                   | BROMEGRASS, TALL FESCUE, JACKET, GLOVES | 261.87    |         |
| 200-200-57200-22022                    | CAPITAL-LAND & BUILDINGS | UNION PACIFIC RAILROAD CO  | QUIET ZONES                             | 14,880.26 |         |
| 200-200-57200-25035                    | CAPITAL-LAND & BUILDINGS | HDR ENGINEERING INC        | 8TH STREET & 12TH AVE INTERSECTION DESI | 16,174.62 |         |
| 200-200-57300-20070                    | CAPITAL-NEW CONSTRUCTION | NE DEPT OF TRANSPORTATION  | PROJECT NO RRZ-TMT-6065 (5)             | 2,971.41  |         |
| Total For Dept 200 STREETS             |                          |                            |   | 57,748.49 |         |
| Dept 202 MECHANICS SHOP                |                          |                            |   |           |         |
| 200-202-52800                          | UNIFORMS                 | JACKSON SERVICES INC       | SHOP TOWELS, UNIFORMS                   | 124.62    |         |
| 200-202-56010                          | SUPPLIES                 | LAWSON PRODUCTS            | LOCK NUTS                               | 27.16     |         |
| 200-202-56090                          | SMALL TOOLS              | ARNOLD MOTOR SUPPLY        | PUMP LEVER ACTION                       | 87.99     |         |
| 200-202-56130                          | SUPPLIES FOR RESALE      | ACE HARDWARE & GARDEN CNT  | NUTS, BOLTS, SCREWS                     | 2.76      |         |
| 200-202-56130                          | SUPPLIES FOR RESALE      | ARMOR EQUIPMENT            | BOLT EYE 1/2 IN                         | 48.63     |         |
| 200-202-56130                          | SUPPLIES FOR RESALE      | ARNOLD MOTOR SUPPLY        | AIR & OIL FILTER, PM 5W20 SYN           | 709.46    |         |
| 200-202-56130                          | SUPPLIES FOR RESALE      | BOMGAARS                   | THREADED ROD, BULK BOLTS, FASTENERS     | 28.28     |         |
| 200-202-56130                          | SUPPLIES FOR RESALE      | MOTION INDUSTRIES INC      | 15" OCTAGONAL LED MINI LIGHT            | 477.58    |         |
| 200-202-56130                          | SUPPLIES FOR RESALE      | NAPA AUTO PARTS OF COLUMBU | WATER PUMP                              | 322.53    |         |
| 200-202-56130                          | SUPPLIES FOR RESALE      | O'REILLY AUTOMOTIVE INC    | CREDIT - CORE RETURN                    | 228.31    |         |
| 200-202-56130                          | SUPPLIES FOR RESALE      | TRUCK CENTER COMPANIES     | GASKET - WATER PUMP, GASKET CONNECTION, | 37.76     |         |
| Total For Dept 202 MECHANICS SHOP      |                          |                            |   | 2,095.08  |         |
| Total For Fund 200 STREETS/ENGINEERING |                          |                            |   | 59,843.57 |         |
| Fund 205 AIRPORT                       |                          |                            |   |           |         |
| Dept 205 AIRPORT                       |                          |                            |   |           |         |
| 205-205-54320                          | EQUIPMENT MAINTENANCE    | MENARDS                    | GREASE FITTING ASST                     | 12.49     |         |
| 205-205-54470                          | FSS BUILDING MAINTENANCE | ACE HARDWARE & GARDEN CNT  | VACUM BREAKER REPAIR KIT                | 8.59      |         |
| 205-205-56010                          | SUPPLIES                 | BOMGAARS                   | KITCHEN BRUSH, STRAP                    | 105.34    |         |
| 205-205-56010                          | SUPPLIES                 | MENARDS                    | HOME DEF, BOUNTY, TOWELS, GLADE, NOZZLE | 110.56    |         |
| Total For Dept 205 AIRPORT             |                          |                            |   | 236.98    |         |
| Total For Fund 205 AIRPORT             |                          |                            |   | 236.98    |         |
| Fund 206 DOWNTOWN BID                  |                          |                            |   |           |         |
| Dept 206 DOWNTOWN BID                  |                          |                            |   |           |         |
| 206-206-53200                          | PROFESSIONAL SERVICES    | LEGACY OUTDOOR ADVERTISING | BILLBOARD HWY 30 6/15/26 TO 12/14/26    | 3,150.00  |         |
| Total For Dept 206 DOWNTOWN BID        |                          |                            |   | 3,150.00  |         |
| Total For Fund 206 DOWNTOWN BID        |                          |                            |   | 3,150.00  |         |
| Fund 220 COMMUNICATIONS - E911         |                          |                            |   |           |         |
| Dept 220 E911                          |                          |                            |   |           |         |
| 220-220-52700                          | TRAINING AND TUITION     | BENCHMARK GOVERNMENT SOLU  | MEAL - NE LETC SPECIAL CLASS            | 13.95     |         |
| 220-220-56020                          | OFFICE SUPPLIES          | HOMETOWN LEASING           | COPIER LEASE                            | 130.21    |         |

INVOICE GL DISTRIBUTION REPORT FOR CITY OF COLUMBUS, NE  
 EXP CHECK RUN DATES 05/05/2026 - 05/05/2026  
 BOTH JOURNALIZED AND UNJOURNALIZED  
 OPEN

| GL Number                                   | Invoice Line Desc              | Vendor                     | Invoice Description                     | Amount    | Check # |
|---|--------------------------------|----------------------------|---|-----------|---------|
| Fund 220 COMMUNICATIONS - E911              |                                |                            |   |           |         |
| Dept 220 E911                               |                                |                            |   |           |         |
| 220-220-56240                               | TELEPHONE                      | AT&T MOBILITY              | CELL PHONE MAR 22 - APR 21              | 91.12     |         |
| 220-220-56240                               | TELEPHONE                      | DAS STATE ACCOUNTING       | MONTHLY NETWORK CHARGES                 | 537.60    |         |
| Total For Dept 220 E911                     |                                |                            |   | 772.88    |         |
| Total For Fund 220 COMMUNICATIONS - E911    |                                |                            |   | 772.88    |         |
| Fund 500 UTILITY SERVICE                    |                                |                            |   |           |         |
| Dept 000                                    |                                |                            |   |           |         |
| 500-000-20100                               | CSX-1                          | BILLS MATHEW               | UB refund for account: 400-68520-01     | 436.54    |         |
| Total For Dept 000                          |                                |                            |   | 436.54    |         |
| Dept 500 WASTEWATER COLLECTION              |                                |                            |   |           |         |
| 500-500-52800                               | UNIFORMS                       | JACKSON SERVICES INC       | UNIFORMS                                | 162.97    |         |
| 500-500-53400                               | COMPUTER SUPPORT/MAINT         | BS&A SOFTWARE              | ANNUAL SERVICE & SUPPORT                | 6,074.60  |         |
| 500-500-54310                               | BUILDING MAINTENANCE           | MENARDS                    | FUSION WEB, FERTILIZER, GARDEN STAPLE   | 48.17     |         |
| 500-500-54320                               | EQUIPMENT MAINTENANCE          | ACE HARDWARE & GARDEN CNT  | 2 CYCLE OIL, SCREW DRIVER, HAMMER, .095 | 59.85     |         |
| 500-500-54320                               | EQUIPMENT MAINTENANCE          | LAKEVIEW SMALL ENGINE INC  | OIL, AIR & FUEL FILTERS, SPARK PLUGS, I | 706.75    |         |
| 500-500-54330                               | VEHICLE MAINTENANCE            | TIRE OUTLET INC            | TIRE REPAIR                             | 20.00     |         |
| 500-500-54390                               | SYSTEM MAINTENANCE             | MENARDS                    | DAWN                                    | 133.68    |         |
| 500-500-54390                               | SYSTEM MAINTENANCE             | PLATTE VALLEY PRINTING     | DOOR HANGERS                            | 70.56     |         |
| 500-500-56020                               | OFFICE SUPPLIES                | EAKES OFFICE SOLUTIONS     | PERFED PAPER - WATER OFFICE             | 283.00    |         |
| 500-500-56090                               | SMALL TOOLS                    | ACE HARDWARE & GARDEN CNT  | 2 CYCLE OIL, SCREW DRIVER, HAMMER, .095 | 48.56     |         |
| Total For Dept 500 WASTEWATER COLLECTION    |                                |                            |   | 7,608.14  |         |
| Dept 501 WASTEWATER TREATMENT FAC           |                                |                            |   |           |         |
| 500-501-52800                               | UNIFORMS                       | JACKSON SERVICES INC       | UNIFORMS                                | 199.68    |         |
| 500-501-54320                               | EQUIPMENT MAINTENANCE          | BOMGAARS                   | GREASE                                  | 95.80     |         |
| 500-501-54320                               | EQUIPMENT MAINTENANCE          | KEAST ENTERPRISES INC.     | SEAL, 2" BEARING DUCTILE HOUSING, COUPI | 301.16    |         |
| 500-501-54320                               | EQUIPMENT MAINTENANCE          | MENARDS                    | STRUT 1/4" SPRING NUT, BEAM CLAMP, SQR  | 37.04     |         |
| 500-501-54320                               | EQUIPMENT MAINTENANCE          | MOTION INDUSTRIES INC      | FITTING, FITTING - MALE CONN, GREASE FI | 85.01     |         |
| 500-501-55640                               | COMPLIANCE TESTING             | PACE ANALYTICAL SERVICES I | WATER TESTING                           | 1,178.00  |         |
| 500-501-56010                               | SUPPLIES                       | BOMGAARS                   | BILK BOLTS                              | 61.48     |         |
| 500-501-56030                               | CLEANING SUPPLIES/SERVICE      | JACKSON SERVICES INC       | MAT                                     | 30.00     |         |
| 500-501-56060                               | CHEMICALS                      | PETE LIEN & SONS INC.      | QUICKLIME FINES                         | 7,858.69  |         |
| 500-501-56100                               | LABORATORY                     | HACH COMPANY               | MODIFIED AGAR PLATES                    | 832.20    |         |
| Total For Dept 501 WASTEWATER TREATMENT FAC |                                |                            |   | 10,679.06 |         |
| Total For Fund 500 UTILITY SERVICE          |                                |                            |   | 18,723.74 |         |
| Fund 520 WATER                              |                                |                            |   |           |         |
| Dept 000                                    |                                |                            |   |           |         |
| 520-000-20100                               | WAM-41                         | DREESEN DON                | UB refund for account: 100-08870-14     | 106.62    |         |
| Total For Dept 000                          |                                |                            |   | 106.62    |         |
| Dept 520 WATER                              |                                |                            |   |           |         |
| 520-520-52700                               | TRAINING AND TUITION           | BALDWIN ZACH               | REIMBURSE -MEALS                        | 89.41     |         |
| 520-520-52700                               | TRAINING AND TUITION           | DWEE                       | WATER OPERATOR LICENSE - ZACH BALDWIN   | 115.00    |         |
| 520-520-52700                               | TRAINING AND TUITION           | LINCOLN WINWATER WORKS     | 2' HYD EXT                              | 813.57    |         |
| 520-520-52700                               | TRAINING AND TUITION           | NDWEE                      | GRADE 1 & 2 COURSE - SCHOENHOFER        | 200.00    |         |
| 520-520-52710                               | EMPLOYEE RECRUITMENT/RETENTION | OCCUPATIONAL HEALTH SERV   | DRUG SCREEN                             | 180.00    |         |
| 520-520-52800                               | UNIFORMS                       | JACKSON SERVICES INC       | UNIFORMS                                | 247.09    |         |
| 520-520-53400                               | COMPUTER SUPPORT/MAINT         | BS&A SOFTWARE              | ANNUAL SERVICE & SUPPORT                | 6,074.60  |         |
| 520-520-54320                               | EQUIPMENT MAINTENANCE          | BOMGAARS                   | PINTLE MOUNT                            | 83.43     |         |

| GL Number                               | Invoice Line Desc         | Vendor                     | Invoice Description                     | Amount    | Check # |
|---|---------------------------|----------------------------|---|-----------|---------|
| Fund 520 WATER                          |                           |                            |   |           |         |
| Dept 520 WATER                          |                           |                            |   |           |         |
| 520-520-54320                           | EQUIPMENT MAINTENANCE     | LAKEVIEW SMALL ENGINE INC  | OIL, AIR & FUEL FILTERS, SPARK PLUGS, I | 706.74    |         |
| 520-520-54390                           | SYSTEM MAINTENANCE        | ACE HARDWARE & GARDEN CNT  | SPRINKLER                               | 94.95     |         |
| 520-520-54390                           | SYSTEM MAINTENANCE        | AUTOMATIC SYSTEMS GROUP LI | WELL #12 BATTERY CHARGER ISSUE          | 7,409.66  |         |
| 520-520-54390                           | SYSTEM MAINTENANCE        | BOMGAARS                   | PINTLE MOUNT                            | 138.00    |         |
| 520-520-54390                           | SYSTEM MAINTENANCE        | ELECTRICAL ENGINEERING &   | LED 13WA19                              | 58.40     |         |
| 520-520-54390                           | SYSTEM MAINTENANCE        | GEHRING CONSTRUCTION &     | 1840 NORTH PARK LANE                    | 381.00    |         |
| 520-520-54390                           | SYSTEM MAINTENANCE        | HUSKER STEEL INC           | 3" STD PIPE                             | 672.00    |         |
| 520-520-54390                           | SYSTEM MAINTENANCE        | JACKSON SERVICES INC       | UNIFORMS                                | 84.12     |         |
| 520-520-54390                           | SYSTEM MAINTENANCE        | KOCH EXCAVATING CO INC     | TOP DIRT                                | 268.16    |         |
| 520-520-54390                           | SYSTEM MAINTENANCE        | PLATE VALLEY PRINTING      | DOOR HANGERS                            | 70.56     |         |
| 520-520-54420                           | WELL MAINTENANCE          | DOWNEY DRILLING            | SS SHAFTS COMPLETE W/SS SLEEVES & COUPI | 3,108.00  |         |
| 520-520-55640                           | COMPLIANCE TESTING        | NEBRASKA PUBLIC HEALTH     | WATER TESTING                           | 468.00    |         |
| 520-520-56020                           | OFFICE SUPPLIES           | EAKES OFFICE SOLUTIONS     | PERFED PAPER - WATER OFFICE             | 283.00    |         |
| 520-520-56030                           | CLEANING SUPPLIES/SERVICE | MENARDS                    | BOUNTY, ANGEL SOFT,PAPER DISC FILTER, F | 12.65     |         |
| 520-520-56060                           | CHEMICALS                 | HAWKINS INC                | CHEMICALS                               | 2,209.56  |         |
| 520-520-56130                           | SUPPLIES FOR RESALE       | CORE & MAIN LP             | 45 - METER SPUDS                        | 1,672.65  |         |
| 520-520-56135                           | AMR RADIO EXPENSE         | CORE & MAIN LP             | 18 - 510M M2 S/POINT WIRED              | 16,670.70 |         |
| Total For Dept 520 WATER                |                           |                            |   | 42,111.25 |         |
| Total For Fund 520 WATER                |                           |                            |   | 42,217.87 |         |
| Fund 560 STORMWATER UTILITY             |                           |                            |   |           |         |
| Dept 000                                |                           |                            |   |           |         |
| 560-000-20100                           | SXF-1                     | DREESEN DON                | UB refund for account: 100-08870-14     | 27.65     |         |
| Total For Dept 000                      |                           |                            |   | 27.65     |         |
| Total For Fund 560 STORMWATER UTILITY   |                           |                            |   | 27.65     |         |
| Fund 570 SOLID WASTE DIVISION           |                           |                            |   |           |         |
| Dept 000                                |                           |                            |   |           |         |
| 570-000-20100                           | SWD-1                     | DREESEN DON                | UB refund for account: 100-08870-14     | 26.74     |         |
| Total For Dept 000                      |                           |                            |   | 26.74     |         |
| Dept 570 TRANSFER STATION               |                           |                            |   |           |         |
| 570-570-52800                           | UNIFORMS                  | JACKSON SERVICES INC       | UNIFORMS                                | 236.18    |         |
| 570-570-53400                           | COMPUTER SUPPORT/MAINT    | BS&A SOFTWARE              | ANNUAL SERVICE & SUPPORT                | 6,074.60  |         |
| 570-570-54310                           | BUILDING MAINTENANCE      | MENARDS                    | OIL DRI                                 | 124.35    |         |
| 570-570-54310                           | BUILDING MAINTENANCE      | STANLEY PETROLEUM          | PUMP 2 - NOT DISPENSING PRODUCT         | 402.50    |         |
| 570-570-54320                           | EQUIPMENT MAINTENANCE     | ARNOLD MOTOR SUPPLY        | OIL & AIR FILTER                        | 70.03     |         |
| 570-570-54330                           | VEHICLE MAINTENANCE       | BOMGAARS                   | PIKSTIK, PAINT STICK, BLADE FUSES       | 51.52     |         |
| 570-570-54330                           | VEHICLE MAINTENANCE       | EXTREME GLASS              | 2026 MACK DRIVER DOOR GLASS             | 370.50    |         |
| 570-570-54330                           | VEHICLE MAINTENANCE       | TIRE OUTLET INC            | 5 - REPAIRS                             | 1,210.00  |         |
| 570-570-54550                           | LANDFILL DISPOSAL         | NORTHEAST NEBRASKA SOLID   | LANDFILL CHARGES                        | 488.40    |         |
| 570-570-56010                           | SUPPLIES                  | ACE HARDWARE & GARDEN CNT  | NUTS, BOLTS, SCREWS                     | 9.30      |         |
| 570-570-56010                           | SUPPLIES                  | MENARDS                    | WATER, BOUNTY PAPER TOWELS              | 59.15     |         |
| Total For Dept 570 TRANSFER STATION     |                           |                            |   | 9,096.53  |         |
| Total For Fund 570 SOLID WASTE DIVISION |                           |                            |   | 9,123.27  |         |
| Fund 600 HEALTH INSURANCE               |                           |                            |   |           |         |
| Dept 600 HEALTH INSURANCE               |                           |                            |   |           |         |
| 600-600-53600                           | HEALTH ADMINISTRATION     | AUXIANT                    | STOPLOSS PREMIUM, FEES                  | 60,420.27 |         |
| Total For Dept 600 HEALTH INSURANCE     |                           |                            |   | 60,420.27 |         |

05/01/2026 01:36 PM  
User: LAURA.RUPP  
DB: Columbus

INVOICE GL DISTRIBUTION REPORT FOR CITY OF COLUMBUS, NE  
EXP CHECK RUN DATES 05/05/2026 - 05/05/2026  
BOTH JOURNALIZED AND UNJOURNALIZED  
OPEN

| GL Number                           | Invoice Line Desc      | Vendor  | Invoice Description | Amount            | Check # |
|-------------------------------------|------------------------|---------|---------------------|-------------------|---------|
| Fund 600 HEALTH INSURANCE           |                        |         |                     |                   |         |
| Total For Fund 600 HEALTH INSURANCE |                        |         |                     | <u>60,420.27</u>  |         |
| Fund 999 PAYROLL CLEARING           |                        |         |                     |                   |         |
| Dept 000                            |                        |         |                     |                   |         |
| 999-000-21510                       | HEALTH ACCOUNT PAYABLE | AUXIANT | HEALTH FUNDING      | 143,448.98        |         |
| 999-000-21530                       | FLEXIBLE SPEND PAYABLE | AUXIANT | FLEX FUNDING        | <u>3,077.20</u>   |         |
| Total For Dept 000                  |                        |         |                     | <u>146,526.18</u> |         |
| Total For Fund 999 PAYROLL CLEARING |                        |         |                     | <u>146,526.18</u> |         |

05/01/2026 01:36 PM  
User: LAURA.RUPP  
DB: Columbus

INVOICE GL DISTRIBUTION REPORT FOR CITY OF COLUMBUS, NE  
EXP CHECK RUN DATES 05/05/2026 - 05/05/2026  
BOTH JOURNALIZED AND UNJOURNALIZED  
OPEN

| GL Number | Invoice Line Desc | Vendor | Invoice Description | Amount | Check # |
|-----------|-------------------|--------|---------------------|--------|---------|
|-----------|-------------------|--------|---------------------|--------|---------|

---

Fund Totals:

|                          |            |
|--------------------------|------------|
| Fund 100 GENERAL FUND    | 215,388.75 |
| Fund 200 STREETS/ENGINEE | 59,843.57  |
| Fund 205 AIRPORT         | 236.98     |
| Fund 206 DOWNTOWN BID    | 3,150.00   |
| Fund 220 COMMUNICATIONS  | 772.88     |
| Fund 500 UTILITY SERVICE | 18,723.74  |
| Fund 520 WATER           | 42,217.87  |
| Fund 560 STORMWATER UTII | 27.65      |
| Fund 570 SOLID WASTE DIV | 9,123.27   |
| Fund 600 HEALTH INSURANC | 60,420.27  |
| Fund 999 PAYROLL CLEARIN | 146,526.18 |

|                      |                   |
|----------------------|-------------------|
| Total For All Funds: | <u>556,431.16</u> |
|----------------------|-------------------|

**5. APPROVAL OF MINUTES: Included in Consent Agenda**

**6. SPECIAL PRESENTATIONS**

6.A. Proclamation declaring week of May 3, 2026, as Professional Municipal Clerks Week.



City Hall  
2500 14th St., Suite 3  
Columbus, NE 68601  
402-562-4220  
[www.columbusne.us](http://www.columbusne.us)

## PROCLAMATION

- WHEREAS,** The Office of the Professional Municipal Clerk, a time-honored and vital part of local Government, exists throughout the world; and
- WHEREAS,** The Office of the Professional Municipal Clerk is the oldest among public servants; and
- WHEREAS,** The Office of the Professional Municipal Clerk provides the professional link between the citizens, the local governing bodies and agencies of government at other levels; and
- WHEREAS,** Professional Municipal Clerks have pledged to be ever mindful of their neutrality and impartiality, rendering equal service to all; and
- WHEREAS,** The Professional Municipal Clerk serves as the information center on functions of local government and community; and
- WHEREAS,** Professional Municipal Clerks continually strive to improve the administration of the affairs of the Office of the Professional Municipal Clerk through participation in education programs, seminars, workshops and the annual meetings of their state, provincial, county and international professional organizations.
- WHEREAS,** It is most appropriate that we recognize the accomplishments of the Office of the Professional Municipal Clerk.

**NOW, THEREFORE, I, James B. Bulkley,** Mayor of the City of Columbus, Nebraska, do hereby recognize the week of May 3 through May 9, 2026, as

### **“Professional Municipal Clerks Week”**

and further extend appreciation to our local Professional Municipal Clerk and her staff, and to all Municipal Clerks for the vital services they perform and their exemplary dedication to the communities they represent.

---

James B. Bulkley, Mayor  
City of Columbus, NE

**7. PUBLIC HEARINGS: None**

**8. PETITIONS AND COMMUNICATIONS: None**

**9. REPORTS OF CITY OFFICES**

9.A. Columbus in Focus - Public Safety.

# CITY OF COLUMBUS

## PUBLIC SAFETY LEADERSHIP TEAM



# MISSION STATEMENT

Our mission is to break down silos, resolve interdepartmental challenges, learn collectively from incidents, and proactively align daily operations and long-term priorities. Through shared leadership, clear communication, and accountability, we aim to improve internal culture, operational effectiveness, and the public's confidence in public safety.



# VISION STATEMENT

**Our vision is to operate as one unified public safety leadership team, working across departments to improve coordination, strengthen trust, and enhance service to the community.**



# ACCOMPLISHMENTS

- Held our first monthly Joint Public Safety Leadership Collaboration meeting.
  - The group consisted of the supervisory teams from each department.
- CFD provided Incident Command Systems and fireground operations training with JCC personnel, which was also attended by CPD Command Staff.
- Initiated conversations between CPD and CFD on forming joint teams for water/ice rescue, drone operations, and tactical medicine.
- Jointly addressed radio communications expectations across all three departments.



# 2026 ACTION ITEMS

- Develop and implement the following policies:
  - Emergency Button Activation
  - MAYDAY (firefighter down)
  - Shots Fired
- Conduct Radio Operations Training
- CPD and JCC to implement reporting and mapping changes
- Train all employees on media relations



# 2026 ACTION ITEMS

- Hold annual open house at CFD and CPD
  - All events will be jointly attended by all three departments
- Add a “tour request” link to department websites
- Hold Incident Command Systems/National Incident Management Systems (ICS/NIMS) training annually for all departments.
- Continue monthly Joint Public Safety Collaboration meetings.





# INDIVIDUAL DEPARTMENT UPDATE

Joint Communications Center

# JCC

- Implemented a new Quality Assurance/Quality Improvement (QA/QI) program to strengthen oversight, consistency, and performance outcomes.
- In the process of launching updated pre-employment testing with remote proctoring capability, eliminating the previous requirement for in-person testing and improving recruitment efficiency.
- Conducting review of departmental policies and procedures, with updates in progress to ensure alignment with current best practices.
- Initiating planning for future replacement of radio consoles, as current systems are expected to become obsolete by 2030.





# INDIVIDUAL DEPARTMENT UPDATE

Columbus Police Department

# CPD

- Established three committees
  - Uniform Committee
    - Our uniform committee has nearly completed their work
  - Policy Review Committee
    - Our policy review committee continues to work on a complete review of our policies
  - Strategic Planning Committee
    - This committee met for the first time and are developing a SWOT analysis
- Canine officer is currently in training in Grand Island
- Computer upgrades in patrol cars are ongoing.



# CPD

## • Trends—Traffic Stops by month

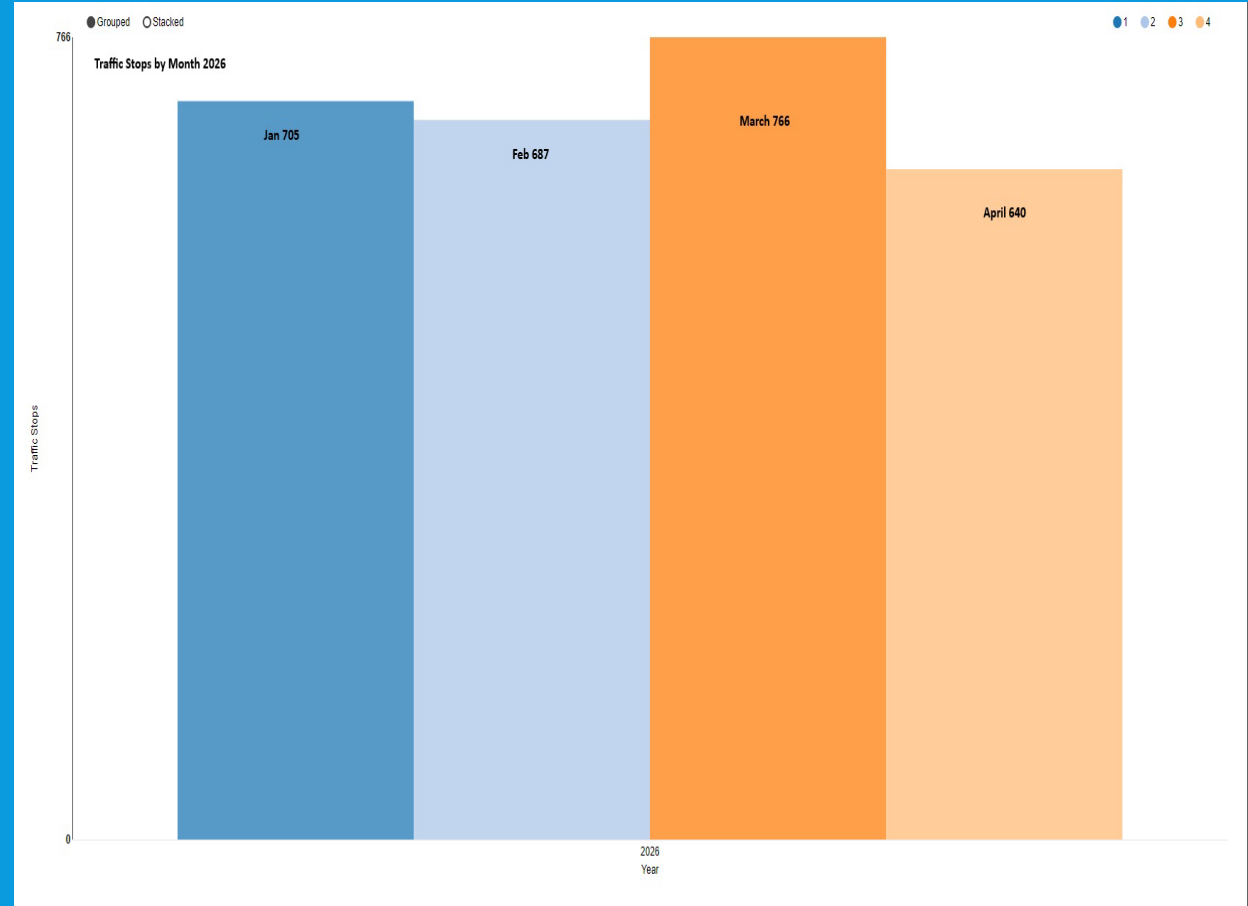
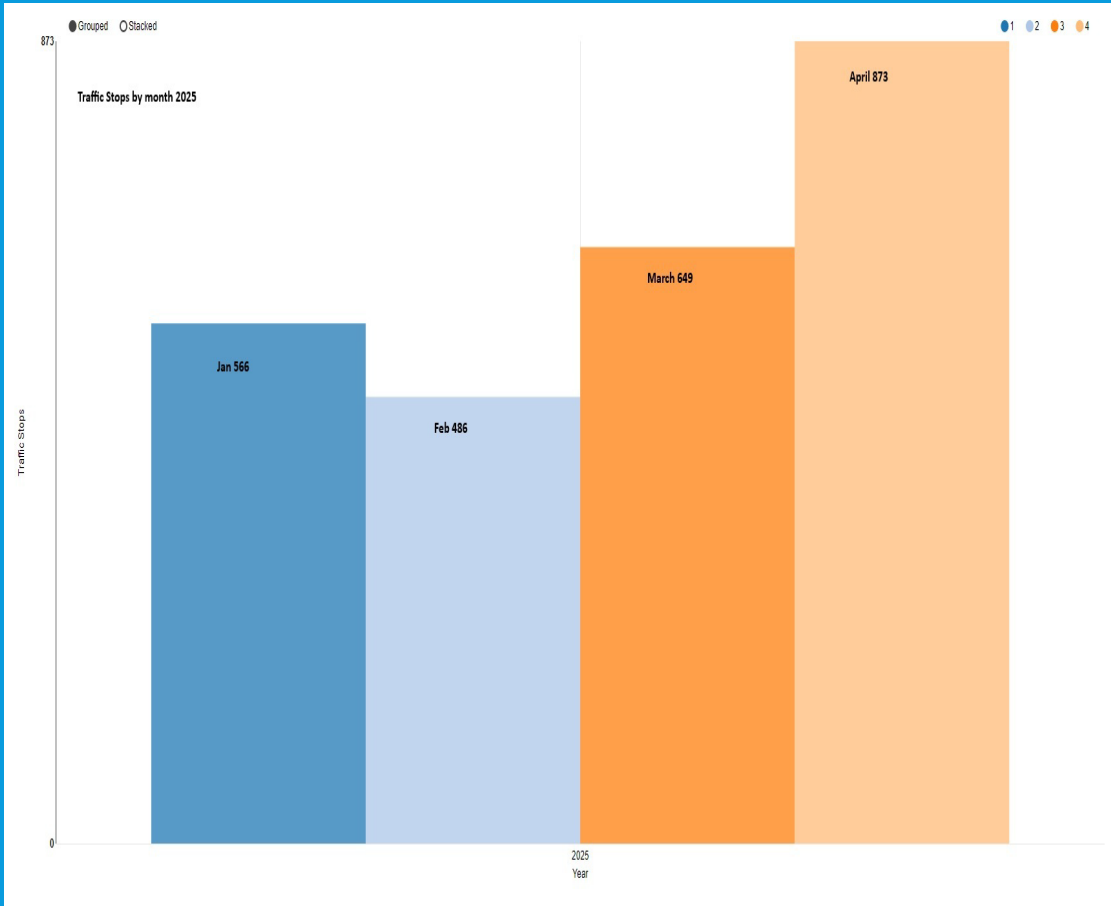

# CPD

- Trends—Traffic Stops by Year

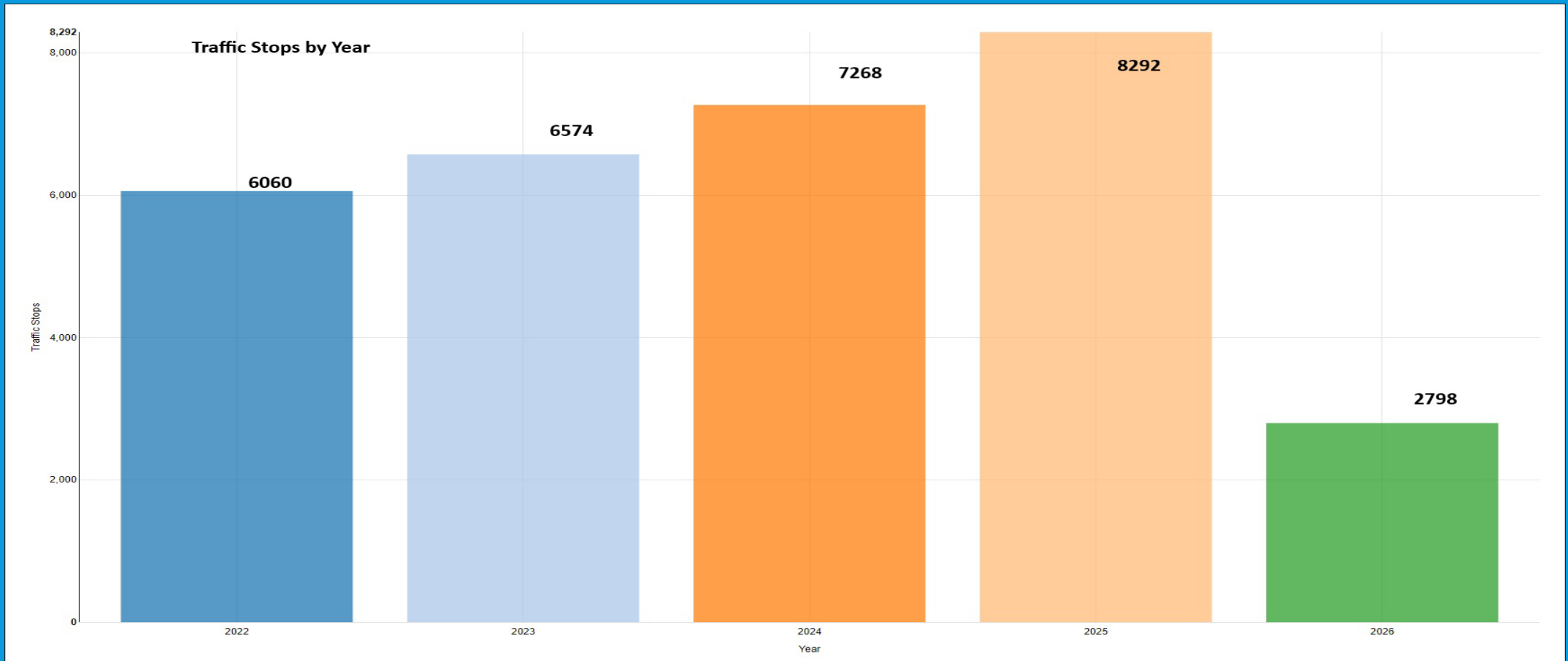

# CPD

- Trends—Calls for Service by Month

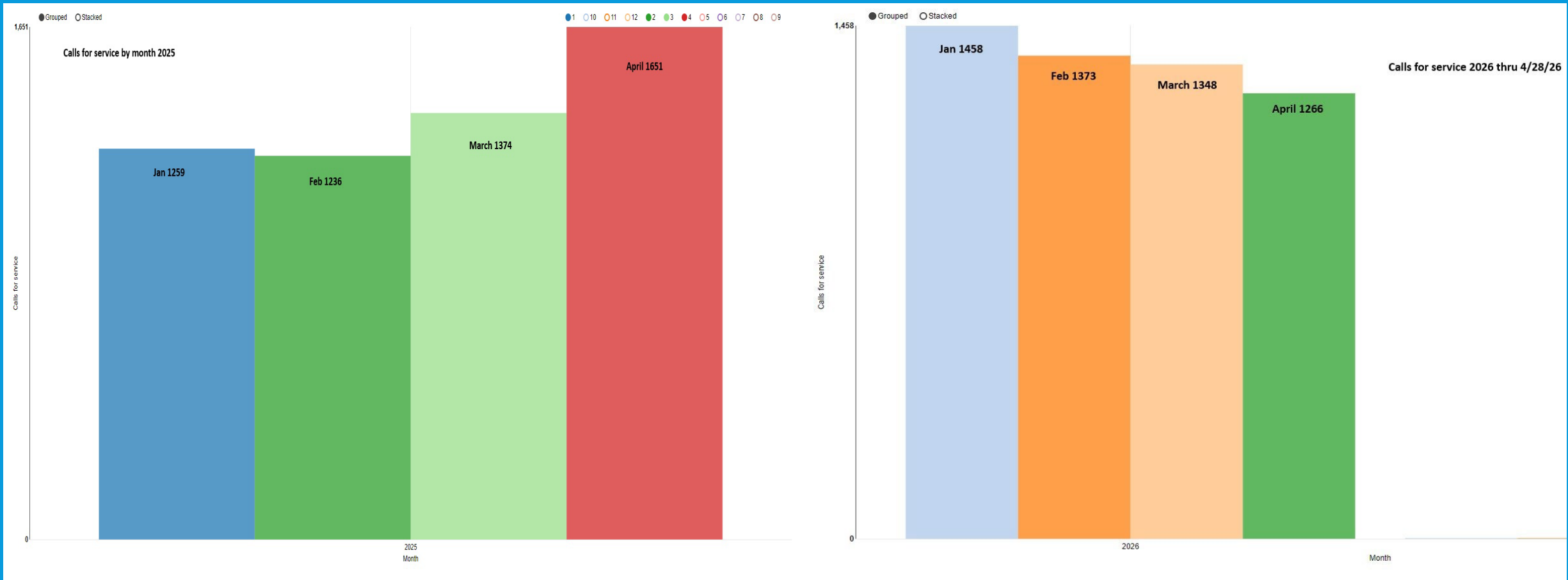

# CPD

- Trends Call for Service by Year

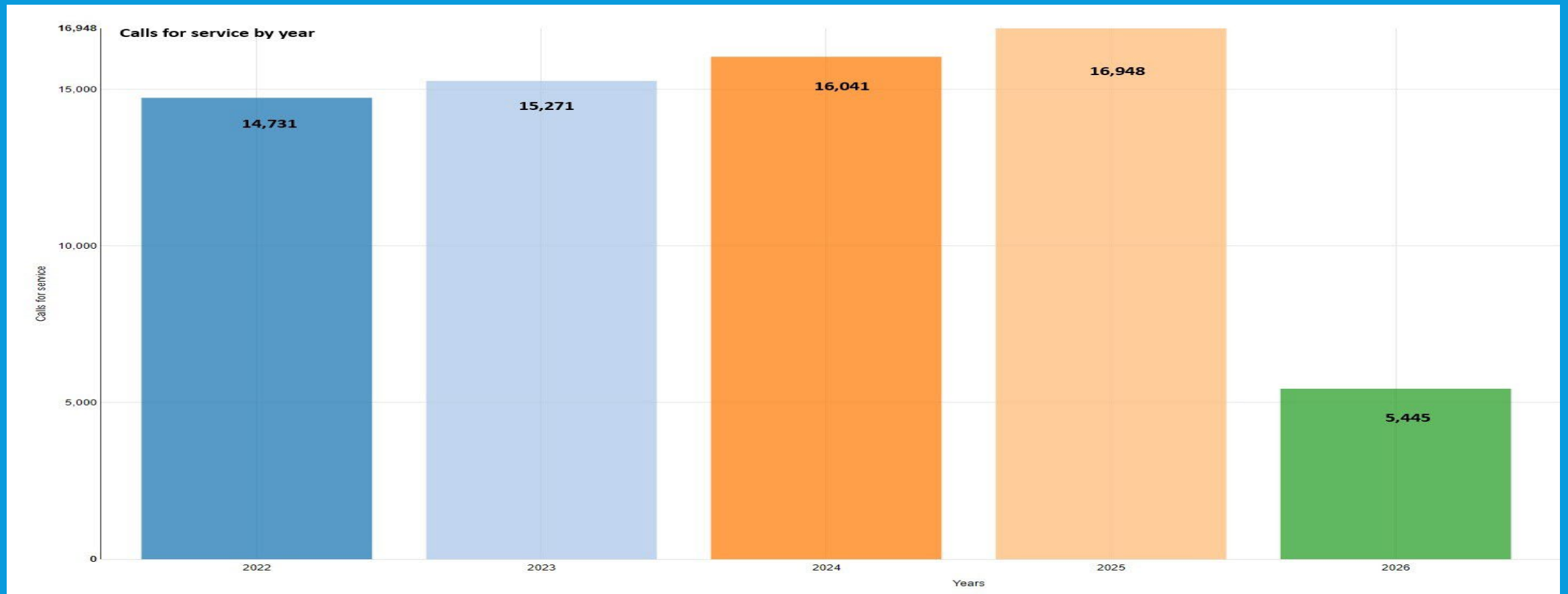



# INDIVIDUAL DEPARTMENT UPDATE

Columbus Fire Department

# CFD

- Completed final inspection on the new ambulance that was ordered in 2023. Expecting delivery in mid-May.
- The department is working through issues with the new national reporting system and state DHHS requirements.
- Firefighter/Paramedic Tom Rathje has started a Hands-Only CPR program for the high schools. He has taught at Lakeview already and is in the process of scheduling with CHS and SCOTUS.
- Chief Gray and Mayor Bulkley attended a VIP event hosted by Nebraska Task Force-1 and saw first-hand the abilities of the team, and what our personnel are learning through the experience.



# DATA AND TRENDS

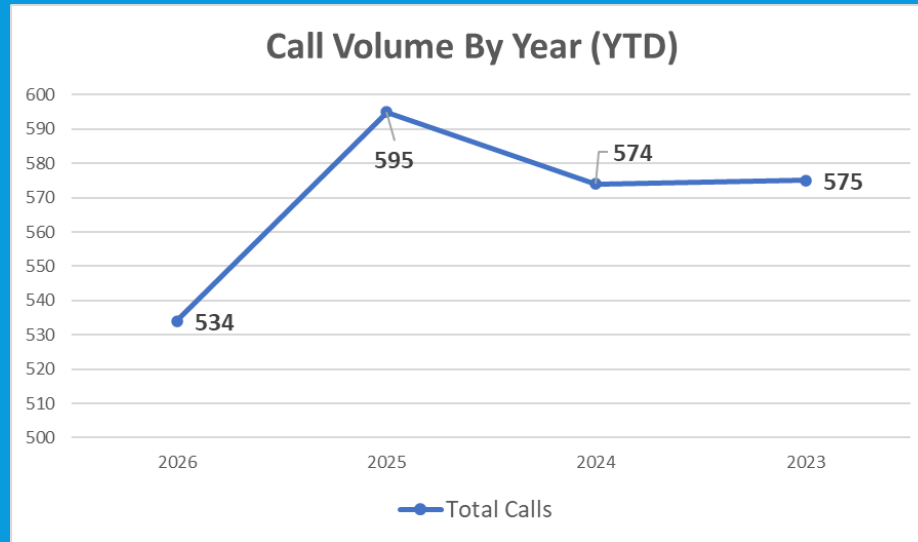
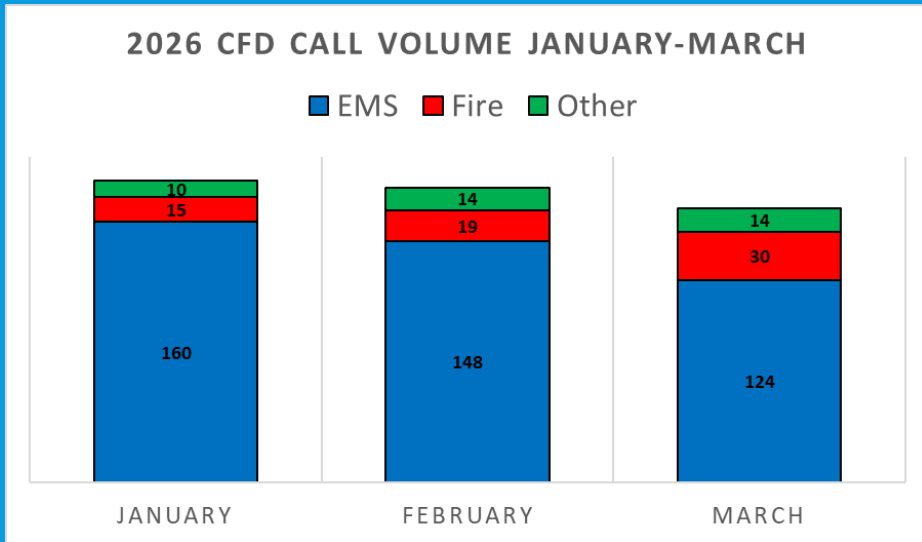

**534 Total Calls for Service**  
 432-EMS  
 64-Fire  
 38-Other

**Incidents by Property**  
 38.2% Single Family  
 20.2% Nursing Facilities  
 8.9% Multi-Family

## Medical

49.8% Illness  
 22.8% Injury  
 2.4% Other

## Fire

3.8% Outside Fire  
 1.4% Structure Fire  
 0.7% Transportation Fire

## Non-Emergency

5.4% False Alarm  
 1.7% Cancelled  
 1.7% Good Intent

## Public Service

4.7% Citizen Assists  
 1.0% Non-Medical Alarms



# LOOKING AHEAD

- We will:
  - Strengthen interdepartmental coordination and trust
  - Improve response consistency and operational readiness
  - Enhance transparency and engagement with the community
  - Maintain a unified approach to public safety leadership



# QUESTIONS



9.B. Reveal of new city seal.



**10. REPORTS OF COUNCIL COMMITTEES**

10.A. Public Property, Safety, and Works Committee - May 4, 2026.

10.A.1. Permanent Sidewalk Easement located in part of Lot 8, Block 4, Evanlawn Addition, to the City of Columbus, Platte County, Nebraska (33rd Avenue and 21st Street).



Accountability - Dedication  
Honesty - Integrity - Respect

---

---

## MEMORANDUM

**DATE:** April 28, 2026  
**TO:** Tara Vasicek, City Administrator  
**FROM:** Richard J. Bogus, City Engineer  
**RE:** Bank of Clarks – Permanent Sidewalk Easement

**RECOMMENDATION:**

I recommend the approval of permanent sidewalk easement with Bank of Clarks.

**DISCUSSION:**

The Bank of Clarks sidewalk in the front abuts US Hwys. 30 & 81/33<sup>rd</sup> Avenue (2155 33<sup>rd</sup> Avenue). The sidewalk is not entirely located in the public right-of-way. Thus, this easement places the sidewalk within a public easement for proper public use.

**FISCAL IMPACT:**

None.

**ALTERNATIVE:**

None.

**SIGNATURE:**

By: Richard J. Bogus

Approved By: [Signature]

---

---

Once Recorded Return To: City of Columbus, Engineering Department, 2500 14<sup>th</sup> Street,  
Ste. 3, Columbus, NE 68601

**SIDEWALK EASEMENT**

THIS SIDEWALK EASEMENT ("Easement") is entered into as of the Effective Date by and between **Bank of Clarks, Columbus Location**, ("Grantor") and **the City of Columbus, a Municipal Corporation in the State of Nebraska**, ("Grantee"). The Effective Date of this Easement shall be the date upon which the last of the parties has signed this Easement.

WHEREAS, Grantor is the owner of certain real property located in Platte County, Nebraska, as legally described as follows (the "Grantor Parcel ");

A six-foot sidewalk easement being the west six feet of that part of Lot 8, Block 4, Evanlawn Addition to the City of Columbus, Platte County, Nebraska, not within Nebraska Department of Transportation Highway 30 and 81 Right-of-Way.

WHEREAS, the Grantor Parcel is immediately adjacent to State of Nebraska right of way known as US Highways 30/81(33<sup>rd</sup> Avenue) in Columbus, Nebraska;

WHEREAS, Grantee has requested and Grantor has agreed to grant Grantee a sidewalk easement over the Grantor Parcel legally described and depicted on Exhibit A attached hereto and incorporated herein by this reference (the " Easement Area") upon the terms and conditions set forth herein.

NOW, THEREFORE, for and in consideration of the mutual promises, covenants and agreements contained herein and for other good and valuable consideration, the receipt and sufficiency of which are hereby conclusively acknowledged, Grantor and Grantee agree as follows:

1. **Grant of Easement.** Grantor hereby grants and conveys unto Grantee and the public a perpetual easement for a sidewalk, upon and through the Easement Area (the "Easement"). Grantor shall remain responsible for all maintenance and snow removal.
2. **Term.** The Term of the Sidewalk Easement shall be perpetual. The Sidewalk Easement is and shall be deemed to be a covenant running with the land and shall be binding upon the parties hereto and upon their successors and assigns. Any modification or amendment shall be effective when duly executed, acknowledged and recorded in the Office of the Register of Deeds of Platte County, Nebraska.

3. Governing Law and Venue. This Easement shall be governed by, and construed and enforced in accordance with, the laws of the State of Nebraska.
4. Entire Agreement. Each party acknowledges that it has read and fully understands the contents of this Easement. This Easement represents the entire and integrated agreement between the parties with respect to the subject matter hereof and supersedes all prior negotiations, representations or agreements, either written or oral. This Easement may be modified only by written instrument duly authorized and executed by all parties.

CITY OF COLUMBUS, a Municipal Corporation in the State of Nebraska, Grantee.

\_\_\_\_\_  
By: James B. Bulkley, Mayor

Grantor:

  
John M. DuBray III, President  
Bank of Clarks

STATE OF NEBRASKA    )  
  ) SS.  
COUNTY OF PLATTE    )

The foregoing instrument was acknowledged before me on Month April 28 2026 by **John M. DuBray III, President Bank of Clarks**

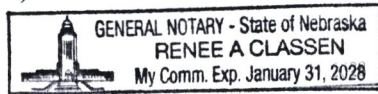

Notary Public 

STATE OF NEBRASKA    )  
  ) SS.  
COUNTY OF PLATTE    )

The foregoing instrument was acknowledged before me on Month \_\_\_\_\_ 2026 by **James B. Bulkley, Mayor of City of Columbus.**

\_\_\_\_\_  
Notary Public

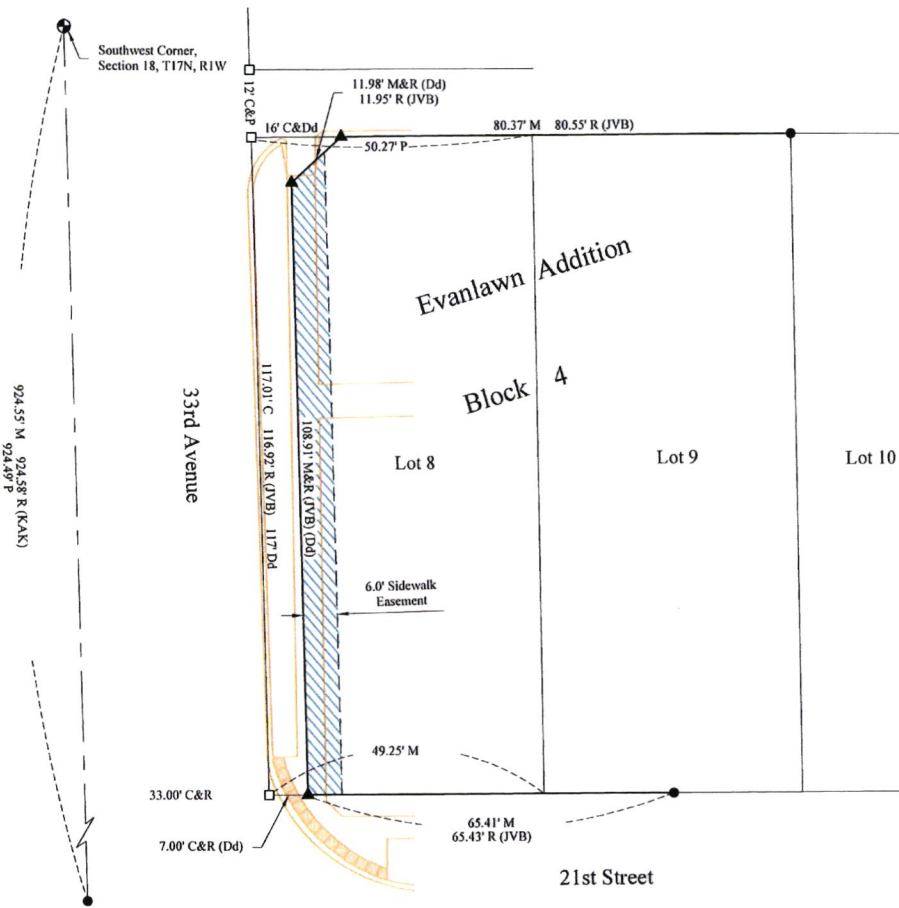

Drawn By: LRR  
 Date: April 14, 2026  
 Project Number: S-071-178  
 Scale: 1" = 20'

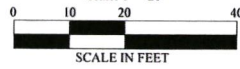

**LEGEND**

- Section Corner Found
- Property Corner Found
- ▲ Property Corner Found (Mag-Spike w/Washer)
- Calculated Point
- M Measured Distance
- C Calculated Distance
- R Recorded Distance (KAK) Kent A. Kennedy, LS #521, dated January 4, 2013. (TAT) Thomas A. Tremel, LS #455, dated April 21, 1990. (JVB) John V. Berry, LS #535, dated September 9, 1996. (Dd) Deed Book #229, Page 1041.

**SIDEWALK EASEMENT**

A six foot sidewalk easement being the west six feet of that part of Lot 8, Block 4, Evenlawn Addition to the City of Columbus, Platte County, Nebraska, not within Nebraska Department of Transportation Highway 30 and 81 Right-of-Way.

**SURVEYOR'S CERTIFICATE**

I, Terry L. Schulz, Nebraska Registered Land Surveyor No. 550, duly registered under the Land Surveyor's Regulation Act, do hereby state that I have performed a survey of the land depicted on the accompanying plat; that said plat is a true delineation of said survey performed personally or under my direct supervision; that said survey was made with reference to known and recorded monuments marked as shown, and to the best of my knowledge and belief is true, correct and in accordance with the Land Surveyor's Regulation Act in effect at the time of this survey.

*Terry L. Schulz*  
 Terry L. Schulz, State of Nebraska, LS #550

4-14-2026  
 Date



**ADVANCED CONSULTING ENGINEERING SERVICES**  
 West Point & Columbus  
 Phone: (402) 372-1923

10.A.2. Drainage Easement located in South 1/2 of the Northeast 1/4 of Section 11, Township 17 North, Range 1 West of the 6th P.M., Platte County, Nebraska (west of Grayhawk Place cul-de-sac).



Accountability - Dedication  
Honesty - Integrity - Respect

---

## MEMORANDUM

**DATE:** April 28, 2026  
**TO:** Tara Vasicek, City Administrator  
**FROM:** Richard J. Bogus, City Engineer  
**RE:** Meadow Ridge Twelfth Addition – Drainage Easement

**RECOMMENDATION:**

I recommend the approval of drainage easement in the NW 1/4, .NE 1/4 of Section 14, Township 17 North, Range 1 West of the 6<sup>th</sup> P.M., Platte County, Nebraska for Meadow Ridge Twelfth Addition.

**DISCUSSION:**

A wider drainage easement than in the final plat is required in order for an open-ditch to drain storm water from Meadow Ridge Twelfth Addition to the west to the storm water treatment facility. Upon subdividing the property located west of Meadow Ridge Twelfth Addition where this drainage ditch is located, the ditch may be enclosed with pipe or lessened in size and the easement will then need to be revised or vacated.

**FISCAL IMPACT:**

None.

**ALTERNATIVE:**

Do not approve.

**SIGNATURE:**

By: Richard J. Bogus

Approved By: [Signature]

---

---

EASEMENT AGREEMENT

THIS EASEMENT AGREEMENT made and entered into on 28<sup>th</sup> day of April, 2026 by and between Meadow Ridge Properties, LLC, herein "Grantor", and the City of Columbus, Nebraska, a Nebraska Municipal Corporation, herein "Grantee".

Grantor hereby grants and conveys to Grantee, its successors, assigns, employees, agents, contractors, invitees and licensees a drainage easement over and upon the following-described real estate, to-wit:

**Drainage Easement**

A 36.00 foot wide Drainage Easement for a drainage ditch and all of its appurtenances, located in part of the NW1/4 NE1/4 of Section 14, Township 17 North, Range 1 West of the 6th P.M., Platte County, Nebraska more particularly described as follows:

A DRAINAGE EASEMENT LOCATED IN THE SOUTH 1/2 OF THE NORTHEAST 1/4 OF SECTION 11, T17N, R1W OF THE 6TH P.M., PLATTE COUNTY, NEBRASKA, MORE PARTICULARLY DESCRIBED AS FOLLOWS: COMMENCING AT THE SOUTHWEST CORNER OF LOT 12, BLOCK A, MEADOW RIDGE TWELFTH ADDITION TO THE CITY OF COLUMBUS, PLATTE COUNTY, NEBRASKA; THENCE N 01°42'52" W ON THE WEST LINE OF SAID LOT 12, 10.00 FEET TO THE POINT OF BEGINNING; THENCE N 01°42'52" W ON THE WEST LINE OF SAID LOT 12, 36.00 FEET; THENCE S 88°06'52" W, 706.97 FEET; THENCE S 02°13'38" E, 36.00 FEET; THENCE N 88°06'52" E, 706.65 FEET TO THE POINT OF BEGINNING, CONTAINING 0.58 ACRES, MORE OR LESS.

The Easement is further described and defined on the map attached hereto marked **EXHIBIT A**, and incorporated herein by reference.

The purpose of the drainage easement is to provide drainage to and from adjoining properties across said drainage easement area described above, to the Grantee, its successors, assigns, employees, agents, contractors, invitees, and licensees, with access to the aforementioned described real estate for the purpose of inspection, maintenance, operation, or repair of drainage facilities and related improvements, and removal of vegetation and hazards, over, across, in, and through the easement area, all at the will of the Grantee. Grantee, its successors, assigns, employees, agents, contractors, invitees, and licensees, is further hereby granted the right of ingress and egress to and from said premises to carry out the rights prescribed in this easement.

\*\*\*\*\*REMAINDER OF PAGE LEFT INTENTIONALLY BLANK\*\*\*\*\*

The Grantor has executed this Drainage Easement on the day and year first above written.

Meadow Ridge Properties, LLC,  
GRANTOR,

By   
Charles Seedschlag, Authorized Member

STATE OF NEBRASKA    )  
  ) ss.  
COUNTY OF PLATTE    )

Acknowledged before me on April 28<sup>th</sup>, 2026, by Charles Seedschlag, Authorized Member of Meadow Ridge Properties, LLC.

  
Notary Public

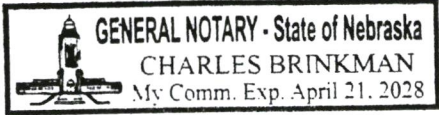

City of Columbus, Nebraska,  
GRANTEE,

By \_\_\_\_\_  
James B. Bulkley, Mayor

STATE OF NEBRASKA    )  
  ) ss.  
COUNTY OF PLATTE    )

Acknowledged before me on \_\_\_\_\_, 2026, by James B. Bulkley, Mayor, City of Columbus, Nebraska.

\_\_\_\_\_  
Notary Public



Drawn By: LRR  
 Date: April 14, 2026  
 Scale: 1"=50'  
 Project Number: S-071-187



● Property Corner Found  
 M Measured Distance

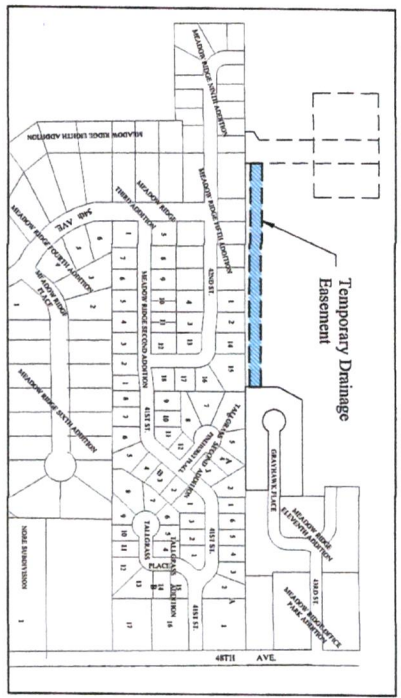

Existing 100' Temporary Drainage Easement

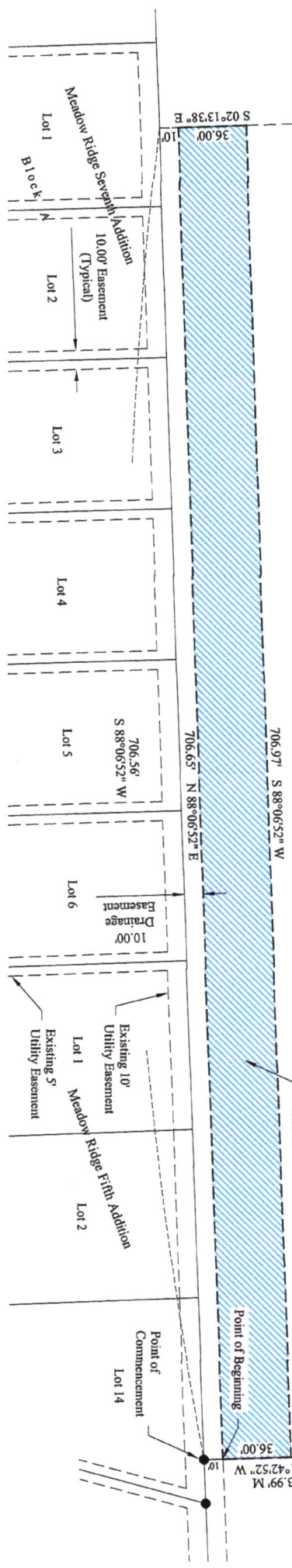

**TEMPORARY DRAINAGE EASEMENT**  
 A temporary drainage easement located in the South 1/2 of the Northeast 1/4 of Section 11, T17N, R1W of the 6th P.M., Platte County, Nebraska, more particularly described as follows:

Commencing at the Southwest corner of T1& 12, Block A, Meadow Ridge Twelfth Addition to the City of Columbus, Platte County, Nebraska; thence N 01°42'52" W on the West line of said Lot 12, 10.00 feet to the Point of Beginning; thence N 01°42'52" W on the West line of said Lot 12, 36.00 feet; thence S 88°06'52" W, 706.97 feet; thence S 02°13'38" E, 36.00 feet; thence N 88°06'52" E, 706.65 feet to the Point of Beginning, containing 0.58 acres, more or less.

**SURVEYOR'S CERTIFICATE**

I, Terry L. Schulz, Nebraska Registered Land Surveyor No. 550, duly registered under the Land Surveyor's Regulation Act, do hereby state that I have performed a survey of the land depicted on the accompanying plat; that said plat is a true delineation of said survey performed personally or under my direct supervision; that said survey was made with reference to known and recorded monuments marked as shown, and to the best of my knowledge and belief is true, correct and in accordance with the Land Surveyor's Regulation Act in effect at the time of this survey.

Terry L. Schulz, State of Nebraska, PLS #550

4/16/2026  
 Date



10.A.3. Amend city code section 50.35 to add regulations regarding handling of solid waste.



Accountability - Dedication  
Honesty - Integrity - Respect

---

---

## MEMORANDUM

**DATE:** 4/21/26  
**TO:** Tara Vasicek, City Administrator  
**FROM:** Capt. Douglas Molczyk  
**RE:** Handling of Solid Waste Ordinance

**RECOMMENDATION:**

To adopt the changes in ordinance § 50.35, changing it from Burning of Garbage to Handling of Solid Waste. Also, changing the ordinance requiring that solid waste be properly disposed once a week, either by a licensed hauler or the person responsible for the property.

**DISCUSSION:**

The purpose of this memorandum is to recommend the revision of Ordinance § 50.35 to increase its scope and improve the regulation of solid waste within the City of Columbus.

**Current Ordinance:**

The existing ordinance § 50.35, titled "*Burning of Garbage*," states:

"It shall be unlawful for any person to burn garbage or refuse within the limits of the city."  
(Prior Code, § 50.40) (Ord. 88-11, passed 3-21-1988) Penalty, see § 50.99

While this provision prohibits the burning of garbage, it is limited in scope and does not address broader solid waste handling practices that impact public health, sanitation, and community standards.

**Proposed Revision:**

It is recommended that § 50.35 be repealed and replaced with a new ordinance titled "*Handling of Solid Waste*," which expands regulatory authority to include the proper storage, removal, and disposal of solid waste. The proposed ordinance includes the following key provisions:

- Prohibits accumulation or disposal of solid waste in a manner that creates a nuisance or health hazard
  - Requires weekly removal and proper disposal of solid waste
  - Allows disposal through a licensed hauler or transport by the responsible party to the City Transfer Station
  - Establishes container requirements to prevent leakage, odor, and animal access
  - Prohibits open dumping and maintains the prohibition on burning of solid waste
- 
-

- Assigns responsibility for compliance to the property owner, occupant, or person in control
- Requires transported waste loads to be properly secured or covered

**Rationale:**

The proposed changes reflect modern waste management practices and provide clear, enforceable standards to:

- Improve public health and sanitation
- Reduce nuisance conditions such as odors, pests, and debris
- Enhance overall community appearance
- Align local regulations with common municipal and environmental standards

**FISCAL IMPACT:** None seen

**ALTERNATIVE:** Continue on with the old ordinance.

**SIGNATURE:**

By:  \_\_\_\_\_

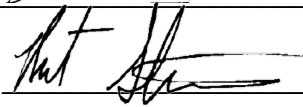
Approved By:  \_\_\_\_\_

Approved By:  \_\_\_\_\_

§ 50.35 ~~BURNING OF GARBAGE.~~

~~—It shall be unlawful for any person to burn garbage or refuse within the limits of the city.~~

~~(Prior Code, § 50.40) (Ord. 88-11, passed 3-21-1988) Penalty, see § 50.99~~

**Handling of Solid Waste**

(A) No person shall accumulate, store, or dispose of solid waste upon any property in a manner that creates a nuisance, health hazard, or violates state or local regulations.

(B) All solid waste generated on any property shall be removed and properly disposed of at least once per week. Disposal shall occur by:

1. A licensed private waste hauler; or
2. The owner, occupant, or person responsible for the property transporting such waste to the City of Columbus Transfer station.

(C) Solid waste shall be stored in suitable containers designed to prevent leakage, odor, and access by animals.

(D) Open dumping and the burning of solid waste are prohibited within the limits of the city.

(E) The owner, occupant, or person in control of the property shall be responsible for compliance with this section.

(F) All loads of waste transported to the City of Columbus Transfer Station in vehicles shall be covered; provided, however, this requirement shall not apply when the entire load of waste is of such bulk that it is unlikely that any of such waste will blow out of or fall out of the vehicle when being driven at the speed of 55 miles per hour.

Penalty, see § 50.99

10.A.4. Proposed changes to parking restrictions for streets and avenues located in the downtown area. (Downtown Business Improvement District recommends approval.)



Accountability - Dedication  
Honesty - Integrity - Respect

---

---

## MEMORANDUM

**DATE:** April 27, 2026  
**TO:** Public Property, Safety and Works Committee  
**FROM:** Tara Vasicek, City Administrator  
**RE:** Downtown Parking Regulations and Changes for Consideration

### **DISCUSSION:**

The City's existing downtown parking regulations are established under Resolution R04-123. This resolution outlines where two-hour parking restrictions apply, where they have been removed, and where overnight parking is prohibited. Recent discussions regarding downtown parking have highlighted concerns related to the existing two-hour parking limits and inconsistent compliance. As context, all public parking spaces are currently subject to a general 24-hour limit, with additional two-hour restrictions applied in only the select downtown areas detailed in R04-123.

### **Current Regulations:**

- **Two-hour parking restrictions** are in place Monday through Saturday, 8:00 a.m. to 6:00 p.m. (excluding holidays) on designated downtown streets and avenues.
- **Handicapped parking spaces** and select courthouse-adjacent spaces are exempt from these time limits.
- **Overnight parking restrictions** currently prohibit parking from 1:00 a.m. to 5:00 a.m. on Mondays on specific downtown corridors to accommodate maintenance activities.

### **Proposed Changes:**

At its most recent meeting, the Downtown Business Improvement District (BID) reviewed parking concerns in detail and advanced a recommendation to the Public Property Committee. The recommendation proposes removing the two-hour parking restriction on downtown avenues where it exists currently, thereby reverting those areas to the standard 24-hour limit. They recommend continuing with the 2-hour limit on 13<sup>th</sup> and 14<sup>th</sup> Street as specified.

This approach reflects a balanced compromise, supporting both short-term parking needs for customers and longer-term parking for employees, residents, and extended visits.

In addition, the Public Works Division has requested an amendment of the no-parking window on select roadways from 2:00 a.m. to 5:00 a.m. to facilitate routine street sweeping and snow removal operations. This request was discussed with the BID and did not raise concerns.

No change is recommended to the handicapped spaces or spaces adjacent to the courthouse.

---

---

**1. Removal of Two-Hour Parking Restrictions on Avenues**

- Two-hour parking limits would be **removed from key downtown avenues**, particularly along 25th, 26th, and 27th Avenues between 12th and 14th Streets.
- These areas would revert to the standard 24-hour parking limit.

**2. Updated Overnight Parking Restrictions (2:00 a.m. – 5:00 a.m.)**

- Existing overnight restrictions would be modified and expanded as follows:
  - Every Tuesday year-round: No parking from 2:00 a.m. to 5:00 a.m.
  - Seasonal (November 1 – March 31): No parking during the same hours on any day when snow has occurred or is forecasted
- Affected locations include:
  - 27th Avenue (12th–13th Streets)
  - 28th Avenue (12th–13th Streets)
  - 13th Street (23rd–30th Avenues)

**CONCURRENCE:**

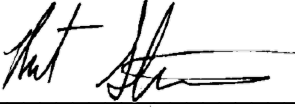
By:   
Bret Strecker, Police Chief

By:   
Chuck Sliva, Director of Public Works

**SIGNATURE:**

Approved By: 

**RESOLUTION NO. R04-123**

A RESOLUTION OF THE MAYOR AND COUNCIL OF THE CITY OF COLUMBUS, NEBRASKA AMENDING RESOLUTION R04-31 SO AS TO REMOVE THE TWO HOUR PARKING RESTRICTION FROM THE DOWNTOWN STREETS AND AVENUES AS LISTED BELOW; TO CREATE TWO HOUR PARKING RESTRICTIONS ON THE DOWNTOWN STREETS AND AVENUES AS LISTED BELOW; TO EXEMPT FROM THE TWO HOUR PARKING TIME LIMIT THOSE CURRENTLY DESIGNATED HANDICAPPED PARKING SPACES AS WELL AS SELECTED PARKING SPACES IN THE AREA OF THE PLATTE COUNTY COURTHOUSE; AND TO PROHIBIT PARKING IN CERTAIN SPECIFIED LOCATIONS BETWEEN THE HOURS OF 1:00 A.M. AND 5:00 A.M. ON MONDAYS; TO AUTHORIZE THE CITY OF COLUMBUS STREET DEPARTMENT TO INSTALL SIGNS IN ACCORDANCE HEREWITH; AND TO AUTHORIZE THE COLUMBUS POLICE DEPARTMENT TO THEREAFTER ENFORCE THE SAME.

BE IT RESOLVED BY THE MAYOR AND COUNCIL OF THE CITY OF COLUMBUS, NEBRASKA that the two hour parking restriction (Monday through Friday, except legal holidays) be removed from the following streets and avenues:

|               |  |
|---------------|--|
| West side of  | 29 <sup>th</sup> Avenue from 14 <sup>th</sup> Street north 66 feet   |
| South side of | 13 <sup>th</sup> Street from 30 <sup>th</sup> Avenue to 23 <sup>rd</sup> Avenue                                    |
| North side of | 13 <sup>th</sup> Street from 28 <sup>th</sup> Avenue to 23 <sup>rd</sup> Avenue                                    |
| East side of  | 28 <sup>th</sup> Avenue from 14 <sup>th</sup> Street to alley between 14 <sup>th</sup> and 15 <sup>th</sup> Street |
| West side of  | 28 <sup>th</sup> Avenue from 14 <sup>th</sup> Street to alley between 14 <sup>th</sup> and 15 <sup>th</sup> Street |
| East side of  | 28 <sup>th</sup> Avenue from 13 <sup>th</sup> Street to alley between 13 <sup>th</sup> and 14 <sup>th</sup> Street |
| West side of  | 28 <sup>th</sup> Avenue from 13 <sup>th</sup> Street to alley between 13 <sup>th</sup> and 14 <sup>th</sup> Street |
| East side of  | 28 <sup>th</sup> Avenue from 12 <sup>th</sup> Street to 13 <sup>th</sup> Street                                    |
| West side of  | 28 <sup>th</sup> Avenue from 12 <sup>th</sup> Street to alley between 12 <sup>th</sup> and 13 <sup>th</sup> Street |
| West side of  | 26 <sup>th</sup> Avenue from 14 <sup>th</sup> Street to alley between 14 <sup>th</sup> and 15 <sup>th</sup> Street |
| East side of  | 26 <sup>th</sup> Avenue from 14 <sup>th</sup> Street to alley between 14 <sup>th</sup> and 15 <sup>th</sup> Street |
| East side of  | 25 <sup>th</sup> Avenue from 14 <sup>th</sup> to 15 <sup>th</sup> Street   |

|               |  |
|---------------|--|
| East side of  | 27 <sup>th</sup> Avenue from 12 <sup>th</sup> to 14 <sup>th</sup> Street   |
| West side of  | 27 <sup>th</sup> Avenue from 12 <sup>th</sup> to 14 <sup>th</sup> Street   |
| West side of  | 25 <sup>th</sup> Avenue from 14 <sup>th</sup> to 15 <sup>th</sup> Street   |
| East side of  | 24 <sup>th</sup> Avenue from 13 <sup>th</sup> to 14 <sup>th</sup> Street   |
| West side of  | 24 <sup>th</sup> Avenue from 13 <sup>th</sup> to 14 <sup>th</sup> Street   |
| West side of  | 24 <sup>th</sup> Avenue from 12 <sup>th</sup> to 13 <sup>th</sup> Street   |
| East side of  | 23 <sup>rd</sup> Avenue from 14 <sup>th</sup> Street to alley between 14 <sup>th</sup> and 13 <sup>th</sup> Street     |
| West side of  | 23 <sup>rd</sup> Avenue from 14 <sup>th</sup> to 13 <sup>th</sup> Street   |
| South side of | 11 <sup>th</sup> Street from 27 <sup>th</sup> to 23 <sup>rd</sup> Avenue   |
| North side of | 11 <sup>th</sup> Street from 24 <sup>th</sup> to 26 <sup>th</sup> Avenue   |
| East side of  | 26 <sup>th</sup> Avenue from 11 <sup>th</sup> Street north to UPRR   |
| East side of  | 25 <sup>th</sup> Avenue from 11 <sup>th</sup> Street north to UPRR   |
| West side of  | 25 <sup>th</sup> Avenue from 11 <sup>th</sup> Street north to UPRR   |
| East side of  | 26 <sup>th</sup> Avenue from 11 <sup>th</sup> Street south to alley between 11 <sup>th</sup> & 10 <sup>th</sup> Street |
| West side of  | 26 <sup>th</sup> Avenue from 11 <sup>th</sup> Street south to alley between 11 <sup>th</sup> & 10 <sup>th</sup> Street |
| East side of  | 25 <sup>th</sup> Avenue from 11 <sup>th</sup> Street south to alley between 11 <sup>th</sup> & 10 <sup>th</sup> Street |
| West side of  | 25 <sup>th</sup> Avenue from 11 <sup>th</sup> Street south to alley between 11 <sup>th</sup> & 10 <sup>th</sup> Street |
| East side of  | 24 <sup>th</sup> Avenue from 11 <sup>th</sup> Street south to alley between 11 <sup>th</sup> & 10 <sup>th</sup> Street |
| North side of | 12 <sup>th</sup> Street from 29 <sup>th</sup> to 30 <sup>th</sup> Avenue   |
| North side of | 12 <sup>th</sup> Street from 26 <sup>th</sup> to 25 <sup>th</sup> Avenue   |

BE IT FURTHER RESOLVED that two hour parking (Monday through Saturday (8:00 a.m. to 6:00 p.m., except legal holidays) be created on the following streets and avenues:

- North side of            13<sup>th</sup> Street from 30<sup>th</sup> to 23<sup>rd</sup> Avenue
- South side of            13<sup>th</sup> Street from 30<sup>th</sup> to 23<sup>rd</sup> Avenue
- North side of            14<sup>th</sup> Street from 24<sup>th</sup> to 27<sup>th</sup> Avenue
- South side of            14<sup>th</sup> Street from 24<sup>th</sup> to 27<sup>th</sup> Avenue

~~East side of 27<sup>th</sup> Avenue from 14<sup>th</sup> to 12<sup>th</sup> Street~~  
~~West side of 27<sup>th</sup> Avenue from 14<sup>th</sup> to 12<sup>th</sup> Street~~  
~~East side of 26<sup>th</sup> Avenue from 14<sup>th</sup> to 12<sup>th</sup> Street~~  
~~West side of 26<sup>th</sup> Avenue from 14<sup>th</sup> to 12<sup>th</sup> Street~~  
~~East side of 25<sup>th</sup> Avenue from alley between 14<sup>th</sup> & 15<sup>th</sup> St. to 12<sup>th</sup> Street~~  
~~West side 25<sup>th</sup> Avenue from alley between 14<sup>th</sup> & 15<sup>th</sup> St. to 12<sup>th</sup> Street~~

BE IT RESOLVED that handicapped designated parking spaces in downtown Columbus, are exempt from the two hour parking limit;

BE IT FURTHER RESOLVED that this Resolution shall not be applicable to parking spaces surrounding the Platte County Courthouse which have been posted with shorter time limit restrictions, such parking spaces remain subject to such ordinances or resolutions establishing shorter parking time limits;

BE IT FURTHER RESOLVED that ~~a no parking restriction shall be in effect is not allowed in for~~ the following streets and avenues as follows: locations: between the hours of 1:00 A.M. and 5:00 A.M. on Mondays:

On 27<sup>th</sup> Avenue from 12<sup>th</sup> to ~~13th~~ 14<sup>th</sup> Street;

- Every day from November 1st through March 31st when it has snowed or if snow is in the forecast, from 2 a.m. to 5 a.m.

On 28<sup>th</sup> Avenue from 12<sup>th</sup> to ~~13th~~ 14<sup>th</sup> Street;

- Every Tuesday year-round, from 2 a.m. to 5 a.m.
- Every day from November 1st through March 31st when it has snowed or if snow is in the forecast, from 2 a.m. to 5 a.m.

On 13<sup>th</sup> Street from ~~27<sup>th</sup> 23rd~~ to ~~28<sup>th</sup> 30th~~ Avenue; and

- Every Tuesday year-round, from 2 a.m. to 5 a.m.
- Every day from November 1st through March 31st when it has snowed or if some is in the forecast, from 2 a.m. to 5 a.m.

~~On the south side of 14<sup>th</sup> Street from 27<sup>th</sup> to 28<sup>th</sup> Avenue.~~

BE IT FURTHER RESOLVED that the City of Columbus Street Department be authorized to remove and install signs in accordance herewith and the Columbus Police Department is hereinafter authorized to enforce the same.

This resolution shall amend Resolution No. R04-31.

INTRODUCED BY COUNCIL MEMBER /s/ Joe Jarecke

PASSED AND ADOPTED THIS 7 DAY OF September, 2004.

/s/ Gary Giebelhaus  
MAYOR

ATTEST:

/s/ Linda L. Walters  
CITY CLERK

APPROVED AS TO FORM BY:

/s/ Eugene G. Schumacher  
CITY ATTORNEY

---

11. **REPORTS OF SPECIAL COMMITTEES: None**

12. **REPORTS ON LEGISLATION: None**

13. **NEW BUSINESS**

13.A.Appointment of Margaret (Peg) Slusarski to the Civil Service Commission filling unexpired term until April 2029.



City Hall  
2500 14th St. Suite 3  
Columbus, NE 68601  
402-562-4220  
[www.columbusne.us](http://www.columbusne.us)

## MEMORANDUM

**DATE:** April 28, 2026  
**TO:** City Council Members  
**FROM:** James B. Bulkley, Mayor  
**SUBJECT:** Appointment

With your permission, I wish to submit the following name to you for consideration and appointment at the May 4, 2026, City Council meeting per City Council rules.

**CIVIL SERVICE COMMISSION (filling unexpired term until April 2029)**

**MARGARET (PEG) SLUSARSKI**

Peg Slusarski is a retired English and speech instructor, a career path influenced by her father, who served as a school superintendent and her mother, a teacher. She began her career at Lakeview High School where she taught for 36 years, followed by 13 years at Central Community College. Although she has retired from full-time teaching, she continues to stay active in the classroom as a substitute teacher.

Peg has won local, state, and national teaching awards; however, she considers her greatest achievements to be the moments when former students thank her for making a meaningful difference in their lives. She has helped them develop skills in public speaking, writing strong memos and essays, and even overcoming addictions.

Peg is currently active in a Bible study group, book club, card club, and church work and serves as co-chairperson of the United Way's Education Committee. She and her husband reside in Columbus and have four adult children and ten grandchildren. Peg is honored to be able to continue serving the community as a member of the Civil Service Commission.

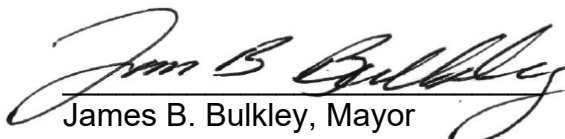
  
James B. Bulkley, Mayor

13.B. Application from 23rd West LLC dba Bo's West Sports Bar to add secondary catering license to existing Retail Class "C" liquor license at 3720 23 Street.



# COLUMBUS POLICE DEPARTMENT

2330 14th Street • Columbus, Nebraska 68601 • Phone (402) 564-3201 • Fax (402) 562-7325

TO: HONORABLE MAYOR AND CITY COUNCIL  
CITY OF COLUMBUS, NEBRASKA

FROM: BRET D. STRECKER, CHIEF OF POLICE  

DATE: APRIL 15, 2026

SUBJECT: LIQUOR LICENSE  
APPLICATION FOR ADDITION TO LIQUOR LICENSE FOR  
CATERING  
BO'S WEST SPORTS BAR  
3720 23<sup>RD</sup> STREET  
COLUMBUS, NEBRASKA  
TIFFANY CECH, OWNER

This application for an addition to the license to allow their catering services to include the serving of beer, wine and distilled spirits. With the addition, it will allow the business to apply for multiple Special Designated Licenses without the additional fee. They will still have to apply individually for each Special Designated License for each event that they are catering. The owner advised that they would follow the standard procedures for serving including checking identifications.

This report will serve as notice that local law enforcement has been informed in advance of this event.

**Nickeson, Linda**

---

**From:** lcc.noreply@nebraska.gov  
**Sent:** Tuesday, April 14, 2026 3:42 PM  
**To:** zzCity Clerks  
**Subject:** NLCC Review Required

**CAUTION:** This email originated from outside of the organization. Do not click links or open attachments unless you recognize the sender and know the content is SAFE.

Please save this email to provide your recommendation. To review the application documents [click here](#).

Review Type: Local Review

Job Type: Amendment Application  
Job Number: 163627

License Type: Class C Beer, Wine, Spirits On and Off Sale  
Secondary Licenses: - Catering (Secondary License)

Licensee: 23RD WEST LLC  
Premises Name: Bo's West Sports Bar  
Premises Address: 3720 23rd St Columbus, NE 68601-3023  
Premises Type: Converted

CLERKS: For NEW APPLICATION jobs (not amendments) there are two key time frames to keep in mind:

- 1) Publicize one time not less than 7 days not more than 14 days prior to date of hearing.
- 2) You have 45 days to conduct a hearing after the date of receipt of the notice from this Commission (Nebraska Revised Statute 53-134). You may choose NOT to make a recommendation of approval or denial to our Commission.

PER NEBRASKA REVISED STATUTE 53-133, THE LIQUOR CONTROL COMMISSION SHALL SET FOR HEARING ANY APPLICATION WHEREIN:

- 1) There is a recommendation of denial from the local governing body
- 2) A citizens protest; or
- 3) Statutory problems that the Commission discovers.

Thank you,  
Nebraska Liquor Control Commission

**This is an automated email message. Please do not reply to this email address.**



## Application Copy

File Number: 163627

AMENDMENT TYPE

Add Secondary License

APPLICATION DATE RECEIVED

2026-04-14

NEW SECONDARY LICENSE(S)

NAME

DESCRIPTION

Catering (Secondary License)

Catering - This is a secondary license that allows a licensee to submit an application for a Special Designated License event without an additional fee to the state.

QUESTIONS

### Secondary License: Catering (Secondary License)

1. Do you intend to apply for multiple Special Designated License this calendar year where you will be serving and/or selling alcohol off your licensed premises? With the Catering Secondary license you will be able to apply for SDLs without an additional fee.

Yes

APPLICANT

Tiffany Cech

DECLARATION

I (We) the applicant(s) agree and consent

I declare under penalty of perjury that I have read the contents of this amendment application and, to the best of my knowledge, believe all statements made in this application are true, correct, and complete.

13.C. Quote from Wemhoff Refrigeration, Inc. in the amount of \$17,383.72 for air conditioning unit for Quail Run pro shop. Reallocated CIP #26-07



City Hall | Parks and Rec  
2500 14<sup>th</sup> St.  
Columbus, NE 68601  
402-562-4232  
columbusne.us

## Memorandum

**Date:** 4/27/2026

**To:** Tara Vasicek, City Administrator

**From:** Betsy Eckhardt, Director of General Services

**RE:** AC Unit Replacements-Quail Run Pro Shop

**Recommendation:** Approve reallocation of capital improvement funds and the proposal from Wemhoff Refrigeration, Inc. to replace the air conditioning units at the Quail Run Pro Shop.

**Discussion:** The air conditioning units at the Quail Run Pro Shop have reached the end of their useful life and are no longer operational. Previous repairs have been made in recent years; however, the system has now failed and requires full replacement.

Staff obtained quotes from local vendors, and Wemhoff Refrigeration, Inc. provided a responsive and qualified proposal for the replacement of the units.

To accommodate this expense, we are requesting funds be reallocated from capital account **100-155-57200-26007**, which was originally designated for a roof replacement project at Van Berg. The allocated amount for that project is insufficient to complete the roof replacement as originally planned, making it an appropriate source for reallocation.

Replacing the AC units will ensure the continued operation and usability of the Pro Shop, particularly during peak seasonal use.

**Fiscal Impact:**

Total project cost of \$17,383.72 from a reallocation from account 100-155-57200-26007

**Concurrence:** *Christopher A. Nguyen*  
By: \_\_\_\_\_

**Signature:**  
By: *Betsy Eckhardt*  
\_\_\_\_\_

Approved By: *[Signature]*  
\_\_\_\_\_

---

## City of Columbus, Nebraska Purchase Request Form

**This form must be fully completed before any purchase, contract, or expenditure of City funds.**

**\*\*When sending to Finance: Subject line on email should read- "Purchase Request Form"**

|   | <b>AMOUNT:</b> 17383.72 |                   |                    |                     |          |
|---|-------------------------|-------------------|--------------------|---------------------|----------|
| <b>PROCESS:</b>                         | \$999 or less           | \$1,000 - \$4,999 | \$5,000 - \$24,999 | \$25,000 - \$74,999 | \$75,000 |
| Purchase Request Form                   |                         | X                 | X                  | X                   | X        |
| 2 Quotes                                |                         | X                 |                    |                     |          |
| Dept Head Approval                      |                         | X                 | X                  | X                   | X        |
| 3 Quotes                                |                         |                   | X                  | X                   |          |
| City Administrator Approval             |                         |                   | X                  | X                   | X        |
| Verification of Funds, Finance Director |                         |                   | X                  | X                   | X        |
| Form Bidding Required                   |                         |                   |                    |                     | X        |
| City Council Approval                   |                         |                   |                    | X                   | X        |

### 1. Requesters Information

Department / Division: Golf

Requesting Employee: Eric Bice

Supervisor: \_\_\_\_\_

Department Head: Sydney Mroczek

Date: 4/23/2026

### 2. Type of Purchase

Goods / Supplies / Equipment

Contractual Services

Professional Services (QBS)

Construction / Capital Improvement

Emergency Purchase

### 3. Purchase Description:

*Fully describe the goods or services and their purpose.*

The AC units for the Quail Run proshop and lounge need to be replaced. We repaired them 3 cycles ago and they have now officially hit the end of life.

**4. Selected Vendor Information:**

Vendor Name: Wemhoff Refrigeration Inc. Contact Name: John Wemhoff  
Phone: 402-564-6557 Email: \_\_\_\_\_  
Cooperative Purchasing (State Contract, Sourcewell, etc.):  Yes  No

**5. Cost & Budget:**

Total Cost: \$17383.72  
Account Number(s): reallocation from 100-155-57200-26007  
Funds Available:  Yes  No

**6. Number of Quotes obtained:** 2

**If this is a sole source quote please explain:**

We were only able to get 2 providers to the location to provide quotes.

**7. Approvals**

Supervisor / Designee: Eric Bice Date: \_\_\_\_\_  
Department Head: Betsy Eckhardt Date: 04/23/2026  
City Administrator (if \$5,000+): [Signature] Date: 4/29/26  
City Council Approval (if \$25,000+): \_\_\_\_\_  
Verification of Funds:  
Finance Director (if \$5,000+): Christopher A. Nuyss Date: 04/28/26

**AS NEEDED: Description of Emergency Purchases**

An "emergency" shall be defined as any event that interrupts the normal administration of municipal services, thereby jeopardizing the life, health of citizens.

*Describe emergency circumstances and justification.*

**PROPOSAL**

**Wemhoff Refrigeration, Inc.**  
**Columbus, NE 68601**  
**PH: 402-564-6557**  
**FAX: 402-246-9200**

**Date:**  
**Proposal:**

|          | <b>Proposal Submitted To</b> | <b>Work To Be Performed At</b> |
|----------|------------------------------|--------------------------------|
| Name:    | Quail Run Golf Course        | same                           |
| Address: | 327 S.5 St.                  |                                |
| City:    | Columbus                     |                                |
| State:   | Ne.                          |                                |
| Zip:     | 68601                        |                                |
| Phone:   | 402-563-1313                 |                                |
| Fax:     |                              |                                |

We hereby propose to furnish all the materials and all labor necessary for: PRO SHOP #2 21/2TON  
(1) ALZS5BA3010 (15.2SEER2) AMANA HEAT PUMP R32; (1)AMST24BU1300 AIR HANDLER W/TXV; (1) HKTSD15XB 15 KW HEAT KIT (1) TH1600U2000 H/W THERMOSTAT; TUBING HOOKUP; FLUSH; SUPPLY PLENUM ADAPTOR; R/A ADAPTOR; DRAIN; ELECTRICAL; LABOR TOTAL \$7546.17

All material is guaranteed to be as specified, and the above work to be performed in accordance with the drawing submitted for above work and completed in a substantial workmanlike manner for the sum as stated above with payments to be made as follows: 20% down, balance due upon completion.

Deviation from above specifications involving extra costs, will be executed only upon written orders, and will become an extra charge over and above the estimate. All agreements contingent upon strikes, accidents or delays beyond our control. Owner to carry fire, tornado and other necessary insurance upon above work. Workman's Compensation and Public Liability Insurance on above work to be taken out by: Wemhoff Refrigeration, Inc.

Respectfully Submitted by Wemhoff Refrigeration, Inc.

Per  \_\_\_\_\_

NOTE – This proposal may be withdrawn by us if not accepted within 60 days.

**ACCEPTANCE OF PROPOSAL**

The above prices, specifications and conditions are satisfactory and are hereby accepted. You are authorized to do the work as specified. Payment will be made as outlined above.

Accepted: \_\_\_\_\_ Signature: \_\_\_\_\_

Date: \_\_\_\_\_ Signature: \_\_\_\_\_

**PROPOSAL**

**Wemhoff Refrigeration, Inc.**  
**Columbus, NE 68601**  
**PH: 402-564-6557**  
**FAX: 402-246-9200**

**Date:**  
**Proposal:**

|          | <b>Proposal Submitted To</b> | <b>Work To Be Performed At</b> |
|----------|------------------------------|--------------------------------|
| Name:    | Quail Run Golf Course        | same                           |
| Address: | 327 S.5 St.                  |                                |
| City:    | Columbus                     |                                |
| State:   | Ne.                          |                                |
| Zip:     | 68601                        |                                |
| Phone:   | 402-563-1313                 |                                |
| Fax:     |                              |                                |

We hereby propose to furnish all the materials and all labor necessary for: LOUNGE # 2 5 TON  
(1) ALZS5BA6010 (15.2SEER2) AMANA HEAT PUMP R32; (1)AMST60CU2000 AIR HANDLER W/TXV; (1) HKTSD15XB 15 KW HEAT KIT (1) TH1600U2000 H/W THERMOSTAT; TUBING HOOKUP; FLUSH; SUPPLY PLENUM ADAPTOR; R/A ADAPTOR; DRAIN; ELECTRICAL; LABOR TOTAL \$9837.55

All material is guaranteed to be as specified, and the above work to be performed in accordance with the drawing submitted for above work and completed in a substantial workmanlike manner for the sum as stated above with payments to be made as follows: 20% down, balance due upon completion.

Deviation from above specifications involving extra costs, will be executed only upon written orders, and will become an extra charge over and above the estimate. All agreements contingent upon strikes, accidents or delays beyond our control. Owner to carry fire, tornado and other necessary insurance upon above work. Workman's Compensation and Public Liability Insurance on above work to be taken out by: Wemhoff Refrigeration, Inc.

Respectfully Submitted by Wemhoff Refrigeration, Inc.

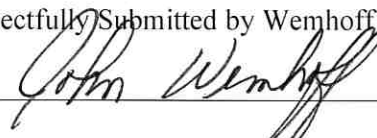
Per 

NOTE – This proposal may be withdrawn by us if not accepted within 60 days.

**ACCEPTANCE OF PROPOSAL**

The above prices, specifications and conditions are satisfactory and are hereby accepted. You are authorized to do the work as specified. Payment will be made as outlined above.

Accepted: \_\_\_\_\_ Signature: \_\_\_\_\_

Date: \_\_\_\_\_ Signature: \_\_\_\_\_

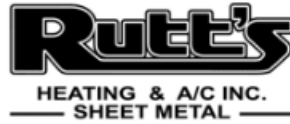

1001 W 1st St, Hastings, NE 68901

Company: Quail Run Golf Course  
Address: P.O. Box# 1677  
Columbus, NE 68601

Date: Mar 19, 2026  
Re: Replace 2-ton AHU and HP  
File Number: 100811  
Property: Quail Run Golf Course  
Address: 327 S. 5th Street  
Columbus, NE 68601

As requested, we are pleased to offer our proposal for the above referenced project as follows:

**SPECIFIC INCLUSIONS**

**Replace 2-ton AHU and HP**

Proposal to replace the small (2-ton) air handler and heat pump in the Pro Shop With a new 2.5-ton 15 SEER "Run Tru" by "Trane" system. We would need to get the water heater moved to the right (south) about 6" to allow for the new air handler.

**Material Description**

- Run Tru A5AHC003A1B30A air handler
- Run Tru A5HP5030A1000A 2.5-ton 15 SEER heat pump
- 10kw heater package BAYHTR1510BRKC
- Filter rack BAYSF1185BAA
- Honeywell TH6320U2008 thermostat
- Refrigeration line set flush and repair
- Heat pump adjustable snow legs
- Condensate pipe
- Sheet metal to connect new system to existing duct  
reclaimer, recovery, filter drier, screws, sealer, etc.
- Shipping

**CLARIFICATIONS**

1. Our offer is firm for thirty days from the date listed above.
2. 50% down payment is required with the signed quote when equipment is being replaced, before equipment will be ordered. If paying by credit card, there will be a credit card surcharge fee of approximately 3% added to the invoice. To inquire about financing for new construction or direct replacements only, please contact our office at 402-463-4853.
3. Our offer is predicated upon a clear and accessible area that will be made available by others, where our work is to be performed.
4. Unless noted in the specific inclusions, our work will be performed during our normal business hours.

**SPECIFIC EXCLUSIONS**

1. Electrical work unless otherwise specified.
2. Refrigerant unless otherwise specified.

**Total Proposal as Outlined Above..... \$8,785.00**

Thank you,  
Kaylinn Nienhueser  
402-984-9369  
knien@ruttsheating.com

### ACCEPTANCE OF PROPOSAL

This proposal represents the entire agreement between the parties. There are no representations, promises or other understandings unless expressly included herein.

Customer Name and/or PO is needed: \_\_\_\_\_

Signature: \_\_\_\_\_

Date: \_\_\_\_\_

**Service Agreement Savings: \$**

### Additional Terms & Conditions

- 1. Services.** Subject to the terms and conditions set forth in the Agreement (as defined below), the counterparty identified in this Agreement (“You”) engage **RUTT'S HEATING AND AIR CONDITIONING, INC.** (“Company.”) to provide, and the Company agrees to provide to You, only those services specifically described in this Agreement (“Services”).
- 2. Complete Agreement.** These additional terms and conditions are incorporated by reference into, and form an integral component of, the proposal, documentation or agreement provided to You by the Company (these additional terms and conditions, together with the proposal, documentation or agreement provided to You by the Company being, collectively, the “Agreement”). Company’s agreement to perform the Services is expressly conditioned on Your agreement with and acceptance of the express terms and conditions in this Agreement, as evidenced by your acceptance or signature of the Agreement. Neither this Agreement nor Your acceptance shall be deemed to include any additional or different terms proposed by You whether communicated orally or in writing that may add to, vary from or conflict with the terms of this Agreement, and Company expressly objects to any term or condition that may add to, vary from or conflict with the terms of this Agreement. You and Company shall mutually agree in writing upon any adjustment or change to the terms of the Services or this Agreement. Company shall not be responsible for any services or work not specifically listed in this Agreement.
- 3. Credit Approval.** This Agreement is subject to credit approval by Company. If the Company does not approve Your credit, or if the Company disapproves Your credit at any time during performance of the Services, Company may (in Company’s sole discretion, and at Company’s option), terminate this Agreement upon notice to You, delay or suspend performance of the Services without any liability, attempt to renegotiate any terms or conditions of this Agreement as Company may determine, and/or exercise any other rights or remedies available to Company. If Company elects, at any time to terminate this Agreement, then the Agreement shall terminate without any liability to Company and You shall immediately pay Company for Services provided prior to the date of termination along with any other costs or expenses incurred by Company in connection with, or in anticipation of, this Agreement and the Services.
- 4. Fees.** You shall pay Company all fees, costs, charges, expenses and other amounts (“Fees”) set forth in or contemplated in this Agreement. Unless otherwise specifically stated elsewhere in this Agreement, all Fees are calculated and determined based on Services being performed on business days and during normal business hours. Services performed on days other than business days and Services performed outside of normal business hours shall be performed at Company’s then-current overtime, holiday, weekend, evening or other applicable rates (as the same may be adjusted from time to time).
- 5. Taxes.** In addition to Fees, You shall pay Company all taxes and similar amounts or charges payable by the Company in connection with the Services and this Agreement.
- 6. Payment.** Unless otherwise specifically stated elsewhere in this Agreement, all payments (including Fees and taxes) are due immediately upon receipt of an invoice or similar document from Company. If payment is not made when due, Company’s remedies shall include, but not be limited to: (a) the assessment of a late charge of two percent (2%) per

month, or the highest rate permitted by law, whichever is less; (b) suspension of the Services until all payments due have been made; (c) termination of this Agreement; and/or (d) the filing and enforcement of a construction lien on Your property. You shall pay to Company upon demand all costs (including attorneys' fees) incurred by Company in collecting or attempting to collect amounts due or otherwise enforcing this Agreement.

7. **Warranties.** Company warrants that the Services shall be performed in a workmanlike manner. Except as expressly set forth in this Agreement, Company makes no representations or warranties, express or implied or otherwise incorporated in this Agreement whether by statute, common law or otherwise, including without limitation, with respect to the Services, the quality of the Services, the results of the Services performed, including, without limitation, any warranties as to merchantability or fitness for a particular purpose, any warranties of correctness, completeness or accuracy, as well as any warranties arising from a course of dealing, usage or trade practice.
8. **Cooperation; Access.** You shall cooperate fully with Company to promptly provide any and all information reasonably requested by Company in connection with the performance of the Services. You shall provide Company with access to your property (and any other necessary premises), and provide Company with access to all required utilities, in order for Company to perform the Services. You shall cooperate with the Company, and provide the Company with such other access, cooperation and materials as the Company may request. Your property and premises shall be safe, shall be a suitable working condition, and shall be in compliance with all applicable laws, rules and regulations. Company may, without limiting any other rights or remedies available to Company, terminate this Agreement or suspend or delay performance of Services if You fail to comply with Your obligations under this Agreement.
9. **Indemnity; Limitations.** During the course of, and upon and after completion of the Services for any reason whatsoever, You agree to indemnify and hold Company and its members, managers, officers, employees, subcontractors, subsidiaries and affiliates harmless from and against any loss, liability, damage or expense whatsoever (including court costs and reasonable attorneys' fees) incident to any claim, action or proceedings against Company, or any member, manager, officer, employee, subcontractor, subsidiary or affiliate thereof, which arise out of or relate to, directly or indirectly, (a) any of Your actions or omissions that directly or indirectly cause any losses to the Company or that impact the timing, performance or quality of the Services; (b) any inaccurate or incomplete information provided by you to Company; (c) any breach of this Agreement by You; (d) any failure by You to adhere to any guidelines, recommendations or instructions from Company or any manufacturer or third party of any kind relating directly or indirectly to the Services or any equipment or materials used in connection with the Services; or (e) any other actions or omissions by You relating to the Services or this Agreement (including, without limitation, any fraud, negligence or misconduct). Company shall not be liable to You or any third party for any anticipated profits, special, indirect, punitive, incidental, lost profits, business interruption, loss of service, loss of business or consequential damages or penalties of any kind. Company's liability on any claim arising out of or relating to this Agreement or the performance of the Services or a breach of this Agreement shall in no case exceed the price paid by You to Company for the performance of the Services giving rise to the claim. You must commence any action against Company arising out of or relating to this Agreement, including, without limitation, for breach of this Agreement or any warranty associated with the Services, within one (1) year from the date the Services are completed by Company (or the termination of this Agreement, if earlier) or any such claim will be forever barred.
10. **Termination by Company.** Without limiting any other rights or remedies in this Agreement, You acknowledge and agree that Company may terminate this Agreement at any time without liability upon notification to You (in which event, You shall immediately pay Company for Services provided prior to the date of termination).
1. **Force Majeure; Unknown Conditions; Timing.** Company shall be excused from its obligations, and shall not be liable for any damages arising out of any delay or default in the performance of the Services, under this Agreement to the extent that any delay or failure in the performance of such obligations results from any cause beyond its reasonable control, including without limitation, performance by third parties, power failures, acts of God, acts of civil or military authority, embargoes, epidemics, pandemics, war, riots, acts of terrorism, severe weather conditions or labor problems. In the event Company determines that this Agreement cannot be performed as intended by the parties due to structural or other defects or conditions at or around Your property, Company may cancel this Agreement without liability upon notification to You (in which event, You shall immediately pay Company for Services provided prior to the date of termination). Any stated or estimated start date or estimated completion date set forth in this Agreement, if any, are merely estimates and are not a guarantee of performance by any certain date. Company shall not be liable for a failure to perform by or in accordance with any estimated dates, if any, set forth in this Agreement.
2. **Exclusivity.** You acknowledge and agree that Company shall be the sole and exclusive provider to You of the Services and any other services that are substantially similar to the Services, and You covenant and agree not to engage any other person or entity during the term of this Agreement to provide You with any Services which are the same as, or substantially similar to, the Services.
3. **Exclusions.** Without limiting any other rights or remedies of, or protections for the benefit of, Company, You acknowledge and agree that, unless otherwise specifically stated elsewhere in this Agreement, the Services do not include,

and Company shall not be responsible for or liable for, any claims, losses, damages or expenses in any way connected with, relating to or arising from, directly or indirectly, any of the following: (a) any guarantee of room conditions or system performance; (b) inspection, maintenance, repair, replacement of or services for: chilled water and condenser water pumps and piping; electrical disconnect switches or circuit breakers; motor starting equipment that is not factory mounted and interconnecting power wiring; recording or portable instruments, gauges or thermometers; non-moving parts or non-maintainable parts of the system, including, but not limited to, storage tanks; pressure vessels, shells, coils, tubes, housings, castings, casings, drain pans, panels, duct work; piping: hydraulic, hydronic, pneumatic, gas, or refrigerant; insulation; pipe covering; refractory material; fuses, unit cabinets; electrical wiring; ductwork or conduit; electrical distribution system; hydronic structural supports and similar items; the appearance of decorative casing or cabinets; damage sustained by other equipment or systems; and/or any failure, misadjustment or design deficiencies in other equipment or systems; (c) damage, repairs or replacement of parts made necessary as a result of electrical power failure, low voltage, burned out main or branch fuses, low water pressure, vandalism, misuse or abuse, wear and tear, end of life failure, water damage, improper operation, unauthorized alteration of equipment, accident, acts or omissions of You or others, damage due to freezing weather, calamity, malicious act, or any force majeure event; (d) any damage or malfunction resulting from vibration, electrolytic action, freezing, contamination, corrosion, erosion, or caused by scale or sludge on internal tubes except where water treatment protection services are provided by Company as part of this Agreement; (e) furnishing any items of equipment, material, or labor/, or performing special tests recommended or required by insurance companies or other third parties; (f) failure or inadequacy of any structure or foundation supporting or surrounding the equipment to be worked on or any portion thereof; (g) building access or alterations that might be necessary to repair or replace Your existing equipment; (h) The normal function of starting and stopping equipment or the opening and closing of valves, dampers or regulators normally installed to protect equipment against damage; (i) valves that are not factory mounted: balance, stop, control, and other valves external to the device; (j) any responsibility for design or redesign of any systems or equipment, obsolescence, safety tests, or removal or reinstallation of valve bodies and dampers; (k) any services, claims, or damages arising out of Your failure to comply with its obligations under this Agreement; (l) Your failure to follow manufacturer recommendations concerning teardown and internal inspection, overhaul and refurbishing of equipment; (m) any claims, damages, losses, or expenses, arising from or related to conditions that existed in, on, or upon the premises before the Services are provided, including, without limitation, damages, losses, or expenses involving pre-existing building envelope issues, mechanical issues, plumbing issues, and/or indoor air quality issues involving mold/mould and/or fungi; (n) replacement of refrigerant and other fluids / supplies is excluded, unless replacement of refrigerant or other fluid / supply is expressly stated as included within the Services, in which case replacement shall in no event exceed the stated percentage of rated system charge per year expressly stated in the Services; (o) crane or rigging costs; (p) any Services, claims, or damages arising out of refrigerant not supplied by Company. Further, You acknowledge and agree that You shall be solely and exclusively responsible for: (x) the cost of any additional replacement refrigerant, fluids or other supplies; (y) operation of any equipment; and (z) any claims, damages, losses, or expenses, arising from or related to work done by or services provided by individuals or entities that are not employed by or hired by Company

4. **Miscellaneous.** No provisions of this Agreement will be waived by any party except in writing, no waiver by any party of a breach shall be construed as a waiver of any subsequent breach by the same party. If any provision of this Agreement is held invalid or unenforceable, the remaining provisions and applications of this Agreement shall remain valid and enforceable. This Agreement may be amended or modified only by a written amendment duly signed by each of the parties. The relationship of the parties established by this Agreement is of independent contractors. You may not assign your rights under this Agreement without the prior written consent of Company. This Agreement shall be construed in accordance with the substantive laws of the State of Nebraska. Any controversy or claim arising out of or relating to this Agreement, or any breach thereof, must be brought in the appropriate state or federal courts located in Omaha, Douglas County, Nebraska. You waive any right you may have to a jury trial with respect to any litigation arising under or in connection with this Agreement, regardless of theory of recovery. This Agreement may be executed in two or more counterparts, each of which shall be deemed an original and all of which taken together shall constitute one and the same instrument. This Agreement may be executed and delivered by facsimile transmission, or by .pdf, .tif, .gif, .jpeg or similar attachment to electronic mail shall be treated in all manner and respects as an original executed counterpart and shall be considered to have the same binding legal effect as if it were the original signed version thereof delivered in person.
5. Due to the evolving nature of U.S. trade policies, including the potential for new or increased tariffs, import duties, or other governmental fees affecting materials and equipment sourced internationally, *Rutt's Heating & A/C, and all affiliated entities* (hereinafter referred to as "Rutt's") reserves the right to adjust contract pricing to reflect these changes. If such tariffs or fees are imposed or increased after contract execution, any additional costs incurred will be passed through to the **Customer**. For the purposes of this agreement, **Customer** shall be defined as any entity or individual contracting with Rutt's for services, equipment, or installation, including but not limited to general contractors, property owners,

developers, subcontractors (such as plumbers and electricians), or any other party responsible for payment under the terms of this contract. Rutt's will notify the Customer promptly of any adjustments and provide supporting documentation. By signing this agreement, the Customer acknowledges and accepts this potential price fluctuation.



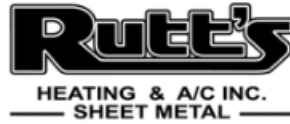

1001 W 1st St, Hastings, NE 68901

Company: Quail Run Golf Course  
Address: P.O. Box# 1677  
Columbus, NE 68601

Date: Mar 19, 2026  
Re: Replace 4-ton AHU and HP  
File Number: 100812  
Property: Quail Run Golf Course  
Address: 327 S. 5th Street  
Columbus, NE 68601

As requested, we are pleased to offer our proposal for the above referenced project as follows:

**SPECIFIC INCLUSIONS**

**Replace 4-ton AHU and HP**

Proposal to replace the large (4-ton) air handler and heat pump in the Pro Shop With a new 5-ton 15 SEER "Run Tru" by "Trane" system.

**Material Description**

- Run Tru A5AHC007A1D30A air handler
- Run Tru A5HP5060A1000A 5-ton 15 SEER heat pump
- 15kw heater package BAYHTR1517BRKA
- Filter rack BAYSF1235BAA
- Honeywell TH6320U2008 thermostat
- Refrigeration line set flush and repair
- Heat pump adjustable snow legs
- Condensate pipe
- Sheet metal to connect new system to existing duct  
reclaimer, recovery, filter drier, screws, sealer, etc.
- Shipping

**CLARIFICATIONS**

1. Our offer is firm for thirty days from the date listed above.
2. 50% down payment is required with the signed quote when equipment is being replaced, before equipment will be ordered. If paying by credit card, there will be a credit card surcharge fee of approximately 3% added to the invoice. To inquire about financing for new construction or direct replacements only, please contact our office at 402-463-4853.
3. Our offer is predicated upon a clear and accessible area that will be made available by others, where our work is to be performed.
4. Unless noted in the specific inclusions, our work will be performed during our normal business hours.

**SPECIFIC EXCLUSIONS**

1. Electrical work unless otherwise specified.
2. Refrigerant unless otherwise specified.

**Total Proposal as Outlined Above..... \$10,520.00**

Thank you,  
Kaylinn Nienhueser  
402-984-9369  
knien@ruttsheating.com

### ACCEPTANCE OF PROPOSAL

This proposal represents the entire agreement between the parties. There are no representations, promises or other understandings unless expressly included herein.

Customer Name and/or PO is needed: \_\_\_\_\_

Signature: \_\_\_\_\_

Date: \_\_\_\_\_

**Service Agreement Savings: \$**

### Additional Terms & Conditions

- 1. Services.** Subject to the terms and conditions set forth in the Agreement (as defined below), the counterparty identified in this Agreement (“You”) engage **RUTT'S HEATING AND AIR CONDITIONING, INC.** (“Company”) to provide, and the Company agrees to provide to You, only those services specifically described in this Agreement (“Services”).
- 2. Complete Agreement.** These additional terms and conditions are incorporated by reference into, and form an integral component of, the proposal, documentation or agreement provided to You by the Company (these additional terms and conditions, together with the proposal, documentation or agreement provided to You by the Company being, collectively, the “Agreement”). Company’s agreement to perform the Services is expressly conditioned on Your agreement with and acceptance of the express terms and conditions in this Agreement, as evidenced by your acceptance or signature of the Agreement. Neither this Agreement nor Your acceptance shall be deemed to include any additional or different terms proposed by You whether communicated orally or in writing that may add to, vary from or conflict with the terms of this Agreement, and Company expressly objects to any term or condition that may add to, vary from or conflict with the terms of this Agreement. You and Company shall mutually agree in writing upon any adjustment or change to the terms of the Services or this Agreement. Company shall not be responsible for any services or work not specifically listed in this Agreement.
- 3. Credit Approval.** This Agreement is subject to credit approval by Company. If the Company does not approve Your credit, or if the Company disapproves Your credit at any time during performance of the Services, Company may (in Company’s sole discretion, and at Company’s option), terminate this Agreement upon notice to You, delay or suspend performance of the Services without any liability, attempt to renegotiate any terms or conditions of this Agreement as Company may determine, and/or exercise any other rights or remedies available to Company. If Company elects, at any time to terminate this Agreement, then the Agreement shall terminate without any liability to Company and You shall immediately pay Company for Services provided prior to the date of termination along with any other costs or expenses incurred by Company in connection with, or in anticipation of, this Agreement and the Services.
- 4. Fees.** You shall pay Company all fees, costs, charges, expenses and other amounts (“Fees”) set forth in or contemplated in this Agreement. Unless otherwise specifically stated elsewhere in this Agreement, all Fees are calculated and determined based on Services being performed on business days and during normal business hours. Services performed on days other than business days and Services performed outside of normal business hours shall be performed at Company’s then-current overtime, holiday, weekend, evening or other applicable rates (as the same may be adjusted from time to time).
- 5. Taxes.** In addition to Fees, You shall pay Company all taxes and similar amounts or charges payable by the Company in connection with the Services and this Agreement.
- 6. Payment.** Unless otherwise specifically stated elsewhere in this Agreement, all payments (including Fees and taxes) are due immediately upon receipt of an invoice or similar document from Company. If payment is not made when due, Company’s remedies shall include, but not be limited to: (a) the assessment of a late charge of two percent (2%) per

month, or the highest rate permitted by law, whichever is less; (b) suspension of the Services until all payments due have been made; (c) termination of this Agreement; and/or (d) the filing and enforcement of a construction lien on Your property. You shall pay to Company upon demand all costs (including attorneys' fees) incurred by Company in collecting or attempting to collect amounts due or otherwise enforcing this Agreement.

7. **Warranties.** Company warrants that the Services shall be performed in a workmanlike manner. Except as expressly set forth in this Agreement, Company makes no representations or warranties, express or implied or otherwise incorporated in this Agreement whether by statute, common law or otherwise, including without limitation, with respect to the Services, the quality of the Services, the results of the Services performed, including, without limitation, any warranties as to merchantability or fitness for a particular purpose, any warranties of correctness, completeness or accuracy, as well as any warranties arising from a course of dealing, usage or trade practice.
8. **Cooperation; Access.** You shall cooperate fully with Company to promptly provide any and all information reasonably requested by Company in connection with the performance of the Services. You shall provide Company with access to your property (and any other necessary premises), and provide Company with access to all required utilities, in order for Company to perform the Services. You shall cooperate with the Company, and provide the Company with such other access, cooperation and materials as the Company may request. Your property and premises shall be safe, shall be a suitable working condition, and shall be in compliance with all applicable laws, rules and regulations. Company may, without limiting any other rights or remedies available to Company, terminate this Agreement or suspend or delay performance of Services if You fail to comply with Your obligations under this Agreement.
9. **Indemnity; Limitations.** During the course of, and upon and after completion of the Services for any reason whatsoever, You agree to indemnify and hold Company and its members, managers, officers, employees, subcontractors, subsidiaries and affiliates harmless from and against any loss, liability, damage or expense whatsoever (including court costs and reasonable attorneys' fees) incident to any claim, action or proceedings against Company, or any member, manager, officer, employee, subcontractor, subsidiary or affiliate thereof, which arise out of or relate to, directly or indirectly, (a) any of Your actions or omissions that directly or indirectly cause any losses to the Company or that impact the timing, performance or quality of the Services; (b) any inaccurate or incomplete information provided by you to Company; (c) any breach of this Agreement by You; (d) any failure by You to adhere to any guidelines, recommendations or instructions from Company or any manufacturer or third party of any kind relating directly or indirectly to the Services or any equipment or materials used in connection with the Services; or (e) any other actions or omissions by You relating to the Services or this Agreement (including, without limitation, any fraud, negligence or misconduct). Company shall not be liable to You or any third party for any anticipated profits, special, indirect, punitive, incidental, lost profits, business interruption, loss of service, loss of business or consequential damages or penalties of any kind. Company's liability on any claim arising out of or relating to this Agreement or the performance of the Services or a breach of this Agreement shall in no case exceed the price paid by You to Company for the performance of the Services giving rise to the claim. You must commence any action against Company arising out of or relating to this Agreement, including, without limitation, for breach of this Agreement or any warranty associated with the Services, within one (1) year from the date the Services are completed by Company (or the termination of this Agreement, if earlier) or any such claim will be forever barred.
10. **Termination by Company.** Without limiting any other rights or remedies in this Agreement, You acknowledge and agree that Company may terminate this Agreement at any time without liability upon notification to You (in which event, You shall immediately pay Company for Services provided prior to the date of termination).
1. **Force Majeure; Unknown Conditions; Timing.** Company shall be excused from its obligations, and shall not be liable for any damages arising out of any delay or default in the performance of the Services, under this Agreement to the extent that any delay or failure in the performance of such obligations results from any cause beyond its reasonable control, including without limitation, performance by third parties, power failures, acts of God, acts of civil or military authority, embargoes, epidemics, pandemics, war, riots, acts of terrorism, severe weather conditions or labor problems. In the event Company determines that this Agreement cannot be performed as intended by the parties due to structural or other defects or conditions at or around Your property, Company may cancel this Agreement without liability upon notification to You (in which event, You shall immediately pay Company for Services provided prior to the date of termination). Any stated or estimated start date or estimated completion date set forth in this Agreement, if any, are merely estimates and are not a guarantee of performance by any certain date. Company shall not be liable for a failure to perform by or in accordance with any estimated dates, if any, set forth in this Agreement.
2. **Exclusivity.** You acknowledge and agree that Company shall be the sole and exclusive provider to You of the Services and any other services that are substantially similar to the Services, and You covenant and agree not to engage any other person or entity during the term of this Agreement to provide You with any Services which are the same as, or substantially similar to, the Services.
3. **Exclusions.** Without limiting any other rights or remedies of, or protections for the benefit of, Company, You acknowledge and agree that, unless otherwise specifically stated elsewhere in this Agreement, the Services do not include,

and Company shall not be responsible for or liable for, any claims, losses, damages or expenses in any way connected with, relating to or arising from, directly or indirectly, any of the following: (a) any guarantee of room conditions or system performance; (b) inspection, maintenance, repair, replacement of or services for: chilled water and condenser water pumps and piping; electrical disconnect switches or circuit breakers; motor starting equipment that is not factory mounted and interconnecting power wiring; recording or portable instruments, gauges or thermometers; non-moving parts or non-maintainable parts of the system, including, but not limited to, storage tanks; pressure vessels, shells, coils, tubes, housings, castings, casings, drain pans, panels, duct work; piping: hydraulic, hydronic, pneumatic, gas, or refrigerant; insulation; pipe covering; refractory material; fuses, unit cabinets; electrical wiring; ductwork or conduit; electrical distribution system; hydronic structural supports and similar items; the appearance of decorative casing or cabinets; damage sustained by other equipment or systems; and/or any failure, misadjustment or design deficiencies in other equipment or systems; (c) damage, repairs or replacement of parts made necessary as a result of electrical power failure, low voltage, burned out main or branch fuses, low water pressure, vandalism, misuse or abuse, wear and tear, end of life failure, water damage, improper operation, unauthorized alteration of equipment, accident, acts or omissions of You or others, damage due to freezing weather, calamity, malicious act, or any force majeure event; (d) any damage or malfunction resulting from vibration, electrolytic action, freezing, contamination, corrosion, erosion, or caused by scale or sludge on internal tubes except where water treatment protection services are provided by Company as part of this Agreement; (e) furnishing any items of equipment, material, or labor/, or performing special tests recommended or required by insurance companies or other third parties; (f) failure or inadequacy of any structure or foundation supporting or surrounding the equipment to be worked on or any portion thereof; (g) building access or alterations that might be necessary to repair or replace Your existing equipment; (h) The normal function of starting and stopping equipment or the opening and closing of valves, dampers or regulators normally installed to protect equipment against damage; (i) valves that are not factory mounted: balance, stop, control, and other valves external to the device; (j) any responsibility for design or redesign of any systems or equipment, obsolescence, safety tests, or removal or reinstallation of valve bodies and dampers; (k) any services, claims, or damages arising out of Your failure to comply with its obligations under this Agreement; (l) Your failure to follow manufacturer recommendations concerning teardown and internal inspection, overhaul and refurbishing of equipment; (m) any claims, damages, losses, or expenses, arising from or related to conditions that existed in, on, or upon the premises before the Services are provided, including, without limitation, damages, losses, or expenses involving pre-existing building envelope issues, mechanical issues, plumbing issues, and/or indoor air quality issues involving mold/mould and/or fungi; (n) replacement of refrigerant and other fluids / supplies is excluded, unless replacement of refrigerant or other fluid / supply is expressly stated as included within the Services, in which case replacement shall in no event exceed the stated percentage of rated system charge per year expressly stated in the Services; (o) crane or rigging costs; (p) any Services, claims, or damages arising out of refrigerant not supplied by Company. Further, You acknowledge and agree that You shall be solely and exclusively responsible for: (x) the cost of any additional replacement refrigerant, fluids or other supplies; (y) operation of any equipment; and (z) any claims, damages, losses, or expenses, arising from or related to work done by or services provided by individuals or entities that are not employed by or hired by Company

4. **Miscellaneous.** No provisions of this Agreement will be waived by any party except in writing, no waiver by any party of a breach shall be construed as a waiver of any subsequent breach by the same party. If any provision of this Agreement is held invalid or unenforceable, the remaining provisions and applications of this Agreement shall remain valid and enforceable. This Agreement may be amended or modified only by a written amendment duly signed by each of the parties. The relationship of the parties established by this Agreement is of independent contractors. You may not assign your rights under this Agreement without the prior written consent of Company. This Agreement shall be construed in accordance with the substantive laws of the State of Nebraska. Any controversy or claim arising out of or relating to this Agreement, or any breach thereof, must be brought in the appropriate state or federal courts located in Omaha, Douglas County, Nebraska. You waive any right you may have to a jury trial with respect to any litigation arising under or in connection with this Agreement, regardless of theory of recovery. This Agreement may be executed in two or more counterparts, each of which shall be deemed an original and all of which taken together shall constitute one and the same instrument. This Agreement may be executed and delivered by facsimile transmission, or by .pdf, .tif, .gif, .jpeg or similar attachment to electronic mail shall be treated in all manner and respects as an original executed counterpart and shall be considered to have the same binding legal effect as if it were the original signed version thereof delivered in person.
5. Due to the evolving nature of U.S. trade policies, including the potential for new or increased tariffs, import duties, or other governmental fees affecting materials and equipment sourced internationally, *Rutt's Heating & A/C, and all affiliated entities* (hereinafter referred to as "Rutt's") reserves the right to adjust contract pricing to reflect these changes. If such tariffs or fees are imposed or increased after contract execution, any additional costs incurred will be passed through to the **Customer**. For the purposes of this agreement, **Customer** shall be defined as any entity or individual contracting with Rutt's for services, equipment, or installation, including but not limited to general contractors, property owners,

developers, subcontractors (such as plumbers and electricians), or any other party responsible for payment under the terms of this contract. Rutt's will notify the Customer promptly of any adjustments and provide supporting documentation. By signing this agreement, the Customer acknowledges and accepts this potential price fluctuation.



13.D.Quote from CDW Government in the total amount of \$49,097.62 for Microsoft 365 mailbox licenses.



## City of Columbus, Nebraska Purchase Request Form

**This form must be fully completed before any purchase, contract, or expenditure of City funds.**

**\*\*When sending to Finance: Subject line on email should read- "Purchase Request Form"**

|   | <b>AMOUNT: 49,097.62</b> |                   |                    |                     |          |
|---|--------------------------|-------------------|--------------------|---------------------|----------|
| <b>PROCESS:</b>                         | \$999 or less            | \$1,000 - \$4,999 | \$5,000 - \$24,999 | \$25,000 - \$74,999 | \$75,000 |
| Purchase Request Form                   |                          | X                 | X                  | X                   | X        |
| 2 Quotes                                |                          | X                 |                    |                     |          |
| Dept Head Approval                      |                          | X                 | X                  | X                   | X        |
| 3 Quotes                                |                          |                   | X                  | X                   |          |
| City Administrator Approval             |                          |                   | X                  | X                   | X        |
| Verification of Funds, Finance Director |                          |                   | X                  | X                   | X        |
| Form Bidding Required                   |                          |                   |                    |                     | X        |
| City Council Approval                   |                          |                   |                    | X                   | X        |

### 1. Requesters Information

Department / Division: Multiple

Requesting Employee: Matt Soukup

Supervisor: \_\_\_\_\_

Department Head: Besty Eckhardt

Date: 4/28/2026

### 2. Type of Purchase

Goods / Supplies / Equipment

Contractual Services

Professional Services (QBS)

Construction / Capital Improvement

Emergency Purchase

### 3. Purchase Description:

*Fully describe the goods or services and their purpose.*

Licenses for Microsoft 365 email subscription accounts.

**4. Selected Vendor Information:**

Vendor Name: CDW-G Contact Name: Mike Elliott  
Phone: (877) 459-7057 Email: mike.elliott@cdwg.com  
Cooperative Purchasing (State Contract, Sourcwell, etc.):  Yes  No

**5. Cost & Budget:**

Total Cost: 49,097.62  
Account Number(s): Multiple Departments Computer Support/Maint  
Funds Available:  Yes  No

**6. Number of Quotes obtained:** 1

**If this is a sole source quote please explain:**

Sourcewell State of Nebraska software pricing

**7. Approvals**

Supervisor / Designee: Matt J Soehner Date: 4/28/2026  
Department Head: Betsy Eckhardt Date: 04/28/2026  
City Administrator (if \$5,000+): [Signature] Date: 4/29/26  
City Council Resolution (if \$25,000+): \_\_\_\_\_  
Verification of Funds:  
Finance Director (if \$5,000+): Christopher A. Nguyen Date: \_\_\_\_\_

**AS NEEDED: Description of Emergency Purchases**

An "emergency" shall be defined as any event that interrupts the normal administration of municipal services, thereby jeopardizing the life, health of citizens.

*Describe emergency circumstances and justification.*



Thank you for choosing CDW. We have received your quote.

Hardware Software Services IT Solutions Brands Research Hub

# QUOTE CONFIRMATION

### Pricing and Availability Notice

Due to ongoing supply chain challenges, some hardware manufacturers cannot guarantee product availability or pricing until the product is shipped. While we make every effort to honor quoted pricing, if a hardware manufacturer increases its price to CDW after a quote is issued or order is accepted, we may need to update your quoted price to reflect that change irrespective of any timeframes or validity periods set forth in the quote, including up to the date of shipment. In the event of a price adjustment, we will notify you prior to shipment. Any price adjustment would only occur if the hardware manufacturer increases its pricing to CDW.

**MATT SOUKUP,**

Thank you for considering CDW•G for your technology needs. The details of your quote are below. **If you are an eProcurement or single sign on customer, please log into your system to access the CDW site.** You can search for your quote to retrieve and transfer back into your system for processing.

For all other customers, click below to convert your quote to an order.

**Convert Quote to Order**

| QUOTE # | QUOTE DATE | QUOTE REFERENCE | CUSTOMER # | GRAND TOTAL        |
|---------|------------|-----------------|------------|--------------------|
| PWDC326 | 4/23/2026  | PWDC326         | 3896862    | <b>\$39,248.02</b> |

### QUOTE DETAILS

| ITEM   | QTY | CDW#    | UNIT PRICE | EXT. PRICE  |
|--|-----|---------|------------|-------------|
| <a href="#">GOV MS MPSA S U M365 G3</a>                            | 98  | 5765609 | \$400.49   | \$39,248.02 |
| Mfg. Part#: AAD-38071-CCD-12MO                                     |     |         |            |             |
| Electronic distribution - NO MEDIA                                 |     |         |            |             |
| Contract: Sourcewell 121923-State of Nebraska Software (111216 04) |     |         |            |             |

|                    |                    |
|--------------------|--------------------|
| <b>SUBTOTAL</b>    | \$39,248.02        |
| <b>SHIPPING</b>    | \$0.00             |
| <b>SALES TAX</b>   | \$0.00             |
| <b>GRAND TOTAL</b> | <b>\$39,248.02</b> |

| PURCHASER BILLING INFO  | DELIVER TO  |
|---|---|
| <b>Billing Address:</b><br>CITY OF COLUMBUS<br>ACCTS PAYABLE<br>2500 14TH ST STE 3<br>COLUMBUS, NE 68601-4958<br><b>Phone:</b> (402) 562-4242<br><b>Payment Terms:</b> Net 30 Days-Govt State/Local | <b>Shipping Address:</b><br>CITY OF COLUMBUS<br>MATT SOUKUP<br>2424 14TH ST<br>COLUMBUS, NE 68601-5038<br><b>Shipping Method:</b> ELECTRONIC DISTRIBUTION |

**Please remit payments to:**

CDW Government  
75 Remittance Drive  
Suite 1515  
Chicago, IL 60675-1515



**Sales Contact Info**

**Mike Elliott** | (877) 459-7057 | [mike.elliott@cdwg.com](mailto:mike.elliott@cdwg.com)

**Need Help?**



My Account



Support



Call 800.800.4239

[About Us](#) | [Privacy Policy](#) | [Terms and Conditions](#)

This order is subject to CDW's Terms and Conditions of Sales and Service Projects at <http://www.cdwg.com/content/terms-conditions/product-sales.aspx>  
For more information, contact a CDW account manager.

© 2026 CDW•G LLC, 200 N. Milwaukee Avenue, Vernon Hills, IL 60061 | 800.808.4239



Thank you for choosing CDW. We have received your quote.

Hardware Software Services IT Solutions Brands Research Hub

# Subscription Quote Confirmation

### Pricing and Availability Notice

Due to ongoing supply chain challenges, some hardware manufacturers cannot guarantee product availability or pricing until the product is shipped. While we make every effort to honor quoted pricing, if a hardware manufacturer increases its price to CDW after a quote is issued or order is accepted, we may need to update your quoted price to reflect that change irrespective of any timeframes or validity periods set forth in the quote, including up to the date of shipment. In the event of a price adjustment, we will notify you prior to shipment. Any price adjustment would only occur if the hardware manufacturer increases its pricing to CDW.

**MATT SOUKUP,**

Thank you for choosing CDW for your subscription service needs. The details of your quote are below.

| Quote # | Quote Date     | PO #   | CUSTOMER # |
|---------|----------------|--------|------------|
| PWGL459 | April 28, 2026 | 260428 | 3896862    |

### Quote Details

| ITEM                  | QTY | UNIT PRICE   | Item Total     |
|-----------------------|-----|--------------|----------------|
| <b>NGE M365 F3 G</b>  |     |              |                |
| <b>CDW #: 7980788</b> |     |              |                |
| NGE M365 F3 A         | 108 | \$91.20/Year | \$9849.60/Year |

**Annual Fee** \$9,849.60/Year  
**Minimum Contract Annual Total\*** **\$9,849.60**

\*Tax will be calculated at the time of invoicing.

### Addon Details - Estimate Items Cost based on Usage\*\*

| Item                                 | Qty | Unit Price   | Item Total  |
|--------------------------------------|-----|--------------|-------------|
| NGE Support A                        | 108 | \$0.00/Year  | \$0.00/Year |
| NGE Migration and Supported Backup A | 0   | \$51.00/Year | \$0.00/Year |
| NGE Standalone Backup w Support A    | 0   | \$27.60/Year | \$0.00/Year |
| NGE Onboard A                        | 108 | \$0.00/Year  | \$0.00/Year |

**Monthly Fee** \$0.00/Year  
**Estimated Additional Annual Total\*** \$0.00  
**Estimated Annual Grand Total** **\$9,849.60**

Billing and Payment Info

**Billing Address**

2500 14TH ST STE 3, COLUMBUS, NE 68601-4958

**Payment Type**

NET 30-VERBAL

**Address of Use**

2424 14TH ST, COLUMBUS, NE 68601-5038

**Subscription Contact Details**

|                          |              |  |
|--------------------------|--------------|--|
| <b>Business Contact</b>  | <b>Name</b>  | MATT SOUKUP  |
|                          | <b>Email</b> | <a href="mailto:matt.soukup@columbusne.us">matt.soukup@columbusne.us</a> |
|                          | <b>Phone</b> | (402) 562-4242   |
| <b>Technical Contact</b> | <b>Name</b>  | MATT SOUKUP  |
|                          | <b>Email</b> | <a href="mailto:matt.soukup@columbusne.us">matt.soukup@columbusne.us</a> |
|                          | <b>Phone</b> | (402) 562-4242   |



**Sales Contact Info**

**Mike Elliott** | (312) 547-2237 | [mike.elliott@cdwg.com](mailto:mike.elliott@cdwg.com)

Need Help?



[My Account](#)



[Support](#)



[Call 800.800.4239](tel:800.800.4239)

[About Us](#) | [Privacy Policy](#) | [Terms and Conditions](#)

This email was sent by CDW LLC. All information and offers are subject to the CDW Terms and Conditions, and CDW policies.

CDW®, CDW•G® and PEOPLE WHO GET IT® are registered trademarks of CDW LLC. All other trademarks and registered trademarks are the sole property of their respective owners.

This email was sent to [mike.elliott@cdwg.com](mailto:mike.elliott@cdwg.com). Please add [cdwsales@cdwemail.com](mailto:cdwsales@cdwemail.com) to your address book.

© 2026 CDW•G LLC, 200 N. Milwaukee Avenue, Vernon Hills, IL 60061 | 800.808.4239

SPS-OC:002 | | SPS 205 | Customer#: 3896862

13.E. Quote from Hydro-Klean, LLC in the amount of \$42,515.93 for storm sewer cleaning.  
CIP #21-96



## City of Columbus, Nebraska Purchase Request Form

**This form must be fully completed before any purchase, contract, or expenditure of City funds.**

**\*\*When sending to Finance: Subject line on email should read- "Purchase Request Form"**

|   | <b>AMOUNT: 50,000</b> |                   |                    |                     |          |
|---|-----------------------|-------------------|--------------------|---------------------|----------|
| <b>PROCESS:</b>                         | \$999 or less         | \$1,000 - \$4,999 | \$5,000 - \$24,999 | \$25,000 - \$74,999 | \$75,000 |
| Purchase Request Form                   |                       | X                 | X                  | X                   | X        |
| 2 Quotes                                |                       | X                 |                    |                     |          |
| Dept Head Approval                      |                       | X                 | X                  | X                   | X        |
| 3 Quotes                                |                       |                   | X                  | X                   |          |
| City Administrator Approval             |                       |                   | X                  | X                   | X        |
| Verification of Funds, Finance Director |                       |                   | X                  | X                   | X        |
| Form Bidding Required                   |                       |                   |                    |                     | X        |
| City Council Approval                   |                       |                   |                    | X                   | X        |

### 1. Requesters Information

Department / Division: Public Works

Requesting Employee: C Sliva

Supervisor: \_\_\_\_\_

Department Head: Chuck sliva

Date: 4/28/2026

### 2. Type of Purchase

Goods / Supplies / Equipment

Contractual Services

Professional Services (QBS)

Construction / Capital Improvement

Emergency Purchase

### 3. Purchase Description:

*Fully describe the goods or services and their purpose.*

**4. Selected Vendor Information:**

Vendor Name: Hrdro Klean Contact Name: \_\_\_\_\_  
Phone: 515-283-0500 Email: Aunderwood@HKsolutions.com  
Cooperative Purchasing (State Contract, Sourcwell, etc.):  Yes  No

**5. Cost & Budget:**

Total Cost: \$50,000.00  
Account Number(s): 560-57510-21096  
Funds Available:  Yes  No

**6. Number of Quotes obtained:** Three, asked for four

**If this is a sole source quote please explain:**

**7. Approvals**

Supervisor / Designee: \_\_\_\_\_ Date: \_\_\_\_\_  
Department Head: Chuck Sliva Date: 4/28/2026  
City Administrator (if \$5,000+): [Signature] Date: 4/29/26  
City Council Approval (if \$25,000+): \_\_\_\_\_  
Verification of Funds:  
Finance Director (if \$5,000+): Christopher A. Nguyen Date: 04/29/26

**AS NEEDED: Description of Emergency Purchases**

An "emergency" shall be defined as any event that interrupts the normal administration of municipal services, thereby jeopardizing the life, health of citizens.

*Describe emergency circumstances and justification.*



Hydro-Klean, LLC  
 333 NW 49th Place  
 Des Moines, IA, 50313  
 Phone: 515-283-0500

## Quote

Quote Nbr.: PQ009355  
 Order Date: 04/21/2026  
 Valid Until: 07/20/2026  
 Sales Person: Alex Underwood  
 Customer ID: 105627  
 Payment Terms:

| Job Site:   |
|---|
| City of Columbus, NE<br>Columbus NE<br>United States of America |

| Bill to:  |
|---|
| City of Columbus, NE<br>Columbus NE<br>United States of America |

### Job Description

Per unit and time and materials cost (if applicable) to conduct the Pipeline Inspection and Proactive Evaluation program as described to the customer. Pricing is conditional to the acceptance and execution of the Pipeline Inspection and Proactive Evaluation Service Agreement.

HK Solutions Group will perform cleaning on 12,683 LF of storm sewer line, along with cleaning of 108 catch basin and 73 manholes.

Any pipe segment that is <25% full will require heavy cleaning (3 passes or more).

Pricing does not include bonding fees, applicable taxes, or any special permits.

Pricing does not include prevailing wage rates, if applicable.

| RESC. QTY. | ITEM                              | QTY.        | UOM  | PRICE    | Amount    |
|------------|-----------------------------------|-------------|------|----------|-----------|
|            | Cleaning (Storm Sewer)            | 12,683.0000 | FOOT | 2.7100   | 34,370.93 |
|            | Cleaning (Catch Basins)           | 108.0000    | EACH | 45.0000  | 4,860.00  |
|            | Cleaning (Manholes)               | 73.0000     | EACH | 45.0000  | 3,285.00  |
|            | Heavy Cleaning (3 or more passes) | 0.0000      | HOUR | 440.0000 | 0.00      |

\*NOTE: Quote does not include any applicable taxes

Prepared By: Alex Underwood  
 Approved By: Michael Ingham

Accepted By: \_\_\_\_\_  
 Date: \_\_\_\_\_  
 PO#: \_\_\_\_\_

\*Quote Total: 42,515.93



P O Box 581  
Columbus, NE 68602-0581  
402-564-2804  
402-562-7950 Fax

4-21-26

City of Columbus Storm Sewer Cleaning

To complete this work per the plan and outline for the sum of \$55,275.00.

Thanks for the opportunity to bid on your project.

John



PO Box 1065  
 Kearney, NE 68848  
 (308) 237-6651 / (308) 440-8464  
 bretm@midlandscontracting.com

# Estimate

**ESTIMATE#** 1086969884  
**DATE** 04/09/2026  
**PO#**

### CUSTOMER

CITY OF COLUMBUS  
 P O BOX 1677  
 COLUMBUS NE 68602  
 (402) 562-4236

### SERVICE LOCATION

P O BOX 1677  
 COLUMBUS NE 68602  
 sliva@columbusne.us

**DESCRIPTION** 2026 Storm Sewer Cleaning Quotes

### ESTIMATE

- Mobilization (LS)  
  
**Qty: 1.00 x \$1,000.00 = \$1,000.00**
- Clean Storm Sewer Laterals and 12" (per LF)  
  
**Qty: 4613.00 x \$4.25 = \$19,605.25**
- Clean Storm Sewer - 15" - 18" (per LF)  
  
**Qty: 3349.00 x \$5.50 = \$18,419.50**
- Clean Storm Sewer - 21" (per LF)  
  
**Qty: 775.00 x \$6.50 = \$5,037.50**
- Clean Storm Sewer - 24" (per LF)  
  
**Qty: 1154.00 x \$8.00 = \$9,232.00**
- Clean Storm Sewer - 30" (per LF)  
  
**Qty: 857.00 x \$12.00 = \$10,284.00**
- Clean Storm Sewer - 58" (per LF)  
  
**Qty: 928.00 x \$15.00 = \$13,920.00**
- Clean Storm Sewer - Box (per LF)  
  
**Qty: 400.00 x \$20.00 = \$8,000.00**
- Clean Storm Sewer - Unknown (per LF)  
  
**Qty: 607.00 x \$10.00 = \$6,070.00**

### ESTIMATE 1

- Mobilization (LS)  
  
**Qty: 1.00 x \$1,000.00 = \$1,000.00**
- Clean and Vacuum Storm Sewer - (per HR)  
  
**Qty: 0.00 x \$475.00 = \$0.00**
- CCTV Storm sewer after cleaning (per LF) if requested  
  
**Qty: 0.00 x \$1.00 = \$0.00**

- Clean Storm Sewer - Manhole/Inlet (per EA)

**Qty: 181.00 x \$100.00 = \$18,100.00**

- CCTV Storm Sewer after Cleaning (per LF) if requested

**Qty: 0.00 x \$1.00 = \$0.00**

**\$109,668.25**

**\$1,000.00**

| ESTIMATE   | CUSTOMER MESSAGE  |
|--|---|
| <p>CLARIFICATIONS: -Quote valid for 120 days. -We require the City to locate, expose, and provide access to all service points (manholes, cleanouts, etc.) -City shall provide water for jetting and a waste disposal site. -JSC will provide basic cones and signs for traffic control, any additional traffic control needed will be the responsibility of the City. -Work will be billed complete by 9/7/26. -All areas provided by City via email on 4/2/26 will be completed under this option.</p> | <p><b>ESTIMATE 1</b></p> <p>CLARIFICATIONS: -Quote valid for 120 days. -We require the City to locate, expose, and provide access to all service points (manholes, cleanouts, etc.) -City shall provide water for jetting and a waste disposal site. -JSC will provide basic cones and signs for traffic control, any additional traffic control needed will be the responsibility of the City. -Work will be billed complete by 9/7/26. -City can designate a dollar amount for us to work up to and we will stop once that budget amount is hit based on total working hours and CCTV footage. This option does not guarantee completion of all areas provided on City maps via email 4/2/26.</p> |

13.F. Comments from mayor and city council members.

14. **RESOLUTIONS**

14.A. Resolution No. R26-63 approving permanent sidewalk easement located at 33rd Avenue and 21st Street.

DRAFT

**RESOLUTION NO. R26-63**

A RESOLUTION OF THE MAYOR AND COUNCIL OF THE CITY OF COLUMBUS, NEBRASKA, APPROVING AN AGREEMENT FOR A SIX-FOOT PERMANENT SIDEWALK EASEMENT BY BANK OF CLARKS, COLUMBUS LOCATION, BEING THE WEST SIX FEET OF THAT PART OF LOT 8, BLOCK 4, EVANLAWN ADDITION TO THE CITY OF COLUMBUS, PLATTE COUNTY, NEBRASKA, NOT WITHIN STATE OF NEBRASKA DEPARTMENT OF TRANSPORTATION US HIGHWAY 30 AND 81 RIGHT-OF-WAY, A COPY OF WHICH IS ATTACHED HERETO AND INCORPORATED HEREIN BY THIS REFERENCE, AND TO REPEAL ALL RESOLUTIONS OR PORTIONS THEREOF IN CONFLICT HEREWITH.

BE IT RESOLVED BY THE MAYOR AND COUNCIL OF THE CITY OF COLUMBUS, NEBRASKA, that the agreement for a permanent sidewalk easement by Bank of Clarks, Columbus location, being the west six feet of that part of Lot 8, Block 4, Evanlawn Addition to the City of Columbus, Platte County, Nebraska, not within State of Nebraska Department of Transportation US Highways 30 and 81 right-of-way, a copy of which is attached hereto and incorporated herein by this reference, executed by Bank of Clarks, be approved by the City of Columbus, Nebraska.

This resolution shall repeal all resolutions or portions thereof in conflict herewith.

INTRODUCED BY COUNCIL MEMBER \_\_\_\_\_

PASSED AND ADOPTED THIS \_\_\_\_ DAY OF \_\_\_\_\_, 2026.

\_\_\_\_\_  
MAYOR

ATTEST:

\_\_\_\_\_  
CITY CLERK

APPROVED AS TO FORM:

\_\_\_\_\_  
CITY ATTORNEY

Once Recorded Return To: City of Columbus, Engineering Department, 2500 14<sup>th</sup> Street,  
Ste. 3, Columbus, NE 68601

**SIDEWALK EASEMENT**

THIS SIDEWALK EASEMENT ("Easement") is entered into as of the Effective Date by and between **Bank of Clarks, Columbus Location**, ("Grantor") and **the City of Columbus, a Municipal Corporation in the State of Nebraska**, ("Grantee"). The Effective Date of this Easement shall be the date upon which the last of the parties has signed this Easement.

WHEREAS, Grantor is the owner of certain real property located in Platte County, Nebraska, as legally described as follows (the "Grantor Parcel ");

A six-foot sidewalk easement being the west six feet of that part of Lot 8, Block 4, Evanlawn Addition to the City of Columbus, Platte County, Nebraska, not within Nebraska Department of Transportation Highway 30 and 81 Right-of-Way.

WHEREAS, the Grantor Parcel is immediately adjacent to State of Nebraska right of way known as US Highways 30/81(33<sup>rd</sup> Avenue) in Columbus, Nebraska;

WHEREAS, Grantee has requested and Grantor has agreed to grant Grantee a sidewalk easement over the Grantor Parcel legally described and depicted on Exhibit A attached hereto and incorporated herein by this reference (the " Easement Area") upon the terms and conditions set forth herein.

NOW, THEREFORE, for and in consideration of the mutual promises, covenants and agreements contained herein and for other good and valuable consideration, the receipt and sufficiency of which are hereby conclusively acknowledged, Grantor and Grantee agree as follows:

1. **Grant of Easement.** Grantor hereby grants and conveys unto Grantee and the public a perpetual easement for a sidewalk, upon and through the Easement Area (the "Easement"). Grantor shall remain responsible for all maintenance and snow removal.
2. **Term.** The Term of the Sidewalk Easement shall be perpetual. The Sidewalk Easement is and shall be deemed to be a covenant running with the land and shall be binding upon the parties hereto and upon their successors and assigns. Any modification or amendment shall be effective when duly executed, acknowledged and recorded in the Office of the Register of Deeds of Platte County, Nebraska.

3. Governing Law and Venue. This Easement shall be governed by, and construed and enforced in accordance with, the laws of the State of Nebraska.
4. Entire Agreement. Each party acknowledges that it has read and fully understands the contents of this Easement. This Easement represents the entire and integrated agreement between the parties with respect to the subject matter hereof and supersedes all prior negotiations, representations or agreements, either written or oral. This Easement may be modified only by written instrument duly authorized and executed by all parties.

CITY OF COLUMBUS, a Municipal Corporation in the State of Nebraska, Grantee.

\_\_\_\_\_  
By: James B. Bulkley, Mayor

Grantor:

  
John M. DuBray III, President  
Bank of Clarks

STATE OF NEBRASKA    )  
  ) SS.  
COUNTY OF PLATTE    )

The foregoing instrument was acknowledged before me on Month April 28 2026 by **John M. DuBray III, President Bank of Clarks**

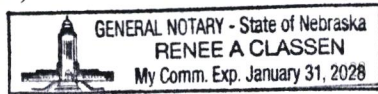

Notary Public 

STATE OF NEBRASKA    )  
  ) SS.  
COUNTY OF PLATTE    )

The foregoing instrument was acknowledged before me on Month \_\_\_\_\_ 2026 by **James B. Bulkley, Mayor of City of Columbus.**

\_\_\_\_\_  
Notary Public

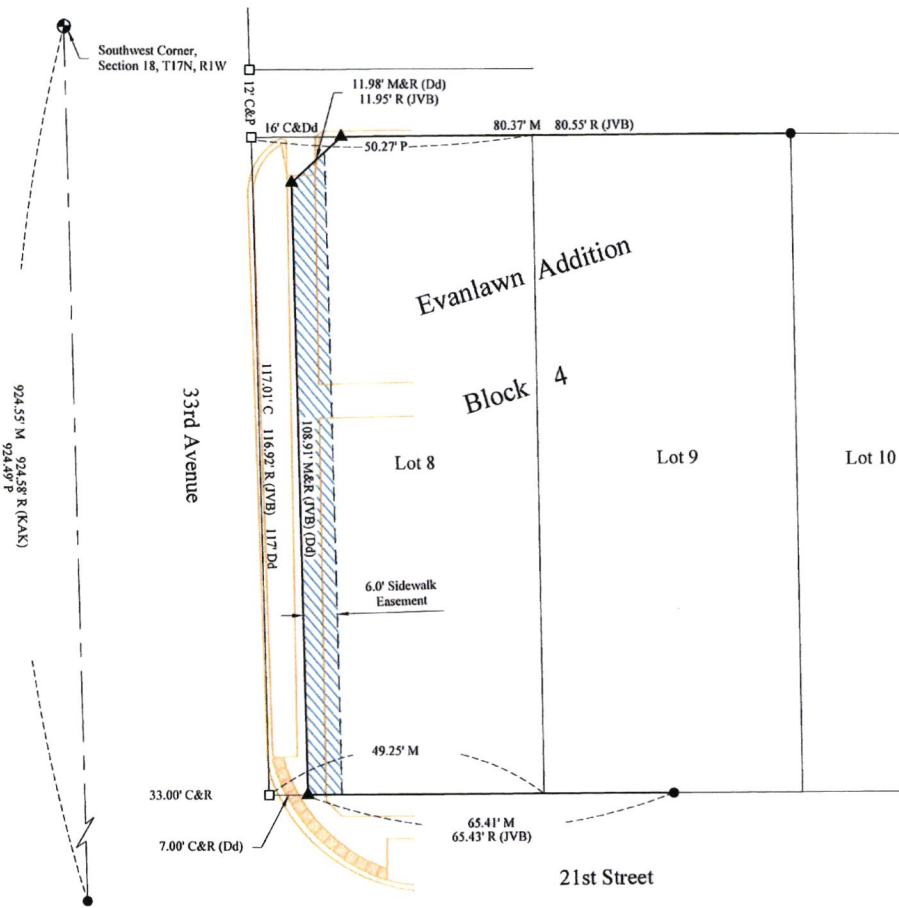

Drawn By: LRR  
Date: April 14, 2026  
Project Number: S-071-178  
Scale: 1" = 20'

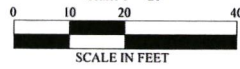

**LEGEND**

- Section Corner Found
- Property Corner Found
- ▲ Property Corner Found (Mag-Spike w/Washer)
- Calculated Point
- M Measured Distance
- C Calculated Distance
- R Recorded Distance (KAK) Kent A. Kennedy, LS #521, dated January 4, 2013. (TAT) Thomas A. Tremel, LS #455, dated April 21, 1990. (JVB) John V. Berry, LS #535, dated September 9, 1996. (Dd) Deed Book #229, Page 1041.

**SIDEWALK EASEMENT**

A six foot sidewalk easement being the west six feet of that part of Lot 8, Block 4, Evanlawn Addition to the City of Columbus, Platte County, Nebraska, not within Nebraska Department of Transportation Highway 30 and 81 Right-of-Way.

**SURVEYOR'S CERTIFICATE**

I, Terry L. Schulz, Nebraska Registered Land Surveyor No. 550, duly registered under the Land Surveyor's Regulation Act, do hereby state that I have performed a survey of the land depicted on the accompanying plat; that said plat is a true delineation of said survey performed personally or under my direct supervision; that said survey was made with reference to known and recorded monuments marked as shown, and to the best of my knowledge and belief is true, correct and in accordance with the Land Surveyor's Regulation Act in effect at the time of this survey.

*Terry L. Schulz*  
Terry L. Schulz, State of Nebraska, LS #550

4-14-2026  
Date



**ADVANCED CONSULTING ENGINEERING SERVICES**  
West Point & Columbus  
Phone: (402) 372-1923

14.B. Resolution No. R26-64 approving drainage easement located west of Grayhawk Place cul-de-sac.

**RESOLUTION NO. R26-64**

A RESOLUTION OF THE MAYOR AND COUNCIL OF THE CITY OF COLUMBUS, NEBRASKA, APPROVING THE AGREEMENT FOR A DRAINAGE EASEMENT LOCATED IN THE SOUTH 1/2 OF THE NORTHEAST 1/4 OF SECTION 11, T17N, R1W OF THE 6TH P.M., PLATTE COUNTY, NEBRASKA, MORE PARTICULARLY DESCRIBED AS FOLLOWS: COMMENCING AT THE SOUTHWEST CORNER OF LOT 12, BLOCK A, MEADOW RIDGE TWELFTH ADDITION TO THE CITY OF COLUMBUS, PLATTE COUNTY, NEBRASKA; THENCE N 01°42'52" W ON THE WEST LINE OF SAID LOT 12, 10.00 FEET TO THE POINT OF BEGINNING; THENCE N 01°42'52" W ON THE WEST LINE OF SAID LOT 12, 36.00 FEET; THENCE S 88°06'52" W, 706.97 FEET; THENCE S 02°13'38" E, 36.00 FEET; THENCE N 88°06'52" E, 706.65 FEET TO THE POINT OF BEGINNING, CONTAINING 0.58 ACRES, MORE OR LESS, A COPY OF WHICH IS ATTACHED HERETO AND INCORPORATED HEREIN BY THIS REFERENCE; AND TO REPEAL ALL RESOLUTIONS OR PORTIONS THEREOF IN CONFLICT HEREWITH.

BE IT RESOLVED BY THE MAYOR AND COUNCIL OF THE CITY OF COLUMBUS, NEBRASKA, that the agreement with Meadow Ridge Properties, LLC, for a drainage easement located in the South 1/2 of the Northeast 1/4 of Section 11, T17N, R1W of the 6th p.m., Platte County, Nebraska, more particularly described as follows: Commencing at the Southwest corner of lot 12, Block A, Meadow Ridge Twelfth Addition to the City of Columbus, Platte County, Nebraska; thence N 01°42'52" W on the West line of said Lot 12, 10.00 feet to the point of beginning; thence N01°42'52" W on the West line of said lot 12, 36.00 feet; thence S 88°06'52" W, 706.97 feet; thence S 02°13'38" E, 36.00 feet; thence N 88°06'52" E, 706.65 feet to the point of beginning, containing 0.58 acres, more or less, as stated in the Easement Agreement, a copy of which is attached hereto and incorporated herein by this reference, executed by Meadow Ridge Properties, LLC, be approved by the City of Columbus, Nebraska.

This resolution shall repeal all resolutions or portions thereof in conflict herewith.

INTRODUCED BY COUNCIL MEMBER \_\_\_\_\_

PASSED AND ADOPTED THIS \_\_\_\_ DAY OF \_\_\_\_\_, 2026.

\_\_\_\_\_  
MAYOR

APPROVED AS TO FORM:

ATTEST:

\_\_\_\_\_  
CITY ATTORNEY

\_\_\_\_\_  
CITY CLERK

EASEMENT AGREEMENT

THIS EASEMENT AGREEMENT made and entered into on 28<sup>th</sup> day of April, 2026 by and between Meadow Ridge Properties, LLC, herein "Grantor", and the City of Columbus, Nebraska, a Nebraska Municipal Corporation, herein "Grantee".

Grantor hereby grants and conveys to Grantee, its successors, assigns, employees, agents, contractors, invitees and licensees a drainage easement over and upon the following-described real estate, to-wit:

**Drainage Easement**

A 36.00 foot wide Drainage Easement for a drainage ditch and all of its appurtenances, located in part of the NW1/4 NE1/4 of Section 14, Township 17 North, Range 1 West of the 6th P.M., Platte County, Nebraska more particularly described as follows:

A DRAINAGE EASEMENT LOCATED IN THE SOUTH 1/2 OF THE NORTHEAST 1/4 OF SECTION 11, T17N, R1W OF THE 6TH P.M., PLATTE COUNTY, NEBRASKA, MORE PARTICULARLY DESCRIBED AS FOLLOWS: COMMENCING AT THE SOUTHWEST CORNER OF LOT 12, BLOCK A, MEADOW RIDGE TWELFTH ADDITION TO THE CITY OF COLUMBUS, PLATTE COUNTY, NEBRASKA; THENCE N 01°42'52" W ON THE WEST LINE OF SAID LOT 12, 10.00 FEET TO THE POINT OF BEGINNING; THENCE N 01°42'52" W ON THE WEST LINE OF SAID LOT 12, 36.00 FEET; THENCE S 88°06'52" W, 706.97 FEET; THENCE S 02°13'38" E, 36.00 FEET; THENCE N 88°06'52" E, 706.65 FEET TO THE POINT OF BEGINNING, CONTAINING 0.58 ACRES, MORE OR LESS.

The Easement is further described and defined on the map attached hereto marked **EXHIBIT A**, and incorporated herein by reference.

The purpose of the drainage easement is to provide drainage to and from adjoining properties across said drainage easement area described above, to the Grantee, its successors, assigns, employees, agents, contractors, invitees, and licensees, with access to the aforementioned described real estate for the purpose of inspection, maintenance, operation, or repair of drainage facilities and related improvements, and removal of vegetation and hazards, over, across, in, and through the easement area, all at the will of the Grantee. Grantee, its successors, assigns, employees, agents, contractors, invitees, and licensees, is further hereby granted the right of ingress and egress to and from said premises to carry out the rights prescribed in this easement.

\*\*\*\*\*REMAINDER OF PAGE LEFT INTENTIONALLY BLANK\*\*\*\*\*

The Grantor has executed this Drainage Easement on the day and year first above written.

Meadow Ridge Properties, LLC,  
GRANTOR,

By   
Charles Seadschlag, Authorized Member

STATE OF NEBRASKA    )  
  ) ss.  
COUNTY OF PLATTE    )

Acknowledged before me on April 28<sup>th</sup>, 2026, by Charles Seadschlag, Authorized Member of Meadow Ridge Properties, LLC.

  
Notary Public

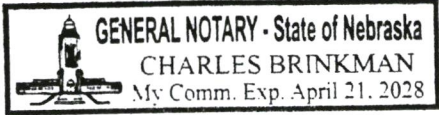

City of Columbus, Nebraska,  
GRANTEE,

By \_\_\_\_\_  
James B. Bulkley, Mayor

STATE OF NEBRASKA    )  
  ) ss.  
COUNTY OF PLATTE    )

Acknowledged before me on \_\_\_\_\_, 2026, by James B. Bulkley, Mayor, City of Columbus, Nebraska.

\_\_\_\_\_  
Notary Public



Drawn By: LRR  
 Date: April 14, 2026  
 Scale: 1"=50'  
 Project Number: S-071-187



● Property Corner Found  
 M Measured Distance

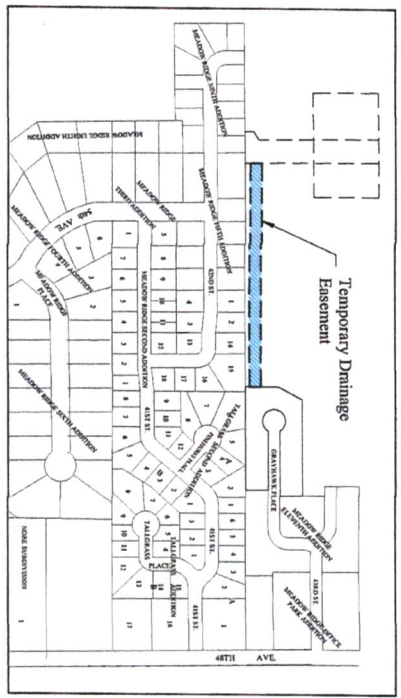

Existing 100' Temporary Drainage Easement

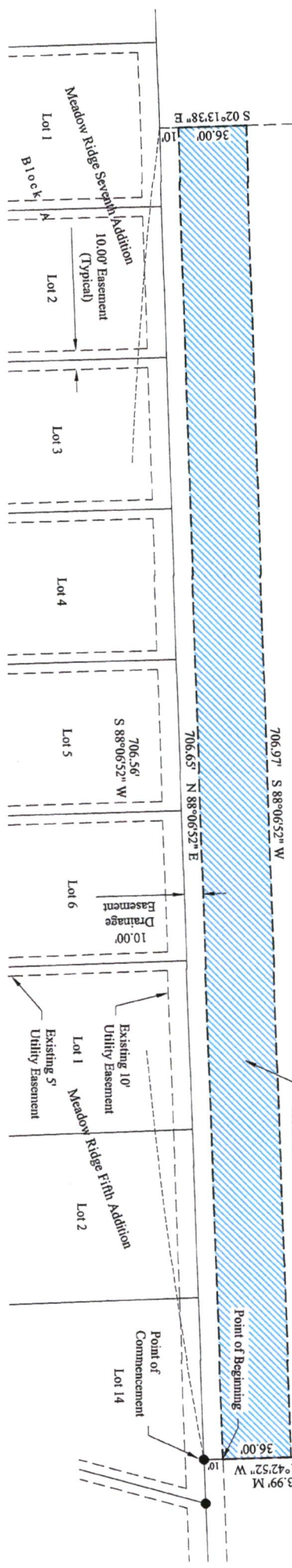

**TEMPORARY DRAINAGE EASEMENT**  
 A temporary drainage easement located in the South 1/2 of the Northeast 1/4 of Section 11, T17N, R1W of the 6th P.M., Platte County, Nebraska, more particularly described as follows:

Commencing at the Southwest corner of L&A 12, Block A, Meadow Ridge Twelfth Addition to the City of Columbus, Platte County, Nebraska; thence N 01°42'52" W on the West line of said Lot 12, 10.00 feet to the Point of Beginning; thence N 01°42'52" W on the West line of said Lot 12, 36.00 feet; thence S 88°06'52" W, 706.97 feet; thence S 02°13'38" E, 36.00 feet; thence N 88°06'52" E, 706.65 feet to the Point of Beginning, containing 0.58 acres, more or less.

**SURVEYOR'S CERTIFICATE**

I, Terry L. Schulz, Nebraska Registered Land Surveyor No. 550, duly registered under the Land Surveyor's Regulation Act, do hereby state that I have performed a survey of the land depicted on the accompanying plat; that said plat is a true delineation of said survey performed personally or under my direct supervision; that said survey was made with reference to known and recorded monuments marked as shown, and to the best of my knowledge and belief its true, correct and in accordance with the Land Surveyor's Regulation Act in effect at the time of this survey;

Terry L. Schulz, State of Nebraska, PLS #550

4/16/2026  
 Date



14.C.Resolution No. R26-65 re-establishing and updating parking restrictions for streets and avenues located in the downtown area.

DRAFT

**RESOLUTION NO. R26-65**

A RESOLUTION OF THE MAYOR AND COUNCIL OF THE CITY OF COLUMBUS, NEBRASKA, TO RE-ESTABLISH AND UPDATE PARKING RESTRICTIONS FOR THE STREETS AND AVENUES LOCATED IN THE DOWNTOWN AREA; AND TO REPEAL ALL RESOLUTIONS OR PORTIONS THEREOF IN CONFLICT HEREWITH.

WHEREAS, parking restrictions in the downtown area were previously updated with Resolution No. R04-123.

WHEREAS, the City desires to adopt a new resolution re-establishing and updating the parking restrictions for the streets and avenues located in the downtown area.

NOW, THEREFORE, BE IT RESOLVED BY MAYOR AND CITY COUNCIL OF COLUMBUS, NEBRASKA, that a two-hour parking restriction, Monday through Saturday from 8 a.m. to 6 p.m., except legal holidays, shall be in effect for the following streets:

|               |                                      |
|---------------|--------------------------------------|
| North side of | 13th Street from 30th to 23rd Avenue |
| South side of | 13th Street from 30th to 23rd Avenue |
| North side of | 14th Street from 24th to 27th Avenue |
| South side of | 14th Street from 24th to 27th Avenue |

BE IT FURTHER RESOLVED that the handicapped designated parking spaces in downtown Columbus, are exempt from the two-hour parking limit;

BE IT FURTHER RESOLVED that this Resolution shall not be applicable to parking spaces surrounding the Platte County Courthouse which have been posted with shorter time limit restrictions, such parking spaces remain subject to such ordinances or resolutions establishing shorter parking time limits;

BE IT FURTHER RESOLVED, that no parking shall be permitted from 2:00 a.m. to 5:00 a.m. on the specified days and dates for the following streets and avenues:

|   |  |
|---|--|
| On 27th Avenue from 12th to 13th Street | - Every day from November 1st through March 31st when it has snowed or if snow is in the forecast.                                 |
| On 28th Avenue from 12th to 13th Street | - Every Tuesday, year-round.<br>- Every day from November 1st through March 31st when it has snowed or if snow is in the forecast. |
| On 13th Street from 23rd to 30th Avenue | - Every Tuesday, year-round.<br>- Every day from November 1st through March 31st when it has snowed or if snow is in the forecast. |

BE IT FURTHER RESOLVED BY MAYOR AND CITY COUNCIL OF COLUMBUS, NEBRASKA, that the City of Columbus Street Department shall be authorized to remove and install signs in accordance herewith and the Columbus Police Department is hereinafter authorized to enforce the same.

This resolution shall repeal all resolutions or portions thereof in conflict herewith.

This Resolution shall take force and effect immediately.

INTRODUCED BY COUNCIL MEMBER \_\_\_\_\_

PASSED AND ADOPTED THIS \_\_\_\_ DAY OF \_\_\_\_\_, 2026.

\_\_\_\_\_  
MAYOR

ATTEST:

\_\_\_\_\_  
CITY CLERK

APPROVED AS TO FORM:

\_\_\_\_\_  
CITY ATTORNEY

14.D.Resolution No. R26-66 approving first amendment to Fire and Emergency Medical Service Agreement with Columbus Rural Fire Protection District.

**RESOLUTION NO. R26-66**

A RESOLUTION OF THE MAYOR AND COUNCIL OF THE CITY OF COLUMBUS, NEBRASKA APPROVING THE FIRST AMENDMENT TO THE FIRE AND EMERGENCY MEDICAL SERVICE AGREEMENT DATED ON OR ABOUT SEPTEMBER 15, 2025, WITH THE COLUMBUS RURAL FIRE PROTECTION DISTRICT, A COPY OF SAID FIRST AMENDMENT IS ATTACHED HERETO AND INCORPORATED HEREIN; TO AUTHORIZE THE MAYOR TO EXECUTE THE SAME ON BEHALF OF THE CITY OF COLUMBUS; AND TO REPEAL ALL RESOLUTIONS OR PORTION THEREOF IN CONFLICT HEREWITH.

WHEREAS, the City and the Columbus Rural Fire Protection District entered into a Fire and Emergency Medical Services Agreement via Resolution No. R25-123 dated on or about September 15, 2025, (hereinafter referred to as the "Underlying Agreement"); and

WHEREAS, the parties desire to amend the Underlying Agreement to change what happens to the old apparatus when the new apparatus is delivered (Section 3d of the Underlying Agreement); and

WHEREAS, a copy of the First Amendment to to the "Fire and Emergency Medical Services Agreement" is attached hereto and incorporated herein by this reference.

NOW, THEREFORE, BE IT RESOLVED BY THE MAYOR AND COUNCIL OF THE CITY OF COLUMBUS, NEBRASKA, that the First Amendment to the Fire and Emergency Medical Services Agreement dated on or about September 15, 2025, with the Columbus Rural Fire Protection District, a copy of which is attached hereto and incorporated herein, is approved and the Mayor is authorized, directed, and empowered to execute the same on behalf of the City of Columbus.

This resolution shall repeal all resolutions or portions thereof in conflict herewith.

INTRODUCED BY COUNCIL MEMBER \_\_\_\_\_

PASSED AND ADOPTED THIS \_\_\_\_ DAY OF \_\_\_\_\_, 2026.

\_\_\_\_\_  
MAYOR

APPROVED AS TO FORM:

ATTEST:

\_\_\_\_\_  
CITY ATTORNEY

\_\_\_\_\_  
CITY CLERK



Columbus Fire Department  
Compassionate-Faithful-Dedicated

---

## MEMORANDUM

**DATE:** 30 April 2026  
**TO:** Tara Vasicek, City Administrator  
**FROM:** Nathan Jones, Assistant Fire Chief  
**RE:** Rural Contract Amendment

**RECOMMENDATION:** Approve the amendment to allow the City to return an apparatus to the District upon delivery of a new apparatus of the same type.

**DISCUSSION:** This simple change in the contract allows the City to transfer ownership of current apparatus back to the District when new apparatus arrive, instead of the City having to put the apparatus on auction and transfer the money to the District, allowing the District to sell the apparatus by any means they choose.

**FISCAL IMPACT:** None

**ALTERNATIVE:** None at this time.

**SIGNATURE:**

By: Nate Jones

Approved By: [Signature]

\_\_\_\_\_

\_\_\_\_\_

---

---

**FIRST AMENDMENT TO THE:  
FIRE AND EMERGENCY MEDICAL SERVICES AGREEMENT  
DATED ON OR ABOUT SEPTEMBER 15, 2025, BETWEEN THE CITY OF  
COLUMBUS AND THE COLUMBUS RURAL FIRE PROTECTION DISTRICT**

THIS FIRST AMENDEMNT to the “Fire and Emergency Medical Services Agreement” dated on or about September 15, 2025, between the City of Columbus and the Columbus Rural Fire Protection District (hereinafter referred to as the “Underlying Agreement”), is entered into by the parties.

WHEREAS, the City of Columbus (the “Municipality”) and the Columbus Rural Fire Protection District (the “District”) desire to amend the terms of the Underlying Agreement relating to Section 3d of the same.

NOW THEREFORE, for good and valuable consideration, the receipt and sufficiency of which is hereby acknowledged, the parties agree and stipulate as follows:

1. That Section 3d of the Underlying Agreement is hereby amended, revised, and replaced, and shall now state and read as follows:

d. The Municipality shall not sell any apparatus without prior agreement of the District’s Board. When an apparatus is replaced, upon delivery, the old apparatus shall be transferred back to the District.

2. That any and all other terms and conditions of the Underlying Agreement which are not expressly altered or amended as provided for in this First Amendment, shall remain in full force and effect and be applicable to the parties.

\*\*\*\*\*REMAINDER OF PAGE LEFT INENTIONAL BLANK\*\*\*\*\*  
\*\*\*\*\*SIGNATURE PAGE TO FOLLOW\*\*\*\*\*

AGREED TO AND EXECUTED ON THE \_\_\_\_ DAY OF \_\_\_\_\_, 2026, BY THE  
CITY OF COLUMBUS, NEBRASKA:

\_\_\_\_\_  
MAYOR

ATTEST:

\_\_\_\_\_  
CITY CLERK

APPROVED AS TO FORM:

\_\_\_\_\_  
CITY ATTORNEY

AGREED TO AND EXECUTED ON THE \_\_\_\_ DAY OF \_\_\_\_\_, 2026, BY THE  
COLUMBUS RURAL FIRE PROTECTION DISTRICT:

\_\_\_\_\_  
BOARD PRESIDENT

ATTEST:

\_\_\_\_\_  
DISTRICT CLERK/SECRETARY

14.E. Resolution No. R26-67 approving Change Order No. 1 to the construction contract with Rutjens Construction, Inc. in the amount of \$17,854.85 for Change Proposal Requests 1 through 5 for North Well No. 20. CIP #25-67

DRAFT

**RESOLUTION NO. R26-67**

A RESOLUTION OF THE MAYOR AND COUNCIL OF THE CITY OF COLUMBUS, NEBRASKA, APPROVING CHANGE ORDER NO. 1 TO THE CONSTRUCTION CONTRACT WITH RUTJENS CONSTRUCTION, INC. IN THE AMOUNT OF \$17,854.85 FOR CHANGE PROPOSAL REQUESTS 1 THROUGH 5 FOR COLUMBUS NORTH WELL NO. 20 PROJECT.

WHEREAS, Resolution R25-136 awarded the construction contract to Rutjens Construction, Inc.; and

WHEREAS, modification, additions, and constructed quantities were measured and determined; and

WHEREAS, city staff and representatives of Rutjens Construction, Inc. and HDR Engineering, Inc. discussed and reviewed said modifications; and

WHEREAS, Rutjens Construction, Inc. has concurred on the proposed modifications as identified in Change Order No. 1.

NOW, THEREFORE, BE IT RESOLVED BY THE MAYOR AND COUNCIL OF THE CITY OF COLUMBUS, NEBRASKA, that Change Order No. 1 to the construction contract with Rutjens Construction, Inc. in the amount of \$17,854.85 for Change Proposal Requests 1 through 5 for Columbus North Well No. 20 is approved and the mayor is authorized to sign on behalf of the City of Columbus.

INTRODUCED BY COUNCIL MEMBER \_\_\_\_\_

PASSED AND ADOPTED THIS \_\_\_\_ DAY OF \_\_\_\_\_, 2026.

\_\_\_\_\_  
MAYOR

ATTEST:

\_\_\_\_\_  
CITY CLERK

APPROVED AS TO FORM:

\_\_\_\_\_  
CITY ATTORNEY



Accountability - Dedication  
Honesty - Integrity - Respect

---

---

## MEMORANDUM

**DATE:** April 28, 2026  
**TO:** Tara Vasicek, City Administrator  
**FROM:** Richard J. Bogus, City Engineer  
**RE:** Columbus Well No. 20

**RECOMMENDATION:**

I recommend approval of Change Order No. 1 with Rutjens Construction, Inc. for Change Proposal Requests (CPR) 1 through 5 for Columbus Well No. 20.

**DISCUSSION:**

Schedule for Change Order No. 1:

- CPR No. 1 – Control conductors from automated transfer switch to generator: \$680.00  
Added low voltage wiring for start-up and shutdown
- CPR No. 2 – Route fiber into structures and add hand holes: \$11,714.85  
Added for SCADA control purposes
- CPR No. 3 – Well casing di-electric coupling: \$24,910.00  
Added for corrosion prevention of dissimilar metals
- CPR No. 4 – Additional 2" HDPE conduit and plywood panel for data racks: \$4,050.00  
Added for SCADA and data monitoring
- CPR No. 5 – Revise well house wall section: (-\$23,500.00)  
Subtracted due to modification of wall insulation approach and construction

**Total for Change Order No. 1: \$17,854.85**

**FISCAL IMPACT:**

\$17,854.85 part of 2025-2026 North Well No. 20 CIP#25-67 in the amount of \$3,200,000. The change order additional funds are available in the budget.

**ALTERNATIVE:**

Field ordered to keep project moving forward.

**CONCURRENCE:**

By: Chuck Sliva

**SIGNATURE:**

By: Richard J. Bogus

Approved By: [Signature]

---

---

**CHANGE ORDER NO. ONE**

Owner: City of Columbus, Nebraska  
 Engineer: HDR  
 Contractor: Rutjens Construction, Inc.  
 Project: Columbus Well No. 20

Owner's Project No.:  
 Engineer's Project No.: 10425904  
 Contractor's Project No.:

Date Issued: 4.14.2026

Effective Date of Change Order: 4.15.26

The Contract is modified as follows upon execution of this Change Order: See Description below.

Description:

See attached schedule for Change Order No. 1

Attachments:

See attached schedule for Change Order No. 1

| Change in Contract Price   | Change in Contract Times  |
|--|---|
| Original Contract Price:<br>\$ <u>1,824,736.00</u>                             | Original Contract Times:<br>Substantial Completion: <u>August 31, 2026</u><br>Ready for final payment: <u>September 30, 2026</u>                        |
| Increase or Decrease from previously approved Change Orders:<br>\$ <u>NONE</u> | Increase or Decrease from previously approved Change Orders:<br>Substantial Completion: <u>None</u><br>Ready for final payment: <u>None</u>             |
| Contract Price prior to this Change Order:<br>\$ <u>1,824,736.00</u>           | Contract Times prior to this Change Order:<br>Substantial Completion: <u>August 31, 2026</u><br>Ready for final payment: <u>September 30, 2026</u>      |
| Increase this Change Order:<br>\$ <u>17,854.85</u>                             | Increase or Decrease this Change Order: <u>None</u><br>Substantial Completion: <u>None</u><br>Ready for final payment: <u>None</u>                      |
| Contract Price incorporating this Change Order:<br>\$ <u>1,842,590.85</u>      | Contract Times with all approved Change Orders:<br>Substantial Completion: <u>August 31, 2026</u><br>Ready for final payment: <u>September 30, 2026</u> |

Recommended by Engineer (if required)

By: Chris J. Koenig, PE  
 Title: Senior Project Manager  
 Date: 4.14.2026

Accepted by Contractor

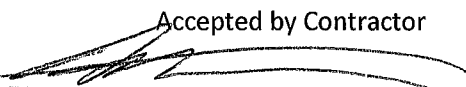
  
 Vice President  
 4/27/2026

Authorized by Owner

By: \_\_\_\_\_  
 Title: \_\_\_\_\_  
 Date: \_\_\_\_\_

Schedule for Change Order No. 1:

1. CPR No 1 – Additional Control Conductors from ATS to Generator: \$680.00
2. CPR No. 2 - Route Fiber into Structures and add Hand Holes: \$11,714.85
3. CPR No. 3 – Well Casing Di-Electric Coupling: \$24,910.00
4. CPR No. 4 - Additional 2” HDPE Conduit and Plywood Panel for Data Racks: \$4,050.00
5. CPR No. 5 – Revise Well House Wall Section: -(\$23,500.00)

**Total for Change Order No. 1: \$17,854.85**

Attachments:

1. CPR No 1 - Additional Control Conductors from ATS to Generator, 6 pages
2. CPR No. 2 – Route Fiber into Structures and add Hand Holes, 12 pages
3. CPR No. 3 - Well Casing Di-Electric Coupling, 4 pages
4. CPR No. 4 – Additional 2” HDPE Conduit and Plywood Panel for Data Racks, 2 pages
5. CPR No. 5 – Revise Well House Wall Section, 8 pages

**CHANGE PROPOSAL NO. 1**  
**CONTROL CONDUCTORS**

Owner: City of Columbus, Nebraska  
Project Name: Columbus Well No. 20

Change Proposal No.: 1

Date: 2.25.2026

Submitted in Response to Proposal Request No.: 1

Contractor Name and No.: **Columbus Well No. 20 - 10425904**

Contractor: **Rutjens Construction, Inc.**

Subject: **Proposal Request No. 1 – Addition of Control conductors between the ATS and Generator.**

The following changes to the Contract as described below are proposed.

**SCOPE OF PROPOSED CHANGE TO CONTRACT:**

1. Proposal Request No. 1 – Control Conductors

**JUSTIFICATION:**

1. Communication between ATS and generator.

**PROPOSED CHANGES IN CONTRACT PRICE AND CONTRACT TIMES:**

We propose that the Contract Price and Contract Times be changed as follows:

***For Contract Price, attach detailed cost breakdowns for Contractor and Subcontractors, Supplier quotations, and other information required.***

***For the Contract Times, state increase, decrease, or no change to Contract Times for Substantial Completion, readiness for final payment, and Milestones, if any. If increase or decrease, state specific number of days for changes to the Contract Times. Submit supporting data, including time impact analysis for the Progress Schedule.***

| Description                       | Amount              | Contract Times (days) |       |
|-----------------------------------|---------------------|-----------------------|-------|
|                                   |                     | Substantial           | Final |
| 1. Control Conductors             | \$__628.00__        |                       |       |
|                                   | \$_____             |                       |       |
| 2.                                | \$_____             |                       |       |
| <b>Total This Change Proposal</b> | <b>\$__628.00__</b> | -                     | -     |

Changes to Milestones, if any: \_\_\_\_\_

Contractor represents that supporting data attached to this Change Proposal are accurate and complete. The requested time or price adjustment indicated in this Change Proposal is the entire adjustment to which Contractor believes it is entitled as a result of the proposed change(s) indicated herein.

Change Proposal by (Contractor): \_\_\_\_\_ Rutjens Construction

Signature of Proposer:  \_\_\_\_\_



# CPR

PROJECT NAME: Columbus Well 20 Design      DATE: 2.20.2026  
PROJECT NUMBER: 10425904  
SUBJECT: Proposal Request No. 1      CPR NO.: 001  
Control Conductors

---

DESCRIPTION OF CHANGE: Conductors from ATS to Generator per Proposal Request No. 1

---

All Work shall be in accordance with the terms, stipulations and conditions of original Contract Documents.

---

Time Change (Calendar Days): 0  
Amount:

---

|   |   |                 |  |
|---|---|-----------------|--|
| Construction Mgr./Contractor:<br>Rutjens Construction | By: Adam Rutjens<br><a href="#">See previous page for signature</a> | Date: 2.24.2026 | Recommendation:<br><input checked="" type="checkbox"/> <b>Approval</b><br><input type="checkbox"/> <b>Rejection</b><br><input type="checkbox"/> <b>No Recommendation</b> |
|---|---|-----------------|--|

---

|                     |                  |                 |   |
|---------------------|------------------|-----------------|---|
| Architect/Engineer: | By: Chris Koenig | Date: 2.25.2026 | Recommendation:<br><input type="checkbox"/> <b>Approval</b><br><input type="checkbox"/> <b>Rejection</b><br><input type="checkbox"/> <b>No Recommendation</b> |
|---------------------|------------------|-----------------|---|

---

|        |     |       |  |
|--------|-----|-------|--|
| Owner: | By: | Date: | Action:<br><input type="checkbox"/> <b>Approval</b><br><input type="checkbox"/> <b>Rejection</b> |
|--------|-----|-------|--|

---

The Contractor is directed to make changes indicated above for the proposed amount and time after Owner approval.  
If allowed by the Contract Documents, this document is considered a fully executed Change Order after Owner approval.

## PROPOSAL REQUEST NO. 1

### CONTROL CONDUCTORS

Owner: City of Columbus, Nebraska

Project Name: Columbus Well No. 20

Proposal Request No.: 1

Date: **January 23, 2026**

Contract Name and No.: **Columbus Well No. 20 - 10425904**

Contractor: **Rutjens Construction, Inc.**

Other Contracts Involved in Proposed Change: **NA**

TO CONTRACTOR: Please submit a complete Change Proposal (template attached) for the proposed modifications described below. If the associated Change Proposal is approved, a Change Order or allowance authorization will be issued to authorize adjustment so the Contract.

This Proposal Request is not a Change Order, Work Change Directive, Field Order, or an authorization to proceed with the proposed Work described below.

#### SCOPE OF PROPOSED CHANGE(S) IN THE WORK:

1. Submittal 26 32 13.13 for the Diesel-Engine-Driven Generator detailed 6#14 conductors required between the ATS and the generator. These conductors are to be added as part of this proposal request.

Attachments to this Proposal Request:

1. Cost Proposal for Change Proposal No. 1.
2. Plan sheet(s): 20E101, 20E602

Proposal requested by: Scott Schmoker  
HDR (Engineer)

Signature of Requestor: \_\_\_\_\_



- GENERAL NOTES**
1. AREA CLASSIFICATION:  
- OUTSIDE: OUTDOOR, WET.  
- INSIDE: INDOOR, WET.
  2. SEE PROCESS SHEETS FOR EXACT EQUIPMENT LOCATIONS.
  3. FIELD ROUTE CONDUITS TO AVOID OBSTRUCTIONS, OTHER UTILITIES AND/OR UNUSUAL LOCATIONS OF EQUIPMENT AND CONDUIT ENTRY LOCATIONS.
  4. REFER TO MECHANICAL/ELECTRICAL COORDINATION SCHEDULE FOR REQUIREMENTS FOR CONNECTING MECHANICAL EQUIPMENT.
  5. PROVIDE A LIGHTNING PROTECTION SYSTEM IN ACCORDANCE TO SPECIFICATION 26.41.15.
- KEYNOTES (#)**
1. PROVIDE LABEL FOR SWITCH TO INDICATE "SOUTH EXTERIOR LIGHT".
  2. PROVIDE THREE 2 IN UNDERGROUND CONDUIT FOR 120V CIRCUITS BETWEEN GENERATOR AND PANEL BP.
  3. INSTALL 4 IN BY 4 IN JUNCTION BOXES ON BUILDING EXTERIOR WHERE SHOWN. PENETRATE 1" CONDUIT INTO BUILDING. ROUTE CONDUIT TO LOCATION OF SECURITY PANEL, SECURITY PANEL BY OTHERS, COORDINATE WITH SECURITY CONTRACTOR.

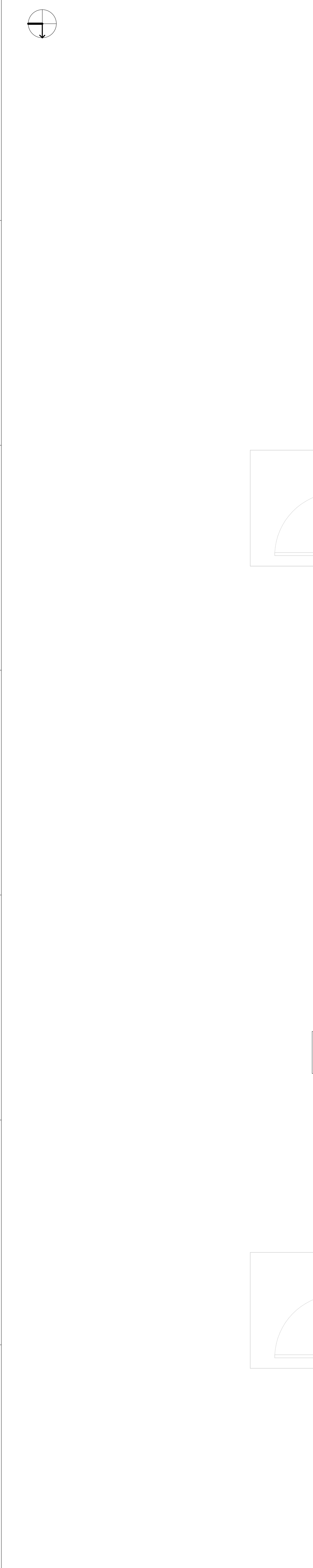

**1** POWER PLAN  
3/8" = 1'-0"

**2** LIGHTING PLAN  
3/8" = 1'-0"

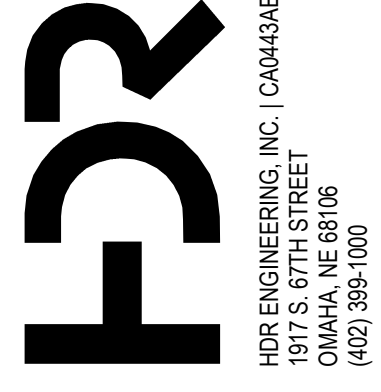
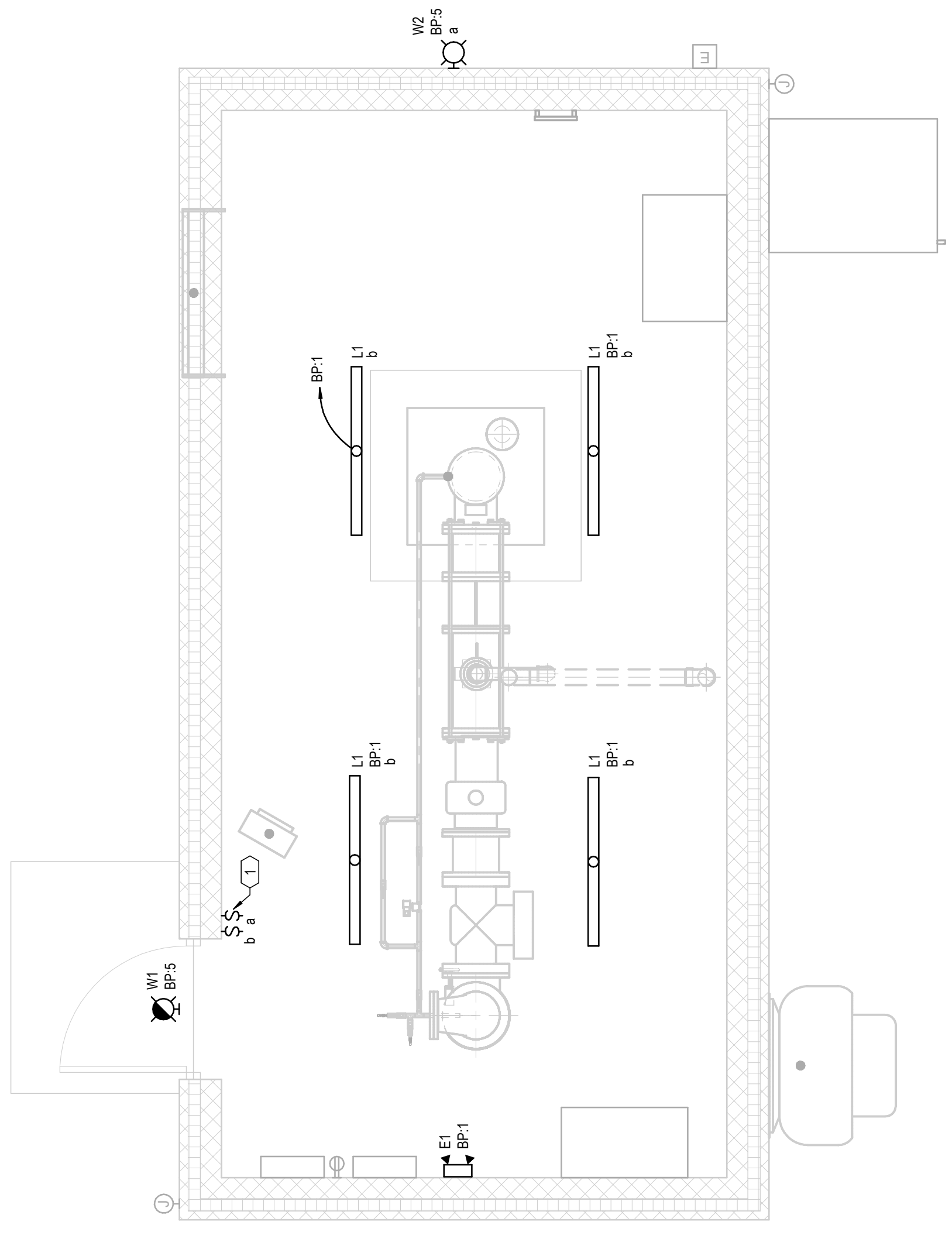

HDR ENGINEERING, INC. | CA043AE  
1917 S. 67TH STREET  
OMAHA, NE 68106  
(402) 399-1000

| ISSUE | DATE      | DESCRIPTION        |
|-------|-----------|--------------------|
| 1     | 1-29-2025 | CPR NO. #1         |
|       | 11-7-2025 | CONFORMED DRAWINGS |

THIS DOCUMENT  
WAS ORIGINALLY  
SIGNED ON  
08/15/2025

The City of **Columbus**  
WELL NO. 20 DESIGN  
6651 33RD AVE. COLUMBUS, NE

ELECTRICAL  
ELECTRICAL PLANS

FILENAME | 10425904-06-E-INT  
SCALE | 3/8" = 1'-0"  
SHEET | 20E101



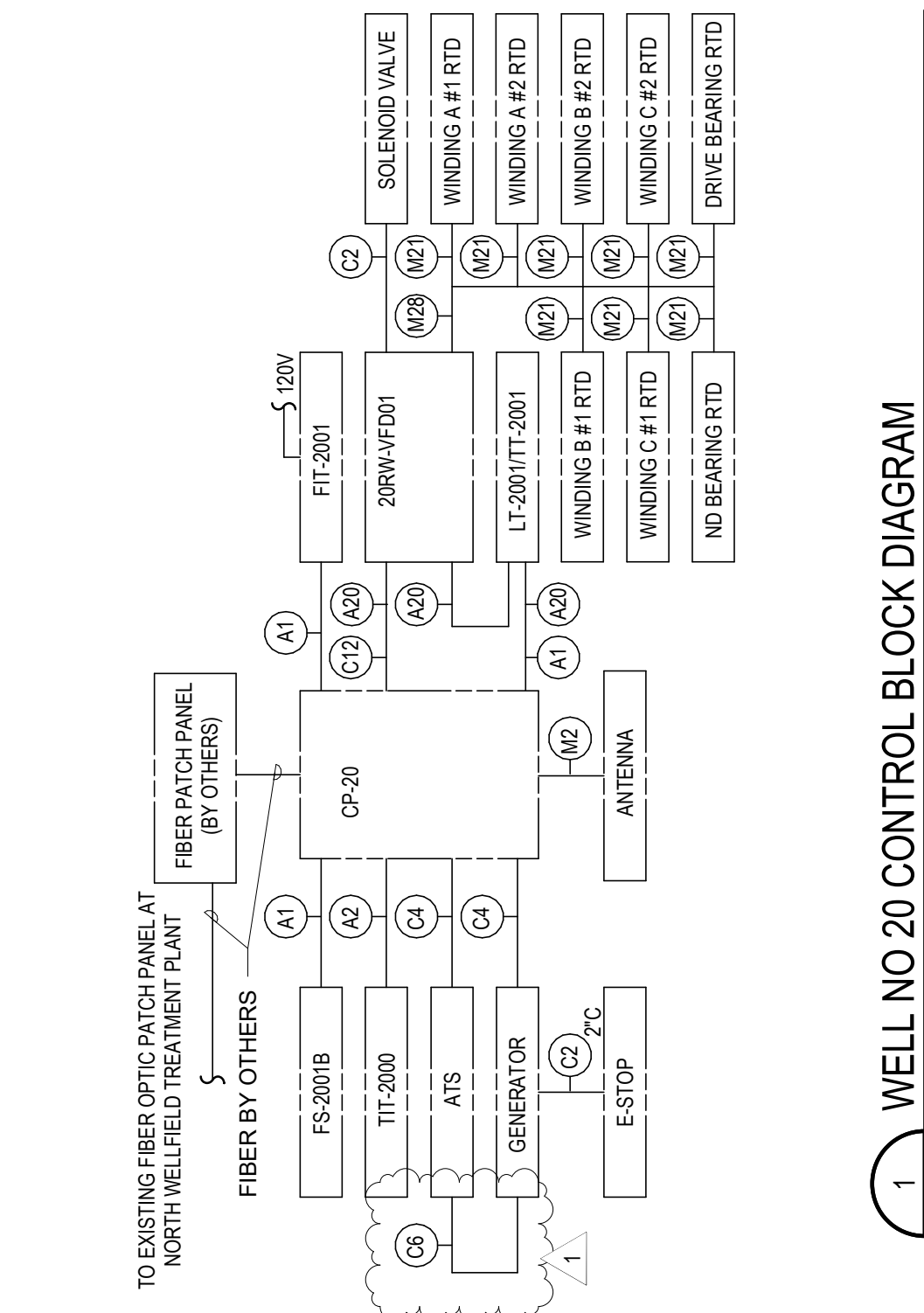

**KEYNOTES (#)**

- ROUTE CONDUIT TO HANDHOLE CONDUIT PENETRATION INTO STRUCTURE BY OTHERS.
- ROUTE CONDUIT WITHIN FIVE FEET OF EXISTING BUILDING AND MARK LOCATION OF CONDUIT PENETRATION INTO STRUCTURE BY OTHERS.

| DWG MARK | CONDUCTOR    | CONDUIT SIZE |        |      |
|----------|--------------|--------------|--------|------|
|          |              | METAL        | PVC    | FLEX |
| P1       | 2#12         | 1-1/2        | 3/4"   | 3/4" |
| P2       | 3#12         | 1-1/2        | 3/4"   | 3/4" |
| P3       | 4#12         | 2-1/2        | 3/4"   | 3/4" |
| P4       | 2#10         | 1-1/0        | 3/4"   | 3/4" |
| P5       | 2#10         | -            | 3/4"   | 3/4" |
| P10      | 1-3C WIG #12 | 3/4"         | 3/4"   | 3/4" |
| P11      | 1-4C WIG #12 | 3/4"         | 3/4"   | 3/4" |
| P12      | 1-4C WIG #12 | 3/4"         | 3/4"   | 3/4" |
| P13      | 2-3C WIG #12 | 1"           | 1-1/4" | 1"   |

| DWG MARK | CONDUCTOR             | CONDUIT SIZE |        |        |
|----------|-----------------------|--------------|--------|--------|
|          |                       | METAL        | PVC    | FLEX   |
| M1       | MANUFACTURER SUPPLIED | 3/4"         | 3/4"   | 3/4"   |
| M2       | MANUFACTURER SUPPLIED | 1"           | 1"     | 1"     |
| M3       | MANUFACTURER SUPPLIED | 2"           | 2"     | 2"     |
| M4       | MANUFACTURER SUPPLIED |              |        |        |
| M5       | MANUFACTURER SUPPLIED |              |        |        |
| M6       | MANUFACTURER SUPPLIED |              |        |        |
| M7       | MANUFACTURER SUPPLIED |              |        |        |
| M8       | MANUFACTURER SUPPLIED |              |        |        |
| M9       | MANUFACTURER SUPPLIED |              |        |        |
| M10      | OWNER SUPPLIED        | 1"           | 1"     | 1"     |
| M11      | 1-2C #14              | 3/4"         | 3/4"   | 3/4"   |
| M12      | 2-2C #14              | 3/4"         | 1"     | 1"     |
| M13      | 3-2C #14              | 1"           | 1-1/4" | 1"     |
| M14      | 4-2C #14              | 1-1/4"       | 1-1/4" | 1"     |
| M15      | 5-2C #14              | 1-1/4"       | 1-1/2" | 1-1/2" |
| M16      | 6-2C #14              | 1-1/2"       | 1-1/2" | 1-1/2" |
| M19      | 9-2C #14              | 2"           | 2"     | 2"     |
| M20      | 10-2C #14             | 2"           | 2"     | 2"     |
| M21      | 1-3C #14              | 3/4"         | 3/4"   | 3/4"   |
| M22      | 2-3C #14              | 1"           | 1-1/4" | 1"     |
| M23      | 3-3C #14              | 1-1/4"       | 1-1/4" | 1-1/4" |
| M24      | 4-3C #14              | 1-1/4"       | 1-1/4" | 1-1/4" |
| M25      | 5-3C #14              | 1-1/4"       | 1-1/2" | 1-1/2" |
| M26      | 6-3C #14              | 1-1/2"       | 2"     | 2"     |
| M27      | 7-3C #14              | 1-1/2"       | 2"     | 2"     |
| M28      | 8-3C #14              | 2"           | 2"     | 2"     |
| M29      | 9-3C #14              | 2"           | 2-1/2" | 2"     |
| M30      | 10-3C #14             | 2"           | 2-1/2" | 2"     |
| M31      | 1-4C #14              | 3/4"         | 3/4"   | 3/4"   |
| M32      | 2-4C #14              | 1-1/4"       | 1-1/4" | 1-1/4" |
| M33      | 3-4C #14              | 1-1/4"       | 1-1/4" | 1-1/4" |
| M34      | 4-4C #14              | 1-1/4"       | 1-1/2" | 1-1/2" |
| M35      | 5-4C #14              | 1-1/2"       | 2"     | 2"     |
| M36      | 6-4C #14              | 2"           | 2"     | 2"     |
| M37      | 7-4C #14              | 2"           | 2"     | 2"     |
| M38      | 8-4C #14              | 2"           | 2-1/2" | 2"     |
| M39      | 9-4C #14              | 3/4"         | 3/4"   | 3/4"   |
| M41      | 1-7C #14              | 1-1/4"       | 1-1/2" | 1-1/4" |
| M42      | 2-7C #14              | 1-1/4"       | 1-1/2" | 1-1/4" |
| M43      | 3-7C #14              | 1-1/4"       | 1-1/2" | 1-1/4" |
| M44      | 4-7C #14              | 1-1/2"       | 2"     | 2"     |
| M45      | 5-7C #14              | 2"           | 2"     | 2"     |
| M46      | 6-7C #14              | 2"           | 2"     | 2"     |
| M47      | 7-7C #14              | 2"           | 2"     | 2"     |
| M51      | 1-9C #14              | 1"           | 1"     | 1"     |
| M52      | 2-9C #14              | 1-1/2"       | 2"     | 1-1/2" |
| M53      | 3-9C #14              | 2"           | 2"     | 2"     |
| M54      | 4-9C #14              | 2"           | 2-1/2" | 2"     |
| M55      | 5-9C #14              | 2-1/2"       | 2-1/2" | 2-1/2" |
| M56      | 6-9C #14              | 2-1/2"       | 3"     | 2-1/2" |
| M61      | 1-12C #14             | 1"           | 1"     | 1"     |

| DWG MARK | CONDUCTOR  | CONDUIT SIZE |        |        |
|----------|------------|--------------|--------|--------|
|          |            | METAL        | PVC    | FLEX   |
| A1       | 1-TSP #16  | 3/4"         | 3/4"   | 3/4"   |
| A2       | 2-TSP #16  | DRAIN        | 3/4"   | 3/4"   |
| A3       | 3-TSP #16  | DRAIN        | 3/4"   | 3/4"   |
| A4       | 4-TSP #16  | DRAIN        | 1"     | 1"     |
| A5       | 5-TSP #16  | DRAIN        | 1"     | 1"     |
| A6       | 6-TSP #16  | DRAIN        | 1-1/4" | 1-1/4" |
| A7       | 7-TSP #16  | DRAIN        | 1-1/4" | 1-1/4" |
| A8       | 8-TSP #16  | DRAIN        | 1-1/2" | 1-1/2" |
| A9       | 9-TSP #16  | DRAIN        | 1-1/2" | 1-1/2" |
| A10      | 10-TSP #16 | DRAIN        | 1-1/2" | 1-1/2" |
| A11      | 11-TSP #16 | DRAIN        | 1-1/2" | 2"     |
| A12      | 12-TSP #16 | DRAIN        | 1-1/2" | 2"     |
| A13      | 13-TSP #16 | DRAIN        | 2"     | 2"     |
| A14      | 14-TSP #16 | DRAIN        | 2"     | 2"     |
| A15      | 15-TSP #16 | DRAIN        | 2"     | 2"     |
| A20      | 1-TST #16  | DRAIN        | 3/4"   | 3/4"   |
| A21      | 2-TST #16  | DRAIN        | 3/4"   | 3/4"   |
| A22      | 3-TST #16  | DRAIN        | 1"     | 1"     |
| A23      | 4-TST #16  | DRAIN        | 1"     | 1"     |
| A24      | 5-TST #16  | DRAIN        | 1-1/4" | 1-1/4" |
| A25      | 6-TST #16  | DRAIN        | 1-1/4" | 1-1/4" |

| DWG MARK | CONDUCTOR | CONDUIT SIZE |        |        |
|----------|-----------|--------------|--------|--------|
|          |           | METAL        | PVC    | FLEX   |
| C1       | 1-#14     | 3/4"         | 1-1/4" | 1-1/4" |
| C2       | 2-#14     | 3/4"         | 1-1/4" | 1-1/4" |
| C3       | 3-#14     | 3/4"         | 1-1/4" | 1-1/4" |
| C4       | 4-#14     | 3/4"         | 1-1/4" | 1-1/4" |
| C5       | 5-#14     | 3/4"         | 1-1/4" | 1-1/4" |
| C6       | 6-#14     | 3/4"         | 1-1/4" | 1-1/4" |
| C7       | 7-#14     | 3/4"         | 1-1/4" | 1-1/4" |
| C8       | 8-#14     | 3/4"         | 1-1/4" | 1-1/4" |
| C9       | 9-#14     | 3/4"         | 1-1/4" | 1-1/4" |
| C10      | 10-#14    | 3/4"         | 1-1/4" | 1-1/4" |
| C11      | 11-#14    | 3/4"         | 1-1/4" | 1-1/4" |
| C12      | 12-#14    | 3/4"         | 1-1/4" | 1-1/4" |
| C13      | 13-#14    | 3/4"         | 1-1/4" | 1-1/4" |
| C14      | 14-#14    | 3/4"         | 1-1/4" | 1-1/4" |
| C15      | 15-#14    | 3/4"         | 1-1/4" | 1-1/4" |
| C16      | 16-#14    | 1"           | 1-1/2" | 1-1/2" |
| C17      | 17-#14    | 1"           | 1-1/2" | 1-1/2" |
| C18      | 18-#14    | 1"           | 1-1/2" | 1-1/2" |
| C19      | 19-#14    | 1"           | 1-1/2" | 1-1/2" |
| C20      | 20-#14    | 1"           | 1-1/2" | 1-1/2" |
| C21      | 21-#14    | 1"           | 1-1/2" | 1-1/2" |
| C22      | 22-#14    | 1"           | 1-1/2" | 1-1/2" |
| C23      | 23-#14    | 1"           | 1-1/2" | 1-1/2" |
| C24      | 24-#14    | 1"           | 1-1/2" | 1-1/2" |
| C25      | 25-#14    | 1"           | 1-1/2" | 1-1/2" |
| C26      | 26-#14    | 1-1/4"       | 1-1/4" | 1-1/4" |
| C27      | 27-#14    | 1-1/4"       | 1-1/4" | 1-1/4" |
| C28      | 28-#14    | 1-1/4"       | 1-1/4" | 1-1/4" |
| C29      | 29-#14    | 1-1/4"       | 1-1/4" | 1-1/4" |
| C30      | 30-#14    | 1-1/4"       | 1-1/4" | 1-1/4" |

| DWG MARK | CONDUCTOR             | CONDUIT SIZE |      |      |
|----------|-----------------------|--------------|------|------|
|          |                       | METAL        | PVC  | FLEX |
| M1       | MANUFACTURER SUPPLIED | 3/4"         | 3/4" | 3/4" |
| M2       | MANUFACTURER SUPPLIED | 1"           | 1"   | 1"   |
| M3       | MANUFACTURER SUPPLIED | 2"           | 2"   | 2"   |
| M4       | MANUFACTURER SUPPLIED |              |      |      |

## CHANGE PROPOSAL NO. 2

### ADDITIONAL FIBER HAND HOLES AND CONDUIT INTO STRUCTURES

Owner: City of Columbus, Nebraska

Project Name: Columbus Well No. 20

Change Proposal No. 2

Date: **February 20, 2026**

Submitted in Response to Proposal Request No. 2

Contractor Name and No.: **Columbus Well No. 20 - 10425904**

Contractor: **Rutjens Construction, Inc.**

Subject: **Proposal Request No. 2, fiber conduit into structures and additional fiber hand holes.**

The following changes to the Contract as described below are proposed.

#### SCOPE OF PROPOSED CHANGE TO CONTRACT:

1. Proposal Request No. 2 – Route fiber conduit into all eight structures and add Fiber Hand Holes at Water Treatment Plant building and Booster Station building.

#### JUSTIFICATION:

1. Keynotes call for conduit into building by others. Installing the conduit at this time is beneficial for coordination and efficiency purposes.
2. The Electrical sheets do not call for a hand hole on the south side of the treatment plan or the east side of the booster building which will be needed to route conduit into these structures.

#### PROPOSED CHANGES IN CONTRACT PRICE AND CONTRACT TIMES:

We propose that the Contract Price and Contract Times be changed as follows:

***For Contract Price, attach detailed cost breakdowns for Contractor and Subcontractors, Supplier quotations, and other information required.***

***For the Contract Times, state increase, decrease, or no change to Contract Times for Substantial Completion, readiness for final payment, and Milestones, if any. If increase or decrease, state specific number of days for changes to the Contract Times. Submit supporting data, including time impact analysis for the Progress Schedule.***

| Description                       | Amount             | Contract Times (days) |          |
|-----------------------------------|--------------------|-----------------------|----------|
|                                   |                    | Substantial           | Final    |
| 1. Materials                      | \$5,423.80         | 0                     | 0        |
| 3. Labor                          | \$5,733.20         | 0                     | 0        |
| 4. Contractor Bond/Markup         | \$557.85           | 0                     | 0        |
| <b>Total This Change Proposal</b> | <b>\$11,714.85</b> | <b>0</b>              | <b>0</b> |

Changes to Milestones, if any: NA

Contractor represents that supporting data attached to this Change Proposal are accurate and complete. The requested time or price adjustment indicated in this Change Proposal is the entire adjustment to which Contractor believes it is entitled as a result of the proposed change(s) indicated herein.

Change Proposal by (Contractor): **Adam Rutjens, Rutjens Construction**

Signature of Proposer: \_\_\_\_\_



# CPR

PROJECT NAME: Columbus Well 20 Design      DATE: 2.20.2026  
PROJECT NUMBER: 10425904  
SUBJECT: Proposal Request No. 2      CPR NO.: 002

---

DESCRIPTION OF CHANGE: Route fiber conduit into 8 structures and add two hand holes per Proposal Request No. 2

---

All Work shall be in accordance with the terms, stipulations and conditions of original Contract Documents.

---

Time Change (Calendar Days): 0  
Amount: \$11,714.85

---

|   |     |       |  |
|---|-----|-------|--|
| Construction Mgr./Contractor:<br>Rutjens Construction | By: | Date: | Recommendation:                              |
|   |     |       | <input checked="" type="checkbox"/> Approval |
|   |     |       | <input type="checkbox"/> Rejection           |
|   |     |       | <input type="checkbox"/> No Recommendation   |

---

|                     |                  |                 |  |
|---------------------|------------------|-----------------|--|
| Architect/Engineer: | By: Chris Koenig | Date: 2.20.2026 | Recommendation:                              |
|                     |                  |                 | <input checked="" type="checkbox"/> Approval |
|                     |                  |                 | <input type="checkbox"/> Rejection           |
|                     |                  |                 | <input type="checkbox"/> No Recommendation   |

---

|        |     |       |                                    |
|--------|-----|-------|------------------------------------|
| Owner: | By: | Date: | Action:                            |
|        |     |       | <input type="checkbox"/> Approval  |
|        |     |       | <input type="checkbox"/> Rejection |

---

The Contractor is directed to make changes indicated above for the proposed amount and time after Owner approval.  
If allowed by the Contract Documents, this document is considered a fully executed Change Order after Owner approval.



Remit To:  
Echo Group, Inc.  
PO Box 336  
Council Bluffs, IA 51502

ECHO ELECTRIC SUPPLY BR 03 SNNE  
700 OMAHA AVE  
NORFOLK, NE 68701-5877  
Phone 402-371-2928  
Fax 402-371-2323



# Quotation



|  |              |
|--|--------------|
| EXPIRATION DATE  | QUOTE NUMBER |
| 01/26/2026   | S011582929   |
| ECHO ELECTRIC SUPPLY BR 03 SNNE<br>700 OMAHA AVE<br>NORFOLK, NE 68701-5877<br>402-371-2928<br>Fax 402-371-2323 |              |
| PAGE NO.<br>1 of 1   |              |

QUOTE TO:

SHIP TO:

COMMONWEALTH ELECTRIC  
472 26TH AVE  
COLUMBUS, NE 68601-6625

COMMONWEALTH ELECTRIC  
472 26TH AVE  
COLUMBUS, NE 68601-6625

| CUSTOMER NUMBER   | CUSTOMER PO NUMBER  | ORDERED BY                       | SALESPERSON        |
|---|---|----------------------------------|--------------------|
| 45485   | 233360  | Chase Lovell                     | Tim Bates 27 SGNE  |
| WRITER  | SHIP VIA  | TERMS                            | SHIP DATE          |
| Brandon Miller 03 SNNE  | ECHO-TRUCK  | 2% 10TH NET EOM                  | 01/12/2026         |
| ORDER QTY   | DESCRIPTION   | UNIT PRICE                       | EXT PRICE          |
|  2 <del>6EA</del>  | QUA PG2436BA24<br>QUA 24X36X24 BOX OPEN BOTTOM<br><br>MFR Spec Sheet                | 945.460/EA                       | <del>5672.76</del> |
|  2 <del>6EA</del> | QUA PG2436CA0012 (TIER 8)<br>QUA COVER 24X36 "COMMUNICATIONS"<br><br>MFR Spec Sheet | 442.890/EA                       | <del>2657.34</del> |
|   |   | <b>Total</b><br><b>\$2776.80</b> |                    |

## This is a Quotation.

All transactions are subject to and exclusively governed by our Terms and Conditions of Sale, which are incorporated herein and available at: <https://www.echogroupinc.com/content/terms.htm>. Additional or conflicting terms are rejected, void, and of no force or effect. Tax is not included unless stated.

|             |                    |
|-------------|--------------------|
| Subtotal    | <del>8330.10</del> |
| S&H Charges | 0.00               |
| Amount Due  | <del>8330.10</del> |



**ELECTRICAL ENGINEERING & EQUIPMENT CO.**  
 418 23RD STREET  
 COLUMBUS, NE68601  
 (402)562-6042 FAX (402)562-6036  
 www.3e-co.com

**QUOTE**

CUST.#: 110941  
 SHIP TO: COMMONWEALTH ELECTRIC  
 ADM  
 3000 E 8TH ST  
 COLUMBUS, NE 68601-6625

| TAKEN BY      | QUOTE DATE | QUOTE NO.  |
|---------------|------------|------------|
| bkru          | 02/18/26   | 9092747-00 |
| P.O. NO.      |            | PAGE #     |
| WELL#20 ADDED |            | 1          |
| PLACED BY     |            |            |

BILL TO: COMMONWEALTH ELECTRIC  
 472 26TH AVENUE  
 COLUMBUS, NE 68601-6625

CORRESPONDENCE TO: Electrical Engineering & Equip  
 953 73RD ST  
 WINDSOR HEIGHTS, IA 50324-1031

| INSTRUCTIONS  | REFERENCE | CASH DISCOUNT: |
|---------------|-----------|----------------|
|               |           |                |
| SHIP POINT    | SHIP VIA  | SHIPPED        |
| 3E - COLUMBUS | 3E TRUCK  |                |
|               |           | IF PAID BY:    |

| LINE NO. | PRODUCT AND DESCRIPTION                                 | QUANTITY ORDERED | QUANTITY B.O.     | QTY. SHIPPED | QTY. U/M    | NET PRICE | AMOUNT (NET)                |
|----------|---|------------------|-------------------|--------------|-------------|-----------|-----------------------------|
| 1        | ECN RIG ELL 90D 200<br>2 RIG GALV 90 ELBOW              | 16               |                   | 16           | C           | 2897.94   | 463.67                      |
| 2        | PVC E942J<br>2 IN SCH 40 FEMALE ADPT                    | 32               |                   | 32           | C           | 107.63    | 34.44                       |
| 3        | COND RIG 200<br>2 IN RIGID CONDUIT                      | 20               |                   | 20           | C           | 1094.95   | 218.99                      |
| 4        | COND PVC SCH80 200<br>49411 2 IN SCH 80 PVC CONDUIT     | 20               |                   | 20           | C           | 156.95    | 31.39                       |
| 5        | KIL OLB-6M<br>2IN MALL LB COND BODY DURALOY 5 SERIES    | 8                |                   | 8            | E           | 56.24     | 449.92                      |
| 6        | ARL 994N<br>2 IN COND GASKET<br>GK200-N                 | 8                |                   | 8            | C           | 29.25     | 2.34                        |
| 7        | KIL OL-60M<br>2IN STEEL COND BDY COVER DURALOY 5 SERIES | 8                |                   | 8            | E           | 10.08     | 80.64                       |
| 8        | APP XJ2004<br>2 IN EXPANSION CPLG                       | 8                |                   | 8            | E           | 170.71    | 1365.68                     |
| 8        | Lines Total   |                  | Qty Shipped Total | 120          | Total Taxes |           | 2647.07<br>TO BE DETERMINED |

**PROPOSAL REQUEST NO. 2**

**ADDITIONAL FIBER HAND HOLES AND CONDUIT INTO STRUCTURES**

Owner: City of Columbus, Nebraska

Project Name: Columbus Well No. 20

Proposal Request No. 2

Date: **February 20, 2026**

Contract Name and No.: **Columbus Well No. 20 - 10425904**

Contractor: **Rutjens Construction, Inc.**

Other Contracts Involved in Proposed Change: **NA**

TO CONTRACTOR: Please submit a complete Change Proposal (template attached) for the proposed modifications described below. If the associated Change Proposal is approved, a Change Order or allowance authorization will be issued to authorize adjustment so the Contract.

This Proposal Request is not a Change Order, Work Change Directive, Field Order, or an authorization to proceed with the proposed Work described below.

**SCOPE OF PROPOSED CHANGE(S) IN THE WORK:**

1. Route Conduit into the six well house buildings and into the Water Treatment Plant (WTP) building and into the Booster Station building.
2. Add a hand hole on the south side of the WTP building and add hand hole on the east side of the Booster Station building.

Attachments to this Proposal Request:

1. Plan sheet(s): 01E101 through 01E105 revised to show conduit into structures and two additional hand holes.

Proposal requested by: Scott Schmoker  
HDR (Engineer)



Signature of Requestor: \_\_\_\_\_



**GENERAL NOTES**

- FURNISH AND INSTALL 2" HDPE SDR 11 CONDUIT FOR FIBER OPTIC ROUTES BETWEEN EXISTING TREATMENT PLANT AND PUMP STATION #20. POPULATE WITH MAXCELL 3 CELL INNERDUCT.
- PLACE COMMUNICATION HANDHOLES WITHIN 5 FEET OF WELL PUMP BUILDING. CONDUIT ROUTING FROM HANDHOLE TO BUILDINGS BY OTHERS.

ALIGNMENT LINE TABLE

| LINE NO. | ALIGNMENT    | LENGTH  | DIRECTION     | START POINT                 | END POINT                   |
|----------|--------------|---------|---------------|-----------------------------|-----------------------------|
| E-L-101  | ELECTRICAL   | 17.07'  | N43° 54' 33"E | N 609170.44<br>E 2361294.65 | N 609170.44<br>E 2361294.65 |
| E-L-102  | ELECTRICAL   | 767.34' | N88° 56' 06"E | N 609184.71<br>E 2361294.65 | N 609184.71<br>E 2362061.86 |
| E-L-103  | ELECTRICAL   | 240.29' | N01° 14' 16"W | N 609184.71<br>E 2362061.86 | N 609424.94<br>E 2362056.67 |
| E-L-104  | ELECTRICAL   | 20.79'  | S89° 42' 43"W | N 609424.94<br>E 2362056.67 | N 609424.48<br>E 2362035.88 |
| E-L-105  | ELECTRICAL   | 25.86'  | N01° 19' 12"W | N 609424.48<br>E 2362035.88 | N 609450.33<br>E 2362052.29 |
| E-L-106  | ELECTRICAL   | 3.71'   | N88° 40' 48"E | N 609450.33<br>E 2362052.29 | N 609450.41<br>E 2362038.99 |
| F-L-201  | FIBEROPTIC-1 | 44.71'  | N01° 19' 12"W | N 609472.10<br>E 2362052.85 | N 609472.10<br>E 2362052.85 |

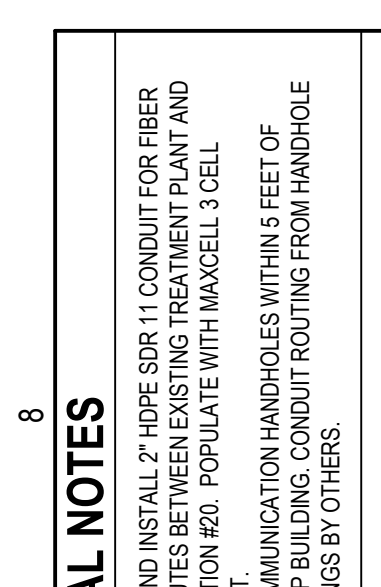

10425904-E-101.dwg  
SCALE 1" = 50'

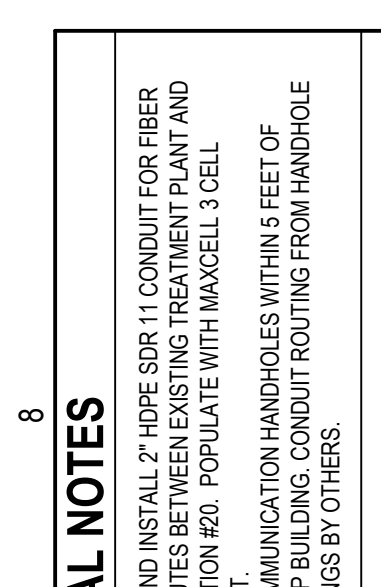

**ELECTRICAL SITE PLAN**

The City of **Columbus**  
WELL NO. 20 DESIGN  
6651 33RD AVE. COLUMBUS, NE

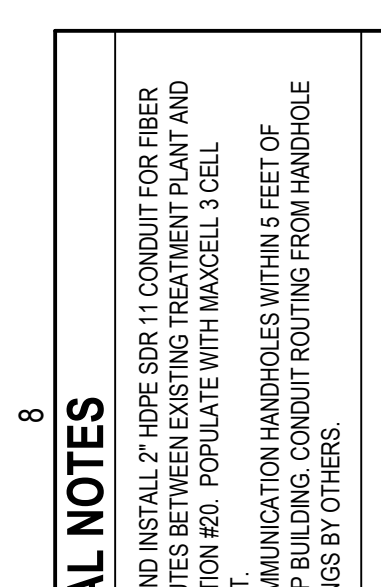

| ISSUE | DATE      | DESCRIPTION                                     |
|-------|-----------|---|
| 2     | 9.19.2025 | CRR NO. 2 - FIBER CONDUIT AND HAND HOLE CHANGES |
| A     | 8-27-2025 | ISSUED FOR BID                                  |

| PROJECT MANAGER | C. KOENIG            |
|-----------------|----------------------|
| CIVIL           | S. SCHMOKER          |
| STRUCTURAL      | J. THOMPSON          |
| ARCHITECTURAL   | W. WILSON            |
| PROCESS         | J. ROBERTS           |
| MECHANICAL      | P. KONECK-WILLERDING |
| ELECTRICAL      | J. JACOBS            |
| INSTRUMENTATION | K. ROLOFF            |
| PROJECT NUMBER  | 10425904             |

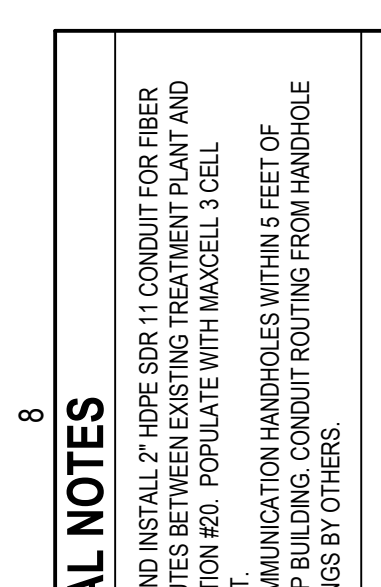





**GENERAL NOTES**

- FURNISH AND INSTALL 2" HDPE SDR 11 CONDUIT FOR FIBER OPTIC ROUTES BETWEEN EXISTING TREATMENT PLANT AND EXISTING PUMP STATIONS. POPULATE WITH MAXCELL 3 CELL INNERDUCT.
- PLACE COMMUNICATION HANDHOLES WITHIN 5 FEET OF WELL PUMP BUILDING CONDUIT ROUTING FROM HANDHOLE TO BUILDING BY OTHERS.

**KEYNOTES (#)**

- INSTALL 4" X 4" JUNCTION BOXES ON BUILDING EXTERIOR WHERE SHOWN. PENETRATE CONDUIT INTO BUILDING. ROUTE CONDUIT TO LOCATION OF SECURITY PANEL. INSTALL GPO RECEPTACLE FOR SECURITY PANEL. SECURITY PANELS TO BE PROVIDED BY OTHERS. COORDINATE WITH SECURITY CONTRACTOR.



**ALIGNMENT LINE TABLE**

| LINE NO. | ALIGNMENT     | LENGTH | DIRECTION     | START POINT                 | END POINT                   |
|----------|---------------|--------|---------------|-----------------------------|-----------------------------|
| F-L-312  | FIBER OPTIC 2 | 902.65 | S86° 03' 27"E | N 610115.41<br>E 2365666.63 | N 610053.35<br>E 2365667.14 |
| F-L-313  | FIBER OPTIC 2 | 92.84  | S43° 35' 20"E | N 610053.35<br>E 2365667.14 | N 609986.10<br>E 2365683.16 |

**ELECTRICAL SITE PLAN**

FILENAME: 10425904-E-101.dwg  
 SCALE: 1" = 50'

SHEET: **01E104**

The City of **Columbus**

**WELL NO. 20 DESIGN**

6651 33RD AVE. COLUMBUS, NE

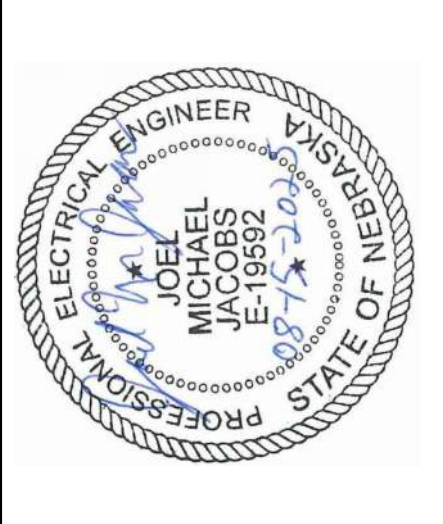

**PROJECT MANAGER**

|                 |                    |
|-----------------|--------------------|
| CIVIL           | C. KOENIG          |
| STRUCTURAL      | J. THOMPSON        |
| ARCHITECTURAL   | W. WILSON          |
| PROCESS         | J. ROBERTS         |
| MECHANICAL      | P. KONECK-WILLBERG |
| ELECTRICAL      | J. JACOBS          |
| INSTRUMENTATION | K. ROHLGFF         |

**PROJECT NUMBER** 1042904

| ISSUE | DATE      | DESCRIPTION                                      |
|-------|-----------|--|
| 2     | 9.10.2023 | COR. NO. 2 - FIBER CONDUIT AND HAND HOLE CHANGES |
| A     | 8-27-2025 | ISSUED FOR BID                                   |

HDR ENGINEERING, INC. | CA0443AE  
 1917 S. 67TH STREET  
 OMAHA, NE 68106  
 (402) 399-1000

**GENERAL NOTES**

- FURNISH AND INSTALL 2" HDPE SDR 11 CONDUIT FOR FIBER OPTIC ROUTES BETWEEN EXISTING BOOSTER STATION AND PUMP STATION #14. POPULATE WITH MAXCELL 3 CELL INNERDUCT.
- PLACE COMMUNICATION HANDHOLES WITHIN 5 FEET OF WELL PUMP BUILDING CONDUIT ROUTING FROM HANDHOLE TO BUILDING BY OTHERS.

**KEYNOTES (#)**

- INSTALL 4" X 4" JUNCTION BOXES ON BUILDING EXTERIOR WHERE SHOWN. PENETRATE CONDUIT INTO BUILDING. ROUTE CONDUIT TO LOCATION OF SECURITY PANEL. INSTALL GPO RECEPTACLE FOR SECURITY PANEL. VERIFY ALL OTHERS COORDINATE WITH SECURITY CONTRACTOR.

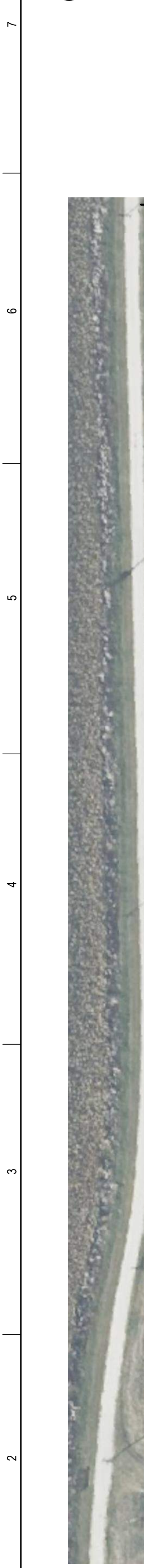
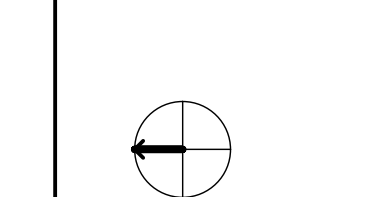

**ALIGNMENT LINE TABLE**

| LINE NO. | ALIGNMENT     | LENGTH | DIRECTION     | START POINT                 | END POINT                   |
|----------|---------------|--------|---------------|-----------------------------|-----------------------------|
| F-1-314  | FIBER OPTIC 2 | 802.65 | S86° 03' 27"E | N 610115.41<br>E 2364666.63 | N 610053.35<br>E 2365567.14 |

**ELECTRICAL SITE PLAN**

FILENAME: 10425904-E-101.dwg  
SCALE: 1" = 50'

SHEET: **01E105**

**The City of Columbus**  
**WELL NO. 20 DESIGN**  
 6651 33RD AVE. COLUMBUS, NE

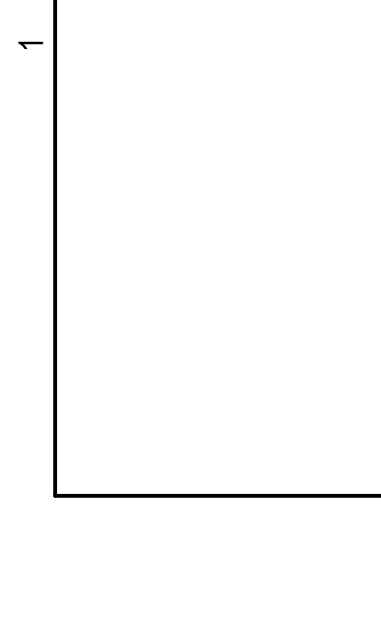

| PROJECT MANAGER | C. KOENIG             |
|-----------------|-----------------------|
| CIVIL           | S. SCHMOKER           |
| STRUCTURAL      | J. THOMPSON           |
| ARCHITECTURAL   | W. WILSON             |
| PROCESS         | J. ROBERTS            |
| MECHANICAL      | P. KONECK-WILLWERDING |
| ELECTRICAL      | L. JACOBS             |
| INSTRUMENTATION | K. ROHLGFF            |
| PROJECT NUMBER  | 10425904              |

| ISSUE | DATE      | DESCRIPTION                                      |
|-------|-----------|--|
| 2     | 9.19.2025 | COR. NO. 2 - FIBER CONDUIT AND HAND HOLE CHANGES |
| A     | 8-27-2025 | ISSUED FOR BID                                   |

**HDR**  
 HDR ENGINEERING, INC. | CA0443AE  
 1917 S. 67TH STREET  
 OMAHA, NE 68106  
 (402) 399-1000

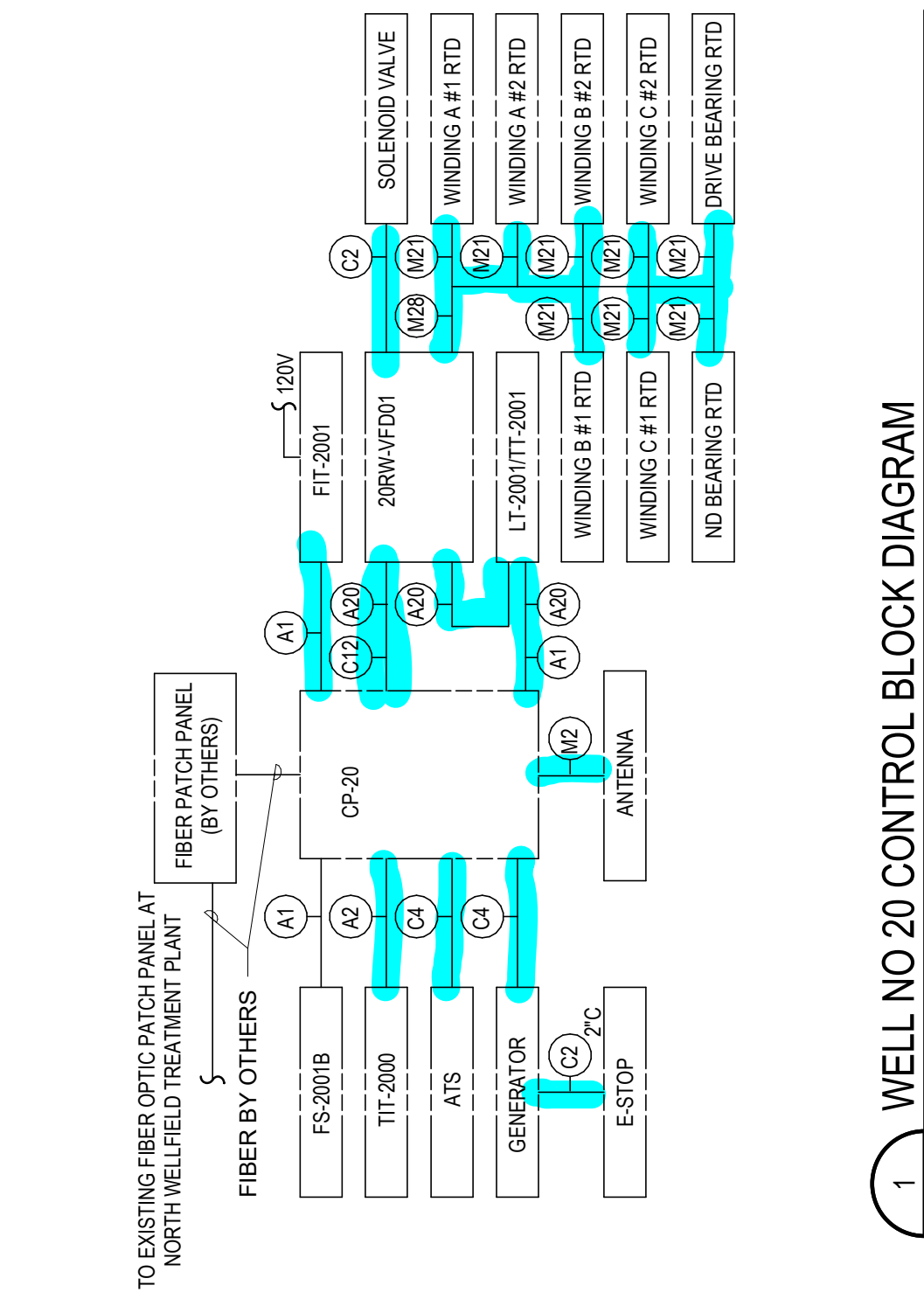

1 WELL NO 20 CONTROL BLOCK DIAGRAM

| CONDUCTOR AND CONDUIT SCHEDULE CONTROL CIRCUITS |           |        |        |        |          |           |        |        |        |
|---|-----------|--------|--------|--------|----------|-----------|--------|--------|--------|
| DWG MARK  | CONDUCTOR | METAL  | PVC    | FLEX   | DWG MARK | CONDUCTOR | METAL  | PVC    | FLEX   |
| C1  | 1- #14    | 3/4"   | 3/4"   | 3/4"   | C31      | 31- #14   | 1 1/4" | 1 1/4" | 1 1/4" |
| C2  | 2- #14    | 3/4"   | 3/4"   | 3/4"   | C32      | 32- #14   | 1 1/4" | 1 1/4" | 1 1/4" |
| C3  | 3- #14    | 3/4"   | 3/4"   | 3/4"   | C33      | 33- #14   | 1 1/4" | 1 1/4" | 1 1/4" |
| C4  | 4- #14    | 3/4"   | 3/4"   | 3/4"   | C34      | 34- #14   | 1 1/4" | 1 1/4" | 1 1/4" |
| C5  | 5- #14    | 3/4"   | 3/4"   | 3/4"   | C35      | 35- #14   | 1 1/4" | 1 1/4" | 1 1/4" |
| C6  | 6- #14    | 3/4"   | 3/4"   | 3/4"   | C36      | 36- #14   | 1 1/4" | 1 1/4" | 1 1/4" |
| C7  | 7- #14    | 3/4"   | 3/4"   | 3/4"   | C37      | 37- #14   | 1 1/4" | 1 1/4" | 1 1/4" |
| C8  | 8- #14    | 3/4"   | 3/4"   | 3/4"   | C38      | 38- #14   | 1 1/4" | 1 1/4" | 1 1/4" |
| C9  | 9- #14    | 3/4"   | 3/4"   | 3/4"   | C39      | 39- #14   | 1 1/4" | 1 1/4" | 1 1/4" |
| C10   | 10- #14   | 3/4"   | 3/4"   | 3/4"   | C40      | 40- #14   | 1 1/4" | 1 1/4" | 1 1/4" |
| C11   | 11- #14   | 3/4"   | 3/4"   | 3/4"   | C41      | 41- #14   | 1 1/4" | 1 1/4" | 1 1/4" |
| C12   | 12- #14   | 3/4"   | 3/4"   | 3/4"   | C42      | 42- #14   | 1 1/4" | 1 1/4" | 1 1/4" |
| C13   | 13- #14   | 3/4"   | 3/4"   | 3/4"   | C43      | 43- #14   | 1 1/4" | 1 1/4" | 1 1/4" |
| C14   | 14- #14   | 3/4"   | 3/4"   | 3/4"   | C44      | 44- #14   | 1 1/4" | 1 1/4" | 1 1/4" |
| C15   | 15- #14   | 3/4"   | 3/4"   | 3/4"   | C45      | 45- #14   | 1 1/4" | 1 1/4" | 1 1/4" |
| C16   | 16- #14   | 1"     | 1"     | 1"     | C46      | 46- #14   | 1 1/2" | 1 1/2" | 1 1/2" |
| C17   | 17- #14   | 1"     | 1"     | 1"     | C47      | 47- #14   | 1 1/2" | 1 1/2" | 1 1/2" |
| C18   | 18- #14   | 1"     | 1"     | 1"     | C48      | 48- #14   | 1 1/2" | 1 1/2" | 1 1/2" |
| C19   | 19- #14   | 1"     | 1"     | 1"     | C49      | 49- #14   | 1 1/2" | 1 1/2" | 1 1/2" |
| C20   | 20- #14   | 1"     | 1 1/4" | 1"     | C50      | 50- #14   | 1 1/2" | 2"     | 1 1/2" |
| C21   | 21- #14   | 1"     | 1 1/4" | 1"     | C21      | 51- #14   | 1 1/2" | 2"     | 1 1/2" |
| C22   | 22- #14   | 1"     | 1 1/4" | 1"     | C52      | 52- #14   | 1 1/2" | 2"     | 1 1/2" |
| C23   | 23- #14   | 1"     | 1 1/4" | 1"     | C53      | 53- #14   | 1 1/2" | 2"     | 1 1/2" |
| C24   | 24- #14   | 1"     | 1 1/4" | 1"     | C54      | 54- #14   | 1 1/2" | 2"     | 1 1/2" |
| C25   | 25- #14   | 1"     | 1 1/4" | 1 1/4" | C55      | 55- #14   | 1 1/2" | 2"     | 1 1/2" |
| C26   | 26- #14   | 1 1/4" | 1 1/4" | 1 1/4" | C56      | 56- #14   | 1 1/2" | 2"     | 1 1/2" |
| C27   | 27- #14   | 1 1/4" | 1 1/4" | 1 1/4" | C57      | 57- #14   | 1 1/2" | 2"     | 2"     |
| C28   | 28- #14   | 1 1/4" | 1 1/4" | 1 1/4" | C58      | 58- #14   | 1 1/2" | 2"     | 2"     |
| C29   | 29- #14   | 1 1/4" | 1 1/4" | 1 1/4" | C59      | 59- #14   | 1 1/2" | 2"     | 2"     |
| C30   | 30- #14   | 1 1/4" | 1 1/4" | 1 1/4" | C60      | 60- #14   | 1 1/2" | 2"     | 2"     |

6 1-#14 GROUND CONDUCTOR WITH CONTROL CONDUCTORS

| CONDUCTOR AND CONDUIT SCHEDULE INSTRUMENTATION CIRCUITS |            |       |        |        |          |             |        |        |        |
|---|------------|-------|--------|--------|----------|-------------|--------|--------|--------|
| DWG MARK  | CONDUCTOR  | METAL | PVC    | FLEX   | DWG MARK | CONDUCTOR   | METAL  | PVC    | FLEX   |
| A1  | 1-TSP #16  | DRAIN | 3/4"   | 3/4"   | M21      | 1-3/8" #14  | 3/4"   | 3/4"   | 3/4"   |
| A2  | 2-TSP #16  | DRAIN | 3/4"   | 3/4"   | M22      | 2-3/8" #14  | 1 1/4" | 1 1/4" | 1 1/4" |
| A3  | 3-TSP #16  | DRAIN | 3/4"   | 3/4"   | M23      | 3-3/8" #14  | 1 1/4" | 1 1/4" | 1 1/4" |
| A4  | 4-TSP #16  | DRAIN | 3/4"   | 3/4"   | M24      | 4-3/8" #14  | 1 1/4" | 1 1/4" | 1 1/4" |
| A5  | 5-TSP #16  | DRAIN | 1"     | 1 1/4" | M25      | 5-3/8" #14  | 1 1/4" | 1 1/2" | 1 1/2" |
| A6  | 6-TSP #16  | DRAIN | 1"     | 1 1/4" | M26      | 6-3/8" #14  | 1 1/2" | 2"     | 2"     |
| A7  | 7-TSP #16  | DRAIN | 1 1/4" | 1 1/4" | M27      | 7-3/8" #14  | 1 1/2" | 2"     | 2"     |
| A8  | 8-TSP #16  | DRAIN | 1 1/2" | 1 1/4" | M28      | 8-3/8" #14  | 2"     | 2"     | 2"     |
| A9  | 9-TSP #16  | DRAIN | 1 1/2" | 1 1/2" | M29      | 9-3/8" #14  | 2"     | 2 1/2" | 2"     |
| A10   | 10-TSP #16 | DRAIN | 1 1/2" | 1 1/2" | M30      | 10-3/8" #14 | 2"     | 2 1/2" | 2"     |
| A11   | 11-TSP #16 | DRAIN | 1 1/2" | 2"     | M31      | 1-4/8" #14  | 3/4"   | 3/4"   | 3/4"   |
| A12   | 12-TSP #16 | DRAIN | 1 1/2" | 2"     | M32      | 2-4/8" #14  | 1 1/4" | 1 1/4" | 1 1/4" |
| A13   | 13-TSP #16 | DRAIN | 2"     | 2"     | M33      | 3-4/8" #14  | 1 1/4" | 1 1/4" | 1 1/4" |
| A14   | 14-TSP #16 | DRAIN | 2"     | 2"     | M34      | 4-4/8" #14  | 1 1/4" | 1 1/2" | 1 1/2" |
| A15   | 15-TSP #16 | DRAIN | 2"     | 2"     | M35      | 5-4/8" #14  | 1 1/2" | 2"     | 2"     |
| A20   | 1-TST #16  | DRAIN | 3/4"   | 3/4"   | M36      | 6-4/8" #14  | 2"     | 2"     | 2"     |
| A21   | 2-TST #16  | DRAIN | 3/4"   | 3/4"   | M37      | 7-4/8" #14  | 2"     | 2"     | 2"     |
| A22   | 3-TST #16  | DRAIN | 1"     | 1"     | M38      | 8-4/8" #14  | 2"     | 2 1/2" | 2"     |
| A23   | 4-TST #16  | DRAIN | 1"     | 1 1/4" | M39      | 9-4/8" #14  | 2"     | 2"     | 2"     |
| A24   | 5-TST #16  | DRAIN | 1 1/4" | 1 1/4" | M40      | 1-7/8" #14  | 3/4"   | 3/4"   | 3/4"   |
| A25   | 6-TST #16  | DRAIN | 1 1/4" | 1 1/4" | M41      | 2-7/8" #14  | 1 1/4" | 1 1/2" | 1 1/4" |
|   |            |       |        |        | M42      | 3-7/8" #14  | 1 1/4" | 1 1/2" | 1 1/4" |
|   |            |       |        |        | M43      | 4-7/8" #14  | 1 1/2" | 2"     | 2"     |
|   |            |       |        |        | M44      | 5-7/8" #14  | 2"     | 2"     | 2"     |
|   |            |       |        |        | M45      | 6-7/8" #14  | 2"     | 2"     | 2"     |
|   |            |       |        |        | M46      | 7-7/8" #14  | 2"     | 2"     | 2"     |
|   |            |       |        |        | M47      | 8-7/8" #14  | 2"     | 2"     | 2"     |
|   |            |       |        |        | M48      | 9-7/8" #14  | 2"     | 2"     | 2"     |
|   |            |       |        |        | M49      | 1-9/8" #14  | 1"     | 1"     | 1"     |
|   |            |       |        |        | M50      | 2-9/8" #14  | 2"     | 2"     | 2"     |
|   |            |       |        |        | M51      | 3-9/8" #14  | 2"     | 2"     | 2"     |
|   |            |       |        |        | M52      | 4-9/8" #14  | 2 1/2" | 2 1/2" | 2 1/2" |
|   |            |       |        |        | M53      | 5-9/8" #14  | 2 1/2" | 2 1/2" | 2 1/2" |
|   |            |       |        |        | M54      | 6-9/8" #14  | 2 1/2" | 2 1/2" | 2 1/2" |
|   |            |       |        |        | M55      | 7-9/8" #14  | 2 1/2" | 2 1/2" | 2 1/2" |
|   |            |       |        |        | M56      | 8-9/8" #14  | 2 1/2" | 2 1/2" | 2 1/2" |
|   |            |       |        |        | M57      | 9-9/8" #14  | 2 1/2" | 2 1/2" | 2 1/2" |

CONDUCTOR AND CONDUIT SCHEDULE NOTES

- ALL MARK NUMBERS MAY NOT BE USED ON THIS PROJECT.
- CONTROL CONDUCTORS IN SAME CONDUIT AS POWER CONDUCTORS
- CONTROL CONDUCTORS IS SEPARATE CONDUIT FROM POWER CONDUCTORS
- TYPE "T" CONDUIT BODY OR OUTLET BOX PER SPECIFICATIONS CUBIC INCH VOLUME PER NEC. POWER CONDUCTORS CAN BE SPLICED. CONTROL CONDUCTORS AND INSTRUMENTATION CABLES SHALL BE UNSPLICED.
- GROUND CONDUCTOR IN SAME CONDUIT AS CONTROL CONDUCTOR
- MULTIPLE MULTICONDUCTOR CABLES IN SAME CONDUIT. REQUIRED CONDUIT SIZE INDICATED.
- FUNCTION BOX SIZED PER NEC. TYPE PER SPECIFICATIONS. USE TERMINAL BLOCKS FOR SPLICES IN CONTROL BOXES. INSTRUMENTATION L-BOXES SHALL BE USED AS PULL BOXES. CABLES SHALL NOT BE SPLICED.

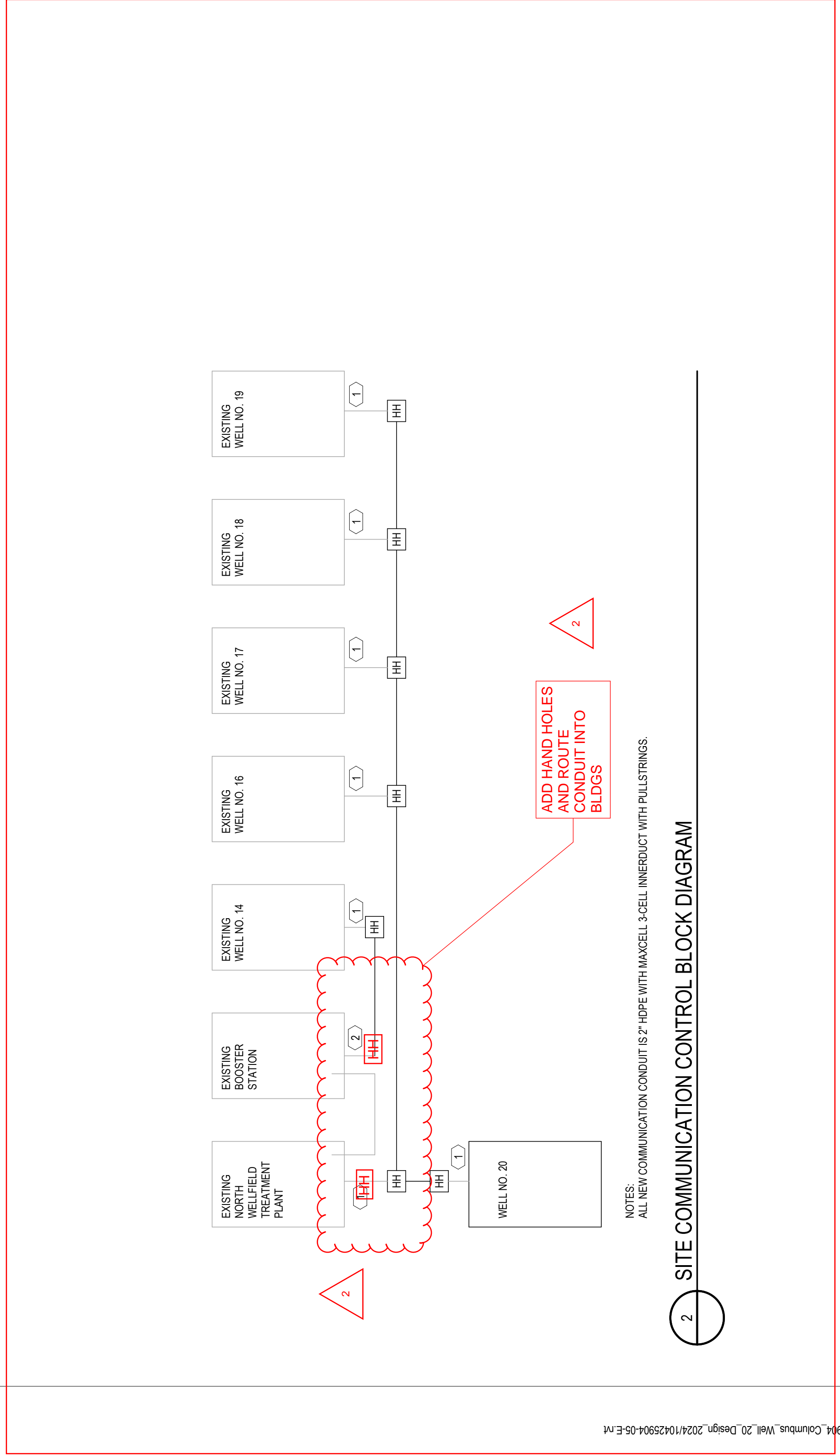

NOTES:  
ALL NEW COMMUNICATION CONDUIT IS 2" HDPE WITH MAXWELL 3-CELL INNERDUCT WITH PULLSTRINGS.

2 SITE COMMUNICATION CONTROL BLOCK DIAGRAM

**KEYNOTES (#)**

- ROUTE CONDUIT TO HANDHOLE CONDUIT PENETRATION INTO STRUCTURE BY OTHERS.
- ROUTE CONDUIT WITHIN FIVE FEET OF EXISTING BUILDING AND MARK LOCATION OF CONDUIT PENETRATION INTO STRUCTURE BY OTHERS.

| CONDUCTOR AND CONDUIT SCHEDULE POWER CIRCUITS |              |        |       |        |      |  |
|---|--------------|--------|-------|--------|------|--|
| DWG MARK                                      | CONDUCTOR    | GROUND | METAL | PVC    | FLEX |  |
| P1  | 2-#12        | 1-#12  | 3/4"  | 3/4"   | 3/4" |  |
| P2  | 3-#12        | 1-#12  | 3/4"  | 3/4"   | 3/4" |  |
| P3  | 4-#12        | 2-#12  | 3/4"  | 3/4"   | 3/4" |  |
| P4  | 2-#10        | 1-#10  | 3/4"  | 3/4"   | 3/4" |  |
| P5  | 2-#10        | -      | 3/4"  | 3/4"   | 3/4" |  |
| P10   | 1-3C WIG #12 | -      | 3/4"  | 3/4"   | 3/4" |  |
| P11   | 1-4C WIG #12 | -      | 3/4"  | 3/4"   | 3/4" |  |
| P12   | 1-4C WIG #12 | -      | 3/4"  | 3/4"   | 3/4" |  |
| P13   | 2-3C WIG #12 | -      | 1"    | 1 1/4" | 1"   |  |

| CONDUCTOR AND CONDUIT SCHEDULE MULTICONDUCTOR CONTROL CIRCUITS |                       |        |        |        |  |  |
|--|-----------------------|--------|--------|--------|--|--|
| DWG MARK   | CONDUCTOR             | METAL  | PVC    | FLEX   |  |  |
| M1   | MANUFACTURER SUPPLIED | 3/4"   | 3/4"   | 3/4"   |  |  |
| M2   | MANUFACTURER SUPPLIED | 1"     | 1"     | 1"     |  |  |
| M3   | MANUFACTURER SUPPLIED | 2"     | 2"     | 2"     |  |  |
| M4   | MANUFACTURER SUPPLIED |        |        |        |  |  |
| M5   | MANUFACTURER SUPPLIED |        |        |        |  |  |
| M6   | MANUFACTURER SUPPLIED |        |        |        |  |  |
| M7   | MANUFACTURER SUPPLIED |        |        |        |  |  |
| M8   | MANUFACTURER SUPPLIED |        |        |        |  |  |
| M9   | MANUFACTURER SUPPLIED |        |        |        |  |  |
| M10  | OWNER SUPPLIED        | 1"     | 1"     | 1"     |  |  |
| M11  | 2-2/C #14             | 3/4"   | 3/4"   | 3/4"   |  |  |
| M12  | 2-2/C #14             | 3/4"   | 3/4"   | 3/4"   |  |  |
| M13  | 3-2/C #14             | 1"     | 1"     | 1"     |  |  |
| M14  | 4-2/C #14             | 1 1/4" | 1 1/4" | 1 1/4" |  |  |
| M15  | 5-2/C #14             | 1 1/4" | 1 1/2" | 1 1/2" |  |  |
| M16  | 6-2/C #14             | 1 1/2" | 1 1/2" | 1 1/2" |  |  |
| M19  | 9-2/C #14             | 2"     | 2"     | 2"     |  |  |
| M20  | 10-2/C #14            | 2"     | 2"     | 2"     |  |  |
| M21  | 1-3/8" #14            | 3/4"   | 3/4"   | 3/4"   |  |  |
| M22  | 2-3/8" #14            | 1 1/4" | 1 1/4" | 1 1/4" |  |  |
| M23  | 3-3/8" #14            | 1 1/4" | 1 1/4" | 1 1/4" |  |  |
| M24  | 4-3/8" #14            | 1 1/4" | 1 1/4" | 1 1/4" |  |  |
| M25  | 5-3/8" #14            | 1 1/4" | 1 1/2" | 1 1/2" |  |  |
| M26  | 6-3/8" #14            | 1 1/2" | 2"     | 2"     |  |  |
| M27  | 7-3/8" #14            | 1 1/2" | 2"     | 2"     |  |  |
| M28  | 8-3/8" #14            | 2"     | 2"     | 2"     |  |  |
| M29  | 9-3/8" #14            | 2"     | 2"     | 2"     |  |  |
| M30  | 10-3/8" #14           | 2"     | 2 1/2" | 2"     |  |  |
| M31  | 1-4/8" #14            | 3/4"   | 3/4"   | 3/4"   |  |  |
| M32  | 2-4/8" #14            | 1 1/4" | 1 1/4" | 1 1/4" |  |  |
| M33  | 3-4/8" #14            | 1 1/4" | 1 1/4" | 1 1/4" |  |  |
| M34  | 4-4/8" #14            | 1 1/4" | 1 1/2" | 1 1/2" |  |  |
| M35  | 5-4/8" #14            | 1 1/2" | 2"     | 2"     |  |  |
| M36  | 6-4/8" #14            | 2"     | 2"     | 2"     |  |  |
| M37  | 7-4/8" #14            | 2"     | 2"     | 2"     |  |  |
| M38  | 8-4/8" #14            | 2"     | 2 1/2" | 2"     |  |  |
| M39  | 9-4/8" #14            | 2"     | 2"     | 2"     |  |  |
| M40  | 1-7/8" #14            | 3/4"   | 3/4"   | 3/4"   |  |  |
| M41  | 2-7/8" #14            | 1 1/4" | 1 1/2" | 1 1/2" |  |  |
| M42  | 3-7/8" #14            | 1 1/4" | 1 1/2" | 1 1/2" |  |  |
| M43  | 4-7/8" #14            | 1 1/2" | 2"     | 2"     |  |  |
| M44  | 5-7/8" #14            | 2"     | 2"     | 2"     |  |  |
| M45  | 6-7/8" #14            | 2"     | 2"     | 2"     |  |  |
| M46  | 7-7/8" #14            | 2"     | 2"     | 2"     |  |  |
| M47  | 8-7/8" #14            | 2"     | 2"     | 2"     |  |  |
| M48  | 9-7/8" #14            | 2"     | 2"     | 2"     |  |  |
| M49  | 1-9/8" #14            | 1"     | 1"     | 1"     |  |  |
| M50  | 2-9/8" #14            | 1 1/2" | 2"     | 2"     |  |  |
| M51  | 3-9/8" #14            | 2"     | 2"     | 2"     |  |  |
| M52  | 4-9/8" #14            | 2 1/2" | 2 1/2" | 2 1/2" |  |  |
| M53  | 5-9/8" #14            | 2 1/2" | 2 1/2" | 2 1/2" |  |  |
| M54  | 6-9/8" #14            | 2 1/2" | 2 1/2" | 2 1/2" |  |  |
| M55  | 7-9/8" #14            | 2 1/2" | 2 1/2" | 2 1/2" |  |  |
| M56  | 8-9/8" #14            | 2 1/2" | 2 1/2" | 2 1/2" |  |  |
| M57  | 9-9/8" #14            | 2 1/2" | 2 1/2" | 2 1/2" |  |  |

| CONDUCTOR AND CONDUIT SCHEDULE DIGITAL CONTROLS |                    |       |      |      |  |  |
|---|--------------------|-------|------|------|--|--|
| DWG MARK  | CONDUCTOR          | METAL | PVC  | FLEX |  |  |
| D1  | 1-CAT 6            | 3/4"  | 3/4" | 3/4" |  |  |
| D2  | 2-CAT 6            | 3/4"  | 3/4" | 3/4" |  |  |
| D3  | 3-CAT 6            | 3/4"  | 3/4" | 3/4" |  |  |
| D4  | 4-CAT 6            | 3/4"  | 3/4" | 3/4" |  |  |
| D5  | 5-CAT 6            | 3/4"  | 3/4" | 3/4" |  |  |
| F1  | 6-STRAND MM FIBER  | 3/4"  | 3/4" | 3/4" |  |  |
| F2  | 12-STRAND MM FIBER | 3/4"  | 3/4" | 3/4" |  |  |
| F3  | 24-STRAND MM FIBER | 3/4"  | 3/4" | 3/4" |  |  |

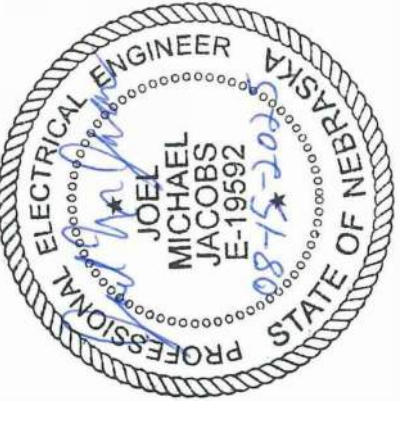

The City of **Columbus**  
WELL NO. 20 DESIGN

6651 33RD AVE. COLUMBUS, NE

| PROJECT MANAGER | C. KOENIG            |
|-----------------|----------------------|
| CIVIL           | S. SCHWOKER          |
| STRUCTURAL      | J. THOMPSON          |
| ARCHITECTURAL   | W. WILSON            |
| PROCESS         | J. ROBERTS           |
| MECHANICAL      | P. KONECK-WILHERDING |
| ELECTRICAL      | J. JACOBS            |
| INSTRUMENTATION | K. ROELOFF           |

| ISSUE | DATE      | DESCRIPTION                                     |
|-------|-----------|---|
| 2     | 2.10.2025 | CSR NO. 2 - FIBER CONDUIT AND HAND HOLE CHANGES |
| A     | 8-27-2025 | ISSUED FOR BID                                  |

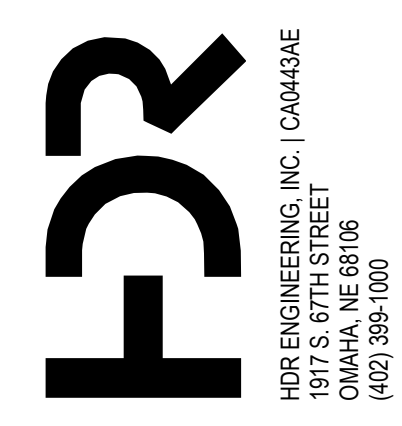

ELECTRICAL CONTROL BLOCK DIAGRAMS

## CHANGE PROPOSAL NO. 3

### WELL CASING DI-ELECTRIC COUPLING

Owner: City of Columbus, Nebraska

Project Name: Columbus Well No. 20

Change Proposal No.: 3

Date: 2.19.2026

Submitted in Response to Proposal Request No.: 3

Contractor Name and No.: Columbus Well No. 20 - 10425904

Contractor: Rutjens Construction, Inc.

Subject: Proposal Request No. 3 – Well Screen Di-Electric Coupling

The following changes to the Contract as described below are proposed.

#### SCOPE OF PROPOSED CHANGE TO CONTRACT:

1. Proposal Request No. 3 – Provide and install dielectric coupler at the transition between well casing and well screen.

#### JUSTIFICATION:

1. Provides protection against galvanic corrosion at the transition between well casing and well screen.

#### PROPOSED CHANGES IN CONTRACT PRICE AND CONTRACT TIMES:

We propose that the Contract Price and Contract Times be changed as follows:

***For Contract Price, attach detailed cost breakdowns for Contractor and Subcontractors, Supplier quotations, and other information required.***

***For the Contract Times, state increase, decrease, or no change to Contract Times for Substantial Completion, readiness for final payment, and Milestones, if any. If increase or decrease, state specific number of days for changes to the Contract Times. Submit supporting data, including time impact analysis for the Progress Schedule.***

| Description                       | Amount             | Contract Times (days) |          |
|-----------------------------------|--------------------|-----------------------|----------|
|                                   |                    | Substantial           | Final    |
| 1. Control Conductors             | \$24,910           | 0                     | 0        |
| <b>Total This Change Proposal</b> | <b>\$24,910.00</b> | <b>0</b>              | <b>0</b> |

Changes to Milestones, if any: \_\_\_\_\_

Contractor represents that supporting data attached to this Change Proposal are accurate and complete. The requested time or price adjustment indicated in this Change Proposal is the entire adjustment to which Contractor believes it is entitled as a result of the proposed change(s) indicated herein.

Change Proposal by (Contractor): Rutjens Construction

Signature of Proposer: See attached page for Contractor signature



CPR

PROJECT NAME: Columbus Well 20 Design      DATE: 2/9/2026  
 PROJECT NUMBER: 10425904  
 SUBJECT: Proposal Request No.3 - Well      CPR NO.: 003  
 Screen Di-Electric Coupling

DESCRIPTION OF CHANGE:1-24" Dielectric Coupling, 9'-24" x.375" 304 Stainless Steel Casing

All Work shall be in accordance with the terms, stipulations and conditions of original Contract Documents.

Time Change (Calendar Days): 0  
 Amount: \$24,910.00

Construction Mgr./Contractor: Rutjens Construction      By:       Date:2/9/2026      Recommendation:  
 Approval  
 Rejection  
 No Recommendation

Architect/Engineer:      By: Chris Koenig      Date:2.19.2026      Recommendation:  
 Approval  
 Rejection  
 No Recommendation

Owner:      By:      Date:      Action:  
 Approval  
 Rejection

The Contractor is directed to make changes indicated above for the proposed amount and time after Owner approval.  
 If allowed by the Contract Documents, this document is considered a fully executed Change Order after Owner approval.

**PROPOSAL REQUEST NO. 3**

**WELL SCREEN DI-ELECTRIC COUPLING**

Owner: City of Columbus, Nebraska

Project Name: Columbus Well No. 20

Proposal Request No.: 3

Date: **February 05, 2026**

Contract Name and No.: **Columbus Well No. 20 - 10425904**

Contractor: **Rutjens Construction, Inc.**

Other Contracts Involved in Proposed Change: **NA**

TO CONTRACTOR: Please submit a complete Change Proposal (template attached) for the proposed modifications described below. If the associated Change Proposal is approved, a Change Order or allowance authorization will be issued to authorize adjustment so the Contract.

This Proposal Request is not a Change Order, Work Change Directive, Field Order, or an authorization to proceed with the proposed Work described below.

**SCOPE OF PROPOSED CHANGE(S) IN THE WORK:**

1. Provide and install a dielectric coupler at the transition between the carbon steel well casing and the stainless steel well screen, located at approximately 115 feet below ground surface. Replace the 24-inch diameter, 0.50-inch-thick carbon steel well casing with 24-inch diameter, 0.375-inch-thick stainless steel well casing between 135 and 144 feet below ground surface. See attached Figure CPR01-20D101.

Attachments to this Proposal Request:

1. Figure 20D101 – Proposal Request No. 3
2. Change Proposal No. 3.

Proposal requested by: Scott Schmoker / Joseph Roberts  
HDR (Engineer)



Signature of Requestor: \_\_\_\_\_

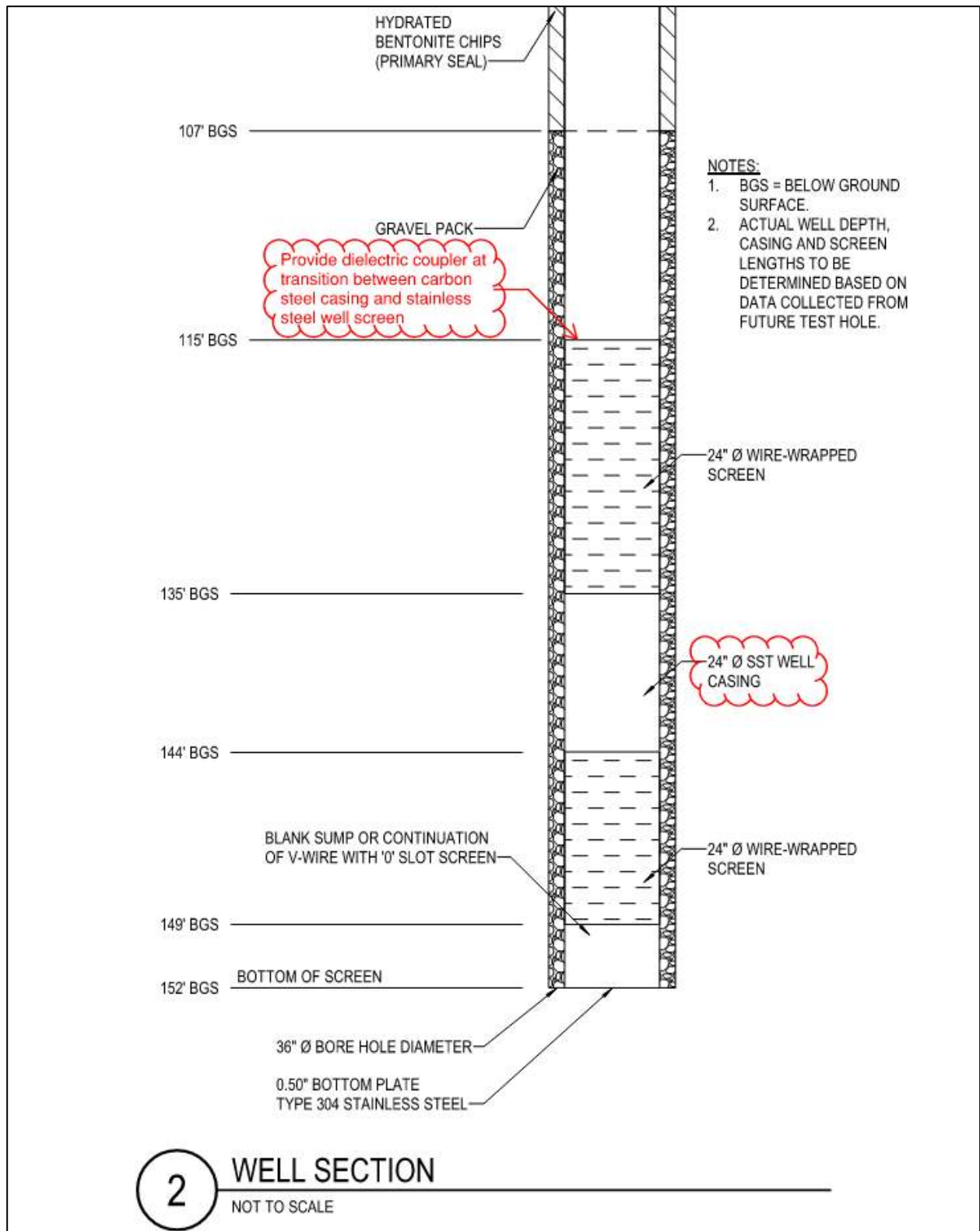

Proposal Request 03 – Figure 20D101

## CHANGE PROPOSAL NO. 4

### 2" HDPE CONDUIT AND PLYWOOD DATA RACK MOUNTING BOARDS

Owner: City of Columbus, Nebraska

Project Name: Columbus Well No. 20

Change Proposal No. 4

Date: **3.23.2026**

Submitted in Response to Proposal Request No. NA

Contractor Name and No.: **Columbus Well No. 20 - 10425904**

Contractor: **Rutjens Construction, Inc.**

Subject: **2" HDPE Conduit under drive from handhole to WTP and Plywood Data Rack Mounts in Well Houses**

The following changes to the Contract as described below are proposed.

#### SCOPE OF PROPOSED CHANGE TO CONTRACT:

1. Additional 2" HDPE under driveway from hand hole to treatment plant per City's employees.
2. Addition of plywood to each well building for data rack and security box. Conduit to be run around exterior of Well No. 14 from south side to east side to reduce the chance of fiber optic damage during well maintenance.

#### JUSTIFICATION:

1. Per request from City.
2. Requested per site visit with Matt Soukup and RVW on 3.04.2026.

#### PROPOSED CHANGES IN CONTRACT PRICE AND CONTRACT TIMES:

We propose that the Contract Price and Contract Times be changed as follows:

***For Contract Price, attach detailed cost breakdowns for Contractor and Subcontractors, Supplier quotations, and other information required.***

***For the Contract Times, state increase, decrease, or no change to Contract Times for Substantial Completion, readiness for final payment, and Milestones, if any. If increase or decrease, state specific number of days for changes to the Contract Times. Submit supporting data, including time impact analysis for the Progress Schedule.***

| Description                       | Amount            | Contract Times (days) |          |
|-----------------------------------|-------------------|-----------------------|----------|
|                                   |                   | Substantial           | Final    |
| 1. Materials                      | \$1,135.00        | 0                     | 0        |
| 3. Labor                          | \$2,548.00        | 0                     | 0        |
| 4. Contractor Bond/Markup         | \$367.00          | 0                     | 0        |
| <b>Total This Change Proposal</b> | <b>\$4,050.00</b> | <b>0</b>              | <b>0</b> |

Changes to Milestones, if any: NA

Contractor represents that supporting data attached to this Change Proposal are accurate and complete. The requested time or price adjustment indicated in this Change Proposal is the entire adjustment to which Contractor believes it is entitled as a result of the proposed change(s) indicated herein.

Change Proposal by (Contractor): **Adam Rutjens, Rutjens Construction**

Signature of Proposer:

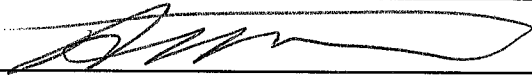

---

## CHANGE PROPOSAL NO. 5

### WELL HOUSE WALL SECTION REVISION

Owner: City of Columbus, Nebraska

Project Name: Columbus Well No. 20

Change Proposal No. 5

Date: 3.23.2026

Submitted in Response to Proposal Request No. NA

Contractor Name and No.: Columbus Well No. 20 - 10425904

Contractor: Rutjens Construction, Inc.

Subject: Well House Wall Section Revision

The following changes to the Contract as described below are proposed.

#### SCOPE OF PROPOSED CHANGE TO CONTRACT:

1. Revise the wall section for Well No. 20 as shown on the attached plan sheets dated 3.18.2026 for CPR No. 5.

##### Plan Sheets for CPR No. 5:

- a. Sheet 20A101 Architecture Floor Plan, Roof Plan and Exterior Sections
- b. Sheet 20A301 Architecture Building Section, Wall Section and Details
- c. Sheet 20A601 Architecture Schedules and Details
- d. Sheet 20S101 Structural Foundation Plan and Roof Framing Plan
- e. Sheet 20S301 Structural Sections and Details
- f. Sheet 00S503 Typical Masonry Details

#### JUSTIFICATION:

1. Cost reduction due to modified wall insulation approach.

#### PROPOSED CHANGES IN CONTRACT PRICE AND CONTRACT TIMES:

We propose that the Contract Price and Contract Times be changed as follows:

***For Contract Price, attach detailed cost breakdowns for Contractor and Subcontractors, Supplier quotations, and other information required.***

*For the Contract Times, state increase, decrease, or no change to Contract Times for Substantial Completion, readiness for final payment, and Milestones, if any. If increase or decrease, state specific number of days for changes to the Contract Times. Submit supporting data, including time impact analysis for the Progress Schedule.*

| Description                       | Amount                | Contract Times (days) |          |
|-----------------------------------|-----------------------|-----------------------|----------|
|                                   |                       | Substantial           | Final    |
| 1. Materials                      | \$ (13,747.00)        | 0                     | 0        |
| 2. Labor                          | \$ (7,403.00)         | 0                     | 0        |
| 3. Contractor Bond/Markup         | \$ (2,350.00)         | 0                     | 0        |
| <b>Total This Change Proposal</b> | <b>\$ (23,500.00)</b> | <b>0</b>              | <b>0</b> |

Changes to Milestones, if any: NA

Contractor represents that supporting data attached to this Change Proposal are accurate and complete. The requested time or price adjustment indicated in this Change Proposal is the entire adjustment to which Contractor believes it is entitled as a result of the proposed change(s) indicated herein.

Change Proposal by (Contractor): **Adam Rutjens, Rutjens Construction**

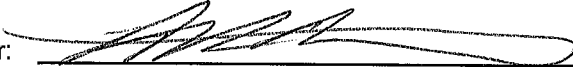
Signature of Proposer:  \_\_\_\_\_

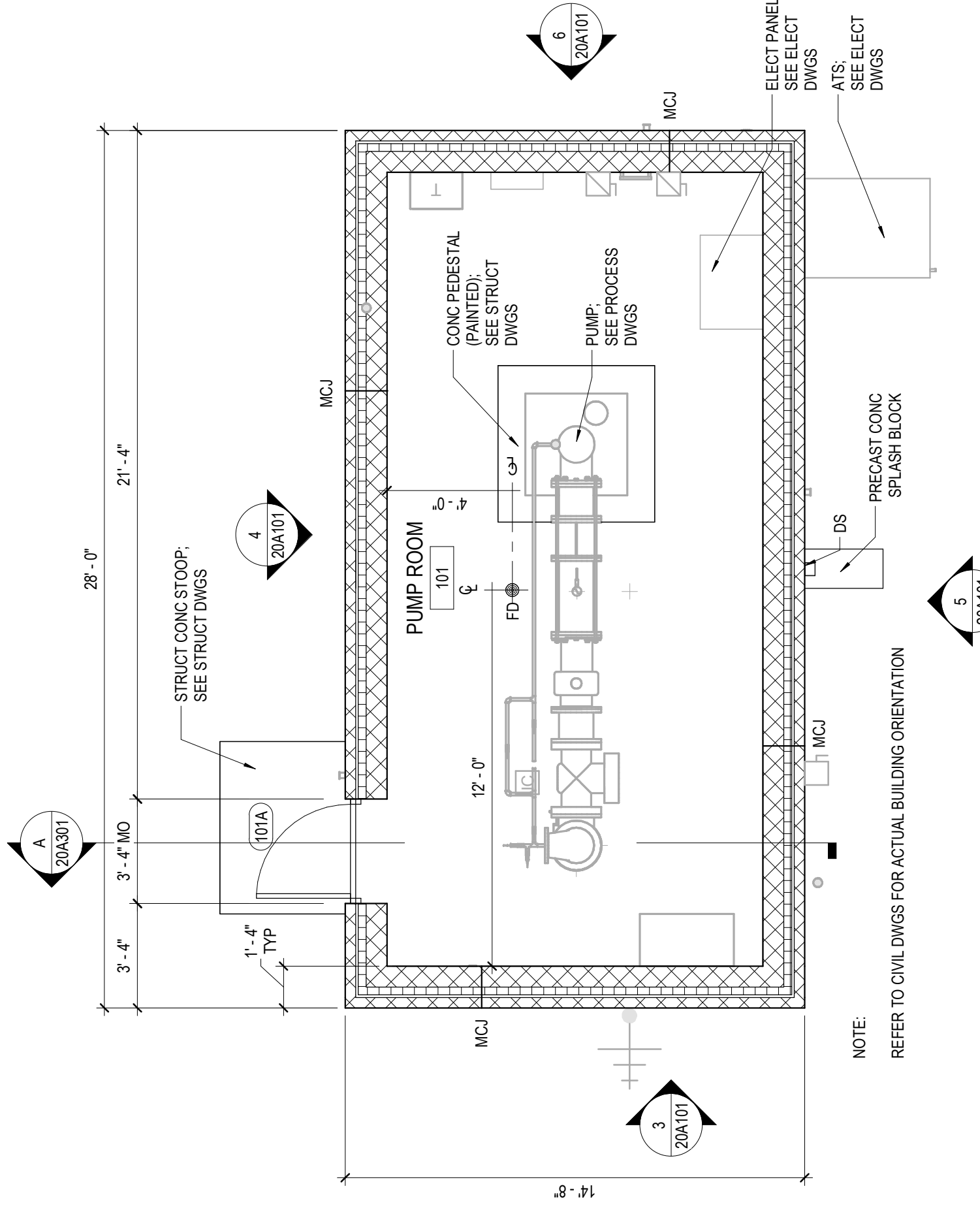

**1**  
FLOOR PLAN  
1/4" = 1'-0"

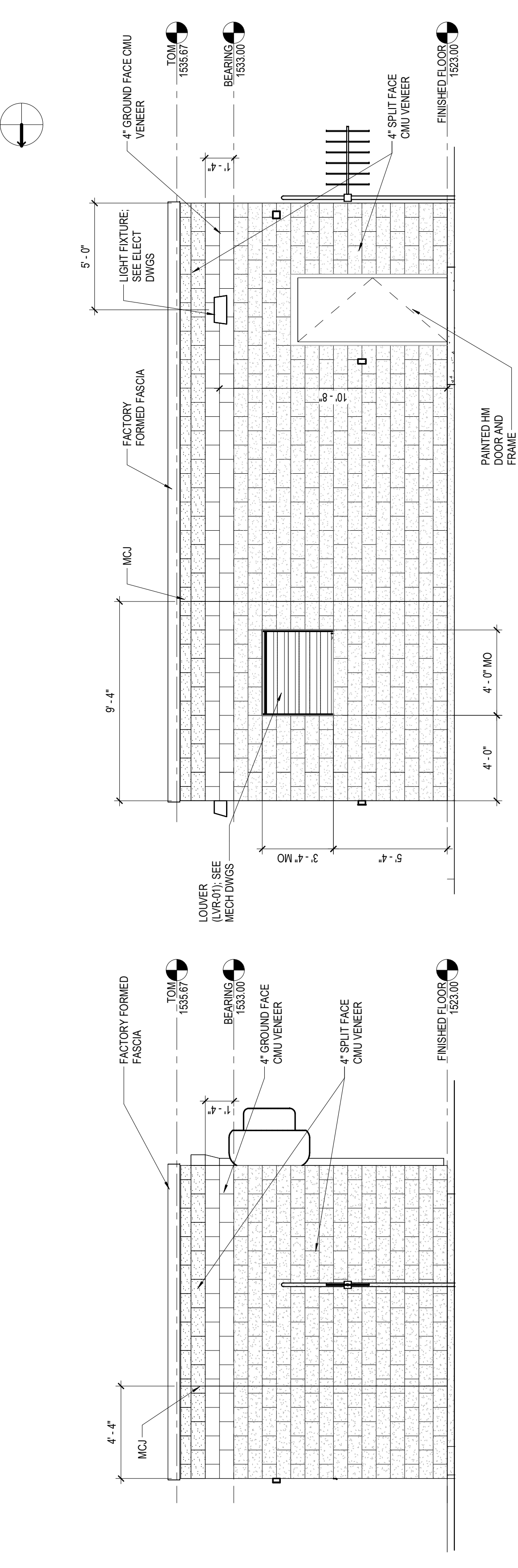

**3**  
NORTH ELEVATION  
1/4" = 1'-0"

**4**  
EAST ELEVATION  
1/4" = 1'-0"

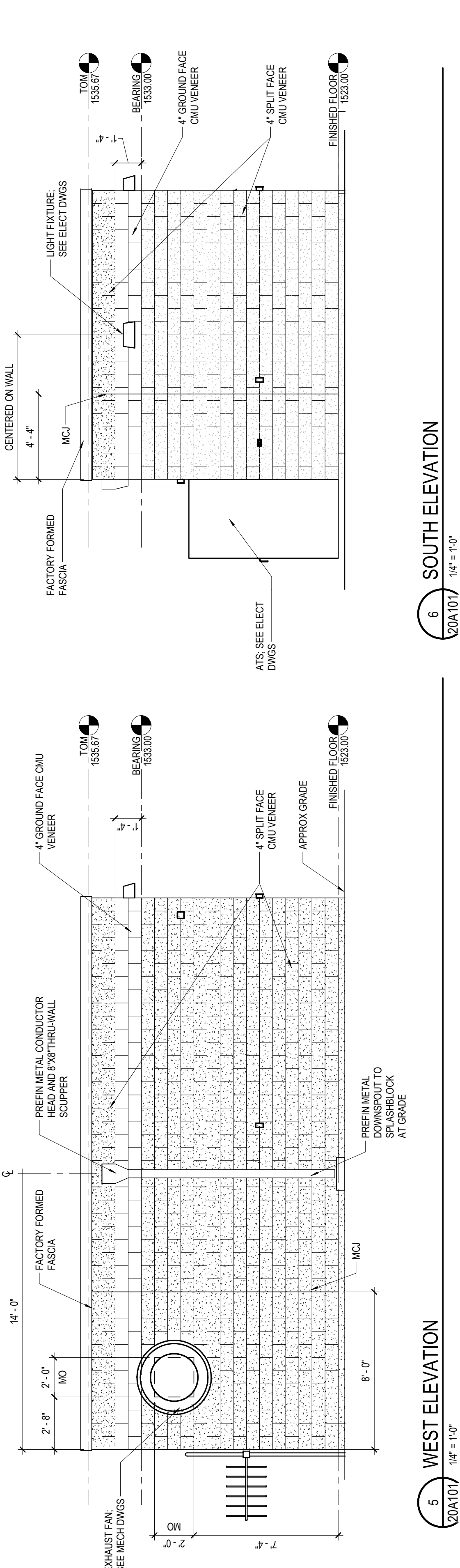

**5**  
WEST ELEVATION  
1/4" = 1'-0"

**6**  
SOUTH ELEVATION  
1/4" = 1'-0"

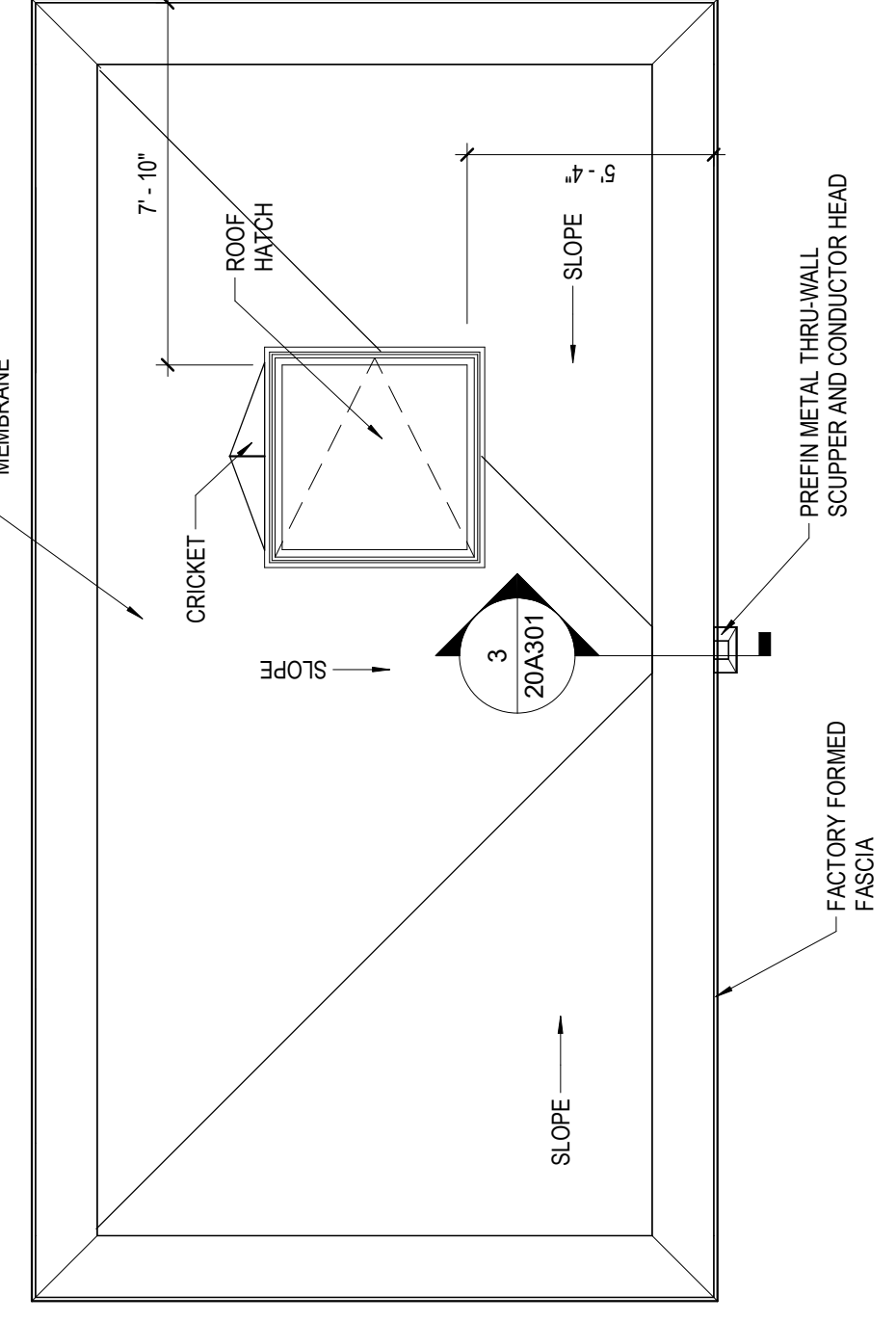

**2**  
ROOF PLAN  
1/4" = 1'-0"



The City of **Columbus**  
WELL NO. 20 DESIGN  
6651 33RD AVE. COLUMBUS, NE

ARCHITECTURE FLOOR PLAN, ROOF PLAN AND EXTERIOR ELEVATIONS  
SHEET **20A101**  
FILENAME | 10425904-06-SA.rvt  
SCALE | 1/4" = 1'-0"  
0 1' 2'

| PROJECT MANAGER | C. KOENIG           | PROJECT NUMBER | 10425904 |
|-----------------|---------------------|----------------|----------|
| CIVIL           | S. SCHWOKER         |                |          |
| STRUCTURAL      | J. THOMPSON         |                |          |
| ARCHITECTURAL   | W. WILSON           |                |          |
| PROCESS         | J. ROBERTS          |                |          |
| MECHANICAL      | P. KONECK-WILBERING |                |          |
| ELECTRICAL      | J. JACOBS           |                |          |
| INSTRUMENTATION | K. ROHLOFF          |                |          |

| ISSUE | DATE      | DESCRIPTION        |
|-------|-----------|--------------------|
| A     | 3/19/2026 | CRR NO. 5          |
|       | 11-7-2025 | CONFORMED DRAWINGS |



| DOOR SCHEDULE |       |        |           |          |        |                |      |              |              |              |        |         |
|---------------|-------|--------|-----------|----------|--------|----------------|------|--------------|--------------|--------------|--------|---------|
| DOOR NUMBER   | WIDTH | HEIGHT | DOOR TYPE | MATERIAL | FINISH | FRAME MATERIAL | TYPE | HARDWARE SET | GLASS RATING | DETAILS JAMB | SILL   | REMARKS |
| 101A          | 3'-0" | 7'-0"  | F         | HM       | HPIC   | HM             | 1    | HM-01        | -            | 3A-6B1       | 4A-6B1 | -       |

| MATERIAL AND FINISH LEGEND |                                     |  |  |  |  |  |  |  |  |
|----------------------------|-------------------------------------|--|--|--|--|--|--|--|--|
| MATERIAL                   | FINISH                              |  |  |  |  |  |  |  |  |
| HM                         | HOLLOW METAL                        |  |  |  |  |  |  |  |  |
| HPIC                       | HIGH PERFORMANCE INDUSTRIAL COATING |  |  |  |  |  |  |  |  |

  

| ROOM FINISH SCHEDULE |           |       |      |       |      |       |      |         |        |         |
|----------------------|-----------|-------|------|-------|------|-------|------|---------|--------|---------|
| ROOM NUMBER          | ROOM NAME | FLOOR | BASE | NORTH | EAST | SOUTH | WEST | CEILING | FINISH | REMARKS |
| 101                  | PUMP ROOM | CS-2  | N    | HPIC  | HPIC | HPIC  | HPIC | HPIC    | HPIC   | 1       |

| MATERIAL AND FINISH LEGEND |  |                                   |  |  |  |  |  |  |  |
|----------------------------|--|-----------------------------------|--|--|--|--|--|--|--|
| FLOOR                      | WALLS                                      | HPIC                              |  |  |  |  |  |  |  |
| CS-2                       | CHEMICAL FLOOR SEALER, HARDENER, DENSIFIER | NONE                              |  |  |  |  |  |  |  |
| HPIC                       | HIGH PERFORMANCE INDUSTRIAL COATING        | PAINTED STRUCTURE WITH HPIC NO. # |  |  |  |  |  |  |  |

NOTES:  
 1. PROVIDE CONCRETE FINISH NO. 5 WHERE CONCRETE IS INDICATED TO BE PAINTED.  
 2. SEE FRAME TYPES DETAIL THIS SHEET FOR FRAME ELEVATIONS.  
 3. SEE DOOR TYPES DETAIL THIS SHEET FOR DOOR ELEVATIONS.

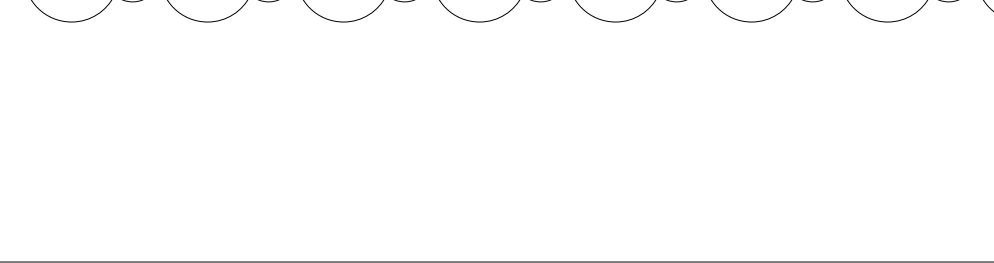
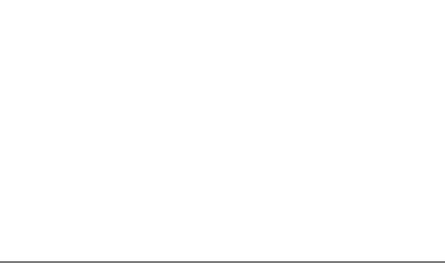
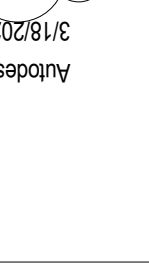
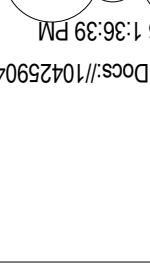
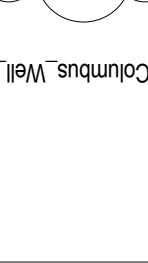
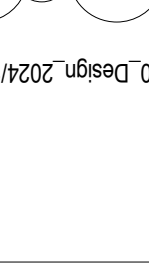
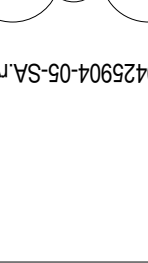
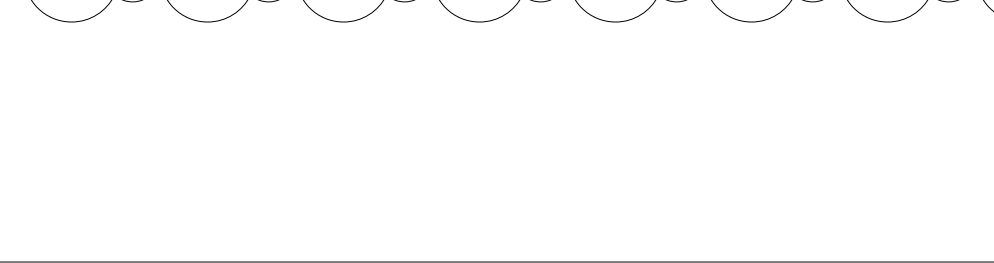
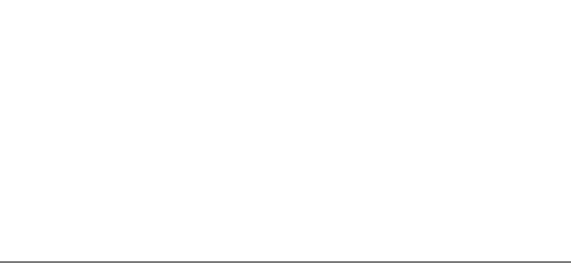
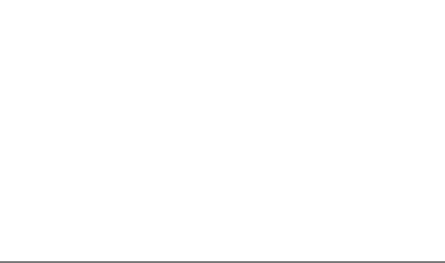
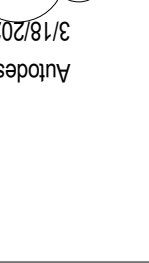
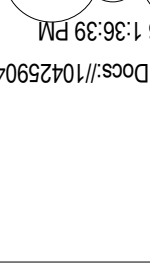
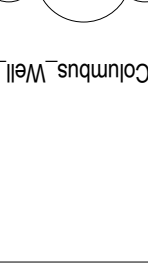
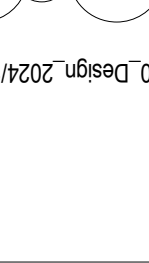
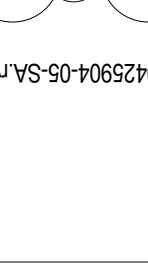
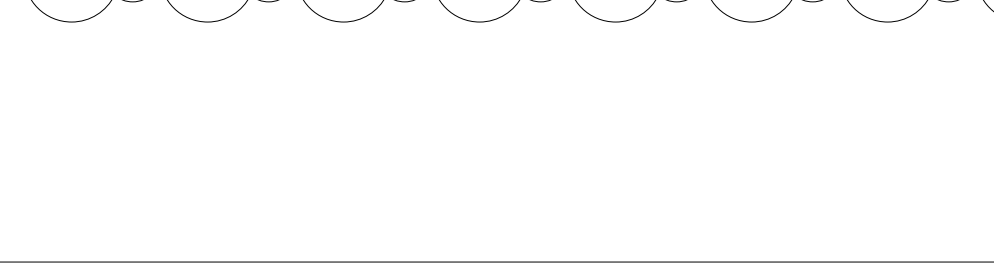
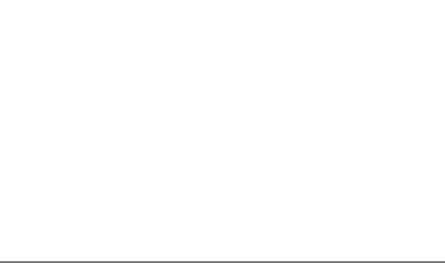
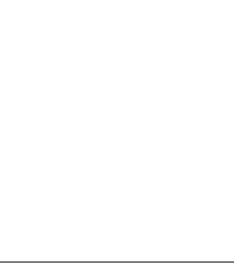
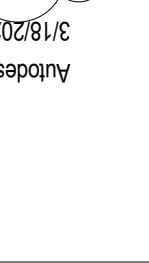
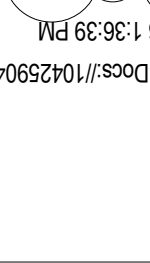
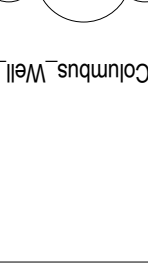
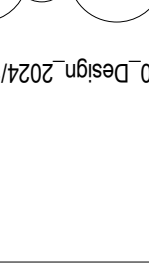
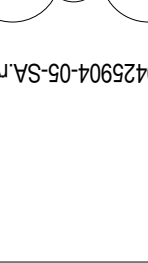
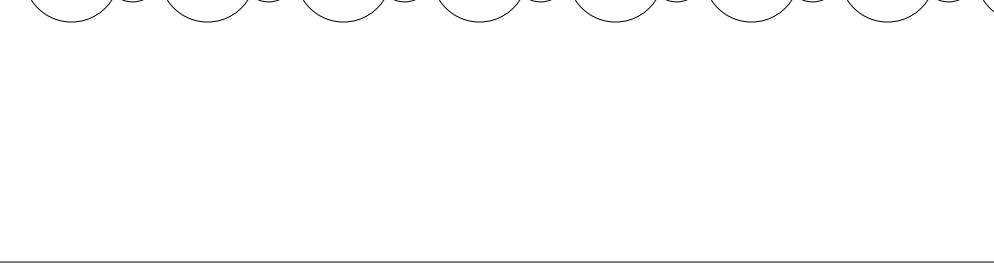
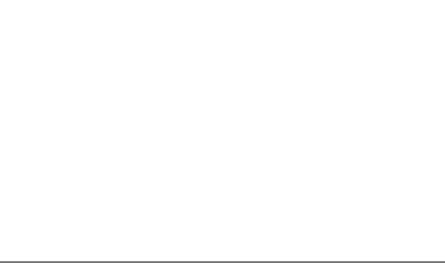
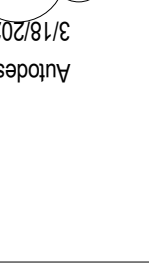
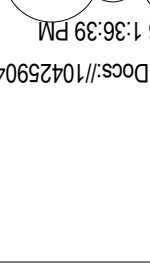
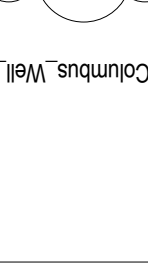
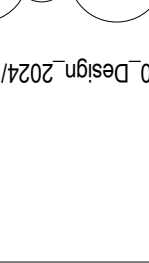
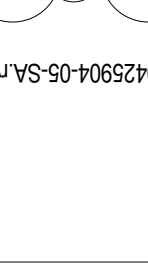
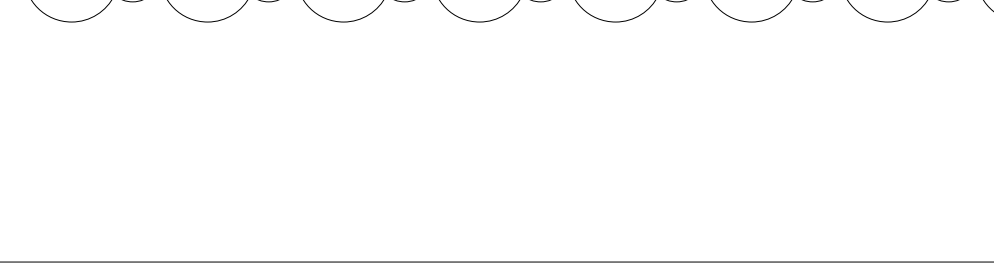
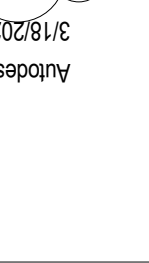
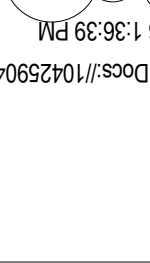
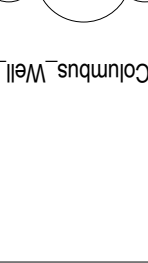
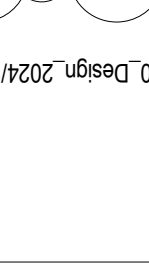
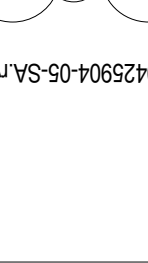
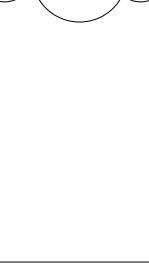
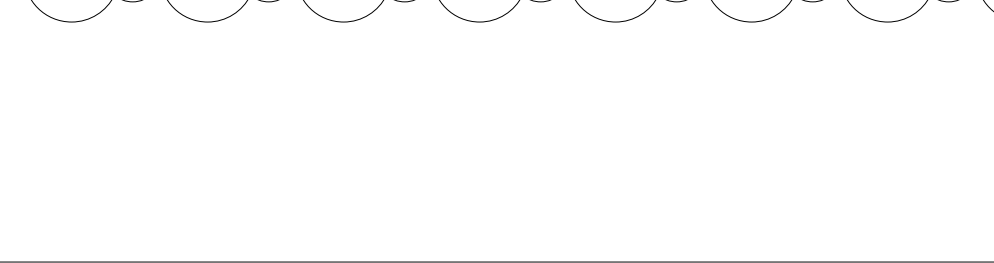
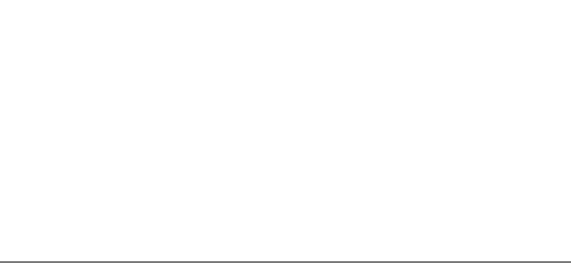
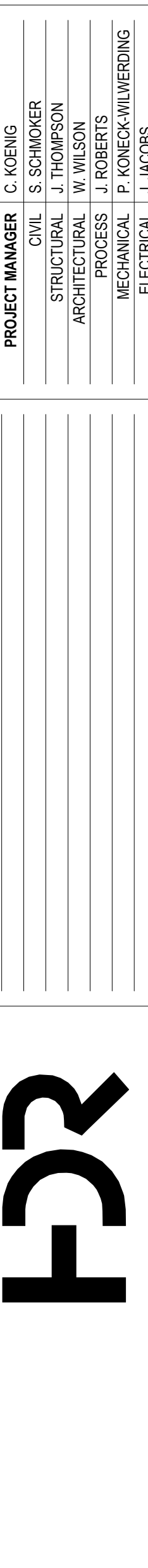
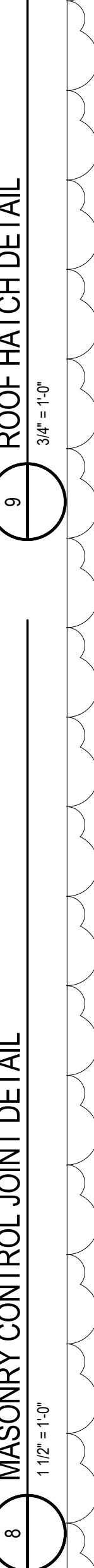
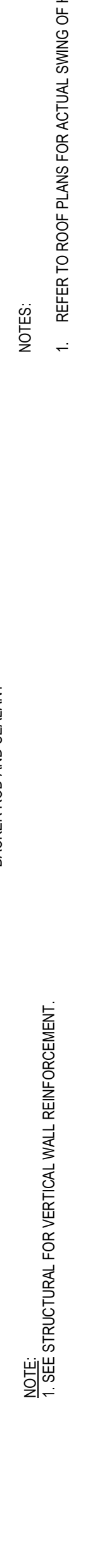
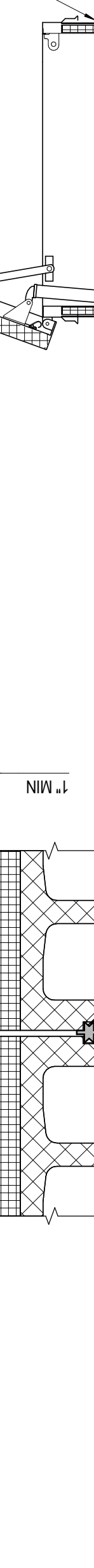
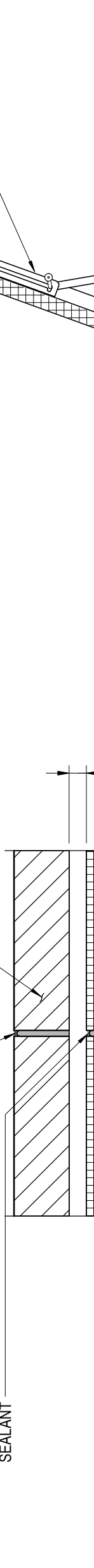
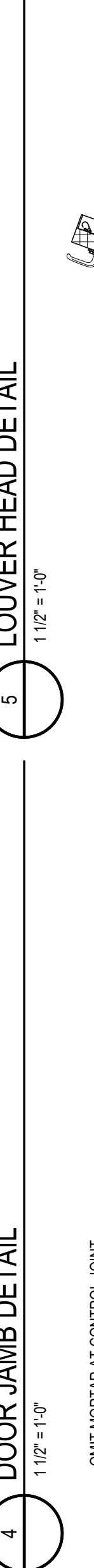
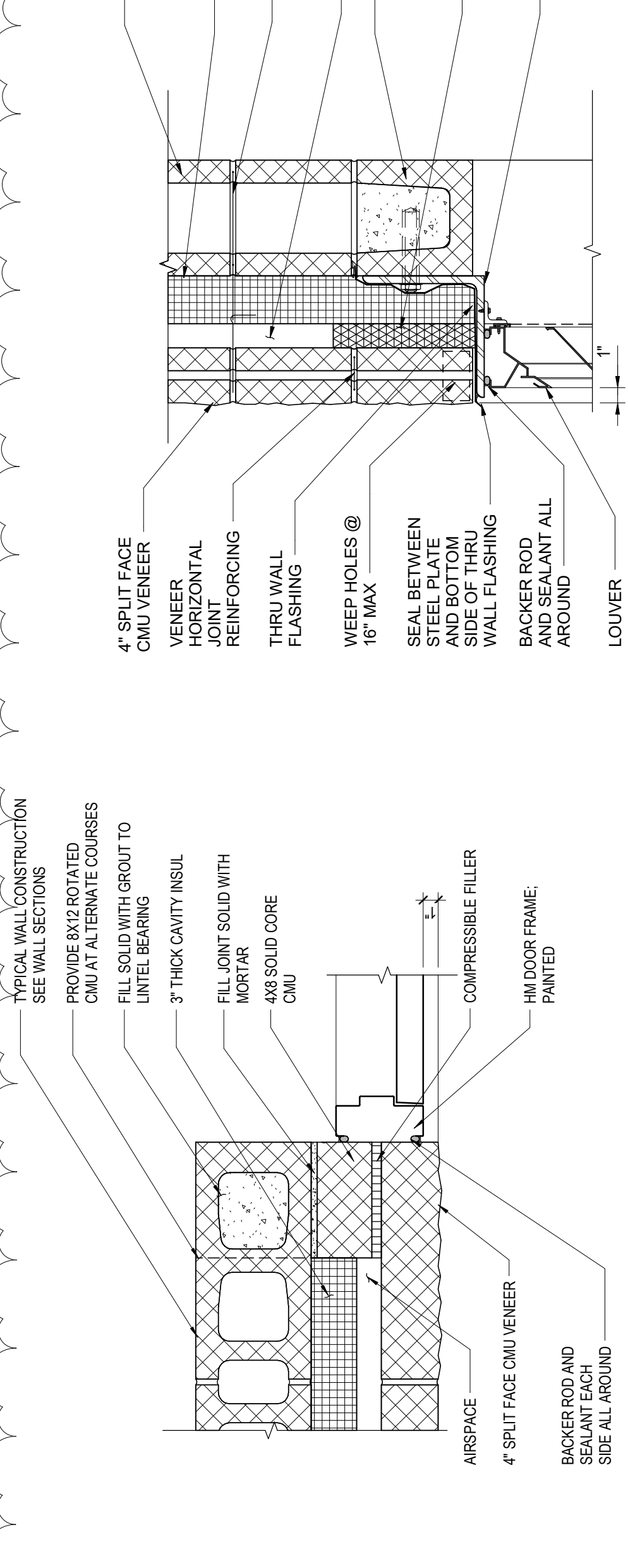
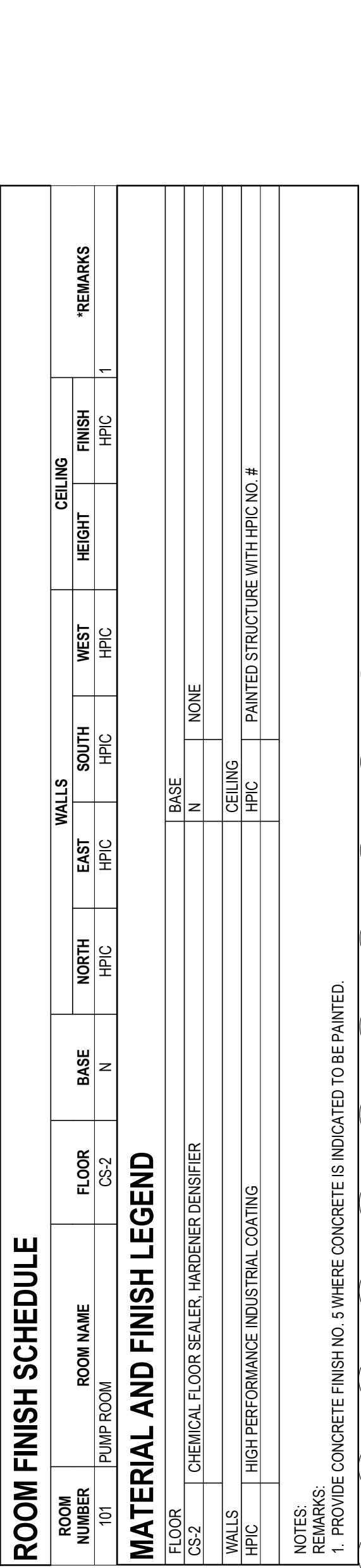

**GENERAL NOTES**

- FOR GENERAL STRUCTURAL NOTES, SEE SHEET 00S001.
- FOR TYPICAL STRUCTURAL DETAILS, SEE SERIES 00S50X.

**FOUNDATION NOTES**

- COORDINATE WALL AND SLAB PENETRATIONS WITH OTHER DISCIPLINES DRAWINGS.

**ROOF FRAMING NOTES**

- ML-X - INDICATES MASONRY LINTEL. SEE SHEET 00S503 FOR SCHEDULE AND DETAILS.

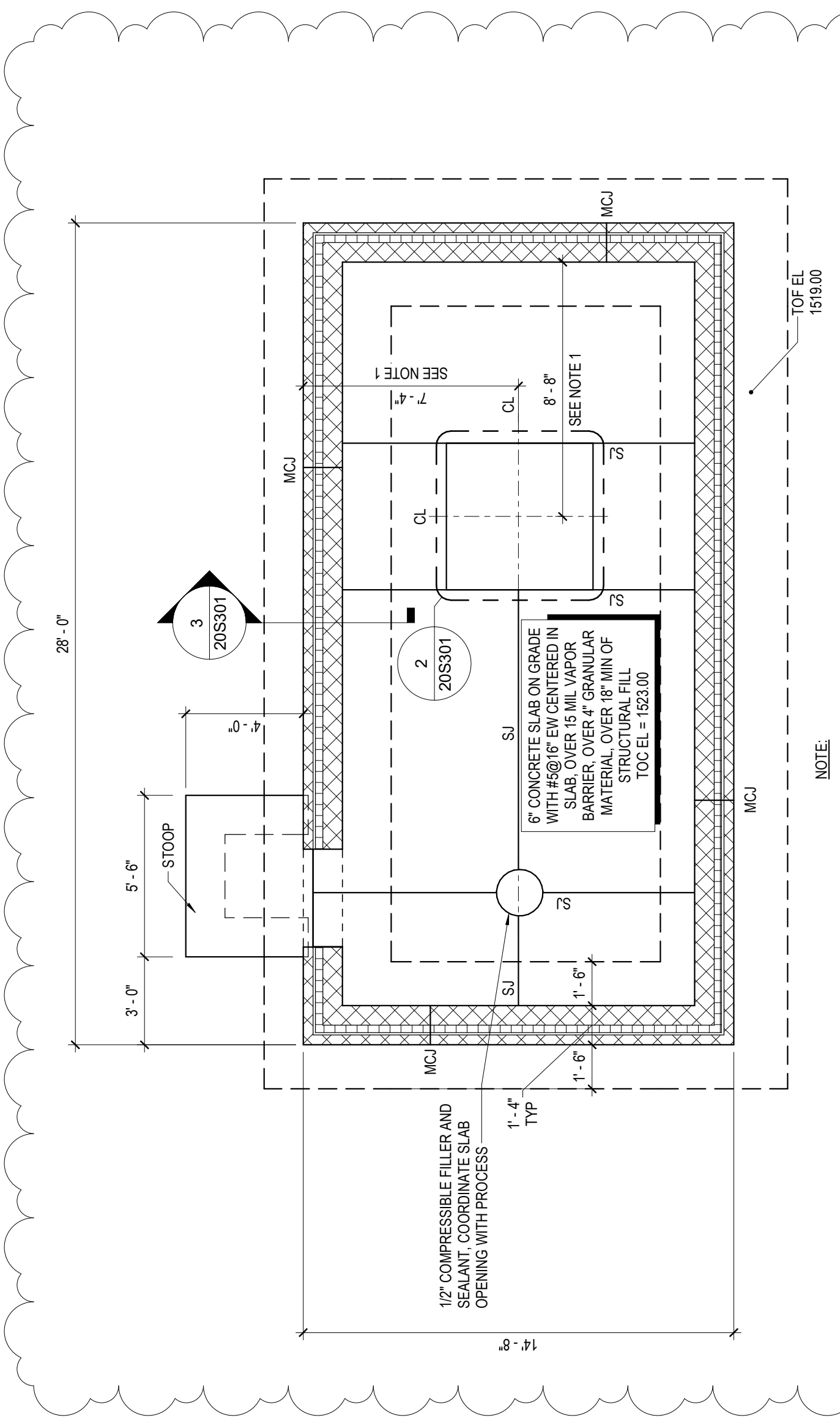
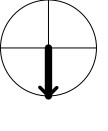

**1** FOUNDATION PLAN  
1/4" = 1'-0"

NOTE:  
1. COORDINATE WITH PROCESS FOR FINAL LOCATION OF PUMP.

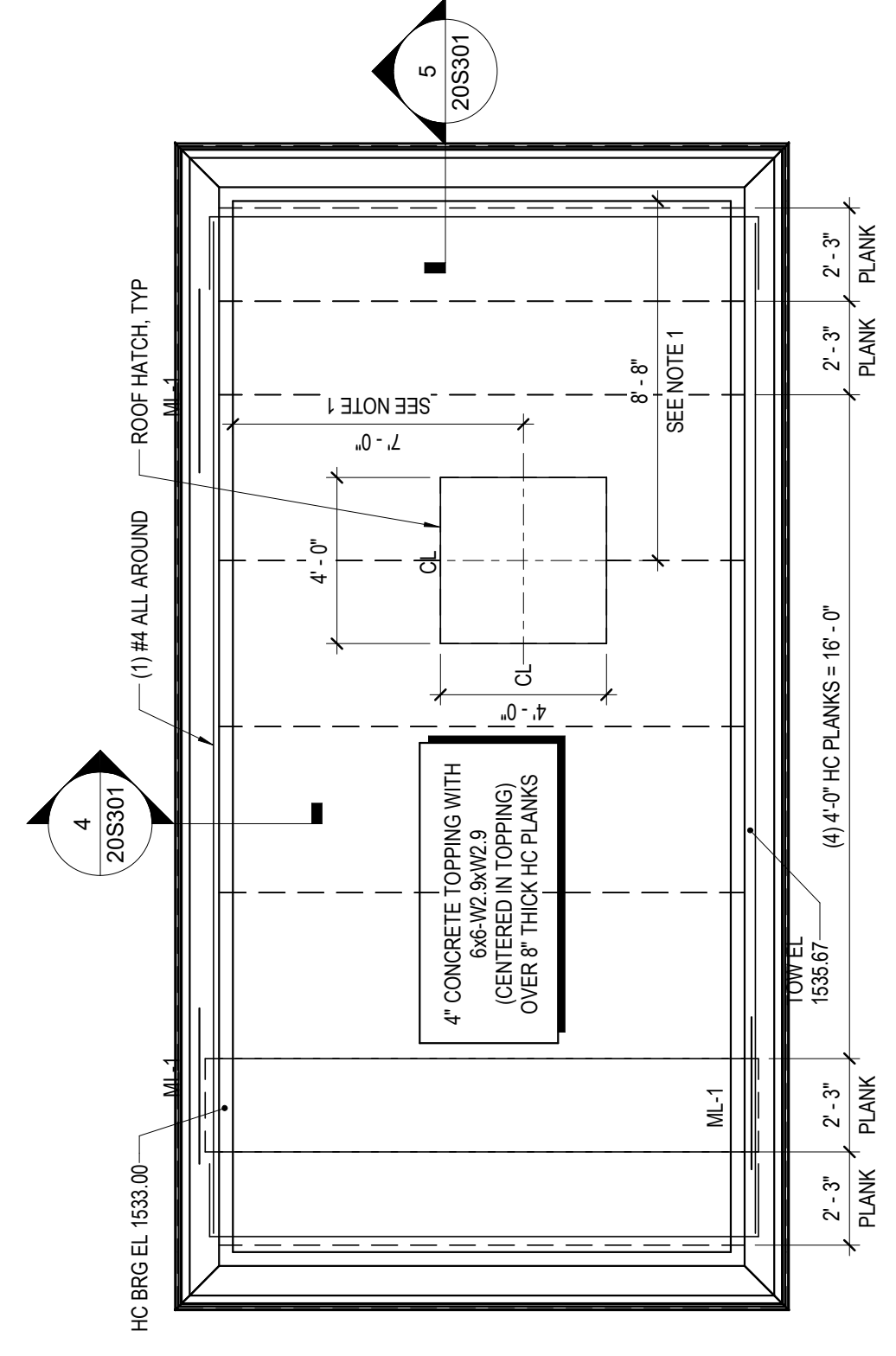

**2** ROOF FRAMING PLAN  
1/4" = 1'-0"

NOTE:  
1. COORDINATE WITH PROCESS FOR FINAL LOCATION OF PUMP.

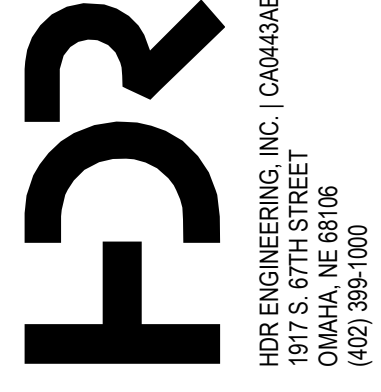

HDR ENGINEERING, INC. | CA0403AE  
1917 S. 67TH STREET  
OMAHA, NE 68106  
(402) 389-1000

| ISSUE | DATE      | DESCRIPTION        |
|-------|-----------|--------------------|
| A     | 3/19/2026 | CPR NO. 5          |
|       | 11-7-2025 | CONFORMED DRAWINGS |

| PROJECT MANAGER | C. KOENIG           |
|-----------------|---------------------|
| CIVIL           | S. SCHWOKER         |
| STRUCTURAL      | J. THOMPSON         |
| ARCHITECTURAL   | W. WILSON           |
| PROCESS         | J. ROBERTS          |
| MECHANICAL      | P. KONECK-WILBERING |
| ELECTRICAL      | J. JACOBS           |
| INSTRUMENTATION | K. ROHLF            |

PROJECT NUMBER 1042904



WELL NO. 20 DESIGN

6651 33RD AVE. COLUMBUS, NE

STRUCTURAL  
FOUNDATION PLAN AND ROOF FRAMING PLAN

FILENAME | 1042904-06-SA.rvt  
SCALE | 1/4" = 1'-0"

SHEET  
20S101



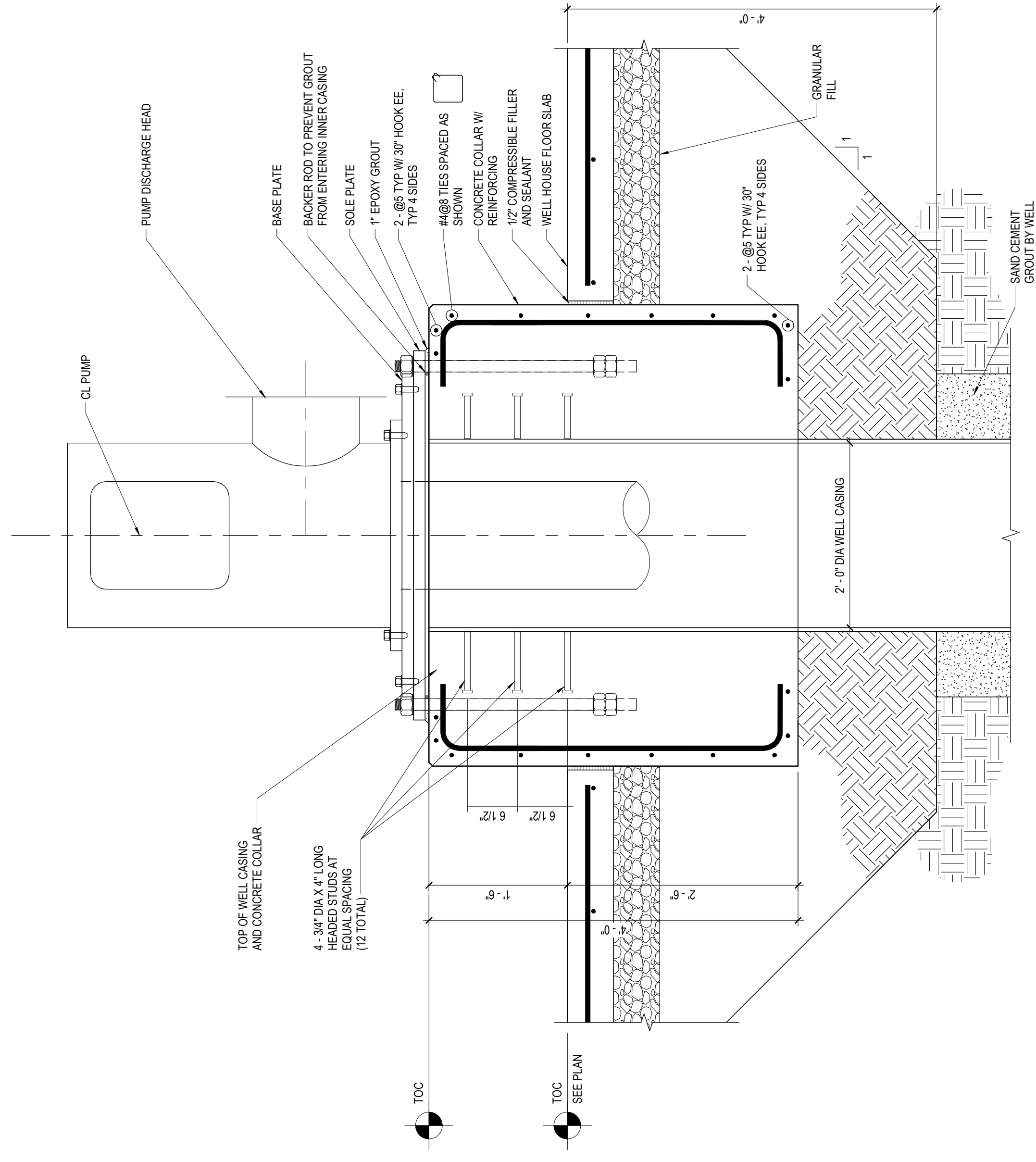

1 WELL PUMP HEAD SECTION  
20S101 1" = 1'-0"

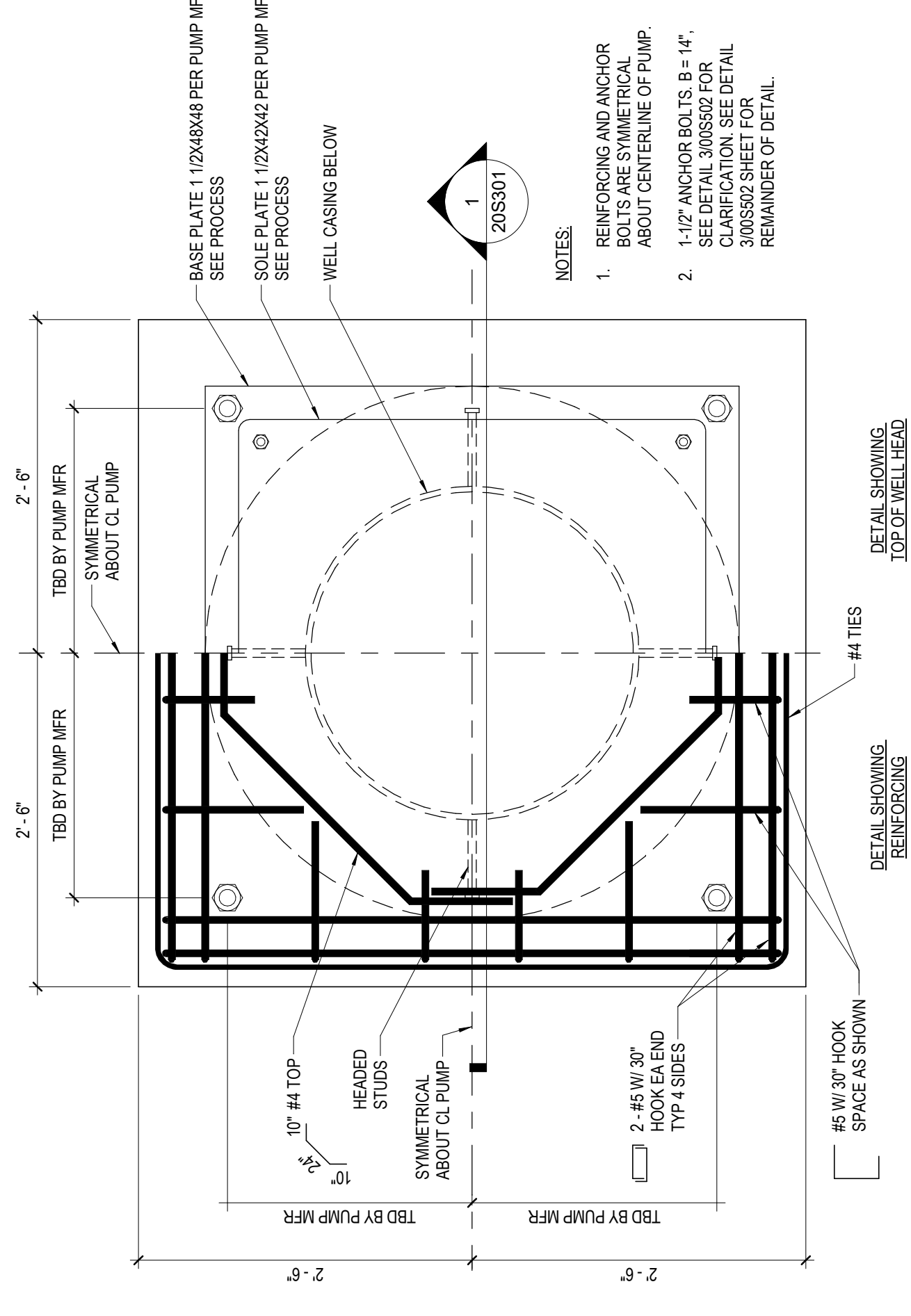

- NOTES:
1. REINFORCING AND ANCHOR BOLTS ARE SYMMETRICAL ABOUT CENTERLINE OF PUMP.
  2. 1-1/2\"/>

2 WELL PUMP HEAD PLAN VIEW DETAIL  
20S101 1" = 1'-0"

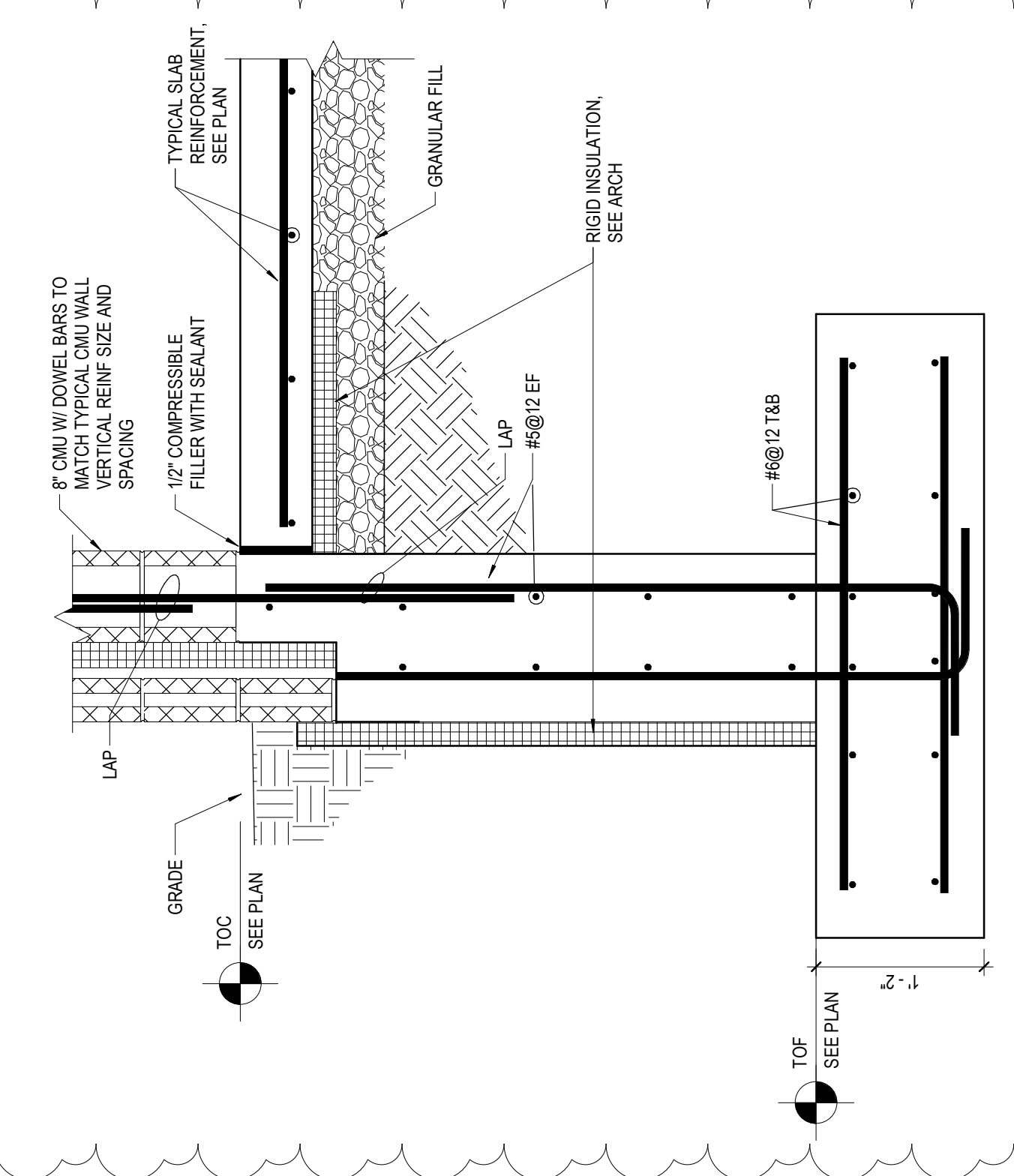

3 WALL SECTION  
20S101 1" = 1'-0"

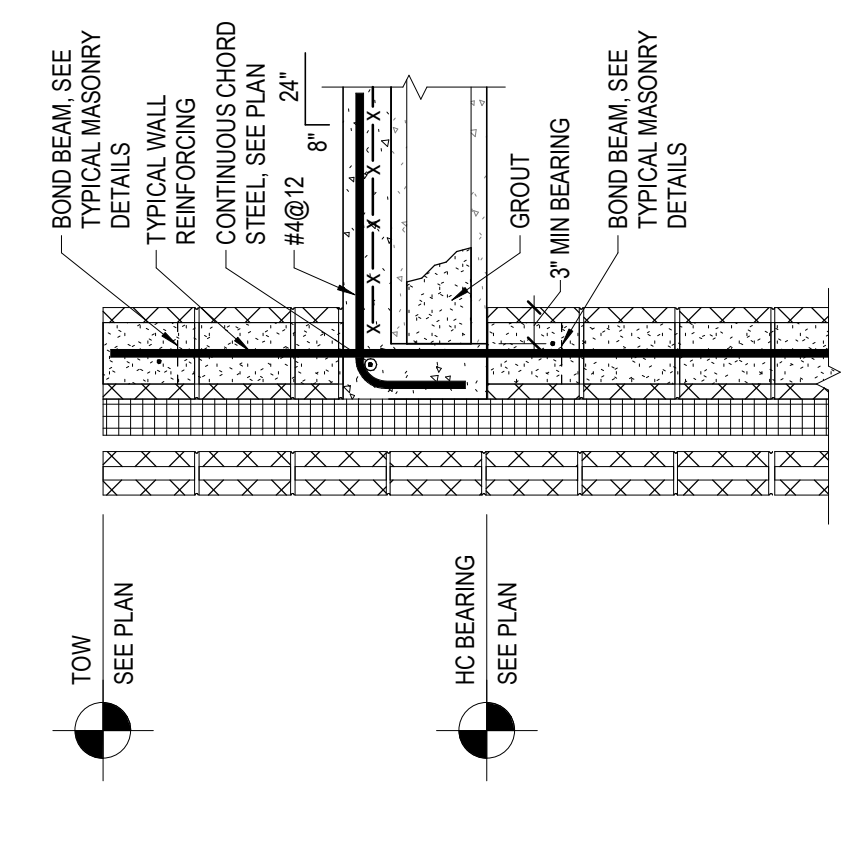

4 TYPICAL HOLLOW CORE BEARING  
20S101 3/4\"/>

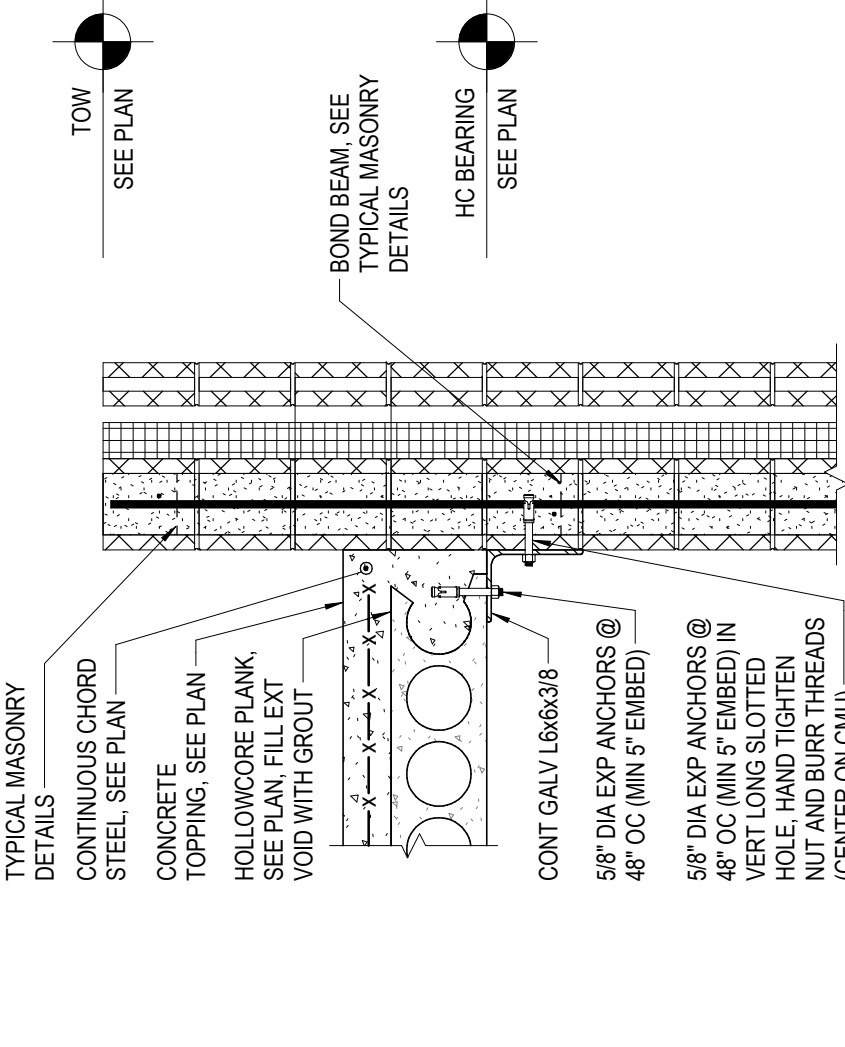

5 TYPICAL HC CONNECTION AT MASONRY  
20S101 3/4\"/>

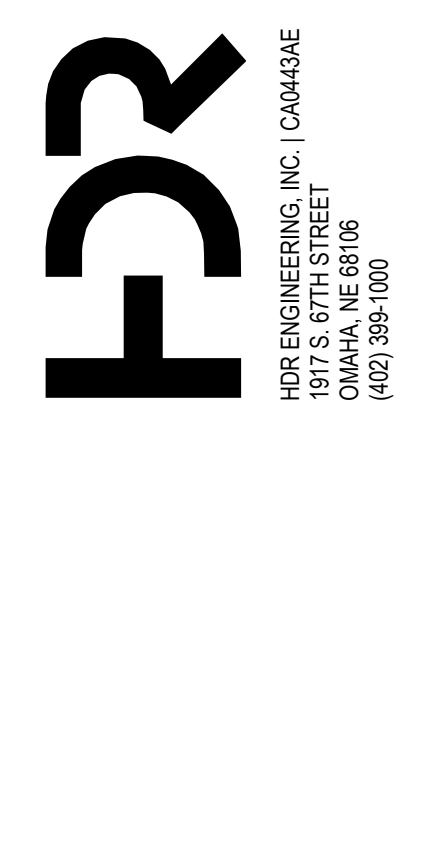

| ISSUE | DATE      | DESCRIPTION        |
|-------|-----------|--------------------|
| A     | 3/19/2026 | COR. NO. 5         |
|       | 11-7-2025 | CONFORMED DRAWINGS |

| PROJECT MANAGER | C. KOENIG           |
|-----------------|---------------------|
| CIVIL           | S. SCHWOKER         |
| STRUCTURAL      | J. THOMPSON         |
| ARCHITECTURAL   | W. WILSON           |
| PROCESS         | J. ROBERTS          |
| MECHANICAL      | P. KONECK-WILBERING |
| ELECTRICAL      | J. JACOBS           |
| INSTRUMENTATION | K. ROHLF            |

PROJECT NUMBER 10425904

The City of **Columbus**  
WELL NO. 20 DESIGN  
6651 33RD AVE. COLUMBUS, NE

STRUCTURAL SECTIONS AND DETAILS

FILENAME 10425904-05-SA.rvt  
SCALE AS INDICATED

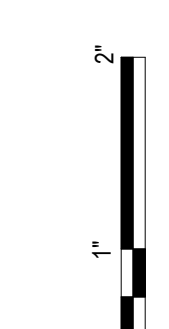

SHEET 20S301



14.F. Resolution No. R26-68 approving professional services agreement with HDR Engineering, Inc. in the amount of \$80,400 for water treatment plant pilot study for the water division. Reallocated CIP #25-67

DRAFT

**RESOLUTION NO. R26-68**

A RESOLUTION OF THE MAYOR AND COUNCIL OF THE CITY OF COLUMBUS, NEBRASKA, APPROVING PROFESSIONAL SERVICES AGREEMENT WITH HDR ENGINEERING, INC. IN THE AMOUNT OF \$80,400 FOR A WATER TREATMENT PLANT PILOT STUDY; A COPY OF WHICH IS ATTACHED HERETO AND INCORPORATED HEREIN BY THIS REFERENCE; TO AUTHORIZE THE MAYOR TO EXECUTE THE SAME ON BEHALF OF THE CITY; AND TO REPEAL ALL RESOLUTIONS OR PORTIONS THEREOF IN CONFLICT HEREWITH.

WHEREAS, HDR Engineering, Inc. is the selected Columbus Water Master Plan and Rate Study engineer, and

WHEREAS, HDR Engineering, Inc. will provide additional professional engineering services in connection with the south water treatment plant project.

NOW, THEREFORE, BE IT RESOLVED BY THE MAYOR AND COUNCIL OF THE CITY OF COLUMBUS, NEBRASKA, that professional services agreement with HDR Engineering, Inc. in the amount of \$80,400 for a water treatment plant pilot study, a copy of which is attached hereto and incorporated herein by this reference, is hereby approved and the Mayor is authorized, directed, and empowered to execute the same on behalf of the City of Columbus.

This resolution shall repeal all resolutions or portions thereof in conflict herewith.

INTRODUCED BY COUNCIL MEMBER \_\_\_\_\_

PASSED AND ADOPTED THIS \_\_\_\_ DAY OF \_\_\_\_\_, 2026.

\_\_\_\_\_  
MAYOR

ATTEST:

\_\_\_\_\_  
CITY CLERK

APPROVED AS TO FORM:

\_\_\_\_\_  
CITY ATTORNEY



Accountability - Dedication  
Honesty - Integrity - Respect

---

---

## MEMORANDUM

**DATE:** April 28, 2026  
**TO:** Tara Vasicek, City Administrator  
**FROM:** Richard J. Bogus, City Engineer  
**RE:** South Water Treatment Plant Pilot Study

**RECOMMENDATION:**

I recommend reallocating funds and approval of the Agreement between Owner (City) and HDR Engineering for Professional Services for the South Water Treatment Plant Pilot Study in the lump sum amount of \$80,400.

**DISCUSSION:**

The 2024 Columbus Water Master Plan addressed the high levels of manganese in the City's drinking water and the recommended approach to provide partial treatment in the form of a greensand filtration system. This pilot plant study is to assess the effectiveness of greensand filter media to achieve enhanced manganese removal at the South Water Treatment Plant, and to identify expected filter loading rates, head loss characteristics and backwash requirements. The pilot plant study would need to be reviewed by the Nebraska Department of Water, Energy and Environment and used in the design of the facility.

The South Water Treatment Plant is next on the Water Rate Study List after Well No. 20. The pilot plant study would begin immediately upon receipt of notice to proceed and be completed by the end of August or first of September.

**FISCAL IMPACT:**

\$80,400 reallocated funds from 2025-2026 budget CIP 25-67 in the amount of \$3,200,000. The North Well No. 20 construction bids were good and came in under budget. It is estimated that the North Well No. 20 expenses will be about \$2,300,000 leaving the excess for reallocation of Water Division needs and services.

**ALTERNATIVE:**

Do not approve.

**CONCURRENCE:**

By: Chuck Sliva

**SIGNATURE:**

By: Richard J. Bogus

Approved By: [Signature]

---

---

**HDR ENGINEERING, INC. FOR PROFESSIONAL SERVICES  
WATER TREATMENT PLANT PILOT STUDY**

**THIS AGREEMENT** is made as of this \_\_\_\_\_ day of May, 2026, between City of Columbus, Nebraska (“OWNER”) a municipal corporation, with principal offices at 2500 14<sup>th</sup> Street, Suite 3, Columbus, NE, and HDR ENGINEERING, INC., (“ENGINEER” or “CONSULTANT”) for services in connection with the project known as Water Treatment Plant Pilot Study (“Project”);

**WHEREAS**, OWNER desires to engage ENGINEER to provide professional engineering, consulting and related services (“Services”) in connection with the Project; and

**WHEREAS**, ENGINEER desires to render these Services as described in SECTION I, Scope of Services.

**NOW, THEREFORE**, OWNER and ENGINEER in consideration of the mutual covenants contained herein, agree as follows:

**SECTION I. SCOPE OF SERVICES**

ENGINEER will provide Services for the Project, which consist of the Scope of Services as outlined on the attached Exhibit A.

**SECTION II. TERMS AND CONDITIONS OF ENGINEERING SERVICES**

The HDR Engineering, Inc. Terms and Conditions, which are attached hereto in Exhibit B, are incorporated into this Agreement by this reference as if fully set forth herein.

**SECTION III. RESPONSIBILITIES OF OWNER**

The OWNER shall provide the information set forth in paragraph 6 of the attached “HDR Engineering, Inc. Terms and Conditions for Professional Services.”

**SECTION IV. COMPENSATION**

Compensation for ENGINEER’S services under this Agreement shall be on the basis of - lump sum. The amount of the lump sum is eighty thousand, four hundred Dollars (\$80,400.00).

The amount of any sales tax, excise tax, value added tax (VAT), or gross receipts tax that may be imposed on this Agreement shall be added to the ENGINEER’S compensation as Reimbursable Expenses.

Compensation terms are defined as follows:

Lump Sum shall mean a fixed amount which shall be the total compensation agreed upon in advance for Scope of Services.

**SECTION V. PERIOD OF SERVICE**

Upon receipt of written authorization to proceed, ENGINEER shall perform the services within the time period described in Exhibit A.

Unless otherwise stated in this Agreement, the rates of compensation for ENGINEER'S services have been agreed to in anticipation of the orderly and continuous progress of the project through completion. If any specified dates for the completion of ENGINEER'S services are exceeded through no fault of the ENGINEER, the time for performance of those services shall be automatically extended for a period which may be reasonably required for their completion and all rates, measures and amounts of ENGINEER'S compensation shall be equitably adjusted.

**SECTION VI. SPECIAL PROVISIONS**

IN WITNESS WHEREOF, the parties hereto have executed this Agreement as of the day and year first written above.

CITY OF COLUMBUS, NEBRASKA  
"OWNER"

BY: \_\_\_\_\_  
NAME: James Bulkley  
TITLE: Mayor  
ADDRESS: 2500 14<sup>th</sup> Street  
Columbus, NE 68601

HDR ENGINEERING, INC.  
"ENGINEER"

BY: *Ann Williams*  
Ann Williams (04/16/2026 08:41:02 CDT)  
NAME: Ann E. Williams, P.E.  
TITLE: Senior Vice President  
ADDRESS: 1917 South 67<sup>th</sup> Street  
Omaha, NE 68106

APPROVED AS TO FORM  
BY \_\_\_\_\_  
CITY ATTORNEY

**EXHIBIT A**

**SCOPE OF SERVICES**

**EXHIBIT A**  
**SCOPE OF SERVICES**

**PART 1.0 PROJECT DESCRIPTION:**

The 2024 Columbus Water Master Plan evaluated options to address the high levels of manganese in the City’s drinking water. The recommended approach is the use of Greensand Filtration. The Nebraska Department of Water Environment and Energy (NDWEE) requires completion of pilot testing to confirm the proposed treatment process achieves the desired treatment goals.

The scope of work is for the completion of a pilot study to assess the effectiveness of greensand filter media to achieve enhanced manganese removal at the South Water Treatment Plant, and to identify expected filter loading rates, headloss characteristics and backwash requirements.

**Items of Work**

1. Coordinating the rental and delivery of the pilot system equipment.
2. Planning the filtration system pilot testing protocol and approach.
3. Coordinating with NDWEE to obtain approval of the pilot protocol and approach.
4. Providing the City with operational assistance during pilot testing and advising on changes to testing conditions.
5. Evaluating collected data and summarizing the findings.
6. Preparation of a technical memorandum that summarizes the findings and provides recommendations for the treatment plant modifications for NDWEE review and approval.

**Key Understandings:**

1. All travel will be in proximity to the City of Columbus, Nebraska.
2. All meetings and presentations will be at the City’s offices or on site.
3. Pilot study is for manganese treatment.
4. HDR will coordinate the delivery of the pilot study equipment to the South Water Treatment Plant.
5. HDR will pay costs for pilot equipment rental from Kurita, not to exceed \$40,000. Kurita will be a subcontractor to HDR.
6. Pilot equipment is assumed to be skid mounted and set up within existing South Water Treatment Plant.
7. Total pilot testing assumed to be no longer than seven (7) weeks of operation, in addition to one week of startup and training. A contract amendment will be requested if it is determined during pilot testing that it would be necessary or desirable to extend the pilot duration beyond 7 weeks.
8. Two (2) filter columns with different filter medias will be piloted simultaneously.

- One column will include 24 IN depth of Greensand Plus and 12 IN depth of anthracite media.
  - One column to include 24 IN depth of alternate primary media and a 12 IN depth anthracite.
10. OWNER will perform work related to the installation of the pilot equipment or hire a contractor to perform this work. Installation activities anticipated to include the following: Off-load pilot equipment upon arrival, installation of pilot equipment, suction and discharge pipe installation, installation of electrical services, and installation of backwash system and chemical feed system if applicable (pumps, tanks, instrumentation, and piping).
  11. Owner staff will operate the pilot equipment in accordance with the Pilot Test Protocol.
  12. Lab costs for water sample analyses will be paid for directly by OWNER, if beyond those analyses self-performed by OWNER.
  13. OWNER will perform work related to decommissioning the pilot equipment or hire a contractor to perform this work. Decommissioning activities anticipated to include the following: disconnect pilot equipment from existing unit processes and remove piping; preparation of the pilot units for shipment; and loading of pilot equipment in truck for return to pilot equipment supplier.
  14. The scope of work does not include preliminary or final design of the water treatment improvements.
  15. Weekly coordination meetings will be held virtually.

## **PART 2.0 SCOPE OF SERVICES TO BE PERFORMED BY ENGINEER**

### **TASK SERIES 100 – PROJECT MANAGEMENT**

**Objective:** Provide management activities over the Project duration including planning, organizing and monitoring Project team activities; and overall project management.

**HDR Activities**     **110 – Project Management**

- Resource management and allocation based on Project schedules and activities.
- Budget and invoice management.

### **TASK SERIES 200 – INFORMATION REVIEW AND PILOT PLANNING**

**Objective:** Collect information and data to use as a basis to define the Filtration System Pilot Testing objectives and procedures.

**HDR Activities**     **Task 210 - Gather / Review Background Information**

- Obtain information on existing facilities and processes needed for the Filtration System Pilot Testing.
- Define list of raw water quality parameters that should be sampled to provide background information.

**Task 220 – Pilot Equipment Supplier Coordination**

- Coordinate pilot unit requirements with the pilot equipment supplier.
- Finalize rental agreement with pilot equipment supplier.

**Task 230 – Identify Installation Requirements for Pilot Testing**

- Determine installation requirements for pilot equipment.
- Coordinate with OWNER on pilot equipment layout for installation at the existing WTP.
- Determine piping and electrical requirements for installation and operation of the pilot equipment.
- Assist OWNER in identifying piping to pilot equipment and discharge piping from pilot equipment. The pilot equipment and piping will be removed at the completion of pilot testing.
- Develop conceptual figures for installing the pilot equipment.

**Task 240 – Prepare Pilot Study Protocol**

- Prepare Pilot Test Protocol for manganese removal. The protocol will address testing requirements, flow rates, constituents to be tested, duration, filter backwash procedure, and site conditions.
- Coordinate with pilot equipment supplier in preparation of test protocol to solicit their input and recommendations. Incorporate information received by pilot equipment supplier.
- Meet with the OWNER to review the Pilot Test Protocol. Incorporate OWNER’s review comments in the Pilot Test Protocol.
- Submit test protocol to NDWEE for review and comment. A conference call will be held with NDWEE personnel to discuss the protocol parameters and objectives prior to submission. NDWEE review comments will be addressed and incorporated as applicable.

**Deliverables:** Conceptual figures demonstrating installation requirements in Task 230.  
Pilot Test Protocol.  
Meeting summary from conference call with NDWEE.

**Task Series 300 – FILTRATION SYSTEM PILOT TESTING**

**Objective:** Assist OWNER in conducting pilot unit testing at the South Water Treatment Plant. Pilot testing will be used to obtain operational water quality data required for state regulatory approval and establish preliminary design criteria.

## HDR Activities

### **Task 310 – Pilot System Installation and Startup**

- Coordinate with pilot equipment supplier to schedule delivery of pilot equipment to the site.
- Provide OWNER assistance during the installation of the pilot unit. Installation work to be performed by OWNER or a contractor hired directly by OWNER. The installation work is anticipated to include, but may not be limited to the following:
  - Off-load of pilot equipment upon arrival to the site.
  - Pilot unit suction and discharge pipe installation.
  - Installation of electrical services.
  - Installation of backwash system and chemical feed system, including pumps, tanks, instrumentation, and piping.
- Coordinate with pilot equipment supplier to provide training to OWNER's operations staff. HDR will attend a portion of the training and provide additional training and guidance for overall pilot system operation and pilot testing protocol, if necessary.

### **Task 320 – Services During Pilot System Operation**

- Provide input to OWNER staff operating the pilot system. OWNER staff will operate the filtration system pilot unit in accordance with the Pilot Test Protocol.
  - Teleconference with OWNER personnel weekly to review testing progress. HDR will advise OWNER on changes recommended in the data collection program and on operation of the pilot system, as appropriate.
  - Review pilot unit operational data provided by OWNER on a weekly basis.
  - Respond to OWNER questions.
  - OWNER will collect and analyze water quality samples or send to an outside laboratory identified by OWNER and HDR for analysis.
  - One visit to site for pilot testing troubleshooting, if necessary.
- Coordinate with pilot equipment supplier during operation of the system.

### **Task 330 – Prepare Pilot Study Report**

- Prepare Pilot Study Report summarizing the results of the work.
- Written report will include the following:
  - Description of the procedures
  - Test results
  - Significant observations
  - Conclusions

- Filter media design criteria
- Recommendations
- Meeting with the Owner to review Pilot Study Report.
- Submit Pilot Study Report to NDWEE for review and approval.

**Deliverables:** Weekly review of pilot system operational data and recommended changes in data collection program or pilot system operation, if any.  
 Pilot Study Report.  
 Responses to NDWEE review comments on Pilot Test Report, if any.

**PART 3.0 OWNER’S RESPONSIBILITIES:**

OWNER will be responsible for the following as identified in the above Scope of Work:

1. Offloading pilot study equipment and completing the installation of the equipment.
2. Operation of the pilot study equipment in accordance with the Pilot Test Protocol.
3. Lab costs for water sample analysis.
4. Reporting the test results to HDR on a timely basis.
5. Decommissioning of the pilot equipment.
6. Participation in weekly progress meetings.

**PART 4.0 PERIODS OF SERVICE:**

|                                   |                 |
|-----------------------------------|-----------------|
| Notice to Proceed                 | May 5, 2026     |
| Pilot Test Initiation             | June 1, 2026    |
| Pilot Test Completion             | July 27, 2026   |
| Pilot Test Report NDWEE Submittal | August 28, 2026 |

**EXHIBIT B**

**TERMS AND CONDITIONS**

# HDR Engineering, Inc. Terms and Conditions for Professional Services

## 1. STANDARD OF PERFORMANCE

The standard of care for all professional engineering, consulting and related services performed or furnished by ENGINEER and its employees under this Agreement will be the care and skill ordinarily used by members of ENGINEER's profession practicing under the same or similar circumstances at the same time and in the same locality. ENGINEER makes no warranties, express or implied, under this Agreement or otherwise, in connection with ENGINEER's services.

## 2. INSURANCE/INDEMNITY

ENGINEER agrees to procure and maintain, at its expense, Workers' Compensation insurance as required by statute; Employer's Liability of \$250,000; Automobile Liability insurance of \$1,000,000 combined single limit for bodily injury and property damage covering all vehicles, including hired vehicles, owned and non-owned vehicles; Commercial General Liability insurance of \$1,000,000 combined single limit for personal injury and property damage; and Professional Liability insurance of \$1,000,000 per claim for protection against claims arising out of the performance of services under this Agreement caused by negligent acts, errors, or omissions for which ENGINEER is legally liable. If flying an Unmanned Aerial System (UAS or drone), ENGINEER will procure and maintain aircraft unmanned aerial systems insurance of \$1,000,000 per occurrence.

OWNER shall be made an additional insured on Commercial General and Automobile Liability insurance policies and certificates of insurance will be furnished to the OWNER. ENGINEER agrees to indemnify OWNER for third party personal injury and property damage claims to the extent caused by ENGINEER's negligent acts, errors or omissions. However, neither Party to this Agreement shall be liable to the other Party for any special, incidental, indirect, or consequential damages (including but not limited to loss of use or opportunity; loss of good will; cost of substitute facilities, goods, or services; cost of capital; and/or fines or penalties), loss of profits or revenue arising out of, resulting from, or in any way related to the Project or the Agreement from any cause or causes, including but not limited to any such damages caused by the negligence, errors or omissions, strict liability or breach of contract. The employees of both parties are intended third party beneficiaries of this waiver of consequential damages.

## 3. OPINIONS OF PROBABLE COST

Any opinions of probable project cost or probable construction cost provided by ENGINEER are made on the basis of information available to ENGINEER and on the basis of ENGINEER's experience and qualifications, and represents its judgment as an experienced and qualified professional engineer. However, since ENGINEER has no control over the cost of labor, materials, equipment or services furnished by others, or over the contractor(s)' methods of determining prices, or over competitive bidding or market conditions, ENGINEER does not guarantee that proposals, bids or actual project or construction cost will not vary from opinions of probable cost ENGINEER prepares.

## 4. CONSTRUCTION PROCEDURES

ENGINEER's observation or monitoring portions of the work performed under construction contracts shall not relieve the contractor from its responsibility for performing work in accordance with applicable contract documents. ENGINEER shall not control or have charge of, and shall not be responsible for, construction means, methods, techniques, sequences, procedures of construction, health or safety programs or precautions connected with the work and shall not manage, supervise, control or have charge of construction. ENGINEER shall not be responsible for the acts or omissions of the contractor or other parties on the project. ENGINEER shall be

entitled to review all construction contract documents and to require that no provisions extend the duties or liabilities of ENGINEER beyond those set forth in this Agreement. OWNER agrees to include ENGINEER as an indemnified party in OWNER's construction contracts for the work, which shall protect ENGINEER to the same degree as OWNER. Further, OWNER agrees that ENGINEER shall be listed as an additional insured under the construction contractor's liability insurance policies.

## 5. CONTROLLING LAW

This Agreement is to be governed by the law of the state where ENGINEER's services are performed.

## 6. SERVICES AND INFORMATION

OWNER will provide all criteria and information pertaining to OWNER's requirements for the project, including design objectives and constraints, space, capacity and performance requirements, flexibility and expandability, and any budgetary limitations. OWNER will also provide copies of any OWNER-furnished Standard Details, Standard Specifications, or Standard Bidding Documents which are to be incorporated into the project.

OWNER will furnish the services of soils/geotechnical engineers or other consultants that include reports and appropriate professional recommendations when such services are deemed necessary by ENGINEER. The OWNER agrees to bear full responsibility for the technical accuracy and content of OWNER-furnished documents and services.

In performing professional engineering and related services hereunder, it is understood by OWNER that ENGINEER is not engaged in rendering any type of legal, insurance or accounting services, opinions or advice. Further, it is the OWNER's sole responsibility to obtain the advice of an attorney, insurance counselor or accountant to protect the OWNER's legal and financial interests. To that end, the OWNER agrees that OWNER or the OWNER's representative will examine all studies, reports, sketches, drawings, specifications, proposals and other documents, opinions or advice prepared or provided by ENGINEER, and will obtain the advice of an attorney, insurance counselor or other consultant as the OWNER deems necessary to protect the OWNER's interests before OWNER takes action or forebears to take action based upon or relying upon the services provided by ENGINEER.

## 7. SUCCESSORS, ASSIGNS AND BENEFICIARIES

OWNER and ENGINEER, respectively, bind themselves, their partners, successors, assigns, and legal representatives to the covenants of this Agreement. Neither OWNER nor ENGINEER will assign, sublet, or transfer any interest in this Agreement or claims arising therefrom without the written consent of the other. No third party beneficiaries are intended under this Agreement.

## 8. RE-USE OF DOCUMENTS

All documents, including all reports, drawings, specifications, computer software or other items prepared or furnished by ENGINEER pursuant to this Agreement, are instruments of service with respect to the project. ENGINEER retains ownership of all such documents. OWNER may retain copies of the documents for its information and reference in connection with the project; however, none of the documents are intended or represented to be suitable for reuse by OWNER or others on extensions of the project or on any other project. Any reuse without written verification or adaptation by ENGINEER for the specific purpose intended will be at OWNER's sole risk and without liability or legal exposure to ENGINEER, and OWNER will defend, indemnify and hold harmless ENGINEER from all claims, damages, losses and expenses, including attorney's fees,

arising or resulting therefrom. Any such verification or adaptation will entitle ENGINEER to further compensation at rates to be agreed upon by OWNER and ENGINEER.

#### 9. TERMINATION OF AGREEMENT

OWNER or ENGINEER may terminate the Agreement, in whole or in part, by giving seven (7) days written notice to the other party. Where the method of payment is "lump sum," or cost reimbursement, the final invoice will include all services and expenses associated with the project up to the effective date of termination. An equitable adjustment shall also be made to provide for termination settlement costs ENGINEER incurs as a result of commitments that had become firm before termination, and for a reasonable profit for services performed.

#### 10. SEVERABILITY

If any provision of this agreement is held invalid or unenforceable, the remaining provisions shall be valid and binding upon the parties. One or more waivers by either party of any provision, term or condition shall not be construed by the other party as a waiver of any subsequent breach of the same provision, term or condition.

#### 11. INVOICES

ENGINEER will submit monthly invoices for services rendered and OWNER will make payments to ENGINEER within thirty (30) days of OWNER's receipt of ENGINEER's invoice.

ENGINEER will retain receipts for reimbursable expenses in general accordance with Internal Revenue Service rules pertaining to the support of expenditures for income tax purposes. Receipts will be available for inspection by OWNER's auditors upon request.

If OWNER disputes any items in ENGINEER's invoice for any reason, including the lack of supporting documentation, OWNER may temporarily delete the disputed item and pay the remaining amount of the invoice. OWNER will promptly notify ENGINEER of the dispute and request clarification and/or correction. After any dispute has been settled, ENGINEER will include the disputed item on a subsequent, regularly scheduled invoice, or on a special invoice for the disputed item only.

OWNER recognizes that late payment of invoices results in extra expenses for ENGINEER. ENGINEER retains the right to assess OWNER interest at the rate of one percent (1%) per month, but not to exceed the maximum rate allowed by law, on invoices which are not paid within thirty (30) days from the date OWNER receives ENGINEER's invoice. In the event undisputed portions of ENGINEER's invoices are not paid when due, ENGINEER also reserves the right, after seven (7) days prior written notice, to suspend the performance of its services under this Agreement until all past due amounts have been paid in full.

#### 12. CHANGES

The parties agree that no change or modification to this Agreement, or any attachments hereto, shall have any force or effect unless the change is reduced to writing, dated, and made part of this Agreement. The execution of the change shall be authorized and signed in the same manner as this Agreement. Adjustments in the period of services and in compensation shall be in accordance with applicable paragraphs and sections of this Agreement. Any proposed fees by ENGINEER are estimates to perform the services required to complete the project as ENGINEER understands it to be defined. For those projects involving conceptual or process development services, activities often are not fully definable in the initial planning. In any event, as the project progresses, the facts developed may dictate a change in the services to be performed, which may alter the scope. ENGINEER will inform OWNER of such situations so that changes in scope and adjustments to the time of performance and compensation can be made as required. If such change, additional services, or suspension of services results in an increase or decrease in the cost of or time required for performance

of the services, an equitable adjustment shall be made, and the Agreement modified accordingly.

#### 13. CONTROLLING AGREEMENT

These Terms and Conditions shall take precedence over any inconsistent or contradictory provisions contained in any proposal, contract, purchase order, requisition, notice-to-proceed, or like document.

#### 14. EQUAL EMPLOYMENT AND NONDISCRIMINATION

In connection with the services under this Agreement, ENGINEER agrees to comply with the applicable provisions of federal and state Equal Employment Opportunity for individuals based on color, religion, sex, or national origin, or disabled veteran, recently separated veteran, other protected veteran and armed forces service medal veteran status, disabilities under provisions of executive order 11246, and other employment, statutes and regulations, as stated in Title 41 Part 60 of the Code of Federal Regulations § 60-1.4 (a-f), § 60-300.5 (a-e), § 60-741 (a-e).

#### 15. HAZARDOUS MATERIALS

OWNER represents to ENGINEER that, to the best of its knowledge, no hazardous materials are present at the project site. However, in the event hazardous materials are known to be present, OWNER represents that to the best of its knowledge it has disclosed to ENGINEER the existence of all such hazardous materials, including but not limited to asbestos, PCB's, petroleum, hazardous waste, or radioactive material located at or near the project site, including type, quantity and location of such hazardous materials. It is acknowledged by both parties that ENGINEER's scope of services do not include services related in any way to hazardous materials. In the event ENGINEER or any other party encounters undisclosed hazardous materials, ENGINEER shall have the obligation to notify OWNER and, to the extent required by law or regulation, the appropriate governmental officials, and ENGINEER may, at its option and without liability for delay, consequential or any other damages to OWNER, suspend performance of services on that portion of the project affected by hazardous materials until OWNER: (i) retains appropriate specialist consultant(s) or contractor(s) to identify and, as appropriate, abate, remediate, or remove the hazardous materials; and (ii) warrants that the project site is in full compliance with all applicable laws and regulations. OWNER acknowledges that ENGINEER is performing professional services for OWNER and that ENGINEER is not and shall not be required to become an "arranger," "operator," "generator," or "transporter" of hazardous materials, as defined in the Comprehensive Environmental Response, Compensation, and Liability Act of 1990 (CERCLA), which are or may be encountered at or near the project site in connection with ENGINEER's services under this Agreement. If ENGINEER's services hereunder cannot be performed because of the existence of hazardous materials, ENGINEER shall be entitled to terminate this Agreement for cause on 30 days written notice. To the fullest extent permitted by law, OWNER shall indemnify and hold harmless ENGINEER, its officers, directors, partners, employees, and subconsultants from and against all costs, losses, and damages (including but not limited to all fees and charges of engineers, architects, attorneys, and other professionals, and all court or arbitration or other dispute resolution costs) caused by, arising out of or resulting from hazardous materials, provided that (i) any such cost, loss, or damage is attributable to bodily injury, sickness, disease, or death, or injury to or destruction of tangible property (other than completed Work), including the loss of use resulting therefrom, and (ii) nothing in this paragraph shall obligate OWNER to indemnify any individual or entity from and against the consequences of that individual's or entity's sole negligence or willful misconduct.

#### 16. EXECUTION

This Agreement, including the exhibits and schedules made part hereof, constitute the entire Agreement between ENGINEER and

OWNER, supersedes and controls over all prior written or oral understandings. This Agreement may be amended, supplemented or modified only by a written instrument duly executed by the parties.

#### 17. ALLOCATION OF RISK

OWNER AND ENGINEER HAVE EVALUATED THE RISKS AND REWARDS ASSOCIATED WITH THIS PROJECT, INCLUDING ENGINEER'S FEE RELATIVE TO THE RISKS ASSUMED, AND AGREE TO ALLOCATE CERTAIN OF THE RISKS, SO, TO THE FULLEST EXTENT PERMITTED BY LAW, THE TOTAL AGGREGATE LIABILITY OF ENGINEER (AND ITS RELATED CORPORATIONS, SUBCONSULTANTS AND EMPLOYEES) TO OWNER AND THIRD PARTIES GRANTED RELIANCE IS LIMITED TO THE LESSER OF \$1,000,000 OR ITS FEE, FOR ANY AND ALL INJURIES, DAMAGES, CLAIMS, LOSSES, OR EXPENSES (INCLUDING ATTORNEY AND EXPERT FEES) ARISING OUT OF ENGINEER'S SERVICES OR THIS AGREEMENT REGARDLESS OF CAUSE(S) OR THE THEORY OF LIABILITY, INCLUDING NEGLIGENCE, INDEMNITY, OR OTHER RECOVERY. ENGINEER'S AND SUBCONSULTANTS' EMPLOYEES ARE INTENDED THIRD PARTY BENEFICIARIES OF THIS ALLOCATION OF RISK.

#### 18. LITIGATION SUPPORT

In the event ENGINEER is required to respond to a subpoena, government inquiry or other legal process related to the services in connection with a legal or dispute resolution proceeding to which ENGINEER is not a party, OWNER shall reimburse ENGINEER for reasonable costs in responding and compensate ENGINEER at its then standard rates for reasonable time incurred in gathering information and documents and attending depositions, hearings, and trial.

#### 19. NO THIRD PARTY BENEFICIARIES

Except as otherwise provided in this Agreement, no third party beneficiaries are intended under this Agreement. In the event a reliance letter or certification is required under the scope of services, the parties agree to use a form that is mutually acceptable to both parties.

#### 20. UTILITY LOCATION

If underground sampling/testing is to be performed, a local utility locating service shall be contacted to make arrangements for all utilities to determine the location of underground utilities. In addition, OWNER shall notify ENGINEER of the presence and location of any underground utilities located on the OWNER's property which are not the responsibility of private/public utilities. ENGINEER shall take reasonable precautions to avoid damaging underground utilities that are properly marked. The OWNER agrees to waive any claim against ENGINEER and will indemnify and hold ENGINEER harmless from any claim of liability, injury or loss caused by or allegedly caused by ENGINEER's damaging of underground utilities that are not properly marked or are not called to ENGINEER's attention prior to beginning the underground sampling/testing.

#### 21. UNMANNED AERIAL SYSTEMS

If operating UAS, ENGINEER will obtain all permits or exemptions required by law to operate any UAS included in the services. ENGINEER's operators have completed the training, certifications and licensure as required by the applicable jurisdiction in which the UAS will be operated. OWNER will obtain any necessary permissions for ENGINEER to operate over private property, and assist, as necessary, with all other necessary permissions for operations.

#### 22. OPERATIONAL TECHNOLOGY SYSTEMS

OWNER agrees that the effectiveness of operational technology systems and features designed, recommended or assessed by ENGINEER (collectively "OT Systems") are dependent upon OWNER's continued operation and maintenance of the OT Systems

in accordance with all standards, best practices, laws, and regulations that govern the operation and maintenance of the OT Systems. OWNER shall be solely responsible for operating and maintaining the OT Systems in accordance with applicable laws, regulations, and industry standards (e.g. ISA, NIST, etc.) and best practices, which generally include but are not limited to, cyber security policies and procedures, documentation and training requirements, continuous monitoring of assets for tampering and intrusion, periodic evaluation for asset vulnerabilities, implementation and update of appropriate technical, physical, and operational standards, and offline testing of all software/firmware patches/updates prior to placing updates into production. Additionally, OWNER recognizes and agrees that OT Systems are subject to internal and external breach, compromise, and similar incidents. Security features designed, recommended or assessed by ENGINEER are intended to reduce the likelihood that OT Systems will be compromised by such incidents. However, ENGINEER does not guarantee that OWNER's OT Systems are impenetrable and OWNER agrees to waive any claims against ENGINEER resulting from any such incidents that relate to or affect OWNER's OT Systems.

#### 23. FORCE MAJEURE

ENGINEER shall not be responsible for delays caused by factors beyond ENGINEER's reasonable control, including but not limited to delays because of strikes, lockouts, work slowdowns or stoppages, government ordered industry shutdowns, power or server outages, acts of nature, widespread infectious disease outbreaks (including, but not limited to epidemics and pandemics), failure of any governmental or other regulatory authority to act in a timely manner, failure of the OWNER to furnish timely information or approve or disapprove of ENGINEER's services or work product, or delays caused by faulty performance by the OWNER's or by contractors of any level or any other events or circumstances not within the reasonable control of the party affected, whether similar or dissimilar to any of the foregoing. When such delays beyond ENGINEER's reasonable control occur, the OWNER agrees that ENGINEER shall not be responsible for damages, nor shall ENGINEER be deemed in default of this Agreement, and the parties will negotiate an equitable adjustment to ENGINEER's schedule and/or compensation if impacted by the force majeure event or condition.

#### 24. EMPLOYEE IMMUNITY

The parties to this Agreement acknowledge that an individual employee or agent may not be held individually liable for negligence with regard to services provided under this Agreement. To the maximum extent permitted by law, the parties intend i) that this limitation on the liability of employees and agents shall include directors, officers, employees, agents and representatives of each party and of any entity for whom a party is legally responsible, and ii) that any such employee or agent identified by name in this Agreement shall not be deemed a party.

14.G.Resolution No. R26-69 approving grant agreement with Nebraska Emergency Management Agency in an amount not to exceed \$142,500 or 75 percent of allowable costs, whichever is less, for Columbus Area Regional Flood Mitigation Assessment and authorizing City Engineer Rick Bogus as the authorized representative to sign. CIP #20-03

DRAFT

**RESOLUTION NO. R26-69**

A RESOLUTION OF THE MAYOR AND COUNCIL OF THE CITY OF COLUMBUS, NEBRASKA, APPROVING THE HAZARDOUS MITIGATION GRANT PROGRAM AGREEMENT BETWEEN THE NEBRASKA EMERGENCY MANAGEMENT AGENCY AND CITY OF COLUMBUS FOR THE COLUMBUS AREA REGIONAL FLOOD MITIGATION ASSESSMENT PROJECT AND AUTHORIZING CITY ENGINEER RICHARD BOGUS AS THE AUTHORIZED REPRESENTATIVE TO SIGN; A COPY OF WHICH IS ATTACHED HERETO AND INCORPORATED HEREIN BY THIS REFERENCE; TO AUTHORIZE THE MAYOR TO EXECUTE THE SAME ON BEHALF OF THE CITY; AND TO REPEAL ALL RESOLUTIONS OR PORTIONS THEREOF IN CONFLICT HEREWITH.

WHEREAS, the City of Columbus is the recipient of the Hazardous Mitigation Grant Program, Columbus Area Regional Flood Mitigation Assessment Project, Grant Agreement Number DR-4778-NE, Project No. 0005

NOW THEREFORE, BE IT RESOLVED BY THE MAYOR AND COUNCIL OF THE CITY OF COLUMBUS, NEBRASKA, approving the Hazardous Mitigation Grant Program Agreement between the Nebraska Emergency Management Agency and the City of Columbus for the Columbus Area Regional Flood Mitigation Assessment Project and authorization of City Engineer Richard Bogus as the authorized representative to sign, a copy of which is attached hereto and incorporated herein by this reference, is hereby approved and the mayor is authorized, directed, and empowered to execute the same on behalf of the City of Columbus, Nebraska.

This resolution shall repeal all resolutions or portions thereof in conflict herewith.

INTRODUCED BY COUNCIL MEMBER \_\_\_\_\_

PASSED AND ADOPTED THIS \_\_\_\_ DAY OF \_\_\_\_\_, 2026.

\_\_\_\_\_  
MAYOR

ATTEST:

\_\_\_\_\_  
CITY CLERK

APPROVED AS TO FORM:

\_\_\_\_\_  
CITY ATTORNEY



Accountability - Dedication  
Honesty - Integrity - Respect

---

---

## MEMORANDUM

**DATE:** April 29, 2026  
**TO:** Tara Vasicek, City Administrator  
**FROM:** Richard J. Bogus, City Engineer  
**RE:** Hazardous Mitigation Grant Program (HMGP) Agreement

**RECOMMENDATION:**

I recommend approval of, and for City Engineer Richard Bogus to sign, the Hazardous Mitigation Grant Program Agreement between Nebraska Emergency Management Agency and City of Columbus for the Columbus Area Regional Flood Mitigation Assessment.

**DISCUSSION:**

The City of Columbus is the subrecipient of the Federal Emergency Management Agency (FEMA), Hazardous Mitigation Grant Program, for Columbus Area Regional Flood Mitigation Assessment, Grant Agreement No. DR-4778-NE, Project No. 0005, administered through the Nebraska Emergency Management Agency (NEMA).

This study will enhance the knowledge, skills and expertise of stakeholders to expand or improve administration of flood mitigation assistance. This includes activities such as building code adjustments, partnerships, project scoping, flood hazard mitigation planning and other planning related activities. The objectives and mitigation outcomes of this regional flood assessment align with the following Continued Mitigation Actions as identified hazard mitigation plan: improve warning systems - specifically for flooding; improve emergency communications - specifically for emergency communications during flooding events; develop/implement hazard/emergency operations and response plan - specifically for emergency flood response; develop/update floodplain information - specifically to identify high risk flood zones where detailed studies are not available (not intended to update FEMA flood maps); and facility flood proofing - specifically for high-risk structures within 1% flood inundation areas. The study area includes rural populations in the southern portions of Platte County and Nance County, eastern portions of Howard County and southeastern portions of the Lower Loup NRD. The city will utilize appropriate local/state/federal procurement procedures to select a highly qualified professional consultant to provide assistance in the development of the flood risk reduction assessment.

**FISCAL IMPACT:**

Grant in the amount not to exceed \$142,500 or 75 percent of allowable costs, whichever is less. City would pay 25 percent up to \$47,500 and all costs above this combined total \$190,000 amount as part of 2025-2026 CIP #20-03.

**ALTERNATIVE:**

None. Requires approval to receive the grant.

**SIGNATURE:**

By: Richard J. Bogus

Approved By: [Signature]

**GRANT AGREEMENT**  
**Between**  
**Nebraska Emergency Management Agency (NEMA)**  
**And**  
**City of Columbus**

**Project Title:** Columbus Area Regional Flood Mitigation Assessment

**Grant Agreement No:** DR-4778-NE

**Project No:** 0005

**Federal Tax ID#:** 47-6006144

**UEI No:** YM4RJGN196F5

**FIPS Code:** 3110110

**Period of performance start date:** 03/03/2026

**Period of performance end date:** 08/01/2029

**Federal funds obligated amount:** \$142,500.00

**Project R&D:** No

**Assistance Listing (AL) #:** 97.039 Hazard Mitigation Grant Program

THIS Hazard Mitigation Grant Agreement (hereinafter "AGREEMENT") is entered into this 3rd day of March, 2026, by and between Nebraska Emergency Management Agency (hereinafter "NEMA" or "RECIPIENT") and the City of Columbus (hereinafter "SUBRECIPIENT").

The effective date of this AGREEMENT is March 03, 2026, the Federal Emergency Management Agency (hereinafter "FEMA") approval date of the project.

All references herein to the SUBRECIPIENT shall include its officers, employees, city council/board members, and agents.

**I. AGREEMENTS**

NEMA shall provide financial oversight and management in the role of RECIPIENT based on the grant guidance, the grant financial guide, and all other applicable State and Federal guidelines. The RECIPIENT shall provide technical assistance and direction to the SUBRECIPIENT on programmatic and financial requirements. The RECIPIENT shall provide all appropriate documents and forms and make payments to the SUBRECIPIENT to complete the approved scope of work.

The RECIPIENT is responsible for monitoring SUBRECIPIENT activities to provide reasonable assurance that the SUBRECIPIENT administers federal awards in compliance with

federal and state requirements. Responsibilities include the accounting of receipts and expenditures; cash management; and the maintaining of adequate financial records.

Additionally, the SUBRECIPIENT shall be monitored by the RECIPIENT to ensure that the program goals, objectives, timelines, budgets, and other related program criteria are being met. Monitoring shall be accomplished through a combination of monthly check-in meetings and quarterly reporting, reviewing of expenditures for reimbursement, and when necessary, on-site monitoring. Monitoring shall involve the review and analysis of the financial, programmatic, and administrative issues relative to the program, and shall identify areas where technical assistance and other support may be needed.

The SUBRECIPIENT shall pass appropriate resolutions to assure NEMA that it is participating in, and shall continue to participate in, the National Flood Insurance Program (NFIP), if mapped. If SUBRECIPIENT is not currently participating in the NFIP, SUBRECIPIENT shall, within twelve (12) months of project approval, adopt appropriate resolutions to assure NEMA of participation in the NFIP.

The SUBRECIPIENT and the SUBRECIPIENT's Authorized Representative agree to provide all supervision, inspection, accounting, and other services necessary to complete the scope of work from inception to closeout with the requirements set forth below.

## **II. AUTHORITIES AND REFERENCES**

Laws, regulations, and endorsements including, but not limited to, the following commonly applicable to FEMA Grants listed hereafter, for reference only.

- 2 CFR Part 200 Uniform Administrative Requirements, Cost Principles and Audit Requirements for Federal Awards".
- Robert T. Stafford Disaster Assistance and Emergency Relief Act (Stafford Act), 42 U.S.C. § 5133, as amended by Section 102 of the Disaster Mitigation Act of 2000 (DMA).
- Title 44 of the Code of Federal Regulations (CFR).
- SUBRECIPIENT's application that was received and approved by NEMA and FEMA.
- State of Nebraska Administrative Plan for the Hazard Mitigation Grant Program.

## **III. COMPLIANCE WITH LAWS**

The SUBRECIPIENT shall comply with all applicable requirements of all federal laws, executive orders, regulations, and policies governing this program including, but not limited to, the following:

- The recipient agrees to abide by the DHS Standard Terms and Conditions applicable at the time of the signing of this Agreement. Changes or modifications to the DHS Standard Terms and Conditions as a result of Court Orders or Agreements shall be incorporated into this Agreement.
- 2 CFR Part 200 Uniform Administrative Requirements, Cost Principles and Audit Requirements for Federal Awards".

- Robert T. Stafford Disaster Assistance and Emergency Relief Act (Stafford Act), 42 U.S.C. § 5133, as amended by Section 102 of the Disaster Mitigation Act of 2000 (DMA).
- Title 44 of the Code of Federal Regulations (CFR).

The SUBRECIPIENT shall comply with all applicable laws, regulations and policies as defined in the State of Nebraska Hazard Mitigation Administrative Plan.

The SUBRECIPIENT is actively encouraged to comply with the Build American, Buy America Act (BABAA), Section 70914 of Public Law No. 117-58 §§ 70901-52.

#### **IV. SCOPE OF WORK**

This AGREEMENT is to provide SUBRECIPIENT with federal assistance from the Hazard Mitigation Grant Program funds for the above referenced mitigation grant. The federal share shall not exceed \$142,500.00 or 75% of the actual allowable project costs, whichever is less. The SUBRECIPIENT shall provide at least \$47,500.00 (25%) through local non-federal (cash and/or in-kind) sources for actual allowable project costs.

The SUBRECIPIENT Management Cost for the above referenced mitigation grant, 100% federally funded, have been approved \$9,500.00 (100% Fed Share). Management Costs are based on actual documented incurred management costs, up to 5% of the total amount expended on the project by the SUBRECIPIENT. Management Costs are subject to incremental funding obligations; therefore, FEMA has released to the state \$9,500.00 (100% Federal funds) in approved Subrecipient Management Cost funding for budget year one. These funds are to assist the SUBRECIPIENT with completing the approved scope of work in accordance with the work schedule, milestones, and scope of work that was submitted to and approved by NEMA and FEMA.

Any changes to the approved scope of work and/or amount budgeted must be submitted to and approved by NEMA prior to executing the changes. The SUBRECIPIENT is required to obtain all necessary permits before construction begins.

#### **V. ACTIVITY COMPLETION TIMEFRAME**

The approved activity completion timeframe for this project is from 03/03/2026 through 08/01/2029. All work shall be completed prior to the activity completion timeframe ending. The SUBRECIPIENT shall not incur costs or obligate funds for any purpose pertaining to the operation of the project, program, or activities beyond the expiration date of the activity completion timeframe.

If a time extension is needed it must be requested at least 75 days prior to the activity completion timeframe end date. All requests shall be supported by adequate justification submitted to NEMA in order to be processed. This justification is a written explanation of the reason or reasons for the delay; an outline of remaining funds available to support the extended activity completion timeframe; and a description of performance measures necessary to complete the project. Without the justification, extension requests will not be processed.

If the activity is not completed by the agreed upon end date, and no extension is granted, NEMA may suspend or terminate any further obligation to provide funding or demand return of grant funds authorized by the AGREEMENT.

## **VI. GRANT MANAGEMENT SYSTEM**

To ensure that federal funds are awarded and expended appropriately, the SUBRECIPIENT shall establish and maintain a grant management system. The standards for SUBRECIPIENT organizations stem from the Office of Management and Budget's (OMB) Uniform Administrative Requirements and Cost Principles. State, local and tribal organizations must follow the uniform administrative requirements standards in 2 CFR Part 200. These standards plus the requirements of the federal Cash Management Improvement Act constitute the basis for all policies, processes and procedures set forth in this grant management system for the SUBRECIPIENT.

The SUBRECIPIENT's grant management system shall include the following:

- Internal controls based on the American Institute for Certified Public Accountants (AICPA) definitions and requirements in the government-wide administrative requirements and cost principles.
- A chart of accounts that includes a separate cost center, fund, or accounting codes for each federal grant or program.
- Compliance with the Cash Management Improvement Act (CMIA), good business processes and Generally Accepted Accounting Principles (GAAP).
- Procedures to minimize federal cash on hand.
- The ability to track expenditures on a cash or accrual basis.
- The ability to track expenditures in both financial and program budgets.
- Procedures to document all grant-related expenditures.
- Procedures to ensure expenditures are eligible and allowable.
- The ability to fulfill government-required financial reporting forms.

## **VII. PROCUREMENT**

All procurement under this AGREEMENT shall be executed by the SUBRECIPIENT. Procurement standards shall be in accordance with the written adopted procedures of the SUBRECIPIENT, provided that the local procurement standards conform to applicable State and Federal law and the standards identified in the 44 CFR and 2 CFR Part 200. The SUBRECIPIENT shall ensure that every purchase order or other contract includes any clauses required by Federal statutes and executive orders and their implementing regulations. Failure to comply with applicable procurement statutes and regulations may result in additional conditions under 2 CFR § 200.208. If failure to comply continues by SUBRECIPIENT, additional remedies or termination of the award under 2 CFR §§ 200.339-200.340 may occur.

### **VIII. PAYMENT REQUEST PROCESS**

Payments to SUBRECIPIENTS are based on eligible expenditures that are specifically related to the approved grant budget and scope of work. SUBRECIPIENTS can request Reimbursement for allowable expenditures already paid at any time during the activity completion timeframe.

Payments shall be limited to the documented cash requirements submitted by the SUBRECIPIENT. The SUBRECIPIENT must submit a completed Payment Request Form and provide supporting documentation of eligible project costs to receive payment of funds.

Reimbursement requests shall include payment verification (i.e. paid invoices, receipts, payroll records with personnel activity reports, cancelled checks, general ledger print outs, etc.).

Payment of funds shall not be made to a SUBRECIPIENT until NEMA has this grant agreement signed and on file.

Payments to SUBRECIPIENT are based on eligible expenditures that are specifically related to the approved subaward budget and scope of work. SUBRECIPIENT has two options available to them when requesting payments from NEMA. SUBRECIPIENT may request either **Reimbursement** for allowable expenditures already paid or request an **Advance** for expenditures to be paid within 30 days. Advance payments will only be entertained for certain projects. Below notes whether or not this project is allowed advance payments:

YES  NO

Payments shall be limited to the documented cash requirements submitted by the SUBRECIPIENT. The SUBRECIPIENT shall submit a completed Payment Request Form and provide supporting documentation of eligible subaward costs to receive payment of funds.

- **Reimbursement** requests shall include payment verification (i.e. paid invoices, receipts, payroll records with personnel activity reports, cancelled checks, general ledger printouts, etc.). NEMA reserves the right to request that the SUBRECIPIENT submit additional documentation expenditures upon request. Additional documentation for Acquisitions: Purchase Offers, HUD Settlement Statements, and copies of tax assessment records, copies of appraisals if used as the basis for pre-flood fair market value, invoices, and copies of all payments.
- **Advance** payment requests shall include the detailed costs the SUBRECIPIENT is obligated to pay (i.e. invoices, accepted quotes, executed contracts, or other documents). Payment verification documents (same documents required for a Reimbursement request) for the advance shall be submitted to NEMA within 30 days after the advance, and before future advances are made.

A SUBRECIPIENT shall submit only reimbursement requests, and is not eligible for Advance payment, if SUBRECIPIENT is unable to demonstrate the following:

- The willingness to maintain written procedures that minimize the time elapsing between the transfer of funds and disbursement by NEMA;
- A financial management system that meets the standards for fund control and accountability as established in 2 CFR Part 200; or
- Is considered a High Risk subrecipient.

No more than thirty (30) days shall elapse between the date of receipt of a warrant and pay out of the funds by the SUBRECIPIENT. All supporting documentation shall be submitted to NEMA immediately following the SUBRECIPIENT's pay out of the funds.

Payment of funds shall not be made to the SUBRECIPIENT until NEMA has on file the following documents:

- FEMA Award Notification (attached to this AGREEMENT).
- Signed Subaward Agreement.
- Substitute W9/Vendor Update Form (if not already on file at NEMA).
- Chart of Accounts verifying that unique revenue and expenditure accounts, cost centers or account codes have been established within the SUBRECIPIENT's cash management/accounting system for each program included in this AGREEMENT.
- Procurement documents: written procurement and conflict of interest documents, method of procurement, bid specifications reviewed by NEMA, copy of approved and executed contracts between the SUBRECIPIENT and contractor.
- Signed certification from the SUBRECIPIENT's authorized representative for the payment request as outlined in 2 CFR, Part 200, Subpart D, Section 200.415.

#### **IX. MATCH VERIFICATION**

The maximum federal share to this mitigation grant shall not exceed 75% of eligible grant expenditures. Therefore, the matching funds (cash and in-kind) shall be at least 25% of eligible grant expenditures. The SUBRECIPIENT is responsible for submitting proof of the local non-federal match that was used for their mitigation grant to NEMA. Expenditures shall be in accordance with the approved scope of work and budget and in accordance with the 2 CFR §§ 200.29 and 200.306.

Cash match may be money contributed to the SUBRECIPIENT by the SUBRECIPIENT, other public agencies and institutions, private organizations and individuals as long as it comes from a non-federal source. Cash spent shall be for allowable costs in accordance with the SUBRECIPIENT's approved scope of work and budget and shall be applicable to the period to which the cost sharing or matching requirement applies.

In-kind match shall comply with the requirements of 2 CFR §§ 200.343 and 200.344. The value of in-kind contributions is also applicable to the period to which the cost sharing or matching requirement applies. The in-kind match provided shall be documented by the third party contributing the in-kind services. The in-kind match shall be specifically stated in the

SUBRECIPIENT's scope of work and budget before in-kind match will be allowed to match any mitigation grant. Documentation may be a letter (on letterhead) from the third party stating the scope of their work, what is being contributed as it relates to the scope of work, the value, a statement to the effect that the value is normally charged, and a statement that the value is being waived on behalf of the SUBRECIPIENT to meet the matching requirements to the SUBRECIPIENT's mitigation grant or a spreadsheet detailing in-kind contributions certified by the Authorized Representative.

If the local match is insufficient to satisfy the local match requirements for receiving all available federal funds, the awarded federal funds shall be reduced accordingly so as not to exceed the maximum federal share allowed under this award.

#### **X. REPORTING REQUIREMENTS**

The mitigation grant requires quarterly programmatic and financial reporting and progress relative to the approved scope of work. SUBRECIPIENTS shall complete the quarterly progress report forms that are provided by NEMA and submit them by the 15th day following each federal fiscal quarter. (See administrative plan for specific date.)

The SUBRECIPIENT shall attend and participate in monthly check-in meetings with RECIPIENT in a manner to be determined by NEMA. The purpose of the meeting is to evaluate project progress and address any other business relating to the project.

#### **XI. RECORDS AND DOCUMENTATION**

The SUBRECIPIENT shall be responsible for keeping records which fully disclose the amount and disposition of funds at all times, and the total costs of each project for which the funds are provided.

The SUBRECIPIENT shall retain all grant records for three (3) years after being notified by the Nebraska Emergency management Agency that the overall grant has been closed by DHS/FEMA.

The State requires the subrecipient to submit back-up documentation to substantiate all costs.

The SUBRECIPIENT shall give the federal awarding agency, the Comptroller General of the United States, and if appropriate, the State, through any authorized representative, access to and the right to examine all records, books, papers, or documents related to the assistance; and shall establish a proper accounting system in accordance with generally accepted accounting standards or agency directives.

#### **XII. INDEPENDENT CONTRACTOR STATUS OF APPLICANT**

The SUBRECIPIENT, its officers, employees, agents and council members shall all perform their obligations under this AGREEMENT as an independent contractor and not in any manner as officers, employees or agents of NEMA or the State of Nebraska.

### **XIII. CONFLICT OF INTEREST**

The SUBRCIPIENT shall establish safeguards to prohibit employees from using their positions for a purpose that constitutes or presents the appearance of personal or organizational conflict of interest or personal gain.

### **XIV. WAGE RATES**

The SUBRECIPIENT shall comply, as applicable, with the provisions of the Davis-Bacon Act (40 U.S.C. §§ 276a to 276a-7), the Copeland Act (40 U.S.C. § 276c and 18 U.S.C. § 874), the Contract Work Hours and Safety Standards Act (40 U.S.C. §§ 327-333) regarding labor standards for federally assisted construction subawards.

### **XV. LOBBYING**

The SUBRECIPIENT shall comply with the provisions of the Hatch Act (5 U.S.C. §§ 1501-1508 and §§ 7324-7328) which limit the political activities of employees whose principal employment activities are funded in whole or in part with federal funds.

### **XVI. AUDIT**

The SUBRECIPIENT shall comply with the required financial and compliance audits in accordance with the Uniform Administrative Requirements, Cost Principles and Audit Requirements for Federal Awards (2 CFR part 200).

### **XVII. FLOODPLAIN**

The SUBRECIPIENT shall comply with all floodplain management laws and regulations including any special conditions placed on the grant.

### **XVIII. WAIVERS**

No conditions or provisions of this AGREEMENT may be waived unless approved by NEMA and the SUBRECIPIENT, in writing. Unless otherwise stated in writing, NEMA's failure to insist upon strict performance of any provision of this AGREEMENT, or to exercise any right based upon a breach, shall not constitute a waiver of any right or obligation specified under this AGREEMENT.

### **XIX. AMENDMENTS AND MODIFICATIONS**

This AGREEMENT may be amended or modified in reference to the grant funds provided, administrative procedures, or any other necessary matter, but shall not take effect until approved, in writing, by NEMA and the SUBRECIPIENT.

### **XX. COMPLIANCE, TERMINATION, AND OTHER REMEDIES**

Unless otherwise stated in writing, NEMA requires strict compliance by the SUBRECIPIENT and its Authorized Representative(s) with the terms of this AGREEMENT, and the requirements of any applicable local, state, and federal statute, rules, regulations; particularly those included in the Assurances attached to this grant agreement.

NEMA may suspend or terminate any obligation to provide funding or demand return of grant funds, following notice from NEMA, if the SUBRECIPIENT fails to meet any obligations under this AGREEMENT or fails to make satisfactory progress toward administration or completion of said project.

Any suspension or termination of funding or demand of return of grant funds by NEMA shall not relieve SUBRECIPIENT of liability for any obligation incurred by SUBRECIPIENT due to said project.

The SUBRECIPIENT understands and agrees that NEMA may enforce the terms of this AGREEMENT by any combination or all remedies available to NEMA under this AGREEMENT, or under any other provision of law, common law, or equity.

#### **XXI. INDEMNIFICATION**

It is understood and agreed by NEMA and the SUBRECIPIENT and its agents that nothing in this AGREEMENT is intended, nor may be construed, to create any rights, confer any benefits, or relieve any liability, of any kind whatsoever in any third person not a party to this AGREEMENT.

The SUBRECIPIENT, on behalf of itself and its successors and assignees, agrees to protect, save, and hold harmless NEMA and the State of Nebraska, and their authorized agents and employees, from all claims, actions, costs, damages, or expenses of any nature whatsoever by reason of the negligent acts, errors, or omissions of the SUBRECIPIENT or its authorized representative, its contractors, subcontractors, assignees, agents, licensees, arising out of or in connection with any acts or activities authorized by this AGREEMENT. The SUBRECIPIENT's obligation to protect, save, and hold harmless as herein provided shall not extend to claims or causes of action for costs, damages, or expenses caused by or resulting from the negligent acts, errors, or omissions of NEMA, the State of Nebraska, or any of their authorized agents or employees.

The SUBRECIPIENT further agrees to defend NEMA, the State of Nebraska, and their authorized agents and employees against any claim or cause of action, or to pay reasonable attorney's fees incurred in the defense of any such claim or cause of action, as to which the SUBRECIPIENT is required to protect, save, or hold harmless said parties pursuant to paragraph 2 of this section. The SUBRECIPIENT's obligation to defend, or to pay attorney's fees for the defense of such claims or causes of action as herein provided, shall not extend to claims or causes of action for costs, damages, or expenses caused by or resulting from the negligent acts, errors, or omissions of NEMA, the State of Nebraska, or any of their authorized agents or employees.

#### **XXII. ACKNOWLEDGMENTS**

The SUBRECIPIENT shall include, in any public or private release of information regarding the project, language that acknowledges the funding contribution through NEMA by FEMA.

**XXIII. RESPONSIBILITY FOR PROJECT**

While NEMA undertakes to provide technical assistance to the SUBRECIPIENT and its authorized representative in the administration of the project, said project remains the sole responsibility of the applicant in accomplishing grant objectives and goals. NEMA undertakes no responsibility to the SUBRECIPIENT, or any third party, other than what is expressly set out in this AGREEMENT.

**XXIV. NOTICES AND COMMUNICATIONS BETWEEN NEMA AND SUBRECIPIENT**

Any notice, request, demand, or other communication required or permitted to be given under the Agreement shall be deemed to have been duly given if in writing and delivered personally or mailed by registered or certified mail, with return receipt, as follows:

If to the SUBRECIPIENT:

Richard J. Bogus, Chief Engineer  
City of Columbus  
2500 14<sup>th</sup> St, Suite 3  
Columbus, NE, 68601

Or the Alternate Point of Contact:

Tara Vasicek, City Administrator  
City of Columbus  
2500 14<sup>th</sup> St, Suite 3  
Columbus, NE, 68601

If to NEMA:

Chelsea Harris, State Hazard Mitigation Officer  
Attention: Hazard Mitigation Unit  
Nebraska Emergency Management Agency  
2433 NW 24<sup>th</sup> Street  
Lincoln, NE 68524

A party may change the recipient or address to which such communications are to be directed by giving written notice to the other party in the manner provided in this section.

**XXV. ENTIRE GRANT AGREEMENT**

This AGREEMENT and attachments/exhibits set forth the entire AGREEMENT between NEMA and the SUBRECIPIENT with respect to subject matter hereof. Commitments, warranties, representations and understandings or agreements not contained, or referred to, herein or amended thereto shall not be binding on either NEMA or the SUBRECIPIENT. Except as may be expressly provided herein, no alteration of any of the terms or conditions of this AGREEMENT will be effective without written consent of both parties.

IN WITNESS WHEREOF, NEMA and the SUBRECIPIENT have executed this AGREEMENT by the signatures of authorized persons of both entities and on the dates indicated below:

**RECIPIENT**

**Nebraska Emergency Management Agency**

\_\_\_\_\_  
Ervin L. Portis, Governor’s Authorized Representative

\_\_\_\_\_  
Date

**SUBRECIPIENT**

**City of Columbus**

\_\_\_\_\_  
Authorized Representative

\_\_\_\_\_  
Date

\_\_\_\_\_  
Authorized Representative Printed Name

\_\_\_\_\_  
Authorized Representative Title

APPROVED AS TO FORM

BY \_\_\_\_\_  
CITY ATTORNEY

## **EXHIBIT A: Scope of Work-Reporting & Administrative Requirements-Project Budget**

### **1. GENERAL DESCRIPTION OF THE PROJECT(S).**

**1.1 Project description:** This assessment will be an activity that will enhance the knowledge, skills, and expertise of stakeholders to expand or improve the administration of flood mitigation assistance. This includes activities such as building code adjustments, partnerships, project scoping, flood hazard mitigation planning, and other planning-related activities. The objectives and mitigation outcomes of this regional flood assessment align with the following Continued Mitigation Actions as identified hazard mitigation plan: improve warning systems - specifically for flooding; improve emergency communications - specifically for emergency communications during flooding events; develop/implement hazard/emergency operations and response plan - specifically for emergency flood response; develop/update floodplain information - specifically to identify high risk flood zones where detailed studies are not available (not intended to update FEMA flood maps); and facility flood proofing - specifically for high-risk structures within 1% flood inundation areas. A brief summary of specific project tasks is included below. Task 1: Project Management - Periodic coordination by the city and other stakeholders will be conducted to share progress reports, and coordinate the collection of data and input. Progress meetings will be conducted as well as contract administration. Task 1A: Grant Administration (Management Costs are not part of the overall project budget) - The City will coordinate with NEMA to ensure the project adheres to grant requirements, and that schedules and budgets are maintained. Quarterly progress reports will be prepared and submitted to NEMA. Task 2: Background Data Collection and Field Visits - Gather and review readily available information such as: pertinent historical records; information provided by local entities; Flood Insurance Studies; Bridge As-builts; Emergency Action Plans; Local Emergency Operation Plans; Historical Records of Flooding and Ice Jams; LiDAR, aerial imagery and other GIS data. Field visits to potential project locations will be conducted as needed to identify key features, such as at ice jam-prone bridges. Task 3: Hydrologic and Hydraulic Analyses - Available existing hydrologic data for the 50-year (2% annual chance exceedance) and 100-year (1% annual chance exceedance) events will be the focus of the hydrologic analyses. Hydraulic analyses will be performed utilizing HEC-RAS 2D and readily available topographic data. The hydrologic and hydraulic analyses will support development of high-risk or high-velocity flood zones in reaches of the Loup River upstream of the City, where a detailed flood study has not been completed and where a floodway has not been designated. The analyses will also support evaluation of upstream bridges, potential relief channels and river bends at known locations at risk to ice jams. Task 4: Stakeholder Collaboration and Public Engagement - To leverage support for the flood mitigation effort, multiple affected partner jurisdictions will be collaborating in this effort. In addition to the City of Columbus, it is anticipated that Platte County, Nance County, the Lower Loup NRD and other key stakeholders will be involved in the project. These partnerships will provide invaluable insight into current flood mitigation and response protocols as well as feasible alternatives. The partnerships will also promote community engagement, such as through educational project fact sheets, online surveys, etc. Partnerships and community engagement efforts will offer substantial benefits towards project implementation and risk

mitigation...WHICH IS THE ULTIMATE GOAL. Task 5: Evaluation of Mitigation Alternatives - A wide array of mitigation alternatives will be considered to reduce flood risks AND increase flood risk awareness considering current conditions, as well as future conditions. Climate change, new development patterns, population change, and other environmental factors all will be considered for future conditions. A 'no-action' alternative will be evaluated, providing a baseline for comparison to other alternatives, also outlining flood risks that will persist with no flood mitigation efforts. Flood mitigation alternatives will include nature-based solutions, structural and non-structural solutions, programmatic and procedural solutions all resulting in a more robust and resilient community response and risk-informed decisions to ever-changing conditions. Refer to the 'Alternatives' portion of this section for additional details and specifics pertaining to flood mitigation alternatives. Conceptual alternatives will be identified, and feasibility assessed based upon input and collaboration with stakeholders and other project partners. This information along with a preliminary benefit/cost assessment will then be used to determine feasibility for the identified projects and prioritize flood risk reduction actions that can be taken to mitigate flood risks in the study area. Task 6: Funding Strategy - A strategy will be developed in coordination with stakeholder collaboration for how to fund recommended structural, non-structural and programmatic mitigation alternatives. The strategy will consider external funding assistance such as grants from FEMA (HMGP or HMGP Post Fire). The strategy will also lay out recommended local funding responsibilities for the City (such as in the CIP), LLNRD, counties, communities and possible private entities. Task 7: FEMA Grant Application Development - A submittal-ready grant application for HMGP will be developed. The application will seek funding assistance for the highest priority, highest feasibility alternative evaluated as part of this assessment. The application will identify project costs and include a FEMA benefit-cost analysis where required. The application will also lay out local-share cost contributions for partner stakeholders, as well as a project schedule meeting grant requirements. Task 8: Deliverables - A draft flood mitigation assessment will be developed to describe the findings and summarize the mitigation alternatives. Potential summary of findings to include: hydrology and hydraulics results; collaboration and public engagement efforts; alternatives analyses and recommendations; funding strategies; grant application development; and associated figures and maps. The draft assessment will then be revised to incorporate input from the City and other stakeholders, and finalized.

**1.2 Project expenses:** Project expenses include those costs identified and approved in the application and budget. Documented pre-award costs related to the development of the grant application as noted in the subapplication and approved budget may also be used to meet local match requirements or reimbursed.

**1.3 Non-Federal Match:** This Grant Requires a non-federal match contribution of 25% of the total Grant budget. The non-Federal match is shared by the City of Columbus.

**1.4 Project Timeline (from approved HMGP subapplication):**

| <b>Project Milestone</b>                                    | <b>Timeframe<br/>(No. of Months)</b> | <b>Expected Completion<br/>Date</b> |
|---|--------------------------------------|-------------------------------------|
| Tasks 1 and 1A: Project Management and Grant Administration | 36                                   | 03/03/2029                          |
| Task 2: Background Data Collection and Field Visits         | 12                                   | 03/03/2027                          |
| Task 3: Hydrologic and Hydraulic Analyses                   | 24                                   | 09/03/2028                          |
| Task 4: Stakeholder Collaboration and Public Engagement     | 24                                   | 09/03/2028                          |
| Task 5: Evaluation of Mitigation Alternatives               | 24                                   | 03/03/2029                          |
| Task 6: Funding Strategy                                    | 12                                   | 03/03/2029                          |
| Task 7: HMGP Application Development                        | 6                                    | 03/03/2029                          |
| Task 8: Deliverables  | 12                                   | 03/03/2029                          |
| Project Closeout  | 1                                    | 03/03/2029                          |
| <b>Total Project Duration:</b>                              | <b>36</b>                            | <b>03/03/2029</b>                   |

**2. DELIVERABLES**

**2.1 Deliverables:** Subrecipient shall submit narrative and financial reports describing project progress and accomplishments, any delays in meeting the objectives and expenditures to date as described in Section 3 of this Exhibit A may result in loss of project funding. Copies of relevant documentation (including invoices, quarterly reports, requests for reimbursement all must be submitted to NEMA in accordance with this grant agreement.

**3. REPORTING REQUIREMENTS:**

**3.1 Quarterly Progress Reports and Financial Status:**

| <b>Report Period</b>          | <b>Due Date</b>   |
|-------------------------------|-------------------|
| Quarter 1 (October- December) | <b>January 15</b> |
| Quarter 2 (January- March)    | <b>April 15</b>   |
| Quarter 3 (April -June)       | <b>July 15</b>    |
| Quarter 4 (July- September)   | <b>October 15</b> |

**3.2 Monthly Check-in:** Subrecipient shall attend and participate in monthly check-in meetings with recipient, in a manner to be determined by NEMA, to evaluate project progress and any other business relating to the project.

**4. ADMINISTRATIVE REQUIREMENTS (Project specific requirements):**

The SUBRECIPIENT shall adhere to the current and applicable FEMA administrative requirements described in the Hazard Mitigation Assistance Guidance and Addendum published March 23, 2023 (or subsequent and superseding program policy, as applicable).

The SUBRECIPIENT shall ensure that all necessary documentation and deliverables are completed and submitted to the State within 30 days of the Grant Agreement expiration date. SUBRECIPIENT shall ensure all closeout requirements outlined in FEMA Hazard Mitigation Assistance Guidance (2023) are met at the time of subaward closeout.

The SUBRECIPIENT and the SUBRECIPIENT’s Authorized Representative shall provide all supervision, inspection, accounting, and other services necessary to complete the scope of work from inception to closeout with the requirements set forth below.

**5. PROJECT BUDGET (as approved in Subapplication):**

| <b>Budget Summary</b>                     |                 |                        |                      |                     |
|---|-----------------|------------------------|----------------------|---------------------|
| <b>Item</b>                               | <b>Quantity</b> | <b>Unit of Measure</b> | <b>Cost per Unit</b> | <b>Total Cost</b>   |
| Task 1: Project Management                | 75              | EA                     | \$200.00             | \$15,000.00         |
| Task 2: Background Data Collection        | 50              | EA                     | \$200.00             | \$10,000.00         |
| Task 3: Hydrologic and Hydraulic Analyses | 200             | EA                     | \$200.00             | \$40,000.00         |
| Task 4: Stakeholder Collaboration         | 150             | EA                     | \$200.00             | \$30,000.00         |
| Task 5: Mitigation Alternatives           | 250             | EA                     | \$200.00             | \$50,000.00         |
| Task 6: Funding Strategy                  | 50              | EA                     | \$200.00             | \$10,000.00         |
| Task 7: HMGP Application Development      | 50              | EA                     | \$200.00             | \$10,000.00         |
| Task 8: Deliverables                      | 125             | EA                     | \$200.00             | \$25,000.00         |
| <b>Grant Total:</b>                       |                 |                        |                      | <b>\$190,000.00</b> |

| <b>Cost Share Breakdown</b> |                    |                     |                            |
|-----------------------------|--------------------|---------------------|----------------------------|
| <b>Source</b>               |                    | <b>Amount</b>       | <b>Percentage of Total</b> |
| <b>Federal Share:</b>       | HMGP Grant Program | \$142,500.00        | 75%                        |
| <b>Non-Federal:</b>         | City of Columbus   | \$47,500.00         | 25%                        |
| <b>Grant Total:</b>         |                    | <b>\$190,000.00</b> | <b>100%</b>                |

| <b>Management Cost Summary</b> |                   |
|--------------------------------|-------------------|
| <b>Item</b>                    | <b>Amount</b>     |
| <b>Total Funds Awarded</b>     | \$9,500.00        |
| <b>Grant Total:</b>            | <b>\$9,500.00</b> |

Hazard Mitigation Grant Program Grant Agreement  
Columbus Area Regional Flood Mitigation Assessment  
DR-4778-NE-0005

**EXHIBIT B: FEMA Award Notification (letter from FEMA)**



**FEMA**

March 3, 2026

Ervin Portis  
Assistant Director  
Nebraska Emergency Management Agency  
Attn: Hazard Mitigation  
2433 Northwest 24<sup>th</sup> Street  
Lincoln, Nebraska 68524-1801

Subject: FEMA-4778-DR-NE  
Hazard Mitigation Grant Program (HMGP) Approval  
Subrecipient: City of Columbus  
Project #: 0005  
Columbus Area Regional Flood Mitigation Assessment

Assistant Director Portis:

The Federal Emergency Management Agency (FEMA) Region 7 has granted approval of your request dated April 22, 2025, for the application submitted by City of Columbus for the Columbus Area Regional Flood Mitigation Assessment project. FEMA will release funds to the state in the amount of \$142,500.00. The non-federal match requirement of \$47,500.00 will be provided through local funding.

The milestones included in the application indicate that the time to complete this subaward will be 36 months from the date of this letter. Any delays or extensions regarding this timeframe must be reported to FEMA. The period of performance for the grant ends on August 1, 2029. It is the responsibility of the recipient and subrecipient to ensure all approved activities associated with this subaward are completed by the end of the period of performance. Any costs incurred that were not identified as pre-award prior to the date of this approval or any costs incurred after the period of performance will be disallowed.

### **Environmental Historic Preservation (EHP) Requirements/Conditions**

A change to the approved statement of work (SOW) requires prior approval from FEMA. The National Environmental Policy Act (NEPA) stipulates that additions or amendments to a HMGP subrecipient SOW shall be reviewed by all state and federal agencies participating in the NEPA process. NEPA sign off for all SOW additions or amendments is essential before the revised SOW can be approved by FEMA or implemented by the Hazard Mitigation Grants Program subrecipient.

This review does not address all federal, state, and local requirements. Acceptance of federal funding requires recipient to comply with all federal, state, and local laws. Failure to obtain all appropriate federal, state, and local environmental permits and clearances may impact federal funding.

Page 2

If ground disturbing activities occur during construction, applicant will monitor ground disturbance and if any potential archeological resources are discovered, will immediately cease construction in that area and notify the state and FEMA.

**Subrecipient Management Costs:**

HMGP Subrecipient Management Costs (SRMC) funds for DR-4778-NE Project #0005, Columbus Area Regional Flood Mitigation Assessment have also been approved. Federal funds will be released to the state in the amount of \$9,500.00 (100% Federal funds).

Federal funding of SRMC is based on actual documented incurred management costs, up to 5% of the total amount of the HMGP award. Recipients and subrecipients are required to maintain appropriate documentation to support expensed claims. All costs must be reasonable, allowable, allocable, and necessary as required by 2 C.F.R. Part 200 Subpart E, applicable program regulations, and the HMA Guide (2023).

Quarterly progress reports for both HMGP projects and Subrecipient MC grants are required; please include this HMGP project and Subrecipient MC grant in your future quarterly reports.

If you should have any questions concerning this action, please contact Brian Woltz, Hazard Mitigation Assistance Branch Chief, at (816) 808-3664 or [Brian.Woltz@fema.dhs.gov](mailto:Brian.Woltz@fema.dhs.gov).

Sincerely,

LAURIE L  
BESTGEN



Digitally signed by  
LAURIE L BESTGEN  
Date: 2026.03.03  
13:37:12 -06'00'

Laurie L. Bestgen, Director  
Mitigation Division

Hazard Mitigation Grant Program Grant Agreement  
Columbus Area Regional Flood Mitigation Assessment  
DR-4778-NE-0005

**EXHIBIT C: FEMA Record of Environmental Consideration**

Hazard Mitigation Grant Program Grant Agreement  
Columbus Area Regional Flood Mitigation Assessment  
DR-4778-NE-0005

**EXHIBIT D: Signed Authorized Representative Form**

## Nebraska Emergency Management Agency

### Recovery Section Authorized Representative Designation

|  |   |   |                 |
|--|---|---|-----------------|
| <b>Applicant's Name</b> (City, County, Government Agency, Tribe, Township, Village, NRD, PNP, PPD, FRF, SID, etc.) |   |   |                 |
| City of Columbus, Nebraska   |   |   |                 |
| <b>Disaster/Grant #</b>  | <b>Assistance Listing (AL) #</b>                                    | <b>UEI # (from SAM.gov)</b>   | <b>Tax ID #</b> |
|  |   | YM4RJGN196F5  | 47-6006144      |
| <b>Applicant's Fiscal Year Start</b>   |   |   |                 |
| Month  |   | Year  |                 |
|  |   |   |                 |
| <b>Chief Elected Official</b>  |   | <b>Authorized Representative</b>                                    |                 |
| <b>Fiscal Officer</b>  |   |   |                 |
| <b>Name</b><br>James B. Bulkley  | <b>Name</b><br>Richard J. Bogus                                     | <b>Name</b><br>Tara Vasicek   |                 |
| <b>Official Position</b><br>Mayor  | <b>Official Position</b><br>City Engineer                           | <b>Official Position</b><br>City Administrator                      |                 |
| <b>Mailing Address</b><br>2500 14 <sup>th</sup> Street, Ste. 3   | <b>Mailing Address</b><br>2500 14 <sup>th</sup> Street, Ste. 3      | <b>Mailing Address</b><br>2500 14 <sup>th</sup> Street, Ste. 3      |                 |
| <b>City, County, State, Zip Code</b><br>Columbus, Platte, NE, 68601  | <b>City, County, State, Zip Code</b><br>Columbus, Platte, NE, 68601 | <b>City, County, State, Zip Code</b><br>Columbus, Platte, NE, 68601 |                 |
| <b>Daytime Telephone</b><br>402-562-4244   | <b>Daytime Telephone</b><br>402-562-4309                            | <b>Daytime Telephone</b><br>402-562-4233                            |                 |
| <b>Fax Number</b><br>NA  | <b>Fax Number</b><br>NA   | <b>Fax Number</b><br>NA   |                 |
| <b>Cell Phone Number (if applicable)</b>   | <b>Cell Phone Number (if applicable)</b>                            | <b>Cell Phone Number (if applicable)</b>                            |                 |
| <b>Email Address</b><br>Jim.bulkley@columbusne.us  | <b>Email Address</b><br>Rick.Bogus@columbusne.us                    | <b>Email Address</b><br>Tara.Vasicek@columbusne.us                  |                 |

The above Authorized Representative is hereby authorized to execute and file any project application on behalf of this organization for the purpose of obtaining state and/or federal financial assistance under the Robert T. Stafford Disaster Relief and Emergency Assistance Act or otherwise available. The designated Authorized Representative is authorized by the below Chief Elected Official to represent and act for this organization in all dealings with the State of Nebraska for all matters pertaining to this grant and will serve as the single point of contact.

  
 \_\_\_\_\_  
 Signature of Chief Elected Official

4-21-25  
 \_\_\_\_\_  
 Date

James B. Bulkley  
 \_\_\_\_\_  
 Printed Name of Chief Elected Official

Mayor  
 \_\_\_\_\_  
 Printed Title of Chief Elected Official

**15. ORDINANCES ON FIRST READING**

15.A. Ordinance No. 26-08 amending city code section 50.35 to add regulations regarding handling of solid waste.

**ORDINANCE NO. 26-08**

AN ORDINANCE OF THE MAYOR AND COUNCIL OF THE CITY OF COLUMBUS, NEBRASKA, AMENDING COLUMBUS CITY CODE (ORDINANCE NO. 24-01) SECTION 50.35 OF CHAPTER 50 OF TITLE V, TO ADD REGULATIONS REGARDING HANDLING OF SOLID WASTE; REPEALING ALL ORDINANCES OR PORTIONS THEREOF IN CONFLICT HEREWITH; PROVIDING FOR AN EFFECTIVE DATE; AND PROVIDING FOR THE PUBLICATION OF THIS ORDINANCE IN PAMPHLET FORM.

WHEREAS, the City of Columbus desires to amend city code to add regulations regarding the handling of solid waste.

NOW, THEREFORE, BE IT ORDAINED BY THE MAYOR AND COUNCIL OF THE CITY OF COLUMBUS, NEBRASKA:

Section 1. That Section 50.35 of Chapter 50 of Title V of the Columbus City Code shall be amended and revised to read as follows:

**Section 50.35 – Handling of Solid Waste**

- (A) No person shall accumulate, store, or dispose of solid waste upon any property in a manner that creates a nuisance, health hazard, or violates state or local regulations.
- (B) All solid waste generated on any property shall be removed and properly disposed of at least once per week. Disposal shall occur by:
  - (1) A licensed solid waste hauler; or
  - (2) The owner, occupant, or person in control of the property transporting such waste to the City of Columbus transfer station.
- (C) Solid waste shall be stored in suitable containers that prevent leakage, odor, and access by animals.
- (D) Open dumping and the burning of solid waste are prohibited within the city limits of Columbus.
- (E) The owner, occupant, or person in control of the property shall be responsible for compliance with this section.
- (F) All waste loads transported in vehicles shall be properly secured and covered; provided, however, this requirement shall not apply when the entire load of waste is of such bulk that it is unlikely that any of such waste will blow out of or fall out of the vehicle when being driven at the speed of 55 miles per hour.

Penalty, see § 50.99

Section 2. This Ordinance shall repeal all Ordinances or portions thereof and conflict herewith.

Section 3. This Ordinance shall be in full force and effect from and after its passage, approval, and publication according to law. Publication shall be in pamphlet form as authorized by Nebraska Revised Statutes § 16-405 with distribution to be made by making copies available to the public upon request at the office of the city clerk.

INTRODUCED BY COUNCIL MEMBER \_\_\_\_\_

PASSED AND ADOPTED THIS \_\_\_\_ DAY OF \_\_\_\_\_, 2026.

\_\_\_\_\_  
MAYOR

ATTEST:

\_\_\_\_\_  
CITY CLERK

APPROVED AS TO FORM:

\_\_\_\_\_  
CITY ATTORNEY

16. **ORDINANCES ON SECOND READING: None**
17. **ORDINANCES ON THIRD READING: None**
18. **PAYROLL AND BILLS ON FILE: Included in Consent Agenda**
19. **UNFINISHED BUSINESS: None**
20. **ADJOURNMENT**