

MONROE PUBLIC SCHOOLS BOARD OF EDUCATION

Virtual - Board Meeting #13 ****Revised Agenda****

Tuesday, August 25, 2020

7:00 PM

AGENDA

A. Roll Call and Call to Order

Mr. Nichols

1. Pledge of Allegiance to the Flag

Mr. Nichols

2. Superintendent's Comments

Dr. Everly

B. Public Commentary - Board Agenda Items Only

Mr. Nichols

1. Acceptance of Reports and/or Committee Reports

5

Mr. Nichols

C. Discussion and Action Items

1. Approval of Minutes

9

August 10, 2020, Special Board Meeting

August 11, 2020, Board Work Session

August 11, 2020, Board Meeting #12

Mr. Nichols

2. Second Reading and Adoption of Board Policy 9000 Relations

22

Move to approve Policy 9000 Relations, as written, effective August 26, 2020.

Dr. Everly

3. Second Reading and Adoption of Board Policy 2370.01 Online

52

Blended Learning Program Policy

Move to approve Policy 2370.01 Online Blended Learning Program, as written,

effective August 26, 2020.

Dr. Everly

4. Teacher Tenure Recognition **57**

Move to confirm and endorse the granting of tenure and removal from probation for Emily Kressbach, Hollie Mazur, Tara Neaves, Travis Trombley, Alysha Vergowven, Emily Nagel, and Lisa Heckler on the appropriate anniversary dates.

Mrs. Flynn

5. Coaching Recommendation **66**

Move to approve the Ernest Sellers, coach for the 2020/21 school year: as per the MCEA master agreement.

Mrs. Flynn

6. Alternate School Year Calendar **67**

Move to approve the Phase 1-4 2020/2021 Calendar.

Mrs. Flynn

7. Corporate Resolution for Bank Depositories **69**

Move to adopt the Corporate Resolution for **Michigan Liquid Asset Fund (MILAF)** for the 2020 calendar year.

Mrs. Eighmey

8. Resolution for Facsimile Signatures **71**

Move to adopt the Resolution for Facsimile Signature - **Michigan Liquid Asset Fund (MILAF)** for the 2020 calendar year.

Mrs. Eighmey

9. Staff Chromebook Purchase **73**

Move to approve the purchase of staff Chromebook at a cost not to exceed \$51,240.00 by Presidio. This purchase will be funded by the Geer Grant.

Mr. Payne

10. Student Chromebook Purchase 76

Move to approve the purchase of student Chromebook and cases at a cost not to exceed \$449,395.75. This purchase will be funded by Cares Act and the Technology Millage.

Mr. Payne

11. Cisco UCS Server Purchase 85

Move to approve the purchase of Cisco UCS Servers at a cost not to exceed \$109,882.50 by Presidio. This purchase will be funded by the Technology Millage.

Mr. Payne

12. Cisco CUWL License Purchase 95

Move to approve the purchase of Cisco CUWL Licenses at a cost not to exceed \$16,761.00 from Presidio. This purchase will be funded by the General Fund and the Technology Millage.

Mr. Payne

13. Monroe High School C-Wing Lighting 101

Move to award the installation of the new light poles and fixtures, at Monroe High School, to Staelgraeve Turner Electric Inc. in the amount of \$20,620.00. Money for this project will come from the Building and Site Sinking Fund.

Mr. Oley

D. Superintendent's Comments

Dr. Everly

1. Old Business

Mr. Nichols

2. New Business

Mr. Nichols

3. Adjournment

112

Move to adjourn the August 25, 2020, Virtual Board Meeting #13.

Mr. Nichols

Board Meeting #13
August 25, 2020
Item #B.1

ACCEPTANCE OF REPORTS AND/OR COMMITTEE REPORTS

REPORTS AND/OR COMMITTEE REPORTS

- Contracted Services Recommendation
- August 3, 2020, Board Curriculum Committee Meeting Minutes

Contracted Services Recommendations

For the 2020/21 School Year, we will continue working with EduStaff to provide Contracted Student Support Services. EduStaff will place the following persons, upon completion of criminal history verifications, in the positions as noted below:

ATHLETICS

None

SOCIAL-EMOTIONAL SUPPORT TEAM

None

TECHNOLOGY SUPPORT TEAM

None

ANCILLARY SUPPORT

Meagan Shanafelt was hired as the district registered nurse. She will begin her position on August 17, 2020.

Monroe Public Schools Curriculum Committee Minutes

Monday, August 3, 2020 – 4:30 p.m.

1. Call to Order: Ms. Joseph called the meeting to order at 4:32 p.m.
2. In Attendance: Heather Boone, Matt Bunkleman, Kathy Eighmey, Julie Everly, Cindy Flynn, Terry Joseph, Cathy Netter, Bob Nichols, Jerry Oley, Rosalie Pasko, David Payne, Larry VanWasshenova, Holly Wallace, Larry Zimmerman
3. Public Commentary (4:30-4:40; 10 minutes): None

Goal I: Student Achievement

The District will demonstrate an increase in math, reading and writing achievement as measured by local assessments.

Objective Measurement Detail

Short-term: 80% proficient in Reading and Math, 78% proficient in Writing

Long-term: 90% proficient in the areas of Reading and Math, and consistent improvement of 2-3% per year between 2019 and 2025

Goal II: Graduation Rate

The District will demonstrate an increase in graduation rate. The measurement used to determine success will be the state standards currently being utilized.

Objective Measurement Detail

The graduation rate will rise 2% per year commencing in 2017

Objective Measurement Detail

2020-2021 Return to Learn Plan (4:40-5:10; 30 minutes): We are excited to share a DRAFT of our fall plans for school. Please click the link below to view the draft version of Monroe Public Schools' Return to Learn Plan.

<https://www.monroe.k12.mi.us/files/user/1692/file/MPS%20Return%20to%20Learn%20Plan%20DRAFT.pdf>

4. Old Business (5:10-5:20; 10 minutes): Staff training with GCN training modules

5. New Business (5:20-5:30; 10 minutes): Monroe County Community College is offering a virtual training in “Implicit Bias: Reducing Racial Disparities Through Understanding” Wednesday August 26, 2020 from 9:00 a.m. to 11:00 a.m. An update on the new Social Studies Curriculum will be provided at an upcoming Curriculum Committee Meeting.
6. Adjournment: Ms. Joseph adjourned the meeting at 7:17p.m.

APPROVAL OF MINUTES

ENCLOSURES

- August 10, 2020, Special Board Meeting
- August 11, 2020, Board Work Session
- August 11, 2020, Board Meeting #12

RECOMMENDATION

Move to approve the following minutes as submitted:

- August 10, 2020, Special Board Meeting
- August 11, 2020, Board Work Session
- August 11, 2020, Board Meeting #12

MOTION: _____ **SUPPORT:** _____ **ACTION:** _____

| | <u>Aye</u> | <u>Nay</u> | <u>Abstain</u> | <u>Absent</u> |
|-------------------|------------|------------|----------------|---------------|
| Mrs. Boone | _____ | _____ | _____ | _____ |
| Mr. Bunkelman | _____ | _____ | _____ | _____ |
| Mrs. Netter | _____ | _____ | _____ | _____ |
| Mr. Nichols | _____ | _____ | _____ | _____ |
| Mrs. Pasko | _____ | _____ | _____ | _____ |
| Mr. VanWasshenova | _____ | _____ | _____ | _____ |
| Mr. Zimmerman | _____ | _____ | _____ | _____ |

MONROE PUBLIC SCHOOLS BOARD OF EDUCATION

Virtual Work Session
Tuesday, August 10, 2020
5:15 p.m.

MINUTES

Roll Call and Call to Order

Board Members Present: President Robert Nichols, Vice President Matthew Bunkelman, Secretary Larry Zimmerman, Parliamentarian Cathleen Netter, Trustee Heather Boone, Trustee Rosalie Pasko, and Trustee Lawrence VanWasshenova

| | <u>Present</u> | <u>Absent</u> |
|-------------------|----------------|---------------|
| Mrs. Boone | <u> x </u> | <u> </u> |
| Mr. Bunkelman | <u> x </u> | <u> </u> |
| Mrs. Netter | <u> x </u> | <u> </u> |
| Mr. Nichols | <u> x </u> | <u> </u> |
| Mrs. Pasko | <u> x </u> | <u> </u> |
| Mr. VanWasshenova | <u> x </u> | <u> </u> |
| Mr. Zimmerman | <u> x </u> | <u> </u> |

Board Members Absent: None

Administrators Present: Julie Everly, Katherine Eighmey, Cindy Flynn, Terry Joseph, Jerry Oley, David Payne

Administrators Absent: None

President Nichols called the meeting to order at 5:18 p.m.

Closed Session

Motion by Mr. Zimmerman; support by Mr. Bunkelman to convene in Closed Session for the purpose of Attorney/Client Privilege to discuss the Board of Education governance, Open Meetings Act, Section 8(c).

Vote: Motion carried by a 7-0 “Aye” vote at 5:18 p.m.

Open Session resumed at 7:24 p.m.

New Business

None

Old Business

None

Adjournment

Motion by Mr. Zimmerman; support by Mrs. Pasko that the 5:15 p.m., August 10, 2020 of the Monroe Public Schools Board of Education be adjourned.

Vote: Motion carried by a 7-0 “Aye” vote at 7:25 p.m.

Larry Zimmerman, Secretary

MONROE PUBLIC SCHOOLS BOARD OF EDUCATION

Virtual Work Session
Tuesday, August 11, 2020
5:30 p.m.

MINUTES

Roll Call and Call to Order

Board Members Present: President Robert Nichols, Vice President Matthew Bunkelman, Secretary Larry Zimmerman, Parliamentarian Cathleen Netter, Trustee Heather Boone, Trustee Rosalie Pasko, and Trustee Lawrence VanWasshenova

| | <u>Present</u> | <u>Absent</u> |
|-------------------|----------------|---------------|
| Mrs. Boone | <u> x </u> | <u> </u> |
| Mr. Bunkelman | <u> x </u> | <u> </u> |
| Mrs. Netter | <u> x </u> | <u> </u> |
| Mr. Nichols | <u> x </u> | <u> </u> |
| Mrs. Pasko | <u> x </u> | <u> </u> |
| Mr. VanWasshenova | <u> x </u> | <u> </u> |
| Mr. Zimmerman | <u> x </u> | <u> </u> |

Board Members Absent: None

Administrators Present: Julie Everly, Katherine Eighmey, Cindy Flynn, Terry Joseph, Jerry Oley, David Payne

Administrators Absent: None

President Nichols called the meeting to order at 5:36 p.m.

Closed Session

Motion by Mr. Zimmerman; support by Mrs. Netter to convene in Closed Session for the purpose of Attorney/Client Privilege to discuss the Board of Education governance, Open Meetings Act, Section 8(c).

Vote: Motion carried by a 7-0 “Aye” vote at 5:37 p.m.

Open Session resumed at 6:51 p.m.

Old Business

None

New Business

None

Adjournment

Motion by Mr. Bunkelman; support by Mr. Zimmerman that the 5:30 p.m., August 11, 2020, Virtual - Work Session of the Monroe Public Schools Board of Education be adjourned.

Vote: Motion carried by a 7-0 “Aye” vote at 6:52 p.m.

Larry Zimmerman, Secretary

MONROE PUBLIC SCHOOLS BOARD OF EDUCATION

Virtual - Board Meeting #12

August 11, 2020

7:00 p.m.

MINUTES

Roll Call and Call to Order

Board Members Present: President Robert Nichols, Vice President Matthew Bunkelman, Secretary Larry Zimmerman, Parliamentarian Cathleen Netter, Trustee Heather Boone, Trustee Rosalie Pasko, and Trustee Lawrence VanWasshenova

| | <u>Present</u> | <u>Absent</u> |
|-------------------|----------------|---------------|
| Mrs. Boone | _x_ | _____ |
| Mr. Bunkelman | _x_ | _____ |
| Mrs. Netter | _x_ | _____ |
| Mr. Nichols | _x_ | _____ |
| Mrs. Pasko | _x_ | _____ |
| Mr. VanWasshenova | _x_ | _____ |
| Mr. Zimmerman | _x_ | _____ |

Board Members Absent: None

Administrators Present: Julie Everly, Katherine Eighmey, Cindy Flynn, Terry Joseph, Jerry Oley, David Payne

Administrators Absent: None

President Nichols called the meeting to order at 7:11 p.m.

Superintendent Comments

Dr. Everly introduced Alison Drougel, a Monroe High School English teacher and advisor for the *Lotus Leaf Media Outlet*. Each year students from Monroe High School participate in the Michigan Interscholastic Press Association summer camp. It is normally held at Michigan State University. This year due to the pandemic, they offered a virtual camp. Three students participated from Monroe Public Schools – Samantha Drougel, Emilia McLeod, and Gabriella Anderson.

Samantha Drougel won the Sparty award. Samantha participated in the broadcasting and podcasting. They started with remote broadcasting with prerecording and uploading, but by the end of the camp, they were broadcasting live with different software. She interviewed Mr. Pollzzie, the new high school principal, and discussed the start of the school year. They were taught how to get into the industry and were provided helpful information.

Emilia McLeod participated in the Social Media session and won an Excellence Award. Emilia shared that she learned a lot. One of her main takeaways was how important the relationships are that journalists make with people. They participated in group work, and she felt she made some great connections with other people from around the United States. She is hopeful that she will be able to do some great things for *Lotus Leaf* on social media this year, as the supervising editor.

Gabriella Anderson attended the Bobby Hawthorne class that was taught by him. She shared all the things that she learned about writing and interviewing that she will take back to the *Lotus Leaf*. Gabby said she

was a little nervous since this was the first year to hold the program virtually, but she felt they did a great job. The instructors left messages on their work, so it felt very personal. They had office hours before the session started because they enjoyed getting to know the students. They showed that if you take a little more time and fix the simple things, it makes your writing a much better product. Gabby said she learned a lot at camp that she will use this year.

Dr. Everly recognized that this program is an example of the rich curriculum that is offered within Monroe Public Schools.

Dr. Everly recognized the seniors that were scholarship recipients. The recipient of the McIntyre Scholarship is Rashaun Adams. Recipients of the Brady Scholarship are Bryan Costello, Jacob Gladioux, Colton Hirst, Blake Lambert, Trevor Malik, and Nicholas Wohfeil. The recipient of the Chris Butler Scholarship is Megan Phillips. The recipients of the Gertz Scholarship are Jackson Longfellow and Nicholas Wohfeil. The recipient of the Horvath Scholarship is Tara Robinson. The recipients of the Kosa Scholarship are Faith Avritt, Henry Germeroth, Jacob Gladioux, Samantha Gonzalez, Adyn Hallahan, Gabriel Johnson, Libby Kelley, Lauren Lebeck, Jackson Longfellow, Rosario Mexicano-Manzano, and Brady Pitcher.

Dr. Everly offered her congratulations to the students and wished them all the best in their postsecondary education.

Public Commentary-Agenda Items Only

Mr. Nichols explained that this is a time for comments. Questions are not answered during public commentary, but someone will get back to the speakers with answers. Comments are limited to three minutes per speaker. The questions that were asked included the following:

- If a family selects remote learning and the state moves to Phase 5, can the student remain in remote learning for the rest of the school year?
- How are the CTE classes going to work?
- How will special education services, IEPs, 504 Plans, and speech work?
- In the Learning Labs, if a student has a one-to-one assistant, will the assistant be with that student?
- How will MOSI/self-contained classrooms work?
- Why isn't there a fourth option for families – to attend traditional school in-person? What is the difference between my children being at school in a moderated learning lab and being in a class with their teacher?
- How will remote learning students receive their lunches?
- Will my student's teacher be looping?
- How will student attendance be recorded?
- What are the staff hours?
- What do I do if my student needs a technology device?
- Will all Monroe Public Schools employees have jobs for the 2020-21 school year?
- Will students be allowed to work on the construction site for the next Trojan Build House?
- If a family chooses the Learning Labs and then decides to Remote Learn, is that an option?
- In the Learning Labs, how will the sibling cohorts work?
- Will there be training for the new app programs for assistants and substitute teachers?
- What are the timelines for when students will receive schedules and when we need to make decisions?

- Is the rumor true about the Monroe High School A/B classes to a 6 period a day?
- What if a family needs childcare? How will that work?
- How will Remote Learning work?
- When will families receive the beginning of the year paperwork?
- Will Waterloo students be required to wear uniforms?
- What is the status of fall sports?
- Is it possible to keep siblings together?
- How is the busing going to work? Will drivers have assistants to help with students?
- Will students in the Learning Labs receive recess breaks?
- How will current employees be notified if they have a position within the district?

Acceptance of Reports and/or Committee Reports

The following reports were received:

- July 20, 2020, Policy Committee Meeting
- Contracted Report

Approval of Minutes

Motion by Mr. Zimmerman; support by Mrs. Pasko to approve the minutes of the following meetings as submitted:

- July 21, 2020, Board Work Session
- July 21, 2020, Board Meeting #11

Discussion: None

Vote: Motion carried by a 7-0 roll call vote.

First Reading and Discussion of Neola Board Policy 9000

Discussion: Dr. Everly shared that this is the final section of revisions for the Board Policies. Mr. Bunkelman thanked everyone that was involved in updating the policies. It was a long and arduous process, and things have been streamlined. The district has moved the policies into the 21st Century.

First Reading and Discussion of Neola Board Policy 2370.01

Discussion: Dr. Everly explained that this is a policy for the virtual learning plan. There were minor updates that needed to be made to be in compliance with some of the Governor's recommendations.

Workplace COVID-19 Officers

Motion by Mrs. Netter; support by Mr. Zimmerman to approve District-Wide COVID-19 Officers: Dr. Julie Everly, Superintendent; Mrs. Kathy Eighmey, Executive Director of Business and Finance; Mrs. Cindy Flynn, Executive Director of Human Resources; Ms. Terry Joseph, Executive Director of Student Services; Mr. David Payne, Executive Director of Technology; Mr. Jerry Oley, Executive Director of Operations; Mr. Timothy Salenbien, Director of Operations; Mr. Frank Henry, Supervisor of Transportation; Mrs. Paula Kipf, Supervisor of Kids Club; Mrs. Delsie Sissoko, Principal of Arborwood Campus; Mrs. Andrea Wylie, Assistant Principal of Arborwood Campus; Mrs. Melissa Bell, Principal of Custer Campus; Mr. James Miller III, Assistant Principal of Custer Elementary; Mrs. Emily Bundon, Principal of Manor Elementary; Mr. Scott Hoppert, Principal of Raisinville Elementary; Mrs. Meghan Gibson, Principal of Waterloo Elementary; Mr. Jeffrey McVeigh, Principal of Monroe Middle School; Ms. Sara Staten, Assistant Principal of Monroe Middle School; Mr. Stephen Pollzzie, Principal of Monroe High School; Mr. Michael Foley, Assistant Principal of Monroe High School; Mrs. Jen Furkas, Assistant

Principal of Monroe High School; Mrs. Leah Morelli, Assistant Principal of Monroe High School; Dr. John Ray, Athletic Director (Dr. Ray will be the COVID-19 officer for all athletic programs), Monroe High School; Mr. Kevin Pilgrim, Principal of Orchard Center High School; Mrs. Vuncia Council, Director of The Learning Bank.

Discussion: In accordance with the MIOSHA guidelines and the guidance for the Safe Return to Work, organizations are required to name a workplace COVID-19 Contact for each worksite. As you read through the list, you will recognize the names of the building administrators; they have been named as COVID-19 Officers. There are district officers and building specific officers.

Vote: Motion carried by a 7-0 roll call vote.

Monroe Public Schools Return to Learn Preparedness Plan

Motion by Mrs. Netter; support by Mr. Bunkelman to approve the Monroe Public Schools Preparedness/Return to Learn Plan.

Discussion: Dr. Everly thanked everyone for being at the meeting and said it is a point of pride for the community to have so many people that care so deeply and value education. She explained that it is required by the state for each school district to submit a framework of the Return to Learn plan to their ISD by August 15, 2020, which outlines district plans for each Michigan Safe Start Phase, in accordance with state requirements.

Dr. Everly shared a PowerPoint with the group and pointed out specifics about the district targets and goals. The district's high expectations and goals for student achievement have not changed. Since the district has no idea what COVID-19 will do in Monroe, Michigan, Dr. Everly read an excerpt from the Return to Learn Plan:

“Please prepare your family. Monroe Public Schools will always assess the current health and safety conditions of our schools and community as the chief factor in decision-making. The district will monitor the data reported online by the Monroe County Health Department (MCHD) daily. A 14-day average for the resident zip codes within the district will be maintained. If this moving average reaches greater than 10 new cases per day, the district will be in consultation with MCHD regarding transitioning our educational practices to stricter mitigation and distancing. Any sort of onsite or community outbreak with high exposure will elicit the same response. With this in mind, the chart provides a reference of what is likely to be expected. However, in any given situation, the district may need to make a different decision in the best interest of our students, staff, families, and community.”

Everything the district does – this plan included – ties to the district's mission and core values. There is much discussion in the district about what our “why” is, and that is the students. The district has guidance that is expected to be followed – guidance from our Governor, the local and state health departments, the legislative bodies, and the Michigan Department of Education. The district will always be in compliance with our mission and Board policies, and the district has also surveyed students, parents, and staff. The Return to Learn plan has been designed upon all of the factors stated above from all stakeholders.

Mr. Andrew Shilling, the Director of Special Education for the Monroe County Intermediate School District (MCISD) was asked to highlight some points and try to answer some of the questions. For students that have an IEP or a 504 plan, their services will be implemented in the fall; it does

not matter which learning plan the parents choose to participate in. This is fully mandated by the Michigan Department of Education. The students will receive their specialized services from a highly qualified special education teacher. Some of the services may look a little different depending on safety; some caveats may be occupational therapy or mobility where those can only be offered one-on-one, the ISD will be working with families individually to determine how to provide those services. The ISD expects the services to be much more rigorous and intense than what was offered in the spring. One-on-one assistants will be determined on an individual student basis. The determination will be made by which learning option is chosen, and what is written in the IEP regarding what the needs are for the assistant.

The Board is being asked to approve the Return to Learn plan as a framework for the district for the school year. The district does not know which phase the Governor may have the State in at any given time. The district does not know how the COVID-19 numbers may change. We certainly hope they improve. Emergency remote learning in March was very different than the remote learning that is being planned for the fall. Please keep in mind the spring was an emergency plan with 48 hours' notice. The district has had a lot of time to plan, so the families will see a lot of changes. The district is planning to provide a device for every single student. For the Learning Lab and the Remote Learning at Home options, the teachers have requested access to their classroom. If there is a student in a Learning Lab, and they need more individualized attention, there may be an opportunity for the teachers to work with very small groups of students with the expectation of distancing and safety. Trojan Build #3 is getting started. As things progress, as long as the district can do it legally, it is the expectation that students will be able to work in small groups at the house or in CTE labs. This expectation will also be true for AP classes and dual enrollment. As a parent of a student in the district, Dr. Everly understands the needs and the challenges.

Mr. Bunkelman explained to the group that he understands that parents have questions and concerns, and the Board does also. The district is still waiting on direction from the State. He understands that the State will be voting on Saturday regarding funding, attendance, and employment. The number one concern is the health and safety of the students and staff. This plan has had considerable conversation with a lot of oversight from different groups. Mr. Bunkelman shared that there have been other superintendents from around the state that have lauded this plan and shared they would like to see it copied for others to use. The district would like to see all of the students and staff back in school as we know it. He would like to have that happen in a safe and healthy environment. He thanked everyone for their input with this plan. He is happy to stand behind it, he feels it is one of the best plans, and he is proud that it came from Monroe. Mr. Zimmerman shared that this decision was taken very seriously. There have been sleepless nights for many. Mrs. Boone shared that she spoke to a lot of parents who are asking why we cannot go back to school in a traditional sense. She suggested looking at the CDC guidelines and with distancing in the classrooms, there is just not enough space. She feels it is a good plan, and it allows for families who would like to have their students back in school to do that. Mrs. Netter thanked the staff, the community partners, and the administration for putting this plan together. She thinks it is creative and will provide the educational rigor that Monroe Public Schools is used to. It will employ the staff while keeping the contact points to a minimum. The plan utilizes data and not perception, and the plan has the capacity to meet the needs of at-risk students and students with special needs. Dr. Everly shared that the district's community health partners have been at our side guiding and directing the district throughout the whole pandemic process. Mr. Bunkelman reminded all of the participants that Monroe Public Schools is the largest district in the county; the district has the most conservative plan because of this. This is a living document; as the State moves through the phases. so will the district with the

plan. Mrs. Boone shared that the district wants to keep all families safe. It is not possible to bring everyone back to school, but we can bring most of the students back and keep everyone safe. Mrs. Pasko reminded everyone that all of this can change. It is all dependent on the COVID-19 numbers; they can go up or down. We may be able to get back to regular school if the numbers go down. Mr. Nichols encouraged all of the families to educate themselves on the virus. Before you decide to send your children into a school, be sure you understand there are some risks. He said that he thinks this is the safest plan he has seen, and it is a good plan, but be sure to educate yourself.

Vote: Motion carried by a 7-0 roll call vote.

Staff New Hire

Motion by Mr. Bunkelman; support by Mr. Zimmerman to approve the appointment of Ainsley McNamara as a Teacher with Monroe Public Schools effective August 31, 2020, and place on the appropriate salary level as contained in the Master Agreement, and upon completion of all pre-employment requirements.

Discussion: Mr. Nichols shared his appreciation for the teacher choosing Monroe Public Schools. Speech teachers are a rarity, and the district is certainly happy to have you in Monroe.

Vote: Motion carried by a 7-0 roll call vote.

Staff Resignation

Motion by Mr. Bunkelman; support by Mrs. Netter to approve the resignation from Monroe Public Schools of Hannah Sheetz, effective August 15, 2020, and the resignation from Monroe Public Schools of Jared Peterson, effective August 19, 2020.

Discussion: None

Vote: Motion carried by a 7-0 roll call vote.

Coaching Recommendations

Motion by Mr. Bunkelman; support by Mr. Zimmerman to approve the named coaches for the 2020/21 school year as per the MCEA master agreement.

Discussion: Mr. Nicholas asked if the coaching contracts will be honored or suspended if the district does not have sports. Dr. Everly shared what happened in the spring; all involved felt it was fair. Even though the fall season has not launched, the coaches have started working. In the spring, there was a proration to provide fair payment for the work that was already done. It will be similar for the fall sports. Mr. Bunkelman shared that the Michigan Legislature is scheduled to vote on the statewide plan on Saturday. The plan includes funding. The district is still in limbo and has a lot of questions that revolve around funding – what the funding will be, how the district will receive the funding, and what the reduction in funding will be. There has also been conversation about defunding school districts. Mr. Bunkelman said the district is hoping that there isn't a cut in funding, but quite often when the state needs to balance their budget, that happens. There have also been comments that the Federal Government may cut funding to schools. He would like the general public to know the district will continue on with all of the programs offered, and coaches will be paid, but the bottom line is quite often the schools are the first to be cut. When it comes to defunding, schools have extensive experience in it.

Vote: Motion carried by a 7-0 roll call vote.

Board Reinstatement Committee Recommendations

Motion by Mr. Bunkelman; support by Mr. Zimmerman to approve the recommendations from the reinstatement committee.

Student A: The Board of Education will approve the reinstatement for the student to attend high school in the home attendance area to earn a high school diploma.

Student B: The Board of Education will approve the reinstatement for the student to attend Monroe High School to earn a high school diploma.

Student C: The Board of Education will approve the reinstatement for the student to attend Monroe High School to earn a high school diploma.

Student D: The Board of Education will approve the reinstatement for the student to attend high school in the home attendance area to earn a high school diploma.

Discussion: Dr. Everly thanked the Board Members who participated in the reinstatement meetings. Mrs. Pasko shared that was such a good experience and all of the students were very well-spoken. They appreciate their education. Mr. Nichols shared that the reinstatement hearings he was involved with went well, and he feels the students are taking the recommendation of the Board more seriously. Mrs. Boone shared that she enjoys the reinstatement hearings. She thought all of the students did a great job.

Vote: Motion carried by a 7-0 roll call vote.

Financing for School Vehicle Purchase

Motion by Mr. Zimmerman; support by Mr. Bunkelman to award the vehicle financing bid to Fifth Third at the fixed rate of 1.72% for three years and reject all other bids.

Discussion: Mr. VanWasshenova asked if all other debts are paid off for the school buses. Mrs. Eighmey stated that they are all paid off. He also asked if there are any other debts the district is still paying on. She explained that two technology leases are still being paid on. He asked if the state is providing any funding for the buses.

Vote: Motion carried by a 7-0 roll call vote.

Corporate Resolution for Bank Depositories

Motion by Mr. Bunkelman; support by Mr. Zimmerman move to table items 11 and 12 for two weeks until Tuesday, August 25, 2020, Board Meeting #13.

Discussion: Mr. VanWasshenova asked whether this organization is public or private. He also wanted to know what their rating is and if they are underwritten by anyone else besides themselves.

Vote: No Vote

Resolution for Facsimile Signatures

The tabling of item 11 resulted in tabling item 12.

Discussion: This item is tabled until the August 25, 2020, Board Meeting #13.

Vote: No Vote

Superintendent's Comments

Dr. Everly shared what an exciting day Wednesday will be. The investors will be sending information throughout the day for the sales of the bonds. If anyone in the community is interested in purchasing bonds, it can be done at Raymond James with Mr. Ron Evans, a retiree from Monroe Public Schools. The support for our students, community, and district is wonderful. Big congratulations are extended to all of the

Summer Learning Academy and Virtual Learning Camps students. More than one hundred students enrolled and participated in SLA.

Old Business

None

New Business

Mr. Oley is meeting with the engineers and architects for the bond millage work. He said there is approximately thirteen million dollars' worth of work to do next summer. They will be prioritizing the jobs, and he hopes to be able to share a list of the jobs soon. It appears there will be multiple jobs being done at the same time.

Public Commentary-Any Topic

Mr. Nichols shared that the ground rules would be the same as those followed for the earlier public commentary, and no questions would be answered during the meeting.

- There were questions about training and if substitute teachers would have some training on the platforms that the district is using.
- A parent wanted to know when schedules will be released.
- An assistant asked if she works in the Learning Lab, will the child she assists be with her or will the student have another assistant?
- A parent of eight children within Monroe Public Schools thanked the Board and staff for everything they are doing. She is proud to be part of a community that takes her children's safety into consideration. She had a good experience in the spring, and the teachers were very supportive of answering questions. She is very happy to be a part of Monroe Public Schools; she thanked everyone and said to keep up the good work.
- A parent has heard rumors that the high school is changing the schedule.
- A teacher asked that everyone consider this year's high school seniors. He also thanked the Board for keeping the staff members safe.

There will be a Frequently Asked Questions document posted online.

Adjournment

Motion by Mr. VanWasshenova; support by Mrs. Boone that the August 11, 2020, Virtual Board Meeting #12 of the Monroe Public Schools Board of Education be adjourned.

Vote: Motion carried by a 7-0 "Aye" vote at 9:15 p.m.

Larry Zimmerman, Secretary

SECOND READING AND ADOPTION OF BOARD POLICY

ENCLOSURE(S)

- Neola Policy 9000 Relations

RECOMMENDATION

Move to approve Policy 9000 Relations, as written, effective August 26, 2020.

MOTION: _____ **SUPPORT:** _____ **ACTION:** _____

| | <u>Aye</u> | <u>Nay</u> | <u>Abstain</u> | <u>Absent</u> |
|-------------------|------------|------------|----------------|---------------|
| Mrs. Boone | _____ | _____ | _____ | _____ |
| Mr. Bunkelman | _____ | _____ | _____ | _____ |
| Mrs. Netter | _____ | _____ | _____ | _____ |
| Mr. Nichols | _____ | _____ | _____ | _____ |
| Mrs. Pasko | _____ | _____ | _____ | _____ |
| Mr. VanWasshenova | _____ | _____ | _____ | _____ |
| Mr. Zimmerman | _____ | _____ | _____ | _____ |

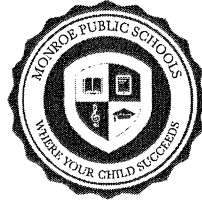

| | |
|---------|---------------------------------------|
| Book | Neola Policy Templates for Processing |
| Section | Policy for the Board |
| Title | TELEPHONE COMMUNICATIONS |
| Code | po9111 |
| Status | Policy Committee |

9111 - TELEPHONE COMMUNICATIONS

The Board of Education is vitally interested in maintaining effective communication with parents, members of the community, vendors, and others who have dealings with the District. The Board realizes that although advances in technology provide the possibility of enhancing communications some innovations can also inhibit effective contact between the public and District personnel.

The Board directs that incoming calls during regular school hours to the central office and to each school, department, and operations office be answered by a District staff member or volunteer and not by a computer-generated voice. This will ensure that each caller's concern is dealt with in an expeditious manner.

If, under certain rare circumstances it is not possible for a staff member or volunteer to be available to answer a telephone call to a main office number, a computer message may be substituted provided the message instructs the caller on how to contact a District staff member who can take some type of action in response to the caller's need.

Telephone calls to extension numbers within the District may be answered by voice mail provided the caller is provided the alternative of dialing 0 and talking to a staff member or volunteer.

Under no circumstances, is the telephone system to operate in such a way that a caller is unable to talk directly to someone who can be of assistance to the caller. In cases of emergency, lack of effective telephone contact could be critical.

© Neola 1996

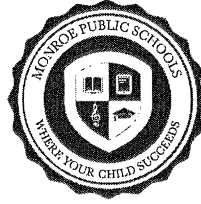

| | |
|---------|---------------------------------------|
| Book | Neola Policy Templates for Processing |
| Section | Policy for the Board |
| Title | PUBLIC INFORMATION PROGRAM |
| Code | po9120 |
| Status | Policy Committee |

9120 - **PUBLIC INFORMATION PROGRAM**

The Board of Education believes that all reasonable means should be employed to keep the public informed on matters of importance regarding District policies, finances, programs, personnel, and operations. It is the purpose of this policy to provide the ways and means to accomplish this purpose.

The Superintendent and/or his/her designee shall direct an information program designed to acquaint the citizens of the community and general public with the achievements and the needs of the schools.

Toward this end, the Board shall provide parents or guardians and other District residents opportunities for orientation and information regarding State regulations and local school procedures, and will utilize, insofar as practical, all appropriate means and media to achieve this end.

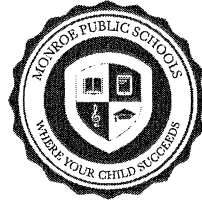

| | |
|---------|---------------------------------------|
| Book | Neola Policy Templates for Processing |
| Section | Policy for the Board |
| Title | PUBLIC COMPLAINTS |
| Code | po9130 |
| Status | Policy Committee |

9130 - **PUBLIC COMPLAINTS**

Any person or group, having a legitimate interest in the operations of this District shall have the right to present a request, suggestion, or complaint concerning District personnel, the program, or the operations of the District. At the same time, the Board of Education has a duty to protect its staff from unnecessary harassment. It is the intent of this policy to provide the means for judging each public complaint in a fair and impartial manner and to seek a remedy where appropriate.

It is the desire of the Board to rectify any misunderstandings between the public and the District by direct discussions of an informal type among the interested parties. It is only when such informal meetings fail to resolve the differences, shall more formal procedures be employed.

Any requests, suggestions, or complaints reaching the Board, Board members, and the administration shall be referred to the Superintendent for consideration according to the following procedure.

Matters Regarding a Professional Staff Member

A. First Level

If it is a matter specifically directed toward a professional staff member, the matter must be addressed, initially, to the concerned staff member who shall discuss it promptly with the complainant and make every effort to provide a reasoned explanation or take appropriate action within his/her authority and District administrative guidelines.

This level does not apply if the matter involves suspected child abuse, substance abuse, or any other serious allegation which may require investigation or inquiry by school officials prior to approaching the professional staff member.

B. Second Level

If the matter cannot be satisfactorily resolved at the First Level, it shall be discussed by the complainant with the staff member's supervisor and in compliance with provisions of a collective bargaining agreement, if applicable.

C. Third Level

If a satisfactory solution is not achieved by discussion with the aforementioned supervisor, a written request for a conference shall be submitted to the Superintendent. This request should include:

1. the specific nature of the complaint and a brief statement of the facts giving rise to it;
2. the respect in which it is alleged that the complainant (or child of the complainant) has been affected adversely;
3. the action which the complainant wishes taken and the reasons why it is felt that such action be taken.

Should the matter be resolved in conference with the Superintendent, the Board shall be advised of the resolution.

D. Fourth Level

Should the matter still not be resolved, or if it is one beyond the Superintendent's authority and requires a Board decision or action, the complainant shall request, in writing, a hearing by the Board.

The Board, after reviewing all material relating to the case, may provide the complainant with its written decision or grant a hearing before a committee of the Board.

The complainant shall be advised, in writing, of the Board's decision no more than seven (7) business days following the next regular meeting. The Board's decision will be final on the matter, and it will not provide a meeting to other complainants on the same issue.

If the complainant contacts an individual Board member to discuss the matter, the Board member shall inform the complainant that s/he has no authority to act in his/her individual capacity and that the complainant must follow the procedure described in this policy.

Matters Regarding the Superintendent

Should the matter be a concern regarding the Superintendent which cannot be resolved through discussion with the Superintendent, the complainant may submit a written request for a conference to the Board. This request should include:

- A. the specific nature of the complaint and a brief statement of the facts giving rise to it;
- B. the respect in which it is alleged that the complainant (or child of the complainant) has been affected adversely;
- C. the reason that matter was not able to be resolved with the Superintendent;
- D. the action which the complainant wishes taken and the reasons why it is felt that such action should be taken.

The Board, after reviewing the request, may grant a hearing before the Board or a committee of the Board or refer the matter to an executive session.

The complainant shall be advised, in writing, of the Board's decision within thirty (30) business days. The Board's decision will be final and not subject to appeal.

Matters Regarding an Administrative Staff Member

Since administrators are considered members of the District's professional staff, the general procedure specified in "Matters Regarding a Professional Staff Member" shall be followed.

Matters Regarding a Support Staff Member

In the case of a support staff member, the complaint is to be directed, initially, toward the person's supervisor, and the matter then brought as required to higher levels in the same manner as prescribed for "Matters Regarding a Professional Staff Member."

Matters Regarding District Services or Operations

If the request, suggestion, complaint, or grievance relates to a matter of District procedure or operation, it should be addressed, initially, to the respective operations supervisor and then brought, in turn, to higher levels of authority in the manner prescribed in "Matters Regarding a Professional Staff Member."

Matters Regarding the Educational Program

If the request, suggestion, complaint, or grievance relates to a matter of District program, it should be addressed, initially, to the program supervisor or advisor and then brought, in turn, to higher levels of authority in the manner prescribed in "Matters Regarding a Professional Staff Member."

Matters Regarding Instructional Materials

The Superintendent shall prepare administrative guidelines to ensure that students and parents are adequately informed each year regarding their right to inspect instructional materials and the procedure for completing such an inspection. (see AG 9130A and Form 9130 F3)

If the request, suggestion, complaint, or grievance relates to instructional materials such as textbooks, library books, reference works, and other instructional aids used in the District, the following procedure shall be followed:

- A. The criticism is to be addressed to the Student Services Administrator, in writing, and shall include:
 1. author;
 2. title;
 3. publisher;
 4. the complainant's familiarity with the material objected to;
 5. sections objected to by page and item;
 6. reasons for objection.
- B. Upon receipt of the information, the Student Services Administrator may, after advising the Superintendent of the complaint, and upon the Superintendent's approval, appoint a review committee which may consist of:
 1. one (1) or more professional staff members including a teacher and administrator;
 2. one (1) or more Board members;
 3. one (1) or more lay persons knowledgeable in the area.
- C. The committee, in evaluating the questioned material, shall be guided by the following criteria:
 1. the appropriateness of the material for the age and maturity level of the students with whom it is being used
 2. the accuracy of the material
 3. the objectivity of the material
 4. the use being made of the material
- D. The committee's recommendation shall be reported to the Superintendent in writing within ten (10) business days following the formation of the committee. The Superintendent will advise the complainant, in writing, of the committee's recommendation and advise the Board of the action taken or recommended.
- E. The complainant may appeal this decision, within thirty (30) business days, to the Board through a written request to the Superintendent, who shall forward the request and all written material relating to the matter

to the Board.

- F. The Board shall review the case and advise the complainant, in writing, of its decision within ten (10) business days.

No challenged material may be removed from the curriculum or from a collection of resource materials except by action of the Board, and no challenged material may be removed solely because it presents ideas that may be unpopular or offensive to some. Any Board action to remove material will be accompanied by the Board's statement of its reasons for the removal.

© Neola 2002

Legal

20 U.S.C. 1232h



| | |
|---------|---------------------------------------|
| Book | Neola Policy Templates for Processing |
| Section | Policy for the Board |
| Title | CITIZENS' ADVISORY COMMITTEES |
| Code | po9140 |
| Status | Policy Committee |

9140 - **CITIZENS' ADVISORY COMMITTEES**

The Board of Education, in its discretion, shall establish citizens' advisory committees when there is a definite function to be performed. All appointments of citizens to advisory committees shall be approved by the Board. All appointments of staff members to citizens' advisory committees shall be made by the Superintendent. Staff members shall never constitute more than a minority of any such committee. Every effort shall be made to ensure that the makeup of an advisory committee is as truly representative of the community as possible. The chairperson of an advisory committee shall be chosen from among the lay members. Board members may be ex-officio members of an advisory committee.

Specific topics for study or well-defined areas of activities shall be assigned in writing to each committee immediately following its appointment. Upon completing its assignment, a committee either shall be given a new problem or shall be dissolved promptly. No advisory committee shall be permitted to continue for prolonged periods without a definite assignment. Each committee shall be instructed as to the length of time each member is asked to serve, the resources the Board intends to provide, the approximate dates on which the Board wishes it to submit reports, and the approximate date on which the Board wishes it to dissolve. Furthermore, the committee shall be instructed as to the relationship it has to the Board, to individual Board members, to the Superintendent, and to the remainder of the professional staff.

The structure and organization of an advisory committee shall be determined by the Board as appropriate to the assignment. Advisory committees shall be encouraged to draw upon a wide variety of resources both inside and outside the School District. Each committee shall be encouraged to draw upon the talents of other local residents and to recommend to the Board the official appointment of any such additional member(s) as the committee may desire.

Expenditure of District funds by an advisory committee shall be made only upon the prior approval of the Superintendent. Supplies, equipment, and personnel from within the School District may be obtained through the appointed staff resource person.

Correspondence between the Board and its committees shall ordinarily be conducted by the Superintendent and/or his/her designee.

The Superintendent shall transmit the contents of any communication from a committee to the Board.

When a committee is ready to submit a report or present on its assigned topic, the Superintendent shall arrange a meeting.

The Board shall have the sole power to dissolve any of its advisory committees and shall reserve the right to exercise this power at any time during the life of any committee.

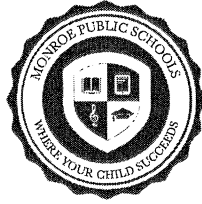

| | |
|---------|---------------------------------------|
| Book | Neola Policy Templates for Processing |
| Section | Policy for the Board |
| Title | SCHOOL VISITORS |
| Code | po9150 |
| Status | Policy Committee |

9150 - **SCHOOL VISITORS**

The Board of Education welcomes and encourages visits to school by parents, other adult residents of the community and interested educators. But in order for the educational program to continue undisturbed when visitors are present and to prevent the intrusion of disruptive persons into the schools, it is necessary to establish visitor guidelines.

The Superintendent or the principal has the authority to prohibit the entry of any person to a school of this District or to expel any person when there is reason to believe the presence of such person would be detrimental to the good order of the school. If such an individual refuses to leave the school grounds or creates a disturbance, the principal is authorized to request from the local law enforcement agency whatever assistance is required to remove the individual.

Nonstaff access to students and classes must be limited and only in accordance with a schedule which has been determined by the principal after consultation with the teacher whose classroom is being visited. Classroom visitations must be nonobtrusive to the educative process and learning environment and should not occur on an excessive basis.

Parent concerns about any aspect of his/her child's educational program should be presented through the procedure set forth in Board Policy 9130 - Public Complaints, a copy of which is available at the Board office and at each school.

The Superintendent shall promulgate such administrative guidelines as are necessary to protect students and employees from disruption to the educational program or the efficient conduct of their assigned tasks.

Rules regarding entry of persons other than students, staff, and faculty upon school grounds or premises shall be posted conspicuously at or near the entrance to such grounds or premises if there are no formal entrances, and at the main entrance to each school building.

Individual Board members who are interested in visiting schools or classrooms on an unofficial basis shall make the appropriate arrangements with the principal. In keeping with Board bylaws, such Board member visits shall not be considered to be official unless designated as such by the Board.

The Board member shall be visiting as an interested individual in a similar capacity of any parent or citizen of the community. These visits should not be considered to be inspections nor as supervisory in nature.

If, during a visit to a school or program, a Board member observes a situation or condition which causes concern, s/he should discuss the situation first with the Superintendent as soon as convenient or appropriate. Such a report or discussion shall not be considered an official one from the Board.

© Neola 2011

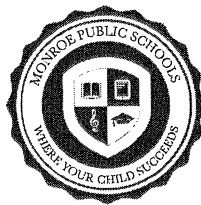

| | |
|---------|---------------------------------------|
| Book | Neola Policy Templates for Processing |
| Section | Policy for the Board |
| Title | PUBLIC ATTENDANCE AT SCHOOL EVENTS |
| Code | po9160 |
| Status | Policy Committee |

9160 - **PUBLIC ATTENDANCE AT SCHOOL EVENTS**

The Board of Education welcomes the attendance of members of the community at athletic and other public events held by the schools in the District, but the Board also acknowledges its duty to maintain order and preserve the facilities of the District during the conduct of such events. The Board retains the right to bar the attendance of or remove any person whose conduct may constitute a disruption at a school event. School administrators are expected to call law enforcement officials if a person violates posted regulations or does not leave school property when reasonably requested. In accordance with Board Policy 7440 and AG 7440B, administrators may use video surveillance/electronic monitoring equipment on school property to protect the safety and well-being of participants and visitors.

The Board directs that no alcoholic beverage or other controlled substance be possessed, consumed, or distributed, at any function occurring on District premises.

Raffles and similar forms of fund-raising by District-related organizations may be permitted by the Superintendent in accordance with Policy 9211 - District Support Organizations and Policy 9700 - Relations with Special Interest Groups.

No qualified person with a disability will, because the District's facilities are inaccessible to or unusable by persons with disabilities, be denied the benefits of, be excluded from participation in, or otherwise be subjected to discrimination under any program or activity to which Section 504/ADA applies.

For facilities constructed or altered after June 3, 1977, the District will comply with applicable accessibility standards. For those existing facilities constructed prior to June 3, 1977, the District is committed to operating its programs and activities so that they are readily accessible to persons with disabilities. This includes, but is not limited to, providing accommodations to parents with disabilities who desire access to their child's educational program or meetings pertinent thereto.

If a student or adult is asked to leave or is removed from a school event, no admission fees shall be refunded.

Individuals with disabilities shall have an equal opportunity to purchase tickets for events that have been sanctioned or approved by the Board in accordance with the provisions of the Americans with Disabilities Act, as amended.

Further, in accordance with the provisions of the Americans with Disabilities Act, as amended, the Board shall permit individuals with disabilities to be accompanied by their service animals in all areas of the District's facilities where members of the public, as participants in services, programs or activities, or as invitees, are allowed to go. (See also Policy 8390)

Smoking and/or the use of tobacco and/or tobacco substitute products is prohibited at any time within any enclosed facility owned or leased or contracted for by the Board, and in areas directly or indirectly under the control of the Board immediately adjacent to locations of ingress or egress to such facilities. Such prohibition also applies to:

- A. school grounds,
- B. any school-related event

The Board is aware of the increasing desire of many parents and other members of an audience to make audio and/or video recordings of school events.

Such recordings can be made by parents or other members of the audience without restriction if the performance is not of copyrighted material. However, if the performance is of copyrighted material, recording can be made if the appropriate license authorizing such recordings has been secured in advance by the District. If the performance is of copyrighted material and the necessary license has not been secured in advance by the District, the audience shall be advised before the performance begins that audio and/or video recordings that will be re-broadcast or distributed in any way, such as posting on the internet, are prohibited.

The Board authorizes the Superintendent to establish rules and procedures governing the use of nondistrict audio/visual recording equipment at any District-sponsored event or activity. Such rules are to be distributed in such a manner that members of the audience who wish to record the event are aware of the rules early enough to make proper arrangements to obtain their recordings without causing delay or disruption to an activity.

Any person or organization seeking to film students or a school activity which is not a public event shall obtain prior permission from the Superintendent.

The Superintendent shall ensure that all notices, signs, schedules, and other communications about school events contain the following statement:

"Upon request to the Administration, the District shall make reasonable accommodation for a disabled person to be able to participate in this activity."

© Neola 2013

Legal

28 C.F.R. Part 35

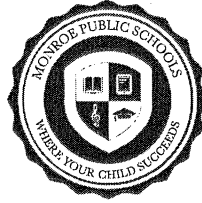

| | |
|---------|---|
| Book | Neola Policy Templates for Processing |
| Section | Policy for the Board |
| Title | CHARGES FOR INDUSTRIAL/TECHNICAL PROJECTS |
| Code | po9190 |
| Status | Policy Committee |

9190 - CHARGES FOR INDUSTRIAL/TECHNICAL PROJECTS

It is the policy of the Board of Education to approve school sponsorship of functional occupational projects as part of the shop instruction related to the occupations being taught by the District school(s).

Careful consideration shall be given to each project to ensure that the service rendered is not being exploited and that the project is of educational benefit to the students.

Patrons shall be charged only for the actual cost of materials used in completing instructional projects.

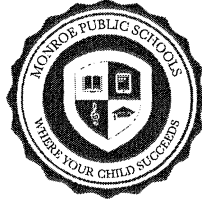

| | |
|---------|---------------------------------------|
| Book | Neola Policy Templates for Processing |
| Section | Policy for the Board |
| Title | PARENT ORGANIZATIONS |
| Code | po9210 |
| Status | Policy Committee |

9210 - **PARENT ORGANIZATIONS**

The Board of Education supports all organizations of parents whose objectives are to promote the educational experiences of District students. However, in using the name of the District or its schools and in organizing a group whose identity derives from a school(s) of this District, the parental organization thereby shares responsibility with this Board for the welfare of participating students.

Any new parent organization desiring to use the name or good offices of the District must obtain the approval of the Superintendent and/or his/her designee as a prerequisite to organizing.

Representatives and members of approved school-related organizations shall in all circumstances be treated by District employees as interested friends of the schools and as supporters of public education in the School District.

Staff members are encouraged to join such organization(s) in their related area(s) of specialization or interest.

The Board relies upon approved organizations to operate in a manner consistent with public expectations for the schools and reserves the right to withdraw sponsorship from organizations which violate the bounds of community taste.

Please see Policy 5830 Students - Student Fundraising, and Policy 6610 Finance - Student Activity Fund; to follow all expectations set forth in these policies.

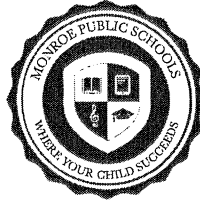

| | |
|---------|---------------------------------------|
| Book | Neola Policy Templates for Processing |
| Section | Policy for the Board |
| Title | DISTRICT SUPPORT ORGANIZATIONS |
| Code | po9211 |
| Status | Policy Committee |

9211 - **DISTRICT SUPPORT ORGANIZATIONS**

The Board of Education appreciates the efforts of all organizations whose objectives are to enhance the educational experiences of District students, to help meet educational needs of students, and/or provide extra educational benefits not provided for, at the time, by the Board.

District support organizations are defined as any non-profit entity, group, or other organization formed and operating for the purpose of supporting District programs. These programs may be educational to parents and/or children.

The District name shall not be used to promote the interests of any school support organization without the approval of the Superintendent.

The Board recognizes that parent-teacher organizations and other school-related community organizations are channels through which school personnel, parents, and other citizens may discuss educational concerns, problems and needs and work together toward solutions.

Each District support organization shall work within the appropriate school setting and in cooperation with the Principal and other staff members.

District support organizations shall allow participation by parents, District staff, and members of the community. All meetings should be communicated to the school and be open to the public. District support organizations shall not discriminate on the basis of race, color, national origin, sex (including sexual orientation or transgender identity), disability, marital status, age (except as authorized by law), religion, military status, ancestry, or genetic information which are classes protected by State and/or Federal law (collectively "protected classes"). Further, persons shall not be excluded from participation in outside support organizations based upon the extent or level of their past participation.

The following rules and procedures shall govern the working relationships between the Board, administration, and any District support organization:

- A. District support organizations shall indemnify and hold the Board harmless from and against any and all claims and causes of action whatsoever arising out of or related to outside support organization acts and omissions in carrying out its activities. Outside support organizations shall purchase liability insurance (riders - self-insured) to cover such indemnification and to protect the outside support organization and Board against claims for damage or injury resulting from any act or omission outside the support organization. The amount of insurance coverage shall not be less than \$1,000,000 and the outside support organization shall provide the Board with sufficient documentation demonstrating that the Board is named as an additional insured on the policy.

- B. It shall be the responsibility of each District support organization to monitor its activities to assure compliance with Board policy.
- C. Each District support organization is encouraged to set goals that are consistent with those of the particular programs, activities or athletics being supported as articulated by the coach/advisor and/or athletic director of such program, activity or athletic event, to avoid duplication of effort and to maximize the benefit to the organization or group.
- D. The activities of the District support organizations shall not involve the use of public funds and the District shall not assume responsibility for any purchases made on behalf of any support organization governed by this policy. The School District tax identification number shall not be used for District support organization purchases.
- E. Each District support organization must abide by the policies and guidelines established for the use of District facilities and grounds. Projects that require any modification or alteration to District property must be pre-approved by the Director of Operations.
- F. The Board permits one (1) fund-raiser per week per school that involve the sale of food items and/or beverages that are not compliant with the current *USDA Dietary Guidelines for Americans* and the *USDA Smart Snacks in Schools* regulations for consumption on campus during the school day by students.

[NOTE: The Michigan Department of Education's Administrative Policy No. 21 sets the upper limit for noncompliant fund-raisers at two (2) per week.]

Other than approved non-compliant fundraisers, the food and/or beverages items to be sold for any other fund-raisers by student clubs and organizations, parent groups, or booster clubs and consumed on campus, shall comply with the current *USDA Dietary Guidelines for Americans*, and the *USDA Smart Snacks in Schools* nutrition standards, and also must be consistent with requirements set forth in Policy 8500 – Food Services.

If approved, fund-raisers that involve the sale of food items or beverages to students on campus must be consistent with regulations established in Policy 8500, Food Services, pertaining to the sale of foods and beverages during food-service hours, whether those food items and beverages are compliant with, or an exception to, the current *USDA Dietary Guidelines for Americans* and the *USDA Smart Snacks in Schools* nutrition standards.

If an exception is granted to the requirement that food items and beverages are compliant with the current *USDA Dietary Guidelines for Americans* and the *USDA Smart Snacks in Schools* nutrition standards, the Principal shall also maintain records for each exception, including, but not limited to, the length of the fund-raiser, the type, quantity, and price of the food item and/or beverage sold, and the gross and net amount raised.

- G. Proceeds from District support organization fund-raisers shall not be commingled with a student activity or other Board accounts. Board employees who commingle such proceeds with a student activity or other Board account shall be subject to discipline.
- H. The Director of Business and Finance will work with staff to develop administrative guidelines that require each District support organization's fund-raising activities be in compliance with Board policies and that the funds generated by such fund-raising activities and donated to the District are used for school-related projects that have the approval of the Superintendent and principal.
- I. District support organizations are encouraged to obtain 501(c)(3) status so that community members may properly take tax deductions for donations to the organization.
- J. School employees and school volunteers may not be compensated in any manner by District support organizations for their work on behalf of the District.
- K. Donations from District support organizations must be made in accordance with Board Policy 7230 and any accompanying guidelines.

Legal

M.C.L. 380.1272b
7 C.F.R. Parts 210 and 220

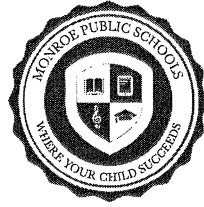

Book Neola Policy Templates for Processing Policy for the Board

Section RELATIONSHIPS WITH PARENTS, LEGAL GUARDIANS, AND CAREGIVERS

Title po9250

Code Policy Committee

Status

9250 - RELATIONS WITH PARENTS

The Board of Education believes that the education of children is a joint responsibility, one it shares with the parents of the school community. To ensure that the best interests of the child are served in this process, a strong program of communication between home and school must be maintained.

The parents have the right to participate in the education of their children as well as the ultimate responsibility for their children's in-school behavior, including the behavior of students who have reached the legal age of majority, but are still, for all practical purposes, under parental authority.

In accordance with Board policies and Policy 2240 – Controversial Issues, Policy 2413 – Critical Health Problems and/or Policy 2414 – Reproductive Health and Planning, and Policy 9150 - School Visitors, the District shall provide the opportunity for parents to review curriculum and instructional materials and to visit the school to observe the instructional process.

With regard to student behavior, during school hours, the Board, through its designated administrators, acts in loco parentis or in place of the parents.

The Board recommends that the following activities be implemented to encourage parent-school cooperation:

- A. parent-teacher conferences to permit two-way communication between home and school;
- B. meetings of staff members and groups of parents of those students having special abilities, disabilities, needs, or problems;
- C. special events of a cultural, ethnic, or topical nature which are initiated by parent groups, involve the cooperative effort of students and parents, and are of general interest to the schools or community;
- D. open houses in District schools to provide parents with the opportunity to see the school facilities, meet the faculty, and sample the program on a first hand basis.

Each school in the District shall hold an open house at least annually.

For the benefit of children, the Board believes that parents have a responsibility to encourage their child's career in school by:

- A. supporting the schools in requiring that the children observe all school rules and regulations, and by accepting their own responsibility for children's willful in-school behavior;
- B. sending children to school with proper attention to their health, hygiene, and attire (pertaining to the dress code);
- C. maintaining an active interest in the student's daily work and making it possible for the student to complete assigned homework by providing a quiet place and suitable conditions for study;
- D. reading all communications from the school, signing, and returning them promptly when required;
- E. cooperating with the school in attending conferences set up for the exchange of information of the child's progress in school.

© Neola 1996

Legal

M.C.L. 380.10, 380.1137

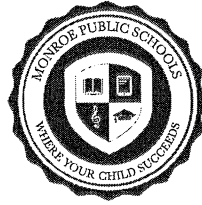

Book Neola Policy Templates for Processing

Section Policy for the Board

Title EQUIVALENT EDUCATION OUTSIDE THE SCHOOLS (HOME SCHOOLING)

Code po9270

Status Policy Committee

9270 - EQUIVALENT EDUCATION OUTSIDE THE SCHOOLS (HOME SCHOOLING)

The Board of Education encourages the enrollment of all school-age children resident in this District in public schools or in State- approved, nonpublic schools so that they may enjoy the benefits of a well-planned, educational program and the socialization possible in a group environment. The Board acknowledges, however, the right of parents to home school within the District, as established by State law.

The Board shall not allow a student who is being educated at home or at a nondistrict school that has not met the reporting requirements of the State to participate in any of the District’s curricular, co-curricular, or extra-curricular activities. However, if the school has met the reporting requirements and the student is enrolled in the District on a part-time basis in noncore classes, s/he may also participate in noncore co-curricular or extra-curricular activities that are directly related to those noncore classes. It is not the purpose of this policy, however, to provide services to nondistrict students beyond the requirements of the law.

The Superintendent shall develop administrative guidelines for implementing this policy.

© Neola 1999

Legal M.C.L. 388.553, 380.1561

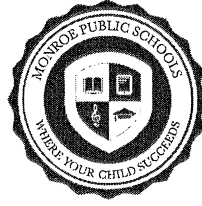

| | |
|---------|---|
| Book | Neola Policy Templates for Processing |
| Section | Policy for the Board |
| Title | RELATIONS WITH EDUCATIONAL INSTITUTIONS AND ORGANIZATIONS |
| Code | po9500 |
| Status | Policy Committee |

9500 - **RELATIONS WITH EDUCATIONAL INSTITUTIONS AND ORGANIZATIONS**

It is the policy of the Board of Education that strong lines of communication be maintained by the District with other districts and with institutions and organizations which provide District students with programs, training, or services not available in the District.

The Superintendent may enter into such cooperative ventures with institutions or organizations for the purpose of providing programs which correlate to the District's curriculum and help students better accomplish the educational outcomes established by the Board. The District shall cooperate with the Intermediate School District in the study of opportunities to share services with other school districts and the Intermediate School District.

Before entering into any agreements, the Superintendent shall keep the Board advised of any arrangements that would affect the use of District resources or require any additional resources of the District.

In order to maintain cordial and constructive relationships with private and parochial schools, the Superintendent shall maintain liaison with the administration of all such schools that enroll significant numbers of students resident in this School District in order to be aware of any program changes that may be planned that could affect this District; and to cooperate fully in the implementation of all State and Federal programs administered by this District that benefit, in whole or in part, eligible students attending private or parochial school.

© Neola 2008

| | |
|-------|-----------------|
| Legal | M.C.L. 380.1296 |
| | M.C.L. 380.761 |

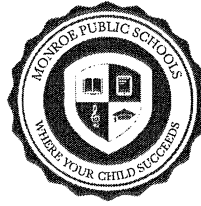

| | |
|---------|---------------------------------------|
| Book | Neola Policy Templates for Processing |
| Section | Policy for the Board |
| Title | PARTNERSHIPS WITH BUSINESS |
| Code | po9555 |
| Status | Policy Committee |

9555 - **PARTNERSHIPS WITH BUSINESS**

The Board of Education is well aware of the role that education will play in increasing the nation's productivity and future well-being. To ensure success requires the combining of talent and resources within the region between business and education. It also recognizes that schools of the District need to operate as an integral part of the economic community if students are to receive the type of education and training they will need to function effectively in the twenty-first century.

The Board will seek to establish not only partnerships between the District and individual companies but also, if possible, consortia involving several companies and/or school districts. The purpose will be to seek opportunities for students and staff to share in new strategies and technologies being created in the business world and offer, in exchange, the knowledge and skill of District personnel in creating more effective continuing education for employees and members of the community. Properly planned and implemented, such partnerships or consortia could have significant impact on the nature and content of the curriculum as well as on the manner in which students are taught to learn.

The Superintendent is authorized to actively seek such partnerships.

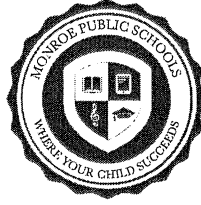

| | |
|---------|---|
| Book | Neola Policy Templates for Processing |
| Section | Policy for the Board |
| Title | STAFF/STUDENT PARTICIPATION IN COMMUNITY EVENTS |
| Code | po9600 |
| Status | Policy Committee |

9600 - **STAFF/STUDENT PARTICIPATION IN COMMUNITY EVENTS**

The Board of Education recognizes that the local community offers many programs and events that provide learning experiences which are not available in the schools and which can help students become more literate, cultured, productive human beings.

The Board seeks to maintain continuing communication with those groups and organizations that enrich the life of the community and authorizes the Superintendent to cooperate with their leaders both in the use of District resources that can aid their efforts and ensuring that members of the staff and student body are made aware of education-related activities of these groups. Further, the Board encourages members of the staff to make their many talents and specialized knowledge available, as time permits, to enhance the quality of such community activities.

The Superintendent shall develop administrative guidelines which will better ensure:

- A. school activities to which the public is invited are scheduled, to the extent possible, so as not to conflict with other events in the community which would appeal to the same audience. Such scheduling conflicts not only diminish the attendance at both the school and the community activities but also deprive the students and staff from deriving the benefits from participation in community programs which enhance learning and the quality of life.

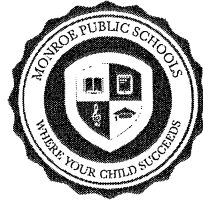

| | |
|---------|--|
| Book | Neola Policy Templates for Processing |
| Section | Policy for the Board |
| Title | RELATIONS WITH SPECIAL INTEREST GROUPS |
| Code | po9700 |
| Status | Policy Committee |

9700 - **RELATIONS WITH SPECIAL INTEREST GROUPS**

Any request from civic institutions, charitable organizations, or special interest groups which involve such activities as patriotic functions, contests, exhibits, sales of products to and by students, sending promotional materials home with students, graduation prizes, fund raising, and free teaching materials must be carefully reviewed to ensure that such activities promote student interests without advancing the special interests of any particular group.

It is the policy of the Board of Education that students, staff members, and District facilities not be used for advertising or promoting the interests of any nonschool agency or organization, public or private, without the approval of the Board or its delegated representative; and any such approval, granted for whatever cause or group, shall not be construed as an endorsement of said cause or group by this Board.

A. Political Interests

All materials or activities proposed by outside political sources for student or staff use or participation shall be reviewed by the Superintendent on the basis of their educational contribution to part or all of the school program, benefit to students, and no such approval shall have the primary purpose of advancing the name, product, or special interest of the proposing group.

The Board shall not permit the use of any type of educational material, program, or equipment in its curricular, co-curricular, or extra-curricular activities or at any time during the school day if such materials, programs, or equipment contain partisan political messages or are designed to persuade students or staff members to acquire a particular product or service offered by a named individual, company, organization, association, or agency. Professional staff may, however, utilize political materials or those provided by special interest-groups in adopted courses of study with the approval of the principal.

School facilities or equipment may not be used as a means of producing or disseminating to the community any materials that advertise or promote a political party, a political cause, or the candidacy of an individual for public office. Students and employees of the Board shall not be used to distribute campaign literature within the schools or on school grounds.

B. Contests/Exhibits

The Board recognizes that contests, exhibits, and the like may benefit individual students or the District as a whole, but participation in such special activities may not:

1. have the primary effect of advancing a special product, group, or company;

2. make unreasonable demands upon the time and energies of staff or students or upon the resources of the District;
3. interrupt the regular school program;
4. involve any direct cost to the District;
5. cause the participants to leave the School District, unless:
 - a. the Board's Policy 2340 - Field and Other District- Sponsored Trips has been complied with in all aspects;
 - b. the Board has granted special permission;
 - c. the parents of a minor student have granted their permission.

C. Distribution/Posting of Literature

No outside organization or staff member or student representing an outside organization may distribute or post literature on that organization's behalf on District property either during or after school hours without the permission and prior review of the Superintendent.

The Superintendent shall establish administrative guidelines which ensure that:

1. criteria established in Policy 5722 – School-Sponsored Publications and Productions - are used to make a decision regarding materials that students seek to post or distribute;
2. distribution or posting of materials employees wish to distribute on behalf of an employee organization comply with the terms of negotiated, collectively-bargained agreements;
3. the school mail system is not used by students or staff for distribution of nonschool-related materials;
4. no materials from any profit-making organization are distributed for students to take home to their parents unless authorized by the Superintendent;
5. the time, place, and manner of distribution of all nonschool-related materials is clearly established and communicated;
6. flyers and notices from outside non-profit organizations may be made available for students to pick-up at the literature distribution rack/table by the school building's office, under the following circumstances:
 - a. the flyer/notice publicizes a specific community activity or event that is age-appropriate for the students that attend the school;
 - b. the organization submits the number of copies of the flyer that it wants placed in the literature distribution rack/table.

No student shall be required to take any of the flyers/notices placed in the literature/distribution rack/table, and the rack/table shall contain a clear notice that the Board does not support or endorse any of the organizations and/or activities/events identified in the flyers/notices.

D. Solicitation of Funds

Because the District cannot accommodate every organization that desires to solicit funds for worthy purposes, the Board shall not permit any organization not related to the District to solicit funds on District property.

Permission to solicit funds will be granted only to those organizations, individuals, or staff members who meet the permission criteria established in the District's administrative guidelines. Solicitation must take place at such times and places and in such a manner as specified in the administrative guidelines. In

accordance with Board Policy 5830, no District student may participate in the solicitation without the Superintendent's approval.

Crowdfunding activities aimed at raising funds for a specific classroom or school activity, including extracurricular activity, or to obtain supplemental resources (e.g., supplies or equipment) that are not required to provide a free appropriate public education to any students in the classroom may be permitted, but only with the specific approval of the Board upon the recommendation of the Superintendent.

All crowdfunding activities are subject to the procedures/guidelines in AG 6605.

E. Prizes/Scholarships

The Board is appreciative of the generosity of organizations which offer scholarships or prizes to deserving students in this District. But, in accepting the offer of such scholarships or prizes, the Board directs that these guidelines be observed:

1. No information, either academic or personal, shall be released from the student's record for the purpose of selecting a scholarship or prize winner without the permission of the student who is eighteen (18), or the parents of a student who is younger in accordance with the Board's policy on student records.
2. The type of scholarship or prize, the criteria for selection of the winner, and any restrictions upon it shall be approved by the Superintendent and/or his/her designee.
3. The principal, together with a committee of staff members designated by the principal, shall be involved in the selection of the recipient. and, if agreeable to the sponsoring organization, the selection shall be left entirely to the principal and staff committee.

F. Sale of School Supplies

In determining the appropriateness of the sale of school supplies by organizations other than the School District, the Board requires that:

1. the organization have a purpose which will benefit the School District and its students;
2. the organization's planned activities are clearly in the best interest of the School District and its students;
3. the organization has submitted the following information and assurances on the form provided by the District: a statement noting the purpose of the organization, financial accountability assurances, and use of facility assurances.

All funds generated by the sale of such school supplies shall be kept separate from other activity funds or other transactions of the Board.

G. Surveys and Questionnaires

Neither District-related nor nondistrict-related organizations shall be allowed to administer a survey or questionnaire to students or staff unless the instrument and the proposed plan is submitted, in advance, to the Superintendent. If approved, a copy of the results and the proposed manner of their communication are to be provided to him/her for review and approval before they are released.

Students shall not be required to complete surveys to provide marketing information to vendors, or distribute to vendors any personal information of students, including but not limited to names, addresses, and telephone numbers, except as may be required by law. In addition, the District shall not enter into any contract for products or services, including electronic media services, where personal information will be collected from the students by the providers of the services.

See also Policy 2416 and AG 2416

© Neola 2016

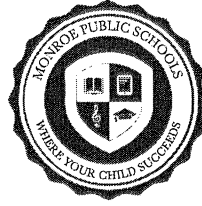

| | |
|---------|---------------------------------------|
| Book | Neola Policy Templates for Processing |
| Section | Policy for the Board |
| Title | ADVERTISING AND COMMERCIAL ACTIVITIES |
| Code | po9700.01 |
| Status | Policy Committee |

9700.01 - **ADVERTISING AND COMMERCIAL ACTIVITIES**

The purpose of this policy is to provide guidelines for the appropriate and inappropriate use of advertising or promoting of commercial products or services to students and parents in the schools.

"Advertising" comes in many different categories and forums and is defined as an oral, written or graphic statement made by the producer, manufacturer, or seller of products, equipment, or services which calls for the public's attention to arouse a desire to buy, use or patronize the product, equipment, or services. This includes the visible promotion of product logos for other than identification purposes. Brand names, trademarks, logos or tags for product or service identification purposes are not considered advertising.

It is further the policy of the Board that its name, students, staff members and District facilities shall not be used for any commercial advertising or otherwise promoting the interests of any commercial, political, nonprofit or other non-school agency or organization, public or private, without the approval of the Board or its designee.

© Neola 2012

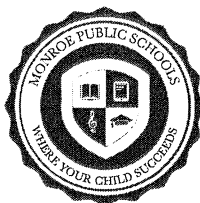

| | |
|---------|---|
| Book | Neola Policy Templates for Processing |
| Section | Policy for the Board |
| Title | HIGH SCHOOL DIPLOMAS TO WORLD WAR II, KOREAN CONFLICT, AND VIETNAM ERA VETERANS |
| Code | po9800 |
| Status | Policy Committee |

9800 - HIGH SCHOOL DIPLOMAS TO WORLD WAR II, KOREAN CONFLICT, AND VIETNAM ERA VETERANS

The Board of Education recognizes the service provided to the country and the individual sacrifices made by veterans of World War II, the Korean Conflict, and the Vietnam Era.

Since many of these veterans left high school in order to fight for their country, the Board wishes to recognize their efforts by awarding a high school diploma to qualified military veterans in accordance with Public Act 181 of 2001, Public Act 203 of 2003, and Public Act 55 of 2014.

The Board authorizes the Superintendent to accept applications and documentation on the forms provided by the Department of Military and Veteran Affairs, Veterans Affairs Directorate. The Board will satisfy itself that the intent of the law has been met and the Board may then authorize the awarding of the high school diploma.

© Neola 2014

| | |
|-------|---------------|
| Legal | M.C.L. 35.341 |
|-------|---------------|

SECOND READING AND ADOPTION OF BOARD POLICY 2370.01

ENCLOSURE

- Neola Policy 2370.01 Online Blended Learning Program

RECOMMENDATION

Move to approve Policy 2370.01 Online Blended Learning Program, as written, effective August 26, 2020.

MOTION: _____ **SUPPORT:** _____ **ACTION:** _____

| | <u>Aye</u> | <u>Nay</u> | <u>Abstain</u> | <u>Absent</u> |
|-------------------|------------|------------|----------------|---------------|
| Mrs. Boone | _____ | _____ | _____ | _____ |
| Mr. Bunkelman | _____ | _____ | _____ | _____ |
| Mrs. Netter | _____ | _____ | _____ | _____ |
| Mr. Nichols | _____ | _____ | _____ | _____ |
| Mrs. Pasko | _____ | _____ | _____ | _____ |
| Mr. VanWasshenova | _____ | _____ | _____ | _____ |
| Mr. Zimmerman | _____ | _____ | _____ | _____ |



| | |
|---------|---------------------------------------|
| Book | Neola Policy Templates for Processing |
| Section | Policy for the Board |
| Title | ON-LINE/BLENDED LEARNING PROGRAM |
| Code | po2370.01 |
| Status | Policy Committee |

2370.01 - **ONLINE/BLENDED LEARNING PROGRAM**

The District shall provide eligible students the option of participating in on-line or blended learning courses. The purpose of the program is to make instruction available to eligible students using on-line and distance education technology in both traditional and nontraditional classroom settings. The District must make all eligible students and their parents or guardians aware of this program.

All traditional seated courses are eligible to be delivered as online virtual courses, or a combination thereof, for the 2020-2021 school year following the guidelines provided within the Michigan Department of Education Pupil Accounting Manual. District and School administration shall coordinate and monitor the implementation for online virtual learning and the adherence to state pupil accounting requirements including student accessibility to online virtual learning, attendance, and participation in lessons and assessments.

A. Definitions

1. **Online Learning** - Means a course of study that is capable of generating a credit or a grade, that is provided in an interactive internet-connected learning environment, in which students and their teachers are separated by time or location, or both, and in which the teacher is responsible for determining appropriate instructional methods for each student, diagnosing learning needs, assessing student learning, prescribing intervention strategies, reporting outcomes, and evaluating the effects of instruction and support strategies.
2. **Blended Learning** - A hybrid instructional delivery model where students are provided content, instruction, and assessment in part at the classroom, with a teacher, and in part through internet-connected learning environments with some degree of student control over time, location, and pace of instruction.

B. Program Eligibility

The District shall offer a program for students in: K -12.

The District may offer a full time or part time program for grade 9-12 students enrolled in dropout prevention, academic intervention, core courses to meet graduation requirements, or dual enrollment programs.

C. Student Eligibility

1. Students eligible for the District on-line/blended learning program must meet at least one of the following conditions:

- a. The student has spent the prior school year in attendance at a public school in this State and was enrolled and reported by a public school district.
- b. The student is a dependent child of a member of the United States Armed Forces who was transferred within the last twelve (12) months to Michigan from another state or foreign country pursuant to the parent's permanent change of station orders.

D. Course Availability and Access

1. The District shall provide access to enroll and participate in the available courses and shall award credit, as may be appropriate, for successful completion. Access shall be available to eligible students during or after the school day and during summer school enrollment. The District will provide at least one of the following:
 - a. Online Learning, pursuant to the requirements set forth in Pupil Accounting Manual 5-O-D.
 - b. Virtual Learning, pursuant to the requirements set forth in Pupil Accounting Manual 5-O-A.
 - c. Independent Study, pursuant to the requirements set forth in the pupil accounting manual.
2. Consent from the student's parent or legal guardian must be obtained for students under the age of eighteen (18).
3. If students are taking more than two (2) courses per semester, the guidance found in the Pupil Accounting Manual 5-O-B shall be followed and seat time waivers obtained.
4. An eligible student may enroll in an on-line course published in the District on-line course syllabus, as described in section 8 below, or the State-wide catalog of on-line courses maintained by the Michigan virtual university.
5. The District may deny a student enrollment in an on-line course if any of the following apply, as determined by the District:
 - a. The student has previously gained the credits provided from the completion of the on-line course.
 - b. The online course is not capable of generating academic credit.
 - c. The online course is inconsistent with the remaining graduation requirements or career interests of the student.
 - d. The student does not possess the prerequisite knowledge and skills to be successful in the on line course or has demonstrated failure in previous online coursework in the same subject.
 - e. The online course is of insufficient quality or rigor. If the District denies a student enrollment for this reason, the District shall make a reasonable effort to assist the student to find an alternative course in the same or a similar subject that is of acceptable rigor and quality.
6. An online learning student shall have the same rights and access to technology in his/her District's school facilities as all other students enrolled in that District.
7. If a student successfully completes an on-line course, as determined by the District, the District shall grant appropriate academic credit for completion of the course and shall count that credit toward completion of graduation and subject area requirements. A student's school record and transcript shall identify the on-line course title as it appears in the on-line course syllabus.

8. The enrollment of a student in one (1) or more online courses shall not result in a student being counted as more than 1.0 full-time equivalent student under this act.

E. Nonresident Applicants

1. The District shall determine whether or not it has capacity to accept applications for enrollment from nonresident applicants in online courses and may use that limit as the reason for refusal to enroll an applicant.
2. If the number of nonresident applicants eligible for acceptance in an on-line course does not exceed the capacity of the District to provide the online course, the District shall accept for enrollment all of the nonresident applicants eligible for acceptance.
3. If the number of nonresident applicants exceeds the District's capacity to provide the online course, the District shall use a random draw system.

F. Requirements Specific to Online Learning Courses

To offer an online course, the District must:

1. Provide the Michigan virtual university with the course syllabus in a form and method prescribed by the Michigan virtual university for inclusion in a state-wide on-line course catalog.
2. Provide on its publicly accessible website a link to the course syllabi for all of the on-line courses offered by the District, as described in section 8, and a link to the State-wide catalog of online courses maintained by the Michigan Virtual University.
3. Offer the on-line course on an open entry and exit method, or aligned to a semester, trimester, or accelerated academic term format.

G. Online Course Syllabus

The District must publish an online course syllabus for each on-line course offered. The online course syllabus must include:

1. State academic standards addressed in an online course.
2. Online course content outline.
3. Online course required assessments.
4. Online course prerequisites.
5. Expectations for actual teacher contact time with the on-line learning student and other student-to-teacher communications.
6. Academic support available to the online learning student.
7. Online course learning outcomes and objectives.
8. Name of the institution or organization providing the on-line instructor.
9. Number of eligible nonresident students that will be accepted by the District in the on-line course.
10. Results of the on-line course quality review using the guidelines and model review process published by the Michigan Virtual University.

Legal

M.C.L. 388.1621f

Michigan Department of Education Guidance on Best Practices as Defined In M.C.L. 388.1622f

TEACHER TENURE RECOGNITION

BACKGROUND:

Teacher Tenure is granted under the Michigan Teacher Tenure Act when a teacher satisfactorily completes a probationary period. Under the revised statute, teachers hired since the 2011 amendment must complete a five-year probation period unless they have received tenure in another Michigan district. Under that condition, a two-year probation must be served.

As of September 1, 2020, Emily Kressbach, Hollie Mazur, Tara Neaves, and Travis Trombley have completed 5-year probationary periods.

As of September 8, 2020, Alysha Vergowven has completed a 5-year probationary period.

As of September 23, 2020, Emily Nagel has completed a 5-year probationary period.

As of September 26, 2020, Lisa Heckler has completed a 5-year probationary period.

On behalf of the administration, I am pleased to report that these teachers have earned good evaluations and recommendations from the appropriate supervisor(s). Even though tenure is granted under the statute, the Board of Education is asked to confirm and endorse the granting of tenure and removal from probation.

ENCLOSURES:

Tenure Recommendations

RECOMMENDATION:

Move to confirm and endorse the granting of tenure and removal from probation for EmilyKressbach, Hollie Mazur, Tara Neaves, Travis Trombley, Alysha Vergowven, Emily Nagel, and Lisa Heckler on the appropriate anniversary dates.

MOTION: _____ **SUPPORT:** _____ **ACTION:** _____

| | <u>Aye</u> | <u>Nay</u> | <u>Abstain</u> | <u>Absent</u> |
|---------------|------------|------------|----------------|---------------|
| Mrs. Boone | _____ | _____ | _____ | _____ |
| Mr. Bunkelman | _____ | _____ | _____ | _____ |
| Mrs. Netter | _____ | _____ | _____ | _____ |
| Mr. Nichols | _____ | _____ | _____ | _____ |
| Mrs. Pasko | _____ | _____ | _____ | _____ |

Mr. VanWasshenova
Mr. Zimmerman

—
—

—
—

—
—

—
—

Monroe Public Schools

1275 N. Macomb Street * P.O. Box 733 * Monroe, MI 48162 * 734-265-3020



TO: Cindy Flynn, Director of Human Resources
FROM: Delsie Sissoko, Principal
DATE: August 13, 2020
RE: **TENURE RECOMMENDATION, Alysha Vergowven**

The 2019/2020 school year completes the five-year probationary cycle for Alysha Vergowven. I have formally evaluated her classroom performance according to the Monroe Public School directives, and I have reviewed all previous evaluations on file.

It is with great pleasure that I recommend Alysha Vergowven for tenure with Monroe Public Schools. Alysha has demonstrated the skills, knowledge, and professionalism necessary to be an effective and positive member of our education team.

Sincerely,

Delsie Sissoko
Principal
Arborwood Elementary

cc: Julie Everly, Superintendent
Alysha Vergowven, Teacher, Arborwood Elementary

Monroe Public Schools

1275 N. Macomb Street * P.O. Box 733 * Monroe, MI 48162 * 734-265-3020



TO: Cindy Flynn, Director of Human Resources
FROM: Kevin Pilgrim, Principal
DATE:
RE: **TENURE RECOMMENDATION, Lisa Heckler**

The 2020/2021 school year completes the five-year probationary cycle for Lisa Heckler. I have formally evaluated her classroom performance according to the Monroe Public School directives, and I have reviewed all previous evaluations on file.

It is with great pleasure that I recommend Lisa Heckler for tenure with Monroe Public Schools. Lisa has demonstrated the skills, knowledge, and professionalism necessary to be an effective and positive member of our education team.

Sincerely,

A handwritten signature in black ink, appearing to read "Kevin Pilgrim", written in a cursive style.

Kevin Pilgrim
Principal
Orchard Center High School

cc: Julie Everly, Superintendent
Lisa Heckler, Teacher, Orchard Center High School

Monroe Public Schools

1275 N. Macomb Street * P.O. Box 733 * Monroe, MI 48162 * 734-265-3020



TO: Cindy Flynn, Director of Human Resources
FROM: Delsie Sissoko, Principal
DATE: August 13, 2020
RE: **TENURE RECOMMENDATION, Emily Kressbach**

The 2019/2020 school year completes the five-year probationary cycle for Emily Kressbach. I have formally evaluated her classroom performance according to the Monroe Public School directives, and I have reviewed all previous evaluations on file.

It is with great pleasure that I recommend Emily Kressbach for tenure with Monroe Public Schools. Emily has demonstrated the skills, knowledge, and professionalism necessary to be an effective and positive member of our education team.

Sincerely,

Delsie Sissoko
Principal
Arborwood Elementary

cc: Julie Everly, Superintendent
Emily Kressbach, Teacher, Arborwood Elementary

Monroe Public Schools

1275 N. Macomb Street * P.O. Box 733 * Monroe, MI 48162 * 734-265-3020



TO: Cindy Flynn, Director of Human Resources
FROM: Steve Pollzzie, Principal
DATE: 7/28/20
RE: **TENURE RECOMMENDATION, Hollie Mazur**

The 2020/2021 school year completes the five-year probationary cycle for Hollie Mazur. We have formally evaluated her classroom performance according to the Monroe Public School directives, and I have reviewed all previous evaluations on file.

It is with great pleasure that I recommend Hollie Mazur for tenure with Monroe Public Schools. Hollie Mazur has demonstrated the skills, knowledge, and professionalism necessary to be an effective and positive member of our education team.

Sincerely,

Steve Pollzzie
Principal
Monroe High School

cc: Julie Everly, Superintendent
Teacher Name, Teacher, School Name

Monroe Public Schools

1275 N. Macomb Street * P.O. Box 733 * Monroe, MI 48162 * 734-265-3020



TO: Cindy Flynn, Director of Human Resources
FROM: Delsie Sissoko, Principal
DATE: August 13, 2020
RE: **TENURE RECOMMENDATION, Emily Nagel**

The 2019/2020 school year completes the five-year probationary cycle for Emily Nagel. I have formally evaluated her classroom performance according to the Monroe Public School directives, and I have reviewed all previous evaluations on file.

It is with great pleasure that I recommend Emily Nagel for tenure with Monroe Public Schools. Emily has demonstrated the skills, knowledge, and professionalism necessary to be an effective and positive member of our education team.

Sincerely,

Delsie Sissoko
Principal
Arborwood Elementary

cc: Julie Everly, Superintendent
Emily Nagel, Teacher, Arborwood Elementary

Monroe Public Schools

1275 N. Macomb Street * P.O. Box 733 * Monroe, MI 48162 * 734-265-3020



TO: Cindy Flynn, Director of Human Resources
FROM: Delsie Sissoko, Principal
DATE: August 13, 2020
RE: **TENURE RECOMMENDATION, Tara Neaves**

The 2019/2020 school year completes the five-year probationary cycle for Tara Neaves. I have formally evaluated her classroom performance according to the Monroe Public School directives, and I have reviewed all previous evaluations on file.

It is with great pleasure that I recommend Tara Neaves for tenure with Monroe Public Schools. Tara has demonstrated the skills, knowledge, and professionalism necessary to be an effective and positive member of our education team.

Sincerely,

Delsie Sissoko
Principal
Arborwood Elementary

cc: Julie Everly, Superintendent
Tara Neaves, Teacher, Arborwood Elementary

Monroe Public Schools

1275 N. Macomb Street * P.O. Box 733 * Monroe, MI 48162 * 734-265-3020



TO: Cindy Flynn, Director of Human Resources
FROM: Steve Pollzzie, Principal
DATE: 7/28/20
RE: **TENURE RECOMMENDATION, Travis Trombley**

The 2020/2021 school year completes the five-year probationary cycle for Travis Trombley. We have formally evaluated his classroom performance according to the Monroe Public School directives, and I have reviewed all previous evaluations on file.

It is with great pleasure that I recommend Travis Trombley for tenure with Monroe Public Schools. Travis Trombley has demonstrated the skills, knowledge, and professionalism necessary to be an effective and positive member of our education team.

Sincerely,

Steve Pollzzie
Principal
Monroe High School

cc: Julie Everly, Superintendent
Teacher Name, Teacher, School Name

COACHING RECOMMENDATIONS

BACKGROUND

The following are Coaching Recommendations for the 2020/21 school year. All pre-employment information has been completed.

| Last Name | First Name | Title | Sport | School | Season |
|-----------|------------|-------|----------------------|--------|--------|
| Sellers | Ernest | Coach | Golf - Varsity Girls | MHS | Fall |

RECOMMENDATION

Move to approve the above-named coach for the 2020/21 school year: as per the MCEA master agreement.

MOTION: _____ **SUPPORT:** _____ **ACTION:** _____

| | <u>Aye</u> | <u>Nay</u> | <u>Abstain</u> | <u>Absent</u> |
|-------------------|------------|------------|----------------|---------------|
| Mrs. Boone | _____ | _____ | _____ | _____ |
| Mr. Bunkelman | _____ | _____ | _____ | _____ |
| Mrs. Netter | _____ | _____ | _____ | _____ |
| Mr. Nichols | _____ | _____ | _____ | _____ |
| Mrs. Pasko | _____ | _____ | _____ | _____ |
| Mr. VanWasshenova | _____ | _____ | _____ | _____ |
| Mr. Zimmerman | _____ | _____ | _____ | _____ |

Alternate 2020-2021 Calendar

BACKGROUND

Monroe Public Schools has adjusted the approved 2020-2021 school calendar to accommodate for Phases 1-4 of the Return to Learn Plan. During Phases 1-4 of the Return to Learn Plan, this calendar will be used, and during Phases 5-6, the previously approved calendar will be used.

ENCLOSURE(S)

Phase 1-4 2020/2021 Calendar

RECOMMENDATION

Move to approve the Phase 1-4 2020/2021 Calendar.

MOTION: _____ **SUPPORT:** _____ **ACTION:** _____

| | <u>Aye</u> | <u>Nay</u> | <u>Abstain</u> | <u>Absent</u> |
|-------------------|-------------------|-------------------|-----------------------|----------------------|
| Mrs. Boone | _____ | _____ | _____ | _____ |
| Mr. Bunkelman | _____ | _____ | _____ | _____ |
| Mrs. Netter | _____ | _____ | _____ | _____ |
| Mr. Nichols | _____ | _____ | _____ | _____ |
| Mrs. Pasko | _____ | _____ | _____ | _____ |
| Mr. VanWasshenova | _____ | _____ | _____ | _____ |
| Mr. Zimmerman | _____ | _____ | _____ | _____ |

COVID-19 Phases 1-4 TEACHER CALENDAR 2020-21

| FACTS | DAYS | HOURS |
|-------------------------------------|------------|---------|
| Total Calendar Days | | |
| Average Hours per Day | 165 X 6.37 | 1051.05 |
| Average Hours per Half Day | 12 X 3.12 | 37.44 |
| Average Hours per Late Start Day | 3 X 5.00 | 15.00 |
| Average Hours per Early Release Day | 0 X 5.37 | 0.00 |

| | |
|----|---|
| 21 | AM - Teachers engage with students per the district schedule. PM - Students continue with learning activities. Teacher collaboration and professional development. |
| 5 | union chosen half days 2 day is a record day - would be full work day 2 days are half days teachers don't report PM |
| 10 | half days for PD Teachers engage with students until 11am, PD in PM |
| 3 | full days of PD - no school 10 hours PD counted as a full student day + 6 for County Wide |
| 2 | full virtual day for students for Conferences* Elementary 10/21, 3-hour flexible daytime schedule and 5-7pm Middle/High School 11/11, 3-hour flexible daytime schedule and 5-7pm PD will be held on day opposite conferences |

| | |
|---------------------|----------------|
| 180 | 1103.49 |
| School Days | 180.0 |
| Teacher Days | 180.0 |

Count Days in October and February

2020

| JULY | | | | | | |
|------|----|----|----|----|----|----|
| S | M | T | W | T | F | S |
| | | | | | | 4 |
| 5 | 6 | 7 | 8 | 9 | 10 | 11 |
| 12 | 13 | 14 | 15 | 16 | 17 | 18 |
| 19 | 20 | 21 | 22 | 23 | 24 | 25 |
| 26 | 27 | 28 | 29 | 30 | 31 | |

| | |
|--------------|-----|
| School Days | 0 |
| Teacher Days | 0.0 |

| AUGUST | | | | | | |
|--------|----|----|----|----|----|----|
| S | M | T | W | T | F | S |
| | | | | | | 1 |
| 2 | 3 | 4 | 5 | 6 | 7 | 8 |
| 9 | 10 | 11 | 12 | 13 | 14 | 15 |
| 16 | 17 | 18 | 19 | 20 | 21 | 22 |
| 23 | 24 | 25 | 26 | 27 | 28 | 29 |
| 30 | 31 | | | | | |

| | |
|-----------------------------|-----|
| School Days | 1 |
| Teacher Days (1 - full day) | 1.0 |

inservice will be a 5 hour day

| SEPTEMBER | | | | | | |
|-----------|----|----|----|----|----|----|
| S | M | T | W | T | F | S |
| | | 1 | 2 | 3 | 4 | 5 |
| 6 | 7 | 8 | 9 | 10 | 11 | 12 |
| 13 | 14 | 15 | 16 | 17 | 18 | 19 |
| 20 | 21 | 22 | 23 | 24 | 25 | 26 |
| 27 | 28 | 29 | 30 | | | |

| | |
|--------------|------|
| School Days | 20 |
| Teacher Days | 20.0 |

Students begin September 2
inservice will be a 5 hour day

| OCTOBER | | | | | | |
|---------|----|----|----|----|----|----|
| S | M | T | W | T | F | S |
| | | | | 1 | 2 | 3 |
| 4 | 5 | 6 | 7 | 8 | 9 | 10 |
| 11 | 12 | 13 | 14 | 15 | 16 | 17 |
| 18 | 19 | 20 | 21 | 22 | 23 | 24 |
| 25 | 26 | 27 | 28 | 29 | 30 | 31 |

| | |
|--------------|------|
| School Days | 21 |
| Teacher Days | 22.0 |

Count Day - 1st Wednesday in October
county wide day is 10/30
PT Conferences
Elementary 10/21, three hour flexible daytime schedule and 5-7pm

| NOVEMBER | | | | | | |
|----------|----|----|----|----|----|----|
| S | M | T | W | T | F | S |
| 1 | 2 | 3 | 4 | 5 | 6 | 7 |
| 8 | 9 | 10 | 11 | 12 | 13 | 14 |
| 15 | 16 | 17 | 18 | 19 | 20 | 21 |
| 22 | 23 | 24 | 25 | 26 | 27 | 28 |
| 29 | 30 | | | | | |

| | |
|-----------------------------------|------|
| School Days | 19 |
| Teacher Days (25th is record day) | 19.0 |

11/6 is end of first quarter (47 days)
11/25 is end of first trimester (60 days)
PT Conferences
Middle/High School 11/11, three hour flexible daytime schedule and 5-7pm

| DECEMBER | | | | | | |
|----------|----|----|----|----|----|----|
| S | M | T | W | T | F | S |
| | | 1 | 2 | 3 | 4 | 5 |
| 6 | 7 | 8 | 9 | 10 | 11 | 12 |
| 13 | 14 | 15 | 16 | 17 | 18 | 19 |
| 20 | 21 | 22 | 23 | 24 | 25 | 26 |
| 27 | 28 | 29 | 30 | 31 | | |

| | |
|---|------|
| School Days | 16 |
| Teacher Days (22nd is teacher half day) | 15.5 |

Christmas break starts December 23

2021

| JANUARY | | | | | | |
|---------|----|----|----|----|----|----|
| S | M | T | W | T | F | S |
| | | | | | | 2 |
| 3 | 4 | 5 | 6 | 7 | 8 | 9 |
| 10 | 11 | 12 | 13 | 14 | 15 | 16 |
| 17 | 18 | 19 | 20 | 21 | 22 | 23 |
| 24 | 25 | 26 | 27 | 28 | 29 | 30 |
| 31 | | | | | | |

| | |
|-----------------------------------|------|
| School Days | 19 |
| Teacher Days (22nd is record day) | 19.0 |

Students Resume January 4
January 18 - non work day
1/22 is end of 2nd quarter (44 days)
1/22 is end of 1st semester (91 days)

| FEBRUARY | | | | | | |
|----------|----|----|----|----|----|----|
| S | M | T | W | T | F | S |
| | 1 | 2 | 3 | 4 | 5 | 6 |
| 7 | 8 | 9 | 10 | 11 | 12 | 13 |
| 14 | 15 | 16 | 17 | 18 | 19 | 20 |
| 21 | 22 | 23 | 24 | 25 | 26 | 27 |
| 28 | | | | | | |

| | |
|--------------|------|
| School Days | 18 |
| Teacher Days | 18.0 |

February 15 - President's Day
Count Day - 2nd Wednesday in February
Winter break - 12, 15

| MARCH | | | | | | |
|-------|----|----|----|----|----|----|
| S | M | T | W | T | F | S |
| | 1 | 2 | 3 | 4 | 5 | 6 |
| 7 | 8 | 9 | 10 | 11 | 12 | 13 |
| 14 | 15 | 16 | 17 | 18 | 19 | 20 |
| 21 | 22 | 23 | 24 | 25 | 26 | 27 |
| 28 | 29 | 30 | 31 | | | |

| | |
|-----------------------------------|------|
| School Days | 23 |
| Teacher Days (12th is record day) | 23.0 |

3/12 is end of 2nd trimester (64 days)
PT Conferences from 5-7 PM - Elementary on 3/25/20.

| APRIL | | | | | | |
|-------|----|----|----|----|----|----|
| S | M | T | W | T | F | S |
| | | | | 1 | 2 | 3 |
| 4 | 5 | 6 | 7 | 8 | 9 | 10 |
| 11 | 12 | 13 | 14 | 15 | 16 | 17 |
| 18 | 19 | 20 | 21 | 22 | 23 | 24 |
| 25 | 26 | 27 | 28 | 29 | 30 | |

| | |
|--------------|------|
| School Days | 16 |
| Teacher Days | 16.0 |

Spring Break April 2 - April 11.
4/1 is end of 3rd quarter (47 days)
Middle School on 4/15 from 5-7 PM and High School PT Conferences 4/22 from 5-7 PM

| MAY | | | | | | |
|-----|----|----|----|----|----|----|
| S | M | T | W | T | F | S |
| | | | | | | 1 |
| 2 | 3 | 4 | 5 | 6 | 7 | 8 |
| 9 | 10 | 11 | 12 | 13 | 14 | 15 |
| 16 | 17 | 18 | 19 | 20 | 21 | 22 |
| 23 | 24 | 25 | 26 | 27 | 28 | 29 |
| 30 | 31 | | | | | |

| | |
|--------------|------|
| School Days | 20 |
| Teacher Days | 20.0 |

May 31 - Memorial Day

| JUNE | | | | | | |
|------|----|----|----|----|----|----|
| S | M | T | W | T | F | S |
| | | 1 | 2 | 3 | 4 | 5 |
| 6 | 7 | 8 | 9 | 10 | 11 | 12 |
| 13 | 14 | 15 | 16 | 17 | 18 | 19 |
| 20 | 21 | 22 | 23 | 24 | 25 | 26 |
| 27 | 28 | 29 | 30 | | | |

| | |
|--|-----|
| School Days | 7 |
| Teacher Days (9th is a teacher half day) | 6.5 |

6/9 is end of 2nd semester (89 days); 3rd trimester (56 days); 4th quarter (42 days)

CORPORATE RESOLUTION FOR BANK DEPOSITORIES

RECOMMENDATION

Move to adopt the Corporate Resolution for **Michigan Liquid Asset Fund (MILAF)** for the 2020 calendar year.

MOTION: _____ **SUPPORT:** _____ **ACTION:** _____

| | <u>Aye</u> | <u>Nay</u> | <u>Abstain</u> | <u>Absent</u> |
|-------------------|------------|------------|----------------|---------------|
| Mrs. Boone | _____ | _____ | _____ | _____ |
| Mr. Bunkelman | _____ | _____ | _____ | _____ |
| Mrs. Netter | _____ | _____ | _____ | _____ |
| Mr. Nichols | _____ | _____ | _____ | _____ |
| Mrs. Pasko | _____ | _____ | _____ | _____ |
| Mr. VanWasshenova | _____ | _____ | _____ | _____ |
| Mr. Zimmerman | _____ | _____ | _____ | _____ |

CORPORATE RESOLUTION

I, _____, Secretary of the Board of Education of Monroe Public Schools, a Corporation organized and existing under the laws of the State of Michigan, do hereby certify that, at a meeting of the Board of Directors of said corporation duly held on the 25th day of August 2020, at which a quorum was present and acting throughout, the following resolution was adopted and is now in full force and effect:

RESOLVED: That the Michigan Liquid Asset Fund (MILAF) be and it hereby is designated as a depository of this Corporation and it is hereby requested, authorized and directed to honor checks, drafts or other orders for the payment of money drawn in this corporation's name, including those payable to the individual order of any person or persons whose name or names appear thereon as signer or signers thereof, when bearing signature of any **one** of the following officers:

_____, Treasurer
(Signature)

_____, Superintendent
(Signature)

Accounts in

None at this time

IN WITNESS WHEREOF, I hereunto set my hand and the seal of said corporation this 25th day of August 2020.

Secretary

(Corporate Seal)

RESOLUTION FOR FACSIMILE SIGNATURES

RECOMMENDATION

Move to adopt the Resolution for Facsimile Signature – **Michigan Liquid Asset Fund (MILAF)** for the 2020 calendar year.

MOTION: _____ **SUPPORT:** _____ **ACTION:** _____

| | <u>Aye</u> | <u>Nay</u> | <u>Abstain</u> | <u>Absent</u> |
|-------------------|------------|------------|----------------|---------------|
| Mrs. Boone | _____ | _____ | _____ | _____ |
| Mr. Bunkelman | _____ | _____ | _____ | _____ |
| Mrs. Netter | _____ | _____ | _____ | _____ |
| Mr. Nichols | _____ | _____ | _____ | _____ |
| Mrs. Pasko | _____ | _____ | _____ | _____ |
| Mr. VanWasshenova | _____ | _____ | _____ | _____ |
| Mr. Zimmerman | _____ | _____ | _____ | _____ |

RESOLUTION FOR FACSIMILE SIGNATURES

I, _____, Secretary of the Board of Education of Monroe Public Schools, a Corporation organized and existing under the laws of the State of Michigan, do hereby certify that, at a meeting of the Board of Directors of said corporation duly held on the 25th day of August 2020, at which a quorum was present and acting throughout, the following resolution was adopted and is now in full force and effect:

RESOLVED: That the Michigan Liquid Asset Fund (MILAF) as a designated depository of the Corporation be and it is hereby requested, authorized and directed to honor checks, drafts or other orders for the payment of money drawn in this corporation’s name, including those payable to the individual order of any person or persons whose name or names appear thereon as signer or signers thereof, when bearing or purporting to bear the facsimile signature(s) of any one of the following:

KATHERINE EIGHMEY

and the Michigan Liquid Asset Fund (MILAF), shall be entitled to honor and to charge this corporation for such checks, drafts or other orders regardless of by whom or by what means the actual or purported facsimile signature or signatures may have been affixed thereto, if such signature or signatures resemble the facsimile specimens duly certified to or filed with the Michigan Liquid Asset Fund (MILAF) by the Secretary or other officers of this corporation.

IN WITNESS WHEREOF, I hereunto set my hand and the seal of said corporation this 25th day of August 2020.

Secretary

(Corporate Seal)

STAFF CHROMEBOOK PURCHASE

BACKGROUND

Please see memo from David Payne for details.

ENCLOSURE(S)

- Memo from Mr. Payne
- Quote

RECOMMENDATION

Move to approve the purchase of staff chromebooks at a cost not to exceed \$51,240.00 by Presidio. This purchase will be funded by the Geer Grant.

MOTION: _____ **SUPPORT:** _____ **ACTION:** _____

| | <u>Aye</u> | <u>Nay</u> | <u>Abstain</u> | <u>Absent</u> |
|-------------------|------------|------------|----------------|---------------|
| Mrs. Boone | _____ | _____ | _____ | _____ |
| Mr. Bunkelman | _____ | _____ | _____ | _____ |
| Mrs. Netter | _____ | _____ | _____ | _____ |
| Mr. Nichols | _____ | _____ | _____ | _____ |
| Mrs. Pasko | _____ | _____ | _____ | _____ |
| Mr. VanWasshenova | _____ | _____ | _____ | _____ |
| Mr. Zimmerman | _____ | _____ | _____ | _____ |



Monroe Public Schools

Technology Department

1275 N. Macomb St

Monroe MI, 48162

MEMO

To: Julie Everly

From: David Payne

Date: 8/20/2020

Subject: Staff Chromebook Purchase

We are recommending the purchase of 120 Dell Chromebooks at a cost not to exceed \$51,240.00 from Presidio. If approved, this purchase will be funded by Geer Grant. Presidio is the REMC bid winner for Dell Chromebooks. These devices will be utilized by the staff supporting the Learning Labs. Once these devices are deployed, all staff supporting our students will be provided with a Dell 14" Chromebook.

TO:
 Monroe Public Schools
 Deanna Rincon
 1275 N. Macomb Street
 Monroe, MI 48161

 rincon@monroe.k12.mi.us
 (p) 734-265-3150

FROM:
 Presidio Networked Solutions Group, LLC
 Katie Murray
 6355 East Paris Ave
 Caledonia, MI 49316-9139

 kmurray@presidio.com
 (p) 616.871.1555

Customer#: MONRO023
Account Manager: Katie Murray
Inside Sales Rep: Todd Steichen
Title: Dell Latitude 5400 Chromebooks

Contract Vehicle: MHEC-07012015 Dell

| # | Part # | Description | Unit Price | Qty | Ext Price |
|---|---------------|---|------------|-----|-------------|
| 1 | Dell Hardware | Dell Latitude 5400 Enterprise Chromebook: Intel Celeron 4305U Processor, 4GB RAM, 128GB SSD, 42 Whr up to 12 hour battery, Dual band AC Wireless, Bluetooth 5.0, 14.0" HD 1366 x 768 Display, (2) USB-C, (3) USB 3.1, combo audio port. HDMI, 720p webcam, Standard keyboard, Touchpad, Dell 1/1/0 mail-in warranty. Comments: P20221700 3000056792790.1 | \$403.00 | 120 | \$48,360.00 |
| 2 | Dell hardware | Google Management License Comments: 206996 3741892 GOG-CROS-SW-DIS-EDU | \$24.00 | 120 | \$2,880.00 |

| | | |
|--|---------------------|--------------------|
| | Sub Total: | \$51,240.00 |
| | Grand Total: | \$51,240.00 |

TERMS AND CONDITIONS OF THE REFERENCED CONTRACT SHALL GOVERN THIS QUOTE.

Customer hereby authorizes and agrees to make timely payment for products delivered and services rendered, including payments for partial shipments

 Customer Signature

 Date

STUDENT CHROMEBOOK PURCHASE

BACKGROUND

Please see memo from David Payne for details.

ENCLOSURE(S)

- Memo from Mr. Payne
- Quotes

RECOMMENDATION

Move to approve the purchase of student Chromebook and cases at a cost not to exceed \$449,395.75. This purchase will be funded by Cares Act and the Technology Millage.

MOTION: _____ **SUPPORT:** _____ **ACTION:** _____

| | <u>Aye</u> | <u>Nay</u> | <u>Abstain</u> | <u>Absent</u> |
|-------------------|------------|------------|----------------|---------------|
| Mrs. Boone | _____ | _____ | _____ | _____ |
| Mr. Bunkelman | _____ | _____ | _____ | _____ |
| Mrs. Netter | _____ | _____ | _____ | _____ |
| Mr. Nichols | _____ | _____ | _____ | _____ |
| Mrs. Pasko | _____ | _____ | _____ | _____ |
| Mr. VanWasshenova | _____ | _____ | _____ | _____ |
| Mr. Zimmerman | _____ | _____ | _____ | _____ |



Monroe Public Schools

Technology Department

1275 N. Macomb St

Monroe MI, 48162

MEMO

To: Julie Everly

From: David Payne

Date: 8/20/2020

Subject: Student Chromebook Purchase

We are recommending the purchase of 1500 Dell Chromebooks and cases at a cost not to exceed \$449,395.75 from Dell and iPearl Inc. If approved, this purchase will be funded by the Cares Act and the Technology Millage. Dell is the REMC bid winner for 3100 model Chromebooks. iPearl Inc supplies us with cases for the non-2n1 models. Every summer, we continue our 24/7 program by upgrading our incoming 5th and 9th-grade students. We are also upgrading our 4th-grade students this year as last year the 3rd-grade students received new Chromebooks. Due to supply chain issues, we were not able to get them during the summer but will receive them later this fall if approved. We wanted to get the order in now so we can make sure and receive them once the supply chain issues are resolved.



A quote for your consideration.

Based on your business needs, we put the following quote together to help with your purchase decision. Below is a detailed summary of the quote we've created to help you with your purchase decision.

To proceed with this quote, you may respond to this email, order online through your [Premier page](#), or, if you do not have Premier, use this [Quote to Order](#).

| | | | |
|------------------|------------------------|-------------------|-------------------------|
| Quote No. | 3000065060654.1 | Sales Rep | Jessica Murray |
| Total | \$434,695.00 | Phone | (800) 456-3355, 6179055 |
| Customer # | 4368588 | Email | Jessica_Murray@Dell.com |
| Quoted On | Jul. 15, 2020 | Billing To | ACCOUNTS PAYABLE |
| Expires by | Aug. 14, 2020 | | MONROE PUBLIC SCHOOLS |
| Deal ID | 19733027 | | P O BOX 733 |
| | | | 1275 NORTH MACOMB ST |
| | | | MONROE, MI 48162-3128 |

Message from your Sales Rep

Please contact your Dell sales representative if you have any questions or when you're ready to place an order. Thank you for shopping with Dell!

Regards,
Jessica Murray

Shipping Group

| Shipping To | Shipping Method |
|---|-------------------|
| DAVID RAY MONROE PUBLIC SCHOOLS 1275 N MACOMB ST MONROE, MI 48162-3128 (313) 241-0330 | Standard Delivery |

| Product | Unit Price | Qty | Subtotal |
|---|------------|------|--------------|
| Chromebook 11 3100 | \$232.85 | 1000 | \$232,850.00 |
| Chromebook 11 3100 2-in-1 | \$331.69 | 500 | \$165,845.00 |
| GOOGLE CHROME OS MANAGEMENT CONSOLE LICENSE, EDUCATION | \$24.00 | 1000 | \$24,000.00 |
| Chrome Education | \$24.00 | 500 | \$12,000.00 |

| | |
|----------------------------|---------------------|
| Subtotal: | \$434,695.00 |
| Shipping: | \$0.00 |
| Non-Taxable Amount: | \$434,695.00 |
| Taxable Amount: | \$0.00 |
| Estimated Tax: | \$0.00 |

| | |
|---------------|---------------------|
| Total: | \$434,695.00 |
|---------------|---------------------|

Special lease pricing may be available for qualified customers. Please contact your DFS Sales Representative for details.

Shipping Group Details

Shipping To

DAVID RAY
MONROE PUBLIC SCHOOLS
1275 N MACOMB ST
MONROE, MI 48162-3128
(313) 241-0330

Shipping Method

Standard Delivery

| | | | |
|---------------------------|-----------------|---------------------------|--|
| Chromebook 11 3100 | \$232.85 | Qty 1000 | Subtotal \$232,850.00 |
|---------------------------|-----------------|---------------------------|--|

Estimated delivery if purchased today:
Dec. 28, 2020
Contract # C000000181093
Customer Agreement # MHEC-07012015

| Description | SKU | Unit Price | Qty | Subtotal |
|---|----------|-----------------|------------|---------------------|
| Dell Chromebook 3100 | 210-ARJL | - | 1000 | - |
| Intel Celeron N4020 (Dual Core, up to 2.8GHz, 4M Cache, 6W) | 338-BUUG | - | 1000 | - |
| 4GB 2400MHz LPDDR4 Non-ECC | 370-ADZI | - | 1000 | - |
| 32GB eMMC Hard Drive | 400-AWCZ | - | 1000 | - |
| 11.6" HD (1366 x 768) Anti-Glare Non-Touch, Camera & Microphone, WLAN Capable | 391-BDXY | - | 1000 | - |
| US English Keyboard, non-backlit | 580-AHRW | - | 1000 | - |
| No Mouse | 570-AADK | - | 1000 | - |
| Intel(R) Dual Band Wireless AC 9560 (802.11ac) 2x2 + Bluetooth 5.0 | 555-BEVK | - | 1000 | - |
| Label 0X02 | 389-DPUI | - | 1000 | - |
| Primary 3-Cell 42Whr Battery | 451-BCNK | - | 1000 | - |
| 65W AC Adapter 250V,1M | 492-BCNV | - | 1000 | - |
| US Power Cord | 537-BBBL | - | 1000 | - |
| Fixed Hardware Configuration | 998-DYKL | - | 1000 | - |
| No UPC Label | 389-BCGW | - | 1000 | - |
| SERI Guide (ENG/FR/Multi) | 340-AGIK | - | 1000 | - |
| Quick Start Guide | 340-CKUZ | - | 1000 | - |
| EAN label | 389-BKKL | - | 1000 | - |
| Not Included | 631-ABBH | - | 1000 | - |
| Non-Touch LCD Cover | 320-BCTK | - | 1000 | - |
| Min Config Packaging | 340-CLRT | - | 1000 | - |
| Dell,Regulatory Label,FCC,25WX13HMM,R0.5 | 389-DPTG | - | 1000 | - |
| Intel(R) Label | 389-BHZJ | - | 1000 | - |
| No Carrying Case | 460-BBEX | - | 1000 | - |
| BTS/BTP Smart Selection Shipment, Chromebook (VS) | 800-BBQM | - | 1000 | - |
| Mail In Service after Remote Diagnosis, 1 Year | 823-5167 | - | 1000 | - |
| Dell Limited Hardware Warranty Initial Year | 823-5168 | - | 1000 | - |
| | | | Qty | Subtotal |
| Chromebook 11 3100 2-in-1 | | \$331.69 | 500 | \$165,845.00 |

Estimated delivery if purchased today:
Dec. 28, 2020

| Description | SKU | Unit Price | Qty | Subtotal |
|--|----------|------------|-----|----------|
| Dell Chromebook 3100 2-in-1 | 210-ARJM | - | 500 | - |
| Intel Celeron N4020 (Dual Core, up to 2.8GHz, 4M Cache, 6W) | 338-BUUH | - | 500 | - |
| 4GB 2400MHz LPDDR4 Non-ECC | 370-ADZI | - | 500 | - |
| 32GB eMMC Hard Drive | 400-AWCZ | - | 500 | - |
| 11.6" HD 1366 x 768 WVA 16:9 Touch with Corning(R) Gorilla(R) Glass NBT, Camera & Microphone | 391-BDYD | - | 500 | - |
| Internal English Keyboard | 580-AHSS | - | 500 | - |
| No Mouse | 570-AADK | - | 500 | - |
| Intel(R) Dual Band Wireless AC 9560 (802.11ac) 2x2 + Bluetooth 5.0 | 555-BEVK | - | 500 | - |
| Primary 3-Cell 42Whr Battery | 451-BCNK | - | 500 | - |
| 65W AC Adapter 250V,1M | 492-BCNV | - | 500 | - |
| US Power Cord | 537-BBBL | - | 500 | - |
| Fixed Hardware Configuration | 998-DWVE | - | 500 | - |
| No UPC Label | 389-BCGW | - | 500 | - |
| Quick Start Guide | 340-CKWI | - | 500 | - |
| EAN label | 389-BKKL | - | 500 | - |
| BTS/BTP Smart Selection Shipment, Chromebook (VS) | 800-BBQM | - | 500 | - |
| Not Included | 631-ABBH | - | 500 | - |
| Touch LCD Cover (EMR pen capable) | 320-BDPX | - | 500 | - |
| System Shipment, Chromebook 3100 2-in-1 | 340-CKYJ | - | 500 | - |
| Intel(R) Label | 389-BHZJ | - | 500 | - |
| Palmrest with World Facing Camera | 346-BEVK | - | 500 | - |
| Label 0X23 | 389-DSKI | - | 500 | - |
| No Carrying Case | 460-BBEX | - | 500 | - |
| SERI Guide (ENG/FR/Multi) | 340-AGIK | - | 500 | - |
| Mail In Service after Remote Diagnosis, 1 Year | 823-5385 | - | 500 | - |
| Dell Limited Hardware Warranty Initial Year | 823-5386 | - | 500 | - |

| | | | | |
|---|--|----------------|-------------|--------------------|
| | | | Qty | Subtotal |
| GOOGLE CHROME OS MANAGEMENT CONSOLE LICENSE, EDUCATION | | \$24.00 | 1000 | \$24,000.00 |

Estimated delivery if purchased today:
 Jul. 31, 2020

| Description | SKU | Unit Price | Qty | Subtotal |
|-------------------------|----------|----------------|------------|--------------------|
| Chrome Education | A7611038 | - | 1000 | - |
| | | | Qty | Subtotal |
| Chrome Education | | \$24.00 | 500 | \$12,000.00 |

Estimated delivery if purchased today:
 Jul. 31, 2020

| Description | SKU | Unit Price | Qty | Subtotal |
|------------------|----------|------------|-----|----------|
| Chrome Education | A7611038 | - | 500 | - |

| | |
|-----------------------|---------------------|
| Subtotal: | \$434,695.00 |
| Shipping: | \$0.00 |
| Estimated Tax: | \$0.00 |
| <hr/> | |
| Total: | \$434,695.00 |

Important Notes

Terms of Sale

This Quote will, if Customer issues a purchase order for the quoted items that is accepted by Supplier, constitute a contract between the entity issuing this Quote ("Supplier") and the entity to whom this Quote was issued ("Customer"). Unless otherwise stated herein, pricing is valid for thirty days from the date of this Quote. All product, pricing and other information is based on the latest information available and is subject to change. Supplier reserves the right to cancel this Quote and Customer purchase orders arising from pricing errors. Taxes and/or freight charges listed on this Quote are only estimates. The final amounts shall be stated on the relevant invoice. Additional freight charges will be applied if Customer requests expedited shipping. Please indicate any tax exemption status on your purchase order and send your tax exemption certificate to Tax_Department@dell.com or ARSalesTax@emc.com, as applicable.

Governing Terms: This Quote is subject to: (a) a separate written agreement between Customer or Customer's affiliate and Supplier or a Supplier's affiliate to the extent that it expressly applies to the products and/or services in this Quote or, to the extent there is no such agreement, to the applicable set of Dell's Terms of Sale (available at www.dell.com/terms or www.dell.com/oemterms), or for cloud/as-a-Service offerings, the applicable cloud terms of service (identified on the Offer Specific Terms referenced below); and (b) the terms referenced herein (collectively, the "Governing Terms"). Different Governing Terms may apply to different products and services on this Quote. The Governing Terms apply to the exclusion of all terms and conditions incorporated in or referred to in any documentation submitted by Customer to Supplier.

Supplier Software Licenses and Services Descriptions: Customer's use of any Supplier software is subject to the license terms accompanying the software, or in the absence of accompanying terms, the applicable terms posted on www.Dell.com/eula. Descriptions and terms for Supplier-branded standard services are stated at www.dell.com/servicecontracts/global or for certain infrastructure products at www.dellemc.com/en-us/customer-services/product-warranty-and-service-descriptions.htm

Offer-Specific, Third Party and Program Specific Terms: Customer's use of third-party software is subject to the license terms that accompany the software. Certain Supplier-branded and third-party products and services listed on this Quote are subject to additional, specific terms stated on www.dell.com/offeringspecificterms ("Offer Specific Terms").

In case of Resale only: Should Customer procure any products or services for resale, whether on standalone basis or as part of a solution, Customer shall include the applicable software license terms, services terms, and/or offer-specific terms in a written agreement with the end-user and provide written evidence of doing so upon receipt of request from Supplier.

In case of Financing only: If Customer intends to enter into a financing arrangement ("Financing Agreement") for the products and/or services on this Quote with Dell Financial Services LLC or other funding source pre-approved by Supplier ("FS"), Customer may issue its purchase order to Supplier or to FS. If issued to FS, Supplier will fulfill and invoice FS upon confirmation that: (a) FS intends to enter into a Financing Agreement with Customer for this order; and (b) FS agrees to procure these items from Supplier. Notwithstanding the Financing Agreement, Customer's use (and Customer's resale of and the end-user's use) of these items in the order is subject to the applicable governing agreement between Customer and Supplier, except that title shall transfer from Supplier to FS instead of to Customer. If FS notifies Supplier after shipment that Customer is no longer pursuing a Financing Agreement for these items, or if Customer fails to enter into such Financing Agreement within 120 days after shipment by Supplier, Customer shall promptly pay the Supplier invoice amounts directly to Supplier.

Customer represents that this transaction does not involve: (a) use of U.S. Government funds; (b) use by or resale to the U.S. Government; or (c) maintenance and support of the product(s) listed in this document within classified spaces. Customer further represents that this transaction does not require Supplier's compliance with any statute, regulation or information technology standard applicable to a U.S. Government procurement.

For certain products shipped to end users in California, a State Environmental Fee will be applied to Customer's invoice. Supplier encourages customers to dispose of electronic equipment properly.

Electronically linked terms and descriptions are available in hard copy upon request.

^Dell Business Credit (DBC):

OFFER VARIES BY CREDITWORTHINESS AS DETERMINED BY LENDER. Offered by WebBank to Small and Medium Business customers with approved credit. Taxes, shipping and other charges are extra and vary. Minimum monthly payments are the greater of \$15 or 3% of account balance. Dell Business Credit is not offered to government or public entities, or business entities located and organized outside of the United States.

2025 Production Drive
 Apex, NC 27539
 Tel: 919-267-9903, Fax: 888-835-8158
 Email: admin@ipearl-inc.com

QUOTE NO. 20200804006
 ISSUE DATE August 4, 2020
 VAILD UNTIL December 2, 2020
 PURCHASE NUMBER
 LOGO

SHIP TO

MONROE PUBLIC SCHOOLS
 ATTN: TECHNOLOGY DEPT
 ADMINISTRATION BUILDING
 1275 N MACOMB ST
 MONROE, MI 48162 USA

| ISSUED BY | EMAIL | CUSTOMER NAME & EMAIL | LOGO REQUIREMENT | SHIPPING TERMS | PAYMENT TERMS |
|-----------|-----------------------|---|------------------|----------------|---------------|
| Tim Liu | timliu@ipearl-inc.com | Deanna Rincon <rincon@monroe.k12.mi.us> | No | Backorder | 30 Days |

| QTY | DESCRIPTION | COLOR | ITEM NO. | UNIT PRICE | AMOUNT |
|-----|---|-------|----------|------------|--------------------|
| 950 | mCover® cases for Dell Chromebook 3100 non-2-in-1 | Clear | #304 | \$24.95 | \$23,702.50 |
| 40% | Educational Discount | | | | -\$9,481.00 |
| 15 | Shipping/Handling (average 64 cases per box) | | | \$31.95 | \$479.25 |

*FINAL UNIT PRICE

| | |
|-------------------------|--------------------|
| \$15.47 | |
| SUBTOTAL | \$14,700.75 |
| SALES TAX(0.00%) | \$0.00 |
| TOTAL | \$14,700.75 |

Comments:

Color Referece:



TERMS & CONDITIONS

- 1, *FINAL UNIT PRICE is including educational discount and shipping/handling, not sales tax.
- 2, Please send scanned signed official purchase order to admin@ipearl-inc.com or fax to 888-835-8158.
- 3, School logo printing(\$10 value) for the direct sale to school is for free.
- 4, All cases sold directly from iPeal Inc. are covered one-year extended warranty.
- 5, Payment link to iPearl inc via PayPal: www.paypal.me/iPearlIncUSA
- 6, Make all checks payable to "iPearl Inc." to the following address:
iPearl Inc., 2025 Production Drive, Apex, NC 27539
- 7, Direct all inquires to:
Tel: 919-267-9903, Email: order@ipearl-inc.com or admin@ipearl-inc.com

Logo Position Choices:



You can request to put your logo at any of the 9 positions. Logo size up to 3 x 3 inches



Over 3,000,000+ Mac | PC | Chromebook owners served!

Over 700,000 mCover® cases in stock!

Over 5,000+K12 schools and over 3,000,000 customers served!

iPearl Inc. is proud of being a BBB Accredited Business with "A+" rating!



THANK YOU FOR YOUR TRUST AND BUSINESS!

CISCO UCS SERVER PURCHASE

BACKGROUND

Please see memo from David Payne for details.

ENCLOSURE(S)

- Memo from Mr. Payne
- Quotes

RECOMMENDATION

Move to approve the purchase of Cisco UCS Servers at a cost not to exceed \$109,882.50 by Presidio. This purchase will be funded by the Technology Millage.

MOTION: _____ **SUPPORT:** _____ **ACTION:** _____

| | <u>Aye</u> | <u>Nay</u> | <u>Abstain</u> | <u>Absent</u> |
|-------------------|------------|------------|----------------|---------------|
| Mrs. Boone | _____ | _____ | _____ | _____ |
| Mr. Bunkelman | _____ | _____ | _____ | _____ |
| Mrs. Netter | _____ | _____ | _____ | _____ |
| Mr. Nichols | _____ | _____ | _____ | _____ |
| Mrs. Pasko | _____ | _____ | _____ | _____ |
| Mr. VanWasshenova | _____ | _____ | _____ | _____ |
| Mr. Zimmerman | _____ | _____ | _____ | _____ |



Monroe Public Schools

Technology Department

1275 N. Macomb St

Monroe MI, 48162

MEMO

To: Julie Everly

From: David Payne

Date: 8/20/2020

Subject: Cisco UCS Server Purchase

We are recommending the purchase of two Cisco UCS Servers at a cost not to exceed \$109,882.50 from Presidio. If approved, this purchase would be funded by the Technology Millage. These new servers will add a much-needed resource for our users. With the additional amount of connections to our virtual environment by staff and students while at home has strained our current infrastructure during peak times. By adding additional servers, we can allow more concurrent connections. Also, within this purchase are two additional NVidia GPU cards and licenses, allowing for more connections by our graphics-intensive users when accessing applications like Adobe Photoshop and AutoCAD.

TO:
 Monroe Public Schools
 Kevin Hauser
 1275 N. Macomb Street
 Monroe, MI 48161

 hauser@monroe.k12.mi.us
 (p) 7342653162

FROM:
 Presidio Networked Solutions Group, LLC
 Mike Martin
 20 N Saint Clair
 3rd Floor
 Toledo, OH 43604

 mgmartin@presidio.com
 (p) 419.214.1414

Customer#: MONRO023
Account Manager: Mike Martin
Inside Sales Rep: Todd Steichen
Title: UCS Expansion - 1.5 TB

| # | Part # | Description | Unit Price | Qty | Ext Price |
|----|------------------|--|------------|-------------------|-------------|
| 1 | UCSB-B200-M5-U | UCS B200 M5 Blade w/o CPU, mem, HDD, mezz (UPG) | \$1,046.05 | 2 | \$2,092.10 |
| 2 | UCS-MR-X64G2RT-H | 64GB DDR4-2933-MHz RDIMM/2Rx4/1.2v | \$1,129.43 | 48 | \$54,212.64 |
| 3 | UCSB-MLOM-40G-04 | Cisco UCS VIC 1440 modular LOM for Blade Servers | \$407.13 | 2 | \$814.26 |
| 4 | N20-FW017 | UCS 5108 Blade Chassis FW Package 4.1 | \$0.00 | 2 | \$0.00 |
| 5 | UCS-SID-INFR-CFS | Converged-FlashStack | \$0.00 | 2 | \$0.00 |
| 6 | UCS-SID-WKL-OW | Other Workload | \$0.00 | 2 | \$0.00 |
| 7 | UCSB-LSTOR-BK | FlexStorage blanking panels w/o controller, w/o drive bays | \$0.00 | 4 | \$0.00 |
| 8 | UCSB-HS-M5-R | CPU Heat Sink for UCS B-Series M5 CPU socket (Rear) | \$0.00 | 2 | \$0.00 |
| 9 | UCSB-HS-M5-F | CPU Heat Sink for UCS B-Series M5 CPU socket (Front) | \$0.00 | 2 | \$0.00 |
| 10 | UCS-CPU-I6230 | Intel 6230 2.1GHz/125W 20C/27.50MB DCP DDR4 2933 MHz | \$1,891.60 | 4 | \$7,566.40 |
| 11 | CON-SNT-BB200M5U | SNTC 8X5XNBD UCS B200 M5 Blade w/o CPU, mem, HDD, mezz (UPG) | \$771.75 | 2 for 36 mo(s) | \$1,543.50 |
| 12 | UCSB-GPU-P6-F= | NVIDIA GRID P6 Front Mezzanine | \$4,320.20 | 2 | \$8,640.40 |
| 13 | NV-GRID-EDS-3YR | EDU - NVIDIA Quadro vDWS SW Subscription - 1CCU - 3 Year | \$164.83 | 80 | \$13,186.40 |
| 14 | UCSB-GPU-P6-R= | NVIDIA GRID P6 Rear Mezzanine | \$4,320.20 | 2 | \$8,640.40 |
| 15 | NV-GRID-EDS-3YR | EDU - NVIDIA Quadro vDWS SW Subscription - 1CCU - 3 Year | \$164.83 | 80 | \$13,186.40 |

| | | |
|--|---------------------|---------------------|
| | Sub Total: | \$109,882.50 |
| | Grand Total: | \$109,882.50 |

Quote valid for 30 days. Payment of invoices are due within 30 days from date of invoice unless other terms are issued. Late payments are subject to interest charges of the lesser of 1½% per month or the maximum amount allowed by law. All prices subject to change without notice. Supply subject to availability. This Quote is subject to Presidio's Standard Terms and Conditions below. Any changes to the following Terms and Conditions must be accepted in writing by Presidio, otherwise, CLIENT agrees to be bound by the following Terms and Conditions and pricing contained herein:

Pricing

- Quoted prices exclude applicable taxes. Invoicing will include applicable taxes unless a valid tax exempt certificate is provided.
- The price included herein reflects a 3% discount for payment by cash, check or wire transfer. This discount will not apply in the event that CLIENT pays using a credit card or debit card.
- Prices exclude freight, handling or insurance (unless itemized in the quote).
- Pricing for Professional Services are best-effort estimates only. Actual pricing will be finalized as part of a mutually-agreeable Statement of Work.

Invoicing

- CLIENT is billed upon shipment from the manufacturer and shall accept and pay for partial shipment of products.
- Usage-Based Services Terms and Conditions. For Usage-Based Services purchased by CLIENT, Presidio shall invoice CLIENT once a month. Notwithstanding the amounts included on the applicable purchase order, the invoice for Usage-Based Services will vary from month to month based upon CLIENT's usage and CLIENT shall be obligated to pay all charges for the Usage-Based Services used by CLIENT in the previous month. If CLIENT is delinquent in its payment obligations for the Usage-Based Services, then, upon reasonable, prior notice, Presidio reserves the right to suspend or discontinue such services at its sole discretion. CLIENT acknowledges and agrees that such discontinuation or suspension by PRESIDIO will not constitute a breach of PRESIDIO'S obligations to CLIENT. CLIENT agrees to indemnify and hold harmless PRESIDIO for any resulting damages due to the suspension or discontinuation of the Usage-Based Services due to CLIENT's delinquent or non-payment.
- Enterprise Software, Licensing and Subscription Services ("Enterprise Agreement"). For Third-Party-provided, enterprise-based software licensing and services, Presidio shall invoice CLIENT according to the terms of the Enterprise Agreement between CLIENT and the Third Party. If CLIENT is delinquent in its payment obligations hereunder, then, upon reasonable, prior notice, Presidio reserves the right to suspend or discontinue such services at its sole discretion. CLIENT acknowledges and agrees that such discontinuation or suspension by PRESIDIO will not constitute a breach of PRESIDIO'S obligations to CLIENT. CLIENT agrees to indemnify and hold harmless PRESIDIO for any resulting damages due to the suspension or discontinuation of the services due to CLIENT's delinquent or non-payment.

Freight, Handling, Shipping

- CLIENT will be billed for Presidio's and/or the manufacturer's freight charges.
- Title/Risk of loss passes to CLIENT Freight on Board (FOB) origin (FOB destination (CONUS) applicable to Federal Government CLIENTS only) unless otherwise agreed to in writing by Presidio. Orders shipped from a manufacturer to Presidio at CLIENT request for warehousing, configuration, storage or otherwise, shall be deemed to have been shipped to CLIENT FOB origin.
- Presidio accepts no responsibility / liability in connection with the shipment.
- International delivery services include (i) Consolidated billing in USD for all international deliveries (ii) Consolidated contracting with one entity, namely Presidio (iii) Single point of contact (iv) Freight forwarding including exportation permits, application of tariff headings, customs clearance (including import permits, licenses, certificates) (v) Asset Management, Tracking & Reporting.
- Goods held in a Presidio warehouse either a) at the CLIENT's request or b) in the event CLIENT refuses to accept delivery, may be subject to warehousing fees of 1% of the list price of such goods.

Warranty and Limitation of Liability

- Product is warranted by the Manufacturer, not by Presidio. Please consult Manufacturer for warranty terms. IN NO EVENT SHALL PRESIDIO BE LIABLE TO CLIENT FOR ANY INDIRECT, INCIDENTAL, SPECIAL, CONSEQUENTIAL, EXEMPLARY, OR PUNITIVE DAMAGES OF ANY KIND WHATSOEVER, ARISING IN CONTRACT, TORT OR OTHERWISE, EVEN IF ADVISED OF THE POSSIBILITY OF SUCH DAMAGES. PRESIDIO'S ENTIRE LIABILITY AND CLIENT'S EXCLUSIVE REMEDY FOR DAMAGES FROM ANY CAUSE WHATSOEVER, INCLUDING, BUT NOT LIMITED TO, NONPERFORMANCE OR MISREPRESENTATION, AND REGARDLESS OF THE FORM OF ACTIONS, SHALL BE LIMITED TO THE AMOUNT WHICH HAS BEEN ACTUALLY PAID TO PRESIDIO BY CLIENT FOR PRODUCTS HEREUNDER.

Return Policy

- CLIENTS return rights are subject to the return policies (& fees including restocking) of the applicable manufacturer
- A Presidio-issued Return Material Authorization (RMA) is required & needs to accompany returned items before any credit is issued to a CLIENT. Presidio reserves the right to deny RMA requests in the event the Manufacturer will not provide for an authorized return. If integration of product is performed at a Presidio facility, transfer of ownership occurs as of inception of integration regardless of shipment terms as manufacturers will not accept return of open product.
- CLIENTS have 15 calendar days from original ship date to request a RMA (unless shorter period is required by manufacturer)
- Items returned must be in original shipping cartons, unopened, unused, undamaged and unaltered failing which Presidio is entitled to reject acceptance of items or charge further fees
- The CLIENT is responsible for shipping fees to the destination highlighted in the RMA
- Opened software cannot be returned

Cancellation Policy

- CLIENT's cancellation of purchase order rights are subject to the cancellation policies (& fees) of the applicable manufacturer

Leases

- In the event Presidio does not receive payment for leased goods purchased on the CLIENT's behalf from the applicable third-party financing entity, CLIENT is obligated to pay Presidio for all such goods as indicated in the applicable Presidio invoice.

Software terms

- Software is subject to the license terms that accompany it.
- License terms are established between the CLIENT & owner of the software
- Unless Presidio is the owner or licensor, Presidio makes no representations and/or warranties relating to its operation, ownership or use.

Term and Termination of Orders: Usage-Based Services, Enterprise Agreements and Multi-Year Orders

- The terms of use for Usage-Based Services (i.e. Cisco-provided WebEx or Software as a Service (Saas)) are established by the applicable third-party provider of such services either at the applicable third-party provider website or via the separate agreement between CLIENT and third-party provider.
- The "Initial Term" of an order for Usage-Based Services and/or Enterprise Agreement ("Order") starts on the date the Usage-Based Services and/or Enterprise Agreement are available for use by CLIENT and lasts for the time period stated in the Order. After the Initial Term, unless prohibited by applicable law, there will be an automatic "Renewal Term" of the same length of time unless CLIENT notifies Presidio in writing that CLIENT does not want to renew at least sixty (60) days before the end of the then current Initial Term or Renewal Term. If the fees will change for the Renewal Term, Presidio will notify CLIENT reasonably in advance of the Renewal and in time for CLIENT to accept or reject renewing the Usage-Based Services and/or Enterprise Agreement. If CLIENT agrees with the fee changes, CLIENT may do nothing and the new fees will apply for the upcoming Renewal Term.
- Either party may terminate an Order by providing the other party written notice of termination at least sixty (60) days before the end of such Initial or Renewal Term. The termination will be effective on the last day of the Initial or Renewal Term and CLIENT will pay for the Usage-Based Services and/or Enterprise Agreement until the end of the current Initial or Renewal Term regardless of when CLIENT provided notice. Notwithstanding the foregoing, Usage-Based Services and Enterprise Agreements ordered are strictly non-cancelable during the Initial Term or Renewal Term except as otherwise provided in the applicable Service Terms and/or otherwise agreed upon in writing by Presidio. CLIENT will not be entitled to any refund for terminated Usage-Based Services or Enterprise Agreements during the Initial Term or Renewal Term except as agreed upon in writing by Provider and/or Presidio

Multi-Year Agreements

- For multi-year agreements, CLIENT expressly agrees to enter into a binding, non-cancelable agreement per the billing schedule set forth in the quote. THE CLIENT ACKNOWLEDGES AND AGREES THAT THE CLIENT'S AGREEMENT AND PAYMENTS FOR A MULTI-YEAR TRANSACTION ARE ESSENTIAL ELEMENTS OF THE BASIS OF THE BARGAIN BETWEEN THE PARTIES FOR MULTI-YEAR AGREEMENTS, SUCH THAT PRESIDIO WOULD NOT HAVE ENTERED INTO A MULTI-YEAR TRANSACTION WITHOUT SUCH AGREEMENT.

SmartNet (Third party Maintenance)

- CLIENTS rights are subject to the terms provided by the applicable manufacturer. (per website address)

Confidential Information.

• CLIENT agrees that this quote is Presidio Confidential Information. CLIENT shall not disclose this quote to any third party for any purpose. CLIENT agrees to protect this Quote to the same extent that it protects its own Confidential Information, but with no less than a reasonable degree of care.

Export Law Compliance.

• CLIENT has been advised that any hardware or software provided to CLIENT via this Quote and/or subsequent purchase order may be subject to the U.S. Export Administration Regulations. CLIENT agrees to comply with all applicable United States export control laws, and regulations, as from time to time amended, including without limitation, the laws and regulations administered by the United States Department of Commerce and the United States Department of State.

Miscellaneous Terms

• Preprinted terms appearing on CLIENT Purchase Orders must be accepted in writing by Presidio to be applicable. Presidio's performance of such purchase order shall not constitute Presidio's acceptance of new or different terms, including pre-printed terms on such order. In absence of a purchase order, CLIENT agrees that its signature below grants Presidio the right to invoice CLIENT and authorizes payment to Presidio for the amounts owed.

Customer hereby authorizes and agrees to make timely payment for products delivered and services rendered, including payments for partial shipments

Customer Signature

Date



Cisco Blade Servers

Prepared for: Monroe Public Schools

Quote # 001609 Version 2

Date: August 20, 2020

PROPRIETARY AND CONFIDENTIAL



Executive Summary

The purpose of this proposal is to provide pricing for the addition of two blade servers for the normal server environment as well as four GPU's for the VDI environment.



Company Overview

Element Four is a managed IT service company that provides organizations with strategic and focused technology solutions. Our team is extremely knowledgeable, and at its best when we are architecting custom solutions. Chris Vinton started Element Four in 2006 and was founded initially to provide hosting, cloud and colocation services for the companies located in the Midwest. Mr. Vinton knew to grow our company exponentially we would need to focus on only a few specific areas of technology and become subject matter experts. Today, Element Four specializes in four core services: Backup as a Service, Cloud Infrastructure and Colocation, Enterprise Consulting and Managed Services.

Element Four is committed to our partners. We ensure the success of our clients and the solutions we recommend, so we vet our partners very carefully. We are proud partners of [Switch](#), a Tier V, 100% uptime rated, data center with locations in Grand Rapids, Las Vegas, Reno, Atlanta, Thailand and Italy. Element Four partners with [Veeam](#), the global leader in intelligent data management and continuity. [Fortinet](#) is the leader in enterprise firewalls and network security solutions. [Cisco](#) is a multinational technology leader that focuses on networking and hyper converged technology solutions.

Server Hardware & Support

* Optional

| Description | Price | Qty | Ext. Price |
|--|------------|-----|-------------|
|  UCSB-B200-M5-U Cisco Barebone System Blade - Intel C620 Chipset - 2 x Processor Support - 3 TB DDR4 SDRAM DDR4-2666/PC4-21300 Maximum RAM Support - 12Gb/s SAS RAID Supported Controller - Matrox G200e 8 MB Integrated - 2 x Total Bays - 2 2.5" Bay(s) - Processor Support (| \$1,200.00 | 2 | \$2,400.00 |
|  UCSB-MLOM-40G-03 Cisco UCS VIC 1340 Adapter for M3 Blade Servers - PCI Express x16 - 2 Port(s) | \$500.00 | 2 | \$1,000.00 |
|  UCS-CPU-6130 Cisco Intel Xeon Gold 6130 Hexadeca-core (16 Core) 2.10 GHz Processor Upgrade - 22 MB Cache - 3.70 GHz Overclocking Speed - 14 nm - Socket 3647 - 125 W | \$2,200.00 | 4 | \$8,800.00 |
| UCS-ML-X64G4RS -H Cisco 64GB DDR4 SDRAM Memory Module - 64 GB (1 x 64 GB) - DDR4-2666/PC4-21300 DDR4 SDRAM - CL19 - 1.20 V - ECC - 288-pin - LRDIMM | \$1,400.00 | 48 | \$67,200.00 |
| CON-SNTP-BB200M5U Cisco Smart Net Total Care - Service - 24 x 7 x 4 Hour - Exchange - Electronic and Physical Service | \$390.00 | 6 | \$2,340.00 |

* Optional Subtotal: \$81,740.00

Nvidia GPU

* Optional

| Description | Price | Qty | Ext. Price |
|---|------------|-----|------------|
| UCSB-GPU-P6-R= Cisco Systems : NVIDIA GRID P6 Rear Mezzanine | \$4,700.00 | 2 | \$9,400.00 |
| UCSB-GPU-P6-F= Cisco Systems : NVIDIA GRID P6 Front Mezzanine | \$4,700.00 | 2 | \$9,400.00 |
| NV-GRID-EDP-3YR Cisco Systems : EDU - NVIDIA Quadro vDWS Production SUMS - 1CCU - 3 Year | \$79.00 | 80 | \$6,320.00 |
| NV-GRD-EDP-3S Cisco Systems : EDU - Quadro Perpetual Lic - NVIDIA vDWS 1CCU; 3Yr SUMS Reqd | \$109.00 | 80 | \$8,720.00 |
| CON-SNTP-SBGUP6R Cisco SMARTnet Extended Service - Service - 24 x 7 x 4 Hour - Exchange - Parts (1-year, 1-card, 12 required for 3-year support on all cards) | \$319.00 | 12 | \$3,828.00 |

* Optional Subtotal: \$37,668.00

Cisco Blade Servers



Prepared by:
 Element Four
 Ben Stratton
 616-275-5581
 ben.stratton@element-4.com

Prepared for:
 Monroe Public Schools
 1275 N. Macomb St.
 Monroe, MI 48162
 David Payne
 (734) 265-3150
 payne@monroe.k12.mi.us

Quote Information:
 Quote #: 001609
 Version: 2
 Delivery Date: 08/20/2020
 Expiration Date: 09/15/2020

*Optional Expenses

| Description | One-Time |
|--|-------------|
| Server Hardware & Support | \$81,740.00 |
| Nvidia GPU | \$37,668.00 |
| Optional Subtotal: \$119,408.00 | |

Taxes, shipping, handling and other fees may apply. Prior to any work being started this proposal must be signed and accepted along with a 50% down payment on all hardware, software and/or warranty items. The remaining 50% balance of the hardware, software and/or warranty items will be invoiced upon delivery. By executing this proposal, Customer hereby also agrees to the terms and conditions of the Work Authorization Form contained herein.

We reserve the right to correct any errors, inaccuracies or omissions to this proposal at any time. Please note that such errors, inaccuracies or omissions may relate to pricing and availability, and we reserve the right to cancel or refuse to accept any order placed based on incorrect pricing or availability information. We apologize for any inconvenience. For any questions or clarification, please contact your Account Executive.

Element Four

Signature: 
 Name: Ben Stratton
 Title: Senior Account Executive
 Date: 08/20/2020

Monroe Public Schools

Signature: _____
 Name: David Payne
 Date: _____

CISCO CUWL LICENSE PURCHASE

BACKGROUND

Please see memo from David Payne for details.

ENCLOSURE(S)

- Memo from Mr. Payne
- Quote

RECOMMENDATION

Move to approve the purchase of Cisco CUWL Licenses at a cost not to exceed \$16,761.00 from Presidio. This purchase will be funded by the General Fund and the Technology Millage.

MOTION: _____ **SUPPORT:** _____ **ACTION:** _____

| | <u>Aye</u> | <u>Nay</u> | <u>Abstain</u> | <u>Absent</u> |
|-------------------|------------|------------|----------------|---------------|
| Mrs. Boone | _____ | _____ | _____ | _____ |
| Mr. Bunkelman | _____ | _____ | _____ | _____ |
| Mrs. Netter | _____ | _____ | _____ | _____ |
| Mr. Nichols | _____ | _____ | _____ | _____ |
| Mrs. Pasko | _____ | _____ | _____ | _____ |
| Mr. VanWasshenova | _____ | _____ | _____ | _____ |
| Mr. Zimmerman | _____ | _____ | _____ | _____ |



Monroe Public Schools

Technology Department

1275 N. Macomb St

Monroe MI, 48162

MEMO

To: Julie Everly

From: David Payne

Date: 8/20/2020

Subject: Cisco CUWL License Purchase

We are recommending the purchase of 150 Cisco CUWL licenses for a cost not to exceed \$16,761.00 from Presidio Networked Solutions Group, LLC. If approved, this purchase would be funded by the Technology Millage and the General Fund, and the split would be 80/20, respectively. By upgrading our current phone system licenses, we would allow staff members access to our district phone system while working remotely. Teachers would be able to call parents from home using their classroom numbers on a computer, tablet, or mobile phone. This technology was piloted with several Monroe Middle School staff members in the spring and proved to be a valuable resource. Presidio was the only vendor that responded to our bid requests. This is common as Cisco only allows one vendor to receive special pricing.

TO:
 Monroe Public Schools
 Kevin Hauser
 1275 N. Macomb Street
 Monroe, MI 48161

 hauser@monroe.k12.mi.us
 (p) 7342653162

FROM:
 Presidio Networked Solutions Group, LLC
 Mike Martin
 20 N Saint Clair
 3rd Floor
 Toledo, OH 43604

 mgmartin@presidio.com
 (p) 419.214.1414

Customer#: MONRO023
Account Manager: Mike Martin
Inside Sales Rep: Todd Steichen
Title: CUWL Migration

| # | Part # | Description | Unit Price | Qty | Ext Price |
|----|--------------------|--|------------|---------------------|------------|
| 1 | CUWL-12X-K9 | Unified Workspace Licensing v. 12.x | \$0.00 | 1 | \$0.00 |
| 2 | UCAPPS-SW-12.0-K9 | Version 12.x Software Kit | \$0.00 | 1 | \$0.00 |
| 3 | NEW-UWL | New or Migration users for a new CUWL Deployment | \$0.00 | 1 | \$0.00 |
| 4 | LIC-TMS-PMP-PAK | TMS PAK for Configuration Use | \$0.00 | 1 | \$0.00 |
| 5 | LIC-TMS-APL-S80100 | TMS Serial Number included with Base Software | \$0.00 | 1 | \$0.00 |
| 6 | EXPWY-VE-C-K9 | Cisco Expressway-C Server, Virtual Edition | \$0.00 | 6 | \$0.00 |
| 7 | SW-TMS-15.X-K9 | TMS Base Software Image Version 15.X | \$0.00 | 1 | \$0.00 |
| 8 | EXPWY-VE-E-K9 | Cisco Expressway-E Server, Virtual Edition | \$0.00 | 6 | \$0.00 |
| 9 | CUCILYNC-CLNT-UWL | Cisco Unified Comm Integration for Lync for CUWL only | \$0.00 | 15 | \$0.00 |
| 10 | JAB-ADR-CLNT-UWL | Jabber for Android CUWL Only | \$0.00 | 45 | \$0.00 |
| 11 | JAB-IPH-CLNT-UWL | Jabber for iPhone CUWL Only | \$0.00 | 60 | \$0.00 |
| 12 | JABBER-SDK | Jabber Software Development Kit | \$0.00 | 2 | \$0.00 |
| 13 | VXME-USR | Cisco VXME Users | \$0.00 | 2 | \$0.00 |
| 14 | JABBER-DESKTOP | Jabber for Desktop for PC and Mac | \$0.00 | 113 | \$0.00 |
| 15 | JABBER-TABLET | Jabber for iPad and Android Tablet | \$0.00 | 45 | \$0.00 |
| 16 | LIC-EXP-DSK | Expressway Desktop Endpoint License | \$0.00 | 150 | \$0.00 |
| 17 | VXME-USR-RTU | VXME Right to Use | \$0.00 | 1 | \$0.00 |
| 18 | UWL-12X-STD | CUWL Standard 12.x Users - Service Use Only | \$0.00 | 150 | \$0.00 |
| 19 | CON-ECMU-UWLT12XS | SWSS UPGRADES CUWL Standard 12.x Users - Service Use O | \$41.30 | 150 for 12 mo(s) | \$6,195.00 |
| 20 | JAB-SDK-K9-RTU | Jabber Software Development Kit RTU | \$0.00 | 1 | \$0.00 |
| 21 | JAB-ADR-RTU | Jabber for Android Right to Use | \$0.00 | 1 | \$0.00 |
| 22 | CUCILYNC-UWL-RTU | CUCILYNC UWL Right to Use Certificate | \$0.00 | 1 | \$0.00 |
| 23 | JAB-IPH-RTU | Jabber for iPhone Right to Use | \$0.00 | 1 | \$0.00 |

| | | | | | |
|----|--------------------|--|---------|-------------------|-------------|
| 24 | JABBER-TABLET-RTU | Jabber for Tablet Right to Use | \$0.00 | 1 | \$0.00 |
| 25 | JABBER-DSK-K9-RTU | Jabber for Desktop Right to Use | \$0.00 | 1 | \$0.00 |
| 26 | LIC-EXP-E-PAK | Expressway Series, Expressway-E PAK | \$0.00 | 1 | \$0.00 |
| 27 | LIC-EXP-GW | Enable GW Feature (H323-SIP) | \$0.00 | 12 | \$0.00 |
| 28 | LIC-EXP-E | Enable Expressway-E Feature Set | \$0.00 | 6 | \$0.00 |
| 29 | LIC-EXP-TURN | Enable TURN Relay Option | \$0.00 | 6 | \$0.00 |
| 30 | LIC-EXP-AN | Enable Advanced Networking Option | \$0.00 | 6 | \$0.00 |
| 31 | LIC-SW-EXP-K9 | License Key Software Encrypted | \$0.00 | 12 | \$0.00 |
| 32 | LIC-EXP-SERIES | Enable Expressway Series Feature Set | \$0.00 | 12 | \$0.00 |
| 33 | SW-EXP-12.X-K9 | Software Image for Expressway with Encryption, Version X12 | \$0.00 | 1 | \$0.00 |
| 34 | MIGB+A-UWL-12X-STD | Migrate Bas UCM + App to UWL Standard Edition 12.x User | \$70.44 | 150 | \$10,566.00 |
| 35 | UCXN | Migrating from Unity Connection Standalone to CUWL | \$0.00 | 1 | \$0.00 |
| 36 | UC-12.X | Version 12.x | \$0.00 | 1 | \$0.00 |
| 37 | CON-ECMU-CUWL212X | SWSS UPGRADES Unified Workspace Licensing v. 12.x | \$0.00 | 1 for 12 mo(s) | \$0.00 |

| | | | |
|--|--|---------------------|--------------------|
| | | Sub Total: | \$16,761.00 |
| | | Grand Total: | \$16,761.00 |

Quote valid for 30 days. Payment of invoices are due within 30 days from date of invoice unless other terms are issued. Late payments are subject to interest charges of the lesser of 1½% per month or the maximum amount allowed by law. All prices subject to change without notice. Supply subject to availability. This Quote is subject to Presidio's Standard Terms and Conditions below. Any changes to the following Terms and Conditions must be accepted in writing by Presidio, otherwise, CLIENT agrees to be bound by the following Terms and Conditions and pricing contained herein:

Pricing

- Quoted prices exclude applicable taxes. Invoicing will include applicable taxes unless a valid tax exempt certificate is provided.
- The price included herein reflects a 3% discount for payment by cash, check or wire transfer. This discount will not apply in the event that CLIENT pays using a credit card or debit card.
- Prices exclude freight, handling or insurance (unless itemized in the quote).
- Pricing for Professional Services are best-effort estimates only. Actual pricing will be finalized as part of a mutually-agreeable Statement of Work.

Invoicing

- CLIENT is billed upon shipment from the manufacturer and shall accept and pay for partial shipment of products.
- Usage-Based Services Terms and Conditions. For Usage-Based Services purchased by CLIENT, Presidio shall invoice CLIENT once a month. Notwithstanding the amounts included on the applicable purchase order, the invoice for Usage-Based Services will vary from month to month based upon CLIENT's usage and CLIENT shall be obligated to pay all charges for the Usage-Based Services used by CLIENT in the previous month. If CLIENT is delinquent in its payment obligations for the Usage-Based Services, then, upon reasonable, prior notice, Presidio reserves the right to suspend or discontinue such services at its sole discretion. CLIENT acknowledges and agrees that such discontinuation or suspension by PRESIDIO will not constitute a breach of PRESIDIO'S obligations to CLIENT. CLIENT agrees to indemnify and hold harmless PRESIDIO for any resulting damages due to the suspension or discontinuation of the Usage-Based Services due to CLIENT's delinquent or non-payment.
- Enterprise Software, Licensing and Subscription Services ("Enterprise Agreement"). For Third-Party-provided, enterprise-based software licensing and services, Presidio shall invoice CLIENT according to the terms of the Enterprise Agreement between CLIENT and the Third Party. If CLIENT is delinquent in its payment obligations hereunder, then, upon reasonable, prior notice, Presidio reserves the right to suspend or discontinue such services at its sole discretion. CLIENT acknowledges and agrees that such discontinuation or suspension by PRESIDIO will not constitute a breach of PRESIDIO'S obligations to CLIENT. CLIENT agrees to indemnify and hold harmless PRESIDIO for any resulting damages due to the suspension or discontinuation of the services due to CLIENT's delinquent or non-payment.

Freight, Handling, Shipping

- CLIENT will be billed for Presidio's and/or the manufacturer's freight charges.
- Title/Risk of loss passes to CLIENT Freight on Board (FOB) origin (FOB destination (CONUS) applicable to Federal Government CLIENTS only) unless otherwise agreed to in writing by Presidio. Orders shipped from a manufacturer to Presidio at CLIENT request for warehousing, configuration, storage or otherwise, shall be deemed to have been shipped to CLIENT FOB origin.
- Presidio accepts no responsibility / liability in connection with the shipment.
- International delivery services include (i) Consolidated billing in USD for all international deliveries (ii) Consolidated contracting with one entity, namely Presidio (iii) Single point of contact (iv) Freight forwarding including exportation permits, application of tariff headings, customs clearance (including import permits, licenses, certificates) (v) Asset Management, Tracking & Reporting.
- Goods held in a Presidio warehouse either a) at the CLIENT's request or b) in the event CLIENT refuses to accept delivery, may be subject to warehousing fees of 1% of the list price of such goods.

Warranty and Limitation of Liability

- Product is warranted by the Manufacturer, not by Presidio. Please consult Manufacturer for warranty terms. IN NO EVENT SHALL PRESIDIO BE LIABLE TO CLIENT FOR ANY INDIRECT, INCIDENTAL, SPECIAL, CONSEQUENTIAL, EXEMPLARY, OR PUNITIVE DAMAGES OF ANY KIND WHATSOEVER, ARISING IN CONTRACT, TORT OR OTHERWISE, EVEN IF ADVISED OF THE POSSIBILITY OF SUCH DAMAGES. PRESIDIO'S ENTIRE LIABILITY AND CLIENT'S EXCLUSIVE REMEDY FOR DAMAGES FROM ANY CAUSE WHATSOEVER, INCLUDING, BUT NOT LIMITED TO, NONPERFORMANCE OR MISREPRESENTATION, AND REGARDLESS OF THE FORM OF ACTIONS, SHALL BE LIMITED TO THE AMOUNT WHICH HAS BEEN ACTUALLY PAID TO PRESIDIO BY CLIENT FOR PRODUCTS HEREUNDER.

Return Policy

- CLIENTS return rights are subject to the return policies (& fees including restocking) of the applicable manufacturer
- A Presidio-issued Return Material Authorization (RMA) is required & needs to accompany returned items before any credit is issued to a CLIENT. Presidio reserves the right to deny RMA requests in the event the Manufacturer will not provide for an authorized return. If integration of product is performed at a Presidio facility, transfer of ownership occurs as of inception of integration regardless of shipment terms as manufacturers will not accept return of open product.
- CLIENTS have 15 calendar days from original ship date to request a RMA (unless shorter period is required by manufacturer)
- Items returned must be in original shipping cartons, unopened, unused, undamaged and unaltered failing which Presidio is entitled to reject acceptance of items or charge further fees
- The CLIENT is responsible for shipping fees to the destination highlighted in the RMA
- Opened software cannot be returned

Cancellation Policy

- CLIENT's cancellation of purchase order rights are subject to the cancellation policies (& fees) of the applicable manufacturer

Leases

- In the event Presidio does not receive payment for leased goods purchased on the CLIENT's behalf from the applicable third-party financing entity, CLIENT is obligated to pay Presidio for all such goods as indicated in the applicable Presidio invoice.

Software terms

- Software is subject to the license terms that accompany it.
- License terms are established between the CLIENT & owner of the software
- Unless Presidio is the owner or licensor, Presidio makes no representations and/or warranties relating to its operation, ownership or use.

Term and Termination of Orders: Usage-Based Services, Enterprise Agreements and Multi-Year Orders

- The terms of use for Usage-Based Services (i.e. Cisco-provided WebEx or Software as a Service (SaaS)) are established by the applicable third-party provider of such services either at the applicable third-party provider website or via the separate agreement between CLIENT and third-party provider.
- The "Initial Term" of an order for Usage-Based Services and/or Enterprise Agreement ("Order") starts on the date the Usage-Based Services and/or Enterprise Agreement are available for use by CLIENT and lasts for the time period stated in the Order. After the Initial Term, unless prohibited by applicable law, there will be an automatic "Renewal Term" of the same length of time unless CLIENT notifies Presidio in writing that CLIENT does not want to renew at least sixty (60) days before the end of the then current Initial Term or Renewal Term. If the fees will change for the Renewal Term, Presidio will notify CLIENT reasonably in advance of the Renewal and in time for CLIENT to accept or reject renewing the Usage-Based Services and/or Enterprise Agreement. If CLIENT agrees with the fee changes, CLIENT may do nothing and the new fees will apply for the upcoming Renewal Term.
- Either party may terminate an Order by providing the other party written notice of termination at least sixty (60) days before the end of such Initial or Renewal Term. The termination will be effective on the last day of the Initial or Renewal Term and CLIENT will pay for the Usage-Based Services and/or Enterprise Agreement until the end of the current Initial or Renewal Term regardless of when CLIENT provided notice. Notwithstanding the foregoing, Usage-Based Services and Enterprise Agreements ordered are strictly non-cancelable during the Initial Term or Renewal Term except as otherwise provided in the applicable Service Terms and/or otherwise agreed upon in writing by Presidio. CLIENT will not be entitled to any refund for terminated Usage-Based Services or Enterprise Agreements during the Initial Term or Renewal Term except as agreed upon in writing by Provider and/or Presidio

Multi-Year Agreements

- For multi-year agreements, CLIENT expressly agrees to enter into a binding, non-cancelable agreement per the billing schedule set forth in the quote. THE CLIENT ACKNOWLEDGES AND AGREES THAT THE CLIENT'S AGREEMENT AND PAYMENTS FOR A MULTI-YEAR TRANSACTION ARE ESSENTIAL ELEMENTS OF THE BASIS OF THE BARGAIN BETWEEN THE PARTIES FOR MULTI-YEAR AGREEMENTS, SUCH THAT PRESIDIO WOULD NOT HAVE ENTERED INTO A MULTI-YEAR TRANSACTION WITHOUT SUCH AGREEMENT.

SmartNet (Third party Maintenance)

- CLIENTS rights are subject to the terms provided by the applicable manufacturer. (per website address)

Confidential Information.

• CLIENT agrees that this quote is Presidio Confidential Information. CLIENT shall not disclose this quote to any third party for any purpose. CLIENT agrees to protect this Quote to the same extent that it protects its own Confidential Information, but with no less than a reasonable degree of care.

Export Law Compliance.

• CLIENT has been advised that any hardware or software provided to CLIENT via this Quote and/or subsequent purchase order may be subject to the U.S. Export Administration Regulations. CLIENT agrees to comply with all applicable United States export control laws, and regulations, as from time to time amended, including without limitation, the laws and regulations administered by the United States Department of Commerce and the United States Department of State.

Miscellaneous Terms

• Preprinted terms appearing on CLIENT Purchase Orders must be accepted in writing by Presidio to be applicable. Presidio's performance of such purchase order shall not constitute Presidio's acceptance of new or different terms, including pre-printed terms on such order. In absence of a purchase order, CLIENT agrees that its signature below grants Presidio the right to invoice CLIENT and authorizes payment to Presidio for the amounts owed.

Customer hereby authorizes and agrees to make timely payment for products delivered and services rendered, including payments for partial shipments

Customer Signature

Date

MHS C-WING LIGHTING

BACKGROUND:

This motion is for the installation of 2 new light poles and fixtures outside of C-Wing at Monroe High School

ENCLOSURE:

Quotes from Staelgraeve Turner Electric Inc. and Mosher Electric Inc.

RECOMMENDATION:

Move to award the installation of the new light poles and fixtures, at Monroe High School, to Staelgraeve Turner Electric Inc. in the amount of \$20,620.00. Money for this project will come from the Building and Site Sinking Fund.

MOTION: _____ **SUPPORT:** _____ **ACTION:** _____

| | <u>Aye</u> | <u>Nay</u> | <u>Abstain</u> | <u>Absent</u> |
|-------------------|------------|------------|----------------|---------------|
| Mrs. Boone | _____ | _____ | _____ | _____ |
| Mr. Bunkelman | _____ | _____ | _____ | _____ |
| Mrs. Netter | _____ | _____ | _____ | _____ |
| Mr. Nichols | _____ | _____ | _____ | _____ |
| Mrs. Pasko | _____ | _____ | _____ | _____ |
| Mr. VanWasshenova | _____ | _____ | _____ | _____ |
| Mr. Zimmerman | _____ | _____ | _____ | _____ |



**STAELOGRAEVE TURNER
ELECTRIC INC.**

1138 HUBER DRIVE

Phone: (734) 241-1398 * FAX: (734) 241-1564
MONROE, MICHIGAN 48162-9527

August 7th, 2020

Monroe Public Schools

4920 W. Albain Road

Monroe, MI 48161

Attn: Mr. Jerry Oley

Re: Monroe High School New Light Poles

Dear Sir,

We present this proposal for the installation of two new light poles with double fixtures at the West access road at Monroe High School. We include all excavation, pole bases, and fiberglass poles with fixtures to match existing. For the installation of the poles with double fixtures our price would be:

\$20,620.00

Twenty Thousand Six Hundred Twenty Dollars

If a third pole is to be installed the additional quote would be:

\$9,620.00

Nine Thousand Six Hundred Twenty Dollars

Thank you for the opportunity to quote this project.

Respectfully,

Gerald Hasley

INDUSTRIAL AND COMMERCIAL ELECTRICAL CONTRACTORS



**STAELGRAEVE TURNER
ELECTRIC INC.**

1138 HUBER DRIVE

Phone: (734) 241-1398 • FAX: (734) 241-1564
MONROE, MICHIGAN 48162-9527

August 7th, 2020

Monroe Public Schools

4920 W. Albain Road

Monroe, MI 48161

Attn: Mr. Jerry Oley

Re: Monroe High School Underground Wiring Repairs – West Lot

Dear Sir,

We offer this proposal to troubleshoot and repair the underground wiring at the teacher parking lot near the middle driveway. Due to the nature of this problem we would offer an hourly rate of \$160.00 for two people on this project. Our intent would be to remove and install new wire without moving the existing light poles.

If the newly proposed light poles were installed a new feed could be installed from those poles and the existing poles could be back-fed and made operational at a cost of \$2,110.00 for the additional trenching, conduit, and wire required.

Please contact me with any questions.

Respectfully,

Gerald Hasley



PO Box 1508, Monroe, MI 48161
(734) 241-5494 / mosherelectric.com

ELECTRICAL ESTIMATE

Customer: Monroe Public Schools
Admin Bldg
Business & Finance Office
1275 N Macomb
Monroe MI 48162

Estimate # 2020-0092

| Description | Amount |
|--|-----------|
| Monroe High School Pole Lights | |
| Option 1 Trench 720' between the two existing poles. Rework wiring to repower the pole that is not working. Add two new pole bases. Install two 30' fiberglass poles. On top of the poles we will install a ULS SB-29 Bracket. Install two RAB ALED fixtures on each pole. Backfill trench and seed lawn. Permit Labor & Material | 24,750.00 |

Payment to be made as follows:

Due on receipt

All material is guaranteed to be as specified. All work to be completed in a professional manner according to standard practices. Any alteration or deviation from above specifications involving extra costs will be executed only upon written orders and will become an extra charge over and above the estimate. All agreements contingent upon strikes, accidents or delays beyond our control. Owner to carry fire, tornado, and other necessary insurance. Our workers are fully covered by Worker's Compensation Insurance. Accounts past due 30 days are subject to a 1.5% per month service charge.

Authorized By: *Paul Bogden*
Date: 8/18/2020

Note: This proposal may be withdrawn if not accepted within 30 days.

Acceptance of Proposal

* * * * *

The above prices, specifications and conditions are satisfactory and are hereby accepted. Moshers Electric is authorized to do the work as specified. Payment will be made as outlined above.

** SIGNATURE REQUIRED

Signature: _____
Signature: _____
Acceptance Date: _____



PO Box 1508, Monroe, MI 48161
(734) 241-5494 / mosherelectric.com

ELECTRICAL ESTIMATE

Customer: Monroe Public Schools
Admin Bldg
Business & Finance Office
1275 N Macomb
Monroe MI 48162

Estimate # 2020-0092

| Description | Amount |
|--|-----------|
| Option 2 Trench 720' between the two existing poles. Rework wiring to repower the pole that is not working. Add two new pole bases. Install two 30' fiberglass poles. On top of the poles we will install a ULS SB-29 Bracket. Install two CREE fixtures on top of each pole. These are the current fixtures installed in the parking lot. Backfill trench and seed lawn. Permit Labor & Material | 25,641.00 |

Payment to be made as follows:

Due on receipt

All material is guaranteed to be as specified. All work to be completed in a professional manner according to standard practices. Any alteration or deviation from above specifications involving extra costs will be executed only upon written orders and will become an extra charge over and above the estimate.

All agreements contingent upon strikes, accidents or delays beyond our control. Owner to carry fire, tornado, and other necessary insurance. Our workers are fully covered by Worker's Compensation Insurance. Accounts past due 30 days are subject to a 1.5% per month service charge.

Authorized By: *Paul Bogden*

Date: 8/18/2020

Note: This proposal may be withdrawn if not accepted within 30 days.

Acceptance of Proposal

The above prices, specifications and conditions are satisfactory and are hereby accepted. Moshier Electric is authorized to do the work as specified. Payment will be made as outlined above.

** SIGNATURE REQUIRED

Signature: _____

Signature: _____

Acceptance Date: _____



PO Box 1508, Monroe, MI 48161
(734) 241-5494 / mosherelectric.com

ELECTRICAL ESTIMATE

Customer: Monroe Public Schools
Admin Bldg
Business & Finance Office
1275 N Macomb
Monroe MI 48162

Estimate # 2020-0092

| Description | Amount |
|--|-----------|
| Option 3 Trench 720' between the two existing poles. Rework wiring to repower the pole that is not working. Add two new pole bases. Install two 30' fiberglass poles. On top of the poles we will install a LITHONIA SBS square bull horn. Install two RAB FXLED fixtures on top of each pole. Backfill trench and seed lawn. Permit Labor & Material | 21,991.00 |

Payment to be made as follows:

Due on receipt

All material is guaranteed to be as specified. All work to be completed in a professional manner according to standard practices. Any alteration or deviation from above specifications involving extra costs will be executed only upon written orders and will become an extra charge over and above the estimate. All agreements contingent upon strikes, accidents or delays beyond our control. Owner to carry fire, tornado, and other necessary insurance. Our workers are fully covered by Worker's Compensation Insurance. Accounts past due 30 days are subject to a 1.5% per month service charge.

Authorized By: *Paul Bogden*
Date: 8/18/2020

Note: This proposal may be withdrawn if not accepted within 30 days.

Acceptance of Proposal

* * * * *

The above prices, specifications and conditions are satisfactory and are hereby accepted. Moshers Electric is authorized to do the work as specified. Payment will be made as outlined above.

** SIGNATURE REQUIRED

Signature: _____
Signature: _____
Acceptance Date: _____

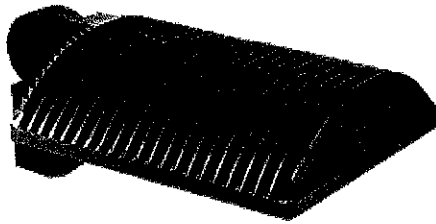

Color: Bronze

Weight: 75.0 lbs

Project:

Type:

Prepared By:

Date:

Driver Info

| | |
|-------------|------------------|
| Type | Constant Current |
| 120V | N/A |
| 208V | N/A |
| 240V | N/A |
| 277V | N/A |
| Input Watts | 254.30W |

LED Info

| | |
|----------------|-----------------|
| Watts | 260W |
| Color Temp | 4000K (Neutral) |
| Color Accuracy | 71 CRI |
| L70 Lifespan | 100,000 |
| Lumens | 28,131 |
| Efficacy | 110.6 lm/W |

Technical Specifications

Listings

UL Listed:

Suitable for wet locations

IESNA LM-79 & IESNA LM-80 Testing:

RAB LED luminaires and LED components have been tested by an independent laboratory in accordance with IESNA LM-79 and LM-80.

DLC Listed:

This product is on the Design Lights Consortium (DLC) Qualified Products List and is eligible for rebates from DLC Member Utilities. DLC Product Code: PKVBD8V8

LED Characteristics

Lifespan:

100,000-hour LED lifespan based on IES LM-80 results and TM-21 calculations

LEDs:

Multi-chip, high-output, long-life LEDs

Color Consistency:

7-step MacAdam Ellipse binning to achieve consistent fixture-to-fixture color

Color Stability:

LED color temperature is warranted to shift no more than 200K in color temperature over a 5-year period

Color Uniformity:

RAB's range of Correlated Color Temperature follows the guidelines of the American National Standard for Specifications for the Chromaticity of Solid State Lighting (SSL) Products, ANSI C78.377-2017.

Construction

IES Classification:

The Type IV distribution (also known as a Forward Throw) is especially suited for mounting on the sides of buildings and walls, and for illuminating the perimeter of parking areas. It produces a semiCircular distribution with essentially the same candlepower at lateral angles from 90° to 270°.

Effective Projected Area:

EPA = 5

Maximum Ambient Temperature:

Suitable for use in 40°C (104°F)

Cold Weather Starting:

Minimum starting temperature is -40°C (-40°F)

Thermal Management:

Superior thermal management with external "Air-Flow" fins

Lens:

Tempered glass lens included

Technical Specifications (continued)

Construction

Housing:

Die-cast aluminum with airflow fins for cooling

Mounting:

Slipfitter with 180° pivot available for mounting on 2 3/8" tenon

IP Rating:

Ingress Protection rating of IP66 for dust and water

Reflector:

Vacuum-metalized polycarbonate

Gaskets:

High-temperature silicone gaskets

Finish:

Formulated for high durability and long-lasting color

Green Technology:

Mercury and UV free. RoHS-compliant components.

Electrical

Drivers:

Constant Current, Class 1, 1660mA, 480V, 50-60Hz, 480V: xxA

Dimming Driver:

Driver includes dimming control wiring for 0-10V dimming systems. Requires separate 0-10V DC dimming circuit. Dims as low as 10%.

Surge Protection:

4kV

For areas prone to surges, upgrade to 10kV surge protection. [See 10kV surge protectors here.](#)

Other

Warranty:

RAB warrants that our LED products will be free from defects in materials and workmanship for a period of five (5) years from the date of delivery to the end user, including coverage of light output, color stability, driver performance and fixture finish. RAB's warranty is subject to all terms and conditions found at rablighting.com/warranty.

Equivalency:

Equivalent to 875W Pulse Start Metal Halide

Buy American Act Compliance:

RAB values USA manufacturing! Upon request, RAB may be able to manufacture this product to be compliant with the Buy American Act (BAA). Please contact customer service to request a quote for the product to be made BAA compliant.

Dimensions

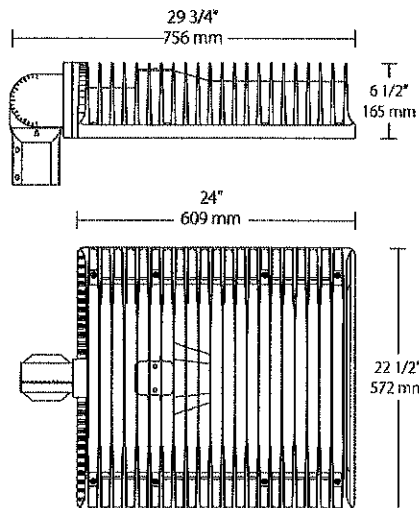

Features

- 66% energy cost savings vs. HID
- 100,000-hour LED lifespan
- 5-Year, No-Compromise Warranty

Ordering Matrix

| Family | Distribution | Wattage | Mounting | Color Temp | Finish | Dimming Driver Options | Sensor Options | Other Options |
|--------|---|--------------------------|---------------------------------|---|-----------------------------|--|--|---|
| ALED | 4T | 260 | SF | N | | /480/D10 | | |
| | 4T = Type IV 3T = Type III 2T = Type II | 260 = 260W 360 = 360W | Blank = Pole SF = Slipfitter | Blank = 5000K (Cool) N = 4000K (Neutral) Y = 3000K (Warm) | Blank = Bronze W = White | /D10 = 120-277V, 0-10V Dim /480/D10 = 480V, 0-10V Dim | Blank = No Option /PCT = 120-277V Twistlock Photocell /PCT4 = 480V Twistlock Photocell /WS4 = Motion Sensor/Photocell ¹ /WS10 = Motion Sensor/Photocell ¹ /LC = Lightcloud® Controller ¹ | Blank = Standard USA = BAA Compliant |

¹ Not available for slipfitter models.

| | | |
|---------------------------------|--------------------------|---|
| SB SPOKE BRACKET SPECIFICATIONS | | 1 |
| CATALOG # | BRACKET TENON | 2 |
| SB-29 | 2 @ 90 | 3 |
| BRACKET EPA (SQ. FT.) | MAX. LUMINAIRE WT. (LBS) | 4 |
| 0.4 | 125 | |
| LUMINAIRE EPA (SQ. FT.) | SHIP WEIGHT (LBS) | |
| 6.0 | 11 | |

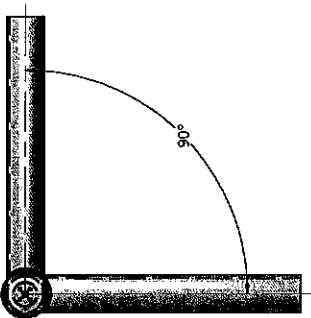

VIEW A-A
SB-29 TOP VIEW DETAIL

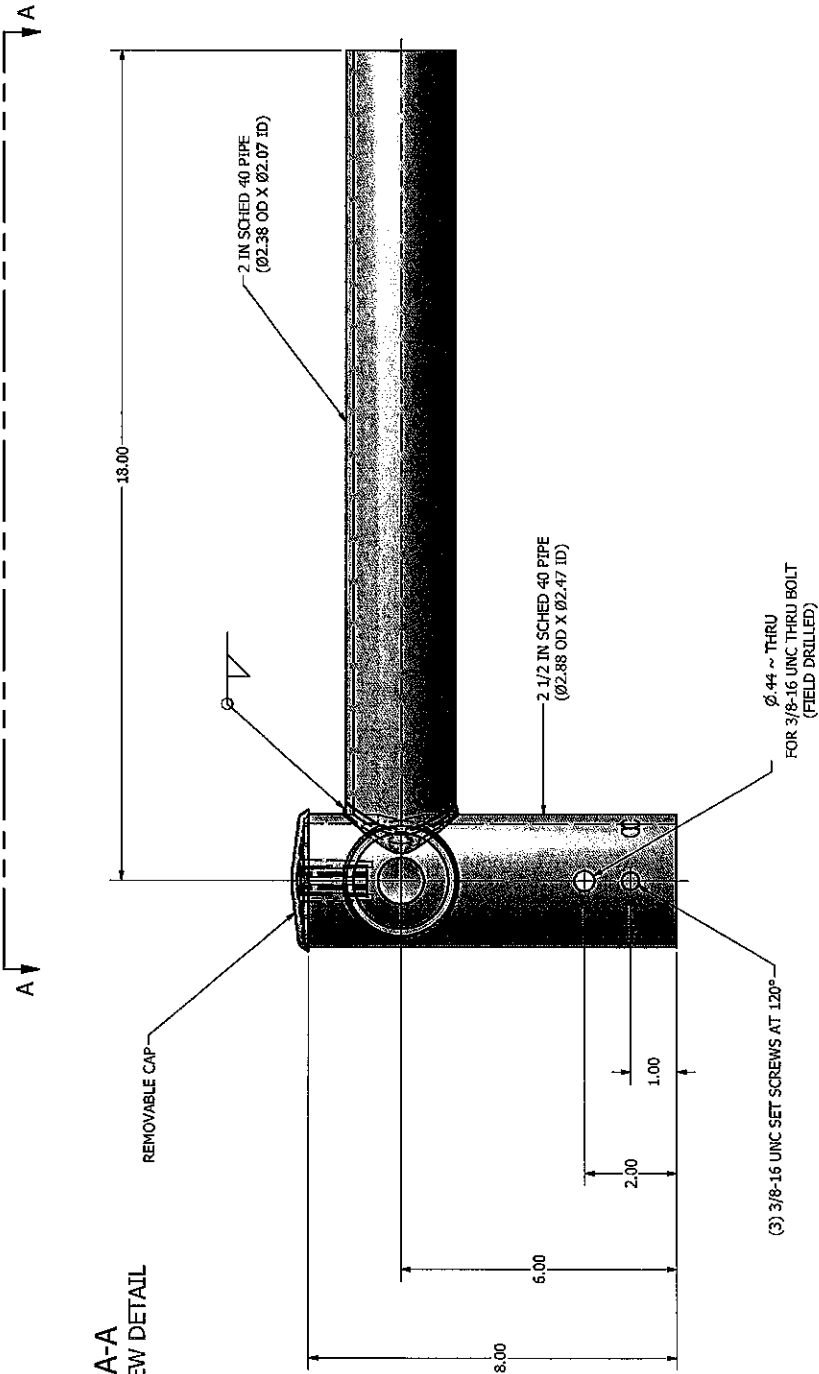

NOTE: SB SERIES POLE TOP MOUNTING BRACKETS SLIP FIT 2 IN PIPE TENONS (Ø2.38 OD). BRACKET ARMS ARE CONSTRUCTED OF 2 IN PIPE. BRACKETS ARE FINISHED TO MATCH POLE.

BRACKETS CATALOGED ARE CONSTRUCTED OF STEEL AND ARE DESIGNED FOR USE WITH STEEL OR ALUMINUM POLES. IF ALUMINUM BRACKETS ARE REQUIRED FOR ALUMINUM POLES, CONTACT YOUR REPRESENTATIVE.

| | | | |
|--|-------------------------|--|-------------------------|
| | | 23171 Grosbeck Hwy. Warren, MI 48089 P: (586) 774-5650 F: (586) 774-5706 www.unitedlightingstandards.com | |
| DRAWN: M. HARVALA CHECKED: _____ REVISION: _____ APPROVED: _____ QUOTE: _____ S.O.# _____ REF: _____ | 2/9/2015 DATE: _____ | TITLE: _____ CATALOG: _____ DWG NO: SB-29 | SIZE: C SHEET 1 OF 1 |
| 180° 270° 90° 0° HAND HOLE | | SCALE: NONE | |

Anchor Base : POST TOP

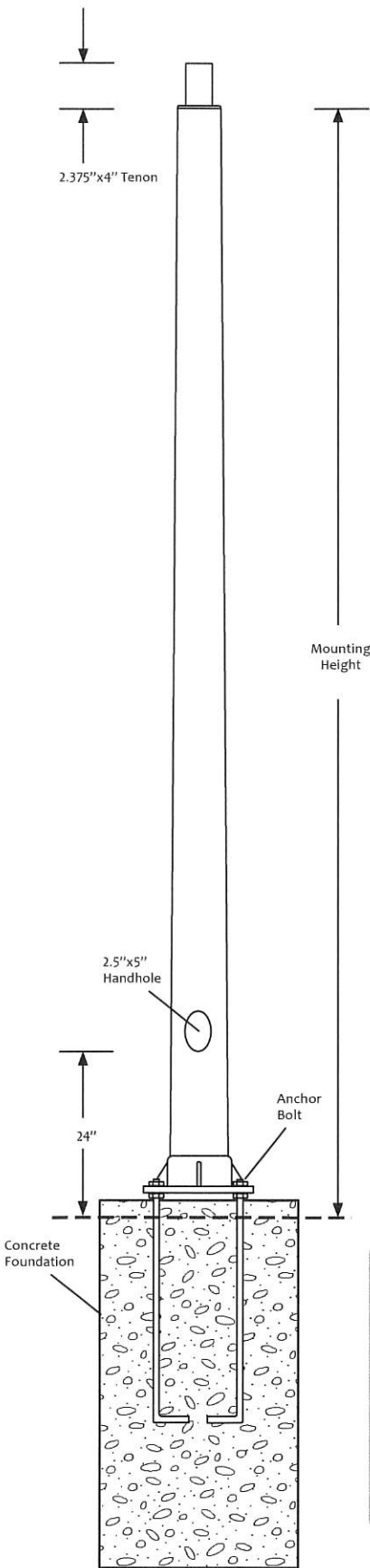

| CMT Catalog Number | Nominal Mounting Height (ft.) | Shaft Length (ft.) | Weight of Pole (lb.) | Tip O.D. (in.) | Butt O.D. (in.) | Maximum EPA | | | Bolt Circle (in.) |
|---------------------------|-------------------------------|--------------------|----------------------|----------------|-----------------|-------------|---------|---------|-------------------|
| | | | | | | 80 MPH | 100 MPH | 120 MPH | |
| 50# Vertical Load | | | | | | | | | |
| TA10-B-50 | 10 | 10 | 37 | 3.00 | 5.20 | 6.5 | 4.0 | 2.0 | 8.625 |
| TA16-B-50 | 16 | 16 | 61 | 3.00 | 6.46 | 6.5 | 4.0 | 3.3 | 8.625 |
| TA20-B-50 | 20 | 20 | 84 | 3.00 | 7.27 | 6.5 | 4.0 | 3.3 | 10.500 |
| 200# Vertical Load | | | | | | | | | |
| TA20-D-200 | 20 | 20 | 108 | 4.41 | 8.68 | 8.5 | 6.0 | 6.0 | 11.875 |
| TA25-D-200 | 25 | 25 | 134 | 4.41 | 9.81 | 7.5 | 5.0 | 5.0 | 13.500 |
| TA30-D-200 | 30 | 30 | 180 | 4.41 | 10.79 | 8.0 | 4.5 | 4.5 | 15.250 |
| TA35-D-200 | 35 | 35 | 210 | 4.41 | 11.97 | 7.5 | 4.5 | 4.5 | 15.250 |
| TA40-D-200 | 40 | 40 | 250 | 4.41 | 12.91 | 9.0 | 5.0 | 5.0 | 16.000 |
| TA45-D-200 | 45 | 45 | 326 | 4.41 | 14.13 | 8.6 | 4.3 | 4.3 | 17.000 |
| 300# Vertical Load | | | | | | | | | |
| TA30-F-300 | 30 | 30 | 193 | 5.12 | 11.50 | 10.5 | 6.3 | 6.3 | 15.250 |
| TA35-F-300 | 35 | 35 | 279 | 5.12 | 12.68 | 10.5 | 6.3 | 6.3 | 16.000 |
| TA40-F-300 | 40 | 40 | 302 | 5.12 | 13.62 | 10.5 | 6.3 | 6.3 | 17.000 |
| TA45-F-300 | 45 | 45 | 374 | 5.12 | 14.84 | 10.5 | 6.0 | 6.0 | 17.000 |

For 140 MPH, see High Wind Speed section.

Don't see what you need? Call us. We can build it!

| Bolt Circle (in.) | Bolt Size (in.) | Base Cover |
|-------------------|-----------------|------------|
| 8.625 | 0.5 x 15 x 4 | BC1 |
| 10.5 | 0.625 x 21 x 4 | BC2 |
| 11.875 | 0.75 x 30 x 4 | BC3 |
| 13.500 | 1 x 36 x 4 | BC4 |
| 15.250 | 1 x 36 x 4 | BC5 |
| 16 | 1 x 36 x 4 | BC6 |
| 17 | 1 x 36 x 4 | BC7 |
| 18 | 1 x 36 x 4 | BC8 |

Maximum EPA is calculated using wind velocities shown with a 1.3 gust factor. Poles are available with other EPA specifications. Contact factory. Total weight of fixture(s) and bracket(s) should not exceed vertical load shown above. Standard features are as shown on drawing. Available optional features are listed in the order grid on Page 2, and in the Accessories pages. Supply drilling template with order

ADJOURNMENT

RECOMMENDATION

Move to adjourn the August 25, 2020, Virtual Board Meeting #13.

VOTE

MOTION: _____ SUPPORT: _____ ACTION: _____

TIME: _____