

Board of Education Regular Meeting
Wednesday, April 9, 2025 6:30 PM
East Butler School
212 South Madison Street
Brainard, NE 68626-0036

1. Call Meeting To Order
2. Roll Call
3. Flag Salute/Open Meetings Act Statement
4. Mission & Vision Statement
5. School Board Goals
6. Patron's Comments
7. Discussion/Informational Items
 - 7.1. Legislative Update
 - 7.2. Summer Projects Update
8. Consent Agenda
 - 8.1. Approval of Minutes
 - 8.2. Treasurer's Report
 - 8.3. Approval of Resignations and Hires
9. Regular Agenda
 - 9.1. Discuss, consider, and take all necessary action on the senior class trip.
 - 9.2. Discuss, consider, and take all necessary action on the graduating class of 2025.
 - 9.3. Discuss, consider, and take all necessary action on the policy revisions.
 - 9.4. Discuss, consider, and take all necessary action on the sealed bids for the 2012 Chevy Impala.

9.5. Discuss, consider, and take all necessary action on the proposed bids for purchasing a new school vehicle.

9.6. Discuss, consider, and take all necessary action on the proposed bids for a new ice machine

9.7. Discuss, consider, and take all necessary action on the proposed demolition bids for the 203 S Madison Street and the 211 S Madison Street, Brainard houses.

9.8. Discuss, consider, and take all necessary action to purchase new iPads.

10. Administrative Comments

11. Adjournment

East Butler Public School District
Board of Education
Goals for 2024-2025

Focus on Academic Excellence and Well-Being for All

- Continue to pursue more dual credit offerings and tuition reimbursement opportunities for high school students, as well as monitor the percentage of graduating seniors that leave with 12+dual credit hours.
- Enhance professional learning opportunities for staff.
- Continue to monitor the effectiveness of our before/after school programming.
- Continued focus on staff retention.
- Expand and further communicate resources and programming for mental and social-emotional health and support for students and staff.

Facility Planning to Address Short-Term and Long-Term Needs

- Work to maximize proactive efficiency through strategic use of 3-5 year building project plans that will be reviewed and adjusted as needed.
- Keep track of phased projects and updates and make sure the progress of each is communicated well throughout our school district communities.
- Identify and implement necessary school safety improvements.

Prioritize Responsible Budgeting and Tax Request Protocols

- Work towards consistent levy management and property tax revenue requests.
- Look at ways to maximize efficiency as we focus on needs vs. wants with a strong checks and balances system in place.
- Align 3-5 year General Fund budget plan with 3-5 year Building Fund project plan

Enhance Communication and Engagement

- Increase the number of special events, promotions, and recognitions.
- Find ways to use existing technology to its maximum capacity.
- Emphasize ways to communicate to all community members.
- Continue to utilize postal mail, paper bulletins, and board briefs.
- Look to maintain or increase student enrollment through continued communication and engagement efforts with current and potential student families.
- Consider implementing some new events like Community Coffees, Lunch & Learns, and/or a Board Town Hall.

Legislative Information

April 9, 2025

Miscellaneous

LB 122 (Meyer) - Require the display of the state and national motto in schools. - STILL IN EDUCATION COMMITTEE

LB 549 (Lippincott) - Allow a school board to employ a chaplain at a school, including in a volunteer capacity. - STILL IN EDUCATION COMMITTEE

LB 550 (Lippincott) - Require school districts to adopt a policy that excuses students to attend a released time course for religious instruction. - STILL IN EDUCATION COMMITTEE

LB 691 (Murman) - Require school districts and private schools to display the Ten Commandments in school buildings. - STILL IN EDUCATION COMMITTEE

Parental Involvement

LB 390 (Murman) - Require each school board to adopt a policy relating to access by a parent, guardian, or educational decisionmaker to certain school library information. - FINAL READING

- Require the creation of an online catalog of all books in the school library.
- Provide the opportunity for a parent/guardian to be notified when the student checks out a book.

LB 428 (Murman) - Change provisions relating to school policies on the involvement of parents, guardians, and educational decision-makers in schools. - SELECT FILE

- This bill is regarding the implementation of surveys for students.

Property Taxes

LB 384 (Storer) - Require a majority of the elected members of the governing bodies of participating political subdivisions to attend joint public hearings under the Property Tax Request Act. - GENERAL FILE

Legislative Information

April 9, 2025

Retirement

LB 645 (Ballard) - Change provisions relating to the School Retirement Fund. - STILL IN NEBRASKA RETIREMENT SYSTEMS COMMITTEE

- This bill would alter the method by which the state contributes to the school retirement fund.

Scholarship Plans

LB 509 (Sorrentino) - Adopt the Opportunity Scholarships Act and provide for income tax credits. - STILL IN REVENUE COMMITTEE

- This is similar to LB 753. Under LB 509, individual and corporate taxpayers would qualify for a non-refundable tax credit equal to the amount the taxpayer contributed to a scholarship-granting organization.

LB 633 (Hansen) - Change provisions relating to applications rejected under the enrollment option program and create the Nebraska Option Enrollment Tuition Account Program. (VOUCHER BILL) - STILL IN EDUCATION COMMITTEE

- Students that are denied admittance my appeal and request that a scholarship account be created by the Department of Education. These funds would be utilized to attend a private school.

School Finance

LB 303 (Hughes) - Change provisions relating to foundation aid and certain certification dates and provide for base levy adjustments under TEEOSA and create the School Finance Reform Commission. - STILL IN EDUCATION COMMITTEE

- It increases Foundation Aid to schools by 6% for the upcoming school year, from \$1500 per formula student to \$1590 per formula student. This generates a \$90 increase for each student in unequalized districts and a \$36 increase in equalized districts.

Legislative Information

April 9, 2025

- It drops the Local Effort Rate (LER) within the formula from \$1.00 to \$0.97. A corresponding drop in the max levy from \$1.05 to \$1.02 occurs.

LB 575 (Hallstrom) - Change Provisions relating to the Property Tax Request Act and property tax levy limits. - STILL IN REVENUE COMMITTEE

- This changes the date in which the public hearing can be held - currently it has to be held somewhere in between September 14th and before September 24th.
- This changes it to July 14th and July 24th.

Student Discipline

LB 149 (Hansen) - Eliminate the prohibition on suspending a student in prekindergarten through second grade. - STILL IN EDUCATION COMMITTEE

LB 430 (Murman) - Provide an additional exception to the prohibition on suspending a student in prekindergarten through second grade and change provisions relating to short-term and long-term suspension under the Student Discipline Act. - STILL IN EDUCATION COMMITTEE

- Would require a district to provide in the written notice the following:
 - Resources the school can provide or recommend to assist the student; and
 - How the school plans to handle such behavior moving forward, including an actionable plan aimed at maximizing strategies to keep the student in school.

Student Safety, Health, and Welfare

LB 140 (Sanders) - Require school policies relating to use of electronic communication devices by students. (Cell Phone) - SELECT FILE

Legislative Information

April 9, 2025

Transgender Issues

LB 89 (Kauth) - Adopt the Stand With Women Act. - GENERAL FILE

LB 605 (Raybould) - Require each school board to adopt a policy relating to transgender student participation in extracurricular activities sponsored by a school or an athletics or activities association. - WITHDRAWN

East Butler Public Schools Facility Plan



Updated - March 2025

Prepared by Michael Eldridge, Supt.

YEAR 1 (SUMMER 2023)

| PROJECT | ESTIMATED COST |
|---|------------------|
| Phase III Bathroom Renovations (Brainard) | \$115,000 |
| Tile Replacement – Ag/Music Hallway (Brainard) | \$5,000-\$10,000 |
| Elementary Wing Roof Restoration (Brainard) | \$189,000 |
| 4th Grade Classroom – Brainard (Carpet, Cabinets, ceiling tile, lighting) | \$50,000 |
| TOTAL ESTIMATED COST | \$364,000 |

YEAR 2 (SUMMER 2024)

| PROJECT | ESTIMATED COST |
|--|------------------|
| Roof Replacement – 1935 addition (Brainard) | \$205,000 |
| Replace Carpet – upstairs math & Elem. SPED | \$10,000 |
| Sand & Restripe (Paint) the MPR Floor | \$12,945 |
| 5th & 6th Cabinet, Lighting, & carpet repl. – Brainard | \$80,822 |
| New Stage Lighting – Gym | \$27,942 |
| TOTAL ESTIMATED COSTS | \$336,709 |

YEAR 3 (SUMMER 2025)

| PROJECT | ESTIMATED COST |
|---|------------------|
| Replace Carpet - Math - 2002 & HS English | \$8,179 |
| Biology Science Classroom - Updates | \$63,877 |
| Madison Street - Tree Removal | \$10,875 |
| 2nd & 3rd Cabinet & Lighting replacement - Brainard | \$66,820 |
| Street Drainage Issue (Brainard Building) | \$100,000 |
| TOTAL ESTIMATED COSTS | \$249,751 |

YEAR 4 (SUMMER 2026)

| PROJECT | ESTIMATED COST |
|--|-----------------------|
| Carpet replacement - Dwight (Pk-2) | \$20,000 |
| K-1st Cabinet & K Lighting replacement - Brainard | \$70,000 |
| Brainard Elementary Hallway (Ceiling Grid & Light) | \$25,000 |
| Replace Rooftop Unit - Boys Locker Room | \$100,000 |
| ReRock High School Parking Lot | \$10,000 |
| TOTAL ESTIMATED COSTS | \$225,000 |

YEAR 5 (SUMMER 2027)

| PROJECT | ESTIMATED COST |
|--|-----------------------|
| Carpet replacement - Dwight (3-6) | \$20,000 |
| Shop Ventilation System | \$100,000 |
| Gutters for Dwight Elementary | \$25,000 |
| Roof Project - Brainard | \$200,000 |
| TOTAL ESTIMATED COSTS | \$325,000 |

ADDITIONAL PROJECTS UNDER CONSIDERATION

| PROJECT | ESTIMATED COST |
|--|-----------------------|
| Practice Track (Rock or all weather) | \$750,000 |
| Dwight Football Field Bathroom Renovations | \$250,000 |
| Staff Parking Lot - Brainard (East Campus) | \$250,000 |

SUMMER PROJECTS 2025

| Project | Est. Cost | Start Date | |
|--|------------------|-------------------|--|
| Madison Street Drainage | \$100,000 | ?? | |
| Madison Street Tree Removal | \$10,875 | ?? | |
| 2nd & 3rd Grade - Brainard - Carpet, Cabinets, lights | \$66,820 | May 27 | |
| HS Biology Classroom | \$54,277 | May 27 | |
| Concrete Work | \$5,000 | July | |
| Main Gym Floor - Resealing | \$3,300 | July 7 | |
| MPR Floor - Resealing | \$1,500 | July 7 | |
| Stripe parking spaces. | \$300 | July | |
| Carpet - HS Math & English | \$8,179 | June | |
| TOTAL | \$250,251 | | |

Board of Education Regular Meeting
Thursday, March 13, 2025 6:30 P.M.
East Butler School - Brainard, NE

1. Call Meeting To Order at 6:30 P.M.

2. Roll Call - Present: Brandon Jisa, Megan Kozisek, Ryan Pekarek, Laurie Smaus, Dylan Spatz, and Sarah Strizek. Also present: Mr. Michael Eldridge, Superintendent, Mr. Mark Cidlik, Secondary Principal, and Mr. Shawn Biltoft, Elementary Principal.

3. Flag Salute/Open Meetings Act Statement

4. Celebration of #EvenBetter - In partnership with First Nebraska Bank (Lindsey Kastl), student tellers (Hannah Buresh, Bryson Petrzilka, Cece Svoboda, Tatum Tejral) from the Tiger Branch School Savings program attended the meeting to share their experiences with the school board. Since the program's inception, East Butler students in grades K-6 have saved \$4,490.

5. Mission Statement - East Butler Public Schools will develop respectful, responsible, and productive citizens. Vision Statements - Create a safe environment of respect and mental well-being for students and staff; Continue the pursuit of commitment, collaboration, and communication among students, staff, and community members; and Construct a curriculum that is rigorous, adaptable, utilizes technology, and aligns with recognized standards.

6. School Board Goals - These include: Focus on Academic Excellence and Well-Being for All; Facility Planning to Address Short-Term and Long-Term Needs; Prioritize Responsible Budgeting and Tax Request Protocols; and Enhance Communication and Engagement

7. Patron's Comments - None

8. Discussion/Informational Items

8.1. Madison Street Drainage Update

The Brainard Village Board and the East Butler School Board conducted a joint meeting to discuss the status of the Madison Street Drainage project. A representative from JEO was present to share the design for the project and discuss the next steps.

Approved design and to begin the project's bid process passed with a motion by Brandon Jisa and a second by Dylan Spatz.

Brandon Jisa: Yea, Megan Kozisek: Yea, Ryan Pekarek: Yea, Laurie Smaus: Yea, Dylan Spatz: Yea, Sarah Strizek: Yea

8.2. Summer Projects Update - Mr. Eldridge provided the board with an update on the summer projects. Projects moving forward for this summer are: 2nd & 3rd - grade classroom - Brainard renovation, Biology Classroom, Madison Street Drainage - Brainard. A majority of these are part of the district's five-year facility plan.

8.3. Extra-Curricular Sponsors 2025-2026 - The current list of extra-curricular sponsors for the 2025-26 school year was shared with the Board.

8.4. Legislative Update - Mr. Eldridge provided a detailed overview of current legislation being discussed that may impact East Butler.

9. Consent Agenda

9.1. Approval of Minutes

9.2. Treasurer's Report

A motion to remove item 9.3 for further discussion but to approve 9.1 and 9.2 which passed with a motion by Sarah Strizek and a second by Ryan Pekarek.

Brandon Jisa: Yea, Megan Kozisek: Yea, Ryan Pekarek: Yea, Laurie Smaus: Yea, Dylan Spatz: Yea, Sarah Strizek: Yea

9.3. Approval of Resignations and Hires

Approval of the retirements of Kathy Bohac, Patti Meysenburg, & Marilyn Walla effective at the end of the 2024-25 school year passed with a motion by Sarah Strizek and a second by Laurie Smaus.

Brandon Jisa: Yea, Megan Kozisek: Yea, Ryan Pekarek: Yea, Laurie Smaus: Yea, Dylan Spatz: Yea, Sarah Strizek: Yea

10. Regular Agenda

10.1. Discuss, consider, and take all necessary action on renewing the girl's wrestling cooperative with David City Public Schools and Shelby-Rising City Public Schools.

Renewal of the girls' wrestling cooperative with David City Public Schools and Shelby-Rising City Public Schools passed with a motion by Dylan Spatz and a second by Ryan Pekarek.

Brandon Jisa: Yea, Megan Kozisek: Yea, Ryan Pekarek: Yea, Laurie Smaus: Yea, Dylan Spatz: Yea, Sarah Strizek: Yea

10.2. Discuss, consider, and take all necessary action to adopt the strategic plan.

At the February board meeting, a representative from the Nebraska Association of School Boards (NASB) presented the final strategic plan document to the board.

Approved adoption of the strategic plan passed with a motion by Ryan Pekarek and a second by Laurie Smaus.

Brandon Jisa: Yea, Megan Kozisek: Yea, Ryan Pekarek: Yea, Laurie Smaus: Yea, Dylan Spatz: Yea, Sarah Strizek: Yea

10.3. Discuss, consider, and take all necessary action on the proposed bids for asbestos abatement in the Biology classroom.

Approval of bid for asbestos abatement in the Biology classroom from ABC Abatement for \$9,600.00 passed with a motion by Brandon Jisa and a second by Dylan Spatz.

Brandon Jisa: Yea, Megan Kozisek: Yea, Ryan Pekarek: Yea, Laurie Smaus: Yea, Dylan Spatz: Yea, Sarah Strizek: Yea

10.4. Discuss, consider, and take all necessary action on the proposed mowing bids.

Approved mowing bid from Buresh Lawn Care for \$500 per mowing passed with a motion by Ryan Pekarek and a second by Laurie Smaus.

Brandon Jisa: Yea, Megan Kozisek: Yea, Ryan Pekarek: Yea, Laurie Smaus: Yea, Dylan Spatz: Yea, Sarah Strizek: Yea

10.5. Discuss, consider, and take all necessary action on the creation of a district advocacy committee. The purpose of this committee would be to advocate on behalf of the district with state and federal legislators and others.

Creation of a school board advocacy committee - Megan Kozisek, Ryan Pekarek, & Laurie Smaus passed with a motion by Megan Kozisek and a second by Laurie Smaus.

Brandon Jisa: Yea, Megan Kozisek: Yea, Ryan Pekarek: Yea, Laurie Smaus: Yea, Dylan Spatz: Yea, Sarah Strizek: Yea

10.6. Discuss, consider, and take all necessary action on the quote for new computers from Apple, Inc. and Dell Technologies.

Approve computer bids from Apple, Inc (9th & 5th Grade computer - \$91,350) and Dell Technologies (drafting computers - \$12,800) passed with a motion by Ryan Pekarek and a second by Sarah Strizek.

Brandon Jisa: Yea, Megan Kozisek: Yea, Ryan Pekarek: Yea, Laurie Smaus: Yea, Dylan Spatz: Yea, Sarah Strizek: Yea

10.7. Discuss, consider, and take all necessary action on the changes to the 2025-2026 school calendar.

The February 18, 2026 parent/teacher conferences will move to February 25, 2026 due to Ash Wednesday being on February 18th passed with a motion by Dylan Spatz and a second by Ryan Pekarek.

Brandon Jisa: Yea, Megan Kozisek: Yea, Ryan Pekarek: Yea, Laurie Smaus: Yea, Dylan Spatz: Yea, Sarah Strizek: Yea

10.8. Discuss, consider, and take all necessary action on the outlined policy revisions. - No action was taken as no changes were made.

10.9. Discuss, consider, and take all necessary action on the LanMan Partnership Agreement with ESU 7.

Approve LanMan Partnership Agreement with ESU 7 (two days per week - \$42,900) passed with a motion by Ryan Pekarek and a second by Dylan Spatz.

Brandon Jisa: Yea, Megan Kozisek: Yea, Ryan Pekarek: Yea, Laurie Smaus: Yea, Dylan Spatz: Yea, Sarah Strizek: Yea

10.10. Discuss, consider, and take all necessary action on the proposed timeline for the property east of the school building in Brainard. (203 S Madison & 211 S Madison).

Mr. Eldridge shared the timeline that the building and grounds committee has created for the property east of the Brainard school building. The school board discussed the sale of the two houses and other items pertaining to the proposed timeline

Approve timeline of property passed with a motion by Laurie Smaus and a second by Sarah Strizek.

Brandon Jisa: Yea, Megan Kozisek: Yea, Ryan Pekarek: Yea, Laurie Smaus: Yea, Dylan Spatz: Yea, Sarah Strizek: Yea

11. Administrative Comments - Mr. Biltoft reported on: Preschool/Kindergarten Round-Up; Parent-Teacher Conferences; Assessment Schedule; Concordia Student Teachers; and TigerBots. Mr. Cidlik reported on: ESU 7 Annual Consultation; Targeted Improvement Plan; Spring ACT; and Event Update.

12. Adjournment

Motion to adjourn at 8:11 P.M. passed with a motion by Ryan Pekarek and a second by Brandon Jisa.

Brandon Jisa: Yea, Megan Kozisek: Yea, Ryan Pekarek: Yea, Laurie Smaus: Yea, Dylan Spatz: Yea, Sarah Strizek: Yea

Kim Fuehrer
Recording Secretary

| | | | |
|--|------------|--|-------------------|
| | | | |
| | | | |
| PAID IN MARCH 2025 | | | |
| | | | |
| | | | |
| | | | |
| PRE-APPROVED BILLS (GENERAL FUND) | | | |
| | | | |
| | | | |
| 3/13/25 | | | |
| | | | |
| | | | |
| Butler Public Power District | Chk# 43827 | Dwight electricity | \$681.25 |
| | | | |
| Ryan Sullivan/Metro Community College | Chk# 43828 | Red Cross Scholarship | \$250.00 |
| | | | |
| | | | |
| 3/24/25 | | | |
| | | | |
| | | | |
| Home Depot Credit Services | Chk# 43829 | Cordless Pressure Washer | \$699.00 |
| | | | |
| US Bank One Card | Chk# 43830 | Convention Trip, Lights & Filters, Bks | \$4,271.24 |
| | | | |
| | | | |
| 3/26/25 | | | |
| | | | |
| | | | |
| Cash - First Nebraska Bank | Chk# 43831 | Petty Cash for Postage | 13.91 |
| | | | |
| The Rose Theater | Chk# 43832 | Pete the Cat K-3 Field Trip | \$456.00 |
| | | | |
| | | | |
| 3/31/25 | | | |
| | | | |
| | | | |
| Cash - First Nebraska Bank | Chk# 43833 | State Meals for FFA & FCCLA | \$1,670.00 |
| | | | |
| | | | |
| | | TOTAL | \$8,041.40 |
| | | | |
| | | | |
| | | | |
| | | | |

| | | | | |
|---|-------|------------|--|--|
| | | | | |
| | | | | |
| | | | | |
| April 9, 2025 | | | | |
| | | | | |
| | | | | |
| | | | | |
| | | | | |
| SPECIAL BUILDING FUND BILLS | | | | |
| | | | | |
| | | | | |
| Spark Electric Co, Inc | | Chk# 1347 | | |
| | | \$2,505.00 | | |
| | | | | |
| US Bank One Card | | Chk# 1348 | | |
| | | \$220.81 | | |
| | | | | |
| | | | | |
| | | | | |
| | Total | \$2,725.81 | | |
| | | | | |
| | | | | |
| DEPRECIATION FUND BILLS | | | | |
| | | | | |
| | | | | |
| | | | | |
| | | | | |
| No Depreciation Bills in March | | | | |
| | | | | |
| | | | | |
| QUALIFIED CAPITAL IMPROVEMENT PURPOSE UNDERTAKING FUND (QCPUF) | | | | |
| | | | | |
| | | | | |
| | | | | |
| No QCPuf Bills in March | | | | |

Activity Fund Balance Report - Account - Exclude Encumbrances

04/2025 - 04/2025

Regular; Beginning Month 04/2025; Processing Month 04/2025; Accounts to Include Accounts with Activity; Fund Number 05

Fund: 05 ACTIVITY FUND

| <u>Chart of Account Number</u> | <u>Chart of Account Description</u> | | <u>Expenses</u> | <u>Revenues</u> | <u>Balance Change</u> | <u>Balance</u> |
|--------------------------------|-------------------------------------|-------------------|-----------------|-----------------|-----------------------|----------------|
| 05 704 | FUND BALANCE | *Previous Balance | | | | 146.40 |
| | | *Ending Balance: | 0.00 | 0.00 | 0.00 | 146.40 |
| 05 704 2001 | ACADEMIC DECATHALON | *Previous Balance | | | | 1,080.80 |
| | | *Ending Balance: | 0.00 | 0.00 | 0.00 | 1,080.80 |
| 05 704 2002 | AG MEMORIALS | *Previous Balance | | | | 2,500.00 |
| | | *Ending Balance: | 0.00 | 0.00 | 0.00 | 2,500.00 |
| 05 704 2003 | ANNUAL | *Previous Balance | | | | 17,348.13 |
| | | *Ending Balance: | 0.00 | 0.00 | 0.00 | 17,348.13 |
| 05 704 2004 | ATHLETIC | *Previous Balance | | | | 37,667.87 |
| | | *Ending Balance: | 0.00 | 0.00 | 0.00 | 37,667.87 |
| 05 704 2006 | CHEERLEADERS | *Previous Balance | | | | 1,239.33 |
| | | *Ending Balance: | 0.00 | 0.00 | 0.00 | 1,239.33 |
| 05 704 2007 | CLOSE UP | *Previous Balance | | | | 17,443.24 |
| | | *Ending Balance: | 0.00 | 0.00 | 0.00 | 17,443.24 |
| 05 704 2008 | COLLEGE ACCESS GRANT | *Previous Balance | | | | 273.75 |
| | | *Ending Balance: | 0.00 | 0.00 | 0.00 | 273.75 |
| 05 704 2009 | CONCESSIONS | *Previous Balance | | | | 5,870.46 |
| | | *Ending Balance: | 0.00 | 0.00 | 0.00 | 5,870.46 |
| 05 704 2010 | DANCE TEAM | *Previous Balance | | | | 204.51 |
| | | *Ending Balance: | 0.00 | 0.00 | 0.00 | 204.51 |
| 05 704 2011 | DRAMA | *Previous Balance | | | | 4,759.16 |
| | | *Ending Balance: | 0.00 | 0.00 | 0.00 | 4,759.16 |
| 05 704 2012 | DRUG FREE PROGRAM | *Previous Balance | | | | 395.49 |
| | | *Ending Balance: | 0.00 | 0.00 | 0.00 | 395.49 |
| 05 704 2014 | FBLA | *Previous Balance | | | | 1,633.87 |
| | | *Ending Balance: | 0.00 | 0.00 | 0.00 | 1,633.87 |
| 05 704 2015 | FCCLA | *Previous Balance | | | | 3,843.64 |
| | | *Ending Balance: | 0.00 | 0.00 | 0.00 | 3,843.64 |
| 05 704 2016 | FFA | *Previous Balance | | | | 22,619.91 |
| | | *Ending Balance: | 0.00 | 0.00 | 0.00 | 22,619.91 |
| 05 704 2017 | FFA GREENHOUSE | *Previous Balance | | | | 12,345.22 |
| | | *Ending Balance: | 0.00 | 0.00 | 0.00 | 12,345.22 |

Activity Fund Balance Report - Account - Exclude Encumbrances

04/2025 - 04/2025

Regular; Beginning Month 04/2025; Processing Month 04/2025; Accounts to Include Accounts with Activity; Fund Number 05

Fund: 05 ACTIVITY FUND

| <u>Chart of Account Number</u> | <u>Chart of Account Description</u> | | <u>Expenses</u> | <u>Revenues</u> | <u>Balance Change</u> | <u>Balance</u> |
|--------------------------------|-------------------------------------|-------------------|-----------------|-----------------|-----------------------|----------------|
| 05 704 2025 | CLASS OF 2025 | *Previous Balance | | | | 1,813.08 |
| | | *Ending Balance: | 0.00 | 0.00 | 0.00 | 1,813.08 |
| 05 704 2026 | CLASS OF 2026 | *Previous Balance | | | | 2,601.84 |
| | | *Ending Balance: | 0.00 | 0.00 | 0.00 | 2,601.84 |
| 05 704 2027 | CLASS OF 2027 | *Previous Balance | | | | 3,482.55 |
| | | *Ending Balance: | 0.00 | 0.00 | 0.00 | 3,482.55 |
| 05 704 2028 | CLASS OF 2028 | *Previous Balance | | | | 71.43 |
| | | *Ending Balance: | 0.00 | 0.00 | 0.00 | 71.43 |
| 05 704 3001 | LAPTOP INITIATIVE | *Previous Balance | | | | 17,751.92 |
| | | *Ending Balance: | 0.00 | 0.00 | 0.00 | 17,751.92 |
| 05 704 3002 | LETTERCLUB | *Previous Balance | | | | 1,588.94 |
| | | *Ending Balance: | 0.00 | 0.00 | 0.00 | 1,588.94 |
| 05 704 3004 | MUSIC | *Previous Balance | | | | 404.73 |
| | | *Ending Balance: | 0.00 | 0.00 | 0.00 | 404.73 |
| 05 704 3005 | NATIONAL HONOR SOCIETY | *Previous Balance | | | | 627.90 |
| | | *Ending Balance: | 0.00 | 0.00 | 0.00 | 627.90 |
| 05 704 3006 | SPEECH | *Previous Balance | | | | 17.76 |
| | | *Ending Balance: | 0.00 | 0.00 | 0.00 | 17.76 |
| 05 704 3007 | STUDENT COUNCIL | *Previous Balance | | | | 2,704.81 |
| | | *Ending Balance: | 0.00 | 0.00 | 0.00 | 2,704.81 |
| 05 704 3009 | WR SPIRIT LEADERS | *Previous Balance | | | | 514.69 |
| | | *Ending Balance: | 0.00 | 0.00 | 0.00 | 514.69 |
| 05 704 3010 | SKILLS USA | *Previous Balance | | | | 5,429.60 |
| | | *Ending Balance: | 0.00 | 0.00 | 0.00 | 5,429.60 |
| 05 704 3011 | CAREER TECHNICAL EDUCATION | *Previous Balance | | | | 9,950.61 |
| | | *Ending Balance: | 0.00 | 0.00 | 0.00 | 9,950.61 |
| 05 704 3012 | BAND TRIP | *Previous Balance | | | | (144.93) |
| | | *Ending Balance: | 0.00 | 0.00 | 0.00 | (144.93) |
| | | Fund Total: 05 | 0.00 | 0.00 | 0.00 | 176,166.71 |

Regular; Processing Month 04/2025; Accounts to Include Accounts with Activity; Fund Number 01

| Fund: 01 GENERAL FUND | | | | | | |
|-----------------------|---------------------------------|-----------------------|---------------------|----------------|--------------------|-----------------------|
| <u>Account Number</u> | <u>Description</u> | <u>Revised Budget</u> | <u>During Month</u> | <u>To Date</u> | <u>% of Budget</u> | <u>Budget Balance</u> |
| 01 1100 | PROPERTY TAXES | 6,476,918.00 | 0.00 | 3,900,859.81 | 60.23 | 2,576,058.19 |
| 01 1115 | CARLINE | 2,500.00 | 0.00 | 220.60 | 8.82 | 2,279.40 |
| 01 1120 | PUBLIC POWER DISTRICT-SALES TAX | 10,000.00 | 0.00 | 3,569.69 | 35.70 | 6,430.31 |
| 01 1125 | MOTOR VEHICLE TAXES | 275,000.00 | 0.00 | 199,607.50 | 72.58 | 75,392.50 |
| 01 1370 | PRE-SCHOOL TUITION | 13,000.00 | 0.00 | 13,600.00 | 104.62 | (600.00) |
| 01 1510 | INTEREST | 2,500.00 | 0.00 | 20,318.12 | 812.72 | (17,818.12) |
| 01 1800 | COMMUNITY SERVICE ACTIVITIES | 0.00 | 0.00 | 14,290.00 | 0.00 | (14,290.00) |
| 01 1911 | LOCAL LICENSE FEES | 0.00 | 0.00 | 2,315.00 | 0.00 | (2,315.00) |
| 01 1990 | MISC LOCAL REV | 20,000.00 | 0.00 | 0.00 | 0.00 | 20,000.00 |
| | Subtotal: LOCAL RECIEPTS | 6,799,918.00 | 0.00 | 4,154,780.72 | 61.10 | 2,645,137.28 |
| 01 2110 | COUNTY FINES/LICENSES | 25,000.00 | 0.00 | 14,033.01 | 56.13 | 10,966.99 |
| | Subtotal: 2000 | 25,000.00 | 0.00 | 14,033.01 | 56.13 | 10,966.99 |
| 01 3110 | STATE AID | 501,247.00 | 0.00 | 350,875.00 | 70.00 | 150,372.00 |
| 01 3120 | SPED PROGRAMS/SCHOOL AGE | 575,000.00 | 0.00 | 312,574.00 | 54.36 | 262,426.00 |
| 01 3125 | SPED TRANSPORTATION/SCHOOL AGE | 15,000.00 | 0.00 | 0.00 | 0.00 | 15,000.00 |
| 01 3130 | HOMESTEAD EXEMPTION | 0.00 | 0.00 | 12,224.23 | 0.00 | (12,224.23) |
| 01 3400 | STATE APPORTIONMENT | 75,000.00 | 0.00 | 147,899.37 | 197.20 | (72,899.37) |
| | Subtotal: 3000 | 1,166,247.00 | 0.00 | 823,572.60 | 70.62 | 342,674.40 |
| 01 4105 | UNIVERSAL SERVICES E-RATE | 7,000.00 | 0.00 | 971.82 | 13.88 | 6,028.18 |
| 01 4310 | REAP | 0.00 | 0.00 | 27,697.00 | 0.00 | (27,697.00) |
| 01 4505 | TITLE I | 0.00 | 0.00 | 26,053.00 | 0.00 | (26,053.00) |
| 01 4511 | TITLE VI (REAP) | 27,697.00 | 0.00 | 0.00 | 0.00 | 27,697.00 |
| 01 4518 | SPED IDEA Part B | 90,000.00 | 0.00 | 0.00 | 0.00 | 90,000.00 |
| 01 4708 | MEDICAID IN PUBLIC SCHOOLS | 10,000.00 | 0.00 | 5,466.54 | 54.67 | 4,533.46 |
| | Subtotal: 4000 | 134,697.00 | 0.00 | 60,188.36 | 44.68 | 74,508.64 |
| 01 5690 | OTHER NON-REVENUE RECEIPTS | 15,000.00 | 0.00 | 28,180.55 | 187.87 | (13,180.55) |
| | Subtotal: 5000 | 15,000.00 | 0.00 | 28,180.55 | 187.87 | (13,180.55) |
| 01 9000 | NON-PROGRAM RECEIPTS | 650,000.00 | 0.00 | 0.00 | 0.00 | 650,000.00 |
| | Subtotal: NON-PROGRAM RECEIPTS | 650,000.00 | 0.00 | 0.00 | 0.00 | 650,000.00 |
| | Fund Total: | 8,790,862.00 | 0.00 | 5,080,755.24 | 57.80 | 3,710,106.76 |

Treasurer's Report for the Board of Education

April 9, 2025

Month of March 2025

General Fund (FNB)

| | |
|----------------------------------|-----------------|
| Beginning of the Month Balance | \$ 1,736,665.18 |
| Receipts | \$ 713,885.86 |
| Interest | \$ 781.57 |
| Expenditures | \$ 703,199.89 |
| Transfer from Bank of the Valley | \$ 0.00 |
| End of Month Balance | \$ 1,748,132.72 |

General Fund (BOV)

| | |
|---------------------------------|---------------|
| Beginning of the Month Balance | \$ 882,593.46 |
| Transfer to First Nebraska Bank | \$ 0.00 |
| Interest | \$ 2,289.09 |
| End of the Month Balance | \$ 884,882.55 |

Total of Accounts \$ 2,633,015.27

MCAULIFFE PRIZE 12 MONTH (due 04/5/21) \$ 559.86

BANK OF THE VALLEY 12 MONTH \$ 437,220.23

Special Building Fund (FNB)

| | |
|----------------------------------|---------------|
| Beginning of the Month Balance | \$ 366,093.65 |
| Butler County Taxes | \$ 9,073.63 |
| Saunders County Taxes | \$ 45,247.01 |
| Seward County Taxes | \$ 1,936.86 |
| Receipts | \$ 56,257.50 |
| Interest | \$ 169.12 |
| Expenditures | \$ 3,909.00 |
| Transfer from Bank of the Valley | \$ 0.00 |
| End of Month Balance | \$ 418,611.27 |

Special Building Fund (BOV)

| | |
|---------------------------------|---------------|
| Beginning of the Month Balance | \$ 265,043.47 |
| Transfer to First Nebraska Bank | \$ 00.00 |
| Interest | \$ 687.39 |
| End of the Month Balance | \$ 265,730.86 |

Total of Accounts \$ 684,342.13

Qualified Capital Purpose Undertaking Fund

| | |
|--------------------------------|---------------|
| Beginning of the Month Balance | \$ 145,881.46 |
| Receipts | \$ 13,749.59 |
| Interest | \$ 65.52 |
| Expenditures | \$ 0.00 |
| End of Month Balance | \$ 159,700.57 |

Student Fees Fund

| | |
|--------------------------------|--------------|
| Beginning of the Month Balance | \$ 7,256.97 |
| Receipts | \$ 10,807.00 |
| Service Charge | \$ 3.00 |
| Expenditure | \$ 338.00 |
| End of Month Balance | \$ 17,722.97 |

Depreciation Fund

| | |
|--------------------------------|---------------|
| Beginning of the Month Balance | \$ 313,220.14 |
| Receipts | \$ 0.00 |
| Transfer | \$ 0.00 |
| Interest | \$ 731.56 |
| Expenditures | \$ 0.00 |
| End of Month Balance | \$ 313,951.70 |

Employee Benefit Fund

| | |
|--------------------------------|--------------|
| Beginning of the Month Balance | \$ 10,439.78 |
| Receipts | \$ 0.00 |
| Transfer | \$ 0.00 |
| Interest | \$ 4.29 |
| Expenditures | \$ 800.00 |
| End of Month Balance | \$ 9,644.07 |

Nebraska Liquid Asset Fund

| | |
|--------------------------------|---------|
| Beginning of the Month Balance | \$ 0.06 |
| Receipts | \$ 0.00 |
| Interest | \$ 0.00 |
| Expenditures | \$ 0.00 |
| End of Month Balance | \$ 0.06 |

Activity Fund

| | |
|---|---------------|
| Beginning of the Month Balance | \$ 187,637.87 |
| Receipts | \$ 11,238.02 |
| Interest | \$ 76.95 |
| Expenditures | \$ 19,564.63 |
| End of Month Balance | \$ 179,388.31 |
| First Nebraska Bank - 12 mo (Close UP CD# 1514) | \$ 2,540.23 |

Lunch Fund

| | |
|--------------------------------|--------------|
| Beginning of the Month Balance | \$ 48,702.63 |
| Receipts | \$ 15,298.33 |
| Interest | \$ 19.33 |
| Expenditures | \$ 29,058.35 |
| End of Month Balance | \$ 34,961.64 |

| | <u>PIK/Gross</u> | <u>Amount</u> | <u>Expense/ Employer</u> | <u>Adjustment Amount</u> | <u>Check Total</u> | <u>Payee ID</u> | <u>Payee Name</u> | |
|--|-------------------|--|------------------------------|--------------------------------|--------------------|-----------------|---------------------------------------|---|
| Check Date: | 04/18/2025 | Batch Description: April 2025 PR-0002 | | | | | | |
| Processing Month: | 04/2025 | Status: | | Calculated Successfully | | | | |
| Checking Account ID: | 1 | | | | | | | |
| ADD | | | | | | | | |
| ACTIVITYTR Activity trips | | | 720.00 | | | | | |
| BEREAVE Bereavement Leave | | | 158.88 | | | | | |
| HOURLY Hourly Pay | | | 65,263.94 | | | | | |
| OT Overtime Pay | | | 1,718.76 | | | | | |
| PARASUB ParaEducator Substitute | | | 1,700.00 | | | | | |
| PERSONAL Personal Time | | | 384.00 | | | | | |
| SICK Sick Time Used | | | 3,412.28 | | | | | |
| SUBDRIVER Substitute Bus Driver | | | 808.68 | | | | | |
| SUBTEACHER Substitute | | | 8,560.00 | | | | | |
| TIGERKIDSC Tiger Kids Club | | | 2,866.00 | | | | | |
| VACATION Vacation Time | | | 658.32 | | | | | |
| | | | <u>86,250.86</u> | | | | | |
| CONTRACT | | | | | | | | |
| C01 Contract 1 | | | 244,593.64 | | | | | |
| C02 Contract 2 | | | 16,795.10 | | | | | |
| C04 Title 1 | | | 1,017.78 | | | | | |
| | | | <u>262,406.52</u> | | | | | |
| DEDUCTION | | | | | | | | |
| ACCIDENT ACCIDENT | | 357.95 | | | 357.95 | AFLACREMI | AFLAC REMITTANCE SERVICES | |
| ACCIDENTCO ACCIDENT-COLONI | | 75.68 | | | 75.68 | COLONIAL | COLONIAL LIFE & ACCIDENT INS. CO | |
| CANCER CANCER | | 213.34 | | | 213.34 | AFLACREMI | AFLAC REMITTANCE SERVICES | |
| CANCERCOLO CANCER-COLONIAL | | 44.20 | | | 44.20 | COLONIAL | COLONIAL LIFE & ACCIDENT INS. CO | |
| COLONSTD COLONIALSTD | | 43.60 | | | 43.60 | COLONIAL | COLONIAL LIFE & ACCIDENT INS. CO | |
| DENTALPOST FAMILY DENTAL | | 1,124.06 | 1,763.17 | | 2,887.23 | BLUECROSS | BLUE CROSS BLUE SHIELD OF NE | |
| DENTALPRE DENTAL | | 285.48 | 238.88 | | 524.36 | BLUECROSS | BLUE CROSS BLUE SHIELD OF NE | |
| DEPCARE DEPENDENT CARE | | 300.00 | | | 300.00 | EASTBTLR2R | EAST BUTLER SCHOOL DIST 2R | |
| HEALTH HEALTH INSURANC | | 1,791.70 | 86,156.36 | | 87,948.06 | BLUECROSS | BLUE CROSS BLUE SHIELD OF NE | |
| HORACEMANN HORACE MANN ANN | | 100.00 | | | 100.00 | HORACEMAN | HORACE MANN LIFE INS CO | |
| HOSPPRE HOSPITAL - PRET | | 142.22 | | | 142.22 | AFLACREMI | AFLAC REMITTANCE SERVICES | |
| STDISAB SHORT TERM DISA | | 114.56 | | | 114.56 | AFLACREMI | AFLAC REMITTANCE SERVICES | |
| URM URM | | 1,140.67 | | | 1,140.67 | EASTBTLR2R | EAST BUTLER SCHOOL DIST 2R | |
| VISION VISION | | 531.03 | | | 531.03 | VISION | VISION SERVICE PLAN | |
| WADREED FTC ANNUITY | | 933.57 | | | 933.57 | WADDELLAN | FTC | |
| | | <u>7,198.06</u> | <u>88,158.41</u> | <u>0.00</u> | <u>95,356.47</u> | | | |
| INDIVIDUAL BANK ACCOUNT DEDUCTION | | | | | | | | |
| HSA HSA | | 310.00 | 3,017.22 | | 3,327.22 | | | D |
| | | <u>310.00</u> | <u>3,017.22</u> | <u>0.00</u> | <u>3,327.22</u> | | | |
| RET DEDUCTION | | | | | | | | |
| NPERS RETIREMENT | 334,648.64 | 32,728.62 | 33,055.93 | | 65,784.55 | RET | NEBRASKA SCHOOL RETIREMENT A SYS | |
| | | <u>32,728.62</u> | <u>33,055.93</u> | <u>0.00</u> | <u>65,784.55</u> | | | |
| TAX | | | | | | | | |
| FIT FIT | 310,233.95 | 21,646.69 | | | 21,646.69 | EFTPS | ELECTRONIC FEDERAL TAX PAYMENT SYSTEM | A |
| FUTA FUTA | 348,611.10 | | | | | | | |
| MEDICARE MEDICARE | 343,996.14 | 4,988.02 | 4,988.02 | | 9,976.04 | EFTPS | ELECTRONIC FEDERAL TAX PAYMENT SYSTEM | A |
| SITNE SIT NE | 310,233.95 | 10,187.93 | | | 10,187.93 | SITNE | NEBRASKA DEPARTMENT OF REVENUE | A |
| SOCSEC SOC SEC | 343,996.14 | 21,327.78 | 21,327.78 | | 42,655.56 | EFTPS | ELECTRONIC FEDERAL TAX PAYMENT SYSTEM | A |
| SUTANE SUTA NE | 348,611.10 | | | | | | | |
| WCNE WORK COMP NE | 345,325.81 | | | | | | | |
| | | <u>58,150.42</u> | <u>26,315.80</u> | <u>0.00</u> | <u>84,466.22</u> | | | |

Payroll Register - Totals
Unposted; Payroll Type Extra, Pay Off Contracts, Regular, Void

| <u>PIK/Gross</u> | <u>Amount</u> | <u>Expense/ Employer</u> | <u>Adjustment Amount</u> | <u>Check Total</u> | <u>Payee ID</u> | <u>Payee Name</u> |
|------------------|---------------|------------------------------|------------------------------|--------------------|-----------------|-------------------|
|------------------|---------------|------------------------------|------------------------------|--------------------|-----------------|-------------------|

Checking Account ID: 1

| | |
|-------------|------------|
| Net Pay: | 250,270.28 |
| Cash Total: | 499,204.74 |

| | |
|-----------------------------------|------------|
| Non - FIT Taxable Deductions | 38,423.43 |
| Non - SIT Taxable Deductions | 38,423.43 |
| Non - SOC SEC Taxable Deductions | 4,661.24 |
| Non - MEDICARE Taxable Deductions | 4,661.24 |
| Direct Deposits | 253,597.50 |
| Automatic Payments | 150,250.77 |
| Adds + Contracts + Deduction Adds | 348,657.38 |

| Vendor Name | Vendor Description | Amount |
|---|-----------------------------|-----------|
| Checking Account ID 1 | Fund Number 01 GENERAL FUND | |
| AMAZON CAPITAL SERVICES | | 1,116.18 |
| APPTEGY, INC | | 9,862.08 |
| AQUACAVE.com | | 759.94 |
| BALE COMPANY | | 200.95 |
| BANNER PRESS | | 69.43 |
| BONGERS, SANDRA | | 54.23 |
| BRABEC, TANYA | | 40.00 |
| BUTLER COUNTY HEALTH | | 4,990.70 |
| BUTLER COUNTY TREASURER. | | 1,951.66 |
| CANON FINANCIAL SERVICES | | 6,213.60 |
| CANON SOLUTIONS AMERICA INC | | 44.93 |
| CLINE WILLIAMS | | 706.50 |
| CTF SERVICE INC | | 11,600.73 |
| CULLIGAN OF COLUMBUS | | 159.00 |
| DALE'S FOOD PRIDE | | 163.89 |
| DAVID CITY ACE HARDWARE | | 179.60 |
| DIDIER GROCERY | | 193.15 |
| DISCOUNT SCHOOL SUPPLY | | 37.26 |
| DIVERSIFIED DRUG TESTING | | 460.00 |
| ELDRIDGE, MICHAEL | | 106.70 |
| ELECTRONIC ENGINEERING COMPANY | | 517.50 |
| ESU #7 | | 33,214.28 |
| EVANS CUSTOM APPAREL | | 502.40 |
| FRONTIER COOPERATIVE CO | | 5,316.14 |
| GAUTHIER, BRITTNEY | | 135.86 |
| GO PHYSICAL THERAPY | | 416.55 |
| HD SUPPLY FORMERLY HOME DEPOT PRO | | 2,082.45 |
| HERMELBRACHT, SOPHIE | | 37.21 |
| HERMITAGE ART COMPANY | | 74.92 |
| INSTRUMENTALIST AWARDS LLC | | 44.50 |
| JOURNEYED.COM, INC. | | 252.00 |
| JW PEPPER AND SON INC | | 854.56 |
| KSB SCHOOL LAW | | 192.50 |
| LIFEGUARD MD, INC. | | 215.00 |
| LINCOLN JOURNAL STAR | | 231.90 |
| MADISON NATIONAL LIFE INS CO | | 781.25 |
| MIDWEST DOOR AND HARDWARE | | 32.00 |
| NEBRASKA COUNCIL OF SCHOOL ADMINISTRATORS | | 75.00 |
| NSAA DIST II | | 305.00 |
| ONE SOURCE THE BACKGROUND CHECK COMPANY | | 33.00 |
| POWER OF ICU | | 2,799.00 |
| QUALITY SOUND & COMMUNICATIONS | | 294.00 |
| QUILL CORPORATION LLC | | 106.05 |
| REGION V SYSTEMS | | 1,309.81 |
| REHMER AUTO PARTS, INC. | | 17.37 |
| SCHOOL SPECIALTY LLC | | 95.27 |
| SCHUYLER COOP ASSOCIATION | | 5,476.76 |
| SEWARD COUNTY INDEPENDENT | | 391.02 |
| SISEL, ANGELA | | 45.45 |
| STAPLES ADVANTAGE | | 153.06 |
| TECH MASTERS | | 483.00 |
| THEATREFOLK,LTD | | 185.95 |
| VILLAGE OF BRAINARD | | 4,774.69 |
| VILLAGE OF PRAGUE | | 50.38 |

East Butler Public Schools
04/04/2025 02:05 PM

Board Report - Newspaper
Unposted; Batch Description General Fund Invoices-0142

Page: 2
User ID: BSJ

| Vendor Name | Vendor Description | Amount |
|---------------------------|--------------------|------------------|
| WAHOO NEWSPAPER | | 113.77 |
| WINDSTREAM NEBRASKA, INC. | | 1,123.58 |
| Fund Number 01 | | <hr/> 101,643.71 |
| Checking Account ID 1 | | <hr/> 101,643.71 |

Authorization of Transfer

\$70,000 - Nutrition

Graduating Class of 2025

Faye Belew

Leah Bongers

Isaiah Coufal

Alexis Forney

Jessi Hasenkamp

Nevayla Hilton

Emily Kamm

Madalynn Marsh

Kaleb Palik

Dakoda Schneider

Mackennah Spatz

Hannah Strizek

Garrett White

Justin Bongers

Logan Buresh

Cooper Englebrecht

Kale Glasshoff

Morgan Havlovic

Brody Johnson

Dylan Marett

Kristen Mika

Jaidyn Roberts

Jakson Smaus

Malorie Spatz

Trenton VanVeldhuizen

Samuel Zegers



Sid Dillon Fleet & Commercial

Ron Fullerton | 402-540-7578 | ron.fullerton@siddillon.com

East Butler Public Schools Dist

Vehicle: [Fleet] 2025 Chevrolet Malibu (1ZC69) 4dr Sdn LS w/1LS





Sid Dillon Fleet & Commercial

Ron Fullerton | 402-540-7578 | ron.fullerton@siddillon.com

Sid Dillon Fleet & Commercial

Dealership Information

Sid Dillon Fleet & Commercial
Wahoo, NE.

Thanks!

Prepared By:

Ron Fullerton
Sid Dillon Fleet & Commercial
402-540-7578
ron.fullerton@siddillon.com

Price Summary

PRICE SUMMARY

| | | MSRP |
|--------------------|-----------------------|--------------------|
| Base Price | \$24,377 ⁻ | \$25,800.00 |
| Total Options | | \$0.00 |
| Vehicle Subtotal | using Bid Assistance | \$25,800.00 |
| Destination Charge | | \$1,195.00 |
| Grand Total | | \$26,995.00 |

This document contains information considered Confidential between GM and its Clients uniquely. The information provided is not intended for public disclosure. Prices, specifications, and availability are subject to change without notice, and do not include certain fees, taxes and charges that may be required by law or vary by manufacturer or region. Performance figures are guidelines only, and actual performance may vary. Photos may not represent actual vehicles or exact configurations. Content based on report preparer's input is subject to the accuracy of the input provided.
Data Version: 25067. Data Updated: Mar 27, 2025 6:45 00 PM PDT.



Sid Dillon Fleet & Commercial

Ron Fullerton | 402-540-7578 | ron.fullerton@siddillon.com

Vehicle: [Fleet] 2025 Chevrolet Malibu (1ZC69) 4dr Sdn LS w/1LS (Complete)

Selected Model and Options

MODEL

| CODE | MODEL |
|-------|--|
| 1ZC69 | 2025 Chevrolet Malibu 4dr Sdn LS w/1LS |

COLORS

| CODE | DESCRIPTION |
|------|--------------|
| GAZ | Summit White |

OPTIONS

| CODE | DESCRIPTION |
|------|---|
| 1LS | LS Preferred Equipment Group includes standard equipment |
| A51 | Seats, front bucket (STD) |
| FE9 | Emissions, Federal requirements |
| GAZ | Summit White |
| H1T | Jet Black, Premium cloth seat trim |
| IOR | Audio system, Chevrolet Infotainment 3 system, 8" diagonal color touchscreen, AM/FM stereo. Additional features for compatible phones include: Bluetooth audio streaming for 2 active devices, voice command pass-through to phone, Apple CarPlay and Android Auto capable. (STD) |
| LFV | Engine, 1.5L turbo DOHC 4-cylinder DI with Variable Valve Timing (VVT) (163 hp [122 kW] @ 5700 rpm, 184 lb-ft torque [248.4 N-m] @ 2500-3000 rpm) (STD) |
| MRG | Transmission, Continuously Variable (CVT) (STD) |
| QC7 | Wheels, 16" (40.6 cm) aluminum (STD) |

Options Total

Standard Equipment

Package

Driver Confidence Package includes (UD7) Rear Park Assist

Chevy Safety Assist includes (UE4) Following Distance Indicator, (UEU) Forward Collision Alert, (UHX) Lane Keep Assist with Lane Departure Warning, (TQ5) IntelliBeam, (UHY) Automatic Emergency Braking and (UKJ) Front Pedestrian Braking

Mechanical

Engine, 1.5L turbo DOHC 4-cylinder DI with Variable Valve Timing (VVT) (163 hp [122 kW] @ 5700 rpm, 184 lb-ft torque [248.4 N-m] @ 2500-3000 rpm) (STD)

Transmission, Continuously Variable (CVT) (STD)

This document contains information considered Confidential between GM and its Clients uniquely. The information provided is not intended for public disclosure. Prices, specifications, and availability are subject to change without notice, and do not include certain fees, taxes and charges that may be required by law or vary by manufacturer or region. Performance figures are guidelines only, and actual performance may vary. Photos may not represent actual vehicles or exact configurations. Content based on report preparer's input is subject to the accuracy of the input provided

Data Version: 25067. Data Updated: Mar 27, 2025 6:45:00 PM PDT.



Sid Dillon Fleet & Commercial

Ron Fullerton | 402-540-7578 | ron.fullerton@siddillon.com

Vehicle: [Fleet] 2025 Chevrolet Malibu (1ZC69) 4dr Sdn LS w/1LS (Complete)

Mechanical

- Engine control, stop-start system
- Axle, 5.10 final drive ratio
- Front wheel drive
- Suspension, front MacPherson strut
- Suspension, rear 4-link, independent
- Brakes, 4-wheel antilock, 4-wheel disc
- Brake rotors, Duralife
- Brake lining, high-performance, noise and dust performance
- Brake, parking, electronic
- Fueling system, capless
- Fuel door, push open

Exterior

- Wheels, 16" (40.6 cm) aluminum (STD)
- Tires, P205/65R16 all-season, blackwall
- Tire inflator kit
- Headlamp control, automatic on and off
- Headlamps, halogen
- IntelliBeam, automatic high beam on/off (Included with (WPS) Chevy Safety Assist.)
- Glass, acoustic, laminated, windshield
- Mirrors, outside power-adjustable, body-color, manual-folding

Entertainment

- Audio system, Chevrolet Infotainment 3 system, 8" diagonal color touchscreen, AM/FM stereo. Additional features for compatible phones include: Bluetooth audio streaming for 2 active devices, voice command pass-through to phone, Apple CarPlay and Android Auto capable. (STD)
- Audio system feature, 6-speaker system
- Display, 8" diagonal LCD touch screen
- Wireless Apple CarPlay/Wireless Android Auto
- Wi-Fi Hotspot capable (Terms and limitations apply. See onstar.com or dealer for details.)
- Antenna, Black

Interior

- Seats, front bucket (STD)

This document contains information considered Confidential between GM and its Clients uniquely. The information provided is not intended for public disclosure. Prices, specifications, and availability are subject to change without notice, and do not include certain fees, taxes and charges that may be required by law or vary by manufacturer or region. Performance figures are guidelines only, and actual performance may vary. Photos may not represent actual vehicles or exact configurations. Content based on report preparer's input is subject to the accuracy of the input provided.

Data Version: 25067. Data Updated: Mar 27, 2025 6:45 00 PM PDT.



Sid Dillon Fleet & Commercial

Ron Fullerton | 402-540-7578 | ron.fullerton@siddillon.com

Vehicle: [Fleet] 2025 Chevrolet Malibu (1ZC69) 4dr Sdn LS w/1LS (✔ Complete)

Interior

- Seat trim, Premium Cloth
- Seat adjuster, driver 6-way manual
- Seat adjuster, front passenger 6-way manual
- Seat, rear 60/40 split-folding
- Floor mats, carpeted front (Deleted when the following LPOs are ordered: PCH, PDH, RIA, VAV.)
- Floor mats, carpeted rear (Deleted when the following LPOs are ordered: PCH, PDH, RIA, VAV.)
- Steering wheel, 3-spoke
- Steering column, tilt and telescopic
- Steering wheel controls mounted controls for audio, phone and cruise
- Driver Information Center, monochromatic display
- Temperature display, outside
- Warning indicator, front passenger seat belt
- Windows, power with Express-Down on all
- Door locks, power programmable
- Keyless Start
- Keyless Open, front doors includes extended range Remote Keyless Entry
- Remote vehicle starter system
- Cruise control, electronic with set and resume speed
- Remote panic alarm
- Theft-deterrent system, content theft alarm
- Power outlet, auxiliary, 12-volt
- Air conditioning, single-zone manual
- Air filter, cabin
- Defogger, rear-window, electric
- Mirror, inside rearview manual day/night
- Visors, driver and front passenger vanity mirrors, covered
- Assist handle, front passenger
- Lighting, interior overhead courtesy lamp dual reading lamps and illuminated trunk area
- Map pocket, front passenger seatback
- Trunk cargo anchors

This document contains information considered Confidential between GM and its Clients uniquely. The information provided is not intended for public disclosure. Prices, specifications, and availability are subject to change without notice, and do not include certain fees, taxes and charges that may be required by law or vary by manufacturer or region. Performance figures are guidelines only, and actual performance may vary. Photos may not represent actual vehicles or exact configurations. Content based on report preparer's input is subject to the accuracy of the input provided.

Data Version: 25067. Data Updated: Mar 27, 2025 6:45:00 PM PDT.



Sid Dillon Fleet & Commercial

Ron Fullerton | 402-540-7578 | ron.fullerton@siddillon.com

Vehicle: [Fleet] 2025 Chevrolet Malibu (1ZC69) 4dr Sdn LS w/1LS (Complete)

Safety-Mechanical

StabiliTrak, stability control system with brake assist includes Traction Control

Front Pedestrian Braking (Included with (WPS) Chevy Safety Assist.)

Automatic Emergency Braking (Included with (WPS) Chevy Safety Assist.)

Braking control, ECM grade

Safety-Exterior

Daytime Running Lamps, integral to headlamps

Safety-Interior

Airbags, 10 total, frontal and knee for driver and front passenger, side-impact seat-mounted and roof rail-mounted head-curtain for front and rear outboard seating positions includes Passenger Sensing System (Always use seat belts and child restraints. Children are safer when properly secured in a rear seat in the appropriate child restraint. See the Owner's Manual for more information.)

OnStar services capable (See onstar.com for details and limitations. Services vary by model. Service plan required.)

Rear Park Assist (Included with (WPR) Drive Confidence Package.)

HD Rear Vision Camera (Rear Vision Camera display is not HD with IOR audio system.)

Lane Keep Assist with Lane Departure Warning (Included with (WPS) Chevy Safety Assist.)

Following Distance Indicator (Included with (WPS) Chevy Safety Assist.)

Forward Collision Alert (Included with (WPS) Chevy Safety Assist.)

Rear Seat Reminder

Buckle to Drive prevents vehicle from being shifted out of Park until driver seat belt is fastened; times out after 20 seconds and encourages seat belt use, can be turned on and off in Settings or Teen Driver menu

LATCH system (Lower Anchors and Tethers for CHildren) for child restraint seats

Door locks, rear child security

Trunk latch, safety, manual release

Tire Pressure Monitor System

Teen Driver a configurable feature that lets you activate customizable vehicle settings associated with a key fob, to help encourage safe driving behavior. It can limit certain available vehicle features, and it prevents certain safety systems from being turned off. An in-vehicle report card gives you information on driving habits and helps you to continue to coach your new driver

OnStar Basics (OnStar Fleet Basics for Fleet) Drive confidently with core OnStar services including remote commands, built-in voice assistance, real-time traffic and navigation, and Automatic Crash Response to help if you're in need. (OnStar Basics includes remote commands, Navigation, Voice Assistance, and Automatic Crash Response, for eligible vehicles with compatible software. For MY25 vehicles, OnStar Basics is standard for 8 years; OnStar plan, working electrical system, cell reception and GPS signal required. OnStar links to emergency services. Service coverage varies with conditions and location. Service availability, features and functionality vary by device and software version. See onstar.com for details and limitations.)

This document contains information considered Confidential between GM and its Clients uniquely. The information provided is not intended for public disclosure. Prices, specifications, and availability are subject to change without notice, and do not include certain fees, taxes and charges that may be required by law or vary by manufacturer or region. Performance figures are guidelines only, and actual performance may vary. Photos may not represent actual vehicles or exact configurations. Content based on report preparer's input is subject to the accuracy of the input provided.

Data Version: 25067. Data Updated: Mar 27, 2025 6:45:00 PM PDT.



402-643-3644

734 SEWARD ST PO BOX 425 SEWARD, NE 68434

Estimate

| | |
|------------|-----------|
| Date | 3/31/2025 |
| Estimate # | EST1653 |

| |
|--|
| Name / Address |
| EAST BUTLER CO SCHOOL PO BOX 36 212 S MADISON BRAINARD, NE 68626-0036 |

| | |
|--|--------------|
| Ship To | 402-429-8771 |
| 212 S MADISON PO BOX 36 BRAINARD, NE 68626 | |
| meldridge@cbutler.esu7.org | |

| | |
|-----|--|
| Rep | |
|-----|--|

| Item | Description |
|--------------|--|
| | Pleased to provide you this estimate for a used cubelet ice machine and bin. |
| F-450MAJ-C | HOSHIZAKI 450# MINI CUBELET ICE MACHINE AIR COOLED 115V WITH B-300SF BIN |
| MISCMATERIAL | MISC MATERIALS |
| ESTLABOR | LABOR ESTIMATE |
| FREIGHT | SHIPPING CHARGE |

| | | |
|---|-------------------------|------------|
| Lee's Refrigeration hereby proposes to furnish materials and labor in accordance with the above specifications. | Subtotal | \$5,881.00 |
| Thank you for your business. Let us know if you have any questions. | Sales Tax (6.5%) | \$0.00 |
| | Total | \$5,881.00 |

Signature _____



F-450MAJ(-C)

MODULAR ICE MACHINE
SLIM-LINE SERIES



F-450MAJ(-C)
08/03/23
Item # 13133

Item #: _____
Project: _____
Qty: _____
AIA#: _____

Features

- ▶ Durable stainless steel exterior
- ▶ Advanced CleanCycle24™ design 
- ▶ Stainless steel auger with greaseless bearing

- F-450MAJ - Up to 492 lbs. of ice production per 24 hours
- F-450MAJ-C - Up to 412 lbs. of ice production per 24 hours
- Mount two units, side-by-side, in only 44" of floor space for double the amount of ice production
- 2 second flush cycle every hour
- Flush cycle removes sediment for cleaner ice
- Infrared bin control for easy cleaning and reliability
- Not recommended for dispensing applications
- R-404A Refrigerant

Available on Bins:

B-250SF B-500SF B-800SF B-1150SS B-1500SS*
B-300SF B-700SF B-900SF B-1300SS B-1650SS*

Top kit may be required. See Bin Spec Sheets. *Two unit application only.

Warranty:

3 Year Parts & Labor on entire machine. 5 Year Parts on Compressor; air-cooled condenser coil. Valid in United States, Canada, Puerto Rico and U.S. Territories. Contact factory for warranty in other countries.

W x D x H
22" x 27^{3/8}" x 22"

F-450MAJ
Air-Cooled Flaker
Shown on optional bin B-300

F-450MAJ-C
Air-Cooled Cubelet

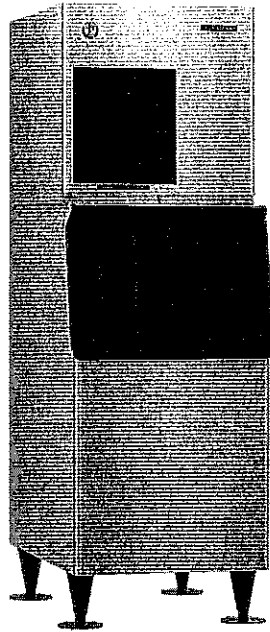

| Condenser | Model | ICE PRODUCTION | | Type of Ice | WATER USAGE | | ELECTRICAL | | | Heat Rejection BTU/hr. | Shipping Weight | ENERGY STAR® | |
|------------|------------|---|-----|-------------|--|--|------------------------------------|-----------------------------|----------|------------------------|-----------------|--------------|---------|
| | | Air / Water Temp Lbs. per 24 hours 70°/ 50°F 90°/ 70°F | | | Potable Gal. per 100 lbs. 90°/ 70°F | Condenser Gal. per 100 lbs. 90°/ 70°F | kWh Used per 100 lbs. 90°/ 70°F | Min. Circuit/Max. Fuse Size | Amperage | | | | Voltage |
| Air-Cooled | F-450MAJ | 492 | 395 | Flaked | 12.0 | N/A | 4.94 | 15A | 10.8A | 115V/60/1 | 4,700 | 170 lbs. | |
| Air-Cooled | F-450MAJ-C | 412 | 316 | Cubelet | 12.0 | N/A | 6.10 | 15A | 10.8A | 115V/60/1 | 4,700 | 170 lbs. | |

Cube Dimensions*

Flaked
F-450MAJ

Cubelet
F-450MAJ-C

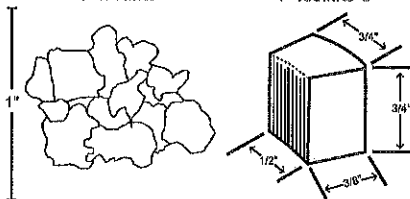

* approximate size in inches, image not to scale

Operating Limits

- Ambient Temp Range 45 - 100°F
- Water Temp Range 45 - 90°F
- Water Pressure 10 - 113 PSIG
- Voltage Range 104-127V
- If GFCI is required, a GFCI breaker MUST be used in lieu of GFCI receptacle

Service

- Panels easily removed and all components accessible for service.
- Removable/cleanable air filter (Air-cooled model only)
- Allow 6" (15 cm) clearance at rear and sides, and 24" (61 cm) clearance at top for proper air circulation and ease of maintenance/service.

Plumbing

- Icemaker Water Supply Line: Minimum 1/4" Nominal ID Copper Water Tubing or Equivalent
- Icemaker Drain Line: Minimum 3/4" Nominal ID Hard Pipe or Equivalent



F-450MAJ(-C)

Modular Ice Machine
Slim-Line Series



F-450MAJ(-C)
08/03/23
Item # 13133

FRONT VIEW
AIR-COOLED

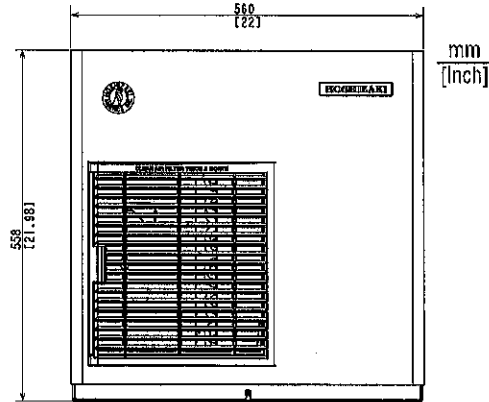

SIDE VIEW
AIR-COOLED

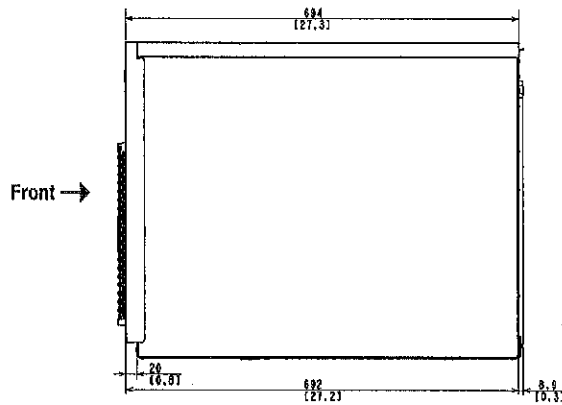

REAR VIEW
AIR-COOLED

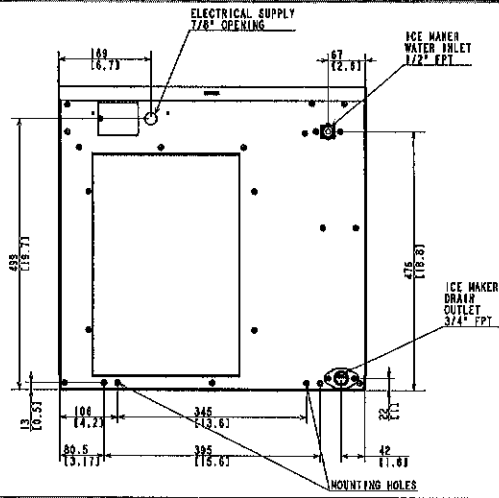

BOTTOM VIEW
AIR-COOLED

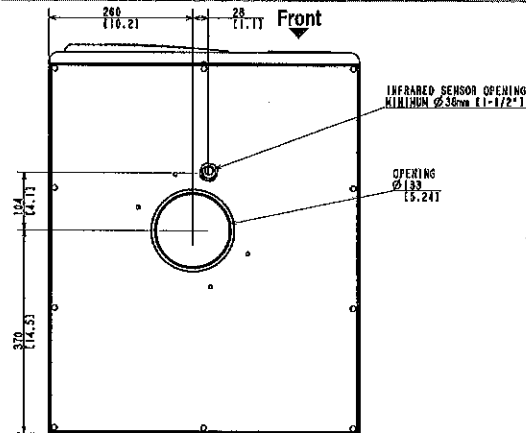



SF Bins

ICE STORAGE BIN SERIES



SF Bins
07/02/24
Item # 13163

Item #: _____
 Project: _____
 Qty: _____
 AIA#: _____

SF - Stainless Steel Finish

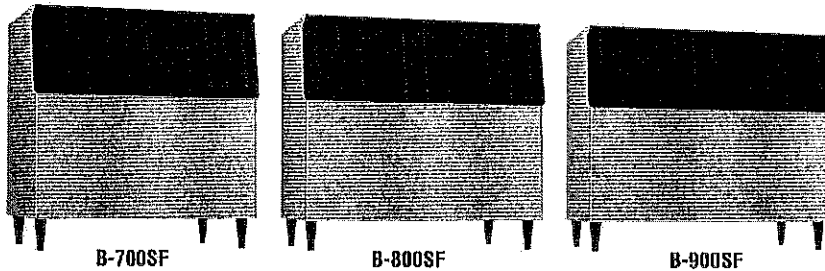
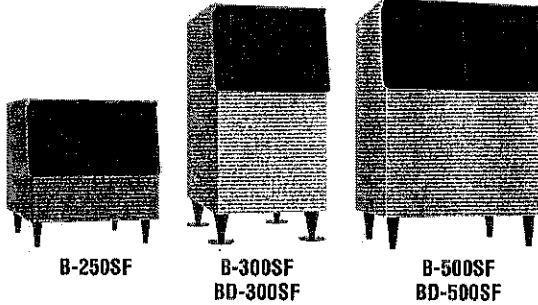

Features

- ▶ Polyethylene bin liner for sanitary storage
- ▶ Sturdy construction for side-by-side or stacked ice machine installation

- Ice storage capacity from 250 lbs. up to 900 lbs.
- Both surfaces are designed for easy cleaning
- Long lasting attractive appearance
- Foamed-in-place polyurethane insulation, in all bin walls and bottom, provides dependable ice storage
- H-GUARD Plus Antimicrobial adds extra protection to the ice scoop (included)

SF - Stainless Steel Finish

BD Bins

- Fit 24" - 24 1/2" deep ice machine without top kit extension

Warranty:

2 Year Parts & Labor (Production prior to January 2012)
 3 Year Parts & Labor (Production January 2012 and after)
 Valid in United States, Canada, Puerto Rico and U.S. Territories. Contact factory for warranty in other countries.



| Model Number | Exterior Dimensions W x D x H* | Interior Dimensions W x D x H | Application Storage Capacity† | Cubic Volume | Shipping Dimensions L x W x H | Shipping Weight (lbs.) |
|--------------|-----------------------------------|----------------------------------|----------------------------------|-----------------------|----------------------------------|------------------------|
| B-250SF | 30" x 32.3" x 33.4" | 27" x 27.7" x 23.7" | 250 lbs. | 10.30 ft ³ | 35" x 32" x 32" | — |
| B-300SF | 22" x 32.3" x 46" | 19" x 27.7" x 37.6" | 300 lbs. | 11.51 ft ³ | 35" x 24" x 45" | 125 |
| BD-300SF | 22" x 32.3" x 46" | 19" x 27.7" x 37.6" | 300 lbs. | 11.51 ft ³ | 35" x 24" x 45" | 130 |
| B-500SF | 30" x 32.3" x 46" | 27" x 27.7" x 37.6" | 500 lbs. | 16.33 ft ³ | 35" x 32" x 45" | 140 |
| BD-500SF | 30" x 32.3" x 46" | 27" x 27.7" x 37.6" | 500 lbs. | 16.33 ft ³ | 35" x 32" x 45" | 140 |
| B-700SF | 44" x 32.3" x 46" | 41" x 27.7" x 37.6" | 700 lbs. | 24.77 ft ³ | 46" x 35" x 45" | 175 |
| B-800SF | 48" x 32.3" x 46" | 45" x 27.7" x 37.6" | 800 lbs. | 26.90 ft ³ | 50.25" x 35" x 45" | 185 |
| B-900SF | 52" x 32.3" x 46" | 49" x 27.7" x 37.6" | 900 lbs. | 29.59 ft ³ | 54.5" x 35" x 45" | 195 |

*Height includes 6" legs

† Capacity based on volume x 30 lb/ft³ average density of ice.

Hoshizaki reserves the right to change specifications without notice.



SF Bins

ICE STORAGE BIN SERIES



SF Bins
07/02/24
Item # 13163

Ice Machine Model Application

| | 22" Width | 22" Width | 30" Width | 30" Width | 44" Width | 44" Width | 48" Width |
|-----------------------------------|--|---|---|---|---|--|--|
| | KM-350M KM-520M KM-660M F-450M F-801M F-1002M | KMD-410M [†] KMS-822M FD-650M-C [†] FD-1002M-C | KM-901M KM-1340M KM-1601M KML Series KMD-505M KMD-705M F-1501M F-2001 | KMD-460M [†] KMD-530M [†] KMD-860M [†] KMS-1402M [†] KMS-2000M [†] | 2 KM-350M 2 KM-520M 2 KM-660M 1M-500S 2 F-450M 2 F-801M 2 F-1002M | 2 KMD-410M 2 FD-650M-C 2 FD-1002M-C | KM-1301S KM-1400S KM-1601S KM-1900S KM-2200S KM-2600S |
| Bins B-300SF DB-130H | — | NEED HS-2153 HS-5424 <i>(KMD-410 on B-300 only)</i> | N/A | N/A | N/A | N/A | N/A |
| Bins B-250SF B-500SF | NEED HS-2033 | NEED HS-2033 & HS-2129 | — | NEED HS-2129 | N/A | N/A | N/A |
| Bins B-700SF | NEED HS-2035 | NEED HS-2035 & HS-2130 | NEED HS-2034 | NEED HS-2130 & HS-2034 | — | NEED HS-2130 <i>(KMD-410 does not apply)</i> | N/A |
| Bins B-800SF | NEED HS-2035 & HS-2032 | NEED HS-2035, HS-2032 & HS-2131 | NEED HS-2034 & HS-2032 | NEED HS-2131, HS-2034 & 2032 | NEED HS-2032 | NEED HS-2032 & HS-2131 | — |
| Bins B-900SF | NEED HS-2035 & HS-2033 | NEED HS-2035, HS-2033 & HS-2132 | NEED HS-2035 | NEED HS-2132 & HS-2035 | NEED HS-2033 | NEED HS-2033 & HS-2132 | NEED HS-2032 |
| Bins DB-200H DM-200B | NEED HS-2036 <i>(KM units only)</i> | N/A | — <i>(KML Series only)</i> NEED HS-2148 <i>(KMD Series on DB-200H only)</i> | N/A | N/A | N/A | N/A |

— No top kit necessary; | N/A Combination of ice maker and bin is not possible;

BD Bins fit 24" - 24 1/2" deep ice machine without Top Kit extension.

† BD-300SF: KMD-410M, KMS-822M, FD-650M-C, FD-1002M-C

† BD-500SF: KMD-460M, KMD-530M, KMD-860M, KMD-505M, KMD-705M

Top Kits:

- HS-2032 - 4" ABS Top Kit
- HS-2033 - 8" ABS Top Kit
- HS-2034 - 14" ABS Top Kit
- HS-2035 - 22" ABS Top Kit
- HS-2036 - (2) 4" ABS Top Kits
- HS-2066 - Seismic Kit for SD 500 Stands
- HS-2071 - Anchored Leg Kit SD 500 Stands
- HS-2111 - 11.3" x 26.2" Stainless Cover/Separator
- HS-2148 - 30" x 3.1" Stainless Cover
- HS-2153 - KMD-410 on B-300 bin
- HS-2160 - 2 KM-901M

B-250SF

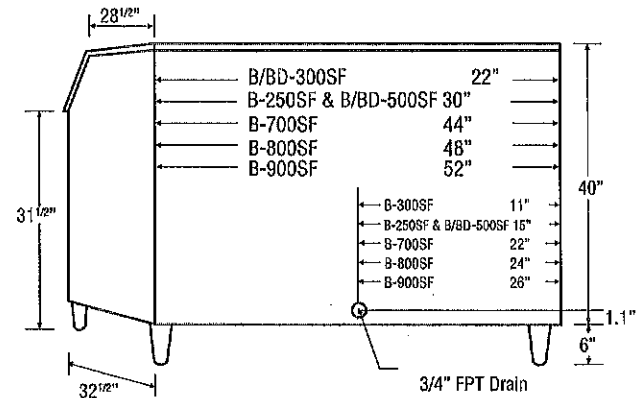
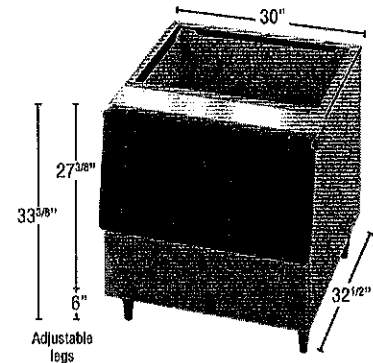

Ice Drop Area

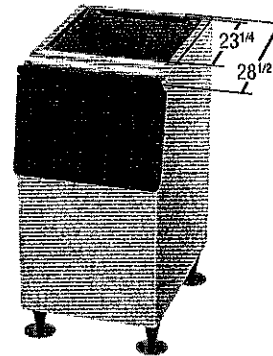

B Bins

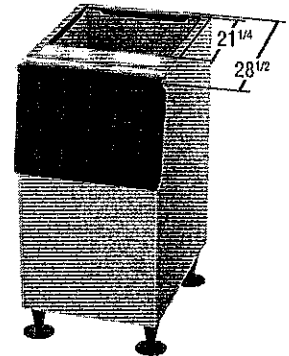

BD Bins

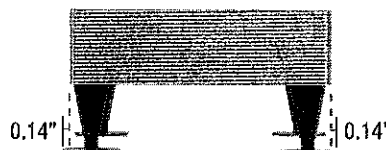

Bin Flanged Legs:
B/BD-300SF

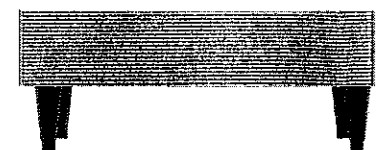

Bin Legs:
B-250SF, B/BD-500SF
B-700SF, B-800SF
B-900SF



402-643-3644

734 SEWARD ST PO BOX 425 SEWARD, NE 68434

Estimate

| | |
|------------|-----------|
| Date | 3/31/2025 |
| Estimate # | EST1654 |

| |
|--|
| Name / Address |
| EAST BUTLER CO SCHOOL PO BOX 36 212 S MADISON BRAINARD, NE 68626-0036 |

| | |
|--|--------------|
| Ship To | 402-429-8771 |
| 212 S MADISON PO BOX 36 BRAINARD, NE 68626 | |
| meldridge@ebutler.esu7.org | |

| | |
|-----|--|
| Rep | |
|-----|--|

| Item | Description |
|--------------|--|
| | Pleased to provide you this estimate for a new undercounter flaker ice machine. |
| F-330BAJ | HOSHIZAKI 300# UNDERCOUNTER FLAKER ICE MACHINE W/ BUILT-IN 80# BIN AIR COOLED 115V |
| MISCMATERIAL | MISC MATERIALS |
| ESTLABOR | LABOR ESTIMATE |
| FREIGHT | SHIPPING CHARGE |

| | | |
|---|-------------------------|------------|
| Lee's Refrigeration hereby proposes to furnish materials and labor in accordance with the above specifications. Thank you for your business. Let us know if you have any questions. | Subtotal | \$7,722.00 |
| | Sales Tax (6.5%) | \$0.00 |
| | Total | \$7,722.00 |

Signature _____

| | | |
|-------------------|---------------------------|--|
| QUOTE FOR: | East Butler School | PROJECT NAME: |
| DATE | 3/25/2025 | New Undercounter Flaker Ice Machine |
| PHONE | | |

| EQUIPMENT | MODEL NUMBER | QTY | COST | | SELL | | PROFIT | |
|------------------------|--------------|-----|-------|--------------|-------|--------------|--------------|-----|
| | | | EA | TOTAL | EA | TOTAL | GP | GP% |
| Hoshizaki | F-330BAJ | 1 | 4,801 | 4,801 | 6,241 | 6,241 | 1,440 | 23% |
| | | | | 0 | 0 | 0 | 0 | 0% |
| | | | | 0 | 0 | 0 | 0 | 0% |
| | | | | 0 | 0 | 0 | 0 | 0% |
| | | | | 0 | 0 | 0 | 0 | 0% |
| | | | | 0 | 0 | 0 | 0 | 0% |
| | | | | 0 | 0 | 0 | 0 | 0% |
| | | | | 0 | 0 | 0 | 0 | 0% |
| EQUIPMENT TOTAL | | | | 4,801 | | 6,241 | 1,440 | |

| MATERIAL | QTY | COST EA | TOTAL | SELL EA | TOTAL | GP | GP% |
|-----------------------|-----|---------|------------|---------|------------|------------|-----|
| Misc. Material | 1 | 150 | 150 | 255 | 255 | 105 | 41% |
| Filter | 1 | 224 | 224 | 381 | 381 | 157 | 41% |
| | | | 0 | 0 | 0 | 0 | 0% |
| | | | 0 | 0 | 0 | 0 | 0% |
| | | | 0 | 0 | 0 | 0 | 0% |
| | | | 0 | 0 | 0 | 0 | 0% |
| | | | 0 | 0 | 0 | 0 | 0% |
| | | | 0 | 0 | 0 | 0 | 0% |
| | | | 0 | 0 | 0 | 0 | 0% |
| | | | 0 | 0 | 0 | 0 | 0% |
| | | | 0 | 0 | 0 | 0 | 0% |
| | | | 0 | 0 | 0 | 0 | 0% |
| TOTAL MATERIAL | | | 374 | | 636 | 262 | |

| LABOR | HRS | COST/HR | TOTAL | SELL/HR | TOTAL | GP | GP% |
|--------------------|-----|----------|------------|---------|------------|------------|-----|
| DRIVE TIME | 1 | 75 | 75 | 110 | 110 | 35 | 32% |
| LABOR | 6 | 75 | 450 | 110 | 660 | 210 | 32% |
| TOTAL LABOR | | 7 | 525 | | 770 | 245 | |

| TOTALS | COST | SELL | GP | GP% |
|-------------------|--------------|--------------|--------------|------------|
| EQUIPMENT | 4,801 | 6,241 | 1,440 | 23% |
| MATERIAL | 374 | 636 | 262 | 41% |
| LABOR | 525 | 770 | 245 | 32% |
| EQUIPMENT RENTAL | 150 | 0 | 0 | 0% |
| EXTENDED WARRANTY | | 0 | 0 | 0% |
| ELECTRICAL | | 0 | 0 | 0% |
| CRANE | | 0 | 0 | 0% |
| FREIGHT | 75 | 75 | 0 | 0% |
| PERMIT | | 0 | 0 | 0% |
| SUBTOTAL | 5,775 | 7,722 | 1,947 | 32% |
| SALES TAX | 0.0000 | 0 | 0 | |
| TOTAL | | 7,722 | | 32% |

| | | | |
|-------------------------|---------------------------|-----------------------------|---------------------------|
| Lease Calculator | Lease Purchase 37m | Lease Purch w/ clean | Straight Lease 24m |
| Bi-Annual Cleaning \$54 | \$270 | \$324 | \$278 |



F-330BAJ(-C)

**SELF-CONTAINED ICE MACHINE
BUILT-IN STORAGE BIN**



F-330BAJ(-C)
07/02/24
Item # 13200

Item #: _____
Project: _____
Qty: _____
AIA#: _____

W x D x H
24" x 26" x 39"*
*with 6" legs

Shipping Dimensions
33" x 25 1/4" x 38 1/2"

F-330BAJ
Air-Cooled

F-330BAJ-C
Air-Cooled

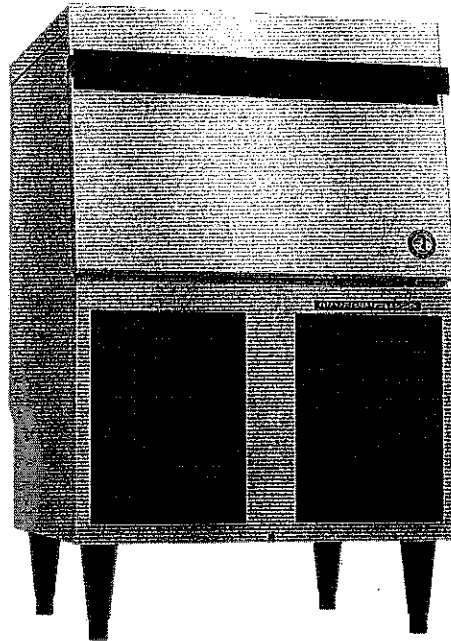

Features

- ▶ Front breathing allows for easier fit into tight spaces
- ▶ Durable stainless steel exterior
- ▶ Stainless steel auger with greaseless bearing

- F-330BAJ - Up to 332 lbs. of ice production per 24 hrs.
- F-330BAJ-C - Up to 288 lbs. of ice production per 24 hrs.
- Built-in storage capacity of 2.7ft³/80 lbs.*
- Advanced CleanCycle24™ design 
- 2 second flush cycle every hour
- Convenient drop down door
- Front access for easier maintenance
- Removable air filters
- Equipped with 8 ft. cord with NEMA 5-15P Plug
- R-404A Refrigerant

Warranty:

3 Year Parts & Labor on entire machine. 5 Year Parts on Compressor; air-cooled condenser coil. Valid in United States, Canada, Puerto Rico and U.S. Territories. Contact factory for warranty in other countries.

*Rated in accordance with AHRI Standard 820(I-P). Capacity based on 100% of total volume x 30 lb/ft³ average density of ice.



| Condenser | Model | ICE PRODUCTION | | WATER USAGE | | ELECTRICAL | | | | | | |
|-----------|-------------------------|--|-----------|---|---|---------------------------------------|------------------------------------|----------|-----------|---------------------------|------------------------------|-----------------------------|
| | | Air / Water Temp Lbs. per 24 hours 70°/ 50°F | 90°/ 70°F | Potable Gal. per 100 lbs. 90°/ 70°F | Condenser Gal. per 100 lbs. 90°/ 70°F | kWh Used per 100 lbs. 90°/ 70°F | Min. Circuit/ Max. Fuse Size | Amperage | Voltage | Heat Rejection BTU/hr. | Refrigerant Charge Amount | Net / Ship Weight (lbs.) |
| Air | F-330BAJ (Flaker) | 332 | 243 | 12.0 | N/A | 5.91 | 15A | 6.9A | 115V/60/1 | 3,400 | 7.1 oz | 147 / 178 |
| Air | F-330BAJ-C (Cubelet) | 288 | 214 | 12.0 | N/A | 7.30 | 15A | 7.1A | 115V/60/1 | 3,400 | 7.1 oz | 148 / 178 |

Cube Dimensions*

Flaked
F-330BAJ

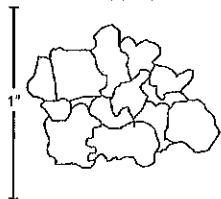

Cubelet
F-330BAJ-C

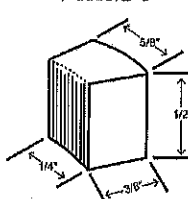

* approximate size in inches, image not to scale

Operating Limits

- Ambient Temp Range 45 - 100°F
- Water Temp Range 45 - 90°F
- Water Pressure 10 - 113 PSIG
- Voltage Range 104-127V
- If GFCI is required, a GFCI breaker MUST be used in lieu of GFCI receptacle

Service

- Panels easily removed and all components accessible for service.
- Removable/cleanable air filter (Air-cooled model only)
- Allow 24"(61 cm) clearance at top for removal of auger.
- Appliance should not be located next to high heat producing equipment.

Plumbing

- Icemaker Water Supply Line: Minimum 1/4" Nominal ID Copper Water Tubing or Equivalent
- Icemaker Drain Line: Minimum 3/4" Nominal ID Hard Pipe or Equivalent



F-330BAJ(-C)

**SELF-CONTAINED ICE MACHINE
BUILT-IN STORAGE BIN**



F-330BAJ(-C)
07/02/24
Item # 13200

FRONT VIEW
AIR-COOLED

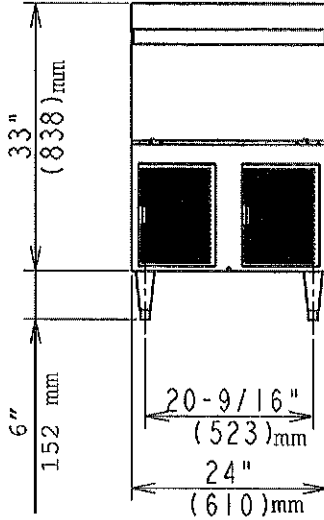

SIDE VIEW

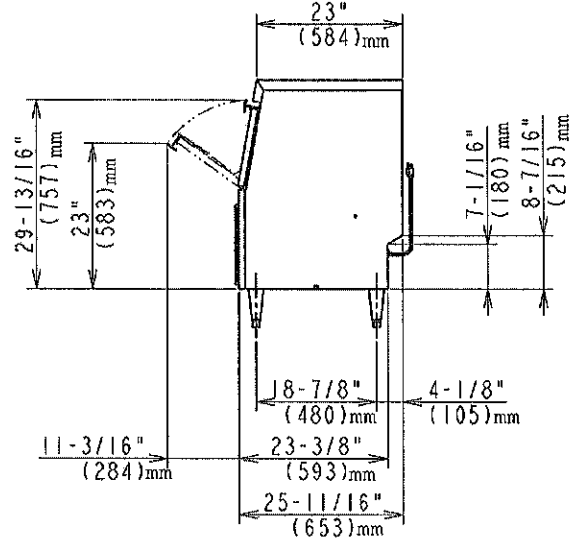

TOP VIEW
AIR-COOLED

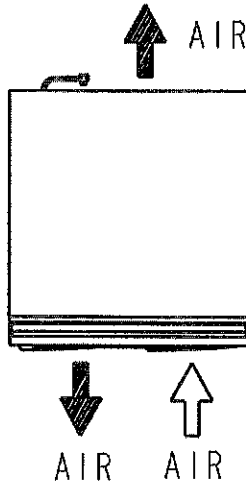

REAR VIEW
AIR-COOLED

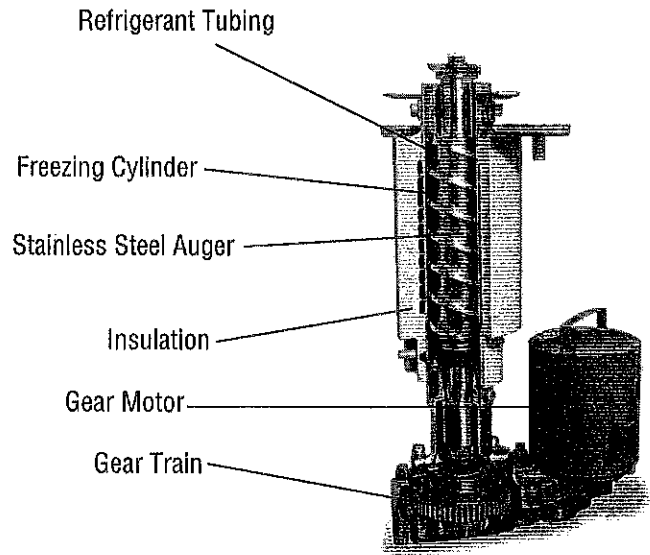
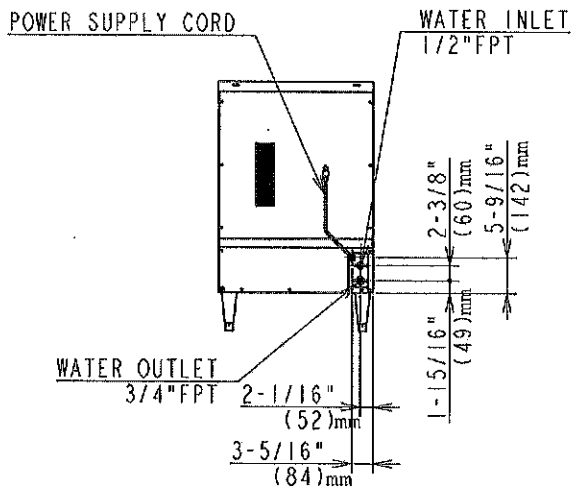

EVAPORATOR



402-643-3644

734 SEWARD ST PO BOX 425 SEWARD, NE 68434

Estimate

| | |
|------------|-----------|
| Date | 3/31/2025 |
| Estimate # | EST1657 |

| |
|--|
| Name / Address |
| EAST BUTLER CO SCHOOL PO BOX 36 212 S MADISON BRAINARD, NE 68626-0036 |

| | |
|--|--------------|
| Ship To | 402-429-8771 |
| 212 S MADISON PO BOX 36 BRAINARD, NE 68626 | |
| meldridge@ebutler.csu7.org | |

| | | |
|--|-----|--|
| | Rep | |
|--|-----|--|

| Item | Description |
|--------------|---|
| | Pleased to provide you this estimate for a new ice machine and bin. |
| KMD-705MAJ | HOSHIZAKI 700LB AIR COOLED ICE MACHINE 30" x 24" 115V |
| B-800SF | HOSHIZAKI 800LB STAINLESS STEEL ICE STORAGE BIN |
| MISCMATERIAL | MISC MATERIALS |
| ESTLABOR | LABOR ESTIMATE |
| FREIGHT | SHIPPING CHARGE |

| | | |
|---|-------------------------|-------------|
| Lee's Refrigeration hereby proposes to furnish materials and labor in accordance with the above specifications. | Subtotal | \$10,698.00 |
| Thank you for your business. Let us know if you have any questions. | Sales Tax (6.5%) | \$0.00 |
| | Total | \$10,698.00 |

Signature _____

QUOTE FOR: East Butler School PROJECT NAME:
 DATE 3/25/2025 Ice Machine And New Bin
 PHONE

| EQUIPMENT | MODEL NUMBER | QTY | COST | | SELL | | PROFIT | |
|------------------------|--------------|-----|-------|--------------|-------|--------------|--------------|-----|
| | | | EA | TOTAL | EA | TOTAL | GP | GP% |
| lctro | IM-0750-AC | | 3,385 | 0 | 4,401 | 0 | 0 | 0% |
| lctro | IB-085-48 | | 1,702 | 0 | 2,213 | 0 | 0 | 0% |
| lctro | IBT-3048B | | 127 | 0 | 241 | 0 | 0 | 0% |
| | | | | 0 | 0 | 0 | 0 | 0% |
| Hoshizaki | KMD-705MAJ | 1 | 4,646 | 4,646 | 6,040 | 6,040 | 1,394 | 23% |
| Hoshizaki | B-800SF | 1 | 1,748 | 1,748 | 2,272 | 2,272 | 524 | 23% |
| | | | | 0 | 0 | 0 | 0 | 0% |
| | | | | 0 | 0 | 0 | 0 | 0% |
| | | | | 0 | 0 | 0 | 0 | 0% |
| EQUIPMENT TOTAL | | | | 6,394 | | 8,313 | 1,918 | |

| MATERIAL | | QTY | COST EA | TOTAL | SELL EA | TOTAL | GP | GP% |
|-----------------------|---------|-----|---------|------------|---------|--------------|------------|-----|
| Misc. Material | HS-2131 | 1 | 227 | 227 | 385 | 385 | 159 | 41% |
| Filter | HS-2134 | 1 | 215 | 215 | 366 | 366 | 151 | 41% |
| | HS-2032 | 1 | 128 | 128 | 244 | 244 | 115 | 47% |
| Misc. Material | | 1 | 100 | 100 | 190 | 190 | 90 | 47% |
| Filter | 9324-01 | 1 | 224 | 224 | 381 | 381 | 157 | 41% |
| | | | | 0 | 0 | 0 | 0 | 0% |
| | | | | 0 | 0 | 0 | 0 | 0% |
| | | | | 0 | 0 | 0 | 0 | 0% |
| | | | | 0 | 0 | 0 | 0 | 0% |
| | | | | 0 | 0 | 0 | 0 | 0% |
| | | | | 0 | 0 | 0 | 0 | 0% |
| | | | | 0 | 0 | 0 | 0 | 0% |
| TOTAL MATERIAL | | | | 894 | | 1,565 | 671 | |

| LABOR | | HRS | COST/HR | TOTAL | SELL/HR | TOTAL | GP | GP% |
|--------------------|--|----------|---------|------------|---------|------------|------------|-----|
| DRIVE TIME | | 1 | 75 | 75 | 110 | 110 | 35 | 32% |
| LABOR | | 6 | 75 | 450 | 110 | 660 | 210 | 32% |
| TOTAL LABOR | | 7 | | 525 | | 770 | 245 | |

| TOTALS | | COST | SELL | GP | GP% |
|-------------------|--------|-------|---------------|-------|------------|
| EQUIPMENT | | 6,394 | 8,313 | 1,918 | 23% |
| MATERIAL | | 894 | 1,565 | 671 | 43% |
| LABOR | | 525 | 770 | 245 | 32% |
| EQUIPMENT RENTAL | | 150 | 0 | 0 | 0% |
| EXTENDED WARRANTY | | | | 0 | 0% |
| ELECTRICAL | | | | 0 | 0% |
| CRANE | | | | 0 | 0% |
| FREIGHT | | 50 | 50 | 0 | 0% |
| PERMIT | | | | 0 | 0% |
| SUBTOTAL | | 7,863 | 10,698 | 2,835 | 33% |
| SALES TAX | 0.0000 | 0 | 0 | | |
| TOTAL | | | 10,698 | | 33% |

| | | | |
|-------------------------|--------------------|----------------------|--------------------|
| Lease Calculator | Lease Purchase 37m | Lease Purch w/ clean | Straight Lease 24m |
| Bi-Annual Cleaning \$54 | \$374 | \$428 | \$364 |



KMD-705M_J(Z)

KMD-705M_J(Z)
08/03/23
Item # 13684

MODULAR CRESCENT CUBER

W x D x H
30" x 24" x 26"



KMD-705MAJ
Air-Cooled model shown
on optional bin B-500

KMD-705MWJ
Water-Cooled

KMD-705MRJZ
Remote Air-Cooled

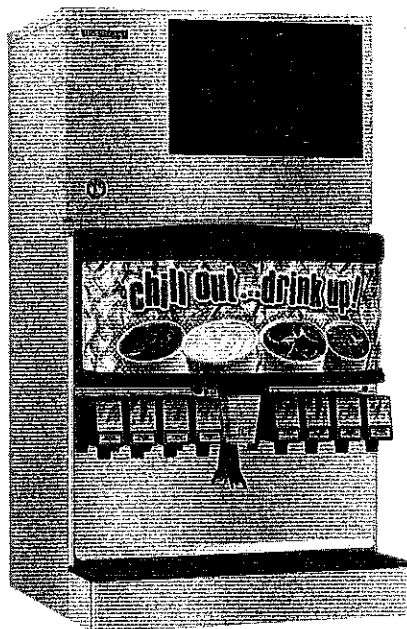

KMEdge™ Cube Dimensions*

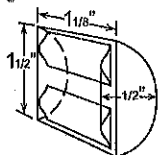

* approximate size in inches, image not to scale



Item #: KMD-705MAJ

Project: East Gate

Qty: 1

AIA#:

Features

- ▶ Individual crescent cube
- ▶ Optimized for use with ice and beverage dispenser
- ▶ Simple one-hour cleaning CLEANASSIST
- ▶ Factory-installed ultrasonic bin control can be adjusted on site
- Durable construction with fewer parts
- Self-diagnostic programming automatically adjusts to changing conditions
- Snap fit parts for easy cleaning
- Stainless steel double-sided evaporator
- CycleSaver™ design
- EverCheck™ alert system
- Removable air filters (air-cooled model only)
- R-404A Refrigerant

Available on Bins:

| | | | |
|----------|----------------|------------|-----------|
| B-250SF | B-700SF | B-1150SS | B-1650SS* |
| B-500SF | B-800SF | B-1300SS | DB-200H |
| BD-500SF | B-900SF | B-1500SS** | DM-200B |

Top kit may be required. See Bin Spec Sheets. *Two unit application only.

Warranty:

3 Year Parts & Labor on entire machine. 5 Year Parts & Labor on Evaporator. 5 Year Parts on Compressor; air-cooled condenser coil. Valid in United States, Canada, Puerto Rico and U.S. Territories. Contact factory for warranty in other countries.

Shipping: (LxWxD) 33.75" x 33.25" X 32" Volume: 20.78ft³

| Condenser | Model | ICE PRODUCTION | | WATER USAGE | | ELECTRICAL | | | | | | | |
|-----------|-------------|--|------------------------------------|--------------------------------------|--------------------------------|-----------------------------|----------|---------|----------------------------------|------------------------|---------------------------|--|-----------|
| | | Air / Water Temp Lbs. per 24 hours 70°/50°F 90°/70°F | Potable Gal. per 100 lbs. 90°/70°F | Condenser Gal. per 100 lbs. 90°/70°F | kWh Used per 100 lbs. 90°/70°F | Min. Circuit/Max. Fuse Size | Amperage | Voltage | Circuit Wires (including ground) | Heat Rejection BTU/hr. | Refrigerant Charge Amount | Net / Ship Weight (lbs.) | |
| Air | KMD-705MAJ | 721 | 620 | 22.0 | N/A | 4.75 | 20A | 14.3A | 115V/60/1 | 3 | 9,400 | 2 lb. 12.1 oz. | 180 / 200 |
| Water | KMD-705MWJ | 773 | 720 | 22.5 | 93 | 3.8 | 20A | 13.0A | 115V/60/1 | 3 | 9,500 | 1 lb. 11.3 oz. | 180 / 200 |
| Remote | KMD-705MRJZ | 727 | 670 | 21.0 | N/A | 4.40 | 20A | 13.7A | 115V/60/1 | 3 | 9,500 | 6 lb. 12.3 oz. 10 lb. 11.1 oz. [†] | 180 / 200 |

† (with condenser)

Operating Limits

- Ambient Temp Range 45 - 100°F
- Water Temp Range 45 - 90°F
- Water Pressure 10 - 113 PSIG
- Voltage Range 104 - 127V
- If GFCI is required, a GFCI breaker MUST be used in lieu of GFCI receptacle

Service

- Panels easily removed and all components accessible for service.
- Removable/cleanable air filters. (Air-cooled model only)
- Allow 6" (15 cm) clearance at rear, sides, and top for proper air circulation and ease of maintenance/service.

Plumbing

- Ice-maker Water Supply Line: Min. 1/4" Nominal ID Copper Water Tubing or Equivalent
- Ice-maker Drain Line: Min. 3/4" Nominal ID Hard Pipe or Equivalent Water-Cooled Model (Lines Must Be Independent of Ice-maker)
- Condenser Water Supply Line: Minimum 1/4" Nominal ID Copper Water Tubing or Equivalent
- Condenser Drain/Return Line: Minimum 1/4" Nominal ID Hard Pipe (open drain system) or Copper Water Tubing (closed loop system) or Equivalent

Accessories

- HS-2148, DB Top Kit
- HS-5562, Remote Monitoring System
- HS-5283, Eco Ice Filter
- HS-5734, Side-Breathing Kit
- H9320-51, Single Water Filter Kit

Hoshizaki reserves the right to change specifications without notice.



KMD-705M_J(Z)

KMD-705M_J(Z)
08/03/23
Item # 13684

MODULAR CRESCENT CUBER

FRONT VIEW

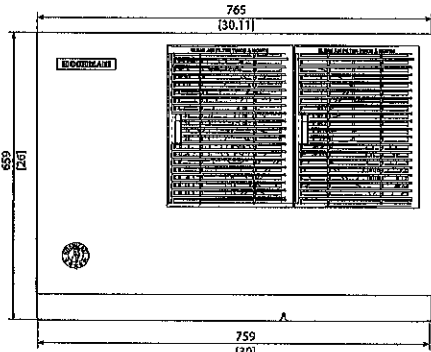

AIR-COOLED

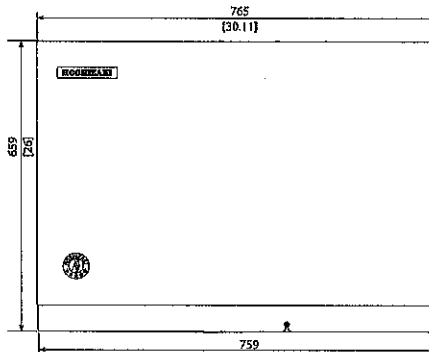

WATER-COOLED / REMOTE AIR-COOLED

mm
Inch

SIDE VIEW

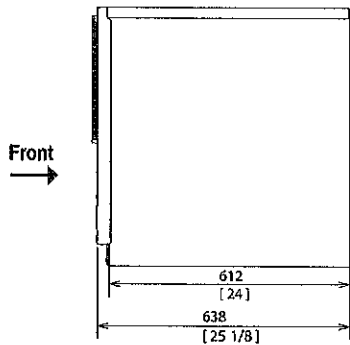

AIR-COOLED

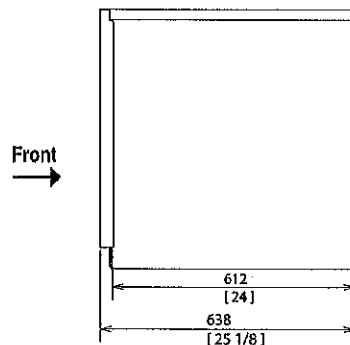

WATER-COOLED / REMOTE AIR-COOLED

BOTTOM VIEW

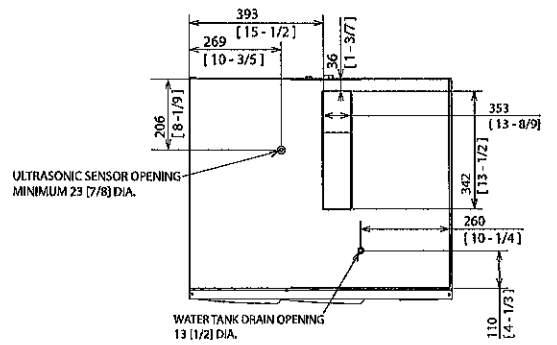

AIR-COOLED / WATER-COOLED / REMOTE AIR-COOLED

REAR VIEW

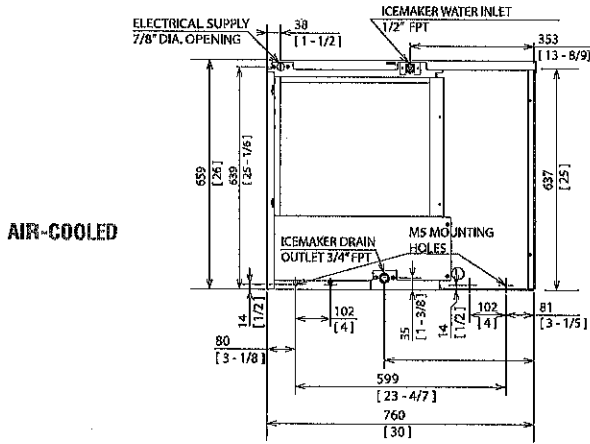

AIR-COOLED

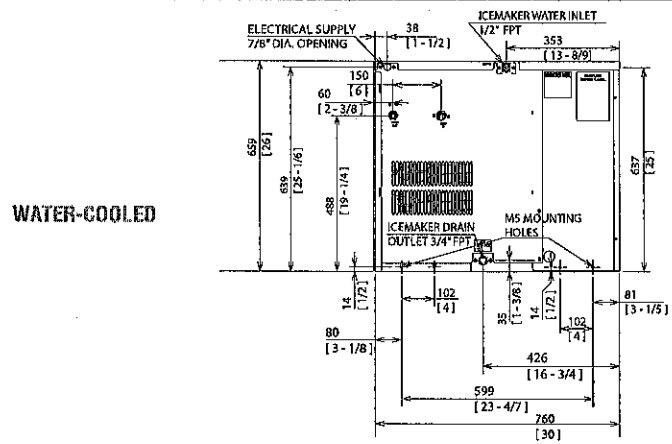

WATER-COOLED

REMOTE AIR-COOLED

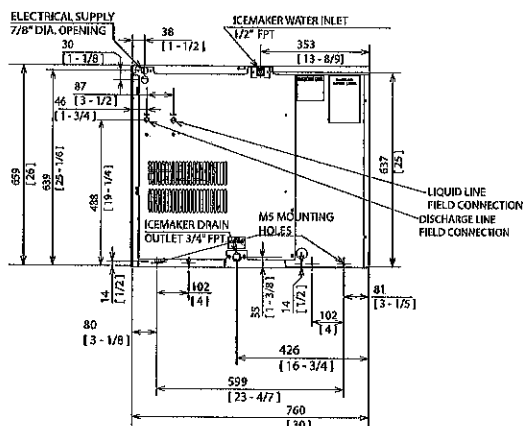

REMOTE CONDENSER
For Use with KMD-705MRJZ

URC-9FZ Remote Condenser (Sold Separately)
(W x D x H) 35 11/16 x 14 1/16 x 36 1/2

Brazer Line Sets (Sold Separately)
25' HS-5504
36' HS-5505
55' HS-5506

Voltage supply for the URC Remote Condenser is supplied from the Ice Maker. No additional circuit is required.

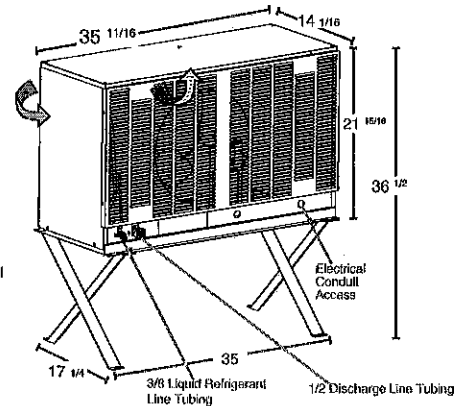

Peitzmeier Demolition and Concrete Cutting, Inc.

6950 N 94th Plaza, Omaha, NE 68122 • Email: evan.dwyer@peitzdemo.com
Cell Phone: 402.709.3599 • Office Phone: 402.346.9297 Office Fax: 402.345.1079

| | |
|---|--------------------------------|
| Company: East Butler Public School ATTN: Michael Eldridge | Job Title: Brainard House Demo |
| Phone number: | Addendums: |
| Email: meldridge@ebutler.esu7.org | Bid Date: 4.02.2025 |

We Propose the Following:

1. Demolition of 203 S Madison Street: **\$22,400.00**
 - a. Includes removal of out building / barn.
 - b. Deduct \$2,850.00 if house and outbuilding are burned down by others.
2. Demolition of 211 S Madison Street: **\$10,200.00**
 - a. There is limited information for this property on the Butler County Assessor website.
 - b. Assumes no basement.
 - c. Excludes demolition of detached garage.
 - d. Deduct \$1,600 if house is burned down by others.

Project specific exclusions:

- Excludes asbestos abatement and handling hazardous materials.
- Excludes utility disconnects.
- Excludes site demolition and tree removals.
- Excludes backfilling the basement of 203 S Madison.

Base Bid: \$32,600.00

Exclusions: MEP Draining & Disconnects, Temporary Protection, Handling Hazardous & Contaminated Waste & Materials, Removal of FF&E, Unspecified Credentials, Testing & Inspections, Removal & Replacement of Unsuitable Soils, Fine Grading, Footing or Structure Excavation & Backfill, Granular Material, Surveying or Layout, Potholing Utilities, Private Utility Locates, Shoring, Bracing, Underpinning, Dewatering, Utility Work, Construction Fence & Gates, Pedestrian & Vehicular Traffic Control, Migratory Species Survey, SWPPP Control Measures & Permit, Site Restoration, Winter Conditions, Bond

This proposal is valid for Forty-Five (45) days from the above bid date.

Proposal completed by: Evan Dwyer



Proposal

Proposal Number

2112090118

Account Number/Name

42098

EAST BUTLER PUBLIC SCHOOLS

Created On

04/07/2025

Created By

Jason Trotter

Thank you for creating your proposal, details are provided below. You can access this proposal from your Apple Store for Education Institution by searching proposal number 2112090118.

| Item | Product / Description | Total Quantity | Unit Price | Total Price |
|------|--|----------------|------------|--------------|
| 1 | MD6L4LL/A 11-inch iPad Wi-Fi 128GB - Silver (Packaged in a 10-pack) | 20 | 324.00 | 6,480.00 USD |

| | |
|---------------|---------------------|
| Subtotal | 6,480.00 USD |
| Estimated Tax | 0.00 USD |
| Total | 6,480.00 USD |

Please note that your order subtotal does not include sales tax or rebates. Sales tax and rebates, if applicable, will be added when your order is processed. Your order total may include estimated sales tax that is subject to change at the time your order is processed.

How to Order

If you would like to convert this Proposal to an order, log into your Apple Store for Education Institution and select 'Proposal' from the pull-down menu. Search for this Proposal by entering the Proposal Number referenced above.

Note: A Purchaser login is required to order. Visit your Apple Store for Education Institution to login or create your Purchaser Apple ID.

The prices and specifications above correspond to those valid at the time the Proposal was created and are subject to change. Purchases are subject to the terms and conditions of your agreement with Apple and the Apple Store for Education Institution.



**Secondary Principal Report
April 2025 – School Board Meeting**

- I. Senior Class Information**
 - A. April 30th, the Senior class will go on their class trip to Topgolf. Their class account will cover the expenses.
 - B. May 2 Seniors vs. Staff 1:30 PM
 - C. May 7 Seniors' last day
 - D. May 10 Graduation at 2:00 PM
 - E. Erin Roh will be the photographer for graduation, and the ceremony will be shown on YouTube.

- II. 9th Grade Registration**
 - A. The current 8th grade class met on March 31 to cover class offerings. Parents and students were in attendance. We had a high turnout 30 out of 32 students were in attendance.

- III. ACT Test March 25**
 - A. The Junior class took the ACT on March 25 at the Klein Center.
 - B. Juniors prepped for the class using the John Baylor Test Prep Course.

- IV. Assessment Dates**
 - A. NSCAS Testing – 7th and 8th grade students will be tested in the following areas and dates: ELA – April 1-4, Math – April 8 and 9, and Science the week of April 14.
 - B. NWEA Maps Testing – The test date is April 30. This has changed from what we've done in years past. Due to Jr. High and High School track meets, we will not be able to have the two days of testing. We have created a schedule to complete all testing in one day.

- V. State Competitions**
 - A. We had two qualifiers in State Speech. Faye Belew and Hannah Strizek. Hannah placed third at state in Serious Prose.
 - B. FFA State – April 2 – 4.
 - C. FCCLA State April 6 – 8.
 - D. SkillsUSA – April 10 – 12.
 - E. Esports – April 11

Elementary Principal Report April Board Meeting



I. PK/Kindergarten Round-Up

- A. Kindergarten Registration and Round-Up was in Dwight on March 24 and in Brainard on March 27 at 6:30 p.m.
- B. Current Registered Kindergarten Numbers:
 - 1. Dwight - 11 Students
 - 2. Brainard - 12 Students
- C. Preschool Registration and Round-Up will take place in Dwight on April 7 and Brainard April 14 from 6:30-7:30.
- D. Anticipated Preschool Numbers:
 - 1. Dwight - 11-13 Students
 - 2. Brainard - 20 Students

II. Cultural Arts Field Trip

- A. Grades K-3 students will be attending a cultural arts field trip on April 23 organized by Mrs. Hines. Students will be attending a performance at the Rose Theater.
- B. Grades 4-6 attended and cultural arts field trip on April 2 in Omaha. Students attended a performance by the Omaha Symphony at the Holland Center. Tatum Tejral and CeCe Svoboda performed with the symphony. Students also toured the newly remodeled Joslyn Art Museum.

III. Spring Music Programs

- A. Friday, April 4 - Brainard Elementary Program 7:00 p.m.
- B. Friday, April 11 - Dwight Elementary Program 7:00 p.m.
- C. Monday, April 14 - High School Pre-contest Concert 6:30 p.m.
- D. Friday, May 5 - 5-12th Grade Band Concert 7:00 p.m.

IV. Assessment Schedule

- A. NSCAS - Gr. 3-6 Reading - April 15-16
- B. NSCAS - Gr. 3-6 Math - April 23-24
- C. NSCAS - Gr. 5 Science - April 29-30
- D. Acadience Testing – May 5-9
- E. NWEA Testing - May 5-9

V. In-School Savings Program

- A. East Butler students involved with the in-school savings program were invited to the state capital to participate in a proclamation signing designating April as financial awareness month. Students also toured the capitol and listened to a presentation by Julia Cook, author of “I am Money.” The “Stellar Tellers” for the year were also recognized. Congratulations to Hannah Buresh and Dylan Patocka!

