

Regular Agenda

Date: Thursday, March 5, 2020

Meeting: Committee of the Whole with a closed session as per OMA and 5ILCS120/2c

Time: 5:00 PM

Location: District Office
650 Dr. John Burkey Drive
Algonquin, IL 60102

Mission Statement: Our learning community will inspire, challenge and empower all students always.

Board of Education Members: President, Mr. Anthony Quagliano; Vice President, Mr. Kevin Gentry; Secretary, Mr. Paul Troy; Mr. William Geheren; Mrs. Melissa Maiorino; Mrs. Lesli Melendy; Mr. Sean Cratty.

Agenda

All times are approximate. D=Discussion, R=Report, A=Action

1. **Call to Order / Roll Call (A)** (Mr. Fleck)

Call to Order the Committee of the Whole meeting for Thursday, March 5, 2020 at __ p.m.

A quorum must be met. **Roll Call:** Ayes / Absent / **Motion** __

2. **Closed Session / Roll Call (A)** (Mr. Fleck)

Move to enter into Closed Session at __ p.m. as indicated in the Open Meetings Act and 5ILCS120/2c for discussion of: (1) The appointment, employment, discipline, performance, or dismissal of specific employees or legal counsel; (2) Collective negotiating matters; (9) Student Disciplinary; (11) Litigation; (21) Discussion of minutes of meetings lawfully closed under this Act.

Roll Call: Ayes / Nays / Absent / **Motion** __

3. **Exit Closed Session / Voice Call (A)** (Mr. Fleck)

Move to exit closed session at __ p.m. and return to open session. **Voice Call:** Ayes / Nays / **Motion** __

4. **Resume in Public Session / Roll Call (A)** (Mr. Fleck)

Resume the Committee of the Whole meeting at __ p.m. **Roll Call:** Ayes / Absent / **Motion** __

5. **Pledge of Allegiance** (Mr. Fleck)

The following students from Mackeben Elementary School will lead us in the Pledge: Zander Lapointe, Kendall Garifo, Callie Isaac, Reagan Rogers, Cameron Berends, Isla Wright, Jacob Pilati, CJ Meyers, Jace Wallace.

6. **Public Comment**

As per Policy 2:230, public comment can be made during this portion of the meeting

7. **Revision and Adoption of the Agenda (A)** (Mr. Fleck)

Motion to adopt the agenda as presented or with changes. **Voice Call:** Ayes / Nays / **Motion** __

8. **Curriculum & Instruction (C&I) Committee** (Mr. Geheren-chair, Mr. Gentry, Mr. Troy)

1. **Vanguard Vision Competency Based Education Update (R)** (Dr. Schlichter) 3

Dr. Schlichter will provide an update on the progress of the Vanguard Vision program at HHS, including progress toward scaling the program to its third year.

9. **Finance Committee** (Mr. Quagliano-chair, Mr. Gentry, Mr. Fleck)

1. **Payables (A)** (Mr. Altmayer) 4

The Finance Committee is submitting the purchase orders at \$415,873.95; imprest checks at \$96,516.29; accounts payable at \$1,426.31; and disbursements issued at \$2,726,430.89; for review and seeking approval to move forward.

2. **Monthly Fiscal Updates (R)** (Mr. Altmayer) 91

Mr. Altmayer will provide the monthly fiscal updates and the Activity Fund Balance Report.

3. **Revenue & Expenditures Report (R)** (Mr. Altmayer) 102

Monthly report for review and comment.

4. **Revenue Contract (A)** (Mr. Altmayer)

Mr. Altmayer will seek approval of the fundraising contracts as presented.

5. **Extra-Curricular Committee Recommendations (A)** (Mr. Altmayer) 124
 The Huntley Extra-Curricular Committee reviewed and recommended additional stipend positions for the 2020-2021 school year.
10. **Human Resources (HR) Committee** (Mr. Gentry-chair, Mrs. Melendy, Mr. Quagliano)
1. **Monthly Human Resources Updates (R)** (Mr. Zehr) 126
 Mr. Zehr will provide the monthly Human Resources updates.
 2. **Reduction of Extra Contract Days (R)** (Mr. Zehr) 127
 Mr. Zehr will present information concerning the Reduction of Extra Contract Days. A resolution will be presented at the next regular meeting seeking approval of the Board.
 3. **HESPA MOU - Probationary Employees (A)** (Mr. Zehr) 128
 Mr. Zehr will present the Memorandum of Understanding between HESPA and the Board of Education. Seeking approval at the next regular meeting.
11. **Building and Grounds (B&G) Committee** (Mr. Troy-chair, Mr. Quagliano, Mr. Fleck)
1. **O&M Updates (R)** (Mr. Renkosik) 130
 Mr. Renkosik will report on O&M project updates.
 2. **HHS Fine Arts Addition Construction Update (R)** (Mr. Renkosik) 137
 Mr. Renkosik will update the Board on the HHS Fine Arts Addition.
 3. **Exterior Window Repair Bid #2020-08 (A)** (Mr. Renkosik) 155
 Mr. Renkosik will present Bid #2020-08 to the Board.
 4. **Thru-wall Flashing Replacement Bid #2020-41 (A)** (Mr. Renkosik) 156
 Mr. Renkosik will present Bid #2020-41 to the Board.
12. **Legislation Committee** (Mrs. Melendy - chair, Mr. Fleck, Mrs. Maiorino)
1. **Legislation Updates (R)** (Mr. Fleck)
 Legislative updates will be given.
13. **Board of Education** (Mr. Fleck)
1. **Minutes (A)** (Mr. Troy) 157
 The following meeting minutes have been prepared for review and approval :Regular Meeting January 16, 2020 and Closed Session Minutes for January 16, 2020.
 February 6, 2020 Regular Meeting, Special Meeting February 6, 2020, February 20, 2020 Committee of the Whole Meeting.
14. **Closed Session / Roll Call (A)** (Mr. Fleck)
 Move to enter into Closed Session at __ p.m. as indicated in the Open Meetings Act and 5ILCS120/2c for discussion of: (1) The appointment, employment, discipline, performance, or dismissal of specific employees or legal counsel; (2) Collective negotiating matters; (9) Student Disciplinary; (11) Litigation; (21) Discussion of minutes of meetings lawfully closed under this Act.
Roll Call: Ayes / Nays / Absent / Motion __
 Members: Mr. Troy, Mr. Geheren, Mr. Fleck, Mr. Gentry, Mr. Quagliano, Mrs. Melendy, Mrs. Maiorino
1. **Exit Closed Session / Voice Call (A)** (Mr. Fleck)
 Move to exit closed session at __ p.m. and return to open session. **Voice Call: Ayes / Nays / Motion __**
15. **Resume in Public Session / Roll Call (A)** (Mr. Fleck)
 Resume the Committee of the Whole meeting at __ p.m. **Roll Call: Ayes / Absent / Motion __**
16. **Adjournment (A)** (Mr. Fleck)
 Motion to adjourn the meeting at __ p.m. **Voice Call: Ayes / Nays / Motion __**



Huntley Community School District 158

650 Academic Drive
Algonquin, Illinois 60102
(847) 659-6158 • www.district158.org

Date: March 5, 2020
To: Curriculum Committee
From: Dr. Erika Schlichter, Assistant Superintendent
Cc: Dr. Scott Rowe, Superintendent
Subject: **Vanguard Vision Update**

Executive Summary

Vanguard Vision, the competency-based program at Huntley High School, began in the 2018-19 school year with the first 4 teachers and the first class of freshmen entering the program. The program scaled to sophomore year, adding 4 additional teachers and a new class of students during the 2019-20 school year. The program is in the process of planning to scale to junior year, adding 4 more core teachers and a third class of incoming freshmen for the 2020-21 school year.

During the three years of enrollment and recruitment, Vanguard has gathered consistent interest from students. Current enrollment is as follows:

- Class of 2022 (current sophomores): 84
- Class of 2023 (current freshmen): 92
- Class of 2024 (incoming freshmen): 94

Teachers have been recruited from each core department and have collaborated intensively to engage in embedded professional learning. Students have been recruited from the current 8th grade class, and have participated in the registration process. Communication to families is ongoing from HHS administration and teachers.

Recommendation

This report is for information only.



Huntley Community School District 158

650 Dr. John Burkey Drive
Algonquin, Illinois 60102
(847) 659-6158 • www.district158.org

To: Board of Education and Administration
From: Mark Altmayer, Chief Financial Officer
Date: March 5, 2020
Subject: **Purchase Order Summary**
Committee of the Whole Meeting, March 5, 2020
Finance Committee

The following is an executive summary of the attached report titled "Purchase Orders" which is a listing of purchase orders issued from February 14, 2020 to February 27, 2020 for which administration is requesting Board Approval to issue payment once invoices have been received. Invoices which exceed an approved Purchase Order by \$100 or 10% of the Purchase Order (whichever is lower) will not be issued without additional Board approval.

Education Fund	\$	184,218.98
Operations & Maintenance Fund		79,698.61
Debt Service Fund		0.00
Transporation Fund		30,251.43
Municipal Retirement and Social Security Fund		0.00
Capital Projects Fund		121,704.93
Working Cash Fund		0.00
Fire Prevention and Safety Fund		0.00
Total	\$	<u><u>415,873.95</u></u>

At this time there is no Supplemental Purchase Order Summary for which Board approval is needed. Therefore, one will be provided in the packet for the upcoming Regular Board meeting. It will consist of an executive summary and an attached report titled "Purchase Orders" which will contain a listing of purchase orders issued for which Administration will request Board Approval to issue payment once invoices have been received.

RECOMMENDATION

Administration requests that the Finance Committee recommends the Board of Education approve the Purchase Order Report at the March 19, 2020 Regular Board of Education meeting.



Huntley Community School District #158

Purchase Orders Report

From February 14, 2020 to February 27, 2020

Printed: 2/27/2020
Page 1 of 28

P.O.#	Vendor Name	A.S.N.	Description	Amount	P.O. Date	State Account Number
0020202531	Advantage Mechanical Inc	20-2542-323-00-79	Repairs & Maint Buildings	552.00	2/24/2020	20-2542-323-00-79
			Total	<u>\$552.00</u>		
0020202532	Advantage Mechanical Inc	20-2542-323-00-79	Repairs & Maint Buildings	156.00	2/24/2020	20-2542-323-00-79
			Total	<u>\$156.00</u>		
0020202533	Advantage Mechanical Inc	20-2542-323-00-79	Repairs & Maint Buildings	1,250.00	2/24/2020	20-2542-323-00-79
			Total	<u>\$1,250.00</u>		
0020202534	Advantage Mechanical Inc	20-2542-323-00-79	Repairs & Maint Buildings	409.00	2/24/2020	20-2542-323-00-79
			Total	<u>\$409.00</u>		
0020202583	Advantage Mechanical Inc	20-2542-323-00-79	Repairs & Maint Buildings	14,437.00	2/26/2020	20-2542-323-00-79
			Total	<u>\$14,437.00</u>		
0020202584	Air Products Equipment Co	20-2542-410-00-79	Supplies B & G	156.00	2/26/2020	20-2542-410-00-79
			Total	<u>\$156.00</u>		
0020202513	Airgas USA LLC	20-2542-410-00-79	Supplies B & G	761.14	2/24/2020	20-2542-410-00-79
		20-2542-410-00-79	Supplies B & G	911.14	2/24/2020	20-2542-410-00-79
			Total	<u>\$1,672.28</u>		
0020202522	Airgas USA LLC	40-2554-410-00-79	Fleet Supplies	197.14	2/24/2020	40-2554-410-00-79
			Total	<u>\$197.14</u>		
0020202450	Albom & Associates LLC	10-2150-310-92-79-600-14	IDEA Sp Path & Audiology Serv	150.00	2/18/2020	10-2150-310-92-79-600-14
			Total	<u>\$150.00</u>		
0020202577	Alexian Brothers	10-4210-670-00-79-600-14	Reg Ed Out of District	440.00	2/26/2020	10-4210-670-00-79-600-14
		10-4210-670-00-79-600-14	Reg Ed Out of District	280.00	2/26/2020	10-4210-670-00-79-600-14
		10-4210-670-00-79-600-14	Reg Ed Out of District	680.00	2/26/2020	10-4210-670-00-79-600-14
			Total	<u>\$1,400.00</u>		
0020202578	Alexian Brothers	10-4210-670-00-79-600-14	Reg Ed Out of District	200.00	2/26/2020	10-4210-670-00-79-600-14
		10-4210-670-00-79-600-14	Reg Ed Out of District	360.00	2/26/2020	10-4210-670-00-79-600-14
			Total	<u>\$560.00</u>		



Huntley Community School District #158

Purchase Orders Report

From February 14, 2020 to February 27, 2020

Printed: 2/27/2020
Page 2 of 28

P.O.#	Vendor Name	A.S.N.	Description	Amount	P.O. Date	State Account Number
0020202487	Anderson Lock Co Inc	20-2542-410-00-79	Supplies B & G	672.60	2/19/2020	20-2542-410-00-79
			Total	<u>\$672.60</u>		
0020202549	Associated Electrical Contractors	10-1110-323-00-71-100-13	Repairs & Maintenance Leggee	2,500.00	2/25/2020	10-1110-323-00-71-100-13
			Total	<u>\$2,500.00</u>		
0020202446	Auto Tech Centers Inc	20-2545-323-00-79-600-14	Vehicle Repairs & Maintenance	694.80	2/18/2020	20-2545-323-00-79-600-14
			Total	<u>\$694.80</u>		
0020202536	Aveanna Healthcare	10-2130-310-00-79-600-14	Health Services	480.00	2/24/2020	10-2130-310-00-79-600-14
		10-2130-310-00-79-600-14	Health Services	528.00	2/24/2020	10-2130-310-00-79-600-14
			Total	<u>\$1,008.00</u>		
0020202514	Barr Mechanical Sales Inc	20-2542-410-00-79	Supplies B & G	968.06	2/24/2020	20-2542-410-00-79
			Total	<u>\$968.06</u>		
0020202488	Behavioral Perspective Inc	10-2210-312-97-79-600-14	All Children Prof Dev	315.00	2/19/2020	10-2210-312-97-79-600-14
		10-2210-312-97-79-600-14	All Children Prof Dev	180.00	2/19/2020	10-2210-312-97-79-600-14
		10-2210-312-97-79-600-14	All Children Prof Dev	292.50	2/19/2020	10-2210-312-97-79-600-14
		10-2210-312-97-79-600-14	All Children Prof Dev	495.00	2/19/2020	10-2210-312-97-79-600-14
		10-2210-312-97-79-600-14	All Children Prof Dev	1,620.00	2/19/2020	10-2210-312-97-79-600-14
		10-2210-312-97-79-600-14	All Children Prof Dev	585.00	2/19/2020	10-2210-312-97-79-600-14
		10-2210-312-97-79-600-14	All Children Prof Dev	695.00	2/19/2020	10-2210-312-97-79-600-14
		10-2210-312-97-79-600-14	All Children Prof Dev	540.00	2/19/2020	10-2210-312-97-79-600-14
		10-2210-312-97-79-600-14	All Children Prof Dev	630.00	2/19/2020	10-2210-312-97-79-600-14
		10-2210-312-97-79-600-14	All Children Prof Dev	607.50	2/19/2020	10-2210-312-97-79-600-14
			Total	<u>\$5,960.00</u>		
0020202523	Blu Petroleum	40-2552-464-00-79	Diesel/Gasoline	463.93	2/24/2020	40-2552-464-00-79
			Total	<u>\$463.93</u>		



Huntley Community School District #158 Purchase Orders Report From February 14, 2020 to February 27, 2020

Printed: 2/27/2020
Page 3 of 28

P.O.#	Vendor Name	A.S.N.	Description	Amount	P.O. Date	State Account Number		
0020202457	BMO Mastercard	10-1120-410-09-72-220-13	Home Ec Marlowe	25.85	2/18/2020	10-1120-410-09-72-220-13		
		10-1120-410-09-72-220-13	Home Ec Marlowe	75.07	2/18/2020	10-1120-410-09-72-220-13		
		10-158	Activity Funds	68.95	2/18/2020	10-158		
		10-158	Activity Funds	226.06	2/18/2020	10-158		
		10-158	Activity Funds	143.72	2/18/2020	10-158		
		10-158	Activity Funds	627.90	2/18/2020	10-158		
		10-158	Activity Funds	68.00	2/18/2020	10-158		
		10-158	Activity Funds	10.97	2/18/2020	10-158		
		10-158	Activity Funds	33.33	2/18/2020	10-158		
					Total	<u>\$1,279.85</u>		
		0020202458	BMO Mastercard	10-1120-332-00-72-220-13	Teacher Travel Marlowe	65.00	2/18/2020	10-1120-332-00-72-220-13
10-1120-332-00-72-220-13	Teacher Travel Marlowe			100.00	2/18/2020	10-1120-332-00-72-220-13		
10-1120-410-00-72-220-13	Inst Supplies Marlowe			257.40	2/18/2020	10-1120-410-00-72-220-13		
10-1120-410-00-72-220-13	Inst Supplies Marlowe			136.60	2/18/2020	10-1120-410-00-72-220-13		
10-1120-410-00-72-220-13	Inst Supplies Marlowe			99.98	2/18/2020	10-1120-410-00-72-220-13		
10-1120-410-00-72-220-13	Inst Supplies Marlowe			55.50	2/18/2020	10-1120-410-00-72-220-13		
10-1120-410-00-72-220-13	Inst Supplies Marlowe			38.92	2/18/2020	10-1120-410-00-72-220-13		
10-1120-410-00-72-220-13	Inst Supplies Marlowe			29.59	2/18/2020	10-1120-410-00-72-220-13		
10-1120-410-00-72-220-13	Inst Supplies Marlowe			17.00	2/18/2020	10-1120-410-00-72-220-13		
10-1120-410-00-72-220-13	Inst Supplies Marlowe			212.37	2/18/2020	10-1120-410-00-72-220-13		
10-1120-410-22-72-220-13	Tech Lab Supplies Marlowe			65.71	2/18/2020	10-1120-410-22-72-220-13		
10-1120-490-00-72-220-13	Instruc Coach/1:1 Supplies MMS			24.00	2/18/2020	10-1120-490-00-72-220-13		
10-1120-490-00-72-220-13	Instruc Coach/1:1 Supplies MMS			19.98	2/18/2020	10-1120-490-00-72-220-13		
10-1120-490-02-72-220-13	Marlowe Fine Arts Supplies			94.97	2/18/2020	10-1120-490-02-72-220-13		
10-1120-490-02-72-220-13	Marlowe Fine Arts Supplies			98.97	2/18/2020	10-1120-490-02-72-220-13		
10-1120-490-02-72-220-13	Marlowe Fine Arts Supplies			376.87	2/18/2020	10-1120-490-02-72-220-13		
10-1120-710-00-72-220-13	Marlowe Non-Capitalized Eqpt			2,584.94	2/18/2020	10-1120-710-00-72-220-13		
10-158	Activity Funds			504.94	2/18/2020	10-158		
10-2220-430-00-72-220-13	Media Center Marlowe			19.98	2/18/2020	10-2220-430-00-72-220-13		
10-2220-430-00-72-220-13	Media Center Marlowe			15.88	2/18/2020	10-2220-430-00-72-220-13		
10-2410-410-00-72-220-13	Office Supplies Marlowe			129.45	2/18/2020	10-2410-410-00-72-220-13		
10-2410-410-00-72-220-13	Office Supplies Marlowe			7.90	2/18/2020	10-2410-410-00-72-220-13		
10-2410-410-00-72-220-14	Copier Paper & Toner Marlowe			218.43	2/18/2020	10-2410-410-00-72-220-14		
				Total	<u>\$5,174.38</u>			



Huntley Community School District #158

Purchase Orders Report

From February 14, 2020 to February 27, 2020

Printed: 2/27/2020
Page 4 of 28

P.O.#	Vendor Name	A.S.N.	Description	Amount	P.O. Date	State Account Number
0020202459	BMO Mastercard	10-1500-332-00-71-300-13	Athletic Trips HS	219.06	2/18/2020	10-1500-332-00-71-300-13
		10-1500-332-00-71-300-13	Athletic Trips HS	103.75	2/18/2020	10-1500-332-00-71-300-13
		10-1500-332-00-71-300-13	Athletic Trips HS	89.59	2/18/2020	10-1500-332-00-71-300-13
		10-1500-332-00-71-300-13	Athletic Trips HS	87.56	2/18/2020	10-1500-332-00-71-300-13
		10-1500-332-00-71-300-13	Athletic Trips HS	64.21	2/18/2020	10-1500-332-00-71-300-13
		10-1500-332-00-71-300-13	Athletic Trips HS	165.15	2/18/2020	10-1500-332-00-71-300-13
		10-1500-332-00-71-300-13	Athletic Trips HS	166.25	2/18/2020	10-1500-332-00-71-300-13
		10-1500-332-00-71-300-13	Athletic Trips HS	800.84	2/18/2020	10-1500-332-00-71-300-13
		10-1500-332-00-71-300-13	Athletic Trips HS	530.75	2/18/2020	10-1500-332-00-71-300-13
		10-1500-332-00-71-300-13	Athletic Trips HS	2,356.48	2/18/2020	10-1500-332-00-71-300-13
		10-1500-332-00-71-300-13	Athletic Trips HS	57.82	2/18/2020	10-1500-332-00-71-300-13
		10-158	Activity Funds	3,100.00	2/18/2020	10-158
		10-158	Activity Funds	27.11	2/18/2020	10-158
		10-158	Activity Funds	27.04	2/18/2020	10-158
		10-158	Activity Funds	62.13	2/18/2020	10-158
		10-158	Activity Funds	53.58	2/18/2020	10-158
		10-158	Activity Funds	50.44	2/18/2020	10-158
		10-158	Activity Funds	29.98	2/18/2020	10-158
		10-158	Activity Funds	123.07	2/18/2020	10-158
		10-158	Activity Funds	64.23	2/18/2020	10-158
10-158	Activity Funds	129.73	2/18/2020	10-158		
				Total		
						<u>\$8,308.77</u>
0020202460	BMO Mastercard	10-2410-332-00-71-300-13	Prin Travel HS	220.67	2/18/2020	10-2410-332-00-71-300-13
		10-2410-490-00-71-300-13	HS Staff Recognition	5.77	2/18/2020	10-2410-490-00-71-300-13
		10-2410-490-00-71-300-13	HS Staff Recognition	47.92	2/18/2020	10-2410-490-00-71-300-13
						Total
0020202461	BMO Mastercard	10-158	Activity Funds	536.99	2/18/2020	10-158
		10-2660-410-00-79-600-14	Supplies Tech	249.99	2/18/2020	10-2660-410-00-79-600-14
						Total
0020202462	BMO Mastercard	10-1120-410-09-72-220-13	Home Ec Marlowe	37.40	2/18/2020	10-1120-410-09-72-220-13
		10-1120-410-09-72-220-13	Home Ec Marlowe	12.14	2/18/2020	10-1120-410-09-72-220-13
		10-1120-410-09-72-220-13	Home Ec Marlowe	41.93	2/18/2020	10-1120-410-09-72-220-13
		10-158	Activity Funds	22.50	2/18/2020	10-158
		10-158	Activity Funds	233.00	2/18/2020	10-158
				Total		<u>\$346.97</u>



Huntley Community School District #158

Purchase Orders Report

From February 14, 2020 to February 27, 2020

Printed: 2/27/2020
Page 5 of 28

P.O.#	Vendor Name	A.S.N.	Description	Amount	P.O. Date	State Account Number
0020202463	BMO Mastercard	10-1800-410-82-79-605-14	TBE/TPI Instructional Supplies	562.51	2/18/2020	10-1800-410-82-79-605-14
		10-2210-490-00-74-500-14	Supplies Curr & Inst	85.00	2/18/2020	10-2210-490-00-74-500-14
		Total			<u>\$647.51</u>	
0020202464	BMO Mastercard	10-158	Activity Funds	81.88	2/18/2020	10-158
		10-158	Activity Funds	15.84	2/18/2020	10-158
		10-158	Activity Funds	25.00	2/18/2020	10-158
		10-158	Activity Funds	266.24	2/18/2020	10-158
		10-158	Activity Funds	54.91	2/18/2020	10-158
		10-158	Activity Funds	84.95	2/18/2020	10-158
		10-158	Activity Funds	89.17	2/18/2020	10-158
		10-158	Activity Funds	149.99	2/18/2020	10-158
		10-158	Activity Funds	51.99	2/18/2020	10-158
		Total			<u>\$819.97</u>	
0020202465	BMO Mastercard	10-1110-410-00-72-120-13	Inst Supplies Martin	-174.99	2/18/2020	10-1110-410-00-72-120-13
		10-1110-410-00-72-120-13	Inst Supplies Martin	-159.02	2/18/2020	10-1110-410-00-72-120-13
		10-1110-410-00-72-120-13	Inst Supplies Martin	174.99	2/18/2020	10-1110-410-00-72-120-13
		10-1110-410-00-72-120-13	Inst Supplies Martin	119.24	2/18/2020	10-1110-410-00-72-120-13
		10-1110-410-12-72-120-13	Music SuppliesMartin	43.99	2/18/2020	10-1110-410-12-72-120-13
		10-158	Activity Funds	65.56	2/18/2020	10-158
		10-158	Activity Funds	231.18	2/18/2020	10-158
		10-2210-314-92-79-605-14	IDEA Impr of Instr-Staff Dev	118.68	2/18/2020	10-2210-314-92-79-605-14
		10-2220-430-00-72-120-13	Media Center Martin	34.35	2/18/2020	10-2220-430-00-72-120-13
		10-2220-430-00-72-120-13	Media Center Martin	8.29	2/18/2020	10-2220-430-00-72-120-13
10-2220-430-00-72-120-13	Media Center Martin	-59.80	2/18/2020	10-2220-430-00-72-120-13		
Total			<u>\$402.47</u>			



Huntley Community School District #158

Purchase Orders Report

From February 14, 2020 to February 27, 2020

Printed: 2/27/2020
Page 6 of 28

P.O.#	Vendor Name	A.S.N.	Description	Amount	P.O. Date	State Account Number
0020202466	BMO Mastercard	10-1130-410-05-71-300-13	English Supplies HS	68.66	2/18/2020	10-1130-410-05-71-300-13
		10-1130-410-13-71-300-13	Science Supplies HS	53.36	2/18/2020	10-1130-410-13-71-300-13
		10-1130-410-13-71-300-13	Science Supplies HS	123.54	2/18/2020	10-1130-410-13-71-300-13
		10-1130-410-33-71-305-13	Academies Supplies	45.28	2/18/2020	10-1130-410-33-71-305-13
		10-1130-490-00-71-300-13	Instructional Coaching Supplies HS	122.14	2/18/2020	10-1130-490-00-71-300-13
		10-1500-332-00-71-300-13	Athletic Trips HS	30.00	2/18/2020	10-1500-332-00-71-300-13
		10-1500-332-00-71-300-13	Athletic Trips HS	8.22	2/18/2020	10-1500-332-00-71-300-13
		10-1500-332-00-71-300-13	Athletic Trips HS	26.38	2/18/2020	10-1500-332-00-71-300-13
		10-1500-332-00-71-300-13	Athletic Trips HS	40.00	2/18/2020	10-1500-332-00-71-300-13
		10-158	Activity Funds	14.47	2/18/2020	10-158
		10-158	Activity Funds	92.70	2/18/2020	10-158
		10-2210-314-92-79-605-14	IDEA Impr of Instr-Staff Dev	30.00	2/18/2020	10-2210-314-92-79-605-14
		10-2220-430-00-71-300-13	Media Center HS	88.00	2/18/2020	10-2220-430-00-71-300-13
		10-2410-410-00-71-300-13	Office Supplies HS	59.88	2/18/2020	10-2410-410-00-71-300-13
		10-2410-410-00-71-300-13	Office Supplies HS	30.00	2/18/2020	10-2410-410-00-71-300-13
		10-2410-410-00-71-300-14	Copier Paper & Toner HS	280.00	2/18/2020	10-2410-410-00-71-300-14
		Total				<u>\$1,112.63</u>
0020202467	BMO Mastercard	10-1110-410-00-74-140-13	Inst Supplies Mackeben	29.98	2/18/2020	10-1110-410-00-74-140-13
		10-1110-410-00-74-140-13	Inst Supplies Mackeben	44.97	2/18/2020	10-1110-410-00-74-140-13
		10-1110-410-00-74-140-13	Inst Supplies Mackeben	30.44	2/18/2020	10-1110-410-00-74-140-13
		10-158	Activity Funds	61.00	2/18/2020	10-158
		10-158	Activity Funds	384.37	2/18/2020	10-158
		10-2410-491-00-74-140-13	Rebate Supplies Mackeben	192.74	2/18/2020	10-2410-491-00-74-140-13
		Total				<u>\$743.50</u>
0020202468	BMO Mastercard	10-1110-410-00-71-100-13	Inst Supplies Leggee	158.94	2/18/2020	10-1110-410-00-71-100-13
		10-1110-410-02-71-100-13	Art Supplies Leggee	59.91	2/18/2020	10-1110-410-02-71-100-13
		10-1110-410-02-71-100-13	Art Supplies Leggee	57.69	2/18/2020	10-1110-410-02-71-100-13
		10-1110-410-02-71-100-13	Art Supplies Leggee	17.99	2/18/2020	10-1110-410-02-71-100-13
		10-1110-410-02-71-100-13	Art Supplies Leggee	68.75	2/18/2020	10-1110-410-02-71-100-13
		10-1110-410-02-71-100-13	Art Supplies Leggee	68.88	2/18/2020	10-1110-410-02-71-100-13
		10-1110-410-02-71-100-13	Art Supplies Leggee	80.88	2/18/2020	10-1110-410-02-71-100-13
		10-1110-410-02-71-100-13	Art Supplies Leggee	48.55	2/18/2020	10-1110-410-02-71-100-13
		10-1110-410-02-71-100-13	Art Supplies Leggee	15.99	2/18/2020	10-1110-410-02-71-100-13
		10-158	Activity Funds	83.09	2/18/2020	10-158
		10-158	Activity Funds	49.47	2/18/2020	10-158
		10-2220-490-00-71-100-13	Media Center AV Leggee	224.00	2/18/2020	10-2220-490-00-71-100-13
		10-2220-490-00-71-100-13	Media Center AV Leggee	179.96	2/18/2020	10-2220-490-00-71-100-13
		10-2220-490-00-71-100-13	Media Center AV Leggee	74.97	2/18/2020	10-2220-490-00-71-100-13
		Total				<u>\$1,189.07</u>



Huntley Community School District #158

Purchase Orders Report

From February 14, 2020 to February 27, 2020

Printed: 2/27/2020
Page 7 of 28

P.O.#	Vendor Name	A.S.N.	Description	Amount	P.O. Date	State Account Number
0020202469	BMO Mastercard	10-1400-410-09-71-300-13	Home Economics Supplies	34.61	2/18/2020	10-1400-410-09-71-300-13
		10-158	Activity Funds	12.98	2/18/2020	10-158
		10-158	Activity Funds	753.32	2/18/2020	10-158
		10-158	Activity Funds	1,050.00	2/18/2020	10-158
		10-158	Activity Funds	139.90	2/18/2020	10-158
		10-158	Activity Funds	244.49	2/18/2020	10-158
		10-158	Activity Funds	400.00	2/18/2020	10-158
		10-158	Activity Funds	257.62	2/18/2020	10-158
		10-158	Activity Funds	339.60	2/18/2020	10-158
		10-158	Activity Funds	250.00	2/18/2020	10-158
		Total				<u>\$3,482.52</u>
0020202470	BMO Mastercard	10-1120-410-00-74-210-13	Inst Supplies Heineman	52.92	2/18/2020	10-1120-410-00-74-210-13
		10-1120-410-00-74-210-13	Inst Supplies Heineman	26.85	2/18/2020	10-1120-410-00-74-210-13
		10-1120-410-00-74-210-13	Inst Supplies Heineman	41.00	2/18/2020	10-1120-410-00-74-210-13
		10-1120-410-00-74-210-13	Inst Supplies Heineman	43.65	2/18/2020	10-1120-410-00-74-210-13
		10-1120-410-00-74-210-13	Inst Supplies Heineman	47.62	2/18/2020	10-1120-410-00-74-210-13
		10-1120-410-00-74-210-13	Inst Supplies Heineman	200.00	2/18/2020	10-1120-410-00-74-210-13
		10-1120-410-09-74-210-13	Home Ec Heineman	127.45	2/18/2020	10-1120-410-09-74-210-13
		10-1120-410-13-74-210-06	Heineman Science Supplies 6	69.68	2/18/2020	10-1120-410-13-74-210-06
		10-1120-410-13-74-210-07	Heineman Science Supplies 7	33.98	2/18/2020	10-1120-410-13-74-210-07
		10-1120-410-13-74-210-07	Heineman Science Supplies 7	42.99	2/18/2020	10-1120-410-13-74-210-07
		10-1120-410-13-74-210-07	Heineman Science Supplies 7	29.98	2/18/2020	10-1120-410-13-74-210-07
		10-1120-410-13-74-210-07	Heineman Science Supplies 7	341.57	2/18/2020	10-1120-410-13-74-210-07
		10-1120-410-13-74-210-07	Heineman Science Supplies 7	33.16	2/18/2020	10-1120-410-13-74-210-07
		10-1120-410-13-74-210-07	Heineman Science Supplies 7	20.48	2/18/2020	10-1120-410-13-74-210-07
		10-1120-410-13-74-210-07	Heineman Science Supplies 7	250.26	2/18/2020	10-1120-410-13-74-210-07
		10-1120-490-02-74-210-13	Heineman Fine Arts Supplies	59.55	2/18/2020	10-1120-490-02-74-210-13
		10-1120-490-02-74-210-13	Heineman Fine Arts Supplies	16.94	2/18/2020	10-1120-490-02-74-210-13
		10-1120-490-02-74-210-13	Heineman Fine Arts Supplies	112.77	2/18/2020	10-1120-490-02-74-210-13
		10-1120-490-02-74-210-13	Heineman Fine Arts Supplies	8.89	2/18/2020	10-1120-490-02-74-210-13
		10-1120-490-02-74-210-13	Heineman Fine Arts Supplies	10.94	2/18/2020	10-1120-490-02-74-210-13
		10-1120-490-02-74-210-13	Heineman Fine Arts Supplies	8.49	2/18/2020	10-1120-490-02-74-210-13
10-1500-410-00-74-210-13	Training Supplies Heineman	34.95	2/18/2020	10-1500-410-00-74-210-13		
10-2220-430-00-74-210-13	Media Center Heineman	78.86	2/18/2020	10-2220-430-00-74-210-13		
Total				<u>\$1,692.98</u>		



Huntley Community School District #158 Purchase Orders Report From February 14, 2020 to February 27, 2020

Printed: 2/27/2020
Page 8 of 28

P.O.#	Vendor Name	A.S.N.	Description	Amount	P.O. Date	State Account Number
0020202471	BMO Mastercard					
		10-1120-410-00-72-220-13	Inst Supplies Marlowe	71.92	2/18/2020	10-1120-410-00-72-220-13
		10-1120-410-00-72-220-13	Inst Supplies Marlowe	48.99	2/18/2020	10-1120-410-00-72-220-13
		10-1120-410-00-72-220-13	Inst Supplies Marlowe	109.17	2/18/2020	10-1120-410-00-72-220-13
		10-1120-410-00-72-220-13	Inst Supplies Marlowe	44.53	2/18/2020	10-1120-410-00-72-220-13
		10-1120-410-00-72-220-13	Inst Supplies Marlowe	69.99	2/18/2020	10-1120-410-00-72-220-13
		10-1120-410-00-72-220-13	Inst Supplies Marlowe	76.40	2/18/2020	10-1120-410-00-72-220-13
		10-1120-410-00-72-220-13	Inst Supplies Marlowe	162.31	2/18/2020	10-1120-410-00-72-220-13
		10-1120-410-00-72-220-13	Inst Supplies Marlowe	299.00	2/18/2020	10-1120-410-00-72-220-13
		10-1120-410-00-72-220-13	Inst Supplies Marlowe	269.99	2/18/2020	10-1120-410-00-72-220-13
		10-1120-490-02-72-220-13	Marlowe Fine Arts Supplies	102.96	2/18/2020	10-1120-490-02-72-220-13
		10-1120-710-00-72-220-13	Marlowe Non-Capitalized Eqpt	-185.92	2/18/2020	10-1120-710-00-72-220-13
		10-2220-430-00-72-220-13	Media Center Marlowe	10.40	2/18/2020	10-2220-430-00-72-220-13
		10-2220-430-00-72-220-13	Media Center Marlowe	24.25	2/18/2020	10-2220-430-00-72-220-13
		10-2220-430-00-72-220-13	Media Center Marlowe	419.80	2/18/2020	10-2220-430-00-72-220-13
		10-2220-430-00-72-220-13	Media Center Marlowe	116.72	2/18/2020	10-2220-430-00-72-220-13
		10-2220-430-00-72-220-13	Media Center Marlowe	12.72	2/18/2020	10-2220-430-00-72-220-13
		10-2220-430-00-72-220-13	Media Center Marlowe	174.04	2/18/2020	10-2220-430-00-72-220-13
		10-2410-410-00-72-220-13	Office Supplies Marlowe	25.79	2/18/2020	10-2410-410-00-72-220-13
		10-2410-410-00-72-220-14	Copier Paper & Toner Marlowe	53.20	2/18/2020	10-2410-410-00-72-220-14
			Total	<u>\$1,906.26</u>		
0020202472	BMO Mastercard					
		10-1500-332-00-71-300-13	Athletic Trips HS	343.50	2/18/2020	10-1500-332-00-71-300-13
		10-1500-332-00-71-300-13	Athletic Trips HS	189.96	2/18/2020	10-1500-332-00-71-300-13
		10-1500-332-00-71-300-13	Athletic Trips HS	604.25	2/18/2020	10-1500-332-00-71-300-13
		10-1500-332-00-71-300-13	Athletic Trips HS	644.02	2/18/2020	10-1500-332-00-71-300-13
		10-1500-332-00-71-300-13	Athletic Trips HS	3,380.16	2/18/2020	10-1500-332-00-71-300-13
		10-1500-332-00-71-300-13	Athletic Trips HS	207.57	2/18/2020	10-1500-332-00-71-300-13
		10-1500-332-00-71-300-13	Athletic Trips HS	50.00	2/18/2020	10-1500-332-00-71-300-13
		10-158	Activity Funds	65.94	2/18/2020	10-158
		10-158	Activity Funds	90.92	2/18/2020	10-158
		10-158	Activity Funds	235.00	2/18/2020	10-158
		10-158	Activity Funds	287.92	2/18/2020	10-158
		10-158	Activity Funds	50.00	2/18/2020	10-158
		10-158	Activity Funds	250.00	2/18/2020	10-158
			Total	<u>\$6,399.24</u>		



Huntley Community School District #158

Purchase Orders Report

From February 14, 2020 to February 27, 2020

Printed: 2/27/2020
Page 9 of 28

P.O.#	Vendor Name	A.S.N.	Description	Amount	P.O. Date	State Account Number
0020202473	BMO Mastercard	10-1110-410-00-72-110-13	Inst Supplies Chesak	209.46	2/18/2020	10-1110-410-00-72-110-13
		10-1110-410-00-72-110-13	Inst Supplies Chesak	197.94	2/18/2020	10-1110-410-00-72-110-13
		10-1110-410-00-72-110-13	Inst Supplies Chesak	155.10	2/18/2020	10-1110-410-00-72-110-13
		10-1110-410-02-72-110-13	Art Supplies Chesak	79.14	2/18/2020	10-1110-410-02-72-110-13
		10-158	Activity Funds	66.96	2/18/2020	10-158
		10-2410-410-00-72-110-14	Copier Paper & Toner Chesak	16.98	2/18/2020	10-2410-410-00-72-110-14
Total				<u>\$725.58</u>		
0020202474	BMO Mastercard	10-2642-350-00-74-500-14	Advertising Human Res	119.00	2/18/2020	10-2642-350-00-74-500-14
		10-2642-410-00-74-500-14	Supplies Human Res	99.19	2/18/2020	10-2642-410-00-74-500-14
		10-2642-410-00-74-500-14	Supplies Human Res	468.42	2/18/2020	10-2642-410-00-74-500-14
Total				<u>\$686.61</u>		
0020202476	BMO Mastercard	10-1800-410-82-79-605-14	TBE/TPI Instructional Supplies	61.19	2/18/2020	10-1800-410-82-79-605-14
Total				<u>\$61.19</u>		
0020202477	BMO Mastercard	10-1800-410-82-79-605-14	TBE/TPI Instructional Supplies	11.09	2/18/2020	10-1800-410-82-79-605-14
		10-1800-410-82-79-605-14	TBE/TPI Instructional Supplies	26.93	2/18/2020	10-1800-410-82-79-605-14
		10-1800-410-82-79-605-14	TBE/TPI Instructional Supplies	53.85	2/18/2020	10-1800-410-82-79-605-14
		10-1800-410-82-79-605-14	TBE/TPI Instructional Supplies	175.93	2/18/2020	10-1800-410-82-79-605-14
Total				<u>\$267.80</u>		
0020202478	BMO Mastercard	10-2520-332-00-74-500-14	Travel Fiscal	545.00	2/18/2020	10-2520-332-00-74-500-14
Total				<u>\$545.00</u>		



Huntley Community School District #158 Purchase Orders Report From February 14, 2020 to February 27, 2020

Printed: 2/27/2020
Page 10 of 28

P.O.#	Vendor Name	A.S.N.	Description	Amount	P.O. Date	State Account Number
0020202493	BMO Mastercard					
		10-158	Activity Funds	63.66	2/21/2020	10-158
		10-158	Activity Funds	199.80	2/21/2020	10-158
		10-158	Activity Funds	162.72	2/21/2020	10-158
		10-158	Activity Funds	133.95	2/21/2020	10-158
		10-158	Activity Funds	126.46	2/21/2020	10-158
		10-158	Activity Funds	104.93	2/21/2020	10-158
		10-158	Activity Funds	102.21	2/21/2020	10-158
		10-158	Activity Funds	213.12	2/21/2020	10-158
		10-158	Activity Funds	68.21	2/21/2020	10-158
		10-158	Activity Funds	3,100.00	2/21/2020	10-158
		10-158	Activity Funds	57.00	2/21/2020	10-158
		10-158	Activity Funds	54.95	2/21/2020	10-158
		10-158	Activity Funds	11.35	2/21/2020	10-158
		10-158	Activity Funds	10.99	2/21/2020	10-158
		10-158	Activity Funds	90.00	2/21/2020	10-158
		10-158	Activity Funds	277.89	2/21/2020	10-158
		10-158	Activity Funds	680.00	2/21/2020	10-158
		10-158	Activity Funds	265.96	2/21/2020	10-158
		10-158	Activity Funds	607.87	2/21/2020	10-158
			Total	<u>\$6,331.07</u>		
0020202494	BMO Mastercard					
		10-1200-410-92-79-600-14	IDEA Instructional Supplies	-32.99	2/21/2020	10-1200-410-92-79-600-14
		10-1200-490-92-79-600-14	IDEA Supplies - Amazon	89.90	2/21/2020	10-1200-490-92-79-600-14
		10-158	Activity Funds	228.00	2/21/2020	10-158
		10-2130-410-92-79-605-14	IDEA Health OTPT & Nurse Sup	57.83	2/21/2020	10-2130-410-92-79-605-14
		10-2210-314-92-79-605-14	IDEA Impr of Instr-Staff Dev	775.18	2/21/2020	10-2210-314-92-79-605-14
		10-2210-410-92-79-600-14	IDEA Impr of Instruction Suppl	607.00	2/21/2020	10-2210-410-92-79-600-14
		10-2330-410-92-79-600-14	IDEA Genl Admin Office Supplie	196.00	2/21/2020	10-2330-410-92-79-600-14
		10-2330-410-92-79-600-14	IDEA Genl Admin Office Supplie	78.00	2/21/2020	10-2330-410-92-79-600-14
		10-2330-410-92-79-600-14	IDEA Genl Admin Office Supplie	10.70	2/21/2020	10-2330-410-92-79-600-14
		10-2330-410-92-79-600-14	IDEA Genl Admin Office Supplie	6.99	2/21/2020	10-2330-410-92-79-600-14
		10-2330-410-92-79-600-14	IDEA Genl Admin Office Supplie	204.76	2/21/2020	10-2330-410-92-79-600-14
			Total	<u>\$2,221.37</u>		
0020202495	BMO Mastercard					
		10-2630-332-00-74-500-14	Communications Travel	1.29	2/21/2020	10-2630-332-00-74-500-14
			Total	<u>\$1.29</u>		



Huntley Community School District #158 Purchase Orders Report From February 14, 2020 to February 27, 2020

Printed: 2/27/2020
Page 11 of 28

P.O.#	Vendor Name	A.S.N.	Description	Amount	P.O. Date	State Account Number
0020202496	BMO Mastercard	10-1125-410-97-79-600-14	All Children Supplies	16.81	2/21/2020	10-1125-410-97-79-600-14
		10-1125-410-97-79-600-14	All Children Supplies	189.62	2/21/2020	10-1125-410-97-79-600-14
		10-1125-410-97-79-600-14	All Children Supplies	36.68	2/21/2020	10-1125-410-97-79-600-14
		10-1125-410-97-79-600-14	All Children Supplies	28.39	2/21/2020	10-1125-410-97-79-600-14
		10-1125-410-97-79-600-14	All Children Supplies	15.38	2/21/2020	10-1125-410-97-79-600-14
		10-1125-410-97-79-600-14	All Children Supplies	35.35	2/21/2020	10-1125-410-97-79-600-14
		10-2130-332-00-79-600-14	Health Travel	51.50	2/21/2020	10-2130-332-00-79-600-14
		10-2560-415-97-79-600-14	All Children Snacks	77.35	2/21/2020	10-2560-415-97-79-600-14
					Total	<u>\$451.08</u>
0020202497	BMO Mastercard	20-2540-310-00-79	Professional & Technical	18.38	2/21/2020	20-2540-310-00-79
		20-2540-410-00-79	Office Supplies B & G	13.48	2/21/2020	20-2540-410-00-79
		20-2540-640-00-79	Dues & Fees	-545.00	2/21/2020	20-2540-640-00-79
		20-2542-410-00-79	Supplies B & G	17.28	2/21/2020	20-2542-410-00-79
		20-2542-410-00-79	Supplies B & G	160.44	2/21/2020	20-2542-410-00-79
		20-2542-410-00-79	Supplies B & G	248.00	2/21/2020	20-2542-410-00-79
		20-2542-410-00-79	Supplies B & G	963.81	2/21/2020	20-2542-410-00-79
		20-2542-410-00-79	Supplies B & G	19.95	2/21/2020	20-2542-410-00-79
			Total	<u>\$896.34</u>		
0020202498	BMO Mastercard	10-2321-440-00-74-500-14	Supt Periodicals	40.00	2/21/2020	10-2321-440-00-74-500-14
					Total	<u>\$40.00</u>



Huntley Community School District #158

Purchase Orders Report

From February 14, 2020 to February 27, 2020

Printed: 2/27/2020
Page 12 of 28

P.O.#	Vendor Name	A.S.N.	Description	Amount	P.O. Date	State Account Number
0020202499	BMO Mastercard	10-1200-310-92-79-600-14	IDEA General Purchased Service	81.11	2/21/2020	10-1200-310-92-79-600-14
		10-1200-310-92-79-600-14	IDEA General Purchased Service	96.49	2/21/2020	10-1200-310-92-79-600-14
		10-1200-410-92-79-600-14	IDEA Instructional Supplies	118.64	2/21/2020	10-1200-410-92-79-600-14
		10-1200-490-92-79-600-14	IDEA Supplies - Amazon	126.88	2/21/2020	10-1200-490-92-79-600-14
		10-1200-490-92-79-600-14	IDEA Supplies - Amazon	108.00	2/21/2020	10-1200-490-92-79-600-14
		10-2210-314-92-79-605-14	IDEA Impr of Instr-Staff Dev	20.10	2/21/2020	10-2210-314-92-79-605-14
		10-2210-314-92-79-605-14	IDEA Impr of Instr-Staff Dev	9.30	2/21/2020	10-2210-314-92-79-605-14
		10-2210-314-92-79-605-14	IDEA Impr of Instr-Staff Dev	14.58	2/21/2020	10-2210-314-92-79-605-14
		10-2210-314-92-79-605-14	IDEA Impr of Instr-Staff Dev	14.95	2/21/2020	10-2210-314-92-79-605-14
		10-2210-314-92-79-605-14	IDEA Impr of Instr-Staff Dev	1,579.60	2/21/2020	10-2210-314-92-79-605-14
		10-2210-314-92-79-605-14	IDEA Impr of Instr-Staff Dev	18.25	2/21/2020	10-2210-314-92-79-605-14
		10-2210-314-92-79-605-14	IDEA Impr of Instr-Staff Dev	60.00	2/21/2020	10-2210-314-92-79-605-14
		10-2210-314-92-79-605-14	IDEA Impr of Instr-Staff Dev	309.00	2/21/2020	10-2210-314-92-79-605-14
		10-2210-314-92-79-605-14	IDEA Impr of Instr-Staff Dev	517.80	2/21/2020	10-2210-314-92-79-605-14
		10-2210-410-92-79-600-14	IDEA Impr of Instruction Suppl	20.00	2/21/2020	10-2210-410-92-79-600-14
		10-2210-410-92-79-600-14	IDEA Impr of Instruction Suppl	77.25	2/21/2020	10-2210-410-92-79-600-14
		10-2330-410-92-79-600-14	IDEA Genl Admin Office Supplie	6.96	2/21/2020	10-2330-410-92-79-600-14
		10-2330-410-92-79-600-14	IDEA Genl Admin Office Supplie	9.63	2/21/2020	10-2330-410-92-79-600-14
		10-2330-410-92-79-600-14	IDEA Genl Admin Office Supplie	15.57	2/21/2020	10-2330-410-92-79-600-14
		10-2330-410-92-79-600-14	IDEA Genl Admin Office Supplie	17.97	2/21/2020	10-2330-410-92-79-600-14
10-2330-410-92-79-600-14	IDEA Genl Admin Office Supplie	22.20	2/21/2020	10-2330-410-92-79-600-14		
10-2330-410-92-79-600-14	IDEA Genl Admin Office Supplie	43.58	2/21/2020	10-2330-410-92-79-600-14		
Total				<u>\$3,287.86</u>		
0020202500	BMO Mastercard	10-2310-410-00-74-500-14	Supplies Board	47.97	2/21/2020	10-2310-410-00-74-500-14
		10-2310-410-00-74-500-14	Supplies Board	12.99	2/21/2020	10-2310-410-00-74-500-14
		10-2321-410-00-74-500-14	Supplies Supt	20.18	2/21/2020	10-2321-410-00-74-500-14
		10-2546-490-00-79-600-14	Security Officer Supplies	9.98	2/21/2020	10-2546-490-00-79-600-14
		10-2546-490-00-79-600-14	Security Officer Supplies	20.78	2/21/2020	10-2546-490-00-79-600-14
		10-2546-490-00-79-600-14	Security Officer Supplies	128.09	2/21/2020	10-2546-490-00-79-600-14
		Total				<u>\$239.99</u>
0020202501	BMO Mastercard	10-2321-332-00-74-500-14	Travel Supt	270.60	2/21/2020	10-2321-332-00-74-500-14
		10-2321-332-00-74-500-14	Travel Supt	124.30	2/21/2020	10-2321-332-00-74-500-14
		10-2321-415-00-74-500-14	Community Supplies	55.90	2/21/2020	10-2321-415-00-74-500-14
Total				<u>\$450.80</u>		



Huntley Community School District #158

Purchase Orders Report

From February 14, 2020 to February 27, 2020

Printed: 2/27/2020
Page 13 of 28

P.O.#	Vendor Name	A.S.N.	Description	Amount	P.O. Date	State Account Number
0020202502	BMO Mastercard					
		10-1110-410-00-74-150-13	Inst Supplies Conley	122.12	2/21/2020	10-1110-410-00-74-150-13
		10-1110-410-12-74-150-13	Conley Music Supplies	17.98	2/21/2020	10-1110-410-12-74-150-13
		10-158	Activity Funds	18.06	2/21/2020	10-158
		10-158	Activity Funds	10.83	2/21/2020	10-158
		10-158	Activity Funds	22.46	2/21/2020	10-158
		10-158	Activity Funds	28.92	2/21/2020	10-158
		10-158	Activity Funds	21.58	2/21/2020	10-158
		10-158	Activity Funds	11.11	2/21/2020	10-158
		10-158	Activity Funds	21.35	2/21/2020	10-158
		10-158	Activity Funds	16.96	2/21/2020	10-158
		10-158	Activity Funds	11.50	2/21/2020	10-158
		10-158	Activity Funds	6.69	2/21/2020	10-158
		10-158	Activity Funds	11.83	2/21/2020	10-158
		10-158	Activity Funds	10.33	2/21/2020	10-158
		10-158	Activity Funds	14.21	2/21/2020	10-158
		10-158	Activity Funds	23.61	2/21/2020	10-158
		10-158	Activity Funds	8.44	2/21/2020	10-158
		10-158	Activity Funds	8.04	2/21/2020	10-158
		10-158	Activity Funds	3.71	2/21/2020	10-158
		10-158	Activity Funds	4.02	2/21/2020	10-158
		10-158	Activity Funds	4.44	2/21/2020	10-158
		10-158	Activity Funds	4.65	2/21/2020	10-158
		10-158	Activity Funds	19.84	2/21/2020	10-158
			Total	<u>\$422.68</u>		
0020202503	BMO Mastercard					
		10-1125-410-97-79-600-14	All Children Supplies	94.86	2/21/2020	10-1125-410-97-79-600-14
		10-1225-410-95-79-600-14	ECE Instr Supplies	86.68	2/21/2020	10-1225-410-95-79-600-14
		10-1225-410-95-79-600-14	ECE Instr Supplies	40.00	2/21/2020	10-1225-410-95-79-600-14
		10-1225-410-95-79-600-14	ECE Instr Supplies	28.77	2/21/2020	10-1225-410-95-79-600-14
		10-1225-410-95-79-600-14	ECE Instr Supplies	-13.98	2/21/2020	10-1225-410-95-79-600-14
		10-1225-410-95-79-600-14	ECE Instr Supplies	8.88	2/21/2020	10-1225-410-95-79-600-14
		10-1225-410-95-79-600-14	ECE Instr Supplies	25.99	2/21/2020	10-1225-410-95-79-600-14
			Total	<u>\$271.20</u>		



Huntley Community School District #158

Purchase Orders Report

From February 14, 2020 to February 27, 2020

Printed: 2/27/2020
Page 14 of 28

P.O.#	Vendor Name	A.S.N.	Description	Amount	P.O. Date	State Account Number	
0020202504	BMO Mastercard	20-2540-410-00-79	Office Supplies B & G	79.95	2/21/2020	20-2540-410-00-79	
		20-2540-410-00-79	Office Supplies B & G	-73.31	2/21/2020	20-2540-410-00-79	
		20-2540-410-00-79	Office Supplies B & G	-4.31	2/21/2020	20-2540-410-00-79	
		20-2540-410-00-79	Office Supplies B & G	111.12	2/21/2020	20-2540-410-00-79	
		20-2540-640-00-79	Dues & Fees	65.00	2/21/2020	20-2540-640-00-79	
		20-2540-640-00-79	Dues & Fees	545.00	2/21/2020	20-2540-640-00-79	
		20-2542-410-00-79	Supplies B & G	342.60	2/21/2020	20-2542-410-00-79	
		Total				<u>\$1,066.05</u>	
0020202505	BMO Mastercard	10-2321-415-00-74-500-14	Community Supplies	55.43	2/21/2020	10-2321-415-00-74-500-14	
		Total				<u>\$55.43</u>	
0020202561	BMO Mastercard	10-158	Activity Funds	283.91	2/26/2020	10-158	
		10-158	Activity Funds	69.32	2/26/2020	10-158	
		10-158	Activity Funds	17.08	2/26/2020	10-158	
		10-158	Activity Funds	-210.55	2/26/2020	10-158	
		10-158	Activity Funds	3,579.26	2/26/2020	10-158	
		10-2660-410-00-79-600-14	Supplies Tech	29.97	2/26/2020	10-2660-410-00-79-600-14	
		10-2660-640-00-79-600-14	Dues & Fees Technology	25.00	2/26/2020	10-2660-640-00-79-600-14	
		Total				<u>\$3,793.99</u>	
0020202562	BMO Mastercard	10-1120-410-09-72-220-13	Home Ec Marlowe	33.87	2/26/2020	10-1120-410-09-72-220-13	
		10-1120-410-09-72-220-13	Home Ec Marlowe	65.49	2/26/2020	10-1120-410-09-72-220-13	
		10-1120-410-09-72-220-13	Home Ec Marlowe	79.60	2/26/2020	10-1120-410-09-72-220-13	
		10-158	Activity Funds	141.00	2/26/2020	10-158	
		10-158	Activity Funds	58.84	2/26/2020	10-158	
		10-158	Activity Funds	122.49	2/26/2020	10-158	
		10-158	Activity Funds	143.41	2/26/2020	10-158	
		Total				<u>\$644.70</u>	
		0020202563	BMO Mastercard	10-2210-490-00-74-500-14	Supplies Curr & Inst	406.75	2/26/2020
10-2210-490-00-74-500-14	Supplies Curr & Inst			68.66	2/26/2020	10-2210-490-00-74-500-14	
10-2210-490-00-74-500-14	Supplies Curr & Inst			8.99	2/26/2020	10-2210-490-00-74-500-14	
10-2210-490-00-74-500-14	Supplies Curr & Inst			8.98	2/26/2020	10-2210-490-00-74-500-14	
Total				<u>\$493.38</u>			
0020202564	BMO Mastercard	10-2212-332-00-74-500-14	Travel & Conference Curr	483.80	2/26/2020	10-2212-332-00-74-500-14	
Total				<u>\$483.80</u>			



Huntley Community School District #158

Purchase Orders Report

From February 14, 2020 to February 27, 2020

Printed: 2/27/2020
Page 15 of 28

P.O.#	Vendor Name	A.S.N.	Description	Amount	P.O. Date	State Account Number
0020202565	BMO Mastercard	10-2520-332-00-74-500-14	Travel Fiscal	60.00	2/26/2020	10-2520-332-00-74-500-14
		10-2520-332-00-74-500-14	Travel Fiscal	106.24	2/26/2020	10-2520-332-00-74-500-14
		10-2560-410-00-74-150-13	Cafe Supplies Conley	134.00	2/26/2020	10-2560-410-00-74-150-13
		Total			\$300.24	
0020202566	BMO Mastercard	10-1130-332-00-71-300-13	Teacher Travel HS	210.48	2/26/2020	10-1130-332-00-71-300-13
		10-1130-410-00-71-300-13	Inst Supplies HS	101.42	2/26/2020	10-1130-410-00-71-300-13
		10-1130-410-00-71-300-13	Inst Supplies HS	29.98	2/26/2020	10-1130-410-00-71-300-13
		10-1400-410-01-71-300-13	Ag Supplies	249.18	2/26/2020	10-1400-410-01-71-300-13
		10-1400-410-09-71-300-13	Home Economics Supplies	13.88	2/26/2020	10-1400-410-09-71-300-13
		10-2120-410-00-71-300-13	Supplies Guidance HS	239.99	2/26/2020	10-2120-410-00-71-300-13
		10-2120-410-00-71-300-13	Supplies Guidance HS	220.00	2/26/2020	10-2120-410-00-71-300-13
		10-2120-410-00-71-300-13	Supplies Guidance HS	161.00	2/26/2020	10-2120-410-00-71-300-13
		10-2120-410-00-71-300-13	Supplies Guidance HS	275.00	2/26/2020	10-2120-410-00-71-300-13
		10-2220-430-00-71-300-13	Media Center HS	70.13	2/26/2020	10-2220-430-00-71-300-13
		10-2220-430-00-71-300-13	Media Center HS	119.96	2/26/2020	10-2220-430-00-71-300-13
		10-2223-410-00-79-600-14	Supplies PAC	85.00	2/26/2020	10-2223-410-00-79-600-14
		10-2223-410-00-79-600-14	Supplies PAC	107.64	2/26/2020	10-2223-410-00-79-600-14
		10-2410-410-00-71-300-13	Office Supplies HS	13.98	2/26/2020	10-2410-410-00-71-300-13
Total			\$1,897.64			
0020202567	BMO Mastercard	10-1110-332-00-74-140-13	Teacher Travel Mackeben	575.00	2/26/2020	10-1110-332-00-74-140-13
		10-1110-410-00-74-140-13	Inst Supplies Mackeben	104.94	2/26/2020	10-1110-410-00-74-140-13
		10-1110-410-00-74-140-13	Inst Supplies Mackeben	21.26	2/26/2020	10-1110-410-00-74-140-13
		10-1110-410-00-74-140-13	Inst Supplies Mackeben	133.51	2/26/2020	10-1110-410-00-74-140-13
		10-1110-410-00-74-140-13	Inst Supplies Mackeben	161.07	2/26/2020	10-1110-410-00-74-140-13
		10-1110-410-00-74-140-13	Inst Supplies Mackeben	180.38	2/26/2020	10-1110-410-00-74-140-13
		10-158	Activity Funds	38.78	2/26/2020	10-158
		10-2410-410-00-74-140-14	Copier Paper & Toner Mackeben	49.94	2/26/2020	10-2410-410-00-74-140-14
Total			\$1,264.88			
0020202568	BMO Mastercard	10-1110-410-00-71-100-13	Inst Supplies Leggee	86.70	2/26/2020	10-1110-410-00-71-100-13
		10-1110-410-00-71-100-13	Inst Supplies Leggee	78.00	2/26/2020	10-1110-410-00-71-100-13
		10-158	Activity Funds	46.46	2/26/2020	10-158
		10-158	Activity Funds	22.96	2/26/2020	10-158
		10-158	Activity Funds	11.30	2/26/2020	10-158
		10-158	Activity Funds	107.51	2/26/2020	10-158
Total			\$352.93			



Huntley Community School District #158

Purchase Orders Report

From February 14, 2020 to February 27, 2020

Printed: 2/27/2020
Page 16 of 28

P.O.#	Vendor Name	A.S.N.	Description	Amount	P.O. Date	State Account Number		
0020202569	BMO Mastercard	10-1543-332-00-71-305-13	Activities Travel	1,048.80	2/26/2020	10-1543-332-00-71-305-13		
		10-158	Activity Funds	481.76	2/26/2020	10-158		
		10-158	Activity Funds	1,330.00	2/26/2020	10-158		
		10-158	Activity Funds	365.75	2/26/2020	10-158		
		10-158	Activity Funds	3,999.12	2/26/2020	10-158		
		10-158	Activity Funds	157.69	2/26/2020	10-158		
		10-158	Activity Funds	67.04	2/26/2020	10-158		
		10-158	Activity Funds	65.38	2/26/2020	10-158		
		10-158	Activity Funds	60.89	2/26/2020	10-158		
		10-158	Activity Funds	42.45	2/26/2020	10-158		
		10-158	Activity Funds	64.20	2/26/2020	10-158		
		10-2410-490-00-71-300-13	HS Staff Recognition	16.85	2/26/2020	10-2410-490-00-71-300-13		
					Total	<u>\$7,699.93</u>		
		0020202570	BMO Mastercard	10-1120-410-00-74-210-13	Inst Supplies Heineman	16.15	2/26/2020	10-1120-410-00-74-210-13
				10-1120-410-00-74-210-13	Inst Supplies Heineman	13.88	2/26/2020	10-1120-410-00-74-210-13
10-1120-410-00-74-210-13	Inst Supplies Heineman			58.33	2/26/2020	10-1120-410-00-74-210-13		
10-1120-410-00-74-210-13	Inst Supplies Heineman			60.46	2/26/2020	10-1120-410-00-74-210-13		
10-1120-410-00-74-210-13	Inst Supplies Heineman			87.08	2/26/2020	10-1120-410-00-74-210-13		
10-1120-410-00-74-210-13	Inst Supplies Heineman			120.63	2/26/2020	10-1120-410-00-74-210-13		
10-1120-410-00-74-210-13	Inst Supplies Heineman			12.76	2/26/2020	10-1120-410-00-74-210-13		
10-1120-410-00-74-210-13	Inst Supplies Heineman			29.00	2/26/2020	10-1120-410-00-74-210-13		
10-1120-410-00-74-210-13	Inst Supplies Heineman			8.00	2/26/2020	10-1120-410-00-74-210-13		
10-1120-410-00-74-210-13	Inst Supplies Heineman			28.99	2/26/2020	10-1120-410-00-74-210-13		
10-1120-410-00-74-210-13	Inst Supplies Heineman			49.28	2/26/2020	10-1120-410-00-74-210-13		
10-1120-410-13-74-210-06	Heineman Science Supplies 6			28.99	2/26/2020	10-1120-410-13-74-210-06		
10-1120-410-13-74-210-07	Heineman Science Supplies 7			26.00	2/26/2020	10-1120-410-13-74-210-07		
10-1120-410-13-74-210-07	Heineman Science Supplies 7			268.94	2/26/2020	10-1120-410-13-74-210-07		
10-1120-410-13-74-210-07	Heineman Science Supplies 7			79.45	2/26/2020	10-1120-410-13-74-210-07		
10-1120-410-13-74-210-07	Heineman Science Supplies 7			51.67	2/26/2020	10-1120-410-13-74-210-07		
10-1120-410-13-74-210-07	Heineman Science Supplies 7			30.24	2/26/2020	10-1120-410-13-74-210-07		
10-1120-490-02-74-210-13	Heineman Fine Arts Supplies			104.82	2/26/2020	10-1120-490-02-74-210-13		
10-1500-412-00-74-210-13	Uniforms Heineman			359.60	2/26/2020	10-1500-412-00-74-210-13		
10-2220-430-00-74-210-13	Media Center Heineman			275.40	2/26/2020	10-2220-430-00-74-210-13		
10-2220-430-00-74-210-13	Media Center Heineman			64.42	2/26/2020	10-2220-430-00-74-210-13		
10-2220-430-00-74-210-13	Media Center Heineman			17.99	2/26/2020	10-2220-430-00-74-210-13		
10-2220-490-00-74-210-13	Media Center AV Heineman			101.50	2/26/2020	10-2220-490-00-74-210-13		
10-2220-490-00-74-210-13	Media Center AV Heineman			77.19	2/26/2020	10-2220-490-00-74-210-13		
10-2410-410-00-74-210-13	Office Supplies Heineman			32.55	2/26/2020	10-2410-410-00-74-210-13		
				Total	<u>\$2,003.32</u>			



Huntley Community School District #158

Purchase Orders Report

From February 14, 2020 to February 27, 2020

Printed: 2/27/2020
Page 17 of 28

P.O.#	Vendor Name	A.S.N.	Description	Amount	P.O. Date	State Account Number
0020202571	BMO Mastercard	10-1110-410-00-74-150-13	Inst Supplies Conley	36.15	2/26/2020	10-1110-410-00-74-150-13
		10-1110-410-02-74-150-13	Art Supplies Conley	89.83	2/26/2020	10-1110-410-02-74-150-13
		10-1110-410-02-74-150-13	Art Supplies Conley	85.40	2/26/2020	10-1110-410-02-74-150-13
		10-1110-410-02-74-150-13	Art Supplies Conley	166.40	2/26/2020	10-1110-410-02-74-150-13
		10-1610-410-00-79-600-14	Supplies Summer School	27.04	2/26/2020	10-1610-410-00-79-600-14
					Total	<u>\$404.82</u>
0020202572	BMO Mastercard	10-2212-332-00-74-500-14	Travel & Conference Curr	205.24	2/26/2020	10-2212-332-00-74-500-14
					Total	<u>\$205.24</u>
0020202573	BMO Mastercard	10-1110-410-00-72-110-13	Inst Supplies Chesak	21.94	2/26/2020	10-1110-410-00-72-110-13
		10-1110-410-00-72-110-13	Inst Supplies Chesak	10.99	2/26/2020	10-1110-410-00-72-110-13
		10-158	Activity Funds	75.90	2/26/2020	10-158
		10-2220-490-00-72-110-13	Media Center AV Chesak	11.98	2/26/2020	10-2220-490-00-72-110-13
		10-2410-410-00-72-110-13	Office Supplies Chesak	563.97	2/26/2020	10-2410-410-00-72-110-13
					Total	<u>\$684.78</u>
0020202574	BMO Mastercard	10-2642-640-00-74-500-14	Dues & Fees Human Res	336.00	2/26/2020	10-2642-640-00-74-500-14
					Total	<u>\$336.00</u>
0020202575	BMO Mastercard	10-158	Activity Funds	121.61	2/26/2020	10-158
		10-158	Activity Funds	100.94	2/26/2020	10-158
		10-158	Activity Funds	100.25	2/26/2020	10-158
		10-158	Activity Funds	52.99	2/26/2020	10-158
		10-158	Activity Funds	26.59	2/26/2020	10-158
		10-158	Activity Funds	21.23	2/26/2020	10-158
		10-158	Activity Funds	130.19	2/26/2020	10-158
					Total	<u>\$553.80</u>



Huntley Community School District #158

Purchase Orders Report

From February 14, 2020 to February 27, 2020

Printed: 2/27/2020
Page 18 of 28

P.O.#	Vendor Name	A.S.N.	Description	Amount	P.O. Date	State Account Number
0020202576	BMO Mastercard	10-1120-332-00-72-220-13	Teacher Travel Marlowe	575.00	2/26/2020	10-1120-332-00-72-220-13
		10-1120-332-00-72-220-13	Teacher Travel Marlowe	405.00	2/26/2020	10-1120-332-00-72-220-13
		10-1120-410-00-72-220-13	Inst Supplies Marlowe	24.66	2/26/2020	10-1120-410-00-72-220-13
		10-1120-410-00-72-220-13	Inst Supplies Marlowe	104.02	2/26/2020	10-1120-410-00-72-220-13
		10-1120-410-00-72-220-13	Inst Supplies Marlowe	95.72	2/26/2020	10-1120-410-00-72-220-13
		10-1120-410-00-72-220-13	Inst Supplies Marlowe	14.99	2/26/2020	10-1120-410-00-72-220-13
		10-1120-410-00-72-220-13	Inst Supplies Marlowe	25.48	2/26/2020	10-1120-410-00-72-220-13
		10-1120-410-13-72-220-06	Marlowe Science Supplies 6	126.20	2/26/2020	10-1120-410-13-72-220-06
		10-1120-410-13-72-220-06	Marlowe Science Supplies 6	60.70	2/26/2020	10-1120-410-13-72-220-06
		10-1120-410-13-72-220-06	Marlowe Science Supplies 6	31.95	2/26/2020	10-1120-410-13-72-220-06
		10-1120-490-02-72-220-13	Marlowe Fine Arts Supplies	29.99	2/26/2020	10-1120-490-02-72-220-13
		10-1120-710-00-72-220-13	Marlowe Non-Capitalized Eqpt	135.99	2/26/2020	10-1120-710-00-72-220-13
		10-1120-710-00-72-220-13	Marlowe Non-Capitalized Eqpt	-135.99	2/26/2020	10-1120-710-00-72-220-13
		10-1120-710-00-72-220-13	Marlowe Non-Capitalized Eqpt	516.76	2/26/2020	10-1120-710-00-72-220-13
		10-1120-710-00-72-220-13	Marlowe Non-Capitalized Eqpt	387.57	2/26/2020	10-1120-710-00-72-220-13
		10-2220-430-00-72-220-13	Media Center Marlowe	6.94	2/26/2020	10-2220-430-00-72-220-13
		10-2220-430-00-72-220-13	Media Center Marlowe	7.97	2/26/2020	10-2220-430-00-72-220-13
		10-2220-430-00-72-220-13	Media Center Marlowe	11.98	2/26/2020	10-2220-430-00-72-220-13
		10-2220-430-00-72-220-13	Media Center Marlowe	33.82	2/26/2020	10-2220-430-00-72-220-13
		10-2220-430-00-72-220-13	Media Center Marlowe	375.84	2/26/2020	10-2220-430-00-72-220-13
		10-2220-430-00-72-220-13	Media Center Marlowe	21.98	2/26/2020	10-2220-430-00-72-220-13
		10-2220-430-00-72-220-13	Media Center Marlowe	21.99	2/26/2020	10-2220-430-00-72-220-13
		10-2220-430-00-72-220-13	Media Center Marlowe	66.80	2/26/2020	10-2220-430-00-72-220-13
		10-2220-490-00-72-220-13	Media Center AV Marlowe	339.98	2/26/2020	10-2220-490-00-72-220-13
		10-2410-332-00-72-220-13	Principal Travel Marlowe	79.00	2/26/2020	10-2410-332-00-72-220-13
		10-2410-332-00-72-220-13	Principal Travel Marlowe	74.99	2/26/2020	10-2410-332-00-72-220-13
		10-2410-410-00-72-220-13	Office Supplies Marlowe	177.13	2/26/2020	10-2410-410-00-72-220-13
		10-2410-410-00-72-220-13	Office Supplies Marlowe	27.96	2/26/2020	10-2410-410-00-72-220-13
		10-2410-491-00-72-220-13	Rebate Supplies Marlowe	39.97	2/26/2020	10-2410-491-00-72-220-13
		10-2410-491-00-72-220-13	Rebate Supplies Marlowe	57.00	2/26/2020	10-2410-491-00-72-220-13
				Total		
						<u>\$3,741.39</u>
0020202535	Boilersource	20-2542-410-00-79	Supplies B & G	218.26	2/24/2020	20-2542-410-00-79
						Total
0020202483	Building Technology Consultants PC	20-2540-310-00-79	Professional & Technical	4,523.65	2/19/2020	20-2540-310-00-79
						Total
0020202506	CDW Government	20-2540-410-00-79	Office Supplies B & G	562.56	2/21/2020	20-2540-410-00-79
						Total



Huntley Community School District #158

Purchase Orders Report

From February 14, 2020 to February 27, 2020

Printed: 2/27/2020
Page 19 of 28

P.O.#	Vendor Name	A.S.N.	Description	Amount	P.O. Date	State Account Number
0020202541	CDW Government	20-2540-410-00-79	Office Supplies B & G	740.99	2/24/2020	20-2540-410-00-79
			Total	<u>\$740.99</u>		
0020202558	CDW Government	60-2530-531-00-71-300	HS Fine Arts Expansion Construction	862.56	2/25/2020	60-2530-531-00-71-300
		60-2530-531-00-71-300	HS Fine Arts Expansion Construction	3,039.87	2/25/2020	60-2530-531-00-71-300
			Total	<u>\$3,902.43</u>		
0020202586	Center for Teaching for Biliteracy	10-2212-310-00-79-505-14	Curriculum Gen Pur Svc	4,600.00	2/26/2020	10-2212-310-00-79-505-14
			Total	<u>\$4,600.00</u>		
0020202587	Center for Teaching for Biliteracy	10-2212-310-00-79-505-14	Curriculum Gen Pur Svc	4,600.00	2/26/2020	10-2212-310-00-79-505-14
			Total	<u>\$4,600.00</u>		
0020202544	Cheer Zone	10-1500-412-00-74-210-13	Uniforms Heineman	1,759.80	2/24/2020	10-1500-412-00-74-210-13
		10-1500-412-00-74-210-13	Uniforms Heineman	59.80	2/24/2020	10-1500-412-00-74-210-13
			Total	<u>\$1,819.60</u>		
0020202530	Child Advocacy Center of McHenry Cou	10-2546-390-00-79-600-14	Security Officer Gnl Purch Svc	30.00	2/24/2020	10-2546-390-00-79-600-14
			Total	<u>\$30.00</u>		
0020202451	CINTAS Corporation	40-2550-325-00-79	Rental Trans	168.49	2/18/2020	40-2550-325-00-79
			Total	<u>\$168.49</u>		
0020202524	CINTAS Corporation	40-2550-325-00-79	Rental Trans	168.49	2/24/2020	40-2550-325-00-79
			Total	<u>\$168.49</u>		
0020202489	Commercial Specialties Inc	20-2542-323-00-79	Repairs & Maint Buildings	2,220.00	2/19/2020	20-2542-323-00-79
			Total	<u>\$2,220.00</u>		
0020202600	Control Technology & Solutions LLC	20-2542-410-00-79	Supplies B & G	4,131.95	2/27/2020	20-2542-410-00-79
			Total	<u>\$4,131.95</u>		
0020202603	Control Technology & Solutions LLC	20-2542-323-00-79	Repairs & Maint Buildings	7,995.00	2/27/2020	20-2542-323-00-79
			Total	<u>\$7,995.00</u>		
0020202550	Crowne Plaza Springfield	10-1543-332-00-71-305-13	Activities Travel	2,585.44	2/25/2020	10-1543-332-00-71-305-13
			Total	<u>\$2,585.44</u>		



Huntley Community School District #158

Purchase Orders Report

From February 14, 2020 to February 27, 2020

Printed: 2/27/2020
Page 20 of 28

P.O.#	Vendor Name	A.S.N.	Description	Amount	P.O. Date	State Account Number
0020202537	Crystal Lake School District 47	10-2130-390-00-79-600-14	Purchased Services Health	206.25	2/24/2020	10-2130-390-00-79-600-14
		10-4120-310-92-79-600-14	IDEA Payments to Other Districts	56.25	2/24/2020	10-4120-310-92-79-600-14
		Total			<u>\$262.50</u>	
0020202545	Dell Marketing LP	10-1110-323-00-74-150-13	Repairs Conley	149.00	2/24/2020	10-1110-323-00-74-150-13
		10-1110-323-00-74-150-13	Repairs Conley	151.00	2/24/2020	10-1110-323-00-74-150-13
		Total			<u>\$300.00</u>	
0020202509	Direct Fitness Solutions	10-1130-410-50-71-300-13	PE Supplies HS	515.00	2/24/2020	10-1130-410-50-71-300-13
		Total			<u>\$515.00</u>	
0020202510	Dreisilker Electric Motors Inc	20-2542-410-00-79	Supplies B & G	622.21	2/24/2020	20-2542-410-00-79
		Total			<u>\$622.21</u>	
0020202484	DuPage Federation on Human Services	10-2212-310-00-79-505-14	Curriculum Gen Pur Svc	14.85	2/19/2020	10-2212-310-00-79-505-14
		Total			<u>\$14.85</u>	
0020202599	Electric Conduit Construction	20-2543-323-00-79	Repairs-Grounds	4,175.62	2/26/2020	20-2543-323-00-79
		Total			<u>\$4,175.62</u>	
0020202590	Elite Uniforms Inc	10-2546-490-00-79-600-14	Security Officer Supplies	3,489.35	2/26/2020	10-2546-490-00-79-600-14
		Total			<u>\$3,489.35</u>	
0020202507	Engineered Corrosion Solutions	20-2540-310-00-79	Professional & Technical	10,700.00	2/21/2020	20-2540-310-00-79
		Total			<u>\$10,700.00</u>	
0020202485	Gage Consulting Engineers Inc	20-2540-310-00-79	Professional & Technical	315.00	2/19/2020	20-2540-310-00-79
		Total			<u>\$315.00</u>	
0020202601	Gage Consulting Engineers Inc	20-2540-310-00-79	Professional & Technical	105.00	2/27/2020	20-2540-310-00-79
		Total			<u>\$105.00</u>	
0020202548	General Parts LLC	10-2560-323-00-74-150-13	Cafe Repairs Conley	4,602.97	2/24/2020	10-2560-323-00-74-150-13
		Total			<u>\$4,602.97</u>	



Huntley Community School District #158 Purchase Orders Report From February 14, 2020 to February 27, 2020

Printed: 2/27/2020
Page 21 of 28

P.O.#	Vendor Name	A.S.N.	Description	Amount	P.O. Date	State Account Number
0020202517	Gordon Flesch Co Inc	10-2900-390-00-79-600-14	Copier Maintenance	7,015.74	2/24/2020	10-2900-390-00-79-600-14
		10-2900-390-00-79-600-14	Copier Maintenance	397.00	2/24/2020	10-2900-390-00-79-600-14
		10-2900-390-00-79-600-14	Copier Maintenance	978.16	2/24/2020	10-2900-390-00-79-600-14
		10-2900-390-00-79-600-14	Copier Maintenance	1,263.07	2/24/2020	10-2900-390-00-79-600-14
		Total		\$9,653.97		
0020202547	Gordon Food Service	10-1120-410-09-74-210-13	Home Ec Heineman	300.00	2/24/2020	10-1120-410-09-74-210-13
		Total		\$300.00		
0020202551	Gordon Food Service	10-1400-410-09-71-300-13	Home Economics Supplies	24.58	2/25/2020	10-1400-410-09-71-300-13
		10-1400-410-09-71-300-13	Home Economics Supplies	46.29	2/25/2020	10-1400-410-09-71-300-13
		10-1400-410-09-71-300-13	Home Economics Supplies	107.06	2/25/2020	10-1400-410-09-71-300-13
		10-1400-410-09-71-300-13	Home Economics Supplies	108.48	2/25/2020	10-1400-410-09-71-300-13
		10-1400-410-09-71-300-13	Home Economics Supplies	25.74	2/25/2020	10-1400-410-09-71-300-13
Total		\$312.15				
0020202594	Gordon Food Service	10-1120-410-09-72-220-13	Home Ec Marlowe	29.61	2/26/2020	10-1120-410-09-72-220-13
		Total		\$29.61		
0020202554	Grismayer, Nicole	10-1120-490-02-72-220-13	Marlowe Fine Arts Supplies	500.00	2/25/2020	10-1120-490-02-72-220-13
		Total		\$500.00		
0020202491	Haile Consulting Co	10-1100-310-89-79-605-14	Title I Instruc Pur Svc	2,000.00	2/19/2020	10-1100-310-89-79-605-14
		Total		\$2,000.00		
0020202479	Honeywell International Inc	10-2546-323-00-79-600-14	Security Officer Repairs	991.42	2/18/2020	10-2546-323-00-79-600-14
		Total		\$991.42		
0020202480	Honeywell International Inc	10-2546-323-00-79-600-14	Security Officer Repairs	856.80	2/18/2020	10-2546-323-00-79-600-14
		Total		\$856.80		
0020202481	Honeywell International Inc	10-2546-323-00-79-600-14	Security Officer Repairs	527.82	2/18/2020	10-2546-323-00-79-600-14
		Total		\$527.82		
0020202515	Honeywell International Inc	10-2546-323-00-79-600-14	Security Officer Repairs	1,129.51	2/24/2020	10-2546-323-00-79-600-14
		Total		\$1,129.51		



Huntley Community School District #158

Purchase Orders Report

From February 14, 2020 to February 27, 2020

Printed: 2/27/2020
Page 22 of 28

P.O.#	Vendor Name	A.S.N.	Description	Amount	P.O. Date	State Account Number
0020202552	Huntley Ford	10-1700-323-21-71-300-13	Driver Ed Repair & Maintenance	202.13	2/25/2020	10-1700-323-21-71-300-13
			Total	<u>\$202.13</u>		
0020202492	Huntley Rotary Club	20-1910	Rentals	306.50	2/19/2020	20-1910
			Total	<u>\$306.50</u>		
0020202579	IASB	10-2310-332-00-74-500-14	Travel Board	190.00	2/26/2020	10-2310-332-00-74-500-14
		10-2310-332-00-74-500-14	Travel Board	140.00	2/26/2020	10-2310-332-00-74-500-14
		10-2310-332-00-74-500-14	Travel Board	280.00	2/26/2020	10-2310-332-00-74-500-14
			Total	<u>\$610.00</u>		
0020202511	Illinois FBLA	10-1543-640-00-71-305-13	Activities Fees	1,625.00	2/24/2020	10-1543-640-00-71-305-13
			Total	<u>\$1,625.00</u>		
0020202482	Illinois State Police	10-2310-390-00-74-500-14	Purchased Service Board	6,000.00	2/18/2020	10-2310-390-00-74-500-14
			Total	<u>\$6,000.00</u>		
0020202582	Illinois State University	10-2210-312-97-79-600-14	All Children Prof Dev	600.00	2/26/2020	10-2210-312-97-79-600-14
			Total	<u>\$600.00</u>		
0020202512	IPA Kishwaukee	10-1500-411-00-74-210-13	Awards Heineman	250.00	2/24/2020	10-1500-411-00-74-210-13
			Total	<u>\$250.00</u>		
0020202443	IPO/DBA Cardinal Office Supply	40-2550-410-00-79	Office Supplies	272.78	2/18/2020	40-2550-410-00-79
			Total	<u>\$272.78</u>		
0020202588	J Tsunami Consulting	10-2212-310-00-79-505-14	Curriculum Gen Pur Svc	150.00	2/26/2020	10-2212-310-00-79-505-14
			Total	<u>\$150.00</u>		
0020202559	Johnson Floor Co	20-2542-323-00-79	Repairs & Maint Buildings	12,795.00	2/25/2020	20-2542-323-00-79
			Total	<u>\$12,795.00</u>		
0020202518	Kane County ROE #31	10-2660-319-61-79-600-14	Software Maintenance	2,917.29	2/24/2020	10-2660-319-61-79-600-14
			Total	<u>\$2,917.29</u>		
0020202516	Kelso Burnett Co	10-2546-323-00-79-600-14	Security Officer Repairs	195.00	2/24/2020	10-2546-323-00-79-600-14
			Total	<u>\$195.00</u>		



Huntley Community School District #158

Purchase Orders Report

From February 14, 2020 to February 27, 2020

Printed: 2/27/2020
Page 23 of 28

P.O.#	Vendor Name	A.S.N.	Description	Amount	P.O. Date	State Account Number
0020202591	Kelso Burnett Co	10-2546-323-00-79-600-14	Security Officer Repairs	135.00	2/26/2020	10-2546-323-00-79-600-14
			Total	<u>\$135.00</u>		
0020202553	Lakeshore Learning Materials	10-1800-410-84-79-605-14	Title III LIPLEPS Supplies	155.88	2/25/2020	10-1800-410-84-79-605-14
		10-1800-410-84-79-605-14	Title III LIPLEPS Supplies	239.92	2/25/2020	10-1800-410-84-79-605-14
		10-1800-410-84-79-605-14	Title III LIPLEPS Supplies	599.88	2/25/2020	10-1800-410-84-79-605-14
		10-1800-410-84-79-605-14	Title III LIPLEPS Supplies	319.84	2/25/2020	10-1800-410-84-79-605-14
		10-1800-410-84-79-605-14	Title III LIPLEPS Supplies	359.88	2/25/2020	10-1800-410-84-79-605-14
		10-1800-410-84-79-605-14	Title III LIPLEPS Supplies	796.00	2/25/2020	10-1800-410-84-79-605-14
		10-1800-410-84-79-605-14	Title III LIPLEPS Supplies	556.00	2/25/2020	10-1800-410-84-79-605-14
		10-1800-410-84-79-605-14	Title III LIPLEPS Supplies	1,788.00	2/25/2020	10-1800-410-84-79-605-14
		10-1800-410-84-79-605-14	Title III LIPLEPS Supplies	600.00	2/25/2020	10-1800-410-84-79-605-14
		10-1800-410-84-79-605-14	Title III LIPLEPS Supplies	760.00	2/25/2020	10-1800-410-84-79-605-14
		10-1800-410-84-79-605-14	Title III LIPLEPS Supplies	1,036.00	2/25/2020	10-1800-410-84-79-605-14
		10-1800-410-84-79-605-14	Title III LIPLEPS Supplies	1,081.71	2/25/2020	10-1800-410-84-79-605-14
			Total	<u>\$8,293.11</u>		
0020202452	Leach Enterprises Inc	40-2554-410-00-79	Fleet Supplies	538.75	2/18/2020	40-2554-410-00-79
		40-2554-410-00-79	Fleet Supplies	595.86	2/18/2020	40-2554-410-00-79
		40-2554-410-00-79	Fleet Supplies	876.60	2/18/2020	40-2554-410-00-79
			Total	<u>\$2,011.21</u>		
0020202525	Leach Enterprises Inc	40-2554-410-00-79	Fleet Supplies	494.12	2/24/2020	40-2554-410-00-79
		40-2554-410-00-79	Fleet Supplies	489.04	2/24/2020	40-2554-410-00-79
			Total	<u>\$983.16</u>		
0020202444	Learning Forward	10-2323-640-00-74-500-14	Dues & Fees Curr & Inst	99.00	2/18/2020	10-2323-640-00-74-500-14
			Total	<u>\$99.00</u>		
0020202542	LMC	60-2530-531-00-71-300	HS Fine Arts Expansion Construction	54,867.50	2/24/2020	60-2530-531-00-71-300
			Total	<u>\$54,867.50</u>		
0020202556	Mainstage Theatrical Supply	10-2223-490-00-79-600-14	PAC Invent Supplies	1,200.00	2/25/2020	10-2223-490-00-79-600-14
			Total	<u>\$1,200.00</u>		
0020202560	Mainstage Theatrical Supply	60-2530-531-00-71-300	HS Fine Arts Expansion Construction	42,950.00	2/25/2020	60-2530-531-00-71-300
			Total	<u>\$42,950.00</u>		



Huntley Community School District #158

Purchase Orders Report

From February 14, 2020 to February 27, 2020

Printed: 2/27/2020
Page 24 of 28

P.O.#	Vendor Name	A.S.N.	Description	Amount	P.O. Date	State Account Number
0020202538	Metro Prep	10-4220-670-00-79-600-14	Sp Ed Private Tuition	4,408.57	2/24/2020	10-4220-670-00-79-600-14
			Total	<u>\$4,408.57</u>		
0020202539	Metro Prep	10-4220-670-00-79-600-14	Sp Ed Private Tuition	4,408.57	2/24/2020	10-4220-670-00-79-600-14
			Total	<u>\$4,408.57</u>		
0020202508	Minnesota Clay	10-1110-410-02-74-150-13	Art Supplies Conley	11.95	2/21/2020	10-1110-410-02-74-150-13
		10-1110-410-02-74-150-13	Art Supplies Conley	144.15	2/21/2020	10-1110-410-02-74-150-13
		10-1110-410-02-74-150-13	Art Supplies Conley	148.00	2/21/2020	10-1110-410-02-74-150-13
			Total	<u>\$304.10</u>		
0020202447	Neuco	20-2542-410-00-79	Supplies B & G	3,232.47	2/18/2020	20-2542-410-00-79
			Total	<u>\$3,232.47</u>		
0020202519	New England Center for Children	10-1200-310-92-79-600-14	IDEA General Purchased Service	664.05	2/24/2020	10-1200-310-92-79-600-14
			Total	<u>\$664.05</u>		
0020202540	North Shore Transit Inc	40-2552-331-00-79	Contracted Transportation	339.12	2/24/2020	40-2552-331-00-79
			Total	<u>\$339.12</u>		
0020202453	Northwestern Medicine Occupational H	40-2550-310-00-79	Prof & Tech Service Trans	2,105.00	2/18/2020	40-2550-310-00-79
			Total	<u>\$2,105.00</u>		
0020202449	Ombudsman	10-1100-310-89-79-605-14	Title I Instruc Pur Svc	2,899.00	2/18/2020	10-1100-310-89-79-605-14
			Total	<u>\$2,899.00</u>		
0020202448	Otis Elevator Company	20-2542-323-00-79	Repairs & Maint Buildings	612.50	2/18/2020	20-2542-323-00-79
			Total	<u>\$612.50</u>		
0020202486	Otis Elevator Company	20-2542-390-00-79	Other Purchased Service	612.50	2/19/2020	20-2542-390-00-79
			Total	<u>\$612.50</u>		
0020202475	P & M Distributors Inc	10-2560-415-00-71-300-13	Cafe Food HS	809.32	2/18/2020	10-2560-415-00-71-300-13
		10-2560-415-00-71-300-13	Cafe Food HS	121.00	2/18/2020	10-2560-415-00-71-300-13
			Total	<u>\$930.32</u>		



Huntley Community School District #158 Purchase Orders Report From February 14, 2020 to February 27, 2020

Printed: 2/27/2020
Page 25 of 28

P.O.#	Vendor Name	A.S.N.	Description	Amount	P.O. Date	State Account Number
0020202454	Patlin Inc	40-2554-410-00-79	Fleet Supplies	145.11	2/18/2020	40-2554-410-00-79
			Total	<u>\$145.11</u>		
0020202595	Pearson	10-2130-410-92-79-605-14	IDEA Health OTPT & Nurse Sup	506.68	2/26/2020	10-2130-410-92-79-605-14
			Total	<u>\$506.68</u>		
0020202589	PMA Securities LLC	10-2520-390-00-74-500-14	Purch Serv Fiscal	2,000.00	2/26/2020	10-2520-390-00-74-500-14
			Total	<u>\$2,000.00</u>		
0020202598	Pro Com Systems Inc	20-2542-410-00-79	Supplies B & G	2,515.60	2/26/2020	20-2542-410-00-79
			Total	<u>\$2,515.60</u>		
0020202602	Pro Com Systems Inc	60-2530-531-00-71-300	HS Fine Arts Expansion Construction	19,985.00	2/27/2020	60-2530-531-00-71-300
			Total	<u>\$19,985.00</u>		
0020202580	Regional Office of Education	10-2321-440-00-74-500-14	Supt Periodicals	200.00	2/26/2020	10-2321-440-00-74-500-14
			Total	<u>\$200.00</u>		
0020202526	Remkes Garage LLC	40-2550-323-00-79	Repairs and Maintenance	5,183.00	2/24/2020	40-2550-323-00-79
			Total	<u>\$5,183.00</u>		
0020202455	Rush Truck Center Huntley	40-2554-410-00-79	Fleet Supplies	98.04	2/18/2020	40-2554-410-00-79
		40-2554-410-00-79	Fleet Supplies	323.50	2/18/2020	40-2554-410-00-79
		40-2554-410-00-79	Fleet Supplies	76.40	2/18/2020	40-2554-410-00-79
		40-2554-410-00-79	Fleet Supplies	858.65	2/18/2020	40-2554-410-00-79
			Total	<u>\$1,356.59</u>		
0020202527	Rush Truck Center Huntley	40-2550-323-00-79	Repairs and Maintenance	185.00	2/24/2020	40-2550-323-00-79
		40-2550-323-00-79	Repairs and Maintenance	240.50	2/24/2020	40-2550-323-00-79
		40-2550-323-00-79	Repairs and Maintenance	252.03	2/24/2020	40-2550-323-00-79
		40-2550-323-00-79	Repairs and Maintenance	649.25	2/24/2020	40-2550-323-00-79
		40-2550-323-00-79	Repairs and Maintenance	1,898.00	2/24/2020	40-2550-323-00-79
		40-2550-323-00-79	Repairs and Maintenance	2,114.54	2/24/2020	40-2550-323-00-79
		40-2550-323-00-79	Repairs and Maintenance	2,756.42	2/24/2020	40-2550-323-00-79
		40-2550-323-00-79	Repairs and Maintenance	4,453.96	2/24/2020	40-2550-323-00-79
		40-2550-323-00-79	Repairs and Maintenance	100.00	2/24/2020	40-2550-323-00-79
			Total	<u>\$12,649.70</u>		



Huntley Community School District #158

Purchase Orders Report

From February 14, 2020 to February 27, 2020

Printed: 2/27/2020
Page 26 of 28

P.O.#	Vendor Name	A.S.N.	Description	Amount	P.O. Date	State Account Number
0020202528	Rush Truck Center Huntley	40-2554-410-00-79	Fleet Supplies	42.20	2/24/2020	40-2554-410-00-79
		40-2554-410-00-79	Fleet Supplies	113.08	2/24/2020	40-2554-410-00-79
		40-2554-410-00-79	Fleet Supplies	89.64	2/24/2020	40-2554-410-00-79
		40-2554-410-00-79	Fleet Supplies	371.22	2/24/2020	40-2554-410-00-79
		40-2554-410-00-79	Fleet Supplies	427.90	2/24/2020	40-2554-410-00-79
		40-2554-410-00-79	Fleet Supplies	513.19	2/24/2020	40-2554-410-00-79
		40-2554-410-00-79	Fleet Supplies	532.51	2/24/2020	40-2554-410-00-79
		40-2554-410-00-79	Fleet Supplies	600.17	2/24/2020	40-2554-410-00-79
		40-2554-410-00-79	Fleet Supplies	962.50	2/24/2020	40-2554-410-00-79
			Total	<u>\$3,652.41</u>		
0020202543	Say It Right	10-2150-410-92-79-605-14	IDEA Sp Path & Audiol Supplies	67.37	2/24/2020	10-2150-410-92-79-605-14
			Total	<u>\$67.37</u>		
0020202456	Schocks Towing	40-2550-323-00-79	Repairs and Maintenance	250.00	2/18/2020	40-2550-323-00-79
			Total	<u>\$250.00</u>		
0020202596	School Health Corporation Bldg	10-2130-410-00-79-600-14	Supplies Health	7.23	2/26/2020	10-2130-410-00-79-600-14
		10-2130-410-00-79-600-14	Supplies Health	20.90	2/26/2020	10-2130-410-00-79-600-14
			Total	<u>\$28.13</u>		
0020202581	Streamwood Behavioral Health	10-4210-670-00-79-600-14	Reg Ed Out of District	420.00	2/26/2020	10-4210-670-00-79-600-14
			Total	<u>\$420.00</u>		
0020202520	Sunbelt Staffing LLC	10-2130-310-92-79-600-14	IDEA Health Services	2,400.00	2/24/2020	10-2130-310-92-79-600-14
			Total	<u>\$2,400.00</u>		



Huntley Community School District #158

Purchase Orders Report

From February 14, 2020 to February 27, 2020

Printed: 2/27/2020
Page 27 of 28

P.O.#	Vendor Name	A.S.N.	Description	Amount	P.O. Date	State Account Number
0020202546	Teachers Discovery	10-1800-410-84-79-605-14	Title III LIPLEPS Supplies	119.94	2/24/2020	10-1800-410-84-79-605-14
		10-1800-410-84-79-605-14	Title III LIPLEPS Supplies	721.97	2/24/2020	10-1800-410-84-79-605-14
		10-1800-410-84-79-605-14	Title III LIPLEPS Supplies	525.00	2/24/2020	10-1800-410-84-79-605-14
		10-1800-410-84-79-605-14	Title III LIPLEPS Supplies	504.00	2/24/2020	10-1800-410-84-79-605-14
		10-1800-410-84-79-605-14	Title III LIPLEPS Supplies	374.25	2/24/2020	10-1800-410-84-79-605-14
		10-1800-410-84-79-605-14	Title III LIPLEPS Supplies	300.00	2/24/2020	10-1800-410-84-79-605-14
		10-1800-410-84-79-605-14	Title III LIPLEPS Supplies	888.00	2/24/2020	10-1800-410-84-79-605-14
		10-1800-410-84-79-605-14	Title III LIPLEPS Supplies	240.00	2/24/2020	10-1800-410-84-79-605-14
		10-1800-410-84-79-605-14	Title III LIPLEPS Supplies	439.00	2/24/2020	10-1800-410-84-79-605-14
		10-1800-410-84-79-605-14	Title III LIPLEPS Supplies	207.20	2/24/2020	10-1800-410-84-79-605-14
		10-1800-410-84-79-605-14	Title III LIPLEPS Supplies	192.00	2/24/2020	10-1800-410-84-79-605-14
		10-1800-410-84-79-605-14	Title III LIPLEPS Supplies	189.50	2/24/2020	10-1800-410-84-79-605-14
		10-1800-410-84-79-605-14	Title III LIPLEPS Supplies	22.35	2/24/2020	10-1800-410-84-79-605-14
		10-1800-410-84-79-605-14	Title III LIPLEPS Supplies	130.00	2/24/2020	10-1800-410-84-79-605-14
		10-1800-410-84-79-605-14	Title III LIPLEPS Supplies	50.00	2/24/2020	10-1800-410-84-79-605-14
		10-1800-410-84-79-605-14	Title III LIPLEPS Supplies	66.00	2/24/2020	10-1800-410-84-79-605-14
		10-1800-410-84-79-605-14	Title III LIPLEPS Supplies	886.80	2/24/2020	10-1800-410-84-79-605-14
		10-1800-410-84-79-605-14	Title III LIPLEPS Supplies	52.50	2/24/2020	10-1800-410-84-79-605-14
		10-1800-410-84-79-605-14	Title III LIPLEPS Supplies	59.60	2/24/2020	10-1800-410-84-79-605-14
		10-1800-410-84-79-605-14	Title III LIPLEPS Supplies	88.50	2/24/2020	10-1800-410-84-79-605-14
		10-1800-410-84-79-605-14	Title III LIPLEPS Supplies	144.00	2/24/2020	10-1800-410-84-79-605-14
10-1800-410-84-79-605-14	Title III LIPLEPS Supplies	75.00	2/24/2020	10-1800-410-84-79-605-14		
				Total		
						<u>\$6,275.61</u>
0020202490	Tennant Sales and Service	20-2542-410-00-79	Supplies B & G	44.70	2/19/2020	20-2542-410-00-79
						Total
0020202597	Therapro, Inc.	10-2130-410-92-79-605-14	IDEA Health OTPT & Nurse Sup	159.44	2/26/2020	10-2130-410-92-79-605-14
						Total
0020202593	Total Fitness	10-1120-323-00-72-220-13	Repairs Marlowe	250.00	2/26/2020	10-1120-323-00-72-220-13
						Total
0020202557	TPI Tyler Press Inc	10-1200-410-66-71-300-13	STEP Supplies	2,295.47	2/25/2020	10-1200-410-66-71-300-13
						Total
0020202592	Translation Today Network Inc	10-2150-310-92-79-600-14	IDEA Sp Path & Audiology Serv	237.60	2/26/2020	10-2150-310-92-79-600-14
		10-2150-310-92-79-600-14	IDEA Sp Path & Audiology Serv	210.50	2/26/2020	10-2150-310-92-79-600-14
						Total



Huntley Community School District #158 Purchase Orders Report From February 14, 2020 to February 27, 2020

Printed: 2/27/2020
Page 28 of 28

P.O.#	Vendor Name	A.S.N.	Description	Amount	P.O. Date	State Account Number
0020202529	Unity School Bus Parts, Inc	40-2554-410-00-79	Fleet Supplies	305.30	2/24/2020	40-2554-410-00-79
			Total	<u>\$305.30</u>		
0020202445	Valley Speech Language Learning Cent	10-1800-410-82-79-605-14	TBE/TPI Instructional Supplies	1,920.00	2/18/2020	10-1800-410-82-79-605-14
		10-1800-410-82-79-605-14	TBE/TPI Instructional Supplies	288.00	2/18/2020	10-1800-410-82-79-605-14
		10-1800-410-82-79-605-14	TBE/TPI Instructional Supplies	1,440.00	2/18/2020	10-1800-410-82-79-605-14
		10-1800-410-82-79-605-14	TBE/TPI Instructional Supplies	450.00	2/18/2020	10-1800-410-82-79-605-14
			Total	<u>\$4,098.00</u>		
0020202585	Wallingford Sales Company	20-2542-410-00-79	Supplies B & G	338.97	2/26/2020	20-2542-410-00-79
			Total	<u>\$338.97</u>		
0020202555	Welch, Janet M	10-1500-411-00-71-300-13	Awards HS	300.00	2/25/2020	10-1500-411-00-71-300-13
			Total	<u>\$300.00</u>		
0020202521	Winston Knolls Education Group	10-4220-670-00-79-600-14	Sp Ed Private Tuition	2,692.80	2/24/2020	10-4220-670-00-79-600-14
			Total	<u>\$2,692.80</u>		
			Total	<u><u>\$415,873.95</u></u>		



Huntley Community School District 158

650 Dr. John Burkey Drive
Algonquin, Illinois 60102
(847) 659-6158 • www.district158.org

To: Board of Education and Administration
From: Mark Altmayer, Chief Financial Officer
Date: March 5, 2020
Subject: **Imprest Checks Issue**
Committee of the Whole Meeting, March 5, 2020
Finance Committee

The following is an executive summary of the attached report titled “Imprest Checks Issued” which is a listing of payments made as of February 27, 2020 for which the Board had not previously approved purchase orders. Therefore Administration is requesting Board Approval acknowledging the issuance of payment:

Education Fund	\$	22,158.51
Operations & Maintenance Fund		74,341.78
Debt Service Fund		0.00
Transporation Fund		0.00
Municipal Retirement and Social Security Fund		16.00
Capital Projects Fund		0.00
Working Cash Fund		0.00
Fire Prevention and Safety Fund		0.00
Total	\$	<u>96,516.29</u>

RECOMMENDATION

Administration requests that the Finance Committee recommend the Board of Education approve the Imprest Checks Issued Report at the March 19, 2020 Regular Board meeting.



Huntley Community School District 158

Imprest Checks Issued

As of: 02/27/2020

Printed: 02/27/2020

Page 1 of 8

Vendor Name		Amount	State Account Number
P.O. Number	Description		
Accardi, David			
	Sports Officials Marlowe	65.00	10-1500-319-00-72-220-13
	Sports Officials Heineman	65.00	10-1500-319-00-74-210-13
	Sports Officials Marlowe	65.00	10-1500-319-00-72-220-13
		<u>195.00</u>	
Anderson, Amos			
	Sports Officials HS	53.00	10-1500-319-00-71-300-13
		<u>53.00</u>	
Androus, Peter			
	Sports Officials HS	67.00	10-1500-319-00-71-300-13
		<u>67.00</u>	
Aschacher, Joe			
	Sports Officials HS	53.00	10-1500-319-00-71-300-13
	Sports Officials HS	67.00	10-1500-319-00-71-300-13
	Sports Officials HS	53.00	10-1500-319-00-71-300-13
		<u>173.00</u>	
Baker, Robert			
	Sports Officials HS	92.00	10-1500-319-00-71-300-13
	Sports Officials HS	92.00	10-1500-319-00-71-300-13
		<u>184.00</u>	
Bert, Jeffrey			
	Sports Officials HS	67.00	10-1500-319-00-71-300-13
		<u>67.00</u>	
Bondi, Michael			
	Sports Officials HS	109.00	10-1500-319-00-71-300-13
		<u>109.00</u>	
Bower, Thomas			
	Sports Officials Heineman	65.00	10-1500-319-00-74-210-13
	Sports Officials Marlowe	65.00	10-1500-319-00-72-220-13
		<u>130.00</u>	
Brach Jr, Fred			
	Sports Officials Heineman	65.00	10-1500-319-00-74-210-13
	Sports Officials Heineman	65.00	10-1500-319-00-74-210-13
		<u>130.00</u>	
Carlson, Brian			
	Sports Officials HS	67.00	10-1500-319-00-71-300-13
		<u>67.00</u>	
Casebolt, Jason			
	Sports Officials Marlowe	65.00	10-1500-319-00-72-220-13
		<u>65.00</u>	
Central High School			
	Conference Travel HS	325.00	10-1500-335-00-71-300-13
		<u>325.00</u>	
Citrano, Michael			
	Sports Officials HS	53.00	10-1500-319-00-71-300-13
		<u>53.00</u>	
Clark, Steve			
	Sports Officials HS	53.00	10-1500-319-00-71-300-13



Huntley Community School District 158

Imprest Checks Issued

As of: 02/27/2020

Printed: 02/27/2020

Page 2 of 8

Vendor Name		Amount	State Account Number
P.O. Number	Description		
		\$53.00	
Collier, Mark			
	Sports Officials Heineman	65.00	10-1500-319-00-74-210-13
		\$65.00	
ComEd			
	Electric	25,166.55	20-2540-466-00-79
	Electric	19,472.66	20-2540-466-00-79
	Electric	17,320.57	20-2540-466-00-79
		\$61,959.78	
Cooper, Timothy			
	Sports Officials HS	53.00	10-1500-319-00-71-300-13
		\$53.00	
Daujotas, Laimote & Avdrius			
	Registration Fee HS	95.00	10-1811-305
		\$95.00	
Dorr, James			
	Sports Officials HS	67.00	10-1500-319-00-71-300-13
		\$67.00	
Doyle, Steven			
	Sports Officials HS	92.00	10-1500-319-00-71-300-13
		\$92.00	
Earle, John			
	Sports Officials HS	67.00	10-1500-319-00-71-300-13
		\$67.00	
Evanston Township High School			
	Athletic Trips HS	100.00	10-1500-332-00-71-300-13
		\$100.00	
Fazel, Chad			
	Sports Officials HS	68.00	10-1500-319-00-71-300-13
		\$68.00	
Folkerts, John			
	Sports Officials Marlowe	65.00	10-1500-319-00-72-220-13
		\$65.00	
Freeport High School			
	Activities Fees	140.00	10-1543-640-00-71-305-13
		\$140.00	
Friederick, David			
	Sports Officials HS	53.00	10-1500-319-00-71-300-13
	Sports Officials HS	53.00	10-1500-319-00-71-300-13
	Sports Officials HS	53.00	10-1500-319-00-71-300-13
	Sports Officials Marlowe	40.00	10-1500-319-00-72-220-13
	Sports Officials HS	53.00	10-1500-319-00-71-300-13
		\$252.00	
Fulk, Trevor			
	Sports Officials HS	53.00	10-1500-319-00-71-300-13
	Sports Officials Marlowe	65.00	10-1500-319-00-72-220-13
		\$118.00	
Garrey, Scott			



Huntley Community School District 158

Imprest Checks Issued

As of: 02/27/2020

Printed: 02/27/2020

Page 3 of 8

Vendor Name		Amount	State Account Number
P.O. Number	Description		
	Sports Officials HS	67.00	10-1500-319-00-71-300-13
		<u>\$67.00</u>	
Giffels, Dave			
	Sports Officials HS	92.00	10-1500-319-00-71-300-13
	Sports Officials HS	53.00	10-1500-319-00-71-300-13
		<u>\$145.00</u>	
Glaser, Thomas			
	Sports Officials HS	67.00	10-1500-319-00-71-300-13
		<u>\$67.00</u>	
Graber, Chuck			
	Sports Officials HS	67.00	10-1500-319-00-71-300-13
		<u>\$67.00</u>	
Grayslake North H.S. c/o Athletics			
	Conference Travel HS	300.00	10-1500-335-00-71-300-13
	Conference Travel HS	200.00	10-1500-335-00-71-300-13
		<u>\$500.00</u>	
Guarino, Rose			
	Student Food Svc - HS	7.50	10-1611-305
		<u>\$7.50</u>	
Haldeman, Ronald			
	Sports Officials Marlowe	65.00	10-1500-319-00-72-220-13
		<u>\$65.00</u>	
HESPA			
	HESPA Dues	5,542.14	10-462
	HESPA Dues	5,533.61	10-462
		<u>\$11,075.75</u>	
Hodge, James			
	Sports Officials Heineman	65.00	10-1500-319-00-74-210-13
	Sports Officials Heineman	65.00	10-1500-319-00-74-210-13
		<u>\$130.00</u>	
Jenkins, Jeffrey			
	Sports Officials Heineman	40.00	10-1500-319-00-74-210-13
		<u>\$40.00</u>	
Jones, William D			
	Registration Fee HS	95.00	10-1811-305
		<u>\$95.00</u>	
Klingberg, Scott			
	Sports Officials HS	67.00	10-1500-319-00-71-300-13
		<u>\$67.00</u>	
Koziol, Richard			
	Sports Officials HS	53.00	10-1500-319-00-71-300-13
		<u>\$53.00</u>	
Krueger, Wesley			
	Sports Officials HS	53.00	10-1500-319-00-71-300-13
	Sports Officials HS	53.00	10-1500-319-00-71-300-13
	Sports Officials Marlowe	65.00	10-1500-319-00-72-220-13
	Sports Officials HS	53.00	10-1500-319-00-71-300-13
		<u>\$224.00</u>	



Huntley Community School District 158

Imprest Checks Issued

As of: 02/27/2020

Printed: 02/27/2020

Page 4 of 8

Vendor Name	Description	Amount	State Account Number
Laman, Mike	Sports Officials HS	67.00	10-1500-319-00-71-300-13
		<u>67.00</u>	
Lampel, Jay	Sports Officials HS	67.00	10-1500-319-00-71-300-13
		<u>67.00</u>	
Lindquist, Joe	Sports Officials HS	68.00	10-1500-319-00-71-300-13
		<u>68.00</u>	
Lipscomb, Jeff	Sports Officials HS	67.00	10-1500-319-00-71-300-13
		<u>67.00</u>	
Lizarraga, Natasha	Student Food Svc - Chesak	17.00	10-1611-115
		<u>17.00</u>	
Lombardo, Tony	Sports Officials Marlowe	65.00	10-1500-319-00-72-220-13
		<u>65.00</u>	
Marach, Dennis	Sports Officials HS	67.00	10-1500-319-00-71-300-13
		<u>67.00</u>	
Mason, Pamela	Sports Officials Marlowe	65.00	10-1500-319-00-72-220-13
	Sports Officials Heineman	40.00	10-1500-319-00-74-210-13
		<u>105.00</u>	
Massie, Steve	Sports Officials HS	67.00	10-1500-319-00-71-300-13
		<u>67.00</u>	
McCullough, Kristian	Sports Officials HS	67.00	10-1500-319-00-71-300-13
		<u>67.00</u>	
McNamara, Lee Ann Johnson	Registration Fee HS	95.00	10-1811-305
		<u>95.00</u>	
McTague, Scott	Sports Officials HS	53.00	10-1500-319-00-71-300-13
	Sports Officials HS	53.00	10-1500-319-00-71-300-13
		<u>106.00</u>	
Most, Brandon	Sports Officials Heineman	65.00	10-1500-319-00-74-210-13
	Sports Officials Heineman	65.00	10-1500-319-00-74-210-13
	Sports Officials Heineman	65.00	10-1500-319-00-74-210-13
		<u>195.00</u>	
Murren, Jason	Sports Officials HS	92.00	10-1500-319-00-71-300-13
	Sports Officials HS	92.00	10-1500-319-00-71-300-13
		<u>184.00</u>	

Murzyn, Steve



Huntley Community School District 158

Imprest Checks Issued

As of: 02/27/2020

Printed: 02/27/2020

Page 5 of 8

Vendor Name		Amount	State Account Number
P.O. Number	Description		
	Sports Officials HS	53.00	10-1500-319-00-71-300-13
		<u>53.00</u>	
NCPERS Group Life Ins			
	IMRF & SS (Board)	16.00	50-481
		<u>16.00</u>	
Nieves, Jennifer			
	Registration Fee HS	95.00	10-1811-305
		<u>95.00</u>	
Orange, Christopher			
	Sports Officials Heineman	40.00	10-1500-319-00-74-210-13
		<u>40.00</u>	
Orris, Bill			
	Sports Officials HS	67.00	10-1500-319-00-71-300-13
		<u>67.00</u>	
Peoria Civic Center			
	Activities Fees	80.00	10-1543-640-00-71-305-13
		<u>80.00</u>	
Pereda, Edgar			
	AP Payroll Net Checks	1,034.45	10-475
		<u>\$1,034.45</u>	
Perko, Thomas			
	Sports Officials HS	58.00	10-1500-319-00-71-300-13
		<u>58.00</u>	
Petersen, Matthew			
	Sports Officials Marlowe	65.00	10-1500-319-00-72-220-13
		<u>65.00</u>	
Peterson, Eric			
	Sports Officials Marlowe	65.00	10-1500-319-00-72-220-13
		<u>65.00</u>	
Petty Cash-HHS SpEd			
	IDEA Instructional Supplies	57.64	10-1200-410-92-79-600-14
	IDEA Instructional Supplies	76.46	10-1200-410-92-79-600-14
	IDEA General Purchased Service	25.00	10-1200-310-92-79-600-14
	IDEA Instructional Supplies	30.45	10-1200-410-92-79-600-14
	IDEA General Purchased Service	70.00	10-1200-310-92-79-600-14
		<u>\$259.55</u>	
Pingel, Rick			
	Sports Officials HS	92.00	10-1500-319-00-71-300-13
		<u>92.00</u>	
Pinter, William			
	Sports Officials HS	53.00	10-1500-319-00-71-300-13
	Sports Officials HS	53.00	10-1500-319-00-71-300-13
	Sports Officials Heineman	40.00	10-1500-319-00-74-210-13
	Sports Officials HS	53.00	10-1500-319-00-71-300-13
		<u>\$199.00</u>	
Price, Charles			
	Sports Officials Marlowe	40.00	10-1500-319-00-72-220-13
		<u>40.00</u>	



Huntley Community School District 158

Imprest Checks Issued

As of: 02/27/2020

Printed: 02/27/2020

Page 6 of 8

Vendor Name	P.O. Number	Description	Amount	State Account Number
Rees, Wayne				
		Sports Officials Marlowe	65.00	10-1500-319-00-72-220-13
			<u>65.00</u>	
Rivera Jr, Rafael				
		Sports Officials Marlowe	65.00	10-1500-319-00-72-220-13
		Sports Officials Marlowe	65.00	10-1500-319-00-72-220-13
			<u>\$130.00</u>	
Rockford Auburn HS				
		Conference Travel HS	300.00	10-1500-335-00-71-300-13
			<u>\$300.00</u>	
Ruggles, Dan				
		Sports Officials Heineman	40.00	10-1500-319-00-74-210-13
			<u>\$40.00</u>	
Saunders, Mark				
		Sports Officials HS	67.00	10-1500-319-00-71-300-13
			<u>\$67.00</u>	
Smith, Kevin				
		Sports Officials HS	92.00	10-1500-319-00-71-300-13
			<u>\$92.00</u>	
Snyder, Alan & Jill				
		Student Food Svc - HS	24.15	10-1611-305
			<u>\$24.15</u>	
Steeber, Dale				
		Sports Officials Heineman	65.00	10-1500-319-00-74-210-13
			<u>\$65.00</u>	
Stephan, Mark				
		Sports Officials HS	53.00	10-1500-319-00-71-300-13
		Sports Officials HS	92.00	10-1500-319-00-71-300-13
			<u>\$145.00</u>	
Stephenson, Kevin				
		Sports Officials Marlowe	65.00	10-1500-319-00-72-220-13
			<u>\$65.00</u>	
Stephenson, Michael				
		Sports Officials HS	68.00	10-1500-319-00-71-300-13
			<u>\$68.00</u>	
Tapanes, Pedro				
		Sports Officials Heineman	65.00	10-1500-319-00-74-210-13
			<u>\$65.00</u>	
Taylor, David				
		Sports Officials HS	67.00	10-1500-319-00-71-300-13
		Sports Officials HS	67.00	10-1500-319-00-71-300-13
			<u>\$134.00</u>	
Tortorice, Sam & Dawn				
		Registration Fee HS	95.00	10-1811-305
			<u>\$95.00</u>	
Trewartha, Dave				
		Sports Officials HS	67.00	10-1500-319-00-71-300-13



Huntley Community School District 158

Imprest Checks Issued

As of: 02/27/2020

Printed: 02/27/2020

Page 7 of 8

Vendor Name		Amount	State Account Number
P.O. Number	Description		
		\$67.00	
Trowbridge, David			
	Sports Officials Marlowe	65.00	10-1500-319-00-72-220-13
	Sports Officials Heineman	65.00	10-1500-319-00-74-210-13
		\$130.00	
United Way of McHenry Co			
	United Way Payable	13.43	10-498
	United Way Payable	13.43	10-498
		\$26.86	
Village of Algonquin			
	Water/Sewer	704.20	20-2540-370-00-79
	Water/Sewer	1,972.45	20-2540-370-00-79
	Water/Sewer	1,318.30	20-2540-370-00-79
	Water/Sewer	1,251.55	20-2540-370-00-79
	Water/Sewer	10.00	20-2540-370-00-79
	Water/Sewer	557.35	20-2540-370-00-79
	Water/Sewer	2,439.70	20-2540-370-00-79
	Water/Sewer	10.00	20-2540-370-00-79
	Water/Sewer	2,506.45	20-2540-370-00-79
	Water/Sewer	1,612.00	20-2540-370-00-79
		\$12,382.00	
Vrugt, Adriaan			
	Sports Officials Marlowe	65.00	10-1500-319-00-72-220-13
	Sports Officials Heineman	40.00	10-1500-319-00-74-210-13
		\$105.00	
Warren, Mike			
	Sports Officials HS	86.00	10-1500-319-00-71-300-13
	Sports Officials Heineman	65.00	10-1500-319-00-74-210-13
	Sports Officials Heineman	65.00	10-1500-319-00-74-210-13
	Sports Officials Marlowe	65.00	10-1500-319-00-72-220-13
	Sports Officials HS	92.00	10-1500-319-00-71-300-13
		\$373.00	
Westfall, James			
	Sports Officials Marlowe	65.00	10-1500-319-00-72-220-13
	Sports Officials Heineman	65.00	10-1500-319-00-74-210-13
		\$130.00	
Wheaton Warrenville South HS			
	Extra-Curricular HS	410.00	10-1500-410-70-71-300-13
		\$410.00	
White, Larry			
	Student Food Svc - HS	13.70	10-1611-305
		\$13.70	
White, Lawrence			
	Registration Fee HS	95.00	10-1811-305
		\$95.00	
Willatts, Linda			
	Student Food Svc - HS	8.65	10-1611-305
		\$8.65	
Willets, Linda			
	Registration Fee HS	95.00	10-1811-305
		\$95.00	



Huntley Community School District 158

Imprest Checks Issued

As of: 02/27/2020

Printed: 02/27/2020

Page 8 of 8

Vendor Name		Amount	State Account Number
P.O. Number	Description		
Williams, Craig M			
	Registration Fee HS	95.00	10-1811-305
	Registration Fee HS	95.00	10-1811-305
		<u>\$190.00</u>	
Williams, Dave			
	Sports Officials HS	53.00	10-1500-319-00-71-300-13
		<u>\$53.00</u>	
Wilmot, Michael			
	Sports Officials HS	53.00	10-1500-319-00-71-300-13
	Sports Officials HS	53.00	10-1500-319-00-71-300-13
		<u>\$106.00</u>	
Wolinsky, Carole			
	Student Food Svc - HS	13.90	10-1611-305
		<u>\$13.90</u>	
Wozny, Michael			
	Sports Officials Marlowe	65.00	10-1500-319-00-72-220-13
		<u>\$65.00</u>	
Zimmerman, Jillian			
	Student Food Svc - HS	80.00	10-1611-305
		<u>\$80.00</u>	
	Report Total	<u><u>\$96,516.29</u></u>	



Huntley Community School District 158

650 Dr. John Burkey Drive
Algonquin, Illinois 60102
(847) 659-6158 • www.district158.org

To: Board of Education and Administration
From: Mark Altmayer, Chief Financial Officer
Date: March 5, 2020
Subject: **Accounts Payable Report**
Committee of the Whole Meeting, March 5, 2020
Finance Committee

The following is an executive summary of the attached report titled “Accounts Payable” which is a listing of open accounts payable for which the Board has not approved purchase orders (i.e. employee reimbursements, refunds for fees, etc.) and therefore Administration is requesting Board Approval to issue payment:

Education Fund	\$	1,395.61
Operations & Maintenance Fund		30.70
Debt Service Fund		0.00
Transporation Fund		0.00
Municipal Retirement and Social Security Fund		0.00
Capital Projects Fund		0.00
Working Cash Fund		0.00
Fire Prevention and Safety Fund		0.00
Total	\$	<u>1,426.31</u>

At this time there is no Supplemental Accounts Payable Report for which Board approval is needed. Therefore, one will be provided in the packet for the upcoming Regular Board meeting. It will consist of an executive summary and an attached report titled “Accounts Payable” which will include an additional listing of open accounts payable for which the Board has not approved purchase orders (i.e. employee reimbursements, refunds for fees, etc.) and therefore Administration will request Board Approval to issue payment.

RECOMMENDATION

Administration requests that the Finance Committee recommend the Board of Education approve the Accounts Payable Report at the March 19, 2020 Regular Board meeting.



Huntley Community School District #158 Accounts Payable Report

Printed: 2/27/2020
Page 1 of 2

Vendor Name	A.S.N.	Description	Amount	State Account Number
Atchison, Charity	10-2210-314-92-79-605-14	IDEA Impr of Instr-Staff Dev	52.20	10-2210-314-92-79-605-14
		Total	<u>\$52.20</u>	
Carpenter, Allison	10-1110-332-00-71-100-13	Teacher Travel Leggee	28.17	10-1110-332-00-71-100-13
		Total	<u>\$28.17</u>	
Dean, Adam	10-2546-332-00-79-600-14	Security Officer Travel	227.70	10-2546-332-00-79-600-14
		Total	<u>\$227.70</u>	
DiRaimondo, Kelley	10-2210-314-92-79-605-14	IDEA Impr of Instr-Staff Dev	52.20	10-2210-314-92-79-605-14
		Total	<u>\$52.20</u>	
Gates, Julie	10-2210-314-92-79-605-14	IDEA Impr of Instr-Staff Dev	44.28	10-2210-314-92-79-605-14
		Total	<u>\$44.28</u>	
Gelasi, Paul	20-2540-332-00-79	Travel	17.25	20-2540-332-00-79
		Total	<u>\$17.25</u>	
Gore, Rita	10-2520-332-00-74-500-14	Travel Fiscal	31.92	10-2520-332-00-74-500-14
		Total	<u>\$31.92</u>	
Higgin, Merry C	10-1130-332-00-71-300-13	Teacher Travel HS	24.15	10-1130-332-00-71-300-13
		Total	<u>\$24.15</u>	
Kapachinski, Jessica	10-1130-410-59-71-300-14	HS Special Ed Supplies	84.48	10-1130-410-59-71-300-14
		Total	<u>\$84.48</u>	
Korn, Jennifer	10-1200-310-92-79-600-14	IDEA General Purchased Service	75.08	10-1200-310-92-79-600-14
		Total	<u>\$75.08</u>	
Langenfeld, Darcy	10-2520-332-00-74-500-14	Travel Fiscal	48.31	10-2520-332-00-74-500-14
		Total	<u>\$48.31</u>	



Huntley Community School District #158 Accounts Payable Report

Printed: 2/27/2020
Page 2 of 2

Vendor Name	A.S.N.	Description	Amount	State Account Number
Neuzil, William	20-2540-332-00-79	Travel	13.45	20-2540-332-00-79
		Total	<u>\$13.45</u>	
O Neill, Brian	10-1400-410-03-71-300-13	Business Supplies	250.00	10-1400-410-03-71-300-13
		Total	<u>\$250.00</u>	
Reed, Richard	10-2561-332-00-79-605-14	Dir Food Service Travel	40.48	10-2561-332-00-79-605-14
		Total	<u>\$40.48</u>	
Roskopf, Janet	10-1120-332-00-72-220-13	Teacher Travel Marlowe	15.00	10-1120-332-00-72-220-13
		Total	<u>\$15.00</u>	
Schmuhl, Jessica	10-1120-410-09-72-220-13	Home Ec Marlowe	57.08	10-1120-410-09-72-220-13
		Total	<u>\$57.08</u>	
Sefton, Grace	10-2520-332-00-74-500-14	Travel Fiscal	10.15	10-2520-332-00-74-500-14
		Total	<u>\$10.15</u>	
Smith, Carly	10-2210-314-92-79-605-14	IDEA Impr of Instr-Staff Dev	118.55	10-2210-314-92-79-605-14
		Total	<u>\$118.55</u>	
Stamatis, Kristi	10-1110-332-00-71-100-13	Teacher Travel Leggee	32.08	10-1110-332-00-71-100-13
		Total	<u>\$32.08</u>	
Surak-Roesner, Linda	10-1110-332-00-71-100-13	Teacher Travel Leggee	11.50	10-1110-332-00-71-100-13
		Total	<u>\$11.50</u>	
Vernsten, Kathryn	10-2150-410-92-79-605-14	IDEA Sp Path & Audiol Supplies	51.27	10-2150-410-92-79-605-14
	10-2210-410-92-79-600-14	IDEA Impr of Instruction Suppl	100.76	10-2210-410-92-79-600-14
		Total	<u>\$152.03</u>	
Zhang, Guangping	10-2520-332-00-74-500-14	Travel Fiscal	40.25	10-2520-332-00-74-500-14
		Total	<u>\$40.25</u>	
		Total	<u>\$1,426.31</u>	



Huntley Community School District 158

650 Dr. John Burkey Drive
Algonquin, Illinois 60102
(847) 659-6158 • www.district158.org

To: Board of Education and Administration
From: Mark Altmayer, Chief Financial Officer
Date: March 5, 2020
Subject: **Disbursements Issued**
Committee of the Whole Meeting, March 5, 2020
Finance Committee

The following is an executive summary of the attached report titled “Disbursements Issued” which is a listing of disbursements issued from January 30, 2020 to February 27, 2020.

Education Fund	\$ 1,680,868.30
Operations & Maintenance Fund	503,631.30
Debt Service Fund	1,557.18
Transportation Fund	156,253.36
Municipal Retirement and Social Security Fund	151,540.52
Capital Projects Fund	232,580.23
Working Cash Fund	0.00
Fire Prevention and Safety Fund	0.00
Total	<u>\$ 2,726,430.89</u>

RECOMMENDATION

Administration requests that the Finance Committee recommend the Board of Education approve the Disbursements Issued Report at the March 19, 2020 Regular Board meeting.



Huntley Community School District #158

Disbursements Issued

From January 30, 2020 to February 27, 2020

Printed: 2/27/2020
Page 1 of 45

Vendor Name	Check #	Check Date	A.S.N.	Description	Amount	PO #	State Account Number
1ST Ayd Corporation	51990	2/21/2020	40-2554-410-00-79	Fleet Supplies	440.43	0020010677	40-2554-410-00-79
	51990	2/21/2020	40-2554-410-00-79	Fleet Supplies	86.58	0020090677	40-2554-410-00-79
				Total	<u>\$527.01</u>		
4 Imprint Inc	51991	2/21/2020	10-1400-410-62-71-300-13	Co-Op Supplies	277.06	0020202329	10-1400-410-62-71-300-13
				Total	<u>\$277.06</u>		
A Parts Warehouse	51992	2/21/2020	40-2554-410-00-79	Fleet Supplies	372.00	0020202330	40-2554-410-00-79
				Total	<u>\$372.00</u>		
ABM Industry Groups LLC	51906	2/14/2020	20-2542-319-00-79-605-14	Contractual Cust. Replacement	460.48	0020120227	20-2542-319-00-79-605-14
	51906	2/14/2020	20-2542-320-00-79-605-14	Contractual Overtime	3,485.83	0020120217	20-2542-320-00-79-605-14
	51906	2/14/2020	40-2550-321-00-79	Bus Sanitation	2,372.40	0020120187	40-2550-321-00-79
	51993	2/21/2020	20-2542-310-00-79	Custodial Contract Service	134,899.73	0020020207	20-2542-310-00-79
				Total	<u>\$141,218.44</u>		
Accardi, David	51907	2/14/2020	10-1500-319-00-72-220-13	Sports Officials Marlowe	65.00		10-1500-319-00-72-220-13
				Total	<u>\$65.00</u>		
Accountable Healthcare Staffing Inc	51740	1/31/2020	10-2140-310-00-79-600-14	Psychological Services	2,533.60	0020010637	10-2140-310-00-79-600-14
	51808	2/7/2020	10-2140-310-00-79-600-14	Psychological Services	2,320.00	0020010637	10-2140-310-00-79-600-14
				Total	<u>\$4,853.60</u>		
ADP LLC	51741	1/31/2020	10-2520-310-00-74-500-14	Prof & Tech Fiscal	4,997.92	0020110437	10-2520-310-00-74-500-14
	51994	2/21/2020	10-2520-310-00-74-500-14	Prof & Tech Fiscal	14,944.35	0020020437	10-2520-310-00-74-500-14
				Total	<u>\$19,942.27</u>		
Advance Auto Parts	51809	2/7/2020	40-2554-410-00-79	Fleet Supplies	602.98	0020120717	40-2554-410-00-79
	51995	2/21/2020	40-2554-410-00-79	Fleet Supplies	224.43	0020120717	40-2554-410-00-79
				Total	<u>\$827.41</u>		



Huntley Community School District #158

Disbursements Issued

From January 30, 2020 to February 27, 2020

Printed: 2/27/2020
Page 2 of 45

Vendor Name	Check #	Check Date	A.S.N.	Description	Amount	PO #	State Account Number
Advantage Mechanical Inc							
	51810	2/7/2020	20-2542-323-00-79	Repairs & Maint Buildings	1,482.50	0020020027	20-2542-323-00-79
	51810	2/7/2020	20-2542-323-00-79	Repairs & Maint Buildings	2,403.00	0020120027	20-2542-323-00-79
	51810	2/7/2020	20-2542-323-00-79	Repairs & Maint Buildings	2,456.61	0020010027	20-2542-323-00-79
	51996	2/21/2020	20-2542-323-00-79	Repairs & Maint Buildings	3,597.00	0020202284	20-2542-323-00-79
	51996	2/21/2020	20-2542-323-00-79	Repairs & Maint Buildings	1,316.00	0020202286	20-2542-323-00-79
	51996	2/21/2020	20-2542-323-00-79	Repairs & Maint Buildings	3,906.00	0020202285	20-2542-323-00-79
				Total	<u>\$15,161.11</u>		
AIA Services LLC							
	51997	2/21/2020	10-1110-410-00-72-120-13	Inst Supplies Martin	134.60	0020202163	10-1110-410-00-72-120-13
				Total	<u>\$134.60</u>		
Ajinomoto Cambrooke Inc							
	51998	2/21/2020	10-2560-415-00-72-110-13	Cafe Food Chesak	145.42	0020202131	10-2560-415-00-72-110-13
	51998	2/21/2020	10-2560-415-00-72-110-13	Cafe Food Chesak	137.45	0020202331	10-2560-415-00-72-110-13
				Total	<u>\$282.87</u>		
Albourn & Associates LLC							
	51999	2/21/2020	10-2212-310-00-79-505-14	Curriculum Gen Pur Svc	35.04	0020202393	10-2212-310-00-79-505-14
	51999	2/21/2020	10-2212-310-00-79-505-14	Curriculum Gen Pur Svc	40.64	0020202394	10-2212-310-00-79-505-14
	51999	2/21/2020	10-2212-310-00-79-505-14	Curriculum Gen Pur Svc	33.60	0020202392	10-2212-310-00-79-505-14
	51999	2/21/2020	10-2212-310-00-79-505-14	Curriculum Gen Pur Svc	36.64	0020202287	10-2212-310-00-79-505-14
	51999	2/21/2020	10-2212-310-00-79-505-14	Curriculum Gen Pur Svc	31.68	0020202288	10-2212-310-00-79-505-14
				Total	<u>\$177.60</u>		
Alexander Leigh Center for Autism							
	51742	1/31/2020	10-4220-670-00-79-600-14	Sp Ed Private Tuition	30,869.17	0020011617	10-4220-670-00-79-600-14
				Total	<u>\$30,869.17</u>		
Alexian Brothers							
	52000	2/21/2020	10-1200-310-92-79-600-14	IDEA General Purchased Service	880.00	0020202158	10-1200-310-92-79-600-14
	52000	2/21/2020	10-1200-310-92-79-600-14	IDEA General Purchased Service	800.00	0020202433	10-1200-310-92-79-600-14
	52000	2/21/2020	10-1200-310-92-79-600-14	IDEA General Purchased Service	400.00	0020202132	10-1200-310-92-79-600-14
	52000	2/21/2020	10-4210-670-00-79-600-14	Reg Ed Out of District	320.00	0020202218	10-4210-670-00-79-600-14
	52000	2/21/2020	10-4210-670-00-79-600-14	Reg Ed Out of District	440.00	0020202147	10-4210-670-00-79-600-14
				Total	<u>\$2,840.00</u>		
Allen, Michele							
	52001	2/21/2020	10-1110-332-00-71-100-13	Teacher Travel Leggee	219.65		10-1110-332-00-71-100-13
				Total	<u>\$219.65</u>		



Huntley Community School District #158

Disbursements Issued

From January 30, 2020 to February 27, 2020

Vendor Name	Check #	Check Date	A.S.N.	Description	Amount	PO #	State Account Number
Alpha Baking Company Inc							
	51908	2/14/2020	10-2560-415-00-71-100-13	Cafe Food Leggee	192.05	0020011077	10-2560-415-00-71-100-13
	51908	2/14/2020	10-2560-415-00-71-300-13	Cafe Food HS	1,227.45	0020011087	10-2560-415-00-71-300-13
	51908	2/14/2020	10-2560-415-00-72-110-13	Cafe Food Chesak	145.79	0020011097	10-2560-415-00-72-110-13
	51908	2/14/2020	10-2560-415-00-72-120-13	Cafe Food Martin	163.14	0020011107	10-2560-415-00-72-120-13
	51908	2/14/2020	10-2560-415-00-72-220-13	Cafe Food Marlowe	477.78	0020011117	10-2560-415-00-72-220-13
	51908	2/14/2020	10-2560-415-00-74-140-13	Cafe Food Mackeben	188.66	0020011127	10-2560-415-00-74-140-13
	51908	2/14/2020	10-2560-415-00-74-150-13	Cafe Food Conley	131.55	0020011137	10-2560-415-00-74-150-13
	51908	2/14/2020	10-2560-415-00-74-210-13	Cafe Food Heineman	321.39	0020011147	10-2560-415-00-74-210-13
Total					\$2,847.81		
Altorfer Industries Inc							
	52002	2/21/2020	20-2542-410-00-79	Supplies B & G	215.97	0020202332	20-2542-410-00-79
Total					\$215.97		
American Reading Company							
	51909	2/14/2020	10-2212-310-00-79-505-14	Curriculum Gen Pur Svc	5,400.00	0020200273	10-2212-310-00-79-505-14
Total					\$5,400.00		
Anderson Lock Co Inc							
	51743	1/31/2020	20-2542-410-00-79	Supplies B & G	446.60	0020010087	20-2542-410-00-79
Total					\$446.60		
Anderson Pest Solutions							
	52003	2/21/2020	20-2542-321-00-79	Sanitation/Exterminating	554.47	0020020037	20-2542-321-00-79
Total					\$554.47		
Anderson, Allison							
	52004	2/21/2020	10-1200-310-92-79-600-14	IDEA General Purchased Service	43.19		10-1200-310-92-79-600-14
Total					\$43.19		
Androus, Peter							
	51910	2/14/2020	10-1500-319-00-71-300-13	Sports Officials HS	67.00		10-1500-319-00-71-300-13
Total					\$67.00		
Apple Inc							
	51911	2/14/2020	10-1110-410-00-72-120-13	Inst Supplies Martin	299.00	0020201668	10-1110-410-00-72-120-13
Total					\$299.00		
Applied Maintenance							
	51811	2/7/2020	40-2554-410-00-79	Fleet Supplies	471.57	0020010807	40-2554-410-00-79
Total					\$471.57		
Aschacher, Joe							
	51912	2/14/2020	10-1500-319-00-71-300-13	Sports Officials HS	53.00		10-1500-319-00-71-300-13
Total					\$53.00		



Huntley Community School District #158

Disbursements Issued

From January 30, 2020 to February 27, 2020

Printed: 2/27/2020
Page 4 of 45

Vendor Name	Check #	Check Date	A.S.N.	Description	Amount	PO #	State Account Number
Associated Electrical Contractors							
	52005	2/21/2020	20-2542-323-00-79	Repairs & Maint Buildings	3,985.00	0020201224	20-2542-323-00-79
	52005	2/21/2020	20-2542-323-00-79	Repairs & Maint Buildings	5,435.00	0020201053	20-2542-323-00-79
Total					<u>\$9,420.00</u>		
AT&T							
	51744	1/31/2020	20-2540-340-00-79	Telephone - Districtwide	3,575.37	0020010327	20-2540-340-00-79
	51812	2/7/2020	20-2540-340-00-79	Telephone - Districtwide	2,860.32	0020010327	20-2540-340-00-79
Total					<u>\$6,435.69</u>		
AT&T Long Distance							
	51913	2/14/2020	20-2540-340-00-79	Telephone - Districtwide	338.59	0020010367	20-2540-340-00-79
Total					<u>\$338.59</u>		
Auto Tech Centers Inc							
	52006	2/21/2020	20-2545-323-00-79-600-14	Vehicle Repairs & Maintenance	55.90	0020202421	20-2545-323-00-79-600-14
Total					<u>\$55.90</u>		
Aveanna Healthcare							
	52007	2/21/2020	10-2130-310-00-79-600-14	Health Services	780.00	0020202335	10-2130-310-00-79-600-14
	52007	2/21/2020	10-2130-310-00-79-600-14	Health Services	3,732.00	0020202334	10-2130-310-00-79-600-14
	52007	2/21/2020	10-2130-310-00-79-600-14	Health Services	1,932.00	0020202333	10-2130-310-00-79-600-14
Total					<u>\$6,444.00</u>		
Baker, Robert							
	51914	2/14/2020	10-1500-319-00-71-300-13	Sports Officials HS	92.00		10-1500-319-00-71-300-13
Total					<u>\$92.00</u>		
Baker, Robert D							
	51745	1/31/2020	10-1500-319-00-74-210-13	Sports Officials Heineman	65.00		10-1500-319-00-74-210-13
Total					<u>\$65.00</u>		
Barnes, Theresa							
	52008	2/21/2020	10-2310-230-00-74-500-14	Tuition Reimbursement	390.00		10-2310-230-00-74-500-14
Total					<u>\$390.00</u>		
Basargin, Beth							
	52009	2/21/2020	10-1200-310-92-79-600-14	IDEA General Purchased Service	48.72		10-1200-310-92-79-600-14
	52009	2/21/2020	10-1200-310-92-79-600-14	IDEA General Purchased Service	69.57		10-1200-310-92-79-600-14
Total					<u>\$118.29</u>		
Belin, Marcus							
	51746	1/31/2020	10-2410-490-00-71-300-13	HS Staff Recognition	21.98		10-2410-490-00-71-300-13
Total					<u>\$21.98</u>		



Huntley Community School District #158

Disbursements Issued

From January 30, 2020 to February 27, 2020

Printed: 2/27/2020
Page 5 of 45

Vendor Name	Check #	Check Date	A.S.N.	Description	Amount	PO #	State Account Number
Benefitfocus.com Inc	2020013104	1/31/2020	10477	Flex Plan	41,633.26		10477
	51915	2/14/2020	10-2310-220-00-79-600-14	Support Serv-Gen Adm Insurance	1,633.53	0020020197	10-2310-220-00-79-600-14
				Total	\$43,266.79		
Bert, Jeffrey	51916	2/14/2020	10-1500-319-00-71-300-13	Sports Officials HS	67.00		10-1500-319-00-71-300-13
				Total	\$67.00		
Bilderback, William	51747	1/31/2020	10-1500-319-00-74-210-13	Sports Officials Heineman	40.00		10-1500-319-00-74-210-13
				Total	\$40.00		
Blick Art Materials	51813	2/7/2020	10-1130-410-02-71-300-13	Art Supplies HS	18.56		10-1130-410-02-71-300-13
	52010	2/21/2020	10-1100-423-00-74-500-14	New Adoption	747.00	0020201705	10-1100-423-00-74-500-14
	52010	2/21/2020	10-1120-410-02-72-220-13	Art Supplies Marlowe	238.29	0020202137	10-1120-410-02-72-220-13
				Total	\$1,003.85		
Blu Petroleum	51814	2/7/2020	40-2552-464-00-79	Diesel/Gasoline	21,438.93	0020120827	40-2552-464-00-79
	51814	2/7/2020	40-2552-464-00-79	Diesel/Gasoline	26,168.59	0020010827	40-2552-464-00-79
	51814	2/7/2020	40-2552-464-00-79	Diesel/Gasoline	754.79	0020021647	40-2552-464-00-79
	51814	2/7/2020	40-2552-464-00-79	Diesel/Gasoline	2,054.88	0020011647	40-2552-464-00-79
	52011	2/21/2020	40-2552-464-00-79	Diesel/Gasoline	955.36	0020202338	40-2552-464-00-79
	52011	2/21/2020	40-2552-464-00-79	Diesel/Gasoline	632.53	0020021647	40-2552-464-00-79
	52011	2/21/2020	40-2552-464-00-79	Diesel/Gasoline	9,658.29	0020010827	40-2552-464-00-79
				Total	\$61,663.37		
Bondi, Michael	51815	2/7/2020	10-1500-319-00-71-300-13	Sports Officials HS	109.00		10-1500-319-00-71-300-13
				Total	\$109.00		
Botts Welding & Truck Svcs Inc	52012	2/21/2020	10-1700-323-21-71-300-13	Driver Ed Repair & Maintenance	42.00	0020202202	10-1700-323-21-71-300-13
				Total	\$42.00		
Boukhari, Adriana	52013	2/21/2020	10-2310-230-00-74-500-14	Tuition Reimbursement	381.65		10-2310-230-00-74-500-14
				Total	\$381.65		
Bower, Thomas	51816	2/7/2020	10-1500-319-00-74-210-13	Sports Officials Heineman	65.00		10-1500-319-00-74-210-13
	51917	2/14/2020	10-1500-319-00-72-220-13	Sports Officials Marlowe	65.00		10-1500-319-00-72-220-13
				Total	\$130.00		



Huntley Community School District #158

Disbursements Issued

From January 30, 2020 to February 27, 2020

Printed: 2/27/2020
Page 6 of 45

Vendor Name	Check #	Check Date	A.S.N.	Description	Amount	PO #	State Account Number
Brach Jr, Fred	51918	2/14/2020	10-1500-319-00-74-210-13	Sports Officials Heineman	65.00		10-1500-319-00-74-210-13
					Total	<u>\$65.00</u>	
Brach Sr, Fred	51748	1/31/2020	10-1500-319-00-72-220-13	Sports Officials Marlowe	65.00		10-1500-319-00-72-220-13
	51748	1/31/2020	10-1500-319-00-74-210-13	Sports Officials Heineman	65.00		10-1500-319-00-74-210-13
					Total	<u>\$130.00</u>	
Bradfields Inc	51817	2/7/2020	10-1110-410-00-72-110-13	Inst Supplies Chesak	450.00	0020200614	10-1110-410-00-72-110-13
					Total	<u>\$450.00</u>	
Breakout Inc	52014	2/21/2020	10-2410-491-00-74-150-13	Rebate Supplies Conley	750.00	0020202322	10-2410-491-00-74-150-13
					Total	<u>\$750.00</u>	
Brehm Preparatory School	52015	2/21/2020	10-4120-670-00-79-605-14	Sp Ed Room & Board	2,860.74	0020202414	10-4120-670-00-79-605-14
	52015	2/21/2020	10-4120-670-00-79-605-14	Sp Ed Room & Board	1,492.56	0020202154	10-4120-670-00-79-605-14
	52015	2/21/2020	10-4220-670-00-79-600-14	Sp Ed Private Tuition	4,431.04	0020202414	10-4220-670-00-79-600-14
	52015	2/21/2020	10-4220-670-00-79-600-14	Sp Ed Private Tuition	2,769.40	0020202154	10-4220-670-00-79-600-14
					Total	<u>\$11,553.74</u>	
Browne, Jenni	52016	2/21/2020	10-2310-230-00-74-500-14	Tuition Reimbursement	375.00		10-2310-230-00-74-500-14
					Total	<u>\$375.00</u>	
Brucker Company	51749	1/31/2020	20-2542-410-00-79	Supplies B & G	6,135.00	0020200898	20-2542-410-00-79
	51749	1/31/2020	20-2542-410-00-79	Supplies B & G	38.50	0020010297	20-2542-410-00-79
	52017	2/21/2020	20-2542-410-00-79	Supplies B & G	38.50	0020010297	20-2542-410-00-79
	52017	2/21/2020	20-2542-410-00-79	Supplies B & G	950.00	0020202342	20-2542-410-00-79
	52017	2/21/2020	20-2542-410-00-79	Supplies B & G	1,087.00	0020202422	20-2542-410-00-79
					Total	<u>\$8,249.00</u>	
BryMax Enterprises Inc	51919	2/14/2020	10-2560-415-00-71-300-13	Cafe Food HS	1,008.00	0020011907	10-2560-415-00-71-300-13
	51919	2/14/2020	10-2560-415-00-72-220-13	Cafe Food Marlowe	1,152.00	0020011917	10-2560-415-00-72-220-13
	51919	2/14/2020	10-2560-415-00-74-210-13	Cafe Food Heineman	432.00	0020011927	10-2560-415-00-74-210-13
					Total	<u>\$2,592.00</u>	



Huntley Community School District #158

Disbursements Issued

From January 30, 2020 to February 27, 2020

Printed: 2/27/2020
Page 7 of 45

Vendor Name	Check #	Check Date	A.S.N.	Description	Amount	PO #	State Account Number
BSN Sports	51750	1/31/2020	10-1505-410-00-71-300-15	Basketball Boys Supplies HS	787.93	0020202203	10-1505-410-00-71-300-15
	51750	1/31/2020	10-1505-410-00-71-300-16	Basketball Girls Supplies HS	787.93	0020202203	10-1505-410-00-71-300-16
					Total	<u>\$1,575.86</u>	
Buck Bros Inc	52018	2/21/2020	20-2543-410-00-79	Grounds Supplies	412.44	0020202423	20-2543-410-00-79
					Total	<u>\$412.44</u>	
Buckley, Timothy	51751	1/31/2020	10-1500-319-00-71-300-13	Sports Officials HS	120.00		10-1500-319-00-71-300-13
					Total	<u>\$120.00</u>	
Budzynski, Christopher	52019	2/21/2020	10-2660-332-00-79-600-14	Travel Technology	424.78		10-2660-332-00-79-600-14
					Total	<u>\$424.78</u>	
Building Technology Consultants PC	52020	2/21/2020	20-2540-310-00-79	Professional & Technical	3,970.00	0020202198	20-2540-310-00-79
					Total	<u>\$3,970.00</u>	
Camelot Education	51752	1/31/2020	10-4220-670-00-79-600-14	Sp Ed Private Tuition	23,009.55	0020120517	10-4220-670-00-79-600-14
					Total	<u>\$23,009.55</u>	
Camelot Schools LLC	52021	2/21/2020	10-4220-670-00-79-600-14	Sp Ed Private Tuition	12,387.33	0020202343	10-4220-670-00-79-600-14
					Total	<u>\$12,387.33</u>	
Carlson, Brian	51818	2/7/2020	10-1500-319-00-71-300-13	Sports Officials HS	67.00		10-1500-319-00-71-300-13
					Total	<u>\$67.00</u>	
Carpenter, Allison	52022	2/21/2020	10-1110-332-00-71-100-13	Teacher Travel Leggee	60.56		10-1110-332-00-71-100-13
	52022	2/21/2020	10-1110-332-00-71-100-13	Teacher Travel Leggee	16.10		10-1110-332-00-71-100-13
					Total	<u>\$76.66</u>	
Cary Grove High School	52023	2/21/2020	10-1130-335-00-71-300-13	Curriculum/FVC Competitions	55.00	0020202344	10-1130-335-00-71-300-13
					Total	<u>\$55.00</u>	
Casebolt, Jason	51920	2/14/2020	10-1500-319-00-72-220-13	Sports Officials Marlowe	65.00		10-1500-319-00-72-220-13
					Total	<u>\$65.00</u>	



Huntley Community School District #158

Disbursements Issued

From January 30, 2020 to February 27, 2020

Printed: 2/27/2020
Page 8 of 45

Vendor Name	Check #	Check Date	A.S.N.	Description	Amount	PO #	State Account Number
Cassandra Strings	52024	2/21/2020	10-1120-410-12-74-210-13	Chorus/Band Supplies Heineman	315.95	0020202345	10-1120-410-12-74-210-13
	52024	2/21/2020	10-1130-410-12-71-300-13	Music Supplies HS	52.66	0020202134	10-1130-410-12-71-300-13
					Total	<u>\$368.61</u>	
Cassier, Ellysa	52025	2/21/2020	10-2310-230-00-74-500-14	Tuition Reimbursement	780.00		10-2310-230-00-74-500-14
					Total	<u>\$780.00</u>	
CDW Government	51753	1/31/2020	10-2660-490-00-79-600-14	Inventoriable Equipment Tech	293.90	0020202109	10-2660-490-00-79-600-14
	51819	2/7/2020	10-2660-319-61-79-600-14	Software Maintenance	1,395.00	0020200323	10-2660-319-61-79-600-14
	51819	2/7/2020	10-2660-490-00-79-600-14	Inventoriable Equipment Tech	1,215.00		10-2660-490-00-79-600-14
	51921	2/14/2020	10-2660-319-61-79-600-14	Software Maintenance	1,935.00	0020202152	10-2660-319-61-79-600-14
	51921	2/14/2020	10-2660-410-00-79-600-14	Supplies Tech	439.56		10-2660-410-00-79-600-14
	52026	2/21/2020	10-2660-410-00-79-600-14	Supplies Tech	822.99	0020202226	10-2660-410-00-79-600-14
	52026	2/21/2020	10-2660-490-00-79-600-14	Inventoriable Equipment Tech	1,728.99	0020202164	10-2660-490-00-79-600-14
					Total	<u>\$7,830.44</u>	
Center for the Collaborative Classroom	52027	2/21/2020	10-1200-410-92-79-600-14	IDEA Instructional Supplies	108.00	0020202418	10-1200-410-92-79-600-14
					Total	<u>\$108.00</u>	
Central DuPage Hospital	52028	2/21/2020	10-1200-310-92-79-600-14	IDEA General Purchased Service	140.00	0020202346	10-1200-310-92-79-600-14
					Total	<u>\$140.00</u>	
Century Springs	52029	2/21/2020	10-2410-490-00-71-300-13	HS Staff Recognition	164.00	0020202347	10-2410-490-00-71-300-13
					Total	<u>\$164.00</u>	
Child Advocacy Center of McHenry County	51922	2/14/2020	10-2130-332-00-79-600-14	Health Travel	30.00	0020202348	10-2130-332-00-79-600-14
					Total	<u>\$30.00</u>	
China Bistro Inc	48180	2/4/2020	10-2310-415-00-74-500-14	Leadership Supplies	-520.00	0020193980	10-2310-415-00-74-500-14
	51820	2/7/2020	10-2310-415-00-74-500-14	Leadership Supplies	520.00	0020193980	10-2310-415-00-74-500-14
					Total	<u>\$0.00</u>	
Cinco Books	51821	2/7/2020	10-1100-421-00-74-500-14	Materials K-12	6,107.16	0020201733	10-1100-421-00-74-500-14
	51923	2/14/2020	10-1100-421-00-74-500-14	Materials K-12	1,239.40	0020201733	10-1100-421-00-74-500-14
	52030	2/21/2020	10-1100-421-00-74-500-14	Materials K-12	4,143.37	0020201733	10-1100-421-00-74-500-14
					Total	<u>\$11,489.93</u>	



Huntley Community School District #158 Disbursements Issued From January 30, 2020 to February 27, 2020

Printed: 2/27/2020
Page 9 of 45

Vendor Name	Check #	Check Date	A.S.N.	Description	Amount	PO #	State Account Number
CINTAS Corporation	51822	2/7/2020	40-2550-325-00-79	Rental Trans	594.57	0020010757	40-2550-325-00-79
	52031	2/21/2020	40-2550-325-00-79	Rental Trans	168.49	0020202349	40-2550-325-00-79
					Total	<u>\$763.06</u>	
Citrano, Michael	51823	2/7/2020	10-1500-319-00-71-300-13	Sports Officials HS	53.00		10-1500-319-00-71-300-13
					Total	<u>\$53.00</u>	
Clarity Assessments LLC	52032	2/21/2020	10-2140-310-92-79-600-14	IDEA Psychological Services	5,197.50	0020202350	10-2140-310-92-79-600-14
					Total	<u>\$5,197.50</u>	
Clark, Steve	51924	2/14/2020	10-1500-319-00-71-300-13	Sports Officials HS	53.00		10-1500-319-00-71-300-13
					Total	<u>\$53.00</u>	
Clarke, Michael	51754	1/31/2020	10-1500-319-00-71-300-13	Sports Officials HS	139.00		10-1500-319-00-71-300-13
					Total	<u>\$139.00</u>	
Classroom Connection Day School	51824	2/7/2020	10-4220-670-00-79-600-14	Sp Ed Private Tuition	7,848.90	0020020587	10-4220-670-00-79-600-14
					Total	<u>\$7,848.90</u>	
ClientFirst Technology Consulting	52033	2/21/2020	10-2660-390-00-79-600-14	Purchased Service Technology	420.00	0020202274	10-2660-390-00-79-600-14
					Total	<u>\$420.00</u>	
Collier, Mark	51925	2/14/2020	10-1500-319-00-74-210-13	Sports Officials Heineman	65.00		10-1500-319-00-74-210-13
					Total	<u>\$65.00</u>	
Comcast	52034	2/21/2020	20-2540-340-00-79	Telephone - Districtwide	7,139.49	0020021627	20-2540-340-00-79
					Total	<u>\$7,139.49</u>	
ComEd	52035	2/21/2020	20-2540-466-00-79	Electric	61,959.78		20-2540-466-00-79
					Total	<u>\$61,959.78</u>	
Commercial Specialties Inc	51825	2/7/2020	20-2542-329-00-79	Buildings - Small Projects	4,470.00	0020201547	20-2542-329-00-79
					Total	<u>\$4,470.00</u>	



Huntley Community School District #158

Disbursements Issued

From January 30, 2020 to February 27, 2020

Printed: 2/27/2020
Page 10 of 45

Vendor Name	Check #	Check Date	A.S.N.	Description	Amount	PO #	State Account Number
Community Unit School District 201	52036	2/21/2020	10-1130-410-13-71-300-13	Science Supplies HS	500.00	0020202351	10-1130-410-13-71-300-13
					Total		
					<u>\$500.00</u>		
Connections Day School	51826	2/7/2020	10-4220-670-00-79-600-14	Sp Ed Private Tuition	22,801.86	0020010537	10-4220-670-00-79-600-14
					Total		
					<u>\$22,801.86</u>		
Conrad, Greg	52037	2/21/2020	10-2660-332-00-79-600-14	Travel Technology	43.59		10-2660-332-00-79-600-14
					Total		
					<u>\$43.59</u>		
Cooper, Timothy	51926	2/14/2020	10-1500-319-00-71-300-13	Sports Officials HS	53.00		10-1500-319-00-71-300-13
					Total		
					<u>\$53.00</u>		
CPC Inc. / Facility Tree	51927	2/14/2020	20-2542-390-00-79	Other Purchased Service	748.80	0020020277	20-2542-390-00-79
					Total		
					<u>\$748.80</u>		
CPI (Crisis Prevention Institute, Inc.)	52038	2/21/2020	10-2210-314-92-79-605-14	IDEA Impr of Instr-Staff Dev	6,900.00	0020202172	10-2210-314-92-79-605-14
					Total		
					<u>\$6,900.00</u>		
Crescent Electric Supply Co	51827	2/7/2020	20-2542-410-00-79	Supplies B & G	268.55	0020120047	20-2542-410-00-79
					Total		
					<u>\$268.55</u>		
Crespo, Danielle	52039	2/21/2020	10-2310-230-00-74-500-14	Tuition Reimbursement	780.00		10-2310-230-00-74-500-14
					Total		
					<u>\$780.00</u>		
Crystal Lake School District 47	52040	2/21/2020	10-4120-310-92-79-600-14	IDEA Payments to Other Districts	75.00	0020202155	10-4120-310-92-79-600-14
					Total		
					<u>\$75.00</u>		
CYT Chicago	52041	2/21/2020	10-1120-490-02-72-220-13	Marlowe Fine Arts Supplies	2,447.50	0020202352	10-1120-490-02-72-220-13
					Total		
					<u>\$2,447.50</u>		
D158 Activity	202013112	1/31/2020	10-158	Activity Funds	7,862.80		10-158
	20201312	1/31/2020	10-158	Activity Funds	24,062.00		10-158
					Total		
					<u>\$31,924.80</u>		



Huntley Community School District #158

Disbursements Issued

From January 30, 2020 to February 27, 2020

Printed: 2/27/2020
Page 11 of 45

Vendor Name	Check #	Check Date	A.S.N.	Description	Amount	PO #	State Account Number
D158 Food Service							
	2020013112	1/31/2020	10-1100-421-00-74-500-14	Materials K-12	25.30		10-1100-421-00-74-500-14
	2020013112	1/31/2020	10-1120-390-00-72-220-13	Marlowe Purchased Service	225.00		10-1120-390-00-72-220-13
	2020013112	1/31/2020	10-121	Food Service Receivable	312.48		10-121
	2020013112	1/31/2020	10-1690-105	Other Food Serv Rev Leggee	-9.25		10-1690-105
	2020013112	1/31/2020	10-1690-125	Other Food Serv Rev Martin	-230.00		10-1690-125
	2020013112	1/31/2020	10-1690-155	Other Food Serv Rev Conley	-16.05		10-1690-155
	2020013112	1/31/2020	10-1690-215	Other Food Serv Rev Heineman	-312.48		10-1690-215
	2020013112	1/31/2020	10-1690-225	Other Food Serv Rev Marlowe	-225.00		10-1690-225
	2020013112	1/31/2020	10-3600-410-82-79-605-14	T Bilingual Com Svc Supplies	230.00		10-3600-410-82-79-605-14
				Total	<u>\$0.00</u>		
D158 LIGHT Program							
	52042	2/21/2020	10-1200-410-66-71-300-13	STEP Supplies	818.65	0020202415	10-1200-410-66-71-300-13
				Total	<u>\$818.65</u>		
Datamation Imaging Services Corp							
	51828	2/7/2020	10-2660-390-00-79-600-14	Purchased Service Technology	125.00	0020010397	10-2660-390-00-79-600-14
				Total	<u>\$125.00</u>		
Daujotas, Laimote & Avdrius							
	51829	2/7/2020	10-1811-305	Registration Fee HS	95.00		10-1811-305
				Total	<u>\$95.00</u>		
Davelis, Craig							
	51755	1/31/2020	10-1500-319-00-71-300-13	Sports Officials HS	67.00		10-1500-319-00-71-300-13
				Total	<u>\$67.00</u>		
Dean, Adam							
	52043	2/21/2020	10-2546-332-00-79-600-14	Security Officer Travel	660.04		10-2546-332-00-79-600-14
				Total	<u>\$660.04</u>		
del Castillo, Rocio							
	52044	2/21/2020	10-1100-421-00-74-500-14	Materials K-12	297.67		10-1100-421-00-74-500-14
	52044	2/21/2020	10-2210-430-82-71-300-14	ESL Prof Library	34.67		10-2210-430-82-71-300-14
	52044	2/21/2020	10-2212-332-00-74-500-14	Travel & Conference Curr	678.53		10-2212-332-00-74-500-14
				Total	<u>\$1,010.87</u>		
Disabato, Amy							
	51830	2/7/2020	10-2310-230-00-74-500-14	Tuition Reimbursement	390.00		10-2310-230-00-74-500-14
				Total	<u>\$390.00</u>		
Dorr, James							
	51928	2/14/2020	10-1500-319-00-71-300-13	Sports Officials HS	67.00		10-1500-319-00-71-300-13
				Total	<u>\$67.00</u>		



Huntley Community School District #158

Disbursements Issued

From January 30, 2020 to February 27, 2020

Printed: 2/27/2020
Page 12 of 45

Vendor Name	Check #	Check Date	A.S.N.	Description	Amount	PO #	State Account Number
Doyle, Steven	51831	2/7/2020	10-1500-319-00-71-300-13	Sports Officials HS	92.00		10-1500-319-00-71-300-13
					Total		
					<u>\$92.00</u>		
Dreisilker Electric Motors Inc	52045	2/21/2020	20-2542-410-00-79	Supplies B & G	156.04	0020202261	20-2542-410-00-79
	52045	2/21/2020	20-2542-410-00-79	Supplies B & G	212.97	0020202355	20-2542-410-00-79
	52045	2/21/2020	20-2542-410-00-79	Supplies B & G	824.38	0020202219	20-2542-410-00-79
					Total		
					<u>\$1,193.39</u>		
Drews, Brian	52046	2/21/2020	10-1110-332-00-71-100-13	Teacher Travel Leggee	157.55		10-1110-332-00-71-100-13
					Total		
					<u>\$157.55</u>		
Duppler, Erica	52047	2/21/2020	10-2310-230-00-74-500-14	Tuition Reimbursement	750.00		10-2310-230-00-74-500-14
					Total		
					<u>\$750.00</u>		
Earle, John	51832	2/7/2020	10-1500-319-00-71-300-13	Sports Officials HS	67.00		10-1500-319-00-71-300-13
					Total		
					<u>\$67.00</u>		
Easterseals	51756	1/31/2020	10-4220-670-00-79-600-14	Sp Ed Private Tuition	12,718.50	0020121557	10-4220-670-00-79-600-14
					Total		
					<u>\$12,718.50</u>		
Easton, Kimberly	52048	2/21/2020	10-1110-332-00-71-100-13	Teacher Travel Leggee	54.15		10-1110-332-00-71-100-13
					Total		
					<u>\$54.15</u>		
Eds Automotive	51833	2/7/2020	40-2550-310-00-79	Prof & Tech Service Trans	975.00	0020120707	40-2550-310-00-79
	52049	2/21/2020	40-2550-310-00-79	Prof & Tech Service Trans	1,115.00	0020010707	40-2550-310-00-79
					Total		
					<u>\$2,090.00</u>		
Elam, Carla	52050	2/21/2020	10-2310-230-00-74-500-14	Tuition Reimbursement	375.00		10-2310-230-00-74-500-14
					Total		
					<u>\$375.00</u>		
Enabling Devices Inc	52051	2/21/2020	10-1200-410-92-79-600-14	IDEA Instructional Supplies	48.95	0020201995	10-1200-410-92-79-600-14
					Total		
					<u>\$48.95</u>		
Ernst, Andrew	52052	2/21/2020	10-2310-230-00-74-500-14	Tuition Reimbursement	750.00		10-2310-230-00-74-500-14
					Total		
					<u>\$750.00</u>		



Huntley Community School District #158

Disbursements Issued

From January 30, 2020 to February 27, 2020

Printed: 2/27/2020
Page 13 of 45

Vendor Name	Check #	Check Date	A.S.N.	Description	Amount	PO #	State Account Number
Evanston Township High School	52217	2/27/2020	10-1500-332-00-71-300-13	Athletic Trips HS	100.00		10-1500-332-00-71-300-13
				Total	<u>\$100.00</u>		
Fazel, Chad	51929	2/14/2020	10-1500-319-00-71-300-13	Sports Officials HS	68.00		10-1500-319-00-71-300-13
				Total	<u>\$68.00</u>		
Fisher, Leslie	52053	2/21/2020	10-1200-310-66-71-300-13	STEP Purchased Services	15.00		10-1200-310-66-71-300-13
	52053	2/21/2020	10-1200-310-66-71-300-13	STEP Purchased Services	15.08		10-1200-310-66-71-300-13
				Total	<u>\$30.08</u>		
Flinn Scientific Inc	52054	2/21/2020	10-1130-410-13-71-300-13	Science Supplies HS	1,193.09	0020202139	10-1130-410-13-71-300-13
				Total	<u>\$1,193.09</u>		
Folkerts, John	51834	2/7/2020	10-1500-319-00-72-220-13	Sports Officials Marlowe	65.00		10-1500-319-00-72-220-13
				Total	<u>\$65.00</u>		
Follett School Solutions Inc	51835	2/7/2020	10-2220-430-00-71-300-13	Media Center HS	348.08	0020201022	10-2220-430-00-71-300-13
	52055	2/21/2020	10-2220-430-00-71-300-13	Media Center HS	452.89	0020201873	10-2220-430-00-71-300-13
	52055	2/21/2020	10-2220-430-00-74-210-13	Media Center Heineman	339.77	0020202357	10-2220-430-00-74-210-13
				Total	<u>\$1,140.74</u>		
Fox Valley Fire Safety	51930	2/14/2020	20-2542-390-00-79	Other Purchased Service	801.00	0020020817	20-2542-390-00-79
	52056	2/21/2020	20-2542-323-00-79	Repairs & Maint Buildings	2,208.00	0020202399	20-2542-323-00-79
				Total	<u>\$3,009.00</u>		
Frederickson, David	51757	1/31/2020	10-1500-319-00-71-300-13	Sports Officials HS	106.00		10-1500-319-00-71-300-13
				Total	<u>\$106.00</u>		
Freeport High School	51904	2/13/2020	10-1543-640-00-71-305-13	Activities Fees	140.00		10-1543-640-00-71-305-13
				Total	<u>\$140.00</u>		
Friederick, David	51931	2/14/2020	10-1500-319-00-71-300-13	Sports Officials HS	159.00		10-1500-319-00-71-300-13
				Total	<u>\$159.00</u>		



Huntley Community School District #158

Disbursements Issued

From January 30, 2020 to February 27, 2020

Printed: 2/27/2020
Page 14 of 45

Vendor Name	Check #	Check Date	A.S.N.	Description	Amount	PO #	State Account Number
Frontline Technologies Group LLC	52057	2/21/2020	10-2642-350-00-74-500-14	Advertising Human Res	2,711.70	0020202143	10-2642-350-00-74-500-14
					Total		
					<u>\$2,711.70</u>		
Fulk, Trevor	51932	2/14/2020	10-1500-319-00-71-300-13	Sports Officials HS	53.00		10-1500-319-00-71-300-13
					Total		
					<u>\$53.00</u>		
Fulling, Maggie	51758	1/31/2020	10-1130-332-00-71-300-13	Teacher Travel HS	48.14		10-1130-332-00-71-300-13
					Total		
					<u>\$48.14</u>		
GameTime	51836	2/7/2020	20-2542-410-00-79	Supplies B & G	26.33	0020200913	20-2542-410-00-79
					Total		
					<u>\$26.33</u>		
Garrey, Scott	51837	2/7/2020	10-1500-319-00-71-300-13	Sports Officials HS	67.00		10-1500-319-00-71-300-13
					Total		
					<u>\$67.00</u>		
Gates, Julie	52058	2/21/2020	10-2150-410-92-79-605-14	IDEA Sp Path & Audiol Supplies	217.90		10-2150-410-92-79-605-14
					Total		
					<u>\$217.90</u>		
General Parts LLC	52059	2/21/2020	10-2560-323-00-71-100-13	Cafe Repairs Leggee	1,203.81	0020011657	10-2560-323-00-71-100-13
	52059	2/21/2020	10-2560-323-00-71-300-13	Cafe Repairs HS	1,184.99	0020071667	10-2560-323-00-71-300-13
	52059	2/21/2020	10-2560-323-00-71-300-13	Cafe Repairs HS	2,289.98	0020011667	10-2560-323-00-71-300-13
	52059	2/21/2020	10-2560-323-00-72-110-13	Cafe Repairs Chesak	1,064.69	0020011677	10-2560-323-00-72-110-13
	52059	2/21/2020	10-2560-323-00-72-120-13	Cafe Repairs Martin	1,264.12	0020011687	10-2560-323-00-72-120-13
	52059	2/21/2020	10-2560-323-00-72-220-13	Cafe Repairs Marlowe	2,928.37	0020071697	10-2560-323-00-72-220-13
	52059	2/21/2020	10-2560-323-00-72-220-13	Cafe Repairs Marlowe	1,166.45	0020011697	10-2560-323-00-72-220-13
	52059	2/21/2020	10-2560-323-00-74-140-13	Cafe Repairs Mackeben	1,225.07	0020011707	10-2560-323-00-74-140-13
	52059	2/21/2020	10-2560-323-00-74-150-13	Cafe Repairs Conley	591.00	0020011717	10-2560-323-00-74-150-13
	52059	2/21/2020	10-2560-323-00-74-210-13	Cafe Repairs Heineman	1,086.71	0020011727	10-2560-323-00-74-210-13
					Total		
					<u>\$14,005.19</u>		



Huntley Community School District #158

Disbursements Issued

From January 30, 2020 to February 27, 2020

Printed: 2/27/2020
Page 15 of 45

Vendor Name	Check #	Check Date	A.S.N.	Description	Amount	PO #	State Account Number
Get Fresh Produce Inc							
	51933	2/14/2020	10-2560-415-00-72-110-13	Cafe Food Chesak	366.36	0020011847	10-2560-415-00-72-110-13
	51933	2/14/2020	10-2560-415-00-72-120-13	Cafe Food Martin	257.77	0020011857	10-2560-415-00-72-120-13
	51933	2/14/2020	10-2560-415-00-72-220-13	Cafe Food Marlowe	325.77	0020011867	10-2560-415-00-72-220-13
	51933	2/14/2020	10-2560-415-00-74-140-13	Cafe Food Mackeben	479.66	0020011877	10-2560-415-00-74-140-13
	51933	2/14/2020	10-2560-415-00-74-150-13	Cafe Food Conley	173.00	0020011887	10-2560-415-00-74-150-13
	51933	2/14/2020	10-2560-415-00-74-210-13	Cafe Food Heineman	310.78	0020011897	10-2560-415-00-74-210-13
				Total	<u>\$1,913.34</u>		
GFC Leasing WI							
	51838	2/7/2020	10-2900-325-00-79-600-14	Copier Leases	5,806.84	0020020617	10-2900-325-00-79-600-14
				Total	<u>\$5,806.84</u>		
Giffels, Dave							
	51839	2/7/2020	10-1500-319-00-71-300-13	Sports Officials HS	92.00		10-1500-319-00-71-300-13
	51934	2/14/2020	10-1500-319-00-71-300-13	Sports Officials HS	53.00		10-1500-319-00-71-300-13
				Total	<u>\$145.00</u>		
Glaser, Thomas							
	51935	2/14/2020	10-1500-319-00-71-300-13	Sports Officials HS	67.00		10-1500-319-00-71-300-13
				Total	<u>\$67.00</u>		
GlenOaks Therapeutic Day School							
	52060	2/21/2020	10-4220-670-00-79-600-14	Sp Ed Private Tuition	1,434.37	0020202159	10-4220-670-00-79-600-14
	52060	2/21/2020	10-4220-670-00-79-600-14	Sp Ed Private Tuition	3,893.29	0020202358	10-4220-670-00-79-600-14
				Total	<u>\$5,327.66</u>		
Gordon Flesch Co Inc							
	52061	2/21/2020	10-2900-390-00-79-600-14	Copier Maintenance	6,270.34	0020202215	10-2900-390-00-79-600-14
				Total	<u>\$6,270.34</u>		



Huntley Community School District #158

Disbursements Issued

From January 30, 2020 to February 27, 2020

Printed: 2/27/2020
Page 16 of 45

Vendor Name	Check #	Check Date	A.S.N.	Description	Amount	PO #	State Account Number
Gordon Food Service							
	51936	2/14/2020	10-1120-410-09-74-210-13	Home Ec Heineman	282.86		10-1120-410-09-74-210-13
	51936	2/14/2020	10-1120-410-09-74-210-13	Home Ec Heineman	764.77	0020200618	10-1120-410-09-74-210-13
	51936	2/14/2020	10-2560-410-00-71-100-13	Cafe Supplies Leggee	336.41	0020011157	10-2560-410-00-71-100-13
	51936	2/14/2020	10-2560-410-00-71-300-13	Cafe Supplies HS	2,250.18	0020011167	10-2560-410-00-71-300-13
	51936	2/14/2020	10-2560-410-00-72-110-13	Cafe Supplies Chesak	541.25	0020011177	10-2560-410-00-72-110-13
	51936	2/14/2020	10-2560-410-00-72-120-13	Cafe Supplies Martin	1,146.23	0020011187	10-2560-410-00-72-120-13
	51936	2/14/2020	10-2560-410-00-72-220-13	Cafe Supplies Marlowe	1,067.16	0020011197	10-2560-410-00-72-220-13
	51936	2/14/2020	10-2560-410-00-74-140-13	Cafe Supplies Mackeben	801.95	0020011207	10-2560-410-00-74-140-13
	51936	2/14/2020	10-2560-410-00-74-150-13	Cafe Supplies Conley	527.67	0020011217	10-2560-410-00-74-150-13
	51936	2/14/2020	10-2560-410-00-74-210-13	Cafe Supplies Heineman	533.11	0020011227	10-2560-410-00-74-210-13
	51936	2/14/2020	10-2560-415-00-71-100-13	Cafe Food Leggee	6,466.85	0020011237	10-2560-415-00-71-100-13
	51936	2/14/2020	10-2560-415-00-71-300-13	Cafe Food HS	39,930.66	0020011247	10-2560-415-00-71-300-13
	51936	2/14/2020	10-2560-415-00-72-110-13	Cafe Food Chesak	5,138.17	0020011257	10-2560-415-00-72-110-13
	51936	2/14/2020	10-2560-415-00-72-120-13	Cafe Food Martin	6,495.17	0020011267	10-2560-415-00-72-120-13
	51936	2/14/2020	10-2560-415-00-72-220-13	Cafe Food Marlowe	16,205.99	0020011277	10-2560-415-00-72-220-13
	51936	2/14/2020	10-2560-415-00-74-140-13	Cafe Food Mackeben	3,905.51	0020011287	10-2560-415-00-74-140-13
	51936	2/14/2020	10-2560-415-00-74-150-13	Cafe Food Conley	4,347.25	0020011297	10-2560-415-00-74-150-13
	51936	2/14/2020	10-2560-415-00-74-210-13	Cafe Food Heineman	10,555.73	0020011307	10-2560-415-00-74-210-13
	52062	2/21/2020	10-1120-410-09-72-220-13	Home Ec Marlowe	34.85	0020202136	10-1120-410-09-72-220-13
	52062	2/21/2020	10-1120-410-09-74-210-13	Home Ec Heineman	77.86		10-1120-410-09-74-210-13
	52062	2/21/2020	10-1400-410-09-71-300-13	Home Economics Supplies	409.65	0020202149	10-1400-410-09-71-300-13
				Total	\$101,819.28		
Goss, Stacy							
	49059	1/31/2020	10-2310-230-00-74-500-14	Tuition Reimbursement	-339.00		10-2310-230-00-74-500-14
				Total	(\$339.00)		
Graber, Chuck							
	51940	2/14/2020	10-1500-319-00-71-300-13	Sports Officials HS	67.00		10-1500-319-00-71-300-13
				Total	\$67.00		
Grainger							
	52063	2/21/2020	20-2542-410-00-79	Supplies B & G	23.94	0020090107	20-2542-410-00-79
				Total	\$23.94		
Graphic Edge							
	52064	2/21/2020	10-1547-410-30-71-300-13	Bowling Girls HS	842.94	0020202257	10-1547-410-30-71-300-13
	52064	2/21/2020	10-1547-410-30-71-300-13	Bowling Girls HS	49.60	0020202359	10-1547-410-30-71-300-13
				Total	\$892.54		



Huntley Community School District #158

Disbursements Issued

From January 30, 2020 to February 27, 2020

Printed: 2/27/2020
Page 17 of 45

Vendor Name	Check #	Check Date	A.S.N.	Description	Amount	PO #	State Account Number
Grayslake North H.S. c/o Athletics	51840	2/7/2020	10-1500-335-00-71-300-13	Conference Travel HS	500.00		10-1500-335-00-71-300-13
				Total	\$500.00		
Gullifor, Kateri	52065	2/21/2020	10-1200-310-92-79-600-14	IDEA General Purchased Service	41.40		10-1200-310-92-79-600-14
				Total	\$41.40		
GW Berkheimer Co Inc	52066	2/21/2020	20-2542-410-00-79	Supplies B & G	154.89	0020202270	20-2542-410-00-79
				Total	\$154.89		
Haldeman, Ronald	51841	2/7/2020	10-1500-319-00-72-220-13	Sports Officials Marlowe	65.00		10-1500-319-00-72-220-13
				Total	\$65.00		
Harris Bank N.A.	202012208	1/31/2020	10-2523-319-00-79-600-14	Banking Fees	1,889.11		10-2523-319-00-79-600-14
				Total	\$1,889.11		
Hartzheim, Greg	51759	1/31/2020	10-1500-319-00-71-300-13	Sports Officials HS	67.00		10-1500-319-00-71-300-13
				Total	\$67.00		
Hayden Construction & Service	52067	2/21/2020	20-2542-323-00-79	Repairs & Maint Buildings	7,080.00	0020202424	20-2542-323-00-79
	52067	2/21/2020	20-2542-390-00-79	Other Purchased Service	9,400.00	0020202425	20-2542-390-00-79
				Total	\$16,480.00		
Heinke, Robert	51760	1/31/2020	10-1611-305	Student Food Svc - HS	39.35		10-1611-305
	51760	1/31/2020	10-1811-305	Registration Fee HS	95.00		10-1811-305
				Total	\$134.35		
Henk, Amanda	52068	2/21/2020	10-2310-230-00-74-500-14	Tuition Reimbursement	520.00		10-2310-230-00-74-500-14
				Total	\$520.00		
Hershey Creamery Company	51941	2/14/2020	10-2560-415-00-72-220-13	Cafe Food Marlowe	163.68	0020011807	10-2560-415-00-72-220-13
	51941	2/14/2020	10-2560-415-00-74-210-13	Cafe Food Heineman	309.36	0020011817	10-2560-415-00-74-210-13
				Total	\$473.04		



Huntley Community School District #158

Disbursements Issued

From January 30, 2020 to February 27, 2020

Printed: 2/27/2020
Page 18 of 45

Vendor Name	Check #	Check Date	A.S.N.	Description	Amount	PO #	State Account Number
HESPA	51761	1/31/2020	10462	HESPA Dues	5,508.11		10462
	51942	2/14/2020	10462	HESPA Dues	5,542.14		10462
				Total	\$11,050.25		
Higgin, Merry C	52069	2/21/2020	10-1130-332-00-71-300-13	Teacher Travel HS	34.50		10-1130-332-00-71-300-13
	52069	2/21/2020	10-1130-332-00-71-300-13	Teacher Travel HS	44.85		10-1130-332-00-71-300-13
				Total	\$79.35		
Hodge, James	51943	2/14/2020	10-1500-319-00-74-210-13	Sports Officials Heineman	65.00		10-1500-319-00-74-210-13
				Total	\$65.00		
Hoffman Estates High School	45573	2/25/2020	10-1500-335-00-71-300-13	Conference Travel HS	-250.00		10-1500-335-00-71-300-13
				Total	(\$250.00)		
Holian Insulation Co Inc	52070	2/21/2020	20-2542-410-00-79	Supplies B & G	431.19	0020202426	20-2542-410-00-79
				Total	\$431.19		
Home Depot Credit Services	51842	2/7/2020	20-2542-410-00-79	Supplies B & G	227.46	0020010067	20-2542-410-00-79
				Total	\$227.46		
Home Depot Pro	52071	2/21/2020	20-2542-410-00-79	Supplies B & G	546.14	0020202360	20-2542-410-00-79
				Total	\$546.14		
Home Juice Corp	51944	2/14/2020	10-2560-415-00-72-220-13	Cafe Food Marlowe	599.32	0020011777	10-2560-415-00-72-220-13
	51944	2/14/2020	10-2560-415-00-72-220-13	Cafe Food Marlowe	630.82		10-2560-415-00-72-220-13
	51944	2/14/2020	10-2560-415-00-74-210-13	Cafe Food Heineman	285.44	0020011787	10-2560-415-00-74-210-13
				Total	\$1,515.58		
Honeywell International Inc	52072	2/21/2020	10-2546-323-00-79-600-14	Security Officer Repairs	1,003.42	0020202255	10-2546-323-00-79-600-14
				Total	\$1,003.42		
Howies Athletic Tape	52073	2/21/2020	10-1500-410-00-71-300-13	Training/Athletic Supplies HS	1,224.00	0020202439	10-1500-410-00-71-300-13
				Total	\$1,224.00		



Huntley Community School District #158

Disbursements Issued

From January 30, 2020 to February 27, 2020

Printed: 2/27/2020
Page 19 of 45

Vendor Name	Check #	Check Date	A.S.N.	Description	Amount	PO #	State Account Number
HR Green	51945	2/14/2020	20-2540-310-00-79	Professional & Technical	931.00	0020201925	20-2540-310-00-79
					Total		
					<u>\$931.00</u>		
Hulen, Kimberly	52074	2/21/2020	10-2210-640-92-79-605-14	IDEA Other Objects	225.00		10-2210-640-92-79-605-14
					Total		
					<u>\$225.00</u>		
Huntley Chamber of Commerce	52075	2/21/2020	10-2321-640-00-74-500-14	Dues & Fees Supt	275.00	0020202361	10-2321-640-00-74-500-14
					Total		
					<u>\$275.00</u>		
Huntley Collision Center	52076	2/21/2020	10-1700-323-21-71-300-13	Driver Ed Repair & Maintenance	2,812.78	0020202362	10-1700-323-21-71-300-13
					Total		
					<u>\$2,812.78</u>		
Huntley Ford	52077	2/21/2020	20-2545-323-00-79-600-14	Vehicle Repairs & Maintenance	366.12	0020202427	20-2545-323-00-79-600-14
					Total		
					<u>\$366.12</u>		
IDES	52078	2/21/2020	10-2310-383-00-74-500-14	Unemployment Insurance	7,542.00	0020202429	10-2310-383-00-74-500-14
					Total		
					<u>\$7,542.00</u>		
Illinois Communications Sales Inc	51843	2/7/2020	10-2546-323-00-79-600-14	Security Officer Repairs	49.00	0020202168	10-2546-323-00-79-600-14
	52079	2/21/2020	10-2546-323-00-79-600-14	Security Officer Repairs	350.00	0020202170	10-2546-323-00-79-600-14
					Total		
					<u>\$399.00</u>		
Illinois Principals Association	52080	2/21/2020	10-1130-640-00-71-300-13	Teacher Dues & Fees HS	363.41	0020202260	10-1130-640-00-71-300-13
	52080	2/21/2020	10-2410-640-00-71-300-13	Office Dues & Fees HS	399.00	0020202140	10-2410-640-00-71-300-13
	52080	2/21/2020	10-2410-640-00-74-150-13	Office Dues & Fees Conley	634.00	0020202323	10-2410-640-00-74-150-13
	52080	2/21/2020	10-2410-640-00-74-150-13	Office Dues & Fees Conley	634.00	0020202324	10-2410-640-00-74-150-13
					Total		
					<u>\$2,030.41</u>		
Illinois Tollway	52081	2/21/2020	40-2552-640-00-79	Dues & Fees	3,865.62	0020202262	40-2552-640-00-79
					Total		
					<u>\$3,865.62</u>		
IMRF	20201806	1/31/2020	50454	IMRF & SS (Board)	151,524.52		50454
					Total		
					<u>\$151,524.52</u>		



Huntley Community School District #158

Disbursements Issued

From January 30, 2020 to February 27, 2020

Printed: 2/27/2020
Page 20 of 45

Vendor Name	Check #	Check Date	A.S.N.	Description	Amount	PO #	State Account Number
Independent Living Aids LLC	52082	2/21/2020	10-1200-710-92-79-600-14	IDEA Instructional Non-Cap Eqp	676.45	0020202000	10-1200-710-92-79-600-14
					Total	\$676.45	
Instrument Barn, The	52083	2/21/2020	10-1110-410-12-72-100-13	Music Supplies Leggee	1,155.00	0020202363	10-1110-410-12-72-100-13
	52083	2/21/2020	10-1200-490-00-74-150-13	Other Supplies Conley	1,155.00	0020202413	10-1200-490-00-74-150-13
					Total	\$2,310.00	
Interstate Battery Center	51762	1/31/2020	20-2542-410-00-79	Supplies B & G	168.24	0020010077	20-2542-410-00-79
					Total	\$168.24	
IPO/DBA Cardinal Office Supply	51946	2/14/2020	10-2130-410-00-79-600-14	Supplies Health	42.39	0020200046	10-2130-410-00-79-600-14
					Total	\$42.39	
J.W. Pepper & Son Inc	52084	2/21/2020	10-1110-410-12-74-140-13	Mackeben Music Supplies	93.47	0020202166	10-1110-410-12-74-140-13
	52084	2/21/2020	10-1120-410-12-74-210-13	Chorus/Band Supplies Heineman	220.83	0020202204	10-1120-410-12-74-210-13
	52084	2/21/2020	10-1120-410-12-74-210-13	Chorus/Band Supplies Heineman	130.48	0020202233	10-1120-410-12-74-210-13
					Total	\$444.78	
Jacqueline A. Rhew LCPC Ltd	52085	2/21/2020	10-2140-310-92-79-600-14	IDEA Psychological Services	700.00	0020202232	10-2140-310-92-79-600-14
					Total	\$700.00	
Jim Gill Inc	51947	2/14/2020	10-1125-390-90-79-600-14	Purchased Serv Parent-Tot	1,250.00	0020202290	10-1125-390-90-79-600-14
					Total	\$1,250.00	
Johnson Floor Co	52086	2/21/2020	20-2542-329-00-79	Buildings - Small Projects	2,489.00	0020202253	20-2542-329-00-79
					Total	\$2,489.00	
Jones, William D	51844	2/7/2020	10-1811-305	Registration Fee HS	95.00		10-1811-305
					Total	\$95.00	
Kambitsis, Caryn	51845	2/7/2020	10-2310-230-00-74-500-14	Tuition Reimbursement	220.00		10-2310-230-00-74-500-14
					Total	\$220.00	
Kasch, Jennifer	52087	2/21/2020	10-1200-310-66-71-300-13	STEP Purchased Services	179.34		10-1200-310-66-71-300-13
					Total	\$179.34	



Huntley Community School District #158 Disbursements Issued From January 30, 2020 to February 27, 2020

Printed: 2/27/2020
Page 21 of 45

Vendor Name	Check #	Check Date	A.S.N.	Description	Amount	PO #	State Account Number
Kehler, Jessica	52088	2/21/2020	10-2310-230-00-74-500-14	Tuition Reimbursement	390.00		10-2310-230-00-74-500-14
					Total	<u>\$390.00</u>	
Kelly, Jill	52089	2/21/2020	10-1200-310-92-79-600-14	IDEA General Purchased Service	121.79		10-1200-310-92-79-600-14
					Total	<u>\$121.79</u>	
Kelso Burnett Co	51763	1/31/2020	20-2542-520-00-79	Building projects	38,998.11	0020190073	20-2542-520-00-79
	52090	2/21/2020	10-2546-390-00-79-600-14	Security Officer Gnl Purch Svc	22,633.00	0020202269	10-2546-390-00-79-600-14
					Total	<u>\$61,631.11</u>	
Kids Therapy Ltd	51948	2/14/2020	10-2130-310-00-79-600-14	Health Services	510.00	0020202156	10-2130-310-00-79-600-14
	52091	2/21/2020	10-2130-310-00-79-600-14	Health Services	722.50	0020202434	10-2130-310-00-79-600-14
					Total	<u>\$1,232.50</u>	
Kienzle, Elizabeth	52092	2/21/2020	10-1200-310-66-71-300-13	STEP Purchased Services	111.94		10-1200-310-66-71-300-13
	52092	2/21/2020	10-1200-310-66-71-300-13	STEP Purchased Services	40.12		10-1200-310-66-71-300-13
					Total	<u>\$152.06</u>	
Kilmer, Jared	51374	2/19/2020	10-1500-319-00-71-300-13	Sports Officials HS	-92.00		10-1500-319-00-71-300-13
	52093	2/21/2020	10-1500-319-00-71-300-13	Sports Officials HS	92.00		10-1500-319-00-71-300-13
					Total	<u>\$0.00</u>	
Kish, Shelly	52094	2/21/2020	10-2410-332-00-71-300-13	Prin Travel HS	66.21		10-2410-332-00-71-300-13
					Total	<u>\$66.21</u>	
Klein Thorpe & Jenkins Ltd	51949	2/14/2020	10-2310-318-00-74-500-14	Legal Board	1,045.50	0020121537	10-2310-318-00-74-500-14
					Total	<u>\$1,045.50</u>	
Kline, Rebecca	37439	2/14/2020	10-1100-323-00-79-600-14	1:1 Repairs	-33.25		10-1100-323-00-79-600-14
					Total	<u>(\$33.25)</u>	
K-Log Inc	52095	2/21/2020	10-1120-710-00-74-210-13	Heineman Non-Capitalized Eqpt	2,297.25	0020201536	10-1120-710-00-74-210-13
					Total	<u>\$2,297.25</u>	



Huntley Community School District #158 Disbursements Issued From January 30, 2020 to February 27, 2020

Printed: 2/27/2020
Page 22 of 45

Vendor Name	Check #	Check Date	A.S.N.	Description	Amount	PO #	State Account Number
Knapke, Nathan	52096	2/21/2020	10-1130-490-02-71-300-13	High School Fine Arts/PAC Supplies	121.90		10-1130-490-02-71-300-13
	52096	2/21/2020	10-1130-490-02-71-300-13	High School Fine Arts/PAC Supplies	923.19		10-1130-490-02-71-300-13
	52096	2/21/2020	10-2223-410-00-79-600-14	Supplies PAC	33.14		10-2223-410-00-79-600-14
	52096	2/21/2020	10-2223-490-00-79-600-14	PAC Invent Supplies	84.91		10-2223-490-00-79-600-14
	52096	2/21/2020	10-2223-490-00-79-600-14	PAC Invent Supplies	79.39		10-2223-490-00-79-600-14
					Total		
							<u>\$1,242.53</u>
Kneip, Denny	51764	1/31/2020	10-1500-319-00-72-220-13	Sports Officials Marlowe	65.00		10-1500-319-00-72-220-13
						Total	
							<u>\$65.00</u>
Knockout Sportswear	52097	2/21/2020	10-1532-410-00-71-300-15	Track Boys Supplies HS	3,615.00	0020202258	10-1532-410-00-71-300-15
						Total	
							<u>\$3,615.00</u>
Knowbuddy Resources	52098	2/21/2020	10-2220-430-00-72-110-13	Media Center Chesak	621.22	0020201961	10-2220-430-00-72-110-13
						Total	
							<u>\$621.22</u>
Knych, Jillian	52099	2/21/2020	10-2130-332-00-79-600-14	Health Travel	175.00		10-2130-332-00-79-600-14
	52099	2/21/2020	10-2130-332-00-79-600-14	Health Travel	6.32		10-2130-332-00-79-600-14
						Total	
							<u>\$181.32</u>
Koehler Scale Inc	52100	2/21/2020	10-1500-410-00-74-210-13	Training Supplies Heineman	285.00	0020202216	10-1500-410-00-74-210-13
						Total	
							<u>\$285.00</u>
Kohler, Tom	51765	1/31/2020	10-1500-319-00-71-300-13	Sports Officials HS	53.00		10-1500-319-00-71-300-13
						Total	
							<u>\$53.00</u>
Kopp, Ellen	38242	2/14/2020	10-2220-490-00-74-210-13	Media Center AV Heineman	-62.67		10-2220-490-00-74-210-13
						Total	
							<u>(\$62.67)</u>
Koziol, Richard	51950	2/14/2020	10-1500-319-00-71-300-13	Sports Officials HS	53.00		10-1500-319-00-71-300-13
						Total	
							<u>\$53.00</u>
Krivosik, Kevin	52101	2/21/2020	10-1130-410-12-71-300-13	Music Supplies HS	95.16		10-1130-410-12-71-300-13
						Total	
							<u>\$95.16</u>



Huntley Community School District #158

Disbursements Issued

From January 30, 2020 to February 27, 2020

Printed: 2/27/2020
Page 23 of 45

Vendor Name	Check #	Check Date	A.S.N.	Description	Amount	PO #	State Account Number
Krueger, Wesley	51846	2/7/2020	10-1500-319-00-71-300-13	Sports Officials HS	53.00		10-1500-319-00-71-300-13
	51951	2/14/2020	10-1500-319-00-71-300-13	Sports Officials HS	53.00		10-1500-319-00-71-300-13
					Total	<u>\$106.00</u>	
Kubitz, Laura	52102	2/21/2020	10-2210-640-92-79-605-14	IDEA Other Objects	225.00		10-2210-640-92-79-605-14
					Total	<u>\$225.00</u>	
KUTA Software	51952	2/14/2020	10-2212-310-00-79-505-14	Curriculum Gen Pur Svc	1,262.00	0020202080	10-2212-310-00-79-505-14
					Total	<u>\$1,262.00</u>	
Laman, Mike	51847	2/7/2020	10-1500-319-00-71-300-13	Sports Officials HS	67.00		10-1500-319-00-71-300-13
					Total	<u>\$67.00</u>	
Lamp Incorporated	52103	2/21/2020	60-2530-531-00-71-300	HS Fine Arts Expansion Construction	226,991.00	0020201355	60-2530-531-00-71-300
					Total	<u>\$226,991.00</u>	
Lampel, Jay	51953	2/14/2020	10-1500-319-00-71-300-13	Sports Officials HS	67.00		10-1500-319-00-71-300-13
					Total	<u>\$67.00</u>	
Landvick, Matthew	52104	2/21/2020	10-1500-332-00-71-300-13	Athletic Trips HS	165.03		10-1500-332-00-71-300-13
					Total	<u>\$165.03</u>	
Langenfeld, Darcy	52105	2/21/2020	10-2520-332-00-74-500-14	Travel Fiscal	56.36		10-2520-332-00-74-500-14
					Total	<u>\$56.36</u>	
Laser Pro Company	52106	2/21/2020	10-2210-490-00-74-500-14	Supplies Curr & Inst	84.00	0020202220	10-2210-490-00-74-500-14
	52106	2/21/2020	10-2410-410-00-74-150-14	Copier Paper & Toner Conley	244.00	0020202282	10-2410-410-00-74-150-14
	52106	2/21/2020	10-2410-410-00-74-150-14	Copier Paper & Toner Conley	400.00	0020202388	10-2410-410-00-74-150-14
	52106	2/21/2020	10-2410-410-00-74-210-14	Copier Paper & Toner Heineman	164.00	0020202395	10-2410-410-00-74-210-14
	52106	2/21/2020	10-2410-410-00-74-210-14	Copier Paper & Toner Heineman	380.00	0020202151	10-2410-410-00-74-210-14
	52106	2/21/2020	10-2410-410-00-74-210-14	Copier Paper & Toner Heineman	642.60	0020202205	10-2410-410-00-74-210-14
					Total	<u>\$1,914.60</u>	
Lauinger, Brad	52107	2/21/2020	10-2560-410-00-72-110-13	Cafe Supplies Chesak	55.00		10-2560-410-00-72-110-13
					Total	<u>\$55.00</u>	



Huntley Community School District #158

Disbursements Issued

From January 30, 2020 to February 27, 2020

Printed: 2/27/2020
Page 24 of 45

Vendor Name	Check #	Check Date	A.S.N.	Description	Amount	PO #	State Account Number
Lawson Products	52108	2/21/2020	20-2542-410-00-79	Supplies B & G	84.50	0020202150	20-2542-410-00-79
Total					<u>\$84.50</u>		
Leach Enterprises Inc	51848	2/7/2020	40-2554-410-00-79	Fleet Supplies	2,073.46	0020010787	40-2554-410-00-79
	51848	2/7/2020	40-2554-410-00-79	Fleet Supplies	681.04	0020120787	40-2554-410-00-79
	51848	2/7/2020	40-2554-410-00-79	Fleet Supplies	490.58	0020110787	40-2554-410-00-79
	52109	2/21/2020	40-2554-410-00-79	Fleet Supplies	74.38	0020120787	40-2554-410-00-79
	52109	2/21/2020	40-2554-410-00-79	Fleet Supplies	858.11	0020202364	40-2554-410-00-79
	52109	2/21/2020	40-2554-410-00-79	Fleet Supplies	5,593.54	0020202263	40-2554-410-00-79
Total					<u>\$9,771.11</u>		
LearnWell	52110	2/21/2020	10-1200-310-92-79-600-14	IDEA General Purchased Service	66.50	0020202256	10-1200-310-92-79-600-14
Total					<u>\$66.50</u>		
Lincoln National Life	51766	1/31/2020	10-2310-220-00-79-600-14	Support Serv-Gen Adm Insurance	74,410.83	0020010447	10-2310-220-00-79-600-14
	51766	1/31/2020	10-2310-220-00-79-600-14	Support Serv-Gen Adm Insurance	74,409.49	0020020447	10-2310-220-00-79-600-14
Total					<u>\$148,820.32</u>		
Lindquist, Joe	51767	1/31/2020	10-1500-319-00-71-300-13	Sports Officials HS	92.00		10-1500-319-00-71-300-13
	51849	2/7/2020	10-1500-319-00-71-300-13	Sports Officials HS	68.00		10-1500-319-00-71-300-13
Total					<u>\$160.00</u>		
Lipscomb, Jeff	51850	2/7/2020	10-1500-319-00-71-300-13	Sports Officials HS	67.00		10-1500-319-00-71-300-13
Total					<u>\$67.00</u>		
Litchfield, James	52111	2/21/2020	10-2410-332-00-74-210-13	Principal Travel Heineman	78.09		10-2410-332-00-74-210-13
	52111	2/21/2020	10-2410-332-00-74-210-13	Principal Travel Heineman	189.24		10-2410-332-00-74-210-13
Total					<u>\$267.33</u>		
Little City Foundation	51768	1/31/2020	10-4220-670-00-79-600-14	Sp Ed Private Tuition	10,911.90	0020120497	10-4220-670-00-79-600-14
Total					<u>\$10,911.90</u>		
LMC	51851	2/7/2020	20-2542-490-00-79	Invent Supplies B & G	3,694.00	0020201057	20-2542-490-00-79
Total					<u>\$3,694.00</u>		



Huntley Community School District #158

Disbursements Issued

From January 30, 2020 to February 27, 2020

Printed: 2/27/2020
Page 25 of 45

Vendor Name	Check #	Check Date	A.S.N.	Description	Amount	PO #	State Account Number
Lombard, Jessica	52112	2/21/2020	10-2323-332-00-74-500-14	Associate Supt Travel	291.76		10-2323-332-00-74-500-14
				Total	\$291.76		
Lombardo, Tony	52113	2/21/2020	10-1500-319-00-72-220-13	Sports Officials Marlowe	65.00		10-1500-319-00-72-220-13
				Total	\$65.00		
Lopriore, Christine	51769	1/31/2020	10-1611-305	Student Food Svc - HS	50.00		10-1611-305
				Total	\$50.00		
Love, Kathryn	52114	2/21/2020	10-2212-332-00-74-500-14	Travel & Conference Curr	90.79		10-2212-332-00-74-500-14
				Total	\$90.79		
Lowe, Nicholas	52115	2/21/2020	10-1110-332-00-74-150-13	Teacher Travel Conley	278.69		10-1110-332-00-74-150-13
				Total	\$278.69		
MacGill & Co	52116	2/21/2020	10-2130-410-00-79-600-14	Supplies Health	72.90	0020202283	10-2130-410-00-79-600-14
				Total	\$72.90		
Manibog, Ben	51770	1/31/2020	10-1500-319-00-72-220-13	Sports Officials Marlowe	65.00		10-1500-319-00-72-220-13
				Total	\$65.00		
Marach, Dennis	51954	2/14/2020	10-1500-319-00-71-300-13	Sports Officials HS	67.00		10-1500-319-00-71-300-13
				Total	\$67.00		
Marklund Children's Home	51955	2/14/2020	10-4220-670-00-79-600-14	Sp Ed Private Tuition	23,974.92	0020010507	10-4220-670-00-79-600-14
				Total	\$23,974.92		
Mason, Pamela	51852	2/7/2020	10-1500-319-00-72-220-13	Sports Officials Marlowe	65.00		10-1500-319-00-72-220-13
				Total	\$65.00		
Maxim Healthcare Services Inc	51771	1/31/2020	10-1101-310-00-79-605-14	Substitute Teacher-Contracted	6,960.00	0020202144	10-1101-310-00-79-605-14
	52117	2/21/2020	10-1101-310-00-79-605-14	Substitute Teacher-Contracted	1,711.00	0020202430	10-1101-310-00-79-605-14
				Total	\$8,671.00		



Huntley Community School District #158

Disbursements Issued

From January 30, 2020 to February 27, 2020

Printed: 2/27/2020
Page 26 of 45

Vendor Name	Check #	Check Date	A.S.N.	Description	Amount	PO #	State Account Number
McMahon, Tim	51772	1/31/2020	10-1500-319-00-71-300-13	Sports Officials HS	53.00		10-1500-319-00-71-300-13
					Total		
					<u>\$53.00</u>		
McMaster Carr Supply Co	52118	2/21/2020	20-2542-410-00-79	Supplies B & G	35.70	0020100287	20-2542-410-00-79
					Total		
					<u>\$35.70</u>		
McNamara, Lee Ann Johnson	51853	2/7/2020	10-1811-305	Registration Fee HS	95.00		10-1811-305
					Total		
					<u>\$95.00</u>		
MCSEEP	52119	2/21/2020	10-1120-410-00-74-210-13	Inst Supplies Heineman	650.00	0020202206	10-1120-410-00-74-210-13
					Total		
					<u>\$650.00</u>		
MDC Environmental Serv	52120	2/21/2020	20-2542-321-00-79	Sanitation/Exterminating	2,250.00	0020020117	20-2542-321-00-79
					Total		
					<u>\$2,250.00</u>		
Menards Inc	51956	2/14/2020	20-2542-410-00-79	Supplies B & G	31.02	0020100127	20-2542-410-00-79
	52121	2/21/2020	20-2543-410-00-79	Grounds Supplies	5,514.10	0020202319	20-2543-410-00-79
					Total		
					<u>\$5,545.12</u>		
Mesirow Insurance Services Inc	52122	2/21/2020	10-1100-220-00-79-600-14	Regular Programs Insurance	16,500.00	0020020467	10-1100-220-00-79-600-14
					Total		
					<u>\$16,500.00</u>		
Meyer, Anna	52123	2/21/2020	10-2520-332-00-74-500-14	Travel Fiscal	18.17		10-2520-332-00-74-500-14
					Total		
					<u>\$18.17</u>		
Mezyk, Eva	51773	1/31/2020	10-1611-105	Student Food Svc - Leggee	1.60		10-1611-105
	51773	1/31/2020	10-1811-105	Registration Fee Leggee	77.50		10-1811-105
					Total		
					<u>\$79.10</u>		



Huntley Community School District #158

Disbursements Issued

From January 30, 2020 to February 27, 2020

Printed: 2/27/2020
Page 27 of 45

Vendor Name	Check #	Check Date	A.S.N.	Description	Amount	PO #	State Account Number
Midland Paper	52124	2/21/2020	10-2410-410-00-71-100-14	Copier Paper & Toner Leggee	1,212.80	0020200798	10-2410-410-00-71-100-14
	52124	2/21/2020	10-2410-410-00-71-300-14	Copier Paper & Toner HS	3,602.02	0020200706	10-2410-410-00-71-300-14
	52124	2/21/2020	10-2410-410-00-72-110-14	Copier Paper & Toner Chesak	1,200.67	0020201063	10-2410-410-00-72-110-14
	52124	2/21/2020	10-2410-410-00-72-120-14	Copier Paper & Toner Martin	1,200.67	0020200370	10-2410-410-00-72-120-14
	52124	2/21/2020	10-2410-410-00-72-220-14	Copier Paper & Toner Marlowe	2,401.34	0020202271	10-2410-410-00-72-220-14
	52124	2/21/2020	10-2410-410-00-74-140-14	Copier Paper & Toner Mackeben	2,401.34	0020202281	10-2410-410-00-74-140-14
	52124	2/21/2020	10-2410-410-00-74-150-14	Copier Paper & Toner Conley	1,200.67	0020200129	10-2410-410-00-74-150-14
				Total	<u>\$13,219.51</u>		
Mikolas, Christine	52125	2/21/2020	10-1200-310-66-71-300-13	STEP Purchased Services	238.18		10-1200-310-66-71-300-13
				Total	<u>\$238.18</u>		
Miller Hall & Triggs	51854	2/7/2020	10-2310-318-00-74-500-14	Legal Board	1,978.60	0020121527	10-2310-318-00-74-500-14
				Total	<u>\$1,978.60</u>		
Mino, Alan	52126	2/21/2020	20-2540-640-00-79	Dues & Fees	50.00		20-2540-640-00-79
				Total	<u>\$50.00</u>		
MobyMax LLC	52127	2/21/2020	10-1110-410-00-72-120-13	Inst Supplies Martin	4,995.00	0020202249	10-1110-410-00-72-120-13
				Total	<u>\$4,995.00</u>		
Moersfelder, Anne	52128	2/21/2020	10-2520-332-00-74-500-14	Travel Fiscal	66.67		10-2520-332-00-74-500-14
				Total	<u>\$66.67</u>		
Moran, Tonya	52129	2/21/2020	10-1200-310-92-79-600-14	IDEA General Purchased Service	225.00		10-1200-310-92-79-600-14
				Total	<u>\$225.00</u>		
Morse, Joanna	51902	2/7/2020	10-1125-390-90-79-600-14	Purchased Serv Parent-Tot	200.00	0020201712	10-1125-390-90-79-600-14
				Total	<u>\$200.00</u>		
Mortensen, Art	51774	1/31/2020	10-1500-319-00-71-300-13	Sports Officials HS	53.00		10-1500-319-00-71-300-13
				Total	<u>\$53.00</u>		



Huntley Community School District #158

Disbursements Issued

From January 30, 2020 to February 27, 2020

Printed: 2/27/2020
Page 28 of 45

Vendor Name	Check #	Check Date	A.S.N.	Description	Amount	PO #	State Account Number
Most, Brandon	51775	1/31/2020	10-1500-319-00-74-210-13	Sports Officials Heineman	65.00		10-1500-319-00-74-210-13
	51855	2/7/2020	10-1500-319-00-74-210-13	Sports Officials Heineman	65.00		10-1500-319-00-74-210-13
	51957	2/14/2020	10-1500-319-00-74-210-13	Sports Officials Heineman	65.00		10-1500-319-00-74-210-13
					Total	<u>\$195.00</u>	
Murren, Jason	51958	2/14/2020	10-1500-319-00-71-300-13	Sports Officials HS	184.00		10-1500-319-00-71-300-13
					Total	<u>\$184.00</u>	
Nardi, Angelo	52130	2/21/2020	20-2540-332-00-79	Travel	23.23		20-2540-332-00-79
					Total	<u>\$23.23</u>	
Nasco	51856	2/7/2020	10-1110-410-02-72-110-13	Art Supplies Chesak	1,284.40	0020201844	10-1110-410-02-72-110-13
					Total	<u>\$1,284.40</u>	
NCPERS Group Life Ins	51776	1/31/2020	50454	IMRF & SS (Board)	16.00		50454
					Total	<u>\$16.00</u>	
Nell, Amy	51959	2/14/2020	10-1125-390-90-79-600-14	Purchased Serv Parent-Tot	700.00	0020202291	10-1125-390-90-79-600-14
					Total	<u>\$700.00</u>	
Neuco	51857	2/7/2020	20-2542-410-00-79	Supplies B & G	357.17	0020010147	20-2542-410-00-79
	51960	2/14/2020	20-2542-410-00-79	Supplies B & G	386.34	0020010147	20-2542-410-00-79
					Total	<u>\$743.51</u>	
New Connections Academy	51858	2/7/2020	10-4220-670-00-79-600-14	Sp Ed Private Tuition	10,243.08	0020010607	10-4220-670-00-79-600-14
	52131	2/21/2020	10-2130-310-00-79-600-14	Health Services	75.00	0020202173	10-2130-310-00-79-600-14
					Total	<u>\$10,318.08</u>	
New England Center for Children	51777	1/31/2020	10-1200-310-92-79-600-14	IDEA General Purchased Service	664.05	0020202160	10-1200-310-92-79-600-14
					Total	<u>\$664.05</u>	
New Hope Academy	51859	2/7/2020	10-4220-670-00-79-600-14	Sp Ed Private Tuition	4,107.61	0020010547	10-4220-670-00-79-600-14
					Total	<u>\$4,107.61</u>	



Huntley Community School District #158

Disbursements Issued

From January 30, 2020 to February 27, 2020

Printed: 2/27/2020
Page 29 of 45

Vendor Name	Check #	Check Date	A.S.N.	Description	Amount	PO #	State Account Number
Nickol, Rebecca	51778	1/31/2020	10-1110-332-00-71-100-13	Teacher Travel Leggee	58.00		10-1110-332-00-71-100-13
					Total		
					<u>\$58.00</u>		
Nieves, Jennifer	51860	2/7/2020	10-1811-305	Registration Fee HS	95.00		10-1811-305
					Total		
					<u>\$95.00</u>		
Niles West HS % Athletics	51399	2/25/2020	10-1500-335-00-71-300-13	Conference Travel HS	-300.00		10-1500-335-00-71-300-13
					Total		
					<u>(\$300.00)</u>		
North American Corporation	52132	2/21/2020	20-2542-410-00-79	Supplies B & G	1,944.90	0020202391	20-2542-410-00-79
	52132	2/21/2020	20-2542-410-00-79	Supplies B & G	442.09	0020202145	20-2542-410-00-79
	52132	2/21/2020	20-2542-410-00-79	Supplies B & G	8,959.60	0020020017	20-2542-410-00-79
	52132	2/21/2020	20-2542-410-00-79	Supplies B & G	777.96	0020202428	20-2542-410-00-79
					Total		
					<u>\$12,124.55</u>		
North Shore Transit Inc	51779	1/31/2020	40-2552-331-00-79	Contracted Transportation	452.23	0020202221	40-2552-331-00-79
	52133	2/21/2020	40-2552-331-00-79	Contracted Transportation	708.16	0020202367	40-2552-331-00-79
					Total		
					<u>\$1,160.39</u>		
Northwestern Medicine	51961	2/14/2020	10-2130-220-00-79-600-14	Health Services Insurance	450.00	0020011547	10-2130-220-00-79-600-14
	51961	2/14/2020	10-2642-390-00-74-500-14	Purchased Service Human Res	60.00	0020011547	10-2642-390-00-74-500-14
					Total		
					<u>\$510.00</u>		
Northwestern Medicine McHenry EMS	52134	2/21/2020	10-2130-410-00-79-600-14	Supplies Health	14.70	0020202208	10-2130-410-00-79-600-14
					Total		
					<u>\$14.70</u>		
Northwestern Medicine Occupational Health	51780	1/31/2020	10-1130-410-33-71-305-13	Academies Supplies	20.00	0020202207	10-1130-410-33-71-305-13
	52135	2/21/2020	40-2550-310-00-79	Prof & Tech Service Trans	2,015.00	0020202368	40-2550-310-00-79
					Total		
					<u>\$2,035.00</u>		
Ombudsman	52136	2/21/2020	10-1130-314-06-71-305-13	Alternative School	79,950.00	0020202369	10-1130-314-06-71-305-13
					Total		
					<u>\$79,950.00</u>		
Oticon Inc	52137	2/21/2020	10-2150-410-92-79-605-14	IDEA Sp Path & Audiol Supplies	80.00	0020202325	10-2150-410-92-79-605-14
					Total		
					<u>\$80.00</u>		



Huntley Community School District #158

Disbursements Issued

From January 30, 2020 to February 27, 2020

Printed: 2/27/2020
Page 30 of 45

Vendor Name	Check #	Check Date	A.S.N.	Description	Amount	PO #	State Account Number
Otis Elevator Company							
	52138	2/21/2020	20-2542-323-00-79	Repairs & Maint Buildings	221.50	0020202229	20-2542-323-00-79
	52138	2/21/2020	20-2542-323-00-79	Repairs & Maint Buildings	589.00	0020202254	20-2542-323-00-79
	52138	2/21/2020	20-2542-323-00-79	Repairs & Maint Buildings	344.00	0020202228	20-2542-323-00-79
	52138	2/21/2020	20-2542-323-00-79	Repairs & Maint Buildings	484.88	0020202230	20-2542-323-00-79
				Total	<u>\$1,639.38</u>		
P & M Distributors Inc							
	52139	2/21/2020	10-2560-415-00-71-300-13	Cafe Food HS	1,393.56	0020202370	10-2560-415-00-71-300-13
	52139	2/21/2020	10-2560-415-00-71-300-13	Cafe Food HS	1,052.00	0020202371	10-2560-415-00-71-300-13
				Total	<u>\$2,445.56</u>		
Paddock Publications Inc							
	52140	2/21/2020	10-2321-410-00-74-500-14	Supplies Supt	342.70	0020202289	10-2321-410-00-74-500-14
	52140	2/21/2020	20-2540-350-00-79	Newspaper bids	404.80	0020202353	20-2540-350-00-79
	52140	2/21/2020	40-2552-640-00-79	Dues & Fees	123.05	0020202354	40-2552-640-00-79
				Total	<u>\$870.55</u>		
Parker, Alicia							
	52141	2/21/2020	10-2410-332-00-74-210-13	Principal Travel Heineman	189.24		10-2410-332-00-74-210-13
				Total	<u>\$189.24</u>		
Partnering for Prevention LLC							
	52142	2/21/2020	10-1130-390-00-71-300-13	Consulting HS	2,795.00	0020202440	10-1130-390-00-71-300-13
				Total	<u>\$2,795.00</u>		
PEARSON Education							
	52143	2/21/2020	10-1100-421-00-74-500-14	Materials K-12	980.08	0020202081	10-1100-421-00-74-500-14
				Total	<u>\$980.08</u>		
Peoria Civic Center							
	51989	2/21/2020	10-1543-640-00-71-305-13	Activities Fees	80.00		10-1543-640-00-71-305-13
				Total	<u>\$80.00</u>		
Pepsi-Cola Gen Bot Inc							
	51781	1/31/2020	10-2560-415-00-71-300-13	Cafe Food HS	2,173.67	0020011487	10-2560-415-00-71-300-13
	51861	2/7/2020	10-2560-415-00-71-300-13	Cafe Food HS	1,756.17	0020011487	10-2560-415-00-71-300-13
	52144	2/21/2020	10-2560-415-00-71-300-13	Cafe Food HS	3,029.07	0020021487	10-2560-415-00-71-300-13
				Total	<u>\$6,958.91</u>		
Pereda, Edgar							
	51905	2/13/2020	10475	AP Payroll Net Checks	1,034.45		10475
				Total	<u>\$1,034.45</u>		



Huntley Community School District #158 Disbursements Issued From January 30, 2020 to February 27, 2020

Printed: 2/27/2020
Page 31 of 45

Vendor Name	Check #	Check Date	A.S.N.	Description	Amount	PO #	State Account Number
Perko, Thomas	51862	2/7/2020	10-1500-319-00-71-300-13	Sports Officials HS	58.00		10-1500-319-00-71-300-13
					Total	<u>\$58.00</u>	
Persino, Jennifer	52145	2/21/2020	10-2560-410-00-74-140-13	Cafe Supplies Mackeben	21.97		10-2560-410-00-74-140-13
					Total	<u>\$21.97</u>	
Person, Scott	51782	1/31/2020	10-1500-319-00-74-210-13	Sports Officials Heineman	40.00		10-1500-319-00-74-210-13
					Total	<u>\$40.00</u>	
Peterson, Eric	52146	2/21/2020	10-1500-319-00-72-220-13	Sports Officials Marlowe	65.00		10-1500-319-00-72-220-13
					Total	<u>\$65.00</u>	
Peterson, Kristin	52147	2/21/2020	10-1200-310-66-71-300-13	STEP Purchased Services	73.20		10-1200-310-66-71-300-13
					Total	<u>\$73.20</u>	
PetroChoice	52148	2/21/2020	40-2554-410-00-79	Fleet Supplies	4,572.45	0020202372	40-2554-410-00-79
					Total	<u>\$4,572.45</u>	
Petty Cash-HHS SpEd	51783	1/31/2020	10-1200-410-92-79-600-14	IDEA Instructional Supplies	46.06		10-1200-410-92-79-600-14
	51863	2/7/2020	10-1200-410-92-79-600-14	IDEA Instructional Supplies	134.10		10-1200-410-92-79-600-14
	51962	2/14/2020	10-1200-310-92-79-600-14	IDEA General Purchased Service	25.00		10-1200-310-92-79-600-14
	51962	2/14/2020	10-1200-410-92-79-600-14	IDEA Instructional Supplies	30.45		10-1200-410-92-79-600-14
					Total	<u>\$235.61</u>	
Phillips, Shannon	52149	2/21/2020	10-2310-230-00-74-500-14	Tuition Reimbursement	1,170.00		10-2310-230-00-74-500-14
					Total	<u>\$1,170.00</u>	
Pingel, Rick	51963	2/14/2020	10-1500-319-00-71-300-13	Sports Officials HS	92.00		10-1500-319-00-71-300-13
					Total	<u>\$92.00</u>	
Pinter, William	51784	1/31/2020	10-1500-319-00-71-300-13	Sports Officials HS	53.00		10-1500-319-00-71-300-13
	51864	2/7/2020	10-1500-319-00-71-300-13	Sports Officials HS	53.00		10-1500-319-00-71-300-13
	51964	2/14/2020	10-1500-319-00-71-300-13	Sports Officials HS	53.00		10-1500-319-00-71-300-13
					Total	<u>\$159.00</u>	



Huntley Community School District #158

Disbursements Issued

From January 30, 2020 to February 27, 2020

Printed: 2/27/2020
Page 32 of 45

Vendor Name	Check #	Check Date	A.S.N.	Description	Amount	PO #	State Account Number
PlumbMaster Inc	52150	2/21/2020	20-2542-410-00-79	Supplies B & G	6.00	0020202209	20-2542-410-00-79
	52150	2/21/2020	20-2542-410-00-79	Supplies B & G	1,541.34	0020202373	20-2542-410-00-79
					Total		
					<u>\$1,547.34</u>		
Pocztowski, Shaina	52151	2/21/2020	10-2410-332-00-71-300-13	Prin Travel HS	83.37		10-2410-332-00-71-300-13
						Total	
					<u>\$83.37</u>		
Pomps Tire Service Inc	52152	2/21/2020	40-2554-410-00-79	Fleet Supplies	2,007.59	0020202264	40-2554-410-00-79
						Total	
					<u>\$2,007.59</u>		
Porter Pipe & Supply	52153	2/21/2020	20-2542-410-00-79	Supplies B & G	447.31	0020202146	20-2542-410-00-79
						Total	
					<u>\$447.31</u>		
Pro Ed Inc	52154	2/21/2020	10-1200-410-92-79-600-14	IDEA Instructional Supplies	691.90	0020202169	10-1200-410-92-79-600-14
						Total	
					<u>\$691.90</u>		
Project Wisdom	52155	2/21/2020	10-1110-410-00-74-150-13	Inst Supplies Conley	299.00	0020202273	10-1110-410-00-74-150-13
						Total	
					<u>\$299.00</u>		
Quagliano, Anthony R	52156	2/21/2020	10-2310-332-00-74-500-14	Travel Board	136.00		10-2310-332-00-74-500-14
						Total	
					<u>\$136.00</u>		
Rees, Wayne	51965	2/14/2020	10-1500-319-00-72-220-13	Sports Officials Marlowe	65.00		10-1500-319-00-72-220-13
						Total	
					<u>\$65.00</u>		
Remkes Garage LLC	52157	2/21/2020	40-2550-323-00-79	Repairs and Maintenance	6,260.09	0020202374	40-2550-323-00-79
						Total	
					<u>\$6,260.09</u>		
Renkosik, Doug	52158	2/21/2020	20-2540-332-00-79	Travel	233.45		20-2540-332-00-79
						Total	
					<u>\$233.45</u>		
Revtrak, Inc.	20201808	1/31/2020	10-2523-319-00-79-600-14	Banking Fees	1,459.82	160	10-2523-319-00-79-600-14
						Total	
					<u>\$1,459.82</u>		



Huntley Community School District #158

Disbursements Issued

From January 30, 2020 to February 27, 2020

Printed: 2/27/2020
Page 33 of 45

Vendor Name	Check #	Check Date	A.S.N.	Description	Amount	PO #	State Account Number
Riley, Chris	52159	2/21/2020	10-1400-410-03-71-300-13	Business Supplies	140.80	0020202217	10-1400-410-03-71-300-13
					Total		
					<u>\$140.80</u>		
Rivera Jr, Rafael	51966	2/14/2020	10-1500-319-00-72-220-13	Sports Officials Marlowe	65.00		10-1500-319-00-72-220-13
					Total		
					<u>\$65.00</u>		
Robert Crown Center	51903	2/7/2020	10-1110-410-00-71-100-13	Inst Supplies Leggee	83.33	0020201708	10-1110-410-00-71-100-13
	51903	2/7/2020	10-1110-410-00-72-120-13	Inst Supplies Martin	83.33	0020201708	10-1110-410-00-72-120-13
	51903	2/7/2020	10-1110-410-00-74-150-13	Inst Supplies Conley	83.34	0020201708	10-1110-410-00-74-150-13
	52160	2/21/2020	10-1110-410-00-72-120-13	Inst Supplies Martin	3,100.00	0020202375	10-1110-410-00-72-120-13
					Total		
					<u>\$3,350.00</u>		
Rock N Kids, Inc	51865	2/7/2020	10-1125-390-90-79-600-14	Purchased Serv Parent-Tot	525.00	0020202292	10-1125-390-90-79-600-14
					Total		
					<u>\$525.00</u>		
Rockford Auburn HS	51967	2/14/2020	10-1500-335-00-71-300-13	Conference Travel HS	300.00		10-1500-335-00-71-300-13
					Total		
					<u>\$300.00</u>		
Rolando, James	52161	2/21/2020	10-1130-332-00-71-300-13	Teacher Travel HS	58.53		10-1130-332-00-71-300-13
					Total		
					<u>\$58.53</u>		
Ronan, Kevin	51785	1/31/2020	10-1500-319-00-74-210-13	Sports Officials Heineman	65.00		10-1500-319-00-74-210-13
					Total		
					<u>\$65.00</u>		
Rootham, Mollie	52162	2/21/2020	10-1200-310-92-79-600-14	IDEA General Purchased Service	142.80		10-1200-310-92-79-600-14
					Total		
					<u>\$142.80</u>		
Ropiak, Kenneth	51786	1/31/2020	10-1500-319-00-71-300-13	Sports Officials HS	53.00		10-1500-319-00-71-300-13
					Total		
					<u>\$53.00</u>		
Ruggles, Dan	51787	1/31/2020	10-1500-319-00-72-220-13	Sports Officials Marlowe	65.00		10-1500-319-00-72-220-13
					Total		
					<u>\$65.00</u>		



Huntley Community School District #158

Disbursements Issued

From January 30, 2020 to February 27, 2020

Printed: 2/27/2020
Page 34 of 45

Vendor Name	Check #	Check Date	A.S.N.	Description	Amount	PO #	State Account Number
Rush Truck Center Huntley							
	51866	2/7/2020	40-2550-323-00-79	Repairs and Maintenance	653.95	0020120737	40-2550-323-00-79
	51866	2/7/2020	40-2554-410-00-79	Fleet Supplies	896.30	0020120747	40-2554-410-00-79
	51866	2/7/2020	40-2554-410-00-79	Fleet Supplies	1,940.85	0020010747	40-2554-410-00-79
	52163	2/21/2020	40-2554-410-00-79	Fleet Supplies	3,517.44	0020202377	40-2554-410-00-79
	52163	2/21/2020	40-2554-410-00-79	Fleet Supplies	1,589.89	0020202376	40-2554-410-00-79
	52163	2/21/2020	40-2554-410-00-79	Fleet Supplies	3,517.44	0020202265	40-2554-410-00-79
	52163	2/21/2020	40-2554-410-00-79	Fleet Supplies	-1,083.51	0020010747	40-2554-410-00-79
				Total	\$11,032.36		
Russo Power Equipment							
	51788	1/31/2020	20-2543-410-00-79	Grounds Supplies	817.50	0020011637	20-2543-410-00-79
	51968	2/14/2020	20-2543-410-00-79	Grounds Supplies	1,436.97	0020111637	20-2543-410-00-79
	52164	2/21/2020	20-2543-410-00-79	Grounds Supplies	504.49	0020121637	20-2543-410-00-79
				Total	\$2,758.96		
Ryan, Debra							
	52165	2/21/2020	10-1200-310-92-79-600-14	IDEA General Purchased Service	13.80		10-1200-310-92-79-600-14
				Total	\$13.80		
Safety Kleen							
	51867	2/7/2020	40-2550-310-00-79	Prof & Tech Service Trans	218.36	0020121067	40-2550-310-00-79
				Total	\$218.36		
Safeway Tuckpointing Co							
	52166	2/21/2020	20-2542-323-00-79	Repairs & Maint Buildings	1,950.00	0020202199	20-2542-323-00-79
				Total	\$1,950.00		
Sanchez, Kirsten							
	52167	2/21/2020	10-2310-230-00-74-500-14	Tuition Reimbursement	375.00		10-2310-230-00-74-500-14
				Total	\$375.00		
SASED-Midwest PBIS Network							
	52168	2/21/2020	10-4120-310-92-79-600-14	IDEA Payments to Other Districts	7,000.00	0020202378	10-4120-310-92-79-600-14
	52168	2/21/2020	10-4220-670-00-79-600-14	Sp Ed Private Tuition	4,155.00	0020202378	10-4220-670-00-79-600-14
				Total	\$11,155.00		
Sauer, Julian							
	52169	2/21/2020	20-2542-410-00-79	Supplies B & G	144.99		20-2542-410-00-79
				Total	\$144.99		
Saunders, Mark							
	51868	2/7/2020	10-1500-319-00-71-300-13	Sports Officials HS	67.00		10-1500-319-00-71-300-13
				Total	\$67.00		



Huntley Community School District #158

Disbursements Issued

From January 30, 2020 to February 27, 2020

Printed: 2/27/2020
Page 35 of 45

Vendor Name	Check #	Check Date	A.S.N.	Description	Amount	PO #	State Account Number
Saxe, David	51807	1/31/2020	10-2130-310-92-79-600-14	IDEA Health Services	1,599.00	0020011960	10-2130-310-92-79-600-14
	51869	2/7/2020	10-2130-310-92-79-600-14	IDEA Health Services	1,599.00	0020011960	10-2130-310-92-79-600-14
	52170	2/21/2020	10-2140-310-92-79-600-14	IDEA Psychological Services	2,665.00	0020021960	10-2140-310-92-79-600-14
				Total	\$5,863.00		
Schaefer, Samantha	52171	2/21/2020	10-1130-332-00-71-300-13	Teacher Travel HS	50.60		10-1130-332-00-71-300-13
				Total	\$50.60		
Schocks Towing	52172	2/21/2020	40-2550-323-00-79	Repairs and Maintenance	185.00	0020202266	40-2550-323-00-79
				Total	\$185.00		
Schoenherr, Heather	52173	2/21/2020	10-1200-310-66-71-300-13	STEP Purchased Services	167.15		10-1200-310-66-71-300-13
				Total	\$167.15		
School Health Corporation	51870	2/7/2020	10-2130-410-00-79-600-14	Supplies Health	54.25	0020200038	10-2130-410-00-79-600-14
	52174	2/21/2020	10-2130-410-00-79-600-14	Supplies Health	44.73	0020200038	10-2130-410-00-79-600-14
	52174	2/21/2020	10-2130-410-00-79-600-14	Supplies Health	165.74	0020200042	10-2130-410-00-79-600-14
	52174	2/21/2020	10-2130-410-00-79-600-14	Supplies Health	210.24	0020200045	10-2130-410-00-79-600-14
	52174	2/21/2020	10-2130-410-00-79-600-14	Supplies Health	35.65	0020200040	10-2130-410-00-79-600-14
	52174	2/21/2020	10-2130-410-00-79-600-14	Supplies Health	129.31	0020200044	10-2130-410-00-79-600-14
	52174	2/21/2020	10-2130-410-00-79-600-14	Supplies Health	189.16	0020200043	10-2130-410-00-79-600-14
				Total	\$829.08		
School Specialty	52175	2/21/2020	10-1200-410-92-79-600-14	IDEA Instructional Supplies	34.90	0020201998	10-1200-410-92-79-600-14
				Total	\$34.90		
Schoolbells Ltd	52176	2/21/2020	40-2552-331-00-79	Contracted Transportation	17,085.00	0020202379	40-2552-331-00-79
				Total	\$17,085.00		
Schultz, Brad	51789	1/31/2020	10-1500-319-00-72-220-13	Sports Officials Marlowe	65.00		10-1500-319-00-72-220-13
				Total	\$65.00		



Huntley Community School District #158

Disbursements Issued

From January 30, 2020 to February 27, 2020

Vendor Name	Check #	Check Date	A.S.N.	Description	Amount	PO #	State Account Number
Schuring & Schuring	51969	2/14/2020	10-2560-415-00-71-100-13	Cafe Food Leggee	2,074.14	0020011317	10-2560-415-00-71-100-13
	51969	2/14/2020	10-2560-415-00-71-300-13	Cafe Food HS	1,790.70	0020011327	10-2560-415-00-71-300-13
	51969	2/14/2020	10-2560-415-00-72-110-13	Cafe Food Chesak	2,074.10	0020011373	10-2560-415-00-72-110-13
	51969	2/14/2020	10-2560-415-00-72-120-13	Cafe Food Martin	1,737.85	0020011374	10-2560-415-00-72-120-13
	51969	2/14/2020	10-2560-415-00-72-220-13	Cafe Food Marlowe	892.04	0020011375	10-2560-415-00-72-220-13
	51969	2/14/2020	10-2560-415-00-74-140-13	Cafe Food Mackeben	1,583.13	0020011367	10-2560-415-00-74-140-13
	51969	2/14/2020	10-2560-415-00-74-150-13	Cafe Food Conley	1,186.82	0020011377	10-2560-415-00-74-150-13
	51969	2/14/2020	10-2560-415-00-74-210-13	Cafe Food Heineman	1,280.77	0020011387	10-2560-415-00-74-210-13
				Total	\$12,619.55		
Schwerzler, Therese	52177	2/21/2020	10-2410-332-00-71-300-13	Prin Travel HS	11.27		10-2410-332-00-71-300-13
				Total	\$11.27		
Secretary of State1	51871	2/7/2020	40-2550-310-00-79	Prof & Tech Service Trans	4.00	0020020847	40-2550-310-00-79
				Total	\$4.00		
Secretary of State10	51872	2/7/2020	40-2550-310-00-79	Prof & Tech Service Trans	4.00	0020020937	40-2550-310-00-79
				Total	\$4.00		
Secretary of State2	51873	2/7/2020	40-2550-310-00-79	Prof & Tech Service Trans	4.00	0020020857	40-2550-310-00-79
				Total	\$4.00		
Secretary of State3	51874	2/7/2020	40-2550-310-00-79	Prof & Tech Service Trans	4.00	0020020867	40-2550-310-00-79
				Total	\$4.00		
Secretary of State4	51875	2/7/2020	40-2550-310-00-79	Prof & Tech Service Trans	4.00	0020020877	40-2550-310-00-79
				Total	\$4.00		
Secretary of State5	51876	2/7/2020	40-2550-310-00-79	Prof & Tech Service Trans	4.00	0020020887	40-2550-310-00-79
				Total	\$4.00		
Secretary of State6	51877	2/7/2020	40-2550-310-00-79	Prof & Tech Service Trans	4.00	0020020897	40-2550-310-00-79
				Total	\$4.00		
Secretary of State7	51878	2/7/2020	40-2550-310-00-79	Prof & Tech Service Trans	4.00	0020020907	40-2550-310-00-79
				Total	\$4.00		
				81	\$4.00		



Huntley Community School District #158

Disbursements Issued

From January 30, 2020 to February 27, 2020

Printed: 2/27/2020
Page 37 of 45

Vendor Name	Check #	Check Date	A.S.N.	Description	Amount	PO #	State Account Number
Secretary of State8	51879	2/7/2020	40-2550-310-00-79	Prof & Tech Service Trans	4.00	0020020917	40-2550-310-00-79
					Total	\$4.00	
Secretary of State9	51880	2/7/2020	40-2550-310-00-79	Prof & Tech Service Trans	4.00	0020020927	40-2550-310-00-79
					Total	\$4.00	
SEDOM of McHenry County	52178	2/21/2020	10-4210-670-00-79-600-14	Reg Ed Out of District	1,120.00	0020202381	10-4210-670-00-79-600-14
	52178	2/21/2020	10-4210-670-00-79-600-14	Reg Ed Out of District	1,200.00	0020202148	10-4210-670-00-79-600-14
					Total	\$2,320.00	
Sefton, Grace	52179	2/21/2020	10-2520-332-00-74-500-14	Travel Fiscal	17.50		10-2520-332-00-74-500-14
					Total	\$17.50	
Shiffer, Joe	51790	1/31/2020	10-1500-319-00-71-300-13	Sports Officials HS	53.00		10-1500-319-00-71-300-13
					Total	\$53.00	
Smith Seckman Reid	51881	2/7/2020	20-2540-310-00-79	Professional & Technical	3,860.00	0020200565	20-2540-310-00-79
					Total	\$3,860.00	
Smith, Carly	52180	2/21/2020	10-2150-410-92-79-605-14	IDEA Sp Path & Audiol Supplies	160.62		10-2150-410-92-79-605-14
					Total	\$160.62	
Smith, Sandra	52181	2/21/2020	10-1200-310-92-79-600-14	IDEA General Purchased Service	152.66		10-1200-310-92-79-600-14
					Total	\$152.66	
Soriano, Missy	52182	2/21/2020	10-1200-310-66-71-300-13	STEP Purchased Services	160.08		10-1200-310-66-71-300-13
					Total	\$160.08	
Southpaw Enterprises	52183	2/21/2020	10-2130-410-92-79-605-14	IDEA Health OPTP & Nurse Sup	230.28	0020202318	10-2130-410-92-79-605-14
					Total	\$230.28	
Spader, Helen	51791	1/31/2020	10-1130-332-00-71-300-13	Teacher Travel HS	47.56		10-1130-332-00-71-300-13
					Total	\$47.56	



Huntley Community School District #158

Disbursements Issued

From January 30, 2020 to February 27, 2020

Printed: 2/27/2020
Page 38 of 45

Vendor Name	Check #	Check Date	A.S.N.	Description	Amount	PO #	State Account Number
Specialized Data Systems Inc	52184	2/21/2020	10-2520-310-00-74-500-14	Prof & Tech Fiscal	6,160.00	0020202162	10-2520-310-00-74-500-14
					Total		
					<u>\$6,160.00</u>		
Speech Corner LLC	52185	2/21/2020	10-2150-410-92-79-605-14	IDEA Sp Path & Audiol Supplies	71.91	0020202326	10-2150-410-92-79-605-14
					Total		
					<u>\$71.91</u>		
Steiner Electric Company	51882	2/7/2020	20-2542-410-00-79	Supplies B & G	29.77	0020193594	20-2542-410-00-79
	51882	2/7/2020	20-2542-410-00-79	Supplies B & G	63.00	0020193546	20-2542-410-00-79
	51882	2/7/2020	20-2542-410-00-79	Supplies B & G	-190.00		20-2542-410-00-79
	51882	2/7/2020	20-2542-410-00-79	Supplies B & G	253.35	0020202027	20-2542-410-00-79
					Total		
					<u>\$156.12</u>		
Stephan, Mark	51883	2/7/2020	10-1500-319-00-71-300-13	Sports Officials HS	53.00		10-1500-319-00-71-300-13
					Total		
					<u>\$53.00</u>		
Stephenson, Kevin	51884	2/7/2020	10-1500-319-00-72-220-13	Sports Officials Marlowe	65.00		10-1500-319-00-72-220-13
					Total		
					<u>\$65.00</u>		
Stephenson, Michael	51970	2/14/2020	10-1500-319-00-71-300-13	Sports Officials HS	68.00		10-1500-319-00-71-300-13
					Total		
					<u>\$68.00</u>		
Stock, Julie	52186	2/21/2020	10-2321-410-00-74-500-14	Supplies Supt	26.59		10-2321-410-00-74-500-14
					Total		
					<u>\$26.59</u>		
Streamwood Behavioral Health	52187	2/21/2020	10-4210-670-00-79-600-14	Reg Ed Out of District	210.00	0020202382	10-4210-670-00-79-600-14
					Total		
					<u>\$210.00</u>		
Sunbelt Staffing LLC	51792	1/31/2020	10-2130-310-92-79-600-14	IDEA Health Services	10,700.00	0020202174	10-2130-310-92-79-600-14
					Total		
					<u>\$10,700.00</u>		
Sunderlage, Jean	52188	2/21/2020	10-3100-332-97-79-605-14	All Children Community Travel	35.61		10-3100-332-97-79-605-14
	52188	2/21/2020	10-3100-332-97-79-605-14	All Children Community Travel	22.04		10-3100-332-97-79-605-14
					Total		
					<u>\$57.65</u>		



Huntley Community School District #158

Disbursements Issued

From January 30, 2020 to February 27, 2020

Printed: 2/27/2020
Page 39 of 45

Vendor Name	Check #	Check Date	A.S.N.	Description	Amount	PO #	State Account Number
Sunrise Southwest LLC							
	51793	1/31/2020	40-2552-331-00-79	Contracted Transportation	3,199.59	0020202222	40-2552-331-00-79
	52189	2/21/2020	40-2552-331-00-79	Contracted Transportation	4,053.62	0020202435	40-2552-331-00-79
Total					\$7,253.21		
Super Duper Publications							
	52190	2/21/2020	10-2150-410-92-79-605-14	IDEA Sp Path & Audiol Supplies	122.85	0020202327	10-2150-410-92-79-605-14
	52190	2/21/2020	10-2150-410-92-79-605-14	IDEA Sp Path & Audiol Supplies	139.85	0020202272	10-2150-410-92-79-605-14
Total					\$262.70		
Superior Test & Balance Inc							
	52191	2/21/2020	20-2542-310-00-79	Custodial Contract Service	5,580.00	0020202111	20-2542-310-00-79
Total					\$5,580.00		
Surak-Roesner, Linda							
	52192	2/21/2020	10-1110-332-00-71-100-13	Teacher Travel Leggee	48.88		10-1110-332-00-71-100-13
	52192	2/21/2020	10-1110-332-00-71-100-13	Teacher Travel Leggee	20.13		10-1110-332-00-71-100-13
Total					\$69.01		
Talerico Martin Corp							
	51971	2/14/2020	10-2560-415-00-71-300-13	Cafe Food HS	1,689.05	0020010378	10-2560-415-00-71-300-13
	51971	2/14/2020	10-2560-415-00-74-210-13	Cafe Food Heineman	906.61	0020010377	10-2560-415-00-74-210-13
Total					\$2,595.66		
Tankov, Lisa							
	52193	2/21/2020	10-2310-230-00-74-500-14	Tuition Reimbursement	520.00		10-2310-230-00-74-500-14
Total					\$520.00		
Taylor, David							
	51972	2/14/2020	10-1500-319-00-71-300-13	Sports Officials HS	67.00		10-1500-319-00-71-300-13
Total					\$67.00		
Teachers Retirement System							
	202012305	1/31/2020	10451	TRS Payable	214,447.88		10451
	202012305	1/31/2020	10468	TRS Health Ins	48,419.63		10468
	20201805	1/31/2020	10451	TRS Payable	209,074.54		10451
	20201805	1/31/2020	10468	TRS Health Ins	47,195.81		10468
Total					\$519,137.86		
Teeter, Lauren							
	51794	1/31/2020	10-1130-332-00-71-300-13	Teacher Travel HS	41.18		10-1130-332-00-71-300-13
Total					\$41.18		
Texthelp Inc							
	52194	2/21/2020	10-1200-310-92-79-600-14	IDEA General Purchased Service	16,625.00	0020202032	10-1200-310-92-79-600-14
Total					\$16,625.00		



Huntley Community School District #158

Disbursements Issued

From January 30, 2020 to February 27, 2020

Printed: 2/27/2020
Page 40 of 45

Vendor Name	Check #	Check Date	A.S.N.	Description	Amount	PO #	State Account Number
The Huntley Education Association							
	202011012	1/31/2020	10460	IEA Dues Payable	26,146.52		10460
	202012912	1/31/2020	10460	IEA Dues Payable	26,146.52		10460
				Total	\$52,293.04		
Therapy Shoppe Inc							
	52195	2/21/2020	10-1200-410-92-79-600-14	IDEA Instructional Supplies	108.04	0020202167	10-1200-410-92-79-600-14
	52195	2/21/2020	10-1200-410-92-79-600-14	IDEA Instructional Supplies	113.30	0020202214	10-1200-410-92-79-600-14
				Total	\$221.34		
Thermosystems Building System							
	52196	2/21/2020	20-2540-390-00-79	SEDOM Operations & Maintenance	3,137.00	0020202200	20-2540-390-00-79
				Total	\$3,137.00		
Thompson, Crystal							
	51795	1/31/2020	10-3100-410-97-79-605-24	All Children Parental Supplies	23.52		10-3100-410-97-79-605-24
				Total	\$23.52		
Timm, Jonathan							
	51796	1/31/2020	40-2552-331-00-79	Contracted Transportation	4,231.68	0020202161	40-2552-331-00-79
				Total	\$4,231.68		
Tohme, Melanie							
	51797	1/31/2020	10-1611-225	Student Food Svc - Marlowe	29.05		10-1611-225
	51797	1/31/2020	10-1811	Textbook Fees	-16.75		10-1811
				Total	\$12.30		
Top Shelf Technology							
	51973	2/14/2020	10-1110-710-00-71-100-13	Non-Cap Eqpt Leggee	5,998.00	0020201754	10-1110-710-00-71-100-13
				Total	\$5,998.00		
Tortorice, Sam & Dawn							
	51885	2/7/2020	10-1811-305	Registration Fee HS	95.00		10-1811-305
				Total	\$95.00		
Tovar Snow Professional							
	51974	2/14/2020	20-2542-322-00-79-605-14	Snow Removal	22,496.85	0020010247	20-2542-322-00-79-605-14
	51974	2/14/2020	20-2542-322-00-79-605-14	Snow Removal	21,945.00	0020100247	20-2542-322-00-79-605-14
	52197	2/21/2020	20-2542-322-00-79-605-14	Snow Removal	440.00	0020020247	20-2542-322-00-79-605-14
	52197	2/21/2020	20-2542-322-00-79-605-14	Snow Removal	33,440.00	0020010247	20-2542-322-00-79-605-14
				Total	\$78,321.85		
TPI Tyler Press Inc							
	51886	2/7/2020	10-2114-410-00-74-500-14	Supplies Registration	146.85	0020201821	10-2114-410-00-74-500-14
				Total	\$146.85		



Huntley Community School District #158

Disbursements Issued

From January 30, 2020 to February 27, 2020

Printed: 2/27/2020
Page 41 of 45

Vendor Name	Check #	Check Date	A.S.N.	Description	Amount	PO #	State Account Number
Trane	52198	2/21/2020	20-2542-390-00-79	Other Purchased Service	2,228.75	0020202201	20-2542-390-00-79
					Total		
					<u>\$2,228.75</u>		
Translation Today Network Inc	52199	2/21/2020	10-2150-310-92-79-600-14	IDEA Sp Path & Audiology Serv	205.15	0020202436	10-2150-310-92-79-600-14
					Total		
					<u>\$205.15</u>		
Tremco/Weatherproofing Tech Inc	51975	2/14/2020	20-2540-310-00-79	Professional & Technical	8,250.00	0020200010	20-2540-310-00-79
					Total		
					<u>\$8,250.00</u>		
Trewartha, Dave	51976	2/14/2020	10-1500-319-00-71-300-13	Sports Officials HS	67.00		10-1500-319-00-71-300-13
					Total		
					<u>\$67.00</u>		
Trowbridge, Daniel	51798	1/31/2020	10-1500-319-00-72-220-13	Sports Officials Marlowe	65.00		10-1500-319-00-72-220-13
					Total		
					<u>\$65.00</u>		
Trowbridge, David	51887	2/7/2020	10-1500-319-00-72-220-13	Sports Officials Marlowe	65.00		10-1500-319-00-72-220-13
					Total		
					<u>\$65.00</u>		
TSA Consulting Group Inc	202011003	1/31/2020	10455	Annuities Payable	63,224.44		10455
	202012903	1/31/2020	10455	Annuities Payable	63,224.44		10455
					Total		
					<u>\$126,448.88</u>		
Tyler Technologies Inc	52200	2/21/2020	40-2550-310-00-79	Prof & Tech Service Trans	16,546.00	0020202267	40-2550-310-00-79
					Total		
					<u>\$16,546.00</u>		
UMB Bank NA	52201	2/21/2020	30-5900-690	Bond Service Charge	107.18	0020202383	30-5900-690
					Total		
					<u>\$107.18</u>		
Unicom Arc	52202	2/21/2020	10-2321-390-00-74-500-14	Purchased Service Supt	4,250.00	0020202441	10-2321-390-00-74-500-14
					Total		
					<u>\$4,250.00</u>		
United Way of McHenry Co	51799	1/31/2020	10461	United Way Payable	13.43		10461
	51977	2/14/2020	10461	United Way Payable	13.43		10461
					Total		
					<u>\$26.86</u>		



Huntley Community School District #158

Disbursements Issued

From January 30, 2020 to February 27, 2020

Printed: 2/27/2020
Page 42 of 45

Vendor Name	Check #	Check Date	A.S.N.	Description	Amount	PO #	State Account Number
Unity School Bus Parts, Inc	52203	2/21/2020	40-2554-410-00-79	Fleet Supplies	466.68	0020202384	40-2554-410-00-79
Total					<u>\$466.68</u>		
US Bank	52204	2/21/2020	30-5900-690	Bond Service Charge	1,450.00	0020202385	30-5900-690
Total					<u>\$1,450.00</u>		
Varidesk LLC	51978	2/14/2020	10-2410-491-00-74-150-13	Rebate Supplies Conley	1,475.00	0020202141	10-2410-491-00-74-150-13
Total					<u>\$1,475.00</u>		
Verizon Wireless	51888	2/7/2020	20-2540-340-00-79	Telephone - Districtwide	126.44	0020021607	20-2540-340-00-79
	51888	2/7/2020	20-2540-340-00-79	Telephone - Districtwide	4,516.91	0020011607	20-2540-340-00-79
Total					<u>\$4,643.35</u>		
Viking Sewing Gallery Inc	51889	2/7/2020	10-1100-423-00-74-500-14	New Adoption	9,681.00	0020200118	10-1100-423-00-74-500-14
Total					<u>\$9,681.00</u>		
Village of Algonquin	51890	2/7/2020	20-2540-370-00-79	Water/Sewer	5,256.50		20-2540-370-00-79
	51979	2/14/2020	20-2546-310-00-71-305	Resource Officer HS	9,444.09	0020020137	20-2546-310-00-71-305
	52205	2/21/2020	20-2546-310-00-71-305	Resource Officer HS	241.02	0020202171	20-2546-310-00-71-305
Total					<u>\$14,941.61</u>		
Village of Huntley	51800	1/31/2020	20-2546-310-00-71-305	Resource Officer HS	5,727.72	0020011517	20-2546-310-00-71-305
	52206	2/21/2020	20-2546-310-00-71-305	Resource Officer HS	5,727.72	0020021517	20-2546-310-00-71-305
	52206	2/21/2020	20-2546-310-00-71-305	Resource Officer HS	2,031.25	0020202437	20-2546-310-00-71-305
Total					<u>\$13,486.69</u>		
Village of Lake in the Hills	51980	2/14/2020	20-2546-310-00-71-305	Resource Officer HS	5,245.00	0020020687	20-2546-310-00-71-305
Total					<u>\$5,245.00</u>		
Villarreal, Javier	51801	1/31/2020	10-1500-319-00-71-300-13	Sports Officials HS	92.00		10-1500-319-00-71-300-13
Total					<u>\$92.00</u>		
Virtual Connections Academy	51891	2/7/2020	10-4220-670-00-79-600-14	Sp Ed Private Tuition	5,069.88	0020011757	10-4220-670-00-79-600-14
Total					<u>\$5,069.88</u>		



Huntley Community School District #158

Disbursements Issued

From January 30, 2020 to February 27, 2020

Printed: 2/27/2020
Page 43 of 45

Vendor Name	Check #	Check Date	A.S.N.	Description	Amount	PO #	State Account Number
Vrugt, Adriaan	51981	2/14/2020	10-1500-319-00-72-220-13	Sports Officials Marlowe	65.00		10-1500-319-00-72-220-13
					Total		
					<u>\$65.00</u>		
VSP of Illinois NFP	51892	2/7/2020	10-2310-220-00-79-600-14	Support Serv-Gen Adm Insurance	7,354.04	0020020457	10-2310-220-00-79-600-14
					Total		
					<u>\$7,354.04</u>		
Walsh, Tracy	52207	2/21/2020	10-1200-310-92-79-600-14	IDEA General Purchased Service	273.86		10-1200-310-92-79-600-14
					Total		
					<u>\$273.86</u>		
Wargo, Brandi	52208	2/21/2020	10-2212-332-00-74-500-14	Travel & Conference Curr	57.88		10-2212-332-00-74-500-14
	52208	2/21/2020	10-2323-640-00-74-500-14	Dues & Fees Curr & Inst	35.00		10-2323-640-00-74-500-14
					Total		
					<u>\$92.88</u>		
Warren, Mike	51893	2/7/2020	10-1500-319-00-71-300-13	Sports Officials HS	86.00		10-1500-319-00-71-300-13
	51982	2/14/2020	10-1500-319-00-74-210-13	Sports Officials Heineman	65.00		10-1500-319-00-74-210-13
					Total		
					<u>\$151.00</u>		
Weigand, Andrew	52209	2/21/2020	10-2310-230-00-74-500-14	Tuition Reimbursement	390.00		10-2310-230-00-74-500-14
					Total		
					<u>\$390.00</u>		
Westfall, James	51894	2/7/2020	10-1500-319-00-72-220-13	Sports Officials Marlowe	65.00		10-1500-319-00-72-220-13
	51983	2/14/2020	10-1500-319-00-74-210-13	Sports Officials Heineman	65.00		10-1500-319-00-74-210-13
					Total		
					<u>\$130.00</u>		
WEX BANK	51895	2/7/2020	10-1700-464-21-71-300-13	Driver Education Gasoline	1,007.65	0020010777	10-1700-464-21-71-300-13
					Total		
					<u>\$1,007.65</u>		
Wheaton North High School	51984	2/14/2020	10-1130-410-15-71-300-13	Social Studies Supplies HS	240.00	0020202386	10-1130-410-15-71-300-13
					Total		
					<u>\$240.00</u>		
Wheaton Warrenville South H.S.	51802	1/31/2020	10-1130-410-06-71-300-13	Foreign Language Supplies HS	100.00	0020202135	10-1130-410-06-71-300-13
					Total		
					<u>\$100.00</u>		
White, Lawrence	51896	2/7/2020	10-1811-305	Registration Fee HS	95.00		10-1811-305
					Total		
					<u>\$95.00</u>		



Huntley Community School District #158

Disbursements Issued

From January 30, 2020 to February 27, 2020

Printed: 2/27/2020
Page 44 of 45

Vendor Name	Check #	Check Date	A.S.N.	Description	Amount	PO #	State Account Number
Whitey's Towing Inc	52210	2/21/2020	40-2550-323-00-79	Repairs and Maintenance	200.00	0020202268	40-2550-323-00-79
					Total		
					<u>\$200.00</u>		
Willetts, Linda	51897	2/7/2020	10-1811-305	Registration Fee HS	95.00		10-1811-305
					Total		
					<u>\$95.00</u>		
Williams, Craig M	51898	2/7/2020	10-1811-305	Registration Fee HS	190.00		10-1811-305
					Total		
					<u>\$190.00</u>		
Williams, Dave	51985	2/14/2020	10-1500-319-00-71-300-13	Sports Officials HS	53.00		10-1500-319-00-71-300-13
					Total		
					<u>\$53.00</u>		
Wilmot, Michael	51803	1/31/2020	10-1500-319-00-71-300-13	Sports Officials HS	53.00		10-1500-319-00-71-300-13
	51986	2/14/2020	10-1500-319-00-71-300-13	Sports Officials HS	106.00		10-1500-319-00-71-300-13
					Total		
					<u>\$159.00</u>		
Wilson, Glen	52211	2/21/2020	10-1500-332-00-71-300-13	Athletic Trips HS	315.28		10-1500-332-00-71-300-13
					Total		
					<u>\$315.28</u>		
Winston Knolls Education Group	51899	2/7/2020	10-4220-670-00-79-600-14	Sp Ed Private Tuition	5,116.32	0020011747	10-4220-670-00-79-600-14
					Total		
					<u>\$5,116.32</u>		
Wold Architects and Engineers	51987	2/14/2020	20-2540-310-00-79	Professional & Technical	296.97	0020200581	20-2540-310-00-79
	51987	2/14/2020	20-2540-310-00-79	Professional & Technical	5,981.05		20-2540-310-00-79
	51987	2/14/2020	60-2530-319-00-71-300	HS Fine Arts Expansion Prof/Tech	5,589.23	0020192563	60-2530-319-00-71-300
					Total		
					<u>\$11,867.25</u>		
Wood, Patrick	51804	1/31/2020	10-1500-319-00-71-300-13	Sports Officials HS	139.00		10-1500-319-00-71-300-13
					Total		
					<u>\$139.00</u>		
Workspace Interiors by Office Depot	52212	2/21/2020	10-2520-410-00-74-500-14	Supplies Fiscal	2,145.48	0020202231	10-2520-410-00-74-500-14
					Total		
					<u>\$2,145.48</u>		
Wozny, Michael	51900	2/7/2020	10-1500-319-00-72-220-13	Sports Officials Marlowe	65.00		10-1500-319-00-72-220-13
					Total		
					<u>\$65.00</u>		



Huntley Community School District #158 Disbursements Issued From January 30, 2020 to February 27, 2020

Printed: 2/27/2020
Page 45 of 45

Vendor Name	Check #	Check Date	A.S.N.	Description	Amount	PO #	State Account Number
Wyman, Tamera	51805	1/31/2020	10-1130-332-00-71-300-13	Teacher Travel HS	39.67		10-1130-332-00-71-300-13
					Total	<u>\$39.67</u>	
Yokas, Robin	52213	2/21/2020	10-2212-332-00-74-500-14	Travel & Conference Curr	46.42		10-2212-332-00-74-500-14
	52213	2/21/2020	10-2212-332-00-74-500-14	Travel & Conference Curr	42.78		10-2212-332-00-74-500-14
					Total	<u>\$89.20</u>	
Zayas, Jennifer	52214	2/21/2020	10-2410-332-00-72-110-13	Prin Travel Chesak	260.13		10-2410-332-00-72-110-13
					Total	<u>\$260.13</u>	
Zhang, Guangping	52215	2/21/2020	10-2520-332-00-74-500-14	Travel Fiscal	57.50		10-2520-332-00-74-500-14
	52215	2/21/2020	10-2520-332-00-74-500-14	Travel Fiscal	80.50		10-2520-332-00-74-500-14
					Total	<u>\$138.00</u>	
Ziegler's Ace Hardware	51806	1/31/2020	20-2542-410-00-79	Supplies B & G	67.67	0020010267	20-2542-410-00-79
	51901	2/7/2020	40-2554-410-00-79	Fleet Supplies	132.95	0020121047	40-2554-410-00-79
	51988	2/14/2020	20-2542-410-00-79	Supplies B & G	7.96	0020110267	20-2542-410-00-79
	52216	2/21/2020	20-2542-410-00-79	Supplies B & G	13.20	0020010267	20-2542-410-00-79
					Total	<u>\$221.78</u>	
				Total	<u>\$2,726,430.89</u>		



Huntley Community School District 158

650 Dr. John Burkey Drive
Algonquin, Illinois 60102
(847) 659-6158 • www.district158.org

To: Board of Education and Administration

From: Mark Altmayer, Chief Financial Officer

Date: March 5, 2020

Subject: **Monthly Fiscal Updates**
Committee of the Whole Meeting, March 5, 2020

Listed below are major tasks and/or projects the Fiscal Department has been working on during the month.

GENERAL

During the month, Fiscal's primary projects included:

- ✓ **January month-end Close** - See the Preliminary Year-end Executive Summary
- ✓ **SB1043** – Met with Senator DeWitte during the month regarding the Certificate of Error and PTAB issue SB1043, Medicaid FreeCare as well as New Construction within Kane County.
- ✓ **Budget & 5 Year Plan** - Continuing the process of accumulating data and resources for the District's FY21 Budget and 5 Year Plan. The Budget and Plan will be presented in two weeks at the March Board Meeting.
- ✓ **Extracurricular Committee** – Over the last several months the Committee has met to review the overall effectiveness of the current extracurricular and athletic activities. As part of that review, the committee is making tiered recommendations for additional stipends (for new activities as well as those sports/activities that have had an increase in participation.) Recommendation under separate cover.

SPECIFIC TASKS TO ADDRESS DURING MARCH:

- **March** – Third transmission of Special Education Personnel Employed Approval is electronically filed with the Illinois State Board of Education (15 ILCS 5/14-13.01).
- **March** – Third transmission of Special Education Funding and Child Tracking (FACTS) is electronically filed with the Illinois State Board Education (105 ILCS 5/14-7.02, 5/14-7.02b, and 5/14-7.03).

OTHER TASKS THAT COULD BE ADDRESSED DURING MARCH 2018

- Bid preparation and solicitation.
- Continue to prepare budget and financial projections.
- Schedule independent audit - Tentatively scheduled for the week of July 27th.



Huntley Community School District 158

650 Dr. John Burkey Drive
Algonquin, Illinois 60102
(847) 659-6158 • www.district158.org

COMING UP IN APRIL

- Expenditure Reports for Categorical Grants. The Illinois State Board of Education will notify school District's via E-mail as to which grants must file on IWAS.



Huntley Community School District 158

650 Dr. John Burkey Drive
Algonquin, Illinois 60102
(847) 659-6158 • www.district158.org

To: Board of Education and Administration

From: Mark Altmayer, Chief Financial Officer

Date: March 5, 2020

Subject: **Activity Fund Balance Report**
Committee of the Whole Meeting – March 5, 2020
Finance Committee

Presented for the Committee's review is the Activity Fund Balance Report as of January 31, 2020.



Huntley Community School District 158

650 Dr. John Burkey Drive
 Algonquin, Illinois 60102
 (847) 659-6158 • www.district158.org

January 2020 Financial Executive Summary - Activity Accounts

The Month to Date results are as follows:

Activity Accounts by Building/Class	Beginning Balance	Revenues	Expenses	Ending Balance
District Office	\$ 89,903.09	\$ 1,565.67	\$ 754.62	\$ 90,714.14
Scholarships	24,080.89	-	-	24,080.89
D158 Foundation	16,133.72	1,925.75	1,586.91	16,472.56
Early Childhood	6,632.57	-	176.54	6,456.03
Gifted	584.38	-	-	584.38
Mackeben	22,826.88	2,929.73	1,078.13	24,678.48
Heineman	48,672.81	6,932.41	9,852.39	45,752.83
Conley	40,399.05	3,167.85	8,281.88	35,285.02
Chesak	23,765.58	4,244.66	931.80	27,078.44
Leggee	32,681.20	693.66	2,053.50	31,321.36
Martin	80,072.52	5,321.92	25,267.48	60,126.96
Marlowe	150,272.71	15,770.45	35,470.15	130,573.01
High School Athletics	278,132.10	70,298.96	94,313.11	254,117.95
High School Activities	249,163.56	43,717.53	33,356.51	259,524.58
Total All Funds	\$ 1,063,321.06	\$ 156,568.59	\$ 213,123.02	\$ 1,006,766.63

The material transactions involving Revenues and Expenditures for the month are as follows:

Heineman: The majority of the \$6,900 of revenue was from Snow Hawks ski trips \$4,400, and Wrestling \$1,200. The majority of the (\$9,900) of expenditures was for Snow Hawks ski trips (\$4,200), 8th Grade Holocaust Museum trips (\$2,100), Cheerleading State competition choreography & apparel (\$1,400), STUCO supplies (\$800), Chorus/Band supplies (\$500), and Wrestling tourney officials (\$450).

Conley: The majority of the \$3,200 of revenue was from Art \$2,200, and In & Out \$900. The majority of the (\$8,300) of expenditures was for Library book fair (\$6,500), Art supplies (\$900), and Field Trips (\$500).

Martin: The majority of the \$5,300 of revenue was from Art \$2,800, Fundraising \$800, Field Trips \$700, and School Store \$300. The majority of the (\$25,300) of expenditures was for sensory panel maze & water cooler stations from fundraising/PTA (\$19,300), Band shirts (\$2,300), Discovery Center Museum field trip (\$1,700), Art supplies (\$1,000), and dinner for parent-teacher conferences (\$600).

Marlowe: The majority of the \$15,800 of revenue was from Chorus/Band \$8,100, Play \$2,600, 8th Grade \$2,000, Philanthropy \$1,100, and Girls Basketball \$1,000. The majority of the (\$35,500) of expenditures was for Chorus/Band fundraising (\$23,800), Boys Basketball apparel (\$4,000), 8th Grade Holocaust Museum trips (\$3,800), Play costuming & supplies (\$1,300), School supplies (\$700), and Wrestling tourney entry fee & apparel (\$500).

High School Athletics: The majority of the \$70,300 of revenue was from Cheerleading \$50,200, Wrestling \$15,500, Bowling \$1,200, Boys Basketball \$800, Poms \$750, Boys Track \$600, and Girls Track \$400. The majority of the (\$94,300) of expenditures was for Cheerleading competition uniforms, apparel, officials, & DJ (\$42,900), Boys Basketball fundraising, warm-ups, & supplies (\$21,300), Poms competition uniforms, apparel, officials, & awards (\$10,300), Wrestling apparel (\$6,400), Football practice packs (\$5,100), Swimming fundraising & suits (\$700), Athletics spirit wear (\$1,800), Softball jerseys (\$900), and Girls Track supplies (\$800).

High School Activities: The majority of the \$43,700 of revenue was from Senior Class Gift \$15,000, Ski Club \$6,300, Assessments \$6,000, Journalism \$4,500, FBLA/School Store \$2,800, Tech & Industrial Arts \$2,600, PE \$1,300, Math Club \$1,100, Dean's Activity \$800, and Co-Op (VICA) \$750. The majority of the (\$33,400) of expenditures was for Assessments supplies (\$5,200), STUCO retreat & 2020 Prom DJ deposit (\$3,800), Engineering Club tourney supplies & supervision (\$3,400), Social Studies Trip transportation (\$3,200), Drama Club Theaterfest lodging (\$2,900), Ski Club trips (\$2,800), Fishing Club fundraising (\$1,900), Tech & Industrial Arts supplies (\$1,600), Science Olympiad invite supplies (\$1,300), Marching Band festival registration & apparel (\$1,200), and Journalism DC trip lodging (\$1,000).

For further detail, see attached list of major cash expenditures and revenues received.

January 2020 Financial Executive Summary - Activity Accounts

Major transactions for the Month include:

Major Cash Expenditures		Description	Major Revenues Received	
Huntley Community School Dist 158	35,607.71	P-Card charges 11/21-12/20	HS Cheerleading	50,191.60
Varsity Spirit Fashions	26,129.60	HS Cheerleading uniforms	HS Wrestling	15,525.00
No Regrets Inc	14,083.70	HS Boys Basketball fundraiser	HS Senior Class Gift	15,000.00
Skool Smartz Inc	12,748.35	MMS Chorus/Band fundraising	Marlowe Chorus/Band	8,145.00
Fundraising Manager	10,573.60	MMS Chorus/Band fundraising	HS Ski Club	6,289.00
Team Reil	8,581.00	Martin playground equipment	HS Assessments	6,022.00
Eastbay Inc	7,676.50	HS Poms & Football apparel	HS Journalism	4,470.00
Scholastic Book Fairs	7,198.96	MMS Chorus/Band trip balance	Heineman Snow Hawks	4,407.75
Nfinity Athletic LLC	7,124.00	HS Cheerleading apparel	Martin Art	2,806.92
Royal Pipe & Supply	6,710.60	Martin water cooler stations	HS School Store	2,773.71
Graphic Edge, The	6,620.02	HS Wrestling apparel	Marlowe Play	2,633.00
IHMEC	5,726.00	MMS/HMS Holocaust Museum trip	HS Tech & Ind Arts	2,615.20
Edge Sports Apparel, The	4,585.00	HS Boys Basketball warm-ups	Chesak Art	2,404.44
Alpine Valley Ski & Snowboard Resort	4,080.00	HMS Snow Hawks ski trips	Conley Art	2,167.19
BSN Sports LLC	4,031.84	MMS Boys Basketball apparel	Marlowe 8th Grade	1,968.00
BusBank, The	3,188.00	HS Social Studies trip trans.	Foundation Grants	1,925.75
Jensens Plumbing & Heating	3,038.63	Martin water cooler installs	Chesak Music	1,760.60
Holiday Inn & Suites	2,384.06	HS Drama Theaterfest lodging	Mackeben Art	1,484.38
Image Market	2,264.60	Martin Music t-shirts	Interest	1,474.36
AIA Services LLC	2,067.23	HS Athl. & HMS Cheer apparel	HS PE	1,280.00
North Central District of Student Council	1,980.00	HS STUCO retreat registration	HS Bowling	1,239.00

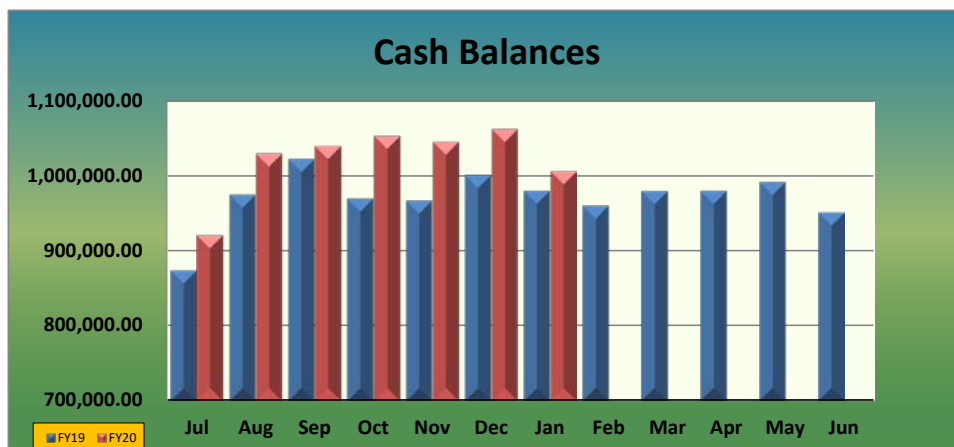

The above chart shows the aggregated fund balances for all Student Activity Accounts for the current and prior years.

Fund Balance Report

Printed: 2/13/2020 4:18 PM

Huntley Community School District 158

Fund	Description	Month to Date		Year to Date		YTD Change	Fund Balance	
		Expense	Income	Expense	Income		Start of Year	Current
100	District In & Out	0.00	0.00	2,670.51	1,975.00	(695.51)	4,345.93	3,650.42
101	Interest/Service Charge	0.00	1,474.36	0.00	12,584.66	12,584.66	47,892.05	60,476.71
102	District Pepsi Account	31.00	91.31	359.16	4,892.59	4,533.43	8,493.79	13,027.22
104	Activity Food Service	0.00	0.00	0.00	0.00	0.00	3,726.24	3,726.24
105	District Recycling	398.62	0.00	712.97	1,016.45	303.48	4,569.48	4,872.96
111	Huntley Hootenanny	0.00	0.00	0.00	0.00	0.00	0.00	0.00
112	Foundation Grants	1,586.91	1,925.75	42,204.09	35,837.75	(6,366.34)	22,838.90	16,472.56
113	Schaffenegger Memorial	0.00	0.00	1,000.00	0.00	(1,000.00)	25,080.89	24,080.89
115	O & M Pop Fund	0.00	0.00	0.00	0.00	0.00	0.00	0.00
118	Gifted Program	0.00	0.00	0.00	0.00	0.00	584.38	584.38
1202	Mackeben Pop	0.00	0.00	0.00	0.00	0.00	1,736.55	1,736.55
1203	Mackeben Recycling	0.00	0.00	0.00	0.00	0.00	4,051.57	4,051.57
1204	Mackeben Art	0.00	1,484.38	0.00	1,648.68	1,648.68	1,638.80	3,287.48
1205	Mackeben Reading	0.00	0.00	0.00	0.00	0.00	0.00	0.00
1209	Mackeben Field Trips	0.00	0.00	1,177.34	1,172.00	(5.34)	4,821.80	4,816.46
1210	Mackeben Library	698.91	757.32	4,726.83	4,834.86	108.03	5,683.24	5,791.27
1212	Mackeben Market Day	0.00	427.08	0.00	427.08	427.08	99.32	526.40
1240	Mackeben In & Out	379.22	260.95	1,477.82	1,162.68	(315.14)	4,783.89	4,468.75
1400	Heineman LRC	0.00	0.00	1,386.06	1,386.06	0.00	1,940.67	1,940.67
1401	Heineman Snow Hawks	4,150.00	4,407.75	5,310.00	9,342.75	4,032.75	199.99	4,232.74
1402	Heineman Play	0.00	0.00	0.00	0.00	0.00	0.00	0.00
1403	Heineman Yearbook	0.00	0.00	0.00	447.00	447.00	3,218.19	3,665.19
1404	Heineman PBIS	19.74	0.00	80.34	0.00	(80.34)	197.55	117.21
1405	Heineman Service Club	0.00	0.00	947.13	966.35	19.22	22.82	42.04
1406	Heineman Chorus/Band	473.09	120.00	41,690.94	49,839.74	8,148.80	209.84	8,358.64
1407	Heineman Wrestling	450.00	1,164.00	450.00	1,164.00	714.00	120.81	834.81
1408	Heineman Cheerleading	1,406.00	0.00	1,972.05	2,315.00	342.95	849.08	1,192.03
1409	Heineman Track	0.00	0.00	0.00	0.00	0.00	917.38	917.38
1410	Heineman Charitable Contributions	0.00	0.00	5,419.88	0.00	(5,419.88)	5,950.56	530.68
1411	Heineman Cross Country	0.00	0.00	667.00	692.00	25.00	128.53	153.53
1412	Heineman Volleyball	0.00	0.00	739.50	750.00	10.50	70.91	81.41
1413	Heineman PE	0.00	0.00	0.00	110.00	110.00	799.26	909.26
1414	Heineman Student Council	767.07	0.00	1,840.26	1,082.00	(758.26)	1,212.04	453.78
1416	Heineman Poms	51.25	48.00	888.45	793.00	(95.45)	130.42	34.97
1417	Heineman Girls Basketball	0.00	0.00	0.00	0.00	0.00	57.16	57.16
1418	Heineman Outdoor Activity	0.00	0.00	47,356.00	48,805.00	1,449.00	2,392.31	3,841.31

96

Specialized Data Systems, Inc.

C:\SDS\SDSData\Activity\Swf_BFFB.RPT

Fund Balance Report

Printed: 2/13/2020 4:18 PM

Huntley Community School District 158

Fund	Description	Month to Date		Year to Date		YTD Change	Fund Balance	
		Expense	Income	Expense	Income		Start of Year	Current
1419	Heineman Athletics	0.00	314.00	778.21	817.00	38.79	2,663.68	2,702.47
1420	Heineman Boys Basketball	0.00	0.00	413.00	505.00	92.00	1,500.87	1,592.87
1421	Heineman Ecology Club	0.00	264.75	220.36	392.75	172.39	453.83	626.22
1422	Heineman Computer Lab	0.00	0.00	0.00	0.00	0.00	743.24	743.24
1423	Heineman Art Club	0.00	0.00	0.00	0.00	0.00	979.22	979.22
1425	Heineman Engineering Club	0.00	0.00	0.00	0.00	0.00	64.34	64.34
1440	Heineman In & Out	314.13	351.91	1,141.91	1,018.16	(123.75)	525.32	401.57
1441	Heineman Foods Club	151.11	0.00	624.01	390.00	(234.01)	1,526.63	1,292.62
1442	Heineman Board Game Club	0.00	0.00	0.00	0.00	0.00	0.00	0.00
1461	Heineman 6th Grade Team 1	0.00	0.00	0.00	0.00	0.00	0.10	0.10
1462	Heineman 6th Grade Team 2	0.00	0.00	0.00	0.00	0.00	0.00	0.00
1471	Heineman 7th Grade Team 1	0.00	0.00	0.00	0.00	0.00	3,781.62	3,781.62
1472	Heineman 7th Grade Team 2	0.00	0.00	300.00	0.00	(300.00)	432.05	132.05
1480	Heineman 8th Grade Trips	0.00	0.00	9,253.46	0.00	(9,253.46)	13,777.10	4,523.64
1481	Heineman 8th Grade Team 1	1,070.00	136.00	1,120.00	1,096.00	(24.00)	86.00	62.00
1482	Heineman 8th Grade Team 2	1,000.00	126.00	1,000.00	939.00	(61.00)	1,549.06	1,488.06
1701	Conley School Store	0.00	0.00	40.99	0.00	(40.99)	8,250.01	8,209.02
1702	Conley Pop	0.00	84.65	0.00	140.62	140.62	103.32	243.94
1703	Conley Recycling	0.00	0.00	0.00	0.00	0.00	106.94	106.94
1704	Conley PBIS	0.00	0.00	0.00	0.00	0.00	2.00	2.00
1706	Conley Band	0.00	0.00	1,304.34	1,058.10	(246.24)	721.70	475.46
1707	Conley Jean Fund	146.16	0.00	146.16	1,120.06	973.90	0.00	973.90
1708	Conley Disc Golf Club	0.00	0.00	0.00	0.00	0.00	0.00	0.00
1709	Conley Field Trips	502.59	0.00	835.13	0.00	(835.13)	8,152.66	7,317.53
1710	Conley Library	6,500.05	46.61	7,490.62	9,173.10	1,682.48	3,864.70	5,547.18
1712	Conley Art	913.42	2,167.19	913.42	2,167.19	1,253.77	2,000.07	3,253.84
1713	Conley Yearbook	219.66	0.00	1,372.63	323.96	(1,048.67)	5,193.86	4,145.19
1740	Conley In & Out	0.00	869.40	870.73	879.40	8.67	5,001.35	5,010.02
195	LIGHT Program	325.00	0.00	870.00	1,500.00	630.00	65.00	695.00
196	Music Camps District-wide	0.00	0.00	0.00	0.00	0.00	3,714.02	3,714.02
197	Pre-K Fieldtrips	0.00	0.00	0.00	0.00	0.00	0.00	0.00
198	MS Orchestra District-wide	0.00	0.00	0.00	0.00	0.00	551.57	551.57
199	Preschool	176.54	0.00	2,003.92	56.69	(1,947.23)	8,403.26	6,456.03
202	Chesak Pop	0.00	79.62	0.00	180.24	180.24	502.18	682.42
203	Chesak Recycling	0.00	0.00	0.00	0.00	0.00	171.34	171.34
204	Chesak Art	0.00	2,404.44	3,099.00	2,404.44	(694.56)	3,484.45	2,789.89

97

Specialized Data Systems, Inc.

C:\SDS\SDSData\Activity\Swf_BFFB.RPT

Fund Balance Report

Printed: 2/13/2020 4:18 PM

Huntley Community School District 158

Fund	Description	Month to Date		Year to Date		YTD Change	Fund Balance	
		Expense	Income	Expense	Income		Start of Year	Current
205	Chesak Yearbook	0.00	0.00	0.00	0.00	0.00	0.00	0.00
206	Chesak Music	200.89	1,760.60	495.88	1,760.60	1,264.72	3,975.51	5,240.23
209	Chesak Field Trips	0.00	0.00	0.00	0.00	0.00	0.00	0.00
210	Chesak Library	0.00	0.00	4,859.31	4,579.85	(279.46)	10,985.89	10,706.43
212	Chesak Dine & Share	0.00	0.00	0.00	0.00	0.00	1,684.77	1,684.77
240	Chesak In & Out	730.91	0.00	11,711.92	3,388.93	(8,322.99)	14,126.35	5,803.36
301	Leggee School Store	293.78	0.00	2,309.13	2,307.00	(2.13)	9,134.80	9,132.67
302	Leggee Pop	0.00	111.71	368.74	338.39	(30.35)	281.50	251.15
303	Leggee Recycling	0.00	0.00	22.72	0.00	(22.72)	38.64	15.92
304	Leggee Art	0.00	0.00	1,640.43	0.00	(1,640.43)	1,819.42	178.99
306	Leggee Fundraisers	162.18	0.00	790.19	407.75	(382.44)	3,191.99	2,809.55
307	Leggee Donations & Grants	0.00	500.00	1,201.93	500.00	(701.93)	2,890.00	2,188.07
308	Leggee Music	750.07	0.00	1,647.13	1,745.50	98.37	317.84	416.21
309	Leggee Field Trips	0.00	0.00	4,672.06	4,990.12	318.06	1,981.38	2,299.44
310	Leggee Library	847.47	20.00	6,442.04	5,629.91	(812.13)	1,953.43	1,141.30
311	Leggee Recreation	0.00	61.95	0.00	61.95	61.95	34.41	96.36
313	Leggee Yearbook	0.00	0.00	177.82	0.00	(177.82)	669.78	491.96
340	Leggee In & Out	0.00	0.00	835.11	12,948.81	12,113.70	186.04	98,12,299.74
400	Marlowe LRC	0.00	0.00	66.98	256.41	189.43	941.75	1,131.18
401	Marlowe Pop	666.09	539.65	1,859.08	2,081.75	222.67	3,026.50	3,249.17
402	Marlowe Fundraiser Funds	0.00	0.00	0.00	0.00	0.00	404.25	404.25
403	Marlowe Yearbook	0.00	0.00	2,267.89	30.00	(2,237.89)	18,826.83	16,588.94
404	Marlowe School Store	302.98	104.70	3,017.14	3,613.70	596.56	1,607.79	2,204.35
405	Marlowe Student Council	0.00	32.10	899.94	112.34	(787.60)	1,745.69	958.09
406	Marlowe Chorus/Band	23,817.40	8,145.00	49,752.77	63,274.50	13,521.73	9,022.97	22,544.70
407	Marlowe Wrestling	530.00	265.00	1,456.17	1,240.00	(216.17)	3,318.26	3,102.09
408	Marlowe Cheerleading	199.00	0.00	1,494.64	1,734.00	239.36	2,005.31	2,244.67
409	Marlowe Track	0.00	0.00	0.00	0.00	0.00	356.76	356.76
410	Marlowe Spanish Club	0.00	0.00	0.00	161.00	161.00	1.44	162.44
411	Marlowe Cross Country	0.00	0.00	0.00	0.00	0.00	14.71	14.71
412	Marlowe Volleyball	0.00	0.00	2,887.71	3,152.00	264.29	1,202.64	1,466.93
413	Marlowe Philanthropy	195.53	1,096.00	2,972.35	1,890.00	(1,082.35)	8,355.58	7,273.23
414	Marlowe Academic Club	0.00	0.00	0.00	0.00	0.00	1.68	1.68
415	Marlowe Play	1,328.00	2,633.00	15,302.13	7,872.00	(7,430.13)	16,012.39	8,582.26
416	Marlowe Service Club	0.00	0.00	312.89	0.00	(312.89)	1,887.98	1,575.09
417	Marlowe Girls Basketball	0.00	950.00	304.50	950.00	645.50	4,129.16	4,774.66

Specialized Data Systems, Inc.

C:\SDS\SDSData\Activity\Swf_BFFB.RPT

Fund Balance Report

Printed: 2/13/2020 4:18 PM

Huntley Community School District 158

Fund	Description	Month to Date		Year to Date		YTD Change	Fund Balance	
		Expense	Income	Expense	Income		Start of Year	Current
418	Marlowe Outdoor Activity	0.00	0.00	70,557.53	73,916.00	3,358.47	5,853.26	9,211.73
419	Marlowe Athletics	21.98	0.00	1,183.57	1,037.51	(146.06)	4,479.99	4,333.93
420	Marlowe Boys Basketball	4,031.84	0.00	6,631.52	2,573.00	(4,058.52)	15,384.73	11,326.21
421	Marlowe Science	0.00	0.00	0.00	0.00	0.00	0.00	0.00
422	Marlowe Tech Lab	0.00	0.00	0.00	0.00	0.00	139.97	139.97
423	Marlowe Art Class	0.00	27.00	251.80	741.00	489.20	2,901.31	3,390.51
424	Marlowe PE	112.23	0.00	689.34	0.00	(689.34)	8,907.78	8,218.44
425	Marlowe Ecology	0.00	0.00	0.00	0.00	0.00	1,156.11	1,156.11
426	Marlowe Poms	158.60	0.00	584.13	2,647.45	2,063.32	4,426.70	6,490.02
427	Marlowe Musical	0.00	0.00	0.00	0.00	0.00	291.90	291.90
428	Marlowe Explorers Club	0.00	0.00	0.00	0.00	0.00	0.00	0.00
440	Marlowe In & Out	0.00	0.00	403.42	0.00	(403.42)	6,017.57	5,614.15
441	Marlowe Foods Club	0.00	0.00	157.76	271.00	113.24	6.00	119.24
461	Marlowe 6th Grade	0.00	0.00	18.44	0.00	(18.44)	53.64	35.20
471	Marlowe 7th Grade	279.14	10.00	706.94	1,264.00	557.06	425.94	983.00
481	Marlowe 8th Grade	3,827.36	1,968.00	18,662.84	3,286.00	(15,376.84)	18,004.24	2,627.40
500	HS Digital Photography	0.00	0.00	780.09	111.55	(668.54)	668.54	0.00
501	HS Raider Nation	0.00	0.00	0.00	0.00	0.00	0.00	99 0.00
502	HS Art	224.66	0.00	224.66	(111.55)	(336.21)	879.52	543.31
503	HS Yearbook	410.00	0.00	503.00	2,680.00	2,177.00	4,548.17	6,725.17
504	HS Girls Cross Country	0.00	0.00	315.00	(410.38)	(725.38)	725.38	0.00
505	HS Student Council	3,778.03	530.00	40,502.77	38,265.38	(2,237.39)	19,948.24	17,710.85
506	HS Music Activity	225.00	0.00	489.19	569.00	79.81	265.72	345.53
507	HS Color Guards	0.00	0.00	173.20	(7,820.77)	(7,993.97)	7,993.97	0.00
508	HS Pop	180.30	271.87	1,319.85	1,425.49	105.64	731.52	837.16
509	HS Math Club	507.00	1,138.50	816.00	1,547.50	731.50	0.00	731.50
510	HS Girls Golf	0.00	0.00	7,877.98	8,674.57	796.59	3,158.02	3,954.61
511	HS Drama Club	2,867.01	0.00	6,921.62	8,726.25	1,804.63	4,070.54	5,875.17
512	HS Pom Pons	10,289.74	753.25	70,538.65	44,060.54	(26,478.11)	32,591.96	6,113.85
513	HS Ski Club	2,776.72	6,289.00	3,208.12	18,451.00	15,242.88	3,521.09	18,763.97
514	HS World Languages Club	0.00	0.00	176.47	0.00	(176.47)	946.33	769.86
515	HS Boys Track	356.96	600.00	1,239.98	1,625.00	385.02	3,318.07	3,703.09
516	HS Dean Activity	0.00	820.00	1,657.99	800.56	(857.43)	13,312.22	12,454.79
517	HS HOSA Medical Club	0.00	0.00	1,476.02	2,030.00	553.98	187.65	741.63
518	HS NHS	712.93	0.00	2,923.01	1,710.00	(1,213.01)	7,035.07	5,822.06
519	HS Co-Op (VICA)	0.00	754.00	1,000.00	3,904.00	2,904.00	12,219.12	15,123.12

Specialized Data Systems, Inc.

C:\SDS\SDSData\Activity\Swf_BFFB.RPT

Fund Balance Report

Printed: 2/13/2020 4:18 PM

Huntley Community School District 158

Fund	Description	Month to Date		Year to Date		YTD Change	Fund Balance	
		Expense	Income	Expense	Income		Start of Year	Current
520	HS Musical	0.00	0.00	0.00	0.00	0.00	3,222.62	3,222.62
521	HS Athletic Varsity	1,821.42	260.00	21,827.88	22,292.23	464.35	11,735.08	12,199.43
522	HS Girls Volleyball	493.07	0.00	38,676.12	43,058.37	4,382.25	958.03	5,340.28
523	HS Boys Golf	0.00	0.00	15,856.13	15,717.58	(138.55)	1,442.36	1,303.81
524	HS Softball	859.80	0.00	7,333.86	5,000.62	(2,333.24)	11,704.41	9,371.17
525	HS Baseball	465.00	20.00	15,512.51	5,353.17	(10,159.34)	9,352.86	(806.48)
526	HS Girls Basketball	0.00	0.00	6,419.66	24,305.81	17,886.15	3,510.26	21,396.41
527	HS Boys Basketball	21,312.31	798.70	38,687.80	37,067.19	(1,620.61)	5,949.74	4,329.13
528	HS Cheerleading	42,879.19	50,191.60	102,039.06	135,458.78	33,419.72	20,426.93	53,846.65
529	HS Wrestling	6,442.49	15,525.00	9,932.14	22,241.38	12,309.24	7,070.59	19,379.83
530	HS Boys Cross Country	0.00	0.00	4,062.16	3,762.19	(299.97)	2,501.70	2,201.73
531	HS School Store	390.00	2,773.71	11,585.87	7,255.05	(4,330.82)	15,180.96	10,850.14
532	HS Local Scholarship	0.00	0.00	500.00	0.00	(500.00)	500.00	0.00
533	HS Speech	0.00	0.00	5,150.80	5,510.00	359.20	3,247.88	3,607.08
534	HS Academic Team	217.71	0.00	217.71	300.00	82.29	99.45	181.74
535	HS Journalism	974.86	4,470.00	23,531.59	40,329.62	16,798.03	6,317.44	23,115.47
536	HS Soccer	0.00	0.00	22,458.23	26,741.78	4,283.55	31,657.35	35,940.90
537	HS Field Trips	672.13	0.00	2,521.07	4,401.50	1,880.43	1,226.86	3,107.29
538	HS Football	5,066.32	0.00	106,016.13	90,944.95	(15,071.18)	57,553.70	42,482.52
539	HS Special Olympics	0.00	0.00	0.00	292.09	292.09	153.00	445.09
540	HS In & Out	253.83	0.00	3,580.75	2,009.91	(1,570.84)	5,383.58	3,812.74
541	HS Tech & Ind Arts	1,550.66	2,615.20	5,035.77	7,005.20	1,969.43	2,315.15	4,284.58
542	HS PE	770.00	1,280.00	21,513.21	20,793.00	(720.21)	9,368.68	8,648.47
543	HS Girls Track	815.86	400.00	1,170.81	1,400.00	229.19	18,527.93	18,757.12
544	HS Blooms Courtyard	0.00	0.00	175.00	5,730.84	5,555.84	0.00	5,555.84
545	HS Tennis	225.00	0.00	5,687.61	3,910.66	(1,776.95)	1,857.55	80.60
546	HS Media Center	0.00	0.00	0.00	0.00	0.00	2,052.25	2,052.25
547	HS Buddies Club	450.00	0.00	3,019.78	7,128.60	4,108.82	1,285.22	5,394.04
548	HS Engineering Club	3,417.67	75.00	18,662.70	16,330.00	(2,332.70)	7,231.28	4,898.58
549	HS Assessments	5,211.00	6,022.00	6,424.31	32,130.00	25,705.69	15,885.83	41,591.52
550	HS Community Service Club	0.00	0.00	0.00	0.00	0.00	2,608.89	2,608.89
551	HS Custom Designs	0.00	0.00	197.46	0.00	(197.46)	2,819.19	2,621.73
552	HS Dance Club	78.40	0.00	1,313.73	965.00	(348.73)	1,819.28	1,470.55
553	HS Recycling	0.00	0.00	769.35	782.00	12.65	584.58	597.23
554	HS Art Club	33.12	40.00	224.40	537.00	312.60	502.64	815.24
555	HS Boys Lacrosse	0.00	278.41	5,003.94	2,778.41	(2,225.53)	3,744.85	1,519.32

Specialized Data Systems, Inc.

C:\SDS\SDSData\Activity\Swf_BFFB.RPT

Fund Balance Report

Printed: 2/13/2020 4:18 PM

Huntley Community School District 158

Fund	Description	Month to Date		Year to Date		YTD Change	Fund Balance	
		Expense	Income	Expense	Income		Start of Year	Current
556	HS Marching Band	1,218.00	60.00	31,037.23	14,547.27	(16,489.96)	18,095.32	1,605.36
557	HS Baking Club	0.00	60.00	0.00	60.00	60.00	289.93	349.93
558	HS Fashion Club	0.00	0.00	113.15	105.00	(8.15)	12.62	4.47
559	HS Social Studies Trips	3,188.00	350.00	3,188.00	5,270.00	2,082.00	71.65	2,153.65
560	HS PBIS Raider Way	65.50	0.00	629.09	1,240.44	611.35	350.48	961.83
561	HS Bowling	0.00	1,239.00	1,077.97	2,149.00	1,071.03	796.39	1,867.42
562	HS Swimming	3,037.50	0.00	11,317.85	14,491.00	3,173.15	281.18	3,454.33
563	HS Fishing Club	1,869.00	438.25	4,279.78	3,303.25	(976.53)	818.57	(157.96)
564	HS Science Club	1,314.98	150.00	2,562.78	5,422.00	2,859.22	3,777.04	6,636.26
565	HS Psychology Club	0.00	0.00	0.00	0.00	0.00	1,657.42	1,657.42
566	HS Horticulture Club	0.00	0.00	0.00	0.00	0.00	2,887.14	2,887.14
567	HS English Book Club	0.00	0.00	0.00	(4.56)	(4.56)	4.56	0.00
568	HS Medical Academy	0.00	0.00	312.35	175.00	(137.35)	292.56	155.21
569	HS Operation Click	0.00	0.00	0.00	0.00	0.00	2,065.70	2,065.70
570	HS SES Coffee Cart	0.00	0.00	200.00	(720.84)	(920.84)	2,193.92	1,273.08
571	HS Girls Lacrosse	248.45	233.00	6,546.29	4,970.76	(1,575.53)	9,257.76	7,682.23
572	HS Autos Club	0.00	580.00	0.00	900.00	900.00	54.65	954.65
573	HS Boys Volleyball	0.00	0.00	580.87	0.00	(580.87)	587.58	101 6.71
574	HS Life Skills	0.00	0.00	0.00	(1,500.00)	(1,500.00)	1,755.76	255.76
575	HS Job Skills	0.00	0.00	0.00	320.00	320.00	541.66	861.66
576	HS Chess Team	0.00	0.00	0.00	0.00	0.00	692.23	692.23
598	HS Incubator Pgm	0.00	0.00	0.00	1,000.00	1,000.00	0.00	1,000.00
599	HS Senior Class Gift	0.00	15,000.00	0.00	15,000.00	15,000.00	5,836.27	20,836.27
701	Martin School Store	251.89	348.00	1,581.49	2,255.00	673.51	8,203.32	8,876.83
702	Martin Pop	575.10	0.00	575.10	89.38	(485.72)	548.87	63.15
703	Martin Recycling	0.00	0.00	0.00	0.00	0.00	629.86	629.86
704	Martin Art	979.07	2,806.92	979.07	2,806.92	1,827.85	8,154.91	9,982.76
706	Martin Band	2,264.60	100.00	3,825.45	4,654.00	828.55	454.97	1,283.52
709	Martin Fieldtrips	1,735.00	736.00	6,169.91	736.00	(5,433.91)	6,848.91	1,415.00
710	Martin Library	156.95	566.00	6,989.69	7,210.38	220.69	10,035.87	10,256.56
712	Martin Fundraising	19,304.87	765.00	20,379.74	765.00	(19,614.74)	42,681.80	23,067.06
713	Martin Yearbook	0.00	0.00	0.00	113.35	113.35	4,052.02	4,165.37
740	Martin In & Out	0.00	0.00	2,147.75	2,076.75	(71.00)	457.85	386.85
		<u>\$213,123.02</u>	<u>\$156,568.59</u>	<u>\$1,168,234.81</u>	<u>\$1,223,375.00</u>	<u>\$55,140.19</u>	<u>\$951,626.44</u>	<u>\$1,006,766.63</u>

January 2020 Financial Executive Summary

The January 2020 month and YTD results are as follows:

Operating Funds: 10, 20, 40, 50, and 70	FY20 January	FY20 YTD	FY20 Budget	
Total Local	\$ 6,131,521	\$ 40,374,833	\$ 74,275,460	54%
Total State	2,857,670	18,739,265	\$ 32,009,974	59%
Total Federal	111,179	1,165,589	\$ 3,562,221	33%
Operating Revenues	<u>\$ 9,100,369</u>	<u>\$ 60,279,688</u>	<u>\$ 109,847,655</u>	55%
Salaries	\$ 5,484,132	\$ 38,621,569	\$ 66,925,152	58%
Employee Benefits	\$ 1,331,374	\$ 8,602,538	\$ 15,590,037	55%
Purchased Services	\$ 641,486	\$ 6,222,222	\$ 9,962,195	62%
Supplies & Materials	\$ 419,604	\$ 3,288,060	\$ 10,443,631	31%
Capital Outlay	\$ 21,575	\$ 234,577	\$ 4,278,521	5%
Other Objects	\$ 369,669	\$ 1,564,373	\$ 2,492,205	63%
Operating Expenses	<u>8,267,840</u>	<u>58,533,340</u>	<u>109,691,741</u>	53%
Net Operating Surplus (Deficit)	<u>\$ 832,530</u>	<u>\$ 1,746,348</u>	<u>\$ 155,914</u>	
Capital Fund: 60	FY20 January	FY20 YTD	FY20 Budget	
Total Revenues	\$ 79,695	\$ 374,133	\$ 215,000	174%
Total Expenses	500,752	1,193,033	4,434,958	27%
Net Capital Surplus (Deficit)	<u>\$ (421,057)</u>	<u>\$ (818,900)</u>	<u>\$ (4,219,958)</u>	

The District closed January with a YTD operating net surplus of \$1.75M. The majority of the YTD revenue is due to recognition of monthly 2019 Levy and receipt of Evidence Based Funding. Operating revenues are at 55% of budget and operating expenditures are at 53% of the budget.

January operating revenues of \$9.1M are primarily due to the recognition of \$5.63M levy 2019 property taxes, the receipt of \$2.4M State Evidence Based Funding (EBF), and the recognition of \$372k for FY20 monthly SpEd Tuition, Regular and Special Ed Transportation. Aside from levy recognition, local revenue of \$6.1M includes foodservice (\$274k) and impact fees (\$76k). Federal revenues are made up of National School Lunch (\$51k) and Title II (\$43k).

Approximately 82 percent of January operating expenditures cover salaries and benefits. Major expenditures making up the \$641k in operating Purchased Services was for the custodial contract (\$135k), HR/PR software usage (\$42k), repairs and maintenance buildings (\$38k), and resource officers (\$27k). The \$420k in operating Supplies & Materials was primarily for cafe food (\$97k), electricity (\$66k), buildings and grounds supplies (\$39k), and transportation diesel/gas (\$37k). The \$370k of Other Objects is primarily for special education private facility tuition.

The District began FY20 with \$58.5 million in cash and as of the end of January 2020, the cash balance approximated \$45.7 million. The District holds \$9.4M with BMO and \$36.3M through PMA.



Huntley Community School District 158

650 Dr. John Burkey Drive
Algonquin, Illinois 60102
(847) 659-6158 • www.district158.org

January 2020 Financial Executive Summary

Major transactions for January 2020 include:

Non-Salary Major Cash Expenditures		Major Revenues Received/Recognized	
UMB Bank NA (Bonds)	\$ 1,260,249	Monthly Op Levy 2019 Recognition	\$5,633,088
Blue Cross Blue Shield (Medical Ins.)	\$ 922,511	Evidence Based Model Funding	\$2,485,514
Lamp Inc. (HHS Fine Arts)	\$ 414,167	Monthly MCAT Recognition	\$372,156
The Bank of NY Mellon (Bonds)	\$ 391,856	Foodservice	\$273,837
Lincoln National (Dental/Life/ADD-2 mo.)	\$ 148,820	Impact Fees	\$76,436
ABM Industry (Custodial Contract)	\$ 142,088	Interest Revenue	\$59,858
BMO Mastercard (PCard)	\$ 86,038	National School Lunch	\$51,304
Thermosystems Building (HHS F.A.)	\$ 78,867		
Gordon Food Service (Cafe Food)	\$ 74,219		
ComEd (Electricity)	\$ 66,079		
Kelso Burnett (Keyless Entry/Cameras)	\$ 56,708		
Alexander Leigh Center (SpEd Tuition)	\$ 56,586		
ADP LLC (HR & PR Services)	\$ 40,098		
Blu Petroleum (Trans Fuel)	\$ 37,092		
ECRA Group (Curriculum)	\$ 33,520		
Woodstock D200 (SpEd Tuition)	\$ 32,043		
Easterseals (SpEd Tuition)	\$ 27,133		
		January 2020 ISBE (State) Receivable	
		FY20 Q2 MCATs	\$1,142,535
		FY20 Q2 Other	\$57,520
		FY20 Q3 MCATs	\$372,156
		Total	\$1,572,210

Monthly Insurance Update:

Claims Paid by Week

	Nov 2019	Dec 2019	Jan 2020	FY20 YTD
Week 1	\$ 54,141	\$ 186,686	\$ 85,817	\$ 818,884
Week 2	\$ 114,572	\$ 249,999	\$ 149,652	\$ 1,366,297
Week 3	\$ 155,570	\$ 187,354	\$ 172,273	\$ 1,222,075
Week 4	\$ 140,862	\$ 88,739	\$ 231,420	\$ 1,125,689
Week 5	\$ 97,668	\$ 51,434	\$ 210,668	\$ 840,170
Total	\$ 562,812	\$ 764,212	\$ 849,831	\$ 5,373,115
Settlement Costs - BC/BS	187,129	187,289	270,755	1,387,580
Average Monthly Claims Based upon the last 12 months of claims	\$ 726,864	\$ 736,611	\$ 748,720	
Total Insurance Costs	\$ 662,112	\$ 820,108	\$ 922,143	\$ 5,674,015

Includes employee contributions

FY20 Budget

\$ 9,585,096

January 2020 claims of \$849,831 compares to \$704,522 in January 2019. FY20 total health costs, including employee contributions, are \$5.67M and tracking slightly greater than budget. Year to date stop loss credits received are (\$890,727).

January settlement fees of \$270k are about \$83k higher than normal. The additional fees seen in January include the annual Aggregate Stop Loss Premium (\$61k), ACA fees that were previously suspended have been reinstated (\$2.5k), the Specific Stop Loss premium increased 39.9% (\$20k per month), as well as slight increases in the PPO Acces Fee and the HMO Capitation fee. On a positive note, Rx rebate credits increased \$12k.

January 2020 Dashboard

Revenue					
	Prior YTD	FY20 YTD	FY20 Tent Bgt	%	Variance
Operating Levies	35,415,850	36,004,777	65,949,872	55%	29,945,095
MCATs	2,688,671	2,769,480	4,524,524	61%	1,755,044
CPPRT	141,533	240,790	436,438	55%	195,648
Registration	1,417,770	1,389,013	1,461,367	95%	72,355
Impact/Transition Fees	45,789	346,705	350,000	99%	3,295
Bldg Rentals	160,656	141,889	285,000	50%	143,111
Foodservice	1,540,436	1,626,804	2,634,864	62%	1,008,060
Natl Lunch	297,574	299,452	685,163	44%	385,711
Medicaid	192,003	211,406	775,000	27%	563,594
IDEA/Room & Board	965,168	490,291	1,520,745	32%	1,030,454

- Tracking with Budget
- Plus or minus 10 percent of Budget
- Unfavorable budget variance exceeding 10%

Monthly Notes - Revenue

- ▶ Most revenue is running consistent with prior year.
- ▶ Building rentals are down from prior year primarily due to no longer renting to Willow Creek.
- ▶ Q2 IDEA reimbursement was received in early February - \$286k.

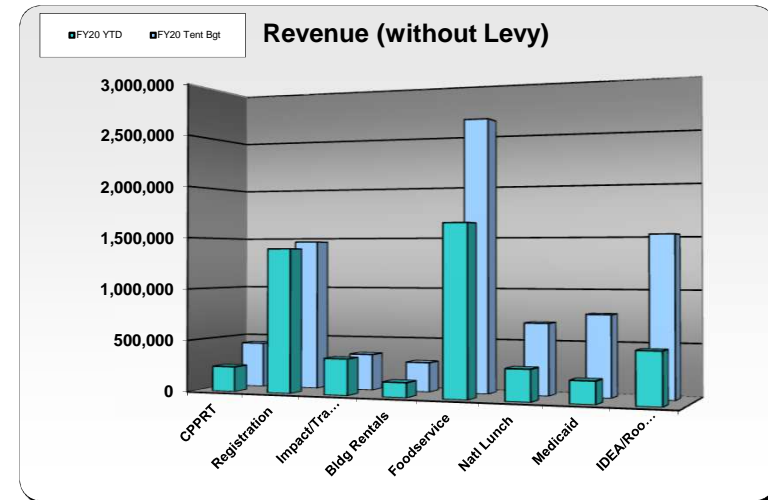

Key Operating Expenditures					
	Prior YTD	FY20 YTD	FY20 Tent Bgt	%	Budget Bal.
Salaries & Benefits	45,295,789	47,224,107	82,428,448	57%	35,204,340
Insurance	5,258,037	5,674,015	9,585,096	59%	3,911,081
Purchased Services	6,118,715	6,222,222	9,962,195	62%	3,739,974
Supplies	3,344,720	3,288,060	10,443,631	31%	7,155,571
Gas & Electric	525,030	517,944	1,139,292	45%	621,348
SpEd Tuition	1,316,038	1,256,819	2,205,000	57%	948,181
Tuition Reimb	116,846	100,085	165,000	61%	64,915
Legal Services	37,822	29,396	100,000	29%	70,604

- Tracking with Budget
- Plus or minus 10 percent of Budget
- Unfavorable budget variance exceeding 10%

Monthly Notes - Expenditures

- ▶ Most expenditures are running consistent with prior year.
- ▶ Salaries and benefits are \$2.0M greater than PY due to increased insurance expense as well as the approximate 4% salary increase.
- ▶ Insurance claims continue to be monitored.

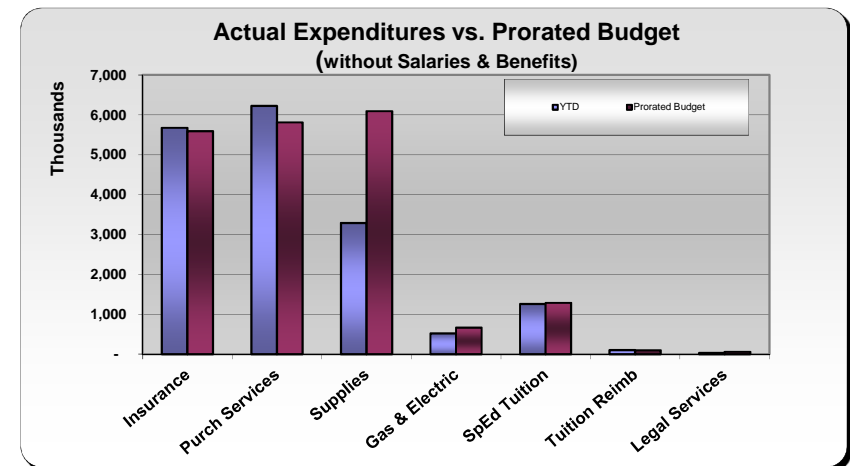

January 2020 Dashboard

Balance Sheet - Cash Flow				
	Prior YTD	FY20 YTD	%	Variance
Cash and Investments	46,123,743	45,676,337	99%	(447,406)
A/R Total	2,254,632	2,240,459	99%	(14,173)
A/R State	1,779,754	1,768,095	99%	(11,659)
Deferred Revenue	70,308,268	72,469,101	103%	2,160,833
Contracts Payable	7,078,035	7,228,892	102%	150,858
Self Insurance Res.	1,919,547	2,158,025	112%	238,478

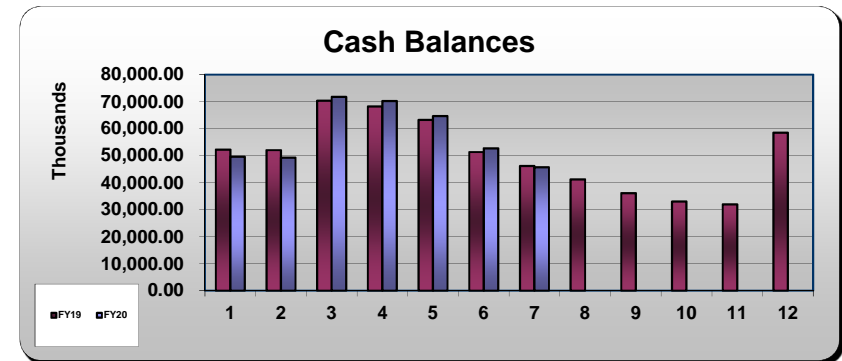

Monthly Notes - Balance Sheet

- ▶ Deferred Revenues are \$2.16M greater than last year due to Levy 2019 recognition.
- ▶ Contracts payable reflect FY20 July and August payrolls.
- ▶ Insurance Fund Reserve was increased in June to reflect actual experience.

FY19 AFR Data				
	FY19	FY18	%	Variance
Fund Balance to Revenue Ratio	0.37	0.37	102%	0.01
Expenditure to Revenue Ratio	0.98	0.98	100%	0.00
Days Cash on Hand	170.82	185.35	92%	(14.53)
Percent Short-Term Borrowing Max Remaining	100.00	100.00	100%	0.00
Percent Long-Term Debt Margin Remaining	54.12	50.12	108%	4.00
ISBE Rating	3.80	3.90	97%	(0.10)
Operating Expense per Pupil	11,439.32	10,570.00	108%	869.32
	RECOGNITION	RECOGNITION		

- ▶ The District continues to improve financially resulting in an ISBE rating of RECOGNITION for FY13 through FY19.
- ▶ The District's Operating Expense per Pupil, utilizing FY17 State Report Card data, continues to be the lowest in McHenry County for all K-12 districts and is well below the State's FY17 Operating Expense per Pupil average of \$13,337.

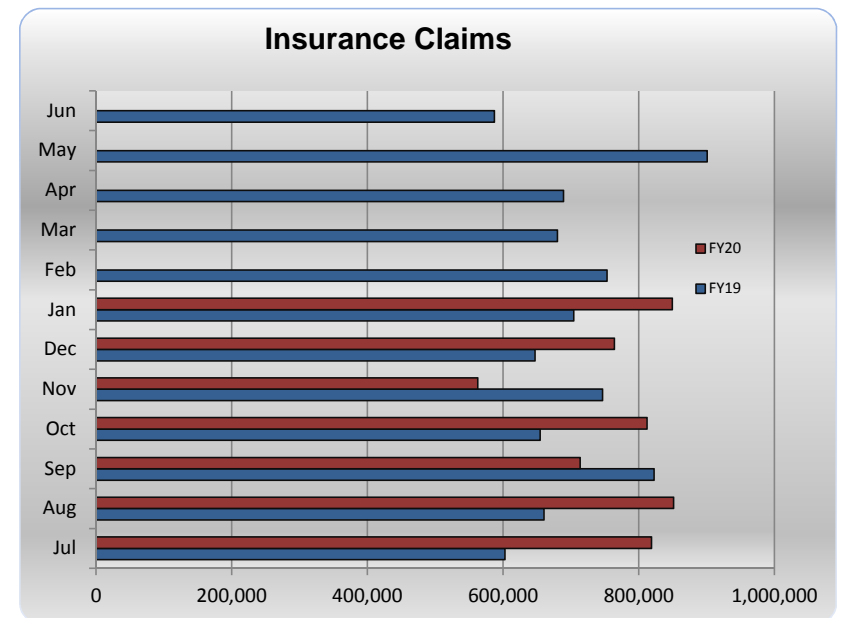

Revenue Report

Printed: 2/14/2020 2:37 PM
Huntley Community School District 158

Educational Fund 10						
Source of Revenue	1000	RECEIPTS/REVENUE FROM LOCAL SOURCES				
Source of Revenue	1100	Designated Levies				
Description	M.T.D. Revenue	Y.T.D. Revenue	Adopted Budget	Budget Bal	% of Budget	Account Number
1100 Designated Levies	4,482,675.00	28,651,677.96	(51,957,300.00)	(23,305,622.04)	55.14	
1200 Payments In Lieu Of Taxes	79,369.59	240,789.56	(309,636.00)	(68,846.44)	77.77	
1300 Tuition	18,425.00	86,589.97	(336,982.02)	(250,392.05)	25.70	
1500 Earnings On Investments	12,793.59	118,050.96	(160,000.00)	(41,949.04)	73.78	
1600 Food Service	273,838.77	1,626,803.81	(2,634,864.18)	(1,008,060.37)	61.88	
1700 District/School Activity Income	12,218.00	322,921.00	(393,613.14)	(70,692.14)	82.04	
1800 Textbook Income	22,973.00	1,389,012.55	(1,461,367.36)	(72,354.81)	94.99	
1900 Other Local Revenues	20,319.27	144,690.05	(2,350,204.70)	(2,205,514.65)	6.16	
1000 RECEIPTS/REVENUE FROM LOCAL SOURCES	4,922,612.22	32,580,535.86	(59,603,967.40)	(27,023,431.54)	54.67	* Source of Revenue
3001 General State Aide	2,485,513.97	14,805,459.87	(22,503,881.00)	(7,698,421.13)	65.79	
3100 Special Education	98,769.46	809,075.56	(1,249,494.04)	(440,418.48)	64.75	
3200 Career And Technical Education (Cte) - Tech Prep	0.00	0.00	(34,058.00)	(34,058.00)	0.00	
3300 Bilingual/StateFreeLunch/Dr Ed	0.00	30,916.38	(67,279.86)	(36,363.48)	45.95	
3500 Transportation - Reg/Voc/SpEd	0.00	0.00	0.00	0.00	0.00	
3700 Early Childhood	0.00	109,301.00	(285,261.02)	(175,960.02)	38.32	
3900 Other State Revenue	0.00	0.00	0.00	0.00	0.00	
3000 RECEIPTS/REVENUE FROM STATE SOURCES	2,584,283.43	15,754,752.81	(24,139,973.92)	(8,385,221.11)	65.26	* Source of Revenue
4100 Title V	0.00	0.00	0.00	0.00	0.00	
4200 Child Nutrition	53,553.69	311,234.10	(705,463.92)	(394,229.82)	44.12	
4300 Title I - Low Income	0.00	0.00	(201,261.00)	(201,261.00)	0.00	
4400 Title IV - Safe And Drug-Free Schools - Formula	0.00	0.00	(13,513.00)	(13,513.00)	0.00	
4620 Federal Special Education - IDEA Flow-Through/ Low	0.00	490,291.40	(1,520,745.14)	(1,030,453.74)	32.24	
4700 CTE	0.00	0.00	(34,345.00)	(34,345.00)	0.00	
4800 Federal - ARRA	0.00	0.00	0.00	0.00	0.00	
4900 Other Restricted Grants Received From Federal	57,625.00	364,063.49	(1,086,893.00)	(722,829.51)	33.50	
4000 RECEIPTS/REVENUE FROM FEDERAL SOURCES	111,178.69	1,165,588.99	(3,562,221.06)	(2,396,632.07)	32.72	* Source of Revenue
7100 Transfers From Various Funds	0.00	0.00	0.00	0.00	0.00	
7200 Proceeds From The Sale Of Bonds	0.00	0.00	0.00	0.00	0.00	
7300 Sale Or Compensation For Loss Of Fixed Assets	0.00	0.00	0.00	0.00	0.00	

Revenue Report

Printed: 2/14/2020 2:37 PM
Huntley Community School District 158

Educational Fund 10						
Source of Revenue	7000	SOURCES OF FUNDS				
Source of Revenue	7400	Transfers From Other Funds To Pay Principal On Cap				
Description	M.T.D. Revenue	Y.T.D. Revenue	Adopted Budget	Budget Bal	% of Budget	Account Number
7400 Transfers From Other Funds To Pay Principal On Cap	0.00	0.00	0.00	0.00	0.00	
7500 Transfers From Other Funds To Pay Interest On Capi	0.00	0.00	0.00	0.00	0.00	
7900 Isbe Loan Proceeds	0.00	0.00	0.00	0.00	0.00	
7000 SOURCES OF FUNDS	0.00	0.00	0.00	0.00	0.00	* Source of Revenue
10 Educational Fund	<u>7,618,074.34</u>	<u>49,500,877.66</u>	<u>(87,306,162.38)</u>	<u>(37,805,284.72)</u>	<u>56.70</u>	Fund

Revenue Report

Printed: 2/14/2020 2:37 PM
Huntley Community School District 158

Operations & Maintenance Fund 20						
Source of Revenue	1000	RECEIPTS/REVENUE FROM LOCAL SOURCES				
Source of Revenue	1100	Designated Levies				
Description	M.T.D. Revenue	Y.T.D. Revenue	Adopted Budget	Budget Bal	% of Budget	Account Number
1100 Designated Levies	693,954.00	4,435,536.44	(8,036,640.00)	(3,601,103.56)	55.19	
1500 Earnings On Investments	14,256.42	122,332.14	(115,000.00)	7,332.14	106.38	
1900 Other Local Revenues	31,121.71	210,688.17	(247,119.00)	(36,430.83)	85.26	
1000 RECEIPTS/REVENUE FROM LOCAL SOURCES	739,332.13	4,768,556.75	(8,398,759.00)	(3,630,202.25)	56.78	* Source of Revenue
3001 General State Aide	0.00	0.00	(4,600,000.00)	(4,600,000.00)	0.00	
3900 Other State Revenue	0.00	0.00	0.00	0.00	0.00	
3000 RECEIPTS/REVENUE FROM STATE SOURCES	0.00	0.00	(4,600,000.00)	(4,600,000.00)	0.00	* Source of Revenue
4500	0.00	0.00	0.00	0.00	0.00	
4900 Other Restricted Grants Received From Federal	0.00	0.00	0.00	0.00	0.00	
4000 RECEIPTS/REVENUE FROM FEDERAL SOURCES	0.00	0.00	0.00	0.00	0.00	* Source of Revenue
7200 Proceeds From The Sale Of Bonds	0.00	0.00	0.00	0.00	0.00	
7300 Sale Or Compensation For Loss Of Fixed Assets	0.00	0.00	0.00	0.00	0.00	
7900 Isbe Loan Proceeds	0.00	0.00	0.00	0.00	0.00	
7000 SOURCES OF FUNDS	0.00	0.00	0.00	0.00	0.00	* Source of Revenue
20 Operations & Maintenance Fund	739,332.13	4,768,556.75	(12,998,759.00)	(8,230,202.25)	36.68	Fund

Revenue Report

Printed: 2/14/2020 2:37 PM
Huntley Community School District 158

Debt Service Fund or Fund Group 30						
Source of Revenue	1000	RECEIPTS/REVENUE FROM LOCAL SOURCES				
Source of Revenue	1100	Designated Levies				
Description	M.T.D. Revenue	Y.T.D. Revenue	Adopted Budget	Budget Bal	% of Budget	Account Number
1100 Designated Levies	929,729.00	5,559,619.14	(10,014,138.00)	(4,454,518.86)	55.52	
1500 Earnings On Investments	17,752.24	152,348.28	(140,000.00)	12,348.28	108.82	
1900 Other Local Revenues	0.00	0.00	0.00	0.00	0.00	
1000 RECEIPTS/REVENUE FROM LOCAL SOURCES	947,481.24	5,711,967.42	(10,154,138.00)	(4,442,170.58)	56.25	* Source of Revenue
7100 Transfers From Various Funds	0.00	0.00	0.00	0.00	0.00	
7200 Proceeds From The Sale Of Bonds	0.00	0.00	0.00	0.00	0.00	
7400 Transfers From Other Funds To Pay Principal On Cap	0.00	0.00	0.00	0.00	0.00	
7500 Transfers From Other Funds To Pay Interest On Capi	0.00	0.00	0.00	0.00	0.00	
7600 Transfers From Other Funds To Pay Principal On Rev	0.00	0.00	0.00	0.00	0.00	
7700 Transfers From Other Funds To Pay Interest On Reve	0.00	0.00	0.00	0.00	0.00	
7900 Isbe Loan Proceeds	0.00	0.00	0.00	0.00	0.00	
7000 SOURCES OF FUNDS	0.00	0.00	0.00	0.00	0.00	* Source of Revenue
30 Debt Service Fund or Fund Group	947,481.24	5,711,967.42	(10,154,138.00)	(4,442,170.58)	56.25	Fund

Revenue Report

Printed: 2/14/2020 2:37 PM
Huntley Community School District 158

Transportation Fund 40						
Source of Revenue	1000	RECEIPTS/REVENUE FROM LOCAL SOURCES				
Source of Revenue	1100	Designated Levies				
Description	M.T.D. Revenue	Y.T.D. Revenue	Adopted Budget	Budget Bal	% of Budget	Account Number
1100 Designated Levies	180,973.00	1,156,731.72	(2,730,583.00)	(1,573,851.28)	42.36	
1400 Transportation Fees	1,320.00	5,755.36	(69,699.93)	(63,944.57)	8.26	
1500 Earnings On Investments	5,481.76	47,346.66	(65,000.00)	(17,653.34)	72.84	
1900 Other Local Revenues	0.00	0.00	0.00	0.00	0.00	
1000 RECEIPTS/REVENUE FROM LOCAL SOURCES	187,774.76	1,209,833.74	(2,865,282.93)	(1,655,449.19)	42.22	* Source of Revenue
3500 Transportation - Reg/Voc/SpEd	273,386.10	1,957,850.27	(3,270,000.00)	(1,312,149.73)	59.87	
3000 RECEIPTS/REVENUE FROM STATE SOURCES	273,386.10	1,957,850.27	(3,270,000.00)	(1,312,149.73)	59.87	* Source of Revenue
7300 Sale Or Compensation For Loss Of Fixed Assets	0.00	0.00	0.00	0.00	0.00	
7900 Isbe Loan Proceeds	0.00	0.00	0.00	0.00	0.00	
7000 SOURCES OF FUNDS	0.00	0.00	0.00	0.00	0.00	* Source of Revenue
40 Transportation Fund	461,160.86	3,167,684.01	(6,135,282.93)	(2,967,598.92)	51.63	Fund

Revenue Report

Printed: 2/14/2020 2:37 PM
Huntley Community School District 158

Municipal Retirement and Social Security Fund 50						
Source of Revenue	1000	RECEIPTS/REVENUE FROM LOCAL SOURCES				
Source of Revenue	1100	Designated Levies				
Description	M.T.D. Revenue	Y.T.D. Revenue	Adopted Budget	Budget Bal	% of Budget	Account Number
1100 Designated Levies	241,357.00	1,542,676.14	(2,825,783.00)	(1,283,106.86)	54.59	
1200 Payments In Lieu Of Taxes	0.00	0.00	(126,802.00)	(126,802.00)	0.00	
1500 Earnings On Investments	5,170.90	44,407.90	(40,000.00)	4,407.90	111.02	
1000 RECEIPTS/REVENUE FROM LOCAL SOURCES	246,527.90	1,587,084.04	(2,992,585.00)	(1,405,500.96)	53.03	* Source of Revenue
50 Municipal Retirement and Social Security Fund	246,527.90	1,587,084.04	(2,992,585.00)	(1,405,500.96)	53.03	Fund

Revenue Report

Printed: 2/14/2020 2:37 PM
Huntley Community School District 158

Capital Projects Fund or Fund Group 60						
Source of Revenue	1000	RECEIPTS/REVENUE FROM LOCAL SOURCES				
Source of Revenue	1500	Earnings On Investments				
Description	M.T.D. Revenue	Y.T.D. Revenue	Adopted Budget	Budget Bal	% of Budget	Account Number
1500 Earnings On Investments	3,259.18	27,495.24	(15,000.00)	12,495.24	183.30	
1900 Other Local Revenues	76,436.00	346,637.42	(200,000.00)	146,637.42	173.32	
1000 RECEIPTS/REVENUE FROM LOCAL SOURCES	79,695.18	374,132.66	(215,000.00)	159,132.66	174.02	* Source of Revenue
3900 Other State Revenue	0.00	0.00	0.00	0.00	0.00	
3000 RECEIPTS/REVENUE FROM STATE SOURCES	0.00	0.00	0.00	0.00	0.00	* Source of Revenue
7100 Transfers From Various Funds	0.00	0.00	0.00	0.00	0.00	
7200 Proceeds From The Sale Of Bonds	0.00	0.00	0.00	0.00	0.00	
7300 Sale Or Compensation For Loss Of Fixed Assets	0.00	0.00	0.00	0.00	0.00	
7900 Isbe Loan Proceeds	0.00	0.00	0.00	0.00	0.00	
7000 SOURCES OF FUNDS	0.00	0.00	0.00	0.00	0.00	* Source of Revenue
60 Capital Projects Fund or Fund Group	79,695.18	374,132.66	(215,000.00)	159,132.66	174.02	Fund

Revenue Report

Printed: 2/14/2020 2:37 PM
Huntley Community School District 158

Working Cash Fund 70						
Source of Revenue	1000	RECEIPTS/REVENUE FROM LOCAL SOURCES				
Source of Revenue	1100	Designated Levies				
Description	M.T.D. Revenue	Y.T.D. Revenue	Adopted Budget	Budget Bal	% of Budget	Account Number
1100 Designated Levies	34,130.00	218,154.69	(399,566.00)	(181,411.31)	54.60	
1500 Earnings On Investments	1,139.64	10,621.33	(15,000.00)	(4,378.67)	70.81	
1000 RECEIPTS/REVENUE FROM LOCAL SOURCES	35,269.64	228,776.02	(414,566.00)	(185,789.98)	55.18	* Source of Revenue
70 Working Cash Fund	35,269.64	228,776.02	(414,566.00)	(185,789.98)	55.18	Fund

Revenue Report

Printed: 2/14/2020 2:37 PM
Huntley Community School District 158

Fire Prevention and Safety Fund or Fund Group 90						
Source of Revenue	1000	RECEIPTS/REVENUE FROM LOCAL SOURCES				
Source of Revenue	1100	Designated Levies				
Description	M.T.D. Revenue	Y.T.D. Revenue	Adopted Budget	Budget Bal	% of Budget	Account Number
1100 Designated Levies	0.00	0.00	0.00	0.00	0.00	
1500 Earnings On Investments	4.47	47.07	(300.00)	(252.93)	15.69	
1000 RECEIPTS/REVENUE FROM LOCAL SOURCES	4.47	47.07	(300.00)	(252.93)	15.69	* Source of Revenue
90 Fire Prevention and Safety Fund or Fund Group	4.47	47.07	(300.00)	(252.93)	15.69	Fund
Report Total:	<u>10,127,545.76</u>	<u>65,339,125.63</u>	<u>(120,216,793.31)</u>	<u>(54,877,667.68)</u>	<u>54.35</u>	

Expenditure Report - Board of Education

Printed: 2/10/2020 3:35 PM
Huntley Community School District 158

Educational Fund 10								
Function	1000	INSTRUCTION						
Object	100	SALARIES						
Description	M.T.D. Activity	Y.T.D. Activity	Open Enc	Adopted Budget	Budget Balance	% of Budget	Account Number	
100 SALARIES	3,670,408.65	25,720,445.52	0.00	45,389,335.28	19,671,963.09	56.66		
200 EMPLOYEE BENEFITS	767,948.15	4,415,997.70	1,296,553.29	8,185,995.01	2,456,944.02	69.99		
300 PURCHASED SERVICES	96,780.05	787,081.73	117,257.92	1,175,002.24	332,898.06	73.28		
400 SUPPLIES & MATERIALS	70,664.36	777,183.31	122,655.51	4,390,072.96	3,352,390.13	21.68		
500 CAPITAL OUTLAY	21,575.30	28,891.30	19,008.58	26,000.00	(15,199.88)	146.48		
600 OTHER OBJECTS	1,775.00	13,023.00	673.41	17,994.94	4,298.53	76.11		
700 NON-CAPITALIZED EQUIPMENT	2,244.76	22,475.31	6,555.75	61,294.15	26,265.09	57.15		
1000 INSTRUCTION	4,631,396.27	31,765,097.87	1,562,704.46	59,245,694.58	25,829,559.04	56.38	* Function	
100 SALARIES	1,457,389.19	10,334,282.54	0.00	17,007,953.08	6,683,670.54	60.73		
200 EMPLOYEE BENEFITS	326,458.61	1,780,964.56	34,942.95	2,734,065.05	906,633.32	66.84		
300 PURCHASED SERVICES	195,512.92	2,419,663.52	382,052.80	3,572,592.65	831,287.80	77.38		
400 SUPPLIES & MATERIALS	183,233.30	1,258,463.03	829,634.85	3,530,193.35	1,489,022.74	58.48		
500 CAPITAL OUTLAY	0.00	0.00	0.00	40,000.00	40,000.00	0.00		
600 OTHER OBJECTS	1,870.59	59,195.59	4,321.00	94,584.62	32,773.03	65.98		
700 NON-CAPITALIZED EQUIPMENT	0.00	50,407.97	985.00	25,446.63	(24,946.34)	194.33		
2000 SUPPORT SERVICES	2,164,464.61	15,902,977.21	1,251,936.60	27,004,835.38	9,958,441.09	63.36	* Function	
100 SALARIES	0.00	0.00	0.00	23,000.00	23,000.00	0.00		
300 PURCHASED SERVICES	0.00	24,091.46	0.00	1,497.00	1,430.93	94.40		
400 SUPPLIES & MATERIALS	1,098.72	5,888.95	339.00	10,200.00	5,972.05	51.05		
3000 COMMUNITY SERVICES	1,098.72	29,980.41	339.00	34,697.00	30,402.98	49.96	* Function	
300 PURCHASED SERVICES	20,000.00	23,037.50	7,000.00	10,000.00	6,887.50	81.39		
600 OTHER OBJECTS	207,484.84	1,256,818.63	404,537.96	2,205,000.00	480,799.43	78.20		
4000 PAYMENTS TO OTHER DISTRICTS AND GOVERNMENTAL UNITS	227,484.84	1,279,856.13	411,537.96	2,215,000.00	487,686.93	78.25	* Function	
10 Educational Fund	7,024,444.44	48,977,911.62	3,226,518.02	88,500,226.96	36,306,090.04	59.07	Fund	

115

Expenditure Report - Board of Education

Printed: 2/10/2020 3:35 PM
Huntley Community School District 158

Operations & Maintenance Fund 20								
Function	2000	SUPPORT SERVICES						
Object	100	SALARIES						
Description	M.T.D. Activity	Y.T.D. Activity	Open Enc	Adopted Budget	Budget Balance	% of Budget	Account Number	
100 SALARIES	108,991.94	874,935.00	0.00	1,360,508.32	485,573.32	64.31		
200 EMPLOYEE BENEFITS	(6,380.09)	91,217.08	0.00	219,665.60	128,448.52	41.53		
300 PURCHASED SERVICES	291,161.98	2,251,316.12	844,717.94	4,386,104.64	1,182,530.86	73.04		
400 SUPPLIES & MATERIALS	107,861.34	806,860.24	234,865.71	1,726,889.63	677,620.84	60.76		
500 CAPITAL OUTLAY	0.00	205,686.04	419,857.55	3,212,521.00	2,586,977.41	19.47		
600 OTHER OBJECTS	0.00	870.00	750.00	3,366.00	1,746.00	48.13		
2000 SUPPORT SERVICES	501,635.17	4,230,884.48	1,500,191.20	10,909,055.19	5,062,896.95	53.59	*	Function
600 OTHER OBJECTS	156,293.75	153,240.31	0.00	166,315.00	13,074.69	92.14		
5000 DEBT SERVICE	156,293.75	153,240.31	0.00	166,315.00	13,074.69	92.14	*	Function
20 Operations & Maintenance Fund	657,928.92	4,384,124.79	1,500,191.20	11,075,370.19	5,075,971.64	54.17		Fund

Expenditure Report - Board of Education

Printed: 2/10/2020 3:35 PM
Huntley Community School District 158

Debt Service Fund or Fund Group 30							
Function	5000	DEBT SERVICE					
Object	600	OTHER OBJECTS					
Description	M.T.D. Activity	Y.T.D. Activity	Open Enc	Adopted Budget	Budget Balance	% of Budget	Account Number
600 OTHER OBJECTS	1,260,248.50	10,252,883.00	1,557.18	10,765,103.00	510,662.82	95.26	
5000 DEBT SERVICE	1,260,248.50	10,252,883.00	1,557.18	10,765,103.00	510,662.82	95.26	* Function
30 Debt Service Fund or Fund Group	1,260,248.50	10,252,883.00	1,557.18	10,765,103.00	510,662.82	95.26	Fund

Expenditure Report - Board of Education

Printed: 2/10/2020 3:35 PM
Huntley Community School District 158

Transportation Fund 40								
Function	2000	SUPPORT SERVICES						
Object	100	SALARIES						
Description	M.T.D. Activity	Y.T.D. Activity	Open Enc	Adopted Budget	Budget Balance	% of Budget	Account Number	
100 SALARIES	247,341.98	1,691,906.13	0.00	3,057,614.41	1,365,708.28	55.33		
200 EMPLOYEE BENEFITS	(12,912.25)	630,549.12	0.00	1,462,994.98	832,445.86	43.10		
300 PURCHASED SERVICES	38,030.86	717,031.37	67,390.66	816,998.84	30,094.93	96.32		
400 SUPPLIES & MATERIALS	56,746.09	439,664.89	114,430.04	786,275.32	174,473.47	77.81		
500 CAPITAL OUTLAY	0.00	0.00	0.00	1,000,000.00	1,000,000.00	0.00		
600 OTHER OBJECTS	0.00	8,342.40	3,988.65	4,944.11	(7,386.94)	249.41		
2000 SUPPORT SERVICES	329,206.68	3,487,493.91	185,809.35	7,128,827.66	3,395,335.60	52.37	*	Function
40 Transportation Fund	329,206.68	3,487,493.91	185,809.35	7,128,827.66	3,395,335.60	52.37		Fund

Expenditure Report - Board of Education

Printed: 2/10/2020 3:35 PM
Huntley Community School District 158

Municipal Retirement and Social Security Fund 50								
Function	1000	INSTRUCTION						
Object	200	EMPLOYEE BENEFITS						
Description	M.T.D. Activity	Y.T.D. Activity	Open Enc	Adopted Budget	Budget Balance	% of Budget	Account Number	
200 EMPLOYEE BENEFITS	96,573.85	634,918.18	0.00	1,218,178.06	583,259.88	52.12		
1000 INSTRUCTION	96,573.85	634,918.18	0.00	1,218,178.06	583,259.88	52.12	*	Function
200 EMPLOYEE BENEFITS	159,685.92	1,048,891.60	0.00	1,769,138.13	720,246.53	59.29		
2000 SUPPORT SERVICES	159,685.92	1,048,891.60	0.00	1,769,138.13	720,246.53	59.29	*	Function
50 Municipal Retirement and Social Security Fund	256,259.77	1,683,809.78	0.00	2,987,316.19	1,303,506.41	56.37	Fund	

Expenditure Report - Board of Education

Printed: 2/10/2020 3:35 PM
Huntley Community School District 158

Capital Projects Fund or Fund Group 60								
Function	2000	SUPPORT SERVICES						
Object	300	PURCHASED SERVICES						
Description	M.T.D. Activity	Y.T.D. Activity	Open Enc	Adopted Budget	Budget Balance	% of Budget	Account Number	
300	PURCHASED SERVICES	5,586.64	46,597.05	17,278.97	550,000.00	480,534.75	12.63	
500	CAPITAL OUTLAY	495,165.24	1,146,435.76	3,060,715.00	3,884,958.00	(322,192.76)	108.29	
2000	SUPPORT SERVICES	500,751.88	1,193,032.81	3,077,993.97	4,434,958.00	158,341.99	96.43	* Function
600	OTHER OBJECTS	235,562.50	714,651.43	0.00	714,728.00	76.57	99.99	
5000	DEBT SERVICE	235,562.50	714,651.43	0.00	714,728.00	76.57	99.99	* Function
60	Capital Projects Fund or Fund Group	736,314.38	1,907,684.24	3,077,993.97	5,149,686.00	158,418.56	96.92	Fund
Report Total:		<u>10,264,402.69</u>	<u>70,693,907.34</u>	<u>7,992,069.72</u>	<u>125,606,530.00</u>	<u>46,749,985.07</u>	<u>62.84</u>	



Huntley Community School District 158

650 Dr. John Burkey Drive
Algonquin, Illinois 60102
(847) 659-6158 • www.district158.org

To: Board of Education and Administration

From: Anna Meyer, Administrative Assistant

Date: March 5, 2020

Subject: **Revenue Contract Approval**
Committee of the Whole Meeting – March 5, 2020
Finance Committee

Presented are Fundraising Contract and Agreement form for the organization listed below.

<u>Organization Benefited</u>	<u>Vendor</u>	<u>Net Revenue</u>
HHS Boys Volleyball	Lou Malnatis	\$1,300
HHS Girls Soccer	Adrenaline Fundraising	\$6,000

RECOMMENDATION

Administration requests that the Finance Committee recommends the Board of Education approve the contracts and agreements form at the March 19, 2020 Regular Board Meeting.

Fund Raising Authorization Form
Fiscal Services

All fund raising activities for school organizations require pre-approval. Please complete this form **in its entirety** and submit the form to your building principal a minimum of **45 days prior** to the desired starting date of the event. The Principal will then forward all documents to the Chief Financial Officer.

Today's Date: 2/19/20 School: HHS

Name of School Organization: Boys Volleyball

Sponsor / Coach's Name: Gerry Marchand Phone: 6552

Starting Date of Event: 4/6 Ending Date of Event: 4/10

Anticipated Revenue and Approximate Value of Non-Monetary Items/Compensation: \$ 1,300.00

Type of Sale / Event: Selling Lou Malnati's frozen pizza cards ✓

Will a Vendor Be Used: Yes* No * *Attach all contracts and agreements to this form.*

Name of Vendor (if applicable): Lou Malnati's (Lakewood)

Type of Product or Service Provided by Vendor: Frozen pizza

How will compensation be used/distributed? Purchase apparel and equipment

Name of Activity Account: HS Boys VB Activity Account #: 573

Submit completed forms with attachments to the Chief Financial Officer. A signed copy will be returned to you indicating approval or non-approval for fundraisers which require Board approval (over \$1,000).

[Signature]
Sponsor Signature

2/19/20
Date

[Signature]
Principal Signature – *I certify that it is a minimum of 45 days prior to the desired starting date of the event*

2/19/20
Date

[Signature]
Chief Financial Officer Signature

Date

* Public Act 94-0714 requires all contracts and agreements that pertain to goods and services that are intended to generate additional revenue and other remunerations for the school district in excess of \$1,000.00 be approved by the school board.

Superintendent's Copy Fiscal Services Copy

Date of Board Approval: _____

Crowdfunding Authorization Form

Fiscal Services

All crowdfunding activities require pre-approval. Crowdfunding services must have at least a three-star rating on Charity Navigator. Please complete this form **in its entirety** and submit the form to your building principal a minimum of **30 days prior** to posting the event online. The Principal will then forward all documents to the Chief Financial Officer.

Requesting Authorization for: Crowdfunding Other _____

Today's Date: 2/20/2020 School: Huntley High School

Name of School Organization: Girls Soccer

Sponsor / Teacher / Coach's Name: Matt Lewandowski Phone: 3/27/2020

Starting Date of Event: 3/13/2020 Ending Date of Event: _____

Anticipated Revenue and Approximate Value of Non-Monetary Items/Compensation: \$ 10,000

Describe Sale/Event: Crowdfunding

Will a Vendor Be Used: Yes* No * Attach all contracts and agreements to this form.

Name of Vendor (if applicable): Adrenaline Fundraising

Type of Product or Service Provided by Vendor: Crowdfunding

Name of Crowdfunding Platform (if applicable): WeFund4U

Crowdfunding Platform Website (if applicable): We Fund 4 U

How will compensation be used/distributed? Equipment & Uniforms

Name of Activity Account: HHS Soccer Activity Account #: _____

Submit completed forms with attachments to the Chief Financial Officer. A signed copy will be returned to you indicating approval / non-approval for crowdfunding events over \$1,000 which require Board approval.

[Signature]
Sponsor Signature

2/20/20
Date

[Signature]
Principal Signature - *certify that it is a minimum of 30 days prior to posting online*

2.24.20
Date

[Signature]
Chief Financial Officer Signature

Date

* Public Act 94-0714 requires all contracts and agreements that pertain to goods and services that are intended to generate additional revenue and other remunerations for the school district in excess of \$1,000.00 be approved by the school board.

Superintendent's Copy Fiscal Services Copy Building Principal / Sponsor / Teacher / Coach's Copy Date of Board Approval: _____



Huntley Community School District 158

650 Dr. John Burkey Drive
 Algonquin, Illinois 60102
 (847) 659-6158 • www.district158.org

To: Board of Education and Administration

From: Extracurricular Committee
 Mark Altmayer, CFO

Date: March 5, 2020

Subject: **2020-2021 Extracurricular Committee recommendations**
 Committee of the Whole Meeting, March 5, 2020
 Finance Committee

The Huntley Extra-Curricular Committee (ECC) continues to follow the current HEA collective bargaining agreement. One of the annual tasks assigned to the ECC is to review the extracurricular stipend schedules, work with their teams and coaches and recommend where additional stipend positions would be needed. In early January, the team met and evaluated the recommended positions. All positions were then ranked and prioritized based upon student safety, enhancement to curriculum, and overall benefit to the students and District. As done in prior years, the ECC ranked all positions by tier, Tiers I-II. Furthermore, the ECC updated analysis outlining the District’s athletic stipends and where we stand versus the average stipends paid. This analysis will continue to be reviewed by the Committee and shared with Administration.

Below, are the Tier I and Tier II recommendations by the Committee.

Tiered Additional Stipends

The following Tiered stipends are stipends that the ECC is recommending. For further information, please see the Description and Notes under each Club/Activity/Athletic recommendation. That being said, Administration and the Board of Education need to take into account the uncertainty of the State budget, the District’s financials as well as the impact of future collective bargaining.

Tier I Recommended - Athletic							
Club/Athletic Activity	School	# Students	# Positions	Recommended Tier	Recommended Starting Lane	Recommended Starting Dollars \$	Description / Notes
HS Cheer (2nd Season)	HHS	100+	1 Head, 3 Asst	Tier 1	Athletics Category C/AC	\$12,728	Per IHSA, Cheer listed as both a competitive sport in the winter season and as a non-competitive activity in the Fall Season. Currently, Cheer is paid an athletic stipend in the winter season, but the Cheerleading coaches are not paid an athletic or activity stipend in the Fall under the current contract. Per review of the FVC, all schools pay two stipends, covering both seasons. Cheer is paid under Group B as a competitive IHSA sport for the Winter. The recommendation is to pay them under Group C for the Fall season (\$3.8k HC and \$2.9k AC).
Track & Field - Indoor Season	HHS	100+	2 Head, 8 Asst	Tier I	Category C/AC	\$31,352	Currently, with the addition of the fieldhouse, Track & Field (T&F) here at Huntley has 2 distinct seasons, indoor and outdoor. Since the addition of the Fieldhouse, a significant number of meets were added to the schedule, creating additional opportunities for our T&F students. The track season is one of the longest seasons of any IHSA sport. Per review of the FVC, for those districts that do have fieldhouses, 2 stipends are currently being paid. T&F is paid under Group B as a competitive IHSA sport for the Spring. The recommendation is to pay them under Group C for both the indoor (Winter) and outdoor (Spring) seasons. Under the current contract, and moving from B to C, the starting stipend for the Head Coach would go from a \$4.4k to \$7.7k.
						124	\$44,080



Huntley Community School District 158

650 Dr. John Burkey Drive
 Algonquin, Illinois 60102
 (847) 659-6158 • www.district158.org

Tier I-II Recommended							
Club/Athletic Activity	School	# Students	Club Started	Tier	Recommended Starting Lane	Starting Dollars \$	Description / Notes
MS Chamber Orchestra	HMS - MMS	15-20	2 or more years ago	Tier 1	Category D	\$1,481	Both Schools - Chamber Orchestra is an open and welcoming environment for students of all ability levels to practice instrumental skills and techniques. The club will cultivate individualized learning through a variety of musical activities and practice techniques.
Orchestra Director	HHS	40	3 or more years ago	Tier I	Category B	\$2,433	The D158 Orchestra Program started in the Middle Schools and is now fully implemented at the High School Level. The High School Orchestra performs a concert each quarter, as well as other informal performances throughout the year. The Orchestra Director is expected to maintain all necessary equipment, build the high school orchestra library, and recruit and retain students to the program.
Police Explorers	MMS	15	3 or more years ago	Tier 1	Category E	\$1,058	The Junior Police Explorers Club is an opportunity for 6-8th graders to see, hear, and experience, some of the skills and tools police officers use in their role as community protector. Many of the members go on to participate in the High School group. Students have hands on interaction with communication devices, strategies, and codes. Evidence gathering equipment (fingerprints, LIDAR, and RADAR). Protective equipment (vests and shields). Patrol vehicles. Students also learn basic tactics and strategies for emergency or confrontational situations. There is physical training as well.
Middle School Ski Club	HMS	40	2 or more years ago	Tier 1	Category E	\$1,058	The Heineman Snow Hawks Club is modeled after the HHS Snow Raiders Club in that it provides the opportunity for students to ski and snowboard. All skill levels are welcome and encouraged to join the group. Sponsors foster a love for the sport by positively encouraging students of all abilities.
Elementary Choir	Conley/Martin	20+	Current Year	Tier 1	Category E	\$2,116	D158 Elementary level Choir fosters a safe and welcoming space for students of all ability levels to develop self-expression and collaborative learning through the performance and practice of choral singing.
Gay Straight Alliance (GSA)	HHS - HMS - MMS	15	3 or more years ago	Tier I	Category F	\$2,145	Gay Straight Alliance is an organization designed to inform, educate, and support all students, regardless of sexual orientation. We believe in a safe and friendly learning environment where everyone is accepted and treated as equals. Our GSA allows students to gain a deeper understanding of a variety of LGBTQ+ topics through an interactive platform. All students are welcome and encouraged to take part in expanding the minds of tomorrow's future by creating a progressive culture for today's youth
Technical Theater Club	HHS	50 (On Average per year)	3 or more years ago	Tier I	Category D	\$1,481	Tech Theater Club provides technical services / labor to both district and community events. In addition, students learn technical skills by "doing" and gain real-life production experience. Without the Tech Theater Club, many events in the PAC would not be possible.
Disc Golf	Conley	120+ 40-50 per grade	2 or more years ago	Tier I	Category G	\$500	The interest in this club has skyrocketed, and has resulted in the need of an additional coach for the purpose of safety and supervision.
Engineering Club	HHS	60+	3 or more years ago	Tier I	Category E	\$1,058	The interest in this club has increased, and has resulted in the need of an additional coach.
Model United Nations	HHS	13	3 or more years ago	Tier II	Category E	\$1,058	Help students understand the United Nations and international issues facing the nations involved through mock debates using the perspectives of their assigned nations. To engage students in international issues and grow responsible and critical thinking global citizens.
Anime Club	HHS	30	3 or more years ago	Tier II	Category G	\$500	Club to discuss and watch anime
						\$14,888	

RECOMMENDATION

The Extracurricular Committee recommends the Board of Education approve the additional extracurricular stipends as noted above at the March 19, 2020 Regular Board meeting.



Huntley Community School District 158

650 Academic Drive
Algonquin, Illinois 60102
(847) 659-6158 • www.district158.org

Date: March 5, 2020
To: Board of Education
From: Adam Zehr, Assistant Superintendent for Human Resources
Subject: Human Resources Updates

During the month of February Human Resources' primary projects included:

- Processing of new hires and or resignations
- Processing mid-year lane changes
- Completing and posting HEA and HESPA Seniority Reports
- Collecting and recording of non-tenure evaluations
- Determining non-renewals for FY21
- Continue staff resource planning for FY21
- Complete Honorable Dismissal List

Specific tasks to address for the month of March:

- Processing non-renewals, non-renewal of extra- curricular assignments, non-renewal of extra days for certified staff
- Collection of administrative evaluations
- Continue to review staffing levels in comparison with enrollment for FY21
- Submission of Honorable Dismissal sequence list to HEA

Updates

Pursuant to Section 24-12 of the Illinois School Code, the Board of Education is required to provide a written Notice of Non-Renewal and Dismissal by certified mail return receipt requested, at least forty-five (45) days before the end of the school term.

Huntley Community School District 158 does not recognize automatic renewals for extra-curricular assignments, thus pursuant to Section 24-12 of the State Code, the Board of Education is required to provide a written notice at least forty-five (45) days before the end of the school term. These will be listed on the Personnel report at the March 19, 2020 Regular Board Meeting.

As required by Senate Bill 7, Human Resources will be required to complete a sequence of honorable dismissal list categorized by positions and with groupings. This list is required to be delivered to the HEA leadership seventy-five (75) calendar days before the end of the school term. This year the list is due March 6, 2020.

Pursuant to Section 24-12 of the Illinois School Code notification to the employees who are part of a reduction in force will occur by April 7, 2020 with Board action occurring on March 19, 2020.



Huntley Community School District 158

650 Academic Drive
Algonquin, Illinois 60102
(847) 659-6158 • www.district158.org

Date: March 5, 2020
To: Human Resources Committee
From: Adam Zehr, Assistant Superintendent of Human Resources
Re: Reduction of Extra Contract Days

Each year the Board of Education must take action to reduce contract days to reflect the base standard days of the HEA Collective Bargaining Agreement for the upcoming school year. Currently, there are several positions that have extra days beyond the 182 of the standard contract. These individuals will be listed on the March 19, 2020 Personnel Report, as well as on Exhibit #1 of Resolution (#2020-03-01).

Per the school code, any reductions or eliminations of days must be approved by the Board of Education within 45 days of the last day of the school year. An evaluation of the staffing needs will be completed and any recommendation for additional days for the 2020-2021 school year will be presented to the Board of Education for approval.

Recommendation

It is recommended that the Human Resources Committee recommend to the Board of Education the elimination of all extra contract days outside of the standard 182 days.



Huntley Community School District 158

650 Dr. John Burkey Drive
Algonquin, Illinois 60102
(847) 659-6158 • www.district158.org

February 12, 2020

The Board of Education of Huntley Community School District 158 ("Board") and the Huntley Educational Support Personnel Association ("HESPA"), in order to clarify the language of the HESPA collective bargaining agreement 2019-2022 have agreed to the following changes to the language of Section 7.02 Probationary Employees:

Section 7.02 Probationary Employees

All new employees shall be employed under probationary status for the first ninety (90) ~~day working period~~ working days. Employees shall have no seniority until completion of a ninety (90) working day probationary period, which can be extended by another ninety (90) working days at the discretion of the Administration, at which time their seniority shall revert to their first day of work. Any time during this period, a probationary employee can be discharged "at will" without recourse or regard to any other provisions in this Agreement, including being prohibited from using the Grievance Procedure for discharge.

Formatted: Not Strikethrough

This Memorandum of Understanding will take effect upon Board approval. This Memorandum shall expire on the date of the current bargaining agreement in effect between the parties, at which time it shall become the replacement for Section 7.02 of the HESPA collective bargaining agreement.

Tammra Fabis – HESPA President

Michael Fleck – CSD158 Board of Education President

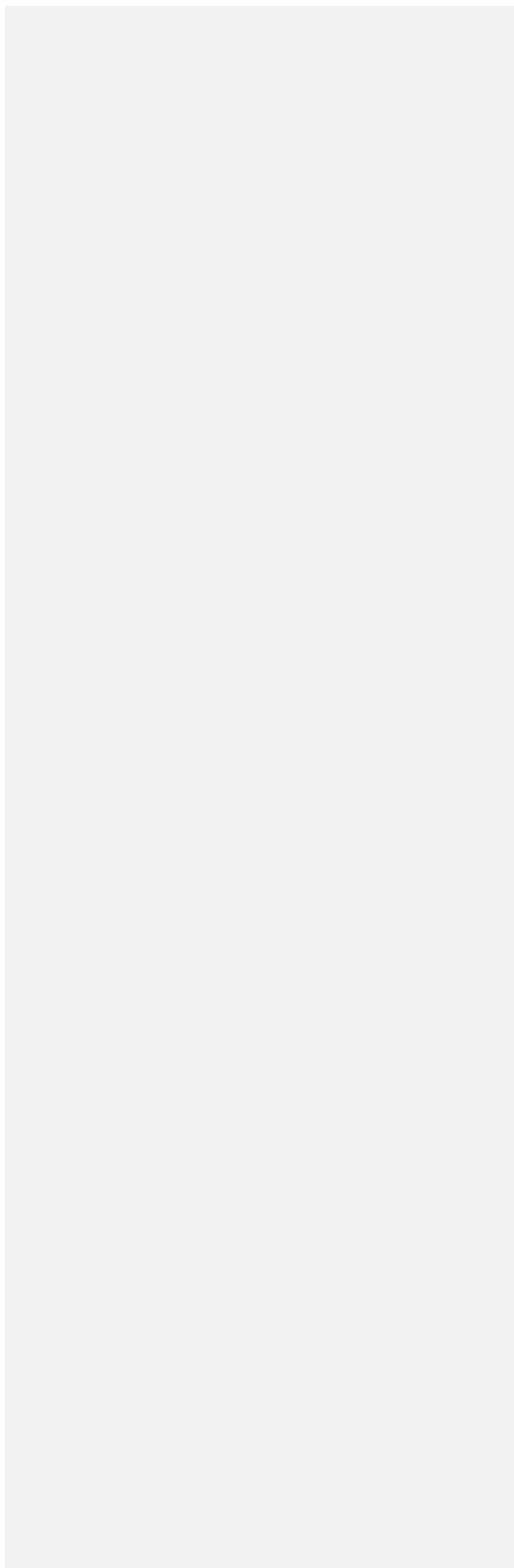



Huntley Community School District 158

650 Academic Drive
Algonquin, Illinois 60102
(847) 659-6158 • www.district158.org

DATE: March 5, 2020
TO: Board of Education
FROM: Doug Renkosik, Director of Operations & Maintenance
RE: O & M Updates(**R**)
Building and Grounds Committee
Committee of the Whole, March 5, 2020

Tasks Completed in February 2020

1. Coordinated many small projects on the FY20 O&M Deferred Maintenance Capital Projects.
2. Lead the District towards development of Solar PV Installation Project with our partner; ForeFront Power, who will be installing a renewable energy system which could generate up to 80% of the School District's annually consumed power. Highlights of project status include:
 - Zoning reviews with the three Villages (;LITH, Algonquin, and Huntley) are completed.
 - All nine ComEd Interconnect Agreements are approved.
 - Forefront's applications for Renewable Energy Credits have been approved by the Illinois Power Agency, the Illinois Commerce Commission, and ComEd.
 - District 158 has transitioned to ComEd as their retail electricity provider effective meter read dates in July 2019.
 - Net Zero Metering tariff applications have been tentatively approved by ComEd contingent on the commercial operational start-up test.
 - Construction review with all three villages completed and acceptance letters in hand.
 - Building Permit Applications to be submitted to McHenry County Regional Office of Education pending peer review endorsement of ForeFront Power's electrical plan set.
 - Forefront's applications for Smart Inverter rebates from ComEd have not yet been submitted.
 - ForeFront Power's best estimate of Commercial operation at this time is revised to mid-March 2020.
 - Construction started at Reed Road on 11-18-19. Commercial operation date estimated as 4-5-20.
 - Construction started on Square Barn Road Campus on 11-25-19. Commercial operation date estimated as 4-5-20.
 - Construction started at Harmony Road Campus on 12-20-19. Commercial operation date estimated as 4-15-20.
3. Completed the final one remaining project from the Summer 2019 Deferred Maintenance Project: Roof Systems Restoration and Replacement at Conley and Mackeben flat roof areas.
4. Coordinate construction administration of the Huntley High School Fine Arts Addition with Wold Architects and Engineers and Lamp Inc.
5. Continue Strategic Energy Management CoHort program participation by moving into the Alumni Group. The program is offered thru the support of NiCor and ComEd via their agent; CLEAResult.
6. Complete the design development coordination for pavement improvements at Conley and Mackeben Elementary Schools. Release project to bid.
7. Present bids to the Board of Education for for asphalt crackfill, sealcoat and traffic paint at Leggee Elementary School, Heineman Middle School, a portion of the west entrance drive at Huntley High, and a portion of Dr. John Burkey Dr.
8. Submit ISBE School Maintenance Grant for approval.

Project Goals for March 2020

1. Coordinated many small projects on the FY20 O&M Deferred Maintenance Capital Projects.
2. Lead the District towards development of Solar PV Installation Project with our partner; ForeFront Power, who will be installing a renewable energy system which could generate up to 80% of the School District's annually consumed power. Highlights of project status include:
 - Zoning reviews with the three Villages (;LITH, Algonquin, and Huntley) are completed.
 - All nine ComEd Interconnect Agreements are approved.
 - Forefront's applications for Renewable Energy Credits have been approved by the Illinois Power Agency, the Illinois Commerce Commission, and ComEd.
 - District 158 has transitioned to ComEd as their retail electricity provider effective meter read dates in July 2019.
 - Net Zero Metering tariff applications have been tentatively approved by ComEd contingent on the commercial operational start-up test.
 - Construction review with all three villages completed and acceptance letters in hand.
 - Building Permit Applications to be submitted to McHenry County Regional Office of Education pending peer review endorsement of ForeFront Power's electrical plan set.
 - Forefront's applications for Smart Inverter rebates from ComEd have not yet been submitted.
 - ForeFront Power's best estimate of Commercial operation at this time is revised to mid-March 2020.
 - Construction started at Reed Road on 11-18-19. Commercial operation date estimated as 4-5-20.
 - Construction started on Square Barn Road Campus on 11-25-19. Commercial operation date estimated as 4-5-20.
 - Construction started at Harmony Road Campus on 12-20-19. Commercial operation date estimated as 4-15-20.
3. Completed the final one remaining project from the Summer 2019 Deferred Maintenance Project: Roof Systems Restoration and Replacement at Conley and Mackeben flat roof areas.
4. Coordinate construction administration of the Huntley High School Fine Arts Addition with Wold Architects and Engineers and Lamp Inc.
5. Continue Strategic Energy Management CoHort program participation by moving into the Alumni Group. The program is offered thru the support of NiCor and ComEd via their agent; CLEAResult.
6. Complete the design development coordination for pavement improvements at Conley and Mackeben Elementary Schools. Release project to bid.
7. Present bids to the Board of Education for the following projects:
 - Thru-Wall Flashing Replacement at Heineman and Martin Schools
 - Exterior Window Repairs at Marlowe Middle School

Attachments

- A. 1st thru 4th quarter 2019 payment statements for EnelX Demand Load Response program participation.

DR/jw



EARNINGS STATEMENT

HAVE A QUESTION ABOUT THIS STATEMENT?

Contact us at +1 888 363 7662
or support.enelx@enel.com

 Visit login.enernoc.com for performance details

Doug Renkosik
Huntley Community School District 158
650 Academic Dr.
Huntley IL 60102

Your Earnings this Period (USD):

\$10,027.49

Payment Date: 5/16/2019
Account ID: 063210

SUMMARY

ENEL X DR: \$10,027.49

ENEL X DR STATEMENT DETAIL

DR TOTAL: \$10,027.49

Period	Product	Description	Amount
Site: Huntley SD158 - Harmony Rd Campus - Huntley - IL (PJM0191805008)			Subtotal: \$3,797.48
01/2019	PJM EMER	Capacity Perf Adj (-118 kW @ \$6.21/kW, 75% Split)	(\$549.28)
01/2019	PJM EMER	Capacity (399 kW @ \$6.21/kW, 75% Split)	\$1,857.30
02/2019	PJM EMER	Capacity Perf Adj (-118 kW @ \$5.61/kW, 75% Split)	(\$496.12)
02/2019	PJM EMER	Capacity (399 kW @ \$5.61/kW, 75% Split)	\$1,677.56
03/2019	PJM EMER	Capacity (399 kW @ \$6.21/kW, 75% Split)	\$1,857.30
03/2019	PJM EMER	Capacity Perf Adj (-118 kW @ \$6.21/kW, 75% Split)	(\$549.28)
Site: Huntley SD158 - Reed Rd Campus - Lake in the Hills - IL (PJM5918032028)			Subtotal: \$1,324.37
01/2019	PJM EMER	Capacity (130 kW @ \$6.21/kW, 75% Split)	\$605.13
01/2019	PJM EMER	Capacity Perf Adj (-32 kW @ \$6.21/kW, 75% Split)	(\$148.96)
02/2019	PJM EMER	Capacity Perf Adj (-32 kW @ \$5.61/kW, 75% Split)	(\$134.54)
02/2019	PJM EMER	Capacity (130 kW @ \$5.61/kW, 75% Split)	\$546.57
03/2019	PJM EMER	Capacity Perf Adj (-32 kW @ \$6.21/kW, 75% Split)	(\$148.96)
03/2019	PJM EMER	Capacity (130 kW @ \$6.21/kW, 75% Split)	\$605.13

Site: Huntley SD158 - Square Barn Rd Campus - Algonquin - IL (PJM1213159017)			Subtotal:	\$4,905.64
01/2019	PJM EMER	Capacity (363 kW @ \$6.21/kW, 75% Split)		\$1,689.72
02/2019	PJM EMER	Capacity (363 kW @ \$5.61/kW, 75% Split)		\$1,526.20
03/2019	PJM EMER	Capacity (363 kW @ \$6.21/kW, 75% Split)		\$1,689.72



EARNINGS STATEMENT

HAVE A QUESTION ABOUT THIS STATEMENT?

Contact us at +1 888 363 7662
or support.enelx@enel.com



Visit apps.enelx.com for performance details

Doug Renkosik
Huntley Community School District 158
650 Academic Dr.
Huntley IL 60102

Your Earnings this Period (USD):

\$9,527.01

Payment Date: 8/14/2019
Account ID: 063210

SUMMARY

ENEL X DR: \$9,527.01

ENEL X DR STATEMENT DETAIL

DR TOTAL: \$9,527.01

Period	Product	Description	Amount
Site: Huntley SD158 - Harmony Rd Campus - Huntley - IL (PJM0191805008)			Subtotal: \$3,786.99
04/2019	PJM EMER	Capacity Perf Adj (-118 kW @ \$6.01/kW, 75% Split)	(\$531.56)
04/2019	PJM EMER	Capacity (399 kW @ \$6.01/kW, 75% Split)	\$1,797.39
05/2019	PJM EMER	Capacity Perf Adj (-118 kW @ \$6.21/kW, 75% Split)	(\$549.28)
05/2019	PJM EMER	Capacity (399 kW @ \$6.21/kW, 75% Split)	\$1,857.30
06/2019	PJM EMER	Capacity (295 kW @ \$5.48/kW, 75% Split)	\$1,213.14
Site: Huntley SD158 - Reed Rd Campus - Lake in the Hills - IL (PJM5918032028)			Subtotal: \$1,132.03
04/2019	PJM EMER	Capacity (130 kW @ \$6.01/kW, 75% Split)	\$585.61
04/2019	PJM EMER	Capacity Perf Adj (-32 kW @ \$6.01/kW, 75% Split)	(\$144.15)
05/2019	PJM EMER	Capacity (130 kW @ \$6.21/kW, 75% Split)	\$605.13
05/2019	PJM EMER	Capacity Perf Adj (-32 kW @ \$6.21/kW, 75% Split)	(\$148.96)
06/2019	PJM EMER	Capacity (57 kW @ \$5.48/kW, 75% Split)	\$234.40
Site: Huntley SD158 - Square Barn Rd Campus - Algonquin - IL (PJM1213159017)			Subtotal: \$4,607.99
04/2019	PJM EMER	Capacity (363 kW @ \$6.01/kW, 75% Split)	\$1,635.22
05/2019	PJM EMER	Capacity (363 kW @ \$6.21/kW, 75% Split)	\$1,689.72
06/2019	PJM EMER	Capacity (312 kW @ \$5.48/kW, 75% Split)	\$1,283.05



EARNINGS STATEMENT

HAVE A QUESTION ABOUT THIS STATEMENT?

Contact us at +1 888 363 7662
or support.enelx@enel.com



Visit apps.enelx.com for performance details

Doug Renkosik
Huntley Community School District 158
650 Academic Dr.
Huntley IL 60102

Your Earnings this Period (USD):

\$8,373.79

Payment Date: 11/13/2019
Account ID: 063210

SUMMARY

ENEL X DR: \$8,373.79

ENEL X DR STATEMENT DETAIL

DR TOTAL: \$8,373.79

Period	Product	Description	Amount
Site: Huntley SD158 - Harmony Rd Campus - Huntley - IL (PJM0191805008)			Subtotal: \$3,720.28
07/2019	PJM EMER	Capacity (295 kW @ \$5.67/kW, 75% Split)	\$1,253.57
08/2019	PJM EMER	Capacity (295 kW @ \$5.67/kW, 75% Split)	\$1,253.57
09/2019	PJM EMER	Capacity (295 kW @ \$5.48/kW, 75% Split)	\$1,213.14
Site: Huntley SD158 - Reed Rd Campus - Lake in the Hills - IL (PJM5918032028)			Subtotal: \$718.84
07/2019	PJM EMER	Capacity (57 kW @ \$5.67/kW, 75% Split)	\$242.22
08/2019	PJM EMER	Capacity (57 kW @ \$5.67/kW, 75% Split)	\$242.22
09/2019	PJM EMER	Capacity (57 kW @ \$5.48/kW, 75% Split)	\$234.40
Site: Huntley SD158 - Square Barn Rd Campus - Algonquin - IL (PJM1213159017)			Subtotal: \$3,934.67
07/2019	PJM EMER	Capacity (312 kW @ \$5.67/kW, 75% Split)	\$1,325.81
08/2019	PJM EMER	Capacity (312 kW @ \$5.67/kW, 75% Split)	\$1,325.81
09/2019	PJM EMER	Capacity (312 kW @ \$5.48/kW, 75% Split)	\$1,283.05



Doug Renkosik <drenkosik@district158.org>

Re: EnelX Demand Load Response program- 4th quarter incentive payment statement attached

1 message

Debra Salm <dsalm@district158.org>

Fri, Feb 14, 2020 at 9:12 AM

To: Doug Renkosik <drenkosik@district158.org>

Cc: Tom Rodriguez <trodriguez@district158.org>, "Altmayer, Mark" <maltmayer@district158.org>

I just checked the bank - I see that it hit our account this morning. Thanks for the document, Doug.

On Fri, Feb 14, 2020 at 8:48 AM Doug Renkosik <drenkosik@district158.org> wrote:

See attached.

Fiscal please let me know when payment received

O&M Core Team - thanks for your support which affords us this opportunity.

--

Doug Renkosik, CPMM, Director of O&M

Please note our street address change below.

Huntley Community School District 158

650 Dr. John Burkey Drive (formerly known as Academic Drive)

Algonquin, IL 60102

office # 847-659-6161

Foster a Clean, Comfortable, Safe Learning Environment for Students Faculty and Staff

Please consider the environment before printing this document.

E-MAIL CONFIDENTIALITY NOTICE: Illinois has a very broad public records law. Most written communications (including email) to or from school district officials and staff are public records available to the public and media upon request. Your email communications may therefore be subject to public disclosure.

--

Debbie Salm

Director of Fiscal Services

Huntley Community School District 158

847-659-6118



Huntley Community School District 158

650 Academic Drive
 Algonquin, Illinois 60102
 (847) 659-6158 • www.district158.org

DATE: March 5, 2020

TO: Building and Grounds Committee

FROM: Doug Renkosik, Director of Operations & Maintenance

RE: HHS Fine Arts Addition Construction Update(R)
 Building and Grounds Committee
 Committee of the Whole, March 5, 2020

Background:

At the September 6, 2018 Committee of the Whole meeting of the Board of Education for Huntley Community School District 158, Superintendent Rowe presented the Board of Education with the outcome of the established goals of the Huntley High School Fine Arts 3000 committee's needs assessment.

At the September 20, 2018 Regular Board Meeting, the Board of Education approved the proposed fee from Wold Architects and Engineers for the Schematic Design Phase of improvements to the Fine Arts wing of Huntley High School.

At the January 17, 2019 Regular Board meeting, Wold Architect's representatives made a presentation of the outcome of their work with the D158 committee on the Schematic Design Phase of the proposed project with considered budgets for the final proposed developments.

At the February 7, 2019 Special Board Meeting, the Board of Education approved engagement of Wold Architects and Engineers for development of plans and specifications for bidding of the Huntley High Fine Arts Addition.

Also at the February 7, 2019 Special Board Meeting, the Board of Education approved the fee letter proposal from Lamp Inc. dated January 23, 2019 for Construction Manager as Adviser services for this project.

On June 6, 2019, Wold and Lamp made a presentation to the Board of Education on the updated design with a revised estimated total project budget.

On July 6, 2019, an advertisement for bids was published.

Bids were received and opened on the afternoon of July 23, 2019.

At the August 15, 2019 Regular Board meeting, the Board of Education approved the award of the bids for the Huntley High School Fine Arts Addition which included award of all trade package bids except the Stage Curtains and the Electrical work.

At the October 10, 2019 Special Board meeting, the Board of Education awarded the bid for the electrical trade package #26-1a for the Huntley High School Fine Arts Addition.

As of January 28, 2020, the blackbox and set shop additions are enclosed, roofed in, and are temporarily being heated.

At their February 6, 2020 Special Meeting, the Board of Education approved award of the Owner Furnished item for the design, procurement, installation and commissioning of the Audio Visual System for the Black Box Theater.

At their February 20, 2020 Meeting, the Board of Education approved award of the Owner Furnished items for the project including:

- Design, procurement, installation and commissioning of the Lighting System for the Black Box Theater
- Procurement of additional music storage lockers for the expended Band Equipment storage room
- Installation of the Stage Curtain System and Pipe Grid support systems for the Black Box Theater

Attachments

1. Lamp fiscal status report
2. PCOs authorized by the Administration for minor project adjustments including:
 - a. PCO # 009 steel lintel and masonry changes
 - b. PCO # 015 additional steel lintel



16172 - D158 Huntley High School Fine Arts Addition

Contract Value Log
 February 25, 2020
 PCO's 000 through 015

PKG #	DESCRIPTION	TRADE CONTRACTOR	ALLOWANCES (\$115,000 beg bal)	ORIGINAL CONTRACT	CURRENT CHANGE ORDERS	CURRENT CONTRACT	PENDING CHANGE ORDERS	Potential Contract Value
03A-1	Building Concrete	JB Contractors	\$ 8,812	\$ 188,131	\$ -	\$ 188,131	\$ -	\$ 188,131
04A-1	Masonry	Joe's Masonry	\$ -	\$ 573,000	\$ -	\$ 573,000	\$ (1,586)	\$ 571,414
05A-1	Structural Steel	Guardian Construction Products	\$ 7,826	\$ 205,000	\$ -	\$ 205,000	\$ -	\$ 205,000
06A-1	General Trades (incl. Demo, DW, Doors, OH Doors)	Hargrave Builders	\$ 8,676	\$ 365,220	\$ -	\$ 365,220	\$ -	\$ 365,220
07A-1	Roofing	Weatherguard Roofing	\$ 4,388	\$ 272,000	\$ -	\$ 272,000	\$ -	\$ 272,000
08B-1	Aluminum, Glass, and Glazing	Rock Valley Glass of Rockford	\$ 5,000	\$ 175,420	\$ -	\$ 175,420	\$ -	\$ 175,420
09B-1	Acoustical Ceilings	Heitkotter, Inc.	\$ 5,000	\$ 58,191	\$ -	\$ 58,191	\$ -	\$ 58,191
09F-1	Flooring	Pinnacle Flooring Company	\$ 5,000	\$ 44,800	\$ -	\$ 44,800	\$ -	\$ 44,800
09G-1	Painting	Oosterbaan & Sons	\$ 5,000	\$ 42,620	\$ -	\$ 42,620	\$ -	\$ 42,620
21A-1	Fire Protection	Absolute Fire Protection	\$ 2,911	\$ 44,300	\$ -	\$ 44,300	\$ -	\$ 44,300
22A-1	Plumbing	Joe Bero Plumbing	\$ 5,000	\$ 59,000	\$ -	\$ 59,000	\$ -	\$ 59,000
23A-1	HVAC	Hartwig Plumbing & Heating	\$ 7,592	\$ 505,088	\$ -	\$ 505,088	\$ -	\$ 505,088
26A-1	Electrical	Carey Electric Contracting	\$ 10,000	\$ 519,900	\$ -	\$ 519,900	\$ -	\$ 519,900
31A-1	Excavation (incl. Site Utilities & Landscaping)	DuPage Topsoil	\$ -	\$ 229,000	\$ 11,150	\$ 240,150	\$ -	\$ 240,150
32A-1	Asphalt Paving	Schroeder Asphalt Services	\$ 5,000	\$ 81,300	\$ -	\$ 81,300	\$ -	\$ 81,300
32C-1	Site Concrete	Chadwick Contracting Company	\$ 5,000	\$ 63,947	\$ -	\$ 63,947	\$ -	\$ 63,947
11A-1	Stage Curtain & Rigging	(*Reject and Rebid)	\$ -	*Inc. in FF&E	\$ -		\$ -	\$ -
		<i>Remaining Allowance Subtotal</i>	\$ 85,205					
				\$ 3,426,917	\$ 11,150	\$ 3,438,067	\$ (1,586)	\$ 3,436,481
701		Preconstruction	\$ 27,500	\$ -	\$ 27,500	\$ -	\$ -	\$ 27,500
702		General Conditions (Supervision)	\$ 284,610	\$ -	\$ 284,610	\$ -	\$ -	\$ 284,610
703		Project General Conditions	\$ 105,340	\$ -	\$ 105,340	\$ -	\$ -	\$ 105,340
704		Lamp Overhead & Fee (3.5%)	\$ 118,865	\$ -	\$ 118,865	\$ -	\$ -	\$ 118,865
705		Insurance	\$ 14,894	\$ -	\$ 14,894	\$ -	\$ -	\$ 14,894
		SUBTOTAL	\$ 3,978,126	\$ 11,150	\$ 3,989,276	\$ (1,586)	\$ 3,987,690	
		Contingency	\$ -	\$ -	\$ -	\$ -	\$ -	\$ -
		SUBTOTAL	\$ 3,978,126	\$ -	\$ 3,989,276	\$ (1,586)	\$ 3,987,690	
		Architectural & Engineering Fees	\$ 199,535	\$ -	\$ 199,535	\$ -	\$ -	\$ 199,535
		Reimbursables	\$ 44,012	\$ -	\$ 44,012	\$ -	\$ -	\$ 44,012
		SUBTOTAL	\$ 243,547	\$ -	\$ 243,547	\$ -	\$ -	\$ 243,547
		Owner Direct Purchase RTUs	\$ 78,867	\$ -	\$ 78,867	\$ -	\$ -	\$ 78,867
		Owner Direct Costs	\$ 361,500	\$ -	\$ 361,500	\$ -	\$ -	\$ 361,500
		SUBTOTAL	\$ 440,367	\$ -	\$ 440,367	\$ -	\$ -	\$ 440,367
		TOTAL	\$ 4,662,040	\$ -	\$ 4,673,190			\$ 4,671,604
		APPROVED BUDGET			\$ 4,677,925			\$ 4,677,925
		OVER/(UNDER) BUDGET			\$ (4,735)			\$ (6,321)
		BALANCE OF ALLOWANCES REMAINING	\$ (85,205)					\$ (85,205)
		PROJECTED COMPLETION COST			\$ 4,587,985			\$ 4,586,399



PCO #009

Lamp Incorporated
460 N. Grove Avenue
Elgin, Illinois

Project: 16172 - D158 - HHS Fine Arts Addition
13917 Harmony Road
Huntley, Illinois 60142

Potential Change Order #009: PR 7

TO: Huntley Community School District 158 650 Dr. John Burkey Drive Algonquin 60102	FROM:
PCO NUMBER/REVISION: 009 / 0	CONTRACT: 1 - D158 - HHS Fine Arts Addition Prime Contract
REQUEST RECEIVED FROM: Kirsta Ehmke (Wold Architects & Engineers)	CREATED BY: Jay Schaack (Lamp Incorporated)
STATUS: Pending - In Review	CREATED DATE: 1/14 /2020
REFERENCE:	LOCATION: Area A/B break line at roof deck

CHANGE REASON: Architect request

POTENTIAL CHANGE ORDER DESCRIPTION: *(The Contract Is Changed As Follows)*

This PCO is in regards to the changes associated with PR 7. PR 7 allows the use of a bent steel support plate to extend the support structure where the 4"cmu was removed from the parapet wall detail above roof.

ATTACHMENTS:

[HHS-Guardian PR 7 pricing.pdf](#), [Copy of Joes Masonry COR PR07 C6 A5.201 delete 4 inch CMU revised 1-13-20.pdf](#), [HHS-PR 7.pdf](#)

#	Cost Code	Description	Type	Amount
1	04-04A-01 - Masonry	04A-Joes Masonry credit for work deletion	Commitment	(\$1,586.00)
2	05-05A-01A - Structural Steel Allowance	05A-Guardian Steel- Supply of bent plate for PR7	Commitment	\$ 1,183.00
Subtotal:				(\$403.00)
Grand Total:				(\$403.00)

 2-12-20
SIGNATURE DATE

 2/12/20
SIGNATURE DATE

MEMO

**GUARDIAN
CONSTRUCTION PRODUCTS, INC.**
10 S. 359 NORMANTOWN RD.
NAPERVILLE, IL 60564
(630) 820-8899
FAX (630) 820-1460

To: Lamp Incorporated - Jay

Date: 12/13/19

Subject: Huntley HS Fine Arts Addition
13719 Harmony Rd Huntley, IL

Job: 7842
Extra #03

There will be an extra cost for the additional work to be performed per PR#7 dated 12/05/19

Furnish and erect steel (prime painted) 3/8" bent plate in lieu of 3x3x1/4 angle per detail B6/S4.00

Materials+Fabrication	\$ 788.00	
Details	\$ 125.00	
Erection (due to size/weight)	\$ 270.00	2hrs @ \$135 hr

TOTAL:	\$ 1,183.00	

Please review and advise if we are to proceed with this work.

Thank you,

Michael W. Straube

Michael W. Straube
Project Manager

STRUCTURAL STEEL * MISC. IRON * JOIST * METAL DECK * ERECTION

	Change Order	PR07 Revised wall sections Delete 4" CMU, insulation and air barrier detail E3/A5.702 25'-0" x 5'-4" tall	
TICKET #: NA			
DATE: 1/13/20	Joe's Masonry		
PROJECT: Huntley High School	470 Walnut Street		
	Elmhurst, IL 60126		
	Phone: (630) 530-8129		
	Fax: (630) 782-0491		
Description: PR07 item 7.1 Delete 4" CMU back-up, cavity insulation and air barrier 25'-0" long by 5'-4"			
Labor:	Hours Worked	Hourly Rate	Sub-Total
Bricklayer Foreman	0	\$ 101.05	\$ -
Bricklayer	(8)	\$ 94.78	(\$758.24)
Laborer	(4)	\$ 88.42	(\$353.68)
		Total Labor	(\$1,111.92)
		Materials	(\$474.01)
		Equipment	\$0.00
		Bond	\$0.00
		Sub-Total	(\$1,585.93)
		OH & P = 10%	\$0.00
		Total Amount Due	(\$1,585.93)
MATERIALS:	Quantity	Unit Price	
4'CMU	(149.00)	\$ 1.05	(\$156.45)
4" wire	(100.00)	\$ 0.22	(\$22.00)
Mortar	(0.40)	\$ 135.00	(\$54.00)
2-1/2" cavity insulation	(132.00)	\$ 1.28	(\$168.96)
Roll on air barrier	(132.00)	\$ 0.55	(\$72.60)
	Sub-total Materials		(\$474.01)
EQUIPMENT USED:	Quantity	Unit Price	
Saw - Table Saw			\$0.00
Saw blade Diamond			\$0.00
	Sub-total Equipment		\$0.00
CLIENT APPROVAL AREA:			
CLIENT: _____			
AUTHORIZED BY: _____			
SIGNATURE: _____		DATE SIGNED: _____	



PROPOSAL REQUEST

District 158 Huntley High School	HHS- Fine Arts Addition
Lamp, Inc.	Attn: Jay Schaack
460 N. Grove Avenue	
Elgin, IL 60120	
(847) 741-7220	Fax: (847) 741-9677
jschaack@lampinc.net	

Submit an itemized (labor and material) quotation for the proposed modifications to the contract documents as described herein within 21 days of receipt. If a cost is not submitted within 21 days, this Proposal Request can be accepted at no additional cost. Written approval is required prior to proceeding with this change. COST EXPECTATIONS: <input type="checkbox"/> DEDUCT <input type="checkbox"/> NO COST <input type="checkbox"/> ADD	PR: # 07
	Comm: # 193011
	Const. Pkg: # N/A

Distribution:

- Doug Renkosik
- Jay Schaack
- Chris Palmer
- Kirsta Ehmke
- Tyler Severson
- Jeff Strzalka
- Kent Adams
- Bob Chen
- Dave McVey

Item	Description
	Provide separate cost for each item listed below
7.1	Revise Wall Section C6 on Sheet A5.201 and Detail E3 on A5.702 as shown on the attached updated Sheets.
7.2	Revise Detail B6 on Sheet S4.00 as shown on the attached updated Sheets.

*Delete. ~~Can be removed~~ - 2nd layer
CREDIT \$400*

Huntley High School - PR #7

1 message

Fri, Dec 6, 2019 at 11:03 AM

Kirsta Ehmke <kehmk@woldae.com>
 To: Jay Schaack <JSchaack@lampinc.net>
 Cc: Chris Palmer <cpalmer@lampinc.net>, "Renkosik, Doug" <DRenkosik@district158.org>, Tyler Severson <tseverson@woldae.com>, Kent Adams <k.adams@jwase.com>, Rachel Rukes <rrokes@lampinc.net>

Jay,

Attached is PR #7 for your use.

Doug, I'm hoping to have my voice back by Monday so I can call to review with you then if you would like. Also Tyler can review with you on site next Wednesday as well. Chris noticed an area that would not be able to be constructed with the current intent of installing the face brick in the Spring. Jay was on site too while we were discussing this, and the revision should be a minor cost if not a wash. But definitely not the cost of paying for winter conditions.

Attachments: Sheet A5.201, A5.702, S4.00

HHS - Fine Arts addition PR 7

1 message

Mon, Dec 9, 2019 at 12:49 PM

Jay Schaack <JSchaack@lampinc.net>
 To: Mike Straube <mstraube@guardiansteel.com>, Sal Calzante <scalzante.joesmasonry@gmail.com>, Sam Newman <sam@weatherguardroofing.net>
 Cc: Chris Palmer <CPalmer@lampinc.net>, Doug Renkosik <DRenkosik@district158.org>

Good afternoon all, please see the attached PR 7. Please figure pricing and respond back by Friday 12/13. In short we are removing the second layer of 4"CMU and extending the deck a bit further. The extended deck will then be supported

HUNTLEY HS FINE ARTS ADDITION

13719 Harmony Road
Huntley, IL 60142

Huntley CSD No. 158
450 S. State Street
Approximate, IL 60102



WOLD ARCHITECTS
AND ENGINEERS
1111 North Dearborn Street, 2nd
Floor, Chicago, IL 60610
Tel: 312.467.1111
Fax: 312.467.1112

REGISTERED PROFESSIONAL ARCHITECT
STATE OF ILLINOIS
NO. 021-0000000-00000000

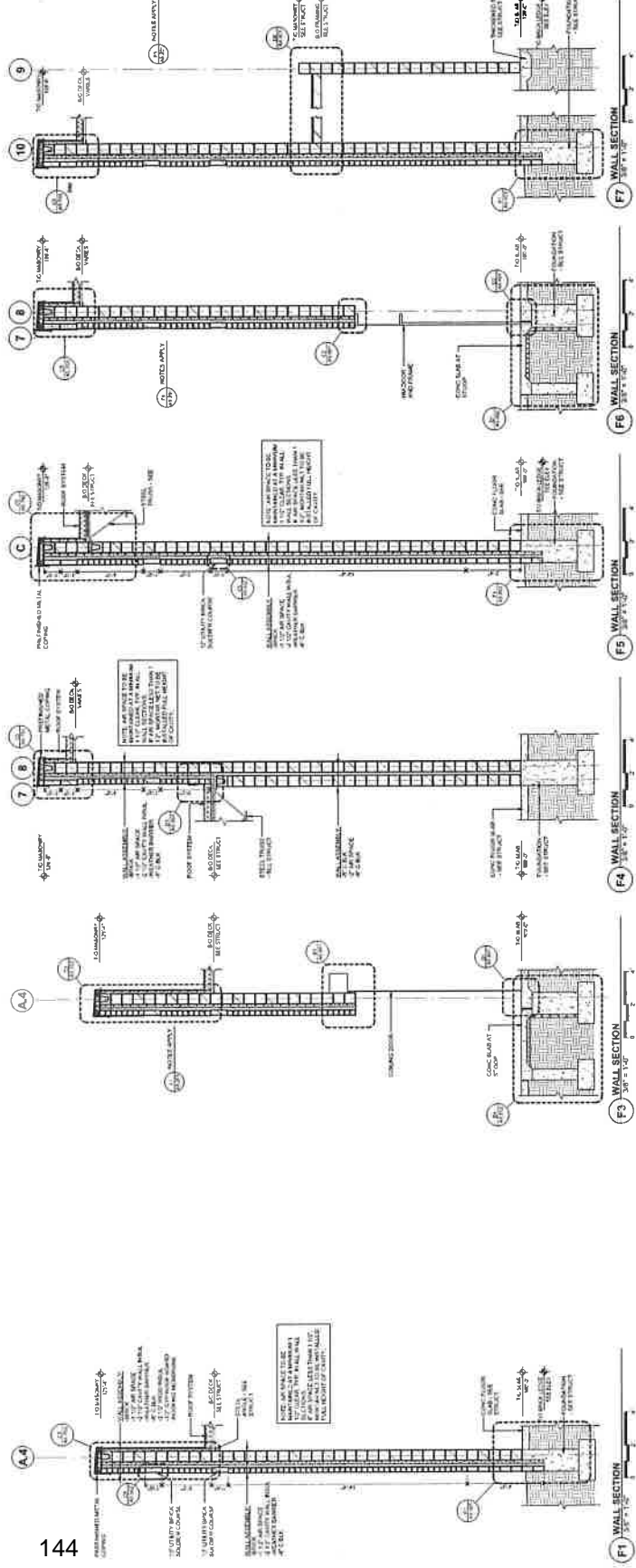
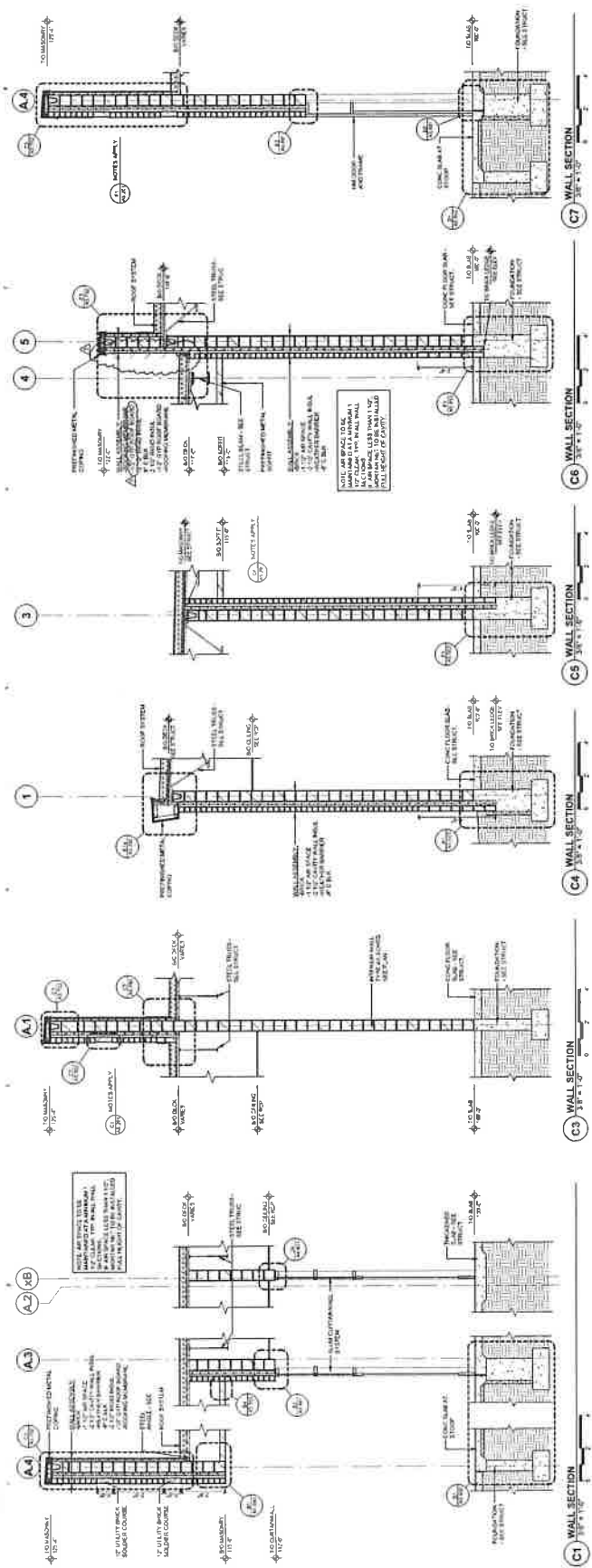

Table with project details: PROJECT NO., SHEET NO., DATE, etc.

WALL SECTIONS

A5.201

CONSTRUCTION SET



144

IL

A



PCO #015

Lamp Incorporated
460 N. Grove Avenue
Elgin, Illinois

Project: 16172 - D158 - HHS Fine Arts Addition
13917 Harmony Road
Huntley, Illinois 60142

Potential Change Order #015: PR 9 Lintel extension

TO: Huntley Community School District 158
650 Dr. John Burkey Drive
Algonquin 60102

FROM:

PCO NUMBER/REVISION: 015 / 0

CONTRACT: 1 - D158 - HHS Fine Arts Addition Prime Contract

REQUEST RECEIVED FROM: Kirsta Ehmke (Wold Architects & Engineers)

CREATED BY: Jay Schaack (Lamp Incorporated)

STATUS: Pending - In Review

CREATED DATE: 1/29 /2020

REFERENCE:

LOCATION: Area A/B break line

CHANGE REASON: Architect request

POTENTIAL CHANGE ORDER DESCRIPTION: *(The Contract Is Changed As Follows)*
This PR 9 was to extend the masonry support lintel at the Area A vestibule.

ATTACHMENTS:

[HHS-Guardian-lintel extension CO-4.pdf](#) [HHS-PR 9.pdf](#)

#	Cost Code	Description	Type	Amount
1	05-05A-01A - Structural Steel Allowance	05A-Guardian Steel allowance- PR 9 Lintel extension	Commitment	\$ 991.00
Subtotal:				\$991.00
Grand Total:				\$991.00

 SIGNATURE DATE

 2/12/20
 SIGNATURE DATE



PROPOSAL REQUEST

District 158 Huntley High School	HHS- Fine Arts Addition
Lamp, Inc.	Attn: Jay Schaack
460 N. Grove Avenue	
Elgin, IL 60120	
(847) 741-7220	Fax: (847) 741-9677
jschaack@lampinc.net	

Submit an itemized (labor and material) quotation for the proposed modifications to the contract documents as described herein within 21 days of receipt. If a cost is not submitted within 21 days, this Proposal Request can be accepted at no additional cost. Written approval is required prior to proceeding with this change. COST EXPECTATIONS: <input type="checkbox"/> DEDUCT <input type="checkbox"/> NO COST <input type="checkbox"/> ADD	PR: # 09
	Comm: # 193011
	Const. Pkg: # N/A

Distribution:

- Doug Renkosik
- Jay Schaack
- Chris Palmer
- Kirsta Ehmke
- Tyler Severson
- Jeff Strzalka
- Kent Adams
- Bob Chen
- Dave McVey
- David Etlinger
-
-
-
-
-
-

Item	Description
9.1	Provide steel lintel extension per SSK1 and SSK2 as shown on the attached Sheets.

Attachments: SSK1-2 (dated 12/27/2019)

Issued By: Tyler Severson

Date: 01/21/2020

Wold Architects and Engineers
 110 North Brockway Street, Suite 220
 Palatine, IL 60067
 148 woldae.com | 847 241 6100

**PLANNERS
 ARCHITECTS
 ENGINEERS**

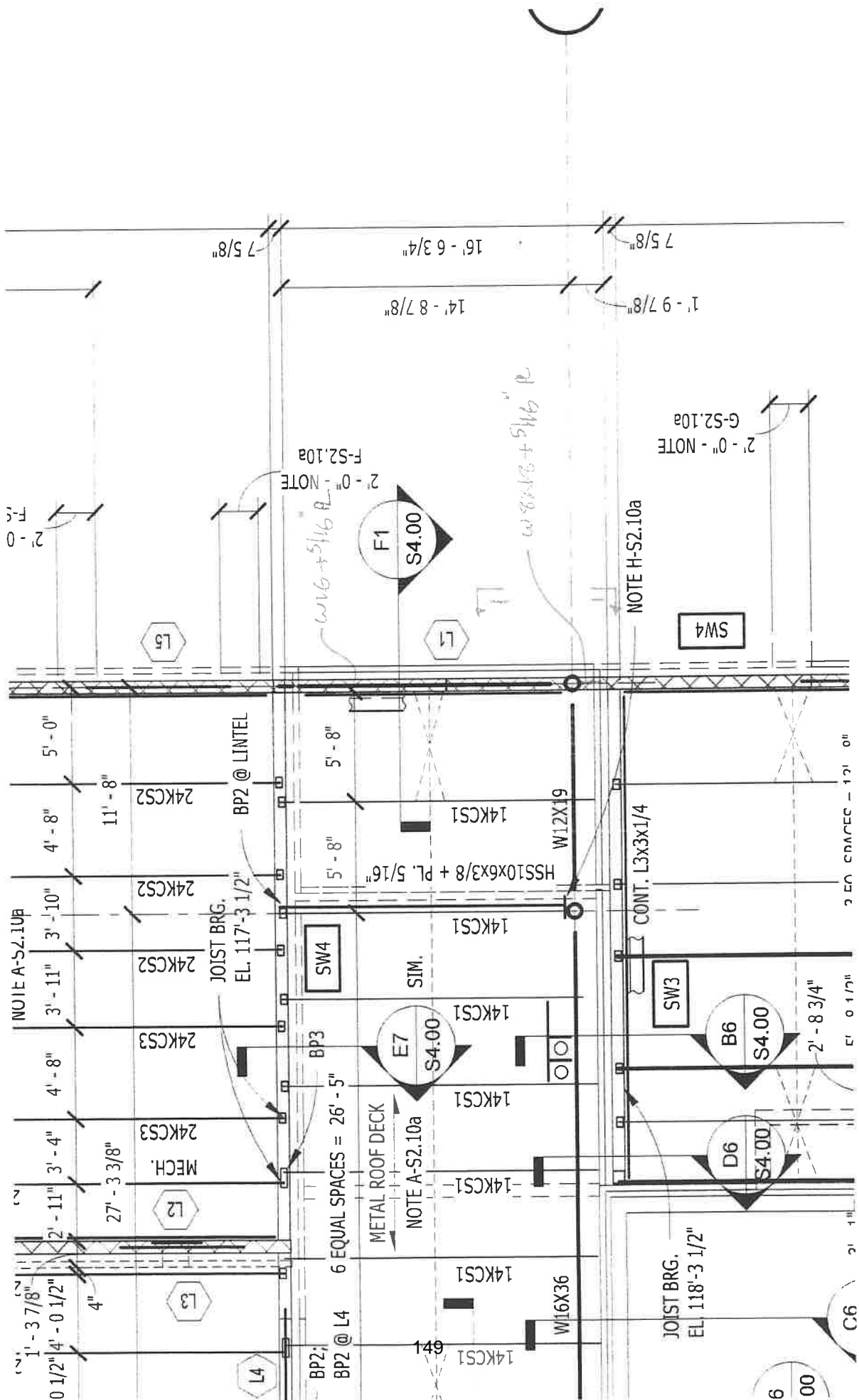

HHS
SSK 1052
12/27/19

J **JOHNSON WILBUR ADAMS, INC.**
W **STRUCTURAL ENGINEERING**
A 330 S. NAPERVILLE ROAD • SUITE 300
 WHEATON, ILLINOIS 60187

JOB HHS NO. 2019079
 SHEET NO. 5522 OF 2
 CALCULATED BY KLA DATE 12/27/19
 CHECKED BY _____ DATE _____
 DESCRIPTION _____

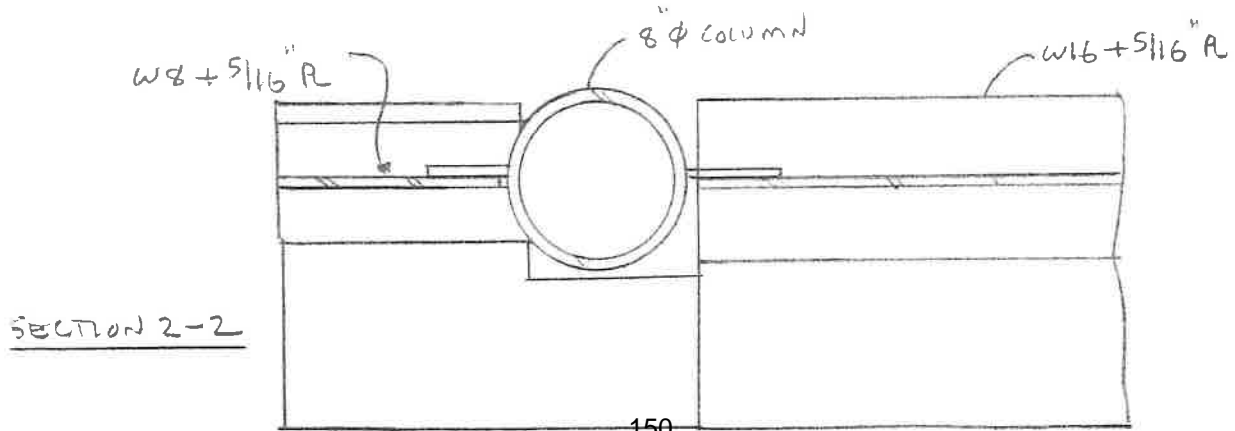
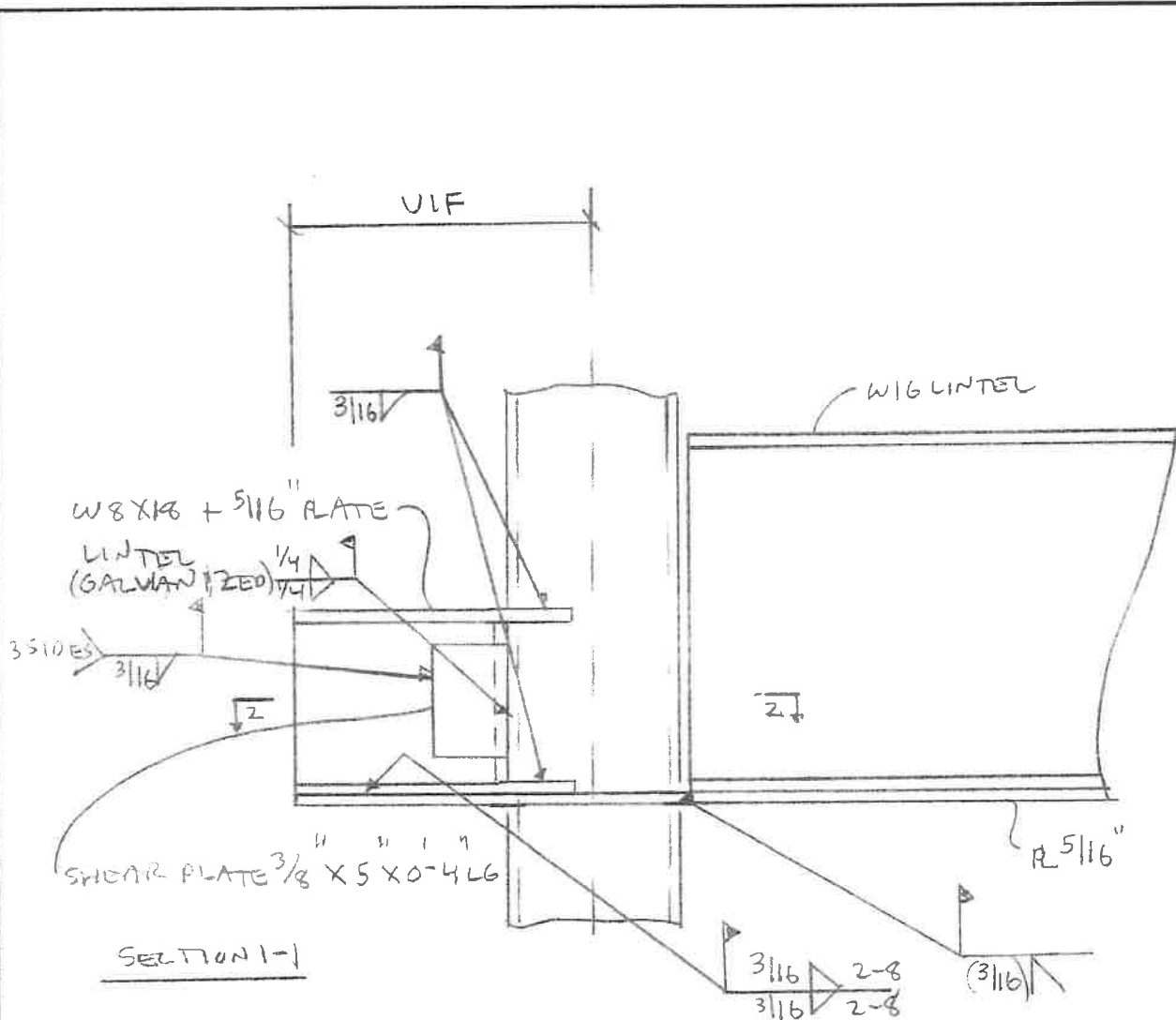

MEMO

**GUARDIAN
CONSTRUCTION PRODUCTS, INC.**
10 S. 359 NORMANTOWN RD.
NAPERVILLE, IL 60564
(630) 820-8899
FAX (630) 820-1460

To: Lamp Incorporated - Jay

Date: 1/24/20

Subject: Huntley HS Fine Arts Addition
13719 Harmony Rd Huntley, IL

Job: 7842
Extra #04

There will be an extra cost for the additional work to be performed per SSK2 dated 12/27/19

Furnish and erect one steel (galv.) lintel extension (W8x18 + 5/16" plate) on the south side of the column at line A.4/4. Attached please find a copy of the signed field ticket

Materials+Fabrication	\$ 327.00
Delivery	\$ 125.00
Erection 1 man @ 4.0 hrs	\$ 538.76

TOTAL: \$ 990.76

Please review and forward your formal change order documents to cover the above as soon as possible.

Thank you,

Michael W. Straube

Michael W. Straube
Project Manager

STRUCTURAL STEEL * MISC. IRON †51 JOIST * METAL DECK * ERECTION



PROPOSAL REQUEST

District 158 Huntley High School	HHS- Fine Arts Addition
Lamp, Inc.	Attn: Jay Schaack
460 N. Grove Avenue	
Elgin, IL 60120	
(847) 741-7220	Fax: (847) 741-9677
jschaack@lampinc.net	

Submit an itemized (labor and material) quotation for the proposed modifications to the contract documents as described herein within 21 days of receipt. If a cost is not submitted within 21 days, this Proposal Request can be accepted at no additional cost. Written approval is required prior to proceeding with this change. COST EXPECTATIONS: <input type="checkbox"/> DEDUCT <input type="checkbox"/> NO COST <input type="checkbox"/> ADD	PR: # 03
	Comm: # 193011
	Const. Pkg: # N/A

Distribution:

- Doug Renkosik
- Jay Schaack
- Chris Palmer
- Kirsta Ehmke
- Tyler Severson
- Jeff Strzalka
- Kent Adams
- Bob Chen
- Dave McVey
- David Etlinger
-
-
-
-
-
-

Item	Description
1.1	Revise Motorized Coiling Door E1308B opening width to 10'-0" clear, per architectural sheet A2.001a.

PRO # 7
 \$945 cancel



Attachments: A2.001a Floor Plan Area A
 Issued By: Tyler Severson Date: 10/18/2019

Wold Architects and Engineers
 110 North Brockway Street, Suite 220
 153 Palatine, IL 60067
 woldae.com | 847 241 6100

**PLANNERS
 ARCHITECTS
 ENGINEERS**



Huntley Community School District 158

650 Academic Drive
 Algonquin, Illinois 60102
 (847) 659-6158 • www.district158.org

DATE: March 5, 2020
 TO: Building and Grounds Committee
 FROM: Doug Renkosik, Director of Operations & Maintenance
 RE: Exterior Window Repairs Bid #2020-08(A)
 Building and Grounds Committee
 Committee of the Whole, March 5, 2020
 Action Item

Background:

The FY 20 O&M Deferred Maintenance capital projects list presented to the Board of Education at the August 2019 Committee of the Whole meeting contained a budget exterior window system repairs at Marlowe Middle School and Heineman Middle School.

A Bid Specification was released for the Marlowe Middle School portion of the budgeted work on January 16, 2020.

Bids were opened on February 6, 2020.

Below is a tabulation of the bids.

BIDDERS	Bid Bond	Addendum 1 Noted	Cert of I.D.H.R.	Cert of Eligibility	Hold Harmless Agreement	Reference List	Cert Comp w/ IL Prevailing Wage Law	Equipment List	Base Bid	UNIT PRICES					
									All curtain wall window openings at Marlowe Middle School	Window Type One Drawing AR201	Window Type Two Drawing AR201	Window Type Three Drawing AR201	Window Type One Drawing AR202	Window Type Two Drawing AR202	Window Type Three Drawing AR202
G & C Glass, Mirror & Const.	1	2	X	X	X	X	X	X	\$123,769.05	\$6,127.18	\$3,676.31	\$3,676.31	\$ 3,676.31	\$ 4,901.74	\$ 6,127.18
Illinois Architectural Glass & Aluminum LLC	X	X	X	X	X	X	X	X	\$95,330.00	\$4,893.00	\$1,985.00	\$1,985.00	\$ 1,985.00	\$ 6,729.00	\$ 4,958.00
Taza Supplies / Tiles In Styles, LLC.	NO BID														

Notes Key:

- 1 = No Bid Bond
- 2 = No Addendum #1 Noted

Recommendation:

The Administration recommends the Building Committee make a recommendation to the Board of Education to award the Exterior Window Repairs Bid # 2020-08 to Illinois Architectural Glass in the total amount of \$95,330.00 at the March 19, 2020 Regular Board Meeting.



Huntley Community School District 158

650 Academic Drive
 Algonquin, Illinois 60102
 (847) 659-6158 • www.district158.org

DATE: March 5, 2020

TO: Building and Grounds Committee

FROM: Doug Renkosik, Director of Operations & Maintenance

RE: Thru-Wall Flashing Replacement Bid # 2020-41(A)
 Building and Grounds Committee
 Committee of the Whole, March 5, 2020
 Action Item

Background:

The FY 20 O&M Deferred Maintenance capital projects list presented to the Board of Education at the August 2019 Committee of the Whole meeting contained a budget masonry wall repairs.

A Bid Specification was released on January 16, 2020 for replacement of a total of approximately 90 linear feet of thru-wall flashing replacement at Heineman Middle School and 24 lineal feet of thru-wall flashing replacement at Martin School where reoccurring leaks have been reported.

Bids were opened on February 3, 2020.

Below is a tabulation of the bids.

Bidder	Bid Bond	Addendum #1 & 2	Cert of I.D.H.R.	Cert of Eligibility	Hold Harmless Agreement	Reference List	Cert of Comp w/ IL Prevailing Wage Law	Equipment List	Base Bid	Unit Price for Brick Replacement	Unit Price for Split Face Block Replacement	Unit Price for Sealant Replacement Including Backer Rod
BAMR	X	X	X	X	X	X	X	X	\$42,000.00	\$70.00	\$115.00	\$18.00
Berglund Construction	X	X	X	X	X	X	X	1	\$68,900.00	\$100.00	\$150.00	\$20.00
Grove Masonry	X	X	X	X	X	X	X	X	\$29,800.00	\$38.00	\$52.00	\$14.00
Safe-Way Tuckpointing	X	X	X	X	X	X	X	1	\$13,500.00	\$12.00	\$45.00	\$17.50
Master Project, Inc.	X	2	X	X	X	X	X	X	\$18,000.00	\$16.00	\$25.00	\$8.00

Key to Note:

- 1. Equipment sheet detail missing
- 2. Addendum # 2 not noted

Recommendation:

The Administration recommends the Building Committee recommend the Board of Education award the Thru-Wall Flashing Replacement Bid # 2020-41 to Safeway Tuckpointing in the amount of \$13,500.00 at their March 19, 2020 Board meeting.

**Huntley Community School District 158 – Board of Education
Committee of the Whole
February 6, 2020 Minutes – draft**

Meeting: Committee of the Whole with a closed session as per OMA and 5ILCS120/2c

Time: 6:00 PM

Location: Administrative Building in the Board Room, 650 Dr. John Burkey Drive, Algonquin, Illinois

Mission Statement: Our learning community will inspire, challenge and empower all students always.

Board of Education Members: President, Mr. Michael Fleck; Vice President, Mr. Anthony Quagliano; Secretary, Mr. Paul Troy; Mr. William Geheren; Mrs. Melissa Maiorino; Mrs. Lesli Melendy.

Minutes

1. Call to Order / Roll Call

Call to Order the Committee of the Whole meeting for February 6, 2020 at 6:01 p.m.

A quorum must be met.

Roll Call: Ayes 5 / Absent 2-Mrs. Melendy, Mrs. Maiorino/ **Motion Carried**

Mrs. Maiorino arrived @ 6:10pm

Members: Mr. Fleck, Mr. Geheren, Mr. Gentry, Mr. Quagliano, Mrs. Melendy, Mr. Troy, Mrs. Maiorino

2. Public Comment -

As per Policy 2:230, public comment can be made during this portion of the meeting.

3. Pledge of Allegiance

The students from the Heineman Snow Hawks Ski/Snowboard Club will lead us in Pledge.

Zoe Bishop, Noah Jensen, Madeline Lackovic, Ashley Phommasack, Jared Sztukowski, Logan Young.

4. Revision and Adoption of the Agenda

The agenda was adopted with the change of the Special Meeting being inserted after item #12.

Voice Call: Ayes 6 / Nays 0/ **Motion Carried**

Mr. Fleck moved/Mrs. Maiorino 2nd

Recommendation: Approved with changes.

5. Curriculum & Instruction (C&I) Committee

6. Policy Committee

PRESS Updates –

Recommendation: Approved as presented.

7. Human Resources (HR) Committee

7. 1. Monthly Human Resources Updates

Mr. Zehr provided the monthly Human Resources project updates.

Recommendation: For informational purposes only.

8. Finance Committee

8. 1. Payables

Mr. Altmayer sought approval of the purchase orders at \$718,402.25; Imprest checks at \$90,062.30; accounts payable at \$3,719.11; and disbursements issued at \$1,610,357.97.

Recommendation: Seeking approval of the Board of Education at their next regular meeting.

8. 2. Revenue & Expenditures Report

The monthly Revenue and Expenditures Report was provided for review.

Recommendation: For informational purposes only.

8. 3. Fiscal Reports

The fiscal reports include the monthly fiscal update and Paid Activity Funds.

Recommendation: For informational purposes only.

8. 4. **Revenue Contract**

Mr. Altmayer sought approval of the fundraising contracts as presented.

Recommendation: Seeking approval of the Board of Education at their next regular meeting.

8. 5. **Establish the Fiscal Year**

Administration is seeking approval of the Finance Committee to establish a fiscal year for Huntley Community SD158 as per 105ILCS 5/17-1, for the period of July 1, 2020 through June 30, 2021.

Recommendation: Seeking approval of the Board at their next Regular meeting.

8. 6. **Designation of Person to Prepare a Tentative Budget**

A resolution seeking appointment of Mr. Altmayer as the person to prepare a Tentative Budget of the Board will be presented.

Recommendation: Seeking approval of the Board at their next regular meeting.

9. **Building and Grounds (B&G) Committee**

9. 1. **Operations & Maintenance (O&M) Updates**

Mr. Renkosik provided the O&M projects updates.

Recommendation: For informational purposes only.

9. 2. **FY20 O&M Department Annual Report**

Mr. Renkosik provided the update on O&M Annual Report.

Recommendation: For informational purposes only.

9. 3. **HHS Fine Arts Addition Construction Update**

Mr. Renkosik provided the updates on HHS Fine Arts Addition.

Recommendation: For informational purposes only.

9. 4. **JCI Service Agreement for Mackeben Chiller Preventative Maintenance**

Mr. Renkosik presented the service agreement, seeking approval of the Board at their next regular meeting.

Recommendation: Seeking approval of the Board of Education at their next regular meeting on February 20, 2020

9. 5. **Asphalt Crackfill, Sealcoat and Traffic Paint Bid**

Mr. Renkosik reported the results of the bid opening with a recommendation for award.

Recommendation: Seeking approval of the Board of Education at their next regular meeting on February 20, 2020

9. 6. **HHS Fine Arts Addition Proposed Change Order (PCO #012) to Contract with Dupage Topsoil**

Mr. Renkosik presented PCO2 to contract with Dupage Topsoil.

Recommendation: Seeking approval of the Board of Education at their next regular meeting on February 20, 2020

9. 7. **Stage Curtain and Pipe Frame Bid**

Mr. Renkosik presented the results of the bid process with a recommendation for award.

Recommendation: Seeking approval of the Board of Education at their next regular meeting on February 20, 2020

9. 8. **Main Stage Theatrical Supply Inc.'s Proposal for Lighting for the Black Box Theatre Construction**

Mr. Renkosik presented the proposal seeking the approval of the Board at its next regular meeting.

Recommendation: Seeking approval of the Board of Education at their next regular meeting on February 20, 2020

9. 9. **Lowery McDonnell Company's Proposal for Music Equipment Storage Lockers**

Mr. Renkosik presented the proposal seeking the approval of the Board at its next regular meeting.

Recommendation: Seeking approval of the Board of Education at their next Regular Meeting on February 20, 2020

10. **Legislation Committee**

10. 1. **Legislation Updates**

Mr. Fleck provided updates on Senate Bill.

Recommendation: For informational purposes only.

11. **Superintendent's Report**

11. 1. **Strategic Plan Mid-year Report**

Dr. Rowe gave the mid-year report on the District's Strategic Plan Indicators for 2020-21 school year.

Recommendation: For informational purposes only

**Suspend COW Meeting @ 7:17p.m. To hold Special Meeting. Mr. Fleck moved/ Mr. Quagliano 2nd.
Special Meeting held @ 7:18 p.m.**

COW resumes @ 7:26p.m. Mr. Fleck moved/Mr. Troy 2nd.

12. **Board of Education**

12. 1. **Board of Education - Minute Review**

The following draft meeting minutes were review and moved forward for approval.

Regular Meeting January 16, 2020 and Closed Session Minutes for January 16, 2020

13. **Closed Session / Roll Call**

Move to enter into closed session at 7:27 p.m. as indicated in the Open Meetings Act and 5ILCS120/2c for discussion of (1) The appointment, employment, discipline, performance, or dismissal of specific employees or legal counsel; (2) Collective negotiating matters.

Roll Call: Ayes 6/ Nays 0 / Absent 1/ **Motion Carried**

Members: Mr. Fleck, Mr. Geheren, Mr. Gentry, Mr. Quagliano, Mrs. Melendy, Mr. Troy, Mrs. Maiorino

13. 1. **Exit Closed Session / Voice Call**

Move to exit closed session at 7:27 p.m. and return to open session. **Voice Call:** Ayes 6 / Nays 0/
Absent/ 1 – Mrs. Melendy. **Motion Carried**

14. **Resume in Public Session / Roll Call**

Resume the Committee of the Whole meeting at 7:27 p.m. **Roll Call:** Ayes / Absent / **Motion Carried**

15. **Adjournment**

Motion to adjourn the meeting at 8:40 p.m. **Voice Call:** Ayes 6/ Nays 0 / **Motion Carried**

Submitted by,
Julie Stock, Board Operations
Paul Troy, Board Secretary

These minutes are subject to approval.

President Date

Secretary Date

Huntley Community School District 158 – Board of Education
Regular Meeting
January 16, 2020 Minutes – draft

Meeting: Regular Meeting with Closed Session as per OMA and 5ILCS120/2c

Time: 6:00 PM

Location: Administrative Building in the Board Room, 650 Dr. John Burkey Dr., Algonquin, Illinois

Mission Statement: Our learning community will inspire, challenge and empower all students always.

Board of Education Members: President, Mr. Michael Fleck; Vice President, Mr. Anthony Quagliano; Secretary, Mr. Paul Troy; Mr. William Geheren; Mrs. Melissa Maiorino; Mrs. Lesli Melendy.

Minutes

1. Call to Order / Roll Call

Call to order the January 16, 2020

Regular Meeting at 6:02 p.m. A quorum must be met.

Roll Call: Ayes 5 / Absent 2 (Mrs. Maiorino, Mr. Quagliano)/ **Motion Carried**

2. Closed Session / Roll Call

Move to enter into closed session at 6:03p.m. as indicated in the Open Meetings Act and 5ILCS120/2c for discussion of: **(1)** The appointment, employment, discipline, performance, or dismissal of specific employees or legal counsel; **(2)** Collective negotiating matters; **(9)** Student Disciplinary; **(11)** Litigation; **(14)** Discussion of minutes of meetings lawfully closed under this Act.

Roll Call: Ayes 5/ Nays 0/ Absent Absent 2 (Mrs. Maiorino, Mr. Quagliano)/ **Motion Carried**

T. Quagliano entered @ 6:26

M. Maiorino entered @ 6:29

2. 1. Exit or Suspend Closed Session / Voice Call

Move to exit closed session at 7:00 p.m. and return to open session.

Voice Call: Ayes 7/ Nays 0/ **Motion Carried**

3. Resume in Public Session / Roll Call

Resume the Regular meeting at 7:05 pm.

Roll Call: Ayes 7 / Absent 0/ **Motion Carried**

3. 1. Action as Required / Roll Call

Action was taken by the BOE. The Board voted to 5-0-2 to expel student #2020-01 as recommended.

Roll Call: Ayes 5/ Nays /Abstain 2 (Mrs. Maiorino, Mr. Quagliano)

Motion Carried

Action: Recommendation will come from the Board.

4. Pledge of Allegiance

Principal Ms. Sheryl Pauwels and student from the Early Childhood Center led us in the pledge.

5. Public Comment - None

6. Revision and Adoption of the Agenda / Voice Call

Move to adopt the agenda with changes. Removal of items # 7,8,10,11,12

Voice Call: Ayes 7/ Nays 0 / **Motion Carried**

Action:

7. Associate Superintendent's Report - None

8. Assistant Superintendent Learning and Innovation - None

9. Chief Financial Officer/Treasurer - None

9. 1. Fiscal Services Reports

Mr. Altmayer provided the Monthly Fiscal Updates and Activity Fund Balance Report.

Recommendation: For informational purposes only.

9. 2. **Revenue and Expenditure Report**

Mr. Altmayer reviewed the packet and fielded questions from the BOE.

Recommendation: For informational purposes only.

10. **Assistant Superintendent of HR Report - None**

11. **Chief Technology Officer - None**

12. **Assistant Superintendent of Special Services - None**

13. **Community Relations & Student Outreach**

13. 1. **Freedom of Information Act (FOIA) Requests**

Mr. Armstrong presented the FOIA report to the BOE

Recommendation: For informational purposes only.

14. **Policy Committee**

14. 1. **Policy Updates** The Board was presented with a number of policy update recommendations as included in the October- November 2019 issue of PRESS. The complete list of recommendations is available online. Most recommendations were in relation to changes in state law. Included in the recommendations were updates in relation to the State's legalization of cannabis, which became effective January 1, 2020. The policies were recommended to move forward for first reading at the Board's next regular meeting. In separate action, the Board approved second readings of two policies as recommended by PRESS in relation to strengthening the District's policies on targeted school violence prevention program and prevention of and response to bullying, intimidation, and harassment, in accordance with school code.

15. **Buildings and Grounds Report**

15. 1. **O&M Updates**

The Board of Education heard a positive report from Mr. Renkosik, director of operations and maintenance, about the ongoing construction of the District's solar energy project. Installation is underway at all three of the District's campuses and is expected to continue through the winter. Systems are expected to be operational in March 2020. The project covers a total of approximately 14 acres of property, and includes 14,117 solar panels.

Recommendation: For informational purposes only.

15. 2. **HHS Fine Arts Addition Construction Update (R)**

Mr. Renkosik reported on Fine Arts Addition progress.

Recommendation: For informational purposes only

16. **President's Report**

16. 1. **Legislative Updates**

Mr. Fleck will provide legislative updates.

Recommendation: For informational purposes only.

17. **Action Items / Roll/Voice Call**

Action items require a motion and a second; discussion if needed, and roll or voice call.

17. 1. **Board of Education**

17. 1. 1. **Minutes**

The following minutes were approved: December 5, 2019 Committee of the Whole; December 19, 2019 Waiver Hearing; Regular Meeting; and Closed Session Minutes for December 5, 2019 and December 19, 2019

Voice Call: Ayes (7) / Nays (0) / **Motion Carried**

Mr. Fleck moved, Mrs. Melendy 2nd

Action: Approved as presented.

17. 2. **Human Resources Committee**

17. 2. 1. **HR Personnel -None**

17. 2. 2. **Grievance Submitted by HEA on Behalf of Lindsay Sara**

Roll Call: Ayes (6) / Nays (1) / **Motion Carried**

Mr. Fleck moved, Mr. Quagliano 2nd

Action: Approved as presented.

17. 3. **Finance Committee**

17. 3. 1. **2016 Debt Refunding Abatement Resolution #2020-01-01**

Sought approval of the Board, to abate \$471,675 by the Resolution providing for the payment of debt service on the outstanding General Obligation Refunding School Bonds, Series 2016, of the District, and abating a portion of the taxes heretofore levied for the year 2019 for said bonds. **Roll Call:** Ayes 7 / Nays 0 / **Motion Carried**

Mr. Fleck moved, Mrs. Maiorino 2nd.

Action: Approved as presented.

17. 3. 2. **Payables**

Seeking approval of the following payables as issued: Purchase Orders at \$3,866,023.39; Accounts Payable at \$20,180.69; Imprest Checks at \$100,349.03; Disbursements at \$17,219,876.89; as presented.

Roll Call: Ayes (7) / Nays (0) / **Motion Carried.**

Action: Approved as presented.

17. 3. 3. **Board Member Expenses**

Per the Local Government Travel Expense Control Act (50 ILCS 150/15), all Board member expenses must be approved by a roll call vote at an open meeting of the Board.

Roll Call: Ayes (6) / Nays (0)/Abstain (1) **Motion Carried**

Mr. Fleck/Mrs. Maiorino 2nd.

Action: Approved as presented.

17. 3. 4. **Audit Engagement Letter**

Mr. Altmayer presented a 2-year audit engagement letter from Evans Marshall & Pease, P.C.

Roll Call: Ayes(7) /Nayes (0) **Motion Carried**

Mr. Fleck moved/Mr. Quagliano 7-0

Action: Approved as presented.

17. 4. **Buildings and Grounds Committee**

17. 4. 1. **Authorized Agent of the Board of Education for Energy Procurement Contracts**

Mr. Renkosik sought approval of the Board of Education to recommend a Board member to act as its authorized agent of the Board to sign approval of natural gas and electricity procurement contracts, until January 2021 Board Meeting.

Roll Call: Ayes (7) / Nays (0)/ **Motion Carried**

Mr. Fleck moved, Mr. Quagliano 2nd.

Action: Approved as presented.

17. 4. 2. **Make Up Air System Bid**

Mr. Renkosik presented the Make Up Air System Bid with a recommendation to award the bid to Jensen Plumbing and Heating in the amount of \$68,490.00

Roll Call: Ayes (7) / Nays (0)/ **Motion Carried**

Mr. Fleck moved, Mr. Troy 2nd.

Action: Approved as presented.

17. 4. 3. **Cafeteria Tables Replacement**

Mr. Renkosik presented the Cafeteria table replacement proposal with a recommendation to purchase 28 folding cafeteria tables from Lowery McDonnell Company according to their proposal dated 1-7-20 as attached at a cost of \$49,428.96.

Roll Call: Ayes (7) / Nays (0)/ Motion Carried

Mr. Fleck moved, Mr. Troy 2nd.

Action: Approved as presented.

17. 4. 4. **HHS Fine Arts Addition Proposed Change Order 006**

Mr. Renkosik presented Proposed Change Order #006 dated 11-25-19 from Lamp Inc. in the amount of \$27,683.00.

Roll Call: Ayes (7) / Nays (0)/ Motion Carried

Mr. Fleck moved, Mr. Geheren 2nd.

Action: Approved as presented.

17. 5. **Policy**

The following policies were submitted as second reading as requested by the Board of Education.

4:190 Targeted School Violence Prevention Program

7:180 Prevention of and Response to Bullying, Intimidation, and Harassment

Roll Call: Ayes (7) / Nays (0)/ Motion Carried

Mr. Fleck moved, Mr. Geheren 2nd.

Action: Approved as presented.

18. **Public Comment** -None

19. **Adjournment**

Motion to adjourn the meeting at 8:02 p.m. **Voice Call: Ayes 7/ Nays 0 / Motion Carried**

Submitted by,
Julie Stock, Board Operations
Paul Troy, Board Secretary

These minutes are subject to approval.

President

Date

Secretary

Date

Huntley Community School District 158 – Board of Education
Regular Meeting
February 20, 2020 Minutes – draft

Meeting: Regular Meeting with Closed Session as per OMA and 5ILCS120/2c

Time: 6:00 PM

Location: Administrative Building in the Board Room, 650 Dr. John Burkey Drive, Algonquin, Illinois

Mission Statement: Our learning community will inspire, challenge and empower all students always.

Board of Education Members: President, Mr. Michael Fleck; Vice President, Mr. Anthony Quagliano; Secretary, Mr. Paul Troy; Mr. William Geheren; Mrs. Melissa Maiorino; Mrs. Lesli Melendy, Mr. Gentry

Minutes

1. Call to Order / Roll Call

Call to Order the Thursday, February 20, 2020 Board of Education's Regular meeting at 6:01p.m. A quorum must be met.

Roll Call: Ayes 5/ Absent 2 /Mr. Mrs. Maiorino, Anthony Quagliano/ **Motion Carried**

Members: Mr. Fleck, Mr. Geheren, Mr. Gentry, Mr. Quagliano, Mrs. Melendy, Mr. Troy, Mrs. Maiorino

2. Closed Session / Roll Call

Move to enter into Closed Session at 6:02 p.m. as indicated in the Open Meetings Act and 5ILCS120/2c for discussion of: (1) The appointment, employment, discipline, performance, or dismissal of specific employees or legal counsel; (2) Collective negotiating matters; (9) Student Disciplinary; (11) Litigation; (21) Discussion of minutes of meetings lawfully closed under this Act.

Roll Call: Ayes 5 / Nays 0/ Absent 2 / **Motion Carried**

Mr. Quagliano arrived @ 6:38 and Mrs. Maiorino arrived @ 6:10

2. 1. Exit or Suspend Closed Session / Voice Call

Move to exit or suspend Closed Session at 7:03 p.m. and return to Open Session.

Voice Call: Ayes 7/ Nays 0 / **Motion Carried**

3. Resume in Public Session / Roll Call

Resume the Regular Meeting at 7:06p.m. **Roll Call:** Ayes 7/ Absent 0/ **Motion Carried**

3. 1. Action as required / Roll Call

Will come from the Board.

Roll Call: Ayes 6/ Abstain 1 /Absent 0/ **Motion Carried**

Student 2020-02 was expelled

Action: Recommendation came from the Board.

4. Pledge of Allegiance

Heineman Middle School Principal Jake Litchfield will introduce Office Dykstra. Campus Resource Officer Dykstra and the CRO Ambassadors lead us in the pledge: Colin Boyle, Jordan Crowley, Benjamin Gaus, Daniel Jarzabek, Isabella Kemblowski, Alexander Moreno, Emilio Perez, Abigail Ressler.

5. Academic Spotlight – HHS Business INCubator Program Highlighted

Three students from the Huntley High School Business INCubator program presented their idea for a startup, representing the class that is in its inaugural year at HHS. Seniors Mark Vandy, Isaiah Wilkerson, and Mitchell Walsh presented their idea for a website/app integrating events and hangouts for teens as a means of improving social access for students. The idea has received initial funding from local business leaders at its initial stage. The class integrates nationally leading entrepreneurship curriculum from INCubatoredu with real-world instruction and mentoring from local entrepreneurs and business leaders. Students will pitch their ideas and business plans to a group of potential investors this spring. Student Ryan Sroka was also in the group but could not attend

6. Staff Recognition

The Board honored Andy Jakubowski, longtime teacher and head baseball coach at Huntley High School, in recognition of his recent induction into the Illinois High School Baseball Coaches Association Hall of Fame earlier this winter. Jakubowski has been head coach at HHS since 2006, achieving a record of 327-192-2, with an overall career record of 422-308-2. His teams have won six FVC titles, seven regional titles, three sectional titles, and a 4th place state finish in 2010 and a 2nd place state finish in 2018. In addition, over 120 of his players have gone on to play collegiately.

7. **Public Comment**

8. **Revision and Adoption of the Agenda / Voice Call**

Move to adopt the agenda as presented (or with changes). **Voice Call:** Ayes 7/ Nays 0 / **Motion Carried**

Agenda adopted with the following changes. Removal of 10,11,12,14.

Motion Carried: 7-0 Mr. Fleck moved, Mrs. Melendy 2nd.

Action: Adoption of the Agenda with changes.

9. **Associate Superintendent's Report**

Recommendation: For informational purposes only.

9. 1. **Wellness Committee**

Ms. Lombard gave the Board an update on the Districts Wellness Committee. The District is compliant with all wellness guidelines.

10. **Assistant Superintendent Learning and Innovation - Removed**

11. **Chief Financial Officer/Treasurer - Removed**

12. **Assistant Superintendent of HR - Removed**

13. **Chief Technology Officer -**

14. **Assistant Superintendent for Special Services - Removed**

15. **Community Relations & Student Outreach**

15. 1. **Freedom of Information Act (FOIA) Requests**

Mr. Armstrong presented the monthly FOIA report to the Board.

Recommendation: For informational purposes only.

16. **President's Report**

16. 1. **Legislative Updates**

Mr. Fleck will provide legislative updates.

Recommendation: For informational purposes only.

17. **Superintendent's Report**

Strategic Planning Update We have completed our 5th strategic planning community engagement session. Our next community engagement session will be a double presentation day. On March 10 from 9-11, we are presenting to Sun City at the Drendel Ballroom. We will be sharing a compilation of all of our presentations, but mainly focusing on finance. We will however, conduct a work activity seeking their feedback on the most important areas for the district to include in the strategic plan to focus on for improvement. The evening presentation will be somewhat of a culmination of the entire process. We will share the collection of pillars that have been identified for our strategic plan to embody and seek feedback as well as any additional area that may not have been captured. Following the March 10 meeting, we will begin working with the plan construction team and work towards our June board presentation of the plan for your approval.

ISBE Strategic Plan The state strategic plan has been making its circulation around the state for feedback. While I was unable to attend one of the feedback sessions I did submit my views via the survey as well as sending a personal letter to Dr. Ayala, the State Superintendent, expressing my displeasure for the lack of innovative vision in the state. I have placed a copy of the letter at your place as well as linked it to the agenda for the public to view. Additionally, I have been in contact with Brent Clark, the director of IASA, Jason Leahey, the director of the IPA, Michael Jacoby, the director of IASBO, as well as the other competency pilot districts to come together and implore the Illinois State Board of Education to continue to push toward educational

innovation, in addition to the other efforts they are currently advocating for, which are needed as well. Mr. Troy, I would ask that you use your position in the IASB Kiswaukee regional board to share our message of advocacy at your next opportunity as well.

18. **Items Removed from the Consent Agenda**

The Consent Agenda was approved as presented to the Board.
Mr. Fleck moved

19. **Consent Agenda / Roll Call**

The following items have gone through the Committee of the Whole. Prior to adoption, revisions are presented here. **Roll Call:** Ayes 7 / Nays 0/ **Motion Carried - Mr. Fleck moved, Mr. Gentry 2nd Members:** Mr. Troy, Mrs. Walker, Mr. Geheren, Mr. Fleck, Mr. Gentry, Mr. Quagliano, Mrs. Melendy

19. 1. **Policy Committee**

19. 1. 1. **Policy**

PRESS Updates

First reading of an update to the District policy for hiring, primarily to reflect changes in state law.

Action: **Approved as presented.**

19. 2. **Finance Committee**

19. 2. 1. **Payables**

Mr. Altmayer will sought approval of the purchase orders at \$718,402.25; Imprest checks at \$90,062.30; accounts payable at \$3,719.11; and disbursements issued at \$1,610,357.97.

Action: **Approved as presented**

19. 2. 2. **Establish the Fiscal Year - Resolution**

Administration is sought approval of the Finance Committee to establish a fiscal year for Huntley Community SD158 as per 105ILCS 5/17-1, for the period of July 1, 2020 through June 30, 2021.

Action: **Approved as presented**

19. 2. 3. **Designation of Person to Prepare a Tentative Budget**

A resolution seeking appointment of Mr. Altmayer as the person to prepare a Tentative Budget of the Board will be presented

Action: **Approved as presented**

19. 2. 4. **Revenue Contract**

Mr. Altmayer will seek approval of the fundraising contracts as presented.

Action: **Approved as presented**

19. 3. **Building and Grounds (B&G) Committee**

19. 3. 1. **JCI Service Agreement for Mackeben Chiller Preventative Maintenance**

At the 2.6.20 COW, the B & G Committee moved forward the service agreement with JCI.

Action: **Approved as presented**

19. 3. 2. **Stage Curtain and Pipe Frame Bid**

At the 2.6.20 COW, the B & G Committee moved forward the bid for Stage Curtain and Pipe Frame Bid.

Action: **Approved as presented**

19. 3. 3. **Lowery McDonnell Company's Proposal for Music Equipment Storage Lockers**

At the 2.6.20 COW, the B & G Committee moved forward the Lowery McDonnell Company's Proposal for Music Equipment Storage Lockers.

Action: **Approved as presented**

19. 3. 4. **Asphalt Crackfill, Seal Coat and Traffic Paint Bid**

At the 2.6.20 COW; the B & G Committee moved forward the Asphalt Crackfill, Sealcoat and Traffic Paint Bid.

Action: Approved as presented

19. 3. 5. **HHS Fine Arts Addition Proposed Change Order (PCO #012) to Contract with Dupage Topsoil**
At the 2.6.20 COW, the B & G Committee moved forward the PCO2 to the contract with Dupage Topsoil.

Action: Approved as presented

19. 4. **Human Resources**

19. 4. 1. **HR Personnel Report**

Seeking approval of the personnel reports provided and reviewed by the Board, which includes explanation for resignations, retirements, terminations, employment, contract revisions, and leave requests, as presented.

Action: Approved as presented

20. **Action Items / Roll Call**

20. 1. **Supplemental Purchase Orders and Supplemental Accounts Payable**

Mr. Altmayer sought approval of the Supplemental Purchase Orders Report at \$2,535,008.01 and the Supplemental Accounts Payable Report at \$15,015.77, as presented.

Roll Call: Ayes 7 / Nays 0/ Motion Carried – Mr. Fleck moved, Mr. Troy 2nd

Action: Approved as presented

20. 2. **Main Stage Theatrical Supply Inc.'s Proposal for Lighting for the Black Box Theater Construction**

Mr. Renkosik presented the proposal seeking the approval of the Board at its next regular meeting.

Roll Call: Ayes 7/ Nays 0/ Motion Carried - Mr. Fleck moved, Mr. Gentry 2nd

Action: Approved as presented

20. 3. **Resolution of Non Re-Employment - Resolution #2020-02-03**

Mr. Zehr presented the Resolution of Non Re-employment.

Roll Call: Ayes 7/ Nays 0/ Motion Carried - Mr. Fleck moved, Mr. Geheren 2nd

Action: Approved as presented

21. **Public Comment** - None

22. **Adjournment**

Motion to adjourn the meeting at 8:26 p.m. **Voice Call: Ayes 7/ Nays 0/ Motion Carried**

Submitted by,
Julie Stock, Board Operations
Paul Troy, Board Secretary

These minutes are subject to approval.

President

Date

Secretary

Date