



**MINOOKA COMMUNITY HIGH SCHOOL DISTRICT #111  
SPECIAL MEETING  
WEDNESDAY, FEBRUARY 9, 2022, 5:30 PM**

The Special Meeting will be held at the  
Central Campus Performing Arts Center  
301 South Wabena Avenue  
Minooka, Illinois 60447

In order to make a public comment, please sign up 5 minutes prior to Roll Call. The public comment portion of the meeting will be in accordance with Policy 2:230. Please review said policy prior to the Board of Education Meeting

**AGENDA**

1. **Call to Order**
2. **Roll Call**
3. **Public Comments**
4. **Discussion**
  - A. Update on TRO/Executive Order/Motion to Stay
5. **Action Items** **3**

Consideration and Possible Approval to re-affirm/update/amend the July 21, 2021 resolution regarding Covid mitigation at Minooka Community High School
6. **Discussion**
  - A. School Calendar Drafts 9
  - B. Policy (Mr. Grzetich)
    1. Final Exams
    2. Policy 6:135 12
    3. Policy 8:80 13
      - a. Davidson Trust Foundation Donation
      - b. Donation to Athletics
  - C. B & G (Mr. Shepard)
    1. Annual Inspection Report
    2. Performance Contracting Bid Update
    3. HVAC/Roof Improvement Updates 14
  - D. Finance (Mrs. Crye)
    1. Financial Reports
      - a. Monthly Financial Report 15
      - b. Payment of Bills/Total
      - c. Employee Payroll 22

d. Imprest Fund Report/Total	23
e. Activity Fund Report	24
f. Treasurer's Report (Cash/YTD - Exp/Rev)	30
2. Fryer Purchase	
E. TIF (Aux Sable) Amendment Notice	138
F. Bus Lease Bid/Van	199
G. Chromebook Purchase/Student Fees 2022/2023	351
H. Personnel (Mr. Brozovich)	
1. Executive Session - to adjourn the meeting to executive session for discussion on matters related to the appointment, compensation, discipline, dismissal, employment and performance of specific employees of the District; individual student discipline, litigation, real property, and collective bargaining.	
2. Return to Open Session	
I. Other	
<b>7. Announcements and Communications</b>	
<b>8. Adjourn</b>	

# DRAFT

## RESOLUTION REGARDING IDPH GUIDANCE FOR COVID-19 PREVENTION IN K-12 SCHOOLS

**WHEREAS**, on July 9, 2021, the IDPH formally adopted the CDC guidance for COVID-19 prevention in K-12 schools.

**WHEREAS**, on July 9, 2021, the ISBE informed all Illinois schools to use the updated CDC guidance to start the 2021-22 school year.

**WHEREAS**, on May 19, 2021, the ISBE passed a resolution stating that all schools statewide must resume fully in-person learning for all student attendance days and limit remote learning to only those students under a quarantine order by a local public health department or the IDPH.

**WHEREAS**, the CDC guidance does not contain a mask mandate, but rather a recommendation that “masks **should** be worn indoors by all individuals (age 2 and older) who are not fully vaccinated.”

**WHEREAS**, the CDC guidance states that students and staff are not required to wear masks outdoors.

**WHEREAS**, the CDC guidance recommends that schools should work with local public health officials to determine the prevention strategies needed in their area by monitoring levels of community transmission, local vaccine coverage, and the use of screening to detect cases.

**WHEREAS**, the CDC guidance states, “Regardless of mask policy at school, passengers and drivers **must** wear a mask on school buses, including on buses operated by public and private school systems.”

**WHEREAS**, Minooka Community High School District #111 believes that all students should have the opportunity to receive in-person learning in the least restrictive environment that maximizes their academic, physical, and mental health.

**WHEREAS**, Minooka Community High School District #111 used multiple COVID mitigation measures with success during the 2020-2021 school year and the beginning of the 2021-2022 school year.

**WHEREAS**, on August 4, 2021 Governor Pritzker issued an emergency order which, among other items, required masks be worn in schools. This order was subsequently followed up by additional orders addressing quarantining, and vaccination/testing.

**WHEREAS**, on February 4, 2022 a Sangamon County Court Judge issued a TRO in a case in which the district is a named defendant. The TRO prevents the district from enforcing the Governor’s emergency orders and the IDPH/ISBE emergency orders on masks, quarantining, and vaccination/testing.

# DRAFT

**NOW, THEREFORE BE IT RESOLVED** by the Minooka Community High School District #111 Board of Education that in accordance with CDC guidance, the following recommendations are adopted for the remainder of the 2021-2022 school year.

1. All students will be provided a full day of in-person instruction.
2. As long as supported by local health data, mask usage will be encouraged for all unvaccinated individuals, but there will be no universal mask mandate for students/staff.
3. Individuals will not be required to disclose their vaccination status to school district officials. Parents, students and staff may wish to voluntarily disclose their vaccination status. ~~to avoid a mandatory quarantine for close contact with a COVID-positive person.~~
4. Masks will be required for all students/staff while on a school bus.
5. Generally, Remote learning will only be offered to those students under a quarantine order by a local public health department or the IDPH. The remote learning experience will be at the discretion of the individual teacher(s). However, the district's remote approval team will continue to evaluate on a case-by-case basis remote learning requests from students and staff based upon their individual circumstances and medical conditions as well as in accordance with any applicable 504 and ADA requirements.
6. All schools will continue with other health and safety prevention strategies such as
  - Maintain social distancing as appropriate for the conditions.
  - daily self-certification for students and staff
  - mandatory quarantines for COVID-positive or symptomatic students and staff
  - Covid symptomatic students and staff may return with a negative test result.
  - ~~mandatory quarantines for unvaccinated individuals in close contact with a COVID-positive person~~
  - encouraging and practicing proper hand and respiratory hygiene
  - ensuring proper ventilation in all schools
  - practicing proper cleaning and disinfection of learning spaces
  - voluntary community-based or in-house COVID testing program for symptomatic students/staff
  - in accordance with CDC guidance, staff and age eligible students (~~currently age 12 and older~~) are encouraged to receive a COVID-19 vaccine and boosters.
7. School district administration will continuously monitor local health data and consult with local public health officials. This health data will be periodically reported to the Board of Education and school district staff/parents/guardians.
8. Should local health data require increased mitigations (i.e. ~~mask mandate~~, increased social distancing, changes in lunch service, remote learning, etc.) the Board of Education will not hesitate to make such changes to ensure the health and safety of all students and staff.
9. To ensure that the district can respond quickly to changing conditions the Board authorizes the administration, after informing the Board, to make such changes to this policy as are necessary to respond to those conditions and then present those changes to the Board at the next meeting.

# DRAFT

**PASSED** this \_\_\_\_\_ day of \_\_\_\_\_, 2021

\_\_\_\_\_  
School Board President

\_\_\_\_\_  
School Board Secretary

Voting No: \_\_\_\_\_

Voting Yes: \_\_\_\_\_

Abstaining: \_\_\_\_\_

## **RESOLUTION REGARDING COVID-19 PREVENTION**

**WHEREAS**, on July 9, 2021 the IDPH formally adopted the CDC guidance for COVID-19 prevention in K-12 schools.

**WHEREAS**, on July 9, 2021, the ISBE informed all Illinois schools to use the updated CDC guidance to start the 2021-22 school year.

**WHEREAS**, on May 19, 2021, the ISBE passed a resolution stating that all schools statewide must resume fully in-person learning for all student attendance days and limit remote learning to only those students under a quarantine order by a local public health department or the IDPH.

**WHEREAS**, the CDC guidance does not contain a mask mandate, but rather a recommendation that "masks *should* be worn indoors by all individuals (age 2 and older) who are not fully vaccinated."

**WHEREAS**, the CDC guidance states that students and staff are not required to wear masks outdoors.

**WHEREAS**, the CDC guidance recommends that schools should work with local public health officials to determine the prevention strategies needed in their area by monitoring levels of community transmission, local vaccine coverage, and the use of screening to detect cases.

**WHEREAS**, the CDC guidance states, "Regardless of mask policy at school, passengers and drivers *must* wear a mask on school buses, including on buses operated by public and private school systems."

**WHEREAS**, Minooka Community High School District #111 believes that all students should have the opportunity to receive in-person learning in the least restrictive environment that maximizes their academic, physical, and mental health.

**WHEREAS**, Minooka Community High School District #111 used multiple COVID mitigation measures with success during the 2020-2021 school year and the beginning of the 2021-2022 school year.

**WHEREAS**, on August 4, 2021 Governor Pritzker issued an emergency order which, among other items, required masks be worn in schools. This order was subsequently followed up by additional orders addressing quarantining, and vaccination/testing.

**WHEREAS**, on February 4, 2022 a Sangamon County Court Judge issued a TRO in a case in which the district is a named defendant. The TRO prevents the district from enforcing the Governor's emergency orders and the IDPH/ISBE emergency orders on masks, quarantining, and vaccination/testing.

**NOW, THEREFORE BE IT RESOLVED** by the Minooka Community High School District #111 Board of Education that in accordance with CDC guidance, the following recommendations are adopted for the remainder of the 2021-2022 school year.

*MW 2/9/2022*

1. All students will be provided a full day of in-person instruction. *Optional*
2. As long as supported by local health data, mask usage will be ~~encouraged~~ for all individuals, but there will be no universal mask mandate for students/staff.
3. Individuals will not be required to disclose their vaccination status to school district officials. Parents, students and staff may wish to voluntarily disclose their vaccination status
4. Masks will be required for all students/staff while on a school bus.
5. Generally, remote learning will only be offered to those students under a quarantine order by a local public health department or the IDPH. The remote learning experience will be at the discretion of the individual teacher(s). However, the district's remote approval team will continue to evaluate on a case-by-case basis remote learning requests from students and staff based upon their individual circumstances and medical conditions as well as in accordance with any applicable 504 and ADA requirements.
6. All schools will continue with other health and safety prevention strategies such as
  - Maintain social distancing as appropriate for the conditions.
  - daily self-certification for students and staff
  - mandatory quarantines for COVID-positive or symptomatic students and staff
  - Covid symptomatic students and staff may return with a negative test result.
  - encouraging and practicing proper hand and respiratory hygiene
  - ensuring proper ventilation in all schools
  - practicing proper cleaning and disinfection of learning spaces
  - voluntary community-based or in-house COVID testing program for symptomatic students/staff
  - in accordance with CDC guidance, staff and age eligible students are encouraged to receive a COVID-19 vaccine and boosters.
7. School district administration will continuously monitor local health data and consult with local public health officials. This health data will be periodically reported to the Board of Education and school district staff/parents/guardians.
8. Should local health data require increased mitigations (i.e. increased social distancing, changes in lunch service, remote learning, etc.) the Board of Education will not hesitate to make such changes to ensure the health and safety of all students and staff.
9. To ensure that the district can respond quickly to changing conditions the Board authorizes the administration, after informing the Board, to make such changes to this policy as are necessary to respond to changing conditions and then present those changes to the Board at the next meeting.

PASSED this 9<sup>th</sup> day of February, 2022

School Board President

School Board Secretary

Voting No:

Jim Grzetich, Mike Brozovich

Voting Yes:

Matt Shepard, Terry Spivey, DecCrye, Dustin Heap, Laura Hrechko

Abstaining:

**Spring break has been moved back a week as a result of trying to coordinate with GAVC schools. Not all of our feeders will match up with our spring break.**

**Calendar Option #1 Some changes to the traditional calendar (1/3/1900)**

August 8 and 9 opening institute

October 25 and 27 Parent Teacher Conferences 4-8 PM

October 28 Institute

November 8-legal holiday-Election Day

November 21-Not in Attendance

November 22-No School-Day off for two evenings of Parent Teacher Conferences

December 22-January 3 Holiday Break

January 4-Institute

February 17-Institute

April 3-10 Spring Break aligned with Easter

May 22-Tentative last day of school

**Calendar Option #2 Typical Rollover-with the exception of moving some institute days (ROLL)**

August 8 and 9 opening institute

November 8-legal holiday-Election Day

November 21-Parent Teacher Conferences

November 22-Institute

December 19-January 2 Holiday Break

January 3-Institute

February 17-Institute

April 3-10 Spring Break

May 23-Tentative last day of school.

August 2022								September 2022								October 2022									
S	M	T	W	T	F	S	Total	S	M	T	W	T	F	S	Total	S	M	T	W	T	F	S	Total		
	1	2	3	4	5	6						1	2	3	2							1	0		
7	8	9	10	11	12	13	3	4	5	6	7	8	9	10	4	2	3	4	5	6	7	8	5		
14	15	16	17	18	19	20	5	11	12	13	14	15	16	17	5	9	10	11	12	13	14	15	4		
21	22	23	24	25	26	27	5	18	19	20	21	22	23	24	5	16	17	18	19	20	21	22	5		
28	29	30	31				3	25	26	27	28	29	30		5	23	24	25**	26	27**	28	29	4		
							0									30	31						1		
							16								21								19		
November 2022								December 2022								January 2023									
S	M	T	W	T	F	S	Total	S	M	T	W	T	F	S	Total	S	M	T	W	T	F	S	Total		
		1	2	3	4		4					1	2	3	2	1	2	3	4	5	6	7	2		
6	7	8	9	10	11		4	4	5	6	7	8	9	10	5	8	9	10	11	12	13	14	5		
13	14	15	16	17	18		5	11	12	13	14	15	16	17	5	15	16	17	18	19	20	21	4		
20	21	XXX	23	24	25		0	18	19	20	21	22	23	24	3	22	23	24	25	26	27	28	5		
27	28	29	30				3	25	26	27	28	29	30	31	0	29	30	31					2		
							16								15								18		
February 2023								March 2023								April 2023									
S	M	T	W	T	F	S	Total	S	M	T	W	T	F	S	Total	S	M	T	W	T	F	S	Total		
			1	2	3	4	3				1	2	3	4	3							1	0		
5	6	7	8	9	10	11	5	5	6	7	8	9	10	11	5	2	3	4	5	6	7	8	0		
12	13	14	15	16	17	18	4	12	13	14	15	16	17	18	5	9	10	11	12	13	14	15	4		
19	20	21	22	23	24	25	4	19	20	21	22	23	24	25	5	16	17	18	19	20	21	22	5		
26	27	28					2	26	27	28	29	30	31		5	23	24	25	26	27	28	29	5		
							18								0	30							14		
							18								23								14		
May 2023								June 2023								July 2023									
S	M	T	W	R	F	S	Total	S	M	T	W	T	F	S	Total	S	M	T	W	T	F	S	Total		
	1	2	3	4	5	6	5					1	2	3	0							1			
7	8	9	10	11	12	13	5	4	5	6	7	8	9	10		2	3	4	5	6	7	8			
14	15	16	17	18	19	20	5	11	12	13	14	15	16	17		9	10	11	12	13	14	15			
21	22	23	24	25	26	27	1	18	19	20	21	22	23	24		16	17	18	19	20	21	22			
28	29	30	31				0	25	26	27	28	29	30			23	24	25	26	27	28	29			
							0									30	31								
							16								0								0		
Legal School Holiday							X	Institute Day - No school for students							O	Non-attendance Day							V		
Holiday Waiver - Students Attend							XW	Homecoming								School Improvement Day							S		
								Full Day Parent/Teacher Conference							PTC	Emergency Day							E		
End of grading period (Sec, Elem)							◆ ◀	Total Days of Student Attendance							176										
1st Grading Period				2nd Grading Period				1st Semester				88	3rd Grading Period				4th Grading Period				2nd Semester				88
1st Grading Period				2nd Grading Period				3rd Grading Period																	

Institute

Institute

Full week

10

Institute

Monday in s

August 2022								September 2022								October 2022								
S	M	T	W	T	F	S	Total	S	M	T	W	T	F	S	Total	S	M	T	W	T	F	S	Total	
	1	2	3	4	5	6						1	2	3	2							1	0	
7	8	9	10	11	12	13	3	4	5	6	7	8	9	10	4	2	3	4	5	6	7	8	5	
14	15	16	17	18	19	20	5	11	12	13	14	15	16	17	5	9	10	11	12	13	14	15	4	
21	22	23	24	25	26	27	5	18	19	20	21	22	23	24	5	16	17	18	19	20	21	22	5	
28	29	30	31				3	25	26	27	28	29	30		5	23	24	25	26	27	28	29	5	
							0									30	31						1	
							16								21								20	
November 2022								December 2022								January 2023								
S	M	T	W	T	F	S	Total	S	M	T	W	T	F	S	Total	S	M	T	W	T	F	S	Total	
		1	2	3	4		4					1	2	3	2	1	2	3	4	5	6	7	3	
6	7	8	9	10	11		4	4	5	6	7	8	9	10	5	8	9	10	11	12	13	14	5	
13	14	15	16	17	18		5	11	12	13	14	15	16	17	5	15	16	17	18	19	20	21	4	
20	21	22	23	24	25		0	18	19	20	21	22	23	24	0	22	23	24	25	26	27	28	5	
27	28	29	30				3	25	26	27	28	29	30	31	0	29	30	31					2	
							16								12								19	
February 2023								March 2023								April 2023								
S	M	T	W	T	F	S	Total	S	M	T	W	T	F	S	Total	S	M	T	W	T	F	S	Total	
			1	2	3	4	3				1	2	3	4	3							1	0	
5	6	7	8	9	10	11	5	5	6	7	8	9	10	11	5	2	3	4	5	6	7	8	0	
12	13	14	15	16	17	18	4	12	13	14	15	16	17	18	5	9	10	11	12	13	14	15	4	
19	20	21	22	23	24	25	4	19	20	21	22	23	24	25	5	16	17	18	19	20	21	22	5	
26	27	28					2	26	27	28	29	30	31		5	23	24	25	26	27	28	29	5	
															0	30								
							18								23								14	
May 2023								June 2023								July 2023								
S	M	T	W	R	F	S	Total	S	M	T	W	T	F	S	Total	S	M	T	W	T	F	S	Total	
	1	2	3	4	5	6	5					1	2	3	0							1		
7	8	9	10	11	12	13	5	4	5	6	7	8	9	10		2	3	4	5	6	7	8		
14	15	16	17	18	19	20	5	11	12	13	14	15	16	17		9	10	11	12	13	14	15		
21	22	23	24	25	26	27	2	18	19	20	21	22	23	24		16	17	18	19	20	21	22		
28	29	30	31				0	25	26	27	28	29	30			23	24	25	26	27	28	29		
							0									30	31							
							17								0								0	
Legal School Holiday							X	Institute Day - No school for students							O	Non-attendance Day							V	
Holiday Waiver - Students Attend							XW	Homecoming								School Improvement Day							S	
								Full Day Parent/Teacher Conference							PTC	Emergency Day							E	
End of grading period (Sec, Elem)							◆ ◀	Total Days of Student Attendance							176									
1st Grading Period				2nd Grading Period				1st Semester				3rd Grading Period				4th Grading Period				2nd Semester				0
1st Grading Period				2nd Grading Period				3rd Grading Period																

Institute

Institute

## INSTRUCTION

### **6:135 Accelerated Placement Program**

The District provides an Accelerated Placement Program (APP). The APP advances the District's goal of providing educational programs with opportunities for each student to develop to his or her maximum potential. The APP provides an educational setting with curriculum options usually reserved for students who are older or in higher grades than the student participating in the APP. APP options include, but may not be limited to: (a) accelerating a student in a single subject; and (b) other grade-level acceleration. Participation in the APP is open to all students who demonstrate high ability and who may benefit from accelerated placement. It is not limited to students who have been identified as gifted and talented. Eligibility to participate in the District's APP shall not be conditioned upon the protected classifications identified in Board policy 7:10, *Equal Educational Opportunities*, or any factor other than the student's identification as an accelerated learner.

The Superintendent or designee shall implement an APP that includes:

1. Decision-making processes that are fair, equitable, and involve multiple individuals, e.g. District administrators, teachers, and school support personnel, and a student's parent(s)/guardian(s);
2. Notification processes that notify a student's parent(s)/guardian(s) of a decision affecting a student's participation in the APP;
3. Assessment processes that include multiple valid, reliable indicators; and
4. By the fall of 2023, the automatic enrollment, in the following school term, of a student into the next most rigorous level of advanced coursework offered by the high school if the student meets or exceeds State standards in English language arts, mathematics, or science on a State assessment administered under [105 ILCS 5/2-3.64a-5](#), as follows:
  - a. A student who meets or exceeds State standards in English language arts shall be automatically enrolled into the next most rigorous level of advanced coursework in English, social studies, humanities, or related subjects.
  - b. A student who meets or exceeds State standards in mathematics shall be automatically enrolled into the next most rigorous level of advanced coursework in mathematics.
  - c. A student who meets or exceeds State standards in science shall be automatically enrolled into the next most rigorous level of advanced coursework in science.

LEGAL REF.:

[105 ILCS 5/14A.](#)

[23 Ill.Admin.Code Part 227](#), Gifted Education.

CROSS REF.: 6:10 (Educational Philosophy and Objectives), 6:130 (Program for the Gifted), 7:10 (Equal Educational Opportunities), 7:50 (School Admissions and Student Transfers To and From Non-District Schools)

Adopted: January 19, 2022

**Minooka CHSD 111**

## COMMUNITY RELATIONS

### **8:80 Gifts to the District**

The School Board appreciates gifts from any education foundation, other entities, or individuals. All gifts must adhere to each of the following:

1. Be accepted by the Board or, if less than \$500.00 in value, the Superintendent or designee. Individuals should obtain a pre-acceptance commitment before identifying the District, any school, or school program or activity as a beneficiary in any fundraising attempt, including without limitation, any Internet fundraising attempt.
2. Be given without a stated purpose or with a purpose deemed by the party with authority to accept the gift to be compatible with the Board's educational objectives and policies.
3. Be consistent with the District's mandate to provide equal educational and extracurricular opportunities to all students in the District as provided in Board policy 7:10, *Equal Educational Opportunities*. State and federal laws require the District to provide equal treatment for members of both sexes to educational programming, extracurricular activities, and athletics. This includes the distribution of athletic benefits and opportunities.
4. Permit the District to maintain resource equity among its learning centers.
5. Be viewpoint neutral. The Superintendent or designee shall manage a process for the review and approval of donations involving the incorporation of messages into or placing messages upon school property.
6. Comply with all laws applicable to the District including, without limitation, the Americans with Disabilities Act, the Prevailing Wage Act, the Health/Life Safety Code for Public Schools, and all applicable procurement and bidding requirements.

The District will provide equal treatment to all individuals and entities seeking to donate money or a gift. Upon acceptance, all gifts become the District's property. The acceptance of a gift is not an endorsement by the Board, District, or school of any product, service, activity, or program. The method of recognition is determined by the party accepting the gift.

LEGAL REF.:

[20 U.S.C. §1681](#) *et seq.*, Title IX of the Education Amendments implemented by [34 C.F.R. Part 106](#).

[105 ILCS 5/16-1](#).

[23 Ill.Admin.Code §200.40](#).

CROSS REF.: 4:60 (Purchases and Contracts), 4:150 (Facility Management and Building Programs), 6:10 (Educational Philosophy and Objectives), 6:210 (Instructional Materials), 7:10 (Equal Educational Opportunities)

ADOPTED: September 23, 2020

**Minooka CHSD 111**

---



# MINOOKA

## COMMUNITY HIGH SCHOOL

District #111 [mchs.net](http://mchs.net)

*Mission: Strengthen **M**astery, **C**ollaboration, **H**igh Expectations, and **S**uccess for All Students.*

---

February 9, 2022

To: Board of Education  
Dr. Kenny Lee

From: John Troy

RE: HVAC

The insurance coverage for the storm damage to various sections of the HVAC totaled \$426,918. We took this opportunity to replace those units rather than repair them. The total cost to replace the numerous units plus add air conditioning to the large gym and the three locker rooms (boys, girls, athletic) is \$2,090,000. The net cost to the district less insurance would be \$1,663,082.

I will provide you with an itemized list of each unit being replaced rather than repaired

Additionally, due to the significant improvements in HVAC and control systems we believe it would be prudent at this time to enter into a maintenance contract with Trane. The cost of the contract would be \$14,923/year. We have a similar contract in place at South Campus.

# Monthly Financial Report - January, 2022

The revenues for the month of January in all funds were \$4,827,847.26 which is 7.99% of the annual budgeted revenue. Total revenue year-to-date was \$41,365,396.35, which is 68.45% of the annual budget revenue. Annual budgeted revenues for the year is \$60,428,034.30.

The expenditures for the month of January in all funds were \$4,030,618.53, which is 6.49% of the annual budgeted expenses. Total expenses year-to-date was \$33,522,927.35, which is 53.94% of the annual budget expense. Annual budgeted expense for the year is \$62,147,469.11.

Enrollment (January 31st)	2,870	South Campus	300,000 sq. ft. / 67 acres
Administrators	16	Central Campus	250,000 sq. ft. / 78 acres
Teachers Full-Time	150	Teachers Part-Time	3
Teachers LOA	3	Support Staff	140

Table 1: Year-to-Date Revenue Expense Summary

Year to Date Revenue Expenses vs. Budget	Revenue Budget	Year to Date Revenue	Expense Budget	Year to Date Expenses	Budget Deficit/Surplus	Current Deficit/Surplus
Education Fund *	37,809,332.67	26,227,299.19	36,048,347.77	20,399,350.80	1,760,984.90	5,827,948.39
Activity Fund	200,000.00	407,947.74	293,680.40	336,072.53	(93,680.40)	71,875.21
Operations & Maint Fund *	6,108,488.64	3,652,164.64	5,505,392.41	2,206,796.86	603,096.23	1,445,367.78
Debt Service Fund or Fund Group	8,854,007.76	5,960,530.69	8,500,150.00	7,296,000.00	353,857.76	(1,335,469.31)
Transportation Fund *	2,992,698.79	2,269,608.85	2,552,867.78	1,598,422.99	439,831.01	671,185.86
I.M.R.F./Soc. Sec. Fund	1,074,209.49	746,679.90	925,096.56	526,236.97	149,112.93	220,442.93
Capital Projects Fund or Fund Group	296,600.00	75,938.14	5,000,000.00	234,811.44	(4,703,400.00)	(158,873.30)
Working Cash Fund *	857,541.05	570,551.75	0.00	0.00	857,541.05	570,551.75
Tort Immunity and Judgment Fund	1,381,714.85	885,250.28	1,321,934.19	925,235.76	59,780.66	(39,985.48)
Fire Prevention & Safety Fund	853,441.05	569,425.17	2,000,000.00	0.00	(1,146,558.95)	569,425.17
<b>Total All Funds</b>	<b>60,428,034.30</b>	<b>41,365,396.35</b>	<b>62,147,469.11</b>	<b>33,522,927.35</b>	<b>(1,719,434.81)</b>	<b>7,842,469.00</b>
<b>* Total Operating Funds</b>	<b>47,768,061.15</b>	<b>32,719,624.43</b>	<b>44,106,607.96</b>	<b>24,204,570.65</b>	<b>3,661,453.19</b>	<b>8,515,053.78</b>

Table 2: Month Revenue, Expense & Fund Balances

Jan	* Education Fund	* Operations & Maint Fund	Debt Service Fund or Fund Group	* Transportation Fund	I.M.R.F./Soc. Sec. Fund	Capital Projects Fund or Fund Group	* Working Cash Fund	Tort Immunity and Judgment	Fire Prevention & Safety Fund	Activity Fund	Total All Funds	* Total Operating Funds
Revenue	4,263,290	142,141	21,032	280,548	31,504	30,636	2,253	12,052	2,090	42,300	4,827,847	4,688,233
Expense	2,850,114	412,710	55,450	187,992	74,398	0	0	394,167	0	55,787	4,030,619	3,450,816
Net	1,413,176	(270,568)	(34,418)	92,556	(42,894)	30,636	2,253	(382,115)	2,090	(13,487)	797,229	1,237,417

Table 3: Expenses by Object - Monthly

Monthly Expenses by Object	Salaries	Employee Benefits	Purchased Services	Supplies And Materials	Capital Outlay	Other	Total
July	1,511,130.51	875,395.25	230,616.49	217,522.51	122,033.50	224,911.70	3,181,609.96
August	1,604,571.99	952,327.83	674,323.85	241,481.24	110,622.61	490,521.93	4,073,849.45
September	1,641,907.88	932,071.00	-98,429.90	281,726.24	209,967.24	692,146.57	3,659,389.03
October	1,682,741.94	856,542.75	550,695.74	239,198.30	173,736.43	3,756,652.31	7,259,567.47
November	1,658,630.67	929,877.61	552,969.82	250,008.80	-38,674.50	3,600,570.81	6,953,383.21
December	1,693,167.45	988,466.99	313,026.16	148,682.11	87,976.74	1,133,190.25	4,364,509.70
January	1,648,420.02	986,966.95	684,411.35	173,728.34	47,144.52	489,947.35	4,030,618.53
February	0.00	0.00	0.00	0.00	0.00	0.00	0.00
March	0.00	0.00	0.00	0.00	0.00	0.00	0.00
April	0.00	0.00	0.00	0.00	0.00	0.00	0.00
May	0.00	0.00	0.00	0.00	0.00	0.00	0.00
June	0.00	0.00	0.00	0.00	0.00	0.00	0.00
YTD	11,440,570.46	6,521,648.38	2,907,613.51	1,552,347.54	712,806.54	10,387,940.92	33,522,927.35

Chart 1: MTD, YTD, & Budget Expenses by Object

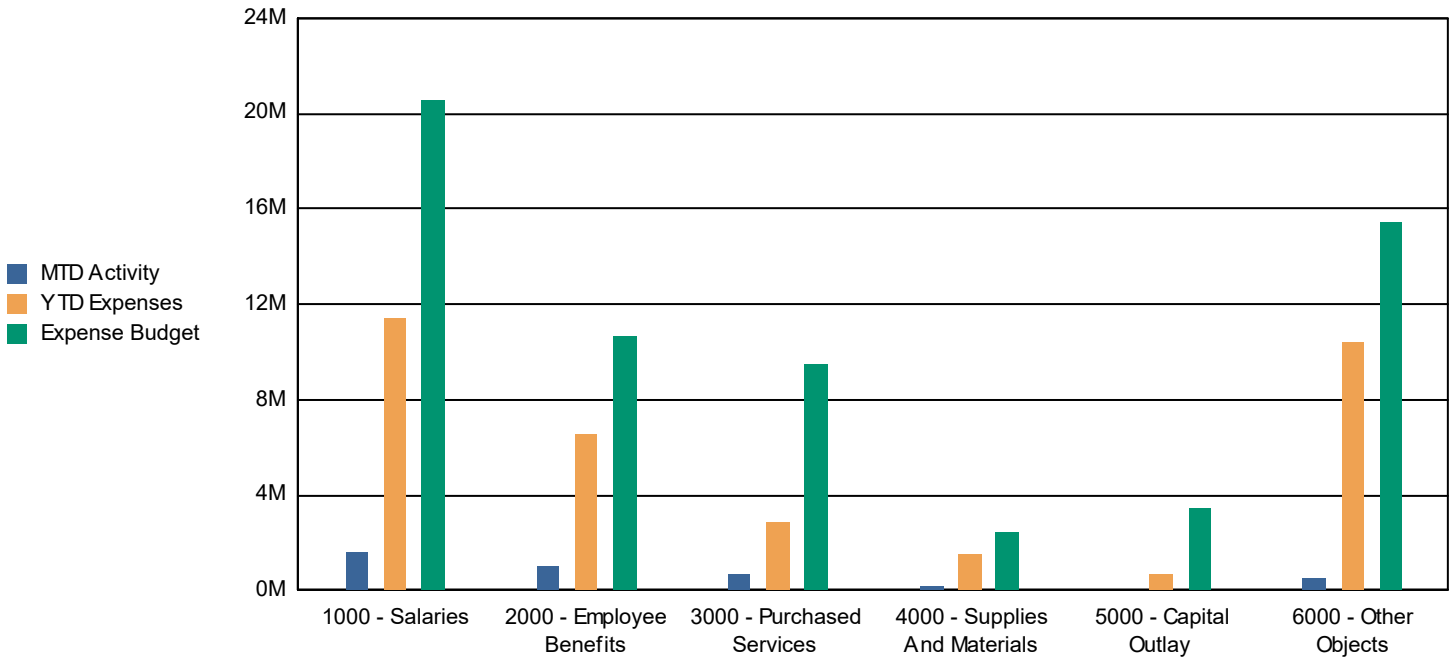
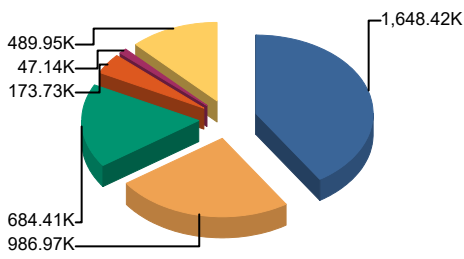

Table 4: Expenses by Object; Budget vs. Year to Date and Three Year History

Annual Revenue Summary by Object	Budget 2021-2022	Actual Year to Date 2021-2022	Percent of Budget Expended	Actual Year End		
				2020-2021	2019-2020	2018-2019
Salaries	20,582,475.79	11,440,570.46	55.58%	18,915,448.18	18,874,811.76	18,427,519.69
Employee Benefits	10,673,586.32	6,521,648.38	61.10%	9,821,573.72	6,238,178.98	6,022,474.80
Purchased Services	9,450,767.72	2,907,613.51	30.77%	5,150,233.25	8,348,470.94	6,368,029.46
Supplies And Materials	2,469,350.57	1,552,347.54	62.86%	1,948,916.62	2,269,978.81	2,236,698.08
Capital Outlay	3,489,081.55	712,806.54	20.43%	6,922,233.77	4,463,647.42	519,280.70
Other Objects	14,173,287.16	10,205,347.64	72.00%	13,496,025.63	14,609,684.68	14,908,980.94
Non-Capitalized Equipment	1,296,420.00	170,093.28	13.12%	3,996.00	0.00	77,348.00
Termination Benefits	12,500.00	12,500.00	100.00%	0.00	0.00	0.00
<b>Total</b>	<b>62,147,469.11</b>	<b>33,522,927.35</b>	<b>53.94%</b>	<b>56,258,427.17</b>	<b>54,804,772.59</b>	<b>48,560,331.67</b>

Chart 2: Monthly Expense



1000 - Salaries	1,648.42K	40.9%
2000 - Employee Benefits	986.97K	24.5%
3000 - Purchased Services	684.41K	17.0%
4000 - Supplies And Materials	173.73K	4.3%
5000 - Capital Outlay	47.14K	1.2%
6000 - Other Objects	489.95K	12.2%
<b>Total:</b>	<b>4,030.62K</b>	<b>100.0%</b>

Chart 3: Year to Date Expense

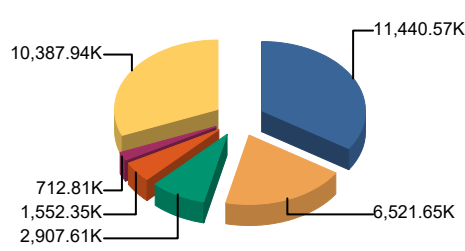

1000 - Salaries	11,440.57K	34.1%
2000 - Employee Benefits	6,521.65K	19.5%
3000 - Purchased Services	2,907.61K	8.7%
4000 - Supplies And Materials	1,552.35K	4.6%
5000 - Capital Outlay	712.81K	2.1%
6000 - Other Objects	10,387.94K	31.0%
<b>Total:</b>	<b>33,522.93K</b>	<b>100.0%</b>

Chart 4: Budget

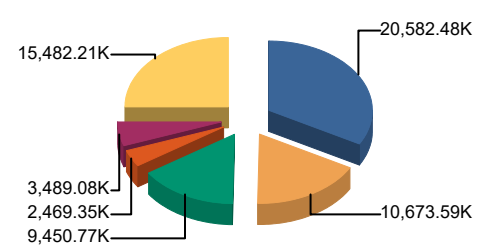

1000 - Salaries	20,582.48K	33.1%
2000 - Employee Benefits	10,673.59K	17.2%
3000 - Purchased Services	9,450.77K	15.2%
4000 - Supplies And Materials	2,469.35K	4.0%
5000 - Capital Outlay	3,489.08K	5.6%
6000 - Other Objects	15,482.21K	24.9%
<b>Total:</b>	<b>62,147.47K</b>	<b>100.0%</b>

Table 5: Expenses by Fund - Monthly

Monthly Expenses by Fund	Education Fund	Operations & Maint Fund	Debt Service Fund or Fund Group	Transportation Fund	I.M.R.F./Soc. Sec. Fund	Capital Projects Fund or Fund	Working Cash Fund	Tort Immunity and Judgment	Fire Prevention & Safety Fund	Total
July	2,627,650.45	216,576.01	0.00	119,943.36	68,812.51	55,701.40	0.00	53,374.60	0.00	3,181,609.96
August	3,246,211.03	265,979.29	0.00	287,716.79	73,700.33	50,367.66	0.00	98,437.95	0.00	4,073,849.45
September	2,863,883.52	300,130.95	0.00	235,731.46	76,798.88	2,841.00	0.00	74,175.58	0.00	3,659,389.03
October	2,977,005.49	317,555.77	3,433,725.00	287,979.66	77,631.64	4,271.93	0.00	139,090.84	0.00	7,259,567.47
November	2,816,052.45	362,865.18	3,212,925.00	251,499.72	75,300.59	110,431.45	0.00	90,054.08	0.00	6,953,383.21
December	3,018,433.91	330,980.09	593,900.00	227,559.91	79,594.85	11,198.00	0.00	75,935.31	0.00	4,364,509.70
January	2,850,113.95	412,709.57	55,450.00	187,992.09	74,398.17	0.00	0.00	394,167.40	0.00	4,030,618.53
February	0.00	0.00	0.00	0.00	0.00	0.00	0.00	0.00	0.00	0.00
March	0.00	0.00	0.00	0.00	0.00	0.00	0.00	0.00	0.00	0.00
April	0.00	0.00	0.00	0.00	0.00	0.00	0.00	0.00	0.00	0.00
May	0.00	0.00	0.00	0.00	0.00	0.00	0.00	0.00	0.00	0.00
June	0.00	0.00	0.00	0.00	0.00	0.00	0.00	0.00	0.00	0.00
YTD	20,399,350.80	2,206,796.86	7,296,000.00	1,598,422.99	526,236.97	234,811.44	0.00	925,235.76	0.00	33,522,927.35

Chart 5: MTD, YTD, & Budget Expenses by Fund

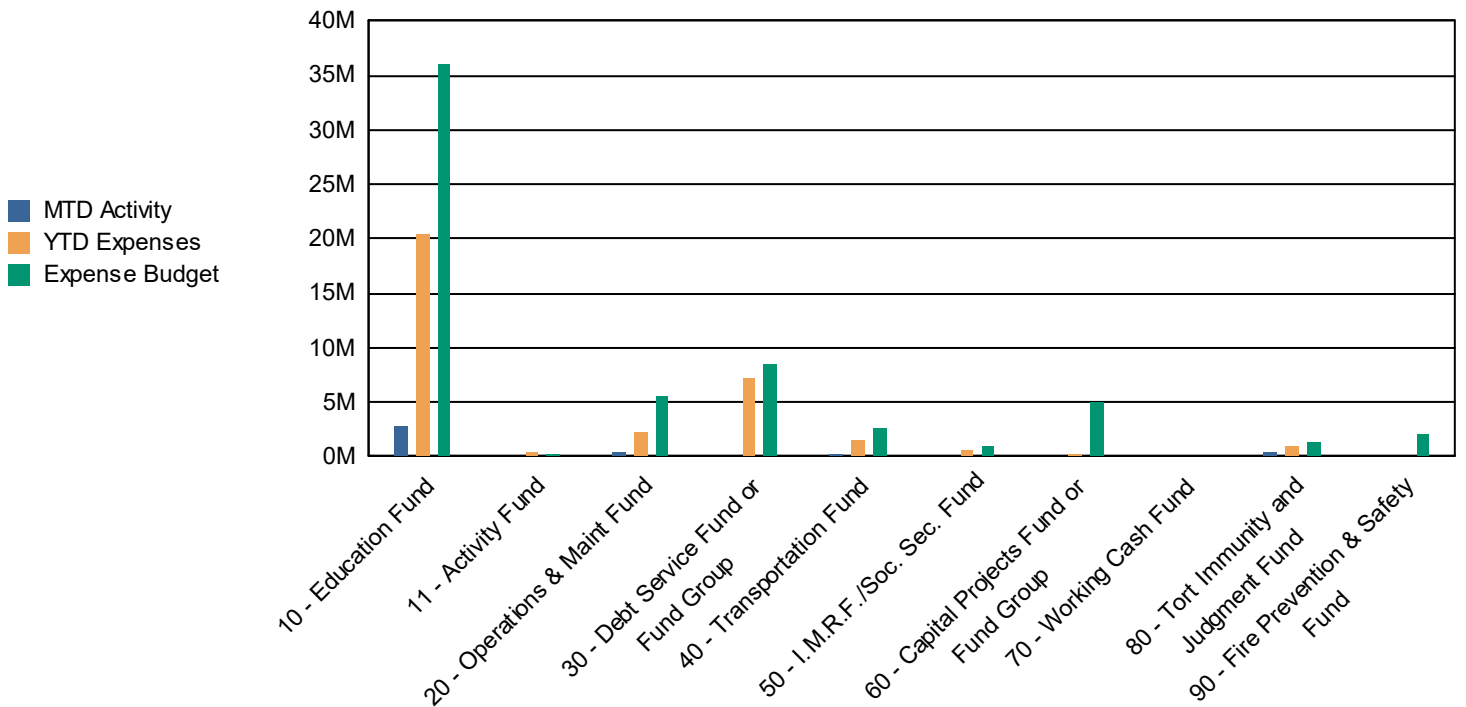

Table 6: Expenses by Fund; Budget vs. Year to Date and Three Year History

Annual Expense Summary by Fund	Budget 2021-2022	Actual Year to Date 2021-2022	Percent of Budget Expended	Actual Year End		
				2020-2021	2019-2020	2018-2019
10 - Education Fund	36,048,347.77	20,399,350.80	56.59%	32,886,815.25	29,181,337.01	27,706,590.17
11 - Activity Fund	293,680.40	336,072.53	114.43%	184,421.16	0.00	0.00
20 - Operations & Maint Fund	5,505,392.41	2,206,796.86	40.08%	3,542,666.07	3,682,838.92	3,898,623.89
30 - Debt Service Fund or Fund Group	8,500,150.00	7,296,000.00	85.83%	7,972,859.50	9,913,299.57	9,157,214.09
40 - Transportation Fund	2,552,867.78	1,598,422.99	62.61%	1,934,833.53	2,546,595.92	2,446,044.23
50 - I.M.R.F./Soc. Sec. Fund	925,096.56	526,236.97	56.88%	851,733.32	880,921.71	880,925.87
60 - Capital Projects Fund or Fund Group	5,000,000.00	234,811.44	4.70%	1,349,597.93	3,568,363.25	(8,291,119.00)
80 - Tort Immunity and Judgment Fund	1,321,934.19	925,235.76	69.99%	1,281,258.00	1,043,324.06	1,087,052.42
90 - Fire Prevention & Safety Fund	2,000,000.00	0.00	0.00%	6,254,242.41	3,988,092.15	0.00
<b>Total</b>	<b>62,147,469.11</b>	<b>33,522,927.35</b>	<b>53.94%</b>	<b>56,258,427.17</b>	<b>54,804,772.59</b>	<b>48,560,331.67</b>

Chart 6: Monthly Expense

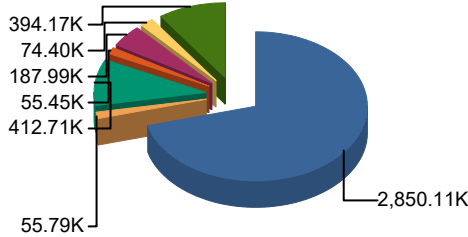

Chart 7: Year to Date Expense

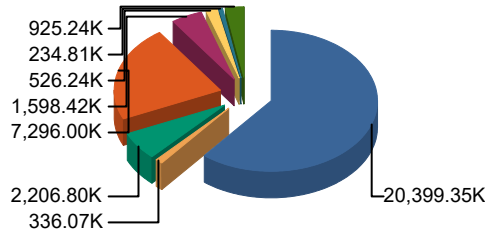
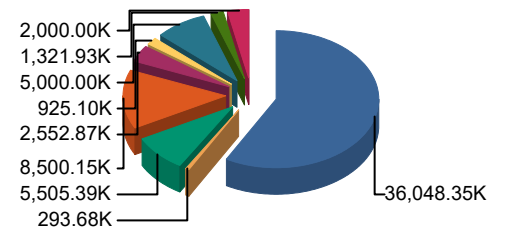

Chart 8: Budget



10 - Education Fund	2,850.11K	70.7%
11 - Activity Fund	55.79K	1.4%
20 - Operations & Maint Fund	412.71K	10.2%
30 - Debt Service Fund or Fund Group	55.45K	1.4%
40 - Transportation Fund	187.99K	4.7%
50 - I.M.R.F./Soc. Sec. Fund	74.40K	1.8%
60 - Capital Projects Fund or Fund Group	0.00K	0.0%
70 - Working Cash Fund	0.00K	0.0%
80 - Tort Immunity and Judgment Fund	394.17K	9.8%
90 - Fire Prevention & Safety Fund	0.00K	0.0%
<b>Total:</b>	<b>4,030.62K</b>	<b>100.0%</b>

10 - Education Fund	20,399.35K	60.9%
11 - Activity Fund	336.07K	1.0%
20 - Operations & Maint Fund	2,206.80K	6.6%
30 - Debt Service Fund or Fund Group	7,296.00K	21.8%
40 - Transportation Fund	1,598.42K	4.8%
50 - I.M.R.F./Soc. Sec. Fund	526.24K	1.6%
60 - Capital Projects Fund or Fund Group	234.81K	0.7%
70 - Working Cash Fund	0.00K	0.0%
80 - Tort Immunity and Judgment Fund	925.24K	2.8%
90 - Fire Prevention & Safety Fund	0.00K	0.0%
<b>Total:</b>	<b>33,522.93K</b>	<b>100.0%</b>

10 - Education Fund	36,048.35K	58.0%
11 - Activity Fund	293.68K	0.5%
20 - Operations & Maint Fund	5,505.39K	8.9%
30 - Debt Service Fund or Fund Group	8,500.15K	13.7%
40 - Transportation Fund	2,552.87K	4.1%
50 - I.M.R.F./Soc. Sec. Fund	925.10K	1.5%
60 - Capital Projects Fund or Fund Group	5,000.00K	8.0%
70 - Working Cash Fund	0.00K	0.0%
80 - Tort Immunity and Judgment Fund	1,321.93K	2.1%
90 - Fire Prevention & Safety Fund	2,000.00K	3.2%
<b>Total:</b>	<b>62,147.47K</b>	<b>100.0%</b>

Table 7: Revenues by Source - Monthly

Monthly Revenue by Source	Local Revenue Levy, CPPRT, Fees Etc.	Flow Through Funds	State Revenue GSA, Categoryicals, Grants, Etc.	Federal Revenue IDEA, Grants, Lunch Program, Etc.	Working Cash Transfer/other	Total
July	7,006,408.96	0.00	504,122.14	229,336.55	0.00	7,739,867.65
August	2,475,490.32	0.00	566,180.00	546.48	0.00	3,042,216.80
September	7,401,297.38	0.00	566,181.00	141,582.00	0.00	8,109,060.38
October	11,408,296.06	0.00	1,060,843.76	5,907.99	0.00	12,475,047.81
November	1,924,569.82	0.00	565,394.84	14,042.72	0.00	2,504,007.38
December	1,962,322.01	0.00	688,348.12	16,678.94	0.00	2,667,349.07
January	1,813,873.94	1,954,385.52	1,058,601.80	986.00	0.00	4,827,847.26
February	0.00	0.00	0.00	0.00	0.00	0.00
March	0.00	0.00	0.00	0.00	0.00	0.00
April	0.00	0.00	0.00	0.00	0.00	0.00
May	0.00	0.00	0.00	0.00	0.00	0.00
June	0.00	0.00	0.00	0.00	0.00	0.00
YTD	33,992,258.49	1,954,385.52	5,009,671.66	409,080.68	0.00	41,365,396.35

Table 8: Revenue by Fund - Monthly

Monthly Revenue by Fund	Education Fund	Operations & Maint Fund	Debt Service Fund or Fund Group	Transportation Fund	I.M.R.F./Soc. Sec. Fund	Capital Projects Fund or Fund	Working Cash Fund	Tort Immunity and	Fire Prevention & Safety Fund	Total
July	4,483,672.81	673,130.09	1,262,516.86	598,461.31	162,289.15	3,017.42	129,867.26	184,128.67	121,245.14	7,739,867.65
August	2,155,176.22	200,145.49	367,563.03	95,788.89	43,203.00	13,868.14	36,743.05	60,731.98	35,484.53	3,042,216.80
September	4,823,244.52	726,249.20	1,488,957.53	350,513.42	161,158.43	512.16	132,547.71	214,878.58	141,946.28	8,109,060.38
October	7,037,144.43	1,193,554.55	2,311,490.94	798,826.49	285,269.15	18,714.18	219,474.26	324,630.44	219,311.82	12,475,047.81
November	1,797,793.73	160,292.33	291,140.35	83,168.02	31,617.62	9,090.27	28,332.10	49,456.54	28,174.91	2,504,007.38
December	1,666,977.44	556,651.63	217,829.90	62,302.26	31,638.55	99.85	21,334.65	39,372.13	21,172.21	2,667,349.07
January	4,263,290.04	142,141.35	21,032.08	280,548.46	31,504.00	30,636.12	2,252.72	12,051.94	2,090.28	4,827,847.26
February	0.00	0.00	0.00	0.00	0.00	0.00	0.00	0.00	0.00	0.00
March	0.00	0.00	0.00	0.00	0.00	0.00	0.00	0.00	0.00	0.00
April	0.00	0.00	0.00	0.00	0.00	0.00	0.00	0.00	0.00	0.00
May	0.00	0.00	0.00	0.00	0.00	0.00	0.00	0.00	0.00	0.00
June	0.00	0.00	0.00	0.00	0.00	0.00	0.00	0.00	0.00	0.00
YTD	26,227,299.19	3,652,164.64	5,960,530.69	2,269,608.85	746,679.90	75,938.14	570,551.75	885,250.28	569,425.17	41,365,396.35

Table 9: Revenue by Fund; Budget vs. Year to Date and Three Year History

Annual Revenue Summary by Fund	Budget 2021-2022	Actual Year to Date 2021-2022	Percent of Budget Expended	Actual Year End		
				2020-2021	2019-2020	2018-2019
10 - Education Fund	37,809,332.67	26,227,299.19	69.37%	33,859,587.81	29,428,651.33	28,243,599.92
11 - Activity Fund	200,000.00	407,947.74	203.97%	184,951.36	0.00	0.00
20 - Operations & Maint Fund	6,108,488.64	3,652,164.64	59.79%	4,260,424.45	4,082,991.73	4,238,088.51
30 - Debt Service Fund or Fund Group	8,854,007.76	5,960,530.69	67.32%	8,206,006.73	8,669,972.93	10,094,819.01
40 - Transportation Fund	2,992,698.79	2,269,608.85	75.84%	3,017,426.77	2,967,996.39	2,943,457.51
50 - I.M.R.F./Soc. Sec. Fund	1,074,209.49	746,679.90	69.51%	1,010,197.30	1,066,904.00	1,024,802.96
60 - Capital Projects Fund or Fund Group	296,600.00	75,938.14	25.60%	277,881.20	185,282.36	1,509,512.00
70 - Working Cash Fund	857,541.05	570,551.75	66.53%	793,663.47	1,040,442.96	12,216,820.45
80 - Tort Immunity and Judgment Fund	1,381,714.85	885,250.28	64.07%	1,287,598.09	1,242,599.63	1,272,707.85
90 - Fire Prevention & Safety Fund	853,441.05	569,425.17	66.72%	747,985.94	797,257.24	9,515,433.74
<b>Total</b>	<b>60,428,034.30</b>	<b>41,365,396.35</b>	<b>68.45%</b>	<b>53,645,723.12</b>	<b>49,482,098.57</b>	<b>71,059,241.95</b>

Table 10: Monthly Cash Report

Month: January 2022 Monthly Cash & Investment Report												
	Education	Oper/ Maint	Debt Service	Trans portation	IMFR/Soc Sec	Capital	Working Cash	Tort	Life & Safety	Total	Activities	Total All Funds
Checking	596,808	437,262	844,342	728,020	138,252	436,522	632,380	94,813	(2,709,846)	1,198,551	399,070	1,597,621
Food Service	1,789,652	-	-	-	-	-	-	-	-	1,789,652	-	1,789,652
Imprest	18,868	100	-	15,954	-	-	-	-	-	34,922	-	34,922
Insurance	1,511,736	284,144	-	20,426	-	-	-	(41,742)	-	1,774,564	-	1,774,564
PMA Cash Account	5,085,995	2,465,207	(538,393)	3,136,527	112,731	-	2,339,126	1,718,680	1,354,041	15,673,915	-	15,673,915
IPTIP	1,990,255	1,176,518	-	-	497,799	-	204,144	-	-	3,868,716	-	3,868,716
<b>Total Cash Accounts</b>	<b>10,993,313</b>	<b>4,363,232</b>	<b>305,949</b>	<b>3,900,927</b>	<b>748,782</b>	<b>436,522</b>	<b>3,175,649</b>	<b>1,771,751</b>	<b>(1,355,806)</b>	<b>24,340,320</b>	<b>399,070</b>	<b>24,739,389</b>
<b>Total Investments</b>	<b>6,589,248</b>	<b>1,935,992</b>	<b>3,182,220</b>	<b>1,277,969</b>	<b>322,502</b>	<b>6,148,631</b>	<b>12,859,613</b>	<b>668,536</b>	<b>3,684,932</b>	<b>36,669,643</b>	<b>361,366</b>	<b>37,031,008</b>
<b>Total Cash &amp; Investments</b>	<b>17,582,562</b>	<b>6,299,224</b>	<b>3,488,169</b>	<b>5,178,897</b>	<b>1,071,284</b>	<b>6,585,152</b>	<b>16,035,262</b>	<b>2,440,287</b>	<b>2,329,126</b>	<b>61,009,962</b>	<b>760,435</b>	<b>61,770,397</b>

## Payroll Summaries

Payroll Run Description: 01-14-22 Payroll; Incentive January 2022; 01-28-2022 Payroll

COUNTY OF GRUNDY SCHOOL DIST 111

Payroll Run	Pay Gross	Fed Gross	Fed Tax	State Gross	State Tax	SS Gross	SS Tax	Med Gross	Med Tax
1/14/22 - 01-14-22 Payroll	825,581.59	758,348.88	83,814.82	758,348.88	36,565.03	159,812.54	9,908.44	789,390.59	11,446.17
1/20/22 - Incentive January 2022	374.10	357.28	0.00	357.28	14.98	374.10	23.18	374.10	5.44
1/28/22 - 01-28-2022 Payroll	827,267.03	762,708.45	80,008.63	762,708.45	36,785.64	165,652.42	10,270.47	794,000.16	11,513.01
<b>Totals:</b>	<b>1,653,222.72</b>	<b>1,521,414.61</b>	<b>163,823.45</b>	<b>1,521,414.61</b>	<b>73,365.65</b>	<b>325,839.06</b>	<b>20,202.09</b>	<b>1,583,764.85</b>	<b>22,964.62</b>

IMPREST

1/31/2022

	EDUCATION	BUILDING	BOND & INT	TRANSPORTATION	SS/IMRF	TORT	TOTAL	
BEG BALANCE	25825.25	100.00	0.00		15954.00	0.00	0.00	41879.25
RECEIPTS	0.00							0.00
DEPOSITS	0.00	0.00			0.00	0.00		0.00
DEPOSITS								0.00
								0.00
VOID								0.00
TOTAL RECEIPTS	0.00	0.00	0.00		0.00	0.00	0.00	0.00
DISBURSEMENTS	150.00							
	120.00	0.00			0.00			120.00
	500.00							
Dance Cash advance - Sect.	250.00							
	2441.60							
Cheer Cash Advance - Sect.	784.00							
Dance Cash Advance - state	1512.00							
Boys Bowling Cash Advance - state	1200.00							
TOTAL DISBURSEMENTS	6957.60	0.00	0.00		0.00	0.00	0.00	6957.60
ENDING BALANCE	18867.65	100.00	0.00		15954.00	0.00	0.00	34921.65

BANK BALANCE	41516.63
OUTSTANDING CHECKS	5461.70
DIFFERENCE	1133.28
REGISTER BALANCE	34921.65

BALANCE

LEDGER BALANCE	34921.65
OUTSTANDING CHECKS	5461.70
VOID	
DIFFERENCE	1133.28
BANK BALANCE	41516.63

BALANCE

## Balance Sheet Detail by Fund

January 2021-2022		COUNTY OF GRUNDY SCHOOL DIST 111				
Fund	Account	Account Description	Beginning Balance	Debit	Credit	Ending Balance
<b>11 - Activity Fund</b>						
A - Asset						
	11 A 1260 0000 00 000 000000	CASH-ACTIVITIES	\$414,714.26	\$60,320.06	\$75,964.66	\$399,069.66
	11 A 1261 0000 00 000 000000	COADY SCHOLARSHIP	\$361,359.35	\$6.20	\$0.00	\$361,365.55
<b>Totals for: 11 A - Asset</b>			<b>\$776,073.61</b>	<b>\$60,326.26</b>	<b>\$75,964.66</b>	<b>\$760,435.21</b>
L - Liability						
	11 L 4310 0000 00 000 000000	AP Liability	\$0.00	\$92,990.65	\$92,990.65	\$0.00
<b>Totals for: 11 L - Liability</b>			<b>\$0.00</b>	<b>\$92,990.65</b>	<b>\$92,990.65</b>	<b>\$0.00</b>
Q - Equity						
	11 Q 7130 0000 00 000 000000		(\$16,646.96)	\$5,207.26	\$18,491.28	(\$29,930.98)
	11 Q 7131 0000 00 000 000000		\$16,646.96	\$18,491.28	\$5,207.26	\$29,930.98
	11 Q 7150 0000 01 000 900000	COADY SCHOLARSHIP	(\$386,359.35)	\$0.00	\$6.20	(\$386,365.55)
	11 Q 7150 0000 30 300 910001	SPORTS - ATHLETIC HALL OF FAME	(\$5,460.86)	\$0.00	\$0.00	(\$5,460.86)
	11 Q 7150 0000 30 300 910002	SPORTS - ATHLETIC POP	(\$5,186.03)	\$0.00	\$0.00	(\$5,186.03)
	11 Q 7150 0000 30 300 910003	SPORTS - ATHLETIC TRAINING	\$699.77	\$408.54	\$0.00	\$1,108.31
	11 Q 7150 0000 30 300 910004	SPORTS - BASEBALL	(\$15,309.93)	\$165.00	\$2,540.00	(\$17,684.93)
	11 Q 7150 0000 30 300 910005	SPORTS - BOYS BASKETBALL	(\$10,404.11)	\$1,253.91	\$10,376.00	(\$19,526.20)
	11 Q 7150 0000 30 300 910006	SPORTS - BOYS BOWLING	(\$1,553.05)	\$804.00	\$500.00	(\$1,249.05)
	11 Q 7150 0000 30 300 910007	SPORTS - BOYS GOLF	(\$2,497.18)	\$0.00	\$0.00	(\$2,497.18)
	11 Q 7150 0000 30 300 910008	SPORTS - BOYS SOCCER	(\$9,939.29)	\$792.86	\$0.00	(\$9,146.43)
	11 Q 7150 0000 30 300 910009	SPORTS - BOYS TENNIS	(\$3,073.10)	\$0.00	\$0.00	(\$3,073.10)

## Balance Sheet Detail by Fund

January 2021-2022		COUNTY OF GRUNDY SCHOOL DIST 111				
Fund	Account	Account Description	Beginning Balance	Debit	Credit	Ending Balance
11 - Activity Fund						
Q - Equity						
	11 Q 7150 0000 30 300 910010	SPORTS - BOYS TRACK	(\$6,271.76)	\$0.00	\$0.00	(\$6,271.76)
	11 Q 7150 0000 30 300 910011	SPORTS - BOYS VOLLEYBALL	(\$6,703.17)	\$0.00	\$0.00	(\$6,703.17)
	11 Q 7150 0000 30 300 910012	SPORTS - CHEERLEADERS	(\$20,459.61)	\$8,845.20	\$0.00	(\$11,614.41)
	11 Q 7150 0000 30 300 910013	SPORTS - CROSS COUNTY CO ED	(\$8,772.53)	\$0.00	\$0.00	(\$8,772.53)
	11 Q 7150 0000 30 300 910014	SPORTS - FOOTBALL	(\$37,987.62)	\$3,300.96	\$640.00	(\$35,326.66)
	11 Q 7150 0000 30 300 910015	SPORTS - FOOTBALL JERSEYS	(\$1,718.13)	\$0.00	\$1,023.84	(\$2,741.97)
	11 Q 7150 0000 30 300 910016	SPORTS - GIRLS BASKETBALL	(\$14,537.03)	\$2,564.46	\$0.00	(\$11,972.57)
	11 Q 7150 0000 30 300 910017	SPORTS - GIRLS BOWLING	(\$1,677.57)	\$0.00	\$0.00	(\$1,677.57)
	11 Q 7150 0000 30 300 910018	SPORTS - GIRLS GOLF	(\$1,413.85)	\$0.00	\$0.00	(\$1,413.85)
	11 Q 7150 0000 30 300 910019	SPORTS - GIRLS SOCCER	(\$879.10)	\$0.00	\$0.00	(\$879.10)
	11 Q 7150 0000 30 300 910020	SPORTS - GIRLS TENNIS	(\$3,213.70)	\$0.00	\$0.00	(\$3,213.70)
	11 Q 7150 0000 30 300 910021	SPORTS - GIRLS TRACK	(\$3,305.96)	\$0.00	\$0.00	(\$3,305.96)
	11 Q 7150 0000 30 300 910022	SPORTS - GIRLS VOLLEYBALL	(\$9,816.73)	\$0.00	\$0.00	(\$9,816.73)
	11 Q 7150 0000 30 300 910023	SPORTS - LACROSSE	(\$513.64)	\$0.00	\$0.00	(\$513.64)
	11 Q 7150 0000 30 300 910024	SPORTS - OUTDOOR ED TRIP	(\$5,212.00)	\$0.00	\$0.00	(\$5,212.00)
	11 Q 7150 0000 30 300 910025	SPORTS - POMS	(\$20,564.28)	\$2,925.58	\$6,011.73	(\$23,650.43)
	11 Q 7150 0000 30 300 910026	SPORTS - SOFTBALL	\$4,260.44	\$0.00	\$0.00	\$4,260.44
	11 Q 7150 0000 30 300 910027	SPORTS - SWIMMING B&G	(\$760.49)	\$0.00	\$0.00	(\$760.49)

## Balance Sheet Detail by Fund

January 2021-2022		COUNTY OF GRUNDY SCHOOL DIST 111				
Fund	Account	Account Description	Beginning Balance	Debit	Credit	Ending Balance
<b>11 - Activity Fund</b>						
Q - Equity						
	11 Q 7150 0000 30 300 910028	SPORTS - WRESTLING	(\$2,896.12)	\$0.00	\$6,235.00	(\$9,131.12)
	11 Q 7150 0000 30 300 910038	SUMMER CAMPS - POMS	(\$1,061.00)	\$0.00	\$0.00	(\$1,061.00)
	11 Q 7150 0000 70 300 900001	ACTIVITIES - POP	(\$5,761.74)	\$1,449.20	\$575.00	(\$4,887.54)
	11 Q 7150 0000 70 300 900002	ACTIVITIES - ART CLUB	(\$692.10)	\$0.00	\$0.00	(\$692.10)
	11 Q 7150 0000 70 300 900003	ACTIVITIES - ATHLETIC LEADERSHIP	(\$342.50)	\$0.00	\$0.00	(\$342.50)
	11 Q 7150 0000 70 300 900004	ACTIVITIES - BAND	(\$18,151.99)	\$36,051.98	\$18,065.99	(\$166.00)
	11 Q 7150 0000 70 300 900005	ACTIVITIES - CHESS	(\$421.00)	\$0.00	\$0.00	(\$421.00)
	11 Q 7150 0000 70 300 900006	ACTIVITIES - CHOIR PROJECTS	(\$62.29)	\$0.00	\$0.00	(\$62.29)
	11 Q 7150 0000 70 300 900007	ACTIVITIES - CHORUS	(\$2,446.82)	\$0.00	\$0.00	(\$2,446.82)
	11 Q 7150 0000 70 300 900011	ACTIVITIES - CLASS OF 2022	(\$5,222.86)	\$0.00	\$0.00	(\$5,222.86)
	11 Q 7150 0000 70 300 900012	ACTIVITIES - CLASS OF 2023	(\$2,440.94)	\$0.00	\$0.00	(\$2,440.94)
	11 Q 7150 0000 70 300 900013	ACTIVITIES - CLASS OF 2024	(\$980.00)	\$0.00	\$0.00	(\$980.00)
	11 Q 7150 0000 70 300 900014	ACTIVITIES - COMMUNITY GARDEN	(\$615.39)	\$0.00	\$0.00	(\$615.39)
	11 Q 7150 0000 70 300 900015	ACTIVITIES - CULINARY ARTS	(\$816.30)	\$0.00	\$0.00	(\$816.30)
	11 Q 7150 0000 70 300 900017	ACTIVITIES - DREAM	(\$500.90)	\$0.00	\$0.00	(\$500.90)
	11 Q 7150 0000 70 300 900018	ACTIVITIES - FASHION MERCHANDISING	(\$223.31)	\$0.00	\$0.00	(\$223.31)
	11 Q 7150 0000 70 300 900019	ACTIVITIES - FCCLA	(\$187.80)	\$0.00	\$60.00	(\$247.80)
	11 Q 7150 0000 70 300 900020	ACTIVITIES - FFA	(\$2,807.22)	\$0.00	\$0.00	(\$2,807.22)

## Balance Sheet Detail by Fund

January 2021-2022

COUNTY OF GRUNDY SCHOOL DIST 111

Fund	Account	Account Description	Beginning Balance	Debit	Credit	Ending Balance
<b>11 - Activity Fund</b>						
	Q - Equity					
	11 Q 7150 0000 70 300 900021	ACTIVITIES - FRENCH NHS	(\$305.91)	\$0.00	\$0.00	(\$305.91)
	11 Q 7150 0000 70 300 900022	ACTIVITIES - FUTURE BUSINESS LEADERS	(\$140.86)	\$0.00	\$0.00	(\$140.86)
	11 Q 7150 0000 70 300 900023	ACTIVITIES - I.O.T.A.	(\$2,888.38)	\$77.00	\$0.00	(\$2,811.38)
	11 Q 7150 0000 70 300 900024	ACTIVITIES - INDIAN CLIMBING CLUB	(\$186.80)	\$0.00	\$0.00	(\$186.80)
	11 Q 7150 0000 70 300 900025	ACTIVITIES - INDIAN NATION	(\$90.21)	\$0.00	\$0.00	(\$90.21)
	11 Q 7150 0000 70 300 900026	ACTIVITIES - INT'L CLUB	(\$1,247.64)	\$115.36	\$0.00	(\$1,132.28)
	11 Q 7150 0000 70 300 900027	ACTIVITIES - INT'L THESPIANS	(\$14,722.42)	\$0.00	\$0.00	(\$14,722.42)
	11 Q 7150 0000 70 300 900028	ACTIVITIES - INTERACT	(\$176.55)	\$0.00	\$0.00	(\$176.55)
	11 Q 7150 0000 70 300 900029	ACTIVITIES - INVESTMENT CLUB	(\$108.16)	\$0.00	\$0.00	(\$108.16)
	11 Q 7150 0000 70 300 900030	ACTIVITIES - JUDO	(\$13,950.21)	\$0.00	\$0.00	(\$13,950.21)
	11 Q 7150 0000 70 300 900031	ACTIVITIES - KALEIDOSOPE	(\$1,094.07)	\$0.00	\$0.00	(\$1,094.07)
	11 Q 7150 0000 70 300 900032	ACTIVITIES - MAC	(\$12,414.52)	\$1,023.84	\$327.00	(\$11,717.68)
	11 Q 7150 0000 70 300 900033	ACTIVITIES - MATH TEAM	(\$230.00)	\$224.00	\$0.00	(\$6.00)
	11 Q 7150 0000 70 300 900034	ACTIVITIES - MCHS BOOK CLUB	(\$598.77)	\$0.00	\$0.00	(\$598.77)
	11 Q 7150 0000 70 300 900035	ACTIVITIES - MEMORIAL GARDEN	(\$888.23)	\$0.00	\$0.00	(\$888.23)
	11 Q 7150 0000 70 300 900036	ACTIVITIES - MUSICAL	(\$4,481.11)	\$0.00	\$0.00	(\$4,481.11)
	11 Q 7150 0000 70 300 900037	ACTIVITIES - NEEDY FAMILIES	(\$4,067.03)	\$0.00	\$0.00	(\$4,067.03)
	11 Q 7150 0000 70 300 900038	ACTIVITIES - NHS	(\$2,008.75)	\$1,401.27	\$492.00	(\$1,099.48)

## Balance Sheet Detail by Fund

January 2021-2022		COUNTY OF GRUNDY SCHOOL DIST 111				
Fund	Account	Account Description	Beginning Balance	Debit	Credit	Ending Balance
<b>11 - Activity Fund</b>						
Q - Equity						
	11 Q 7150 0000 70 300 900039	ACTIVITIES - ORCHESIS	(\$4,023.20)	\$0.00	\$569.80	(\$4,593.00)
	11 Q 7150 0000 70 300 900040	ACTIVITIES - PAC RESTORATION	(\$1,733.88)	\$0.00	\$0.00	(\$1,733.88)
	11 Q 7150 0000 70 300 900041	ACTIVITIES - PERCUSSION	(\$3,713.00)	\$7,102.69	\$9,000.00	(\$5,610.31)
	11 Q 7150 0000 70 300 900043	ACTIVITIES - NEWSPAPER	(\$834.26)	\$0.00	\$0.00	(\$834.26)
	11 Q 7150 0000 70 300 900044	ACTIVITIES - SADD	(\$381.95)	\$0.00	\$0.00	(\$381.95)
	11 Q 7150 0000 70 300 900045	ACTIVITIES - SCHOLASTIC BOWL	(\$400.47)	\$92.94	\$0.00	(\$307.53)
	11 Q 7150 0000 70 300 900046	ACTIVITIES - SPANISH NHS	(\$406.32)	\$260.00	\$40.00	(\$186.32)
	11 Q 7150 0000 70 300 900047	ACTIVITIES - SPEECH	(\$3,548.13)	\$42.40	\$0.00	(\$3,505.73)
	11 Q 7150 0000 70 300 900048	ACTIVITIES - STUDENT COUNCIL	(\$42,712.19)	\$231.57	\$0.00	(\$42,480.62)
	11 Q 7150 0000 70 300 900049	ACTIVITIES - TSA	(\$2,791.66)	\$0.00	\$0.00	(\$2,791.66)
	11 Q 7150 0000 70 300 900050	ACTIVITIES - UNDERWATER ROBOTIC	(\$894.95)	\$135.00	\$160.00	(\$919.95)
	11 Q 7150 0000 70 300 900051	ACTIVITIES - WINTERGUARD	(\$9,330.06)	\$8,233.18	\$5,737.96	(\$6,834.84)
	11 Q 7150 0000 70 300 900052	ACTIVITIES - WYSE	(\$418.94)	\$0.00	\$0.00	(\$418.94)
	11 Q 7150 0000 70 300 900053	ACTIVITIES - YEARBOOK	(\$29,743.88)	\$10.42	\$0.00	(\$29,733.46)
	11 Q 7150 0000 70 300 900055	CYBRARY	(\$1,238.29)	\$0.00	\$0.00	(\$1,238.29)
	11 Q 7150 0000 70 300 900056	FACULTY POP	(\$2,925.47)	\$587.56	\$0.00	(\$2,337.91)
	11 Q 7150 0000 70 300 900057	PROJECT INDIAN	(\$2,085.53)	\$0.00	\$0.00	(\$2,085.53)
	11 Q 7150 0000 70 300 900058	PROM	(\$8,088.75)	\$0.00	\$0.00	(\$8,088.75)

## Balance Sheet Detail by Fund

January 2021-2022		COUNTY OF GRUNDY SCHOOL DIST 111				
Fund	Account	Account Description	Beginning Balance	Debit	Credit	Ending Balance
<b>11 - Activity Fund</b>						
	Q - Equity					
	11 Q 7150 0000 70 300 900059	SCHOLARSHIP	\$24,250.09	\$0.00	\$0.00	\$24,250.09
	11 Q 7150 0000 70 300 900060	TV PRODUCTION	(\$10.60)	\$0.00	\$0.00	(\$10.60)
	11 Q 7150 0000 70 300 900061	ASL - AMERICAN SIGN LANGUAGE CLUB	(\$162.79)	\$0.00	\$0.00	(\$162.79)
	11 Q 7150 0000 70 300 900062	GREEN HOUSE	(\$821.75)	\$0.00	\$100.00	(\$921.75)
	11 Q 7150 0000 70 300 900063	CLASS OF 2025	(\$197.87)	\$0.00	\$0.00	(\$197.87)
<b>Totals for: 11 Q - Equity</b>			<b>(\$776,073.61)</b>	<b>\$101,797.46</b>	<b>\$86,159.06</b>	<b>(\$760,435.21)</b>
<b>Totals for Fund: 11 - Activity Fund</b>			<b>\$0.00</b>	<b>\$255,114.37</b>	<b>\$255,114.37</b>	<b>\$0.00</b>
			<b>Beginning Balance</b>	<b>Debit</b>	<b>Credit</b>	<b>Ending Balance</b>
<b>Totals for: A - Asset</b>			\$776,073.61	\$60,326.26	\$75,964.66	\$760,435.21
<b>Totals for: L - Liability</b>			\$0.00	\$92,990.65	\$92,990.65	\$0.00
<b>Totals for: Q - Equity</b>			(\$776,073.61)	\$101,797.46	\$86,159.06	(\$760,435.21)
<b>Grand Totals:</b>			<b>\$0.00</b>	<b>\$255,114.37</b>	<b>\$255,114.37</b>	<b>\$0.00</b>

Input Report Date 1/31/2022

Cash and Investments Report

	Education	Oper/ Maint.	Debt Service *	Transporation	IMRF/ Soc Sec	Capital **	Working Cash	Tort	Life Safety	Total	Fund 11 Activities	Total Funds
Checking	\$596,807.76	\$437,262.12	\$844,341.84	\$728,020.05	\$138,251.82	\$436,521.69	\$632,379.54	\$94,812.75	(\$2,709,846.41)	\$1,198,551.16	\$399,069.66	\$1,597,620.82
Food Service Account	\$1,789,652.20									\$1,789,652.20	0	\$1,789,652.20
Imprest	\$18,867.65	\$100.00		\$15,954.00						\$34,921.65	0	\$34,921.65
Insurance Account	\$1,511,735.70	\$284,144.23		\$20,425.92				(41741.63)		\$1,774,564.22	0	\$1,774,564.22
PMA Cash Account	\$5,085,995.33	\$2,465,207.26	(\$538,392.86)	\$3,136,527.21	\$112,731.43	\$0.00	\$2,339,126.21	\$1,718,679.70	\$1,354,040.52	\$15,673,914.80	0	\$15,673,914.80
IP/TIP	\$1,990,254.79	\$1,176,518.38	\$0.00	\$0.00	\$497,798.78	\$0.00	\$204,143.59	\$0.00	\$0.00	\$3,868,715.54	0	\$3,868,715.54
<b>Total Cash accounts</b>	<b>\$10,993,313.43</b>	<b>\$4,363,231.99</b>	<b>\$305,948.98</b>	<b>\$3,900,927.18</b>	<b>\$748,782.03</b>	<b>\$436,521.69</b>	<b>\$3,175,649.34</b>	<b>\$1,771,750.82</b>	<b>(\$1,355,805.89)</b>	<b>\$24,340,319.57</b>	<b>\$399,069.66</b>	<b>\$24,739,389.23</b>
PMA Investments	\$5,965,056.19	\$1,934,583.10	\$3,073,719.11	\$1,129,404.17	\$315,453.86	\$377,491.74	\$12,859,612.71	\$668,535.85	\$3,684,931.98	\$30,008,788.71	361,365.55	30,370,154.26
PMA 101 Investments	\$5,684,583.69	\$1,257,110.99	\$2,789,752.06	\$595,233.17	\$296,881.43	\$325,000.00	\$225,117.01	\$418,392.21	\$248,494.90	\$11,840,565.46	-	\$11,840,565.46
PMA 62 (Working Cash)						\$0.00				\$0.00	-	\$0.00
PMA 202						\$0.00				\$0.00	-	\$0.00
PMA 203 - 2006 Bond			\$129,319.17							\$129,319.17	-	\$129,319.17
PMA 65 (Capital)										\$0.00	-	\$0.00
US Bank	\$0.00									\$0.00	-	\$0.00
PMA 205 Working Cash							\$12,554,951.43			\$12,554,951.43	-	\$12,554,951.43
PMA 68										\$0.00	0	\$0.00
PMA 104 - General Reserve	\$280,472.50	\$677,472.11	\$154,647.88	\$534,171.00	\$18,572.43	\$52,491.74	\$79,544.27	\$250,143.64	\$450,995.27	\$2,498,510.84	0	\$2,498,510.84
PMA 208 - Health Life Safety									\$2,985,441.81	\$2,985,441.81	0	\$2,985,441.81
PMA 209 - Capital						\$5,771,138.96				\$5,771,138.96	0	\$5,771,138.96
Private Bank Investments	\$624,419.24	\$1,408.44	\$108,501.27	\$148,565.20	\$7,049.90	\$0.00	\$0.00	\$0.00	\$0.00	\$889,944.05	0	\$889,944.05
PMA 103 - Coady Scholarship										\$0.00	361,365.55	\$361,365.55
<b>Total Investments</b>	<b>\$6,589,475.43</b>	<b>\$1,935,991.54</b>	<b>\$3,182,220.38</b>	<b>\$1,277,969.37</b>	<b>\$322,503.76</b>	<b>\$6,148,630.70</b>	<b>\$12,859,612.71</b>	<b>\$668,535.85</b>	<b>\$3,684,931.98</b>	<b>\$36,669,871.72</b>	<b>361,365.55</b>	<b>\$37,031,237.27</b>
<b>Total Cash &amp; Investment:</b>	<b>\$17,582,788.86</b>	<b>\$6,299,223.53</b>	<b>\$3,488,169.36</b>	<b>\$5,178,896.55</b>	<b>\$1,071,285.79</b>	<b>\$6,585,152.39</b>	<b>\$16,035,262.05</b>	<b>\$2,440,286.67</b>	<b>\$2,329,126.09</b>	<b>\$61,010,191.29</b>	<b>\$760,435.21</b>	<b>\$61,770,626.50</b>

## Expenditure Report

Fiscal Year: 2021-2022  
Month: January

COUNTY OF GRUNDY SCHOOL DIST 111

Fund Description	Account	Account Description	Revised Budget	Encumbrance	MTD Activity	Pending Activity	Available Funds	Year to Date Activity	Percent of Budget Used
Education Fund	111134900	ESSER I Digital Equity Grant	0.00	0.00	0.00	0.00	-1,768.00	1,768.00	0.00
Education Fund	111137000	ESSER I Digital Equity Grant	185,000.00	0.00	3,996.00	0.00	10,910.72	170,093.28	91.94
Education Fund	11130100	TITLE 1 SALARIES	0.00	4,302.48	0.00	0.00	-21,777.71	21,777.71	0.00
Education Fund	1011130110	HIGH SCHOOL	0.00	0.00	0.00	0.00	0.00	0.00	0.00
Education Fund	11130110	DETENTION HALL SUPVSN	0.00	399.60	0.00	0.00	-6,630.40	6,630.40	0.00
Education Fund	11130127	ELL INSTRUCTION	0.00	0.00	0.00	0.00	0.00	0.00	0.00
Education Fund	1113011002	ART SALARY	186,227.04	15,518.92	0.00	0.00	78,309.08	107,917.96	57.95
Education Fund	1113011005	ENGLISH/DRAMA SALARY	1,695,683.28	141,198.88	0.00	0.00	726,228.56	969,454.72	57.17
Education Fund	1113011006	FOREIGN LANG SALARY	798,294.48	65,418.68	0.00	0.00	338,962.22	459,332.26	57.54
Education Fund	1113011011	MATH SALARY	1,345,195.44	112,284.42	0.00	0.00	551,197.17	793,998.27	59.02
Education Fund	1113011012	MUSIC SALARY	254,266.08	21,188.84	0.00	0.00	102,328.21	151,937.87	31 59.76
Education Fund	1113011013	NATURAL SCIENCE	1,352,051.28	112,609.34	0.00	0.00	566,707.13	785,344.15	58.09
Education Fund	1113011015	SOCIAL SCIENCE SALARY	1,298,241.60	108,186.80	0.00	0.00	544,883.31	753,358.29	58.03
Education Fund	1113011021	DRIVER ED SALARY	0.00	0.00	0.00	0.00	0.00	0.00	0.00
Education Fund	1113011121	DRIVER ED SUMMER	0.00	0.00	0.00	0.00	0.00	0.00	0.00
Education Fund	1113011027	DEPT CHAIR SALARY	767,620.56	63,968.38	0.00	0.00	333,458.98	434,161.58	56.56
Education Fund	1113011050	PHYS ED SALARY	1,168,552.08	97,139.68	0.00	0.00	495,372.07	673,180.01	57.61
Education Fund	11130111	OVERLOAD	106,191.36	8,849.28	0.00	0.00	45,400.38	60,790.98	57.25
Education Fund	11130112	PLAN TIME	203,037.12	17,229.64	0.00	0.00	83,397.59	119,639.53	58.92
Education Fund	11130120	CAMPUS MONITOR	0.00	0.00	0.00	0.00	0.00	0.00	0.00
Education Fund	11130121	SUB TEACHER SALARY	284,290.32	16,308.49	0.00	0.00	165,525.37	118,764.95	41.78
Education Fund	11130122	MENTORING	14,000.00	-8,000.00	0.00	0.00	8,762.38	5,237.62	37.41
Education Fund	11130125	SUMMER CURRIC	9,500.00	0.00	0.00	0.00	9,214.00	286.00	3.01
Education Fund	11130126	POST RETIREMENT	140,000.00	23,465.73	0.00	0.00	116,534.27	23,465.73	16.76

## Expenditure Report

Fiscal Year: 2021-2022  
Month: January

COUNTY OF GRUNDY SCHOOL DIST 111

Fund Description	Account	Account Description	Revised Budget	Encumbrance	MTD Activity	Pending Activity	Available Funds	Year to Date Activity	Percent of Budget Used
Education Fund	11130128	SUMMER SCHOOL SALARY	26,000.00	0.00	0.00	0.00	26,000.00	0.00	0.00
Education Fund	11130130	HOMEBOUND	4,000.00	377.63	0.00	0.00	2,833.99	1,166.01	29.15
Education Fund	10-1130-211	OVERLOAD (IC)	15,000.00	0.00	0.00	0.00	15,000.00	0.00	0.00
Education Fund	1113021	INSTRUCTIONAL TRS	12,746.16	1,107.52	0.00	0.00	5,287.94	7,458.22	58.51
Education Fund	11130211	SUB TEACHER TRS	52,529.04	3,871.83	0.00	0.00	25,020.40	27,508.64	52.37
Education Fund	11130212	MENTORING TRS	2,700.00	0.00	0.00	0.00	1,617.83	1,082.17	40.08
Education Fund	11130213	SUMMER CURRIC TRS	500.00	0.00	0.00	0.00	465.67	34.33	6.87
Education Fund	111302135	TRS PENALTY	16,000.00	0.00	0.00	0.00	12,539.74	3,460.26	21.63
Education Fund	1113021101	INSTRUCTIONAL TRS	0.00	0.00	0.00	0.00	0.00	0.00	0.00
Education Fund	1113021102	ART TRS	22,352.16	1,862.70	0.00	0.00	9,258.39	13,093.77	58.58
Education Fund	1113021105	ENGLISH/DRAMA TRS	203,530.80	16,947.93	0.00	0.00	85,933.00	117,597.80	32 57.78
Education Fund	1113021106	FOREIGN LANGUAGE TRS	95,817.84	7,852.07	0.00	0.00	40,097.49	55,720.35	58.15
Education Fund	111302111	MATH TRS	161,462.40	13,477.37	0.00	0.00	64,898.72	96,563.68	59.81
Education Fund	1113021112	MUSIC TRS	30,518.16	2,543.18	0.00	0.00	12,060.99	18,457.17	60.48
Education Fund	1113021113	NAT SCI TRS	162,284.64	13,516.39	0.00	0.00	66,895.36	95,389.28	58.78
Education Fund	1113021115	SOC SCI TRS	155,826.48	12,985.53	0.00	0.00	64,361.50	91,464.98	58.70
Education Fund	1113021121	DRIVER ED TRS	0.00	0.00	0.00	0.00	0.00	0.00	0.00
Education Fund	1113021127	INSTR LEADER TRS	94,055.52	7,837.96	0.00	0.00	40,324.54	53,730.98	57.13
Education Fund	1113021150	PHYS ED TRS	140,260.32	11,659.53	0.00	0.00	58,528.70	81,731.62	58.27
Education Fund	10-1130-	DEPT CHAIR SALARY (GTL)	0.00	0.00	0.00	0.00	0.00	0.00	0.00
Education Fund	10-1130-222	DIST 111 GROUP MEDICAL	3,000,000.00	341,586.49	0.00	0.00	926,861.92	2,073,138.08	69.10
Education Fund	10-1130-	HIGH SCHOOL	0.00	0.00	0.00	0.00	0.00	0.00	0.00
Education Fund		TEACHING GROUP INS	2,646.48	85.23	0.00	0.00	1,379.08	1,267.40	47.89
Education Fund		10 E 1130 2220 00 300	0.00	0.00	0.00	0.00	-1,418.88	1,418.88	0.00

## Expenditure Report

Fiscal Year: 2021-2022  
Month: January

COUNTY OF GRUNDY SCHOOL DIST 111

Fund Description	Account	Account Description	Revised Budget	Encumbrance	MTD Activity	Pending Activity	Available Funds	Year to Date Activity	Percent of Budget Used
Education Fund	1113022201	TEACHING GROUP INS	0.00	0.00	0.00	0.00	0.00	0.00	0.00
Education Fund	1113022202	ART GROUP INS	44,946.00	3,745.50	0.00	0.00	18,727.50	26,218.50	58.33
Education Fund	1113022205	ENGLISH GROUP INS	393,926.40	32,827.20	0.00	0.00	170,154.18	223,772.22	56.81
Education Fund	1113022206	FOREIGN LANG GROUP	234,111.12	19,509.26	0.00	0.00	98,307.81	135,803.31	58.01
Education Fund	1113022211	MATH GROUP INS	330,884.64	27,698.78	0.00	0.00	135,354.97	195,529.67	59.09
Education Fund	1113022212	MUSIC GROUP INS	56,149.20	4,679.10	0.00	0.00	23,390.70	32,758.50	58.34
Education Fund	1113022213	NAT SCI GROUP INS	305,990.16	26,159.36	0.00	0.00	124,095.42	181,894.74	59.44
Education Fund	1113022215	SOC SCI GROUP INS	249,614.16	20,957.46	0.00	0.00	104,433.48	145,180.68	58.16
Education Fund	1113022221	DRIVER ED GROUP INS	0.00	0.00	0.00	0.00	0.00	0.00	0.00
Education Fund	1113022225	CAMPUS MONITOR GROUP	0.00	0.00	0.00	0.00	0.00	0.00	0.00
Education Fund	1113022227	INSTR LDR GROUP	198,651.12	16,554.26	0.00	0.00	84,024.78	114,626.34	33 57.70
Education Fund	1113022250	PHYS ED GROUP INS	243,803.52	24,203.32	0.00	0.00	94,394.94	149,408.58	61.28
Education Fund		DIST 111 GROUP DENTAL	329,748.00	15,164.34	0.00	0.00	232,220.85	97,527.15	29.58
Education Fund		10 E 1130 2230 00 300	0.00	0.00	0.00	0.00	-73.60	73.60	0.00
Education Fund		10 E 1130 2230 02 300	883.20	75.56	0.00	0.00	366.04	517.16	58.56
Education Fund		10 E 1130 2230 05 300	8,666.40	741.44	0.00	0.00	3,667.45	4,998.95	57.68
Education Fund		10 E 1130 2230 06 300	4,857.60	415.58	0.00	0.00	2,006.83	2,850.77	58.69
Education Fund		10 E 1130 2230 11 300	7,065.60	604.48	0.00	0.00	2,876.01	4,189.59	59.30
Education Fund		10 E 1130 2230 12 300	1,324.80	113.34	0.00	0.00	549.06	775.74	58.56
Education Fund		10 E 1130 2230 13 300	7,507.20	642.26	0.00	0.00	3,056.57	4,450.63	59.28
Education Fund		10 E 1130 2230 15 300	6,789.60	579.76	0.00	0.00	2,858.44	3,931.16	57.90
Education Fund		DEPT CHAIR INS	8,832.72	755.90	0.00	0.00	3,738.00	5,094.72	57.68
Education Fund		10 E 1130 2230 50 300	4,857.60	453.36	0.00	0.00	1,920.24	2,937.36	60.47
Education Fund	11131230	COLLEGE TUITION REIMB	70,000.00	8,700.00	0.00	2,679.00	8,383.12	58,937.88	84.20

## Expenditure Report

Fiscal Year: 2021-2022  
Month: January

COUNTY OF GRUNDY SCHOOL DIST 111

Fund Description	Account	Account Description	Revised Budget	Encumbrance	MTD Activity	Pending Activity	Available Funds	Year to Date Activity	Percent of Budget Used
Education Fund		10 E 1130 2340 13 300	0.00	0.00	0.00	0.00	-500.00	500.00	0.00
Education Fund	1113030006	FOREIGN LANG CONTR	1,150.00	0.00	0.00	0.00	1,150.00	0.00	0.00
Education Fund	1113030006	FOREIGN LANG CONT	0.00	0.00	0.00	0.00	0.00	0.00	0.00
Education Fund	1110030012	BAND PURCHASE SERV	12,500.00	0.00	0.00	1,321.00	1,639.55	9,539.45	76.32
Education Fund	1110030112	CHORUS PURCHASE SERV	10,000.00	423.00	0.00	0.00	6,554.55	3,445.45	34.45
Education Fund	1110030212	STRINGS PURCHASE	0.00	0.00	0.00	0.00	0.00	0.00	0.00
Education Fund	1110030012	BAND CONT SERV S	0.00	0.00	0.00	0.00	0.00	0.00	0.00
Education Fund	1110030112	CHORUS CONT SERV S	0.00	0.00	0.00	0.00	0.00	0.00	0.00
Education Fund	1110030212	STRINGS CONT SERV S	0.00	0.00	0.00	0.00	0.00	0.00	0.00
Education Fund	1113030021	DRIVER ED CONTRACT	0.00	0.00	0.00	0.00	0.00	0.00	0.00
Education Fund	1113031025	POLICE LIAISON	0.00	0.00	0.00	0.00	0.00	0.00	34 0.00
Education Fund	1113031125	EVENT SECURITY	0.00	0.00	0.00	0.00	0.00	0.00	0.00
Education Fund	11131314	CURRIC DEVEL/LRNG OBJ	0.00	0.00	0.00	0.00	0.00	0.00	0.00
Education Fund	11131315	STAFF DEVELOPMENT	0.00	0.00	0.00	0.00	0.00	0.00	0.00
Education Fund	11130322	TOWEL CONTRACT SERV	0.00	0.00	0.00	0.00	0.00	0.00	0.00
Education Fund	1113032302	ART CONTRACT SERV	0.00	0.00	0.00	0.00	0.00	0.00	0.00
Education Fund	1113032302	ART CONT SERV S	0.00	0.00	0.00	0.00	0.00	0.00	0.00
Education Fund	1113032305	ENGLISH CONTRACT SERV	5,000.00	0.00	0.00	0.00	5,000.00	0.00	0.00
Education Fund	1113032305	ENGLISH CONT SERV S	0.00	0.00	0.00	0.00	0.00	0.00	0.00
Education Fund	1110032312	BAND REPAIR & MAINT	6,000.00	252.00	0.00	0.00	1,962.11	4,037.89	67.30
Education Fund	1110032412	CHORUS REPAIR & MAINT	2,200.00	0.00	510.00	0.00	1,690.00	0.00	0.00
Education Fund	1110032512	STRINGS REPAIR & MAINT	0.00	0.00	0.00	0.00	0.00	0.00	0.00
Education Fund	1110032312	BAND REPAIR & MAINT S	0.00	0.00	0.00	0.00	0.00	0.00	0.00
Education Fund	1110032412	CHORUS REPAIR & MAINT	0.00	0.00	0.00	0.00	-340.00	340.00	0.00

## Expenditure Report

Fiscal Year: 2021-2022  
Month: January

COUNTY OF GRUNDY SCHOOL DIST 111

Fund Description	Account	Account Description	Revised Budget	Encumbrance	MTD Activity	Pending Activity	Available Funds	Year to Date Activity	Percent of Budget Used
Education Fund	1110032512	STRINGS REPAIR & MAINT	0.00	0.00	0.00	0.00	0.00	0.00	0.00
Education Fund	1113032313	NAT SCI CONTRACT SERV	3,000.00	0.00	0.00	0.00	3,000.00	0.00	0.00
Education Fund	1113032313	NAT SCI CONT SERV S	0.00	0.00	0.00	0.00	0.00	0.00	0.00
Education Fund	1113032315	SOC SCI CONTRACT SERV	189.00	189.00	0.00	0.00	0.00	189.00	100.00
Education Fund	1113032315	SOC SCI CONT SERV S	0.00	0.00	0.00	0.00	0.00	0.00	0.00
Education Fund	1113032350	PHYS ED CONTRACT SERV	3,440.00	3,249.00	0.00	0.00	-529.00	3,969.00	115.38
Education Fund	1113032351	BOWING COSTS	0.00	0.00	0.00	0.00	0.00	0.00	0.00
Education Fund	1113032350	PHYS ED CONT SERV S	0.00	0.00	0.00	0.00	0.00	0.00	0.00
Education Fund	11130332	GENERAL EDUCATION	1,000.00	0.00	0.00	0.00	947.22	52.78	5.28
Education Fund	11131332	TYPE 75 TRAVEL	0.00	0.00	0.00	0.00	0.00	0.00	0.00
Education Fund	11130380	UNEMPLOYMENT	0.00	0.00	0.00	0.00	-4,984.92	4,984.92	35 0.00
Education Fund	11130381	WORKERS COMP	0.00	0.00	0.00	0.00	0.00	0.00	0.00
Education Fund	1113038021	DRIVER ED CAR	0.00	0.00	0.00	0.00	0.00	0.00	0.00
Education Fund	11130400	TITLE 1 SUPPLIES	0.00	0.00	0.00	0.00	0.00	0.00	0.00
Education Fund	1113040005	ENGLISH RESALE	0.00	0.00	0.00	0.00	0.00	0.00	0.00
Education Fund	1113040011	MATH SUPPLIES RESALE	0.00	0.00	0.00	0.00	0.00	0.00	0.00
Education Fund	1113040050	PHYS ED RESALE	4,628.00	2,993.13	0.00	0.00	1,634.87	2,993.13	64.67
Education Fund	1113040050	PHYS ED RESALE	0.00	0.00	0.00	0.00	0.00	0.00	0.00
Education Fund	11130410	GEN ED	20,000.00	0.00	0.00	0.00	3,164.58	16,835.42	84.18
Education Fund	11130411	ECOLAB GRANT SUPPLIES	0.00	0.00	0.00	0.00	0.00	0.00	0.00
Education Fund	11131410	CURRIC DEVEL/LRNG	0.00	0.00	0.00	0.00	0.00	0.00	0.00
Education Fund	11131411	STAFF DEVELOPMENT	0.00	0.00	0.00	0.00	0.00	0.00	0.00
Education Fund	11131412	TPI GRANT SUPPLIES	0.00	0.00	0.00	0.00	0.00	0.00	0.00
Education Fund	111304102	GEN ED SUPPLIES S	0.00	0.00	0.00	0.00	0.00	0.00	0.00

## Expenditure Report

Fiscal Year: 2021-2022  
Month: January

COUNTY OF GRUNDY SCHOOL DIST 111

Fund Description	Account	Account Description	Revised Budget	Encumbrance	MTD Activity	Pending Activity	Available Funds	Year to Date Activity	Percent of Budget Used
Education Fund	1113041002	ART SUPPLIES	17,880.00	239.70	2,051.54	0.00	4,953.30	10,875.16	60.82
Education Fund	1113041102	ART/COMP TECH	1,800.00	0.00	0.00	0.00	1,729.82	70.18	3.90
Education Fund	1113041002	ART SUPPLIES S	0.00	0.00	0.00	0.00	0.00	0.00	0.00
Education Fund	1113041102	ART/COMP TECH SUPPLY	0.00	0.00	0.00	0.00	0.00	0.00	0.00
Education Fund	1113041005	ENGLISH/DRAMA	1,744.00	0.00	0.00	0.00	1,744.00	0.00	0.00
Education Fund	1113041505	ENGLISH/COMP TECH	0.00	0.00	0.00	0.00	0.00	0.00	0.00
Education Fund	1113041005	ENGLISH/DRAMA SUPPLY	0.00	0.00	0.00	0.00	0.00	0.00	0.00
Education Fund	1113041505	ENGLISH/COMP TECH SUP	0.00	0.00	0.00	0.00	0.00	0.00	0.00
Education Fund	1113041006	FOREIGN LANG SUPPLIES	1,369.00	0.00	390.95	0.00	179.92	798.13	58.30
Education Fund	1113041106	FOREIGN LANG/COMP	0.00	0.00	0.00	0.00	0.00	0.00	0.00
Education Fund	1113041006	FORN LANG SUPPLIES S	0.00	0.00	0.00	0.00	0.00	0.00	36 0.00
Education Fund	1113041106	FORN LANG COMP TECH S	0.00	0.00	0.00	0.00	0.00	0.00	0.00
Education Fund	1113041011	MATH SUPPLIES	2,265.00	0.00	358.80	0.00	1,151.54	754.66	33.32
Education Fund	1113041211	MATH/COMP TECH	389.00	0.00	262.35	0.00	75.56	51.09	13.13
Education Fund	1113041011	MATH SUPPLIES S	0.00	0.00	0.00	0.00	0.00	0.00	0.00
Education Fund	1113041211	MATH/COMP TECH SUP S	0.00	0.00	0.00	0.00	0.00	0.00	0.00
Education Fund	1110041012	BAND SUPPLIES	8,165.20	0.00	0.00	0.00	2,493.98	5,671.22	69.46
Education Fund	1110041112	CHORUS SUPPLIES	3,500.00	566.49	49.75	0.00	1,028.29	2,421.96	69.20
Education Fund	1110041212	STRINGS SUPPLIES	2,500.00	0.00	0.00	0.00	2,500.00	0.00	0.00
Education Fund	1113041012	BAND-CHORUS/COMP	0.00	0.00	0.00	0.00	0.00	0.00	0.00
Education Fund	1110041012	BAND SUPPLIES S	0.00	0.00	0.00	0.00	0.00	0.00	0.00
Education Fund	1110041112	GENERAL MUSIC	8,590.00	0.00	0.00	0.00	8,069.01	520.99	6.07
Education Fund	1110041212	STRINGS SUPPLIES S	0.00	0.00	0.00	0.00	0.00	0.00	0.00
Education Fund	1113041012	BAND-CHORUS/COMP	0.00	0.00	0.00	0.00	0.00	0.00	0.00

## Expenditure Report

Fiscal Year: 2021-2022  
Month: January

COUNTY OF GRUNDY SCHOOL DIST 111

Fund Description	Account	Account Description	Revised Budget	Encumbrance	MTD Activity	Pending Activity	Available Funds	Year to Date Activity	Percent of Budget Used
Education Fund	1113041013	NAT SCI SUPPLIES	21,150.00	182.74	437.16	215.79	16,178.64	4,318.41	20.42
Education Fund	1113041113	NAT SCI/COMP TECH	0.00	0.00	0.00	0.00	-7,860.00	7,860.00	0.00
Education Fund	1113041013	NAT SCI SUPPLIES S	0.00	0.00	0.00	0.00	-2,086.55	2,086.55	0.00
Education Fund	1113041113	NAT SCI/COMP TECH S	0.00	0.00	0.00	0.00	0.00	0.00	0.00
Education Fund	1113041015	SOC SCI SUPPLIES	5,000.00	1,780.33	0.00	0.00	2,282.17	2,717.83	54.36
Education Fund	1113041115	SOC SCI/COMP TECH	0.00	0.00	0.00	0.00	0.00	0.00	0.00
Education Fund	1113041015	SOC SCI SUPPLIES S	0.00	0.00	0.00	0.00	2,000.00	-2,000.00	0.00
Education Fund	1113041115	SCO SCI/COMP TECH S	0.00	0.00	0.00	0.00	0.00	0.00	0.00
Education Fund	1113041021	DRIVER ED SUPPLIES	0.00	0.00	0.00	0.00	0.00	0.00	0.00
Education Fund	1113041050	PHYS ED SUPPLIES	30,000.00	1,008.00	8,916.39	0.00	-865.67	21,949.28	73.16
Education Fund	1113041150	PHYS ED COMP TECH	500.00	0.00	0.00	0.00	500.00	0.00	37 0.00
Education Fund	1113041050	PHS ED SUPPLIES S	0.00	0.00	0.00	0.00	0.00	0.00	0.00
Education Fund	1113041150	PHYS ED COMP TECH	0.00	0.00	0.00	0.00	0.00	0.00	0.00
Education Fund	11130420	GENERAL EDUC	0.00	0.00	0.00	0.00	-13.46	13.46	0.00
Education Fund	111304202	GENERAL ED TEXTBOOKS	0.00	0.00	0.00	0.00	0.00	0.00	0.00
Education Fund	1113042002	ART TEXTBOOKS	0.00	0.00	0.00	0.00	0.00	0.00	0.00
Education Fund	1113042002	ART TEXTBOOKS S	0.00	0.00	0.00	0.00	0.00	0.00	0.00
Education Fund	1113042005	ENGLISH/DRAMA	7,000.00	803.88	0.00	0.00	3,705.29	3,294.71	47.07
Education Fund	1113042005	ENGLISH/DRAMA TEXTBK S	0.00	0.00	0.00	0.00	-722.52	722.52	0.00
Education Fund	1113042006	FOREIGN LANG	6,607.00	0.00	0.00	0.00	1,916.20	4,690.80	71.00
Education Fund	1113042006	FORN LANG TEXTBOOKS S	0.00	0.00	0.00	0.00	0.00	0.00	0.00
Education Fund	1113042011	MATH TEXTBOOKS	19,974.00	0.00	0.00	0.00	-0.13	19,974.13	100.00
Education Fund	1113042011	MATH TEXTBOOKS S	0.00	0.00	0.00	0.00	0.00	0.00	0.00
Education Fund	1110042012	BAND TEXTBOOKS	0.00	0.00	0.00	0.00	0.00	0.00	0.00

## Expenditure Report

Fiscal Year: 2021-2022  
Month: January

COUNTY OF GRUNDY SCHOOL DIST 111

Fund Description	Account	Account Description	Revised Budget	Encumbrance	MTD Activity	Pending Activity	Available Funds	Year to Date Activity	Percent of Budget Used
Education Fund	1110042112	MUSIC TEXTBOOKS	1,200.00	167.85	0.00	0.00	873.31	326.69	27.22
Education Fund	1110042212	STRINGS TEXTBOOKS	0.00	0.00	0.00	0.00	0.00	0.00	0.00
Education Fund	1110042012	BAND TEXTBOOKS S	0.00	0.00	0.00	0.00	0.00	0.00	0.00
Education Fund	1110042112	CHORUS TEXTBOOKS S	0.00	0.00	0.00	0.00	0.00	0.00	0.00
Education Fund	1110042212	STRINGS TEXTBOOKS S	0.00	0.00	0.00	0.00	0.00	0.00	0.00
Education Fund	1113042013	NAT SCI TEXTBOOKS	8,046.00	0.00	0.00	0.00	976.43	7,069.57	87.86
Education Fund	1113042013	NAT SCI TEXTBOOKS S	0.00	0.00	0.00	0.00	0.00	0.00	0.00
Education Fund	1113042015	SOC SCI TEXTBOOKS	16,000.00	0.00	653.94	0.00	15,346.06	0.00	0.00
Education Fund	1113042015	SOC SCI TEXTBOOKS S	0.00	0.00	0.00	0.00	0.00	0.00	0.00
Education Fund	1113042021	DRIVER ED TEXTBOOKS	0.00	0.00	0.00	0.00	0.00	0.00	0.00
Education Fund	1113042050	PHYS ED TEXTBOOKS	0.00	0.00	0.00	0.00	0.00	0.00	38 0.00
Education Fund	1113042050	PHS ED TEXTBOOKS S	0.00	0.00	0.00	0.00	0.00	0.00	0.00
Education Fund	1113043002	ART PERIODICALS	0.00	0.00	0.00	0.00	0.00	0.00	0.00
Education Fund	1113043002	ART PERIODICALS S	0.00	0.00	0.00	0.00	0.00	0.00	0.00
Education Fund	1113043005	ENGLISH PERIODICALS	0.00	0.00	0.00	0.00	0.00	0.00	0.00
Education Fund	1113043005	ENGLISH PERIODICALS S	0.00	0.00	0.00	0.00	0.00	0.00	0.00
Education Fund	1113043015	SOC SCI PERIODICALS	0.00	0.00	0.00	0.00	0.00	0.00	0.00
Education Fund	1113043015	SOC SCI PERIODICALS S	0.00	0.00	0.00	0.00	0.00	0.00	0.00
Education Fund	1113043050	PHYS ED PERIODICALS	0.00	0.00	0.00	0.00	0.00	0.00	0.00
Education Fund	1113043050	PHYS ED PERIODICALS S	0.00	0.00	0.00	0.00	0.00	0.00	0.00
Education Fund	1113049002	ART VIDEO/SOFTWARE	0.00	0.00	0.00	0.00	0.00	0.00	0.00
Education Fund	1113049002	ART VIDEO/SOFTWARE S	0.00	0.00	0.00	0.00	0.00	0.00	0.00
Education Fund	1113049005	ENGLISH	0.00	0.00	0.00	0.00	-5,000.00	5,000.00	0.00
Education Fund	1113049005	ENGLISH	0.00	0.00	0.00	0.00	0.00	0.00	0.00

## Expenditure Report

Fiscal Year: 2021-2022  
Month: January

COUNTY OF GRUNDY SCHOOL DIST 111

Fund Description	Account	Account Description	Revised Budget	Encumbrance	MTD Activity	Pending Activity	Available Funds	Year to Date Activity	Percent of Budget Used
Education Fund	1113049006	FOREIGN LANG	0.00	0.00	0.00	0.00	0.00	0.00	0.00
Education Fund	1113049006	FORN LANG	0.00	0.00	0.00	0.00	0.00	0.00	0.00
Education Fund	1113049011	MATH VIDEO/SOFTWARE	480.00	0.00	0.00	0.00	480.00	0.00	0.00
Education Fund	1113049011	MATH VIDEO/SOFTWARE S	0.00	0.00	0.00	0.00	0.00	0.00	0.00
Education Fund	1110049112	BAND VIDEO/SOFTWARE	0.00	0.00	0.00	0.00	0.00	0.00	0.00
Education Fund	1110049212	CHORUS	0.00	0.00	0.00	0.00	0.00	0.00	0.00
Education Fund	1110049312	STRINGS	0.00	0.00	0.00	0.00	0.00	0.00	0.00
Education Fund	1110049112	BAND VIDEO/SOFTWARE S	0.00	0.00	0.00	0.00	0.00	0.00	0.00
Education Fund	1110049212	CHORUS	0.00	0.00	0.00	0.00	0.00	0.00	0.00
Education Fund	1110049312	STRINGS	0.00	0.00	0.00	0.00	0.00	0.00	0.00
Education Fund	1113049013	NAT SCI	7,990.00	0.00	0.00	0.00	7,990.00	0.00	39 0.00
Education Fund	1113049013	NAT SCI	0.00	0.00	0.00	0.00	0.00	0.00	0.00
Education Fund	1113049015	SOC SCI	0.00	0.00	0.00	0.00	0.00	0.00	0.00
Education Fund	1113049015	SOC SCI	0.00	0.00	0.00	0.00	0.00	0.00	0.00
Education Fund	1113049021	DRIVER ED	0.00	0.00	0.00	0.00	0.00	0.00	0.00
Education Fund	1113049050	PE/HEALTH	0.00	0.00	0.00	0.00	0.00	0.00	0.00
Education Fund	1113049050	PHYS ED	0.00	0.00	0.00	0.00	0.00	0.00	0.00
Education Fund	1113054002	ART EQUIPMENT	0.00	0.00	0.00	0.00	0.00	0.00	0.00
Education Fund	1113054002	ART EQUIPMENT S	0.00	0.00	0.00	0.00	0.00	0.00	0.00
Education Fund	1113054005	ENGLISH EQUIPMENT	0.00	0.00	0.00	0.00	0.00	0.00	0.00
Education Fund	1113054005	ENGLISH EQUIPMENT S	0.00	0.00	0.00	0.00	0.00	0.00	0.00
Education Fund	1113054006	FOREIGN LANG	0.00	0.00	0.00	0.00	0.00	0.00	0.00
Education Fund	1113054006	FORN LANG EQUIPMENT S	0.00	0.00	0.00	0.00	0.00	0.00	0.00
Education Fund	1113054011	MATH EQUIPMENT	0.00	0.00	0.00	0.00	0.00	0.00	0.00

## Expenditure Report

Fiscal Year: 2021-2022  
Month: January

COUNTY OF GRUNDY SCHOOL DIST 111

Fund Description	Account	Account Description	Revised Budget	Encumbrance	MTD Activity	Pending Activity	Available Funds	Year to Date Activity	Percent of Budget Used
Education Fund	1113054011	MATH EQUIPMENT S	0.00	0.00	0.00	0.00	0.00	0.00	0.00
Education Fund	1110054012	BAND EQUIPMENT	51,649.80	0.00	262.80	0.00	45,264.26	6,122.74	11.85
Education Fund	1110054112	CHORUS EQUIPMENT	2,900.00	0.00	0.00	0.00	2,900.00	0.00	0.00
Education Fund	1110054212	STRINGS EQUIPMENT	0.00	0.00	0.00	0.00	0.00	0.00	0.00
Education Fund	1110054012	BAND EQUIPMENT S	0.00	0.00	0.00	0.00	0.00	0.00	0.00
Education Fund	1110054112	CHORUS EQUIPMENT S	0.00	0.00	0.00	0.00	0.00	0.00	0.00
Education Fund	1110054212	STRINGS EQUIPMENT S	0.00	0.00	0.00	0.00	0.00	0.00	0.00
Education Fund	1113054013	NAT SCI EQUIPMENT	0.00	0.00	0.00	0.00	0.00	0.00	0.00
Education Fund	1113054013	NAT SCI EQUIPMENT S	0.00	0.00	0.00	0.00	0.00	0.00	0.00
Education Fund	1113054015	SOC SCI EQUIPMENT	0.00	0.00	0.00	0.00	0.00	0.00	0.00
Education Fund	1113054015	SOC SCI EQUIPMENT S	0.00	0.00	0.00	0.00	0.00	0.00	40 0.00
Education Fund	1113054021	DRIVER ED EQUIPMENT	0.00	0.00	0.00	0.00	0.00	0.00	0.00
Education Fund	1113054050	PHYS ED EQUIPMENT	0.00	0.00	0.00	0.00	-85.57	85.57	0.00
Education Fund	1113054050	PHYS ED EQUIPMENT S	0.00	0.00	0.00	0.00	0.00	0.00	0.00
Education Fund	1113055021	DRIVER ED VEHICLES	0.00	0.00	0.00	0.00	0.00	0.00	0.00
Education Fund	11130642	JJC TUITION	0.00	0.00	0.00	0.00	0.00	0.00	0.00
Education Fund	1113064002	ART DUES/FEES/LIT	0.00	0.00	0.00	0.00	0.00	0.00	0.00
Education Fund	1113064005	ENGLISH DUES/FEES	0.00	0.00	0.00	0.00	0.00	0.00	0.00
Education Fund	1113064005	ENGLISH DUES/FEES/LIT	0.00	0.00	0.00	0.00	0.00	0.00	0.00
Education Fund	1113064006	FOREIGN LANG	0.00	0.00	0.00	0.00	0.00	0.00	0.00
Education Fund	1113064006	FORN LANG	0.00	0.00	0.00	0.00	0.00	0.00	0.00
Education Fund	1113064011	MATH DUES & FEES	0.00	0.00	0.00	0.00	0.00	0.00	0.00
Education Fund	1113064011	MATH DUES/FEES/LIT S	0.00	0.00	0.00	0.00	0.00	0.00	0.00
Education Fund	1110064012	BAND CLINICS	1,500.00	0.00	0.00	0.00	1,500.00	0.00	0.00

## Expenditure Report

Fiscal Year: 2021-2022  
Month: January

COUNTY OF GRUNDY SCHOOL DIST 111

Fund Description	Account	Account Description	Revised Budget	Encumbrance	MTD Activity	Pending Activity	Available Funds	Year to Date Activity	Percent of Budget Used
Education Fund	1110064112	CHORUS CLINICS	750.00	0.00	0.00	0.00	750.00	0.00	0.00
Education Fund	1110064212	STRINGS CLINICS	0.00	0.00	0.00	0.00	0.00	0.00	0.00
Education Fund	1110064312	BAND ENTRY FEES	5,485.00	0.00	0.00	0.00	5,960.00	-475.00	-8.66
Education Fund	1110064412	CHORUS ENTRY FEES	1,500.00	0.00	0.00	0.00	506.00	994.00	66.27
Education Fund	1110064512	STRINGS ENTRY FEES	2,100.00	0.00	0.00	0.00	2,100.00	0.00	0.00
Education Fund	1110064012	BAND CLINICS S	0.00	0.00	0.00	0.00	0.00	0.00	0.00
Education Fund	1110064112	CHORUS CLINICS S	0.00	0.00	0.00	0.00	0.00	0.00	0.00
Education Fund	1110064212	STRINGS CLINICS S	0.00	0.00	0.00	0.00	0.00	0.00	0.00
Education Fund	1110064312	BAND ENTRY FEES S	0.00	0.00	0.00	0.00	0.00	0.00	0.00
Education Fund	1110064412	CHORUS ENTRY FEES S	0.00	0.00	0.00	0.00	0.00	0.00	0.00
Education Fund	1110064512	STRINGS ENTRY FEES S	0.00	0.00	0.00	0.00	0.00	0.00	41 0.00
Education Fund	1113064013	NAT SCI DUES/FEES/LIT	750.00	0.00	0.00	0.00	750.00	0.00	0.00
Education Fund	1113064113	SCIENCE FIELD TRIP	0.00	0.00	0.00	0.00	0.00	0.00	0.00
Education Fund	1113064013	NAT SCI DUES/FEES/LIT S	0.00	0.00	0.00	0.00	0.00	0.00	0.00
Education Fund	1113064015	SOC SCI DUES/FEES/LIT	0.00	0.00	0.00	0.00	0.00	0.00	0.00
Education Fund	1113064015	SOC SCI DUES/FEES/LIT S	0.00	0.00	0.00	0.00	0.00	0.00	0.00
Education Fund	1113064021	DRIVER ED DUES/FEES/LIT	0.00	0.00	0.00	0.00	0.00	0.00	0.00
Education Fund	1113064050	PHYS ED DUES/FEES/LIT	0.00	0.00	0.00	0.00	0.00	0.00	0.00
Education Fund	1113064050	PHYS ED DUES/FEES/LIT S	0.00	0.00	0.00	0.00	0.00	0.00	0.00
Education Fund	11130800	HOMEBOUND/HOP REG ED	0.00	0.00	0.00	0.00	0.00	0.00	0.00
Education Fund	11130690	REFUND ACCOUNT	5,000.00	0.00	0.00	0.00	5,000.00	0.00	0.00
Education Fund	11200110	SPECIAL ED SALARY	1,272,122.16	105,233.38	0.00	0.00	549,189.93	722,932.23	56.83
Education Fund	11200111	SPECIAL ED AIDES	0.00	0.00	0.00	0.00	0.00	0.00	0.00
Education Fund	11200112	IDEA PART B SP ED	113,031.60	9,293.70	0.00	0.00	51,263.58	61,768.02	54.65

## Expenditure Report

Fiscal Year: 2021-2022  
Month: January

COUNTY OF GRUNDY SCHOOL DIST 111

Fund Description	Account	Account Description	Revised Budget	Encumbrance	MTD Activity	Pending Activity	Available Funds	Year to Date Activity	Percent of Budget Used
Education Fund	11200113	IDEA PART B SP ED	37,381.44	3,115.12	0.00	0.00	15,575.60	21,805.84	58.33
Education Fund	11200114	IDEA PART B SP ED	0.00	0.00	0.00	0.00	0.00	0.00	0.00
Education Fund	11200211	SPECIAL ED TRS	152,692.32	12,631.01	0.00	0.00	64,717.39	87,974.93	57.62
Education Fund	11200222	SPECIAL ED INSURANCE	268,413.36	22,302.70	0.00	0.00	105,189.02	163,224.34	60.81
Education Fund		SPECIAL ED AIDES INS	0.00	0.00	0.00	0.00	0.00	0.00	0.00
Education Fund		IDEA PART B SP ED	8,803.44	1,218.53	0.00	0.00	2,476.52	6,326.92	71.87
Education Fund		IDEA PART B SP ED	8,520.00	710.00	0.00	0.00	3,550.00	4,970.00	58.33
Education Fund	11200223	IDEA PART B SP ED	0.00	0.00	0.00	0.00	0.00	0.00	0.00
Education Fund		10 E 1200 2230 00 300	8,390.40	717.82	0.00	0.00	3,481.84	4,908.56	58.50
Education Fund		10 E 1200 2230 00 300	441.60	37.78	0.00	0.00	183.02	258.58	58.56
Education Fund	11200300	SPECIAL ED PURCHASE	189.36	0.00	0.00	0.00	-617.32	806.68	42426.00
Education Fund	11200301	IDEA GRANT PURCHASE	1,437.12	4,006.50	0.00	0.00	-7,276.50	8,713.62	606.33
Education Fund	11200311	COOP HOUSING ASSESS	0.00	0.00	0.00	0.00	0.00	0.00	0.00
Education Fund	11200312	COOP ADMIN ASSESS	0.00	0.00	0.00	0.00	0.00	0.00	0.00
Education Fund	11200410	SPECIAL ED SUPPLIES	3,500.00	0.00	0.00	0.00	2,177.02	1,322.98	37.80
Education Fund	11200411	SPECIAL ED COMP TECH	2,600.00	0.00	0.00	0.00	2,600.00	0.00	0.00
Education Fund	11200412	IDEA PART B SP ED	2,713.00	133.12	0.00	22.18	1,268.08	1,422.74	52.44
Education Fund	11200420	SPECIAL ED TEXTBOOKS	150.00	0.00	0.00	0.00	150.00	0.00	0.00
Education Fund	11200490	SPECIAL ED	0.00	0.00	0.00	0.00	0.00	0.00	0.00
Education Fund	11200500	IDEA PART B SP ED	9,500.00	0.00	0.00	0.00	6,870.95	2,629.05	27.67
Education Fund	11200641	SPECIAL ED - OTHER	1,800.00	136.64	0.00	0.00	1,663.36	136.64	7.59
Education Fund	11200640	SPECIAL ED	0.00	0.00	0.00	0.00	0.00	0.00	0.00
Education Fund	11200800	COOP TUITION	0.00	0.00	0.00	0.00	0.00	0.00	0.00
Education Fund	11200801	OUT OF DIST TUITION	0.00	0.00	0.00	0.00	0.00	0.00	0.00

## Expenditure Report

Fiscal Year: 2021-2022  
Month: January

COUNTY OF GRUNDY SCHOOL DIST 111

Fund Description	Account	Account Description	Revised Budget	Encumbrance	MTD Activity	Pending Activity	Available Funds	Year to Date Activity	Percent of Budget Used
Education Fund	11200802	COOP HOMEBOUND/HOSP	35,614.16	5,527.08	0.00	691.60	2,596.58	32,325.98	90.77
Education Fund	11250211	COOP TRS	0.00	0.00	0.00	0.00	0.00	0.00	0.00
Education Fund	11250311	COOP HOUSING ASSESS	0.00	0.00	0.00	0.00	0.00	0.00	0.00
Education Fund	11250312	COOP ADMN ASSESS	0.00	0.00	0.00	0.00	0.00	0.00	0.00
Education Fund	11250800	COOP TUITION	0.00	0.00	0.00	0.00	0.00	0.00	0.00
Education Fund	11250801	OUT OF DIST TUITION	0.00	0.00	0.00	0.00	0.00	0.00	0.00
Education Fund	11250802	COOP HOMEBOUND/HOSP	0.00	0.00	0.00	0.00	0.00	0.00	0.00
Education Fund	1140041011	CTE SALARY	284,933.52	23,806.06	0.00	0.00	122,165.63	162,767.89	57.12
Education Fund	1140011010	INDUSTRIAL TECH SALARY	188,292.96	15,115.08	0.00	0.00	82,822.51	105,470.45	56.01
Education Fund	11400211	VOC ED GRANT TRS	34,200.48	2,857.39	0.00	0.00	14,441.65	19,758.83	57.77
Education Fund	1140021110	INDUSTRIAL TECH TRS	22,600.08	1,814.24	0.00	0.00	9,804.67	12,795.41	43 56.62
Education Fund	1140021111	CTE TRS	0.00	0.00	0.00	0.00	0.00	0.00	0.00
Education Fund	10-1400-	CTE SALARY (BMF 2)	80,846.64	6,737.22	0.00	0.00	37,492.67	43,353.97	53.62
Education Fund	1140022210	IND TECH GROUP INS	63,120.48	5,260.04	0.00	0.00	26,300.20	36,820.28	58.33
Education Fund		10 E 1400 2230 00 300	1,766.40	151.12	0.00	0.00	773.16	993.24	56.23
Education Fund		10 E 1400 2230 10 300	1,324.80	113.34	0.00	0.00	549.06	775.74	58.56
Education Fund	1140032310	IND TECH REPAIR/MAINT	25,000.00	109.00	260.00	0.00	23,095.64	1,644.36	6.58
Education Fund	1140032310	IND TECH REPAIR/MAINT S	0.00	0.00	0.00	0.00	0.00	0.00	0.00
Education Fund	1140041032	CTEIG SUPPLIES	0.00	0.00	0.00	0.00	0.00	0.00	0.00
Education Fund	11400410	VOC ED GRANT SUPPLIES	0.00	0.00	0.00	0.00	0.00	0.00	0.00
Education Fund	1140041010	IND ARTS COMP TECH	0.00	0.00	0.00	0.00	0.00	0.00	0.00
Education Fund	1140041110	IND TECH SUPPLIES	68,412.00	5,618.52	16,650.79	2,779.09	17,060.01	31,922.11	46.66
Education Fund	1140041210	ECO LAB GRANT	0.00	0.00	0.00	0.00	0.00	0.00	0.00
Education Fund	1140041010	IND TECH/COMP TECH S	0.00	0.00	0.00	0.00	0.00	0.00	0.00

## Expenditure Report

Fiscal Year: 2021-2022  
Month: January

COUNTY OF GRUNDY SCHOOL DIST 111

Fund Description	Account	Account Description	Revised Budget	Encumbrance	MTD Activity	Pending Activity	Available Funds	Year to Date Activity	Percent of Budget Used
Education Fund	1140041110	IND TECH SUPPLIES S	0.00	0.00	0.00	0.00	0.00	0.00	0.00
Education Fund	1140042010	IND TECH TEXTBOOKS	0.00	0.00	0.00	0.00	0.00	0.00	0.00
Education Fund	1140042010	IND TECH TEXTBOOKS S	0.00	0.00	0.00	0.00	0.00	0.00	0.00
Education Fund	11400490	IND TECH	0.00	0.00	0.00	0.00	0.00	0.00	0.00
Education Fund	114004902	IND TECH	0.00	0.00	0.00	0.00	0.00	0.00	0.00
Education Fund	1140054010	IND TECH EQUIPMENT	0.00	0.00	0.00	0.00	0.00	0.00	0.00
Education Fund	1140054010	IND TECH EQUIPMENT S	0.00	0.00	0.00	0.00	0.00	0.00	0.00
Education Fund	11400640	IND TECH DUES/FEES/LIT	3,200.00	0.00	0.00	0.00	0.00	3,200.00	100.00
Education Fund	114006402	IND TECH DUES/FEES/LIT	0.00	0.00	0.00	0.00	0.00	0.00	0.00
Education Fund	11459800	GAVC TUITION	0.00	0.00	0.00	0.00	0.00	0.00	0.00
Education Fund	1140111001	AG SALARY	236,962.56	19,746.88	0.00	0.00	100,409.00	136,553.56	44 57.63
Education Fund	1140121101	AG TRS	28,442.40	2,370.20	0.00	0.00	11,877.76	16,564.64	58.24
Education Fund	1140122201	AG GROUP INS	35,564.40	2,963.70	0.00	0.00	14,818.50	20,745.90	58.33
Education Fund		10 E 1401 2230 01 300	883.20	75.56	0.00	0.00	366.04	517.16	58.56
Education Fund	1140130001	AG CONTRACT SERV	1,500.00	0.00	0.00	0.00	450.00	1,050.00	70.00
Education Fund	1140130001	AG CONT SERVICE S	0.00	0.00	0.00	0.00	0.00	0.00	0.00
Education Fund	1140139001	AG GRANT PUR SERV	0.00	0.00	0.00	0.00	0.00	0.00	0.00
Education Fund	1140140001	AG RESALE SUPPLIES	0.00	0.00	0.00	0.00	0.00	0.00	0.00
Education Fund	1140141001	AG SUPPLIES	17,000.00	0.00	750.00	317.65	12,513.04	3,419.31	20.11
Education Fund	1140141101	AG COMP TECH SUPPLIES	0.00	0.00	0.00	0.00	0.00	0.00	0.00
Education Fund	1140141001	AG SUPPLIES S	0.00	0.00	0.00	0.00	0.00	0.00	0.00
Education Fund	1140141101	AG/COMP TECH SUPPLIES	0.00	0.00	0.00	0.00	0.00	0.00	0.00
Education Fund	1140142001	AG TEXTBOOKS	0.00	0.00	0.00	0.00	0.00	0.00	0.00
Education Fund	1140142001	AG TEXTBOOKS S	0.00	0.00	0.00	0.00	0.00	0.00	0.00

## Expenditure Report

Fiscal Year: 2021-2022  
Month: January

COUNTY OF GRUNDY SCHOOL DIST 111

Fund Description	Account	Account Description	Revised Budget	Encumbrance	MTD Activity	Pending Activity	Available Funds	Year to Date Activity	Percent of Budget Used
Education Fund	11401430	AG PERIODICALS	0.00	0.00	0.00	0.00	0.00	0.00	0.00
Education Fund	114014302	AG PERIODICALS S	0.00	0.00	0.00	0.00	0.00	0.00	0.00
Education Fund	11401490	AG VIDEO/SOFTWARE	0.00	0.00	0.00	0.00	0.00	0.00	0.00
Education Fund	114014902	AG VIDEO/SOFTWARE S	0.00	0.00	0.00	0.00	0.00	0.00	0.00
Education Fund	1140150001	AG GRANT EQUIPMENT	0.00	0.00	0.00	0.00	0.00	0.00	0.00
Education Fund	1140154001	AG EQUIPMENT	23,352.00	0.00	0.00	0.00	23,352.00	0.00	0.00
Education Fund	1140154001	AG EQUIPMENT S	0.00	0.00	0.00	0.00	0.00	0.00	0.00
Education Fund	1140164001	AG DUES/FEES/LIT	3,850.00	0.00	0.00	0.00	3,850.00	0.00	0.00
Education Fund	1140164001	AG DUES/FEES/LIT S	0.00	0.00	0.00	0.00	0.00	0.00	0.00
Education Fund	1140711003	BUSINESS ED SALARY	221,839.92	18,270.66	0.00	0.00	94,601.99	127,237.93	57.36
Education Fund	1140721103	BUSINESS ED TRS	26,627.28	2,193.04	0.00	0.00	11,189.91	15,437.37	45 57.98
Education Fund	1140722203	BUSINESS ED GROUP INS	54,478.80	5,236.84	0.00	0.00	21,924.77	32,554.03	59.76
Education Fund		10 E 1407 2230 03 300	1,298.40	111.08	0.00	0.00	536.90	761.50	58.65
Education Fund	1140730003	BUSINESS ED PURCHASE	0.00	0.00	0.00	0.00	0.00	0.00	0.00
Education Fund	1140731003	TREES CETI GRANT	0.00	0.00	0.00	0.00	-31.81	31.81	0.00
Education Fund	1140732303	BUSINESS ED	0.00	0.00	0.00	0.00	0.00	0.00	0.00
Education Fund	1140732303	BUSINESS ED	0.00	0.00	0.00	0.00	0.00	0.00	0.00
Education Fund	1140741003	BUSINESS ED SUPPLIES	3,500.00	0.00	24.98	0.00	1,967.02	1,508.00	43.09
Education Fund	1140741103	BUSINESS ED COMP TECH	0.00	0.00	0.00	0.00	0.00	0.00	0.00
Education Fund	1140741003	BUSINESS ED SUPPLIES S	0.00	0.00	0.00	0.00	0.00	0.00	0.00
Education Fund	1140741103	BUSINESS ED/COMP TECH	0.00	0.00	0.00	0.00	0.00	0.00	0.00
Education Fund	1140742003	BUSINESS ED TEXTBOOKS	0.00	0.00	0.00	0.00	0.00	0.00	0.00
Education Fund	1140742003	BUSINESS ED TEXTBOOKS	0.00	0.00	0.00	0.00	0.00	0.00	0.00
Education Fund	11407430	BUSINESS ED	0.00	0.00	0.00	0.00	0.00	0.00	0.00

## Expenditure Report

Fiscal Year: 2021-2022  
Month: January

COUNTY OF GRUNDY SCHOOL DIST 111

Fund Description	Account	Account Description	Revised Budget	Encumbrance	MTD Activity	Pending Activity	Available Funds	Year to Date Activity	Percent of Budget Used
Education Fund	114074302	BUSINESS ED	0.00	0.00	0.00	0.00	0.00	0.00	0.00
Education Fund	1140749003	BUSINESS ED	13,275.00	0.00	0.00	0.00	394.00	12,881.00	97.03
Education Fund	1140749003	BUSINESS ED	0.00	0.00	0.00	0.00	0.00	0.00	0.00
Education Fund	1140754003	BUSINESS ED EQUIPMENT	0.00	0.00	0.00	0.00	0.00	0.00	0.00
Education Fund	1140754003	BUSINESS ED EQUIPMENT	0.00	0.00	0.00	0.00	0.00	0.00	0.00
Education Fund	1140764003	BUSINESS ED	315.00	0.00	0.00	0.00	315.00	0.00	0.00
Education Fund	1140764003	BUSINESS ED	0.00	0.00	0.00	0.00	0.00	0.00	0.00
Education Fund	11410110	VIDEO EDIT SALARY	0.00	0.00	0.00	0.00	0.00	0.00	0.00
Education Fund	11410211	VIDEO EDIT TRS	0.00	0.00	0.00	0.00	0.00	0.00	0.00
Education Fund	11410222	VIDEO EDIT GROUP INS	565.00	0.00	0.00	0.00	565.00	0.00	0.00
Education Fund	11410390	VIDEO EDIT PURCHASE	0.00	0.00	0.00	0.00	0.00	0.00	46 0.00
Education Fund	114103902	VIDEO EDIT CONT SERV S	0.00	0.00	0.00	0.00	0.00	0.00	0.00
Education Fund	11410400	VIDEO EDIT RESALE	0.00	0.00	0.00	0.00	0.00	0.00	0.00
Education Fund	11410410	VIDEO EDIT SUPPLIES	500.00	0.00	0.00	0.00	438.88	61.12	12.22
Education Fund	11410411	VIDEO EDIT COMP TECH	0.00	0.00	0.00	0.00	0.00	0.00	0.00
Education Fund	114104102	VIDEO EDIT SUPPLIES S	0.00	0.00	0.00	0.00	0.00	0.00	0.00
Education Fund	114104112	VIDEO EDIT/COMP TECH S	0.00	0.00	0.00	0.00	0.00	0.00	0.00
Education Fund	11410430	VIDEO EDIT PERIODICALS	0.00	0.00	0.00	0.00	0.00	0.00	0.00
Education Fund	114104302	VIDEO EDIT PERIODICALS	0.00	0.00	0.00	0.00	0.00	0.00	0.00
Education Fund	11410490	VIDEO EDIT	0.00	0.00	0.00	0.00	0.00	0.00	0.00
Education Fund	114104902	VIDEO EDIT	0.00	0.00	0.00	0.00	0.00	0.00	0.00
Education Fund	11410540	VIDEO EDIT EQUIPMENT	3,500.00	0.00	0.00	0.00	3,180.08	319.92	9.14
Education Fund	114105402	VIDEO EDIT EQUIPMENT S	0.00	0.00	0.00	0.00	0.00	0.00	0.00
Education Fund	11410640	VIDEO EDIT	0.00	0.00	0.00	0.00	0.00	0.00	0.00

## Expenditure Report

Fiscal Year: 2021-2022  
Month: January

COUNTY OF GRUNDY SCHOOL DIST 111

Fund Description	Account	Account Description	Revised Budget	Encumbrance	MTD Activity	Pending Activity	Available Funds	Year to Date Activity	Percent of Budget Used
Education Fund	114106402	VIDEO EDIT	0.00	0.00	0.00	0.00	0.00	0.00	0.00
Education Fund	11411110	INST. TECH SALARY	82,477.92	6,873.16	0.00	0.00	34,745.38	47,732.54	57.87
Education Fund	11411211	INST TECH TRS	9,899.52	824.96	0.00	0.00	4,108.43	5,791.09	58.50
Education Fund	11411222	INST TECH INS	27,996.24	2,333.02	0.00	0.00	11,665.10	16,331.14	58.33
Education Fund		10 E 1411 2230 00 300	441.60	37.78	0.00	0.00	187.04	254.56	57.64
Education Fund	11411390	INST TECH PUR SERV	0.00	0.00	0.00	0.00	0.00	0.00	0.00
Education Fund	11411410	INST TECH SUPPLIES	0.00	0.00	0.00	0.00	0.00	0.00	0.00
Education Fund	11411540	INST TECH EQUIPMENT	0.00	0.00	0.00	0.00	0.00	0.00	0.00
Education Fund	11417110	ATHLETIC TRAINER	55,582.32	4,631.86	0.00	0.00	23,159.30	32,423.02	58.33
Education Fund	11417221	ATHLETIC TRAINER INS	0.00	0.00	0.00	0.00	0.00	0.00	0.00
Education Fund	10-1417-	ATHLETIC TRAINER	27,996.24	2,333.02	0.00	0.00	11,665.10	16,331.14	47 58.33
Education Fund		10 E 1417 2230 00 300	441.60	37.78	0.00	0.00	183.02	258.58	58.56
Education Fund	11417332	ATHLETIC TRAINER	0.00	0.00	0.00	0.00	0.00	0.00	0.00
Education Fund	11417390	ATHLETIC TRAINER PUR	0.00	10,500.00	0.00	0.00	-21,000.00	21,000.00	0.00
Education Fund	11417410	ATHLETIC TRAINER	603.36	110.00	0.00	2,754.88	-3,305.67	1,154.15	191.29
Education Fund	11417540	AHTLETIC TRAINER EQUIP	0.00	0.00	0.00	0.00	0.00	0.00	0.00
Education Fund	11417640	ATHLETIC TRAINER	0.00	0.00	0.00	0.00	0.00	0.00	0.00
Education Fund	1142011009	FAM/CONS SCIENCE	201,840.96	16,943.28	0.00	0.00	91,258.31	110,582.65	54.79
Education Fund	1142021109	FAM/CONS SCIENCE TRS	24,226.08	2,033.67	0.00	0.00	10,801.07	13,425.01	55.42
Education Fund	1142022209	FAM/CONS SCIENCE INS	28,200.96	2,350.08	0.00	0.00	11,754.40	16,446.56	58.32
Education Fund		10 E 1420 2230 09 300	883.20	75.56	0.00	0.00	366.04	517.16	58.56
Education Fund	1142032309	FAM/CONS SCIENCE	1,500.00	0.00	0.00	0.00	1,500.00	0.00	0.00
Education Fund	1142032309	FAM/CONS SCI	0.00	0.00	0.00	0.00	0.00	0.00	0.00
Education Fund	1142041009	FAM/CONS SCIENCE	38,000.00	799.05	17,007.67	164.79	8,876.43	11,951.11	31.45

## Expenditure Report

Fiscal Year: 2021-2022  
Month: January

COUNTY OF GRUNDY SCHOOL DIST 111

Fund Description	Account	Account Description	Revised Budget	Encumbrance	MTD Activity	Pending Activity	Available Funds	Year to Date Activity	Percent of Budget Used
Education Fund	1142041109	FAM/CONS SCI COMP	0.00	0.00	0.00	0.00	0.00	0.00	0.00
Education Fund	1142041009	FAM/CONS SCI SUPPLIES	0.00	0.00	0.00	0.00	0.00	0.00	0.00
Education Fund	1142041109	FAM/CONS SCI/COMP	0.00	0.00	0.00	0.00	0.00	0.00	0.00
Education Fund	1142042009	FAM/CONS SCIENCE	40,125.00	0.00	0.00	0.00	40,125.00	0.00	0.00
Education Fund	1142042009	FAM/CONS SCI	0.00	0.00	0.00	0.00	0.00	0.00	0.00
Education Fund	1142043009	FAM/CONS SCIENCE	0.00	0.00	0.00	0.00	0.00	0.00	0.00
Education Fund	1142043009	FAM/CONS SCI	0.00	0.00	0.00	0.00	0.00	0.00	0.00
Education Fund	1142049009	FAM/CONS SCI	0.00	0.00	0.00	0.00	0.00	0.00	0.00
Education Fund	1142049009	FAM/CONS SCI	0.00	0.00	0.00	0.00	0.00	0.00	0.00
Education Fund	1142054009	FAM/CONS SCIENCE	0.00	0.00	0.00	0.00	0.00	0.00	0.00
Education Fund	1142054009	FAM/CONS SCI	0.00	0.00	0.00	0.00	0.00	0.00	48 0.00
Education Fund	1142064009	FAM/CONS SCI	625.00	0.00	0.00	0.00	625.00	0.00	0.00
Education Fund	1142064009	FAM/CONS SCI	0.00	0.00	0.00	0.00	0.00	0.00	0.00
Education Fund	11421410	TECH PREP SUPPLIES	0.00	0.00	0.00	0.00	0.00	0.00	0.00
Education Fund	11421490	TECH PREP	0.00	0.00	0.00	0.00	0.00	0.00	0.00
Education Fund	11421540	TECH PREP EQUIPMENT	0.00	0.00	0.00	0.00	0.00	0.00	0.00
Education Fund	1150011030	ATHLETIC DIRECTOR	139,337.04	11,611.42	0.00	0.00	58,057.10	81,279.94	58.33
Education Fund	1150011130	ATHLETIC DIR SECY	50,238.96	4,186.58	0.00	0.00	20,932.90	29,306.06	58.33
Education Fund	1150011230	ASST ATHLETIC DIR	10,007.28	1,107.62	0.00	0.00	2,623.01	7,384.27	73.79
Education Fund	1150011070	ACTIVITY DIRECTOR	92,190.00	7,682.50	0.00	0.00	38,748.21	53,441.79	57.97
Education Fund	1150011170	ACTIVITY DIR SECY	46,978.56	3,914.88	0.00	0.00	19,574.40	27,404.16	58.33
Education Fund	1150011270	ASST ACTIVITY DIR	15,812.16	1,317.68	0.00	0.00	6,642.75	9,169.41	57.99
Education Fund	1150012170	MAIN OFFICE SECY	0.00	0.00	0.00	0.00	0.00	0.00	0.00
Education Fund	1150012930	WEIGHTROOM	0.00	1,854.00	0.00	0.00	-3,006.00	3,006.00	0.00

## Expenditure Report

Fiscal Year: 2021-2022  
Month: January

COUNTY OF GRUNDY SCHOOL DIST 111

Fund Description	Account	Account Description	Revised Budget	Encumbrance	MTD Activity	Pending Activity	Available Funds	Year to Date Activity	Percent of Budget Used
Education Fund	1150013030	GIRLS BOWLING COACH	14,287.92	1,190.66	0.00	0.00	6,019.26	8,268.66	57.87
Education Fund	1150013130	EXTRA DUTY COMP-	51,876.72	7,392.59	0.00	0.00	7,734.70	44,142.02	85.09
Education Fund	1150013230	BOYS GOLF COACH	12,252.48	1,021.04	0.00	0.00	5,146.54	7,105.94	58.00
Education Fund	1150013330	SOFTBALL COACH	16,012.08	1,334.34	0.00	0.00	6,731.02	9,281.06	57.96
Education Fund	1150013430	GIRLS TENNIS COACH	9,415.44	784.62	0.00	0.00	3,964.46	5,450.98	57.89
Education Fund	1150013530	BOYS TRACK COACH	27,877.68	2,596.82	0.00	0.00	10,438.58	17,439.10	62.56
Education Fund	1150013630	GIRLS SOCCER COACH	20,986.80	1,748.90	0.00	0.00	9,222.83	11,763.97	56.05
Education Fund	1150013730	GIRLS VOLLEYBALL	151,128.96	1,677.82	0.00	0.00	128,276.00	22,852.96	15.12
Education Fund	1150013830	CROSS COUNTRY COACH	26,819.52	2,234.96	0.00	0.00	11,223.95	15,595.57	58.15
Education Fund	1150013930	FOOTBALL COACH	240,832.32	4,406.90	0.00	0.00	191,818.87	49,013.45	20.35
Education Fund	1150014030	BASEBALL COACH	84,401.76	3,292.74	0.00	0.00	57,503.43	26,898.33	49 31.87
Education Fund	1150014130	GIRLS BASKETBALL	18,410.16	2,083.74	0.00	0.00	3,055.77	15,354.39	83.40
Education Fund	1150014230	WRESTLING COACH	19,209.60	3,166.09	0.00	0.00	-3,601.88	22,811.48	118.75
Education Fund	1150014330	BOYS TENNIS COACH	9,415.44	784.62	0.00	0.00	3,964.46	5,450.98	57.89
Education Fund	1150014430	BOYS SOCCER COACH	22,443.36	1,870.28	0.00	0.00	8,807.99	13,635.37	60.75
Education Fund	1150014530	CHEERLEADER COACH	116,064.00	0.00	0.00	0.00	99,382.40	16,681.60	14.37
Education Fund	1150014630	POMS COACH	21,424.32	1,964.10	0.00	0.00	8,390.82	13,033.50	60.84
Education Fund	1150014730	BOYS BASKETBALL	30,275.76	2,522.98	0.00	0.00	10,675.80	19,599.96	64.74
Education Fund	1150014830	BOYS BOWLING COACH	6,961.68	580.14	0.00	0.00	916.70	6,044.98	86.83
Education Fund	1150014930	GIRLS GOLF COACH	8,818.80	734.90	0.00	0.00	3,713.52	5,105.28	57.89
Education Fund	1150015030	GIRLS TRACK COACH	24,027.60	2,433.76	0.00	0.00	7,001.89	17,025.71	70.86
Education Fund	1150015130	BOYS VOLLEYBALL	16,961.28	1,413.44	0.00	0.00	1,835.74	15,125.54	89.18
Education Fund	1150015230	ATHLETIC SCHEDULER	0.00	0.00	0.00	0.00	0.00	0.00	0.00
Education Fund	1150015330	POST SEASON SALARY	9,786.17	0.00	0.00	0.00	9,786.17	0.00	0.00

## Expenditure Report

Fiscal Year: 2021-2022  
Month: January

COUNTY OF GRUNDY SCHOOL DIST 111

Fund Description	Account	Account Description	Revised Budget	Encumbrance	MTD Activity	Pending Activity	Available Funds	Year to Date Activity	Percent of Budget Used
Education Fund	1150015430	INVITATIONAL WKRS	3,646.62	0.00	0.00	0.00	3,646.62	0.00	0.00
Education Fund	1150015530	BOYS LACROSSE COACH	18,456.94	0.00	0.00	0.00	18,456.94	0.00	0.00
Education Fund	1150015630	GIRLS LACROSSE COACH	11,946.76	382.88	0.00	0.00	10,330.62	1,616.14	13.53
Education Fund	1150012970	STDNT ACT SENIOR	2,886.72	240.56	0.00	0.00	1,224.04	1,662.68	57.60
Education Fund	1150013070	FALL PLAY/CHLDRNS	0.00	116.44	0.00	0.00	-3,151.10	3,151.10	0.00
Education Fund	1150013170	TECH STDNT ASSOC	6,355.44	529.62	0.00	0.00	2,693.07	3,662.37	57.63
Education Fund	1150013171	EXTRA DUTY COMP-	11,190.00	1,351.67	0.00	902.00	-4,431.23	14,719.23	131.54
Education Fund	1150013270	SCHOLASTIC BOWL	4,892.40	407.70	0.00	0.00	2,059.80	2,832.60	57.90
Education Fund	1150013370	SPEECH SPONSOR	12,071.52	1,005.96	0.00	0.00	5,087.14	6,984.38	57.86
Education Fund	1150013470	INTL CLUB SPONSOR	4,818.00	401.50	0.00	0.00	2,007.50	2,810.50	58.33
Education Fund	1150013570	INTL THESPIANS	0.00	0.00	0.00	0.00	0.00	0.00	50 0.00
Education Fund	1150013670	INDIANS ON THE AIR	2,339.76	194.98	0.00	0.00	991.52	1,348.24	57.62
Education Fund	1150013770	BAND ACTIVITIES	20,126.88	1,677.24	0.00	0.00	8,386.56	11,740.32	58.33
Education Fund	1150013870	CHOIR ACTIVITIES	9,880.08	823.34	0.00	0.00	4,181.71	5,698.37	57.68
Education Fund	1150013970	NHS SPONSOR	12,688.80	1,057.40	0.00	0.00	5,349.09	7,339.71	57.84
Education Fund	1150014070	YEARBOOK SPONSOR	5,375.28	447.94	0.00	0.00	2,272.14	3,103.14	57.73
Education Fund	1150014170	SENIOR CLASS SPONSOR	8,043.60	670.30	0.00	0.00	3,386.33	4,657.27	57.90
Education Fund	1150014270	FBLA SPONSOR	0.00	0.00	0.00	0.00	0.00	0.00	0.00
Education Fund	1150014370	STUDENT COUNCIL	13,371.36	1,114.28	0.00	0.00	5,788.84	7,582.52	56.71
Education Fund	1150014470	SOPH CLASS SPONSOR	2,095.92	174.66	0.00	0.00	873.22	1,222.70	58.34
Education Fund	1150014570	MUSICAL	3,144.00	262.00	0.00	0.00	1,310.00	1,834.00	58.33
Education Fund	1150014670	WYSE SPONSOR	2,305.44	192.12	0.00	0.00	960.44	1,345.00	58.34
Education Fund	1150014770	ENVIRONMENTAL CLUB	0.00	0.00	0.00	0.00	0.00	0.00	0.00
Education Fund	1150014870	JSA SPONSOR	0.00	0.00	0.00	0.00	0.00	0.00	0.00

## Expenditure Report

Fiscal Year: 2021-2022  
Month: January

COUNTY OF GRUNDY SCHOOL DIST 111

Fund Description	Account	Account Description	Revised Budget	Encumbrance	MTD Activity	Pending Activity	Available Funds	Year to Date Activity	Percent of Budget Used
Education Fund	1150014970	JUNIOR CLASS SPONSOR	7,280.16	606.68	0.00	0.00	3,033.52	4,246.64	58.33
Education Fund	1150015070	FRESHMAN CLASS	2,095.92	174.66	0.00	0.00	873.22	1,222.70	58.34
Education Fund	1150015170	SADD/TATU SPONSOR	3,379.92	281.66	0.00	0.00	985.65	2,394.27	70.84
Education Fund	1150015270	WEB SITE SPONSOR	0.00	0.00	0.00	0.00	0.00	0.00	0.00
Education Fund	1150015370	ART CLUB SPONSOR	2,207.52	183.96	0.00	0.00	941.04	1,266.48	57.37
Education Fund	1150015470	FFA SPONSOR	11,161.68	930.14	0.00	0.00	4,709.56	6,452.12	57.81
Education Fund	1150015570	MATH CLUB SPONSOR	5,351.52	445.96	0.00	0.00	2,251.04	3,100.48	57.94
Education Fund	1150015670	FLAG	0.00	174.66	0.00	0.00	-4,080.63	4,080.63	0.00
Education Fund	1150015770	FRENCH NHS SPONSOR	0.00	0.00	0.00	0.00	-212.25	212.25	0.00
Education Fund	1150015870	LITERARY MAGAZINE	2,934.48	244.54	0.00	0.00	1,248.84	1,685.64	57.44
Education Fund	1150015970	SPANISH NHS SPONSOR	2,886.72	240.56	0.00	0.00	1,224.04	1,662.68	51 57.60
Education Fund	1150016070	NEWSPAPER SPONSOR	6,027.84	502.32	0.00	0.00	2,532.76	3,495.08	57.98
Education Fund	1150016170	INVESTMENT CLUB	2,886.72	240.56	0.00	0.00	1,224.04	1,662.68	57.60
Education Fund	1150016270	PIT ORCHESTRA	0.00	0.00	0.00	0.00	-262.07	262.07	0.00
Education Fund	1150016370	MUSICAL VOCAL	3,982.32	331.86	0.00	0.00	1,685.49	2,296.83	57.68
Education Fund	1150016470	TECH DIRECTOR	2,724.72	227.06	0.00	0.00	1,132.96	1,591.76	58.42
Education Fund	1150016570	PERCUSSION	0.00	0.00	0.00	0.00	-1,698.00	1,698.00	0.00
Education Fund	1150016670	ODESSEY BOOK CLUB	1,698.00	141.50	0.00	0.00	707.50	990.50	58.33
Education Fund	1150016770	MADRIGAL SPONSOR	0.00	0.00	0.00	0.00	-1,698.00	1,698.00	0.00
Education Fund	1150016870	HOPE SPONSOR	0.00	0.00	0.00	0.00	0.00	0.00	0.00
Education Fund	1150016970	MARK SPONSOR	0.00	0.00	0.00	0.00	0.00	0.00	0.00
Education Fund	1150017070	IALC SPONSOR	2,037.60	169.80	0.00	0.00	849.00	1,188.60	58.33
Education Fund	1150017170	INTERACT CLUB SPONSOR	4,558.08	379.84	0.00	0.00	2,111.51	2,446.57	53.68
Education Fund	1150017270	STUDENT ACTIVITIES	0.00	0.00	0.00	0.00	0.00	0.00	0.00

## Expenditure Report

Fiscal Year: 2021-2022  
Month: January

COUNTY OF GRUNDY SCHOOL DIST 111

Fund Description	Account	Account Description	Revised Budget	Encumbrance	MTD Activity	Pending Activity	Available Funds	Year to Date Activity	Percent of Budget Used
Education Fund	1150017370	MADRIGAL HELPERS	0.00	0.00	0.00	0.00	0.00	0.00	0.00
Education Fund	1150017470	MAC SPONSOR	5,221.20	1,865.10	0.00	0.00	388.05	4,833.15	92.57
Education Fund	1150017570	CLIMBING CLUB SPONSOR	2,037.60	169.80	0.00	0.00	849.00	1,188.60	58.33
Education Fund	1150017670	INDOOR PERCUSSION	0.00	0.00	0.00	0.00	0.00	0.00	0.00
Education Fund	1150017770	ORCHESIS SPONSOR	4,932.24	411.02	0.00	0.00	2,291.38	2,640.86	53.54
Education Fund	1150017870	CHESS CLUB SPONSOR	2,305.68	192.14	0.00	0.00	960.76	1,344.92	58.33
Education Fund	1150017970	SUMMER CAMP COACHES	5,000.00	0.00	0.00	0.00	8,642.49	-3,642.49	-72.85
Education Fund	1150018070	JAZZ TRANSIT CHOIR	1,900.00	0.00	0.00	0.00	1,900.00	0.00	0.00
Education Fund	1150018170	UNDERWATER ROV	2,515.20	209.60	0.00	0.00	1,048.00	1,467.20	58.33
Education Fund	1150018270	PAC LIGHT/SOUND	0.00	2,860.00	0.00	0.00	-2,860.00	2,860.00	0.00
Education Fund		YMCA TEEN ACHIEVERS	0.00	187.50	0.00	0.00	-281.25	281.25	52 0.00
Education Fund	10-1500-211	INVITATIONAL WORKERS	0.00	0.00	0.00	0.00	0.00	0.00	0.00
Education Fund	10-1500-	ASST ATHLETIC DIR	0.00	0.00	0.00	0.00	0.00	0.00	0.00
Education Fund	1150021130	ATHLETIC TRS	17,072.88	1,645.76	0.00	0.00	6,752.03	10,320.85	60.45
Education Fund	1150021230	ASST ATHLETIC DIRECTOR	1,715.04	142.92	0.00	0.00	711.79	1,003.25	58.50
Education Fund		ATH/ACT	4,710.48	655.05	0.00	0.00	963.56	3,746.92	79.54
Education Fund		ATH/ACT	1,470.48	122.54	0.00	0.00	608.29	862.19	58.63
Education Fund		ATH/ACT	1,921.92	160.14	0.00	0.00	795.81	1,126.11	58.59
Education Fund		ATH/ACT	1,130.40	94.20	0.00	0.00	468.92	661.48	58.52
Education Fund		ATH/ACT	3,346.32	311.75	0.00	0.00	1,228.96	2,117.36	63.27
Education Fund		ATH/ACT	2,518.56	209.89	0.00	0.00	1,093.38	1,425.18	56.59
Education Fund		ATH/ACT	18,139.44	201.36	0.00	0.00	15,381.35	2,758.09	15.20
Education Fund		ATH/ACT	3,219.60	268.30	0.00	0.00	1,326.89	1,892.71	58.79
Education Fund		ATH/ACT	6,361.44	530.12	0.00	0.00	2,308.01	4,053.43	63.72

## Expenditure Report

Fiscal Year: 2021-2022  
Month: January

COUNTY OF GRUNDY SCHOOL DIST 111

Fund Description	Account	Account Description	Revised Budget	Encumbrance	MTD Activity	Pending Activity	Available Funds	Year to Date Activity	Percent of Budget Used
Education Fund		ATH/ACT	3,882.24	396.30	0.00	0.00	1,140.19	2,742.05	70.63
Education Fund		ATH/ACT	2,228.16	185.70	0.00	0.00	558.36	1,669.80	74.94
Education Fund		ATH/ACT	2,305.92	192.16	0.00	0.00	842.17	1,463.75	63.48
Education Fund		ATH/ACT	1,130.16	94.18	0.00	0.00	468.80	661.36	58.52
Education Fund		ATH/ACT	2,076.96	173.08	0.00	0.00	858.08	1,218.88	58.69
Education Fund		ATH/ACT	2,571.36	235.76	0.00	0.00	990.17	1,581.19	61.49
Education Fund		ATH/ACT	3,633.84	302.84	0.00	0.00	1,575.16	2,058.68	56.65
Education Fund		ATH/ACT	835.68	69.64	0.00	0.00	342.77	492.91	58.98
Education Fund		ATH/ACT	1,058.88	88.22	0.00	0.00	439.38	619.50	58.51
Education Fund		ATH/ACT	2,884.32	292.12	0.00	0.00	815.30	2,069.02	71.73
Education Fund		ATH/ACT	2,035.68	169.64	0.00	0.00	771.56	1,264.12	53 62.10
Education Fund	1150021171	EXTRA-CURRICULAR TRS	11,642.40	970.20	0.00	0.00	4,820.05	6,822.35	58.60
Education Fund	1150021270	ACTIVITIES TRS	0.00	13.94	0.00	0.00	-378.14	378.14	0.00
Education Fund		ATH/ACT	2,660.40	221.72	0.00	0.00	1,103.64	1,556.76	58.52
Education Fund		10 E 1500 2110 70 300	794.88	154.10	0.00	0.00	-368.91	1,163.79	146.41
Education Fund		ATH/ACT	586.80	48.92	0.00	0.00	243.20	343.60	58.55
Education Fund		ATH/ACT	1,449.12	120.76	0.00	0.00	601.72	847.40	58.48
Education Fund		ATH/ACT	374.40	31.21	0.00	0.00	153.56	220.84	58.99
Education Fund		ATH/ACT	280.80	23.40	0.00	0.00	117.27	163.53	58.24
Education Fund		ATH/ACT	2,416.56	201.38	0.00	0.00	991.34	1,425.22	58.98
Education Fund		ATH/ACT	1,185.60	98.80	0.00	0.00	494.48	691.12	58.29
Education Fund		ATH/ACT	1,545.12	128.76	0.00	0.00	641.66	903.46	58.47
Education Fund		ATH/ACT	645.36	53.78	0.00	0.00	268.80	376.56	58.35
Education Fund		ATH/ACT	978.00	81.50	0.00	0.00	405.60	572.40	58.53

## Expenditure Report

Fiscal Year: 2021-2022  
Month: January

COUNTY OF GRUNDY SCHOOL DIST 111

Fund Description	Account	Account Description	Revised Budget	Encumbrance	MTD Activity	Pending Activity	Available Funds	Year to Date Activity	Percent of Budget Used
Education Fund		ATH/ACT	1,604.88	133.73	0.00	0.00	685.73	919.15	57.27
Education Fund		ATH/ACT	251.52	20.97	0.00	0.00	103.10	148.42	59.01
Education Fund		ATH/ACT	377.28	31.45	0.00	0.00	154.75	222.53	58.98
Education Fund		ATH/ACT	276.72	23.05	0.00	0.00	113.47	163.25	58.99
Education Fund		ATH/ACT	874.08	72.84	0.00	0.00	358.59	515.49	58.98
Education Fund		ATH/ACT	251.52	20.97	0.00	0.00	103.10	148.42	59.01
Education Fund		ATH/ACT	405.60	33.80	0.00	0.00	113.01	292.59	72.14
Education Fund		ATH/ACT	265.20	22.10	0.00	0.00	111.49	153.71	57.96
Education Fund		ATH/ACT	1,339.92	111.66	0.00	0.00	557.07	782.85	58.43
Education Fund		ATH/ACT	642.72	53.56	0.00	0.00	266.41	376.31	58.55
Education Fund		10 E 1500 2110 70 300	0.00	21.00	0.00	0.00	-115.40	115.40	54 0.00
Education Fund		ATH/ACT	0.00	0.00	0.00	0.00	-26.82	26.82	0.00
Education Fund		ATH/ACT	352.08	29.34	0.00	0.00	147.68	204.40	58.05
Education Fund		ATH/ACT	346.80	28.90	0.00	0.00	145.01	201.79	58.19
Education Fund		ATH/ACT	723.36	60.28	0.00	0.00	299.34	424.02	58.62
Education Fund		ATH/ACT	346.80	28.90	0.00	0.00	144.95	201.85	58.20
Education Fund		ATH/ACT	0.00	0.00	0.00	0.00	-33.10	33.10	0.00
Education Fund		ATH/ACT	478.56	39.88	0.00	0.00	199.67	278.89	58.28
Education Fund		10 E 1500 2110 70 300	327.12	27.26	0.00	0.00	133.90	193.22	59.07
Education Fund		ATH/ACT	203.76	16.98	0.00	0.00	83.56	120.20	58.99
Education Fund		ATH/ACT	244.80	20.40	0.00	0.00	100.44	144.36	58.97
Education Fund		ATH/ACT	547.68	45.64	0.00	0.00	251.63	296.05	54.06
Education Fund		ATH/ACT	626.88	52.24	0.00	0.00	257.12	369.76	58.98
Education Fund		ATH/ACT	244.32	20.37	0.00	0.00	100.06	144.26	59.05

## Expenditure Report

Fiscal Year: 2021-2022  
Month: January

COUNTY OF GRUNDY SCHOOL DIST 111

Fund Description	Account	Account Description	Revised Budget	Encumbrance	MTD Activity	Pending Activity	Available Funds	Year to Date Activity	Percent of Budget Used
Education Fund		10 E 1500 2110 70 300	0.00	0.00	0.00	0.00	0.00	0.00	0.00
Education Fund		ATH/ACT	251.76	20.98	0.00	0.00	103.29	148.47	58.97
Education Fund		ATH/ACT	276.72	23.06	0.00	0.00	113.50	163.22	58.98
Education Fund		ATH/ACT	0.00	0.00	0.00	0.00	-2,838.38	2,838.38	0.00
Education Fund		ATH/ACT	301.68	25.14	0.00	0.00	123.72	177.96	58.99
Education Fund		10 E 1500 2110 70 300	0.00	22.52	0.00	0.00	-33.78	33.78	0.00
Education Fund	10-1500-	ATHLETIC DIRECTOR	0.00	0.00	0.00	0.00	0.00	0.00	0.00
Education Fund	10-1500-	ACTIVITY DIRECTOR	0.00	0.00	0.00	0.00	0.00	0.00	0.00
Education Fund	10-1500-222	INVITATIONAL WKRS	0.00	0.00	0.00	0.00	0.00	0.00	0.00
Education Fund	11500222	MAIN OFFICE INS	0.00	0.00	0.00	0.00	0.00	0.00	0.00
Education Fund	10-1500-	ASST ATHLETIC DIR	0.00	0.00	0.00	0.00	0.00	0.00	55 0.00
Education Fund	1150022230	ATHLETIC DIR/SECY	28,207.44	2,350.62	0.00	0.00	11,753.10	16,454.34	58.33
Education Fund		ATH/ACT	18,169.92	1,514.16	0.00	0.00	7,570.80	10,599.12	58.33
Education Fund		ATH/ACT	1,670.40	203.46	0.00	0.00	479.96	1,190.44	71.27
Education Fund		10 E 1500 2220 30 300	0.00	0.00	0.00	0.00	0.00	0.00	0.00
Education Fund		ATH/ACT	0.00	0.00	0.00	0.00	0.00	0.00	0.00
Education Fund		10 E 1500 2220 30 300	0.00	0.00	0.00	0.00	-0.07	0.07	0.00
Education Fund		ATH/ACT	0.00	0.00	0.00	0.00	-220.23	220.23	0.00
Education Fund		10 E 1500 2220 30 300	0.00	0.00	0.00	0.00	-54.17	54.17	0.00
Education Fund	1150022270	STUDENT ACT/SECY	198.00	16.50	0.00	0.00	82.74	115.26	58.21
Education Fund		ATH/ACT	27,996.24	2,333.02	0.00	0.00	11,665.10	16,331.14	58.33
Education Fund		ATH/ACT	1,958.16	0.00	0.00	0.00	970.41	987.75	50.44
Education Fund		10 E 1500 2220 70 300	0.00	0.00	0.00	0.00	-706.05	706.05	0.00
Education Fund		10 E 1500 2220 70 300	0.00	174.75	0.00	0.00	-789.14	789.14	0.00

## Expenditure Report

Fiscal Year: 2021-2022  
Month: January

COUNTY OF GRUNDY SCHOOL DIST 111

Fund Description	Account	Account Description	Revised Budget	Encumbrance	MTD Activity	Pending Activity	Available Funds	Year to Date Activity	Percent of Budget Used
Education Fund		10 E 1500 2220 70 300	0.00	0.00	0.00	0.00	-82.52	82.52	0.00
Education Fund		10 E 1500 2220 70 300	0.00	212.03	0.00	0.00	-212.03	212.03	0.00
Education Fund		ATH/ACT	0.00	0.00	0.00	0.00	-0.44	0.44	0.00
Education Fund		ATH/ACT	1,408.56	120.54	0.00	0.00	583.74	824.82	58.56
Education Fund		10 E 1500 2230 30 300	441.60	37.78	0.00	0.00	183.02	258.58	58.56
Education Fund		10 E 1500 2230 30 300	26.40	3.36	0.00	0.00	2.03	24.37	92.31
Education Fund		10 E 1500 2230 70 300	441.60	37.78	0.00	0.00	183.02	258.58	58.56
Education Fund		10 E 1500 2230 70 300	441.60	37.78	0.00	0.00	183.02	258.58	58.56
Education Fund		10 E 1500 2230 70 300	0.00	0.00	0.00	0.00	-14.86	14.86	0.00
Education Fund		10 E 1500 2230 70 300	0.00	0.00	0.00	0.00	-4.28	4.28	0.00
Education Fund	1150030030	GIRLS TRACK PUR SERV	0.00	0.00	0.00	0.00	0.00	0.00	56 0.00
Education Fund	1150030130	BOYS SOCCER PUR SERV	0.00	0.00	0.00	0.00	-422.00	422.00	0.00
Education Fund	1150030230	BOYS BASKETBALL PUR	0.00	0.00	0.00	0.00	0.00	0.00	0.00
Education Fund	1150030330	WRESTLING PUR SERV	0.00	0.00	0.00	0.00	0.00	0.00	0.00
Education Fund	1150030430	BOYS VOLLEYBALL PUR	0.00	0.00	0.00	0.00	0.00	0.00	0.00
Education Fund	1150030530	SOFTBALL PUR SERV	0.00	0.00	0.00	0.00	0.00	0.00	0.00
Education Fund	1150030630	CHEERLEADER PUR SERV	0.00	0.00	0.00	0.00	0.00	0.00	0.00
Education Fund	1150030730	GIRLS VOLLEYBALL PUR	0.00	0.00	0.00	0.00	0.00	0.00	0.00
Education Fund	1150030830	GIRLS BOWLING PUR	2,200.00	0.00	0.00	0.00	2,200.00	0.00	0.00
Education Fund	1150030930	GOLF PURCHASE SERV	2,000.00	0.00	0.00	0.00	2,000.00	0.00	0.00
Education Fund	1150031030	CROSS COUNTRY PUR	0.00	0.00	0.00	0.00	0.00	0.00	0.00
Education Fund	1150031130	GIRLS BASKETBALL PUR	0.00	0.00	0.00	0.00	0.00	0.00	0.00
Education Fund	1150031230	BASEBALL PUR SERV	8,000.00	0.00	6,438.58	0.00	1,561.42	0.00	0.00
Education Fund	1150031330	GIRLS TENNIS PUR SERV	0.00	0.00	0.00	0.00	0.00	0.00	0.00

## Expenditure Report

Fiscal Year: 2021-2022  
Month: January

COUNTY OF GRUNDY SCHOOL DIST 111

Fund Description	Account	Account Description	Revised Budget	Encumbrance	MTD Activity	Pending Activity	Available Funds	Year to Date Activity	Percent of Budget Used
Education Fund	1150031430	POMS PUR SERV	0.00	0.00	0.00	6,192.31	-6,512.31	320.00	0.00
Education Fund	1150031530	FOOTBALL PUR SERV	25,000.00	0.00	2,536.08	0.00	1,950.29	20,513.63	82.05
Education Fund	1150031630	BOYS TRACK PUR SERV	0.00	0.00	0.00	0.00	-250.00	250.00	0.00
Education Fund	1150031730	GIRLS SOCCER PUR SERV	0.00	0.00	0.00	0.00	0.00	0.00	0.00
Education Fund	1150032130	GEN ATHLETIC PUR SERV	0.00	0.00	0.00	0.00	0.00	0.00	0.00
Education Fund	1150033330	SUMMER BASEBALL PUR	0.00	0.00	0.00	0.00	0.00	0.00	0.00
Education Fund	1150033630	ATH TRAINER PUR SERV	0.00	0.00	0.00	0.00	0.00	0.00	0.00
Education Fund	1150033730	BOYS BOWLING PUR SERV	4,000.00	0.00	0.00	0.00	4,000.00	0.00	0.00
Education Fund	1150039330	BOYS TENNIS PUR SERV	0.00	0.00	0.00	0.00	0.00	0.00	0.00
Education Fund	1150039530	SWIMMING PUR SERVICE	30,414.00	0.00	0.00	0.00	30,414.00	0.00	0.00
Education Fund	1150031170	INVESTMENT CLUB	0.00	0.00	0.00	0.00	0.00	0.00	57 0.00
Education Fund	1150031270	SADD/TATU RED RIBBON	0.00	0.00	0.00	0.00	0.00	0.00	0.00
Education Fund	1150031370	THESPIAN THEATRE FEST	0.00	-1,280.00	0.00	0.00	0.00	0.00	0.00
Education Fund	1150031470	CHAPERONE FOR	0.00	0.00	0.00	0.00	0.00	0.00	0.00
Education Fund	1150031570	ICTM MATH TEAM	0.00	0.00	0.00	0.00	0.00	0.00	0.00
Education Fund	1150031770	TSA STATE	0.00	0.00	0.00	0.00	0.00	0.00	0.00
Education Fund	1150031870	JOURNALISM IHSA	0.00	0.00	0.00	0.00	0.00	0.00	0.00
Education Fund	1150032170	FFA	0.00	0.00	0.00	0.00	0.00	0.00	0.00
Education Fund	1150030070	MUSICAL PUR SERV	11,000.00	500.00	0.00	0.00	7,595.00	3,405.00	30.95
Education Fund	1150030170	FALL PLAY PUR SERV	3,000.00	0.00	0.00	0.00	1,755.68	1,244.32	41.48
Education Fund	1150030270	STUDENT ACT PUR SERV	2,500.00	190.00	0.00	0.00	2,135.00	365.00	14.60
Education Fund	1150030370	NEWSPAPER PUR SERV	5,000.00	617.00	0.00	0.00	3,266.00	1,734.00	34.68
Education Fund	1150030470	CHILDRENS THEATRE PUR	1,500.00	0.00	0.00	0.00	1,500.00	0.00	0.00
Education Fund	1150030570	INTL CLUB PUR SERV	0.00	0.00	0.00	0.00	0.00	0.00	0.00

## Expenditure Report

Fiscal Year: 2021-2022  
Month: January

COUNTY OF GRUNDY SCHOOL DIST 111

Fund Description	Account	Account Description	Revised Budget	Encumbrance	MTD Activity	Pending Activity	Available Funds	Year to Date Activity	Percent of Budget Used
Education Fund	1150030670	WINTERGUARD PUR SERV	2,000.00	750.00	500.00	500.00	250.00	750.00	37.50
Education Fund	1150030770	NHS PUR SERV	0.00	0.00	0.00	0.00	0.00	0.00	0.00
Education Fund	1150030870	FFA PUR SERV	0.00	0.00	0.00	0.00	0.00	0.00	0.00
Education Fund	1150030970	STUDENT ORGANIZATION	0.00	0.00	0.00	0.00	0.00	0.00	0.00
Education Fund	1150031070	BOOK CLUB SPEAKER	250.00	0.00	0.00	0.00	250.00	0.00	0.00
Education Fund	1150031670	MINOOKA ANGLERS	1,200.00	0.00	0.00	0.00	937.84	262.16	21.85
Education Fund	1150032070	FBLA	0.00	0.00	0.00	0.00	0.00	0.00	0.00
Education Fund	1150032270	FOOTBALL CLEANUP	1,200.00	0.00	0.00	0.00	0.00	1,200.00	100.00
Education Fund	1150032370	REVTRAK ACTIVITY	75,000.00	-3,014.97	0.00	0.00	37,479.31	37,520.69	50.03
Education Fund	1150031930	GIRLS VOLLEYBALL	2,822.40	0.00	0.00	0.00	-424.60	3,247.00	115.04
Education Fund	1150032030	BOYS SOCCER OFFICIAL	3,614.10	0.00	0.00	0.00	505.10	3,109.00	58 86.02
Education Fund	1150032230	SOFTBALL OFFICIAL	0.00	0.00	65.00	0.00	-112.10	47.10	0.00
Education Fund	1150032330	FOOTBALL OFFICIAL	5,217.45	0.00	0.00	0.00	71.45	5,146.00	98.63
Education Fund	1150032430	BOYS BASKETBALL	6,805.05	745.00	2,168.00	1,169.00	2,589.05	879.00	12.92
Education Fund	1150032530	GIRLS BASKETBALL	4,625.25	1,610.00	1,373.00	611.00	445.25	2,196.00	47.48
Education Fund	1150032630	WRESTLING OFFICIAL	2,710.05	453.00	454.00	0.00	1,525.05	731.00	26.97
Education Fund	1150032730	BASEBALL OFFICIALS	756.00	0.00	109.00	0.00	588.50	58.50	7.74
Education Fund	1150032830	CROSS COUNTRY	449.40	0.00	0.00	0.00	-264.60	714.00	158.88
Education Fund	1150032930	BOYS VOLLEYBALL	81.90	0.00	0.00	0.00	81.90	0.00	0.00
Education Fund	1150033030	GIRLS TRACK OFFICIAL	0.00	0.00	0.00	0.00	0.00	0.00	0.00
Education Fund	1150033130	BOYS TRACK OFFICIAL	0.00	0.00	0.00	0.00	-50.00	50.00	0.00
Education Fund	1150033230	GIRLS SOCCER OFFICIAL	192.15	0.00	0.00	0.00	192.15	0.00	0.00
Education Fund	1150033830	INVITATIONAL OFFICIALS	304.50	0.00	0.00	0.00	304.50	0.00	0.00
Education Fund	1150033930	LACROSSE OFFICIALS	0.00	0.00	0.00	0.00	-262.88	262.88	0.00

## Expenditure Report

Fiscal Year: 2021-2022  
Month: January

COUNTY OF GRUNDY SCHOOL DIST 111

Fund Description	Account	Account Description	Revised Budget	Encumbrance	MTD Activity	Pending Activity	Available Funds	Year to Date Activity	Percent of Budget Used
Education Fund	1150031970	STUDENT ACT	1,443.75	680.00	0.00	0.00	763.75	680.00	47.10
Education Fund	1150031830	ATHLETIC TOWEL	0.00	0.00	0.00	0.00	0.00	0.00	0.00
Education Fund	1150033430	GENERAL ATHLETIC	0.00	0.00	0.00	0.00	0.00	0.00	0.00
Education Fund	1150033530	ATHLETIC DIRECTOR	175.00	0.00	0.00	0.00	175.00	0.00	0.00
Education Fund	1150033270	STUDENT ACT/TRAVEL	3,390.91	0.00	0.00	0.00	3,390.91	0.00	0.00
Education Fund	1150033570	ACTIVITY DIRECTOR	408.39	0.00	0.00	0.00	132.95	275.44	67.45
Education Fund	1150039030	GEN ATHLETIC	20,000.00	450.00	0.00	0.00	-4,541.00	24,541.00	122.71
Education Fund	1150039430	GEN ATHLETIC POST	30,000.00	7,834.34	89.99	2,925.13	-523.57	27,508.45	91.69
Education Fund	1150139030	GATE RECEIPTS CASH	0.00	0.00	0.00	0.00	0.00	0.00	0.00
Education Fund	1150041030	WRESTLING SUPPLIES	6,500.00	0.00	5,254.50	0.00	-46.50	1,292.00	19.88
Education Fund	1150041130	GIRLS TENNIS SUPPLIES	1,000.00	0.00	996.00	0.00	4.00	0.00	59 0.00
Education Fund	1150041230	BOYS TENNIS SUPPLIES	1,000.00	0.00	1.20	0.00	2.80	996.00	99.60
Education Fund	1150041330	CROSS COUNTRY	1,500.00	0.00	0.00	0.00	1,500.00	0.00	0.00
Education Fund	1150041430	CHEERLEADER SUPPLIES	2,000.00	0.00	0.00	0.00	1,600.00	400.00	20.00
Education Fund	1150041530	BOYS GOLF SUPPLIES	4,500.00	0.00	0.00	0.00	5.86	4,494.14	99.87
Education Fund	1150041630	BOYS TRACK SUPPLIES	1,700.00	0.00	389.60	0.00	1,310.40	0.00	0.00
Education Fund	1150041730	GIRLS TRACK SUPPLIES	2,000.00	0.00	1,105.00	0.00	895.00	0.00	0.00
Education Fund	1150041830	GEN ATHLETIC SUPPLIES	4,500.00	0.00	0.00	0.00	35.75	4,464.25	99.21
Education Fund	1150041930	GIRLS SOCCER SUPPLIES	3,300.00	0.00	3,266.00	0.00	34.00	0.00	0.00
Education Fund	1150042030	BASEBALL SUPPLIES	4,500.00	0.00	6,694.32	0.00	-2,194.32	0.00	0.00
Education Fund	1150042130	SOFTBALL SUPPLIES	4,500.00	0.00	0.00	0.00	2,581.00	1,919.00	42.64
Education Fund	1150042230	BOYS VOLLEYBALL	2,000.00	0.00	1,902.00	0.00	-158.73	256.73	12.84
Education Fund	1150042330	GIRLS VOLLEYBALL	4,000.00	0.00	0.00	0.00	-5.72	4,005.72	100.14
Education Fund	1150042430	GIRLS BASKETBALL	1,400.00	368.00	650.00	0.00	382.00	368.00	26.29

## Expenditure Report

Fiscal Year: 2021-2022  
Month: January

COUNTY OF GRUNDY SCHOOL DIST 111

Fund Description	Account	Account Description	Revised Budget	Encumbrance	MTD Activity	Pending Activity	Available Funds	Year to Date Activity	Percent of Budget Used
Education Fund	1150042530	BOYS SOCCER SUPPLIES	1,750.00	0.00	753.06	0.00	-295.40	1,292.34	73.85
Education Fund	1150042630	BOYS BASKETBALL	1,350.00	26.75	1,094.08	0.00	109.17	146.75	10.87
Education Fund	1150042730	ATHLETIC DIRECTOR	5,500.00	-476.28	243.00	0.00	3,371.69	1,885.31	34.28
Education Fund	1150042830	FOOTBALL SUPPLIES	42,000.00	298.00	0.00	0.00	371.02	41,628.98	99.12
Education Fund	1150042930	GIRLS BOWLING SUPPLIES	200.00	0.00	0.00	0.00	200.00	0.00	0.00
Education Fund	1150043030	POMS SUPPLIES	3,600.00	0.00	324.20	0.00	-849.80	4,125.60	114.60
Education Fund	1150043130	ATHLETIC AWARD	22,500.00	0.00	0.00	236.00	10,220.98	12,043.02	53.52
Education Fund	1150043230	GIRLS GOLF SUPPLIES	3,700.00	0.00	0.00	0.00	800.41	2,899.59	78.37
Education Fund	1150043330	SUMMER BASEBALL	1,400.00	0.00	0.00	0.00	1,400.00	0.00	0.00
Education Fund	1150043430	BOYS BOWLING SUPPLIES	200.00	0.00	0.00	0.00	200.00	0.00	0.00
Education Fund	1150043530	ATHLETIC COMP TECH	0.00	0.00	0.00	0.00	0.00	0.00	60 0.00
Education Fund	1150043630	LACROSSE SUPPLIES	4,000.00	0.00	0.00	0.00	4,000.00	0.00	0.00
Education Fund	1150044030	BOYS GOLF UNIFORMS	0.00	0.00	0.00	0.00	0.00	0.00	0.00
Education Fund	1150044130	GIRLS GOLF UNIFORMS	0.00	0.00	0.00	0.00	0.00	0.00	0.00
Education Fund	1150044230	GIRLS TENNIS UNIFORMS	0.00	0.00	0.00	0.00	0.00	0.00	0.00
Education Fund	1150044330	BOYS BOWLING	0.00	0.00	0.00	0.00	0.00	0.00	0.00
Education Fund	1150044430	GIRLS BOWLING	0.00	0.00	0.00	0.00	0.00	0.00	0.00
Education Fund	1150044530	WRESTLING UNIFORMS	1,800.00	0.00	0.00	0.00	1,800.00	0.00	0.00
Education Fund	1150044630	BOYS TRACK UNIFORMS	1,800.00	0.00	1,490.00	0.00	310.00	0.00	0.00
Education Fund	1150044730	GIRLS TRACK UNIFORMS	5,100.00	0.00	983.00	0.00	4,117.00	0.00	0.00
Education Fund	1150044830	BOYS TENNIS UNIFORMS	0.00	0.00	0.00	0.00	0.00	0.00	0.00
Education Fund	1150044930	BASEBALL UNIFORMS	4,400.00	0.00	2,895.12	0.00	-1,708.81	3,213.69	73.04
Education Fund	1150045030	SOFTBALL UNIFORMS	0.00	0.00	0.00	0.00	0.00	0.00	0.00
Education Fund	1150045130	GIRLS BASKETBALL	2,700.00	85.00	0.00	0.00	-49.00	2,749.00	101.81

## Expenditure Report

Fiscal Year: 2021-2022  
Month: January

COUNTY OF GRUNDY SCHOOL DIST 111

Fund Description	Account	Account Description	Revised Budget	Encumbrance	MTD Activity	Pending Activity	Available Funds	Year to Date Activity	Percent of Budget Used
Education Fund	1150045230	BOYS SOCCER UNIFORMS	2,500.00	0.00	0.00	0.00	2,500.00	0.00	0.00
Education Fund	1150045330	GIRLS VOLLEYBALL	2,500.00	0.00	2,185.00	0.00	-1,870.00	2,185.00	87.40
Education Fund	1150045430	CROSS COUNTRY	4,500.00	0.00	1,809.60	0.00	2,690.40	0.00	0.00
Education Fund	1150045530	POMS UNIFORMS	5,500.00	0.00	0.00	0.00	5,500.00	0.00	0.00
Education Fund	1150045630	BOYS BASKETBALL	4,000.00	524.19	0.00	0.00	-1,168.75	5,168.75	129.22
Education Fund	1150045730	BOYS VOLLEYBALL	2,500.00	0.00	0.00	0.00	2,500.00	0.00	0.00
Education Fund	1150045830	GIRLS SOCCER UNIFORMS	2,500.00	0.00	2,472.60	0.00	27.40	0.00	0.00
Education Fund	1150045930	FOOTBALL UNIFORMS	0.00	0.00	0.00	0.00	0.00	0.00	0.00
Education Fund	1150046030	CHEERLEADING	5,000.00	0.00	0.00	0.00	0.00	5,000.00	100.00
Education Fund	1150046130	LACROSSE UNIFORMS	4,000.00	0.00	0.00	0.00	4,000.00	0.00	0.00
Education Fund	1150141030	ATHLETIC TRAINER	0.00	0.00	0.00	0.00	0.00	0.00	61 0.00
Education Fund	1150042770	INTERNATIONAL CLUB	0.00	0.00	0.00	0.00	0.00	0.00	0.00
Education Fund	1150042970	YEARBOOK SUPPLIES	0.00	0.00	0.00	0.00	0.00	0.00	0.00
Education Fund	1150043270	WEBSITE	0.00	0.00	0.00	0.00	0.00	0.00	0.00
Education Fund	1150043570	INVESTMENT CLUB	0.00	0.00	0.00	0.00	0.00	0.00	0.00
Education Fund	1150041070	NEWSPAPER SUPPLIES	100.00	0.00	0.00	0.00	100.00	0.00	0.00
Education Fund	1150041170	SPEECH SUPPLIES	100.00	0.00	0.00	0.00	100.00	0.00	0.00
Education Fund	1150041270	KALEIDOSCOPE SUPPLIES	100.00	0.00	0.00	0.00	4.63	95.37	95.37
Education Fund	1150041370	NHS SUPPLIES	1,500.00	45.52	0.00	0.00	954.97	545.03	36.34
Education Fund	1150041470	MUSICAL SUPPLIES	5,000.00	364.18	691.00	1,047.77	2,897.05	364.18	7.28
Education Fund	1150041570	FALL PLAY SUPPLIES	1,400.00	0.00	0.00	0.00	-68.01	1,468.01	104.86
Education Fund	1150041670	STUDENT ACT SUPPLIES	1,800.00	0.00	300.00	0.00	515.54	984.46	54.69
Education Fund	1150041770	ACTIVITY OFFICE	500.00	0.00	0.00	0.00	61.87	438.13	87.63
Education Fund	1150041870	CHILDRENS THEATRE	1,000.00	0.00	396.00	0.00	604.00	0.00	0.00

## Expenditure Report

Fiscal Year: 2021-2022  
Month: January

COUNTY OF GRUNDY SCHOOL DIST 111

Fund Description	Account	Account Description	Revised Budget	Encumbrance	MTD Activity	Pending Activity	Available Funds	Year to Date Activity	Percent of Budget Used
Education Fund	1150041970	INTL CLUB SUPPLIES	0.00	0.00	0.00	0.00	0.00	0.00	0.00
Education Fund	1150042070	WINTERGUARD SUPPLIES	5,000.00	131.14	1,570.75	0.00	2,828.17	601.08	12.02
Education Fund	1150042170	BOOK CLUB AWARDS	100.00	0.00	0.00	0.00	100.00	0.00	0.00
Education Fund	1150042270	FBLA SUPPLIES	0.00	0.00	0.00	0.00	0.00	0.00	0.00
Education Fund	1150042370	FNHS INDUCTION	100.00	0.00	0.00	0.00	100.00	0.00	0.00
Education Fund	1150042470	INVESTMENT CLUB	100.00	0.00	0.00	0.00	100.00	0.00	0.00
Education Fund	1150042570	SPANISH NHS INDUCTION	100.00	0.00	0.00	0.00	100.00	0.00	0.00
Education Fund	1150042670	SADD/TATU SUPPLIES	100.00	0.00	0.00	0.00	100.00	0.00	0.00
Education Fund	1150042870	SCHOLASTIC BOWL	100.00	0.00	0.00	0.00	100.00	0.00	0.00
Education Fund	1150043170	MADRIGAL SUPPLIES	0.00	0.00	0.00	0.00	0.00	0.00	0.00
Education Fund	1150043370	SENIOR MURAL	250.00	0.00	0.00	0.00	250.00	0.00	62 0.00
Education Fund	1150043470	COLOR PAPER SUPPLIES	400.00	0.00	0.00	0.00	400.00	0.00	0.00
Education Fund	1150043670	ACTIVITY P-CARD ORDERS	3,000.00	0.00	0.00	60.00	2,740.00	200.00	6.67
Education Fund	1150043770	INTL THESPIAN SUPPLIES	500.00	0.00	0.00	0.00	371.00	129.00	25.80
Education Fund	1150043870	CHESS TEAM SUPPLIES	100.00	0.00	0.00	0.00	100.00	0.00	0.00
Education Fund	1150043970	PAC SOUND ROOM	500.00	1,089.65	12,479.98	585.26	-15,477.38	2,912.14	582.43
Education Fund	1150043070	STUDENT ACT	0.00	0.00	0.00	0.00	0.00	0.00	0.00
Education Fund	1150049070	STUDENT ACT	0.00	0.00	0.00	0.00	0.00	0.00	0.00
Education Fund	1150054030	GIRLS TRACK EQUIPMENT	0.00	0.00	0.00	0.00	0.00	0.00	0.00
Education Fund	1150054130	BOYS TENNIS EQUIPMENT	0.00	0.00	0.00	0.00	0.00	0.00	0.00
Education Fund	1150054230	FOOTBALL EQUIPMENT	0.00	0.00	0.00	0.00	0.00	0.00	0.00
Education Fund	1150054330	GIRLS TENNIS EQUIPMENT	0.00	0.00	0.00	0.00	0.00	0.00	0.00
Education Fund	1150054430	BOYS TRACK EQUIPMENT	0.00	0.00	0.00	0.00	0.00	0.00	0.00
Education Fund	1150054530	GENERAL ATHLETIC	20,000.00	0.00	0.00	0.00	1,717.02	18,282.98	91.41

## Expenditure Report

Fiscal Year: 2021-2022  
Month: January

COUNTY OF GRUNDY SCHOOL DIST 111

Fund Description	Account	Account Description	Revised Budget	Encumbrance	MTD Activity	Pending Activity	Available Funds	Year to Date Activity	Percent of Budget Used
Education Fund	1150054630	BASEBALL EQUIPMENT	0.00	0.00	0.00	0.00	0.00	0.00	0.00
Education Fund	1150054730	BOYS GOLF EQUIPMENT	0.00	0.00	0.00	0.00	0.00	0.00	0.00
Education Fund	1150054830	GIRLS VOLLEYBALL	0.00	0.00	0.00	0.00	0.00	0.00	0.00
Education Fund	1150054930	BOYS VOLLEYBALL	0.00	0.00	0.00	0.00	0.00	0.00	0.00
Education Fund	1150055030	BOYS BASKETBALL	0.00	0.00	0.00	0.00	0.00	0.00	0.00
Education Fund	1150055130	SOFTBALL EQUIPMENT	0.00	0.00	0.00	0.00	0.00	0.00	0.00
Education Fund	1150055230	WRESTLING EQUIPMENT	0.00	0.00	0.00	0.00	0.00	0.00	0.00
Education Fund	1150055330	GIRLS BASKETBALL	0.00	0.00	0.00	0.00	0.00	0.00	0.00
Education Fund	1150055430	CROSS COUNTRY	0.00	0.00	0.00	0.00	0.00	0.00	0.00
Education Fund	1150055530	GIRLS BOWLING	0.00	0.00	0.00	0.00	0.00	0.00	0.00
Education Fund	1150055630	BOYS SOCCER	0.00	0.00	0.00	0.00	0.00	0.00	63 0.00
Education Fund	1150055730	ATHLETIC DIRECTOR	0.00	0.00	0.00	0.00	0.00	0.00	0.00
Education Fund	1150055830	GIRLS SOCCER	0.00	0.00	0.00	0.00	0.00	0.00	0.00
Education Fund	1150055930	POMS EQUIPMENT	0.00	0.00	0.00	0.00	0.00	0.00	0.00
Education Fund	1150056030	GIRLS GOLF EQUIPMENT	0.00	0.00	0.00	0.00	0.00	0.00	0.00
Education Fund	1150056130	CHEERLEADER	0.00	0.00	0.00	0.00	0.00	0.00	0.00
Education Fund	1150056230	BOYS BOWLING	0.00	0.00	0.00	0.00	0.00	0.00	0.00
Education Fund	1150056330	SUMMER BASEBALL	0.00	0.00	0.00	0.00	0.00	0.00	0.00
Education Fund	1150056430	LACROSSE EQUIPMENT	5,000.00	0.00	0.00	0.00	5,000.00	0.00	0.00
Education Fund	1150154030	ATHLETIC TRAINER	0.00	0.00	0.00	0.00	0.00	0.00	0.00
Education Fund	1150054070	STUDENT ACT EQUIPMENT	0.00	0.00	0.00	0.00	0.00	0.00	0.00
Education Fund	1150054170	MAIN OFFICE EQUIPMENT	0.00	0.00	0.00	0.00	0.00	0.00	0.00
Education Fund	1150054270	WINTERGUARD	0.00	0.00	0.00	0.00	0.00	0.00	0.00
Education Fund	1150054370	PAC SOUND ROOM	5,000.00	247.24	0.00	0.00	4,330.76	669.24	13.38

## Expenditure Report

Fiscal Year: 2021-2022  
Month: January

COUNTY OF GRUNDY SCHOOL DIST 111

Fund Description	Account	Account Description	Revised Budget	Encumbrance	MTD Activity	Pending Activity	Available Funds	Year to Date Activity	Percent of Budget Used
Education Fund	1150039130	GEN ATHLETIC CLINICS	5,500.00	0.00	0.00	0.00	4,415.14	1,084.86	19.72
Education Fund	1150039230	ATHLETIC DIRECTOR	500.00	0.00	0.00	0.00	294.00	206.00	41.20
Education Fund	1150064030	ATHLETIC DUES/FEES	200.00	3,500.00	300.00	424.00	-4,744.00	4,220.00	2,110.00
Education Fund	1150064570	TSA FEES	0.00	0.00	0.00	0.00	0.00	0.00	0.00
Education Fund	1150064970	FNHS DUES	0.00	0.00	0.00	0.00	0.00	0.00	0.00
Education Fund	1150065070	SADD/TUTA REG/TRAINING	0.00	0.00	0.00	0.00	0.00	0.00	0.00
Education Fund	1150039070	SPEECH ENTRY FEES	1,000.00	120.00	0.00	90.00	440.00	470.00	47.00
Education Fund	1150064070	SPEECH DUES/FEES	0.00	0.00	0.00	0.00	0.00	0.00	0.00
Education Fund	1150064170	STUDENT ACT	0.00	0.00	0.00	0.00	0.00	0.00	0.00
Education Fund	1150064270	ICTM REGIONAL/ORAL	300.00	0.00	0.00	0.00	0.00	300.00	100.00
Education Fund	1150064370	WYSE REGISTRATION	300.00	80.00	0.00	0.00	220.00	80.00	64 26.67
Education Fund	1150064470	FBLA COMPETITION FEES	0.00	0.00	0.00	0.00	0.00	0.00	0.00
Education Fund	1150064670	SPANISH NHS	100.00	0.00	0.00	0.00	100.00	0.00	0.00
Education Fund	1150064770	JOURNALISM FEES/STATE	250.00	0.00	0.00	0.00	250.00	0.00	0.00
Education Fund	1150064870	FFA	0.00	0.00	0.00	0.00	0.00	0.00	0.00
Education Fund	1150065170	WINTERGUARD CIRCUIT	2,100.00	0.00	0.00	0.00	-800.00	2,900.00	138.10
Education Fund	1150065270	INDOOR PERCUSSION	1,500.00	0.00	400.00	0.00	610.00	490.00	32.67
Education Fund	11600110	SUMMER SCHOOL SALARY	0.00	0.00	0.00	0.00	0.00	0.00	0.00
Education Fund	11600211	SUMMER SCHOOL TRS	0.00	0.00	0.00	0.00	0.00	0.00	0.00
Education Fund	10-1600-	SUMMER SCHOOL SALARY	0.00	0.00	0.00	0.00	0.00	0.00	0.00
Education Fund	11650390	GIFTED PUR SERV	0.00	0.00	0.00	0.00	0.00	0.00	0.00
Education Fund	11650410	GIFTED SUPPLIES	0.00	0.00	0.00	0.00	0.00	0.00	0.00
Education Fund	11650540	GIFTED EQUIPMENT	0.00	0.00	0.00	0.00	0.00	0.00	0.00
Education Fund	11700110	DRIVER ED SALARY	414,650.00	35,975.68	0.00	0.00	164,892.44	249,757.56	60.23

## Expenditure Report

Fiscal Year: 2021-2022  
Month: January

COUNTY OF GRUNDY SCHOOL DIST 111

Fund Description	Account	Account Description	Revised Budget	Encumbrance	MTD Activity	Pending Activity	Available Funds	Year to Date Activity	Percent of Budget Used
Education Fund	11700111	SUMMER DR ED SALARY	22,066.00	0.00	0.00	0.00	22,066.00	0.00	0.00
Education Fund	11700211	SUMMER DR ED TRS	2,787.00	0.00	0.00	0.00	2,787.00	0.00	0.00
Education Fund	1170021121	DRIVER ED TRS	52,355.00	4,318.10	0.00	0.00	22,040.90	30,314.10	57.90
Education Fund	11700222	DR ED INS	5,239.82	0.00	0.00	0.00	5,239.82	0.00	0.00
Education Fund	10-1700-	DRIVER ED SALARY	84,463.26	7,491.04	0.00	0.00	37,104.98	47,358.28	56.07
Education Fund		10 E 1700 2230 21 300	0.00	226.68	0.00	0.00	-1,551.48	1,551.48	0.00
Education Fund	1170030021	DRIVERS ED CONT SERV	0.00	0.00	0.00	0.00	0.00	0.00	0.00
Education Fund	1170030021	DRIVERS ED CONT SERV S	0.00	0.00	0.00	0.00	0.00	0.00	0.00
Education Fund	11700323	DRIVERS ED	0.00	0.00	0.00	0.00	0.00	0.00	0.00
Education Fund	1170038021	DRIVER ED CAR INS	0.00	0.00	0.00	0.00	0.00	0.00	0.00
Education Fund	1170041021	DRIVERS ED SUPPLIES	2,018.00	0.00	0.00	0.00	-588.13	2,606.13	65129.14
Education Fund	1170041021	DRIVERS ED SUPPLIES S	0.00	0.00	0.00	0.00	0.00	0.00	0.00
Education Fund	1170041121	DR ED COMP TECH	0.00	0.00	0.00	0.00	0.00	0.00	0.00
Education Fund	1170042021	DRIVERS ED TEXTBOOKS	1,673.00	0.00	0.00	0.00	1,673.00	0.00	0.00
Education Fund	1170042021	DRIVERS ED TEXTBOOKS	0.00	0.00	0.00	0.00	0.00	0.00	0.00
Education Fund	11700464	DR ED GAS	7,700.00	261.53	0.00	489.31	3,267.57	3,943.12	51.21
Education Fund	1170049021	DRIVERS ED	0.00	0.00	0.00	0.00	0.00	0.00	0.00
Education Fund	1170049021	DRIVERS ED	0.00	0.00	0.00	0.00	0.00	0.00	0.00
Education Fund	1170054021	DRIVERS ED EQUIPMENT	0.00	0.00	0.00	0.00	0.00	0.00	0.00
Education Fund	1170054021	DRIVERS ED EQUIPMENT	0.00	0.00	0.00	0.00	0.00	0.00	0.00
Education Fund	1170055021	DRIVERS ED VEHICLES	25,000.00	0.00	0.00	0.00	25,000.00	0.00	0.00
Education Fund	1170064021	DRIVERS ED	0.00	0.00	0.00	0.00	0.00	0.00	0.00
Education Fund	1170064021	DRIVERS ED	0.00	0.00	0.00	0.00	0.00	0.00	0.00
Education Fund	11800110	ELL INSTRUCTION	0.00	0.00	0.00	0.00	0.00	0.00	0.00

## Expenditure Report

Fiscal Year: 2021-2022  
Month: January

COUNTY OF GRUNDY SCHOOL DIST 111

Fund Description	Account	Account Description	Revised Budget	Encumbrance	MTD Activity	Pending Activity	Available Funds	Year to Date Activity	Percent of Budget Used
Education Fund	11800211	ELL TRS	0.00	0.00	0.00	0.00	0.00	0.00	0.00
Education Fund	11900110	PROJ IND DIR SALARY	102,781.20	8,565.10	0.00	0.00	43,165.98	59,615.22	58.00
Education Fund	11900112	PROJ INDIAN AIDE	33,126.96	2,760.58	0.00	0.00	13,872.20	19,254.76	58.12
Education Fund	11900211	PROJ IND TRS	12,336.72	1,028.06	0.00	0.00	5,071.25	7,265.47	58.89
Education Fund	11900222	PROJ IND GROUP INS	27,996.24	2,333.02	0.00	0.00	11,665.10	16,331.14	58.33
Education Fund		PROJ INDIAN AIDE INS	18,169.92	1,514.16	0.00	0.00	7,570.80	10,599.12	58.33
Education Fund		10 E 1900 2230 00 301	441.60	37.78	0.00	0.00	183.02	258.58	58.56
Education Fund	11900390	PROJ IND PUR SERV	0.00	0.00	0.00	0.00	0.00	0.00	0.00
Education Fund	11900332	PROJ IND WORKSHOPS	0.00	0.00	0.00	0.00	0.00	0.00	0.00
Education Fund	11900410	PROJ IND SUPPLIES	0.00	0.00	0.00	0.00	0.00	0.00	0.00
Education Fund	11900411	PROJ IND COMP TECH	0.00	0.00	0.00	0.00	0.00	0.00	66 0.00
Education Fund	11900420	PROJ IND TEXTBOOKS	0.00	0.00	0.00	0.00	0.00	0.00	0.00
Education Fund	11900540	PROJ IND EQUIPMENT	0.00	0.00	0.00	0.00	0.00	0.00	0.00
Education Fund	11900640	PROJ IND DUES/FEES/LIT	0.00	0.00	0.00	0.00	0.00	0.00	0.00
Education Fund	11912670	SPECIAL EDUCATION	1,898,981.00	108,563.01	0.00	28,294.35	1,013,762.10	856,924.55	45.13
Education Fund	12100112	ASST PRIN-LEARNING	0.00	0.00	0.00	0.00	0.00	0.00	0.00
Education Fund	12100113	MAIN OFFICE SECY	37,442.64	2,899.30	0.00	0.00	17,481.58	19,961.06	53.31
Education Fund	12100110	DIRECTOR STUDENT	129,424.32	10,785.36	0.00	0.00	53,926.80	75,497.52	58.33
Education Fund	12100111	DIR OF STUDENT SERV	0.00	0.00	0.00	0.00	0.00	0.00	0.00
Education Fund	12100120	SUMMER MAIN OFFICE	0.00	0.00	0.00	0.00	0.00	0.00	0.00
Education Fund	12100211	DIR OF STUDENT SERV	0.00	0.00	0.00	0.00	0.00	0.00	0.00
Education Fund	121002111	ASST PRIN-LEARNING TRS	0.00	0.00	0.00	0.00	0.00	0.00	0.00
Education Fund	10-2100-	DIRECTOR STUDENT	15,858.00	1,321.50	0.00	0.00	6,607.50	9,250.50	58.33
Education Fund	10-2100-	DIRECTOR STUDENT	0.00	0.00	0.00	0.00	0.00	0.00	0.00

## Expenditure Report

Fiscal Year: 2021-2022  
Month: January

COUNTY OF GRUNDY SCHOOL DIST 111

Fund Description	Account	Account Description	Revised Budget	Encumbrance	MTD Activity	Pending Activity	Available Funds	Year to Date Activity	Percent of Budget Used
Education Fund	12100222	MAIN OFFICE GROUP INS	0.00	0.00	0.00	0.00	0.00	0.00	0.00
Education Fund		10 E 2100 2220 00 300	0.00	2,203.96	0.00	0.00	-2,203.96	2,203.96	0.00
Education Fund	12100223	DIRECTOR STUDENT	96.00	8.00	0.00	0.00	40.00	56.00	58.33
Education Fund	12100300	MAIN OFFICE PUR SERV	0.00	0.00	0.00	0.00	0.00	0.00	0.00
Education Fund	12100390	DIRECTOR STUDENT SERV	3,000.00	0.00	0.00	0.00	2,968.68	31.32	1.04
Education Fund	12100400	DIRECTOR STUDENT SERV	500.00	0.00	0.00	0.00	402.29	97.71	19.54
Education Fund	12100410	MAIN OFFICE SUPPLIES	250.00	0.00	0.00	0.00	250.00	0.00	0.00
Education Fund	12100540	MAIN OFFICE EQUIPMENT	0.00	0.00	0.00	0.00	0.00	0.00	0.00
Education Fund	12100640	CLINICS/WORKSHOPS	0.00	0.00	0.00	0.00	0.00	0.00	0.00
Education Fund	12100641	PROFESSIONAL DUES	0.00	0.00	0.00	0.00	0.00	0.00	0.00
Education Fund	12100642	DIR STUDENT SER	400.00	163.60	0.00	0.00	236.40	163.60	67 40.90
Education Fund	12100643	DIR STUDENT SERV	750.00	0.00	0.00	0.00	750.00	0.00	0.00
Education Fund		10 E 2110 0000 00 000	0.00	0.00	0.00	0.00	0.00	0.00	0.00
Education Fund	12110100	TITLE 1 SALARIES	41,178.47	3,446.86	0.00	0.00	17,144.31	24,034.16	58.37
Education Fund	10-2110-211	TITLE 1 SALARIES (IC)	4,298.10	364.94	0.00	0.00	1,733.02	2,565.08	59.68
Education Fund	10-2110-222	TITLE 1 SALARIES (BMF 2)	11,021.97	903.76	0.00	0.00	4,661.88	6,360.09	57.70
Education Fund		10 E 2110 2230 00 000	90.88	15.40	0.00	0.00	-15.09	105.97	116.60
Education Fund	12113110	SOCIAL WORKER SALARY	260,179.20	17,985.04	0.00	0.00	131,445.15	128,734.05	49.48
Education Fund	12113211	SOCIAL WORKER TRS	31,229.52	2,158.76	0.00	0.00	15,582.21	15,647.31	50.10
Education Fund	12113222	SOCIAL WORKERS GROUP	52,323.36	4,360.28	0.00	0.00	21,835.17	30,488.19	58.27
Education Fund		10 E 2113 2230 00 300	1,144.80	97.94	0.00	0.00	475.03	669.77	58.51
Education Fund	12113390	SOCIAL WORKER PUR	0.00	0.00	0.00	0.00	0.00	0.00	0.00
Education Fund	121133902	SOCIAL WOKER CONT	0.00	0.00	0.00	0.00	0.00	0.00	0.00
Education Fund	12113332	SOCIAL WORKER	0.00	0.00	0.00	0.00	0.00	0.00	0.00

## Expenditure Report

Fiscal Year: 2021-2022  
Month: January

COUNTY OF GRUNDY SCHOOL DIST 111

Fund Description	Account	Account Description	Revised Budget	Encumbrance	MTD Activity	Pending Activity	Available Funds	Year to Date Activity	Percent of Budget Used
Education Fund	121133322	SOCIAL WORKER	0.00	0.00	0.00	0.00	0.00	0.00	0.00
Education Fund	12113410	SOCIAL WORKER	500.00	0.00	0.00	0.00	500.00	0.00	0.00
Education Fund	12113411	SOCIAL WKR COMP TECH	0.00	0.00	0.00	0.00	0.00	0.00	0.00
Education Fund	12113414	SOCIAL WORKER TESTING	1,500.00	0.00	0.00	0.00	1,500.00	0.00	0.00
Education Fund	121134102	SOCIAL WORKER	0.00	0.00	0.00	0.00	0.00	0.00	0.00
Education Fund	121134112	SOC WKR COMP TECK	0.00	0.00	0.00	0.00	0.00	0.00	0.00
Education Fund	121134142	SOCIAL WORKER TESTING	0.00	0.00	0.00	0.00	0.00	0.00	0.00
Education Fund	12113490	SOC WORKER	0.00	0.00	0.00	0.00	0.00	0.00	0.00
Education Fund	121134902	SOCIAL WORKER	0.00	0.00	0.00	0.00	0.00	0.00	0.00
Education Fund	12113640	SOC WORKER	0.00	0.00	0.00	0.00	0.00	0.00	0.00
Education Fund	121136402	SOCIAL WORKER	0.00	0.00	0.00	0.00	0.00	0.00	68 0.00
Education Fund	12120110	GUIDANCE SALARY	585,206.40	43,016.08	0.00	0.00	273,285.82	311,920.58	53.30
Education Fund		ESSER III - GUIDANCE	0.00	3,986.26	0.00	0.00	-12,122.87	12,122.87	0.00
Education Fund	12120211	GUIDANCE TRS	70,242.00	5,163.18	0.00	0.00	32,438.53	37,803.47	53.82
Education Fund		10 E 2120 2110 00 300	0.00	889.43	0.00	0.00	-2,704.96	2,704.96	0.00
Education Fund	12120222	GUIDANCE GROUP INS	116,458.08	9,704.84	0.00	0.00	48,524.20	67,933.88	58.33
Education Fund		10 E 2120 2220 00 300	0.00	710.00	0.00	0.00	-1,410.94	1,410.94	0.00
Education Fund		10 E 2120 2230 00 300	2,649.60	226.68	0.00	0.00	1,098.12	1,551.48	58.56
Education Fund		10 E 2120 2230 00 300	0.00	37.78	0.00	0.00	-74.58	74.58	0.00
Education Fund	12120314	GUIDANCE PUR SERV	1,600.00	0.00	0.00	0.00	1,500.00	100.00	6.25
Education Fund	12120415	A.P. TESTING SERVICES	0.00	0.00	0.00	0.00	0.00	0.00	0.00
Education Fund	121203142	GUIDANCE CONT SERV S	0.00	0.00	0.00	0.00	0.00	0.00	0.00
Education Fund	121204152	A.P. TESTING SERVICES S	0.00	0.00	0.00	0.00	0.00	0.00	0.00
Education Fund	12120411	GUIDANCE COMP TECH	0.00	0.00	0.00	0.00	0.00	0.00	0.00

## Expenditure Report

Fiscal Year: 2021-2022  
Month: January

COUNTY OF GRUNDY SCHOOL DIST 111

Fund Description	Account	Account Description	Revised Budget	Encumbrance	MTD Activity	Pending Activity	Available Funds	Year to Date Activity	Percent of Budget Used
Education Fund	12120412	GUIDANCE SUPPLIES	500.00	0.00	0.00	0.00	-69.73	569.73	113.95
Education Fund	12120414	GUIDANCE TESTING	500.00	0.00	0.00	0.00	500.00	0.00	0.00
Education Fund	1212041030	ALC SUPPLIES & S/W	0.00	0.00	0.00	0.00	0.00	0.00	0.00
Education Fund	121204112	GUIDANCE COMP TECH	0.00	0.00	0.00	0.00	0.00	0.00	0.00
Education Fund	121204122	GUIDANCE SUPPLIES S	200.00	0.00	0.00	0.00	-30.88	230.88	115.44
Education Fund	121204142	GUIDANCE TESTING S	0.00	0.00	0.00	0.00	0.00	0.00	0.00
Education Fund	12120420	GUIDANCE REF BOOKS	0.00	0.00	0.00	0.00	0.00	0.00	0.00
Education Fund	121204202	GUIDANCE REFERENCE	0.00	0.00	0.00	0.00	0.00	0.00	0.00
Education Fund	12120540	GUIDANCE EQUIPMENT	0.00	0.00	0.00	0.00	0.00	0.00	0.00
Education Fund	121205402	GUIDANCE EQUIPMENT S	0.00	0.00	0.00	0.00	0.00	0.00	0.00
Education Fund	12120640	GUIDANCE DUES	0.00	0.00	0.00	0.00	0.00	0.00	69 0.00
Education Fund	12120641	GUIDANCE	0.00	0.00	0.00	0.00	0.00	0.00	0.00
Education Fund	121206402	GUIDANCE DUES/FEES/LIT	0.00	0.00	0.00	0.00	0.00	0.00	0.00
Education Fund	121206412	GUIDANCE	0.00	0.00	0.00	0.00	0.00	0.00	0.00
Education Fund	12125110	REGISTRAR SALARY	51,512.40	3,666.66	0.00	0.00	22,825.56	28,686.84	55.69
Education Fund	12125111	ACADEMIC RESOURCE	47,229.60	2,202.50	0.00	0.00	20,182.00	27,047.60	57.27
Education Fund	12125112	ASST. REGISTRAR	34,860.00	2,697.50	0.00	0.00	14,823.80	20,036.20	57.48
Education Fund	12125211	CAREER CENTER TRS	0.00	0.00	0.00	0.00	0.00	0.00	0.00
Education Fund	12125222	REGISTRAR GROUP INS	26,604.24	2,217.02	0.00	0.00	11,085.10	15,519.14	58.33
Education Fund	12125223	CAREER CTR GROUP INS	8,363.28	0.00	0.00	0.00	4,526.11	3,837.17	45.88
Education Fund	10-2125-	ASST. REGISTRAR (BMF)	48.00	4.00	0.00	0.00	20.12	27.88	58.08
Education Fund		10 E 2125 2230 00 300	441.60	37.78	0.00	0.00	183.02	258.58	58.56
Education Fund		10 E 2125 2230 00 302	0.00	0.00	0.00	0.00	0.00	0.00	0.00
Education Fund	12125300	REGISTRAR PUR SERV	0.00	0.00	0.00	0.00	0.00	0.00	0.00

## Expenditure Report

Fiscal Year: 2021-2022  
Month: January

COUNTY OF GRUNDY SCHOOL DIST 111

Fund Description	Account	Account Description	Revised Budget	Encumbrance	MTD Activity	Pending Activity	Available Funds	Year to Date Activity	Percent of Budget Used
Education Fund	12125390	CAREER CTR PUR SERV	0.00	0.00	0.00	0.00	0.00	0.00	0.00
Education Fund	121253002	REGISTRAR CONT SERV S	7,850.50	0.00	0.00	0.00	5,858.14	1,992.36	25.38
Education Fund	121253902	CAREER CTR CONT SERV	0.00	0.00	0.00	0.00	0.00	0.00	0.00
Education Fund	12125323	CAREER CTR	0.00	0.00	0.00	0.00	0.00	0.00	0.00
Education Fund	12125324	REGISTRAR REPAIR/MAINT	0.00	0.00	0.00	0.00	0.00	0.00	0.00
Education Fund	121253232	CAREER CTR	0.00	0.00	0.00	0.00	0.00	0.00	0.00
Education Fund	121253242	REGISTRAR REPAIR/MAINT	0.00	0.00	0.00	0.00	0.00	0.00	0.00
Education Fund	12125410	CAREER CENTER	0.00	0.00	0.00	0.00	0.00	0.00	0.00
Education Fund	121254101	CAREER CENTER COMP	0.00	0.00	0.00	0.00	0.00	0.00	0.00
Education Fund	12125411	REGISTRAR SUPPLIES	1,500.00	0.00	0.00	0.00	852.58	647.42	43.16
Education Fund	12125412	REGISTRAR COMP TECH	0.00	0.00	0.00	0.00	0.00	0.00	70 0.00
Education Fund	121254102	CAREER CTR SUPPLIES S	0.00	0.00	0.00	0.00	0.00	0.00	0.00
Education Fund	121254112	REGISTRAR SUPPLIES S	0.00	0.00	0.00	0.00	0.00	0.00	0.00
Education Fund	121254122	REGISTRAR COMP TECH	0.00	0.00	0.00	0.00	0.00	0.00	0.00
Education Fund	12125540	CAREER CTR EQUIPMENT	0.00	0.00	0.00	0.00	0.00	0.00	0.00
Education Fund	12125541	REGISTRAR EQUIPMENT	0.00	0.00	0.00	0.00	0.00	0.00	0.00
Education Fund	121255402	CAREER CTR EQUIPMENT	0.00	0.00	0.00	0.00	0.00	0.00	0.00
Education Fund	121255412	REGISTRAR EQUIPMENT S	0.00	0.00	0.00	0.00	0.00	0.00	0.00
Education Fund	12134110	NURSE SALARY	67,846.32	5,215.20	0.00	0.00	40,744.61	27,101.71	39.95
Education Fund	12134111	NURSE SALARY S.C.	35,537.04	4,418.60	0.00	0.00	13,500.58	22,036.46	62.01
Education Fund	12134211	NURSE TRS	0.00	0.00	0.00	0.00	0.00	0.00	0.00
Education Fund	10-2134-	NURSE SALARY S.C. (IC)	0.00	0.00	0.00	0.00	0.00	0.00	0.00
Education Fund	12134222	NURSE GROUP INS	54.72	6.56	0.00	0.00	28.38	26.34	48.14
Education Fund	10-2134-	NURSE SALARY S.C.	45.60	5.80	0.00	0.00	17.15	28.45	62.39

## Expenditure Report

Fiscal Year: 2021-2022  
Month: January

COUNTY OF GRUNDY SCHOOL DIST 111

Fund Description	Account	Account Description	Revised Budget	Encumbrance	MTD Activity	Pending Activity	Available Funds	Year to Date Activity	Percent of Budget Used
Education Fund	12134300	NURSE PUR SERV	0.00	0.00	0.00	0.00	0.00	0.00	0.00
Education Fund	121343002	NURSE CONT SERV S	0.00	0.00	0.00	0.00	0.00	0.00	0.00
Education Fund	12134323	NURSE REPAIR/MAINT	0.00	0.00	0.00	0.00	-30.00	30.00	0.00
Education Fund	121343232	NURSE REPAIR/MAINT S	0.00	0.00	0.00	0.00	-30.00	30.00	0.00
Education Fund	12134410	NURSE SUPPLIES	8,000.00	210.97	1,440.95	0.00	5,184.84	1,374.21	17.18
Education Fund	12134411	NURSES SUPPLIES-BBP	0.00	0.00	0.00	0.00	0.00	0.00	0.00
Education Fund	12134412	NURSE COMP TECH	0.00	0.00	0.00	0.00	0.00	0.00	0.00
Education Fund	121344102	NURSE SUPPLIES S	0.00	0.00	0.00	0.00	0.00	0.00	0.00
Education Fund	121344112	NURSES SUPPLIES-BBP S	0.00	0.00	0.00	0.00	0.00	0.00	0.00
Education Fund	121344122	NURSE COMP TECH	0.00	0.00	0.00	0.00	0.00	0.00	0.00
Education Fund	12134420	RN REFERENCE BOOKS	0.00	0.00	0.00	0.00	0.00	0.00	71 0.00
Education Fund	121344202	NURSE REFERENCE	0.00	0.00	0.00	0.00	0.00	0.00	0.00
Education Fund	12134540	NURSE EQUIPMENT	0.00	0.00	0.00	0.00	0.00	0.00	0.00
Education Fund	121345402	NURSE EQUIPMENT S	0.00	0.00	0.00	0.00	0.00	0.00	0.00
Education Fund	12140110	PSYCHOLOGIST SALARY	193,590.48	12,384.04	0.00	0.00	103,760.71	89,829.77	46.40
Education Fund	10-2140-211	PSYCHOLOGIST SALARY	23,236.56	1,486.44	0.00	0.00	12,343.38	10,893.18	46.88
Education Fund	12140222	PSYCHOLOGIST	96.00	8.00	0.00	0.00	40.00	56.00	58.33
Education Fund	12140400	PSYCHOLOGIST SUPPLIES	0.00	0.00	0.00	0.00	0.00	0.00	0.00
Education Fund	12142300	PSYCHOLOGICAL	0.00	0.00	0.00	0.00	0.00	0.00	0.00
Education Fund	10-2190-	CSBO SALARY (BIMRF)	0.00	0.00	0.00	0.00	0.00	0.00	0.00
Education Fund		TITLE II SALARIES	0.00	0.00	0.00	0.00	-1,144.00	1,144.00	0.00
Education Fund	12210110	DIRECTOR C/I SALARY	123,763.68	10,313.64	0.00	0.00	40,615.32	83,148.36	67.18
Education Fund	12210112	PROF. DEVELOPMENT	0.00	0.00	0.00	0.00	0.00	0.00	0.00
Education Fund	12210113	SPECIAL ED TEACHERS -	0.00	0.00	0.00	0.00	0.00	0.00	0.00

## Expenditure Report

Fiscal Year: 2021-2022  
Month: January

COUNTY OF GRUNDY SCHOOL DIST 111

Fund Description	Account	Account Description	Revised Budget	Encumbrance	MTD Activity	Pending Activity	Available Funds	Year to Date Activity	Percent of Budget Used
Education Fund	122101173	Title II Salaries	0.00	8,000.00	0.00	0.00	-8,000.00	8,000.00	0.00
Education Fund	12210111	DIR C/I SEC. SALARY	35,934.48	3,076.28	0.00	0.00	14,998.53	20,935.95	58.26
Education Fund		10 E 2210 2110 00 000	0.00	0.00	0.00	0.00	-263.53	263.53	0.00
Education Fund	10-2210-	DIRECTOR C/I SALARY (BT)	15,164.40	1,263.70	0.00	0.00	4,905.41	10,258.99	67.65
Education Fund	12210211	DIR OF C/I TRS	0.00	0.00	0.00	0.00	0.00	0.00	0.00
Education Fund	10-2210-	DIRECTOR C/I SALARY	0.00	0.00	0.00	0.00	0.00	0.00	0.00
Education Fund	12210222	DIRECTOR C/I INS	26,800.08	2,233.34	0.00	0.00	8,080.99	18,719.09	69.85
Education Fund	12210223	DIR C/I SEC INSURANCE	26,604.24	2,217.02	0.00	0.00	11,222.55	15,381.69	57.82
Education Fund		10 E 2210 2230 00 300	1,408.56	120.54	0.00	0.00	583.74	824.82	58.56
Education Fund		10 E 2210 2230 00 302	441.60	37.78	0.00	0.00	185.30	256.30	58.04
Education Fund	12210305	TITLE II PURCHASE	25,792.00	3,607.00	0.00	0.00	8,015.00	17,777.00	72 68.92
Education Fund	12200303	IDEA PART B SP ED PROF	0.00	0.00	0.00	0.00	0.00	0.00	0.00
Education Fund	12200304	IDEA PART B SP ED PROF	0.00	0.00	0.00	0.00	0.00	0.00	0.00
Education Fund	12210300	IDEA PART B SP ED PROF	1,957.88	245.00	0.00	0.00	-1,832.12	3,790.00	193.58
Education Fund	12210302	IDEA PART B SP ED PROF	0.00	0.00	0.00	0.00	0.00	0.00	0.00
Education Fund	12210303	IDEA PART B SP ED PROF	0.00	0.00	0.00	0.00	0.00	0.00	0.00
Education Fund	12210304	IDEA PART B SP ED PROF	0.00	0.00	0.00	0.00	0.00	0.00	0.00
Education Fund	12210306	TESTING SERVICE	80,000.00	1,990.00	0.00	0.00	78,698.00	1,302.00	1.63
Education Fund	12210390	DIRECTOR C/I PURCHASE	0.00	0.00	0.00	0.00	0.00	0.00	0.00
Education Fund	1221031005	FPROF DEVEL ENGLISH	3,800.00	175.00	0.00	0.00	3,455.00	345.00	9.08
Education Fund	1221031106	PROF DEVEL WORLD	3,800.00	0.00	0.00	0.00	3,770.00	30.00	0.79
Education Fund	1221031210	PROF DEVEL CTE	3,800.00	0.00	525.00	0.00	3,275.00	0.00	0.00
Education Fund	1221030811	PROF DELEV MATH	3,800.00	0.00	0.00	0.00	3,800.00	0.00	0.00
Education Fund	1221030913	PROF DEVEL SCIENCE	3,800.00	525.00	0.00	0.00	2,644.20	1,155.80	30.42

## Expenditure Report

Fiscal Year: 2021-2022  
Month: January

COUNTY OF GRUNDY SCHOOL DIST 111

Fund Description	Account	Account Description	Revised Budget	Encumbrance	MTD Activity	Pending Activity	Available Funds	Year to Date Activity	Percent of Budget Used
Education Fund	1221031315	PROF DEVEL SOCIAL	3,800.00	0.00	175.00	0.00	2,967.00	658.00	17.32
Education Fund	1221030750	PROF DEVEL	3,800.00	0.00	0.00	0.00	3,310.00	490.00	12.89
Education Fund	12210301	PROF. DEVELOPMENT	17,000.00	250.00	0.00	0.00	13,708.41	3,291.59	19.36
Education Fund	12210401	SPECIAL ED GRANT	0.00	0.00	0.00	0.00	0.00	0.00	0.00
Education Fund	12210400	DIRECTOR C/I SUPPLIES	0.00	0.00	0.00	0.00	-51.50	51.50	0.00
Education Fund	12210402	TITLE II SUPPLIES	0.00	0.00	0.00	0.00	0.00	0.00	0.00
Education Fund	12210640	DIRECTOR C/I	500.00	0.00	0.00	0.00	500.00	0.00	0.00
Education Fund	12210642	DIRECTOR C/I	500.00	0.00	0.00	0.00	500.00	0.00	0.00
Education Fund	12212211	CURR DEVELOP/LEARN	0.00	0.00	0.00	0.00	0.00	0.00	0.00
Education Fund	12213211	TYPE 75 TRS	0.00	0.00	0.00	0.00	0.00	0.00	0.00
Education Fund		10 E 2220 0000 00 000	0.00	0.00	0.00	0.00	0.00	0.00	73 0.00
Education Fund		10 E 2220 1100 00 300	0.00	0.00	0.00	0.00	0.00	0.00	0.00
Education Fund	12220400	LIBRARY CHAPTER II	0.00	0.00	0.00	0.00	0.00	0.00	0.00
Education Fund	12222110	CYBRARY AIDE SALARY	52,047.60	4,105.42	0.00	0.00	22,487.30	29,560.30	56.79
Education Fund	12222111	LIBRARY SALARY	51,127.92	4,260.66	0.00	0.00	19,250.59	31,877.33	62.35
Education Fund	12222112	CYBRARY AIDE SALARY	26,730.00	2,227.50	0.00	0.00	11,249.70	15,480.30	57.91
Education Fund	12222211	LIBRARY TRS	0.00	0.00	0.00	0.00	0.00	0.00	0.00
Education Fund		LIBRARY TRS	6,137.04	511.42	0.00	0.00	2,266.77	3,870.27	63.06
Education Fund	122222112	LIB ASST TRS S.C.	0.00	0.00	0.00	0.00	0.00	0.00	0.00
Education Fund	12222222	LIBRARY AIDE GROUP INS	26,447.52	2,203.96	0.00	0.00	11,019.80	15,427.72	58.33
Education Fund		LIBRARY GROUP INS	8,520.00	710.00	0.00	0.00	3,550.00	4,970.00	58.33
Education Fund	10-2222-	LIB ASST SALARY S.C.	26,447.52	2,203.96	0.00	0.00	11,019.80	15,427.72	58.33
Education Fund		10 E 2222 2230 00 300	441.60	37.78	0.00	0.00	183.02	258.58	58.56
Education Fund	12222300	LIBRARY CONTRACT SERV	0.00	0.00	0.00	0.00	0.00	0.00	0.00

## Expenditure Report

Fiscal Year: 2021-2022  
Month: January

COUNTY OF GRUNDY SCHOOL DIST 111

Fund Description	Account	Account Description	Revised Budget	Encumbrance	MTD Activity	Pending Activity	Available Funds	Year to Date Activity	Percent of Budget Used
Education Fund	122223002	LIBRARY CONT SERV S.C.	0.00	0.00	0.00	0.00	0.00	0.00	0.00
Education Fund	12222410	LIBRARY SUPPLIES	7,800.00	222.38	1,172.26	0.00	4,399.22	2,228.52	28.57
Education Fund	12222411	LIBRARY COMP TECH	0.00	0.00	0.00	0.00	0.00	0.00	0.00
Education Fund	122224102	LIBRARY SUPPLIES S.C.	0.00	0.00	0.00	0.00	0.00	0.00	0.00
Education Fund	122224112	LIBRARY COMP TECH	0.00	0.00	0.00	0.00	0.00	0.00	0.00
Education Fund	12222430	LIBRARY BOOKS	20,000.00	1,186.14	1,183.88	-2.22	5,377.31	13,441.03	67.21
Education Fund	12222431	PER CAPITA GRANT	1,978.50	0.00	0.00	0.00	1,978.50	0.00	0.00
Education Fund	122224302	LIBRARY BOOKS S.C.	0.00	0.00	0.00	0.00	0.00	0.00	0.00
Education Fund	12222440	LIBRARY PERIODICALS	60,134.86	1,469.00	21,626.93	0.00	8,258.11	30,249.82	50.30
Education Fund	122224402	LIBRARY PERIODICALS	0.00	0.00	0.00	0.00	0.00	0.00	0.00
Education Fund	12222540	LIBRARY EQUIPMENT	0.00	0.00	0.00	0.00	0.00	0.00	74 0.00
Education Fund	122225402	LIBRARY EQUIPMENT S.C.	0.00	0.00	0.00	0.00	0.00	0.00	0.00
Education Fund	12222640	LIBRARY DUES/FEES/LIT	0.00	0.00	0.00	0.00	0.00	0.00	0.00
Education Fund	122226402	LIBRARY DUES/FEES/LIT S	0.00	0.00	0.00	0.00	0.00	0.00	0.00
Education Fund	12225110	TECH COORD SALARY	92,031.12	7,669.26	0.00	0.00	38,346.30	53,684.82	58.33
Education Fund	12225111	TECH ASST SALARY	70,404.48	5,867.04	0.00	0.00	28,802.06	41,602.42	59.09
Education Fund	12225112	TECH/CYBRARY AIDE	0.00	0.00	0.00	0.00	0.00	0.00	0.00
Education Fund	12225113	TECH ASST SALARY S.C.	64,147.68	5,345.64	0.00	0.00	27,072.50	37,075.18	57.80
Education Fund	12225120	SUMMER TECH HELPERS	7,000.00	0.00	0.00	0.00	-3,130.25	10,130.25	144.72
Education Fund	12225211	TECH/CYBRARY AIDE TRS	0.00	0.00	0.00	0.00	0.00	0.00	0.00
Education Fund	10-2225-	TECH ASST SALARY S.C.	0.00	0.00	0.00	0.00	0.00	0.00	0.00
Education Fund	12225222	TECHNOLOGY GROUP INS	27,996.24	2,333.02	0.00	0.00	11,665.10	16,331.14	58.33
Education Fund		TECH ASST GROUP INS	27,996.24	2,333.02	0.00	0.00	11,665.10	16,331.14	58.33
Education Fund		10 E 2225 2220 00 302	126.48	2,223.56	0.00	0.00	-3,217.67	3,344.15	2,644.01

## Expenditure Report

Fiscal Year: 2021-2022  
Month: January

COUNTY OF GRUNDY SCHOOL DIST 111

Fund Description	Account	Account Description	Revised Budget	Encumbrance	MTD Activity	Pending Activity	Available Funds	Year to Date Activity	Percent of Budget Used
Education Fund		10 E 2225 2230 00 300	0.00	0.00	0.00	0.00	0.00	0.00	0.00
Education Fund		10 E 2225 2230 00 300	441.60	37.78	0.00	0.00	183.02	258.58	58.56
Education Fund		10 E 2225 2230 00 302	220.80	56.68	0.00	0.00	7.72	213.08	96.50
Education Fund	12225300	COMPUTER CONTRACT	5,000.00	0.00	0.00	0.00	3,932.42	1,067.58	21.35
Education Fund	12225301	INTERNET SERVICE	57,000.00	5,107.54	0.00	95.40	31,408.48	25,496.12	44.73
Education Fund	12225390	CLOSING THE GAP	0.00	0.00	0.00	0.00	0.00	0.00	0.00
Education Fund	12225393	POWER SCHOOL TECH	60,000.00	0.00	16,181.58	5,241.00	288.84	38,288.58	63.81
Education Fund	12225400	COMPUTER RESALE	29.00	0.00	0.00	0.00	29.00	0.00	0.00
Education Fund	12225410	COMPUTER SUPPLIES	32,000.00	6,763.50	1,724.84	193.93	13,690.28	16,390.95	51.22
Education Fund	12225411	COMPUTER COMP TECH	0.00	0.00	0.00	0.00	0.00	0.00	0.00
Education Fund	12225420	COMPUTER TEXTBOOKS	0.00	0.00	0.00	0.00	0.00	0.00	75 0.00
Education Fund	12225490	COMPUTER SOFTWARE	154,000.00	6,127.30	2,219.96	-899.98	-11,908.23	164,588.25	106.88
Education Fund	12225540	COMPUTER EQUIPMENT	361,111.57	-1,369.00	765.99	0.00	248,865.58	111,480.00	30.87
Education Fund	12225541	TECH COMPUTER LEASE	400,000.00	0.00	0.00	0.00	125,193.86	274,806.14	68.70
Education Fund	12225542	COMPUTER LEASE	0.00	0.00	0.00	0.00	0.00	0.00	0.00
Education Fund	12225543	POWER SCHOOL	0.00	0.00	0.00	0.00	0.00	0.00	0.00
Education Fund	12225640	COMPUTER DUES &	0.00	0.00	0.00	0.00	0.00	0.00	0.00
Education Fund	12225710	COMPUTERS - NON	0.00	0.00	0.00	0.00	0.00	0.00	0.00
Education Fund		DIST 111 GROUP DENTAL	0.00	0.00	0.00	0.00	0.00	0.00	0.00
Education Fund	12230300	TITLE 1 PURCHASE	0.00	0.00	0.00	0.00	0.00	0.00	0.00
Education Fund	12230400	IDEA SUPPLIES SOC	2,281.25	76.00	0.00	0.00	1,915.05	366.20	16.05
Education Fund	12300100	TITLE 1 DIRECTOR	0.00	0.00	0.00	0.00	0.00	0.00	0.00
Education Fund	12300120	TEST PROCTOR	2,388.83	0.00	0.00	0.00	2,388.83	0.00	0.00
Education Fund	10-2300-211	TEST PROCTOR (BT)	232.57	0.00	0.00	0.00	232.57	0.00	0.00

## Expenditure Report

Fiscal Year: 2021-2022  
Month: January

COUNTY OF GRUNDY SCHOOL DIST 111

Fund Description	Account	Account Description	Revised Budget	Encumbrance	MTD Activity	Pending Activity	Available Funds	Year to Date Activity	Percent of Budget Used
Education Fund	10-2300-222	TEST PROCTOR (BME	0.00	0.00	0.00	0.00	0.00	0.00	0.00
Education Fund	12300500	IDEA GRANT DIR STUDENT	0.00	0.00	0.00	0.00	0.00	0.00	0.00
Education Fund	12310200	BOARD OF ED-OTHER	0.00	0.00	0.00	0.00	0.00	0.00	0.00
Education Fund	12310211	BOARD OF ED TRS	0.00	0.00	0.00	0.00	0.00	0.00	0.00
Education Fund	12310222	COBRA INSURANCE	0.00	0.00	0.00	0.00	0.00	0.00	0.00
Education Fund	12310301	FORMER EMPLOYEE	0.00	0.00	0.00	0.00	0.00	0.00	0.00
Education Fund	12310300	BOARD OF ED PUR SERV	65,000.00	-3,067.00	0.00	0.00	56,517.00	8,483.00	13.05
Education Fund	12310302	COBRA INSURANCE	0.00	0.00	0.00	0.00	0.00	0.00	0.00
Education Fund	12310310	ARCHITECT FEES	25,000.00	0.00	0.00	0.00	23,912.50	1,087.50	4.35
Education Fund	12310311	HEARING OFFICER PUR	5,000.00	0.00	0.00	0.00	1,475.00	3,525.00	70.50
Education Fund	12310316	TREES ADMIN	5,000.00	0.00	0.00	0.00	75.00	4,925.00	76 98.50
Education Fund	12310314	COLLECTION FEE CC	35,000.00	1,005.64	0.00	7.50	9,943.45	25,049.05	71.57
Education Fund	12310317	AUDIT SERVICES	12,500.00	0.00	0.00	0.00	2,000.00	10,500.00	84.00
Education Fund	12310315	ASSESSMENT APPEALS	0.00	0.00	0.00	0.00	0.00	0.00	0.00
Education Fund	12310318	ATTORNEY FEES	0.00	0.00	0.00	0.00	0.00	0.00	0.00
Education Fund	12310319	BACKGROUND INVEST	0.00	0.00	0.00	0.00	0.00	0.00	0.00
Education Fund	12310380	GEN LIABILITY INSURANCE	0.00	0.00	0.00	0.00	0.00	0.00	0.00
Education Fund	12310381	INSURANCE CONSULTING	0.00	0.00	0.00	0.00	0.00	0.00	0.00
Education Fund	12310382	TREASURERS BOND	12,000.00	0.00	0.00	0.00	2,299.00	9,701.00	80.84
Education Fund	12310390	BOARD OF ED/OTH PUR	0.00	0.00	0.00	0.00	0.00	0.00	0.00
Education Fund	12310411	DONATIONS	0.00	0.00	0.00	0.00	0.00	0.00	0.00
Education Fund	12310410	BOARD OF ED SUPPLIES	35,000.00	1,793.07	0.00	1,499.83	21,209.65	12,290.52	35.12
Education Fund	12310412	EDUCATION FOUNDATION	0.00	0.00	0.00	0.00	-612.00	612.00	0.00
Education Fund	12310540	BOARD OF ED EQUIPMENT	0.00	0.00	0.00	0.00	0.00	0.00	0.00

## Expenditure Report

Fiscal Year: 2021-2022  
Month: January

COUNTY OF GRUNDY SCHOOL DIST 111

Fund Description	Account	Account Description	Revised Budget	Encumbrance	MTD Activity	Pending Activity	Available Funds	Year to Date Activity	Percent of Budget Used
Education Fund	12310640	BOARD OF ED CLINICS	8,000.00	0.00	0.00	0.00	80.33	7,919.67	99.00
Education Fund	12310641	BOARD OF ED DUES	36,000.00	0.00	0.00	0.00	33,637.00	2,363.00	6.56
Education Fund	12312110	BOARD SECY SALARY	0.00	0.00	0.00	0.00	0.00	0.00	0.00
Education Fund	12313110	PERFORMANCE PAY	0.00	0.00	0.00	0.00	0.00	0.00	0.00
Education Fund	12313211	PERFORMANCE TRS	0.00	0.00	0.00	0.00	0.00	0.00	0.00
Education Fund	12313216	PERFORMANCE ANNUITY	0.00	0.00	0.00	0.00	0.00	0.00	0.00
Education Fund	12321110	SUPT SECY SALARY	51,765.60	4,313.80	0.00	0.00	25,882.80	25,882.80	50.00
Education Fund	12321111	SUPT SALARY	201,458.16	16,788.18	0.00	0.00	83,940.90	117,517.26	58.33
Education Fund	12321112	PRIOR SUPERINTENDENT	0.00	0.00	0.00	0.00	0.00	0.00	0.00
Education Fund	12321113	INTERIM SUPT SALARY	0.00	0.00	0.00	0.00	0.00	0.00	0.00
Education Fund	12321211	SUPT TRS	0.00	0.00	0.00	0.00	0.00	0.00	77 0.00
Education Fund	12321212	INTERIM SUPT TRS	27,000.00	2,057.02	0.00	0.00	12,600.86	14,399.14	53.33
Education Fund	12321216	SUPT ANNUITY	0.00	0.00	0.00	0.00	0.00	0.00	0.00
Education Fund	10-2321-	SUPT SALARY (GTL)	0.00	0.00	0.00	0.00	0.00	0.00	0.00
Education Fund	12321222	SUPT GROUP INS	8,700.00	2,217.02	0.00	0.00	-4,610.65	13,310.65	153.00
Education Fund	12321223	SUPT SECY GROUP INS	8,665.92	722.16	0.00	0.00	3,610.80	5,055.12	58.33
Education Fund		10 E 2321 2230 00 300	441.60	37.78	0.00	0.00	201.42	240.18	54.39
Education Fund		10 E 2321 2230 00 300	441.60	37.78	0.00	0.00	183.02	258.58	58.56
Education Fund	12321390	SUPT CONTRACT SERV	0.00	0.00	0.00	0.00	0.00	0.00	0.00
Education Fund	12321310	SUPT PHYSICAL	0.00	0.00	0.00	0.00	0.00	0.00	0.00
Education Fund	12321323	SUPT REPAIR/MAINT	0.00	0.00	0.00	0.00	0.00	0.00	0.00
Education Fund	12321332	SUPT SECY MILEAGE	0.00	0.00	0.00	0.00	0.00	0.00	0.00
Education Fund	12321333	SUPT MILEAGE	1,500.00	59.92	0.00	0.00	622.48	877.52	58.50
Education Fund	12321410	SUPT SUPPLIES	0.00	0.00	0.00	0.00	-1,994.83	1,994.83	0.00

## Expenditure Report

Fiscal Year: 2021-2022  
Month: January

COUNTY OF GRUNDY SCHOOL DIST 111

Fund Description	Account	Account Description	Revised Budget	Encumbrance	MTD Activity	Pending Activity	Available Funds	Year to Date Activity	Percent of Budget Used
Education Fund	12321540	SUPT EQUIPMENT	0.00	0.00	0.00	0.00	0.00	0.00	0.00
Education Fund	12321640	SUPT DUES/LIT	2,000.00	0.00	0.00	0.00	1,340.00	660.00	33.00
Education Fund	12321641	SUPT SECY CLINIC	0.00	0.00	0.00	0.00	0.00	0.00	0.00
Education Fund	12321642	SUPT CLINIC	0.00	0.00	0.00	0.00	-888.54	888.54	0.00
Education Fund	12300400	IDEA GRANT GENERAL	0.00	0.00	0.00	0.00	0.00	0.00	0.00
Education Fund	12410110	PRIN SECYS SALARY	40,599.12	3,383.26	0.00	0.00	16,916.30	23,682.82	58.33
Education Fund	12410111	PRINCIPAL SALARY	144,615.36	12,051.28	0.00	0.00	60,256.40	84,358.96	58.33
Education Fund	12410112	ASST PRIN SECY SALARY	55,281.84	4,606.82	0.00	0.00	23,034.10	32,247.74	58.33
Education Fund	12410113	ASST PRINCIPAL SALARY	124,145.28	10,345.44	0.00	0.00	51,727.20	72,418.08	58.33
Education Fund	12410115	DEANS SALARY	308,118.24	25,676.52	0.00	0.00	133,593.46	174,524.78	56.64
Education Fund	124101132	ASST PRIN SALARY S.C.	105,000.00	8,750.00	0.00	0.00	43,750.00	61,250.00	78 58.33
Education Fund	12410114	PRINCIPAL SALARY S.C.	0.00	0.00	0.00	0.00	0.00	0.00	0.00
Education Fund	12410211	PRINCIPAL TRS	0.00	0.00	0.00	0.00	0.00	0.00	0.00
Education Fund	12410212	PRINCIPAL TRS	17,719.44	1,476.62	0.00	0.00	7,383.10	10,336.34	58.33
Education Fund		ASST PRINCIPAL TRS	15,211.44	1,267.62	0.00	0.00	6,338.10	8,873.34	58.33
Education Fund		DEANS TRS	36,984.24	3,082.06	0.00	0.00	15,800.00	21,184.24	57.28
Education Fund	12410214	PRINCIPAL TRS S.C.	12,865.44	1,072.12	0.00	0.00	5,360.60	7,504.84	58.33
Education Fund	10-2410-	PRINCIPAL SALARY (GTL)	0.00	0.00	0.00	0.00	0.00	0.00	0.00
Education Fund	10-2410-	ASST PRIN SALARY S.C.	0.00	0.00	0.00	0.00	0.00	0.00	0.00
Education Fund	12410222	PRIN SEC GROUP INS	8,960.16	746.68	0.00	0.00	3,733.40	5,226.76	58.33
Education Fund	12410223	PRINCIPAL GROUP INS	26,820.24	2,235.02	0.00	0.00	11,175.10	15,645.14	58.33
Education Fund	12410224	ASST PRIN GROUP INS	18,169.92	1,514.16	0.00	0.00	7,570.80	10,599.12	58.33
Education Fund		ASST PRIN GROUP INS	28,193.04	2,349.42	0.00	0.00	11,747.10	16,445.94	58.33
Education Fund		DEANS GROUP INS	69,228.24	5,769.02	0.00	0.00	30,784.98	38,443.26	55.53

## Expenditure Report

Fiscal Year: 2021-2022  
Month: January

COUNTY OF GRUNDY SCHOOL DIST 111

Fund Description	Account	Account Description	Revised Budget	Encumbrance	MTD Activity	Pending Activity	Available Funds	Year to Date Activity	Percent of Budget Used
Education Fund	10-2410-	ASST PRIN SALARY S	334.32	27.86	0.00	0.00	139.30	195.02	58.33
Education Fund		10 E 2410 2230 00 300	441.60	37.78	0.00	0.00	183.02	258.58	58.56
Education Fund		10 E 2410 2230 00 300	1,408.56	120.54	0.00	0.00	583.74	824.82	58.56
Education Fund		10 E 2410 2230 00 300	441.60	37.78	0.00	0.00	183.02	258.58	58.56
Education Fund		10 E 2410 2230 00 300	1,408.56	120.54	0.00	0.00	583.74	824.82	58.56
Education Fund		10 E 2410 2230 00 300	1,545.60	132.24	0.00	0.00	672.76	872.84	56.47
Education Fund		10 E 2410 2230 00 302	0.00	0.00	0.00	0.00	0.00	0.00	0.00
Education Fund	12410390	ASST PRIN PURCHASE	10,000.00	0.00	0.00	0.00	10,000.00	0.00	0.00
Education Fund	12410391	PRIN PURCHASE SERV	13,000.00	0.00	0.00	0.00	13,000.00	0.00	0.00
Education Fund	124103902	ASST PRIN CONT SERV S	0.00	0.00	0.00	0.00	0.00	0.00	0.00
Education Fund	124103912	PRIN CONT SERV S	0.00	0.00	0.00	0.00	0.00	0.00	79 0.00
Education Fund	12410340	POSTAGE	31,000.00	2,650.00	0.00	0.00	21,520.85	9,479.15	30.58
Education Fund	12410410	ASST PRIN SUPPLIES	9,000.00	0.00	0.00	0.00	-4,813.70	13,813.70	153.49
Education Fund	12410411	PRINCIPAL SUPPLIES	15,000.00	494.81	28.79	0.00	4,120.10	10,851.11	72.34
Education Fund	12410412	GRADUATION SUPPLIES	15,000.00	0.00	0.00	12.30	10,757.32	4,230.38	28.20
Education Fund	12410413	PRINCIPAL COMP TECH	0.00	0.00	0.00	0.00	0.00	0.00	0.00
Education Fund	12410414	ASST PRIN COMP TECH	0.00	0.00	0.00	0.00	0.00	0.00	0.00
Education Fund	12410415	IMTT GRANT SUPPLIES	5,000.00	0.00	0.00	0.00	5,000.00	0.00	0.00
Education Fund	124104102	ASST PRIN SUPPLIES S	8,000.00	0.00	0.00	0.00	7,948.50	51.50	0.64
Education Fund	124104112	PRINCIPAL SUPPLIES S	0.00	0.00	0.00	0.00	0.00	0.00	0.00
Education Fund	124104132	PRINCIPAL COMP TECH	0.00	0.00	0.00	0.00	0.00	0.00	0.00
Education Fund	124104142	ASST PRIN COMP TECH	0.00	0.00	0.00	0.00	0.00	0.00	0.00
Education Fund	12410540	PRINCIPAL EQUIPMENT	0.00	0.00	0.00	0.00	0.00	0.00	0.00
Education Fund	12410541	ASST PRIN EQUIPMENT	0.00	0.00	0.00	0.00	0.00	0.00	0.00

## Expenditure Report

Fiscal Year: 2021-2022  
Month: January

COUNTY OF GRUNDY SCHOOL DIST 111

Fund Description	Account	Account Description	Revised Budget	Encumbrance	MTD Activity	Pending Activity	Available Funds	Year to Date Activity	Percent of Budget Used
Education Fund	124105402	PRINCIPAL EQUIPMENT S	0.00	0.00	0.00	0.00	0.00	0.00	0.00
Education Fund	124105412	ASST PRIN EQUIPMENT S	0.00	0.00	0.00	0.00	0.00	0.00	0.00
Education Fund	12410640	PRINCIPAL DUES/LIT	2,500.00	0.00	0.00	0.00	1,502.00	998.00	39.92
Education Fund	12410641	ASST PRIN DUES/LIT	500.00	199.00	0.00	0.00	-98.00	598.00	119.60
Education Fund	12410642	PRINCIPAL	2,000.00	0.00	0.00	0.00	1,451.26	548.74	27.44
Education Fund	12410643	ASST PRIN	500.00	0.00	0.00	0.00	500.00	0.00	0.00
Education Fund	12410644	SPC DUES	9,000.00	-1,800.00	0.00	0.00	3,300.00	5,700.00	63.33
Education Fund	124106402	PRINCIPAL DUES/LIT S	0.00	0.00	0.00	0.00	0.00	0.00	0.00
Education Fund	124106412	ASST PRIN DUES/LIT S	0.00	0.00	0.00	0.00	0.00	0.00	0.00
Education Fund	124106422	PRINCIPAL	0.00	0.00	0.00	0.00	0.00	0.00	0.00
Education Fund	124106432	ASST PRIN	500.00	0.00	0.00	0.00	500.00	0.00	80 0.00
Education Fund	12490110	DEANS SECY SALARY	62,006.88	5,313.22	0.00	0.00	25,588.04	36,418.84	58.73
Education Fund	12490112	DEANS SALARY	0.00	0.00	0.00	0.00	0.00	0.00	0.00
Education Fund	12490212	DEANS TRS	0.00	0.00	0.00	0.00	0.00	0.00	0.00
Education Fund	12490222	DEANS SEC INS	39,003.60	3,250.30	0.00	0.00	14,100.78	24,902.82	63.85
Education Fund	12490223	DEANS GROUP INS	0.00	0.00	0.00	0.00	0.00	0.00	0.00
Education Fund		10 E 2490 2230 00 300	545.04	46.62	0.00	0.00	185.38	359.66	65.99
Education Fund	12490390	DEANS PURCHASE	1,000.00	0.00	0.00	0.00	1,000.00	0.00	0.00
Education Fund	124903902	DEANS CONT SERV S	0.00	0.00	0.00	0.00	0.00	0.00	0.00
Education Fund	12490410	DEANS SUPPLIES	4,000.00	0.00	0.00	0.00	3,575.55	424.45	10.61
Education Fund	12490411	DEANS COMP TECH	0.00	0.00	0.00	0.00	0.00	0.00	0.00
Education Fund	124904102	DEANS SUPPLIES S	0.00	0.00	0.00	0.00	0.00	0.00	0.00
Education Fund	124904112	DEANS COMP TECH	0.00	0.00	0.00	0.00	0.00	0.00	0.00
Education Fund	12490540	DEANS EQUIPMENT	0.00	0.00	0.00	0.00	0.00	0.00	0.00

## Expenditure Report

Fiscal Year: 2021-2022  
Month: January

COUNTY OF GRUNDY SCHOOL DIST 111

Fund Description	Account	Account Description	Revised Budget	Encumbrance	MTD Activity	Pending Activity	Available Funds	Year to Date Activity	Percent of Budget Used
Education Fund	124905402	DEANS EQUIPMENT S	0.00	0.00	0.00	0.00	0.00	0.00	0.00
Education Fund	12490640	DEANS MILEAGE	0.00	0.00	0.00	0.00	0.00	0.00	0.00
Education Fund	12490641	DEANS PROF DUES &	0.00	0.00	0.00	0.00	0.00	0.00	0.00
Education Fund	124906402	DEANS MILEAGE S	0.00	0.00	0.00	0.00	0.00	0.00	0.00
Education Fund	124906412	DEANS DUES/LIT S	0.00	0.00	0.00	0.00	0.00	0.00	0.00
Education Fund	12510110	CSBO SALARY	57,969.84	4,830.82	0.00	0.00	24,154.10	33,815.74	58.33
Education Fund	12510211	CSBO TRS	0.00	0.00	0.00	0.00	0.00	0.00	0.00
Education Fund	10-2510-	CSBO SALARY (BIMRF)	0.00	227.62	0.00	0.00	-659.47	659.47	0.00
Education Fund	10-2510-	CSBO SALARY (GTL)	0.00	0.00	0.00	0.00	0.00	0.00	0.00
Education Fund	12510222	CSBO GROUP INS	8,951.04	745.92	0.00	0.00	3,729.60	5,221.44	58.33
Education Fund		10 E 2510 2230 00 300	469.68	40.18	0.00	0.00	194.66	275.02	81 58.55
Education Fund	12510332	CSBO MILEAGE	2,000.00	0.00	0.00	0.00	2,000.00	0.00	0.00
Education Fund	12510640	CSBO DUES/CLINICS	4,000.00	0.00	0.00	180.00	3,621.00	199.00	4.98
Education Fund	12510641	SECY SUPPORT CLINICS	0.00	0.00	0.00	0.00	0.00	0.00	0.00
Education Fund	12525110	BUSINESS OFFICE SALARY	196,374.96	14,064.93	0.00	0.00	94,395.60	101,979.36	51.93
Education Fund	12525222	BUSINESS OFFICE GRP	16,314.24	1,359.52	0.00	0.00	9,767.78	6,546.46	40.13
Education Fund		10 E 2525 2230 00 300	1,059.84	90.66	0.00	0.00	448.46	611.38	57.69
Education Fund	12525390	BUSINESS OFFICE PUR	10,000.00	0.00	0.00	120.00	9,192.00	688.00	6.88
Education Fund	12525323	BUSINESS OFFICE REPAIR	0.00	0.00	0.00	0.00	0.00	0.00	0.00
Education Fund	12525332	BOOKKEEPER MILEAGE	400.00	0.00	0.00	0.00	400.00	0.00	0.00
Education Fund	12525391	BUSINESS OFFICE CONT	0.00	0.00	0.00	0.00	0.00	0.00	0.00
Education Fund	12525411	BUSINESS OFFICE COMP	0.00	0.00	0.00	0.00	0.00	0.00	0.00
Education Fund	12525410	BUSINESS OFFICE	3,500.00	680.81	0.00	0.00	1,539.65	1,960.35	56.01
Education Fund	12525540	BUSINESS OFFICE	2,500.00	0.00	0.00	0.00	2,500.00	0.00	0.00

## Expenditure Report

Fiscal Year: 2021-2022  
Month: January

COUNTY OF GRUNDY SCHOOL DIST 111

Fund Description	Account	Account Description	Revised Budget	Encumbrance	MTD Activity	Pending Activity	Available Funds	Year to Date Activity	Percent of Budget Used
Education Fund	12525640	BOOKKEEPER CLINICS	500.00	0.00	0.00	0.00	500.00	0.00	0.00
Education Fund	12560300	CAFETERIA CONTRACT	500,000.00	77,576.85	0.00	0.00	-70,644.86	570,644.86	114.13
Education Fund	12560302	CAFE TECH CONT SERV	0.00	0.00	0.00	0.00	0.00	0.00	0.00
Education Fund	125603002	CAFE PUR SER SOUTH	0.00	0.00	0.00	0.00	0.00	0.00	0.00
Education Fund	12560301	SPECIAL FUNCTION	35,000.00	0.00	0.00	0.00	35,000.00	0.00	0.00
Education Fund	125603012	SPECIAL FUNCTION	0.00	0.00	0.00	0.00	0.00	0.00	0.00
Education Fund	12560323	CAFETERIA REPAIR/MAINT	0.00	0.00	0.00	0.00	0.00	0.00	0.00
Education Fund	125603232	CAFE REPAIR/MAINT	0.00	0.00	0.00	0.00	0.00	0.00	0.00
Education Fund	12560410	CAFETERIA SUPPLIES	4,000.00	0.00	0.00	0.00	4,000.00	0.00	0.00
Education Fund	12560411	CAFE COMP TECH	0.00	0.00	0.00	0.00	0.00	0.00	0.00
Education Fund	125604102	CAFE SUPPLIES SOUTH	0.00	0.00	0.00	0.00	0.00	0.00	82 0.00
Education Fund	125604112	CAFE COMP TECH	0.00	0.00	0.00	0.00	0.00	0.00	0.00
Education Fund	12560540	CAFETERIA EQUIPMENT	5,000.00	0.00	0.00	0.00	5,000.00	0.00	0.00
Education Fund	125605402	CAFE EQUIPMENT SOUTH	0.00	0.00	0.00	0.00	0.00	0.00	0.00
Education Fund	125606902	CAFE SOUTH REFUND	0.00	0.00	0.00	0.00	0.00	0.00	0.00
Education Fund	12632110	INTERNAL INFO SALARY	27,820.32	2,360.32	0.00	0.00	11,733.77	16,086.55	57.82
Education Fund	12632211	INTERNAL INFO TRS	0.00	0.00	0.00	0.00	0.00	0.00	0.00
Education Fund	12632222	INTERNAL INFO GROUP	13,302.24	1,108.52	0.00	0.00	5,019.88	8,282.36	62.26
Education Fund		10 E 2632 2230 00 300	220.80	18.90	0.00	0.00	91.50	129.30	58.56
Education Fund	12632390	INTERNAL INFO PUR	400,000.00	4,557.54	5,744.00	3,950.00	315,366.78	74,939.22	18.73
Education Fund	12632323	INTERNAL INFO	0.00	0.00	0.00	0.00	0.00	0.00	0.00
Education Fund	12632411	INTERNAL INFO COMP	0.00	0.00	0.00	0.00	0.00	0.00	0.00
Education Fund	12632410	INTERNAL INFO SUPPLIES	2,000.00	0.00	0.00	0.00	2,000.00	0.00	0.00
Education Fund	12632540	INTERNAL INFO EQUIP	0.00	0.00	0.00	0.00	0.00	0.00	0.00

## Expenditure Report

Fiscal Year: 2021-2022  
Month: January

COUNTY OF GRUNDY SCHOOL DIST 111

Fund Description	Account	Account Description	Revised Budget	Encumbrance	MTD Activity	Pending Activity	Available Funds	Year to Date Activity	Percent of Budget Used
Education Fund	12633110	COMM RELATIONS	71,716.80	6,597.44	0.00	0.00	27,192.25	44,524.55	62.08
Education Fund	12633222	COMM RELATIONS GROUP	0.00	711.99	0.00	0.00	-735.99	735.99	0.00
Education Fund		10 E 2633 2230 00 300	0.00	37.78	0.00	0.00	-37.78	37.78	0.00
Education Fund	12633390	COMM RELATIONS PUR	12,000.00	0.00	0.00	0.00	12,000.00	0.00	0.00
Education Fund	12633323	COMM RELATIONS	0.00	0.00	0.00	0.00	0.00	0.00	0.00
Education Fund	12633332	COMM RELATIONS	0.00	0.00	0.00	0.00	0.00	0.00	0.00
Education Fund	12633410	COMM RELATIONS	500.00	0.00	0.00	0.00	500.00	0.00	0.00
Education Fund	12633540	COMM RELATIONS	0.00	0.00	0.00	0.00	0.00	0.00	0.00
Education Fund	12633640	COMM RELATIONS DUES	1,000.00	0.00	0.00	0.00	735.00	265.00	26.50
Education Fund	12900400	TITLE 1 HOMELESS	1,000.00	0.00	0.00	0.00	1,000.00	0.00	0.00
Education Fund	13000300	TITLE 1 PARENT	1,000.00	0.00	0.00	0.00	1,000.00	0.00	83 0.00
Education Fund	13000400	TITLE 1 PARENT	1,000.00	0.00	0.00	0.00	1,000.00	0.00	0.00
Education Fund	13200130	WELLNESS	0.00	0.00	0.00	0.00	0.00	0.00	0.00
Education Fund	13200131	WELLNESS CNTR/PUBLIC	0.00	0.00	0.00	0.00	0.00	0.00	0.00
Education Fund	13200211	WELLNESS CENTER TRS	0.00	0.00	0.00	0.00	0.00	0.00	0.00
Education Fund	10-3200-	WELLNESS	0.00	0.00	0.00	0.00	0.00	0.00	0.00
Education Fund	13200500	WELNESS CENTER	10,000.00	0.00	14,125.20	0.00	-14,125.20	10,000.00	100.00
Education Fund		GCSEC Tuition IDEA Flow	0.00	69,286.75	0.00	20,670.00	-211,258.75	190,588.75	0.00
Education Fund	14100110	TITLE I SALARY	0.00	0.00	0.00	0.00	0.00	0.00	0.00
Education Fund	14100300	TITLE I PUR SERV	0.00	0.00	0.00	0.00	0.00	0.00	0.00
Education Fund	14100332	TITLE II	0.00	0.00	0.00	0.00	0.00	0.00	0.00
Education Fund	14100390	TITLE II-PART D	0.00	0.00	0.00	0.00	0.00	0.00	0.00
Education Fund	14100412	TITLE IV	0.00	0.00	0.00	0.00	0.00	0.00	0.00
Education Fund	14100411	TITLE V SUPPLIES	0.00	0.00	0.00	0.00	0.00	0.00	0.00

## Expenditure Report

Fiscal Year: 2021-2022  
Month: January

COUNTY OF GRUNDY SCHOOL DIST 111

Fund Description	Account	Account Description	Revised Budget	Encumbrance	MTD Activity	Pending Activity	Available Funds	Year to Date Activity	Percent of Budget Used
Education Fund	14100540	TITLE V EQUIPMENT	0.00	0.00	0.00	0.00	0.00	0.00	0.00
Education Fund	14120300	COOP HOUSING ASSESS	0.00	0.00	0.00	0.00	0.00	0.00	0.00
Education Fund	14120301	COOP ADMIN ASSESS	0.00	0.00	0.00	0.00	0.00	0.00	0.00
Education Fund	14120670	COOP HOMEBOUND/HOSP	15,000.00	0.00	0.00	0.00	15,000.00	0.00	0.00
Education Fund	14140600	GAVC ED EXPENSE	750,000.00	32,466.19	0.00	0.00	410,051.21	339,948.79	45.33
Education Fund	14180	DISBURSEMENTS/EXPEND	0.00	0.00	0.00	0.00	0.00	0.00	0.00
Education Fund	14190600	CHANNAHON TAX	65,000.00	0.00	0.00	0.00	-125,415.06	190,415.06	292.95
Education Fund	14210670	PAYMENTS FOR REGULAR	0.00	0.00	0.00	0.00	0.00	0.00	0.00
Education Fund	14220670	PAYMENTS SPECIAL ED	2,419,617.00	187,059.69	0.00	210,898.70	1,097,502.29	1,111,216.01	45.93
Education Fund	10-481-212-	IMRF (BIM)	0.00	0.00	0.00	0.00	0.00	0.00	0.00
Education Fund	10-481-212-	IMRF (BIM)	0.00	0.00	0.00	0.00	0.00	0.00	84 0.00
Education Fund	10-481-222-	IMRF (BMF 3000)	0.00	0.00	0.00	0.00	0.00	0.00	0.00
Education Fund	10-481-222-	IMRF (BMF 3000)	0.00	0.00	0.00	0.00	0.00	0.00	0.00
Education Fund	15900390	SERVICE CHARGE	0.00	0.00	0.00	0.00	0.00	0.00	0.00
Education Fund	18130660	PERM TRANS TO O & M	0.00	0.00	0.00	0.00	0.00	0.00	0.00
Education Fund	18400660	TRANS TO DEBT	0.00	0.00	0.00	0.00	0.00	0.00	0.00
Education Fund	18500660	TRANS TO DEBT	0.00	0.00	0.00	0.00	0.00	0.00	0.00
<b>10 - -----</b>			<b>36,048,347.77</b>	<b>2,850,113.95</b>	<b>183,877.16</b>	<b>296,438.57</b>	<b>15,168,681.24</b>	<b>20,399,350.80</b>	
Activity Fund	111999	STUDENT ACTIVITY	0.00	0.00	0.00	0.00	0.00	0.00	0.00
Activity Fund		SPORTS - ATHLETIC HALL	0.00	0.00	0.00	0.00	0.00	0.00	0.00
Activity Fund		SPORTS - ATHLETIC POP	9,923.92	0.00	0.00	178.20	6,979.13	2,766.59	27.88
Activity Fund		SPORTS - ATHLETIC	0.00	408.54	0.00	-2,319.13	-408.54	2,727.67	0.00
Activity Fund		SPORTS - BASEBALL	2,642.50	165.00	0.00	186.30	-14,208.80	16,665.00	630.65
Activity Fund		SPORTS - BOYS	7,502.20	1,253.91	572.40	2,017.00	3,103.90	1,808.90	24.11

## Expenditure Report

Fiscal Year: 2021-2022  
Month: January

COUNTY OF GRUNDY SCHOOL DIST 111

Fund Description	Account	Account Description	Revised Budget	Encumbrance	MTD Activity	Pending Activity	Available Funds	Year to Date Activity	Percent of Budget Used
Activity Fund		SPORTS - BOYS BOWLING	1,040.00	804.00	0.00	76.00	160.00	804.00	77.31
Activity Fund		SPORTS - BOYS GOLF	369.00	0.00	0.00	0.00	318.00	51.00	13.82
Activity Fund		SPORTS - BOYS SOCCER	3,580.46	792.86	7,617.50	4,796.00	-11,073.83	2,240.79	62.58
Activity Fund		SPORTS - BOYS TENNIS	609.80	0.00	0.00	0.00	609.80	0.00	0.00
Activity Fund		SPORTS - BOYS TRACK	11,903.73	0.00	0.00	0.00	10,821.54	1,082.19	9.09
Activity Fund		SPORTS - BOYS	59.54	0.00	0.00	0.00	59.54	0.00	0.00
Activity Fund		SPORTS - CHEERLEADERS	20,616.81	8,845.20	0.00	0.00	-4,275.03	24,891.84	120.74
Activity Fund		SPORTS - CROSS COUNTY	5,199.85	0.00	0.00	0.00	-4,325.91	9,525.76	183.19
Activity Fund		SPORTS - FOOTBALL	45,465.61	1,250.00	1,639.97	5,331.42	-14,152.74	52,646.96	115.80
Activity Fund		SPORTS - FOOTBALL	0.00	-1,023.84	0.00	0.00	-1,324.00	1,324.00	0.00
Activity Fund		SPORTS - GIRLS	2,958.42	2,564.46	0.00	215.76	178.20	2,564.46	85 86.68
Activity Fund		SPORTS - GIRLS BOWLING	640.00	0.00	0.00	0.00	292.00	348.00	54.38
Activity Fund		SPORTS - GIRLS GOLF	0.00	0.00	0.00	0.00	0.00	0.00	0.00
Activity Fund		SPORTS - GIRLS SOCCER	4,817.03	0.00	0.00	0.00	4,817.03	0.00	0.00
Activity Fund		SPORTS - GIRLS TENNIS	1,450.85	0.00	0.00	0.00	1,309.10	141.75	9.77
Activity Fund		SPORTS - GIRLS TRACK	4,128.80	0.00	0.00	130.00	2,666.97	1,331.83	32.26
Activity Fund		SPORTS - GIRLS	4,484.50	0.00	0.00	0.00	1,433.63	3,050.87	68.03
Activity Fund		SPORTS - LACROSSE	7,382.37	0.00	0.00	0.00	8,728.71	-1,346.34	-18.24
Activity Fund		SPORTS - OUTDOOR ED	0.00	0.00	0.00	0.00	0.00	0.00	0.00
Activity Fund		SPORTS - POMS	3,079.30	2,825.22	2,189.81	0.00	-10,777.40	11,666.89	378.88
Activity Fund		SPORTS - SOFTBALL	3,062.38	0.00	2,515.26	-2,925.13	409.87	3,062.38	100.00
Activity Fund		SPORTS - SWIMMING B&G	0.00	0.00	0.00	0.00	0.00	0.00	0.00
Activity Fund		SPORTS - WRESTLING	370.00	0.00	0.00	1,462.80	-1,092.80	0.00	0.00
Activity Fund		SUMMER CAMPS - BAND	1,229.01	0.00	0.00	0.00	0.00	1,229.01	100.00

## Expenditure Report

Fiscal Year: 2021-2022  
Month: January

COUNTY OF GRUNDY SCHOOL DIST 111

Fund Description	Account	Account Description	Revised Budget	Encumbrance	MTD Activity	Pending Activity	Available Funds	Year to Date Activity	Percent of Budget Used
Activity Fund		SUMMER CAMPS -	0.00	0.00	0.00	0.00	0.00	0.00	0.00
Activity Fund		SUMMER CAMPS - BOYS	8,699.50	0.00	0.00	0.00	0.00	8,699.50	100.00
Activity Fund		SUMMER CAMPS - BOYS	0.00	0.00	0.00	0.00	0.00	0.00	0.00
Activity Fund		SUMMER CAMPS -	0.00	0.00	0.00	0.00	0.00	0.00	0.00
Activity Fund		SUMMER CAMPS - CROSS	1,323.00	0.00	0.00	0.00	0.00	1,323.00	100.00
Activity Fund		SUMMER CAMPS -	13,503.50	0.00	0.00	0.00	0.00	13,503.50	100.00
Activity Fund		SUMMER CAMPS - GIRLS	2,958.50	0.00	0.00	0.00	0.00	2,958.50	100.00
Activity Fund		SUMMER CAMPS - GIRLS	107.68	0.00	0.00	0.00	-9,745.50	9,853.18	9,150.43
Activity Fund		SUMMER CAMPS - POMS	0.00	0.00	0.00	0.00	0.00	0.00	0.00
Activity Fund		SUMMER CAMPS -	540.00	0.00	0.00	0.00	100.00	440.00	81.48
Activity Fund		SUMMER CAMPS -	1,896.00	0.00	0.00	0.00	0.00	1,896.00	86100.00
Activity Fund		SUMMER CAMPS - TENNIS	1,008.00	0.00	0.00	0.00	0.00	1,008.00	100.00
Activity Fund		SUMMER CAMPS -	0.00	0.00	0.00	0.00	0.00	0.00	0.00
Activity Fund		ACTIVITIES - POP	4,526.20	349.20	0.00	0.00	-1,246.63	5,772.83	127.54
Activity Fund		ACTIVITIES - ART CLUB	0.00	0.00	0.00	0.00	0.00	0.00	0.00
Activity Fund		ACTIVITIES - ATHLETIC	0.00	0.00	0.00	0.00	0.00	0.00	0.00
Activity Fund		ACTIVITIES - BAND	0.00	18,025.99	0.00	0.00	-18,025.99	18,025.99	0.00
Activity Fund		ACTIVITIES - CHESS	0.00	0.00	0.00	0.00	0.00	0.00	0.00
Activity Fund		ACTIVITIES - CHOIR	0.00	0.00	0.00	0.00	0.00	0.00	0.00
Activity Fund		ACTIVITIES - CHORUS	1,248.00	0.00	0.00	0.00	1,248.00	0.00	0.00
Activity Fund		ACTIVITIES - CLASS OF	0.00	0.00	0.00	0.00	0.00	0.00	0.00
Activity Fund		ACTIVITIES - CLASS OF	0.00	0.00	0.00	0.00	0.00	0.00	0.00
Activity Fund		ACTIVITIES - CLASS OF	3,803.35	0.00	0.00	0.00	3,730.91	72.44	1.90
Activity Fund		ACTIVITIES - CLASS OF	1,975.00	0.00	0.00	0.00	1,339.56	635.44	32.17

## Expenditure Report

Fiscal Year: 2021-2022  
Month: January

COUNTY OF GRUNDY SCHOOL DIST 111

Fund Description	Account	Account Description	Revised Budget	Encumbrance	MTD Activity	Pending Activity	Available Funds	Year to Date Activity	Percent of Budget Used
Activity Fund		ACTIVITIES - CLASS OF	509.00	0.00	0.00	0.00	-1,670.90	2,179.90	428.27
Activity Fund		ACTIVITIES - CLASS OF	20.00	0.00	0.00	0.00	20.00	0.00	0.00
Activity Fund		ACTIVITIES - COMMUNITY	0.00	0.00	0.00	0.00	0.00	0.00	0.00
Activity Fund		ACTIVITIES - CULINARY	0.00	0.00	0.00	0.00	0.00	0.00	0.00
Activity Fund		ACTIVITIES - DEBATE	0.00	0.00	0.00	0.00	0.00	0.00	0.00
Activity Fund		ACTIVITIES - DREAM	0.00	0.00	0.00	0.00	0.00	0.00	0.00
Activity Fund		ACTIVITIES - FASHION	0.00	0.00	0.00	0.00	0.00	0.00	0.00
Activity Fund		ACTIVITIES - FCCLA	0.00	0.00	0.00	60.00	-60.00	0.00	0.00
Activity Fund		ACTIVITIES - FFA	121.78	0.00	0.00	0.00	-1,301.02	1,422.80	1,168.34
Activity Fund		ACTIVITIES - FRENCH NHS	0.00	0.00	0.00	0.00	0.00	0.00	0.00
Activity Fund		ACTIVITIES - FUTURE	0.00	0.00	0.00	0.00	0.00	0.00	87 0.00
Activity Fund		ACTIVITIES - I.O.T.A.	30.00	77.00	0.00	66.00	-311.00	275.00	916.67
Activity Fund		ACTIVITIES - INDIAN	1,219.06	0.00	0.00	0.00	1,219.06	0.00	0.00
Activity Fund		ACTIVITIES - INDIAN	0.00	0.00	0.00	0.00	0.00	0.00	0.00
Activity Fund		ACTIVITIES - INT'L CLUB	481.53	115.36	0.00	0.00	-2,273.94	2,755.47	572.23
Activity Fund		ACTIVITIES - INT'L	586.44	0.00	0.00	0.00	-5,259.28	5,845.72	996.81
Activity Fund		ACTIVITIES - INTERACT	32.65	0.00	0.00	0.00	-6.77	39.42	120.74
Activity Fund		ACTIVITIES - INVESTMENT	0.00	0.00	0.00	0.00	0.00	0.00	0.00
Activity Fund		ACTIVITIES - JUDO	105.00	0.00	0.00	0.00	105.00	0.00	0.00
Activity Fund		ACTIVITIES -	0.00	0.00	0.00	0.00	0.00	0.00	0.00
Activity Fund		ACTIVITIES - MAC	6,647.33	1,023.84	0.00	0.00	-956.82	7,604.15	114.39
Activity Fund		ACTIVITIES - MATH TEAM	0.00	224.00	0.00	0.00	-224.00	224.00	0.00
Activity Fund		ACTIVITIES - MCHS BOOK	0.00	0.00	0.00	0.00	0.00	0.00	0.00
Activity Fund		ACTIVITIES - MEMORIAL	0.00	0.00	0.00	0.00	0.00	0.00	0.00

## Expenditure Report

Fiscal Year: 2021-2022  
Month: January

COUNTY OF GRUNDY SCHOOL DIST 111

Fund Description	Account	Account Description	Revised Budget	Encumbrance	MTD Activity	Pending Activity	Available Funds	Year to Date Activity	Percent of Budget Used
Activity Fund		ACTIVITIES - MUSICAL	88.36	0.00	0.00	0.00	67.63	20.73	23.46
Activity Fund		ACTIVITIES - NEEDY	766.16	0.00	0.00	0.00	-61.69	827.85	108.05
Activity Fund		ACTIVITIES - NHS	4,720.00	1,401.27	0.00	0.00	417.03	4,302.97	91.16
Activity Fund		ACTIVITIES - ORCHESTRIS	2,750.00	0.00	0.00	0.00	0.00	2,750.00	100.00
Activity Fund		ACTIVITIES - PAC	0.00	0.00	0.00	0.00	117.07	-117.07	0.00
Activity Fund		ACTIVITIES - PERCUSSION	1,500.00	7,102.69	3,082.67	0.00	-11,723.25	10,140.58	676.04
Activity Fund		ACTIVITIES - POKEMON	0.00	0.00	0.00	0.00	0.00	0.00	0.00
Activity Fund		ACTIVITIES - NEWSPAPER	0.00	0.00	0.00	0.00	0.00	0.00	0.00
Activity Fund		ACTIVITIES - SADD	0.00	0.00	0.00	0.00	0.00	0.00	0.00
Activity Fund		ACTIVITIES - SCHOLASTIC	0.00	92.94	0.00	0.00	-92.94	92.94	0.00
Activity Fund		ACTIVITIES - SPANISH NHS	377.58	260.00	0.00	0.00	117.58	260.00	88 68.86
Activity Fund		ACTIVITIES - SPEECH	150.00	42.40	0.00	84.00	23.60	42.40	28.27
Activity Fund		ACTIVITIES - STUDENT	30,000.00	231.57	522.88	0.00	-361.46	29,838.58	99.46
Activity Fund		ACTIVITIES - TSA	785.00	0.00	0.00	50.60	-1,627.90	2,362.30	300.93
Activity Fund		ACTIVITIES -	0.00	135.00	0.00	0.00	-668.84	668.84	0.00
Activity Fund		ACTIVITIES -	180.00	8,233.18	1,248.40	182.35	-9,983.93	8,733.18	4,851.77
Activity Fund		ACTIVITIES - WYSE	0.00	0.00	0.00	0.00	0.00	0.00	0.00
Activity Fund		ACTIVITIES - YEARBOOK	2,584.45	0.00	0.00	0.00	832.97	1,751.48	67.77
Activity Fund		COADY SCHOLARSHIP	0.00	0.00	0.00	0.00	0.00	0.00	0.00
Activity Fund		CYBRARY	0.00	0.00	0.00	0.00	0.00	0.00	0.00
Activity Fund		FACULTY POP	0.00	587.56	0.00	0.00	-587.56	587.56	0.00
Activity Fund		PROJECT INDIAN	0.00	0.00	0.00	0.00	0.00	0.00	0.00
Activity Fund		PROM	7,421.25	0.00	0.00	0.00	7,421.25	0.00	0.00
Activity Fund		SCHOLARSHIP	36,000.00	0.00	0.00	0.00	-1,500.00	37,500.00	104.17

## Expenditure Report

Fiscal Year: 2021-2022  
Month: January

COUNTY OF GRUNDY SCHOOL DIST 111

Fund Description	Account	Account Description	Revised Budget	Encumbrance	MTD Activity	Pending Activity	Available Funds	Year to Date Activity	Percent of Budget Used
Activity Fund		TV PRODUCTION	0.00	0.00	0.00	0.00	0.00	0.00	0.00
Activity Fund		ASL - AMERICAN SIGN	0.00	0.00	0.00	0.00	0.00	0.00	0.00
Activity Fund	1119997062	GREEN HOUSE	0.00	0.00	0.00	0.00	-756.25	756.25	0.00
Activity Fund	1119997063	CLASS OF 2025	0.00	0.00	0.00	0.00	64.45	-64.45	0.00
Activity Fund		COADY SCHOLARSHIP	12,500.00	0.00	0.00	0.00	0.00	12,500.00	100.00
<b>11 - -----</b>			<b>293,680.40</b>	<b>55,787.35</b>	<b>19,388.89</b>	<b>9,592.17</b>	<b>-71,373.19</b>	<b>336,072.53</b>	
<b>1- - -----</b>			<b>36,342,028.17</b>	<b>2,905,901.30</b>	<b>203,266.05</b>	<b>306,030.74</b>	<b>15,097,308.05</b>	<b>20,735,423.33</b>	
Operations & Maint		DIST 111 GROUP MEDICAL	66,450.00	14,196.40	0.00	0.00	-14,878.29	81,328.29	122.39
Operations & Maint		DIST 111 GROUP DENTAL	5,800.00	931.32	0.00	0.00	1,165.85	4,634.15	79.90
Operations & Maint		20 E 2220 0000 00 000	0.00	0.00	0.00	0.00	0.00	0.00	0.00
Operations & Maint	22310200	BOARD OF ED-OTHER	0.00	0.00	0.00	0.00	0.00	0.00	89 0.00
Operations & Maint	22510110	CSBO SALARY	57,952.56	4,829.38	0.00	0.00	24,146.90	33,805.66	58.33
Operations & Maint	22510211	CSBO TRS	0.00	0.00	0.00	0.00	0.00	0.00	0.00
Operations & Maint		20 E 2510 2120 00 300	0.00	227.56	0.00	0.00	-659.29	659.29	0.00
Operations & Maint	20-2510-	CSBO SALARY (GTL)	0.00	0.00	0.00	0.00	0.00	0.00	0.00
Operations & Maint	22510222	CSBO GROUP INS	8,948.40	745.70	0.00	0.00	3,728.50	5,219.90	58.33
Operations & Maint		20 E 2510 2230 00 300	469.44	40.18	0.00	0.00	194.54	274.90	58.56
Operations & Maint	22510332	CSBO MILEAGE	0.00	0.00	0.00	0.00	0.00	0.00	0.00
Operations & Maint	22510640	CSBO DUES/CLINICS	0.00	0.00	0.00	0.00	0.00	0.00	0.00
Operations & Maint	22540100	DIR OF BUILDING/GROUND	0.00	0.00	0.00	0.00	0.00	0.00	0.00
Operations & Maint	22540110	CUSTODIANS SALARY	650,000.00	50,555.30	0.00	0.00	296,324.13	353,675.87	54.41
Operations & Maint	22540111	CUSTODIAN SALARY S.C.	31,190.40	0.00	0.00	0.00	25,782.75	5,407.65	17.34
Operations & Maint	22540130	CUSTODIAN OVERTIME	30,000.00	1,268.35	0.00	0.00	22,377.26	7,622.74	25.41
Operations & Maint	22540131	BUILDING EXTRA PAY	0.00	0.00	0.00	0.00	0.00	0.00	0.00

## Expenditure Report

Fiscal Year: 2021-2022  
Month: January

COUNTY OF GRUNDY SCHOOL DIST 111

Fund Description	Account	Account Description	Revised Budget	Encumbrance	MTD Activity	Pending Activity	Available Funds	Year to Date Activity	Percent of Budget Used
Operations & Maint	20-2540-	CUSTODIANS SALARY (IC)	0.00	0.00	0.00	0.00	0.00	0.00	0.00
Operations & Maint	22540222	CUSTODIAN GROUP INS	363.60	17.62	0.00	0.00	2,548.51	-2,184.91	-600.91
Operations & Maint		Custodian Group Ins	197,662.32	15,776.38	0.00	0.00	85,824.04	111,838.28	56.58
Operations & Maint	20-2540-	CUSTODIAN GROUP INS	0.00	0.00	0.00	0.00	0.00	0.00	0.00
Operations & Maint		20 E 2540 2230 00 300	5,740.80	491.14	0.00	0.00	2,533.42	3,207.38	55.87
Operations & Maint	22540300	WAN PURCHASE SERV	0.00	0.00	0.00	0.00	0.00	0.00	0.00
Operations & Maint	22540301	BLDG CONTRACT SERV	35,000.00	0.00	0.00	0.00	33,407.36	1,592.64	4.55
Operations & Maint	22540302	HVAC - CENTRAL	65,000.00	0.00	0.00	0.00	62,536.20	2,463.80	3.79
Operations & Maint	22540303	LAWN CARE	15,000.00	0.00	0.00	0.00	15,000.00	0.00	0.00
Operations & Maint	22540304	SNOW REMOVAL -	25,000.00	0.00	0.00	254.00	24,746.00	0.00	0.00
Operations & Maint	22540305	EXTERMINATING FEES -	2,000.00	185.00	0.00	0.00	625.00	1,375.00	90 68.75
Operations & Maint	225403022	HVAC - SOUTH	70,000.00	7,000.00	0.00	0.00	58,708.89	11,291.11	16.13
Operations & Maint	225403032	LAWN CARE - SOUTH	5,000.00	0.00	0.00	0.00	4,961.01	38.99	0.78
Operations & Maint	225403042	SNOW REMOVAL - SOUTH	25,000.00	0.00	0.00	218.00	24,782.00	0.00	0.00
Operations & Maint	225403052	EXTERMINATING FEES -	2,500.00	175.00	0.00	0.00	1,275.00	1,225.00	49.00
Operations & Maint	22540310	CUSTODIAN HEALTH	0.00	0.00	0.00	0.00	0.00	0.00	0.00
Operations & Maint	22540311	CUSTODIAN LICENSE	0.00	0.00	0.00	0.00	0.00	0.00	0.00
Operations & Maint	22540318	A & E FEES	0.00	0.00	0.00	0.00	0.00	0.00	0.00
Operations & Maint	22540321	DISTRICT OFFICE LEASE	0.00	0.00	0.00	0.00	0.00	0.00	0.00
Operations & Maint	22540320	PROJ IND LEASE	22,000.00	1,660.80	0.00	0.00	10,374.40	11,625.60	52.84
Operations & Maint	225403211	GARBAGE - CENTRAL	35,000.00	0.00	0.00	4,354.63	5,839.37	24,806.00	70.87
Operations & Maint	225403212	GARBAGE - SOUTH	46,000.00	0.00	0.00	5,826.65	11,901.28	28,272.07	61.46
Operations & Maint	22540322	PCU LEASES	0.00	0.00	0.00	0.00	0.00	0.00	0.00
Operations & Maint	22540323	BLDG REPAIR/MAINT	60,000.00	61,087.10	17,684.28	4,121.36	-103,719.46	141,913.82	236.52

## Expenditure Report

Fiscal Year: 2021-2022  
Month: January

COUNTY OF GRUNDY SCHOOL DIST 111

Fund Description	Account	Account Description	Revised Budget	Encumbrance	MTD Activity	Pending Activity	Available Funds	Year to Date Activity	Percent of Budget Used
Operations & Maint	22540324	HVAC REPAIRS - CENTRAL	0.00	21,263.17	0.00	1,345.00	-26,459.40	25,114.40	0.00
Operations & Maint	225403232	BLDG REPAIR/MAINT	85,000.00	5,142.65	88.00	485.00	72,369.73	12,057.27	14.19
Operations & Maint	225403242	HVAC REPAIRS - SOUTH	0.00	2,235.00	103.36	0.00	-34,039.23	33,935.87	0.00
Operations & Maint	22540332	CUSTODIAN MILEAGE	1,000.00	0.00	0.00	0.00	1,000.00	0.00	0.00
Operations & Maint	22540340	DISTRICT OFF UTILITIES	0.00	0.00	0.00	0.00	0.00	0.00	0.00
Operations & Maint	22540342	PHONE	68,094.89	5,286.20	18,683.00	732.33	1,926.32	46,753.24	68.66
Operations & Maint	22540341	PROJ INDIAN UTILITIES	2,200.00	240.20	0.00	238.20	167.37	1,794.43	81.57
Operations & Maint	22540370	WATER-SEWER SERVICES	22,000.00	3,758.59	0.00	0.00	10,819.66	11,180.34	50.82
Operations & Maint	225403702	WATER-SEWER SOUTH	25,000.00	1,951.42	0.00	0.00	-12,083.52	37,083.52	148.33
Operations & Maint	22540380	UNEMPLOY INSURANCE	0.00	0.00	0.00	0.00	0.00	0.00	0.00
Operations & Maint	22540381	WORKERS COMP	0.00	0.00	0.00	0.00	0.00	0.00	91 0.00
Operations & Maint	22540382	BLDG FLEET INSURANCE	0.00	0.00	0.00	0.00	0.00	0.00	0.00
Operations & Maint	22540391	BLDG SECURITY PUR	0.00	0.00	0.00	0.00	0.00	0.00	0.00
Operations & Maint	225403902	CONTRACT SERV S.C.	60,000.00	2,450.49	0.00	4,280.76	8,209.54	47,509.70	79.18
Operations & Maint	225403903	SOUTH MAINTENANCE	810,000.00	53,078.00	0.00	53,078.00	385,176.00	371,746.00	45.89
Operations & Maint	225403912	BLDG SECURITY PS	0.00	0.00	0.00	0.00	0.00	0.00	0.00
Operations & Maint	22540392	PRECISION CONTROL -	0.00	0.00	0.00	0.00	0.00	0.00	0.00
Operations & Maint	225403932	SOUTH SITE CROP	0.00	0.00	0.00	0.00	0.00	0.00	0.00
Operations & Maint	22540410	BUILDING SUPPLIES	175,000.00	1,509.95	1,410.90	5,799.83	116,318.65	51,470.62	29.41
Operations & Maint	22540411	GROUND SUPPLIES	35,000.00	10,913.32	540.92	6,696.91	-9,013.08	36,775.25	105.07
Operations & Maint	225404102	BLDG SUPPLIES SOUTH	25,000.00	5,754.34	373.10	2,185.03	-16,756.84	39,198.71	156.79
Operations & Maint	225404122	SOUTH SITE CROP	12,000.00	0.00	0.00	0.00	4,490.88	7,509.12	62.58
Operations & Maint	22540465	NATURAL GAS	120,000.00	3,112.16	0.00	6,023.82	98,050.15	15,926.03	13.27
Operations & Maint	225404652	NATURAL GAS SOUTH	60,000.00	7,024.11	0.00	3,250.92	42,236.38	14,512.70	24.19

## Expenditure Report

Fiscal Year: 2021-2022  
Month: January

COUNTY OF GRUNDY SCHOOL DIST 111

Fund Description	Account	Account Description	Revised Budget	Encumbrance	MTD Activity	Pending Activity	Available Funds	Year to Date Activity	Percent of Budget Used
Operations & Maint	22540466	ELECTRICITY	225,000.00	18,401.46	0.00	20,813.67	68,585.55	135,600.78	60.27
Operations & Maint	225404662	ELECTRICITY SOUTH	315,000.00	26,805.89	0.00	0.00	139,151.38	175,848.62	55.82
Operations & Maint	22540490	911 SOFTWARE	0.00	0.00	0.00	0.00	0.00	0.00	0.00
Operations & Maint	2254049001	ESSER I GRANT SUPPLIES	0.00	0.00	0.00	0.00	0.00	0.00	0.00
Operations & Maint	2254049002	ESSER II GRANT SUPPLIES	0.00	0.00	0.00	0.00	0.00	0.00	0.00
Operations & Maint	2254049003	ESSER III GRANT	0.00	0.00	0.00	0.00	0.00	0.00	0.00
Operations & Maint	22540541	BLDG EQUIPMENT	55,000.00	0.00	27,754.36	0.00	15,677.08	11,568.56	21.03
Operations & Maint	22540542	WAN EQUIPMENT	0.00	0.00	0.00	0.00	0.00	0.00	0.00
Operations & Maint	22540540	PROJ IND EQUIP	2,500.00	0.00	0.00	0.00	2,500.00	0.00	0.00
Operations & Maint	225405412	BLDG EQUIPMENT SOUTH	15,000.00	0.00	51.96	229.99	13,161.28	1,556.77	10.38
Operations & Maint	22540640	CUSTODIAN CLINIC	500.00	0.00	0.00	0.00	500.00	0.00	92 0.00
Operations & Maint	22540690	REAL ESTATE TAXES-	3,600.00	0.00	0.00	0.00	1,654.05	1,945.95	54.05
Operations & Maint	2254070001	ESSER II GRANT	281,358.00	0.00	0.00	0.00	281,358.00	0.00	0.00
Operations & Maint	2254070003	ESSER III GRANT	830,062.00	0.00	0.00	0.00	830,062.00	0.00	0.00
Operations & Maint	22541120	SUMMER CUSTODIAN	35,000.00	0.00	0.00	0.00	26,307.25	8,692.75	24.84
Operations & Maint	22541390	BLDG SECURITY	0.00	0.00	0.00	0.00	0.00	0.00	0.00
Operations & Maint	22541391	BLDG SECURITY/PUR	40,000.00	0.00	0.00	0.00	40,000.00	0.00	0.00
Operations & Maint	225413902	BLDG SECURITY CS	0.00	0.00	0.00	0.00	0.00	0.00	0.00
Operations & Maint	225413912	BLDG SECURITY PS	0.00	0.00	0.00	0.00	0.00	0.00	0.00
Operations & Maint	22541410	BLDG SECURITY SUPPLIES	20,000.00	0.00	0.00	0.00	20,000.00	0.00	0.00
Operations & Maint	225414102	BLDG SECURITY SUPPLY S	0.00	0.00	0.00	0.00	0.00	0.00	0.00
Operations & Maint	22541540	BLDG SECURITY	150,000.00	0.00	0.00	0.00	79,102.00	70,898.00	47.27
Operations & Maint	225415402	BLDG SECURITY EQ	25,000.00	0.00	0.00	0.00	25,000.00	0.00	0.00
Operations & Maint	22542530	SITE IMPROVEMENT	50,000.00	0.00	0.00	0.00	50,000.00	0.00	0.00

## Expenditure Report

Fiscal Year: 2021-2022  
Month: January

COUNTY OF GRUNDY SCHOOL DIST 111

Fund Description	Account	Account Description	Revised Budget	Encumbrance	MTD Activity	Pending Activity	Available Funds	Year to Date Activity	Percent of Budget Used
Operations & Maint	22542531	BLDG IMPROVEMENT	0.00	0.00	0.00	0.00	0.00	0.00	0.00
Operations & Maint	225425302	SITE IMPROVEMNT SOUTH	20,000.00	0.00	0.00	0.00	20,000.00	0.00	0.00
Operations & Maint	225425312	BLDG IMPROVEMNT	20,000.00	0.00	0.00	0.00	11,432.51	8,567.49	42.84
Operations & Maint	22543540	ATHLETIC FIELDS	75,000.00	0.00	0.00	0.00	71,097.24	3,902.76	5.20
Operations & Maint	2380600	COMMERCIAL LIAB	0.00	0.00	0.00	0.00	0.00	0.00	0.00
Operations & Maint	24140520	GAVC-BUILDING COSTS	0.00	0.00	0.00	0.00	0.00	0.00	0.00
Operations & Maint	24140600	GAVC BUILD EXPENSES	380,000.00	84,595.39	0.00	0.00	174,445.25	205,554.75	54.09
Operations & Maint	24140620	GAVC CTE PROGRAMS	0.00	0.00	0.00	0.00	0.00	0.00	0.00
Operations & Maint	20-481-222-	IMRF (BMF 3000)	0.00	0.00	0.00	0.00	0.00	0.00	0.00
Operations & Maint	20-481-222-	IMRF (BMF 3000)	0.00	0.00	0.00	0.00	0.00	0.00	0.00
Operations & Maint	28130	TRANS TO TORT	0.00	0.00	0.00	0.00	0.00	0.00	93 0.00
Operations & Maint	28400	TRANS TO B & I	0.00	0.00	0.00	0.00	0.00	0.00	0.00
Operations & Maint	28800660	TRANS TO CAPITOL	0.00	0.00	0.00	0.00	0.00	0.00	0.00
<b>20 - -----</b>			<b>5,505,392.41</b>	<b>412,709.57</b>	<b>66,689.88</b>	<b>119,934.10</b>	<b>3,111,971.57</b>	<b>2,206,796.86</b>	
<b>2- - -----</b>			<b>5,505,392.41</b>	<b>412,709.57</b>	<b>66,689.88</b>	<b>119,934.10</b>	<b>3,111,971.57</b>	<b>2,206,796.86</b>	
Debt Service Fund or	34190690	DEVELOPMENT	0.00	0.00	0.00	0.00	0.00	0.00	0.00
Debt Service Fund or	35140620	INTEREST ON BONDS-2001	0.00	0.00	0.00	0.00	0.00	0.00	0.00
Debt Service Fund or	35140621	INTEREST ON BONDS-1999	0.00	0.00	0.00	0.00	0.00	0.00	0.00
Debt Service Fund or	35140622	INTEREST ON BONDS-2005	0.00	0.00	0.00	0.00	0.00	0.00	0.00
Debt Service Fund or	35140623	INTEREST ON CONST	0.00	0.00	0.00	0.00	0.00	0.00	0.00
Debt Service Fund or	35140624	INTEREST ON VAR RATE	0.00	0.00	0.00	0.00	0.00	0.00	0.00
Debt Service Fund or	35140626	INTEREST ON BONDS-2008	0.00	0.00	0.00	0.00	0.00	0.00	0.00
Debt Service Fund or	35140627	INTEREST ON BONDS 2010	0.00	0.00	0.00	0.00	0.00	0.00	0.00
Debt Service Fund or	35140628	INTEREST ON BONDS -	0.00	0.00	0.00	0.00	0.00	0.00	0.00

## Expenditure Report

Fiscal Year: 2021-2022  
Month: January

COUNTY OF GRUNDY SCHOOL DIST 111

Fund Description	Account	Account Description	Revised Budget	Encumbrance	MTD Activity	Pending Activity	Available Funds	Year to Date Activity	Percent of Budget Used
Debt Service Fund or	35140629	INTEREST ON BONDS	0.00	0.00	0.00	0.00	0.00	0.00	0.00
Debt Service Fund or	35140630	INTEREST ON BONDS	284,100.00	0.00	0.00	0.00	142,050.00	142,050.00	50.00
Debt Service Fund or	35140625	APPLE LEASE INTEREST	0.00	0.00	0.00	0.00	0.00	0.00	0.00
Debt Service Fund or	35140631	INTEREST ON BONDS 2014	253,050.00	0.00	0.00	0.00	98,175.00	154,875.00	61.20
Debt Service Fund or	35140632	INTEREST ON BONDS -	0.00	0.00	0.00	0.00	0.00	0.00	0.00
Debt Service Fund or	35140633	INTEREST ON BONDS -	365,200.00	0.00	0.00	0.00	182,600.00	182,600.00	50.00
Debt Service Fund or	35140634	INTEREST ON BONDS-	0.00	0.00	0.00	0.00	0.00	0.00	0.00
Debt Service Fund or	35140635	INTEREST ON BONDS-	238,400.00	0.00	0.00	0.00	119,200.00	119,200.00	50.00
Debt Service Fund or	35140636	INTEREST ON BONDS -	77,800.00	0.00	0.00	0.00	38,900.00	38,900.00	50.00
Debt Service Fund or	35140637	INTEREST ON BONDS 2019	738,550.00	0.00	0.00	0.00	341,125.00	397,425.00	53.81
Debt Service Fund or	35200619	BONDS RETIRED 2011	0.00	0.00	0.00	0.00	0.00	0.00	94 0.00
Debt Service Fund or	35200620	BONDS RETIRED 2012A	0.00	0.00	0.00	0.00	0.00	0.00	0.00
Debt Service Fund or	35200621	BONDS RETIRED 2012B	0.00	0.00	0.00	0.00	0.00	0.00	0.00
Debt Service Fund or	35200622	BOND RETIRED THROUGH	0.00	0.00	0.00	0.00	0.00	0.00	0.00
Debt Service Fund or	35200610	BONDS RETIRED 2006B	0.00	0.00	0.00	0.00	0.00	0.00	0.00
Debt Service Fund or	35200611	BOND RETIRED-1999	0.00	0.00	0.00	0.00	0.00	0.00	0.00
Debt Service Fund or	35200612	BONDS RETIRED-2005	0.00	0.00	0.00	0.00	0.00	0.00	0.00
Debt Service Fund or	35200613	BOND RETIRED 2006A	0.00	0.00	0.00	0.00	0.00	0.00	0.00
Debt Service Fund or	35200614	BOND RETIRED 2010	0.00	0.00	0.00	0.00	0.00	0.00	0.00
Debt Service Fund or	35200615	APPLE LEASE PRINCIPAL	0.00	0.00	0.00	0.00	0.00	0.00	0.00
Debt Service Fund or	35200616	BONDS RETIRED - 2001	0.00	0.00	0.00	0.00	0.00	0.00	0.00
Debt Service Fund or	35200617	BONDS RETIRED	0.00	0.00	0.00	0.00	0.00	0.00	0.00
Debt Service Fund or	35200618	BONDS RETIRED 2008	0.00	0.00	0.00	0.00	0.00	0.00	0.00
Debt Service Fund or	35200629	PRINCIPAL ON BONDS	2,815,000.00	0.00	0.00	0.00	0.00	2,815,000.00	100.00

## Expenditure Report

Fiscal Year: 2021-2022  
Month: January

COUNTY OF GRUNDY SCHOOL DIST 111

Fund Description	Account	Account Description	Revised Budget	Encumbrance	MTD Activity	Pending Activity	Available Funds	Year to Date Activity	Percent of Budget Used
Debt Service Fund or	35200623	INTEREST PAYMENT ON	0.00	0.00	0.00	0.00	0.00	0.00	0.00
Debt Service Fund or	35300624	PRINCIPAL ON BONDS	555,000.00	0.00	0.00	0.00	0.00	555,000.00	100.00
Debt Service Fund or	35300611	BOND PRINCIPAL	0.00	0.00	0.00	0.00	0.00	0.00	0.00
Debt Service Fund or	35300612	COST OF BOND ISSUANCE	0.00	0.00	0.00	0.00	0.00	0.00	0.00
Debt Service Fund or	35300613	PRINCIPAL ON BOND	0.00	0.00	0.00	0.00	0.00	0.00	0.00
Debt Service Fund or	35300614	PRINCIPAL ON BOND 2008	0.00	0.00	0.00	0.00	0.00	0.00	0.00
Debt Service Fund or	35300615	PRINCIPAL ON BOND 2010	0.00	0.00	0.00	0.00	0.00	0.00	0.00
Debt Service Fund or	35300616	PRINCIPAL ON BONDS	0.00	0.00	0.00	0.00	0.00	0.00	0.00
Debt Service Fund or	35300617	PRINCIPAL ON BONDS	0.00	0.00	0.00	0.00	0.00	0.00	0.00
Debt Service Fund or	35300618	PRINCIPAL ON BONDS	0.00	0.00	0.00	0.00	0.00	0.00	0.00
Debt Service Fund or	35300619	PRINCIPAL ON BONDS	2,835,000.00	0.00	0.00	0.00	0.00	2,835,000.00	95100.00
Debt Service Fund or	35300620	PRINCIPAL ON BONDS	0.00	0.00	0.00	0.00	0.00	0.00	0.00
Debt Service Fund or	35300621	PRINCIPAL ON BONDS	0.00	0.00	0.00	0.00	0.00	0.00	0.00
Debt Service Fund or	35300622	PRINCIPAL ON BONDS	0.00	0.00	0.00	0.00	0.00	0.00	0.00
Debt Service Fund or	35300623	PRINCIPAL ON BONDS	335,000.00	0.00	0.00	0.00	335,000.00	0.00	0.00
Debt Service Fund or	35300712	COMPUTER LEASE	0.00	0.00	0.00	0.00	0.00	0.00	0.00
Debt Service Fund or	35300710	PRINTROOM COPIER	0.00	0.00	0.00	0.00	0.00	0.00	0.00
Debt Service Fund or	35300711	OTHER COPIERS LEASE	0.00	0.00	0.00	0.00	0.00	0.00	0.00
Debt Service Fund or	35300714	DISTRICT OFFICE LEASE	0.00	0.00	0.00	0.00	0.00	0.00	0.00
Debt Service Fund or	35300715	PROJECT INDIAN LEASE	0.00	0.00	0.00	0.00	0.00	0.00	0.00
Debt Service Fund or	353007122	PRINTROOM COPIER	0.00	0.00	0.00	0.00	0.00	0.00	0.00
Debt Service Fund or	353007132	OTHER COPIERS LEASE	0.00	0.00	0.00	0.00	0.00	0.00	0.00
Debt Service Fund or	35900318	BOND LEGAL FEES	0.00	0.00	0.00	0.00	0.00	0.00	0.00
Debt Service Fund or	35900319	BOND CLOSING COSTS	0.00	55,450.00	0.00	0.00	-55,450.00	55,450.00	0.00

## Expenditure Report

Fiscal Year: 2021-2022  
Month: January

COUNTY OF GRUNDY SCHOOL DIST 111

Fund Description	Account	Account Description	Revised Budget	Encumbrance	MTD Activity	Pending Activity	Available Funds	Year to Date Activity	Percent of Budget Used
Debt Service Fund or	35900320	BOND PREMIUM ESCROW	0.00	0.00	0.00	0.00	0.00	0.00	0.00
Debt Service Fund or	35900390	SERVICE CHARGE	3,050.00	0.00	0.00	0.00	2,550.00	500.00	16.39
Debt Service Fund or	35900391	REMARKETING AGENT	0.00	0.00	0.00	0.00	0.00	0.00	0.00
Debt Service Fund or	35900611	ESCROW ADJUSTMENTS	0.00	0.00	0.00	0.00	0.00	0.00	0.00
Debt Service Fund or	38990000	OTHER MISC FINANCING	0.00	0.00	0.00	0.00	0.00	0.00	0.00
<b>30 - -----</b>			<b>8,500,150.00</b>	<b>55,450.00</b>	<b>0.00</b>	<b>0.00</b>	<b>1,204,150.00</b>	<b>7,296,000.00</b>	
<b>3- - -----</b>			<b>8,500,150.00</b>	<b>55,450.00</b>	<b>0.00</b>	<b>0.00</b>	<b>1,204,150.00</b>	<b>7,296,000.00</b>	
Transportation Fund		DIST 111 GROUP MEDICAL	202,721.76	13,843.08	0.00	0.00	52,899.95	149,821.81	73.91
Transportation Fund		DIST 111 GROUP DENTAL	2,943.60	344.99	0.00	0.00	1,702.21	1,241.39	42.17
Transportation Fund	42190110	CSBO SALARY	57,952.32	4,829.36	0.00	0.00	24,146.80	33,805.52	58.33
Transportation Fund	42190211	CSBO TRS	0.00	0.00	0.00	0.00	0.00	0.00	96 0.00
Transportation Fund		40 E 2190 2120 00 300	0.00	227.56	0.00	0.00	-659.29	659.29	0.00
Transportation Fund	40-2190-	CSBO SALARY (GTL)	0.00	0.00	0.00	0.00	0.00	0.00	0.00
Transportation Fund	42190222	CSBO GROUP INS	8,948.64	745.72	0.00	0.00	3,728.60	5,220.04	58.33
Transportation Fund		40 E 2190 2230 00 300	469.44	40.18	0.00	0.00	194.54	274.90	58.56
Transportation Fund	42190332	CSBO MILEAGE	0.00	0.00	0.00	0.00	0.00	0.00	0.00
Transportation Fund	42190640	CSBO DUES/CLINICS	0.00	0.00	0.00	0.00	0.00	0.00	0.00
Transportation Fund		40 E 2220 0000 00 000	0.00	0.00	0.00	0.00	0.00	0.00	0.00
Transportation Fund		40 E 2220 1100 00 300	0.00	0.00	0.00	0.00	0.00	0.00	0.00
Transportation Fund		DIST 111 GROUP DENTAL	0.00	0.00	0.00	0.00	0.00	0.00	0.00
Transportation Fund	42310200	BOARD OF ED-OTHER	0.00	0.00	0.00	0.00	0.00	0.00	0.00
Transportation Fund	42550110	TRANS SECY SALARY	70,000.00	11,266.60	0.00	0.00	37,663.34	32,336.66	46.20
Transportation Fund	42550111	GAVC/PREMIER ROUTE	0.00	0.00	0.00	0.00	0.00	0.00	0.00
Transportation Fund	42550112	OUT OF DISTRICT ROUTE	375,000.00	33,809.02	0.00	0.00	113,958.53	261,041.47	69.61

## Expenditure Report

Fiscal Year: 2021-2022  
Month: January

COUNTY OF GRUNDY SCHOOL DIST 111

Fund Description	Account	Account Description	Revised Budget	Encumbrance	MTD Activity	Pending Activity	Available Funds	Year to Date Activity	Percent of Budget Used
Transportation Fund	42550113	REGULAR ROUTE SALARY	475,000.00	47,273.95	0.00	0.00	152,911.57	322,088.43	67.81
Transportation Fund	42550114	BKKPER TRANS SALARY	6,614.88	551.24	0.00	0.00	2,756.20	3,858.68	58.33
Transportation Fund	42550115	OUT OF DISTRICT BUS	75,000.00	5,071.61	0.00	0.00	36,367.19	38,632.81	51.51
Transportation Fund	42550116	SHUTTLE(S)	0.00	0.00	0.00	0.00	0.00	0.00	0.00
Transportation Fund	42550117	BUS SUBS 201 FOR 111	0.00	0.00	0.00	0.00	0.00	0.00	0.00
Transportation Fund	42550118	IDEA PART B SP ED BUS	0.00	0.00	0.00	0.00	0.00	0.00	0.00
Transportation Fund	42550119	FULL TIME DRIVER	65,000.00	5,768.35	0.00	0.00	27,590.26	37,409.74	57.55
Transportation Fund	42550130	EXTRA DUTY (non-drive)	82,065.12	533.31	0.00	0.00	65,951.52	16,113.60	19.64
Transportation Fund	42550131	ACADEMIC TRIP(S)	10,000.00	1,725.46	0.00	0.00	-9,828.45	19,828.45	198.28
Transportation Fund	42550132	ATHLETIC/ACTIVITES	40,000.00	7,389.14	0.00	0.00	-5,288.40	45,288.40	113.22
Transportation Fund	42550133	ACTIVITIES TRIP	0.00	0.00	0.00	0.00	0.00	0.00	97 0.00
Transportation Fund	42550223	TRANS SEC INSURANCE	600.00	0.00	0.00	0.00	600.00	0.00	0.00
Transportation Fund	42554223	TRANS. DIR. INSURANCE	0.00	0.00	0.00	0.00	0.00	0.00	0.00
Transportation Fund	40-2550-	TRANSPORTATION	16,949.76	1,412.48	0.00	0.00	7,214.51	9,735.25	57.44
Transportation Fund		40 E 2550 2220 00 300	0.00	0.00	0.00	0.00	-348.47	348.47	0.00
Transportation Fund		40 E 2550 2220 00 300	0.00	0.00	0.00	0.00	-0.38	0.38	0.00
Transportation Fund		BKKPER TRANS GROUP	852.00	71.00	0.00	0.00	355.00	497.00	58.33
Transportation Fund		40 E 2550 2220 00 300	8,363.28	2,900.90	0.00	0.00	-9,739.06	18,102.34	216.45
Transportation Fund		40 E 2550 2230 00 300	441.60	37.78	0.00	0.00	183.02	258.58	58.56
Transportation Fund		40 E 2550 2230 00 300	44.16	3.78	0.00	0.00	18.30	25.86	58.56
Transportation Fund	42550230	COURSE	0.00	0.00	0.00	0.00	0.00	0.00	0.00
Transportation Fund	42550310	TRANS HEALTH EXAMS	2,000.00	0.00	0.00	381.00	-4,573.25	6,192.25	309.61
Transportation Fund	42551310	TANK TESTING	0.00	0.00	0.00	0.00	0.00	0.00	0.00
Transportation Fund	42550320	BUS LEASES	350,000.00	38,092.68	0.00	0.00	143,513.18	206,486.82	59.00

## Expenditure Report

Fiscal Year: 2021-2022  
Month: January

COUNTY OF GRUNDY SCHOOL DIST 111

Fund Description	Account	Account Description	Revised Budget	Encumbrance	MTD Activity	Pending Activity	Available Funds	Year to Date Activity	Percent of Budget Used
Transportation Fund	42550321	GARBAGE DISPOSAL	5,500.00	0.00	0.00	0.00	1,679.13	3,820.87	69.47
Transportation Fund	42550322	CLEANING SERVICES	5,000.00	347.76	0.00	0.00	1,588.52	3,411.48	68.23
Transportation Fund	42551322	SNOW REMOVAL-BUS	11,000.00	0.00	0.00	0.00	4,715.61	6,284.39	57.13
Transportation Fund	42550331	SPECIAL ED TRANS	10,000.00	0.00	0.00	0.00	10,000.00	0.00	0.00
Transportation Fund	42550332	TRANS MILEAGE	2,500.00	90.44	0.00	151.94	1,966.17	381.89	15.28
Transportation Fund	42550340	PHONE-BUS GARAGE	2,500.00	41.52	0.00	0.00	1,884.58	615.42	24.62
Transportation Fund	42551340	TRANS POSTAGE	0.00	0.00	0.00	0.00	0.00	0.00	0.00
Transportation Fund	42550350	TRANS ADVERTISING	500.00	0.00	0.00	0.00	500.00	0.00	0.00
Transportation Fund	42550370	WATER-BUS GARAGE	2,500.00	115.09	0.00	0.00	2,029.67	470.33	18.81
Transportation Fund	42550380	UNEMPLOY INSURANCE	0.00	0.00	0.00	0.00	0.00	0.00	0.00
Transportation Fund	42550381	WORKERS COMP	0.00	0.00	0.00	0.00	0.00	0.00	98 0.00
Transportation Fund	42550382	BUS FLEET INSURANCE	0.00	0.00	0.00	0.00	0.00	0.00	0.00
Transportation Fund	42550390	MECHANICS	0.00	0.00	0.00	0.00	0.00	0.00	0.00
Transportation Fund	42550391	ROUTING SOFTWARE	4,000.00	0.00	0.00	0.00	951.47	3,048.53	76.21
Transportation Fund	42550464	VAN GAS & SUPPLIES	15,000.00	2,085.73	0.00	1,938.32	-6,644.51	19,706.19	131.37
Transportation Fund	42550640	TRANS DIR	600.00	50.00	0.00	0.00	-1,867.75	2,467.75	411.29
Transportation Fund	42550690	REFUND ACCOUNT	0.00	0.00	0.00	0.00	0.00	0.00	0.00
Transportation Fund	42552410	BUS SUPPLIES	25,000.00	1,592.42	0.00	1,997.83	20,180.64	2,821.53	11.29
Transportation Fund	42552411	MECH/CUST SUPPLIES	5,000.00	0.00	0.00	503.16	3,974.24	522.60	10.45
Transportation Fund	42552464	BUS FUEL	100,000.00	3,693.61	0.00	20,288.74	-25,134.16	104,845.42	104.85
Transportation Fund	42552465	NATURAL GAS-BUS	2,200.00	249.74	0.00	0.00	1,568.33	631.67	28.71
Transportation Fund	42552466	ELECTRICITY-BUS	7,500.00	653.79	0.00	0.00	3,162.71	4,337.29	57.83
Transportation Fund	42554110	BUS MECHANIC SALARY	115,976.64	1,660.26	0.00	0.00	75,011.39	40,965.25	35.32
Transportation Fund	42554111	TRANS DIRECTORS	75,014.16	-3,125.59	0.00	0.00	58,939.69	16,074.47	21.43

## Expenditure Report

Fiscal Year: 2021-2022  
Month: January

COUNTY OF GRUNDY SCHOOL DIST 111

Fund Description	Account	Account Description	Revised Budget	Encumbrance	MTD Activity	Pending Activity	Available Funds	Year to Date Activity	Percent of Budget Used
Transportation Fund	42554222	BUS MECH GROUP INS	55,883.76	3,176.00	0.00	0.00	30,581.62	25,302.14	45.28
Transportation Fund		TRANS DIRECTORS	17,833.68	-687.87	0.00	0.00	14,057.13	3,776.55	21.18
Transportation Fund		40 E 2554 2230 00 300	883.20	-34.84	0.00	0.00	586.84	296.36	33.56
Transportation Fund		40 E 2554 2230 00 300	441.60	-72.62	0.00	0.00	403.82	37.78	8.56
Transportation Fund	42554300	TRANS CONTR SERV	5,000.00	437.50	0.00	0.00	949.04	4,050.96	81.02
Transportation Fund	42554323	TRANS REPAIR/MAINT	90,000.00	7,358.96	0.00	9,020.66	24,778.59	56,200.75	62.45
Transportation Fund	42554339	INSPECTION/LICENSE	10,000.00	664.00	0.00	494.00	197.61	9,308.39	93.08
Transportation Fund	42554540	TRANS EQUIPMENT	5,000.00	0.00	0.00	0.00	5,000.00	0.00	0.00
Transportation Fund	42554550	TRANS VEHICLES	75,000.00	0.00	0.00	0.00	75,000.00	0.00	0.00
Transportation Fund	42559520	BUS GARAGE ADDITION	0.00	0.00	0.00	0.00	0.00	0.00	0.00
Transportation Fund	42559530	TRANS BLDG IMPROVE	52,068.18	-6,242.00	0.00	0.00	-27,708.66	79,776.84	99153.22
Transportation Fund	42559690	TRANS - OTHER	0.00	0.00	0.00	0.00	0.00	0.00	0.00
Transportation Fund	40-481-222-	IMRF (BMF 3000)	0.00	0.00	0.00	0.00	0.00	0.00	0.00
Transportation Fund	40-481-222-	IMRF (BMF 3000)	0.00	0.00	0.00	0.00	0.00	0.00	0.00
<b>40 - -----</b>			<b>2,552,867.78</b>	<b>187,992.09</b>	<b>0.00</b>	<b>34,775.65</b>	<b>919,669.14</b>	<b>1,598,422.99</b>	
<b>4 - -----</b>			<b>2,552,867.78</b>	<b>187,992.09</b>	<b>0.00</b>	<b>34,775.65</b>	<b>919,669.14</b>	<b>1,598,422.99</b>	
I.M.R.F./Soc. Sec. Fund	50-1130-212	TITLE 1 SALARIES (RM)	2,000.16	425.94	0.00	0.00	-216.91	2,217.07	110.84
I.M.R.F./Soc. Sec. Fund	51130212	INSTR IMRF	0.00	1,712.88	0.00	0.00	-7,211.22	7,211.22	0.00
I.M.R.F./Soc. Sec. Fund		50 E 1130 2120 00 300	0.00	41.05	0.00	0.00	-169.38	169.38	0.00
I.M.R.F./Soc. Sec. Fund		50 E 1130 2120 00 300	0.00	105.95	0.00	0.00	-426.45	426.45	0.00
I.M.R.F./Soc. Sec. Fund		50 E 1130 2120 00 300	0.00	0.00	0.00	0.00	0.00	0.00	0.00
I.M.R.F./Soc. Sec. Fund	5113021250	ATH TRAINER IMRF	0.00	0.00	0.00	0.00	0.00	0.00	0.00
I.M.R.F./Soc. Sec. Fund	50-1130-213	TITLE 1 SALARIES (FR)	1,209.84	266.75	0.00	0.00	-140.34	1,350.18	111.60
I.M.R.F./Soc. Sec. Fund	51130213	INSTR FICA	0.00	948.04	0.00	0.00	-3,903.98	3,903.98	0.00

## Expenditure Report

Fiscal Year: 2021-2022  
Month: January

COUNTY OF GRUNDY SCHOOL DIST 111

Fund Description	Account	Account Description	Revised Budget	Encumbrance	MTD Activity	Pending Activity	Available Funds	Year to Date Activity	Percent of Budget Used
I.M.R.F./Soc. Sec. Fund		50 E 1130 2130 00 300	535.68	25.70	0.00	0.00	347.50	188.18	35.13
I.M.R.F./Soc. Sec. Fund		50 E 1130 2130 00 300	0.00	56.55	0.00	0.00	-221.19	221.19	0.00
I.M.R.F./Soc. Sec. Fund		50 E 1130 2130 00 300	0.00	0.00	0.00	0.00	0.00	0.00	0.00
I.M.R.F./Soc. Sec. Fund		50 E 1130 2130 00 300	0.00	0.00	0.00	0.00	0.00	0.00	0.00
I.M.R.F./Soc. Sec. Fund	5113021305	ENGLISH/DRAMA FICA	0.00	0.00	0.00	0.00	0.00	0.00	0.00
I.M.R.F./Soc. Sec. Fund	5113021312	MUSIC SALARY FICA	0.00	0.00	0.00	0.00	0.00	0.00	0.00
I.M.R.F./Soc. Sec. Fund	5113021321	DRIVER ED FICA	0.00	0.00	0.00	0.00	0.00	0.00	0.00
I.M.R.F./Soc. Sec. Fund	50-1130-	INSTR LEADER SALARY	0.00	0.00	0.00	0.00	0.00	0.00	0.00
I.M.R.F./Soc. Sec. Fund	5113021350	ATH TRAINER FICA	0.00	0.00	0.00	0.00	0.00	0.00	0.00
I.M.R.F./Soc. Sec. Fund	50-1130-214	OVERLOAD (MR)	282.96	62.39	0.00	0.00	-32.82	315.78	111.60
I.M.R.F./Soc. Sec. Fund	51130214	INSTR MEDICARE	1,539.12	355.48	0.00	0.00	-265.54	1,804.66	10017.25
I.M.R.F./Soc. Sec. Fund		INSTR MEDICARE	7,066.80	497.99	0.00	0.00	3,537.75	3,529.05	49.94
I.M.R.F./Soc. Sec. Fund		50 E 1130 2140 00 300	0.00	62.32	0.00	0.00	-380.04	380.04	0.00
I.M.R.F./Soc. Sec. Fund		INSTR MEDICARE	0.00	0.00	0.00	0.00	-4.15	4.15	0.00
I.M.R.F./Soc. Sec. Fund		INSTR MEDICARE	0.00	340.25	0.00	0.00	-340.25	340.25	0.00
I.M.R.F./Soc. Sec. Fund		50 E 1130 2140 00 300	0.00	0.00	0.00	0.00	0.00	0.00	0.00
I.M.R.F./Soc. Sec. Fund	5113021402	ART MEDICARE	2,536.80	211.36	0.00	0.00	1,067.42	1,469.38	57.92
I.M.R.F./Soc. Sec. Fund	5113021405	ENGLISH/DRAMA	23,651.52	1,969.94	0.00	0.00	10,126.50	13,525.02	57.18
I.M.R.F./Soc. Sec. Fund	5113021406	FOREIGN LANG MEDICARE	10,919.52	885.00	0.00	0.00	4,652.70	6,266.82	57.39
I.M.R.F./Soc. Sec. Fund	5113021411	MATH MEDICARE	18,520.08	1,541.30	0.00	0.00	7,586.48	10,933.60	59.04
I.M.R.F./Soc. Sec. Fund	5113021412	MUSIC MEDICARE	3,450.24	287.44	0.00	0.00	1,385.24	2,065.00	59.85
I.M.R.F./Soc. Sec. Fund	5113021413	NAT SCIENCE MEDICARE	18,809.04	1,563.62	0.00	0.00	7,881.46	10,927.58	58.10
I.M.R.F./Soc. Sec. Fund	5113021415	SOC SCIENCE MEDICARE	17,987.52	1,506.28	0.00	0.00	7,577.45	10,410.07	57.87
I.M.R.F./Soc. Sec. Fund	5113021421	DRIVER ED MEDICARE	0.00	0.00	0.00	0.00	0.00	0.00	0.00

## Expenditure Report

Fiscal Year: 2021-2022  
Month: January

COUNTY OF GRUNDY SCHOOL DIST 111

Fund Description	Account	Account Description	Revised Budget	Encumbrance	MTD Activity	Pending Activity	Available Funds	Year to Date Activity	Percent of Budget Used
I.M.R.F./Soc. Sec. Fund	5113021427	INSTR LDR MEDICARE	10,642.56	886.16	0.00	0.00	4,623.92	6,018.64	56.55
I.M.R.F./Soc. Sec. Fund	5113021450	PHYS ED MEDICARE	16,161.60	1,339.46	0.00	0.00	6,841.91	9,319.69	57.67
I.M.R.F./Soc. Sec. Fund	50-1200-	IDEA PART B SP ED	0.00	0.00	0.00	0.00	0.00	0.00	0.00
I.M.R.F./Soc. Sec. Fund	50-1200-	IDEA SP ED LOCAL (RM)	0.00	0.00	0.00	0.00	0.00	0.00	0.00
I.M.R.F./Soc. Sec. Fund		SPEC ED AIDE IMRF	11,585.76	920.10	0.00	0.00	5,286.99	6,298.77	54.37
I.M.R.F./Soc. Sec. Fund		SPEC ED SEC IMRF	3,831.60	308.40	0.00	0.00	1,607.40	2,224.20	58.05
I.M.R.F./Soc. Sec. Fund	50-1200-	IDEA PART B SP ED	0.00	0.00	0.00	0.00	0.00	0.00	0.00
I.M.R.F./Soc. Sec. Fund	50-1200-	IDEA SP ED LOCAL (FR)	0.00	0.00	0.00	0.00	0.00	0.00	0.00
I.M.R.F./Soc. Sec. Fund		SPEC ED AIDE FICA	6,915.12	567.82	0.00	0.00	3,143.37	3,771.75	54.54
I.M.R.F./Soc. Sec. Fund		SPEC ED SEC FICA	2,243.28	186.94	0.00	0.00	934.70	1,308.58	58.33
I.M.R.F./Soc. Sec. Fund	50-1200-	SPECIAL ED SALARY	17,820.72	1,472.02	0.00	0.00	7,691.00	10,129.72	10156.84
I.M.R.F./Soc. Sec. Fund		50 E 1200 2140 00 300	0.00	0.00	0.00	0.00	0.00	0.00	0.00
I.M.R.F./Soc. Sec. Fund		SPEC ED AIDE MEDICARE	1,617.36	132.81	0.00	0.00	735.14	882.22	54.55
I.M.R.F./Soc. Sec. Fund		SPEC ED SEC MEDICARE	524.64	43.72	0.00	0.00	218.60	306.04	58.33
I.M.R.F./Soc. Sec. Fund	51250212	COOP HOMEBOUND/HOSP	0.00	0.00	0.00	0.00	0.00	0.00	0.00
I.M.R.F./Soc. Sec. Fund	51250213	COOP HOMEBOUND/HOSP	0.00	0.00	0.00	0.00	0.00	0.00	0.00
I.M.R.F./Soc. Sec. Fund	51250214	COOP HB/HOSP	0.00	0.00	0.00	0.00	0.00	0.00	0.00
I.M.R.F./Soc. Sec. Fund	50-1400-	CTE SALARY IMRF	0.00	0.00	0.00	0.00	0.00	0.00	0.00
I.M.R.F./Soc. Sec. Fund	51400213	VOC ED GRANT FICA	0.00	0.00	0.00	0.00	0.00	0.00	0.00
I.M.R.F./Soc. Sec. Fund	51400214	VOC ED GRANT MEDICARE	3,852.00	315.72	0.00	0.00	1,642.79	2,209.21	57.35
I.M.R.F./Soc. Sec. Fund	5140021410	IND TECH MEDICARE	2,622.00	210.10	0.00	0.00	1,155.84	1,466.16	55.92
I.M.R.F./Soc. Sec. Fund	5140121401	AG MEDICARE	3,263.28	270.64	0.00	0.00	1,385.21	1,878.07	57.55
I.M.R.F./Soc. Sec. Fund	5140721403	BUSINESS ED MEDICARE	3,131.04	256.54	0.00	0.00	1,337.22	1,793.82	57.29
I.M.R.F./Soc. Sec. Fund	51410214	VIDEO EDIT MEDICARE	0.00	0.00	0.00	0.00	0.00	0.00	0.00

## Expenditure Report

Fiscal Year: 2021-2022  
Month: January

COUNTY OF GRUNDY SCHOOL DIST 111

Fund Description	Account	Account Description	Revised Budget	Encumbrance	MTD Activity	Pending Activity	Available Funds	Year to Date Activity	Percent of Budget Used
I.M.R.F./Soc. Sec. Fund	5141121430	INST. TECH MEDICARE	1,127.76	93.96	0.00	0.00	475.41	652.35	57.84
I.M.R.F./Soc. Sec. Fund	51417212	ATHLETIC TRAINER IMRF	5,697.12	458.56	0.00	0.00	2,390.00	3,307.12	58.05
I.M.R.F./Soc. Sec. Fund	51417213	ATHLETIC TRAINER FICA	3,378.48	281.40	0.00	0.00	1,407.84	1,970.64	58.33
I.M.R.F./Soc. Sec. Fund	51417214	ATHLETIC TRAINER	790.08	65.82	0.00	0.00	329.22	460.86	58.33
I.M.R.F./Soc. Sec. Fund	5142021409	FAM/CONS SCI MEDICARE	2,867.28	240.69	0.00	0.00	1,293.52	1,573.76	54.89
I.M.R.F./Soc. Sec. Fund	50-1500-212	INVITATIONAL WKRS (RM)	0.00	0.00	0.00	0.00	0.00	0.00	0.00
I.M.R.F./Soc. Sec. Fund	5150021230	ATHLETIC DIR SECY IMRF	0.00	0.00	0.00	0.00	0.00	0.00	0.00
I.M.R.F./Soc. Sec. Fund		ATHLETIC DIR SECY IMRF	5,149.44	414.48	0.00	0.00	2,160.23	2,989.21	58.05
I.M.R.F./Soc. Sec. Fund		50 E 1500 2120 30 300	2,321.28	301.21	0.00	0.00	688.95	1,632.33	70.32
I.M.R.F./Soc. Sec. Fund		50 E 1500 2120 30 300	0.00	54.40	0.00	0.00	-167.07	167.07	0.00
I.M.R.F./Soc. Sec. Fund		TECH DIR IMRF	526.56	42.38	0.00	0.00	160.15	366.41	10269.59
I.M.R.F./Soc. Sec. Fund		50 E 1500 2120 30 300	0.00	0.00	0.00	0.00	-222.79	222.79	0.00
I.M.R.F./Soc. Sec. Fund		50 E 1500 2120 30 300	0.00	37.90	0.00	0.00	-116.38	116.38	0.00
I.M.R.F./Soc. Sec. Fund	51500212	MAIN OFFICE IMRF	0.00	0.00	0.00	0.00	0.00	0.00	0.00
I.M.R.F./Soc. Sec. Fund	5150021270	ACTIVITY DIR SECY IMRF	4,815.12	387.57	0.00	0.00	2,019.89	2,795.23	58.05
I.M.R.F./Soc. Sec. Fund		50 E 1500 2120 70 300	0.00	0.00	0.00	0.00	0.00	0.00	0.00
I.M.R.F./Soc. Sec. Fund		50 E 1500 2120 70 300	468.00	6.70	0.00	0.00	64.07	403.93	86.31
I.M.R.F./Soc. Sec. Fund		50 E 1500 2120 70 300	174.00	14.00	0.00	0.00	73.00	101.00	58.05
I.M.R.F./Soc. Sec. Fund		ATH/ACT	0.00	141.57	0.00	0.00	-178.20	178.20	0.00
I.M.R.F./Soc. Sec. Fund		50 E 1500 2120 70 300	290.64	23.40	0.00	0.00	146.14	144.50	49.72
I.M.R.F./Soc. Sec. Fund		ATH/ACT	0.00	0.00	0.00	0.00	-217.43	217.43	0.00
I.M.R.F./Soc. Sec. Fund	50-1500-213	INVITATIONAL WKRS (FR)	0.00	0.00	0.00	0.00	0.00	0.00	0.00
I.M.R.F./Soc. Sec. Fund	5150021330	GOLF COACH FICA	0.00	0.00	0.00	0.00	0.00	0.00	0.00
I.M.R.F./Soc. Sec. Fund		ATH/ACT	2,834.16	236.12	0.00	0.00	1,180.96	1,653.20	58.33

## Expenditure Report

Fiscal Year: 2021-2022  
Month: January

COUNTY OF GRUNDY SCHOOL DIST 111

Fund Description	Account	Account Description	Revised Budget	Encumbrance	MTD Activity	Pending Activity	Available Funds	Year to Date Activity	Percent of Budget Used
I.M.R.F./Soc. Sec. Fund		50 E 1500 2130 30 300	1,403.76	188.62	0.00	0.00	140.48	1,263.28	89.99
I.M.R.F./Soc. Sec. Fund		50 E 1500 2130 30 300	0.00	0.00	0.00	0.00	0.00	0.00	0.00
I.M.R.F./Soc. Sec. Fund		50 E 1500 2130 30 300	0.00	0.00	0.00	0.00	0.00	0.00	0.00
I.M.R.F./Soc. Sec. Fund		50 E 1500 2130 30 300	11,652.96	0.00	0.00	0.00	10,681.88	971.08	8.33
I.M.R.F./Soc. Sec. Fund		50 E 1500 2130 30 300	3,234.24	0.00	0.00	0.00	2,959.95	274.29	8.48
I.M.R.F./Soc. Sec. Fund		50 E 1500 2130 30 300	0.00	34.08	0.00	0.00	-102.24	102.24	0.00
I.M.R.F./Soc. Sec. Fund		50 E 1500 2130 30 300	0.00	97.05	0.00	0.00	-719.57	719.57	0.00
I.M.R.F./Soc. Sec. Fund		ATH/ACT	318.72	26.54	0.00	0.00	96.18	222.54	69.82
I.M.R.F./Soc. Sec. Fund		50 E 1500 2130 30 300	7,195.92	0.00	0.00	0.00	6,161.67	1,034.25	14.37
I.M.R.F./Soc. Sec. Fund		50 E 1500 2130 30 300	0.00	0.00	0.00	0.00	-161.85	161.85	0.00
I.M.R.F./Soc. Sec. Fund		50 E 1500 2130 30 300	0.00	0.00	0.00	0.00	-123.01	123.01	103 0.00
I.M.R.F./Soc. Sec. Fund		50 E 1500 2130 30 300	0.00	0.00	0.00	0.00	-294.26	294.26	0.00
I.M.R.F./Soc. Sec. Fund		50 E 1500 2130 30 300	0.00	0.00	0.00	0.00	0.00	0.00	0.00
I.M.R.F./Soc. Sec. Fund		50 E 1500 2130 30 300	0.00	23.74	0.00	0.00	-100.21	100.21	0.00
I.M.R.F./Soc. Sec. Fund	51500213	MAIN OFFICE FICA	0.00	0.00	0.00	0.00	0.00	0.00	0.00
I.M.R.F./Soc. Sec. Fund	5150021370	ACTIVITIES FICA	2,696.16	224.54	0.00	0.00	1,123.54	1,572.62	58.33
I.M.R.F./Soc. Sec. Fund		50 E 1500 2130 70 300	0.00	0.00	0.00	0.00	0.00	0.00	0.00
I.M.R.F./Soc. Sec. Fund		50 E 1500 2130 70 300	283.20	4.20	0.00	0.00	34.61	248.59	87.78
I.M.R.F./Soc. Sec. Fund		50 E 1500 2130 70 300	105.36	8.78	0.00	0.00	43.90	61.46	58.33
I.M.R.F./Soc. Sec. Fund		50 E 1500 2130 70 300	0.00	0.00	0.00	0.00	0.00	0.00	0.00
I.M.R.F./Soc. Sec. Fund		50 E 1500 2130 70 300	0.00	0.00	0.00	0.00	-193.44	193.44	0.00
I.M.R.F./Soc. Sec. Fund		50 E 1500 2130 70 300	0.00	0.00	0.00	0.00	-105.28	105.28	0.00
I.M.R.F./Soc. Sec. Fund		50 E 1500 2130 70 300	0.00	0.00	0.00	0.00	-105.28	105.28	0.00
I.M.R.F./Soc. Sec. Fund		ATH/ACT	0.00	86.42	0.00	0.00	-108.59	108.59	0.00

## Expenditure Report

Fiscal Year: 2021-2022  
Month: January

COUNTY OF GRUNDY SCHOOL DIST 111

Fund Description	Account	Account Description	Revised Budget	Encumbrance	MTD Activity	Pending Activity	Available Funds	Year to Date Activity	Percent of Budget Used
I.M.R.F./Soc. Sec. Fund		50 E 1500 2130 70 300	175.92	14.66	0.00	0.00	87.96	87.96	50.00
I.M.R.F./Soc. Sec. Fund		ATH/ACT	0.00	0.00	0.00	0.00	-338.15	338.15	0.00
I.M.R.F./Soc. Sec. Fund		50 E 1500 2130 70 300	0.00	0.00	0.00	0.00	0.00	0.00	0.00
I.M.R.F./Soc. Sec. Fund		50 E 1500 2130 70 300	0.00	177.32	0.00	0.00	-177.32	177.32	0.00
I.M.R.F./Soc. Sec. Fund	50-1500-214	INVITATIONAL WKRS (MR)	0.00	0.00	0.00	0.00	0.00	0.00	0.00
I.M.R.F./Soc. Sec. Fund	5150021530	ASST ATHLETIC DIR	0.00	0.00	0.00	0.00	0.00	0.00	0.00
I.M.R.F./Soc. Sec. Fund	50-1500-	ASST ATHLETIC DIR	0.00	0.00	0.00	0.00	0.00	0.00	0.00
I.M.R.F./Soc. Sec. Fund	5150021430	ATHLETIC MEDICARE	2,003.04	193.82	0.00	0.00	785.06	1,217.98	60.81
I.M.R.F./Soc. Sec. Fund		ATH/ACT	870.24	72.50	0.00	0.00	363.60	506.64	58.22
I.M.R.F./Soc. Sec. Fund		ATH/ACT	896.88	122.97	0.00	0.00	150.56	746.32	83.21
I.M.R.F./Soc. Sec. Fund		ATH/ACT	177.84	14.82	0.00	0.00	74.70	103.14	10458.00
I.M.R.F./Soc. Sec. Fund		ATH/ACT	232.08	19.34	0.00	0.00	97.56	134.52	57.96
I.M.R.F./Soc. Sec. Fund		ATH/ACT	136.80	11.38	0.00	0.00	57.71	79.09	57.81
I.M.R.F./Soc. Sec. Fund		ATH/ACT	404.16	37.38	0.00	0.00	151.54	252.62	62.50
I.M.R.F./Soc. Sec. Fund		ATH/ACT	304.32	25.35	0.00	0.00	133.76	170.56	56.05
I.M.R.F./Soc. Sec. Fund		ATH/ACT	2,191.20	24.32	0.00	0.00	1,859.90	331.30	15.12
I.M.R.F./Soc. Sec. Fund		ATH/ACT	389.04	32.38	0.00	0.00	162.88	226.16	58.13
I.M.R.F./Soc. Sec. Fund		ATH/ACT	3,491.76	63.89	0.00	0.00	2,781.25	710.51	20.35
I.M.R.F./Soc. Sec. Fund		ATH/ACT	1,223.76	47.71	0.00	0.00	833.86	389.90	31.86
I.M.R.F./Soc. Sec. Fund		ATH/ACT	266.88	30.22	0.00	0.00	44.25	222.63	83.42
I.M.R.F./Soc. Sec. Fund		ATH/ACT	278.64	45.92	0.00	0.00	-52.20	330.84	118.73
I.M.R.F./Soc. Sec. Fund		ATH/ACT	136.56	11.38	0.00	0.00	57.50	79.06	57.89
I.M.R.F./Soc. Sec. Fund		ATH/ACT	325.44	27.10	0.00	0.00	127.81	197.63	60.73
I.M.R.F./Soc. Sec. Fund		50 E 1500 2140 30 300	1,682.88	0.00	0.00	0.00	1,441.00	241.88	14.37

## Expenditure Report

Fiscal Year: 2021-2022  
Month: January

COUNTY OF GRUNDY SCHOOL DIST 111

Fund Description	Account	Account Description	Revised Budget	Encumbrance	MTD Activity	Pending Activity	Available Funds	Year to Date Activity	Percent of Budget Used
I.M.R.F./Soc. Sec. Fund		ATH/ACT	310.56	28.47	0.00	0.00	121.60	188.96	60.84
I.M.R.F./Soc. Sec. Fund		ATH/ACT	438.96	36.56	0.00	0.00	154.84	284.12	64.73
I.M.R.F./Soc. Sec. Fund		ATH/ACT	100.80	8.40	0.00	0.00	13.20	87.60	86.90
I.M.R.F./Soc. Sec. Fund		ATH/ACT	127.68	10.62	0.00	0.00	53.85	73.83	57.82
I.M.R.F./Soc. Sec. Fund		ATH/ACT	348.48	35.28	0.00	0.00	101.66	246.82	70.83
I.M.R.F./Soc. Sec. Fund		ATH/ACT	246.00	20.50	0.00	0.00	26.65	219.35	89.17
I.M.R.F./Soc. Sec. Fund		50 E 1500 2140 30 300	0.00	0.00	0.00	0.00	0.00	0.00	0.00
I.M.R.F./Soc. Sec. Fund		50 E 1500 2140 30 300	0.00	5.56	0.00	0.00	-23.46	23.46	0.00
I.M.R.F./Soc. Sec. Fund	5150021470	ACTIVITIES MEDICARE	1,378.56	114.88	0.00	0.00	578.99	799.57	58.00
I.M.R.F./Soc. Sec. Fund		ATH/ACT	630.72	54.20	0.00	0.00	217.25	413.47	65.56
I.M.R.F./Soc. Sec. Fund		ATH/ACT	321.36	26.78	0.00	0.00	135.34	186.02	10557.89
I.M.R.F./Soc. Sec. Fund		50 E 1500 2140 70 300	162.48	19.61	0.00	0.00	-35.96	198.44	122.13
I.M.R.F./Soc. Sec. Fund		ATH/ACT	70.80	5.89	0.00	0.00	29.83	40.97	57.87
I.M.R.F./Soc. Sec. Fund		ATH/ACT	174.96	14.59	0.00	0.00	73.72	101.24	57.86
I.M.R.F./Soc. Sec. Fund		ATH/ACT	70.08	5.84	0.00	0.00	29.24	40.84	58.28
I.M.R.F./Soc. Sec. Fund		ATH/ACT	33.84	2.82	0.00	0.00	14.34	19.50	57.62
I.M.R.F./Soc. Sec. Fund		ATH/ACT	291.12	24.26	0.00	0.00	121.33	169.79	58.32
I.M.R.F./Soc. Sec. Fund		ATH/ACT	143.28	11.94	0.00	0.00	60.63	82.65	57.68
I.M.R.F./Soc. Sec. Fund		ATH/ACT	184.08	15.34	0.00	0.00	77.60	106.48	57.84
I.M.R.F./Soc. Sec. Fund		ATH/ACT	78.00	6.50	0.00	0.00	32.98	45.02	57.72
I.M.R.F./Soc. Sec. Fund		ATH/ACT	116.64	9.72	0.00	0.00	49.12	67.52	57.89
I.M.R.F./Soc. Sec. Fund		ATH/ACT	193.92	16.16	0.00	0.00	83.95	109.97	56.71
I.M.R.F./Soc. Sec. Fund		ATH/ACT	30.24	2.54	0.00	0.00	12.47	17.77	58.76
I.M.R.F./Soc. Sec. Fund		ATH/ACT	45.60	3.80	0.00	0.00	19.02	26.58	58.29

## Expenditure Report

Fiscal Year: 2021-2022  
Month: January

COUNTY OF GRUNDY SCHOOL DIST 111

Fund Description	Account	Account Description	Revised Budget	Encumbrance	MTD Activity	Pending Activity	Available Funds	Year to Date Activity	Percent of Budget Used
I.M.R.F./Soc. Sec. Fund		ATH/ACT	33.60	2.81	0.00	0.00	14.00	19.60	58.33
I.M.R.F./Soc. Sec. Fund		ATH/ACT	105.60	8.76	0.00	0.00	44.04	61.56	58.30
I.M.R.F./Soc. Sec. Fund		ATH/ACT	30.48	2.54	0.00	0.00	12.70	17.78	58.33
I.M.R.F./Soc. Sec. Fund		ATH/ACT	48.96	4.08	0.00	0.00	14.24	34.72	70.92
I.M.R.F./Soc. Sec. Fund		ATH/ACT	31.92	2.66	0.00	0.00	13.60	18.32	57.39
I.M.R.F./Soc. Sec. Fund		ATH/ACT	162.00	13.50	0.00	0.00	68.38	93.62	57.79
I.M.R.F./Soc. Sec. Fund		ATH/ACT	77.52	6.46	0.00	0.00	32.60	44.92	57.95
I.M.R.F./Soc. Sec. Fund		50 E 1500 2140 70 300	0.00	2.54	0.00	0.00	-58.85	58.85	0.00
I.M.R.F./Soc. Sec. Fund		ATH/ACT	0.00	0.00	0.00	0.00	-3.09	3.09	0.00
I.M.R.F./Soc. Sec. Fund		ATH/ACT	42.48	3.54	0.00	0.00	18.06	24.42	57.49
I.M.R.F./Soc. Sec. Fund		ATH/ACT	41.76	3.48	0.00	0.00	17.69	24.07	10657.64
I.M.R.F./Soc. Sec. Fund		ATH/ACT	87.36	7.28	0.00	0.00	36.70	50.66	57.99
I.M.R.F./Soc. Sec. Fund		ATH/ACT	41.76	3.48	0.00	0.00	17.70	24.06	57.61
I.M.R.F./Soc. Sec. Fund		ATH/ACT	0.00	0.00	0.00	0.00	-3.81	3.81	0.00
I.M.R.F./Soc. Sec. Fund		ATH/ACT	57.84	4.82	0.00	0.00	24.49	33.35	57.66
I.M.R.F./Soc. Sec. Fund		50 E 1500 2140 70 300	39.60	3.30	0.00	0.00	16.48	23.12	58.38
I.M.R.F./Soc. Sec. Fund		50 E 1500 2140 70 300	0.00	0.00	0.00	0.00	-24.62	24.62	0.00
I.M.R.F./Soc. Sec. Fund		ATH/ACT	24.72	2.06	0.00	0.00	10.30	14.42	58.33
I.M.R.F./Soc. Sec. Fund		50 E 1500 2140 70 300	0.00	0.00	0.00	0.00	-24.62	24.62	0.00
I.M.R.F./Soc. Sec. Fund		ATH/ACT	29.52	2.46	0.00	0.00	12.30	17.22	58.33
I.M.R.F./Soc. Sec. Fund		ATH/ACT	66.24	5.52	0.00	0.00	30.70	35.54	53.65
I.M.R.F./Soc. Sec. Fund		ATH/ACT	75.60	26.51	0.00	0.00	6.10	69.50	91.93
I.M.R.F./Soc. Sec. Fund		ATH/ACT	29.52	2.45	0.00	0.00	12.31	17.21	58.30
I.M.R.F./Soc. Sec. Fund		50 E 1500 2140 70 300	0.00	0.00	0.00	0.00	0.00	0.00	0.00

## Expenditure Report

Fiscal Year: 2021-2022  
Month: January

COUNTY OF GRUNDY SCHOOL DIST 111

Fund Description	Account	Account Description	Revised Budget	Encumbrance	MTD Activity	Pending Activity	Available Funds	Year to Date Activity	Percent of Budget Used
I.M.R.F./Soc. Sec. Fund		ATH/ACT	71.52	5.96	0.00	0.00	33.22	38.30	53.55
I.M.R.F./Soc. Sec. Fund		ATH/ACT	33.36	2.78	0.00	0.00	13.90	19.46	58.33
I.M.R.F./Soc. Sec. Fund		ATH/ACT	0.00	0.00	0.00	0.00	-421.39	421.39	0.00
I.M.R.F./Soc. Sec. Fund		50 E 1500 2140 70 300	0.00	0.00	0.00	0.00	0.00	0.00	0.00
I.M.R.F./Soc. Sec. Fund		ATH/ACT	36.48	3.04	0.00	0.00	15.20	21.28	58.33
I.M.R.F./Soc. Sec. Fund		50 E 1500 2140 70 300	0.00	41.47	0.00	0.00	-41.47	41.47	0.00
I.M.R.F./Soc. Sec. Fund		50 E 1500 2140 70 300	0.00	2.72	0.00	0.00	-4.08	4.08	0.00
I.M.R.F./Soc. Sec. Fund	50-1600-	SUMMER SCHOOL SALARY	0.00	0.00	0.00	0.00	0.00	0.00	0.00
I.M.R.F./Soc. Sec. Fund	50-1600-	SUMMER SCHOOL SALARY	0.00	0.00	0.00	0.00	0.00	0.00	0.00
I.M.R.F./Soc. Sec. Fund	51600214	SUMMER SCHOOL	0.00	0.00	0.00	0.00	0.00	0.00	0.00
I.M.R.F./Soc. Sec. Fund	50-1700-	SUMMER DR ED SALARY	0.00	0.00	0.00	0.00	0.00	0.00	107 0.00
I.M.R.F./Soc. Sec. Fund	50-1700-	SUMMER DR ED SALARY	0.00	0.00	0.00	0.00	0.00	0.00	0.00
I.M.R.F./Soc. Sec. Fund	5170021430	SUMMER DR ED	0.00	0.00	0.00	0.00	0.00	0.00	0.00
I.M.R.F./Soc. Sec. Fund	5170021421	DRIVER ED MEDICARE	5,918.88	488.10	0.00	0.00	2,499.72	3,419.16	57.77
I.M.R.F./Soc. Sec. Fund	51900212	PROJ IND SECY IMRF	0.00	0.00	0.00	0.00	0.00	0.00	0.00
I.M.R.F./Soc. Sec. Fund		PROJ IND SECY IMRF	3,395.52	273.30	0.00	0.00	1,431.56	1,963.96	57.84
I.M.R.F./Soc. Sec. Fund	51900213	PROJ IND SECY FICA	0.00	0.00	0.00	0.00	0.00	0.00	0.00
I.M.R.F./Soc. Sec. Fund		PROJ IND SECY FICA	1,822.80	151.90	0.00	0.00	763.77	1,059.03	58.10
I.M.R.F./Soc. Sec. Fund	51900214	PROJ IND SECY MEDICARE	1,422.24	118.50	0.00	0.00	593.67	828.57	58.26
I.M.R.F./Soc. Sec. Fund		PROJ IND SECY MEDICARE	426.24	35.52	0.00	0.00	178.58	247.66	58.10
I.M.R.F./Soc. Sec. Fund	50-2100-	MAIN OFFICE SECY	0.00	0.00	0.00	0.00	0.00	0.00	0.00
I.M.R.F./Soc. Sec. Fund		MAIN OFFICE SECY	3,837.84	287.02	0.00	0.00	1,801.97	2,035.87	53.05
I.M.R.F./Soc. Sec. Fund	521002121	PROJ IND DIR SECY IMRF	0.00	0.00	0.00	0.00	0.00	0.00	0.00
I.M.R.F./Soc. Sec. Fund	50-2100-	DIR OF STUDENT SERV	0.00	0.00	0.00	0.00	0.00	0.00	0.00

## Expenditure Report

Fiscal Year: 2021-2022  
Month: January

COUNTY OF GRUNDY SCHOOL DIST 111

Fund Description	Account	Account Description	Revised Budget	Encumbrance	MTD Activity	Pending Activity	Available Funds	Year to Date Activity	Percent of Budget Used
I.M.R.F./Soc. Sec. Fund	50-2100-	MAIN OFFICE SECY	0.00	0.00	0.00	0.00	0.00	0.00	0.00
I.M.R.F./Soc. Sec. Fund		MAIN OFFICE SECY	2,321.52	171.08	0.00	0.00	1,092.57	1,228.95	52.94
I.M.R.F./Soc. Sec. Fund	521002131	PROJ IND DIR SECY FICA	0.00	0.00	0.00	0.00	0.00	0.00	0.00
I.M.R.F./Soc. Sec. Fund	50-2100-	DIR OF STUDENT SERV	0.00	0.00	0.00	0.00	0.00	0.00	0.00
I.M.R.F./Soc. Sec. Fund	52100214	ASST PRIN-LEARN MED	0.00	0.00	0.00	0.00	0.00	0.00	0.00
I.M.R.F./Soc. Sec. Fund		MAIN OFFICE SECY	542.88	40.02	0.00	0.00	255.50	287.38	52.94
I.M.R.F./Soc. Sec. Fund	50-2100-	DIR STUDENT SERV. SA	1,876.56	156.38	0.00	0.00	780.24	1,096.32	58.42
I.M.R.F./Soc. Sec. Fund	52100215	DIR OF STUD SER	0.00	0.00	0.00	0.00	0.00	0.00	0.00
I.M.R.F./Soc. Sec. Fund	50-2110-212	TITLE 1 SALARIES IMRF	2,227.92	179.32	0.00	0.00	941.04	1,286.88	57.76
I.M.R.F./Soc. Sec. Fund	50-2110-213	TITLE 1 SALARIES FICA	1,347.60	112.30	0.00	0.00	565.37	782.23	58.05
I.M.R.F./Soc. Sec. Fund	50-2110-214	TITLE 1 SALARIES	593.28	49.42	0.00	0.00	248.60	344.68	10858.10
I.M.R.F./Soc. Sec. Fund	52113214	SOCIAL WORKER	3,761.52	259.82	0.00	0.00	1,897.37	1,864.15	49.56
I.M.R.F./Soc. Sec. Fund		50 E 2120 0000 00 000	0.00	0.00	0.00	0.00	0.00	0.00	0.00
I.M.R.F./Soc. Sec. Fund		50 E 2120 1100 00 300	0.00	0.00	0.00	0.00	0.00	0.00	0.00
I.M.R.F./Soc. Sec. Fund		50 E 2120 1100 00 300	0.00	0.00	0.00	0.00	0.00	0.00	0.00
I.M.R.F./Soc. Sec. Fund	50-2120-	GUIDANCE SALARY (RM)	0.00	0.00	0.00	0.00	0.00	0.00	0.00
I.M.R.F./Soc. Sec. Fund	50-2120-	GUIDANCE SALARY (FR)	0.00	0.00	0.00	0.00	0.00	0.00	0.00
I.M.R.F./Soc. Sec. Fund	52120214	GUIDANCE MEDICARE	8,103.60	560.34	0.00	0.00	3,835.00	4,268.60	52.68
I.M.R.F./Soc. Sec. Fund		50 E 2120 2140 00 300	0.00	56.34	0.00	0.00	-174.34	174.34	0.00
I.M.R.F./Soc. Sec. Fund	521252120	REGISTRAR IMRF	5,280.00	363.00	0.00	0.00	2,352.41	2,927.59	55.45
I.M.R.F./Soc. Sec. Fund	521252121	STDNT CENTER IMRF	4,841.04	202.00	0.00	0.00	2,187.23	2,653.81	54.82
I.M.R.F./Soc. Sec. Fund	521252122	ASST REGISTRAR IMRF	3,573.12	267.06	0.00	0.00	1,528.82	2,044.30	57.21
I.M.R.F./Soc. Sec. Fund	52125213	REGISTRAR FICA	2,865.60	199.84	0.00	0.00	1,267.76	1,597.84	55.76
I.M.R.F./Soc. Sec. Fund	521252131	STDNT CENTER FICA	2,900.88	136.56	0.00	0.00	1,237.27	1,663.61	57.35

## Expenditure Report

Fiscal Year: 2021-2022  
Month: January

COUNTY OF GRUNDY SCHOOL DIST 111

Fund Description	Account	Account Description	Revised Budget	Encumbrance	MTD Activity	Pending Activity	Available Funds	Year to Date Activity	Percent of Budget Used
I.M.R.F./Soc. Sec. Fund	521252132	ASST REGISTRAR FICA	2,161.44	167.24	0.00	0.00	919.21	1,242.23	57.47
I.M.R.F./Soc. Sec. Fund	52125214	CAREER CENTER	670.08	46.74	0.00	0.00	296.41	373.67	55.76
I.M.R.F./Soc. Sec. Fund		ACAD RESOURCE CTR	678.24	31.93	0.00	0.00	289.24	389.00	57.35
I.M.R.F./Soc. Sec. Fund		ASST REGISTRAR	505.44	39.12	0.00	0.00	214.89	290.55	57.48
I.M.R.F./Soc. Sec. Fund		50 E 2130 0000 00 000	0.00	0.00	0.00	0.00	0.00	0.00	0.00
I.M.R.F./Soc. Sec. Fund		50 E 2130 1100 00 300	0.00	0.00	0.00	0.00	0.00	0.00	0.00
I.M.R.F./Soc. Sec. Fund		50 E 2130 1100 00 300	0.00	0.00	0.00	0.00	0.00	0.00	0.00
I.M.R.F./Soc. Sec. Fund	52134212	NURSE IMRF	5,166.48	516.32	0.00	0.00	2,481.29	2,685.19	51.97
I.M.R.F./Soc. Sec. Fund	521342122	NURSE IMRF S.C.	3,642.48	437.43	0.00	0.00	1,399.25	2,243.23	61.59
I.M.R.F./Soc. Sec. Fund	52134213	NURSE FICA	4,206.48	323.38	0.00	0.00	2,526.11	1,680.37	39.95
I.M.R.F./Soc. Sec. Fund	521342132	NURSE FICA S.C.	2,203.44	273.96	0.00	0.00	837.12	1,366.32	10962.01
I.M.R.F./Soc. Sec. Fund	50-2134-	NURSE SALARY (MR)	983.52	75.61	0.00	0.00	590.62	392.90	39.95
I.M.R.F./Soc. Sec. Fund	50-2134-	NURSE SALARY S.C. (MR)	515.28	64.07	0.00	0.00	195.76	319.52	62.01
I.M.R.F./Soc. Sec. Fund		50 E 2140 0000 00 000	0.00	0.00	0.00	0.00	0.00	0.00	0.00
I.M.R.F./Soc. Sec. Fund		50 E 2140 1100 00 300	0.00	0.00	0.00	0.00	0.00	0.00	0.00
I.M.R.F./Soc. Sec. Fund		50 E 2140 1100 00 300	0.00	0.00	0.00	0.00	0.00	0.00	0.00
I.M.R.F./Soc. Sec. Fund	50-2140-214	PSYCHOLOGIST SALARY	2,807.04	179.57	0.00	0.00	1,504.48	1,302.56	46.40
I.M.R.F./Soc. Sec. Fund	50-2190-	CSBO SALARY IMRF	0.00	500.64	0.00	0.00	-1,484.00	1,484.00	0.00
I.M.R.F./Soc. Sec. Fund	50-2190-	CSBO SALARY FICA	3,593.04	306.08	0.00	0.00	2,153.62	1,439.42	40.06
I.M.R.F./Soc. Sec. Fund	52190214	BUSINESS MGR MEDICARE	840.48	71.59	0.00	0.00	339.38	501.10	59.62
I.M.R.F./Soc. Sec. Fund	50-2210-	PROF. DEVELOPMENT	0.00	0.00	0.00	0.00	0.00	0.00	0.00
I.M.R.F./Soc. Sec. Fund	50-2210-	DIR C/I SEC. SALARY IMRF	3,683.28	304.55	0.00	0.00	1,548.11	2,135.17	57.97
I.M.R.F./Soc. Sec. Fund	50-2210-	PROF. DEVELOPMENT	0.00	0.00	0.00	0.00	0.00	0.00	0.00
I.M.R.F./Soc. Sec. Fund	50-2210-	DIR C/I SEC. SALARY (FR)	2,085.84	178.75	0.00	0.00	861.23	1,224.61	58.71

## Expenditure Report

Fiscal Year: 2021-2022  
Month: January

COUNTY OF GRUNDY SCHOOL DIST 111

Fund Description	Account	Account Description	Revised Budget	Encumbrance	MTD Activity	Pending Activity	Available Funds	Year to Date Activity	Percent of Budget Used
I.M.R.F./Soc. Sec. Fund		50 E 2210 2140 00 000	0.00	0.00	0.00	0.00	-16.58	16.58	0.00
I.M.R.F./Soc. Sec. Fund	50-2210-	DIRECTOR C/I SALARY	1,692.00	140.84	0.00	0.00	540.69	1,151.31	68.04
I.M.R.F./Soc. Sec. Fund		DIRECTOR C/I SEC	487.92	41.81	0.00	0.00	201.49	286.43	58.70
I.M.R.F./Soc. Sec. Fund	52212214	CURR DEVLOP/LEARN OBJ	0.00	0.00	0.00	0.00	0.00	0.00	0.00
I.M.R.F./Soc. Sec. Fund	52213212	STAFF DEVELOPMENT	0.00	0.00	0.00	0.00	0.00	0.00	0.00
I.M.R.F./Soc. Sec. Fund	52213213	STAFF DEVELOPMENT	0.00	0.00	0.00	0.00	0.00	0.00	0.00
I.M.R.F./Soc. Sec. Fund	52213214	TYPE 75 MEDICARE	0.00	0.00	0.00	0.00	0.00	0.00	0.00
I.M.R.F./Soc. Sec. Fund	52222212	LIBRARY IMRF	5,334.96	406.44	0.00	0.00	2,319.40	3,015.56	56.52
I.M.R.F./Soc. Sec. Fund	522222122	LIBRARY IMRF S.C.	2,739.84	220.52	0.00	0.00	1,160.89	1,578.95	57.63
I.M.R.F./Soc. Sec. Fund	52222213	LIBRARY FICA	3,227.04	254.54	0.00	0.00	1,394.27	1,832.77	56.79
I.M.R.F./Soc. Sec. Fund	522222132	LIB ASST FICA S.C.	1,525.68	126.94	0.00	0.00	642.86	882.82	11057.86
I.M.R.F./Soc. Sec. Fund	52222214	LIBRARY MEDICARE	754.56	59.52	0.00	0.00	325.97	428.59	56.80
I.M.R.F./Soc. Sec. Fund		LIB ASST FICA	723.84	60.32	0.00	0.00	271.84	452.00	62.44
I.M.R.F./Soc. Sec. Fund	522222142	LIB ASST MEDICARE S.C.	356.88	29.68	0.00	0.00	150.41	206.47	57.85
I.M.R.F./Soc. Sec. Fund	52225212	TECH IMRF	9,433.20	759.26	0.00	0.00	3,957.34	5,475.86	58.05
I.M.R.F./Soc. Sec. Fund		LIB ASST IMRF	7,216.56	580.84	0.00	0.00	2,972.81	4,243.75	58.81
I.M.R.F./Soc. Sec. Fund	522252122	TECH IMRF S.C.	6,575.04	529.24	0.00	0.00	2,957.20	3,617.84	55.02
I.M.R.F./Soc. Sec. Fund	52225213	TECH FICA	5,452.08	454.22	0.00	0.00	1,643.64	3,808.44	69.85
I.M.R.F./Soc. Sec. Fund		LIB ASST FICA	4,223.04	348.68	0.00	0.00	1,729.79	2,493.25	59.04
I.M.R.F./Soc. Sec. Fund	522252132	TECH ASST FICA S.C.	3,959.52	291.58	0.00	0.00	1,808.53	2,150.99	54.32
I.M.R.F./Soc. Sec. Fund	52225214	TECH/CYBRARY AIDE	1,275.12	106.24	0.00	0.00	384.40	890.72	69.85
I.M.R.F./Soc. Sec. Fund		TECH ASST MEDICARE	987.60	81.54	0.00	0.00	404.52	583.08	59.04
I.M.R.F./Soc. Sec. Fund	50-2225-	TECH ASST SALARY S.C.	926.16	68.20	0.00	0.00	423.05	503.11	54.32
I.M.R.F./Soc. Sec. Fund	50-2300-212	TEST PROCTOR IMRF	0.00	0.00	0.00	0.00	0.00	0.00	0.00

## Expenditure Report

Fiscal Year: 2021-2022  
Month: January

COUNTY OF GRUNDY SCHOOL DIST 111

Fund Description	Account	Account Description	Revised Budget	Encumbrance	MTD Activity	Pending Activity	Available Funds	Year to Date Activity	Percent of Budget Used
I.M.R.F./Soc. Sec. Fund	50-2300-213	TEST PROCTOR FICA	0.00	0.00	0.00	0.00	0.00	0.00	0.00
I.M.R.F./Soc. Sec. Fund	50-2300-214	TEST PROCTOR	0.00	0.00	0.00	0.00	0.00	0.00	0.00
I.M.R.F./Soc. Sec. Fund	52310213	BOARD OF ED FICA	0.00	0.00	0.00	0.00	0.00	0.00	0.00
I.M.R.F./Soc. Sec. Fund	52310214	BOARD OF ED MEDICARE	0.00	0.00	0.00	0.00	0.00	0.00	0.00
I.M.R.F./Soc. Sec. Fund	52312212	BOARD SECY IMRF	0.00	0.00	0.00	0.00	0.00	0.00	0.00
I.M.R.F./Soc. Sec. Fund	52312213	BOARD SECY FICA	0.00	0.00	0.00	0.00	0.00	0.00	0.00
I.M.R.F./Soc. Sec. Fund	52313214	PERFORMANCE	0.00	0.00	0.00	0.00	0.00	0.00	0.00
I.M.R.F./Soc. Sec. Fund	52321212	SUPT SECY IMRF	5,305.92	427.06	0.00	0.00	2,340.78	2,965.14	55.88
I.M.R.F./Soc. Sec. Fund	52321213	SUPT SECY FICA	2,769.84	230.68	0.00	0.00	1,173.06	1,596.78	57.65
I.M.R.F./Soc. Sec. Fund	52321214	SUPT SECY MEDICARE	647.76	53.94	0.00	0.00	274.33	373.43	57.65
I.M.R.F./Soc. Sec. Fund		SUPT MEDICARE	2,921.04	190.50	0.00	0.00	1,267.42	1,653.62	1156.61
I.M.R.F./Soc. Sec. Fund	52367212	CAMPUS MONITOR IMRF	20,505.36	0.00	0.00	0.00	15,078.96	5,426.40	26.46
I.M.R.F./Soc. Sec. Fund		NURSE IMRF	463.68	0.00	0.00	0.00	382.76	80.92	17.45
I.M.R.F./Soc. Sec. Fund		DEANS SECY IMRF	1,269.60	0.00	0.00	0.00	958.60	311.00	24.50
I.M.R.F./Soc. Sec. Fund	52367213	CAMPUS MONITOR FICA	10,922.88	0.00	0.00	0.00	8,005.24	2,917.64	26.71
I.M.R.F./Soc. Sec. Fund		NURSE FICE	280.32	0.00	0.00	0.00	231.40	48.92	17.45
I.M.R.F./Soc. Sec. Fund		DEANS SECY FICA	651.12	0.00	0.00	0.00	496.97	154.15	23.67
I.M.R.F./Soc. Sec. Fund	52367214	CAMPUS MONITOR	2,554.32	0.00	0.00	0.00	1,871.97	682.35	26.71
I.M.R.F./Soc. Sec. Fund		NURSE MEDICARE	65.76	0.00	0.00	0.00	54.30	11.46	17.43
I.M.R.F./Soc. Sec. Fund		DEANS SECY MEDICARE	743.28	0.00	0.00	0.00	568.64	174.64	23.50
I.M.R.F./Soc. Sec. Fund	52410212	PRINCIPAL SECY IMRF	4,161.36	334.94	0.00	0.00	1,745.74	2,415.62	58.05
I.M.R.F./Soc. Sec. Fund		AP SECY IMRF	5,666.40	456.08	0.00	0.00	2,377.12	3,289.28	58.05
I.M.R.F./Soc. Sec. Fund	52140213	PRINCIPAL SECY FICA	2,406.00	200.44	0.00	0.00	1,002.45	1,403.55	58.34
I.M.R.F./Soc. Sec. Fund		AP SECY FICA	3,280.80	273.34	0.00	0.00	1,367.06	1,913.74	58.33

## Expenditure Report

Fiscal Year: 2021-2022  
Month: January

COUNTY OF GRUNDY SCHOOL DIST 111

Fund Description	Account	Account Description	Revised Budget	Encumbrance	MTD Activity	Pending Activity	Available Funds	Year to Date Activity	Percent of Budget Used
I.M.R.F./Soc. Sec. Fund	52410214	PRINCIPAL SECY	562.56	46.88	0.00	0.00	234.30	328.26	58.35
I.M.R.F./Soc. Sec. Fund		PRINCIPAL MEDICARE	1,992.48	166.04	0.00	0.00	828.59	1,163.89	58.41
I.M.R.F./Soc. Sec. Fund		AP SECY MEDICARE	767.28	63.92	0.00	0.00	319.72	447.56	58.33
I.M.R.F./Soc. Sec. Fund		ASST PRINCIPAL	1,695.60	141.30	0.00	0.00	700.54	995.06	58.68
I.M.R.F./Soc. Sec. Fund		DEANS MEDICARE	4,140.48	343.97	0.00	0.00	1,784.23	2,356.25	56.91
I.M.R.F./Soc. Sec. Fund	524102142	PRINCIPAL MEDICARE S.C.	1,522.56	126.88	0.00	0.00	633.97	888.59	58.36
I.M.R.F./Soc. Sec. Fund	52490212	DEANS SECY IMRF	6,355.68	525.98	0.00	0.00	2,641.40	3,714.28	58.44
I.M.R.F./Soc. Sec. Fund	52490213	DEANS SECY FICA	3,320.40	285.59	0.00	0.00	1,381.41	1,938.99	58.40
I.M.R.F./Soc. Sec. Fund	52490214	DEANS OFFICE MEDICARE	776.40	66.77	0.00	0.00	323.00	453.40	58.40
I.M.R.F./Soc. Sec. Fund	50-2510-	CSBO SALARY IMRF	0.00	1,001.42	0.00	0.00	-2,968.48	2,968.48	0.00
I.M.R.F./Soc. Sec. Fund	50-2510-	CSBO SALARY FICA	7,187.28	612.23	0.00	0.00	4,308.06	2,879.22	11240.06
I.M.R.F./Soc. Sec. Fund	52510214	CSBO MEDICARE	1,680.72	143.18	0.00	0.00	678.62	1,002.10	59.62
I.M.R.F./Soc. Sec. Fund	52525212	BOOKKEEPER IMRF	20,128.56	1,392.41	0.00	0.00	9,888.49	10,240.07	50.87
I.M.R.F./Soc. Sec. Fund	52525213	BOOKKEEPER FICA	11,949.12	848.25	0.00	0.00	5,863.91	6,085.21	50.93
I.M.R.F./Soc. Sec. Fund		BOOKKEEPER MEDICARE	2,794.56	198.37	0.00	0.00	1,371.41	1,423.15	50.93
I.M.R.F./Soc. Sec. Fund	52540212	CUSTODIAN IMRF	2,405.28	125.57	0.00	0.00	1,628.37	776.91	32.30
I.M.R.F./Soc. Sec. Fund		CUSTODIAN IMRF	56,540.88	4,827.66	0.00	0.00	22,640.29	33,900.59	59.96
I.M.R.F./Soc. Sec. Fund	525402122	CUSTODIAN IMRF S.C.	0.00	0.00	0.00	0.00	0.00	0.00	0.00
I.M.R.F./Soc. Sec. Fund	52540213	CUSTODIAN FICA	1,454.64	78.63	0.00	0.00	982.05	472.59	32.49
I.M.R.F./Soc. Sec. Fund		CUSTODIAN FICA	35,878.32	3,054.73	0.00	0.00	14,596.07	21,282.25	59.32
I.M.R.F./Soc. Sec. Fund	525402132	CUSTODIAN FICA S.C.	1,933.92	0.00	0.00	0.00	1,598.64	335.28	17.34
I.M.R.F./Soc. Sec. Fund	50-2540-	CUSTODIANS SALARY	340.32	18.39	0.00	0.00	229.79	110.53	32.48
I.M.R.F./Soc. Sec. Fund		CUSTODIANS MEDICARE	8,390.88	690.21	0.00	0.00	3,458.36	4,932.52	58.78
I.M.R.F./Soc. Sec. Fund		50 E 2540 2140 00 302	452.16	0.00	0.00	0.00	373.75	78.41	17.34

## Expenditure Report

Fiscal Year: 2021-2022  
Month: January

COUNTY OF GRUNDY SCHOOL DIST 111

Fund Description	Account	Account Description	Revised Budget	Encumbrance	MTD Activity	Pending Activity	Available Funds	Year to Date Activity	Percent of Budget Used
I.M.R.F./Soc. Sec. Fund	52541212	SUMMER CUSTODIAN	0.00	0.00	0.00	0.00	0.00	0.00	0.00
I.M.R.F./Soc. Sec. Fund	52541213	SUMMER CUSTODIAN FICA	0.00	0.00	0.00	0.00	-538.97	538.97	0.00
I.M.R.F./Soc. Sec. Fund		SUMMER CUSTODIAN	0.00	0.00	0.00	0.00	-126.04	126.04	0.00
I.M.R.F./Soc. Sec. Fund	52550212	TRANS SECY IMRF	11,863.44	218.28	0.00	0.00	8,887.56	2,975.88	25.08
I.M.R.F./Soc. Sec. Fund		50 E 2550 2120 00 300	0.00	146.71	0.00	0.00	-1,939.91	1,939.91	0.00
I.M.R.F./Soc. Sec. Fund		BUS DRIVER OOD ROUTE	51,182.88	3,979.72	0.00	0.00	20,645.34	30,537.54	59.66
I.M.R.F./Soc. Sec. Fund		BUS DRIVER REG ROUTE	48,605.04	4,275.98	0.00	0.00	19,021.24	29,583.80	60.87
I.M.R.F./Soc. Sec. Fund		BOOKKEEPER IMRF	678.00	54.58	0.00	0.00	284.42	393.58	58.05
I.M.R.F./Soc. Sec. Fund		BUS AID OOD IMRF	3,065.04	470.73	0.00	0.00	216.70	2,848.34	92.93
I.M.R.F./Soc. Sec. Fund		FULL TIME DRIVER IMRF	3,420.96	571.06	0.00	0.00	-393.36	3,814.32	111.50
I.M.R.F./Soc. Sec. Fund	52550213	TRANS SECY FICA	7,139.52	133.58	0.00	0.00	5,333.42	1,806.10	11325.30
I.M.R.F./Soc. Sec. Fund		50 E 2550 2130 00 300	0.00	106.97	0.00	0.00	-1,229.30	1,229.30	0.00
I.M.R.F./Soc. Sec. Fund		BUS DRIVER OOD ROUTE	31,099.92	2,554.26	0.00	0.00	12,107.51	18,992.41	61.07
I.M.R.F./Soc. Sec. Fund		BUS DRIVER REG ROUTE	36,584.16	2,931.00	0.00	0.00	16,607.40	19,976.76	54.60
I.M.R.F./Soc. Sec. Fund		BOOKKEEPER FICA	387.84	31.78	0.00	0.00	162.14	225.70	58.19
I.M.R.F./Soc. Sec. Fund		BUS AID OOD FICA	2,763.36	314.45	0.00	0.00	368.14	2,395.22	86.68
I.M.R.F./Soc. Sec. Fund		FULL TIME DRIVER FICA	1,998.00	347.99	0.00	0.00	-265.28	2,263.28	113.28
I.M.R.F./Soc. Sec. Fund		TRANS SECY MEDICARE	1,669.92	31.24	0.00	0.00	1,247.74	422.18	25.28
I.M.R.F./Soc. Sec. Fund		50 E 2550 2140 00 300	0.00	25.03	0.00	0.00	-287.54	287.54	0.00
I.M.R.F./Soc. Sec. Fund		BUS DRIVER OOD ROUTE	7,272.72	597.34	0.00	0.00	2,831.06	4,441.66	61.07
I.M.R.F./Soc. Sec. Fund		BUS DRIVER REG ROUTE	8,556.72	685.56	0.00	0.00	3,884.56	4,672.16	54.60
I.M.R.F./Soc. Sec. Fund		BOOKKEEPER MEDICARE	90.72	7.44	0.00	0.00	37.92	52.80	58.20
I.M.R.F./Soc. Sec. Fund		BUS AID OOD MEDICARE	646.08	73.56	0.00	0.00	85.90	560.18	86.70
I.M.R.F./Soc. Sec. Fund		FULL TIME DRIVER	467.28	81.38	0.00	0.00	-62.02	529.30	113.27

## Expenditure Report

Fiscal Year: 2021-2022  
Month: January

COUNTY OF GRUNDY SCHOOL DIST 111

Fund Description	Account	Account Description	Revised Budget	Encumbrance	MTD Activity	Pending Activity	Available Funds	Year to Date Activity	Percent of Budget Used
I.M.R.F./Soc. Sec. Fund	52554212	BUS MECHANIC IMRF	11,887.68	982.58	0.00	0.00	6,043.94	5,843.74	49.16
I.M.R.F./Soc. Sec. Fund		TRANS DIRECTORS IMRF	7,688.88	-342.25	0.00	0.00	6,063.16	1,625.72	21.14
I.M.R.F./Soc. Sec. Fund	52554213	BUS MECHANIC FICA	6,750.72	801.73	0.00	0.00	3,011.63	3,739.09	55.39
I.M.R.F./Soc. Sec. Fund		TRANS DIRECTORS FICA	4,577.04	-190.77	0.00	0.00	3,729.66	847.38	18.51
I.M.R.F./Soc. Sec. Fund		BUS MECHANIC MEDICARE	1,578.72	15.84	0.00	0.00	949.59	629.13	39.85
I.M.R.F./Soc. Sec. Fund		TRANS DIRECTORS	1,070.40	-44.62	0.00	0.00	707.14	363.26	33.94
I.M.R.F./Soc. Sec. Fund	52632212	INTERNAL INFO IMRF	2,851.92	233.70	0.00	0.00	1,211.18	1,640.74	57.53
I.M.R.F./Soc. Sec. Fund	52632213	INTERNAL INFO FICA	1,523.76	129.50	0.00	0.00	643.79	879.97	57.75
I.M.R.F./Soc. Sec. Fund	52632214	INTERNAL INFO MEDICARE	356.40	30.30	0.00	0.00	150.56	205.84	57.76
I.M.R.F./Soc. Sec. Fund	52633212	PUBLIC INFO IMRF	7,350.96	653.14	0.00	0.00	2,810.30	4,540.66	61.77
I.M.R.F./Soc. Sec. Fund	52633213	PUBLIC INFO FICA	4,446.48	398.81	0.00	0.00	1,696.17	2,750.31	11461.85
I.M.R.F./Soc. Sec. Fund		PUBLIC INFO MEDICARE	1,039.92	93.27	0.00	0.00	396.69	643.23	61.85
I.M.R.F./Soc. Sec. Fund	53200212	WELLNESS CENTER IMRF	0.00	0.00	0.00	0.00	0.00	0.00	0.00
I.M.R.F./Soc. Sec. Fund	53200213	WELLNESS CENTER	0.00	0.00	0.00	0.00	0.00	0.00	0.00
I.M.R.F./Soc. Sec. Fund	532002131	WELLNESS CENTER	0.00	0.00	0.00	0.00	0.00	0.00	0.00
I.M.R.F./Soc. Sec. Fund	53200214	WELLNESS CENTER	0.00	0.00	0.00	0.00	0.00	0.00	0.00
I.M.R.F./Soc. Sec. Fund	50-4100-	TITLE I SALARY (RM)	0.00	0.00	0.00	0.00	0.00	0.00	0.00
I.M.R.F./Soc. Sec. Fund	50-4100-	TITLE I SALARY (FR)	0.00	0.00	0.00	0.00	0.00	0.00	0.00
I.M.R.F./Soc. Sec. Fund	54120214	SPEC ED HB MEDICARE	0.00	0.00	0.00	0.00	0.00	0.00	0.00
I.M.R.F./Soc. Sec. Fund	50-481-212-	IMRF (RM)	0.00	0.00	0.00	0.00	0.00	0.00	0.00
I.M.R.F./Soc. Sec. Fund	50-481-212-	IMRF (RM)	0.00	0.00	0.00	0.00	0.00	0.00	0.00
I.M.R.F./Soc. Sec. Fund	50-481-213-	IMRF (FR)	0.00	0.00	0.00	0.00	0.00	0.00	0.00
I.M.R.F./Soc. Sec. Fund	50-481-213-	IMRF (FR)	0.00	0.00	0.00	0.00	0.00	0.00	0.00
<b>50 - -----</b>			<b>925,096.56</b>	<b>74,398.17</b>	<b>0.00</b>	<b>0.00</b>	<b>398,859.59</b>	<b>526,236.97</b>	

## Expenditure Report

Fiscal Year: 2021-2022  
Month: January

COUNTY OF GRUNDY SCHOOL DIST 111

Fund Description	Account	Account Description	Revised Budget	Encumbrance	MTD Activity	Pending Activity	Available Funds	Year to Date Activity	Percent of Budget Used
<b>5- - - - -</b>			<b>925,096.56</b>	<b>74,398.17</b>	<b>0.00</b>	<b>0.00</b>	<b>398,859.59</b>	<b>526,236.97</b>	
Capital Projects Fund or	62530500	FAC ACQ & CONSTR SERV	0.00	0.00	0.00	0.00	0.00	0.00	0.00
Capital Projects Fund or	62530501	FAC ACQ & CONSTR SERV	0.00	0.00	0.00	0.00	0.00	0.00	0.00
Capital Projects Fund or	62532390	REIMB EXPENSES	0.00	0.00	0.00	0.00	0.00	0.00	0.00
Capital Projects Fund or	62532520	TRANS BULDING	0.00	0.00	0.00	0.00	-25,000.00	25,000.00	0.00
Capital Projects Fund or	62532530	SIGNALIZATION	0.00	0.00	0.00	0.00	0.00	0.00	0.00
Capital Projects Fund or	62533316	A & E FEES/ 2011	0.00	0.00	0.00	0.00	0.00	0.00	0.00
Capital Projects Fund or	62533314	TCC CONST FEES	0.00	0.00	0.00	0.00	0.00	0.00	0.00
Capital Projects Fund or	62533310	A & E FEES/PROJECT 2279	0.00	0.00	0.00	0.00	0.00	0.00	0.00
Capital Projects Fund or	62533311	A & E FEES/PROJECT 2299	0.00	0.00	0.00	0.00	0.00	0.00	0.00
Capital Projects Fund or	62533312	A & E FEES/PROJECT 2386	0.00	0.00	0.00	0.00	0.00	0.00	115 0.00
Capital Projects Fund or	62533313	A & E FEES/PROJECT 6003	0.00	0.00	0.00	0.00	0.00	0.00	0.00
Capital Projects Fund or	62533315	A & E FEES/2009	0.00	0.00	0.00	0.00	0.00	0.00	0.00
Capital Projects Fund or	62533320	A & E FEES/PROJECT	0.00	0.00	0.00	0.00	0.00	0.00	0.00
Capital Projects Fund or	62533318	LEGAL SERVICES	0.00	0.00	0.00	0.00	0.00	0.00	0.00
Capital Projects Fund or	62533319	PROF TECH SERV	0.00	0.00	0.00	0.00	0.00	0.00	0.00
Capital Projects Fund or	62533390	OTHER PUR SERV-STRC	0.00	0.00	0.00	0.00	-2,841.00	2,841.00	0.00
Capital Projects Fund or	62533391	OTHER PUR SERV-STRC	0.00	0.00	0.00	0.00	0.00	0.00	0.00
Capital Projects Fund or	62535315	BLDRS RISK COVERAGE	0.00	0.00	0.00	0.00	0.00	0.00	0.00
Capital Projects Fund or	62535325	CAPITAL IMPROVEMENT	5,000,000.00	0.00	35,723.58	0.00	4,771,933.64	192,342.78	3.85
Capital Projects Fund or	62535323	BLEACHER REPAIR &	0.00	0.00	0.00	0.00	0.00	0.00	0.00
Capital Projects Fund or	62535324	CENTRAL PAC	0.00	0.00	0.00	0.00	0.00	0.00	0.00
Capital Projects Fund or	62535523	BLEACHER CAPITAL	0.00	0.00	0.00	0.00	0.00	0.00	0.00
Capital Projects Fund or	62535525	CAPITAL IMPROVEMENTS	0.00	0.00	0.00	0.00	-14,627.66	14,627.66	0.00

## Expenditure Report

Fiscal Year: 2021-2022  
Month: January

COUNTY OF GRUNDY SCHOOL DIST 111

Fund Description	Account	Account Description	Revised Budget	Encumbrance	MTD Activity	Pending Activity	Available Funds	Year to Date Activity	Percent of Budget Used
Capital Projects Fund or	62535554	CONTINGENCY COSTS	0.00	0.00	0.00	0.00	0.00	0.00	0.00
Capital Projects Fund or	62535555	CONSTR COSTS #6003	0.00	0.00	0.00	0.00	0.00	0.00	0.00
Capital Projects Fund or	62535559	CONSTRUCTION COST	0.00	0.00	0.00	0.00	0.00	0.00	0.00
Capital Projects Fund or	62535558	TRANSPORTATION COST	0.00	0.00	0.00	0.00	0.00	0.00	0.00
Capital Projects Fund or	62535558	CONSTRUCTION COST	0.00	0.00	0.00	0.00	0.00	0.00	0.00
Capital Projects Fund or	62535550	CONSTR COSTS #2279	0.00	0.00	0.00	0.00	0.00	0.00	0.00
Capital Projects Fund or	62535551	CONSTR COSTS #2299	0.00	0.00	0.00	0.00	0.00	0.00	0.00
Capital Projects Fund or	62535552	CONTINGENCY COSTS	0.00	0.00	0.00	0.00	0.00	0.00	0.00
Capital Projects Fund or	62535553	CONTINGENCY COSTS	0.00	0.00	0.00	0.00	0.00	0.00	0.00
Capital Projects Fund or	62535556	FF & E COSTS #6003	0.00	0.00	0.00	0.00	0.00	0.00	0.00
Capital Projects Fund or	62535557	CONSTR COSTS/2009	0.00	0.00	0.00	0.00	0.00	0.00	116 0.00
Capital Projects Fund or	68140	TRANS OF INTEREST	0.00	0.00	0.00	0.00	0.00	0.00	0.00
Capital Projects Fund or	68180611	PERM TRANS FROM W/C	0.00	0.00	0.00	0.00	0.00	0.00	0.00
<b>60 - -----</b>			<b>5,000,000.00</b>	<b>0.00</b>	<b>35,723.58</b>	<b>0.00</b>	<b>4,729,464.98</b>	<b>234,811.44</b>	
<b>6- - -----</b>			<b>5,000,000.00</b>	<b>0.00</b>	<b>35,723.58</b>	<b>0.00</b>	<b>4,729,464.98</b>	<b>234,811.44</b>	
Working Cash Fund	78180611	PERM TRANS FROM W/C	0.00	0.00	0.00	0.00	0.00	0.00	0.00
Working Cash Fund	78180710	PERM TRANS OF W/C-	0.00	0.00	0.00	0.00	0.00	0.00	0.00
Working Cash Fund	78990	OTHER USES NOT	0.00	0.00	0.00	0.00	0.00	0.00	0.00
<b>70 - -----</b>			<b>0.00</b>	<b>0.00</b>	<b>0.00</b>	<b>0.00</b>	<b>0.00</b>	<b>0.00</b>	
<b>7- - -----</b>			<b>0.00</b>	<b>0.00</b>	<b>0.00</b>	<b>0.00</b>	<b>0.00</b>	<b>0.00</b>	
Tort Immunity and	81130100	CAMPUS MONITOR	50,000.00	17,301.60	0.00	0.00	-73,883.82	123,883.82	247.77
Tort Immunity and	81130101	NURSE SALARY	45,000.00	414.67	0.00	0.00	42,544.43	2,455.57	5.46
Tort Immunity and	81130102	DEANS SALARY	50,000.00	4,738.18	0.00	0.00	17,815.20	32,184.80	64.37
Tort Immunity and		80 E 1130 2110 00 300	0.00	440.20	0.00	0.00	-1,768.19	1,768.19	0.00

## Expenditure Report

Fiscal Year: 2021-2022  
Month: January

COUNTY OF GRUNDY SCHOOL DIST 111

Fund Description	Account	Account Description	Revised Budget	Encumbrance	MTD Activity	Pending Activity	Available Funds	Year to Date Activity	Percent of Budget Used
Tort Immunity and		DIST 111 GROUP MEDICAL	24,000.00	0.00	0.00	0.00	-15,070.60	39,070.60	162.79
Tort Immunity and		80 E 1130 2220 00 300	0.00	7,339.58	0.00	0.00	-29,294.42	29,294.42	0.00
Tort Immunity and		80 E 1130 2220 00 300	0.00	0.44	0.00	0.00	-1.75	1.75	0.00
Tort Immunity and		80 E 1130 2220 00 300	0.00	1,600.34	0.00	0.00	-6,401.35	6,401.35	0.00
Tort Immunity and		DIST 111 GROUP DENTAL	27,043.44	14,440.77	0.00	0.00	11,207.63	15,835.81	58.56
Tort Immunity and		80 E 1130 2230 00 300	0.00	28.92	0.00	0.00	-113.46	113.46	0.00
Tort Immunity and		80 E 2110 0000 00 000	0.00	0.00	0.00	0.00	0.00	0.00	0.00
Tort Immunity and		80 E 2220 0000 00 000	0.00	0.00	0.00	0.00	0.00	0.00	0.00
Tort Immunity and	82310200	BOARD OF ED-OTHER	1,780.58	0.00	0.00	0.00	1,780.58	0.00	0.00
Tort Immunity and	82310318	ATTORNEY FEES	20,000.00	9,382.50	0.00	112.50	-73,408.06	93,295.56	466.48
Tort Immunity and	82362381	WORK COMP PREMIUMS	31,000.00	15,494.00	0.00	15,494.00	-77,458.00	92,964.00	11799.88
Tort Immunity and	82363380	UNEMPLOYMENT INS	0.00	0.00	0.00	0.00	0.00	0.00	0.00
Tort Immunity and	82364382	PROPERTY INLAND	62,000.00	0.00	0.00	0.00	62,000.00	0.00	0.00
Tort Immunity and	82364383	GEN LIABILITY INS	180,000.00	234,304.00	0.00	0.00	-54,304.00	234,304.00	130.17
Tort Immunity and	82364384	SLEO/SMM	0.00	0.00	0.00	0.00	0.00	0.00	0.00
Tort Immunity and	82364385	UMBRELLA	0.00	0.00	0.00	0.00	0.00	0.00	0.00
Tort Immunity and	82364386	STUDENT CATASTROPHIC	195,522.00	0.00	0.00	0.00	192,422.00	3,100.00	1.59
Tort Immunity and	82365395	SAFETY/INSURANCE	0.00	15,960.00	0.00	422.00	-16,382.00	15,960.00	0.00
Tort Immunity and	82365390	EVENT SECURITY P.S.	15,000.00	462.62	0.00	2,643.31	-1,197.84	13,554.53	90.36
Tort Immunity and	82365391	SRO	2,834.67	0.00	0.00	0.00	0.00	2,834.67	100.00
Tort Immunity and	82365393	BUILD REPAIR MAINT/FIRE	16,500.00	4,669.20	0.00	402.00	-3,316.35	19,414.35	117.66
Tort Immunity and	82365394	BUILD REPAIR/COMM	15,000.00	0.00	0.00	0.00	15,000.00	0.00	0.00
Tort Immunity and	823653922	SRO - S.C.	95,000.00	4,787.10	0.00	11,019.21	36,785.83	47,194.96	49.68
Tort Immunity and	82367110	CAMPUS MONITOR SUB	250,000.00	0.00	0.00	0.00	249,913.00	87.00	0.03

## Expenditure Report

Fiscal Year: 2021-2022  
Month: January

COUNTY OF GRUNDY SCHOOL DIST 111

Fund Description	Account	Account Description	Revised Budget	Encumbrance	MTD Activity	Pending Activity	Available Funds	Year to Date Activity	Percent of Budget Used
Tort Immunity and	82367130	CAMPUS MON. EXTRA	4,000.00	0.00	0.00	0.00	4,000.00	0.00	0.00
Tort Immunity and	82367211	DEANS TRS	60,000.00	0.00	0.00	0.00	60,000.00	0.00	0.00
Tort Immunity and		DEANS TRS	1,037.52	0.00	0.00	0.00	-220.10	1,257.62	121.21
Tort Immunity and	80-2367-	DEANS SALARY (BCE-P)	18,715.76	0.00	0.00	0.00	-3,669.79	22,385.55	119.61
Tort Immunity and		80 E 2367 2220 00 300	0.22	0.00	0.00	0.00	-0.71	0.93	422.73
Tort Immunity and		DEANS INS	5,500.00	0.00	0.00	0.00	386.11	5,113.89	92.98
Tort Immunity and		DEANS DENTAL	80,000.00	0.00	0.00	0.00	79,905.38	94.62	0.12
Tort Immunity and	82542301	BUILDING SECURITY	0.00	0.00	0.00	0.00	0.00	0.00	0.00
Tort Immunity and	82542320	BUILDING INSPECTIONS	0.00	8,295.00	0.00	0.00	-8,795.00	8,795.00	0.00
Tort Immunity and	82546410	SECURITY SUPPLIES	27,000.00	0.00	0.00	0.00	-14,356.49	41,356.49	153.17
Tort Immunity and	825464102	SECURITY SUPPLIES	25,000.00	0.00	0.00	0.00	25,000.00	0.00	118 0.00
Tort Immunity and	82546540	SECURITY EQUIPMENT	5,000.00	54,508.28	0.00	0.00	-67,512.82	72,512.82	1,450.26
Tort Immunity and	825465402	SECURITY EQUIPMENT	15,000.00	0.00	0.00	0.00	15,000.00	0.00	0.00
<b>80 - -----</b>			<b>1,321,934.19</b>	<b>394,167.40</b>	<b>0.00</b>	<b>30,093.02</b>	<b>366,605.41</b>	<b>925,235.76</b>	
<b>8- - -----</b>			<b>1,321,934.19</b>	<b>394,167.40</b>	<b>0.00</b>	<b>30,093.02</b>	<b>366,605.41</b>	<b>925,235.76</b>	
Fire Prevention & Safety	92542310	LIFE SAFETY A & E	0.00	0.00	0.00	0.00	0.00	0.00	0.00
Fire Prevention & Safety	92542311	SAFETY CONSULTATION	0.00	0.00	0.00	0.00	0.00	0.00	0.00
Fire Prevention & Safety	92542312	GAVC PROJECT	0.00	0.00	0.00	0.00	0.00	0.00	0.00
Fire Prevention & Safety	92542530	LIFE SAFETY REPAIRS	2,000,000.00	0.00	0.00	0.00	2,000,000.00	0.00	0.00
Fire Prevention & Safety	92542531	LIFE SAFETY - ROOFING	0.00	0.00	0.00	0.00	0.00	0.00	0.00
<b>90 - -----</b>			<b>2,000,000.00</b>	<b>0.00</b>	<b>0.00</b>	<b>0.00</b>	<b>2,000,000.00</b>	<b>0.00</b>	
<b>9- - -----</b>			<b>2,000,000.00</b>	<b>0.00</b>	<b>0.00</b>	<b>0.00</b>	<b>2,000,000.00</b>	<b>0.00</b>	
<b>Account Monthly Activity Grand Totals:</b>			<b>62,147,469.11</b>	<b>4,030,618.53</b>	<b>305,679.51</b>	<b>490,833.51</b>	<b>27,828,028.74</b>	<b>33,522,927.35</b>	



# Revenue Report

Fiscal Year: 2021-2022  
Month: January

COUNTY OF GRUNDY SCHOOL DIST 111

Fund Description	Account Number	Account Description	Revised Budget	Monthly Activity	Pending Activity	Available Funds	Year to Date Activity	Percent of Budget Used
Education Fund	10 R 1110 0000 00 000 000000	PRIOR YEAR TAXES	0.00	0.00		0.00	0.00	0.00
Education Fund	10 R 1111 0000 00 000 000000	GRUNDY CO TAXES	7,292,016.00	0.00	0.00	170,727.08	7,121,288.92	97.66
Education Fund	10 R 1112 0000 00 000 000000	KENDALL CO TAXES	1,031,061.24	0.00	0.00	12,124.39	1,018,936.85	98.82
Education Fund	10 R 1113 0000 00 000 000000	WILL CO TAXES	5,698,988.00	49,505.03	0.00	-34,463.31	5,733,451.31	100.60
Education Fund	10 R 1114 0000 00 000 000000	GRUNDY CO EDPA SURPLUS	0.00	672,615.32	0.00	-672,615.32	672,615.32	0.00
Education Fund	10 R 1122 0000 00 000 000000	KENDALL CO - EARLY DISTR	1,153,484.00	0.00		1,153,484.00	0.00	0.00
Education Fund	10 R 1123 0000 00 000 000000	WILL CO - EARLY DISTR	5,570,354.00	0.00		5,570,354.00	0.00	0.00
Education Fund	10 R 1210 0000 00 000 000000	MOBILE HOME TAX	0.00	0.00		0.00	0.00	0.00
Education Fund	10 R 1211 0000 00 000 000000	MOBILE HOME TAX SPECIAL ED	0.00	0.00		0.00	0.00	0.00
Education Fund	10 R 1211 0000 00 000 000001	GRUNDY CO TORT	0.00	0.00		0.00	0.00	0.00
Education Fund	10 R 1212 0000 00 000 000000	MOBILE HOME TAX - LEASE	0.00	0.00		0.00	0.00	0.00
Education Fund	10 R 1212 0000 00 000 000001	KENDALL CO TORT	0.00	0.00		0.00	0.00	120 0.00
Education Fund	10 R 1213 0000 00 000 000000	WILL CO TORT	0.00	0.00		0.00	0.00	0.00
Education Fund	10 R 1222 0000 00 000 000000	KENDALL CO TORT-EARLY DISTR	0.00	0.00		0.00	0.00	0.00
Education Fund	10 R 1223 0000 00 000 000000	WILL CO TORT-EARLY DISTR	0.00	0.00		0.00	0.00	0.00
Education Fund	10 R 1230 0000 00 000 000000	CPPRT	567,435.00	128,756.16	0.00	129,458.12	437,976.88	77.19
Education Fund	10 R 1290 0000 00 000 000000	PAYMENTS IN LIEU OF TAXES	0.00	0.00		0.00	0.00	0.00
Education Fund	10 R 1291 0000 00 000 000000	LAG FEES	0.00	0.00		0.00	0.00	0.00
Education Fund	10 R 1292 0000 00 000 000000	PAYMENT IN LIEU OF TAXES SP ED	0.00	0.00		0.00	0.00	0.00
Education Fund	10 R 1293 0000 00 000 000000	PAYMENT IN LIEU OF TAXES LEASE	0.00	0.00		0.00	0.00	0.00
Education Fund	10 R 1311 0000 00 000 000000	NON-RESIDENT TUITION	12,000.00	0.00		12,000.00	0.00	0.00
Education Fund	10 R 1311 0000 00 000 000001	GRUNDY CO LEASE	187,261.00	0.00	0.00	4,386.87	182,874.13	97.66
Education Fund	10 R 1312 0000 00 000 000000	KENDALL CO LEASE	27,692.43	0.00	0.00	598.72	27,093.71	97.84
Education Fund	10 R 1313 0000 00 000 000000	WILL CO LEASE	147,931.00	1,261.97	0.00	1,774.99	146,156.01	98.80
Education Fund	10 R 1314 0000 00 000 000000	GRUNDY CO LEASE EDPA SURPLUS	0.00	0.00		0.00	0.00	0.00
Education Fund	10 R 1321 0000 00 000 000000	TOTAL SUMMER SCHOOL TUITION	0.00	0.00		0.00	0.00	0.00

# Revenue Report

Fiscal Year: 2021-2022  
Month: January

COUNTY OF GRUNDY SCHOOL DIST 111

Fund Description	Account Number	Account Description	Revised Budget	Monthly Activity	Pending Activity	Available Funds	Year to Date Activity	Percent of Budget Used
Education Fund	10 R 1322 0000 00 000 000000	KENDALL CO LEASE-EARLY DISTR	0.00	0.00		0.00	0.00	0.00
Education Fund	10 R 1323 0000 00 000 000000	WILL CO LEASE-EARLY DISTR	141,997.00	0.00		141,997.00	0.00	0.00
Education Fund	10 R 1411 0000 00 000 000000	GRUNDY CO SPEC ED	119,541.00	0.00	0.00	2,798.55	116,742.45	97.66
Education Fund	10 R 1411 0000 00 000 000001	GRUNDY CO SPEC ED TIF	0.00	0.00		0.00	0.00	0.00
Education Fund	10 R 1412 0000 00 000 000000	KENDALL CO SPEC ED	17,074.00	0.00	0.00	370.11	16,703.89	97.83
Education Fund	10 R 1413 0000 00 000 000000	WILL CO SPEC ED	92,974.00	811.56	0.00	-1,017.01	93,991.01	101.09
Education Fund	10 R 1414 0000 00 000 000000	GRUNDY CO SPEC ED EDPA SURPLUS	0.00	0.00		0.00	0.00	0.00
Education Fund	10 R 1422 0000 00 000 000000	KENDALL CO SPEC ED-EARLY DISTR	18,909.00	0.00		18,909.00	0.00	0.00
Education Fund	10 R 1423 0000 00 000 000000	WILL CO SPEC ED-EARLY DISTR	91,317.00	0.00		91,317.00	0.00	0.00
Education Fund	10 R 1510 0000 00 000 000000	CHECKING INTEREST	0.00	0.00		0.00	0.00	0.00
Education Fund	10 R 1511 0000 00 000 000000	INVESTMENT INTEREST	27,000.00	374.36	0.00	24,053.79	2,946.21	10.91
Education Fund	10 R 1611 0000 00 000 000000	CAFETERIA SALES CASH	275,000.00	24,850.22	2285.00	127,314.24	145,400.76	52.87
Education Fund	10 R 1612 0000 00 000 000000	CAFETERIA SALES CREDIT CARD	575,000.00	69,787.27	0.00	55,811.62	519,188.38	90.29
Education Fund	10 R 1620 0000 00 000 000000	COFFEE SALES	0.00	0.00		0.00	0.00	0.00
Education Fund	10 R 1709 0000 00 000 000000	POST SEASON GATE RECEIPTS	1,000.00	0.00	0.00	-11,545.50	12,545.50	1,254.55
Education Fund	10 R 1710 0000 00 000 000000	ATHLETIC ENTRY FEES RECD	1,500.00	3,825.00	0.00	-7,675.00	9,175.00	611.67
Education Fund	10 R 1711 0000 00 000 000000	SOCCER ADMISSIONS	0.00	0.00		0.00	0.00	0.00
Education Fund	10 R 1712 0000 00 000 000000	FOOTBALL ADMISSIONS	6,000.00	0.00	0.00	-8,029.90	14,029.90	233.83
Education Fund	10 R 1713 0000 00 000 000000	XC ADMISSIONS	0.00	0.00		0.00	0.00	0.00
Education Fund	10 R 1714 0000 00 000 000000	WRESTLING ADMISSIONS	500.00	968.00	0.00	-1,257.00	1,757.00	351.40
Education Fund	10 R 1715 0000 00 000 000000	BOYS BSKTBLL ADMISSIONS	500.00	2,857.00	0.00	-2,841.00	3,341.00	668.20
Education Fund	10 R 1716 0000 00 000 000000	GIRLS BSKTBLL ADMISSIONS	500.00	712.00	0.00	-863.00	1,363.00	272.60
Education Fund	10 R 1717 0000 00 000 000000	VOLLEYBALL ADMISSIONS	500.00	0.00	0.00	-1,611.00	2,111.00	422.20
Education Fund	10 R 1718 0000 00 000 000000	SPORT PASSES	0.00	0.00		0.00	0.00	0.00
Education Fund	10 R 1719 0000 00 000 000000	TRACK ADMISSIONS	0.00	0.00		0.00	0.00	0.00
Education Fund	10 R 1720 0000 00 000 000000	DRIVER EDUC FEES	0.00	0.00	0.00	-15,600.00	15,600.00	0.00

# Revenue Report

Fiscal Year: 2021-2022  
Month: January

COUNTY OF GRUNDY SCHOOL DIST 111

Fund Description	Account Number	Account Description	Revised Budget	Monthly Activity	Pending Activity	Available Funds	Year to Date Activity	Percent of Budget Used
Education Fund	10 R 1721 0000 00 000 000000	LOCK FEES	0.00	1,968.00	0.00	-7,125.00	7,125.00	0.00
Education Fund	10 R 1722 0000 00 000 000000	MISCELLANEOUS FEES	169,990.00	1,486.95	-200.00	130,910.15	39,279.85	23.11
Education Fund	10 R 1723 0000 00 000 000000	P.E. UNIFORMS	0.00	0.00	0.00	-3,082.00	3,082.00	0.00
Education Fund	10 R 1724 0000 00 000 000000	STUDENT PARKING FEES	95,000.00	1,949.00	-375.00	-4,815.00	100,190.00	105.46
Education Fund	10 R 1725 0000 00 000 000000	BOWLING ADMISSIONS	0.00	365.00	0.00	-365.00	365.00	0.00
Education Fund	10 R 1726 0000 00 000 000000	SPRING MUSICAL ADMISSIONS	1,500.00	0.00		1,500.00	0.00	0.00
Education Fund	10 R 1727 0000 00 000 000000	FALL PLAY ADMISSIONS	2,000.00	0.00	0.00	437.98	1,562.02	78.10
Education Fund	10 R 1728 0000 00 000 000000	STUDENT PURCHASES	0.00	0.00		0.00	0.00	0.00
Education Fund	10 R 1729 0000 00 000 000000	INVITE ADMISSIONS	100.00	0.00		100.00	0.00	0.00
Education Fund	10 R 1730 0000 00 000 000000	MADRIGALS ADMISSIONS	500.00	0.00	-6425.00	500.00	6,425.00	1,285.00
Education Fund	10 R 1731 0000 00 000 000000	ACTIVITY MISC	600.00	0.00		600.00	0.00	0.00
Education Fund	10 R 1732 0000 00 000 000000	SPORT PASSES	500.00	0.00		500.00	0.00	0.00
Education Fund	10 R 1733 0000 00 000 000000	LACROSSE ADMISSIONS	0.00	0.00		0.00	0.00	122 0.00
Education Fund	10 R 1790 0000 00 000 000000	OTHER PUPIL ACT REVENUE	0.00	0.00		0.00	0.00	0.00
Education Fund	10 R 1811 0000 00 000 000000	TEXTBOOK FEES	610,000.00	17,339.80	-285.00	-126,536.53	736,821.53	120.79
Education Fund	10 R 1825 0000 00 000 000000	AP TESTING FEE	0.00	0.00		0.00	0.00	0.00
Education Fund	10 R 1826 0000 00 000 000000	SAT TESTING FEES	5,000.00	0.00	0.00	-1,406.00	6,406.00	128.12
Education Fund	10 R 1827 0000 00 000 000000	SALE OF EQUIPMENT	500.00	0.00	0.00	-4,395.00	4,895.00	979.00
Education Fund	10 R 1828 0000 00 000 000000	A/P TEST FEES	65,000.00	564.00	0.00	14,454.00	50,546.00	77.76
Education Fund	10 R 1829 0000 00 000 000000	MATH RESALE REVENUE	0.00	0.00		0.00	0.00	0.00
Education Fund	10 R 1920 0000 00 000 000000	IMTT GRANT	0.00	0.00		0.00	0.00	0.00
Education Fund	10 R 1950 0000 00 000 000000	REFUND OF PRIOR YR EXPENSES	44,000.00	0.00		44,000.00	0.00	0.00
Education Fund	10 R 1970 0000 00 000 000000	DR ED FEES	40,000.00	1,400.00	0.00	21,625.00	18,375.00	45.94
Education Fund	10 R 1971 0000 00 000 000000	SUMMER DR ED FEES	30,000.00	23,075.00	0.00	6,925.00	23,075.00	76.92
Education Fund	10 R 1993 0000 00 000 000000	WELLNESS CENTER	0.00	0.00		0.00	0.00	0.00
Education Fund	10 R 1998 0000 00 000 000000	EDUCATION FOUNDATION GRANTS	5,000.00	0.00	0.00	2,302.49	2,697.51	53.95
Education Fund	10 R 1999 0000 00 000 000000	OTHER-LOCAL SOURCES	115,000.00	185,200.00	0.00	-131,313.12	246,313.12	214.19

# Revenue Report

Fiscal Year: 2021-2022  
Month: January

COUNTY OF GRUNDY SCHOOL DIST 111

Fund Description	Account Number	Account Description	Revised Budget	Monthly Activity	Pending Activity	Available Funds	Year to Date Activity	Percent of Budget Used
Education Fund	10 R 1999 2220 00 000 000000	DIST 111 GROUP MEDICAL REVENUE	3,332,919.00	308,030.24	0.00	1,253,491.54	2,079,427.46	62.39
Education Fund	10 R 1999 2230 00 000 000000	DIST 111 GROUP DENTAL REVENUE	165,000.00	15,654.74	0.00	60,523.47	104,476.53	63.32
Education Fund	10 R 2100 0000 00 000 000000	ECO LAB GRANT	0.00	0.00		0.00	0.00	0.00
Education Fund	10 R 2901 0000 00 000 000000	GRUNDY CO EDUCATION TIF	1,804,635.00	1,954,385.52	0.00	-149,750.52	1,954,385.52	108.30
Education Fund	10 R 2902 0000 00 000 000000	GRUNDY CO LEASE TIF	0.00	0.00		0.00	0.00	0.00
Education Fund	10 R 2903 0000 00 000 000000	GRUNDY CO SPEC ED TIF	0.00	0.00		0.00	0.00	0.00
Education Fund	10 R 3001 0000 00 000 000000	GENERAL STATE AID	6,228,000.00	566,182.00	0.00	2,830,911.00	3,397,089.00	54.55
Education Fund	10 R 3002 0000 00 000 000000	GSA HOLD HARMLESS	0.00	0.00		0.00	0.00	0.00
Education Fund	10 R 3030 0000 00 000 000000	FAST GROWTH GRANTS	0.00	0.00		0.00	0.00	0.00
Education Fund	10 R 3099 0000 00 000 000000	TRANSITION ASSISTANCE	0.00	0.00		0.00	0.00	0.00
Education Fund	10 R 3100 0000 00 000 000000	SPEC ED-PRIVATE FACILITY	700,000.00	209,133.60	0.00	83,802.47	616,197.53	88.03
Education Fund	10 R 3105 0000 00 000 000000	SPEC ED- EXTRAORDINARY	0.00	0.00		0.00	0.00	123 0.00
Education Fund	10 R 3110 0000 00 000 000000	SPEC ED- PERSONNEL	0.00	0.00		0.00	0.00	0.00
Education Fund	10 R 3120 0000 00 000 000000	SPEC ED- ORPHANAGE/INDIV	25,000.00	0.00	0.00	29,288.65	-4,288.65	-17.15
Education Fund	10 R 3130 0000 00 000 000000	SP ED ORPHANAGE SUMMER IND	0.00	0.00		0.00	0.00	0.00
Education Fund	10 R 3145 0000 00 000 000000	SPEC ED- SUMMER SCHOOL	0.00	0.00		0.00	0.00	0.00
Education Fund	10 R 3215 0000 00 000 000000	VOC ED-FORMULA	0.00	0.00		0.00	0.00	0.00
Education Fund	10 R 3220 0000 00 000 000000	CAREER/TECH EDUC IMPR GRNT	68,000.00	0.00	0.00	-4,085.00	72,085.00	106.01
Education Fund	10 R 3225 0000 00 000 000000	VOC ED FORMULA REIMB.	0.00	0.00		0.00	0.00	0.00
Education Fund	10 R 3226 0000 00 000 000000	VOC ED PROGRAM IMPROVMT.	0.00	0.00		0.00	0.00	0.00
Education Fund	10 R 3235 0000 00 000 000000	VOC ED AG EDUC INCENTIVE	2,000.00	0.00		2,000.00	0.00	0.00
Education Fund	10 R 3305 0000 00 000 000000	BILINGUAL ED-DOWNSTATE	0.00	0.00		0.00	0.00	0.00
Education Fund	10 R 3350 0000 00 000 000000	GIFTED EDUCATION	0.00	0.00		0.00	0.00	0.00
Education Fund	10 R 3360 0000 00 000 000000	STATE FREE LUNCH & BRKFST	1,000.00	336.84	0.00	453.52	546.48	54.65

# Revenue Report

Fiscal Year: 2021-2022  
Month: January

COUNTY OF GRUNDY SCHOOL DIST 111

Fund Description	Account Number	Account Description	Revised Budget	Monthly Activity	Pending Activity	Available Funds	Year to Date Activity	Percent of Budget Used
Education Fund	10 R 3370 0000 00 000 000000	DRIVERS ED REIMBURSEMENT	65,000.00	18,909.46	-175.00	9,321.62	55,853.38	85.93
Education Fund	10 R 3610 0000 00 000 000000	LEARNING IMPR-CHANGE GRNT	0.00	0.00		0.00	0.00	0.00
Education Fund	10 R 3640 0000 00 000 000000	PROF DEVELOP BLOCK GRANT	0.00	0.00		0.00	0.00	0.00
Education Fund	10 R 3696 0000 00 000 000000	REGIONAL SAFE SCHOOLS PROGRAM	60,000.00	0.00		60,000.00	0.00	0.00
Education Fund	10 R 3740 0000 00 000 000000	CRIM BACKGROUND CHECKS	0.00	0.00		0.00	0.00	0.00
Education Fund	10 R 3775 0000 00 000 000000	ADA SAFETY BLOCK GRANT	0.00	0.00		0.00	0.00	0.00
Education Fund	10 R 3781 0000 00 000 000000	TECH INTEGRATION GRANT	0.00	0.00		0.00	0.00	0.00
Education Fund	10 R 3792 0000 00 000 000000	TECH-CLOSING THE GAP	0.00	0.00		0.00	0.00	0.00
Education Fund	10 R 3800 0000 00 000 000000	STATE LIBRARY GRANT	0.00	0.00		0.00	0.00	0.00
Education Fund	10 R 3998 0000 00 000 000000	RECEIPTS/REVENUE ON BEHALF PAYMENTS	0.00	0.00		0.00	0.00	0.00
Education Fund	10 R 3999 0000 00 000 000000	OTH GRANTS-IN-AID/STATE SOURCE	0.00	0.00		0.00	0.00	0.00
Education Fund	10 R 4100 0000 00 000 000000	TITLE V	0.00	0.00		0.00	0.00	0.00
Education Fund	10 R 4101 0000 00 000 000000	HOMELESS GRANT	0.00	0.00		0.00	0.00	0.00
Education Fund	10 R 4215 0000 00 000 000000	SPECIAL MILK PROGRAM	387,000.00	0.00	0.00	385,379.98	1,620.02	0.42
Education Fund	10 R 4225 0000 00 000 000000	Summer Foods Program	0.00	0.00	0.00	0.00	0.00	0.00
Education Fund	10 R 4300 0000 00 000 000000	TITLE I	72,000.00	0.00	10980.00	18,442.00	42,578.00	59.14
Education Fund	10 R 4400 0000 00 000 000000	TITLE IV DRUG FREE GRANT	10,000.00	0.00	0.00	535.00	9,465.00	94.65
Education Fund	10 R 4620 0000 00 000 000000	SPEC ED-IDEA FLOW THRU	0.00	0.00		0.00	0.00	0.00
Education Fund	10 R 4625 0000 00 000 000000	SPEC ED-IDEA-RM & BOARD	415,000.00	0.00	0.00	268,016.07	146,983.93	35.42
Education Fund	10 R 4745 0000 00 000 000000	AG EDUC GRANT	1,200.00	986.00	0.00	-70.00	1,270.00	105.83
Education Fund	10 R 4850 0000 00 000 000000	ARRA - GENERAL STATE AID	0.00	0.00		0.00	0.00	0.00
Education Fund	10 R 4870 0000 00 000 000000	ARRA -GSA-SFSF	0.00	0.00		0.00	0.00	0.00
Education Fund	10 R 4880 0000 00 000 000000	ARRA-Educ Jobs Fund Prgm	0.00	0.00		0.00	0.00	0.00
Education Fund	10 R 4930 0000 00 000 000000	TITLE II EISENHWR PROF DVLPMNT	0.00	0.00		0.00	0.00	0.00
Education Fund	10 R 4932 0000 00 000 000000	Title II - Teacher Quality	29,529.00	0.00	18277.00	6,431.00	4,821.00	16.33

124

# Revenue Report

Fiscal Year: 2021-2022  
Month: January

COUNTY OF GRUNDY SCHOOL DIST 111

Fund Description	Account Number	Account Description	Revised Budget	Monthly Activity	Pending Activity	Available Funds	Year to Date Activity	Percent of Budget Used
Education Fund	10 R 4935 0000 00 000 000000	TITLE II EISENHWR MATH/SCI	0.00	0.00		0.00	0.00	0.00
Education Fund	10 R 4971 0000 00 000 000000	TITLE II PART D TECH GRANT	0.00	0.00		0.00	0.00	0.00
Education Fund	10 R 4991 0000 00 000 000000	MEDICAID/ADMN OUTREACH	15,000.00	0.00	0.00	-1,517.73	16,517.73	110.12
Education Fund	10 R 4992 0000 00 000 000000	MEDICAID MATCHING	0.00	0.00		0.00	0.00	0.00
Education Fund	10 R 4998 0000 00 000 499801	DIGITAL EQUITY GRANT	185,825.00	0.00	0.00	0.00	185,825.00	100.00
Education Fund	10 R 7110 0000 00 000 000000	PERM TRANS FROM W/C-ABATEMENT	0.00	0.00		0.00	0.00	0.00
Education Fund	10 R 7180 0000 00 000 000000	PERM TRANS FROM W/C-ABATEMENT	0.00	0.00		0.00	0.00	0.00
Education Fund	10 R 7900 0000 00 000 000000	DEBT PROCEEDS	0.00	0.00		0.00	0.00	0.00
Education Fund	10 R 9601 0000 00 000 000000	TIF SURPLUS DONATION	0.00	0.00		0.00	0.00	0.00
<b>10 - -----</b>	<b>Education Fund</b>	<b>TIF SURPLUS DONATION</b>	<b>37,809,332.67</b>	<b>4,263,290.04</b>	<b>24082.00</b>	<b>11,557,951.48</b>	<b>26,227,299.19</b>	
Activity Fund	11 R 1799 0000 00 000 000000	ACTIVITY FUND ACCOUNT	0.00	0.00		0.00	0.00	0.00
Activity Fund	11 R 1799 0000 01 000 900000	COADY SCHOLARSHIP	1,000.00	6.20	0.00	956.62	43.38	125 4.34
Activity Fund	11 R 1799 0000 30 300 910001	SPORTS - ATHLETIC HALL OF FAME	0.00	0.00		0.00	0.00	0.00
Activity Fund	11 R 1799 0000 30 300 910002	SPORTS - ATHLETIC POP	5,500.00	0.00	0.00	-1,995.24	7,495.24	136.28
Activity Fund	11 R 1799 0000 30 300 910003	SPORTS - ATHLETIC TRAINING	0.00	0.00	0.00	-300.00	300.00	0.00
Activity Fund	11 R 1799 0000 30 300 910004	SPORTS - BASEBALL	500.00	2,540.00	0.00	-2,040.00	2,540.00	508.00
Activity Fund	11 R 1799 0000 30 300 910005	SPORTS - BOYS BASKETBALL	2,712.00	10,376.00	0.00	-7,664.00	10,376.00	382.60
Activity Fund	11 R 1799 0000 30 300 910006	SPORTS - BOYS BOWLING	400.00	500.00	0.00	-100.00	500.00	125.00
Activity Fund	11 R 1799 0000 30 300 910007	SPORTS - BOYS GOLF	400.00	0.00		400.00	0.00	0.00
Activity Fund	11 R 1799 0000 30 300 910008	SPORTS - BOYS SOCCER	6,761.61	0.00	0.00	-3,778.79	10,540.40	155.89
Activity Fund	11 R 1799 0000 30 300 910009	SPORTS - BOYS TENNIS	0.00	0.00		0.00	0.00	0.00
Activity Fund	11 R 1799 0000 30 300 910010	SPORTS - BOYS TRACK	1,981.00	0.00	0.00	1,077.18	903.82	45.62
Activity Fund	11 R 1799 0000 30 300 910011	SPORTS - BOYS VOLLEYBALL	400.00	0.00		400.00	0.00	0.00
Activity Fund	11 R 1799 0000 30 300 910012	SPORTS - CHEERLEADERS	19,796.53	0.00	0.00	-11,105.47	30,902.00	156.10
Activity Fund	11 R 1799 0000 30 300 910013	SPORTS - CROSS COUNTY CO ED	4,089.75	0.00	0.00	-2,985.25	7,075.00	172.99
Activity Fund	11 R 1799 0000 30 300 910014	SPORTS - FOOTBALL	23,222.50	640.00	0.00	-47,122.50	70,345.00	302.92

# Revenue Report

Fiscal Year: 2021-2022  
Month: January

COUNTY OF GRUNDY SCHOOL DIST 111

Fund Description	Account Number	Account Description	Revised Budget	Monthly Activity	Pending Activity	Available Funds	Year to Date Activity	Percent of Budget Used
Activity Fund	11 R 1799 0000 30 300 910015	SPORTS - FOOTBALL JERSEYS	0.00	0.00		0.00	0.00	0.00
Activity Fund	11 R 1799 0000 30 300 910016	SPORTS - GIRLS BASKETBALL	270.00	0.00	0.00	-9,608.00	9,878.00	3,658.52
Activity Fund	11 R 1799 0000 30 300 910017	SPORTS - GIRLS BOWLING	0.00	0.00		0.00	0.00	0.00
Activity Fund	11 R 1799 0000 30 300 910018	SPORTS - GIRLS GOLF	400.00	0.00		400.00	0.00	0.00
Activity Fund	11 R 1799 0000 30 300 910019	SPORTS - GIRLS SOCCER	3,866.61	0.00		3,866.61	0.00	0.00
Activity Fund	11 R 1799 0000 30 300 910020	SPORTS - GIRLS TENNIS	915.00	0.00	0.00	890.00	25.00	2.73
Activity Fund	11 R 1799 0000 30 300 910021	SPORTS - GIRLS TRACK	4,352.00	0.00	0.00	4,106.91	245.09	5.63
Activity Fund	11 R 1799 0000 30 300 910022	SPORTS - GIRLS VOLLEYBALL	5,770.00	0.00	0.00	-4,414.00	10,184.00	176.50
Activity Fund	11 R 1799 0000 30 300 910023	SPORTS - LACROSSE	100.00	0.00		100.00	0.00	0.00
Activity Fund	11 R 1799 0000 30 300 910024	SPORTS - OUTDOOR ED TRIP	0.00	0.00		0.00	0.00	0.00
Activity Fund	11 R 1799 0000 30 300 910025	SPORTS - POMS	12,180.50	6,011.73	0.00	-20,127.53	32,732.83	268.73
Activity Fund	11 R 1799 0000 30 300 910026	SPORTS - SOFTBALL	500.00	0.00		500.00	0.00	126 0.00
Activity Fund	11 R 1799 0000 30 300 910027	SPORTS - SWIMMING B&G	300.00	0.00		300.00	0.00	0.00
Activity Fund	11 R 1799 0000 30 300 910028	SPORTS - WRESTLING	400.00	6,235.00	0.00	-5,835.00	6,235.00	1,558.75
Activity Fund	11 R 1799 0000 30 300 910029	SUMMER CAMPS - BAND CAMP	724.00	0.00	0.00	-17,807.00	18,531.00	2,559.53
Activity Fund	11 R 1799 0000 30 300 910030	SUMMER CAMPS - BASEBALL	0.00	0.00		0.00	0.00	0.00
Activity Fund	11 R 1799 0000 30 300 910031	SUMMER CAMPS - BOYS BASKETBALL	11,080.00	0.00	0.00	6,170.00	4,910.00	44.31
Activity Fund	11 R 1799 0000 30 300 910032	SUMMER CAMPS - BOYS VOLLEYBALL	0.00	0.00		0.00	0.00	0.00
Activity Fund	11 R 1799 0000 30 300 910033	SUMMER CAMPS - CHEERLEADING	250.00	0.00	0.00	-1,350.00	1,600.00	640.00
Activity Fund	11 R 1799 0000 30 300 910034	SUMMER CAMPS - CROSS COUNTRY	0.00	0.00	0.00	-4,200.00	4,200.00	0.00
Activity Fund	11 R 1799 0000 30 300 910035	SUMMER CAMPS - FOOTBALL	11,100.00	0.00	0.00	-1,925.00	13,025.00	117.34
Activity Fund	11 R 1799 0000 30 300 910036	SUMMER CAMPS - GIRLS BASKETBALL	2,850.00	0.00	0.00	425.00	2,425.00	85.09
Activity Fund	11 R 1799 0000 30 300 910037	SUMMER CAMPS - GIRLS VOLLEYBALL	3,750.00	0.00	-40.00	-3,390.00	7,180.00	191.47
Activity Fund	11 R 1799 0000 30 300 910038	SUMMER CAMPS - POMS	500.00	0.00	0.00	-2,661.00	3,161.00	632.20
Activity Fund	11 R 1799 0000 30 300 910039	SUMMER CAMPS - SOCCER	720.00	0.00	0.00	-280.00	1,000.00	138.89

# Revenue Report

Fiscal Year: 2021-2022  
Month: January

COUNTY OF GRUNDY SCHOOL DIST 111

Fund Description	Account Number	Account Description	Revised Budget	Monthly Activity	Pending Activity	Available Funds	Year to Date Activity	Percent of Budget Used
Activity Fund	11 R 1799 0000 30 300 910040	SUMMER CAMPS - CONDITIONING	1,440.00	0.00	0.00	-250.00	1,690.00	117.36
Activity Fund	11 R 1799 0000 30 300 910041	SUMMER CAMPS - TENNIS CO-ED	525.00	0.00	0.00	-3,375.00	3,900.00	742.86
Activity Fund	11 R 1799 0000 30 300 910042	SUMMER CAMPS - WOMENS FITNESS	0.00	0.00		0.00	0.00	0.00
Activity Fund	11 R 1799 0000 70 300 900001	ACTIVITIES - POP	822.51	575.00	9.99	-10,528.12	11,340.64	1,378.78
Activity Fund	11 R 1799 0000 70 300 900002	ACTIVITIES - ART CLUB	0.00	0.00		0.00	0.00	0.00
Activity Fund	11 R 1799 0000 70 300 900003	ACTIVITIES - ATHLETIC LEADERSHIP	0.00	0.00		0.00	0.00	0.00
Activity Fund	11 R 1799 0000 70 300 900004	ACTIVITIES - BAND	0.00	40.00	0.00	-40.00	40.00	0.00
Activity Fund	11 R 1799 0000 70 300 900005	ACTIVITIES - CHESS	0.00	0.00		0.00	0.00	0.00
Activity Fund	11 R 1799 0000 70 300 900006	ACTIVITIES - CHOIR PROJECTS	0.00	0.00		0.00	0.00	0.00
Activity Fund	11 R 1799 0000 70 300 900007	ACTIVITIES - CHORUS	2,813.78	0.00		2,813.78	0.00	0.00
Activity Fund	11 R 1799 0000 70 300 900008	ACTIVITIES - CLASS OF 2019	0.00	0.00		0.00	0.00	0.00
Activity Fund	11 R 1799 0000 70 300 900009	ACTIVITIES - CLASS OF 2020	0.00	0.00		0.00	0.00	0.00
Activity Fund	11 R 1799 0000 70 300 900010	ACTIVITIES - CLASS OF 2021	40.11	0.00		40.11	0.00	0.00
Activity Fund	11 R 1799 0000 70 300 900011	ACTIVITIES - CLASS OF 2022	180.11	0.00	0.00	-5,946.74	6,126.85	3,401.73
Activity Fund	11 R 1799 0000 70 300 900012	ACTIVITIES - CLASS OF 2023	0.00	0.00	0.00	-4,129.84	4,129.84	0.00
Activity Fund	11 R 1799 0000 70 300 900013	ACTIVITIES - CLASS OF 2024	0.00	0.00		0.00	0.00	0.00
Activity Fund	11 R 1799 0000 70 300 900014	ACTIVITIES - COMMUNITY GARDEN	0.00	0.00		0.00	0.00	0.00
Activity Fund	11 R 1799 0000 70 300 900015	ACTIVITIES - CULINARY ARTS	0.00	0.00		0.00	0.00	0.00
Activity Fund	11 R 1799 0000 70 300 900016	ACTIVITIES - DEBATE CLUB	0.00	0.00		0.00	0.00	0.00
Activity Fund	11 R 1799 0000 70 300 900017	ACTIVITIES - DREAM	0.00	0.00		0.00	0.00	0.00
Activity Fund	11 R 1799 0000 70 300 900018	ACTIVITIES - FASHION MERCHANDISING	0.00	0.00		0.00	0.00	0.00
Activity Fund	11 R 1799 0000 70 300 900019	ACTIVITIES - FCCLA	0.00	60.00	0.00	-60.00	60.00	0.00
Activity Fund	11 R 1799 0000 70 300 900020	ACTIVITIES - FFA	172.50	0.00	1332.00	-1,693.50	534.00	309.57
Activity Fund	11 R 1799 0000 70 300 900021	ACTIVITIES - FRENCH NHS	0.00	0.00		0.00	0.00	0.00

127

# Revenue Report

Fiscal Year: 2021-2022  
Month: January

COUNTY OF GRUNDY SCHOOL DIST 111

Fund Description	Account Number	Account Description	Revised Budget	Monthly Activity	Pending Activity	Available Funds	Year to Date Activity	Percent of Budget Used
Activity Fund	11 R 1799 0000 70 300 900022	ACTIVITIES - FUTURE BUSINESS LEADERS	0.00	0.00		0.00	0.00	0.00
Activity Fund	11 R 1799 0000 70 300 900023	ACTIVITIES - I.O.T.A.	500.00	0.00		500.00	0.00	0.00
Activity Fund	11 R 1799 0000 70 300 900024	ACTIVITIES - INDIAN CLIMBING CLUB	189.00	0.00		189.00	0.00	0.00
Activity Fund	11 R 1799 0000 70 300 900025	ACTIVITIES - INDIAN NATION	0.00	0.00		0.00	0.00	0.00
Activity Fund	11 R 1799 0000 70 300 900026	ACTIVITIES - INT'L CLUB	0.00	0.00	0.00	-3,180.00	3,180.00	0.00
Activity Fund	11 R 1799 0000 70 300 900027	ACTIVITIES - INT'L THESPIANS	420.00	0.00	0.00	-8,394.06	8,814.06	2,098.59
Activity Fund	11 R 1799 0000 70 300 900028	ACTIVITIES - INTERACT	0.00	0.00		0.00	0.00	0.00
Activity Fund	11 R 1799 0000 70 300 900029	ACTIVITIES - INVESTMENT CLUB	0.00	0.00		0.00	0.00	0.00
Activity Fund	11 R 1799 0000 70 300 900030	ACTIVITIES - JUDO	0.00	0.00	0.00	-400.00	400.00	0.00
Activity Fund	11 R 1799 0000 70 300 900031	ACTIVITIES - KALEIDOSOPE	0.00	0.00		0.00	0.00	0.00
Activity Fund	11 R 1799 0000 70 300 900032	ACTIVITIES - MAC	4,283.00	327.00	0.00	-6,246.00	10,529.00	245.83
Activity Fund	11 R 1799 0000 70 300 900033	ACTIVITIES - MATH TEAM	0.00	0.00		0.00	0.00	0.00
Activity Fund	11 R 1799 0000 70 300 900034	ACTIVITIES - MCHS BOOK CLUB	0.00	0.00		0.00	0.00	0.00
Activity Fund	11 R 1799 0000 70 300 900035	ACTIVITIES - MEMORIAL GARDEN	0.00	0.00		0.00	0.00	0.00
Activity Fund	11 R 1799 0000 70 300 900036	ACTIVITIES - MUSICAL	1,675.23	0.00		1,675.23	0.00	0.00
Activity Fund	11 R 1799 0000 70 300 900037	ACTIVITIES - NEEDY FAMILIES	0.00	0.00	0.00	-8,609.82	8,609.82	0.00
Activity Fund	11 R 1799 0000 70 300 900038	ACTIVITIES - NHS	4,925.00	492.00	0.00	-145.57	5,070.57	102.96
Activity Fund	11 R 1799 0000 70 300 900039	ACTIVITIES - ORCHESIS	0.00	569.80	0.00	-1,087.81	1,087.81	0.00
Activity Fund	11 R 1799 0000 70 300 900040	ACTIVITIES - PAC RESTORATION	1,607.80	0.00		1,607.80	0.00	0.00
Activity Fund	11 R 1799 0000 70 300 900041	ACTIVITIES - PERCUSSION	3,000.00	8,000.00	2604.00	-9,364.00	9,760.00	325.33
Activity Fund	11 R 1799 0000 70 300 900042	ACTIVITIES - POKEMON CLUB	0.00	0.00		0.00	0.00	0.00
Activity Fund	11 R 1799 0000 70 300 900043	ACTIVITIES - NEWSPAPER	0.00	0.00	0.00	-442.00	442.00	0.00
Activity Fund	11 R 1799 0000 70 300 900044	ACTIVITIES - SADD	0.00	0.00		0.00	0.00	0.00
Activity Fund	11 R 1799 0000 70 300 900045	ACTIVITIES - SCHOLASTIC BOWL	0.00	0.00		0.00	0.00	0.00
Activity Fund	11 R 1799 0000 70 300 900046	ACTIVITIES - SPANISH NHS	485.00	40.00	0.00	265.00	220.00	45.36

128

# Revenue Report

Fiscal Year: 2021-2022  
Month: January

COUNTY OF GRUNDY SCHOOL DIST 111

Fund Description	Account Number	Account Description	Revised Budget	Monthly Activity	Pending Activity	Available Funds	Year to Date Activity	Percent of Budget Used
Activity Fund	11 R 1799 0000 70 300 900047	ACTIVITIES - SPEECH	0.00	0.00	0.00	-42,960.00	42,960.00	0.00
Activity Fund	11 R 1799 0000 70 300 900048	ACTIVITIES - STUDENT COUNCIL	430.00	0.00	0.00	-6,620.00	7,050.00	1,639.53
Activity Fund	11 R 1799 0000 70 300 900049	ACTIVITIES - TSA	1,095.65	0.00	0.00	-2,689.35	3,785.00	345.46
Activity Fund	11 R 1799 0000 70 300 900050	ACTIVITIES - UNDERWATER ROBOTIC	0.00	160.00	0.00	-1,415.34	1,415.34	0.00
Activity Fund	11 R 1799 0000 70 300 900051	ACTIVITIES - WINTERGUARD	755.00	5,737.96	2275.90	-10,693.86	9,172.96	1,214.96
Activity Fund	11 R 1799 0000 70 300 900052	ACTIVITIES - WYSE	0.00	0.00		0.00	0.00	0.00
Activity Fund	11 R 1799 0000 70 300 900053	ACTIVITIES - YEARBOOK	11,247.30	-10.42	10.42	3,802.74	7,434.14	66.10
Activity Fund	11 R 1799 0000 70 300 900054	COADY SCHOLARSHIP ENDOWMENT	1,000.00	0.00		1,000.00	0.00	0.00
Activity Fund	11 R 1799 0000 70 300 900055	CYBRARY	0.00	0.00		0.00	0.00	0.00
Activity Fund	11 R 1799 0000 70 300 900056	FACULTY POP	240.72	0.00	0.00	67.77	172.95	71.85
Activity Fund	11 R 1799 0000 70 300 900057	PROJECT INDIAN	0.00	0.00		0.00	0.00	0.00
Activity Fund	11 R 1799 0000 70 300 900058	PROM	10,290.00	0.00		10,290.00	0.00	129 0.00
Activity Fund	11 R 1799 0000 70 300 900059	SCHOLARSHIP	24,000.00	0.00	0.00	21,000.00	3,000.00	12.50
Activity Fund	11 R 1799 0000 70 300 900060	TV PRODUCTION	0.00	0.00		0.00	0.00	0.00
Activity Fund	11 R 1799 0000 70 300 900061	ASL - AMERICAN SIGN LANGUAGE CLUB	162.79	0.00	0.00	162.79	0.00	0.00
Activity Fund	11 R 1799 0000 70 300 900062	GREEN HOUSE	908.00	0.00	0.00	238.00	670.00	73.79
Activity Fund	11 R 1799 0000 70 300 900063	CLASS OF 2025	0.00	0.00	0.00	0.00	0.00	0.00
<b>11 - -----</b>	<b>Activity Fund</b>	<b>CLASS OF 2025</b>	<b>200,000.00</b>	<b>42,300.27</b>	<b>6192.31</b>	<b>-213,715.25</b>	<b>407,947.74</b>	
Operations & Maint Fund	20 R 1110 0000 00 000 000000	PRIOR YEAR TAXES	0.00	0.00		0.00	0.00	0.00
Operations & Maint Fund	20 R 1111 0000 00 000 000000	GRUNDY CO TAXES	1,494,265.00	0.00	0.00	34,984.50	1,459,280.50	97.66
Operations & Maint Fund	20 R 1112 0000 00 000 000000	KENDALL CO TAXES	211,282.83	0.00	0.00	2,484.29	208,798.54	98.82
Operations & Maint Fund	20 R 1113 0000 00 000 000000	WILL CO TAXES	1,177,269.39	10,144.47	0.00	2,381.83	1,174,887.56	99.80
Operations & Maint Fund	20 R 1114 0000 00 000 000000	GRUNDY CO EDPA SURPLUS	0.00	0.00		0.00	0.00	0.00
Operations & Maint Fund	20 R 1122 0000 00 000 000000	KENDALL CO - EARLY DISTR	236,369.42	0.00		236,369.42	0.00	0.00
Operations & Maint Fund	20 R 1123 0000 00 000 000000	WILL CO - EARLY DISTR	1,326,302.00	0.00		1,326,302.00	0.00	0.00
Operations & Maint Fund	20 R 1210 0000 00 000 000000	MOBILE HOME TAX	0.00	0.00		0.00	0.00	0.00
Operations & Maint Fund	20 R 1211 0000 00 000 000000	GRUNDY CO TORT	0.00	0.00		0.00	0.00	0.00

# Revenue Report

Fiscal Year: 2021-2022  
Month: January

COUNTY OF GRUNDY SCHOOL DIST 111

Fund Description	Account Number	Account Description	Revised Budget	Monthly Activity	Pending Activity	Available Funds	Year to Date Activity	Percent of Budget Used
Operations & Maint Fund	20 R 1212 0000 00 000 000000	KENDALL CO TORT	0.00	0.00		0.00	0.00	0.00
Operations & Maint Fund	20 R 1213 0000 00 000 000000	WILL CO TORT	0.00	0.00		0.00	0.00	0.00
Operations & Maint Fund	20 R 1222 0000 00 000 000000	KENDALL CO TORT-EARLY DIST	0.00	0.00		0.00	0.00	0.00
Operations & Maint Fund	20 R 1223 0000 00 000 000000	WILL CO TORT-EARLY DISTR	0.00	0.00		0.00	0.00	0.00
Operations & Maint Fund	20 R 1230 0000 00 000 000000	CPPRT	250,000.00	56,652.71	0.00	46,211.99	203,788.01	81.52
Operations & Maint Fund	20 R 1290 0000 00 000 000000	ESCROW PMTS/LIEU OF TAXES	0.00	0.00		0.00	0.00	0.00
Operations & Maint Fund	20 R 1311 0000 00 000 000000	GRUNDY CO LEASE	0.00	0.00		0.00	0.00	0.00
Operations & Maint Fund	20 R 1312 0000 00 000 000000	KENDALL CO LEASE	0.00	0.00		0.00	0.00	0.00
Operations & Maint Fund	20 R 1313 0000 00 000 000000	WILL CO LEASE	0.00	0.00		0.00	0.00	0.00
Operations & Maint Fund	20 R 1322 0000 00 000 000000	KENDALL CO LEASE-EARLY DISTR	0.00	0.00		0.00	0.00	0.00
Operations & Maint Fund	20 R 1323 0000 00 000 000000	WILL CO LEASE-EARLY DISTR	0.00	0.00		0.00	0.00	0.00
Operations & Maint Fund	20 R 1510 0000 00 000 000000	CHECKING INTEREST	0.00	0.00		0.00	0.00	0.00
Operations & Maint Fund	20 R 1511 0000 00 000 000000	INVESTMENT INTEREST	3,000.00	110.68	0.00	2,076.96	923.04	30.77
Operations & Maint Fund	20 R 1910 0000 00 000 000000	CLASSROOM RENTAL	0.00	0.00		0.00	0.00	0.00
Operations & Maint Fund	20 R 1911 0000 00 000 000000	BUILDING RENTAL	0.00	6,375.86	0.00	-6,375.86	6,375.86	0.00
Operations & Maint Fund	20 R 1912 0000 00 000 000000	FARM LEASE PAYMENTS	62,000.00	52,478.11	0.00	9,521.89	52,478.11	84.64
Operations & Maint Fund	20 R 1950 0000 00 000 000000	REFUND OF PRIOR YR EXPENSES	0.00	0.00		0.00	0.00	0.00
Operations & Maint Fund	20 R 1991 0000 00 000 000000	SP ED HOUSING ASSESMENT	0.00	0.00		0.00	0.00	0.00
Operations & Maint Fund	20 R 1996 0000 00 000 000000	SALE OF CROPS	0.00	0.00		0.00	0.00	0.00
Operations & Maint Fund	20 R 1997 0000 00 000 000000	INSURANCE	0.00	0.00	0.00	-350,000.00	350,000.00	0.00
Operations & Maint Fund	20 R 1998 0000 00 000 000000	SALE OF EQUIPMENT	0.00	0.00		0.00	0.00	0.00
Operations & Maint Fund	20 R 1999 0000 00 000 000000	OTHER-LOCAL SOURCES	20,000.00	0.00	0.00	4,399.56	15,600.44	78.00
Operations & Maint Fund	20 R 1999 2220 00 000 000000	DIST 111 GROUP MEDICAL REVENUE	205,180.00	15,568.12	0.00	81,500.87	123,679.13	60.28
Operations & Maint Fund	20 R 1999 2230 00 000 000000	DIST 111 GROUP DENTAL REVENUE	11,400.00	811.40	0.00	5,046.55	6,353.45	55.73
Operations & Maint Fund	20 R 2901 0000 00 000 000000	GRUNDY CO TIF EXT	0.00	0.00		0.00	0.00	0.00
Operations & Maint Fund	20 R 3925 0000 00 000 000000	SCHOOL MAINTENANCE PROJECTS	0.00	0.00	0.00	-50,000.00	50,000.00	0.00

130

# Revenue Report

Fiscal Year: 2021-2022  
Month: January

COUNTY OF GRUNDY SCHOOL DIST 111

Fund Description	Account Number	Account Description	Revised Budget	Monthly Activity	Pending Activity	Available Funds	Year to Date Activity	Percent of Budget Used
Operations & Maint Fund	20 R 3999 0000 00 000 000000	OTH GRANTS-IN-AID/STATE SOURCE	0.00	0.00		0.00	0.00	0.00
Operations & Maint Fund	20 R 4590 0000 00 000 000000	COPS GRANT - MINOOKA	0.00	0.00		0.00	0.00	0.00
Operations & Maint Fund	20 R 4998 0000 00 000 499801	ESSER 1	0.00	0.00	0.00	0.00	0.00	0.00
Operations & Maint Fund	20 R 4998 0000 00 000 499802	ESSER II	281,358.00	0.00	0.00	281,358.00	0.00	0.00
Operations & Maint Fund	20 R 4998 0000 00 000 499803	ESSER III	830,062.00	0.00	0.00	830,062.00	0.00	0.00
Operations & Maint Fund	20 R 7110 0000 00 000 000000	PERM TRANS FROM W/C-ABATEMENT	0.00	0.00		0.00	0.00	0.00
Operations & Maint Fund	20 R 7130 0000 00 000 000000	PERM TRANS AMONG FUNDS	0.00	0.00		0.00	0.00	0.00
Operations & Maint Fund	20 R 7900 0000 00 000 000000	DEBT PROCEEDS	0.00	0.00		0.00	0.00	0.00
Operations & Maint Fund	20 R 8410 0000 00 000 000000	TAXES PLEDGED/PRINC-CAP LEASE	0.00	0.00		0.00	0.00	0.00
Operations & Maint Fund	20 R 9601 0000 00 000 000000	TIF SURPLUS DONATION	0.00	0.00		0.00	0.00	0.00
<b>20 - -----</b>	<b>Operations &amp; Maint Fund</b>	<b>TIF SURPLUS DONATION</b>	<b>6,108,488.64</b>	<b>142,141.35</b>	<b>0.00</b>	<b>2,456,324.00</b>	<b>3,652,164.64</b>	
Debt Service Fund or Fund Group	30 R 1110 0000 00 000 000000	PRIOR YEAR TAXES	0.00	0.00		0.00	0.00	131 0.00
Debt Service Fund or Fund Group	30 R 1111 0000 00 000 000000	GRUNDY CO TAXES	3,115,842.00	0.00	0.00	30,226.11	3,085,615.89	99.03
Debt Service Fund or Fund Group	30 R 1112 0000 00 000 000000	KENDALL CO TAXES	460,656.32	0.00	0.00	9,968.85	450,687.47	97.84
Debt Service Fund or Fund Group	30 R 1113 0000 00 000 000000	WILL CO TAXES	2,428,000.44	20,921.96	0.00	4,912.35	2,423,088.09	99.80
Debt Service Fund or Fund Group	30 R 1114 0000 00 000 000000	GRUNDY CO EPDA SURPLUS	0.00	0.00		0.00	0.00	0.00
Debt Service Fund or Fund Group	30 R 1122 0000 00 000 000000	KENDALL CO - EARLY DISTR	490,967.00	0.00		490,967.00	0.00	0.00
Debt Service Fund or Fund Group	30 R 1123 0000 00 000 000000	WILL CO - EARLY DISTR	2,354,542.00	0.00		2,354,542.00	0.00	0.00
Debt Service Fund or Fund Group	30 R 1210 0000 00 000 000000	MOBILE HOME TAX	0.00	0.00		0.00	0.00	0.00
Debt Service Fund or Fund Group	30 R 1290 0000 00 000 000000	PAYMENT IN LIEU OF TAXES BONDS	0.00	0.00		0.00	0.00	0.00
Debt Service Fund or Fund Group	30 R 1301 0000 00 000 000000	GRUNDY CO LEASE	0.00	0.00		0.00	0.00	0.00
Debt Service Fund or Fund Group	30 R 1302 0000 00 000 000000	KENDALL CO LEASE	0.00	0.00		0.00	0.00	0.00
Debt Service Fund or Fund Group	30 R 1303 0000 00 000 000000	WILL CO LEASE	0.00	0.00		0.00	0.00	0.00

# Revenue Report

Fiscal Year: 2021-2022  
Month: January

COUNTY OF GRUNDY SCHOOL DIST 111

Fund Description	Account Number	Account Description	Revised Budget	Monthly Activity	Pending Activity	Available Funds	Year to Date Activity	Percent of Budget Used
Debt Service Fund or Fund Group	30 R 1323 0000 00 000 000000	WILL CO LEASE-EARLY DIST	0.00	0.00		0.00	0.00	0.00
Debt Service Fund or Fund Group	30 R 1510 0000 00 000 000000	CHECKING INTEREST	0.00	0.00		0.00	0.00	0.00
Debt Service Fund or Fund Group	30 R 1511 0000 00 000 000000	INVESTMENT INTEREST	4,000.00	110.12	0.00	2,860.76	1,139.24	28.48
Debt Service Fund or Fund Group	30 R 1512 0000 00 000 000000	BOND INTEREST	0.00	0.00		0.00	0.00	0.00
Debt Service Fund or Fund Group	30 R 1999 0000 00 000 000000	OTHER-LOCAL SOURCES	0.00	0.00	5106.71	-5,106.71	0.00	0.00
Debt Service Fund or Fund Group	30 R 2901 0000 00 000 000000	GRUNDY CO TIF EXT	0.00	0.00		0.00	0.00	0.00
Debt Service Fund or Fund Group	30 R 7210 0000 00 000 000000	PRINCIPAL ON BONDS SOLD	0.00	0.00		0.00	0.00	0.00
Debt Service Fund or Fund Group	30 R 7220 0000 00 000 000000	PREMIUM ON BONDS SOLD	0.00	0.00		0.00	0.00	0.00
Debt Service Fund or Fund Group	30 R 7230 0000 00 000 000000	INTEREST ON BONDS SOLD	0.00	0.00		0.00	0.00	0.00
Debt Service Fund or Fund Group	30 R 7400 0000 00 000 000000	TRANS FROM OTHER FUNDS	0.00	0.00		0.00	0.00	132 0.00
Debt Service Fund or Fund Group	30 R 7401 0000 00 000 000000	TRANS FROM OBM LEASE	0.00	0.00		0.00	0.00	0.00
Debt Service Fund or Fund Group	30 R 7500 0000 00 000 000000	TRANS FROM OTHER FUNDS	0.00	0.00		0.00	0.00	0.00
Debt Service Fund or Fund Group	30 R 8990 0000 00 000 000000	DISCOUNT ON BONDS SOLD	0.00	0.00		0.00	0.00	0.00
Debt Service Fund or Fund Group	30 R 8991 0000 00 000 000000	REFUNDED PRINCIPAL	0.00	0.00		0.00	0.00	0.00
Debt Service Fund or Fund Group	30 R 8992 0000 00 000 000000	REFUNDED INTEREST	0.00	0.00		0.00	0.00	0.00
Debt Service Fund or Fund Group	30 R 9601 0000 00 000 000000	TIF SURPLUS DONATION	0.00	0.00		0.00	0.00	0.00
<b>30 - -----</b>	<b>Debt Service Fund or Fund</b>	<b>TIF SURPLUS DONATION</b>	<b>8,854,007.76</b>	<b>21,032.08</b>	<b>5106.71</b>	<b>2,888,370.36</b>	<b>5,960,530.69</b>	
Transportation Fund	40 R 1110 0000 00 000 000000	PRIOR YEAR TAXES	0.00	0.00		0.00	0.00	0.00
Transportation Fund	40 R 1111 0000 00 000 000000	GRUNDY CO TAXES	710,074.53	0.00	0.00	9,619.89	700,454.64	98.65
Transportation Fund	40 R 1112 0000 00 000 000000	KENDALL CO TAXES	101,416.59	0.00	0.00	12,038.30	89,378.29	88.13
Transportation Fund	40 R 1113 0000 00 000 000000	WILL CO TAXES	565,090.02	4,869.35	0.00	1,143.99	563,946.03	99.80
Transportation Fund	40 R 1114 0000 00 000 000000	GRUNDY CO EPDA SURPLUS	0.00	0.00		0.00	0.00	0.00
Transportation Fund	40 R 1122 0000 00 000 000000	KENDALL CO-EARLY DISTR	113,457.45	0.00	0.00	102,612.45	10,845.00	9.56

# Revenue Report

Fiscal Year: 2021-2022  
Month: January

COUNTY OF GRUNDY SCHOOL DIST 111

Fund Description	Account Number	Account Description	Revised Budget	Monthly Activity	Pending Activity	Available Funds	Year to Date Activity	Percent of Budget Used
Transportation Fund	40 R 1123 0000 00 000 000000	WILL CO-EARLY DISTR	547,904.20	0.00		547,904.20	0.00	0.00
Transportation Fund	40 R 1210 0000 00 000 000000	MOBILE HOME TAX	0.00	0.00		0.00	0.00	0.00
Transportation Fund	40 R 1211 0000 00 000 000000	GRUNDY CO TORT	0.00	0.00		0.00	0.00	0.00
Transportation Fund	40 R 1212 0000 00 000 000000	KENDALL CO TORT	0.00	0.00		0.00	0.00	0.00
Transportation Fund	40 R 1213 0000 00 000 000000	WILL CO TORT	0.00	0.00		0.00	0.00	0.00
Transportation Fund	40 R 1223 0000 00 000 000000	WILL CO TORT-EARLY DISTR	0.00	0.00		0.00	0.00	0.00
Transportation Fund	40 R 1230 0000 00 000 000000	CPPRT	0.00	0.00		0.00	0.00	0.00
Transportation Fund	40 R 1290 0000 00 000 000000	PAYMENT IN LIEU OF TAXES TRANS	0.00	0.00		0.00	0.00	0.00
Transportation Fund	40 R 1442 0000 00 000 000000	SP ED TRAN OTHER DISTRICT	0.00	0.00		0.00	0.00	0.00
Transportation Fund	40 R 1510 0000 00 000 000000	CHECKING INTEREST	0.00	0.00		0.00	0.00	0.00
Transportation Fund	40 R 1511 0000 00 000 000000	INVESTMENT INTEREST	1,500.00	22.71	0.00	901.29	598.71	39.91
Transportation Fund	40 R 1950 0000 00 000 000000	REFUND OF PRIOR YR EXPENSES	0.00	0.00		0.00	0.00	133 0.00
Transportation Fund	40 R 1998 0000 00 000 000000	SALE OF EQUIPMENT	5,000.00	0.00	0.00	2,200.00	2,800.00	56.00
Transportation Fund	40 R 1999 0000 00 000 000000	OTHER-LOCAL SOURCES	0.00	0.00		0.00	0.00	0.00
Transportation Fund	40 R 1999 2220 00 000 000000	DIST 111 GROUP MEDICAL REVENUE	97,813.00	11,220.83	0.00	21,123.21	76,689.79	78.40
Transportation Fund	40 R 1999 2230 00 000 000000	DIST 111 GROUP DENTAL REVENUE	4,116.00	395.67	0.00	1,408.53	2,707.47	65.78
Transportation Fund	40 R 2901 0000 00 000 000000	GRUNDY CO TIF EXT	0.00	0.00		0.00	0.00	0.00
Transportation Fund	40 R 3500 0000 00 000 000000	TRANS - REGULAR REIMB	83,724.00	28,668.61	0.00	-37,001.08	120,725.08	144.19
Transportation Fund	40 R 3505 0000 00 000 000000	TRANS - VOCATIONAL REIMB	0.00	0.00		0.00	0.00	0.00
Transportation Fund	40 R 3510 0000 00 000 000000	TRANS-SPEC ED REIMB	762,603.00	235,371.29	0.00	61,139.16	701,463.84	91.98
Transportation Fund	40 R 3999 0000 00 000 000000	OTHER RESTRICTED REV STATE	0.00	0.00		0.00	0.00	0.00
Transportation Fund	40 R 4999 0000 00 000 000000	OTHER RESTRICTED REV FEDERAL	0.00	0.00		0.00	0.00	0.00
Transportation Fund	40 R 7130 0000 00 000 000000	PERM TRANS AMONG FUNDS	0.00	0.00		0.00	0.00	0.00
Transportation Fund	40 R 7140 0000 00 000 000000	INT TRANS FROM SITE/CONST	0.00	0.00		0.00	0.00	0.00
Transportation Fund	40 R 9601 0000 00 000 000000	TIF SURPLUS DONATION	0.00	0.00		0.00	0.00	0.00

# Revenue Report

Fiscal Year: 2021-2022  
Month: January

COUNTY OF GRUNDY SCHOOL DIST 111

Fund Description	Account Number	Account Description	Revised Budget	Monthly Activity	Pending Activity	Available Funds	Year to Date Activity	Percent of Budget Used
<b>40 - -----</b>	<b>Transportation Fund</b>	<b>TIF SURPLUS DONATION</b>	<b>2,992,698.79</b>	<b>280,548.46</b>	<b>0.00</b>	<b>723,089.94</b>	<b>2,269,608.85</b>	
I.M.R.F./Soc. Sec. Fund	50 R 1110 0000 00 000 000000	PRIOR YEAR TAXES	0.00	0.00		0.00	0.00	0.00
I.M.R.F./Soc. Sec. Fund	50 R 1111 0000 00 000 000000	GRUNDY CO IMRF	149,056.38	0.00	0.00	2,021.24	147,035.14	98.64
I.M.R.F./Soc. Sec. Fund	50 R 1112 0000 00 000 000000	KENDALL CO IMRF	31,940.37	0.00	0.00	10,158.51	21,781.86	68.20
I.M.R.F./Soc. Sec. Fund	50 R 1113 0000 00 000 000000	WILL CO IMRF	117,726.84	1,014.45	0.00	238.07	117,488.77	99.80
I.M.R.F./Soc. Sec. Fund	50 R 1114 0000 00 000 000000	GRUNDY CO IMRF EDPA SURPLUS	0.00	0.00		0.00	0.00	0.00
I.M.R.F./Soc. Sec. Fund	50 R 1122 0000 00 000 000000	KENDALL CO-EARLY DISTR	20,000.00	0.00		20,000.00	0.00	0.00
I.M.R.F./Soc. Sec. Fund	50 R 1123 0000 00 000 000000	WILL CO-EARLY DISTR	110,000.00	0.00		110,000.00	0.00	0.00
I.M.R.F./Soc. Sec. Fund	50 R 1210 0000 00 000 000000	MOBILE HOME TAX	0.00	0.00		0.00	0.00	0.00
I.M.R.F./Soc. Sec. Fund	50 R 1211 0000 00 000 000000	MOBILE HOME TAX IMRF	0.00	0.00		0.00	0.00	0.00
I.M.R.F./Soc. Sec. Fund	50 R 1212 0000 00 000 000000	MOBILE HOME TAX SOC SEC	0.00	0.00		0.00	0.00	0.00
I.M.R.F./Soc. Sec. Fund	50 R 1230 0000 00 000 000000	CPPRT	125,000.00	29,184.73	0.00	20,886.48	104,113.52	83.29
I.M.R.F./Soc. Sec. Fund	50 R 1290 0000 00 000 000000	PAYMENT IN LIEU OF TAXES IMRF	0.00	0.00		0.00	0.00	0.00
I.M.R.F./Soc. Sec. Fund	50 R 1291 0000 00 000 000000	PAYMENT IN LIEU OF TAXES SOC SEC	0.00	0.00		0.00	0.00	0.00
I.M.R.F./Soc. Sec. Fund	50 R 1510 0000 00 000 000000	CHECKING INTEREST	0.00	0.00		0.00	0.00	0.00
I.M.R.F./Soc. Sec. Fund	50 R 1511 0000 00 000 000000	INVESTMENT INTEREST	1,700.00	46.91	0.00	1,094.54	605.46	35.62
I.M.R.F./Soc. Sec. Fund	50 R 1511 0000 00 000 000001	GRUNDY CO SS	185,388.39	0.00	0.00	2,513.00	182,875.39	98.64
I.M.R.F./Soc. Sec. Fund	50 R 1512 0000 00 000 000000	KENDALL CO SS	27,416.07	0.00	0.00	322.36	27,093.71	98.82
I.M.R.F./Soc. Sec. Fund	50 R 1513 0000 00 000 000000	WILL CO SS	145,981.44	1,257.91	0.00	295.39	145,686.05	99.80
I.M.R.F./Soc. Sec. Fund	50 R 1514 0000 00 000 000000	GRUNDY CO SS EDPA SURPLUS	0.00	0.00		0.00	0.00	0.00
I.M.R.F./Soc. Sec. Fund	50 R 1522 0000 00 000 000000	KENDALL CO SS-EARLY DISTR	25,000.00	0.00		25,000.00	0.00	0.00
I.M.R.F./Soc. Sec. Fund	50 R 1523 0000 00 000 000000	WILL CO SS-EARLY DISTR	135,000.00	0.00		135,000.00	0.00	0.00
I.M.R.F./Soc. Sec. Fund	50 R 1999 0000 00 000 000000	OTHER-LOCAL SOURCES	0.00	0.00		0.00	0.00	0.00
I.M.R.F./Soc. Sec. Fund	50 R 2901 0000 00 000 000000	GRUNDY CO IMRF TIF	0.00	0.00		0.00	0.00	0.00
I.M.R.F./Soc. Sec. Fund	50 R 2902 0000 00 000 000000	GRUNDY CO SS TIF	0.00	0.00		0.00	0.00	0.00
I.M.R.F./Soc. Sec. Fund	50 R 9601 0000 00 000 000000	TIF SURPLUS DONATION	0.00	0.00		0.00	0.00	0.00
<b>50 - -----</b>	<b>I.M.R.F./Soc. Sec. Fund</b>	<b>TIF SURPLUS DONATION</b>	<b>1,074,209.49</b>	<b>31,504.00</b>	<b>0.00</b>	<b>327,529.59</b>	<b>746,679.90</b>	

134

# Revenue Report

Fiscal Year: 2021-2022  
Month: January

COUNTY OF GRUNDY SCHOOL DIST 111

Fund Description	Account Number	Account Description	Revised Budget	Monthly Activity	Pending Activity	Available Funds	Year to Date Activity	Percent of Budget Used
Capital Projects Fund or Fund Group	60 R 1291 0000 00 000 000000	FACILITIES IMPACT FEES	170,000.00	20,225.94	0.00	121,851.99	48,148.01	28.32
Capital Projects Fund or Fund Group	60 R 1292 0000 00 000 000000	SCHOOL SITE FEES	122,000.00	10,351.94	0.00	104,278.11	17,721.89	14.53
Capital Projects Fund or Fund Group	60 R 1510 0000 00 000 000000	CHECKING INTEREST	0.00	0.00		0.00	0.00	0.00
Capital Projects Fund or Fund Group	60 R 1511 0000 00 000 000000	INVESTMENT INTEREST	4,600.00	58.24	0.00	3,524.56	1,075.44	23.38
Capital Projects Fund or Fund Group	60 R 1520 0000 00 000 000000	GAIN/LOSS ON INVESTMENTS	0.00	0.00		0.00	0.00	0.00
Capital Projects Fund or Fund Group	60 R 1930 0000 00 000 000000	IMPACT FEES	0.00	0.00	0.00	-8,992.80	8,992.80	0.00
Capital Projects Fund or Fund Group	60 R 1999 0000 00 000 000000	OTHER-LOCAL SOURCES	0.00	0.00		0.00	0.00	0.00
Capital Projects Fund or Fund Group	60 R 4590 0000 00 000 000000	COPS GRANT - CHANNAHON	0.00	0.00		0.00	0.00	0.00
Capital Projects Fund or Fund Group	60 R 7110 0000 00 000 000000	PERM TRANS FROM W/C-ABATEMENT	0.00	0.00		0.00	0.00	0.00
Capital Projects Fund or Fund Group	60 R 7210 0000 00 000 000000	PRINCIPAL ON BONDS SOLD	0.00	0.00		0.00	0.00	135 0.00
Capital Projects Fund or Fund Group	60 R 7800 0000 00 000 000000	TRANS FROM OTHER FUNDS	0.00	0.00		0.00	0.00	0.00
<b>60 - -----</b>	<b>Capital Projects Fund or</b>	<b>TRANS FROM OTHER</b>	<b>296,600.00</b>	<b>30,636.12</b>	<b>0.00</b>	<b>220,661.86</b>	<b>75,938.14</b>	
Working Cash Fund	70 R 1110 0000 00 000 000000	PRIOR YEAR TAXES	0.00	0.00		0.00	0.00	0.00
Working Cash Fund	70 R 1111 0000 00 000 000000	GRUNDY CO TAXES	295,864.47	0.00	0.00	4,008.36	291,856.11	98.65
Working Cash Fund	70 R 1112 0000 00 000 000000	KENDALL CO TAXES	42,256.17	0.00	0.00	496.46	41,759.71	98.83
Working Cash Fund	70 R 1113 0000 00 000 000000	WILL CO TAXES	235,453.68	2,028.89	0.00	476.18	234,977.50	99.80
Working Cash Fund	70 R 1114 0000 00 000 000000	GRUNDY CO EDPA SURPLUS	0.00	0.00		0.00	0.00	0.00
Working Cash Fund	70 R 1122 0000 00 000 000000	KENDALL CO-EARLY DISTR	47,273.67	0.00		47,273.67	0.00	0.00
Working Cash Fund	70 R 1123 0000 00 000 000000	WILL CO-EARLY DISTR	228,293.06	0.00		228,293.06	0.00	0.00
Working Cash Fund	70 R 1210 0000 00 000 000000	MOBILE HOME TAX	0.00	0.00		0.00	0.00	0.00
Working Cash Fund	70 R 1230 0000 00 000 000000	CPPRT	0.00	0.00	0.00	0.00	0.00	0.00
Working Cash Fund	70 R 1290 0000 00 000 000000	PAYMENT IN LIEU OF TAXES WORKING CASH	0.00	0.00		0.00	0.00	0.00
Working Cash Fund	70 R 1510 0000 00 000 000000	CHECKING INTEREST	0.00	0.00		0.00	0.00	0.00
Working Cash Fund	70 R 1511 0000 00 000 000000	INVESTMENT INTEREST	8,400.00	223.83	0.00	6,441.57	1,958.43	23.31
Working Cash Fund	70 R 1960 0000 00 000 000000	TIF SURPLUS DONATION	0.00	0.00		0.00	0.00	0.00

# Revenue Report

Fiscal Year: 2021-2022  
Month: January

COUNTY OF GRUNDY SCHOOL DIST 111

Fund Description	Account Number	Account Description	Revised Budget	Monthly Activity	Pending Activity	Available Funds	Year to Date Activity	Percent of Budget Used
Working Cash Fund	70 R 1999 0000 99 000 000000	OTHER-LOCAL SOURCES	0.00	0.00		0.00	0.00	0.00
Working Cash Fund	70 R 2901 0000 00 000 000000	GRUNDY CO TIF EXT	0.00	0.00		0.00	0.00	0.00
Working Cash Fund	70 R 7210 0000 00 000 000000	PRIN ON BONDS SOLD	0.00	0.00		0.00	0.00	0.00
Working Cash Fund	70 R 7220 0000 00 000 000000	PREMIUM ON BONDS SOLD	0.00	0.00		0.00	0.00	0.00
Working Cash Fund	70 R 8110 0000 00 000 000000	ABATEMENT OF W/C FUND	0.00	0.00		0.00	0.00	0.00
<b>70 - -----</b>	<b>Working Cash Fund</b>	<b>ABATEMENT OF W/C FUND</b>	<b>857,541.05</b>	<b>2,252.72</b>	<b>0.00</b>	<b>286,989.30</b>	<b>570,551.75</b>	
Tort Immunity and Judgment Fund	80 R 1110 0000 00 000 000000	PRIOR YEAR TAXES	0.00	0.00		0.00	0.00	0.00
Tort Immunity and Judgment Fund	80 R 1111 0000 00 000 000000	GRUNDY CO TORT	427,109.76	0.00	0.00	5,792.90	421,316.86	98.64
Tort Immunity and Judgment Fund	80 R 1112 0000 00 000 000000	KENDALL CO TORT	63,148.14	0.00	0.00	742.44	62,405.70	98.82
Tort Immunity and Judgment Fund	80 R 1113 0000 00 000 000000	WILL CO TORT	337,170.24	2,905.38	0.00	682.45	336,487.79	99.80
Tort Immunity and Judgment Fund	80 R 1114 0000 00 000 000000	GRUNDY CO TORT EDPA SURPLUS	0.00	0.00		0.00	0.00	0.00
Tort Immunity and Judgment Fund	80 R 1122 0000 00 000 000000	KENDALL CO TORT-EARLY DISTR	70,645.68	0.00		70,645.68	0.00	0.00
Tort Immunity and Judgment Fund	80 R 1123 0000 00 000 000000	WILL CO TORT-EARLY DISTR	326,916.03	0.00		326,916.03	0.00	0.00
Tort Immunity and Judgment Fund	80 R 1210 0000 00 000 000000	MOBILE HOME TAX	0.00	0.00		0.00	0.00	0.00
Tort Immunity and Judgment Fund	80 R 1290 0000 00 000 000000	PAYMENT IN LIEU OF TAXES LIABILITY	0.00	0.00		0.00	0.00	0.00
Tort Immunity and Judgment Fund	80 R 1510 0000 00 000 000000	CHECKING INTEREST	0.00	0.00		0.00	0.00	0.00
Tort Immunity and Judgment Fund	80 R 1511 0000 00 000 000000	INVESTMENT INTEREST	1,400.00	16.50	0.00	884.57	515.43	36.82
Tort Immunity and Judgment Fund	80 R 1960 0000 00 000 000000	TIF SURPLUS DONATION	0.00	0.00		0.00	0.00	0.00
Tort Immunity and Judgment Fund	80 R 1999 0000 00 000 000000	OTHER-LOCAL SOURCES	0.00	0.00		0.00	0.00	0.00
Tort Immunity and Judgment Fund	80 R 1999 2220 00 000 000000	DIST 111 GROUP MEDICAL REVENUE	153,625.00	8,932.87	0.00	90,481.67	63,143.33	41.10
Tort Immunity and Judgment Fund	80 R 1999 2230 00 000 000000	DIST 111 GROUP DENTAL REVENUE	1,700.00	197.19	0.00	318.83	1,381.17	81.25
Tort Immunity and Judgment Fund	80 R 2901 0000 00 000 000000	GRUNDY CO TIF EXT	0.00	0.00		0.00	0.00	0.00
Tort Immunity and Judgment Fund	80 R 4008 0000 00 000 000000	COPS GRANT CHANNAHON	0.00	0.00		0.00	0.00	0.00

136

# Revenue Report

Fiscal Year: 2021-2022  
Month: January

COUNTY OF GRUNDY SCHOOL DIST 111

Fund Description	Account Number	Account Description	Revised Budget	Monthly Activity	Pending Activity	Available Funds	Year to Date Activity	Percent of Budget Used
Tort Immunity and Judgment Fund	80 R 4009 0000 00 000 000000	COPS GRANT MINOOKA	0.00	0.00		0.00	0.00	0.00
Tort Immunity and Judgment Fund	80 R 7130 0000 00 000 000000	TRANS FROM ED TORT	0.00	0.00		0.00	0.00	0.00
Tort Immunity and Judgment Fund	80 R 7990 0000 00 000 000000	TRANS FROM OBM TORT	0.00	0.00		0.00	0.00	0.00
<b>80 - -----</b>	<b>Tort Immunity and Judgment</b>	<b>TRANS FROM OBM TORT</b>	<b>1,381,714.85</b>	<b>12,051.94</b>	<b>0.00</b>	<b>496,464.57</b>	<b>885,250.28</b>	
Fire Prevention & Safety Fund	90 R 1110 0000 00 000 000000	PRIOR YEAR TAXES	0.00	0.00		0.00	0.00	0.00
Fire Prevention & Safety Fund	90 R 1111 0000 00 000 000000	GRUNDY CO TAXES	295,864.47	0.00	0.00	4,008.36	291,856.11	98.65
Fire Prevention & Safety Fund	90 R 1112 0000 00 000 000000	KENDALL CO TAXES	42,256.17	0.00	0.00	496.46	41,759.71	98.83
Fire Prevention & Safety Fund	90 R 1113 0000 00 000 000000	WILL CO TAXES	235,453.68	2,028.89	0.00	476.18	234,977.50	99.80
Fire Prevention & Safety Fund	90 R 1114 0000 00 000 000000	GRUNDY CO EDPA SURPLUS	0.00	0.00		0.00	0.00	0.00
Fire Prevention & Safety Fund	90 R 1122 0000 00 000 000000	KENDALL CO-EARLY DISTR	47,273.67	0.00		47,273.67	0.00	0.00
Fire Prevention & Safety Fund	90 R 1123 0000 00 000 000000	WILL CO-EARLY DISTR	228,293.06	0.00		228,293.06	0.00	0.00
Fire Prevention & Safety Fund	90 R 1210 0000 00 000 000000	MOBIL HOME TAX	0.00	0.00		0.00	0.00	137
Fire Prevention & Safety Fund	90 R 1290 0000 00 000 000000	PAYMENT IN LIEU OF TAXES FIRE SAFETY	0.00	0.00		0.00	0.00	0.00
Fire Prevention & Safety Fund	90 R 1510 0000 00 000 000000	CHECKING INTEREST	0.00	0.00		0.00	0.00	0.00
Fire Prevention & Safety Fund	90 R 1511 0000 00 000 000000	INVESTMENT INTEREST	4,300.00	61.39	0.00	3,468.15	831.85	19.35
Fire Prevention & Safety Fund	90 R 1960 0000 00 000 000000	TIF SURPLUS DONATION	0.00	0.00		0.00	0.00	0.00
Fire Prevention & Safety Fund	90 R 1999 0000 00 000 000000	OTHER-LOCAL SOURCES	0.00	0.00		0.00	0.00	0.00
Fire Prevention & Safety Fund	90 R 2901 0000 00 000 000000	GRUNDY CO TIF EXT	0.00	0.00		0.00	0.00	0.00
Fire Prevention & Safety Fund	90 R 7210 0000 00 000 000000	PRIN ON BONDS SOLD	0.00	0.00		0.00	0.00	0.00
Fire Prevention & Safety Fund	90 R 7220 0000 00 000 000000	PREMIUM ON BONDS SOLD	0.00	0.00		0.00	0.00	0.00
<b>90 - -----</b>	<b>Fire Prevention &amp; Safety</b>	<b>PREMIUM ON BONDS SOLD</b>	<b>853,441.05</b>	<b>2,090.28</b>	<b>0.00</b>	<b>284,015.88</b>	<b>569,425.17</b>	
<b>Grand Totals:</b>			<b>60,428,034.30</b>	<b>4,827,847.26</b>	<b>35381.02</b>	<b>19,027,681.73</b>	<b>41,365,396.35</b>	



January 17, 2022

Lauren Offerman  
Executive Director  
Three Rivers Library District

Jeff Heap  
Sr. Director Finance Services & Controller  
Joliet Junior College

Chris Balkema  
Chairman  
Grundy Co. Board

Al Yancey  
Chief  
Minooka Fire Prot. Dist.

Mike Leonard  
Executive Director  
Channahon Park District

Dr. Kris Monn  
Superintendent  
Minooka Dist. 201

John Troy  
Asst. Superintendent of Bus.  
Minooka Dist. 111

Tim Harms  
Supervisor  
AuxSable Township

Ray Underhill  
Hwy. Commissioner  
AuxSable Tep. Highway

Mary Robinson  
Business Manager  
Minooka Dist. 201

## RE: Village of Channahon NI-Gas TIF District (Aux Sable Liquid Products)

In 1998 The Village of Channahon established a tax increment finance district in conjunction with the Aux Sable Liquid Products development (the "TIF"). At the time that the TIF was created the Village entered into an Intergovernmental Agreement ("IGA") with all of the Taxing Districts affected by the TIF. Shortly after, the TIF was established, the Illinois General Assembly changed the law with respect to the termination of TIF districts to permit TIF districts to extend until December 31 of the year in which payment of increment is made to the Village for taxes levied in the 23<sup>rd</sup> calendar year after the TIF was established.

In order to effectuate this change, the Village is required to amend its Redevelopment Plan for the TIF. Because the IGA is in place, we believe it is best to request that each Taxing District execute the attached Notice acknowledging and consenting to the amendment to allow the TIF to conform with current state law.

The Village and the School District have discussed extending the TIF with the new owner of Aux Sable Liquid Products, however, no agreement has yet been reached. By making this plan amendment, the Village and the School District will have time to cultivate discussions concerning a possible extension of the TIF which will then be presented to the Taxing Districts.



This matter was discussed at the Joint Review Board Meeting held on December 9, 2021 and all the JRB members present were in favor of this initial step.

It is important to note that to extend the TIF beyond this 23<sup>rd</sup> year of taxes, several steps must be completed:

- 1) all Taxing Districts must agree to amend the IGA which would include new terms for any further relief to the owner.
- 2) all Taxing Districts must notify the Illinois General Assembly that they support the extension.
- 3) the General Assembly must enact legislation to extend the TIF.

After these steps are complete then the Village could initiate the extension process.

You should be aware that by making this currently proposed change to the Redevelopment Plan, the Redevelopment Agreement between the Village and the owners is not extended. The Redevelopment Plan is set to expire in February, 2022 and with it, the owners right to a portion of the tax increment also expires. This agreement cannot be extended without the consent of taxing districts. Also, due to expire soon is the property valuation agreement between the property owners and all of the Taxing Districts, this proposed amendment will also provide time for discussion of a possible extension / amendment of this agreement.

Please contact me if you have any questions. We would like to have the Notices executed by an official at your district and returned to me prior to February 15, 2022 so that the Village Board can proceed with the amendment to the Redevelopment Plan.

I have included a copy of the Notice along with a copy of the IGA for your reference.

Sincerely,

Thomas J. Durkin, AICP  
Village Administrator

**NOTICE OF AMENDMENT TO REDEVELOPMENT PLAN AND PROJECT**

WHEREAS, the Taxing District set forth below is a party to that certain Intergovernmental Agreement by and between the Village of Channahon, The County of Grundy, Aux Sable Township, Minooka Grade School District 201, Minooka High School District 111, Minooka Fire Protection District, Three-Rivers Library District, Joliet Junior College District 525, The Aux Sable Township Highway Commission and Channahon Park District regarding the creation of a Tax Increment Allocation Finance District within the Village of Channahon (the “IGA”); and

WHEREAS, Section 2 of the IGA provides that the Redevelopment Project Area shall be for a period of twenty-three (23) years and shall be subject to the terms of a Redevelopment Agreement between the Village of Channahon and Aux Sable Liquid Products; and

WHEREAS, subsequent to the IGA and creation of the Redevelopment Project Area, the General Assembly amended the Tax Increment Allocation Redevelopment Act (the “Act”) to provide that the estimated date of completion of the Redevelopment Project and retirement of obligations shall not be later than December 31 of the year in which payment is made to the Municipal Treasurer with respect to Ad Valorem taxes levied in the 23<sup>rd</sup> calendar year after which the ordinance approving the Redevelopment Project Area was adopted; and

WHEREAS, the Village of Channahon intends to adopt an amendment to the Redevelopment Plan and Project in the form of Exhibit A attached hereto (the “Amendment”); and

WHEREAS, the Amendment does not affect the termination date of February 15, 2022 of that certain Amended and Restated Redevelopment Agreement by and between the Village of Channahon and Aux Sable Liquid Products LP; and

WHEREAS, the Joint Review Board for this Tax Increment Finance District informally unanimously supported this Amendment at the Joint Review Board meeting held on December 9, 2021.

WHEREAS, the taxing body stated below does hereby acknowledge and consent to the Amendment.

By: \_\_\_\_\_  
Its \_\_\_\_\_

**EXHIBIT A**

**ORDINANCE NO. \_\_\_\_\_**

**AND ORDINANCE AMENDING THE REDEVELOPMENT PROJECT AND PLAN  
FOR THE VILLAGE OF CHANNAHON NIGAS TAX INCREMENT FINANCE  
DISTRICT**

WHEREAS, on or about the 15<sup>th</sup> day of February, 1999 the Village of Channahon adopted and approved a “Redevelopment Project and Plan for the Establishment of a Redevelopment Project Area in the Village of Channahon, Illinois, prepared by Ernst and Young dated February 2, 1998 (the “Plan”); and,

WHEREAS, the Plan was adopted by Ordinance No. 1029; and

WHEREAS, the area described in the Plan was designated as a “Redevelopment Project Area” on the 15<sup>th</sup> day of February, 1999, by Ordinance No. 1030; and

WHEREAS, Tax Increment Allocation Financing was adopted for the Redevelopment Project Area on the 15<sup>th</sup> day of February, 1999, by Ordinance No. 1031; and

WHEREAS, subsequent to adoption of the Plan, the Illinois Tax Increment Allocation Redevelopment Act (65 ILCS 5/11-74.4-1 et seq.) (the “Act”) was amended with respect to the estimated time of completion of projects within the Redevelopment Project Area; and

WHEREAS, the Village of Channahon desires to amend the Plan in conformance with such amendment to the Act.

WHEREFORE, the Plan is hereby amended as set forth in Section 1.

**SECTION 1. PLAN AMENDMENT**

The Plan be and is hereby amended to include the following:

Notwithstanding any other term or provision of this Plan, the estimated date of completion of the Redevelopment Projects and retirement of obligations to finance Redevelopment Project Costs (including refunding bonds under 65 ILCS 5/11-74.4-7) shall be not later than December 31 of the year in which the payment to the Village Treasurer, as provided by 65 ILCS 5/11-74.4-8(b), is to be made with respect to Ad Valorem taxes levied in the 23<sup>rd</sup> calendar year after the year in which the ordinance approving the Redevelopment Project area was adopted.

**SECTION 2. SEVERABILITY**

If any section, paragraph, clause or provision of this Ordinance is held invalid, the invalidity of such section, paragraph, clause or provision shall not affect any of the other provisions of this Ordinance.

**SECTION 3. REPEALER**

All ordinances and resolutions, or parts thereof, in conflict with the provisions of this Ordinance are, to the extent of the conflict, expressly repealed on the effective date of this Ordinance.

**SECTION 4. EFFECTIVE DATE**

This Ordinance shall be in full force and effect from and after its passage and approval and publication as required by law.

PASSED this \_\_\_\_\_ day of \_\_\_\_\_, 2022, with \_\_\_\_\_ trustees voting aye, \_\_\_\_\_ trustees voting nay, \_\_\_\_\_ trustees abstaining or passing, and with \_\_\_\_\_ trustees absent, the President \_\_\_\_\_ voting: said vote being:

HOST	_____	PERINAR	_____
GRECO	_____	McMILLIN	_____
SLOCUM	_____	SCAGGS	_____

\_\_\_\_\_  
Village Clerk

APPROVED this \_\_\_\_ day of \_\_\_\_\_, 2022.

\_\_\_\_\_  
MISSEY MOORMAN-SCHUMACHER,  
Village President

(SEAL)

ATTEST:

\_\_\_\_\_  
Village Clerk

RESOLUTION NO. 296

A Resolution Authorizing The Execution Of An Intergovernmental Agreement By And Between The Village Of Channahon, The County Of Grundy, Aux Sable Township, Minooka Grade School District 201, Minooka High School District 111, Minooka Fire Protection District, Three-Rivers Library District, Joliet Junior College District 525, The Aux Sable Township Highway Commission and Channahon Park District Regarding The Creation Of A TIF Within The Village Of Channahon

---

WHEREAS, the Village of Channahon has activity been working since September 1997 to create a Tax Increment Finance District (TIF) FOR Aux Sable Liquid Products; and,

WHEREAS, the Village has consistently committed to communicating with Aux Sable Township, Minooka Grade School District 201, Minooka High School District 111, Minooka Fire Protection District, Three-Rivers Library District, Joliet Junior College District 525, The Aux Sable Township Highway Commission and Channahon Park District collectively referred to as the affected Taxing Bodies; and,

WHEREAS, the Village has held in excess of fifteen (15) meetings to foster communication and cooperation with all effected taxing bodies; and

WHEREAS, the Village has since its first meeting offered the taxing bodies an intergovernmental agreement guaranteeing certain performance by the Village during the length of the TIF; and,

WHEREAS, the Village, Aux Sable Liquid Product, and the Taxing Bodies have reached an agreement on the terms of the intergovernmental agreement.

NOW THEREFORE BE IT RESOLVED, that the Corporate Authorities of the Village of Channahon authorize the Village President to execute an Intergovernmental Agreement with the Taxing Bodies substantially in the form set forth in Exhibit "A" attached hereto.

PASSED this 2<sup>nd</sup> day of June, 1998 with 6 members voting aye 0 members voting nay, the President not voting, with 0 members absenting or passing and said vote being:

COOK ayf

BAKER ayf

MUENCH ayf

LYONS ayf

NASH ayf

GRECO ayf

Kay Muench  
Kay Muench, Deputy Village Clerk

APPROVED this 29<sup>th</sup> day of June, 1998

[Signature]  
Wayne W. Chesson, Village President

(SEAL)  
ATTEST:

Kay Muench  
Kay Muench, Deputy Village Clerk

## INTERGOVERNMENTAL AGREEMENT

This Agreement is made the \_\_\_\_ day of \_\_\_\_\_, 1998, by and between the VILLAGE OF CHANNAHON, WILL AND GRUNDY COUNTIES, ILLINOIS (hereinafter referred to as the "VILLAGE") and THE COUNTY OF GRUNDY, AUX SABLE TOWNSHIP, MINOOKA GRADE SCHOOL DISTRICT 201, MINOOKA HIGH SCHOOL DISTRICT 111, MINOOKA FIRE PROTECTION DISTRICT, THREE-RIVERS LIBRARY DISTRICT, JOLIET JUNIOR COLLEGE DISTRICT 525, THE AUX SABLE TOWNSHIP HIGHWAY COMMISSION, and CHANNAHON PARK DISTRICT (hereinafter sometimes collectively referred to as the "TAXING BODIES").

WHEREAS, the VILLAGE is a home rule municipal corporation pursuant to the statutes and Constitution of the State of Illinois; and

WHEREAS, the VILLAGE is situated in Will and Grundy Counties, Illinois; and

WHEREAS, the VILLAGE and the TAXING BODIES are entering into this Agreement based upon the Intergovernmental Cooperation provisions of the Illinois Constitution, the Intergovernmental Cooperation Act (5 ILCS 20/1 et seq) and such other applicable power and authority as may exist; and

WHEREAS, AUX SABLE Liquid Products L P (hereinafter referred to as "AUX SABLE") has requested that the VILLAGE create a Tax Increment Finance District ("TIF") on the property described in Exhibit "A" attached hereto (the "AUX SABLE SITE"); and

WHEREAS, AUX SABLE intends to acquire the Aux Sable site and design, construct and operate a natural gas liquids extraction plant (the "AUX SABLE PLANT") which plant is expected to have a total construction cost, including the acquisition of the AUX SABLE SITE of approximately \$200 Million Dollars; and

WHEREAS, the VILLAGE and the TAXING BODIES recognize that AUX SABLE will not make such investment unless the TIF is created and the economic incentives hereinafter set forth are provided; and

WHEREAS, it is contemplated that the VILLAGE will issue Revenue Bonds in an amount sufficient to yield an amount not to exceed Four Million One Hundred Thousand (\$4.1 million) Dollars in net proceeds to AUX SABLE which will be used by AUX SABLE to finance such redevelopment project costs as are permitted under the Tax Increment Allocation Redevelopment Act (65 ILCS 5/11-74.4-1 et seq) (the "TIF Act"). In addition to the aforesaid amount the bond issue will include an amount sufficient to pay the TIF eligible redevelopment project costs of AUX SABLE and the VILLAGE with regard to the fees and costs associated with the issuance of said Bonds and the creation of the TIF (hereinafter sometimes referred to as the "BONDS"); and

WHEREAS, such fees and TIF eligible Redevelopment project costs shall include without limitation, bond counsel fees, underwriters fees, bond agent fees, TIF consultant fees, attorney's fees and all other expenses authorized by the TIF Act ( hereinafter referred to as the "TIF FEES"); and

TIF.intsgm  
3rd draft  
02062998

1

WHEREAS, in addition to the bond proceeds available to AUX SABLE, it is contemplated that One Million Four Hundred Thousand (\$1.4 million) Dollars in net bond proceeds will be made available to the Minooka Fire Protection District to construct a public safety facility within the TIF area; and

WHEREAS, the Taxing Bodies have incurred fees and costs associated with the review of the TIF process and documents including fees paid to Kane, McKenna and Associates and fees paid to the legal counsel of some of the Taxing Bodies (hereinafter referred to as ("Taxing Bodies' Fees").

NOW, THEREFORE, for good and valuable consideration, the receipt and sufficiency of which is hereby acknowledged by the parties, BE IT AGREED AS FOLLOWS:

**Section 1. Incorporation of Preamble and Exhibits.**

The Preamble to this Agreement and any exhibits thereto are hereby incorporated into this Agreement as if fully set forth in this Section 1.

**Section 2. Creation of Tax Increment Finance District.**

The VILLAGE shall create the TIF, which TIF shall include the property described on Exhibit "A" attached hereto. The TIF shall be for a period of twenty-three (23) years and shall be subject to the terms and conditions of a Redevelopment Agreement between the VILLAGE and AUX SABLE. The Redevelopment Agreement shall include such terms and conditions as are required to effectuate the terms and conditions of this Agreement.

**Section 3. Distribution of TIF Proceeds.**

It is recognized that AUX SABLE will annually pay to the Grundy County Treasurer the amount of ad valorem taxes properly assessed against the Aux Sable Site and that said Treasurer will then pay over to the VILLAGE pursuant to TIF Act, the tax increment which results from the construction of the AUX SABLE PLANT (said tax increment is hereinafter sometimes referred to as the "INCREMENT"). The VILLAGE shall then deposit the Increment into a Special Tax Allocation Fund as provided in the TIF Act. After making all payments required by the bonds and all the TIF Fees, and other expenses related to administration of the TIF as permitted by the TIF Act; the VILLAGE shall distribute forty (40%) percent of the balance remaining in the Tax Allocation Fund to AUX SABLE or its designee for payment of TIF redevelopment project costs as permitted by the TIF Act and the sixty (60%) percent then remaining shall be declared as surplus and distributed in accordance with each tax district's percentage of the property tax bill as provided by the terms of the TIF Act.

The Taxing Bodies' Fees shall be paid from the Special Tax Allocation Fund prior to determination/distribution of Aux Sable's share unless such arrangement is not approved by the Village's TIF Counsel. In the event the Village's TIF Counsel makes a determination that all or any portion of the Taxing Bodies' Fees do not qualify as redevelopment project costs, then in that event, Aux Sable shall pay the Taxing Bodies' Fees which are not paid from the Increment. Provided further that the payment of the Taxing Bodies' Fees shall not

reduce the Village's share of revenues received.

Provided further that the Taxing Bodies' Fees shall not exceed Seventy Five Thousand Dollars (\$75,000).

**Section 4. Annual Audit.**

Each year of the TIF the VILLAGE shall cause an audit of all TIF funds to be conducted by a good and reputable certified public accounting firm in accordance with the TIF Act. A true and correct copy of each year's audit shall be distributed to each of the Taxing Bodies within one hundred eighty (180) days after close of the fiscal year. Additionally, the Village shall comply with all the requirements of the TIF Act.

**Section 5. Modification/Expansion of TIF.**

The VILLAGE shall not increase the geographical limits of the TIF, amend or modify the Redevelopment Agreement or change, alter, or modify the improvements subject to TIF benefits without first giving at least thirty (30) days prior written notice to the Taxing Bodies and any and all other notice required by law. Provided, however that the VILLAGE reserves the right to delete property from the TIF as provided in the TIF Act. Provided, further that it is recognized that the forty (40%) percent payment to AUX SABLE from the Special Tax Allocation Fund, as contemplated by paragraph 3 hereof, shall be limited to the increment created by the assessment from time to time of the proposed Aux Sable plant. While nothing herein shall prevent AUX SABLE from constructing ethane recovery and/or fractionation facilities ("the additional improvements") within the TIF, in the event that AUX SABLE (or an affiliated entity) desires "TIF benefits" for such additional improvements then, in addition to compliance with all applicable laws, the following process shall be followed:

1. AUX SABLE shall submit a written request to the VILLAGE requesting such additional TIF benefits. (The "Application").
2. The Application shall include all information reasonably necessary to demonstrate to the VILLAGE that additional TIF benefit is necessary to provide an economic incentive to AUX SABLE to locate within the TIF as opposed to another site.
3. The VILLAGE shall distribute a copy of the Application to each of the Taxing Bodies, within thirty days of receipt of the Application.
4. The Joint Review Board shall be reconvened and shall issue a recommendation with regard to the Application to the VILLAGE Board with thirty days thereafter.
5. The VILLAGE Board shall either grant or deny the Application in whole or in part. Provided however, that in no event shall the VILLAGE provide additional benefits which involve the issuance of bonds in amounts not authorized in Section 6 of this Agreement nor shall AUX SABLE'S share of

such additional benefits exceed twenty (20%) percent of the increment arising as a result of the assessed value created by the additional improvements. Provided, however, that such twenty (20%) percent amount may be increased with the written concurrence of the units of government representing at least seventy-five (75%) percent of the ad valorem property taxes properly levied against the Aux Sable site.

**Section 6. TIF Bond Issues.**

The VILLAGE may issue Revenue Bonds secured by the Increment in the following amounts and for the following purposes:

1. In an amount sufficient to pay the TIF Fees.
2. In an amount sufficient to produce Four Million One Hundred Thousand (\$4.1 million) Dollars in net proceeds to AUX SABLE to be used to pay for redevelopment project costs as permitted pursuant to the TIF Act.
3. In an amount sufficient to produce One Million Four Hundred Thousand (\$1.4 million) Dollars in net proceeds to be used by the Minooka Fire Protection District for the construction of a public safety building as set forth in paragraph 7 herein.

**Section 7. Public Safety Facility.**

The Minooka Fire Protection District shall utilize the One Million Four Hundred Thousand (\$1.4 million) Dollar bond proceeds to design and construct a public safety facility within the AUX SABLE TIF District. The VILLAGE shall provide in its Redevelopment Agreement with AUX SABLE that in addition to making said bond proceeds available to the Minooka Fire Protection District, that AUX SABLE donate to said Fire District a parcel of land (which donation may include such deed restrictions as appropriate to restrict the use of the property to the use herein contemplated) within the TIF approximately three (3) acres in size, said parcel shall be located adjacent to the Township parcel of land with frontage on U.S. Route 6 and shall be generally rectangular in shape. The public safety building constructed by the Fire District shall include approximately one thousand (1,000) square feet of appropriately finished space acceptable to the VILLAGE and shall be by its police and other departments. The VILLAGE and the Fire Protection District shall enter into a lease agreement whereby the VILLAGE will be permitted to occupy said space without the payment of rents or other charges for a period of 99 years.

**Section 8. VILLAGE Expense CAP.**

After payment of all TIF fees incurred in issuing bonds and establishing and/or defending the validity of the AUX SABLE TIF have been paid, the VILLAGE shall thereafter limit its annual expense payable by TIF funds to \$25,000.00 which amount shall be increased annually by an inflation factor of five (5%) percent. Provided, further that in the event that there is a change of law which will result in greater expenses to the VILLAGE than is required by the TIF Act as it exists on the date that the AUX SABLE TIF is

established then in that event, said \$25,000.00 amount shall be increased annually by the additional costs reasonably associated with such changes in law.

**Section 9. No Challenge to TIF.**

None of the Taxing Bodies or any of their agents, officers, board members, employees, or personnel shall in any manner, whether directly or indirectly, challenge or bring any action or make any claims, or threaten to challenge or bring any action or make any claim, or finance in whole or in part, any challenge, threat of challenge, action or claim respecting the TIF in any way whatsoever, including, but not limited to, whether the Aux Sable site or any other parcels annexed in conjunction with the annexation of the Aux Sable site and necessary for the Village to maintain contiguity with the Aux Sable site (the "Annexation Parcels") were validly and properly annexed, or whether the TIF was properly established so long as the TIF and its administration substantially conform with this Agreement and the geographical limits of the Aux Sable are not expanded beyond the area described in Exhibit "A". Also, none of the Taxing Bodies shall request that any other person or entity, including the State's Attorney of any county, or the Illinois Attorney General, challenge or bring any action or make any claim attacking the TIF in any manner whatsoever including, but not limited to whether the TIF was validly and properly created or the validity of the annexation of the AUX SABLE site (or any off the Annexation Parcels

**Section 10. Grundy County Zoning.**

In the event that any property in Grundy County is annexed to and later disconnected from the corporate limits of the VILLAGE, then in that event, Grundy County shall, upon request of the then property owner, take all actions necessary or appropriate to restore the zoning of said property as it existed on June 1, 1998.

**Section 11. Notice.**

Any notice required under this Agreement shall be sent by certified mail, return receipt requested, with sufficient postage attached thereto and shall be deemed given on the date of the post mark and shall be sent to:

If to the VILLAGE:

Village of Channahon  
Attn: Village Administrator  
24441 West Eames Street  
Channahon, IL 60410

With a copy to:

David J. Silverman  
Mahoney, Silverman & Cross, Ltd.  
805 West Jefferson Street  
Suite A  
Shorewood, IL 60431

If to any of the Taxing Districts then to the address set forth on the signature page hereof.

TIF.intgmn  
2nd draft  
02062998

**Section 12. Complete Agreement.**

This Agreement shall represent the complete agreement and understanding of the parties hereto with respect to all matters regarding the subject matter of this Agreement. All prior agreements or understandings, whether written or oral, shall be of no force, effect or consequence.

**Section 13. Amendment.**

Any amendment to this Agreement must be in writing, signed by each of the parties, and adopted in the same manner as is required for adoption of this Agreement.

**Section 14. Approval.**

This Agreement shall not be effective unless executed by all of the Taxing Bodies, further, each party shall approve this Agreement by ordinance or resolution after a lawful vote of its governing body.

**Section 15. Severability.**

This Agreement and every provision thereof, shall be considered severable. In the event that any court of competent jurisdiction may find and declare any word, phrase, clause, sentence, paragraph, provision or section or part of a phrase, clause, sentence, paragraph, provision or section of this Agreement is void or unconstitutional, the remaining words, phrases, clauses, sentences, paragraphs and provisions and parts of phrases, clauses, sentences, paragraphs, provisions and sections not ruled void or unconstitutional shall continue in full force and effect.

**Section 16. Certified Copies.**

Upon approval, each party shall provide to the VILLAGE twelve (12) executed copies of this Agreement together with twelve (12) certified copies of the Ordinance or Resolution approving this Agreement.

**Section 17. Multiple Counterparts.**

This Agreement may be executed in two (2) or more counterparts, each of which shall be deemed an original and all of which taken together shall be deemed one (1) Agreement.

**Section 18. Headings.**

All Section headings contained herein are for convenient reference only and shall not be deemed a part of the text of this Agreement.

TIF.intgmn  
3rd draft  
02062998

Executed this \_\_\_ day of \_\_\_\_\_, 1998.

VILLAGE OF CHANNAHON

By: \_\_\_\_\_  
Wayne W. Chesson, Its President

Attest: \_\_\_\_\_  
Christine Pucel, its Clerk

AUX SABLE TOWNSHIP

By: \_\_\_\_\_

Attest: \_\_\_\_\_

Notice to:  
\_\_\_\_\_  
\_\_\_\_\_  
\_\_\_\_\_

MINOOKA HIGH SCHOOL DISTRICT 111

By: \_\_\_\_\_

Attest: \_\_\_\_\_

Notice to:  
\_\_\_\_\_  
\_\_\_\_\_  
\_\_\_\_\_

THREE RIVERS LIBRARY DISTRICT

By: \_\_\_\_\_

Attest: \_\_\_\_\_

Notice to:  
\_\_\_\_\_  
\_\_\_\_\_  
\_\_\_\_\_

GRUNDY COUNTY

By: \_\_\_\_\_

Attest: \_\_\_\_\_

Notice to:  
\_\_\_\_\_  
\_\_\_\_\_  
\_\_\_\_\_

MINOOKA GRADE SCHOOL DISTRICT 201

By: \_\_\_\_\_

Attest: \_\_\_\_\_

Notice to:  
\_\_\_\_\_  
\_\_\_\_\_  
\_\_\_\_\_

MINOOKA FIRE PROTECTION DISTRICT

By: \_\_\_\_\_

Attest: \_\_\_\_\_

Notice to:  
\_\_\_\_\_  
\_\_\_\_\_  
\_\_\_\_\_

JOLIET JUNIOR COLLEGE DISTRICT 525

By: \_\_\_\_\_

Attest: \_\_\_\_\_

Notice to:  
\_\_\_\_\_  
\_\_\_\_\_  
\_\_\_\_\_

TIF.intlgn  
nd draft  
02062998

**AUX SABLE TOWNSHIP HIGHWAY  
COMMISSIONER**

By: \_\_\_\_\_

Attest: \_\_\_\_\_

Notice to:  
\_\_\_\_\_  
\_\_\_\_\_  
\_\_\_\_\_

**CHANNAHON PARK DISTRICT**

By: \_\_\_\_\_

Attest: \_\_\_\_\_

Notice to:  
\_\_\_\_\_  
\_\_\_\_\_  
\_\_\_\_\_

TIF.intgmn  
2nd draft  
02062998



**INTERGOVERNMENTAL AGREEMENT**

This Agreement is made the 8<sup>th</sup> day of September 1998, by and between the VILLAGE OF CHANNAHON, WILL AND GRUNDY COUNTIES, ILLINOIS (hereinafter referred to as the "VILLAGE") and THE COUNTY OF GRUNDY, AUX SABLE TOWNSHIP, MINOOKA GRADE SCHOOL DISTRICT 201, MINOOKA HIGH SCHOOL DISTRICT 111, MINOOKA FIRE PROTECTION DISTRICT, THREE-RIVERS LIBRARY DISTRICT, JOLIET JUNIOR COLLEGE DISTRICT 525, , and CHANNAHON PARK DISTRICT (hereinafter sometimes collectively referred to as the "TAXING BODIES").

WHEREAS, the VILLAGE is a home rule municipal corporation pursuant to the statutes and Constitution of the State of Illinois; and

WHEREAS, the Taxing Bodies and the VILLAGE are herein sometimes referred to as the "Taxing Districts"; and

WHEREAS, the VILLAGE is situated in Will and Grundy Counties, Illinois; and

WHEREAS, the VILLAGE and the TAXING BODIES are entering into this Agreement based upon the Intergovernmental Cooperation provisions of the Illinois Constitution, the Intergovernmental Cooperation Act (5 ILCS 20/1 et seq) and such other applicable power and authority as may exist; and

WHEREAS, AUX SABLE Liquid Products L P (hereinafter referred to as "AUX SABLE") has requested that the VILLAGE create a Tax Increment Finance District ("TIF") on the property described in Exhibit "A" attached hereto (the "AUX SABLE SITE"); and

WHEREAS, AUX SABLE intends to acquire the Aux Sable site and design, construct and operate a natural gas liquids extraction plant as further described/depicted on Exhibit "B" attached hereto, (the "AUX SABLE PLANT") which plant is expected to have a total construction cost, including the acquisition of the AUX SABLE SITE of approximately \$200 Million Dollars; and

WHEREAS, the VILLAGE and the TAXING BODIES recognize that AUX SABLE will not make such investment unless the TIF is created and the economic incentives hereinafter set forth are provided; and

WHEREAS, it is contemplated that the VILLAGE will issue Revenue Bonds in an amount sufficient to yield an amount not to exceed Four Million One Hundred Thousand (\$4.1 million) Dollars in net proceeds to AUX SABLE which will be used by AUX SABLE to finance such Redevelopment Project Costs as are generally described in the Redevelopment Plan and Project and are permitted under the Tax Increment Allocation Redevelopment Act (65 ILCS 5/11-74.4-1 et seq) (the "TIF Act"). In addition to the aforesaid amount the bond issue will include an amount sufficient to pay the TIF eligible redevelopment project costs of AUX SABLE and the VILLAGE with regard to the fees and costs associated with the issuance of said Bonds and the creation of the TIF (hereinafter sometimes referred to as the

"BONDS"); and

WHEREAS, such fees which are TIF eligible Redevelopment Project Costs shall include without limitation, bond counsel fees, underwriters fees, bond agent fees, TIF consultant fees, attorney's fees and all other expenses authorized by the TIF Act (hereinafter referred to as the "TIF FEES"); and

WHEREAS, in addition to the bond proceeds available to AUX SABLE, One Million Four Hundred Thousand (\$1.4 million) Dollars in net bond proceeds shall be made available to the Minooka Fire Protection District at the closing of the bonds to construct a public safety facility within the TIF area; and

WHEREAS, the Taxing Bodies have incurred fees and costs associated with the review of the TIF process and documents including fees paid to Kane, McKenna and Associates and fees paid to the legal counsel of some of the Taxing Bodies (hereinafter referred to as ("Taxing Bodies' Fees").

NOW, THEREFORE, for good and valuable consideration, the receipt and sufficiency of which is hereby acknowledged by the parties, BE IT AGREED AS FOLLOWS:

**Section 1. Incorporation of Preamble and Exhibits.**

The Preamble to this Agreement and any exhibits thereto are hereby incorporated into this Agreement as if fully set forth in this Section 1.

**Section 2. Creation of Tax Increment Finance District.**

The VILLAGE shall create the TIF, which TIF shall include the property described on Exhibit "A" attached hereto. The TIF shall be for a period of twenty-three (23) years and shall be subject to the terms and conditions of a Redevelopment Agreement between the VILLAGE and AUX SABLE and any Ordinance or Resolution approved pursuant to the bonds. The Redevelopment Agreement, a copy of which shall be supplied to each of the Taxing Bodies, shall include such terms and conditions as are required to effectuate the terms and conditions of this Agreement.

**Section 3. Distribution of TIF Proceeds.**

It is recognized that Aux Sable will annually pay to the Grundy County Treasurer the amount of ad valorem property taxes properly levied against the respective properties constituting the Tax Increment Finance District, and that the Treasurer will then pay over to the Village, pursuant to the Tax Increment Allocation Redevelopment Act (the "TIF Act") (65 ILCS 5/11-74.4-1, et seq.), the portion of such taxes attributable to the increase in the current equalized assessed valuation of each of the taxable parcels constituting the site and TIF district, over the initial equalized assessed value of each such parcel ("Increment").

The Village shall then deposit the Increment into a Special Tax Allocation Fund as

provided in the TIF Act. From the Special Tax Allocation Fund into which such incremental taxes are deposited, the Village shall first pay debt service on the bonds issued for project costs as herein described, and shall maintain such reserves and redemption requirements as are certified as required by the bond underwriters (hereinafter collectively referred to as "debt service requirements"). It is agreed that, notwithstanding the distributions hereinafter described, the debt service requirements shall constitute a first priority and lien on the Special Tax Allocation Fund.

The Village shall annually distribute the balance of the fund [less appropriate costs of administration as set forth in Section 9] as follows:

- a. not less than sixty percent (60%) of the balance of the fund, which is properly attributable to the taxable improvements constituting the Aux Sable Plant as determined by the Grundy county Supervisor of Assessments, shall annually be deemed surplus funds by the Village and shall be paid over to Grundy County Treasurer for redistribution to the Taxing Districts in accordance with Section 7 of the Act (65 ILCS 5/11-74.4-7);
- b. not more than forty percent (40%) of the balance of the fund, which is properly attributable to the Aux Sable Plant improvements, as determined by the Grundy County Supervisor of Assessments, shall annually be paid or pledged for redevelopment project costs as permitted by the Act; and
- c. The balance of the fund properly attributable to taxable improvements within the TIF as determined by the Grundy County Supervisor of Assessments, shall also be distributed in accordance with Section 6 of this Agreement.

#### **Section 4. Payment of Taxing Bodies' Fees.**

The Taxing Bodies' fees shall be paid from the first available incremental tax deposits to the Special Tax Allocation Fund not otherwise required for debt service, and prior to the distribution of any balance of the Fund in accordance with Section 3 of this Agreement unless such arrangement is not approved by the Village's TIF Counsel. In the event the Village's TIF Counsel makes a determination that all or any portion of the Taxing Bodies' Fees do not qualify as Redevelopment Project Costs, then in that event, Aux Sable shall, prior to receiving any distribution from the Fund, pay the Taxing Bodies' Fees which are not paid from the Increment. The Village agrees that it shall include the obligation for Aux Sable's payment of the Taxing Bodies' Fees in the annexation and/or redevelopment agreements for the Aux Sable site.

The payment of the Taxing Bodies' Fees shall not reduce the amount otherwise payable to the Village in accordance with the surplus distributions to the Taxing Districts as provided herein and shall not exceed \$75,000.00.

## **Section 5. Annual Audit.**

Each year of the TIF the VILLAGE shall cause an audit of all TIF funds to be conducted by a good and reputable certified public accounting firm in accordance with the TIF Act. A true and correct copy of each year's audit shall be distributed to each of the Taxing Bodies within one hundred eighty (180) days after close of the fiscal year. Additionally, the Village shall comply with all the requirements of the TIF Act.

## **Section 6. Modification/Expansion of TIF.**

The VILLAGE shall not increase the geographical limits of the TIF, amend or modify the Redevelopment Agreement or change, alter, or modify the improvements subject to TIF benefits without full compliance with the TIF Act and first giving at least thirty (30) days prior written notice to the Taxing Bodies and any and all other notice required by law. Provided, however that the VILLAGE reserves the right to delete property from the TIF as provided in the TIF Act. Provided, further that it is recognized that the forty (40%) percent payment to AUX SABLE from the Special Tax Allocation Fund, as contemplated by paragraph 3 hereof, shall be limited to the increment created by the assessment from time to time of the proposed Aux Sable Plant. While nothing herein shall prevent AUX SABLE from constructing ethane recovery and/or fractionation facilities or other additional improvements ("the additional improvements") within the TIF, in the event that AUX SABLE (or an affiliated entity) desires "TIF benefits" for such additional improvements then, in addition to compliance with all applicable laws, the following process shall be followed:

1. AUX SABLE shall submit a written request to the VILLAGE requesting such additional TIF benefits. (The "Application").
2. The Application shall include all information reasonably necessary to demonstrate to the VILLAGE that additional TIF benefit is necessary to provide an economic incentive to AUX SABLE to locate within the TIF as opposed to another site.
3. The VILLAGE shall distribute a copy of the Application to each of the Taxing Bodies, within thirty days of receipt of the Application.
4. The Joint Review Board shall be reconvened within thirty (30) days of the Taxing Bodies' receipt of the application and shall issue a recommendation with regard to the Application to the VILLAGE Board within thirty days after the Joint Review Board has recovered.
5. The VILLAGE Board shall either grant or deny the Application in whole or in part. Provided however, that in no event shall the VILLAGE provide additional benefits which involve the issuance of bonds in amounts not authorized in Section 7 of this Agreement nor shall AUX SABLE'S share of such additional benefits exceed twenty (20%) percent of the increment arising as a result of the assessed value created by the additional

improvements. Provided, however, that such twenty (20%) percent amount may be increased with the written concurrence of the units of government representing at least seventy-five (75%) percent of the ad valorem property taxes properly levied against the Aux Sable site.

**Section 7. TIF Bond Issues.**

- A. The VILLAGE shall issue Revenue Bonds secured by the Increment in the following amounts and for the following purposes (the Revenue Bonds):
  - 1. In an amount sufficient to pay the TIF Fees.
  - 2. In an amount sufficient to produce Four Million One Hundred Thousand (\$4.1 million) Dollars in net proceeds to AUX SABLE to be used to pay for Redevelopment Project Costs as permitted pursuant to the TIF Act. In the event that Aux Sable does not have \$4.1 million in bond eligible Redevelopment Project Costs, the amount of the bond issue under this Section shall be reduced accordingly.
- B. The Village shall issue Revenue Bonds in an amount sufficient to produce One Million Four Hundred Thousand (\$1.4 million) Dollars in net proceeds to be used by the Minooka Fire Protection District for the construction of a public safety building as set forth in paragraph 8 herein. In the event the Minooka Fire Protection District does not require \$1.4 million Dollars to complete the public safety building the amount of the bond issued under this section shall be reduced accordingly.
- C. The Village shall not issue the Revenue Bonds described in paragraph A without issuing the Revenue Bonds described in paragraph 7(B).
- D. Any Revenue Bonds issued may include commercially reasonable capitalized interest and reserves and payment/reimbursement of TIF eligible Redevelopment Project fees and costs.

**Section 8. Public Safety Facility.**

The Minooka Fire Protection District shall utilize the One Million Four Hundred Thousand (\$1.4 million) Dollar bond proceeds to design and construct a public safety facility within the AUX SABLE TIF District. The VILLAGE shall provide in its Redevelopment Agreement with AUX SABLE that in addition to making said bond proceeds available to the Minooka Fire Protection District, that AUX SABLE donate to said Fire District a parcel of land (which donation may include such deed restrictions as appropriate to restrict the use of the property to the use herein contemplated) within the TIF approximately three (3) acres in size, said parcel shall be located adjacent to the Township parcel of land with frontage on U.S. Route 6 and shall be generally rectangular in shape. The public safety building constructed by the Fire District shall include approximately one

thousand (1,000) square feet of appropriately finished space acceptable to the VILLAGE and shall be by its police and other departments. The VILLAGE and the Fire Protection District shall enter into a lease agreement whereby the VILLAGE will be permitted to occupy said space without the payment of rents or other charges except reasonable costs of operation and maintenance of the Village's facility for a period of 99 years.

**Section 9. VILLAGE Expense CAP.**

After payment of all TIF fees incurred in issuing bonds and establishing and/or defending the validity of the AUX SABLE TIF have been paid, the VILLAGE shall thereafter limit its annual expense payable by TIF funds to \$25,000.00 which amount shall be increased annually by an inflation factor of five (5%) percent. Provided, further that in the event that there is a change of law which will result in greater expenses to the VILLAGE than is required by the TIF Act as it exists on the date that the AUX SABLE TIF is established then in that event, said \$25,000.00 amount shall be increased annually by the additional costs reasonably associated with such changes in law.

**Section 10. No Challenge to TIF.**

None of the Taxing Bodies or any of their agents, officers, board members, employees, or personnel shall in any manner, whether directly or indirectly, challenge or bring any action or make any claims, or threaten to challenge or bring any action or make any claim, or finance in whole or in part, any challenge, threat of challenge, action or claim respecting the TIF in any way whatsoever, are including, but not limited to, whether the Aux Sable site or any other parcels annexed in conjunction with the annexation of the Aux Sable site and necessary for the Village to maintain contiguity with the Aux Sable site (the "Annexation Parcels") which annexation parcels are described in Exhibit "C" attached hereto were validly and properly annexed, or whether the TIF was properly established hereinafter collectively referred to as "TIF Challenges" so long as the TIF and its administration substantially conform with this Agreement and the geographical limits of the Aux Sable TIF are not expanded beyond the area described in Exhibit "A". Also, none of the Taxing Bodies shall request that any other person or entity, including the State's Attorney of any county, or the Illinois Attorney General, challenge or bring any action or make any claim attacking the TIF in any manner whatsoever including, but not limited to whether the TIF was validly and properly created or the validity of the annexation of the AUX SABLE site (or any off the Annexation Parcels). This Agreement shall not prohibit TIF Challenges in the event that the Village materially breaches this Agreement. Further, this Agreement shall not prohibit the Taxing Districts from challenging any other additional Tax Increment Finance District which might be created by the Village.

**Section 11. Grundy County Zoning.**

In the event that any property in Grundy County is annexed to and later disconnected from the corporate limits of the VILLAGE, then in that event, Grundy County shall, upon request of the then property owner, take all actions necessary or appropriate to restore the zoning of said property as it existed on June 1, 1998.

**Section 12. Notice.**

Any notice required under this Agreement shall be sent by certified mail, return receipt requested, with sufficient postage attached thereto and shall be deemed given on the date of the post mark and shall be sent to:

If to the VILLAGE:

Village of Channahon  
Attn: Village Administrator  
24441 West Eames Street  
Channahon, IL 60410

With a copy to:

David J. Silverman  
Mahoney, Silverman & Cross, Ltd.  
805 West Jefferson Street  
Suite A  
Shorewood, IL 60431

If to any of the Taxing Districts then to the address set forth on the signature page hereof.

**Section 13. Complete Agreement.**

This Agreement shall represent the complete agreement and understanding of the parties hereto with respect to all matters regarding the subject matter of this Agreement. All prior agreements or understandings, whether written or oral, shall be of no force, effect or consequence.

**Section 14. Amendment.**

Any amendment to this Agreement must be in writing, signed by each of the parties, and adopted in the same manner as is required for adoption of this Agreement.

**Section 15. Approval.**

This Agreement shall not be effective unless executed by all of the Taxing Districts, further, each party shall approve this Agreement by ordinance or resolution after a lawful vote of its governing body. Provided further that this Agreement shall not be effective until the Village adopts by Resolution the Intergovernmental Agreement attached hereto marked as Exhibit "D".

**Section 16. Severability.**

This Agreement and every provision thereof, shall be considered severable. In the event that any court of competent jurisdiction may find and declare any word, phrase, clause, sentence, paragraph, provision or section or part of a phrase, clause, sentence,

paragraph, provision or section of this Agreement is void or unconstitutional, the remaining words, phrases, clauses, sentences, paragraphs and provisions and parts of phrases, clauses, sentences, paragraphs, provisions and sections not ruled void or unconstitutional shall continue in full force and effect.

**Section 17. Certified Copies.**

Upon approval, each party shall provide to the VILLAGE twelve (12) executed copies of this Agreement together with twelve (12) certified copies of the Ordinance or Resolution approving this Agreement.

**Section 18. Multiple Counterparts.**

This Agreement may be executed in two (2) or more counterparts, each of which shall be deemed an original and all of which taken together shall be deemed one (1) Agreement.

**Section 19. Headings.**

All Section headings contained herein are for convenient reference only and shall not be deemed a part of the text of this Agreement.

**Section 20. Term.**

This Agreement shall continue in full force and effect until the distribution of the last payment to the Taxing Districts from the Special Tax Allocation Fund and approval of the final audit of the Village's Special Tax Allocation Fund.

Executed this 5<sup>th</sup> day of September, 1998.

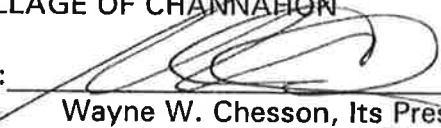
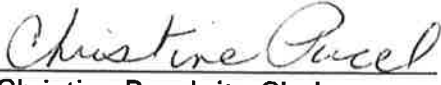
VILLAGE OF CHANNAHON  
By:   
Wayne W. Chesson, Its President  
Attest:   
Christine Pucel, its Clerk

GRUNDY COUNTY  
By: \_\_\_\_\_  
Attest: \_\_\_\_\_  
Notice to:  
\_\_\_\_\_  
\_\_\_\_\_  
\_\_\_\_\_

AUX SABLE TOWNSHIP  
By: \_\_\_\_\_  
Attest: \_\_\_\_\_

RESOLUTION

WHEREAS, the Aux Sable Township Board (the Board) has reviewed a proposed Intergovernmental Agreement (the Agreement) between various taxing bodies and the Village of Channahon; and

WHEREAS the Board has determined that it is in the Township's interest to enter into said Intergovernmental Agreement.

THEREFORE BE IT RESOLVED that the Aux Sable Township Board hereby approves the proposed Intergovernmental Agreement concerning the development of the Aux Sable Liquid Products plant site and the formation of a Tax Increment Finance District by the Village of Channahon.

BE IT FURTHER RESOLVED that the Township Supervisor and the Township Clerk are authorized to execute the Intergovernmental Agreement on the Township's behalf.

Dated: September 12, 1998



Mr. Leonard Bols, Aux Sable  
Township Supervisor

ATTEST:

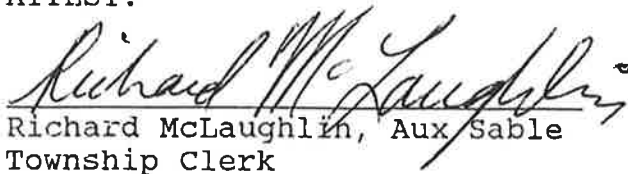

Richard McLaughlin, Aux Sable  
Township Clerk

Ayes 4

Nays 0

Abstains 0

Absent 1

paragraph, provision or section of this Agreement is void or unconstitutional, the remaining words, phrases, clauses, sentences, paragraphs and provisions and parts of phrases, clauses, sentences, paragraphs, provisions and sections not ruled void or unconstitutional shall continue in full force and effect.

**Section 17. Certified Copies.**

Upon approval, each party shall provide to the VILLAGE twelve (12) executed copies of this Agreement together with twelve (12) certified copies of the Ordinance or Resolution approving this Agreement.

**Section 18. Multiple Counterparts.**

This Agreement may be executed in two (2) or more counterparts, each of which shall be deemed an original and all of which taken together shall be deemed one (1) Agreement.

**Section 19. Headings.**

All Section headings contained herein are for convenient reference only and shall not be deemed a part of the text of this Agreement.

**Section 20. Term.**

This Agreement shall continue in full force and effect until the distribution of the last payment to the Taxing Districts from the Special Tax Allocation Fund and approval of the final audit of the Village's Special Tax Allocation Fund.

Executed this \_\_\_ day of \_\_\_\_\_, 1998.

VILLAGE OF CHANNAHON

GRUNDY COUNTY

By: \_\_\_\_\_  
Wayne W. Chesson, Its President

By: \_\_\_\_\_

Attest: \_\_\_\_\_  
Christine Pucel, its Clerk

Attest: \_\_\_\_\_

Notice to:  
\_\_\_\_\_  
\_\_\_\_\_  
\_\_\_\_\_

AUX SABLE TOWNSHIP

By: *[Signature]*

Attest: *[Signature]*

Notice to:

Leonard Bols  
7465 East Route 6  
Minooka, IL 60447

MINOOKA HIGH SCHOOL DISTRICT 111

By: \_\_\_\_\_

Attest: \_\_\_\_\_

Notice to:

\_\_\_\_\_  
\_\_\_\_\_  
\_\_\_\_\_

THREE RIVERS LIBRARY DISTRICT

By: \_\_\_\_\_

Attest: \_\_\_\_\_

Notice to:

\_\_\_\_\_  
\_\_\_\_\_  
\_\_\_\_\_

AUX SABLE TOWNSHIP HIGHWAY  
COMMISSIONER

By: \_\_\_\_\_

Attest: \_\_\_\_\_

Notice to:

\_\_\_\_\_  
\_\_\_\_\_  
\_\_\_\_\_

MINOOKA GRADE SCHOOL DISTRICT  
201

By: \_\_\_\_\_

Attest: \_\_\_\_\_

Notice to:

\_\_\_\_\_  
\_\_\_\_\_  
\_\_\_\_\_

MINOOKA FIRE PROTECTION DISTRICT

By: \_\_\_\_\_

Attest: \_\_\_\_\_

Notice to:

\_\_\_\_\_  
\_\_\_\_\_  
\_\_\_\_\_

JOLIET JUNIOR COLLEGE DISTRICT 525

By: \_\_\_\_\_

Attest: \_\_\_\_\_

Notice to:

\_\_\_\_\_  
\_\_\_\_\_  
\_\_\_\_\_

CHANNAHON PARK DISTRICT

By: \_\_\_\_\_

Attest: \_\_\_\_\_

Notice to:

\_\_\_\_\_  
\_\_\_\_\_  
\_\_\_\_\_

paragraph, provision or section of this Agreement is void or unconstitutional, the remaining words, phrases, clauses, sentences, paragraphs and provisions and parts of phrases, clauses, sentences, paragraphs, provisions and sections not ruled void or unconstitutional shall continue in full force and effect.

**Section 17. Certified Copies.**

Upon approval, each party shall provide to the VILLAGE twelve (12) executed copies of this Agreement together with twelve (12) certified copies of the Ordinance or Resolution approving this Agreement.

**Section 18. Multiple Counterparts.**

This Agreement may be executed in two (2) or more counterparts, each of which shall be deemed an original and all of which taken together shall be deemed one (1) Agreement.

**Section 19. Headings.**

All Section headings contained herein are for convenient reference only and shall not be deemed a part of the text of this Agreement.

**Section 20. Term.**

This Agreement shall continue in full force and effect until the distribution of the last payment to the Taxing Districts from the Special Tax Allocation Fund and approval of the final audit of the Village's Special Tax Allocation Fund.

Executed this 8<sup>th</sup> day of September, 1998.

VILLAGE OF CHANNAHON

By: \_\_\_\_\_  
Wayne W. Chesson, Its President

Attest: \_\_\_\_\_  
Christine Pucel, its Clerk

AUX SABLE TOWNSHIP

By: \_\_\_\_\_

Attest: \_\_\_\_\_

GRUNDY COUNTY

By: Donald R. Langman

Attest: Rosa J. Phillips

Notice to:  
Chairman, Grundy County Board  
1320 Union St.  
\_\_\_\_\_  
Morris, IL. 60450

Notice to:

\_\_\_\_\_  
\_\_\_\_\_  
\_\_\_\_\_

MINOOKA HIGH SCHOOL DISTRICT 111

By: Larry Larson

Attest: Kim Ledbetter

Notice to:

Superintendent of Schools  
301 S. Wabena  
Minooka, IL 60447

THREE RIVERS LIBRARY DISTRICT

By: \_\_\_\_\_

Attest: \_\_\_\_\_

Notice to:

\_\_\_\_\_  
\_\_\_\_\_  
\_\_\_\_\_

AUX SABLE TOWNSHIP HIGHWAY  
COMMISSIONER

By: \_\_\_\_\_

Attest: \_\_\_\_\_

Notice to:

\_\_\_\_\_  
\_\_\_\_\_  
\_\_\_\_\_

MINOOKA GRADE SCHOOL DISTRICT  
201

By: Craig R. Williams

Attest: Judith A. Block

Notice to:

Superintendent of Schools  
400 Coady Drive  
Minooka, IL 60447

MINOOKA FIRE PROTECTION DISTRICT

By: \_\_\_\_\_

Attest: \_\_\_\_\_

Notice to:

\_\_\_\_\_  
\_\_\_\_\_  
\_\_\_\_\_

JOLIET JUNIOR COLLEGE DISTRICT 525

By: \_\_\_\_\_

Attest: \_\_\_\_\_

Notice to:

\_\_\_\_\_  
\_\_\_\_\_  
\_\_\_\_\_

CHANNAHON PARK DISTRICT

By: \_\_\_\_\_

Attest: \_\_\_\_\_

Notice to:

\_\_\_\_\_  
\_\_\_\_\_  
\_\_\_\_\_

**THREE RIVERS PUBLIC LIBRARY DISTRICT**  
**Channahon and Minooka, Illinois**

**STATE OF ILLINOIS)**  
**COUNTIES OF WILL)                   SS:**  
**GRUNDY & KENDALL)**

**CERTIFICATION OF RESOLUTION 98-R1**

The undersigned, Ivan Kimble, hereby certifies that he is the Secretary of the Board of Library Trustees of the Three Rivers Public Library District of Will, Grundy and Kendall Counties, Illinois; that he was duly elected, has qualified and is now acting as Secretary of the Board; that he is the keeper of the records and seal of said District and that the document attached hereto is a true, complete and correct copy of Resolution 1 "A Resolution Adopting the Channahon TIF Intergovernmental Agreement (6th draft) [98-R1] which was duly passed by the Board of Library Trustees of this same District on 2 September, 1998 and which Resolution has been filed with the undersigned Secretary of the Three Rivers Public Library District and is now in full force and effect.

IN WITNESS THEREOF, the undersigned has set his signature, affixed the corporate seal of the Three Rivers Public Library District of Will, Grundy and Kendall Counties, Illinois this 2th day of September, 1998.

  
\_\_\_\_\_  
Ivan Kimble, Secretary  
Board of Library Trustees  
Three Rivers Public Library District

**THREE RIVERS PUBLIC LIBRARY DISTRICT  
Channahon and Minooka, Illinois**

**RESOLUTION 98-R1**

**A RESOLUTION ADOPTING THE CHANNAHON TIF  
INTERGOVERNMENTAL AGREEMENT (6<sup>TH</sup> DRAFT)**

WHEREAS, the Three Rivers Public Library District of Will, Grundy and Kendall Counties, Illinois is interested in increasing revenues, and;

WHEREAS, the District has been made aware of a proposed Aux Sable Liquid Products plant, and:

WHEREAS, this plant and its economic impact on the District has been discussed, and:

WHEREAS, the library district will realize tax revenues from this venture:

NOW, THEREFORE BE IT RESOLVED BY THE BOARD OF LIBRARY TRUSTEES OF THE THREE RIVERS PUBLIC LIBRARY DISTRICT OF WILL, GRUNDY AND KENDALL COUNTIES, ILLINOIS AS FOLLOWS:

1. That the above preamble is hereby incorporated and made part of this resolution.
2. That the document known as the INTERGOVERNMENTAL AGREEMENT (6<sup>TH</sup> DRAFT) hereby be adopted at the regular Board meeting, September 2, 1998.

This resolution (98-R1) was adopted this 2<sup>nd</sup> day of September, 1998 by a majority vote of the Library Trustees present.

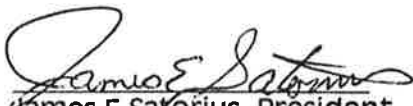

James E. Satorius, President  
Board of Library Trustees  
Three Rivers Public Library District

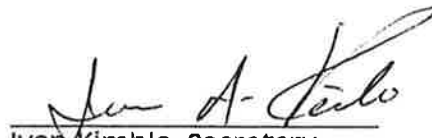

Ivan Kimble, Secretary  
Board of Library Trustees  
Three Rivers Public Library District

Notice to:  
\_\_\_\_\_  
\_\_\_\_\_  
\_\_\_\_\_

MINOOKA HIGH SCHOOL DISTRICT 111

By: \_\_\_\_\_

Attest: \_\_\_\_\_

Notice to:  
\_\_\_\_\_  
\_\_\_\_\_  
\_\_\_\_\_

THREE RIVERS LIBRARY DISTRICT

By: James E Satorius  
President/Board of Library Trustees

Attest: Jul A Satorius  
Secretary/Board of Library Trustees

Notice to:  
James E Satorius/ Three Rivers Library  
PO Box 300  
Channahon IL 60410-0300

AUX SABLE TOWNSHIP HIGHWAY COMMISSIONER

By: \_\_\_\_\_

Attest: \_\_\_\_\_

Notice to:  
\_\_\_\_\_  
\_\_\_\_\_  
\_\_\_\_\_

MINOOKA GRADE SCHOOL DISTRICT 201

By: \_\_\_\_\_

Attest: \_\_\_\_\_

Notice to:  
\_\_\_\_\_  
\_\_\_\_\_  
\_\_\_\_\_

MINOOKA FIRE PROTECTION DISTRICT

By: \_\_\_\_\_

Attest: \_\_\_\_\_

Notice to:  
\_\_\_\_\_  
\_\_\_\_\_  
\_\_\_\_\_

JOLIET JUNIOR COLLEGE DISTRICT 525

By: \_\_\_\_\_

Attest: \_\_\_\_\_

Notice to:  
\_\_\_\_\_  
\_\_\_\_\_  
\_\_\_\_\_

CHANNAHON PARK DISTRICT

By: \_\_\_\_\_

Attest: \_\_\_\_\_

Notice to:  
\_\_\_\_\_  
\_\_\_\_\_  
\_\_\_\_\_

STATE OF ILLINOIS            )  
  )  
COUNTIES OF GRUNDY,        )  
KENDALL AND WILL            )

SS

**SECRETARY'S CERTIFICATE**

I, Angela Robinson, the duly qualified and acting Secretary of the Board of Trustees of the Minooka Fire Protection District, Grundy, Kendall and Will Counties, Illinois, do hereby certify that attached hereto is a true and correct copy of an Ordinance entitled:

ORDINANCE NO. 98 01

**AN ORDINANCE AUTHORIZING AN INTERGOVERNMENTAL AGREEMENT BY THE MINOOKA FIRE PROTECTION DISTRICT**

which Ordinance was duly adopted by said Board of Trustees at a meeting held on the 11th day of August, 1998.

I do further certify that a quorum of said Board of Trustees was present at said meeting, and that the Board complied with all requirements of the Illinois Open Meetings Act.

IN WITNESS WHEREOF, I have hereunto set my hand this 11th day of August, 1998.

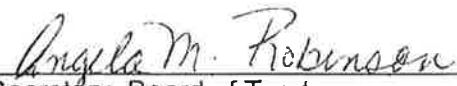
  
\_\_\_\_\_  
Secretary, Board of Trustees  
Minooka Fire Protection District

ORDINANCE NO. 98-01

**AN ORDINANCE AUTHORIZING AN INTERGOVERNMENTAL AGREEMENT BY THE MINOOKA FIRE PROTECTION DISTRICT**

**WHEREAS**, the Board of Trustees (the "Board") of the Minooka Fire Protection District, Grundy, Kendall and Will Counties, Illinois, (the "District") has the authority to enter into intergovernmental agreements; and

**WHEREAS**, Article VII, Section 10 of the Illinois Constitution of 1970 authorizes units of local government to cooperate with each other in order to accomplish common goals and objectives; and

**WHEREAS**, 5 ILCS 220/3 entitled "Intergovernmental Cooperation Act", provides that any power or powers, privilege or authority exercised or which may be exercised by a public agency may be exercised and enjoyed jointly with any other public agency; and

**WHEREAS**, 5 ILCS 220/2 defines a public agency as "any unit of local government;" and

**WHEREAS**, the District, as a unit of local government, is a public agency as defined by statute; and

**WHEREAS**, the Board has determined that it is in the best interest of the District to enter into an Intergovernmental Agreement regarding the creation of a tax increment financing ("TIF") district, the division of TIF-related tax revenues between Aux Sable Liquid Products L.P. and the governmental bodies serving the site and to establish other TIF-related benefits for the various parties to the Intergovernmental Agreement.

**NOW, THEREFORE, Be It Ordained**, by the Board of Trustees of the Minooka Fire Protection District, Grundy, Kendall and Will Counties, Illinois, as follows:

**Section One:** The President and Secretary are authorized to enter into an Intergovernmental Agreement in substantially the same form as the "Intergovernmental Agreement" attached hereto and made a part hereof as **EXHIBIT A**.

Section Two: This Ordinance shall be in full force and effect upon its adoption and shall supersede any agreement, ordinance, resolution, or motion, or part of any agreement, ordinance, resolution, or motion in conflict with any part herein, any such agreement, ordinance, resolution, or motion or part thereof is hereby repealed.

ADOPTED this 11th day of August, 1998, by a roll call vote as follows:

AYES: D. Bolte, A. Robinson, D. Roberts

NAYS: N/A

ABSENT: L. Nelson, D. Thompson

  
\_\_\_\_\_  
President, Board of Trustees  
Minooka Fire Protection District

ATTEST:

  
\_\_\_\_\_  
Secretary, Board of Trustees  
Minooka Fire Protection District

Notice to:

\_\_\_\_\_  
\_\_\_\_\_  
\_\_\_\_\_

MINOOKA HIGH SCHOOL DISTRICT 111

By: \_\_\_\_\_

Attest: \_\_\_\_\_

Notice to:

\_\_\_\_\_  
\_\_\_\_\_  
\_\_\_\_\_

THREE RIVERS LIBRARY DISTRICT

By: \_\_\_\_\_

Attest: \_\_\_\_\_

Notice to:

\_\_\_\_\_  
\_\_\_\_\_  
\_\_\_\_\_

AUX SABLE TOWNSHIP HIGHWAY  
COMMISSIONER

By: \_\_\_\_\_

Attest: \_\_\_\_\_

Notice to:

\_\_\_\_\_  
\_\_\_\_\_  
\_\_\_\_\_

MINOOKA GRADE SCHOOL DISTRICT  
201

By: \_\_\_\_\_

Attest: \_\_\_\_\_

Notice to:

\_\_\_\_\_  
\_\_\_\_\_  
\_\_\_\_\_

MINOOKA FIRE PROTECTION DISTRICT

By: Ernie M. Robert

Attest: Angela M. Robinson

Notice to:

\_\_\_\_\_  
\_\_\_\_\_  
\_\_\_\_\_

JOLIET JUNIOR COLLEGE DISTRICT 525

By: \_\_\_\_\_

Attest: \_\_\_\_\_

Notice to:

\_\_\_\_\_  
\_\_\_\_\_  
\_\_\_\_\_

CHANNAHON PARK DISTRICT

By: \_\_\_\_\_

Attest: \_\_\_\_\_

Notice to:

\_\_\_\_\_  
\_\_\_\_\_  
\_\_\_\_\_

Notice to:

\_\_\_\_\_  
\_\_\_\_\_  
\_\_\_\_\_

MINOOKA HIGH SCHOOL DISTRICT 111

By: \_\_\_\_\_

Attest: \_\_\_\_\_

Notice to:

\_\_\_\_\_  
\_\_\_\_\_  
\_\_\_\_\_

THREE RIVERS LIBRARY DISTRICT

By: \_\_\_\_\_

Attest: \_\_\_\_\_

Notice to:

\_\_\_\_\_  
\_\_\_\_\_  
\_\_\_\_\_

AUX SABLE TOWNSHIP HIGHWAY  
COMMISSIONER

By: \_\_\_\_\_

Attest: \_\_\_\_\_

Notice to:

\_\_\_\_\_  
\_\_\_\_\_  
\_\_\_\_\_

MINOOKA GRADE SCHOOL DISTRICT  
201

By: \_\_\_\_\_

Attest: \_\_\_\_\_

Notice to:

\_\_\_\_\_  
\_\_\_\_\_  
\_\_\_\_\_

MINOOKA FIRE PROTECTION DISTRICT

By: \_\_\_\_\_

Attest: \_\_\_\_\_

Notice to:

\_\_\_\_\_  
\_\_\_\_\_  
\_\_\_\_\_

JOLIET JUNIOR COLLEGE DISTRICT 525

By: David R. Caylor  
Chairman, Board of Trustees

Attest: \_\_\_\_\_

Notice to:  
Thomas E. Ryan, Vice President  
Joliet Junior College

1215 Houbolt Road  
Joliet IL 60431

CHANNAHON PARK DISTRICT

By: \_\_\_\_\_

Attest: \_\_\_\_\_

Notice to:

\_\_\_\_\_  
\_\_\_\_\_  
\_\_\_\_\_

STATE OF ILLINOIS     )  
  )  
  )     SS  
COUNTY OF WILL        )  
COUNTY OF GRUNDY     )

I, the undersigned, do hereby certify that I am the duly qualified and acting Secretary of the Channahon Park District, Will and Grundy Counties, Illinois, in the Counties and State aforesaid, and as such Secretary, I am the keeper of the records and files of the Board of Commissioners of said Park District, and I do further certify that attached hereto is a full, true, and complete copy of

**An executed Intergovernmental Agreement concerning the Aux Sable Liquid Products, LP Tax Increment Financing project as approved by resolution of the Board of Commissioners of the Channahon Park District**

DATED AT Channahon, Illinois, this 8th day of September, 1998.

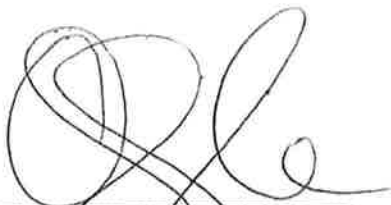

Charles J. Szoke, Secretary  
Channahon Park District  
Will and Grundy Counties, Illinois

Notice to:

\_\_\_\_\_  
\_\_\_\_\_  
\_\_\_\_\_

MINOOKA HIGH SCHOOL DISTRICT 111

By: \_\_\_\_\_

Attest: \_\_\_\_\_

Notice to:

\_\_\_\_\_  
\_\_\_\_\_  
\_\_\_\_\_

THREE RIVERS LIBRARY DISTRICT

By: \_\_\_\_\_

Attest: \_\_\_\_\_

Notice to:

\_\_\_\_\_  
\_\_\_\_\_  
\_\_\_\_\_

AUX SABLE TOWNSHIP HIGHWAY  
COMMISSIONER

By: \_\_\_\_\_

Attest: \_\_\_\_\_

Notice to:

\_\_\_\_\_  
\_\_\_\_\_  
\_\_\_\_\_

MINOOKA GRADE SCHOOL DISTRICT  
201

By: \_\_\_\_\_

Attest: \_\_\_\_\_

Notice to:

\_\_\_\_\_  
\_\_\_\_\_  
\_\_\_\_\_

MINOOKA FIRE PROTECTION DISTRICT

By: \_\_\_\_\_

Attest: \_\_\_\_\_

Notice to:

\_\_\_\_\_  
\_\_\_\_\_  
\_\_\_\_\_

JOLIET JUNIOR COLLEGE DISTRICT 525

By: \_\_\_\_\_

Attest: \_\_\_\_\_

Notice to:

\_\_\_\_\_  
\_\_\_\_\_  
\_\_\_\_\_

CHANNAHON PARK DISTRICT

By: Ronald D. Lehman

Ronald D. Lehman, President

Attest: Charles J. Szoke

Charles J. Szoke, Secretary

Notice to:

Secretary

Channahon Park District

24856 W. Eames Street

Channahon, IL 60410

REDEVELOPMENT PROJECT AREA  
 PARCELS 03-22-100-003-0000 and 03-22-100-004-0000  
 LEGAL DESCRIPTION

All that part of the north half of Section 22, Township 34 North, Range 8 East of the Third Principal Meridian, Aux Sable Township, Grundy County, Illinois, lying west of the west right-of way line of the Elgin Joliet and Eastern Railroad; EXCEPTING THEREFROM, all of the south 150 feet in equal width thereof; ALSO EXCEPTING THEREFROM, commencing at the northwest corner of said section 22, thence south 0 degrees 36 minutes 20 seconds west 69.52 feet along the west line of the northwest quarter of said section 22 to a point on a 57,360.78 foot radius curve to the left on the south right of way line of u.s. Route 6. Thence southeasterly 100.0 feet along said curve to the left and said south right of way line whose chord bears south 89 degrees 33 minutes 14 seconds east 100.0 feet to a point, thence south 0 degrees 36 minutes 20 seconds west 529.74 feet along a line parallel with the west line of the northwest quarter of said section 22 to the true point of beginning. Thence south 89 degrees 59 minutes 50 seconds east 633.46 feet along a line parallel with the north line of the northwest quarter of said section 22 to a point, thence south 0 degrees 12 minutes 54 seconds east 560.52 feet to a point, thence north 89 degrees 23 minutes 15 seconds west 641.45 feet to a point on a line 100 feet east of the west line of the northwest quarter of said section 22, thence north 0 degrees 36 minutes 20 seconds east 553.72 feet along a line 100 feet east of and parallel with the west line of the northwest quarter of said section 22 to the point of beginning. Also excepting therefrom, all that right-of-way situated within the northernmost portion thereof previously dedicated/conveyed for U.S. Route 6; ALSO EXCEPTING THEREFROM the following described parcel: Commencing at the northwest corner of the Northwest Quarter of said Section 22; thence South 00 degrees 36' 20" West 69.57 feet along the west line of said Northwest Quarter Section to the south right-of-way line of U.S. Route 6; thence South 89 degrees 48' 22" East 100.00 feet along said south right-of-way line of U.S. Route 6 to the POINT OF BEGINNING; thence continuing South 89 degrees 48' 22" East 300.01 feet along said south right-of-way line of U.S. Route 6; thence South 00 degrees 36' 20" West 429.10 feet parallel with and 400 feet east of the west line of said Northwest Quarter Section; thence due west 300.02 feet and parallel with and 500 feet south of the north line of said Northwest Quarter Section; thence North 00 degrees 36' 20" East 430.12 feet parallel with and 100 feet east of the west line of said Northwest Quarter Section to the point of beginning; ALSO EXCEPTING THEREFROM Parcel 1: The North One Hundred (100) feet of the South Two Hundred Fifty (250) feet of the North half of Section 22 west of the Elgin, Joliet and Eastern Railway Company right-of way all in Township 34 North, Range 8 East of the Third Principal Meridian, Aux Sable Township, Grundy County, Illinois AND Parcel 2: A triangular parcel of land lying north of and contiguous to Parcel 1 and described as follows: Beginning at the point of intersection of the north line of Parcel 1 with the west line of the E. J. & E. Railway Company right of way as now located; thence westerly along said north line of Parcel 1, 300 feet to a point; thence northeasterly along a straight line to a point of intersection with the above described E. J. & E. right of way line that is 155 feet northerly of, as measured along said right of way line, the north line of Parcel 1; thence southerly along said right of way line to the point and place of beginning, all in the North Half of Section 22, Township 34 North, Range 8 East of the Third Principal meridian in Grundy County, Illinois.

STATE OF ILLINOIS  
 COUNTY OF WILL

THIS IS TO CERTIFY THAT I, JAMES J. GIBBONS, AN ILLINOIS PROFESSIONAL LAND SURVEYOR, HAVE PREPARED THIS PLAT OF THE ABOVE CAPTIONED LANDS, AND THAT THIS PLAT IS A TRUE AND ACCURATE REPRESENTATION THEREOF.

GIVEN UNDER MY HAND AND SEAL THIS 22<sup>ND</sup> DAY OF JUNE 1998.

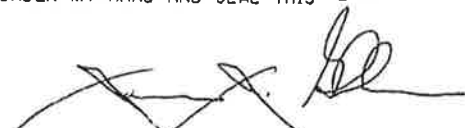
  
 JAMES J. GIBBONS  
 ILLINOIS PROFESSIONAL LAND SURVEYOR NO. 2283



REDEVELOPMENT PROJECT AREA

SCALE: HOR. 1" = 500'

DATE: 6-22-98  
 DES BY: CHK BY: JG  
 DWN BY: JCN APP BY:  
 PRINTED:

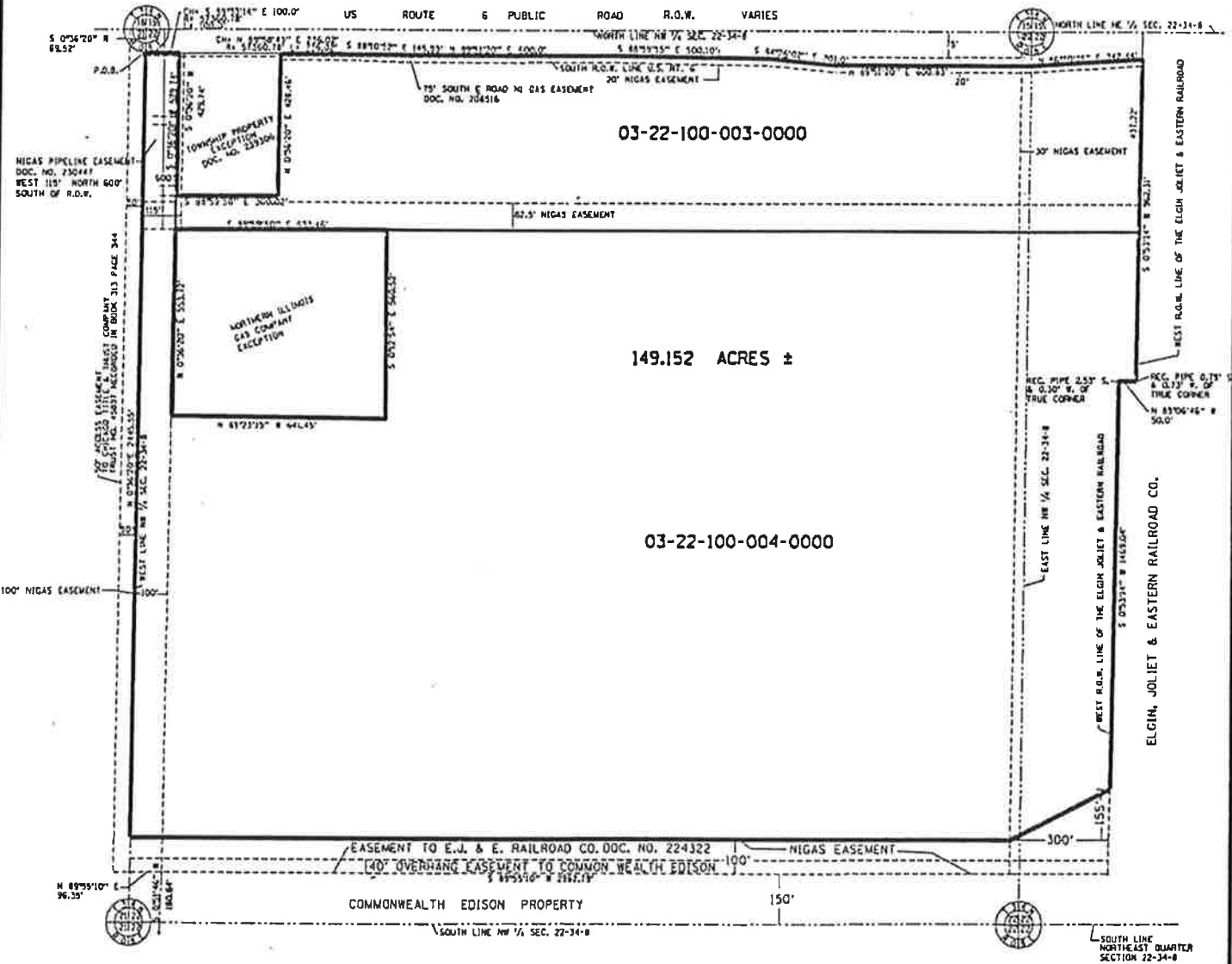

179 REDEVELOPMENT PROJECT AREA

SCALE: HOR. 1" = 500'  
 DATE: 6-22-98  
 DES BY: CHK BY: JG  
 OWN BY: JCN APP BY:  
 PRINTED:

### **Extraction Plant Facilities**

Various buildings, structures, equipment and machinery and systems will be constructed and operated on the Aux Sable Site as part of the Extraction Plant.

The extraction function will be performed in two separate trains, each of which will operate as follows. The feed gas received from the Alliance pipeline first passes through dehydrators to remove water from the gas to prevent freezing in the cryogenic facilities. After heat exchange with cold residue gases (inlet gas chilling), the feed gas passes through the expander side of the turbo-expander removing energy from the gas. This results in a significant decrease in the temperature of the gas and liquefaction of part of the feed gas stream.

Liquids condensed in this process are fed to the de-methanizer column to separate methane or methane and ethane from the propane, butanes and condensate liquids.

The cold gas streams leaving the de-methanizers are heat exchanged against warm incoming feed gas before the gas streams flow to the compressor side of the turbo-expander. After partial re-compression in this compressor, the remaining re-compression is done in electric drive re-compressors. From the re-compressors the gas is returned to the Alliance pipeline for delivery to downstream customers.

Unless ethane recovery and fractionation facilities are also located on the Aux Sable Site, the liquid streams leaving the de-methanizers will be cooled, stored in on-site storage facilities and finally pumped to a pipeline system.

Included with the facilities described above, the Extraction Plant will have systems for power, heat, air, nitrogen, cooling water, and control functions, as well as maintenance buildings and offices for plant staff.

The attached drawing provides a schematic description of the facilities.

AUX SABLE LIQUIDS EXTRACTION PLANT

EXTRACTION

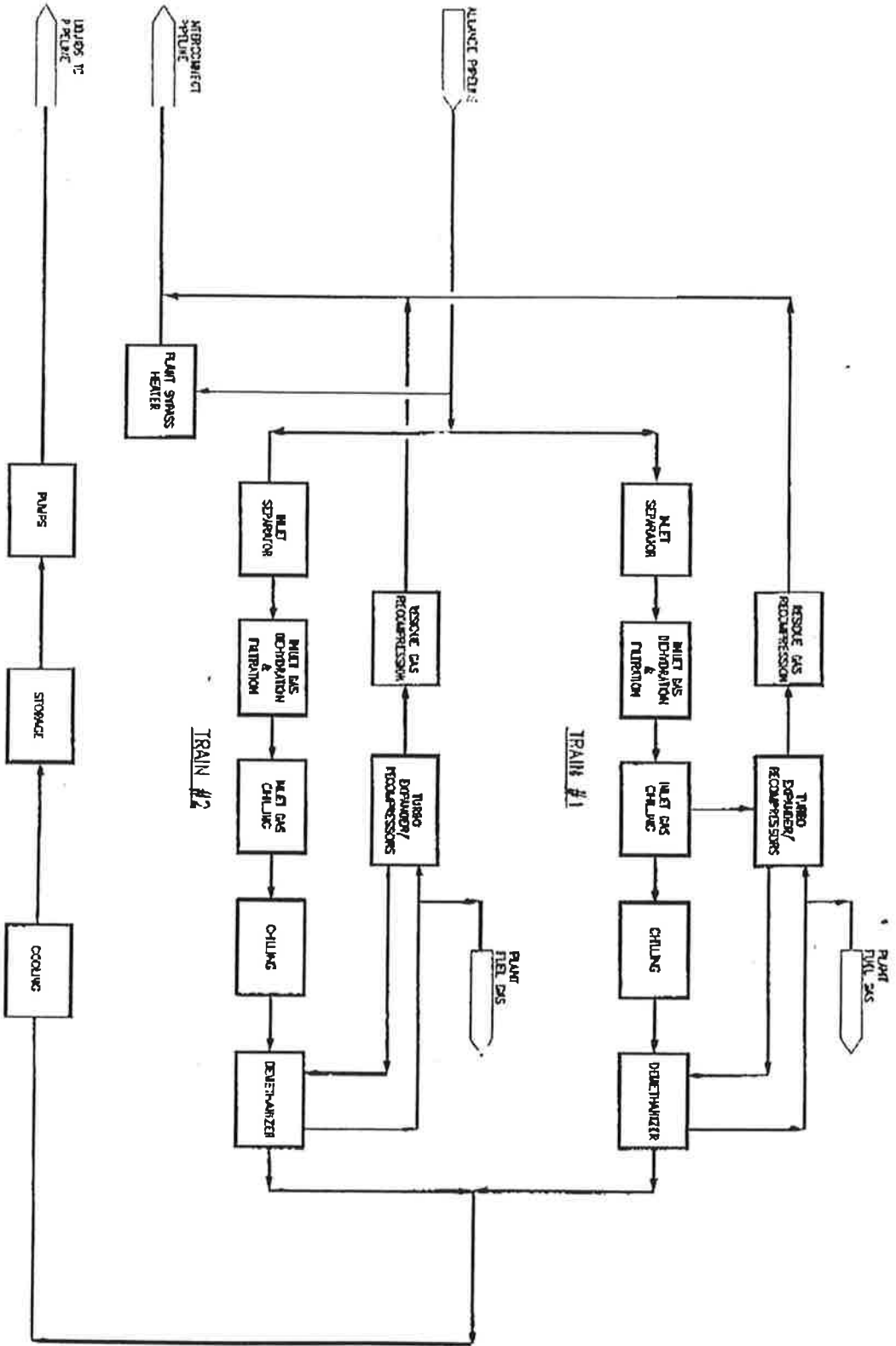

**ANNEXATION TRACT****AUX SABLE LIQUID PRODUCTS**

ALL THAT PART OF THE NORTH HALF OF SECTION 22, TOWNSHIP 34 NORTH, RANGE 8 EAST OF THE THIRD PRINCIPAL MERIDIAN, AUX SABLE TOWNSHIP, GRUNDY COUNTY, ILLINOIS, LYING WEST OF THE WEST RIGHT-OF-WAY LINE OF THE ELGIN JOLIET AND EASTERN RAILROAD; EXCEPTING THEREFROM, ALL OF THE SOUTH 150 FEET IN EQUAL WIDTH THEREOF (BEING A COMMONWEALTH EDISON COMPANY TRANSMISSION RIGHT-OF-WAY); ALSO EXCEPTING THEREFROM, ALL THAT RIGHT-OF-WAY SITUATED WITHIN THE NORTHERNMOST PORTION THEREOF PREVIOUSLY DEDICATED/CONVEYED FOR US RT 6; ALSO EXCEPTING THEREFROM, ALL THAT PART OF THE SOUTH 430 FEET OF THE EAST 300 FEET OF THE WEST 400 FEET OF THE NORTH 500 FEET OF THE NORTHWEST QUARTER OF THE NORTHWEST QUARTER OF SAID SECTION 22 PREVIOUSLY CONVEYED TO AUX SABLE TOWNSHIP BY DOCUMENT #239306; ALSO EXCEPTING THEREFROM, COMMENCING AT THE NORTHWEST CORNER OF SAID SECTION 22, THENCE SOUTH 0 DEGREES 36 MINUTES 20 SECONDS WEST 69.52 FEET ALONG THE WEST LINE OF THE NORTHWEST QUARTER OF SAID SECTION 22 TO A POINT ON A 57,360.78 FOOT RADIUS CURVE TO THE LEFT ON THE SOUTH RIGHT OF WAY LINE OF U.S. ROUTE 6. THENCE SOUTHEASTERLY 100.0 FEET ALONG SAID CURVE TO THE LEFT AND SAID SOUTH RIGHT OF WAY LINE WHOSE CHORD BEARS SOUTH 89 DEGREES 33 MINUTES 14 SECONDS EAST 100.0 FEET TO A POINT, THENCE SOUTH 0 DEGREES 36 MINUTES 20 SECONDS WEST 529.74 FEET ALONG A LINE PARALLEL WITH THE WEST LINE OF THE NORTHWEST QUARTER OF SAID SECTION 22 TO THE TRUE POINT OF BEGINNING. THENCE SOUTH 89 DEGREES 59 MINUTES 50 SECONDS EAST 633.46 FEET ALONG A LINE PARALLEL WITH THE NORTH LINE OF THE NORTHWEST QUARTER OF SAID SECTION 22 TO A POINT, THENCE SOUTH 0 DEGREES 12 MINUTES 54 SECONDS EAST 560.52 FEET TO A POINT, THENCE NORTH 89 DEGREES 23 MINUTES 15 SECONDS WEST 641.45 FEET TO A POINT ON A LINE 100 FEET EAST OF THE WEST LINE OF THE NORTHWEST QUARTER OF SAID SECTION 22, THENCE NORTH 0 DEGREES 36 MINUTES 20 SECONDS EAST 553.72 FEET ALONG A LINE 100 FEET EAST OF AND PARALLEL WITH THE WEST LINE OF THE NORTHWEST QUARTER OF SAID SECTION 22 TO THE POINT OF BEGINNING

**A & R TRANSPORT**

THAT PART OF THE SOUTHEAST QUARTER OF SECTION 21 AND THE SOUTHWEST QUARTER OF SECTION 22, TOWNSHIP 34 NORTH, RANGE 8 EAST OF THE THIRD PRINCIPAL MERIDIAN DESCRIBED AS FOLLOWS: BEGINNING AT THE NORTHWEST CORNER OF THE SOUTHWEST QUARTER OF SAID SECTION 22; THENCE NORTH 89 DEGREES 11 MINUTES 03 SECONDS EAST 2690.02 FEET TO THE NORTHEAST CORNER OF SAID SOUTHWEST QUARTER; THENCE, SOUTH 0 DEGREES 17 MINUTES 11 SECONDS EAST 1351.21 FEET ON THE EAST LINE OF SAID SOUTHWEST QUARTER; THENCE, SOUTH 89 DEGREES 11 MINUTES 03 SECONDS WEST 2701.55 FEET TO THE EAST LINE OF THE SOUTHEAST QUARTER OF SAID SECTION 21; THENCE, NORTH 89 DEGREES 50 MINUTES 34 SECONDS WEST 2698.60 FEET TO THE WEST LINE OF SAID SOUTHEAST QUARTER; THENCE, NORTH 0 DEGREES 18 MINUTES 36 SECONDS EAST 1351.37 FEET TO THE NORTHWEST CORNER OF THE SOUTHEAST QUARTER OF SAID SECTION 21; THENCE, SOUTH 89 DEGREES 50 MINUTES 34 SECONDS EAST 2696.07 FEET TO THE POINT OF BEGINNING CONTAINING 167.298 ACRES, MORE OR LESS, AND ALL BEING SITUATED IN AUX SABLE TOWNSHIP, GRUNDY COUNTY, ILLINOIS.

#### **STATE OF ILLINOIS, ILLINOIS RIVER**

ALL THAT PORTION OF THE ILLINOIS RIVER NOT PREVIOUSLY ANNEXED TO THE VILLAGE OF CHANNAHON LYING IN SECTION 25, SECTION 26 AND THE EAST HALF OF SECTION 27, TOWNSHIP 34 NORTH, RANGE 8 EAST OF THE THIRD PRINCIPAL MERIDIAN, MORE PARTICULARLY DESCRIBED AS THOSE PARTS OF THE ILLINOIS AND DES PLAINES RIVERS LYING EAST OF THE ELGIN, JOLIET AND EASTERN RAILWAY RIGHT-OF-WAY AND WEST OF THE GRUNDY-WILL COUNTY LINE.

EXCEPTING THEREFROM, THAT PART OF SECTION 25, TOWNSHIP 34 NORTH RANGE 8 EAST OF THE THIRD PRINCIPAL MERIDIAN, LYING WITHIN A CIRCULAR AREA HAVING A RADIUS OF 2640.00 FEET AND HAVING A CENTER POINT DESCRIBED AS FOLLOWS: COMMENCING AT THE SOUTHEAST CORNER OF SAID SECTION 26; THENCE NORTH 90 DEGREES 00 MINUTES 00 SECONDS WEST ALONG THE SOUTH LINE OF SAID SECTION 26 A DISTANCE OF 376.29 FEET; THENCE SOUTH 00 DEGREES 00 MINUTES 00 SECONDS EAST A DISTANCE OF 94.75 FEET TO SAID CENTER POINT OF SAID CIRCULAR AREA, ALL IN GRUNDY COUNTY, ILLINOIS.

#### **STATE OF ILLINOIS, I & M CANAL**

ALL THAT PORTION OF THE ILLINOIS AND MICHIGAN CANAL AND THE ILLINOIS AND MICHIGAN CANAL RESERVE NOT PREVIOUSLY ANNEXED TO THE VILLAGE OF CHANNAHON LYING IN SECTION 26 AND THE EAST HALF OF SECTION 22, TOWNSHIP 34 NORTH, RANGE 8 EAST OF THE THIRD PRINCIPAL MERIDIAN, SITUATED IN THE COUNTY OF GRUNDY, IN THE STATE OF ILLINOIS.

#### **STATE OF ILLINOIS, DRESDEN ISLAND**

AN ISLAND IN THE ILLINOIS RIVER SITUATED ON THE EAST HALF (E ½) OF SECTION NUMBER TWENTY-SEVEN (27) AND THE WEST HALF (W 1\2) OF SECTION NUMBER TWENTY-SIX (26) IN TOWNSHIP NUMBER THIRTY-FOUR (34) NORTH, RANGE NUMBER EIGHT (8) EAST OF THE THIRD PRINCIPAL MERIDIAN ALL OF THE ABOVE BEING LOCATED IN GRUNDY COUNTY, ILLINOIS

#### **STATE OF ILLINOIS, PARCEL IX**

FROM A STONE MARKING THE NORTH EAST CORNER OF SECTION 26, MEASURE SOUTH 0 DEGREES 26 MINUTES 11 SECONDS WEST 1173.1 FEET ALONG EAST BOUNDARY OF SAID SECTION TO A POINT IN THE SOUTH BOUNDARY OF THE RIGHT-OF-WAY OF THE ILLINOIS AND MICHIGAN CANAL WHICH POINT IS THE BEGINNING POINT, OF THIS DESCRIPTION : THENCE FROM SAID BEGINNING POINT, CONTINUING SOUTH ALONG SAID SECTION LINE, SOUTH 0 DEGREES 26 MINUTES 11 SECONDS WEST 19.9 FEET TO NORTH BANK OF ILLINOIS RIVER: THENCE WITH SAID NORTH BANK THE FOLLOWING COURSES: NORTH 83 DEGREES 59 MINUTES 49 SECONDS WEST 144 FEET: NORTH 89 DEGREES 24 MINUTES 19 SECONDS WEST 778.9 FEET: SOUTH 83 DEGREES 33 MINUTES 11 SECONDS WEST 545.9 FEET: NORTH 83 DEGREES 42 MINUTES 49 SECONDS WEST 155.9 FEET: SOUTH 76 DEGREES 58 MINUTES 41 SECONDS WEST 194.8 FEET: NORTH 82 DEGREES 21 MINUTES 49 SECONDS WEST 203.3 FEET: NORTH 77 DEGREES 17 MINUTES 19 SECONDS WEST 798.8 FEET: SOUTH 79 DEGREES 21 MINUTES 41 SECONDS WEST 278.6 FEET: NORTH 79 DEGREES 07 MINUTES 19 SECONDS WEST APPROXIMATELY 829 FEET TO A POINT ON THE WEST LINE OF THE EAST 1400 FEET OF THE NORTHWEST QUARTER OF SECTION 26, SAID POINT BEING THE POINT OF BEGINNING; THENCE CONTINUING WITH SAID NORTH BANK THE FOLLOWING COURSES: NORTH 79 DEGREES 07 MINUTES 19 SECONDS WEST APPROXIMATELY 96 FEET: SOUTH 86 DEGREES 37

MINUTES 41` SECONDS WEST 105.6 FEET: SOUTH 81 DEGREES 11 MINUTES 41 SECONDS WEST 968.4 FEET: THENCE, LEAVING SAID RIVER, NORTH 02 DEGREES 40 MINUTES 41 SECONDS EAST 166.6 FEET: THENCE NORTH 79 DEGREES 29 MINUTES 41 SECONDS EAST 900 FEET: THENCE NORTH 02 DEGREES 40 MINUTES 41 SECONDS EAST 543.2 FEET TO A POINT IN THE SOUTH BOUNDARY OF THE RIGHT OF WAY OF THE ILLINOIS AND MICHIGAN CANAL: THENCE WITH SAID SOUTH BOUNDARY THE FOLLOWING COURSES: SOUTH 68 DEGREES 11 MINUTES 19 SECONDS EAST APPROXIMATELY 262 FEET TO THE INTERSECTION OF THE WEST LINE OF THE EAST 1400 FEET OF THE NORTHWEST QUARTER OF SECTION 26: THENCE SOUTH 00 DEGREES 23 MINUTES 35 SECONDS WEST ALONG SAID WEST LINE APPROXIMATELY 639 FEET TO THE POINT OF BEGINNING. ALL IN TOWNSHIP 34 NORTH, RANGE 8 EAST OF THE THIRD PRINCIPAL MERIDIAN, LOCATED IN AUX SABLE TOWNSHIP, GRUNDY COUNTY, ILLINOIS

**STATE OF ILLINOIS, PARCEL X**

BEGINNING AT A STAKE IN THE EAST LINE OF SECTION 26, TOWNSHIP 34 NORTH, RANGE 8, EAST OF THE THIRD PRINCIPAL MERIDIAN, SITUATED IN GRUNDY COUNTY, STATE OF ILLINOIS, DISTANT NORTH 00 DEGREES 34 MINUTES 50 SECONDS WEST 2,741.0 FEET FROM AN IRON PIPE MARKING THE SOUTHEAST CORNER OF SAID SECTION 26; THENCE NORTH 29 DEGREES 42 MINUTES 19 SECONDS WEST 175.5 FEET; THENCE NORTH 80 DEGREES 59 MINUTES 49 SECONDS WEST, 897.6 FEET; THENCE SOUTH 80 DEGREES 20 MINUTES 41 SECONDS WEST 507.6 FEET; THENCE NORTH 89 DEGREES 19 MINUTES 19 SECONDS WEST 658.0 FEET; THENCE SOUTH 10 DEGREES 16 MINUTES 41 SECONDS WEST 171.8 FEET; THENCE SOUTH 67 DEGREES 45 MINUTES 19 SECONDS EAST 755.5 FEET; THENCE SOUTH 06 DEGREES 59 MINUTES 19 SECONDS EAST 323.6 FEET; THENCE NORTH 68 DEGREES 39 MINUTES 19 SECONDS WEST 1,093.4 FEET TO A STAKE; THENCE SOUTH 89 DEGREES 25 MINUTES 41 SECONDS WEST 2,740.0 FEET TO A STAKE; THENCE NORTH 04 DEGREES 34 MINUTES 19 SECONDS WEST 476.2 FEET TO A STAKE ON THE SOUTH BANK OF THE ILLINOIS RIVER, THENCE WITH SAID SOUTH BANK THE FOLLOWING COURSES; NORTH 82 DEGREES 41 MINUTES 11 SECONDS EAST 859.5 FEET; SOUTH 84 DEGREES 52 MINUTES 49 SECONDS EAST 609.2 FEET; NORTH 78 DEGREES 13 MINUTES 11 SECONDS EAST 288.1 FEET NORTH 83 DEGREES 31 MINUTES 11 SECONDS EAST 579.7 FEET; NORTH 82 DEGREES 31 MINUTES 11 SECONDS EAST 728.7 FEET; NORTH 86 DEGREES 27 MINUTES 11 SECONDS EAST 888.0 FEET; NORTH 78 DEGREES 17 MINUTES 41 SECONDS EAST 240.0 FEET; SOUTH 83 DEGREES 29 MINUTES 19 SECONDS EAST 649.2 FEET; NORTH 71 DEGREES 19 MINUTES 41 SECONDS EAST 175.1 FEET; NORTH 87 DEGREES 48 MINUTES 11 SECONDS EAST 242.0 FEET, TO A STAKE IN THE EAST LINE OF SAID SECTION 26; THENCE WITH SAID EAST LINE, SOUTH 00 DEGREES 34 MINUTES 50 SECONDS EAST 508.9 FEET TO THE PLACE OF BEGINNING;

EXCEPTING THEREFROM, THAT PART OF SECTION 25, TOWNSHIP 34 NORTH RANGE 8 EAST OF THE THIRD PRINCIPAL MERIDIAN, LYING WITHIN A CIRCULAR AREA HAVING A RADIUS OF 2640.00 FEET AND HAVING A CENTER POINT DESCRIBED AS FOLLOWS: COMMENCING AT THE SOUTHEAST CORNER OF SAID SECTION 26; THENCE NORTH 90 DEGREES 00 MINUTES 00 SECONDS WEST ALONG THE SOUTH LINE OF SAID SECTION 26 A DISTANCE OF 376.29 FEET; THENCE SOUTH 00 DEGREES 00 MINUTES 00 SECONDS EAST A DISTANCE OF 94.75 FEET TO SAID CENTER POINT OF SAID CIRCULAR AREA, ALL IN GRUNDY COUNTY, ILLINOIS.

**STATE OF ILLINOIS, PARCEL XV**

ALL OF THAT PORTION OF SECTION TWENTY-FIVE IN TOWNSHIP THIRTY-FOUR NORTH, RANGE EIGHT EAST OF THE THIRD PRINCIPAL MERIDIAN, LYING BETWEEN THE KANKAKEE AND ILLINOIS RIVERS AND A DIAGONAL LINE DRAWN FROM A POINT ON THE SOUTH LINE OF SAID SECTION WHICH POINT IS TWENTY-ONE HUNDRED AND SEVENTY FEET EAST OF THE SOUTHWEST CORNER OF SAID SECTION AND EXTENDING THENCE NORTH-WESTERLY TO A POINT ON

THE WEST LINE OF SAID SECTION WHICH POINT IS THIRTY-TWO HUNDRED AND EIGHTY FEET NORTH OF SAID SOUTH-WEST CORNER OF SAID SECTION;

EXCEPTING THEREFROM, THAT PART OF SECTION 25, TOWNSHIP 34 NORTH RANGE 8 EAST OF THE THIRD PRINCIPAL MERIDIAN, LYING WITHIN A CIRCULAR AREA HAVING A RADIUS OF 2640.00 FEET AND HAVING A CENTER POINT DESCRIBED AS FOLLOWS: COMMENCING AT THE SOUTHEAST CORNER OF SAID SECTION 26; THENCE NORTH 90 DEGREES 00 MINUTES 00 SECONDS WEST ALONG THE SOUTH LINE OF SAID SECTION 26 A DISTANCE OF 376.29 FEET; THENCE SOUTH 00 DEGREES 00 MINUTES 00 SECONDS EAST A DISTANCE OF 94.75 FEET TO SAID CENTER POINT OF SAID CIRCULAR AREA, ALL IN GRUNDY COUNTY, ILLINOIS.

**COMED PARCEL 1:**

THAT PART OF THE NORTHWEST QUARTER OF SECTION 25, TOWNSHIP 34 NORTH, RANGE 8 EAST OF THIRD PRINCIPAL MERIDIAN, LYING SOUTH AND WEST OF THE ILLINOIS RIVER, ALL IN GRUNDY COUNTY, ILLINOIS.

**COMED PARCEL 2:**

THAT PART OF THE SOUTHWEST QUARTER OF SECTION 25, TOWNSHIP 34 NORTH, RANGE 8 EAST OF THE THIRD PRINCIPAL MERIDIAN, LYING SOUTH AND WEST OF THE ILLINOIS RIVER, MORE PARTICULARLY DESCRIBED AS FOLLOWS: COMMENCING AT THE SOUTHWEST CORNER OF THE SOUTHWEST QUARTER OF SAID SECTION 25; THENCE NORTH 00 DEGREES 34 MINUTES 50 SECONDS EAST ALONG THE WEST LINE OF THE SOUTHWEST QUARTER OF SAID SECTION 25, A DISTANCE OF 2514.63 FEET TO THE POINT OF BEGINNING; THENCE CONTINUING ALONG THE LAST DESCRIBED LINE, 125.37 FEET TO THE NORTHWEST CORNER OF SAID SOUTHWEST QUARTER; THENCE SOUTH 89 DEGREES 57 MINUTES 10 SECONDS EAST ALONG THE NORTH LINE OF SAID SOUTHWEST QUARTER, 423.43 FEET TO THE WESTERLY LINE OF LAND CONVEYED BY WARRANTY DEED RECORDED IN BOOK 105 ON PAGE 450; THENCE SOUTH 33 DEGREES 04 MINUTES 09 SECONDS EAST ALONG SAID WESTERLY LINE, 358.04 FEET; THENCE NORTHWESTERLY ALONG AN ARC OF A NON-TANGENT CURVE CONCAVE TO THE SOUTH WITH A RADIUS OF 2640.00 FEET, AN ARC LENGTH OF 645.90 FEET (CHORD BEARING IS NORTH 74 DEGREES 14 MINUTES 15 SECONDS WEST AND THE CHORD LENGTH IS 644.29 FEET) TO THE POINT OF BEGINNING, ALL IN GRUNDY COUNTY, ILLINOIS.

**COMED PARCEL 3:**

THE SOUTHEAST QUARTER OF SECTION 26, TOWNSHIP 34 NORTH, RANGE 8 EAST OF THE THIRD PRINCIPAL MERIDIAN, EXCEPTING THEREFROM THE SOUTH 2500.00 FEET (AS MEASURED ALONG THE EAST LINE OF THE SOUTHEAST QUARTER OF SAID SECTION 26) AND ALSO EXCEPTING THEREFROM THAT PART AS DESCRIBED BY DOCUMENT NUMBER 92344, AND ALSO EXCEPTING THEREFROM THE FOLLOWING DESCRIBED PARCEL- COMMENCING AT THE SOUTHEAST CORNER OF THE SOUTHEAST QUARTER OF SAID SECTION 26; THENCE NORTH 00 DEGREES 34 MINUTES 50 SECONDS EAST, ALONG THE EAST LINE OF THE SOUTHEAST QUARTER OF SAID SECTION 26, A DISTANCE OF 2500.00 FEET TO THE POINT OF BEGINNING OF THIS EXCEPTION; THENCE CONTINUING ALONG THE LAST DESCRIBED LINE, 14.63 FEET; THENCE WESTERLY ALONG AN ARC OF A NON-TANGENT CURVE CONCAVE TO THE SOUTH WITH A RADIUS OF 2640.00 FEET, AN ARC LENGTH OF 893.53 FEET (CHORD BEARING IS SOUTH 89 DEGREES 03 MINUTES 27 SECONDS WEST AND THE CHORD LENGTH IS 889.27 FEET) TO A POINT ON A LINE THAT IS 2500.00 FEET NORTH OF (AS MEASURED ALONG THE EAST LINE OF SAID SOUTHEAST QUARTER) AND PARALLEL WITH THE SOUTH LINE OF SAID SOUTHEAST QUARTER; THENCE SOUTH 90 DEGREES 00 MINUTES 00 SECONDS EAST

ALONG SAID PARALLEL LINE, 889.00 FEET TO THE POINT OF BEGINNING OF THIS EXCEPTION, ALL IN GRUNDY COUNTY, ILLINOIS.

**COMED PARCEL 4:**

THE SOUTHWEST QUARTER OF SECTION 26, TOWNSHIP 34 NORTH, RANGE 8 EAST OF THE THIRD PRINCIPAL MERIDIAN, EXCEPTING THEREFROM THE SOUTH 2500.00 FEET (AS MEASURED ALONG THE EAST LINE OF THE SOUTHEAST QUARTER OF SAID SECTION 26) AND ALSO EXCEPTING THEREFROM THAT PART AS DESCRIBED BY DOCUMENT NUMBER 92344, ALL IN GRUNDY COUNTY, ILLINOIS.

**COMED PARCEL 5:**

THAT PART OF THE NORTHEAST QUARTER OF SECTION 26. TOWNSHIP 34 NORTH, RANGE 8 EAST OF THE THIRD PRINCIPAL MERIDIAN, LYING SOUTH OF THE ILLINOIS RIVER, EXCEPTING THEREFROM THAT PART AS DESCRIBED BY DOCUMENT NUMBER 92344, ALL IN GRUNDY COUNTY, ILLINOIS.

**COMED PARCEL 6:**

THAT PART OF THE NORTHWEST QUARTER OF SECTION 26, TOWNSHIP 34 NORTH, RANGE 8 EAST OF THE THIRD PRINCIPAL MERIDIAN, LYING SOUTH OF THE ILLINOIS RIVER, EXCEPTING THEREFROM THAT PART AS DESCRIBED BY DOCUMENT NUMBER 92344, ALL IN GRUNDY COUNTY, ILLINOIS.

**COMED PARCEL 7:**

THAT PART OF THE SOUTHEAST QUARTER OF SECTION 27, TOWNSHIP 34 NORTH, RANGE 8 EAST OF THE THIRD PRINCIPAL MERIDIAN, LYING SOUTH OF THE ILLINOIS RIVER AND LYING EAST OF THE EAST RIGHT OF WAY LINE OF THE ELGIN, JOLIET AND EASTERN RAILWAY COMPANY, EXCEPTING THEREFROM THE SOUTH 2000.00 FEET (AS MEASURED ALONG THE EAST LINE OF THE SOUTHEAST QUARTER OF SAID SECTION 27), ALL IN GRUNDY COUNTY, ILLINOIS.

**COMED PARCEL 8:**

THAT PART OF THE NORTHEAST QUARTER OF SECTION 27, TOWNSHIP 34 NORTH, RANGE 8 EAST OF THE THIRD PRINCIPAL MERIDIAN, LYING SOUTH OF THE ILLINOIS RIVER, ALL IN GRUNDY COUNTY, ILLINOIS.

**COMED PARCEL 9:**

THAT PART OF THE SOUTHEAST QUARTER OF SECTION 27, TOWNSHIP 34 NORTH, RANGE 8 EAST OF THE THIRD PRINCIPAL MERIDIAN, LYING NORTH OF THE ILLINOIS RIVER AND LYING EAST OF THE EAST RIGHT OF WAY LINE OF THE ELGIN, JOLIET AND EASTERN RAILWAY COMPANY, ALL IN GRUNDY COUNTY, ILLINOIS.

**COMED PARCEL 10:**

THAT PART OF THE NORTHEAST QUARTER OF SECTION 27, TOWNSHIP 34 NORTH, RANGE 8 EAST OF THE THIRD PRINCIPAL MERIDIAN, LYING NORTH OF THE ILLINOIS RIVER AND LYING EAST OF THE EAST RIGHT OF WAY LINE OF THE ELGIN, JOLIET AND EASTERN RAILWAY COMPANY MORE PARTICULARLY DESCRIBED AS FOLLOWS: COMMENCING AT THE NORTHWEST CORNER OF THE NORTHEAST QUARTER OF SAID SECTION 27; THENCE SOUTH 89 DEGREES 59 MINUTES 35 SECONDS EAST ALONG THE NORTH LINE OF THE NORTHEAST QUARTER OF SAID SECTION 27, A DISTANCE OF 452.89 FEET TO A POINT ON THE EAST RIGHT OF WAY LINE OF THE ELGIN, JOLIET AND EASTERN RAILWAY COMPANY, SAID POINT ALSO BEING THE POINT OF BEGINNING; THENCE CONTINUING ALONG THE LAST DESCRIBED LINE, 750.11 FEET; THENCE SOUTH 00 DEGREES 59 MINUTES 03 SECONDS WEST 2340.00 FEET TO THE NORTH BANK OF THE ILLINOIS RIVER THENCE SOUTHWESTERLY ALONG THE NORTH BANK OF THE ILLINOIS RIVER, 753.74 FEET TO THE SOUTH LINE OF SAID NORTHEAST QUARTER; THENCE SOUTH 89 DEGREES 52 MINUTES 38 SECONDS WEST ALONG THE SOUTH LINE OF SAID NORTHEAST QUARTER, 88.14 FEET TO THE EAST RIGHT OF WAY LINE OF THE ELGIN, JOLIET AND EASTERN RAILWAY COMPANY; THENCE NORTH 00 DEGREES 59 MINUTES 03 SECONDS EAST, ALONG SAID EAST RIGHT OF WAY LINE, 1866.88 FEET; THENCE SOUTH 89 DEGREES 00 MINUTES 59 SECONDS EAST. ALONG A JOG IN SAID EAST RIGHT OF WAY LINE, 25.00 FEET; THENCE NORTH 00 DEGREES 59 MINUTES 03 SECONDS EAST ALONG SAID EAST RIGHT OF WAY LINE, 772.41 FEET TO THE POINT OF BEGINNING, ALL IN GRUNDY COUNTY, ILLINOIS.

**COMED PARCEL 11:**

THAT PART OF THE SOUTHEAST QUARTER OF SECTION 22, TOWNSHIP 34 NORTH, RANGE 8 EAST OF THIRD PRINCIPAL MERIDIAN, LYING EAST OF THE RIGHT OF WAY LINE OF THE ELGIN, JOLIET AND EASTERN RAILWAY COMPANY MORE PARTICULARLY DESCRIBED AS FOLLOWS: COMMENCING AT THE SOUTHWEST CORNER OF THE SOUTHEAST QUARTER OF SAID SECTION 22; THENCE SOUTH 89 DEGREES 59 MINUTES 35 SECONDS EAST ALONG THE SOUTH LINE OF THE SOUTHEAST QUARTER OF SAID SECTION 22, A DISTANCE OF 452.89 FEET TO A POINT ON THE EAST RIGHT OF WAY LINE OF THE ELGIN, JOLIET AND EASTERN RAILWAY COMPANY, SAID POINT ALSO BEING THE POINT OF BEGINNING; THENCE NORTH 00 DEGREES 59 MINUTES 03 SECONDS EAST ALONG SAID EAST RIGHT OF WAY LINE, 731.76 FEET TO THE SOUTH LINE OF THE ILLINOIS AND MICHIGAN CANAL RESERVE; THENCE SOUTH 84 DEGREES 38 MINUTES 20 SECONDS EAST ALONG SAID SOUTH LINE, 752.19 FEET; THENCE SOUTH 00 DEGREES 59 MINUTES 03 SECONDS WEST, 661.57 FEET TO THE SOUTH LINE OF THE SOUTHEAST QUARTER OF SAID SECTION 22; THENCE NORTH 89 DEGREES 59 MINUTES 35 SECONDS WEST, ALONG THE SOUTH LINE OF THE SOUTHEAST QUARTER OF SAID SECTION 22, A DISTANCE OF 750.11 FEET TO THE POINT OF BEGINNING, ALL IN GRUNDY COUNTY, ILLINOIS.

**COMED PARCEL 12:**

THAT PART OF THE SOUTHEAST QUARTER OF SECTION 22, TOWNSHIP 34 NORTH, RANGE 8 EAST OF THIRD PRINCIPAL MERIDIAN, LYING EAST OF THE EAST RIGHT OF WAY LINE OF THE ELGIN, JOLIET AND EASTERN RAILWAY COMPANY MORE PARTICULARLY DESCRIBED AS FOLLOWS: COMMENCING AT THE NORTHWEST CORNER OF THE SOUTHEAST QUARTER OF SAID SECTION 22; THENCE SOUTH 89 DEGREES 58 MINUTES 19 SECONDS EAST, ALONG THE NORTH LINE OF THE SOUTHEAST QUARTER OF SAID SECTION 22, A DISTANCE OF 422.38 FEET TO A POINT ON THE EAST RIGHT OF WAY LINE OF THE ELGIN, JOLIET AND EASTERN RAILWAY COMPANY, SAID POINT ALSO BEING THE POINT BEGINNING; THENCE CONTINUING ALONG THE LAST DESCRIBED LINE, 800.12 FEET; THENCE SOUTH 00 DEGREES 59 MINUTES 03 SECONDS

PREPARED BY:

VILLAGE OF CHANNAHON  
24555 S. NAVAJO DRIVE  
CHANNAHON, IL 60410

MAIL TO:

VILLAGE OF CHANNAHON  
24555 S. NAVAJO DRIVE  
CHANNAHON, IL 60410

RECORDER'S STAMP

ORDINANCE NO. 1727

**AN ORDINANCE APPROVING AND AUTHORIZING THE EXECUTION OF  
A CERTAIN AMENDMENT TO INTERGOVERNMENTAL AGREEMENT DATED  
SEPTEMBER 8, 1998 BY AND BETWEEN THE VILLAGE OF CHANNAHON,  
THE COUNTY OF GRUNDY, AUX SABLE TOWNSHIP, MINOOKA COMMUNITY HIGH  
SCHOOL DISTRICT NO. 111, MINOOKA CONSOLIDATED SCHOOL DISTRICT 201,  
MINOOKA FIRE DISTRICT, THREE-RIVERS LIBRARY DISTRICT, JOLIET  
JUNIOR COLLEGE DISTRICT 525 AND CHANNAHON PARK DISTRICT**

**ADOPTED BY THE  
BOARD OF TRUSTEES  
VILLAGE OF CHANNAHON**

THIS 21<sup>st</sup> DAY OF January, 2013

**PUBLISHED IN PAMPHLET FORM BY AUTHORITY OF THE BOARD OF TRUSTEES OF THE  
VILLAGE OF CHANNAHON, WILL AND GRUNDY COUNTIES, ILLINOIS**

THIS 21<sup>st</sup> DAY OF January, 2013

ORDINANCE NO. 1727

AN ORDINANCE APPROVING AND  
AUTHORIZING THE EXECUTION OF  
A CERTAIN AMENDMENT TO INTERGOVERNMENTAL AGREEMENT  
DATED SEPTEMBER 8, 1998 BY AND BETWEEN THE VILLAGE OF CHANNAHON,  
THE COUNTY OF GRUNDY, AUX SABLE TOWNSHIP, MINOOKA  
COMMUNITY HIGH SCHOOL DISTRICT NO. 111, MINOOKA  
CONSOLIDATED SCHOOL DISTRICT 201, MINOOKA FIRE  
DISTRICT, THREE-RIVERS LIBRARY DISTRICT, JOLIET  
JUNIOR COLLEGE DISTRICT 525 AND CHANNAHON PARK DISTRICT

BE IT ORDAINED by the President and Board of Trustees of the Village of Channahon,  
Will and Grundy Counties, Illinois as follows:

**SECTION 1. APPROVAL.** The Intergovernmental Agreement in substantially the form  
of Exhibit A attached hereto (the "IGA") be and the same is hereby approved and accepted by  
the Village of Channahon. The Village President is authorized and directed to execute the  
Agreement on behalf of the Village and the Village Clerk is authorized and directed to attest to  
such signature.

**SECTION 2. SEVERABILITY.** If any section, paragraph, clause or provision of this  
ordinance is held invalid, the invalidity of such section, paragraph, clause or provision shall not  
affect any of the other provisions of this ordinance.

**SECTION 3. REPEALER.** All ordinances, resolutions, orders or parts thereof, which  
conflict with the provisions of this ordinance, is to the extent of such conflict, hereby repealed.

**SECTION 4. EFFECTIVE DATE.** This ordinance shall be in full force and effect after  
its passage and approval.

PASSED this 21<sup>st</sup> day of January, 2013 with 5 Trustees voting aye,  
0 Trustees voting nay, the President not voting, with 0 Trustees abstaining or  
passing and with 1 Trustees absent and said vote being:

GRECO aye

McMILLIN aye

MILITELLO aye

NASH aye

PAPESH absent

SLOCUM aye

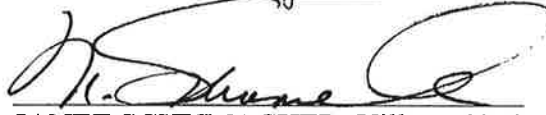
  
JANET SCHUMACHER, Village Clerk

APPROVED this 21<sup>st</sup> day of January, 2013.

(SEAL)

  
JOSEPH COOK, Village President

ATTEST:

  
JANET SCHUMACHER, Village Clerk

**AMENDMENT TO INTERGOVERNMENTAL AGREEMENT**  
**OF SEPTEMBER 8, 1998**

The Village of Channahon, Will and Grundy Counties, Illinois (the "Village"), and the County of Grundy, Aux Sable Township, Minooka Community High School District No. 111, Minooka Consolidated School District No. 201, Minooka Fire Protection District, Three-Rivers Library District, Joliet Junior College District 525, and Channahon Park District (hereinafter sometimes collectively referred to as the "Taxing Districts"), being parties to a certain Intergovernmental Agreement (the "IGA") dated September 8, 1998, hereby agree that the IGA should be amended and revised as follows:

1. The provisions of Section 6 of the IGA are waived to the extent necessary to extend the benefits of the Tax Increment Finance District to certain additional improvements ("Improvements"), including the ISOM facility placed in service in 2007, and other improvements as defined in Section 5 of the Aux Sable Liquid Products Settlement Agreement dated December 31, 2012, such Improvements to be treated as "downstream" facilities for purpose of proportional distribution of net incremental tax revenues to the Village and the Taxing Districts and to Aux Sable Liquid Products LP ("Aux Sable").
2. It is the parties intention by this Amendment that the procedure contemplated by Section 6 of the IGA will not be applicable to the Improvements.
3. Aux Sable's share of the incremental taxes attributable to the Improvements shall be twenty percent (20%) of the net increment arising as a result of the assessed value created by the Improvements, after deduction of debt service costs and Village expenses as provided for in Section 9 of the IGA. The Village and Taxing District share of the incremental taxes attributable to the Improvements shall be eighty percent (80%) of the net increment arising as a result of the assessed value created by the Improvements, after deduction of debt service costs and Village expenses as provided for in Section 9 of the IGA.
4. The parties acknowledge that the Settlement Agreement provides for the assessment of the portion Aux Sable Liquid Products Channahon facility which is included in the Village's Tax Increment Financing District for tax (assessment) years from 2011 through 2022, including specific assessment treatment of new Improvements on a partial basis for a period of years. The provisions of Section 3 of the IGA shall continue to govern the distribution of surplus tax revenues attributable to the original "extraction" facilities (the 60% - 40% allocation) with all "downstream" facilities, including the Improvements at 80% to the Village and Taxing Districts, and 20% to Aux Sable. The Grundy County Supervisor of Assessments is expected to continue to allocate common improvements (offices, warehouses, parking facilities, etc.) based upon the percentage of the value of the extraction and downstream facilities respectively that exist from time to time.
5. The parties further acknowledge that the Revenue Bonds contemplated in Section 7 of the IGA were issued. The parties agree that the Village shall issue "Refunding Bonds" in a par amount sufficient to refund the outstanding principal on the original Revenue Bonds, interest currently outstanding, reserve funds, and reasonable costs of issuance.

6. The Village agrees that any Amendment to the Amended and Restated Redevelopment Agreement between the Village and Aux Sable Liquid Products LP shall be consistent with the terms of the IGA, this Amendment and the Settlement Agreement.

7. The terms and conditions of the IGA shall remain in full force and effect except as specifically altered by this Amendment. The provisions of this Amendment shall take precedent over any inconsistent provision of the IGA.

DATED: December 31, 2012

VILLAGE OF CHANNAHON

GRUNDY COUNTY

By: \_\_\_\_\_

By: \_\_\_\_\_

MINOOKA CONSOLIDATED SCHOOL DISTRICT NO. 201

MINOOKA COMMUNITY HIGH SCHOOL DISTRICT NO. 111

By: 

By: 

AUX SABLE TOWNSHIP

MINOOKA FIRE PROTECTION DISTRICT

By:   
Superintendent

By: \_\_\_\_\_

AUX SABLE TOWNSHIP HIGHWAY COMMISSIONER

JOLIET JUNIOR COLLEGE COLLEGE DISTRICT 525

By: 

By: \_\_\_\_\_

CHANNAHON PARK DISTRICT

THREE RIVERS LIBRARY DISTRICT

By: \_\_\_\_\_

By: \_\_\_\_\_

6. The Village agrees that any Amendment to the Amended and Restated Redevelopment Agreement between the Village and Aux Sable Liquid Products LP shall be consistent with the terms of the IGA, this Amendment and the Settlement Agreement.

7. The terms and conditions of the IGA shall remain in full force and effect except as specifically altered by this Amendment. The provisions of this Amendment shall take precedent over any inconsistent provision of the IGA.

DATED: December 31, 2012

VILLAGE OF CHANNAHON

GRUNDY COUNTY

By: \_\_\_\_\_

By:   
Vice Chairman

MINOOKA CONSOLIDATED SCHOOL DISTRICT NO. 201

MINOOKA COMMUNITY HIGH SCHOOL DISTRICT NO. 111

By: \_\_\_\_\_

By: \_\_\_\_\_

AUX SABLE TOWNSHIP

MINOOKA FIRE PROTECTION DISTRICT

By: \_\_\_\_\_

By: \_\_\_\_\_

AUX SABLE TOWNSHIP HIGHWAY COMMISSIONER

JOLIET JUNIOR COLLEGE COLLEGE DISTRICT 525

By: \_\_\_\_\_

By: \_\_\_\_\_

CHANNAHON PARK DISTRICT

THREE RIVERS LIBRARY DISTRICT

By: \_\_\_\_\_

By: \_\_\_\_\_

6. The Village agrees that any Amendment to the Amended and Restated Redevelopment Agreement between the Village and Aux Sable Liquid Products LP shall be consistent with the terms of the IGA, this Amendment and the Settlement Agreement.

7. The terms and conditions of the IGA shall remain in full force and effect except as specifically altered by this Amendment. The provisions of this Amendment shall take precedent over any inconsistent provision of the IGA.

DATED: December 31, 2012

VILLAGE OF CHANNAHON

GRUNDY COUNTY

By: \_\_\_\_\_

By: \_\_\_\_\_

MINOOKA CONSOLIDATED SCHOOL DISTRICT NO. 201

MINOOKA COMMUNITY HIGH SCHOOL DISTRICT NO. 111

By: \_\_\_\_\_

By: \_\_\_\_\_

AUX SABLE TOWNSHIP

MINOOKA FIRE PROTECTION DISTRICT

By: \_\_\_\_\_

By: *Daniel M. Poff*

AUX SABLE TOWNSHIP HIGHWAY COMMISSIONER

JOLIET JUNIOR COLLEGE COLLEGE DISTRICT 525

By: \_\_\_\_\_

By: \_\_\_\_\_

CHANNAHON PARK DISTRICT

THREE RIVERS LIBRARY DISTRICT

By: \_\_\_\_\_

By: \_\_\_\_\_

6. The Village agrees that any Amendment to the Amended and Restated Redevelopment Agreement between the Village and Aux Sable Liquid Products LP shall be consistent with the terms of the IGA, this Amendment and the Settlement Agreement.

7. The terms and conditions of the IGA shall remain in full force and effect except as specifically altered by this Amendment. The provisions of this Amendment shall take precedent over any inconsistent provision of the IGA.

DATED: December 31, 2012

VILLAGE OF CHANNAHON

GRUNDY COUNTY

By:  \_\_\_\_\_

By: \_\_\_\_\_

MINOOKA CONSOLIDATED SCHOOL DISTRICT NO. 201

MINOOKA COMMUNITY HIGH SCHOOL DISTRICT NO. 111

By: \_\_\_\_\_

By: \_\_\_\_\_

AUX SABLE TOWNSHIP

MINOOKA FIRE PROTECTION DISTRICT

By: \_\_\_\_\_

By: \_\_\_\_\_

AUX SABLE TOWNSHIP HIGHWAY COMMISSIONER

JOLIET JUNIOR COLLEGE COLLEGE DISTRICT 525

By: \_\_\_\_\_

By: \_\_\_\_\_

CHANNAHON PARK DISTRICT

THREE RIVERS LIBRARY DISTRICT

By: \_\_\_\_\_

By: \_\_\_\_\_

6. The Village agrees that any Amendment to the Amended and Restated Redevelopment Agreement between the Village and Aux Sable Liquid Products LP shall be consistent with the terms of the IGA, this Amendment and the Settlement Agreement.

7. The terms and conditions of the IGA shall remain in full force and effect except as specifically altered by this Amendment. The provisions of this Amendment shall take precedent over any inconsistent provision of the IGA.

DATED: December 31, 2012

VILLAGE OF CHANNAHON

GRUNDY COUNTY

By: \_\_\_\_\_

By: \_\_\_\_\_

MINOOKA CONSOLIDATED SCHOOL DISTRICT NO. 201

MINOOKA COMMUNITY HIGH SCHOOL DISTRICT NO. 111

By: \_\_\_\_\_

By: \_\_\_\_\_

AUX SABLE TOWNSHIP

MINOOKA FIRE PROTECTION DISTRICT

By: \_\_\_\_\_

By: \_\_\_\_\_

AUX SABLE TOWNSHIP HIGHWAY COMMISSIONER

JOLIET JUNIOR COLLEGE COLLEGE DISTRICT 525

By: \_\_\_\_\_

By: Barbara DeLaney

CHANNAHON PARK DISTRICT

THREE RIVERS LIBRARY DISTRICT

By: \_\_\_\_\_

By: \_\_\_\_\_

6. The Village agrees that any Amendment to the Amended and Restated Redevelopment Agreement between the Village and Aux Sable Liquid Products LP shall be consistent with the terms of the IGA, this Amendment and the Settlement Agreement.

7. The terms and conditions of the IGA shall remain in full force and effect except as specifically altered by this Amendment. The provisions of this Amendment shall take precedent over any inconsistent provision of the IGA.

DATED: December 31, 2012

VILLAGE OF CHANNAHON

GRUNDY COUNTY

By: \_\_\_\_\_

By: \_\_\_\_\_

MINOOKA CONSOLIDATED SCHOOL DISTRICT NO. 201

MINOOKA COMMUNITY HIGH SCHOOL DISTRICT NO. 111

By: \_\_\_\_\_

By: \_\_\_\_\_

AUX SABLE TOWNSHIP

MINOOKA FIRE PROTECTION DISTRICT

By: \_\_\_\_\_

By: \_\_\_\_\_

AUX SABLE TOWNSHIP HIGHWAY COMMISSIONER

JOLIET JUNIOR COLLEGE COLLEGE DISTRICT 525

By: \_\_\_\_\_

By: \_\_\_\_\_

CHANNAHON PARK DISTRICT

THREE RIVERS LIBRARY DISTRICT

By: \_\_\_\_\_

By:  \_\_\_\_\_

6. The Village agrees that any Amendment to the Amended and Restated Redevelopment Agreement between the Village and Aux Sable Liquid Products LP shall be consistent with the terms of the IGA, this Amendment and the Settlement Agreement.

7. The terms and conditions of the IGA shall remain in full force and effect except as specifically altered by this Amendment. The provisions of this Amendment shall take precedent over any inconsistent provision of the IGA.

DATED: December 31, 2012

VILLAGE OF CHANNAHON

GRUNDY COUNTY

By: \_\_\_\_\_

By: \_\_\_\_\_

MINOOKA CONSOLIDATED SCHOOL DISTRICT NO. 201

MINOOKA COMMUNITY HIGH SCHOOL DISTRICT NO. 111

By: \_\_\_\_\_

By: \_\_\_\_\_

AUX SABLE TOWNSHIP

MINOOKA FIRE PROTECTION DISTRICT

By: \_\_\_\_\_

By: \_\_\_\_\_

AUX SABLE TOWNSHIP HIGHWAY COMMISSIONER

JOLIET JUNIOR COLLEGE COLLEGE DISTRICT 525

By: \_\_\_\_\_

By: \_\_\_\_\_

CHANNAHON PARK DISTRICT

THREE RIVERS LIBRARY DISTRICT

By:  \_\_\_\_\_

By: \_\_\_\_\_

Ronald D. Lehman, President

**Minooka Community High School  
District No. 111**

**&**

**Minooka Consolidated Community School  
District No. 201**

**Joint Request for Proposal for:**

**Leased School Buses**

**MINOOKA COMMUNITY HIGH SCHOOL  
DISTRICT No. 111  
26655 W. Eames Street  
Channahon, Illinois 60410  
(815) 521-4294**

**MINOOKA COMMUNITY CONSOLIDATED  
DISTRICT No. 201  
305 Church Street  
Minooka, Illinois 60410  
(815) 467-6121**

**Invitation to Provide Proposal – School Bus Lease & Purchase of Districts’ Used School Buses**

Minooka Community High School District No. 111 and Minooka Community Consolidated School District No. 201 operate a shared bus barn and are accepting proposals for leased school buses and seeking offers for the purchase of their used buses. Sealed proposals are due by **11:00 am on Thursday, January 6, 2022**, at which time they will be publicly opened and read aloud. Proposals are to be submitted to:

Minooka Community High School District 111  
Attn: John Troy, Assistant Superintendent & General Counsel  
26655 W. Eames Street  
Minooka, IL 60410

Failure to comply with these proposal documents and submit all required forms may lead to disqualification of your proposal.

We look forward to your participation in this request for proposal.

Sincerely,

Mr. John Troy  
Asst. Superintendent & General Counsel  
MCHS No. 111

Kris Monn  
Superintendent  
Minooka CCSD 201

## INSTRUCTIONS TO BIDDERS

1. BIDS MUST BE RECEIVED IN OUR OFFICE BY 11:00 am Thursday, January 6, 2022 at when they will be publicly opened and the contents announced. They will be held without right of withdrawal and shall be considered valid for sixty (60) days for new buses, thirty (30) days for used buses. The sealed envelope shall be marked in bottom left hand corner identifying contents as "Transportation Bid". Any bid(s) received after the bid opening time shall be returned to the bidder unopened. It is the bidder's responsibility to assure that the bid is delivered on time. The transmittal of the bid proposal is at seller's risk of untimely receipt by the Board. Faxed and/or emailed copies are not acceptable.
2. All interested parties are cordially invited to be present at the public proposal opening to be held at the time the sealed proposals are due. Proposals will be publicly opened and results announced. Awards, however, will not be made until after the staff has made a thorough analysis of all proposals received. Proposals will be officially awarded at a subsequent meeting of the Board of Education.
3. The Board of Education reserves the right to split the bid on the basis of best quotation. The Board reserves the right to reject any and all bids or any part thereof, to waive nonconformities in the bidding, and to accept the bid deemed most favorable to the Board after all bids have been examined and evaluated. Among the items to be considered in awarding bid are price, warranty, service, bus model and specifications. The Board of Education decisions are final in all instances and not subject to recourse. All bidders will be notified of the results of the Board of Education action, with a summary of bids provided. No corrections can be made after the time of opening.
4. Delivery of the new vehicles shall be made Minooka Transportation Center, 700 E. Minooka Road, 60447 attention Director of Transportation, Cathy Haase. **Delivery must be made, route ready, on or before Monday July 18, 2022. The successful bidder upon award of the bid must submit a delivery guaranty check in the amount of \$1,000 dollars to each district. This delivery guaranty check shall be forfeited to the district for failure to deliver the district's entire order of buses by the scheduled time.**
5. YOUR BID PRICE MUST BE F. O. B. MINOOKA, IL, WITH ALL TRANSPORTATION AND HANDLING CHARGES PAID BY THE BIDDER AND INCLUDED IN THE PRICE OF THE BUS. The Bidder must deliver units ready to operate.
6. **PROPOSALS MUST CONTAIN COMPLETE DETAILS OF THE LEASING COSTS AND THE INTEREST RATE. PROPOSALS MUST CONTAIN ALL LEASING DOCUMENTS REQUIRED BY THE LENDER. THE BOARDS OF EDUCATION WILL NOT AWARD ANY BID THAT DOES NOT HAVE ALL SUPPORTING LEASING DOCUMENTS INCLUDED.**
7. **THE DISTRICTS WILL ALSO SEEK COMPETITIVE LEASING ARRANGEMENTS IN CONJUNCTION WITH THIS BID. ALL BIDS MUST CONTAIN THE FULL PRICE OF THE BUS AS WELL AS A GUARANTEED "BUY-BACK" DOLLAR AMOUNT AT THE END OF THE LEASE TERM.**
7. Bidder shall include the cost of title transfer and license application with the bid.
8. Detailed warranty information must be included with the Bid Packet

9. Bidders must be in full compliance with all provisions of the acts of the General Assembly of Illinois relating to employment, including equal employment opportunity requirements and any other affidavits as required by law.

10. Supplier shall agree to comply with the provisions of the latest edition of the Occupational Safety and Health regulations and the standards and regulations issued there under and shall certify that all items furnished under this bid will conform to and comply with said standards and regulations.

11. Supplier shall agree to comply with provisions of the latest edition of the Consumer Product Safety Act of 1972 and certify that items furnished under this bid conform with applicable standards including all State and Federal requirements for school buses.

12. Title to the goods herein described shall not pass until said goods have actually been received by the Board or its consignee. Risk of loss prior to such actual receipt by Board or its consignee shall be borne by seller. Nothing herein contained, however, shall be construed to deprive the Board of its interest, or limiting such interest, in goods herein described prior to such actual receipt.

13. The Boards of Education reserves the right to reject any goods which contain defects in material or workmanship or which fail to meet specifications contained herein or seller's warranties (express or implied.) Rejected goods shall be removed at the expense of the seller, including transportation both ways, promptly after notification of rejection. As to rejected goods, seller shall bear all costs of inspection and all risk of loss. The District reserves the right to select independently for specific bid items from any vendor bidding.

14. Payment by the Boards for goods supplied hereunder shall not constitute acceptance thereof if subsequent inspection discloses defects in material or workmanship or a failure to meet the specification contained herein. Payment shall not be processed until District has proper title certificate on file.

15. The Boards' failure to enforce any of the terms, conditions, and specifications of the bid or any breach shall not in any way affect, limit, or waive the Board's right thereafter to enforce and compel strict compliance with every term, condition, and specification hereof. By submitting bid the bidders accepts the terms of this bid document and agrees to be bound by the same.

16. Any interpretation of the proposed documents will be made only by an addendum duly issued by the District. A copy of such addendum will be faxed to each prospective bidder. Failure on the part of the prospective bidder to receive a written interpretation prior to the time of the opening of bids will not be grounds for withdrawal of his proposal. All requests for clarification must be received by the District not less than three (3) business days prior to bid opening. Inquiries after that time will may not receive a response in order to preserve a fair process for all bidders.

17. Award will be made by official Board documents. Bidder order form is not acceptable and cannot be used.

18. The Boards are exempt from paying Illinois Use Tax and sales the Boards are exempt from Illinois Retailer's Occupation Tax. The Boards are exempt from paying Federal Excise Taxes.

19. Payment Terms: Payment shall not be processed until the District has proper paperwork on file. Districts process checks once per month. Payment by Boards for goods supplied hereunder shall not constitute acceptance thereof if subsequent inspection discloses defects in material or workmanship or a failure to meet the specification contained herein. Payments are processed

following submittal and approval of the Board of Education at the regular monthly meeting provided they have been received and accepted on time.

20. Bidder must complete and submit bid on bid forms included with this specification. The bidder may photocopy the form. The bidder must include signed copies for all attachments indicating a signature (Non-Collusion Affidavit and Project Qualification Form ). Failure to complete and submit any of these forms shall be cause for bid to be rejected since it would be an incomplete bid.

21. All buses must meet Illinois specifications and legal requirements.

22. All used buses must state individually the year, mileage, and must state expected mileage remaining on brakes and provide tread depth measurements for each tire on the bid form for the used bus clearly identifying the bus for which the information applies.

23. All used buses must have at least 50% of brake and tire life minimum remaining for each wheel and tire.

**STATE OF ILLINOIS**

SS:

MONTGOMERY COUNTY

The undersigned vendor or agent, being duly sworn, on oath says that s(he) has not, nor has any other member, representative, or agent of the firm, company, corporation or partnership represented by him/her, entered into any combination, collusion or agreement with any person relative to the price to be proposal by anyone at such letting, nor to prevent any person from bidding nor to induce anyone to refrain from bidding, and that this proposal is made without reference to any other proposal and without any agreement, understanding or combination with any other person in reference to such bidding.

S(he) further states that no person or persons, firms, or corporation has, have or will receive directly or indirectly, any rebate, fee, gift, commission or thing of value resulting from such sale.

RANDY SWANSON  
Name

For MIDWEST BUS SALES, INC.  
Firm or Corporation

Subscribed and sworn to before me on this 3RD day of JANUARY, 2022

My commission expires:

5-12-2025

Signature:

Taffney Lea Kilduff

Notary Public

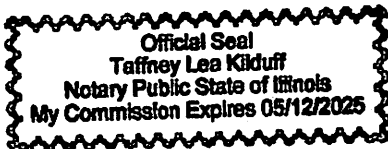

Taffney Lea Kilduff  
Signature

**NON-COLLUSION AFFIDAVIT**



# Customer Quotation

Prepared For:  
MINOOKA CHSD #111 & CCSD #201  
26655 W EAMES ST.  
MINOOKA, IL 60410

Prepared By :  
RANDY SWANSON  
MIDWEST BUS SALES INC.-LITCHFIELD  
18 SKYVIEW DR  
LITCHFIELD, IL 62056

Quote Number:  
379244

Quote Date:  
1/3/2022

Customer Order No:  
226073C2-226139

## Model Profile: Saf-T-Liner C2 340TS

Product Type:	School Transportation
Year:	2023
Chassis Model:	B2 106
Chassis MFG:	FLNER
GVWR:	GVWR
Passenger Capacity:	71
Headroom:	78
Wheelbase:	279
Brake Type:	HYDRAULIC
Engine Type:	CUMMINS B6.7 220 DIESEL, 6 Cyl, 220 HP, 2600 RPM
Fuel Type:	DIESEL
Fuel Tank Capacity:	100
Transmission Type:	AUTOMATIC
Axle, Front:	10000-lb Capacity
Axle, Rear:	21000-lb Capacity
Tires, Front:	RADIAL FRONT TIRE, MICHELIN XZE2, 11R22.5 16 PLY
Tires, Rear:	MICHELIN X MULTI D 11R22.5 16 PLY REAR TIRES
Suspension Front:	10,000-lb Capacity
Suspension Rear :	COMFORT-TEC SUSPENSION

Three year annual lease with 18,953 per year miles: \$ 18,659.06 per bus/per year  
 Five year annual lease with 18,953 per year miles: \$ 16,969.94 per bus/per year  
 Five year annual lease/purchase payment: \$ 23,660.71 per bus/per year  
 Estimated delivery 220-260 days ARO  
 Payment due upon delivery of unit  
 Quote valid for 30 days  
 Price is subject to school bus availability.

*These are stock buses and will be July 2022 delivery*  
 1-4-2022 RS

**CUSTOMER** Customer Signature\*\*: \_\_\_\_\_ Date: \_\_\_\_\_

**New bus(es) Info:**

Name on bus: \_\_\_\_\_

Bus Number (s): \_\_\_\_\_

**\*\* I have reviewed the quote detail for accuracy and I agree to order the bus(es) as listed.**

**\*New stock unit subject to prior sale and/or availability. Letter of intent to buy or purchase order is required to put bus on hold.**

Dealer Signature: RES Date: 1-4-2022

The equipment proposed meets and/or exceeds all requirements set forth in the Federal Minimum Standards for School Buses and Federal Motor Vehicle Safety Standards established by the Federal Department of Transportation.

**Includes the Following Equipment:**

**BODY**

**ACCESSORIES**

- 1 LOC-1ST.SEAT DRVRSIDE REFL TRIANGLE
- 1 LOCKS-KEYED ALIKE #CH545
- 1 METHOD-FASTENER SCREWS
- 1 HOLDER-CERTIFICATE 4"X 6"

**CERTIFICATION/SAFETY**

- 1 REFLECTTAPE-RR END YEL 2" 3M
- 1 REFLECTTAPE-FRT END YEL
- 1 FIRE EXTINGUISHER-5 3A-40BC
- 1 REFLECTORS-AMBER (4) MID/FRONT 3"
- 1 REFLECTORS-RED (4) RR/RR SI 3"
- 1 HATCH-RF ESC MODEL 1100 ENG(2)
- 1 ELECTRICAL-ROOF ESCAPE HATCH POS 3
- 1 HANDLES-W/S SERVICE, BLACK
- 1 KIT - BODY FLUID CLEAN-UP NATIONAL STANDARDS
- 1 SWITCH-ROCKER CROSSING ARM DEACTIVATION
- 1 LABEL-PASS ADVISOR INSTRUCTION
- 1 LOC-O/H STOR LS 10 UNIT B.F.C
- 1 LOC-VEST.FLR.PLT.LEFT 5LB F.E. & BOX
- 1 KIT.FIRST AID 10 UNIT ILL.
- 1 CUTTER-SEAT BELT W/HAND GRIP
- 1 TRIANGLES-REFL. 3 W/BOX
- 1 MOTOR-XING ARM ELEC.SPECIALTY
- 1 BRACKET-XING ARM STOWAGE 1/4" BUMP
- 1 OPEN VIEW - ES, HEATED, REMOTE
- 1 MIRROR-B EXTERIOR CROSSVIEW HEATED BLACK BRACKET
- 1 SIGN-STOP, ELEC FRT #SE1-7970C
- 1 SIGN-STOP, ELEC RR #SE1-7971C
- 1 MIRROR-INTERIOR 6"X30" WITH RUBBER EDGE
- 1 LABEL(S)-SPECIAL DATA, IL
- 1 LABEL-VEHICLE CERTIFICATION
- 1 FRONT BUMP MT CROSS ARM W/DEACTIVATION SWITCH-ELECTRIC

**DOORS**

- 1 STEP-RS ALUM.ENT.DR W/HTR 8.75"RISER
- 1 HANDLE-EXTERIOR REAR DOOR WITH RECESS
- 1 LATCH-DOOR INTERIOR STORAGE OVER WINDSHIELD
- 1 VANDALOCK-REAR DOOR W/BOLT
- 1 DOOR-ENT AG2 TINT TEMP LOCK
- 1 PWR SYST.-AG2 ELECTRIC ENTRANCE DOOR
- 1 ELEC-AG2 ELECTRICAL OPERATED ENTRANCE DOOR
- 1 OPER-DOOR ELEC.ENT.W/ BAT.
- 1 VANDALOCK-ALUM.ENT.DR.CYLINDER W/KEY
- 1 PULL-ENTRANCE DOOR, EXTERNAL ALUMINUM
- 1 KEY-VANDALOCK REAR DOOR NONE
- 1 TRIM-ENTRANCE DOOR INTERIOR
- 1 PAD-DR HEADER, RR EMER 36"W
- 1 TRIM-STEPWELL HORIZONTAL WITH RIBBED NOSE
- 1 RAIL-ASSIST FRT ENT DR 39"YEL
- 1 RAIL-ASSIST FRT ENT DR RS YEL 1"

**ELECTRICAL - BODY**

- 1 FAN-CIRC MID W/S HDR BLACK
- 1 ELEC-FAN MID W/S HDR
- 1 FAN-CIRC DRV'S WDO HDR BLACK
- 1 ELECTRICAL-FAN DRIVER'S WINDOW HEADER
- 1 RADIO-AM/FM DEA700 W/PAGE
- 1 OPER-AUTOMATIC FAST IDLE
- 1 ELEC-COAXIAL TWO-WAY RADIO ROOF

207

- 1 KIT-ANTENNA MOUNT AT ROOF
- 1 ELEC-ZONAR STANDARD MONITORING
- 1 ELEC-PWR CELL PHONE OUTLET LS
- 1 OPERATION-DOOR REAR EMERGENCY WITH BUZZER/PILOT LAMPS
- 1 MONITOR-LPS WARN NONE
- 1 LPS-DOME OVER DRIVER LED
- 1 LPS-DOME PASS 6 MIN LED 340T
- 1 ELEC-PASS DOME LPS W/REAR MOST (6)
- 1 SWITCH-RKR DOME LPS FRT/RR
- 1 MODULE-PWR.DIST.ELEC.SYS.
- 1 SWITCH-ROCKER PANEL LAMPS DIMMER
- 1 LPS-INT RED LED OVER RR EMG DR
- 1 LPS-EXT AFT OF ENT DOOR LED
- 1 ELEC-LPS EXT AFT OF ENT DOOR
- 1 OPER-STPWLL LPSW/PARKLPS&ENT DR.
- 1 LPS-STPWLL LED W/O HOOD (1)
- 1 LPS-STP/TAIL/DIR AMBER/REV LED
- 1 ELEC-LPS STOP/TAIL/TURN/REV
- 1 ADVISORY-PASSENGER BUZZER ACTIVATION, WITH SWITCH
- 1 LPS-PILOT VANDALOCK STATUS RED
- 1 ELEC-PWR, GND, NETWORK, BUZZ
- 1 LAMPS-PILOT BRAKE LIGHTS RED
- 1 LAMPS-PILOT REAR EMERGENCY DOOR RED
- 1 LAMPS-PILOT POST TRIP INSPECTION RED
- 1 LAMPS-4" AUXILIARY L.E.D.
- 1 LPS-SI DIR AMBER FRT. LED PIN
- 1 ELEC-LPS SI FRT DIRECTIONAL ONLY
- 1 LPS-WARNING LED (8)
- 1 OPERATION-LAMPS WARNING (8) PACKAGE 14
- 1 OPERATION-LAMPS REVERSE WITH REAR EMERGENCY DOOR OPEN
- 1 LPS-ID AMB/RED LED
- 1 LPS-MKR ROOF FRT/RR LED PIN
- 1 LPS-MKR ROOF MID LED PIN
- 1 STROBE-ECCO 7460CC 6' FROM REAR
- 1 LPS- STOP/TAIL 4" FLS.MT L.E.D.
- 1 SWITCH-ROCKER FAN DEFROST WINDSHIELD
- 1 SWITCH-ROCKER NOISE SUPPRESSION ON/OFF
- 1 SWITCH-ROCKER STROBE LAMPS
- 1 LAMPS-PILOT WARNING LIGHTS RED
- 1 LAMPS-PILOT WARNING LIGHTS AMBER
- 1 OPERATION-LAMP STROBE, IGNITION & SWITCH ACTIVATED
- 1 ELEC-CABLE PRIM PWR & GND-CUSTOMER ACCESS
- 1 OPERATION-LAMPS SIDE DIRECT.OONLY
- 1 BLOCK-FUSE CUSTOMER ACCESS
- 1 LPS-DOME REAR MOST LED
- 1 OPER-PRE-TRIP INSPECTION
- 1 ELEC-SEAT BELT PILOT LAMP
- 1 OPER-SEAT BELT PILOT LAMP
- 1 LAYOUT-ROCKER SWITCH STANDARD
- 1 ELEC-ELECTRIC STOP SIGN 1ST WINDOW POSITION
- 1 SPEAKERS-INT. 30 WAT.(6) 340T
- 1 ELEC- (6) INT SPEAKERS 340T
- 1 SWITCH-RKR HTR BOOST PUMP
- 1 ELEC-HTR ENT DOOR STEPWELL
- 1 112DB BACKUP ALARM

## **EXTERIOR**

- 1 FLAPS-MUD, REAR 22.5"W
- 1 FLAPS-MUD, FRONT 16"W X 12"H
- 1 STEPS-EXT W/S SERVICE
- 1 FENDER-QUARTER 24" BATTERY BOX DOOR
- 1 BODY ADJUSTMENT-FREIGHTLINER, BTR RS FUEL FILL LOCATION
- 1 REINFORCEMENT-FRAME STD 24" BATTERY BOX DOOR
- 1 CAP-ENTRANCE DOOR STANDARD
- 1 FLOOR-NON ADA
- 1 BUMPER-RR 2 BRACES LS EXH HOLE

- 1 SKT.FWD.STPWLL LO DEF
- 1 CAP-FRONT ROOF W/WARN.LPS.
- 1 CAP-REAR ROOF W/WARN.LPS.
- 1 GUSSET-21"H LWR SIDE SHEET
- 1 SHEET-LWR, L MID 20G,21"
- 1 SHEET-LWR,L RR 20G,21"
- 1 SHEET-LWR,R MID 20G,21"
- 1 SHEET-LWR,R RR 20G,21"
- 1 DOOR-U/B L BATTERY 24"
- 1 DOOR-FUEL FILL ACCESS BTR
- 1 FENDERETTE-STL 21" SKIRT
- 1 LATCH-BATT DOOR NON-LOCKING
- 1 LATCH-FUEL FILL ACCESS (THUMB)
- 1 VENT-STATIC NONE
- 1 PILASTER - 340T, 800
- 1 LATCH-NON-LOCKING DEF ACCESS DOOR
- 1 RAIL-SNOW RAIL PRESENT
- 1 HARDWARE-MOUNTING CLIPS STANDARD

### **HVAC**

- 1 AIR COND - NONE
- 1 HTR-U/S LS 84,000 BTU LOC 3
- 1 HTR-U/S LS 84,000 BTU LOC 10
- 1 HOSE-HTR BLUSTRIP W/ W/H POS 10
- 1 HEATER-ENTRANCE DOOR STEPWELL
- 1 CLAMPS-PLUMBING HEATER CONSTANT TORQUE
- 1 CLAMPS-UNDERSEAT HEATER CONSTANT TORQUE
- 1 CONN-HTR(1) CONST TORQ/BLUSTRIP
- 1 VALVE-SHUTOFF LS U/SEAT HTR WHOUSE
- 1 NO AIR CONDITIONING COMPRESSOR

### **INTERIOR**

- 1 VISOR-WINDSHIELD SUN 6"X30" TINTED
- 1 DOOR-STORAGE BOX W/O GLASS
- 1 TRIM-LOWER REAR HEATER NO A/C
- 1 REINFORCEMENT-REAR STOP SIGNAL 40"
- 1 DOOR-ACC SOLID PANEL
- 1 LATCH-DR INT STOR OVR DRVRSHDR
- 1 BTR FUEL FILL RECESS, W/DOOR
- 1 COVER-TRIM DRVS HDR W/STORAGE
- 1 COVER-TRIM FRT END W/S HEADER
- 1 COVER-TRIM FRT ENT.ALUM.DR HDR.ELEC.OP.
- 1 FLR-BLK VINYL W/13" CTR AISLE 340T
- 1 FLR-BLK WHEELHOUSE AND HEATER
- 1 FLR-PLYWOOD 5/8" 340T
- 1 LINING-SIDE INT.
- 1 INSULATION-FRT BULKHEAD W/ACRSY 2"POLY
- 1 H/L-1ST WDO SEC ACOUS GRY 340T
- 1 INSULATION - URETHANE
- 1 HOLDER-STORAGE, CLIP BOARD
- 1 TUBE-FILL BTR & OVERFLOW HOSE
- 1 CAP-FUEL FILL BTR NON-LOCKING
- 1 IN DASH STORAGE BIN

### **MISC**

- 1 PDI IDENTIFIER-DEALER PERFORMED
- 1 MANUAL-DRVR'S/MAINT.ENGLISH
- 1 APPLICATION - SCHOOL
- 1 NO COOLANT HEATER - GAS/DIESEL
- 1 ALL UNIT(S) KEYED ALIKE WITH CUSTOMER SPECIFIED KEY #FT1001
- 1 NO A/C PLUMBING - MAIN
- 1 70 MPH ROAD SPEED LIMIT
- 1 SAF-T-LINER C2

### **PAINT/LETTERING**

- 1 DECAL-UNITED AUTO WORKERS
- 4 LABEL-P/O WDO EMER EXIT 2" BLACK
- 1 LABEL-ENGLISH AG2.ELEC.ENT DR

- 4 REFLECTTAPE-P/O WDO YEL 3M
- 1 REFLECTTAPE-EMER DR RR YEL 3M
- 1 REFLECTTAPE-SI 2" ABV FLR YEL 3M
- 1 LETTER - OVERHEAD STORAGE BOX "SAFETY EQUIP"
- 1 DECAL-BACKING ALARM
- 1 DECAL-LOW SULFUR FUEL
- 1 LABEL-RR DR EMERGENCY DOOR DO NOT BLOCK
- 1 DECAL-ENTRANCE DOOR VANDALOCK ENGLISH
- 1 LABEL-RR EMERGENCY DOOR INSTRUCTION
- 1 LABEL-"DEF ONLY"
- 1 LABEL-REGENERATION WARNING 2010/2013 EPA ENGLISH
- 1 HANDLE-INT RR DR RED
- 1 PAINT-EXT HNDLE(S) BLACK
- 1 DECAL-REFL FRT CAP "SCHOOL BUS" 3M
- 1 DECAL-REFL RR CAP "SCHOOL BUS" 3M
- 1 DECAL-"DIESEL"
- 1 PAINT-EXTERIOR ROOF WHITE 340T
- 1 PAINT-EXT WINDOW AREA BLACK
- 1 PAINT-EXT GRD RAIL @ WINDOW BLACK
- 1 PAINT-EXT GRD RAIL @ SEAT BLACK
- 1 PAINT-EXT GRD RAIL @ FLOOR BLACK
- 1 PAINT-EXT GRD RAIL @ SKRT BLACK
- 1 PAINT-EXT BUMPER REAR BLACK
- 1 PAINT-BLACK TRIM-FRONT/REAR ROOF CAPS
- 1 PAINT-SOLID COLOR YELLOW
- 1 DECAL-APPROVED FUEL TYPE
- 1 DECALS-WDO STRIPE 340T
- 1 HEADLINING-VESTIBULE ACOUSTIC, GRAY, DRIVER LAMP
- 1 PAINT:ONE SOLID COLOR,BASE/CLEARCOAT
- 1 CAB COLOR A:L5898EB SCHOOL BUS YELLOW ELITE BC
- 1 CAB COLOR B - NONE
- 1 CAB COLOR C: NONE
- 1 GRILLE: SILVER N3388H IMRON 5000

### **SEATS**

- 1 OFF-SET LS BARRIER 4"
- 1 2014 SEATING ALERT
- 1 SEAT BELT - DRIVERS SEAT
- 1 39" BARR-VERT,WALL MT 45"H RS 2009
- 1 39"8DEG BARR-REV. WALL-MT 45"H 2009
- 2 PROFORM EDO BLUE UPHOLSTERY-45"HIGH RECESSED BARRIER
- 1 BACK-NATIONAL DRV'S SEAT
- 1 ARMREST NATIONAL DRVR'S ST. RS
- 1 UPH DR.ST.FABRIC BLK NATIONAL
- 1 PEDASTAL-DR ST MECH TYPE
- 1 COVER PEDASTAL NATIONAL NONE
- 1 SLIDE STOP NATIONAL DR.ST. NONE
- 1 RETAINER NATIONAL DR.ST.BELT
- 1 POUCH-DR.ST.STORAGE NONE
- 1 KICKPLATE-MOD.PANEL RS 39"
- 1 RISER-DRIVERS SEAT, NATIONAL
- 1 Haptics-Not Present
- 12 S3B 39"RS WALL MT RESTRAINING/NO BELT
- 1 S3B 26" LS WALL MT RESTRAINING/NO BELT
- 11 S3B 39"LS WALL MT RESTRAINING/NO BELT
- 24 FIREBLOCK BLUE UPHOLSTERY - S3B SEAT
- 24 S3B WALL MT HARDWARE-RESTRAINT

### **WINDOWS/GLASS**

- 1 GLASS-WINDSHIELD ONE PIECE WITH TINTED BAND
- 1 GLASS-RS FRT STAT TNT TEMP
- 1 GLASS-LS FRT STAT TNT TEMP
- 1 GLASS-REAR STAT TINTED TEMP
- 1 FRAME-WDO SPLIT
- 16 FRAME-WDO SPLIT 30"W
- 2 FRAME-WDO SPLIT 40"W
- 2 FRAME-WDO P/O VERT TEMP TNT LS

- 2 WDO P/O VERT TEMP TNT RS
- 16 GLASS-WDO TINT TEMP 30"
- 2 GLASS-WDO TINT TEMP 40"
- 1 STOPS-WDO 12"
- 1 GLS-LWR RR DR TEMP TNT BONDED
- 1 GLS-UPR RR DR TEMP TNT BONDED
- 1 WDO-DRIVER'S TEMP TINT

### OTHER

- 1 2019 CUMMINS ENGINE TARIFF
- 1 SURCHARGE-RAW MATERIAL (STEEL)
- 1 2022 PIP INCENTIVE
- 1 LOGO-FRT RS & RR
- 1 LOGO-THOMAS DECALS YELLOW
- 1 ELEC-RF ESC HATCH POS 9
- 1 ARM ASSEMBLY-WINDSHIELD WIPER (2)
- 1 ELECTRICAL-ROOF HATCH OR P/O WINDOW (DASH)
- 1 OPER-FAN W/S HDR
- 1 OPER-FAN DRV'S WDO HDR
- 1 OPER-ALARM BACKING W/REV.
- 1 OPER-RF HATCH BUZZER
- 1 LOC-O/H ENT.DOOR RS CERT.HLDR
- 1 LOCATION-OVERHEAD STORAGE CENTER 10 F.A.K.
- 1 AC DUCT-NOT PRESENT NO SIDE EVAP
- 1 CONDENSER ALERT - NONE
- 1 EVAPORATOR QTY - NONE
- 1 OPER-XING ARM DEACTIVATION
- 1 ANTENNA - RADIO SWIVEL BASE
- 1 ELEC-ANTENNA RADIO COAXIAL
- 1 KIT-RADIO ANTENNA MOUNTING @ DRIVER'S HEADER
- 1 ALERT-CONDENSER NONE
- 1 340T30\_N
- 1 TRIM-A POST
- 1 WHEELHOUSES-REAR L&R
- 1 STRINGER-ROOF 340T
- 1 FRONT END FRAME
- 1 FRT END FRAME MTG KIT
- 1 REAR END FRAME-18.68" DEEP
- 1 FLOOR-GALVALUME STEEL MID BODY
- 1 LOC-40" RAF SP 11TH 340T
- 1 RS TANK ALERT - NONE
- 1 DOOR ALERT - LS ENT NONE
- 1 TRIM-REAR DOOR
- 1 HINGES-REAR DOOR PIN TYPE
- 1 LATCH-SINGLE-POINT, REAR EMERGENCY DOOR
- 1 STOP-DOOR REAR EMERGENCY, 1-POS
- 1 OPERATION-VANDLOCK ENTRANCE/EMGENCY DOOR(S) WITH PILOT LAMPS
- 1 ELEC-SIDE EMERGENCY DOOR(S)
- 1 DOOR-LS ENT RS EXIT -NONE REQD
- 1 INT COLOR -RR DOOR GRAY
- 1 VANDALOCK-NONE REQUIRED RS
- 1 VANDALOCK-NONE REQUIRED LS
- 1 DOOR ALERT - RS EXIT NONE
- 1 SWITCH-PAD. SERV. DOOR ELEC.
- 1 DOOR, REAR EMERGENCY
- 1 THRESHOLD REAR EMGERGENCY DOOR
- 1 ELEC-DRIVER'S DOME LPS
- 1 OPERATION-SWITCH, PANEL LAMPS DIMMER
- 1 ELEC-LPS-INT RED O/H RR EMG DR
- 1 ELEC-PASSENGER ADVISORY 340T
- 1 OPER-PASS ADV IGN/WARN/BUZZER
- 1 SWITCH-RKR FAN DEFROST L.S.
- 1 BUZZER-SWITCH PANEL 1 TONE
- 1 OPERATION-NOISE SUPPRESSION
- 1 ELEC-LPS WARNING,8 LPS 340T
- 1 OPER-LPS, DOME STANDARD

- 1 OPER-LPS BODY TAIL W/PARK SW.
- 1 LAMPS-LICENSE PLATE ILLUMINATION
- 1 ELEC-LPS ID/MKR PARK/SW.340T
- 1 SWITCH-ROCKER DOME LAMPS DRIVER ON/OFF
- 1 ELECTRICAL-LAMPS STROBE 6' FROM REAR
- 1 OPER-DRVR'S DOME LPS ON/OFF
- 1 OPER-HTR BOOSTER PUMP OPER WITH SWITCH
- 1 OPERATION-LAMPS INTERIOR/EXTERIOR RIGHT FRONT ENTRANCE DOOR
- 1 OPERATION-LAMPS SERVICE BRAKE WITH PILOT LAMPS
- 1 OPERATION-SWITCH ID/MARKER LAMPS WITH PARK
- 1 OPER-LPS DOME (2)ON/OFF
- 1 OPER-LPS REVERSE
- 1 ELEC-(3) SWITCH BANKS
- 1 SWITCH-WARN.LPS ON/AMB ACT.
- 1 ELEC-HARNESS COMP ASM 340T
- 1 ELEC-ELECTRONIC COMP ASM
- 1 OPER-LPS DIR./HAZ.
- 1 SWITCH-RKR MIRROR HTR.
- 1 ELEC-MIR A HTD & RC
- 1 ELECTRICAL-ELECTRIC STOP SIGN REAR
- 1 RAIL-EXTERIOR GUARD @ WINDOW,SEAT,FLOOR,SKIRT
- 1 RAIL-EXT GRD @ SEAT FRT END LS
- 1 RAIL-EXT GRD@ FLOOR, NONE
- 1 TRIM-FRT CAP RS/LS
- 1 PANELS-EXT RR W/4"AUXLPS
- 1 SHEET-DRIVERS EXTERIOR 20 GA.
- 1 SHEET-UPPER SIDE EXTERIOR
- 1 OPER-MIRRORS EXT HTD.
- 1 UNDERCOATING-ASPHALT EMULSION
- 1 HEADERS-WINDOW INTERIOR 340T
- 1 PAINT-EXT ENT DOOR NONE
- 1 PANELS-EXTERIOR REAR SIDE SHORT
- 1 LS STORAGE BOX 1 - NONE
- 1 LS STORAGE BOX 2 - NONE
- 1 ROOF SHEETS-(2)HATCH-340T
- 1 RS STORAGE BOX 1 - NONE
- 1 RS STORAGE BOX 2 - NONE
- 1 RS STORAGE BOX ROH - NONE
- 1 LS STORAGE BOX ROH - NONE
- 1 PANELS-REAR END INTERIOR REAR GALVALUME
- 1 PANELS-REAR END INTERIOR SIDE SHORT
- 1 BULKHEAD-RR END INT.GRY
- 1 PANELS-ACCESS RR GRAY PASS ADVISORY
- 1 COVER-HARNESS ACCESS@HDR
- 1 COVER-ACCESS RR END HARNESS
- 1 COVER-ACCESS FRT END HARNESS
- 1 H/L-RR SHORT SMOOTH GRAY W/LPS
- 1 STRIPS - AISLE, SNAP-IN BLACK
- 1 COVER-FUEL SENDING INSPECTION
- 1 MOLDING-SHOE 340T
- 1 SWITCH-ROCKER HEATER STEPWELL
- 1 LUGGAGE RACK ALERT - NONE
- 1 SWITCH-ROCKER HEATER LEFT 1ST
- 1 SWITCH-ROCKER HEATER LEFT 2ND
- 1 ELEC-HTR U/ SEAT POS 3
- 1 ELECTRICAL-HEATER UNDERSEAT POSITION 10
- 1 RAIL-SEAT
- 1 LAYOUT-SEAT RAIL HOLES RS
- 1 LAYOUT-SEAT RAIL HOLES LS
- 1 CABINET-SW, FWD
- 1 CABINET-SWITCH, LOWER WITHOUT POCKET
- 1 CABINET-SWITCH, UPPER
- 1 CABINET-TOP PLATE (3 BANK)
- 1 TREAD-STEP ALUMINUM ENTRANCE DOOR BLACK
- 1 OPER-HTR U/ SEAT LS FWD

- 1 PANEL-ACCESSORY MOUNTING SAFTEY EQUIPMENT
- 1 OPER-HTR STEPWELL
- 1 INSULATION-VEST HEADLINING 2"
- 1 INSULATION-SIDELINING 2" POLY
- 1 INSULATION-RR BULKHEAD 2" POLY
- 1 OPER-HTR U/ SEAT LS AFT
- 1 HEADERS-WINDOW EXTERIOR 340T
- 1 HARNESS COVER COLOR - GRAY
- 1 SPEAKER ALERT - PRESENT
- 1 DOME LPS - MINIMUM
- 1 HEADLINING COLOR - GREY
- 1 HDLINING TYPE-1ST WDO ACOUSTIC
- 1 MAT, FLOOR VESTIBULE
- 1 TRIM-INTERIOR DASH FORWARD
- 1 INSTALLATION-PARK BRAKE ASSEMBLY
- 1 INSULATION-INT SHORT REAR END
- 1 LUGGAGE RACK ALERT - NONE
- 1 PLATE-ACCELERATOR
- 1 OPER-WDO P/O
- 1 VANDALOCK,STARTER DISABLE W/ANY LOCKED EMER DR(S),LH PT LAMP
- 1 LOWER RADIATOR GUARD
- 1 REINFORCED NYLON FUEL LINES
- 1 PAINTED FUEL TANK, PAINTED BANDS
- 1 SINGLE SUCTION AND RETURN FUEL LINES
- 1 FUEL TANK MOUNTED BETWEEN RAILS, AFT OF REAR AXLE, WITH CAGE
- 1 STAINLESS STEEL CHARGE AIR COOLER PLUMBING
- 1 REMOTE-MOUNTED SURGE TANK
- 1 BASIC WIRING SCHEMATIC,UNMOUNTED,12-VOLT NEGATIVE GROUND SYS
- 1 PAINTED BATTERY PANEL COVER
- 1 BATTERY BOX FRAME MOUNTED
- 1 INTEGRAL ELECTRONIC TURN SIGNAL FLASHER
- 1 BATT ENABLED 3 AMBER INBOARD ID LAMPS,2 AMBER OUTBOARD MARKE
- 1 STROBE LAMP, IGNITION SWITCH OR LH DASH SWITCH ACTIVATED
- 1 LED WARNING SYSTEM LAMPS
- 1 STANDARD BODY VISUAL WARNING,LOWER RR,REV LAMPS ON DR/OPEN
- 1 STANDARD WIRING
- 1 DRIVER'S IGNITION OPERATED DOME LP WITH ON/OFF SW
- 1 PASSENGER COMPARTMENT DOME LAMPS, IGNITION ACTIVATED
- 1 PASSENGER COMPARTMENT DOME LPS, DUAL ON/OFF SWITCH
- 1 STEPWELL LAMP ON WITH DOOR OPEN AND MARKER LAMPS ON
- 1 EIGHT LAMP WARNING SYSTEM,LH DASH SWITCH(S), PACKAGE 14
- 1 SHIFT LEVER, CABLE LINKAGE, AUTOMATIC TRANSMISSION
- 1 DRIVELINE GUARD
- 1 NON-ASBESTOS FRONT BRAKE LININGS
- 1 FRONT SHOCK ABSORBERS
- 1 NON-ASBESTOS REAR BRAKE LININGS
- 1 WABCO NG HYDRAULIC ABS/ATC W/SHUTOFF SWITCH
- 1 NO POLISHED FRONT WHEELS
- 1 NO POLISHED REAR WHEELS
- 1 TWO QUART SEE THRU POWER STEERING RESERVOIR
- 1 POWER STEERING PUMP
- 1 ZINC-PLATED HEXHEAD CHASSIS FASTENERS
- 1 3675MM (145") REAR FRAME OVERHANG
- 1 SQUARE END OF FRAME
- 1 BUMPER MOUNTING FOR SINGLE LICENSE PLATE
- 1 LED COMB S/T/T/R LAMPS, & (2)4"ROUND REVERSE LAMPS
- 1 RR EMER DR,IGN CTRL,BZ ON W/DR
- 1 MAINTENANCE-FREE RUBBER BUSHINGS - FRONT SUSPENSION
- 1 21K TAPERLEAF SPRING REAR SUSPENSION
- 1 CAB MOUNTING FOR HOOD AND COWL CHASSIS
- 1 RH FRONT ENTRANCE DOOR, BATTERY CONTROLLED,ELECTRICALLY OPER
- 1 MANUAL ENT DOOR LOCK/BUZZER ON W/EMERGENCY DOORS UNLATCHED
- 1 ONE GALLON WINDSHIELD WASHER RESERVOIR
- 1 BLACK HOOD MOUNTED AIR INTAKE GRILLE
- 1 SINGLE ELECTRIC WINDSHIELD WIPER MOTOR W/DELAY

- 1 GRAY/CHARCOAL FLAT DASH
- 1 NO FCCC SUPPLIED AC COMPONENTS ON COMPLETED VEHICLE
- 1 STANDARD TUNNEL/FIREWALL LINER
- 1 NO AIR CONDITIONER CONDENSER
- 1 HEATER AND DEFROSTER
- 1 STANDARD HVAC DUCTING
- 1 MAIN HVAC CONTROLS WITHOUT RECIRCULATION SWITCH,& NOISE SUPP
- 1 WINDSHIELD FAN,(1) HEADER MOUNTED
- 1 DRIVER'S FAN,(1) MOUNTED ABOVE SIDE WINDOW
- 1 AUX BODY HEATER,UNDER SEAT,FWD
- 1 AUXILIARY BODY HEATER, UNDER SEAT, AFT
- 1 GRAY INSTRUMENT PANEL-DRIVER
- 1 BODY SUPPLIED HEATED MIRRORS
- 1 ROOF MOUNTED VENT/ESCAPE HATCH
- 1 PUSH OUT BODY SIDE WINDOWS, BUZZER WITH WINDOW UNLATCHED
- 1 PROVISION FOR EVIR ZONAR
- 1 SEPARATE PANEL LAMP DIMMER,LH DRIVER'S SWITCH PANEL
- 1 CHASSIS COWL AND HOOD ONLY
- 1 NO TCU-TRANSMISSION OPTIMIZED(NO FUEL SENSE)
- 1 PILOT,LH DASH,STOP LAMP MONITOR
- 1 BUMPER: BLACK
- 1 NO SPARE WHEEL PAINT
- 1 CHASSIS: VENDOR BLACK
- 1 J1939 ELECTRICAL ARCHITECTURE
- 1 EXPECTED GROSS VEHICLE WEIGHT CAPACITY
- 1 EXPECTED FRONT AXLE(S) LOAD
- 1 EXPECTED REAR DRIVE AXLE(S) LOAD
- 1 SCHOOL BUS SERVICE
- 1 COWL CHASSIS CONFIGURATION COMPLIES WITH SBMTC
- 1 BUS BODY WITH WHEELWELL
- 1 PASSENGER COMMODITY
- 1 100% ON-HIGHWAY (CITY) TERRAIN
- 1 DOMICILED USA 50 STATES (CALIFORNIA)
- 1 DOMICILED ILLINOIS
- 1 THOMAS BUILT SCHOOL BUS 340T

## **CHASSIS**

### **AXLES AND SUSPENSIONS**

- 1 ALIGNMENT-4-WHEEL SAF-T-LINER C2
- 1 SPL100 DANA SPICER MAIN DRIVELINE
- 1 DA-F-10-3 10,000# FF1 71.5 KPI/3.74 DROP SINGLE FRONT AXLE
- 1 CHICAGO RAWHIDE FRONT OIL SEALS
- 1 SYNTHETIC 75W-90 FRONT AXLE LUBE
- 1 CONMET IRON FRONT HUBS
- 1 SYNTHETIC 75W-90 REAR AXLE LUBE
- 1 DA-RS-21-4 21K R-SERIES SINGLE REAR AXLE
- 1 6.14 REAR AXLE RATIO
- 1 IRON REAR AXLE CARRIER HOUSING
- 1 REAR SHOCK ABSORBERS - ONE AXLE
- 1 CHICAGO RAWHIDE (SCOT) REAR OIL SEALS
- 1 GUNITE IRON REAR HUBS
- 1 10,000 LB. TAPERLEAF FRONT SUSPENSION
- 1 COMFORT-TEC SUSPENSION

### **BRAKES**

- 1 ALERT-ENHANCED STABILITY CONTROL
- 1 BOSCH HYDRAULIC BRAKE PACKAGE
- 1 BOSCH HYDRAULIC PIN-SLIDE DISC FRONT
- 1 FRONT DISC BRAKE ROTORS W/SEPARATE TONE RINGS
- 1 BOSCH HYDRAULIC PIN-SLIDE DISC REAR
- 1 REAR BRAKE DUST SHIELDS
- 1 FRONT BRAKE DUST SHIELDS
- 1 TRANSMISSION-MOUNTED PARK BRAKE
- 1 REAR DISC BRAKE ROTORS W/SEPARATE TONE RINGS
- 1 NYCLAD HYDRAULIC CHASSIS TUBING
- 1 FT OPER PARK BRAKE w/SERVICE BRAKE INTERLOCK w/INDICATOR

## **CHASSIS EQUIPMENT**

- 1 EXHAUST-LS, THRU REAR BUMPER
- 1 ANTI-FREEZE, OAT -34 DEGREE
- 1 WINTERFRONT-CHASSIS GRILLE YELLOW
- 1 SHIELD-EXHAUST PIPE
- 1 B2 106 CONVENTIONAL CHASSIS
- 1 SET-BACK AXLE - TRUCK
- 1 ELECTRIC GRID AIR INTAKE WARMER
- 1 DELCO 12V 29MT STARTER WITH INTEGRATED M
- 1 NO CLUTCH PEDAL WITH NON-ADJUSTABLE
- 1 ENGINE COMPARTMENT MOUNTED AIR RESTRICTION INDICATOR W/LIGHT
- 1 RIGHT HAND SIDE-FILL FUEL TANK CAP
- 1 100GALLON/378 LITER STEEL RECTANGULAR FUEL TANK,BETWEEN RAIL
- 1 HORIZONTAL TAILPIPE, LH SIDE, EXIT THROUGH BUMPER
- 1 11.5 GALLON DEF TANK
- 1 ENGINE AFTER TREATMENT DEVICE AUTOMATIC
- 1 MAGNETIC ENGINE DRAIN, REAR AXLE DRAIN & FILL PLUG
- 1 NO TRACTION STABILIZER
- 1 TILT ONLY STEERING COLUMN
- 1 TRW THP-60 POWER STEERING
- 1 450MM(18") LK FOUR-SPOKE CHARCOAL STEERING WHEEL
- 1 7075MM (279") WHEELBASE
- 1 5/16" X 3.00" X 10 1/8" STEEL FRAME (7.94 X 76.5 X 257.2")
- 1 1-PIECE 14" PTD STL 1/4" HD BUMPER JACK PROVISION
- 1 FRONT FRAME-MOUNTED TOW HOOKS
- 1 REAR TOW HOOKS
- 1 STANDARD DUTY HOOD MOUNTING
- 1 FIBERGLASS HOOD
- 1 PAINTED PLASTIC GRILLE
- 1 YELLOW WINTERFRONT
- 1 (2) CUPHOLDERS, LEFT HAND AND RIGHT HAND DASH

## **ELECTRICAL - CHASSIS**

- 1 LN 12V 240 AMP AVI PAD MOUNT ALTERNATOR
- 1 PROG RPM CTRL W A/C OR 12.75V LOW VOLT AUTO HI IDLE, DASH SW
- 1 CRUISE CONTROL-ELEC ENG,W/SWITCHES IN LH SWITCH PANEL
- 1 DIAGNOSTIC INTERFACE CONNECTOR,9-PIN, S
- 1 IGNITION SWITCH CONTROLLED ENGINE STOP
- 1 12VOLT POWER SUPPLY LH PANEL
- 1 SOLID STATE CIRCUIT PROTECTION, PDMS WIT
- 1 (3) ALLIANCE 1031,GROUP 31,12 VOLT,MF 2280 CCA BATTERIES
- 1 COLE HERSEE BATTERY CUT-OFF SWITCH, BATTERY BOX MOUNTED
- 1 SELF CANCEL TURN SIGNAL SWITCH W/DIM/WASH&HAZZARD IN HANDLE
- 1 STANDARD FRONT TURN SIGNAL LIGHTS
- 1 PARK LMP SW INTGRAL W/HL SWITCH, ID/MARKER/CLEARANCE/PARK ON
- 1 NO FENDER MTD TURN/MARK COMBO LPS
- 1 AMBER LED MIDSHIP TURN SIGNALS
- 1 DAYTIME RUNNING LIGHTS SET @ 85%
- 1 INTEGRAL HEADLIGHT/MARKER ASSEMBLY
- 1 NO UTILITY/ADVERTISING LIGHT
- 1 STOP SIGN PRESENT
- 1 NO BAGGAGE COMPARTMENT LAMP
- 1 NO BODY MTD INT SPOT/WORK LAMP
- 1 ELECTRONIC STABILITY CONTROL
- 1 BAT PWD 2-POS INT DOOR CONTROL LS SWITCH PANEL
- 1 DUAL ELEC HORN, PASSENGER ADVISORY BUZZER ON W/IGN AND WARN
- 1 NO OBSTACLE DETECTION SYSTEM
- 1 NO CAMERA/VIDEO/IMAGING SYSTEM
- 1 C/F J1939 RADIO W/PA
- 1 CUSTOMER FURNISHED 2-WAY RADIO
- 1 FASTEN SEAT BELT INDICATOR FOR CUSTOMER SUPPLIED SEAT BELT
- 1 LOCATING SYSTEM WITH VEHICLE MONITORING
- 1 ELECTRONIC SPEEDOMETER WITH SECONDARY KPH SCALE, NO ODOMETER
- 1 DRIVER MESSAGE CENTER WITH LCD DISPLAY
- 1 ELECTRONIC 3500 RPM TACHOMETER
- 1 NO INFORMATION CENTER

215

- 1 PRE/POST TRIP SYSTEM TEST
- 1 ENGINE AND HOUR METERS INTEGRAL WITH DRIVER DISPLAY
- 1 DIGITAL VOLTAGE DISPLAY INTEGRAL WITH DRIVER DISPLAY
- 1 ELECTRIC FUEL GAUGE
- 1 ELECTRIC ENGINE OIL PRESSURE GAUGE
- 1 ELECTRICAL ENGINE COOLANT TEMPERATURE GAUGE

### **ENGINE AND EQUIPMENT**

- 1 CUM B6.7 220 HP @ 2400 RPM, 2600 GOV, 600 LB/FT @ 1600 RPM
- 1 ANTI-FREEZE TO -34F, OAT (NITRITE AND SILICATE FREE)EXT LIFE
- 1 ENGINE-MOUNTED OIL CHECK AND FILL
- 1 CUMMINS SPIN ON FUEL FILTER
- 1 STANDARD ENGINE OIL
- 1 FULL FLOW OIL FILTER
- 1 DETROIT F/W SEP W/WIF SENSOR & HAND PRIMER & 12V HEATER
- 1 CUMMINS INTEGRAL EXHAUST BRAKE WITH VARIABLE TURBO
- 1 ALUMINUM FLYWHEEL HOUSING
- 1 PHILLIPS 750 WATT/115 VOLT BLOCK HEATER
- 1 STANDARD OIL PAN
- 1 ENGINE HEATER RECEPTACLE MOUNTED FACE OF BUMPER, LEFT SIDE
- 1 ELECTRONIC ENGINE INTEGRAL WARNING AND DERATE PROTECTION
- 1 ADDL AUX LINES W/MANIFOLD PLUMBING AND COMBINED SHUTOFF
- 1 GATES BLUE STRIPE COOLANT HOSES
- 1 CONSTANT TORQUE BREEZE CLAMPS ON 1" IN DIA GREATER, SS C
- 1 CAST BOOSTER PUMP
- 1 30,600 BTU STEPWELL HEATER, RH FRONT ENTRANCE DOOR
- 1 DONALDSON ONE-STAGE AIR CLEANER
- 1 700 SQUARE INCH ALUMINUM RADIATOR
- 1 VISCOUS FAN DRIVE
- 1 OMIT STANDARD EXHAUST DIFFUSER
- 1 NO IDLE SHUTDOWN CONFIGURATION
- 1 DIGITAL TRANS OIL TEMP IN DRIVER DISPLAY

### **TRANSMISSION AND EQUIPMENT**

- 1 ALLISON 2500 PTS AUTOMATIC TRANSMISSION
- 1 ALLISON VOCATIONAL PACKAGE 354 - FIFTH GEN
- 1 TRANSMISSION OIL CHECK AND FILL
- 1 SYNTHETIC 50W TRANSMISSION LUBE (TES-295 COMPLIANT)
- 1 WATER TO OIL TRANSMISSION COOLER - IN RADIATOR END TANK
- 1 PRIMARY MODE GEARS, 6 FORWARD
- 1 NO TCU-LBSS VAC
- 1 NO MODE SWITCH

### **WHEELS AND TIRES**

- 1 RADIAL FRONT TIRE, MICHELIN XZE2, 11R22.5 16 PLY
- 1 MICHELIN X MULTI D 11R22.5 16 PLY REAR TIRES
- 1 NO TIRE PRESSURE CONTROL/SENSOR
- 1 MAXION 90262 22.5 X 8.25 10 HOLE HUB PILOT 5-HAND
- 1 MAXION 90262 22.5 X 8.25 10 HOLE HUB PILOT 5-HAND
- 1 TIRE/WHEEL BALANCING-LEAD FREE WEIGHTS
- 1 ACCURIDE PK-BLACK21 POWDER BLACK WHEEL (N0001H)- FRONT
- 1 ACCURIDE PKBLK21 POWDER BLACK WHEEL (N0001H) – REAR

### **DEALER ADD On's**

#### **EQUIPMENT**

- 1 CUSTOMER LETTERING
- 1 ILLINOIS STATE INSPECTION, TITLE AND LICENSE FEE

**Meets all FMVSS requirements in effect at the time of manufacture.**

Customer Signature: \_\_\_\_\_

Date: \_\_\_\_\_





# Customer Quotation

Prepared For:  
MINOOKA CHSD #111 & CCSD #201  
26655 W EAMES ST.  
MINOOKA, IL 60410

Prepared By :  
RANDY SWANSON  
MIDWEST BUS SALES INC.  
18 SKYVIEW DR.  
LITCHFIELD, IL 62056

Quote Number:  
369213

Quote Date:  
1/3/2022

Customer Order No:  
216166C2-216188

## Model Profile: Saf-T-Liner C2 341TS

Product Type:	School Transportation
Year:	2022
Chassis Model:	B2 106
Chassis MFG:	FLNER
GVWR:	GVWR
Passenger Capacity:	77
Headroom:	78
Wheelbase:	279
Brake Type:	HYDRAULIC
Engine Type:	DETROIT DIESEL DD5 220 DIESEL, 4 Cyl, 220 HP, 2600 RPM
Fuel Type:	DIESEL
Fuel Tank Capacity:	100
Transmission Type:	AUTOMATIC
Axle, Front:	10000-lb Capacity
Axle, Rear:	21000-lb Capacity
Tires, Front:	RADIAL FRONT TIRE, MICHELIN XZE2, 11R22.5 16 PLY
Tires, Rear:	MICHELIN X MULTI D 11R22.5 16 PLY REAR TIRES
Suspension Front:	10000-lb Capacity
Suspension Rear :	COMFORT-TEC SUSPENSION

Three year annual lease with 18,953 per year miles: \$ 16,430.15 per bus/per year  
 Five year annual lease with 18,953 per year miles: \$ 14,999.90 per bus/per year  
 Five year annual lease/purchase payment: \$ 20,913.90 per bus/per year  
 Estimated delivery 140-180 days ARO  
 Payment due upon delivery of unit  
 Quote valid for 30 days  
 Price is subject to school bus availability.

**CUSTOMER** Customer Signature\*\* : \_\_\_\_\_ Date: \_\_\_\_\_

**New bus(es) Info:**

Name on bus: \_\_\_\_\_

Bus Number (s): \_\_\_\_\_

**\*\* I have reviewed the quote detail for accuracy and I agree to order the bus(es) as listed.**  
**\*New stock unit subject to prior sale and/or availability. Letter of intent to buy or purchase order is required to put bus on hold.**

Dealer Signature: \_\_\_\_\_ Date: \_\_\_\_\_

The equipment proposed meets and/or exceeds all requirements set forth in the Federal Minimum Standards for School Buses and Federal Motor Vehicle Safety Standards established by the Federal Department of Transportation.

**Includes the Following Equipment:**

**BODY**

**ACCESSORIES**

- 1 LOC-1ST.SEAT DRVRSIDE REFL TRIANGLE
- 1 LOCKS-KEYED ALIKE #CH545
- 1 METHOD-FASTENER SCREWS
- 1 HOLDER-CERTIFICATE 4"X 6"

**CERTIFICATION/SAFETY**

- 1 REFLECTTAPE-RR END YEL 2" 3M
- 1 REFLECTTAPE-FRT END YEL
- 1 FIRE EXTINGUISHER-5 3A-40BC
- 1 REFLECTORS-AMBER (4) MID/FRONT 3"
- 1 REFLECTORS-RED (4) RR/RR SI 3"
- 1 HATCH-RF ESC MODEL 1100 ENG(2)
- 1 ELECTRICAL-ROOF ESCAPE HATCH POS 3
- 1 HANDLES-W/S SERVICE, BLACK
- 1 KIT - BODY FLUID CLEAN-UP NATIONAL STANDARDS
- 1 SWITCH-ROCKER CROSSING ARM DEACTIVATION
- 1 LABEL-PASS ADVISOR INSTRUCTION
- 1 LOC-O/H STOR LS 10 UNIT B.F.C
- 1 LOC-VEST.FLR.PLT.LEFT 5LB F.E. & BOX
- 1 KIT.FIRST AID 10 UNIT ILL.
- 1 CUTTER-SEAT BELT W/HAND GRIP
- 1 TRIANGLES-REFL. 3 W/BOX
- 1 MOTOR-XING ARM ELEC.SPECIALTY
- 1 BRACKET-XING ARM STOWAGE 1/4" BUMP
- 1 OPEN VIEW - ES, HEATED, REMOTE
- 1 MIRROR-B EXTERIOR CROSSVIEW HEATED BLACK BRACKET
- 1 SIGN-STOP, ELEC FRT #SE1-7970C
- 1 SIGN-STOP, ELEC RR #SE1-7971C
- 1 MIRROR-INTERIOR 6"X30" WITH RUBBER EDGE
- 1 LABEL(S)-SPECIAL DATA, IL
- 1 LABEL-VEHICLE CERTIFICATION
- 1 FRONT BUMP MT CROSS ARM W/DEACTIVATION SWITCH-ELECTRIC

**DOORS**

- 1 STEP-RS ALUM.ENT.DR W/HTR 8.75"RISER
- 1 HANDLE-EXTERIOR REAR DOOR WITH RECESS
- 1 LATCH-DOOR INTERIOR STORAGE OVER WINDSHIELD
- 1 VANDALOCK-REAR DOOR W/BOLT
- 1 DOOR-ENT AG2 TINT TEMP LO. STEP
- 1 PWR SYST.-AG2 ELECTRIC ENTRANCE DOOR
- 1 ELEC-AG2 ELECTRICAL OPERATED ENTRANCE DOOR
- 1 OPER-DOOR ELEC.ENT.EXT.CNTRL.& BAT.
- 1 RELEASE-ALUM.ELEC.ENT DR.ELEC.OP.EXT.W/KEY
- 1 PULL-ENTRANCE DOOR, EXTERNAL ALUMINUM
- 1 KEY-VANDALOCK REAR DOOR NONE
- 1 TRIM-ENTRANCE DOOR INTERIOR
- 1 PAD-DR HEADER, RR EMER 36"W
- 1 TRIM-STEPWELL HORIZONTAL WITH RIBBED NOSE
- 1 RAIL-ASSIST FRT ENT DR 39"YEL
- 1 RAIL-ASSIST FRT ENT DR RS YEL 1"

**ELECTRICAL - BODY**

- 1 FAN-CIRC MID W/S HDR BLACK
- 1 ELEC-FAN MID W/S HDR
- 1 FAN-CIRC DRV'S WDO HDR BLACK
- 1 ELECTRICAL-FAN DRIVER'S WINDOW HEADER
- 1 RADIO-AM/FM DEA510 W/PAGE
- 1 OPER-AUTOMATIC FAST IDLE
- 1 ELEC-COAXIAL TWO-WAY RADIO ROOF

- 1 KIT-ANTENNA MOUNT AT ROOF
- 1 ELEC-ZONAR STANDARD MONITORING
- 1 ELEC-PWR CELL PHONE OUTLET LS
- 1 OPERATION-DOOR REAR EMERGENCY WITH BUZZER/PILOT LAMPS
- 1 MONITOR-LPS WARN NONE
- 1 LAMPS-DOME OVER DRIVER
- 1 LPS-DOME PASS 6 MIN LED 341T
- 1 ELEC-PASS DOME LPS W/REAR MOST (6)
- 1 SWITCH-RKR DOME LPS FRT/RR
- 1 MODULE-PWR.DIST.ELEC.SYS.
- 1 SWITCH-ROCKER PANEL LAMPS DIMMER
- 1 LPS-INT RED LED OVER RR EMG DR
- 1 LPS-EXT AFT OF ENT DOOR LED
- 1 ELEC-LPS EXT AFT OF ENT DOOR
- 1 OPER-STPWLL LPSW/PARKLPS&ENT DR.
- 1 LPS-STPWLL LED W/O HOOD (1)
- 1 LPS-STP/TAIL/DIR AMBER/REV LED
- 1 ELEC-LPS STOP/TAIL/TURN/REV
- 1 ADVISORY-PASSENGER BUZZER ACTIVATION, WITH SWITCH
- 1 LPS-PILOT VANDALOCK STATUS RED
- 1 ELEC-PWR, GND, NETWORK, BUZZ
- 1 LAMPS-PILOT BRAKE LIGHTS RED
- 1 LAMPS-PILOT REAR EMERGENCY DOOR RED
- 1 LAMPS-PILOT POST TRIP INSPECTION RED
- 1 LAMPS-4" AUXILIARY L.E.D.
- 1 LPS-LIC PLATE ILLUMINATION LED
- 1 LPS-SI DIR AMBER FRT. LED PIN
- 1 ELEC-LPS SI FRT DIRECTIONAL ONLY
- 1 LPS-WARNING LED (8)
- 1 OPERATION-LAMPS WARNING (8) PACKAGE 14
- 1 OPERATION-LAMPS REVERSE WITH REAR EMERGENCY DOOR OPEN
- 1 LPS-ID AMB/RED LED
- 1 LPS-MKR ROOF FRT/RR LED PIN
- 1 LPS-MKR ROOF MID LED PIN
- 1 STROBE-ECCO 7460CC 6' FROM REAR
- 1 LPS- STOP/TAIL 4" FLS.MT L.E.D.
- 1 SWITCH-ROCKER FAN DEFROST WINDSHIELD
- 1 SWITCH-ROCKER NOISE SUPPRESSION ON/OFF
- 1 SWITCH-ROCKER STROBE LAMPS
- 1 LAMPS-PILOT WARNING LIGHTS RED
- 1 LAMPS-PILOT WARNING LIGHTS AMBER
- 1 OPERATION-LAMP STROBE, IGNITION & SWITCH ACTIVATED
- 1 ELEC-CABLE PRIM PWR & GND-CUSTOMER ACCESS
- 1 OPERATION-LAMPS SIDE DIRECT.OONLY
- 1 BLOCK-FUSE CUSTOMER ACCESS
- 1 LPS-DOME REAR MOST LED
- 1 OPER-PRE-TRIP INSPECTION
- 1 ELEC-SEAT BELT PILOT LAMP
- 1 OPER-SEAT BELT PILOT LAMP
- 1 LAYOUT-ROCKER SWITCH STANDARD
- 1 ELEC-ELECTRIC STOP SIGN 1ST WINDOW POSITION
- 1 SPEAKERS-INT. 30 WAT.(6) 341T
- 1 ELEC- (6) INT SPEAKERS 341T
- 1 SWITCH-RKR HTR BOOST PUMP
- 1 ELEC-HTR ENT DOOR STEPWELL
- 1 112DB BACKUP ALARM

## **EXTERIOR**

- 1 FLAPS-MUD, REAR 22.5"W
- 1 FLAPS-MUD, FRONT 16"W X 12"H
- 1 STEPS-EXT W/S SERVICE
- 1 FENDER-QUARTER 24" BATTERY BOX DOOR
- 1 BODY ADJUSTMENT-FREIGHTLINER, BTR RS FUEL FILL LOCATION
- 1 REINFORCEMENT-FRAME STD 24" BATTERY BOX DOOR
- 1 CAP-ENTRANCE DOOR STANDARD
- 1 FLOOR-NON ADA

- 1 BUMPER-RR 2 BRACES LS EXH HOLE
- 1 SKT.FWD.STPWLL LO DEF
- 1 CAP-FRONT ROOF W/WARN.LPS.
- 1 CAP-REAR ROOF W/WARN.LPS.
- 1 GUSSET-21"H LWR SIDE SHEET
- 1 SHEET-LWR, L MID 20G,21"
- 1 SHEET-LWR,L RR 20G,21"
- 1 SHEET-LWR,R MID 20G,21"
- 1 SHEET-LWR,R RR 20G,21"
- 1 DOOR-U/B L BATTERY 24"
- 1 DOOR-FUEL FILL ACCESS BTR
- 1 FENDERETTE-STL 21" SKIRT
- 1 LATCH-BATT DOOR NON-LOCKING
- 1 LATCH-FUEL FILL ACCESS (THUMB)
- 1 VENT-STATIC NONE
- 1 PILASTER - 341T, 900
- 1 LATCH-NON-LOCKING DEF ACCESS DOOR
- 1 RAIL-SNOW RAIL PRESENT
- 1 HARDWARE-MOUNTING CLIPS STANDARD

### **HVAC**

- 1 AIR COND - NONE
- 1 HTR-U/S LS 84,000 BTU LOC 3
- 1 HTR-U/S LS 84,000 BTU LOC 10
- 1 HOSE-HTR BLUSTRIP W/ W/H POS 10
- 1 HEATER-ENTRANCE DOOR STEPWELL
- 1 CLAMPS-PLUMBING HEATER CONSTANT TORQUE
- 1 CLAMPS-UNDERSEAT HEATER CONSTANT TORQUE
- 1 CONN-HTR(1) CONST TORQ/BLUSTRIP
- 1 VALVE-SHUTOFF LS U/SEAT HTR WHOUSE
- 1 NO AIR CONDITIONING COMPRESSOR

### **INTERIOR**

- 1 VISOR-WINDSHIELD SUN 6"X30" TINTED
- 1 DOOR-STORAGE BOX W/O GLASS
- 1 TRIM-LOWER REAR HEATER NO A/C
- 1 REINFORCEMENT-REAR STOP SIGNAL 40"
- 1 DOOR-ACC SOLID PANEL
- 1 LATCH-DR INT STOR OVR DRVRSHDR
- 1 BTR FUEL FILL RECESS, W/DOOR
- 1 COVER-TRIM DRVS HDR W/STORAGE
- 1 COVER-TRIM FRT END W/S HEADER
- 1 COVER-TRIM FRT ENT.ALUM.DR HDR.ELEC.OP.
- 1 STRIPS - AISLE, ALUMINUM 341T
- 1 FLR-BLK VINYL W/13" CTR AISLE 341T
- 1 FLR-BLK WHEELHOUSE AND HEATER
- 1 FLR-PLYWOOD 5/8" 341T
- 1 LINING-SIDE INT.
- 1 INSULATION-FRT BULKHEAD W/ACRSY 2"POLY
- 1 H/L-1ST WDO SEC ACOUS GRY 341T
- 1 INSULATION - URETHANE
- 1 HOLDER-STORAGE, CLIP BOARD
- 1 TUBE-FILL BTR & OVERFLOW HOSE
- 1 CAP-FUEL FILL BTR NON-LOCKING
- 1 IN DASH STORAGE BIN

### **MISC**

- 1 PDI IDENTIFIER-DEALER PERFORMED
- 1 MANUAL-DRVR'S/MAINT.ENGLISH
- 1 APPLICATION - SCHOOL
- 1 NO COOLANT HEATER - GAS/DIESEL
- 1 ALL UNIT(S) KEYED ALIKE WITH CUSTOMER SPECIFIED KEY #FT1001
- 1 NO A/C PLUMBING - MAIN
- 1 SAF-T-LINER C2

### **PAINT/LETTERING**

- 1 DECAL-UNITED AUTO WORKERS
- 4 LABEL-P/O WDO EMER EXIT 2" BLACK

- 1 LABEL-ENGLISH AG2.ELEC.ENT DR
- 4 REFLECTTAPE-P/O WDO YEL 3M
- 1 REFLECTTAPE-EMER DR RR YEL 3M
- 1 REFLECTTAPE-SI 2" ABV FLR YEL 3M
- 1 LETTER - OVERHEAD STORAGE BOX "SAFETY EQUIP"
- 1 DECAL-BACKING ALARM
- 1 DECAL-LOW SULFUR FUEL
- 1 LABEL-RR DR EMERGENCY DOOR DO NOT BLOCK
- 1 LABEL-RR EMERGENCY DOOR INSTRUCTION
- 1 LABEL-"DEF ONLY"
- 1 LABEL-REGENERATION WARNING 2010/2013 EPA ENGLISH
- 1 HANDLE-INT RR DR RED
- 1 PAINT-EXT HNDLE(S) BLACK
- 1 DECAL-REFL FRT CAP "SCHOOL BUS" 3M
- 1 DECAL-REFL RR CAP "SCHOOL BUS" 3M
- 1 DECAL-"DIESEL"
- 1 PAINT-EXTERIOR ROOF WHITE 341T
- 1 PAINT-EXT WINDOW AREA BLACK
- 1 PAINT-EXT GRD RAIL @ WINDOW BLACK
- 1 PAINT-EXT GRD RAIL @ SEAT BLACK
- 1 PAINT-EXT GRD RAIL @ FLOOR BLACK
- 1 PAINT-EXT GRD RAIL @ SKRT BLACK
- 1 PAINT-EXT BUMPER REAR BLACK
- 1 PAINT-BLACK TRIM-FRONT/REAR ROOF CAPS
- 1 PAINT-SOLID COLOR YELLOW
- 1 DECAL-APPROVED FUEL TYPE
- 1 DECALS-WDO STRIPE 341T
- 1 HEADLINING-VESTIBULE ACOUSTIC, GRAY, DRIVER LAMP
- 1 PAINT:ONE SOLID COLOR,BASE/CLEARCOAT
- 1 CAB COLOR A:L5898EB SCHOOL BUS YELLOW ELITE BC
- 1 CAB COLOR B - NONE
- 1 CAB COLOR C: NONE
- 1 GRILLE: SILVER N3388H IMRON 5000

### **SEATS**

- 1 OFF-SET LS BARRIER 4"
- 1 2014 SEATING ALERT
- 1 SEAT BELT - DRIVERS SEAT
- 1 39" BARR-VERT,WALL MT 45"H RS 2009
- 1 39"8DEG BARR-REV. WALL-MT 45"H 2009
- 2 PROFORM EDO BLUE UPHOLSTERY-45"HIGH RECESSED BARRIER
- 1 BACK-NATIONAL DRV'S SEAT
- 1 ARMREST NATIONAL DRVR'S ST. RS
- 1 UPH DR.ST.FABRIC BLK NATIONAL
- 1 PEDASTAL-DR ST MECH TYPE
- 1 COVER PEDASTAL NATIONAL NONE
- 1 RETAINER NATIONAL DR.ST.BELT NONE
- 1 POUCH-DR.ST.STORAGE NONE
- 1 KICKPLATE-MOD.PANEL RS 39"
- 1 RISER-DRIVERS SEAT, NATIONAL
- 1 Haptics-Not Present
- 13 S3B 39"RS WALL MT RESTRAINING/NO BELT
- 1 S3B 26" LS WALL MT RESTRAINING/NO BELT
- 12 S3B 39"LS WALL MT RESTRAINING/NO BELT
- 26 FIREBLOCK BLUE UPHOLSTERY - S3B SEAT
- 26 S3B WALL MT HARDWARE-RESTRAINT

### **WINDOWS/GLASS**

- 1 GLASS-WINDSHIELD ONE PIECE WITH TINTED BAND
- 1 GLASS-RS FRT STAT TNT TEMP
- 1 GLASS-LS FRT STAT TNT TEMP
- 1 GLASS-REAR STAT TINTED TEMP
- 1 FRAME-WDO SPLIT
- 16 FRAME-WDO SPLIT 30"W
- 2 FRAME-WDO SPLIT 40"W
- 2 FRAME-WDO P/O VERT TEMP TNT LS
- 2 WDO P/O VERT TEMP TNT RS

- 16 GLASS-WDO TINT TEMP 30"
- 2 GLASS-WDO TINT TEMP 40"
- 1 STOPS-WDO 12"
- 1 GLS-LWR RR DR TEMP TNT BONDED
- 1 GLS-UPR RR DR TEMP TNT BONDED
- 1 WDO-DRIVER'S TEMP TINT

#### **OTHER**

- 1 2021 PIP INCENTIVE
- 1 LOGO-FRT RS & RR
- 1 LOGO-THOMAS DECALS YELLOW
- 1 ELEC-RF ESC HATCH POS 9
- 1 ARM ASSEMBLY-WINDSHIELD WIPER (2)
- 1 ELECTRICAL-ROOF HATCH OR P/O WINDOW (DASH)
- 1 OPER-FAN W/S HDR
- 1 OPER-FAN DRV'S WDO HDR
- 1 OPER-ALARM BACKING W/REV.
- 1 OPER-RF HATCH BUZZER
- 1 LOC-O/H ENT.DOOR RS CERT.HLDR
- 1 LOCATION-OVERHEAD STORAGE CENTER 10 F.A.K.
- 1 AC DUCT-NOT PRESENT NO SIDE EVAP
- 1 CONDENSER ALERT - NONE
- 1 EVAPORATOR QTY - NONE
- 1 OPER-XING ARM DEACTIVATION
- 1 ANTENNA - RADIO SWIVEL BASE
- 1 ELEC-ANTENNA RADIO COAXIAL
- 1 KIT-RADIO ANTENNA MOUNTING @ DRIVER'S HEADER
- 1 341T30\_N
- 1 TRIM-A POST
- 1 WHEELHOUSES-REAR L&R
- 1 STRINGER-ROOF 341T
- 1 FRONT END FRAME
- 1 FRT END FRAME MTG KIT
- 1 REAR END FRAME-28.68"DEEP
- 1 FLOOR-GALVALUME STEEL MID BODY
- 1 LOC-40" RAF SP 11TH 341T
- 1 RS TANK ALERT - NONE
- 1 DOOR ALERT - LS ENT NONE
- 1 TRIM-REAR DOOR
- 1 HINGES-REAR DOOR PIN TYPE
- 1 LATCH-SINGLE-POINT, REAR EMERGENCY DOOR
- 1 STOP-DOOR REAR EMERGENCY, 1-POS
- 1 OPERATION-VANDLOCK ENTRANCE/EMGENCY DOOR(S) WITH PILOT LAMPS
- 1 ELEC-SIDE EMERGENCY DOOR(S)
- 1 DOOR-LS ENT RS EXIT -NONE REQD
- 1 INT COLOR -RR DOOR GRAY
- 1 VANDALOCK-NONE REQUIRED RS
- 1 VANDALOCK-NONE REQUIRED LS
- 1 DOOR ALERT - RS EXIT NONE
- 1 SWITCH-PAD. SERV. DOOR ELEC.
- 1 DOOR, REAR EMERGENCY
- 1 THRESHOLD REAR EMERGENCY DOOR
- 1 ELEC-DRIVER'S DOME LPS
- 1 OPERATION-SWITCH, PANEL LAMPS DIMMER
- 1 ELEC-LPS-INT RED O/H RR EMG DR
- 1 ELEC-PASSENGER ADVISORY 341T
- 1 OPER-PASS ADV IGN/WARN/BUZZER
- 1 SWITCH-RKR FAN DEFROST L.S.
- 1 BUZZER-SWITCH PANEL 1 TONE
- 1 OPERATION-NOISE SUPPRESSION
- 1 ELECTRICAL-LAMPS WARNING,8 LAMPS 341T
- 1 OPER-LPS, DOME STANDARD
- 1 OPER-LPS BODY TAIL W/PARK SW.
- 1 ELECTRICAL-LAMPS ID/MARKER PARK/SWITCH 341T
- 1 SWITCH-ROCKER DOME LAMPS DRIVER ON/OFF
- 1 ELECTRICAL-LAMPS STROBE 6' FROM REAR223

- 1 OPER-DRVR'S DOME LPS ON/OFF
- 1 OPER-HTR BOOSTER PUMP OPER WITH SWITCH
- 1 OPERATION-LAMPS INTERIOR/EXTERIOR RIGHT FRONT ENTRANCE DOOR
- 1 OPERATION-LAMPS SERVICE BRAKE WITH PILOT LAMPS
- 1 OPERATION-SWITCH ID/MARKER LAMPS WITH PARK
- 1 OPER-LPS DOME (2)ON/OFF
- 1 OPER-LPS REVERSE
- 1 ELEC-(3) SWITCH BANKS
- 1 SWITCH-WARN.LPS ON/AMB ACT.
- 1 ELEC-HARNESS COMP ASM 341T
- 1 ELEC-ELECTRONIC COMP ASM
- 1 OPER-LPS DIR./HAZ.
- 1 SWITCH-RKR MIRROR HTR.
- 1 ELEC-MIR A HTD & RC
- 1 ELECTRICAL-ELECTRIC STOP SIGN REAR
- 1 RAIL-EXTERIOR GUARD @ WINDOW,SEAT,FLOOR,SKIRT
- 1 RAIL-EXT GRD @ SEAT FRT END LS
- 1 RAIL-EXT GRD@ FLOOR, NONE
- 1 TRIM-FRT CAP RS/LS
- 1 PANELS-EXT RR W/4"AUXLPS
- 1 SHEET-DRIVERS EXTERIOR 20 GA.
- 1 SHEET-UPPER SIDE EXTERIOR
- 1 OPER-MIRRORS EXT HTD.
- 1 UNDERCOATING-ASPHALT EMULSION
- 1 HEADERS-WINDOW INTERIOR 341T
- 1 PAINT-EXT ENT DOOR NONE
- 1 PANELS-EXT REAR SIDE LONG PANEL
- 1 LS STORAGE BOX 1 - NONE
- 1 LS STORAGE BOX 2 - NONE
- 1 ROOF SHEETS-(2)HATCH - 341T
- 1 RS STORAGE BOX 1 - NONE
- 1 RS STORAGE BOX 2 - NONE
- 1 RS STORAGE BOX ROH - NONE
- 1 LS STORAGE BOX ROH - NONE
- 1 PANELS-REAR END INTERIOR REAR GALVALUME
- 1 PANELS-REAR END INTERIOR SIDE LONG WITH SOLID PANEL
- 1 BULKHEAD-RR END INT.GRY
- 1 PANELS-ACCESS RR GRAY PASS ADVISORY
- 1 COVER-HARNESS ACCESS@HDR
- 1 COVER-ACCESS RR END HARNESS
- 1 COVER-ACCESS FRT END HARNESS
- 1 H/L-RR LONG SMOOTH GRAY W/LPS
- 1 COVER-FUEL SENDING INSPECTION
- 1 MOLDING-SHOE 341T
- 1 SWITCH-ROCKER HEATER STEPWELL
- 1 LUGGAGE RACK ALERT - NONE
- 1 SWITCH-ROCKER HEATER LEFT 1ST
- 1 SWITCH-ROCKER HEATER LEFT 2ND
- 1 ELEC-HTR U/ SEAT POS 3
- 1 ELECTRICAL-HEATER UNDERSEAT POSITION 10
- 1 RAIL-SEAT
- 1 LAYOUT-SEAT RAIL HOLES RS
- 1 LAYOUT-SEAT RAIL HOLES LS
- 1 CABINET-SW, FWD
- 1 CABINET-SWITCH, LOWER WITHOUT POCKET
- 1 CABINET-SWITCH, UPPER
- 1 CABINET-TOP PLATE (3 BANK)
- 1 TREAD-STEP ALUMINUM ENTRANCE DOOR BLACK
- 1 OPER-HTR U/ SEAT LS FWD
- 1 PANEL-ACCESSORY MOUNTING SAFTEY EQUIPMENT
- 1 OPER-HTR STEPWELL
- 1 INSULATION-VEST HEADLINING 2"
- 1 INSULATION-SIDELINING 2" POLY
- 1 INSULATION-RR BULKHEAD 2" POLY
- 1 OPER-HTR U/ SEAT LS AFT

- 1 HEADERS-WINDOW EXTERIOR 341T
- 1 HARNESS COVER COLOR - GRAY
- 1 SPEAKER ALERT - PRESENT
- 1 DOME LPS - MINIMUM
- 1 HEADLINING COLOR - GREY
- 1 HDLINING TYPE-1ST WDO ACOUSTIC
- 1 MAT, FLOOR VESTIBULE
- 1 TRIM-INTERIOR DASH FORWARD
- 1 INSTALLATION-PARK BRAKE ASSEMBLY
- 1 INSULATION-INT LONG REAR END
- 1 LUGGAGE RACK ALERT - NONE
- 1 PLATE-ACCELERATOR
- 1 OPER-WDO P/O
- 1 SLIDE STOP NATIONAL DR.ST. NONE
- 1 DD5 5.1L 4 CYL 220HP@2200 RPM,2600 GOV RPM,660 LB/FT@1200 RP
- 1 NO AIR INTAKE WARMER
- 1 VANDALOCK,STARTER DISABLE W/ANY LOCKED EMER DR(S),LH PT LAMP
- 1 LOWER RADIATOR GUARD
- 1 REINFORCED NYLON FUEL LINES
- 1 PAINTED FUEL TANK, PAINTED BANDS
- 1 SINGLE SUCTION AND RETURN FUEL LINES
- 1 FUEL TANK MOUNTED BETWEEN RAILS, AFT OF REAR AXLE, WITH CAGE
- 1 REMOTE-MOUNTED SURGE TANK
- 1 BASIC WIRING SCHEMATIC,UNMOUNTED,12-VOLT NEGATIVE GROUND SYS
- 1 PAINTED BATTERY PANEL COVER
- 1 BATTERY BOX FRAME MOUNTED
- 1 INTEGRAL ELECTRONIC TURN SIGNAL FLASHER
- 1 BATT ENABLED 3 AMBER INBOARD ID LAMPS,2 AMBER OUTBOARD MARKE
- 1 STROBE LAMP, IGNITION SWITCH OR LH DASH SWITCH ACTIVATED
- 1 LED WARNING SYSTEM LAMPS
- 1 STANDARD BODY VISUAL WARNING,LOWER RR,REV LAMPS ON DR/OPEN
- 1 STANDARD WIRING
- 1 DRIVER'S IGNITION OPERATED DOME LP WITH ON/OFF SW
- 1 PASSENGER COMPARTMENT DOME LAMPS, IGNITION ACTIVATED
- 1 PASSENGER COMPARTMENT DOME LPS, DUAL ON/OFF SWITCH
- 1 STEPWELL LAMP ON WITH DOOR OPEN AND MARKER LAMPS ON
- 1 EIGHT LAMP WARNING SYSTEM,LH DASH SWITCH(S), PACKAGE 14
- 1 SHIFT LEVER, CABLE LINKAGE, AUTOMATIC TRANSMISSION
- 1 DRIVELINE GUARD
- 1 NON-ASBESTOS FRONT BRAKE LININGS
- 1 FRONT SHOCK ABSORBERS
- 1 NON-ASBESTOS REAR BRAKE LININGS
- 1 WABCO NG HYDRAULIC ABS/ATC W/SHUTOFF SWITCH
- 1 NO POLISHED FRONT WHEELS
- 1 NO POLISHED REAR WHEELS
- 1 TWO QUART SEE THRU POWER STEERING RESERVOIR
- 1 POWER STEERING PUMP
- 1 ZINC-PLATED HEXHEAD CHASSIS FASTENERS
- 1 3975MM (155") REAR FRAME OVERHANG
- 1 SQUARE END OF FRAME
- 1 BUMPER MOUNTING FOR SINGLE LICENSE PLATE
- 1 LED COMB S/T/T/R LAMPS, & (2)4"ROUND REVERSE LAMPS
- 1 RR EMER DR,IGN CTRL,BZ ON W/DR
- 1 MAINTENANCE-FREE RUBBER BUSHINGS - FRONT SUSPENSION
- 1 21K TAPERLEAF SPRING REAR SUSPENSION
- 1 CAB MOUNTING FOR HOOD AND COWL CHASSIS
- 1 RH FRONT ENTRANCE DOOR, BATTERY CONTROLLED,ELECTRICALLY OPER
- 1 KEYED ENT DOOR LOCK/BUZZER ON W/EMERGENCY DOORS UNLATCHED
- 1 ONE GALLON WINDSHIELD WASHER RESERVOIR
- 1 BLACK HOOD MOUNTED AIR INTAKE GRILLE
- 1 SINGLE ELECTRIC WINDSHIELD WIPER MOTOR W/DELAY
- 1 GRAY/CHARCOAL FLAT DASH
- 1 STANDARD TUNNEL/FIREWALL LINER
- 1 NO AIR CONDITIONER CONDENSER
- 1 HEATER AND DEFROSTER

- 1 STANDARD HVAC DUCTING
- 1 MAIN HVAC CONTROLS WITHOUT RECIRCULATION SWITCH,& NOISE SUPP
- 1 WINDSHIELD FAN,(1) HEADER MOUNTED
- 1 DRIVER'S FAN,(1) MOUNTED ABOVE SIDE WINDOW
- 1 AUX BODY HEATER,UNDER SEAT,FWD
- 1 AUXILIARY BODY HEATER, UNDER SEAT, AFT
- 1 GRAY INSTRUMENT PANEL-DRIVER
- 1 BODY SUPPLIED HEATED MIRRORS
- 1 ROOF MOUNTED VENT/ESCAPE HATCH
- 1 PUSH OUT BODY SIDE WINDOWS, BUZZER WITH WINDOW UNLATCHED
- 1 SEPARATE PANEL LAMP DIMMER,LH DRIVER'S SWITCH PANEL
- 1 CHASSIS COWL AND HOOD ONLY
- 1 NO TCU-TRANSMISSION OPTIMIZED(NO FUEL SENSE)
- 1 PILOT,LH DASH,STOP LAMP MONITOR
- 1 BUMPER: BLACK
- 1 NO SPARE WHEEL PAINT
- 1 CHASSIS: VENDOR BLACK
- 1 EXPECTED GROSS VEHICLE WEIGHT CAPACITY
- 1 EXPECTED FRONT AXLE(S) LOAD
- 1 EXPECTED REAR DRIVE AXLE(S) LOAD
- 1 SCHOOL BUS SERVICE
- 1 COWL CHASSIS CONFIGURATION COMPLIES WITH SBMTC
- 1 BUS BODY WITH WHEELWELL
- 1 PASSENGER COMMODITY
- 1 100% ON-HIGHWAY (CITY) TERRAIN
- 1 DOMICILED USA 50 STATES (CALIFORNIA)
- 1 DOMICILED ILLINOIS
- 1 THOMAS BUILT SCHOOL BUS 341T

## **CHASSIS**

### **AXLES AND SUSPENSIONS**

- 1 ALIGNMENT-4-WHEEL SAF-T-LINER C2
- 1 SPL100 DANA SPICER MAIN DRIVELINE
- 1 DA-F-10-3 10,000# FF1 71.5 KPI/3.74 DROP SINGLE FRONT AXLE
- 1 CHICAGO RAWHIDE FRONT OIL SEALS
- 1 SYNTHETIC 75W-90 FRONT AXLE LUBE
- 1 CONMET IRON FRONT HUBS
- 1 SYNTHETIC 75W-90 REAR AXLE LUBE
- 1 DA-RS-21-4 21K R-SERIES SINGLE REAR AXLE
- 1 6.14 REAR AXLE RATIO
- 1 IRON REAR AXLE CARRIER HOUSING
- 1 REAR SHOCK ABSORBERS - ONE AXLE
- 1 CHICAGO RAWHIDE (SCOT) REAR OIL SEALS
- 1 GUNITE IRON REAR HUBS
- 1 10,000 LB. TAPERLEAF FRONT SUSPENSION
- 1 COMFORT-TEC SUSPENSION

### **BRAKES**

- 1 ALERT-ENHANCED STABILITY CONTROL
- 1 BOSCH HYDRAULIC BRAKE PACKAGE
- 1 BOSCH HYDRAULIC PIN-SLIDE DISC FRONT
- 1 FRONT DISC BRAKE ROTORS W/SEPARATE TONE RINGS
- 1 BOSCH HYDRAULIC PIN-SLIDE DISC REAR
- 1 REAR BRAKE DUST SHIELDS
- 1 FRONT BRAKE DUST SHIELDS
- 1 TRANSMISSION-MOUNTED PARK BRAKE
- 1 REAR DISC BRAKE ROTORS W/SEPARATE TONE RINGS
- 1 NYCLAD HYDRAULIC CHASSIS TUBING
- 1 FT OPER PARK BRAKE w/SERVICE BRAKE INTERLOCK w/INDICATOR

### **CHASSIS EQUIPMENT**

- 1 EXHAUST-LS, THRU REAR BUMPER
- 1 ANTI-FREEZE, OAT -34 DEGREE
- 1 WINTERFRONT-CHASSIS GRILLE YELLOW
- 1 SHIELD-EXHAUST PIPE
- 1 B2 106 CONVENTIONAL CHASSIS
- 1 SET-BACK AXLE - TRUCK

- 1 DETROIT ENG MTD FUEL WATER SEPARATOR WIF LIGHT, PUMP
- 1 DELCO 12V 29MT STARTER WITH INTEGRATED M
- 1 NO CLUTCH PEDAL WITH NON-ADJUSTABLE
- 1 ENGINE COMPARTMENT MOUNTED AIR RESTRICTION INDICATOR W/LIGHT
- 1 RIGHT HAND SIDE-FILL FUEL TANK CAP
- 1 100GALLON/378 LITER STEEL RECTANGULAR FUEL TANK,BETWEEN RAIL
- 1 HORIZONTAL TAILPIPE, LH SIDE, EXIT THROUGH BUMPER
- 1 11.5 GALLON DEF TANK
- 1 MAGNETIC ENGINE DRAIN, REAR AXLE DRAIN & FILL PLUG
- 1 NO TRACTION STABILIZER
- 1 TILT ONLY STEERING COLUMN
- 1 TRW THP-60 POWER STEERING
- 1 450MM(18") LK FOUR-SPOKE CHARCOAL STEERING WHEEL
- 1 7075MM (279") WHEELBASE
- 1 5/16" X 3.00" X 10 1/8" STEEL FRAME (7.94 X 76.5 X 257.2")
- 1 1-PIECE 14" PTD STL 1/4" HD BUMPER JACK PROVISION
- 1 FRONT FRAME-MOUNTED TOW HOOKS
- 1 REAR TOW HOOKS
- 1 STANDARD DUTY HOOD MOUNTING
- 1 FIBERGLASS HOOD
- 1 PAINTED PLASTIC GRILLE
- 1 YELLOW WINTERFRONT
- 1 (2) CUPHOLDERS, LEFT HAND AND RIGHT HAND DASH

### **ELECTRICAL - CHASSIS**

- 1 LN 12V 240 AMP AVI PAD MOUNT ALTERNATOR
- 1 PROG RPM CTRL W A/C OR 12.75V LOW VOLT AUTO HI IDLE, DASH SW
- 1 CRUISE CONTROL-ELEC ENG,W/SWITCHES IN LH SWITCH PANEL
- 1 DIAGNOSTIC INTERFACE CONNECTOR,9-PIN, S
- 1 IGNITION SWITCH CONTROLLED ENGINE STOP
- 1 12VOLT POWER SUPPLY LH PANEL
- 1 SOLID STATE CIRCUIT PROTECTION, PDMS WIT
- 1 (3) ALLIANCE 1031,GROUP 31,12 VOLT,MF 2280 CCA BATTERIES
- 1 COLE HERSEE BATTERY CUT-OFF SWITCH, BATTERY BOX MOUNTED
- 1 SELF CANCEL TURN SIGNAL SWITCH W/DIM/WASH&HAZZARD IN HANDLE
- 1 STANDARD FRONT TURN SIGNAL LIGHTS
- 1 PARK LMP SW INTGRAL W/HL SWITCH, ID/MARKER/CLEARANCE/PARK ON
- 1 NO FENDER MTD TURN/MARK COMBO LPS
- 1 AMBER LED MIDSHIP TURN SIGNALS
- 1 DAYTIME RUNNING LIGHTS SET @ 85%
- 1 INTEGRAL HEADLIGHT/MARKER ASSEMBLY
- 1 NO UTILITY/ADVERTISING LIGHT
- 1 STOP SIGN PRESENT
- 1 NO BAGGAGE COMPARTMENT LAMP
- 1 NO BODY MTD INT SPOT/WORK LAMP
- 1 ELECTRONIC STABILITY CONTROL
- 1 BAT PWD 2-POS INT DOOR CONTROL LS SWITCH PANEL
- 1 DUAL ELEC HORN, PASSENGER ADVISORY BUZZER ON W/IGN AND WARN
- 1 NO OBSTACLE DETECTION SYSTEM
- 1 NO CAMERA/VIDEO/IMAGING SYSTEM
- 1 C/F J1939 RADIO W/PA
- 1 CUSTOMER FURNISHED 2-WAY RADIO
- 1 FASTEN SEAT BELT INDICATOR FOR CUSTOMER SUPPLIED SEAT BELT
- 1 LOCATING SYSTEM WITH VEHICLE MONITORING
- 1 ELECTRONIC SPEEDOMETER WITH SECONDARY KPH SCALE, NO ODOMETER
- 1 DRIVER MESSAGE CENTER WITH LCD DISPLAY
- 1 ELECTRONIC 3500 RPM TACHOMETER
- 1 VT-HU CONNECTIVITY PLATFORM HARDWARE & TBB ZONAR DASH MTD
- 1 NO INFORMATION CENTER
- 1 PRE/POST TRIP SYSTEM TEST
- 1 ENGINE AND HOUR METERS INTEGRAL WITH DRIVER DISPLAY
- 1 DIGITAL VOLTAGE DISPLAY INTEGRAL WITH DRIVER DISPLAY
- 1 ELECTRIC FUEL GAUGE
- 1 ELECTRIC ENGINE OIL PRESSURE GAUGE
- 1 ELECTRICAL ENGINE COOLANT TEMPERATURE GAUGE

### **ENGINE AND EQUIPMENT**

227

- 1 ANTI-FREEZE TO -34F, OAT (NITRITE AND SILICATE FREE)EXT LIFE
- 1 ENGINE-MOUNTED OIL CHECK AND FILL
- 1 10W-30 WEIGHT ENGINE OIL
- 1 FULL FLOW OIL FILTER
- 1 DETROIT FUEL/WATER SEPARATOR W/BYPASS & 12V PREHEATER
- 1 EXHAUST BRAKE NONE
- 1 ALUMINUM FLYWHEEL HOUSING
- 1 PHILLIPS 750 WATT/115 VOLT BLOCK HEATER
- 1 STANDARD OIL PAN
- 1 ENGINE HEATER RECEPTACLE MOUNTED FACE OF BUMPER, LEFT SIDE
- 1 ENGINE INTEGRAL SHUTDOWN PROT W/OVERRIDE SW,LW COOLANT&LIGHT
- 1 ADDL AUX LINES W/MANIFOLD PLUMBING AND COMBINED SHUTOFF
- 1 GATES BLUE STRIPE COOLANT HOSES
- 1 CONSTANT TORQUE BREEZE CLAMPS ON 1" IN DIA GREATER, SS C
- 1 CAST BOOSTER PUMP
- 1 30,600 BTU STEPWELL HEATER, RH FRONT ENTRANCE DOOR
- 1 DONALDSON ONE-STAGE AIR CLEANER
- 1 700 SQUARE INCH ALUMINUM RADIATOR
- 1 BORG WARNER ELECTRONIC VISCOUS FAN DRIVE
- 1 OMIT STANDARD EXHAUST DIFFUSER
- 1 69 MPH ROAD SPEED LIMIT
- 1 NO IDLE SHUTDOWN CONFIGURATION
- 1 DIGITAL TRANS OIL TEMP IN DRIVER DISPLAY

### **TRANSMISSION AND EQUIPMENT**

- 1 ALLISON 2500 PTS AUTOMATIC TRANSMISSION
- 1 ALLISON VOCATIONAL PACKAGE 354 - FIFTH GEN
- 1 TRANSMISSION OIL CHECK AND FILL
- 1 SYNTHETIC 50W TRANSMISSION LUBE (TES-295 COMPLIANT)
- 1 WATER TO OIL TRANSMISSION COOLER - IN RADIATOR END TANK
- 1 PRIMARY MODE GEARS, 6 FORWARD
- 1 NO TCU-LBSS VAC
- 1 NO TCU-ENGINE LOAD REDUCTION FUNCTION
- 1 NO MODE SWITCH

### **WHEELS AND TIRES**

- 1 RADIAL FRONT TIRE, MICHELIN XZE2, 11R22.5 16 PLY
- 1 MICHELIN X MULTI D 11R22.5 16 PLY REAR TIRES
- 1 NO TIRE PRESSURE CONTROL/SENSOR
- 1 MAXION 90262 22.5 X 8.25 10 HOLE HUB PILOT 5-HAND
- 1 MAXION 90262 22.5 X 8.25 10 HOLE HUB PILOT 5-HAND
- 1 TIRE/WHEEL BALANCING-LEAD FREE WEIGHTS
- 1 ACCURIDE PK-BLACK21 POWDER BLACK WHEEL (N0001H)- FRONT
- 1 ACCURIDE PKBLK21 POWDER BLACK WHEEL (N0001H) – REAR

### **DEALER ADD-ONS**

- 1 CUSTOMER LETTERING
- 1 ILLINOIS STATE INSPECTION, TITLE AND LICENSE FEE

**Meets all FMVSS requirements in effect at the time of manufacture.**





# Customer Quotation

Prepared For:  
MINOOKA CHSD #111 & CCSD #201  
26655 W EAMES ST.  
MINOOKA, IL 60410

Prepared By :  
RANDY SWANSON  
MIDWEST BUS SALES INC  
18 SKYVIEW DR  
LITCHFIELD, IL 62056

Quote Number:  
370117

Quote Date:  
1/3/2022

Customer Order No:  
216305C2-216314

### Model Profile: Saf-T-Liner C2 340TS

Product Type:	School Transportation
Year:	2021
Chassis Model:	B2 106
Chassis MFG:	FLNER
GVWR:	GVWR
Passenger Capacity:	71
Headroom:	78
Wheelbase:	279
Brake Type:	HYDRAULIC
Engine Type:	DETROIT DIESEL DD5 220 DIESEL, 4 Cyl, 220 HP, 2600 RPM
Fuel Type:	DIESEL
Fuel Tank Capacity:	100
Transmission Type:	AUTOMATIC
Axle, Front:	10000-lb Capacity
Axle, Rear:	21000-lb Capacity
Tires, Front:	RADIAL FRONT TIRE, MICHELIN XZE2,11R22.5 16 PLY
Tires, Rear:	MICHELIN X MULTI D 11R22.5 16 PLY REAR TIRES
Suspension Front:	10000-lb Capacity
Suspension Rear :	COMFORT-TEC SUSPENSION

Three year annual lease with 18,953 per year miles: \$ 16,430.15 per bus/per year  
 Five year annual lease with 18,953 per year miles: \$ 14,999.90 per bus/per year  
 Five year annual lease/purchase payment: \$ 20,913.90 per bus/per year  
 Estimated delivery 140-180 days ARO  
 Payment due upon delivery of unit  
 Quote valid for 30 days  
 Price is subject to school bus availability.

*these are in inventory and will be July 2022 delivery*  
*1-4-2022 RS*

**CUSTOMER** Customer Signature\*\*: \_\_\_\_\_ Date: \_\_\_\_\_

**New bus(es) Info:**

Name on bus: \_\_\_\_\_

Bus Number (s): \_\_\_\_\_

**\*\* I have reviewed the quote detail for accuracy and I agree to order the bus(es) as listed.**

**\*New stock unit subject to prior sale and/or availability. Letter of intent to buy or purchase order is required to put bus on hold.**

Dealer Signature: RES Date: 1-4-2022

The equipment proposed meets and/or exceeds all requirements set forth in the Federal Minimum Standards for School Buses and Federal Motor Vehicle Safety Standards established by the Federal Department of Transportation.

Includes the Following Equipment:

## **BODY**

### **ACCESSORIES**

- 1 LOC-1ST.SEAT DRVRSIDE REFL TRIANGLE
- 1 LOCKS-KEYED ALIKE #CH545
- 1 METHOD-FASTENER SCREWS
- 1 HOLDER-CERTIFICATE 4"X 6"

### **CERTIFICATION/SAFETY**

- 1 REFLECTTAPE-RR END YEL 2" 3M
- 1 REFLECTTAPE-FRT END YEL
- 1 FIRE EXTINGUISHER-5 3A-40BC
- 1 REFLECTORS-AMBER (4) MID/FRONT 3"
- 1 REFLECTORS-RED (4) RR/RR SI 3"
- 1 HATCH-RF ESC MODEL 1100 ENG(2)
- 1 ELECTRICAL-ROOF ESCAPE HATCH POS 3
- 1 HANDLES-W/S SERVICE, BLACK
- 1 KIT - BODY FLUID CLEAN-UP NATIONAL STANDARDS
- 1 SWITCH-ROCKER CROSSING ARM DEACTIVATION
- 1 LABEL-PASS ADVISOR INSTRUCTION
- 1 LOC-O/H STOR LS 10 UNIT B.F.C
- 1 LOC-VEST.FLR.PLT.LEFT 5LB F.E. & BOX
- 1 KIT.FIRST AID 10 UNIT ILL.
- 1 CUTTER-SEAT BELT W/HAND GRIP
- 1 TRIANGLES-REFL. 3 W/BOX
- 1 MOTOR-XING ARM ELEC.SPECIALTY
- 1 BRACKET-XING ARM STOWAGE 1/4" BUMP
- 1 OPEN VIEW - ES, HEATED, REMOTE
- 1 MIRROR-B EXTERIOR CROSSVIEW HEATED BLACK BRACKET
- 1 SIGN-STOP, ELEC FRT #SE1-7970C
- 1 SIGN-STOP, ELEC RR #SE1-7971C
- 1 MIRROR-INTERIOR 6"X30" WITH RUBBER EDGE
- 1 LABEL(S)-SPECIAL DATA, IL
- 1 LABEL-VEHICLE CERTIFICATION
- 1 FRONT BUMP MT CROSS ARM W/DEACTIVATION SWITCH-ELECTRIC

### **DOORS**

- 1 STEP-RS ALUM.ENT.DR W/HTR 8.75"RISER
- 1 HANDLE-EXTERIOR REAR DOOR WITH RECESS
- 1 LATCH-DOOR INTERIOR STORAGE OVER WINDSHIELD
- 1 VANDALOCK-REAR DOOR W/BOLT
- 1 DOOR-ENT AG2 TINT TEMP LO. STEP
- 1 PWR SYST.-AG2 ELECTRIC ENTRANCE DOOR
- 1 ELEC-AG2 ELECTRICAL OPERATED ENTRANCE DOOR
- 1 OPER-DOOR ELEC.ENT.EXT.CNTRL.& BAT.
- 1 RELEASE-ALUM.ELEC.ENT DR.ELEC.OP.EXT.W/KEY
- 1 PULL-ENTRANCE DOOR, EXTERNAL ALUMINUM
- 1 KEY-VANDALOCK REAR DOOR NONE
- 1 TRIM-ENTRANCE DOOR INTERIOR
- 1 PAD-DR HEADER, RR EMER 36"W
- 1 TRIM-STEPWELL HORIZONTAL WITH RIBBED NOSE
- 1 RAIL-ASSIST FRT ENT DR 39"YEL
- 1 RAIL-ASSIST FRT ENT DR RS YEL 1"

### **ELECTRICAL - BODY**

- 1 FAN-CIRC MID W/S HDR BLACK
- 1 ELEC-FAN MID W/S HDR
- 1 FAN-CIRC DRV'S WDO HDR BLACK
- 1 ELECTRICAL-FAN DRIVER'S WINDOW HEADER
- 1 RADIO-AM/FM DEA510 W/PAGE
- 1 OPER-AUTOMATIC FAST IDLE
- 1 ELEC-COAXIAL TWO-WAY RADIO ROOF
- 1 KIT-ANTENNA MOUNT AT ROOF

231

- 1 ELEC-ZONAR STANDARD MONITORING
- 1 ELEC-PWR CELL PHONE OUTLET LS
- 1 OPERATION-DOOR REAR EMERGENCY WITH BUZZER/PILOT LAMPS
- 1 MONITOR-LPS WARN NONE
- 1 LAMPS-DOME OVER DRIVER
- 1 LPS-DOME PASS 6 MIN LED 340T
- 1 ELEC-PASS DOME LPS W/REAR MOST (6)
- 1 SWITCH-RKR DOME LPS FRT/RR
- 1 MODULE-PWR.DIST.ELEC.SYS.
- 1 SWITCH-ROCKER PANEL LAMPS DIMMER
- 1 LPS-INT RED LED OVER RR EMG DR
- 1 LPS-EXT AFT OF ENT DOOR LED
- 1 ELEC-LPS EXT AFT OF ENT DOOR
- 1 OPER-STPWLL LPSW/PARKLPS&ENT DR.
- 1 LPS-STPWLL LED W/O HOOD (1)
- 1 LPS-STP/TAIL/DIR AMBER/REV LED
- 1 ELEC-LPS STOP/TAIL/TURN/REV
- 1 ADVISORY-PASSENGER BUZZER ACTIVATION, WITH SWITCH
- 1 LPS-PILOT VANDALOCK STATUS RED
- 1 ELEC-PWR, GND, NETWORK, BUZZ
- 1 LAMPS-PILOT BRAKE LIGHTS RED
- 1 LAMPS-PILOT REAR EMERGENCY DOOR RED
- 1 LAMPS-PILOT POST TRIP INSPECTION RED
- 1 LAMPS-4" AUXILIARY L.E.D.
- 1 LPS-LIC PLATE ILLUMINATION LED
- 1 LPS-SI DIR AMBER FRT. LED PIN
- 1 ELEC-LPS SI FRT DIRECTIONAL ONLY
- 1 LPS-WARNING LED (8)
- 1 OPERATION-LAMPS WARNING (8) PACKAGE 14
- 1 OPERATION-LAMPS REVERSE WITH REAR EMERGENCY DOOR OPEN
- 1 LPS-ID AMB/RED LED
- 1 LPS-MKR ROOF FRT/RR LED PIN
- 1 LPS-MKR ROOF MID LED PIN
- 1 STROBE-ECCO 7460CC 6' FROM REAR
- 1 LPS- STOP/TAIL 4" FLS.MT L.E.D.
- 1 SWITCH-ROCKER FAN DEFROST WINDSHIELD
- 1 SWITCH-ROCKER NOISE SUPPRESSION ON/OFF
- 1 SWITCH-ROCKER STROBE LAMPS
- 1 LAMPS-PILOT WARNING LIGHTS RED
- 1 LAMPS-PILOT WARNING LIGHTS AMBER
- 1 OPERATION-LAMP STROBE, IGNITION & SWITCH ACTIVATED
- 1 ELEC-CABLE PRIM PWR & GND-CUSTOMER ACCESS
- 1 OPERATION-LAMPS SIDE DIRECT.ONLY
- 1 BLOCK-FUSE CUSTOMER ACCESS
- 1 LPS-DOME REAR MOST LED
- 1 OPER-PRE-TRIP INSPECTION
- 1 ELEC-SEAT BELT PILOT LAMP
- 1 OPER-SEAT BELT PILOT LAMP
- 1 LAYOUT-ROCKER SWITCH STANDARD
- 1 ELEC-ELECTRIC STOP SIGN 1ST WINDOW POSITION
- 1 SPEAKERS-INT. 30 WAT.(6) 340T
- 1 ELEC- (6) INT SPEAKERS 340T
- 1 SWITCH-RKR HTR BOOST PUMP
- 1 ELEC-HTR ENT DOOR STEPWELL
- 1 112DB BACKUP ALARM

## **EXTERIOR**

- 1 FLAPS-MUD, REAR 22.5"W
- 1 FLAPS-MUD, FRONT 16"W X 12"H
- 1 STEPS-EXT W/S SERVICE
- 1 FENDER-QUARTER 24" BATTERY BOX DOOR
- 1 BODY ADJUSTMENT-FREIGHTLINER, BTR RS FUEL FILL LOCATION
- 1 REINFORCEMENT-FRAME STD 24" BATTERY BOX DOOR
- 1 CAP-ENTRANCE DOOR STANDARD
- 1 FLOOR-NON ADA
- 1 BUMPER-RR 2 BRACES LS EXH HOLE

- 1 SKT.FWD.STPWLL LO DEF
- 1 CAP-FRONT ROOF W/WARN.LPS.
- 1 CAP-REAR ROOF W/WARN.LPS.
- 1 GUSSET-21"H LWR SIDE SHEET
- 1 SHEET-LWR, L MID 20G,21"
- 1 SHEET-LWR,L RR 20G,21"
- 1 SHEET-LWR,R MID 20G,21"
- 1 SHEET-LWR,R RR 20G,21"
- 1 DOOR-U/B L BATTERY 24"
- 1 DOOR-FUEL FILL ACCESS BTR
- 1 FENDERETTE-STL 21" SKIRT
- 1 LATCH-BATT DOOR NON-LOCKING
- 1 LATCH-FUEL FILL ACCESS (THUMB)
- 1 VENT-STATIC NONE
- 1 PILASTER - 340T, 800
- 1 LATCH-NON-LOCKING DEF ACCESS DOOR
- 1 RAIL-SNOW RAIL PRESENT
- 1 HARDWARE-MOUNTING CLIPS STANDARD

### **HVAC**

- 1 AIR COND - NONE
- 1 HTR-U/S LS 84,000 BTU LOC 3
- 1 HTR-U/S LS 84,000 BTU LOC 10
- 1 HOSE-HTR BLUSTRIP W/ W/H POS 10
- 1 HEATER-ENTRANCE DOOR STEPWELL
- 1 CLAMPS-PLUMBING HEATER CONSTANT TORQUE
- 1 CLAMPS-UNDERSEAT HEATER CONSTANT TORQUE
- 1 CONN-HTR(1) CONST TORQ/BLUSTRIP
- 1 VALVE-SHUTOFF LS U/SEAT HTR WHOUSE
- 1 NO AIR CONDITIONING COMPRESSOR

### **INTERIOR**

- 1 VISOR-WINDSHIELD SUN 6"X30" TINTED
- 1 DOOR-STORAGE BOX W/O GLASS
- 1 TRIM-LOWER REAR HEATER NO A/C
- 1 REINFORCEMENT-REAR STOP SIGNAL 40"
- 1 DOOR-ACC SOLID PANEL
- 1 LATCH-DR INT STOR OVR DRVRSHDR
- 1 BTR FUEL FILL RECESS, W/DOOR
- 1 COVER-TRIM DRVS HDR W/STORAGE
- 1 COVER-TRIM FRT END W/S HEADER
- 1 COVER-TRIM FRT ENT.ALUM.DR HDR.ELEC.OP.
- 1 STRIPS - AISLE, ALUMINUM 340T
- 1 FLR-BLK VINYL W/13" CTR AISLE 340T
- 1 FLR-BLK WHEELHOUSE AND HEATER
- 1 FLR-PLYWOOD 5/8" 340T
- 1 LINING-SIDE INT.
- 1 INSULATION-FRT BULKHEAD W/ACRSY 2"POLY
- 1 H/L-1ST WDO SEC ACOUS GRY 340T
- 1 INSULATION - URETHANE
- 1 HOLDER-STORAGE, CLIP BOARD
- 1 TUBE-FILL BTR & OVERFLOW HOSE
- 1 CAP-FUEL FILL BTR NON-LOCKING
- 1 IN DASH STORAGE BIN

### **MISC**

- 1 PDI IDENTIFIER-DEALER PERFORMED
- 1 MANUAL-DRVR'S/MAINT.ENGLISH
- 1 APPLICATION - SCHOOL
- 1 NO COOLANT HEATER - GAS/DIESEL
- 1 ALL UNIT(S) KEYED ALIKE WITH CUSTOMER SPECIFIED KEY #FT1001
- 1 NO A/C PLUMBING - MAIN
- 1 SAF-T-LINER C2

### **PAINT/LETTERING**

- 1 DECAL-UNITED AUTO WORKERS
- 4 LABEL-P/O WDO EMER EXIT 2" BLACK
- 1 LABEL-ENGLISH AG2.ELEC.ENT DR

- 4 REFLECTTAPE-P/O WDO YEL 3M
- 1 REFLECTTAPE-EMER DR RR YEL 3M
- 1 REFLECTTAPE-SI 2" ABV FLR YEL 3M
- 1 LETTER - OVERHEAD STORAGE BOX "SAFETY EQUIP"
- 1 DECAL-BACKING ALARM
- 1 DECAL-LOW SULFUR FUEL
- 1 LABEL-RR DR EMERGENCY DOOR DO NOT BLOCK
- 1 LABEL-RR EMERGENCY DOOR INSTRUCTION
- 1 LABEL-"DEF ONLY"
- 1 LABEL-REGENERATION WARNING 2010/2013 EPA ENGLISH
- 1 HANDLE-INT RR DR RED
- 1 PAINT-EXT HNDLE(S) BLACK
- 1 DECAL-REFL FRT CAP "SCHOOL BUS" 3M
- 1 DECAL-REFL RR CAP "SCHOOL BUS" 3M
- 1 DECAL-"DIESEL"
- 1 PAINT-EXTERIOR ROOF WHITE 340T
- 1 PAINT-EXT WINDOW AREA BLACK
- 1 PAINT-EXT GRD RAIL @ WINDOW BLACK
- 1 PAINT-EXT GRD RAIL @ SEAT BLACK
- 1 PAINT-EXT GRD RAIL @ FLOOR BLACK
- 1 PAINT-EXT GRD RAIL @ SKRT BLACK
- 1 PAINT-EXT BUMPER REAR BLACK
- 1 PAINT-BLACK TRIM-FRONT/REAR ROOF CAPS
- 1 PAINT-SOLID COLOR YELLOW
- 1 DECAL-APPROVED FUEL TYPE
- 1 DECALS-WDO STRIPE 340T
- 1 HEADLINING-VESTIBULE ACOUSTIC, GRAY, DRIVER LAMP
- 1 PAINT:ONE SOLID COLOR,BASE/CLEARCOAT
- 1 CAB COLOR A:L5898EB SCHOOL BUS YELLOW ELITE BC
- 1 CAB COLOR B - NONE
- 1 CAB COLOR C: NONE
- 1 GRILLE: SILVER N3388H IMRON 5000

## **SEATS**

- 1 OFF-SET LS BARRIER 4"
- 1 2014 SEATING ALERT
- 1 SEAT BELT - DRIVERS SEAT
- 1 39" BARR-VERT,WALL MT 45"H RS 2009
- 1 39"8DEG BARR-REV. WALL-MT 45"H 2009
- 2 PROFORM EDO BLUE UPHOLSTERY-45"HIGH RECESSED BARRIER
- 1 BACK-NATIONAL DRV'S SEAT
- 1 ARMREST NATIONAL DRVR'S ST. RS
- 1 UPH DR.ST.FABRIC BLK NATIONAL
- 1 PEDASTAL-DR ST MECH TYPE
- 1 COVER PEDASTAL NATIONAL NONE
- 1 SLIDE STOP NATIONAL DR.ST. NONE
- 1 RETAINER NATIONAL DR.ST.BELT
- 1 POUCH-DR.ST.STORAGE NONE
- 1 KICKPLATE-MOD.PANEL RS 39"
- 1 RISER-DRIVERS SEAT, NATIONAL
- 1 Haptics-Not Present
- 12 S3B 39"RS WALL MT RESTRAINING/NO BELT
- 1 S3B 26" LS WALL MT RESTRAINING/NO BELT
- 11 S3B 39"LS WALL MT RESTRAINING/NO BELT
- 24 FIREBLOCK BLUE UPHOLSTERY - S3B SEAT
- 24 S3B WALL MT HARDWARE-RESTRAINT

## **WINDOWS/GLASS**

- 1 GLASS-WINDSHIELD ONE PIECE WITH TINTED BAND
- 1 GLASS-RS FRT STAT TNT TEMP
- 1 GLASS-LS FRT STAT TNT TEMP
- 1 GLASS-REAR STAT TINTED TEMP
- 1 FRAME-WDO SPLIT
- 16 FRAME-WDO SPLIT 30"W
- 2 FRAME-WDO SPLIT 40"W
- 2 FRAME-WDO P/O VERT TEMP TNT LS
- 2 WDO P/O VERT TEMP TNT RS

- 16 GLASS-WDO TINT TEMP 30"
- 2 GLASS-WDO TINT TEMP 40"
- 1 STOPS-WDO 12"
- 1 GLS-LWR RR DR TEMP TNT BONDED
- 1 GLS-UPR RR DR TEMP TNT BONDED
- 1 WDO-DRIVER'S TEMP TINT

#### **OTHER**

- 1 2021 PIP INCENTIVE
- 1 LOGO-FRT RS & RR
- 1 LOGO-THOMAS DECALS YELLOW
- 1 ELEC-RF ESC HATCH POS 9
- 1 ARM ASSEMBLY-WINDSHIELD WIPER (2)
- 1 ELECTRICAL-ROOF HATCH OR P/O WINDOW (DASH)
- 1 OPER-FAN W/S HDR
- 1 OPER-FAN DRV'S WDO HDR
- 1 OPER-ALARM BACKING W/REV.
- 1 OPER-RF HATCH BUZZER
- 1 LOC-O/H ENT.DOOR RS CERT.HLDR
- 1 LOCATION-OVERHEAD STORAGE CENTER 10 F.A.K.
- 1 AC DUCT-NOT PRESENT NO SIDE EVAP
- 1 CONDENSER ALERT - NONE
- 1 EVAPORATOR QTY - NONE
- 1 OPER-XING ARM DEACTIVATION
- 1 ANTENNA - RADIO SWIVEL BASE
- 1 ELEC-ANTENNA RADIO COAXIAL
- 1 KIT-RADIO ANTENNA MOUNTING @ DRIVER'S HEADER
- 1 340T30\_N
- 1 TRIM-A POST
- 1 WHEELHOUSES-REAR L&R
- 1 STRINGER-ROOF 340T
- 1 FRONT END FRAME
- 1 FRT END FRAME MTG KIT
- 1 REAR END FRAME-18.68" DEEP
- 1 FLOOR-GALVALUME STEEL MID BODY
- 1 LOC-40" RAF SP 11TH 340T
- 1 RS TANK ALERT - NONE
- 1 DOOR ALERT - LS ENT NONE
- 1 TRIM-REAR DOOR
- 1 HINGES-REAR DOOR PIN TYPE
- 1 LATCH-SINGLE-POINT, REAR EMERGENCY DOOR
- 1 STOP-DOOR REAR EMERGENCY, 1-POS
- 1 OPERATION-VANDLOCK ENTRANCE/EMGENCY DOOR(S) WITH PILOT LAMPS
- 1 ELEC-SIDE EMERGENCY DOOR(S)
- 1 DOOR-LS ENT RS EXIT -NONE REQD
- 1 INT COLOR -RR DOOR GRAY
- 1 VANDALOCK-NONE REQUIRED RS
- 1 VANDALOCK-NONE REQUIRED LS
- 1 DOOR ALERT - RS EXIT NONE
- 1 SWITCH-PAD. SERV. DOOR ELEC.
- 1 DOOR, REAR EMERGENCY
- 1 THRESHOLD REAR EMERGENCY DOOR
- 1 ELEC-DRIVER'S DOME LPS
- 1 OPERATION-SWITCH, PANEL LAMPS DIMMER
- 1 ELEC-LPS-INT RED O/H RR EMG DR
- 1 ELEC-PASSENGER ADVISORY 340T
- 1 OPER-PASS ADV IGN/WARN/BUZZER
- 1 SWITCH-RKR FAN DEFROST L.S.
- 1 BUZZER-SWITCH PANEL 1 TONE
- 1 OPERATION-NOISE SUPPRESSION
- 1 ELEC-LPS WARNING,8 LPS 340T
- 1 OPER-LPS, DOME STANDARD
- 1 OPER-LPS BODY TAIL W/PARK SW.
- 1 ELEC-LPS ID/MKR PARK/SW.340T
- 1 SWITCH-ROCKER DOME LAMPS DRIVER ON/OFF
- 1 ELECTRICAL-LAMPS STROBE 6' FROM REAR 235

- 1 OPER-DRVR'S DOME LPS ON/OFF
- 1 OPER-HTR BOOSTER PUMP OPER WITH SWITCH
- 1 OPERATION-LAMPS INTERIOR/EXTERIOR RIGHT FRONT ENTRANCE DOOR
- 1 OPERATION-LAMPS SERVICE BRAKE WITH PILOT LAMPS
- 1 OPERATION-SWITCH ID/MARKER LAMPS WITH PARK
- 1 OPER-LPS DOME (2)ON/OFF
- 1 OPER-LPS REVERSE
- 1 ELEC-(3) SWITCH BANKS
- 1 SWITCH-WARN.LPS ON/AMB ACT.
- 1 ELEC-HARNESS COMP ASM 340T
- 1 ELEC-ELECTRONIC COMP ASM
- 1 OPER-LPS DIR./HAZ.
- 1 SWITCH-RKR MIRROR HTR.
- 1 ELEC-MIR A HTD & RC
- 1 ELECTRICAL-ELECTRIC STOP SIGN REAR
- 1 RAIL-EXTERIOR GUARD @ WINDOW,SEAT,FLOOR,SKIRT
- 1 RAIL-EXT GRD @ SEAT FRT END LS
- 1 RAIL-EXT GRD@ FLOOR, NONE
- 1 TRIM-FRT CAP RS/LS
- 1 PANELS-EXT RR W/4"AUXLPS
- 1 SHEET-DRIVERS EXTERIOR 20 GA.
- 1 SHEET-UPPER SIDE EXTERIOR
- 1 OPER-MIRRORS EXT HTD.
- 1 UNDERCOATING-ASPHALT EMULSION
- 1 HEADERS-WINDOW INTERIOR 340T
- 1 PAINT-EXT ENT DOOR NONE
- 1 PANELS-EXTERIOR REAR SIDE SHORT
- 1 LS STORAGE BOX 1 - NONE
- 1 LS STORAGE BOX 2 - NONE
- 1 ROOF SHEETS-(2)HATCH-340T
- 1 RS STORAGE BOX 1 - NONE
- 1 RS STORAGE BOX 2 - NONE
- 1 RS STORAGE BOX ROH - NONE
- 1 LS STORAGE BOX ROH - NONE
- 1 PANELS-REAR END INTERIOR REAR GALVALUME
- 1 PANELS-REAR END INTERIOR SIDE SHORT
- 1 BULKHEAD-RR END INT.GRY
- 1 PANELS-ACCESS RR GRAY PASS ADVISORY
- 1 COVER-HARNESS ACCESS@HDR
- 1 COVER-ACCESS RR END HARNESS
- 1 COVER-ACCESS FRT END HARNESS
- 1 H/L-RR SHORT SMOOTH GRAY W/LPS
- 1 COVER-FUEL SENDING INSPECTION
- 1 MOLDING-SHOE 340T
- 1 SWITCH-ROCKER HEATER STEPWELL
- 1 LUGGAGE RACK ALERT - NONE
- 1 SWITCH-ROCKER HEATER LEFT 1ST
- 1 SWITCH-ROCKER HEATER LEFT 2ND
- 1 ELEC-HTR U/ SEAT POS 3
- 1 ELECTRICAL-HEATER UNDERSEAT POSITION 10
- 1 RAIL-SEAT
- 1 LAYOUT-SEAT RAIL HOLES RS
- 1 LAYOUT-SEAT RAIL HOLES LS
- 1 CABINET-SW, FWD
- 1 CABINET-SWITCH, LOWER WITHOUT POCKET
- 1 CABINET-SWITCH, UPPER
- 1 CABINET-TOP PLATE (3 BANK)
- 1 TREAD-STEP ALUMINUM ENTRANCE DOOR BLACK
- 1 OPER-HTR U/ SEAT LS FWD
- 1 PANEL-ACCESSORY MOUNTING SAFTEY EQUIPMENT
- 1 OPER-HTR STEPWELL
- 1 INSULATION-VEST HEADLINING 2"
- 1 INSULATION-SIDELINING 2" POLY
- 1 INSULATION-RR BULKHEAD 2" POLY
- 1 OPER-HTR U/ SEAT LS AFT

- 1 HEADERS-WINDOW EXTERIOR 340T
- 1 HARNESS COVER COLOR - GRAY
- 1 SPEAKER ALERT - PRESENT
- 1 DOME LPS - MINIMUM
- 1 HEADLINING COLOR - GREY
- 1 HDLINING TYPE-1ST WDO ACOUSTIC
- 1 MAT, FLOOR VESTIBULE
- 1 TRIM-INTERIOR DASH FORWARD
- 1 INSTALLATION-PARK BRAKE ASSEMBLY
- 1 INSULATION-INT SHORT REAR END
- 1 LUGGAGE RACK ALERT - NONE
- 1 PLATE-ACCELERATOR
- 1 OPER-WDO P/O
- 1 DD5 5.1L 4 CYL 220HP@2200 RPM,2600 GOV RPM,660 LB/FT@1200 RP
- 1 NO AIR INTAKE WARMER
- 1 VANDALOCK,STARTER DISABLE W/ANY LOCKED EMER DR(S),LH PT LAMP
- 1 LOWER RADIATOR GUARD
- 1 REINFORCED NYLON FUEL LINES
- 1 PAINTED FUEL TANK, PAINTED BANDS
- 1 SINGLE SUCTION AND RETURN FUEL LINES
- 1 FUEL TANK MOUNTED BETWEEN RAILS, AFT OF REAR AXLE, WITH CAGE
- 1 REMOTE-MOUNTED SURGE TANK
- 1 BASIC WIRING SCHEMATIC,UNMOUNTED,12-VOLT NEGATIVE GROUND SYS
- 1 PAINTED BATTERY PANEL COVER
- 1 BATTERY BOX FRAME MOUNTED
- 1 INTEGRAL ELECTRONIC TURN SIGNAL FLASHER
- 1 BATT ENABLED 3 AMBER INBOARD ID LAMPS,2 AMBER OUTBOARD MARKE
- 1 STROBE LAMP, IGNITION SWITCH OR LH DASH SWITCH ACTIVATED
- 1 LED WARNING SYSTEM LAMPS
- 1 STANDARD BODY VISUAL WARNING,LOWER RR,REV LAMPS ON DR/OPEN
- 1 STANDARD WIRING
- 1 DRIVER'S IGNITION OPERATED DOME LP WITH ON/OFF SW
- 1 PASSENGER COMPARTMENT DOME LAMPS, IGNITION ACTIVATED
- 1 PASSENGER COMPARTMENT DOME LPS, DUAL ON/OFF SWITCH
- 1 STEPWELL LAMP ON WITH DOOR OPEN AND MARKER LAMPS ON
- 1 EIGHT LAMP WARNING SYSTEM,LH DASH SWITCH(S), PACKAGE 14
- 1 SHIFT LEVER, CABLE LINKAGE, AUTOMATIC TRANSMISSION
- 1 DRIVELINE GUARD
- 1 NON-ASBESTOS FRONT BRAKE LININGS
- 1 FRONT SHOCK ABSORBERS
- 1 NON-ASBESTOS REAR BRAKE LININGS
- 1 WABCO NG HYDRAULIC ABS/ATC W/SHUTOFF SWITCH
- 1 NO POLISHED FRONT WHEELS
- 1 NO POLISHED REAR WHEELS
- 1 TWO QUART SEE THRU POWER STEERING RESERVOIR
- 1 POWER STEERING PUMP
- 1 ZINC-PLATED HEXHEAD CHASSIS FASTENERS
- 1 3675MM (145") REAR FRAME OVERHANG
- 1 SQUARE END OF FRAME
- 1 BUMPER MOUNTING FOR SINGLE LICENSE PLATE
- 1 LED COMB S/T/T/R LAMPS, & (2)4"ROUND REVERSE LAMPS
- 1 RR EMER DR,IGN CTRL,BZ ON W/DR
- 1 MAINTENANCE-FREE RUBBER BUSHINGS - FRONT SUSPENSION
- 1 21K TAPERLEAF SPRING REAR SUSPENSION
- 1 CAB MOUNTING FOR HOOD AND COWL CHASSIS
- 1 RH FRONT ENTRANCE DOOR, BATTERY CONTROLLED,ELECTRICALLY OPER
- 1 KEYED ENT DOOR LOCK/BUZZER ON W/EMERGENCY DOORS UNLATCHED
- 1 ONE GALLON WINDSHIELD WASHER RESERVOIR
- 1 BLACK HOOD MOUNTED AIR INTAKE GRILLE
- 1 SINGLE ELECTRIC WINDSHIELD WIPER MOTOR W/DELAY
- 1 GRAY/CHARCOAL FLAT DASH
- 1 STANDARD TUNNEL/FIREWALL LINER
- 1 NO AIR CONDITIONER CONDENSER
- 1 HEATER AND DEFROSTER
- 1 STANDARD HVAC DUCTING

- 1 MAIN HVAC CONTROLS WITHOUT RECIRCULATION SWITCH,& NOISE SUPP
- 1 WINDSHIELD FAN,(1) HEADER MOUNTED
- 1 DRIVER'S FAN,(1) MOUNTED ABOVE SIDE WINDOW
- 1 AUX BODY HEATER,UNDER SEAT,FWD
- 1 AUXILIARY BODY HEATER, UNDER SEAT, AFT
- 1 GRAY INSTRUMENT PANEL-DRIVER
- 1 BODY SUPPLIED HEATED MIRRORS
- 1 ROOF MOUNTED VENT/ESCAPE HATCH
- 1 PUSH OUT BODY SIDE WINDOWS, BUZZER WITH WINDOW UNLATCHED
- 1 SEPARATE PANEL LAMP DIMMER,LH DRIVER'S SWITCH PANEL
- 1 CHASSIS COWL AND HOOD ONLY
- 1 NO TCU-TRANSMISSION OPTIMIZED(NO FUEL SENSE)
- 1 PILOT,LH DASH,STOP LAMP MONITOR
- 1 BUMPER: BLACK
- 1 NO SPARE WHEEL PAINT
- 1 CHASSIS: VENDOR BLACK
- 1 EXPECTED GROSS VEHICLE WEIGHT CAPACITY
- 1 EXPECTED FRONT AXLE(S) LOAD
- 1 EXPECTED REAR DRIVE AXLE(S) LOAD
- 1 SCHOOL BUS SERVICE
- 1 COWL CHASSIS CONFIGURATION COMPLIES WITH SBMTC
- 1 BUS BODY WITH WHEELWELL
- 1 PASSENGER COMMODITY
- 1 100% ON-HIGHWAY (CITY) TERRAIN
- 1 DOMICILED USA 50 STATES (CALIFORNIA)
- 1 DOMICILED ILLINOIS
- 1 THOMAS BUILT SCHOOL BUS 340T

## **CHASSIS**

### **AXLES AND SUSPENSIONS**

- 1 ALIGNMENT-4-WHEEL SAF-T-LINER C2
- 1 SPL100 DANA SPICER MAIN DRIVELINE
- 1 DA-F-10-3 10,000# FF1 71.5 KPI/3.74 DROP SINGLE FRONT AXLE
- 1 CHICAGO RAWHIDE FRONT OIL SEALS
- 1 SYNTHETIC 75W-90 FRONT AXLE LUBE
- 1 CONMET IRON FRONT HUBS
- 1 SYNTHETIC 75W-90 REAR AXLE LUBE
- 1 DA-RS-21-4 21K R-SERIES SINGLE REAR AXLE
- 1 6.14 REAR AXLE RATIO
- 1 IRON REAR AXLE CARRIER HOUSING
- 1 REAR SHOCK ABSORBERS - ONE AXLE
- 1 CHICAGO RAWHIDE (SCOT) REAR OIL SEALS
- 1 GUNITE IRON REAR HUBS
- 1 10,000 LB. TAPERLEAF FRONT SUSPENSION
- 1 COMFORT-TEC SUSPENSION

### **BRAKES**

- 1 ALERT-ENHANCED STABILITY CONTROL
- 1 BOSCH HYDRAULIC BRAKE PACKAGE
- 1 BOSCH HYDRAULIC PIN-SLIDE DISC FRONT
- 1 FRONT DISC BRAKE ROTORS W/SEPARATE TONE RINGS
- 1 BOSCH HYDRAULIC PIN-SLIDE DISC REAR
- 1 REAR BRAKE DUST SHIELDS
- 1 FRONT BRAKE DUST SHIELDS
- 1 TRANSMISSION-MOUNTED PARK BRAKE
- 1 REAR DISC BRAKE ROTORS W/SEPARATE TONE RINGS
- 1 NYCLAD HYDRAULIC CHASSIS TUBING
- 1 FT OPER PARK BRAKE w/SERVICE BRAKE INTERLOCK w/INDICATOR

### **CHASSIS EQUIPMENT**

- 1 EXHAUST-LS, THRU REAR BUMPER
- 1 ANTI-FREEZE, OAT -34 DEGREE
- 1 WINTERFRONT-CHASSIS GRILLE YELLOW
- 1 SHIELD-EXHAUST PIPE
- 1 B2 106 CONVENTIONAL CHASSIS
- 1 SET-BACK AXLE - TRUCK
- 1 DETROIT ENG MTD FUEL WATER SEPARATOR W/IF LIGHT, PUMP

- 1 DELCO 12V 29MT STARTER WITH INTEGRATED M
- 1 NO CLUTCH PEDAL WITH NON-ADJUSTABLE
- 1 ENGINE COMPARTMENT MOUNTED AIR RESTRICTION INDICATOR W/LIGHT
- 1 RIGHT HAND SIDE-FILL FUEL TANK CAP
- 1 100GALLON/378 LITER STEEL RECTANGULAR FUEL TANK,BETWEEN RAIL
- 1 HORIZONTAL TAILPIPE, LH SIDE, EXIT THROUGH BUMPER
- 1 11.5 GALLON DEF TANK
- 1 MAGNETIC ENGINE DRAIN, REAR AXLE DRAIN & FILL PLUG
- 1 NO TRACTION STABILIZER
- 1 TILT ONLY STEERING COLUMN
- 1 TRW THP-60 POWER STEERING
- 1 450MM(18") LK FOUR-SPOKE CHARCOAL STEERING WHEEL
- 1 7075MM (279") WHEELBASE
- 1 5/16" X 3.00" X 10 1/8" STEEL FRAME (7.94 X 76.5 X 257.2")
- 1 1-PIECE 14" PTD STL 1/4" HD BUMPER JACK PROVISION
- 1 FRONT FRAME-MOUNTED TOW HOOKS
- 1 REAR TOW HOOKS
- 1 STANDARD DUTY HOOD MOUNTING
- 1 FIBERGLASS HOOD
- 1 PAINTED PLASTIC GRILLE
- 1 YELLOW WINTERFRONT
- 1 (2) CUPHOLDERS, LEFT HAND AND RIGHT HAND DASH

### **ELECTRICAL - CHASSIS**

- 1 LN 12V 240 AMP AVI PAD MOUNT ALTERNATOR
- 1 PROG RPM CTRL W A/C OR 12.75V LOW VOLT AUTO HI IDLE, DASH SW
- 1 CRUISE CONTROL-ELEC ENG,W/SWITCHES IN LH SWITCH PANEL
- 1 DIAGNOSTIC INTERFACE CONNECTOR,9-PIN, S
- 1 IGNITION SWITCH CONTROLLED ENGINE STOP
- 1 12VOLT POWER SUPPLY LH PANEL
- 1 SOLID STATE CIRCUIT PROTECTION, PDMS WIT
- 1 (3) ALLIANCE 1031,GROUP 31,12 VOLT,MF 2280 CCA BATTERIES
- 1 COLE HERSEE BATTERY CUT-OFF SWITCH, BATTERY BOX MOUNTED
- 1 SELF CANCEL TURN SIGNAL SWITCH W/DIM/WASH&HAZZARD IN HANDLE
- 1 STANDARD FRONT TURN SIGNAL LIGHTS
- 1 PARK LMP SW INTGRAL W/HL SWITCH, ID/MARKER/CLEARANCE/PARK ON
- 1 NO FENDER MTD TURN/MARK COMBO LPS
- 1 AMBER LED MIDSHIP TURN SIGNALS
- 1 DAYTIME RUNNING LIGHTS SET @ 85%
- 1 INTEGRAL HEADLIGHT/MARKER ASSEMBLY
- 1 NO UTILITY/ADVERTISING LIGHT
- 1 STOP SIGN PRESENT
- 1 NO BAGGAGE COMPARTMENT LAMP
- 1 NO BODY MTD INT SPOT/WORK LAMP
- 1 ELECTRONIC STABILITY CONTROL
- 1 BAT PWD 2-POS INT DOOR CONTROL LS SWITCH PANEL
- 1 DUAL ELEC HORN, PASSENGER ADVISORY BUZZER ON W/IGN AND WARN
- 1 NO OBSTACLE DETECTION SYSTEM
- 1 NO CAMERA/VIDEO/IMAGING SYSTEM
- 1 C/F J1939 RADIO W/PA
- 1 CUSTOMER FURNISHED 2-WAY RADIO
- 1 FASTEN SEAT BELT INDICATOR FOR CUSTOMER SUPPLIED SEAT BELT
- 1 LOCATING SYSTEM WITH VEHICLE MONITORING
- 1 ELECTRONIC SPEEDOMETER WITH SECONDARY KPH SCALE, NO ODOMETER
- 1 DRIVER MESSAGE CENTER WITH LCD DISPLAY
- 1 ELECTRONIC 3500 RPM TACHOMETER
- 1 VT-HU CONNECTIVITY PLATFORM HARDWARE & TBB ZONAR DASH MTD
- 1 NO INFORMATION CENTER
- 1 PRE/POST TRIP SYSTEM TEST
- 1 ENGINE AND HOUR METERS INTEGRAL WITH DRIVER DISPLAY
- 1 DIGITAL VOLTAGE DISPLAY INTEGRAL WITH DRIVER DISPLAY
- 1 ELECTRIC FUEL GAUGE
- 1 ELECTRIC ENGINE OIL PRESSURE GAUGE
- 1 ELECTRICAL ENGINE COOLANT TEMPERATURE GAUGE

### **ENGINE AND EQUIPMENT**

- 1 ANTI-FREEZE TO -34F, OAT (NITRITE AND SILICATE FREE)EXT LIFE

- 1 ENGINE-MOUNTED OIL CHECK AND FILL
- 1 10W-30 WEIGHT ENGINE OIL
- 1 FULL FLOW OIL FILTER
- 1 DETROIT FUEL/WATER SEPARATOR W/BYPASS & 12V PREHEATER
- 1 EXHAUST BRAKE NONE
- 1 ALUMINUM FLYWHEEL HOUSING
- 1 PHILLIPS 750 WATT/115 VOLT BLOCK HEATER
- 1 STANDARD OIL PAN
- 1 ENGINE HEATER RECEPTACLE MOUNTED FACE OF BUMPER, LEFT SIDE
- 1 ENGINE INTEGRAL SHUTDOWN PROT W/OVERRIDE SW,LW COOLANT&LIGHT
- 1 ADDL AUX LINES W/MANIFOLD PLUMBING AND COMBINED SHUTOFF
- 1 GATES BLUE STRIPE COOLANT HOSES
- 1 CONSTANT TORQUE BREEZE CLAMPS ON 1" IN DIA GREATER, SS C
- 1 CAST BOOSTER PUMP
- 1 30,600 BTU STEPWELL HEATER, RH FRONT ENTRANCE DOOR
- 1 DONALDSON ONE-STAGE AIR CLEANER
- 1 700 SQUARE INCH ALUMINUM RADIATOR
- 1 BORG WARNER ELECTRONIC VISCOUS FAN DRIVE
- 1 OMIT STANDARD EXHAUST DIFFUSER
- 1 69 MPH ROAD SPEED LIMIT
- 1 NO IDLE SHUTDOWN CONFIGURATION
- 1 DIGITAL TRANS OIL TEMP IN DRIVER DISPLAY

### **TRANSMISSION AND EQUIPMENT**

- 1 ALLISON 2500 PTS AUTOMATIC TRANSMISSION
- 1 ALLISON VOCATIONAL PACKAGE 354 - FIFTH GEN
- 1 TRANSMISSION OIL CHECK AND FILL
- 1 SYNTHETIC 50W TRANSMISSION LUBE (TES-295 COMPLIANT)
- 1 WATER TO OIL TRANSMISSION COOLER - IN RADIATOR END TANK
- 1 PRIMARY MODE GEARS, 6 FORWARD
- 1 NO TCU-LBSS VAC
- 1 NO TCU-ENGINE LOAD REDUCTION FUNCTION
- 1 NO MODE SWITCH

### **WHEELS AND TIRES**

- 1 RADIAL FRONT TIRE, MICHELIN XZE2, 11R22.5 16 PLY
- 1 MICHELIN X MULTI D 11R22.5 16 PLY REAR TIRES
- 1 NO TIRE PRESSURE CONTROL/SENSOR
- 1 MAXION 90262 22.5 X 8.25 10 HOLE HUB PILOT 5-HAND
- 1 MAXION 90262 22.5 X 8.25 10 HOLE HUB PILOT 5-HAND
- 1 TIRE/WHEEL BALANCING-LEAD FREE WEIGHTS
- 1 ACCURIDE PK-BLACK21 POWDER BLACK WHEEL (N0001H)- FRONT
- 1 ACCURIDE PKBLK21 POWDER BLACK WHEEL (N0001H) – REAR

### **DEALER ADD-ONS**

- 1 CUSTOMER LETTERING
- 1 ILLINOIS STATE INSPECTION, TITLE AND LICENSE FEE





# Customer Quotation

**Prepared For:**  
MINOOKA CHSD #111 & CCSD #201  
26655 W EAMES ST.  
MINOOKA, IL 60410

**Prepared By :**  
RANDY SWANSON  
MIDWEST BUS SALES, INC.  
18 SKYVIEW DR.  
LITCHFIELD, IL 62056

**Quote Number:**  
374177

**Quote Date:**  
1/3/2022

**Customer Order No:**  
226001C2-226020

## Model Profile: Saf-T-Liner C2 340TS

<b>Product Type:</b>	School Transportation
<b>Year:</b>	2022
<b>Chassis Model:</b>	B2 106
<b>Chassis MFG:</b>	FLNER
<b>GVWR:</b>	GVWR
<b>Passenger Capacity:</b>	71
<b>Headroom:</b>	78
<b>Wheelbase:</b>	279
<b>Brake Type:</b>	HYDRAULIC
<b>Engine Type:</b>	CUMMINS B6.7 220 DIESEL, 6 Cyl, 220 HP, 2600 RPM
<b>Fuel Type:</b>	DIESEL
<b>Fuel Tank Capacity:</b>	100
<b>Transmission Type:</b>	AUTOMATIC
<b>Axle, Front:</b>	10000-lb Capacity
<b>Axle, Rear:</b>	21000-lb Capacity
<b>Tires, Front:</b>	RADIAL FRONT TIRE, MICHELIN XZE2, 11R22.5 16 PLY
<b>Tires, Rear:</b>	MICHELIN X MULTI D 11R22.5 16 PLY REAR TIRES
<b>Suspension Front:</b>	10,000 LB. TAPERLEAF FRONT SUSPENSION
<b>Suspension Rear :</b>	COMFORT-TEC SUSPENSION

Three year annual lease with 18,953 per year miles: \$ 16,430.15 per bus/per year  
 Five year annual lease with 18,953 per year miles: \$ 14,999.90 per bus/per year  
 Five year annual lease/purchase payment: \$ 20,913.90 per bus/per year  
 Estimated delivery 140-180 days ARO  
 Payment due upon delivery of unit  
 Quote valid for 30 days  
 Price is subject to school bus availability.

**CUSTOMER Customer Signature\*\*:** \_\_\_\_\_ **Date:** \_\_\_\_\_

**New bus(es) Info:**  
 Name on bus: \_\_\_\_\_  
 Bus Number (s): \_\_\_\_\_

*\*\* I have reviewed the quote detail for accuracy and I agree to order the bus(es) as listed.  
 \*New stock unit subject to prior sale and/or availability. Letter of intent to buy or purchase order is required to put bus on hold.*

**Dealer Signature:** \_\_\_\_\_ **Date:** \_\_\_\_\_

The equipment proposed meets and/or exceeds all requirements set forth in the Federal Minimum Standards for School Buses and Federal Motor Vehicle Safety Standards established by the Federal Department of Transportation.

242

**Includes the Following Equipment:**

**BODY**

**ACCESSORIES**

- 1 LOC-1ST.SEAT DRVRSIDE REFL TRIANGLE
- 1 LOCKS-KEYED ALIKE #CH545
- 1 METHOD-FASTENER SCREWS
- 1 HOLDER-CERTIFICATE 4"X 6"

**CERTIFICATION/SAFETY**

- 1 REFLECTTAPE-RR END YEL 2" 3M
- 1 REFLECTTAPE-FRT END YEL
- 1 FIRE EXTINGUISHER-5 3A-40BC
- 1 REFLECTORS-AMBER (4) MID/FRONT 3"
- 1 REFLECTORS-RED (4) RR/RR SI 3"
- 1 HATCH-RF ESC MODEL 1100 ENG(2)
- 1 ELECTRICAL-ROOF ESCAPE HATCH POS 3
- 1 HANDLES-W/S SERVICE, BLACK
- 1 KIT - BODY FLUID CLEAN-UP NATIONAL STANDARDS
- 1 SWITCH-ROCKER CROSSING ARM DEACTIVATION
- 1 LABEL-PASS ADVISOR INSTRUCTION
- 1 LOC-O/H STOR LS 10 UNIT B.F.C
- 1 LOC-VEST.FLR.PLT.LEFT 5LB F.E. & BOX
- 1 KIT.FIRST AID 10 UNIT ILL.
- 1 CUTTER-SEAT BELT W/HAND GRIP
- 1 TRIANGLES-REFL. 3 W/BOX
- 1 MOTOR-XING ARM ELEC.SPECIALTY
- 1 BRACKET-XING ARM STOWAGE 1/4" BUMP
- 1 OPEN VIEW - ES, HEATED, REMOTE
- 1 MIRROR-B EXTERIOR CROSSVIEW HEATED BLACK BRACKET
- 1 SIGN-STOP, ELEC FRT #SE1-7970C
- 1 SIGN-STOP, ELEC RR #SE1-7971C
- 1 MIRROR-INTERIOR 6"X30" WITH RUBBER EDGE
- 1 LABEL(S)-SPECIAL DATA, IL
- 1 LABEL-VEHICLE CERTIFICATION
- 1 FRONT BUMP MT CROSS ARM W/DEACTIVATION SWITCH-ELECTRIC

**DOORS**

- 1 STEP-RS ALUM.ENT.DR W/HTR 8.75"RISER
- 1 HANDLE-EXTERIOR REAR DOOR WITH RECESS
- 1 LATCH-DOOR INTERIOR STORAGE OVER WINDSHIELD
- 1 VANDALOCK-REAR DOOR W/BOLT
- 1 DOOR-ENT AG2 TINT TEMP LOCK
- 1 PWR SYST.-AG2 ELECTRIC ENTRANCE DOOR
- 1 ELEC-AG2 ELECTRICAL OPERATED ENTRANCE DOOR
- 1 OPER-DOOR ELEC.ENT.W/ BAT.
- 1 VANDALOCK-ALUM.ENT.DR.CYLINDER W/KEY
- 1 PULL-ENTRANCE DOOR, EXTERNAL ALUMINUM
- 1 KEY-VANDALOCK REAR DOOR NONE
- 1 TRIM-ENTRANCE DOOR INTERIOR
- 1 PAD-DR HEADER, RR EMER 36"W
- 1 TRIM-STEPWELL HORIZONTAL WITH RIBBED NOSE
- 1 RAIL-ASSIST FRT ENT DR 39"YEL
- 1 RAIL-ASSIST FRT ENT DR RS YEL 1"

**ELECTRICAL - BODY**

- 1 FAN-CIRC MID W/S HDR BLACK
- 1 ELEC-FAN MID W/S HDR
- 1 FAN-CIRC DRV'S WDO HDR BLACK
- 1 ELECTRICAL-FAN DRIVER'S WINDOW HEADER
- 1 RADIO-AM/FM DEA700 W/PAGE
- 1 OPER-AUTOMATIC FAST IDLE
- 1 ELEC-COAXIAL TWO-WAY RADIO ROOF
- 1 KIT-ANTENNA MOUNT AT ROOF
- 1 ELEC-ZONAR STANDARD MONITORING

- 1 ELEC-PWR CELL PHONE OUTLET LS
- 1 OPERATION-DOOR REAR EMERGENCY WITH BUZZER/PILOT LAMPS
- 1 MONITOR-LPS WARN NONE
- 1 LPS-DOME OVER DRIVER LED
- 1 LPS-DOME PASS 6 MIN LED 340T
- 1 ELEC-PASS DOME LPS W/REAR MOST (6)
- 1 SWITCH-RKR DOME LPS FRT/RR
- 1 MODULE-PWR.DIST.ELEC.SYS.
- 1 SWITCH-ROCKER PANEL LAMPS DIMMER
- 1 LPS-INT RED LED OVER RR EMG DR
- 1 LPS-EXT AFT OF ENT DOOR LED
- 1 ELEC-LPS EXT AFT OF ENT DOOR
- 1 OPER-STPWLL LPSW/PARKLPS&ENT DR.
- 1 LPS-STPWLL LED W/O HOOD (1)
- 1 LPS-STP/TAIL/DIR AMBER/REV LED
- 1 ELEC-LPS STOP/TAIL/TURN/REV
- 1 ADVISORY-PASSENGER BUZZER ACTIVATION, WITH SWITCH
- 1 LPS-PILOT VANDALOCK STATUS RED
- 1 ELEC-PWR, GND, NETWORK, BUZZ
- 1 LAMPS-PILOT BRAKE LIGHTS RED
- 1 LAMPS-PILOT REAR EMERGENCY DOOR RED
- 1 LAMPS-PILOT POST TRIP INSPECTION RED
- 1 LAMPS-4" AUXILIARY L.E.D.
- 1 LPS-LIC PLATE ILLUMINATION LED
- 1 LPS-SI DIR AMBER FRT. LED PIN
- 1 ELEC-LPS SI FRT DIRECTIONAL ONLY
- 1 LPS-WARNING LED (8)
- 1 OPERATION-LAMPS WARNING (8) PACKAGE 14
- 1 OPERATION-LAMPS REVERSE WITH REAR EMERGENCY DOOR OPEN
- 1 LPS-ID AMB/RED LED
- 1 LPS-MKR ROOF FRT/RR LED PIN
- 1 LPS-MKR ROOF MID LED PIN
- 1 STROBE-ECCO 7460CC 6' FROM REAR
- 1 LPS- STOP/TAIL 4" FLS.MT L.E.D.
- 1 SWITCH-ROCKER FAN DEFROST WINDSHIELD
- 1 SWITCH-ROCKER NOISE SUPPRESSION ON/OFF
- 1 SWITCH-ROCKER STROBE LAMPS
- 1 LAMPS-PILOT WARNING LIGHTS RED
- 1 LAMPS-PILOT WARNING LIGHTS AMBER
- 1 OPERATION-LAMP STROBE, IGNITION & SWITCH ACTIVATED
- 1 ELEC-CABLE PRIM PWR & GND-CUSTOMER ACCESS
- 1 OPERATION-LAMPS SIDE DIRECT.OONLY
- 1 BLOCK-FUSE CUSTOMER ACCESS
- 1 LPS-DOME REAR MOST LED
- 1 OPER-PRE-TRIP INSPECTION
- 1 ELEC-SEAT BELT PILOT LAMP
- 1 OPER-SEAT BELT PILOT LAMP
- 1 LAYOUT-ROCKER SWITCH STANDARD
- 1 ELEC-ELECTRIC STOP SIGN 1ST WINDOW POSITION
- 1 SPEAKERS-INT. 30 WAT.(6) 340T
- 1 ELEC- (6) INT SPEAKERS 340T
- 1 SWITCH-RKR HTR BOOST PUMP
- 1 ELEC-HTR ENT DOOR STEPWELL
- 1 112DB BACKUP ALARM

## **EXTERIOR**

- 1 FLAPS-MUD, REAR 22.5"W
- 1 FLAPS-MUD, FRONT 16"W X 12"H
- 1 STEPS-EXT W/S SERVICE
- 1 FENDER-QUARTER 24" BATTERY BOX DOOR
- 1 BODY ADJUSTMENT-FREIGHTLINER, BTR RS FUEL FILL LOCATION
- 1 REINFORCEMENT-FRAME STD 24" BATTERY BOX DOOR
- 1 CAP-ENTRANCE DOOR STANDARD
- 1 FLOOR-NON ADA
- 1 BUMPER-RR 2 BRACES LS EXH HOLE
- 1 SKT.FWD.STPWLL LO DEF

- 1 CAP-FRONT ROOF W/WARN.LPS.
- 1 CAP-REAR ROOF W/WARN.LPS.
- 1 GUSSET-21"H LWR SIDE SHEET
- 1 SHEET-LWR, L MID 20G,21"
- 1 SHEET-LWR,L RR 20G,21"
- 1 SHEET-LWR,R MID 20G,21"
- 1 SHEET-LWR,R RR 20G,21"
- 1 DOOR-U/B L BATTERY 24"
- 1 DOOR-FUEL FILL ACCESS BTR
- 1 FENDERETTE-STL 21" SKIRT
- 1 LATCH-BATT DOOR NON-LOCKING
- 1 LATCH-FUEL FILL ACCESS (THUMB)
- 1 VENT-STATIC NONE
- 1 PILASTER - 340T, 800
- 1 LATCH-NON-LOCKING DEF ACCESS DOOR
- 1 RAIL-SNOW RAIL PRESENT
- 1 HARDWARE-MOUNTING CLIPS STANDARD

### **HVAC**

- 1 AIR COND - NONE
- 1 HTR-U/S LS 84,000 BTU LOC 3
- 1 HTR-U/S LS 84,000 BTU LOC 10
- 1 HOSE-HTR BLUSTRIP W/ W/H POS 10
- 1 HEATER-ENTRANCE DOOR STEPWELL
- 1 CLAMPS-PLUMBING HEATER CONSTANT TORQUE
- 1 CLAMPS-UNDERSEAT HEATER CONSTANT TORQUE
- 1 CONN-HTR(1) CONST TORQ/BLUSTRIP
- 1 VALVE-SHUTOFF LS U/SEAT HTR WHOUSE
- 1 NO AIR CONDITIONING COMPRESSOR

### **INTERIOR**

- 1 VISOR-WINDSHIELD SUN 6"X30" TINTED
- 1 DOOR-STORAGE BOX W/O GLASS
- 1 TRIM-LOWER REAR HEATER NO A/C
- 1 REINFORCEMENT-REAR STOP SIGNAL 40"
- 1 DOOR-ACC SOLID PANEL
- 1 LATCH-DR INT STOR OVR DRVRSHDR
- 1 BTR FUEL FILL RECESS, W/DOOR
- 1 COVER-TRIM DRVS HDR W/STORAGE
- 1 COVER-TRIM FRT END W/S HEADER
- 1 COVER-TRIM FRT ENT.ALUM.DR HDR.ELEC.OP.
- 1 STRIPS - AISLE, ALUMINUM 340T
- 1 FLR-BLK VINYL W/13" CTR AISLE 340T
- 1 FLR-BLK WHEELHOUSE AND HEATER
- 1 FLR-PLYWOOD 5/8" 340T
- 1 LINING-SIDE INT.
- 1 INSULATION-FRT BULKHEAD W/ACRSY 2"POLY
- 1 H/L-1ST WDO SEC ACOUS GRY 340T
- 1 INSULATION - URETHANE
- 1 HOLDER-STORAGE, CLIP BOARD
- 1 TUBE-FILL BTR & OVERFLOW HOSE
- 1 CAP-FUEL FILL BTR NON-LOCKING
- 1 IN DASH STORAGE BIN

### **MISC**

- 1 PDI IDENTIFIER-DEALER PERFORMED
- 1 MANUAL-DRVR'S/MAINT.ENGLISH
- 1 APPLICATION - SCHOOL
- 1 NO COOLANT HEATER - GAS/DIESEL
- 1 ALL UNIT(S) KEYED ALIKE WITH CUSTOMER SPECIFIED KEY #FT1001
- 1 NO A/C PLUMBING - MAIN
- 1 70 MPH ROAD SPEED LIMIT
- 1 SAF-T-LINER C2

### **PAINT/LETTERING**

- 1 DECAL-UNITED AUTO WORKERS
- 4 LABEL-P/O WDO EMER EXIT 2" BLACK
- 1 LABEL-ENGLISH AG2.ELEC.ENT DR

245

- 4 REFLECTTAPE-P/O WDO YEL 3M
- 1 REFLECTTAPE-EMER DR RR YEL 3M
- 1 REFLECTTAPE-SI 2" ABV FLR YEL 3M
- 1 LETTER - OVERHEAD STORAGE BOX "SAFETY EQUIP"
- 1 DECAL-BACKING ALARM
- 1 DECAL-LOW SULFUR FUEL
- 1 LABEL-RR DR EMERGENCY DOOR DO NOT BLOCK
- 1 DECAL-ENTRANCE DOOR VANDALOCK ENGLISH
- 1 LABEL-RR EMERGENCY DOOR INSTRUCTION
- 1 LABEL-"DEF ONLY"
- 1 LABEL-REGENERATION WARNING 2010/2013 EPA ENGLISH
- 1 HANDLE-INT RR DR RED
- 1 PAINT-EXT HNDLE(S) BLACK
- 1 DECAL-REFL FRT CAP "SCHOOL BUS" 3M
- 1 DECAL-REFL RR CAP "SCHOOL BUS" 3M
- 1 DECAL-"DIESEL"
- 1 PAINT-EXTERIOR ROOF WHITE 340T
- 1 PAINT-EXT WINDOW AREA BLACK
- 1 PAINT-EXT GRD RAIL @ WINDOW BLACK
- 1 PAINT-EXT GRD RAIL @ SEAT BLACK
- 1 PAINT-EXT GRD RAIL @ FLOOR BLACK
- 1 PAINT-EXT GRD RAIL @ SKRT BLACK
- 1 PAINT-EXT BUMPER REAR BLACK
- 1 PAINT-BLACK TRIM-FRONT/REAR ROOF CAPS
- 1 PAINT-SOLID COLOR YELLOW
- 1 DECAL-APPROVED FUEL TYPE
- 1 DECALS-WDO STRIPE 340T
- 1 HEADLINING-VESTIBULE ACOUSTIC, GRAY, DRIVER LAMP
- 1 PAINT:ONE SOLID COLOR,BASE/CLEARCOAT
- 1 CAB COLOR A:L5898EB SCHOOL BUS YELLOW ELITE BC
- 1 CAB COLOR B - NONE
- 1 CAB COLOR C: NONE
- 1 GRILLE: SILVER N3388H IMRON 5000

### **SEATS**

- 1 OFF-SET LS BARRIER 4"
- 1 2014 SEATING ALERT
- 1 SEAT BELT - DRIVERS SEAT
- 1 39" BARR-VERT,WALL MT 45"H RS 2009
- 1 39"8DEG BARR-REV. WALL-MT 45"H 2009
- 2 PROFORM EDO BLUE UPHOLSTERY-45"HIGH RECESSED BARRIER
- 1 BACK-NATIONAL DRV'S SEAT
- 1 ARMREST NATIONAL DRVR'S ST. RS
- 1 UPH DR.ST.FABRIC BLK NATIONAL
- 1 PEDASTAL-DR ST MECH TYPE
- 1 COVER PEDASTAL NATIONAL NONE
- 1 SLIDE STOP NATIONAL DR.ST. NONE
- 1 RETAINER NATIONAL DR.ST.BELT
- 1 POUCH-DR.ST.STORAGE NONE
- 1 KICKPLATE-MOD.PANEL RS 39"
- 1 RISER-DRIVERS SEAT, NATIONAL
- 1 Haptics-Not Present
- 12 S3B 39"RS WALL MT RESTRAINING/NO BELT
- 1 S3B 26" LS WALL MT RESTRAINING/NO BELT
- 11 S3B 39"LS WALL MT RESTRAINING/NO BELT
- 24 FIREBLOCK BLUE UPHOLSTERY - S3B SEAT
- 24 S3B WALL MT HARDWARE-RESTRAINT

### **WINDOWS/GLASS**

- 1 GLASS-WINDSHIELD ONE PIECE WITH TINTED BAND
- 1 GLASS-RS FRT STAT TNT TEMP
- 1 GLASS-LS FRT STAT TNT TEMP
- 1 GLASS-REAR STAT TINTED TEMP
- 1 FRAME-WDO SPLIT
- 16 FRAME-WDO SPLIT 30"W
- 2 FRAME-WDO SPLIT 40"W
- 2 FRAME-WDO P/O VERT TEMP TNT LS

- 2 WDO P/O VERT TEMP TNT RS
- 16 GLASS-WDO TINT TEMP 30"
- 2 GLASS-WDO TINT TEMP 40"
- 1 STOPS-WDO 12"
- 1 GLS-LWR RR DR TEMP TNT BONDED
- 1 GLS-UPR RR DR TEMP TNT BONDED
- 1 WDO-DRIVER'S TEMP TINT

#### **OTHER**

- 1 2019 CUMMINS ENGINE TARIFF
- 1 LOGO-FRT RS & RR
- 1 LOGO-THOMAS DECALS YELLOW
- 1 ELEC-RF ESC HATCH POS 9
- 1 ARM ASSEMBLY-WINDSHIELD WIPER (2)
- 1 ELECTRICAL-ROOF HATCH OR P/O WINDOW (DASH)
- 1 OPER-FAN W/S HDR
- 1 OPER-FAN DRV'S WDO HDR
- 1 OPER-ALARM BACKING W/REV.
- 1 OPER-RF HATCH BUZZER
- 1 LOC-O/H ENT.DOOR RS CERT.HLDR
- 1 LOCATION-OVERHEAD STORAGE CENTER 10 F.A.K.
- 1 AC DUCT-NOT PRESENT NO SIDE EVAP
- 1 CONDENSER ALERT - NONE
- 1 EVAPORATOR QTY - NONE
- 1 OPER-XING ARM DEACTIVATION
- 1 ANTENNA - RADIO SWIVEL BASE
- 1 ELEC-ANTENNA RADIO COAXIAL
- 1 KIT-RADIO ANTENNA MOUNTING @ DRIVER'S HEADER
- 1 ALERT-CONDENSER NONE
- 1 340T30\_N
- 1 TRIM-A POST
- 1 WHEELHOUSES-REAR L&R
- 1 STRINGER-ROOF 340T
- 1 FRONT END FRAME
- 1 FRT END FRAME MTG KIT
- 1 REAR END FRAME-18.68" DEEP
- 1 FLOOR-GALVALUME STEEL MID BODY
- 1 LOC-40" RAF SP 11TH 340T
- 1 RS TANK ALERT - NONE
- 1 DOOR ALERT - LS ENT NONE
- 1 TRIM-REAR DOOR
- 1 HINGES-REAR DOOR PIN TYPE
- 1 LATCH-SINGLE-POINT, REAR EMERGENCY DOOR
- 1 STOP-DOOR REAR EMERGENCY, 1-POS
- 1 OPERATION-VANDLOCK ENTRANCE/EMGENCY DOOR(S) WITH PILOT LAMPS
- 1 ELEC-SIDE EMERGENCY DOOR(S)
- 1 DOOR-LS ENT RS EXIT -NONE REQD
- 1 INT COLOR -RR DOOR GRAY
- 1 VANDALOCK-NONE REQUIRED RS
- 1 VANDALOCK-NONE REQUIRED LS
- 1 DOOR ALERT - RS EXIT NONE
- 1 SWITCH-PAD. SERV. DOOR ELEC.
- 1 DOOR, REAR EMERGENCY
- 1 THRESHOLD REAR EMERGENCY DOOR
- 1 ELEC-DRIVER'S DOME LPS
- 1 OPERATION-SWITCH, PANEL LAMPS DIMMER
- 1 ELEC-LPS-INT RED O/H RR EMG DR
- 1 ELEC-PASSENGER ADVISORY 340T
- 1 OPER-PASS ADV IGN/WARN/BUZZER
- 1 SWITCH-RKR FAN DEFROST L.S.
- 1 BUZZER-SWITCH PANEL 1 TONE
- 1 OPERATION-NOISE SUPPRESSION
- 1 ELEC-LPS WARNING,8 LPS 340T
- 1 OPER-LPS, DOME STANDARD
- 1 OPER-LPS BODY TAIL W/PARK SW.
- 1 ELEC-LPS ID/MKR PARK/SW.340T

- 1 SWITCH-ROCKER DOME LAMPS DRIVER ON/OFF
- 1 ELECTRICAL-LAMPS STROBE 6' FROM REAR
- 1 OPER-DRVR'S DOME LPS ON/OFF
- 1 OPER-HTR BOOSTER PUMP OPER WITH SWITCH
- 1 OPERATION-LAMPS INTERIOR/EXTERIOR RIGHT FRONT ENTRANCE DOOR
- 1 OPERATION-LAMPS SERVICE BRAKE WITH PILOT LAMPS
- 1 OPERATION-SWITCH ID/MARKER LAMPS WITH PARK
- 1 OPER-LPS DOME (2)ON/OFF
- 1 OPER-LPS REVERSE
- 1 ELEC-(3) SWITCH BANKS
- 1 SWITCH-WARN.LPS ON/AMB ACT.
- 1 ELEC-HARNESS COMP ASM 340T
- 1 ELEC-ELECTRONIC COMP ASM
- 1 OPER-LPS DIR./HAZ.
- 1 SWITCH-RKR MIRROR HTR.
- 1 ELEC-MIR A HTD & RC
- 1 ELECTRICAL-ELECTRIC STOP SIGN REAR
- 1 RAIL-EXTERIOR GUARD @ WINDOW,SEAT ,FLOOR,SKIRT
- 1 RAIL-EXT GRD @ SEAT FRT END LS
- 1 RAIL-EXT GRD@ FLOOR, NONE
- 1 TRIM-FRT CAP RS/LS
- 1 PANELS-EXT RR W/4"AUXLPS
- 1 SHEET-DRIVERS EXTERIOR 20 GA.
- 1 SHEET-UPPER SIDE EXTERIOR
- 1 OPER-MIRRORS EXT HTD.
- 1 UNDERCOATING-ASPHALT EMULSION
- 1 HEADERS-WINDOW INTERIOR 340T
- 1 PAINT-EXT ENT DOOR NONE
- 1 PANELS-EXTERIOR REAR SIDE SHORT
- 1 LS STORAGE BOX 1 - NONE
- 1 LS STORAGE BOX 2 - NONE
- 1 ROOF SHEETS-(2)HATCH-340T
- 1 RS STORAGE BOX 1 - NONE
- 1 RS STORAGE BOX 2 - NONE
- 1 RS STORAGE BOX ROH - NONE
- 1 LS STORAGE BOX ROH - NONE
- 1 PANELS-REAR END INTERIOR REAR GALVALUME
- 1 PANELS-REAR END INTERIOR SIDE SHORT
- 1 BULKHEAD-RR END INT.GRY
- 1 PANELS-ACCESS RR GRAY PASS ADVISORY
- 1 COVER-HARNESS ACCESS@HDR
- 1 COVER-ACCESS RR END HARNESS
- 1 COVER-ACCESS FRT END HARNESS
- 1 H/L-RR SHORT SMOOTH GRAY W/LPS
- 1 COVER-FUEL SENDING INSPECTION
- 1 MOLDING-SHOE 340T
- 1 SWITCH-ROCKER HEATER STEPWELL
- 1 LUGGAGE RACK ALERT - NONE
- 1 SWITCH-ROCKER HEATER LEFT 1ST
- 1 SWITCH-ROCKER HEATER LEFT 2ND
- 1 ELEC-HTR U/ SEAT POS 3
- 1 ELECTRICAL-HEATER UNDERSEAT POSITION 10
- 1 RAIL-SEAT
- 1 LAYOUT-SEAT RAIL HOLES RS
- 1 LAYOUT-SEAT RAIL HOLES LS
- 1 CABINET-SW, FWD
- 1 CABINET-SWITCH, LOWER WITHOUT POCKET
- 1 CABINET-SWITCH, UPPER
- 1 CABINET-TOP PLATE (3 BANK)
- 1 TREAD-STEP ALUMINUM ENTRANCE DOOR BLACK
- 1 OPER-HTR U/ SEAT LS FWD
- 1 PANEL-ACCESSORY MOUNTING SAFTEY EQUIPMENT
- 1 OPER-HTR STEPWELL
- 1 INSULATION-VEST HEADLINING 2"
- 1 INSULATION-SIDELINING 2" POLY

- 1 INSULATION-RR BULKHEAD 2" POLY
- 1 OPER-HTR U/ SEAT LS AFT
- 1 HEADERS-WINDOW EXTERIOR 340T
- 1 HARNESS COVER COLOR - GRAY
- 1 SPEAKER ALERT - PRESENT
- 1 DOME LPS - MINIMUM
- 1 HEADLINING COLOR - GREY
- 1 HDLINING TYPE-1ST WDO ACOUSTIC
- 1 MAT, FLOOR VESTIBULE
- 1 TRIM-INTERIOR DASH FORWARD
- 1 INSTALLATION-PARK BRAKE ASSEMBLY
- 1 INSULATION-INT SHORT REAR END
- 1 LUGGAGE RACK ALERT - NONE
- 1 PLATE-ACCELERATOR
- 1 OPER-WDO P/O
- 1 VANDALOCK,STARTER DISABLE W/ANY LOCKED EMER DR(S),LH PT LAMP
- 1 LOWER RADIATOR GUARD
- 1 REINFORCED NYLON FUEL LINES
- 1 PAINTED FUEL TANK, PAINTED BANDS
- 1 SINGLE SUCTION AND RETURN FUEL LINES
- 1 FUEL TANK MOUNTED BETWEEN RAILS, AFT OF REAR AXLE, WITH CAGE
- 1 REMOTE-MOUNTED SURGE TANK
- 1 BASIC WIRING SCHEMATIC,UNMOUNTED,12-VOLT NEGATIVE GROUND SYS
- 1 PAINTED BATTERY PANEL COVER
- 1 BATTERY BOX FRAME MOUNTED
- 1 INTEGRAL ELECTRONIC TURN SIGNAL FLASHER
- 1 BATT ENABLED 3 AMBER INBOARD ID LAMPS,2 AMBER OUTBOARD MARKE
- 1 STROBE LAMP, IGNITION SWITCH OR LH DASH SWITCH ACTIVATED
- 1 LED WARNING SYSTEM LAMPS
- 1 STANDARD BODY VISUAL WARNING,LOWER RR,REV LAMPS ON DR/OPEN
- 1 STANDARD WIRING
- 1 DRIVER'S IGNITION OPERATED DOME LP WITH ON/OFF SW
- 1 PASSENGER COMPARTMENT DOME LAMPS, IGNITION ACTIVATED
- 1 PASSENGER COMPARTMENT DOME LPS, DUAL ON/OFF SWITCH
- 1 STEPWELL LAMP ON WITH DOOR OPEN AND MARKER LAMPS ON
- 1 EIGHT LAMP WARNING SYSTEM,LH DASH SWITCH(S), PACKAGE 14
- 1 SHIFT LEVER, CABLE LINKAGE, AUTOMATIC TRANSMISSION
- 1 DRIVELINE GUARD
- 1 NON-ASBESTOS FRONT BRAKE LININGS
- 1 FRONT SHOCK ABSORBERS
- 1 NON-ASBESTOS REAR BRAKE LININGS
- 1 WABCO NG HYDRAULIC ABS/ATC W/SHUTOFF SWITCH
- 1 NO POLISHED FRONT WHEELS
- 1 NO POLISHED REAR WHEELS
- 1 TWO QUART SEE THRU POWER STEERING RESERVOIR
- 1 POWER STEERING PUMP
- 1 ZINC-PLATED HEXHEAD CHASSIS FASTENERS
- 1 3675MM (145") REAR FRAME OVERHANG
- 1 SQUARE END OF FRAME
- 1 BUMPER MOUNTING FOR SINGLE LICENSE PLATE
- 1 LED COMB S/T/T/R LAMPS, & (2)4"ROUND REVERSE LAMPS
- 1 RR EMER DR,IGN CTRL,BZ ON W/DR
- 1 MAINTENANCE-FREE RUBBER BUSHINGS - FRONT SUSPENSION
- 1 21K TAPERLEAF SPRING REAR SUSPENSION
- 1 CAB MOUNTING FOR HOOD AND COWL CHASSIS
- 1 RH FRONT ENTRANCE DOOR, BATTERY CONTROLLED,ELECTRICALLY OPER
- 1 MANUAL ENT DOOR LOCK/BUZZER ON W/EMERGENCY DOORS UNLATCHED
- 1 ONE GALLON WINDSHIELD WASHER RESERVOIR
- 1 BLACK HOOD MOUNTED AIR INTAKE GRILLE
- 1 SINGLE ELECTRIC WINDSHIELD WIPER MOTOR W/DELAY
- 1 GRAY/CHARCOAL FLAT DASH
- 1 NO FCCC SUPPLIED AC COMPONENTS ON COMPLETED VEHICLE
- 1 STANDARD TUNNEL/FIREWALL LINER
- 1 NO AIR CONDITIONER CONDENSER
- 1 HEATER AND DEFROSTER

- 1 STANDARD HVAC DUCTING
- 1 MAIN HVAC CONTROLS WITHOUT RECIRCULATION SWITCH,& NOISE SUPP
- 1 WINDSHIELD FAN,(1) HEADER MOUNTED
- 1 DRIVER'S FAN,(1) MOUNTED ABOVE SIDE WINDOW
- 1 AUX BODY HEATER,UNDER SEAT,FWD
- 1 AUXILIARY BODY HEATER, UNDER SEAT, AFT
- 1 GRAY INSTRUMENT PANEL-DRIVER
- 1 BODY SUPPLIED HEATED MIRRORS
- 1 ROOF MOUNTED VENT/ESCAPE HATCH
- 1 PUSH OUT BODY SIDE WINDOWS, BUZZER WITH WINDOW UNLATCHED
- 1 SEPARATE PANEL LAMP DIMMER,LH DRIVER'S SWITCH PANEL
- 1 CHASSIS COWL AND HOOD ONLY
- 1 NO TCU-TRANSMISSION OPTIMIZED(NO FUEL SENSE)
- 1 PILOT,LH DASH,STOP LAMP MONITOR
- 1 BUMPER: BLACK
- 1 NO SPARE WHEEL PAINT
- 1 CHASSIS: VENDOR BLACK
- 1 EXPECTED GROSS VEHICLE WEIGHT CAPACITY
- 1 EXPECTED FRONT AXLE(S) LOAD
- 1 EXPECTED REAR DRIVE AXLE(S) LOAD
- 1 SCHOOL BUS SERVICE
- 1 COWL CHASSIS CONFIGURATION COMPLIES WITH SBMTC
- 1 BUS BODY WITH WHEELWELL
- 1 PASSENGER COMMODITY
- 1 100% ON-HIGHWAY (CITY) TERRAIN
- 1 DOMICILED USA 50 STATES (CALIFORNIA)
- 1 DOMICILED ILLINOIS
- 1 THOMAS BUILT SCHOOL BUS 340T

## **CHASSIS**

### **AXLES AND SUSPENSIONS**

- 1 ALIGNMENT-4-WHEEL SAF-T-LINER C2
- 1 SPL100 DANA SPICER MAIN DRIVELINE
- 1 DA-F-10-3 10,000# FF1 71.5 KPI/3.74 DROP SINGLE FRONT AXLE
- 1 CHICAGO RAWHIDE FRONT OIL SEALS
- 1 SYNTHETIC 75W-90 FRONT AXLE LUBE
- 1 CONMET IRON FRONT HUBS
- 1 SYNTHETIC 75W-90 REAR AXLE LUBE
- 1 DA-RS-21-4 21K R-SERIES SINGLE REAR AXLE
- 1 6.14 REAR AXLE RATIO
- 1 IRON REAR AXLE CARRIER HOUSING
- 1 REAR SHOCK ABSORBERS - ONE AXLE
- 1 CHICAGO RAWHIDE (SCOT) REAR OIL SEALS
- 1 GUNITE IRON REAR HUBS
- 1 10,000 LB. TAPERLEAF FRONT SUSPENSION
- 1 COMFORT-TEC SUSPENSION

### **BRAKES**

- 1 ALERT-ENHANCED STABILITY CONTROL
- 1 BOSCH HYDRAULIC BRAKE PACKAGE
- 1 BOSCH HYDRAULIC PIN-SLIDE DISC FRONT
- 1 FRONT DISC BRAKE ROTORS W/SEPARATE TONE RINGS
- 1 BOSCH HYDRAULIC PIN-SLIDE DISC REAR
- 1 REAR BRAKE DUST SHIELDS
- 1 FRONT BRAKE DUST SHIELDS
- 1 TRANSMISSION-MOUNTED PARK BRAKE
- 1 REAR DISC BRAKE ROTORS W/SEPARATE TONE RINGS
- 1 NYCLAD HYDRAULIC CHASSIS TUBING
- 1 FT OPER PARK BRAKE w/SERVICE BRAKE INTERLOCK w/INDICATOR

### **CHASSIS EQUIPMENT**

- 1 EXHAUST-LS, THRU REAR BUMPER
- 1 ANTI-FREEZE, OAT -34 DEGREE
- 1 WINTERFRONT-CHASSIS GRILLE YELLOW
- 1 SHIELD-EXHAUST PIPE
- 1 B2 106 CONVENTIONAL CHASSIS
- 1 SET-BACK AXLE - TRUCK

- 1 ELECTRIC GRID AIR INTAKE WARMER
- 1 DELCO 12V 29MT STARTER WITH INTEGRATED M
- 1 NO CLUTCH PEDAL WITH NON-ADJUSTABLE
- 1 ENGINE COMPARTMENT MOUNTED AIR RESTRICTION INDICATOR W/LIGHT
- 1 RIGHT HAND SIDE-FILL FUEL TANK CAP
- 1 100GALLON/378 LITER STEEL RECTANGULAR FUEL TANK,BETWEEN RAIL
- 1 HORIZONTAL TAILPIPE, LH SIDE, EXIT THROUGH BUMPER
- 1 11.5 GALLON DEF TANK
- 1 ENGINE AFTER TREATMENT DEVICE AUTOMATIC
- 1 MAGNETIC ENGINE DRAIN, REAR AXLE DRAIN & FILL PLUG
- 1 NO TRACTION STABILIZER
- 1 TILT ONLY STEERING COLUMN
- 1 TRW THP-60 POWER STEERING
- 1 450MM(18") LK FOUR-SPOKE CHARCOAL STEERING WHEEL
- 1 7075MM (279") WHEELBASE
- 1 5/16" X 3.00" X 10 1/8" STEEL FRAME (7.94 X 76.5 X 257.2")
- 1 1-PIECE 14" PTD STL 1/4" HD BUMPER JACK PROVISION
- 1 FRONT FRAME-MOUNTED TOW HOOKS
- 1 REAR TOW HOOKS
- 1 STANDARD DUTY HOOD MOUNTING
- 1 FIBERGLASS HOOD
- 1 PAINTED PLASTIC GRILLE
- 1 YELLOW WINTERFRONT
- 1 (2) CUPHOLDERS, LEFT HAND AND RIGHT HAND DASH

### **ELECTRICAL - CHASSIS**

- 1 LN 12V 240 AMP AVI PAD MOUNT ALTERNATOR
- 1 PROG RPM CTRL W A/C OR 12.75V LOW VOLT AUTO HI IDLE, DASH SW
- 1 CRUISE CONTROL-ELEC ENG,W/SWITCHES IN LH SWITCH PANEL
- 1 DIAGNOSTIC INTERFACE CONNECTOR,9-PIN, S
- 1 IGNITION SWITCH CONTROLLED ENGINE STOP
- 1 12VOLT POWER SUPPLY LH PANEL
- 1 SOLID STATE CIRCUIT PROTECTION, PDMS WIT
- 1 (3) ALLIANCE 1031,GROUP 31,12 VOLT,MF 2280 CCA BATTERIES
- 1 COLE HERSEE BATTERY CUT-OFF SWITCH, BATTERY BOX MOUNTED
- 1 SELF CANCEL TURN SIGNAL SWITCH W/DIM/WASH&HAZZARD IN HANDLE
- 1 STANDARD FRONT TURN SIGNAL LIGHTS
- 1 PARK LMP SW INTGRAL W/HL SWITCH, ID/MARKER/CLEARANCE/PARK ON
- 1 NO FENDER MTD TURN/MARK COMBO LPS
- 1 AMBER LED MIDSHIP TURN SIGNALS
- 1 DAYTIME RUNNING LIGHTS SET @ 85%
- 1 INTEGRAL HEADLIGHT/MARKER ASSEMBLY
- 1 NO UTILITY/ADVERTISING LIGHT
- 1 STOP SIGN PRESENT
- 1 NO BAGGAGE COMPARTMENT LAMP
- 1 NO BODY MTD INT SPOT/WORK LAMP
- 1 ELECTRONIC STABILITY CONTROL
- 1 BAT PWD 2-POS INT DOOR CONTROL LS SWITCH PANEL
- 1 DUAL ELEC HORN, PASSENGER ADVISORY BUZZER ON W/IGN AND WARN
- 1 NO OBSTACLE DETECTION SYSTEM
- 1 NO CAMERA/VIDEO/IMAGING SYSTEM
- 1 C/F J1939 RADIO W/PA
- 1 CUSTOMER FURNISHED 2-WAY RADIO
- 1 FASTEN SEAT BELT INDICATOR FOR CUSTOMER SUPPLIED SEAT BELT
- 1 LOCATING SYSTEM WITH VEHICLE MONITORING
- 1 ELECTRONIC SPEEDOMETER WITH SECONDARY KPH SCALE, NO ODOMETER
- 1 DRIVER MESSAGE CENTER WITH LCD DISPLAY
- 1 ELECTRONIC 3500 RPM TACHOMETER
- 1 TBB ZONAR DASH MOUNTED
- 1 NO INFORMATION CENTER
- 1 PRE/POST TRIP SYSTEM TEST
- 1 ENGINE AND HOUR METERS INTEGRAL WITH DRIVER DISPLAY
- 1 DIGITAL VOLTAGE DISPLAY INTEGRAL WITH DRIVER DISPLAY
- 1 ELECTRIC FUEL GAUGE
- 1 ELECTRIC ENGINE OIL PRESSURE GAUGE
- 1 ELECTRICAL ENGINE COOLANT TEMPERATURE GAUGE

## **ENGINE AND EQUIPMENT**

- 1 CUM B6.7 220 HP @ 2400 RPM, 2600 GOV, 600 LB/FT @ 1600 RPM
- 1 ANTI-FREEZE TO -34F, OAT (NITRITE AND SILICATE FREE)EXT LIFE
- 1 ENGINE-MOUNTED OIL CHECK AND FILL
- 1 CUMMINS SPIN ON FUEL FILTER
- 1 STANDARD ENGINE OIL
- 1 FULL FLOW OIL FILTER
- 1 DETROIT F/W SEP W/WIF SENSOR & HAND PRIMER & 12V HEATER
- 1 CUMMINS INTEGRAL EXHAUST BRAKE WITH VARIABLE TURBO
- 1 ALUMINUM FLYWHEEL HOUSING
- 1 PHILLIPS 750 WATT/115 VOLT BLOCK HEATER
- 1 STANDARD OIL PAN
- 1 ENGINE HEATER RECEPTACLE MOUNTED FACE OF BUMPER, LEFT SIDE
- 1 ELECTRONIC ENGINE INTEGRAL WARNING AND DERATE PROTECTION
- 1 ADDL AUX LINES W/MANIFOLD PLUMBING AND COMBINED SHUTOFF
- 1 GATES BLUE STRIPE COOLANT HOSES
- 1 CONSTANT TORQUE BREEZE CLAMPS ON 1" IN DIA GREATER, SS C
- 1 CAST BOOSTER PUMP
- 1 30,600 BTU STEPWELL HEATER, RH FRONT ENTRANCE DOOR
- 1 DONALDSON ONE-STAGE AIR CLEANER
- 1 700 SQUARE INCH ALUMINUM RADIATOR
- 1 VISCOUS FAN DRIVE
- 1 OMIT STANDARD EXHAUST DIFFUSER
- 1 NO IDLE SHUTDOWN CONFIGURATION
- 1 DIGITAL TRANS OIL TEMP IN DRIVER DISPLAY

## **TRANSMISSION AND EQUIPMENT**

- 1 ALLISON 2500 PTS AUTOMATIC TRANSMISSION
- 1 ALLISON VOCATIONAL PACKAGE 354 - FIFTH GEN
- 1 TRANSMISSION OIL CHECK AND FILL
- 1 SYNTHETIC 50W TRANSMISSION LUBE (TES-295 COMPLIANT)
- 1 WATER TO OIL TRANSMISSION COOLER - IN RADIATOR END TANK
- 1 PRIMARY MODE GEARS, 6 FORWARD
- 1 NO TCU-LBSS VAC
- 1 NO MODE SWITCH

## **WHEELS AND TIRES**

- 1 RADIAL FRONT TIRE, MICHELIN XZE2,11R22.5 16 PLY
- 1 MICHELIN X MULTI D 11R22.5 16 PLY REAR TIRES
- 1 NO TIRE PRESSURE CONTROL/SENSOR
- 1 MAXION 90262 22.5 X 8.25 10 HOLE HUB PILOT 5-HAND
- 1 MAXION 90262 22.5 X 8.25 10 HOLE HUB PILOT 5-HAND
- 1 TIRE/WHEEL BALANCING-LEAD FREE WEIGHTS
- 1 ACCURIDE PK-BLACK21 POWDER BLACK WHEEL (N0001H)- FRONT
- 1 ACCURIDE PKBLK21 POWDER BLACK WHEEL (N0001H) - REAR

## **DEALER ADD On's**

### **EQUIPMENT**

- 1 CUSTOMER LETTERING
- 1 ILLINOIS STATE INSPECTION, TITLE AND LICENSE FEE

**Meets all FMVSS requirements in effect at the time of manufacture.**



## 2022 Thomas C2 Saf-T-Liner 71 Passenger

The District is always looking for the most cost effective way to transport their students safely, while doing that they want to be the most cost effective. Below are some extra options we have included with our product to help with cost savings. While the District did not ask for these specifications, we now include them on all of our buses as we are striving to be the lowest cost per mile product on the market.

### Options that exceed Minooka's Bid Requests

LED 8 way lights with optional strobe setting, full LED lights on entire bus

Remote Control Mirrors

Zinc Coated Tone Rings for ABS (90% of issues are from rusty tone rings)

2 way wiring and antennae lead installed

Engine Exhaust Brake

Michelin Tires

Zonar Telematics system

Electric entrance door from exterior

Battery shut off switch

LED lights require little to no maintenance and by a simple switch of the plug the lights can be strobes instead of just wig wag lights

Remote control mirrors allow drivers to properly adjust their mirrors if they are in a bus they normally do not drive. This allows them to be safer and lessens the chance of incidents that may damage the bus

Zinc coated tone rings reduce the probability of ABS lights from corrosion and allows mechanics to not have to clear trouble codes for faulty readings.

All of our buses now come pre wired with 2 way radio wiring. This allows for a simple "plug and play" install for radios. Doing this option from the factory reduces install time at the district by over 2 hours per bus.

Michelin tires have the deepest tread pattern and the longest wear down rating of all tire manufacturers.

Zonar Telematics system can be used for over the air diagnostics of a bus, it can be utilized to track fleet travel patterns, fuel economy, bus routes, and can even have geo fences installed per bus that will signal when a driver is off route, and has a hard acceleration or a hard stop g force tracking. It can also be used to combat complaints from parents on bus pickup times. The system can track the speed of the bus, where it has stopped, when the 8 ways were activated and when the bus has taken off again.

We have included an option for the DD5 engine platform. This engine is supported by Virtual Technician. If the bus has a check engine light come on it will email our support staff letting them know what code the engine has. Before the bus has even returned off route we are aware of any issue that is going on, what part could be the problem and can be working on a solution before the bus makes it back into the transportation parking lot. We can also do updates via the internet as well as clear non active engine codes.

The last 2 options listed below are items for convenience more then cost effectiveness, however they do affect the bottom line. Having a power opening entrance door from the exterior allows the bus to be safely locked without using a Vanda lock that creates maintenance. The battery shutoff switch can be used for long breaks to make sure there are no dead batteries on buses from sitting an extended period of time

If the District has any questions on the above listed added options, please contact me at your convenience to discussion.

Sincerely,

A handwritten signature in black ink, appearing to read 'Randy Swanson', with a long horizontal line extending to the right.

Randy Swanson

Regional Account Manager

Midwest Bus Sales

Midwest Bus Leasing

Kincaid Group



Midwest Transit Equipment, Inc.  
146 W Issert Dr  
Kankakee, IL 60901  
(800) 933-2412

Jan. 6<sup>th</sup>, 2022

John Troy (Assistant Superintendent and General Counsel)  
Cathy Haase (Director of Transportation)  
Minooka Community High School District #111  
Minooka Consolidated Community School District #201  
26655 W Eames Street  
Channahon, IL 60410

We wish to thank you for the opportunity to bid on your SCHOOL BUS requirements. Enclosed are our lease quotations for New 2023 Diesel and Gas Conventional School buses you requested, which meet all Federal, State of Illinois and The Minooka Public Schools specifications. Any other specifications included in the equipment are as attached to this quote. No other specifications apply. Trade values are contingent on the leasing of buses from Midwest Transit Equipment.. There are no Federal, State, or Local taxes included in this quotation and all available fleet discounts have been deducted from the quote price. For the convenience of your Accounting Department, we will supply an invoice and other required documents 30 to 45 days in advance of delivery to allow for payment processing. Certificate of Origin will be released to School only after payment in full is received. Please note credit cards cannot be used for full or partial payment of school buses.

A copy of the IC warranty is enclosed with this quote. All body and chassis service work can be done by International dealers, Midwest Transit Equipment, or by arrangements with Midwest Transit for others. The purchaser is responsible for delivery of the Bus/Buses to the authorized servicing dealer for any warranty work that is needed.

Trades are accepted on a one for one basis unless otherwise noted. Trades will have a current Illinois Safety Sticker at the time the new Bus/Buses delivery. Purchaser is responsible for all maintenance on units to be traded, and Midwest Transit Equipment expects the trade in Bus/Buses to be in running, drivable condition at the time of new unit delivery. Trade in Bus/Buses will be released to Midwest Transit Equipment at the time of the new Bus/Buses delivery, unless prior arrangements have been made. Quotation is good for 90 days and may be extended by contacting our office prior to 30 days.

**PLEASE NOTE:** Midwest Transit Equipment, Inc. is engaged in the business of buying, selling and servicing buses, not leasing them. It has, however, established a relationship with a respected independent leasing company to offer customers who wish to lease buses a convenient and reasonably-priced means of doing so. Accordingly, if you elect to lease the bus, the leasing company will purchase the bus from Midwest Transit for lease to you, and Midwest Transit will provide you with all warranty and maintenance services.

Respectfully,

A handwritten signature in blue ink that reads 'Matt Lawrence'. The signature is stylized and cursive.

Matt Lawrence



**Midwest Transit Equipment, Inc.**  
 146 W Issert Dr  
 Kankakee, IL 60901  
 (800) 933-2412

## 72 Conventional Bus Lease Quotations

New  X  Pre-Driven  X

**Prepared For:** John Troy (Assistant Superintendent and General Counsel)  
 Cathy Haase (Director of Transportation)  
 Minooka Consolidated Community School District #201  
 26655 W Eames Street  
 Channahon, IL 60410

**Unit Price:** (10) New 2023 IC/CE 72 Passenger Diesel Engine School Buses  
**Option 1** Three year Annual Lease payment.....\$17,838 per bus  
 Five year Annual Lease payment.....\$13,881 per bus

**Unit Price:** (10) New 2023 IC/CE 72 Passenger Gas Engine School Buses  
**Option 2** Three year Annual Lease payment.....\$17,708 per bus  
 Five year Annual Lease payment.....\$13,881 per bus

**Mileage Allowance per year:** 17,000 with a \$0.35 per mile overage charge

**Estimated Delivery:** Summer 2022

**Lease APR** (3) year term 3.30%, (5) year term 3.30%

- Due to the ongoing COVID 19 Supply issues, this quotation is subject to manufacture surcharges beyond Midwest Transit's Control until a P.O. or official purchase letter is received
- **Quotes include Full Body Chassis warranty for term of lease ( Copy of warranty included)**
- Original License and Title is **INCLUDED**
- Credit card cannot be accepted for full or partial payment
- Quotes DO NOT Include Cameras, 2way radios, GPS or any other Dealer installed accessory

**PLEASE NOTE:** Midwest Transit Equipment, Inc. is engaged in the business of buying, selling and servicing buses, not leasing them. It has, however, established a relationship with a respected independent leasing company to offer customers who wish to lease buses a convenient and reasonably-priced means of doing so. Accordingly, if you elect to lease the bus, the leasing company will purchase the bus from Midwest Transit for lease to you, and Midwest Transit will provide you with all warranty and maintenance services.

Submitted By:   
 Regional Sales Manager 01/06/2022  
 Midwest Transit Equipment, inc 257



**Midwest Transit Equipment, Inc.**  
 146 W Issert Dr  
 Kankakee, IL 60901  
 (800) 933-2412

## 72 Conventional Bus Lease Quotations

New  X  Pre-Driven  X

**Prepared For:** John Troy (Assistant Superintendent and General Counsel)  
 Cathy Haase (Director of Transportation)  
 Minooka Community High School District #111  
 26655 W Eames Street  
 Channahon, IL 60410

**Unit Price:** (10) New 2023 IC/CE 72 Passenger Diesel Engine School Buses  
**Option 1** Three year Annual Lease payment.....\$17,838 per bus  
 Five year Annual Lease payment.....\$13,881 per bus

**Unit Price:** (10) New 2023 IC/CE 72 Passenger Gas Engine School Buses  
**Option 2** Three year Annual Lease payment.....\$17,708 per bus  
 Five year Annual Lease payment.....\$13,881 per bus

**Mileage Allowance per year:** 17,000 with a \$0.35 per mile overage charge

**Estimated Delivery:** Summer 2022

**Lease APR** (3) year term 3.30%, (5) year term 3.30%

- Due to the ongoing COVID 19 Supply issues, this quotation is subject to manufacture surcharges beyond Midwest Transit's Control until a P.O. or official purchase letter is received
- **Quotes include Full Body Chassis warranty for term of lease ( Copy of warranty included)**
- Original License and Title is **INCLUDED**
- Credit card cannot be accepted for full or partial payment
- Quotes DO NOT Include Cameras, 2way radios, GPS or any other Dealer installed accessory

**PLEASE NOTE:** Midwest Transit Equipment, Inc. is engaged in the business of buying, selling and servicing buses, not leasing them. It has, however, established a relationship with a respected independent leasing company to offer customers who wish to lease buses a convenient and reasonably-priced means of doing so. Accordingly, if you elect to lease the bus, the leasing company will purchase the bus from Midwest Transit for lease to you, and Midwest Transit will provide you with all warranty and maintenance services.

Submitted By:

  
 Regional Sales Manager  
 Midwest Transit Equipment, inc

01/06/2022

**SPECIFICATIONS**

**Part 1:**

1. The Districts are interested in receiving proposals for the following:

**District 111:** Ten (10) 71 passenger school buses, leased

**District 201:** Ten (10) 71 passenger school buses, leased

2. The proposal will detail the bus and van specifications that the vendor feels best meets the needs of the Districts.
3. The Districts will consider proposals for new vehicles as well as 1-3 year old vehicles
4. The Districts will consider proposals for diesel, gasoline, and propane buses.
5. The proposed lease shall be inclusive of preparation, delivery, lettering, inspection, sticker, title, license and all other fees.
6. Vehicles shall be route condition ready and available for delivery on or before Monday, July 18, 2022
7. Mileage for leases shall be quoted on the number of miles included per year with the per mile charge for overage.
8. Warranty shall be quoted as the manufacturer warranty plus any charge for additional warranty throughout the term of the lease (warranty details to be provided with proposal).
9. The District will consider three (3) year leases and five (5) year leases.
10. Proposal shall detail price differential for quantities of more or less than the above stated.

Please use the following matrix for quoting prices **APR is 3.30% for both 3 and 5 year options**

Type of Bus	Diesel Lease	Diesel Total Price	Diesel Guaranteed Buy Back Price	Diesel Mileage	Gas Lease	Gas Total Price	Gas Guaranteed Buy Back Price	Gas Mileage
New (lease - 3yr)	\$17,838 per bus	\$96,276 per bus	will provide upon request	17,000 per year \$0.35 Overage charge	\$17,708 per bus	\$95,897 per bus	will provide upon request	17,000 per year \$0.35 Overage charge
New (Lease - 5yr)	\$13,881 per bus	\$97,826 per bus	will provide upon request	17,000 per year \$0.35 Overage charge	\$13,881 per bus	\$97,447 per bus	will provide upon request	17,000 per year \$0.35 Overage charge

Please duplicate the above matrix for 1, 2 and 3 year old buses.

**Minooka Community High School  
District No. 111**

**&**

**Minooka Consolidated Community School  
District No. 201**

**Joint Request for Proposal for:**

**Leased School Buses**

**MINOOKA COMMUNITY HIGH SCHOOL  
DISTRICT No. 111  
26655 W. Eames Street  
Channahon, Illinois 60410  
(815) 521-4294**

**MINOOKA COMMUNITY CONSOLIDATED  
DISTRICT No. 201  
305 Church Street  
Minooka, Illinois 60410  
(815) 467-6121**

**Invitation to Provide Proposal – School Bus Lease & Purchase of Districts’ Used School Buses**

Minooka Community High School District No. 111 and Minooka Community Consolidated School District No. 201 operate a shared bus barn and are accepting proposals for leased school buses and seeking offers for the purchase of their used buses. Sealed proposals are due by **11:00 am on Thursday, January 6, 2022**, at which time they will be publicly opened and read aloud. Proposals are to be submitted to:

Minooka Community High School District 111  
Attn: John Troy, Assistant Superintendent & General Counsel  
26655 W. Eames Street  
Minooka, IL 60410

Failure to comply with these proposal documents and submit all required forms may lead to disqualification of your proposal.

We look forward to your participation in this request for proposal.

Sincerely,

Mr. John Troy  
Asst. Superintendent & General Counsel  
MCHS No. 111

Kris Monn  
Superintendent  
Minooka CCSD 201

## INSTRUCTIONS TO BIDDERS

1. BIDS MUST BE RECEIVED IN OUR OFFICE BY **11:00 am Thursday, January 6, 2022** at when they will be publicly opened and the contents announced. They will be held without right of withdrawal and shall be considered valid for sixty (60) days for new buses, thirty (30) days for used buses. The sealed envelope shall be marked in bottom left hand corner identifying contents as "Transportation Bid". Any bid(s) received after the bid opening time shall be returned to the bidder unopened. It is the bidder's responsibility to assure that the bid is delivered on time. The transmittal of the bid proposal is at seller's risk of untimely receipt by the Board. Faxed and/or emailed copies are not acceptable.

2. All interested parties are cordially invited to be present at the public proposal opening to be held at the time the sealed proposals are due. Proposals will be publicly opened and results announced. Awards, however, will not be made until after the staff has made a thorough analysis of all proposals received. Proposals will be officially awarded at a subsequent meeting of the Board of Education.

3. The Board of Education reserves the right to split the bid on the basis of best quotation. The Board reserves the right to reject any and all bids or any part thereof, to waive nonconformities in the bidding, and to accept the bid deemed most favorable to the Board after all bids have been examined and evaluated. Among the items to be considered in awarding bid are price, warranty, service, bus model and specifications. The Board of Education decisions are final in all instances and not subject to recourse. All bidders will be notified of the results of the Board of Education action, with a summary of bids provided. No corrections can be made after the time of opening.

4. Delivery of the new vehicles shall be made Minooka Transportation Center, 700 E. Minooka Road, 60447 attention Director of Transportation, Cathy Haase. **Delivery must be made, route ready, on or before Monday July 18, 2022. The successful bidder upon award of the bid must submit a delivery guaranty check in the amount of \$1,000 dollars to each district. This delivery guaranty check shall be forfeited to the district for failure to deliver the district's entire order of buses by the scheduled time.** *Due to the ongoing world wide supply chain issues caused by the COVID 19 pandemic MTE can not and will not be held responsible for delivery delays out of our control, all efforts will be made to*

5. YOUR BID PRICE MUST BE F. O. B. MINOOKA, IL, WITH ALL TRANSPORTATION *deliver on tin* AND HANDLING CHARGES PAID BY THE BIDDER AND INCLUDED IN THE PRICE OF THE BUS. The Bidder must deliver units ready to operate.

6. **PROPOSALS MUST CONTAIN COMPLETE DETAILS OF THE LEASING COSTS AND THE INTEREST RATE. PROPOSALS MUST CONTAIN ALL LEASING DOCUMENTS REQUIRED BY THE LENDER. THE BOARDS OF EDUCATION WILL NOT AWARD ANY BID THAT DOES NOT HAVE ALL SUPPORTING LEASING DOCUMENTS INCLUDED.**

7. **THE DISTRICTS WILL ALSO SEEK COMPETITIVE LEASING ARRANGEMENTS IN CONJUNCTION WITH THIS BID. ALL BIDS MUST CONTAIN THE FULL PRICE OF THE BUS AS WELL AS A GUARANTEED "BUY-BACK" DOLLAR AMOUNT AT THE END OF THE LEASE TERM.**

7. Bidder shall include the cost of title transfer and license application with the bid.

8. Detailed warranty information must be included with the Bid Packet

9. Bidders must be in full compliance with all provisions of the acts of the General Assembly of Illinois relating to employment, including equal employment opportunity requirements and any other affidavits as required by law.
10. Supplier shall agree to comply with the provisions of the latest edition of the Occupational Safety and Health regulations and the standards and regulations issued there under and shall certify that all items furnished under this bid will conform to and comply with said standards and regulations.
11. Supplier shall agree to comply with provisions of the latest edition of the Consumer Product Safety Act of 1972 and certify that items furnished under this bid conform with applicable standards including all State and Federal requirements for school buses.
12. Title to the goods herein described shall not pass until said goods have actually been received by the Board or its consignee. Risk of loss prior to such actual receipt by Board or its consignee shall be borne by seller. Nothing herein contained, however, shall be construed to deprive the Board of its interest, or limiting such interest, in goods herein described prior to such actual receipt.
13. The Boards of Education reserves the right to reject any goods which contain defects in material or workmanship or which fail to meet specifications contained herein or seller's warranties (express or implied.) Rejected goods shall be removed at the expense of the seller, including transportation both ways, promptly after notification of rejection. As to rejected goods, seller shall bear all costs of inspection and all risk of loss. The District reserves the right to select independently for specific bid items from any vendor bidding.
14. Payment by the Boards for goods supplied hereunder shall not constitute acceptance thereof if subsequent inspection discloses defects in material or workmanship or a failure to meet the specification contained herein. Payment shall not be processed until District has proper title certificate on file.
15. The Boards' failure to enforce any of the terms, conditions, and specifications of the bid or any breach shall not in any way affect, limit, or waive the Board's right thereafter to enforce and compel strict compliance with every term, condition, and specification hereof. By submitting bid the bidders accepts the terms of this bid document and agrees to be bound by the same.
16. Any interpretation of the proposed documents will be made only by an addendum duly issued by the District. A copy of such addendum will be faxed to each prospective bidder. Failure on the part of the prospective bidder to receive a written interpretation prior to the time of the opening of bids will not be grounds for withdrawal of his proposal. All requests for clarification must be received by the District not less than three (3) business days prior to bid opening. Inquiries after that time will may not receive a response in order to preserve a fair process for all bidders.
17. Award will be made by official Board documents. Bidder order form is not acceptable and cannot be used.
18. The Boards are exempt from paying Illinois Use Tax and sales the Boards are exempt from Illinois Retailer's Occupation Tax. The Boards are exempt from paying Federal Excise Taxes.
19. Payment Terms: Payment shall not be processed until the District has proper paperwork on file. Districts process checks once per month. Payment by Boards for goods supplied hereunder shall not constitute acceptance thereof if subsequent inspection discloses defects in material or workmanship or a failure to meet the specification contained herein. Payments are processed

following submittal and approval of the Board of Education at the regular monthly meeting provided they have been received and accepted on time.

20. Bidder must complete and submit bid on bid forms included with this specification. The bidder may photocopy the form. The bidder must include signed copies for all attachments indicating a signature (Non-Collusion Affidavit and Project Qualification Form ). Failure to complete and submit any of these forms shall be cause for bid to be rejected since it would be an incomplete bid.

21. All buses must meet Illinois specifications and legal requirements.

22. All used buses must state individually the year, mileage, and must state expected mileage remaining on brakes and provide tread depth measurements for each tire on the bid form for the used bus clearly identifying the bus for which the information applies.

23. All used buses must have at least 50% of brake and tire life minimum remaining for each wheel and tire.

Part 2:

1. The Districts are also interested in receiving proposals for the purchase several of its used buses. The list of buses being sold are attached and the buses may be inspected by appointment during normal schools hours. The buses are being sold "As-Is.

District 111 Trade In

None at this time

District 201 Trade In

None at this time

NON-COLLUSION AFFIDAVIT

STATE OF ILLINOIS

SS:

Kankakee, COUNTY

The undersigned vendor or agent, being duly sworn, on oath says that s(he) has not, nor has any other member, representative, or agent of the firm, company, corporation or partnership represented by him/her, entered into any combination, collusion or agreement with any person relative to the price to be proposal by anyone at such letting, nor to prevent any person from bidding nor to induce anyone to refrain from bidding, and that this proposal is made without reference to any other proposal and without any agreement, understanding or combination with any other person in reference to such bidding.

S(he) further states that no person or persons, firms, or corporation has, have or will receive directly or indirectly, any rebate, fee, gift, commission or thing of value resulting from such sale.

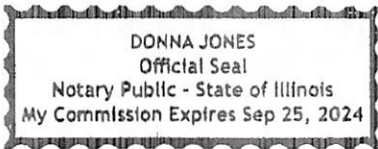

Matt Lawrence  
Name

For Midwest Transit Equipment, Inc.  
Firm or Corporation

Subscribed and sworn to before me on this 6 day of January, 2022

My commission expires:

September 25, 2024

Notary Public

Signature:

Donna Jones

M. Lawrence  
Signature

## PROJECT QUALIFICATION FORM

A responsible vendor is defined by meeting the following criteria and is able to submit evidence of such compliance. By signing this required form, the undersigned agrees that said vendor is responsible as defined below.

### SEXUAL HARRASSMENT

Each vendor certifies that he has complied with the requirement of 2-105 of the Illinois Human Rights Act (775ILCS5/2-105)-1257) with respect to sexual harassment policies. The terms of that law, as applicable, are hereby incorporated into this contract.

### DRUG FREE WORKPLACE

The vendor or contractor, having 25 employees or more, does hereby certify pursuant to Section 3 of the Illinois Drug-Free Workplace Act (30ILCS580/3) that he shall provide a drug-free workplace for all employees engaged in the performance of work under the contract by complying with the requirements of the Illinois Drug-Free Workplace Act and, further certifies that he is not ineligible for award of this contract by reason of debarment for a violation of the Illinois Drug-Free Workplace Act.

### NON-DISCRIMINATION AFFIRMATION

Vendors must assure that all persons employed by the vendor, and all applicants for such employment, will not be discriminated against because of their race, religion, nationality, gender, disability, physical characteristics or sexual orientation. Vendor must also comply with all rules and regulations of the Illinois Department of Human Rights, Illinois Human Rights Commission and the Equal Employment Opportunity Commission.

### CONFLICT OF INTEREST

By signing below, vendor certifies that they are in accordance with the School Code, and the Public Officer Prohibited Practice Act, 50 ILCS 105/0.01 et seq., no Board of Education member or District employee shall be directly or indirectly involved or own an interest in any contract, work, or business of the District, or in the sale of any article by or to the District.

### CERTIFICATION OF NOT BARRED FROM BIDDING

The Vendor hereby certifies that the bidder is not barred from bidding on this contract as a result of a violation of either the proposal-rigging or proposal-rotating provisions of Article 33E of the Criminal Code of 1961, as amended.

Signed:  Name (printed): Matt Lawrence

Title: Regionsl Sales Manage Company Name: Midwest Transit Equipment, Inc.

Address: 146 W. ISSERT Dr. Kankakee, IL 60901

Telephone Number: 800-933-2412 Date: 01/06/2022



**OBTAINING SERVICE**

Return this vehicle to any IC Bus Dealer authorized to service this model vehicle and engine.

**DISCLAIMER**

NO WARRANTIES ARE GIVEN BEYOND THOSE DESCRIBED HEREIN. THIS WARRANTY IS IN LIEU OF ALL OTHER WARRANTIES, EXPRESSED OR IMPLIED. THE COMPANY SPECIFICALLY DISCLAIMS WARRANTIES OF MERCHANTABILITY AND FITNESS FOR A PARTICULAR PURPOSE, ALL OTHER REPRESENTATIONS TO THE USER/PURCHASER, AND ALL OTHER OBLIGATIONS OR LIABILITIES. THE COMPANY FURTHER EXCLUDES LIABILITY FOR INCIDENTAL AND CONSEQUENTIAL DAMAGES, ON THE PART OF THE COMPANY OR SELLER. No person is authorized to give any other warranties or to assume any liabilities on the Company's behalf unless made or assumed in writing by the Company; and no other person is authorized to give any warranties or to assume any liabilities on the seller's behalf unless made or assumed in writing by the seller.

**Remedies Under State or Provincial Law:** Any suit for breach of this Limited Warranty must be initiated within one year after breach. Some States and Provinces do not allow the exclusion or limitation of incidental or consequential damages, so the above limitation or exclusion may not apply to the owner. This warranty gives the owner specific legal rights, and he may also have other legal rights which may vary by state or province.

**RECORD OF OWNERSHIP**

Upon receipt of new vehicle by original owner, complete the following: I have read this Warranty Brochure and fully understand the warranty coverage, and the limitations and exclusions. I acknowledge that I have received a copy of the Owner's Limited Warranty and I accept the terms described herein.

Customer Signature _____	Date _____
Owner's Address _____	City _____ State/Prov _____ Postal Code _____
Bus Model _____	Vehicle Identification Number _____
Engine Number _____	Engine Serial Number _____
Date Delivered to User (DTU) _____	Odometer Reading at Delivery _____

**IMPORTANT:** The information contained in this Warranty Policy explains the coverage provided on your new IC Bus™ brand vehicle. This policy should be kept in the vehicle for presentation to the Dealer when you request warranty services.

Any provisions of this Limited Warranty that are prohibited or not enforceable in any jurisdiction shall be, as to such jurisdiction, ineffective to the extent of such prohibition or non-enforceability without invalidating the remaining provisions hereof, and any such prohibition or non-enforceability in any jurisdiction shall not invalidate or render non-enforceable any such provisions in any other jurisdiction.

All claims under this Limited Warranty must be submitted in writing to an authorized IC Bus dealer within the warranty period as stated herein. If you have questions regarding this Limited Warranty, contact IC Bus, LLC dealer. To locate nearest dealer, visit the IC Bus website [www.ICBus.com](http://www.ICBus.com).

**EFFECTIVE WITH VEHICLES BUILT MARCH 01, 2017 OR LATER**

**LIMITED WARRANTY FOR SCHOOL BUS MODELS**

**CE Series (PB105), RE Series (PB305), BE Series (PB405)**

IC Bus, LLC warrants to the original purchaser (the "Purchaser") that IC Bus, LLC brand buses and component parts thereof are, at the time of purchase, free from defects in material and workmanship and will remain free from such defects under normal use after delivery to the Purchaser as provided herein. Warranty shall begin at the time of delivery unless otherwise approved by IC Bus, LLC. The delivery limitations as set forth herein shall run from the date of delivery to the Purchaser in the United States of America and Canada. The remedy available under this Limited Warranty is non-cumulative in nature and is limited to repair or replacement at IC Bus, LLC option of the bus or component parts thereof that are returned to locations approved by IC Bus, LLC transportation charges prepaid, and which IC Bus, LLC examination disclosed to its satisfaction to be defective. IC Bus, LLC, at its option, will repair or replace any part of this vehicle which proves defective in material and/or workmanship in normal use and service, with new or ReNEWed parts. Exceptions are listed below under *What Is Not Covered*.

*This warranty is automatically transferred to subsequent owners at no charge. Visit your local IC Bus Dealer for name and address change information.*

**COMPONENT COVERAGE**

The components described below are given additional warranty coverage of variable time periods and distance traveled limitations, as shown in the *Warranty Coverage Schedule*.

1. Frame Rails and Crossmembers
2. Body/Cowl Structure
  - Body Structure defined as the steel body frame (which includes the roof, metal floor, sides and front and rear sections only).
  - As to items not considered Body Structure include but are not limited to the following: doors, corner moldings, inner ABS panels, interior wall, plywood, floor covering, windows, and trim moldings.
3. The Body/Cowl is warranted against perforation due to corrosion, except for perforation caused by industrial chemicals and/or corrosion caused by use in a corrosive industrial environment.
4. Navistar Diesel Engine Coverage Includes: Navistar Diesel Engine block, cylinder heads, internally lubricated components fuel pump, high pressure pump, turbocharger, water pump, air compressor, injectors/nozzles; electronic engine modules, engine relays, engine sensors and regulators required for electronic engine operation, and certain aftertreatment components. Excluding: attaching accessories (e.g., fan clutch, alternator, starter, etc.), and externally mounted electrical and filtration systems.
5. Power Solutions International 8.8L Propane Engine Coverage Includes: Engine block, cylinder heads, internally lubricated components, water pump, air compressor, injectors/nozzles, fuel system components; electronic engine modules, engine relays, engine sensors and regulators required for electronic engine operation, exhaust catalyst. Excluding: attaching accessories (e.g., fan clutch, alternator, starter, etc.)
6. Spicer front & rear axles and propeller shaft, when used with Allison transmission; excluding brakes, wheel ends axle shafts, controls & attachments.

THE PROVISIONS HEREOF CONSTITUTE THE EXCLUSIVE AND COMPLETE WARRANTY BY IC BUS, LLC ON IC BUS™ BRAND BUSES AND COMPONENT PARTS THEREOF MANUFACTURED BY IT, OR APPROVED BUS BODY CONTRACT MANUFACTURERS AND IS IN LIEU OF ALL OTHER OBLIGATIONS OR LIABILITIES OF IC BUS, LLC WHETHER EXPRESS OR IMPLIED.

**Note:** The customer has 365 days and up to a maximum of 100,000 miles (160,000 km) from DTU (delivery to end user) to purchase an extended warranty on the unit. For extended warranty purchases between 181 and 365 days from DTU and <100,000 miles (160,000 km) an additional fee will be assessed. See your local IC Bus dealer for details.



Items Covered	Months	Miles/Km (000)	WHAT IS NOT COVERED
<b>BASIC VEHICLE COVERAGE</b>			<p><b>AFTER THE FIRST 90 DAYS FROM DELIVERY TO USER (DTU):</b></p> <ul style="list-style-type: none"> <li>• Correction of loose fasteners, squeaks, rattles and unusual noises.</li> <li>• Towing (vehicles with non-engine failures only)</li> <li>• Adjustments (e.g., headlights, brake/clutch adjustments, steering system adjustments, coolant levels, doors).</li> </ul> <p><b>COMPONENTS / ITEMS:</b></p> <ul style="list-style-type: none"> <li>• Warranted by their respective manufacturers (e.g., non Navistar brand engines, tires &amp; tubes, Allison Transmissions, Hybrid electric, lubricants, etc.)</li> <li>• Bodies, equipment and accessories installed by other than authorized IC Bus employees at IC Bus manufacturing plants.</li> <li>• Front and rear axle alignment.</li> <li>• Front &amp; Rear axle coverage excludes brakes, wheel ends, axle shafts, controls &amp; attachments.</li> </ul> <p><b>REPAIRS:</b></p> <ul style="list-style-type: none"> <li>• Maintenance-related items/repairs or those as a result of normal wear and tear, including tune-ups, brake/clutch lining, windshield wiper blades, tire balancing, lubrication and other similar procedures/parts required to keep vehicle in good working condition.</li> <li>• To any part of the vehicle subjected to misuse, negligence, improper maintenance, improper operation, or which is the result of an accident.</li> <li>• Fade, runs, mismatch or damage to paint, trim items, upholstery, chrome, polished surfaces, etc., resulting from environmental causes, improper polishes, cleaners or washing solutions, or chemical and industrial fallout.</li> <li>• In which power train, propeller shaft and suspension sales guidelines (specifications) are not strictly adhered to by all owners and operators of this vehicle.</li> </ul> <p><b>OTHER:</b></p> <ul style="list-style-type: none"> <li>• Vehicles sold and/or operated outside the United States and Canada.</li> <li>• Vehicles/components that have had unauthorized alterations or modifications.</li> <li>• Vehicles on which the odometer reading has been altered.</li> <li>• Loss of time or use of the vehicle, loss of profits, inconvenience, or other consequential or incidental damages or expenses.</li> <li>• Replacement of defective parts with parts other than those provided by IC Bus, LLC.</li> </ul> <p><i>This warranty does not apply, or include coverage for defects attributable to the following:</i></p> <ol style="list-style-type: none"> <li>Damage resulting from: (i) misuse, abuse, accident, neglect, negligence, vandalism, fire, riot, war, or Acts of God;</li> <li>(ii) Structural or other modifications or alteration without prior express written authorization by IC Bus, LLC; (iii) Repair or attempted repair by unauthorized persons; (iv) Replacement of original components with substitutes without prior express written authorization by IC Bus, LLC; (v) Failure to perform routine preventative maintenance as customarily accepted within the industry or failure to provide proof of such preventative maintenance having been performed; (vi) Exposure to corrosives, contaminants, chemicals, salt, irradiation or atmospheric or environmental conditions; (vii) Usage or loading in excess of recommended capacities or in non-standard applications, including off-road.</li> <li>Fading or discoloration of paint, lettering or decals.</li> <li>Effects of aftermarket installation and aftermarket parts installed by the dealer or customer.</li> </ol>
Basic Vehicle Warranty	12	Unlimited	
Towing (Chassis related issues)	3	Unlimited	
Towing (Vehicles with Navistar built engine failures only)	24	Unlimited	
Towing (Vehicles with Power Solutions International, Inc. 8.8L Propane engine failures only)	60	Unlimited	
Towing (Vehicles with Power Solutions International, Inc. 8.8L Gasoline engine failures only)	60	Unlimited	
<b>COMPONENTS</b>			
Frame Rails and Crossmembers	60	Unlimited	
Body/Cowl Structure (Roof, Metal Floor, Sides and Front and Rear Sections)	60	Unlimited	
Body/Cowl Perforation Corrosion	60	Unlimited	
Bumper Corrosion and Paint Delamination	36	Unlimited	
Body/Cowl/Hood Paint Delamination	60	Unlimited	
Brightwork, Chassis Paint and Corrosion	6	Unlimited	
IC Bus, LLC Factory Installed Air-Conditioning (IC Air)	30	Unlimited	
<b>SEATS**IC Bus manufactured Seats Only</b>			
Foam	48	50/80	
Upholstery	24	24/40	
Frame and Barriers	60	Unlimited	
<b>ENGINE*</b>			
Power Solutions International, Inc. 8.8L Propane Engine	60	Unlimited	
Power Solutions International, Inc. 8.8L Gasoline Engine	60	Unlimited	
<b>DRIVETRAIN**</b>			
Eaton Precision Transmission	12	Unlimited	
Spicer - 3 Part Dana Drivetrain (Front & Rear Axles, Propeller Shaft, When Used With Allison Transmission Only)	48	50/80	
Meritor Axles	48	75/120	

\*Emission Coverage: Refer to engine operator's manual for emission coverage.  
 \*\*Drivetrain:  
 • Allison Transmissions products or Transynd lubricants and fluids are not covered under this warranty. For warranty information see: [www.allisontransmission.com/publications/](http://www.allisontransmission.com/publications/)  
 • For specific Eaton/Fuller Warranty coverage, see supplier information: [www.roadrangerwarranty.com](http://www.roadrangerwarranty.com)  
 • For extended component warranty: [www.roadranger.com/Roadranger/warranty/ExtendedWarranty/index.htm](http://www.roadranger.com/Roadranger/warranty/ExtendedWarranty/index.htm)  
 \*\*\*For non IC Bus Manufactured seats, contact the seat supplier for their warranty coverage.  
 For Enova charge sustaining and charge depleting standard warranty to: <http://enovasytems.com/customersupport.html>

\*1/24/2019 removed MaxxFoCe Engines from coverage as Buses built post March,1,2017 no longer offered this engine.



**RE/CE BUS EXTENDED VEHICLE COVERAGE  
INCLUDING BUS BODY**

This **Extended Vehicle Coverage Including Bus Body option(s)** provides coverage for time or distance traveled from new vehicle delivery date, whichever expiration occurs first.

During the period selected, Navistar, Inc. will repair or replace any of the covered components as defined below which proven defective in material and/or workmanship in normal use, with new or ReNEWed parts. Exceptions are listed herein under *What is Not Covered*.

**GROUP 01 - FRAME AND BUMPER**

- |                           |                               |                                |
|---------------------------|-------------------------------|--------------------------------|
| 067 - Carrier, Tire       | 306 - Outrigger, Bus Platform | 581 - Bumper Frame             |
| 071 - Bumper              | Mounting                      | 660 - Rail, Frame Side         |
| 211 - Bracket or Mounting | 307 - Crossmember             | 739 - Reinforcement or Gussets |
|                           | 309 - Crossmember, Engine     |                                |

**GROUP 02 - FRONT AXLE**

- |                          |                         |                          |
|--------------------------|-------------------------|--------------------------|
| 016 - Arm, Steering      | 353 - Fitting/Zerk      | 667 - King Pin & Bushing |
| 032 - I-Beam, Front Axle | 535 - Knuckle, Steering | 799 - Seal, King Pin     |

**GROUP 03 - SUSPENSION**

- |  |  |                                    |
|--|--|------------------------------------|
| 062 - Equalizer / Rocker Arm and Bushing | 264 - Control (Air Suspension Only)            | 468 - Spring Leaf Assembly         |
| 066 - Torque Arm & Bushing Assembly      | 341 - Bracket, Shock Absorber Mounting         | 584 - Bracket Assembly, Spring     |
| 074 - Walking Beam & Bushing Assembly    | 406 - Bolt, Center                             | 646 - Shackles, Pins & Bushing     |
| 203 - Air Bag Assembly                   | 437 - Suspension Air Control Manifold Assembly | 711 - Crossmember, Rear Suspension |
|  | 438 - Suspension, ECM                          | 769 - Sway Bar Assembly            |
|  |  | 804 - Stop, Axle                   |

**GROUP 04 - BRAKES**

- |  |   |  |
|--|---|--|
| 003 - Tank, Air, Vacuum                        | 429 - Cable/Linkage, Parking Brake                    | 811 - Relay/Magnetic Switch                      |
| 005 - Knob                                     | 461 - Linkage / Cam / Camshaft, Wheel Brake Actuating | 812 - Valve, Modulator                           |
| 007 - Pumps                                    | 462 - Linkage/Pedal/Spring Brake Actuating            | 816 - Sender, Wheel                              |
| 009 - Accumulators                             | 511 - Power Assist Unit                               | 826 - Caliper                                    |
| 010 - Hydraulic Power Brake (HPB) Unit         | 617 - Backing Plate/Anchor/Dust Shield                | 840 - Caliper Bracket                            |
| 012 - Solenoid Valve                           | 634 - Pump, Back-Up (Less Motor)                      | 842 - Switch, Flow                               |
| 013 - Adjuster, Slack                          | 636 - Motor, Back-Up                                  | 846 - Switch, Back-Up Motor                      |
| 020 - Cylinder, Self Actuate Hydraulic Release | 643 - End Cover, Unloader Valve Air Dryer             | 847 - Switch, Pressure Differential              |
| 036 - Adjuster Assembly, Automatic             | 662 - Spring, Brake Shoe Return                       | 848 - Module, Monitor                            |
| 105 - Bracket, Brake Chamber                   | 747 - Spring Applied Air Release (Saar) Canister      | 851 - Valve, Spring Brake Control                |
| 231 - Chamber                                  | 751 - Sensor, Steering Angle                          | 852 - Brake Assembly, Drive Line                 |
| 232 - Diaphragm, Chamber                       | 753 - Sender, Stability Control                       | 909 - Harness, Cab                               |
| 255 - Cylinder, Master                         | 801 - Control Unit, Electronic ECU                    | 913 - Valve, Foot Control or Pedal               |
| 390 - Reservoir                                |   | 920 - Valve, Hand Control                        |
| 392 - Switch, Fluid Level                      |   | 923 - Harness, Front End (Wires/Connectors/Term) |
| 397 - Governor and Mounting, Air               |   | 932 - Valve, Front Wheel Limiting & Mounting     |
| 428 - Lever/Pedal, Parking Brake               |   |  |

940 - Harness, PDM  
Distribution

**GROUP 05 - STEERING**

018 - Arm, Pitman  
069 - Link, Drag  
164 - Column Assy. &  
Mounting, Steering  
167 - Wheel Mechanism, Tilt  
Steering  
206 - Couplings/U-Joint,  
Steering Shaft

**GROUP 06 - PROP SHAFT**

101 - Bearing  
165 - Mounting, Bearing

**GROUP 07 - EXHAUST**

107 - Assembly, Basic  
143 - Bracket/Support,  
Mounting  
426 - Guard / Heat Shield

**GROUP 08 - ELECTRICAL**

005 - Knob  
018 - Alternator Assembly  
038 - Multiplex Signal Module  
(MSM)  
041 - Telematics Control  
Module (TCM)  
049 - Switch, SOS  
059 - Regulator, Voltage  
063 - Solenoid Base, Pneumatic  
Accessory  
065 - Solenoid Unit, Pneumatic  
Accessory  
073 - Amplifier, Pyrometer  
074 - Gauge, Voltmeter  
076 - Gauge, Fuel Level  
088 - Gauge, Oil Pressure  
(Electrical)  
097 - Gauge, Coolant  
Temperature (Electrical)  
099 - Gauge, Ammeter  
109 - Gauge, Engine Oil  
Temperature  
110 - Gauge, Pyrometer  
111 - Gauge, Rear Axle Oil  
Temperature  
116 - Gauge, Speedometer  
(Electrical)  
117 - Gauge, Tachometer  
(Electrical)  
118 - Gauge, Transmission Oil  
Temperature  
124 - Sender, Fuel Level

944 - Valve, Quick Release  
955 - Pully

252 - Wheel, Steering  
311 - Gear Assembly, Steering  
314 - Gasket, Power Steering  
Pump Mounting  
316 - Wheel Mechanism,  
Telescoping Steering  
370 - Bracket/Mounting,  
Steering Gear

391 - Joint, Universal  
475 - Boot / Clamp, Slip Joint

533 - Tail Pipe, Exhaust Gas  
Cooler  
551 - Pipe, Crossover  
576 - Pipe & Flange, Exhaust

127 - Tachometer/Trip Recorder  
(Elec Driven)  
155 - Sender, Pyrometer  
156 - Sender, Rear Axle Oil  
Temperature  
159 - Sender, Transmission Oil  
Temperature  
202 - Motor, Starter  
217 - Solenoid, Starter Motor  
221 - Bezel/Cover Plate  
223 - Circuit Board  
224 - Switch, Speedometer /  
Tachometer Dip  
(Reprogramming Only)  
225 - Panel, Circuit  
Breaker/Relay/Fuse  
226 - Mounting, Circuit  
Breaker/Relay/Fuse Panel  
251 - Harness, Coiled Ribbon  
(Clock Spring)  
266 - Switch, Clutch  
269 - Module, Coolant Probe  
270 - Probe, Coolant Level  
284 - Antenna and Lead-In  
347 - Mounting  
372 - Module, Pyrometer  
373 - Module, Ammeter  
374 - Circuit Housing,  
Speedometer / Tachometer  
375 - Sender, Air Pressure  
388 - Lamp Assembly

990 - Wiring

555 - Cylinder Assembly &  
Valves  
653 - Cooler Assembly, Oil  
701 - Pump Assembly  
757 - Reservoir Assembly  
818 - Valve, Control  
955 - Pulley

478 - Shaft  
703 - Yoke/Spline

615 - Pipe/Stack, Tail  
775 - Cap, Stack  
824 - Pipe, Flex

401 - Clean Power Cable  
(Battery To Cab)  
404 - Flasher  
405 - Beeper, Hydraulic Brake  
Warning  
407 - Alarm, High Water  
Temp/Low Oil Press.  
408 - Beeper, Low Air Pressure  
418 - Regulator & Motor  
Assembly  
424 - Hourmeter  
430 - Odometer  
487 - Horn Assembly  
499 - Contact Ring/Button, Horn  
508 - Monitor, Driver Display  
Unit  
510 - Sensor, Radar Side/Front  
512 - Display, Side Sensor  
514 - Sensor, Turn Assembly  
516 - Magnet, Turn Sensor  
Assembly  
518 - Harness, Side Sensor  
585 - Automatic Headlight  
Sensor  
586 - Antenna, Tire Pressure  
Monitor  
587 - Brake Stroke Chamber  
W/Sensor  
588 - Display, Vehicle  
Information  
589 - Fuel Filter Restriction  
Globe W/Sensor

595 - Module/Controller, Tire Pressure Monitor  
596 - Module, Vehicle Sensor  
598 - Batteries, Jumper Cable  
599 - Sensor, Brake Pad Wear  
601 - Wheel Module, Tire Pressure Monitor  
607 - Switch, Air Horn  
608 - Clock  
609 - Switch, Cruise On/Off  
618 - Switch, Cruise Set/Reset  
620 - Switch, Engine Brake On/Off  
621 - Switch, Headlight Interrupt  
623 - Switch, Marker Interrupt  
624 - Switch, Radio  
628 - Switch, Transmission Mode  
629 - Switch, Transmission Shift  
637 - Alarm, Back-Up  
705 - Solenoid, Air  
718 - Solenoid

## GROUP 09 - COOLING

012 - Solenoid Valves  
022 - Core  
026 - Shutter Assembly  
047 - Hose/Pipe, Radiator  
064 - Tank & Neck, Radiator  
083 - Shroud Clamp  
085 - Shroud Mounting Bracket  
091 - Shroud, Engine Mounted  
108 - Cylinder Assembly, Actuating  
123 - Mounting, Radiator  
136 - Motor  
142 - Rod Assembly, Control

## GROUP 10 - INSTRUMENTS

053 - Head Assembly

## GROUP 11 - CLUTCH

059 - Bearing and Sleeve Assembly, Release  
101 - Cylinder, Master  
133 - Cylinder, Slave

## GROUP 12 - ENGINE

222 - Solenoid  
740 - Blade Assembly, Fan  
744 - Fan Drive, Viscous  
746 - Fan Drive, On/Off  
748 - Control, Fan Clutch  
750 - Pulley, Fan  
802 - Sart Module

743 - Clean Power Cable (Batt to Engine Connect)  
745 - Daytime Running Light Switch  
758 - Central Processing Unit (CPU)  
783 - Compass, Electronic  
784 - Thermometer, Electronic  
797 - Clean Power Cable (Batt to Transmission)  
811 - Relay/Magnetic Switch  
815 - Switch, Key/Ignition  
821 - Switch, Push Button Starter  
828 - Switch, Dimmer  
835 - Switch, Back-Up Light  
840 - Switch, Neutral Start  
848 - Module Monitor  
850 - Switch, Low Oil Pressure  
854 - Controller, Esc  
863 - Switch, Stoplight (Air)  
864 - Switch, Stoplight (Hydraulic)

176 - Shroud  
197 - Shutterstat  
210 - Glass, Sight  
211 - Tank & Mounting, Surge  
222 - Solenoid  
240 - Motor / Pump  
427 - Bottle and Hose, Coolant Recovery  
504 - Fan Module  
616 - Cooler, In Tank Oil  
701 - Pump Assembly  
740 - Blade Assembly, Fan  
755 - Electronic Fan Controller

292 - Fork and Cross Shaft, Clutch Release  
349 - Lever Assembly, Relay  
403 - External Linkage

811 - Relay/Magnetic Switch  
814 - Pedal Assembly, Accelerator  
828 - Front Mount/Bolt  
836 - Rear Mount/Bolt  
865 - Switch, Temperature

865 - Switch, High Water Temperature  
870 - Switch, Low Air Pressure  
871 - Switch, Low Coolant Level  
872 - Switch, Parking Brake  
884 - Switch, Headlight  
885 - Switch, Marker/Interrupt  
886 - Switch, Turn Signal  
887 - Programming  
907 - Actuator, Switch Pack  
908 - Switch Pack (Base)  
909 - Harness, Cab Wires Conn's & Terminals  
923 - Harness, Front End (Wires, Connectors And  
940 - Harness, PDM Distribution  
955 - Pulley  
996 - Monitor, Battery Run Down Protection

756 - Hydraulic Fluid Reservoir  
767 - Oil Cooler (Oil-To-Air)  
811 - Relay/Magnetic Switch  
852 - Pipe, Charge Air Cooler  
865 - Switch, Temperature  
909 - Harness, Cab (Wires/Connectors/Term)  
925 - Charge Air Cooler, Chassis Mounted  
940 - Harness, PDM Distribution

440 - Self Adjusting Mechanism  
462 - Pedal  
639 - Intermediate Plat  
862 - Plate Assembly, Pressure

905 - Bracket, Air Compressor Mtg.  
909 - Harness, Cab (Wires/Connectors/Term)  
911 - Bracket, Alternator Mtg.  
914 - Bracket, Refrigerant Compressor Mounting

919 - Bracket, Power Steering  
Pump Mounting  
930 - Coupling, Accessory  
Drive

**GROUP 13 - TRANSMISSION**

114 - Case  
125 - Flange, Companion  
138 - Block, Resistor  
139 - Housing, Bell  
191 - Retainer, Bearing  
313 - Detent Poppet Ball &  
Spring

**GROUP 14 - REAR AXLE**

013 - Adjuster, Slack  
016 - Arm, Steering  
068 - Spring, Lift  
135 - Flange/Yoke, Comp  
147 - Carrier  
170 - Housing, Axle  
203 - Air Bag Assembly  
216 - Stud  
231 - Chamber  
265 - Control (Air Suspension  
Control)  
323 - Hanger and Crossmember  
Assembly

**GROUP 15 - FUEL SYSTEM**

011 - Cap/Scoop, Air Inlet  
014 - Box/Water Separator, Air  
Inlet  
026 - Pipe, Air Inlet  
029 - Control System, Air Inlet  
Temperature  
142 - Pre-Heater Element  
143 - Valve, Drain  
144 - Valve, Check  
145 - Cap, Vent

**GROUP 16 - CAB**

006 - Stop, Hood  
018 - Bezel, Head or Tail Lamp  
027 - Step, Cab  
053 - Cable, Hood  
071 - Channel, Glass Run  
078 - Remote Control/Cable,  
Door  
086 - Crossmember, Cab  
Mounting  
102 - Cab Tilt Lock Mechanism  
103 - Cab Tilt Hinge  
Mechanism  
104 - Cowl/Firewall/SC or FC  
Platform

938 - Gear, Power Steering  
Pump Driver  
946 - Tensioner, Belt  
955 - Pulley/Idler/Bearing

616 - Cooler, Oil (Oil-To-Air)  
677 - Line, Oil Cooler  
785 - Linkage/Cable, Remote  
Shift Control  
825 - Switch, On/Off  
839 - Switch, Brake  
866 - Mounting

357 - Bearings, Internal (Axle  
Carrier)  
376 - Gears, Bushings & Cross,  
Differential  
395 - Differential, Limited Slip  
424 - Bolt, Ring Gear  
441 - Wheel End Gearboxes  
448 - Gears, Helical  
472 - Gears, Planetary  
496 - Gears, Ring & Pinion  
590 - Shaft, Helical Drive Gear  
606 - Clutch, Sliding  
619 - Control, Air Shift

146 - Pump, Primer  
147 - Collar  
148 - Body  
177 - Filler Neck/Cap & Gasket  
196 - Sensor, Water in Fuel  
216 - Bracket, Stack Mounting  
263 - Air Intake Grill  
479 - Finish (Metal)  
500 - Bracket & Bolts,  
Mounting

121 - Suspension, Sleeper Bunk  
122 - Cylinder, Lift  
123 - Latch Assembly  
129 - Cabinets  
130 - Door  
131 - Window, Sleeper  
135 - Cylinder, Lift  
139 - Door Assembly, Radiator  
Access  
146 - Shade, Sun  
248 - Grille Assembly  
264 - Handle, Grab  
265 - Handle, Hood  
282 - Hinge

909 - Harness, Cab (Wires,  
Connectors & Term)  
940 - Harness, PDM  
Distribution

630 - Cylinder, Air Shift  
654 - Fork, Shift  
679 - Motor, Air Shift  
707 - Bearing/Ret, P.D.  
713 - Pump, Oil  
719 - Case, P.D. Diff.  
730 - Gears/Bushing & Cross  
Power Divider  
747 - Tank, Air Or Vacuum  
969 - Knuckle, Steerable  
970 - King Pin, Knuckle

637 - Tank Body  
787 - Tube, Fuel Outlet  
857 - Indicator, Air Restriction  
890 - Transfer Pump, Electric  
(Tank to Tank)  
892 - Valve/Control, Fuel Tank  
909 - Harness, Cab Wires  
Conn's & Terminals  
976 - Vent, Air  
988 - Guard, Crash

291 - Hinge, Hood/Engine  
Access Door Hatch  
295 - Hood Guides  
300 - Bunk Occupant Restraint  
Strap/Tent  
301 - Cowl Tray  
309 - Hood  
329 - Insulation  
330 - Shield, Sound  
336 - Insulation, Engine  
Compartment  
345 - Latch & Exterior Handle  
362 - Latch, Hood

368 - Latch, Doghouse  
Panel/Engine  
398 - Map Pocket, Passenger  
Door  
409 - Air Intake Baffle/Water  
Sep. Baffle  
421 - Mirror, Spot  
423 - Mirror, Exterior (Basic)  
433 - Mirror, Interior  
459 - Mounting, Front Cab  
463 - Mounting, Intermediate  
Body  
468 - Mounting  
546 - Panel, Back  
555 - Doghouse Panel/Engine  
Cover  
567 - Panel, Floor  
568 - Panel, Halo  
569 - Panel, Engine Surround  
584 - Panel, Instrument  
611 - Panel, Splash  
619 - Panel / Skin  
625 - Rivet/Fastener  
627 - Weld

637 - Structure  
666 - Regulator & Handle,  
Window  
675 - Arm Rest  
684 - Roof  
721 - Spring/Shock Absorber &  
Mounting, Cab  
739 - Stop Assembly, Door  
748 - Sub-Frame  
799 - Console  
802 - Manifest Box/Door Pouch  
804 - Trim, Interior  
805 - Trim, Bunk  
806 - Mirror, Interior  
807 - Under Bunk Lift Assist  
Shock  
811 - Relay/Magnetic Switch  
(Electric Mirror)  
825 - Switch, Electric Mirror  
833 - Valve, Control  
844 - Ventilator  
855 - Visor, Sun  
877 - Vent Window & Seal  
896 - Trim, Hood

909 - Harness, Cab  
(Wires/Connectors/Term)  
926 - Shor Power Connection  
928 - Door, Hood / Engine  
Access  
929 - Hinge / Bracket, Front  
Hood Mounting  
934 - Reinforcement, Hood  
935 - Torsion Bar, Hood Assist  
936 - Latch, Engine Access  
Door  
958 - Bracket, Sun Shade  
Mounting  
972 - Panel, Rear Trim  
973 - Panel, Door Trim - Driver  
Side  
974 - Panel, Door Trim -  
Passenger Side  
975 - Holder, Cup  
991 - Motor, Mirror  
992 - Heater, Mirror  
994 - Bracket, Mirror

#### GROUP 17 - WHEELS

031 - Disc Wheel  
087 - Hub (Disc Wheel)  
108 - Rim (Demountable)  
386 - Spoke Wheel

#### GROUP 18 - SCR AFTERTREATMENT

045 - Hose, Pump to Tank  
Supply / Suction  
046 - Hose, Pump to Tank  
Return  
047 - Hose, Pump to Doser /  
Injector  
124 - Sensor Assembly, Def  
Tank  
177 - Cap, Filler Tank  
180 - Cover, Supply Module  
181 - Heater, Tank  
350 - Hose, Tee to Doser  
351 - Hose, Doser To Tee  
500 - Bracket/Strap, Def Tank  
501 - Bracket, Supply Module  
Pump  
502 - Bracket, ACM  
565 - Wiring, (Sensor)  
637 - Tank, Diesel Exhaust  
Fluid  
787 - Pickup, Tank  
793 - Tank Def, Coolant Flow  
Valve  
801 - Module, PDM  
906 - Wiring, ACM  
907 - Wiring, Supply Module  
908 - Wiring, Heated Line  
909 - Wiring, Head Unit

#### GROUP 19 - ACCESSORIES

001 - Fan, Defroster  
015 - Clutch, Compressor  
028 - Compressor/Reciprocating  
029 - Compressor/Rotary  
043 - Condenser  
045 - Linkage, Wiper  
070 - Switch, Radiator  
Fan/Shutter Override  
076 - Core (Heater)  
094 - Evaporator  
100 - Meter Assembly, Engine  
105 - Wheel, Blower  
138 - Block, Resistor  
149 - Accumulator/Dryer  
182 - Valve, Expansion  
183 - Valve, Rear Expansion  
187 - Ducting, Air  
Cond/Heater/Defroster  
197 - Horn Assembly  
214 - Valve, Control  
251 - Harness, Coiled Ribbon  
(Clock Spring)  
310 - A/C O Ring  
317 - Schrader Valve, Low Side  
318 - Schrader Valve, High Side  
325 - Solenoid, Pneumatic  
327 - Switch, Air Horns  
331 - Electric Air Compressor,  
Seat  
343 - Shock, Seat  
344 - Adjuster Assembly, Seat  
351 - Frame, Seat  
353 - Fitting  
354 - Control, Air Seat  
355 - Mounting/Housing (Main  
Case)  
363 - Bag, Air  
381 - Retractor, Seat Belt  
386 - Belt, Seat  
411 - Plate, Fifth Wheel  
417 - Control, Fifth Wheel

435 - Heater Assembly, Engine  
436 - Socket, Engine Heater  
443 - Back-Up Camera  
472 - Reservoir  
506 - Lock Cylinder, Fifth Wheel  
632 - HVAC Hose, Under Cab to Rear  
675 - Rest, Arm  
708 - Module, Blower Speed LPM  
709 - Module, HVAC Control  
733 - Actuator, Motor/Door - Blend Air

734 - Actuator, Motor / Door - Fresh Air  
735 - Actuator, Motor/Door - Air Distribution  
763 - Sensor, Refrigerant Pressure  
764 - Thermistor, Inlet  
765 - Thermistor, Outlet  
807 - Module, Vehicle Personality (VPM)  
825 - Switch  
826 - Switch, Bunk-On/Off  
827 - Switch Bunk-Temperature Control

830 - Switch, Intermittent  
837 - Switch, Clutch  
838 - Switch, Set-Resume  
849 - Module, Diagnostic - APADS  
880 - Switch, Pressure-Low  
881 - Switch, Pressure-High  
882 - Switch, Thermostatic  
885 - Freeze Sensor  
909 - Harness, Cab (Wires, Connectors and Terminals)  
923 - Harness, Front End (Wires/Connectors/Term)

## GROUP 22 - GENESIS BODY - COMP

001 - Fan, Defroster  
040 - Bows  
042 - Cowl, Front  
044 - Frame, Rear  
046 - Rails, Drip  
048 - Rails, Seat  
050 - Spacers, Bow  
052 - Steps  
055 - Bumper, Front  
056 - Bumper, Rear  
060 - Header, Entrance Door  
061 - Frame, Entrance Door  
062 - Drivers Seat Sub-Frame (K Frame)  
063 - Frame, Side Emergency Door  
064 - Frame, Rear Emergency Door  
065 - Frame, Lift Door  
066 - Frame, Body to Cab Floor  
067 - Frame, Body to Cab Roof  
068 - Frame, Davenport  
080 - Bars, Light  
082 - Bumpers, Header  
084 - Caps, Inside  
086 - Insulation  
088 - Lining, Lower  
090 - Lining, Overhead  
092 - Racks, Luggage  
094 - Rails Grab  
096 - Rails, Shoulder  
098 - Rails, Standee  
100 - Reduction, Noise  
120 - Bracket, License Plate  
122 - Caps, Outside  
124 - Caps, Post  
126 - Door, Fuel  
128 - Handles, Access  
129 - Front Fiberglass Panel

130 - Panels, Rear Inside Window  
131 - Front Sheet Metal  
134 - Rails, Rub  
136 - Rails, Snow  
138 - Sheets, Side  
140 - Skins, Rear Outside  
141 - Hatch, Roof  
142 - Skirts  
146 - Roof Panels(Topping)  
148 - Door, Engine  
151 - Door, W/S Wiper  
152 - Grille  
200 - Electrical Access Compartment  
204 - Battery, Compartment  
208 - Spare Tire Compartment  
212 - Luggage Compartment  
214 - Safety Compartment  
216 - Destination Sign Compartment  
218 - Tool Compartment  
239 - Controls Air  
240 - Boxes, Buzzer  
241 - Controls Electric  
243 - Controls, Manual  
244 - Devices, Hold Bac  
246 - Doors, Entrance  
248 - Doors, Lift - Single / Double  
250 - Doors, Emer. Rear  
252 - Doors, Emer. Side  
254 - Handles, Door  
256 - Hinges  
258 - Locks, Door  
262 - Vandalocks  
275 - Light, Step  
281 - Electric Panel  
283 - Fuse Panel  
284 - Horns

294 - Speakers  
296 - Switches  
297 - Radio  
298 - Antenna  
322 - Panels, Floor  
326 - Sills, Floor  
330 - Tiedown Bolts, Plates, J-Bolts, U-Bolts  
332 - Wheel pocket Assy.  
339 - Transition Panel / Cowl Filler Panel  
340 - Doors, Engine Service  
350 - Cross View Mirror  
360 - Cover, Wheel-Pocket  
364 - Moulding, Cove  
366 - Treads, Step  
369 - Wig-Wag  
389 - Child Check Mate  
402 - Window, Driver's  
410 - Window, Emergency Exit  
416 - Window, Split Sash  
423 - Thermistor, Inlet  
425 - Switch, Radiator Fan / Shutter Override  
426 - Window, Split Storm  
427 - Switch, Pressure - Low  
429 - Clutch, Compressor  
430 - A/C Compressor, Rotary  
431 - Ducting, Air Conditioner  
432 - Wheel, Blower  
433 - Hose, A/C  
434 - O-Ring, A/C  
435 - Schrader Valve, Low Side  
436 - Sensor, Refrigerant Pressure  
437 - Switch  
438 - Accumulator / Dryer  
439 - Switch, Pressure - High  
440 - Heater, Under Seat

441 - Harness, (Wires, Connectors, & Terminals)	471 - Harness, Power Distribution (On Flasher Plate)	544 - Red Light
442 - Heater, Rear	472 - Switch, Thermostatic	546 - Stop Light
444 - Covers/Trim, Hose	474 - Thermistor, Outlet	548 - Stop/Tail Light
445 - Control Cable	475 - Tube, Drain	550 - Strobe Light
446 - Driver's Heater	476 - Tube, Orifice	554 - Warning Light
447 - Core, Heater	478 - Motor	556 - Lift Door Light, Interior
449 - Motors, Heater	479 - A/C Electric Control Panel	558 - Lift Door Light, Exterior
450 - Stepwell Heater	480 - Panels, Modesty	560 - Cowl Mount Mirror
451 - Pump, Booster Heater	484 - Restraints, Lap	562 - Fender Mount Mirror / Rear View
453 - Condenser	488 - Stanchions	564 - Heated Mirror
454 - Fan, Condenser	493 - Harness, Left Hand Body	566 - Inside Rear View Mirror
455 - Evaporator	494 - Harness, Right Hand Body	568 - Spy Mirror
456 - Defroster Duct	495 - Harness, Flasher to Cowl	640 - Alarms, Backing
457 - Valve, Expansion	498 - Harness, Body Options External (Engine)	662 - Sign, Designation
459 - Fitting / Pipe (A/C)	499 - Microphone	682 - Crash Barrier Frame
460 - Harness, Front End	501 - Harness, Dash	684 - Belts, Seat
462 - Relay / Magnetic Switch	520 - Back-Up Light	692 - Passenger Seat Frame
463 - Schrader Valve, High Side	524 - Instrument Cluster Light	694 - Shields, Courtesy
464 - Harness, Flasher Plate	526 - Directional Light	697 - Flip Seat Frame
465 - Harness, LH Switch Panel	528 - Directional, Side Light Assembly	720 - Stop Arm
466 - Harness, Rh Switch Panel	534 - Fog Light	726 - Gates, Crossing
467 - Harness, Over Head Switch Panel	536 - Headlights	740 - Motor, Stop Arm
468 - Valve, Water (Dash Mounted A/C Heater Unit)	540 - License Plate Light, Assembly	742 - Motor, Stop Arm Module
469 - Harness, Front Cap	542 - Marker Light	762 - Static Vent
470 - Harness, Rear Cap		810 - Motor, Drive
		812 - Washer

## WHAT IS NOT COVERED

### Components / Items:

- o Correction of loose fasteners, squeaks, rattles and unusual noises.
- o Adjustments (e.g., headlights, brake/clutch adjustments, steering system adjustments, coolant levels).
- o Items warranted by their respective manufacturers (e.g., non-Navistar brand engines, tires & tubes, Allison Transmissions, clutch, batteries, radios, lubricants, etc).
- o Any part that is not a Navistar part number.
- o Unauthorized parts other than Navistar service parts or ReNEWed® parts.
- o Bodies, equipment and accessories installed by other than authorized Navistar employees at Navistar manufacturing plants.
- o Front and rear axle alignment.
- o Engine, Engine Electronics, Injectors, Turbocharger.
- o Hybrid Electric Components (except Hybrid/Electric Drive Cooling).

### Repairs:

- o Maintenance-related items/ repairs or those as a result of normal wear and tear, including tune-ups, brake/clutch lining, clutch brake, windshield wiper blades, windshield wiper nozzles, gaskets, belts, seals, tire balancing, lubrication, batteries and other similar procedures/parts required to keep vehicle in good working condition. Such maintenance items or repairs include, but are not limited to oil changes, oil filters, air filters, desiccant cartridge, fuel filters, tire rotation, cleaning/polishing, engine tune-up, adding oils, tightening of air intake and coolant clamps, ash tray, cigarette lighter element, fire extinguishers, fluorescent ballast and tubes, fuses, gladhand and gladhand rubbers, trailer hoses, hose tenders, trailer electrical cables, light bulbs, mattress, mud flaps, mud flap mounting bracket.



- Repairs to any part of the vehicle subjected to misuse, negligence, improper maintenance, improper operation, or which is the result of an accident.
- Fades, runs, mismatch or damage to paint, trim items, upholstery, chrome, polished surfaces, etc., resulting from environmental causes, improper polishes, cleaners or washing solutions, or chemical and industrial fallout.
- No coverage will be granted if Power Train, Propshaft and Suspension sales guidelines (specifications) are not strictly adhered to by all owners and operators of this vehicle.
- Accidents, acts of nature or other events beyond control of Navistar.
- Any single repair requiring less than \$40.00 parts and labor to complete.

**Other:**

- Vehicles sold and/or operated outside the United States or Canada.
- Vehicles/components which have had unauthorized alterations or modifications.
- Vehicles on which the odometer reading has been altered.
- Incidental or consequential costs or expenses which the owner may incur as a result of a malfunction or failure covered by this warranty, such as vehicle damage, communication expenses, meals, lodging, overtime, loss of use of engine or vehicle ("downtime"), loss of time, inconvenience, cargo loss or damage, and other similar costs and expenses.
- Replacement of defective parts, which were, not authorized Navistar equipment when first installed.
- Towing, unless additionally purchased.

**OBTAINING SERVICE**

To obtain service under this Service Contract, return this vehicle to any Navistar truck dealer authorized to service this model vehicle and engine. To locate an authorized dealer near you, please call the Navistar Customer Service Center at 800-44-TRUCK (800-448-7825).

**DISCLAIMER**

NO WARRANTIES ARE GIVEN BEYOND THOSE DESCRIBED HEREIN. THIS WARRANTY IS IN LIEU OF ALL OTHER WARRANTIES, EXPRESSED OR IMPLIED. THE COMPANY SPECIFICALLY DISCLAIMS WARRANTIES OF MERCHANTABILITY AND FITNESS FOR A PARTICULAR PURPOSE, ALL OTHER REPRESENTATIONS TO THE USER/PURCHASER, AND ALL OTHER OBLIGATIONS OR LIABILITIES. THE COMPANY FURTHER EXCLUDES LIABILITY FOR INCIDENTAL AND CONSEQUENTIAL DAMAGES, ON THE PART OF THE COMPANY OR SELLER. No person is authorized to give any other warranties or to assume any liabilities on the company's behalf unless made or assumed in writing by the Company; and no other person is authorized to give any warranties or to assume any liabilities on the seller's behalf unless made or assumed in writing by the seller.

**Remedies Under State or Provincial Law:** Some States and Provinces do not allow the exclusion or limitation of incidental or consequential damages, so the above limitation or exclusion may not apply to the owner. This warranty gives the owner specific legal rights, and he may also have other legal rights which may vary by state or province.

**Navistar, Inc., except in Canada where it is Navistar Canada, Inc.**

# MUNICIPAL LEASE AGREEMENT

**LESSOR:**

Santander Leasing, LLC  
 3 Huntington Quadrangle, Suite 101N  
 Melville, NY 11747 631-531-0610

**LESSEE:**

Name: \_\_\_\_\_  
 Street: \_\_\_\_\_  
 City/State/Zip: \_\_\_\_\_  
 Responsible Official: \_\_\_\_\_  
 Phone: ( ) \_\_\_\_\_

**1. LEASE OF VEHICLES:** LESSOR hereby agrees to lease to LESSEE and LESSEE hereby agrees to lease from LESSOR the school buses or other motor vehicles and equipment and accessories thereon (herein "Vehicles") on the terms and conditions provided in this Agreement and the schedule and additional schedules annexed hereto (each a "Schedule" and collectively, the "Schedules"). Each Schedule shall be a separately enforceable Lease, the terms and conditions of which shall be those set forth herein and on each Schedule (each a "Lease" and collectively, the "Leases").

**2. COVENANTS:** LESSEE represents, covenants and warrants that (a) It is a public body corporate and politic, (b) It is a "tax- exempt issuer" within the meaning of the Internal Revenue Code, (c) It is authorized by all applicable laws to make, and perform under, this Lease, (d) The Vehicles are essentially needed for its proper, efficient and economic operation, (e) At the time of making the Lease, sufficient funds were appropriated to fulfill the Lessee's obligations of the current fiscal year, (f) It will do all things lawfully within its power to obtain and maintain funds from which payments under this Lease may be made, including making provisions for such payments in each annual budget and using bona fide best efforts to have such portion of the budgets approved, and (g) LESSEE has not previously terminated a lease for non-appropriation.

**3. TERM AND RENT:** The Lease term shall commence as of the date that the Vehicles are delivered to LESSEE, or LESSEE's Agent (the "Commencement Date") and shall continue for the term shown on the attached Schedule relating thereto, unless Lessee notifies LESSOR that an Event of Non-appropriation (described below) has occurred or LESSEE exercises its option under Section 18. At the end of such term LESSEE shall acquire legal title to the Vehicles and terminate this Lease with respect thereto by paying to LESSOR all amounts then due and unpaid hereunder and the remaining principal balance with respect to such Vehicles as shown on the Schedule relating thereto. In lieu of such payment LESSOR hereby grants LESSEE the option to renew this Lease with respect to such Vehicles for the additional period as shown on the Schedule relating thereto, provided that the rate of interest applicable to such additional period shall be mutually agreed upon by LESSOR and LESSEE. LESSEE shall give written notice to LESSOR at least ninety (90) days prior to the end of the Lease term as to whether it will terminate this Lease and acquire the Vehicles or exercise its option to renew in accordance with this Section 3. LESSOR shall endeavor to give written notice to LESSEE at least sixty (60) days prior to the end of the Lease term if no such notice has been received from LESSEE. The rent under this Lease shall be payable in lawful money of the United States of America, from any and all legally available funds, and at the times and in the amounts as indicated on each attached Schedule. In lieu of cash, LESSOR will accept payment by check or wire transfer of immediately available funds only. Each payment will consist of a principal and interest component.

**4. EVENT OF NON-APPROPRIATION:** Lessee shall notify LESSOR promptly (and in no case later than thirty (30) days prior to the last day of its current fiscal year) if sufficient funds are not appropriated for the payments for the next fiscal period (an "Event of Non-appropriation"). If LESSEE terminates this Lease or an Event of Non-appropriation occurs, Lessee agrees, to the extent not prohibited or required by law, not to: (a) purchase, lease, rent, or otherwise acquire vehicles performing functions similar to those performed by the Vehicles, or (b) contract with another party to furnish services that the Vehicles had provided, for one (1) year after such termination or occurrence.

**5. PAYMENTS UNCONDITIONAL:** Lessee has examined, tested and accepted the vehicles covered by this lease and schedules, and subject only to an event of non-appropriation, lessee's obligation to pay rent and other payments hereunder shall be absolute and unconditional and not subject to any abatement, set-off, defense or counterclaim for any reason whatsoever, regardless of loss, damage, destruction, malfunction or disrepair of the equipment, or dispute with the manufacturer or supplier of the vehicles or for any other reason.

**6. DISCLAIMER OF WARRANTIES:** LESSOR, NEITHER BEING THE MANUFACTURER, NOR A SUPPLIER, NOR A DEALER IN THE VEHICLES, MAKES NO WARRANTY, EXPRESS OR IMPLIED, TO ANYONE, AS TO DESIGN, CONDITION, CAPACITY, PERFORMANCE OR ANY OTHER ASPECT OF THE VEHICLES OR THEIR MATERIAL OR WORKMANSHIP. LESSOR ALSO DISCLAIMS ANY WARRANTY OF MERCHANTABILITY OR FITNESS FOR USE OR PURPOSE WHETHER ARISING BY OPERATION OF LAW OR OTHERWISE. LESSOR FURTHER DISCLAIMS ANY LIABILITY FOR LOSS, DAMAGE OR INJURY TO LESSEE OR THIRD PARTIES AS A RESULT OF ANY DEFECTS, LATENT OR OTHERWISE, IN THE VEHICLES WHETHER ARISING FROM THE APPLICATION OF THE LAWS OF STRICT LIABILITY OR OTHERWISE. AS TO LESSOR, LESSEE LEASES THE VEHICLES "AS-IS". LESSEE HAS SELECTED THE SUPPLIER OF THE VEHICLES AND ACKNOWLEDGES THAT LESSOR HAS NOT RECOMMENDED SUPPLIER. LESSOR SHALL HAVE NO OBLIGATION TO MAINTAIN, OR SERVICE THE VEHICLES. If the Vehicles are unsatisfactory for any reason, LESSEE shall make claim on account thereof solely against Supplier, and any of Suppliers vendors, and shall nevertheless pay LESSOR all rent payable under the Lease. LESSOR hereby assigns to LESSEE all of the rights which LESSOR may have against Supplier and Suppliers vendors for breach of warranty or other representations respecting the Vehicles. LESSEE understands and agrees that neither Supplier nor any agent of Supplier; is an agent of LESSOR or is authorized to waive or alter any term or condition of this Lease.

**7. RISK OF LOSS:** LESSEE shall bear all risks of loss of and damage to Vehicles from any cause; occurrence of such loss or damage shall not relieve LESSEE of any obligation hereunder. In the event of loss or damage, LESSEE, at its option, shall (a) replace the damaged Vehicle in good repair, condition and working order; or (b) replace lost or damaged Vehicles with like Vehicles in good repair, condition and working order, with documentation creating a lien or favor of LESSOR or its assignee; or (c) purchase the Vehicles for the casualty value as listed on the Schedule in the term sheets.

**8. INSURANCE:** LESSEE will purchase and maintain in force during the term of this Agreement, insurance policies in at least the amounts listed below covering the Vehicles between the time of delivery thereof to LESSEE and final disposition by LESSOR. Said insurance shall be written by an insurance company or companies acceptable to LESSOR, insuring LESSEE against any loss, damage, claims, suits, actions or liability, and by endorsement naming LESSOR as [an Additional] Named Insured and Loss Payee. Such endorsement or endorsements shall provide in each case that said insurance company or companies shall give to LESSOR at least thirty (30) days' notice in writing of proposed cancellation, modification, or alteration of any said insurance.

<u>Type</u>	<u>Amount</u>
Public Liability and Property Damage (Comprehensive)	\$5,000,000 Combined Single Limit (per occurrence) (\$5,000,000) for multi-passenger or I.C.C. Regulated Vehicles)
Collision, Fire and Theft (ALL RISK)	Not less than replacement value

The above insurance shall also include the following, in amounts not less than the applicable minimum legal requirements: (a) uninsured/underinsured motorist coverage, and (b) no fault protection. LESSEE shall in addition provide general liability insurance covering LESSEE'S indemnification responsibilities hereunder. Prior to the date that any Vehicle is placed in service by LESSEE, LESSEE shall furnish LESSOR with a certificate of insurance or other evidence thereof acceptable to LESSOR. Policies covering the aforementioned fire and theft and collision insurance shall bear endorsements to the effect that proceeds thereof shall be payable to LESSOR and/or LESSEE as their interests may appear. LESSEE hereby appoints LESSOR as LESSEE'S attorney-in-fact to receive payment of and endorse all checks and other documents and to take any other action necessary to pursue insurance claims and recover payments if LESSEE fails to do so. Any expense of LESSOR in adjusting or collecting insurance shall be borne by LESSEE. In the event a Vehicle is involved in a material accident, LESSEE shall immediately notify LESSOR and provide

(a) a detailed report describing the accident, (b) copies of all reports provided to an insurance carrier or governmental agency, and (c) copies of any legal papers relating to the accident.

**9. LESSEE'S OPERATION OF VEHICLES:** LESSEE shall use the Vehicles primarily in the state of registration and only in the conduct of its traditional educational operations. LESSEE shall operate its Vehicles in a safe and lawful manner, and shall comply with all federal, state, county and municipal statutes, ordinances and regulations which may be applicable to the leasing, use or operation of the Vehicles. LESSEE shall, at its sole expense, maintain the Vehicles in good operating condition and repair. In addition, LESSEE shall prepare and furnish to LESSOR all documents, returns or forms legally required to be prepared by LESSEE. LESSEE shall be solely responsible for any fines or penalties assessed for violations of any statute, ordinance, by law or regulation of any duly constituted governmental authority, as a result of the use or operation of the Vehicles by any of LESSEE's employees, agents, sublessees or subcontractors, and indemnify LESSOR against any costs, fines or charges LESSOR is required to pay. LESSEE agrees to operate only those Vehicles which have adequate insurance coverage and to comply with all conditions of insurance related to the Vehicles, to maintain the Vehicles and all accessories and equipment thereof in safe and good mechanical condition and running order at all times during the term of this Agreement and to furnish all supplies, accessories, and other essentials required for the use or operation of the Vehicles. In no event will the Vehicles be used to transport any hazardous substances.

**10. TITLE; REDELIVERY OF VEHICLES:** Each Vehicle shall be titled in the name of the LESSOR c/o Lessee. If this Lease is terminated with respect to any Vehicles pursuant to Section 4 or Section 13 hereof, the LESSOR may repossess such Vehicles. If the LESSOR is entitled to repossess the Vehicles, the LESSEE shall permit the LESSOR or its agents to enter the premises where the Vehicles are located. In the event of any repossession, you shall execute and deliver such documents as reasonably required to restore possession of the Vehicles to the LESSOR, free of all liens and security interests incurred by the LESSEE. In the event of the exercise by LESSEE of its rights under Section 3 or Section 18 to acquire legal title with respect to any Vehicles, LESSOR shall transfer legal title to such Vehicles to LESSEE AS IS, WITHOUT WARRANTIES, EXPRESS OR IMPLIED, INCLUDING WITHOUT LIMITATION WARRANTIES OF MERCHANTABILITY OR FITNESS FOR ANY PARTICULAR PURPOSE OR FITNESS FOR THE USE CONTEMPLATED BY LESSEE, except such Vehicles shall be free of all liens and security interests incurred by LESSOR, and LESSOR shall execute and deliver such documents as LESSEE shall reasonably request with respect thereto.

**11. NON-ASSIGNABILITY BY LESSEE:** LESSEE shall not assign, sub-lease, transfer or otherwise encumber its rights in and to this Lease or the Vehicles without the prior written consent of the LESSOR, except as otherwise provided in Section 18.

**12. ASSIGNMENT BY LESSOR:** This Lease, the Vehicles and any payments by LESSEE due or to become due under it, may be assigned or otherwise transferred, either in whole or in part, by LESSOR and its assignee, without affecting any obligations of LESSEE, and in such event LESSOR's transferee or assignee shall have all the rights, powers, privileges and remedies of LESSOR hereunder. Any assignee's rights shall be free from all defenses, set-offs or counterclaims which LESSEE may be entitled to assert against LESSOR. No assignee shall be obligated to perform any duty or condition required to be performed by LESSOR under the terms of this Lease.

**13. DEFAULT:** In the event of default by LESSEE, in the payment of any sums due under this Lease when due which continues uncured for thirty (30) days, or receivership, insolvency, or proceedings by or against LESSEE under the bankruptcy laws, or LESSEE's failure to observe or perform any other required provision of this Lease, and such default continues for fifteen (15) days after written notice thereof, by LESSOR, to LESSEE, LESSOR shall have the right to exercise any one or more of the following remedies: (a) to declare all sums due and to become due hereunder, during the LESSEE's current fiscal period, immediately due and payable, without notice or demand to LESSEE; (b) to sue for and recover all payments then accrued or thereafter accruing with respect to the Vehicles; (c) to take possession of the Vehicles without demand or notice wherever it may be located, with or without legal process, and retain it free from any claims of LESSEE whatsoever; (d) to terminate this Lease; or (e) to pursue any other remedy at law or in equity. If LESSOR sells or re-leases any of the repossessed Vehicles, the net proceeds of such sale or lease, less LESSOR's expenses incurred in connection therewith, including attorneys' fees, shall be applied to the total amount due by LESSEE under this Lease and related Schedule and LESSEE shall be obligated to pay LESSOR any deficiency. All of the foregoing remedies are cumulative and may be exercised concurrently or separately. LESSEE shall pay all costs and legal expenses incurred by LESSOR in collecting, or attempting to collect, any sums due hereunder or in securing possession of the Vehicles. LESSEE consents to the personal jurisdiction of the courts, and the applicability of the laws, of the State of New York with respect to any dispute arising out of the Lease.

**14. FEDERAL, STATE AND LOCAL TAXES:** In addition to payments specified herein, LESSEE shall promptly pay all taxes, assessments and other governmental charges (including *ad valorem* taxation, penalties, interest, recording and registration fees, if any) levied or assessed: upon the ownership, use or operation of the Vehicles and the payments due hereunder. LESSEE acknowledges that its compliance with the reporting requirements of the Internal Revenue Code is essential to the exemption from Federal income tax of the interest portion of payments made by LESSEE hereunder. Accordingly, LESSEE agrees that its failure to comply with those requirements shall constitute a Default hereunder. LESSEE certifies that it reasonably anticipates that not more than \$10,000,000 of "qualified tax-exempt obligations" (as that term is defined in Section 265(b)(3)(D) of the Internal Revenue Code, as amended by the Tax Reform Act of 1986, (the "Code")) will be issued by it and subordinate entities during the calendar year in which the Lease begins. Further, LESSEE will, by resolution, designate the Lease as comprising a portion of the \$10,000,000 in aggregate issues to be designated as "qualified tax exempt obligations" eligible for the exception contained in Section 265(b)(3)(D) of the Code allowing for an exemption to the general rule of the Code which provides for a total disallowance of a deduction for interest expense allocable to the carrying of tax exempt obligations. If for any reason the payments due hereunder are not exempt from federal taxes, then LESSEE shall pay LESSOR such amounts as will permit LESSOR to realize the same after tax income as if such payments were so exempt, together with all costs, liabilities, damages, expenses, taxes and penalties (including Federal income tax penalties and interest) incurred as a consequence thereof, which LESSEE agrees to pay upon written demand therefor.

**15. ADMINISTRATIVE SUPPORT:** LESSEE may, from time to time, be required to file, or assist in the filing of, reports to regulatory and/or taxing authorities, which may be necessary to establish, perfect or maintain the legality and/or tax-exempt status of this Lease, or to execute documents needed for LESSOR's financing. LESSEE promises to promptly make such filings or to render such assistance as may, from time to time, be reasonably requested by LESSOR or its Assigns, and to indemnify and hold harmless LESSOR or its assigns from any cost, expense or other damage caused by its failure to do so. LESSEE hereby further authorizes LESSOR to file UCC-1 financing statements without LESSEE'S signature, and to fill in dates and other obvious minor corrections on this Lease.

**16. SEVERABILITY:** Any term or provision of this Lease found to be prohibited by law or unenforceable shall be ineffective to the extent of such prohibition or unenforceability without, to the extent reasonably possible, invalidating the remainder of the Lease.

**17. INDEMNIFICATION:** The LESSEE agrees to indemnify the LESSOR and its officers, agents, employees, servicers, successors and assignees against any and all loss, damage, injury, claims, fees, fines, penalties, and expenses (including legal fees) of every kind that relate to the use, operation, ownership, possession, or condition of the Vehicles.

**18. EXERCISE OF OPTION:** In the event LESSEE exercises its option under Section 3 to renew this Lease, during the term of such renewal LESSEE shall have the right to acquire legal title to any Vehicles and terminate this Lease with respect thereto: (i) on any payment date by paying to LESSOR on such date all amounts then due and unpaid hereunder and the principal portion of all future rental payments due with respect thereto, provided that LESSEE gives to LESSOR sixty days written notice of its intent to exercise such option; or (ii) on the last payment date with respect to any Vehicle by paying all amounts then due hereunder with respect to such Vehicle and the amount of \$1.00, which option shall be deemed exercised unless LESSEE gives to LESSOR sixty days written notice to the contrary. LESSOR hereby consents to the exercise of the purchase option and the termination of this Lease with respect to any Vehicles, on any date prior to the renewal hereof pursuant to Section 3 and upon sixty days written notice from LESSEE, at a price of all unpaid principal with respect to such Vehicles and interest thereon accrued and unpaid to the date of exercise of such option, provided that such Vehicles are immediately assigned by LESSEE to Midwest Transit Equipment.

**19. FINANCIAL INFORMATION:** LESSEE shall provide LESSOR with current financial statements, budgets, proof of appropriation for the ensuing fiscal year and such other information relating to the ability of LESSEE to continue this Agreement within 180 days after the end of each fiscal year of LESSEE and at the request of LESSOR.

**20. ENTIRE AGREEMENT:** This Lease constitutes the entire agreement between the parties regarding the Vehicles, and there are no representations, warranties, promises, guarantees or agreements, oral or written, expressed or implied, between the parties hereto with respect to the

Lease. No modification or amendment hereof shall be binding upon the LESSOR unless made in writing and executed on behalf of LESSOR by its duly authorized officer or agent.

Board Minutes of Lessor approving this transaction on (date) \_\_\_\_\_ are attached and included with these documents.

LESSOR: Santander Leasing, LLC

LESSEE:

Signature: \_\_\_\_\_

Signature: \_\_\_\_\_

Print Name: \_\_\_\_\_

Title: \_\_\_\_\_

Date: \_\_\_\_\_

Print Name: \_\_\_\_\_

**Please Have Notary sign and stamp below, or use school seal stamp.**

Title: \_\_\_\_\_

Date of this Lease: \_\_\_\_\_

"Signed and sworn before me this \_\_\_\_\_ day of \_\_\_\_\_".

\_\_\_\_\_

**OPINION OF LESSEE'S COUNSEL IN LIEU OF BOARD CERTIFICATION**

As Counsel for aforementioned LESSEE, it is my opinion that:

- (a) LESSEE is a political subdivision of the State, duly organized, existing and operating under the constitution and laws of the State.
- (b) The Lease has been duly authorized and has been executed by an authorized representative.
- (c) The Lease creates a legal, valid and binding obligation of the LESSEE and that such Lease is enforceable in accordance with its terms.
- (d) The equipment covered by the Lease is not being used for other than a public purpose.

COUNSEL FOR LESSEE:

Print Name: \_\_\_\_\_

Firm Name: \_\_\_\_\_

Title: \_\_\_\_\_

Address: \_\_\_\_\_

Signature: \_\_\_\_\_

Date: \_\_\_\_\_

Included with this bid packet is a quote from Kansas State Bank. This is a separate identity from Midwest Bus Leasing and Midwest Bus Sales. This lending institution is aggressive with their interest rates and we do have customers utilizing them for their financing options.

We had Kansas State Bank work up pricing as an option and have included that with our proposal. Kansas State Bank would work directly with the district to secure the funding using Midwest Bus Sales selling price for the buses as well as using our residual prices. Midwest Bus Sales will buy the leased units back at the guaranteed residual value at the end of the lease terms. If you have any questions on this please contact me at your convenience to discuss



Baystone Government Finance

January 4, 2022

### FORMAL PROPOSAL

**OBLIGOR:** MINOOKA CCSD, IL

- ✓ This is a finance/ownership contract.
- ✓ Fixed interest rate for the three (3) year, and five (5) year terms.

**EQUIPMENT:** SCHOOL BUSES

<b>OPTION 1: 3yr</b>					
Acquisition Cost:	\$102,453.00	Term:	Three (3) years	First Payment Due:	At Closing <i>Cummins</i>
Down Payment:	\$ 0.00	Payment Mode:	Annual in Advance	Payment Amount (1-3):	\$16,434.40
Trade In:	\$ 0.00	Interest Rate:	2.260%	Final Payment Due:	1 yr after 3 <sup>rd</sup> payment
Principal Balance:	\$102,453.00	Rate Factor:	0.160409	Final Payment Amount:	\$57,992.00
<b>OPTION 2: 5yr</b>					
Acquisition Cost:	\$105,434.00	Term:	Five (5) years	First Payment Due:	At Closing <i>Cummins</i>
Down Payment:	\$ 0.00	Payment Mode:	Annual in Advance	Payment Amount (1-5):	\$14,615.06
Trade In:	\$ 0.00	Interest Rate:	2.280%	Final Payment Due:	1 yr after 5 <sup>th</sup> payment
Principal Balance:	\$105,434.00	Rate Factor:	0.138618	Final Payment Amount:	\$39,786.00
<b>OPTION 3: 3yr</b>					
Acquisition Cost:	\$ 90,214.00	Term:	Three (3) years	First Payment Due:	At Closing <i>DD5</i>
Down Payment:	\$ 0.00	Payment Mode:	Annual in Advance	Payment Amount (1-3):	\$14,471.25
Trade In:	\$ 0.00	Interest Rate:	2.260%	Final Payment Due:	1 yr after 3 <sup>rd</sup> payment
Principal Balance:	\$ 90,214.00	Rate Factor:	0.160410	Final Payment Amount:	\$51,064.00
<b>OPTION 4: 5yr</b>					
Acquisition Cost:	\$ 93,194.00	Term:	Five (5) years	First Payment Due:	At Closing <i>DD5</i>
Down Payment:	\$ 0.00	Payment Mode:	Annual in Advance	Payment Amount (1-5):	\$12,918.40
Trade In:	\$ 0.00	Interest Rate:	2.280%	Final Payment Due:	1 yr after 5 <sup>th</sup> payment
Principal Balance:	\$ 93,194.00	Rate Factor:	0.138618	Final Payment Amount:	\$35,167.00

---

**1010 Westloop Place, Manhattan, KS 66502**  
**800.752.3562 ~ Fax: 785.537.4806**

---

**OPTION 4: 5yr - Selling Price \$93,194**

---

Compounding Period: Annual

Nominal Annual Rate: 2.280%

**Cash Flow Data - Loans and Payments**

Event	Date	Amount	Number	Period	End Date
1 Loan	02/01/2022	93,194.00	1		
2 Payment	02/01/2022	12,918.40	5	Annual	02/01/2026
3 Payment	02/01/2027	35,167.00	1		

**TValue Amortization Schedule - Normal, 360 Day Year**

	Date	Payment	Interest	Principal	Balance
Loan	02/01/2022				93,194.00
1	02/01/2022	12,918.40	0.00	12,918.40	80,275.60
2	02/01/2023	12,918.40	1,830.28	11,088.12	69,187.48
3	02/01/2024	12,918.40	1,577.47	11,340.93	57,846.55
4	02/01/2025	12,918.40	1,318.90	11,599.50	46,247.05
5	02/01/2026	12,918.40	1,054.43	11,863.97	34,383.08
6	02/01/2027	35,167.00	783.92	34,383.08	0.00
<b>Grand Totals</b>		<b>99,759.00</b>	<b>6,565.00</b>	<b>93,194.00</b>	

Last interest amount decreased by 0.01 due to rounding.

---

**OPTION 3: 3yr - Selling Price \$90,214**

---

Compounding Period: Annual

Nominal Annual Rate: 2.260%

**Cash Flow Data - Loans and Payments**

Event	Date	Amount	Number	Period	End Date
1 Loan	02/01/2022	90,214.00	1		
2 Payment	02/01/2022	14,471.25	3	Annual	02/01/2024
3 Payment	02/01/2025	51,064.00	1		

**TValue Amortization Schedule - Normal, 360 Day Year**

	Date	Payment	Interest	Principal	Balance
Loan	02/01/2022				90,214.00
1	02/01/2022	14,471.25	0.00	14,471.25	75,742.75
2	02/01/2023	14,471.25	1,711.79	12,759.46	62,983.29
3	02/01/2024	14,471.25	1,423.42	13,047.83	49,935.46
4	02/01/2025	51,064.00	1,128.54	49,935.46	0.00
<b>Grand Totals</b>		<b>94,477.75</b>	<b>4,263.75</b>	<b>90,214.00</b>	

**OPTION 2: 5yr - Selling Price \$105,434**

Compounding Period: Annual

Nominal Annual Rate: 2.280%

**Cash Flow Data - Loans and Payments**

Event	Date	Amount	Number	Period	End Date
1 Loan	02/01/2022	105,434.00	1		
2 Payment	02/01/2022	14,615.06	5	Annual	02/01/2026
3 Payment	02/01/2027	39,786.00	1		

**TValue Amortization Schedule - Normal, 360 Day Year**

	Date	Payment	Interest	Principal	Balance
Loan	02/01/2022				105,434.00
1	02/01/2022	14,615.06	0.00	14,615.06	90,818.94
2	02/01/2023	14,615.06	2,070.67	12,544.39	78,274.55
3	02/01/2024	14,615.06	1,784.66	12,830.40	65,444.15
4	02/01/2025	14,615.06	1,492.13	13,122.93	52,321.22
5	02/01/2026	14,615.06	1,192.92	13,422.14	38,899.08
6	02/01/2027	39,786.00	886.92	38,899.08	0.00
<b>Grand Totals</b>		<b>112,861.30</b>	<b>7,427.30</b>	<b>105,434.00</b>	

Last interest amount increased by 0.02 due to rounding.

---

**OPTION 1: 3yr - Selling Price \$102,453**

---

Compounding Period: Annual

Nominal Annual Rate: 2.260%

**Cash Flow Data - Loans and Payments**

	Event	Date	Amount	Number	Period	End Date
1	Loan	02/01/2022	102,453.00	1		
2	Payment	02/01/2022	16,434.40	3	Annual	02/01/2024
3	Payment	02/01/2025	57,992.00	1		

**TValue Amortization Schedule - Normal, 360 Day Year**

	Date	Payment	Interest	Principal	Balance
Loan	02/01/2022				102,453.00
1	02/01/2022	16,434.40	0.00	16,434.40	86,018.60
2	02/01/2023	16,434.40	1,944.02	14,490.38	71,528.22
3	02/01/2024	16,434.40	1,616.54	14,817.86	56,710.36
4	02/01/2025	57,992.00	1,281.64	56,710.36	0.00
<b>Grand Totals</b>		<b>107,295.20</b>	<b>4,842.20</b>	<b>102,453.00</b>	

Last interest amount decreased by 0.01 due to rounding.

- **This is a proposal only and is not a commitment to finance. This proposal is subject to credit review and approval and proper execution of mutually acceptable documentation.**
- Failure to consummate this transaction once credit approval is granted and the documents are drafted and delivered to Obligor will result in a documentation fee being assessed to the Obligor.
- This transaction must be credit approved, all documents properly executed and returned to Baystone Government Finance and the transaction funded on ALL proposals on or before February 4, 2022. If funding does not occur within that time-frame, or there is a change of circumstance which adversely affects the expectations, rights, or security of Obligee or its assignees, then Obligee or its assignees reserve the right to adjust and determine a new interest rate factor and payment amount, or withdraw this proposal in its entirety.
- This transaction must be designated as tax-exempt under Section 103 of the Internal Revenue Code of 1986 as amended.
- **OBLIGOR'S TOTAL AMOUNT OF TAX-EXEMPT DEBT TO BE ISSUED IN THIS CALENDAR YEAR WILL NOT EXCEED THE \$10,000,000 LIMIT, OR THE INTEREST RATE IS SUBJECT TO CHANGE.**
- FORMAL PROPOSAL IS BASED UPON THE OBLIGOR ENTERING INTO A FIRM TERM FINANCING OBLIGATION, NOT SUBJECT TO ANNUAL APPROPRIATIONS.

**BAYSTONE GOVERNMENT FINANCE**

**MINOOKA CUSD, IL**

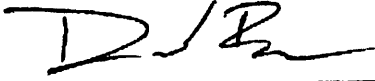

David Burr ~ dburr@ksstate.bank  
Assistant Vice President

Signature

Title

Date



**SPECIFICATIONS**

**Part 1:**

1. The Districts are interested in receiving proposals for the following:

**District 111:** Ten (10) 71 passenger school buses, leased

**District 201:** Ten (10) 71 passenger school buses, leased

2. The proposal will detail the bus and van specifications that the vendor feels best meets the needs of the Districts.
3. The Districts will consider proposals for new vehicles as well as 1-3 year old vehicles
4. The Districts will consider proposals for diesel, gasoline, and propane buses.
5. The proposed lease shall be inclusive of preparation, delivery, lettering, inspection, sticker, title, license and all other fees.
6. Vehicles shall be route condition ready and available for delivery on or before Monday, July 18, 2022
7. Mileage for leases shall be quoted on the number of miles included per year with the per mile charge for overage.
8. Warranty shall be quoted as the manufacturer warranty plus any charge for additional warranty throughout the term of the lease (warranty details to be provided with proposal).
9. The District will consider three (3) year leases and five (5) year leases.
10. Proposal shall detail price differential for quantities of more or less than the above stated.

*Detroit ENGINE*

*\$ .35 mileage overage charge*

Please use the following matrix for quoting prices 2022 MODEL YEAR BUSES QUOTES 369213, 370117, 374177

Type of Bus	Diesel Lease	Diesel Total Price	Diesel Guaranteed Buy Back Price	Diesel Mileage	Gas Lease	Gas Total Price	Gas Guaranteed Buy Back Price	Gas Mileage
New (lease - 3yr)	\$16,430.15 PER BUS/ PER YEAR	\$90,214.00 PER BUS	\$51,064.00 PER BUS	18,953 PER BUS/ PER YEAR	NO BID	NO BID	NO BID	NO BID
New (Lease - 5yr)	\$14,999.90 PER BUS/ PER YEAR	\$93,194.00 PER BUS	\$35,167.00 PER BUS	18,953 PER BUS/ PER YEAR	NO BID	NO BID	NO BID	NO BID

Please duplicate the above matrix for 1, 2 and 3 year old buses.

FIVE YEAR LEASE/PURCHASE ON DIESEL BUS: \$20,913.90 PER BUS/PER YEAR

**Part 2:**

1. The Districts are also interested in receiving proposals for the purchase several of its used buses. The list of buses being sold are attached and the buses may be inspected by appointment during normal schools hours. The buses are being sold "As-Is.

**District 111 Trade In**

**None at this time**

**District 201 Trade In**

**None at this time**

**NON-COLLUSION AFFIDAVIT**

**STATE OF ILLINOIS**

SS:

MONTGOMERY COUNTY

The undersigned vendor or agent, being duly sworn, on oath says that s(he) has not, nor has any other member, representative, or agent of the firm, company, corporation or partnership represented by him/her, entered into any combination, collusion or agreement with any person relative to the price to be proposal by anyone at such letting, nor to prevent any person from bidding nor to induce anyone to refrain from bidding, and that this proposal is made without reference to any other proposal and without any agreement, understanding or combination with any other person in reference to such bidding.

S(he) further states that no person or persons, firms, or corporation has, have or will receive directly or indirectly, any rebate, fee, gift, commission or thing of value resulting from such sale.

RANDY SWANSON  
Name

For MIDWEST BUS SALES, INC.  
Firm or Corporation

Subscribed and sworn to before me on this 3RD day of JANUARY, 2022

My commission expires:

Signature:

\_\_\_\_\_

\_\_\_\_\_

Notary Public

\_\_\_\_\_  
Signature

## PROJECT QUALIFICATION FORM

A responsible vendor is defined by meeting the following criteria and is able to submit evidence of such compliance. By signing this required form, the undersigned agrees that said vendor is responsible as defined below.

### SEXUAL HARRASSMENT

Each vendor certifies that he has complied with the requirement of 2-105 of the Illinois Human Rights Act (775ILCS5/2-105)-1257) with respect to sexual harassment policies. The terms of that law, as applicable, are hereby incorporated into this contract.

### DRUG FREE WORKPLACE

The vendor or contractor, having 25 employees or more, does hereby certify pursuant to Section 3 of the Illinois Drug-Free Workplace Act (30ILCS580/3) that he shall provide a drug-free workplace for all employees engaged in the performance of work under the contract by complying with the requirements of the Illinois Drug-Free Workplace Act and, further certifies that he is not ineligible for award of this contract by reason of debarment for a violation of the Illinois Drug-Free Workplace Act.

### NON-DISCRIMINATION AFFIRMATION

Vendors must assure that all persons employed by the vendor, and all applicants for such employment, will not be discriminated against because of their race, religion, nationality, gender, disability, physical characteristics or sexual orientation. Vendor must also comply with all rules and regulations of the Illinois Department of Human Rights, Illinois Human Rights Commission and the Equal Employment Opportunity Commission.

### CONFLICT OF INTEREST

By signing below, vendor certifies that they are in accordance with the School Code, and the Public Officer Prohibited Practice Act, 50 ILCS 105/0.01 et seq., no Board of Education member or District employee shall be directly or indirectly involved or own an interest in any contract, work, or business of the District, or in the sale of any article by or to the District.

### CERTIFICATION OF NOT BARRED FROM BIDDING

The Vendor hereby certifies that the bidder is not barred from bidding on this contract as a result of a violation of either the proposal-rigging or proposal-rotating provisions of Article 33E of the Criminal Code of 1961, as amended.

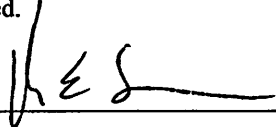
Signed:  Name (printed): RANDY SWANSON

ILLINOIS SALES  
Title: REPRESENTATIVE Company Name: MIDWEST BUS SALES, INC.

Address: 18 SKYVIEW DR., LITCHFIELD, IL 62056

Telephone Number: 217-324-2119 Date: 1/3/2022

Compound Period: Daily

Nominal Annual Rate: 5.560%

CASH FLOW DATA

Event	Date	Amount	Number	Period	End Date
Payment	7/21/2022	18,659.06	3	Annual	7/21/2024

AMORTIZATION SCHEDULE - Normal Amortization

	Date	Payment	Interest	Principal
1	7/21/2022	18,659.06	0.00	18,659.06
2022 Totals		18,659.06	0.00	18,659.06
2	7/21/2023	18,659.06	4,790.52	13,868.54
2023 Totals		18,659.06	4,790.52	13,868.54
3	7/21/2024	18,659.06	4,008.91	14,650.15
2024 Totals		18,659.06	4,008.91	14,650.15

Last interest amount decreased by 0.01 due to rounding.

Compound Period: Daily

Nominal Annual Rate: 5.930%

CASH FLOW DATA

Event	Date	Amount	Number	Period	End Date
2 Payment	7/21/2022	16,969.94	5	Annual	7/21/2026

AMORTIZATION SCHEDULE - Normal Amortization

	Date	Payment	Interest	Principal
1	7/21/2022	16,969.94	0.00	16,969.94
2022 Totals		16,969.94	0.00	16,969.94
2	7/21/2023	16,969.94	5,404.13	11,565.81
2023 Totals		16,969.94	5,404.13	11,565.81
3	7/21/2024	16,969.94	4,710.85	12,259.09
2024 Totals		16,969.94	4,710.85	12,259.09
4	7/21/2025	16,969.94	3,948.70	13,021.24
2025 Totals		16,969.94	3,948.70	13,021.24
5	7/21/2026	16,969.94	3,153.26	13,816.68
2026 Totals		16,969.94	3,153.26	13,816.68

Last interest amount increased by 0.03 due to rounding.

Compound Period: Daily

Nominal Annual Rate: 5.930%

## CASH FLOW DATA

Event	Date	Amount	Number	Period	End Date
1 Loan	7/21/2022	105,434.00	1		
2 Payment	7/21/2022	23,660.71	5	Annual	7/21/2026
3 Payment	6/1/2027	0.00	1		

## AMORTIZATION SCHEDULE - Normal Amortization

	Date	Payment	Interest	Principal	Balance
Loan	7/21/2022				105,434.00
1	7/21/2022	23,660.71	0.00	23,660.71	81,773.29
2022 Totals		23,660.71	0.00	23,660.71	
2	7/21/2023	23,660.71	4,995.40	18,665.31	63,107.98
2023 Totals		23,660.71	4,995.40	18,665.31	
3	7/21/2024	23,660.71	3,866.05	19,794.66	43,313.32
2024 Totals		23,660.71	3,866.05	19,794.66	
4	7/21/2025	23,660.71	2,645.94	21,014.77	22,298.55
2025 Totals		23,660.71	2,645.94	21,014.77	
5	7/21/2026	23,660.71	1,362.18	22,298.53	0.02
2026 Totals		23,660.71	1,362.18	22,298.53	
6	6/1/2027	0.00	-0.02	0.02	0.00
2027 Totals		0.00	-0.02	0.02	
Grand Totals		118,303.55	12,869.55	105,434.00	

Last interest amount decreased by 0.02 due to rounding.

Compound Period: Daily

Nominal Annual Rate: 5.560%

CASH FLOW DATA

Event	Date	Amount	Number	Period	End Date
Payment	7/21/2022	16,430.15	3	Annual	7/21/2024

AMORTIZATION SCHEDULE - Normal Amortization

	Date	Payment	Interest	Principal
1	7/21/2022	16,430.15	0.00	16,430.15
2022 Totals		16,430.15	0.00	16,430.15
2	7/21/2023	16,430.15	4,218.24	12,211.91
2023 Totals		16,430.15	4,218.24	12,211.91
3	7/21/2024	16,430.15	3,530.00	12,900.15
2024 Totals		16,430.15	3,530.00	12,900.15

Last interest amount increased by 0.01 due to rounding.

Compound Period: Daily

Nominal Annual Rate: 5.930%

CASH FLOW DATA

Event	Date	Amount	Number	Period	End Date
Payment	7/21/2022	14,999.90	5	Annual	7/21/2026

AMORTIZATION SCHEDULE - Normal Amortization

	Date	Payment	Interest	Principal
1	7/21/2022	14,999.90	0.00	14,999.90
2022 Totals		14,999.90	0.00	14,999.90
2	7/21/2023	14,999.90	4,776.75	10,223.15
2023 Totals		14,999.90	4,776.75	10,223.15
3	7/21/2024	14,999.90	4,163.95	10,835.95
2024 Totals		14,999.90	4,163.95	10,835.95
4	7/21/2025	14,999.90	3,490.29	11,509.61
2025 Totals		14,999.90	3,490.29	11,509.61
5	7/21/2026	14,999.90	2,787.18	12,212.72
2026 Totals		14,999.90	2,787.18	12,212.72

Last interest amount increased by 0.01 due to rounding.

Compound Period: Daily

Nominal Annual Rate: 5.930%

CASH FLOW DATA

Event	Date	Amount	Number	Period	End Date
1 Loan	7/21/2022	93,194.00	1		
2 Payment	7/21/2022	20,913.90	5	Annual	7/21/2026
3 Payment	6/1/2027	0.00	1		

AMORTIZATION SCHEDULE - Normal Amortization

Date	Payment	Interest	Principal	Balance
Loan 7/21/2022				93,194.00
1 7/21/2022	20,913.90	0.00	20,913.90	72,280.10
2022 Totals	20,913.90	0.00	20,913.90	
2 7/21/2023	20,913.90	4,415.48	16,498.42	55,781.68
2023 Totals	20,913.90	4,415.48	16,498.42	
3 7/21/2024	20,913.90	3,417.23	17,496.67	38,285.01
2024 Totals	20,913.90	3,417.23	17,496.67	
4 7/21/2025	20,913.90	2,338.77	18,575.13	19,709.88
2025 Totals	20,913.90	2,338.77	18,575.13	
5 7/21/2026	20,913.90	1,204.05	19,709.85	0.03
2026 Totals	20,913.90	1,204.05	19,709.85	
6 6/1/2027	0.00	-0.03	0.03	0.00
2027 Totals	0.00	-0.03	0.03	
Grand Totals	104,569.50	11,375.50	93,194.00	

Last interest amount decreased by 0.03 due to rounding.

**SAMPLE LEASE ONLY  
VEHICLES LEASE AGREEMENT**

LESSOR: Midwest Bus Sales, Inc.  
23889 W 40<sup>th</sup> St, Shawnee, KS 66226

LESSEE: Minooka CHSD #111 & CCD #201  
26655 W. Eames St., Channahon, IL 60410

---

**PROPERTY LEASED.** Subject to the terms of this Commercial Vehicles Lease Agreement (this "Agreement"), Lessor agrees to lease to Lessee and Lessee agrees to lease from Lessor all of the personal property (each, a "Vehicle" and, collectively, the "Vehicles") described on Exhibit I attached hereto and made a part hereof. Any modifications to or deletions from Exhibit I when agreed to by both parties, or any agreed variation in models or types of Vehicles, shall be evidenced by a supplement to this Agreement. Lessee shall inspect the Vehicles at delivery and report any defects to Lessor in writing within 48 hours of delivery. Failure to report any defects within such time period shall constitute Lessee's acceptance of the Vehicles in their delivered condition. Lessee agrees that all equipment, accessories, replacements, additions or substitutions now or hereafter added to the Vehicles shall immediately, by accession, become integral parts of the Vehicles. This Agreement shall constitute the master lease with respect to the Vehicles and shall be deemed to comprise as many individual leases as there are Vehicles that may be delivered to Lessee.

---

**OWNERSHIP OF VEHICLES.** This is an agreement to lease only and shall not be construed as a contract for the sale of Vehicles. Lessee acknowledges that Lessor is the owner of all Vehicles leased hereunder. Lessee further agrees that it does not acquire any legal or equitable interest in the Vehicles, but merely shall have the possessory right to use and operate the Vehicles in accordance with the terms of this Agreement, which possessory right shall be forfeited upon the termination, cancellation or expiration of this Agreement as herein provided.

---

**LEASE PAYMENTS.** Lessee shall pay to Lessor a lease payment in the amount set forth for each Vehicle on **Exhibit I**. Lessee shall remit lease payments to Lessor at Midwest Bus Leasing, LLC, P.O. Box 844725, Kansas City, MO 64184-4725, or as otherwise directed in writing by Lessor. The lease payment obligation begins with respect to each Vehicle on the delivery of such Vehicle. Any down payment deposit Lessor may require with respect to any Vehicle shall be paid upon start of the lease for such Vehicle. Lessee shall have no right of deduction, setoff or counterclaim, all of which Lessee hereby waives. If Lessee fails to make any lease payment required by this Agreement within ten (10) days of the due date therefor, Lessee shall pay to Lessor a service charge of 5% of such unpaid amount; provided that in no event shall such service charge exceed any maximum amount established by applicable law, and any payment of such service charge shall not operate to cure or waive any Event of Default arising from such failure to pay.

---

**LEASE TERM.** The lease term for the Vehicles shall be from \_\_\_\_\_.

---

**PAYMENT OF PERSONAL PROPERTY TAXES AND REGISTRATION.** Lessee shall pay all federal, state and local sales, use, excise, personal property, and other taxes and all other governmental assessments, fees and charges imposed on or in connection with any Vehicle, or on the lease, use, ownership or possession thereof, and any registration charges related to the Vehicles. Lessee shall file any necessary returns connected with the above taxes and charges, and shall furnish adequate proof of payment to Lessor. Lessor may advance payment for these expenses and invoice Lessee for same. Payment of such invoiced amounts shall be due within ten (10) days of invoice date.

---

**REGISTRATION AND LICENSES.** Lessee shall title, register and license the Vehicles in the name or names directed by Lessor (including any lienholder designations directed by Lessor). Lessee shall promptly forward such title and/or certificate of registration to Lessor. Lessee shall also have the Vehicles inspected and pay for same as required by any governmental authority.

**INSURANCE.**

a) Lessee, at its own expense, shall provide and maintain for each Vehicle insurance of the types and amounts set forth below:

1. Fire, theft and comprehensive insurance with deductible amounts not to exceed \$2,500.00 per Vehicle. Lessee shall maintain at all times at such party's expense collision insurance with deductible amounts not to exceed \$2,500.00 per Vehicle.
2. Physical damage including comprehensive and collision for actual cash value of each Vehicle and be evidenced on the applicable certificate of insurance.
3. Bodily injury and property damage liability insurance to cover accidents arising out of the ownership, maintenance, operation or use of each Vehicle and with a minimum of a \$1,000,000.00 combined single limit bodily injury and property damage.

b) Lessee agrees to indemnify Lessor and hold Lessor harmless from any loss or damage caused by Lessee's failure to maintain said insurance coverage (whether as a result of the expiration, cancellation, revocation or other termination of any insurance coverage or otherwise).

c) All policies of insurance required under this Agreement must by appropriate endorsement or otherwise name each of Mercedes-Benz Financial Services, USA LLC, 14372 Heritage Parkway, Fort Worth, Texas, 76177, and Midwest Bus Leasing LLC, 23889 W 40<sup>th</sup> St, Shawnee, KS 66226, as an additional insured and as a loss payee, in each case as their interests may appear. Further, each such insurance policy must provide (1) that the same may not be canceled, changed or modified until after the insurer has given Lessor at least 30 days prior written notice of such proposed cancellation, change or modification, (2) full breach of warranty protection and (3) that the coverage is "primary coverage" for the protection of Lessee and Lessor notwithstanding any other coverage carried by Lessee or Lessor protecting against similar risks. Lessee shall furnish Lessor original certificates evidencing such coverage and endorsements, and a copy of each policy, together with proof of payment of premium at least 30 days prior to the delivery of any Vehicle under this Agreement and annually prior to expiration of the current policy. Lessee hereby appoints Lessor as Lessee's attorney-in-fact to adjust, receive payment of, to endorse all checks and other documents and to take any other actions necessary to pursue insurance claims and recover payments if Lessee fails to do so. Lessee will bear any expense Lessor incurs in adjusting or collecting insurance, and shall pay such amounts within ten (10) days of Lessor's demand therefor.

d) Lessee agrees to cooperate fully with Lessor and the insurance carriers insuring the hazards enumerated in this Agreement in the investigation, defense and prosecution of any and all claims or suits arising from the use or operation of any Vehicle. If any claim is made or action commenced for death, personal injury or property damage resulting from the ownership, maintenance, use or operation of any Vehicle, Lessee agrees to promptly notify Lessor of such claim or action in writing and to forward to Lessor a copy of every demand, notice, summons or other process received in connection therewith. Lessee hereby appoints Lessor as Lessee's authorized agent for the limited purpose of certifying that Lessee has and will maintain financial responsibility with respect to each Vehicle.

e) The Certificate of Title for each Vehicle will be in the name of Lessee, with Mercedes-Benz Financial Services, USA LLC, named as the first lienholder unless otherwise agreed by the parties and Midwest Bus Leasing LLC named as the second lienholder.

If Lessee fails to comply in any respect with the foregoing provisions, then Lessor may procure and keep in force any insurance required hereunder that Lessee has failed to maintain and charge the cost thereof to Lessee, payable within ten (10) days after Lessor's demand therefor.

**NET LEASE.** This is a "net lease." Lessor shall not be required to provide any services or do any act in connection with the Vehicles except as specifically provided in this Agreement. The lease payment obligations and any other charges shall be paid to Lessor without any claim on the part of Lessee for diminution or abatement, except as provided in this Agreement, and the fact that Lessee's use of the Vehicles may be disturbed or prevented for any cause whatsoever, except Lessor's willful actions, shall

not in any way suspend, abate or reduce the lease payments and other charges to be paid by Lessee per this Agreement.

**LOSS OR DAMAGE.** Lessee shall bear the entire risk of loss, theft, damage or destruction of the Vehicles from any cause whatsoever. No loss, theft, damage or destruction of any Vehicle shall relieve Lessee of the obligation to make lease payments or to comply with any other obligation under this Agreement. In the event of damage to any Vehicle, Lessee shall immediately place the same in good repair at Lessee's expense. If Lessor determines that a Vehicle is lost, stolen, destroyed or damaged beyond repair, the lease shall terminate with respect to that Vehicle. Such a termination shall be effective thirty (30) days from the date of notice by Lessee of loss, theft, or damage. If a Vehicle is lost, stolen or so damaged, or disappears or is destroyed, under this section, Lessee is not relieved of the obligation to pay under this Agreement, notwithstanding any termination of the lease with respect to such Vehicle. In addition, Lessor reserves the option to offer a replacement or substitute Vehicle, which Vehicle shall be subject to the terms of this Agreement, or Lessor and Lessee may execute a new Lease Agreement. If Lessor exercises its option to provide a replacement or substitute Vehicle, Lessee agrees to pay Lessor any additional rental costs for the substituted or replacement Vehicle that exceed the original lease rental costs.

**USE OF VEHICLES.** Lessee hereby warrants and represents that the Vehicles will be used for business purposes only or, if Lessee is a school district, for the purposes of transportation of students, faculty, staff and others normally transported in vehicles similar to the Vehicles in the course of Lessee's normal operations, and not for consumer, personal, family or household purposes. Lessee shall not permit any Vehicle to be used in violation of any federal, state or municipal statutes, laws, ordinances, rules or regulations, or contrary to the provisions of any applicable insurance policy. Lessee shall indemnify and hold Lessor harmless from any and all fines, forfeitures, damages or penalties resulting from violation of any such statutes, laws, ordinances, rules or regulations. Except with the written consent of Lessor, the use of all Vehicles shall be limited to the continental limits of the United States.

**MILEAGE AND ODOMETER.** The total mileage allowance with respect to each Vehicle is set forth on Exhibit I. Lessor reserves the right to audit the Vehicle mileage at any time during the lease term.

**MAINTENANCE.** Lessee, at its own expense, shall: (a) maintain each Vehicle according to the manufacturer's required maintenance schedule for warranty validation and in substantially the same mechanical condition as the date of delivery of such Vehicle, ordinary wear and tear excepted; (b) lubricate Vehicles as frequently as specified by the manufacturer; and (c) furnish gas, oil, wash, tires, and pay any storage charges for Vehicles. Lessee shall be responsible for any depreciation, loss or any reduction to Vehicles that Lessor, in its reasonable judgment, shall determine was caused by Lessee's failure to comply with the requirements set forth in the preceding sentence. Lessor will inspect each Vehicle upon return and, if Lessor identifies any unperformed maintenance or damage other than normal wear and tear, then Lessee will reimburse Lessor, within ten (10) days after Lessor's demand therefor, for repair of such damage and performance of such maintenance at Lessor's labor rate and parts cost plus 35%.

**DRIVERS OF VEHICLES.** Lessee shall permit only properly licensed and qualified drivers to operate the Vehicles. All drivers will be instructed periodically in all practices which will insure the greatest amount of safety and protection for the party being transported by Lessee. Lessee shall ensure that each driver operates the Vehicles in a safe manner and in accordance with the laws of the State of operation and the ordinances of any city in which such Vehicle operates. In no event shall any Vehicle be operated by any person under the influence of alcohol or narcotics. Lessor shall have the right to demand that any person operating any Vehicle in violation of the foregoing be forbidden to drive any Vehicle, and Lessee shall immediately comply with any such demand.

**NOTICE OF ACCIDENT.** Lessee shall, within twenty-four (24) hours after it receives notice of the occurrence of any Vehicle mishap, accident or traffic violation, notify Lessor in writing of such occurrence. Such notification shall contain a full and complete statement of all relevant facts. Lessee shall keep Lessor and the applicable insurer fully informed of all claims, suits or proceedings arising out of any accident involving a Vehicle. Lessee shall forward to insurer and Lessor a copy of every demand,

notice, summons, or other process received in connection with any and all claims, suits or other legal proceedings resulting from an accident involving a Vehicle.

**RIGHT TO INSPECT.** Lessor reserves the right at any time to inspect the Vehicles and all maintenance records, driver logs and other records relating to the operation or maintenance of the Vehicles (collectively, "Records"), and from time to time make such requests as may be necessary to assure compliance with the terms and provisions of this Agreement and applicable law. If Lessee fails or refuses to return any Vehicle to Lessor upon demand by Lessor and in violation of this Agreement, said failure or refusal to return such Vehicle may be considered as a conversion and treated as a theft of such Vehicle and Lessor shall have the right to notify and request the police authorities to recover same as a stolen Vehicle, in addition to all other rights and remedies of Lessor hereunder and under applicable law. During any such holdover period, Lessee shall continue to comply with all of the terms and conditions of this Agreement, and shall pay 120% of the prorated applicable daily rent for each day from such due date until the date on which Lessee returns the applicable Vehicles to Lessor in the manner required under this Agreement. Upon the return of a Vehicle, Lessee shall deliver or cause to be delivered to Lessor all Records maintained by Lessee with respect to such Vehicle.

**INDEMNIFICATION.** Lessee shall defend, indemnify and hold harmless Lessor, its parent, subsidiary and affiliated companies and their directors, officers, employees, agents and other representatives from and against any and all damages, loss, theft, or destruction of any Vehicle, and against all losses, liabilities, damages, injuries, claims, demands, costs, and expenses of every kind and nature, including legal fees and disbursements arising out of and in connection with the use, condition or operation of Vehicles.

**DISCLAIMER OF WARRANTIES. LESSEE ACKNOWLEDGES AND AGREES THAT LESSOR HAS NOT MADE, DOES NOT MAKE, AND HEREBY EXPRESSLY DISCLAIM ANY REPRESENTATION, WARRANTY OR COVENANT, EXPRESSED OR IMPLIED WITH RESPECT TO THE MERCHANTABILITY, CONDITION, QUALITY, DURABILITY, TITLE, DESIGN, OPERATION, FITNESS FOR USE, FITNESS FOR A PARTICULAR PURPOSE, OR SUITABILITY OF THE VEHICLES OR ANY COMPONENT THEREOF IN ANY RESPECT WHATSOEVER OR IN CONNECTION WITH OR FOR THE PURPOSES AND USES OF LESSEE, OR ANY OTHER REPRESENTATION, WARRANTY OR COVENANT OF ANY KIND AND CHARACTER, EXPRESSED OR IMPLIED, WITH RESPECT THERETO. LESSEE IS ACCEPTING THE VEHICLES "AS IS AND WITH ALL FAULTS" AND LESSOR SHALL NOT BE LIABLE FOR ANY ACTUAL, INCIDENTAL, CONSEQUENTIAL OR OTHER DAMAGES OF OR TO LESSEE OR ANY OTHER PERSON WHATSOEVER.**

In no case shall Lessor be liable for any special, incidental, or consequential damages based upon breach of warranty, breach of contract, negligence, strict tort, or any other legal theory. Such damages include, but are not limited to, loss of profits, loss of savings or revenue, loss of use of the leased Vehicles or any associated equipment, loss of capital, loss of substitute equipment, facilities or services, down time, the claims of third parties and injury to property, and Lessee hereby releases Lessor from same. This limitation does not apply to damages caused by breach of warranty of title. Some states do not allow limitations on warranties, or on remedies for breach in certain transactions. In such states, the limits in this paragraph and in the preceding paragraph may not apply. Lessor assumes no liability or responsibility for any acts or omissions of Lessee or of Lessee's agents, servants or employees, or any other person, or for property that is damaged, lost or stolen in or from the Vehicles, and Lessee hereby releases Lessor from same.

**ASSIGNMENT AND LIENS.** Lessee shall not assign or transfer its interest in this Agreement or the Vehicles, and shall not grant or permit a security interest or other lien against the Vehicles, without the written consent of Lessor. Lessor may assign this Agreement in whole or in part and/or encumber the Vehicles without notice to Lessee, and its assignee or lienholder may reassign this Agreement and/or such encumbrance, without notice to Lessee, and each such assignee and/or lienholder shall have all of the rights but none of the obligations of Lessor under this Agreement. Lessee shall recognize each such assignment and/or encumbrance, and shall not assert against the assignee and/or lienholder any claim, defense, counterclaim, or set off that Lessee may have against Lessor.

Lessee acknowledges that any assignment of Lessor's interest would neither materially change Lessee's duty nor materially increase the burden or risk imposed on Lessee under this Agreement. Lessee acknowledges that any assignment by Lessor will be permitted even if the assignment would be deemed to materially affect Lessee's interest.

Lessee shall notify Lessor immediately in writing of any charges or liens of any kind whatsoever imposed upon the Vehicles, and at its option, Lessor may discharge the same on behalf of Lessee and all such advances by Lessor shall be added to the unpaid balance of the rentals due hereunder, and shall be repayable by Lessee to Lessor on demand, together with interest thereon at the highest legal contract rate until paid or such advances may be deducted from any security deposit held by Lessor.

**BINDING ON HEIRS.** This Agreement inures to the benefit of and is binding upon the heirs, legatees, devisees, personal representative, survivors, successors in interest and assigns, if any, of the parties.

**WRITTEN NOTIFICATION.** Whenever written notification is required by this Agreement, such written notice shall be sent to the applicable party by certified mail, return receipt requested, at the addresses shown above. If either party hereto changes its mailing address during the term of this Agreement, it shall immediately notify the other party of such change.

**WAIVER; AMENDMENT.** No waiver under this Agreement is effective unless it is in writing and signed by an authorized representative of the party waiving its right. The waiver by Lessor of any default on the part of Lessee shall not be a waiver of any subsequent default. No amendment to or rescission, termination or discharge of, this Agreement shall be effective unless it is in writing and signed by an authorized representative of each party to this Agreement.

**FINANCE LEASE.** Lessee and Lessor intend that: (a) each lease under this Agreement constitutes a true "lease" that is a "finance lease" as such terms are defined in Article 2A of the Uniform Commercial Code (the "UCC") and does not create a "security interest" as defined in the UCC; (b) Lessor is and shall remain the owner of the Vehicles (unless sold by Lessor); (c) Lessee shall not acquire any right, title, equity or interest in or to such Vehicles other than the right to possess and use the Vehicles in accordance with Lessee's leasehold interest under this Agreement. If, notwithstanding the intention of the parties and the economic realities of this Agreement, any lease is deemed to create a security interest, Lessee shall be deemed to have granted to Lessor as security for Lessee's obligations hereunder, a first priority security interest in the Vehicles and all proceeds thereof. Lessee hereby authorizes Lessor to file one or more UCC financing statements (including without limitation "precautionary filings") naming Lessee as "debtor", and such amendments and continuations thereof, in each case as Lessor in its sole discretion may deem necessary or advisable. Until Lessee's obligations with respect to all Vehicles are satisfied in full, if requested by Lessor or if required by applicable law, Lessee shall at Lessee's sole cost and expense permanently affix and maintain on any or all Vehicles, as determined by Lessor or as required by applicable law, a sign, legend, plate, plaque, tag or other identifying label in a prominent place that discloses Lessor's ownership or that such Vehicles are leased from Lessor under this Agreement.

**SUBORDINATION.** This Agreement and any Vehicle hereunder will be subject to any rights and interests in and to the Vehicles under any respective contract or contracts or security interest granted by Lessor to any person, firm or entity.

**SALES TAX.** Lessor shall invoice and remit to appropriate state, sales tax as charged on each Invoice. Lessee is responsible for any and all other applicable taxes.

**WARRANTY.** Warranty shall be original manufacturer's warranty period with all terms and conditions set forth by such manufacturer. Any Vehicles that are received by Lessee that do not contain a manufacturer's warranty shall be the responsibility of Lessor until new Vehicles are provided.

**REPRESENTATIONS AND WARRANTIES OF LESSEE.** Lessee is duly organized, validly existing and in good standing under the laws of its jurisdiction of organization and has full power and authority to

own, operate or lease the properties and assets now owned, operated or leased by it (including the Vehicles) and to carry on its business as currently conducted. Lessee has full power and authority to execute and deliver this Agreement, to perform its obligations hereunder and to consummate the transactions contemplated hereby. The execution and delivery by Lessee of this Agreement, the performance by Lessee of its obligations hereunder, and the consummation by Lessee of the transactions contemplated hereby have been duly authorized by all requisite action on the part of Lessee. This Agreement has been duly executed and delivered by Lessee, and constitutes a legal, valid and binding obligation of Lessee enforceable against Lessee in accordance with its terms, except to the extent that the enforcement of remedies may be limited under applicable bankruptcy and insolvency laws.

**EVENTS OF DEFAULT.** Each of the following events shall constitute an Event of Default under this Agreement: (a) if Lessee fails to pay in full any installment of rent, any loss payment or any other monetary obligation under this Agreement when due and payable, whether by acceleration or otherwise; (b) if Lessee fails to observe or perform any obligation under this Agreement; (c) if any representation or warranty made by Lessee in this Agreement or in any other written statement furnished to Lessor shall prove to have been untrue or incorrect in any material respect when made; (d) if Lessee is in material default under any other agreement with Lessor; (e) if this Agreement shall at any time for any reason cease to be in full force and effect or shall be declared to be null and void by a court of competent jurisdiction, or if the validity or enforceability of this Agreement shall be contested or denied by Lessee, or if Lessee shall deny that it has any further liability or obligation under this Agreement; (f) if Lessee's interest in this Agreement, the Vehicles or any portion thereof devolves on or passes to any person or entity, whether by operation of law or otherwise; (g) if Lessee (i) does not, or is unable to, or admits in writing its inability to, pay its debts as they become due; (ii) commences or institutes any case, proceeding or other action seeking relief on its behalf as debtor, or to adjudicate it a bankrupt or insolvent, or seeking reorganization, arrangement, adjustment, winding up, liquidation, dissolution, composition or other relief with respect to it or its debts under any existing or future law of any jurisdiction, domestic or foreign, relating to bankruptcy, insolvency, reorganization or relief of debtors; (iii) commences or institutes any case, proceeding or other action seeking appointment of a receiver, trustee, custodian or other similar official for it or for all or any substantial part of its property; or (iv) makes a general assignment for the benefit of creditors; or (h) if a receiver, trustee, custodian or other similar official is appointed for any substantial part of the assets of Lessee, which appointment is not vacated or stayed within 30 days.

**REMEDIES.** If an Event of Default occurs and is continuing, Lessor may, in its sole discretion, exercise one or more of the following remedies: (a) declare this Agreement in default; (b) terminate this Agreement and the leases hereunder in whole or in part, effective immediately upon Lessor's notice of such termination to Lessee; (c) declare the entire amount of rent and other obligations due, and to become due, under this Agreement for the entire term immediately due and payable; (d) immediately take possession of, or render unusable, each Vehicle wherever it may be located, without demand or notice, without any court order or other process of law and without liability to Lessee for any damages occasioned by such action, and no such actions shall constitute a termination of this Agreement and Lessee expressly authorizes Lessor and its agents to enter on any premises where any Vehicle may be found, for the purpose of repossessing or rendering unusable such Vehicle, and expressly waives any further interest in such Vehicle and any right of action arising out of such entry and repossession; (e) require Lessee to deliver the Vehicles to a location designated by Lessor, and for each day that Lessee shall fail to return any Vehicle, Lessor may demand an amount equal to the rent for such Vehicle, prorated on the basis of a thirty-day month, in effect immediately prior to such Event of Default; (f) recover from Lessee, not as a penalty but as liquidated damages, an amount equal to the sum of (i) all accrued and unpaid rent as of the date Lessor obtains possession of a Vehicle following Lessee's default (the "Repossession Date"), plus (ii) the present value of all future rent reserved in this Agreement for such Vehicle and contracted to be paid over the term of the lease, discounted at a discount rate determined by Lessor as of the Repossession Date, plus (iii) all reasonable costs and expenses incurred by Lessor by reason of such Event of Default and Lessor's exercise of its rights and remedies under this Agreement (collectively, "Enforcement Expenses"), including without limitation reasonable legal fees and expenses and expenses incurred in connection with the return, repossession or other recovery of a Vehicle and the sale, re-lease or other disposition thereof, plus (iv) the present value of the estimated residual value of such Vehicle as of the expiration of the lease, discounted at a Discount Rate determined by Lessor as of the Repossession Date, minus (v) any amounts received by Lessor from the sale of re-

lease of such Vehicle; (g) proceed on any collateral or other security given in connection with this Agreement; (h) proceed by court action to enforce performance by Lessee of this Agreement or to recover all damages and expenses incurred by Lessor by reason of any Event of Default; (i) terminate any other agreement that Lessor may have with Lessee; (j) sell the Vehicles at public or private sale, with or without notice to Lessee or advertisement (unless required by law), or otherwise dispose of, hold, use, operate, lease to others, or keep idle the Vehicles, and without any duty to account to Lessee for such action or inaction or for any proceeds with respect thereto (unless required by law), and apply the net proceeds thereof (after deducting all Enforcement Expenses incurred in connection therewith) to the amounts owed to Lessor under this Agreement; provided, however, that Lessee shall remain liable to Lessor for any deficiency that remains after any sale or lease of the Vehicles; and (k) exercise any other right or remedy available to Lessor under this Agreement or at law or in equity, including damages, specific performance, or rights and remedies under the UCC.

All of the foregoing rights and remedies are cumulative and will be in addition to all other rights and remedies available to Lessor under this Agreement. Lessor's failure to strictly enforce any provisions of this Agreement or any other right available to Lessor will not be deemed a waiver thereof and will not excuse Lessee from future performance.

**GOVERNING LAW; WAIVER OF JURY TRIAL; CHOICE OF FORUM.** This Agreement and the rights and obligations of the parties hereto shall be governed and interpreted according to the laws of the State of Kansas (without regard to the conflict of laws principles of such state), including all matters of construction, validity and performance, regardless of the location of the Vehicles. LESSEE AND LESSOR HEREBY IRREVOCABLY WAIVE THE RIGHT TO TRIAL BY JURY OF ANY CAUSE OF ACTION, CLAIM, COUNTERCLAIM OR CROSS-COMPLAINT IN ANY ACTION OR PROCEEDING TO WHICH LESSEE AND/OR LESSOR MAY BE A PARTY ON ANY MATTER WHATSOEVER BASED UPON, ARISING OUT OF, OR IN ANY WAY PERTAINING OR RELATED TO, OR CONNECTED WITH, THIS AGREEMENT OR ANY OTHER AGREEMENT OR INSTRUMENT EXECUTED IN CONNECTION HERewith OR ANY OBLIGATIONS HEREUNDER OR THEREUNDER. This waiver is knowingly, willingly and voluntarily made by Lessee and Lessor, who acknowledge that no representations have been made by any individual to induce this waiver of trial by jury or in any way to modify or nullify its effect. This waiver shall apply to any amendments, renewals, supplements or modifications to this Agreement or such other agreements or instruments. Each party irrevocably and unconditionally agrees that it will not commence any action, litigation or proceeding of any kind whatsoever against the other party in any way arising from or relating to this Agreement, and all other transactions, including, but not limited to, contract, equity, tort, fraud and statutory claims, in any forum other than the United States District Court for the District of Kansas or the courts of the State of Kansas sitting in Shawnee County, and any appellate court from any thereof. Each party irrevocably and unconditionally submits to the exclusive jurisdiction of such courts and agrees to bring any such action, litigation or proceeding only in the such courts. Each party agrees that a final judgment in any such action, litigation or proceeding is conclusive and may be enforced in other jurisdictions by suit on the judgment or in any other manner provided by law.

**Further Assurances.** Lessee will, and will cause third parties to, from time to time, do and perform any other act and execute, acknowledge, deliver, file and record (and will refile and rerecord whenever required) any and all further instruments required by law or reasonably requested by Lessor in order to carry out the intent and purpose of this Agreement, to establish and protect Lessor's rights and remedies hereunder or under applicable Law, and to perfect Lessor's ownership (including Lessor's tax ownership) of the Vehicles, in each case to Lessor's satisfaction, including such certificates of title as Lessor shall request, and Lessee hereby authorizes Lessor, in Lessee's name and as Lessee's attorney in fact, to do or file any of the foregoing without Lessee's authentication. Lessee hereby authorizes Lessor to correct any manifest errors in this Agreement, and Lessee will execute, or cause third parties to execute, any agreement, instrument or other document reasonably required by Lessor to evidence any such correction.

**ENTIRE AGREEMENT.** This written document contains the entire understanding between the parties hereto. No party has relied on any verbal representations from the other before entering into this Agreement.

By execution hereof, the signer hereby certifies that he has read the Lease, including all pages of the Lease and acknowledges receipt of this Agreement.

**LESSEE:**

Minooka CHSD#111 & CCD#201

By: \_\_\_\_\_

Name:

Title:

**LESSOR:**

Midwest Bus Sales, Inc.

By: \_\_\_\_\_

Name:

Title:

SAMPLE ONLY

Lease Date: \_\_\_\_\_

Lessee: \_\_\_\_\_

Vehicle I.D. # See Exhibit I

THIS ASSIGNMENT AND ACKNOWLEDGMENT OF ASSIGNMENT OF LEASE (*Assignment and Acknowledgment*) is entered into as of the 7/1/2022 by and between the above named Lessee and MIDWEST BUS LEASING LLC., a Kansas limited liability company ("Lessor," by assignment from Midwest Bus Sales, Inc.), with regard to MERCEDES-BENZ FINANCIAL SERVICES, USA LLC dba DAIMLER TRUCK FINANCIAL ("Lender"). Lessee and Lessor are sometimes collectively referred to herein as the "Parties."

1. Assignment. Lessor hereby collaterally assigns to Lender in accordance with the terms of that certain Security Agreement, Lessor's rights under the Vehicles Lease Agreement dated , between Midwest Bus Sales, Inc. (as lessor) and Lessee (the "Lease"), including without limitation Lessor's ownership interest, lien and other rights in the Vehicle(s) identified above, together with all rights which may have arisen before the date of this Assignment and Acknowledgment. Lessee and Lessor acknowledge and agree that Lender, in its sole discretion, may direct Lessee to make payment directly to Lender.
  
1. Acknowledgment of Encumbrance. The Parties acknowledge that the Vehicle(s) is encumbered by the lien of Lender, pursuant to that certain Security Agreement between Lessor and Lender; which lien is, and shall be, superior to the rights of Lessor and Lessee under the Lease. Lessee acknowledges and agrees that its rights under the Lease, including, but not limited to, the option to purchase, if any, and its rights in the Vehicle(s) identified above are in all respects subordinate, inferior and subject to the lien of Lender in the Lease and the Vehicle(s). The Parties acknowledge: (i) such lien shall continue to attach to the Vehicle(s) until all sums owed to Lender by Lessor are paid in full, together with all interest thereon; (ii) upon notice from Lender, Lessee will make lease or rental payments directly to Lender; (iii) Lessee will not make more than one rental payment in advance to Lessor; and (iv) Lessee will not hold Lender liable for the performance or non performance of any of Lessor's obligations under the Lease, or otherwise, nor will it withhold lease or rental payments from Lender on account of Lessor's performance or non-performance. Lessee hereby agrees not to sell, lease, sublease or assign any interest in the Vehicle(s) without the prior written consent of Lessor and Lender. The Parties acknowledge and agree that they shall provide notice of Lender's lien to any subsequent purchaser or lessee of the Vehicle, and shall further indemnify Lender from any liabilities or damages which may arise as a result of the failure to provide: (i) notice of Lender's lien; or (ii) notice to Lender of any transaction relating to the Vehicle. It is acknowledged by the Parties that Lender is intended to be a third-party beneficiary of this Assignment and Acknowledgment.
  
2. Binding Effect. This Assignment and Acknowledgment shall be binding upon the successors and assigns of each of the Parties.

**IN WITNESS WHEREOF, the undersigned have executed this Assignment and Acknowledgment as of the date first hereinabove written.**

**LESSEE:**

Minooka CHSD #111 & CCD  
#201

By: \_\_\_\_\_

Name:

Title:

**LESSOR:**

MIDWEST BUS LEASING, LLC, a Kansas  
Limited Liability Company

By: \_\_\_\_\_

Name:

Title:

SAMPLE ONLY

**ASSIGNMENT AND ASSUMPTION AGREEMENT**

**THIS ASSIGNMENT AND ASSUMPTION AGREEMENT**

(the "*Agreement*"), effective as of 7/1/2022 (the "*Effective Date*"), is by and between MIDWEST BUS SALES, INC., a Kansas corporation ("*Assignor*"), and MIDWEST BUS LEASING LLC, a Kansas limited liability company ("*Assignee*").

WHEREAS, Assignor has agreed to assign all of its rights, title and interests in, and Assignee has agreed to assume all of Assignor's duties and obligations under, that certain Vehicles Lease Agreement dated 12/28/2020, by and between Assignor and Sangamon Valley Cusd #9 (the "*Assigned Lease*").

NOW, THEREFORE, in consideration of the mutual covenants, terms and conditions set forth herein, and for other good and valuable consideration, the receipt and sufficiency of which are hereby acknowledged, the parties agree as follows:

1. \_\_\_\_\_ Assignor hereby sells, assigns, grants, conveys and transfers to Assignee all of Assignor's right, title and interest in and to (a) the Assigned Lease and (b) all vehicles described in, or subject to, the Assigned Lease. Assignee hereby accepts such assignment and assumes all of Assignor's duties and obligations under the Assigned Lease and agrees to pay, perform and discharge, as and when due, all of the obligations of Assignor under the Assigned Lease accruing on and after the Effective Date.

2. **Governing Law.** This Agreement shall be governed by and construed in accordance with the internal laws of the State of Kansas.

3. **Counterparts.** This Agreement may be executed in counterparts, each of which shall be deemed an original, but all of which together shall be deemed to be one and the same agreement. A signed copy of this Agreement delivered by email or other means of electronic transmission shall be deemed to have the same legal effect as delivery of an original signed version of this Agreement.

4. **Further Assurances.** Each of the parties hereto shall execute and deliver, at the reasonable request of the other party hereto, such additional documents, instruments, conveyances and assurances and take such further actions as such other party may reasonably request to carry out the provisions hereof and give effect to the transactions contemplated by this Agreement.

**IN WITNESS WHEREOF, the parties have executed this Agreement to be effective as of the Effective Date.**

**MIDWEST BUS SALES, INC.**

By: \_\_\_\_\_

**MIDWEST BUS LEASING LLC**

By: \_\_\_\_\_

# CSB Financial

An Affiliate of Central States Bus Sales

January 5, 2022

Minooka Community High School District # 111  
26655 W. Eames St.  
Channahon IL, 60410

PROPOSED LESSEE: Minooka Community High School District # 111  
PROPOSED LESSOR: CSB Financial  
DEALER: Central States Bus Sales, Inc.

Dear Sir or Madam:

CSB Financial and Central States Bus Sales are pleased to provide the following proposal for your review.

## PROPOSED TRANSACTION TERMS

<u>Quantity / Equipment</u>	<u>Unit Price</u>	<u>Term</u>	<u>Transaction Type</u>	<u>Rate</u>	<u>Annual Payment Per Unit</u>	<u>Balloon Payment Per Unit</u>
{10} New Blue Bird BBCV 77 pass	\$104,202	5 Years	Tax-Exempt Municipal Lease-Purchase; Annual Payments in Advance	3.25%	\$17,230.22	\$27,500.00

**Required Documents:** Agreement incorporating the Transaction Terms described above or other Transaction Terms mutually agreed by Customer and Lessor, together with additional terms and conditions set forth in such agreement, and related documentation.

**Taxes:** The prices and payment amounts set forth above are exclusive of all applicable taxes.

This proposal is a non-binding rate indication for discussion purposes only, and does not represent a commitment or obligation on the part of Lessor to enter into a lease or other agreement with Lessee to provide lease or other financing. Pricing with respect to any definitive transaction relating to any specific schedule of equipment will be adjusted to reflect any changes in market interest rates subsequent to the date of this proposal. Any lease or financing arrangement is subject to Lessor's underwriting procedures which include, but are not limited to (1) credit approval, including full disclosure of Lessee's and any other relevant party's financial statements and financial condition, and the absence of any deterioration in such financial condition subsequent to the date of this proposal; (2) pricing approval, residual approval (if applicable), risk and legal review and approval of all transaction documents; (3) satisfactory completion of Lessor's due diligence process; and (4) execution of all necessary definitive documentation.

If the proposed transaction is a tax-exempt municipal lease-purchase, this proposal further assumes that (i) Lessee is a state or a political subdivision thereof within the meaning of Section 103c of the Internal Revenue Code of 1986, as amended (the "Code"), (ii) the Equipment is essential to Lessee's government operation, (iii) the interest components of payments made by Lessee under any financing described in this proposal would be exempt from federal income tax and (iv) any obligation of Lessee to make payments under any financing described in this proposal would be a "tax-exempt obligation" for the purposes and within the meaning of Section 265(b)(3) of the Code.

This proposal is presented to Lessee on a commercial, arm's-length basis, and neither CSB Financial nor any of its affiliates or agents has previously or by virtue of or in connection with this proposal provided any advice or recommendation to Lessee with respect to the proposed transaction or otherwise and has not and is not acting as a "municipal advisor" within the meaning of Section 975 of the Dodd-Frank Wall Street Reform and Consumer Protection Act, as amended and in effect from time to time, together with the rules and regulations promulgated thereunder and in effect from time to time. **Lessee is free to retain an advisor with respect to the proposed transaction.**

Thank you very much for the opportunity to provide this proposal. We look forward to your favorable reply.

Kind regards,

CSB Financial

Minooka Community High School District # 111 1-5-22  
 Compound Period: Monthly  
 Nominal Annual Rate: 3.250 %

**AMORTIZATION SCHEDULE - Normal Amortization, 360 Day Year**

	<b>Date</b>	<b>Lease Payment</b>	<b>Balloon</b>	<b>Interest</b>	<b>Principal</b>	<b>Balance</b>
<b>Lease</b>	07/18/2022					104,202.00
<b>1</b>	07/18/2022	17,230.22		0.00	17,230.22	86,971.78
<b>2</b>	07/18/2023	17,230.22		2,869.11	14,361.11	72,610.67
<b>3</b>	07/18/2024	17,230.22		2,395.35	14,834.87	57,775.80
<b>4</b>	07/18/2025	17,230.22		1,905.97	15,324.25	42,451.55
<b>5</b>	07/18/2026	17,230.22		1,400.44	15,829.78	26,621.77
<b>Balloon</b>	07/18/2027		27,500.00	878.23	26,621.77	0.00
<b>Grand Totals</b>		<b>86,151.10</b>	<b>27,500.00</b>	<b>9,449.10</b>	<b>104,202.00</b>	

# CSB Financial

An Affiliate of Central States Bus Sales

January 5, 2022

Minooka Community Consolidated School District #201  
305 West Church St.  
Minooka, IL 60447

PROPOSED LESSEE: Minooka Community Consolidated School District #201  
PROPOSED LESSOR: CSB Financial  
DEALER: Central States Bus Sales, Inc.

Dear Sir or Madam:

CSB Financial and Central States Bus Sales are pleased to provide the following proposal for your review.

## PROPOSED TRANSACTION TERMS

<u>Quantity / Equipment</u>	<u>Unit Price</u>	<u>Term</u>	<u>Transaction Type</u>	<u>Rate</u>	<u>Annual Payment Per Unit</u>	<u>Balloon Payment Per Unit</u>
{10} New Blue Bird BBCV 77 pass	\$104,202	5 Years	Tax-Exempt Municipal Lease-Purchase; Annual Payments in Advance	3.25%	\$17,230.22	\$27,500.00

**Required Documents:** Agreement incorporating the Transaction Terms described above or other Transaction Terms mutually agreed by Customer and Lessor, together with additional terms and conditions set forth in such agreement, and related documentation.

**Taxes:** The prices and payment amounts set forth above are exclusive of all applicable taxes.

This proposal is a non-binding rate indication for discussion purposes only, and does not represent a commitment or obligation on the part of Lessor to enter into a lease or other agreement with Lessee to provide lease or other financing. Pricing with respect to any definitive transaction relating to any specific schedule of equipment will be adjusted to reflect any changes in market interest rates subsequent to the date of this proposal. Any lease or financing arrangement is subject to Lessor's underwriting procedures which include, but are not limited to (1) credit approval, including full disclosure of Lessee's and any other relevant party's financial statements and financial condition, and the absence of any deterioration in such financial condition subsequent to the date of this proposal; (2) pricing approval, residual approval (if applicable), risk and legal review and approval of all transaction documents; (3) satisfactory completion of Lessor's due diligence process; and (4) execution of all necessary definitive documentation.

If the proposed transaction is a tax-exempt municipal lease-purchase, this proposal further assumes that (i) Lessee is a state or a political subdivision thereof within the meaning of Section 103c of the Internal Revenue Code of 1986, as amended (the "Code"), (ii) the Equipment is essential to Lessee's government operation, (iii) the interest components of payments made by Lessee under any financing described in this proposal would be exempt from federal income tax and (iv) any obligation of Lessee to make payments under any financing described in this proposal would be a "tax-exempt obligation" for the purposes and within the meaning of Section 265(b)(3) of the Code.

This proposal is presented to Lessee on a commercial, arm's-length basis, and neither CSB Financial nor any of its affiliates or agents has previously or by virtue of or in connection with this proposal provided any advice or recommendation to Lessee with respect to the proposed transaction or otherwise and has not and is not acting as a "municipal advisor" within the meaning of Section 975 of the Dodd-Frank Wall Street Reform and Consumer Protection Act, as amended and in effect from time to time, together with the rules and regulations promulgated thereunder and in effect from time to time. **Lessee is free to retain an advisor with respect to the proposed transaction.**

Thank you very much for the opportunity to provide this proposal. We look forward to your favorable reply.

Kind regards,

CSB Financial

Minooka Community Consolidated School District #201 1-5-22  
 Compound Period: Monthly  
 Nominal Annual Rate: 3.250 %

**AMORTIZATION SCHEDULE - Normal Amortization, 360 Day Year**

	<b>Date</b>	<b>Lease Payment</b>	<b>Balloon</b>	<b>Interest</b>	<b>Principal</b>	<b>Balance</b>
<b>Lease</b>	07/18/2022					104,202.00
<b>1</b>	07/18/2022	17,230.22		0.00	17,230.22	86,971.78
<b>2</b>	07/18/2023	17,230.22		2,869.11	14,361.11	72,610.67
<b>3</b>	07/18/2024	17,230.22		2,395.35	14,834.87	57,775.80
<b>4</b>	07/18/2025	17,230.22		1,905.97	15,324.25	42,451.55
<b>5</b>	07/18/2026	17,230.22		1,400.44	15,829.78	26,621.77
<b>Balloon</b>	07/18/2027		27,500.00	878.23	26,621.77	0.00
<b>Grand Totals</b>		<b>86,151.10</b>	<b>27,500.00</b>	<b>9,449.10</b>	<b>104,202.00</b>	

**PLEASE NOTE: This Sample Contract, presented upon your request, may or may not contain the same language as the contract proposed after credit approval is obtained. As such, no negotiation of contract terms will occur until after credit approval and issuance of formal contract.**

## GOVERNMENT OBLIGATION CONTRACT

**Obligor**

, Illinois

**Dated as of**

**Obligee**

Central States Bus Sales, Inc.

2450 Cassens Drive

St. Louis, Missouri 63026

This Government Obligation Contract dated as of the date listed above is between Obligee and Obligor listed directly above. Obligee desires to finance the purchase of the Equipment described in Exhibit A to Obligor and Obligor desires to have Obligee finance the purchase of the Equipment subject to the terms and conditions of this Contract which are set forth below.

### I. Definitions

**Section 1.01 Definitions.** The following terms will have the meanings indicated below unless the context clearly requires otherwise:

- "Additional Schedule" refers to the proper execution of additional schedules to Exhibit A and Exhibit B, as well as other exhibits or documents that may be required by the Obligee all of which relate to the financing of additional Equipment.
- "Budget Year" means the Obligor's fiscal year.
- "Commencement Date" is the date when Obligor's obligation to pay Contract Payments begins.
- "Contract" means this Government Obligation Contract and all Exhibits attached hereto, all addenda, modifications, schedules, refinancings, guarantees and all documents relied upon by Obligee prior to execution of this Contract.
- "Contract Payments" means the payments Obligor is required to make under this Contract as set forth on Exhibit B.
- "Contract Term" means the Original Term and all Renewal Terms.
- "Exhibit" includes the Exhibits attached hereto, and any "Additional Schedule", whether now existing or subsequently created.
- "Equipment" means all of the Items of Equipment listed on Exhibit A and any Additional Schedule, whether now existing or subsequently created, and all replacements, restorations, modifications and improvements.
- "Government" as used in the title hereof means a State or a political subdivision of the State within the meaning of Section 103(a) of the Internal Revenue Code of 1986, as amended ("Code"), or a constituted authority or district authorized to issue obligations on behalf of the State or political subdivision of the State within the meaning of Treasury Regulation 1.103-1(b), or a qualified volunteer fire company within the meaning of section 150(e)(1) of the Code.
- "Obligee" means the entity originally listed above as Obligee or any of its assignees.
- "Obligor" means the entity listed above as Obligor and which is financing the Equipment through Obligee under the provisions of this Contract.
- "Original Term" means the period from the Commencement Date until the end of the Budget Year of Obligor.
- "Renewal Term" means the annual term which begins at the end of the Original Term and which is simultaneous with Obligor's Budget Year and each succeeding Budget Year for the number of Budget Years necessary to comprise the Contract Term.
- "State" means the state in which Obligor is located.

### II. Obligor Warranties

**Section 2.01 Obligor represents, warrants and covenants as follows for the benefit of Obligee or its assignees:**

- (a) Obligor is an "issuer of tax exempt obligations" because Obligor is the State or a political subdivision of the State within the meaning of Section 103(a) of the Internal Revenue Code of 1986, as amended, (the "Code") or because Obligor is a constituted authority or district authorized to issue obligations on behalf of the State or political subdivision of the State within the meaning of Treasury Regulation 1.103-1(b), or a qualified volunteer fire company within the meaning of section 150(e)(1) of the Code.
- (b) Obligor has complied with any requirement for a referendum and/or competitive bidding.
- (c) Obligor has complied with all statutory laws and regulations that may be applicable to the execution of this Contract; Obligor, and its officer executing this Contract, are authorized under the Constitution and laws of the State to enter into this Contract and have used and followed all proper procedures of its governing body in executing and delivering this Contract. The officer of Obligor executing this Contract has the authority to execute and deliver this Contract. This Contract constitutes a legal, valid, binding and enforceable obligation of the Obligor in accordance with its terms.
- (d) Obligor shall use the Equipment only for essential, traditional government purposes.
- (e) In the event that the Internal Revenue Code of 1986, as currently amended (the "Code"), should be further amended or replaced: (i) to reduce corporate and/or individual income tax rates or (ii) to reduce or eliminate the extent to which the interest portion of the Contract Payments is excludable from gross income, then, at the written request of Obligee or its assigns, Obligor shall pay to Obligee or its assigns with each Contract Payment payable after the effective date of such amendment or replacement such additional amount as necessary to bring the after tax yield on each such Contract Payment to the same effective rate that Obligee or its assigns would have received had there occurred no such amendment to or replacement of the Code. Notwithstanding any other provision of this Agreement, Obligor shall have the right to exercise its option to purchase the Equipment pursuant to Section 3.04 hereof on the effective date of any such amendment or replacement.
- (f) Obligor will submit to the Secretary of the Treasury an information reporting statement as required by the Code.
- (g) Upon request by Obligee, Obligor will provide Obligee with current financial statements, reports, budgets or other relevant fiscal information.
- (h) Obligor shall retain the Equipment free of any hazardous substances as defined in the Comprehensive Environmental Response, Compensation and Liability Act, 42 U.S.C. 9601 et. seq. as amended and supplemented.
- (i) Obligor hereby warrants the General Fund of the Obligor is the primary source of funds or a backup source of funds from which the Contract Payments will be made.
- (j) Obligor presently intends to continue this Contract for the Original Term and all Renewal Terms as set forth on Exhibit B hereto. The official of Obligor responsible for budget preparation will include in the budget request for each Budget Year the Contract Payments to become due in such Budget Year, and will use all reasonable and lawful means available to secure the appropriation of money for such Budget Year sufficient to pay the Contract Payments coming due therein. Obligor reasonably believes that moneys can and will lawfully be appropriated and made available for this purpose.
- (k) Obligor has selected both the Equipment and the vendor(s) from whom the Equipment is to be purchased upon its own judgment and without reliance on any manufacturer, merchant, vendor or distributor, or agent thereof, of such equipment to the public.
- (l) Obligor owns free and clear of any liens any additional collateral pledged, subject only to the lien described herein; Obligor has not and will not, during the Contract Term, create, permit, incur or assume any levies, liens or encumbrances of any kind with respect to the Equipment and any additional collateral except those created by this Contract.
- (m) The indebtedness incurred under this Contract when aggregated with existing indebtedness may not exceed the debt limits provided by applicable law under either/or the Local Government Debt Reform Act and the Illinois Municipal Code.

**Section 2.02 Escrow Agreement.** In the event both Obligee and Obligor mutually agree to utilize an Escrow Account, then immediately following the execution and delivery of this Contract, Obligee and Obligor agree to execute and deliver and to cause Escrow Agent to execute and deliver the Escrow Agreement. This Contract shall take effect only upon execution and delivery of the Escrow Agreement by the parties thereto. Obligee shall deposit or cause to be deposited with the Escrow Agent for credit to the Equipment Acquisition Fund the sum of N/A, which shall be held, invested and disbursed in accordance with the Escrow Agreement.

### III. Acquisition of Equipment, Contract Payments and the Purchase Option Price

**Section 3.01 Acquisition and Acceptance.** Obligor shall be solely responsible for the ordering of the Equipment and for the delivery and installation of the Equipment. Execution of the Certificate of Acceptance or, alternatively, Payment Request and Equipment Acceptance Form, by a duly authorized representative of Obligor, shall constitute acceptance of the Equipment on behalf of the Obligor.

**Section 3.02 Contract Payments.** Obligor shall pay Contract Payments exclusively to Obligee or its assignees in lawful, legally available money of the United States of America. The Contract Payments shall be sent to the location specified by the Obligee or its assignees. The Contract Payments, payable without notice or demand, are due as set forth on Exhibit B. Obligee shall have

the option to charge interest at the highest lawful rate on any Contract Payment received later than the due date for the number of days that the Contract Payment(s) were late, plus any additional accrual on the outstanding balance for the number of days that the Contract Payment(s) were late. Obligees shall also have the option, on monthly payments only, to charge a late fee of up to 10% of the monthly Contract Payment that is past due. Furthermore, Obligor agrees to pay any fees associated with the use of a payment system other than check, wire transfer, or ACH. Once all amounts due Obligees hereunder have been received, Obligees will release any and all of its rights, title and interest in the Equipment.

**Section 3.03 CONTRACT PAYMENTS UNCONDITIONAL.** THE OBLIGATIONS OF OBLIGOR TO MAKE CONTRACT PAYMENTS AND TO PERFORM AND OBSERVE THE OTHER COVENANTS CONTAINED IN THIS CONTRACT SHALL BE ABSOLUTE AND UNCONDITIONAL IN ALL EVENTS WITHOUT ABATEMENT, DIMINUTION, DEDUCTION, SET-OFF, OR SUBJECT TO DEFENSE OR COUNTERCLAIM.

**Section 3.04 Purchase Option Price.** Upon thirty (30) days written notice, Obligor shall have the option to pay, in addition to the Contract Payment, the corresponding Purchase Option Price which is listed on the same line on Exhibit B. This option is only available to the Obligor on the Contract Payment date and no partial prepayments are allowed. If Obligor chooses this option and pays the Purchase Option Price to Obligees then Obligees will transfer any and all of its rights, title and interest in the Equipment to Obligor.

**Section 3.05 Contract Term.** The Contract Term shall be the Original Term and all Renewal Terms until all the Contract Payments are paid as set forth on Exhibit B except as provided under Section 9.01 below.

**Section 3.06 Disclaimer of Warranties.** OBLIGEE MAKES NO WARRANTY OR REPRESENTATION, EITHER EXPRESS OR IMPLIED, AS TO THE VALUE, DESIGN, CONDITION, MERCHANTABILITY, FITNESS FOR PARTICULAR PURPOSE OR ANY OTHER WARRANTY WITH RESPECT TO THE EQUIPMENT. OBLIGEE IS NOT A MANUFACTURER, SELLER, VENDOR OR DISTRIBUTOR, OR AGENT THEREOF, OF SUCH EQUIPMENT; NOR IS OBLIGEE A MERCHANT OR IN THE BUSINESS OF DISTRIBUTING SUCH EQUIPMENT TO THE PUBLIC. OBLIGEE SHALL NOT BE LIABLE FOR ANY INCIDENTAL, INDIRECT, SPECIAL OR CONSEQUENTIAL DAMAGE ARISING OUT OF THE INSTALLATION, OPERATION, POSSESSION, STORAGE OR USE OF THE EQUIPMENT BY OBLIGOR.

#### IV. Appropriation of Money

**Section 4.01 Appropriation.** Obligor shall be obligated to appropriate sufficient money to make all the Contract Payments for the Original Term and each successive Renewal Term as each Contract Payment comes due. If Obligor fails to make an appropriation of money to make any Contract Payment, then an Event of Default will be deemed to have occurred as set forth under Section IX below. This Contract represents a binding and enforceable promise to pay in accordance with the terms herein by the Obligor.

#### V. Insurance, Damage, Insufficiency of Proceeds

**Section 5.01 Insurance.** Obligor shall maintain both property insurance and liability insurance at its own expense with respect to the Equipment. Obligor shall be solely responsible for selecting the insurer(s) and for making all premium payments and ensuring that all policies are continuously kept in effect during the period when Obligor is required to make Contract Payments. Obligor shall provide Obligees with a Certificate of Insurance which lists the Obligees and/or assigns as a loss payee and an additional insured on the policies with respect to the Equipment.

- (a) Obligor shall insure the Equipment against any loss or damage by fire and all other risks covered by the standard extended coverage endorsement then in use in the State and any other risks reasonably required by Obligees in an amount at least equal to the then applicable Purchase Option Price of the Equipment. Alternatively, Obligor may insure the Equipment under a blanket insurance policy or policies.
- (b) The liability insurance shall insure Obligees from liability and property damage in any form and amount satisfactory to Obligees.
- (c) Obligor may self-insure against the casualty risks and liability risks described above. If Obligor chooses this option, Obligor must furnish Obligees with a certificate and/or other documents which evidences such coverage.
- (d) All insurance policies issued or affected by this Section shall be so written or endorsed such that the Obligees and its assignees are named additional insureds and loss payees and that all losses are payable to Obligor and Obligees or its assignees as their interests may appear. Each policy issued or affected by this Section shall contain a provision that the insurance company shall not cancel or materially modify the policy without first giving thirty (30) days advance notice to Obligees or its assignees. Obligor shall furnish to Obligees certificates evidencing such coverage throughout the Contract Term.

**Section 5.02 Damage to or Destruction of Equipment.** Obligor assumes the risk of loss or damage to the Equipment. If the Equipment or any portion thereof is lost, stolen, damaged, or destroyed by fire or other casualty, Obligor will immediately report all such losses to all possible insurers and take the proper procedures to obtain all insurance proceeds. At the option of Obligees, Obligor shall either (1) apply the Net Proceeds to replace, repair or restore the Equipment or (2) apply the Net Proceeds to the applicable Purchase Option Price. For purposes of this Section and Section 5.03, the term Net Proceeds shall mean the amount of insurance proceeds collected from all applicable insurance policies after deducting all expenses incurred in the collection thereof.

**Section 5.03 Insufficiency of Net Proceeds.** If there are no Net Proceeds for whatever reason or if the Net Proceeds are insufficient to pay in full the cost of any replacement, repair, restoration, modification or improvement of the Equipment, then Obligor shall, at the option of Obligees, either (1) complete such replacement, repair, restoration, modification or improvement and pay any costs thereof in excess of the amount of the Net Proceeds or (2) apply the Net Proceeds to the Purchase Option Price and pay the deficiency, if any, to the Obligees.

**Section 5.04 Obligor Negligence.** Obligor assumes all risks and liabilities, whether or not covered by insurance, for loss or damage to the Equipment and for injury to or death of any person or damage to any property whether such injury or death be with respect to agents or employees of Obligor or of third parties, and whether such property damage be to Obligor's property or the property of others (including, without limitation, liabilities for loss or damage related to the release or threatened release of hazardous substances under the Comprehensive Environmental Response, Compensation and Liability Act, the Resource Conservation and Recovery Act or similar or successor law or any State or local equivalent now existing or hereinafter enacted which in any manner arise out of or are incident to any possession, use, operation, condition or storage of any Equipment by Obligor), which is proximately caused by the negligent conduct of Obligor, its officers, employees and agents.

**Section 5.05 Reimbursement.** Obligor hereby assumes responsibility for and agrees to reimburse Obligees for all liabilities, obligations, losses, damages, penalties, claims, actions, costs and expenses (including reasonable attorneys' fees) of whatsoever kind and nature, imposed on, incurred by or asserted against Obligees that in any way relate to or arise out of a claim, suit or proceeding, based in whole or in part upon the negligent conduct of Obligor, its officers, employees and agents, or arose out of installation, operation, possession, storage or use of any item of the Equipment, to the maximum extent permitted by law.

#### VI. Title and Security Interest

**Section 6.01 Title.** Title to the Equipment shall vest in Obligor when Obligor acquires and accepts the Equipment. Title to the Equipment will automatically transfer to the Obligees in the event Obligor defaults under Section 9.01. In such event, Obligor shall execute and deliver to Obligees such documents as Obligees may request to evidence the passage of legal title to the Equipment to Obligees.

**Section 6.02 Security Interest.** To secure the payment of all Obligor's obligations under this Contract, as well as all other obligations, debts and liabilities, plus interest thereon, whether now existing or subsequently created, Obligor hereby grants to Obligees a security interest under the Uniform Commercial Code constituting a first lien on the Equipment described more fully on Exhibit A. Furthermore, Obligor agrees that any other collateral securing any other obligation(s) to Obligees, whether offered prior to or subsequent hereto, also secures this obligation. The security interest established by this section includes not only all additions, attachments, repairs and replacements to the Equipment but also all proceeds therefrom. Obligor authorizes Obligees to prepare and record any Financing Statement required under the Uniform Commercial Code to perfect the security interest created hereunder. Obligor agrees that any Equipment listed on Exhibit A is and will remain personal property and will not be considered a fixture even if attached to real property.

#### VII. Assignment

**Section 7.01 Assignment by Obligees.** All of Obligees's rights, title and/or interest in and to this Contract may be assigned and reassigned in whole or in part to one or more assignees or sub-assignees by Obligees at any time without the consent of Obligor. No such assignment shall be effective as against Obligor until the assignor shall have filed with Obligor written notice of assignment identifying the assignee. Obligor shall pay all Contract Payments due hereunder relating to such Equipment to or at the direction of Obligees or the assignee named in the notice of assignment. Obligor shall keep a complete and accurate record of all such assignments.

**Section 7.02 Assignment by Obligor.** None of Obligor's right, title and interest under this Contract and in the Equipment may be assigned by Obligor unless Obligees approves of such assignment in writing before such assignment occurs and only after Obligor first obtains an opinion from nationally recognized counsel stating that such assignment will not jeopardize the tax-exempt status of the obligation.

#### VIII. Maintenance of Equipment

**Section 8.01 Equipment.** Obligor shall keep the Equipment in good repair and working order, and as required by manufacturer's and warranty specifications. If Equipment consists of copiers, Obligor is required to enter into a copier maintenance/service agreement. Obligees shall have no obligation to inspect, test, service, maintain, repair or make improvements or additions to the Equipment under any circumstances. Obligor will be liable for all damage to the Equipment, other than normal wear and tear, caused by Obligor, its employees or its agents. Obligor shall pay for and obtain all permits, licenses and taxes related to the ownership, installation, operation, possession, storage or use of the Equipment. If the Equipment includes any titled vehicle(s), then Obligor is responsible for obtaining such title(s) from the State and also for ensuring that Obligees is listed as First Lienholder on all of the title(s). Obligor shall not use the Equipment to haul, convey or transport hazardous waste as defined in the Resource Conservation and Recovery Act, 42 U.S.C. 6901 et. seq. Obligor agrees that Obligees or its Assignee may execute any additional documents including financing statements, affidavits, notices, and similar instruments, for and on behalf of Obligor which Obligees deems necessary or appropriate to protect Obligees's interest in the Equipment and in this Contract. Obligor shall allow Obligees to examine and inspect the Equipment at all reasonable times.

#### IX. Default

**Section 9.01 Events of Default defined.** The following events shall constitute an "Event of Default" under this Contract:

- (a) Failure by Obligor to pay any Contract Payment listed on Exhibit B for fifteen (15) days after such payment is due according to the Payment Date listed on Exhibit B.

- (b) Failure to pay any other payment required to be paid under this Contract at the time specified herein and a continuation of said failure for a period of fifteen (15) days after written notice by Obligees that such payment must be made. If Obligor continues to fail to pay any payment after such period, then Obligees may, but will not be obligated to, make such payments and charge Obligor for all costs incurred plus interest at the highest lawful rate.
- (c) Failure by Obligor to observe and perform any warranty, covenant, condition, promise or duty under this Contract for a period of thirty (30) days after written notice specifying such failure is given to Obligor by Obligees, unless Obligees agrees in writing to an extension of time. Obligees will not unreasonably withhold its consent to an extension of time if corrective action is instituted by Obligor. Subsection (c) does not apply to Contract Payments and other payments discussed above.
- (d) Any statement, material omission, representation or warranty made by Obligor in or pursuant to this Contract which proves to be false, incorrect or misleading on the date when made regardless of Obligor's intent and which materially adversely affects the rights or security of Obligees under this Contract.
- (e) Any provision of this Contract which ceases to be valid for whatever reason and the loss of such provision would materially adversely affect the rights or security of Obligees.
- (f) Obligor admits in writing its inability to pay its obligations.
- (g) Obligor defaults on one or more of its other obligations.
- (h) Obligor becomes insolvent, is unable to pay its debts as they become due, makes an assignment for the benefit of creditors, applies for or consents to the appointment of a receiver, trustee, conservator, custodian, or liquidator of Obligor, or all or substantially all of its assets, or a petition for relief is filed by Obligor under federal bankruptcy, insolvency or similar laws, or is filed against Obligor and is not dismissed within thirty (30) days thereafter.

**Section 9.02 Remedies on Default.** Whenever any Event of Default exists, Obligees shall have the right to take one or any combination of the following remedial steps:

- (a) Obligees, with or without terminating this Contract, may collect each installment of Contract Payments as it becomes due and payable with respect to the Equipment in accordance with Exhibit B for the entire Contract Term.
- (b) Obligees, with or without terminating this Contract, may repossess any or all of the Equipment by giving Obligor written notice to deliver the Equipment to the location designated by Obligees. In the event Obligor fails to do so within ten (10) days after receipt of such notice, Obligees may enter upon Obligor's premises where the Equipment is kept and take possession of the Equipment and charge Obligor for costs incurred in repossessing the Equipment, including reasonable attorneys' fees. Obligor hereby expressly waives any damages occasioned by such repossession. If the Equipment or any portion of it has been destroyed or damaged beyond repair, Obligor shall pay the applicable Purchase Option Price of the damaged or destroyed Equipment as set forth in the Installment Payment Schedule. Notwithstanding the fact that Obligees has taken possession of the Equipment, Obligor shall continue to be responsible for the Contract Payments with respect thereto as and when such Contract Payments become or would have become due and payable.
- (c) If Obligees, in its discretion, takes possession and disposes of the Equipment or any portion thereof, Obligees shall apply the proceeds of any such disposition to pay the following items in the following order: (i) all costs (including, but not limited to, attorneys' fees) incurred in securing possession of the Equipment; (ii) all expenses incurred in completing the disposition; (iii) any sales or transfer taxes; and (iv) the balance of any Contract Payments with respect thereto as and when such Installment Payment would become due and payable. Any disposition proceeds remaining after the requirements of clauses (i), (ii), (iii), (iv) have been met shall be paid to Obligor.
- (d) Obligees may take any other remedy available at law or in equity with respect to an Event of Default, including (without limitation) those requiring Obligor to perform any of its obligations under this Contract or to pay any moneys due and payable to Obligees, provided Obligees shall have no right to accelerate Contract Payments or otherwise declare any Contract Payments not then in default to be immediately due and payable.

**Section 9.03 No Remedy Exclusive.** No remedy herein conferred upon or reserved to Obligees is intended to be exclusive and every such remedy shall be cumulative and shall be in addition to every other remedy given under this Contract now or hereafter existing at law or in equity. No delay or omission to exercise any right or power accruing upon any default shall impair any such right or shall be construed to be a waiver thereof.

**Section 9.04 Return of Equipment and Storage.**

- (a) **Surrender:** The Obligor shall, at its own expense, surrender the Equipment, any additional collateral and all required documentation to evidence transfer of title from Obligor to the Obligees in the event of a default by delivering the Equipment and any additional collateral to the Obligees to a location accessible by common carrier and designated by Obligees. In the case that any of the Equipment and any additional collateral consists of software, Obligor shall destroy all intangible items constituting such software and shall deliver to Obligees all tangible items constituting such software. At Obligees's request, Obligor shall also certify in a form acceptable to Obligees that Obligor has complied with the above software return provisions and that they will immediately cease using the software and that they shall permit Obligees and/or the vendor of the software to inspect Obligor's locations to verify compliance with the terms hereto.
- (b) **Delivery:** The Equipment and any additional collateral shall be delivered to the location designated by the Obligees by a common carrier unless the Obligees agrees in writing that a common carrier is not needed. When the Equipment and any additional collateral is delivered into the custody of a common carrier, the Obligor shall arrange for the shipping of the item and its insurance in transit in accordance with the Obligees's instructions and at the Obligor's sole expense. Obligor at its expense shall completely sever and disconnect the Equipment and any additional collateral or its component parts from the Obligor's property all without liability to the Obligees. Obligor shall pack or crate the Equipment and any additional collateral and all of the component parts of the Equipment and any additional collateral carefully and in accordance with any recommendations of the manufacturer. The Obligor shall deliver to the Obligees the plans, specifications, operation manuals or other warranties and documents furnished by the manufacturer or vendor on the Equipment and any additional collateral and such other documents in the Obligor's possession relating to the maintenance and methods of operation of such Equipment and any additional collateral.
- (c) **Condition:** When the Equipment is surrendered to the Obligees it shall be in the condition and repair required to be maintained under this Contract. It will also meet all legal regulatory conditions necessary for the Obligees to sell or lease it to a third party and be free of all liens. If Obligees reasonably determines that the Equipment or an item of the Equipment, once it is returned, is not in the condition required hereby, Obligees may cause the repair, service, upgrade, modification or overhaul of the Equipment or an item of the Equipment to achieve such condition and upon demand, Obligor shall promptly reimburse Obligees for all amounts reasonably expended in connection with the foregoing.
- (d) **Storage:** Upon written request by the Obligees, the Obligor shall provide free storage for the Equipment and any additional collateral for a period not to exceed 60 days after the expiration of the Contract Term before returning it to the Obligees. The Obligor shall arrange for the insurance described to continue in full force and effect with respect to such item during its storage period and the Obligees shall reimburse the Obligor on demand for the incremental premium cost of providing such insurance.

**X. Miscellaneous**

**Section 10.01 Notices.** All notices shall be sufficiently given and shall be deemed given when delivered or mailed by registered mail, postage prepaid, to the parties at their respective places of business as first set forth herein or as the parties shall designate hereafter in writing.

**Section 10.02 Binding Effect.** Obligor acknowledges this Contract is not binding upon the Obligees or its assignees unless the Conditions to Funding listed on the Documentation Instructions have been met to Obligees's satisfaction, and Obligees has executed the Contract. Thereafter, this Contract shall inure to the benefit of and shall be binding upon Obligees and Obligor and their respective successors and assigns.

**Section 10.03 Severability.** In the event any provision of this Contract shall be held invalid or unenforceable by any court of competent jurisdiction, such holding shall not invalidate or render unenforceable any other provision hereof.

**Section 10.04 Amendments, Addenda, Changes or Modifications.** This Contract may be amended, added to, changed or modified by written agreement duly executed by Obligees and Obligor. Furthermore, Obligees reserves the right to directly charge or amortize into the remaining balance due from Obligor, a reasonable fee, to be determined at that time, as compensation to Obligees for the additional administrative expense resulting from such amendment, addenda, change or modification requested by Obligor.

**Section 10.05 Execution in Counterparts.** This Contract may be simultaneously executed in several counterparts, each of which shall be an original and all of which shall constitute but one and the same instrument.

**Section 10.06 Captions.** The captions or headings in this Contract do not define, limit or describe the scope or intent of any provisions or sections of this Contract.

**Section 10.07 Master Contract.** This Contract can be utilized as a Master Contract. This means that the Obligees and the Obligor may agree to the financing of additional Equipment under this Contract at some point in the future by executing one or more Additional Schedules to Exhibit A and Exhibit B, as well as other exhibits or documents that may be required by Obligees. Additional Schedules will be consecutively numbered on each of the exhibits which make up the Additional Schedule and all the terms and conditions of the Contract shall govern each Additional Schedule.

**Section 10.08 Entire Writing.** This Contract constitutes the entire writing between Obligees and Obligor. No waiver, consent, modification or change of terms of this Contract shall bind either party unless in writing and signed by both parties, and then such waiver, consent, modification or change shall be effective only in the specific instance and for the specific purpose given. There are no understandings, agreements, representations, conditions, or warranties, express or implied, which are not specified herein regarding this Contract, the Equipment or any additional collateral, financed hereunder. Any terms and conditions of any purchase order or other documents submitted by Obligor in connection with this Contract which are in addition to or inconsistent with the terms and conditions of this Contract will not be binding on Obligees and will not apply to this Contract.

Obligee and Obligor have caused this Contract to be executed in their names by their duly authorized representatives listed below.

**Central States Bus Sales, Inc.  
By Constant Capital Corp., Its Agent**

\_\_\_\_\_  
Signature  
\_\_\_\_\_  
Printed Name and Title

\_\_\_\_\_  
Signature  
\_\_\_\_\_  
Printed Name and Title

SAMPLE

EXHIBIT A

DESCRIPTION OF EQUIPMENT

RE: Government Obligation Contract dated as of \_\_\_\_\_, between Central States Bus Sales, Inc. (Obligee) and (Obligor)

---

Below is a detailed description of all the items of Equipment including quantity, model number and serial number where applicable:

SAMPLE

Physical Address of Equipment after Delivery : \_\_\_\_\_

EXHIBIT B  
PAYMENT SCHEDULE

RE: Government Obligation Contract dated as of \_\_\_\_\_, between Central States Bus Sales, Inc. (Obligee) and (Obligor)

---

Date of First Payment:  
Original Balance:  
Total Number of Payments:  
Number of Payments Per Year:

<u>Pmt No.</u>	<u>Due Date</u>	<u>Contract Payment</u>	<u>Applied to Interest</u>	<u>Applied to Principal</u>	<u>*Purchase Option Price</u>
----------------	-----------------	-------------------------	----------------------------	-----------------------------	-------------------------------

\_\_\_\_\_  
Signature

\_\_\_\_\_  
Printed Name and Title

\*Assumes all Contract Payments due to date are paid

SAMPLE

EXHIBIT C  
CERTIFICATE OF ACCEPTANCE

RE: Government Obligation Contract dated as of \_\_\_\_\_, between Central States Bus Sales, Inc. (Obligee) and (Obligor)

I, the undersigned, hereby certify that I am a duly qualified representative of Obligor and that I have been given the authority by the Governing Body of Obligor to sign this Certificate of Acceptance with respect to the above referenced Contract. I hereby certify that:

1. The Equipment described on Exhibit A has been delivered and installed in accordance with Obligor's specifications.
2. Obligor has conducted such inspection and/or testing of the Equipment as it deems necessary and appropriate and hereby acknowledges that it accepts the Equipment for all purposes.
3. Obligor has appropriated and/or taken other lawful actions necessary to provide moneys sufficient to pay all Contract Payments required to be paid under the Contract during the current Budget Year of Obligor, and such moneys will be applied in payment of all Contract Payments due and payable during such current Budget Year.
4. Obligor has obtained insurance coverage as required under the Contract from an insurer qualified to do business in the State.
5. No event or condition that constitutes or would constitute an Event of Default exists as of the date hereof.
6. The governing body of Obligor has approved the authorization, execution and delivery of this Contract on its behalf by the authorized representative of Obligor who signed the Contract.
7. Please list the Source of Funds (Fund Item in Budget) for the Contract Payments that come due under Exhibit B of this Contract.

Source of Funds : \_\_\_\_\_  
By signing below, Obligor hereby authorizes the General Fund of the Obligor as a backup source of funds from which the Contract Payments can be made.

\_\_\_\_\_  
Signature

\_\_\_\_\_  
Printed Name and Title

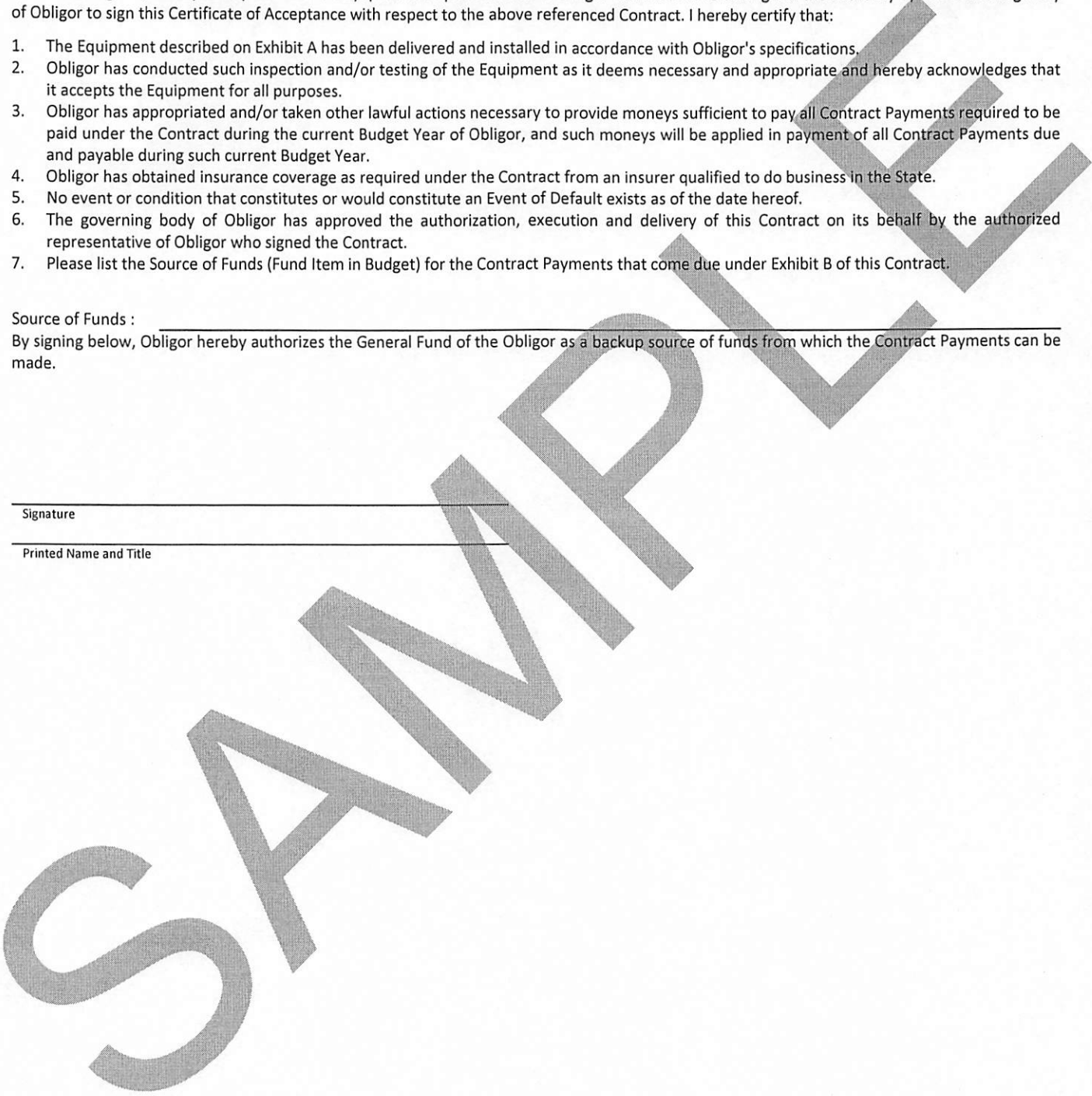

EXHIBIT D  
OBLIGOR RESOLUTION

RE: Government Obligation Contract dated as of \_\_\_\_\_, between Central States Bus Sales, Inc. (Obligee) and (Obligor)

At a duly called meeting of the Governing Body of the Obligor (as defined in the Contract) held on \_\_\_\_\_ the following resolution was introduced and adopted:

BE IT RESOLVED by the Governing Body of Obligor as follows:

- Determination of Need.** The Governing Body of Obligor has determined that a true and very real need exists for the acquisition of the Equipment described on Exhibit A of the Government Obligation Contract dated as of \_\_\_\_\_, between (Obligor) and Central States Bus Sales, Inc. (Obligee).
- Approval and Authorization.** The Governing Body of Obligor has determined that the Contract, substantially in the form presented to this meeting, is in the best interests of the Obligor for the acquisition of such Equipment, and the Governing Body hereby approves the entering into of the Contract by the Obligor and hereby designates and authorizes the following person(s) to execute and deliver the Contract on Obligor's behalf with such changes thereto as such person(s) deem(s) appropriate, and any related documents, including any Escrow Agreement, necessary to the consummation of the transaction contemplated by the Contract.

Authorized Individual(s): \_\_\_\_\_

(Typed or Printed Name and Title of individual(s) authorized to execute the Contract)

- Adoption of Resolution.** The signatures below from the designated individuals from the Governing Body of the Obligor evidence the adoption by the Governing Body of this Resolution.

Signature: \_\_\_\_\_

(Signature of Secretary, Board Chairman or other member of the Governing Body)

Printed Name & Title: \_\_\_\_\_

(Printed Name and Title of individual who signed directly above)

Attested By: \_\_\_\_\_

(Signature of one additional person who can witness the passage of this Resolution)

Printed Name & Title: \_\_\_\_\_

(Printed Name of individual who signed directly above)

SAMPLE

EXHIBIT E  
BANK QUALIFIED CERTIFICATE

RE: Government Obligation Contract dated as of \_\_\_\_\_, between Central States Bus Sales, Inc. (Obligee) and (Obligor)

Whereas, Obligor hereby represents that it is a "Bank Qualified" Issuer for the calendar year in which this Contract is executed by making the following designations with respect to Section 265 of the Internal Revenue Code of 1986, as amended (the "Code"). (A "Bank Qualified Issuer" is an issuer that issues less than ten million (\$10,000,000) dollars of tax-exempt obligations other than "private activity bonds" as defined in Section 141 of the Code, excluding certain "qualified 501(c)(3) bonds" as defined in Section 145 of the Code, during the calendar year).

Now, therefor, Obligor hereby designates this Contract as follows:

1. **Designation as Qualified Tax-Exempt Obligation.** Pursuant to Section 265(b)(3)(B)(i) of the Code, the Obligor hereby specifically designates the Contract as a "qualified tax-exempt obligation" for purposes of Section 265(b)(3) of the Code. In compliance with Section 265(b)(3)(D) of the Code, the Obligor hereby represents that the Obligor will not designate more than \$10,000,000 of obligations issued by the Obligor in the calendar year during which the Contract is executed and delivered as such "qualified tax-exempt obligations".
2. **Issuance Limitation.** In compliance with the requirements of Section 265(b)(3)(C) of the Code, the Obligor hereby represents that the Obligor (including all subordinate entities of the Obligor within the meaning of Section 265(b)(3)(E) of the Code) reasonably anticipates not to issue in the calendar year during which the Contract is executed and delivered, obligations bearing interest exempt from federal income taxation under Section 103 of the Code (other than "private activity bonds" as defined in Section 141 of the Code and excluding certain "qualified 501(c)(3) bonds" as defined in Section 145 of the Code) in an amount greater than \$10,000,000.

\_\_\_\_\_  
Signature

\_\_\_\_\_  
Printed Name and Title

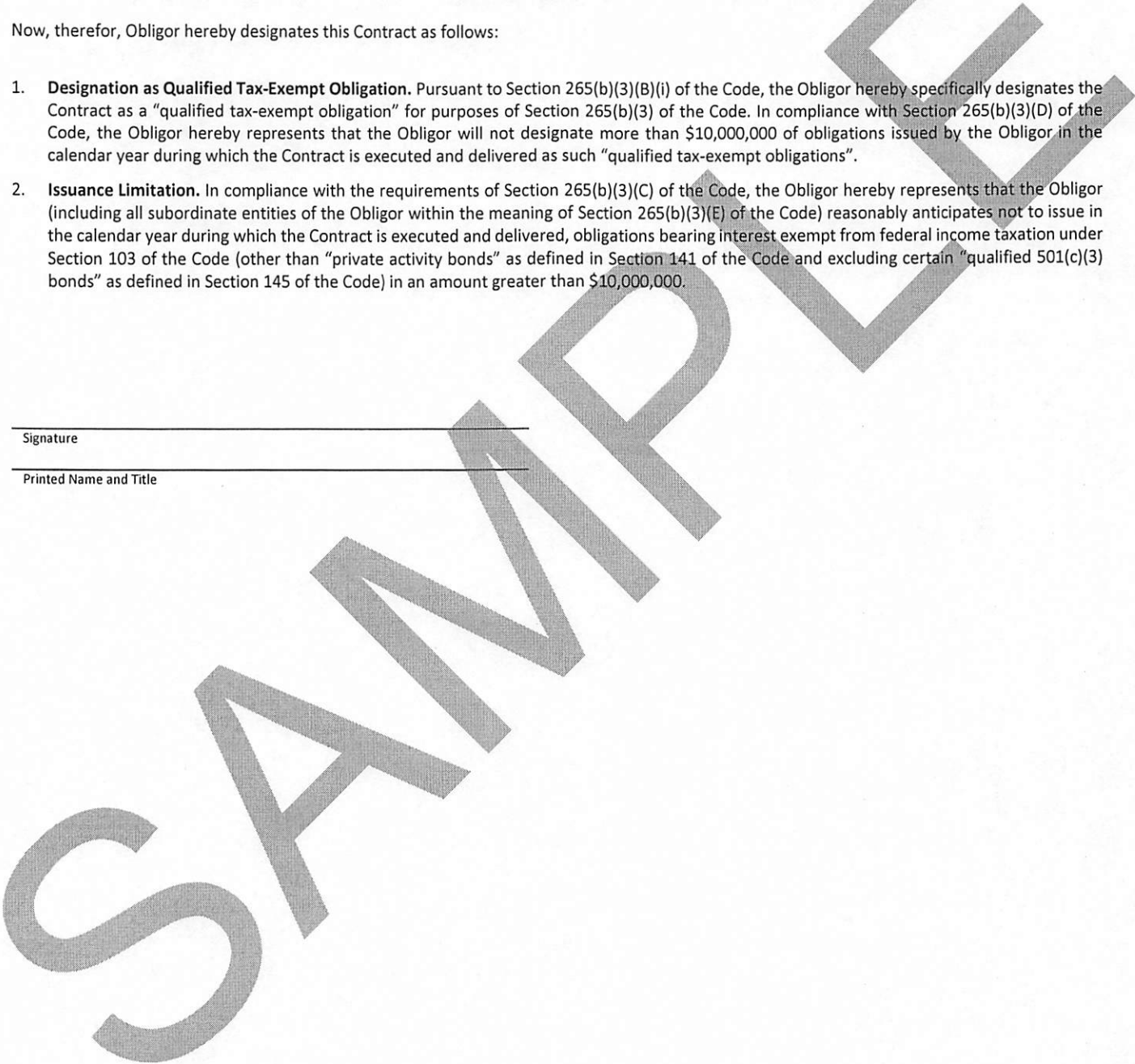

NOTICE OF ASSIGNMENT

---

Central States Bus Sales, Inc. (Obligee/Assignor) hereby gives notice of an Assignment between Obligee/Assignor and KS StateBank (Assignee) of the Government Obligation Contract (Contract) between Obligee/Assignor and , dated as of

All Contract Payments coming due pursuant to the Contract shall be made to:

KS StateBank  
1010 Westloop, P.O. Box 69  
Manhattan, Kansas 66505-0069

**Central States Bus Sales, Inc., Obligee/Assignor  
By Constant Capital Corp., Its Agent**

\_\_\_\_\_  
Signature

\_\_\_\_\_  
Printed Name and Title

---

ACKNOWLEDGEMENT OF AND CONSENT TO ASSIGNMENT

---

(Obligor) as party to a Government Obligation Contract dated as of \_\_\_\_\_ between Obligor and Central States Bus Sales, Inc. (Obligee), hereby acknowledges receipt of a Notice of Assignment dated \_\_\_\_\_ whereby Obligee gave notice of its assignment to KS StateBank of its right to receive all Contract Payments due from Obligor under the Contract and hereby consents to that Assignment. Pursuant to the Notice of Assignment from Obligee, Obligor agrees to deliver all Contract Payments coming due under the Contract to:

KS StateBank  
1010 Westloop, P.O. Box 69  
Manhattan, Kansas 66505-0069

\_\_\_\_\_  
Signature

\_\_\_\_\_  
Printed Name and Title

# Information Return for Tax-Exempt Governmental Obligations

► Under Internal Revenue Code section 149(e)  
 ► See separate instructions.

OMB No. 1545-0720

Caution: If the issue price is under \$100,000, use Form 8038-GC.

<b>Part I Reporting Authority</b>		If Amended Return, check here <input type="checkbox"/>
1 Issuer's name		2 Issuer's employer identification number (EIN)
3a Name of person (other than issuer) with whom the IRS may communicate about this return (see instructions)		3b Telephone number of other person shown on 3a
4 Number and street (or P.O. box if mail is not delivered to street address)	Room/suite	5 Report number (For IRS Use Only)
6 City, town, or post office, state, and ZIP code		7 Date of issue
8 Name of issue		9 CUSIP number
10a Name and title of officer or other employee of the issuer whom the IRS may call for more information (see instructions)		10b Telephone number of officer or other employee shown on 10a

**Part II Type of Issue (enter the issue price).** See the instructions and attach schedule.

11 Education	11
12 Health and hospital	12
13 Transportation	13
14 Public safety	14
15 Environment (including sewage bonds)	15
16 Housing	16
17 Utilities	17
18 Other. Describe ►	18
19 If obligations are TANs or RANs, check only box 19a <input type="checkbox"/>	
If obligations are BANs, check only box 19b <input type="checkbox"/>	
20 If obligations are in the form of a lease or installment sale, check box <input checked="" type="checkbox"/>	

**Part III Description of Obligations.** Complete for the entire issue for which this form is being filed.

(a) Final maturity date	(b) Issue price	(c) Stated redemption price at maturity	(d) Weighted average maturity	(e) Yield
21	\$	\$	years	%

**Part IV Uses of Proceeds of Bond Issue (including underwriters' discount)**

22 Proceeds used for accrued interest	22
23 Issue price of entire issue (enter amount from line 21, column (b))	23
24 Proceeds used for bond issuance costs (including underwriters' discount)	24
25 Proceeds used for credit enhancement	25
26 Proceeds allocated to reasonably required reserve or replacement fund	26
27 Proceeds used to currently refund prior issues	27
28 Proceeds used to advance refund prior issues	28
29 Total (add lines 24 through 28)	29
30 Nonrefunding proceeds of the issue (subtract line 29 from line 23 and enter amount here)	30

**Part V Description of Refunded Bonds.** Complete this part only for refunding bonds.

31 Enter the remaining weighted average maturity of the bonds to be currently refunded	►	_____ years
32 Enter the remaining weighted average maturity of the bonds to be advance refunded	►	_____ years
33 Enter the last date on which the refunded bonds will be called (MM/DD/YYYY)	►	_____
34 Enter the date(s) the refunded bonds were issued ► (MM/DD/YYYY)		_____

**Part VI Miscellaneous**

<b>35</b>	Enter the amount of the state volume cap allocated to the issue under section 141(b)(5) . . . . .	<b>35</b>		
<b>36a</b>	Enter the amount of gross proceeds invested or to be invested in a guaranteed investment contract (GIC) (see instructions) . . . . .	<b>36a</b>		
<b>b</b>	Enter the final maturity date of the GIC ▶ _____			
<b>c</b>	Enter the name of the GIC provider ▶ _____			
<b>37</b>	Pooled financings: Enter the amount of the proceeds of this issue that are to be used to make loans to other governmental units . . . . .	<b>37</b>		
<b>38a</b>	If this issue is a loan made from the proceeds of another tax-exempt issue, check box <input type="checkbox"/> and enter the following information:			
<b>b</b>	Enter the date of the master pool obligation ▶ _____			
<b>c</b>	Enter the EIN of the issuer of the master pool obligation ▶ _____			
<b>d</b>	Enter the name of the issuer of the master pool obligation ▶ _____			
<b>39</b>	If the issuer has designated the issue under section 265(b)(3)(B)(i)(III) (small issuer exception), check box . . . . .			<input checked="" type="checkbox"/>
<b>40</b>	If the issuer has elected to pay a penalty in lieu of arbitrage rebate, check box . . . . .			<input type="checkbox"/>
<b>41a</b>	If the issuer has identified a hedge, check here <input type="checkbox"/> and enter the following information:			
<b>b</b>	Name of hedge provider ▶ _____			
<b>c</b>	Type of hedge ▶ _____			
<b>d</b>	Term of hedge ▶ _____			
<b>42</b>	If the issuer has superintegrated the hedge, check box . . . . .			<input type="checkbox"/>
<b>43</b>	If the issuer has established written procedures to ensure that all nonqualified bonds of this issue are remediated according to the requirements under the Code and Regulations (see instructions), check box . . . . .			<input type="checkbox"/>
<b>44</b>	If the issuer has established written procedures to monitor the requirements of section 148, check box . . . . .			<input type="checkbox"/>
<b>45a</b>	If some portion of the proceeds was used to reimburse expenditures, check here <input type="checkbox"/> and enter the amount of reimbursement. . . . . ▶ _____			
<b>b</b>	Enter the date the official intent was adopted ▶ _____			

<b>Signature and Consent</b>	Under penalties of perjury, I declare that I have examined this return and accompanying schedules and statements, and to the best of my knowledge and belief, they are true, correct, and complete. I further declare that I consent to the IRS's disclosure of the issuer's return information, as necessary to process this return, to the person that I have authorized above.				
	▶ _____ ▶		▶ _____ ▶		
	Signature of issuer's authorized representative		Date		Type or print name and title
<b>Paid Preparer Use Only</b>	Print/Type preparer's name	Preparer's signature	Date	Check <input type="checkbox"/> if self-employed	PTIN
	Firm's Name ▶	Firm's EIN ▶			
	Firm's Address ▶	Phone no.			

**OPINION OF COUNSEL**  
(Must be Re-typed onto attorney's letterhead)

(Date, must be on or after the meeting date listed on Exhibit D, Obligor Resolution)

Central States Bus Sales, Inc.  
1200 Sugar Creek Square  
Fenton, Missouri 63026

**RE: Government Obligation Contract dated as of \_\_\_\_\_, between Central States Bus Sales, Inc. (Obligee) and \_\_\_\_\_ (Obligor)**

Ladies and Gentlemen:

1. Obligor is a political subdivision of the State of Illinois, or a constituted authority authorized to issue obligations on behalf of a political subdivision of the State.
2. Obligor has the requisite power and authority to purchase the Equipment and to execute and deliver the Contract and to perform its obligations under the Contract. The Contract and the other documents either attached hereto or required herein have been duly authorized, approved and executed by and on behalf of Obligor, and the Contract is a legal, valid and binding obligation of Obligor enforceable in accordance with its terms.
3. The authorization, approval and execution of the Contract and all other proceedings of Obligor relating to the transactions contemplated thereby have been performed in accordance with all open meeting laws, public bidding laws and all other applicable state and federal laws.
4. There is no litigation, action, suit or proceeding pending or before any court, administrative agency, arbitrator or governmental body that challenges the authority of the Obligor or any of the Obligor's officers or employees to enter into the Contracts.
5. The above opinion is for the sole benefit of the Obligee listed above and can only be relied upon by the Obligee or any permitted assignee or subassignee or successor of Obligee under the Contract.

Signature of Legal Counsel

**Central States Bus Sales, Inc.**  
30 Baseline Road. Oswego, IL 60543  
630-556-3130 • FAX:866-300-8893 • 800-376-1644  
*"The Bus Experts"* **www.centralstatesbus.com**

January 5, 2022

Minooka C.C.S.D.# 201  
Minooka C.S.D.#111  
Minooka, Illinois 60447

Mr. John Troy and Mr. Kris Monn,

I'm happy to help you with your transportation needs. Central States Bus Sales, Inc. is the authorized distributor for Blue Bird Body Company in Illinois, Missouri, Arkansas, Tennessee, and Kentucky and we have the facilities and experience to support all of the products we sell. Blue Bird School Buses are unsurpassed in Quality, Durability, and Built-In Safety Features.

In accordance with your request, I have prepared a lease proposal for (20) NEW 2023 77 Passenger Blue Bird Vision school buses. The Bluebird Visions are equipped with Cummins diesel engines and Allison transmissions. All buses are equipped to meet or exceed all State, Federal, and District specifications and include all equipment listed on the attached Equipment Summary. All buses will be delivered in route ready condition and include new camera system TO SPEC for each district along with Zonar system installation.

If you have any questions or require additional information, please feel free to contact me by phone at (309) 453-8203 or by e-mail at [jmartin@centralstatesbus.com](mailto:jmartin@centralstatesbus.com). Thanks again, and I hope to be hearing from you soon.

Sincerely,

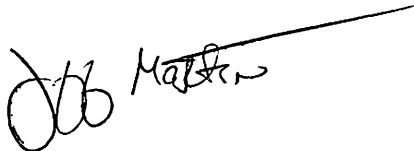

Jeff Martin  
Regional Sales Manager  
Central States Bus Sales, Inc.

# Central States Bus Sales, Inc.

30 Baseline Road. Oswego, IL 60543  
630-556-3130 • FAX:866-300-8893 • 800-376-1644  
**www.centralstatesbus.com**

## (20) NEW 2023 Bluebird Vision Diesel 77 Passenger Equipment

\*Cummins ISB-21 Diesel  
\*23,000LB Rear Axle  
\*100 Gallon Fuel Tank  
\*Fr+Rr Tow Hooks  
\*Balanced Wheels Fr+Rr  
\*(3) Group 31 Batts  
\*75 mph governor  
\*Traction Control

\*Allison 2500 w/Synthetic Fluid  
\*10,000LB Front Springs  
\*Side Exit Exhaust  
\*11R Tires, traction  
\*4 Wheel Aligned  
\*Heavy Duty Brakes  
\*Hydraulic ABS

\*12,000LB Front Axle  
\*23,000LB Rear Springs  
\*Engine Block Heater  
\*8.25x22.5 Hub Piloted  
\*240 AMP Alternator  
\*Dust Shields Fr.+RR  
\*Stability Control

### **-CONSTRUCTION and SAFETY-**

\*Colorado Rack Test Certified  
\*2 Emergency Roof Hatches  
\*Child Check System  
\*Triangles

\*Kentucky Pole Test Certified  
\*112 db Backing Alarm  
\*Noise Cancel Switch  
\*First Aid Kit

\*4 Push Out Windows  
\*Strobe Light  
\*Fire Extinguisher  
\*Body Fluid Kit

### **-BODY EXTERIOR-**

\*Dark Tinted Windows  
\*Bell Mounts X-Views  
\*Key lock for Entry Door  
\*Folding Cowl Steps  
\*Keyed alike ignitions all buses

\*Fr+Rr Mud Flaps  
\*Electric Stop Arm  
\*Locking Fuel Door  
\*WS Grip Handles  
\*LED lighting

\*Rear Rubber Fenders  
\*(4) HD Rub Rails  
\*Wet Arm W/S Wipers  
\*Electric Entry Door  
\*Adjustable driver's seat

### **-BODY INTERIOR-**

\*Tilt and Telescope Steering Wheel  
\*Roof Bow Cavity Insulation  
\*50,000 BTU Stepwell Heater  
\*Console Mounted Storage Box  
\*5/8" treated Subfloor  
\*Driver's Dome Light  
\*Stepwell Light  
\*Dual Grabrails  
\*Brown Fire Block Seats  
\*Drivers Acoustic headliner  
\*Certificate Holder  
\*NEW Camera system included

\*Cruise Control  
\*2 Auxiliary Fans  
\*80,000 BTU Rear Heater  
\*Integrated Cup holder  
\*Heavy Rubber Floor  
\*Dual Row Dome Lights  
\*AM/FM/MP3/PA System  
\*Slide Lock Rear Door  
\*Access panels  
\*Cloth Driver Seat  
\*Heated Remote Mirrors  
\*Swap of current Zonar Systems Included

\*Insulated Firewall  
\*90,000 BTU Main Heater  
\*Locking Dash Glove Box  
\*77" Headroom  
\*Fore and Aft Grab Rails  
\*Rear Domes Switched  
\*8 Interior Speak  
\*Pre-Trip Light  
\*RH Modesty Panel  
\*Driver's Armrest

### **-PAINT & DECALS-**

\*White Painted Roof  
\*Black Grill  
\*3M "SB" Signs Fr+Rr  
\*Bus #'s (5) Locations

\*Black Rubrails  
\*Black W/L Background  
\*3M Tape Perimeter all Exits

\*Sound Cancel Coating  
\*3M Refl Tape Sides/Rear  
\*Window Stop Lines

### **-WARRANTY-**

- 5 Year 100k drivetrain Warranty \*Bluebird Tow Warranty \*Cummins Tow Warranty  
- Premium Bumper to Bumper type warranty for *entire* lease term.



**School Bus Lease Proposal**

Minooka C.C.S.D. #201

Minooka C.S.D. # 111

We appreciate the opportunity to assist you in your transportation needs. The following is a 5 year lease proposal quote for up to (20) NEW 2023 Bluebird Vision 77 passenger buses.

**5 Year Lease**

**Annual Payment**

**(20) NEW 2023 Bluebird Vision 77 passenger.....\$ 17,230.22 each**

**Above pricing includes:**

- Preparation, delivery, lettering/decals, inspection sticker, title, license and all fees included.
- Buses include 18,000 miles per year with \$0.35 overage charge per mile.
- All lease pricing above is quoted at an lease rate of 3.25%.
- Available July 2022.

Sincerely,

Jeff Martin  
 Regional Sales Manager  
 Central States Bus Sales, Inc.

**Minooka Community High School  
District No. 111**

**&**

**Minooka Consolidated Community School  
District No. 201**

**Joint Request for Proposal for:**

**Leased School Buses**

**MINOOKA COMMUNITY HIGH SCHOOL  
DISTRICT No. 111  
26655 W. Eames Street  
Channahon, Illinois 60410  
(815) 521-4294**

**MINOOKA COMMUNITY CONSOLIDATED  
DISTRICT No. 201  
305 Church Street  
Minooka, Illinois 60410  
(815) 467-6121**

**Invitation to Provide Proposal – School Bus Lease & Purchase of Districts’ Used School Buses**

Minooka Community High School District No. 111 and Minooka Community Consolidated School District No. 201 operate a shared bus barn and are accepting proposals for leased school buses and seeking offers for the purchase of their used buses. Sealed proposals are due by **11:00 am on Thursday, January 6, 2022**, at which time they will be publicly opened and read aloud. Proposals are to be submitted to:

Minooka Community High School District 111  
Attn: John Troy, Assistant Superintendent & General Counsel  
26655 W. Eames Street  
Minooka, IL 60410

Failure to comply with these proposal documents and submit all required forms may lead to disqualification of your proposal.

We look forward to your participation in this request for proposal.

Sincerely,

Mr. John Troy  
Asst. Superintendent & General Counsel  
MCHS No. 111

Kris Monn  
Superintendent  
Minooka CCSD 201

## INSTRUCTIONS TO BIDDERS

1. **BIDS MUST BE RECEIVED IN OUR OFFICE BY 11:00 am Thursday, January 6, 2022** at when they will be publicly opened and the contents announced. They will be held without right of withdrawal and shall be considered valid for sixty (60) days for new buses, thirty (30) days for used buses. The sealed envelope shall be marked in bottom left hand corner identifying contents as "Transportation Bid". Any bid(s) received after the bid opening time shall be returned to the bidder unopened. It is the bidder's responsibility to assure that the bid is delivered on time. The transmittal of the bid proposal is at seller's risk of untimely receipt by the Board. Faxed and/or emailed copies are not acceptable.

2. All interested parties are cordially invited to be present at the public proposal opening to be held at the time the sealed proposals are due. Proposals will be publicly opened and results announced. Awards, however, will not be made until after the staff has made a thorough analysis of all proposals received. Proposals will be officially awarded at a subsequent meeting of the Board of Education.

3. The Board of Education reserves the right to split the bid on the basis of best quotation. The Board reserves the right to reject any and all bids or any part thereof, to waive nonconformities in the bidding, and to accept the bid deemed most favorable to the Board after all bids have been examined and evaluated. Among the items to be considered in awarding bid are price, warranty, service, bus model and specifications. The Board of Education decisions are final in all instances and not subject to recourse. All bidders will be notified of the results of the Board of Education action, with a summary of bids provided. No corrections can be made after the time of opening.

4. Delivery of the new vehicles shall be made Minooka Transportation Center, 700 E. Minooka Road, 60447 attention Director of Transportation, Cathy Haase. **Delivery must be made, route ready, on or before Monday July 18, 2022. The successful bidder upon award of the bid must submit a delivery guaranty check in the amount of \$1,000 dollars to each district. This delivery guaranty check shall be forfeited to the district for failure to deliver the district's entire order of buses by the scheduled time.**

5. **YOUR BID PRICE MUST BE F. O. B. MINOOKA, IL, WITH ALL TRANSPORTATION AND HANDLING CHARGES PAID BY THE BIDDER AND INCLUDED IN THE PRICE OF THE BUS.** The Bidder must deliver units ready to operate.

6. **PROPOSALS MUST CONTAIN COMPLETE DETAILS OF THE LEASING COSTS AND THE INTEREST RATE. PROPOSALS MUST CONTAIN ALL LEASING DOCUMENTS REQUIRED BY THE LENDER. THE BOARDS OF EDUCATION WILL NOT AWARD ANY BID THAT DOES NOT HAVE ALL SUPPORTING LEASING DOCUMENTS INCLUDED.**

7. **THE DISTRICTS WILL ALSO SEEK COMPETITIVE LEASING ARRANGEMENTS IN CONJUNCTION WITH THIS BID. ALL BIDS MUST CONTAIN THE FULL PRICE OF THE BUS AS WELL AS A GUARANTEED "BUY-BACK" DOLLAR AMOUNT AT THE END OF THE LEASE TERM.**

7. Bidder shall include the cost of title transfer and license application with the bid.

8. Detailed warranty information must be included with the Bid Packet

9. Bidders must be in full compliance with all provisions of the acts of the General Assembly of Illinois relating to employment, including equal employment opportunity requirements and any other affidavits as required by law.

10. Supplier shall agree to comply with the provisions of the latest edition of the Occupational Safety and Health regulations and the standards and regulations issued there under and shall certify that all items furnished under this bid will conform to and comply with said standards and regulations.

11. Supplier shall agree to comply with provisions of the latest edition of the Consumer Product Safety Act of 1972 and certify that items furnished under this bid conform with applicable standards including all State and Federal requirements for school buses.

12. Title to the goods herein described shall not pass until said goods have actually been received by the Board or its consignee. Risk of loss prior to such actual receipt by Board or its consignee shall be borne by seller. Nothing herein contained, however, shall be construed to deprive the Board of its interest, or limiting such interest, in goods herein described prior to such actual receipt.

13. The Boards of Education reserves the right to reject any goods which contain defects in material or workmanship or which fail to meet specifications contained herein or seller's warranties (express or implied.) Rejected goods shall be removed at the expense of the seller, including transportation both ways, promptly after notification of rejection. As to rejected goods, seller shall bear all costs of inspection and all risk of loss. The District reserves the right to select independently for specific bid items from any vendor bidding.

14. Payment by the Boards for goods supplied hereunder shall not constitute acceptance thereof if subsequent inspection discloses defects in material or workmanship or a failure to meet the specification contained herein. Payment shall not be processed until District has proper title certificate on file.

15. The Boards' failure to enforce any of the terms, conditions, and specifications of the bid or any breach shall not in any way affect, limit, or waive the Board's right thereafter to enforce and compel strict compliance with every term, condition, and specification hereof. By submitting bid the bidders accepts the terms of this bid document and agrees to be bound by the same.

16. Any interpretation of the proposed documents will be made only by an addendum duly issued by the District. A copy of such addendum will be faxed to each prospective bidder. Failure on the part of the prospective bidder to receive a written interpretation prior to the time of the opening of bids will not be grounds for withdrawal of his proposal. All requests for clarification must be received by the District not less than three (3) business days prior to bid opening. Inquiries after that time will may not receive a response in order to preserve a fair process for all bidders.

17. Award will be made by official Board documents. Bidder order form is not acceptable and cannot be used.

18. The Boards are exempt from paying Illinois Use Tax and sales the Boards are exempt from Illinois Retailer's Occupation Tax. The Boards are exempt from paying Federal Excise Taxes.

19. Payment Terms: Payment shall not be processed until the District has proper paperwork on file. Districts process checks once per month. Payment by Boards for goods supplied hereunder shall not constitute acceptance thereof if subsequent inspection discloses defects in material or workmanship or a failure to meet the specification contained herein. Payments are processed

following submittal and approval of the Board of Education at the regular monthly meeting provided they have been received and accepted on time.

20. Bidder must complete and submit bid on bid forms included with this specification. The bidder may photocopy the form. The bidder must include signed copies for all attachments indicating a signature (Non-Collusion Affidavit and Project Qualification Form ). Failure to complete and submit any of these forms shall be cause for bid to be rejected since it would be an incomplete bid.

21. All buses must meet Illinois specifications and legal requirements.

22. All used buses must state individually the year, mileage, and must state expected mileage remaining on brakes and provide tread depth measurements for each tire on the bid form for the used bus clearly identifying the bus for which the information applies.

23. All used buses must have at least 50% of brake and tire life minimum remaining for each wheel and tire.

**SPECIFICATIONS**

**Part 1:**

1. The Districts are interested in receiving proposals for the following:

**District 111:** Ten (10) 71 passenger school buses, leased      INCLUDED

**District 201:** Ten (10) 71 passenger school buses, leased      INCLUDED

2. The proposal will detail the bus and van specifications that the vendor feels best meets the needs of the Districts.      DETAILED EQUIPMENT SUMMARIES INCLUDED
3. The Districts will consider proposals for new vehicles as well as 1-3 year old vehicles  
NEW BUSES ONLY-CENTRAL STATES BUS SALES
4. The Districts will consider proposals for diesel, gasoline, and propane buses.  
DIESEL BUSES ONLY-CENTRAL STATES BUS SALES
5. The proposed lease shall be inclusive of preparation, delivery, lettering, inspection, sticker, title, license and all other fees.      YES-INCLUDED
6. Vehicles shall be route condition ready and available for delivery on or before Monday, July 18, 2022  
YES
7. Mileage for leases shall be quoted on the number of miles included per year with the per mile charge for overage.      YES-18,000 MILES PER YEAR /EACH BUS WITH \$0.35 PER MILE OVERAGE CHARGE
8. Warranty shall be quoted as the manufacturer warranty plus any charge for additional warranty throughout the term of the lease (warranty details to be provided with proposal).  
FULL BUMPER TO BUMPER WARRANTY INCLUDED FOR ENTIRE LEASE TERM
9. The District will consider three (3) year leases and five (5) year leases.  
5 YEAR LEASE ONLY-CENTRAL STATES BUS SALES
10. Proposal shall detail price differential for quantities of more or less than the above stated.  
PRICING IS FIRM FOR UP TO 30 UNITS TOTAL

Please use the following matrix for quoting prices

Type of Bus	Diesel Lease	Diesel Total Price	Diesel Guaranteed Buy Back Price	Diesel Mileage	Gas Lease	Gas Total Price	Gas Guaranteed Buy Back Price	Gas Mileage
New (lease - 3yr)	NO BID				NO BID			
New (Lease - 5yr)	\$17,230.22 EACH PER YEAR	\$104,202 EACH	\$ 27,500.00 EACH	18,000 ANNUAL EACH	NO BID			

Please duplicate the above matrix for 1, 2 and 3 year old buses.

Part 2:

1. The Districts are also interested in receiving proposals for the purchase several of its used buses. The list of buses being sold are attached and the buses may be inspected by appointment during normal schools hours. The buses are being sold "As-Is."

District 111 Trade In

None at this time

District 201 Trade In

None at this time

**NON-COLLUSION AFFIDAVIT**

**STATE OF ILLINOIS**

Illinois SS:  
DeKalb COUNTY

The undersigned vendor or agent, being duly sworn, on oath says that s(he) has not, nor has any other member, representative, or agent of the firm, company, corporation or partnership represented by him/her, entered into any combination, collusion or agreement with any person relative to the price to be proposal by anyone at such letting, nor to prevent any person from bidding nor to induce anyone to refrain from bidding, and that this proposal is made without reference to any other proposal and without any agreement, understanding or combination with any other person in reference to such bidding.

S(he) further states that no person or persons, firms, or corporation has, have or will receive directly or indirectly, any rebate, fee, gift, commission or thing of value resulting from such sale.

Name J. J. Martin  
For Central States Bus Labs, Inc.  
Firm or Corporation

Subscribed and sworn to before me on this 3 day of January, 2022

My commission expires:  
12/08/2024

Notary Public

Signature:  
Elizabeth A. Schubbe



Signature J. J. Martin

## PROJECT QUALIFICATION FORM

A responsible vendor is defined by meeting the following criteria and is able to submit evidence of such compliance. By signing this required form, the undersigned agrees that said vendor is responsible as defined below.

### SEXUAL HARRASSMENT

Each vendor certifies that he has complied with the requirement of 2-105 of the Illinois Human Rights Act (775ILCS/2-105)-1257) with respect to sexual harassment policies. The terms of that law, as applicable, are hereby incorporated into this contract.

### DRUG FREE WORKPLACE

The vendor or contractor, having 25 employees or more, does hereby certify pursuant to Section 3 of the Illinois Drug-Free Workplace Act (30ILCS580/3) that he shall provide a drug-free workplace for all employees engaged in the performance of work under the contract by complying with the requirements of the Illinois Drug-Free Workplace Act and, further certifies that he is not ineligible for award of this contract by reason of debarment for a violation of the Illinois Drug-Free Workplace Act.

### NON-DISCRIMINATION AFFIRMATION

Vendors must assure that all persons employed by the vendor, and all applicants for such employment, will not be discriminated against because of their race, religion, nationality, gender, disability, physical characteristics or sexual orientation. Vendor must also comply with all rules and regulations of the Illinois Department of Human Rights, Illinois Human Rights Commission and the Equal Employment Opportunity Commission.

### CONFLICT OF INTEREST

By signing below, vendor certifies that they are in accordance with the School Code, and the Public Officer Prohibited Practice Act, 50 ILCS 105/0.01 et seq., no Board of Education member or District employee shall be directly or indirectly involved or own an interest in any contract, work, or business of the District, or in the sale of any article by or to the District.

### CERTIFICATION OF NOT BARRED FROM BIDDING

The Vendor hereby certifies that the bidder is not barred from bidding on this contract as a result of a violation of either the proposal-rigging or proposal-rotating provisions of Article 33E of the Criminal Code of 1961, as amended.

Signed:  Name (printed): JEFF MARTIN

Title: REGIONAL SALES MGR. Company Name: CENTRAL STATES BUS SALES, INC

Address: 30 BASELINE RD. OSWEGO IL 60543

Telephone Number: 1-800-376-1644 Date: 01/03/2022



### **Limited Warranty: Gold 5/10 - Buses with Option 31300-24**

If acquired, this warranty is in lieu of the standard limited warranty. This warranty is applicable to Blue Bird bus products T3FE, T3RE and BBCV built on or after August 29, 2016 specifically for and operated in the United States of America, Canada, Puerto Rico, U.S. Virgin Islands, Guam, and American Samoa.

Blue Bird Body Company (Blue Bird) warrants each bus to be free from defects in material and workmanship under normal use and service within the specified limits below. The warranty period begins either on the Delivery Date of the bus to the original user or on the Manufacture Date of the bus. Blue Bird's obligation is limited to the repair or replacement of such parts as shall, under normal use and service, appear to be defective in workmanship or material.

#### 1. For ten years from Delivery Date:

- Front steer axle, including kingpin assembly, steering arm assembly, and upper and lower steering knuckle assembly, excluding kingpin bushings, kingpin wear, thrust bearings, tie rods and tie rod ends, brakes and axle end components.

#### 2. For five years from Manufacture Date:

- Paint gloss. During first three years, gloss reading shall not drop below 60 on 60<sup>0</sup> meter (70% of initial gloss). For five years, gloss reading shall not drop below 30 on 60<sup>0</sup> meter.
- Paint color retention. During first three years, color coat shall not shift colors more than 4ΔE from the centroid of the national standard. For five years, color coat shall not shift colors more than 8ΔE from the centroid of the national standard.

#### 3. For five years from Delivery Date:

- All other components not specified above, excluding engines, propane fuel systems, automatic transmissions, wheelchair lifts, non-Blue Bird air conditioners, and batteries. The warranties of the excluded components are the responsibility of the respective manufacturers, and are not a part of Blue Bird's limited warranty.

Your Blue Bird Dealer will register the bus with Blue Bird and can assist with registering components that are warranted by the component manufacturers. During the warranty period, this warranty is transferable to subsequent Owners-Operator in the U.S.A. or Canada.

THIS LIMITED WARRANTY IS EXPRESSLY IN LIEU OF ALL OTHER WARRANTIES EXPRESSED OR IMPLIED AND ALL OTHER OBLIGATIONS OR LIABILITIES. NO PERSON, INCLUDING SALESPERSONS, DEALERS, OR FACTORY REPRESENTATIVES OF BLUE BIRD, IS AUTHORIZED TO MAKE ANY REPRESENTATION OR WARRANTY CONCERNING BLUE BIRD PRODUCTS EXCEPT TO REFER PURCHASERS TO THIS LIMITED WARRANTY. BLUE BIRD MAKES NO WARRANTY OF MERCHANTABILITY OR FITNESS FOR A PARTICULAR PURPOSE. BLUE BIRD SHALL NOT BE LIABLE FOR INCIDENTAL OR CONSEQUENTIAL DAMAGES.

### **Obtaining Warranty Service**

Contact your Blue Bird Dealer immediately upon discovery of a defect and within the warranty period. Your Blue Bird Dealer will help arrange for repairs by the Dealer or another qualified repair facility. Defects must be repaired immediately upon discovery and within the warranty period. It is the responsibility of the Owner-Operator to return the bus to the Blue Bird Dealer, or a qualified repair facility authorized by the Blue Bird Dealer. The Owner-Operator is responsible for operating and maintaining the bus as described in the Driver Handbook and Service Manual. The Owner-Operator shall retain all maintenance records, and present them to the Blue Bird Dealer or the component manufacturer, if requested.

If the defective component is warranted by Blue Bird and the repair is performed by the Blue Bird Dealer, the Blue Bird Dealer will prepare and submit a warranty claim to Blue Bird.

If the defective component is warranted by Blue Bird and the repair is performed by the Owner-Operator or another qualified repair facility, detailed labor and parts invoices must be sent to the Blue Bird Dealer not later than 30 days after the repair date. The Blue Bird Dealer will prepare and submit a warranty claim to Blue Bird.

If the defective component is warranted by the component manufacturer and the repair is performed by the component manufacturer's authorized repair facility, the repair facility will prepare and submit a warranty claim to the component manufacturer.

## Limitations and Exclusions

In addition to the limitations described on the previous pages, items specifically not covered include, but are not limited to:

- Engines, automatic transmissions, wheelchair lifts, air conditioners (other than Blue Bird Air™ system), tires, and batteries. The limited warranties for these components are provided solely by and are the responsibility of the component manufacturers and are not a part of Blue Bird's limited warranty.
- Loss of use and incidental consequential expenses, including but not limited to commercial loss, loss of commercial fares, driver time or pay, lease or rental of substitute vehicle, storage, lodging, meals, telephone calls, and other travel costs.
- Any parts or components which must be repaired, replaced, or adjusted during the warranty period due to wear, wear-out, or consumption, including but not limited to brake pads and linings, drums and rotors, wiper blades, light bulbs, filters, lubricants, fluids, belts, bearings other than those specifically covered by the limited warranty, suspension pins and bushings, batteries, worn seat covers, worn stepreads and floor covering, worn door and window seals, discharged fire extinguishers, damaged (scratched, cracked) gauge and light lenses, and tires. Wear not only includes friction-type wear but can also include environmental deterioration including but not limited to surface corrosion on exhaust pipes or clamps and brake drums or rotors, as well as fading, cracking, or discoloration of seat covers caused by U.V.
- Maintenance including but not limited to tightening loose fasteners, axle and wheel alignments, wheel-balancing, tightening body tie-downs, door adjustments, tightening hose clamps, and sealing or caulking windows, doors, roof hatches, and lights.
- Any parts or components which must be repaired, replaced or adjusted during the warranty period as a result of accident damage, abnormal operation, misuse, or abuse, including but not limited to excessive operation on unpaved or unmaintained roads, operation on cross-country trails or off-road conditions, collision, fire, vandalism, explosion, objects striking the vehicle, theft, freezing, riot, or flood.
- Paint adhesion, gloss, or color failures resulting from accidents or abrasions, road chemicals, caustic detergents or cleaners, or improper maintenance. Paint adhesion failures, whether warrantable defects or non-warrantable events, which are not repaired immediately upon discovery of the failure, may deteriorate the finish or panels underneath. Surface corrosion or other progressive deterioration resulting from failure to paint adhesion failures immediately is not covered by this warranty. Contact your Blue Bird Dealer before making any repairs to the paint finish.
- Paint gloss and color failures without evidence of proper care and maintenance, as recommended in the Driver Handbook, or repairs to correct paint gloss or color failures without preapproval by Blue Bird. Contact your Blue Bird Dealer before making any repairs to the paint finish.
- Vehicle modifications or equipment installations performed without the written approval of Blue Bird. To the extent the modifications or equipment installations adversely affect other vehicle components or performance, Blue Bird shall not accept any product liability or claims under the terms of the limited warranty. These claims become the sole responsibility of the company performing the modifications or installations.

- Transportation expenses to deliver the bus to a Blue Bird Dealer or nearest qualified repair facility, including but not limited to, fuel, driver time or pay, mileage and towing.
- Repairs to parts or components which have been previously replaced with parts not obtained from Blue Bird or failures caused by non-Blue Bird parts or components. Rework of repairs not performed by or approved by a Blue Bird Dealer.
- Excessive labor hours, premium labor costs, overtime labor costs, or local taxes. This limited warranty covers reasonable labor to perform replacement or repair.
- Defects not reported to a Blue Bird Dealer and repaired during the warranty period. Repairs are to be made immediately upon discovery of the defect.
- Damage caused by using improper or contaminated fluids, including but not limited to fuels, lubricants, and coolants. Damage caused by using fluids which do not meet Blue Bird's or the Manufacturers' minimum recommendations. Damage caused by the lack of fluids or improper fluid maintenance.
- Using non-Blue Bird service parts. Usage of non-Blue Bird parts will affect future warranty coverage.
- Overloading beyond the normal seated and standee capacity voids all warranties.

Blue Bird reserves the right to make changes in design and changes or improvements upon its products without imposing any obligations upon itself to install the same upon products theretofore manufactured. Any suit alleging a breach of this limited warranty or of any other alleged warranty, including any claim for rescission or revocation of acceptance, must be filed within one year of breach.

### Controlling Law and Severability

This limited warranty shall be governed by and construed in accordance with the laws of the State of Georgia, U.S.A. The Owner-Operator agrees and consents to the exclusive jurisdiction of the courts of the State of Georgia for all purposes regarding this limited warranty and further agrees and consents that venue of any action involving this limited warranty or any other alleged warranty, including any claim for rescission or revocation of acceptance, shall be exclusively in Peach County, Georgia. Owner-Operator hereby submits to personal jurisdiction in Peach County, Georgia and waives any objection or argument related to venue, personal jurisdiction, forum non-convenience, or transfer. If any portion hereof is found to be void or unenforceable, the remaining provisions of the limited warranty shall remain in full force and effect.

# Cummins Warranty

**All Engines United States And Canada School Bus**

## Coverage

### Products Warranted

This Warranty applies to new diesel, LPG, compressed or liquid natural gas fueled Engines sold by Cummins Inc. or Cummins Westport and delivered to the first user on or after September 15, 1996, that are used in school bus\* applications in the United States\*\* or Canada.

### Base Engine Warranty

The Base Engine Warranty covers any failures of the Engine which result, under normal use and service, from a defect in material or factory workmanship (Warrantable Failure). This Coverage begins with the sale of the Engine by Cummins and continues for five years or 100,000 miles (160,934 kilometers), whichever occurs first, from the date of delivery of the Engine to the first user.

Engine aftertreatment components included in the Cummins Critical Parts List (CPL) and marked with a Cummins part number are covered under Base Engine Warranty.

### Extended Major Components Warranty

The Extended Major Components Warranty applies to all except ISV, ISB6.7 G, B and ISB Series Engines and covers Warrantable Failures of the Engine cylinder block, camshaft, crankshaft and connecting rods (Covered Parts).

Bushing and bearing failures are not covered.

This Coverage begins with the expiration of the Base Engine Warranty and ends three years or 300,000 miles (482,804 kilometers), whichever occurs first, from the date of delivery of the Engine to the first user.

### Emission Warranty

Additional Coverage is outlined under the Emission Warranty.

**THESE WARRANTIES ARE MADE TO ALL OWNERS IN THE CHAIN OF DISTRIBUTION AND COVERAGE CONTINUES TO ALL SUBSEQUENT OWNERS UNTIL THE END OF THE PERIODS OF COVERAGE.**

## Cummins Responsibilities

### During The Base Engine Warranty

Cummins will pay for all parts and labor needed to repair the damage to the Engine resulting from a Warrantable Failure.

Cummins will pay for the lubricating oil, antifreeze, filter elements, belts, hoses and other maintenance items that are not reusable due to the Warrantable Failure.

Cummins will pay for reasonable labor costs for Engine removal and reinstallation when necessary to repair a Warrantable Failure.

Cummins will pay reasonable costs for towing a vehicle disabled by a Warrantable Failure to the nearest

authorized repair location when necessary to make the repair for the first 2 years from the date of delivery of the Engine to the first user. In lieu of towing expenses, Cummins will pay reasonable costs for mechanics to travel to and from the location of the vehicle, including meals, mileage and lodging, when the repair is performed at the site of the failure.

### During The Extended Major Components Warranty

Cummins will pay for the repair or, at its option, replacement of the defective Covered Part and any Covered Part damaged by a Warrantable Failure of the defective Covered Part.

## Owner Responsibilities

### During The Base Engine Warranty

Owner is responsible for the cost of lubricating oil, antifreeze, filter elements and other maintenance items provided during Warranty repairs unless such items are not reusable due to the Warrantable Failure.

### During The Extended Major Components Warranty

Owner is responsible for the cost of all labor needed to repair the Engine, including the labor to remove and reinstall the Engine. When Cummins elects to repair a part instead of replacing it, Owner is not responsible for the labor needed to repair the part.

Owner is responsible for the cost of all parts required for the repair except for the defective Covered Part and any Covered Part damaged by a Warrantable Failure of the defective Covered Part.

Owner is responsible for the cost of lubricating oil, antifreeze, filter elements and other maintenance items replaced during the repair.

### During The Base Engine And Extended Major Components Warranties

Owner is responsible for the operation and maintenance of the Engine as specified in the applicable Cummins Operation and Maintenance Manual. Owner is also responsible for providing proof that all recommended maintenance has been performed.

Before the expiration of the applicable Warranty, Owner must notify a Cummins distributor, authorized dealer or other repair location approved by Cummins of any Warrantable Failure and make the Engine available for repair by such facility. Except for Engines disabled by a Warrantable Failure during the first two years from the date of delivery of the Engine to the first user, Owner must also deliver the Engine to the repair facility.

Service locations are listed on the Cummins Worldwide Service Locator at [cummins.com](http://cummins.com).

Owner is responsible for communication expenses, meals, lodging and similar costs incurred as a result of a Warrantable Failure.

Owner is responsible for non-Engine repairs and for "downtime" expenses, passenger delays, fines, all applicable taxes, all business costs and other losses resulting from a Warrantable Failure.

## Limitations

Engines with an emissions certification listed below must be operated using only diesel fuel having no more than the corresponding maximum sulfur content. Failure to use the specified fuel as listed in the Cummins Fuel Bulletin #3379001 Table 1 (Cummins Inc. Required Diesel Fuel Specifications) can damage the Engine and aftertreatment system within a short period of time. This damage could cause the Engine to become inoperable and failures attributable to the use of incorrect fuels will be denied Warranty Coverage. Fuel specifications also need to comply with local fuel regulations (EN590 for Europe and ASTM D975 for North America) for Warranty eligibility.

### Maximum sulfur levels by emissions certification level as listed on the Engine's dataplate are:

EPA 2007/2010/2013/2017/2021	max. 15 parts per million
EPA Tier 4 Interim / Final / Stage V in North America	max. 15 parts per million
EU Stage IIIB 2011	max. 15 parts per million
EU Stage IV 2011	max. 15 parts per million
EU Stage V	max. 10 parts per million
Euro 4/5	max. 50 parts per million
Euro 6	max. 10 parts per million

Cummins is not responsible for failures or damage resulting from what Cummins determines to be abuse or neglect, including, but not limited to: operation without adequate coolants or lubricants; overfueling; overspeeding; lack of maintenance of lubricating, cooling or intake systems; improper storage, starting, warm-up, run-in or shutdown practices; unauthorized modifications of the Engine.

Any unauthorized modifications to the aftertreatment system could negatively affect emissions certification and void the Warranty.

Cummins is also not responsible for failures caused by incorrect oil, fuel or diesel exhaust fluid or by water, dirt or other contaminants in the fuel, oil or diesel exhaust fluid.

Alternators and starters are covered for the first two years from the date of delivery of the Engine to the first user, or the expiration of the Base Engine Warranty, whichever occurs first.

Excessive oil consumption for ISV and B Series Engines is covered for the duration of the Coverage. Before a claim for excessive oil consumption will be considered, Owner must submit adequate documentation to show that consumption exceeds Cummins published standards.

Failures of belts and hoses supplied by Cummins are not covered beyond the first year from the date of delivery of the Engine to the first user or the expiration of the applicable Base Engine Warranty, whichever occurs first.

Parts used to repair a Warrantable Failure may be new Cummins parts, Cummins approved rebuilt parts or repaired parts. Cummins is not responsible for failures resulting from the use of parts not approved by Cummins.

A new Cummins or Cummins approved rebuilt part used to repair a Warrantable Failure assumes the identity of the part it replaced and is entitled to the remaining Coverage hereunder.

Cummins, Inc. reserves the right to interrogate Electronic Control Module (ECM) data for purposes of failure analysis.

### **CUMMINS DOES NOT COVER WEAR OR WEAROUT OF COVERED PARTS.**

### **CUMMINS IS NOT RESPONSIBLE FOR INCIDENTAL OR CONSEQUENTIAL DAMAGES.**

**THESE WARRANTIES AND THE EMISSION WARRANTY SET FORTH HEREINAFTER ARE THE SOLE WARRANTIES MADE BY CUMMINS IN REGARD TO THESE ENGINES. CUMMINS MAKES NO OTHER WARRANTIES, EXPRESS OR IMPLIED, OR OF MERCHANTABILITY OR FITNESS FOR A PARTICULAR PURPOSE.**

This Warranty gives you specific legal rights, and you may also have other rights which vary from state to state.

## Emission Warranty

### Products Warranted

This Emission Warranty applies to new Engines marketed by Cummins that are used in the United States\*\* or Canada in vehicles designed for transporting persons or property on a street or highway. This Warranty applies to Engines delivered to the ultimate purchaser on or after January 1, 1996.

### Coverage

Cummins warrants to the ultimate purchaser and each subsequent purchaser that the Engine is designed, built and equipped so as to conform at the time of sale by Cummins with all U.S. federal emission regulations applicable at the time of manufacture and that it is free from defects in material or factory workmanship which would cause it not to meet these regulations within the longer of the following periods: (A) Five years or 100,000 miles (160,934 kilometers) of operation, whichever occurs first, as measured from the date of delivery of the Engine to the ultimate purchaser, or (B) The Base Engine Warranty.

If the vehicle in which the Engine is installed is registered in the state of California, a separate California Emission Warranty also applies.

## Limitations

Engines with an emissions certification listed below must be operated using only diesel fuel having no more than the corresponding maximum sulfur content. Failure to use the specified fuel as listed in the Cummins Fuel Bulletin #3379001 Table 1 (Cummins Inc. Required Diesel Fuel Specifications) can damage the engine and aftertreatment system within a short period of time. This damage could cause the engine to become inoperable and failures attributable to the use of incorrect fuels will be denied Warranty Coverage. Fuel specifications also need to comply with local fuel regulations (EN590 for Europe and ASTM D975 for North America) for Warranty eligibility.

### Maximum sulfur levels by emissions certification level as listed on the Engine's dataplate are:

EPA 2007/2010/2013/2017/2021	max. 15 parts per million
EPA Tier 4 Interim / Final / Stage V in North America	max. 15 parts per million
EU Stage IIIB 2011	max. 15 parts per million
EU Stage IV 2011	max. 15 parts per million
EU Stage V	max. 10 parts per million
Euro 4/5	max. 50 parts per million
Euro 6	max. 10 parts per million

Failures, other than those resulting from defects in material or factory workmanship, are not covered by this Warranty.

Cummins is not responsible for failures or damage resulting from what Cummins determines to be abuse or neglect, including, but not limited to: operation without adequate coolants or lubricants; overfueling; overspeeding; lack of maintenance of lubricating, cooling or intake systems; improper storage, starting, warm-up, run-in or shutdown practices; unauthorized modifications of the Engine.

Any unauthorized modifications to the aftertreatment system could negatively affect emissions certification and void the Warranty.

Cummins is also not responsible for failures caused by incorrect oil, fuel or diesel exhaust fluid or by water, dirt or other contaminants in the fuel, oil or diesel exhaust fluid.

Cummins is not responsible for non-Engine repairs, "downtime" expenses, cargo damage, fines, all applicable taxes, all business costs or other losses resulting from a Warrantable Failure.

### **CUMMINS IS NOT RESPONSIBLE FOR INCIDENTAL OR CONSEQUENTIAL DAMAGES.**

\* A vehicle used to transport students to and from school. Vehicle must be painted yellow, should have warning lights and the words 'SCHOOL BUS' written on the front

and rear roof caps. The requirements pertaining to paint color, warning lights and 'SCHOOL BUS' inscription would not apply if the vehicle is exclusively used to transport students for school related activities and it is owned by a school district.

\*\* United States includes American Samoa, the Commonwealth of Northern Mariana Islands, Guam, Puerto Rico and the U.S. Virgin Islands.



Cummins Inc.  
Box 3005  
Columbus, IN 47202-3005  
U.S.A.

Bulletin No. 3381329  
Printed in U.S.A. Rev 3/20  
©1999 Cummins Inc.



February 18, 2020

**Subject: Allison Transmission 7 year Warranty Coverage for OEM Blue Bird**

The letter below outlines details of the 7-year transmission warranty coverage for OEM Blue Bird for models using Allison 2300PTS, 2350PTS, 2500PTS, 2550PTS and 2575PTS transmissions for use in school buses and similar buses manufactured for non-school use (similar duty cycle to school bus) such as a church bus, private academy bus, prison bus, work bus, poultry bus, etc.

For Allison Transmission models mentioned above shipped to OEM Blue Bird beginning Jan 1, 2020 until December 31, 2020, total transmission coverage will be 7 years. Note: 7-year warranty coverage DOES NOT APPLY to 3000PTS model or any other model not mentioned above. Warranty coverage is described as follows:

**Standard Limited Warranty**

All Allison transmissions carry a comprehensive Standard Limited Warranty covering 100% parts and labor. The length of Standard Limited Warranty coverage for Blue Bird School Bus models with an Allison 2300/2350/2500/2550/2575 PTS Series™ transmission is 5 years. Details on Standard Limited Warranty can be found on Parchment document SE0610EN located on Attachment A.

**Extended Transmission Coverage:**

In addition to Standard Limited Warranty, transmissions are eligible for Extended Transmission Coverage which begins at the end of the Standard Limited Warranty period. The length of Extended Transmission Coverage for Blue Bird School Bus applications with a 2300/2350/2500/2550/2575 PTS Series™ transmission shipped from Allison to Blue Bird beginning January 1, 2020 through December 31, 2020, is 2 years beyond the Standard Limited Warranty for a total of 7 years of coverage.

**NOTE:** Except as noted, all transmissions with Extended Transmission Coverage Warranty have 100% parts and labor coverage with no mileage limitations.

**REQUIREMENTS:** Use of Allison Approved TES 295® transmission fluid\* and Genuine Allison Filters is required. Failure to use Allison Approved TES 295® transmission fluid and Genuine Allison Filters will result in no coverage for repair beyond the Standard Limited Warranty period. If the transmission is not OEM factory filled with Allison Approved TES 295® transmission fluid and Genuine Allison Filters, then Allison Approved TES 295® transmission fluid and Genuine Allison Filters must be installed at the time of Extended Transmission Coverage. Transmissions not OEM factory filled with Allison Approved TES 295® transmission fluid, or transmissions operating with non-TES 295® fluids, must be drained and filled with Allison Approved TES 295® transmission fluid to achieve 100% concentration. One hundred percent concentration is not achieved until the second consecutive fluid change using Allison Approved TES 295® transmission fluid. The second consecutive change must be achieved at the time of Extended Transmission Coverage.

\* For a list of current Allison Approved TES 295® transmission fluids, go to:  
<https://www.allisontransmission.com/parts-service/approved-fluids>

[The following text is extremely faint and illegible due to the quality of the scan. It appears to be a multi-paragraph document.]



88E 1 063

ATTACHMENT A

NEW PRODUCT WARRANTY



PARTICIPATING OEM SALES  
DISTRIBUTOR SALES

LIMITED WARRANTY ON NEW ALLISON AUTOMATIC TRANSMISSIONS  
USED IN SCHOOL BUS APPLICATIONS

Allison Transmission, Inc. will provide for repairs or replacement, at its option, during the warranty period of each new Allison transmission listed below that is installed in a School Bus in accordance with the following terms, conditions, and limitations.

WHAT IS COVERED

- **WARRANTY APPLIES** — This warranty is for new Allison transmission models listed below installed in a School Bus and is provided to the original and any subsequent owner(s) of the vehicle during the warranty period.
- **REPAIRS COVERED** — The warranty covers repairs or replacement, at Allison Transmission's option, to correct any transmission malfunction resulting from defects in material or workmanship occurring during the warranty period. Needed repairs or replacements will be performed using the method Allison Transmission determines most appropriate under the circumstances.
- **TOWING** — Towing is covered to the nearest Allison Transmission Distributor or authorized Dealer only when necessary to prevent further damage to your transmission.
- **PAYMENT TERMS** — Warranty repairs, including parts and labor, will be covered per the schedule shown in the chart contained in section "APPLICABLE MODELS, WARRANTY LIMITATIONS, AND ADJUSTMENT SCHEDULE."
- **OBTAINING REPAIRS** — To obtain warranty repairs, take the vehicle to any Allison Transmission Distributor or authorized Dealer within a reasonable amount of time and request the needed repairs. A reasonable amount of time must be allowed for the Distributor or Dealer to perform necessary repairs.
- **TRANSMISSION REMOVAL AND REINSTALLATION** — Labor costs for the removal and reinstallation of the transmission, when necessary to make a warranty repair, are covered by this warranty.
- **WARRANTY PERIOD** — The warranty period for all coverages shall begin on the date the transmission is delivered to the first retail purchaser, with the following exception:

**Demonstration Service** - A transmission in a new truck or bus may be demonstrated to a total of 5000 miles (8000 kilometers). If the vehicle is within this limit when sold to a retail purchaser, the warranty start date is the date of purchase. Normal warranty services are applicable to the demonstrating Dealer. Should the truck or bus be sold to a retail purchaser after these limits are reached, the warranty period will begin on the date the vehicle was first placed in demonstration service and the purchaser will be entitled to the remaining warranty.

APPLICABLE MODELS, WARRANTY LIMITATIONS, AND ADJUSTMENT SCHEDULE

APPLICABLE MODELS	WARRANTY LIMITATIONS (Whichever occurs first)		ADJUSTMENT CHARGE TO BE PAID BY THE CUSTOMER	
	Months	Transmission Miles Or Kilometers	Parts	Labor
<b>R-MD-HD</b> 1000 Series 2000 Series 2400 Series	0-36	No Limit	No Charge	No Charge
1000 PTS 2100 PTS 2200 PTS 2300 PTS 2400 PTS 2500 PTS 3000 PTS 3100 PTS 3200 PTS 3300 PTS 3400 PTS 3500 PTS 3600 PTS 3700 PTS 3800 PTS 3900 PTS 4000 PTS 4100 PTS 4200 PTS 4300 PTS 4400 PTS 4500 PTS 4600 PTS 4700 PTS 4800 PTS 4900 PTS 5000 PTS	0-36*	0-100,000 mi 0-160,000 km	No Charge	No Charge

\* Effective July 2006, the Allison transmission in your vehicle may be covered by additional extended coverage, dependent on the Original Equipment Manufacturer (OEM) which manufactured your vehicle. This additional coverage requires continued use of an Allison Approved TES 295 automatic transmission fluid and genuine Allison filters. Please consult your OEM Dealer or authorized Allison Transmission Distributor or Dealer for specific information.



ATTACHMENT A (CONTINUED)

WHAT IS NOT COVERED

- **DAMAGE DUE TO ACCIDENT, MISUSE, or ALTERATION** — Defects and damage caused as the result of any of the following are not covered:
  - Flood, collision, fire, theft, freezing, vandalism, riot, explosion, or objects striking the vehicle;
  - Misuse of the vehicle;
  - Installation into unapproved applications and installations;
  - Alterations or modification of the transmission or the vehicle, and
  - Damage resulting from improper storage (refer to long-term storage procedure outlined in the applicable Allison Service Manual)
  - Anything other than defects in Allison Transmission material or workmanship

**NOTE:** This warranty is void on transmissions used in vehicles currently or previously titled as salvaged, scrapped, junked, or totaled.

- **CHASSIS, BODY, and COMPONENTS** — The chassis and body company (assemblers) and other component and equipment manufacturers are solely responsible for warranties on the chassis, body, component(s), and equipment they provide. Any transmission repair caused by an alteration(s) made to the Allison transmission or the vehicle which allows the transmission to be installed or operated outside of the limits defined in the appropriate Allison Installation Guideline is solely the responsibility of the entity making the alteration(s).
- **DAMAGE CAUSED by LACK of MAINTENANCE or by the USE of TRANSMISSION FLUIDS NOT RECOMMENDED in the OPERATOR'S MANUAL** — Defects and damage caused by any of the following are not covered:
  - Failure to follow the recommendations of the maintenance schedule intervals applicable to the transmission;
  - Failure to use transmission fluids or maintain transmission fluid levels recommended in the Operator's Manual.
- **MAINTENANCE** — Normal maintenance (such as replacement of filters, screens, and transmission fluid) is not covered and is the owner's responsibility.
- **REPAIRS by UNAUTHORIZED DEALERS** — Defects and damage caused by a service outlet that is not an authorized Allison Transmission Distributor or Dealer are not covered.
- **USE of OTHER THAN GENUINE ALLISON TRANSMISSION PARTS** — Defects and damage caused by the use of parts that are not genuine Allison Transmission parts are not covered.
- **EXTRA EXPENSES** — Economic loss and extra expenses are not covered. Examples include but are not limited to: loss of vehicle use; inconvenience; storage; payment for loss of time or pay; vehicle rental expense; lodging; meals; or other travel costs.
- **"DENIED PARTY" OWNERSHIP** — Warranty repair parts and labor costs are not reimbursed to any participating or non-participating OEMs, dealers or distributors who perform warranty work for, or on behalf of, end users identified by the United States as being a "denied party" or who are citizens of sanctioned or embargoed countries as defined by the U.S. Department of Treasury Office of Foreign Assets Control. Furthermore, warranty reimbursements are not guaranteed if the reimbursement would be contrary to any United States export control laws or regulations as defined by the U.S. Department of Commerce, the U.S. Department of State, or the U.S. Department of Treasury.

**OTHER TERMS APPLICABLE TO CONSUMERS AS DEFINED by the MAGNUSON-MOSS WARRANTY ACT**

This warranty gives you specific legal rights and you may also have other rights which vary from state to state.

Allison Transmission does not authorize any person to create for it any other obligation or liability in connection with these transmissions. **ANY IMPLIED WARRANTY OF MERCHANTABILITY OR FITNESS FOR A PARTICULAR PURPOSE APPLICABLE TO THESE TRANSMISSIONS IS LIMITED IN DURATION TO THE DURATION OF THIS WRITTEN WARRANTY. PERFORMANCE OF REPAIRS AND NEEDED ADJUSTMENTS IS THE EXCLUSIVE REMEDY UNDER THIS WRITTEN WARRANTY OR ANY IMPLIED WARRANTY. ALLISON TRANSMISSION SHALL NOT BE LIABLE FOR INCIDENTAL OR CONSEQUENTIAL DAMAGES (SUCH AS, BUT NOT LIMITED TO, LOST WAGES OR VEHICLE RENTAL EXPENSES) RESULTING FROM BREACH OF THIS WRITTEN WARRANTY OR ANY IMPLIED WARRANTY.\*\***

\*\* Some states do not allow limitations on how long an implied warranty will last or the exclusion or limitation of incidental or consequential damages, so the above limitations or exclusions may not apply to you.

**OTHER TERMS APPLICABLE TO OTHER END-USERS**

**THIS WARRANTY IS THE ONLY WARRANTY APPLICABLE TO THE ALLISON TRANSMISSION MODELS LISTED ABOVE AND IS EXPRESSLY IN LIEU OF ANY OTHER WARRANTIES, EXPRESS OR IMPLIED, INCLUDING ANY IMPLIED WARRANTY OF MERCHANTABILITY OR FITNESS FOR A PARTICULAR PURPOSE. ALLISON TRANSMISSION DOES NOT AUTHORIZE ANY PERSON TO CREATE FOR IT ANY OTHER OBLIGATION OR LIABILITY IN CONNECTION WITH SUCH TRANSMISSIONS. ALLISON TRANSMISSION SHALL NOT BE LIABLE FOR INCIDENTAL OR CONSEQUENTIAL DAMAGES RESULTING FROM BREACH OF THIS WARRANTY OR ANY IMPLIED WARRANTY.**

**QUESTIONS**

If you have any questions regarding this warranty or the performance of warranty obligations, you may contact any Allison Transmission Distributor or Dealer or write to:

Allison Transmission, Inc.  
P.O. Box 894  
Indianapolis, IN 46206-0894  
Attention: Warranty Administration PF-9  
Form SE0610EN (201612)



# MINOOKA COMMUNITY HIGH SCHOOL DISTRICT #111

*Mission: To inspire and motivate our students with an educational experience that leads to achievement and success.*

John Troy  
Assistant Superintendent & General Counsel

Date: February 16, 2022

Subject: Leased Buses

The transportation department has concluded their review of the bus lease proposals. The bus that they would like to recommend is the Midwest Bus Sales (option 1 below). The past performance, warranty, and mileage were factors in this determination.

The district will be financing this lease separately and the lowest financing was received from Kansas State bank at \$14,615/year per bus.

	Company	Purchase Price	Guaranteed Buy Back	Quoted Lease- 5 years	Bus	Engine	Miles allowed	Overage	Lease Price w/American Capital	Annual Cost Lease (using lowest financing option)	5 Year Lease
Option 1	Midwest Bus Sales	\$ 105,434.00	\$39,786	16,970/14615	Thomas	Cummins	18,953	.35/mi	\$14,849.00	\$ 146,150.00	\$ 730,750.00
Option 2	Central States	\$ 104,202.00	\$27,500	17,230	Bluebird	Cummins	18,000	.35/mi	\$16,883.00	\$ 168,830.00	\$ 844,150.00
Option 3	Midwest Transit	\$ 97,826.00	\$38,000	13,881	International	Cummins	17,000	.35/mi	\$13,575.00	\$ 135,750.00	\$ 678,750.00
Option 4	Midwest Bus Sales	\$ 93,194.00	\$35,167	14999/12918	Thomas	Detroit DD5	18,953	.35/mi	\$13,125.00	\$ 129,180.00	\$ 645,900.00

**MCHS - CENTRAL CAMPUS**  
301 S. Wabena Avenue  
Minooka, Illinois 60447  
815-467-2140

**DISTRICT 111 OFFICE**  
203 W. Mondamin Street, P.O. Box 827  
Minooka, IL 60447  
815-467-3557

**MCHS - SOUTH CAMPUS**  
26655 W. Eames Street  
Channahon, Illinois 60410  
815-521-4001



# MINOOKA COMMUNITY HIGH SCHOOL

District #111 mchs.net

*Mission: Strengthen **M**astery, **C**ollaboration, **H**igh Expectations, and **S**uccess for All Students.*

*Jim Kelly  
Director of Technology*

01/26/2022

Re: Students Chromebooks and Tech Fees 2022-23 School Year

Attached are both quotes for the incoming Freshmen 2022-23 devices, financing documentation through American Capital and the Student Fees for last year. It is my recommendation to choose the HP 11 G8 Chromebook through Trafera for the incoming Freshmen for the 2021-22 school year. These devices will come with:

- UZBL cases to protect the device from external damage
- 4-year accidental warranty
- Student owned after successful Tech Fee payments

The cost will be a buyout lease via American Capital that will cost \$67,911.66 per year for 4 years. The cost per Chromebook is \$331 each. This is a decrease in price per Chromebook from the previous year (21-22 Student Chromebook Lease was \$72,063 per year).

The new Technology fee will only affect the incoming Freshmen (22-23) since the lease rate is locked for 4 years. Sophomores, Juniors, and Seniors will continue to pay the same Technology Fee payment as the previous school year and will own the device upon graduating and successful previous payments.

	<b>Jr/Sr.</b>	<b>Soph.</b>	<b>Fresh.</b>
<b>Technology/Chromebook Fee</b>	\$105	\$120	\$110

**Bill to**  
**MINOOKA CHSD 111**  
**Customer No:** 84919  
 26655 W Eames Street  
 Channahon IL 60410  
 USA

**Ship to**  
**MINOOKA CHSD 111**  
 26655 W Eames Street  
 Channahon IL 60410  
 USA  
 815-521-4017

**Quote Details**  
 Created: January 19, 2022  
 Expiration: February 18, 2022  
 Created by: Marie Muenchow  
 marie.muenchow@trafera.com

**Estimate No:** E000063426

**Contract**  
 None

## Products & Services

Items and Descriptions	Overview	Notes	Qty	Unit Price	Totals
HP 11A G8 EE CBK A4-9120C 4GB/32GB	HP 11A G8 EE Chromebook - 11.6" HD Display (1366 x 768) - A-Series A4-9120C - 4GB DDR4 RAM - 32GB eMMC SSD - AMD Radeon R4 Graphic - 2 x USB 2.0 Type-A, 2 x USB 3.2 Type-C - Chrome OS - Webcam - WiFi + BT		785	\$299.00	\$234,715.00
Trafera CBN Warranty - Plat - 4 Yr - A	Trafera CBN Warranty - Plat - 4 Yr - Includes Accidental Damage Protection (Per device limit of ADP: Unlimited) - \$0.00 Deductible - Hardware Fail Covered - Spare Parts On-site (restrictions apply) - We Pay to Ship Both Ways - Theft / Loss (up to 2%; please see warranty statement for details) - 3-Year Battery warranty on New Chrome devices (Limit 1 replacement) - Stylus/EMR Pen/Apple Pencil coverage (restrictions apply) - Power Adapter 1 ADP Incident (restrictions apply)		785	\$0.00	\$0.00
CASE HP G8/G9 CHROME HARD SHELL	UZBL HP G8 Chromebook Hard Shell Case		785	\$0.00	\$0.00
Case Installation with White Glove			785	\$0.00	\$0.00
Google Chrome Management Perpetual EDU	Google Chrome Management Perpetual EDU License		785	\$32.00	\$25,120.00

Trafera White Glove 300 Units and Above	Trafera White Glove 300 Units and Above - Pre-enrolled in Google Apps® domain - Custom themes and settings applied - Hardware functionality check - Google Console OU management	785	\$0.00	\$0.00
Trafera Green Packing		785	\$0.00	\$0.00
				<b>Subtotal</b> \$259,835.00
				<b>Tax</b> \$0.00
				<b>Total</b> <b>\$259,835.00</b>
				<b>Net Terms</b> <b>N30</b>

**Terms and Conditions**

This quote is confidential and is to be viewed solely by individuals within the organization to whom it is addressed. Unauthorized distribution or disclosure of the contents of this quote is prohibited. If you are not from the organization addressed, please notify us immediately so we can prepare a quote specific to you. Prices and availability may change without notice prior to the quote expiration date.

**Questions? Contact me**

**Chad Dehmlow**

chad.dehmlow@trafera.com



**Trafera**

2550 University Ave W, Suite 315 - S  
St. Paul MN 55114  
United States