

# Regular Meeting of the Board of Education

Tuesday, February 25, 2025 6:30 PM

Moraine Elementary School, 46811 W. Eight Mile, Northville, MI 48167

1. **Call to Order**

2. **Pledge of Allegiance**

3. **Roll Call**

4. **Adoption of Agenda**

5. **Consent Resolutions**

5.a) Minutes of the February 18, 2025 Board of Education Meeting

5.b) Minutes of the February 18, 2025 Closed Session Meeting

5.c) Instructional Materials adoption for ELA 10 & Honors English 10 *It Won't Always Be Like This* by Malaka Gharib

5.d) Middle School Course Name Change from Digital Journey 6 to STEAM 6

6. **Communications**

6.a) npsboe@northvilleschools.org communications

7. **Moraine Presentation**

8. **Superintendent's Report/Update**

8.a) ABCD Awards

9. **Public Comments**

10. **Hillside Middle School: Interim Asst. Principal**

**Presenter:** Ms. Carin Meyer, Policy & HR Liaison

11. **Bid Awards: Bond 2023**

**Presenter:** Ms. Melissa Stuart, Treasurer

12. **Educational Technology: Fiber, Cabling, Desktops/Laptops**

**Presenter:** Ms. Melissa Stuart, Board Treasurer

13. **First Reading: Policy 2120 Student Enrollment: Children of Employees & Board Standards of Practice**

14. **2025-26 Early Childhood Tuition Rates**

**Presenter:** Ms. Melissa Stuart, Board Treasurer

15. **2025 Michigan Association of School Boards (MASB) Board of Directors Election**

**Presenter:** Ms. Jena Mabrey, MASB Liaison

16. **Added Agenda Items**

17. **Public Comments**

18. **Questions/Comments from Board Members**

19. **Adjournment**

# Minutes of Special Call Meeting of the Board of Education

## The Board of Trustees Northville Public Schools

---

A Special Call Meeting of the Board of Education of the Board of Trustees of Northville Public Schools was held Tuesday, February 18, 2025, beginning at 8:00 PM in the Old Village School, 405 W. Main St, Northville, MI 48167.

### 1. Call to Order

Meeting called to order by President McIntyre at 9:22 p.m.

### 2. Pledge of Allegiance

President McIntyre led the Board in the Pledge of Allegiance.

### 3. Roll Call

Ms. Lisa McIntyre, President	Dr. RJ Webber, Superintendent
Dr. Kim Campbell-Voytal, Vice President	Mr. Brian Sumner, Director of Human Resources
Ms. Carin Meyer, Secretary	Ms. Rebecca Pek, Asst. Supt. for Communications, Development, and Equity
Ms. Melissa Stuart, Treasurer	Mr. Devin Kling, Asst. Supt. for Finance & Operations
Mr. Ron Frazier, Trustee	Dr. Sandra Brock, Director of Instructional Programs
Ms. Meredith Riggan Maurer, Trustee	Ms. Beth Santer, Exec. Director of Special Services
Ms. Jena Mabrey, Trustee	Ms. Darby Hoppenstedt, Dir. for Wellness

### 4. Adoption of Agenda

Motion No. 24/25-077 by Vice President Campbell-Voytal supported by Treasurer Stuart, that the agenda be adopted as presented. Motion carried 7-0.

### 5. Consent Resolutions

Motion No. 24/25-078 by Vice President Campbell-Voytal, supported by Trustee Riggan Maurer, that the Board accept the consent agenda items for approval as presented:

a) Minutes of the February 11, 2025 Board of Education Meeting

Motion carried 7-0.

**6. Communications**

Secretary Meyer reported one communication:

a) npsboe@northvilleschools.org communications

**7. Public Comments**

None.

**8. Added Agenda Items**

None.

**9. Public Comments**

None.

**10. Closed Session**

Motion No. 24/25-079 by Vice President Campbell-Voytal, supported by Secretary Meyer, that the Board convene in Closed Session Pursuant to Public Act 267, of the Open Meetings Act, under Section 8(c) Negotiations. Roll Call Vote: McIntyre – yes; Campbell-Voytal – yes; Stuart – yes; Meyer – yes; Frazier – yes; Mabrey – yes; Riggan-Maurer – yes. Motion carried 7-0.

The Board moved to enter Closed Session at 9:28 p.m.

The Board convened in Closed Session from 9:36 – 11:59 p.m.

The Board returned to Open Session at 12:01 a.m.

**11. Adjournment**

There being no further business the meeting adjourned at 12:02 a.m.

---

Carin Meyer, Secretary



# REQUEST FOR TEXTBOOK APPROVAL

I. Course: English 10 and Honors English 10

Grade: 10

Change from: *(if applicable)*

Change to:

Title: Persepolis

Title: It Won't Always Be Like This

Author: Marjane Satrapi

Author: Malaka Gharib

Publisher: Pantheon Books  
ISBN 9780375714573

Publisher: Penguin Random House  
ISBN 9781984860293

Copyright: 2003

Copyright: 2022

II.

Title of Text, Software, Manipulatives, Etc.	ISBN Number	Quantity
<i>It Won't Always Be Like This</i> by Malaka Gharib	9781984860293	700
	Currently on Amazon Business (12/11/24)	\$11.89
	<b>Total</b>	<b>\$8,323</b>

Note: The Office of Instruction will contact the publishers for exact costs. Please attach any cost estimates or contact information that you feel might be helpful.

Committee Members:

Matthew Stetson  
(Dept. Chairperson)

[Signature]  
(Facilitator)

Tony Koski  
(Administrator)

Matthew Stetson  
(Teacher)

12/18/24  
Date

Board Instructional Services

# Northville Public Schools

**Subcommittee:**

\_\_\_\_\_ (Chairperson)

\_\_\_\_\_ (Date)

**Board of Education:**

\_\_\_\_\_ (Chairperson)

\_\_\_\_\_ (Date)

**Return completed form to the Office of Instruction.**

Cc: Building Principal, DCC Administrator, Curriculum Facilitator, Department Chairperson

## Text Information

**Title:** *It Won't Always Be Like This: A Graphic Memoir*

**Author:** Malaka Gharib

**Book information/ISBN:** 9781984860293

## Synopsis

*It Won't Always Be Like This* is a graphic memoir by Malaka Gharib that delves into the complexities of identity, family, and cultural displacement. Gharib, a Filipino-Egyptian-American, chronicles her annual summer visits to Cairo, where she navigates the intricacies of her Egyptian father's new family and culture.

Initially, these visits are a familiar routine. However, her father's remarriage introduces significant changes, forcing her to adapt to a new family dynamic and a foreign cultural landscape. Gharib's initial discomfort and alienation are compounded by her unique identity as a young woman straddling multiple cultures. She grapples with questions of belonging, acceptance, and the tension between her American upbringing and her Egyptian heritage.

Through her honest and insightful storytelling, Gharib explores themes of self-discovery, family bonds, and the fluidity of identity. She candidly discusses her struggles with self-image, cultural identity, and the challenges of adolescence. The graphic novel format allows Gharib to visually convey her experiences, enhancing the emotional impact of her narrative.

Ultimately, *It Won't Always Be Like This* is a heartwarming and thought-provoking exploration of one young woman's journey of self-discovery and cultural assimilation. Gharib's poignant reflections on her childhood summers in Egypt offer a unique perspective on the complexities of identity and the power of human connection.

## Justification (need in curriculum):

Rationale for Replacing *Persepolis* with *It Won't Always Be Like This*

The decision to replace *Persepolis* with *It Won't Always Be Like This* in our curriculum stems from a careful consideration of several factors. While *Persepolis* is a critically acclaimed graphic novel, it has faced increasing scrutiny due to its limited portrayal of the Middle East and Islam. In recent years, there has been a growing tension surrounding the Middle East, around the world and particularly in the United States. This heightened sensitivity has made it challenging for some students and teachers to engage with the text without discomfort.

# Northville Public Schools

To address these concerns, we sought a graphic novel that would offer a more nuanced and contemporary perspective on the Middle Eastern experience. *It Won't Always Be Like This* meets these criteria by featuring a female Middle Eastern/North African narrator. This choice aligns with our commitment to diversity and inclusivity, providing students with a relatable and empowering figure. Furthermore, the non-fiction nature of *It Won't Always Be Like This* offers a grounded and authentic portrayal of the author's personal experiences. By sharing her own story, Malaka Gharib provides students with a firsthand account of cultural identity, family dynamics, and the challenges of navigating multiple cultural contexts.

Replacing *Persepolis* with *It Won't Always Be Like This* allows us to offer a more sensitive, relevant, and inclusive reading experience for our students. This shift reflects our ongoing commitment to fostering empathy, understanding, and critical thinking.

## **Academic Relevance:**

Common Core Standards:

- **Reading Literature:**

- Cite strong and thorough textual evidence to support analysis of what the text says explicitly as well as inferences drawn from the text.
- Analyze how complex characters (e.g., those with multiple or conflicting motivations) develop over the course of a text, interact with other characters, and advance the plot or theme.
- Analyze the impact of the author's choices regarding how to structure a text (e.g., chronological order, parallel plots).

- **Reading Informational Text:**

- Analyze how the author unfolds an argument or series of ideas over the course of a text.
- Determine an author's point of view or purpose in a text and analyze how an author uses rhetoric to advance that point of view or purpose.

Michigan ELA Standards:

- **Reading Literature:**

- Analyze the development of complex characters and their relationships with other characters.
- Analyze the author's use of literary devices to create meaning and enhance the reader's understanding of the text.

- **Reading Informational Text:**

- Analyze the author's purpose in a text and how the author uses rhetoric to achieve that purpose.
- Evaluate the credibility and accuracy of information presented in a text.

## Northville Public Schools

By engaging with *It Won't Always Be Like This*, students can develop a deeper understanding of cultural identity, family dynamics, and the human experience. The graphic novel format also offers a visually compelling way to explore complex themes and ideas, making it accessible to a wide range of learners.

### **Potential Objectionable Material:**

While *It Won't Always Be Like This* is a powerful and insightful graphic memoir, it contains some mature content that may be objectionable to certain readers. The book contains instances of strong language, such as "shit" (pages 78 and 118) and "fuck" (pages 92, 95, 164). The narrative includes references to sexual assault (pages 90 and 94), and the book depicts characters smoking hookah and cigarettes.

It is important to note that these elements are presented within the context of the narrative and serve to enhance the authenticity and emotional impact of the story. While *It Won't Always Be Like This* does contain mature content, the nature and frequency of such content is significantly less intense than that found in *Persepolis*, the book it will replace. *Persepolis* delves into the harsh realities of war, including explicit depictions of violence, torture, and death. In contrast, *It Won't Always Be Like This* focuses on personal experiences of cultural identity, family dynamics, and adolescent challenges. While the book touches on sensitive topics like sexual assault, it does so with a more nuanced and less graphic approach.

### **Accolades**

"What a joy it is to read Malaka Gharib's *It Won't Always Be Like This*, to have your heart expertly broken and put back together within the space of a few panels, to have your wonder in the world restored by her electric mind." – Mira Jacob, author of *Good Talk: A Memoir in Conversations*

ONE OF THE BEST BOOKS OF THE YEAR: *Book Riot*

"A delightful account capturing the highs and lows of shifting family dynamics . . . Malaka's tenderness for her family and Egypt are heartwarming and genuine." – Diana Abouali, Director, Arab American National Museum

"This is the book that's been missing from my bookshelf. Gharib's writing and illustrations made me laugh and cry and transported me back to some of the best days of my life in Egypt. This unforgettable graphic memoir is written from the heart." – Aya Khalil, author of *The Arabic Quilt*

"Intimate and wide-open, *It Won't Always Be Like This* is a coming-of-age comic imbued with the wisdom of a mature and powerful mind. Gharib is the real deal." – Kristen Radtke, author of *Seek You: A Journey Through American Loneliness*

"Malaka Gharib recounts her teenage memories with an open heart and an eye for detail. *It Won't Always Be Like This* is her best work yet. I wish everyone could write (and draw) about their lives with this much honesty, specificity, and warmth." – Adrian Tomine, author of *The Loneliness of the Long-Distance Cartoonist*

"Gharib's drawings are freehanded and energetic, with brightly detailed marketplaces, beach scenes, and cityscapes, peppered with excerpts from Gharib's actual adolescent diaries. This work will resonate with any graphic novel memoir fan who felt like a fish out of water growing up, and promises teen crossover appeal." – *Publishers Weekly*

## **Text Information**

**Title:** *It Won't Always Be Like This: A Graphic Memoir*

**Author:** Malaka Gharib

**Book information/ISBN:** 9781984860293

## **Synopsis**

*It Won't Always Be Like This* is a graphic memoir by Malaka Gharib that delves into the complexities of identity, family, and cultural displacement. Gharib, a Filipino-Egyptian-American, chronicles her annual summer visits to Cairo, where she navigates the intricacies of her Egyptian father's new family and culture.

Initially, these visits are a familiar routine. However, her father's remarriage introduces significant changes, forcing her to adapt to a new family dynamic and a foreign cultural landscape. Gharib's initial discomfort and alienation are compounded by her unique identity as a young woman straddling multiple cultures. She grapples with questions of belonging, acceptance, and the tension between her American upbringing and her Egyptian heritage.

Through her honest and insightful storytelling, Gharib explores themes of self-discovery, family bonds, and the fluidity of identity. She candidly discusses her struggles with self-image, cultural identity, and the challenges of adolescence. The graphic novel format allows Gharib to visually convey her experiences, enhancing the emotional impact of her narrative.

Ultimately, *It Won't Always Be Like This* is a heartwarming and thought-provoking exploration of one young woman's journey of self-discovery and cultural assimilation. Gharib's poignant reflections on her childhood summers in Egypt offer a unique perspective on the complexities of identity and the power of human connection.

## **Justification (need in curriculum):**

Rationale for Replacing *Persepolis* with *It Won't Always Be Like This*

The decision to replace *Persepolis* with *It Won't Always Be Like This* in our curriculum stems from a careful consideration of several factors. While *Persepolis* is a critically acclaimed graphic novel, it has faced increasing scrutiny due to its limited portrayal of the Middle East and Islam. In recent years, there has been a growing tension surrounding the Middle East, around the world and particularly in the United States. This heightened sensitivity has made it challenging for some students and teachers to engage with the text without discomfort.

To address these concerns, we sought a graphic novel that would offer a more nuanced and contemporary perspective on the Middle Eastern experience. *It Won't Always Be Like This* meets these criteria by featuring a female Middle Eastern/North African narrator. This choice aligns with our commitment to diversity and inclusivity, providing students with a relatable and

empowering figure. Furthermore, the non-fiction nature of *It Won't Always Be Like This* offers a grounded and authentic portrayal of the author's personal experiences. By sharing her own story, Malaka Gharib provides students with a firsthand account of cultural identity, family dynamics, and the challenges of navigating multiple cultural contexts.

Replacing *Persepolis* with *It Won't Always Be Like This* allows us to offer a more sensitive, relevant, and inclusive reading experience for our students. This shift reflects our ongoing commitment to fostering empathy, understanding, and critical thinking.

### **Academic Relevance:**

Common Core Standards:

- **Reading Literature:**
  - Cite strong and thorough textual evidence to support analysis of what the text says explicitly as well as inferences drawn from the text.
  - Analyze how complex characters (e.g., those with multiple or conflicting motivations) develop over the course of a text, interact with other characters, and advance the plot or theme.
  - Analyze the impact of the author's choices regarding how to structure a text (e.g., chronological order, parallel plots).
  
- **Reading Informational Text:**
  - Analyze how the author unfolds an argument or series of ideas over the course of a text.
  - Determine an author's point of view or purpose in a text and analyze how an author uses rhetoric to advance that point of view or purpose.

Michigan ELA Standards:

- **Reading Literature:**
  - Analyze the development of complex characters and their relationships with other characters.
  - Analyze the author's use of literary devices to create meaning and enhance the reader's understanding of the text.
- **Reading Informational Text:**

- Analyze the author’s purpose in a text and how the author uses rhetoric to achieve that purpose.
- Evaluate the credibility and accuracy of information presented in a text.

By engaging with *It Won't Always Be Like This*, students can develop a deeper understanding of cultural identity, family dynamics, and the human experience. The graphic novel format also offers a visually compelling way to explore complex themes and ideas, making it accessible to a wide range of learners.

### **Potential Objectionable Material:**

While *It Won't Always Be Like This* is a powerful and insightful graphic memoir, it contains some mature content that may be objectionable to certain readers. The book contains instances of strong language, such as "shit" (pages 78 and 118) and "fuck" (pages 92, 95, 164). The narrative includes references to sexual assault (pages 90 and 94), and the book depicts characters smoking hookah and cigarettes.

It is important to note that these elements are presented within the context of the narrative and serve to enhance the authenticity and emotional impact of the story. While *It Won't Always Be Like This* does contain mature content, the nature and frequency of such content is significantly less intense than that found in *Persepolis*, the book it will replace. *Persepolis* delves into the harsh realities of war, including explicit depictions of violence, torture, and death. In contrast, *It Won't Always Be Like This* focuses on personal experiences of cultural identity, family dynamics, and adolescent challenges. While the book touches on sensitive topics like sexual assault, it does so with a more nuanced and less graphic approach.

### **Accolades**

“What a joy it is to read Malaka Gharib’s *It Won't Always Be Like This*, to have your heart expertly broken and put back together within the space of a few panels, to have your wonder in the world restored by her electric mind.” – Mira Jacob, author of *Good Talk: A Memoir in Conversations*

ONE OF THE BEST BOOKS OF THE YEAR: *Book Riot*

“A delightful account capturing the highs and lows of shifting family dynamics . . . Malaka’s tenderness for her family and Egypt are heartwarming and genuine.” – Diana Abouali, Director, Arab American National Museum

“This is the book that’s been missing from my bookshelf. Gharib’s writing and illustrations made me laugh and cry and transported me back to some of the best days of my life in Egypt. This unforgettable graphic memoir is written from the heart.” – Aya Khalil, author of *The Arabic Quilt*

“Intimate and wide-open, *It Won't Always Be Like This* is a coming-of-age comic imbued with the wisdom of a mature and powerful mind. Gharib is the real deal.” – Kristen Radtke, author of

*Seek You: A Journey Through American Loneliness*

"Malaka Gharib recounts her teenage memories with an open heart and an eye for detail. *It Won't Always Be Like This* is her best work yet. I wish everyone could write (and draw) about their lives with this much honesty, specificity, and warmth." – Adrian Tomine, author of *The Loneliness of the Long-Distance Cartoonist*

"Gharib's drawings are freehanded and energetic, with brightly detailed marketplaces, beach scenes, and cityscapes, peppered with excerpts from Gharib's actual adolescent diaries. This work will resonate with any graphic novel memoir fan who felt like a fish out of water growing up, and promises teen crossover appeal." – *Publishers Weekly*



## COURSE CHANGE REQUEST FORM

Date: 1/10/25

I. **Course Name Change – STEAM 6** to **Projected Date of Implementation:**  
September 2025

II. **Existing Course Name:** Digital Journey 6 **Change To: STEAM 6**

III. **Rationale For Course Change:**

The main rationale is to better align the K-8 STEAM offerings as a unified program. Digital Journey 6 was somewhat more limited in scope and changing the name to STEAM 6 allows for a more accurate and comprehensive description of what will be taught (Science, Technology, Engineering, Arts, Math).

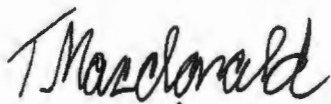
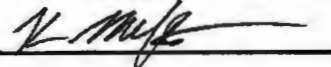
Department Chairperson

Principal

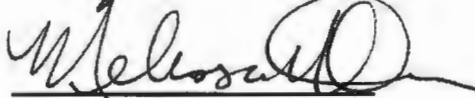
 2/7/25

Office of Instruction

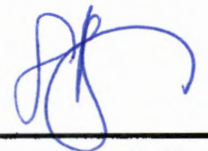
**Projected Dates of Approval:**

# Northville Public Schools



District Curriculum Council

Committee of the Whole (COW)

Board of Education

**Return completed form to the Office of Instruction.**  
cc: Building Principal, DCC Administrator, OOI, Department Chairperson



# Moraine Elementary

Teaching for Learning for All!

Empowering students to be lifelong learners, who positively impact the world through innovation, integrity, collaboration, and kindness.



## Agenda

### **Pledge of Allegiance**

Leaders from Moraine Kindergarten Classrooms

### **Introduction and Welcome**

5th Grade Students

Everett Witter, Moraine Student Alum  
and Kim Richardson-Hippler Leadership Award Winner

### **Student Rotations:**

Kindness Symbol  
Peace Path  
Building Thinking Classrooms

**Follow Up Questions from The Board of Education**





---

**Dr. RJ Webber**  
**Superintendent**

---



---

***Above and Beyond***  
***the Call of Duty***

---

February 25, 2025

Cecelia Brown  
1st Grade Teacher, Moraine

Dear Cecelia,

I am pleased to notify you that the administration received a couple “Above and Beyond the Call of Duty” submissions on your behalf, which are attached. The ABCD designation was established to provide an avenue of recognition and appreciation for staff contributions that are believed to rise beyond the norm, making significant contributions to the classroom, school and/or community. ABCD accolades can come from parents, students or colleagues.

The two parents who made separate submissions on your behalf states (paraphrased):

Caregiver: Mrs. Brown embodies a perfect harmony of care, dedication, expectations, and love within her classroom. Teachers as a whole are often held to extremely high expectations and standards, Mrs. Brown blows away any expectation or standard that is set and makes it look effortless. Mrs. Brown makes every child who enters her classroom feel loved and special, she truly is a gift, and we are better people for knowing her.

Parent: Mrs. Brown made a huge impact on my son's elementary school experience. She helped him grow in his strengths and gave him the confidence he needed to work on things that didn't come as easily.

On behalf of our administration leadership team and Board of Education, thank you for your contributions and efforts to enhance our school community. The contributions noted here on your behalf exemplify Northville Public Schools and contribute to our mission to open a World of Possibilities for and with each and every student.

It is well documented that educators dedicate themselves to the profession seeking to make a difference. We would like to congratulate you and thank you for your dedication to the students, families and staff of Northville Public Schools. Your contribution to our school community has been noticed!

Sincerely,

Dr. RJ Webber  
Superintendent



Do you want the world to know how a wonderful NPS staff member goes **Above and Beyond the Call of Duty** to support you, other students, staff and/or our community? Please tell us about that person by nominating them for an ABCD Award! Students, parents and colleagues are ALL encouraged to nominate an NPS staff member for this award.

**How does it work?** Students, staff or parents may complete this form detailing something truly Above and Beyond the Call of Duty by an NPS staff member. Submissions are received by the district and will be reviewed by the Board of Education's Policy/Personnel Sub-Committee for award consideration. Recognition may include presentation at public Board of Education meetings and/or inclusion in District communications.

**This nomination is submitted by:** Caregiver

**Date:** 10/1/2024

**My role:** Caregiver

**The person being nominated is:** Cecelia Brown

**School or Department:** 1st Grade Teacher, Moraine Elementary

**Do you wish for the staff member nominated to know who submitted this form?** No

**Please describe how this staff member went "above and beyond" and what impact it has had:**

Mrs. Brown embodies a perfect harmony of care, dedication, expectations, and love within her classroom. I am eternally grateful for the experience and knowledge my little guy gained under her guidance during his time in her class. I am even more thankful for the lasting connection she has maintained with him over the last 2 years. Teachers as a whole are often held to extremely high expectations and standards, Mrs. Brown blows away any expectation or standard that is set and makes it look effortless. Throughout the last two summers, Mrs. Brown has consistently written letters and sent postcards and pictures which have become a summer favorite for my guy. He truly looks forward to checking the mail to see if the next letter from her has arrived. She truly sets the bar high and goes above and beyond! My little guy no longer attends Moraine, but he shuttles there after school and one of the best parts of his day is when he gets off the shuttle and gets to see her! He recently asked if we could nominate her for teacher of the year because "she is the best teacher I've ever had and I've been in school for FOUR years". That statement from him speaks volumes about her because he has been so fortunate to have the most wonderful educators each year. Mrs. Brown makes every child who enters her classroom feel loved and special, she truly is a gift, and we are better people for knowing her.



Do you want the world to know how a wonderful NPS staff member goes **Above and Beyond** the **Call of Duty** to support you, other students, staff and/or our community? Please tell us about that person by nominating them for an ABCD Award! Students, parents and colleagues are ALL encouraged to nominate an NPS staff member for this award.

***How does it work?*** Students, staff or parents may complete this form detailing something truly Above and Beyond the Call of Duty by an NPS staff member. Submissions are received by the district and will be reviewed by the Board of Education's Policy/Personnel Sub-Committee for award consideration. Recognition may include presentation at public Board of Education meetings and/or inclusion in District communications.

**This nomination is submitted by:** Nora Errickson

**Date:** 2/12/25

**My role:** Parent

**The person being nominated is:** Cecelia Brown

**School or Department:** 1st Grade Teacher, Moraine Elementary

**Do you wish for the staff member nominated to know who submitted this form?** Yes

**Please describe how this staff member went "above and beyond" and what impact it has had:**

Mrs. Brown made a huge impact on my son's elementary school experience. She helped him grow in his strengths and gave him the confidence he needed to work on things that didn't come as easily. The love she showed each and every student really emanated throughout the classroom. Even though he's no longer a first grader, my son looks forward to seeing Mrs. Brown at school so he can get a hug. Thank you, Mrs. Brown, for your passion for making sure every student succeeds.



---

**Dr. RJ Webber**  
**Superintendent**

---



---

***Above and Beyond***  
***the Call of Duty***

---

February 25, 2025

James O'Brien  
3rd Grade Teacher, Amerman

Dear James,

I am pleased to notify you that the administration received a couple "Above and Beyond the Call of Duty" submissions on your behalf, which are attached. The ABCD designation was established to provide an avenue of recognition and appreciation for staff contributions that are believed to rise beyond the norm, making significant contributions to the classroom, school and/or community. ABCD accolades can come from parents, students or colleagues.

The two parents who made separate submissions on your behalf states (paraphrased):

Parent: I have spoken with many fellow parents of his current class and we just are so appreciative of how much effort and care he puts into making the classroom a place where every student feels safe, loved, encouraged, inspired, and excited to learn. All the room parents were so blown away by how well his students treat each other whenever we do class activities- we know that kind of behavior comes from great leadership in the front of the classroom.

Parent: I have been so impressed with the positive and supportive environment he has created for his students, the kind yet firm way he directs the class, and the care he takes with each student in working with their different needs.

On behalf of our administration leadership team and Board of Education, thank you for your contributions and efforts to enhance our school community. The contributions noted here on your behalf exemplify Northville Public Schools and contribute to our mission to open a World of Possibilities for and with each and every student.

It is well documented that educators dedicate themselves to the profession seeking to make a difference. We would like to congratulate you and thank you for your dedication to the students, families and staff of Northville Public Schools. Your contribution to our school community has been noticed!

Sincerely,

Dr. RJ Webber  
Superintendent



Do you want the world to know how a wonderful NPS staff member goes **Above and Beyond the Call of Duty** to support you, other students, staff and/or our community? Please tell us about that person by nominating them for an ABCD Award! Students, parents and colleagues are ALL encouraged to nominate an NPS staff member for this award.

***How does it work?*** Students, staff or parents may complete this form detailing something truly Above and Beyond the Call of Duty by an NPS staff member. Submissions are received by the district and will be reviewed by the Board of Education's Policy/Personnel Sub-Committee for award consideration. Recognition may include presentation at public Board of Education meetings and/or inclusion in District communications.

**This nomination is submitted by:** Carrie Mullen

**Date:** 1/18/25

**My role:** Parent

**The person being nominated is:** James O'Brien

**School or Department:** 3rd Grade Teacher, Amerman Elementary

**Do you wish for the staff member nominated to know who submitted this form?** Yes

**Please describe how this staff member went "above and beyond" and what impact it has had:**

My daughter was so excited to get Mr. O'Brien as her 3rd grade teacher this year! She goes to school every day excited to learn and comes home eager to tell us about what they are working on. I have been so impressed with the positive and supportive environment he has created for his students, the kind yet firm way he directs the class, and the care he takes with each student in working with their different needs. From donning full costumes for the Victorian festival and Halloween, to cheering on students at their weekend sports games (!), Mr. O'Brien truly goes above and beyond to show up for his students. I cannot overstate what it means to these kids to have such a dedicated teacher invested in their wellbeing and futures, and how much a positive learning environment contributes to their success!



Do you want the world to know how a wonderful NPS staff member goes **Above and Beyond the Call of Duty** to support you, other students, staff and/or our community? Please tell us about that person by nominating them for an ABCD Award! Students, parents and colleagues are ALL encouraged to nominate an NPS staff member for this award.

**How does it work?** Students, staff or parents may complete this form detailing something truly Above and Beyond the Call of Duty by an NPS staff member. Submissions are received by the district and will be reviewed by the Board of Education's Policy/Personnel Sub-Committee for award consideration. Recognition may include presentation at public Board of Education meetings and/or inclusion in District communications.

**This nomination is submitted by:** Courtney Nagel

**Date:** 12/20/24

**My role:** Parent

**The person being nominated is:** James O'Brien

**School or Department:** 3rd Grade Teacher, Amerman Elementary

**Do you wish for the staff member nominated to know who submitted this form?** Yes

**Please describe how this staff member went "above and beyond" and what impact it has had:**

Mr. O'Brien is an amazing teacher. I want to share what a positive and supportive environment he has created for the students in his class. I have spoken with many fellow parents of his current class and we just are so appreciative of how much effort and care he puts into making the classroom a place where every student feels safe, loved, encouraged, inspired, and excited to learn. All the room parents were so blown away by how well his students treat each other whenever we do class activities- we know that kind of behavior comes from great leadership in the front of the classroom.

I just want to share all the hard work Jimmy is putting in to make school such an enjoyable and enriching experience for my daughter and her classmates. The effort and energy of this first year teacher is so very valued!



---

**Dr. RJ Webber**  
**Superintendent**

---



---

***Above and Beyond***  
***the Call of Duty***

---

February 25, 2025

Jennifer Frederick  
2nd Grade Teacher, Moraine

Dear Jennifer,

I am pleased to notify you that the administration received an “Above and Beyond the Call of Duty” submission on your behalf, which is attached. The ABCD designation was established to provide an avenue of recognition and appreciation for staff contributions that are believed to rise beyond the norm, making significant contributions to the classroom, school and/or community. ABCD accolades can come from parents, students or colleagues.

The \*parent who made this submission on your behalf states (paraphrased):

Parent: Our daughter was a covid preschooler and sometimes emotional navigation is challenging for her. Mrs. Frederick takes time from her day to check on how our evening went at home the night prior. This has made a huge difference in our daughter’s behavior which in turn is helping our whole family system. This is something we realize not all teachers would be thrilled to do but her heart is in the right place & that is for our children's best interest.

On behalf of our administration leadership team and Board of Education, thank you for your contributions and efforts to enhance our school community. The contributions noted here on your behalf exemplify Northville Public Schools and contribute to our mission to open a World of Possibilities for and with each and every student.

It is well documented that educators dedicate themselves to the profession seeking to make a difference. We would like to congratulate you and thank you for your dedication to the students, families and staff of Northville Public Schools. Your contribution to our school community has been noticed!

Sincerely,

Dr. RJ Webber  
Superintendent



Do you want the world to know how a wonderful NPS staff member goes **Above and Beyond the Call of Duty** to support you, other students, staff and/or our community? Please tell us about that person by nominating them for an ABCD Award! Students, parents and colleagues are ALL encouraged to nominate an NPS staff member for this award.

**How does it work?** Students, staff or parents may complete this form detailing something truly Above and Beyond the Call of Duty by an NPS staff member. Submissions are received by the district and will be reviewed by the Board of Education's Policy/Personnel Sub-Committee for award consideration. Recognition may include presentation at public Board of Education meetings and/or inclusion in District communications.

**This nomination is submitted by:** Crystal and Justin Gerwatowski

**Date:** 12/18/24

**My role:** Parent

**The person being nominated is:** Jennifer Frederick

**School or Department:** 2nd Grade Teacher, Moraine Elementary

**Do you wish for the staff member nominated to know who submitted this form?** Yes

**Please describe how this staff member went "above and beyond" and what impact it has had:**

Mrs. Frederick had our oldest daughter for two years due to one of the years being a split class. Our youngest daughter now has her and we couldn't be more thankful. Leona was a covid preschooler and sometimes emotional navigation is challenging for her. We've worked incredibly hard as a family to help her but eventually this year we realized we needed evaluation and support from the school. Although Leona doesn't meet the criteria to get an IEP through NPS she was gifted a wonderful Psychologist at NPS AND Mrs. Frederick. We've decreased conflicts at home by working with a check-in system that her personal therapist had suggested in the classroom with Mrs. Frederick. Mrs. Frederick takes time from her day to check on how our evening went at home the night prior. This has made a huge difference in Leona's behavior which in turn is helping our whole family system. This is something we realize not all teachers would be thrilled to do but her heart is in the right place & that is for our children's best interest. Leona's behavior is ok at school but Moraine recognizes the importance of collaboration with home life and school life. In addition, she consistently been a positive role model for both of our kids when it comes

to academics AND their emotional state. She is attuned to her students and knew Lstruggles at school within the first week without much input from us. She's always optimistic, loving and academically challenging when needed. We have watched her handle so many obstacles as a teacher and if nothing else we hope she gets recognized as one of the districts best. Although we believe she is the perfect candidate to be acknowledged as one that goes above and beyond.



---

**Dr. RJ Webber**  
**Superintendent**

---

---

***Above and Beyond***  
***the Call of Duty***

---

February 25, 2025

Katie Grimm  
Resource Room Teacher, Moraine

Dear Katie,

I am pleased to notify you that the administration received several "Above and Beyond the Call of Duty" submissions on your behalf, which are attached. The ABCD designation was established to provide an avenue of recognition and appreciation for staff contributions that are believed to rise beyond the norm, making significant contributions to the classroom, school and/or community. ABCD accolades can come from parents, students or colleagues.

The **individuals** who made separate submissions on your behalf states (paraphrased):

Parent: Katie Grimm truly demonstrated exceptional commitment and care in her approach with our son. She took the time to connect with him on a personal level, making him feel valued and understood. Her willingness to go above and beyond included tailoring her support to meet our students' unique needs, fostering a safe environment where he felt empowered to excel.

Parent: Mrs. Grimm has built such a strong relationship with my son. She is there for him in so many ways, she advocates for him, and she shows him how to be his own advocate.

Parent: Mrs. Grimm has gone above and beyond to help my son excel and grow during his nearly 4 years at Moraine. She knows when to encourage him and challenge him to push himself. My husband and I have seen our son's confidence and independence flourish.

On behalf of our administration leadership team and Board of Education, thank you for your contributions and efforts to enhance our school community. The contributions noted here on your behalf exemplify Northville Public Schools and contribute to our mission to open a World of Possibilities for and with each and every student.

It is well documented that educators dedicate themselves to the profession seeking to make a difference. We would like to congratulate you and thank you for your dedication to the students, families and staff of Northville Public Schools. Your contribution to our school community has been noticed!

Sincerely,

Dr. RJ Webber  
Superintendent



Do you want the world to know how a wonderful NPS staff member goes **Above and Beyond** the **Call of Duty** to support you, other students, staff and/or our community? Please tell us about that person by nominating them for an ABCD Award! Students, parents and colleagues are ALL encouraged to nominate an NPS staff member for this award.

**How does it work?** Students, staff or parents may complete this form detailing something truly Above and Beyond the Call of Duty by an NPS staff member. Submissions are received by the district and will be reviewed by the Board of Education's Policy/Personnel Sub-Committee for award consideration. Recognition may include presentation at public Board of Education meetings and/or inclusion in District communications.

**This nomination is submitted by:** Angela Jaafar

**Date:** 2/12/25

**My role:** Parent

**The person being nominated is:** Katie Grimm

**School or Department:** Resource Room Teacher, Moraine Elementary

**Do you wish for the staff member nominated to know who submitted this form?** Yes

**Please describe how this staff member went "above and beyond" and what impact it has had:**

Katie Grimm truly demonstrated exceptional commitment and care in her approach with our son. She took the time to connect with him on a personal level, making him feel valued and understood. By engaging in meaningful conversations and showing genuine interest in his activities and feelings, she was able to build a strong rapport with him.

Katie's ability to gain his trust allowed her to encourage him to express himself more openly and confidently. She didn't just focus on academic achievements; she nurtured his emotional and social development, helping him navigate the challenges he faced during this significant growth phase.

Her willingness to go above and beyond included tailoring her support to meet our students' unique needs, fostering a safe environment where he felt empowered to excel. Whether through thoughtful

encouragement, additional resources, or simply being there to listen, Katie made a profound impact on our child's progress and growth.

Through her dedication, she not only helped Zayn reach his potential but also inspired him to become the best version of himself.



Do you want the world to know how a wonderful NPS staff member goes **Above and Beyond** the **Call of Duty** to support you, other students, staff and/or our community? Please tell us about that person by nominating them for an ABCD Award! Students, parents and colleagues are ALL encouraged to nominate an NPS staff member for this award.

***How does it work?*** Students, staff or parents may complete this form detailing something truly Above and Beyond the Call of Duty by an NPS staff member. Submissions are received by the district and will be reviewed by the Board of Education's Policy/Personnel Sub-Committee for award consideration. Recognition may include presentation at public Board of Education meetings and/or inclusion in District communications.

**This nomination is submitted by:** Nora Errickson

**Date:** 2/13/25

**My role:** Parent

**The person being nominated is:** Katie Grimm

**School or Department:** Resource Room Teacher, Moraine Elementary

**Do you wish for the staff member nominated to know who submitted this form?** Yes

**Please describe how this staff member went "above and beyond" and what impact it has had:**

Mrs. Grimm has built such a strong relationship with my son. She is there for him in so many ways, she advocates for him, and she shows him how to be his own advocate. She knows what motivates him and partners with him to help him meet his goals. He is so proud to earn his punches and prizes. It's amazing to see his progress and to see his confidence grow. I am grateful that my son has someone he trusts so much while at school.



Do you want the world to know how a wonderful NPS staff member goes **Above and Beyond** the **Call of Duty** to support you, other students, staff and/or our community? Please tell us about that person by nominating them for an ABCD Award! Students, parents and colleagues are ALL encouraged to nominate an NPS staff member for this award.

***How does it work?*** Students, staff or parents may complete this form detailing something truly Above and Beyond the Call of Duty by an NPS staff member. Submissions are received by the district and will be reviewed by the Board of Education's Policy/Personnel Sub-Committee for award consideration. Recognition may include presentation at public Board of Education meetings and/or inclusion in District communications.

**This nomination is submitted by:** Nicole Thompson

**Date:** 2/13/25

**My role:** Parent

**The person being nominated is:** Katie Grimm

**School or Department:** Resource Room Teacher, Moraine Elementary

**Do you wish for the staff member nominated to know who submitted this form?** Yes

**Please describe how this staff member went "above and beyond" and what impact it has had:**

Mrs. Grimm has gone above and beyond to help my son excel and grow during his nearly 4 years at Moraine. She knows when to encourage him and challenge him to push himself. My husband and I have seen our son's confidence and independence flourish. We are so thankful she is a part of our son's education team.



---

**Dr. RJ Webber**  
**Superintendent**

---



---

***Above and Beyond***  
***the Call of Duty***

---

February 25, 2025

Molly Garcia  
Supervisor of Special Services - Elementary

Dear Molly,

I am pleased to notify you that the administration received an “Above and Beyond the Call of Duty” submission on your behalf, which is attached. The ABCD designation was established to provide an avenue of recognition and appreciation for staff contributions that are believed to rise beyond the norm, making significant contributions to the classroom, school and/or community. ABCD accolades can come from parents, students or colleagues.

The \*colleague who made this submission on your behalf states (paraphrased):

Molly has been a huge asset to us at Ridge Wood. She has provided so much support and gone above and beyond to make her schedule work to be here when we needed her. She supports so many buildings and yet finds the time to be where she is most needed. She tackles her very challenging role with such grace and positivity and is a very calming presence. When she comes into Ridge Wood, the relief is palpable because we know we have an amazing resource to help the students that need it.

On behalf of our administration leadership team and Board of Education, thank you for your contributions and efforts to enhance our school community. The contributions noted here on your behalf exemplify Northville Public Schools and contribute to our mission to open a World of Possibilities for and with each and every student.

It is well documented that educators dedicate themselves to the profession seeking to make a difference. We would like to congratulate you and thank you for your dedication to the students, families and staff of Northville Public Schools. Your contribution to our school community has been noticed!

Sincerely,

Dr. RJ Webber  
Superintendent



Do you want the world to know how a wonderful NPS staff member goes **Above and Beyond** the **Call of Duty** to support you, other students, staff and/or our community? Please tell us about that person by nominating them for an ABCD Award! Students, parents and colleagues are ALL encouraged to nominate an NPS staff member for this award.

***How does it work?*** Students, staff or parents may complete this form detailing something truly Above and Beyond the Call of Duty by an NPS staff member. Submissions are received by the district and will be reviewed by the Board of Education's Policy/Personnel Sub-Committee for award consideration. Recognition may include presentation at public Board of Education meetings and/or inclusion in District communications.

**This nomination is submitted by:** Tania Nevelos

**Date:** 9/24/24

**My role:** Colleague

**The person being nominated is:** Molly Garcia

**School or Department:** Supervisor of Special Services - Elementary, Central Office

**Do you wish for the staff member nominated to know who submitted this form?** Yes

**Please describe how this staff member went "above and beyond" and what impact it has had:**

Molly has been a huge asset to us at Ridge Wood. She has provided so much support and gone above and beyond to make her schedule work to be here when we needed her. She supports so many buildings and yet finds the time to be where she is most needed. She tackles her very challenging role with such grace and positivity and is a very calming presence. When she comes into Ridge Wood, the relief is palpable because we know we have an amazing resource to help the students that need it. Nothing is ever too much. NPS is very lucky to have her.



---

**Dr. RJ Webber**  
**Superintendent**

---



---

***Above and Beyond***  
***the Call of Duty***

---

February 25, 2025

Sarah Cox  
3rd Grade Teacher, Silver Springs

Dear Sarah,

I am pleased to notify you that the administration received an “Above and Beyond the Call of Duty” submission on your behalf, which is attached. The ABCD designation was established to provide an avenue of recognition and appreciation for staff contributions that are believed to rise beyond the norm, making significant contributions to the classroom, school and/or community. ABCD accolades can come from parents, students or colleagues.

The \*student who made this submission on your behalf states (paraphrased):

*Student: Ms.Cox went out of her many times to make every single one of her students feel comforted and supported. When Ms.Cox was my teacher she did not only teach me math and science, she taught me how to be a good friend, how to apply myself to leadership roles, and most importantly how to be a good example to fellow students. I have learned to chase my dreams and lead by example. Ms.Cox is an amazing teacher who I will forever be grateful for.*

On behalf of our administration leadership team and Board of Education, thank you for your contributions and efforts to enhance our school community. The contributions noted here on your behalf exemplify Northville Public Schools and contribute to our mission to open a World of Possibilities for and with each and every student.

It is well documented that educators dedicate themselves to the profession seeking to make a difference. We would like to congratulate you and thank you for your dedication to the students, families and staff of Northville Public Schools. Your contribution to our school community has been noticed!

Sincerely,

Dr. RJ Webber  
Superintendent



Do you want the world to know how a wonderful NPS staff member goes **Above and Beyond** the **Call of Duty** to support you, other students, staff and/or our community? Please tell us about that person by nominating them for an ABCD Award! Students, parents and colleagues are ALL encouraged to nominate an NPS staff member for this award.

**How does it work?** Students, staff or parents may complete this form detailing something truly Above and Beyond the Call of Duty by an NPS staff member. Submissions are received by the district and will be reviewed by the Board of Education's Policy/Personnel Sub-Committee for award consideration. Recognition may include presentation at public Board of Education meetings and/or inclusion in District communications.

**This nomination is submitted by:** Delaney Parker

**Date:** 12/19/24

**My role:** Student

**The person being nominated is:** Sarah Cox

**School or Department:** 3rd Grade Teacher, Silver Springs Elementary

**Do you wish for the staff member nominated to know who submitted this form?** Yes

**Please describe how this staff member went "above and beyond" and what impact it has had:**

Ms.Cox went out of her many times to make every single one of her students feel comforted and supported. When Ms.Cox was my teacher she did not only teach me math and science, she taught me how to be a good friend, how to apply myself to leadership roles, and most importantly how to be a good example to fellow students. I have learned to chase my dreams and lead by example. Ms.Cox is an amazing teacher who I will forever be grateful for.

# Memo

**TO:** RJ Webber, Superintendent

**FROM:** Rebecca Pek, Assistant Superintendent of Human Resources & Development

**CC:** COLT Administrators

**DATE:** February 25, 2025

**RE:** Interim Assistant Principal – Hillside Middle School Contract

---

Due to a mid-year resignation, the district is appointing Ms. Kelly Moffett as Interim Assistant Principal at Hillside Middle School for the remainder of the 2024-2025 school year. The district has secured a well-respected long-term substitute for the resulting classroom vacancy, with support from Ms. Moffett and the department during this time. This interim placement ensures our students will continue to receive high-quality educational opportunities and will help our school community adjust smoothly to this mid-year transition with a familiar and trusted individual.

I recommend that Ms. Kelly Moffett be temporarily moved to the NASA pay scale and contract through June 30, 2025. During this period, Ms. Moffett will undertake all duties and responsibilities associated with the Assistant Principal position at Hillside Middle School.



---

*RJ Webber*  
*Superintendent*

---

---

*Steve Banchemo*  
*Director of Operations*  
*and Capital Improvements*

---

TO: Devin Kling, Assistant Superintendent for Finance and Operations

FROM: Steve Banchemo, Director of Operations and Capital Improvements

DATE: February 13, 2025

RE: 2025 Meads Mill Asbestos Abatement Bid Award

On January 15, 2025, we received nine bids for the 2025 Meads Mill Middle School Asbestos Abatement project. Our environmental consultant, Arch Environmental Group, conducted post-bid interviews with the low bidder and determined that the bid was accurate and complete. This is the first phase of the abatement work for the Meads Mill project. A second phase of abatement will be bid later this year.

I recommend the Board of Education award a contract to Environmental Maintenance Engineers, Inc., Inc. for \$68,000.00.

Funding for this project would come from the 2023 Bond.

Please let me know if you have any questions.



CONTRACT AWARD REQUEST
Environmental Projects

January 23, 2025

Mr. Steve Banchemo
Director of Operations
Northville Public Schools
405 West Main Street
Northville, Michigan 48167
banchemost@northvilleschools.org

RE: Contract Award Request for Bid No. 24.02
Asbestos Abatement
Environmental Maintenance Engineers, Inc.
Meads Mill Middle School

Dear Mr. Banchemo:

Sealed bids for asbestos abatement activities at Meads Mill Middle School were received on Wednesday, January 15, 2025, and opened by representatives of Arch Environmental Group, Inc. (AEG) and Northville Public Schools. AEG has reviewed and evaluated the submitted bid from the low bidder, Environmental Maintenance Engineers, Inc. and conducted a post-bid meeting to discuss the scope of work and schedule for Bid No. 24.02 ("Asbestos Abatement at Meads Mill Middle School"). AEG has determined that the submitted bid was inclusive and correct. AEG requests that a Purchase Order or contract be issued in the amount shown to:

Table with 2 columns: Contractor and Contract Award. Contractor: Environmental Maintenance Engineers, Inc., 25281 Trowbridge, Inkster, Michigan 48141. Contract Award: \$68,000.00.

A complete bid tabulation for the bid with the selected bid highlighted is attached, as well as copies of Environmental Maintenance Engineers, Inc.'s submitted bid form for Bid No. 24.02, "Familial Relationship Disclosure Statement", and "Affidavit of Compliance - Iran Economics Sanctions Act".

Please show your approval to issue a Purchase Order or contract to Environmental Maintenance Engineers, Inc. by signing the "Approved By" section below (following formal approval by the Board of Education) and returning one copy of this letter to our office. AEG will coordinate with Northville Public Schools for the issuance of a Purchase Order or contract after receiving your approval of this Contract Award Request.

Approved By: \_\_\_\_\_ Date: \_\_\_\_\_
Northville Public Schools

**Contract Award Request for Bid No. 24.02**

Environmental Maintenance Engineers, Inc.

Northville Public Schools

Meads Mill Middle School

Page 2

Arch Environmental Group, Inc. looks forward to working with you in the future and helping you to address any concerns regarding environmental health and safety. If you have any questions regarding this recommendation or require any additional documentation in support of Environmental Maintenance Engineers, Inc., please feel free to contact me at (248) 426-0165.

Sincerely,

**Arch Environmental Group, Inc.**

**Environmental Services**



Pedro Pacheco

Project Consultant II, healthAIR

Attachments: Bid No. 24.02 Bid Tabulation  
Submitted bid forms for Bid No. 24.02  
Submitted "Familial Relationship Disclosure Statement"  
Submitted "Affidavit of Compliance – Iran Economics Sanctions Act"

cc: Mr. Jeff Cheney, Environmental Maintenance Engineers, Inc.

File: AE240298

**Bid No. 24.02 -  
Meads Mill Middle School - Asbestos Abatement (Base Bid)**

The Bidder hereby agrees and certifies to comply with all requirements described within this Project Specification and the listed and acknowledged Addenda and agrees to accept a payment of

**Base Bid**  
SIXTY Eight Thousand dollars (\$ 68,000<sup>00</sup>)

**Per Man-Hour Rate**  
Eighty Five dollars (\$ 85<sup>00</sup>)

for all work regarding this bid as described in the "Project Scope of Work and Requirements", including the Project Summary, Abatement Activities, Abatement Requirements, Additional Requirements and Information, Project Diagrams and the Time Schedule.

The Bidder agrees and certifies that the above stated cost includes all charges for all wages, overtime, taxes, materials, supplies, equipment, disposal costs, general conditions, supervision, insurance, overhead, profit and incidental expenses and fees. The Bidder hereby agrees and certifies that if the projects are not completed by the final due date the Bidder will accept a penalty as described in the project specifications.

The Undersigned, a Representative of the Bidder, hereby authorizes and requests any person, firm, or corporation to furnish any information requested by Northville Public Schools and/or their Representatives in verification of the recitals comprising the Bidder's Statement of Qualifications. When requested, a breakdown of the bid by building will be submitted following award of a contract.

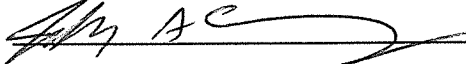
COMPANY NAME Environmental Maintenance Engineers, Inc  
PRINT NAME Jeffrey A. Cloney  
TITLE Vice President  
SIGNATURE 

**Alternate Bids Provided:**  
 None  
 Attached - List Below:

**Bidder Noted Conditions/Restrictions on Bid:**  
 None  
 Listed Below:

**Bid No. 24.02 -  
Meads Mill Middle School - Asbestos Abatement (Power, Water)**

The Bidder hereby agrees and certifies to comply with all requirements described within this Project Specification and the listed and acknowledged Addenda and agrees to accept a payment of

**Electrical Power**  
Six Thousand Five Hundred dollars (\$ 6,500<sup>00</sup> )

**Water**  
One Thousand Five Hundred dollars (\$ 1,500 )

**Mobilization**  
Seven Hundred dollars (\$ 700<sup>00</sup> )

to supply a source for sufficient amounts of electrical power and water necessary to complete all work regarding this bid as described in the "Project Scope of Work and Requirements," including the Project Summary, Abatement Activities, Abatement Requirements, Additional Requirements and Information, Project Diagrams and the Time Schedule.

The Bidder agrees and certifies that the above stated cost includes all charges for all wages, overtime, taxes, materials, supplies, equipment, disposal costs, general conditions, supervision, insurance, overhead, profit and incidental expenses and fees (limited to actual costs plus fifteen percent).

**Details and Determination of Costs - Electrical Power (attach additional sheets if necessary):**

n/a

**Details and Determination of Costs - Water (attach additional sheets if necessary):**

n/a

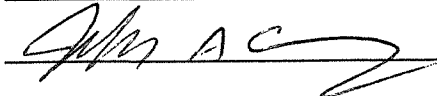
COMPANY NAME Environmental Maintenance Engineers, Inc.  
PRINT NAME Jeffery A. Chesel  
TITLE Vice President  
SIGNATURE 

**Bidder Noted Conditions/Restrictions on Bid:**

- None  
 Listed Below:

FAMILIAL RELATIONSHIP DISCLOSURE STATEMENT

Important: This disclosure statement must be included with your bid as required by state law (Public Act 232 of 2005).

As required by Public Act 232 of 2005, all bids shall be accompanied by a sworn and notarized statement disclosing any familial relationship that exists between the owner or any employee of the bidder and any member of the Northville Public Schools's Board of Education or the Superintendent of Schools. The Board of Education shall not accept a bid that does not include this sworn and notarized disclosure statement.

++++

The undersigned, the owner or authorized officer of Environmental Maintenance Engineers, Inc (the "Bidder"), pursuant to the familial disclosure requirement provided in the Northville Public Schools advertisement for construction bids, hereby represent and warrant, except as provided below, that no familial relationships exist between the owner(s) or any employee of the company and any member of the Northville Public Schools's Board of Education or the Superintendent of Schools. If such a relationship exists, please explain:

No Such Relationship Exist

Attach additional pages if necessary

By: [Signature] (bidder signature)

Title: Vice President (type or print)

Date: 1/14/2025

Subscribed and Sworn to Before Me:

This 14th day of January, 2025 A.D., in and for the County of Wayne, Michigan.

My commission expires: November 4th, 2029

Acting in the County of: Wayne

[Signature]
Signature of Notary

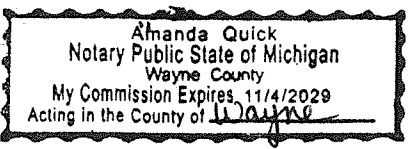

**AFFIDAVIT OF COMPLIANCE - IRAN ECONOMIC SANCTIONS ACT**

**Important: This disclosure statement must be included with your bid as required by state law (Public Act 517 of 2012).**

The undersigned, the owner or authorized officer of Edvinson and Markensie Engineers, Inc. (the "Contractor"), hereby certifies, represents and warrants that the Contractor (including its officers, directors and employees) is not an "Iran linked business" within the meaning of the Iran Economic Sanctions Act, Michigan Public Act No. 517 of 2012 (the "Act"), and that, in the event Contractor is awarded a contract as a result of the aforementioned Request For Proposal, the Contractor will not become an "Iran linked business" at any time during the course of performing the Work or any services under the contract.

The Contractor understands and agrees that, if Northville Public Schools receives credible information that this Affidavit includes false information, Northville Public Schools will conduct an investigation that may lead to the termination of this contract as provided in the Act. The Contractor agrees to indemnify Northville Public Schools (including its agents, employees and representatives), and hold them harmless, for all actual attorneys' fees and costs, settlements, awards, judgments, interest and bonds arising from or relating to any such investigation.

The Contractor further acknowledges that any person who is found to have submitted a false certification may be responsible for a civil penalty of not more than \$250,000.00 or 2 times the amount of the contract or proposed contract for which the false certification was made, whichever is greater, the cost of the Northville Public Schools's investigation, and reasonable attorney fees, in addition to the fine. Moreover, any person who submitted a false certification shall be ineligible to bid on a request for proposal for three (3) years from the date the it is determined that the person has submitted the false certification.

By: [Signature] (bidder signature)  
Title: Vice President (type or print)  
Date: 1/14/2025

Subscribed and Sworn to Before Me:

This 14<sup>th</sup> day of January, 2025 A.D., in and for the County of Wayne, Michigan.  
My commission expires: November 4<sup>th</sup> 2029

Acting in the County of: Wayne

[Signature]  
Signature of Notary

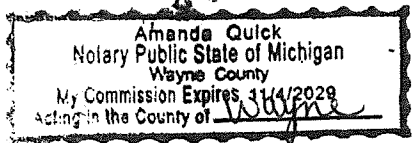

**BID TABULATION**



Northville Public Schools  
 Bid No. 24.02  
 Asbestos Abatement  
 Asbestos Abatement at Meads Mill Middle School

Bids Due: 11:00 A.M., Wednesday, January 15, 2025

Bid Opening: 11:30 A.M., Wednesday, January 15, 2025

BID RESULTS	Bidder Acknowledgements								Bid No. 24.02	Bid No. 24.02	Bid No. 24.02	Bid No. 24.02	Bid No. 24.02
	BB	FRDS	IRAN	PBM	A1	A2	A3	Qualified	Base Bid	Per Man-Hour Rate	Electrical Power	Water	Mobilization
BDS Environmental, LLC	Yes	Yes	Yes	Yes	Yes	Yes	Yes	Yes	\$71,500.00	\$99.00	\$5,000.00	\$3,000.00	\$900.00
Dore & Associates, Inc.	Yes	Yes	Yes	Yes	Yes	Yes	Yes	Yes	\$148,300.00	\$89.50	\$7,500.00	\$3,000.00	\$2,500.00
Environmental Maintenance Engineers, Inc.	Yes	Yes	Yes	Yes	Yes	Yes	Yes	Yes	\$68,000.00	\$85.00	\$6,500.00	\$1,500.00	\$700.00
Environmental Specialty Services, Inc.	Yes	Yes	Yes	Yes	Yes	Yes	Yes	Yes	\$173,500.00	\$135.00	\$640.00 Per Day	\$500.00/2,000 Gal.	\$1,950.00
Global Green Services Group, LLC	Yes	Yes	Yes	Yes	Yes	Yes	Yes	Yes	\$143,330.00	\$98.00	\$4,500.00	\$1,500.00	\$1,200.00
Qualified Abatement Services, Inc.	Yes	Yes	Yes	Yes	Yes	Yes	Yes	Yes	\$84,000.00	\$95.00	\$8,500.00	\$4,000.00	\$800.00
Quality Environmental Services, Inc.	Yes	Yes	Yes	Yes	Yes	Yes	Yes	Yes	\$189,000.00	\$95.00	\$3,000.00	\$2,500.00	\$800.00
Mid-Michigan Management, LLC	Yes	Yes	Yes	Yes	Yes	Yes	Yes	Yes	\$155,120.00	\$95.00	\$3,500.00	\$1,500.00	\$700.00
Total Environmental Services, LLC	Yes	Yes	Yes	Yes	Yes	Yes	Yes	Yes	\$136,400.00	\$90.00	\$5,000.00	\$3,000.00	\$850.00

S&M Contracting, LLC      ---    ---    ---    ---    ---    ---    ---    ---      No Bid      No Bid      No Bid      No Bid      No Bid

Low Bid Amount	\$68,000.00	\$85.00	\$3,000.00	\$1,500.00	\$700.00
Low Bidder	Environmental Maintenance Engineers, Inc.	Environmental Maintenance Engineers, Inc.	Quality Environmental Services, Inc.	Environmental Maintenance Services, Inc.	Environmental Maintenance Services, Inc.

**Notes:**

- 1 - The low submitted bid(s) is highlighted.
- 2 - Qualified Bid: All necessary acknowledgements have been made and a bid bond has been submitted.
- 3 - All bids opened by Mr. Pedro Pacheco , Arch Environmental Group, Inc.; and Mr. Steve Banchemo, Northville Public Schools and accepted by Northville Public Schools.



---

*RJ Webber*  
*Superintendent*

---

---

*Steve Banchemo*  
*Director of Operations*  
*and Capital Improvements*

---

TO: Devin Kling, Assistant Superintendent for Finance and Operations

FROM: Steve Banchemo, Director of Operations and Capital Improvements

DATE: February 14, 2025

RE: Bond 2023 Meads Mill Phase 1 Furniture Award

As part of the 2023 Bond scope, furniture in spaces impacted by renovations will be replaced and upgraded. TMP Architecture is leading this process on behalf of Northville Public Schools.

We are breaking up the procurement of Meads Mill furniture into two or more phases. This is because of the overall length of the construction process and allows for the design team to finalize some details with the Meads Mill staff for the later phases.

Final selections are procured through consortium buying contracts. The attached recommendation letter from TMP outlines the selected furniture contractor, manufacturer, vendor amount, and consortium contract for the furniture category. This approach is consistent with the process used in the 2017 bond.

**Recommendation:**

I recommend that the Board of Education approve purchase orders totaling \$94,030.75, as outlined in the TMP Recommendation Letter dated February 18, 2025. Funding for this project will come from the proceeds of the 2023 Bond.

Please let me know if you have any questions.



February 18, 2025

Mr. Devin Kling  
Assistant Superintendent for Finance and Operations  
Northville Public Schools  
405 W. Main Street  
Northville, MI 48167

Re: Furnishing Recommendation  
Additions and Remodeling at Meads Mill Middle School – Phase 1  
TMP Project No. 23023A

Dear Mr. Kling:

Proposals were received for the furniture for the Additions and Remodeling at Meads Mill Middle School by multiple Furniture Contractors. Below is a spreadsheet which identifies each Manufacturer Category's associated costs and Contracts used. TMP recommends the procurement of furnishing packages as follows:

<u>FURNITURE CONTRACTOR</u>	<u>MANUFACTURER CATEGORY</u>	<u>AMOUNT</u>	<u>CONTRACT</u>
Dew-EI	Category A: MiEN	\$80,129.35	Omnia
NBS Commercial Interiors	Category B: Integra Category C: Steelcase	\$13,901.40	NPP E&I
	<b>TOTAL AMOUNT:</b>	<b>\$94,030.75</b>	

This leaves us with a remaining Furnishings Budget of \$152,969,25. This furniture recommendation relates to the center Main Collaboration spaces only as Phase 1. There will be a separate package to furnish additional spaces such as the STEAM addition in the next Phase where the balance of this Budget will be utilized.

Sincerely,

TMP ARCHITECTURE, INC.

A handwritten signature in black ink, appearing to read 'Jessica Hartwig', is written over a light blue horizontal line.

Jessica Hartwig  
Interior Designer/Associate

JLH/jlh

Enclosure



# Northville Public Schools

---

## PRICE PROPOSAL

**Date: 2/12/2025**

---

Quote Number: 3361-28887

Valid For 30 Days

Prepared by: Steve Timmer

Confidential

© 2025 Dew-El Corporation. The information in this transmittal is proprietary to Dew-El Corporation. It is provided on the condition that it remains in confidence between Dew-El Corporation and the recipient of this quote. Do Not Copy, Distribute nor Share the Contents of this proposal without the written permission of Dew-El Corporation.

**Project Scope**

**Bill To**

Northville Public Schools  
 501 West Main Street  
 Northville, MI 48168

**Install To**

Northville Public Schools  
 501 West Main Street  
 Northville, MI 48168

**Project Investment**

Project Total	\$80,129.35
Tax (0%)	\$0.00
<b>Grand Total</b>	<b>\$80,129.35</b>

**Payment Schedule**

100% Due Net 30	<b>Net 30</b> \$80,129.35
-----------------	------------------------------

**Price Summary by Phase**

Option	Phase / TAG	Price	Tax	Total
Meads MS	Exist. Corridor D136	\$13,129.23	\$0.00	\$13,129.23
	Exist. Corridor D139	\$57,250.12	\$0.00	\$57,250.12
	Freight	\$4,000.00	\$0.00	\$4,000.00
	Installation	\$5,750.00	\$0.00	\$5,750.00
<b>Grand Total</b>		<b>\$80,129.35</b>	<b>\$0.00</b>	<b>\$80,129.35</b>

Dew-El Corporation  
 10841 Paw Paw Drive  
 Holland, MI 49424  
 Phone: (616) 396-6554  
 Fax: (616) 396-6669  
 http://www.Dew-El.com



# QUOTATION

# 3361-28887

VALID UNTIL 3/14/2025

## BILL TO

Northville Public Schools  
 501 West Main Street  
 Northville, MI 48168

## INSTALL TO

Northville Public Schools  
 501 West Main Street  
 Northville, MI 48168

Salesperson  
 Steve Timmer

Payment Terms  
 Net 30

## Meads MS

### Exist. Corridor D136

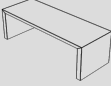
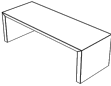



LINE #	QTY	UNIT	PART # / DESCRIPTION	PRICE EA	EXT PRICE
1	6.00	EA	HRD-RKR-1716-29-G-G08 / Hard RKR Stool 29"h Stool, With Foot Ring Grade 08 Mayer Fabric A Selection: BL-014 Mayer BELMONT Reef Grade 08 TAG: A8	\$829.51	\$4,977.08
					
2	1.00	EA	SHR-MTR-9636-42-D-N / SHARE Table 96"l x 36"w x 42"h Mitered Edge No Grommets 2 x Power Units (2 Power, 2 USB 2-Port), Black Share/KIO Laminate A: 8827-58 Formica Sarum Twill Share/KIO Laminate B: 8827-58 Formica Sarum Twill TAG: A7	\$4,464.46	\$4,464.46
					
3	1.00	EA	SHR-MTR-9636-30-N-N / SHARE Table 96"l x 36"w x 30"h Mitered Edge No Grommets No Power Share/KIO Laminate A: 8849-58 Formica Natural Teak Share/KIO Laminate B: 8849-58 Formica Natural Teak TAG: A6	\$3,687.69	\$3,687.69
					

### Exist. Corridor D139

LINE #	QTY	UNIT	PART # / DESCRIPTION	PRICE EA	EXT PRICE
4	2.00	EA	Custom KIO / Custom KIO Straight High Top Table, 84"w, 18"d, 42"h, Stationary (SO24101 Northville Middle School) 8827-58 Formica Sarum Twill, Northsea Edgeband ***Customer drawing signoff required Sits 3 users TAG: A5	\$1,880.89	\$3,761.79
5	5.00	EA	HATCH-OVL-2519-H / Hatch Pneumatic Side Table 25" x 19" Oval Pneumatic Height Adjustable 26"h - 41"H Laminate A Selection: 8827-58 Formica Sarum Twill Northsea Edgeband 25" x 19" Oval Top 26" - 41"h Height Adjustment, Glides TAG: A4	\$411.53	\$2,057.66
					

**Meads MS**

**Exist. Corridor D139**

LINE #	QTY	UNIT	PART # / DESCRIPTION	PRICE EA	EXT PRICE
6	3.00	EA	FEVO-NSC-3939-35-S-G08 / Flex 2-Step EVO Inside Corner - Single Fabric & Laminate No Power Grade 08 Mayer Fabric A Selection: BL-014 Mayer BELMONT Reef Grade 08 Laminate A Selection: 8849-58 FORMICA NATURAL TEAK TAG: A3	\$3,145.44	\$9,436.31
					
7	1.00	EA	FEVO-OSC-3939-35-S-N-G08 / Flex 2-Step EVO Outside Corner - Single Fabric & Laminate No Power Grade 08 Mayer Fabric A Selection: BL-014 Mayer BELMONT Reef Grade 08 Laminate A Selection: 8849-58 FORMICA NATURAL TEAK TAG: A2B	\$3,145.44	\$3,145.44
					
8	7.00	EA	FEVO-OSC-3939-35-S-N-G08 / Flex 2-Step EVO Outside Corner - Single Fabric & Laminate No Power Grade 08 Mayer Fabric A Selection: BL-002 Mayer BELMONT Citrus Grade 08 Laminate A Selection: 8849-58 FORMICA NATURAL TEAK TAG: A2A	\$3,145.44	\$22,018.05
					
9	7.00	EA	FEVO-2SU-3539-35-S-N-G09 / Flex 2-Step EVO 2-Step Unit, Single Fabric & Laminate No Power No Power Unit Grade 09 C.F. Stinson Fabric A Selection: CF Stinson POLYGON Party POL15 Grade 09 Laminate A Selection: 8849-58 FORMICA NATURAL TEAK TAG: A1	\$2,404.41	\$16,830.87
					

**Freight**

LINE #	QTY	UNIT	PART # / DESCRIPTION	PRICE EA	EXT PRICE
10	1.00	EA	Freight / Freight / Shipping / Packaging	\$4,000.00	\$4,000.00

**Installation**

LINE #	QTY	UNIT	PART # / DESCRIPTION	PRICE EA	EXT PRICE
11	1.00	EA	INSTALL / Labor to Receive, Deliver, Install, and remove debris	\$5,750.00	\$5,750.00

Dew-El Corporation  
10841 Paw Paw Drive  
Holland, MI 49424  
Phone: (616) 396-6554  
Fax: (616) 396-6669  
<http://www.Dew-El.com>



# QUOTATION

# 3361-28887

VALID UNTIL 3/14/2025

## Meads MS

### CUSTOMER SIGN OFF

subtotal	\$80,129.35
sales tax	\$0.00
<b>total</b>	<b>\$80,129.35</b>

\_\_\_\_\_  
Authorized Signature

\_\_\_\_\_  
Accepted Date

\_\_\_\_\_  
Print Name

Dew-El Corporation  
10841 Paw Paw Drive  
Holland, MI 49424  
Phone: (616) 396-6554  
Fax: (616) 396-6669  
<http://www.Dew-El.com>



# QUOTATION

# 3361-28887

VALID UNTIL 3/14/2025

Pricing for MiEN is provided according to National Purchasing Contract OMNIA Region 14 ESC - TX,  
contract number 07-107



**yourNBS.com**      **Remit Payments to:** NBS, 6973 Reliable Parkway, Chicago, IL 60686

**Customer** N00164  
**Terms** NET 10 DAYS  
**Account Representative** ANNE MARIE TREMBERTH  
**Project** 250220

**Quote To**

Accounts Payable  
 Northville Public Schools  
 405 W MAIN ST  
 NORTHVILLE, MI, 48167-1577

**Ship To**

Jessica Hartwig  
 Meads Mill Middle School  
 16700 Franklin  
 Northville, MI, 48167-1576

**Phone** +1 (248) 344-3514  
 npsaccountspayable@northvilleschools.org

**Phone** +1 (248) 338-4561  
 jhartwig@tmp-architecture.com

**Sales Location** Troy

**Following contracts utilized for pricing on this quote/ project**

**E&I: Steelcase**  
**NPP: Integra**  
 School is responsible for contract membership enrollment. Changes to specifications and quantity could affect tiered contract pricing.

**Pricing valid for 30 days.**  
 Please verify finish selections prior to order placement.

If due to unforeseen circumstances the building is not ready to receive furniture, additional fees may be incurred to double handle and/or store the furniture. Circumstances include, but are not limited to construction delays and COVID-19.

Storage Free for 30 days, after which storage is charged per hundred weight or per SF per month.

Quote includes Non-Union labor for NBS to receive, deliver and install during Normal Business Hours; any owner requested changes requiring additional delivery trip(s) will result in additional charges to be quoted separately.

Overtime Labor (evening after hours and weekends) additional.

Purchase Order and 40% Deposit is required before order placement; please reference NBS quote number on PO. Receipt of PO indicates owner approval of product as specified; upon release of order, no changes, cancellations or returns can be made.

Description	Quantity	Unit Price	Extended Price
1    TS31204A - Shortcut-Chair, Multi purpose, X base <b>Shell Finish:</b> Plastic - PG2 6BD6 - LAGOON <b>Base Finish:</b> Smooth Metallic 4799 - PLATINUM METALLIC  <b>Cushion:</b> No Cushion <b>Glide:</b> Standard Glides STEELCASE CORPORATION <b>Tag For</b> C1	6	317.86	1,907.16

TITLE OF PRODUCT TRANSFERS UPON RECEIPT BY CUSTOMER.

ACCEPTED BY \_\_\_\_\_ TITLE \_\_\_\_\_ DATE \_\_\_\_\_

Description	Quantity	Unit Price	Extended Price
1			
<b>Qty Description</b>			
6 Exist. Corridor D136			
2	6	436.54	2,619.24
TS31205B - Shortcut-Stool, Multi purpose, X base <b>Shell Finish:</b> Plastic - PG1 6249 - PLATINUM SOLID <b>Base Finish:</b> ACCENT PAINT 4CZ5 - HONEY <b>Cushion:</b> No Cushion <b>Glide:</b> Standard Glides STEELCASE CORPORATION <b>Tag For</b> C2			
<b>Qty Description</b>			
6 Exist. Corridor D139			
3	4	1,347.00	5,388.00
COST-1-30 - Coffee House Straight Chair Dual Upholstery 1200 lb Dynamic; 2000 lb Static Weight Capacities  Clean Out between Seat and Back Gang to B1's and B2's per Drawing Brushed Aluminum Leg  Size: 30" W x 30" D x 33" H (18" SH) Finishes: Back Fabric: Stinson, Polygon in Party POL 15 (GR R) Seat Fabric: Mayer, Belmont in Citrus BL-002 (GR R) INTEGRA <b>Tag For</b> B1			
<b>Qty Description</b>			
4 Exist. Corridor D136			
4	4	810.00	3,240.00
COT2 - Coffee House Ottoman Upholstered Top, Single Upholstery 1000 lb Dynamic; 2000 lb Static Weight Capacities  Gang to B1's and B2's per Drawing  Brushed Aluminum Leg Size: 30" W x 30" D x 17.5" H			

TITLE OF PRODUCT TRANSFERS UPON RECEIPT BY CUSTOMER.

ACCEPTED BY \_\_\_\_\_ TITLE \_\_\_\_\_ DATE \_\_\_\_\_



**yourNBS.com**      **Remit Payments to:** NBS, 6973 Reliable Parkway, Chicago, IL 60686

Description	Quantity	Unit Price	Extended Price
4 Finishes: Fabric: Mayer, Belmont in Reef BL-014 (GR R) INTEGRA <b>Tag For</b> B2  <div style="border: 1px solid black; padding: 2px; margin: 5px 0;"> <b>Qty Description</b>                          4 Exist. Corridor D136                     </div>			
5    COSTO - RIGID PLATE CONNECTOR Plate Leg: INTEGRA <b>Tag For</b> B1&B2	10	14.00	140.00
6    LOAD - Receive, Deliver, and Install product. Non-union labor, normal business hours.  Free and clear space; does not include removal of any existing product.  No stair carry. All work to be done at one time.  NBS Troy	1	607.00	607.00



<b>Quotation Totals</b>	
<b>Sub Total</b>	<b>13,901.40</b>
<b>NON-TAXABLE SCHOOL OR GOVERNMENTAL</b>	<b>0.00</b>
<b>NON-TAXABLE CHARITY/CHURCHES</b>	<b>0.00</b>
<b>Grand Total</b>	<b>13,901.40</b>

**End of Quotation**

TITLE OF PRODUCT TRANSFERS UPON RECEIPT BY CUSTOMER.

ACCEPTED BY \_\_\_\_\_ TITLE \_\_\_\_\_ DATE \_\_\_\_\_

## Finish Summary

Product Line	Finish Group Description	Finish Description	Finish
Shortcut	Shell Finish	6BD6 - LAGOON	
Shortcut	Base Finish	4799 - PLATINUM METALLIC	
Shortcut	Shell Finish	6249 - PLATINUM SOLID	
Shortcut	Base Finish	4CZ5 - HONEY	

TITLE OF PRODUCT TRANSFERS UPON RECEIPT BY CUSTOMER.

ACCEPTED BY \_\_\_\_\_ TITLE \_\_\_\_\_ DATE \_\_\_\_\_



---

*RJ Webber*  
*Superintendent*

---



---

*Steve Banchemo*  
*Director of Operations*  
*and Capital Improvements*

---

TO: Devin Kling, Assistant Superintendent for Finance and Operations

FROM: Steve Banchemo, Director of Operations and Capital Improvements

DATE: February 14, 2025

RE: Bond 2023 Amerman Furniture Award

As part of the 2023 Bond scope, furniture in spaces impacted by renovations will be replaced and upgraded. TMP Architecture is leading this process on behalf of Northville Public Schools.

The design and selection process for furniture begins approximately halfway through the architectural design phase. The TMP team held multiple meetings with Principal Caudill and her staff to discuss furniture and color selections. In the fall of 2024, a furniture fair was held at Amerman Elementary for STEAM furniture. Vendors provided sample pieces for staff from all STEAM classrooms to review. Their feedback was collected and used as a key factor in the selection process.

Final selections are procured through consortium buying contracts. The attached recommendation letter from TMP outlines the selected furniture contractor, manufacturer, vendor amount, and consortium contract for the furniture category. This approach is consistent with the process used in the 2017 bond.

**Recommendation:**

I recommend that the Board of Education approve purchase orders totaling \$188,557.22, as outlined in the TMP Recommendation Letter dated February 18, 2025. Funding for this project will come from the proceeds of the 2023 Bond.

Please let me know if you have any questions.



February 18, 2025

Mr. Devin Kling  
 Assistant Superintendent for Finance and Operations  
 Northville Public Schools  
 405 W. Main Street  
 Northville, MI 48167

Re: Furnishing Recommendation  
 Additions and Remodeling at Amerman Elementary School  
 TMP Project No. 23024A

Dear Mr. Kling:

Proposals were received for the furniture for the Additions and Remodeling at Amerman Elementary School by multiple Furniture Contractors. Below is a spreadsheet which identifies each Manufacturer Category's associated costs and Contracts used. TMP recommends the procurement of furnishing packages as follows:

<u>FURNITURE CONTRACTOR</u>	<u>MANUFACTURER CATEGORY</u>	<u>AMOUNT</u>	<u>CONTRACT</u>
Great Lakes Furniture Supply	<b>Category A:</b> VS America	\$12,290.20	Omnia
NBS Commercial Interiors	<b>Category B:</b> Steelcase <b>Category G:</b> Wisconsin Bench <b>Category H:</b> Muzo <b>Category J:</b> Sico <b>Category L:</b> FomCore (P1/P2) <b>Category N:</b> Smith Systems <b>Category S:</b> Fleetwood <b>Category T:</b> Egan	\$108,730.36	E&I TIPS BuyBoard TIPS PEPPM E&I NCPA Omnia
Interior Environments	<b>Category D:</b> Allsteel (P1/P2) <b>Category F:</b> HON <b>Category R:</b> OFS	\$23,095.15	Omnia Omnia Omnia
Dew-EI	<b>Category E:</b> Media Technologies (P2) <b>Category M:</b> MiEN (P1/P2)	\$41,443.42	Omnia Omnia
<u>Demco</u>	<b>Category K:</b> Demco	<u>\$645.59</u>	Omnia
<b>TOTAL AMOUNT:</b>		<b>\$188,557.22</b>	

This leaves us with a remaining Furnishings Budget of \$22,442.78.

Categories C, I, O, P, Q were not used. Some Categories have 2 installation phases, based on the initial construction schedule, which were quoted separately to break out installation costs. These Categories are denoted above with 'P1/P2', or 'P2' if Phase 2 only, all others are Phase 1 only. Phase 2 scope represents the Media Center and adjacent collaboration area.

Sincerely,

TMP ARCHITECTURE, INC.

A handwritten signature in black ink, appearing to read "Jessica Hartwig". The signature is fluid and cursive, written over a light blue horizontal line.

Jessica Hartwig  
Interior Designer/Associate

JLH/jlh

Enclosure



# Quotation

---

**Quote Number** 0200251727

**Revision** 3

**Revision Date** 02/11/2025

**Customer** Northville Public Schools  
405 W. Main Street  
Northville MI 48167  
United States

**Customer Reference** **GLFS-Northville PS Amerman**

**Date Quoted** 01/13/2025

---

**Inside Sales Contact** Ella Stumpf  
e.stumpf@vsamerica.com

**Territory Manager** Christine Debrot  
c.debrot@vsamerica.com

---

**Contract** Omnia Partners Region 4 ESC (R191818)  
Contract # R191818

To Whom It May Concern:

Please note the following pricing has been presented in Omnia Partners Region 4 ESC Contract NET values, based on the stated models, colors, finishes, and quantities. Any alterations will be subject to updated pricing.

Pricing is valid for 30 days\* for projects delivering within 9 months of the receipt of a complete PO. Orders with delivery requirements outside of 9 months must be requoted. Please discuss specific project requirements with your VS America Territory Manager.

Factory-direct orders qualify for free shipping if the total net amount is over \$50,000 USD. Freight charges do apply for any orders fulfilled from the VS America Stock / Quickship Program. Please refer to the Customer Freight Terms document, Omnia Region 4 Freight Terms, for a complete list of exclusions and restrictions.

Installation is not included in unit pricing.

Please check all details prior to submitting an order. Where details have been left unspecified in the request, default selections have been quoted. If you have any questions, please contact your Inside Sales Representative or Territory Manager at the numbers shown above.

Best Regards,

VS America Inc.

\*Barring the announcement of a formal price increase.

Item	Model/Description	Quantity	Unit Net Price	Extended price
1	A1 <b>31400</b> PantoSwing-LuPo, chair with polypropylene seat and backrest shell, tested to DIN EN 1729	10	\$ 124.00	\$ 1,240.00
	<b>204 seat height</b> 043 43cm size green			
	<b>230 metal color</b> 059 arctic			
	<b>280 seat / backrest plastic</b> 073 black grey			
	<b>500 glides / castors</b> 001 plastic glides			
	<b>903 packaging</b> 002 with export protection			
	<b>Unit List Price</b> \$ 155.00			
	<b>Discount (%)</b> 20.00000			
	<b>Article MID</b> 31400-00431			
2	A2 <b>03826</b> Solo stool, stackable, with 4 footrests at different heights	12	\$ 144.00	\$ 1,728.00
	<b>206 seat height</b> 052 52cm			
	<b>230 metal color</b> 059 arctic			
	<b>262 wooden parts seat / backrest</b> 023 light grey			
	<b>500 glides / castors</b> 001 plastic glides			
	<b>903 packaging</b> 002 with export protection			
	<b>Unit List Price</b> \$ 180.00			
	<b>Discount (%)</b> 20.00000			
	<b>Article MID</b> 03826-01094			
3	A3 <b>31400</b> PantoSwing-LuPo, chair with polypropylene seat and backrest shell, tested to DIN EN 1729	4	\$ 124.00	\$ 496.00
	<b>204 seat height</b> 043 43cm size green			
	<b>230 metal color</b> 059 arctic			
	<b>280 seat / backrest plastic</b> 030 light blue			
	<b>500 glides / castors</b> 001 plastic glides			
	<b>903 packaging</b> 002 with export protection			
	<b>Unit List Price</b> \$ 155.00			
	<b>Discount (%)</b> 20.00000			
	<b>Article MID</b> 31400-00247			
4	A4 <b>45245</b> Serie 600 storage module, with running rails for plastic trays, 3 narrow compartments, WxHxD 125x123.6x48cm	2	\$ 1,560.00	\$ 3,120.00
	<b>231 metal color frame</b> 059 arctic			
	<b>340 body</b> 022 perforated metal			
	<b>343 body color steel</b> 059 arctic			
	<b>500 glides / castors</b> 067 design castors d= 7.5cm			
	<b>524 shelves</b> 001 chipboard décor			
	<b>533 shelf color laminate</b> 017 astral silver			
	<b>903 packaging</b> 002 with export protection			
	<b>Unit List Price</b> \$ 1950.00			
	<b>Discount (%)</b> 20.00000			
	<b>Article MID</b> 45245-00055			
5	A4 <b>09197</b> Serie 600 plastic box, 31.2x42.7cm, 15cm high	36	\$ 36.00	\$ 1,296.00
	<b>522 color</b> 002 blue			
	<b>903 packaging</b> 002 with export protection			
	<b>Unit List Price</b> \$ 45.00			
	<b>Discount (%)</b> 20.00000			
	<b>Article MID</b> 09197-00003			

Item	Model/Description	Quantity	Unit Net Price	Extended price
6	A7 <b>45302</b> <b>Special</b> Shift+ Landscape low cabinet w/shelves, middle partition center back panel	2	\$ 1,377.60	\$ 2,755.20
<b>506</b>	<b>sliding handle</b>	009	2 sliding handles	
<b>237</b>	<b>metal color handle</b>	059	arctic	
<b>340</b>	<b>body</b>	001	chipboard décor	
<b>341</b>	<b>body color laminate</b>	999	body color laminate special	
<b>344</b>	<b>base type</b>	029	mobile, spec.castors, d= 10cm	
<b>361</b>	<b>finished back</b>	022	perforated metal	
<b>362</b>	<b>color finished back</b>	059	arctic	
<b>505</b>	<b>equipment</b>	074	with magnet for linking	
<b>519</b>	<b>shelf</b>	008	8, same as body	
<b>903</b>	<b>packaging</b>	002	with export protection	
<b>Width</b>	105.5 cm			
<b>Height</b>	91.5 cm			
<b>Depth</b>	52.7 cm			
<b>Unit List Price</b>	\$ 1722.00			
<b>Discount (%)</b>	20.00000			
<b>Article MID</b>	45302-01039			

<b>Subtotal</b>	\$ 10,635.20
<b>Shipping ( Holland, MI 49423 )</b>	\$ 645.00
<b>Installation</b>	\$ 1,010.00
<b>Total</b>	<b>\$ 12,290.20</b>

Payment Terms: Net 30 days

Please send POs to: [orders@vsamerica.com](mailto:orders@vsamerica.com)



**Quotation 382913**

**Quote Date** 2025-02-13  
**Customer Order** DRW - SPECS  
**Customer** N00164  
**Terms** NET 10 DAYS  
**Account Representative** ANNE MARIE TREMBERTH  
**Project** 242140

**yourNBS.com**      **Remit Payments to:** NBS, 6973 Reliable Parkway, Chicago, IL 60686

**Quote To**

Accounts Payable  
 Northville Public Schools  
 405 W MAIN ST  
 NORTHVILLE, MI, 48167-1577

**Ship To**

Jessica Hartwig  
 Amerman Elementary  
 847 N CENTER ST  
 NORTHVILLE, MI, 48167-1118

**Phone** +1 (248) 344-3514  
 npsaccountspayable@northvilleschools.org

**Phone** +1 (248) 338-4561  
 jhartwig@tmp-architecture.com

**Sales Location** Troy

**Following contracts +Additional project discounting utilized for pricing on this quote/ project**

- Fomcore PEPPM
- Muzo: BuyBoard
- Steelcase, Smith System E&I
- SICO, Surface Works, WB TIPS
- Egan, Safco Omnia
- Fleetwood NCPA

**School is responsible for contract membership enrollment. Changes to specifications and quantity could affect tiered contract pricing.**

**Pricing valid for 30 days. Please verify finish selections prior to order placement.**

**If due to unforeseen circumstances the building is not ready to receive furniture, additional fees may be incurred to double handle and/or store the furniture. Circumstances include, but are not limited to construction delays and COVID-19.**

**Storage Free for 30 days, after which storage is charged per hundred weight or per SF per month.**

**Quote includes Non-Union labor for NBS to receive, deliver and install during Normal Business Hours; any owner requested changes requiring additional delivery trip(s) will result in additional charges to be quoted separately.**

**Overtime Labor (evening after hours and weekends) additional.**

**Purchase Order and 40% Deposit is required before order placement; please reference NBS quote number on PO. Receipt of PO indicates owner approval of product as specified; upon release of order, no changes, cancellations or returns can be made.**

Description	Quantity	Unit Price	Extended Price
1    FLXPR1 - Flex Perch Stool <b>Frame Finish:</b> Plastic - PG1 6527 - MERLE STEELCASE CORPORATION	1	238.50	238.50

TITLE OF PRODUCT TRANSFERS UPON RECEIPT BY CUSTOMER.

ACCEPTED BY \_\_\_\_\_ TITLE \_\_\_\_\_ DATE \_\_\_\_\_

Description	Quantity	Unit Price	Extended Price
1 <b>Tag For</b> B1 <div style="border: 1px solid black; padding: 2px; margin-top: 5px;"> <b>Qty Description</b>                      1 STEAM/Maker Space C109                 </div>			
2 VWB2 - Verb; Whiteboard, 2 sides STEELCASE CORPORATION <b>Tag For</b> B2 <div style="border: 1px solid black; padding: 2px; margin-top: 5px;"> <b>Qty Description</b>                      12 STEAM/Maker Space C109                 </div>	12	133.92	1,607.04
3 VWT6 - Verb; Walltrack, 6L in ft STEELCASE CORPORATION <b>Tag For</b> B3 <div style="border: 1px solid black; padding: 2px; margin-top: 5px;"> <b>Qty Description</b>                      3 STEAM/Maker Space C109                 </div>	3	186.24	558.72
4 TS4TWP - Campfire; Table-Personal <b>TOP OPT:</b> *OPT:TOP SELECTION <b>HPL TOP:</b> HPL TOP <b>TOP-SURF:</b> TOP SURFACE <b>OLLO1:</b> *TOP-SURF:OLLO1 PRICE GROUP 1 <b>2900:</b> MISC LAMINATE STEELCASE CORPORATION Laminate: CLAY WENGE - ZHCW STEELCASE CORPORATION <b>Tag For</b> B4 <div style="border: 1px solid black; padding: 2px; margin-top: 5px;"> <b>Qty Description</b>                      1 Relaxation room A143                 </div>	1	362.48	362.48
5 490410C - Move; Chair, Plastic back, No arms, Casters <b>Frame Finish:</b> METALLIC PAINT 4799 - PLATINUM METALLIC <span style="display: inline-block; width: 15px; height: 15px; background-color: gray; vertical-align: middle;"></span>	1	291.40	291.40

TITLE OF PRODUCT TRANSFERS UPON RECEIPT BY CUSTOMER.

ACCEPTED BY \_\_\_\_\_ TITLE \_\_\_\_\_ DATE \_\_\_\_\_

Description	Quantity	Unit Price	Extended Price
5 <b>Shell Finish:</b> PLASTIC 6249 - PLATINUM SOLID <b>Upholstery Finish:</b> COGENT: CONNECT 5SD3 - LAGOON <b>Caster:</b> HARD CASTERS <b>Soil Retardant:</b> NO SOIL RETARDANT TREATMENT STEELCASE CORPORATION <b>Tag For</b> <u>Qty Description</u> 1 MAIN OFFICE A139			
6 490410C - Move; Chair, Plastic back, No arms, Casters <b>Frame Finish:</b> METALLIC PAINT 4799 - PLATINUM METALLIC <b>Shell Finish:</b> PLASTIC 6249 - PLATINUM SOLID <b>Upholstery Finish:</b> FOUNDATION 5876 - NAVY <b>Caster:</b> SOFT CASTERS <b>Soil Retardant:</b> NO SOIL RETARDANT TREATMENT STEELCASE CORPORATION <b>Tag For</b> B6 <u>Qty Description</u> 2 KITCHEN D104	2	308.32	616.64
7 435A00 - Steelcase Series 1; Chair-Task <b>Back Finish :</b> 3D Microknit 5T29 - GRAPHITE <b>Back Color Scheme:</b> Non-Contrasting Outer Back <b>Outer Back Finish:</b> Plastic - PG1 6295 - NEAR BLACK <b>Seat Finish :</b> LINK 5A25 - NAVY <b>Headrest Option:</b> No Headrest <b>Coat Hanger:</b> No Coat Hanger <b>Frame Finish :</b> Plastic - PG1 6205 - BLACK <b>Color Scheme :</b> Black <b>Arm Type :</b> Height,Width,Pivot,Depth Arm <b>Cylinder Type :</b> Standard Range <b>Base Type :</b> Plastic Base <b>Base Finish:</b> Plastic - PG1 6205 - BLACK <b>Lumbar Option :</b> Adjustable Lumbar <b>Caster or Glide Type:</b> Hard Casters <b>Soil Retardant Option :</b> No Soil Retardant	1	425.59	425.59

TITLE OF PRODUCT TRANSFERS UPON RECEIPT BY CUSTOMER.

ACCEPTED BY \_\_\_\_\_ TITLE \_\_\_\_\_ DATE \_\_\_\_\_

Description	Quantity	Unit Price	Extended Price
7 <b>Sewn Upholstery Type :</b> Sewn STEELCASE CORPORATION <b>Tag For</b> B7 <hr/> <b>Qty Description</b> 1 CLASSROOM C107/A14			
8 611000000 - Cascade Mega-Cabinet-Open, Shelves, Casters <b>Edge Panel Config:</b> P- Pltnm Body w/Solid End Pnls <b>End Panel Finish:</b> Smith System Paint CE - CERULEAN SMITH SYSTEM <b>Tag For</b> N1 <hr/> <b>Qty Description</b> 4 Cafeteria D108 -	4	718.90	2,875.60
9 910000066 - Cascade Mega Tower - 3 Column Metal Case, Open with Totes (6) 6" Totes and (6) 12" Totes 4" Casters (2 Locking) for Hard Floors Size: 19" D x 43" W x 61.4" H Finishes: Accent Metal: Cerulean Metal: Platinum Totes: SMITH SYSTEM <b>Tag For</b> N2 <hr/> <b>Qty Description</b> 1 STEAM/Maker Space C109	1	1,335.18	1,335.18
10 910009093 - Cascade Mega-Tower - Open, 9-3" and 9-6" and 3-12" Standard Width Totes, Casters <b>Edge Panel Config:</b> P- Pltnm Body w/Solid End Pnls <b>End Panel Finish:</b> Smith System Paint CE - CERULEAN <b>Tote:</b> Clear SMITH SYSTEM <b>Tag For</b> N3	1	1,434.51	1,434.51

TITLE OF PRODUCT TRANSFERS UPON RECEIPT BY CUSTOMER.

ACCEPTED BY \_\_\_\_\_ TITLE \_\_\_\_\_ DATE \_\_\_\_\_



Description	Quantity	Unit Price	Extended Price
10			
<b>Qty Description</b> 1 STEAM/ Maker Space C109			
11	1	1,395.00	1,395.00
610124000 - Cascade Mega-Cabinet-Open, 24-3" Standard Width Totes, Casters, Riser <b>Edge Panel Config:</b> P- Pltnm Body w/Solid End Pnls <b>End Panel Finish:</b> Smith System Paint CE - CERULEAN <b>Laminate Top Finish:</b> Smith System Laminate 790960 - FUSION MAPLE LAMINATE <b>Edge:</b> F - 1 1/4in Top w 3mm Edgbnd <b>Edge Finish:</b> Smith System Plastic MAP - FUSION MAPLE  <b>Tote:</b> Clear SMITH SYSTEM <b>Tag For</b> N4			
<b>Qty Description</b> 1 STEAM/ Maker C109			
12	2	578.41	1,156.82
311000000 - Cascade Mega-Case - Open, Shelves, Casters <b>Edge Panel Config:</b> P- Pltnm Body w/Solid End Pnls <b>End Panel Finish:</b> Smith System Paint PLT - PLATINUM SMITH SYSTEM <b>Tag For</b> N5  INSTALL BELOW N7 TABLES			
<b>Qty Description</b> 2 STEAM/Maker Space C109			
13	1	746.89	746.89
110F05000P - Cascade Mini-Case Metal Case, Open with Totes and Riser (5) 3" Totes 4" Casters (2 Locking) for Rubber Floors  Size: 21" W x19" D x 37" H  Finishes: Accent Metal: Cerulean Metal: Platinum Totes: Clear Riser Laminate: Fusion Maple Edge: Platinum			

TITLE OF PRODUCT TRANSFERS UPON RECEIPT BY CUSTOMER.

ACCEPTED BY \_\_\_\_\_ TITLE \_\_\_\_\_ DATE \_\_\_\_\_

Description	Quantity	Unit Price	Extended Price						
13 SMITH SYSTEM <b>Tag For</b> N6									
<table border="1"> <thead> <tr> <th>Qty</th> <th>Description</th> </tr> </thead> <tbody> <tr> <td>1</td> <td>STEAM/Maker Space C109</td> </tr> </tbody> </table>				Qty	Description	1	STEAM/Maker Space C109		
Qty	Description								
1	STEAM/Maker Space C109								
14 04101 - Interchange Activity Table, 24" Depth x 48" Width <b>Worksurface Finish:</b> Smith System Laminate 790960 - FUSION MAPLE LAMINATE <b>Edge:</b> F - 1 1/4in Top w 3mm Edgbnd <b>Edge Finish:</b> Smith System Plastic PLATINUM - PLATINUM <b>Frame Finish:</b> Smith System Paint PLT - Platinum SMITH SYSTEM <b>Tag For</b> N7 - INSTALL AT 32" HIGH, N5 TO INSTALL BELOW	1	370.43	370.43						
<table border="1"> <thead> <tr> <th>Qty</th> <th>Description</th> </tr> </thead> <tbody> <tr> <td>1</td> <td>STEAM / Maker Space C109</td> </tr> </tbody> </table>				Qty	Description	1	STEAM / Maker Space C109		
Qty	Description								
1	STEAM / Maker Space C109								
15 17576 - 3" Dual Wheel Pack,Dual-Wheel, Set of 4 Locking SMITH SYSTEM <b>Tag For</b> N7	1	57.62	57.62						
<table border="1"> <thead> <tr> <th>Qty</th> <th>Description</th> </tr> </thead> <tbody> <tr> <td>1</td> <td>STEAM/MAKER SPACE C109</td> </tr> </tbody> </table>				Qty	Description	1	STEAM/MAKER SPACE C109		
Qty	Description								
1	STEAM/MAKER SPACE C109								
16 04107 - Interchange Activity Table, 30" Depth x 60" Width <b>Worksurface Finish:</b> Smith System Laminate 790960 - FUSION MAPLE LAMINATE <b>Edge:</b> F - 1 1/4in Top w 3mm Edgbnd <b>Edge Finish:</b> Smith System Plastic PLATINUM - PLATINUM <b>Frame Finish:</b> Smith System Paint PLT - Platinum SMITH SYSTEM <b>Tag For</b> N8  INSTALL AT 29" HIGH	3	462.07	1,386.21						
<table border="1"> <thead> <tr> <th>Qty</th> <th>Description</th> </tr> </thead> <tbody> <tr> <td>2</td> <td>STEAM/ Maker Space C109</td> </tr> <tr> <td>1</td> <td>KITCHEN D104</td> </tr> </tbody> </table>				Qty	Description	2	STEAM/ Maker Space C109	1	KITCHEN D104
Qty	Description								
2	STEAM/ Maker Space C109								
1	KITCHEN D104								

TITLE OF PRODUCT TRANSFERS UPON RECEIPT BY CUSTOMER.

ACCEPTED BY \_\_\_\_\_ TITLE \_\_\_\_\_ DATE \_\_\_\_\_



[yourNBS.com](http://yourNBS.com)

Remit Payments to: NBS, 6973 Reliable Parkway, Chicago, IL 60686

Description	Quantity	Unit Price	Extended Price
16			
17 17576 - 3" Dual Wheel Pack,Dual-Wheel, Set of 4 Locking SMITH SYSTEM  <b>Tag For</b> N8  INSTALL AT 29" HIGH  <b>Qty Description</b> 2 STEAM/MAKER SPACE C109 1 KITCHEN D104	3	57.62	172.86
18 04101 - Interchange Activity Table, 24" Depth x 48" Width <b>Worksurface Finish:</b> Smith System Laminate 790960 - FUSION MAPLE LAMINATE <b>Edge:</b> F - 1 1/4in Top w 3mm Edgbnd <b>Edge Finish:</b> Smith System Plastic PLATINUM - PLATINUM <b>Frame Finish:</b> Smith System Paint PLT - Platinum SMITH SYSTEM <b>Tag For</b> N9  INSTALL AT 36" HIGH  <b>Qty Description</b> 1 STORAGE C110	1	370.43	370.43
19 77158 - High Range Insert on Glides <b>Glide Finish:</b> Smith System Paint PLT - Smith System Platinum SMITH SYSTEM <b>Tag For</b> N9  INSTALL AT 36" HIGH  <b>Qty Description</b> 1 STORAGE C110	1	71.34	71.34
20 921000000 - Cascade Mega-Tower - Door, Shelves, Casters <b>Edge Panel Config:</b> P- Pltnm Body w/Solid End Pnls <b>End Panel Finish:</b> Smith System Paint CE - CERULEAN SMITH SYSTEM <b>Tag For</b> N10	2	1,111.28	2,222.56

TITLE OF PRODUCT TRANSFERS UPON RECEIPT BY CUSTOMER.

ACCEPTED BY \_\_\_\_\_ TITLE \_\_\_\_\_ DATE \_\_\_\_\_

Description	Quantity	Unit Price	Extended Price
20			
<b>Qty Description</b>			
2 CAFETERIA D108			
21	10	15.91	159.10
67000 - SW 3" SINGLE DEPTH TOTE CLEAR SMITH SYSTEM			
<b>Tag For</b> N11 MARCH 2023 TO CURRENT PRODUCT extra totes for existing product			
<b>Qty Description</b>			
10 STEAM/Maker Space C109			
22	10	143.00	1,430.00
FK007-18X3-Z - Round Lily Pad Uphostered High Density Foam Seat, Fully Zippered Single Upholstery Size: 18" Dia. x 3" H			
Finishes: Fabric: Designtex, Beguiled By The Wild in Purple Starling 3043-602 (GR 5)			
FOMCORE			
<b>Tag For</b> L2A			
<b>Qty Description</b>			
10 STEAM / Maker Space C109			
23	10	143.00	1,430.00
KF007-18X3-Z - Round Lily Pad Uphostered High Density Foam Seat, Fully Zippered Single Upholstery Size: 18" Dia. x 3" H			
Finishes: Fabric: Designtex, Beguiled By The Wild in Blue Heron 3043-407 (GR 5)			
FOMCORE			
<b>Tag For</b> L2B			
<b>Qty Description</b>			
10 STEAM/Maker C109			

TITLE OF PRODUCT TRANSFERS UPON RECEIPT BY CUSTOMER.

ACCEPTED BY \_\_\_\_\_ TITLE \_\_\_\_\_ DATE \_\_\_\_\_

**yourNBS.com**      **Remit Payments to:** NBS, 6973 Reliable Parkway, Chicago, IL 60686

Description	Quantity	Unit Price	Extended Price
23			
24 FK007-CART2 - Lily Cart V2, Metal Powder coated FOMCORE  <b>Tag For</b> L3	2	227.50	455.00
<b>Qty Description</b>			
2 STEAM/ MAKer Space C109			
25 FK034-30X15X28.5-Z - Hug Chair - 2.0 upholstered High Density Foam Seat, Fully Zippered Dual Upholstery 8 lbs. 30" x 15" x 28.5" with a 15" Seat Height  Finishes: Banding Fabric: Arc-Com, Insight AC-63534, Denim #14 (GR3) Side Fabric: Arc-Com, Insight AC-63542, Storm #23 (GR3) FOMCORE  <b>Tag For</b> L4	1	681.37	681.37
<b>Qty Description</b>			
1 RELAXATION ROOM A143			
26 F005-18X16-G1 - Round Ottoman Upholstered High Density Foam Seat, Fully Zippered Dual Upholstery, Wave Pattern Glides Size: 18" Dia. X 16" H  Finishes: Top Fabric: Arc-Com, Insight AC-63534, Denim #14 (GR3) Bottom Fabric: Stinson, Petal Dots in Dusk PDO 56 (GR8) FOMCORE  <b>Tag For</b> L5	1	337.13	337.13
<b>Qty Description</b>			
1 RELAXATION ROOM A143			
27 XBRICKOR - Multifunctional Furniture - (Color: Orange) Xbrick MUZO	6	210.75	1,264.50

TITLE OF PRODUCT TRANSFERS UPON RECEIPT BY CUSTOMER.

ACCEPTED BY \_\_\_\_\_ TITLE \_\_\_\_\_ DATE \_\_\_\_\_

Description	Quantity	Unit Price	Extended Price
27			
<p><b>Tag For</b> H1</p> <p><b>Qty Description</b>                      6 STEAM/ Maker Space C109</p>			
28	6	210.75	1,264.50
<p>XBRICKBU - Multifunctional Furniture -                      (Color: Blue)                      X Brick                      MUZO</p> <p><b>Tag For</b> H2</p> <p><b>Qty Description</b>                      6 STEAM/Maker Space C109</p>			
29	12	32.25	387.00
<p>XCONN - Wooden Connector for XBrick                      MUZO</p> <p><b>Tag For</b> H1 AND H2</p> <p><b>Qty Description</b>                      12 STEAM/Maker Space C109</p>			
30	8	3,025.05	24,200.40
<p>CLN9107-4-1133-AC - CLN9107-4-1133-AC (CLN9107-4-113330-AC-4MA/P)                      Mini Nucleus Four cabinet Assembly. Top and deck Only, 48" Width, 48" Depth, 30" Height, Finished Both Ends, No Lock Needed                      (48" x 48" Hardwood Top, 30"W x 30" Casebody: HPL Handspun Dove Casebody w/ Dove Grey Edge Band, Connecting Magnets for Hangout Stools (4 Locations)</p> <p>2 Open Cabinets with Adjustable Shelf/Shelves, 2 Cabinets with Single locking Door and Adjustable Shelf/Shelves, 2 Locking &amp; 2 Non-Locking 3" Casters                      -- Unit Weight: 357.0000</p> <p>*** All units to be keyed alike with the same key # ****                      WB MANUFACTURING LLC</p> <p><b>Tag For</b> G1</p> <p><b>Qty Description</b>                      8 STEAM/MAKER SPACE C109</p>			

TITLE OF PRODUCT TRANSFERS UPON RECEIPT BY CUSTOMER.

ACCEPTED BY \_\_\_\_\_ TITLE \_\_\_\_\_ DATE \_\_\_\_\_

**yourNBS.com**      **Remit Payments to:** NBS, 6973 Reliable Parkway, Chicago, IL 60686

Description	Quantity	Unit Price	Extended Price
30			
31 HS18 - HangOut Stool, Square Steel Seat, Non-Maring Feet, Fixed Height 18", Smooth Silver Finish Footring WB MANUFACTURING LLC  Tag For G2	32	92.05	2,945.60
<b>Qty Description</b>			
32 STEAM/MAKER SPACE C109			
32 SP425646-1 - SpC (SP425646-1 CUSTMOD-RPLW) Quote for Special Cabinet, Model # SP425646-1  (Custom Replay Open Mobile Base Cabinet, Based on CRB1145-48"W x 54"H x 22" D/23" Overall Depth. (1) VerticalDivider, (2) Fixed shelves to create (4) Cubbies w/Roll-Out Drawer. (4) Grommets. Includes Retaining Rods & Perforated Metal Back Panel. Handspun Dove (5034-38) HPL w/Folkstone 3MM. Battleship Grey Grommets. Reference SP403774-3 for similar model.) WB MANUFACTURING LLC	1	2,723.35	2,723.35
33 TBC71GABR05BGQ0505JS - BY-65 Bench Table 12' Lifting Table with Attached Bench Seats Seating Capacity: 16 Children HPL Top with Armor-Edge Powdercoated Metal Base Casters for Rubber Flooring In Use Size: 144" W x 51.5" D x 30" H (18.5" SH) Storage Dimension: 35.5" W x 42" D x 79.5" H  Finishes: Top Laminate: Pewter Mesh (W-4878) Bench Laminate: Formica, Yellow Felt (F-4972-58) Edge: Dark Blue (05) Base/Legs: Silver Caster Accent: Dark Blue (05) SICO  Tag For J1	12	2,538.75	30,465.00
<b>Qty Description</b>			
11 CAFETERIA D108			

TITLE OF PRODUCT TRANSFERS UPON RECEIPT BY CUSTOMER.

ACCEPTED BY \_\_\_\_\_ TITLE \_\_\_\_\_ DATE \_\_\_\_\_

Description	Quantity	Unit Price	Extended Price
33			
<b>Qty Description</b> 1 STORAGE D109			
34	1	2,458.75	2,458.75
TBB71GABR05BGQ0505JS - BY-65 Bench Table 10' Lifting Table with Attached Bench Seats Seating Capacity: 12 Children HPL Top with Armor-Edge Powdercoated Metal Base Casters for Rubber Flooring In Use Size: 120" W x 51.5" D x 30" H (18.5" SH) Storage Dimension: 34" W x 42" D x 70.5" H  Finishes: Top Laminate: Pewter Mesh (W-4878) Bench Laminate: Formica, Yellow Felt (F-4972-58) Edge: Dark Blue (05) Base/Legs: Silver Caster Accent: Dark Blue (05) SICO  <b>Tag For</b> J2			
<b>Qty Description</b> 1 STORAGE D109			
35	1	720.55	720.55
NL3060 - Elemental Table 30" Depth X 60" Width Nest and Fold, With Casters  <b>Worksurface Finish:</b> Smith System Laminate 487860 - PEWTER MESH LAMINATE <b>Edge:</b> F - 1 1/4in Top w 3mm Edgbnd <b>Edge Finish:</b> Smith System Plastic NAVY - NAVY <b>Leg Finish:</b> Smith System Paint PLT - PLATINUM <b>Height:</b> EF - Fixed Height SMITH SYSTEM  <b>Tag For</b> N12			
<b>Qty Description</b> 1 CAFETERIA D108			
36	2	710.00	1,420.00
TUNW6030M42W - Standing Height Pillow Table Round Steel Legs, Pin-Set Height Adjustable H Frame with HPL Top  Wheelbarrow, (2) Glides and (2) Locking Casters			

TITLE OF PRODUCT TRANSFERS UPON RECEIPT BY CUSTOMER.

ACCEPTED BY \_\_\_\_\_ TITLE \_\_\_\_\_ DATE \_\_\_\_\_

Description	Quantity	Unit Price	Extended Price
-------------	----------	------------	----------------

36

Size: 60" W x 24-30" D x 34-42" H

Finishes:

Laminate: Fusion Maple W268

Edge: Match Fusion Maple

Metal: Silver

FLEETWOOD GROUP

**Tag For** S1

\*\* INSTALL AT 36" HIGH \*\*

**Qty Description**

2 CLASSROOM C107/A14

37	DPJ14220374D - Designer 2.0 Project Cart   holds up to 12 Gratnells Trays locking door & drawer 1 adj shelf single sided 100mm casters 42w 20d 37h	1	2,161.25	2,161.25
----	----------------------------------------------------------------------------------------------------------------------------------------------------------------	---	----------	----------

Case Material Option: TFL G1 case material

Case Color Option: Etched Gray laminate

Case Edgeband Color Option: Graphite edgeband

Back Material Option: Magnetic pegboardback

Pegboard Color Option: Silver paint

Shelf Material Option: Laminate adjustable shelf (1)

Shelf Color Option:

Laminate shelf color is matched to case color

Tray Configuration Option: Option D (8) 3" high & (2) 6" high trays

Metal Reveal Color Option: Silver paint

Pull Option: Arch pull 128mm. Available in chrome

Pull Color Option: Chrome

Side Handle Color Option: Fleetwood paint color to be selected later

Top Material Option: Maple Block.

Top Edgeband Color Option: Maple Block edge is maple block

Power Option: No power required

Assembly Option: Product is factory assembled

FLEETWOOD GROUP

TITLE OF PRODUCT TRANSFERS UPON RECEIPT BY CUSTOMER.

ACCEPTED BY \_\_\_\_\_ TITLE \_\_\_\_\_ DATE \_\_\_\_\_

Description	Quantity	Unit Price	Extended Price
37			
<p><b>Tag For</b>      S2</p> <p style="text-align: center;"><u>Qty Description</u></p> <p style="text-align: center;">1 CLASSROOM C107/A14</p>			
38	1	1,182.50	1,182.50
<p>VSF3066EE - Mobile Markerboards                      V Series Single Panel                      4-Point Base                      EVS Markerboard Surface on Both Sides                      Locking Casters                      Include (1) Magnetic Egancloth Caddy                      Size: 30" W x 20" D x 66" H                      Finishes:                      Markerboard: White                      Frame: Silver                      EGAN VISUAL INTERNATIONAL</p> <p><b>Tag For</b>      T1</p> <p style="text-align: center;"><u>Qty Description</u></p> <p style="text-align: center;">1 CLASSROOM C107/A14</p>			
39	1	8,033.00	8,033.00
<p>LOT - Receive, Deliver, and Install product.                      Non-union labor, normal business hours.                      Free and clear space; does not include removal of any existing product.                      No stair carry.                      All work to be done at one time.                      Wall mounting into drywall                      Site is Semi truck accessible                      30 days free storage</p> <p>ROSE MOVING &amp; STORAGE</p>			
40	1	No Charge	No Charge
<p>CONTINGENCY - Estimating 2-3 days for install ****</p> <p>If due to unforeseen circumstances the building is not ready to receive furniture, including construction delays, additional fees may be incurred to double handle and/or store the furniture. Installation is quoted as one phase.</p> <p>Additional Trip charge cost to return to site and complete installation: \$300                      ****</p> <p>Storage fee per month: 729 for all product****</p> <p>ROSE MOVING &amp; STORAGE</p>			

TITLE OF PRODUCT TRANSFERS UPON RECEIPT BY CUSTOMER.

ACCEPTED BY \_\_\_\_\_ TITLE \_\_\_\_\_ DATE \_\_\_\_\_

**yourNBS.com**      **Remit Payments to:** NBS, 6973 Reliable Parkway, Chicago, IL 60686

<b>Quotation Totals</b>	
<b>Sub Total</b>	<b>101,414.82</b>
<b>MU0001 FREIGHT</b>	<b>829.33</b>
<b>WB0001 FREIGHT</b>	<b>1,960.00</b>
<b>SM0043 FREIGHT</b>	<b>1,787.64</b>
<b>SI0187 FREIGHT</b>	<b>1,840.00</b>
<b>EA0001 FREIGHT</b>	<b>398.57</b>
<b>FL0092 FREIGHT</b>	<b>500.00</b>
<b>NON-TAXABLE SCHOOL OR GOVERNMENTAL</b>	<b>0.00</b>
<b>NON-TAXABLE CHARITY/CHURCHES</b>	<b>0.00</b>
<b>Grand Total</b>	<b>108,730.36</b>

**End of Quotation**

TITLE OF PRODUCT TRANSFERS UPON RECEIPT BY CUSTOMER.

ACCEPTED BY \_\_\_\_\_ TITLE \_\_\_\_\_ DATE \_\_\_\_\_

## Finish Summary

Product Line	Finish Group Description	Finish Description	Finish
Flex	Frame Finish	6527 - MERLE	
490 Move	Frame Finish	4799 - PLATINUM METALLIC	
490 Move	Shell Finish	6249 - PLATINUM SOLID	
490 Move	Upholstery Finish	5SD3 - LAGOON	
490 Move	Upholstery Finish	5876 - NAVY	
Steelcase Series 1	Back Finish	5T29 - GRAPHITE	
Steelcase Series 1	Outer Back Finish	6295 - NEAR BLACK	
Steelcase Series 1	Seat Finish	5A25 - NAVY	
Steelcase Series 1	Frame Finish	6205 - BLACK	
Steelcase Series 1	Base Finish	6205 - BLACK	
Cascade	End Panel Finish	CE - CERULEAN	
Cascade	Laminate Top Finish	790960 - FUSION MAPLE LAMINATE	
Cascade	Edge Finish	MAP - FUSION MAPLE	
Cascade	End Panel Finish	PLT - PLATINUM	
Interchange	Worksurface Finish	790960 - FUSION MAPLE LAMINATE	
Interchange	Edge Finish	PLATINUM - PLATINUM	
Interchange	Frame Finish	PLT - Platinum	
Interchange	Glide Finish	PLT - Smith System Platinum	
Elemental	Worksurface Finish	487860 - PEWTER MESH LAMINATE	
Elemental	Edge Finish	NAVY - NAVY	
Elemental	Leg Finish	PLT - PLATINUM	

TITLE OF PRODUCT TRANSFERS UPON RECEIPT BY CUSTOMER.

ACCEPTED BY \_\_\_\_\_ TITLE \_\_\_\_\_ DATE \_\_\_\_\_



**yourNBS.com**      **Remit Payments to:** NBS, 6973 Reliable Parkway, Chicago, IL 60686

**Customer** N00164  
**Terms** NET 10 DAYS  
**Account Representative** ANNE MARIE TREMBERTH

**Quote To**

Accounts Payable  
 Northville Public Schools  
 405 W MAIN ST  
 NORTHVILLE, MI, 48167-1577

**Ship To**

Jessica Hartwig  
 Amerman Elementary  
 847 N CENTER ST  
 Phase 2  
 NORTHVILLE, MI, 48167-1118

**Phone** +1 (248) 344-3514  
 npsaccountspayable@northvilleschools.org

**Phone** +1 (248) 338-4561  
 jhartwig@tmp-architecture.com

**Sales Location** Troy

Description	Quantity	Unit Price	Extended Price
1 F001-18X16X16-G1 - Rectangle Ottoman Upholstered High Density Foam Seat, Fully Zippered Dual Upholstery 1" Nylon Glides 16" Seat Height 18"W x 16"D x 16"H Finishes: Top Fabric: Arc-Com, Insight AC-63523, Sunflower #4 (GR13) Bottom Fabric: Arc-Com, Zip, AC-64457, Amethyst #8 (GR14) FOMCORE  <b>Tag For</b> L6	5	437.50	2,187.50
<b>Qty Description</b> 5 MEDIA CENTER A108			
2 LOAD - Receive, Deliver, and Install product. Non-union labor, normal business hours. Free and clear space; does not include removal of any existing product. No stair carry. All work to be done at one time.  NBS Troy	1	165.00	165.00

TITLE OF PRODUCT TRANSFERS UPON RECEIPT BY CUSTOMER.

ACCEPTED BY \_\_\_\_\_ TITLE \_\_\_\_\_ DATE \_\_\_\_\_



[yourNBS.com](http://yourNBS.com)

Remit Payments to: NBS, 6973 Reliable Parkway, Chicago, IL 60686

**Quotation Totals**

<b>Sub Total</b>	<b>2,352.50</b>
<b>NON-TAXABLE SCHOOL OR GOVERNMENTAL</b>	<b>0.00</b>
<b>NON-TAXABLE CHARITY/CHURCHES</b>	<b>0.00</b>
<b>Grand Total</b>	<b>2,352.50</b>

**End of Quotation**

TITLE OF PRODUCT TRANSFERS UPON RECEIPT BY CUSTOMER.

ACCEPTED BY \_\_\_\_\_ TITLE \_\_\_\_\_ DATE \_\_\_\_\_



# Proposal

**Interior Environments - Novi**  
**48700 Grand River Ave**  
**Novi, MI 48374**  
**Phone: (248) 213-3010**

Order Number	20113
Date	02/11/2025
Customer PO No	
Customer Name	Northville Public Schools
Salesperson	Betsy Pethoud
Terms	NET 10
Page	1 of 18

T Northville Public Schools  
 O 501 W Main St  
 Northville, MI 48167

ATTN: INVOICE CONTACT  
 Email: NPSaccounts payable@northvilleschools.org

I Amerman Elementary School  
 N 847 N Center St  
 S Northville, MI 48167  
 T  
 A  
 L ATTN: Jessica Hartwig  
 L Phone: 248-338-4561  
 A Email: jhartwig@tmp-architecture.com  
 T

Prepared for : Betsy Pethoud

Allsteel - Omnia Contract R191802

Hon - Omnia Contract R191804

OFS - Omnia Contract R191813 CDA: GO-104800

Group	Quantity	Description	Unit Price	Extended Amount
Allsteel	1.0		14,344.72	14,344.72

Line	Quantity	Description	Unit Price	Extended Amount
1	1.00 Each	T53066S--\$(L1STD)-.LAHS-.E9-.P Primary 30Dx66W Flat Eg Lam w/Grommets \$(L1STD):Grd L1 Standard Laminates .LAHS:Handspun Slate .E9:Flint .P:Plastic Grommet Tag: Tag TG: D1-WS1 Tag L1: 30x66 Tag L3: PHASE 2	267.18	267.18
2	1.00 Each	T52460S--\$(L1STD)-.LAHS-.E9-.P Primary 24Dx60W Flat Eg Lam w/Grommets \$(L1STD):Grd L1 Standard Laminates .LAHS:Handspun Slate .E9:Flint .P:Plastic Grommet Tag: Tag TG: D1-WS1 Tag L1: 24x60 Tag L3: PHASE 2	225.70	225.70
3	1.00 Each	T52472S--\$(L1STD)-.LAHS-.E9-.P Primary 24Dx72W Flat Eg Lam w/Grommets \$(L1STD):Grd L1 Standard Laminates .LAHS:Handspun Slate .E9:Flint .P:Plastic Grommet Tag: Tag TG: D1-WS1 Tag L1: 24x72 Tag L3: PHASE 2	256.20	256.20
4	1.00 Each	T52436SN--\$(L1STD)-.LAHS-.E9 Primary 24Dx36W Flat Eg Lam w/o Grom \$(L1STD):Grd L1 Standard Laminates	152.20	152.20



# Proposal

**Interior Environments - Novi**  
**48700 Grand River Ave**  
**Novi, MI 48374**  
**Phone: (248) 213-3010**

Order Number	20113
Date	02/11/2025
Customer PO No	
Customer Name	Northville Public Schools
Salesperson	Betsy Pethoud
Terms	NET 10
Page	2 of 18

		.LAHS:Handspun Slate .E9:Flint Tag: Tag TG: D1-WS1 Tag L1: 24x36 Tag L3: PHASE 2		
5	2.00 Each	CEP3029F--\$(P1)-.P02 Freestanding 30DX29-1/2H End Pnl Sup \$(P1):P1 Paint Opts .P02:Flint Tag: Tag TG: D1-WS1 Tag L1: FEP Tag L3: PHASE 2	103.40	206.80
6	1.00 Each	CS669--\$(P1)-.P02 Full-Hgt 29-1/2Hx66W Mod Pnl \$(P1):P1 Paint Opts .P02:Flint Tag: Tag TG: D1-WS1 Tag L1: MP 29.5Hx66W Tag L3: PHASE 2	96.69	96.69
7	1.00 Each	T624FB Flat Bracket 24D Tag: Tag TG: D1-WS1 Tag L1: FB Tag L3: PHASE 2	25.32	25.32
8	1.00 Each	Z5SC60 48W External Supt Channel for 60W W/S Tag: Tag TG: D1-WS1 Tag L1: SC 48 Tag L3: PHASE 2	34.77	34.77
9	1.00 Each	Z5SC66 54W External Supt Channel for 66W W/S Tag: Tag TG: D1-WS1 Tag L1: SC 54 Tag L3: PHASE 2	40.26	40.26
10	1.00 Each	Y629LKNP--\$(P1)-.P02 Lt Scale 29-1/2H Leg Non-handed Pntd \$(P1):P1 Paint Opts .P02:Flint Tag: Tag TG: D1-WS1 Tag L1: LSPL Tag L3: PHASE 2	124.75	124.75
11	1.00 Each	CDG--\$(P1)-.P02 Gussets (1 Pr) \$(P1):P1 Paint Opts .P02:Flint Tag: Tag TG: D1-WS1 Tag L1: CDG Tag L3: PHASE 2	60.70	60.70
12	1.00 Each	CSL2429F--\$(P1)-.P02 Freestanding 24Dx29-1/2H Sup Leg \$(P1):P1 Paint Opts .P02:Flint	80.83	80.83



# Proposal

**Interior Environments - Novi**  
**48700 Grand River Ave**  
**Novi, MI 48374**  
**Phone: (248) 213-3010**

<b>Order Number</b>	20113
<b>Date</b>	02/11/2025
<b>Customer PO No</b>	
<b>Customer Name</b>	Northville Public Schools
<b>Salesperson</b>	Betsy Pethoud
<b>Terms</b>	NET 10
<b>Page</b>	3 of 18

		Tag: Tag TG: D1-WS1 Tag L1: FSL Tag L3: PHASE 2		
13	1.00 Each	PM187-183A--\$(P1)-.P02-.EL-.OMT Essentials Mobile Ped BBF 28Hx18Dx15W BBF Arch Pull \$(P1):P1 Paint Opts .P02:Flint .EL:Matte Silver .OMT:OMT Core to Ord key Alike Tag: Tag TG: D1-WS1 Tag L1: MB/B/F Tag L3: PHASE 2	392.84	392.84
14	1.00 Each	ESC236A--\$(P1)-.P02-.EL-.OMT Essentials 28Hx36W Storage Cabinet Arch Pull \$(P1):P1 Paint Opts .P02:Flint .EL:Matte Silver .OMT:OMT Core to Ord key Alike Tag: Tag TG: D1-WS1 Tag L1: SC 28x36 Tag L3: PHASE 2	534.96	534.96
15	1.00 Each	EBC236--\$(P1)-.P02 Essentials Bookcase 28H (2H) 36W 18D Open Cabinet \$(P1):P1 Paint Opts .P02:Flint Tag: Tag TG: D1-WS1 Tag L1: BC 28x18x36 Tag L3: PHASE 2	442.08	442.08
16	1.00 Each	ZWMTB2060--\$(A)-.TP-940 Strd 20Hx60W Wall-Mounted Tackboard \$(A):Grd A FAB .TP:Tempest 940:Wind Chill Tag: Tag TG: D1-WS1 Tag L1: TB 20x60 Tag L3: PHASE 2	332.76	332.76
17	1.00 Each	LKFE2SLV--\$(KEYNUM)-.X145-.1 Lock Core Kit Silver - 2 Cores 2 Keys \$(KEYNUM):Key Number .X145:Key Number 145 .1:1 Tag: Tag TG: D1-WS1 Tag L1: KEY CORES Tag L3: PHASE 2	19.22	19.22
18	2.00 Each	TK03524WR--\$(P1)-.P02 Structural Raceway Panel Frame-No Top Trim 35Hx24W \$(P1):P1 Paint Opts .P02:Flint Tag: Tag TG: D1-WS2 Tag L1: NEW ADD ON EXISTING Tag L3: PHASE 2	124.14	248.28
19	1.00	TK03530WF--\$(P1)-.P02	127.49	127.49



# Proposal

Interior Environments - Novi  
 48700 Grand River Ave  
 Novi, MI 48374  
 Phone: (248) 213-3010

Order Number	20113
Date	02/11/2025
Customer PO No	
Customer Name	Northville Public Schools
Salesperson	Betsy Pethoud
Terms	NET 10
Page	4 of 18

	Each	Structural Footed Pnl Frame-No Top Trim 35Hx30W \$(P1):P1 Paint Opts .P02:Flint Tag: Tag TG: D1-WS2 Tag L1: NEW ADD ON EXISTING Tag L3: PHASE 2		
20	1.00 Each	TKG43024LM--X-\$(L1STD)-.LM16-.E9-.VST Laminate Tile 30h x 24w .X:Non-FSC Wood \$(L1STD):Grd L1 Standard Laminates .LM16:Flint .E9:Flint .VST:Vertical Grain Tag: Tag TG: D1-WS2 Tag L1: NEW ADD ON EXISTING Tag L3: PHASE 2	190.02	190.02
21	3.00 Each	TKG40724T--\$(A)-.APN-916 Ter Tackable Acoustic Tile 7.5H x 24W \$(A):GRD A FAB .APN:Appoint 916:Nimbus Tag: Tag TG: D1-WS2 Tag L1: NEW ADD ON EXISTING Tag L3: PHASE 2	36.30	108.90
22	3.00 Each	TKG42224T--\$(B)-.TRRN-10 Ter Tackable Acoustic Tile 22.5H x 24W \$(B):Grd B FAB .TRRN:Terrain 10:Delta Tag: Tag TG: D1-WS2 Tag L1: NEW ADD ON EXISTING Tag L3: PHASE 2	50.63	151.89
23	3.00 Each	TKSK24 Ter 24W Segment Kit Tag: Tag TG: D1-WS2 Tag L1: NEW ADD ON EXISTING Tag L3: PHASE 2	10.07	30.21
24	2.00 Each	TKSK30 Ter 30W Segment Kit Tag: Tag TG: D1-WS2 Tag L1: NEW ADD ON EXISTING Tag L3: PHASE 2	10.07	20.14
25	2.00 Each	TK324PTFK--\$(P1)-.P02 Flat Top Trim 24W w/clips \$(P1):P1 Paint Opts .P02:Flint Tag: Tag TG: D1-WS2 Tag L1: NEW ADD ON EXISTING Tag L3: PHASE 2	20.74	41.48
26	1.00 Each	TK330PTFK--\$(P1)-.P02 Flat Top Trim 30W w/clips \$(P1):P1 Paint Opts	23.49	23.49



# Proposal

Interior Environments - Novi  
 48700 Grand River Ave  
 Novi, MI 48374  
 Phone: (248) 213-3010

Order Number	20113
Date	02/11/2025
Customer PO No	
Customer Name	Northville Public Schools
Salesperson	Betsy Pethoud
Terms	NET 10
Page	5 of 18

		.P02:Flint Tag: Tag TG: D1-WS2 Tag L1: NEW ADD ON EXISTING Tag L3: PHASE 2		
27	1.00 Each	T52424SN--\$(L1STD)-.LT11-.E9 Primary 24Dx24W Flat Eg Lam w/o Grom \$(L1STD):Grd L1 Standard Laminates .LT11:Titium .E9:Flint Tag: Tag TG: D1-WS2 Tag L1: NEW ADD ON EXISTING Tag L3: PHASE 2	128.10	128.10
28	1.00 Each	T52454SN--\$(L1STD)-.LT11-.E9 Primary 24Dx54W Flat Eg Lam w/o Grom \$(L1STD):Grd L1 Standard Laminates .LT11:Titium .E9:Flint Tag: Tag TG: D1-WS2 Tag L1: NEW ADD ON EXISTING Tag L3: PHASE 2	198.86	198.86
29	2.00 Each	T6BK--\$(P1)-.P02 Worksurface Bracket Kit \$(P1):P1 Paint Opts .P02:Flint Tag: Tag TG: D1-WS2 Tag L1: NEW ADD ON EXISTING Tag L3: PHASE 2	23.18	46.36
30	2.00 Each	T6CB18L--\$(P1)-.P02 Cantilever Bracket 18D LH Terrace \$(P1):P1 Paint Opts .P02:Flint Tag: Tag TG: D1-WS2 Tag L1: NEW ADD ON EXISTING Tag L3: PHASE 2	24.40	48.80
31	2.00 Each	T6CB18R--\$(P1)-.P02 Cantilever Bracket 18D RH Terrace \$(P1):P1 Paint Opts .P02:Flint Tag: Tag TG: D1-WS2 Tag L1: NEW ADD ON EXISTING Tag L3: PHASE 2	24.40	48.80
71	2.00 Each	PM187-183A--\$(P1)-.P02-.EL-.OMT Essentials Mobile Ped BBF 28Hx18Dx15W BBF Arch Pull \$(P1):P1 Paint Opts .P02:Flint .EL:Matte Silver .OMT:OMT Core to Ord key Alike Tag: Tag TG: D2 Tag L1: MB/B/F Tag L3: PHASE 2	392.84	785.68
72	1.00 Each	LKFE1SLV--\$(KEYNUM)-.X128-.1 Lock Core Kit Silver - 1 Core 2 Keys	9.46	9.46



# Proposal

Interior Environments - Novi  
 48700 Grand River Ave  
 Novi, MI 48374  
 Phone: (248) 213-3010

Order Number	20113
Date	02/11/2025
Customer PO No	
Customer Name	Northville Public Schools
Salesperson	Betsy Pethoud
Terms	NET 10
Page	6 of 18

		\$(KEYNUM):Key Number .X128:Key Number 128 .1:1 Tag: Tag TG: D2 - D104 Tag L1: KEY CORES D104 Tag L3: PHASE 2		
73	1.00 Each	LKFE1SLV--\$(KEYNUM)-.X127-.1 Lock Core Kit Silver - 1 Core 2 Keys \$(KEYNUM):Key Number .X127:Key Number 127 .1:1 Tag: Tag TG: D2 - C107 Tag L1: KEY CORES C107 Tag L3: PHASE 2	9.46	9.46
74	1.00 Each	ECF536HA--\$(P1)-.P02-.EL-.OMT Ess Combination 64-1/4Hx36W File Hinge Drs Arch \$(P1):P1 Paint Opts .P02:Flint .EL:Matte Silver .OMT:OMT 2 Cores To Ord key Alike Tag: Tag TG: D3 Tag L1: CF 64x30 Tag L3: PHASE 2	1,175.04	1,175.04
75	1.00 Each	L919491 Single Rail Hanging File Racks(Pack of 4) Tag: Tag TG: D3 Tag L3: PHASE 2	25.20	25.20
76	1.00 Each	LKFE2SLV--\$(KEYNUM)-.X127-.1 Lock Core Kit Silver - 2 Cores 2 Keys \$(KEYNUM):Key Number .X127:Key Number 127 .1:1 Tag: Tag TG: D3 - C107 Tag L1: KEY CORES C107 Tag L3: PHASE 2	19.22	19.22
77	2.00 Each	ELF442NA--\$(P1)-.P02-.EL-.OMT Ess Lat 42W 52-1/2H 4-12" Drs Arch Pull \$(P1):P1 Paint Opts .P02:Flint .EL:Matte Silver .OMT:OMT Core to Ord key Alike Tag: Tag TG: D4 Tag L1: LF 4/42 Tag L3: PHASE 2	1,142.28	2,284.56
78	1.00 Each	LKFE2SLV--\$(KEYNUM)-.X101-.1 Lock Core Kit Silver - 2 Cores 2 Keys \$(KEYNUM):Key Number .X101:Key Number 101 .1:1 Tag: Tag TG: D4 - A139 Tag L1: KEY CORES C107 Tag L3: PHASE 2	19.22	19.22



# Proposal

**Interior Environments - Novi**  
**48700 Grand River Ave**  
**Novi, MI 48374**  
**Phone: (248) 213-3010**

<b>Order Number</b>	20113
<b>Date</b>	02/11/2025
<b>Customer PO No</b>	
<b>Customer Name</b>	Northville Public Schools
<b>Salesperson</b>	Betsy Pethoud
<b>Terms</b>	NET 10
<b>Page</b>	7 of 18

79	2.00 Each	ESC230A--\$(P1)-.P02-.EL-.OMT Essentials 28Hx30W Storage Cabinet Arch Pull \$(P1):P1 Paint Opts .P02:Flint .EL:Matte Silver .OMT:OMT Core to Ord key Alike Tag: Tag TG: D5 Tag L1: SC 28x30 Tag L3: PHASE 2	480.24	960.48
80	1.00 Each	ISLAUTNPNB4236S1--.X-\$(L1STD)-.LAHS-.E9 Stor Isla Top 42Wx36D S1 .X:Non-FSC Wood \$(L1STD):Grd L1 Standard Laminates .LAHS:Handspun Slate .E9:Flint Tag: Tag TG: D5 Tag L1: 42Wx36D-S1 Tag L3: PHASE 2	230.04	230.04
81	1.00 Each	LKFE2SLV--\$(KEYNUM)-.X101-.1 Lock Core Kit Silver - 2 Cores 2 Keys \$(KEYNUM):Key Number .X101:Key Number 101 .1:1 Tag: Tag TG: D5 - A139 Tag L1: KEY CORES C107 Tag L3: PHASE 2	19.22	19.22
82	1.00 Each	AMPTLFPO30RND--.X-\$(L1STD)-.LAHS-.E9-.C0 Structure 30" Round Top Lam-Square Edge .X:Standard Wood \$(L1STD):Grd L1 Standard Laminates .LAHS:Handspun Slate .E9:Flint .C0:No Cutout Tag: Tag TG: D6 Tag L1: 30 Tag L3: PHASE 2	189.00	189.00
83	1.00 Each	AMPTPR18M--\$(P1)-.P7A Structure Round Ped Base Med. Occasional Height \$(P1):P1 Paint Grade .P7A:Textured Flint Tag: Tag TG: D6 Tag L1: RP18 Tag L3: PHASE 2	334.80	334.80
84	1.00 Each	ECF530HA--\$(P1)-.P02-.EL-.OMT Ess Combination 64-1/4Hx30W File Hinge Drs Arch \$(P1):P1 Paint Opts .P02:Flint .EL:Matte Silver .OMT:OMT 2 Cores To Ord key Alike Tag: Tag TG: D7 Tag L1: CF 64x30 Tag L3: PHASE 2	1,032.84	1,032.84
85	1.00	L919491	25.20	25.20



# Proposal

**Interior Environments - Novi**  
**48700 Grand River Ave**  
**Novi, MI 48374**  
**Phone: (248) 213-3010**

Order Number	20113
Date	02/11/2025
Customer PO No	
Customer Name	Northville Public Schools
Salesperson	Betsy Pethoud
Terms	NET 10
Page	8 of 18

	Each	Single Rail Hanging File Racks(Pack of 4) Tag: Tag TG: D7 Tag L3: PHASE 2		
86	1.00 Each	LKFE2SLV--\$(KEYNUM)-.X101-.1 Lock Core Kit Silver - 2 Cores 2 Keys \$(KEYNUM):Key Number .X101:Key Number 101 .1:1 Tag: Tag TG: D7 - A139 Tag L1: KEY CORES C107 Tag L3: PHASE 2	19.22	19.22
87	1.00 Each	Labor ALLSTEEL Furniture Installation: PHASE 1 - DISASSEMBLE EXISTING WORKSTATION AND STORE ON SITE :STRAIGHT TIME :NON UNION :NO STAIR CARRY - ELEVATOR USE :NO PERMITS :NO HARDWIRE DATA OR ELECTRICAL CONNECTIONS :ALL DEBRIS REMOVAL INCLUDED Tag: Tag L3: PHASE 1	700.00	700.00
88	1.00 Each	Labor ALLSTEEL Furniture Installation: PHASE 2 - REASSEMBLE EXISTING WORKSTATION ON SITE WITH ADDITIONAL ALLSTEEL PRODUCTS :STRAIGHT TIME :NON UNION :NO STAIR CARRY - ELEVATOR USE :NO PERMITS :NO HARDWIRE DATA OR ELECTRICAL CONNECTIONS :ALL DEBRIS REMOVAL INCLUDED Tag: Tag L3: PHASE 2	1,800.00	1,800.00

Group	Quantity	Description	Unit Price	Extended Amount
CUSTOMER INVENTORY	1.0		0.00	0.00

Line	Quantity	Description	Unit Price	Extended Amount
32	2.00 Each	TK03524WR--\$(P1)-.P02 Structural Raceway Panel Frame-No Top Trim 35Hx24W \$(P1):P1 Paint Opts .P02:Flint Tag: Tag TG: D1-WS2_REUSE Tag L1: D1-WS2_REUSE Tag L3: PHASE 1 UNASSEMBLE / PHASE 2 REUSE	0.00	0.00
33	2.00 Each	TK03530WR--\$(P1)-.P02 Structural Raceway Panel Frame-No Top Trim 35Hx30W \$(P1):P1 Paint Opts .P02:Flint Tag: Tag TG: D1-WS2_REUSE Tag L1: D1-WS2_REUSE	0.00	0.00



# Proposal

Interior Environments - Novi  
 48700 Grand River Ave  
 Novi, MI 48374  
 Phone: (248) 213-3010

Order Number	20113
Date	02/11/2025
Customer PO No	
Customer Name	Northville Public Schools
Salesperson	Betsy Pethoud
Terms	NET 10
Page	9 of 18

		Tag L3: PHASE 1 UNASSEMBLE / PHASE 2 REUSE		
34	4.00 Each	TK03536WR--\$(P1)-.P02 Structural Raceway Panel Frame-No Top Trim 35Hx36W \$(P1):P1 Paint Opts .P02:Flint Tag: Tag TG: D1-WS2_REUSE Tag L1: D1-WS2_REUSE Tag L3: PHASE 1 UNASSEMBLE / PHASE 2 REUSE	0.00	0.00
35	2.00 Each	TK03542WR--\$(P1)-.P02 Structural Raceway Panel Frame-No Top Trim 35Hx42W \$(P1):P1 Paint Opts .P02:Flint Tag: Tag TG: D1-WS2_REUSE Tag L1: D1-WS2_REUSE Tag L3: PHASE 1 UNASSEMBLE / PHASE 2 REUSE	0.00	0.00
36	1.00 Each	TKG43030LM--.X-\$(L1STD)-.LM16-.E9-.VST Laminate Tile 30h x 30w .X:Non-FSC Wood \$(L1STD):Grd L1 Standard Laminates .LM16:Flint .E9:Flint .VST:Vertical Grain Tag: Tag TG: D1-WS2_REUSE Tag L1: D1-WS2_REUSE Tag L3: PHASE 1 UNASSEMBLE / PHASE 2 REUSE	0.00	0.00
37	1.00 Each	TKG43036LM--.X-\$(L1STD)-.LM16-.E9-.VST Laminate Tile 30h x 36w .X:Non-FSC Wood \$(L1STD):Grd L1 Standard Laminates .LM16:Flint .E9:Flint .VST:Vertical Grain Tag: Tag TG: D1-WS2_REUSE Tag L1: D1-WS2_REUSE Tag L3: PHASE 1 UNASSEMBLE / PHASE 2 REUSE	0.00	0.00
38	2.00 Each	TKSK24 Ter 24W Segment Kit Tag: Tag TG: D1-WS2_REUSE Tag L1: D1-WS2_REUSE Tag L3: PHASE 1 UNASSEMBLE / PHASE 2 REUSE	0.00	0.00
39	3.00 Each	TKSK30 Ter 30W Segment Kit Tag: Tag TG: D1-WS2_REUSE Tag L1: D1-WS2_REUSE Tag L3: PHASE 1 UNASSEMBLE / PHASE 2 REUSE	0.00	0.00
40	7.00 Each	TKSK36 Ter 36W Segment Kit Tag: Tag TG: D1-WS2_REUSE Tag L1: D1-WS2_REUSE Tag L3: PHASE 1 UNASSEMBLE / PHASE 2 REUSE	0.00	0.00
41	4.00 Each	TKSK42 Ter 42W Segment Kit	0.00	0.00



# Proposal

**Interior Environments - Novi**  
**48700 Grand River Ave**  
**Novi, MI 48374**  
**Phone: (248) 213-3010**

Order Number	20113
Date	02/11/2025
Customer PO No	
Customer Name	Northville Public Schools
Salesperson	Betsy Pethoud
Terms	NET 10
Page	10 of 18

		Tag: Tag TG: D1-WS2_REUSE Tag L1: D1-WS2_REUSE Tag L3: PHASE 1 UNASSEMBLE / PHASE 2 REUSE		
42	2.00 Each	TKG40724T--\$(A)-.APN-916 Ter Tackable Acoustic Tile 7.5H x 24W \$(A):GRD A FAB .APN:Appoint 916:Nimbus Tag: Tag TG: D1-WS2_REUSE Tag L1: D1-WS2_REUSE Tag L3: PHASE 1 UNASSEMBLE / PHASE 2 REUSE	0.00	0.00
43	3.00 Each	TKG40730T--\$(A)-.APN-916 Ter Tackable Acoustic Tile 7.5H x 30W \$(A):Grd A FAB .APN:Appoint 916:Nimbus Tag: Tag TG: D1-WS2_REUSE Tag L1: D1-WS2_REUSE Tag L3: PHASE 1 UNASSEMBLE / PHASE 2 REUSE	0.00	0.00
44	7.00 Each	TKG40736T--\$(A)-.APN-916 Ter Tackable Acoustic Tile 7.5H x 36W \$(A):Grd A FAB .APN:Appoint 916:Nimbus Tag: Tag TG: D1-WS2_REUSE Tag L1: D1-WS2_REUSE Tag L3: PHASE 1 UNASSEMBLE / PHASE 2 REUSE	0.00	0.00
45	4.00 Each	TKG40742T--\$(A)-.APN-916 Ter Tackable Acoustic Tile 7.5H x 42W \$(A):Grd A FAB .APN:Appoint 916:Nimbus Tag: Tag TG: D1-WS2_REUSE Tag L1: D1-WS2_REUSE Tag L3: PHASE 1 UNASSEMBLE / PHASE 2 REUSE	0.00	0.00
46	2.00 Each	TKG42224T--\$(B)-.TRRN-10 Ter Tackable Acoustic Tile 22.5H x 24W \$(B):Grd B FAB .TRRN:Terrain 10:Delta Tag: Tag TG: D1-WS2_REUSE Tag L1: D1-WS2_REUSE Tag L3: PHASE 1 UNASSEMBLE / PHASE 2 REUSE	0.00	0.00
47	3.00 Each	TKG42230T--\$(B)-.TRRN-10 Ter Tackable Acoustic Tile 22.5H x 30W \$(B):Grd B FAB .TRRN:Terrain 10:Delta Tag: Tag TG: D1-WS2_REUSE Tag L1: D1-WS2_REUSE Tag L3: PHASE 1 UNASSEMBLE / PHASE 2 REUSE	0.00	0.00
48	7.00	TKG42236T--\$(B)-.TRRN-10	0.00	0.00



# Proposal

**Interior Environments - Novi**  
**48700 Grand River Ave**  
**Novi, MI 48374**  
**Phone: (248) 213-3010**

Order Number	20113
Date	02/11/2025
Customer PO No	
Customer Name	Northville Public Schools
Salesperson	Betsy Pethoud
Terms	NET 10
Page	11 of 18

	Each	Ter Tackable Acoustic Tile 22.5H x 36W \$(B):Grd B FAB .TRRN:Terrain 10:Delta Tag: Tag TG: D1-WS2_REUSE Tag L1: D1-WS2_REUSE Tag L3: PHASE 1 UNASSEMBLE / PHASE 2 REUSE		
49	4.00 Each	TKG42242T--\$(B)-.TRRN-10 Ter Tackable Acoustic Tile 22.5H x 42W \$(B):Grd B FAB .TRRN:Terrain 10:Delta Tag: Tag TG: D1-WS2_REUSE Tag L1: D1-WS2_REUSE Tag L3: PHASE 1 UNASSEMBLE / PHASE 2 REUSE	0.00	0.00
50	2.00 Each	TKG43024T--\$(B)-.TRRN-10 Ter Tackable Acoustic Tile 30H x 24W \$(B):Grd B FAB .TRRN:Terrain 10:Delta Tag: Tag TG: D1-WS2_REUSE Tag L1: D1-WS2_REUSE Tag L3: PHASE 1 UNASSEMBLE / PHASE 2 REUSE	0.00	0.00
51	2.00 Each	TK324PTFK--\$(P1)-.P02 Flat Top Trim 24W w/clips \$(P1):P1 Paint Opts .P02:Flint Tag: Tag TG: D1-WS2_REUSE Tag L1: D1-WS2_REUSE Tag L3: PHASE 1 UNASSEMBLE / PHASE 2 REUSE	0.00	0.00
52	1.00 Each	TK330PTFK--\$(P1)-.P02 Flat Top Trim 30W w/clips \$(P1):P1 Paint Opts .P02:Flint Tag: Tag TG: D1-WS2_REUSE Tag L1: D1-WS2_REUSE Tag L3: PHASE 1 UNASSEMBLE / PHASE 2 REUSE	0.00	0.00
53	4.00 Each	TK335EF--\$(P1)-.P02 E End Trim Flat ConnKit - 35"H base panel \$(P1):P1 Paint Opts .P02:Flint Tag: Tag TG: D1-WS2_REUSE Tag L1: D1-WS2_REUSE Tag L3: PHASE 1 UNASSEMBLE / PHASE 2 REUSE	0.00	0.00
54	3.00 Each	TK335LF--\$(P1)-.P02 L 90-degree Flat ConnKit - 35"H base panel \$(P1):P1 Paint Opts .P02:Flint Tag: Tag TG: D1-WS2_REUSE Tag L1: D1-WS2_REUSE Tag L3: PHASE 1 UNASSEMBLE / PHASE 2 REUSE	0.00	0.00
55	3.00	TK336PTFK--\$(P1)-.P02	0.00	0.00



# Proposal

**Interior Environments - Novi**  
**48700 Grand River Ave**  
**Novi, MI 48374**  
**Phone: (248) 213-3010**

Order Number	20113
Date	02/11/2025
Customer PO No	
Customer Name	Northville Public Schools
Salesperson	Betsy Pethoud
Terms	NET 10
Page	12 of 18

	Each	Flat Top Trim 36W w/clips \$(P1):P1 Paint Opts .P02:Flint Tag: Tag TG: D1-WS2_REUSE Tag L1: D1-WS2_REUSE Tag L3: PHASE 1 UNASSEMBLE / PHASE 2 REUSE		
56	2.00 Each	TK342PTFK--\$(P1)-.P02 Flat Top Trim 42W w/clips \$(P1):P1 Paint Opts .P02:Flint Tag: Tag TG: D1-WS2_REUSE Tag L1: D1-WS2_REUSE Tag L3: PHASE 1 UNASSEMBLE / PHASE 2 REUSE	0.00	0.00
57	3.00 Each	A871236--.P Power Harness 36W .P:Black Tag: Tag TG: D1-WS2_REUSE Tag L1: D1-WS2_REUSE Tag L3: PHASE 1 UNASSEMBLE / PHASE 2 REUSE	0.00	0.00
58	2.00 Each	A871242--.P Power Harness 42W .P:Black Tag: Tag TG: D1-WS2_REUSE Tag L1: D1-WS2_REUSE Tag L3: PHASE 1 UNASSEMBLE / PHASE 2 REUSE	0.00	0.00
59	9.00 Each	A873501--.EV Ter/2.6/Align Duplex Receptacle Circuit 1 .EV:Loft Tag: Tag TG: D1-WS2_REUSE Tag L1: D1-WS2_REUSE Tag L3: PHASE 1 UNASSEMBLE / PHASE 2 REUSE	0.00	0.00
60	1.00 Each	A876072--.P Base Infeed 6'Sealtight Cable .P:Black Tag: Tag TG: D1-WS2_REUSE Tag L1: D1-WS2_REUSE Tag L3: PHASE 1 UNASSEMBLE / PHASE 2 REUSE	0.00	0.00
61	2.00 Each	T52430SN--\$(L1STD)-.LT11-.E9 Primary 24Dx30W Flat Eg Lam w/o Grom \$(L1STD):Grd L1 Standard Laminates .LT11:Titanium .E9:Flint Tag: Tag TG: D1-WS2_REUSE Tag L1: D1-WS2_REUSE Tag L3: PHASE 1 UNASSEMBLE / PHASE 2 REUSE	0.00	0.00
62	2.00 Each	T52442SN--\$(L1STD)-.LT11-.E9 Primary 24Dx42W Flat Eg Lam w/o Grom \$(L1STD):Grd L1 Standard Laminates .LT11:Titanium .E9:Flint Tag: Tag TG: D1-WS2_REUSE Tag L1: D1-WS2_REUSE	0.00	0.00



# Proposal

**Interior Environments - Novi**  
**48700 Grand River Ave**  
**Novi, MI 48374**  
**Phone: (248) 213-3010**

Order Number	20113
Date	02/11/2025
Customer PO No	
Customer Name	Northville Public Schools
Salesperson	Betsy Pethoud
Terms	NET 10
Page	13 of 18

63	2.00 Each	Tag L3: PHASE 1 UNASSEMBLE / PHASE 2 REUSE T53624CRN--\$(L1STD)-.LT11-.E9 Corner 24Dx36W w/Radial Leading Eg Flat w/o G \$(L1STD):Grd L1 Standard Laminates .LT11:Titantium .E9:Flint Tag: Tag TG: D1-WS2_REUSE Tag L1: D1-WS2_REUSE Tag L3: PHASE 1 UNASSEMBLE / PHASE 2 REUSE	0.00	0.00
64	1.00 Each	TK851566PF--\$(P1)-.P02 Ter DNA 66W Strght Cntr Paint Flat Top Trim Kit \$(P1):P1 Paint Opts .P02:Flint Tag: Tag TG: D1-WS2_REUSE Tag L1: D1-WS2_REUSE Tag L3: PHASE 1 UNASSEMBLE / PHASE 2 REUSE	0.00	0.00
65	1.00 Each	Y51566S--\$(L1STD)-.LT11-.E9 Straight 15Dx66W Cntp \$(L1STD):Grd L1 Standard Laminates .LT11:Titantium .E9:Flint Tag: Tag TG: D1-WS2_REUSE Tag L1: D1-WS2_REUSE Tag L3: PHASE 1 UNASSEMBLE / PHASE 2 REUSE	0.00	0.00
66	1.00 Each	T6BK--\$(P1)-.P02 Worksurface Bracket Kit \$(P1):P1 Paint Opts .P02:Flint Tag: Tag TG: D1-WS2_REUSE Tag L1: D1-WS2_REUSE Tag L3: PHASE 1 UNASSEMBLE / PHASE 2 REUSE	0.00	0.00
67	6.00 Each	T6CB18L--\$(P1)-.P02 Cantilever Bracket 18D LH Terrace \$(P1):P1 Paint Opts .P02:Flint Tag: Tag TG: D1-WS2_REUSE Tag L1: D1-WS2_REUSE Tag L3: PHASE 1 UNASSEMBLE / PHASE 2 REUSE	0.00	0.00
68	2.00 Each	T6CB18R--\$(P1)-.P02 Cantilever Bracket 18D RH Terrace \$(P1):P1 Paint Opts .P02:Flint Tag: Tag TG: D1-WS2_REUSE Tag L1: D1-WS2_REUSE Tag L3: PHASE 1 UNASSEMBLE / PHASE 2 REUSE	0.00	0.00
69	4.00 Each	PF197-233A--\$(P1)-.P02-.EL-.STD Essentials Support Ped BBF 28Hx22-7/8Dx15W Arch Pull \$(P1):P1 Paint Opts .P02:Flint .EL:Matte Silver .STD:Standard Random key Tag: Tag TG: D1-WS2_REUSE	0.00	0.00



# Proposal

**Interior Environments - Novi**  
**48700 Grand River Ave**  
**Novi, MI 48374**  
**Phone: (248) 213-3010**

Order Number	20113
Date	02/11/2025
Customer PO No	
Customer Name	Northville Public Schools
Salesperson	Betsy Pethoud
Terms	NET 10
Page	14 of 18

		Tag L1: D1-WS2_REUSE Tag L3: PHASE 1 UNASSEMBLE / PHASE 2 REUSE		
70	1.00 Each	PF198-182A--\$(P1)-.P02-.EL-.STD Essentials Support Ped FF 28Hx18Dx15W Arch Pull \$(P1):P1 Paint Opts .P02:Flint .EL:Matte Silver .STD:Standard Random key Tag: Tag TG: D1-WS2_REUSE Tag L1: D1-WS2_REUSE Tag L3: PHASE 1 UNASSEMBLE / PHASE 2 REUSE	0.00	0.00

Group	Quantity	Description	Unit Price	Extended Amount
HON	1.0		754.30	754.30

Line	Quantity	Description	Unit Price	Extended Amount
90	1.00 Each	HCFEU--.W0-.STC-.A-.S-\$(2)-.SMYRRDR-044-.CHS-TC00-.SB Cofi Executive Height Chair .W0:Weight Activated .STC:Standard Cylinder .A:Height - Width Adj Arm .S:Black All-Surface Caster \$(2):Grade 2 Uph .SMYRRDR:Ryder 044:Navy .CHS:Channel Stitch TC00:Coordinating .SB:Standard Base Tag: Tag TG: F1 Tag L1: HCFEU Tag L3: PHASE 2	604.30	604.30
91	1.00 Each	Labor HON Furniture Installation: PHASE 2 - :STRAIGHT TIME :NON UNION :NO STAIR CARRY - ELEVATOR USE :NO PERMITS :NO HARDWIRE DATA OR ELECTRICAL CONNECTIONS :ALL DEBRIS REMOVAL INCLUDED Tag: Tag L3: PHASE 2	150.00	150.00

Group	Quantity	Description	Unit Price	Extended Amount
OFS	1.0		4,581.48	4,581.48

Line	Quantity	Description	Unit Price	Extended Amount
93	3.00	119041-MT--X9-ETC8-3104593-ETC14-3129210	1,427.16	4,281.48



## Proposal

**Interior Environments - Novi**  
**48700 Grand River Ave**  
**Novi, MI 48374**  
**Phone: (248) 213-3010**

Order Number	20113
Date	02/11/2025
Customer PO No	
Customer Name	Northville Public Schools
Salesperson	Betsy Pethoud
Terms	NET 10
Page	15 of 18

	Each	Ally Seating, Slipper Chair, 25.5"W x 26"D x 29.75"H - Multiple Textile X9:No Pull ETC8:Graded-in - Grade 8 3104593:Maharam Beryl Waterfront (Grade 8) ETC14:Graded-in - Grade 14 3129210:Maharam Canopy Matter (Grade 14) Tag: Tag TG: R1 Tag L3: PHASE 2		
94	1.00 Each	Labor OFS Furniture Installation: PHASE 2 - :STRAIGHT TIME :NON UNION :NO STAIR CARRY - ELEVATOR USE :NO PERMITS :NO HARDWIRE DATA OR ELECTRICAL CONNECTIONS :ALL DEBRIS REMOVAL INCLUDED Tag: Tag L3: PHASE 2	300.00	300.00

<b>Order Sub-Total :</b>	<b>\$19,680.50</b>
<b>TOTAL ORDER :</b>	<b>\$19,680.50</b>
Required Deposit 50.00% :	\$9,840.25

PLEASE REVIEW THIS QUOTATION AND NOTIFY US PROMPTLY OF ANY CORRECTIONS REQUIRED    THANK YOU FOR THE OPPORTUNITY TO BE OF SERVICE

**A FINANCE CHARGE OF 1-1/2% PER MONTH WHICH IS AN ANNUAL PERCENTAGE RATE OF 18% WILL BE CHARGED ON ACCOUNTS PAST DUE.**

Signature: \_\_\_\_\_ Name: \_\_\_\_\_ Title: \_\_\_\_\_ Date: \_\_\_\_\_



## Proposal

Interior Environments - Novi  
48700 Grand River Ave  
Novi, MI 48374  
Phone: (248) 213-3010

Order Number	20113
Date	02/11/2025
Customer PO No	
Customer Name	Northville Public Schools
Salesperson	Betsy Pethoud
Terms	NET 10
Page	16 of 18

### Balco Interiors LLC / IE Connect LLC / Interior Environments Atlanta, LLC - d/b/a INTERIOR ENVIRONMENTS

#### 1. PROPOSALS AND ORDERS

---

- A. **TERM:** All prices quoted by Interior Environments ("Seller") are valid for 30 days from date of proposal.
- B. **OFFER AND ACCEPTANCE:** All orders for the purchase of goods and services from Seller require a proposal prepared by Seller which has been approved and signed by an authorized signatory of Buyer. Seller's proposal shall constitute an offer and Buyer's approval of the proposal shall constitute acceptance of that offer. If Buyer submits a purchase order before Seller issues a proposal, Seller's proposal shall constitute a counteroffer and Buyer's approval of the Seller's proposal shall constitute acceptance of that counter offer without any additional terms or conditions.
- C. **AGREEMENT:** Following the offer and acceptance described above and Seller's payment as provided in paragraph 2 below, an "Agreement" between the parties shall be deemed to have been formed with such Agreement comprised solely of Seller's proposal together with these Terms and Conditions of Sale. The Agreement shall be deemed to supersede any prior written or oral agreements and any different or conflicting terms in any quote, invoice, Buyer purchase order, shipper or any other document. For the avoidance of doubt, any different, additional or conflicting terms provided on any ancillary Buyer document(s) are expressly rejected by Seller.
- D. **MODIFICATIONS/CHANGES/CANCELLATIONS:** Any requested modification to an Agreement is subject to the approval of Seller and the manufacturer or supplier of the goods ordered. Buyer will pay any and all additional charges resulting from order modifications, cancellations, and changes. Express Ship Orders cannot be changed or cancelled. All goods are custom manufactured to customer specifications and, therefore, cannot be returned. Restocking programs are not available. Any modifications of an Agreement must be made via a signed and dated revised proposal.

#### 2. DEPOSITS

---

Unless otherwise specified and agreed to by both parties, a deposit of 50% is required on all orders. No interest shall accrue on such deposits. The Agreement is deemed entered upon such payment by Buyer.

#### 3. OWNERSHIP AND RISK OF LOSS

---

Transfer of title to the goods as between Seller and Buyer shall be deemed to have occurred when the Agreement is entered, and thereafter Buyer shall insure against risk of loss. If the goods are first received on behalf of Buyer by Seller, such goods shall be considered held by Seller subject to bailment for the sole benefit of Buyer.

#### 4. PAYMENT

---

- A. **TIMING:** Any remaining balance on goods purchased under this Agreement and any related installation or other services will be invoiced upon delivery of the goods to the job site or, if installed by Seller, following substantial completion. Direct shipments from manufacturers will be invoiced upon shipment from the manufacturer. Any goods being held at Buyer's request, due to delays or otherwise, will be invoiced for product only upon Seller's receipt of same with separate invoicing for installation or other related services upon substantial completion.
- B. **PAYMENT TERMS:** Seller has the right to increase its prices at any time upon notice to Buyer to reflect any and all unusual or unforeseen increases in Seller cost, provided that any such increase shall be limited to the increase actually incurred by Seller. Buyer will not offset or recoup any claim against amounts due Seller. All invoices are due on the date noted on the related invoice. A monthly service charge of 1.5% (18% A.P.R.) will be assessed on all unpaid balances, including accrued but unpaid monthly service charges, after the invoice due date. A service charge of three percent (3%) of the invoice amount will be added to all invoices paid by credit card.
- C. **FREIGHT:** Buyer is solely responsible for any applicable freight and handling charges, including tariffs, for delivery from the manufacturer to Seller and is FOB origin. If not included in the proposal, such charges are not included in a price quotation and will be invoiced to Buyer separately after the Seller is invoiced by the carrier or manufacturer.
- D. **TAXES:** Buyer is solely responsible for any applicable sales, use, excise, or other taxes. If not included in the proposal, applicable taxes will be invoiced separately. If Buyer possesses tax-exempt status, a certificate of resale, or tax exemption is to be provided prior to order placement.
- E. **DELAYS:** If Buyer is unable or unwilling to receive goods at the prescribed shipping site on the mutually agreed delivery date any goods thereafter stored by Seller will be at Buyer's expense until such time as Buyer is able to accept delivery. Seller shall have no obligation or liability to Buyer whatsoever for failure to ship goods by a particular date.



## Proposal

Interior Environments - Novi  
48700 Grand River Ave  
Novi, MI 48374  
Phone: (248) 213-3010

Order Number	20113
Date	02/11/2025
Customer PO No	
Customer Name	Northville Public Schools
Salesperson	Betsy Pethoud
Terms	NET 10
Page	17 of 18

### 5. DELIVERY AND INSTALLATION

- A. **DELIVERY AND INSTALLATION:** Any contracted delivery and installation will be made during Seller's normal business hours of 7:00 a.m. to 3:30 p.m., Monday through Friday. Overtime delivery or installation performed at the Buyer's request will be subject to labor rates reflecting time-and-a-half for weekdays and double time for weekends and holidays. If applicable trade regulations require employing union tradesmen to complete the installation or delivery, any additional incremental costs will be invoiced to and paid by the Buyer. Seller shall not be liable for failure or delay in installation due to the installation site not being ready for installation. Any shipping, delivery, and performance dates are estimates only, and time is not of the essence. Seller may ship or direct shipments of all the goods at one time or in portions from time to time. Seller has the right, but not the obligation, to determine the method of shipment and routing of the goods, unless otherwise stated in Seller's delivery and installation proposal or acknowledgement.
- B. **SELLER'S RESPONSIBILITIES:** Unless received by Buyer or Buyer's agent directly, Seller will receive, inspect, stage, and if contracted, install Buyer's goods. All furnishings will be left clean and in working order. Carton and packing materials will be removed to the Buyer's waste disposal containers, and the premises will be left broom clean. At Seller's option, Seller may direct shipments directly to the job site.
- C. **BUYER'S ACCEPTANCE:** Buyer agrees to have an agent on the premises at the agreed upon time to accept goods, deliveries, installation, and completed work. All goods and services shall be considered accepted after Buyer or his agent has signed an acknowledgement document(s). All claims or exceptions must be made in writing the date the work is substantially complete. Notwithstanding the foregoing, if Buyer or Buyer's agent is unavailable or unwilling to sign acknowledgment document(s), Buyer shall be deemed to have accepted the goods and services "as is" or as otherwise noted by Seller on the acknowledgement document.
- D. **DROP SHIPMENTS:** In case of drop shipments where goods are delivered without installation, Buyer will receive, inspect, and install ordered goods. Buyer is also responsible for filing necessary freight claims in the event of damage. Buyer shall have no claims against Seller due to damage and may not withhold payment on account thereof.
- E. **CONDITION OF JOB SITE:** Buyer's job site shall be clean, clear of all obstructions, and free of debris prior to any Seller installation. Charges will be assessed to the Buyer for excessive handling, storage and transportation incurred because of site conditions, activity of other trades, or other reasons not specifically identified in the price quotation, at a standard hourly rate, or at actual charges plus fees, if labor is performed by a third party.
- F. **JOB SITE SERVICES:** Buyer will furnish electrical current, heating, lighting, trash disposal containers, hoisting and/or elevator services, and suitable unobstructed dock space and staging areas at the job site without charge to Seller if Seller is to provide installation. If Seller is required to remove or handle existing furniture, the additional cost of moving and transporting shall be billed to the Buyer on an hourly basis. Once installation has begun, Buyer agrees to assume any expense incurred by Seller due to changes made at the Buyer's request or for any reason beyond Seller's reasonable commercial control.
- G. **ELECTRICAL INSTALLATION:** A licensed electrician may be required to install electrical product including outlets, task lights, and hook-ups to base building power. If Seller determines that an electrician is required, Buyer will be responsible for contracting and paying the electrician.
- H. **PROTECTION OF DELIVERED GOODS:** Buyer is responsible for security and safekeeping of goods after delivery to Buyer's site, or into storage negotiated by Buyer if the job site is not ready on an agreed upon delivery date, and Buyer shall assume any risk of damage or loss thereof.
- I. **CONCEALED DAMAGED GOODS:** Buyer is required to report all concealed or damage packaged goods within seven (7) business days or receipt. In addition, Buyer is required to report all damage goods revealed upon unpackaging within seven (7) days of the same. Likewise, Buyer is required to and must send pictures of damaged goods, packages and labels to initiate any available warranty claim(s). Failure to report damages within the required reporting period with the required information may negate any warranty claims and Buyer shall accept responsibility for any and all costs associated with replacement or repairs of damaged goods.
- J. **DELIVERY AND INSTALL WARRANTY:** Seller shall warrant all delivery and installation services against defects in performance for a period of one (1) year following delivery unless stated otherwise in the documents accompanying these Terms and Conditions of Sale. If this proposal includes the provision of delivery and installation services, Seller warrants that delivery and installation services performed by Seller or by a permitted subcontractor or agent of Seller shall be performed in a good and workmanlike manner consistent with the best practices in the industry. In the event of a delivery and installation service defect, the Seller shall, at Buyer's discretion, repair or re-perform the defective services at no cost to the Buyer. All delivery and installation services performed after the one (1) year delivery and install



## Proposal

Interior Environments - Novi  
48700 Grand River Ave  
Novi, MI 48374  
Phone: (248) 213-3010

Order Number	20113
Date	02/11/2025
Customer PO No	
Customer Name	Northville Public Schools
Salesperson	Betsy Pethoud
Terms	NET 10
Page	18 of 18

warranty period including but not limited to product warranties, service, repairs, replacement, etc. shall be paid for by Buyer at Buyer's expense.

### 6. ADDITIONAL TERMS

- A. **DISCLAIMER OF WARRANTIES:** BUYER AGREES THAT THE GOODS ARE OF THE SIZE AND DESIGN SELECTED BY BUYER AND THAT BUYER IS SATISFIED THAT SAME IS SUITABLE FOR BUYER'S PURPOSES. SELLER HAS MADE NO REPRESENTATION OR WARRANTY AS TO ANY MATTER WHATSOEVER. SELLER DISCLAIMS AND BUYER EXPRESSLY WAIVES AS TO SELLER, ALL WARRANTIES WITH RESPECT TO THE GOODS, INCLUDING BUT NOT LIMITED TO ALL EXPRESS OR IMPLIED WARRANTIES OF MERCHANTABILITY AND FITNESS FOR A PARTICULAR PURPOSE, QUALITY, CAPACITY, OR WORKMANSHIP. NOTHING CONTAINED HEREIN SHALL DIMINISH THE RIGHT OF BUYER TO EXERCISE ALL RIGHTS AND REMEDIES AGAINST THE MANUFACTURER OF THE GOODS FOR MANUFACTURER WARRANTIES. IN NO EVENT SHALL SELLER BE LIABLE UNDER ANY THEORY AT LAW OR EQUITY FOR ANY LOSS OF USE, REVENUE, ANTICIPATED PROFIT OR SPECIAL, INDIRECT, INCIDENTAL OR CONSEQUENTIAL DAMAGES ARISING OUT OF OR RELATED TO THE DESIGN AND USE OF THE GOODS. SELLER SHALL ADVISE BUYER OF ALL RELATED MANUFACTURERS' WARRANTIES UPON BUYER'S REQUEST.
- B. **RESALE:** On any resale of the goods, Buyer shall contractually limit its buyer's warranty against both Buyer and Seller to the same extent that Paragraph 6(A) above limits the warranty offered by Seller.
- C. **ACTS BEYOND REASONABLE CONTROL:** Seller shall not be liable for any delay or failure to deliver any or all of the goods caused by installation site delays, labor disputes, strikes, acts of God, or other delays beyond the reasonable control of Seller.
- D. **ASSIGNMENT:** Buyer shall not assign its rights or obligations under this Agreement without the prior written consent of Seller.
- E. **INDEMNIFICATION:** Buyer shall indemnify, defend, and hold harmless Seller with respect to all damages, losses, claims, and expenses, including, without limitation, consequential and incidental damages and reasonable attorney fees arising from or related to : i) Buyer's breach of any of Buyer's obligations under this Agreement and from; ii) Seller's interior design, project management, delivery, installation, or any other services except when caused by Seller's gross negligence or willful misconduct.
- F. **DEFAULT:** If Buyer fails to pay any amount herein provided within ten (10) days after the same is due and payable, or if Buyer fails to observe, keep, or perform any other provision of this Agreement, then Seller shall have the right to exercise any one or more of the following remedies without prejudice to such remedies as may otherwise exist at law or in equity: i) to declare the entire amount due hereunder immediately due and payable without notice or demand to Buyer; ii) to sue for and recover all payments, then accrued or thereafter accruing; iii) to take possession of the goods provided hereunder, without demand or notice wherever located, without any court order or other process of law. Buyer hereby grants free and full access to the premises and hereby waives any and all damages occasioned by such taking of possession.
- G. **NO WAIVER:** Seller's waiver of any right on one occasion shall not be a waiver of any future exercise of that right.
- H. **TIME FOR BRINGING ACTION:** Any action that Buyer brings against Seller that arises out of or relates to the goods and services provided by Seller to Buyer must be brought by Buyer within one year after the cause of action occurs.
- I. **LAW:** The Agreement shall be deemed entered into, and performed in substantial part, in Oakland County, Michigan. The Agreement shall be governed by and construed in accordance with the laws of the State of Michigan, without regard to its conflict of law provisions. The parties hereto agree to submit to the exclusive personal jurisdiction of the state or federal courts serving Oakland County, Michigan for the resolution of any claim or cause of action that arises from or related to this Agreement or the goods or services provided by Seller.



# Proposal

**Interior Environments - Novi**  
**48700 Grand River Ave**  
**Novi, MI 48374**  
**Phone: (248) 213-3010**

<b>Order Number</b>	20991
<b>Date</b>	02/11/2025
<b>Customer PO No</b>	
<b>Customer Name</b>	Northville Public Schools
<b>Salesperson</b>	Betsy Pethoud
<b>Terms</b>	NET 10
<b>Page</b>	1 of 5

T Northville Public Schools  
 O 501 W Main St  
 Northville, MI 48167

ATTN: INVOICE CONTACT  
 Email: NPSaccounts payable@northvilleschools.org

I Amerman Elementary School  
 N 847 N Center St.  
 S North, MI 48167  
 T  
 A  
 L ATTN: Jessica Hartwig  
 L Phone: 248-338-4561  
 A Email: jhartwig@tmp-architecture.com  
 T

Prepared for : Betsy Pethoud

Allsteel - Omnia Contract R191802

Group	Quantity	Description	Unit Price	Extended Amount
Allsteel	1.0		3,414.65	3,414.65

Line	Quantity	Description	Unit Price	Extended Amount
1	1.00 Each	EBC436--\$(P1)-.P02 Essentials Bkcase 52-1/2H (4H) 36W 18D Open Cab \$(P1):P1 Paint Opts .P02:Flint Tag: Tag TG: D8	573.12	573.12
2	2.00 Each	ESC336A--\$(P1)-.P02-.EL-.OMT Essentials 39-1/8Hx36W StorageCabinet Arch \$(P1):P1 Paint Opts .P02:Flint .EL:Matte Silver .OMT:OMT Core to Ord key Alike Tag: Tag TG: D9	607.68	1,215.36
3	1.00 Each	LKFE2SLV--\$(KEYNUM)-.X101-.1 Lock Core Kit Silver - 2 Cores 2 Keys \$(KEYNUM):Key Number .X101:Key Number 101 .1:1 Tag: Tag TG: D9	19.22	19.22
4	1.00 Each	YPTP572424RFFM--.BK-.A-PR0-\$(P1)-.P02-\$(MATCH)-.NA-.X Align 57x24x24 Personal Twr MetFront Plinth .BK:Flush Plinth .A:Arch PR0:Anodized Silver \$(P1):P1 Paint Opts .P02:Flint \$(MATCH):Match Case .NA:Match Case .X:Omit Lock Tag: Tag TG: D10	1,274.40	1,274.40
5	1.00 Each	LKFE1SLV--\$(KEYNUM)-.X101-.1 Lock Core Kit Silver - 1 Core 2 Keys \$(KEYNUM):Key Number	9.46	9.46



## Proposal

**Interior Environments - Novi**  
**48700 Grand River Ave**  
**Novi, MI 48374**  
**Phone: (248) 213-3010**

Order Number	20991
Date	02/11/2025
Customer PO No	
Customer Name	Northville Public Schools
Salesperson	Betsy Pethoud
Terms	NET 10
Page	2 of 5

		.X101:Key Number 101 .1:1 Tag: Tag TG: D10		
6	1.00 Each	LABOR/EST RDI: (1) Open Bookcase, (2) Bookcases with locking Doors and (1) Wardrobe Unit :STRAIGHT TIME :NON UNION :NO STAIR CARRY :NO PERMITS :NO HARDWIRE DATA OR ELECTRICAL CONNECTIONS :ALL DEBRIS REMOVAL INCLUDED	323.09	323.09

Order Sub-Total :	\$3,414.65
<b>TOTAL ORDER :</b>	<b>\$3,414.65</b>
Required Deposit 50.00% :	\$1,707.33

PLEASE REVIEW THIS QUOTATION AND NOTIFY US PROMPTLY OF ANY CORRECTIONS REQUIRED    THANK YOU FOR THE OPPORTUNITY TO BE OF SERVICE  
**A FINANCE CHARGE OF 1-1/2% PER MONTH WHICH IS AN ANNUAL PERCENTAGE RATE OF 18% WILL BE CHARGED ON ACCOUNTS PAST DUE.**

Signature: \_\_\_\_\_ Name: \_\_\_\_\_ Title: \_\_\_\_\_ Date: \_\_\_\_\_



## Proposal

Interior Environments - Novi  
48700 Grand River Ave  
Novi, MI 48374  
Phone: (248) 213-3010

Order Number	20991
Date	02/11/2025
Customer PO No	
Customer Name	Northville Public Schools
Salesperson	Betsy Pethoud
Terms	NET 10
Page	3 of 5

### Balco Interiors LLC / IE Connect LLC / Interior Environments Atlanta, LLC - d/b/a INTERIOR ENVIRONMENTS

#### 1. PROPOSALS AND ORDERS

---

- A. **TERM:** All prices quoted by Interior Environments ("Seller") are valid for 30 days from date of proposal.
- B. **OFFER AND ACCEPTANCE:** All orders for the purchase of goods and services from Seller require a proposal prepared by Seller which has been approved and signed by an authorized signatory of Buyer. Seller's proposal shall constitute an offer and Buyer's approval of the proposal shall constitute acceptance of that offer. If Buyer submits a purchase order before Seller issues a proposal, Seller's proposal shall constitute a counteroffer and Buyer's approval of the Seller's proposal shall constitute acceptance of that counter offer without any additional terms or conditions.
- C. **AGREEMENT:** Following the offer and acceptance described above and Seller's payment as provided in paragraph 2 below, an "Agreement" between the parties shall be deemed to have been formed with such Agreement comprised solely of Seller's proposal together with these Terms and Conditions of Sale. The Agreement shall be deemed to supersede any prior written or oral agreements and any different or conflicting terms in any quote, invoice, Buyer purchase order, shipper or any other document. For the avoidance of doubt, any different, additional or conflicting terms provided on any ancillary Buyer document(s) are expressly rejected by Seller.
- D. **MODIFICATIONS/CHANGES/CANCELLATIONS:** Any requested modification to an Agreement is subject to the approval of Seller and the manufacturer or supplier of the goods ordered. Buyer will pay any and all additional charges resulting from order modifications, cancellations, and changes. Express Ship Orders cannot be changed or cancelled. All goods are custom manufactured to customer specifications and, therefore, cannot be returned. Restocking programs are not available. Any modifications of an Agreement must be made via a signed and dated revised proposal.

#### 2. DEPOSITS

---

Unless otherwise specified and agreed to by both parties, a deposit of 50% is required on all orders. No interest shall accrue on such deposits. The Agreement is deemed entered upon such payment by Buyer.

#### 3. OWNERSHIP AND RISK OF LOSS

---

Transfer of title to the goods as between Seller and Buyer shall be deemed to have occurred when the Agreement is entered, and thereafter Buyer shall insure against risk of loss. If the goods are first received on behalf of Buyer by Seller, such goods shall be considered held by Seller subject to bailment for the sole benefit of Buyer.

#### 4. PAYMENT

---

- A. **TIMING:** Any remaining balance on goods purchased under this Agreement and any related installation or other services will be invoiced upon delivery of the goods to the job site or, if installed by Seller, following substantial completion. Direct shipments from manufacturers will be invoiced upon shipment from the manufacturer. Any goods being held at Buyer's request, due to delays or otherwise, will be invoiced for product only upon Seller's receipt of same with separate invoicing for installation or other related services upon substantial completion.
- B. **PAYMENT TERMS:** Seller has the right to increase its prices at any time upon notice to Buyer to reflect any and all unusual or unforeseen increases in Seller cost, provided that any such increase shall be limited to the increase actually incurred by Seller. Buyer will not offset or recoup any claim against amounts due Seller. All invoices are due on the date noted on the related invoice. A monthly service charge of 1.5% (18% A.P.R.) will be assessed on all unpaid balances, including accrued but unpaid monthly service charges, after the invoice due date. A service charge of three percent (3%) of the invoice amount will be added to all invoices paid by credit card.
- C. **FREIGHT:** Buyer is solely responsible for any applicable freight and handling charges, including tariffs, for delivery from the manufacturer to Seller and is FOB origin. If not included in the proposal, such charges are not included in a price quotation and will be invoiced to Buyer separately after the Seller is invoiced by the carrier or manufacturer.
- D. **TAXES:** Buyer is solely responsible for any applicable sales, use, excise, or other taxes. If not included in the proposal, applicable taxes will be invoiced separately. If Buyer possesses tax-exempt status, a certificate of resale, or tax exemption is to be provided prior to order placement.
- E. **DELAYS:** If Buyer is unable or unwilling to receive goods at the prescribed shipping site on the mutually agreed delivery date any goods thereafter stored by Seller will be at Buyer's expense until such time as Buyer is able to accept delivery. Seller shall have no obligation or liability to Buyer whatsoever for failure to ship goods by a particular date.



## Proposal

Interior Environments - Novi  
48700 Grand River Ave  
Novi, MI 48374  
Phone: (248) 213-3010

Order Number	20991
Date	02/11/2025
Customer PO No	
Customer Name	Northville Public Schools
Salesperson	Betsy Pethoud
Terms	NET 10
Page	4 of 5

### 5. DELIVERY AND INSTALLATION

- A. **DELIVERY AND INSTALLATION:** Any contracted delivery and installation will be made during Seller's normal business hours of 7:00 a.m. to 3:30 p.m., Monday through Friday. Overtime delivery or installation performed at the Buyer's request will be subject to labor rates reflecting time-and-a-half for weekdays and double time for weekends and holidays. If applicable trade regulations require employing union tradesmen to complete the installation or delivery, any additional incremental costs will be invoiced to and paid by the Buyer. Seller shall not be liable for failure or delay in installation due to the installation site not being ready for installation. Any shipping, delivery, and performance dates are estimates only, and time is not of the essence. Seller may ship or direct shipments of all the goods at one time or in portions from time to time. Seller has the right, but not the obligation, to determine the method of shipment and routing of the goods, unless otherwise stated in Seller's delivery and installation proposal or acknowledgement.
- B. **SELLER'S RESPONSIBILITIES:** Unless received by Buyer or Buyer's agent directly, Seller will receive, inspect, stage, and if contracted, install Buyer's goods. All furnishings will be left clean and in working order. Carton and packing materials will be removed to the Buyer's waste disposal containers, and the premises will be left broom clean. At Seller's option, Seller may direct shipments directly to the job site.
- C. **BUYER'S ACCEPTANCE:** Buyer agrees to have an agent on the premises at the agreed upon time to accept goods, deliveries, installation, and completed work. All goods and services shall be considered accepted after Buyer or his agent has signed an acknowledgement document(s). All claims or exceptions must be made in writing the date the work is substantially complete. Notwithstanding the foregoing, if Buyer or Buyer's agent is unavailable or unwilling to sign acknowledgment document(s), Buyer shall be deemed to have accepted the goods and services "as is" or as otherwise noted by Seller on the acknowledgement document.
- D. **DROP SHIPMENTS:** In case of drop shipments where goods are delivered without installation, Buyer will receive, inspect, and install ordered goods. Buyer is also responsible for filing necessary freight claims in the event of damage. Buyer shall have no claims against Seller due to damage and may not withhold payment on account thereof.
- E. **CONDITION OF JOB SITE:** Buyer's job site shall be clean, clear of all obstructions, and free of debris prior to any Seller installation. Charges will be assessed to the Buyer for excessive handling, storage and transportation incurred because of site conditions, activity of other trades, or other reasons not specifically identified in the price quotation, at a standard hourly rate, or at actual charges plus fees, if labor is performed by a third party.
- F. **JOB SITE SERVICES:** Buyer will furnish electrical current, heating, lighting, trash disposal containers, hoisting and/or elevator services, and suitable unobstructed dock space and staging areas at the job site without charge to Seller if Seller is to provide installation. If Seller is required to remove or handle existing furniture, the additional cost of moving and transporting shall be billed to the Buyer on an hourly basis. Once installation has begun, Buyer agrees to assume any expense incurred by Seller due to changes made at the Buyer's request or for any reason beyond Seller's reasonable commercial control.
- G. **ELECTRICAL INSTALLATION:** A licensed electrician may be required to install electrical product including outlets, task lights, and hook-ups to base building power. If Seller determines that an electrician is required, Buyer will be responsible for contracting and paying the electrician.
- H. **PROTECTION OF DELIVERED GOODS:** Buyer is responsible for security and safekeeping of goods after delivery to Buyer's site, or into storage negotiated by Buyer if the job site is not ready on an agreed upon delivery date, and Buyer shall assume any risk of damage or loss thereof.
- I. **CONCEALED DAMAGED GOODS:** Buyer is required to report all concealed or damage packaged goods within seven (7) business days or receipt. In addition, Buyer is required to report all damage goods revealed upon unpackaging within seven (7) days of the same. Likewise, Buyer is required to and must send pictures of damaged goods, packages and labels to initiate any available warranty claim(s). Failure to report damages within the required reporting period with the required information may negate any warranty claims and Buyer shall accept responsibility for any and all costs associated with replacement or repairs of damaged goods.
- J. **DELIVERY AND INSTALL WARRANTY:** Seller shall warrant all delivery and installation services against defects in performance for a period of one (1) year following delivery unless stated otherwise in the documents accompanying these Terms and Conditions of Sale. If this proposal includes the provision of delivery and installation services, Seller warrants that delivery and installation services performed by Seller or by a permitted subcontractor or agent of Seller shall be performed in a good and workmanlike manner consistent with the best practices in the industry. In the event of a delivery and installation service defect, the Seller shall, at Buyer's discretion, repair or re-perform the defective services at no cost to the Buyer. All delivery and installation services performed after the one (1) year delivery and install



## Proposal

Interior Environments - Novi  
48700 Grand River Ave  
Novi, MI 48374  
Phone: (248) 213-3010

Order Number	20991
Date	02/11/2025
Customer PO No	
Customer Name	Northville Public Schools
Salesperson	Betsy Pethoud
Terms	NET 10
Page	5 of 5

warranty period including but not limited to product warranties, service, repairs, replacement, etc. shall be paid for by Buyer at Buyer's expense.

### 6. ADDITIONAL TERMS

- A. **DISCLAIMER OF WARRANTIES: BUYER AGREES THAT THE GOODS ARE OF THE SIZE AND DESIGN SELECTED BY BUYER AND THAT BUYER IS SATISFIED THAT SAME IS SUITABLE FOR BUYER'S PURPOSES. SELLER HAS MADE NO REPRESENTATION OR WARRANTY AS TO ANY MATTER WHATSOEVER. SELLER DISCLAIMS AND BUYER EXPRESSLY WAIVES AS TO SELLER, ALL WARRANTIES WITH RESPECT TO THE GOODS, INCLUDING BUT NOT LIMITED TO ALL EXPRESS OR IMPLIED WARRANTIES OF MERCHANTABILITY AND FITNESS FOR A PARTICULAR PURPOSE, QUALITY, CAPACITY, OR WORKMANSHIP. NOTHING CONTAINED HEREIN SHALL DIMINISH THE RIGHT OF BUYER TO EXERCISE ALL RIGHTS AND REMEDIES AGAINST THE MANUFACTURER OF THE GOODS FOR MANUFACTURER WARRANTIES. IN NO EVENT SHALL SELLER BE LIABLE UNDER ANY THEORY AT LAW OR EQUITY FOR ANY LOSS OF USE, REVENUE, ANTICIPATED PROFIT OR SPECIAL, INDIRECT, INCIDENTAL OR CONSEQUENTIAL DAMAGES ARISING OUT OF OR RELATED TO THE DESIGN AND USE OF THE GOODS. SELLER SHALL ADVISE BUYER OF ALL RELATED MANUFACTURERS' WARRANTIES UPON BUYER'S REQUEST.**
- B. **RESALE:** On any resale of the goods, Buyer shall contractually limit its buyer's warranty against both Buyer and Seller to the same extent that Paragraph 6(A) above limits the warranty offered by Seller.
- C. **ACTS BEYOND REASONABLE CONTROL:** Seller shall not be liable for any delay or failure to deliver any or all of the goods caused by installation site delays, labor disputes, strikes, acts of God, or other delays beyond the reasonable control of Seller.
- D. **ASSIGNMENT:** Buyer shall not assign its rights or obligations under this Agreement without the prior written consent of Seller.
- E. **INDEMNIFICATION:** Buyer shall indemnify, defend, and hold harmless Seller with respect to all damages, losses, claims, and expenses, including, without limitation, consequential and incidental damages and reasonable attorney fees arising from or related to : i) Buyer's breach of any of Buyer's obligations under this Agreement and from; ii) Seller's interior design, project management, delivery, installation, or any other services except when caused by Seller's gross negligence or willful misconduct.
- F. **DEFAULT:** If Buyer fails to pay any amount herein provided within ten (10) days after the same is due and payable, or if Buyer fails to observe, keep, or perform any other provision of this Agreement, then Seller shall have the right to exercise any one or more of the following remedies without prejudice to such remedies as may otherwise exist at law or in equity: i) to declare the entire amount due hereunder immediately due and payable without notice or demand to Buyer; ii) to sue for and recover all payments, then accrued or thereafter accruing; iii) to take possession of the goods provided hereunder, without demand or notice wherever located, without any court order or other process of law. Buyer hereby grants free and full access to the premises and hereby waives any and all damages occasioned by such taking of possession.
- G. **NO WAIVER:** Seller's waiver of any right on one occasion shall not be a waiver of any future exercise of that right.
- H. **TIME FOR BRINGING ACTION:** Any action that Buyer brings against Seller that arises out of or relates to the goods and services provided by Seller to Buyer must be brought by Buyer within one year after the cause of action occurs.
- I. **LAW:** The Agreement shall be deemed entered into, and performed in substantial part, in Oakland County, Michigan. The Agreement shall be governed by and construed in accordance with the laws of the State of Michigan, without regard to its conflict of law provisions. The parties hereto agree to submit to the exclusive personal jurisdiction of the state or federal courts serving Oakland County, Michigan for the resolution of any claim or cause of action that arises from or related to this Agreement or the goods or services provided by Seller.



# Northville Public Schools

---

## PRICE PROPOSAL

**Date: 2/13/2025**

---

Quote Number: 3321-28844

Valid For 106 Days

Prepared by: Steve Timmer

**Confidential**

© 2025 Dew-El Corporation. The information in this transmittal is proprietary to Dew-El Corporation. It is provided on the condition that it remains in confidence between Dew-El Corporation and the recipient of this quote. Do Not Copy, Distribute nor Share the Contents of this proposal without the written permission of Dew-El Corporation.

**Project Scope**

**Bill To**

Northville Public Schools  
 501 West Main Street  
 Northville, MI 48168

**Install To**

Northville Public Schools  
 501 West Main Street  
 Northville, MI 48168

**Project Investment**

Project Total	\$41,443.42
Tax (0%)	\$0.00
<b>Grand Total</b>	<b>\$41,443.42</b>

**Payment Schedule**

100% Due Net 30	<b>Net 30</b> \$41,443.42
-----------------	------------------------------

**Price Summary by Phase**

Option	Phase / TAG	Price	Tax	Total
Northville - Ameman ES	Phase 1 - MiEN	\$4,214.63	\$0.00	\$4,214.63
	Phase 2 - Media Technologies	\$22,982.01	\$0.00	\$22,982.01
	Phase 2 - MiEN	\$14,246.78	\$0.00	\$14,246.78
		<b>\$41,443.42</b>	<b>\$0.00</b>	<b>\$41,443.42</b>
<b>Grand Total</b>		<b>\$41,443.42</b>	<b>\$0.00</b>	<b>\$41,443.42</b>

Dew-El Corporation  
 10841 Paw Paw Drive  
 Holland, MI 49424  
 Phone: (616) 396-6554  
 Fax: (616) 396-6669  
 http://www.Dew-El.com



# QUOTATION

# 3321-28844

VALID UNTIL 5/30/2025

## BILL TO

Northville Public Schools  
 501 West Main Street  
 Northville, MI 48168

## INSTALL TO



Northville Public Schools  
 501 West Main Street  
 Northville, MI 48168

Salesperson  
 Steve Timmer

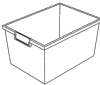

Payment Terms  
 Net 30

## Northville - Ameman ES

### Phase 1 - MiEN

LINE #	QTY	UNIT	PART # / DESCRIPTION	PRICE EA	EXT PRICE
1	2.00	EA	SBN-1216-09-P0006 / SBN-1216-09-P0006] Plastic Storage Bins Triple 9" Cool Grey Bin TAG: M1	\$50.10	\$100.21
					
2	1.00	EA	KIO-TNK-4848-17-S / KIO Tinker, Mobile Bookcase/Table, 48"d x 48"w, Standard Duo Tone (A: Horizontal, B: Vertical) (Bins Sold separately) (17" high). Share/KIO Laminate A: 5034-38 Wilsonart Handspun Dove Dove Grey Edgeband Share/KIO Laminate B: Wilsonart Island D498-60  TAG: M1	\$3,404.42	\$3,404.42
					
3	1.00	EA	Freight / Freight / Shipping / Packaging	\$260.00	\$260.00
4	1.00	EA	INSTALL / Labor to Receive, Deliver, Install, and remove debris	\$450.00	\$450.00

### Phase 2 - Media Technologies

LINE #	QTY	UNIT	PART # / DESCRIPTION	PRICE EA	EXT PRICE
5	1.00	EA	CSC-C3060L-29-SHM / Cirrus Computer Table 30"W x 60"L x 29"H. Worksurface HPL: Formica Amber Maple 7012-58 Worksurface PVC: Rehau Fusion Maple CP20564 Panel HPL: Formica Amber Maple 7012-58 Panel PVC: Rehau Fusion Maple CP20564 Powder Coat: 809 Silver  TAG E1	\$1,062.00	\$1,062.00
					
6	8.00	EA	V21-4824M-MOB-L / Bookmark Shelving Double Faced Starter 37"W x 24"D x 48"H Maple veneer construction, 4 adjustable 1" veneer core and 2 base shelves. 4 casters. HPL Top: Formica Amber Maple 7012-58 Finish on Maple: Natural Maple NM30 TAG: E3	\$1,345.26	\$10,762.11
					
7	5.00	EA	V21-4212M-L / Bookmark Shelving Single Faced Starter 37"W x 12"D x 42"H Maple veneer construction, 2 adjustable 1" veneer core and 1 base shelf. HPL Top: Formica Amber Maple 7012-58 Finish on Maple: Natural Maple NM30 TAG: E4	\$667.42	\$3,337.11
					

**Northville - Ameman ES**

**Phase 2 - Media Technologies**

LINE #	QTY	UNIT	PART # / DESCRIPTION	PRICE EA	EXT PRICE
8	5.00	EA	21-12SHM-MAG / Wood Magazine Shelf 35"W x 12"D, Maple (13-1/2" x 34-13/16") Maple bookcase magazine shelf. Please specify stain finish on maple. Ref. of 100-005736-001. Finish: Natural Maple NM 30 TAG: E5	\$98.05	\$490.26
9	10.00	EA	31-LK / Leveling Kit for use on 11/21/31 Series shelving,1 set needed for an adder and 2 sets needed for a starter. TAG: E4	\$8.05	\$80.53
10	1.00	EA	Custom Circulation Desk / Existing Desk, remove transaction top and cut sides down to be leveled with existing work surface. Done at Media Technologies factory. Any transportation damage is customers responsibility. No additional warranty. This includes transportation cost.  TAG: E2	\$2,500.00	\$2,500.00
11	1.00	EA	Freight / Freight / Shipping / Packaging	\$2,250.00	\$2,250.00
12	1.00	EA	INSTALL / Labor to Receive, Deliver, Install, and remove debris	\$2,500.00	\$2,500.00

**Phase 2 - MiEN**

LINE #	QTY	UNIT	PART # / DESCRIPTION	PRICE EA	EXT PRICE
13	2.00	EA	FEVO-OSC-3939-35-S-N-G15 / Flex 2-Step EVO Outside Corner - Single Fabric & Laminate No Power Grade 15 Designtex Fabric A Selection: Designtex SILICONE CHEER Splash 9820-903 Grade 15 Laminate A Selection: 7806-60 Wilsonart Bannister Oak TAG: M3	\$3,410.90	\$6,821.80
14	2.00	EA	FEVO-2SU-3539-35-S-G / FEVO-2SU-3539-35-S-N-G15] / Flex 2-Step EVO 2-Step Unit, Single Fabric & Laminate No Power No Power Unit Grade 15 Designtex Fabric A Selection: Designtex SILICONE CHEER Splash 9820-903 Grade 15 Laminate A Selection: 7806-60 Wilsonart Bannister Oak TAG: M2	\$2,587.49	\$5,174.98
15	1.00	EA	Freight / Freight / Shipping / Packaging	\$750.00	\$750.00
16	1.00	EA	INSTALL / Labor to Receive, Deliver, Install, and remove debris	\$1,500.00	\$1,500.00



Dew-El Corporation  
10841 Paw Paw Drive  
Holland, MI 49424  
Phone: (616) 396-6554  
Fax: (616) 396-6669  
<http://www.Dew-El.com>



# QUOTATION

# 3321-28844

VALID UNTIL 5/30/2025

## Northville - Ameman ES

### CUSTOMER SIGN OFF

subtotal	\$41,443.42
sales tax	\$0.00
<b>total</b>	<b>\$41,443.42</b>

\_\_\_\_\_  
Authorized Signature

\_\_\_\_\_  
Accepted Date

\_\_\_\_\_  
Print Name

Dew-El Corporation  
10841 Paw Paw Drive  
Holland, MI 49424  
Phone: (616) 396-6554  
Fax: (616) 396-6669  
http://www.Dew-El.com



# QUOTATION

# 3321-28844

VALID UNTIL 5/30/2025

Dew-El Corporation would like to thank you for the opportunity to quote your furniture needs. The attached proposal outlines the specifications and pricing based on the information provided. By signing and returning this quote, you agree to be bound by the terms and conditions contained herein which shall become the fully integrated agreement between you, the Client, and Dew-El Corporation.

## DELIVERY AND INSTALLATION

1. Delivery/installation services are performed during normal business hours Monday through Friday 8:00am to 5:00pm unless otherwise specified; Client may incur additional charges for services performed after hours and/or weekends. All labor is quoted as a single-phase installation unless noted otherwise. If additional trips or phases are required due to the Client not being prepared for delivery or the site not being ready, it may result in added cost to the labor quote. Product will be delivered and installed on a mutually agreed upon date. All available spaces must be ready for furniture; installation of all carpet, painting, lighting, and ceiling tiles must be completed. If delivery and/or installation are requested by the Client to an uncompleted space, Client accepts responsibility for any damage to or theft of the product. The Client may request partial delivery and/or installation when placing the order. If so, the Client agrees to both take delivery and pay for all delivered items on a partial basis.
2. Prior to the installation, Dew-El Corporation is to be informed of the following guidelines or restrictions for proper access to the building: dock accessibility, sidewalks, parking lots, elevator access above the first floor, time restrictions, security checks or any safety requirements needed for access to your facility during the time of the installation. Any notification that delivery and/or installation cannot be accepted must be communicated to Dew-El Corporation no later than 12:00pm on the business day prior to the scheduled delivery and/or installation date. Dew-El Corporation requests product to be shipped by our manufacturers according to customer needs. If a Client has requested product to be installed by a specific date, Dew-El Corporation will work with the manufacturer to have all product received in time for the installation date requested by the customer. Dew-El Corporation shall not be held liable for manufacturing/delivery delays outside of Dew-El Corporation's control. If for any reason the customer delays the original installation date, Dew-El Corporation reserves the right to invoice for all product shipped according to the customer requested delivery date.

## SALES TAX

Prices quoted include sales tax, and taxes will be included upon invoicing, unless an exemption certificate is furnished by the Client. If tax-exempt, please send a copy of your exemption certificate along with your signed quote.

## PAYMENT TERMS

1. The following estimate is valid for 30 days. Payment terms are net due 30 days from invoice date, which is initiated upon shipment and/or fulfillment of service.
2. In the event of project delays due to construction, trades or equipment, the Client is expected to bring payments to a net retainage of 90% of the estimate. The Client is permitted to hold as retainage an amount equal to the value of uncompleted work, damaged or incorrect items.
3. Should Client default in payment of this Contract, charges shall be added from the date of default at the rate of one and one half percent (1 1/2%) per month, (18% per annum).
4. Client agrees to pay a Transaction Convenience fee of three point eight percent (3.8%) of the sell price shown on the proposal (including applicable sales tax) when the method of payment is in any form other than Dew-El Corporation's standard payment methods, which include cash, check, or ACH/direct deposit.

## ACCEPTANCE

All sales are final; specified product is non-returnable and non-refundable. Claims for defects, errors or shortages must be made in writing within twenty business days after delivery. Failure to make a claim within such period shall constitute acceptance of the items.

## CANCELLATIONS AND CHANGES

To accept the following estimate, drawings, specifications and delivery and installation conditions please sign both below and the last page of the estimate. If a purchase order is required for payment, that order number must be provided at the time of order placement. Any change(s) to an existing order may incur additional fees once the order has been placed. Such charges may include but not limited to; date moves, product changes/deletions, and "ship to" changes. Your signature approves Dew-El Corporation Terms and Conditions stated above.

Authorized Signature \_\_\_\_\_ Date \_\_\_\_\_

Title \_\_\_\_\_ PO No. \_\_\_\_\_

Company \_\_\_\_\_

Pricing for MiEN is provided according to National Purchasing Contract OMNIA Region 14 ESC - TX, contract number 07-107 Pricing for Media Technologies is provided according to National Purchasing Contract OMNIA Region 14 ESC - TX, Contract Number 07-106

# Amerman Elementary School - TMP Architects - TMP



4810 Forest Run Road  
Madison WI 53708-8548  
fax 800.730.8094

**Project ID: D5010060**

<b>FOR:</b> Amerman Elem School Email: null Phone: 8103493400	<b>SALES REP:</b> Steve Scicchitano Email: steves@demco.com Phone: 800-858-2720 Fax: 855-356-8138	<b>PROJECT COORDINATOR:</b> Lee Gumienny Email: leeg@demco.com Phone: 608.415.4989 Fax:	<b>QUOTE ID:</b> T5042045 <b>QUOTE VERSION/TYPE:</b> Version 02 <b>QUOTE ISSUE DATE:</b> 02/11/2025 <b>QUOTE EXPIRATION DATE:</b> 03/13/2025 <b>CONTRACT:</b> OMNIA
------------------------------------------------------------------------	---------------------------------------------------------------------------------------------------------------	-----------------------------------------------------------------------------------------------------	---------------------------------------------------------------------------------------------------------------------------------------------------------------------------------

## ROOM: 001 ROOM

<u>Line #</u>	<u>Tag</u>	<u>Product #</u>	<u>Quantity</u>	<u>Unit Price</u>	<u>Discount %</u>	<u>Discount Unit Price</u>	<u>Extended Price</u>
1.00		13771720	1	\$839.00	53%	\$394.33	\$394.33

**Description:** Demco Mobile Hanging Bag Rack 57-1/4Hx30-3/8Wx24-3/4D

Like many businesses, we are experiencing unexpected price increases and extended lead times from our vendor partners for materials and transportation. We are trying to absorb the costs as much as possible, but in some cases, we have been forced to raise prices on our products. As such, the prices on this quote expire on the date listed and must be re-quoted after that date.

Demco may require a down payment on this order, please contact your Demco Consultant for more information.

<b>Sub Total</b>	\$394.33
<b>Shipping</b>	\$251.26
<b>Other Services</b>	N/A
<b>Tax</b>	TAX EXEMPT
<b>GRAND TOTAL</b>	<b>\$645.59</b>

**Quote ID:** T5042045

**Shipping & Delivery Options** *If this quote includes options, they are based on the following list, (note: shipping options may only apply to certain shipments):*

- [6PG] Power Lift Gate
- [0CA] Call Ahead - Delivery Appt.
- [3ID] Inside Delivery

<b>Billing Information</b> Northville Public Schools Accounts Payable 405 W Main St Northville, MI, 48167-1582  Bill Contact:  2483493400	<b>Shipping</b> Amerman Elem School 847 N Center St Northville MI 48167-1196	<b>Customer Contact</b>  810.349.3400 null	<b>Designer</b> null Drawing ID:
-------------------------------------------------------------------------------------------------------------------------------------------------------------------	---------------------------------------------------------------------------------------	-----------------------------------------------------	----------------------------------------

**Signature that authorizes Demco to place this order:**

\_\_\_\_\_  
Signature Date

\_\_\_\_\_

# DEMCO INTERIORS

## TERMS AND CONDITIONS

Please read these terms and conditions carefully. All orders for goods and any related services ("Products") by any buyer ("customer") from Demco Interiors are governed by these terms and conditions. Demco Interiors is a service offered by Demco, Inc.

**1. Exclusive Terms.** Demco agrees to sell its products only on these terms and conditions, unless otherwise agreed upon in writing by both parties. You shall be deemed to have accepted these terms and conditions by any written indication of acceptance, by submitting an order in response to a quotation, by any action affirming your order without objection to these terms and conditions, by accepting any whole or partial shipment of Products, or by making any whole or partial payment to Demco.

**2. Price.** Unless Demco agrees otherwise in writing, you agree to pay Demco's product price in effect at the time an order is accepted by Demco. In any project, critical decision points will occur requiring timely communication by customer of color, fabric, finish choices. If decisions are not made in a timely fashion, Demco reserves the right, by giving you notice at any time before delivery, to increase the price of the Products to reflect any increase in the manufacturing or production cost to Demco, any change to delivery dates, quantities or specifications for the Products requested by you, or any delay caused by your instructions or your failure to give Demco adequate information or instructions.

**3. Cancellation of Orders.** By submitting an order to Demco, you are accepting responsibility for beginning the procurement of products wherein returns or cancellations of customized products are generally not allowed. You may not cancel an order, in whole or in part, without the written consent of Demco. No cancellation will be accepted by Demco except on terms that will fully indemnify and reimburse Demco against loss, including recovery of all costs incurred by Demco, and including indirect and overhead charges and profit.

**4. Delivery.** You acknowledge that shipment dates and delivery dates are estimates only. Demco agrees to use all reasonable efforts to meet the estimated shipping date subject to your prompt provision of all necessary specifications and information; however, Demco will not be held responsible for any failure to meet an estimated date. If you request a delay in shipment, Demco shall have the right to (i) bill you for the Products at the initial requested delivery date, and (ii) bill you for any storage charges incurred. In the case of delivery of Products by installments, you agree that you will not treat the delivery of faulty Products in any one installment or the late delivery or non-delivery of any one installment as a repudiation of the whole contract. Unless special shipping instructions are received and accepted by Demco before the shipment date, Demco shall, in its sole judgment, determine the means and routing of shipment, or store the Products at your expense until you provide shipping instructions.

**5. Risk and Title to Products.** Unless otherwise expressly agreed by Demco, all shipments are F.O.B. point of shipment. "Point of shipment" shall be, as applicable: Demco's dock; for drop shipments, manufacturer's or distributor's dock; for international Products, the United States point of entry. Demco will select the origin of all shipments, and all delivery destinations will be subject to Demco's approval. Title to and risk of loss for Products will pass at the F.O.B. point.

**6. Exclusion of Warranties.** You acknowledge that Demco is not the manufacturer of the Products, and therefore (a) Demco makes no express or implied warranties of any kind with respect to the products, and (b) Demco expressly disclaims any implied warranty of merchantability or fitness for a particular purpose. All Products are warranted only to the extent of the manufacturer's warranties, which Demco will provide to you at your request.

**7. Limitation of Remedies and Damages.** Demco's liability and your remedies under this Agreement will be limited solely to replacement or credit, at Demco's option, with respect to Products for which Demco has received, within fourteen (14) days after your receipt of the Products, evidence satisfactory to Demco of defective or incorrect Products. Demco's liability will in no event be greater in amount than the purchase price of the products. Demco will not be liable, under any circumstance for consequential, incidental, special or punitive damages, including, but not limited to, labor costs or lost profits resulting from the products being incorporated in or becoming a component of any other article. Neither party will have any negligence or other tort liability to the other, or to any third party arising from any breach of this agreement.

**8. Variations.** Any minor shortages or defects that do not materially affect the use for which the Products are intended will not affect the terms of payment. Products, specifications, and colors may differ slightly from those illustrated in Demco's literature and samples. Any typographical or clerical omission in any sales literature, price list, quotation, acceptance of offer, invoice or other document or other information issued by Demco shall be subject to correction without any liability on the part of Demco.

**9. Claims.** Demco's responsibility for shipment shall cease upon delivery to the carrier. Any claims for damages or loss occurring in shipment shall be made by Demco on your behalf directly to the carrier. All other claims for damages, defects, loss, shortages, or incorrect Products must be made within fourteen (14) days after receipt of the Products, unless otherwise agreed by the parties in writing. Your failure to make any claim within the specified time period will result in the unconditional waiver of that claim. Demco reserves the right to accept or reject any claim in whole or in part. Demco shall not be responsible for any defects caused by your willful or negligent acts, incorrect storage or installation of the Products, or normal wear and tear. Any claim based on a manufacturer's warranty shall be made within the period prescribed by the warranty.

**10. Credit Report and Payment.** You hereby give Demco permission to make all reasonable inquiries into your credit history. Following such reviews, Demco will notify you of the payment terms for your orders, which will be one of the following:

- a. *Net 30 Days.* If these terms apply to you, all amounts due under this contract shall be paid within 30 days following your receipt of an invoice.
- b. *25% Down, Net 30 Days.* If these terms apply to you, you must pay 25% of the contract upon notice from Demco of the terms of payment, and the remaining amount due shall be paid within 30 days following your receipt of an invoice.
- c. *50% Down, Net 30 Days.* If these terms apply to you, you must pay 50% of the contract amount upon notice from Demco of the terms of payment, and the remaining amount due shall be paid within 30 days following your receipt of an invoice.
- d. *100% Down or Payment Bond.* If these terms apply to you, all amounts due under this contract shall be paid upon notice from Demco of the terms of payment. Alternatively, you may provide a payment bond or other security acceptable to Demco.

If you are required to make a down payment under the preceding payment terms, Demco may not process your order for Products under this contract until such down payment is received by Demco. You agree that you will not withhold payment of any amount due because of any other claims or set-off you may have against Demco.

**11. Collection and Other Fees.** You agree to pay Demco all costs, including reasonable attorneys' fees, incurred by Demco in collecting amounts you owe to Demco or in otherwise enforcing, asserting, or defending these terms and conditions.

**12. Indemnity.** If the Products are to be manufactured or any process is to be applied to the Products in accordance with a specification submitted by you, you hereby indemnify Demco against all loss, damages, costs and expenses awarded against or incurred by Demco in connection with or paid or agreed to be paid by Demco in settlement of any claim whatsoever including, but not limited to, infringement of any patent, copyright, design, trademark or other intellectual property rights of any other person that results from Demco's use of your specification.

**13. No Installation.** These terms and conditions do not govern the installation of any Products purchased from Demco. Please refer to your installation agreement for the terms relating to installation.

### 14. General

**Force Majeure.** Demco shall not be liable for any delay or default in performing this contract if such delay or default is caused by conditions beyond its control including, but not limited to, Acts of God, Government restrictions, wars, insurrections and/or any other cause beyond the reasonable control of Demco.

**Legal Interpretation.** Any disputes relating to this contract shall be decided in accordance with the laws of the State of Wisconsin without reference to conflicts of laws principles. Exclusive jurisdiction and venue for any lawsuit relating to this contract shall lie in the state and federal courts of Dane County, Wisconsin. The prevailing party in any lawsuit relating to this contract shall be entitled to recover its costs and reasonable attorneys' fees.

**Severance and Waiver.** The invalidity or unenforceability of any provision of this contract shall not affect the validity or enforceability of any other provisions of this contract, and this contract shall be construed as if such invalid or unenforceable provision were not included in this contract. Failure or neglect by Demco to enforce any of the provisions hereof shall not be construed as nor be deemed to be a waiver of Demco's rights hereunder, and Demco's right to take subsequent action shall not be prejudiced thereby.

**Successors and Assigns.** This contract shall inure to the benefit of and be binding upon each of the parties hereto and their respective heirs, executors, administrators, legal personnel, representatives, successors and assigns, but shall not be assignable by you without the written consent of Demco.

**Entire Agreement.** This Agreement constitutes the entire agreement between the parties hereto with respect to the Installation services and supersedes all prior agreements, representations, warranties, statements, promises, arrangements and understandings whether written or oral, expressed or implied with respect thereto. Any changes or additions to the Installation services or this contract must be agreed in writing by Demco and you.

**Notice.** Any notice required or permitted to be given by either party in this contract shall be in writing and addressed to the other party at its registered office or principal place of business or such other address as may have been provided by written notice.









# Northville Public Schools

## 2025 Furniture Review

02.18.2025

# Overall Review



## Furniture Scope

- AMERMAN ELEMENTARY
  - STEAM
  - Additional Classroom
  - Main Office
  - Cafeteria
  - Media Center (*Phase 2*)



- MEADS MILL MIDDLE SCHOOL
  - Main Collaboration Areas



# Design Approach

- Involve Users in Our Design Process!
- Furniture Fair provides full size Physical Sample Review
- Review of Technical Characteristics & Attributes
- Reuse Plan for Existing Makerspace Furniture

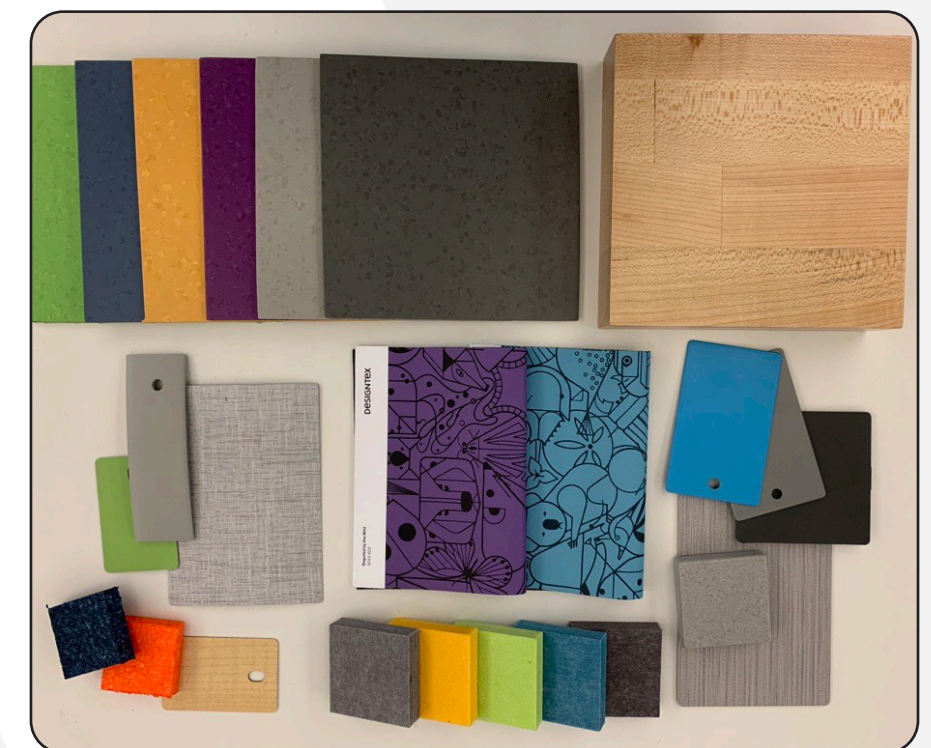
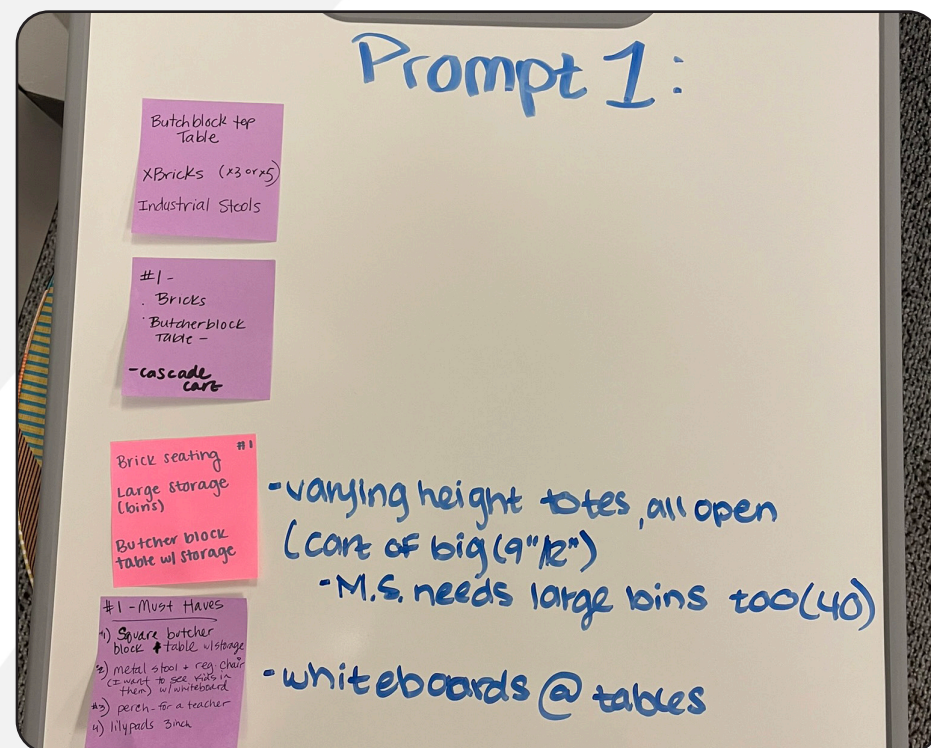

# STEAM Tours

- NBS Launchpad Showroom Tour

- Furniture Dealer NBS hosted the STEAM teachers from all buildings and Furniture Committee Members and TMP at their new Launchpad Showroom.

- The team was able to try out and learn more about furniture pieces from multiple manufacturers to help us select items for their STEAM spaces.

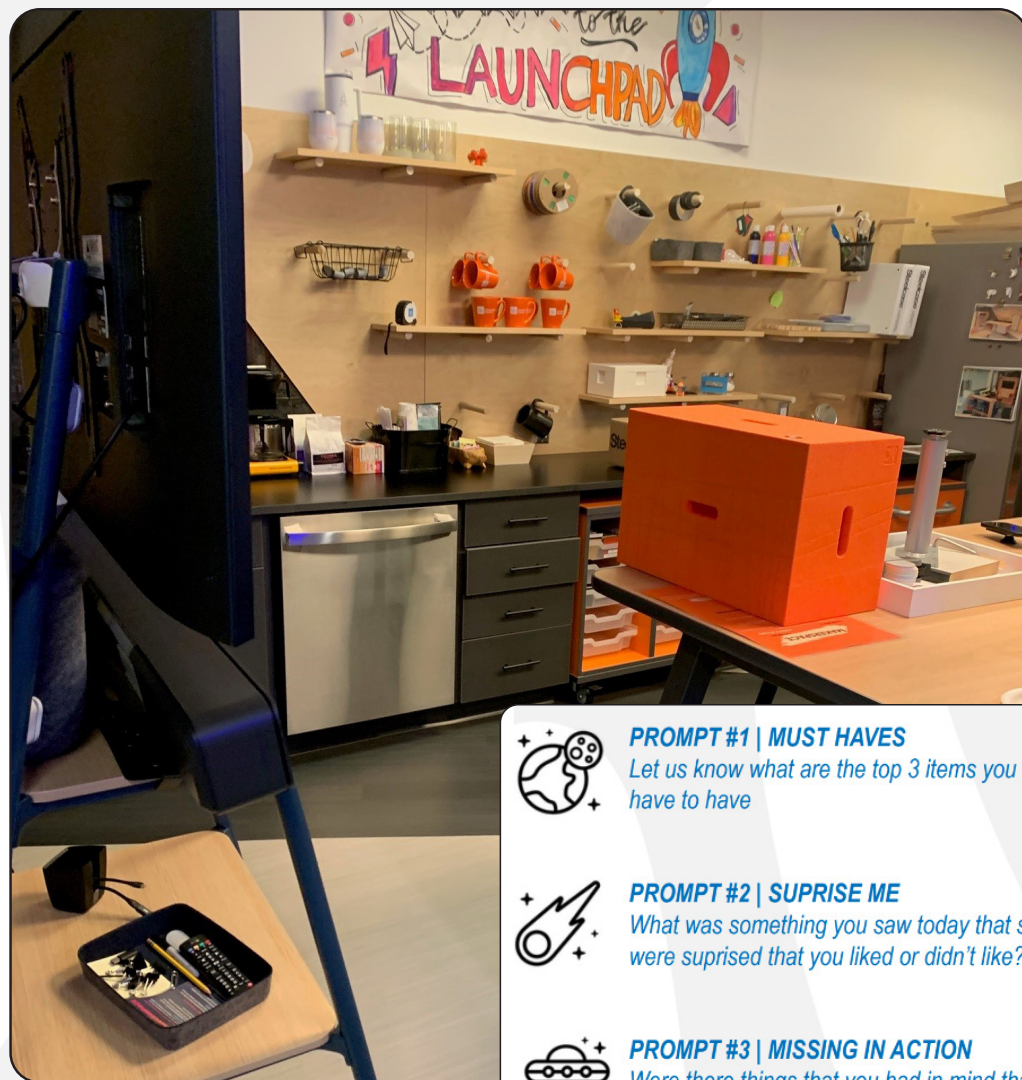

 **PROMPT #1 | MUST HAVES**  
*Let us know what are the top 3 items you saw today that you have to have*

 **PROMPT #2 | SURPRISE ME**  
*What was something you saw today that surprised you or you were surprised that you liked or didn't like?*

 **PROMPT #3 | MISSING IN ACTION**  
*Were there things that you had in mind that you didn't see here that we should be adding to the furniture fair?*

# STEAM Furniture Fair

- From the feedback gathered at NBS and previous Furniture Meetings, the TMP team organized a STEAM Furniture Fair at Amerman.
- Multiple furniture pieces were on display at Amerman for teachers and students to try out. Surveys were available for both teachers and students and feedback was used to help make our final recommendations.
- We got some great feedback here and appreciated the participation!

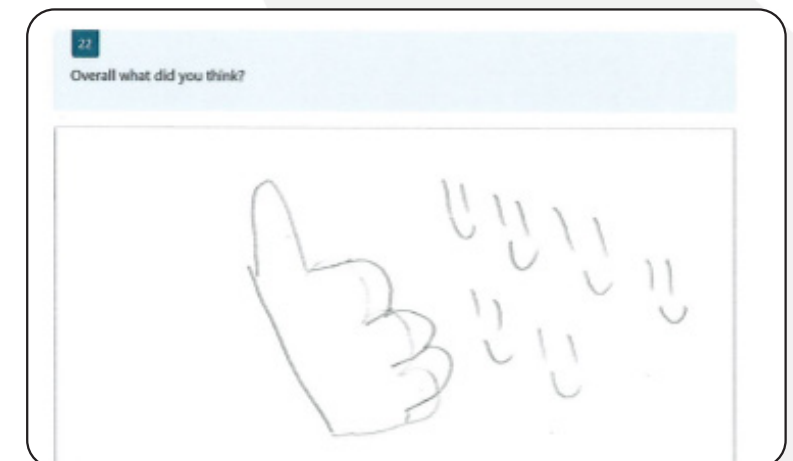

Student Chair | C2  
vs, Solo Stool

**ATTRIBUTES:**  
This stool has a wood seat on a metal frame and is stackable, up to 4 high.

**PAIRED WITH:**  
This 18" H chair works well with Student Table option T3, T4 and T6.

**SIZE:**  
At the typical 18" H size, the multiple foot rings allow for all ages to use comfortably.

**COLOR:**  
This seat is available in multiple stained wood colors. We would recommend this in natural finish on the seat with a silver frame (like in Music).



# Budget Update

- Both Furniture Packages for 2025 are anticipating a Positive Variance!

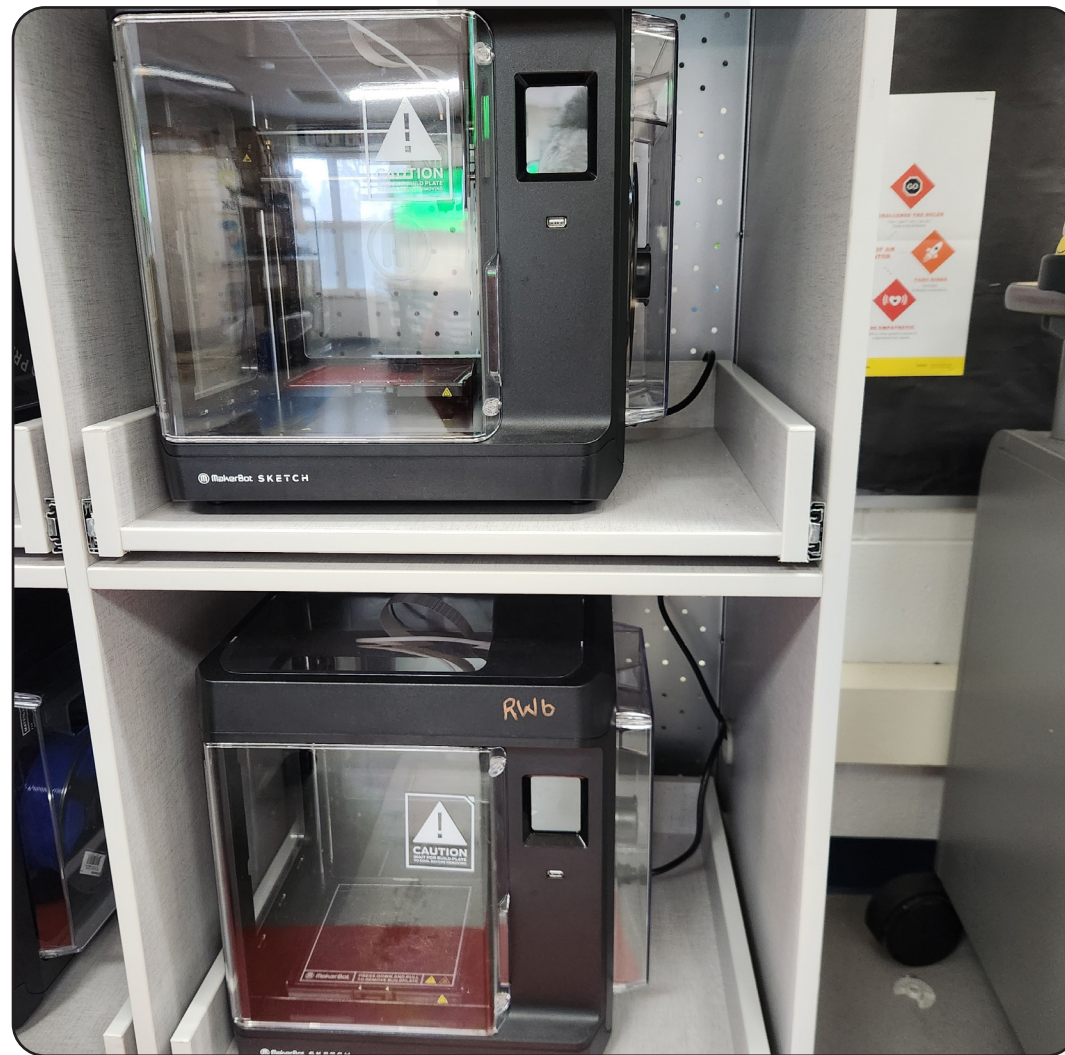

# Amerman Elementary

# STEAM Furniture

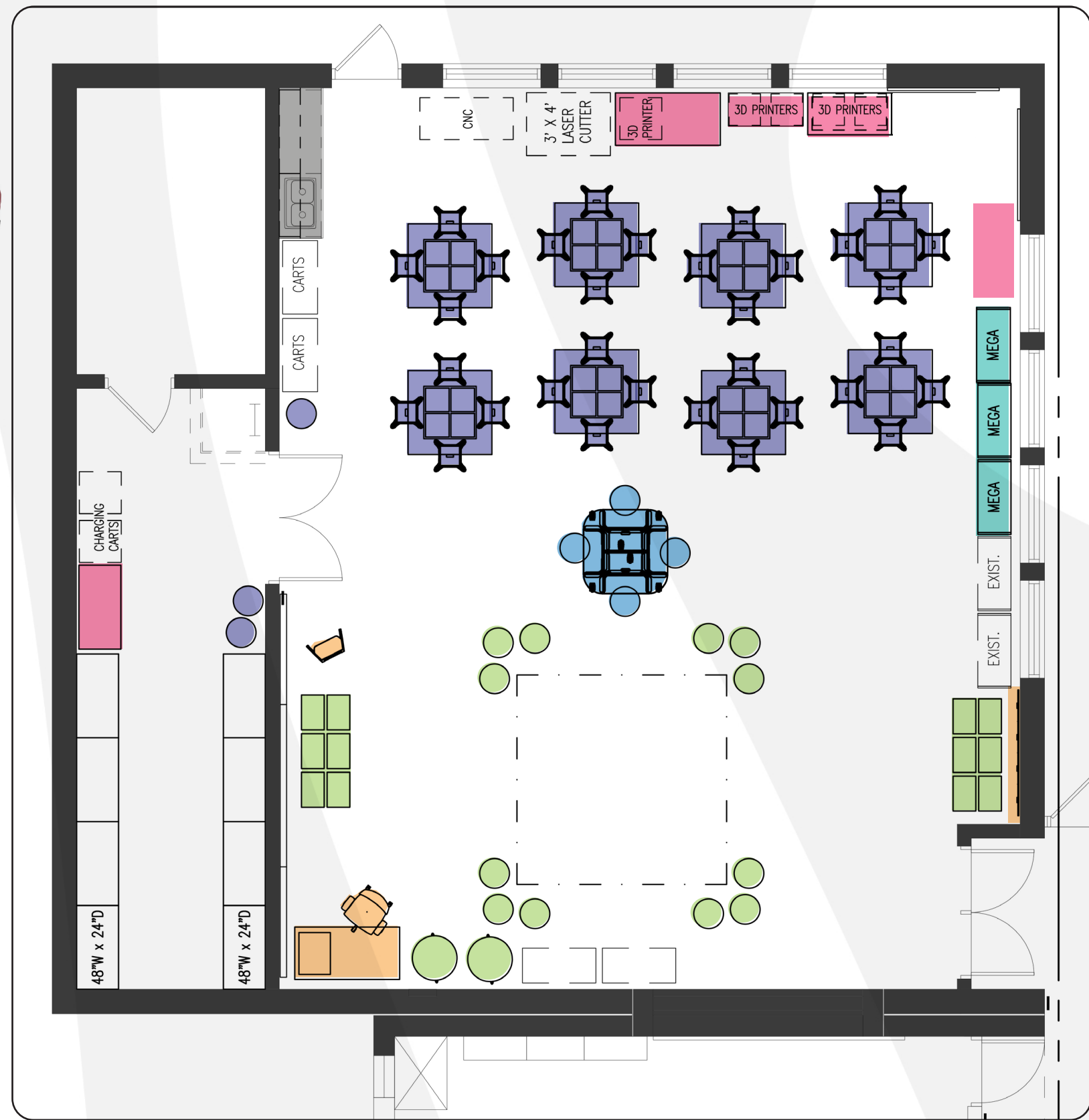
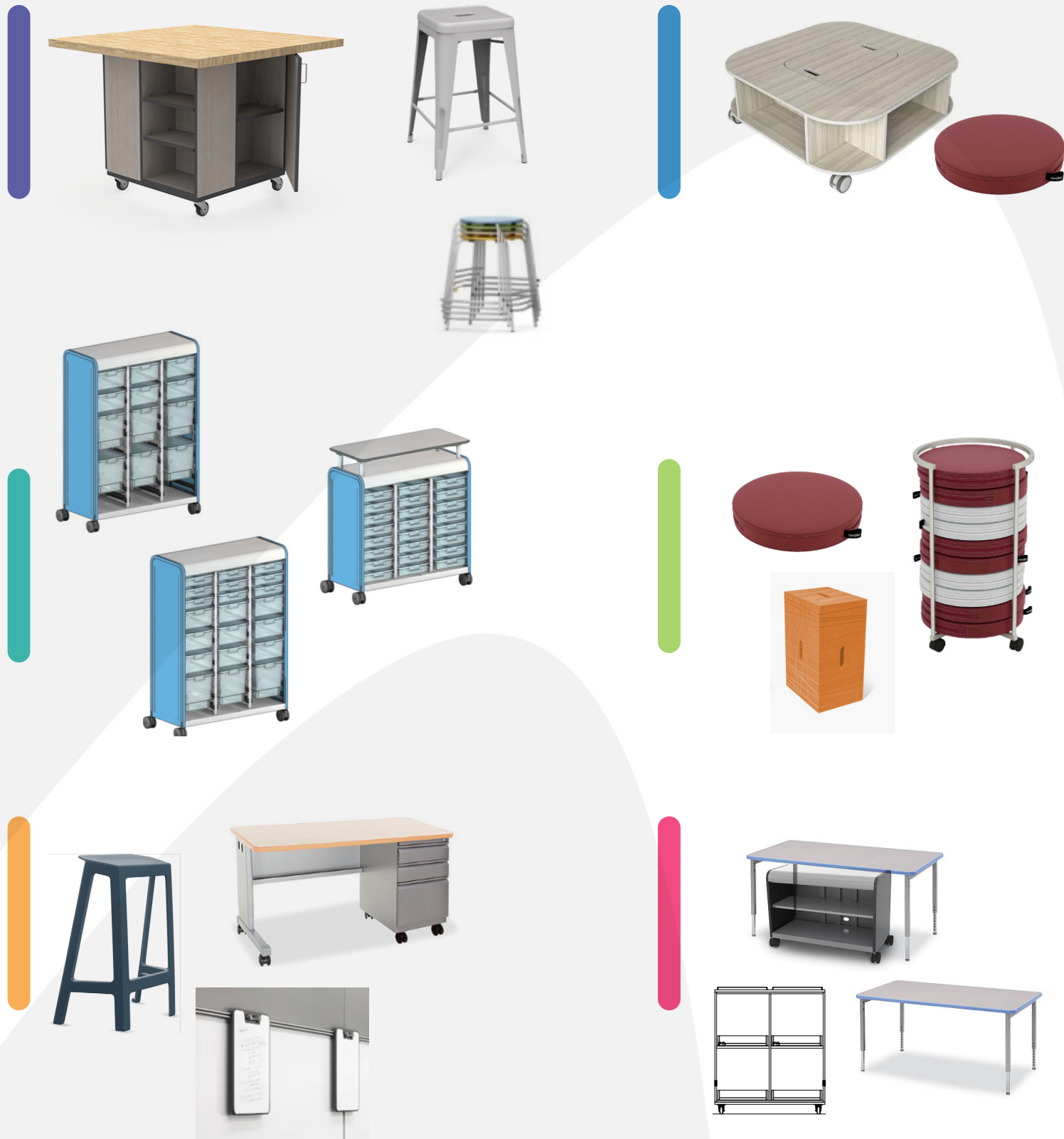

# Media Center | Additional Items

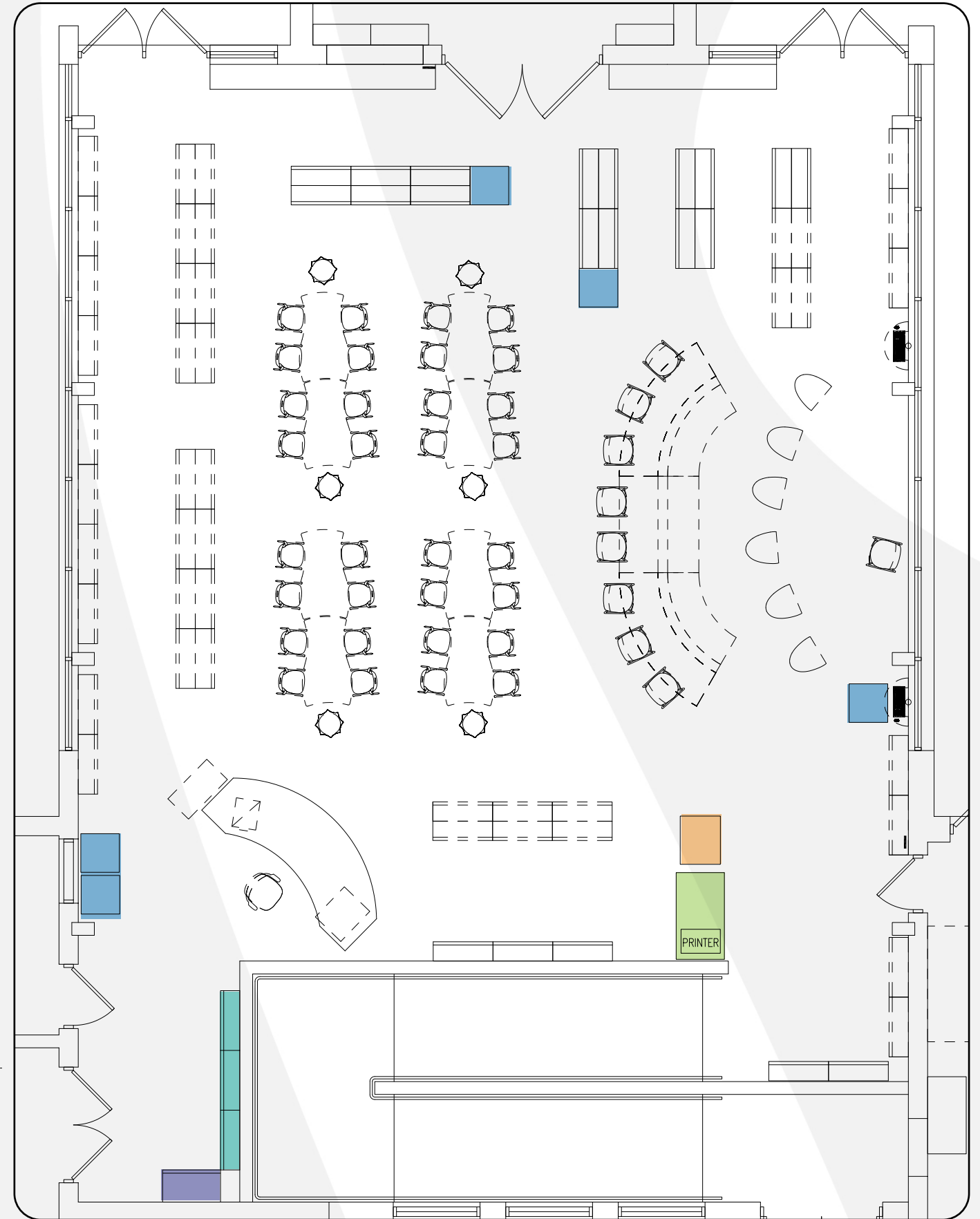
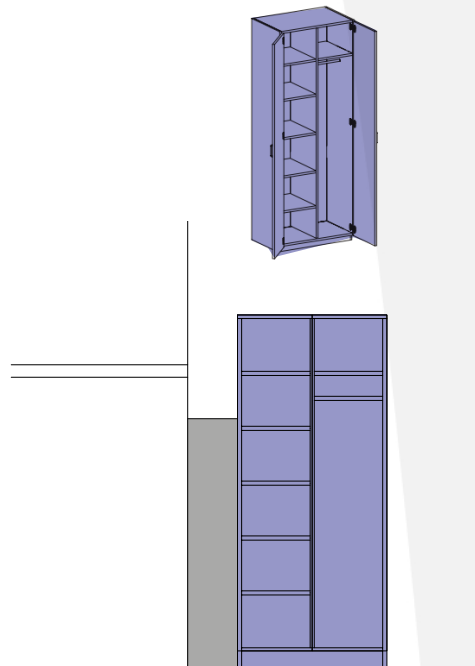
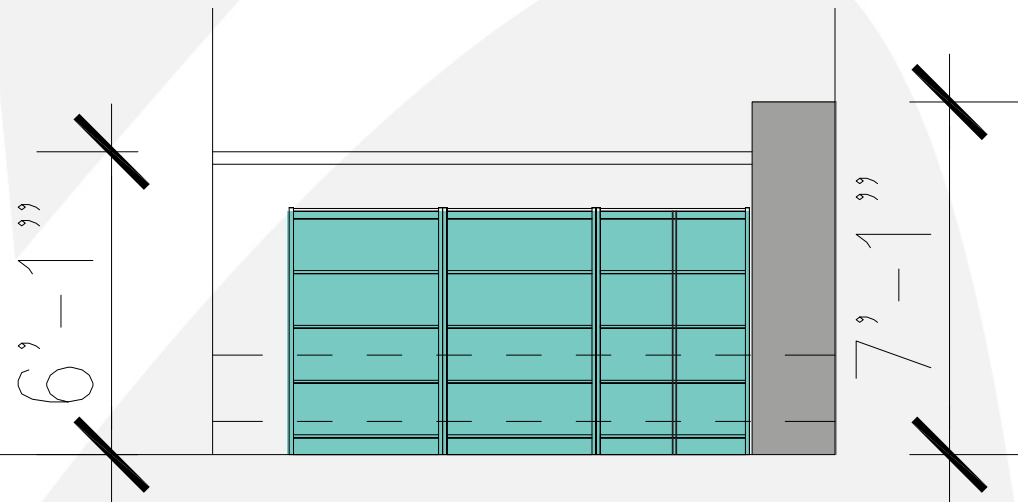
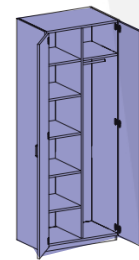
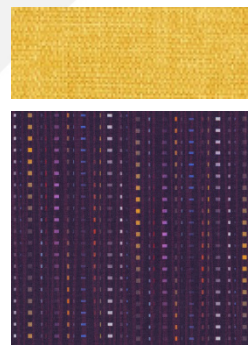
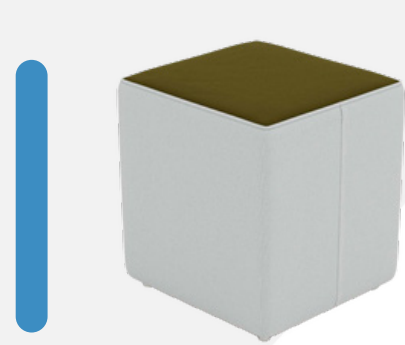

\*All items dashed in are existing to be reused

# Media Center | Collaboration

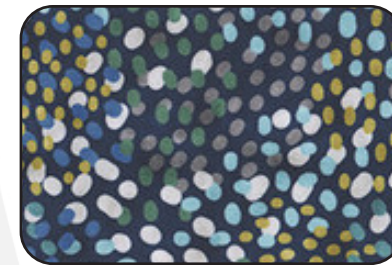
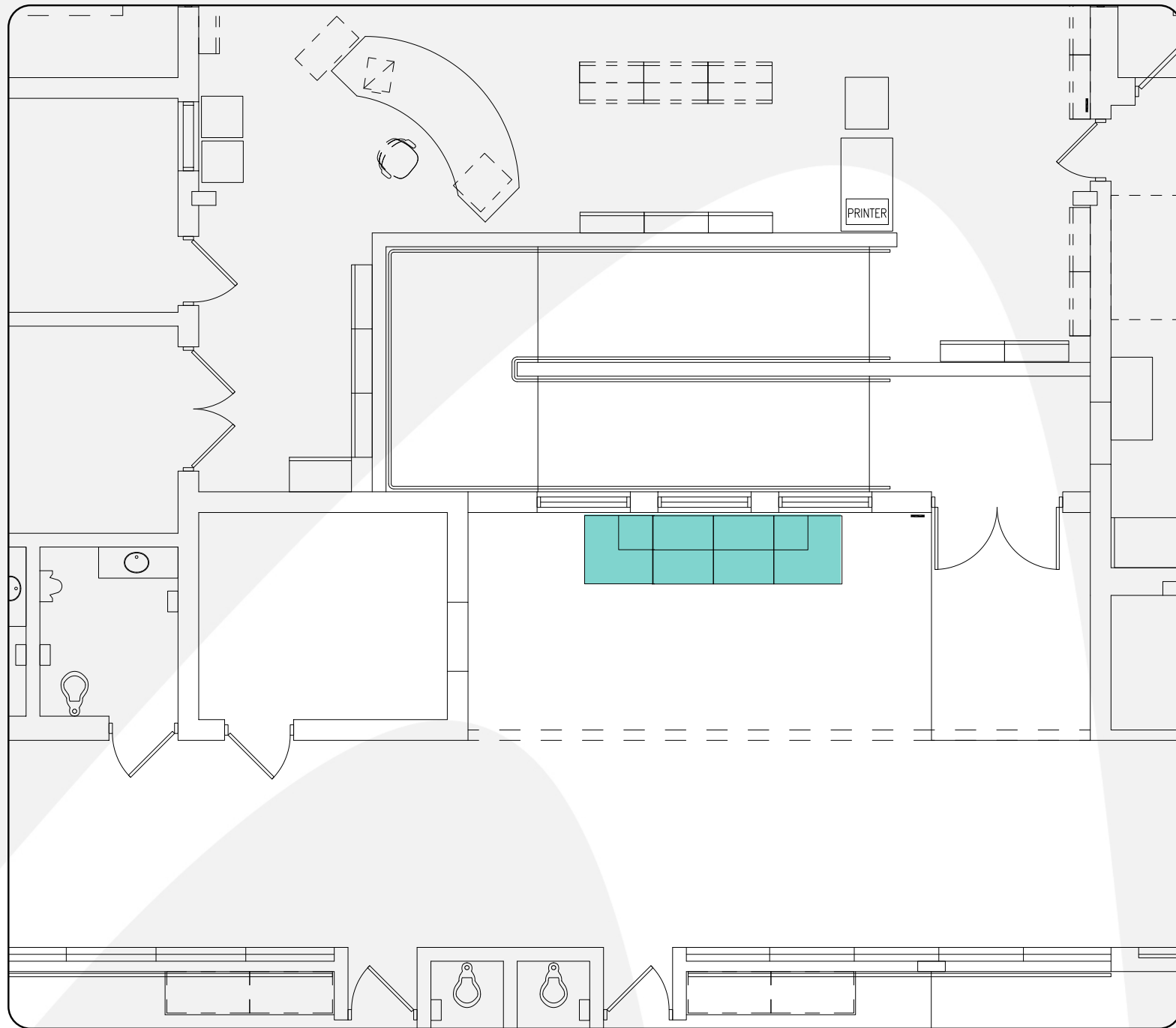

# Main Office

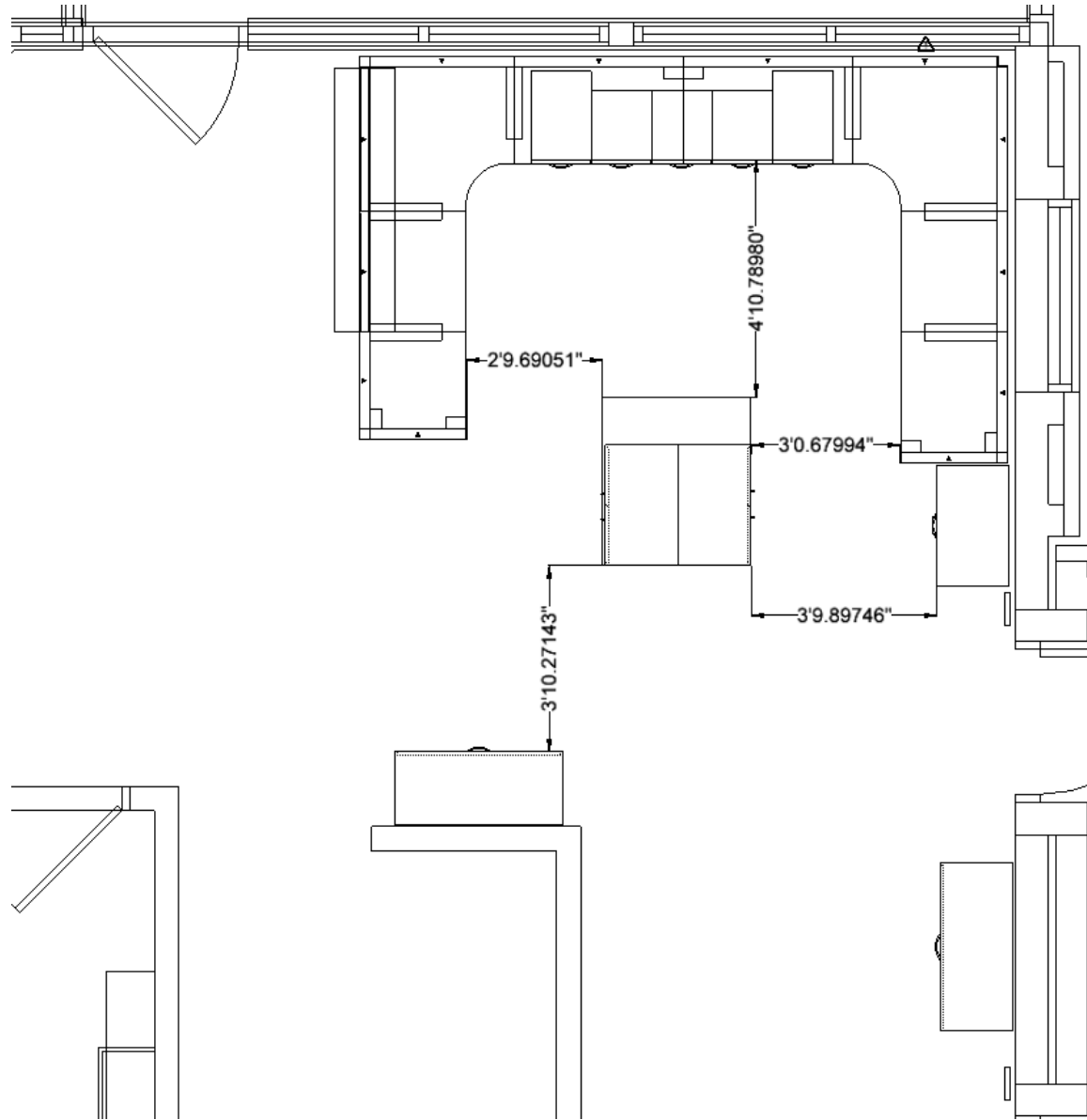

\*Existing Main Office Front Desk to be Reused, with some Additional Surfaces Added



**ALLSTEEL, TERRACE**  
30"W X 24"D SURFACE  
30"W X 35"H PANEL  
ACOUSTICAL FABRIC TILES

**ALLSTEEL, ESSENTIALS**  
LATERAL/CLOSED STORAGE  
COMBINATION CABINET  
36"W X 18"D

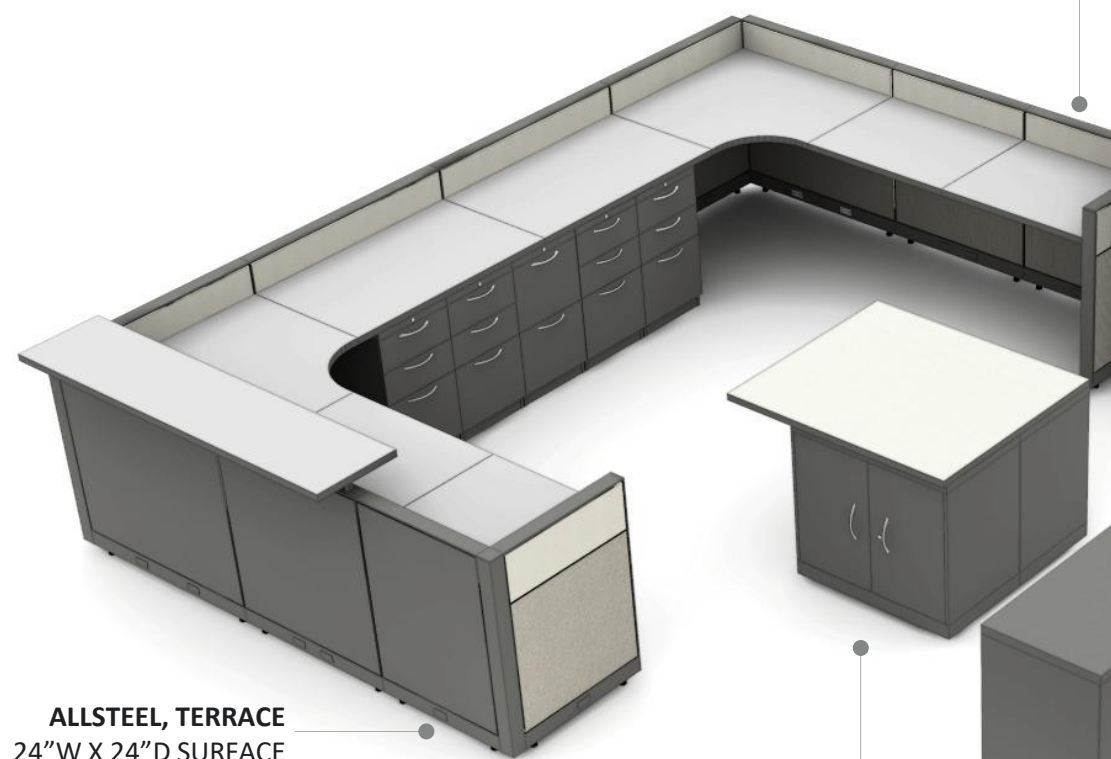

**ALLSTEEL, TERRACE**  
24"W X 24"D SURFACE  
24"W X 35"H PANEL  
LAMINATE AND  
ACOUSTICAL FABRIC TILES

**ALLSTEEL, ESSENTIALS**  
4H 42"W X 18"D LATERAL FILES  
QTY 2

**ALLSTEEL, ESSENTIALS**  
STORAGE ISLAND  
(2) 2H 30"W X 18"D STORAGE CABINETS  
LAMINATE COMMON TOP - 42"W X 36"D  
12" OVERHANG



# Principal's Office

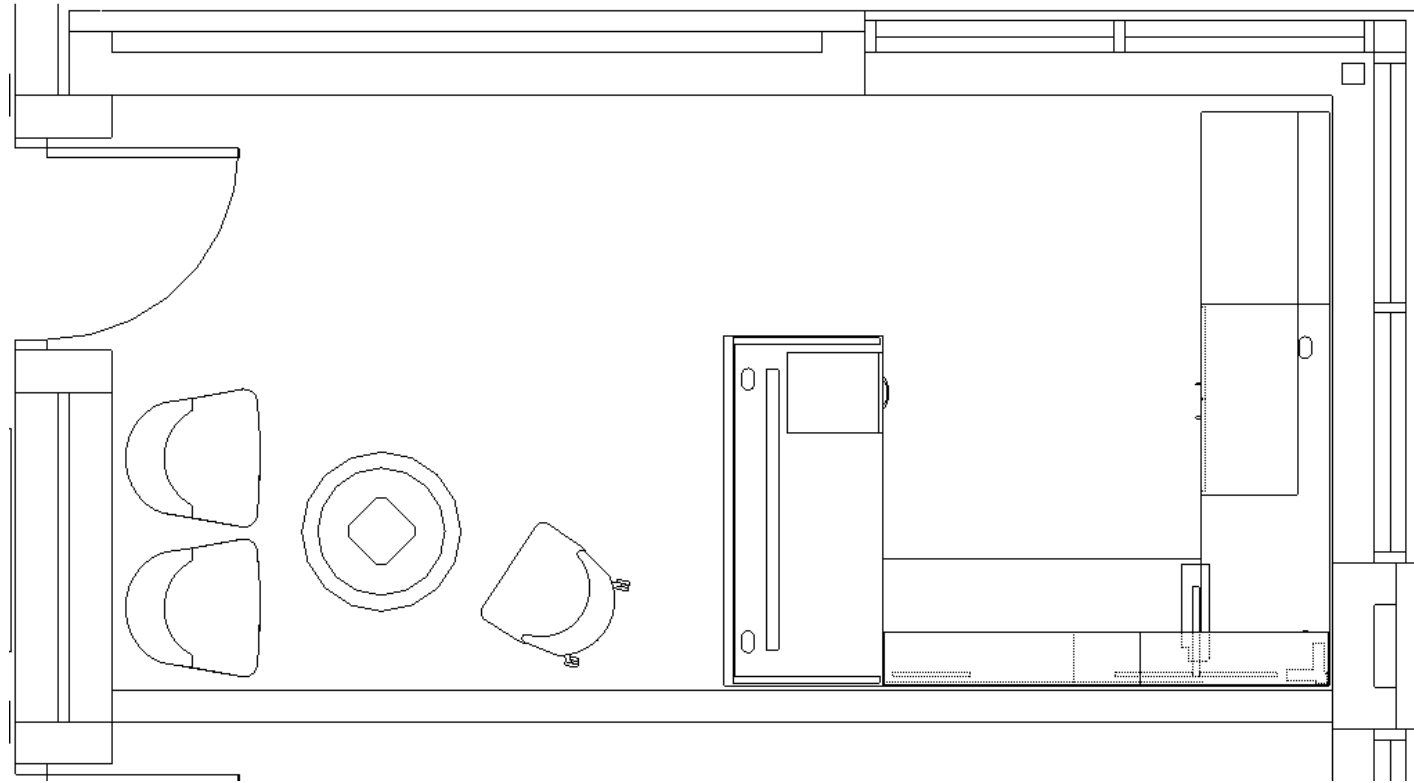

**NATIONAL, LOCHLYN**  
LAMINATE FLOATING SHELF (1) 48", (1) 60"

*SHELVES FOR DISPLAY ONLY –  
55 LB WEIGHT LIMIT PER SHELF  
QTY 2*



**KIMBALL, NATE AND NATTY**  
ARMLESS LOUNGE CHAIR  
STATIC BASE WITH GLIDES  
QTY 3



**ALLSTEEL, CADENCE/ESSENTIALS**  
U-SHAPE WORKSTATION

**MAIN WORKSURFACE**

30"D X 66"W LAMINATE WORKSURFACE WITH GROMMETS  
FULL HEIGHT MODESTY PANEL  
ESSENTIALS MOBILE PEDESTAL BOX/BOX/FILE  
15"W X 18"D X 28"H

**BRIDGE**

24"D X 60"W LAMINATE TOP WITH GROMMETS

**CREDENZA**

24"D X 72"W LAMINATE TOP WITH GROMMETS  
24"D X 36"W LAMINATE TOP NO GROMMETS  
18"D X 36"W STORAGE CABINET  
18"D X 36"W BOOCASE



**ALLSTEEL, STRUCTURE**  
ROUND TABLE WITH OCCASIONAL  
HEIGHT PED BASE  
30"DIA X 18"H

# Relaxation Room

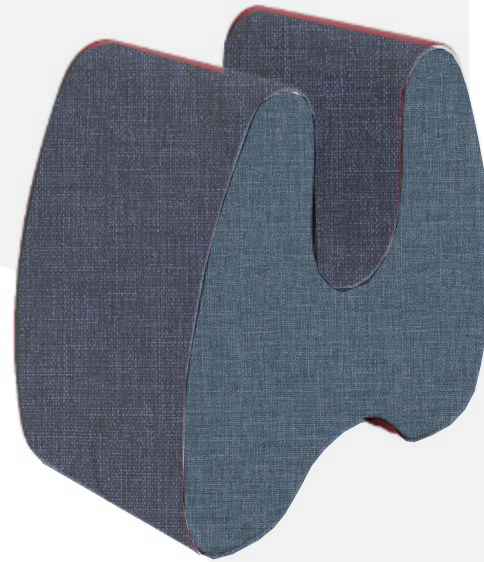
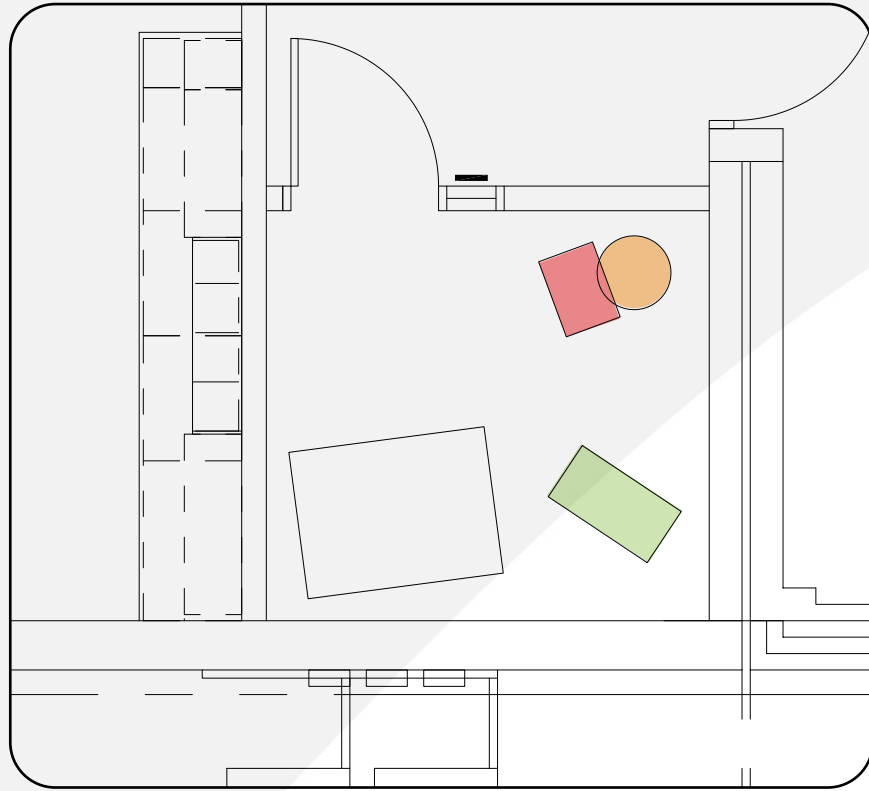

## FomCore | Hug Chair

2 Tone Vinyl

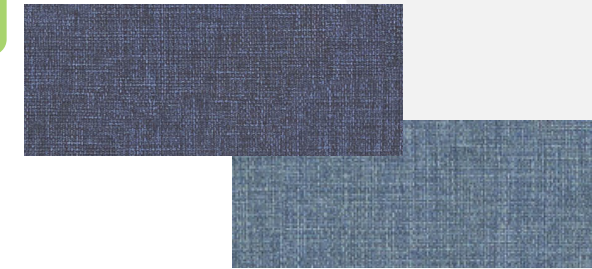

## FomCore | Ottoman

2 Tone Vinyl

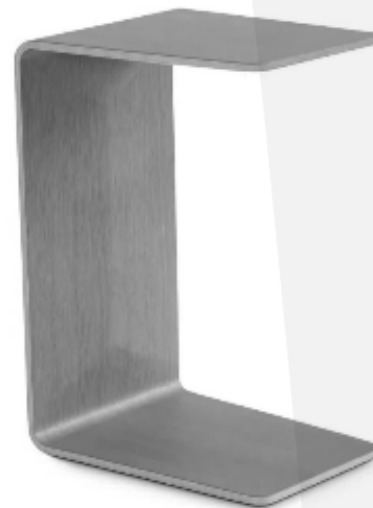

## Laptop Table

Laminate



# Cafeteria Furniture

**180 SEATS**  
 11 tables with 16 seats each  
 1 table with 4 seats

2 tables in Storage Room:  
 1 with 16 seats  
 1 with 14 seats

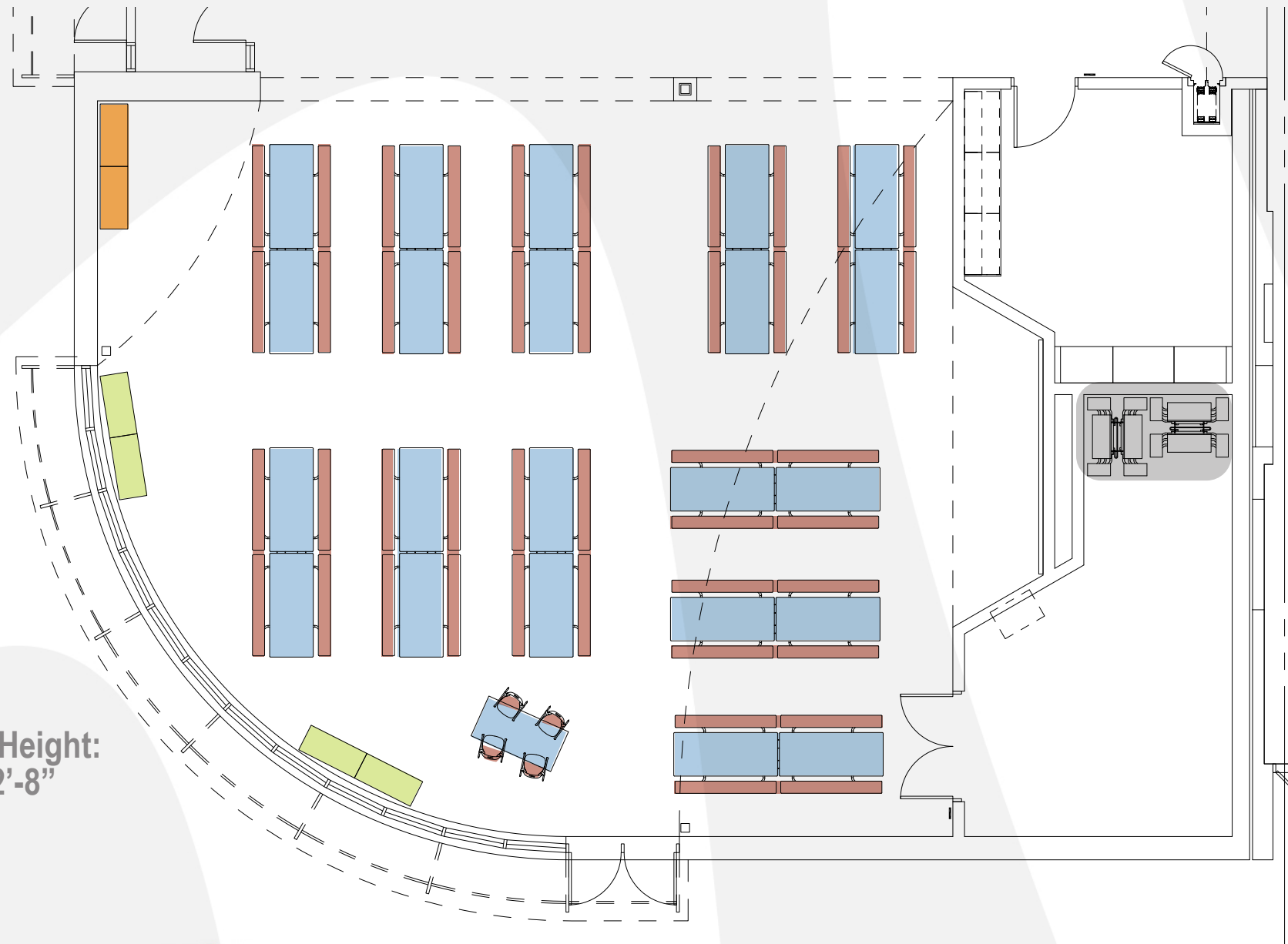

C030 light blue



Sill Height:  
2'-8"

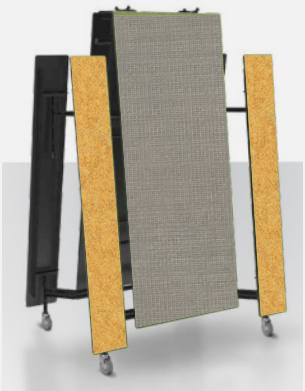

Smith Systems  
 Cascade Mega Tower  
 Doors and Shelves  
 Qty: 2



Smith Systems  
 Cascade Mega Cabinet  
 Open with Shelves  
 Qty: 4



# Kitchen

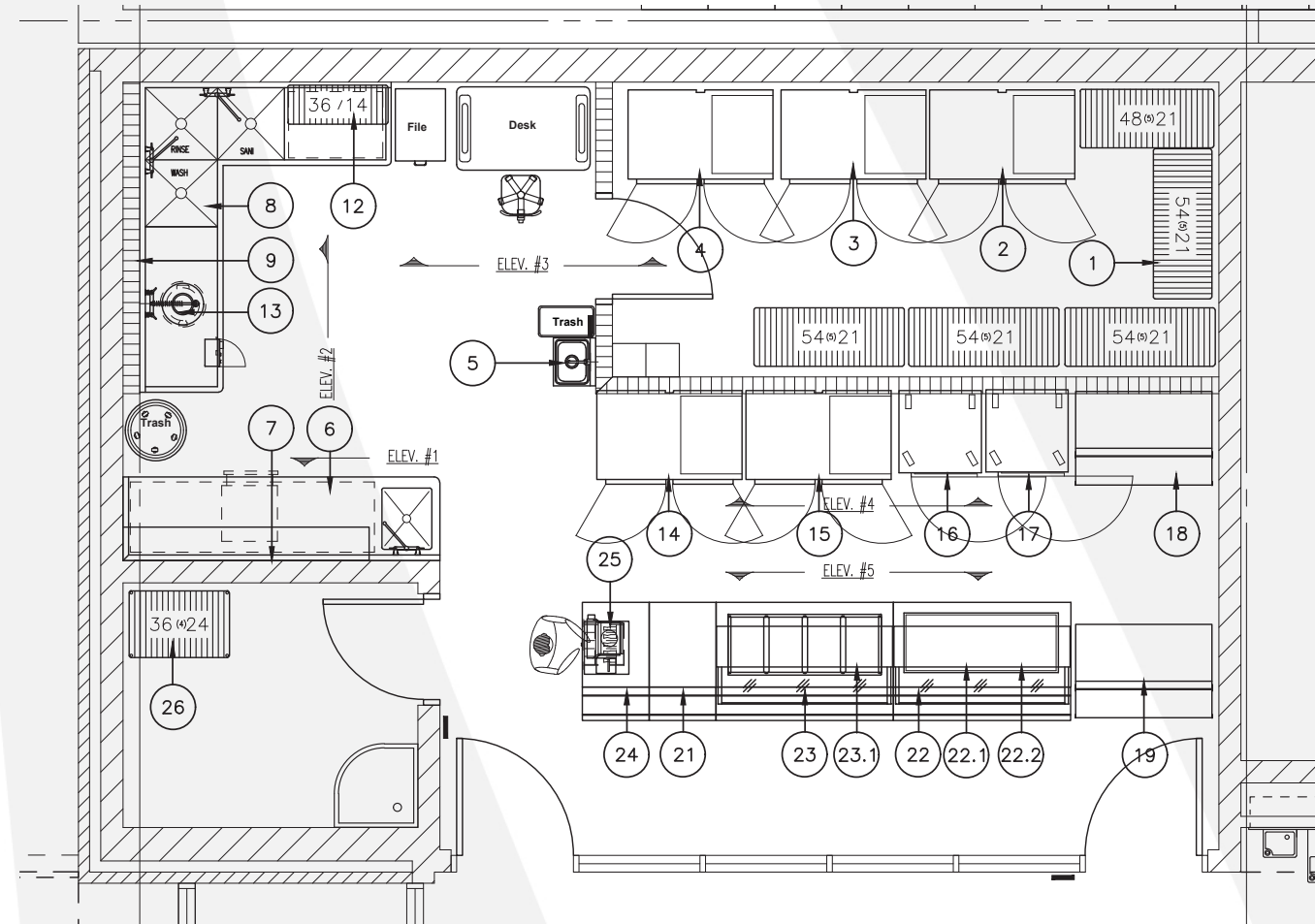
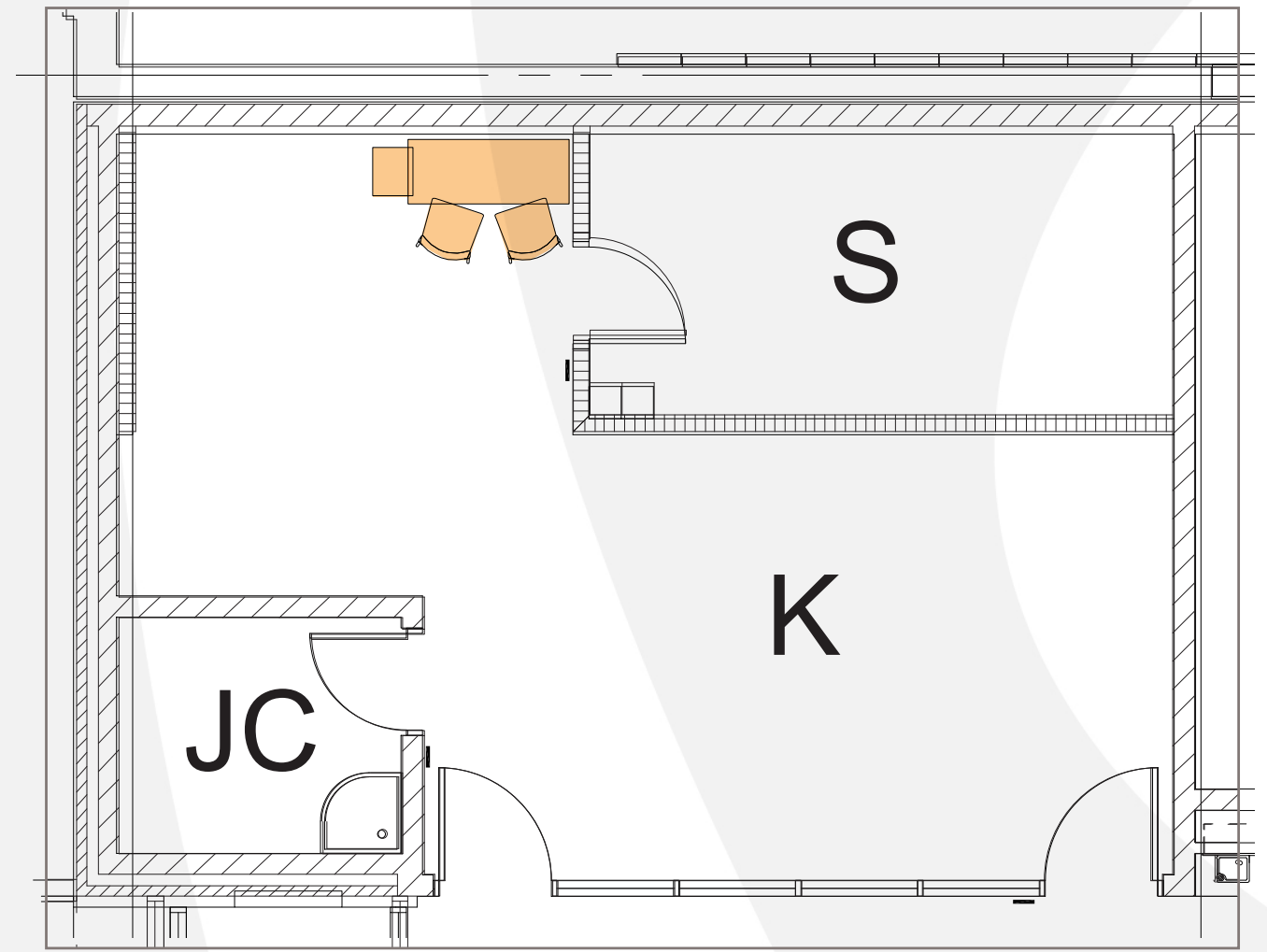

# Additional Furniture

- Additional Classroom - Upper Elementary to Match Existing Classrooms

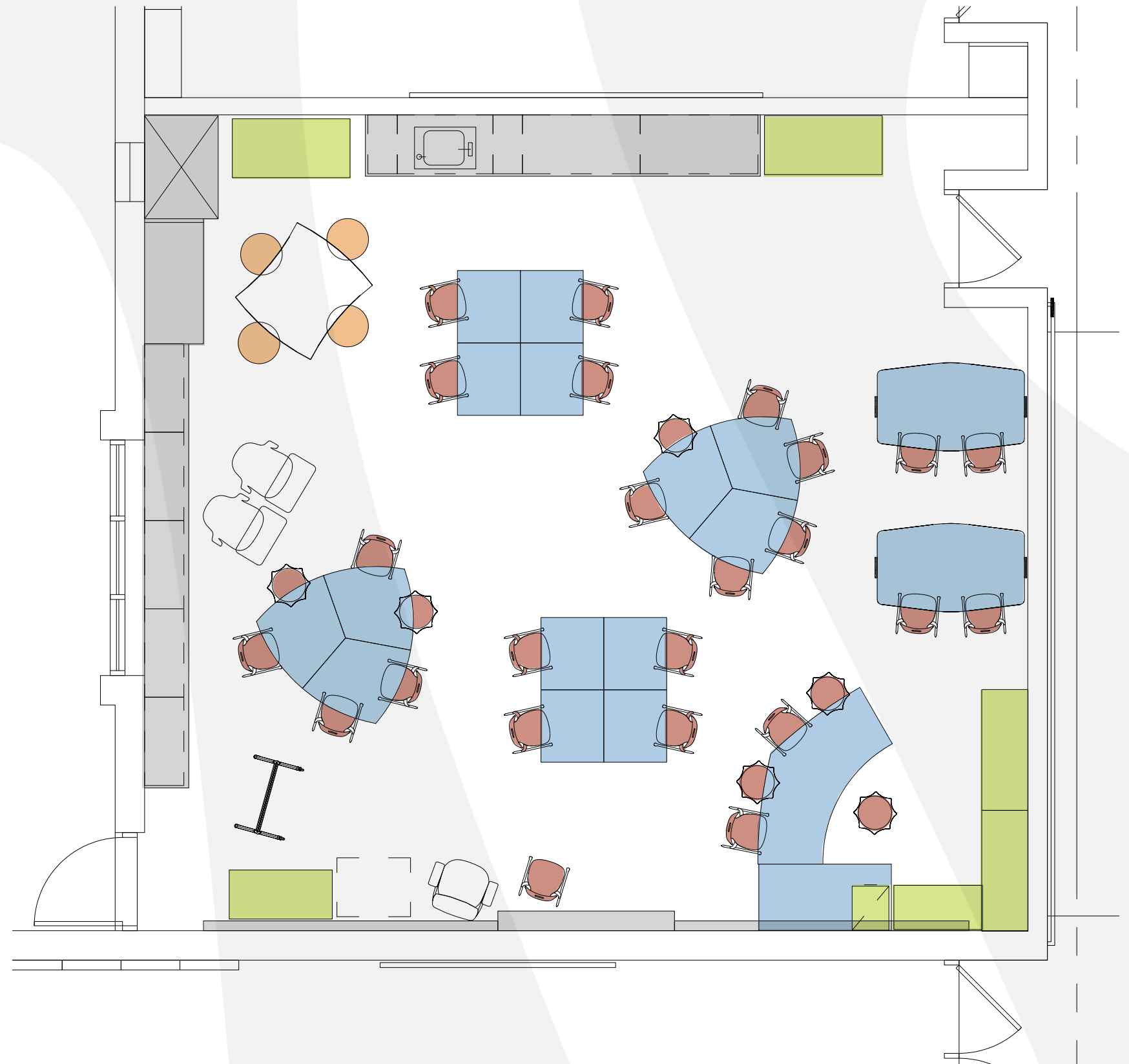

# Furniture Schedule + Phasing

<b>Documentation</b>			
Begin Documentation	9-Dec-24	5 weeks	TMP to write furniture specifications for pricing
<b>Pricing</b>			
Specifications Issued for Pricing	13-Jan-25	3 weeks	Furniture dealers to provide pricing via consortiums
Pricing Received and Evaluated	3-Feb-25	3 weeks	TMP evaluate quotations for accuracy
Letter of Recommendation Issued to NPS	24-Feb-25	1 week	TMP to deliver furniture package to District
Committee of the Whole Meeting	4-Mar-25	1 week	Confirm date with district
NPS Board Meeting	11-Mar-25	2 weeks	Confirm date with district
Furniture Purchase Orders Issued	24-Mar-25	20 weeks	
<b>Installation</b>			
Furniture Install Begins (Phases 1-3)	11-Aug-25	1 week	Pending construction schedule
Furniture Punch List (Phases 1-3)	18-Aug-25	1 week	TMP to punch list all installed furnishings
Completion (Phases 1-3)	26-Aug-25		
Furniture Install Begins (Phase 4)	6-Oct-25	1 week	Pending construction schedule
Furniture Punch List (Phase 4)	13-Oct-25	1 week	TMP to punch list all installed furnishings
Completion (Phase 4)	20-Oct-25		

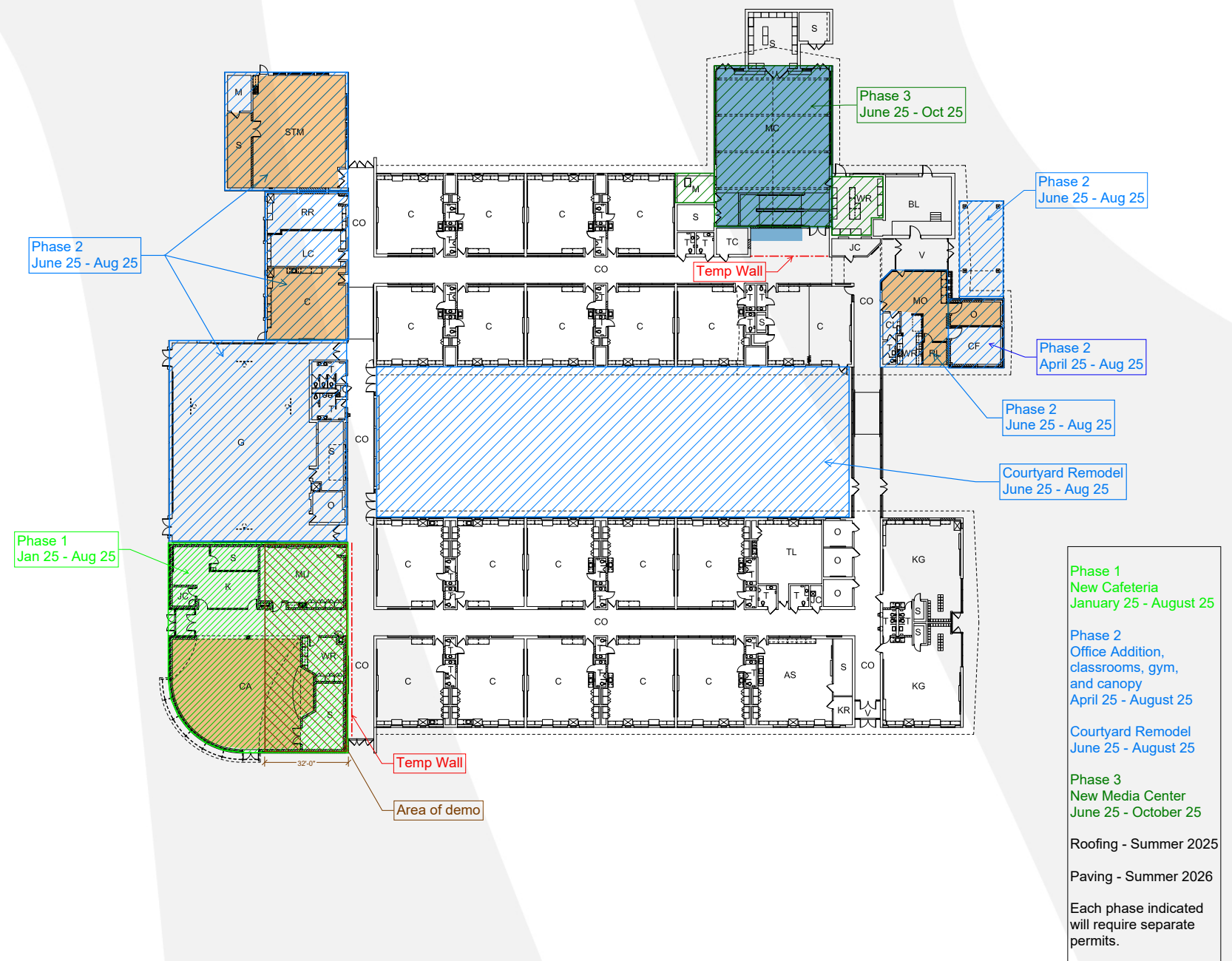

- Furniture Phase 1:  
Main Office, Classroom,  
STEAM, Cafeteria
- Furniture Phase 2:  
Media Center

# **Meads Mill Middle School**

# North Collaboration

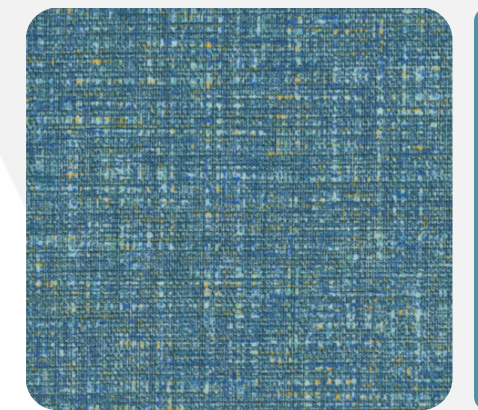

NEW STOOLS

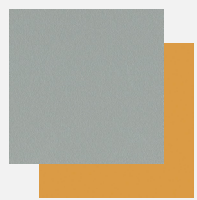

\*DOTTED SECTIONS DENOTE TOP STEP

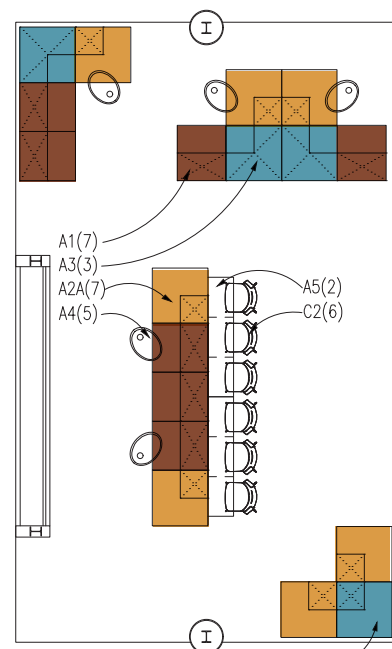

# South Collaboration



NEW CHAIRS

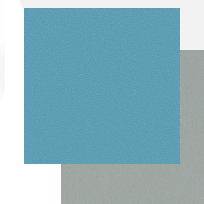

NEW STOOLS

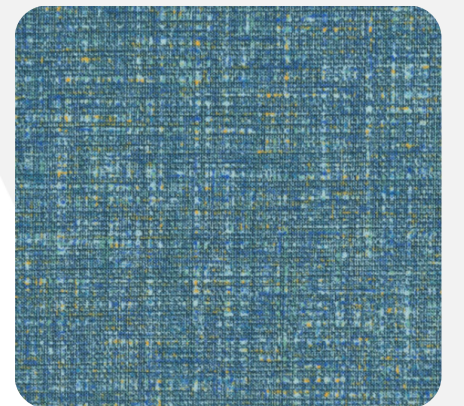
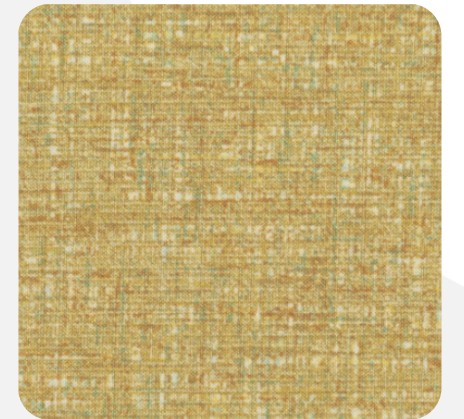
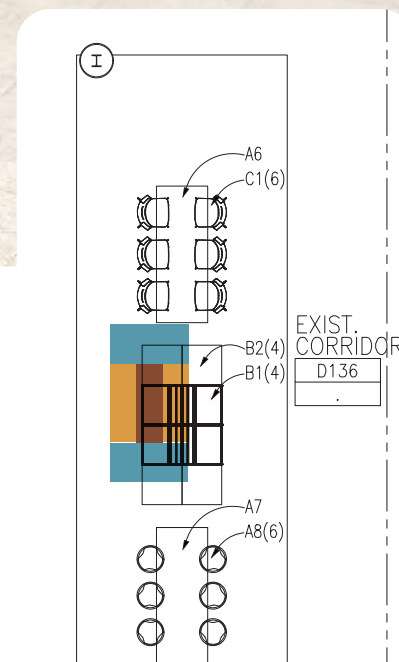
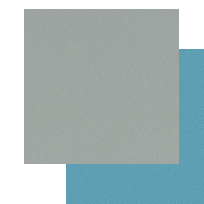

# Timeline

- Furniture Phase 1: Main Collaboration - August 2025
- Furniture Phase 2: STEAM - December 2025
- Furniture Phase 3: Gym Classrooms - February 2026
- Furniture Phase 4: Cafeteria, Kitchen, Gym Offices - August 2026

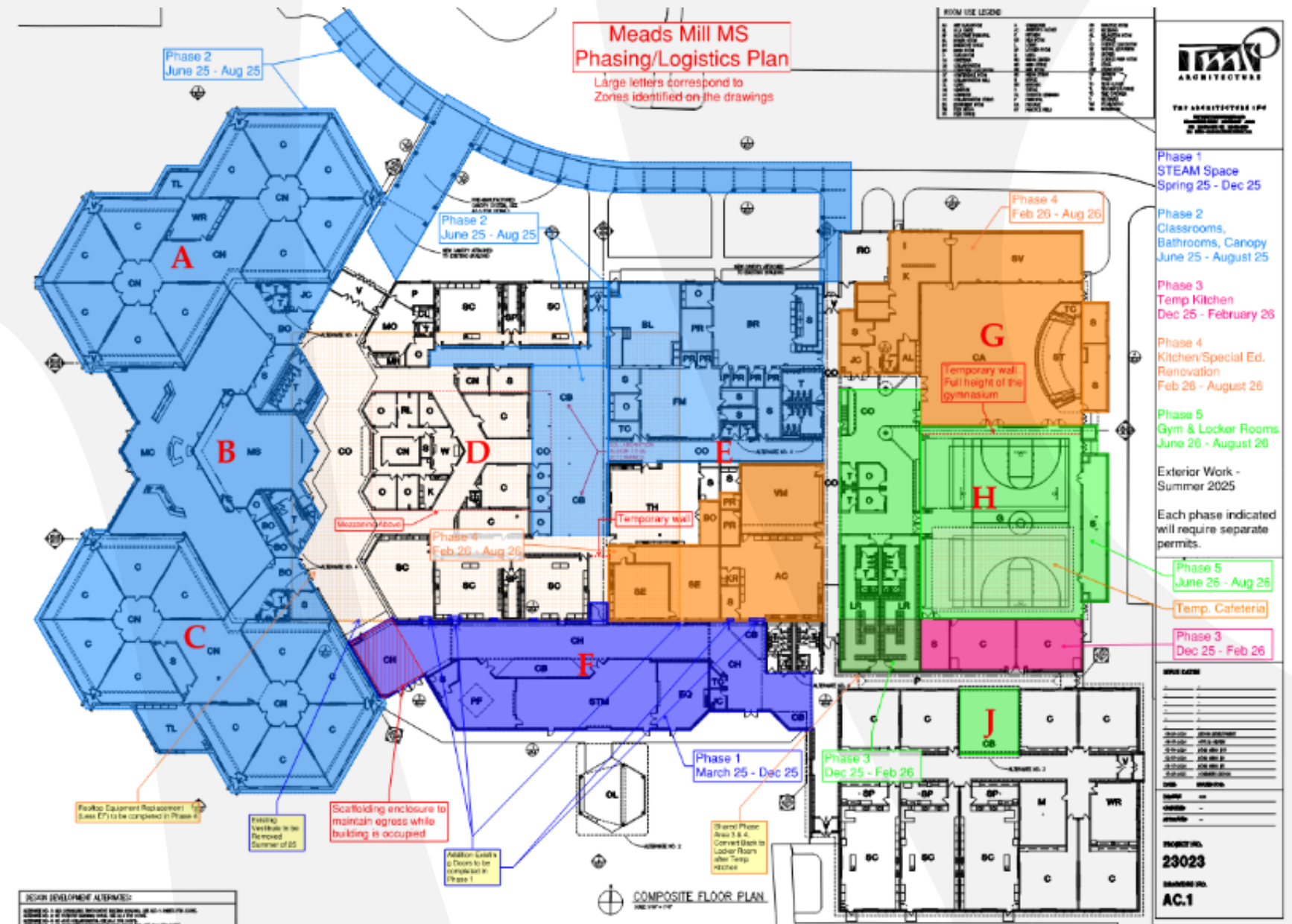

**Thank you!**

# Memo

**To:** Devin Kling

**From:** Andrew Piazza

**cc:**

**Date:** February 18, 2025

**Re:** Fiber Maintenance Agreement

---

Northville Schools went out to bid for a 3-year fiber maintenance agreement to ensure the continued reliability and performance of our fiber optic network. Amcomm Inc. was the sole respondent to this bid, offering a total of \$78,400 per year for a 3-year agreement.

This agreement will cover various essential services, including routine maintenance, handling of outages, and necessary repairs. Specifically, we will schedule and perform regular maintenance and inspections to keep the fiber network in optimal condition. We will also establish maintenance windows and scheduling practices for planned outages to minimize disruption to school operations. In the event of unscheduled outages, we will implement procedures to address them promptly and respond to customer problem reports efficiently. Additionally, we will contact the assigned district representative before performing any dig location services to prevent accidental damage to the fiber network. The agreement includes provisions for repairing and/or replacing any damaged fiber or fiber that no longer meets specifications to maintain network integrity.

This agreement will also handle Miss Dig 811 ticket processing and locating services to ensure compliance with safety regulations. Furthermore, we will provide all necessary tree trimming on an annual basis to prevent interference with the fiber network. This 3-year fiber maintenance agreement is crucial for maintaining the reliability and performance of our fiber optic network.

The maintenance is based on a use-as-needed, when-needed basis. The district will only be charged for what is needed, not the whole amount unless the whole amount is used. This amount will be submitted to USAC E-Rate, and a percentage will qualify for reimbursement. This contract will be paid out of the general fund for a total not to exceed \$78,400 per year for a contract term of 3 years.

# Memo

**To:** Devin Kling

**From:** Andrew Piazza

**cc:**

**Date:** February 18, 2025

**Re:** Fiber Infrastructure Upgrade

---

Northville Public Schools accepted bids for a new fiber network. Our existing fiber network has been experiencing significant issues that affect the reliability and efficiency of our communication and data transfer systems. Some segments of our fiber network were installed in 1990 and are prone to frequent disruptions, leading to delays in communication and hindering our ability to provide seamless educational services. Additionally, the old infrastructure is not equipped to handle the increasing data demands of our modern educational environment, resulting in being maxed out at 10Gbps.

By investing in a new fiber network, we can ensure a more reliable and faster connection between buildings. This upgrade will support our growing data needs, handling modern speeds of 40Gbps to 100Gbps, and provide a stable foundation for future technological advancements. Furthermore, establishing a direct connection to our Internet Service Provider (ISP), via Plymouth Canton Schools, will enhance our network's reliability by reducing latency, improving internet speeds, and providing a more consistent and dependable connection.

The new fiber network will require less maintenance and fewer repairs, leading to long-term cost savings. With a more reliable network, we can reduce downtime and increase productivity, ultimately saving on operational costs. Additionally, a direct connection to our ISP can lower our internet service costs by eliminating the need for intermediary connections.

Upgrading our fiber network infrastructure is a crucial step towards ensuring that our school district remains at the forefront of educational technology. The proposed improvements will provide a more reliable, efficient, and cost-effective solution. This project will be submitted to USAC E-rate for a percentage of federal reimbursement.

We received two bids: one from Amcomm Inc. for \$2,648,653.00 and another from Verita for \$2,717,103.26. We would like to accept Amcomm's proposal for \$2,648,653.00, to be paid out of Series 1 of Bond 2023.

Amcomm INC	\$2,648,653.00
Verita	\$2,717,103.26

Northville Schools would like to award the fiber installation to Amcomm Inc for \$2,648,653.00 paid out of Series 1 of Bond 2023.

February 13, 2025

Northville Public Schools  
Devin Kling, Assistant Superintendent for Finance & Operations  
405 W. Main St.  
Northville, MI 48167



<http://wriighthunter.com>  
818 West 11 Mile Road  
Royal Oak, MI 48067  
**248.594.5850**  
**FAX:248.594.5851**

Dear Mr. Kling,

As you are aware, bids were received on February 4, 2025, for the Structured Cabling Systems. This bid includes new structured cabling for Amerman Elementary School and Meads Mill Middle School.

We received bid responses from four (3) different vendors. We have carefully reviewed all of the responses to the Structured Cabling Systems, Request for Bid. The base bid breakdowns are as follows:

<b>Vendor</b>	<b>Base Bid</b>
Amcomm Incorporated	\$89,000.00
Trendset Communications Group	\$98,855.47
Professional Cabling Solutions	\$101,771.00

Amcomm Incorporated did not acknowledge written receipt of Addendum #3 on the RFB Bid Forms. This Addendum referenced vendor pre-bid meeting notes, bid clarifications, and a vendor questions and answers section. In the Wright & Hunter Post-Bid interview document sent to Amcomm Inc., acknowledged and accepted all items in Addendum #3, in writing, with no additional costs to Northville Public Schools.

Additionally, Amcomm did not include the demolition of (60) data cables at Meads Mill Middle School in their bid response. However, they supplied unit pricing for the demolition of (30) data cables in in the Unit Pricing section of the Bid Forms. Amcomm’s price to demo thirty (30) data cables was \$825.00. Since there are a total of sixty (60) cables to be removed at Meads Mill, Amcomm’s adjusted Base Bid is increased by \$1,650.00. (\$825.00 x 2). The updated Base Bid pricing is as follows:

<b>Vendor</b>	<b>Base Bid</b>
Amcomm Incorporated	\$90,650.00
Trendset Communications Group	\$98,855.47
Professional Cabling Solutions	\$101,771.00

Wright & Hunter verified all pricing, deliverables, as well as all terms and conditions of the RFB, and determined that Amcomm Incorporated was the lowest compliant bid. Considering Amcomm’s extensive experience with NPS and the complexity of this project, Wright & Hunter and the District recommend that the Structured Cabling Systems bid be awarded to **Amcomm Incorporated in the amount of \$90,650.00.**

The funding sources for this project is Bond 2023.

Please contact me with any questions regarding this matter.

Sincerely,

Scott Brune  
President & CEO

# Memo

**To:** Devin Kling  
**From:** Andrew Piazza  
**cc:**  
**Date:** February 18, 2025  
**Re:** Desktop and Laptop Purchase

---

Northville Public Schools is upgrading the PC laptop and desktop fleet and starting with the high school desktop computer labs and transitioning to laptops. Additionally, we plan to upgrade the laptops in the middle school and refresh all desktops across all buildings. This transition to laptops will enhance mobility and flexibility, allowing students to work from various locations and fostering a more dynamic learning environment. Upgrading to laptops ensures that students have access to the latest technology, which is crucial for their academic success. Furthermore, removing desktop labs will free up valuable space that can be repurposed for other educational activities.

We will be purchasing off the REMC contract from Inacomp TSG for a total of \$1,093,732.00 paid form series 1 of Bond 2023

Type	Description	Price Each	Quantity	Total
Student Laptop	HP Probook 440 g11 u5-125u 16gb ram 512gb SSD, 14" FHD screen, wifi6e wireless, BT 5.3, 56whr battery, 45 watt USB-C ac adaptor, Win 11 Pro, 3yr warranty	\$699.00	906	\$633,294.00
CAD Laptop	HP Z Studio G11 u7-165H 32gbm ram RTX 4070 8gb graphics, 16" FHD screen, 1tb SSD, wifi7 wireless, BT 5.4 vpro, Win 11 Pro, 3yr warranty	\$2,373.00	42	\$99,666.00

Staff Desktop	HP Prodesk 400 g6 SFF i5-14500 16gb ram, 512gb SSD, Vpro, win 11 Pro 3yr warranty	\$593.00	329	\$195,097.00
Cad Desktop	HP Z2 SFF g9 Desktop i7-14700 32gb ram, 1TB SSD, Nvidia t1000 8gb graphics, 2-acp mDP -DP adaptor Win 11 Pro, 3yr warranty	\$1,445.00	50	\$72,250.00
Monitor	HP Series 5 524PF 23.8" display	185	505	\$93,425.00
			<b>Total</b>	<b>\$1,093,732.00</b>



**Date:**  
2/11/2025  
**Quote:**

**Inacomp TSG**  
17250 W 12 mile Rd  
Southfield, Mi 48076  
Phone: 248.559-5700

**Customer:** Northville Schools  
**Contact:** Andrew Piazza  
**Address:**

**REMC Contract**

*Inacomp TSG is pleased to provide you with the following estimate for products and/or services.*

<u>Line Qty</u>	<u>Part Number</u>	<u>Description</u>	<u>Unit Price</u>	<u>Ext. Price</u>
		<b>Probook 460 G11</b>		
1	8z677av	HP Probook 460 G11 u5-125u 16gb ram 512gb SSD, 16" FHD screen, wifi6e wireless, bt 5.3, 56whr battery, 45 watt USB-C ac adaptor, Win 11 Pro, 1yr warr	\$665.00	\$665.00
1	u86dme	HP carepack upgrade to 3/3/0 depot warranty for 440, and 460 g11	\$34.00	\$34.00
		<b>CAD Notebook</b>		
1	9q572av	HP Z Studio G11 u7-165H 32gbm ram RTX 4070 8gb graphics, 16" FHD screen, 1tb SSD, wifi7 wireless, bt 5.4 86whr battery, 150w slim 3-pin ac adptr vpro, Win 11 Pro, 1yr warranty	\$2,283.00	\$2,283.00
1	u85qde	hp carepack upgrade to 3/3/0 depot warranty for Z Studio	\$90.00	\$90.00
		<b>Desktops</b>		
1	8y4t6av u10n3e	HP Prodesk 400 g6 SFF i5-14500 16gb ram, 512gb SSD, Vpro, win 11 pro 3yr warranty	\$593.19	\$593.19

		<b>Cad Desktop</b>			
	1	4y0g1av	HP Z2 SFF g9 Desktop i7-14700	\$1,445.00	\$1,445.00
			32gb ram, 1TB SSD, Nvidia t1000 8gb		
			graphics, 2-acp mDP -DP adaptor		
			Win 11 Pro, 3yr warranty		
			<b>Total</b>		

It is my personal goal as well as Inacomp's goal to provide you with exceptional customer service. Should you ever feel that we are falling short of that, please do not hesitate to call. I appreciate your business and the opportunity to serve you!

Jamie J. Ogden  
 President Public Sector Division  
 248-444-0623 Cell  
 248-286-9003 Direct  
[jamie.ogden@inacomptsg.com](mailto:jamie.ogden@inacomptsg.com)

\*This quote is valid for a period of 30 days. Please request updated pricing after 30 days. Thank you.

# Memo

**TO:** RJ Webber, Superintendent

**FROM:** Rebecca Pek, Assistant Superintendent of Human Resources & Development

**CC:** COLT Administrators

**DATE:** February 25, 2025

**RE:** Board Policy 2120 and Board of Education Standards of Practice Proposed Updates

---

## **Policy Update Overview:**

- **BOE Standards of Practice:** The Board of Education Standards of Practice (BOE SOP) document was last reviewed and reaffirmed on February 13, 2018. The current Board of Education determined that a full review and discussion was merited given the last review cycle. As a result, Board reviewed the BOE SOP, and collectively made suggested updates at both the January 2025 Committee of the Whole meeting and at the February 2025 Committee of the Whole meeting. After a thorough review, these suggested changes are presented for Board approval.
- **Policy 2120 Student Enrollment: Children of Employees:** This policy is being updated to allow our Head Coaches of all of our Michigan High School Athletic Association teams the opportunity to bring their children to Northville Public Schools under this allowable exception under the Michigan School Code as it relates to out of district children. After working closely with our Athletic Director and consulting with legal counsel, this action will provide greater leadership stability with our highly competitive MHSAA teams. All MHSAA Head Coaches will be directly employed by the district and all MHSAA Head Coaches will have this enrollment option.

**NORTHVILLE PUBLIC SCHOOLS  
Northville, Michigan**

**BOARD POLICY**

**STUDENT ENROLLMENT: CHILDREN OF EMPLOYEES**

The District shall accept applications from employees of the District to request enrollment of their child (children) under State Law then in effect, subject to space availability, and, if the student resides in a contiguous ISD, a Section 105c agreement acceptable to the District. This policy applies to regular part-time or full-time employees, including Northville Education Foundation staff working at the District, but excludes guest teachers, ~~non-faculty~~third party coaches and contract services. There is no cost for enrollment. Accepted students are allowed to attend District schools through the completion of high school, provided the employee remains continuously employed, or was laid off through a workforce reduction.

The superintendent or designee may establish administrative procedures to implement this policy.

Adopted: June 2010  
Revised: November 2012  
Revised & Renumbered: May 2017  
Revised: October 2018  
Revised: March 2022  
Revised: March 2025

# NORTHVILLE PUBLIC SCHOOLS

## Board of Education Standards of Practice\*

### To Promote Leadership Capacity

- Keep academic achievement and our Commitment to All for all students as our #1 priority.
- Commit to the development and ongoing review of the district's school-continuous improvement process, while focusing on what's best for the overall district and community.
- Maintain an open mind when deliberating on issues before making decisions; being mindful of our own individual air time and aware of potential keeping emotions or biases in our comments/conversations in check.
- Focus on setting direction on the 'what' not on the 'how'.
- Make no promises as individuals and remember that final authority rests with the full board.

### To Promote Effective Communications & Trusting Relationships

- Commit to act professionally with honesty, integrity and respect.
- Commit to act in the best interest of the Northville Public Schools, making decisions about NPS and the use of its assets solely in terms of the benefits to NPS and will not be influenced by any private profit, personal gain or outside benefit for staff or board members.
- Acknowledge mistakes.
- Commit to an environment of "no surprises".
- Adhere to timelines on agenda discussions. A Board Member may be assigned as a timekeeper.
- Bring governance concerns to the board president, superintendent or full board, as appropriate.
- Understand that confidential information will become available to board members and shall not be divulged outside the board.
- Remember one's obligation as a member of the Board of Education when speaking in public. Dedicate oneself to always speaking with a clear, factual, consistent message when communicating positions on critical issues.
- Agree that if anything should occur during the year that would not allow a member to keep the intention of being a positive contributor to the BOE, board member should resign.

### Nuts & Bolts

- Understand that serving on the NPS Board of Education requires the equivalent of several hours per week of member's time, including preparation and meetings. Agree to dedicate that time and expect to attend all board meetings.
- Attending both regularly scheduled Bboard Mmetings and Committee of the Whole Meetings as scheduled per month.
- Agree to serve on committees and at least one community liaison position.
- Focus on policy and keep daily operations at the superintendent level to the extent possible.
- Direct public concerns to the appropriate source and chain of command.
- Recognize that the board president and superintendent act as the key spokespeople for the district, and others will serve as asked.
- Commit to setting goals as a board and participating in an annual board self-evaluation.

Drafted following the 7/27/11 Board Study Session; revised 12/1/11 Board Study Session and finalized and agreed to 1/3/12 Board Study Session.

Revised 12-4-12; Adopted 1-15-13.

Reaffirmed 1-14-14

Revised 7-7-15; Adopted 7-14-15

\*Reaffirmed 2-13-18

\* Revised 12-18-2025; Adopted March 2025



Northville Public Schools

## Early Childhood Education and Extended Day Programs

49775 Six Mile Road, Northville, MI 48168  
248-465-2550 fax 248-465-2561

Date: February 25, 2025  
To: Board of Education  
From: Chelsea Simons, Program Coordinator  
Joanne Sawicki, Assistant Program Coordinator  
RE: 2025-26 Tuition Rates/Budget

In establishing a recommendation for the 2025-26 tuition rates, comparisons were completed with neighboring school districts, enrollment trends were reviewed, and anticipated costs and future expenditures were considered. A projected budget was prepared and reviewed prior to establishing recommendations for the upcoming school year.

We are proposing a tuition increase in all of our program offerings for the 2025-26 school year. This will support a step increase for our staff as well as continued curriculum enhancements.

[2025-26 Budget Proposal](#)

[2025-26 Proposed Classes and Rates](#)



MASB  
MICHIGAN ASSOCIATION  
OF SCHOOL BOARDS



**BOARD *of*  
DIRECTORS  
ELECTIONS**

**2025**

## MASB Bylaws – Article IV – Membership

**Section 2.** Active Members. The board of education of any public school district in Michigan may become an active member of the Association. Active members of the Association shall be divided into eight regions. The regions shall be designated according to intermediate school district boundaries. The regions shall be as follows:

**Region 1.** Copper Country ISD, Delta-Schoolcraft ISD, Dickinson-Iron ISD, Eastern Upper Peninsula ISD, Gogebic-Ontonagon ISD, Marquette-Alger RESA and Menominee County ISD.

**Region 2.** Alpena-Montmorency-Alcona ESD, Charlevoix- Emmet ISD, Cheboygan-Otsego-Presque Isle ESD, COOR ISD, Iosco RESA, Manistee ISD, Northwest Education Services and Wexford-Missaukee ISD.

**Region 3.** Ionia County ISD, Kent ISD, Mecosta-Osceola ISD, Montcalm Area ISD, Muskegon Area ISD, Newaygo County RESA, Ottawa Area ISD and West Shore ESD.

**Region 4.** Bay-Arenac ISD, Clare-Gladwin RESD, Clinton County RESA, Gratiot-Isabella RESD, Midland County ESA, Saginaw ISD and Shiawassee RESD.

**Region 5.** Genesee ISD, Huron ISD, Lapeer County ISD, Sanilac ISD, St. Clair County RESA and Tuscola ISD.

**Region 6.** Allegan Area ESA, Barry ISD, Berrien RESA, Branch ISD, Calhoun ISD, Heritage Southwest ISD, Kalamazoo RESA, St. Joseph County ISD and Van Buren ISD.

**Region 7.** Eaton RESA, Hillsdale County ISD, Ingham ISD, Jackson County ISD, Lenawee ISD, Livingston ESA, Monroe County ISD and Washtenaw ISD.

**Region 8.** Macomb ISD, Oakland Schools and Wayne RESA.

**Active members shall also be divided into the following seven groups based on pupil membership.**

**Group I** All intermediate districts;

**Group II** School districts with a pupil membership of 0 - 1,400;

**Group III** School districts with a pupil membership of 1,401 - 2,500;

**Group IV** School districts with a pupil membership of 2,501 - 5,000;

**Group V** School districts with a pupil membership of 5,001 - 11,000;

**Group VI** School districts with a pupil membership of 11,001 - 40,000; and

**Group VII** School districts with a pupil membership more than 40,000.

## Table of Contents

### Board of Directors' Elections—Candidate Information and Email Voting Procedures 4

#### Region 6 (One-Year Term)

TiAnna Harrison	Kalamazoo Public Schools, Kalamazoo County	5
Elizabeth O'Dell	St. Joseph County ISD, St. Joseph County	6

#### Region 7 (Three-Year Term)

<b>Guillermo Z. Lopez</b>	<b>Lansing School District, Ingham County</b>	7
Cory McLaughlin	Jefferson Schools, Monroe County	8
Jack Temsey	Eaton RESA, Eaton County	9

#### Region 8 (Three-Year Term)

Jason Babbage	Allen Park Public Schools, Wayne County	10
Dr. Anisha Hannah	Pontiac School District, Oakland County	11
Paul Kolin	Bloomfield Hills Schools, Oakland County	12
Roderick Means	Westwood Community School District, Wayne County	13
Randel Meisner	Fitzgerald Public Schools, Macomb County	14
Scott Wallace	Fraser Public Schools	15
Ursula (Wester) Rogers	Romulus Community Schools, Wayne County	16
Lisa Valerio-Nowc	Clintondale Community Schools, Macomb County	17

Note: Incumbents are **bolded**

## Board of Directors' Elections—Candidate Information and Email Voting Procedures

This year, eight seats on the MASB Board of Directors are up for election.

The MASB Board of Directors is comprised of 23 members, including three at-large directors. Sixteen directors shall be elected from the eight regions, with two elected from each region; and one director per group shall be elected from Groups V, VI and VII. Directors are elected by active member school boards and, each year, several seats are up for election. The MASB President will nominate a member to serve as an at-large director, subject to Board approval.

### Board Limitations:

Article VIII, Section 6 of the MASB Bylaws permits only one director to be elected or appointed from any one local or intermediate school district board.

According to MASB Bylaws Article VIII, Section 8, if any nomination for the Board of Directors is unopposed, the Board of Directors shall declare the unopposed candidate elected without conducting an election for the uncontested group or region.

**This year, the following seats on the MASB Board are up for election (one seat each, three-year terms unless otherwise noted): Regions 1 (two-year term), 3, 4, 6 (open seat; one-year term), 7, 8 (open seat) and Groups V and VI. If you're unsure of your district's region or group, please see the list on page 2.**

- **Region 1 will continue to be represented by Kristen Cambensy, Marquette Area Public Schools, (unopposed, no ballots will be sent)**
- **Region 3 will continue to be represented by Rick Dernberger, Zeeland Public Schools and Ottawa Area Intermediate School District, (unopposed, no ballots will be sent)**
- **Region 4 will continue to be represented by John Tramontana, DeWitt Public Schools, (unopposed, no ballots will be sent)**
- **Group V will continue to be represented by Stephen Hyer, Clarkston Community Schools, (unopposed, no ballots will be sent)**
- **Group VI will continue to be represented by Marc Siegler, Walled Lake Consolidated Schools, (unopposed, no ballots will be sent)**

**Voting in Regions 6, 7 and 8** will take place via an online ballot. No local district/ISD funds can be used to campaign for anyone running for a seat. To help your board make an informed decision, the following pages contain background information and statements from each of the candidates.

Each district received ONE ballot, which was emailed to the superintendent secretary on record with MASB on Friday, Jan. 24, 2025. These ballots **CANNOT** be forwarded to anyone else. Once your board makes a decision on which candidate it wishes to vote for, please convey this information to your superintendent secretary.

Completed ballots must be cast and confirmed by the superintendent secretary by **1 p.m. on Wednesday, March 5, 2025.**

Unofficial election results will be available on the voicemail recording at 517.327.5915 as soon as possible, but generally after 2 p.m. on the deadline date. They will also be sent out via email that afternoon. Official results will be approved at the March 14, 2025, Board of Directors' meeting, which newly elected directors should plan to attend.

To summarize:

- Ballot deadline is **1 p.m. on Wednesday, March 5, 2025.**
- MASB would like to remind all candidates for the MASB Board of Directors that no school district funds can be used for campaigning during the election. This rule prohibits a candidate from using their school district email account to send messages to other school board members. Therefore, a personal email account must be used for campaigning purposes when running for the MASB Board of Directors. If you have any questions about what may or may not constitute an expenditure of school district funds, please contact MASB's Legal Counsel Brad Banasik, J.D. at [bbanasik@masb.org](mailto:bbanasik@masb.org) or **517.327.5929.**
- An electronic file containing the physical addresses and email addresses for the voting group or region shall be made available to each candidate running for election to the board of directors. The revokable license to use the addresses shall be limited to contacting school board members to share information about the MASB Board of Directors' election.
- Have questions? Contact Cheryl Huffman at **517.327.5915** or [chuffman@masb.org](mailto:chuffman@masb.org).

## Region 6 (One-Year Term)



### TiAnna Harrison

**Kalamazoo Public Schools, Kalamazoo County**

Time served on this board:

**10** years

Offices held:

President, Vice President, Secretary and Treasurer

### MASB Certification:

Certified Boardmember Award  
Award of Merit  
Award of Distinction  
Master Boardmember  
Master Diamond

### Election Statement:

My name is TiAnna Harrison, and as the current Board President for Kalamazoo Public Schools Board of Education, I bring over a decade of governance and leadership experience. Appointed in 2014, and reelected in 2020, I have had the honor of serving my community in various capacities, including Vice President, Secretary and Treasurer.

Through these positions, I have had a firsthand view of the challenges and opportunities in education, especially as we work to ensure all students have equitable access to high-quality learning experiences.

My experience serving in a district with diverse needs has given me a comprehensive understanding of the complexities facing school boards across Michigan, and I believe I can bring valuable insights to MASB. I am passionate about the power of public education to transform lives. Our work as school board members is critical in ensuring that every child has access to a high-quality education, no matter where they live.

From advocating for equitable funding to addressing the mental health needs of students, the role of school boards has never been more important. Through my years of service, I have seen firsthand how strategic decision-making, thoughtful governance, and strong community partnerships can improve outcomes for students. I am seeking a seat on the MASB Board of Directors because I believe that the challenges we face in Michigan's education system require a unified and strategic approach.

I am particularly focused on the importance of state-level policies that allow local school boards to address the unique needs of their districts. I want to ensure that Michigan school boards have the tools and support they need to make informed decisions that benefit all students.

From ensuring equitable funding to supporting the mental and emotional well-being of students and staff, I am eager to contribute my experience and insights to support school boards across the state and advocate for policies that will create better outcomes for Michigan's children.

I would be honored to not only serve on the MASB Board of Directors, but also to continue advocating for policies that prioritize the needs of students, support educators, and strengthen our communities. Together, we can ensure that every Michigan student has the opportunity to succeed.

Thank you for your consideration.

Sincerely,

TiAnna L. Harrison

Kalamazoo Public Schools

Trustee – Board of Education



## Region 6 (One-Year Term)

### Elizabeth O'Dell

St. Joseph County ISD, St. Joseph County

Time served on this board:

**27** years

Offices held:

President, Vice President, Secretary and Treasurer

#### MASB Certification:

- Certified Boardmember Award
- Award of Merit
- Award of Distinction
- Master Boardmember
- Master Diamond

#### Election Statement:

The MASB is our collective voice on education at the state level, and it allows board members to be informed about educational issues. I think the Director for the Region's role is to ensure that our voice is heard as the MASB discusses issues and concerns. The Past President, Kathleen Moore, was able to model how to accomplish that task positively. I cannot fill her shoes; I am unsure if anyone can.

I have been an active St. Joseph County ISD member for 27 years. I have taken advantage of opportunities to learn about best practices for serving and supporting the education process in our communities. I have held various positions, from member to president.

I have worked with the parent-teacher association, band, and athletic booster clubs. I have served on the special education advisory committee. I have enjoyed serving as a delegate to MASB membership meetings in my county. Through this process, I have learned what various boards are concerned about as they present resolutions and amendments to the Board of Directors, which has deepened my understanding of how our collective needs are connected.

I have and will continue to advocate for a strong public education. My children and I are products of public education. I obtained my bachelor's degree from Ball State University and my graduate degree from Western Michigan University.

I am not new to service, advocacy, listening, and striving to assist others to make positive change. I am a retired CEO of St. Joseph County Community Mental Health and use my time currently as a volunteer in my church, for American Red Cross Disaster Relief, as a substitute teacher, as well as working with a variety of social action services through my sorority, Delta Sigma Theta Sorority, Incorporated.

I am seeking this position to advocate for the needs of our small and large communities. I am a champion for public education, and with your vote, I can take my commitment to this service to the next level.

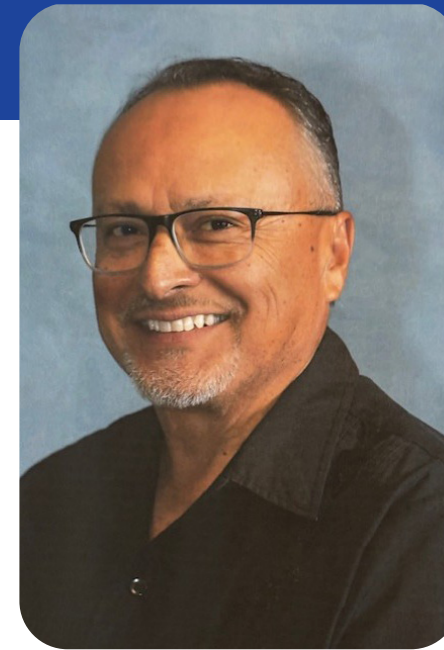

## Region 7 (Three-Year Term)

### Guillermo Z Lopez INCUMBENT

Lansing School District, Ingham County

Time served on this board:

**24** years

Offices held:

President, and Treasurer

#### MASB Certification:

- Certified Boardmember Award
- Award of Merit
- Award of Distinction
- Master Boardmember

#### Election Statement:

As we welcome the new year, we are also aware that changes in education funding from the federal government are very possible. As your director from Region 7, I will work closely with our MASB staff and pay close attention to how these changes may affect our educational system here in Michigan. I will also continue to support the work MASB has done in the area of equity in education in all its forms. Additionally, I will continue supporting districts that need training but are not in a position to cover the costs. I very much appreciate MASB staff who are continually looking at ways that we can expand these funding efforts. Finally, I hope you have enjoyed the newsletter coming directly from Region 7.

## Region 7 (Three-Year Term)



### Cory McLaughlin

Jefferson Schools, Monroe County

Time served on this board:

**11** years

Offices held:

President and Secretary

MASB Certification:

Certified Boardmember (CBA 101)

### Election Statement:

Since joining the Jefferson School Board in 2014, I have been dedicated to ensuring that every decision we make is in the best interest of our students. I am passionate about creating opportunities for all learners and believe that every child deserves access to a high-quality education that meets their unique needs and aspirations.

Career and Technical Education (CTE) programs are a priority for me because they provide students with real-world skills and open doors to meaningful careers. I also strongly advocate for advanced classes to challenge and inspire high-achieving students, ensuring they are prepared for post-secondary education and beyond. Equally important is my commitment to special education, as I believe every child, regardless of ability, deserves the resources and support to thrive.

My experience on the Jefferson School Board has taught me the importance of collaboration, fiscal responsibility and community engagement. I bring a student-centered approach to decision-making and strive to build partnerships that benefit our schools. Serving on the MASB Board of Directors would allow me to expand this work, sharing best practices and advocating for policies that empower all districts to succeed.

I am running for this position because I am deeply committed to advancing education in Michigan and ensuring that every child has access to the tools and opportunities they need to achieve their full potential.

## Region 7 (Three-Year Term)



### Jack Temsey

Eaton RESA, Eaton County

Time served on another board:

**8** years

Potterville Public Schools

Offices held:

Secretary and Treasurer

Time served on this board:

**8** years

Offices held:

President, Vice President, Secretary and Treasurer

MASB Certification:

Certified Boardmember Award

Award of Merit

Award of Distinction

Master Boardmember

Master Diamond

Master Platinum

### Election Statement:

As a Board of Education Trustee, I feel we are the voice for our children. We need to utilize this voice to ensure we can offer our children the education they deserve, regardless of the struggles that we face behind the scenes.

We need to direct this voice to those who create legislation that we feel will adversely affect public education, as well as remember to offer praise to those who show us favor and offer to help. I believe the voice of our boards and communities can make a difference. I have strived to become the best board member I can be. One of the ways that I have tried to accomplish this is by becoming certified through the MASB's CBA program. I have gained a wealth of knowledge by attending classes, conferences and other various events as well as networking with board members from around the state.

Public education is as diverse as our country. There are no single fix-all solutions that work for every school district. I feel that bringing the voice of small communities and small districts to the forefront is important. I would like to continue advocating to provide

adequate and equitable funding for ALL districts. Adequate funding is sufficient funding to provide basic schooling. Equitable funding is based on fairness.

I previously served the Potterville Public Schools Board of Education for eight years. During this time, I served on the Policy, Community Relations and Technology Committees, as well as Secretary and Treasurer. I have been an Eaton RESA Trustee for eight years, serving on the Building and Grounds and Finance and Audit Committees as well as Secretary, Vice President and Treasurer. I am currently serving again as President.

Additionally, I have served MASB as a member of the Curriculum and Instruction Committee and Government Relations Committee plus served as its Vice Chairman, also on the Resolutions and Bylaws committee, and as its Vice Chairman. I am currently serving again on the Government Relations Committee as its Vice Chairman.

I would be honored to serve on the MASB Board of Directors to represent you, our Region, and our students. I want to bring your voices to the table to further benefit the future of public education.



## Region 8 (Three-Year Term)

### Jason Babbage

Allen Park Public Schools, Wayne County

Time served  
on this board:

**2** years

**MASB Certification:**

Certified Boardmember Award  
Award of Merit

### Election Statement:

I am an alumnus and lifelong resident of the Allen Park Public School District. Family and education are at the top of my interests, loves and passions, and certainly go hand in hand with the MASB Board of Directors position for Region 8. Inspired by family members holding political positions leading the way and showing me what it is to serve the community; I can only hope to follow in their footsteps and use my unique position and family connections to influence policy.

I am looking forward to serving on the MASB Board of Directors to help promote a unified and communitive board of directors that focuses on the major issues facing us in the educational community. Some of these issues include unfunded policies, declining enrollment, higher education standards, advances in educational technology, and more. To navigate these issues, we need to be open to change and willing to support new ideas whether it is adding sensory rooms or going from textbooks to technology.

I hold a master's degree in automotive systems engineering and a bachelor's degree in mechanical engineering from U-M Dearborn, and work at Ford Motor Company as an engineer in exterior automotive lighting and am considered one of the top experts in headlamp aim (HLA). I achieved my MASB Level 2 award of merit and look forward to getting more MASB classes under my belt. I have two children attending Allen Park schools and it's family that's been the driving force of involvement in the community and schools.

I would like to serve on the MASB Board of Directors because I believe I will bring a different perspective, drive and policy influence that will be beneficial to Region 8.



## Region 8 (Three-Year Term)

### Dr. Anisha Hannah

Pontiac School District, Oakland County

Time served  
on this board:

**3** years

**Offices held:**

President and  
Secretary

**MASB Certification:**

Certified Boardmember  
Award of Merit  
Award of Distinction

### Election Statement:

I view education as the key to unlocking the door of possibilities. I believe that every child should have access to a quality education. One that will equip them with the skills and knowledge to lead productive, fruitful lives and make a positive contribution to society. I believe that every student can learn; some may require the use of different methodologies. My concern about the educational system is that too much emphasis has been placed on test scores as opposed to the success of the whole child.

Currently, as the Director of Strategic Partnership & Initiatives with the Pontiac Collective Impact Partnership, I lead collaborative efforts with nonprofits, government agencies, and educational institutions to enhance economic and academic outcomes. In this role, I have successfully developed initiatives and set goals for the City of Pontiac with partners that support Oakland County's goal of 80 by 30, ensuring program sustainability and growth. My experience as Board President with the City of Pontiac School Board of Education has further honed my ability to manage complex budgets, engage with diverse stakeholders, and advocate for initiatives that benefit community members from various socioeconomic backgrounds. These experiences have equipped me with the skills to identify challenges, implement data-driven improvements, and ensure that programs achieve measurable outcomes.

It is my desire to serve on the MASB Board of Directors to provide a voice for the minority students that reside in lower socioeconomic backgrounds. The views and opinions of minority students and families are often overlooked and unheard. Serving on the MASB Board of Directors would allow me the opportunity to represent a demographic and community who benefits the most from public education.

I am enthusiastic about the opportunity to learn and contribute to impactful programs and policies that will support children in Michigan's school districts.

I am eager to bring my dedication to education and the Pontiac community to the MASB platform.

## Region 8 (Three-Year Term)



### Paul Kolin

Bloomfield Hills Schools, Oakland County

Time served on this board:

10 years

Offices held:

President, Vice President, Secretary and Treasurer

#### MASB Certification:

Certified Boardmember Award  
Award of Merit  
Award of Distinction

#### Election Statement:

Education is the cornerstone of our society, shaping not only the minds of the next generation but also the future of our communities and the world. I believe that a high-quality education system equips students with the skills and knowledge necessary to thrive, fosters critical thinking, and nurtures a lifelong love of learning. Beyond academics, education must prepare individuals to engage as informed, empathetic and responsible citizens.

My passion for education stems from witnessing its transformative power in my own life and in the lives of others. I firmly believe that every child deserves access to equitable opportunities, regardless of their background or circumstances. This requires a commitment to removing barriers, supporting educators, and fostering innovative practices that address the diverse needs of all learners.

Serving on the MASB board is an opportunity to advocate for these values at a broader level. The Michigan Association of School Boards plays a pivotal role in strengthening public education by providing leadership, governance and support to local districts. As a board member, I would work collaboratively to ensure that policies and resources are aligned with the goal of fostering student success and community engagement.

My background in Bloomfield Hills for the last 10 years and being a teacher in the past has equipped me with the skills to navigate complex challenges, analyze data-driven solutions, and build consensus among diverse stakeholders. I am committed to listening to educators, parents, and students to understand their needs and bring their voices to the decision-making table.

By serving on the MASB board, I hope to contribute to a shared vision of educational excellence, ensuring that every child in Michigan receives the education they deserve. Together, we can create a stronger future for our students and our communities.

## Region 8 (Three-Year Term)



### Roderick Means

Westwood Community School District, Wayne County

Time served on this board:

28 years

Offices held:

President, Vice President, Secretary and Treasurer

#### MASB Certification:

Certified Boardmember Award  
Award of Merit  
Award of Distinction  
Master Boardmember  
Master Diamond  
Master Platinum  
President's Award

#### Election Statement:

As a passionate advocate for quality education, my vision for our educational system centers on equity, innovation and community engagement. Every student, regardless of background, should have access to high-quality educational opportunities that prepare them for future success. My primary concerns include addressing disparities in educational resources, integrating technology, and fostering strong partnerships within our communities.

As a single parent of two young boys, I began as a little league baseball and football coach. I served a Cub and Boy Scout leader, from Tiger Cub Coordinator to Cubmaster and Assistance Boy Scout leader. I served on many Athletic and booster clubs in the High School. I spearheaded initiatives that improved academic outcomes and strengthened community ties. For the last 20 years, I have worked as an Application Developer at the University of Michigan Ann Arbor, gaining valuable insights into educational technology.

I have actively contributed to the field of education beyond my immediate roles by serving on various MASB committees, including Government Relations, Bylaws and Policy, and Board Leadership and Training. These committees have allowed me to work collaboratively on critical issues affecting our schools and have deepened my understanding of governance and policy frameworks. Additionally, I have served as an MASB Board Mentor, supporting new board members in their roles and fostering effective leadership and governance.

My decision to seek a position on the MASB Board of Directors stems from a deep commitment to effecting systemic change. Serving on the board will allow me to leverage my experience to advocate for equitable funding, support professional development for educators, and integrate technology to enhance learning. I am dedicated to fostering transparency and accountability to ensure that all decisions are in the best interest of our students. In conclusion, my extensive experience in education, coupled with my dedication to improving our educational system, uniquely positions me to contribute meaningfully to the MASB Board of Directors. I am eager to drive positive change, support our educators, and ensure every student has the opportunity to succeed. Thank you for considering my candidacy.

## Region 8 (Three-Year Term)



### Randel Meisner

Fitzgerald Public Schools, Macomb County

Time served  
on this board:

**12** years

**Offices held:**

Vice President,  
Secretary and  
Treasurer

**MASB Certification:**

- Certified Boardmember Award
- Award of Merit
- Award of Distinction
- Master Boardmember
- Master Diamond
- Master Platinum
- President's Award

**Election Statement:**

CONCERNS: We need sustainable funding for public education at all levels. Teacher retention. Teacher shortages. Full funding for special education. Offset the MPSERS cost.

EXPERIENCE: MISD Legislative Committee, MISD Budget Review, participate in annual legislative strategic planning sessions. Attend the state Annual Leadership Conferences and National School Board Conferences. Awarded the MASB President's Award.

I would appreciate a chance to serve on the MASB board of directors so that I can add a fresh viewpoint to the board. I enjoy working with other board members for a common goal.

## Region 8 (Three-Year Term)



### Scott Wallace

Fraser Public Schools

Time served  
on this board:

**8** years

**Offices held:**

President, Vice  
President and  
Treasurer

**MASB Certification:**

- Certified Boardmember Award
- Award of Merit
- Award of Distinction
- Master Boardmember

**Election Statement:**

Region 8 is comprised of many different students with many different backgrounds, and all deserve a quality education regardless of where they live.

I am proud to serve in the same district where I, and my three children, have graduated from. I am an Eagle Scout and have coached soccer and basketball as well as served as an officer on the Board of Directors for the Fraser Soccer Club for four years. I have been the President of Fraser Public Schools Board of Education since 2022 and a board member since 2017.

I have worked with the MASB since becoming a school board member and have seen the many good things that come from us all working towards making education in Michigan better for all of our kids.

Working on the MASB legislative committee for three years I got to see up close how important it is for us to continue to be heard in Lansing and I hope to take this opportunity to continue making sure our region's concerns are heard. I thank you for the opportunity to serve.



## Region 8 (Three-Year Term)

### Ursula (Wester) Rogers

Romulus Community Schools, Wayne County

Time served  
on this board:

8 years

Offices held:

President, Secretary  
and Treasurer

#### MASB Certification:

Certified Boardmember Award  
Award of Merit  
Award of Distinction  
Master Boardmember

#### Election Statement:

I am deeply passionate about ensuring that every student in Michigan has access to a high-quality, equitable education. However, there are significant challenges that must be addressed, including disparities in funding, access to resources, and the growing mental health needs of students. These issues disproportionately impact students from marginalized communities, and I firmly believe it is our collective responsibility to create a system that is inclusive, supportive, and designed to meet the needs of all learners.

Throughout my career, I have had the privilege of working in various educational settings, including as a substitute teacher, secretary, human resources professional, and school board member. These roles have provided me with a firsthand understanding of the challenges educators face, from budget cuts to the increasing demands on teachers' time and resources. Additionally, I have served on committees focused on policy, human resources, school improvement, and curriculum, gaining valuable insights into the intricacies of school governance.

Beyond my professional experience, I have been actively involved with the Romulus Athletic Club for 24 years as treasurer and cheerleading coach for a youth football organization. This work has allowed me to connect with students in alternative ways, providing them with positive outlets to compete, grow, and discover what drives them. Through all of these experiences, I have gained a comprehensive understanding of how local school boards can influence state and national education policies. These experiences have strengthened my expertise in governance and advocacy, which I believe would be an asset to the MASB Board of Directors.

I wish to serve on the MASB Board of Directors because I am committed to ensuring that Michigan's school boards have the tools, resources, and support they need to advocate effectively for students. MASB is uniquely positioned to unite school boards across the state to address shared challenges, promote best practices, and advocate for policies that improve funding, access to resources, and student outcomes. I am eager to collaborate with fellow board members to create lasting, positive change for Michigan's students and educators.

Thank you for considering my candidacy.

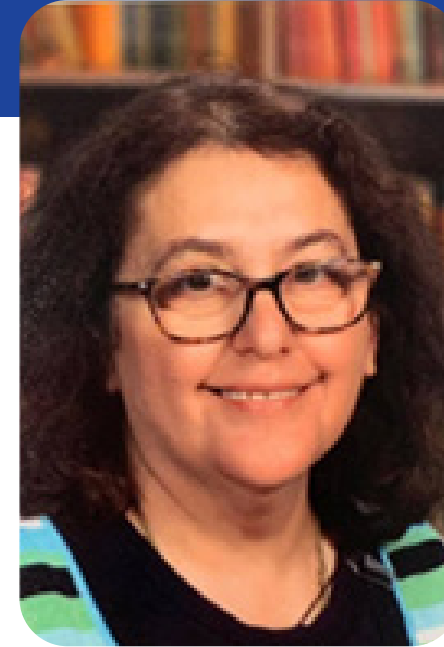

## Region 8 (Three-Year Term)

### Lisa Valerio-Nowc

Clintondale Community Schools, Macomb County

Time served  
on this board:

2 years

Offices held:

Secretary

#### MASB Certification:

Certified Boardmember Award  
Award of Merit

#### Election Statement:

As a librarian for over thirty years with experiences in school libraries, and in the classroom, I understand the complex issues in education today. Teachers and students are finding their classrooms changing almost daily with new technology, apps and tools that, at times, seem overwhelming. Added to this are the challenges that are faced every day of surviving in a society that seems to be controlled by "notifications" on our phones and computers. My aim is to make my school district a safe place to learn and grow. With this in mind, as a MASB Board member, I believe that my contributions will aid the organization in finding meaningful solutions that will help schools support their communities better.

Education is not just a word that conveys what a person learns. It is what that person does with the education that makes an impact on our community and world. It is an honor to be a part of a profession that guides the next generation. I have been a School Librarian, Library Director of Baker College, and served in leadership positions in public libraries. Currently, I am the Assistant Manager/Children's Librarian at Chaney Branch/Detroit Public Library. In each of these positions I have made it a goal to help children and adults with their lifelong pursuit of learning. In my opinion, once you stop learning, you stop growing.

In closing, it is without a doubt in my mind that I am qualified and ready to serve as a Board of Director member for the MASB. I am ready to serve and make a positive impact with the organization.



## MISSION

*To provide high-quality educational leadership services for all Michigan boards of education and to advocate for an equitable and exceptional public education that leads to improved outcomes for all students.*

## VISION

*A well-governed, effective public school for every Michigan student.*

**INFO@MASB.ORG | MASB.ORG | 517.327.5900**

**1001 Centennial Way, Suite 400 • Lansing, Michigan 48917-8249**