

**Richland County Community Unit School District No.1
Board of Education**

**Regular Meeting
Thursday, March 19, 2026
Richland County High School
1200 E. Laurel St.
Olney, IL 62450
6:00 PM**

I.	Call to Order and Pledge of Allegiance	
II.	Roll Call	
III.	Public Hearing	
	A. Hear testimony on the proposal to sell bonds of the District in an amount not to exceed \$9,000,000 for the purpose of altering, repairing and equipping school buildings and facilities and improving school sites.	
	B. Adjourn Alternate Bonds Hearing and Convene to Regular Meeting	
IV.	Recognition and Comments from Employees and Public	
	A. Recognize RCES 5th Grade, RCMS 8th Grade and RCHS Senior IPA Nominees	
	B. Recognize RCMS MathCounts Students	
V.	Consent Agenda	
	A. * Minutes of Previous Meetings	
	1. * Regular and Closed Minutes of the Regular Board Meeting on Thursday, February 19, 2026, and Special Board Meeting of March 4, 2026.	3
	B. * Closed Minutes	
	1. * Approve Destruction of Audio Recordings of August 15, 2024.	
	C. * Communication	
	1. Thank-You Notes	12
	D. * February FOIA Log	16
	E. * IHSA Agreement	18
	F. * Building Reports	
	1. * RCELC	19
	2. * RCES	20
	3. * RCMS	23
	4. * RCHS	28
	5. * RiseUp	32
	6. * Special Education	34
	G. * Approve Fundraisers	35
VI.	Financial Reports	
	A. Treasurer's Report	40
	B. Balance Sheet	41
	C. Approval of Bills	46
	D. All Other Financial Reports	
	1. Comparison of Funds - February 2025 with February 2026	94
	2. Monthly Financial Report	95

3.	Financial Update/Review	146
VII.	Administrative Reports	
A.	Superintendent's Report	
1.	Graduation/End of Year Dates	
2.	Hourly vs Annualized Pay	
3.	Holly Road Discussion	
4.	Summer School Fee	
B.	Assistant Superintendent's Report	
1.	Construction Update on the Athletic Complex by GeoSurfaces	
2.	South Building Estimates	
3.	State Testing Update	
VIII.	Unfinished Business	
IX.	New Business	
A.	Approve Amended 2025-2026 School Calendar	149
B.	Approve 2026-2027 School Calendar	151
C.	Approve Athletic Building Bid	153
D.	Approve Purchase of RCES Canopies	159
E.	Approve Changes in 2026-2027 Student Handbooks	171
F.	Approve Summer 2026 Maintenance Project List	182
X.	Enter Executive Session	
A.	2(c)(1) To Consider Information Regarding Appointment, Employment, Compensation, Discipline, Performance, or Dismissal of Individual Employees	
B.	2(c)(11) To Discuss Matters of Possible or Pending Litigation	
C.	2(c)(21) To Discuss Matters of Closed Session Minutes	
XI.	Exit Executive Session	
XII.	Possible Suspension without Pay of a RCCU1 Educational Support Staff Member	
XIII.	Personnel Action	
XIV.	Approve 2026-2027 Rehire List for Administrative Team	
XV.	Approve 2026-2027 Rehire List for Licensed Staff	
XVI.	Approve 2026-2027 Rehire List for Educational Support Staff	
XVII.	Approve 2026-2027 Educational Support Staff Wage Increase	
XVIII.	Adjournment	

Regular Meeting
Thursday, February 19, 2026 6:00 PM Central

Richland County High School
1200 E. Laurel St.
Olney, IL 62450

The meeting was open to the public and viewable via live stream at <http://live.rccu1.net>

I. Call to Order and Pledge of Allegiance – The regular meeting of the Richland County Board of Education was called to order by President Scott Snyder at 6:00 p.m. on Thursday, February 19, 2026.

II. Roll Call

- Dennis Anderson: Present
 - Jake Anderson: Present
 - Cindy Bailey: Present
 - Dusty Kocher: Present
 - Cindy Lockley: Present
Exited the meeting at 9:37 p.m.
 - Scott Snyder: Present
 - Jeff Wilson: Present
- Present: 7.

III. Public Hearing

III.A. Hear testimony on the proposal to sell bonds of the District in an amount not to exceed \$9,000,000 for the purpose of altering, repairing and equipping school buildings and facilities and improving school sites.

No comments, No written testimony, and No oral testimony.

III.B. Adjourn Alternate Bonds Hearing and Convene to Regular Meeting

Motion to adjourn Alternate Bonds Hearing and convene to regular meeting at 6:02 p.m. This motion, made by Jeff Wilson and seconded by Cindy Bailey, Passed.

Dennis Anderson: Yea, Jake Anderson: Yea, Cindy Bailey: Yea, Dusty Kocher: Yea, Cindy Lockley: Yea, Scott Snyder: Yea, Jeff Wilson: Yea
Yea: 7, Nay: 0

IV. Recognition and Comments from Employees and Public

IV.A. The board recognized RCHS Band Students Lila Balding, Jereme Higginbotham, and Emma Gilreath for being selected for the All-State Orchestra and Joshua Ochs for All-State Band.

V. Consent Agenda

Motion to approve the consent agenda as presented. This motion, made by Dennis Anderson and seconded by Cindy Lockley, Passed.

Dennis Anderson: Yea, Jake Anderson: Yea, Cindy Bailey: Yea, Dusty Kocher: Yea, Cindy Lockley: Yea, Scott Snyder: Yea, Jeff Wilson: Yea
Yea: 7, Nay: 0

V.A. * Minutes of Previous Meetings

V.A.1. * Regular and Closed Minutes of the Regular Board Meeting of Thursday, January 15, 2026, and Special Board Meeting of February 2, 2026.

V.B. * Closed Minutes

V.B.1. * Approve Destruction of Audio Recordings of July 3, 2024 and July 18, 2024.

V.C. * Communication

V.C.1. * Thank-You Notes – We received thank-you notes for flowers sent, from Janice Pampe for the death of her father, Dale Tibbs, Melinda and Jason Smith for the death of her father, Don Dunahee, and Jennifer Burgener for the death of her father, Roger Charleston.

V.D. * January FOIA Log – Document Registry 26-02-01 A FOIA request from East Central Reporter requesting all vendor contracts over \$1000.00 for current fiscal year.

V.E. * Building Reports – Submitted from Administration from each building.

V.E.1. * RCELC

V.E.2. * RCES

V.E.3. * RCMS

V.E.4. * RCHS

V.E.5. * Special Education

V.E.6. * RiseUp

V.F. * Approve Fundraisers

VI. Financial Reports

Motion to approve financial reports as presented. This motion, made by Jeff Wilson and seconded by Dennis Anderson, Passed.

Dennis Anderson: Yea, Jake Anderson: Yea, Cindy Bailey: Yea, Dusty Kocher: Yea, Cindy Lockley: Yea, Scott Snyder: Yea, Jeff Wilson: Yea

Yea: 7, Nay: 0

VI.A. Treasurer's Report – The monthly treasurer's report was presented.

VI.B. Balance Sheet – The monthly balance sheet was presented.

VI.C. Approval of Bills – The monthly bill listing in the amount of \$2,258,157.79 was presented for payment.

VI.D. All Other Financial Reports

VI.D.1. Comparison of Funds - January 2025 with January 2026

VI.D.2. Monthly Financial Report – The monthly financial report was presented.

VI.D.3. Financial Update/Review – Mr. Rusk reviewed the financial reports and presented a Budget Fund Comparison as of January 31, 2026.

FY26 Original Budget					
Fund	Fund Balance July 1, 2025	FY26 Revenue	FY26 Expenditures	Fund Balance July 1, 2026	Difference
10-Education*	\$25,768,189.00	\$26,830,026.00	\$27,489,927.00	\$25,108,288.00	-\$659,901.00
20-Operations & Maintenance**	\$2,997,941.00	\$1,902,000.00	\$1,874,959.00	\$3,024,982.00	\$27,041.00
30-Debt Service	\$257,114.00	\$2,871,769.00	\$2,831,140.00	\$297,743.00	\$40,629.00
40-Transportation***	\$953,209.00	\$1,552,700.00	\$1,544,989.00	\$960,920.00	\$7,711.00
50-IMRF/SS	\$806,282.00	\$1,083,050.00	\$1,081,989.00	\$807,343.00	\$1,061.00
60-Capital Projects****	\$1,029,516.00	\$865,000.00	\$840,000.00	\$1,054,516.00	\$25,000.00
70-Working Cash	\$1,410,650.00	\$217,170.00	\$0.00	\$1,627,820.00	\$217,170.00
80-Tort Immunity	\$13,753.00	\$1,728,400.00	\$1,727,679.00	\$14,474.00	\$721.00
90-Fire Prevention & Safety	\$213,878.00	\$177,170.00	\$75,000.00	\$316,048.00	\$102,170.00
					\$0.00
Total	\$33,450,532.00	\$37,227,285.00	\$37,465,683.00	\$33,212,134.00	-\$238,398.00
Current Revenue/Expenditure Compared to Budgeted					
Fund	Current Revenue	% Compared to Budget	Current Expenditure	% Compared to Budget	
10-Education	\$15,079,596.00	56.20%	\$15,455,063.00	56.22%	
20-Operations & Maintenance	\$1,822,764.00	95.83%	\$939,848.00	50.13%	
30-Debt Service	\$2,876,707.00	100.17%	\$2,291,546.00	80.94%	
40-Transportation	\$1,160,855.00	74.76%	\$834,035.00	53.98%	
50-IMRF/SS	\$1,095,302.00	101.13%	\$626,986.00	57.95%	
60-Capital Projects	\$2,561,103.00	296.08%	\$1,443,194.00	171.81%	
70-Working Cash	\$210,913.00	97.12%	\$0.00	100%	
80-Tort Immunity	\$1,712,967.00	99.11%	\$568,960.00	32.93%	
90-Fire Prevention & Safety	\$179,782.00	101.47%	\$39,278.00	52.37%	
	\$26,699,989.00		\$22,198,910.00		
Total All Fund Comparison					
	Total Revenue Compared to Budget	Total Expenditure Compared to Budget			
Total for All Funds	71.72%	59.25%			

VII. Administrative Reports

VII.A. Superintendent's Report

VII.A.1. RCHS Graduation & RCMS Promotion Dates were discussed. RCHS Graduation will be May 17 – 3pm and RCMS Promotion will be May 19 – 6pm.

VII.A.2. Damon West Assembly will be held on February 23 in the Ron Herrin Gym and all RCMS and RCHS Students and Staff will attend.

VII.A.3. IASB Wabash Valley Spring Division Meeting for board members will be March 17, 2026 in Casey, IL.

VII.A.4. 5Essentials Survey window is open until March 13, 2026. This survey is taken by parents, guardians, staff and students.

The Athletic Building Pre-Bid Conference will be February 26 at 10:00 a.m. in the RCPAC. Bids will be accepted until 2:00 p.m. on March 12.

VII.B. Assistant Superintendent's Report

VII.B.1. Construction Update on the Athletic Complex by Houston Meyer with GeoSurfaces. He shared aerial pictures of the complex showing the work being done.

VII.B.2. Maintenance & Custodial Teams – Mr. Rusk commended and thanked the Maintenance and Custodial Teams for a job well done during the recent snow storm in January.

VII.B.3. High School Math Pathways was discussed by Mrs. Rodgers.

VII.B.4. Parent/Teacher Conferences were held on February 9 & 11 from 4 – 7:30 p.m. each evening. Mrs. Rodgers thanked everyone involved for their hard work.

VIII. Unfinished Business

IX. New Business

IX.A. Approve Amended 2025-2026 School Calendar – **Document Registry 26-02-02**
Motion to approve the amended 2025-2026 school calendar to reflect 4 emergency days used on January 26, 27, 28, and 29. This motion, made by Dennis Anderson and seconded by Dusty Kocher, Passed.

Dennis Anderson: Yea, Jake Anderson: Yea, Cindy Bailey: Yea, Dusty Kocher: Yea, Cindy Lockley: Yea, Scott Snyder: Yea, Jeff Wilson: Yea
Yea: 7, Nay: 0

IX.B. Approve RCHS Graduation Date of Sunday, May 17, 2026
Motion to approve the Richland County High School graduation date of Sunday, May 17, 2026 at 3:00 p.m. This motion, made by Cindy Bailey and seconded by Cindy Lockley, Passed.

Dennis Anderson: Yea, Jake Anderson: Yea, Cindy Bailey: Yea, Dusty Kocher: Yea, Cindy Lockley: Yea, Scott Snyder: Yea, Jeff Wilson: Yea
Yea: 7, Nay: 0

IX.C. Approve Performance Rankings File (Licensed Staff) – **Document Registry 26-02-03**
Motion to approve the 2025-2026 Performance Rankings File as presented. This motion, made by Jeff Wilson and seconded by Cindy Lockley, Passed.

Dennis Anderson: Yea, Jake Anderson: Yea, Cindy Bailey: Yea, Dusty Kocher: Yea, Cindy Lockley: Yea, Scott Snyder: Yea, Jeff Wilson: Yea
Yea: 7, Nay: 0

IX.D. Approve Educational Support Staff Seniority List – **Document Registry 26-02-04**
Motion to approve the 2025-2026 Educational Support Staff Seniority List as presented. This motion, made by Cindy Lockley and seconded by Dennis Anderson, Passed.

Dennis Anderson: Yea, Jake Anderson: Yea, Cindy Bailey: Yea, Dusty Kocher: Yea, Cindy

Lockley: Yea, Scott Snyder: Yea, Jeff Wilson: Yea
Yea: 7, Nay: 0

IX.E. Approve 2026-2027 RCHS Curriculum Guide – **Document Registry 26-02-05**

Motion to approve the 2026-2027 RCHS Curriculum Guide as presented. This motion, made by Dusty Kocher and seconded by Dennis Anderson, Passed.

Dennis Anderson: Yea, Jake Anderson: Yea, Cindy Bailey: Yea, Dusty Kocher: Yea, Cindy Lockley: Yea, Scott Snyder: Yea, Jeff Wilson: Yea
Yea: 7, Nay: 0

The board asked if Admin could check on the possibility of a CNA class.

IX.F. Approve New Job Descriptions – **Document Registry 26-02-06**

Motion to approve the new job descriptions of Part-time Transportation Secretary and Noon Hour Supervision Aide as presented. This motion, made by Jeff Wilson and seconded by Dennis Anderson, Passed.

Dennis Anderson: Yea, Jake Anderson: Yea, Cindy Bailey: Yea, Dusty Kocher: Yea, Cindy Lockley: Yea, Scott Snyder: Yea, Jeff Wilson: Yea
Yea: 7, Nay: 0

IX.G. Approve Revised Job Description – **Document Registry 26-02-07**

Motion to approve the revised job description of Supervision Aide as presented. This motion, made by Jeff Wilson and seconded by Dennis Anderson, Passed.

Dennis Anderson: Yea, Jake Anderson: Yea, Cindy Bailey: Yea, Dusty Kocher: Yea, Cindy Lockley: Yea, Scott Snyder: Yea, Jeff Wilson: Yea
Yea: 7, Nay: 0

IX.H. Approve Purchase of Real Estate Property – **Document Registry 26-02-08**

Motion to approve the purchase of real estate property (vacant lot) located at 1126 E. Butler St., Olney, IL in the amount of \$30,000.00 plus closing costs. This motion, made by Dennis Anderson and seconded by Jeff Wilson, Passed.

Dennis Anderson: Yea, Jake Anderson: Yea, Cindy Bailey: Yea, Dusty Kocher: Yea, Cindy Lockley: Yea, Scott Snyder: Yea, Jeff Wilson: Yea
Yea: 7, Nay: 0

IX.I. Approve RCMS BAS Delta Control Upgrade Agreement and RCMS three-year TSP Maintenance Agreement with ENTEC – **Document Registry 26-02-09**

Motion to approve with ENTEC the RCMS BAS Delta Control Upgrade Agreement for a total project cost for the scope of work in the amount of \$424,675.00 and RCMS three-year TSP Maintenance Agreement of a first year investment of \$28,200.00, second year \$29,046.00 and third year \$29,918.00. This motion, made by Dennis Anderson and seconded by Cindy Lockley, Passed.

Dennis Anderson: Yea, Jake Anderson: Yea, Cindy Bailey: Yea, Dusty Kocher: Yea, Cindy Lockley: Yea, Scott Snyder: Yea, Jeff Wilson: Yea
Yea: 7, Nay: 0

Mr. Rusk said the system at RCMS is almost 17 years old. The estimated savings would be \$15,000.00 annually by installing a new system. The board would like to see a comparison study for RCES since they have already had the new system for a year. Mr. Rusk stated that A.J., Dan and Randy are very pleased with the new system and the efficiency at RCES.

IX.J. Approve Three-Year District Beverage Provider – Document Registry 26-02-10
Motion to approve RCCU1 District Beverage Provider to Pepsi Mid America from July 1, 2026 through June 30, 2029. This motion, made by Dennis Anderson and seconded by Cindy Lockley, Passed.

Dennis Anderson: Yea, Jake Anderson: Yea, Cindy Bailey: Yea, Dusty Kocher: Yea, Cindy Lockley: Yea, Scott Snyder: Yea, Jeff Wilson: Yea
Yea: 7, Nay: 0

IX.K. Approve Athletic Complex Change Order – Document Registry 26-02-11
Motion to approve an Athletic Complex Change Order with GeoSurfaces for Baseball and Softball backstop extensions (additional 135' for baseball and 155' for softball) in the amount of \$34,800.00. This motion, made by Dennis Anderson and seconded by Jeff Wilson, Passed.

Dennis Anderson: Yea, Jake Anderson: Yea, Cindy Bailey: Yea, Dusty Kocher: Yea, Cindy Lockley: Yea, Scott Snyder: Yea, Jeff Wilson: Yea
Yea: 7, Nay: 0

IX.L. Approve District Administration to begin work on the FY27 Budget
Motion to approve District Administration to begin work on the FY27 Budget. This motion, made by Dennis Anderson and seconded by Jeff Wilson, Passed.

Dennis Anderson: Yea, Jake Anderson: Yea, Cindy Bailey: Yea, Dusty Kocher: Yea, Cindy Lockley: Yea, Scott Snyder: Yea, Jeff Wilson: Yea
Yea: 7, Nay: 0

X. Enter Executive Session

Motion to enter executive session at 7:05 p.m. This motion, made by Cindy Bailey and seconded by Dennis Anderson, Passed.

Dennis Anderson: Yea, Jake Anderson: Yea, Cindy Bailey: Yea, Dusty Kocher: Yea, Cindy Lockley: Yea, Scott Snyder: Yea, Jeff Wilson: Yea
Yea: 7, Nay: 0

X.A. 2(c)(1) To Consider Information Regarding Appointment, Employment, Compensation, Discipline, Performance, or Dismissal of Individual Employees

X.B. 2(c)(5) To Discuss the Purchase or Lease of Real Property

X.C. 2(c)(9) To Discuss Student Disciplinary Cases

X.D. 2(c)(11) To Discuss Matters of Possible or Pending Litigation

X.E. 2(c)(21) To Discuss Matters of Closed Session Minutes

XI. Exit Executive Session

Motion to exit executive session at 11:12 p.m. This motion, made by Cindy Bailey and seconded by Dennis Anderson, Passed.

Cindy Lockley: (Absent), Dennis Anderson: Yea, Jake Anderson: Yea, Cindy Bailey: Yea, Dusty Kocher: Yea, Scott Snyder: Yea, Jeff Wilson: Yea
Yea: 6, Nay: 0, Absent: 1

XII. Personnel Action

Motion to approve all personnel action as presented; the employment of Sierra Jade Heffron as RCES Paraprofessional and Kurtis Mehl as RCMS Head Custodian effective the completion of

new hire paperwork, Sierra Ellison as RCMS Family and Consumer Sciences Teacher for the 2026-2027 school year and the transfer of Darla Johnson from RCES Nurse to RCHS Nurse effective July 1, 2026, the extra-duty assignment of Jacob Pampe as RCHS Head Boys Soccer Coach for the 2026-2027 school year and volunteers of Casey Fulk - RCHS Bass Fishing and August Michels - RCMS Volleyball for the 2025-2026 school year and the resignation of Grace Painter as RCES K/1 Special Education Teacher effective March 6, 2026. This motion, made by Cindy Bailey and seconded by Dennis Anderson, Passed.

Cindy Lockley: Absent, Dennis Anderson: Yea, Jake Anderson: Yea, Cindy Bailey: Yea, Dusty Kocher: Yea, Scott Snyder: Yea, Jeff Wilson: Yea

Yea: 6, Nay: 0, Absent: 1

Motion to approve the employment of Breanne Clark as RCES Assistant Principal effective July 1, 2026. This motion, made by Dennis Anderson and seconded by Jeff Wilson, Passed.

Cindy Lockley: Absent, Dusty Kocher: Nay, Dennis Anderson: Yea, Jake Anderson: Yea, Cindy Bailey: Yea, Scott Snyder: Yea, Jeff Wilson: Yea

Yea: 5, Nay: 1, Absent: 1

Dusty Kocher: Nay

XIII. Adjournment

Motion to adjourn at 11:15 p.m. This motion, made by Jeff Wilson and seconded by Cindy Bailey, Passed.

Cindy Lockley: Absent, Dennis Anderson: Yea, Jake Anderson: Yea, Cindy Bailey: Yea, Dusty Kocher: Yea, Scott Snyder: Yea, Jeff Wilson: Yea

Yea: 6, Nay: 0, Absent: 1

Approved:

President: _____

Secretary: _____

Special Meeting
Wednesday, March 4, 2026 5:00 PM Central

Unit Office Board Room
1100 E Laurel St
Olney, Illinois 62450

I. Call to Order and Pledge of Allegiance – The special meeting of the Richland County Board of Education was called to order by President Scott Snyder at 5:00 p.m. on Wednesday, March 4, 2026.

II. Roll Call

Dennis Anderson: Present
Jake Anderson: Absent
Cindy Bailey: Absent
Dusty Kocher: Present
Cindy Lockley: Present
Scott Snyder: Present
Jeff Wilson: Present

Present: 5, Absent: 2.

III. Recognition and Comments from Employees and Public - None

IV. Enter Executive Session

Motion to enter executive session at 5:01 p.m. This motion, made by Dennis Anderson and seconded by Cindy Lockley, Passed.

Jake Anderson: Absent, Cindy Bailey: Absent, Dennis Anderson: Yea, Dusty Kocher: Yea, Cindy Lockley: Yea, Scott Snyder: Yea, Jeff Wilson: Yea

Yea: 5, Nay: 0, Absent: 2

IV.A. 2(c)(1) To Consider Information Regarding Appointment, Employment, Compensation, Discipline, Performance, or Dismissal of Individual Employees

IV.B. 2(c)(9) To Discuss Student Disciplinary Cases

IV.C. 2(c)(11) To Discuss Matters of Possible or Pending Litigation

V. Exit Executive Session

Motion to exit executive session at 6:03 p.m. This motion, made by Jeff Wilson and seconded by Dennis Anderson, Passed.

Jake Anderson: Absent, Cindy Bailey: Absent, Dennis Anderson: Yea, Dusty Kocher: Yea, Cindy Lockley: Yea, Scott Snyder: Yea, Jeff Wilson: Yea

Yea: 5, Nay: 0, Absent: 2

VI. Possible Student Discipline Action on Student A – **Document Registry 26-03-01**

Motion to expel Student A for the remainder of the 2025-2026 school year and the 2026-2027 school year. Student A will be referred to an alternative school. Student A may return on Principals' Probation the first semester of the 2026-2027 school year if Student A completes 20 hours of approved counseling, passes the hair follicle drug test and follows all rules while attending an alternative school. This motion, made by Dennis Anderson and seconded by Cindy

Lockley, Passed.

Jake Anderson: Absent, Cindy Bailey: Absent, Dennis Anderson: Yea, Dusty Kocher: Yea, Cindy Lockley: Yea, Scott Snyder: Yea, Jeff Wilson: Yea

Yea: 5, Nay: 0, Absent: 2

VII. Possible Action on Dismissal of a RCCU1 Educational Support Staff Member – **Document Registry 26-03-02**

Motion to terminate a RCCU1 Educational Support Staff Member effective immediately. This motion, made by Jeff Wilson and seconded by Dusty Kocher, Passed.

Jake Anderson: Absent, Cindy Bailey: Absent, Dennis Anderson: Yea, Dusty Kocher: Yea, Cindy Lockley: Yea, Scott Snyder: Yea, Jeff Wilson: Yea

Yea: 5, Nay: 0, Absent: 2

VIII. Adjournment

Motion to adjourn at 6:05 p.m. This motion, made by Dennis Anderson and seconded by Dusty Kocher, Passed.

Jake Anderson: Absent, Cindy Bailey: Absent, Dennis Anderson: Yea, Dusty Kocher: Yea, Cindy Lockley: Yea, Scott Snyder: Yea, Jeff Wilson: Yea

Yea: 5, Nay: 0, Absent: 2

Approved:

President: _____

Secretary: _____

Thank you for the
beautiful floral arrangement
in memory of my
mother. I appreciate
all the support I
received from RCCU #1 at
this time. This
district is the best!

Joyce Anderson

To thank you for your
kindness
and sympathy 12
at a time
when it was
deeply appreciated

The family of
Jeanne Dehlinger

In Deep Appreciation

Thank you for the
beautiful flowers in
memory of my dad.

Your kindness and
thoughtfulness during
this difficult time
mean so much.

Thanks again,

Heather
Tait

Richland County
Board of Education
and Administration

To thank you for your

kindness

and sympathy

14

at a time

when it was

deeply appreciated

The Family of
Roger Charleston

~ Heather Tait

In Deep Appreciation

February 2026 FOIA Request Log

Date Received	Sender	Request	Response	Date of Response
2/4/2026	Sunlight Access Oshea Smith o-smith@sunlight-record.com	Requesting copies of the most recent contracts, agreements, amendments, and renewals from January 1, 2021 through January 29, 2026 in connection with the following vendors: Mastery Prep, Albert.io, IXL, Edgenuity, Khan Academy, Jumpstart, Texas College Bridge, Kaplan, Princeton Review.	Response emailed to o-smith@sunlight-record.com with invoices and correspondence for IXL and Edgenuity which are the only two vendors we use.	2/4/2026
2/5/2026	Andrea McDowell andreamcdowell88@gmail.com	Requesting the video coverage of the February 4, 2026, 6th grade boys basketball game located at RCHS in the auxiliary gym. Specifically 2nd quarter of the A game.	Response emailed to andreamcdowell88@gmail.com Per counsel's direction, the district is denying your request due to the video in question being a permanent student record of all nine students seen on the video at the time of question. These students are from both Richland County and Salem. Without signed releases from all eight of the other players, counsel has directed the district to deny the request but retain the video.	2/11/2026

2/5/2026	Michael F. Henry	Requesting the Districts Primary Attorney and Documentation of Background Checks for Board Members prior to Oath of Office.	Response letter emailed to michaelhenry@live.com stating Franczek as District Attorney and No records responsive to background checks for board members (as it is not required by Illinois law).	2/11/2026
2/16/2026	Illinois Retired Teachers Association freedom@irtaonline.org	Requesting list of names and email addresses of any certified staff retiring this year. (2026)	Response emailed to: freedom@irtaonline.org Five certified retiring in 2026; Charissa Burgener, Kristin Flanagan, Margaret Hahn, Robert Kirby, and Cheryl Wall	2/16/2026
2/23/2026	Illinois Policy Research research@illinoispolicy.org	Requesting information on School Board Policy 7:40 in regards to partial enrollment and participation in extracurriculars by non-public school students.	Response emailed to research@illinoispolicy.org with link to the online policy 7:40. https://boardpolicyonline.com/?b=east_richland&s=99511	2/23/2026



March 2026

To the Principal/IHSA Official Representative Addressed:

It is time again for your school to renew its membership in the Illinois High School Association. For the 2026-2027 school term, IHSA membership will not require payment for membership dues or state series entry fees per action of the IHSA Board of Directors.

Your school may renew membership in the Illinois High School Association by confirming that your school continues to be Recognized by the Illinois State Board of Education and by certifying that your Board of Education/Governing Board has voted to adopt and abide by the Constitution, By-laws, Terms and Conditions, and Administrative Procedures, Guidelines, and Policies of the Association for the 2026-27 school term.

Your 2026-27 membership renewal is due by June 30, 2026. Please do not delay. Obtain your Board of Education's action on the membership resolution and email it to twood@ihsa.org or fax (309) 663-7479.

Sincerely,

Craig Anderson
Executive Director

**THIS FORM MUST BE SIGNED BELOW, ON THE APPROPRIATE LINE, BY THE PRINCIPAL OR OFFICIAL REPRESENTATIVE AND THE BOARD PRESIDENT OR SECRETARY.
DO NOT DETACH**

To: IHSA Executive Director

We certify that RICHLAND COUNTY High School is recognized by the Illinois State Board of Education. It is understood that failure to be recognized by the Illinois State Board of Education will disqualify our school for membership in the IHSA and that if this were to occur; it is our responsibility to immediately notify the Association of this change in status.

We further certify our Board of Education/Governing Board, at its meeting held on MARCH 19, 2026, voted to renew membership in the Illinois High School Association, and to adopt and abide by the Constitution, By-laws, Terms and Conditions, and Administrative Procedures, Guidelines and Policies of the Illinois High School Association for the year of July 1, 2026, through June 30, 2027.

Principal/Official Representative Signature

Board President or Board Secretary Signature

JEFF THOMPSON (618) 393-2191

Print Name and Phone Number

Print Name and Phone Number

RICHLAND COUNTY High School OLNEY, Illinois

2026-27 Membership Renewal/ Second Reminder



Richland County Early Learning Center March 2026

Enrollment

Program:	Total Enrollment (3/9/26)
Birth-3	54
Preschool For All	169
Early Childhood	18

Bright Beginnings (Birth-3)

Mission: Bright Beginnings *in partnership with families and the community* is to enhance each child's development by nurturing a positive, healthy parent-child relationship as a foundation for success in all areas of life.

Preschool for All

Mission: To provide the educational foundation for the learners and leaders of tomorrow.

Current and Upcoming Events

- No School - Monday, March 2 - Pulaski Day
- Preschool Picture Day - Friday, March 6
- Bright Beginnings Playgroup - Tuesday, March 12, 9:30 am - 10:30 am
- Bright Beginnings Donuts & Discuss - Wednesday, March 18, 9:30 am - 10:30 am
- Spring Fling Family Event - Tuesday, March 31, 4:30 pm - 6:00 pm



RCES Building Report

March 2026

Enrollment Figures by Grade Level at the beginning of March 2026: as of 02/28/26											Totals
Kg	15	16	16	17	16	16					96
1st	19	19	20	18	20	19	18				134
2nd	20	19	19	19	19	19	19				134
Pri LD/MMI	7	3	5								15
3rd	23	22	22	21	20	26	22				156
4th	23	23	23	20	23	22	23				157
5th	25	25	24	26	25	25					150
Int LD/MMI	5	7	11	9							32
Total											874

SESE Classes	
SESE Autism Room	11
Off Site Location	10
Homebound	0
RCES/SESE Total	21

February Attendance Percentage:	
Kindergarten	92.25
1st Grade	93.81
2nd Grade	92.21
3rd Grade	92.85
4th Grade	93.80
5th Grade	93.42

--	--

February Discipline Report:	
Bus Suspension	0
In School Suspension	7
Out of School Suspension	4

Updates:

- All K-2 Staff, including special education at those levels, received Secret Stories Training from Elizabeth Sparks so that everyone is implementing the same both in intensity and intentionality. Future training for 3-5 is planned.
- Worked collaboratively with all specialists to evaluate and recreate a special subjects schedule for the 2026-2027 school year that meets their needs, thus giving them a voice.
- Began a pilot program with 5th grade of having interventions during conferring, flooding the grade level with TA's and interventionists to provide very concise interventions with small groups, thus eliminating the majority of students having to be pulled from special subject classes. We will work the kinks out at this level and then expand to other levels if it is efficient. Our goal is to ensure students are all still receiving core instruction but refrain from pulling as many students from their special subjects as that is often an area where students who struggle are able to shine and enjoy.
- A Tier 2 system is being created using the PALS classroom and counseling system
 - Zones of Regulation has been purchased for these individuals and professional development will occur this spring so that we can use it effectively by fall.
 - The expectation that counseling involvement precedes Pals and intertwines with its implementation has been established.
 - A site visit was conducted to Fairfield to evaluate their Tier 2 programming.
- We have begun evaluating our current technology systems
 - All teams and subgroups were given a copy of current technology systems purchased to evaluate those systems still in use, defining their role and evaluating their cost effectiveness and impact on the curriculum to ensure that all systems are being utilized and are effective expenditures

- We are creating a document to ensure that we know who is responsible for which system, getting many of those systems regulated at the office level instead of with individual teachers to decrease work for teachers and increase efficiency.
- The following fifth grade students were nominated for the IPA Principal's Award. Each candidate received a celebratory pizza lunch with Mrs. Fox. Nominees included: Victoria Tyler, Scarlett Scherer, Natalie Hubbard, Rhett Eastin, Presley Bechman, Corinna Wells, Austyn Walters, Jasper Aldridge, Gracelinn Emmons, Piper Bishop, Bria Short, and Josie Runyon were our nominees. Rhett Eastin and Natalie Hubbard were chosen as winners and were honored at an IPA banquet on March 4 at the West End Event Center.

News and Events:

- 3/13- End of Third Quarter
- 3/13- Fifth Grade Music Performance 9:30 & 1:30
- 3/24-4/1 - IAR Testing
- 3/27 - Kindergarten Music Performance 9:30 & 1:30
- 4/8-4/10 - ISA Testing





Richland County
Middle School



March Board Report

Jennifer Tedford, Principal
Michelle Klingler, Assistant Principal

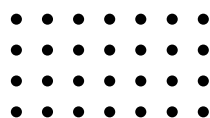

Student Enrollment

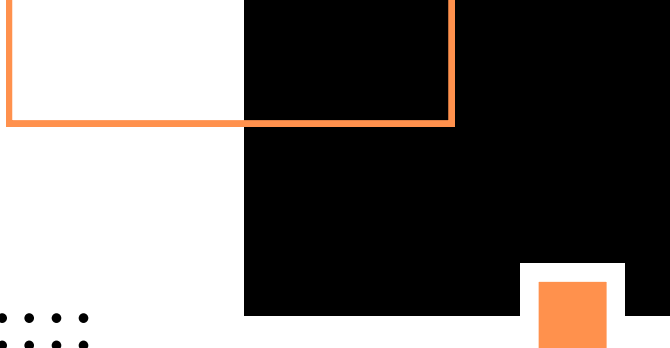
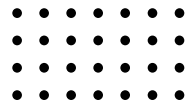

Enrollment as of 2/27/2026

6th Grade: 159
7th Grade: 149
8th Grade: 134
Offsite: 14
Speech Only: 3

Attendance Percentage

6th Grade: 95.37%
7th Grade: 93.35%
8th Grade: 92.66%
RCMS Student Attendance: 93.87%

Enrollments and Withdrawals

Enrollments: 3
Withdrawals: 1

Discipline

ISS: 3
OSS: 0

Upcoming Important

Dates

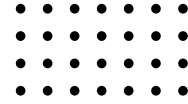

MONTH	DAY	EVENT	TIME
March	23-31	IAR Testing	
March	25	Dismiss @ 2PM	
April	2	Dismiss @ 2PM	
April	3 - 6	Easter Break	



Athletics

TRACK & FIELD

DATE	LOCATION	TIME
March 26	Fairfield	4:00PM
April 7	Franklin Park	4:00PM
April 9	Newton	4:00PM
April 13	Floyd Henson	4:00PM
April 15	Carmi	4:00PM

Staff

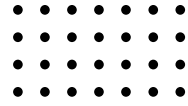

Birthdays

- Stephanie West- March 30
- Ashley Kuhn- April 1
- Haley Hundley- April 16
- Caitlin Ochs- April 22
- Michelle Powell- April 24
- Drew Bunting- April 30



Richland Co.
High School
School Board Report
 March 2026

Enrollment by Grade Level as of (2/28/26):	Totals	Attendance % by Grade Level for previous month:
Freshman	154	93.33%
Sophomore	165	92.74%
Junior	155	92.59%
Senior	149	93.28%
Total	623	92.98%

Building Discipline Report for previous month:	Freshman	Sophomore	Junior	Senior	Total
ISS	9	3	1	1	14
OSS	2	-	2	-	4
Lunch Detention	21	24	32	25	102
AM Detention	-	-	2	9	11
PM Detention	5	6	4	5	20
Bus Suspension	-	-	-	-	-
Expulsion	-	-	-	-	-

RCHS Events for March

Date	Event
*Sporting events in BOLD are home games	
3/1	RCMS Band Concert in PAC @ 2p
3/3-3/5	STAR Lab in Ron Herrin Gym for RCES students
3/4/26	IPA Student Recognition
3/5/26	Softball parent meeting in Commons - 5p Tiger Track parent meeting in Commons - 6p
3/6-3/7	RCMS Musical Matilda in RCPAC - 7p Fire Drill @ OTA Lady Tiger Varsity Track @ EIU
3/7	RCMS Musical Matilda in RCPAC - 7p IHSA Band Solo & Ensemble Contest hosted at RCES Tiger Track Varsity v EIU - 9a
3/8	RCMS Musical Matilda in RCPAC - 2p
3/11	LIC Principal Meeting
3/12	CEO Freshmen Recruiting Event
3/13	HS only Early Dismissal - School Improvement @ 2 Spring into Spring Teacher Banquet
3/14	Tiger Varsity Track @ Mt. Zion Invite - 10a Lady Tiger Varsity Track @ Mt. Zion - 10a
3/16	Lady Tiger Softball v Cisne - 4:30p @ Musgrove Park
3/17	Lady Tiger Softball v N. Clay - 4:30p @ Musgrove Park
3/18	RCES Author Visit in PAC *Lady Tiger JV Soccer v Benton - 4:30p @ RCMS *Tiger Baseball v Effingham - 4:30p @ Musgrove *Lady Tiger Softball v Benton - 4:30p @ Musgrove
3/19	CEO Sophomore Recruiting Event @ OTA RCES Author Visit in PAC *Tiger JV Baseball v Red Hill - 4:30p @ Musgrove Tiger Baseball @ Cumberland - 4:30p

	<p>Lady Tiger Soccer @ Mt. Vernon - 4:30p RCCU1 Board Meeting in RCPAC - 6p</p>
3/20	<p>FFA Section Chapter Social in Ron Herrin Gym</p>
3/21	<p>Tiger Tennis @ Triad Tourney - 8:30a Tiger Track @ U of I Invite - 11:30a Tiger JV Baseball @ North Clay - 12:30p Spring Fling Dance 8:00-10:30p in Auxiliary Gym</p>
3/23	<p>*Tiger JV Baseball v St Anthony - 4:30p @ Musgrove Tiger Baseball @ St Anthonys - 4:30p</p>
3/24	<p>ACT Testing *Tiger Varsity Baseball v Marion - 4:30p @ Musgrove *Lady Tiger Softball v St Anthony - 4:30p @ Musgrove</p>
3/25	<p>ACT Testing (Day 2) District-wide Early Dismissal - School Improvement @ 2 Lady Tiger Varsity Track @ Lawrenceville - 4p Lady Tiger Varsity Softball @ Cumberland - 4:30p</p>
3/26	<p>*Tiger JV Baseball v Lawrenceville - 4:30p *Lady Tiger Softball v Mt. Vernon - 4:30p</p>
3/27	<p>*Tiger JV Baseball v Flora - 4:30p *Tiger Varsity Baseball v Centralia - 4:30p</p>
3/28	<p>Tiger & Lady Tiger Varsity Track @ Bloomington Tiger Varsity Tennis @ Red & White Invite - 9:30a *Lady Tiger Varsity Soccer Olney Tourney - 10a Tiger Baseball @ North Clay - 12p Bass Fishing @ Newton Lake - 1p Olney Rebels Basketball Fundraiser - Firefighters v Police - 4pm in Ron Herrin Gym</p>
3/30	<p>Freshmen ERFAE Awards in PAC Tiger Varsity Tennis @ Charleston - 4:15p Tiger JV/V Baseball @ Mattoon - 4:30p Lady Tiger Varsity Softball @ Teutopolis - 4:30p</p>
3/31	<p>Sophomore ERFAE Awards in PAC *Tiger Varsity Baseball v Fairfield - 4:30p *Lady Tiger Varsity Soccer v Charleston - 4:30p *Lady Tiger Softball v Fairfield - 4:30p *Tiger JV Baseball v Fairfield - 6p</p>

Staff Birthdays

3/3: Scott Hahn	3/12: Curt Nealis
3/5: Candice Henton	3/16: Sue Pixley
3/11: Briauna Baltzell	

RISEUP February School Board Report



"Learn with Purpose and RiseUp with Pride!"

Enrollment

School	Enrollment as of (3/10/26)
RCHS	5
RCMS	9

Discipline Report

Discipline Report for October:	RCHS	RCMS
Office Referral	0	0
OSS	0	0

Attendance

School	Unexcused	Excused
RCHS	5	5
RCMS	17.5	14.5

3/5 Erin's Law / Faith's Law @ 10

3/6 Star Reading Test @ 9 (MS)

3/10 1SA for 8th Graders

3/11 1SA for 8th Graders

3/12 1SA for 8th Graders

3/13 End of Term 3

3/13-3/20 1AR ELA Testing

3/24 Dental Safari (MS)

Juniors ACT @ High School

3/25 Juniors ACT @ High School

3/26 1AR (MS)

3/30 1AR (MS)

3/31 ACT for Fresh/Soph

1AR (MS)

RCCU#1 Monthly Board Meeting

March 2026 —

Director of Special Services

Kristen Jurgilanis

Special Education Student Data

313 - Total number of students with Individual Education Plans (IEPs)

56 - Number of students attending SESE classrooms or out of district

SESE MSI - Bridgeport Grade School (1)

SESE MSI I and II - North Clay Elementary (5)

SESE MSI III - North Clay Junior/High (1)

SESE MSI IV - Richland County High (6)

SESE ECE - Early Learning Center (19)

SESE ED I & II - Clay City Elementary (4)

SESE ED III - Clay City Junior High (0)

SEES Autism I,II - Richland County Elementary (11)

SESE Autism III - Clay City Junior High (0)

SESE Autism IV - Clay City High (6)

Willow Hill ED - Next Step Day School Willow Hill (3)

25 - Total number of pending re-evaluations

8 - Total number of pending initial evaluations

13 - Total number of new students with IEPs

11 - Total number of students who were dismissed or left district with IEPs

70 - Total number of meetings held in February

504 Student Data

84 - Total number of students with 504 Plans

Richland County Early Learning Center (0)

Richland County Elementary School (19)

Richland County Middle School (27)

Richland County High School (38)

SESE - Southeastern Special Education Cooperative

ED - Emotional Disability

ECE - Early Childhood Education

MSI - Moderate to Severely Impaired

RICHLAND COUNTY HIGH SCHOOL FUNDRAISER REQUEST

Organization Name: Olney Tiger Baseball

Type of Project: Snap Fundraiser

Start and End Dates of Fundraiser: March 23rd - April 23rd

Purpose of Raised Funds: Hats, Practice gear, Baseballs

Sponsor's Name: Ken Laughlin

Date: 3/6/26

Approved

Disapproved

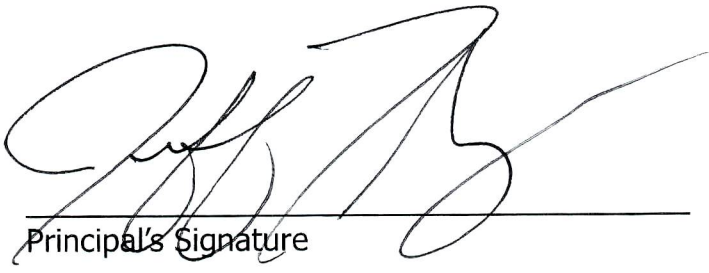

Principal's Signature

Fund your program and support what matters with Snap! Raise.

Snap! Raise helps teams, groups, and school programs:

Raise more, guaranteed.

Our fundraising approach has proven to be so successful that we can guarantee you will raise the same or more than your previous fundraiser!*

Fundraise and message on the go.

The Snap! Mobile app helps you and your participants stay connected to your Snap! Raise fundraiser, your Snap! Store, and important info for your program. Groups and teams can also chat before, during, and after their fundraiser using the Messaging feature.

Manage your funds securely.

Our anti-fraud practices keep your funds safe. Every transaction is PCI DSS and federal regulation compliant. At Snap! Raise, we never share or sell program, participant, or donor data – period.

Get a custom fundraising webpage.

Each fundraiser gets a dedicated customizable webpage to engage donors. Add your logo, team colors, and pictures to the page, and view your community's comments of support on the cheer wall.

Personalize donor engagement.

Throughout your 28-day fundraiser, participants can reach out to potential donors using our personalized email and text messaging tools.

Track participants and incentives.

Our easy-to-use dashboard allows you to monitor your fundraiser and send reminders to participants. You can incentivize your fundraiser by offering rewards as participants hit fundraising milestones.

Pull financial reports.

As a coach or group leader, you can see everyone who donated to your campaign and get access to all your financial data – like donations and expenditures – any time you like.

Access support whenever needed.

A dedicated Snap! rep helps get your campaign up and running and our support team is available every step of the way. No chat bots, no call centers – just real people ready to help before, during, and after your fundraiser!

\$950M+
Raised Nationwide

150,000+
Groups and Teams

12.5M+
Donors and Participants



Scan to Schedule a Meeting

Need funds before the fundraiser?

With Early Access, you can get a portion of your funds before the fundraiser — no sweat.

RICHLAND COUNTY HIGH SCHOOL FUNDRAISER REQUEST

Organization Name: RCHS Tiger Football

Type of Project: Gridiron Club (Sponsorship)

Start and End Dates of Fundraiser: Start: April 17th 2026 End: July 31st 2026

Purpose of Raised Funds: Replenish Activity Account To Help Purchase & Update Equipment

Sponsor's Name: Luke Carmody

Date:

Approved

Disapproved

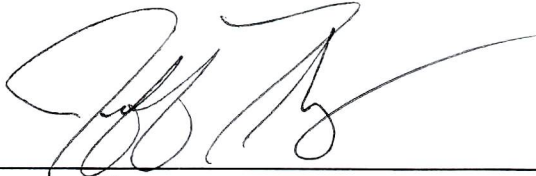

Principal's Signature

RICHLAND COUNTY HIGH SCHOOL FRUNDRAISER REQUEST

Organization RCHS Bands

Type of Project: Show Me Dough Fundraiser

Start and End Dates of Fundraiser: Wednesday, 3/10/2026 to 3/23/2026

Purpose of Raised Funds: Student Fundraiser to earn money for band apparel, camp, and activities

Sponsor's Name: Nancy Deimel

Date:

Approved

Disapproved

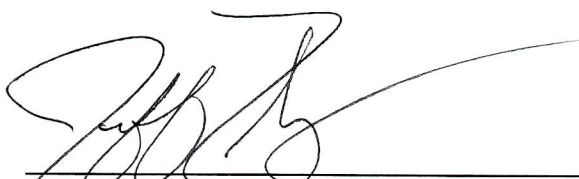

Principal's Signature

RICHLAND COUNTY HIGH SCHOOL FUNDRAISER REQUEST

Organization Name: Olney Tiger Track

Type of Project: Snap Raise (Crowdfunding)... we do this fundraiser every other year.

Start and End Dates of Fundraiser: March 28th - April 25th, 2026

Purpose of Raised Funds: Equipment, travel expenses, athlete nutrition, etc.

Sponsor's Name: Ryan Denton

Date: 3/11/2026

Approved

Disapproved

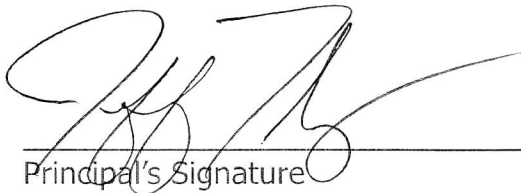

Principal's Signature

Richland County Community Unit #1
Olney, Illinois
Treasurer's Report

	Beginning Cash Balance	Cash Receipts/Adjusting Entries Month Ended	Cash Disbursements/Adjusting Entries Month Ended	Investments Cashed(+) or Invested(-)	Cash Balance	Difference from Prior Month	Certificate of Deposit Investments	CD and Cash Total
Fund	01/31/26	02/28/26	02/28/26	02/28/26	02/28/26	02/28/26	02/28/26	02/28/26
Education	\$ 25,383,388.40	\$ 467,922.57	\$ 1,897,622.79		\$ 23,953,688.18	\$ (1,429,700.22)	-	23,953,688.18
Operations & Maint	\$ 3,880,852.77	\$ 11,566.48	\$ 55,779.78		\$ 3,836,639.47	\$ (44,213.30)	-	3,836,639.47
Debt Service	\$ 842,273.96	\$ 2,516.91	\$ -		\$ 844,790.87	\$ 2,516.91	-	844,790.87
Transportation	\$ 1,278,942.78	\$ 3,848.78	\$ 113,916.91		\$ 1,168,874.65	\$ (110,068.13)	-	1,168,874.65
IMRF/Social Security	\$ 1,274,672.52	\$ 3,800.78	\$ 78,956.59		\$ 1,199,516.71	\$ (75,155.81)	-	1,199,516.71
Capital Projects	\$ 2,147,426.19	\$ 1,296,216.11	\$ 1,686,785.85		\$ 1,756,856.45	\$ (390,569.74)	-	1,756,856.45
Working Cash	\$ 1,621,562.98	\$ 4,830.48	\$ -		\$ 1,626,393.46	\$ 4,830.48	-	1,626,393.46
Tort	\$ 1,157,760.16	\$ 3,455.87	\$ 23,367.92		\$ 1,137,848.11	\$ (19,912.05)	-	1,137,848.11
Fire Prevention/Life Safety	\$ 354,381.06	\$ 1,056.27	\$ 1,681.69		\$ 353,755.64	\$ (625.42)	-	353,755.64
Total	37,941,260.82	1,795,214.25	3,858,111.53	-	35,878,363.54		-	35,878,363.54
					35,878,363.54			
Add CD's	-							
Total with CD's	37,941,260.82	1,795,214.25	3,858,111.53		35,878,363.54			
Assets								
Student Activity Fund	\$ 553,965.84				\$ 553,965.84			
IHI Reserve Checking	\$ 14,572.73				\$ 14,616.55			
Health Fund Checking	\$ 143,655.07				\$ 169,112.84			
Building Trades								
Revolving Funds	\$ 8,000.00				\$ 8,000.00			
Total Assets	720,193.64				745,695.23			
Total with Assets	38,661,454.46				36,624,058.77			

Account Level				Beginning	February 2025-26	February 2025-26	Ending	2025-26		
FDTLOC	FUNC	OBJ	SJ	Description	Balance	Beginning Balance	Monthly Activity	Balance	FYTD Activity	
10A010	1052	0000	00	000000	RCHS Revolving Fund	6,000.00	6,000.00	0.00	6,000.00	0.00
10A010	1053	0000	00	000000	RCMS Revolving Fund	2,000.00	2,000.00	0.00	2,000.00	0.00
10A010	1120	0000	00	000000	ED Cash On Hand	10,453,179.77	25,383,388.40	-1,429,700.22	23,953,688.18	13,500,508.41
10A010	1125	0000	00	000000	IHI Reserve MMCH	13,031.06	13,364.72	43.82	13,408.54	377.48
10A010	1126	0000	00	000000	RCCU Health Ins CH	65,127.48	143,655.07	25,457.77	169,112.84	103,985.36
10A010	1210	0000	00	000000	ED CD	15,300,000.00	0.00	0.00	0.00	-15,300,000.00
10A010	1721	0000	00	000000	Building Trades 1403 Heather L	0.00	0.00	0.00	0.00	0.00
10A010	1722	0000	00	000000		0.00	0.00	0.00	0.00	0.00
10A010	1723	0000	00	000000	1311 Heather Lane	0.00	0.00	0.00	0.00	0.00
10A999	1260	0000	00	000000	Studnt Activ Fnd Cash/Invest	553,965.84	553,965.84	0.00	553,965.84	0.00
10A---	----	----	--	-----		26,393,304.15	26,102,374.03	-1,404,198.63	24,698,175.40	-1,695,128.75
10L010	4310	0000	00	000000	Accounts Payable	-100.03	-100.03	0.00	-100.03	0.00
10L010	4811	0000	00	000000	TRS (Teacher Retire System)	0.00	0.00	0.00	0.00	0.00
10L010	4812	0000	00	000000	FIT (Federal Income Tax)	0.00	-7.36	0.00	-7.36	-7.36
10L010	4813	0000	00	000000	SIT (State Income Tax)	0.00	-45.97	0.00	-45.97	-45.97
10L010	4814	0000	00	000000	IMRF(IL Municipal Retire Fund)	0.00	0.00	0.00	0.00	0.00
10L010	4815	0000	00	000000	Annuities Payable	0.00	0.00	0.00	0.00	0.00
10L010	4816	0000	00	000000	Employee Ins Payable	-63,661.55	-142,507.91	-25,501.59	-168,009.50	-104,347.95
10L010	4817	0000	00	000000	FICA (Fed Ins Contrib Act)	0.00	-60.29	0.00	-60.29	-60.29
10L010	4817	0000	10	000000	Medicare - N/C	0.00	0.00	0.00	0.00	0.00
10L010	4818	0000	00	000000	Medicare Cert	0.00	-14.10	0.00	-14.10	-14.10
10L010	4819	0000	00	000000	Other P/R Deduction	-7,388.05	-7,388.05	0.00	-7,388.05	0.00
10L010	4990	0000	00	000000	Misc Liab Direct Deposit	0.00	0.00	0.00	0.00	0.00
10L100	9235	0000	00	000000	Future Tigers	0.00	0.00	0.00	0.00	0.00
10L---	----	----	--	-----		-71,149.63	-150,123.71	-25,501.59	-175,625.30	-104,475.67
10Q010	7300	0000	00	000000	ED Fund Balance	-2,170,047.95	-2,170,047.95	0.00	-2,170,047.95	0.00
10Q010	7310	0000	00	000000	ED Rev/Exp Summary	-22,485,308.29	-22,115,404.09	1,429,700.22	-20,685,703.87	1,799,604.42
10Q010	7320	0000	00	000000	Emcumbrance	0.00	0.00	0.00	0.00	0.00
10Q010	7330	0000	00	000000	Excess/Difference	-1,112,832.44	-1,112,832.44	0.00	-1,112,832.44	0.00
10Q999	7150	0000	00	000000	Reserved StudentActiv Fund Bal	-553,965.84	-553,965.84	0.00	-553,965.84	0.00
10Q---	----	----	--	-----		-26,322,154.52	-25,952,250.32	1,429,700.22	-24,522,550.10	1,799,604.42
10----	----	----	--	-----		0.00	0.00	0.00	0.00	0.00
20A010	1120	0000	00	000000	BLDG CASH ON HAND	1,797,936.99	3,880,852.77	-44,213.30	3,836,639.47	2,038,702.48
20A010	1210	0000	00	000000	BLDG CD	1,200,000.00	0.00	0.00	0.00	-1,200,000.00
20A010	1310	0000	00	000000	DUE FROM BLDG FUND	0.00	0.00	0.00	0.00	0.00
20A---	----	----	--	-----		2,997,936.99	3,880,852.77	-44,213.30	3,836,639.47	838,702.48

Account Level				Beginning	February 2025-26	February 2025-26	Ending	2025-26	
FDTLOC	FUNC	OBJ	SJ	Description	Balance	Beginning Balance	Monthly Activity	Balance	FYTD Activity
20L010	4310	0000	00 000000	Accounts Payable	0.00	0.00	0.00	0.00	0.00
20L010	4812	0000	00 000000	FIT	0.00	0.00	0.00	0.00	0.00
20L010	4813	0000	00 000000	SIT	0.00	0.00	0.00	0.00	0.00
20L010	4814	0000	00 000000	IMRF	0.00	0.00	0.00	0.00	0.00
20L010	4815	0000	00 000000	ANNUITIES PAYABLE	0.00	0.00	0.00	0.00	0.00
20L010	4816	0000	00 000000	EMPLOYEE INS PAYABLE	0.00	0.00	0.00	0.00	0.00
20L010	4817	0000	00 000000	FICA	0.00	0.00	0.00	0.00	0.00
20L010	4817	0000	10 000000	MEDICARE N/C	0.00	0.00	0.00	0.00	0.00
20L010	4818	0000	00 000000	MEDICARE CERT	0.00	0.00	0.00	0.00	0.00
20L010	4819	0000	00 000000	OTHER P/R DEDUCTIONS	3.80	3.80	0.00	3.80	0.00
20L010	4990	0000	00 000000	MISC LIAB DIRECT DEP	0.00	0.00	0.00	0.00	0.00
20L---	----	----	-- -----		3.80	3.80	0.00	3.80	0.00
20Q010	7300	0000	00 000000	BLDG FUND BALANCE	-120,593.72	-120,593.72	0.00	-120,593.72	0.00
20Q010	7310	0000	00 000000	BLDG REV/EXP SUMMARY	-2,569,687.18	-3,452,602.96	44,213.30	-3,408,389.66	-838,702.48
20Q010	7320	0000	00 000000	Emcumbrance	0.00	0.00	0.00	0.00	0.00
20Q010	7330	0000	00 000000	EXCESS/DIFFERENCE	-307,659.89	-307,659.89	0.00	-307,659.89	0.00
20Q---	----	----	-- -----		-2,997,940.79	-3,880,856.57	44,213.30	-3,836,643.27	-838,702.48
20----	----	----	-- -----		0.00	0.00	0.00	0.00	0.00
30A010	1120	0000	00 000000	DEBT SERVICES CASH ON HAND	257,113.52	842,273.96	2,516.91	844,790.87	587,677.35
30A010	1210	0000	00 000000	DEBT SERVICES CD	0.00	0.00	0.00	0.00	0.00
30A---	----	----	-- -----		257,113.52	842,273.96	2,516.91	844,790.87	587,677.35
30L010	4310	0000	00 000000	Accounts Payable	0.00	0.00	0.00	0.00	0.00
30L---	----	----	-- -----		0.00	0.00	0.00	0.00	0.00
30Q010	7300	0000	00 000000	DEBT SERVICES FUND BALANCE	-282,524.23	-282,524.23	0.00	-282,524.23	0.00
30Q010	7310	0000	00 000000	BOND REV/EXP SUMMARY	539,844.21	-45,316.23	-2,516.91	-47,833.14	-587,677.35
30Q010	7320	0000	00 000000	BOND AND INTEREST	0.00	0.00	0.00	0.00	0.00
30Q010	7330	0000	00 000000	EXCESS/DIFFERENCE	-514,433.50	-514,433.50	0.00	-514,433.50	0.00
30Q---	----	----	-- -----		-257,113.52	-842,273.96	-2,516.91	-844,790.87	-587,677.35
30----	----	----	-- -----		0.00	0.00	0.00	0.00	0.00
40A010	1120	0000	00 000000	TRANS CASH ON HAND	952,122.65	1,278,942.78	-110,068.13	1,168,874.65	216,752.00
40A010	1125	0000	00 000000	TRANS IHI RESERVE	1,208.01	1,208.01	0.00	1,208.01	0.00
40A010	1210	0000	00 000000	TRANS CD	0.00	0.00	0.00	0.00	0.00
40A---	----	----	-- -----		953,330.66	1,280,150.79	-110,068.13	1,170,082.66	216,752.00

Account Level				Beginning	February 2025-26	February 2025-26	Ending	2025-26		
FDTLOC	FUNC	OBJ	SJ	Description	Balance	Beginning Balance	Monthly Activity	Balance	FYTD Activity	
40L010	4310	0000	00	000000	Accounts Payable	0.00	0.00	0.00	0.00	0.00
40L010	4811	0000	00	000000	TRS	0.00	0.00	0.00	0.00	0.00
40L010	4812	0000	00	000000	FIT	0.00	0.00	0.00	0.00	0.00
40L010	4813	0000	00	000000	SIT	0.00	0.00	0.00	0.00	0.00
40L010	4814	0000	00	000000	IMRF	0.00	0.00	0.00	0.00	0.00
40L010	4815	0000	00	000000	ANNUITIES PAYABLE	0.00	0.00	0.00	0.00	0.00
40L010	4816	0000	00	000000	EMPLOYEE INS PAYABLE	0.00	0.00	0.00	0.00	0.00
40L010	4817	0000	00	000000	FICA	0.00	0.00	0.00	0.00	0.00
40L010	4817	0000	10	000000	MEDICARE N/C	0.00	0.00	0.00	0.00	0.00
40L010	4818	0000	00	000000	MEDICARE CERT	0.00	0.00	0.00	0.00	0.00
40L010	4819	0000	00	000000	OTHER P/R DEDUCTIONS	-121.45	-121.45	0.00	-121.45	0.00
40L010	4990	0000	00	000000	MISC LIAB DIRECT DEPOSIT	0.00	0.00	0.00	0.00	0.00
40L---	----	----	--	-----		-121.45	-121.45	0.00	-121.45	0.00
40Q010	7300	0000	00	000000	TRANS FUND BALANCE	191,152.90	191,152.90	0.00	191,152.90	0.00
40Q010	7310	0000	00	000000	TRAN REV/EXP SUMMARY	-1,028,015.01	-1,354,835.14	110,068.13	-1,244,767.01	-216,752.00
40Q010	7320	0000	00	000000	Emcumbrance	0.00	0.00	0.00	0.00	0.00
40Q010	7330	0000	00	000000	EXCESS/DIFFERENCE	-116,347.10	-116,347.10	0.00	-116,347.10	0.00
40Q---	----	----	--	-----		-953,209.21	-1,280,029.34	110,068.13	-1,169,961.21	-216,752.00
40----	----	----	--	-----		0.00	0.00	0.00	0.00	0.00
50A010	1120	0000	00	000000	IMRF CASH ON HAND	806,281.80	1,274,672.52	-75,155.81	1,199,516.71	393,234.91
50A010	1210	0000	00	000000	IMRF CD	0.00	0.00	0.00	0.00	0.00
50A---	----	----	--	-----		806,281.80	1,274,672.52	-75,155.81	1,199,516.71	393,234.91
50L010	4310	0000	00	000000	Accounts Payable	0.00	0.00	0.00	0.00	0.00
50L010	4814	0000	00	000000	IMRF	0.00	0.00	0.00	0.00	0.00
50L010	4816	2120	00	000000		0.00	0.00	0.00	0.00	0.00
50L010	4816	2130	00	000000		0.00	0.00	0.00	0.00	0.00
50L010	4816	2140	00	000000		0.00	0.00	0.00	0.00	0.00
50L010	4817	0000	00	000000	FICA	0.00	-60.29	0.00	-60.29	-60.29
50L010	4818	0000	00	000000	MEDICARE	0.00	-14.10	0.00	-14.10	-14.10
50L010	4990	0000	00	000000	MISC LIAB DD	0.00	0.00	0.00	0.00	0.00
50L---	----	----	--	-----		0.00	-74.39	0.00	-74.39	-74.39
50Q010	7300	0000	00	000000	IMRF FUND BALANCE	-108,931.74	-108,931.74	0.00	-108,931.74	0.00
50Q010	7310	0000	00	000000	IMRF/SS REV/EXP SUMMARY	-496,003.62	-964,319.95	75,155.81	-889,164.14	-393,160.52
50Q010	7330	0000	00	000000	EXCESS/DIFFERENCE	-201,346.44	-201,346.44	0.00	-201,346.44	0.00
50Q---	----	----	--	-----		-806,281.80	-1,274,598.13	75,155.81	-1,199,442.32	-393,160.52

Account Level				Beginning	February 2025-26	February 2025-26	Ending	2025-26	
FDTLOC	FUNC	OBJ	SJ	Description	Balance	Beginning Balance	Monthly Activity	Balance	FYTD Activity
50----	----	----	----		0.00	0.00	0.00	0.00	0.00
60A010	1120	0000	00	000000	1,029,516.35	2,147,426.19	-390,569.74	1,756,856.45	727,340.10
60A010	1210	0000	00	000000	0.00	0.00	0.00	0.00	0.00
60A---	----	----	----		1,029,516.35	2,147,426.19	-390,569.74	1,756,856.45	727,340.10
60L010	4310	0000	00	000000	0.00	0.00	0.00	0.00	0.00
60L---	----	----	----		0.00	0.00	0.00	0.00	0.00
60Q010	7300	0000	00	000000	0.00	0.00	0.00	0.00	0.00
60Q010	7310	0000	00	000000	-1,029,516.35	-2,147,426.19	390,569.74	-1,756,856.45	-727,340.10
60Q010	7320	0000	00	000000	0.00	0.00	0.00	0.00	0.00
60Q010	7330	0000	00	000000	0.00	0.00	0.00	0.00	0.00
60Q---	----	----	----		-1,029,516.35	-2,147,426.19	390,569.74	-1,756,856.45	-727,340.10
60----	----	----	----		0.00	0.00	0.00	0.00	0.00
70A010	1120	0000	00	000000	910,649.63	1,621,562.98	4,830.48	1,626,393.46	715,743.83
70A010	1210	0000	00	000000	500,000.00	0.00	0.00	0.00	-500,000.00
70A---	----	----	----		1,410,649.63	1,621,562.98	4,830.48	1,626,393.46	215,743.83
70Q010	7300	0000	00	000000	-1,482,040.21	-1,482,040.21	0.00	-1,482,040.21	0.00
70Q010	7310	0000	00	000000	185,893.04	-25,020.31	-4,830.48	-29,850.79	-215,743.83
70Q010	7330	0000	00	000000	-114,502.46	-114,502.46	0.00	-114,502.46	0.00
70Q---	----	----	----		-1,410,649.63	-1,621,562.98	-4,830.48	-1,626,393.46	-215,743.83
70----	----	----	----		0.00	0.00	0.00	0.00	0.00
80A010	1120	0000	00	000000	13,752.77	1,157,760.16	-19,912.05	1,137,848.11	1,124,095.34
80A---	----	----	----		13,752.77	1,157,760.16	-19,912.05	1,137,848.11	1,124,095.34
80L010	4310	0000	00	000000	0.00	0.00	0.00	0.00	0.00
80L010	4812	0000	00	000000	0.00	0.00	0.00	0.00	0.00
80L010	4813	0000	00	000000	0.00	0.00	0.00	0.00	0.00
80L010	4814	0000	00	000000	0.00	0.00	0.00	0.00	0.00
80L010	4817	0000	00	000000	0.00	0.00	0.00	0.00	0.00
80L010	4818	0000	00	000000	0.00	0.00	0.00	0.00	0.00
80L010	4990	0000	00	000000	0.00	0.00	0.00	0.00	0.00
80L---	----	----	----		0.00	0.00	0.00	0.00	0.00

Account Level				Beginning	February 2025-26	February 2025-26	Ending	2025-26		
FDTLOC	FUNC	OBJ	SJ	Description	Balance	Beginning Balance	Monthly Activity	Balance	FYTD Activity	
80Q010	7300	0000	00	000000	Tort Fund Balance	0.00	0.00	0.00	0.00	0.00
80Q010	7310	0000	00	000000	TORT REV/EXP SUMMARY	213,577.67	-930,429.72	19,912.05	-910,517.67	-1,124,095.34
80Q010	7320	0000	00	000000	Tort Encumbrance	0.00	0.00	0.00	0.00	0.00
80Q010	7330	0000	00	000000	EXCESS/DIFFERENCE	-227,330.44	-227,330.44	0.00	-227,330.44	0.00
80Q---	----	----	--	-----		-13,752.77	-1,157,760.16	19,912.05	-1,137,848.11	-1,124,095.34
80----	----	----	--	-----		0.00	0.00	0.00	0.00	0.00
90A010	1120	0000	00	000000	LIFE SAFETY CASH ON HAND	213,877.76	354,381.06	-625.42	353,755.64	139,877.88
90A010	1210	0000	00	000000	LIFE SAFETY CD	0.00	0.00	0.00	0.00	0.00
90A---	----	----	--	-----		213,877.76	354,381.06	-625.42	353,755.64	139,877.88
90L010	4310	0000	00	000000	Accounts Payable	0.00	0.00	0.00	0.00	0.00
90L010	4812	0000	00	000000	L/S FIT	0.00	0.00	0.00	0.00	0.00
90L010	4813	0000	00	000000	L/S SIT	0.00	0.00	0.00	0.00	0.00
90L010	4817	0000	00	000000	L/S FICA	0.00	0.00	0.00	0.00	0.00
90L010	4817	0000	10	000000	L/S Medicare NC	0.00	0.00	0.00	0.00	0.00
90L---	----	----	--	-----		0.00	0.00	0.00	0.00	0.00
90Q010	7300	0000	00	000000	LIFE SAFETY FUND BALANCE	-1,128,737.03	-1,128,737.03	0.00	-1,128,737.03	0.00
90Q010	7310	0000	00	000000	LIFE SAFETY REV/EXP SUMMARY	204,256.93	63,753.63	625.42	64,379.05	-139,877.88
90Q010	7320	0000	00	000000	Emcumbrance	0.00	0.00	0.00	0.00	0.00
90Q010	7330	0000	00	000000	EXCESS/DIFFERENCE	710,602.34	710,602.34	0.00	710,602.34	0.00
90Q---	----	----	--	-----		-213,877.76	-354,381.06	625.42	-353,755.64	-139,877.88
90----	----	----	--	-----		0.00	0.00	0.00	0.00	0.00
Grand Asset Totals					34,075,763.63	38,661,454.46	-2,037,395.69	36,624,058.77	2,548,295.14	
Grand Liability Totals					-71,267.28	-150,315.75	-25,501.59	-175,817.34	-104,550.06	
Grand Equity Totals					-34,004,496.35	-38,511,138.71	2,062,897.28	-36,448,241.43	-2,443,745.08	
Grand Totals					0.00	0.00	0.00	0.00	0.00	

45

Number of Accounts: 120

***** End of report *****

REPORT SPECIFICATIONS

DISTRICT: Richland County Community Unit #1
REPORT TITLE: AP Invoice Listing Report
REQUESTED BY: cgraves DATE: 03/18/26
PROGRAM NAME: fin/3aprpt01. TIME: 2:09:44 PM
COPIES: 1 LPI: 6
RUN ON SERVER: yes CREATE ASCII FILE: NO

REPORT SEQUENCE: Vendor
INVOICE TYPE(S): HISTORY
CHECK TYPE(S): ALL

PRINT DETAIL: no PRINT ACCOUNTING: no
STARTING PO #: 0 ENDING PO #: 9999999999
STARTING INVOICE #: ENDING INVOICE #: ZZZZZZZZZZZZZZZZZZZ
STARTING VENDOR KEY: ENDING VENDOR KEY: ZZZZZZZZZZZ
STARTING BATCH #: feba ENDING BATCH #: febz
STARTING BANK CASH CODE: trust ENDING BANK CASH CODE: trust
STARTING INVOICE DATE: ENDING INVOICE DATE: 12/31/9999
STARTING DUE DATE: ENDING DUE DATE: 12/31/9999
STARTING CREATED BY: ENDING CREATED BY: ZZZZZZZZZZZ
STARTING CREATED DATE: 07/01/2025 ENDING CREATED DATE: 12/31/9999
STARTING INVOICE AMOUNT: -999,999,999.00 ENDING INVOICE AMOUNT: 9999,999,999.99

VEN-KEY	VENDOR NAME	INVOICE #	PO NUMBER	BATCH	BANK	DESCRIPTION	LQ	S	INV DATE	DUE DATE	C	NET AMOUNT
	ACH VOID DOWNLOAD	DISCOUNT DESCRIPTION			DISC AMT	ADJUSTMENT DESCRIPTION	FY		ADJ AMT	CHECK NBR		INVOICE AMOUNT
AHMADATA000	AHMAD, ATALLAH	020726	0000000000	FEBPP	Trust	LOWES REIMBURSEMENT ELC	H		02/09/2026	02/10/2026	A	\$198.53
									25-26	252600466		\$198.53
NUMBER OF INVOICES: 1												
\$198.53												
AMPLIFY 000	AMPLIFY	INV-432572	0000000000	FEBPP	Trust	Amplify CKLA 3rd Grade Skills Classroom Kit and Amplify CKLA 3rd Grade Skills Teacher License - 4 year (2025-2029) Amplify Shipping and Handling RECODE	H		02/24/2026	02/28/2026	W	\$0.00
												47
									25-26	202500512		\$0.00
NUMBER OF INVOICES: 1												
\$0.00												
COLWEHEA000	COLWELL, HEATHER	013126	0000000000	FEBPP	Trust	FUEL FFA CDE	H		01/31/2026	01/31/2026	A	\$66.82
									25-26	252600464		\$66.82
NUMBER OF INVOICES: 1												
\$66.82												
DEARBORN000	DEARBORN LIFE INSURANCE CO	022826	9002600007	FEBPP	TRUST	LIFE INSURANCE	DH		02/24/2026	02/24/2026	R	\$3,345.71
									25-26			\$3,345.71
DEARBORN000	DEARBORN LIFE INSURANCE CO	022826	9002600007	FEBPP	Trust	LIFE INSURANCE	H		02/24/2026	02/24/2026	W	\$3,345.71
									25-26	202500511		\$3,345.71
DEARBORN000	DEARBORN LIFE INSURANCE CO	022826	9002600007	FEBPP	TRUST	LIFE INSURANCE	VH		02/24/2026	02/24/2026	R	\$3,345.71
									25-26			\$3,345.71
NUMBER OF INVOICES: 3												
\$3,345.71												
GONZAEDW000	GONZALEZ, EDWARD JR	9245625700	1002600365	FEBPP	Trust	Reimbursement for Professional Development Conference-Get Your Teach On-Nashville, TN	H		02/05/2026	02/23/2026	A	\$459.97
									25-26	252600514		\$459.97

<u>VEN-KEY</u>	<u>VENDOR NAME</u>	<u>INVOICE #</u>	<u>PO NUMBER</u>	<u>BATCH</u>	<u>BANK</u>	<u>DESCRIPTION</u>	<u>LQ</u>	<u>S</u>	<u>INV DATE</u>	<u>DUE DATE</u>	<u>C</u>	<u>NET AMOUNT</u>
<u>ACH VOID DOWNLOAD</u>		<u>DISCOUNT DESCRIPTION</u>		<u>DISC AMT</u>		<u>ADJUSTMENT DESCRIPTION</u>	<u>FY</u>		<u>ADJ AMT</u>	<u>CHECK NBR</u>	<u>INVOICE AMOUNT</u>	
NUMBER OF INVOICES: 1											\$459.97	
HARTSMAC000	HARTSEY, MACKENZIE	021426	1002600362	FEBPP	Trust	reimbursement for food at conference :)	H		02/19/2026	02/23/2026	A	\$90.79
									25-26	252600515		\$90.79
NUMBER OF INVOICES: 1											\$90.79	
JOHN D H000	JOHN D HURN & SON, INC	607299	9002600083	FEBHURN	Trust	Hot Water Boiler Drain Valve \$9.49	H		02/05/2026	02/23/2026	R	48 02
						0.47			25-26	39825		\$9.49
JOHN D H000	JOHN D HURN & SON, INC	608410	0000000000	FEBHURN	Trust	BUS BARN SUPPLIES	H		02/18/2026	01/31/2026	R	\$32.76
									25-26	39825		\$32.76
JOHN D H000	JOHN D HURN & SON, INC	608480	0000000000	FEBHURN	Trust	ES SUPPLIES	H		02/19/2026	01/31/2026	R	\$66.47
						3.50			25-26	39825		\$69.97
JOHN D H000	JOHN D HURN & SON, INC	608487	9002600097	FEBHURN	Trust	trim nails	H		02/19/2026	02/23/2026	R	\$15.67
						0.82			25-26	39825		\$16.49
JOHN D H000	JOHN D HURN & SON, INC	608610	1002600342	FEBHURN	Trust	custodial supplies	H		02/20/2026	02/23/2026	R	\$7.52
						0.40			25-26	39825		\$7.92
JOHN D H000	JOHN D HURN & SON, INC	608638	0000000000	FEBHURN	Trust	MS SUPPLIES	H		02/20/2026	02/23/2026	R	\$51.92
						2.73			25-26	39825		\$54.65
JOHN D H000	JOHN D HURN & SON, INC	608755	0000000000	FEBHURN	Trust	ES SUPPLIES	H		02/23/2026	02/23/2026	R	\$106.13
						5.59			25-26	39825		\$111.72
JOHN D H000	JOHN D HURN & SON, INC	608780	3002600215	FEBHURN	Trust	paint, tape, bolts, and other supplies	H		02/23/2026	01/31/2026	R	\$21.24
						1.12			25-26	39825		\$22.36
JOHN D H000	JOHN D HURN & SON, INC	608802	0000000000	FEBHURN	Trust	ES SUPPLIES	H		02/23/2026	02/23/2026	R	\$51.37
						2.70			25-26	39825		\$54.07

<u>VEN-KEY</u>	<u>VENDOR NAME</u>	<u>INVOICE #</u>	<u>PO NUMBER</u>	<u>BATCH</u>	<u>BANK</u>	<u>DESCRIPTION</u>	<u>LQ</u>	<u>S</u>	<u>INV DATE</u>	<u>DUE DATE</u>	<u>C</u>	<u>NET AMOUNT</u>
<u>ACH VOID DOWNLOAD</u>		<u>DISCOUNT DESCRIPTION</u>		<u>DISC AMT</u>		<u>ADJUSTMENT DESCRIPTION</u>	<u>FY</u>		<u>ADJ AMT</u>	<u>CHECK NBR</u>		<u>INVOICE AMOUNT</u>
NUMBER OF INVOICES: 9												\$362.10
JOHN DEE000	JOHN DEERE FINANCIAL	4199599	000000000	FEBJD	Trust	RCES TRACTOR PART	H		02/05/2026	02/28/2026	R	\$336.17
							25-26			39839		\$336.17
JOHN DEE000	JOHN DEERE FINANCIAL	D60224	3002600333	FEBJD	Trust	various shop supplies. nuts, bolts, bsatteries, chop saw blades, lube, cleaner, etc	H		02/18/2026	02/28/2026	R	\$136.95
							25-26			39839		49 \$136.95
JOHN DEE000	JOHN DEERE FINANCIAL	D60358	9002600096	FEBJD	Trust	trailer hitch/ Maintenance/shop	H		02/19/2026	02/23/2026	R	\$70.48
							25-26			39839		\$70.48
JOHN DEE000	JOHN DEERE FINANCIAL	D60506	8002600366	FEBJD	Trust	Marking red-orange spray paint (6)	H		02/19/2026	02/23/2026	R	\$53.94
							25-26			39839		\$53.94
JOHN DEE000	JOHN DEERE FINANCIAL	D61823	3002600333	FEBJD	Trust	various shop supplies. nuts, bolts, bsatteries, chop saw blades, lube, cleaner, etc	H		02/24/2026	02/23/2026	R	\$22.78
							25-26			39839		\$22.78
NUMBER OF INVOICES: 5												\$620.32
MUELLALE000	MUELLER, ALEXIS	013026	3002600322	FEBPP	Trust	CTEI Travel - One Room for One Night Lexi Mueller SIU Ground Zero 1/30	H		01/20/2026	01/30/2026	A	\$156.96
							25-26			252600465		\$156.96
MUELLALE000	MUELLER, ALEXIS	013126	3002600325	FEBPP	Trust	Reimburse Alexis Mueller for Fuel for SIU Ground Zero	H		01/20/2026	01/30/2026	A	\$30.02
							25-26			252600465		\$30.02

VEN-KEY	VENDOR NAME	INVOICE #	PO NUMBER	BATCH	BANK	DESCRIPTION	LQ	S	INV DATE	DUE DATE	C	NET AMOUNT
	ACH VOID DOWNLOAD	DISCOUNT DESCRIPTION		DISC AMT		ADJUSTMENT DESCRIPTION	FY		ADJ AMT	CHECK NBR		INVOICE AMOUNT
MUELLALE000	MUELLER, ALEXIS	2021-22186	3002600326	FEBPP	Trust	Reimburse Mueller CTEI Travel Advisor Meals SIU Ground Zero	H		01/20/2026	01/30/2026	A	\$53.84
									25-26	252600465		\$53.84
						NUMBER OF INVOICES: 3						\$240.82
PAMPEJAC001	PAMPE, JACOB	ERIN20260205A	0000000000	FEBPP	Trust	2/3/2026 Chemistry lab supplies bought for the week of 2/2-2/6	H		02/05/2026	08/01/2024	A	\$71.68
									25-26	252600467		\$71.68
						NUMBER OF INVOICES: 1						\$71.68
PIXLESUE000	PIXLEY, SUE	021826	3002600348	FEBPP	Trust	Sliders, Tapes, Pens, Pallette Containers, Ink and Shelving Unit	H		02/16/2026	02/23/2026	A	\$411.72
									25-26	252600516		\$411.72
						NUMBER OF INVOICES: 1						\$411.72
RCCU #1 000	RCCU #1	013026	3002600324	FEBPP	Trust	Ad Sales Postage	H		01/30/2026	02/04/2026	W	\$0.00
									25-26	202500447		\$0.00
RCCU #1 000	RCCU #1	26027	0000000000	FEBPP	Trust	NEW TEACHER BREAKFAST	H		02/02/2026	02/04/2026	W	\$0.00
									25-26	202500444		\$0.00
RCCU #1 000	RCCU #1	26031	0000000000	FEBPP	Trust	NEW TEACHER BREAKFAST	H		02/04/2026	02/04/2026	W	\$0.00
									25-26	202500464		\$0.00
						NUMBER OF INVOICES: 3						\$0.00
RCHS - A000	RCHS - ACTIVITY	021726	0000000000	FEBPP	Trust	RISE UP WALMART SPARK FOR GOOD GRANT	H		02/17/2026	01/31/2026	R	\$2,500.00
									25-26	39822		\$2,500.00

<u>VEN-KEY</u>	<u>VENDOR NAME</u>	<u>INVOICE #</u>	<u>PO NUMBER</u>	<u>BATCH</u>	<u>BANK</u>	<u>DESCRIPTION</u>	<u>LQ</u>	<u>S</u>	<u>INV DATE</u>	<u>DUE DATE</u>	<u>C</u>	<u>NET AMOUNT</u>
<u>ACH VOID DOWNLOAD</u>		<u>DISCOUNT DESCRIPTION</u>			<u>DISC AMT</u>	<u>ADJUSTMENT DESCRIPTION</u>	<u>FY</u>	<u>ADJ AMT</u>		<u>CHECK NBR</u>	<u>INVOICE AMOUNT</u>	
RCHS - A000	RCHS - ACTIVITY	022326	0000000000	FEBPP	Trust	WALMART GRANT RISE UP	H	02/24/2026	02/23/2026	R	\$1,350.00	
							25-26			39824	\$1,350.00	
NUMBER OF INVOICES: 2											\$3,850.00	
RCHS - R000	RCHS - REVOLVING	013126	0000000000	FEBPP	Trust	REIMBURSEMENT	H	02/04/2026	02/04/2026	R	\$3,635.00	
							25-26			39706	\$3,635.00	
NUMBER OF INVOICES: 1											\$3,635.00	
RCMS 000	RCMS	013126	0000000000	FEBPP	Trust	REIMBURSEMENT	H	02/04/2026	02/04/2026	R	\$1,620.00	
							25-26			39707	\$1,620.00	
NUMBER OF INVOICES: 1											\$1,620.00	
RUSK AMY000	RUSK, AMY	020526	3002600344	FEBPP	Trust	Jostens Conference, Tour, & Meeting with Cover Artist	H	02/11/2026	02/12/2026	A	\$198.12	
							25-26			252600517	\$198.12	
RUSK AMY000	RUSK, AMY	020626	0000000000	FEBPP	Trust	FUEL REIMBURSEMENT ROAD RANGER	H	02/06/2026	02/04/2026	A	\$10.00	
							25-26			252600468	\$10.00	
NUMBER OF INVOICES: 2											\$208.12	
STEELHAS000	STEELE, HASSAN	021326	3502600017	FEBPP	Trust	Reimbursement for Wrestling Costs	H	02/20/2026	02/23/2026	A	\$388.40	
							25-26			252600518	\$388.40	
NUMBER OF INVOICES: 1											\$388.40	
VISA 000	VISA	21	0000000000	FEBPP	Trust	MOVE JORDAN ELLISON HOTEL TO METT	H	02/04/2026	02/04/2026	M	\$0.00	
							25-26			39680	\$0.00	

VEN-KEY	VENDOR NAME	INVOICE #	PO NUMBER	BATCH	BANK	DESCRIPTION	LQ	S	INV DATE	DUE DATE	C	NET AMOUNT
<u>ACH VOID DOWNLOAD</u>		<u>DISCOUNT DESCRIPTION</u>			<u>DISC AMT</u>	<u>ADJUSTMENT DESCRIPTION</u>	<u>FY</u>	<u>ADJ AMT</u>		<u>CHECK NBR</u>	<u>INVOICE AMOUNT</u>	
						NUMBER OF INVOICES:	1				\$0.00	
WIBBEAMB000	WIBBENMEYER, AMBER	021326	1002600360	FEBPP	Trust	Reimbursement for hotel and food from professional development	H		02/19/2026	02/23/2026	A	\$399.28
							25-26			252600519	\$399.28	
						NUMBER OF INVOICES:	1				\$399.28	
WILSOCOU001	WILSON, COURTNEY	022426	0000000000	FEBPP	Trust	FOODSERVICE REFUND BROOKLYN AND GRACELYN	H		02/24/2026	02/23/2026	R	\$11.50
							25-26			39823	\$11.50	
						NUMBER OF INVOICES:	1				\$11.50	
WISNEANG000	WISNER, ANGELA	012926	0000000000	FEBPP	Trust	REIMBURSE BOE TABLE CLOTHS	H		02/04/2026	02/05/2026	A	\$37.99
							25-26			252600469	\$37.99	
						NUMBER OF INVOICES:	1				\$37.99	
WYATTHEA001	WYATT, HEAVEN	021326	1002600370	FEBPP	Trust	Reimbursement for food from professional development	H		02/19/2026	02/23/2026	A	\$53.52
							25-26			252600520	\$53.52	
						NUMBER OF INVOICES:	1				\$53.52	
						TOTAL NUMBER OF HISTORY INVOICES:	42				\$16,072.27	
							15			ACH CHECK INVOICES	\$2,627.64	
							21			COMPUTER CHECK INVOICES	\$10,098.92	
							1			MANUAL CHECK INVOICES	\$0.00	
							5			WIRE TRAN CHECK INVOICES	\$3,345.71	
						TOTAL INVOICES:	42				\$16,072.27	

<u>VEN-KEY</u>	<u>VENDOR NAME</u>	<u>INVOICE #</u>	<u>PO NUMBER</u>	<u>BATCH</u>	<u>BANK</u>	<u>DESCRIPTION</u>	<u>LQ</u>	<u>S</u>	<u>INV DATE</u>	<u>DUE DATE</u>	<u>C</u>	<u>NET AMOUNT</u>
	<u>ACH VOID DOWNLOAD</u>	<u>DISCOUNT DESCRIPTION</u>			<u>DISC AMT</u>	<u>ADJUSTMENT DESCRIPTION</u>	<u>FY</u>		<u>ADJ AMT</u>	<u>CHECK NBR</u>		<u>INVOICE AMOUNT</u>

<u>BANK TOTALS:</u>	<u>BANK</u>	<u>BANK ACCOUNT #</u>	<u>INVOICE AMOUNT</u>	<u>NET AMOUNT</u>
	Trust	**A010 1120 0000 00 000000	\$16,089.60	\$16,072.27

LIQUIDATION STATUS (LQ) CODE LEGEND:
L = LIQUIDATION PENDING C = CLOSED PO/NOT RECEIVING
P = PARTIAL LIQUIDATION F = FULL LIQUIDATION
BLANK = NO LIQUIDATION

***** End of report *****

REPORT SPECIFICATIONS

DISTRICT: Richland County Community Unit #1
REPORT TITLE: AP Invoice Listing Report
REQUESTED BY: cgraves DATE: 03/18/26
PROGRAM NAME: fin/3aprpt01. TIME: 2:11:28 PM
COPIES: 1 LPI: 6
RUN ON SERVER: yes CREATE ASCII FILE: NO

REPORT SEQUENCE: Vendor
INVOICE TYPE(S): HISTORY
CHECK TYPE(S): ALL

PRINT DETAIL: no PRINT ACCOUNTING: no
STARTING PO #: 0 ENDING PO #: 9999999999
STARTING INVOICE #: ENDING INVOICE #: ZZZZZZZZZZZZZZZZZZZ
STARTING VENDOR KEY: ENDING VENDOR KEY: ZZZZZZZZZZZ
STARTING BATCH #: BEMAR ENDING BATCH #: BEMARV
STARTING BANK CASH CODE: trust ENDING BANK CASH CODE: trust
STARTING INVOICE DATE: ENDING INVOICE DATE: 12/31/9999
STARTING DUE DATE: ENDING DUE DATE: 12/31/9999
STARTING CREATED BY: ENDING CREATED BY: ZZZZZZZZZZZ
STARTING CREATED DATE: 07/01/2025 ENDING CREATED DATE: 12/31/9999
STARTING INVOICE AMOUNT: -999,999,999.00 ENDING INVOICE AMOUNT: 9999,999,999.99

<u>VEN-KEY</u>	<u>VENDOR NAME</u>	<u>INVOICE #</u>	<u>PO NUMBER</u>	<u>BATCH</u>	<u>BANK</u>	<u>DESCRIPTION</u>	<u>LQ S</u>	<u>INV DATE</u>	<u>DUE DATE</u>	<u>C</u>	<u>NET AMOUNT</u>
	<u>ACH VOID DOWNLOAD</u>	<u>DISCOUNT DESCRIPTION</u>			<u>DISC AMT</u>	<u>ADJUSTMENT DESCRIPTION</u>	<u>FY</u>		<u>ADJ AMT</u>	<u>CHECK NBR</u>	<u>INVOICE AMOUNT</u>
A-1 QUAL001	A-1 QUALITY GLASS CO INC	115381	8002600384	BBMAR	Trust	Bus #8 - Replace driver side windshield	H	03/09/2026	03/10/2026	R	\$314.00
							25-26			39898	\$314.00
NUMBER OF INVOICES: 1											\$314.00
AGPARTS 000	AGPARTS WORLDWIDE, INC	AR032901	9502600062	BBMAR	Trust	Chromebook Screens	H	02/20/2026	02/23/2026	R	\$994.50
							25-26			39842	\$994.50
NUMBER OF INVOICES: 1											\$994.50
AMAZON C000	AMAZON CAPITAL SERVICES, INC	1333-9lgx-kg9g	3002600377	BBMAR	Trust	Books for the library.	H	03/18/2026	03/18/2026	A	\$682.44
							25-26			252600570	\$682.44
AMAZON C000	AMAZON CAPITAL SERVICES, INC	13KQ-NY64-PYN1	1002600386	BBMAR	Trust	1st Grade Go Math Supplies	H	03/09/2026	03/10/2026	A	\$31.93
							25-26			252600557	\$31.93
AMAZON C000	AMAZON CAPITAL SERVICES, INC	1619-TXYQ-P47P	3002600345	BBMAR	Trust	Emergency plan frames for Gymnasiums	H	02/18/2026	01/31/2026	A	\$38.69
							25-26			252600535	\$38.69
AMAZON C000	AMAZON CAPITAL SERVICES, INC	16DC-YCPL-7JY7	3002600375	BBMAR	Trust	Yearbook Supplies	H	03/12/2026	03/10/2026	A	\$25.86
							25-26			252600557	\$25.86
AMAZON C000	AMAZON CAPITAL SERVICES, INC	16GV-7M19-NPVK	1002600350	BBMAR	Trust	Library Book and Supplies	H	02/23/2026	02/23/2026	A	\$125.30
							25-26			252600535	\$125.30
AMAZON C000	AMAZON CAPITAL SERVICES, INC	16NJ-C6JC-CPHF	5002600022	BBMAR	Trust	Guest speaker books	H	03/03/2026	03/18/2026	A	\$-272.00
							25-26			252600557	\$-272.00
AMAZON C000	AMAZON CAPITAL SERVICES, INC	179H-LRHJ-CT79	5002600022	BBMAR	Trust	Guest speaker books	H	02/24/2026	03/18/2026	A	\$-26.00
							25-26			252600557	\$-26.00
AMAZON C000	AMAZON CAPITAL SERVICES, INC	17DK-FFXW-39LM	3002600342	BBMAR	Trust	Wheels and Axles for Engineering class	H	02/23/2026	02/23/2026	A	\$53.99
							25-26			252600535	\$53.99

VEN-KEY	VENDOR NAME	INVOICE #	PO NUMBER	BATCH	BANK	DESCRIPTION	LQ	S	INV DATE	DUE DATE	C	NET AMOUNT
	ACH VOID DOWNLOAD	DISCOUNT DESCRIPTION			DISC AMT	ADJUSTMENT DESCRIPTION	FY		ADJ AMT	CHECK NBR		INVOICE AMOUNT
AMAZON C000	AMAZON CAPITAL SERVICES, INC	196L-MG6P-FYYX	1002600358	BBMAR	Trust	Student Prizes for 5 Essentials Survey	H	02/20/2026	01/31/2026	A		\$167.48
							25-26			252600535		\$167.48
AMAZON C000	AMAZON CAPITAL SERVICES, INC	1CG1-HKPT-XNQL	6502600024	BBMAR	Trust	Nurse supply order for HS.	H	03/13/2026	03/13/2026	A		\$715.16
							25-26			252600557		\$715.16
AMAZON C000	AMAZON CAPITAL SERVICES, INC	1CXP-4K4V-WXNL	1002600377	BBMAR	Trust	Laminating Film	H	03/15/2026	03/13/2026	A		\$-193.98
							25-26			252600557		\$-156.98
AMAZON C000	AMAZON CAPITAL SERVICES, INC	1DL1-6V7K-LW6H	1002600361	BBMAR	Trust	Storage bins or Kensley Kocher	H	02/20/2026	02/23/2026	A		\$66.89
							25-26			252600535		\$66.89
AMAZON C000	AMAZON CAPITAL SERVICES, INC	1DPT-MHWQ-9JJK	1002600391	BBMAR	Trust	Kindergarten Night - decor	H	03/12/2026	03/10/2026	A		\$23.93
							25-26			252600557		\$23.93
AMAZON C000	AMAZON CAPITAL SERVICES, INC	1DTN-KDVG-KJ79	1002600359	BBMAR	Trust	Noise Reduction Headphones	H	02/20/2026	02/23/2026	A		\$91.82
							25-26			252600535		\$91.82
AMAZON C000	AMAZON CAPITAL SERVICES, INC	1F61-TJNT-4HC7	5002600023	BBMAR	Trust	Replacement Order for Damon West books	H	03/03/2026	03/18/2026	A		\$510.00
							25-26			252600557		\$510.00
AMAZON C000	AMAZON CAPITAL SERVICES, INC	1FTT-FDF9-CPHH	0000000000	BBMAR	Trust	SRO FIRST AID KIT SUPPLIES	H	03/03/2026	03/03/2026	A		\$1,555.04
							25-26			252600535		\$1,555.04
AMAZON C000	AMAZON CAPITAL SERVICES, INC	1FXY-TK9F-3WFF	5502600082	BBMAR	Trust	Prevention Initiative Supplies	H	03/03/2026	02/26/2026	A		\$109.50
							25-26			252600535		\$109.50
AMAZON C000	AMAZON CAPITAL SERVICES, INC	1HLH-LQDM-G1L7	1002600369	BBMAR	Trust	1st Grade Go Math Supplies	H	03/03/2026	03/05/2026	A		\$224.00
							25-26			252600535		\$224.00
AMAZON C000	AMAZON CAPITAL SERVICES, INC	1HLV-GFKX-G7XT	1002600364	BBMAR	Trust	Masking Tape for STEM Class	H	02/20/2026	02/23/2026	A		\$48.92
							25-26			252600535		\$48.92

<u>VEN-KEY</u>	<u>VENDOR NAME</u>	<u>INVOICE #</u>	<u>PO NUMBER</u>	<u>BATCH</u>	<u>BANK</u>	<u>DESCRIPTION</u>	<u>LQ</u>	<u>S</u>	<u>INV DATE</u>	<u>DUE DATE</u>	<u>C</u>	<u>NET AMOUNT</u>
	<u>ACH VOID DOWNLOAD</u>	<u>DISCOUNT DESCRIPTION</u>		<u>DISC AMT</u>		<u>ADJUSTMENT DESCRIPTION</u>	<u>FY</u>		<u>ADJ AMT</u>	<u>CHECK NBR</u>		<u>INVOICE AMOUNT</u>
AMAZON C000	AMAZON CAPITAL SERVICES, INC	1JGF-LG4L-HW79	1002600389	BBMAR	Trust	K. Bunting Classroom Supplies	H	03/16/2026	03/18/2026	A		\$127.11
							25-26		252600557			\$127.11
AMAZON C000	AMAZON CAPITAL SERVICES, INC	1JGF-LG4L-PDXQ	1002600393	BBMAR	Trust	Reading Rewards-Mrs. Fox Dry Erase Erasers-Ms. Workman STEM Supplies-Mrs. Smith	H	03/16/2026	03/18/2026	A		\$65.52
							25-26		252600557			\$65.52
AMAZON C000	AMAZON CAPITAL SERVICES, INC	1JLF-T9CM-KWL6	1002600376	BBMAR	Trust	Leadership Day items	H	03/05/2026	03/09/2026	A		\$720.63
							25-26		252600557			\$720.63
AMAZON C000	AMAZON CAPITAL SERVICES, INC	1JQC-P96R-7YNP	5502600080	BBMAR	Trust	B3 Supplies	H	02/24/2026	02/23/2026	A		\$145.86
							25-26		252600535			\$145.86
AMAZON C000	AMAZON CAPITAL SERVICES, INC	1JQJ-W7TY-V439	3002600356	BBMAR	Trust	Books and supplies for the library.	H	03/08/2026	03/09/2026	A		\$20.70
							25-26		252600557			\$20.70
AMAZON C000	AMAZON CAPITAL SERVICES, INC	1JVN-CJ3T-13VN	2002600136	BBMAR	Trust	art supplies	H	03/17/2026	03/18/2026	A		\$401.70
							25-26		252600557			\$401.70
AMAZON C000	AMAZON CAPITAL SERVICES, INC	1KDC-DTLC-D734	5002600022	BBMAR	Trust	Guest speaker books	H	02/24/2026	03/18/2026	A		\$-17.00
							25-26		252600557			\$-17.00
AMAZON C000	AMAZON CAPITAL SERVICES, INC	1KTJ-RH9P-LJPH	6502600023	BBMAR	Trust	Amazon order for Darla-RCES.	H	03/10/2026	03/10/2026	A		\$540.60
							25-26		252600557			\$540.60
AMAZON C000	AMAZON CAPITAL SERVICES, INC	1KYH-T3RT-RXYQ	1002600369	BBMAR	Trust	1st Grade Go Math Supplies	H	03/02/2026	02/26/2026	A		\$13.96
							25-26		252600535			\$13.96
AMAZON C000	AMAZON CAPITAL SERVICES, INC	1LHF-MHMR-LWD6	3002600359	BBMAR	Trust	Acct 10E500 1250 4100 per K. Rodgers Replacement copies of The Great Gatsby and To Kill A Mockingbird	H	03/08/2026	03/09/2026	A		\$576.43

57

<u>VEN-KEY</u>	<u>VENDOR NAME</u>	<u>INVOICE #</u>	<u>PO NUMBER</u>	<u>BATCH</u>	<u>BANK</u>	<u>DESCRIPTION</u>	<u>LQ S</u>	<u>INV DATE</u>	<u>DUE DATE</u>	<u>C</u>	<u>NET AMOUNT</u>
	<u>ACH VOID DOWNLOAD</u>	<u>DISCOUNT DESCRIPTION</u>		<u>DISC AMT</u>		<u>ADJUSTMENT DESCRIPTION</u>	<u>FY</u>	<u>ADJ AMT</u>	<u>CHECK NBR</u>		<u>INVOICE AMOUNT</u>
AMAZON C000	AMAZON CAPITAL SERVICES, INC	1LHF-MHMR-LWD6				*****CONTINUED*****					
							25-26		252600557		\$576.43
AMAZON C000	AMAZON CAPITAL SERVICES, INC	1LJV-CXTG-1NC7	9002600093	BBMAR	Trust	high school	H	02/23/2026	02/23/2026	A	\$47.04
							25-26		252600535		\$47.04
AMAZON C000	AMAZON CAPITAL SERVICES, INC	1M67-PTYK-CQGH	5002600022	BBMAR	Trust	Guest speaker books	H	02/24/2026	03/18/2026	A	\$-17.00
							25-26		252600557		\$-17.00
AMAZON C000	AMAZON CAPITAL SERVICES, INC	1MCT-DP1L-VNX6	1002600395	BBMAR	Trust	Label dots for Passports Velcro for K. Wells	H	03/16/2026	03/18/2026	A	\$91.88
							25-26		252600557		\$91.88
AMAZON C000	AMAZON CAPITAL SERVICES, INC	1MG1-JYWX-7L6Y	1002600367	BBMAR	Trust	Jennifer Hall - Classroom supplies	H	03/03/2026	02/26/2026	A	\$78.52
							25-26		252600535		\$78.52
AMAZON C000	AMAZON CAPITAL SERVICES, INC	1MGJ-WDGK-XKHP	1002600387	BBMAR	Trust	Items for Maddy Rusk	H	03/13/2026	03/13/2026	A	\$52.88
							25-26		252600557		\$52.88
AMAZON C000	AMAZON CAPITAL SERVICES, INC	1MNW-DQFF-3LGM	5502600084	BBMAR	Trust	PK Snack Cups	H	03/03/2026	02/26/2026	A	\$136.00
							25-26		252600535		\$136.00
AMAZON C000	AMAZON CAPITAL SERVICES, INC	1MNW-DQFF-973D	5002600022	BBMAR	Trust	Guest speaker books	H	02/24/2026	03/18/2026	A	\$-17.00
							25-26		252600557		\$-17.00
AMAZON C000	AMAZON CAPITAL SERVICES, INC	1MNW-DQFF-9G17	5002600022	BBMAR	Trust	Guest speaker books	H	02/24/2026	03/18/2026	A	\$-34.00
							25-26		252600557		\$-34.00
AMAZON C000	AMAZON CAPITAL SERVICES, INC	1MNW-DQFF-9TNJ	5002600022	BBMAR	Trust	Guest speaker books	H	02/24/2026	03/18/2026	A	\$-34.00
							25-26		252600557		\$-34.00
AMAZON C000	AMAZON CAPITAL SERVICES, INC	1MPD-9X9R-64TD	4502600028	BBMAR	Trust	Supplies	H	02/23/2026	02/23/2026	A	\$97.34
							25-26		252600535		\$97.34

58

<u>VEN-KEY</u>	<u>VENDOR NAME</u>	<u>INVOICE #</u>	<u>PO NUMBER</u>	<u>BATCH</u>	<u>BANK</u>	<u>DESCRIPTION</u>	<u>LQ</u>	<u>S</u>	<u>INV DATE</u>	<u>DUE DATE</u>	<u>C</u>	<u>NET AMOUNT</u>
	<u>ACH VOID DOWNLOAD</u>	<u>DISCOUNT DESCRIPTION</u>				<u>ADJUSTMENT DESCRIPTION</u>	<u>FY</u>		<u>ADJ AMT</u>	<u>CHECK NBR</u>		<u>INVOICE AMOUNT</u>
AMAZON C000	AMAZON CAPITAL SERVICES, INC	1N7K-GP1J-1VXY	9002600087	BBMAR	Trust	high school	H	02/23/2026	02/23/2026	A		\$72.78
							25-26		252600535			\$72.78
AMAZON C000	AMAZON CAPITAL SERVICES, INC	1NPY-H9X1-7C6D	2002600117	BBMAR	Trust	IAR Earbud Bulk Order- To be taken out to student activity	H	02/23/2026	02/26/2026	A		\$230.25
							25-26		252600535			\$230.25
AMAZON C000	AMAZON CAPITAL SERVICES, INC	1NPY-H9X1-FNDC	6002600053	BBMAR	Trust	Speech Therapy Materials for T. Stanley	H	02/23/2026	02/23/2026	A		\$59.79
							25-26		252600535			\$69.79
AMAZON C000	AMAZON CAPITAL SERVICES, INC	1P7D-4TWT-4KYL	5002600022	BBMAR	Trust	Guest speaker books	H	02/24/2026	02/23/2026	A		\$1,636.00
							25-26		252600535			\$1,636.00
AMAZON C000	AMAZON CAPITAL SERVICES, INC	1PVT-DDGT-7VVL	1002600351	BBMAR	Trust	Playdoh for Jenna Henton Cardstock for Music Class	H	02/20/2026	02/26/2026	A		\$47.07
							25-26		252600535			\$47.07
AMAZON C000	AMAZON CAPITAL SERVICES, INC	1QDP-KNJV-QWHJ	3002600352	BBMAR	Trust	Items for girls' track.	H	02/23/2026	02/23/2026	A		\$67.81
							25-26		252600535			\$67.81
AMAZON C000	AMAZON CAPITAL SERVICES, INC	1QNT-P4VY-KWJC	1002600375	BBMAR	Trust	Library Books	H	03/09/2026	03/10/2026	A		\$267.49
							25-26		252600557			\$267.49
AMAZON C000	AMAZON CAPITAL SERVICES, INC	1R3T-39CQ-LCYL	2002600129	BBMAR	Trust	New Books	H	03/14/2026	03/13/2026	A		\$578.16
							25-26		252600557			\$578.16
AMAZON C000	AMAZON CAPITAL SERVICES, INC	1R76-4Q4F-934T	6502600025	BBMAR	Trust	Nurse supply order Berger- RCMS	H	03/10/2026	03/10/2026	A		\$312.26
							25-26		252600557			\$312.26
AMAZON C000	AMAZON CAPITAL SERVICES, INC	1RKC-MMTF-7MTP	2002600125	BBMAR	Trust	State Awards	H	03/12/2026	03/10/2026	A		\$178.87
							25-26		252600557			\$178.87

VEN-KEY	VENDOR NAME	INVOICE #	PO NUMBER	BATCH	BANK	DESCRIPTION	LQ	S	INV DATE	DUE DATE	C	NET AMOUNT
	ACH VOID DOWNLOAD	DISCOUNT DESCRIPTION		DISC AMT		ADJUSTMENT DESCRIPTION	FY		ADJ AMT	CHECK NBR		INVOICE AMOUNT
AMAZON C000	AMAZON CAPITAL SERVICES, INC	1RVJ-QLHC-KHDY	9502600066	BBMAR	Trust	supplies for summer, plotter paper and ink, algo box for es paging	H		03/14/2026	03/18/2026	A	\$919.89
									25-26	252600575		\$919.89
AMAZON C000	AMAZON CAPITAL SERVICES, INC	1TJQ-G9PH-3VV9	2002600108	BBMAR	Trust	Books	H		02/24/2026	02/23/2026	A	\$-42.80
									25-26	252600535		\$-42.80
AMAZON C000	AMAZON CAPITAL SERVICES, INC	1TQK-9FPX-JHCG	3002600361	BBMAR	Trust	Brad nail guns for new wood working class next year. These will replace the 2 I have that no longer work	H		02/27/2026	02/26/2026	A	\$60.07
									25-26	252600535		\$92.07
AMAZON C000	AMAZON CAPITAL SERVICES, INC	1TW6-XYWW-RFG7	3002600353	BBMAR	Trust	Classroom, departmental, and curriculum supplies for the English department - 2nd semester	H		03/02/2026	02/26/2026	A	\$245.77
									25-26	252600535		\$245.77
AMAZON C000	AMAZON CAPITAL SERVICES, INC	1VJK-PRKG-XGFD	4502600028	BBMAR	Trust	Supplies	H		02/21/2026	02/23/2026	A	\$294.96
									25-26	252600535		\$294.96
AMAZON C000	AMAZON CAPITAL SERVICES, INC	1VP6-NQQF-DQ6F	2002600126	BBMAR	Trust	P.E. Equipment	H		03/12/2026	03/13/2026	A	\$1,303.98
									25-26	252600557		\$1,303.98
AMAZON C000	AMAZON CAPITAL SERVICES, INC	1VPV-KMCD-C1FG	5002600022	BBMAR	Trust	Guest speaker books	H		02/24/2026	03/18/2026	A	\$-102.00
									25-26	252600557		\$-102.00
AMAZON C000	AMAZON CAPITAL SERVICES, INC	1VTT-3L6Y-41HX	3002600364	BBMAR	Trust	filament for 3d printers for engineering class	H		03/10/2026	03/10/2026	A	\$306.97
									25-26	252600557		\$306.97
AMAZON C000	AMAZON CAPITAL SERVICES, INC	1VTT-3L6Y-FREX	1002600383	BBMAR	Trust	Professional Upright Vacuum Cleaner	H		03/10/2026	03/10/2026	A	\$351.92
									25-26	252600557		\$351.92

VEN-KEY	VENDOR NAME	INVOICE #	PO NUMBER	BATCH	BANK	DESCRIPTION	LQ	S	INV DATE	DUE DATE	C	NET AMOUNT
	ACH VOID DOWNLOAD	DISCOUNT DESCRIPTION				ADJUSTMENT DESCRIPTION	FY		ADJ AMT	CHECK NBR		INVOICE AMOUNT
AMAZON C000	AMAZON CAPITAL SERVICES, INC	1VVK-7YKJ-K4NR	1002600287	BBMAR	Trust	Library Books	H		02/23/2026	02/23/2026	A	\$12.94
							25-26			252600535		\$12.94
AMAZON C000	AMAZON CAPITAL SERVICES, INC	1WLC-LMT6-KCRJ	3002600353	BBMAR	Trust	Classroom, departmental, and curriculum supplies for the English department - 2nd semester	H		02/25/2026	02/28/2026	A	\$414.75
							25-26			252600535		\$414.75
AMAZON C000	AMAZON CAPITAL SERVICES, INC	1WWH-XG9L-YQPP	0000000000	BBMAR	Trust	FIRST AID BACKPACK	H		03/09/2026	03/09/2026	A	\$32.96
							25-26			252600557		\$32.96
AMAZON C000	AMAZON CAPITAL SERVICES, INC	1X6V-11MT-LNTN	6502600024	BBMAR	Trust	Nurse supply order for HS.	H		03/11/2026	03/10/2026	A	\$49.87
							25-26			252600557		\$49.87
AMAZON C000	AMAZON CAPITAL SERVICES, INC	1YLD-13N6-R7P4	2002600108	BBMAR	Trust	Books	H		02/19/2026	02/23/2026	A	\$54.56
							25-26			252600535		\$54.56
AMAZON C000	AMAZON CAPITAL SERVICES, INC	1YX6-CDJQ-C7RH	1002600377	BBMAR	Trust	Laminating Film	H		03/05/2026	02/28/2026	A	\$969.90
							25-26			252600535		\$969.90
NUMBER OF INVOICES: 64											\$15,342.36	
APPLE IN000	APPLE, INC	MC57417821	3002600037	BBMAR	Trust	Apple Mac Mini Apple M4 chip with 10-core CPU, 10-core GPU, 16-core Neural Engine 24GB unified memory 512GB SSD storage Gigabit Ethernet Three Thunderbolt 4 ports, HDMI port, two USB-C ports, headphone jack	H		03/12/2026	03/13/2026	R	\$899.00
							25-26			39899		\$899.00
NUMBER OF INVOICES: 1											\$899.00	
AUTO WHE000	AUTO WHEEL AND RIM SERVICE CO, INC	4081421-00	8002600349	BBMAR	Trust	Lube spin on (2) & Fuel spin	H		02/06/2026	01/31/2026	R	\$71.57

<u>VEN-KEY</u>	<u>VENDOR NAME</u>	<u>INVOICE #</u>	<u>PO NUMBER</u>	<u>BATCH</u>	<u>BANK</u>	<u>DESCRIPTION</u>	<u>LQ S</u>	<u>INV DATE</u>	<u>DUE DATE</u>	<u>C</u>	<u>NET AMOUNT</u>
	<u>ACH VOID DOWNLOAD</u>	<u>DISCOUNT DESCRIPTION</u>		<u>DISC AMT</u>		<u>ADJUSTMENT DESCRIPTION</u>	<u>FY</u>	<u>ADJ AMT</u>	<u>CHECK NBR</u>		<u>INVOICE AMOUNT</u>
AUTO WHE000	AUTO WHEEL AND RIM SERVICE CO, INC	4081421-00				*****CONTINUED*****					
						on					
							25-26		39843		\$71.57
						NUMBER OF INVOICES: 1					\$71.57
AWARDS A000	AWARDS AMERICA, INC	0090813-IN	2502600027	BBMAR		Trust O's and pins	H	02/20/2026	02/23/2026	R	\$630.61
							25-26		39844		\$630.61
											62
						NUMBER OF INVOICES: 1					\$630.61
BLICK AR000	BLICK ART MATERIALS	7442733	3002600349	BBMAR		Trust Mattes, clay and glazes	H	02/18/2026	02/23/2026	R	\$807.58
							25-26		39845		\$807.58
BLICK AR000	BLICK ART MATERIALS	7561974	3002600349	BBMAR		Trust Mattes, clay and glazes	H	03/04/2026	03/13/2026	R	\$3.96
							25-26		39900		\$3.96
						NUMBER OF INVOICES: 2					\$811.54
BM TRUCK000	BM TRUCK EQUIPMENT	012659838	0000000000	BBMAR		Trust SHOP	H	02/25/2026	03/03/2026	R	\$50.48
							25-26		39846		\$50.48
BM TRUCK000	BM TRUCK EQUIPMENT	012659848	0000000000	BBMAR		Trust RCES	H	02/25/2026	03/03/2026	R	\$260.00
							25-26		39846		\$260.00
BM TRUCK000	BM TRUCK EQUIPMENT	022659902	0000000000	BBMAR		Trust HS SUPPLIES	H	03/04/2026	03/05/2026	R	\$1,819.31
							25-26		39846		\$1,819.31
						NUMBER OF INVOICES: 3					\$2,129.79
BMO HARR001	BMO HARRIS BANK	10	4502600027	BBMAR		Trust DAIRY QUEEN INCENTIVE	H	02/16/2026	03/20/2026	W	\$7.61
							25-26		202500513		\$7.61
BMO HARR001	BMO HARRIS BANK	11	4502600027	BBMAR		Trust C VANMATRE DAIRY QUEEN	H	02/06/2026	03/20/2026	W	\$15.23
							25-26		202500514		\$15.23

<u>VEN-KEY</u>	<u>VENDOR NAME</u>	<u>INVOICE #</u>	<u>PO NUMBER</u>	<u>BATCH</u>	<u>BANK</u>	<u>DESCRIPTION</u>	<u>LQ</u>	<u>S</u>	<u>INV DATE</u>	<u>DUE DATE</u>	<u>C</u>	<u>NET AMOUNT</u>
<u>ACH VOID DOWNLOAD</u>		<u>DISCOUNT DESCRIPTION</u>			<u>DISC AMT</u>	<u>ADJUSTMENT DESCRIPTION</u>	<u>FY</u>	<u>ADJ AMT</u>		<u>CHECK NBR</u>	<u>INVOICE AMOUNT</u>	
BMO HARR001	BMO HARRIS BANK	12	3002600363	BBMAR	Trust	Purchasing card for use on Monday, March 2nd to pay for student meals while at the ACES Regional competition in Robinson.	H		02/06/2026	03/20/2026	W	\$178.35
							25-26			202500515		\$178.35
BMO HARR001	BMO HARRIS BANK	13	3002600357	BBMAR	Trust	Ag Travel - Meals for Kinkade while taking students to the IL Beef Expo Livestock Judging Contest in Springfield, IL	H		02/20/2026	03/20/2026	W	\$25.27
							25-26			202500516		\$25.27
BMO HARR001	BMO HARRIS BANK	14	3002600373	BBMAR	Trust	Meals for Dist V proficiency Awards. Mueller, Kinkade, VanDyke (supper) @ Culver's	H		02/20/2026	03/20/2026	W	\$49.12
							25-26			202500517		\$49.12
BMO HARR001	BMO HARRIS BANK	15	4502600027	BBMAR	Trust	H BAKER DAIRY QUEEN	H		02/20/2026	03/20/2026	W	\$7.61
							25-26			202500518		\$7.61
BMO HARR001	BMO HARRIS BANK	16	3002600343	BBMAR	Trust	P Card for Meats Judging Feb 14th Slagel Meats, Forrest IL Money for teacher meals - #63 Fuel \$100.00 Total \$163.00	H		02/14/2026	03/20/2026	W	\$8.80
							25-26			202500519		\$8.80
NUMBER OF INVOICES: 7											\$291.99	
BSN SPOR001	BSN SPORTS LLC	933207515	3002600360	BBMAR	Trust	Game Day Hydration Package - (1/2 Paid by JFL)	H		02/26/2026	02/28/2026	R	\$2,650.00
							25-26			39847		\$2,650.00

<u>VEN-KEY</u>	<u>VENDOR NAME</u>	<u>INVOICE #</u>	<u>PO NUMBER</u>	<u>BATCH</u>	<u>BANK</u>	<u>DESCRIPTION</u>	<u>LQ S</u>	<u>INV DATE</u>	<u>DUE DATE</u>	<u>C</u>	<u>NET AMOUNT</u>
	<u>ACH VOID DOWNLOAD</u>	<u>DISCOUNT DESCRIPTION</u>		<u>DISC AMT</u>		<u>ADJUSTMENT DESCRIPTION</u>	<u>FY</u>	<u>ADJ AMT</u>	<u>CHECK NBR</u>		<u>INVOICE AMOUNT</u>
BSN SPOR001	BSN SPORTS LLC	933281437	3502600019	BBMAR	Trust	4 nets for Ron Herrin Gym Basketball goals	H	02/25/2026	02/26/2026	R	\$32.00
							25-26		39847		\$32.00
NUMBER OF INVOICES: 2											\$2,682.00
BULK BOO000	BULK BOOKSTORE	228854	3002600369	BBMAR	Trust	Class sets of books for the Shelby Van Pelt author visit.	H	03/05/2026	03/10/2026	A	\$1,868.30
							25-26		252600558		\$1,868.30
NUMBER OF INVOICES: 1											\$1,868.30
BUSHUE B000	BUSHUE BACKGROUND SCREENING	1-20260228	0000000000	BBMAR	Trust	FINGERPRINTING	H	03/03/2026	03/03/2026	A	\$348.00
							25-26		252600536		\$348.00
BUSHUE B000	BUSHUE BACKGROUND SCREENING	VOLS-20260228	0000000000	BBMAR	Trust	VOLUNTEERS	H	03/03/2026	03/03/2026	A	\$120.00
							25-26		252600536		\$120.00
NUMBER OF INVOICES: 2											\$468.00
C & T / 000	C & T / RICHLAND MOTOR PARTS	256103	0000000000	BBMAR	Trust	HS SUPPLIES	H	01/28/2026	01/21/2026	R	\$15.98
							25-26		39848		\$15.98
C & T / 000	C & T / RICHLAND MOTOR PARTS	256231	0000000000	BBMAR	Trust	HS SUPPLIES	H	01/29/2026	01/30/2026	R	\$76.48
							25-26		39848		\$76.48
C & T / 000	C & T / RICHLAND MOTOR PARTS	256608	8002600337	BBMAR	Trust	Tow Strap	H	02/03/2026	01/31/2026	R	\$118.99
							25-26		39848		\$118.99
C & T / 000	C & T / RICHLAND MOTOR PARTS	256638	0000000000	BBMAR	Trust	HS SUPPLIES	H	02/04/2026	01/31/2026	R	\$168.48
							25-26		39848		\$168.48
C & T / 000	C & T / RICHLAND MOTOR PARTS	256700	0000000000	BBMAR	Trust	ELC SUPPLIES	H	02/05/2026	02/04/2026	R	\$135.98
							25-26		39848		\$135.98

<u>VEN-KEY</u>	<u>VENDOR NAME</u>	<u>INVOICE #</u>	<u>PO NUMBER</u>	<u>BATCH</u>	<u>BANK</u>	<u>DESCRIPTION</u>	<u>LQ</u>	<u>S</u>	<u>INV DATE</u>	<u>DUE DATE</u>	<u>C</u>	<u>NET AMOUNT</u>
	<u>ACH VOID DOWNLOAD</u>	<u>DISCOUNT DESCRIPTION</u>		<u>DISC AMT</u>		<u>ADJUSTMENT DESCRIPTION</u>	<u>FY</u>		<u>ADJ AMT</u>	<u>CHECK NBR</u>		<u>INVOICE AMOUNT</u>
C & T / 000	C & T / RICHLAND MOTOR PARTS	256787	0000000000	BBMAR	Trust	HS SUPPLIES	H	02/06/2026	02/26/2026	R		\$169.55
							25-26			39848		\$169.55
C & T / 000	C & T / RICHLAND MOTOR PARTS	257680	0000000000	BBMAR	Trust	ES SUPPLIES	H	02/19/2026	01/31/2026	R		\$105.38
							25-26			39848		\$105.38
C & T / 000	C & T / RICHLAND MOTOR PARTS	258030	1002600145	BBMAR	Trust	custodial supplies	H	02/24/2026	02/23/2026	R		\$11.44
							25-26			39848		\$11.44
NUMBER OF INVOICES: 8												
\$802.28												
CARLE 000	CARLE	030526	8002600390	BBMAR	Trust	Bus driver drug tests for renewal (2)	H	02/27/2026	03/13/2026	R		\$80.00
							25-26			39901		\$80.00
NUMBER OF INVOICES: 1												
\$80.00												
CENTRAL 003	CENTRAL STATES BUS SALES	IN690845	8002600352	BBMAR	Trust	Battery retainer strap assy (3)	H	02/06/2026	01/31/2026	R		\$104.91
							25-26			39849		\$104.91
CENTRAL 003	CENTRAL STATES BUS SALES	IN690860	8002600353	BBMAR	Trust	Battery retainer strap assy (3)	H	02/06/2026	01/31/2026	R		\$104.91
							25-26			39849		\$104.91
CENTRAL 003	CENTRAL STATES BUS SALES	IN691971	8002600365	BBMAR	Trust	Bus #15 - Engine led light cmpt t3re	H	02/16/2026	02/23/2026	R		\$40.86
							25-26			39849		\$40.86
CENTRAL 003	CENTRAL STATES BUS SALES	IN692614	8002600369	BBMAR	Trust	Exhaust tube and pipe exh rr axle spring susp	H	02/20/2026	02/23/2026	R		\$1,095.35
							25-26			39849		\$1,095.35
CENTRAL 003	CENTRAL STATES BUS SALES	IN692619	8002600370	BBMAR	Trust	Exhaust pipe c7 spring susp, exhaust clamp (5), u-bolt clamp kit (2), exhaust	H	02/20/2026	02/23/2026	R		\$349.73

<u>VEN-KEY</u>	<u>VENDOR NAME</u>	<u>INVOICE #</u>	<u>PO NUMBER</u>	<u>BATCH</u>	<u>BANK</u>	<u>DESCRIPTION</u>	<u>LQ</u>	<u>S</u>	<u>INV DATE</u>	<u>DUE DATE</u>	<u>C</u>	<u>NET AMOUNT</u>
	<u>ACH VOID DOWNLOAD</u>	<u>DISCOUNT DESCRIPTION</u>		<u>DISC AMT</u>		<u>ADJUSTMENT DESCRIPTION</u>	<u>FY</u>		<u>ADJ AMT</u>	<u>CHECK NBR</u>		<u>INVOICE AMOUNT</u>
CENTRAL 003	CENTRAL STATES BUS SALES	IN692619		*****CONTINUED*****		isolator (2), exhaust hanger rod (2), & exhaust hanger bracket (4)			25-26		39849	\$349.73
CENTRAL 003	CENTRAL STATES BUS SALES	IN692825	8002600372	BBMAR	Trust	Fuel/water separator filter	H	02/23/2026	02/26/2026	R		\$380.14
								25-26		39849		\$380.14
NUMBER OF INVOICES: 6												\$2,075.90
CHADDOCK000	CHADDOCK	CATSIN-003990	0000000000	BBMAR	Trust	TUITION	H	03/02/2026	02/26/2026	A		\$22,561.46
								25-26		252600537		\$22,561.46
NUMBER OF INVOICES: 1												\$22,561.46
CINTAS 000	CINTAS	4258177430	0000000000	BBMAR	Trust	RCES SERVICE	H	02/04/2026	02/05/2026	R		\$241.94
								25-26		39850		\$241.94
CINTAS 000	CINTAS	4258177510	0000000000	BBMAR	Trust	RCHS SERVICE	H	02/04/2026	02/05/2026	R		\$140.00
								25-26		39850		\$140.00
CINTAS 000	CINTAS	4258177511	0000000000	BBMAR	Trust	RCMS SERVICE	H	02/04/2026	02/05/2026	R		\$239.04
								25-26		39850		\$239.04
CINTAS 000	CINTAS	4259671974	0000000000	BBMAR	Trust	ES SERVICE	H	02/17/2026	02/17/2026	R		\$241.94
								25-26		39850		\$241.94
CINTAS 000	CINTAS	4259672013	0000000000	BBMAR	Trust	HS SERVICE	H	02/17/2026	02/17/2026	R		\$140.00
								25-26		39850		\$140.00
CINTAS 000	CINTAS	4259672022	0000000000	BBMAR	Trust	MS SERVICE	H	02/17/2026	02/17/2026	R		\$239.04
								25-26		39850		\$239.04
CINTAS 000	CINTAS	4260408645	0000000000	BBMAR	Trust	ELC SERVICE	H	02/24/2026	03/03/2026	R		\$96.16
								25-26		39850		\$96.16

<u>VEN-KEY</u>	<u>VENDOR NAME</u>	<u>INVOICE #</u>	<u>PO NUMBER</u>	<u>BATCH</u>	<u>BANK</u>	<u>DESCRIPTION</u>	<u>LQ</u>	<u>S</u>	<u>INV DATE</u>	<u>DUE DATE</u>	<u>C</u>	<u>NET AMOUNT</u>
	<u>ACH VOID DOWNLOAD</u>	<u>DISCOUNT DESCRIPTION</u>		<u>DISC AMT</u>		<u>ADJUSTMENT DESCRIPTION</u>	<u>FY</u>		<u>ADJ AMT</u>	<u>CHECK NBR</u>		<u>INVOICE AMOUNT</u>
						NUMBER OF INVOICES: 7						\$1,338.12
CITY OF 002	CITY OF OLNEY	021026	9002600004	BBMAR	Trust	WATER BILL	H	02/12/2026	02/26/2026	R		\$5,273.30
							25-26			39851		\$5,273.30
						NUMBER OF INVOICES: 1						\$5,273.30
CLAY CIT003	CLAY CITY SCHOOL DISTRICT #10	2026-211	0000000000	BBMAR	Trust	LUNCHES AND BREAKFASTS	H	02/23/2026	02/24/2026	R		\$322.70
							25-26			39852		\$367.70
CLAY CIT003	CLAY CITY SCHOOL DISTRICT #10	2026-302	0000000000	BBMAR	Trust	BREAKFASTS AND LUNCHES	H	03/09/2026	03/09/2026	R		\$579.10
							25-26			39902		\$579.10
						NUMBER OF INVOICES: 2						\$901.80
COOPEJES000	COOPER, JESSICA R.	ERIN20260303A	0000000000	BBMAR	Trust	2/2/2026-2/27/2026 Travel to and from different buildings in the district	H	03/03/2026	03/03/2026	A		\$39.24
							25-26			252600538		\$39.24
						NUMBER OF INVOICES: 1						\$39.24
CORONLAU000	CORONA, LAURA	022726	5502600086	BBMAR	Trust	Translation Services	H	02/03/2026	02/26/2026	R		\$150.00
							25-26			39853		\$150.00
						NUMBER OF INVOICES: 1						\$150.00
CUMMINS 001	CUMMINS CSSNA - US, INC	R5-260386189	8002600379	BBMAR	Trust	Bus #12 - Replace Nitrogen Oxide Sensor	H	03/04/2026	03/09/2026	R		\$1,447.25
							25-26			39903		\$1,447.25
						NUMBER OF INVOICES: 1						\$1,447.25
DATA MAN000	DATA MANAGEMENT SHREDDING	76360	9002600006	BBMAR	Trust	SHREDDING SERVICES	H	03/11/2026	03/13/2026	R		\$45.00
							25-26			39904		\$45.00

VEN-KEY	VENDOR NAME	INVOICE #	PO NUMBER	BATCH	BANK	DESCRIPTION	LQ	S	INV DATE	DUE DATE	C	NET AMOUNT
	<u>ACH VOID DOWNLOAD</u>	<u>DISCOUNT DESCRIPTION</u>				<u>ADJUSTMENT DESCRIPTION</u>	FY		ADJ AMT	CHECK NBR		<u>INVOICE AMOUNT</u>
NUMBER OF INVOICES: 1											\$45.00	
EFFINGHA001	EFFINGHAM BUILDERS SUPPLY	0000151455-002	0000000000	BBMAR	Trust	MS SUPPLIES	H		03/13/2026	03/13/2026	R	\$55.50
							25-26			39905		\$55.50
EFFINGHA001	EFFINGHAM BUILDERS SUPPLY	0000151589-001	0000000000	BBMAR	Trust	MS SUPPLIES	H		03/17/2026	03/18/2026	R	\$86.00
							25-26			39905		\$86.00
EFFINGHA001	EFFINGHAM BUILDERS SUPPLY	000149739-001	0000000000	BBMAR	Trust	MS SUPPLIES	H		03/09/2026	03/09/2026	R	\$595.00
							25-26			39905		\$595.00
NUMBER OF INVOICES: 3											\$736.50	
ENTECS000	ENTECSERVICES, INC	SIN062948	9002600076	BBMAR	Trust	HEAT EXCHANGER	F	H	02/12/2026	02/26/2026	A	\$24,990.00
							25-26			252600539		\$24,990.00
ENTECS000	ENTECSERVICES, INC	SIN063183	0000000000	BBMAR	Trust	RCHS QUARTERLY BILLING	H		03/04/2026	03/05/2026	A	\$2,245.00
							25-26			252600539		\$2,245.00
NUMBER OF INVOICES: 2											\$27,235.00	
ERWINMEL000	ERWIN, MELISSA	ERIN20260303A	0000000000	BBMAR	Trust	2/2/2026-2/26/2026 Mileage for February home visits	H		03/03/2026	03/03/2026	A	\$208.80
							25-26			252600540		\$208.80
NUMBER OF INVOICES: 1											\$208.80	
FEHRENBA001	FEHRENBACHER OIL CO, INC	1013710	8002600334	BBMAR	Trust	Bus #2 Inspection	H		02/03/2026	02/04/2026	R	\$66.00
							25-26			39854		\$66.00
FEHRENBA001	FEHRENBACHER OIL CO, INC	1013812	8002600336	BBMAR	Trust	Bus #13 Inspection	H		02/03/2026	02/04/2026	R	\$66.00
							25-26			39854		\$66.00
FEHRENBA001	FEHRENBACHER OIL CO, INC	1014619	8002600346	BBMAR	Trust	Bus #21 Inspection	H		02/06/2026	01/31/2026	R	\$66.00
							25-26			39854		\$66.00

<u>VEN-KEY</u>	<u>VENDOR NAME</u>	<u>INVOICE #</u>	<u>PO NUMBER</u>	<u>BATCH</u>	<u>BANK</u>	<u>DESCRIPTION</u>	<u>LQ</u>	<u>S</u>	<u>INV DATE</u>	<u>DUE DATE</u>	<u>C</u>	<u>NET AMOUNT</u>
	<u>ACH VOID DOWNLOAD</u>	<u>DISCOUNT DESCRIPTION</u>		<u>DISC AMT</u>		<u>ADJUSTMENT DESCRIPTION</u>	<u>FY</u>		<u>ADJ AMT</u>	<u>CHECK NBR</u>		<u>INVOICE AMOUNT</u>
FEHRENBA001	FEHRENBACHER OIL CO, INC	1020632	8002600354	BBMAR	Trust	Bus #23 Inspection	H	02/09/2026	01/31/2026	R		\$66.00
							25-26			39854		\$66.00
FEHRENBA001	FEHRENBACHER OIL CO, INC	1020668	8002600355	BBMAR	Trust	Bus #27 Inspection	H	02/09/2026	01/31/2026	R		\$66.00
							25-26			39854		\$66.00
FEHRENBA001	FEHRENBACHER OIL CO, INC	1020701	8002600356	BBMAR	Trust	Bus #28 Inspection	H	02/10/2026	01/31/2026	R		\$66.00
							25-26			39854		\$66.00
FEHRENBA001	FEHRENBACHER OIL CO, INC	1020965	8002600359	BBMAR	Trust	Bus #49 Inspection	H	02/10/2026	01/31/2026	R		\$66.00
							25-26			39854		\$66.00
FEHRENBA001	FEHRENBACHER OIL CO, INC	1024843	8002600373	BBMAR	Trust	Bus #25 Inspection	H	02/24/2026	02/26/2026	R		\$66.00
							25-26			39854		\$66.00
FEHRENBA001	FEHRENBACHER OIL CO, INC	1025277	8002600374	BBMAR	Trust	Bus #55 Inspection	H	02/25/2026	02/26/2026	R		\$66.00
							25-26			39854		\$66.00
FEHRENBA001	FEHRENBACHER OIL CO, INC	1028564	8002600326	BBMAR	Trust	Bus #1 Inspection	H	02/02/2026	01/31/2026	R		\$66.00
							25-26			39854		\$66.00
FEHRENBA001	FEHRENBACHER OIL CO, INC	1028926	8002600335	BBMAR	Trust	Bus #8 Inspection	H	02/03/2026	02/04/2026	R		\$66.00
							25-26			39854		\$66.00
FEHRENBA001	FEHRENBACHER OIL CO, INC	1029242	8002600342	BBMAR	Trust	Bus #3 Inspection	H	02/04/2026	01/31/2026	R		\$66.00
							25-26			39854		\$66.00
FEHRENBA001	FEHRENBACHER OIL CO, INC	1029736	8002600343	BBMAR	Trust	Bus #9 Inspection	H	02/05/2026	01/31/2026	R		\$66.00
							25-26			39854		\$66.00
FEHRENBA001	FEHRENBACHER OIL CO, INC	1029991	8002600345	BBMAR	Trust	Bus #20 Inspection	H	02/06/2026	01/31/2026	R		\$66.00
							25-26			39854		\$66.00
NUMBER OF INVOICES: 14												\$924.00
FGM ARCH000	FGM ARCHITECTS INC	25-4232.01-5	000000000	BBMAR	Trust	ATHLETIC COMPLEX	H	02/23/2026	02/24/2026	R		\$140,921.81

VEN-KEY	VENDOR NAME	INVOICE #	PO NUMBER	BATCH	BANK	DESCRIPTION	LQ	S	INV DATE	DUE DATE	C	NET AMOUNT
<u>ACH VOID DOWNLOAD</u>		<u>DISCOUNT DESCRIPTION</u>	<u>DISC AMT</u>		<u>ADJUSTMENT DESCRIPTION</u>		<u>FY</u>	<u>ADJ AMT</u>		<u>CHECK NBR</u>	<u>INVOICE AMOUNT</u>	
FGM ARCH000	FGM ARCHITECTS INC	25-4232.01-5	*****CONTINUED*****				25-26			39855	\$140,921.81	
NUMBER OF INVOICES: 1											\$140,921.81	
FISHER A000	FISHER AUTO PARTS	358-231454	8002600344	BBMAR	Trust	Headlight connector	H	02/05/2026	01/31/2026	R	\$11.69	
25-26											39856	\$11.69
FISHER A000	FISHER AUTO PARTS	358-231471	8002600348	BBMAR	Trust	Chevy Blazer - Wiper blades (2)	H	02/06/2026	01/31/2026	R	\$70.14	
25-26											39856	\$27.14
FISHER A000	FISHER AUTO PARTS	358-231525	8002600358	BBMAR	Trust	Wiper Blades (2)	H	02/10/2026	01/31/2026	R	\$14.36	
25-26											39856	\$14.36
FISHER A000	FISHER AUTO PARTS	358-231529	8002600387	BBMAR	Trust	Trico wipers(12)	H	02/10/2026	03/10/2026	R	\$120.00	
25-26											39906	\$120.00
FISHER A000	FISHER AUTO PARTS	358-231530	8002600388	BBMAR	Trust	Trico wipers (2)	H	02/10/2026	03/10/2026	R	\$20.00	
25-26											39906	\$20.00
FISHER A000	FISHER AUTO PARTS	358-231531	8002600172	BBMAR	Trust	Windshield wipers (10) & Windshield washer fluid (9)	H	02/11/2026	03/10/2026	R	-\$35.96	
25-26											39906	-\$35.96
NUMBER OF INVOICES: 6											\$157.23	
FRANCZEK000	FRANCZEK P.C.	247737	0000000000	BBMAR	Trust	PROFESSIONAL SERVICES	H	03/18/2026	03/18/2026	A	\$2,935.00	
25-26											252600571	\$2,935.00
NUMBER OF INVOICES: 1											\$2,935.00	
GEOSURFA000	GEOSURFACES	3	0000000000	BBMAR	Trust	ATHLETIC COMPLEX	H	03/13/2026	03/16/2026	A	\$1,066,500.00	
25-26											252600559	\$1,066,500.00

<u>VEN-KEY</u>	<u>VENDOR NAME</u>	<u>INVOICE #</u>	<u>PO NUMBER</u>	<u>BATCH</u>	<u>BANK</u>	<u>DESCRIPTION</u>	<u>LQ</u>	<u>S</u>	<u>INV DATE</u>	<u>DUE DATE</u>	<u>C</u>	<u>NET AMOUNT</u>
<u>ACH VOID DOWNLOAD</u>		<u>DISCOUNT DESCRIPTION</u>		<u>DISC AMT</u>		<u>ADJUSTMENT DESCRIPTION</u>	<u>FY</u>		<u>ADJ AMT</u>	<u>CHECK NBR</u>		<u>INVOICE AMOUNT</u>
NUMBER OF INVOICES: 1												\$1,066,500.00
GFI DIGI000	GFI DIGITAL	3461186	1002600403	BBMAR	Trust	Staples for Workroom Copiers	H		02/27/2026	03/13/2026	A	\$216.38
							25-26			252600560		\$216.38
NUMBER OF INVOICES: 1												\$216.38
GLOBAL W000	GLOBAL WATER TECHNOLOGY	183876	0000000000	BBMAR	Trust	CLOSED SYSTEM TREATMENT	H		03/09/2026	03/12/2026	R	\$602.48
							25-26			39907		\$671.48
NUMBER OF INVOICES: 1												\$602.48
GRAINGER000	GRAINGER	9789481182	0000000000	BBMAR	Trust	ES SUPPLIES	H		03/04/2026	03/05/2026	R	\$84.34
							25-26			39857		\$84.34
GRAINGER000	GRAINGER	9796165083	0000000000	BBMAR	Trust	ELC SUPPLIES	H		03/04/2026	03/05/2026	R	\$60.79
							25-26			39857		\$60.79
GRAINGER000	GRAINGER	9801097545	0000000000	BBMAR	Trust	HS SUPPLIES	H		03/04/2026	03/05/2026	R	\$165.28
							25-26			39857		\$165.28
GRAINGER000	GRAINGER	9810971557	0000000000	BBMAR	Trust	HS SUPPLIES	H		03/04/2026	03/05/2026	R	\$69.49
							25-26			39857		\$69.49
GRAINGER000	GRAINGER	9814338688	0000000000	BBMAR	Trust	ES SUPPLIES	H		03/04/2026	03/05/2026	R	\$428.19
							25-26			39857		\$428.19
GRAINGER000	GRAINGER	9814338696	0000000000	BBMAR	Trust	HS SUPPLIES	H		03/04/2026	03/05/2026	R	\$71.66
							25-26			39857		\$71.66
GRAINGER000	GRAINGER	9814614336	0000000000	BBMAR	Trust	MS SUPPLIES	H		03/04/2026	03/05/2026	R	\$141.78
							25-26			39857		\$141.78
GRAINGER000	GRAINGER	9820128552	0000000000	BBMAR	Trust	MS SUPPLIES	H		03/04/2026	03/05/2026	R	\$64.60
							25-26			39857		\$64.60

VEN-KEY	VENDOR NAME	INVOICE #	PO NUMBER	BATCH	BANK	DESCRIPTION	LQ	S	INV DATE	DUE DATE	C	NET AMOUNT
<u>ACH VOID DOWNLOAD</u>		<u>DISCOUNT DESCRIPTION</u>			<u>DISC AMT</u>	<u>ADJUSTMENT DESCRIPTION</u>	<u>FY</u>	<u>ADJ AMT</u>		<u>CHECK NBR</u>	<u>INVOICE AMOUNT</u>	
GRAINGER000	GRAINGER	9820903012	0000000000	BBMAR	Trust	HS SUPPLIES	H		03/04/2026	03/05/2026	R	\$74.43
							25-26				39857	\$74.43
GRAINGER000	GRAINGER	9837947317	0000000000	BBMAR	Trust	Mattes, clay and glazes	H		03/11/2026	03/13/2026	R	\$63.35
							25-26				39908	\$63.35
GRAINGER000	GRAINGER	9840104385	0000000000	BBMAR	Trust	ES SUPPLIES	H		03/12/2026	03/13/2026	R	\$268.43
							25-26				39908	\$268.43
GRAINGER000	GRAINGER	9840104393	0000000000	BBMAR	Trust	MS SUPPLIES	H		03/12/2026	03/13/2026	R	\$206.36
							25-26				39908	\$206.36
NUMBER OF INVOICES: 12											\$1,698.70	
HARMOMIR000	HARMON, MIRANDA	ERIN20260304A	0000000000	BBMAR	Trust	2/1/2026-3/31/2026 Mileage reimbursement for nurse travel	H		03/04/2026	08/01/2024	A	\$40.60
							25-26				252600541	\$40.60
NUMBER OF INVOICES: 1											\$40.60	
HD SUPPL000	HD SUPPLY FACILITIES MAINTENANCE	9245625700	1002600341	BBMAR	Trust	custodial supplies	H		02/05/2026	02/23/2026	R	\$301.93
							25-26				39858	\$301.93
HD SUPPL000	HD SUPPLY FACILITIES MAINTENANCE	9245782924	0000000000	BBMAR	Trust	HS SUPPLIES	H		02/10/2026	03/09/2026	R	\$101.20
							25-26				39909	\$101.20
HD SUPPL000	HD SUPPLY FACILITIES MAINTENANCE	9245819704	0000000000	BBMAR	Trust	CREDIT	H		02/11/2026	03/09/2026	R	-\$52.44
							25-26				39909	-\$52.44
HD SUPPL000	HD SUPPLY FACILITIES MAINTENANCE	9246063991	0000000000	BBMAR	Trust	custodial supplies	H		02/18/2026	02/26/2026	R	-\$125.08
							25-26				39858	-\$125.08
HD SUPPL000	HD SUPPLY FACILITIES MAINTENANCE	9246121569	0000000000	BBMAR	Trust	ELC SUPPLIES 9246077162 9246121569	H		03/05/2026	03/09/2026	R	\$23.52
							25-26				39909	\$23.52

<u>VEN-KEY</u>	<u>VENDOR NAME</u>	<u>INVOICE #</u>	<u>PO NUMBER</u>	<u>BATCH</u>	<u>BANK</u>	<u>DESCRIPTION</u>	<u>LQ</u>	<u>S</u>	<u>INV DATE</u>	<u>DUE DATE</u>	<u>C</u>	<u>NET AMOUNT</u>
	<u>ACH VOID DOWNLOAD</u>	<u>DISCOUNT DESCRIPTION</u>		<u>DISC AMT</u>		<u>ADJUSTMENT DESCRIPTION</u>	<u>FY</u>		<u>ADJ AMT</u>	<u>CHECK NBR</u>		<u>INVOICE AMOUNT</u>
HD SUPPL000	HD SUPPLY FACILITIES MAINTENANCE	9246168131	1002600355	BBMAR	Trust	custodial supplies	H	02/20/2026	02/26/2026	R		\$2,253.04
							25-26			39858		\$2,253.04
HD SUPPL000	HD SUPPLY FACILITIES MAINTENANCE	9246171401	0000000000	BBMAR	Trust	ELC SUPPLIES	H	03/09/2026	03/09/2026	R		\$358.26
							25-26			39909		\$358.26
HD SUPPL000	HD SUPPLY FACILITIES MAINTENANCE	9246223684	0000000000	BBMAR	Trust	ELC SUPPLIES	H	03/10/2026	03/12/2026	R		\$124.53
							25-26			39909		\$124.53
												73
HD SUPPL000	HD SUPPLY FACILITIES MAINTENANCE	9246262907	0000000000	BBMAR	Trust	MS SUPPLIES	H	02/24/2026	03/09/2026	R		\$145.35
							25-26			39909		\$145.35
						NUMBER OF INVOICES: 9						\$3,130.31
HENDRBRE000	HENDRICKSON, BRENDA	ERIN20260303A	0000000000	BBMAR	Trust	2/1/2026-2/28/2026 February home visits	H	03/03/2026	03/03/2026	A		\$237.08
							25-26			252600542		\$237.08
						NUMBER OF INVOICES: 1						\$237.08
HOMEFIEL000	HOMEFIELD ENERGY	031120030527	9002600014	BBMAR	Trust	ELECTRIC CHARGES	H	03/11/2026	03/13/2026	A		\$28,063.86
							25-26			252600561		\$28,063.86
						NUMBER OF INVOICES: 1						\$28,063.86
HOUCHENS000	HOUCHENS NORTH FOODS, LLC	00320075	3002600178	BBMAR	Trust	Local purchases for FCS Department Shared by all 3 teachers Food and supplies.	H	02/09/2026	02/04/2026	R		\$36.29
							25-26			39859		\$36.29
HOUCHENS000	HOUCHENS NORTH FOODS, LLC	00320077	4002600051	BBMAR	Trust	Cucumbers	H	02/09/2026	01/31/2026	R		\$8.33
							25-26			39859		\$8.33
HOUCHENS000	HOUCHENS NORTH FOODS, LLC	00321890	3002600178	BBMAR	Trust	Local purchases for FCS Department Shared by all 3 teachers Food and supplies.	H	02/19/2026	02/23/2026	R		\$18.40

<u>VEN-KEY</u>	<u>VENDOR NAME</u>	<u>INVOICE #</u>	<u>PO NUMBER</u>	<u>BATCH</u>	<u>BANK</u>	<u>DESCRIPTION</u>	<u>LQ S</u>	<u>INV DATE</u>	<u>DUE DATE</u>	<u>C</u>	<u>NET AMOUNT</u>
	<u>ACH VOID DOWNLOAD</u>	<u>DISCOUNT DESCRIPTION</u>		<u>DISC AMT</u>		<u>ADJUSTMENT DESCRIPTION</u>	<u>FY</u>	<u>ADJ AMT</u>	<u>CHECK NBR</u>		<u>INVOICE AMOUNT</u>
HOUCHENS000	HOUCHENS NORTH FOODS, LLC	00321890				*****CONTINUED*****					
							25-26		39859		\$18.40
HOUCHENS000	HOUCHENS NORTH FOODS, LLC	442428 - 022826	0000000000	BBMAR	Trust	FUNERAL FLOWERS	H	03/04/2026	02/26/2026	R	\$180.00
						003-00307034, 003-00307033, 003-00307146, 003-00307174					
							25-26		39859		\$180.00
NUMBER OF INVOICES: 4											\$274.02
HUMMERT 000	HUMMERT INTERNATIONAL	208372	3002600382	BBMAR	Trust	Ag Supply Hummert International Greenhouse Soil and Plants	H	02/26/2026	03/13/2026	A	\$1,199.85
							25-26		252600562		\$1,199.85
HUMMERT 000	HUMMERT INTERNATIONAL	208426	3002600382	BBMAR	Trust	Ag Supply Hummert International Greenhouse Soil and Plants	H	02/27/2026	03/13/2026	A	\$929.89
							25-26		252600562		\$929.89
HUMMERT 000	HUMMERT INTERNATIONAL	208728	3002600382	BBMAR	Trust	Ag Supply Hummert International Greenhouse Soil and Plants	H	02/26/2026	03/13/2026	A	\$66.20
							25-26		252600562		\$66.20
HUMMERT 000	HUMMERT INTERNATIONAL	209220	3002600382	BBMAR	Trust	Ag Supply Hummert International Greenhouse Soil and Plants	H	02/27/2026	03/13/2026	A	\$358.14
							25-26		252600562		\$358.14
NUMBER OF INVOICES: 4											\$2,554.08
IL ASSOC000	IL ASSOC OF SCHOOL BUSINESS	0071184	0000000000	BBMAR	Trust	REGIONAL CONFERENCE SPEAKER FEE	H	03/03/2026	03/05/2026	R	\$100.00
							25-26		39860		\$100.00

<u>VEN-KEY</u>	<u>VENDOR NAME</u>	<u>INVOICE #</u>	<u>PO NUMBER</u>	<u>BATCH</u>	<u>BANK</u>	<u>DESCRIPTION</u>	<u>LQ</u>	<u>S</u>	<u>INV DATE</u>	<u>DUE DATE</u>	<u>C</u>	<u>NET AMOUNT</u>
	<u>ACH VOID DOWNLOAD</u>	<u>DISCOUNT DESCRIPTION</u>			<u>DISC AMT</u>	<u>ADJUSTMENT DESCRIPTION</u>	<u>FY</u>		<u>ADJ AMT</u>	<u>CHECK NBR</u>		<u>INVOICE AMOUNT</u>
						NUMBER OF INVOICES: 1						\$100.00
IL GAS C000	IL GAS COMPANY	030426	9002600008	BBMAR	Trust	GAS BILL	H	03/13/2026	03/13/2026	R		\$13,400.79
							25-26			39910		\$13,400.79
						NUMBER OF INVOICES: 1						\$13,400.79
IL STATE001	IL STATE UNIVERSITY	89147	6002600054	BBMAR	Trust	IEP Toolkit - PD for Sped Teachers	H	03/02/2026	02/26/2026	R		\$1,750.00
							25-26			39861		75 \$1,750.00
						NUMBER OF INVOICES: 1						\$1,750.00
ILLINOIS033	ILLINOIS ASSOCIATION FFA	292-24385	0000000000	BBMAR	Trust	IAVAT CONFERENCE	H	03/09/2026	03/09/2026	R		\$1,920.00
							25-26			39911		\$1,920.00
						NUMBER OF INVOICES: 1						\$1,920.00
ILMEA ST001	ILMEA STATE OFFICE	92811	2002600071	BBMAR	Trust	ILMEA Fees	H	03/03/2026	02/28/2026	R		\$190.00
							25-26			39862		\$190.00
						NUMBER OF INVOICES: 1						\$190.00
J & A AU001	J & A AUTO CLINIC	66850	8002600380	BBMAR	Trust	Ford Van - Replaced spark plugs and O2 sensor	H	02/25/2026	03/09/2026	R		\$784.08
							25-26			39912		\$784.08
						NUMBER OF INVOICES: 1						\$784.08
JOHN D H000	JOHN D HURN & SON, INC	609164	0000000000	BBMAR	Trust	HS SUPPLIES	H	02/26/2026	02/26/2026	R		\$114.99
					6.05		25-26			39863		\$121.04
JOHN D H000	JOHN D HURN & SON, INC	609205	9002600098	BBMAR	Trust	Caulking gun, roof sealant	H	02/26/2026	02/28/2026	R		\$28.85
					1.52		25-26			39863		\$30.37

<u>VEN-KEY</u>	<u>VENDOR NAME</u>	<u>INVOICE #</u>	<u>PO NUMBER</u>	<u>BATCH</u>	<u>BANK</u>	<u>DESCRIPTION</u>	<u>LQ</u>	<u>S</u>	<u>INV DATE</u>	<u>DUE DATE</u>	<u>C</u>	<u>NET AMOUNT</u>
	<u>ACH VOID DOWNLOAD</u>	<u>DISCOUNT DESCRIPTION</u>		<u>DISC AMT</u>		<u>ADJUSTMENT DESCRIPTION</u>	<u>FY</u>		<u>ADJ AMT</u>	<u>CHECK NBR</u>		<u>INVOICE AMOUNT</u>
JOHN D H000	JOHN D HURN & SON, INC	609226	0000000000	BBMAR	Trust	HS SUPPLIES	H	02/26/2026	02/28/2026	R		\$28.08
					1.48		25-26			39863		\$29.56
JOHN D H000	JOHN D HURN & SON, INC	609279	0000000000	BBMAR	Trust	HS SUPPLIES	H	02/27/2026	03/03/2026	R		\$5.75
							25-26			39863		\$5.75
JOHN D H000	JOHN D HURN & SON, INC	609491	1002600342	BBMAR	Trust	custodial supplies	H	03/02/2026	02/26/2026	R		\$22.31
					1.17		25-26			39863		\$23.48
JOHN D H000	JOHN D HURN & SON, INC	609710	0000000000	BBMAR	Trust	BUS BARN SUPPLIES	H	03/04/2026	02/26/2026	R		\$11.87
							25-26			39863		\$11.87
JOHN D H000	JOHN D HURN & SON, INC	609725	0000000000	BBMAR	Trust	BUS BARN SUPPLIES	H	03/04/2026	02/26/2026	R		\$37.89
					1.99		25-26			39863		\$39.88
JOHN D H000	JOHN D HURN & SON, INC	609816	0000000000	BBMAR	Trust	BUS BARN SUPPLIES	H	03/05/2026	03/05/2026	R		\$23.43
					1.23		25-26			39863		\$24.66
JOHN D H000	JOHN D HURN & SON, INC	609979	0000000000	BBMAR	Trust	MS SUPPLIES	H	03/06/2026	02/28/2026	R		\$65.58
					3.45		25-26			39863		\$69.03
JOHN D H000	JOHN D HURN & SON, INC	610242	0000000000	BBMAR	Trust	MS SUPPLIES	H	03/09/2026	03/10/2026	R		\$23.63
					1.24		25-26			39913		\$24.87
JOHN D H000	JOHN D HURN & SON, INC	610319	1002600342	BBMAR	Trust	custodial supplies	H	03/10/2026	03/10/2026	R		\$141.69
					7.46		25-26			39913		\$149.15
JOHN D H000	JOHN D HURN & SON, INC	610360	0000000000	BBMAR	Trust	BUS BARN SUPPLIES	H	03/10/2026	03/10/2026	R		\$71.23
					3.75		25-26			39913		\$74.98
JOHN D H000	JOHN D HURN & SON, INC	611039	0000000000	BBMAR	Trust	BUS BARN SUPPLIES	H	03/17/2026	03/13/2026	R		\$64.93
					3.42		25-26			39913		\$68.35
JOHN D H000	JOHN D HURN & SON, INC	611107	0000000000	BBMAR	Trust	MS SUPPLIES	H	03/17/2026	03/18/2026	R		\$49.16
					2.59		25-26			39913		\$51.75

76

<u>VEN-KEY</u>	<u>VENDOR NAME</u>	<u>INVOICE #</u>	<u>PO NUMBER</u>	<u>BATCH</u>	<u>BANK</u>	<u>DESCRIPTION</u>	<u>LQ</u>	<u>S</u>	<u>INV DATE</u>	<u>DUE DATE</u>	<u>C</u>	<u>NET AMOUNT</u>
	<u>ACH VOID DOWNLOAD</u>	<u>DISCOUNT DESCRIPTION</u>			<u>DISC AMT</u>	<u>ADJUSTMENT DESCRIPTION</u>	<u>FY</u>		<u>ADJ AMT</u>	<u>CHECK NBR</u>		<u>INVOICE AMOUNT</u>
JOHN D H000	JOHN D HURN & SON, INC	611114	0000000000	BBMAR	Trust	HS SUPPLIES	H	03/17/2026	03/18/2026	R		\$17.65
					0.93		25-26			39913		\$18.58
NUMBER OF INVOICES: 15												\$707.04
JOHN DEE000	JOHN DEERE FINANCIAL	D64442	3002600333	BBMAR	Trust	various shop supplies. nuts, bolts, bsatteries, chop saw blades, lube, cleaner, etc	H	03/04/2026	02/26/2026	R		\$43.98
							25-26			39864		77 \$43.98
JOHN DEE000	JOHN DEERE FINANCIAL	D64821	3002600333	BBMAR	Trust	various shop supplies. nuts, bolts, batteries, chop saw blades, lube, cleaner, etc	H	03/05/2026	03/09/2026	R		\$57.91
							25-26			39915		\$57.91
JOHN DEE000	JOHN DEERE FINANCIAL	D65169	3002600376	BBMAR	Trust	paint for city park for softball/baseball fields	H	03/06/2026	03/20/2026	R		\$59.94
							25-26			39915		\$59.94
JOHN DEE000	JOHN DEERE FINANCIAL	D65909	3002600333	BBMAR	Trust	various shop supplies. nuts, bolts, batteries, chop saw blades, lube, cleaner, etc	H	03/09/2026	03/09/2026	R		\$139.89
							25-26			39915		\$139.89
JOHN DEE000	JOHN DEERE FINANCIAL	D66969	3002600333	BBMAR	Trust	various shop supplies. nuts, bolts, bsatteries, chop saw blades, lube, cleaner, etc	H	03/12/2026	03/10/2026	R		\$319.98
							25-26			39915		\$319.98
JOHN DEE000	JOHN DEERE FINANCIAL	D68633	3002600381	BBMAR	Trust	Msc welding and shop supplies for Welding 1 and II Nuts, bolts, cords,	H	03/17/2026	03/18/2026	R		\$125.64

<u>VEN-KEY</u>	<u>VENDOR NAME</u>	<u>INVOICE #</u>	<u>PO NUMBER</u>	<u>BATCH</u>	<u>BANK</u>	<u>DESCRIPTION</u>	<u>LQ</u>	<u>S</u>	<u>INV DATE</u>	<u>DUE DATE</u>	<u>C</u>	<u>NET AMOUNT</u>
	<u>ACH VOID DOWNLOAD</u>	<u>DISCOUNT DESCRIPTION</u>		<u>DISC AMT</u>		<u>ADJUSTMENT DESCRIPTION</u>	<u>FY</u>		<u>ADJ AMT</u>	<u>CHECK NBR</u>		<u>INVOICE AMOUNT</u>
JOHN DEE000	JOHN DEERE FINANCIAL	D68633				*****CONTINUED***** paint primer, cutoff wheels, grinders, connectors etc						
							25-26			39915		\$125.64
						NUMBER OF INVOICES: 6						\$747.34
JOHNSTON000	JOHNSTONE SUPPLY	1077960	0000000000	BBMAR	Trust	MS SUPPLIES	H	03/04/2026	03/05/2026	R		\$86.93
							25-26			39865		\$78 .93
JOHNSTON000	JOHNSTONE SUPPLY	1078158	0000000000	BBMAR	Trust	MS SUPPLIES	H	03/10/2026	03/10/2026	R		\$165.93
							25-26			39916		\$165.93
						NUMBER OF INVOICES: 2						\$252.86
JOSTENS 000	JOSTENS	38934049	2002600130	BBMAR	Trust	Diploma Signature Change	H	02/23/2026	03/09/2026	R		\$13.05
							25-26			39917		\$13.05
JOSTENS 000	JOSTENS	39049542	2002600134	BBMAR	Trust	8th Grade Diploma Inserts	H	03/02/2026	03/10/2026	R		\$587.95
							25-26			39917		\$587.95
						NUMBER OF INVOICES: 2						\$601.00
JOSTENS 003	JOSTENS (SALES REP OFFICE)	RCHS2026MKV	1002600388	BBMAR	Trust	McKinney Vento cap, gown, tassel unit for seniors *RCHS: IP, CR, TL, DW, HJ, CB, TK	H	02/13/2026	03/10/2026	R		\$283.50
							25-26			39918		\$283.50
						NUMBER OF INVOICES: 1						\$283.50
JW PEPPE000	JW PEPPER & SON, INC	368206057	2002600111	BBMAR	Trust	JW Pepper Sheet Music	H	01/21/2026	02/26/2026	A		\$552.99
							25-26			252600543		\$552.99
JW PEPPE000	JW PEPPER & SON, INC	368283381	2002600111	BBMAR	Trust	JW Pepper Sheet Music	H	01/21/2026	02/26/2026	A		\$75.00
							25-26			252600543		\$75.00

<u>VEN-KEY</u>	<u>VENDOR NAME</u>	<u>INVOICE #</u>	<u>PO NUMBER</u>	<u>BATCH</u>	<u>BANK</u>	<u>DESCRIPTION</u>	<u>LQ</u>	<u>S</u>	<u>INV DATE</u>	<u>DUE DATE</u>	<u>C</u>	<u>NET AMOUNT</u>
	<u>ACH VOID DOWNLOAD</u>	<u>DISCOUNT DESCRIPTION</u>			<u>DISC AMT</u>	<u>ADJUSTMENT DESCRIPTION</u>	<u>FY</u>		<u>ADJ AMT</u>	<u>CHECK NBR</u>		<u>INVOICE AMOUNT</u>
						NUMBER OF INVOICES: 2						\$627.99
KIDDER M000	KIDDER MEDIA	3005	0000000000	BBMAR	Trust	NEWSLETTER	H	03/04/2026	03/05/2026	R		\$9,835.50
							25-26			39866		\$9,835.50
						NUMBER OF INVOICES: 1						\$9,835.50
KINKAHAY000	KINKADE, HAYDEN	061626	0000000000	BBMAR	Trust	IAVAT PERDIEM	H	03/17/2026	03/18/2026	A		\$189.00
							25-26			252600572		\$179.00
						NUMBER OF INVOICES: 1						\$189.00
KOCHEBRI000	KOCHER, BRITTANIA	ERIN20260303A	0000000000	BBMAR	Trust	2/1/2026-2/28/2026 February 2026 Mileage	H	03/03/2026	03/03/2026	A		\$231.30
							25-26			252600544		\$231.30
						NUMBER OF INVOICES: 1						\$231.30
KOHL WHO000	KOHL WHOLESALE	38934049	4002600055	BBMAR	Trust	Food & Supplies February 2026	H	02/23/2026	03/09/2026	R		\$34,030.82
							25-26			39919		\$34,030.82
						NUMBER OF INVOICES: 1						\$34,030.82
LAKELAND001	LAKELAND COLLEGE	031026	3002600380	BBMAR	Trust	Ag Entry Fees - Registration for LakeLand College Livestock Judging CDE - 12 students x \$15/each	H	03/14/2026	03/13/2026	R		\$180.00
							25-26			39920		\$180.00
						NUMBER OF INVOICES: 1						\$180.00
LAKESHOR000	LAKESHORE LEARNING MATERIALS, LLC	93480216	1002600374	BBMAR	Trust	K. Bunting Classroom Supplies	H	02/28/2026	02/26/2026	A		\$658.93
							25-26			252600545		\$658.93

VEN-KEY	VENDOR NAME	INVOICE #	PO NUMBER	BATCH	BANK	DESCRIPTION	LQ S	INV DATE	DUE DATE	C	NET AMOUNT
	ACH VOID DOWNLOAD	DISCOUNT DESCRIPTION		DISC AMT		ADJUSTMENT DESCRIPTION	FY	ADJ AMT	CHECK NBR		INVOICE AMOUNT
						NUMBER OF INVOICES: 1					\$658.93
LIFE VAC000	LIFE VAC LLC	219882	6502600022	BBMAR	Trust	52 Life vacs per M. Harmon RN request for Bus and SRO	H	02/27/2026	02/26/2026	A	\$2,912.00
							25-26		252600546		\$2,912.00
						NUMBER OF INVOICES: 1					\$2,912.00
LINCOLN 000	LINCOLN PRAIRIE BHC	2021-22253	0000000000	BBMAR	Trust	TUITION	H	02/17/2026	02/23/2026	R	\$600.00
							25-26		39867		\$600.00
						NUMBER OF INVOICES: 1					\$600.00
LORENZ S000	LORENZ SUPPLY CO	673110	3002600365	BBMAR	Trust	INDUSTRIAL DEGREASER 4/1GL/CS EX-14304B-GL 1 1 0 19.89 N \$19.89 CONCENTRATE GREASINATOR * SDS EX-14304B-GL Required * SUPER BLUE FLOOR CLEAN 4GAL/CS MPC-SUB14MN-GL 1 1 0 21.60 N \$21.60 4/1GL/CASE ALL PURPOSE * SDS MPC-SUB14MN-CS Required RED RECTANGULAR PAD 14X20 NOR-93014-CS 1 1 0 36.76 N \$36.76 5/CS	H	02/25/2026	02/28/2026	R	\$82.25
							25-26		39868		\$82.25
						NUMBER OF INVOICES: 1					\$82.25
MARATHON002	MARATHON TIRE SERV, INC	022675098	8002600368	BBMAR	Trust	Bus #1 RRO tire repair	H	02/20/2026	02/23/2026	R	\$50.00
							25-26		39869		\$50.00
MARATHON002	MARATHON TIRE SERV, INC	022675213	8002600377	BBMAR	Trust	Bus #7 RRO Flat Repair	H	02/27/2026	02/26/2026	R	\$58.00
							25-26		39869		\$58.00

<u>VEN-KEY</u>	<u>VENDOR NAME</u>	<u>INVOICE #</u>	<u>PO NUMBER</u>	<u>BATCH</u>	<u>BANK</u>	<u>DESCRIPTION</u>	<u>LQ</u>	<u>S</u>	<u>INV DATE</u>	<u>DUE DATE</u>	<u>C</u>	<u>NET AMOUNT</u>
	<u>ACH VOID DOWNLOAD</u>	<u>DISCOUNT DESCRIPTION</u>		<u>DISC AMT</u>		<u>ADJUSTMENT DESCRIPTION</u>	<u>FY</u>		<u>ADJ AMT</u>	<u>CHECK NBR</u>		<u>INVOICE AMOUNT</u>
						NUMBER OF INVOICES: 2						\$108.00
MUELLALE000	MUELLER, ALEXIS	061626	0000000000	BBMAR	Trust	IAVAT PERDIEM	H	03/17/2026	03/18/2026	A		\$189.00
							25-26			252600573		\$189.00
						NUMBER OF INVOICES: 1						\$189.00
NEVCO SP000	NEVCO SPORTS, LLC	272523	2502600026	BBMAR	Trust	Nevco MPC/MPCW Control Carrying Case	H	02/27/2026	02/26/2026	R		\$128.73
							25-26			39870		81 \$128.73
						NUMBER OF INVOICES: 1						\$128.73
NORRIS E000	NORRIS ELECTRIC CO-OP	6227	9002600013	BBMAR	Trust	ELECTRIC ES & ELC	H	03/06/2026	02/28/2026	R		\$20,893.21
							25-26			39871		\$20,893.21
						NUMBER OF INVOICES: 1						\$20,893.21
NORTH AM001	NORTH AMERICAN CORP OF ILLINOIS	E429257	2002600109	BBMAR	Trust	RCMS Building Supplies	H	02/20/2026	02/23/2026	R		\$124.00
							25-26			39872		\$124.00
						NUMBER OF INVOICES: 1						\$124.00
O'REILLY001	O'REILLY AUTO PARTS	1411-284734	8002600347	BBMAR	Trust	HD Air Filter	H	02/06/2026	01/31/2026	R		\$39.44
							25-26			39873		\$39.44
O'REILLY001	O'REILLY AUTO PARTS	1411-284774	0000000000	BBMAR	Trust	HS SUPPLIES	H	02/06/2026	02/04/2026	R		\$32.98
							25-26			39873		\$32.98
O'REILLY001	O'REILLY AUTO PARTS	1411-285137	8002600357	BBMAR	Trust	Air Filter	H	02/10/2026	01/31/2026	R		\$39.44
							25-26			39873		\$39.44
O'REILLY001	O'REILLY AUTO PARTS	1411-286074	0000000000	BBMAR	Trust	ES SUPPLIES	H	02/17/2026	01/31/2026	R		\$60.97
							25-26			39873		\$60.97

<u>VEN-KEY</u>	<u>VENDOR NAME</u>	<u>INVOICE #</u>	<u>PO NUMBER</u>	<u>BATCH</u>	<u>BANK</u>	<u>DESCRIPTION</u>	<u>LQ</u>	<u>S</u>	<u>INV DATE</u>	<u>DUE DATE</u>	<u>C</u>	<u>NET AMOUNT</u>	
	<u>ACH VOID DOWNLOAD</u>	<u>DISCOUNT DESCRIPTION</u>				<u>DISC AMT</u>			<u>ADJ AMT</u>	<u>CHECK NBR</u>		<u>INVOICE AMOUNT</u>	
O'REILLY001	O'REILLY AUTO PARTS	1411-287071	8002600376	BBMAR	Trust	Chevy #1 - Shocks	H		02/25/2026	02/26/2026	R	\$164.44	
									25-26		39873	\$164.44	
												NUMBER OF INVOICES: 5	\$337.27
OLNEAN 000	THE OLNEAN	Y202957199	0000000000	BBMAR	Trust	YEARBOOKS FOR BOARD MEMBERS	H		02/23/2026	03/05/2026	R	\$520.00	
									25-26		39874	\$520.00	
												NUMBER OF INVOICES: 1	\$520.00
OLNEY CE001	OLNEY CENTRAL COLLEGE	022626	0000000000	BBMAR	Trust	DUAL CREDIT BOOK CHARGES	H		02/26/2026	02/28/2026	R	\$1,172.86	
									25-26		39875	\$1,172.86	
												NUMBER OF INVOICES: 1	\$1,172.86
PALS ELE000	PALS ELECTRIC INC	20941	0000000000	BBMAR	Trust	DATA LOGGED SERVICE TO THE BUILDING	H		03/05/2026	03/09/2026	R	\$385.00	
									25-26		39921	\$385.00	
												NUMBER OF INVOICES: 1	\$385.00
PEORIA M000	PEORIA MARRIOTT PERE MARQUETTE	84531805	0000000000	BBMAR	Trust	CONFIRMATION NUMBER 84531805 HOTEL AND PARKING	H		03/16/2026	03/18/2026	R	\$492.75	
									25-26		39935	\$492.75	
												NUMBER OF INVOICES: 1	\$492.75
PEORIA M000	PEORIA MARRIOTT PERE MARQUETTE	84531808	0000000000	BBMARV	Trust	CONFIRMATION NUMBER 84531808 NO PARKING	H		03/16/2026	03/18/2026	R	\$445.05	
									25-26		39933	\$445.05	
												NUMBER OF INVOICES: 2	\$937.80
PRAIRIE 001	PRAIRIE FARMS DAIRY, INC	022826	4002600057	BBMAR	Trust	Dairy Purchases Feb 2026	H		03/09/2026	03/09/2026	A	\$10,302.62	
									25-26		252600563	\$10,302.62	
												NUMBER OF INVOICES: 1	\$10,302.62
PRINTFOR000	PRINTFORCE, INC	303155	5502600083	BBMAR	Trust	ELC Office Supplies	H		03/04/2026	02/26/2026	R	\$280.40	

VEN-KEY	VENDOR NAME	INVOICE #	PO NUMBER	BATCH	BANK	DESCRIPTION	LQ	S	INV DATE	DUE DATE	C	NET AMOUNT	
ACH VOID DOWNLOAD		DISCOUNT DESCRIPTION	DISC AMT		ADJUSTMENT DESCRIPTION		FY	ADJ AMT	CHECK NBR	INVOICE AMOUNT			
PRINTFOR000	PRINTFORCE, INC	303155	*****CONTINUED*****										
							25-26			39876		\$280.40	
PRINTFOR000	PRINTFORCE, INC	303205	1002600404	BBMAR		Trust Car Passes - Invoice 303205	H		03/16/2026	03/18/2026	R	\$367.80	
							25-26			39936		\$367.80	
NUMBER OF INVOICES: 2											\$648.20		
PUCKECHE000	PUCKETT, CHELSEA	022526	0000000000	BBMAR		Trust TUITION REIMBURSEMENT	H		02/25/2026	02/28/2026	A	\$1,620.00	
							25-26			252600547		\$1,620.00	
NUMBER OF INVOICES: 1											\$1,620.00		
QUILL CO000	QUILL CORPORATION	47651873	5502600076	BBMAR		Trust Supplies	H		02/04/2026	03/18/2026	A	\$177.58	
							25-26			252600564		\$177.58	
QUILL CO000	QUILL CORPORATION	47676097	8002600338	BBMAR		Trust Copy Paper for Bus Barn	H		02/05/2026	02/26/2026	A	\$175.96	
							25-26			252600548		\$175.96	
QUILL CO000	QUILL CORPORATION	47872332	3002600351	BBMAR		Trust Pallet of paper	H		02/18/2026	02/26/2026	A	\$1,789.18	
							25-26			252600548		\$1,789.18	
QUILL CO000	QUILL CORPORATION	47909181	2002600123	BBMAR		Trust Peppermints for IAR	H		02/24/2026	03/05/2026	A	\$229.35	
							25-26			252600548		\$229.35	
NUMBER OF INVOICES: 4											\$2,372.07		
RCHS BAN000	RCHS BAND ESCROW ACCT	030126	0000000000	BBMAR		Trust ANNUAL DEPOSIT INTO BAND ACCOUNT FOR UNIFORMS	H		03/03/2026	03/03/2026	R	\$6,000.00	
							25-26			39877		\$6,000.00	
NUMBER OF INVOICES: 1											\$6,000.00		
READ'S I000	READ'S INC.	34644	0000000000	BBMAR		Trust MS REPAIR	H		03/03/2026	03/05/2026	R	\$412.04	
							25-26			39878		\$412.04	

<u>VEN-KEY</u>	<u>VENDOR NAME</u>	<u>INVOICE #</u>	<u>PO NUMBER</u>	<u>BATCH</u>	<u>BANK</u>	<u>DESCRIPTION</u>	<u>LQ</u>	<u>S</u>	<u>INV DATE</u>	<u>DUE DATE</u>	<u>C</u>	<u>NET AMOUNT</u>
	<u>ACH VOID DOWNLOAD</u>	<u>DISCOUNT DESCRIPTION</u>			<u>DISC AMT</u>	<u>ADJUSTMENT DESCRIPTION</u>	<u>FY</u>		<u>ADJ AMT</u>	<u>CHECK NBR</u>		<u>INVOICE AMOUNT</u>
READ'S I000	READ'S INC.	34660	0000000000	BBMAR	Trust	HS REPAIR	H	03/18/2026	03/18/2026	R		\$370.00
							25-26			39937		\$370.00
						NUMBER OF INVOICES: 2						\$782.04
RENTOKIL000	RENTOKIL	93058789	0000000000	BBMAR	Trust	RCES WAREHOUSE PEST CONTROL	H	03/09/2026	03/09/2026	R		\$588.60
							25-26			39922		\$588.60
						NUMBER OF INVOICES: 1						\$588.60
REPUBLIC000	REPUBLIC SERVICES, INC	0694-003988133	9002600010	BBMAR	Trust	TRASH SERVICES	H	02/20/2026	03/03/2026	A		\$6,567.78
							25-26			252600549		\$6,567.78
						NUMBER OF INVOICES: 1						\$6,567.78
REVTRAK,000	REVTRAK, INC	022826	9002600011	BBMAR	Trust	FEES	H	03/04/2026	03/04/2026	W		\$177.46
							25-26			202500507		\$177.46
						NUMBER OF INVOICES: 1						\$177.46
REYNOBOB001	REYNOLDS, BOBBY	ERIN20260309A	0000000000	BBMAR	Trust	2/1/2026-2/28/2026 FEB Mileage	H	03/09/2026	08/01/2024	A		\$13.05
							25-26			252600565		\$13.05
						NUMBER OF INVOICES: 1						\$13.05
RICHLAND009	RICHLAND CO TREASURER	3-031226	0000000000	BBMAR	Trust	SRO OFFICERS	H	03/12/2026	03/16/2026	R		\$14,044.05
							25-26			39923		\$14,044.05
						NUMBER OF INVOICES: 1						\$14,044.05
ROE 12 -001	ROE 12 - ROBINSON	1697	5502600089	BBMAR	Trust	ROE presentation	H	02/27/2026	03/05/2026	R		\$250.00
							25-26			39879		\$250.00
						NUMBER OF INVOICES: 1						\$250.00
ROUTIROS000	ROUTIEN, ROSA	022826	0000000000	BBMAR	Trust	TRANSPORATION OF CHILD TO	H	03/03/2026	03/03/2026	R		\$3,201.60

<u>VEN-KEY</u>	<u>VENDOR NAME</u>	<u>INVOICE #</u>	<u>PO NUMBER</u>	<u>BATCH</u>	<u>BANK</u>	<u>DESCRIPTION</u>	<u>LQ S</u>	<u>INV DATE</u>	<u>DUE DATE</u>	<u>C</u>	<u>NET AMOUNT</u>	
	<u>ACH VOID DOWNLOAD</u>	<u>DISCOUNT DESCRIPTION</u>		<u>DISC AMT</u>		<u>ADJUSTMENT DESCRIPTION</u>	<u>FY</u>		<u>ADJ AMT</u>	<u>CHECK NBR</u>	<u>INVOICE AMOUNT</u>	
ROUTIROS000	ROUTIEN, ROSA	022826		*****CONTINUED*****		SCHOOL		25-26		39880	\$3,201.60	
											NUMBER OF INVOICES: 1	\$3,201.60
RUSK AMY000	RUSK, AMY	ERIN20260309A	000000000	BBMAR	Trust	3/6/2026 Term 3 Mileage	H	03/09/2026	08/01/2024	A	\$87.73	
								25-26		252600566	\$87.73	
											85	\$87.73
											NUMBER OF INVOICES: 1	
S & S WO001	S & S WORLDWIDE, INC	IN101724340	2002600097	BBMAR	Trust	RCMS Building supplies	H	02/18/2026	02/23/2026	R	\$1,448.97	
								25-26		39881	\$1,448.97	
											NUMBER OF INVOICES: 1	\$1,448.97
SCHOLAST009	SCHOLASTIC INC	M7666419	1002600184	BBMAR	Trust	Scholastic News-1st Grade	H	02/03/2026	02/23/2026	R	\$921.26	
								25-26		39882	\$921.26	
											NUMBER OF INVOICES: 1	\$921.26
SECRETAR000	SECRETARY OF STATE	043027	000000000	BBMAR	Trust	FOOTBALL TRAILER REGISTRATION	H	03/16/2026	03/18/2026	R	\$36.00	
								25-26		39924	\$36.00	
											NUMBER OF INVOICES: 1	\$36.00
SECURITY000	SECURITY ALARM CORP, INC	247741	9002600074	BBMAR	Trust	REPLACE RECALLED ADDRESSABLE PULL STATIONS	F H	03/11/2026	03/10/2026	R	\$3,830.00	
								25-26		39925	\$3,830.00	
											NUMBER OF INVOICES: 1	\$3,830.00
SHILLIS000	SHILLING, LISA	ERIN20260303A	000000000	BBMAR	Trust	2/2/2026-2/27/2026 Mileage for travel to the Middle school for work from	H	03/03/2026	03/03/2026	A	\$24.65	

<u>VEN-KEY</u>	<u>VENDOR NAME</u>	<u>INVOICE #</u>	<u>PO NUMBER</u>	<u>BATCH</u>	<u>BANK</u>	<u>DESCRIPTION</u>	<u>LQ S</u>	<u>INV DATE</u>	<u>DUE DATE</u>	<u>C</u>	<u>NET AMOUNT</u>	
	<u>ACH VOID DOWNLOAD</u>	<u>DISCOUNT DESCRIPTION</u>		<u>DISC AMT</u>		<u>ADJUSTMENT DESCRIPTION</u>	<u>FY</u>	<u>ADJ AMT</u>	<u>CHECK NBR</u>		<u>INVOICE AMOUNT</u>	
SHILLIS000	SHILLING, LISA	ERIN20260303A				*****CONTINUED***** Rise Up						
							25-26		252600550		\$24.65	
											NUMBER OF INVOICES: 1	\$24.65
SKYLINE 001	SKYLINE COMMUNICATION	33885	1002600324	BBMAR	Trust	Parts for Laminators	H	02/05/2026	01/31/2026	R	\$546.26	
							25-26		39883		\$546.26	
											86	\$546.26
											NUMBER OF INVOICES: 1	\$546.26
SOUTH EA000	SOUTH EASTERN SPECIAL EDUCATION	040126	0000000000	BBMAR	Trust	MONTHLY SERVICES	H	03/03/2026	03/03/2026	R	\$194,419.25	
							25-26		39884		\$194,419.25	
											NUMBER OF INVOICES: 1	\$194,419.25
SPILLSCO000	SPILLMAN, SCOTT	022826	0000000000	BBMAR	Trust	MILEAGE FEBRUARY 2026	H	02/28/2026	03/09/2026	A	\$885.95	
							25-26		252600567		\$885.95	
											NUMBER OF INVOICES: 1	\$885.95
STAR STU000	STAR STUDIO	030226	5502600088	BBMAR	Trust	Star Studio rental fee	H	03/02/2026	03/05/2026	R	\$105.00	
							25-26		39885		\$105.00	
											NUMBER OF INVOICES: 1	\$105.00
SUMMIT F000	SUMMIT FINANCIAL RESOURCES, LP	S288515	4002600053	BBMAR	Trust	Commodity Delivery Fee February 2026	H	02/25/2026	02/28/2026	A	\$228.47	
							25-26		252600551		\$228.47	
											NUMBER OF INVOICES: 1	\$228.47
SYSKO FO000	SYSKO FOOD SERVICE	022826	4002600056	BBMAR	Trust	Additional food and supplies not avail through Kohl Feb 2026	H	02/28/2026	03/09/2026	R	\$5,135.91	
							25-26		39926		\$5,135.91	

<u>VEN-KEY</u>	<u>VENDOR NAME</u>	<u>INVOICE #</u>	<u>PO NUMBER</u>	<u>BATCH</u>	<u>BANK</u>	<u>DESCRIPTION</u>	<u>LQ</u>	<u>S</u>	<u>INV DATE</u>	<u>DUE DATE</u>	<u>C</u>	<u>NET AMOUNT</u>
	<u>ACH VOID DOWNLOAD</u>	<u>DISCOUNT DESCRIPTION</u>			<u>DISC AMT</u>	<u>ADJUSTMENT DESCRIPTION</u>	<u>FY</u>		<u>ADJ AMT</u>	<u>CHECK NBR</u>		<u>INVOICE AMOUNT</u>
						NUMBER OF INVOICES: 1						\$5,135.91
TENNIMEG000	TENNIS, MEGAN	030626	1002600398	BBMAR	Trust	Expense Reimbursement For: MEGAN TENNIS, Expense Date Range: 03/05/2026 thru 03/06/2026, Purpose: Gas and one meal from ILASCD Conference	H		03/06/2026	03/13/2026	A	\$64.97
									25-26	252600568		\$67.97
						NUMBER OF INVOICES: 1						\$64.97
THE MUSI000	THE MUSIC SHOPPE, INC	4139742	2002600122	BBMAR	Trust	Mapex Concert Snare Drum	H		02/23/2026	03/03/2026	R	\$499.99
									25-26	39886		\$499.99
THE MUSI000	THE MUSIC SHOPPE, INC	4141020	3002600358	BBMAR	Trust	Drum heads	H		02/25/2026	02/28/2026	R	\$261.30
									25-26	39927		\$261.30
						NUMBER OF INVOICES: 2						\$761.29
TRAVICHR000	TRAVIS, CHRISTY	022826	4002600054	BBMAR	Trust	Reimbursement for batteries for thermometer	H		02/28/2026	03/09/2026	A	\$14.99
									25-26	252600569		\$14.99
						NUMBER OF INVOICES: 1						\$14.99
TRITON T000	TRITON TOWING AND RECOVERY, LLC	204	8002600375	BBMAR	Trust	Bus #44 winch out of ditch	H		02/03/2026	02/26/2026	A	\$200.00
									25-26	252600552		\$200.00
						NUMBER OF INVOICES: 1						\$200.00
TRUCK CE000	TRUCK CENTERS, INC	F200295068:01	8002600367	BBMAR	Trust	Disc pad repair kit	H		02/19/2026	02/23/2026	R	\$153.04
									25-26	39887		\$153.04
TRUCK CE000	TRUCK CENTERS, INC	F200295159:01	8002600361	BBMAR	Trust	Brake Rotor, gasket, seal, reman LC, and core	H		02/27/2026	02/26/2026	R	\$-126.00

<u>VEN-KEY</u>	<u>VENDOR NAME</u>	<u>INVOICE #</u>	<u>PO NUMBER</u>	<u>BATCH</u>	<u>BANK</u>	<u>DESCRIPTION</u>	<u>LQ S</u>	<u>INV DATE</u>	<u>DUE DATE</u>	<u>C</u>	<u>NET AMOUNT</u>
<u>ACH VOID DOWNLOAD</u>		<u>DISCOUNT DESCRIPTION</u>	<u>DISC AMT</u>		<u>ADJUSTMENT DESCRIPTION</u>		<u>FY</u>	<u>ADJ AMT</u>	<u>CHECK NBR</u>	<u>INVOICE AMOUNT</u>	
TRUCK CE000	TRUCK CENTERS, INC	F200295159:01	*****CONTINUED*****				25-26		39887		\$-126.00
NUMBER OF INVOICES: 2											
\$27.04											
ULINE 000	ULINE	205469919	9002600100	BBMAR	Trust	Security Gates and Signs for RCHS	H	03/16/2026	03/18/2026	R	\$1,348.25
							25-26		39939		\$1,348.25
NUMBER OF INVOICES: 1											
88											
\$1,348.25											
VANDYJAM000	VANDYKE, JAMIE	061626	0000000000	BBMAR	Trust	IAVAT PERDIEM	H	03/17/2026	03/18/2026	A	\$189.00
							25-26		252600574		\$189.00
NUMBER OF INVOICES: 1											
\$189.00											
VERIZONW000	VERIZONWIRELESS	6137791902	0000000000	BBMAR	Trust	CELL PHONE BILL	H	03/18/2026	03/18/2026	R	\$637.39
							25-26		39938		\$637.39
NUMBER OF INVOICES: 1											
\$637.39											
VISA 000	VISA	022826	0000000000	BBMARV	Trust	ST JOSEPH SCHOOL VISA	H	03/13/2026	03/13/2026	R	\$239.69
							25-26		39934		\$239.69
VISA 000	VISA	10	3002600311	BBMAR	Trust	CC J THOMPSON FCS DEPARTMENT	H	03/10/2026	03/10/2026	R	\$807.25
							25-26		39930		\$807.25
VISA 000	VISA	11	3002600348	BBMAR	Trust	CC J THOMPSON S PIXLEY WALMART	H	03/10/2026	03/10/2026	R	\$518.41
							25-26		39930		\$518.41
VISA 000	VISA	12	9502600061	BBMAR	Trust	CC J THOMPSON R ROARK INK TECH	H	03/10/2026	03/10/2026	R	\$248.40
							25-26		39930		\$248.40

VEN-KEY	VENDOR NAME	INVOICE #	PO NUMBER	BATCH	BANK	DESCRIPTION	LQ	S	INV DATE	DUE DATE	C	NET AMOUNT
<u>ACH VOID DOWNLOAD</u>		<u>DISCOUNT DESCRIPTION</u>			<u>DISC AMT</u>	<u>ADJUSTMENT DESCRIPTION</u>	<u>FY</u>	<u>ADJ AMT</u>		<u>CHECK NBR</u>	<u>INVOICE AMOUNT</u>	
VISA	000 VISA	13	0000000000	BBMAR	Trust	CC JASON FOX FEBRUARY CHARGES	H		03/10/2026	03/10/2026	R	\$1,802.74
								25-26		39930		\$1,802.74
VISA	000 VISA	14	3002600346	BBMAR	Trust	CC C GRAVES L MUELLER Fuel for State Vet Science and Horse Judging	H		03/10/2026	03/10/2026	R	\$77.56
								25-26		39930		\$77.56
VISA	000 VISA	15	8002600371	BBMAR	Trust	CC B INYART Drug & Alcohol Clearinghouse Query Plan	H		02/05/2028	03/10/2026	R	\$125.00
								25-26		39930		\$125.00
VISA	000 VISA	16	3002600336	BBMAR	Trust	CC C GRAVES L MUELLER TRAVEL STATE VET SCIENCE	H		02/05/2028	03/10/2026	R	\$162.74
								25-26		39930		\$162.74
VISA	000 VISA	17	0000000000	BBMAR	Trust	CC C GRAVES TOLLS G EDWARDS UNION MEETING	H		02/05/2028	03/10/2026	R	\$7.20
								25-26		39930		\$7.20
VISA	000 VISA	18	0000000000	BBMAR	Trust	CC A WISNER FEBRUARY 2026	H		02/05/2028	03/10/2026	R	\$149.14
								25-26		39930		\$149.14
VISA	000 VISA	19	5502600085	BBMAR	Trust	CC J WEIDNER WALMART	H		02/05/2028	03/10/2026	R	\$127.48
								25-26		39930		\$127.48
VISA	000 VISA	20	5502600081	BBMAR	Trust	CC J WEIDNER WALMART	H		02/05/2028	03/10/2026	R	\$296.94
								25-26		39930		\$296.94
VISA	000 VISA	21	5502600078	BBMAR	Trust	CC J WEIDNER WALMART DOLLAR TREE	H		02/05/2028	03/10/2026	R	\$206.04
								25-26		39930		\$206.04
VISA	000 VISA	22	5502600077	BBMAR	Trust	CC J WEIDNER WALMART	H		02/05/2028	03/10/2026	R	\$131.43
								25-26		39930		\$131.43

89

<u>VEN-KEY</u>	<u>VENDOR NAME</u>	<u>INVOICE #</u>	<u>PO NUMBER</u>	<u>BATCH</u>	<u>BANK</u>	<u>DESCRIPTION</u>	<u>LQ S</u>	<u>INV DATE</u>	<u>DUE DATE</u>	<u>C</u>	<u>NET AMOUNT</u>
	<u>ACH VOID DOWNLOAD</u>	<u>DISCOUNT DESCRIPTION</u>		<u>DISC AMT</u>		<u>ADJUSTMENT DESCRIPTION</u>	<u>FY</u>		<u>ADJ AMT</u>	<u>CHECK NBR</u>	<u>INVOICE AMOUNT</u>
VISA	000 VISA	23	5502600075	BBMAR	Trust	CC J WEIDNER WALMART	H	02/05/2028	03/10/2026	R	\$209.25
							25-26			39930	\$209.25
VISA	000 VISA	24	0000000000	BBMAR	Trust	CC K RODGERS IRC CONFERENCE ISTE & ASCD MEMBERSHIP	H	02/05/2028	03/10/2026	R	\$1,644.00
							25-26			39930	\$1,644.00
VISA	000 VISA	25	4002600049	BBMAR	Trust	CC A THOMAS WALMART	H	02/05/2028	03/10/2026	R	\$49.54
							25-26			39930	\$90 .54
VISA	000 VISA	26	4002600052	BBMAR	Trust	CC A THOMAS WALMART	H	02/05/2028	03/10/2026	R	\$118.91
							25-26			39930	\$118.91
VISA	000 VISA	27	0000000000	BBMAR	Trust	CC R RUSK FEBRUARY 2026	H	02/05/2028	03/10/2026	R	\$910.00
							25-26			39930	\$910.00
VISA	000 VISA	28	1002600379	BBMAR	Trust	CC J FOX K WEIDNER WALMART	H	02/05/2028	03/10/2026	R	\$341.50
							25-26			39930	\$341.50
VISA	000 VISA	29	1002600381	BBMAR	Trust	CC JEN FOX WALMART	H	02/05/2028	03/10/2026	R	\$110.94
							25-26			39930	\$110.94
VISA	000 VISA	30	1002600382	BBMAR	Trust	CC JEN FOX JONES OF REGULATION	H	02/05/2028	03/10/2026	R	\$348.00
							25-26			39930	\$348.00
VISA	000 VISA	31	1002600380	BBMAR	Trust	CC JEN FOX T GROVE HV'S	H	02/05/2028	03/10/2026	R	\$56.81
							25-26			39930	\$56.81
VISA	000 VISA	32	1002600372	BBMAR	Trust	CC JEN FOX WALMART	H	02/05/2028	03/10/2026	R	\$71.53
							25-26			39930	\$71.53
VISA	000 VISA	33	1002600373	BBMAR	Trust	CC JEN FOX DAYLIGHT DONUTS	H	02/05/2028	03/10/2026	R	\$39.15
							25-26			39930	\$39.15

VEN-KEY	VENDOR NAME	INVOICE #	PO NUMBER	BATCH	BANK	DESCRIPTION	LQ	S	INV DATE	DUE DATE	C	NET AMOUNT
<u>ACH VOID DOWNLOAD</u>		<u>DISCOUNT DESCRIPTION</u>	<u>DISC AMT</u>		<u>ADJUSTMENT DESCRIPTION</u>		<u>FY</u>	<u>ADJ AMT</u>		<u>CHECK NBR</u>	<u>INVOICE AMOUNT</u>	
VISA	000 VISA	34	1002600371	BBMAR	Trust	CC JEN FOX E RUSK TPT	H	02/05/2028	03/10/2026	R	\$89.90	
							25-26			39930	\$89.90	
VISA	000 VISA	35	1002600366	BBMAR	Trust	CC JEN FOX CASEYS	H	02/05/2028	03/10/2026	R	\$115.95	
							25-26			39930	\$115.95	
VISA	000 VISA	36	1002600363	BBMAR	Trust	CC JEN FOX PIZZA FAST	H	02/05/2028	03/10/2026	R	\$937.17	
							25-26			39930	\$937.17	
VISA	000 VISA	37	1002600343	BBMAR	Trust	CC JEN FOX K WEIDNER WALMART	H	02/05/2028	03/10/2026	R	\$260.88	
						020525	25-26			39930	\$260.88	
VISA	000 VISA	38	1002600352	BBMAR	Trust	CC JEN FOX WALMART.COM	H	02/05/2028	03/10/2026	R	\$155.58	
							25-26			39930	\$155.58	
VISA	000 VISA	39	1002600349	BBMAR	Trust	CC JEN FOX E RUSK PALS	H	02/05/2028	03/10/2026	R	\$15.43	
						REWARD MCDONALDS	25-26			39930	\$15.43	
VISA	000 VISA	40	1002600347	BBMAR	Trust	CC JEN FOX WALMART.COM	H	02/05/2028	03/10/2026	R	\$38.17	
							25-26			39930	\$38.17	
VISA	000 VISA	41	1002600346	BBMAR	Trust	CC JEN FOX WALMART.COM	H	02/05/2028	03/10/2026	R	\$74.95	
							25-26			39930	\$74.95	
VISA	000 VISA	42	1002600344	BBMAR	Trust	CC JEN FOX WALMART	H	02/05/2028	03/10/2026	R	\$81.52	
							25-26			39930	\$81.52	
VISA	000 VISA	43	2002600135	BBMAR	Trust	CC J TEDFORD MATH COUNTS	H	03/11/2026	03/10/2026	R	\$544.86	
						HOTEL	25-26			39930	\$544.86	
VISA	000 VISA	44	2002600119	BBMAR	Trust	CC J TEDFORD Flocabulary	H	03/11/2026	03/10/2026	R	\$138.00	
						Subscription	25-26			39930	\$138.00	

91

<u>VEN-KEY</u>	<u>VENDOR NAME</u>	<u>INVOICE #</u>	<u>PO NUMBER</u>	<u>BATCH</u>	<u>BANK</u>	<u>DESCRIPTION</u>	<u>LQ</u>	<u>S</u>	<u>INV DATE</u>	<u>DUE DATE</u>	<u>C</u>	<u>NET AMOUNT</u>
<u>ACH VOID DOWNLOAD</u>		<u>DISCOUNT DESCRIPTION</u>		<u>DISC AMT</u>		<u>ADJUSTMENT DESCRIPTION</u>	<u>FY</u>		<u>ADJ AMT</u>	<u>CHECK NBR</u>	<u>INVOICE AMOUNT</u>	
						NUMBER OF INVOICES: 36					\$11,252.06	
WABASH C003	WABASH COMMUNICATIONS	032826	9002600030	BBMAR	Trust	INTERNET SERVICE	H	03/28/2026	03/09/2026	R	\$4,583.16	
							25-26			39931	\$4,583.16	
						NUMBER OF INVOICES: 1					\$4,583.16	
WABASH V002	WABASH VALLEY SERVICE CO	022826	8002600313	BBMAR	Trust	Fuel for 2025-2026 School Year	H	03/04/2026	02/26/2026	R	\$15,261.84	
							25-26			39888	92 \$15,261.84	
						NUMBER OF INVOICES: 1					\$15,261.84	
WEASE EQ000	WEASE EQUIPMENT, INC	W32220	8002600364	BBMAR	Trust	Bus #12 - Diagnose fault for aftertreatment temp sensor. Repaired wires and performed regen.	H	02/12/2026	01/31/2026	R	\$285.12	
							25-26			39889	\$285.12	
WEASE EQ000	WEASE EQUIPMENT, INC	W32421	8002600378	BBMAR	Trust	Bus #55 - Replace LR wheel speed sensor	H	02/23/2026	03/05/2026	R	\$227.54	
							25-26			39889	\$227.54	
						NUMBER OF INVOICES: 2					\$512.66	
WELLS FA005	WELLS FARGO	5037888413	0000000000	BBMAR	Trust	COPIER LEASE	H	03/09/2026	03/09/2026	R	\$4,745.15	
							25-26			39932	\$4,745.15	
						NUMBER OF INVOICES: 1					\$4,745.15	
XEROX IT000	XEROX IT SOLUTIONS, INC	01627091	9502600064	BBMAR	Trust	earbuds/headphones for testing	H	02/24/2026	02/28/2026	R	\$450.00	
							25-26			39890	\$450.00	
XEROX IT000	XEROX IT SOLUTIONS, INC	01627364	9502600064	BBMAR	Trust	earbuds/headphones for testing	H	02/25/2026	02/28/2026	R	\$250.00	

<u>VEN-KEY</u>	<u>VENDOR NAME</u>	<u>INVOICE #</u>	<u>PO NUMBER</u>	<u>BATCH</u>	<u>BANK</u>	<u>DESCRIPTION</u>	<u>LQ S</u>	<u>INV DATE</u>	<u>DUE DATE</u>	<u>C</u>	<u>NET AMOUNT</u>
<u>ACH VOID DOWNLOAD</u>		<u>DISCOUNT DESCRIPTION</u>	<u>DISC AMT</u>		<u>ADJUSTMENT DESCRIPTION</u>		<u>FY</u>	<u>ADJ AMT</u>	<u>CHECK NBR</u>	<u>INVOICE AMOUNT</u>	
XEROX IT000	XEROX IT SOLUTIONS, INC	01627364	*****CONTINUED*****								
							25-26		39890	\$250.00	
NUMBER OF INVOICES: 2										\$700.00	
TOTAL NUMBER OF HISTORY INVOICES:										321	\$1,727,037.85
105 ACH CHECK INVOICES										\$1,195,649.66	
208 COMPUTER CHECK INVOICES										\$530,908.74	
8 WIRE TRAN CHECK INVOICES										\$469.45	
TOTAL INVOICES:										321	\$1,727,037.85
BANK TOTALS:		BANK	BANK ACCOUNT #				INVOICE AMOUNT		NET AMOUNT		
		Trust	**A010 1120 0000 00 000000				\$1,727,074.13		\$1,727,037.85		

LIQUIDATION STATUS (LQ) CODE LEGEND:
L = LIQUIDATION PENDING C = CLOSED PO/NOT RECEIVING
P = PARTIAL LIQUIDATION F = FULL LIQUIDATION
BLANK = NO LIQUIDATION

***** End of report *****

Comparison of Funds for February		
FUND	2025 February	2026 February
Education	\$ 25,336,492.87	\$ 23,953,688.18
Operations and Maintenance	\$ 3,353,689.35	\$ 3,836,639.47
Debt Services	\$ 1,008,048.17	\$ 844,790.87
Transportation	\$ 916,077.60	\$ 1,168,874.65
IMRF/Social Security	\$ 1,098,943.30	\$ 1,199,516.71
Capital Projects	\$ 325,794.32	\$ 1,756,856.45
Working Cash	\$ 1,384,507.90	\$ 1,626,393.46
Tort Fund	\$ 931,064.72	\$ 1,137,848.11
Fire Prevention and Safety	\$ 235,212.96	\$ 353,755.64
Total Cash (Includes CD's)	\$ 34,589,831.19	\$ 35,878,363.54
Assets	\$ 701,463.03	\$ 745,695.23
Total Cash and Assets	\$ 35,291,294.22	\$ 36,624,058.77
GRAND TOTAL	\$ 35,291,294.22	\$ 36,624,058.77

Account Level					2025-26	February 2025-26	2025-26	2025-26	Encumbered	2025-26
FDTLOC	FUNC	OBJ	SJ	Description	Budget	Monthly Activity	FYTD Activity	Batch Activity	Amount	Available Funds
10R010	1110	0000	00	000000	6,340,000.00	28.17	6,347,053.11	0.00	0.00	-7,053.11
10R---	1110	0---	--	-----	6,340,000.00	28.17	6,347,053.11	0.00	0.00	-7,053.11
10R010	1140	0000	00	000000	137,000.00	0.61	137,064.21	0.00	0.00	-64.21
10R---	1140	0---	--	-----	137,000.00	0.61	137,064.21	0.00	0.00	-64.21
10R010	1210	0000	00	000000	28,000.00	0.00	26,355.07	0.00	0.00	1,644.93
10R---	1210	0---	--	-----	28,000.00	0.00	26,355.07	0.00	0.00	1,644.93
10R010	1220	0000	00	000000	18,000.00	0.00	19,451.85	0.00	0.00	-1,451.85
10R---	1220	0---	--	-----	18,000.00	0.00	19,451.85	0.00	0.00	-1,451.85
10R010	1230	0000	00	000000	750,000.00	0.00	477,583.20	0.00	0.00	272,416.80
10R---	1230	0---	--	-----	750,000.00	0.00	477,583.20	0.00	0.00	272,416.80
10R010	1311	0000	00	000000	0.00	0.00	162.30	0.00	0.00	-162.30
10R---	1311	0---	--	-----	0.00	0.00	162.30	0.00	0.00	-162.30
10R010	1510	0000	00	000000	1,100,000.00	75,602.54	876,877.38	0.00	0.00	223,122.62
10R---	1510	0---	--	-----	1,100,000.00	75,602.54	876,877.38	0.00	0.00	223,122.62
10R010	1613	0000	00	000000	6,000.00	785.75	5,912.25	0.00	0.00	87.75
10R---	1613	0---	--	-----	6,000.00	785.75	5,912.25	0.00	0.00	87.75
10R010	1615	0000	00	000000	15,000.00	-665.55	820.55	0.00	0.00	14,179.45
10R---	1615	0---	--	-----	15,000.00	-665.55	820.55	0.00	0.00	14,179.45
10R010	1620	0000	00	000000	8,000.00	747.20	5,992.10	0.00	0.00	2,007.90
10R---	1620	0---	--	-----	8,000.00	747.20	5,992.10	0.00	0.00	2,007.90
10R010	1690	0000	00	000000	2,500.00	262.11	797.53	0.00	0.00	1,702.47
10R---	1690	0---	--	-----	2,500.00	262.11	797.53	0.00	0.00	1,702.47
10R010	1711	0000	00	000000	60,000.00	8,613.00	60,613.50	0.00	0.00	-613.50
10R---	1711	0---	--	-----	60,000.00	8,613.00	60,613.50	0.00	0.00	-613.50
10R010	1720	0000	00	000000	0.00	0.00	24.80	0.00	0.00	-24.80
10R---	1720	0---	--	-----	0.00	0.00	24.80	0.00	0.00	-24.80
10R010	1790	0000	00	000000	7,000.00	380.00	6,746.80	0.00	0.00	253.20
10R---	1790	0---	--	-----	7,000.00	380.00	6,746.80	0.00	0.00	253.20
10R010	1811	0000	00	000000	160,000.00	3,230.50	148,125.10	0.00	0.00	11,874.90
10R---	1811	0---	--	-----	160,000.00	3,230.50	148,125.10	0.00	0.00	11,874.90
10R010	1910	0000	00	000000	5,000.00	400.00	61,200.00	0.00	0.00	-56,200.00
10R---	1910	0---	--	-----	5,000.00	400.00	61,200.00	0.00	0.00	-56,200.00
10R010	1940	0000	00	000000	0.00	0.00	1,544.10	0.00	0.00	-1,544.10
10R---	1940	0---	--	-----	0.00	0.00	1,544.10	0.00	0.00	-1,544.10
10R010	1950	0000	00	000000	75,000.00	0.00	26,583.79	0.00	0.00	48,416.21
10R---	1950	0---	--	-----	75,000.00	0.00	26,583.79	0.00	0.00	48,416.21
10R010	1970	0000	00	000000	20,000.00	175.00	14,659.75	0.00	0.00	5,340.25
10R---	1970	0---	--	-----	20,000.00	175.00	14,659.75	0.00	0.00	5,340.25
10R010	1999	0000	00	000000	1,500.00	1,424.40	75,678.76	0.00	0.00	-74,178.76
10R010	1999	0000	01	000000	30,000.00	0.00	68,922.88	0.00	0.00	-38,922.88

Account Level				2025-26	February 2025-26	2025-26	2025-26	Encumbered	2025-26	
FDTLOC	FUNC	OBJ	SJ	Description	Budget	Monthly Activity	FYTD Activity	Batch Activity	Amount	Available Funds
10R010	1999	0000	09	000000	Other Local Revenues	2,000.00	0.00	0.00	0.00	2,000.00
10R680	1999	0000	00	680000	Carrie Winters	1,500.00	0.00	0.00	0.00	1,500.00
10R690	1999	0000	00	690000	CEO Program	37,000.00	0.00	27,355.93	0.00	9,644.07
10R730	1999	0000	00	730000	JFF Programs	5,000.00	0.00	0.00	0.00	5,000.00
10R---	1999	0---	--	-----		77,000.00	1,424.40	171,957.57	0.00	-94,957.57
10R---	1---	----	--	-----		8,808,500.00	90,983.73	8,389,524.96	0.00	418,975.04
10R010	3001	0000	00	000000	General State Aid	11,954,019.00	0.00	4,346,912.00	0.00	7,607,107.00
10R---	3001	0---	--	-----		11,954,019.00	0.00	4,346,912.00	0.00	7,607,107.00
10R260	3100	0000	00	260000	Sp Ed Priv Facility	0.00	0.00	23,257.92	0.00	-23,257.92
10R---	3100	0---	--	-----		0.00	0.00	23,257.92	0.00	-23,257.92
10R640	3120	0000	00	640000	Sp Ed Orphan	100,000.00	0.00	216,899.03	0.00	-116,899.03
10R---	3120	0---	--	-----		100,000.00	0.00	216,899.03	0.00	-116,899.03
10R490	3235	0000	00	490000	Ag Inc 3 Circles	38,000.00	2,634.00	19,622.00	0.00	18,378.00
10R---	3235	0---	--	-----		38,000.00	2,634.00	19,622.00	0.00	18,378.00
10R780	3299	0000	00	780000	Voc Ed Formula	110,000.00	0.00	85,520.33	0.00	24,479.67
10R---	3299	0---	--	-----		110,000.00	0.00	85,520.33	0.00	24,479.67
10R350	3360	0000	00	350000	St Lunch/Bfast Reimb	12,000.00	689.28	6,372.39	0.00	5,627.61
10R---	3360	0---	--	-----		12,000.00	689.28	6,372.39	0.00	5,627.61
10R310	3370	0000	00	310000	Drivers Education Reimb	24,000.00	0.00	10,810.40	0.00	13,189.60
10R---	3370	0---	--	-----		24,000.00	0.00	10,810.40	0.00	13,189.60
10R110	3705	0000	00	110000	Early Child Block Grant	800,000.00	0.00	128,838.00	0.00	671,162.00
10R510	3705	0000	00	510000	ECE Block Grant-FY06	140,000.00	49,438.00	382,870.00	0.00	-242,870.00
10R---	3705	0---	--	-----		940,000.00	49,438.00	511,708.00	0.00	428,292.00
10R240	3999	0000	00	240000	Library Grant	1,500.00	0.00	0.00	0.00	1,500.00
10R---	3999	0---	--	-----		1,500.00	0.00	0.00	0.00	1,500.00
10R---	3---	----	--	-----		13,179,519.00	52,761.28	5,221,102.07	0.00	7,958,416.93
10R420	4210	0000	00	420000	Fed Lunch Prog Reimb	720,000.00	58,419.54	389,740.48	0.00	330,259.52
10R---	4210	0---	--	-----		720,000.00	58,419.54	389,740.48	0.00	330,259.52
10R420	4215	0000	00	420000	Fed Special Milk Program	240,000.00	0.00	0.00	0.00	240,000.00
10R---	4215	0---	--	-----		240,000.00	0.00	0.00	0.00	240,000.00
10R430	4220	0000	00	430000	Fed Bfast Prog Reimb	180,000.00	17,940.42	107,058.84	0.00	72,941.16
10R---	4220	0---	--	-----		180,000.00	17,940.42	107,058.84	0.00	72,941.16
10R100	4300	0000	00	100000	Title I Grant - Reading	500,000.00	0.00	273,138.00	0.00	226,862.00
10R500	4300	0000	00	500000	Title I	700,000.00	143,289.00	333,210.00	0.00	366,790.00
10R---	4300	0---	--	-----		1,200,000.00	143,289.00	606,348.00	0.00	593,652.00
10R170	4400	0000	00	170000	Title IV Grant	18,000.00	1,514.00	3,256.00	0.00	14,744.00
10R570	4400	0000	00	570000	Title IV Grant	50,000.00	0.00	21,199.00	0.00	28,801.00
10R---	4400	0---	--	-----		68,000.00	1,514.00	24,455.00	0.00	43,545.00
10R150	4600	0000	00	150000	Sp Ed IDEA Pre School	40,000.00	2,453.00	19,624.00	0.00	20,376.00
10R---	4600	0---	--	-----		40,000.00	2,453.00	19,624.00	0.00	20,376.00

Account Level				2025-26	February 2025-26	2025-26	2025-26	Encumbered	2025-26	
FDTLOC	FUNC	OBJ	SJ	Description	Budget	Monthly Activity	FYTD Activity	Batch Activity	Amount	Available Funds
10R150	4620	0000	00	150000	Sp Ed Flow thru SESE	700,000.00	50,432.00	407,807.00	0.00	292,193.00
10R344	4620	0000	00	344000	ARP IDEA Flow Thru SESE	50,000.00	0.00	0.00	0.00	50,000.00
10R---	4620	0---	--	-----		750,000.00	50,432.00	407,807.00	0.00	342,193.00
10R260	4625	0000	00	260000	Fed SpEd IDEA Rm/Board	0.00	34,166.46	139,113.37	0.00	-139,113.37
10R---	4625	0---	--	-----		0.00	34,166.46	139,113.37	0.00	-139,113.37
10R782	4745	0000	00	000000	METT Grant Revenue	35,000.00	0.00	16,784.99	0.00	18,215.01
10R---	4745	0---	--	-----		35,000.00	0.00	16,784.99	0.00	18,215.01
10R390	4799	0000	00	390000	V E Perkins T-IIC 2 Tutor	20,000.00	0.00	13,114.00	0.00	6,886.00
10R---	4799	0---	--	-----		20,000.00	0.00	13,114.00	0.00	6,886.00
10R330	4932	0000	00	330000	Title II Teacher Quality	65,000.00	0.00	39,743.00	0.00	25,257.00
10R530	4932	0000	00	530000	Title II	120,500.00	9,185.00	56,413.00	0.00	64,087.00
10R---	4932	0---	--	-----		185,500.00	9,185.00	96,156.00	0.00	89,344.00
10R920	4991	0000	00	920000	Medicaid Adm Outreach	25,000.00	0.00	64,407.35	0.00	-39,407.35
10R---	4991	0---	--	-----		25,000.00	0.00	64,407.35	0.00	-39,407.35
10R920	4992	0000	00	920000	Medicaid Fee For Service	90,000.00	0.00	4,929.66	0.00	85,070.34
10R---	4992	0---	--	-----		90,000.00	0.00	4,929.66	0.00	85,070.34
10R345	4998	0000	00	000000	ARP McKinney Vento	2,500.00	0.00	0.00	0.00	2,500.00
10R---	4998	0---	--	-----		2,500.00	0.00	0.00	0.00	2,500.00
10R410	4999	0000	00	000000	JROTC	65,000.00	6,778.14	47,353.70	0.00	17,646.30
10R---	4999	0---	--	-----		65,000.00	6,778.14	47,353.70	0.00	17,646.30
10R---	4---	----	--	-----		3,621,000.00	324,177.56	1,936,892.39	0.00	1,684,107.61
1-R---	----	----	--	-----		25,609,019.00	467,922.57	15,547,519.42	0.00	10,061,499.58
20R010	1111	0000	00	000000	Building Levy	1,722,000.00	7.65	1,713,211.21	0.00	8,788.79
20R---	1111	0---	--	-----		1,722,000.00	7.65	1,713,211.21	0.00	8,788.79
20R010	1510	0000	00	000000	Earnings on Investments	130,000.00	11,558.83	114,754.17	0.00	15,245.83
20R---	1510	0---	--	-----		130,000.00	11,558.83	114,754.17	0.00	15,245.83
20R010	1999	0000	00	000000	Other Bldg Rev-Ins Reim etc	0.00	0.00	6,365.32	0.00	-6,365.32
20R---	1999	0---	--	-----		0.00	0.00	6,365.32	0.00	-6,365.32
20R---	1---	----	--	-----		1,852,000.00	11,566.48	1,834,330.70	0.00	17,669.30
20R010	3925	0000	00	000000	St Maint Grant Bldg	50,000.00	0.00	0.00	0.00	50,000.00
20R---	3925	0---	--	-----		50,000.00	0.00	0.00	0.00	50,000.00
20R---	3---	----	--	-----		50,000.00	0.00	0.00	0.00	50,000.00
2-R---	----	----	--	-----		1,902,000.00	11,566.48	1,834,330.70	0.00	67,669.30
30R010	1112	0000	00	000000	Bond & Interest Levy	1,859,000.00	8.26	1,857,296.61	0.00	1,703.39
30R---	1112	0---	--	-----		1,859,000.00	8.26	1,857,296.61	0.00	1,703.39
30R010	1510	0000	00	000000	Earnings on Investments	25,000.00	2,508.65	34,158.62	0.00	-9,158.62
30R---	1510	0---	--	-----		25,000.00	2,508.65	34,158.62	0.00	-9,158.62
30R010	1983	0000	00	000000	School Facility Occp Sales Tax	987,769.00	0.00	987,769.00	0.00	0.00
30R---	1983	0---	--	-----		987,769.00	0.00	987,769.00	0.00	0.00
30R---	1---	----	--	-----		2,871,769.00	2,516.91	2,879,224.23	0.00	-7,455.23

Account Level				2025-26	February 2025-26	2025-26	2025-26	Encumbered	2025-26	
FDTLOC	FUNC	OBJ	SJ	Description	Budget	Monthly Activity	FYTD Activity	Batch Activity	Amount	Available Funds
3-R---	----	----	----		2,871,769.00	2,516.91	2,879,224.23	0.00	0.00	-7,455.23
40R080	1113	0000	00 000000	Trans Levy	688,700.00	3.06	685,320.97	0.00	0.00	3,379.03
40R---	1113	0---	--		688,700.00	3.06	685,320.97	0.00	0.00	3,379.03
40R080	1412	0000	00 000000	Reg Trans from Pre-K	10,000.00	0.00	33,086.40	0.00	0.00	-23,086.40
40R---	1412	0---	--		10,000.00	0.00	33,086.40	0.00	0.00	-23,086.40
40R080	1413	0000	00 000000	Reg Trans Fee Private	1,500.00	36.48	3,246.36	0.00	0.00	-1,746.36
40R---	1413	0---	--		1,500.00	36.48	3,246.36	0.00	0.00	-1,746.36
40R080	1415	0000	00 000000	Reg Trans Pupil Co-Curr	15,000.00	0.00	0.00	0.00	0.00	15,000.00
40R---	1415	0---	--		15,000.00	0.00	0.00	0.00	0.00	15,000.00
40R080	1510	0000	00 000000	Earnings on Investments	45,000.00	3,809.24	34,676.79	0.00	0.00	10,323.21
40R---	1510	0---	--		45,000.00	3,809.24	34,676.79	0.00	0.00	10,323.21
40R080	1999	0000	00 000000	Insrnc Rmb/Othr Misc	2,500.00	0.00	276.00	0.00	0.00	2,224.00
40R---	1999	0---	--		2,500.00	0.00	276.00	0.00	0.00	2,224.00
40R---	1---	----	----		762,700.00	3,848.78	756,606.52	0.00	0.00	6,093.48
40R080	3500	0000	00 000000	Transportation Regular	650,000.00	0.00	283,713.85	0.00	0.00	366,286.15
40R---	3500	0---	--		650,000.00	0.00	283,713.85	0.00	0.00	366,286.15
40R620	3510	0000	00 620000	State Trans Spec Ed	140,000.00	0.00	124,384.28	0.00	0.00	15,615.72
40R---	3510	0---	--		140,000.00	0.00	124,384.28	0.00	0.00	15,615.72
40R---	3---	----	----		790,000.00	0.00	408,098.13	0.00	0.00	381,901.87
4-R---	----	----	----		1,552,700.00	3,848.78	1,164,704.65	0.00	0.00	387,995.35
50R010	1114	0000	00 000000	IMRF Levy	445,950.00	1.98	447,785.79	0.00	0.00	-1,835.79
50R---	1114	0---	--		445,950.00	1.98	447,785.79	0.00	0.00	-1,835.79
50R010	1150	0000	00 000000	Tax Levy Social Security	516,100.00	2.29	517,399.84	0.00	0.00	-1,299.84
50R---	1150	0---	--		516,100.00	2.29	517,399.84	0.00	0.00	-1,299.84
50R010	1230	0000	00 000000	Corp Pers Prop Tax	96,000.00	0.00	96,000.00	0.00	0.00	0.00
50R---	1230	0---	--		96,000.00	0.00	96,000.00	0.00	0.00	0.00
50R010	1510	0000	00 000000	Earnings on Investments	25,000.00	3,796.51	37,917.62	0.00	0.00	-12,917.62
50R---	1510	0---	--		25,000.00	3,796.51	37,917.62	0.00	0.00	-12,917.62
50R---	1---	----	----		1,083,050.00	3,800.78	1,099,103.25	0.00	0.00	-16,053.25
5-R---	----	----	----		1,083,050.00	3,800.78	1,099,103.25	0.00	0.00	-16,053.25
60R010	1510	0000	00 000000	Cap Projects Int	15,000.00	6,395.95	31,443.39	0.00	0.00	-16,443.39
60R---	1510	0---	--		15,000.00	6,395.95	31,443.39	0.00	0.00	-16,443.39
60R010	1983	0000	00 000000	School Fac Occp Sales Tax	850,000.00	203,092.16	565,692.60	0.00	0.00	284,307.40
60R---	1983	0---	--		850,000.00	203,092.16	565,692.60	0.00	0.00	284,307.40
60R---	1---	----	----		865,000.00	209,488.11	597,135.99	0.00	0.00	267,864.01
60R010	3001	0000	00 000000	EVIDENCE BASED FUNDING	0.00	1,086,728.00	3,260,184.00	0.00	0.00	-3,260,184.00
60R---	3001	0---	--		0.00	1,086,728.00	3,260,184.00	0.00	0.00	-3,260,184.00
60R---	3---	----	----		0.00	1,086,728.00	3,260,184.00	0.00	0.00	-3,260,184.00
6-R---	----	----	----		865,000.00	1,296,216.11	3,857,319.99	0.00	0.00	-2,992,319.99
70R010	1115	0000	00 000000	Working Cash Levy	172,170.00	0.77	171,330.18	0.00	0.00	839.82

Account Level				2025-26	February 2025-26	2025-26	2025-26	Encumbered	2025-26	
FDTLOC	FUNC	OBJ	SJ	Description	Budget	Monthly Activity	FYTD Activity	Batch Activity	Amount	Available Funds
70R---	1115	0---	--	-----	172,170.00	0.77	171,330.18	0.00	0.00	839.82
70R010	1510	0000	00	000000	Earnings on Investments	45,000.00	4,829.71	44,413.65	0.00	586.35
70R---	1510	0---	--	-----	45,000.00	4,829.71	44,413.65	0.00	0.00	586.35
70R---	1---	----	--	-----	217,170.00	4,830.48	215,743.83	0.00	0.00	1,426.17
7-R---	----	----	--	-----	217,170.00	4,830.48	215,743.83	0.00	0.00	1,426.17
80R010	1120	0000	00	000000	TORT LEVY	1,703,400.00	7.57	1,691,446.31	0.00	11,953.69
80R---	1120	0---	--	-----	1,703,400.00	7.57	1,691,446.31	0.00	0.00	11,953.69
80R010	1510	0000	00	000000	Tort Int	25,000.00	3,448.30	24,977.43	0.00	22.57
80R---	1510	0---	--	-----	25,000.00	3,448.30	24,977.43	0.00	0.00	22.57
80R---	1---	----	--	-----	1,728,400.00	3,455.87	1,716,423.74	0.00	0.00	11,976.26
8-R---	----	----	--	-----	1,728,400.00	3,455.87	1,716,423.74	0.00	0.00	11,976.26
90R010	1118	0000	00	000000	Life Safety Levy	172,170.00	0.77	171,330.18	0.00	839.82
90R---	1118	0---	--	-----	172,170.00	0.77	171,330.18	0.00	0.00	839.82
90R010	1510	0000	00	000000	Earnings on Investments	5,000.00	1,055.50	9,508.36	0.00	-4,508.36
90R---	1510	0---	--	-----	5,000.00	1,055.50	9,508.36	0.00	0.00	-4,508.36
90R---	1---	----	--	-----	177,170.00	1,056.27	180,838.54	0.00	0.00	-3,668.54
9-R---	----	----	--	-----	177,170.00	1,056.27	180,838.54	0.00	0.00	-3,668.54
--R---	----	----	--	-----	36,006,278.00	1,795,214.25	28,495,208.35	0.00	0.00	7,511,069.65
10E343	1100	1110	00	000000	ESSER III AIDE/ASST SALARY	0.00	-404.64	-404.64	0.00	404.64
10E---	1100	1---	--	-----	0.00	-404.64	-404.64	0.00	0.00	404.64
10E730	1100	3190	00	730000	JFF Purchased Services	4,000.00	0.00	219.75	0.00	3,780.25
10E---	1100	3---	--	-----	4,000.00	0.00	219.75	0.00	0.00	3,780.25
10E730	1100	4100	00	730000	JFF SUPPLIES	10,000.00	0.00	572.72	1,172.86	8,254.42
10E010	1100	4990	00	000000	Teacher Retention Supplies	0.00	215.38	2,985.65	0.00	-2,985.65
10E---	1100	4---	--	-----	10,000.00	215.38	3,558.37	1,172.86	0.00	5,268.77
10E730	1100	5500	00	730000	JFF Equipment	10,000.00	0.00	0.00	0.00	10,000.00
10E---	1100	5---	--	-----	10,000.00	0.00	0.00	0.00	0.00	10,000.00
10E010	1100	6000	00	000000	Other Expenditures	15,000.00	0.00	29,043.13	0.00	-14,043.13
10E---	1100	6---	--	-----	15,000.00	0.00	29,043.13	0.00	0.00	-14,043.13
10E015	1105	1100	00	000000	ELC Mentoring Salaries	0.00	0.00	297.00	0.00	-297.00
10E---	1105	1---	--	-----	0.00	0.00	297.00	0.00	0.00	-297.00
10E015	1105	2110	00	000000		0.00	0.00	33.46	0.00	-33.46
10E---	1105	2---	--	-----	0.00	0.00	33.46	0.00	0.00	-33.46
10E015	1105	3190	00	000000	RCELC Purchased Services	6,200.00	213.03	2,145.77	0.00	4,054.23
10E---	1105	3---	--	-----	6,200.00	213.03	2,145.77	0.00	0.00	4,054.23
10E015	1105	4100	00	000000	Early Learning Center Supplies	3,000.00	0.00	244.76	0.00	356.23
10E015	1105	4700	00	000000	Early Learning Center Software	500.00	0.00	0.00	0.00	500.00
10E---	1105	4---	--	-----	3,500.00	0.00	244.76	0.00	356.23	2,899.01
10E015	1105	5500	00	000000	Early Learning Center Equipm	3,000.00	0.00	0.00	0.00	3,000.00
10E015	1105	5500	61	000000	ELC Computer Equipment	2,000.00	0.00	0.00	0.00	2,000.00

Account Level				2025-26	February 2025-26	2025-26	2025-26	Encumbered	2025-26	
FDTLOC	FUNC	OBJ	SJ	Description	Budget	Monthly Activity	FYTD Activity	Batch Activity	Amount	Available Funds
10E---	1105	5---	--	-----	5,000.00	0.00	0.00	0.00	0.00	5,000.00
10E020	1110	1100	00	000000	RCES Teach Sal	2,977,580.00	187,890.14	1,679,610.46	0.00	1,297,969.54
10E020	1110	1110	00	000000	RCES Aide/TA Sal	179,257.00	12,144.04	92,705.22	0.00	86,551.78
10E020	1110	1200	00	000000	RCES Sub Teach Sal	20,867.00	14,244.48	92,949.54	0.00	-72,082.54
10E020	1110	1210	00	000000	RCES Sub Teach Aide Sal	42,641.00	2,334.88	32,178.86	0.00	10,462.14
10E---	1110	1---	--	-----	3,220,345.00	216,613.54	1,897,444.08	0.00	0.00	1,322,900.92
10E020	1110	2110	00	000000	RCES TRS	327,616.00	21,261.57	194,706.38	0.00	132,909.62
10E020	1110	2200	00	000000	RCES Ins Benefit	235,000.00	24,363.31	231,231.22	0.00	3,768.78
10E020	1110	2300	00	000000	RCES Tuition Reimbursement	15,000.00	0.00	11,680.00	0.00	3,320.00
10E---	1110	2---	--	-----	577,616.00	45,624.88	437,617.60	0.00	0.00	139,998.40
10E020	1110	3190	00	000000	RCES Pur Ser Agreements	153,000.00	6,880.67	37,813.50	0.00	115,186.50
10E020	1110	3190	12	000000	RCES Music Purchased Service	260.00	0.00	0.00	0.00	260.00
10E020	1110	3190	31	000000	RCES Stem Purchased Services	1,000.00	0.00	0.00	0.00	1,000.00
10E020	1110	3230	00	000000	RCES Repair/Maintenance	500.00	0.00	0.00	0.00	500.00
10E020	1110	3230	61	000000	RCES Computer Rep/Maint	500.00	0.00	0.00	0.00	500.00
10E020	1110	3320	00	000000	RCES Travel	500.00	0.00	0.00	0.00	500.00
10E---	1110	3---	--	-----	155,760.00	6,880.67	37,813.50	0.00	0.00	117,946.50
10E020	1110	4100	00	000000	RCES Supplies	130,000.00	2,160.59	60,643.82	52.88	8,355.26
10E020	1110	4110	00	000000	RCES Instructional Supp	2,500.00	0.00	0.00	0.00	2,500.00
10E020	1110	4200	00	000000	RCES Textbooks	1,250.00	0.00	0.00	0.00	1,250.00
10E020	1110	4240	00	000000	RCES Copier Paper/Toner	10,000.00	0.00	10,735.08	0.00	-735.08
10E020	1110	4700	00	000000	RCES Software	10,000.00	0.00	1,598.75	0.00	1,407.00
10E---	1110	4---	--	-----	153,750.00	2,160.59	72,977.65	52.88	9,762.26	70,957.21
10E020	1110	5500	00	000000	RCES Equipment	10,000.00	0.00	622.71	0.00	9,377.29
10E020	1110	5500	61	000000	RCES Computer Equipment	4,000.00	0.00	0.00	0.00	1,729.62
10E---	1110	5---	--	-----	14,000.00	0.00	622.71	0.00	1,729.62	11,647.67
10E040	1120	1100	00	000000	RCMS Teach Sal	1,642,463.00	115,730.03	1,038,905.21	0.00	603,557.79
10E040	1120	1110	00	000000	RCMS TA/Aide Sal	32,036.00	1,454.78	18,800.22	0.00	13,235.78
10E040	1120	1200	00	000000	RCMS Sub Teach Sal	60,000.00	1,792.00	17,121.89	0.00	42,878.11
10E040	1120	1210	00	000000	RCMS Sub TA/Aide Sal	1,000.00	0.00	1,660.50	0.00	-660.50
10E---	1120	1---	--	-----	1,735,499.00	118,976.81	1,076,487.82	0.00	0.00	659,011.18
10E040	1120	2110	00	000000	RCMS TRS	179,795.00	13,050.34	117,475.27	0.00	62,319.73
10E040	1120	2200	00	000000	RCMS Ins Benefit	265,000.00	16,632.36	139,238.80	0.00	125,761.20
10E---	1120	2---	--	-----	444,795.00	29,682.70	256,714.07	0.00	0.00	188,080.93
10E040	1120	3190	00	000000	RCMS Pur Serv Agreements	48,400.00	629.22	41,097.78	0.00	138.00
10E---	1120	3---	--	-----	48,400.00	629.22	41,097.78	0.00	138.00	7,164.22
10E040	1120	4100	00	000000	RCMS Gen Classroom Supp	6,000.00	392.15	2,463.75	229.35	2,010.20
10E040	1120	4100	02	000000	RCMS Art Supplies	3,500.00	0.00	3,038.23	0.00	51.96
10E040	1120	4100	05	000000	RCMS Lang Art Supp	650.00	0.00	0.00	0.00	650.00
10E040	1120	4100	08	000000	RCMS Health Class Supp	150.00	0.00	0.00	0.00	150.00

Account Level				2025-26	February 2025-26	2025-26	2025-26	Encumbered	2025-26		
FDTLOC	FUNC	OBJ	SJ	Description	Budget	Monthly Activity	FYTD Activity	Batch Activity	Amount	Available Funds	
10E040	1120	4100	10	000000	RCMS Enrichment Class Supplies	250.00	0.00	0.00	0.00	250.00	
10E040	1120	4100	11	000000	RCMS Math Supplies	1,000.00	0.00	0.00	0.00	1,000.00	
10E040	1120	4100	12	000000	RCMS Band Supp	2,400.00	0.00	0.00	1,617.82	782.18	
10E040	1120	4100	13	000000	RCMS Science Supplies	2,000.00	169.14	417.82	0.00	950.41	631.77
10E040	1120	4100	15	000000	RCMS Social Studies Supp	1,000.00	0.00	109.03	0.00	0.00	890.97
10E040	1120	4100	50	000000	RCMS PE Supplies	1,350.00	0.00	0.00	0.00	0.00	1,300.00
10E040	1120	4100	61	000000	RCMS Computer Supplies	4,000.00	451.25	553.01	0.00	0.00	3,446.99
10E040	1120	4200	00	000000	RCMS Textbooks	30,000.00	0.00	18,093.60	0.00	0.00	11,906.40
10E040	1120	4240	00	000000	RCMS Copier Ppr/Tnr	10,000.00	0.00	5,046.16	0.00	0.00	4,953.84
10E040	1120	4700	00	000000	RCMS Software	1,000.00	0.00	0.00	0.00	0.00	1,000.00
10E040	1120	4910	00	000000	RCMS PE Uniforms	7,575.00	0.00	6,870.00	0.00	0.00	755.00
10E---	1120	4---	--	-----		70,875.00	1,012.54	36,591.60	229.35	4,630.39	29,423.66
10E040	1120	5500	00	000000	RCMS Equipment	12,000.00	0.00	182,892.32	0.00	0.00	-170,892.32
10E040	1120	5500	61	000000	RCMS Computer Equipment	2,000.00	0.00	0.00	0.00	0.00	2,000.00
10E040	1120	5500	80	000000	RCMS Band & Chorus Equip	2,400.00	0.00	799.00	0.00	0.00	1,601.00
10E---	1120	5---	--	-----		16,400.00	0.00	183,691.32	0.00	0.00	-167,291.32
10E110	1125	1100	00	110000	Pre K Teacher Salary	24,500.00	0.00	9,281.34	0.00	0.00	15,218.66
10E510	1125	1100	00	510000	Pre K Teacher Salary	254,149.00	22,494.20	144,118.99	0.00	0.00	110,030.01
10E110	1125	1110	00	110000	Pre K Aide Salary	0.00	0.00	15,018.61	0.00	0.00	-15,018.61
10E510	1125	1110	00	510000	Pre K Aide Salary	176,791.00	13,606.32	100,313.72	0.00	0.00	76,477.28
10E510	1125	1200	00	510000	Pre K Sub Teach Salary	5,206.00	145.00	2,260.00	0.00	0.00	2,946.00
10E110	1125	1210	00	110000	Pre K Sub Aide Salary	2,000.00	0.00	57.75	0.00	0.00	1,942.25
10E510	1125	1210	00	510000	Pre K Sub Aide Salary	3,940.00	231.00	1,328.25	0.00	0.00	2,611.75
10E---	1125	1---	--	-----		466,586.00	36,476.52	272,378.66	0.00	0.00	194,207.34
10E110	1125	2110	00	110000	Pre K TRS	6,100.00	0.00	1,045.32	0.00	0.00	5,054.68
10E510	1125	2110	00	510000	Pre K TRS	22,446.00	2,292.60	15,759.38	0.00	0.00	6,686.62
10E110	1125	2200	00	110000	Pre K Ins Ben	75,000.00	0.00	4,048.14	0.00	0.00	70,951.86
10E510	1125	2200	00	510000	Pre K Ins Ben	12,000.00	7,883.34	46,947.88	0.00	0.00	-34,947.88
10E---	1125	2---	--	-----		115,546.00	10,175.94	67,800.72	0.00	0.00	47,745.28
10E510	1125	3190	00	510000	Pre K Pur Serv	1,990.00	0.00	1,990.00	0.00	0.00	0.00
10E---	1125	3---	--	-----		1,990.00	0.00	1,990.00	0.00	0.00	0.00
10E510	1125	4100	00	510000	Pre K Supplies	2,000.00	0.00	684.99	0.00	0.00	1,315.01
10E---	1125	4---	--	-----		2,000.00	0.00	684.99	0.00	0.00	1,315.01
10E050	1130	1100	00	000000	RCHS Teacher Salary	1,880,827.00	133,582.94	1,196,922.09	0.00	0.00	683,904.91
10E050	1130	1110	00	000000	RCHS Aide/Asst Sal	77,126.00	3,412.90	20,603.85	0.00	0.00	56,522.15
10E050	1130	1200	00	000000	RCHS Sub Teach Sal	16,564.00	3,175.00	26,542.38	0.00	0.00	-9,978.38
10E050	1130	1210	00	000000	RCHS Sub Aide/Asst Sal	0.00	33.00	99.00	0.00	0.00	-99.00
10E---	1130	1---	--	-----		1,974,517.00	140,203.84	1,244,167.32	0.00	0.00	730,349.68
10E050	1130	2110	00	000000	RCHS Teach TRS	202,968.00	15,123.10	155,699.41	0.00	0.00	47,268.59
10E050	1130	2200	00	000000	RCHS Ins Benefit	245,000.00	20,101.00	154,077.49	0.00	0.00	90,922.51

Account Level				2025-26	February 2025-26	2025-26	2025-26	Encumbered	2025-26	
FDTLOC	FUNC	OBJ	SJ	Description	Budget	Monthly Activity	FYTD Activity	Batch Activity	Amount	Available Funds
10E050	1130	2300	00 000000	RDHS Tuition Reimbursement	10,000.00	0.00	0.00	1,620.00	0.00	8,380.00
10E---	1130	2---	-- -----		457,968.00	35,224.10	309,776.90	1,620.00	0.00	146,571.10
10E050	1130	3190	00 000000	RDHS Purchase Serv	28,200.00	956.63	41,067.88	0.00	0.00	-12,867.88
10E050	1130	3190	06 000000	RDHS Foreign Lang P/S	2,100.00	0.00	1,550.35	0.00	0.00	549.65
10E050	1130	3190	11 000000	HS Math Purchased Services	2,000.00	0.00	486.17	0.00	0.00	1,513.83
10E050	1130	3190	12 000000	RDHS Vocal Music Pur Ser	1,800.00	0.00	650.00	0.00	460.00	690.00
10E050	1130	3190	13 000000	RDHS Science Pur Serv	11,000.00	0.00	4.56	0.00	0.00	10,995.44
10E050	1130	3190	60 000000	RDHS Ren Scholarship	1,000.00	0.00	0.00	0.00	0.00	1,000.00
10E050	1130	3190	80 000000	RDHS Instr Music Pur Ser	8,065.00	0.00	6,656.62	0.00	500.00	908.38
10E050	1130	3230	00 000000	RDHS Repair/Maint	750.00	0.00	0.00	0.00	0.00	750.00
10E050	1130	3230	13 000000	RDHS Science Rep/Maint	500.00	0.00	0.00	0.00	0.00	500.00
10E050	1130	3230	61 000000	RDHS Computer Rep/Maint	2,000.00	0.00	0.00	0.00	994.50	1,005.50
10E050	1130	3230	80 000000	RDHS Instr Mus Rep/Maint	4,090.00	94.00	3,924.00	0.00	256.00	-90.00
10E050	1130	3320	00 000000	RDHS Travel	1,000.00	203.00	203.00	0.00	468.77	328.23
10E050	1130	3320	12 000000	RDHS Vocal Travel	200.00	0.00	0.00	0.00	0.00	200.00
10E050	1130	3320	80 000000	RDHS Band Travel	1,600.00	0.00	1,493.59	0.00	0.00	106.41
10E---	1130	3---	-- -----		64,305.00	1,253.63	56,036.17	0.00	2,679.27	5,589.56
10E050	1130	4100	00 000000	RDHS Gen Clsrm Supplies	2,100.00	0.00	2,210.44	0.00	1,789.18	-1,899.62
10E050	1130	4100	02 000000	RDHS Art Supplies	5,400.00	1,138.43	3,712.06	411.72	1,322.83	-46.61
10E050	1130	4100	04 000000	RDHS Yearbook Supplies	1,500.00	0.00	0.00	0.00	0.00	1,500.00
10E050	1130	4100	05 000000	RDHS Drama	800.00	162.52	162.52	0.00	6.14	631.34
10E050	1130	4100	06 000000	RDHS Foreign Lang Supp	250.00	0.00	263.51	0.00	0.00	-13.51
10E050	1130	4100	08 000000	RDHS Health Supplies	250.00	0.00	0.00	0.00	0.00	250.00
10E050	1130	4100	11 000000	RDHS Math Supplies	12,000.00	0.00	11,835.46	0.00	24.68	139.86
10E050	1130	4100	12 000000	RDHS Vocal Music Supp	1,200.00	0.00	966.69	0.00	33.31	200.00
10E050	1130	4100	13 000000	RDHS Science Supplies	6,350.00	2,347.68	3,396.08	0.00	0.00	2,953.92
10E050	1130	4100	15 000000	RDHS Social Studies Supp	1,215.00	0.00	683.44	0.00	0.00	531.56
10E050	1130	4100	28 000000	RDHS Communications Supp	810.00	0.00	0.00	0.00	667.51	142.49
10E050	1130	4100	50 000000	RDHS PE Supplies	3,000.00	306.38	452.60	0.00	0.00	2,547.40
10E050	1130	4100	60 000000	RDHS Renaissance Supp	3,500.00	0.00	0.00	0.00	0.00	3,500.00
10E050	1130	4100	61 000000	RDHS Computer Supplies	5,000.00	253.03	3,553.11	0.00	0.00	1,446.89
10E050	1130	4100	80 000000	RDHS Instrum Music Supp	3,845.00	1,043.90	2,975.45	0.00	545.97	323.58
10E050	1130	4200	00 000000	RDHS New Textbooks	30,000.00	0.00	29,477.41	0.00	0.00	522.59
10E050	1130	4240	00 000000	RDHS Copier Paper/Toner	9,500.00	0.00	10,025.25	0.00	0.00	-525.25
10E050	1130	4700	00 000000	RDHS Software	1,000.00	0.00	0.00	0.00	0.00	1,000.00
10E050	1130	4910	00 000000	RDHS PE Uniforms	7,000.00	0.00	6,093.00	0.00	0.00	907.00
10E---	1130	4---	-- -----		94,720.00	5,251.94	75,807.02	411.72	4,389.62	14,111.64
10E050	1130	5500	00 000000	RDHS Equipment	15,000.00	0.00	500,698.96	0.00	0.00	-485,698.96
10E050	1130	5500	02 000000	RDHS Art Equipment	2,500.00	0.00	0.00	0.00	0.00	2,500.00
10E050	1130	5500	61 000000	RDHS Computer Equipment	2,000.00	0.00	0.00	0.00	0.00	2,000.00

Account Level					2025-26	February 2025-26	2025-26	2025-26	Encumbered	2025-26	
FDTLOC	FUNC	OBJ	SJ	Description	Budget	Monthly Activity	FYTD Activity	Batch Activity	Amount	Available Funds	
10E050	1130	5500	80	000000	RCHS Instru Music Equipment	5,080.00	0.00	540.00	0.00	4,184.86	355.14
10E---	1130	5---	--	-----		24,580.00	0.00	501,238.96	0.00	4,184.86	-480,843.82
10E045	1145	1100	00	000000	RISE UP Certified Salary	114,109.00	8,424.24	56,721.04	0.00	0.00	57,387.96
10E045	1145	1110	00	000000	RISE Up Support Staff Salary	46,884.00	51.88	247.12	0.00	0.00	46,636.88
10E045	1145	1200	00	000000		0.00	0.00	270.00	0.00	0.00	-270.00
10E045	1145	1210	00	000000	Rise Up Non Cert Subs Salary	0.00	0.00	553.25	0.00	0.00	-553.25
10E---	1145	1---	--	-----		160,993.00	8,476.12	57,791.41	0.00	0.00	103,201.59
10E045	1145	2110	00	000000	RISE UP Teacher TRS	12,853.00	948.88	5,898.87	0.00	0.00	6,954.13
10E045	1145	2200	00	000000		0.00	860.00	8,004.56	0.00	0.00	-8,004.56
10E---	1145	2---	--	-----		12,853.00	1,808.88	13,903.43	0.00	0.00	-1,050.43
10E045	1145	3190	00	000000	Rise Up Purchased Services	3,000.00	0.00	0.00	0.00	0.00	3,000.00
10E045	1145	3320	00	000000	RISE UP Travel	2,500.00	44.29	128.56	63.89	0.00	2,307.55
10E---	1145	3---	--	-----		5,500.00	44.29	128.56	63.89	0.00	5,307.55
10E045	1145	4100	00	000000	Rise Up Supplies	6,500.00	400.47	2,528.55	0.00	961.73	3,009.72
10E---	1145	4---	--	-----		6,500.00	400.47	2,528.55	0.00	961.73	3,009.72
10E045	1145	5500	00	000000	Rise Up Equipment	6,500.00	0.00	4,917.00	0.00	0.00	1,583.00
10E---	1145	5---	--	-----		6,500.00	0.00	4,917.00	0.00	0.00	1,583.00
10E330	1170	1100	00	330000	Title II Teach Qual Salary	80,000.00	0.00	15,087.85	0.00	0.00	64,912.15
10E530	1170	1100	00	530000	Title II Teach Sal	69,043.00	6,361.40	40,883.76	0.00	0.00	28,159.24
10E---	1170	1---	--	-----		149,043.00	6,361.40	55,971.61	0.00	0.00	93,071.39
10E330	1170	2110	00	330000	Title II Teach Qual TRS	18,000.00	0.00	3,413.53	0.00	0.00	14,586.47
10E530	1170	2110	00	530000	Title II Teach TRS	5,000.00	716.52	4,605.01	0.00	0.00	394.99
10E530	1170	2200	00	530000	Title II Ins Ben	6,884.00	430.00	430.00	0.00	0.00	6,454.00
10E---	1170	2---	--	-----		29,884.00	1,146.52	8,448.54	0.00	0.00	21,435.46
10E710	1180	4100	00	710000	Elementary Career Supplies	5,337.00	0.00	12,739.91	0.00	996.20	-8,399.11
10E---	1180	4---	--	-----		5,337.00	0.00	12,739.91	0.00	996.20	-8,399.11
10E140	1200	1100	00	140000	Special Ed IEP Salaries	4,080.00	717.75	2,499.75	0.00	0.00	1,580.25
10E---	1200	1---	--	-----		4,080.00	717.75	2,499.75	0.00	0.00	1,580.25
10E140	1200	2110	00	140000		0.00	80.87	281.51	0.00	0.00	-281.51
10E---	1200	2---	--	-----		0.00	80.87	281.51	0.00	0.00	-281.51
10E140	1204	1110	00	140000	Prsnl Aide/Asst Sal	289,460.00	12,078.65	136,083.51	0.00	0.00	153,376.49
10E140	1204	1210	00	140000	Prsnl Aide/Ast Sub Sal	34,932.00	346.50	2,772.50	0.00	0.00	32,159.50
10E---	1204	1---	--	-----		324,392.00	12,425.15	138,856.01	0.00	0.00	185,535.99
10E140	1204	2110	00	140000	Prsnl Aide/Ast TRS	0.00	0.00	5.07	0.00	0.00	-5.07
10E140	1204	2200	00	140000	Prsnl Aide/Ast Ins Ben	55,000.00	0.00	6,615.40	0.00	0.00	48,384.60
10E---	1204	2---	--	-----		55,000.00	0.00	6,620.47	0.00	0.00	48,379.53
10E920	1204	4100	00	920000	Ind Supp 504 status	500.00	0.00	454.99	0.00	0.00	45.01
10E---	1204	4---	--	-----		500.00	0.00	454.99	0.00	0.00	45.01
10E920	1204	5500	00	920000	Ind Equip 504 Status	1,000.00	0.00	28.83	0.00	0.00	971.17
10E---	1204	5---	--	-----		1,000.00	0.00	28.83	0.00	0.00	971.17

103

Account Level				2025-26	February 2025-26	2025-26	2025-26	Encumbered	2025-26		
FDTLOC	FUNC	OBJ	SJ	Description	Budget	Monthly Activity	FYTD Activity	Batch Activity	Amount	Available Funds	
10E140	1205	1100	00	140000	LD Teacher Sal	305,533.00	16,563.90	161,282.53	0.00	0.00	144,250.47
10E140	1205	1200	00	140000	LD Sub Teacher Sal	18,700.00	145.00	2,865.00	0.00	0.00	15,835.00
10E140	1205	1300	00	140000	Late Stay Salaries	5,167.00	247.36	2,296.02	0.00	0.00	2,870.98
10E---	1205	1---	--	-----		329,400.00	16,956.26	166,443.55	0.00	0.00	162,956.45
10E140	1205	2110	00	140000	LD Teacher TRS	34,414.00	1,865.70	18,524.29	0.00	0.00	15,889.71
10E140	1205	2200	00	140000	LD Insurance Ben	31,000.00	1,720.00	25,138.28	0.00	0.00	5,861.72
10E---	1205	2---	--	-----		65,414.00	3,585.70	43,662.57	0.00	0.00	21,751.43
10E920	1205	3190	00	920000	LD Speaker Fee	3,000.00	0.00	2,100.00	0.00	800.00	100.00
10E920	1205	3320	00	920000	LD Travel	625.00	0.00	0.00	0.00	0.00	625.00
10E---	1205	3---	--	-----		3,625.00	0.00	2,100.00	0.00	800.00	725.00
10E920	1205	4100	00	920000	LD Self Cont Supp	500.00	0.00	111.02	0.00	0.00	388.98
10E920	1205	4110	00	920000	LD Inclusion Supplies	1,000.00	0.00	122.74	0.00	0.00	877.26
10E---	1205	4---	--	-----		1,500.00	0.00	233.76	0.00	0.00	1,266.24
10E140	1206	1110	00	140000	Visually Imaired Non Cert Sal	0.00	0.00	1,585.25	0.00	0.00	-1,585.25
10E140	1206	1200	00	140000		0.00	0.00	250.50	0.00	0.00	-250.50
10E140	1206	1210	00	140000		0.00	0.00	231.00	0.00	0.00	-231.00
10E---	1206	1---	--	-----		0.00	0.00	2,066.75	0.00	0.00	-2,066.75
10E140	1206	2110	00	140000		0.00	0.00	1.69	0.00	0.00	-1.69
10E---	1206	2---	--	-----		0.00	0.00	1.69	0.00	0.00	-1.69
10E920	1206	3190	00	920000	Visually Impaired Purch Serv	150.00	0.00	0.00	0.00	0.00	150.00
10E---	1206	3---	--	-----		150.00	0.00	0.00	0.00	0.00	150.00
10E920	1206	4100	00	920000	Visual Imp Supplies	500.00	0.00	0.00	0.00	0.00	500.00
10E---	1206	4---	--	-----		500.00	0.00	0.00	0.00	0.00	500.00
10E920	1207	3230	00	920000	Hearing Imprd Rep/Maint	500.00	0.00	0.00	0.00	0.00	500.00
10E---	1207	3---	--	-----		500.00	0.00	0.00	0.00	0.00	500.00
10E920	1207	4100	00	920000	Hearing Imprd Supplies	500.00	0.00	0.00	0.00	0.00	500.00
10E---	1207	4---	--	-----		500.00	0.00	0.00	0.00	0.00	500.00
10E920	1207	5500	00	920000	Hearing Equipment	3,000.00	0.00	615.09	0.00	0.00	2,384.91
10E---	1207	5---	--	-----		3,000.00	0.00	615.09	0.00	0.00	2,384.91
10E920	1212	4100	00	920000	RCHS ED Supp	300.00	0.00	0.00	0.00	0.00	300.00
10E---	1212	4---	--	-----		300.00	0.00	0.00	0.00	0.00	300.00
10E280	1213	1100	00	280000	Homebound Teach Sal	19,965.00	1,287.00	5,445.00	0.00	0.00	14,520.00
10E280	1213	1200	00	280000		263.00	0.00	0.00	0.00	0.00	263.00
10E---	1213	1---	--	-----		20,228.00	1,287.00	5,445.00	0.00	0.00	14,783.00
10E280	1213	2110	00	280000	Homebound Teach TRS	2,500.00	122.65	457.17	0.00	0.00	2,042.83
10E---	1213	2---	--	-----		2,500.00	122.65	457.17	0.00	0.00	2,042.83
10E920	1213	3320	00	920000	Homebound Travel	1,000.00	0.00	0.00	0.00	0.00	1,000.00
10E---	1213	3---	--	-----		1,000.00	0.00	0.00	0.00	0.00	1,000.00
10E280	1216	1110	00	280000	Autism Aide Sal	25,000.00	-136.42	4,211.00	0.00	0.00	20,789.00
10E280	1216	1200	00	280000	Autism Sub Salary	112.00	0.00	0.00	0.00	0.00	112.00

FDTLOC	FUNC	OBJ	SJ	Account Level	2025-26	February 2025-26	2025-26	2025-26	Encumbered	2025-26
				Description	Budget	Monthly Activity	FYTD Activity	Batch Activity	Amount	Available Funds
10E280	1216	1210	00	280000	Autism Sub Aide Sal	458.00	0.00	0.00	0.00	458.00
10E---	1216	1---	--	-----	25,570.00	-136.42	4,211.00	0.00	0.00	21,359.00
10E920	1216	3190	00	920000	Autism Purchase Serv	750.00	0.00	0.00	450.00	300.00
10E---	1216	3---	--	-----	750.00	0.00	0.00	0.00	450.00	300.00
10E920	1216	4100	00	920000	Autism Supplies	1,000.00	99.79	119.06	0.00	880.94
10E---	1216	4---	--	-----	1,000.00	99.79	119.06	0.00	0.00	880.94
10E920	1216	5500	00	920000	Autism Equipment	1,000.00	0.00	0.00	0.00	1,000.00
10E---	1216	5---	--	-----	1,000.00	0.00	0.00	0.00	0.00	1,000.00
10E140	1220	1100	00	140000	Cross Cat Teacher Sal	690,615.00	57,756.79	483,667.89	0.00	206,947.11
10E140	1220	1110	00	140000	Cross Cat Aide/Asst Sal	159,512.00	9,060.27	89,095.41	0.00	70,416.59
10E140	1220	1200	00	140000	Cross Cat Sub Teach Sal	9,518.00	1,712.50	18,201.82	0.00	-8,683.82
10E140	1220	1210	00	140000	Cross Cat Sub Aide/Asst Sal	3,704.00	57.75	981.75	0.00	2,722.25
10E---	1220	1---	--	-----	863,349.00	68,587.31	591,946.87	0.00	0.00	271,402.13
10E140	1220	2110	00	140000	Cross Cat Teacher TRS	73,303.00	6,522.40	54,637.81	0.00	18,665.19
10E140	1220	2200	00	140000	Cross Cat Insurance Ben	130,000.00	8,980.00	82,996.23	0.00	47,003.77
10E---	1220	2---	--	-----	203,303.00	15,502.40	137,634.04	0.00	0.00	65,668.96
10E920	1220	3190	00	920000	Cross Cat PUR SERV	1,000.00	0.00	168.00	500.00	332.00
10E920	1220	3320	00	920000	Cross Cat Travel	800.00	0.00	0.00	0.00	800.00
10E---	1220	3---	--	-----	1,800.00	0.00	168.00	0.00	500.00	1,132.00
10E920	1220	4100	00	920000	Cross Cat Supplies	5,000.00	94.75	2,221.56	0.00	457.80
10E920	1220	4100	61	000000	Cross Cat Comp Supp	500.00	0.00	0.00	0.00	500.00
10E920	1220	4200	00	920000	Cross Cat Textbks	2,500.00	0.00	1,241.40	0.00	1,258.60
10E---	1220	4---	--	-----	8,000.00	94.75	3,462.96	0.00	457.80	4,079.24
10E100	1250	1100	00	100000	Title I Teacher Sal	75,000.00	0.00	3,554.82	0.00	71,445.18
10E500	1250	1100	00	500000	Title I Teach Sal Prior	260,432.00	3,787.00	24,615.47	0.00	235,816.53
10E100	1250	1110	00	100000	Title I Aide/Asst Sal	80,000.00	0.00	73,360.46	0.00	6,639.54
10E500	1250	1110	00	500000	Title I Aide/Asst Sal Pr	281,680.00	30,162.43	210,749.42	0.00	70,930.58
10E100	1250	1300	00	100000	Title I Tutoring Sal	8,250.00	0.00	6,225.76	0.00	2,024.24
10E500	1250	1300	00	500000	Title I Tutor Sal	32,102.00	585.75	2,796.75	0.00	29,305.25
10E100	1250	1310	00	100000	Title I N/C Tutoring	1,000.00	0.00	2,814.20	0.00	-1,814.20
10E500	1250	1310	00	500000	Title I Tutor Aide Sal	3,827.00	0.00	0.00	0.00	3,827.00
10E---	1250	1---	--	-----	742,291.00	34,535.18	324,116.88	0.00	0.00	418,174.12
10E100	1250	2110	00	100000	Title I Teacher TRS	16,000.00	0.00	3,442.87	0.00	12,557.13
10E500	1250	2110	00	500000	Title I TRS	73,351.00	979.95	6,192.35	0.00	67,158.65
10E100	1250	2200	00	100000	Title I Insurance Ben	51,500.00	0.00	5,953.80	0.00	45,546.20
10E500	1250	2200	00	500000	Title I Ins Ben Prior	0.00	1,977.55	20,123.28	0.00	-20,123.28
10E---	1250	2---	--	-----	140,851.00	2,957.50	35,712.30	0.00	0.00	105,138.70
10E100	1250	3190	00	100000	Title I Pur Serv	0.00	0.00	36,052.00	0.00	-36,052.00
10E170	1250	3190	00	170000	Title IV P/S for students	0.00	10,000.00	10,000.00	0.00	-10,000.00
10E500	1250	3190	00	500000	Title I Pur Serv	55,000.00	6,000.00	14,650.52	0.00	40,349.48

Account Level				2025-26	February 2025-26	2025-26	2025-26	Encumbered	2025-26	
FDTLOC	FUNC	OBJ	SJ	Description	Budget	Monthly Activity	FYTD Activity	Batch Activity	Amount	Available Funds
10E---	1250	3---	--	-----	55,000.00	16,000.00	60,702.52	0.00	0.00	-5,702.52
10E100	1250	4100	00	100000	Title I Supplies	15,000.00	0.00	7,588.15	0.00	7,411.85
10E170	1250	4100	00	170000	Title IV Deprived Supplies	0.00	56.20	1,156.20	0.00	-1,156.20
10E500	1250	4100	00	500000	Title I Supp	17,000.00	0.00	4,820.38	0.00	849.99
10E---	1250	4---	--	-----	32,000.00	56.20	13,564.73	0.00	849.99	17,585.28
10E500	1250	5500	00	500000	Title I Equipment	0.00	0.00	5,824.00	2,912.00	0.00
10E---	1250	5---	--	-----	0.00	0.00	5,824.00	2,912.00	0.00	-8,736.00
10E050	1400	1100	00	000000	RCBS Voc Teach Sal	538,499.00	26,554.14	352,237.78	0.00	0.00
10E390	1400	1100	00	390000	Vocational Tutor-Perki Sal	6,205.00	33.00	660.00	0.00	0.00
10E480	1400	1100	00	480000	Ag 3 Circles	26,867.00	1,665.36	15,698.19	0.00	0.00
10E780	1400	1100	00	780000	CTEI SALARIES	5,000.00	0.00	20,691.53	0.00	0.00
10E782	1400	1100	00	000782	METT CERT SALARY	0.00	15,000.00	15,000.00	0.00	0.00
10E050	1400	1200	00	000000	RCBS Voc Sub Teach Sal	12,000.00	1,525.00	13,042.50	0.00	0.00
10E780	1400	1200	00	780000		0.00	0.00	135.00	0.00	0.00
10E---	1400	1---	--	-----	588,571.00	44,777.50	417,465.00	0.00	0.00	171,106.00
10E050	1400	2110	00	000000	RCBS Voc TRS	60,654.00	4,692.42	44,771.06	0.00	0.00
10E390	1400	2110	00	390000	Perkins TRS	705.00	3.71	108.59	0.00	0.00
10E480	1400	2110	00	480000	Ag 3 Circles TRS	3,026.00	187.56	1,768.09	0.00	0.00
10E780	1400	2110	00	780000		0.00	-0.01	2,332.28	0.00	0.00
10E050	1400	2200	00	000000	RCBS Voc Ins Benefit	75,000.00	5,260.00	46,881.48	0.00	0.00
10E---	1400	2---	--	-----	139,385.00	10,143.68	95,861.50	0.00	0.00	43,523.50
10E050	1400	3140	00	000000	RCBS OCC Dual Credit Classes	65,000.00	0.00	50,928.00	0.00	0.00
10E050	1400	3190	01	000000	RCBS Ag Entry Fees	7,000.00	330.00	5,008.00	0.00	624.00
10E390	1400	3190	00	390000	Perkins Pur Serv	13,320.00	0.00	12,751.00	0.00	0.00
10E780	1400	3190	00	780000	CTEI Pur Serv	14,952.00	995.88	14,189.88	0.00	0.00
10E050	1400	3230	00	000000	RCBS Gen Voc Rep/Maint	1,500.00	0.00	0.00	0.00	0.00
10E050	1400	3230	01	000000	RCBS Ag Repair/Maint	100.00	0.00	0.00	0.00	0.00
10E050	1400	3320	01	000000	RCBS Ag Travel	3,650.00	0.00	2,349.87	84.12	1,075.45
10E780	1400	3320	00	780000	CTEI Travel	4,100.00	198.12	2,085.36	0.00	0.00
10E---	1400	3---	--	-----	109,622.00	1,524.00	87,312.11	84.12	1,699.45	20,526.32
10E050	1400	4100	01	000000	RCBS Ag Supplies	12,000.00	531.24	5,453.10	0.00	1,978.86
10E050	1400	4100	07	000000	RCBS Health Occ Supplies	500.00	0.00	75.98	0.00	0.00
10E050	1400	4100	09	000000	RCBS FCS SUPPLIES	6,480.00	0.00	326.00	0.00	118.76
10E050	1400	4100	10	000000	RCBS Ind Occ Supplies	0.00	170.07	170.07	0.00	213.80
10E050	1400	4100	14	000000	RCBS Business Supplies	1,000.00	0.00	195.17	0.00	0.00
10E050	1400	4100	61	000000	RCBS Computer Lab Supp	2,500.00	314.10	2,088.88	0.00	248.40
10E390	1400	4100	00	390000	Perkins Grant Supp	1,680.00	0.00	0.00	0.00	0.00
10E490	1400	4100	00	490000	RCBS AG Grant Supplies	2,000.00	0.00	3,132.76	0.00	7.53
10E780	1400	4100	00	780000	CTEI Supplies	35,506.00	1,168.26	23,004.10	0.00	2,148.92
10E782	1400	4100	00	000782	METT Supplies	5,000.00	179.58	3,793.09	0.00	244.22

Account Level				2025-26	February 2025-26	2025-26	2025-26	Encumbered	2025-26		
FDTLOC	FUNC	OBJ	SJ	Description	Budget	Monthly Activity	FYTD Activity	Batch Activity	Amount	Available Funds	
10E050	1400	4200	00	000000	RCHS Textbooks	90,000.00	0.00	805.73	0.00	486.00	88,708.27
10E780	1400	4700	00	780000	CTEI Software	4,389.00	0.00	614.25	0.00	0.00	3,774.75
10E782	1400	4700	00	000782	METT Software	5,000.00	0.00	0.00	0.00	0.00	5,000.00
10E---	1400	4---	--	-----		166,055.00	2,363.25	39,659.13	0.00	5,446.49	120,949.38
10E050	1400	5500	01	000000	RCHS Ag Equipment	3,000.00	0.00	539.59	0.00	0.00	2,460.41
10E050	1400	5500	14	000000	RCHS Voc Busns Equip	500.00	0.00	0.00	0.00	0.00	500.00
10E490	1400	5500	00	490000	Ag Grant Equip	3,000.00	0.00	0.00	0.00	0.00	3,000.00
10E780	1400	5500	00	780000	CTEI Equipment	40,962.00	2,420.25	34,454.85	-37.99	0.00	6,545.14
10E782	1400	5500	00	000782	METT Equipment	35,000.00	0.00	14,556.09	0.00	0.00	20,443.91
10E---	1400	5---	--	-----		82,462.00	2,420.25	49,550.53	-37.99	0.00	32,949.46
10E050	1400	6400	00	000000	RCHS Dues/Fees	3,000.00	2,404.02	2,404.02	0.00	0.00	595.98
10E050	1400	6410	00	000000	RCHS Voc Reg Del Match Fee	3,000.00	0.00	0.00	0.00	0.00	3,000.00
10E---	1400	6---	--	-----		6,000.00	2,404.02	2,404.02	0.00	0.00	3,595.98
10E410	1459	1110	00	410000	JROTC Instructor Sal	210,967.00	13,226.20	108,896.62	0.00	0.00	102,070.38
10E---	1459	1---	--	-----		210,967.00	13,226.20	108,896.62	0.00	0.00	102,070.38
10E050	1500	1100	00	000000	RCHS A D Sal	58,420.00	4,384.68	40,895.49	0.00	0.00	17,524.51
10E---	1500	1---	--	-----		58,420.00	4,384.68	40,895.49	0.00	0.00	17,524.51
10E050	1500	2110	00	000000	RCHS A D TRS	6,420.00	493.86	7,125.53	0.00	0.00	-705.53
10E050	1500	2200	00	000000		0.00	516.00	3,850.10	0.00	0.00	-3,850.10
10E---	1500	2---	--	-----		6,420.00	1,009.86	10,975.63	0.00	0.00	-4,555.63
10E050	1500	3190	00	000000	RCHS AD Purchased Services	20,000.00	0.00	16,796.00	0.00	0.00	3,204.00
10E050	1500	3230	00	000000	RCHS A D Rep/Maint	600.00	0.00	198.85	0.00	0.00	401.15
10E050	1500	3260	00	000000	RCHS A D Postage	100.00	0.00	11.50	0.00	7.30	81.20
10E050	1500	3320	00	000000	RCHS A D Travel	900.00	0.00	0.00	0.00	0.00	900.00
10E050	1500	3910	00	000000	RCHS A D Playoffs	8,000.00	388.40	1,962.51	0.00	0.00	6,037.49
10E---	1500	3---	--	-----		29,600.00	388.40	18,968.86	0.00	7.30	10,623.84
10E050	1500	4100	00	000000	RCHS A D Supplies	1,500.00	0.00	1,006.99	0.00	260.50	232.51
10E050	1500	4110	00	000000	RCHS A D Awards	3,000.00	0.00	800.00	0.00	8.00	2,192.00
10E050	1500	4120	00	000000	RCHS Sport uniforms	12,000.00	0.00	4,814.46	0.00	2,303.38	4,882.16
10E---	1500	4---	--	-----		16,500.00	0.00	6,621.45	0.00	2,571.88	7,306.67
10E050	1500	5500	00	000000	RCHS AD Equipment	6,000.00	0.00	3,742.40	0.00	0.00	2,257.60
10E---	1500	5---	--	-----		6,000.00	0.00	3,742.40	0.00	0.00	2,257.60
10E050	1500	6400	00	000000	RCHS A D Dues/Fees	150.00	0.00	156.00	0.00	0.00	-6.00
10E---	1500	6---	--	-----		150.00	0.00	156.00	0.00	0.00	-6.00
10E050	1505	1100	00	000000	RCHS FBLA Sponsor Sal	3,358.00	258.40	2,288.96	0.00	0.00	1,069.04
10E---	1505	1---	--	-----		3,358.00	258.40	2,288.96	0.00	0.00	1,069.04
10E050	1505	2110	00	000000	RCHS FBLA Spon TRS	370.00	29.10	257.81	0.00	0.00	112.19
10E---	1505	2---	--	-----		370.00	29.10	257.81	0.00	0.00	112.19
10E050	1509	1100	00	000000	RCHS Pep Club Advisor Sal	1,247.00	96.00	959.88	0.00	0.00	287.12
10E---	1509	1---	--	-----		1,247.00	96.00	959.88	0.00	0.00	287.12

Account Level					2025-26	February 2025-26	2025-26	2025-26	Encumbered	2025-26
FDTLOC	FUNC	OBJ	SJ	Description	Budget	Monthly Activity	FYTD Activity	Batch Activity	Amount	Available Funds
10E050	1509	2110	00 000000	RCHS Pep Club TRS	140.00	10.82	108.15	0.00	0.00	31.85
10E---	1509	2---	--		140.00	10.82	108.15	0.00	0.00	31.85
10E050	1510	1100	00 000000	RCHS Cheerldr Spons Sal	11,432.00	2,549.88	7,649.64	0.00	0.00	3,782.36
10E050	1510	1110	00 000000	RCHS NonCert Cheer Salary	0.00	1,344.99	1,344.99	0.00	0.00	-1,344.99
10E---	1510	1---	--		11,432.00	3,894.87	8,994.63	0.00	0.00	2,437.37
10E050	1510	2110	00 000000	RCHS Cheerldr Spons TRS	450.00	287.21	574.42	0.00	0.00	-124.42
10E---	1510	2---	--		450.00	287.21	574.42	0.00	0.00	-124.42
10E050	1510	3190	00 000000	RCHS Cheerldr Part Exp	750.00	-200.00	675.00	0.00	0.00	75.00
10E---	1510	3---	--		750.00	-200.00	675.00	0.00	0.00	75.00
10E050	1510	4100	00 000000	RCHS Cheerldr Supplies	230.00	0.00	0.00	0.00	0.00	230.00
10E---	1510	4---	--		230.00	0.00	0.00	0.00	0.00	230.00
10E050	1511	1100	00 000000	RCHS Golf Coach Sal	9,166.00	0.00	9,746.69	0.00	0.00	-580.69
10E---	1511	1---	--		9,166.00	0.00	9,746.69	0.00	0.00	-580.69
10E050	1511	2110	00 000000	RCHS Golf Coach TRS	1,050.00	0.00	643.36	0.00	0.00	406.64
10E---	1511	2---	--		1,050.00	0.00	643.36	0.00	0.00	406.64
10E050	1511	3190	00 000000	RCHS Golf Part Exp	2,000.00	0.00	2,032.91	0.00	0.00	-32.91
10E---	1511	3---	--		2,000.00	0.00	2,032.91	0.00	0.00	-32.91
10E050	1511	4100	00 000000	RCHS Golf Supplies	275.00	0.00	242.00	0.00	0.00	33.00
10E---	1511	4---	--		275.00	0.00	242.00	0.00	0.00	33.00
10E050	1512	1100	00 000000	RCHS X-Country Sal	8,609.00	0.00	8,609.09	0.00	0.00	-0.09
10E050	1512	1120	00 000000	RCHS X-Country Workers	63.00	0.00	250.80	0.00	0.00	-187.80
10E---	1512	1---	--		8,672.00	0.00	8,859.89	0.00	0.00	-187.89
10E050	1512	2110	00 000000	RCHS X-Country TRS	915.00	0.00	1,034.82	0.00	0.00	-119.82
10E---	1512	2---	--		915.00	0.00	1,034.82	0.00	0.00	-119.82
10E050	1512	3190	00 000000	RCHS X-Country Part Exp	1,000.00	0.00	987.20	0.00	0.00	12.80
10E---	1512	3---	--		1,000.00	0.00	987.20	0.00	0.00	12.80
10E050	1512	4100	00 000000	RCHS X-Country Supplies	250.00	0.00	0.00	0.00	250.00	0.00
10E---	1512	4---	--		250.00	0.00	0.00	0.00	250.00	0.00
10E050	1514	3190	00 000000	RCHS Girl's Golf Entry Fees	500.00	0.00	705.00	0.00	0.00	-205.00
10E---	1514	3---	--		500.00	0.00	705.00	0.00	0.00	-205.00
10E050	1514	4100	00 000000	RCHS Girl's Golf Supplies	275.00	0.00	0.00	0.00	0.00	275.00
10E---	1514	4---	--		275.00	0.00	0.00	0.00	0.00	275.00
10E050	1520	1100	00 000000	RCHS Girls Tennis Coach	4,082.00	0.00	0.00	0.00	0.00	4,082.00
10E050	1520	1110	00 000000	RCHS NonCert Girl Tennis Coach	0.00	0.00	4,034.97	0.00	0.00	-4,034.97
10E---	1520	1---	--		4,082.00	0.00	4,034.97	0.00	0.00	47.03
10E050	1520	3190	00 000000	RCHS Girls Tennis Part Exp	150.00	0.00	110.00	0.00	0.00	40.00
10E---	1520	3---	--		150.00	0.00	110.00	0.00	0.00	40.00
10E050	1520	4100	00 000000	RCHS Girls Tennis Supplies	225.00	0.00	0.00	0.00	0.00	225.00
10E---	1520	4---	--		225.00	0.00	0.00	0.00	0.00	225.00
10E050	1521	1100	00 000000	RCHS Volleyball1 Coach Salary	22,532.00	0.00	15,596.36	0.00	0.00	6,935.64

Account Level				2025-26	February 2025-26	2025-26	2025-26	Encumbered	2025-26	
FDTLOC	FUNC	OBJ	SJ	Description	Budget	Monthly Activity	FYTD Activity	Batch Activity	Amount	Available Funds
10E050	1521	1110	00	000000	0.00	0.00	65.00	0.00	0.00	-65.00
10E050	1521	1120	00	000000	1,780.00	0.00	1,385.00	0.00	0.00	395.00
10E---	1521	1---	--	-----	24,312.00	0.00	17,046.36	0.00	0.00	7,265.64
10E050	1521	2110	00	000000	850.00	0.00	1,447.56	0.00	0.00	-597.56
10E---	1521	2---	--	-----	850.00	0.00	1,447.56	0.00	0.00	-597.56
10E050	1521	3100	00	000000	1,750.00	0.00	1,440.00	0.00	0.00	310.00
10E050	1521	3190	00	000000	1,250.00	0.00	1,020.00	0.00	0.00	230.00
10E---	1521	3---	--	-----	3,000.00	0.00	2,460.00	0.00	0.00	540.00
10E050	1521	4100	00	000000	700.00	0.00	700.00	0.00	0.00	0.00
10E---	1521	4---	--	-----	700.00	0.00	700.00	0.00	0.00	0.00
10E050	1522	1100	00	000000	16,507.00	18,369.69	18,369.69	0.00	0.00	-1,862.69
10E050	1522	1120	00	000000	1,045.00	785.00	1,500.00	0.00	0.00	-455.00
10E---	1522	1---	--	-----	17,552.00	19,154.69	19,869.69	0.00	0.00	-2,317.69
10E050	1522	2110	00	000000	1,500.00	2,069.11	2,082.05	0.00	0.00	-582.05
10E---	1522	2---	--	-----	1,500.00	2,069.11	2,082.05	0.00	0.00	-582.05
10E050	1522	3100	00	000000	4,000.00	810.00	2,805.00	0.00	0.00	1,195.00
10E050	1522	3190	00	000000	500.00	0.00	175.00	0.00	0.00	325.00
10E---	1522	3---	--	-----	4,500.00	810.00	2,980.00	0.00	0.00	1,520.00
10E050	1522	4100	00	000000	1,275.00	0.00	0.00	0.00	0.00	1,275.00
10E---	1522	4---	--	-----	1,275.00	0.00	0.00	0.00	0.00	1,275.00
10E050	1523	1100	00	000000	8,383.00	0.00	700.00	0.00	0.00	7,683.00
10E050	1523	1120	00	000000	877.00	0.00	40.00	0.00	0.00	837.00
10E---	1523	1---	--	-----	9,260.00	0.00	740.00	0.00	0.00	8,520.00
10E050	1523	2110	00	000000	675.00	0.00	0.00	0.00	0.00	675.00
10E---	1523	2---	--	-----	675.00	0.00	0.00	0.00	0.00	675.00
10E050	1523	3100	00	000000	500.00	0.00	0.00	0.00	0.00	500.00
10E050	1523	3190	00	000000	1,750.00	0.00	150.00	0.00	0.00	1,600.00
10E---	1523	3---	--	-----	2,250.00	0.00	150.00	0.00	0.00	2,100.00
10E050	1523	4100	00	000000	640.00	0.00	0.00	0.00	67.81	572.19
10E---	1523	4---	--	-----	640.00	0.00	0.00	0.00	67.81	572.19
10E050	1524	1100	00	000000	8,434.00	0.00	0.00	0.00	0.00	8,434.00
10E---	1524	1---	--	-----	8,434.00	0.00	0.00	0.00	0.00	8,434.00
10E050	1524	2110	00	000000	1,210.00	0.00	0.00	0.00	0.00	1,210.00
10E---	1524	2---	--	-----	1,210.00	0.00	0.00	0.00	0.00	1,210.00
10E050	1524	3100	00	000000	4,250.00	0.00	0.00	0.00	0.00	4,250.00
10E050	1524	3190	00	000000	1,100.00	0.00	0.00	0.00	0.00	1,100.00
10E---	1524	3---	--	-----	5,350.00	0.00	0.00	0.00	0.00	5,350.00
10E050	1524	4100	00	000000	1,575.00	0.00	0.00	0.00	0.00	1,575.00
10E---	1524	4---	--	-----	1,575.00	0.00	0.00	0.00	0.00	1,575.00
10E050	1525	1100	00	000000	11,152.00	0.00	2,241.65	0.00	0.00	8,910.35

Account Level					2025-26	February 2025-26	2025-26	2025-26	Encumbered	2025-26
FDTLOC	FUNC	OBJ	SJ	Description	Budget	Monthly Activity	FYTD Activity	Batch Activity	Amount	Available Funds
10E050	1525	1120	00 000000	RCHS Girls Soccer Ticket	230.00	0.00	0.00	0.00	0.00	230.00
10E---	1525	1---	--		11,382.00	0.00	2,241.65	0.00	0.00	9,140.35
10E050	1525	3100	00 000000	RCHS Girls Soccer Officl	2,500.00	0.00	0.00	0.00	0.00	2,500.00
10E050	1525	3190	00 000000	RCHS Girls Soccer Part Exp	500.00	0.00	70.00	0.00	0.00	430.00
10E---	1525	3---	--		3,000.00	0.00	70.00	0.00	0.00	2,930.00
10E050	1525	4100	00 000000	RCHS Girls Soccer Supp	900.00	0.00	422.06	0.00	0.00	477.94
10E---	1525	4---	--		900.00	0.00	422.06	0.00	0.00	477.94
10E050	1530	1100	00 000000	RCHS Boys Tennis Coach Sal	4,930.00	0.00	0.00	0.00	0.00	4,930.00
10E---	1530	1---	--		4,930.00	0.00	0.00	0.00	0.00	4,930.00
10E050	1530	3190	00 000000	RCHS Boys Tennis Part Exp	400.00	200.00	200.00	0.00	0.00	200.00
10E---	1530	3---	--		400.00	200.00	200.00	0.00	0.00	200.00
10E050	1530	4100	00 000000	RCHS Boys Tennis Supplies	225.00	0.00	0.00	0.00	0.00	225.00
10E---	1530	4---	--		225.00	0.00	0.00	0.00	0.00	225.00
10E050	1531	1100	00 000000	RCHS Football Coach Sal	22,476.00	0.00	29,422.47	0.00	0.00	-6,946.47
10E050	1531	1120	00 000000	RCHS Football Game Wrks	3,366.00	280.00	4,541.00	0.00	0.00	-1,175.00
10E---	1531	1---	--		25,842.00	280.00	33,963.47	0.00	0.00	-8,121.47
10E050	1531	2110	00 000000	RCHS Football Coach TRS	1,900.00	0.00	1,600.79	0.00	0.00	299.21
10E---	1531	2---	--		1,900.00	0.00	1,600.79	0.00	0.00	299.21
10E050	1531	3100	00 000000	RCHS Football Officials	5,000.00	0.00	4,650.00	0.00	0.00	350.00
10E050	1531	3190	00 000000	RCHS Football Part Exp	500.00	0.00	6,080.25	0.00	0.00	-5,580.25
10E050	1531	3230	00 000000	RCHS Football Recond Equip	6,000.00	0.00	0.00	0.00	0.00	6,000.00
10E---	1531	3---	--		11,500.00	0.00	10,730.25	0.00	0.00	769.75
10E050	1531	4100	00 000000	RCHS Football Supplies	4,800.00	0.00	904.80	0.00	3,335.39	3,209.81
10E---	1531	4---	--		4,800.00	0.00	904.80	0.00	3,335.39	3,209.81
10E050	1531	5500	00 000000	RCHS Football Equipment	17,550.00	0.00	17,519.37	0.00	0.00	30.63
10E---	1531	5---	--		17,550.00	0.00	17,519.37	0.00	0.00	30.63
10E050	1531	7500	00 000000	RCHS Football Non Cap Equip	2,650.00	0.00	0.00	2,650.00	0.00	-2,650.00
10E---	1531	7---	--		2,650.00	0.00	0.00	2,650.00	0.00	-2,650.00
10E050	1532	1100	00 000000	RCHS Boys Basketball Cch Sal	19,747.00	18,755.05	15,308.43	0.00	0.00	4,438.57
10E050	1532	1120	00 000000	RCHS Boys Basketball Wrk Sal	2,599.00	535.00	1,420.00	0.00	0.00	1,179.00
10E---	1532	1---	--		22,346.00	19,290.05	16,728.43	0.00	0.00	5,617.57
10E050	1532	2110	00 000000	RCHS Boys Basketball TRS	1,500.00	0.00	-388.21	0.00	0.00	1,888.21
10E---	1532	2---	--		1,500.00	0.00	-388.21	0.00	0.00	1,888.21
10E050	1532	3100	00 000000	RCHS Boys Basketball Official	4,900.00	1,750.00	3,250.00	0.00	0.00	1,650.00
10E050	1532	3190	00 000000	RCHS Boys Basketball Part Exp	500.00	0.00	0.00	0.00	0.00	500.00
10E---	1532	3---	--		5,400.00	1,750.00	3,250.00	0.00	0.00	2,150.00
10E050	1532	4100	00 000000	RCHS Boys Basketball Supplies	1,275.00	145.00	994.79	0.00	0.00	280.21
10E---	1532	4---	--		1,275.00	145.00	994.79	0.00	0.00	280.21
10E050	1533	1100	00 000000	RCHS Boys Track Coach Sal	9,019.00	0.00	700.00	0.00	0.00	8,319.00
10E050	1533	1110	00 000000	RCHS Boys Track Non Cert Coach	750.00	0.00	-1,576.33	0.00	0.00	2,326.33

Account Level				2025-26	February 2025-26	2025-26	2025-26	Encumbered	2025-26	
FDTLOC	FUNC	OBJ	SJ	Description	Budget	Monthly Activity	FYTD Activity	Batch Activity	Amount	Available Funds
10E---	1533	1---	--	-----	9,769.00	0.00	-876.33	0.00	0.00	10,645.33
10E050	1533	2110	00	000000	1,030.00	0.00	0.00	0.00	0.00	1,030.00
10E---	1533	2---	--	-----	1,030.00	0.00	0.00	0.00	0.00	1,030.00
10E050	1533	3100	00	000000	500.00	0.00	0.00	0.00	0.00	500.00
10E050	1533	3190	00	000000	2,250.00	0.00	150.00	0.00	0.00	2,100.00
10E---	1533	3---	--	-----	2,750.00	0.00	150.00	0.00	0.00	2,600.00
10E050	1533	4100	00	000000	640.00	0.00	0.00	0.00	0.00	640.00
10E---	1533	4---	--	-----	640.00	0.00	0.00	0.00	0.00	640.00
10E050	1534	1100	00	000000	6,567.00	0.00	0.00	0.00	0.00	6,567.00
10E050	1534	1120	00	000000	750.00	0.00	0.00	0.00	0.00	750.00
10E---	1534	1---	--	-----	7,317.00	0.00	0.00	0.00	0.00	7,317.00
10E050	1534	2110	00	000000	760.00	0.00	0.00	0.00	0.00	760.00
10E---	1534	2---	--	-----	760.00	0.00	0.00	0.00	0.00	760.00
10E050	1534	3100	00	000000	3,750.00	0.00	0.00	0.00	0.00	3,750.00
10E050	1534	3190	00	000000	150.00	0.00	0.00	0.00	0.00	150.00
10E---	1534	3---	--	-----	3,900.00	0.00	0.00	0.00	0.00	3,900.00
10E050	1534	4100	00	000000	1,575.00	0.00	0.00	0.00	0.00	1,575.00
10E---	1534	4---	--	-----	1,575.00	0.00	0.00	0.00	0.00	1,575.00
10E050	1536	1100	00	000000	8,776.00	0.00	6,949.12	0.00	0.00	1,826.88
10E---	1536	1---	--	-----	8,776.00	0.00	6,949.12	0.00	0.00	1,826.88
10E050	1536	3100	00	000000	2,500.00	0.00	2,570.00	0.00	0.00	-70.00
10E050	1536	3190	00	000000	500.00	0.00	710.00	0.00	0.00	-210.00
10E---	1536	3---	--	-----	3,000.00	0.00	3,280.00	0.00	0.00	-280.00
10E050	1536	4100	00	000000	900.00	0.00	900.00	0.00	60.75	-60.75
10E---	1536	4---	--	-----	900.00	0.00	900.00	0.00	60.75	-60.75
10E050	1537	1100	00	000000	2,465.00	0.00	0.00	0.00	0.00	2,465.00
10E---	1537	1---	--	-----	2,465.00	0.00	0.00	0.00	0.00	2,465.00
10E050	1537	3190	00	000000	300.00	0.00	0.00	0.00	0.00	300.00
10E---	1537	3---	--	-----	300.00	0.00	0.00	0.00	0.00	300.00
10E040	1540	1100	00	000000	38,000.00	2,923.12	26,308.08	0.00	0.00	11,691.92
10E---	1540	1---	--	-----	38,000.00	2,923.12	26,308.08	0.00	0.00	11,691.92
10E040	1540	2110	00	000000	4,280.00	329.26	2,342.25	0.00	0.00	1,937.75
10E040	1540	2200	00	000000	0.00	344.00	2,766.78	0.00	0.00	-2,766.78
10E---	1540	2---	--	-----	4,280.00	673.26	5,109.03	0.00	0.00	-829.03
10E040	1540	3190	00	000000	250.00	0.00	300.00	0.00	0.00	-50.00
10E040	1540	3320	00	000000	650.00	0.00	0.00	0.00	0.00	650.00
10E040	1540	3910	00	000000	365.00	0.00	245.93	0.00	0.00	119.07
10E---	1540	3---	--	-----	1,265.00	0.00	545.93	0.00	0.00	719.07
10E040	1540	4100	00	000000	355.00	0.00	199.85	0.00	125.00	30.15
10E040	1540	4110	00	000000	1,700.00	54.39	751.64	0.00	630.61	317.75

Account Level				2025-26	February 2025-26	2025-26	2025-26	Encumbered	2025-26	
FDTLOC	FUNC	OBJ	SJ	Description	Budget	Monthly Activity	FYTD Activity	Batch Activity	Amount	Available Funds
10E040	1540	4120	00 000000	RCMS Athletic Uniforms	20,000.00	0.00	7,899.30	0.00	0.00	12,100.70
10E---	1540	4---	--		22,055.00	54.39	8,850.79	0.00	755.61	12,448.60
10E040	1540	6400	00 000000	RCMS A D Dues/Fees	1,200.00	240.00	790.00	0.00	0.00	410.00
10E---	1540	6---	--		1,200.00	240.00	790.00	0.00	0.00	410.00
10E040	1550	1100	00 000000	RCMS Chrlldr Spons Sal	5,604.00	0.00	0.00	0.00	0.00	5,604.00
10E040	1550	1110	00 000000	RCMS Cheer Sponsor Non Cert	5,000.00	0.00	0.00	0.00	0.00	5,000.00
10E---	1550	1---	--		10,604.00	0.00	0.00	0.00	0.00	10,604.00
10E040	1550	4100	00 000000	RCMS Chrlldr Supplies	500.00	0.00	0.00	0.00	0.00	500.00
10E---	1550	4---	--		500.00	0.00	0.00	0.00	0.00	500.00
10E040	1551	1100	00 000000	RCMS X-Country Coach Sal	4,386.00	0.00	5,416.33	0.00	0.00	-1,030.33
10E040	1551	1120	00 000000	RCMS X-Country Wrk Sal	770.00	0.00	0.00	0.00	0.00	770.00
10E---	1551	1---	--		5,156.00	0.00	5,416.33	0.00	0.00	-260.33
10E040	1551	2110	00 000000	RCMS X-Country Coach TRS	510.00	0.00	508.14	0.00	0.00	1.86
10E040	1551	2200	00 000000		0.00	0.00	395.02	0.00	0.00	-395.02
10E---	1551	2---	--		510.00	0.00	903.16	0.00	0.00	-393.16
10E040	1551	3100	00 000000	MS Cross Country Officials	100.00	0.00	382.00	0.00	0.00	-282.00
10E040	1551	3190	00 000000	RCMS X-Country Part Exp	150.00	0.00	485.00	0.00	0.00	-335.00
10E---	1551	3---	--		250.00	0.00	867.00	0.00	0.00	-617.00
10E040	1551	4100	00 000000	RCMS X-Country Supplies	500.00	0.00	500.00	0.00	0.00	0.00
10E---	1551	4---	--		500.00	0.00	500.00	0.00	0.00	0.00
10E040	1552	1100	00 000000	RCMS Baseball Coaches Salary	3,699.00	0.00	2,784.43	0.00	0.00	914.57
10E---	1552	1---	--		3,699.00	0.00	2,784.43	0.00	0.00	914.57
10E040	1552	2110	00 000000	RCMS Baseball Coaches TRS	275.00	0.00	275.72	0.00	0.00	-0.72
10E---	1552	2---	--		275.00	0.00	275.72	0.00	0.00	-0.72
10E040	1552	3100	00 000000	RCMS Baseball Officals	1,500.00	0.00	480.00	0.00	0.00	1,020.00
10E040	1552	3190	00 000000	RCMS Baseball Particip Expense	750.00	0.00	550.00	0.00	0.00	200.00
10E---	1552	3---	--		2,250.00	0.00	1,030.00	0.00	0.00	1,220.00
10E040	1552	4100	00 000000	RCMS Baseball Supplies	1,250.00	0.00	105.90	0.00	500.04	644.06
10E---	1552	4---	--		1,250.00	0.00	105.90	0.00	500.04	644.06
10E040	1552	5500	00 000000	RCMS Baseball Equipment	750.00	0.00	0.00	0.00	0.00	750.00
10E---	1552	5---	--		750.00	0.00	0.00	0.00	0.00	750.00
10E040	1553	1100	00 000000	RCMS Softball Coaches Salary	3,923.00	0.00	4,079.80	0.00	0.00	-156.80
10E---	1553	1---	--		3,923.00	0.00	4,079.80	0.00	0.00	-156.80
10E040	1553	2110	00 000000	RCMS Softball Coaches TRS	320.00	0.00	459.53	0.00	0.00	-139.53
10E040	1553	2200	00 000000		0.00	0.00	940.87	0.00	0.00	-940.87
10E---	1553	2---	--		320.00	0.00	1,400.40	0.00	0.00	-1,080.40
10E040	1553	3100	00 000000	RCMS Softball Officials	1,500.00	0.00	160.00	0.00	0.00	1,340.00
10E040	1553	3190	00 000000	RCMS Softball Particip Expense	750.00	0.00	1,030.00	0.00	0.00	-280.00
10E---	1553	3---	--		2,250.00	0.00	1,190.00	0.00	0.00	1,060.00
10E040	1553	4100	00 000000	RCMS Softball Supplies	1,250.00	0.00	393.25	0.00	0.00	856.75

Account Level				2025-26	February 2025-26	2025-26	2025-26	Encumbered	2025-26	
FDTLOC	FUNC	OBJ	SJ	Description	Budget	Monthly Activity	FYTD Activity	Batch Activity	Amount	Available Funds
10E---	1553	4---	--	-----	1,250.00	0.00	393.25	0.00	0.00	856.75
10E040	1553	5500	00	000000	RCMS Softball Equipment	750.00	0.00	0.00	0.00	750.00
10E---	1553	5---	--	-----	750.00	0.00	0.00	0.00	0.00	750.00
10E040	1560	1100	00	000000	RCMS Girls Basketball Cch Sal	8,070.00	0.00	8,069.94	0.00	0.06
10E040	1560	1120	00	000000	RCMS Girls Basketball Wrks Sal	3,003.00	255.00	1,695.00	0.00	1,308.00
10E---	1560	1---	--	-----	11,073.00	255.00	9,764.94	0.00	0.00	1,308.06
10E040	1560	2110	00	000000	RCMS Girls Basketball Coach TR	420.00	9.57	9.57	0.00	410.43
10E---	1560	2---	--	-----	420.00	9.57	9.57	0.00	0.00	410.43
10E040	1560	3100	00	000000	RCMS Girls Basketball Official	2,500.00	160.00	1,160.00	0.00	1,340.00
10E040	1560	3190	00	000000	RCMS Girls Basketball Part Exp	0.00	0.00	200.00	0.00	-200.00
10E---	1560	3---	--	-----	2,500.00	160.00	1,360.00	0.00	0.00	1,140.00
10E040	1560	4100	00	000000	RCMS Girls Basketball Supplies	1,250.00	0.00	347.00	0.00	903.00
10E---	1560	4---	--	-----	1,250.00	0.00	347.00	0.00	0.00	903.00
10E040	1560	6400	00	000000	RCMS Girls Basktbball Due/Fees	100.00	0.00	0.00	0.00	100.00
10E---	1560	6---	--	-----	100.00	0.00	0.00	0.00	0.00	100.00
10E040	1561	1100	00	000000	RCMS Volleybl Coach Sal	9,606.00	0.00	0.00	0.00	9,606.00
10E040	1561	1120	00	000000	RCMS Volleybl Gm Wrk Sal	767.00	490.00	730.00	0.00	37.00
10E---	1561	1---	--	-----	10,373.00	490.00	730.00	0.00	0.00	9,643.00
10E040	1561	2110	00	000000	RCMS Volleybl Coach TRS	1,800.00	0.00	0.00	0.00	1,800.00
10E---	1561	2---	--	-----	1,800.00	0.00	0.00	0.00	0.00	1,800.00
10E040	1561	3100	00	000000	RCMS Volleybl Officials	1,100.00	0.00	0.00	0.00	1,100.00
10E040	1561	3190	00	000000	RCMS Volleybl Part Exp	700.00	125.00	125.00	0.00	575.00
10E---	1561	3---	--	-----	1,800.00	125.00	125.00	0.00	0.00	1,675.00
10E040	1561	4100	00	000000	RCMS Volleybl Supplies	500.00	465.68	465.68	0.00	34.32
10E---	1561	4---	--	-----	500.00	465.68	465.68	0.00	0.00	34.32
10E040	1562	1100	00	000000	RCMS Grls Trk Coach Sal	3,531.00	0.00	0.00	0.00	3,531.00
10E040	1562	1120	00	000000	RCMS Girls Track Workers	1,084.00	0.00	0.00	0.00	1,084.00
10E---	1562	1---	--	-----	4,615.00	0.00	0.00	0.00	0.00	4,615.00
10E040	1562	2110	00	000000	RCMS Grls Trk Cch TRS	420.00	0.00	0.00	0.00	420.00
10E---	1562	2---	--	-----	420.00	0.00	0.00	0.00	0.00	420.00
10E040	1562	3190	00	000000	RCMS Girls Track Part Exp	400.00	0.00	375.00	0.00	25.00
10E---	1562	3---	--	-----	400.00	0.00	375.00	0.00	0.00	25.00
10E040	1562	4100	00	000000	RCMS Grls Trk Supplies	750.00	0.00	0.00	0.00	750.00
10E---	1562	4---	--	-----	750.00	0.00	0.00	0.00	0.00	750.00
10E040	1563	1100	00	000000	RCMS 6th girls BBall Coach Sal	3,100.00	3,138.31	3,138.31	0.00	-38.31
10E---	1563	1---	--	-----	3,100.00	3,138.31	3,138.31	0.00	0.00	-38.31
10E040	1563	2110	00	000000	RCMS 6th girls BBall Coach TRS	330.00	0.00	0.00	0.00	330.00
10E---	1563	2---	--	-----	330.00	0.00	0.00	0.00	0.00	330.00
10E040	1563	3100	00	000000	RCMS 6th girls BBall Officials	1,000.00	320.00	320.00	0.00	680.00
10E040	1563	3190	00	000000	MS 6th girls BBall Partic Exp	100.00	0.00	0.00	0.00	100.00

Account Level				2025-26	February 2025-26	2025-26	2025-26	Encumbered	2025-26	
FDTLOC	FUNC	OBJ	SJ	Description	Budget	Monthly Activity	FYTD Activity	Batch Activity	Amount	Available Funds
10E---	1563	3---	--	-----	1,100.00	320.00	320.00	0.00	0.00	780.00
10E040	1564	1100	00	000000	RCMS 6th Boys Bb Coach Salary	3,138.00	3,138.31	3,138.31	0.00	-0.31
10E040	1564	1120	00	000000	RCMS 6th Boys Bball workers	84.00	75.00	75.00	0.00	9.00
10E---	1564	1---	--	-----	3,222.00	3,213.31	3,213.31	0.00	0.00	8.69
10E040	1564	3100	00	000000	RCMS 6th Boys Bball Officials	1,000.00	160.00	160.00	0.00	840.00
10E040	1564	3190	00	000000	RCMS 6th Boys Bball Partic Exp	100.00	0.00	0.00	0.00	100.00
10E---	1564	3---	--	-----	1,100.00	160.00	160.00	0.00	0.00	940.00
10E040	1570	1100	00	000000	RCMS Boys Basketball Coach Sal	8,070.00	8,069.94	8,069.94	0.00	0.06
10E040	1570	1120	00	000000	RCMS Boys Basketball Wrk Sal	1,756.00	925.00	2,970.00	0.00	-1,214.00
10E---	1570	1---	--	-----	9,826.00	8,994.94	11,039.94	0.00	0.00	-1,213.94
10E040	1570	2110	00	000000	RCMS Boys Basketball Coach TRS	730.00	5.07	12.95	0.00	717.05
10E---	1570	2---	--	-----	730.00	5.07	12.95	0.00	0.00	717.05
10E040	1570	3100	00	000000	RCMS Boys Basketball Official	2,500.00	855.00	1,815.00	0.00	685.00
10E---	1570	3---	--	-----	2,500.00	855.00	1,815.00	0.00	0.00	685.00
10E040	1570	4100	00	000000	RCMS Boys Basketball Supplies	1,250.00	0.00	322.00	0.00	248.00
10E---	1570	4---	--	-----	1,250.00	0.00	322.00	0.00	248.00	680.00
10E040	1570	6400	00	000000	RCMS Boys Basketball Due/Fees	100.00	0.00	0.00	0.00	100.00
10E---	1570	6---	--	-----	100.00	0.00	0.00	0.00	0.00	100.00
10E040	1571	1100	00	000000	RCMS Boys Track Coach Sal	5,915.00	0.00	0.00	0.00	5,915.00
10E040	1571	1120	00	000000	RCMS Boys Track Workers	717.00	0.00	0.00	0.00	717.00
10E---	1571	1---	--	-----	6,632.00	0.00	0.00	0.00	0.00	6,632.00
10E040	1571	3190	00	000000	RCMS Boys Track Part Exp	400.00	0.00	375.00	0.00	25.00
10E---	1571	3---	--	-----	400.00	0.00	375.00	0.00	0.00	25.00
10E040	1571	4100	00	000000	RCMS Boys Track Supplies	750.00	0.00	0.00	0.00	750.00
10E---	1571	4---	--	-----	750.00	0.00	0.00	0.00	0.00	750.00
10E050	1572	1100	00	000000	RCHS Wrestling Coach	7,846.00	7,845.78	7,845.78	0.00	0.22
10E050	1572	1120	00	000000	RCHS Wrestling Workers Sal	108.00	25.00	100.00	0.00	8.00
10E---	1572	1---	--	-----	7,954.00	7,870.78	7,945.78	0.00	0.00	8.22
10E050	1572	3100	00	000000	RCHS Wrestling Officials	1,400.00	275.00	1,040.00	0.00	360.00
10E050	1572	3190	00	000000	RCHS Wrestling Entry Fees	1,300.00	600.00	1,501.00	0.00	-201.00
10E---	1572	3---	--	-----	2,700.00	875.00	2,541.00	0.00	0.00	159.00
10E050	1572	4100	00	000000	RCHS Wrestling Supp	510.00	0.00	0.00	0.00	510.00
10E---	1572	4---	--	-----	510.00	0.00	0.00	0.00	0.00	510.00
10E040	1575	1100	00	000000	RCMS Yearbook Sponsor Sal	4,158.00	319.90	3,038.50	0.00	1,119.50
10E---	1575	1---	--	-----	4,158.00	319.90	3,038.50	0.00	0.00	1,119.50
10E040	1575	2110	00	000000	RCMS Yearbook Sponsor TRS	425.00	36.04	342.28	0.00	82.72
10E---	1575	2---	--	-----	425.00	36.04	342.28	0.00	0.00	82.72
10E040	1576	1100	00	000000	RCMS Student Council Sp	2,354.00	188.40	1,300.04	0.00	1,053.96
10E---	1576	1---	--	-----	2,354.00	188.40	1,300.04	0.00	0.00	1,053.96
10E040	1576	2110	00	000000	RCMS Student Council TRS	230.00	21.24	151.91	0.00	78.09

Account Level				2025-26	February 2025-26	2025-26	2025-26	Encumbered	2025-26	
FDTLOC	FUNC	OBJ	SJ	Description	Budget	Monthly Activity	FYTD Activity	Batch Activity	Amount	Available Funds
10E040	1576	2200	00	000000	0.00	0.00	13.98	0.00	0.00	-13.98
10E---	1576	2---	--	-----	230.00	21.24	165.89	0.00	0.00	64.11
10E040	1577	1100	00	000000	1,569.00	0.00	0.00	0.00	0.00	1,569.00
10E---	1577	1---	--	-----	1,569.00	0.00	0.00	0.00	0.00	1,569.00
10E040	1577	2110	00	000000	140.00	0.00	0.00	0.00	0.00	140.00
10E---	1577	2---	--	-----	140.00	0.00	0.00	0.00	0.00	140.00
10E050	1580	1100	00	000000	2,401.00	0.00	831.65	0.00	0.00	1,569.35
10E050	1580	1120	00	000000	918.00	0.00	55.00	0.00	0.00	863.00
10E---	1580	1---	--	-----	3,319.00	0.00	886.65	0.00	0.00	2,432.35
10E050	1580	2110	00	000000	365.00	0.00	93.67	0.00	0.00	271.33
10E---	1580	2---	--	-----	365.00	0.00	93.67	0.00	0.00	271.33
10E050	1580	3190	00	000000	0.00	0.00	80.00	0.00	0.00	-80.00
10E---	1580	3---	--	-----	0.00	0.00	80.00	0.00	0.00	-80.00
10E050	1581	1100	00	000000	3,923.00	0.00	0.00	0.00	0.00	3,923.00
10E---	1581	1---	--	-----	3,923.00	0.00	0.00	0.00	0.00	3,923.00
10E050	1581	2110	00	000000	460.00	0.00	0.00	0.00	0.00	460.00
10E---	1581	2---	--	-----	460.00	0.00	0.00	0.00	0.00	460.00
10E050	1582	1100	00	000000	14,066.00	0.00	14,301.77	0.00	0.00	-235.77
10E---	1582	1---	--	-----	14,066.00	0.00	14,301.77	0.00	0.00	-235.77
10E050	1582	2110	00	000000	1,320.00	0.00	1,307.92	0.00	0.00	12.08
10E---	1582	2---	--	-----	1,320.00	0.00	1,307.92	0.00	0.00	12.08
10E050	1582	3190	00	000000	2,200.00	0.00	497.14	0.00	0.00	1,702.86
10E---	1582	3---	--	-----	2,200.00	0.00	497.14	0.00	0.00	1,702.86
10E050	1582	4100	00	000000	300.00	0.00	0.00	0.00	0.00	300.00
10E---	1582	4---	--	-----	300.00	0.00	0.00	0.00	0.00	300.00
10E050	1583	1100	00	000000	23,271.00	1,357.80	12,911.84	0.00	0.00	10,359.16
10E050	1583	1110	00	000000	4,600.00	0.00	2,447.88	0.00	0.00	2,152.12
10E---	1583	1---	--	-----	27,871.00	1,357.80	15,359.72	0.00	0.00	12,511.28
10E050	1583	2110	00	000000	1,542.00	114.10	1,542.41	0.00	0.00	-0.41
10E---	1583	2---	--	-----	1,542.00	114.10	1,542.41	0.00	0.00	-0.41
10E050	1583	3190	00	000000	3,920.00	0.00	3,920.00	0.00	0.00	0.00
10E---	1583	3---	--	-----	3,920.00	0.00	3,920.00	0.00	0.00	0.00
10E010	1583	4100	00	000000	6,000.00	0.00	0.00	6,000.00	0.00	0.00
10E050	1583	4100	00	000000	2,400.00	715.80	1,223.57	0.00	261.30	915.13
10E---	1583	4---	--	-----	8,400.00	715.80	1,223.57	6,000.00	261.30	915.13
10E050	1585	1100	00	000000	8,042.00	645.60	5,646.53	0.00	0.00	2,395.47
10E---	1585	1---	--	-----	8,042.00	645.60	5,646.53	0.00	0.00	2,395.47
10E050	1585	2110	00	000000	850.00	72.74	636.15	0.00	0.00	213.85
10E---	1585	2---	--	-----	850.00	72.74	636.15	0.00	0.00	213.85
10E050	1586	1100	00	000000	3,531.00	282.50	2,515.29	0.00	0.00	1,015.71

Account Level				2025-26	February 2025-26	2025-26	2025-26	Encumbered	2025-26	
FDTLOC	FUNC	OBJ	SJ	Description	Budget	Monthly Activity	FYTD Activity	Batch Activity	Amount	Available Funds
10E---	1586	1---	--	-----	3,531.00	282.50	2,515.29	0.00	0.00	1,015.71
10E050	1586	2110	00	000000	420.00	31.82	283.24	0.00	0.00	136.76
10E---	1586	2---	--	-----	420.00	31.82	283.24	0.00	0.00	136.76
10E050	1586	4100	00	000000	1,500.00	141.33	401.21	0.00	814.28	284.51
10E---	1586	4---	--	-----	1,500.00	141.33	401.21	0.00	814.28	284.51
10E050	1589	1100	00	000000	2,354.00	188.70	1,750.24	0.00	0.00	603.76
10E---	1589	1---	--	-----	2,354.00	188.70	1,750.24	0.00	0.00	603.76
10E050	1589	2110	00	000000	320.00	21.26	197.16	0.00	0.00	122.84
10E---	1589	2---	--	-----	320.00	21.26	197.16	0.00	0.00	122.84
10E050	1590	1110	00	000000	7,771.00	366.20	2,962.30	0.00	0.00	4,808.70
10E---	1590	1---	--	-----	7,771.00	366.20	2,962.30	0.00	0.00	4,808.70
10E050	1590	3320	00	000000	50.00	0.00	0.00	0.00	0.00	50.00
10E---	1590	3---	--	-----	50.00	0.00	0.00	0.00	0.00	50.00
10E040	1591	1100	00	000000	4,708.00	641.29	6,010.30	0.00	0.00	-1,302.30
10E---	1591	1---	--	-----	4,708.00	641.29	6,010.30	0.00	0.00	-1,302.30
10E040	1591	2110	00	000000	300.00	72.23	676.95	0.00	0.00	-376.95
10E---	1591	2---	--	-----	300.00	72.23	676.95	0.00	0.00	-376.95
10E040	1591	3190	00	000000	1,000.00	105.00	105.00	0.00	0.00	895.00
10E---	1591	3---	--	-----	1,000.00	105.00	105.00	0.00	0.00	895.00
10E040	1591	6400	00	000000	100.00	0.00	100.00	0.00	0.00	0.00
10E---	1591	6---	--	-----	100.00	0.00	100.00	0.00	0.00	0.00
10E040	1592	3190	00	000000	1,000.00	0.00	90.00	0.00	70.00	840.00
10E---	1592	3---	--	-----	1,000.00	0.00	90.00	0.00	70.00	840.00
10E040	1593	1100	00	000000	1,569.00	0.00	1,631.92	0.00	0.00	-62.92
10E---	1593	1---	--	-----	1,569.00	0.00	1,631.92	0.00	0.00	-62.92
10E040	1593	2110	00	000000	185.00	0.00	183.81	0.00	0.00	1.19
10E---	1593	2---	--	-----	185.00	0.00	183.81	0.00	0.00	1.19
10E040	1593	4100	00	000000	200.00	0.00	0.00	0.00	0.00	200.00
10E---	1593	4---	--	-----	200.00	0.00	0.00	0.00	0.00	200.00
10E040	1598	1100	00	000000	250.00	0.00	0.00	0.00	0.00	250.00
10E---	1598	1---	--	-----	250.00	0.00	0.00	0.00	0.00	250.00
10E040	1598	2110	00	000000	30.00	0.00	0.00	0.00	0.00	30.00
10E---	1598	2---	--	-----	30.00	0.00	0.00	0.00	0.00	30.00
10E040	1599	1100	00	000000	2,000.00	0.00	0.00	0.00	0.00	2,000.00
10E---	1599	1---	--	-----	2,000.00	0.00	0.00	0.00	0.00	2,000.00
10E040	1599	2110	00	000000	230.00	0.00	0.00	0.00	0.00	230.00
10E---	1599	2---	--	-----	230.00	0.00	0.00	0.00	0.00	230.00
10E040	1599	3320	00	000000	1,000.00	0.00	0.00	0.00	0.00	1,000.00
10E---	1599	3---	--	-----	1,000.00	0.00	0.00	0.00	0.00	1,000.00
10E050	1700	1100	00	000000	50,435.00	156.75	20,121.75	0.00	0.00	30,313.25

Account Level				2025-26	February 2025-26	2025-26	2025-26	Encumbered	2025-26	
FDTLOC	FUNC	OBJ	SJ	Description	Budget	Monthly Activity	FYTD Activity	Batch Activity	Amount	Available Funds
10E050	1700	1200	00 000000	Drivers Ed Sub Sal	0.00	1,600.50	7,276.50	0.00	0.00	-7,276.50
10E---	1700	1---	--		50,435.00	1,757.25	27,398.25	0.00	0.00	23,036.75
10E050	1700	2110	00 000000	Drivers Ed TRS	11,000.00	17.64	1,085.00	0.00	0.00	9,915.00
10E050	1700	2200	00 000000	Drivers Ed Ins Ben	5,200.00	0.00	0.00	0.00	0.00	5,200.00
10E---	1700	2---	--		16,200.00	17.64	1,085.00	0.00	0.00	15,115.00
10E050	1700	3190	00 000000	Drivers Ed Pur Serv	230.00	0.00	110.00	0.00	0.00	120.00
10E050	1700	3230	00 000000	Drivers Ed Rep/Maint	500.00	0.00	165.60	0.00	0.00	334.40
10E050	1700	3320	00 000000	Drivers Ed Travel	25.00	0.00	0.00	0.00	0.00	25.00
10E---	1700	3---	--		755.00	0.00	275.60	0.00	0.00	479.40
10E050	1700	4100	00 000000	Drivers Ed Supplies	1,000.00	0.00	91.06	0.00	0.00	908.94
10E050	1700	4640	00 000000	Drivers Ed Fuel	2,500.00	0.00	0.00	0.00	0.00	2,500.00
10E---	1700	4---	--		3,500.00	0.00	91.06	0.00	0.00	3,408.94
10E010	1800	1100	00 000000	Bilingual Prog Sal	1,421.00	0.00	767.25	0.00	0.00	653.75
10E010	1800	1110	00 000000	LLS Aide Sal	10,000.00	0.00	0.00	0.00	0.00	10,000.00
10E---	1800	1---	--		11,421.00	0.00	767.25	0.00	0.00	10,653.75
10E010	1800	2110	00 000000	Bilingual Program TRS	500.00	0.00	86.42	0.00	0.00	413.58
10E---	1800	2---	--		500.00	0.00	86.42	0.00	0.00	413.58
10E010	1800	4100	00 000000	Bilingual Supplies	1,000.00	0.00	128.00	0.00	0.00	872.00
10E---	1800	4---	--		1,000.00	0.00	128.00	0.00	0.00	872.00
10E010	1911	6700	00 000000	Residential Tuition	5,000.00	396.00	2,491.48	0.00	0.00	2,508.52
10E---	1911	6---	--		5,000.00	396.00	2,491.48	0.00	0.00	2,508.52
10E260	1912	6700	00 260000	Sp Ed Priv Tuition	200,000.00	31,247.67	195,942.90	23,161.46	0.00	-19,104.36
10E---	1912	6---	--		200,000.00	31,247.67	195,942.90	23,161.46	0.00	-19,104.36
10E---	1---	----	--		15,249,044.00	1,041,586.49	9,780,741.18	38,320.29	48,974.27	5,381,008.26
10E100	2110	3190	00 100000	Title I Coaching Purch Service	0.00	0.00	3,800.00	0.00	0.00	-3,800.00
10E500	2110	3190	00 500000	Title I Purchased Services	3,500.00	0.00	0.00	0.00	0.00	3,500.00
10E---	2110	3---	--		3,500.00	0.00	3,800.00	0.00	0.00	-300.00
10E020	2120	1100	00 000000	RCES Guidance Sal	61,218.00	4,593.70	40,796.19	0.00	0.00	20,421.81
10E040	2120	1100	00 000000	RCMS Guidance Sal	96,924.00	7,619.00	59,535.49	0.00	0.00	37,388.51
10E050	2120	1100	00 000000	RCHS Guidance Salary SAL	119,732.00	13,637.74	120,048.40	0.00	0.00	-316.40
10E020	2120	1110	00 000000	RCES Guidance Non Cert	0.00	3,464.67	9,349.75	0.00	0.00	-9,349.75
10E050	2120	1110	00 000000	RCHS Guidance Sec Salary	35,560.00	2,679.30	25,459.79	0.00	0.00	10,100.21
10E500	2120	1110	00 500000	Title I Neg/Deliq NC Salary	0.00	0.00	-0.12	0.00	0.00	0.12
10E---	2120	1---	--		313,434.00	31,994.41	255,189.50	0.00	0.00	58,244.50
10E020	2120	2110	00 000000	RCES Guidance TRS	11,500.00	517.42	4,595.08	0.00	0.00	6,904.92
10E040	2120	2110	00 000000	RCMS Guidance TRS	5,500.00	858.20	6,705.95	0.00	0.00	-1,205.95
10E050	2120	2110	00 000000	RCHS Guidance TRS	20,000.00	1,536.14	13,800.91	0.00	0.00	6,199.09
10E020	2120	2200	00 000000	RCES Ins Ben	21,000.00	1,720.00	9,790.71	0.00	0.00	11,209.29
10E040	2120	2200	00 000000	RCMS Guidance Ins Ben	10,500.00	1,720.00	12,436.84	0.00	0.00	-1,936.84
10E050	2120	2200	00 000000	RCHS Guidance Ins Ben	42,500.00	3,530.00	29,680.86	0.00	0.00	12,819.14

Account Level				2025-26	February 2025-26	2025-26	2025-26	Encumbered	2025-26	
FDTLOC	FUNC	OBJ	SJ	Description	Budget	Monthly Activity	FYTD Activity	Batch Activity	Amount	Available Funds
10E---	2120	2---	--	-----	111,000.00	9,881.76	77,010.35	0.00	0.00	33,989.65
10E020	2120	3190	00	000000	100.00	0.00	0.00	0.00	0.00	100.00
10E040	2120	3190	00	000000	150.00	0.00	0.00	0.00	0.00	150.00
10E170	2120	3190	00	170000	5,000.00	0.00	3,100.00	0.00	0.00	1,900.00
10E500	2120	3190	00	500000	5,000.00	0.00	0.00	0.00	0.00	5,000.00
10E570	2120	3190	00	570000	5,000.00	0.00	0.00	0.00	0.00	5,000.00
10E040	2120	3320	00	000000	500.00	0.00	0.00	0.00	0.00	500.00
10E050	2120	3320	00	000000	600.00	0.00	0.00	0.00	0.00	600.00
10E---	2120	3---	--	-----	16,350.00	0.00	3,100.00	0.00	0.00	13,250.00
10E040	2120	4100	00	000000	500.00	0.00	437.88	0.00	0.00	62.12
10E050	2120	4100	00	000000	500.00	0.00	229.04	0.00	0.00	270.96
10E170	2120	4100	00	170000	1,257.00	0.00	677.73	0.00	0.00	579.27
10E---	2120	4---	--	-----	2,257.00	0.00	1,344.65	0.00	0.00	912.35
10E050	2120	5500	00	000000	1,000.00	0.00	0.00	0.00	0.00	1,000.00
10E---	2120	5---	--	-----	1,000.00	0.00	0.00	0.00	0.00	1,000.00
10E050	2120	6400	00	000000	150.00	0.00	378.00	0.00	0.00	-228.00
10E---	2120	6---	--	-----	150.00	0.00	378.00	0.00	0.00	-228.00
10E010	2130	1100	00	000000	32,502.00	9,858.20	87,222.97	0.00	0.00	-54,720.97
10E010	2130	1110	00	000000	27,470.00	12,098.20	96,673.97	0.00	0.00	-69,203.97
10E010	2130	1200	00	000000	1,044.00	0.00	857.50	0.00	0.00	186.50
10E010	2130	1210	00	000000	0.00	185.50	4,254.76	0.00	0.00	-4,254.76
10E---	2130	1---	--	-----	61,016.00	22,141.90	189,009.20	0.00	0.00	-127,993.20
10E010	2130	2110	00	000000	15,500.00	1,110.40	9,824.42	0.00	0.00	5,675.58
10E010	2130	2200	00	000000	21,000.00	3,440.00	16,869.20	0.00	0.00	4,130.80
10E---	2130	2---	--	-----	36,500.00	4,550.40	26,693.62	0.00	0.00	9,806.38
10E010	2130	3190	00	000000	7,500.00	0.00	5,034.00	0.00	0.00	2,466.00
10E920	2130	3190	00	920000	3,500.00	0.00	2,161.00	0.00	0.00	1,339.00
10E920	2130	3230	00	920000	500.00	0.00	0.00	0.00	0.00	500.00
10E920	2130	3320	00	920000	0.00	22.48	252.78	40.60	0.00	-293.38
10E---	2130	3---	--	-----	11,500.00	22.48	7,447.78	40.60	0.00	4,011.62
10E140	2140	1100	00	140000	970.00	0.00	0.00	0.00	0.00	970.00
10E---	2140	1---	--	-----	970.00	0.00	0.00	0.00	0.00	970.00
10E280	2150	1100	00	280000	309,995.00	23,830.10	209,823.22	0.00	0.00	100,171.78
10E---	2150	1---	--	-----	309,995.00	23,830.10	209,823.22	0.00	0.00	100,171.78
10E280	2150	2110	00	280000	34,893.00	2,684.12	23,633.48	0.00	0.00	11,259.52
10E280	2150	2200	00	280000	45,000.00	3,440.00	28,842.88	0.00	0.00	16,157.12
10E---	2150	2---	--	-----	79,893.00	6,124.12	52,476.36	0.00	0.00	27,416.64
10E920	2150	3190	00	920000	600.00	0.00	387.00	0.00	0.00	213.00
10E920	2150	3320	00	920000	500.00	0.00	0.00	0.00	0.00	500.00
10E---	2150	3---	--	-----	1,100.00	0.00	387.00	0.00	0.00	713.00

Account Level				2025-26	February 2025-26	2025-26	2025-26	Encumbered	2025-26		
FDTLOC	FUNC	OBJ	SJ	Description	Budget	Monthly Activity	FYTD Activity	Batch Activity	Amount	Available Funds	
10E920	2150	4100	00	920000	District Speech Supplies	800.00	0.00	261.27	0.00	69.79	468.94
10E920	2150	4130	00	920000	District Speech Testing Suppli	617.00	0.00	411.05	0.00	0.00	205.95
10E920	2150	4200	00	920000	District Bilingual Test Suppli	1,000.00	0.00	0.00	0.00	0.00	1,000.00
10E---	2150	4---	--	-----		2,417.00	0.00	672.32	0.00	69.79	1,674.89
10E920	2150	6400	00	920000	District Speech Dues & Fees	2,700.00	0.00	1,761.25	0.00	250.00	688.75
10E---	2150	6---	--	-----		2,700.00	0.00	1,761.25	0.00	250.00	688.75
10E020	2190	1100	00	000000	RCES Behavior Interv. Salary	1,000.00	0.00	12,332.38	0.00	0.00	-11,332.38
10E040	2190	1100	00	000000	RCMS Detention/In School Susp	347.00	0.00	0.00	0.00	0.00	347.00
10E050	2190	1100	00	000000	RCHS Detention/In School Susp	2,108.00	0.00	0.00	0.00	0.00	2,108.00
10E020	2190	1110	00	000000	Supervision Aide Salary	135,728.00	7,952.79	79,107.87	0.00	0.00	56,620.13
10E020	2190	1200	00	000000	Sub Supervision Cert Sal	0.00	0.00	115.50	0.00	0.00	-115.50
10E020	2190	1210	00	000000	RCES Sub Supervision Aide	3,000.00	57.75	1,402.50	0.00	0.00	1,597.50
10E---	2190	1---	--	-----		142,183.00	8,010.54	92,958.25	0.00	0.00	49,224.75
10E010	2210	1100	00	000000	District Instructional Coach	143,191.00	11,040.10	97,917.20	0.00	0.00	45,273.80
10E100	2210	1100	00	100000	Title I Imp Stipends	56,000.00	0.00	0.00	0.00	0.00	56,000.00
10E110	2210	1100	00	110000	At Risk Improv Salary	0.00	-198.00	-165.00	0.00	0.00	165.00
10E170	2210	1100	00	170000	Title IV Stipends	2,500.00	0.00	0.00	0.00	0.00	2,500.00
10E480	2210	1100	00	480000	Ag 3 Circles Impr of Inst Sal	11,000.00	416.34	3,747.04	0.00	0.00	7,252.96
10E500	2210	1100	00	500000	Title I Imp Stipends	0.00	5,036.80	32,739.20	0.00	0.00	-32,739.20
10E510	2210	1100	00	510000	At Risk Improv Sal	1,335.00	198.00	0.00	0.00	0.00	1,335.00
10E530	2210	1100	00	530000	Title II Stipend	3,300.00	0.00	1,629.00	0.00	0.00	1,671.00
10E510	2210	1110	00	510000	PreK Professional Devel Salary	50.00	0.00	0.00	0.00	0.00	50.00
10E100	2210	1200	00	100000	Title I Improv Subs	1,000.00	0.00	0.00	0.00	0.00	1,000.00
10E330	2210	1200	00	330000	Title II Teach Sub Sal	2,500.00	0.00	0.00	0.00	0.00	2,500.00
10E510	2210	1200	00	510000	Pre K Imp Inst Sub Salary	456.00	0.00	0.00	0.00	0.00	456.00
10E570	2210	1200	00	570000	Title IV Sub Sal	5,000.00	0.00	0.00	0.00	0.00	5,000.00
10E---	2210	1---	--	-----		226,332.00	16,493.24	135,867.44	0.00	0.00	90,464.56
10E010	2210	2110	00	000000	District Improv of Instr TRS	16,128.00	1,243.54	11,028.58	0.00	0.00	5,099.42
10E100	2210	2110	00	100000	Title I Improv TRS	23,000.00	0.00	0.00	0.00	0.00	23,000.00
10E110	2210	2110	00	110000	EC Sub TRS	0.00	-22.30	-18.58	0.00	0.00	18.58
10E170	2210	2110	00	170000	Title IV Subs TRS	535.00	0.00	0.00	0.00	0.00	535.00
10E480	2210	2110	00	480000	Ag 3 Circles TRS	1,300.00	46.86	421.81	0.00	0.00	878.19
10E500	2210	2110	00	500000	Title I TRS	250.00	1,139.50	5,404.11	0.00	0.00	-5,154.11
10E510	2210	2110	00	510000	EC TRS	0.00	22.30	0.00	0.00	0.00	0.00
10E530	2210	2110	00	530000	Prior Yr Title II TRS	0.00	0.00	48.25	0.00	0.00	-48.25
10E570	2210	2110	00	570000	Title IV Sub TRS	600.00	0.00	0.00	0.00	0.00	600.00
10E010	2210	2200	00	000000	District Instr Coach Insurance	31,500.00	2,300.00	19,284.64	0.00	0.00	12,215.36
10E100	2210	2200	00	100000	Title I Impr Of Instruc Insura	10,500.00	0.00	0.00	0.00	0.00	10,500.00
10E---	2210	2---	--	-----		83,813.00	4,729.90	36,168.81	0.00	0.00	47,644.19
10E330	2210	3140	00	330000	Title II Consultant	3,000.00	0.00	0.00	0.00	0.00	3,000.00

Account Level				2025-26	February 2025-26	2025-26	2025-26	Encumbered	2025-26		
FDTLOC	FUNC	OBJ	SJ	Description	Budget	Monthly Activity	FYTD Activity	Batch Activity	Amount	Available Funds	
10E010	2210	3190	00	000000	District Improv of Instr Regis	3,000.00	0.00	0.00	0.00	3,000.00	
10E100	2210	3190	00	100000	Title I Improv Reg Fee	5,000.00	0.00	32,653.25	0.00	-27,653.25	
10E110	2210	3190	00	110000	EC 3-5 Pur Serv	0.00	0.00	750.00	0.00	-750.00	
10E170	2210	3190	00	170000	Title IV Purchase Service	6,500.00	30.00	3,607.00	0.00	70.00	2,823.00
10E330	2210	3190	00	330000	Title II Purchase Serv	5,000.00	0.00	5,523.00	0.00	0.00	-523.00
10E500	2210	3190	00	500000	Title I Pur Serv	28,000.00	51.00	711.00	0.00	0.00	27,289.00
10E510	2210	3190	00	510000	PI Reg, Mileage	1,990.00	0.00	0.00	0.00	0.00	1,990.00
10E530	2210	3190	00	530000	Title II Pur Serv	14,000.00	550.00	7,893.00	0.00	0.00	6,107.00
10E570	2210	3190	00	570000	Title IV Purchase Service	6,000.00	0.00	4,206.91	0.00	0.00	1,793.09
10E780	2210	3190	00	780000	CTEI PD Purch Service	4,100.00	0.00	6,310.00	0.00	0.00	-2,210.00
10E782	2210	3190	00	000782	METT Workshop	0.00	0.00	865.00	0.00	0.00	-865.00
10E010	2210	3320	00	000000	District Improv of Instr Mieag	1,000.00	0.00	0.00	0.00	0.00	1,000.00
10E170	2210	3320	00	170000	Title IV Meals Motel Reg	0.00	0.00	13.72	0.00	0.00	-13.72
10E330	2210	3320	00	330000	Title II Travel	3,000.00	0.00	4,510.65	0.00	0.00	-1,510.65
10E510	2210	3320	00	510000	At Risk Improv Trav	3,000.00	0.00	0.00	0.00	0.00	3,000.00
10E530	2210	3320	00	530000	Prior Yr Title II Travel	8,000.00	1,392.43	2,289.97	0.00	0.00	5,710.03
10E570	2210	3320	00	570000	Title IV Travel	5,000.00	0.00	4,026.60	0.00	0.00	973.40
10E780	2210	3320	00	780000	CTEI PD Travel	4,410.00	-217.56	5,399.79	0.00	0.00	-989.79
10E782	2210	3320	00	000782	METT PD Travel	0.00	711.08	885.08	0.00	0.00	-885.08
10E---	2210	3---	--	-----		101,000.00	2,516.95	79,644.97	0.00	70.00	21,285.03
10E100	2210	4100	00	100000	Title I Supp	0.00	0.00	1,429.02	0.00	0.00	-1,429.02
10E500	2210	4100	00	500000	Title I Supplies	0.00	0.00	97.22	0.00	0.00	-97.22
10E510	2210	4100	00	510000	Early Childhood PD Supplies	250.00	0.00	0.00	0.00	0.00	250.00
10E530	2210	4100	00	530000	Title II Supplies	1,598.00	40.99	194.71	0.00	2,695.00	-1,291.71
10E---	2210	4---	--	-----		1,848.00	40.99	1,720.95	0.00	2,695.00	-2,567.95
10E500	2210	5500	00	500000	TITLE I Equipment	0.00	2,912.00	2,912.00	-2,912.00	0.00	0.00
10E---	2210	5---	--	-----		0.00	2,912.00	2,912.00	-2,912.00	0.00	0.00
10E020	2220	1100	00	000000	RCES IMC Salary	62,068.00	4,774.60	42,402.55	0.00	0.00	19,665.45
10E040	2220	1100	00	000000	RCMS IMC Salary	51,168.00	3,936.10	34,955.79	0.00	0.00	16,212.21
10E050	2220	1100	00	000000	RCHS IMC Teach Sal	75,254.00	5,788.90	51,280.28	0.00	0.00	23,973.72
10E040	2220	1110	00	000000	RCMS Aide/Asst Salary	14,124.00	0.00	8,250.33	0.00	0.00	5,873.67
10E050	2220	1110	00	000000	RCHS Library TA	14,102.00	0.00	8,250.22	0.00	0.00	5,851.78
10E020	2220	1200	00	000000	RCES IMC Sub Sal	634.00	135.00	1,012.50	0.00	0.00	-378.50
10E040	2220	1200	00	000000	RCMS Lib Sub Sal	1,000.00	0.00	0.00	0.00	0.00	1,000.00
10E050	2220	1200	00	000000	RCHS IMC Sub Teach Sal	395.00	0.00	0.00	0.00	0.00	395.00
10E---	2220	1---	--	-----		218,745.00	14,634.60	146,151.67	0.00	0.00	72,593.33
10E020	2220	2110	00	000000	RCES IMC TRS	6,991.00	539.50	4,788.80	0.00	0.00	2,202.20
10E040	2220	2110	00	000000	RCMS IMC TRS	5,763.00	443.34	3,937.24	0.00	0.00	1,825.76
10E050	2220	2110	00	000000	RCHS IMC TRS	8,476.00	652.06	5,776.11	0.00	0.00	2,699.89
10E020	2220	2200	00	000000	RCES IMC Ins Benefit	10,500.00	1,150.00	9,642.32	0.00	0.00	857.68

120

FDTLOC	FUNC	OBJ	SJ	Account Level Description	2025-26 Budget	February 2025-26 Monthly Activity	2025-26 FYTD Activity	2025-26 Batch Activity	Encumbered Amount	2025-26 Available Funds
10E040	2220	2200	00	000000	RCMS IMC Ins Benefit	10,500.00	860.00	7,210.72	0.00	3,289.28
10E050	2220	2200	00	000000	RCHS IMC Ins Benefit	10,500.00	860.00	7,210.72	0.00	3,289.28
10E---	2220	2---	--	-----		52,730.00	4,504.90	38,565.91	0.00	14,164.09
10E020	2220	3140	00	000000	RCES Library Fees	1,000.00	0.00	0.00	0.00	1,000.00
10E020	2220	3190	00	000000	RCES Library Purchased Service	2,100.00	0.00	1,135.56	0.00	964.44
10E040	2220	3190	00	000000	RCMS Library Pur Serv	1,230.00	0.00	1,135.56	0.00	94.44
10E050	2220	3190	00	000000	RCHS IMC Pur Service	4,000.00	3.99	1,917.96	0.00	2,064.07
10E020	2220	3230	00	000000	RCES IMC Repair/Maint	1,000.00	0.00	0.00	0.00	1,000.00
10E---	2220	3---	--	-----		9,330.00	3.99	4,189.08	0.00	5,122.95
10E020	2220	4100	00	000000	RCES IMC Supplies	3,500.00	644.18	2,190.15	0.00	1,192.70
10E040	2220	4100	00	000000	RCMS IMC Supplies	1,620.00	142.38	1,153.11	0.00	466.89
10E050	2220	4100	00	000000	RCHS IMC Supplies	2,200.00	0.00	1,303.14	0.00	877.39
10E240	2220	4100	00	240000	IL St Library Grnt Supp	3,000.00	0.00	797.98	0.00	2,183.76
10E570	2220	4100	00	570000	Title IV LibraryMedia Supplies	0.00	0.00	3,550.60	0.00	-3,550.60
10E020	2220	4300	00	000000	RCES IMC Books	7,000.00	468.28	5,643.37	12.94	380.95
10E040	2220	4300	00	000000	RCMS IMC Books	6,600.00	796.03	5,765.41	0.00	188.04
10E050	2220	4300	00	000000	RCHS IMC Books	9,000.00	1,020.00	5,567.48	0.00	496.61
10E020	2220	4400	00	000000	RCES IMC Periodicals	300.00	0.00	0.00	0.00	300.00
10E020	2220	4700	00	000000	RCES IMC Software	300.00	0.00	0.00	0.00	300.00
10E040	2220	4700	00	000000	RCMS IMC Software/E-Resources	3,000.00	0.00	3,000.00	0.00	0.00
10E---	2220	4---	--	-----		36,520.00	3,070.87	28,971.24	12.94	1,220.48
10E020	2220	6400	00	000000	RCES IMC Dues/Fees	400.00	0.00	0.00	0.00	400.00
10E040	2220	6400	00	000000	RCMS IMC Dues/Fees	700.00	400.00	400.00	0.00	277.87
10E---	2220	6---	--	-----		1,100.00	400.00	400.00	0.00	277.87
10E100	2230	3140	00	100000	Title I Scoring	35,000.00	0.00	0.00	0.00	35,000.00
10E500	2230	3140	00	500000	Title I Scoring	27,000.00	0.00	26,615.15	0.00	384.85
10E780	2230	3190	00	780000	CTEI Testing/Certification	1,279.00	0.00	0.00	0.00	1,279.00
10E---	2230	3---	--	-----		63,279.00	0.00	26,615.15	0.00	36,663.85
10E010	2310	3170	00	000000	BOE Audit Fee	34,000.00	15,075.00	33,075.00	0.00	925.00
10E010	2310	3180	00	000000	BOE Reg Chicago	20,000.00	0.00	11,534.00	0.00	8,466.00
10E010	2310	3190	00	000000	BOE Other Pur Ser	12,000.00	153.76	683.12	0.00	11,316.88
10E010	2310	3320	00	000000	BOE Travel	1,600.00	0.00	150.97	0.00	1,449.03
10E010	2310	3500	00	000000	BOE Advertising	2,000.00	0.00	1,943.05	754.85	-697.90
10E010	2310	3800	00	000000	BOE Pd Cert Life Ins	42,000.00	3,345.71	27,089.08	0.00	14,910.92
10E---	2310	3---	--	-----		111,600.00	18,574.47	74,475.22	754.85	36,369.93
10E010	2310	4100	00	000000	BOE Supplies	15,000.00	4,816.41	22,590.43	10,535.50	-18,125.93
10E010	2310	4110	00	000000	BOE Serv Awards Supp	250.00	0.00	0.00	0.00	250.00
10E---	2310	4---	--	-----		15,250.00	4,816.41	22,590.43	10,535.50	-17,875.93
10E010	2310	6400	00	000000	BOE Dues/Fees	7,200.00	0.00	0.00	0.00	7,200.00
10E---	2310	6---	--	-----		7,200.00	0.00	0.00	0.00	7,200.00

Account Level				2025-26	February 2025-26	2025-26	2025-26	Encumbered	2025-26	
FDTLOC	FUNC	OBJ	SJ	Description	Budget	Monthly Activity	FYTD Activity	Batch Activity	Amount	Available Funds
10E010	2320	1100	00	000000	168,575.00	13,730.80	127,295.95	0.00	0.00	41,279.05
10E010	2320	1110	00	000000	63,779.00	4,572.63	43,327.42	0.00	0.00	20,451.58
10E---	2320	1---	--	-----	232,354.00	18,303.43	170,623.37	0.00	0.00	61,730.63
10E010	2320	2110	00	000000	20,105.00	1,546.58	17,086.85	0.00	0.00	3,018.15
10E010	2320	2200	00	000000	10,500.00	1,150.00	9,642.32	0.00	0.00	857.68
10E---	2320	2---	--	-----	30,605.00	2,696.58	26,729.17	0.00	0.00	3,875.83
10E010	2320	3190	00	000000	6,700.00	160.00	2,783.10	100.00	0.00	3,816.90
10E010	2320	3250	00	000000	4,000.00	951.96	2,855.88	0.00	0.00	1,144.12
10E010	2320	3260	00	000000	3,000.00	-102.12	-113.62	0.00	0.00	3,113.62
10E010	2320	3320	00	000000	5,000.00	271.90	1,482.57	0.00	0.00	3,517.43
10E---	2320	3---	--	-----	18,700.00	1,281.74	7,007.93	100.00	0.00	11,592.07
10E010	2320	4100	00	000000	10,000.00	0.00	3,109.87	0.00	0.00	6,890.13
10E---	2320	4---	--	-----	10,000.00	0.00	3,109.87	0.00	0.00	6,890.13
10E010	2320	5500	00	000000	5,000.00	0.00	0.00	0.00	0.00	5,000.00
10E---	2320	5---	--	-----	5,000.00	0.00	0.00	0.00	0.00	5,000.00
10E010	2320	6400	00	000000	3,000.00	980.00	1,230.00	0.00	0.00	1,770.00
10E---	2320	6---	--	-----	3,000.00	980.00	1,230.00	0.00	0.00	1,770.00
10E010	2330	1100	00	000000	171,100.00	16,077.04	145,539.52	0.00	0.00	25,560.48
10E100	2330	1100	00	100000	11,000.00	0.00	1,269.24	0.00	0.00	9,730.76
10E500	2330	1100	00	500000	14,000.00	846.16	5,500.04	0.00	0.00	8,499.96
10E010	2330	1110	00	000000	48,464.00	4,160.00	34,511.53	0.00	0.00	13,952.47
10E100	2330	1110	00	100000	6,273.00	0.00	629.77	0.00	0.00	5,643.23
10E110	2330	1110	00	110000	2,100.00	0.00	3,310.91	0.00	0.00	-1,210.91
10E500	2330	1110	00	500000	661.00	493.92	3,193.49	0.00	0.00	-2,532.49
10E510	2330	1110	00	510000	25,472.00	1,968.68	13,804.11	0.00	0.00	11,667.89
10E---	2330	1---	--	-----	279,070.00	23,545.80	207,758.61	0.00	0.00	71,311.39
10E010	2330	2110	00	000000	23,541.00	1,897.40	17,181.36	0.00	0.00	6,359.64
10E100	2330	2110	00	100000	1,239.00	0.00	157.38	0.00	0.00	1,081.62
10E500	2330	2110	00	500000	75.00	104.92	681.98	0.00	0.00	-606.98
10E010	2330	2200	00	000000	10,500.00	1,634.00	13,694.98	0.00	0.00	-3,194.98
10E100	2330	2200	00	100000	0.00	0.00	119.07	0.00	0.00	-119.07
10E500	2330	2200	00	500000	0.00	86.00	522.59	0.00	0.00	-522.59
10E510	2330	2200	00	510000	8.00	0.00	0.00	0.00	0.00	8.00
10E---	2330	2---	--	-----	35,363.00	3,722.32	32,357.36	0.00	0.00	3,005.64
10E100	2330	3170	00	100000	1,500.00	0.00	1,500.00	0.00	0.00	0.00
10E010	2330	3190	00	000000	3,500.00	2,367.00	2,899.31	0.00	0.00	600.69
10E010	2330	3320	00	000000	1,500.00	72.80	1,626.24	0.00	0.00	-126.24
10E---	2330	3---	--	-----	6,500.00	2,439.80	6,025.55	0.00	0.00	474.45
10E110	2330	4100	00	110000	40.00	0.00	339.30	0.00	0.00	-299.30
10E510	2330	4100	00	510000	750.00	0.00	12.99	0.00	180.90	556.11

FDTLOC	FUNC	OBJ	SJ	Account Level Description	2025-26 Budget	February 2025-26 Monthly Activity	2025-26 FYTD Activity	2025-26 Batch Activity	Encumbered Amount	2025-26 Available Funds
10E---	2330	4---	--	-----	790.00	0.00	352.29	0.00	180.90	256.81
10E010	2330	6400	00	000000 Asst Supt Dues/Fees	600.00	0.00	1,398.00	0.00	0.00	-798.00
10E---	2330	6---	--	-----	600.00	0.00	1,398.00	0.00	0.00	-798.00
10E280	2331	1100	00	280000 Sp Ed Dir Sal	105,912.00	7,686.00	69,173.65	0.00	0.00	36,738.35
10E110	2331	1110	00	110000 Admin PI Sec Sal	0.00	0.00	2,446.95	0.00	0.00	-2,446.95
10E280	2331	1110	00	280000 Sp Ed Sec Sal	38,000.00	1,930.83	23,341.01	0.00	0.00	14,658.99
10E510	2331	1110	00	510000 0-3 Pre K Adm Sec	10,917.00	843.72	5,916.04	0.00	0.00	5,000.96
10E---	2331	1---	--	-----	154,829.00	10,460.55	100,877.65	0.00	0.00	53,951.35
10E280	2331	2110	00	280000 Sp Needs Dir TRS	11,929.00	865.74	7,791.44	0.00	0.00	4,137.56
10E280	2331	2200	00	280000 Sp Ed Ins Ben	21,000.00	860.00	9,114.42	0.00	0.00	11,885.58
10E510	2331	2200	00	510000 Admin PI Sec Ben	4.00	0.00	0.00	0.00	0.00	4.00
10E---	2331	2---	--	-----	32,933.00	1,725.74	16,905.86	0.00	0.00	16,027.14
10E510	2331	3190	00	510000 PI Pur Serv	2,000.00	0.00	2,000.00	0.00	0.00	0.00
10E920	2331	3190	00	920000 Sp Ed Purchase Service	20,000.00	0.00	8,998.80	0.00	0.00	11,001.20
10E920	2331	3320	00	920000 Sp Ed Travel	650.00	60.00	60.00	0.00	0.00	590.00
10E---	2331	3---	--	-----	22,650.00	60.00	11,058.80	0.00	0.00	11,591.20
10E510	2331	4100	00	510000 PI Adm Supp	1,500.00	0.00	0.00	0.00	99.50	1,400.50
10E920	2331	4100	00	920000 Sp Ed Supplies	5,000.00	29.69	507.33	127.11	728.08	3,637.48
10E920	2331	4700	00	920000 Sp Ed Dir Software	10,000.00	300.00	8,735.94	0.00	0.00	1,264.06
10E---	2331	4---	--	-----	16,500.00	329.69	9,243.27	127.11	827.58	6,302.04
10E920	2331	5500	00	920000 Sp Ed Adm Equip	2,500.00	0.00	0.00	0.00	0.00	2,500.00
10E---	2331	5---	--	-----	2,500.00	0.00	0.00	0.00	0.00	2,500.00
10E920	2331	6400	00	920000 Sp Needs Coord. Dues/Fees	300.00	0.00	424.00	0.00	0.00	-124.00
10E---	2331	6---	--	-----	300.00	0.00	424.00	0.00	0.00	-124.00
10E015	2410	1100	00	000000 ELC Principal Salary	67,500.00	5,769.30	51,923.70	0.00	0.00	15,576.30
10E020	2410	1100	00	000000 RCES Prin Sal	282,615.00	24,155.30	217,397.70	0.00	0.00	65,217.30
10E040	2410	1100	00	000000 RCMS Principal Sal	185,825.00	15,882.60	142,943.40	0.00	0.00	42,881.60
10E045	2410	1100	00	000000 RISE UP Director Salary	72,000.00	5,538.50	49,846.50	0.00	0.00	22,153.50
10E050	2410	1100	00	000000 RCHS Principal Salary	184,500.00	15,769.40	141,924.60	0.00	0.00	42,575.40
10E020	2410	1110	00	000000 RCES Sec Sal	160,088.00	10,355.48	100,005.18	0.00	0.00	60,082.82
10E040	2410	1110	00	000000 RCMS Secretarial Sal	62,634.00	4,963.90	44,489.33	0.00	0.00	18,144.67
10E045	2410	1110	00	000000 RISE UP Secretary Salary	33,024.00	2,291.04	17,967.12	0.00	0.00	15,056.88
10E050	2410	1110	00	000000 RCHS Principal Sec Sal	101,827.00	8,405.99	76,928.62	0.00	0.00	24,898.38
10E020	2410	1210	00	000000 RCES Sub Sec Sal	2,000.00	0.00	0.00	0.00	0.00	2,000.00
10E050	2410	1210	00	000000 RCHS Principal Sub Sec Sal	2,000.00	0.00	0.00	0.00	0.00	2,000.00
10E---	2410	1---	--	-----	1,154,013.00	93,131.51	843,426.15	0.00	0.00	310,586.85
10E015	2410	2110	00	000000 ELC Principal TRS	8,448.00	649.84	9,546.56	0.00	0.00	-1,098.56
10E020	2410	2110	00	000000 RCES Prin TRS	35,369.00	2,720.76	24,486.60	0.00	0.00	10,882.40
10E040	2410	2110	00	000000 RCMS Principal TRS	23,256.00	1,788.98	16,100.66	0.00	0.00	7,155.34
10E045	2410	2110	00	000000 RISE UP Director TRS	8,110.00	623.84	7,805.87	0.00	0.00	304.13

123

Account Level				2025-26	February 2025-26	2025-26	2025-26	Encumbered	2025-26	
FDTLOC	FUNC	OBJ	SJ	Description	Budget	Monthly Activity	FYTD Activity	Batch Activity	Amount	Available Funds
10E050	2410	2110	00 000000	RCHS Principal TRS	23,090.00	1,776.18	15,985.62	0.00	0.00	7,104.38
10E015	2410	2200	00 000000	ELC Principal Ins Benefit	10,500.00	1,150.00	9,642.32	0.00	0.00	857.68
10E020	2410	2200	00 000000	RCES Prin Ins Benefit	41,500.00	2,870.00	19,605.24	0.00	0.00	21,894.76
10E040	2410	2200	00 000000	RCMS Principal Ins Ben	21,000.00	860.00	13,561.44	0.00	0.00	7,438.56
10E045	2410	2200	00 000000	RISE UP Director Insurance	0.00	860.00	6,813.80	0.00	0.00	-6,813.80
10E050	2410	2200	00 000000	RCHS Principal Ins Ben	21,000.00	860.00	7,210.72	0.00	0.00	13,789.28
10E---	2410	2---	-- -----		192,273.00	14,159.60	130,758.83	0.00	0.00	61,514.17
10E015	2410	3190	00 000000	ELC Principal Purch Services	2,500.00	0.00	2,347.92	0.00	0.00	152.08
10E020	2410	3190	00 000000	RCES Prin Off Pur Serv	13,000.00	0.00	10,733.58	0.00	0.00	2,266.42
10E040	2410	3190	00 000000	RCMS Principal Purchase Serv	12,000.00	678.33	11,660.88	0.00	250.00	89.12
10E050	2410	3190	00 000000	RCHS Principal Purchase Serv	13,000.00	0.00	11,275.08	0.00	0.00	1,724.92
10E015	2410	3320	00 000000	ELC Principal Travel	1,000.00	60.00	60.00	0.00	0.00	940.00
10E020	2410	3320	00 000000	RCES Prin Off Travel	2,500.00	210.00	277.20	0.00	0.00	2,222.80
10E040	2410	3320	00 000000	RCMS Principal Travel	500.00	0.00	213.17	0.00	0.00	286.83
10E045	2410	3320	00 000000	RISE UP Director Travel	1,000.00	30.00	60.00	0.00	0.00	940.00
10E050	2410	3320	00 000000	RCHS Principal Travel	1,800.00	150.00	150.00	0.00	0.00	1,650.00
10E020	2410	3600	00 000000	RCES Printing	2,500.00	329.42	1,260.22	0.00	0.00	1,239.78
10E040	2410	3600	00 000000	RCMS Printing	1,400.00	0.00	322.00	0.00	0.00	1,078.00
10E050	2410	3600	00 000000	RCHS Printing	500.00	0.00	135.74	0.00	0.00	364.26
10E---	2410	3---	-- -----		51,700.00	1,457.75	38,495.79	0.00	250.00	12,954.21
10E015	2410	4100	00 000000	ELC Principal Office Supplies	1,000.00	22.99	311.23	0.00	0.00	688.77
10E020	2410	4100	00 000000	RCES Prin Off Supplies	10,000.00	24.45	730.95	0.00	115.95	9,153.10
10E040	2410	4100	00 000000	RCMS Principal Supplies	4,000.00	0.00	1,185.91	0.00	94.57	2,719.52
10E050	2410	4100	00 000000	RCHS Principal Supplies	10,000.00	1,416.00	7,697.21	0.00	874.94	1,427.85
10E---	2410	4---	-- -----		25,000.00	1,463.44	9,925.30	0.00	1,085.46	13,989.24
10E020	2410	5500	00 000000	RCES Principal Equip	5,000.00	0.00	0.00	0.00	0.00	5,000.00
10E040	2410	5500	00 000000	RCMS Principal Equip	5,000.00	0.00	0.00	0.00	0.00	5,000.00
10E050	2410	5500	00 000000	RCHS Principal Equip	3,000.00	0.00	625.00	0.00	0.00	2,375.00
10E---	2410	5---	-- -----		13,000.00	0.00	625.00	0.00	0.00	12,375.00
10E015	2410	6400	00 000000	ELC Principal Dues/Fees	750.00	160.00	509.00	0.00	0.00	241.00
10E020	2410	6400	00 000000	RCES Prin Dues/Fees	2,000.00	160.00	1,407.00	0.00	0.00	593.00
10E040	2410	6400	00 000000	RCMS Principal Dues/Fees	1,200.00	160.00	609.00	0.00	0.00	591.00
10E045	2410	6400	00 000000	RISE UP Director Dues/Fees	800.00	0.00	150.00	0.00	0.00	650.00
10E050	2410	6400	00 000000	RCHS Principal Dues/Fees	1,500.00	160.00	958.00	0.00	0.00	542.00
10E---	2410	6---	-- -----		6,250.00	640.00	3,633.00	0.00	0.00	2,617.00
10E010	2520	1110	00 000000	Fiscal Service Salaries	185,532.00	9,606.68	111,791.08	0.00	0.00	73,740.92
10E---	2520	1---	-- -----		185,532.00	9,606.68	111,791.08	0.00	0.00	73,740.92
10E010	2520	2200	00 000000	Fiscal Service Ins Ben	10,500.00	1,150.00	9,642.32	0.00	0.00	857.68
10E---	2520	2---	-- -----		10,500.00	1,150.00	9,642.32	0.00	0.00	857.68
10E010	2520	3190	00 000000	Fiscal Service Pur Serv	48,000.00	811.30	47,337.12	0.00	0.00	662.88

124

FDTLOC	FUNC	OBJ	SJ	Account Level Description	2025-26 Budget	February 2025-26 Monthly Activity	2025-26 FYTD Activity	2025-26 Batch Activity	Encumbered Amount	2025-26 Available Funds
10E010	2520	3320	00	000000	Fiscal Service Travel	2,000.00	0.00	233.55	0.00	1,766.45
10E---	2520	3---	--	-----		50,000.00	811.30	47,570.67	0.00	2,429.33
10E010	2520	4100	00	000000	Fiscal Service Supplies	4,000.00	0.00	1,062.50	0.00	2,937.50
10E---	2520	4---	--	-----		4,000.00	0.00	1,062.50	0.00	2,937.50
10E010	2521	4100	00	000000	District Co-op Supplies	10,000.00	0.00	7,078.27	0.00	2,921.73
10E080	2521	4100	00	000000	Trans Co-op Supplies	1,500.00	140.90	900.60	0.00	599.40
10E---	2521	4---	--	-----		11,500.00	140.90	7,978.87	0.00	3,521.13
10E015	2540	1110	00	000000	ELC Custodian Salary	32,000.00	3,599.38	29,368.56	0.00	2,631.44
10E020	2540	1110	00	000000	RCES Cust Sal	211,137.00	21,084.66	176,332.16	0.00	34,804.84
10E040	2540	1110	00	000000	RCMS Custodial Salary	128,255.00	14,181.90	121,712.72	0.00	6,542.28
10E050	2540	1110	00	000000	RCHS Custodial Salary	348,461.00	21,586.18	212,362.32	0.00	136,098.68
10E050	2540	1200	00	000000	RCHS Custodial Sub Sal	0.00	134.13	2,067.40	0.00	-2,067.40
10E015	2540	1210	00	000000	ELC Sub Custodian Salary	265.00	0.00	0.00	0.00	265.00
10E020	2540	1210	00	000000	RCES Cust Sub Sal	2,410.00	416.25	2,797.40	0.00	-387.40
10E040	2540	1210	00	000000	RCMS Custodial Sub Sal	841.00	0.00	0.00	0.00	841.00
10E050	2540	1210	00	000000	RCHS Custodial Sub Salary	8,323.00	135.75	5,215.51	0.00	3,107.49
10E---	2540	1---	--	-----		731,692.00	61,138.25	549,856.07	0.00	181,835.93
10E015	2540	2200	00	000000	ELC Custodian Ins Benefit	10,500.00	860.00	7,210.72	0.00	3,289.28
10E020	2540	2200	00	000000	RCES Cust Ins Benefit	41,500.00	3,440.00	28,842.88	0.00	12,657.12
10E040	2540	2200	00	000000	RCMS Custodial Ins Ben	31,000.00	1,720.00	15,086.08	0.00	15,913.92
10E050	2540	2200	00	000000	RCHS Custodial Ins Ben	53,000.00	1,150.00	24,725.28	0.00	28,274.72
10E---	2540	2---	--	-----		136,000.00	7,170.00	75,864.96	0.00	60,135.04
10E110	2540	3190	00	110000	Pre K Playground Pur Serv	0.00	0.00	1,950.00	0.00	-1,950.00
10E---	2540	3---	--	-----		0.00	0.00	1,950.00	0.00	-1,950.00
10E015	2540	4100	00	000000	ELC Playground Supplies	500.00	0.00	0.00	0.00	500.00
10E110	2540	4100	00	110000	Pre K Playground Supp	0.00	0.00	3,145.00	0.00	-3,145.00
10E170	2540	4100	00	170000	Title IV SRO Supplies	500.00	0.00	0.00	0.00	500.00
10E570	2540	4100	00	570000	Title IV Maintenance Supplies	0.00	0.00	4,300.00	0.00	-4,300.00
10E020	2540	4650	00	000000	RCES Natural Gas	55,000.00	18,409.15	34,145.39	0.00	20,854.61
10E040	2540	4650	00	000000	RCMS Natural Gas	8,000.00	3,440.26	4,821.08	0.00	3,178.92
10E050	2540	4650	00	000000	RCHS Natural Gas	35,000.00	13,398.54	22,266.85	0.00	12,733.15
10E015	2540	4660	00	000000	ELC Electric	60,000.00	4,364.00	28,609.61	0.00	31,390.39
10E020	2540	4660	00	000000	RCES Electric	215,000.00	15,267.09	143,714.88	0.00	71,285.12
10E040	2540	4660	00	000000	RCMS Electric	105,000.00	21,729.54	74,981.24	0.00	30,018.76
10E045	2540	4660	00	000000	RISE UP Electric	15,000.00	2,061.86	3,470.73	0.00	11,529.27
10E050	2540	4660	00	000000	RCHS Electric	165,000.00	33,551.96	134,750.27	0.00	30,249.73
10E---	2540	4---	--	-----		659,000.00	112,222.40	454,205.05	0.00	204,794.95
10E100	2550	1110	00	100000	Summer School Trans Sal	5,000.00	0.00	0.00	0.00	5,000.00
10E110	2550	1110	00	110000	PreK Transport Sal	4,500.00	0.00	4.99	0.00	4,495.01
10E510	2550	1110	00	510000	At Risk Trans Sal	137,665.00	5,108.34	46,930.48	0.00	90,734.52

Account Level				2025-26	February 2025-26	2025-26	2025-26	Encumbered	2025-26	
FDTLOC	FUNC	OBJ	SJ	Description	Budget	Monthly Activity	FYTD Activity	Batch Activity	Amount	Available Funds
10E110	2550	1210	00	110000	0.00	0.00	16.00	0.00	0.00	-16.00
10E510	2550	1210	00	510000	1,739.00	0.00	495.52	0.00	0.00	1,243.48
10E---	2550	1---	--	-----	148,904.00	5,108.34	47,446.99	0.00	0.00	101,457.01
10E080	2550	3190	00	000000	100.00	0.00	173.00	0.00	0.00	-73.00
10E080	2550	3230	00	000000	3,000.00	0.00	0.00	1,568.16	0.00	1,431.84
10E100	2550	3310	00	100000	10,000.00	0.00	0.00	0.00	0.00	10,000.00
10E110	2550	3310	00	110000	40,500.00	0.00	33,086.40	0.00	0.00	7,413.60
10E510	2550	3310	00	510000	1,884.00	0.00	0.00	0.00	0.00	1,884.00
10E080	2550	3700	00	000000	500.00	0.00	320.00	0.00	0.00	180.00
10E---	2550	3---	--	-----	55,984.00	0.00	33,579.40	1,568.16	0.00	20,836.44
10E080	2550	4100	00	000000	4,000.00	0.00	174.26	0.00	191.58	3,634.16
10E080	2550	4640	00	000000	21,000.00	106.84	1,384.00	0.00	77.56	19,538.44
10E080	2550	4650	00	000000	4,000.00	1,724.40	3,274.52	0.00	0.00	725.48
10E080	2550	4660	00	000000	3,000.00	1,324.51	3,184.63	0.00	0.00	-184.63
10E---	2550	4---	--	-----	32,000.00	3,155.75	8,017.41	0.00	269.14	23,713.45
10E080	2550	5520	00	000000	150,000.00	0.00	148,501.18	0.00	0.00	1,498.82
10E---	2550	5---	--	-----	150,000.00	0.00	148,501.18	0.00	0.00	1,498.82
10E420	2560	1110	00	420000	467,464.00	37,901.15	318,095.80	0.00	0.00	149,368.20
10E420	2560	1200	00	420000	0.00	0.00	877.60	0.00	0.00	-877.60
10E420	2560	1210	00	420000	9,676.00	2,588.98	10,310.02	0.00	0.00	-634.02
10E---	2560	1---	--	-----	477,140.00	40,490.13	329,283.42	0.00	0.00	147,856.58
10E420	2560	2130	00	420000	0.00	0.00	67.65	0.00	0.00	-67.65
10E420	2560	2200	00	420000	70,000.00	5,446.68	47,487.48	0.00	0.00	22,512.52
10E---	2560	2---	--	-----	70,000.00	5,446.68	47,555.13	0.00	0.00	22,444.87
10E350	2560	3190	00	350000	15,000.00	0.00	11,648.00	0.00	0.00	3,352.00
10E---	2560	3---	--	-----	15,000.00	0.00	11,648.00	0.00	0.00	3,352.00
10E420	2560	4100	00	420000	595,000.00	37,653.34	288,642.27	49,807.04	405.25	256,145.44
10E510	2560	4100	00	510000	10,000.00	578.05	4,337.42	0.00	750.13	4,912.45
10E420	2560	4640	00	420000	100.00	0.00	0.00	0.00	0.00	100.00
10E420	2560	4700	00	420000	5,200.00	0.00	0.00	0.00	0.00	5,200.00
10E---	2560	4---	--	-----	610,300.00	38,231.39	292,979.69	49,807.04	1,155.38	266,357.89
10E430	2560	5500	00	430000	30,000.00	0.00	0.00	0.00	0.00	30,000.00
10E---	2560	5---	--	-----	30,000.00	0.00	0.00	0.00	0.00	30,000.00
10E010	2630	3190	00	000000	0.00	300.00	300.00	0.00	0.00	-300.00
10E010	2630	3410	00	000000	10,000.00	61.72	1,071.33	0.00	0.00	8,928.67
10E010	2630	3420	00	000000	40,000.00	4,583.05	23,181.42	0.00	0.00	16,818.58
10E---	2630	3---	--	-----	50,000.00	4,944.77	24,552.75	0.00	0.00	25,447.25
10E010	2660	1110	00	000000	263,145.00	19,738.57	183,282.15	0.00	0.00	79,862.85
10E010	2660	1120	00	000000	0.00	86.02	2,257.59	0.00	0.00	-2,257.59
10E---	2660	1---	--	-----	263,145.00	19,824.59	185,539.74	0.00	0.00	77,605.26

Account Level				2025-26	February 2025-26	2025-26	2025-26	Encumbered	2025-26	
FDTLOC	FUNC	OBJ	SJ	Description	Budget	Monthly Activity	FYTD Activity	Batch Activity	Amount	Available Funds
10E010	2660	2110	00 000000	District Comp Tech TRS	0.00	0.00	18.58	0.00	0.00	-18.58
10E010	2660	2200	00 000000	District Computer Tech Ins	21,000.00	2,670.00	22,386.80	0.00	0.00	-1,386.80
10E---	2660	2---	-- -----		21,000.00	2,670.00	22,405.38	0.00	0.00	-1,405.38
10E010	2660	3190	00 000000	District Comp Tech Pur Serv	180,000.00	13,562.14	201,615.06	0.00	0.00	-21,615.06
10E010	2660	3230	00 000000	District Comp Tech Rep/Maint	1,000.00	0.00	0.00	0.00	0.00	1,000.00
10E010	2660	3320	00 000000	District Computer Tech Mileage	500.00	8.70	171.80	0.00	0.00	328.20
10E---	2660	3---	-- -----		181,500.00	13,570.84	201,786.86	0.00	0.00	-20,286.86
10E010	2660	4100	00 000000	District Comp Tech Supplies	100,000.00	334.76	74,539.73	230.25	818.76	24,411.26
10E010	2660	4700	00 000000	District Comp Tech Software	2,500.00	249.99	1,289.99	0.00	0.00	1,210.01
10E---	2660	4---	-- -----		102,500.00	584.75	75,829.72	230.25	818.76	25,621.27
10E010	2660	5500	00 000000	District Comp Tech Equipment	225,800.00	81.86	78,243.62	0.00	0.00	147,556.38
10E---	2660	5---	-- -----		225,800.00	81.86	78,243.62	0.00	0.00	147,556.38
10E020	2900	1100	00 000000	ES Team Leader	16,869.00	1,351.30	13,031.68	0.00	0.00	3,837.32
10E040	2900	1100	00 000000	MS Team Leader	17,199.00	1,146.30	10,247.94	0.00	0.00	6,951.06
10E050	2900	1100	00 000000	HS Team Leader	21,776.00	1,530.90	14,337.37	0.00	0.00	7,438.63
10E070	2900	1100	00 000000	21st Century Fac Sal	0.00	8.14	24.41	0.00	0.00	-24.41
10E---	2900	1---	-- -----		55,844.00	4,036.64	37,641.40	0.00	0.00	18,202.60
10E020	2900	2110	00 000000	ES Team Leader TRS	1,900.00	152.18	1,467.77	0.00	0.00	432.23
10E040	2900	2110	00 000000	MS Team Leader TRS	1,700.00	129.10	1,154.31	0.00	0.00	545.69
10E050	2900	2110	00 000000	HS Team Leader TRS	2,600.00	172.38	1,614.61	0.00	0.00	985.39
10E---	2900	2---	-- -----		6,200.00	453.66	4,236.69	0.00	0.00	1,963.31
10E500	2900	3190	00 500000	Title I SES Services	1,000.00	0.00	0.00	0.00	0.00	1,000.00
10E---	2900	3---	-- -----		1,000.00	0.00	0.00	0.00	0.00	1,000.00
10E100	2900	4100	00 100000	Title I Homeless Supplies	5,000.00	0.00	2,846.16	0.00	0.00	2,153.84
10E500	2900	4100	00 500000	Title I Homeless supplies	5,000.00	0.00	1,621.15	283.50	300.00	2,795.35
10E---	2900	4---	-- -----		10,000.00	0.00	4,467.31	283.50	300.00	4,949.19
10E010	2900	6900	00 000000	Property Taxes	1,760.00	0.00	5,636.16	0.00	0.00	-3,876.16
10E---	2900	6---	-- -----		1,760.00	0.00	5,636.16	0.00	0.00	-3,876.16
10E---	2---	----	-- -----		8,614,943.00	686,490.91	5,961,562.54	60,547.95	9,488.33	2,583,344.18
10E100	3000	1100	00 100000	Title I Prnt Invl Sal	0.00	0.00	800.25	0.00	0.00	-800.25
10E110	3000	1100	00 110000	PreK 0-3 Teach Sal	3,500.00	0.00	37,808.89	0.00	0.00	-34,308.89
10E150	3000	1100	00 150000	SESE Flow Thru St Joe Spch Sal	7,879.00	0.00	0.00	0.00	0.00	7,879.00
10E500	3000	1100	00 500000	Title I Prnt Invl Sal Pr	11,065.00	272.25	3,341.25	0.00	0.00	7,723.75
10E510	3000	1100	00 510000	Prek 0-3 Cert Salary	177,471.00	13,144.85	95,233.66	0.00	0.00	82,237.34
10E100	3000	1110	00 100000	Title I N/C	10,000.00	0.00	0.00	0.00	0.00	10,000.00
10E510	3000	1110	00 510000	Pre K Non Cert Salary	6,930.00	0.00	0.00	0.00	0.00	6,930.00
10E---	3000	1---	-- -----		216,845.00	13,417.10	137,184.05	0.00	0.00	79,660.95
10E110	3000	2110	00 110000	PreK 0-3 Teacher TRS	433.00	0.00	2,994.36	0.00	0.00	-2,561.36
10E500	3000	2110	00 500000	Title I Prnt Inl Vl TRS	1,257.00	0.00	0.00	0.00	0.00	1,257.00
10E510	3000	2110	00 510000	PI 0-3 TRS	18,836.00	1,239.48	8,060.33	0.00	0.00	10,775.67

127

Account Level				2025-26	February 2025-26	2025-26	2025-26	Encumbered	2025-26	
FDTLOC	FUNC	OBJ	SJ	Description	Budget	Monthly Activity	FYTD Activity	Batch Activity	Amount	Available Funds
10E110	3000	2200	00	110000	PreK 0-3 Teach Ins Ben	8,280.00	0.00	0.00	0.00	8,280.00
10E510	3000	2200	00	510000	PI 0-3 Ins Ben Prior	102.00	0.00	0.00	0.00	102.00
10E---	3000	2---	--	-----		28,908.00	1,239.48	11,054.69	0.00	17,853.31
10E010	3000	3190	00	000000	District Comm Serv Pur Serv	1,000.00	0.00	0.00	0.00	1,000.00
10E510	3000	3190	00	510000	PI 0-3 Pur Servcs	1,126.00	111.75	450.75	150.00	525.25
10E110	3000	3320	00	110000	PreK 0-3 Travel	492.00	0.00	1,195.60	0.00	-703.60
10E510	3000	3320	00	510000	PI 0-3 Trav	0.00	520.58	3,188.28	677.18	-3,865.46
10E---	3000	3---	--	-----		2,618.00	632.33	4,834.63	677.18	-3,043.81
10E100	3000	4100	00	100000	Title I Prnt Invl Supp	7,500.00	0.00	2,952.10	0.00	4,547.90
10E110	3000	4100	00	110000	PreK 0-3 Supplies	32,600.00	0.00	21,942.65	0.00	10,657.35
10E500	3000	4100	00	500000	Title I Parent Coord Supplies	7,000.00	467.47	1,297.38	0.00	5,702.62
10E510	3000	4100	00	510000	PI 0-3 Supp	29,975.00	538.37	2,403.51	99.99	26,716.43
10E500	3000	4110	00	500000	Title I St Joe Supp	250.00	0.00	0.00	0.00	250.00
10E---	3000	4---	--	-----		77,325.00	1,005.84	28,595.64	99.99	47,874.30
10E110	3002	1100	00	110000	PreK Comm Serv Sal	12,813.00	0.00	1,072.49	0.00	11,740.51
10E510	3002	1100	00	510000	PreK Com Serv Sal Prior	16,964.00	-1,582.85	3,935.25	0.00	13,028.75
10E---	3002	1---	--	-----		29,777.00	-1,582.85	5,007.74	0.00	24,769.26
10E110	3002	2110	00	110000	PreK Comm Serv TRS	0.00	0.00	99.42	0.00	-99.42
10E510	3002	2110	00	510000	Pre-K Comm Serv TRS	1,911.00	-211.75	99.42	0.00	1,811.58
10E510	3002	2200	00	510000	PreK Block Com Prior	0.00	-430.00	-33.08	0.00	33.08
10E---	3002	2---	--	-----		1,911.00	-641.75	165.76	0.00	1,745.24
10E510	3002	3190	00	510000	PreK Comm Serv Purch Services	202.00	0.00	819.90	0.00	-617.90
10E---	3002	3---	--	-----		202.00	0.00	819.90	0.00	-617.90
10E510	3002	4100	00	510000	PreKdgm. Comm Serv Supp	0.00	0.00	530.69	0.00	-530.69
10E---	3002	4---	--	-----		0.00	0.00	530.69	0.00	-530.69
10E150	3700	1100	00	150000	SESE Flow Thru-NonPublicSpeech	53,639.00	4,398.80	34,069.19	0.00	19,569.81
10E150	3700	1110	00	150000	Non Cert SpecialEd Flow St Joe	0.00	0.00	150.00	0.00	-150.00
10E100	3700	1300	00	100000	Title I St Joe Tutor Sal	10,500.00	60.00	6,075.00	0.00	4,425.00
10E500	3700	1300	00	500000	Title I St Joe Tutor Sal	13,041.00	684.75	4,183.25	0.00	8,857.75
10E---	3700	1---	--	-----		77,180.00	5,143.55	44,477.44	0.00	32,702.56
10E150	3700	2110	00	150000	SESE Flow Thru Non Public TRS	9,636.00	825.96	6,684.01	0.00	2,951.99
10E500	3700	2110	00	500000	Title I St. Joe TRS	1,481.00	0.00	0.00	0.00	1,481.00
10E---	3700	2---	--	-----		11,117.00	825.96	6,684.01	0.00	4,432.99
10E100	3700	3190	00	100000	NonPublic School Purchase Serv	6,000.00	0.00	0.00	0.00	6,000.00
10E170	3700	3190	00	170000	Title IV St Joe MMM Reg	1,900.00	0.00	0.00	0.00	1,900.00
10E500	3700	3190	00	500000	TITLE I ST JOE PURCHASED SERV	6,000.00	0.00	7,915.50	0.00	-1,915.50
10E530	3700	3190	00	500000	Title II St Joe Reg	7,243.00	100.00	6,320.00	0.00	923.00
10E570	3700	3190	00	570000	Title IV St Joe Pur Serv	1,000.00	0.00	0.00	0.00	1,000.00
10E330	3700	3320	00	330000	Title II St Joe MMM	3,000.00	0.00	883.52	0.00	2,116.48
10E530	3700	3320	00	500000	Title II St Joe Trav	0.00	454.48	2,166.06	0.00	-2,166.06

Account Level				2025-26	February 2025-26	2025-26	2025-26	Encumbered	2025-26		
FDTLOC	FUNC	OBJ	SJ	Description	Budget	Monthly Activity	FYTD Activity	Batch Activity	Amount	Available Funds	
10E570	3700	3320	00	570000	Title IV St Joe MMM	1,500.00	0.00	0.00	0.00	1,500.00	
10E---	3700	3---	--	-----		26,643.00	554.48	17,285.08	0.00	9,357.92	
10E100	3700	4100	00	100000	Title ST Joe	10,000.00	0.00	162.08	0.00	9,837.92	
10E500	3700	4110	00	500000	Title I St Joe Supp	6,000.00	0.00	2,290.98	0.00	3,709.02	
10E---	3700	4---	--	-----		16,000.00	0.00	2,453.06	0.00	13,546.94	
10E---	3---	----	--	-----		488,526.00	20,594.14	259,092.69	777.17	905.07	227,751.07
10E150	4120	3190	00	150000	IDEA Flow thru SESE	587,453.00	45,683.17	411,148.53	86,751.50	0.00	89,552.97
10E150	4120	3190	01	150000	IDEA Flow Thru SESE PreSchool	25,725.00	2,453.08	22,077.72	6,852.75	0.00	-3,205.47
10E---	4120	3---	--	-----		613,178.00	48,136.25	433,226.25	93,604.25	0.00	86,347.50
10E050	4170	3190	00	000000	IECC Distance Learning Pur Ser	6,000.00	0.00	0.00	0.00	0.00	6,000.00
10E---	4170	3---	--	-----		6,000.00	0.00	0.00	0.00	0.00	6,000.00
10E010	4190	3190	00	000000	In-State Govt Purchased Serv	5,000.00	0.00	0.00	0.00	0.00	5,000.00
10E---	4190	3---	--	-----		5,000.00	0.00	0.00	0.00	0.00	5,000.00
10E010	4220	6700	00	000000	Sp Ed Public SESE Tutition	1,210,000.00	100,815.00	907,335.00	100,815.00	0.00	201,850.00
10E---	4220	6---	--	-----		1,210,000.00	100,815.00	907,335.00	100,815.00	0.00	201,850.00
10E---	4---	----	--	-----		1,834,178.00	148,951.25	1,340,561.25	194,419.25	0.00	299,197.50
1-E---	----	----	--	-----		26,186,691.00	1,897,622.79	17,341,957.66	294,064.66	59,367.67	8,491,301.01
20E010	2540	3190	00	000000	District Maint-Purch Serv/Phys	1,500.00	2,691.00	4,040.00	38.75	0.00	-2,578.75
20E015	2540	3190	00	000000	ELC Maintenance Agreement	5,000.00	96.16	673.12	481.16	0.00	3,845.72
20E020	2540	3190	00	000000	RCES Maint Agreement	230,000.00	1,238.88	307,620.43	985.82	0.00	-78,606.25
20E040	2540	3190	00	000000	RCMS Maint agreement	15,000.00	1,449.33	12,948.86	1,075.66	0.00	975.48
20E045	2540	3190	00	000000	RISE UP Custodian P/S	2,000.00	0.00	2,045.00	0.00	0.00	-45.00
20E050	2540	3190	00	000000	RCHS Purchase Services	55,000.00	2,771.50	69,709.86	3,745.00	0.00	-18,454.86
20E050	2540	3200	00	000000	RCHS Athletic Fld Maintenance	5,000.00	0.00	0.00	0.00	0.00	5,000.00
20E010	2540	3210	00	000000	District Terminx	0.00	0.00	375.00	0.00	0.00	-375.00
20E015	2540	3210	00	000000	ELC Terminix/Trash Services	10,000.00	459.43	2,883.30	0.00	0.00	7,116.70
20E020	2540	3210	00	000000	RCES Termnx/Trash Serv	15,000.00	1,604.11	11,368.95	0.00	0.00	3,631.05
20E040	2540	3210	00	000000	RCMS Termnxs/Trash Serv	10,000.00	933.13	6,931.13	0.00	0.00	3,068.87
20E045	2540	3210	00	000000	RISE UP Terminix/Trash	1,500.00	0.00	0.00	0.00	1.00	1,499.00
20E050	2540	3210	00	000000	RCHS Termnx/Trash Serv	32,000.00	3,237.31	21,699.74	0.00	0.00	10,300.26
20E010	2540	3320	00	000000	District Maint Travel	500.00	0.00	0.00	0.00	0.00	500.00
20E015	2540	3700	00	000000	ELC Water/Sewer	1,500.00	138.11	920.69	0.00	0.00	579.31
20E020	2540	3700	00	000000	RCES Water/Sewer	22,000.00	1,762.71	11,325.61	0.00	0.00	10,674.39
20E040	2540	3700	00	000000	RCMS Water/Sewer	20,000.00	1,124.87	8,731.97	0.00	0.00	11,268.03
20E045	2540	3700	00	000000	RISE UP Water & Sewer	2,500.00	34.69	246.85	0.00	0.00	2,253.15
20E050	2540	3700	00	000000	RCHS Water/Sewer	18,000.00	1,121.16	10,189.05	0.00	0.00	7,810.95
20E---	2540	3---	--	-----		446,500.00	18,662.39	471,709.56	6,326.39	1.00	-31,536.95
20E010	2540	4100	00	000000	District Maint Supplies	15,000.00	3,378.97	16,231.43	84.92	730.00	-2,046.35
20E015	2540	4100	00	000000	ELC Custodian Supplies	8,000.00	574.55	1,872.61	522.22	0.00	5,605.17
20E020	2540	4100	00	000000	RCES Cust Supp	45,000.00	4,803.34	21,597.99	565.24	9,749.40	13,087.37

FDTLOC	FUNC	OBJ	SJ	Account Level Description	2025-26 Budget	February 2025-26 Monthly Activity	2025-26 FYTD Activity	2025-26 Batch Activity	Encumbered Amount	2025-26 Available Funds	
20E040	2540	4100	00	000000	RCMS Custodial Supplies	22,000.00	2,039.30	13,598.44	346.81	706.61	7,348.14
20E045	2540	4100	00	000000	RISE UP Custodian Supplies	3,500.00	166.77	2,772.96	0.00	947.09	-220.05
20E050	2540	4100	00	000000	RCHS Custodial Supplies	40,000.00	5,858.11	29,388.64	1,732.46	2,641.10	6,237.80
20E050	2540	4110	00	000000	RCHS Athletic Fld Supp	5,000.00	0.00	0.00	0.00	0.00	5,000.00
20E010	2540	4640	00	000000	District Maint Fuel	5,000.00	0.00	0.00	0.00	70.48	4,929.52
20E---	2540	4---	--	-----		143,500.00	16,821.04	85,462.07	3,251.65	14,844.68	39,941.60
20E010	2540	5500	00	000000	District Maint Equip	5,000.00	0.00	22,395.00	0.00	0.00	-17,395.00
20E015	2540	5500	00	000000	ELC Custodian Equipment	2,500.00	0.00	0.00	0.00	0.00	2,500.00
20E020	2540	5500	00	000000	RCES Cust Equipment	8,000.00	0.00	14,931.84	0.00	2,668.23	-9,600.07
20E040	2540	5500	00	000000	RCMS Custodial Equip	5,000.00	670.66	6,899.14	0.00	0.00	-1,899.14
20E050	2540	5500	00	000000	RCHS Custodian Equip	10,000.00	0.00	9,039.27	0.00	24,990.00	-24,029.27
20E---	2540	5---	--	-----		30,500.00	670.66	53,265.25	0.00	27,658.23	-50,423.48
20E050	2540	7500	00	000000	RCHS Non Capitalized Equipment	0.00	4,754.00	4,754.00	0.00	0.00	-4,754.00
20E---	2540	7---	--	-----		0.00	4,754.00	4,754.00	0.00	0.00	-4,754.00
20E010	2541	1110	00	000000	District Maint Sal	82,177.00	13,151.69	76,464.17	0.00	0.00	5,712.83
20E---	2541	1---	--	-----		82,177.00	13,151.69	76,464.17	0.00	0.00	5,712.83
20E010	2541	2200	00	000000	District Maint Ins Ben	10,500.00	1,720.00	8,070.72	0.00	0.00	2,429.28
20E---	2541	2---	--	-----		10,500.00	1,720.00	8,070.72	0.00	0.00	2,429.28
20E010	2541	4650	00	000000	District Warehouse Nat Gas	3,000.00	0.00	352.89	0.00	0.00	2,647.11
20E---	2541	4---	--	-----		3,000.00	0.00	352.89	0.00	0.00	2,647.11
20E010	2542	1110	00	000000	District Summer Maint Sal	138,282.00	0.00	82,890.89	0.00	0.00	55,391.11
20E---	2542	1---	--	-----		138,282.00	0.00	82,890.89	0.00	0.00	55,391.11
20E010	2542	3190	00	000000	District Summer Maint Pur Serv	950,000.00	0.00	164,416.16	0.00	0.00	785,583.84
20E010	2542	3320	00	000000	District Summer Maint Trav	500.00	0.00	116.71	0.00	0.00	383.29
20E---	2542	3---	--	-----		950,500.00	0.00	164,532.87	0.00	0.00	785,967.13
20E010	2542	4100	00	000000	District Summer Maint Supp	60,000.00	0.00	39,079.98	0.00	0.00	20,920.02
20E---	2542	4---	--	-----		60,000.00	0.00	39,079.98	0.00	0.00	20,920.02
20E010	2542	5500	00	000000	Sumr Maint Equipment	10,000.00	0.00	9,045.82	0.00	0.00	954.18
20E---	2542	5---	--	-----		10,000.00	0.00	9,045.82	0.00	0.00	954.18
20E---	2---	----	--	-----		1,874,959.00	55,779.78	995,628.22	9,578.04	42,503.91	827,248.83
2-E---	----	----	--	-----		1,874,959.00	55,779.78	995,628.22	9,578.04	42,503.91	827,248.83
30E010	5200	6200	00	000000	Long Term Bond Interest	1,444,140.00	0.00	760,546.88	0.00	0.00	683,593.12
30E010	5200	6250	00	000000	Long Term Bond Maintenance Fee	2,000.00	0.00	1,000.00	0.00	0.00	1,000.00
30E---	5200	6---	--	-----		1,446,140.00	0.00	761,546.88	0.00	0.00	684,593.12
30E010	5300	6100	00	000000	Long Term Bond Principal	1,385,000.00	0.00	1,530,000.00	0.00	0.00	-145,000.00
30E---	5300	6---	--	-----		1,385,000.00	0.00	1,530,000.00	0.00	0.00	-145,000.00
30E---	5---	----	--	-----		2,831,140.00	0.00	2,291,546.88	0.00	0.00	539,593.12
3-E---	----	----	--	-----		2,831,140.00	0.00	2,291,546.88	0.00	0.00	539,593.12
40E080	2550	1110	00	000000	Trans Mechanic/Maint Sal	91,864.00	7,592.03	58,678.43	0.00	0.00	33,185.57
40E080	2550	1110	61	000000	Trans Bus Drivers Sal	309,934.00	36,300.87	328,368.80	0.00	0.00	-18,434.80

FDTLOC	FUNC	OBJ	SJ	Account Level Description	2025-26 Budget	February 2025-26 Monthly Activity	2025-26 FYTD Activity	2025-26 Batch Activity	Encumbered Amount	2025-26 Available Funds
40E080	2550	1110	70	000000	Trans Sec/Supervisor Sal	320,716.00	10,813.17	101,989.04	0.00	218,726.96
40E620	2550	1110	00	620000	Trans Spec Ed bus Aide Sal	159,040.00	5,869.00	51,798.98	0.00	107,241.02
40E080	2550	1210	00	000000	Trans Sub Drivers Sal	0.00	2,419.95	16,130.63	0.00	-16,130.63
40E080	2550	1210	61	000000	Reg Rte Sub Bus Driver Sal	15,114.00	1,352.50	8,419.86	0.00	6,694.14
40E620	2550	1210	00	620000	Trans Sub Spec Ed Aide Sal	786.00	1,002.88	2,501.38	0.00	-1,715.38
40E080	2550	1310	00	000000	Trans Trip Drvr Sal	71,285.00	5,071.57	44,724.78	0.00	26,560.22
40E---	2550	1---	--	-----		968,739.00	70,421.97	612,611.90	0.00	356,127.10
40E080	2550	2110	00	000000	Trans TRS	0.00	0.00	75.15	0.00	-75.15
40E080	2550	2200	00	000000	Trans Dir Ins Benefit	0.00	1,146.68	4,586.73	0.00	-4,586.73
40E080	2550	2200	61	000000	Trans Drivers Ins Ben	125,000.00	9,498.27	69,102.30	0.00	55,897.70
40E080	2550	2200	70	000000	Trans Sec/Supvr Ins Ben	21,000.00	860.00	19,515.32	0.00	1,484.68
40E620	2550	2200	00	620000	Trans Spec Ed Ins Ben	24,000.00	2,293.36	13,760.16	0.00	10,239.84
40E---	2550	2---	--	-----		170,000.00	13,798.31	107,039.66	0.00	62,960.34
40E080	2550	3190	00	000000	Trans Physicals/LicenseRenewal	10,000.00	95.00	-991.44	0.00	10,991.44
40E620	2550	3190	00	620000	Sp Ed Trans Contract Fee	16,000.00	4,287.65	22,918.85	3,201.60	-10,120.45
40E080	2550	3210	00	000000	Trans Trash P/U	2,500.00	286.80	1,679.57	0.00	820.43
40E080	2550	3230	00	000000	Trans Repair/Maint	40,000.00	1,196.98	30,857.14	1,447.25	6,655.20
40E080	2550	3270	00	000000	Trans Charter Bus Service	1,500.00	0.00	0.00	0.00	1,500.00
40E080	2550	3320	00	000000	Trans Travel	0.00	0.00	51.46	0.00	-51.46
40E080	2550	3390	00	000000	Trans Drug/Fngrprnt Fee	5,000.00	120.00	4,682.00	0.00	125.00
40E080	2550	3600	00	000000	Trans Printing	500.00	0.00	18.88	0.00	481.12
40E080	2550	3900	00	000000	Trans Bus Inspection Fee	7,500.00	450.00	3,516.00	66.00	924.00
40E---	2550	3---	--	-----		83,000.00	6,436.43	62,732.46	4,714.85	2,089.41
40E080	2550	4100	00	000000	Trans Supplies	65,000.00	6,015.74	48,135.34	-126.00	2,709.36
40E080	2550	4240	00	000000	Trans. Copier Paper & Toner	250.00	0.00	0.00	0.00	250.00
40E080	2550	4620	00	000000	Trans Oil	8,000.00	769.58	3,686.41	0.00	4,313.59
40E080	2550	4640	00	000000	Trans Fuel	180,000.00	15,217.60	104,437.65	0.00	23,158.34
40E080	2550	4700	00	000000	Trans Software	20,000.00	0.00	0.00	0.00	20,000.00
40E---	2550	4---	--	-----		273,250.00	22,002.92	156,259.40	-126.00	25,867.70
40E080	2550	5500	00	000000	Trans Equipment	50,000.00	1,257.28	9,309.23	0.00	40,690.77
40E---	2550	5---	--	-----		50,000.00	1,257.28	9,309.23	0.00	40,690.77
40E---	2---	----	--	-----		1,544,989.00	113,916.91	947,952.65	4,588.85	27,957.11
4-E---	----	----	--	-----		1,544,989.00	113,916.91	947,952.65	4,588.85	27,957.11
50E343	1100	2120	00	000000	ESSER III IMRF	1,000.00	-37.71	-37.71	0.00	1,037.71
50E470	1100	2120	00	470000	21st Century IMRF	3,700.00	0.00	0.00	0.00	3,700.00
50E070	1100	2130	00	000000	21st Century FICA	10.00	0.00	0.00	0.00	10.00
50E343	1100	2130	00	000000	ESSER III FICA	750.00	-25.09	-25.09	0.00	775.09
50E470	1100	2130	00	470000	21st Century FICA	4,400.00	0.00	0.00	0.00	4,400.00
50E070	1100	2140	00	000000	21st Century Med	30.00	0.00	0.00	0.00	30.00
50E343	1100	2140	00	000000	ESSER III Inst. Medicare	750.00	-5.87	-5.87	0.00	755.87

131

Account Level				2025-26	February 2025-26	2025-26	2025-26	Encumbered	2025-26	
FDTLOC	FUNC	OBJ	SJ	Description	Budget	Monthly Activity	FYTD Activity	Batch Activity	Amount	Available Funds
50E470	1100	2140	00	470000	21st Century Med	3,350.00	0.00	0.00	0.00	3,350.00
50E---	1100	2---	--	-----	13,990.00	-68.67	-68.67	0.00	0.00	14,058.67
50E015	1105	2120	00	000000	ELC IMRF	510.00	0.00	0.00	0.00	510.00
50E015	1105	2130	00	000000	ELC FICA	510.00	0.00	0.00	0.00	510.00
50E015	1105	2140	00	000000	ELC Medicare	255.00	0.00	4.23	0.00	250.77
50E---	1105	2---	--	-----	1,275.00	0.00	4.23	0.00	0.00	1,270.77
50E020	1110	2120	00	000000	RCES IMRF	2,289.00	1,131.87	9,565.26	0.00	-7,276.26
50E020	1110	2130	00	000000	RCES FICA	14,897.00	854.98	7,553.51	0.00	7,343.49
50E020	1110	2140	00	000000	RCES Medicare	45,626.00	2,962.84	25,875.33	0.00	19,750.67
50E---	1110	2---	--	-----	62,812.00	4,949.69	42,994.10	0.00	0.00	19,817.90
50E040	1120	2120	00	000000	RCMS IMRF	3,168.00	135.58	1,844.55	0.00	1,323.45
50E040	1120	2130	00	000000	RCMS FICA	10,009.00	70.23	1,280.18	0.00	8,728.82
50E040	1120	2140	00	000000	RCMS Medicare	24,280.00	1,553.14	14,193.60	0.00	10,086.40
50E---	1120	2---	--	-----	37,457.00	1,758.95	17,318.33	0.00	0.00	20,138.67
50E110	1125	2120	00	110000	Pre K IMRF	12,000.00	0.00	1,485.35	0.00	10,514.65
50E510	1125	2120	00	510000	Pre K IMRF	3,016.00	1,467.62	10,133.41	0.00	-7,117.41
50E110	1125	2130	00	110000	Pre K FICA	7,350.00	0.00	880.64	0.00	6,469.36
50E510	1125	2130	00	510000	Pre K FICA	12,087.00	893.49	6,103.95	0.00	5,983.05
50E110	1125	2140	00	110000	Pre K Medicare	3,500.00	0.00	324.59	0.00	3,175.41
50E510	1125	2140	00	510000	Pre K Medicare	5,716.00	487.35	3,311.31	0.00	2,404.69
50E---	1125	2---	--	-----	43,669.00	2,848.46	22,239.25	0.00	0.00	21,429.75
50E050	1130	2120	00	000000	RCHS IMRF	3,675.00	333.78	2,034.08	0.00	1,640.92
50E050	1130	2130	00	000000	RCHS FICA	5,250.00	207.28	1,244.77	0.00	4,005.23
50E050	1130	2140	00	000000	RCHS Medicare	27,922.00	1,854.69	16,691.81	0.00	11,230.19
50E---	1130	2---	--	-----	36,847.00	2,395.75	19,970.66	0.00	0.00	16,876.34
50E045	1145	2120	00	000000		0.00	4.83	20.60	0.00	-20.60
50E045	1145	2130	00	000000		2,907.00	3.14	38.77	0.00	2,868.23
50E045	1145	2140	00	000000		2,334.00	118.57	789.77	0.00	1,544.23
50E---	1145	2---	--	-----	5,241.00	126.54	849.14	0.00	0.00	4,391.86
50E330	1170	2140	00	330000	Title II Teach Qual MED	1,900.00	0.00	218.78	0.00	1,681.22
50E530	1170	2140	00	530000	Title II Med	0.00	92.24	592.74	0.00	-592.74
50E---	1170	2---	--	-----	1,900.00	92.24	811.52	0.00	0.00	1,088.48
50E140	1200	2130	00	140000		253.00	0.00	0.00	0.00	253.00
50E140	1200	2140	00	140000		59.00	9.67	31.67	0.00	27.33
50E---	1200	2---	--	-----	312.00	9.67	31.67	0.00	0.00	280.33
50E140	1204	2120	00	140000	Prsnl Aide/Ast IMRF	4,186.00	1,125.73	13,324.26	0.00	-9,138.26
50E140	1204	2130	00	140000	Prsnl Aide/Ast FICA	11,770.00	762.65	8,385.56	0.00	3,384.44
50E140	1204	2140	00	140000	Prsnl Aide/Ast Med	2,753.00	178.36	1,967.07	0.00	785.93
50E---	1204	2---	--	-----	18,709.00	2,066.74	23,676.89	0.00	0.00	-4,967.89
50E140	1205	2120	00	140000	LD Aide/Asst IMRF	0.00	23.06	224.69	0.00	-224.69

Account Level				2025-26	February 2025-26	2025-26	2025-26	Encumbered	2025-26	
FDTLOC	FUNC	OBJ	SJ	Description	Budget	Monthly Activity	FYTD Activity	Batch Activity	Amount	Available Funds
50E140	1205	2130	00	140000 LD Aide/Asst FICA	7,048.00	352.10	2,411.93	0.00	0.00	4,636.07
50E140	1205	2140	00	140000 LD Medicare	4,776.00	229.66	2,257.98	0.00	0.00	2,518.02
50E---	1205	2---	--	-----	11,824.00	604.82	4,894.60	0.00	0.00	6,929.40
50E140	1206	2120	00	140000	0.00	0.00	156.78	0.00	0.00	-156.78
50E140	1206	2130	00	140000	0.00	0.00	119.77	0.00	0.00	-119.77
50E140	1206	2140	00	140000	0.00	0.00	29.97	0.00	0.00	-29.97
50E---	1206	2---	--	-----	0.00	0.00	306.52	0.00	0.00	-306.52
50E280	1213	2130	00	280000 Homebound FICA	1,254.00	0.00	0.00	0.00	0.00	1,254.00
50E280	1213	2140	00	280000 Homebound Medicare	293.00	17.49	76.29	0.00	0.00	216.71
50E---	1213	2---	--	-----	1,547.00	17.49	76.29	0.00	0.00	1,470.71
50E280	1216	2120	00	280000 Autism IMRF	3,000.00	-12.71	417.25	0.00	0.00	2,582.75
50E280	1216	2130	00	280000 Autism FICA	35.00	-8.28	256.58	0.00	0.00	-221.58
50E280	1216	2140	00	280000 Autism Med	8.00	-1.94	60.01	0.00	0.00	-52.01
50E---	1216	2---	--	-----	3,043.00	-22.93	733.84	0.00	0.00	2,309.16
50E140	1220	2120	00	140000 EMH/LD Aide/Asst IMRF	4,696.00	844.42	8,712.53	0.00	0.00	-4,016.53
50E140	1220	2130	00	140000 EMH/LD Aide/Asst FICA	8,189.00	520.37	5,210.27	0.00	0.00	2,978.73
50E140	1220	2140	00	140000 EMH/LD Medicare	10,965.00	903.47	7,965.21	0.00	0.00	2,999.79
50E---	1220	2---	--	-----	23,850.00	2,268.26	21,888.01	0.00	0.00	1,961.99
50E100	1250	2120	00	100000 Title I IMRF	38,000.00	0.00	6,993.60	0.00	0.00	31,006.40
50E500	1250	2120	00	500000 Title I IMRF Prior	0.00	2,811.18	20,554.80	0.00	0.00	-20,554.80
50E100	1250	2130	00	100000 Title I FICA	27,500.00	0.00	4,294.21	0.00	0.00	23,205.79
50E500	1250	2130	00	500000 Title I FICA Prior	21,545.00	1,840.63	12,709.65	0.00	0.00	8,835.35
50E100	1250	2140	00	100000 Title I Medicare	8,400.00	0.00	1,212.85	0.00	0.00	7,187.15
50E500	1250	2140	00	500000 Title I Medicare Prior	7,050.00	488.12	3,329.09	0.00	0.00	3,720.91
50E---	1250	2---	--	-----	102,495.00	5,139.93	49,094.20	0.00	0.00	53,400.80
50E050	1400	2130	00	000000 RCHS BT/Voc FICA	850.00	0.00	57.50	0.00	0.00	792.50
50E390	1400	2130	00	390000 Voc Tutor FICA	385.00	0.00	0.00	0.00	0.00	385.00
50E780	1400	2130	00	780000	310.00	0.00	0.00	0.00	0.00	310.00
50E050	1400	2140	00	000000 RCHS Voc Medicare	7,808.00	546.74	4,975.79	0.00	0.00	2,832.21
50E390	1400	2140	00	390000 Voc Tutor Med	90.00	0.44	9.23	0.00	0.00	80.77
50E480	1400	2140	00	480000 Ag 3 Circles Med	390.00	20.66	206.19	0.00	0.00	183.81
50E780	1400	2140	00	780000	73.00	0.01	295.49	0.00	0.00	-222.49
50E---	1400	2---	--	-----	9,906.00	567.85	5,544.20	0.00	0.00	4,361.80
50E410	1459	2120	00	410000 JROTC Instructor IMRF	16,000.00	1,232.66	10,619.03	0.00	0.00	5,380.97
50E410	1459	2130	00	410000 JROTC Instructor FICA	13,080.00	817.17	6,748.68	0.00	0.00	6,331.32
50E410	1459	2140	00	410000 JROTC Instructor Med	3,059.00	191.10	1,578.29	0.00	0.00	1,480.71
50E---	1459	2---	--	-----	32,139.00	2,240.93	18,946.00	0.00	0.00	13,193.00
50E050	1500	2120	00	000000 RCHS AD IMRF	55.00	0.00	0.00	0.00	0.00	55.00
50E050	1500	2130	00	000000 RCHS AD FICA	88.00	0.00	0.00	0.00	0.00	88.00
50E050	1500	2140	00	000000 RCHS A D Medicare	847.00	62.77	587.95	0.00	0.00	259.05

Account Level				2025-26	February 2025-26	2025-26	2025-26	Encumbered	2025-26	
FDTLOC	FUNC	OBJ	SJ	Description	Budget	Monthly Activity	FYTD Activity	Batch Activity	Amount	Available Funds
50E---	1500	2---	--	-----	990.00	62.77	587.95	0.00	0.00	402.05
50E050	1505	2140	00	000000	49.00	2.61	25.04	0.00	0.00	23.96
50E---	1505	2---	--	-----	49.00	2.61	25.04	0.00	0.00	23.96
50E050	1509	2140	00	000000	18.00	1.40	13.96	0.00	0.00	4.04
50E---	1509	2---	--	-----	18.00	1.40	13.96	0.00	0.00	4.04
50E050	1510	2120	00	000000	325.00	0.00	0.00	0.00	0.00	325.00
50E050	1510	2130	00	000000	280.00	83.39	241.48	0.00	0.00	38.52
50E050	1510	2140	00	000000	166.00	55.18	128.10	0.00	0.00	37.90
50E---	1510	2---	--	-----	771.00	138.57	369.58	0.00	0.00	401.42
50E050	1511	2120	00	000000	55.00	0.00	399.06	0.00	0.00	-344.06
50E050	1511	2130	00	000000	228.00	0.00	228.18	0.00	0.00	-0.18
50E050	1511	2140	00	000000	133.00	0.00	136.18	0.00	0.00	-3.18
50E---	1511	2---	--	-----	416.00	0.00	763.42	0.00	0.00	-347.42
50E050	1512	2120	00	000000	0.00	0.00	12.45	0.00	0.00	-12.45
50E050	1512	2130	00	000000	254.00	0.00	549.06	0.00	0.00	-295.06
50E050	1512	2140	00	000000	126.00	0.00	127.05	0.00	0.00	-1.05
50E---	1512	2---	--	-----	380.00	0.00	688.56	0.00	0.00	-308.56
50E050	1520	2120	00	000000	0.00	0.00	399.06	0.00	0.00	-399.06
50E050	1520	2130	00	000000	253.00	0.00	250.17	0.00	0.00	2.83
50E050	1520	2140	00	000000	59.00	0.00	58.51	0.00	0.00	0.49
50E---	1520	2---	--	-----	312.00	0.00	707.74	0.00	0.00	-395.74
50E050	1521	2120	00	000000	35.00	0.00	38.07	0.00	0.00	-3.07
50E050	1521	2130	00	000000	277.00	0.00	524.56	0.00	0.00	-247.56
50E050	1521	2140	00	000000	353.00	0.00	240.52	0.00	0.00	112.48
50E---	1521	2---	--	-----	665.00	0.00	803.15	0.00	0.00	-138.15
50E050	1522	2120	00	000000	60.00	27.03	40.38	0.00	0.00	19.62
50E050	1522	2130	00	000000	65.00	313.86	350.43	0.00	0.00	-285.43
50E050	1522	2140	00	000000	255.00	271.78	281.65	0.00	0.00	-26.65
50E---	1522	2---	--	-----	380.00	612.67	672.46	0.00	0.00	-292.46
50E050	1523	2120	00	000000	0.00	0.00	69.23	0.00	0.00	-69.23
50E050	1523	2130	00	000000	54.00	0.00	45.88	0.00	0.00	8.12
50E050	1523	2140	00	000000	134.00	0.00	10.68	0.00	0.00	123.32
50E---	1523	2---	--	-----	188.00	0.00	125.79	0.00	0.00	62.21
50E050	1524	2130	00	000000	146.00	0.00	0.00	0.00	0.00	146.00
50E050	1524	2140	00	000000	122.00	0.00	0.00	0.00	0.00	122.00
50E---	1524	2---	--	-----	268.00	0.00	0.00	0.00	0.00	268.00
50E050	1525	2130	00	000000	691.00	0.00	138.98	0.00	0.00	552.02
50E050	1525	2140	00	000000	162.00	0.00	32.50	0.00	0.00	129.50
50E---	1525	2---	--	-----	853.00	0.00	171.48	0.00	0.00	681.52
50E050	1530	2130	00	000000	306.00	0.00	0.00	0.00	0.00	306.00

Account Level					2025-26	February 2025-26	2025-26	2025-26	Encumbered	2025-26
FDTLOC	FUNC	OBJ	SJ	Description	Budget	Monthly Activity	FYTD Activity	Batch Activity	Amount	Available Funds
50E050	1530	2140	00 000000	RCHS Boys Tennis Cch Med	71.00	0.00	0.00	0.00	0.00	71.00
50E---	1530	2---	-- -----		377.00	0.00	0.00	0.00	0.00	377.00
50E050	1531	2120	00 000000	RCHS Football IMRF	110.00	0.00	123.11	0.00	0.00	-13.11
50E050	1531	2130	00 000000	RCHS Football FICA	1,167.00	17.36	1,674.17	0.00	0.00	-507.17
50E050	1531	2140	00 000000	RCHS Football Coach Medicare	375.00	3.95	500.89	0.00	0.00	-125.89
50E---	1531	2---	-- -----		1,652.00	21.31	2,298.17	0.00	0.00	-646.17
50E050	1532	2120	00 000000	RCHS Boys Basketball IMRF	170.00	23.30	43.50	0.00	0.00	126.50
50E050	1532	2130	00 000000	RCHS Boys Basketball FICA	829.00	1,195.56	1,250.00	0.00	0.00	-421.00
50E050	1532	2140	00 000000	RCHS Boys Basketball Medicare	324.00	279.30	242.22	0.00	0.00	81.78
50E---	1532	2---	-- -----		1,323.00	1,498.16	1,535.72	0.00	0.00	-212.72
50E050	1533	2120	00 000000	RCHS Boys Track IMRF	60.00	0.00	0.00	0.00	0.00	60.00
50E050	1533	2130	00 000000	RCHS Boys Track FICA	130.00	0.00	43.40	0.00	0.00	86.60
50E050	1533	2140	00 000000	RCHS Boys Track Medicare	131.00	0.00	10.15	0.00	0.00	120.85
50E---	1533	2---	-- -----		321.00	0.00	53.55	0.00	0.00	267.45
50E050	1534	2130	00 000000	RCHS Boys Baseball FICA	152.00	0.00	0.00	0.00	0.00	152.00
50E050	1534	2140	00 000000	RCHS Boys Baseball Med	95.00	0.00	0.00	0.00	0.00	95.00
50E---	1534	2---	-- -----		247.00	0.00	0.00	0.00	0.00	247.00
50E050	1536	2130	00 000000	RCHS Soccer Coach FICA	152.00	0.00	430.85	0.00	0.00	-278.85
50E050	1536	2140	00 000000	RCHS Soccer Coach Med	127.00	0.00	100.76	0.00	0.00	26.24
50E---	1536	2---	-- -----		279.00	0.00	531.61	0.00	0.00	-252.61
50E050	1537	2130	00 000000	HS Bass Fishing FICA	153.00	0.00	0.00	0.00	0.00	153.00
50E050	1537	2140	00 000000	HS Bass Fishing Medicare	36.00	0.00	0.00	0.00	0.00	36.00
50E---	1537	2---	-- -----		189.00	0.00	0.00	0.00	0.00	189.00
50E040	1540	2140	00 000000	RCMS AD Med	551.00	41.85	378.23	0.00	0.00	172.77
50E---	1540	2---	-- -----		551.00	41.85	378.23	0.00	0.00	172.77
50E040	1550	2130	00 000000	RCMS Chrldr Spons FICA	347.00	0.00	0.00	0.00	0.00	347.00
50E040	1550	2140	00 000000	RCMS Cheerleader Medicare	81.00	0.00	0.00	0.00	0.00	81.00
50E---	1550	2---	-- -----		428.00	0.00	0.00	0.00	0.00	428.00
50E040	1551	2130	00 000000	RCMS X-Country FICA	48.00	0.00	320.34	0.00	0.00	-272.34
50E040	1551	2140	00 000000	RCMS X-Country Medicare	75.00	0.00	76.88	0.00	0.00	-1.88
50E---	1551	2---	-- -----		123.00	0.00	397.22	0.00	0.00	-274.22
50E040	1552	2130	00 000000	RCMS Baseball IMRF	83.00	0.00	20.87	0.00	0.00	62.13
50E040	1552	2140	00 000000	RCMS Baseball Medicare	54.00	0.00	40.38	0.00	0.00	13.62
50E---	1552	2---	-- -----		137.00	0.00	61.25	0.00	0.00	75.75
50E040	1553	2130	00 000000		0.00	0.00	73.43	0.00	0.00	-73.43
50E040	1553	2140	00 000000	RCMS Softball Medicare	57.00	0.00	57.15	0.00	0.00	-0.15
50E---	1553	2---	-- -----		57.00	0.00	130.58	0.00	0.00	-73.58
50E040	1560	2120	00 000000	RCMS Girls Basketball IMRF	275.00	15.84	67.07	0.00	0.00	207.93
50E040	1560	2130	00 000000	RCMS Girls Basketball FICA	687.00	10.54	598.77	0.00	0.00	88.23
50E040	1560	2140	00 000000	RCMS Girls Basketball Medicare	161.00	3.60	139.49	0.00	0.00	21.51

Account Level				2025-26	February 2025-26	2025-26	2025-26	Encumbered	2025-26	
FDTLOC	FUNC	OBJ	SJ	Description	Budget	Monthly Activity	FYTD Activity	Batch Activity	Amount	Available Funds
50E---	1560	2---	--	-----	1,123.00	29.98	805.33	0.00	0.00	317.67
50E040	1561	2120	00	000000	RCMS Volleyball Workers IMRF	170.00	18.17	18.17	0.00	151.83
50E040	1561	2130	00	000000	RCMS Volleyball Workers FICA	157.00	30.38	45.26	0.00	111.74
50E040	1561	2140	00	000000	RCMS Volleyball Medicare	150.00	6.82	10.24	0.00	139.76
50E---	1561	2---	--	-----	477.00	55.37	73.67	0.00	0.00	403.33
50E040	1562	2120	00	000000	RCMS Girls Track IMRF	60.00	0.00	0.00	0.00	60.00
50E040	1562	2130	00	000000	RCMS Girls Track FICA	67.00	0.00	0.00	0.00	67.00
50E040	1562	2140	00	000000	RCMS Girls Track Med	67.00	0.00	0.00	0.00	67.00
50E---	1562	2---	--	-----	194.00	0.00	0.00	0.00	0.00	194.00
50E040	1563	2120	00	000000	RCMS 6th Girls Basketball IMRF	25.00	0.00	0.00	0.00	25.00
50E040	1563	2130	00	000000	RCMS 6th Girls Basketball FICA	200.00	194.58	194.58	0.00	5.42
50E040	1563	2140	00	000000	RCMS 6th Girls Basketb Medicare	60.00	45.51	45.51	0.00	14.49
50E---	1563	2---	--	-----	285.00	240.09	240.09	0.00	0.00	44.91
50E040	1564	2120	00	000000	RCMS 6th Boys Basketball IMRF	30.00	6.99	6.99	0.00	23.01
50E040	1564	2130	00	000000	RCMS 6th Boys Basketball FICA	200.00	199.23	199.23	0.00	0.77
50E040	1564	2140	00	000000	RCMS 6th Boy Basketbl Medicare	47.00	46.60	46.60	0.00	0.40
50E---	1564	2---	--	-----	277.00	252.82	252.82	0.00	0.00	24.18
50E040	1570	2120	00	000000	RCMS Boys Basketball IMRF	105.00	34.02	104.81	0.00	0.19
50E040	1570	2130	00	000000	RCMS Boys Basketball FICA	609.00	553.99	676.04	0.00	-67.04
50E040	1570	2140	00	000000	RCMS Boys Basketball Medicare	142.00	129.68	158.24	0.00	-16.24
50E---	1570	2---	--	-----	856.00	717.69	939.09	0.00	0.00	-83.09
50E040	1571	2120	00	000000	RCMS Boys Track IMRF	60.00	0.00	0.00	0.00	60.00
50E040	1571	2130	00	000000	RCMS Boys Track FICA	411.00	0.00	0.00	0.00	411.00
50E040	1571	2140	00	000000	RCMS Boys Track Medicare	96.00	0.00	0.00	0.00	96.00
50E---	1571	2---	--	-----	567.00	0.00	0.00	0.00	0.00	567.00
50E050	1572	2120	00	000000	RCHS Wrestling IMRF	60.00	2.33	9.60	0.00	50.40
50E050	1572	2130	00	000000	RCHS Wrestling Workers FICA	493.00	487.17	490.66	0.00	2.34
50E050	1572	2140	00	000000	RCHS Wrestling Medicare	115.00	113.93	114.75	0.00	0.25
50E---	1572	2---	--	-----	668.00	603.43	615.01	0.00	0.00	52.99
50E040	1575	2140	00	000000	RCMS Yearbook Sponsor Med	60.00	3.64	37.50	0.00	22.50
50E---	1575	2---	--	-----	60.00	3.64	37.50	0.00	0.00	22.50
50E040	1576	2140	00	000000	RCMS Student Council Med	34.00	2.58	17.75	0.00	16.25
50E---	1576	2---	--	-----	34.00	2.58	17.75	0.00	0.00	16.25
50E040	1577	2140	00	000000	RCMS Musical Medicare	23.00	0.00	0.00	0.00	23.00
50E---	1577	2---	--	-----	23.00	0.00	0.00	0.00	0.00	23.00
50E050	1580	2130	00	000000	RCHS Scholar Bowl FICA	57.00	0.00	3.41	0.00	53.59
50E050	1580	2140	00	000000	RCHS Scholastic Bowl Med	48.00	0.00	10.94	0.00	37.06
50E---	1580	2---	--	-----	105.00	0.00	14.35	0.00	0.00	90.65
50E050	1581	2130	00	000000	HS Play FICA	60.00	0.00	0.00	0.00	60.00
50E050	1581	2140	00	000000	HS Play Medicare	57.00	0.00	0.00	0.00	57.00

Account Level				2025-26	February 2025-26	2025-26	2025-26	Encumbered	2025-26	
FDTLOC	FUNC	OBJ	SJ	Description	Budget	Monthly Activity	FYTD Activity	Batch Activity	Amount	Available Funds
50E---	1581	2---	--	-----	117.00	0.00	0.00	0.00	0.00	117.00
50E050	1582	2130	00	000000	167.00	0.00	246.45	0.00	0.00	-79.45
50E050	1582	2140	00	000000	204.00	0.00	204.02	0.00	0.00	-0.02
50E---	1582	2---	--	-----	371.00	0.00	450.47	0.00	0.00	-79.47
50E050	1583	2130	00	000000	278.00	0.00	0.00	0.00	0.00	278.00
50E050	1583	2140	00	000000	337.00	18.40	225.73	0.00	0.00	111.27
50E---	1583	2---	--	-----	615.00	18.40	225.73	0.00	0.00	389.27
50E050	1585	2140	00	000000	117.00	8.19	74.37	0.00	0.00	42.63
50E---	1585	2---	--	-----	117.00	8.19	74.37	0.00	0.00	42.63
50E050	1586	2140	00	000000	51.00	3.38	31.51	0.00	0.00	19.49
50E---	1586	2---	--	-----	51.00	3.38	31.51	0.00	0.00	19.49
50E050	1588	2120	00	000000	35.00	0.00	0.00	0.00	0.00	35.00
50E050	1588	2130	00	000000	35.00	0.00	0.00	0.00	0.00	35.00
50E050	1588	2140	00	000000	35.00	0.00	0.00	0.00	0.00	35.00
50E---	1588	2---	--	-----	105.00	0.00	0.00	0.00	0.00	105.00
50E050	1589	2140	00	000000	34.00	2.35	23.05	0.00	0.00	10.95
50E---	1589	2---	--	-----	34.00	2.35	23.05	0.00	0.00	10.95
50E050	1590	2120	00	000000	710.00	34.14	288.83	0.00	0.00	421.17
50E050	1590	2130	00	000000	482.00	22.66	183.65	0.00	0.00	298.35
50E050	1590	2140	00	000000	113.00	5.30	42.99	0.00	0.00	70.01
50E---	1590	2---	--	-----	1,305.00	62.10	515.47	0.00	0.00	789.53
50E040	1591	2130	00	000000	0.00	6.81	81.72	0.00	0.00	-81.72
50E040	1591	2140	00	000000	68.00	9.29	87.08	0.00	0.00	-19.08
50E---	1591	2---	--	-----	68.00	16.10	168.80	0.00	0.00	-100.80
50E040	1593	2140	00	000000	23.00	0.00	22.63	0.00	0.00	0.37
50E---	1593	2---	--	-----	23.00	0.00	22.63	0.00	0.00	0.37
50E040	1594	2140	00	000000	35.00	0.00	0.00	0.00	0.00	35.00
50E---	1594	2---	--	-----	35.00	0.00	0.00	0.00	0.00	35.00
50E040	1598	2120	00	000000	10.00	0.00	0.00	0.00	0.00	10.00
50E040	1598	2130	00	000000	10.00	0.00	0.00	0.00	0.00	10.00
50E040	1598	2140	00	000000	10.00	0.00	0.00	0.00	0.00	10.00
50E---	1598	2---	--	-----	30.00	0.00	0.00	0.00	0.00	30.00
50E040	1599	2140	00	000000	30.00	0.00	0.00	0.00	0.00	30.00
50E---	1599	2---	--	-----	30.00	0.00	0.00	0.00	0.00	30.00
50E050	1700	2130	00	000000	3,127.00	0.00	0.00	0.00	0.00	3,127.00
50E050	1700	2140	00	000000	731.00	25.43	396.44	0.00	0.00	334.56
50E---	1700	2---	--	-----	3,858.00	25.43	396.44	0.00	0.00	3,461.56
50E010	1800	2120	00	000000	2,200.00	0.00	0.00	0.00	0.00	2,200.00
50E010	1800	2130	00	000000	88.00	0.00	0.00	0.00	0.00	88.00
50E010	1800	2140	00	000000	21.00	0.00	10.22	0.00	0.00	10.78

Account Level				2025-26	February 2025-26	2025-26	2025-26	Encumbered	2025-26	
FDTLOC	FUNC	OBJ	SJ	Description	Budget	Monthly Activity	FYTD Activity	Batch Activity	Amount	Available Funds
50E---	1800	2---	--	-----	2,309.00	0.00	10.22	0.00	0.00	2,298.78
50E---	1---	----	--	-----	431,727.00	29,416.61	244,540.54	0.00	0.00	187,186.46
50E020	2120	2120	00	000000	RCES Guid IMRF	0.00	322.90	890.86	0.00	-890.86
50E050	2120	2120	00	000000	RCHS Guidance IMRF	3,475.00	249.72	2,485.96	0.00	989.04
50E500	2120	2120	00	500000		0.00	0.00	-0.01	0.00	0.01
50E020	2120	2130	00	000000	RCES Guid FICA	93.00	204.12	558.74	0.00	-465.74
50E050	2120	2130	00	000000	RCHS Guidance FICA	2,218.00	86.35	1,048.74	0.00	1,169.26
50E500	2120	2130	00	500000		0.00	0.00	-0.43	0.00	0.43
50E020	2120	2140	00	000000	RCES Guid Med	888.00	110.59	714.82	0.00	173.18
50E040	2120	2140	00	000000	RCMS Guid Medicare	1,395.00	103.40	799.54	0.00	595.46
50E050	2120	2140	00	000000	RCHS Guidance Medicare	2,252.00	198.01	1,855.18	0.00	396.82
50E470	2120	2140	00	470000	21st Century Med	25.00	0.00	0.00	0.00	25.00
50E500	2120	2140	00	500000		0.00	0.00	-0.11	0.00	0.11
50E---	2120	2---	--	-----	10,346.00	1,275.09	8,353.29	0.00	0.00	1,992.71
50E010	2130	2120	00	000000	District Nurse Aide IMRF	6,300.00	1,127.54	9,425.43	0.00	-3,125.43
50E320	2130	2120	00	320000		0.00	0.00	31.00	0.00	-31.00
50E010	2130	2130	00	000000	District Nurse FICA	6,988.00	714.39	6,160.50	0.00	827.50
50E320	2130	2130	00	320000		0.00	0.00	18.87	0.00	-18.87
50E010	2130	2140	00	000000	District Nurse Medicare	3,493.00	297.25	2,621.72	0.00	871.28
50E320	2130	2140	00	320000		0.00	0.00	4.41	0.00	-4.41
50E---	2130	2---	--	-----	16,781.00	2,139.18	18,261.93	0.00	0.00	-1,480.93
50E140	2140	2130	00	140000		60.00	0.00	0.00	0.00	60.00
50E140	2140	2140	00	140000	Psychologist Med	14.00	0.00	0.00	0.00	14.00
50E---	2140	2---	--	-----	74.00	0.00	0.00	0.00	0.00	74.00
50E280	2150	2130	00	280000	District Speech FICA	13.00	0.00	0.00	0.00	13.00
50E280	2150	2140	00	280000	District Speech Medicare	4,495.00	325.10	2,843.89	0.00	1,651.11
50E---	2150	2---	--	-----	4,508.00	325.10	2,843.89	0.00	0.00	1,664.11
50E020	2190	2120	00	000000	RCES Supervision Aide IMRF	12,000.00	741.20	8,149.69	0.00	3,850.31
50E020	2190	2130	00	000000	RCES Supervision Aide FICA	6,944.00	492.33	5,184.96	0.00	1,759.04
50E040	2190	2130	00	000000		21.00	0.00	0.00	0.00	21.00
50E050	2190	2130	00	000000		131.00	0.00	0.00	0.00	131.00
50E020	2190	2140	00	000000	RCES Behavior Intervention Med	1,624.00	115.18	1,330.89	0.00	293.11
50E040	2190	2140	00	000000		5.00	0.00	0.00	0.00	5.00
50E050	2190	2140	00	000000		31.00	0.00	0.00	0.00	31.00
50E---	2190	2---	--	-----	20,756.00	1,348.71	14,665.54	0.00	0.00	6,090.46
50E110	2210	2120	00	110000	PreK Improv Instr IMRF	35.00	0.00	0.00	0.00	35.00
50E470	2210	2120	00	470000	21st Century IMRF	55.00	0.00	0.00	0.00	55.00
50E110	2210	2130	00	110000	Pre K Imp Inst FICA	35.00	0.00	0.00	0.00	35.00
50E470	2210	2130	00	470000	21st Century FICA	110.00	0.00	0.00	0.00	110.00
50E510	2210	2130	00	510000	At Risk Fica/NC	114.00	0.00	0.00	0.00	114.00

FDTLOC	FUNC	OBJ	SJ	Account Level Description	2025-26 Budget	February 2025-26 Monthly Activity	2025-26 FYTD Activity	2025-26 Batch Activity	Encumbered Amount	2025-26 Available Funds
50E010	2210	2140	00	000000	Improv of Instru Dist Med	2,076.00	133.52	1,254.98	0.00	821.02
50E100	2210	2140	00	100000	Title I Improv Medicare	35.00	0.00	0.00	0.00	35.00
50E110	2210	2140	00	110000	PreK Improv Instr Med	0.00	-2.82	-2.34	0.00	2.34
50E330	2210	2140	00	330000	Title II Teach Medicare	35.00	0.00	0.00	0.00	35.00
50E343	2210	2140	00	000000	ESSER III Imp of Instr Med	400.00	0.00	0.00	0.00	400.00
50E470	2210	2140	00	470000	21st Century Med	55.00	0.00	0.00	0.00	55.00
50E480	2210	2140	00	480000	Ag 3 Circles Med	175.00	5.16	49.08	0.00	125.92
50E500	2210	2140	00	500000	Title I Med	0.00	72.02	468.24	0.00	-468.24
50E510	2210	2140	00	510000	At Risk Med	27.00	2.82	-0.01	0.00	27.01
50E530	2210	2140	00	530000	Prior Yr Title II Med	0.00	0.00	5.97	0.00	-5.97
50E570	2210	2140	00	570000	Title IV Improv Instruc Med	100.00	0.00	0.00	0.00	100.00
50E---	2210	2---	--	-----		3,252.00	210.70	1,775.92	0.00	1,476.08
50E040	2220	2120	00	000000	RCMS IMC IMRF	0.00	0.00	811.12	0.00	-811.12
50E050	2220	2120	00	000000	RCHS IMC IMRF	440.00	0.00	811.04	0.00	-371.04
50E020	2220	2130	00	000000	RCES IMC FICA	39.00	0.00	0.00	0.00	39.00
50E040	2220	2130	00	000000	RCMS IMC FICA	876.00	0.00	511.53	0.00	364.47
50E050	2220	2130	00	000000	RCHS IMC FICA	899.00	0.00	511.49	0.00	387.51
50E020	2220	2140	00	000000	RCES IMC Medicare	909.00	53.24	501.82	0.00	407.18
50E040	2220	2140	00	000000	RCMS IMC Medicare	947.00	53.32	605.43	0.00	341.57
50E050	2220	2140	00	000000	RCHS IMC Medicare	1,301.00	77.15	828.95	0.00	472.05
50E---	2220	2---	--	-----		5,411.00	183.71	4,581.38	0.00	829.62
50E010	2310	2120	00	000000	BOE Treasure/Sec IMRF	950.00	0.00	0.00	0.00	950.00
50E010	2310	2130	00	000000	BOE Treasure/Sec FICA	550.00	0.00	0.00	0.00	550.00
50E010	2310	2140	00	000000	BOE Treas/Sec Med	110.00	0.00	0.00	0.00	110.00
50E---	2310	2---	--	-----		1,610.00	0.00	0.00	0.00	1,610.00
50E010	2320	2120	00	000000	Supt Office IMRF	5,800.00	426.38	4,232.40	0.00	1,567.60
50E010	2320	2130	00	000000	Supt Office FICA	3,954.00	283.51	2,686.32	0.00	1,267.68
50E010	2320	2140	00	000000	Supt Office Medicare	3,513.00	254.73	2,346.75	0.00	1,166.25
50E---	2320	2---	--	-----		13,267.00	964.62	9,265.47	0.00	4,001.53
50E010	2330	2120	00	000000	Asst Supt Sec IMRF	4,300.00	387.72	3,365.76	0.00	934.24
50E100	2330	2120	00	100000	Title I Admin IMRF	110.00	0.00	62.28	0.00	47.72
50E110	2330	2120	00	110000	PreK Administrative IMRF	0.00	0.00	327.45	0.00	-327.45
50E470	2330	2120	00	470000	21st Century IMRF	250.00	0.00	0.00	0.00	250.00
50E500	2330	2120	00	500000	Title I IMRF	0.00	46.04	310.15	0.00	-310.15
50E510	2330	2120	00	510000	PreK Admin IMRF Prior	0.00	183.48	1,342.77	0.00	-1,342.77
50E010	2330	2130	00	000000	Asst Supt Sec FICA	3,005.00	246.80	2,075.69	0.00	929.31
50E070	2330	2130	00	000000	21st Century FICA	10.00	0.00	0.00	0.00	10.00
50E100	2330	2130	00	100000	Title I Admin FICA	389.00	0.00	39.05	0.00	349.95
50E110	2330	2130	00	110000	PreK Administrative FICA	2,100.00	0.00	202.59	0.00	1,897.41
50E470	2330	2130	00	470000	21st Century FICA	145.00	0.00	0.00	0.00	145.00

Account Level				2025-26	February 2025-26	2025-26	2025-26	Encumbered	2025-26		
FDTLOC	FUNC	OBJ	SJ	Description	Budget	Monthly Activity	FYTD Activity	Batch Activity	Amount	Available Funds	
50E500	2330	2130	00	500000	Title I FICA	41.00	30.62	197.97	0.00	0.00	-156.97
50E510	2330	2130	00	510000	PreK Admin FICA Prior	1,579.00	120.28	844.47	0.00	0.00	734.53
50E010	2330	2140	00	000000	Building & Grounds Dir Med	3,733.00	284.40	2,551.47	0.00	0.00	1,181.53
50E070	2330	2140	00	000000	21st Century Med	160.00	0.00	0.00	0.00	0.00	160.00
50E100	2330	2140	00	100000	Title I Adm Medicare	250.00	0.00	26.78	0.00	0.00	223.22
50E110	2330	2140	00	110000	PreK Adm Med	1,300.00	0.00	47.38	0.00	0.00	1,252.62
50E470	2330	2140	00	470000	21st Century Med	110.00	0.00	0.00	0.00	0.00	110.00
50E500	2330	2140	00	500000	Title I Med	10.00	18.72	122.51	0.00	0.00	-112.51
50E510	2330	2140	00	510000	PreK Admin Med	369.00	28.12	197.47	0.00	0.00	171.53
50E---	2330	2---	--	-----	17,861.00	1,346.18	11,713.79	0.00	0.00	0.00	6,147.21
50E110	2331	2120	00	110000	PI Sec IMRF	1,100.00	0.00	242.00	0.00	0.00	858.00
50E280	2331	2120	00	280000	Sp Ed Sec IMRF	3,700.00	179.96	2,289.54	0.00	0.00	1,410.46
50E510	2331	2120	00	510000	PI Adm Sec IMRF	0.00	78.64	575.47	0.00	0.00	-575.47
50E110	2331	2130	00	110000	PI Sec FICA	950.00	0.00	149.69	0.00	0.00	800.31
50E280	2331	2130	00	280000	Sp Ed Sec FICA	2,200.00	117.10	1,412.45	0.00	0.00	787.55
50E510	2331	2130	00	510000	PI Adm Fica	677.00	51.56	361.98	0.00	0.00	315.02
50E110	2331	2140	00	110000	PI Sec Med	265.00	0.00	35.01	0.00	0.00	229.99
50E280	2331	2140	00	280000	Sp Needs Dir Med	1,536.00	104.43	1,266.63	0.00	0.00	269.37
50E510	2331	2140	00	510000	Pre K Adm Sec Med	158.00	12.06	84.69	0.00	0.00	73.31
50E---	2331	2---	--	-----	10,586.00	543.75	6,417.46	0.00	0.00	0.00	4,168.54
50E015	2410	2120	00	000000	ELC Principal IMRF	510.00	0.00	0.00	0.00	0.00	510.00
50E020	2410	2120	00	000000	RCES Principal IMRF	11,000.00	965.10	8,900.10	0.00	0.00	2,099.90
50E040	2410	2120	00	000000	RCMS Principal IMRF	5,250.00	462.63	4,346.68	0.00	0.00	903.32
50E045	2410	2120	00	000000		0.00	213.53	1,754.46	0.00	0.00	-1,754.46
50E050	2410	2120	00	000000	RCHS Principal IMRF	12,600.00	783.43	7,208.22	0.00	0.00	5,391.78
50E015	2410	2130	00	000000	ELC Principal FICA	510.00	0.00	0.00	0.00	0.00	510.00
50E020	2410	2130	00	000000	RCES Principal FICA	9,925.00	628.97	6,199.55	0.00	0.00	3,725.45
50E040	2410	2130	00	000000	RCMS Principal FICA	3,883.00	307.76	2,733.23	0.00	0.00	1,149.77
50E045	2410	2130	00	000000		2,047.00	130.15	1,065.51	0.00	0.00	981.49
50E050	2410	2130	00	000000	RCHS Principal FICA	6,313.00	510.48	4,664.62	0.00	0.00	1,648.38
50E015	2410	2140	00	000000	ELC Principal Medicare	1,088.00	61.86	627.78	0.00	0.00	460.22
50E020	2410	2140	00	000000	RCES Principal Medicare	6,875.00	476.59	4,490.42	0.00	0.00	2,384.58
50E040	2410	2140	00	000000	RCMS Principal Medicare	3,902.00	293.56	2,631.16	0.00	0.00	1,270.84
50E045	2410	2140	00	000000		1,523.00	106.76	950.03	0.00	0.00	572.97
50E050	2410	2140	00	000000	RCHS Principal Medicare	4,449.00	338.99	3,079.81	0.00	0.00	1,369.19
50E---	2410	2---	--	-----	69,875.00	5,279.81	48,651.57	0.00	0.00	0.00	21,223.43
50E050	2490	2140	00	000000	RCHS Team leader Medicare	250.00	0.00	0.00	0.00	0.00	250.00
50E---	2490	2---	--	-----	250.00	0.00	0.00	0.00	0.00	0.00	250.00
50E010	2520	2120	00	000000	Fiscal Service IMRF	11,500.00	895.34	10,948.18	0.00	0.00	551.82
50E010	2520	2130	00	000000	Fiscal Services FICA	11,503.00	448.08	5,830.55	0.00	0.00	5,672.45

140

Account Level				2025-26	February 2025-26	2025-26	2025-26	Encumbered	2025-26	
FDTLOC	FUNC	OBJ	SJ	Description	Budget	Monthly Activity	FYTD Activity	Batch Activity	Amount	Available Funds
50E010	2520	2140	00 000000	Fiscal Serv Med	2,690.00	104.80	1,363.58	0.00	0.00	1,326.42
50E---	2520	2---	--		25,693.00	1,448.22	18,142.31	0.00	0.00	7,550.69
50E015	2540	2120	00 000000	ELC Custodian IMRF	4,052.00	335.46	2,865.71	0.00	0.00	1,186.29
50E020	2540	2120	00 000000	RCES Cust IMRF	13,008.00	1,997.82	17,444.31	0.00	0.00	-4,436.31
50E040	2540	2120	00 000000	RCMS Custodial IMRF	4,362.00	1,321.76	11,878.94	0.00	0.00	-7,516.94
50E050	2540	2120	00 000000	RCHS Custodial IMRF	17,752.00	2,021.91	20,616.69	0.00	0.00	-2,864.69
50E015	2540	2130	00 000000	ELC Custodian FICA	5,591.00	203.78	1,699.50	0.00	0.00	3,891.50
50E020	2540	2130	00 000000	RCES Cust FICA	16,512.00	1,254.45	10,333.08	0.00	0.00	6,178.92
50E040	2540	2130	00 000000	RCMS Custodial FICA	9,992.00	821.79	6,735.23	0.00	0.00	3,256.77
50E050	2540	2130	00 000000	RCHS Custodial FICA	27,522.00	1,253.41	12,762.69	0.00	0.00	14,759.31
50E015	2540	2140	00 000000	ELC Custodian Medicare	1,308.00	47.66	397.47	0.00	0.00	910.53
50E020	2540	2140	00 000000	RCES Cust Med	3,862.00	293.40	2,416.61	0.00	0.00	1,445.39
50E040	2540	2140	00 000000	RCMS Custodial Med	2,337.00	192.19	1,575.12	0.00	0.00	761.88
50E050	2540	2140	00 000000	RCHS Custodial Med	6,437.00	293.11	2,984.73	0.00	0.00	3,452.27
50E---	2540	2---	--		112,735.00	10,036.74	91,710.08	0.00	0.00	21,024.92
50E010	2541	2120	00 000000	District Maint IMRF	7,800.00	1,225.73	7,437.73	0.00	0.00	362.27
50E010	2541	2130	00 000000	District Maint FICA	5,095.00	766.76	4,503.68	0.00	0.00	591.32
50E010	2541	2140	00 000000	District Maint Med	1,192.00	179.31	1,053.27	0.00	0.00	138.73
50E---	2541	2---	--		14,087.00	2,171.80	12,994.68	0.00	0.00	1,092.32
50E010	2542	2120	00 000000	District Summer Maint IMRF	7,300.00	0.00	2,586.06	0.00	0.00	4,713.94
50E010	2542	2130	00 000000	District Summer Maint FICA	8,574.00	0.00	5,103.39	0.00	0.00	3,470.61
50E010	2542	2140	00 000000	District Summer Maint Med	2,005.00	0.00	1,193.55	0.00	0.00	811.45
50E---	2542	2---	--		17,879.00	0.00	8,883.00	0.00	0.00	8,996.00
50E070	2550	2120	00 000000	21st Century Trans IMRF	750.00	0.00	0.00	0.00	0.00	750.00
50E080	2550	2120	00 000000	Trans IMRF	11,500.00	1,330.30	10,133.99	0.00	0.00	1,366.01
50E080	2550	2120	61 000000	Trans Reg Driver IMRF	44,000.00	3,382.24	31,960.11	0.00	0.00	12,039.89
50E080	2550	2120	70 000000	TRans Sec IMRF	12,600.00	1,007.77	9,963.90	0.00	0.00	2,636.10
50E100	2550	2120	00 100000	Summer School IMRF	110.00	0.00	0.00	0.00	0.00	110.00
50E110	2550	2120	00 110000	PreK Trans IMRF	8,000.00	0.00	-8.43	0.00	0.00	8,008.43
50E470	2550	2120	00 470000	21st Century IMRF	1,700.00	0.00	0.00	0.00	0.00	1,700.00
50E510	2550	2120	00 510000	Prek Trans IMRF	0.00	451.14	4,524.55	0.00	0.00	-4,524.55
50E610	2550	2120	00 610000	Trans Voc Ed IMRF	6,600.00	0.00	0.00	0.00	0.00	6,600.00
50E620	2550	2120	00 620000	Trans Spec Ed IMRF	6,000.00	549.30	4,889.71	0.00	0.00	1,110.29
50E070	2550	2130	00 000000	21st Century Trans FICA	450.00	0.00	0.00	0.00	0.00	450.00
50E080	2550	2130	00 000000	Trans FICA	10,115.00	888.23	7,188.30	0.00	0.00	2,926.70
50E080	2550	2130	61 000000	TRANS Reg Driver FICA	20,153.00	2,020.00	18,625.50	0.00	0.00	1,527.50
50E080	2550	2130	70 000000	Trans Sec FICA	19,114.00	651.06	6,177.42	0.00	0.00	12,936.58
50E100	2550	2130	00 100000	Summer School FICA	110.00	0.00	0.00	0.00	0.00	110.00
50E110	2550	2130	00 110000	PreK Trans FICA	5,500.00	0.00	5.57	0.00	0.00	5,494.43
50E470	2550	2130	00 470000	21st Century FICA	550.00	0.00	0.00	0.00	0.00	550.00

141

Account Level				2025-26	February 2025-26	2025-26	2025-26	Encumbered	2025-26	
FDTLOC	FUNC	OBJ	SJ	Description	Budget	Monthly Activity	FYTD Activity	Batch Activity	Amount	Available Funds
50E510	2550	2130	00	510000	Prek Trans FICA	8,643.00	268.74	2,617.53	0.00	6,025.47
50E610	2550	2130	00	610000	Trans Voc Ed FICA	5,500.00	0.00	0.00	0.00	5,500.00
50E620	2550	2130	00	620000	Trans Spec Ed FICA	6,854.00	361.38	2,936.57	0.00	3,917.43
50E070	2550	2140	00	000000	21st Century Trans Med	110.00	0.00	0.00	0.00	110.00
50E080	2550	2140	00	000000	Trans Medicare	2,366.00	207.58	1,689.58	0.00	676.42
50E080	2550	2140	61	000000	Trans Reg Driv Med	4,713.00	472.43	4,355.92	0.00	357.08
50E080	2550	2140	70	000000	Trans Sec Med	4,650.00	152.26	1,444.72	0.00	3,205.28
50E100	2550	2140	00	100000	Summer School MED	60.00	0.00	0.00	0.00	60.00
50E110	2550	2140	00	110000	PreK Trans Med	1,150.00	0.00	1.30	0.00	1,148.70
50E470	2550	2140	00	470000	21st Century Trans Med	220.00	0.00	0.00	0.00	220.00
50E510	2550	2140	00	510000	Prek Tran Med	2,021.00	62.86	612.19	0.00	1,408.81
50E610	2550	2140	00	610000	Trans Voc Ed Med	1,100.00	0.00	0.00	0.00	1,100.00
50E620	2550	2140	00	620000	Trans Spec Ed Med	1,603.00	84.53	686.74	0.00	916.26
50E---	2550	2---	--	-----		186,242.00	11,889.82	107,805.17	0.00	78,436.83
50E070	2560	2120	00	000000	21st Century Food Serv IMRF	40.00	0.00	0.00	0.00	40.00
50E420	2560	2120	00	420000	Food Service IMRF	9,082.00	3,554.66	31,118.94	0.00	-22,036.94
50E470	2560	2120	00	470000	21st Century Food Serv IMRF	775.00	0.00	0.00	0.00	775.00
50E070	2560	2130	00	000000	21st Century Food Serv FICA	10.00	0.00	0.00	0.00	10.00
50E420	2560	2130	00	420000	Food Service FICA	31,108.00	2,350.35	18,793.19	0.00	12,314.81
50E470	2560	2130	00	470000	21st Century Food Serv FICA	775.00	0.00	0.00	0.00	775.00
50E420	2560	2140	00	420000	Food Serv Med	7,275.00	549.71	4,395.07	0.00	2,879.93
50E470	2560	2140	00	470000	21st Century Food Serv Med	90.00	0.00	0.00	0.00	90.00
50E---	2560	2---	--	-----		49,155.00	6,454.72	54,307.20	0.00	-5,152.20
50E470	2620	2120	00	470000	21st Century Eval IMRF	80.00	0.00	0.00	0.00	80.00
50E470	2620	2130	00	470000	21st Century Eval FICA	25.00	0.00	0.00	0.00	25.00
50E470	2620	2140	00	470000	21st Century Plan/Research Med	25.00	0.00	0.00	0.00	25.00
50E---	2620	2---	--	-----		130.00	0.00	0.00	0.00	130.00
50E010	2660	2120	00	000000	District Comp Tech IMRF	23,000.00	1,847.65	18,107.44	0.00	4,892.56
50E010	2660	2130	00	000000	District Comp Tech FICA	16,315.00	1,067.98	10,320.92	0.00	5,994.08
50E010	2660	2140	00	000000	District Comp Tech Medicare	3,816.00	249.76	2,416.08	0.00	1,399.92
50E---	2660	2---	--	-----		43,131.00	3,165.39	30,844.44	0.00	12,286.56
50E070	2900	2120	00	000000	21st Century IMRF	0.00	0.76	2.37	0.00	-2.37
50E470	2900	2120	00	470000	21st Century Other IMRF	950.00	0.00	0.00	0.00	950.00
50E040	2900	2130	00	000000		146.00	0.00	0.00	0.00	146.00
50E050	2900	2130	00	000000		146.00	0.00	0.00	0.00	146.00
50E070	2900	2130	00	000000	21st Century FICA	0.00	0.50	1.51	0.00	-1.51
50E470	2900	2130	00	470000	21st Century Other FICA	550.00	0.00	0.00	0.00	550.00
50E020	2900	2140	00	000000	ES Team Leader Medicare	245.00	18.62	182.31	0.00	62.69
50E040	2900	2140	00	000000	MS Team Leader Medicare	249.00	14.38	122.36	0.00	126.64
50E050	2900	2140	00	000000	HS Team Leader Medicare	316.00	19.45	184.82	0.00	131.18

142

Account Level				2025-26	February 2025-26	2025-26	2025-26	Encumbered	2025-26	
FDTLOC	FUNC	OBJ	SJ	Description	Budget	Monthly Activity	FYTD Activity	Batch Activity	Amount	Available Funds
50E070	2900	2140	00 000000	21st Century Med	0.00	0.12	0.36	0.00	0.00	-0.36
50E470	2900	2140	00 470000	21st Century Med	440.00	0.00	0.00	0.00	0.00	440.00
50E---	2900	2---	-- -----		3,042.00	53.83	493.73	0.00	0.00	2,548.27
50E---	2---	----	-- -----		626,671.00	48,837.37	451,710.85	0.00	0.00	174,960.15
50E110	3000	2120	00 110000	Pre K Babysit IMRF	5,800.00	0.00	1,110.04	0.00	0.00	4,689.96
50E510	3000	2120	00 510000	PreK 0-3 Comm Serv IMRF	0.00	199.50	2,318.86	0.00	0.00	-2,318.86
50E100	3000	2130	00 100000	Title I Pnt Inl Sec FICA	0.00	0.00	49.62	0.00	0.00	-49.62
50E110	3000	2130	00 110000	Pre K FICA	3,400.00	0.00	682.99	0.00	0.00	2,717.01
50E150	3000	2130	00 150000		489.00	0.00	0.00	0.00	0.00	489.00
50E500	3000	2130	00 500000	Title I Pnt Inl FICA Pr	686.00	16.88	207.17	0.00	0.00	478.83
50E510	3000	2130	00 510000	PreK 0-3 FICA	2,283.00	129.92	1,447.45	0.00	0.00	835.55
50E100	3000	2140	00 100000	Title I Pnt Inl Medicare	0.00	0.00	11.60	0.00	0.00	-11.60
50E110	3000	2140	00 110000	PreK 0-3 Teach Medicare	3,100.00	0.00	543.71	0.00	0.00	2,556.29
50E150	3000	2140	00 150000		114.00	0.00	0.00	0.00	0.00	114.00
50E500	3000	2140	00 500000	Title I Prnt Inv Med Pr	160.00	3.94	48.44	0.00	0.00	111.56
50E510	3000	2140	00 510000	PreK 0-3 Medicare Prior	2,590.00	189.29	1,372.16	0.00	0.00	1,217.84
50E---	3000	2---	-- -----		18,622.00	539.53	7,792.04	0.00	0.00	10,829.96
50E110	3002	2120	00 110000	PreK Blk Com Serv IMRF	110.00	0.00	0.00	0.00	0.00	110.00
50E510	3002	2120	00 510000	PreK Com Serv IMRF	0.00	0.00	31.64	0.00	0.00	-31.64
50E110	3002	2130	00 110000	PreK Blk Comm Serv FICA	60.00	0.00	11.77	0.00	0.00	48.23
50E510	3002	2130	00 510000	PreK Com Serv FICA	1,064.00	18.41	208.07	0.00	0.00	855.93
50E110	3002	2140	00 110000	PreK Comm Serv Med	625.00	0.00	15.55	0.00	0.00	609.45
50E510	3002	2140	00 510000	PreK Comm Serv Med Prior	249.00	-22.49	61.33	0.00	0.00	187.67
50E---	3002	2---	-- -----		2,108.00	-4.08	328.36	0.00	0.00	1,779.64
50E100	3700	2130	00 100000	Title I St Joe Tut FICA	575.00	3.72	385.96	0.00	0.00	189.04
50E150	3700	2130	00 150000		0.00	46.38	280.56	0.00	0.00	-280.56
50E330	3700	2130	00 330000	Title II SJS FICA	240.00	0.00	0.00	0.00	0.00	240.00
50E500	3700	2130	00 500000	Title I St Joe FICA	809.00	42.46	259.37	0.00	0.00	549.63
50E100	3700	2140	00 100000	Title I St Joe Med	145.00	0.88	90.31	0.00	0.00	54.69
50E150	3700	2140	00 150000	SESE Flow Thru St Joe Med	778.00	63.79	494.04	0.00	0.00	283.96
50E330	3700	2140	00 330000	Title II SJS Medicare	15.00	0.00	0.00	0.00	0.00	15.00
50E500	3700	2140	00 500000	Title I St Joe Med	189.00	9.93	60.70	0.00	0.00	128.30
50E---	3700	2---	-- -----		2,751.00	167.16	1,570.94	0.00	0.00	1,180.06
50E---	3---	----	-- -----		23,481.00	702.61	9,691.34	0.00	0.00	13,789.66
5-E---	----	----	-- -----		1,081,879.00	78,956.59	705,942.73	0.00	0.00	375,936.27
60E010	2530	3190	00 000000	Site Construction Pur Serv	500,000.00	1,482,219.17	2,884,267.65	140,921.81	0.00	-2,525,189.46
60E---	2530	3---	-- -----		500,000.00	1,482,219.17	2,884,267.65	140,921.81	0.00	-2,525,189.46
60E010	2530	4100	00 000000	Site & Construction supplies	40,000.00	289.18	41,434.74	0.00	0.00	-1,434.74
60E---	2530	4---	-- -----		40,000.00	289.18	41,434.74	0.00	0.00	-1,434.74
60E010	2530	5500	00 000000	Site and Constriction Equip	100,000.00	204,277.50	204,277.50	0.00	204,272.50	-308,550.00

143

Account Level				2025-26	February 2025-26	2025-26	2025-26	Encumbered	2025-26	
FDTLOC	FUNC	OBJ	SJ	Description	Budget	Monthly Activity	FYTD Activity	Batch Activity	Amount	Available Funds
60E---	2530	5---	--	-----	100,000.00	204,277.50	204,277.50	0.00	204,272.50	-308,550.00
60E---	2---	----	--	-----	640,000.00	1,686,785.85	3,129,979.89	140,921.81	204,272.50	-2,835,174.20
6-E---	----	----	--	-----	640,000.00	1,686,785.85	3,129,979.89	140,921.81	204,272.50	-2,835,174.20
80E320	1100	1100	00	320000	Tort Regular Salaries	104,976.00	0.00	0.00	0.00	104,976.00
80E---	1100	1---	--	-----	104,976.00	0.00	0.00	0.00	0.00	104,976.00
80E320	1400	1100	00	320000	Tort Voc Salaries	74,293.00	0.00	0.00	0.00	74,293.00
80E---	1400	1---	--	-----	74,293.00	0.00	0.00	0.00	0.00	74,293.00
80E---	1---	----	--	-----	179,269.00	0.00	0.00	0.00	0.00	179,269.00
80E320	2130	1100	00	320000	Tort Nurse Salaries	179,914.00	0.00	313.50	0.00	179,600.50
80E---	2130	1---	--	-----	179,914.00	0.00	313.50	0.00	0.00	179,600.50
80E320	2130	4100	00	320000	Tort Nursing Supplies	7,000.00	391.24	5,433.80	0.00	3,585.62
80E---	2130	4---	--	-----	7,000.00	391.24	5,433.80	0.00	3,585.62	-2,019.42
80E320	2190	1110	00	320000	Tort Supervision Sal	42,000.00	0.00	0.00	0.00	42,000.00
80E---	2190	1---	--	-----	42,000.00	0.00	0.00	0.00	0.00	42,000.00
80E320	2320	1100	00	320000	Tort Supt Salary	8,925.00	0.00	0.00	0.00	8,925.00
80E---	2320	1---	--	-----	8,925.00	0.00	0.00	0.00	0.00	8,925.00
80E320	2330	1100	00	320000	Tort Asst Supt Salary	20,900.00	0.00	0.00	0.00	20,900.00
80E---	2330	1---	--	-----	20,900.00	0.00	0.00	0.00	0.00	20,900.00
80E320	2365	3190	00	320000	Bush/Nav/ISCOR/Alice/SRO/Lega	350,000.00	22,976.68	173,367.42	468.00	176,164.58
80E320	2365	3800	00	320000	Tort WC Ins and all other ins	489,000.00	0.00	410,169.97	0.00	78,830.03
80E320	2365	3810	00	320000	Unemployment Ins	10,000.00	0.00	0.00	0.00	10,000.00
80E---	2365	3---	--	-----	849,000.00	22,976.68	583,537.39	468.00	0.00	264,994.61
80E320	2365	4100	00	320000	Tort Risk Mngmnt Supplies	2,000.00	0.00	1,237.29	4,467.04	-3,704.33
80E---	2365	4---	--	-----	2,000.00	0.00	1,237.29	4,467.04	0.00	-3,704.33
80E320	2365	5500	00	320000	Tort Equipment	0.00	0.00	1,806.42	0.00	-1,806.42
80E---	2365	5---	--	-----	0.00	0.00	1,806.42	0.00	0.00	-1,806.42
80E320	2410	1100	00	320000	Tort Principal Salaries	80,048.00	0.00	0.00	0.00	80,048.00
80E---	2410	1---	--	-----	80,048.00	0.00	0.00	0.00	0.00	80,048.00
80E320	2540	1110	00	320000	Tort Custodian Salaries	179,962.00	0.00	0.00	0.00	179,962.00
80E---	2540	1---	--	-----	179,962.00	0.00	0.00	0.00	0.00	179,962.00
80E320	2550	1110	00	320000	Tort Transportation Salaries	131,250.00	0.00	0.00	0.00	131,250.00
80E---	2550	1---	--	-----	131,250.00	0.00	0.00	0.00	0.00	131,250.00
80E320	2560	1110	00	320000	Tort Food Serv Salaries	24,603.00	0.00	0.00	0.00	24,603.00
80E---	2560	1---	--	-----	24,603.00	0.00	0.00	0.00	0.00	24,603.00
80E---	2---	----	--	-----	1,525,602.00	23,367.92	592,328.40	4,935.04	3,585.62	924,752.94
80E320	4120	3190	00	320000	Tort SESE Administration	22,808.00	0.00	0.00	0.00	22,808.00
80E---	4120	3---	--	-----	22,808.00	0.00	0.00	0.00	0.00	22,808.00
80E---	4---	----	--	-----	22,808.00	0.00	0.00	0.00	0.00	22,808.00
8-E---	----	----	--	-----	1,727,679.00	23,367.92	592,328.40	4,935.04	3,585.62	1,126,829.94
90E010	2530	3190	00	000000	L/S Purchases Services	50,000.00	1,146.69	20,559.55	0.00	29,440.45

Account Level				2025-26	February 2025-26	2025-26	2025-26	Encumbered	2025-26	
FDTLOC	FUNC	OBJ	SJ	Description	Budget	Monthly Activity	FYTD Activity	Batch Activity	Amount	Available Funds
90E---	2530	3---	--	-----	50,000.00	1,146.69	20,559.55	0.00	0.00	29,440.45
90E010	2530	4100	00	000000	10,000.00	535.00	5,393.11	0.00	3,830.00	776.89
90E---	2530	4---	--	-----	10,000.00	535.00	5,393.11	0.00	3,830.00	776.89
90E010	2530	5500	00	000000	15,000.00	0.00	15,008.00	0.00	0.00	-8.00
90E---	2530	5---	--	-----	15,000.00	0.00	15,008.00	0.00	0.00	-8.00
90E---	2---	-----	--	-----	75,000.00	1,681.69	40,960.66	0.00	3,830.00	30,209.34
9-E---	-----	-----	--	-----	75,000.00	1,681.69	40,960.66	0.00	3,830.00	30,209.34
--E---	-----	-----	--	-----	35,962,337.00	3,858,111.53	26,046,297.09	454,088.40	341,516.81	9,120,434.70
Grand Revenue Totals					36,006,278.00	1,795,214.25	28,495,208.35	0.00	0.00	7,511,069.65
Grand Expense Totals					35,962,337.00	3,858,111.53	26,046,297.09	454,088.40	341,516.81	9,120,434.70
Grand Totals					43,941.00	2,062,897.28	2,448,911.26	454,088.40	341,516.81	1,609,365.05
					Profit	Loss	Profit	Loss	Loss	Loss

145

Number of Accounts: 1406

***** End of report *****

FY26 Original Budget

Fund	Fund Balance July 1, 2025	FY26 Revenue	FY26 Expenditures	Fund Balance July 1, 2026	Difference
10-Education*	\$25,768,189.00	\$26,830,026.00	\$27,489,927.00	\$25,108,288.00	-\$659,901.00
20-Operations & Maintenance**	\$2,997,941.00	\$1,902,000.00	\$1,874,959.00	\$3,024,982.00	\$27,041.00
30-Debt Service	\$257,114.00	\$2,871,769.00	\$2,831,140.00	\$297,743.00	\$40,629.00
40-Transportation***	\$953,209.00	\$1,552,700.00	\$1,544,989.00	\$960,920.00	\$7,711.00
50-IMRF/SS	\$806,282.00	\$1,083,050.00	\$1,081,989.00	\$807,343.00	\$1,061.00
60-Capital Projects****	\$1,029,516.00	\$865,000.00	\$840,000.00	\$1,054,516.00	\$25,000.00
70-Working Cash	\$1,410,650.00	\$217,170.00	\$0.00	\$1,627,820.00	\$217,170.00
80-Tort Immunity	\$13,753.00	\$1,728,400.00	\$1,727,679.00	\$14,474.00	\$721.00
90-Fire Prevention & Safety	\$213,878.00	\$177,170.00	\$75,000.00	\$316,048.00	\$102,170.00
					\$0.00
Total	\$33,450,532.00	\$37,227,285.00	\$37,465,683.00	\$33,212,134.00	-\$238,398.00

Current Revenue/Expenditure Compared to Budgeted

Fund	Current Revenue	% Compared to Budget	Current Expenditure	% Compared to Budget
10-Education	\$15,547,519.42	57.95%	\$17,637,094.49	64.16%
20-Operations & Maintenance	\$1,834,330.70	96.44%	\$1,043,416.89	55.65%
30-Debt Service	\$2,879,224.23	100.26%	\$2,291,456.88	80.94%
40-Transportation	\$1,164,704.65	75.01%	\$971,121.94	62.86%
50-IMRF/SS	\$1,099,103.25	101.48%	\$705,942.73	65.24%
60-Capital Projects	\$3,857,319.99	445.93%	\$3,270,901.70	389.39%
70-Working Cash	\$215,743.83	99.34%	\$0.00	100%
80-Tort Immunity	\$1,716,423.74	99.31%	\$597,263.44	34.57%
90-Fire Prevention & Safety	\$180,838.54	102.07%	\$40,960.66	54.61%
	\$28,495,208.35		\$26,558,158.73	

Total All Fund Comparison

	Total Revenue Compared to Budget	Total Expenditure Compared to Budget
Total for All Funds	76.54%	70.89%

Richland County Community Unit School District #1 State Money Pending

FY26

Program	FY26	Date of Voucher
St Aide-3001	\$543,364.00	3/17/2026
Special Ed Priv Facility-3100 *		
Special Ed Personnel-3110 *		
Special Ed X-Ordinary-3105 *		
Special Ed Orphan -3120		
Special Ed Summer School -3145		
Ag Ed-3235	\$2,634.00	3/4/2026
State Lunch/Breakfast-3360	\$877.24	3/4/2026
Driver's Ed-3370		
Transportation Regular-3500 *		
Transportation Spec Ed-3510 *		
TAOEP 3695		
Early Childhood-3705	\$74,816.00	3/4/2026
Fine Arts Grant-3962		
Other State -PSAT 3999		
Federal Lunch 4210	\$70,002.62	3/17/2026
Federal Milk 4215		
Federal Bfast 4220	\$22,960.06	3/17/2026
Federal Summer Lunch 4225		
Title II - 4932		
Title I - 4300		
Title I S & A 4331		
Title IV 4400		
21st Century - 4421		
SESE PREK Flow Thru 4600		
SESE Flow Thru 4620		
Fed Room/Board 4625		
Rural Ed Grant-4107		
Other Fed Program/ESSER-DE(21)		
Other Fed Program/ESSER- 4998		
Other Fed Program/ESSER-E2 4998		
Other Fed Program/ESSER-E3 4998		
Other Fed Program/D24999		
Other Fed Program/PS-ID		
Other Fed Program/HL		
* is M-CATS (Mandated Catagoricals-Qtrly)		
Grand Total	\$714,653.92	\$714,653.92
3/18/2026		

**

\$0.00

Richland County Community Unit School District No.1

2025-2026 District Calendar

Monday & Tuesday, August 11 & 12	No School	Teacher Institute Days
Wednesday, August 13	First Day of Student Attendance	
Wednesday, August 27	Early Dismissal-2:10pm	School Improvement/Faculty Mtgs
Monday, September 1	No School	Labor Day
Wednesday, September 17	Early Dismissal-12:10pm	School Improvement Day
Thursday, September 25	Early Dismissal-2:10pm	School Improvement/Faculty Mtgs
Monday, October 13	No School	Columbus Day
Tuesday, October 21	Regular Dismissal	P/T Conferences (4:00 – 7:30 p.m.)
Thursday, October 23	Early Dismissal-12:10pm	School Improvement Day
Thursday, October 23		P/T Conferences (4:00 – 7:30 p.m.)
Friday, October 24	No School	
Wednesday, October 29	Early Dismissal-2:10pm	School Improvement/Faculty Mtgs
Tuesday, November 11	No School	Veterans Day
Thursday, November 20	Early Dismissal-2:10pm	School Improvement/Faculty Mtgs
Tuesday, November 25	Early Dismissal-2:10pm	Thanksgiving Vacation
Wednesday, November 26	No School	Thanksgiving Vacation
Thursday, November 27	No School	Thanksgiving
Friday, November 28	No School	Thanksgiving Vacation
Wednesday, December 17	Early Dismissal-2:10pm	School Improvement/Faculty Mtgs
Friday, December 19	Early Dismissal-2:10pm	Early Dismissal – Winter Vacation
Monday, December 22	No School	Winter Vacation Begins
Friday, January 2	No School	Teacher Institute
Monday, January 5		School Resumes for Students
Monday, January 19	No School	Martin Luther King, Jr. Day
Monday, Jan 26 – Thursday, Jan 29	No School	Snow Emergency Days
Monday, February 9	Regular Dismissal	P/T Conferences (4:00 – 7:30 p.m.)
Wednesday, February 11	Early Dismissal-12:10pm	School Improvement Day
Wednesday, February 11		P/T Conferences (4:00 – 7:30 p.m.)
Thursday, February 12	No School	Lincoln’s Birthday
Friday, February 13	No School	
Thursday, February 26	Early Dismissal-2:10pm	School Improvement/Faculty Mtgs
Monday, March 2	No School	Casimir Pulaski Day
Wednesday, March 25	Early Dismissal-2:10pm	School Improvement/Faculty Mtgs
Thursday, April 2	Early Dismissal-2:10pm	Early Dismissal – Easter Vacation
Friday, April 3	No School	Easter Vacation
Monday, April 6	No School	Easter Vacation
Thursday, April 23	Early Dismissal-2:10pm	School Improvement/Faculty Mtgs
Friday, May 1	Early Dismissal-11:10am	School Improvement Day
Wednesday, May 20	Early Dismissal-2:10pm	Last Day of Student Attendance
Thursday, May 21	No School	Teacher Institute Day

	Student Attendance	Parent/Teacher Conference	Institute	Total
1st Quarter	42	0	2	44
2nd Quarter	44	1	0	45
3rd Quarter	42	1	1	44
4th Quarter	46	0	1	47
Total	174¹	2	4²	180³

¹ 179 pupil attendance days are initially scheduled so as to insure 174 days actual school attendance.

² Full-day institutes are scheduled with two in the first half of the year and two in the second half.

³ The school calendar shall be amended at the end of the year to total 180 days.

Five snow days are built into the calendar for 2025-2026.

2026-2027 Proposed Public School Calendar for Richland County CUSD 1, Draft, as of 3/13/2026

Codes: X = attendance day; XHI, XHPT, XID, XDS, XHS, XHSW, XHIH, XHPH, XHSH = half attendance day; XH = holiday attendance waiver; FPT, FPTH, WFPT = full day parent teacher conference; FI, WFI, FIH = teacher inservice; PI, TI, TIH = parent/teacher institute; ED = emergency day; XED = proposed emergency day; HOL = holiday; NIA = not in attendance

Total Days of Attendance: 176 **Regular Day:** **Instruct. Day Lgth:**

July 2026							August 2026							September 2026						
Mon	Tue	Wed	Thu	Fri	Sat	Sun	Mon	Tue	Wed	Thu	Fri	Sat	Sun	Mon	Tue	Wed	Thu	Fri	Sat	Sun
29	30	1	2	3	4 HOL	5	27	28	29	30	31	1	2	31	1 X	2 X	3 X	4 X	5	6
6	7	8	9	10	11	12	3	4	5	6	7	8	9	7 HOL	8 X	9 X	10 X	11 X	12	13
13	14	15	16	17	18	19	10 TI	11 TI	12 X	13 X	14 X	15	16	14 X	15 X	16 XHS	17 X	18 X	19	20
20	21	22	23	24	25	26	17 X	18 X	19 X	20 X	21 X	22	23	21 X	22 X	23 X	24 X	25 X	26	27
27	28	29	30	31	1	2	24 X	25 X	26 X	27 X	28 X	29	30	28 X	29 X	30 X	1	2	3	4
3	4	5	6	7	8	9	31 X	1	2	3	4	5	6	5	6	7	8	9	10	11

July Atnd: 0 Accum: 0 Aug Atnd: 14 Accum: 14 Sept Atnd: 21 Accum: 35

October 2026							November 2026							December 2026						
Mon	Tue	Wed	Thu	Fri	Sat	Sun	Mon	Tue	Wed	Thu	Fri	Sat	Sun	Mon	Tue	Wed	Thu	Fri	Sat	Sun
28	29	30	1 X	2 X	3	4	26	27	28	29	30	31	1	30	1 X	2 X	3 X	4 X	5	6
5 X	6 X	7 X	8 X	9 X	10	11	2 X	3 X	4 X	5 X	6 X	7	8	7 X	8 X	9 X	10 X	11 X	12	13
12 HOL	13 X	14 X	15 X	16 X	17	18	9 X	10 X	11 HOL	12 X	13 X	14	15	14 X	15 X	16 X	17 X	18 X	19	20
19 X	20 X	21 X	22 XHS	23 FPT	24	25	16 X	17 X	18 X	19 X	20 X	21	22	21 X	22 X	23 NIA	24 NIA	25 HOL	26	27
26 X	27 X	28 X	29 X	30 X	31	1	23 X	24 X	25 NIA	26 HOL	27 NIA	28	29	28 NIA	29 NIA	30 NIA	31 NIA	1	2	3
2	3	4	5	6	7	8	30 X	1	2	3	4	5	6	4	5	6	7	8	9	10

Oct Atnd: 21 Accum: 56 Nov Atnd: 17 Accum: 73 Dec Atnd: 16 Accum: 89

January 2027							February 2027							March 2027						
Mon	Tue	Wed	Thu	Fri	Sat	Sun	Mon	Tue	Wed	Thu	Fri	Sat	Sun	Mon	Tue	Wed	Thu	Fri	Sat	Sun
28	29	30	31	1 HOL	2	3	25	26	27	28	29	30	31	22	23	24	25	26	27	28
4 TI	5 X	6 X	7 X	8 X	9	10	1 X	2 X	3 X	4 X	5 X	6	7	1 HOL	2 X	3 X	4 X	5 X	6	7
11 X	12 X	13 X	14 X	15 X	16	17	8 X	9 X	10 X	11 XHS	12 HOL	13	14	8 X	9 X	10 X	11 X	12 X	13	14
18 HOL	19 X	20 X	21 X	22 X	23	24	15 FPT	16 X	17 X	18 X	19 X	20	21	15 X	16 X	17 X	18 X	19 X	20	21
25 X	26 X	27 X	28 X	29 X	30	31	22 X	23 X	24 X	25 X	26 X	27	28	22 X	23 X	24 X	25 X	26 NIA	27	28
1	2	3	4	5	6	7	1	2	3	4	5	6	7	29 NIA	30 X	31 X	1	2	3	4

Jan Atnd: 18 Accum: 107 Feb Atnd: 19 Accum: 126 Mar Atnd: 20 Accum: 146

April 2027							May 2027							June 2027						
Mon	Tue	Wed	Thu	Fri	Sat	Sun	Mon	Tue	Wed	Thu	Fri	Sat	Sun	Mon	Tue	Wed	Thu	Fri	Sat	Sun
29	30	31	1 X	2 X	3	4	26	27	28	29	30	1	2	31	1	2	3	4	5	6
5 X	6 X	7 X	8 X	9 X	10	11	3 X	4 X	5 X	6 X	7 X	8	9	7	8	9	10	11	12	13
12 X	13 X	14 X	15 X	16 NIA	17	18	10 X	11 X	12 X	13 X	14 XED	15	16	14	15	16	17	18	19 HOL	20
19 X	20 X	21 X	22 X	23 X	24	25	17 XED	18 XED	19 XED	20 XED	21 TI	22	23	21	22	23	24	25	26	27
26 X	27 X	28 XHS	29 X	30 X	1	2	24	25	26	27	28	29	30	28	29	30	1	2	3	4
3	4	5	6	7	8	9	31 HOL	1	2	3	4	5	6	5	6	7	8	9	10	11

Apr Atnd: 21 Accum: 167 May Atnd: 9 Accum: 176 June Atnd: 0 Accum: 176

2026-2027 Richland County CUSD 1 as of 3/13/2026

Calendar Legend - Totals for the Year

Calendar Code	Code Description	No. of Days	Totals
X	Pupil Attendance Day	170	
XHS	Half-Day School Improvement Program	4	
FPT	Full-Day Parent/Teacher Conference	2	
			Total Days Toward Pupil Attendance: 176
XED	Emergency Day-Proposed	5	
TI	Teacher Institute/Workshop	4	
			Total Calendar Days: 185
HOL	Holiday	12	
NIA	Not in Attendance	11	

PT /In-Service/Act of God/Explanations

School Begin Date: School End Date:

Regular Day: Instruct. Day Lgth:

Cal. Date	Cal. Code	Code Descr.	Student Attend.	Activity Time	Brief Explanation for Activity or School Closing
08/10/2026	TI	Teacher Institute/Workshop			Full Day Workshop
08/11/2026	TI	Teacher Institute/Workshop			Full Day Workshop
09/16/2026	XHS	Half-Day School Improvement Program	8:00AM 12:10PM	12:10PM 3:00PM	Half-day Student Attendance/Half-day School Improvement
10/22/2026	XHS	Half-Day School Improvement Program	8:00AM 12:10PM	12:10PM 3:00PM	Half-day Student Attendance/Half-day School Improvement
10/23/2026	FPT	Full-Day Parent/Teacher Conference		8:00AM 3:00PM	P/T Conferences will be held from 3:30pm to 7:00pm on 10/20 and 10/22
01/04/2027	TI	Teacher Institute/Workshop			
02/11/2027	XHS	Half-Day School Improvement Program	8:00AM 12:10PM	12:10PM 3:00PM	Half-day Student Attendance/Half-day School Improvement
02/15/2027	FPT	Full-Day Parent/Teacher Conference		8:00PM 3:00PM	P/T Conferences will be held from 3:30pm to 7:00pm on 2/9 and 2/11
04/28/2027	XHS	Half-Day School Improvement Program	8:00AM 12:10PM	12:10PM 3:00PM	Half-day Student Attendance/Half-day School Improvement
05/21/2027	TI	Teacher Institute/Workshop			



RICHLAND COUNTY SCHOOL DISTRICT #1
NEW ATHLETIC BUILDING
415 N. LINCOLN
OLNEY, IL 62450



Poettker Construction

EST. BUDGET SCORECARD

Bid Package		Bidder Name	Base Bid		Totals		Variance	
			Est. Budget	Actual	Est. Budget	Actual	\$	%
1	General Trades	Grunloh Construction	\$ 1,155,933	\$ 889,000.00	\$ 1,155,933	\$ 889,000.00	\$ 266,933	23%
2	Concrete	JB Esker	\$ 259,253	\$ 268,000.00	\$ 259,253	\$ 268,000.00	\$ (8,747)	-3%
3	Masonry	Wagner Masonry	\$ 909,281	\$ 925,000.00	\$ 909,281	\$ 925,000.00	\$ (15,719)	-2%
4	Structural Steel	S&S Urethane	\$ 250,375	\$ 192,591.00	\$ 250,375	\$ 192,591.00	\$ 57,784	23%
5	Roofing & Sht. Mtl.	Martin Roofing	\$ 206,158	\$ 154,030.00	\$ 206,158	\$ 154,030.00	\$ 52,128	25%
6	Fire Suppression	F.E. Moran	\$ 61,376	\$ 46,500.00	\$ 61,376	\$ 46,500.00	\$ 14,876	24%
7 & 8	Plumbing & HVAC	Davis-Houk Mechanical	\$ 1,264,367	\$ 908,000.00	\$ 1,264,367	\$ 908,000.00	\$ 356,367	28%
9	Electrical	Rowdy Electric	\$ 467,630	\$ 410,700.00	\$ 467,630	\$ 410,700.00	\$ 56,930	12%
			\$4,574,374	\$3,793,821	\$4,574,374	\$3,793,821	\$780,553	17.06%

RCCU #1
Athletics Building

Scope: Construct new Athletics Building.

Date of Probable Project Cost Estimate: **March 12, 2026**
 Project Phase: **Post Bid**
 Document Ref. Date: **February 19, 2026**
 Budget Version: **6.0**
 Construction Duration: **7 Months**
 Project Size: **10,800 G.S.F.**

A. Indirect Construction Cost Estimate

1. Administration Cost			\$7,500
a. Solicitation Printing	\$0	n/a	
b. Advertising	\$500	Estimated	
c. Land Cost	\$0	n/a	
d. Permit	\$0	n/a	
e. Bond Cost	\$0	n/a	
f. Builder's Risk	\$7,000	Estimated	
g. Other	\$0	n/a	
2. Equipment & Furniture			\$50,400
a. Furniture	\$33,600	Estimated	
b. Food Service Equipment	\$16,800	Estimated	
c. Other	\$0	Inc Above	
d. Construction Equip.	\$0	Inc Above	
3. Technology			\$10,800
a. Technology Costs	\$10,800	\$1/SF	
b. Phone & Security	\$0	Inc Above	
c. Computers	\$0	Inc Above	
c. Other	\$0	Inc Above	
4. Architectural / Engineering Fees			\$452,000
a. Basic Services	\$452,000	FGM	
b. Civil	\$0	Inc Above	
c. Code Required Inspections	\$0	Inc Above	
d. Reimbursable	\$0	Inc Above	
e. Other	\$0	n/a	
e.			
5. Services			\$0
a. Utility Taps	\$0	Inc Below	
b. Temporary Utilities	\$0	Inc Below	
c. Meter Fees	\$0	Inc Below	
d. Upgrade Electrical Service	\$0	Inc Below	
e. Site Improvements and Fields	\$0	GeoSurfaces	
6. Testing & Investigation			\$24,201
a. Survey	\$0	Estimated	
b. Geotech Report	\$9,201	Holcomb	
c. Material Testing	\$15,000	Estimated	
d.			
e.			
f.			

7. Estimate of Indirect Costs	\$544,901
	\$50 S.F.

B. Direct Construction Cost Estimate

1. Work Divisions			\$ 3,883,821
a. Div. 00 - CM Allowances	\$	90,000	
b. BP #1 - General Trades - Grunloh Construction	\$	889,000	
c. BP #2 - Concrete - JB Esker	\$	268,000	
d. BP #3 - Masonry - Wagner Masonry	\$	925,000	
e. BP #4 - Structural Steel - S&S Urethane	\$	192,591	
f. BP #5 - Roofing & Sheet Metal - Martin Roofing	\$	154,030	
g. BP #6 - Fire Suppression - F.E. Moran	\$	46,500	
h. BP #7 & #8 - Plumbing & HVAC - Davis-Houk	\$	908,000	
i. BP #9 - Electrical - Rowdy Electric	\$	410,700	
j.			
k.			
l.			
m.			
n.			
o.			
p.			
q.			
r.			
s.			
t.			
u.			
v.			
w.			
2. Contractor Bonds			\$0
a. Bonds	0.00%	\$0	
3. Contractor Insurance			\$0
a. Insurance	0.00%	\$0	
4. Construction Management			\$576,025
5. Sub-Total Estimate of Direct Costs			\$4,459,846
6. Contingency			\$116,515
a. Scope & Design	0.0%	\$0	
b. Construction	3.0%	\$116,515	
c. Market & Escalation	0.0%	\$0	

7. Estimate of Direct Costs	\$4,576,361
	\$424 S.F.

ESTIMATED TOTAL PROJECT COST	\$5,121,262
	\$474 S.F.



BID TABULATION

BID SUBMITTAL INFORMATION	Base Bid
Bidder Name	
BID PACKAGE #1 - GENERAL TRADES	
Poettker Construction	\$ 1,075,000.00
Grunloh Construction	\$ 889,000.00
BID PACKAGE #2 - CONCRETE	
JB Esker	\$ 268,000.00
Bergstrom Construction	\$ 293,445.00
BID PACKAGE #3 - MASONRY	
Wagner Masonry	\$ 925,000.00
Sangiolo & Baker Masonry	\$ 1,325,420.00
BID PACKAGE #4 - STUCTURAL STEEL	
S&S Urethane	\$ 192,591.00
Tri-County Welding	\$ 203,400.00
BID PACKAGE #5 - ROOFING & SHEET METAL	
Martin Roofing	\$ 154,030.00
D7 Roofing	\$ 175,106.00
BID PACKAGE #6 - FIRE SUPPRESSION	
Boyer Fire	\$ 61,960.00
F.E. Moran	\$ 46,500.00
Apex Fire	\$ 55,325.00
Twin Lakes	\$ 49,980.00
Tri-State Fire Protection	\$ 65,000.00

RICHLAND COUNTY SCHOOL DISTRICT #1
NEW ATHLETIC BUILDING
415 N. LINCOLN
OLNEY, IL 62450



BID TABULATION

BID SUBMITTAL INFORMATION Bidder Name	Base Bid
BID PACKAGE #7 - PLUMBING	
Davis-Houk Mechanical	\$ 457,000.00
BID PACKAGE #8 - HVAC	
Davis-Houk Mechanical	\$ 466,000.00
Baer Heating & Cooling	\$ 462,069.00
Merz	\$ 522,766.00
BID PACKAGE #7 & #8 - COMBO BID	
Davis-Houk Mechanical	\$ 908,000.00
BID PACKAGE #9 - ELECTRICAL	
Commercial Electric	\$ 511,506.00
Anderson Electric	\$ 446,200.00
Lytle Electric	\$ 547,900.00
Pals Electric	\$ 439,000.00
Rowdy Electric	\$ 410,700.00



March 18, 2026

Mr. Jason Fox
Richland County Community School District Unit #1
1100 E. Laurel St.
Olney, IL 62450

RE: Richland County New Athletic Building
Contractor Award Recommendations

Dear Mr. Fox,

Poettker Construction Company (hereafter PCC) is pleased to present this letter of recommendation to the Richland County Community Unit School District #1 Board of Education in regard to the bids received on March 12, 2026, for the construction of the Richland County New Athletic Building project in Olney, IL.

PCC has reviewed the scope of work with the lowest responsive and responsible bidders in each category and is confident that these contractors have submitted bids in accordance with the requirements of the plans and specifications.

Based on the bids received and PCC's bid review and analysis, we are pleased to recommend that the Richland County Community Unit School District #1 Board of Education award contracts for base bid to the following contractors:

Bid Package No. 1 – General Trades

- Grunloh Construction
 - Total Contract = \$889,000.00

Bid Package No. 2 – Concrete

- JB Esker
 - Total Contract = \$268,000.00

Bid Package No. 3 – Masonry

- Wagner Masonry
 - Total Contract = \$925,000.00

Bid Package No. 4 – Structural Steel

- S&S Urethane
 - Total Contract = \$192,591.00

Bid Package No. 5 – Roofing and Sheet Metal

- DE Martin Roofing
 - Total Contract = \$154,030.00

Bid Package No. 6 – Fire Suppression

- F.E. Moran
 - Total Contract = \$46,500.00

Bid Package No. 7 & 8 – Plumbing & HVAC

- Davis-Houk Mechanical
 - Total Contract = \$908,000.00

Bid Package No. 9 – Electric

- Rowdy Electric
 - Total Contract = \$410,700.00

Thank you again for the opportunity to serve the Richland County Community Unit School District #1 Board of Education. Please do not hesitate to contact me with any questions or concerns regarding these recommendations.

Sincerely,
Poettker Construction Company



Ryan Fuhler
Project Director



Name/Address		
Richland County Community Schools 1100 E Laurel St Olney, IL 62450-2508		
Date	Quotation #	REP
03/04/26	14762	BJH

Terms
TBD

Quantity	Description	Total
1	<p>POLIGON SOURCEWELL CONTRACT - #092325-PPC</p> <p>QTY (2) - POLIGON MODEL CWC (CANTILEVERED) 10X50 – 10' X 50' - PRIMARY ROOF – MULTI-RIB - NO ELECTRICAL ACCESS OR CUTOUTS - GUTTERS & DOWNSPOUTS - ANCHOR BOLTS - SIGNED/SEALED – ENGINEERED DRAWINGS/CALCS</p> <p>WE ARE ONLY ABLE TO CONSULT & PROVIDE INFORMATION FOR MATERIALS SHOWN ON THE POLIGON PRE-LIM DRAWINGS & FINAL POLIGON PROVIDED COMPLETED ENGINEERED DRAWINGS. PRICES ARE QUOTED WITH STANDARD POLIGON DOCUMENTATION ONLY / POLIGON STANDARD CLOSEOUT DOCS ONLY / POLIGON STANDARD COLOR SELECTION. POLIGON STANDARD WARRANTY PROVIDED ONLY</p>	135,812.00T
1	<p>INSTALL OF POLIGON STRUCTURES & FOOTINGS W/PREVAILING WAGES, UNLOAD STRUCTURE ON-SITE AND TARP FOR STORAGE / SECURITY BY OTHER. FOOTING SPOILS TO BE LEFT ON-SITE</p> <p>PLEASE NOTE: PRICING ASSUMES 4 COLUMNS PER STRUCTURE - EXTERNAL ANCHORS. STRUCTURES ARE IDENTICAL, ORDERED, FABRICATED, & SHIPPED TOGETHER. BASED ON PRELIMINARY DRAWING 85137. IF NEEDED PERMITS AND LOCAL</p>	

The acceptance signature below serves as authorization to order the items quoted & indicates acceptance of the listed prices and terms enclosed. Signature will not substitute for a Purchase Order.

Total

Unloading, storage and installation of equipment upon arrival is not included in above pricing unless specifically noted on quote.

Acceptance Signature: _____

Printed Name: _____



Name/Address		
Richland County Community Schools 1100 E Laurel St Olney, IL 62450-2508		
Date	Quotation #	REP
03/04/26	14762	BJH

Terms
TBD

Quantity	Description	Total
	LICENSES NOT INCLUDED IN PRICING AND BY OTHER. TRASH DUMPSTER BY OTHER. OTHER TO PROVIDE AS NEEDED SITE SECURITY & SECURE STORAGE OF MATERIALS ON-SITE UNTIL STRUCTURES ARE FULLY INSTALLED AND READY FOR USE. CUSTOMER TO PROVIDE LOCATIONS ON GOOGLE MAPS AT THE TIME OF ORDER WHERE STRUCTURES WILL BE PLACED ON-SITE. Tax Exempt	0.00

Total	\$135,812.00
--------------	---------------------

The acceptance signature below serves as authorization to order the items quoted & indicates acceptance of the listed prices and terms enclosed. Signature will not substitute for a Purchase Order.

Unloading, storage and installation of equipment upon arrival is not included in above pricing unless specifically noted on quote.

Acceptance Signature: _____

Printed Name: _____



PROJECT: RICHLAND COUNTY - OPT A
 LOCATION: OLNEY, IL
 BUILDING TYPE: CWC 10X50
 ROOF TYPE: MULTI-RIB
 BUILDING NUMBER: P23463
 ORDER NUMBER: 85137
 QUOTE NUMBER: 27896

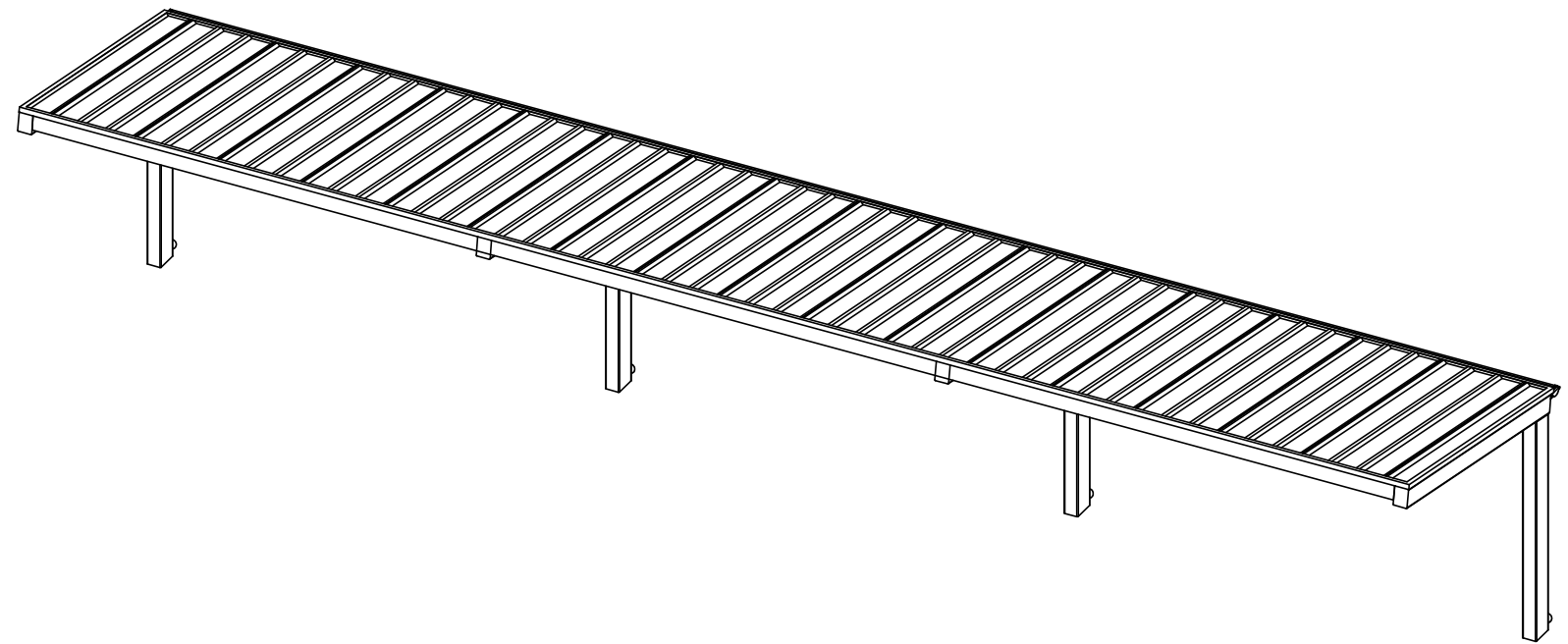

DRAWING LIST:

SHEET NUMBER	DRAWING DESCRIPTION
CS	COVER SHEET
1	ARCHITECTURAL ELEVATIONS
2	STRUCTURAL FRAMING PLAN
3	COLUMN LAYOUT

CERTIFICATES:
 MIAMI-DADE COUNTY CERTIFICATE OF COMPETENCY NO. 24-0903.04
 PCI (POWDER COATING INSTITUTE) 4000 CERTIFIED

FABRICATOR APPROVALS:
 CITY OF PHOENIX, AZ APPROVED FABRICATOR #C08-2010
 CITY OF LOS ANGELES, CA APPROVED FABRICATOR #FB01596
 CITY OF RIVERSIDE, CA APPROVED FABRICATOR #SF_000042
 CITY OF HOUSTON, TX APPROVED FABRICATOR #470
 CLARK COUNTY, NV APPROVED FABRICATOR #264
 STATE OF UTAH APPROVED FABRICATOR 02008-14
 AISC APPROVED FABRICATOR C-00026910
 AWS CERTIFIED WELDING FABRICATOR #240707F

MATERIALS:	DESCRIPTION	ASTM DESIGNATION
	TUBE STEEL	A500 (GRADE B)
	SCHEDULE PIPE	A53 (GRADE B)
	RMT PIPE	A519
	LIGHT GAGE COLD FORMED	A1003 (GRADE 50)
	STRUCTURAL STEEL PLATE	A36
	ROOF PANELS (STEEL)	A653



GENERAL NOTES:
 UNLESS NOTED OTHERWISE, THIS STRUCTURE WAS DESIGNED TO ONLY SUPPORT WHAT IS SHOWN ON THESE DRAWINGS. THE MANUFACTURER MUST BE CONTACTED IF ANYTHING ELSE IS TO BE ATTACHED TO THIS STRUCTURE (WALLS, COLUMN WRAPS, RAILINGS, ETC.) SO THE DESIGN OF THIS STRUCTURE CAN BE REVIEWED AND POSSIBLY REVISED.

UNLESS NOTED OTHERWISE, THIS STRUCTURE WAS DESIGNED ASSUMING A 20' SEPARATION BETWEEN ANY ADJACENT STRUCTURE WITH AN EAVE HEIGHT EQUAL TO OR GREATER THAN THE EAVE HEIGHT OF THIS STRUCTURE. IF THAT SEPARATION DOES NOT EXIST, THE MANUFACTURER MUST BE CONTACTED SO THE DESIGN OF THIS STRUCTURE CAN BE REVIEWED AND POSSIBLY REVISED.

STRUCTURAL STEEL SHALL BE DETAILED, FABRICATED, AND ERECTED IN ACCORDANCE WITH THE LATEST EDITION OF THE AMERICAN INSTITUTE OF STEEL CONSTRUCTION (AISC) SPECIFICATION MANUAL.

ALL WELDING IS PERFORMED BY AMERICAN WELDING SOCIETY (AWS) CERTIFIED WELDERS AND CONFORMS TO THE LATEST EDITION OF AWS D1.1 OR D1.3 AS REQUIRED.

PARTS SHOWN MAY BE UPGRADED DUE TO STANDARDIZED FABRICATION. REFER TO THE SHIPPING BILL OF MATERIALS FOR POSSIBLE SUBSTITUTIONS.

FOR PROPER FIELD INSTALLATION OF THE BUILDING IT IS RECOMMENDED THAT THE PRIMARY FRAME INSTALLER AND THE ROOF INSTALLER HAVE A MINIMUM FIVE (5) YEARS DOCUMENTED EXPERIENCE INSTALLING THIS TYPE OF PRODUCT.

FOR PROPER FIELD INSTALLATION OF THE BUILDING IT IS RECOMMENDED THAT ELECTRIC WIRING, IF REQUIRED, BE RUN THROUGH THE STRUCTURAL MEMBERS BEFORE THE BUILDING IS ERECTED.

STOP!!
NOT FOR CONSTRUCTION
 USE FOR PRELIMINARY
 PLANNING AND ESTIMATING
 ONLY

poligon
 by PORTER CORP
 WWW.POLIGON.COM
 MAIN: (616) 888-3500
 FIELD SUPPORT: (616) 888-3504

REV LEVEL: A
 SCALE: 1:72
 DRAWN BY: michael.leitch
 PRINT DATE: 12/26/2025
 JOB NO: P23463
 CAD MODEL: P23463-E1

PROJECT: RICHLAND COUNTY - OPT A
 PROJECT LOCATION: OLNEY, IL
 DRAWING: COVER SHEET



GENERAL ROOF NOTES:

1. METAL ROOFING:
 - 24 GAUGE
 - GALVALUME COATED
 - KYNAR 500 PAINTED
2. TRIM COLOR MATCHES ROOF
3. SEE POLIGON.COM FOR COLOR OPTIONS

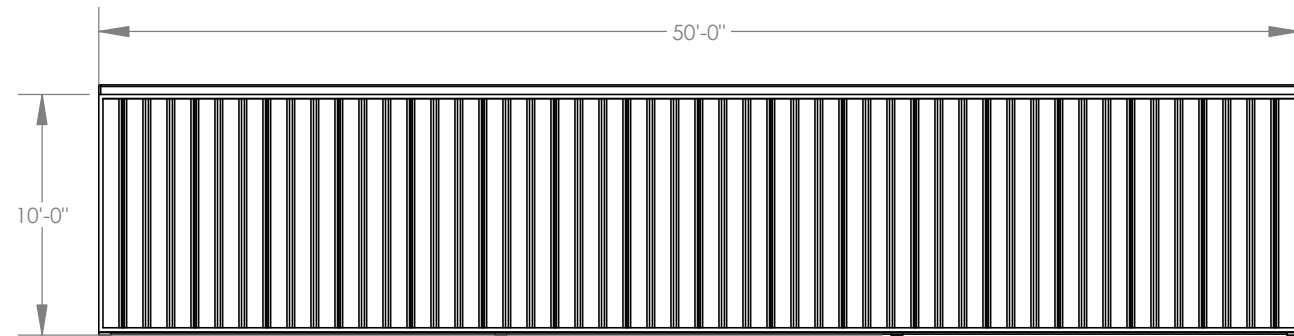

TOP VIEW

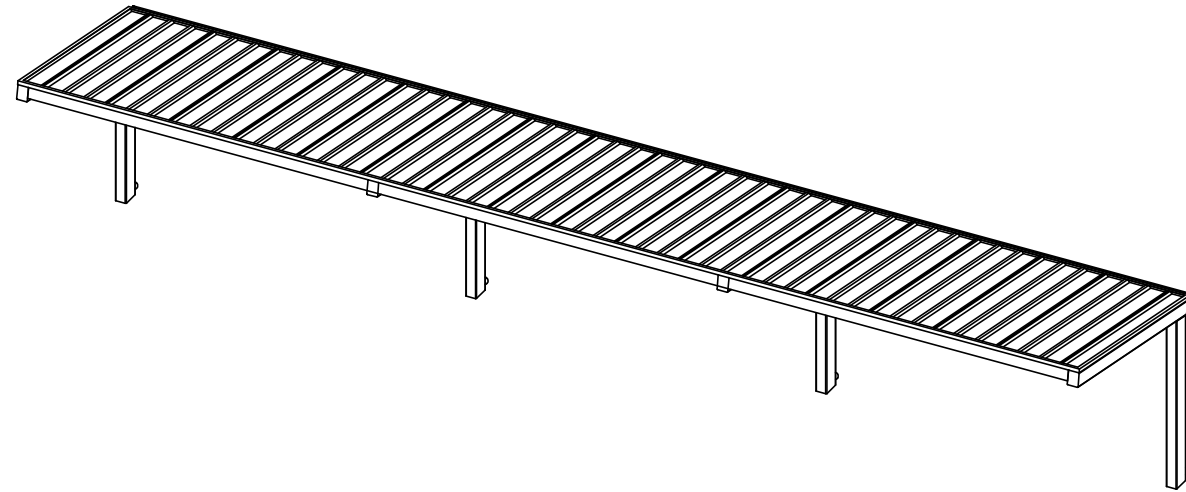

ISOMETRIC VIEW

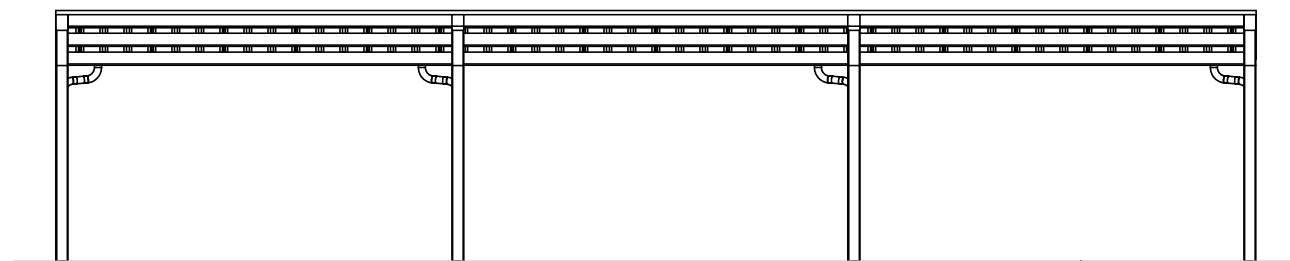

FRONT VIEW

FINISH GRADE
(ASSUMED AT CONSTANT
ELEVATION UNLESS
OTHERWISE NOTED)

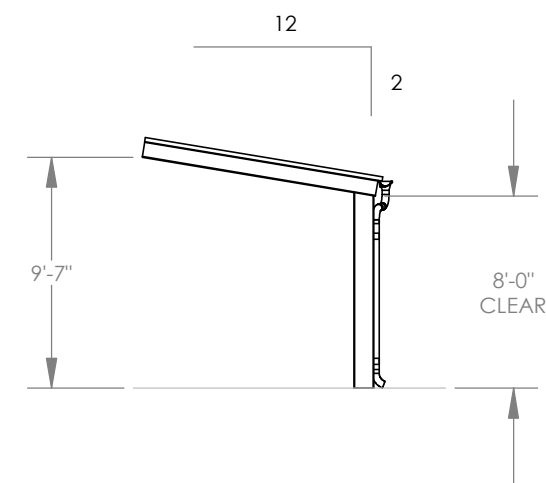

SIDE VIEW

STOP!!
NOT FOR CONSTRUCTION

USE FOR PRELIMINARY
PLANNING AND ESTIMATING
ONLY

REV LEVEL:	A
SCALE:	1:96
DRAWN BY:	michael.leitch
PRINT DATE:	12/26/2025
JOB NO.:	P23463
CAD MODEL:	P23463-E1

PROJECT:	RICHLAND COUNTY - OPT A
PROJECT LOCATION:	OLNEY, IL
DRAWING:	ARCHITECTURAL ELEVATIONS

SHEET

1

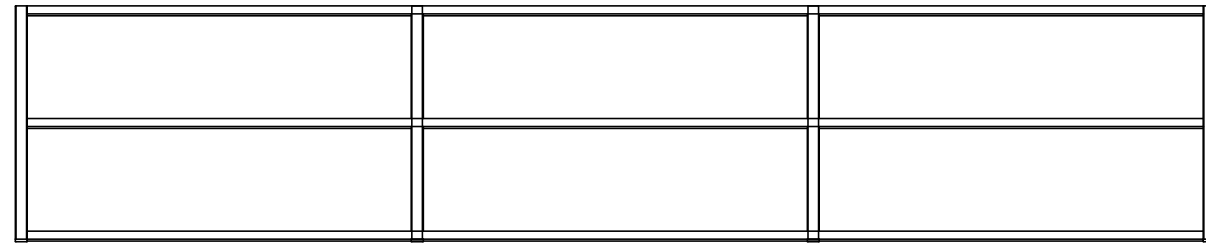

TOP VIEW

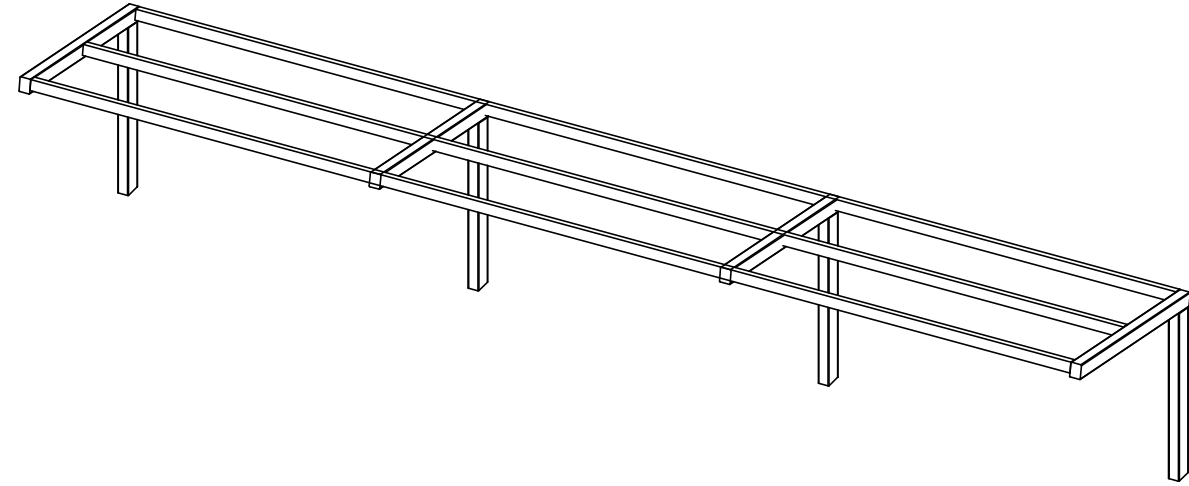

ISOMETRIC VIEW

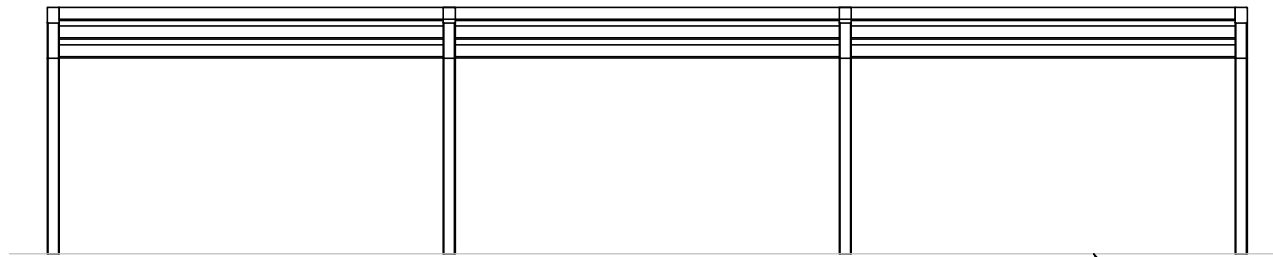

FRONT VIEW

FINISH GRADE
(ASSUMED AT CONSTANT
ELEVATION UNLESS
OTHERWISE NOTED)

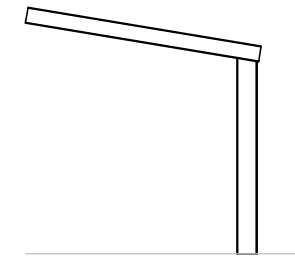

SIDE VIEW

STOP!!
NOT FOR CONSTRUCTION
USE FOR PRELIMINARY
PLANNING AND ESTIMATING
ONLY

REV LEVEL:	A
SCALE:	1:96
DRAWN BY:	michael.leitch
PRINT DATE:	12/26/2025
JOB NO.:	P23463
CAD MODEL:	P23463-E1

PROJECT:	RICHLAND COUNTY - OPT A
PROJECT LOCATION:	OLNEY, IL
DRAWING:	STRUCTURAL FRAMING PLAN

SHEET

2

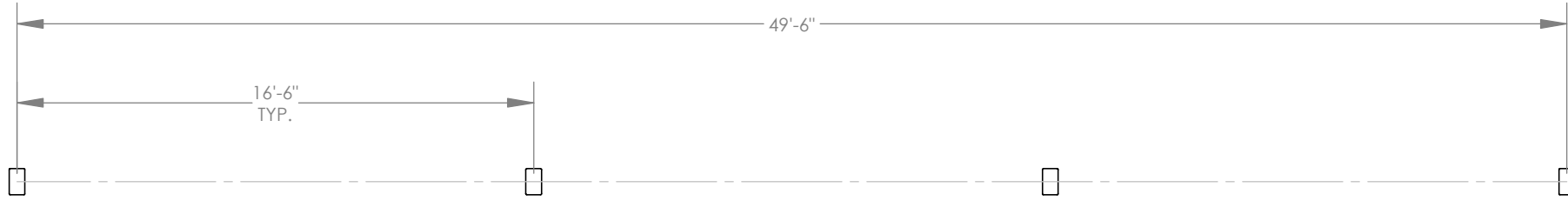

ANCHOR BOLT LAYOUT NOTES:

1. ENGINEERING WILL DETERMINE REQUIRED ANCHOR BOLT LAYOUT AFTER ENGINEERING PACKAGE IS ORDERED.
2. CUSTOMER MAY SUGGEST PREFERRED ANCHOR BOLT LAYOUT.

STOP!!
NOT FOR CONSTRUCTION

USE FOR PRELIMINARY
 PLANNING AND ESTIMATING
 ONLY

PROJECT:	RICHLAND COUNTY - OPT A	PRINT DATE:	12/26/2025	DRAWN BY:	michael.leitch	REV LEVEL:	A
PROJECT LOCATION:	OLNEY, IL	JOB NO.:	P23463			SCALE:	1:64
DRAWING:	COLUMN LAYOUT	CAD MODEL:	P23463-E1				

SHEET

3



FRAME COLOR: **BUMPER BLACK**
ROOF COLOR: **BRITE RED**
COLORS MAY VARY SLIGHTLY FROM RENDERED IMAGE

RICHLAND COUNTY - OPT A
OLNEY, IL
CWC 10X50



FRAME COLOR: **BUMPER BLACK**
ROOF COLOR: **BRITE RED**
COLORS MAY VARY SLIGHTLY FROM RENDERED IMAGE

RICHLAND COUNTY - OPT A
OLNEY, IL
CWC 10X50

Hutchinson Recreation & Design - Terms and Conditions

Page 1 of 4 (Terms and Conditions & Proposal Facts)

The quotation, terms and conditions, and proposal facts must be attached and included as an exhibit to any contract, which is entered into as a result of this quotation. Failure to do so will result in such contract being returned unsigned until these items have been included, thus delaying the processing of your order.

PLEASE NOTE FOR ALL QUOTES / BIDS – INSTALLATION IS NOT INCLUDED UNLESS SPECIFICALLY NOTED ON THE QUOTE / BID.

Equipment orders with installation service: Continuous access will be provided to the installation crew for heavy equipment traffic without obstruction for delivery and installation of equipment, safety surfacing, and any other materials or furnishings provided on this quotation throughout the installation. The site is free of any private utilities or underground items unless marked by owner. Any local labor requirements are by other. All items below are not included unless specifically stated on the quotation. Excessive rock excavation is not included in standard pricing. Proper site grade has been completed prior to the arrival of the installation crew. Additional mobilization costs will be charged for each trip if site is not ready for the installation of the equipment. Core drilling or saw cutting of existing or new concrete or asphalt is not included. The installation of all furnishings and equipment not indicated as surface mount or portable should be scheduled for installation prior to concrete or asphalt construction or blocked out for in concrete forms. Installation prices assume normal soil conditions, easy access to site with trucks. If it becomes necessary to cross landscaping, sidewalks, or grass areas to reach project area, re-seeding or sodding may be necessary - the customer will be responsible unless otherwise noted on quote. Installation does not include any allowance for moving or repairing any underground utility lines such as electrical, telephone, gas, water or sprinkler lines that may be encountered during installation operations. Any additional costs incurred as a result of hard rock conditions requiring extra equipment, or for utility removal or repair resulting in delay is for customer's account, unless they are detailed on as built site drawings or marked on the ground prior to quotation, fabrication and installation.

Owner/Contractor site preparation and installation notes and instructions:

- **DO NOT SPREAD SAFETY SURFACE OR GRAVEL DRAINAGE PRIOR TO INSTALLATION OF PLAYGROUND EQUIPMENT.**
- If site conditions become too wet to install equipment, drying agents such as lime can be applied at additional costs to be borne by Owner. The application of drying agents must be pre-approved via written instrument, signed by both Owner and Hutchinson Recreation & Design, before application begins.
- Any on-site installation, site work, or surfacing change orders must be pre-approved via written instrument, signed by Owner & Hutchinson Recreation & Design, Inc. before change orders are executed. Hutchinson Recreation & Design, Inc. is not responsible or liable for any verbal or other negotiations with installers made without approval and a signed change order from our office.
- Removal and replacement of existing surfacing materials is not included unless specifically indicated on the quotation.
- Owner is responsible for locating and marking all private utility locations and notification of any other underground items prior to quotation, fabrication, and installation. Hutchinson Recreation & Design will not be responsible for any underground items encountered or any damage to such items not marked or pointed out by the owner. Any delay or cost to repair as a result will be at an additional cost to the owner. If installation is included on quote public locates will be called out by the install company prior to install – NOT private locates.
- Quotations for Engineered Wood Fiber do not include gravel drainage systems; gravel sumps or daylight drains unless specifically noted on quote / bid..
- Required installation grade includes: Site excavated to proper depth and grade should be no greater than 2% for drainage. Owner/Contractor will provide safety/storage of equipment/security fencing until equipment and surfacing is ready for installation and use – unless specifically noted on quote as included by us.

Additional information regarding Safety Surfacing for Playground Projects:

- Purchaser shall be responsible for storage of all products and security, as needed, to prevent vandalism and/or damage of any type to the surface during installation process, curing time, and after the installation is completed. Surface quotes are based on thickness/critical fall heights performances as tested by an accredited laboratory, and are not subject to results generated by hand held, suspect field-testing equipment.
- Purchaser is responsible for storage of all resin, glue, and binder in a temperature controlled environment. Any materials left outside will be at the sole cost of the purchaser if replacement products are needed.
- If site is prepared by other and if the site is over the square foot agreed upon the customer will be charged for the additional square foot based on the critical fall height of equipment and price/square foot.
- Price excludes concrete, asphalt, site work, base aggregate, compaction or preparation etc.
- If customer or other is preparing the sub base for unitary surfacing, then customer or other is responsible to adhere to manufacturers sub base requirements/specifications and provide photo field verification to our office prior to scheduling of surfacing install crews. PLEASE NOTE: Lead times vary for the scheduling of the surfacing install crews at certain times of the year. Please check with our office for tentative scheduling dates at the time of order.
- If loose fill engineered wood fiber is being purchased customer is aware that: Due to the nature of wood fiber, wood fiber will vary in size and type of wood if purchased in differing time frames. Engineered Wood fiber surfacing is for safety purposes 1st and the aesthetic look and feel of the wood fiber is inconsistent. The variance will meet all required guidelines/specifications from the manufacturer.

Owner/Contractor delivery and receipt of shipment:

- Unloading is not included with installation unless specifically noted on the quote / bid.
- The Owner/Contractor will be notified 24 hours or more prior to delivery whenever possible.
- It is assumed that all materials can be delivered to the jobsite, and the Owner/Contractor will provide a secure location to store the equipment prior to installation. Installation price does not include transportation of materials from a secondary secure delivery location to job site.
- Delivery does not include lift-gate service-unless specifically noted on quote/bid. Those services, depending on product, may be available by request for an extra cost to the owner.
- Lead-times vary by manufacture and are subject to change without notice. Please ask our office at the time of order for approximate shipping lead times. Please provide firm shipment schedules at time of order, delivery dates requested outside of normal manufacturing days may be subject price increases from suppliers for materials and freight.

Insurance: This proposal contains standard General Liability and Workers Compensation coverage – when applicable. Any waivers of subrogation and primary no-contributory endorsement requirements require additional premium to the provider. Any additional such charges to our policies as a result of the awarding of a contract based upon this proposal will be passed through to you at your additional expense.

Quotation does NOT include the following (Unless specifically stated on the quotation / bid): taxes, prevailing wages, permits, local business license, state or local approvals, performance/payment bond, engineering seals, testing, site preparation, or storage of equipment, installation, supervision, removal of excess dirt from footings or any site excavation, borders, safety surfacing, unloading of equipment, security, fencing, custom colors on equipment or materials, or landscaping!

Order and Payment Terms: Any orders that are tax-exempt will require a copy of the tax-exempt certificate at the time of order. All applicable tax will be added to final invoice. Payment terms to be determined at the time of order. If applying for credit, unless credit is approved by Hutchinson Recreation & Design and/or Manufacturing Company, a 50% or 100% prepayment may be required. Cash in advance discounts available on certain equipment, NO retainage/retentions allowed. Quotation is valid for 21 days. Past due accounts will be assessed interest at the rate of 1.5% per month. Hutchinson Recreation & Design shall be entitled to recover its reasonable attorneys' fees and costs if legal action is brought to collect amounts due. Please Note: Due to the Global Pandemic our suppliers/partners are experiencing labor shortages, raw material shortages and disruptions in supply chains worldwide. Global production for factories worldwide has been significantly affected. Lead times are now approximate only. All orders are subject to delay. We appreciate your business and understanding.

Failure to comply with these terms and conditions will result in additional charges or contract change orders. Please contact our office with any questions concerning the attached quotation or terms and conditions, or if any additional services are required for your Project. Thank you for the opportunity to provide this quotation.

Poligon Products only:

1. Pricing assumes Risk Category II for all structures with roof coverings and Risk Category I for all other structures (e.g. trellis, portal, etc.) as well as Wind Exposure C and clear wind flow as defined by ASCE 7, unless noted otherwise.
2. Pricing assumes a 20' separation between any adjacent structure with an eave height equal to or greater than the eave height of this structure if the ground snow load is greater than 0 PSF to account for drifted snow, unless noted otherwise.
3. Pricing assumes standard size electrical cutouts, unless noted otherwise: 2-3/8" wide x 4" tall single gang cutouts in columns at 18" or 48" above finish grade or 3/4" diameter cutouts in roof framing members.
4. Quotation is based on Poligon's interpretation of any drawings or documentation provided at time of quote request.
5. Deviation of design from the supplied quote and preliminary drawing may result in price changes. All design changes should be submitted to Poligon for re-quoting purposes.
6. Poligon provides pricing and engineering for the most cost effective and efficient frame, meeting Poligon's design philosophy of hidden bolted connections (no field welding required).
7. If this quotation does not reference specific design elements that must be incorporated, please work with Hutchinson Recreation & Design to update the quotation as required (e.g. column sizes, column locations, roof pitch, etc.).
8. All member sizes are preliminary until the engineering package has been completed. Preliminary reaction forces and foundation sizing may be provided upon request and should be used for budget purposes only.

Acceptance of Quotation:

The undersigned, by its duly authorized representative hereby authorizes Hutchinson Recreation to have the manufacturer ship the equipment listed on the accompanying quote, and complete the specified tasks, for which the undersigned agrees to pay the total amount specified. The undersigned acknowledges that it has read and agreed to the Terms and Conditions. Payment terms to be determined at the time of order. Non-taxable customers must provide proper tax exemption certificate to manufacturer at time of order or tax will be added to final invoice.

Customer Acceptance Signature Date

Hutchinson Recreation & Design – PROPOSAL FACTS

PROPOSAL / QUOTE / BID (Items listed below are additional items available on certain products/services quoted. If these items are not listed as included or line itemed out on your quote then they are not included in your price of items quoted. If you would like pricing on any of these items added to your quote, please call our main office to inquire about availability.)

Unloading equipment	Lift gate services	Removal of excess material, dirt or old equipment from site	Concrete pad prices are (plus/minus) one-degree grade
Site Work	Drainage	Site Restoration	Installation of equipment
Safety Surfacing (Wood Fiber, Poured in Place, Tile, etc.)	Installation of safety surface	Any extra material/labor necessary to get grade is additional costs	Trash Dumpster
Taxes	Supervision	Fencing or Landscaping	Performance and Payment Bonds
Storage	Security	Testing/Permits/State or Local Approvals/Engineering Seals	Engineered Drawings & Calcs

NOTE: INSTALLATION QUOTE IS BASED ON "NORMAL" MISSOURI / ILLINOIS SOIL AND OR WATER TABLE CONDITIONS AND LEVELS. SEE TERMS SHEET FOR MORE INFORMATION ON INSTALLATION LIMITATIONS AND CUSTOMER RESPONSIBILITIES. ALL SUPERVISIONS WILL BE BILLED DIRECT BY AN INDEPENDENT SUPERVISOR.

OWNER SITE PREPARATION AND INSTALLATION NOTES:

Owner **MUST** provide safety fencing to be used around the site by the installer – unless specifically noted on our quote / bid. Desired install grade includes: sod removal flat/level surface w/drainage.

FOR PLAYGROUND PROJECTS - DO NOT SPREAD SAFETY SURFACE PRIOR TO EQUIPMENT INSTALLATION.

READ installation specifications brochures prior to installation.

Install equipment according to manufacturer's specifications.

You **MUST** call underground utilities prior to excavation – public and private lines. Public lines will be called out prior to install by us if

installation is included on quote. All private lines must be marked by other with or without install options chosen.

DELIVERY INFORMATON:

Delivery day assistance needed to unload - the driver will be either a factory representative who may assist you or commercial carrier depending on manufacture. Depending on manufacture and equipment it will take anywhere between **2-5 sturdy people to unload equipment**. Shelters, and some bigger equipment may require use of machinery to assist in the unloading of equipment. The cost of that machinery is not included in our pricing unless specifically noted on the quotation or bid. Lift gate services may be available upon request, this would be at an additional cost to the owner. Delivery point should be close to construction site - in secured area. Equipment should be inventoried carefully after unloading, along with notations of any discrepancies. NOTE: MISSING PARTS CLAIMED AFTER 48 HOURS FROM THE DATE OF DELIVERY WILL NOT BE HONORED. MISSING PARTS NOTIFIED TO US AFTER 48 HOURS WILL REQUIRE RE-PURCHASE OF PARTS.

CUSTOMER RESPONSIBILITY FOR PLAYGROUND PROJECTS:

During installation and at the completed installation or installation sign-off, the owner becomes responsible for keeping children off of the playground for 72 hours to allow cement to set up. If poured-in-place surfacing is installed the owner is responsible to keep children off to allow for the surfacing to properly cure – which may be up to 72 hours. It is advised to have security throughout the poured-in-place surfacing installation and during this curing process to prevent damage to the surfacing. It is the owner's responsibility to maintain the safety surfacing and schedule regular safety and maintenance inspections of the equipment.

INDEMNIFICATION:

HUTCHINSON RECREATION & DESIGN MAKES NO EQUIPMENT WARRANTIES EXCEPT FOR THOSE STANDARD WARRANTIES ISSUED WITH THE EQUIPMENT DIRECT FROM THE MANUFACTURER AND INSTALLATION COMPANIES, WHICH ARE INCORPORATED HEREIN BY THIS REFERENCE. HUTCHINSON RECREATION & DESIGN SPECIFICALLY DISCLAIMS ANY IMPLIED WARRANTY OF MERCHANTABILITY OR FITNESS FOR A PARTICULAR PURPOSE AND ANY LIABILITY FOR INCIDENTAL OR CONSEQUENTIAL DAMAGES. CUSTOMER AGREES TO DEFEND, INDEMNIFY AND SAVE HUTCHINSON RECREATION & DESIGN AND IT'S PRODUCT MANUFACTURERS HARMLESS FROM ALL CLAIMS OF ANY KIND FOR DAMAGES OF ANY KIND ARISING OUT OF CUSTOMER'S ALTERATION OF THE EQUIPMENT (WITHOUT THE MANUFACTURERS' EXPRESS WRITTEN CONSENT), ITS FAILURE TO MAINTAIN THE EQUIPMENT, ITS FAILURE TO PROPERLY FOLLOW THE RESPECTIVE MANUFACTURERS' INSTALLATION INSTRUCTIONS, ITS FAILURE TO PROPERLY SUPERVISE EQUIPMENT USE. FOR PLAYGROUND EQUIPMENT THEIR FAILURE TO PROVIDE AND MAINTAIN APPROPRIATE TYPES AND DEPTHS OF SAFETY SURFACING BENEATH AND AROUND THE EQUIPMENT IN ACCORDANCE WITH THE RESPECTIVE MANUFACTURERS' INSTALLATION AND OWNER'S MANUALS AND THE MOST CURRENT CONSUMER PRODUCT SAFETY COMMISSION HANDBOOK FOR PUBLIC PLAYGROUND SAFETY.

PLEASE NOTE:

For playground projects, to the best of our knowledge, the proposed components/parts bring your play structure into compliance with current guidelines and standards. If it is determined at a later date that additional components/parts are required there will be an additional cost for these components/parts. The proposed equipment from the manufacturer meets applicable federal guidelines and is not ensured to meet specific state and local codes.

For shelters and shades with engineered drawings / calcs included will be engineered to meet local IBC codes.

For all projects the customer is responsible, if applicable, to bring any concerns for state and local codes to the attention of Hutchinson Recreation & Design prior to quotation, ordering, and installation of equipment – otherwise any additional costs incurred will be the full responsibility of the owner.

NOTICE TO OWNER

FAILURE OF THIS CONTRACTOR TO PAY THOSE PERSONS SUPPLYING MATERIAL OR SERVICES TO COMPLETE THIS CONTRACT CAN RESULT IN THE FILING OF A MECHANIC'S LIEN ON THE PROPERTY WHICH IS THE SUBJECT OF THIS CONTRACT PURSUANT TO CHAPTER 429, RSMO. TO AVOID THIS RESULT YOU MAY ASK THIS CONTRACTOR FOR "LIEN WAIVERS" FROM ALL PERSONS SUPPLYING MATERIAL OR SERVICES FOR THE WORK DESCRIBED IN THIS CONTRACT. FAILURE TO SECURE LIEN WAIVERS MAY RESULT IN YOUR PAYING FOR LABOR AND MATERIAL TWICE.

PRODUCT INFORMATION:

PLEASE VISIT OUR WEBSITE AT WWW.HUTCHINSON-RECREATION.COM AND CLICK ON THE MANUFACTURERS WEBSITE LINKS FOR UP TO DATE PRODUCT INFORMATION, PRODUCT WARRANTIES, INSTALLATION INFORMATION. IF YOU WOULD LIKE ANY COPIES SENT TO YOU VIA EMAIL OR MAIL PLEASE CONTACT OUR MAIN OFFICE.

Acceptance of Proposal Facts and Conditions:

The undersigned acknowledges that it has read and agreed to the proposal facts.

Customer Acceptance Signature Date

RCCU#1 Early Learning Center Handbook Review Committee Meeting

February 27, 2026 - 12:00 PM

- I. Purpose of Handbook and Distribution Procedures
- II. Current Proposed Changes
 - A. Page 1 - Date Change
 - 1. From 2025-2026 to 2026-2027
 - B. Page 2 - Addition & Removal of Staff
 - 1. Added - Megan Taylor, Amanda Brinkley, & Bailey Buerster
 - 2. Removed - Natalie Shryock
 - C. Page 2 - Date Updated Change
 - 1. From 4/2025 to 2/27/26
 - D. Page 4 - Starting Date Change
 - 1. From Wednesday, August 13, 2025 to Wednesday, August 12, 2026
 - E. Page 6 - Added a statement referencing the District Attendance Policy.
 - 1. Added the following:

This is a great time to establish attendance routines as your child prepares to transition to older grades. In Kindergarten the district attendance policy for students K-12 is, “ Students will be allowed 8 excused absences via parent call in including up to 5 absences for mental or behavioral health illness of the student, from school. Once a student has reached * days absent (excused), all other absences will be considered unexcused unless a note from a medical professional is provided or the student is checked by the school nurse. Nothing other than a documented illness will be considered excused once a student has reached parent call in absences.”
- III. Handbook Discussion
- IV. Approval of Changes

**RCES Student Handbook
Proposed Updates 2026 - 2027 School Year**

Page 8

BIRTHDAY CELEBRATIONS

Parents have the option of providing birthday treats for their child's classroom only. It is the responsibility of the parent to coordinate treats with the classroom teacher. All treats must be prepackaged and sent to school with the child or dropped off at the secretary's desk.

~~For birthday celebrations please do not send treats to school. Birthdays are celebrated with stickers, wearing a birthday hat or vest, name on announcements, etc. Your cooperation is appreciated. A parent is welcome to come to school and eat lunch with his/her child or visit a child's classroom. These visits should be arranged in advance with the classroom teacher.~~

Page 13-14

VISITING

~~SCHOOL VISITATION RIGHTS ACT (Move highlight area to VISITORS section)~~

~~The School Visitation Rights Act permits employed parents/guardians, who are unable to meet with educators because of a work conflict, the right to time off from work under certain conditions to attend necessary school functions such as parent-teacher conferences, academic meetings and behavioral meetings. Letters verifying participation in this program are available from the school office upon request.~~

PROCEDURES

~~Safety of our school children is one of our major concerns. As a result of our concern for the safety of all students, we ask that you follow the procedure below when visiting our schools:~~

~~All parents and visitors entering a school must first report to the office and sign the visitors' book.~~

~~A "Visitor" pass will be issued and must be worn to indicate to the staff that the person has first gone to the office and gained permission to be in the building.~~

~~Upon completion of the visit, the visitor will return the pass to the building office.~~

~~Parents wanting to visit are welcome. However, prior arrangements must be made with the building principal for such visits.~~

~~In order to assist with pedestrian traffic flow and student safety, parents picking up children at the end of the school day are asked to wait in their vehicles or park in the lot and wait outside until school is dismissed.~~

VISITORS

SCHOOL VISITATION RIGHTS ACT (Move highlight area to VISITORS section)

The School Visitation Rights Act permits employed parents/guardians, who are unable to meet with educators because of a work conflict, the right to time off from work under certain conditions to attend necessary school functions such as parent-teacher conferences, academic meetings and behavioral meetings. Letters verifying participation in this program are available from the school office upon request.

Page 15

~~In order to assist with pedestrian traffic flow and student safety, parents picking up children at the end of the school day are asked to wait in their vehicles or park in the lot and wait outside until school is dismissed.~~

Page 16

~~Each child will be allowed 10 such excused absences as well as up to 5 additional absences for mental or behavioral health illness of the student, from school. Once a student has reached 10 absences (excused or unexcused), all other absences will be considered unexcused unless a note from a medical professional is provided or the student is checked by the school nurse. Nothing other than a documented illness will be considered excused once a student has reached 10 absences.~~

~~**Potential change:** In March board meeting we are looking at a change for days to move from 10 excused absences, and additional 5 mental health days shifting to a total of 8 days before a required dismissal from the nurse, or a doctor's note is required in order to be excused.~~

Page 20

Parents/guardians who drive their children to school are not permitted to walk students to class. Students should be dropped at the front door and walk to class on their own. Special circumstances such as the first day of school for ~~Pre-K and~~ Kindergarten students may be permitted.

Page 23

1. Educational Opportunities for Parents

- a. Workshops will be provided for Title I families. Title I parents will be surveyed and asked for input regarding needed workshops.
- b. Newsletters will be sent home with students containing a variety of helpful hints and information for parents.
- ~~c. A parent resource library is available for parents to borrow educational materials. In addition, booklets and pamphlets are given to parents.~~
- ~~d. The Title I Program will work with other community programs to assist preschool children as they begin school. The school will coordinate activities with its Little Wonders and Partners in Education (PIE) Programs.~~ Wording will be updated based upon language secured from the Federal Title I Grant.

Page 25

HEALTH REQUIREMENTS

Health examinations are required for students entering ~~pre-kindergarten and~~ kindergarten. Exams must be completed within one year prior to the date of entering school. Health examinations and proof of immunizations and a lead screening are due at the time of school registration.

Page 33

Late Stay

Late Stay will be utilized after school ~~until 4:15 p.m.~~ in order to teach students appropriate ways to correct their behavior and to teach strategies to help them meet behavior expectations in the future. Students will be placed in Late Stay when repeated misconduct occurs and or during incidents that are more severe in nature.

STUDENT CONDUCT - ELECTRONIC DEVICES

Appropriate electronic devices, including cell phones and all other smart devices, that are brought to school are to be kept stored away and turned off in student cubbies or lockers during the school day. Such devices are brought at the student's own risk as the school assumes no liability for these items. Electronic devices deemed inappropriate by administration are not to be brought into the building. Electronic devices will be confiscated by administration if the policy is abused and only the parents/guardians may pick them up in the office.

STUDENT CONDUCT – THREATS

Threats will not be tolerated in the Richland County School District. Any student found guilty of making bodily harm or property damage threats will be referred to the RCES threat assessment team and receive appropriate discipline. ~~The local law enforcement agencies may be contacted if the situation warrants this.~~

DISCIPLINARY RESPONSE

**DISCIPLINARY PROCEDURES:
OPTIONS:**

The student is referred to the administrator for appropriate disciplinary action.

The administrator meets with the student and/or teacher and effects the most appropriate response.

A record of the offense and disciplinary action is agency or maintained by the administrator services

DISCIPLINARY

- Conference with parents (by phone or in person)
- Conference with student
- Detention
- Late Stay
- Written assignment
- Withdrawal of privileges
- Referral to an outside district support

~~- Saturday school~~

- In School Suspension

DISCIPLINARY RESPONSE

**DISCIPLINARY PROCEDURES:
OPTIONS:**

The administrator initiates disciplinary action by class investigating the infraction and conferring with the staff and the student about the misconduct and subsequent disciplinary actions to be taken. disruptive youth

Parents will be informed by a discipline report mailed home and/or by conference.

cases

incurred

A proper and accurate record of the offenses and disciplinary actions is maintained by the administrator.

DISCIPLINARY

- Temporary removal from and/or recess
- Alternative programs
 - a. Program for
 - b. Homebound instruction
 - c. Other appropriate district alternatives
 - Financial restitution (in where damage or loss is
- Late Stay
- In School Suspension
 - **Saturday School**
- Out-of-School Suspension
- Suspension of bus privileges (maximum of 10 days)

RCMS 2026-27 Student Handbook Changes

Page 9 *Level II - 1-10 discipline points assigned*

Repeated violation of Level I

3 or more tardies

Abuse of Computer/Internet

Foul/obscene language/gestures

Minor vandalism

Skipped detention

Disrespect/insubordination

Inappropriate Physical Contact

Page 11 **TOBACCO AND SMOKING**

The *Board of Education* and the Administration would like to discourage students from the use or possession of tobacco products because of the apparent hazardous effect upon the health of the individual. To eliminate the element of danger, student use or possession of tobacco products is prohibited on the Middle School campus and private property adjacent to school premises. This includes possession or use of electronic cigarettes/e-cigarettes, vapor pens, and **healthy/vitamin-infused vapor pens.**

Page 14 **ALTERNATIVE EDUCATION PLACEMENT**

The RiseUp Alternative Education Center is an alternative education program for the Richland County Community Unit School District #1 (RCCU 1). According to program policies and district presentations:

1. **Referral Criteria:** Students may be referred to RiseUp if they are not making adequate progress with behaviors or grades and fail to show growth after standard interventions have been implemented.
2. **Placement Duration:** A placement at RiseUp typically lasts from 9 weeks to 1 school year.
3. **Campus Restrictions:** Students attending the RiseUp program are strictly prohibited from being on other RCCU 1 grounds at any time. This includes, but is not limited to, participation in extracurricular activities, attending extracurricular activities, concerts, and dances.
4. **Program Mission:** RiseUp focuses on providing a specialized, individual learning environment that fosters social-emotional skills, introduces career and technical education, includes students in civil engagements, and helps students complete class hours for promotion or graduation.

Page 16 II Grades

- A. All ~~athletes and cheerleaders~~ **student-athletes** are expected to maintain good grades.
- B. ~~Any athlete or cheerleader that does not have a 2.0 out of a 4.0 grade point average of all classes is not eligible until the grade point average of all classes are brought up to a 2.0 out of a 4.0 grade point average. Failing (F) two or more subjects will make the athlete or cheerleader ineligible. Eligibility will be checked every Sunday and will run from Monday through the following Sunday. Each~~

student-athlete must have a 2.0 grade point average out of 4.0 and not have more than one "F" in all their classes. Grades will be checked at the end of each week by the athletic director. Coaches and student-athletes will be notified by the athletic director of any student who is ineligible for the week. The week for ineligibility runs from Monday-Sunday.

Page 19 Students will be allowed **eight (8) excused absences via parent call-in, including up to five (5) absences for mental or behavioral health illness** each year. All absences after **eight (8)** will be considered unexcused absences **unless a note from a medical professional is provided or the student is checked by the school nurse. Nothing other than a documented illness will be considered excused once a student has reached eight (8) parent call-in absences.** Pre-arranged absences and special circumstances approved by the administration will be excused.

PREARRANGED ABSENCES — Parents should call the office when the dates for such absences are known in advance. The student should then obtain advance assignments from his/her teachers and complete as much work as possible in advance. Any tests missed must be made up after the student returns to class. Credit will be given for work completed. Prearranged absences should be limited.

UNEXCUSED ABSENCES — An absence with no parental contact **or after eight (8) excused absences** will be considered unexcused. Truancy and unauthorized absence from school will be classified as an unexcused absence. For each day of unexcused absence, the student will be expected to do the work and learn the material. Credit will be given per Administrative decision, except in the case of suspensions. In this case, the student will be allowed to make up work for full credit.

Page 23 BREAKFAST

Breakfast will be served every school day starting at ~~7:30~~ **7:45** A.M.

Page 25 Students may have a water bottle that closes, containing only water, in their locker. Open drinks or food are prohibited in student lockers. Students are not permitted to have energy drinks during the school day.

Page 27 TITLE I HOME/SCHOOL COMPACT (District-wide)

The Richland County Title I Program envisions the highest level of success for every individual. We make the commitment to motivate, to challenge, and to encourage each student to become the best he/she can possibly be. To accomplish this task, we all need to work together.

Parents -- This school year I will do my best to:

- Read with or to my child on a regular basis.
- Review the papers and notes in my child's backpack nightly.
- Help my child attend school and be on time.
- Keep lines of communication open with the classroom teacher.
- Attend Title I parent/family activities.
- Volunteer as a classroom or library helper.

Teacher/Title I Teacher -- This school year I will do my best to:

- Teach reading and math skills necessary for school success.
- Provide a caring environment where your child will be encouraged to be responsible for his/her own learning and behavior.
- Take into account individual strengths in your child.
- Keep you informed about your child's progress.

- Assist you in helping your child at home.

TITLE I PARENTAL INVOLVEMENT POLICY

The parent is the child's first and most important teacher. The parents' involvement in the child's education is essential for the success of that child. The Title I program is committed to building a strong home-school partnership with Title I parents.

This partnership will begin and be continually strengthened in the following manner:

1. Notification of Selection and Program Orientation

- a. RCMS has school wide programs designed to assist students by primarily improving their math, reading and writing skills as well as motivating students to be lifelong learners. Students are tested annually. Based on test results and teacher recommendation students are targeted for more direct and explicit instruction. Some students require minimal help while others may have greater needs.
- b. The annual parent orientation meeting will be held to explain the Title I program. This offers the opportunity for parents to ask questions, to provide input into the program, and to meet the Title I staff.
- c. The school handbook states all staff are highly qualified and properly certified.

2. Consultation with Parents

- a. Parent conferences are held at a minimum of once a year and at other appropriate times.
- b. Progress of students is sent home each grading period.
- c. Additional communication will be done when necessary by phone, email or the district communication app (Rooms).
- d. Parents will be encouraged to visit Title I classrooms (RCES only) to see the program in action. Parents are asked to notify the principal to arrange a classroom visit.

3. Educational Opportunities for Parents

- a. Workshops will be provided for RCCU #1 families throughout the school year.
- b. Newsletters will be shared with families throughout the school year containing a variety of helpful hints and information for parents.
- c. A parent resource library is available for parents to borrow educational materials.

4. Evaluation and Assessment of Parent Involvement Program

- a. Parents will be surveyed to assess needs and/or interests for the parent involvement program.
- b. Workshops will be evaluated by those in attendance.
- c. The Parent Advisory Committee will meet at least yearly to provide input, feedback, and evaluation regarding the Title I program and the parent involvement programs and activities.
- d. Parents will be given the opportunity to complete a yearly evaluation/survey.

5. Organization of Parent Involvement

- a. The Title I coordinator, Title I teachers, and the Title I parent coordinator will coordinate, organize, and supervise the parent involvement program.
- b. Parent volunteers may be asked to assist at parent involvement programs or in the school.

6. Parent Involvement Training for Title I Staff

- a. An emphasis will be placed on Title I teachers increasing their knowledge and effectiveness in working with parents.
- b. Title I staff will continually attend workshops and share professional literature on parent involvement.

7. Parent Compacts

- a. A copy of the parent compact is in the school handbook.
- b. Both parents and teachers are responsible and accountable for each child's learning.

2026-2027 Parent Handbook Meeting Agenda
 Monday, March 9, 2026
 3:15 PM

Proposed Changes for the 26-27 Student Handbook-

Section 2: Attendance, Truancy, and Tardiness

2.1 General Attendance Information

Current: Students will be allowed 10 excused absences as well as up to 5 additional absences for mental or behavioral health illness of the student, from school. Once the student has reached 10 days absent (excused or unexcused), all other absences will be unexcused unless a note from a medical professional is provided or the student is checked by the school nurse. Nothing other than a documented illness will be considered excluded once a student has reached 10 absences.

Proposed: Students will be allowed 8 excused absences via parent call including up to 5 absences for mental or behavioral health illness of the student, from school. Once a student has reached 8 days absent (excused), all other absences will be considered unexcused unless a note from a medical professional is provided or the student is checked by the school nurse. Nothing other than a documented illness will be considered excused once a student has reached 8 parent call in absences.

Section 5: Instruction and Curriculum Information

5.5 Weighted Courses:

Current	New
DC Composition & Analysis	DC Composition & Analysis
Pre-Calculus/Trigonometry	Pre-Calculus/Trigonometry
Calculus	DC Calculus I
	DC Calculus II
DC Biology	DC College Algebra
	DC Introduction to Statistics
DC General Chemistry I	DC Finite Mathematics
	DC Biology (OCC)
Physics	DC General Chemistry I
	DC General Chemistry II (OGC)

SUMMER 2026

RCHS	Project	Cost
	StraightUp Solar (Fund 10)	\$2,500,000
	Replace Roof Top Units in Ag hallway (Existing Unit #1 and #5)	\$90,000
	Tuckpointing	\$20,000
	Refinish gym floors (RHG 6/26/2026 & Aux Gym 6/24/2026)	\$12,000
	New gutters on Ag (Welding) Shop	\$10,000
	Sewer line outside ag building	\$5,000
	Science pit (limestones cleaning and flush sewer line/descaling)	\$4,000
	Replace (red oak) tree on east side of building (north tree) dying	\$3,000
	Exit Lights rooms 227,125,121,123,161,163,167	\$2,000
	Various Painting	\$1,500
	Install electrical in Ag Lab for air cleaners	\$1,500
	1 additional outlet for each hallway (4) & 1 in 212	\$1,000
	Change 1 sink in room 119 (make deeper)	\$500
	Girls PE Office Down spout leaking	\$500
	Right serving line glass in cafeteria needs replaced	\$500
	Caulk in Aux Gym on panels then repaint	\$500
	Paint interior door of Ag hallway (Exterior)	\$500
	Room 006 Overhead Drainline re-routed to exterior	\$300
	R125 Dimmer Switch install	\$200
	Vape Dector Faculty (1st restroom)	\$50
	Replace Boiler Room Door from Science Commons	\$0
	HS rooftop unit cleaning	\$0
	Clean warmer/fridge on top due to compressors (cafeteria)	\$0
	Touch up stain on Exterior bricks	\$0
	Clean all VAV's	\$0
	TOTAL	\$2,653,050
RCMS	Project	Cost
	StraightUp Solar (Fund 10)	\$900,000
	ENTEC automation Controls	\$424,675
	Seal Parking lot seal and bus lane	\$20,000
	CTE Classroom lab remodel	\$15,000
	Replace Gym mats on walls	\$7,000
	Refinish gym floor (7/16/2026)	\$5,000
	Install Fob entrance on Exit 1	\$5,000
	Lights for pickleball courts (6)	\$5,000
	Install 2 cameras on west side of building for outside	\$4,000
	Sound absorbing panels in cafeteria	\$3,000
	Bus lane concrete curb repair	\$1,000
	Install Basketball Goals (3)	\$500
	Gym Bleachers Hand Rails	\$500
	Kitchen dish washer roll up door	\$250
	Install 4 roof ladders	\$50
	Boys & Girls Bathroom LED lights	\$0
	Camera adjustment (Parking lot)	\$0
	3 windows to install in Office doors	\$0
	Painting pickleball courts	

	TOTAL	\$1,390,975
RCES	Project	Cost
	Install Canopy for Drop Off / Pick Up	\$136,000
	RCES parking lot/sidewalk repairs	\$25,000
	Seal asphalt-RCES faculty lot & playground	\$25,000
	Touch up Paint classrooms/hallway in 300,400,600,500 pod at RCES	\$7,000
	PALS Sensory Room upgrades	\$6,000
	Refinish gym floor (6/18/2026)	\$5,000
	Drain excavation work	\$5,000
	Art room (Inskeep) install new tile	\$5,000
	Science room (Seals) install new tile	\$5,000
	Pallett of mulch for landscaping	\$3,000
	Remove overgrown plant & replant with new plants	\$3,000
	Install Manitowac Ice Machine in Teacher work room	\$3,000
	Replace several exterior signs	\$2,000
	Bogen System replacement	\$2,000
	Painting Bicycle rack and portable exit deck	\$1,000
	Replace Canopy lights	\$1,000
	Playground Dome Installation (Paid for by PTO and installed)	\$0
	Install new classroom blinds (600)	
	TOTAL	\$234,000
RCELC	Project	Cost
	Playground tree removal (limbs falling out of tree)	\$2,000
	Re-paint directional Arrows	\$1,000
	Mulch landscape area	\$1,000
	Various touch up painting areas	\$1,000
	Room 106 backsplash install	\$300
	TOTAL	\$5,300
RiseUp	Project	Cost
	Install dual zones for HVAC	\$5,000
	Re-paint Parking lines	\$1,000
	Touch up paint/drywall	\$1,000
	Touch up holes in siding	\$500
	Powerwash exterior of building	\$250
	TOTAL	\$7,750
Bus Barn	Project	Cost
	Chip/Seal Parking lot	\$8,000
	New Storm door for white building	\$400
	4x6 post replaced/repair (6)	\$250
	Ceiling Tiles in Offices	\$100
	TOTAL	\$8,750

GRAND TOTAL	\$4,299,825
Solar Project Fund 10	\$3,400,000
Minus Maintenance Grant	\$50,000
Total Operations & Maintenance Fund 20	\$849,825